

OUTDOOR
SOUND
ANTENNAS

SERVICE

THE TECHNICAL JOURNAL OF THE TELEVISION-RADIO TRADE

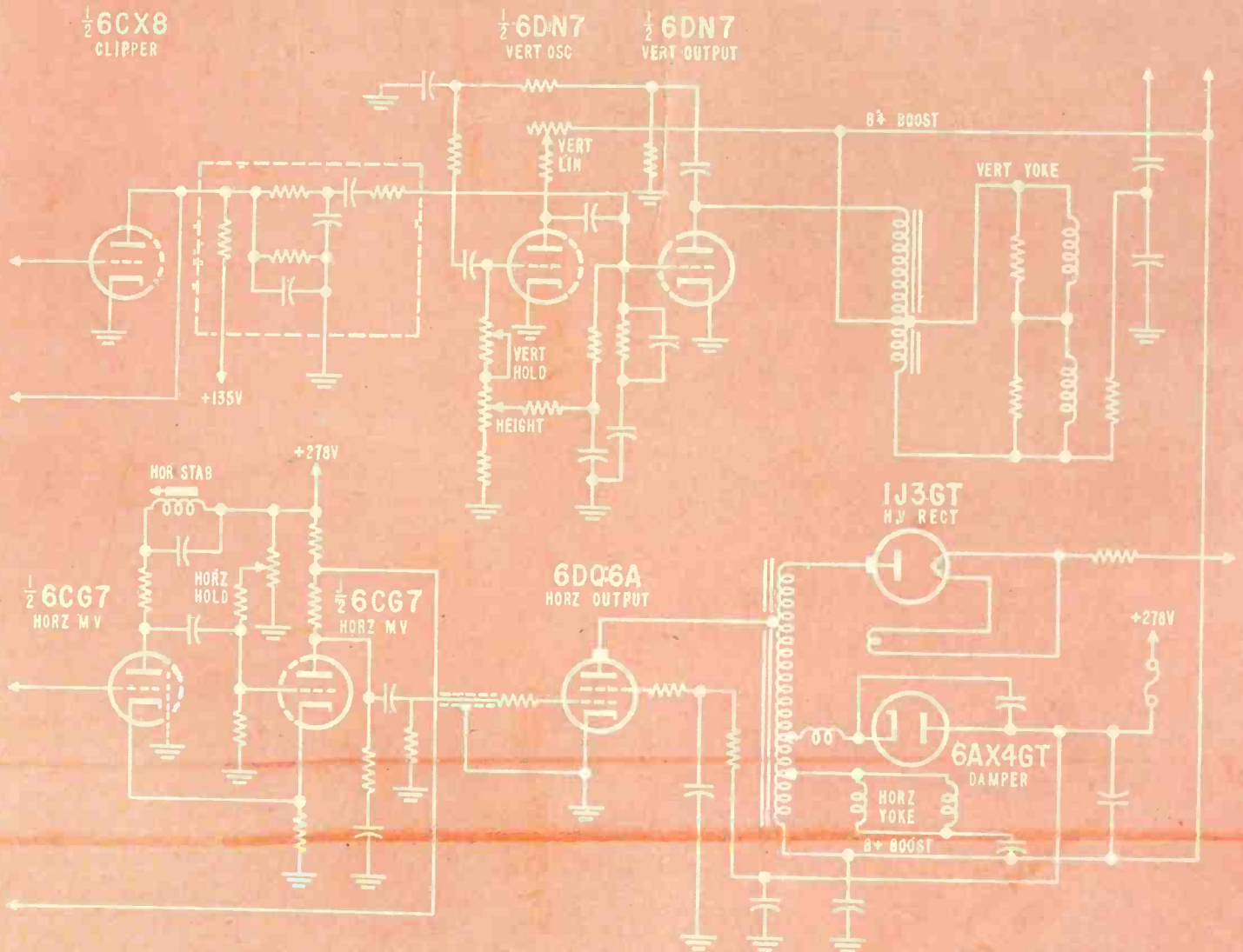

See circuit analysis, this issue

F H FINGADO
 1653 CALIFORNIA ST
 DENVER 2, COLO
 2-60

Introducing



the world's first universal
all-transistor car radio!



Luxurious 24-carat, gold-plated trim plate, knobs and push-buttons. Trimmed in contrasting black enamel. Push-pull 6 x 9 speaker. 12 volts. Model GV800. Specifications subject to change without notice.

MOTOROLA[®] "GOLDEN TRANSISTOR"

Designed to fit most cars on the road

With the greatest car radio advances in 30 years

- 8 lifetime transistors.
- 8 watts of power. More amplification with less distortion. Push-pull circuitry supplies richer, clearer hi-fi sound to speaker.
- Lowest battery drain and highest power output of any car radio. Uses 75% less current than corresponding tube sets.
- Lowest signal-to-noise ratio ever attained in a car radio.
- Plays moment it's turned on. No "warm-up" required.
- Trouble-free operation measured in terms of years.
- Most compact push-button car radio ever built.
- Adjustable shaft centers make installation in most dashes simple.

**More to enjoy means
more to sell from**



MOTOROLA

World's Largest Exclusive Electronics Manufacturer

**POWER TUBES
E-290T**
triodes, tetrodes,
pentodes and beam tubes
— 8 pages.



**MILITARY AND SPECIAL-
PURPOSE TUBES
E-290S**
military, computer,
uhf, hi-fi and pass tubes
— 12 pages.

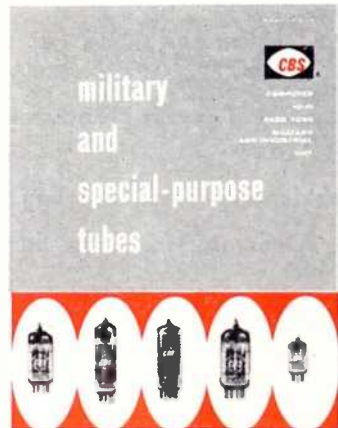

**GAS TUBES AND
POWER RECTIFIERS
E-290C**
gas diodes, gas triodes
and tetrodes (cold cathode
and thyatron) and power
rectifiers — 16 pages.



**PHOTOTUBES AND
PHOTOCELLS
E-290P**
vacuum and gas
phototubes and photocells
— 12 pages.

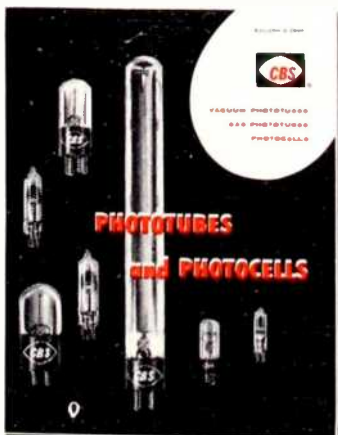

Now...the most comprehensive industrial tube line ...over 400 CBS types!

In keeping with the growing importance of industrial tubes, CBS-Hytron has more than doubled its industrial tube line. Over 400 types make it the most extensive line. For example, CBS-Hytron now offers the widest selection of gas tubes, phototubes and photocells.

The four industrial tube catalogs illustrated include: reference charts with ratings and typical operating conditions, basing and circuit diagrams, and application notes. Ask your CBS-Hytron distributor or write us for the ones you need.



CBS-HYTRON, Danvers, Mass.
A Division of
Columbia Broadcasting System, Inc.

For the best in entertainment tune to CBS

"OUTPERFORMS THEM ALL"



I. J. Saltzman, *Globe Sound Service, Jamaica, N. Y.*, experienced commercial sound engineer, says: "On side by side comparison test, the CJ-44 outperforms them all."

NEW!
ATLAS "King Cobra-Jector"

CJ-44



Shown with GB-1 Universal Mounting Bracket

Complete with "Acousti-Match" Built-in Driver Unit

List \$72.50

NET \$43.50

A wide-angle, all-purpose, all-weather Public Address Speaker, complete with integral high-power super-efficient "Acousti-Matched" driver unit. "Acoustic-Matched" means "Controlled Response" within the frequency limits most useful in P. A. and high level music reproduction. "Controlled Response" offers conversion efficiency never before obtainable in high-powered speakers. "Controlled Response" results in *smooth* reproduction — free from peaks which so often create and sustain acoustic feedback.

The CJ-44 conserves costly amplifier output power — fewer speakers do a complete job. The speaker horn is easily rotated for horizontal or vertical dispersion patterns.

The CJ-44 is the only high-powered P. A. speaker that can be equipped with the new Atlas Universal Mounting Bracket, permitting quick and secure directional adjustment on both planes. Simple to make a horizontal or vertical adjustment as a final "touch-up" to the installation.

The CJ-44 is designed for the "tough jobs." No gimmicks, no fluffs, no wild claims — just a reliable super-efficient speaker for all applications.

Input Power: 30 watts constant
50 watts peak

Input Impedance: 16 ohms

Response: 150-9,000 cps

Dimensions: Bell 23" x 13";
Over-all length 19"

Net Weight: 16 lbs.

Write for free Catalog 58.



**ATLAS
SOUND CORP.**

1442-39 St., Brooklyn 18, N. Y.
Atlas Radio Ltd., Toronto, Canada

Vol. 27 No. 6

JUNE, 1958



SERVICE

THE TECHNICAL JOURNAL OF THE TELEVISION-RADIO TRADE
Including RADIO MERCHANDISING and TELEVISION MERCHANDISING
Registered U. S. Patent Office

Page

FEATURES

- 9 This Month in SERVICE
- 10 New Designer Series TV Sets Feature Easy Serviceability
(Cover Circuit) Norman Szeremy
- 12 Ultra - Modern Roosevelt Raceway Features Low - Level Outdoor
Sound System Norman H. Crowhurst
- 14 Counterbalancing-Principle Fringe Antenna Bob Raynor
- 17 New Bar Generator for Color Servicing Irving Rebeschini
- 18 Design and Installation Techniques for Outdoor Public Address
Systems Louis S. Hoodwin
- 20 New Multi-Set TV Antenna Coupler Simon Holzman
- 22 Books and Catalogs
- 23 Association News
- 27 Tube News
- 28 Antennas and Accessories
- 30 Servicing Two-Band Transistor Radios Carl Finzer and
Leroy Wolff
- 32 New Industrial Sound System Techniques Leo G. Sands
- 34 Sync Clipping in Community TV Systems Jack Darr
- 37 Outdoor Sound Equipment
- 40 Operation and Servicing of Dry Batteries J. J. Coleman

CIRCUIT DIAGRAMS

- 20 Autotransformer-Type Two-Set Antenna Coupler
- 38 Common Emitter Transistor Amplifier Circuit
- 11 General Electric Designer Series TV Chassis
- 20 JFD AC-40 Two-Set Antenna Coupler
- 31 Motorola Noise Generator for Transistor-Radio Servicing
- 30 Motorola 6X39 Portable Transistor Radio
- 20 Resistive-Type Two-Set Antenna Coupler
- 32 70-Volt Constant-Output Paging System

ADVERTISERS IN SERVICE

© 1958 by Bryan Davis Publishing Co., Inc. All rights reserved.

Second-Class mail privileges authorized at New York, N. Y.; additional entry at the Post Office, Norwalk, Conn. . . . Subscription price: \$2.00 per year (\$5.00 for 3 years) in the U.S.A. and Canada; 25 cents per copy, \$3.00 per year in foreign countries; 35 cents per copy.



Editor
Solomon R. Kunis

Associate Editor
David E. Pearsall II

Consulting Technical Editors
Howard Jennings
Arnold Gewirtz

Field Editor (Midwest)
Rudolph T. Plemich

Art Director
Anthony R. Aliffi

Supervisor, Circuit Diagrams
Michael D. Bellezza

BUSINESS DEPARTMENT

Advertising Manager
Aaron L. Lafer

Assistant Advertising Manager
Astrid Kelly

Business Manager
B. S. Davis

Assistant Business Manager
B. Early

Circulation Manager
A. Goebel

Assistant Circulation Manager
A. Kiernan

Mailing Supervisor
L. Trubia

PACIFIC COAST

Leo Sands, District Manager
920 Commercial Street
Palo Alto, California
Tel.: YOrkshire 8-4478

Published Monthly by

Bryan Davis Publishing Company, Inc.
52 Vanderbilt Ave., New York 17, N. Y.
Tel.: MURray Hill 4-0170

B. S. Davis, Pres. A. Goebel, Secy.



Printed in U.S.A. by
O'Brien Suburban Press, Norwalk, Conn.

Carefully Balanced Packaged Circuit Inventory

with the

NEW **Centralab**

PCK-40

Kit



With almost eighty million Centralab packaged circuits (identified by PEC*) already incorporated in TV chassis, packaged circuit replacement is getting to be bigger business for you all the time. Make it extra profitable by avoiding special trips and phone calls to your distributor.

The carefully balanced inventory of the new Centralab PCK-40 Kit covers 80% of your PEC* needs. You'll have the circuit you need, on hand, *when you need it*. The Kit contains 40 PEC*, divided among 14 of the most frequently used types, each in its individual rigid plastic package. They are conveniently arranged, for instant identification, in a rugged metal cabinet.

Ask your distributor to show you the new Centralab PCK-40 Kit now, with the FREE cabinet and handy guide. Price \$26.93 dealer net.

Centralab products are listed in PHOTOFACTS, COUNTERFACTS, and THE RADIO-ELECTRONIC MASTER. PEC* Guide No. 4 available on request from your local distributor or direct from Centralab.

Centralab

*Trademark  Y-5832

A DIVISION OF GLOBE-UNION, INC.
934F E. KEEFE AVE. • MILWAUKEE 1, WIS.
In Canada: Mt. Pleasant Rd. • Toronto, Ontario

**SWITCHES • PACKAGED ELECTRONIC CIRCUITS • CERAMIC CAPACITORS
CONTROLS • ENGINEERED CERAMICS • SEMI-CONDUCTOR PRODUCTS**



BUSS FUSES *can help protect your reputation
for sales and service*

When you sell or install BUSS fuses — you help avoid 'kicks' or complaints from customers that the fuses you furnish fail to protect when trouble occurs — or that the fuses blow needlessly.

BUSS fuses provide dependable electrical protection under all service conditions because . . . every BUSS fuse is tested in a sensitive

electronic device that automatically rejects any fuse not correctly calibrated, properly constructed and right in all physical dimensions.

Why take a chance with your good name by furnishing fuses that might be faulty? Standardize on genuine BUSS fuses. They protect your profits and reputation.

To meet service needs . . . there's a complete line of BUSS fuses, — plus a companion line of fuse clips, blocks and holders.

For more information on BUSS and FUSETRON Small Dimension fuses and fuseholders, write for bulletin SFB.

BUSSMANN MFG. DIVISION
McGraw-Edison Company
University of Jefferson, St. Louis 7, Mo.

BUSS fuses are made to protect — not to blow needlessly

S-658



A COMPLETE LINE OF FUSES FOR HOME, FARM, COMMERCIAL, ELECTRONIC, AUTOMOTIVE AND INDUSTRIAL USE.

NOW... AN *Electro-Voice*[®] PUBLIC ADDRESS SPEAKER FOR ANY APPLICATION

For SUPERIOR SOUND ... CONTROLLED COVERAGE

See Electro-Voice public address projectors. They offer perfect voice penetration and full-range "musicasting." They're weatherproof, splashproof and blastproof.

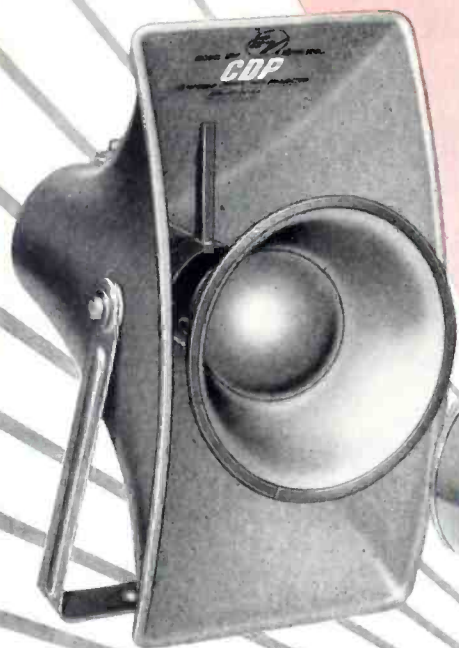

\$75.00
LIST

Model 848LT Long Throw CDP* (With 1000-cycle concentrating horn). For projecting intelligible, extended-range sound over great distances.

*CDP (Compound Diffraction Projection Design Patent 169,904. Additional Patent Pending.

Model 844 30-Watt Paging Unit. Compact, economical unit for quality, high-efficiency voice reproduction.

\$34.50
LIST

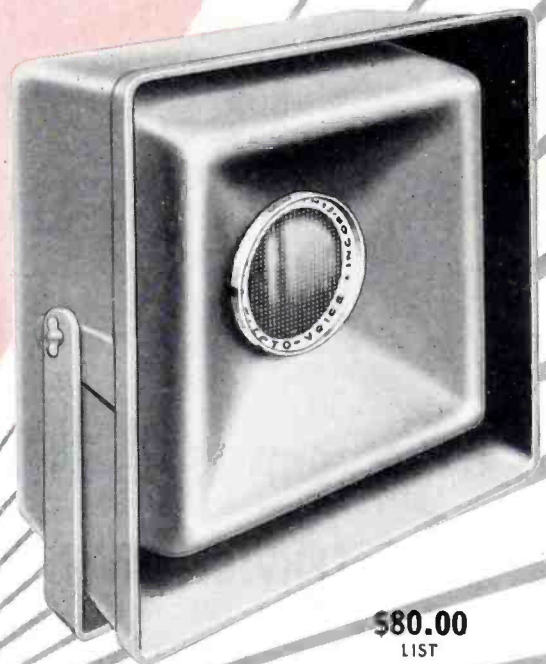

\$80.00
LIST

The New Electro-Voice Musicaster. Rugged, weatherproof high-fidelity speaker system for high-quality music reproduction.



Model 848 30-Watt CDP. For wide-angle coverage and extended range. Standard of the industry.

\$75.00
LIST



Model 847 25-Watt CDP. Smaller version of Model 848.

\$46.33
LIST



Model LS-12. For interior installations requiring full-range response.

\$32.50
LIST



Model LS-8. Smaller version of Model LS-12.

\$30.00
LIST

THESE ELECTRO-VOICE MICROPHONES ARE
ESPECIALLY OUTSTANDING FOR PUBLIC ADDRESS



\$85.00
LIST

Model 664 Cardioid Dynamic. Broadcast-quality for every public address installation.



\$49.50
LIST

Model 951 Cardioid Crystal. Excellent, wide-range, all-purpose microphone.

The Sound of Electro-Voice... Assures Superior Installations, Customer Satisfaction, Your Reputation!

Electro-Voice[®]

ELECTRO-VOICE, INC.
BUCHANAN, MICH.

In Canada: E-V of Canada Ltd., 73 Crockford Blvd., Scarborough, Ontario
Cables: ARLAB

YES! WE HAVE

STILL NO PRINTED CIRCUITRY IN CHASSIS



Even though Dr. Alexander Ellett, head of Zenith's research department, is recognized as the daddy of printed circuitry through his work on radio proximity fuses, still Zenith uses no printed circuitry in its TV chassis because it means more service headaches and often causes service delays.

LESS SERVICE HEADACHES FOR SERVICEMEN

Easier to service...more accessible

ZENITH'S **HANDCRAFTED**
SERVICE-SAVER **HORIZONTAL**
CHASSIS WITH **NO PRINTED**
CIRCUITS IN THE CHASSIS

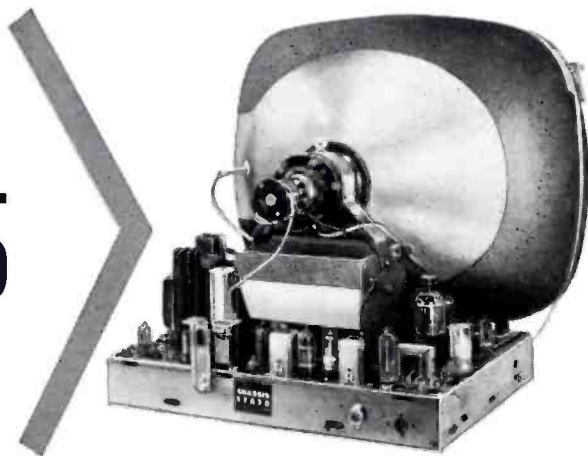

We think it's worth the extra cost of HANDcrafted standard circuitry to get the best performance and fewer service headaches and so do thousands of dealers who would sooner sell customer satisfaction than a price tag.



ZENITH RADIO CORPORATION, Chicago 39, Illinois

The quality goes in before the Zenith name goes on.

Backed by 39 years of leadership in radionics exclusively.

Also makers of Radio, High-Fidelity Instruments and fine Hearing Aids.

NO PRINTED
CIRCUITS IN
ZENITH
TV CHASSIS

**ZENITH HANDCRAFTED
STANDARD CIRCUITRY
COSTS MORE BUT IT MEANS MORE
SATISFIED CUSTOMERS FOR
ZENITH DEALERS AND SERVICEMEN**

QUALITY BY

ZENITH®

THE ROYALTY OF TELEVISION

NEW, IMPROVED



1B3GT

Made possible by

RUGGED, RAYTHEON FLY-BACK LIFE TESTS

At Raytheon, we test tubes to find out how *good* they are, not how bad. Accepted methods of testing tubes like the 1B3GT often resulted in subpar tubes. To improve and maintain the quality of Raytheon 1B3GT Tubes, Raytheon developed an expensive but super-accurate method of life testing these tubes.

Tests on the improved Raytheon 1B3GT far exceeded our expectations. Receiver life tests of the Raytheon 1B3GT showed not a single failure at 600 hours. (No worries about early life tube failure here.) At 1850 hours a sensational 93% of these tubes were still operating at rated efficiency in spite of the fact that *these sets were operated at 10% above their rated line input and cycled on and off every two hours.*

These torturous Raytheon Tube tests not only prove the quality of Raytheon Tubes, they help maintain

that quality. Tubes are constantly checked and tested and any variance in quality is instantly noted and quickly corrected.

That's why you can use Raytheon TV and Radio Tubes with complete confidence in their quality — with full knowledge that you are giving your customers tubes that are **RIGHT . . .** for Sound and Sight.

New Raytheon 1G3GT, 1J3GT and 1K3GT Tubes

are also subjected to the Raytheon Fly-Back Tests—and as a result meet Raytheon's highest standards of quality. Ask your Raytheon Tube Distributor for them.



RAYTHEON MANUFACTURING COMPANY

Receiving Tube and Semiconductor Operations

NEWTON 58, MASS.
55 Chapel Street

CHICAGO, ILL.
9501 Grand Ave. (Franklin Park)

ATLANTA 6, GA. 1202 Zonolite Rd., N.E.
LOS ANGELES 7, CALIF. 2419 So. Grand Ave.

Raytheon makes
all these

Receiving and Picture Tubes, Reliable Subminiature and Miniature Tubes,
Semiconductor Diodes and Transistors, Nucleonic Tubes, Microwave Tubes.



Excellence in Electronics

THIS MONTH IN SERVICE

ELECTRONICS CONTINUES GROWTH--A new record has been established by electronics manufacturers during the fiscal year 1957-58, reaching an estimated \$7.5 billion level compared with \$5.7 billion recorded during the previous year, EIA Marketing Data Policy Committee said in an annual report delivered in Chicago during the Association's 34th annual convention on May 22. . . . The costs of installing and servicing electronic equipment has now reached over \$2.6 billion, EIA Service Committee reported. . . . Exports of American radio and television broadcast station equipment, it was reported, were valued at nearly \$11.2 million last year, a gain of approximately \$3 million from 1956. . . . Despite "transitory setbacks" during the past year, "the growth potential of the electronics industry is as sound as ever," Dr. W. R. G. Baker, president of the Electronic Industries Association, concluded.

RIAA ESTABLISHES STEREO STANDARDS--The Record Industry Association of America has established a set of standards for stereophonic records. The cutting system to be used will be the 45°-45° Westrex method in which the two recording grooves are cut at angles of 45 degrees from the surface of the disc. The recommended tip radius for playback needles has been set at 0.5 mils.

FIRST QUARTER BUSINESS UP--First quarter profits of Zenith Radio Corp. jumped 23 per cent and sales, 15 per cent from a year ago, stockholders were told at the company's annual meeting last month. . . . Winegard Co. sales have increased 9.6 per cent in the first quarter of 1958 over the same period in 1957, according to president John Winegard. . . . The Burlington, Iowa, antenna manufacturer said that the quarter's gain was made this year despite a slow start in January due to "bad weather." . . . General Instrument Corporation recorded the highest sales in its 35-year history and per-share earnings double those of the previous year, board chairman Martin H. Benedek told shareholders in the Annual Report issued on May 29.

JUNE IS PORTABLE RADIO MONTH--For the fifth consecutive year, June has been designated as Portable Radio Month by the broadcast industry and radio battery manufacturers. . . . Intended to promote the use and sale of portable radios through publicity on network and local radio and in the newspapers, Portable Radio Month emphasizes the fun of outdoor radio entertainment with music plus informative weather and news reports. . . . This year, Portable Radio Month will also accent the variety of styles, colors and sizes of today's high quality portables.

TWO-WAY RADIO AIDS CRIME FIGHTERS--A new pocket-size two-way radio system developed by the Radio Corporation of America soon will be aiding New York City policemen in their fight against crime in the city's sprawling 34,000-acre park system. . . . The unit, which can be carried in the pocket or clipped to the belt, and has a range of up to two miles, will enable the wearer to summon help from any spot on his beat. . . . The Tuscan Hotel, which was first in the country to introduce such features as telephones in every bathroom and walkie-talkies for the staff, has now become the first hotel in the United States to install color television in every guest room, Robert A. Seidel, RCA's executive vice president, consumer products, announced last month.

STYLING TRENDS MAY STABILIZE ANTENNAS--The highly competitive indoor antenna market may be starting on the road to stability if television manufacturers continue their present styling trends, Edward J. Finkel, secretary-treasurer and sales manager of JFD Manufacturing Co., Brooklyn, N. Y., predicted recently. . . . He indicated that with the introduction of the built-in antennas, antenna manufacturers will exercise tighter control over their products in the replacement market.

BATTERY-OPERATED TV IN NEAR FUTURE--Portable television sets that run on batteries and transistors will be on the market in the near future, it was predicted today by the Westinghouse television-radio division. . . . E. J. Kelly, general manager, reported that Westinghouse now has a laboratory model that uses 23 transistors instead of vacuum tubes, and can operate either on house current or rechargeable batteries.

New Designer Series TV Receivers Feature Easy Serviceability

[See Front Cover]

By NORMAN SZEREMY

Production Engineer, Television Receiver Dept., General Electric Co.

THAT ALL TELEVISION receiver manufacturers know and appreciate the Service Man's problems is a recognized fact. That serviceability should ever become a major TV set design consideration may have seemed a remote prospect. Close examination of the new Designer series^o 17-in. and 21-in. TV sets will reveal that a major step has been taken toward service simplification. A full-chassis TV set has been designed with ease of servicing previously found only in table model radios.

From its beginning, serviceability was one of the Designer series most important design objectives. It was decided that these sets should excel in all three major areas of service: presale adjustments, house calls, and bench work.

Presale Adjustments

Presale adjustments of the Designer series TV sets can be made with a minimum amount of effort and time. Three features contribute to this desirable fact. First there is no critical ion trap adjustment. The sets are equipped with straight gun picture tubes that give a better overall focus quality without the use of an ion trap.

Secondly, all local oscillator adjustments are easily accessible after the removal of only the channel selector and fine-tuning knobs.

Finally, the Designer series is equipped with a dust seal, so that the nuisance of cleaning the picture tube face, particularly from shipping dust, is non-existent.

House Calls

House calls are the most frequent occasions when a serviceman has to work on a TV set. Therefore, designing a set to facilitate the rapid completion of a service call is especially important.

The Designer series has a number of features that make troubleshooting

easy and minor repairs completely a matter of routine.

Because the Designer series TV sets are equipped with full power transformers, burned out filaments are instantly recognized. Every major supply circuit has at least one wire wrap terminal eminently good for voltage and resistance checks. This design features three separate printed-circuit boards: one for the signal circuits, one for the sweep and sync circuits and a new video detector board. A conventionally wired horizontal output circuit and a tuner, provide easy separation of circuits and localization of B-plus or other shorts.

The complete sweep output sub-assembly B-plus is separately fused. All paper capacitors are the standard tubular type rather than standoffs with easily accessible ends for testing from the component side of the printed boards.

The audio system can be aligned easily on a commercial TV signal

without instruments. Most important of all, with only the back removed and the chassis still secured in place, any of the standard components (tubes, resistors, capacitors) can be replaced easily with the single exception of specific tuner parts.

Bench Work

With only the back removed from these new Designer sets, every circuit and component has at least one easily accessible point where measurements can be made. This accessibility is evident in Fig. 1 which shows a Designer set with the back removed and the entire chassis exposed within easy reach of the Service Man.

Many of the objections so frequently voiced by Service Men to printed-board design have been overcome. By careful arrangement of the supporting surfaces and generous clearance holes in the chassis, all solder areas are within easy reach of the normal small soldering iron. A new concept in printed board layout has resulted in relatively large contact areas making

(Continued on page 24)

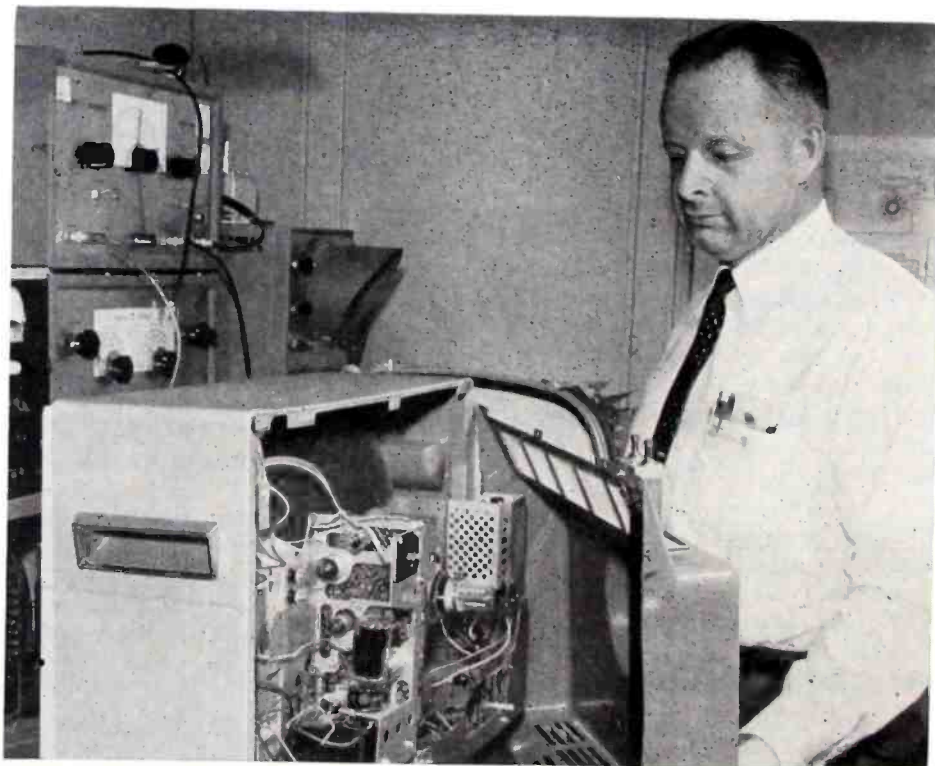

FIG. 1: THE NEW GENERAL ELECTRIC Designer series TV sets feature a two-section cabinet design. With back removed for servicing, the entire front, back, sides and bottom of chassis are exposed to easy reach of the Service Man.

^oManufactured by General Electric Co.

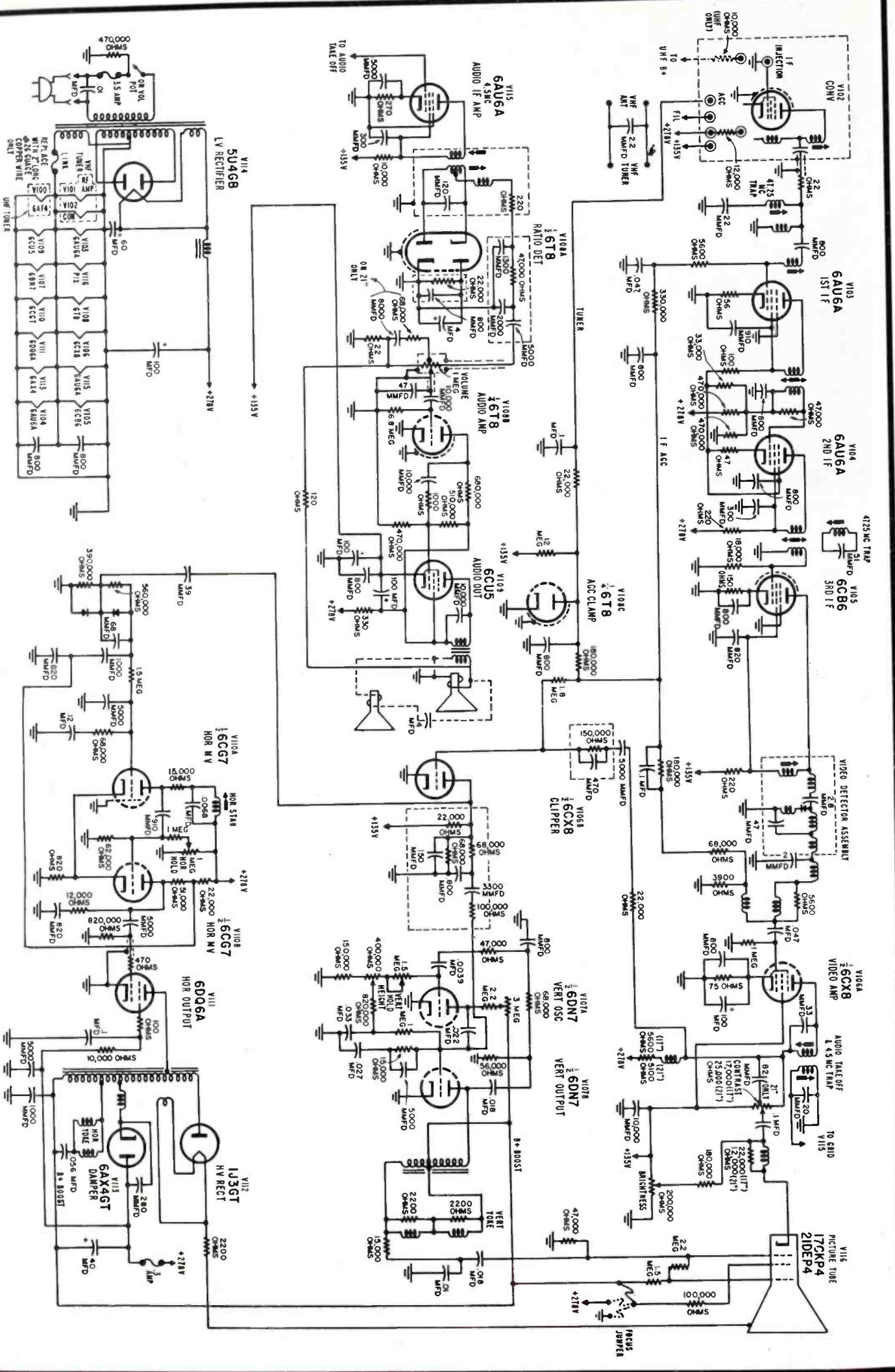

FIG. 2: SCHEMATIC DIAGRAM of General Electric Designer Series TV Chassis available in both 17-in. and 21-in. models.

Ultra-Modern Roosevelt Raceway Features Low-Level Outdoor Sound System



By NORMAN H. CROWHURST

MODERN OUTDOOR SOUND installations are a far cry from the shrill squawk boxes that used to be found at sports arenas and street-corner rallies ten or fifteen years ago. Today efficient sound systems, carefully designed and engineered, provide listening comfort for large audiences spread over wide areas.

A recently completed sound installation exemplifying this trend is the famed Roosevelt Raceway at Westbury, Long Island which caters to New York's harness racing fans. The modernized styling of this multi-million dollar racing plant required an efficient, unobtrusive sound system, and Watkin Sharp^o who designed the installation, met this challenge.

The sound system is low level throughout and utilizes approximately 2000 speakers strategically located in the stands, enclosed areas and dining rooms. This makes it possible for the racing fan to hear the trotting calls, post time, race results and program music anywhere in the large arena.

It is even possible for the more affluent trotting fancier to see and hear the entire racing program without leaving his table in the fabulous glass-enclosed Cloud Casino restaurant. The hearing part is made possible by means of flush-mounted 8-inch speakers¹ which are unobtrusively blended into the ceiling decor. Because of the stepped flooring, the ceiling height

varies throughout the restaurant, but this is taken care of by suitable adjustment of the power distribution.

A similar method is used in the lower restaurant, but this is far less ideal acoustically. The ceiling is rather low and it seems over-reverberant to sounds from the adjoining kitchen and conversation. Accordingly a larger number of units are used to overcome this difficult spot, by working at really low level.

The spacious and lofty entrance area is likewise served by ceiling units. Careful attention to height and area differences, making due compensation by feeding individual units at varying levels to suit, results in very pleasingly uniform coverage and freedom from an undesirable degree of reverberation.

Almost half of the main stand area

is enclosed behind an enormous vertical glass front, like the luxury dining area. This creates a reverberation problem that did not exist with the older type open-front stand, because the area is now an enormous box to fill with sound, of which one of the major surfaces is glass (see Fig. 1a). This has been very successfully solved with speaker units¹ mounted in long boxes, as shown in Fig. 1b. Each of these makes a *line radiator* that tends to radiate into a cylindrical area.

The glass front and the back part of the roof are in the *dead* part of the radiation pattern, thus avoiding the major problem surfaces. The speakers are arranged at intervals along the length of the stand so their service areas overlap. When you consider the number of units used, this amounts to a low-level system. The sound is only fed to the audience area, not to the unwanted reflection

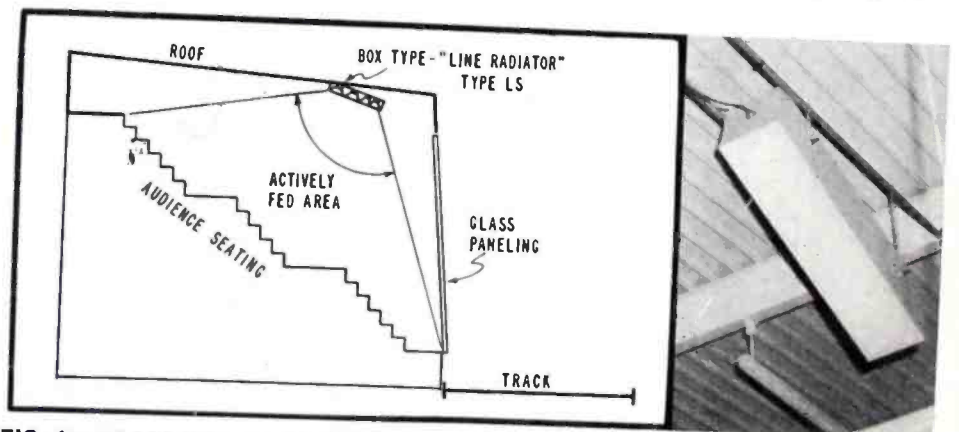

FIG. 1a: GLASS-ENCLOSED GRANDSTAND presented a difficult acoustic problem as illustrated in sketch above. Fig. 1b pictures the Jensen line radiator box unit which solved problem by channeling sound away from glass panel and roof.

^oVocalaire, Inc.

¹Manufactured by Jensen.

areas, although a first glance at the relatively large distance from speaker to audience makes it look more like a high-pressure system.

Many of the corridor areas and refreshment areas are served by flush-mounted ceiling units of the same type and styling as in the dining room areas. But some spots, particularly the spaces provided in front of the lines of betting windows could not be adequately served by ceiling-mounted units. These spaces are large as well as high and are entirely concrete-surfaced. The overhead air conditioning system and concrete support pillars would also obstruct sound from ceiling-mounted units.

Satisfactory low-level coverage of these areas has been achieved decoratively by use of a spherical baffle² developed especially for this job and shown in Fig. 2. This enables the loudspeakers¹ to be brought down unobtrusively to a much lower level than ceiling mounting would permit and avoids feeding the useless empty concrete-lined space with sound.

Another interesting feature of this PA system is that some of the loudspeakers are wired for speech reproduction only and require equalization of the output of their associated amplifiers. Other loudspeakers require equalization of speech and full-range music, and still a third wide-range group of speakers, serving the outer grandstand (see Fig. 3), are used for music reproduction only. The above requirements called for the creation of equalized speech circuits only, combined equalized speech and full-range music circuits, and full-range music circuits only. These requirements were met through the use of a large number of isolation amplifiers.

In addition to the main system for the public, there is an auxiliary system which links all the betting booths throughout the park. This provides instructions for booth operators from a central transmitting point. This information is received over small inter-

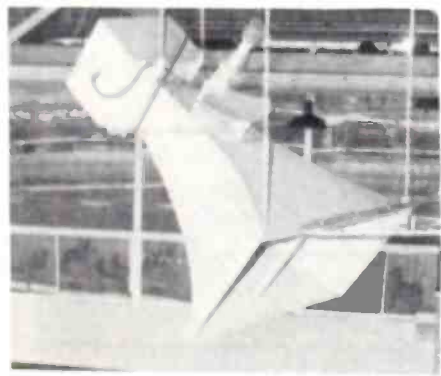

FIG. 3: CUSTOM-BUILT WOOFER coupled with Altec tweeter used to provide full-range music reproduction in grandstand.



FIG. 2: SPHERICAL BAFFLES suspended from unfinished ceiling at left and flat fixtures at right are employed in areas where flush ceiling mounting could not be utilized. Both types of fixtures were designed by Soundolier and contain Jensen speakers.

com units⁴ located in each booth.

An audience of fans, each somewhat noisily intent on seeing his favorite trotter win, requires feeding considerable audio power—even in a low-level system. The audio power house at Roosevelt Raceway has row upon row of special 60-watt amplifiers³, each feeding its own section of the total load, plus an adequate number of spares.

A speaker line patching bay provides for throwing any spare amplifier into service when any particular amplifier goes bad. The amplifiers are mounted in convenient slide-out racks so they can be removed for service. Another good unit can be inserted to continue maximum service reserve until the faulty one has received attention elsewhere.

Incoming microphone lines, plus tape and phono sources, are handled by a similar versatile patching panel and mixer in another control room. This panel is located just behind the central control area for the raceway, in a front roof section which affords a full view of the entire track and is out of the way of the audience's line of vision.

The input control is rendered as foolproof as possible by having the control key positions clearly announced to the operator by a system of indicator lights. Faders use a type of control widely employed in sound

console mixers, giving at-a-glance indication of the individual control positions.

Controls between the preamplifier-mixer section and the feed to power amplifiers, feeding individual loudspeaker lines, enable the level fed to different sections to be adjusted independently, so optimum sound distribution can be maintained at all times.

Relative levels between units on the same line, feeding different sections of the same general area are adjusted so that the correct *relative* level is obtained locally by line matching transformers.

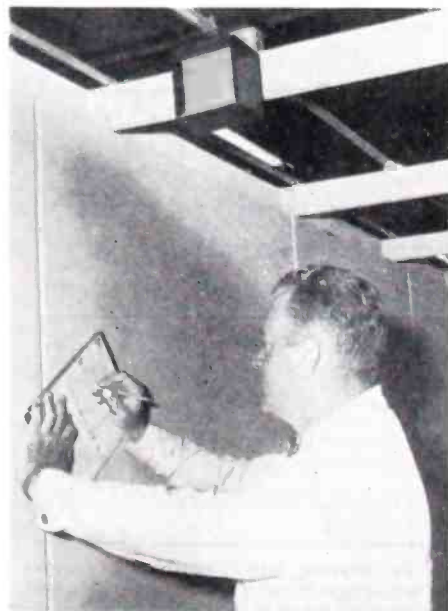

FIG. 4: AUXILIARY SOUND SYSTEM provides information to betting booth operators through Webster Electric intercom units shown above.

¹Manufactured by Soundolier.

²Manufactured by Altec-Lansing.

³Manufactured by Webster Electric.

⁴Manufactured by McIntosh.

Counterbalancing-Principle Fringe Antenna

by BOB RAYNOR

Vice President, Sales and Engineering,
Clear Beam Antenna Corporation

AS A NATURAL OUTGROWTH of increasingly heavier saturation, TV antenna manufacturers generally have had to reach out further and further into the fringe to find new markets. As a result, the greatest percentage of new antennas which have been introduced on the market, in the past several years, have shown a tendency to become not only more powerful but also more expensive.

With the long-awaited replacement market finally beginning to take shape in numerous areas, many Service Men have met with sales resistance when they attempt to sell expensive fringe arrays. What has been needed therefore has been an antenna which will out-perform the inexpensive two-bay conical in the fringes but which is priced within a logical step-up range.

Developing Yagi Antenna

Unfortunately this is considerably easier said than done. To develop a Yagi-style antenna which equals or out-performs a two-bay conical has required, until recently, rather complicated and therefore expensive configurations.

The basic problem in designing a high-gain all-channel fringe antenna is to develop an array which provides only positive voltages on both the high and low channels. Since television antennas operate on dipoles cut to one-half wave length, it is ob-

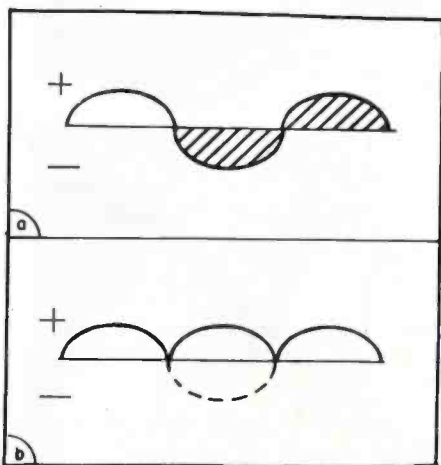

FIG. 1a: WAVE DISTRIBUTION developed when low-band dipole is operated on high band. Diagonal lines indicate cancellation effect. Wave distribution developed when low-band dipole is operated on high band in conjunction with a high band reversal device is shown in Fig. 1b.

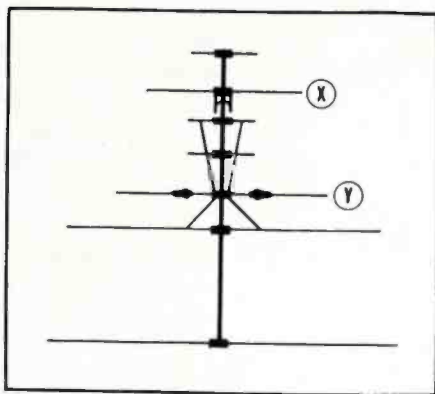

FIG. 2: ELEMENT CONFIGURATION utilizing counterbalanced antenna principle. Dual side-by-side director and dual reflectors at X and Y develop extra-high voltages on the high band.

vious that a dipole cut for the low band, would be oversized if operated on the high band. In practice a three to one ratio is generally utilized so that the length of the low band dipole would represent $1\frac{1}{2}$ half-wave lengths on the high band.

Due to this extra length, one-third of the dipole produces negative voltages as illustrated by the portion of the wave below the line in Fig. 1a. As also can be noted by the shaded area in this figure, the negative voltage shown below the line cancels out an equal amount of voltage above the line, thus in theory leaving a configuration which is the equivalent of a simple single half wave dipole. Although this configuration might be strong enough to produce acceptable reception in primary areas, it is quite objectionable if it is to be utilized for all-channel fringe-area reception.

Reversing Negative Voltage

In order to overcome this problem, most fringe antennas attempt to reverse the negative voltage and produce a low-band dipole which provides three positive voltage half waves when the low-band dipole is operating on the high band. The end result of what is achieved is shown in Fig. 1b. Although many fringe antennas accomplish this successfully, they require intricate cross-harnessing arrangements, wave-reversal plates or similar devices which tremendously increase the materials, labor and end cost of the antenna.

In recent experiments conducted by Dr. Jan Kobler, who has received

°°Produced by Walsco Electronics Mfg. Co.

much acclaim for his development of the Wizard° series of fringe antennas, it was learned that it was possible to utilize a counterbalancing of voltages and thereby eliminate the necessity of wave reversal. Since wave reversal configurations were the chief cause of increased cost in fringe antennas, their elimination could provide antenna arrays which would find a more ready market acceptance.

The operation of a new fringe antenna°° which does not require wave reversal is illustrated in Fig. 2. Instead this counterbalanced array utilizes (see X & Y in Fig. 2) a dual side-by-side director and dual reflectors to develop extra-high positive voltages on the high band. The high-band section of the antenna is then isolated from the low-band portion of the antenna by utilizing two separate delta matching harnesses. In essence this creates two separate antennas, one for the high band the other for the low both mounted on the same boom with integrated parasitic directors and reflectors.

Balancing Voltages

As indicated by the wave pattern in Fig. 3, the excess positive voltage created in the high-band portion of the antenna balances out the negative voltage created on the low band portion of the antenna. The end result of the counter balancing produces a wave form which in essence is the equivalent to that produced by wave reversal. For additional gain the entire array utilizes extra-wide element spacing.

Both single and two-bay conicals are used at present in the marketing area for which the counterbalanced antenna is designed. Comparative tests indicate an average 4 db gain of the counterbalanced antenna over the corresponding standard type.

°°Clear Beam's Dura-Gold Corvette.

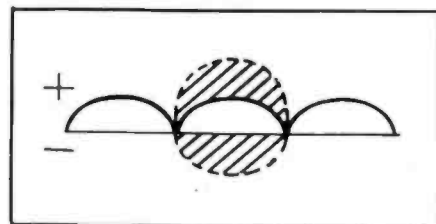
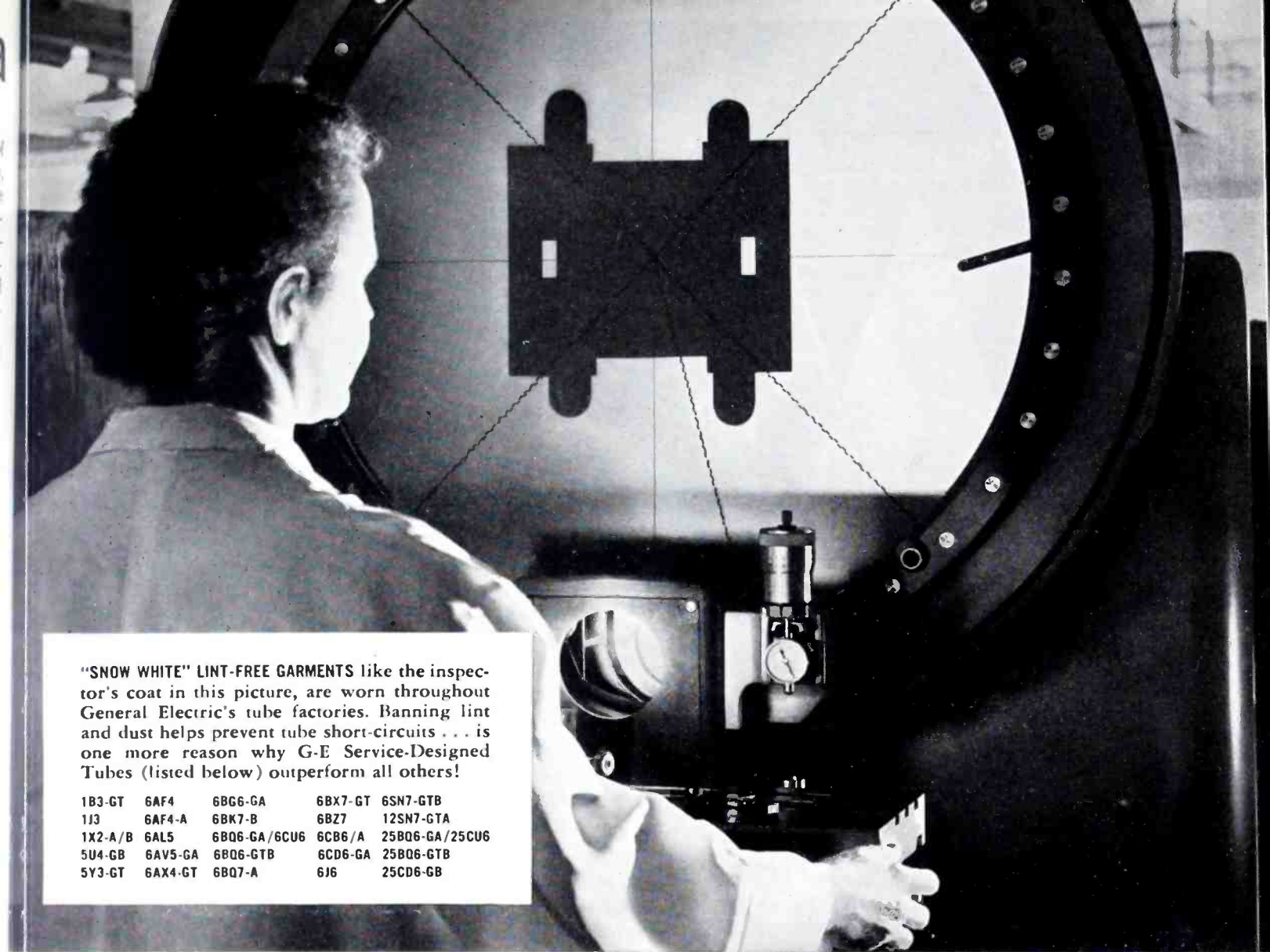

FIG. 3: WAVE DISTRIBUTION developed when low-band dipole is operated on high band and where dipole is utilized in counterbalanced antenna configuration. Diagonal lines indicate cancellation effect.



"SNOW WHITE" LINT-FREE GARMENTS like the inspector's coat in this picture, are worn throughout General Electric's tube factories. Banning lint and dust helps prevent tube short-circuits . . . is one more reason why G-E Service-Designed Tubes (listed below) outperform all others!

1B3-GT	6AF4	6BG6-GA	6BX7-GT	6SN7-GTB
1J3	6AF4-A	6BK7-B	6BZ7	12SN7-GTA
1X2-A/B	6AL5	6BQ6-GA/6CU6	6CB6/A	25BQ6-GA/25CU6
5U4-GB	6AV5-GA	6BQ6-GTB	6CD6-GA	25BQ6-GTB
5Y3-GT	6AX4-GT	6BQ7-A	6J6	25CD6-GB

Easy to see, in G-E Service-Designed Tubes ... high-precision workmanship!

What you're looking at is a comparator—or industrial "magic lantern"—which shows the plate of a General Electric Service-Designed 6BQ7-A magnified in area 1,600 times.

The G-E inspector is checking close-to-perfect workmanship. Remember, the plate itself is less than $\frac{1}{2}$ inch wide and long! Yet symmetry of structure is apparent; so are the plate's clean, precise outlines. Tolerances of this part are held to a few thousandths of an inch.

General Electric Service-Designed Tubes do a superior job in television sets because they're

far better designed and built. High-precision manufacture such as you see above—of plates, cathodes, heaters, grids—pays off for you in fewer customer complaints and callbacks.

Best news of all: Service-Designed Tubes cost you no more! Your G-E tube distributor has them. Phone him today! *Distributor Sales, Electronic Components Division, General Electric Company, Owensboro, Kentucky.*

Progress Is Our Most Important Product

GENERAL  ELECTRIC

mounts in seconds!

completely waterproof! highest "Q"!

NOW...
LOK-MATIC by WARD!

It's today's most revolutionary antenna!
Truly a "fingertip" installation—done in seconds—by one man—entirely from the outside!
So advanced, it will fit all cars—even '59 and '60 models.
Positive . . . easy . . . fool-proof. New exclusive triple interlocking parts fall into place automatically—provide tighter, easier installation. The *only* completely waterproof mount—highest "Q" ever. The Lok-matic antenna extends to 55" from 19½" collapsed. Has 3 sections. Adjusts to 43°. 54" low-loss Elektran lead cable. Fits any hole from 15/16" to 1 1/8". Popularly priced. Put the easiest mount of all at *your* fingertips—order the Lok-matic antenna (Model L-1000) from your distributor today! Pre-assembled—no loose parts. *Only* Ward has it!

Self-locating rocker locks automatically, can't spread. Positive ground. Self-aligning pad. Completely waterproof. Interlocking features of insulator and cap prevent twisting. Dome-shaped nut.

Pat. App. For

watch **w a r d** WARD PRODUCTS CORP.

1148 Euclid Ave., Cleveland 15, Ohio • Division of The Gabriel Company
In Canada: Atlas Radio Corp., Ltd., 50 Wingold Avenue, Toronto, Canada

New Bar Generator for Color Servicing

by IRVING REBESCHINI
Project Engineer, Simpson Electric Co.



SIMPSON MODEL 430 color bar generator.

SPURRED ON BY the increasing number of TV shows in full color, the popularity of color sets is bound to increase. As the number and age of color sets in use increases, servicing color TV will assume a growing importance. One of the new test instruments that the Service Man will require for efficient servicing and adjusting of color TV is a color bar generator.

Many changes and improvements have taken place in color TV receivers since the introduction of the first compatible sets. The most significant differences can be noticed in the chrominance channels. The early sets used I and Q systems, but the newer sets have introduced the use of R-Y

*Simpson Model 430.

and B-Y as well as R-Y and G-Y systems.

The manufacturers of service equipment have kept up with the color TV field by creating increased flexibility into their color bar generators. A new color bar generator* recently introduced serves to illustrate this trend. This bar generator provides the choice of the following outputs: R-Y, B-Y, R-Y and B-Y simultaneously, I, Q, I and Q simultaneously and G-Y at 90°, sync and burst, color bar pattern, and chroma and Y. RF and video outputs as well as 3.58 and 4.5-megacycle and 15,750-cycle signals are provided.

A typical setup for demodulator alignment is shown in Fig. 1. The color bar generator provides a modulated rf signal to the input of the receiver at point A, and a 15,750 cps voltage is fed by the generator to the 'scope for the horizontal sync. The vertical input to the 'scope is taken from the output of the B-Y demodulator at point B, through a low-capacitance probe. When the R-Y demodulator is adjusted, the probe should be moved to point C.

The modulation of the rf signal at point A should have the wave shape shown in Fig. 2a. If the B-Y demodulator is incorrectly adjusted, the 'scope will indicate the output at B as shown in Fig. 2b. Proper adjustment will bring the R-Y output to zero as shown in Fig. 2c. With the output taken at point A, an incorrect adjustment of the R-Y demodulator will show up by producing the wave form shown in Fig. 2d. The output in Fig. 2e will appear when the phase is properly adjusted.

The proper operation of the G-Y matrix of this receiver will be indi-

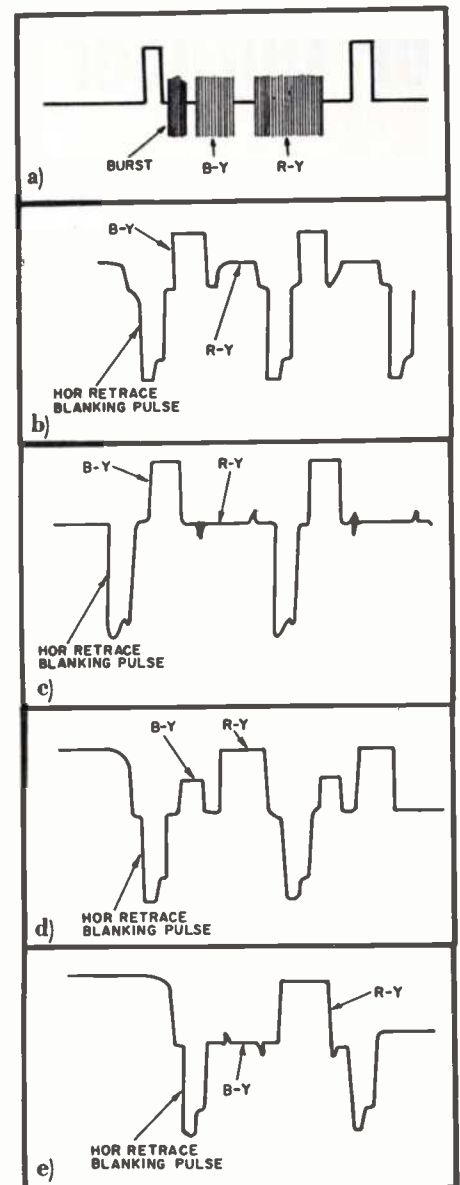

FIG. 2: TYPICAL WAVEFORMS obtained in adjusting color demodulator circuits.

cated by a null output when a G-Y at 90° signal is applied.

The adjustments described above apply only to a color receiver using R-Y and B-Y demodulation. The wide choice of outputs of this generator, however, makes it possible to use it for color demodulation adjustments on color sets using I and Q as well. The generator is also said to have less than 5 per cent phase modulation, which puts it well within the 10 per cent NTSC specifications.

The presence of a defective delay line can be detected by switching from simultaneous Y to simultaneous chroma only and the color display (chroma and Y both). A defective delay line causes a misregistration of about 3/16-inch maximum on a 21-inch tube.

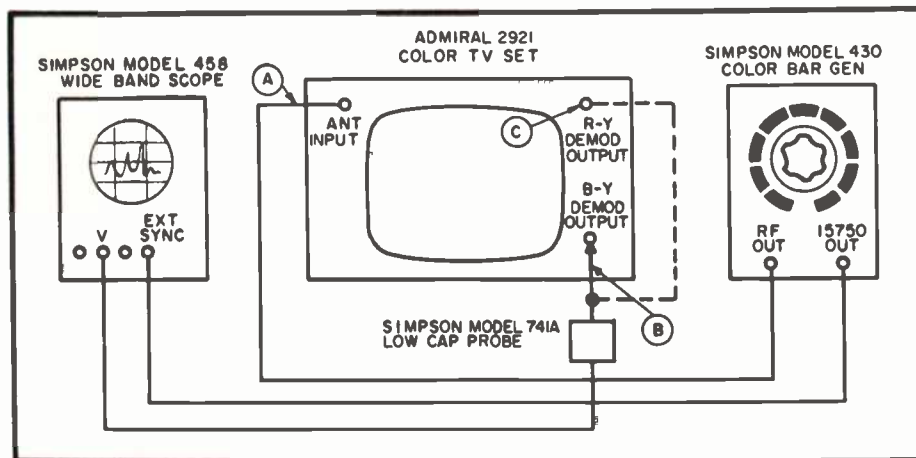

FIG. 1: TYPICAL SETUP for demodulator alignment uses a color bar generator connected to TV receiver and wideband 'scope.

Design and Installation Techniques For Outdoor Public Address Systems

By LOUIS S. HOODWIN
Chief Engineer, Loudspeakers, Electro-Voice, Inc.

MANY TIMES A Service Man is called upon to make an outdoor public address speaker installation and without previous experience, the task may appear formidable. Actually, the outdoor installation is easier to design than one placed indoors since there are no problems of room reverberation. The task is simply to provide a signal with the proper frequency, level, and lack of distortion at the position of the listener. In order to do this it is first necessary to know the capabilities of various speakers.

The most important characteristics of a speaker, with regard to its performance in a public address installation, are its frequency response, polar response, efficiency, and power handling capacity. If the requirements of any installation are first translated into these terms, the choice of the proper speaker is fairly easy.

For voice communication a limited frequency response range of 500-4000 cps may be tolerated, but most listeners prefer the added intelligibility provided by increased high-frequency response and the added quality provided by increased low-frequency response. For good music reproduction, it is essential to extend the bass response beyond the lower limit permissible for speech. A speaker with flat response down to 100 cps will provide excellent music reproduction. However, attempting to go below 100 cps usually results in considerable added expense (especially in horn-type loudspeakers) for relatively little return in performance.

Frequency Response

A speaker with good response to 150 cycles may be adequate for music in many cases. A loudspeaker designed for music reproduction, however, may not prove useful for speech. In attempting to emphasize the bass response, some loudspeakers are designed with inadequate response in the mid-frequency region (800-2000 cycles) which is essential for good speech reproduction.

The design objective of the public address system is to produce the de-

sired frequency response at the position of the listener. Although virtually all frequency response curves on speakers are run on their axis, the vast majority of the listening audience is not on the axis of any speaker in an installation. Polar response data show how the speaker is distributing the sound to the audience. A good indication of the polar response may be obtained by determining the angle off the axis at which the response at 3000 cycles is 10 db below the response on the axis. This should be the maximum angle to the axis of the speaker at which any member of the audience should be expected to be located.

Power Handling Capacity

There is a good deal of misunderstanding concerning power handling capacity or wattage ratings of speakers. Many persons interpret the wattage ratings of speakers in the same manner as the wattage ratings of hot plates or light bulbs. They feel that a high power-handling capacity rating for a speaker means that the speaker will produce a great amount of sound. This is not necessarily true.

The power handling capacity generally is determined as the maximum amount of electrical power that can be put into a speaker for a prolonged

period of time without causing any physical damage due to excessive heat. Thus, it is possible to make a speaker which can dissipate a great amount of heat, but which will have very low efficiency. Such a speaker would still have a high power-handling capacity rating.

Reducing Costs

But it is generally true that high efficiency and high power-handling capacity go together. All of the power in the input signal must be dissipated by the speaker, and since a more efficient speaker converts more of the input signal into radiated acoustic energy, there is less energy remaining which must be dissipated in the form of heat.

In public address work, the most important reason for using high efficiency speakers is to reduce costs. If an installation is relatively small and the output of the smallest available amplifier can drive even an inefficient speaker to produce an adequate sound level, there is no need for a more efficient speaker. But, when high amplifier powers are involved it is often possible to obtain sizeable savings by using more efficient speakers.

For example, let us assume a survey indicates the need for 120 watts of audio power to drive an array of five speakers of a particular type. Let us also assume that the amplifier arrangement consists of a standard 60-watt amplifier and a 60-watt booster

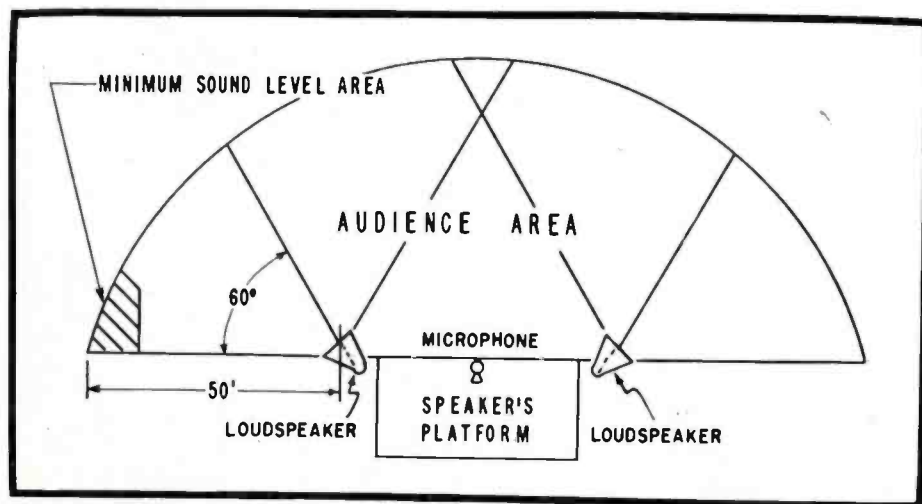

FIG. 1: TYPICAL LOUDSPEAKER LAYOUT for political rally. Speeches will be made from elevated platform and audience area is expected to extend about 50 feet from speakers.

line amplifier which costs \$70.00. If a speaker costing \$10.00 more is available that is 3 db more efficient, only half the audio power originally figured would be necessary and the 60-watt booster amplifier would not be needed. The added cost of \$50.00 for the speaker array is more than offset by the \$70.00 savings in amplifier expense.

Designing Speaker Installation

There is another benefit to be gained by using the more efficient speakers. The better speakers probably have higher power-handling capacity, thereby reducing the amount of power being delivered to the speaker and increasing the factor of safety against overloads.

To design a good speaker installation, first determine the frequency response needed or desired. The second step is to determine the sound level required to at least equal the noise level in the audience. Next find the positions where speakers are to be located. Finally choose speakers with the proper frequency response, polar response, efficiency and power-handling capacity to fulfill the requirements determined by the first three steps with consideration for economy.

For example, assume a situation

where a speaker installation is to be used for a political rally. Before and after the speeches, the program committee intends to provide music to help rouse the enthusiasm of the audience. The speeches will be made from an elevated platform. The audience will be permitted to come up to the front and around toward the sides of the platform and is expected to extend about 50 feet from the platform. Due to crowd noises, a minimum sound level of 80 db is required.

This situation and possible speaker locations are illustrated in Fig. 1. In this case, the speakers have been placed in front of the microphone to prevent feedback. The minimum sound level areas are about 50 feet from each speaker at an angle of 60° to each speaker axis.

Required Rating

In order to determine if a particular speaker will be useable, it will usually be necessary to convert the performance data provided by the manufacturer to fit the actual application as shown in Table I. Subtract 6 db from the sound level every time the distance from the speaker is doubled or add 6 db when the distance is halved. Add 3 db each time the power to the speaker is doubled,

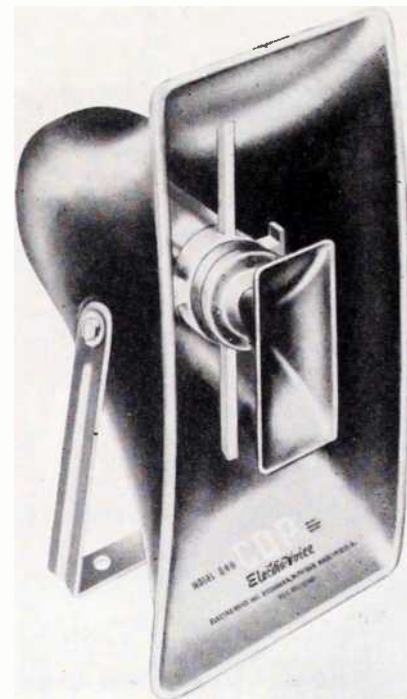

FIG. 2: ELECTRO-VOICE SPEAKER model 848 is suitable for installation at political rallies and similar outdoor events.

or subtract 3 db each time the power is halved.

A speaker which is rated at 96 db output at 3000 cycles at 3 feet with ¼ watt input and is 10 db down in level from its axial response at 60° off the axis should be able to fulfill the requirements for the political rally installation described above. A typical loudspeaker* that fully meets these requirements is illustrated in Fig. 2.

The computations in Table I indicate that if the speakers used in the example can handle 16 watts each they will be satisfactory. The music requirement implies that the speakers should have good response down to at least 150 cycles. But since the prime purpose of the rally is to convey information, the speakers must provide a high degree of intelligibility; therefore, the 800-3000 cps response should not be lower than the bass response. A 30-watt amplifier would be satisfactory. More efficient speakers would permit the use of a smaller amplifier, but the savings in amplifier cost would have to be compared to the increased speaker cost to see if the more efficient speakers would be practical.

Analyzing Installation

Some installations are more complicated than the one described in the example, but excellent results may be obtained by analyzing each installation to determine its specific requirements and by selecting the proper speakers to satisfy those requirements.

*Electro-Voice model 848.

TABLE I — LOUDSPEAKER PERFORMANCE COMPUTATIONS

PERFORMANCE OBJECTIVE	80 db at 50 ft., 60° off axis at 3000 ~				
LOUDSPEAKER RATING	96 db at 3 ft., 1/4 watt input, -10 db at 60° at 3000 ~				
ORIGINAL CONDITIONS	96 db	3 ft.	Level change	1/4 watt	Level change
		6	-6	1/2	+3
		12	-6	1	+3
		24	-6	2	+3
		48	-6	4	+3
				8	+3
				16	+3
Total Level Change	-6 db		-24db		+18db
Level corrected for power and distance	90 db				
Correction for 60° polar angle	-10 db				
Final level with 16 watts input	80 db				



by SIMON HOLZMAN

Chief Engineer, JFD Electronics Corp.

THERE ARE TWO BASIC types of multi-set couplers, or line splitters, on the market today, the resistive and the autotransformer types. Both of these units have certain inherent shortcomings which, until now, have not been overcome.

The circuit of a standard type of resistive set coupler is shown in Fig. 1a. Looking into the input terminals (Fig. 1b) it is evident that in theory, a good impedance match exists between the line and the two outputs. A straightforward *dc* analysis shows that $Z_1=Z_2=Z_3=300$ ohms. This match, however, is resistive in nature while the line and set impedances are, more often than not, reactive. In general, this causes a standing wave to be set up on the line and results in an insertion loss of up to 3 db.

Ideal Line Splitter

Theoretically, the ideal line splitter delivers one-half the input signal to each output. In effect, the output signal is 6 db down from the input. Since this network is resistive, the internal I^2R loss is an additional 6 db

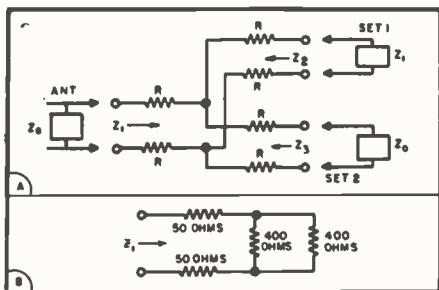

FIG. 1a: CIRCUIT DIAGRAM of a typical resistive-type of set coupler. Fig. 1b shows the ideal impedance match which exists between the line and the two outputs.

per line, which when added to the standing wave ratio loss can total 15 db per line. At best, each output is 12 db (4:1) down.

The above analysis ignores the possibility of distributed reactances in the resistors which cause increasing losses with increasing frequency.

The basic autotransformer circuit shown in Fig. 2 consists of a pair of

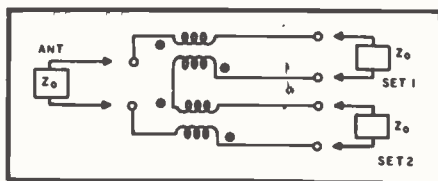

FIG. 2: SCHEMATIC DIAGRAM of basic autotransformer circuit consisting of a pair of bifilar coils wound on plastic or air core.

bifilar coils wound on a plastic or air core. The bifilar winding is an attempt to achieve a coefficient of coupling as close to unity as possible. Due to the high reluctance of the air path of the flux, there is an appreciable flux loss resulting in an insertion loss of from 1.5 to 2 db per line. Since the coefficient of coupling is less than 1, the network is predominantly inductive. In an inductive circuit, the current cannot change instantaneously with a change in input voltage. This fact results in poor transient response and the coupler will have a tendency to cause a smear on the high frequency video components of the signal.

The output signals of this type coupler will, therefore, be between 7 and 8 db (2.25:1 and 2.5:1) below the input signal with a definite loss of picture detail.

Recent developments in the art of high-frequency ferrite manufacture

have made it possible to design a new multi-set coupler* which overcomes the basic objections to the two standard types. At the same time the coupler provides full power line isolation from set-to-set and set-to-antenna and eliminates shock hazard.

The basic circuit shown in Fig. 3 consists of a pair of transformers with a 1:1 turns ratio. The primaries are connected in series and the secondaries are left free. Connected in this manner, the transformation ratio is 2:1 per leg.

Ferrite Cores Used

The ferrite cores used have negligible magnetic losses at frequencies in excess of 200 mc. These cores are tubular in shape, providing a high permeability flux path with no air gaps. This minimizes leakage flux and retains a coefficient of coupling of better than 0.99. Fairly large diameter wire is used in the windings to keep I^2R losses at a minimum. Since television signals are at a comparatively low level, the transformer operates on the linear portion of the B-H curve and stays well below saturation. Because of this, there is no danger of peak clipping of high-amplitude signals.

The insertion loss of this unit consists only of the minute I^2R loss when both outputs are terminated since the load impedances are perfectly reflected in the primary. The final figures for the insertion loss are in the order of 0.01 to 0.1 db per leg. Each output is, therefore, 6 db (2:1) below the input.

Since this coupler is of the full-transformer type, there is no direct connection between sets and/or antenna. When used with *ac-dc* sets, there will be no leakage line current transmitted from one set to the other or to the antenna. This eliminates the possibility of shock hazard should the set or sets be plugged in with the wrong polarity.

*JFD model AC-40.

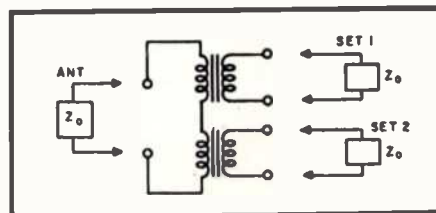

FIG. 3: BASIC CIRCUIT of JFD model AC-40 multi-set coupler, consists of a pair of transformers with a 1:1 turns ratio.

GUIDE AUTRONIC-EYE[®]

TRAINING COURSES

MEAN MORE

BUSINESS FOR YOU!



Courses for experienced service technicians provide latest repair information—enable you to do the job faster and more efficiently.

Quick, accurate circuit diagnosis and repair to factory specifications boosts your profits. That's why so many qualified auto technicians attend these Guide training courses at no cost other than transportation and living expenses.

The Guide Lamp diploma, awarded only to those who successfully complete the course, is proof that you're equipped to give more and better service to more people—and that means business.

If you're an auto radio service dealer, come yourself, or send your technicians. There's one of 30 GM Training Centers near you. Apply through your local United Motors Service Division Distributor or write

GUIDE LAMP DIVISION • GENERAL MOTORS CORP. • ANDERSON, INDIANA

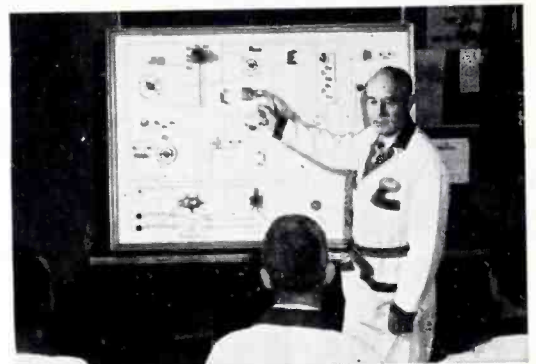

Jumbo-size operational panel of Guide's Autronic-Eye Circuit puts all parts out front for better, more efficient instruction.



Thirty modern GM Training Centers offer newest equipment and latest service techniques. There's one nearby . . . no matter where you live.



**BLINKY MEANS
BUSINESS!**

**LEADING
SET
MAKERS
SPECIFY
TUNG-SOL**

**HIGH
IN PERFORMANCE**

BLUE CHIP
QUALITY



TUNG-SOL®

Magic Mirror Aluminized

PICTURE TUBES

ELECTRON TUBE DIVISION  TUNG-SOL ELECTRIC INC.
NEWARK 4, NEW JERSEY

Books and Catalogs

AMERICAN MICROPHONE MANUFACTURING Co., 412 S. Wyman St., Rockford, Ill., has issued 16-page illustrated catalog 58 describing microphones for tape recording, broadcast, public address and general purposes, as well as handsets, phono cartridges and arms, mobile equipment and accessories.

ANTENNA SPECIALISTS Co., 12435 Euclid Ave., Cleveland 6, Ohio, has released an illustrated catalog with technical data on a complete line of communication antennas and accessories.

BELL SOUND SYSTEMS, INC., Columbus 7, Ohio, has issued brochures covering the 5600 and *Pacemaker* lines of public address units and systems. Also available is a booklet describing four basic tape transport units for monaural and stereo use.

CONSOLIDATED WIRE AND ASSOCIATED COMPANIES, 1635 S. Clinton St., Chicago 16, Ill., has published a catalog containing specifications on hook-up wire, aerial wire, leadin wire, transmission cable, radio and TV specialty cords, lightning arrestors, test-prod wire and accessories.

HEATH Co., Benton Harbor, Mich., has published a 24-page illustrated booklet featuring a new line of stereophonic hi-fi equipment kits as well as marine radio, amateur and test equipment units.

IE MANUFACTURING, 325 N. Hoyne Ave., Chicago 12, Ill., has issued catalog 18 with data and specifications on TV antenna hardware and accessories, indoor TV antennas, adjustable table-model TV bases and radio parts.

JENSEN INDUSTRIES, INC., 7333 W. Harrison St., Forest Park, Ill., has published a 48-page phonograph needle sales manual. Included are merchandising and customer education aids. Manual has many valuable suggestions for independent service dealers.

OXFORD ELECTRIC CORP., 3911 S. Michigan Ave., Chicago 15, Ill., has released a 28-page booklet, *Dimensional Data of Oxford Speakers*, covering 22 units 2½ to 15 inches in various constructions and shapes.

PARKER METAL GOODS Co., 85 Prescott St., Worcester, Mass., has issued a circular describing antenna leadin standoffs which can be used as wood screws or in combination with a strap as a mast strap-on.

PHILCO CORP., ACCESSORY DIV., C & Westmoreland Sts., Philadelphia 34, Pa., has released a specification sheet on a new universal audio output transformer line. Electrical and mechanical characteristics and cross reference data are included.

QUAM-NICHOLS Co., 234 E. Marquette Rd., Chicago 37, Ill., has issued a specification sheet covering *Adjust-A-Cone* public address, intercom and outdoor speakers.

MARK SIMPSON MANUFACTURING Co., INC., 32-28 49th St., Long Island City 3, N. Y., has released a 12-page illustrated catalog, 3100 covering sound and intercommunication equipment. Included are amplifiers, portable systems, phono attachments, mobile systems, microphone mixers and preamplifiers, and portable speaker units.

Association News

ESDA, Western Pennsylvania

Joseph S. Doyle has been re-elected to a second term as president of the Electronic Service Dealers Association of Western Pennsylvania, Inc. Other officers are Robert Barozzini, vice president; Regis McGlory, executive secretary; Joseph Simandel, recording secretary; and Charles Baroffsky, treasurer. Harry Shaupp and Taylor Thompson were elected trustees. The executive board consists of Frank Dattilo, John Gonsowski, George Oswald, Norman Falk, Thomas Ulrich, Stanley Weiss, William Hartman, Sr., and Thomas Scholler. Bert A. Bregenzer was chosen NATESA Director for the group.

RTTG, Miami, Fla.

At a recent meeting of the Radio Television Technicians Guild of Miami Leo Smith of Zenith Radio Corp. and Fred Linehart of Cain & Bultman presented the latest information on the theory and troubleshooting of the Zenith Space Command remote control. Frank Martell of Radio Electronic Television Schools spoke on the various courses offered by his school for electronic technicians as well as beginners. Business survey report forms covering electronic service conditions were distributed to those present at the meeting. These are to be filled out and returned to NATESA.

TSDA, San Mateo County, Calif.

Winston D. Haines has been chosen president of the Television Service Dealers' Association of San Mateo County. Lloyd Williams was named first vice president; M. W. Kehler, second vice president; F. McCarthy, secretary; and Gordon Cole, treasurer.

TSA, Michigan

Karl Heinzman has been re-elected president of the Television Service Association of Michigan. Other officers include Charles March, central vice president; Thomas W. Taber, Jr., north vice president; Charles Judd, northwest vice president; Edward J. Brown, east vice president; Stephen Raboczky, southwest vice president; Samuel J. Mooney, secretary; and Mike Dallen, treasurer.

TEN YEARS AGO IN SERVICE

John F. Rider sponsored a monthly meeting of the Associated Radio Servicemen of New York which was attended by more than 1,500 Service Men. C. A. Tuthill presented a talk on public address system problems. A comprehensive discussion of TV and FM receiving antennas was conducted by Seymour D. Uslan. John Meagher of RCA described various types of test equipment used in TV servicing. An award "in grateful appreciation of his meritorious achievements in behalf of the radio service industry (during the years) 1921-1948" was presented to John Rider. . . . A national campaign to boost radio repair sales for authorized Service Men was launched by the radio tube division of Sylvania Electric Products, Inc. . . . The first in a nationwide series of forums on TV antenna installation and servicing sponsored by JFD Manufacturing Co. was held in Newark, N. J. The meeting was attended by 350 parts distributors and Service Men.

LEADING INDEPENDENT SERVICE DEALERS CHOOSE TUNG-SOL

LOW IN CALLBACKS



BLUE CHIP
QUALITY

TUNG-SOL® RECEIVING TUBES

ELECTRON TUBE DIVISION  TUNG-SOL ELECTRIC INC.
NEWARK 4, NEW JERSEY



TWO-WAY RADIO

communications equipment

VHF-FM FOR: MOBILE AIRCRAFT MARINE MOTORCYCLE PORTABLE BASE	VHF-AM FOR: AIRPORT VEHICLES GROUND STATIONS POINT-TO-POINT	VHF ANTENNAS REMOTE CONTROLS ACCESSORIES
--	---	--



MODEL 278 SERIES CONTROLLER

VHF-AM TWO-WAY RADIO
for airport vehicles and ground stations

The CONTROLLER mobile unit was specifically designed for airport vehicles requiring two-way communication with control towers and planes.

For use in ramp jeeps, electrician's trucks, crash trucks, tow tractors, snow plows, executive cars, police cars and at temporary locations such as construction sites.



FEATURES

- **FREQUENCY RANGE:** 118 to 400 MC. crystal controlled.
- **SINGLE OR DUAL CHANNEL:** maximum spread 500 Kc.
- **POWER OUTPUT:** 3 to 4 watts, more than enough for airport service.
- **LOW BATTERY DRAIN:** total standby 10 amps. at 6 volts, 5 amps. at 12 volts.
- **UNIVERSAL:** instantly changeable from 6 to 12 volt operation.
- **COMPACT:** under dash or trunk mounting, case 5½" x 11" x 13".
- **LOW COST MAINTENANCE:** thousands of CONTROLLERS have earned an excellent reputation for trouble-free operation.

NEW!

FLIGHTCOM

12/24 VOLT VHF-FM FOR AIRCRAFT

Provides communications between ground FM systems and executive, patrolling and utility aircraft. Used by fishing fleets, petroleum producers, pipe line helicopters, State police, Conservation departments, crop dusters, power companies and departments of the U. S. government.

FEATURES

- **COMPACT** . . . case size 14" x 11½" x 6½".
- **LIGHT** . . . 22 lbs. (without antenna and speaker).
- **UNIVERSAL** . . . instantly changed from 12 volt to 24 volt operation.
- **POWERFUL** . . . 25 watts output.
- **EFFICIENT** . . . low battery drain.
- **LOUD** . . . 1 watt minimum.
- **PERFORMANCE** . . . meets all existing and proposed FCC and FCDA requirements.

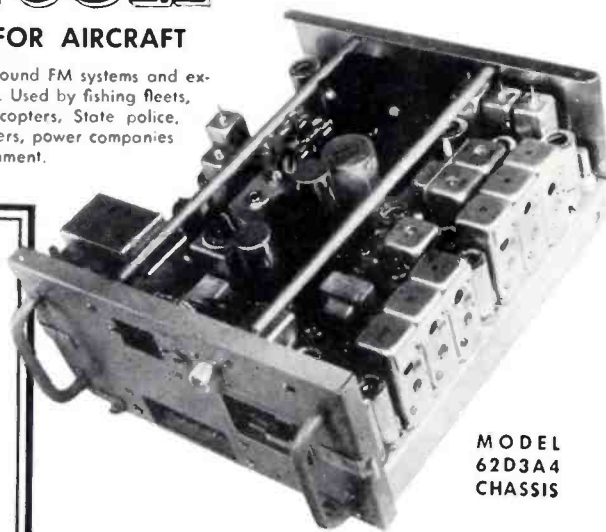

**MODEL
62D3A4
CHASSIS**

Package consists of: Chassis, case, shock mounting rack, control box, cables, microphone.

ATTENTION DEALERS!
Write for available territories.



DESIGNERS AND MANUFACTURERS OF **COMCO** RADIO COMMUNICATIONS EQUIPMENT

COMMUNICATIONS COMPANY, Inc.

FOUNDED 1938

CORAL GABLES, MIAMI 34, FLORIDA

the Designer series chassis is a multi-vibrator combining the functions of oscillator and output in one double purpose tube. The basic circuit is one that has proven its performance and reliability in previous designs. A new feature in this model provides temperature compensation in the charging network for normal shrinkage of vertical size during warm-up due to heating of the deflection yoke, output transformer and other components.

Vertical Circuit

The 6DN7 tube used in this circuit (See Fig. 2) was designed specifically for the Designer series circuit application. The large output section is electrically similar to one-half of the 6BL7, while the discharge tube section is electrically similar to one-half of a 6SN7. Thus, each section of the 6DN7 is designed for the function to be performed. The use of dissimilar triodes to correspond to the circuit application results in less heater power, lower bulb temperature and longer tube life. The mechanical construction of the tube has been made more rugged to reduce microphonics, provide longer life and to produce more uniform linearity.

A new long-life 1J3 high-voltage rectifier tube is used in the new Designer series TV sets. This new tube gives full 360-degree, top to bottom shielding against filament distortion from the electrostatic pull of high anode voltages. Consequently, electrostatic effect is reduced by more than two to one over any predecessor tube. This is made possible by a spiral-wound shield surrounding the filament.

High-Voltage Rectifier Tube

This tube gives efficient protection against the most common cause of short circuits and filament breaks in previous similar tubes.

All in all the Designer series has been constructed with the servicing factor clearly in mind, a feature which Service Men will be sure to appreciate.

CORRECTION

Because of a typographical error, incorrect values were given for the operating characteristics of the Electro model EFB *dc* power supply which was described on page 16 of the May 1958 issue of SERVICE. The unit is a dual-range power supply which provides 0 to 32 v at continuous current up to 4 amps and 0 to 16 v at continuous current up to 8 amps.

Tube News

TWO MULTI-PURPOSE miniature tubes for series-string TV receivers have been introduced by Sylvania.

The 5CR8 is a 9-pin triode-pentode with a suppressor grid and internal shield tied to the triode cathode, permitting partially unbypassed cathode bias on the pentode to minimize *if* detuning with *agc* changes. It has a 600 *ma* heater with controlled warm-up.

A 9-pin medium-mu triode and sharp cutoff pentode, 6BR8A, is a combined VHF oscillator-mixer. It has a 450 *ma* heater with controlled warm-up.

RAYTHEON has added ten new receiving tubes to its replacement line.

The 1J3GT and 1K3GT are filament diodes for use as half-wave rectifiers for high-voltage pulses produced in TV scanning circuits.

A miniature heater-cathode semi-remote cutoff pentode, 3BA6, is a wide-band amplifier for series-string TV sets and has a 600 *ma* heater rating.

The 4BZ6 is a miniature heater-cathode pentode for use as an automatic gain controlled *if* amplifier. It has a 450 *ma* heater rating and controlled warm-up.

A heater-cathode high-vacuum rectifier, 5V4GA, is for use in full-wave applications.

The 6AX8 is a miniature heater-cathode triode and pentode designed as a video amplifier in the triode section and a sync separator in the pentode section. It has a 450 *ma* heater rating.

Designed for use as a horizontal deflection amplifier is the 6BQ6GTB, a heater-cathode high-perveance beam-power tube.

The 6CX8 is a miniature heater-cathode sharp-cutoff pentode and medium-mu triode. The pentode section is used as a video amplifier and the triode section as a sound *if* amplifier, sync separator, amplifier or clipper. It has a 750 *ma* heater rating and controlled warm-up.

A miniature heater-cathode double-triode, 8CS7, has one section used as a vertical deflection oscillator; the other as a vertical deflection amplifier. It has a 450 *ma* heater rating.

The 12DE8 is a miniature heater-cathode cutoff pentode and diode. The diode section is used as a detector; the pentode section as an *rf* or *if* amplifier where the heater, plate and screen grid potentials are obtained directly from an auto battery.

CDR ROTORS

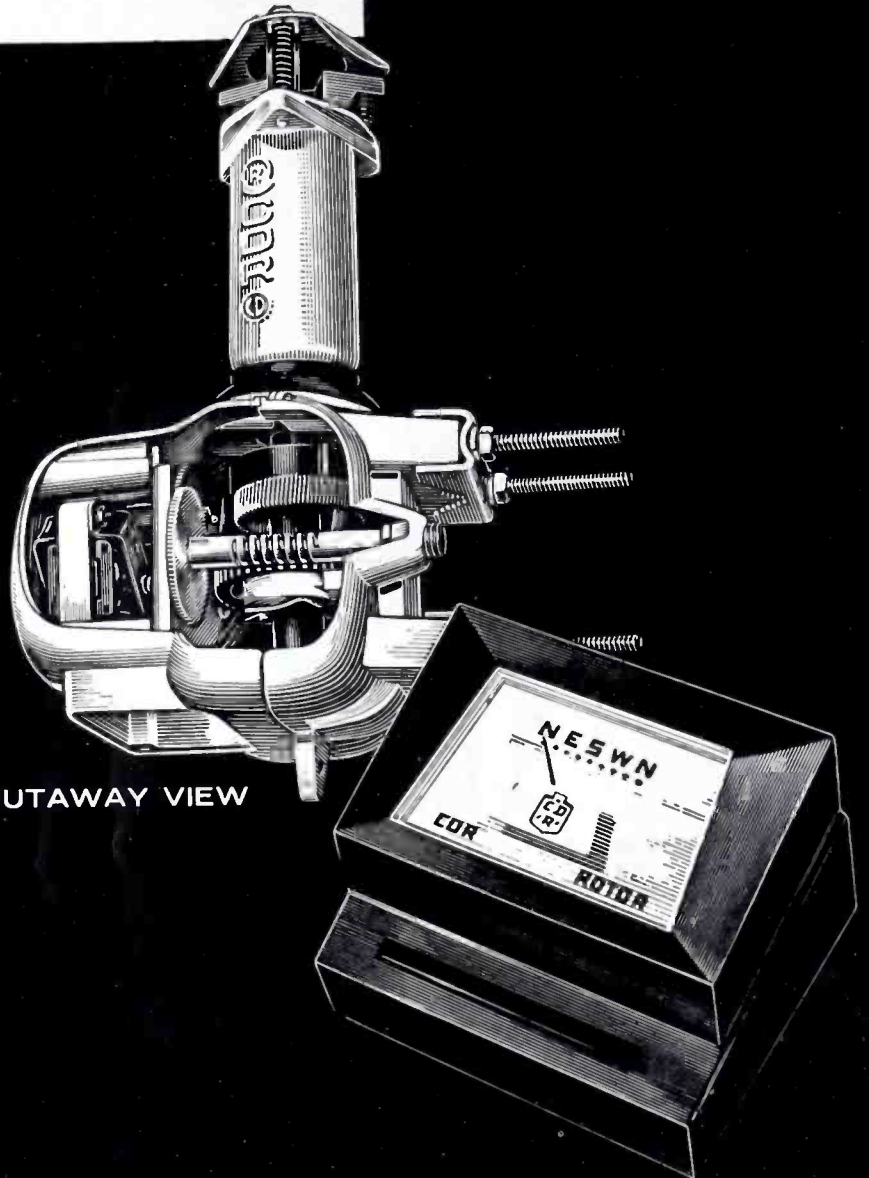

CUTAWAY VIEW

All new features

Completely designed from the ground up, CDR Model TR-15 and TR-16 Rotors have features never before available in the popular price range. Check these refinements and you'll see why: Quick mounting mast collet... speedy installation (no loose parts to assemble)... self-centering sawtooth clamps take masts up to 1½" O.D.... instant locking prevents drift... mechanical brake releases magnetically... instantly reversible... makes complete revolution in 45 seconds... meets JAN salt water test... great strength thrust bearing support... low weight... completely weather-sealed... fits standard towers... streamlined to reduce wind resistance... mahogany or blonde finish control box. Get full details today from your local CDR distributor.

CORNELL-DUBILIER ELECTRIC CORP.
South Plainfield, New Jersey

THE RADIART CORPORATION
Indianapolis, Indiana



CDR

Antenna Rotors

Old Hands at Dependability

SUMMER

vi-fi

SPECIAL!



-3 for cost of 2

Or buy 4 and receive 2 free with an extra "special" discount! Under either plan, you can't afford to miss the extra profits of this "Summer Vi-Fi Special"!

Vi-Fi is the *only* indoor antenna that has the modern, slim lines of the new tv sets. Vi-Fi is the *only* indoor antenna with transformer coupling and variable inductors for sharp pictures. Vi-Fi is always a good buy; this "Summer Special" makes it the biggest antenna bargain ever!

Your Authorized AMPHENOL Distributor has all the details. See him right now!

THE BIGGEST ANTENNA BARGAIN EVER!

SEE YOUR

AUTHORIZED DISTRIBUTOR

AMPHENOL



ANTENNAS AND

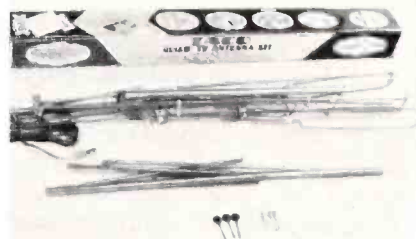

Antenna kit designed and field tested to insure high performance and durability. Antenna is factory-assembled to mast. Mounting, mast and antenna have a golden anodized finish. Shipped fully assembled with transmission line anchored to antenna terminal points. (Quikie 444; Technical Appliance Corp., Shelburne, N. Y.)

* * *



UHF converter for fringe area and local reception. Contains a built-in UHF antenna for local use. Features two-cavity coaxial tuner, a stage of high-gain amplification and pre-selection stage for eliminating interference. Slide-rule dial is coupled to a vernier tuning mechanism. (Ultracon FTC; Jerrold Electronics Corp., 15th and Lehigh, Philadelphia 12, Pa.)

* * *



Weather-proof two-set coupler merchandising package and display stand. Each coupler is enclosed in a clear plastic bag with card flap that has installation instructions on the back. (Humi-Kup; R-Columbia Products Co., Inc., 305 Waukegan Ave., Highwood, Ill.)

ACCESSORIES

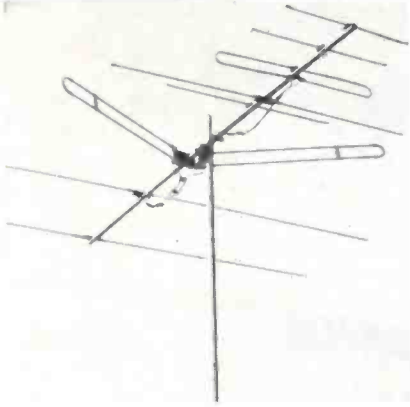

All-channel VHF antenna for intermediate signal areas. Flat, inline combination hi-lo Yagi has a T-W type controlled impedance dipole. Three elements are driven. Elements are fully preassembled and snap into place. Heavy-duty brackets provide extra strength. (Color Prince 3353A; Channel Master Corp., Ellenville N. Y.)

* * *

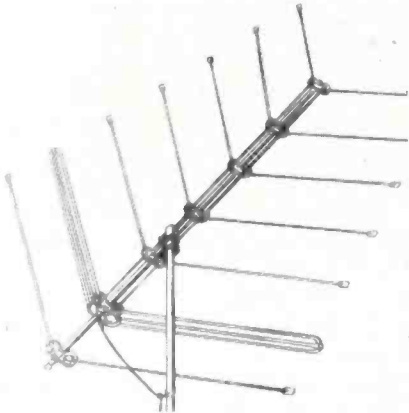

All-channel antenna said to produce extra-high gain. Available as a 3-element model for local or primary areas; 5-element model for fringe areas; and 7-element model for extreme fringe areas. 5- and 7-element models have Quadro-Grip U-bolt assembly which grips and secures antenna crossarm to mast four times. (Fringe Master Jr.; Radio Merchandise Sales, Inc., 2016 Bronxdale Ave., New York 62, N. Y.)

* * *



UHF converter featuring three-section tuner with dual-input section. Said to comply with FCC radiation standards. Single knob tunes channels 14 through 82. Double-tuned rf section and 300-ohm impedance match are used. (199R; Blonder-Tongue Laboratories, Inc., 9-25 Alling St., Newark 2, N. J.)



SUITS NEED PRESSING— MERIT DEFLECTION YOKES DO NOT!

Merit deflection yokes are cosine wound TO FORM, not pressed. Pressing can lead to distortion and poor focusing. Pressing after winding frequently causes breakdown.

MERIT COILS AND TRANSFORMERS HAVE
"BUILT-IN" ADVANTAGES.



Each Merit yoke is
100% LIVE TESTED



COMPARE IT WITH MERIT

MERIT COIL AND TRANSFORMER CORP
MERIT PLAZA • HOLLYWOOD, FLORIDA

Servicing Two-Band Transistor Radios

by CARL FINZER & LEROY WOLFF
Motorola, Inc.

TWO-BAND PORTABLE radios are now on the market which cover both standard broadcasts and the 200 to 420 kc beacon band. Stations on this band broadcast weather information at regular intervals. Although generally used by pilots of ships and aircraft, these stations are also popular with amateur outdoorsmen, particularly during the summer months. The service and maintenance of a typical two-band portable, shown schematically in Fig. 1, is covered in this report. Many of the procedures included here also apply to any type of transistorized portable receiver.

Preliminary Inspection

Before proceeding to the more complex aspects of service, the batteries should be checked and the set should be given a thorough visual inspection for obvious faults such as broken leads. Weak batteries or batteries showing any signs of corrosion should be discarded. All traces of corrosion or leaked electrolyte should be removed from the battery box. A weak solution of borax in water is recommended for this purpose. In case of severe corrosion the battery box should be replaced and the customer advised to remove weak batteries immediately. Most battery manufacturers supply batteries de-

°Motorola model 6X39 transistor radio.



TWO-BAND PORTABLES, like the Motorola Weatherama above, cover both standard broadcasts and the 200 to 420 kc beacon band.

signed and labeled for use in transistor radios. Maintenance of a fresh supply of these batteries may provide an additional source of floor traffic for the Service Man.

Signal Tracing

To a person used to servicing vacuum tube receivers, there is nothing as unresponsive as a dead transistor receiver. The vacuum-tube technique of shorting components to produce clicks or a response must not be used in transistor circuits as it may, under some conditions, cause damage. In actual practice, the use of a noise source to signal-trace the set has been found to be a great time saver. The recommended noise generator is a multivibrator operating on a funda-

mental in the audio range at approximately 400 cycles and creating harmonics up through the broadcast band. It is obvious that this type of generator will save a great deal of time in switching frequencies from audio to *if* to *rf*. One type of noise generator° is shown in Fig. 2 and is illustrated schematically in Fig. 3.

To trace the set with this generator, the signal is first applied between the base and ground of the driver transistor (V4) to determine if the audio stages are functioning. Then proceed toward the output or input of the set, one stage at a time, to determine the defective stage. Always apply the generator between base and ground. When the defective stage is located, the next step is to analyze the fault in terms of emitter voltage as outlined later in this article.

A variable output control is included on the generator to provide the operator with a means of determining the relative gain of the various stages. The loop antenna provides a radiated signal. If a radiated signal is present from the noise source, but the set fails to pick up stations, it may be assumed that the oscillator is inactive.

The loopstick-radiated signals may also be used for tracking. Since interaction exists in transistor circuits between oscillator and *rf* tuning, it may be found that a noise source is very desirable for peaking the loop trimmer and tracking the oscillator to the loop inductance at the low end of the

°Developed by Motorola, Inc.

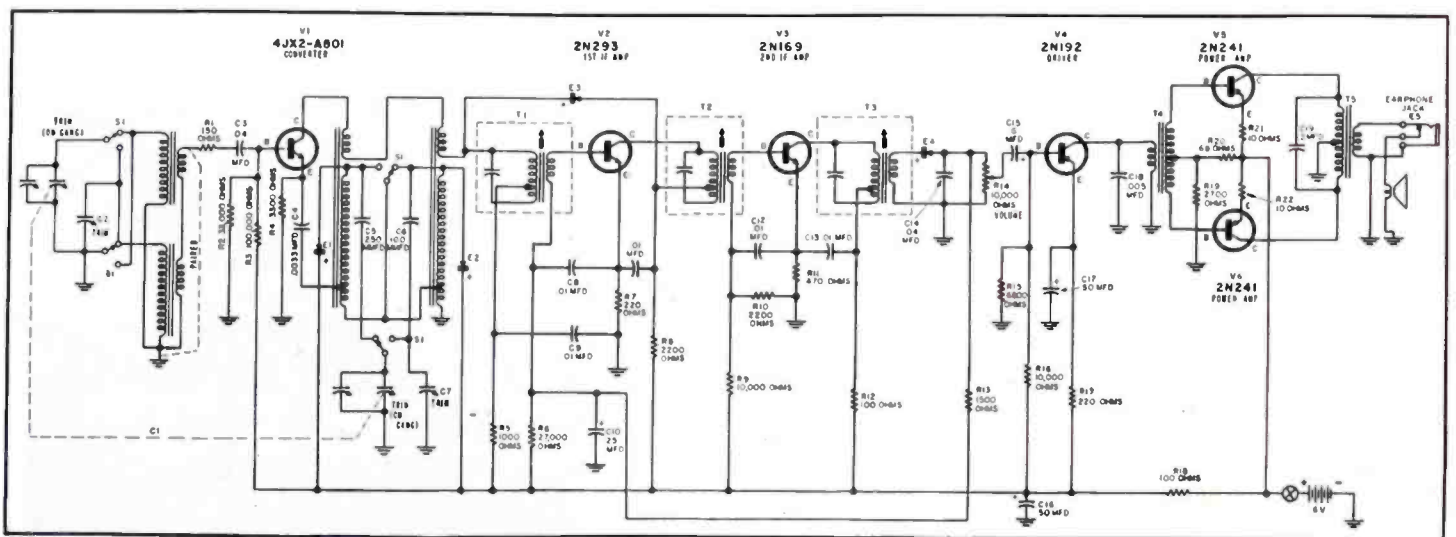

FIG. 1: CIRCUIT DIAGRAM of the Weatherama portable transistor radio model 6X39 manufactured by Motorola, Inc.

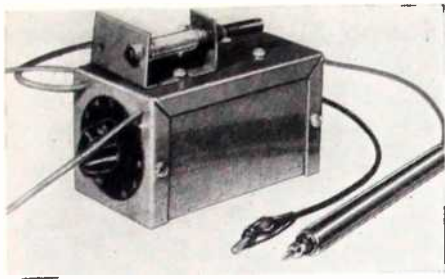

FIG. 2: TYPICAL NOISE GENERATOR used in servicing transistor radios.

band. To use the noise generator signal source for tracking, first align the *if* and oscillator per the manufacturers instructions. Then place the generator near the radio. Keep the signal to the radio at a relatively low level. This can be controlled by varying the distance between the generator loop and the radio loop antenna and also by the relative positions of the two loops. Maximum coupling is obtained when the loops are parallel to each other.

Tune the set between stations in the vicinity of 1400 kc and use the noise source signal to peak the antenna trimmer. Tune the set between stations in the vicinity of 600 kc and adjust the oscillator core to track with the antenna inductance. Best tracking is obtained when the output from the noise source is maximum in the radio speaker.

On a two-band radio repeat the tuning at 220 and 400 kc respectively, with the band switch in the *beacon* band position which switches in a separate loop antenna, oscillator coil and antenna trimmer capacitor, all designed for low-frequency operation.

Only a small adjustment of the oscillator coil should be required to achieve desired results. Large adjustments would be indicative of tampering with the adjustment or some circuit malfunction.

Analyzing Emitter Voltages

Most Service Men can readily determine the defects in conventional tube-equipped radios by taking voltage and resistance measurements. Un-

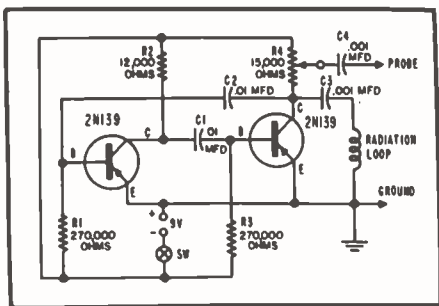

FIG. 3: SCHEMATIC DIAGRAM of a noise generator developed by Motorola, Inc.

fortunately this technique cannot be applied as easily to transistorized portables. Since the transistor is primarily a current device, it is the current rather than the voltage that should be evaluated to determine the operation of the circuit. Since current measurement is somewhat cumbersome, particularly on the compact chassis found on most units, service is generally accomplished without the benefit of actual current measurement.

At this stage of the art, the common emitter circuit shown in Fig. 4 has been found to be the most practical as an amplifier and is used in this receiver as well as in most transistor

radios currently manufactured. For purposes of stability, the common emitter circuit usually includes a resistor (R11) in the emitter circuit. It is obvious that the voltage across this resistor will give a good indication of the current drawn by the transistor. Therefore we can evaluate the current drawn by the transistor in terms of the emitter resistor voltage.

The circuit in Fig. 4, in a sense, can be considered to be a transistor checker. If the emitter current as indicated by the voltage across R11 is of the proper order, it can be assumed that the transistor and its *dc* supply cir-

(Continued on page 38)

No. 6 of a series of questions for progressive technicians.

Can You Handle This Problem?

audio output stage

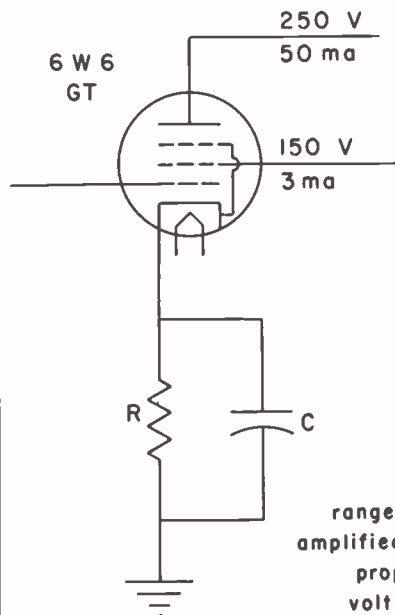

What Value Should You Use for R And For C?

(Answer printed below)

This may at first look like a difficult problem. Yet, for any technician who knows basic electronic fundamentals, it can be easily solved.

Knowing these principles and fundamentals is your key to getting ahead today in electronics. Unless you really know fundamental electronic theory,

you can't take advantage of your opportunities.

It will pay you to find out how to increase your income by adding to your kit of "mental tools".

Answer to problem above:

Answer: C = 50 microfarad, R = 170 ohms.

Cleveland Institute of Radio Electronics

4900 Euclid Avenue, Dept. S-13, Cleveland 3, Ohio

Successful
Electronics
Training

Please send me detailed solution to problem above and information on how I may prepare for the increasing opportunities in electronics. There is no obligation.

NAME

ADDRESS

CITY ZONE STATE

Accredited by The National Home Study Council

S-13

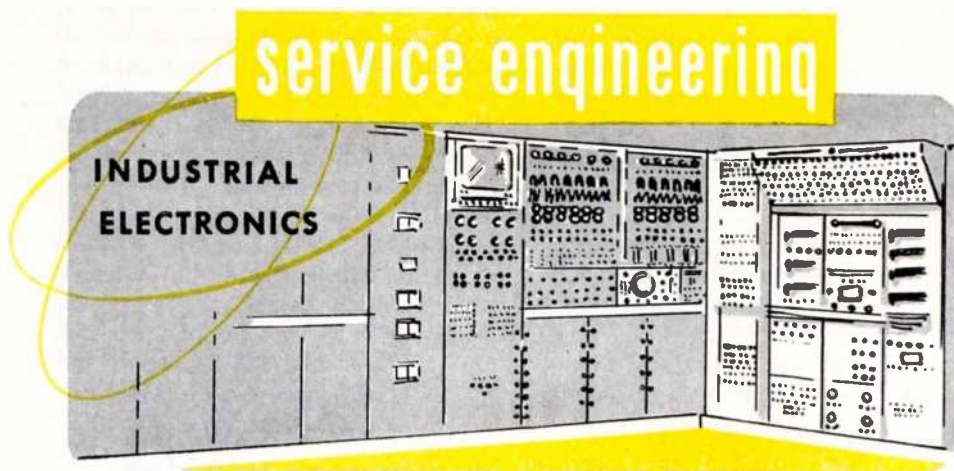

by LEO G. SANDS

INDUSTRY AND TRANSPORTATION services utilize sound systems for extending communications to outdoor areas such as large industrial plants and vast railroad yards. While similar in many respects to indoor sound systems, outdoor systems must meet more rigid requirements. Equipment installed out of doors is exposed to the elements and must therefore be designed to resist moisture and extreme temperature variations. In addition, the equipment should be tamper-proof.

Amplifiers and control equipment are generally installed indoors or at least in weatherproof housings. Speakers, cables and, sometimes, microphones are installed out of doors. Maintenance of constant sound levels is important in order to avoid disturbing nearby residents and to assure ample but not excessive sound levels.

A typical railroad yard or industrial plant paging system consists of a small number of high-level loudspeakers oriented to cover a wide area. Sometimes a large number of speakers may be used, operated at relatively low levels and oriented so as to cover specific areas only with a minimum of spillover.

Ordinarily, a considerable amount of audio power is required. This may be provided by a single high-power amplifier, a bank of two or more amplifiers, each feeding a group of loudspeakers, or a bank of two or more *stacked* amplifiers feeding a common speaker line.

Since the amplifiers may be required to operate 24 hours per day, seven days a week, as in railroad yards, the amplifiers must be de-

signed for continuous operation. This is a more stringent requirement than may be apparent. An amplifier designed for normal, intermittent duty may not suffice in industrial applications.

In many industrial applications, great dependence is placed on the sound system. Thus, equipment failures cannot be tolerated. To prevent loss of communications, duplicate stand-by amplifiers are often used which are switched into service in case of tube or component failure.

Where overhead wiring might interfere with operations or constitute hazards to personnel, speaker-feed cables are often run underground. Several wire manufacturers make suitable cables for underground installation.

Many types of loudspeakers are available which can be depended upon to perform satisfactorily when installed out of doors. Line matching transformers are also available which can be used out of doors, exposed or

installed in suitable weather-protective housings.

Microphones for outdoor use are rare, however. Generally, microphones are kept inside of protective housings when installed out of doors and are removed from their housings only when actually used.

Outdoor-type loudspeakers, which can be left exposed, are sometimes used as microphones. Since the frequency response of paging systems is generally limited to voice frequencies (300-3000 cps), many types of outdoor loudspeakers can be used as outdoor microphones.

Typical System

A widely used kind of industrial paging system employs what is known as the *constant output* technique. In this system, shown schematically in Fig. 1, audio is delivered to all loudspeakers at a constant 70-volt level. There is no volume control. Instead, the sound output of each speaker or cluster of speakers is adjusted at each speaker location to the desired level by selecting the appropriate tap on the line matching transformer.

Once the desired sound level has been determined, further adjustment is not required. The technician is not concerned with impedances, only voltage levels. Speakers may be added or disconnected without disturbing the sound level of other speakers on the line.

In a 50-watt system, only one amplifier is required, except when a stand-by amplifier is provided. The amplifier delivers 70 volts of audio to the speaker feed line. Any number of speakers may be connected to the line through line matching transformers provided that the sum total

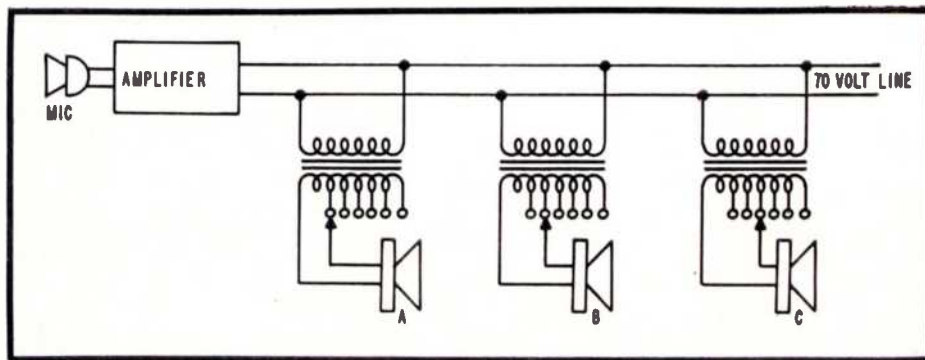

FIG. 1: CIRCUIT DIAGRAM of constant-output paging system which operates at a 70-volt level. Speakers may be added or removed without disturbing sound level of other speakers on line and no volume controls are required.



FIG. 2: SERIES 50 AMPLIFIER produced by Electronic Communications Co. delivers 70 volts and is rated at 50 watts.

power consumption of the speakers does not exceed 50 watts.

Suppose that ten speakers, each consuming five watts, are connected across the line. Any of the speakers, or all of them, may be disconnected from the line without significantly affecting the voltage level across the line.

Thus, the speaker feed line is comparable to a power line. In a home, for example, several lamps, radios and a TV set as well as other appliances may be connected and disconnected from the power line without causing a significant change in line voltage.

To make this possible, an amplifier is used which employs a considerable amount of negative feedback. This reduces the output impedance of the amplifier and improves its output regulation. A typical amplifier^o used in such an installation is shown in Fig. 2. It delivers 70 volts ± 1.5 db at its full-rated 50 watts or with no load at all.

The use of the *constant output* technique simplifies paging system design. Impedance matching is no longer a problem. Speakers can be disconnected from the system without affecting the level of other speakers and without requiring rearrangement of wiring or substitution of the speaker with a dummy load.

Each speaker location is equipped with a line transformer. The primary is bridged across the line. The speaker (or speakers at a single location) is connected to one end of the secondary winding and one of the secondary taps.

For example, with an 8-ohm speaker, two 4-ohm speakers in series or two 16-ohm speakers in parallel, 5 watts will be consumed by the speaker (or speakers) when connected to the 6.3-volt transformer tap. If 20 watts are required, the speaker is connected to the 12.5-volt tap, and so on. By selection of the proper transformer taps, the sound level can

(Continued on page 36)

^oElectronic Communication Equipment Co. series 50.

MORE ACTIVE! EFFECTIVE!

KESTER "RESIN-FIVE" CORE SOLDER



THE BEST FOR TV-RADIO WORK...
EVERYTHING ELECTRICAL - Kester "Resin-Five" Core Solder is better and faster than any solder ever developed. It has an activated flux-core that does a perfect job on all metals including zinc and nickel-plate. The flux residue is absolutely non-corrosive and non-conductive.

Available in all practical Tin-Lead Alloys; 40/60, 50/50 and 60/40 in diameters of $\frac{3}{32}$ ", $\frac{1}{16}$ ", $\frac{3}{64}$ ", $\frac{1}{32}$ " and others.

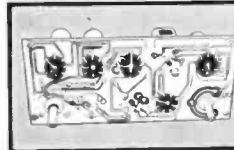

Printed Circuit Soldering
On Copper-etched boards use 60% Tin - 40% Lead Alloy... for those that are Silver-surfaced use 3% Silver-61½% Tin-35½% Lead

KESTER SOLDER COMPANY

4248 Wrightwood Avenue, Chicago 39, Illinois • Newark 5, New Jersey, Brantford, Canada



**THESE
TUBE SALES
CAN BE YOURS!**

A self-service tube testing route is a natural for servicemen. It's just like having branches of your shop in drug stores, luncheonettes, super-markets and other retail locations in your area, testing and selling tubes for you 12 hours a day — 7 days a week. Each Century self-service tube tester you place can net up to \$1000 a year... and there is no limit to how many you can handle.

Century's low manufacturer-to-you prices enable you to place more units with less investment... yet you are assured of the most versatile, accurate and durable testers available. Century backs you up with a proven plan of operation, sales literature, window streamers, etc. Learn how you can make money automatically and keep your income growing, without giving up your present source of revenue. Write today for FREE booklet that tells all about this booming business.

MAIL THIS COUPON TODAY FOR FREE BOOKLET!

CENTURY ELECTRONICS CO., INC.
Dept. 606, 111 Roosevelt Avenue, Mineola, N. Y.

Please send me without obligation, FREE booklet and particulars about setting-up a self-service tube tester route. I understand no salesman will call.

Name _____ Please print clearly
Address _____
City _____ State _____

Sync Clipping in Community TV Systems

by JACK DARR

THE BASIC OBJECT of the community-TV antenna system is to deliver snow-free, stable pictures to the homes of its subscribers. Of course, as in all electronic apparatus, the operation of such a system is subject to certain peculiar troubles. Some of these are real; some imaginary. Chief among these is *sync-clipping on the cable*, a favorite alibi of some Service Men for difficult set troubles. This is hotly disputed by engineers and operators of community-TV systems. In an effort to determine the validity of these claims, a series of tests were made under varying conditions on a typical system, and the results are presented here.

To sum up the results in advance, in no case was the system or amplifiers found guilty of actually clipping sync. By this is meant that the amplifiers never *removed the sync*, leaving a normal picture, which could be locked in place by the holding controls.

Many cases of sync trouble were found, but in each of these the defect was traced to the circuitry of the TV receiver itself, and remedied by repairing the set. In a few cases slight modification of the set was required, due to slight design faults. Quite a few cases were found to be due to misadjustment of the operating controls.

Antenna System Amplifiers

A careful analysis of the response curves of the broadband amplifiers and other equipment used in community antenna systems will show that it would be extremely difficult to make them clip sync pulses from the TV signals. As a rule, most cases of sync clipping originate in a circuit with an extremely sharp cutoff, frequency-wise, very bad low-frequency response, or high-frequency response. Thus, it would be theoretically possible for a Yagi antenna, very sharply tuned, to drop off at the high side of its response curve so rapidly that the horizontal sync pulses would be attenuated, or color burst lost. This is only a theoretical case, as no antenna of any type ever tested by myself or my associates has ever displayed a curve of such steepness as shown in Fig. 1b.

All amplifiers used in community antenna work are very broad-band types, covering a range of frequencies from 75 to 250 mc., so as to deliver usable amplification from channel 2 up through channel 13. In fact, unless they have appreciable gain over this tremendous spread of frequency, they are not very practical for community antenna applications. Unless one of the amplifiers developed a very sharp *notch* in its response curve, exactly in the right place relative to a given channel's sync signals, it would be impossible for the amplifiers to clip sync.

It is always possible for a defective amplifier tube to cause symptoms with a similar appearance, from overloading or distortion, but this is easily detectable and as easily remedied. It shows up immediately on all sets on the branch following the defective amplifier.

Sync Clipping

We are concerned with actual cases of sync-clipping blamed on the *cable*. In such cases, picture elements would be normal and the picture could be held in place momentarily by adjustment of the hold controls. In addition to the broadband characteristics of the amplifiers, all of them are *agc* controlled and operated well below their maximum output capabilities to avoid trouble from overload caused by sudden increases in signal strength at the antennas. With a given amount of reserve power available, the amplifiers will always be running on an undistorted portion of the curve and the chances of distortion are very slight.

Actually, the major cause of this

type of trouble seems to be in the TV sets themselves. Sync circuits, noise cancellers, and *agc* circuits are the most frequent offenders aside from the common difficulties caused by shorted tubes, etc., that are not immediately apparent. These are designated as *cable trouble* by the careless Service Man since the antenna connection may be removed and held close to the antenna terminals, resulting in a fairly good picture due to the decrease in signal strength.

TV Set Troubles

These are as widely varied as the circuitry of the sets themselves. In sets using the common dual sync separators, clippers, etc., and with such tubes as 12AU7, 12AT7, the trouble may be due to tubes that are slightly weak or a bit gassy. Due to the very critical nature of the circuit, components that vary only slightly from their rated value can cause trouble. Plate load resistors in sync separator stages are *very critical*, as are bias resistors and resistors used in voltage divider networks to supply grid and plate voltages. Also, certain sets are very critical in the use of tube types. For instance, in the Philco 89 and 91 *rf* chassis, a 12AV7 is used as the sync separator. Although there are several twin-triodes in this category with very close characteristics, it has been noted in the field that only a very good 12AV7 will give satisfactory service in this socket. In fact, it would pay the Service Man to test a group of 12AV7's, and reserve the extra hot ones for use in these sets. In several cases, tubes have been removed from the sync separator socket

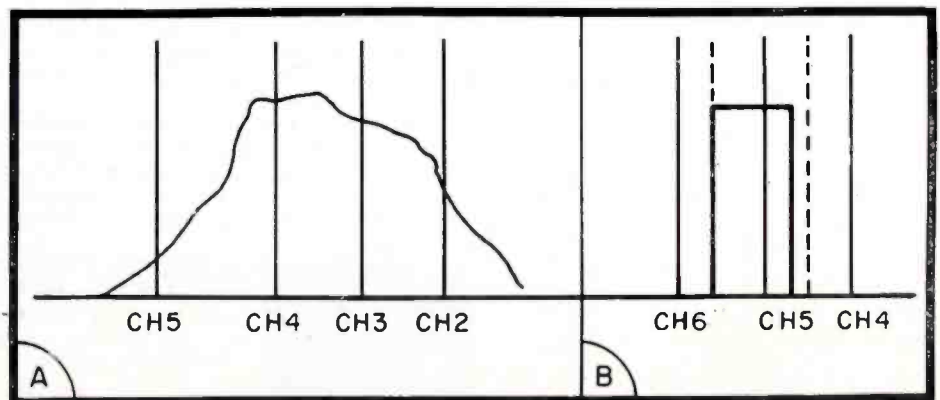

FIG. 1a: RESPONSE CURVE of sharply tuned Yagi antenna. Curve would have to attain waveform shown in Fig. 1b before clipping can occur.

CONVERT TV PROBLEMS INTO PROFITS!



INDOOR SET COUPLERS

SERVICE SAVERS



Operate up to 4 TV sets from single antenna. Ultra low-loss ferrite core transformers for maximum signal transfer and set isolation on every VHF channel. Write for Service-Saver brochure showing 40 money-making TV accessories now at all JFD distributors.

model	Sets Joined	List
SC2	2	\$10.95
TC2*	2	11.95
SC4	4	11.95
TC4*	4	12.95

* with built-in UL Lightning Arrester

Pioneers in electronics since 1929
J F D Electronics Corp.
 Brooklyn 4, New York

ask the
"Man-on-the-Roof"
 why he prefers

South River

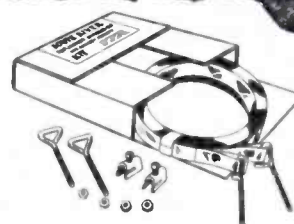

NOW! Banding Kits NEW! for EXTRA LARGE CHIMNEYS

- KIT XL "ST":** (Consists of)
 2—18" x 3/4" STAINLESS STEEL STRAPS with eyebolts attached
 2—Eyebolts Unattached
 4—Nuts to Fit Eyebolts
 2—KWIK KLIP Strapping Fasteners
- Also available, **KIT XL "G"**, same as above with 18' GALVANIZED STRAPS.

Universal—may be used with any chimney antenna mount.
 Write for NEW 1958 Catalog

SOUTH RIVER
 METAL PRODUCTS CO., INC.
 South River, New Jersey

pioneer & outstanding producer of finest line of antenna mounts

and used in other sockets with perfect results.

Troubles with quite similar symptoms have been traced to *agc* circuits. In another Philco chassis, the 90, a bad case of sync instability was located in the video *if* amplifier; a high cathode-heater leakage in the second video *if* amplifier (a 6CB6) was causing this stage to overload on strong signals. The symptoms were exactly like those found in sync-separator troubles which caused quite a bit of lost time.

Weak tubes in the *agc* amplifier socket (in sets using separate tubes for this purpose) will cause the same trouble. This tube, usually a 6AU6 or equivalent, furnishes the *agc* voltage for the video *if* and *rf* stages. If it becomes quite weak, this voltage will be much lower than normal. Therefore, on the high signal levels commonly found in community antenna systems overloading takes place in either the tuner or the video *if* amplifier, and sync clipping and distortion are seen.

Faulty Combination Tubes

The combination tubes (such as 6X8 and 6AU8) are often found at fault when used in these critical circuits. Some of them are used as sound *if-agc*, third video *if-agc*, etc. If the triode section becomes weak or gassy, trouble occurs. One unusual case was found where a set with a two-stage video amplifier caused sync clipping. The tube in the first video amplifier was quite weak and it reached saturation too quickly on high signals. Peculiarly enough, this did not seem to affect picture quality but only the sync. Evidently, the tube was not overloading until after it had reached the *black level*, just below the point where actual sync is located on the signal.

Other troubles *apparently* centering in tubes may be caused by dirty or corroded tube-socket connections, bad solder joints and leaky wiring. One particularly annoying case was located in a bad tube socket connection on the 12AU7 phase comparer socket. Replacement of the tube *apparently* cured the trouble, but it reappeared in a few days. This trouble was thermal; it showed up only when the set had been turned on long enough to heat thoroughly. After the corroded socket connection and the original tube had been replaced, the set worked perfectly.

[To Be Continued]

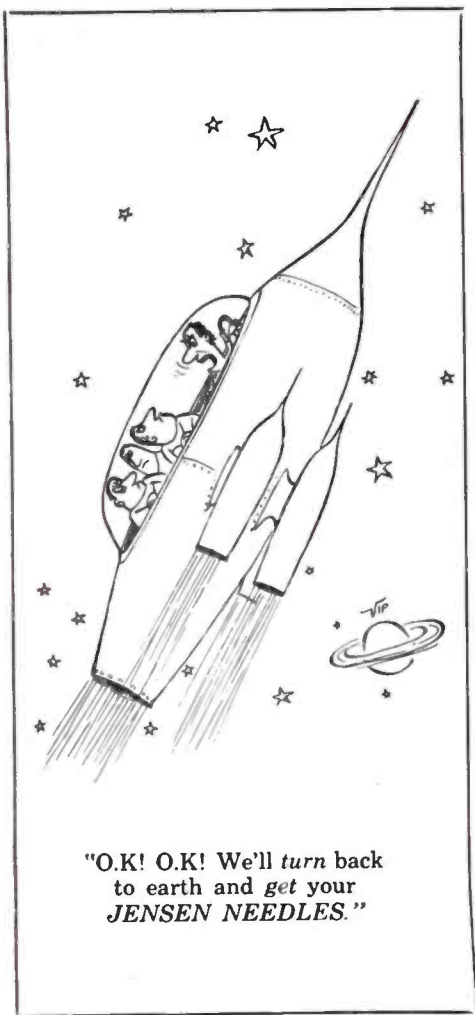

"O.K! O.K! We'll turn back to earth and get your JENSEN NEEDLES."

G-C Service Plugs & Jacks

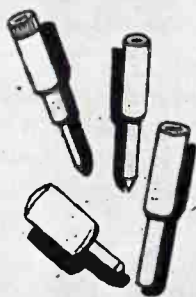

... also Clips—Test Prods—Connectors—Binding Posts—Accessories, All Kinds

G-C PHONE PLUGS
 Complete line of quality phone plugs ... Solder lug, screw and solderless types. Available in red and black.

G-C MILITARY JACKS

Open and closed type jacks made to rigid military specifications ... styles for every requirement.



GENERAL CEMENT MFG. CO.

Division of Textron Inc., Los Angeles—Rockford, Illinois

ASK YOUR G-C JOBBER

FREE CATALOG ... send postcard today!



good idea

for making service calls more profitable

9 out of 10 phonographs need new needles

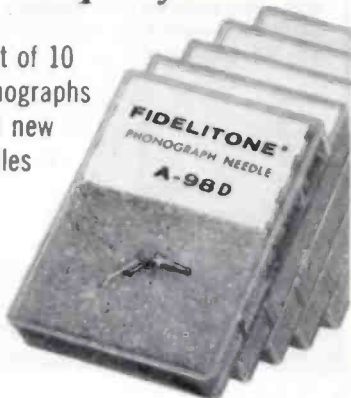

On your next service call, ask your customer if you can check his phonograph needle. Chances are nine out of ten that it's worn to the point of damaging records. With a stock of Fidelitone Needles in your service kit, you've made a profitable sale.

A Fidelitone Diamond is the best replacement buy

A Fidelitone Diamond gives your customers the maximum number of safe playing hours. This high quality needle is scientifically produced to cartridge manufacturers' specifications; always precision mounted for perfect alignment and orientation.

Be ready to make the sale

It's far easier to make the sale if you have the right needle with you. Even though there are hundreds of needle types made, you can replace the majority by carrying a minimum of Fidelitone needles. Carry a representative stock of Fidelitone with you and include the fast selling Diamonds for more profit on service calls. Call your Fidelitone Distributor today.

Fidelitone

Chicago 26, Illinois

"Best buy on records"

Industrial Sound

(Continued from page 33)

be set to the desired level. One speaker may be set for 10 watts, another for two watts, others for one watt, etc.

When more than 50 watts are required, amplifiers of suitable design may be stacked. This means that the inputs of all of the amplifiers are connected together and all of the outputs are connected together. Two amplifiers are stacked for 100 watts output, three for 150 watts and four for 200 watts output. As many as six amplifiers have been stacked successfully, delivering 300 watts.

When stacked in this manner, the output is still 70 volts, ± 1.5 db, no load to full load. A single 3-inch loudspeaker may be connected to the output through a suitable matching transformer adjusted for one-watt output, or 20 loudspeakers may be connected to the output, each consuming 10 watts. Thus, the amplifier stack is literally a power house, capable of feeding constant voltage to a minute load or at its full-rated capacity.

Obviously the amplifiers deliver 70 volts only when a suitable input signal is present. The output of a microphone varies with the speech it picks up. Amplifiers designed for constant output may also include an *avc* circuit. This circuit compensates for wide variations in microphone output, causing the amplifier to deliver a constant, but modulated, output signal.

The voice of a person speaking quietly into a microphone from a distance or one that booms directly into the microphone produces approximately the same level into the speaker line. Thus, all sounds appear to have the same level as far as listeners are concerned. This is an important consideration in an industrial sound system.

Some amplifiers (see Fig. 2) are provided with a preamplifier with inputs for a 30-50 ohm dynamic microphone and a 600/1200 ohm line. When two or more amplifiers are stacked only one need be equipped with a preamplifier. The output of the preamplifier is strapped to the input of its own power amplifier and to the inputs of the other amplifiers which do not have preamplifiers.

Amplifiers, designed to deliver 70 volts to a speaker line, but not equipped with *avc* are also used. However, with such amplifiers the output level varies with the output of the associated microphone.

Amplifiers not designed to be stacked may have their inputs paralleled but not their outputs. In many instances all of the amplifiers are provided with built-in preamplifiers. However, the preamplifier of only one of the amplifiers is required. Its output is fed to the succeeding stages of the same amplifier as well as to the phono, or equivalent, inputs of the other amplifiers.

When using amplifiers not designed for stacking, the output of each amplifier is fed to a separate, and isolated, speaker feed line. In some systems, an external preamplifier is used whose output is connected to the inputs of each of the associated power amplifiers. Here again, if the amplifiers are not designed for stacking, each feeds its own speaker feed line.

While a 70-volt speaker feed line is most commonly used, some systems use 25-volt or 140-volt feed lines. The principles are the same and appropriate line transformers are required.

The speaker feed line must be heavy enough to prevent excessive power losses in the line itself. When long runs are contemplated, it may be advisable to run more than one line.



SERVICE MEN KNOW THERE IS JUST ONE

HUSH

Reg. U. S. Pat. Off.

Chemically engineered for tuners and switching mechanism

Hush comes in a 6 oz. pressure can with sufficient pressure to reach all contacts to wash-away that dirt, leaving clean and positive contacts, protected with a lasting lubricant film.

Hush also available in 2 oz., 8 oz. and 32 oz. containers. **\$2.25 net**

EVER-QUIET

Reg. U. S. Pat. Off.

Since 1949 the Original Volume Control and Contact Restorer

EVER-QUIET is a free-flowing liquid that leaves no powder residue. Scientifically designed to seep around the shaft and penetrate the control or potentiometer, cleaning and contacts and leaving a safe protecting film. Harmless to metals, wire or carbon. Will not affect inductance, capacitance or resistance.

2 oz. bottle with handy dispenser **79¢ net**
(32 oz. size available)

See your distributor or write to



CHEMICAL ELECTRONIC ENGINEERING INC. Matawan, New Jersey

OUTDOOR SOUND EQUIPMENT

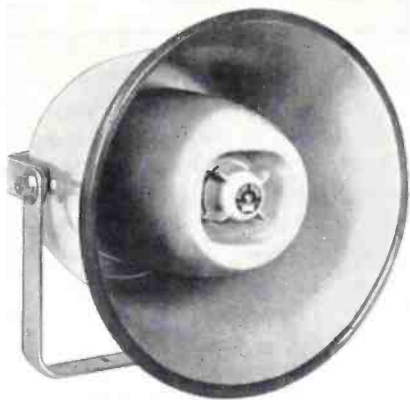

Hi-fi coax-projector with two individual drivers, two individual horns and built-in electronic crossover combined in a single unit. Low frequencies are reproduced by a high-efficiency woofer loaded with a folded exponential horn; high frequencies by a wide-angle tweeter. Power capacity is 15 watts. (WT-6; Atlas Sound Corp., 1449 39th St., Brooklyn 18, N. Y.)

* * *



PA system amplifier designed for use with any standard crystal or dynamic microphone. Phono input allows music and voice to be mixed. Available in 10, 20 and 30 w units. 30-w unit (above) has output impedances of 4, 8, 16, 250 and 500 ohms; two microphone inputs and one phono input. (Radionic Industries, 8859 S. Kedzie Ave., Evergreen Park 43, Ill.)

* * *



Multi-use microphone engineered to function as a hand, stand, desk or lavalier mike. Available as a crystal, dynamic or ceramic for broadcast, TV, PA, recording and amateur communications applications. Unit has satin chrome finish and comes with a 12-ft. cable. (200 Series; The Turner Co., 909 17th St., N.E., Cedar Rapids, Ia.)



Uni-directional dynamic cardioid microphone for TV, radio, studio, industrial and PA applications. On-off switch has lock-on feature. Cartridge assembly is internally shock mounted. Adjustable hinge permits tilting microphone head 90° backward from vertical position. Comes in both standard and gold finishes. (77; The Astatic Corp., Harbor & Jackson Sts., Conneaut, Ohio)

* * *



Outdoor speaker that connects to indoor hi-fi sets, record players, radios or intercom systems. Housing is heavy-gauge, rust-proof spun aluminum. Speaker is 6-in. extended-range model combined with fiber glass baffles to provide a 360° tone boom. Power rating is 6 w. Available in base-equipped or stake-type models. (Audiolier; Shalda Manufacturing Co., Inc., 156 W. Providencia Ave., Burbank, Calif.)

* * *



Booster amplifier for use with PA amplifiers to provide 60 w of added output power with only .4-v input. Input level control adjusts volume to meet specific requirements. Output taps are provided for matching 4, 8, 16, 250 and 500 ohms, as well as 70.7-v. lines. (KN-3061; Allied Radio Corp., 100 N. Western Ave., Chicago 80, Ill.)

CONVERT TV PROBLEMS INTO PROFITS!



INTERFERENCE ELIMINATORS SERVICE SAVERS



Capacitive tuned wavetraps for narrowest rejection characteristics shut-out spurious TV signals and harmonics caused by diathermy, ham, local TV sets on channels 2 to 13. Only the desired picture comes through sharp, and steady. Instant mounting. Write for Service-Saver brochure showing 40 money-making TV accessories now at all JFD distributors.

model	channels	list
WT26	2 to 6	\$4.50
WT713	7 to 13	4.50

Pioneers in electronics since 1929
JFD Electronics Corp.
Brooklyn 4, New York

NEW

IMPROVED SENCORE LC3 Leakage Checker

Another Sencore Time-Saver

Check these outstanding New Features

Now -- For the first time . . .

- Checks 130 different tube types — more than any other "grid circuit" type checker. Includes UHF and latest type tubes.
- Checks picture tubes without removing tube from cabinet or chassis.
- New Roll Chart prevents obsolescence — just dial the tube type and save time. Chart is easily replaced at no extra cost.
- Dynamic Filament checks including heater to cathode leakage & shorts — no need for a second filament tester.
- Two spare preheating sockets to cut down testing time.
- Capacitor checks simplified.

The LC3 provides all these new improved features in addition to those employed in earlier leakage or "grid circuit" testers. A must for any TV service technician.

\$28.95

DEALER NET

Really Tough Dogs

SERVICE

INSTRUMENTS CORP.

171 Official Rd • Addison, Ill.

In stock at your local parts distributor

Cut out this ad now for further information

The **NEW** **YEATS "Shorty"**
STATION WAGON & PANEL PICK-UP
appliance dolly



YEATS Model No. 5

Aluminum alloy
Height 47"
Weight 32 lbs.

Only 47" tall, this new YEATS dolly is designed for TV and appliance men who make deliveries by station wagon or panel truck. No need to detach appliance for loading into the "wagon" or pick-up... the YEATS "Shorty" will slide into your vehicle with ease. Has aluminum alloy frame with padded felt front, quick fastening (30 second) strap ratchet, and endless, rubber belt step glide. New YEATS folding platform attachment, at left, saves back-breaking work handling TV chassis or table models. Call your YEATS dealer today!



Folding platform is 13 1/2" x 24 1/2" —attaches instantly. (Platform only) \$9.95.



Furniture Pad

SEND postcard for full information on our complete line TODAY!

"Everlast" COVERS & PADS

YEATS semi-fitted covers are made of tough water repellant fabric with adjustable web straps and soft, scratchless white flannel liners. All shapes and sizes—Write.



TV Cover

YEATS appliance dolly

2109 N. 12th St.

sales co.
Milwaukee, Wis.

Superior's
New
Model 82

RAPID TESTER

The Very Best Value In Multi-Socket Tube Testers!

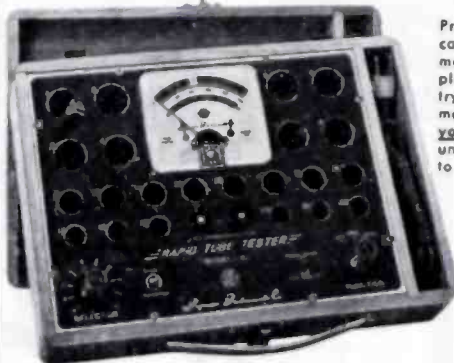

YES—COMPLETELY WIRED AND TESTED,
READY TO USE—ONLY \$36.50

To test any tube, you simply insert it into a numbered socket as designated, turn the filament switch and press down

the quality switch—THAT'S ALL! Read quality on meter. Inter-element leakage, if any indicates automatically.

Production of this Model was delayed a full year pending careful study by Superior's engineering staff of this new method of testing tubes. We don't expect it to completely replace conventional testers but if you want to try this new type of tester, you can do no better than mail the coupon below. Don't let the low price mislead you! We claim Model 82 will outperform similar looking units which sell for much more—and as proof, we offer to ship it on our examine-before-you-buy policy.

FEATURES:

- Dual Scale meter permits testing of low current tubes.
- 7 and 9 pin straighteners mounted on panel.
- All sections of multi-element tubes tested simultaneously.
- Use of 22 sockets, permits testing all popular tube types and prevents possible obsolescence.
- Ultra-sensitive leakage test circuit will indicate leakage up to 5 megohms.

\$36.50
NET

SHIPPED ON APPROVAL
NO MONEY WITH ORDER — NO C. O. D.

Try it for 10 days before you buy. If completely satisfied send \$6.50 and pay balance of \$6.00 per month for 5 months. —No Interest or Finance Charges Added. If not completely satisfied, return to us, no explanation necessary.

MOSS ELECTRONIC DISTRIBUTING CO., INC.
Dept. D-500, 3849 Tenth Ave., New York 34, N. Y.

Please rush one Model 82. I agree to pay \$6.50 within 10 days after receipt and \$6.00 per month thereafter. Otherwise I may return, cancelling all further obligation.

NAME _____
ADDRESS _____
CITY _____ ZONE _____ STATE _____

All prices net, F.O.B., N.Y.C.

Two-Band Transistor Radios

(Continued from page 31)

cuits are in order. If signal tracing indicates that this stage is defective, it would be most efficient to confine one's efforts to investigating the condition of the *rf* circuits such as an open capacitor or shorted winding in an *if* transformer. If abnormal emitter voltage is encountered, a circuit check with an ohmmeter is in order before the transistor is replaced.

Because the transistor is active even with the set turned off, the ohmmeter reading may be upset, but obvious faults such as shorted capacitors or open windings can easily be detected. With the small currents encountered, resistor failures or changing values are very unlikely. Therefore, the fault is more likely to be of an obvious nature making an ohmmeter check well worth while.

The circuit shown in Fig. 4 is frequently used as the second *if* stage and since it performs no converter or *avc* functions, it is the easiest stage to evaluate and will be discussed first. If the emitter voltage in this stage is very high, the cause may be a shorted transistor or a shorted bypass capacitor (C13). If the emitter voltage is less than normal, the cause may be an open collector junction in the transistor, and open collector circuit, or a shorted capacitor (C12). To determine which may be at fault, measure voltage at the collector terminal. If proper voltage exists, the transistor may be open. If no voltage exists, check for an opening between collector terminal and battery. An open collector will allow some reduced value of current through the emitter resistor. This current will be a function of the forward bias between the base and emitter.

If the emitter voltage is zero, the cause may be an open emitter junction in the transistor or an open emitter return to ground. To determine which of the above is at fault, turn the set off and check the emitter re-

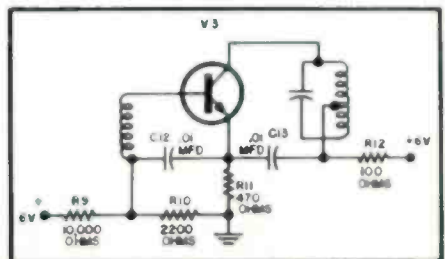

FIG. 4: COMMON EMITTER CIRCUIT operates as an amplifier and is used in one or more stages of most transistorized radios.

ADVERTISERS IN SERVICE JUNE, 1958

	Page
Aerovox Corp.	25
Amphenol Electronics Corp.	28
Atlas Sound Corp.	2
Bussmann Manufacturing Co.	4
CBS-Hytron, A Div. of Columbia Broadcasting System, Inc.	1
Centralab, A Div. of Globe-Union, Inc.	3
Century Electronics Co., Inc.	33
Chemical Electronic Engineering, Inc.	35
Cleveland Institute of Radio Electronics	31
Communications Co.	26
Cornell-Dubilier Electric Corp.	27
Electro-Voice, Inc.	5
Fidelitone	36
General Cement Manufacturing Co., A Div. of Textron, Inc.	35
General Electric Co., Electric Compo- nents Div.	15
General Motors Corp., Guide Lamp Div.	21
Heath Co.	24
Jensen Industries, Inc.	35
JFD Electronics Corp.	35, 37, 39
Kester Solder Co.	33
Merit Coil & Transformer Corp.	29
Moss Electronic Distributing Co., Inc.	38
Motorola, Inc.	Inside Front Cover
Quietrole Co.	39
The Radiart Corp.	27
Radio Corporation of America, Electron Tube Div.	Back Cover
Radio Receptor Co., Inc., Subsid. of Gen. Inst. Corp.	Inside Back Cover
Raytheon Manufacturing Co.	8
Service Instruments Corp.	37
South River Metal Products Co., Inc.	35
Tung-Sol Electric, Inc.	22, 23
Ward Products Corp., Div. of The Gabriel Co.	16
Yeats Appliance Dolly Sales Co.	38
Zenith Radio Corp.	6, 7

turn circuit. If correct, the transistor should be suspected; if incorrect, an ohmmeter check should disclose the opening. In general, it may be said that the transistor is a very rugged device and, unlike its tube counterpart, it is no more likely to fail than any other component.

The converter stage (V1) employs a common transistor and separate antennas and oscillator coils for the *beacon* and *broadcast* bands. The two-band operation can be considered an aid to service. If only one band is inoperative or otherwise defective, the trouble may be isolated to the antenna and oscillator circuit associated with this band. Here again, an ohmmeter check of the antenna and oscillator circuits is in order if one of the bands is inoperative. The band switch, of course, should be included in this check. An analysis of problems in

terms of emitter voltage is the same as previously outlined.

Lower than normal emitter voltage accompanied by a weak set may be caused by a leaky or shorted coupling capacitor (C3 in the converter stage) which will lower the forward bias and, therefore, lower the gain of the stage.

An indication of oscillator activity can be obtained by shorting out the oscillator section of the tuning gang and noting the effect on the converter stage emitter voltage. If the oscillator is active, shorting the tuning gang should result in approximately 0.1 volt drop in the voltage existing at the emitter.

For *avc* action, a portion of the second detector current is fed back through the first *if* bias network in such a direction as to decrease the forward bias on this stage with an increase in signal. The results of this action can be checked by measuring the voltage across emitter resistor R7. With no signal the reading should be 0.2 volts; with a strong signal 0.03 volts.

Very strong signal overload is prevented by diode E3. This diode conducts only on very strong signals due to the delay voltage. If a strong signal overload is present, check this diode by disconnecting one end and measuring the front to back ratio. If this diode is shorted, the set obviously will be very weak.

The audio driver and output transistors are of the PNP type which requires a positive potential on the emitter. Hence the emitter resistor is returned to the positive power source and emitter voltage measurements, used to evaluate transistor current, should be made by measuring the voltage drop across the emitter resistor directly.

The case or housing of the three transistors in the audio driver and output applications is connected to the base. When using the noise generator to signal-trace these stages, a connection to the transistor base can be accomplished most easily by touching the generator probe to the transistor housing. Slight pressure of the needle-nose test probe will allow penetration of the paint and connection to the base of the transistor.

To determine the balance of the two transistors in the push-pull output stage, tune in a signal and turn up the volume to slightly under overload conditions. Note the emitter voltage variation across each of the emitter resistors. Some indication of balance may be obtained by comparing the average value of the fluctua-

CONVERT TV PROBLEMS INTO PROFITS!



INDOOR SET COUPLERS

SERVICE SAVERS



Make one antenna do the work of two — at a neat profit for you. Low loss ferrite core transformer design for top-notch set isolation and signal transfer. Write for JFD Service-Saver brochure showing 40 money-making TV accessories now at your JFD distributor.

model	description	list
BC2	Joins 2 sets	\$2.85
BC3	Joins 3 sets	3.20
BC4	Joins 4 sets	3.60

Pioneers in electronics since 1929
JFD Electronics Corp.
Brooklyn 4, New York

STAMP OF APPROVAL!



Only Known Merit marks a product as the "BEST"

for quieting Noisy Controls and Switches
QUIETROLE produces results superior to any other product. That's why it's known as the "Best" and that's why more users prefer it to any other... It's the dependable Original product of its kind... a first in the industry.



QUIETROLE Spray- Pack

or the QUIETROLE
Bottle with the Eye Dropper Cap
QUIETROLE offers you both types of containers. Either way assures you of the same un-failing results that QUIETROLE is known for.



The Lubricant Cleaner of the Electronic World. Tailored for the industry by over 15 years of authentic research, plus 4 years of rigid and exacting tests before marketing.

In 2 oz. bottle with dropper and 6 oz. QUIETROLE SPRAY-PACK

Ask for QUIETROLE and be sure you get it!



manufactured by
**QUIETROLE
COMPANY**
Spartanburg, South Carolina

Operation and Servicing of Dry Batteries

by Dr. J. J. COLEMAN

Vice-President for Engineering,
Burgess Battery Co.

AS ALL SERVICE MEN know, portable radios and similar equipment receive their greatest use in the summer time. Because virtually all portable equipment is battery operated and servicing problems are often associated with the battery supply, a review of the operation and servicing of dry-cell batteries is useful at this time of the year.

The most common type of dry cell is shown in Fig. 1 and contains one zinc electrode and one carbon electrode. This combination produces a cell having a nominal 1.5 volts. The term *dry* is used because the electrolyte is made non-spillable by combining it with an absorbent or gelatinous material such as starch. The cell may then be discharged in any position.

The zinc electrode (negative) is made from a special zinc alloy with controlled purity of 99.99%. The carbon electrode (positive) consists of a carbon rod or plate surrounded by a mixture of manganese dioxide, acetylene black, ammonium chloride, zinc chloride, chrome inhibitor and water. This mixture serves as a depolarizing agent to prevent the formation of bubbles of hydrogen on the positive carbon electrode as discharge progresses. The effectiveness of the depolarizer depends on the type of manganese dioxide used. Natural manganese dioxides as obtained from the mine may be satisfactory for some applications. However, the most active forms are prepared artificially and result in greatly increased battery service life.

Flashlight Type Batteries

The name *flashlight type* is frequently used loosely to refer to single-cell batteries of nominal 1.5 volts each. These are made in six common physical sizes. Within each size group there are frequently several different types, each designed to perform best on a particular service application.

For flashlight service the battery must furnish current for a lamp filament which normally requires from 0.25 to 0.5 ampere, depending on the lamp used. Periods of use are usually fairly short and in the range of 4 to 5 minutes each. A typical day's use may be made up of one or more short periods and may range from 5 to 30

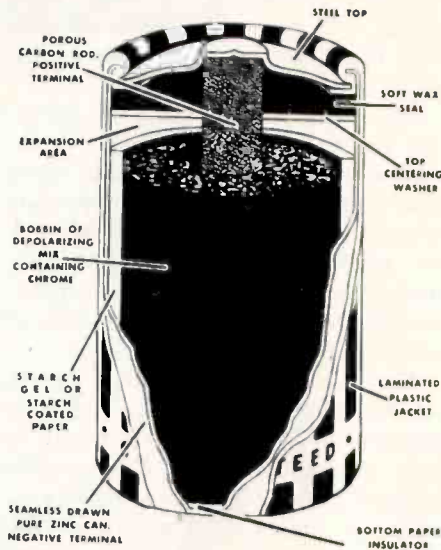

FIG. 1: CUT-AWAY VIEW of typical dry cell containing one zinc and one carbon electrode.

minutes per day to as high as 130 per day for industrial users.

Photoflash service requires that the battery furnish a heavy surge current to fire a photoflash lamp. The current is in the range of 2 amperes to 5 amperes. The duration is less than one second. Transistor portable radio service requires that the battery furnish current in the range of 15 to 50 milliamperes. Use is normally about 4 hours per day.

It can be seen from the above service descriptions that a wide difference exists in the service a battery may be required to deliver. For this reason batteries have been developed with special internal construction designed for maximum performance on each type of service.

Temperature plays an important part in dry cell service. Most dry batteries are designed to operate near 70° F. Prolonged exposure to temperatures much above 130° F may cause the battery to fail suddenly. With this qualification it may be said that the higher the discharge temperature, the greater the energy output.

A reduction in discharge temperature reduces the energy output. If ordinary dry batteries have been stored at room temperature of about 70° F and are then removed to a cold location of 0° F or below, it will require several hours for battery temperature to drop significantly. During this period the battery will continue to operate, though at slightly lower voltage caused by the lower temperature. In many instances it may be possible to insulate or protect the

battery to prevent rapid cooling. When this is done, nearly normal service may be obtained, depending only on how rapidly the battery is allowed to cool.

After prolonged exposure to 0° F or slightly below, ordinary batteries will give very little service except on relatively light drains. After prolonged exposure to about -10° F they will become useless even on light drains. Special types, using electrolyte designed for low temperature operation, must be used where batteries are to be stored and operated at this temperature range.

Service life at low temperature is reduced because of retarded chemical action within the cell. Exposure to low temperatures will not damage dry cells. In fact, low temperature storage is extremely beneficial to shelf life. Batteries can be stored for years with little or no deterioration at temperatures near 0° F. When removed from low-temperature storage the cells may be warmed to return them to their original condition.

High-temperature storage is harmful to dry cells and serves to reduce their shelf life. This is due to accelerated chemical action and to loss of moisture from within the cell at higher temperatures. For this reason dry batteries should be stored in cool locations. Refrigerated storage is very beneficial as previously stated.

The service life of dry cells can be extended by recharging. This must be started before the battery has been completely discharged. Best results are obtained by alternating periods of discharge and recharge. The charging rate should be varied in proportion to the physical size of the cell.

A new development in the dry cell field is the *wafer cell*,^o which makes possible a 30 percent increase in battery life and power. The cell consists of a cake composed largely of artificial manganese dioxide sandwiched between a thin disc of zinc and a thin sheet of conductive plastic. A stack of these cells contained in an aluminum tube forms a wafer-cell battery.

The complete dry cell is barely the size of a fingertip yet it develops useful power at 22½ volts in a battery only 2 inches long. This dry cell is being used extensively in portable radios, hearing aids, Geiger counters, and other small electronic devices.

^oDeveloped by Burgess Battery Co.

*now available
to servicemen
from Radio Receptor*

AUTOMATIC

SILICON RECTIFIER

for universal replacement

The choice of leading TV manufacturers as original parts in many new models!

- **hermetically sealed**
- **no pressure contacts used**
- **no heat sinks required**

Today more and more TV set manufacturers are turning to General Instrument Corporation's Automatic Manufacturing Division for the finest silicon rectifier made. Now Radio Receptor offers the service industry the *same* outstanding rectifier with characteristics that greatly improve the performance of any radio or TV set.

A single type - AUTOMATIC PT5 - can be used for all rectifier replacement. It's smaller, longer lived and cuts installation work in half. Pigtail leads can be connected to existing unused terminals or suitable terminal strips are available if needed. Start using them now and give those old sets a lift!

PT5,
rated at
500 mA
at
130V A.C.

General Instrument Distributor Division
RADIO RECEPTOR COMPANY, INC.
Subsidiary of General Instrument Corporation
240 Wythe Avenue, Brooklyn 11, N. Y., EVergreen 8-6000



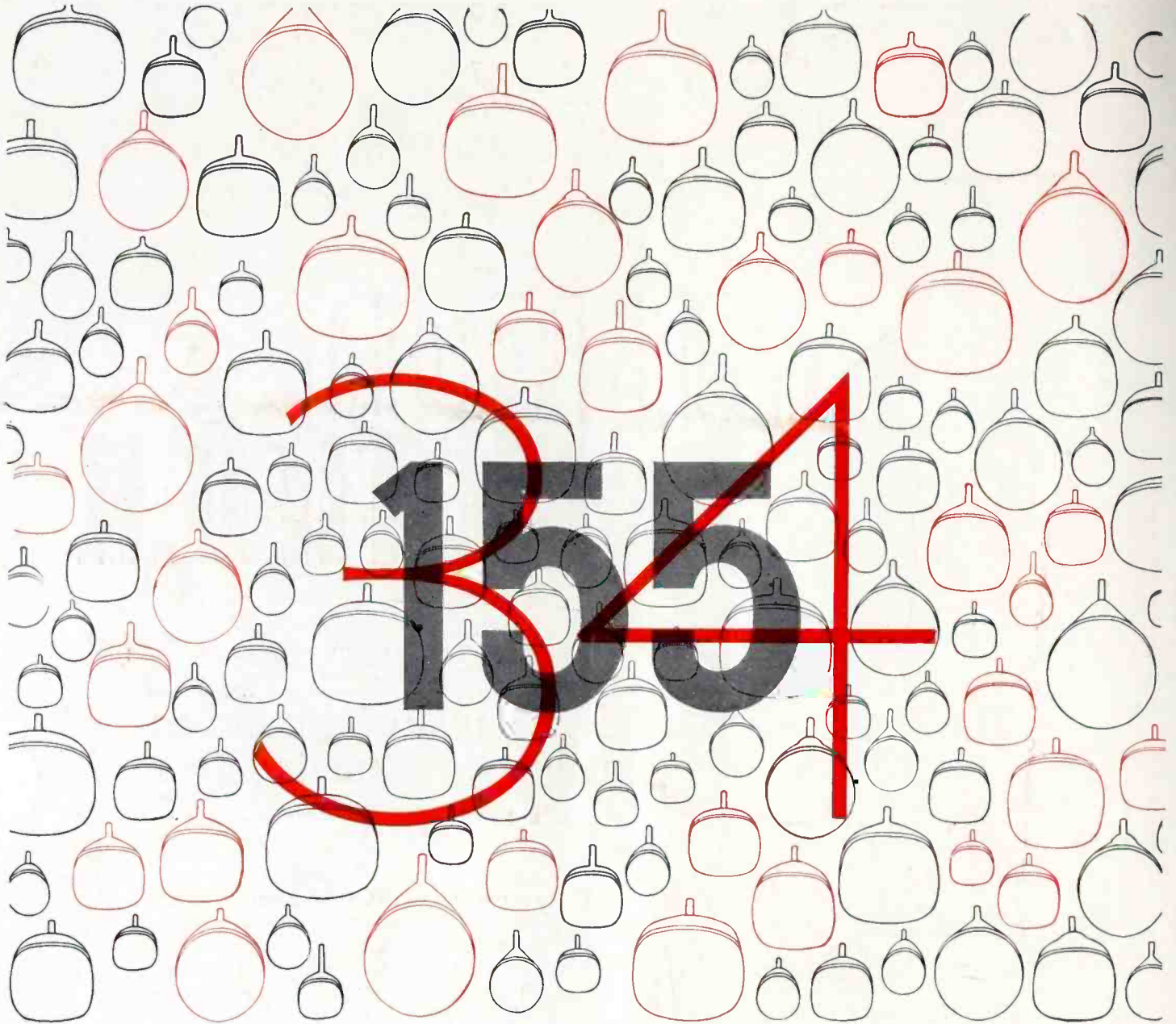

Just 34 RCA Silverama Picture Tubes now replace 155 types!

RCA cuts Picture Tube inventory and complex replacement problems, by nearly 80%. Simplification—that's like money in the bank—as every TV service technician knows.

Best of all, your customer is satisfied, too. He gets a brand name he knows and trusts... that gives his old set a picture that's often clearer and brighter than when the set was new... and that carries a full year's warranty, backed by RCA.

See your local Authorized RCA Distributor for your copy of the Silverama Replacement Chart

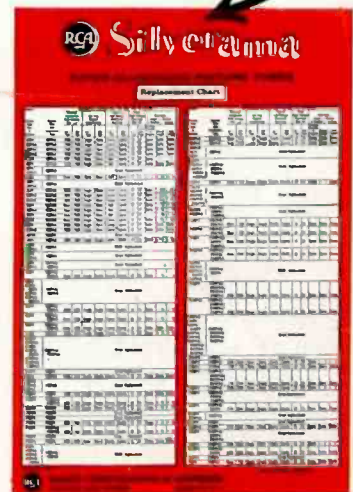

RADIO CORPORATION OF AMERICA

Electron Tube Division

Harrison, N. J.

Silverama®