

SERVICE

THE TECHNICAL JOURNAL OF THE TELEVISION-RADIO TRADE

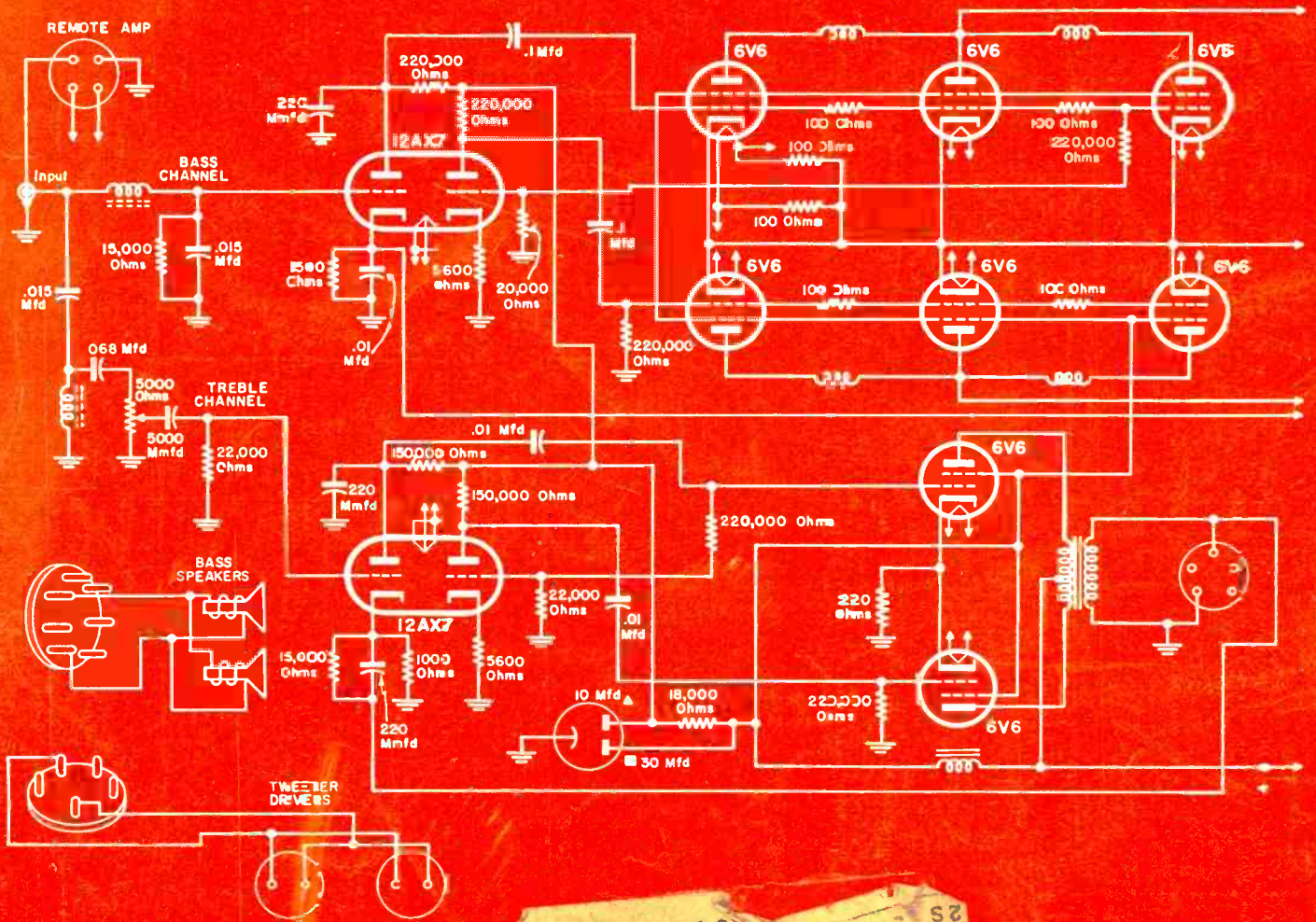

Power amplifier featuring bass and treble channels and six 6V6s in push-pull parallel circuit.

See circuit analysis, this issue

AL BOWEN
 1962 S STEARNS DR
 LOS ANGELES 34, CAL
 2-57

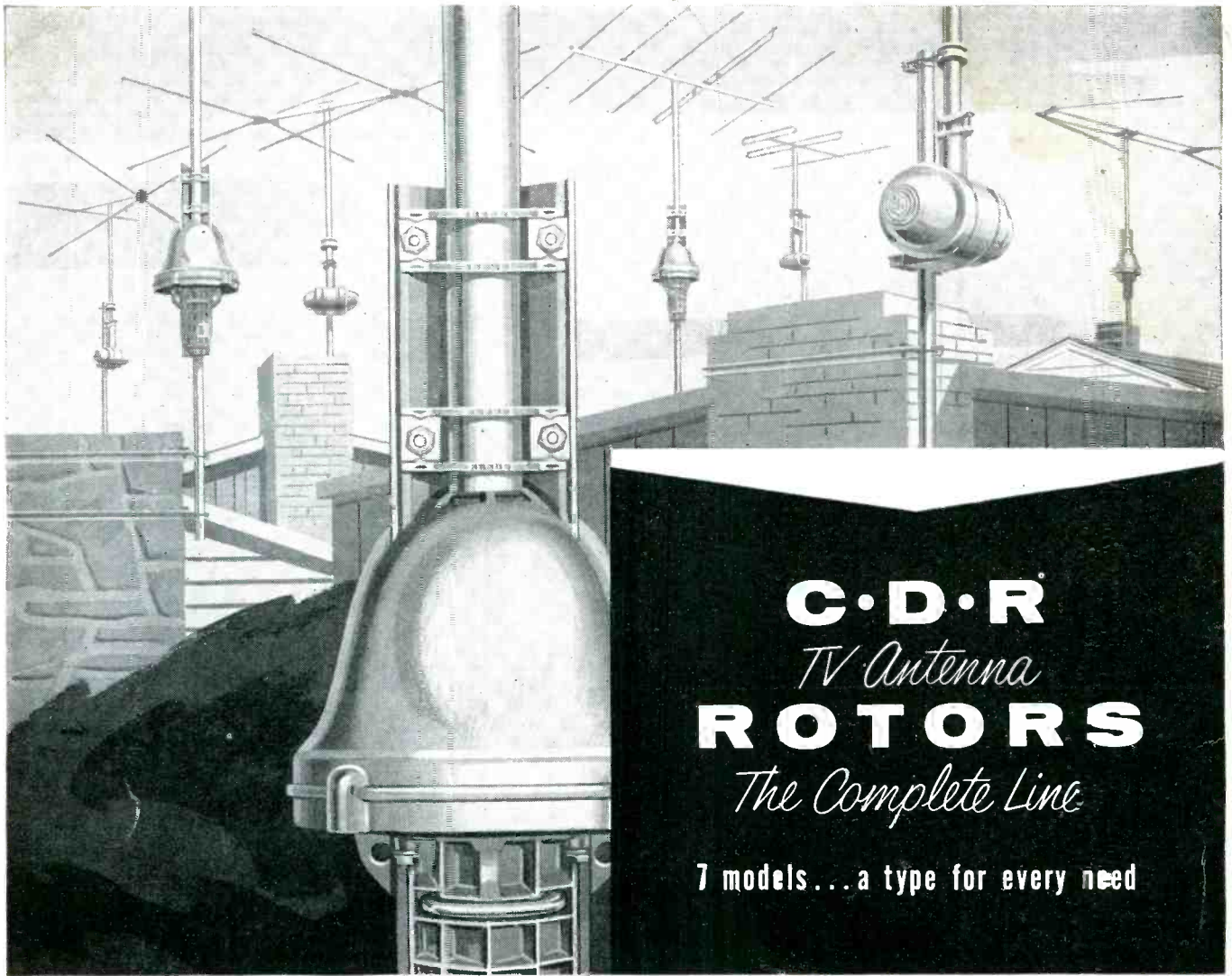

C·D·R
TV Antenna
ROTORS
The Complete Line

7 models... a type for every need

featuring **C·D·R automatic ROTORS**

Here they are . . . the fastest selling line of rotors . . . complete in every detail . . . including three models in completely **AUTOMATIC** rotors! The AR-1 and AR-2 and the AR-22 which is the automatic version of the famous TR-2. **ALL FIELD TESTED AND PROVEN BY THOUSANDS OF SATISFIED USERS!**

TR-2 The heavy duty rotor with plastic cabinet featuring "compass control" illuminated perfect pattern dial . . . uses 8 wire cable.

TR-12 Complete rotor **INCLUDING** thrust bearing. Handsome modern cabinet with meter control dial, uses 4 wire cable.

TR-4 The heavy duty rotor complete with handsome new, modern cabinet with **METER** control dial, uses 4 wire cable.

TR-11 Same as model TR-12 without thrust bearing.

pre-sold PRE-SOLD to millions with the greatest concentration of TV Spots in our history.

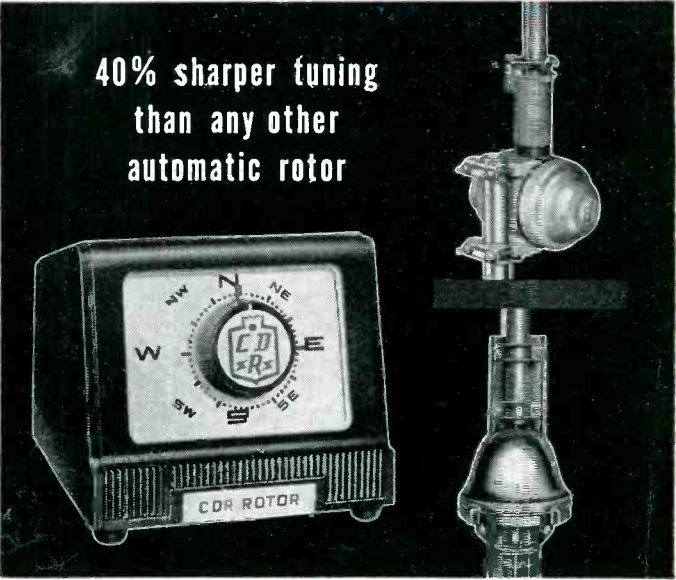

40% sharper tuning than any other automatic rotor



CORNELL-DUBILIER
 SOUTH PLAINFIELD, N. J.



THE RADIART CORP.
 CLEVELAND 13, OHIO

WHAT'S IN A FUSE?

Only a fuse element, glass & caps?

No! Every fuse carries
with it the skill and quality of its manufacturer.

You can't reach out and touch or taste this,
you can't even be sure it will do
its job when needed except
by purchasing from a company
that has the know how of 25 years
of manufacturing fine fuses.

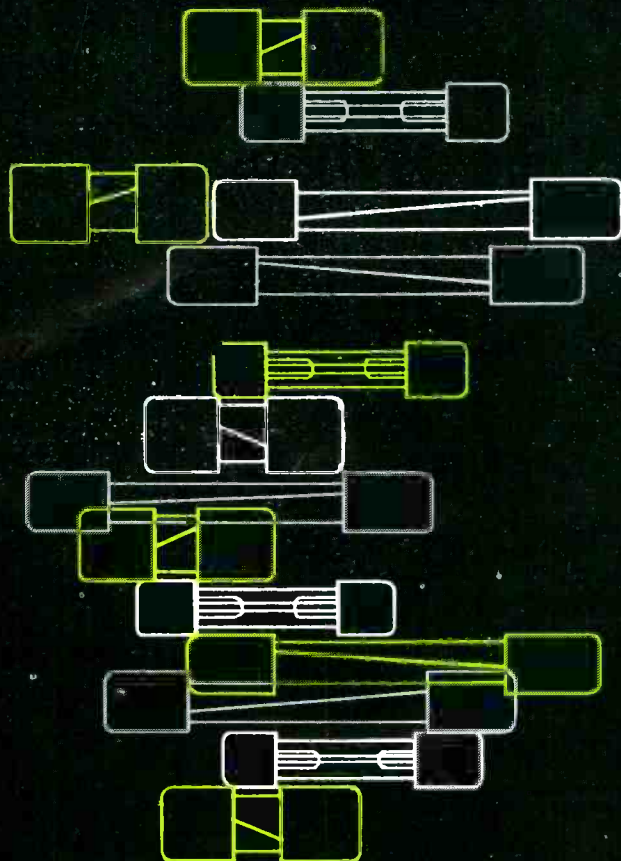

BURTON BROWNE ADVERTISING

LITTELFUSE

1865 Miner Street · Des Plaines, Illinois

New!

Technician's Quickie bench

RADIO MARK

Speeds Repairs On the Spot
Increases Profit Per Call
Builds Customer's Satisfaction

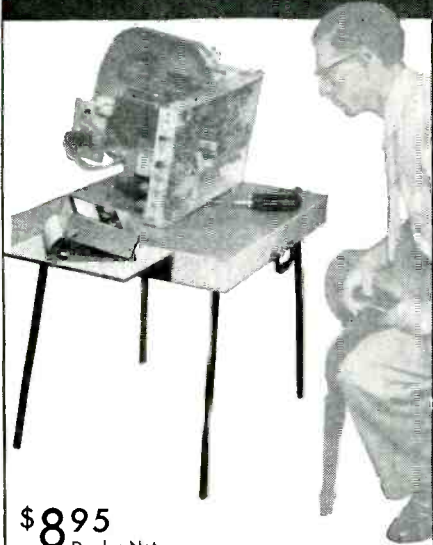

\$895
Dealer Net

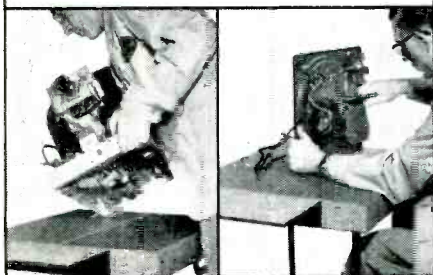

STRONG
with "Craftsmanship in Cabinets"

VERSATILE
use for any repairs.

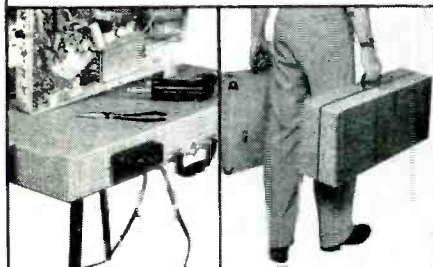

EXTRA GADGETS
can easily be added. Not incl.

CARRIES EASILY
only 26x11x6 1/4"
Can fit under arm.

ASK YOUR PARTS DISTRIBUTOR
OR WRITE FOR FOLDER

Argos

PRODUCTS COMPANY
310 MAIN STREET - GENOA, ILLINOIS

Vol. 24 No. 12

SERVICE

DECEMBER, 1955

The Technical Journal of the Television-Radio Trade

Including SERVICE—A Monthly Digest of Radio and Allied Maintenance: RADIO MERCHANDISING and TELEVISION MERCHANDISING. Registered U. S. Patent Office.

COVER CIRCUIT

30-Watt Amp for AM/FM/Phono (Magnavox) 18

FEATURES

Editorial	Lewis Winner	8
The Village Independent Service Shop	Herman G. Seehausen	10
Evolution of The Modern Radio	George Hatherson	12
Autotransformer-Powered 21-Inch TV Chassis (With Complete Circuit)	Robert D. Wengenroth	14
SERVICE . . . The National Scene		17
AM/FM Phono for Remote 4-Speaker 30-W Amp (With Complete Circuits)	Dan Graef	18
Broad-Band Yagi Design	Jan Kobler	20
Wide-Angle Deflection Trend in Picture Tubes	Dwight V. Jones	22
Annual Index to SERVICE		24
Vacuum Chassis Cleaners . . . Troubleshooting Auto Radios (Service Helps)		30
Speaker Deterioration and Replacement		33
Record Player Servicing Tips (3-Speed and 45 Portables)		38
Circuit Diagrams In This Issue		40

DEPARTMENTS

UHF/VHF TV Antenna Digest	20
TV Accessories . . . Parts	21
Tube News	22
Audio Installation and Service	33
Personnel	43
Association News	44
Ten Years Ago in SERVICE	44
Bench-Field Tools	45
Instruments	46
Catalogs and Bulletins	47
Jots and Flashes	48
Index to Advertisers	47

Entire Contents Copyright 1955, Bryan Davis Publishing Co., Inc.

Second-Class mail privileges authorized at New York, N. Y.; additional entry at the Post Office, Norwalk, Conn.

Subscription price: \$2.00 per year in the U.S.A. and Canada; 25 cents per copy. \$3.00 per year in foreign countries; 35 cents per copy.



EDITOR and PUBLICATION DIRECTOR

Lewis Winner

Associate Editor: David E. Pearsall II
Assistant Editor: Robert D. Wengenroth
Editorial Assistant: Jess Dines

Art Director: Anthony R. Aliff

Supervisor, Circuit Diagrams:
Michael D. Bellezza

Editorial Production: Astrid Kelly

CIRCULATION DEPARTMENT

Circulation Manager: A. Goebel

Ass't Circulation Mgr.: A. Kiernan

ADVERTISING DEPARTMENT

Advertising Mgr.: Aaron L. Lafer

Business Mgr.: F. W. Boyd

Mid-West Mgr.: Stuart J. Osten
333 N. Michigan Ave.
Chicago 1, Ill.
Tel.: DEarborn 2-3507

East-Central Rep.: James C. Munn
2253 Delaware Dr.
Cleveland 6, O.
Tel.: ERIevue 1-1726

Pacific Coast Rep.: Brand & Brand
1052 W. 6th St.
Los Angeles 17, Cal.
Tel.: MADison 6-1371

Published Monthly By
Bryan Davis Publishing Company, Inc.
52 Vanderbilt Ave., New York 17, N. Y.
Tel.: MURray Hill 4-0170

B. S. Davis, Pres. F. W. Boyd, Sec'y



SELL General

36 YEARS OF RADIO-BATTERY MANUFACTURING!

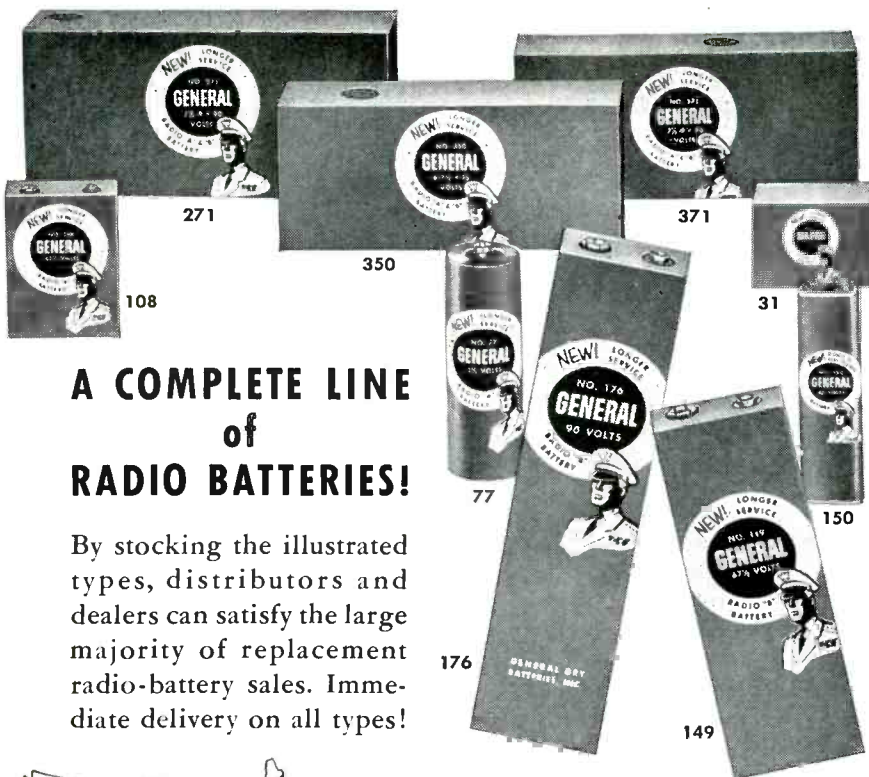

A COMPLETE LINE of RADIO BATTERIES!

By stocking the illustrated types, distributors and dealers can satisfy the large majority of replacement radio-battery sales. Immediate delivery on all types!



11 CONVENIENT SHIPPING POINTS! WITHIN EASY DISTANCE OF MOST DISTRIBUTORS.
Boston, Mass.; Silver Springs, Md.; Cleveland, Ohio; Atlanta, Georgia; Dubuque, Iowa; Memphis, Tenn.; Dallas, Texas; Denver, Colorado; Los Angeles, Cal.; San Francisco, Cal.; Portland, Oreg.



NEW SALES-BUILDING PACKAGING
General's new labeling stimulates impulse buying . . . makes these batteries look like what they are: *fresh, dependable, powerful, long lasting.*

AND—A COMPLETE LINE OF GENERAL MERCURY BATTERIES FOR INDUSTRIAL ELECTRONIC AND RADIO APPLICATIONS
The fine quality of General Mercury Batteries is being used in many products with transistor or electronic circuits—like Geiger Counters — Tachometers — Guided Missiles — Pocket Radios — Numerous Test Devices, etc.

Look to General for the Best in Batteries!



The "K.O." is Fantastic!

Features the highest front-to-back ratios ever recorded for any TV antenna:

- **Low band:** from 20:1 to 50:1 relative VOLTAGE.
 - **High band:** Up to 13:1 relative VOLTAGE.
- High gain:** Low band, 7 to 9 DB. High band, 8.5 to 10.5 DB. (Single bay figures). Balanced for COLOR.

Ends co-channel interference!
Knocks out "Venetian Blinds"!

Channel Masters "K.O." puts an INVISIBLE BARRIER in the path of rear signals, preventing co-channel interference. The "K.O." is completely preassembled with time-saving "Snap-Lock" Action. 100% aluminum.

LICENSED BY KAY-TOWNES ANTENNA CO., ROME, GA.

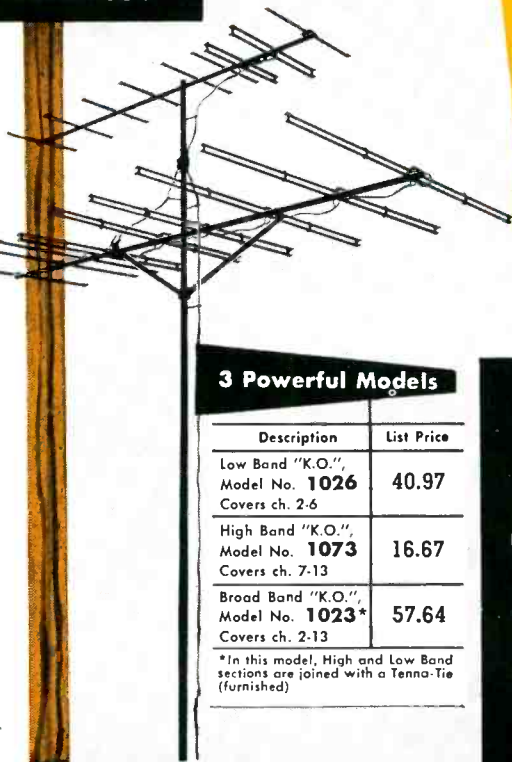

3 Powerful Models

Description	List Price
Low Band "K.O.", Model No. 1026 Covers ch. 2-6	40.97
High Band "K.O.", Model No. 1073 Covers ch. 7-13	16.67
Broad Band "K.O.", Model No. 1023* Covers ch. 2-13	57.64

*In this model, High and Low Band sections are joined with a Tenna-Tie (furnished)

**New
Antennas!**

**New
Accessories!**

**CHANNEL
MASTER**
now
provides you

The ^{new} Super Fan

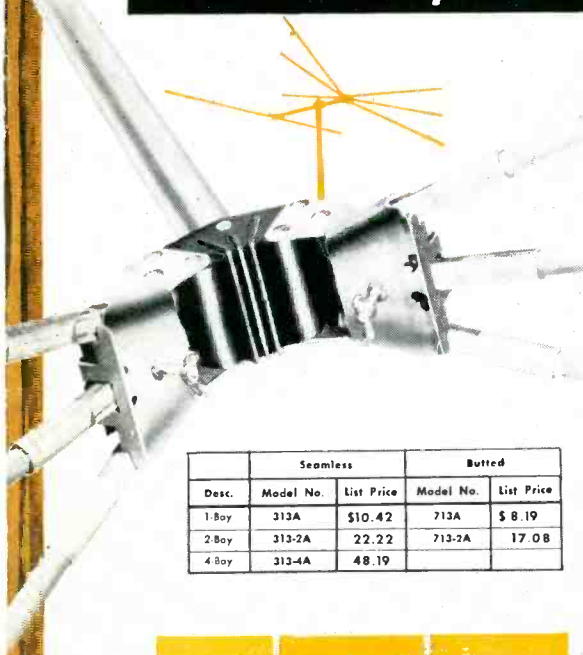

- "Super-Sembled"!
- Re-designed!
- Better than ever!

Channel Master's Super Fan is the original fan antenna. Famous for its superb quality, it has been in continuous demand for six years. Millions are in current use.

- Assembles with NO HARDWARE or tightening.
- Massive, heavy-duty, molded fan head. Unaffected by moisture and extreme temperatures.
- Reinforced elements. External sleeves prevent breakage.

Desc.	Seamless		Butted	
	Model No.	List Price	Model No.	List Price
1-Bay	313A	\$10.42	713A	\$ 8.19
2-Bay	313-2A	22.22	713-2A	17.08
4-Bay	313-4A	48.19		



CHANNEL MASTER CORP. ELLENVILLE, N. Y.

the world's largest manufacturer of television antennas and accessories

CHANNEL MASTER'S

new

TV TRANSMISSION LINE

The first TV wire to give you the benefits of

20

strands per conductor (20/33 pure copper).

with
EVERYTHING
but the roof!

installation. From now on, guarantee customer satisfaction with a **COMPLETE CHANNEL MASTER INSTALLATION — FROM TOP TO BOTTOM.**

It's a wood screw insulator



It's a machine screw insulator



All standard types and sizes available, including full assortment of specialized hardware. See your Channel Master distributor

it's got
FLEX-APPEAL!

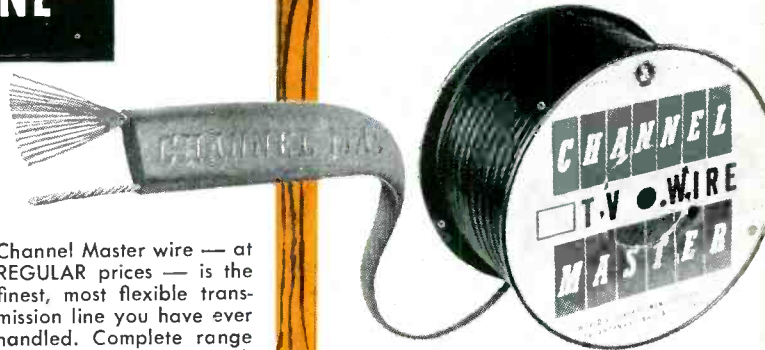

Channel Master wire — at REGULAR prices — is the finest, most flexible transmission line you have ever handled. Complete range of web thicknesses available. Colorful display packaging.

Two outstanding lines:

(both featuring exclusive 20-strand conductor):

"TWIN TWENTY"

- Marked every 10 feet. Saves time, ends waste.
- Full width. Available in silver or brown.
- Pure VIRGIN polyethylene.

"CHALLENGER"

Fine quality transmission line at today's VERY LOWEST PRICES.

new

STANDOUT insulators

Featuring this revolutionary new **2 in 1** screw thread design!

Eliminates the need for stocking separate machine and wood screws. Cuts your inventory investment in standoffs by more than 65%.

- Needle sharp point, made possible by finer thread. Easier to work in wood. Prevents slipping on mast.
- STANDOUT buckle has 8 machined threads.
- Convenient "Taper-Tip" strapping, available in galvanized or stainless steel.



Copyright 1955, Channel Master Corp.



.. a source you can trust for fuses of unquestioned high quality!

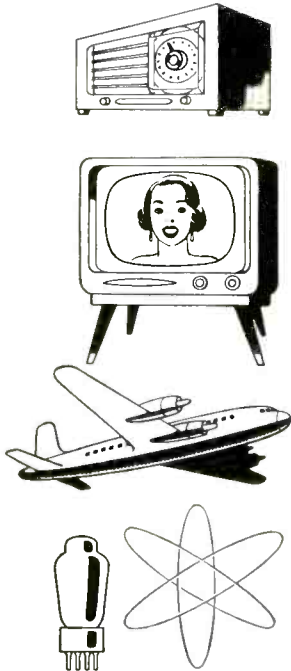

The BUSS trademark has appeared on millions upon millions of fuses used in homes, farms, and in industries, as well as electronic equipment over the past 41 years. It is a trademark known and recognized by manufacturers, service organizations and customers as standing for the highest quality in fuses.

To make sure the BUSS reputation for dependable electrical protection is maintained — every BUSS fuse, normally used by the Electronic Industries, is tested in a sensitive electronic device. Any fuse not correctly calibrated, properly constructed and right in all physical dimensions is automatically rejected.

This careful testing results in fuses that will open and prevent damage to equipment when there is trouble on the circuit . . . and just as important, BUSS fuses won't blow when trouble doesn't exist. Users are not annoyed with useless shutdowns caused by needless blows.

So rely on BUSS for all your fuse needs. You will be protecting your goodwill, reputation and profits against troubles and complaints often caused by use of poor quality fuses.

For more information on BUSS and FUSETRON small dimension fuses and fuseholders . . . Write for bulletin SFB.

Makers of a complete line of fuses for home, farm, commercial, electronic and industrial use.

BUSSMANN MFG. CO. (Div. of McGraw Electric Co.)

University at Jefferson, St. Louis 7, Mo.



Speed-Up Your Work with the *All-New*
RCA SENIOR VOLTOHMYST®

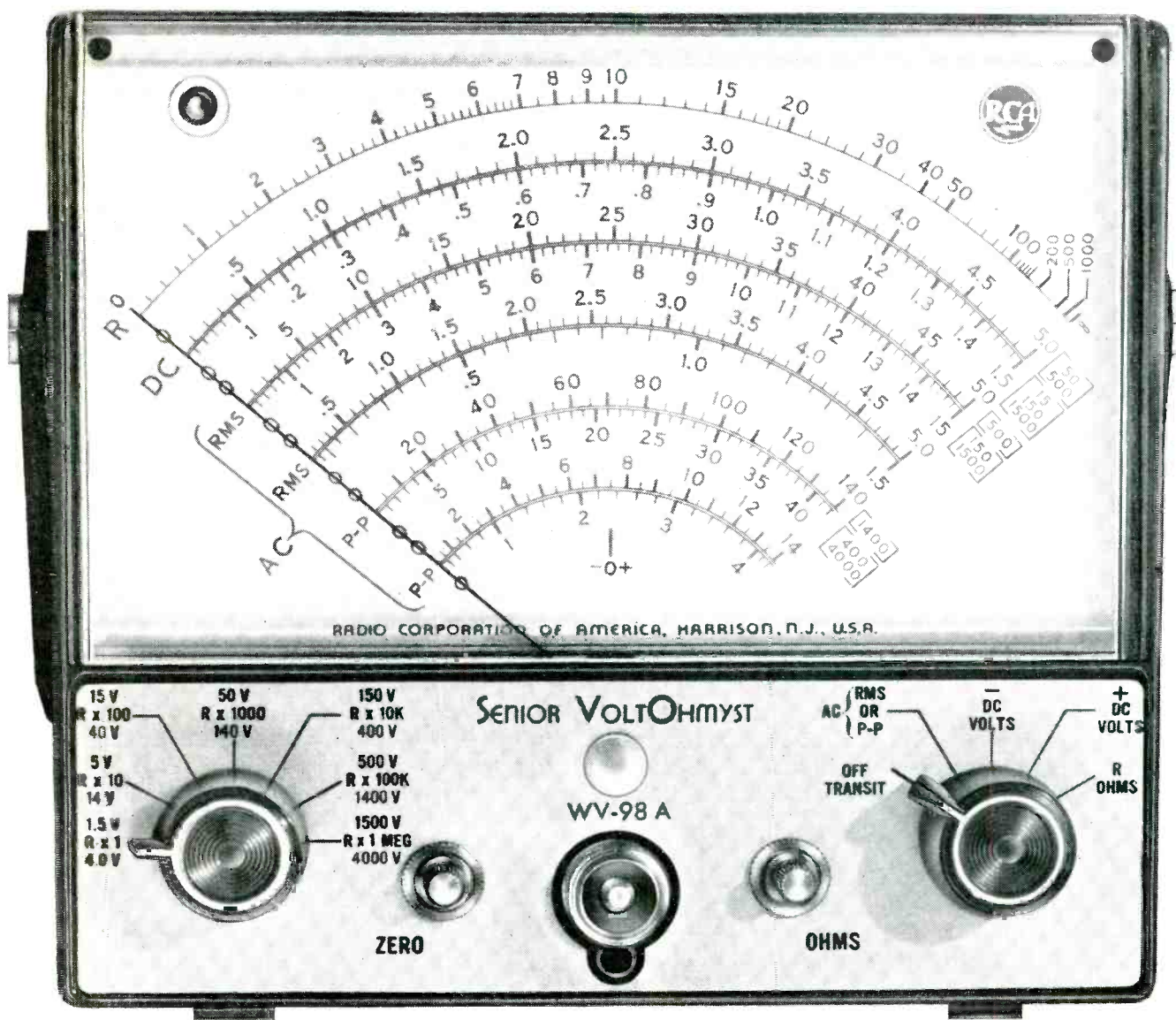

Senior VoltOhmyst, RCA WV-98A, only \$75.00 User Price* including probe and cable, instruction booklet, complete and ready-to-use . . . Shown slightly smaller than actual size.

* Optional

new!

You can work faster, more accurately—when you own and use the new RCA WV-98A SENIOR VOLTOHMYST with the extra-large full-vision meter-face. "Speed-up" in your service work—without the slightest sacrifice in quality—means a "build-up" in your profits. Look at the easy-to-read expanded scales. Then look at some of the other advanced features you also get.

- Large, easy-to-read, wide-vision meter (6½" w).
- Expanded meter scales . . . separate peak-to-peak voltage scales.
- Accuracy of 3% full-scale on BOTH ac and dc voltage measurements.
- Sturdy, single-unit streamlined probe with built-in ac-ohms/dc switch.
- Rugged die-cast aluminum case.
- Compact design: 7" wide, 3¼" deep, 6½" high, 6 lbs.

The all-new WV-98A has all the important, time-proved performance features of earlier VoltOhmysts including direct reading of peak-to-peak voltages of complex waveforms. See this highly accurate, versatile, service instrument at your RCA Distributor! Order now.

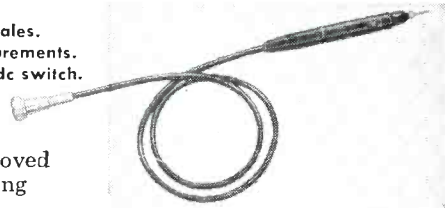

NEW! WG-299A slim, single unit DC/AC-Ohms Probe and Shielded cable is provided with the RCA WV-98A. Probe has handy built-in switch permitting instant selection of dc or ac/ohm operation.



RADIO CORPORATION of AMERICA
 TEST EQUIPMENT HARRISON, N. J.

® Trade Mark "VoltOhmyst" Reg. U.S. Pat. Off.

SERVICE

The Technical Journal of the Television-Radio Trade

1955 In Review

THIS IS ALWAYS a particularly interesting time of the year, for the record books are now being closed and we have an opportunity to look back and see just what has been accomplished.

Industry has done a grand job this year; giant strides have been made in every field.

Black and white TV, after a balky start, hit the headlines with portables, vertical chassis and wide-band models. The early models were confused affairs, but designers took note and solid improvements began to appear in most chassis.

Playing a title role in this progress were the wide-angle 90° picture tubes* and modified sweep and deflection components which resolved practically all of the pin-cushioning and barrel-shaped problems. Now, even shallower tubes with 110° and 120° deflection angles are being designed for more compact chassis. It has been found that the increased deflection angle; which further accents the problems of sweep power, pin-cushioning and bad focus at the edges, can be minimized by a smaller neck to reduce sweep power, picture-straightener magnets to curb pin-cushioning and dynamic focus to improve edge focus. The widest applications of these tubes is expected to be in 14- and 17-inch models.

THE PRINTED WIRING or plated boards, which in the early stages of development were a nuisance, also went through the design wringer, with complete revisions in processing, layout and application, providing better products. While still not perfect, requiring extremely careful handling, they are today serviceable. Practical plug-in components are now available, and special tools and test equipment have been produced to ease installation and repair work.

REMOTE CONTROLS, for years complex systems, pushed away the barriers of mystery during the year and became a popular tuning accessory. Novel and streamlined, most of the controls now employ simplified servo mechanisms, motor and step-control relays, system-contact plugs or station-seeking switches, and palm control units which provide channel selection, volume and brightness adjustments, tuning and on-off operation.

*See exclusive field report on wide-angle tubes in this issue.

ALSO CONTRIBUTING to the parade of advancements were completely-rebuilt vertical chassis. Borrowing proven techniques used in communications and broadcast equipment, set designers included such features as tilt-out chassis, angled tube sockets, equalized heating-time tubes (for series hook-ups), and autotransformer power supplies for dual-parallel filament strings. In addition, receiver engineers included cascode tuners to up fringe-area signals, noise inverters to hold pictures and maintain contrast in high-interference areas, and adjustable *agc* for picture stability. And to minimize early tube breakdown, circuits were designed so that tubes could be operated well below their maximum load ratings.

THE YEAR ALSO witnessed the formal debut of the transistorization era, with the arrival of a parade of portable transistor radios, using from four to seven transistors, providing up to 100 milliwatts of power. This is quite a contrast to the six to twelve milliwatts of power, tops not too long ago.

THE COMPLETELY NEW CONCEPT of auto-radio tuning, introduced by the signal-seeking system, originally designed for one line of cars, won industry-wide acceptance during the year. Like the TV remotes, the automatic tuners popularized a number of unusual control methods involving 12-v drive motors, reversing switch relays, sensitivity switching, detectors acting as trigger tubes, and planetary gear systems serving as switches to transfer motor power.

COLOR-TV also became a full-fledged member of industry during the year, thanks to a long list of circuitry and component developments. No longer a bulky, 40-tube small-screen oddity, the '55 versions are now housed in smart cabinets, display large 21-inch screens, have but 26 to 29 tubes, and offer substantially improved performance.

Circuit improvements include four-stage *if* amps, and crystal detectors for luminance and chrominance. Chrominance amplifier gain is controlled by an automatic chroma gain system designed to compensate for variations found in color cameras and color scenes. Subcarrier oscillators are crystal controlled for stability and supplemented by automatic frequency control to assure absolute accuracy of phase and frequency.

CERTAINLY A NOTABLE record of progress has been filed for '55: It's one that will surely pay big dividends during the bright new year ahead.—L. W.

this **RAYTHEON** "Bond" pays a 10% "Dividend"*

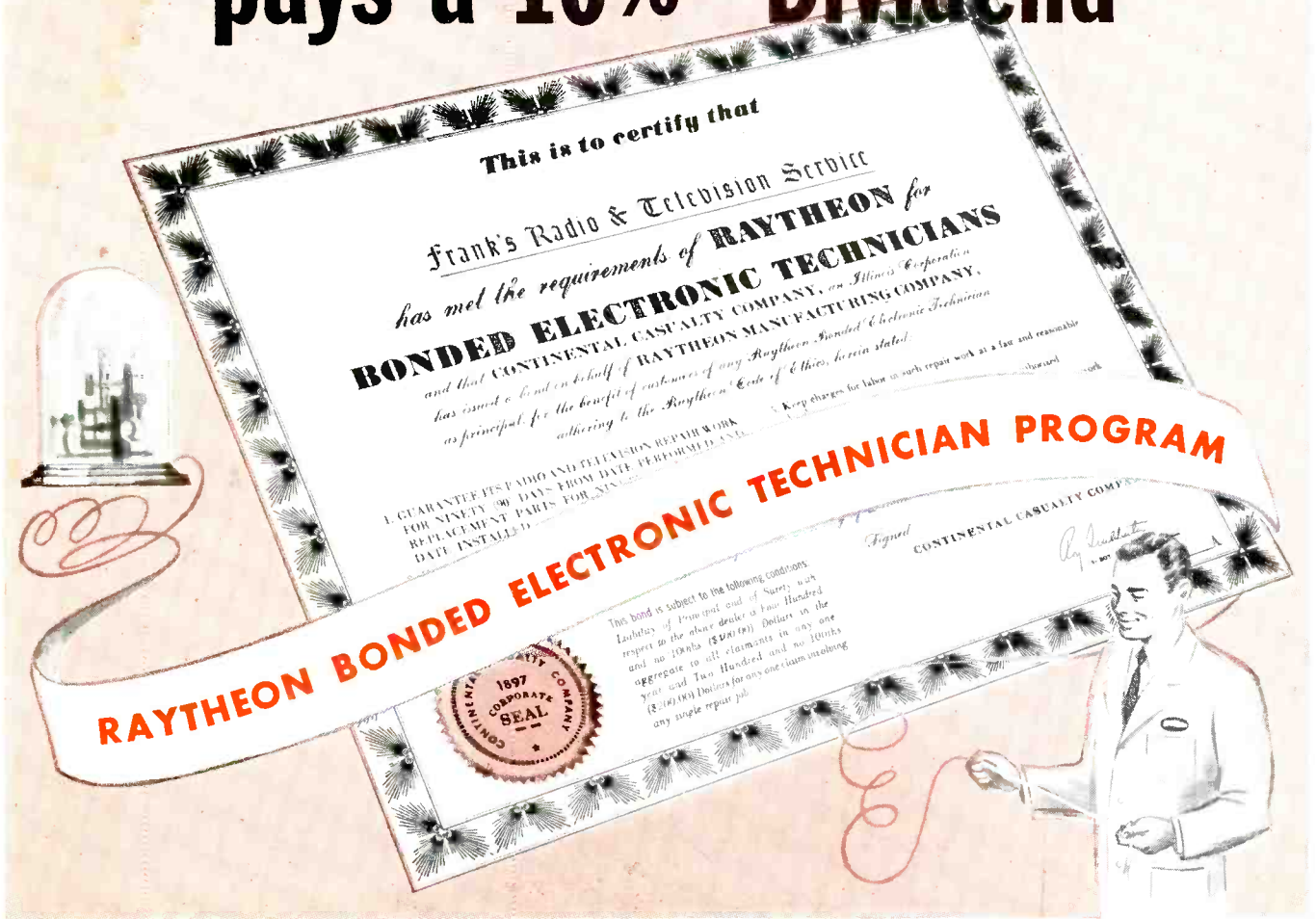

If you are interested in increasing your Radio & TV Service business and profits 10% or more call the Raytheon Tube Distributor in your area right now.

Ask him to tell you how the Raytheon Bond gives you a national backing of your 90 day guarantee, increases customer confidence in you and your shop.

Ask him to show you the many free business builders — Creed Displays, Decals, Certificate, Identification Cards, ad mats, etc. — that Raytheon makes available to you to help you tell your customers and prospects you're "Bonded".

Ask him about the Raytheon national advertising that makes it easy for you to get more business and then ask him if you can qualify for this exclusive Raytheon business builder. If you can, it costs you nothing — it's Raytheon's investment in your future.

*Recent surveys prove the Raytheon Bonded Program improves business by at least 10 per cent.



RAYTHEON MANUFACTURING COMPANY

Receiving and Cathode Ray Tube Operations

Newton, Mass. • Chicago • Atlanta, Ga. • Los Angeles, Calif.

Raytheon makes all these:

Receiving and Picture Tubes • Reliable Subminiature and Miniature Tubes
Semiconductor Diodes and Transistors • Nucleonic Tubes • Microwave Tubes



The Village

A Field Report

calls. Lately, it has been necessary to work in the shop during evennigs to keep up with the bench work.

Servicing for Dealers

Dealers here follow the widespread practice of farming out their service work to the independent shops. In our case, we handle the service work, antenna installation and new set repairs for a general hardware and appliance store directly across the street from our shop. When I need help on antenna jobs the appliance store supplies the manpower.

TV Antenna Problems

Unusual TV antenna-pickup conditions obtain in this area. Antenna heights, types and arrays vary considerably within my 25-mile radius. The highest point in this section of the state is just three to four miles south of the town, where, in some instances, indoor antennas have provide reliable pickup.

Yet just 2 miles away from this point, it has been found necessary to install large, directional antennas mounted as high as practical, to provide reliable pickup.

In some instances, the antennas have been mounted on 30' or 40' rooftop masts or on towers located several hundred feet from the house on

**Frewsburg, New York.*

(Above)

Seehausen preparing for a field trip with a repaired TV chassis, as his wife looks on.

(Left)

A view of the TV-radio work bench in the Seehausen shop.



OUR SHOP, a one-man operation located in a rural community* with about 2000 residents, is ringed by a number of deeply-wooded villages and several large towns, too. Our working area extends possibly into a trading population of 100,000 people in New York and Pennsylvania, whose border line is but four miles from us. Accordingly, my service problems envelop a wide range and require an extremely versatile setup.

A Dual Shop

My store, which is 30 feet across the front and 65 feet deep, is a divided affair, with a small gift shop,

operated by my wife, in the front, and the service section in the rear. My wife serves as my secretary, bookkeeper and telephone operator; an arrangement that is extremely helpful for it enables me to keep the shop open while I'm out on antenna work or customer house calls.

AM/PM Schedule

Because of the one-man setup, it is necessary to hold to a tight bench and field-work schedule. Except for occasional morning service calls, the forenoon is reserved for shop repair work. The afternoons are set aside for antenna installations and house



Independent Service Shop

by HERMAN G. SEEHAUSEN

higher ground. Signal strengths have been found to vary from as low as 30 to as high as 1000 microvolts.

Case History System

Our operation involves not only TV installation and repair, but radio, hi-fi and tape recorder service, too. An easily accessible card-file case history of every job is kept so that it is possible to refer to it before making a call; these cards show the make and model of a set, previous work done and when, and the type of antenna used. This system has been found very helpful, especially on long distance calls, where it might be necessary to complete a job in the home.

These remarks are supplemented by trouble information supplied during a phone call for service. Specific questions asked enable me to trace the problem on the schematic for the particular model involved, so that I can stock my field kit with the parts that might be needed to affect a repair.

Field Call Test Equipment

For field calls, a tube and tool kit, tube tester, and *vtvm* are carried.

In the home if a tube test does not reveal the trouble, the chassis is removed from the cabinet and voltage checks are then made. Where the voltage test does not pinpoint the trouble, the chassis is carried to the shop for further diagnosis.

Shop Facilities

Where the picture tube is mounted separately, only the chassis is returned to the shop. For this purpose both 17-inch and 21-inch picture tubes are kept in the shop to expedite testing. Also in the shop is a universal speaker, choke and output transformer unit, that covers most of the receivers, and makes it possible to leave the speaker assemblies in the home.

Work Benches

The work bench has been designed to permit repair of six sets simultaneously. For flexibility none of the test equipment is bolted down or built in; the test pieces can thus be moved around and used as needed for each job. In the event that the

workbench is too crowded, instruments are placed on two movable tables fitted with casters.

For those house calls close to the shop and in the village itself, in-the-home work is terminated with tube testing, chassis and picture tube cleaning and minor adjustments. This method has been found to speed up calls and allow me to reach more customers.

A ranch wagon is used as the family car and for service calls, too. It has been found ideal for pickup and deliveries, allowing for easy loading and removal of chassis.

Mobile Service Truck Plans

At present, I am planning to supplement my shop transportation with a service truck to house ladders and a movable shop for my distant calls. The mobile setup will be equipped with a small repair bench large enough to work on one receiver, and such vital test equipment as a tube tester, *vtvm*, scope and signal generator. This will cut down on chassis returns to the shop and will increase on-the-job repair.

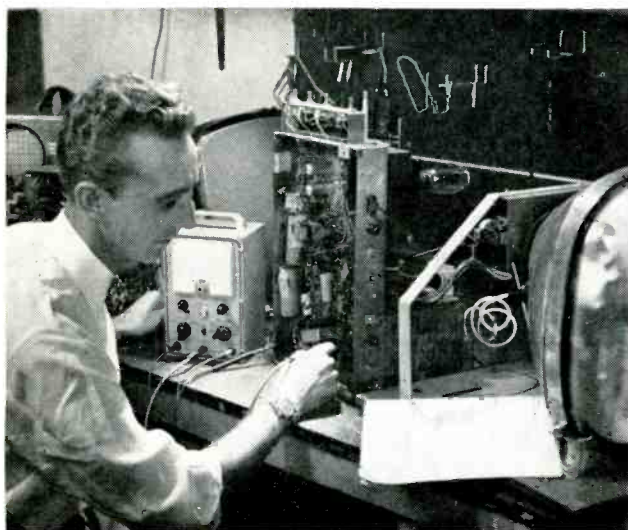

Seehausen checking a TV chassis in his village service shop.



Adjusting TV chassis that's been installed in dealer's showroom.

Evolution of the Modern Radio

A Field Research Program Report

by GEORGE HATHERSON

WHILE THE PERFORMANCE of radio receivers has improved steadily for years, the improvements have not been due to radical changes in circuitry, but rather to advanced designs in components and tubes. The circuits designed fifteen or twenty years ago have simply been modified to accommodate today's superior parts and tubes.

Examples of the tube-component changes appear in the old and new popular *ac-dc* superhet receivers. A large number of receivers had been built with a tube lineup consisting of a 12SA7 converter, 12SK7 *if* amplifier, 12SQ7 detector and audio amplifier, and 50L6GT audio output amplifier. The rectifier was consistently a 35Z5GT, with a dial light across part of the heater. The basic circuit remained essentially unchanged even when the 12BE6, 12BA6, 12AT7, 50B5, and 35W4 miniatures became

available, and subsequently when higher-gain miniatures were introduced.

The *ac-dc* superhet receivers typically have a loop-type antenna, pentagrid converter, simple *if* pentode amplifier with remote cutoff characteristics, diode detector which also supplies *avc* voltage to the converter and *if* amplifiers, a contact-biased audio amplifier, and a simple pentode power output amplifier. The rectifier is half-wave with a capacitor input *rc* filter. Modern receivers are less likely to include a pilot light than are the older receivers.

A receiver,* typical of modern *ac-dc* receivers, illustrating advanced component-tube design, is shown in Fig. 1. This chassis employs plated wiring, which provides better control

**Motorola chassis HS-487, in models 56R1 through 4.*

of stray capacities in production, and a printed circuit. The *if* transformers are slug-tuned miniatures.

The loop antenna (item 1) consists of a number of turns of wire on the receiver back; no provisions were made in this model for an external antenna because of the receiver's sensitivity and the increased number of stations now on the air. This is typical of the modern trend; pre-war receivers included a few turns of wire coupled to the loop to provide sufficient signal for those locations which had no local stations. Another modern element which has replaced the large loop on the rear of the cabinet is the ferrite-core antenna. Electrically and schematically, its performance is the same as the air loop; however, more signal is developed. In any case, the antenna is

Continued on page 41)

Fig. 1. Schematic of Motorola HS-487 (models 56R1-4) illustrating improved components and tubes, and modified circuitry (indicated by numerical references) used in modern radios.

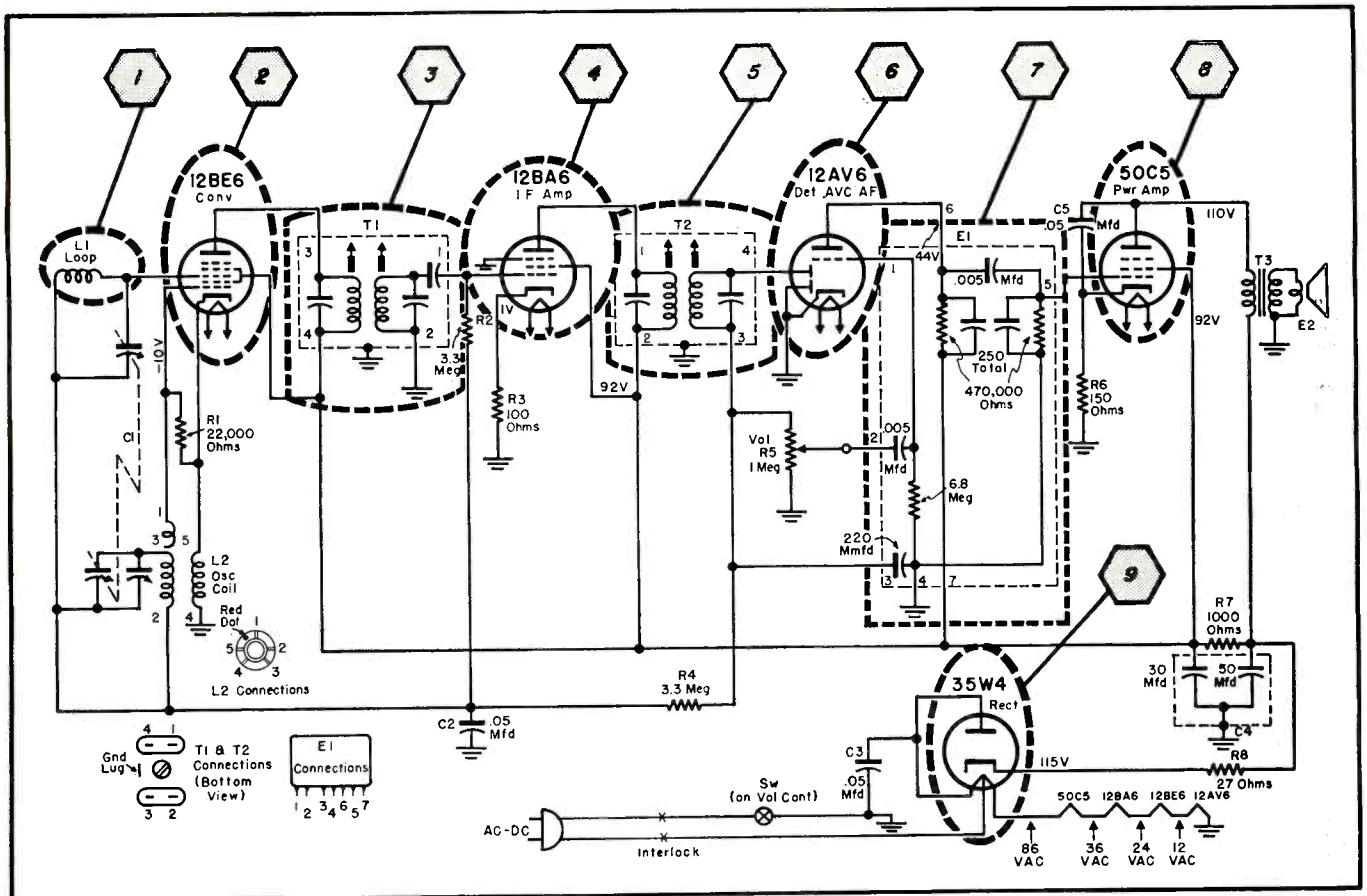



Consider ONLY a

PERFECT REPLACEMENT

when original quality disappears

When the *original* goes, the substitute should be a *Perfect Replacement*. Ordinarily there is only one perfect replacement—something that looks and works as good as the original when new—or *better*. When the original picture tube goes, the *perfect* replacement is a Du Mont Twin-Screen Hi-Lite[®]. The set will sparkle with new picture life . . . you'll have "new set" quality—or *better*. A Du Mont Twin-Screen Hi-Lite picture tube *replaces* age with "like new" performance.

[®]the ultimate in aluminized picture tubes.

DU MONT[®]



CATHODE-RAY TUBE DIVISION, ALLEN B. DU MONT LABORATORIES, INC., CLIFTON, N. J.

SERVICE, DECEMBER, 1955 • 13

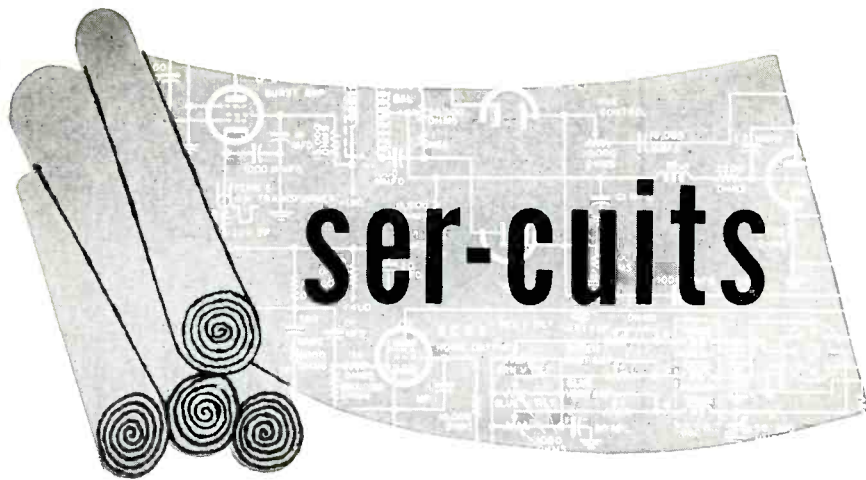

DeWald Autotransformer-Powered 21-Inch TV Chassis

by ROBERT D. WENGENROTH

THE RECENT TREND to small, compact TV chassis has focused attention on the electrical and physical economies that can be affected in the power supply.

The series-string approach has been adopted by many as a solution. Recently another method* was evolved, using a reflex-design power system that permits the use of a smaller transformer used as an auto type.

In this new technique a 5U4 is operated as a half-wave rectifier from the autotransformer, while the heaters for the set's tubes are operated from a center-tapped 12.6-v winding on the same core.

While most of the advantages of transformer-type supplies are provided, one feature, isolation from the power line, is lacking. One side of the power line is connected to the chassis; thus the usual precautions against shock and damage to service

equipment must be observed when this set is under repair.

The autotransformer, fed from the usual 117-v input, provides an output of 270 v. Two auxiliary windings are included, a 5-v rectifier filament winding and a 12.6-v center-tapped heater winding. Because, say the designers of this power supply, the line voltage is added to the high-voltage secondary voltage, 117 v worth (or 43 per cent) of the secondary normally required is eliminated. And, because the power represented by this 117-v portion of the winding does not have to be transformed, both the iron core and the primary winding can be made lighter; since heater and high voltage powers are comparable, the saving is approximately 20 per cent in the core and

*DeWald models J-215, J-216, J-217, J-212DA.

in the copper wire in the primary. The total power required by the set is 150 watts.

The heaters of the tubes are supplied from the 12.6-v center-tapped winding. One 12-v tube, a 12L6 (audio output), is connected across the entire winding; the remaining tubes are connected from ground to an end of the winding, with the load split evenly between the two halves.

The B+ supply employs a half-wave rectifier and a pi-section filter. The 5U4 is operated as a half-wave rectifier, with the two sections in parallel supplied by the autotransformer. The half-wave circuit permits operation from the autotransformer with the transformer economies described, while parallel operation preserves the power-handling capabilities of the 5U4. The pi-section filter is conventional, except that the output capacitor consists of a pair of 200-mfd units in series; thus the same capacitors filter both the 250-v and the 121-v supplies.

The B+ distribution of this set includes a series arrangement of stages which permits effective use of rectified power, as illustrated in Fig. 2. The full rectified 250 v is applied to the tuner, the video amplifier, and the screen of the horizontal output amplifier. It is boosted by the damper to 500 v and supplied to the horizontal and vertical output amplifiers, and the vertical oscillator. A voltage of 245 (from the 250-v supply, through an rc filter of 1000 ohms and 5 mfd) is applied to the audio amplifier and the horizontal afc and oscillator.

The remaining stages receive their power via the series arrangement. The audio output stage is connected to the 250-v supply; its current drain equals that of the video if amplifiers, the sync separators and the sound if amplifier. Therefore these stages are connected to the 121-v bus, which is supplied from the audio output stage cathode. This can lead to some nuisance problems in servicing; for example, a defective 12L6 audio output tube will upset the operation of the if amplifiers and the sync separators.

The receiver employs either of two cascade tuners, straight vhf or a combination chf-uhf tuner, each with 41-mc if output. Five tuned circuits and two traps of the if system produce the required response, as shown in Fig. 3. Two 6CB6s and a 6AM8 are employed as the if amplifiers. The diode section of the 6AM8 serves as the second detector. The dc component of the detector output is filtered to remove the video signal and

(Continued on page 42)

Fig. 1. DeWald power supply system for TV chassis utilizing an autotransformer.

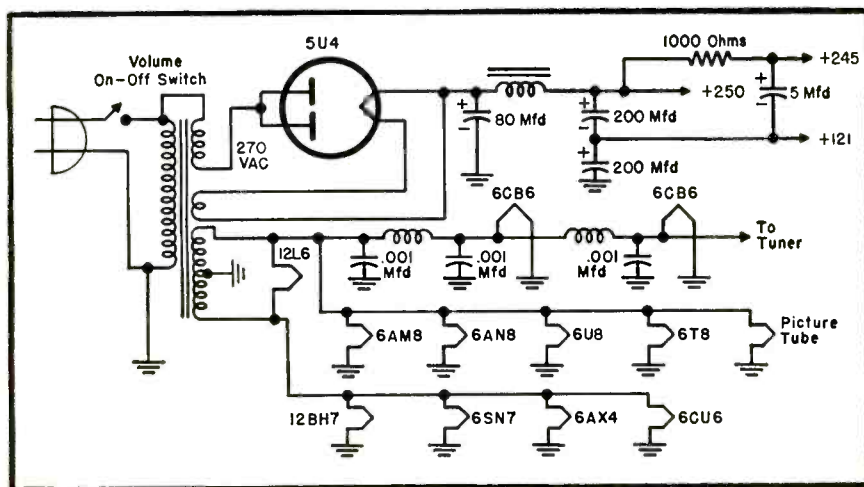

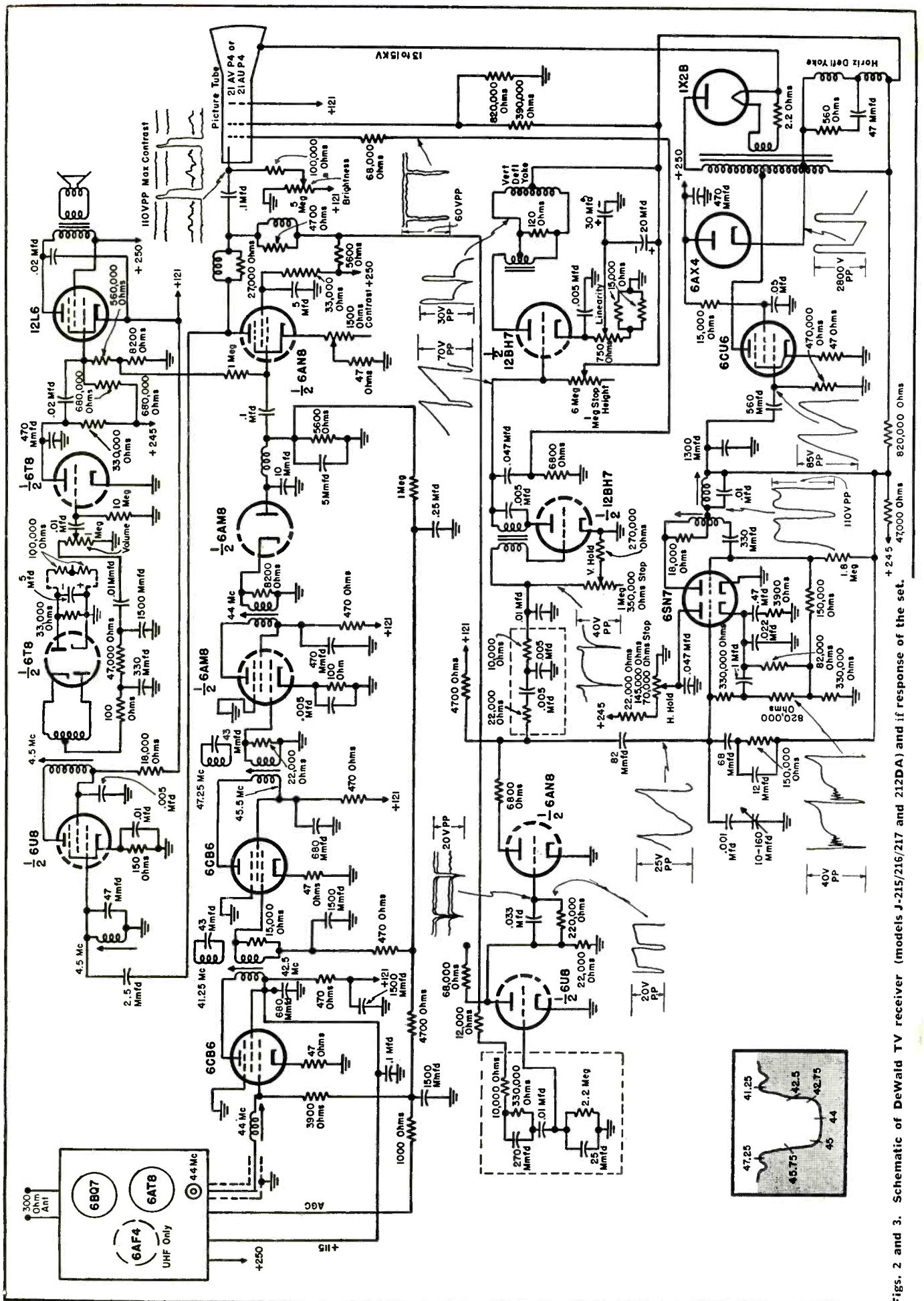

Figs. 2 and 3. Schematic of DeWald TV receiver (models J-215/216/217 and 212DA) and if response of the set.

An open letter to all TV service-dealers

FACTS ARE FACTS...

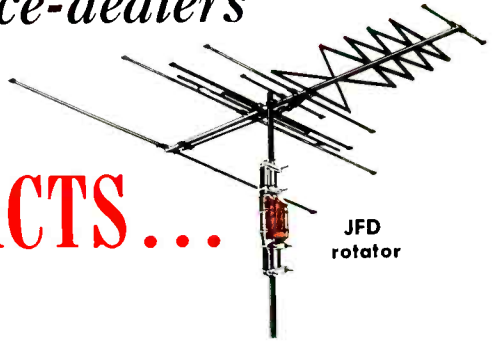

FACTS ARE FACTS and you—as a serviceman—must be prepared to face them. All rotators eventually break down and require servicing. This usually means dismantling the antenna installation and disrupting your customer's TV enjoyment for days. It not only costs you time, effort, and money, but strained customer relations. Moreover, your cost of servicing the rotator is greater than the profit you make on the original installation.

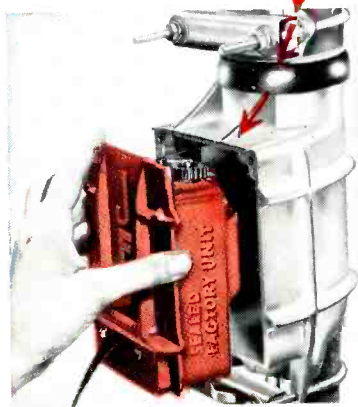

THE ANSWER MUST BE *BUILT* RIGHT INTO THE ROTATOR. The unit must be designed to give superior performance and yet be easy to service. That is why the JFD Roto-King Rotator is the solution to your problems. To service, *simply remove the old unit and replace with a new, moderately-priced factory-sealed unit.* Service is restored in a matter of *minutes*, without loss of customer goodwill.

Your nearest JFD distributor has Roto-King Rotators in stock at attractive prices, in 4 different models to suit any location requirement. Control cases can be obtained in either mahogany, ebony, or ivory. Be sure to ask for the JFD Roto-King—the *only* rotator with the *replaceable* power cartridge.



The Roto-King Rotator was designed, engineered, and manufactured in the JFD plant.



MANUFACTURING CO., Inc.

Brooklyn 4, N. Y.

Go Forward with JFD Engineering!

SERVICE... The National Scene

ENORMOUS MARKET FOR SERVICE IN '56 SEEN BY INDUSTRY HEADS--The booming interest in TV, radio and audio, across the nation, will mount during '56 and provide phenomenal opportunities in installation, repair and maintenance, scores of set, accessory and component executives have predicted. . . . According to the prexy of a leading tube-chassis maker, we'll have well over a billion-dollar service market in '56. He based his optimism on the '55 spurt in b-w TV production, the expected grand push to color and the extraordinary enthusiasm in phonos. . . . Before the year is over, the production of TV sets will have set a new record high of at least 8-million units, topping the previous peak of 7½-million chassis made in 1950. . . . Supporting this bright forecast, another company chieftain said that the dollar volume of the industry will jump at least 15% during the coming year. Ten years ago, he noted, the electronics industry had annual sales of about 1½-billion dollars. Five years ago it passed the 6-billion dollar figure and now it is well over the 11-billion dollar mark. Next year, it was estimated, the electronics industry volume should hit around 13-billion dollars. . . . Commenting on the cheery future, still another expert noted that: "The pace of our industry is so fast that everybody must be constantly on the alert for the development and introduction of new products. . . . More than 80% of the products now in production did not exist ten years ago. And, in another ten years, regardless of the size of the radio and television industry, more than half of the volume will be in products and services that do not exist today."

MILLIONS OF AUTOS AND PLEASURE BOATS BOOM NEED FOR NOISE SUPPRESSORS--The huge army of cars now on the roads and especially the spectacular growth of pleasure boat buyers, who have equipped their craft with all kinds of appliances and TV, radio, phonos and recorders, have developed an unparalleled market for noise suppressor filters. . . . It has been estimated that there are some 5-million boats afloat today that could use filters of one type or another. . . . The filters, it was noted, could be used to screen out noise from fuel, water-pressure, flush and refrigerator pumps, as well as motors used for windshield wipers, air compressors, freezers, electric shavers and, of course, the craft's engine.

FCC TO REAPPRAISE UHF/VHF ALLOCATIONS--The long-expected probe of the confused low-high band situation will begin, shortly after the first of the year, in the nation's capital. . . . In a special notice, the FCC said it hoped to find out why it has not been possible to reach the objectives of its 1952 order which called for at least one service to all areas, at least one station in the largest possible number of communities and multiple service in as many communities as possible. According to the Commission, 90% of the population can now get some TV service, while about 75% have service available from two or more stations. However, the Commission pointed out, the nationwide competitive TV service, which it was hoped would be established by now, has not been realized. Many of the smaller communities are still without a first local outlet and the expansion of a multiple competing service is lagging. Difficulties encountered in achieving successful operation of stations in the ultrahigh band, it was said, have been a significant factor leading to this situation.

SELF-LICENSING PLAN PROPOSED BY CINCINNATI ASSOCIATION--A unique proposal that would provide for the licensing of all association members has been prepared by a group in Cincinnati, Ohio. . . . In its licensing provisions, 27 qualifications have been listed. . . . To earn a license, members will have to show proof of possession of adequate test equipment, adequate service data and an adequate stock of replacement parts. To qualify for the top accreditation, one must certify that he has a minimum of four years or 8000 hours of practical experience in TV servicing and must pass oral or written examinations supervised by a board of governors. In addition, a prospective license holder will have to show that he operates from a place of business in a location zoned for business with free access for the public, or in a location not in conflict with local zoning ordinances. License fees will be \$15 per shop plus \$2.50 per man.



AM/FM/PHONO

Designed For Remote 4-Speaker/30-W Amp Console

by DAN GRAEF, Engineering Department, The Magnavox Company

IN THE DEVELOPMENT of packaged hi-fi phonos, it is important to consider carefully and collectively the acoustical design of the cabinetry, frequency characteristics of the pickup, the amplifiers and the speakers, so that wide-range response can be achieved.

In the conventional hi-fi system a speaker crossover network is used to channel bass and treble frequencies into respective producers. In one packaged system¹ it has been found possible to obtain hi-fi results by integrating the cabinet, amplifier and speaker, and introducing a dual-channel amplifier each feeding speakers designed for their respective functions. The circuit of the amplifier developed for this purpose is shown, in part, on the cover and completely in Fig. 1. For amplifier control a pre-amp is used; this is located on the radio tuner offering a selection of AM or FM, phono or external signal (tape recorder, etc.) inputs. Phono pickup compensation is accomplished

[See Front Cover]

by special circuitry in both the grid and plate circuits of a 6AV6. Plate section compensation is variable for matching recording curves of RIAA, LP, FFRR and older 78 records. These four curves were selected because they are the most popular, and additionally represent maximum variation in frequency characteristics.

Output of a phono compensation switch is fed into a loudness control compensated to maintain proper frequency balance at low volume settings. The signal is then connected to the bass and treble control circuits and into one section of a 12AT7. Serving as the output stage on the radio tuner chassis, a 12AT7 cathode-follower circuit allows the signal to be

¹Used in *Magnavox Imperial Symphony and Modern Symphony*.

carried over unshielded wiring for considerable distances without hum pickup or limiting frequency response.

This is a necessary feature because in this system, the speakers and amplifier are housed in a separate, matching cabinet located at a distance from the radio tuner and record changer equipment cabinet.²

The low-impedance characteristics of the cathode-follower circuit make it possible to connect additional speaker-amplifiers to the control amplifier, and hold the frequency response. Provision has been made in this radio-phono combination for the connection of multiple speaker amplifiers.

The speaker-amplifier system is a two-channel amplifier with a crossover filter ahead of the driver tubes of the treble and bass channel stages. The crossover frequency is 2000 cycles.

Bass frequencies (below 2000 cycles) are channeled into a bass amplifier through inductance L_{107} and a .015-mfd capacitor, C_{101} . Thirty watts of power are obtained from six 6V6GTs in a push-pull, parallel circuit.

Treble frequencies reach the treble amplifier through inductance L_{108} and a .068-mfd capacitor, C_{115} . Two 6V6GTs in push-pull give the treble amplifier an output of 10 watts. Level of the treble amplifier is precisely balanced with the bass amplifier by means of a separate volume control.

Type 6V6GTs were chosen because of their freedom from noise, extreme reliability and easy accessibility from

(Continued on page 40)

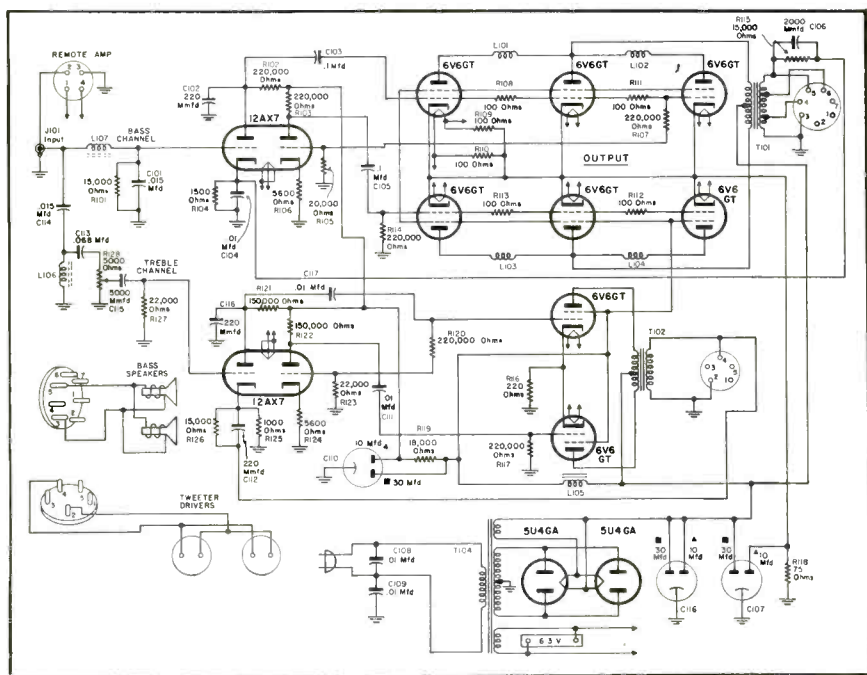

²A chairside tier table containing AM-FM radio tuner and record changer with input controls is optionally available.

Fig. 1. Schematic of power amplifier designed for Magnavox Imperial Symphony and Modern Symphony radio-phonos.

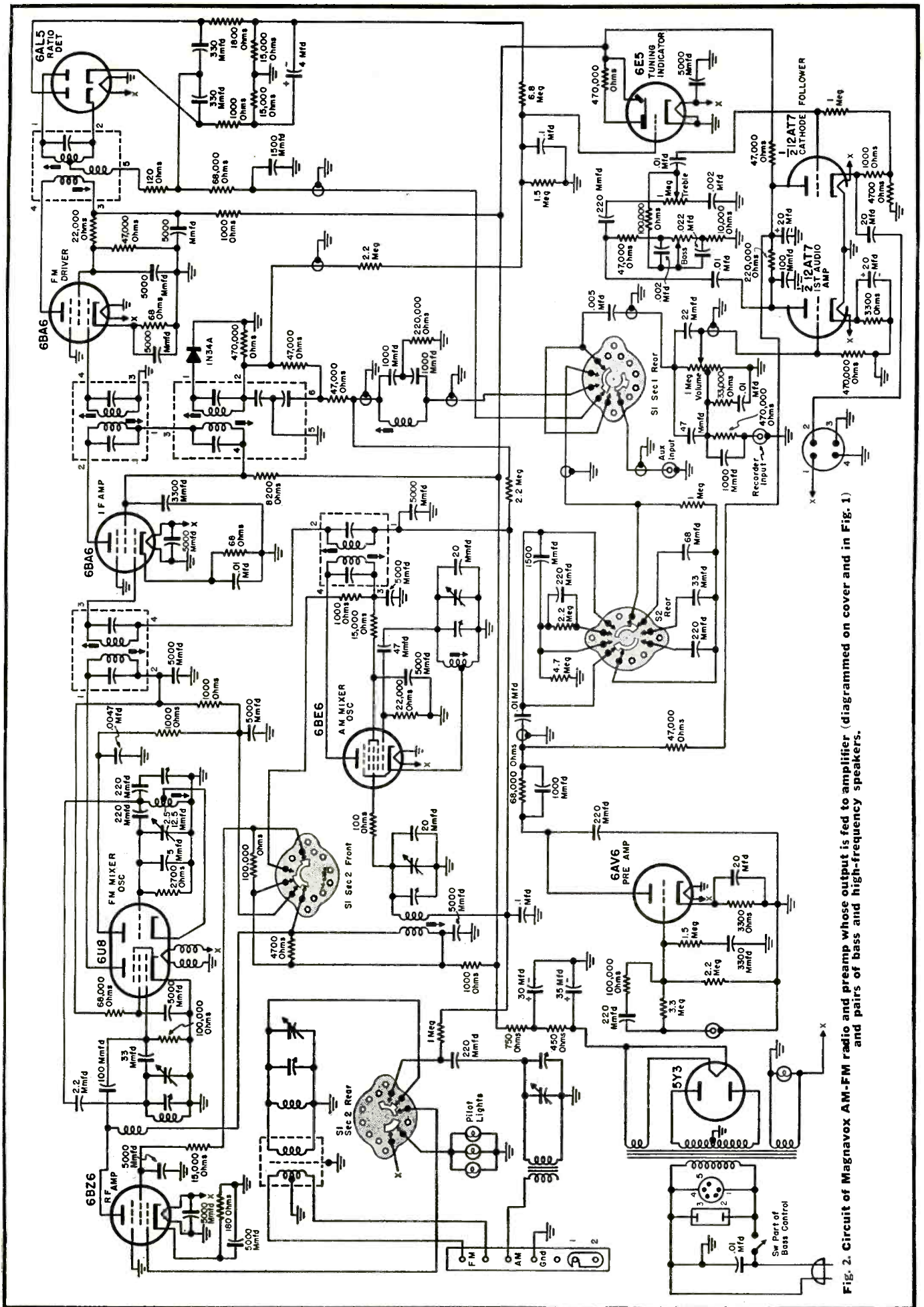
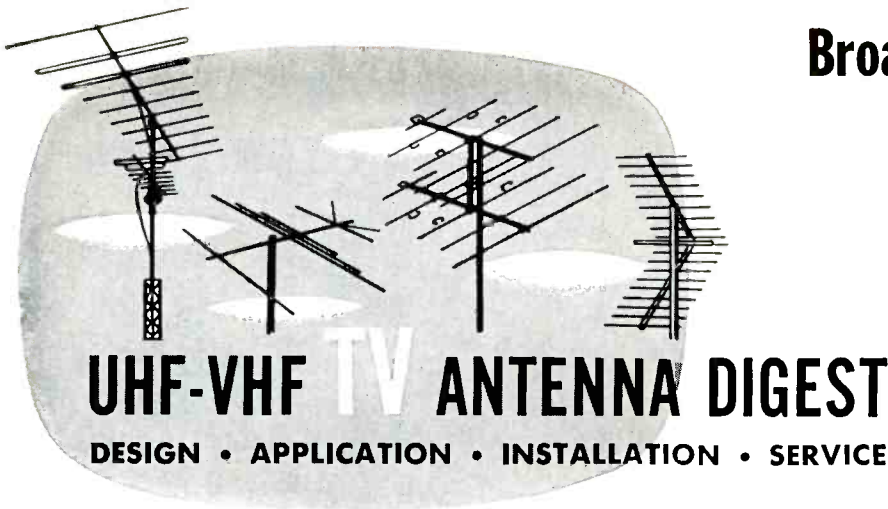

FIG. 2. Circuit of Magnavox AM-FM radio and preamp whose output is fed to amplifier (diagrammed on cover and in Fig. 1) and pairs of bass and high-frequency speakers.

Broad-Band Yagi Design



by **JAN KOBLER**, Chief Antenna Engineer, Walsco Electronics Corp.

POWER INCREASES, transmitter - site changes and tower-height boosts, which have extended station coverage and expanded the fringe zones, has accented the growing need for sharply directional, higher gain, and mechanically rugged TV antenna systems. Problems in these areas include multi-path and co-channel quirks.

A sharp single forward lobe has been found necessary to prevent multi-path reception and reduce

ghosts; this is particularly important in color TV reception where multi-path effects can severely mar images.

To reduce co-channel interference, generally characterized by *venetian blind* effects, antennas must feature high front-to-back ratios.

The sharp highly-directional forward lobe and high front-to-back ratio requirements can normally be met by the yagi type of antenna. For a single yagi antenna array to operate over all channels of the *vhf* television bands a number of considerations must be resolved.

A half-wave folded dipole, designed to be resonant in the low *vhf* band and centered at the channel 3-4 range, is resonant also at its three half-wave dimension in the high *vhf* band, centered at the channel 10-11 range. The current distribution curve of a folded dipole (with a parasitic

reflector) at its half-wave low-band resonant frequency shown in Fig. 2, has the familiar dipole radiation pattern shown in Fig. 1.

The current distribution of the same antenna at the three-half-wave length resonant frequency is illustrated in Fig. 4. It will be noted that the center half-wave of the current distribution curve has an opposite phase direction to the outer half-waves, as shown by the arrows. Phase reversal of the center half-wave section of the antenna at its three half-wave frequency results in the butterfly radiation pattern indicated in Fig. 3. The butterfly type of radiation pattern has been found to be undesirable because the forward lobe is almost cancelled and the maximum sensitivity is in two directions, approximately 43° on either side of the forward direction. While satisfactory for the low *vhf* band, such an arrangement is not satisfactory for dual-band operation on both the low and the high *vhf* band.

If the phase of the current distribution of the center half-wave section

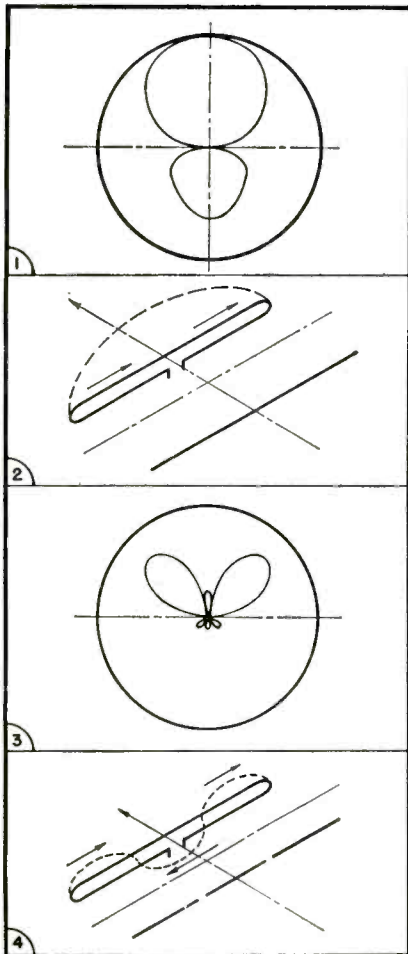

(Left)
Figs. 1, 2, 3 and 4. Radiation pattern of folded dipole at half-wave low-band resonant frequency is shown in Fig. 1; Current distribution of this antenna is shown in Fig. 2. The butterfly radiation pattern provided by phase reversal of center half-wave section of a dipole at three half-wave frequency is shown in Fig. 3, while the current distribution of the antenna under these conditions shows up as illustrated in Fig. 4.

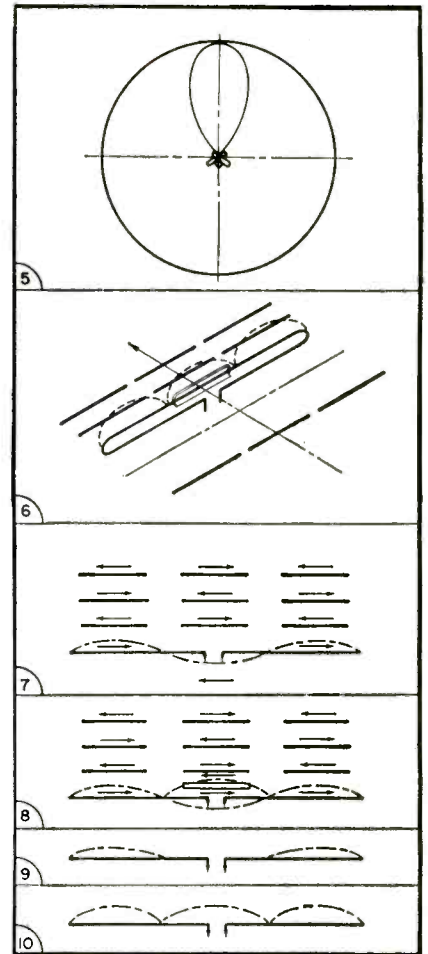

(Right)
Figs. 5, 6, 7, 8, 9 and 10. Polar radiation pattern for antenna array with parasitic phase-reversing element is shown in Fig. 5; the antenna featuring this principle is illustrated in Fig. 6. In Fig. 7 appears an array of driven three half-wave dipole elements with three sets of half-wave directors. The same array and current distribution with parasitic phase-reversal elements inserted in the central half-wave position, close to the driven element, is illustrated in Fig. 8. Current distribution when the central current loop is cancelled is shown in Fig. 9, while Fig. 10 shows the net in-phase current, which is substantially equal to current in outer half-wave portions of the dipole.

Antenna . . . Accessory Developments

of the three-half-wavelength antenna can be inverted to be in phase with the outer half-wave sections, the resulting current distribution curve will then have three half-wave current lobes in the same direction. The radiation pattern is thus corrected so as to make the antenna useful on low and high bands. One also finds the gain of the antenna on the high band increased and the forward lobe sharpened as if three separate half-wave antennas were lined up in a horizontal array. The three separate reflectors for the high band are necessary to provide proper directivity at the three half-wave frequencies.

In a yagi each parasitic element spaced substantially less than $\frac{1}{4}$ wavelength affects a 180° phase difference in the current induced in the succeeding element. This is illustrated in Fig. 7, where we see an array of a driven three half-wave dipole element with three sets of half-wave directors. Arrows show the current distribution in the various elements of the dipole array. The horizontal radiation pattern of such an antenna is the same as illustrated in Fig. 3, from which it is clearly evident that in the center forward direction practically no energy is received by the antenna, whereas 43° on either side of center the greatest sensitivity is found.

Fig. 8 shows the same array and its current distribution with a parasitic phase-reversal element inserted in the central halfwave portion, in close proximity to the driven element.

As disclosed in Fig. 8, with the parasitic element in place, the current in the central half-wave portion of the driven element is cancelled by the current induced through the action of the parasitic element reradiating a current 180° out of phase with that of the current, normally induced in the central portion of the dipole by the incoming signal.

If this were the only effect of the phase reversal element, the current distribution in the driven element would appear as shown at Fig. 9. The central current loop would be cancelled. In other words at the three half-wave resonant frequency only the energy in the outer half-wave sections would be utilized. While this creates a single forward lobe, the resulting gain is not the optimum that may be expected from such an array.

An array of two colinear yagis has been found to provide an increase in gain over a single yagi by a theoretical 3 db; a third yagi colinearly placed in the array brings the total

(Continued on page 40)

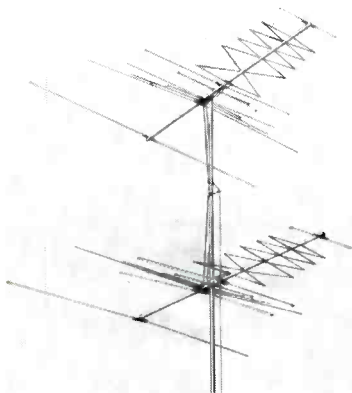

All-channel fringe-area antenna with microwave helical design, used in conjunction with a flat-plane dipole, a poly-phase triple resonator. Driven element design features one long element, measuring one-half wavelength on channel 2, which receives both channels 2 and 3; next element is one-half wavelength on channel 5, and receives channels 4 and 5. Improved gain and directivity are said to be obtained on channel 6 by combining the back section of the helix with a specially-designed harness, to form a closed loop. (Power Helix, single and dual bays, models PX911 and PX911S; JFD Manufacturing Co., 6101 16 Ave., Brooklyn 4, N. Y.)

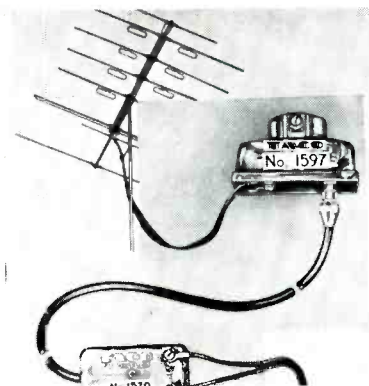

Solderless coax coupler system utilizing a shielded line. Coupler mounted at antenna transforms signal to 72 ohms, terminating in a coax type fitting. At receiver end, reverse procedure is followed in a unit having provision for connection to line and having screw terminals for flat type transmission line. By shielding the down-lead, the pickup signal in the cable is said to be eliminated. (Models 1597 and 1570; Technical Appliance Corp., Sherburne, N. Y.)

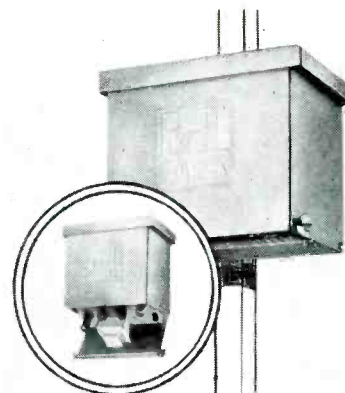

Broadband vhf amplifier said to feature a low-noise circuit, multi-voltage power supply and weatherproof housing, providing about 25 db gain on vhf channels. Operates automatically through power unit near TV set. Heavy duty 300-ohm line carries ac power to remote unit and also carries amplified TV signals down to receiver. Power unit supplies either 24 or 117 volts to the amplifier. Filter networks are built into each unit. Taps claimed to compensate for 10%, 20%, or 30% ac voltage drop in long transmission lines. Has swing-down chassis design. (Model AB; Blonder-Tongue Laboratories, Inc., 526-526 North Ave., Westfield, N. J.)

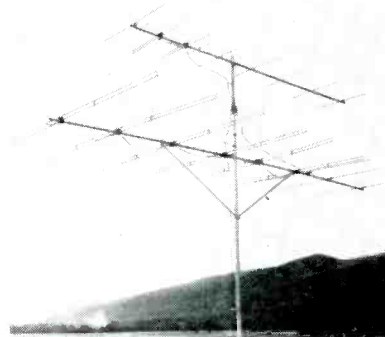

Driven end-fire fringe antenna claimed to have front-to-back ratios ranging from 20:1 to 50:1 relative voltage on the low band, and up to 13:1 relative voltage on the high band; the antenna is also said to exhibit gain of from 7 to 9 db on the low band, and from 8.5 to 10.5 db on the high band for the single bay. In effect model is designed as two individual antennas. There is a low-band model, with six driven elements, covering channels 2 through 6, and a high-band model with two driven elements, covering 7 through 13. There is also a broadband model in which both arrays are joined with an impedance matching hi-lo connecting harness. Low-band model is boom-braced with high temper seamless aluminum tubing. (K. O. models 1026, 1073 and 1023; Channel Master, Ellenville, N. Y.)



The Wide Angle Deflection

Trend in Picture Tubes

by DWIGHT V. JONES

Tube Department, General Electric Co.

THE WIDER DEFLECTION angle used today in TV picture tubes has permitted larger screens without materially increasing the length of the tube or amount of floor space required by a TV set.

The major difference between 70° and 90° tubes is a change in the contour and physical dimensions of the bulb to permit a 20° increase for the total deflection at the diagonal. The 90° tubes are approximately three inches shorter than the 70° tubes in total length. The electron gun can be identical for both types of tubes; thus the video drive and electrode voltage requirements are the same.

The 90° yoke requires approximately 50% more vertical and 25% more horizontal deflection energy than a similar 70° yoke. More efficient sweep systems have been evolved by coordinated development of the picture tube contour, deflection yoke, and sweep output transformers.

The relationship of the deflected electron beam to the yoke is illustrated in Fig. 2; an approximate equation of the deflection current in the yoke is also shown. From this equation and diagram one can determine the deflection current requirements as the deflection angle or size of the scanned surface (picture) is increased.

The overall length of the 90° yoke has increased slightly over that of the

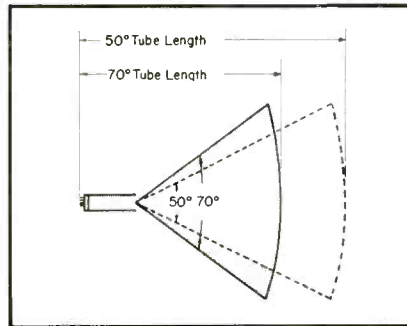

Fig. 1. Drawing illustrating decreased length possible with picture tube featuring a wider deflection angle.

70° type, and there is more of a flare that extends up on the contour of the 90° bulb. This flare moves the effective center of deflection forward toward the phosphor screen, and also decreases the deflection current requirements. Although the flared section of 90° yokes is less effective in producing deflection, it is very effective in reducing distortion of the focused spot near the edges of the screen. The amount of flare is a compromise, because of the increased material and difficulty of winding, and the diminishing returns when extending this section toward the screen. For instance, about one-third of the active length of a 90° yoke lies in the flared section, but less than a fifth

of the total sweep action takes place in the flared portion of the yoke, because of the increased air path for the flux.* The influence of the yoke's field on the electron beam begins about three inches in front of the yoke and extends approximately two inches beyond the other end of the yoke towards the screen. Of course, the extension of the field beyond the ends of the yoke will vary with the design of the yoke coil and type of core used.

The 90° deflection tubes became popular as the efficiency of the sweep system increased. As a result, the deflection power required from the sweep circuits was not appreciably different than some of the older 70° circuits.

There is little advantage in modifying an old TV set to accept a wider deflection angle tube with the same size screen, unless the elimination of the doghouse on the back of the cabinet is worth the effort involved. How difficult the conversion job may be depends somewhat on the design of the particular TV set.

The first requirement for conversion to a 90° picture tube would be a 90° deflection yoke with the correct impedance match for both vertical and horizontal sweep output transformers. It is most likely that both sweep output transformers will have to be

*Torsch, C. E., *High Efficiency 90° Cathode-Ray Sweep System*, Tele-Tech and Electronic Industries; June, 1953.

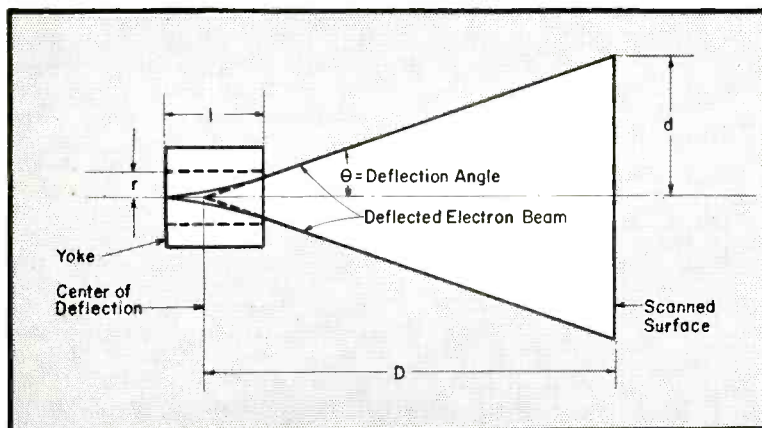

(Left)
Fig. 2. Relationship of the deflected electron beam to yoke. Deflection-current equation for this condition is (Deflection current in yoke) $i \approx k \frac{rd}{D}$

$$i \approx k \frac{rd}{D}$$

Where $k = \text{Constant}$; $r = \text{Inside radius of yoke}$; $l = \text{Length of yoke}$; $L_y = \text{Inductance of yoke}$; $V_a = \text{Accelerating voltage}$; $d = \text{Displacement of electron beam from undeflected point}$; $D = \text{Distance from center of deflection to scanned surface}$.

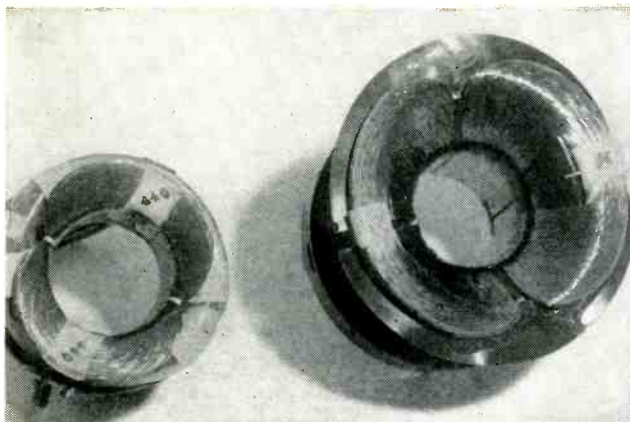

(Above)
The 70° (left) and 90° (right) yokes.

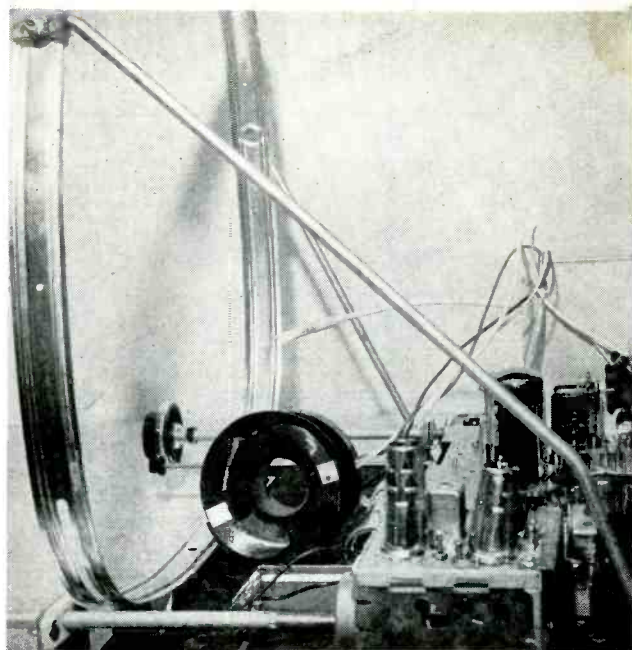

(Right)
G.E. chassis (S model) with 90° picture tube.

changed to achieve this match. It is also probable that both sweep output tubes and associated circuit will require some changes to provide sufficient sweep power. The need for the latter change will depend on the design of the particular TV set involved.

The present 90° tubes are about on the borderline, as far as being able to correct pin-cushioning with a non-linear yoke field, for this type of field also distorts the electron beam near the edges of the screen. A non-linear yoke field produces a barrel-shaped raster and a linear yoke field produces a pin-cushioned raster. In actual practice, the yoke is designed for a field configuration that lies between the barrel-shaped and pin-cushioned affairs, resulting in the desired rectangular raster. The amount of distortion on the electron beam at the edges is small, since the amount of non-uniformity introduced in the yoke field to correct for pin-cushioning is small.

Some segments of the TV industry are investigating deflection angles

greater than 90°. Increased deflection angle presents problems involving sweep power, pin-cushioning, and bad focus at edges. These problems can be minimized by various methods, such as a smaller neck to reduce sweep power, picture straightener magnets to reduce pin-cushioning and dynamic focus to improve edge focus. These procedures tend to increase the cost of a TV set; and the only advantage is decreasing the depth of the cabinet.

A large portion of the industry's picture tube engineering effort is being applied toward color tube development.

Some of the new developments that will result from the color work may be applicable to monochrome. Wide-angle deflection presents even more problems, such as convergence in color TV than monochrome. Present color picture tubes are in the 70° deflection angle group. Only time will tell if deflection angles greater than 90° become popular.

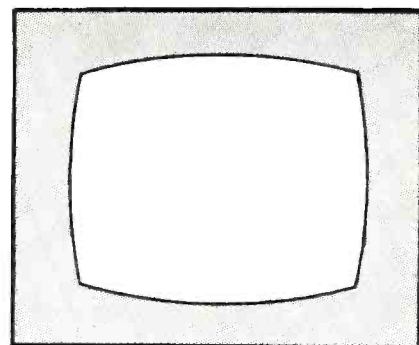
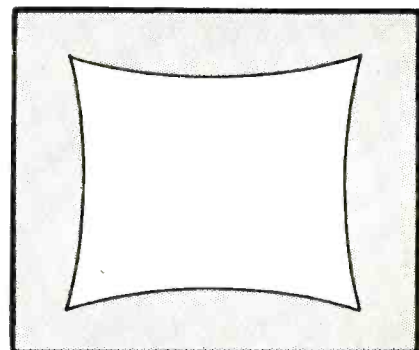

Fig. 3. Barrel-shaped raster produced by a non-linear yoke field.

Fig. 4. Pin-cushioned raster obtained when using a uniform yoke field.



(Left)
Table I: Deflection angle trend

(Below)
Table II: Available 90° picture tubes

Total Deflection Angle At The Diagonal	Representative Tube Type
50° Group	10BP4 12LP4 16AP4
70° Group	16KP4 and similar types 16GP4 17BP4A 20CP4 21EP4A and 21YP4A
90° Group	21ALP4 21ACP4

17"	21"	24"	27"	30"
17ATP4 and A 17AVP4 and A	21ACP4 and A 21AMP4 and A 21AQP4 and A 21ALP4 and B/A 21ANP4 and A 21ATP4 21BAP4 21AMP23A 21BNP4	24CP4 and A 24QP4 24TP4 24VP4 and A 24XP4 24DP4 and A 24YP4 24ZP4	27EP4 27GP4 27NP4 27RP4 27LP4 27SP4 27UP4 27MP4 27AP4	30BP4

ANNUAL INDEX

January-December, 1955

ASSOCIATIONS

Association News.....Jan.-Dec.

AUDIO*

AM/FM/Phono Designed for Remote 4-Speaker/30-W Amp. Consol; *Dan Graef*, Dec.
 Amplifier for Two-Speed Tape Recorder-Reproducer; *(Cover)*; *M. W. Percy*, May
 Audio Service Notes: Shipping of 45-RPM Records . . . Erratic Trip Action
 Eliminating Hum in Audio Amp Models, Apr.
 Audio Service Notes: Remedies for Trip Failure and Groove Skipping in RCA 45s . . . Eliminating Rumble and Flutter in Magnavox Record Changers . . . Baffle-Mount Suggestions . . . Troubleshooting Phonos . . . May
 Audio Service Notes: Obtaining Maximum Efficiency from Line Stromberg-Carlson Preamps . . . Determining Speaker Line Wire Sizes . . . RCA Record Changer Cycle-Stall Remedies . . . Troubleshooting Motorola Phonos . . . June
 Audio Service Notes: Causes and Cures of Tape Squeal . . . Care and Handling of Tape . . . Three-Speed RCA Variable-Reluctance Record Changer Repair Notes . . . Four-Pole Shaded-Pole Motor Cycling Operation . . . July
 Audio Service Notes: Curbing Intermittent Stall in Record Changers . . . Stylus Replacement in Dual Styli Pickups . . . Adjustment of Damping Factor With Instruments . . . Aug.
 Audio Service Notes: Troubleshooting Radio-Phonos . . . Installation-Repair Notes for 30-Watt PA Amplifiers . . . Servicing Changers for Record Shutoff and Drop Failures, Ejector Lever Faults and Cycle Problems . . . Sept.
 Cartridge Design Factors . . . Jan.
 Ceramic Replacement Cartridges . . . June
 Converting Audio Amplifiers to Provide Hi-Fi Results; *Mark Vito* . . . Jan.
 Crystal Pickup Cartridge Replacement . . . Mar.
 Effect of Room Environment on Reproduction; *Mark Vito* . . . Nov.
 Extending HF Response of Old Radio-Phonos; *T. L. Gifford* . . . Jan.
 High Fidelity Aspects of Record Changers; *William Brown* . . . Feb.
 Hi-Fi Power Amplifiers; *Victor H. Pomper*, Feb.
 Hi-Fi Results Though Audio Amplifier Conversion; *Mark Vito* . . . Feb.
 Horn Design and Application for PA and Home; *Lee Scott* . . . Aug.
 LF-HF Cutoff Filter and Compensator Applications . . . May
 Loudspeaker Crossovers; *Alexis Badmateff*, Feb.
 Loudspeakers and Non-Resonant Enclosures; *Mark Vito* . . . Mar.
 Microphones for Initial or Replacement Installation; *Norman Crosthurst* . . . July
 Multiple Loudspeaker (8-14 Speakers) System Installation Methods; *Jesse Dines* . . . May
 Outdoor Sound System Installation Report (PA Amplifier, Speaker and Microphone Requirements, and Installation and Servicing Practices); *Michael Anthony* . . . June
 Outdoor Sound System Installation . . . Maintenance; *Michael Anthony* . . . July
 Outdoor Sound: Installation . . . Maintenance; *Michael Anthony* . . . Aug.
 PA in Stadiums; *Norman Crosthurst* . . . Apr.
 Phono Pickup Replacements: How to Screen Cartridges to Fit Phono Job; *Maxwell Alberts* . . . Sept.
 Phono Needle Replacements: Types of Needles . . . Relation of Physical and Acoustical Characteristics to Needle Performance . . . Requirements of Cartridge Design to Match Needle Structures; *Maxwell Alberts* . . . Oct.
 Phono-Tape Motor Design-Repair; *F. R. Sailes* . . . Oct.
 Practical Points on Loudspeaker Use . . . June
 Professional Turntable Design . . . Mar.
 Record-Player Service Tips . . . Dec.
 Reducing RF Pickup in Audio Amps; *Douglas Stevens* . . . Mar.
 RF Signal Pickup in Audio Stages; *Douglas Stevens* . . . Feb.
 Role of Room Acoustics in Music Listening . . . Apr.
 Six Vital Areas in Speakers That Deteriorate With Age . . . Dec.
 Speaker Loading . . . Apr.
 Tape Maintenance and Service Tips . . . Nov.
 The Horn in the Audio System: Shapes Drivers . . . Response; *Jesse Dines* . . . July
 Three-Speed Portable Battery-Operated 45 Repair . . . Dec.

Unity Coupled Power Amplifier; *Cullen H. MacPherson* . . . Jan.
 Variable Damping Factors in Audio Amplifiers; *Mark Vito* . . . July
 Variable Reluctance Stylus Change . . . June

B-W TV**

ATR 21-Inch Wide-Band 41-Mc B-W TV Receiver; *Robert D. Wengenroth* . . . Oct.
 B-W and Color-TV Oscillators (Basic and Typical Vertical Blocking, Horizontal and Relaxation Oscillators); *Jesse Dines* . . . Sept.
 G.E. 13-Tube 14-Inch Vertical Chassis Plated-Circuit Portable; *Wyn Martin* . . . Sept.
 DeWald Autotransformer-Powered 21-Inch TV Chassis; *Robert D. Wengenroth* . . . Dec.
 Oscillators in B-W and Color-TV Chassis (Report on Ten Types Now Being Used in B-W/Color); *Jesse Dines* . . . Aug.
 Printed Circuit 41.25/45.75-Mc IF Strip Circuitry; *M. W. Percy* . . . Mar.
 RF High-Voltage TV Power Supplies . . . May
 Sectionalized Printed-Circuit TV Chassis; *(Cover)*; *L. Richard Chase* . . . Feb.
 Sentinel TV Set Remote Control; *Robert D. Wengenroth* . . . Nov.
 Sweeping the TV Circuit; *Robert E. Rickelts* . . . Mar.
 TV Spurious Radiation Problem Report . . . Apr.
 Vertical-TV Chassis Horizontal and Vertical Oscillators; *Lee Scott* . . . Nov.

CHARTS . . . TABLES . . . GRAPHS

Absorption Coefficients of Materials . . . Nov.
 Approximate Temperature Rise for Power Wire-Wound Resistors Mounted in Free Air . . . Oct.
 Available 90° Pictures Tubes . . . Dec.
 Bar Generator Results Obtained in Checking 19-Inch Color Chassis . . . Feb.
 Bass Response of Loudspeaker Where Q of Speaker Amp System is Varied . . . July
 BFO Outputs for Above-Below Frequencies . . . Jan.
 Color-TV Alignment Check Points . . . May
 Color-TV Bar-Generator Chart Analysis (19-Inch Chassis) . . . Mar.
 Color-TV Phase Diagram . . . Jan.
 Color-TV Stages and Function . . . Jan.
 De Wald 215 Series IF Response . . . Dec.
 Directional Patterns of Standard Types of Microphones . . . July
 Effect of Angle on Response Characteristics of a 24-Inch Diameter Horn . . . Aug.
 Effect of Different Loading-Resistor Values on Response of Variable Reluctance Cartridge . . . Sept.
 Effect of Different Transformers on Overall Frequency Response of Ribbon or Moving Coil Cartridges . . . Sept.
 Effect of Different Values of Loading Resistance in Input of Ribbon or Moving-Coil Cartridges . . . Sept.
 Frequency Response of Ceramic Cartridges with Various Loading-Resistor Values . . . Sept.
 Frequency Response Ranges of Horn-Loaded Speakers . . . Apr.
 Frequency Response of UHF Two-Antenna Coupler for Channels 50 and 62 . . . July
 G.E. A1-901 Record Filter Compensator Positions for Domestic and Foreign Recordings . . . May
 General-Purpose Diodes and Continuous Reverse-Working Voltage Ratings . . . Sept.
 Graph Illustrating Equalization Necessary for Flat Response at Various Distances Because of Attenuation of High Frequencies Through Air . . . July
 List of Events Requiring Outdoor Sound Systems . . . June
 Molded Composition Resistor, RF Choke and Capacitor Color Codes . . . Feb.
 Picture-Tube Deflection-Angle Trend Chart . . . Dec.
 Plot of Axial Length, Height and Width of a Horn Antenna in Relation to Gain Achieved . . . June
 Relationship of Deflected Electron Beam to Yoke . . . Dec.
 Resistance-Coupled Amplifier Chart for 6SQ7 . . . Jan.
 Resistor Characteristics and Relation to Circuit Requirements . . . June
 Six Vital Areas in Speakers That Deteriorate With Age . . . Dec.
 Speaker Line Loss Chart . . . June
 Speakers Required for Different Amplifier Outputs . . . June
 Stub Lengths (300-ohm Flat Twin Lead) to Curb VHF Channel-Interference . . . Jan.

Sylvania 2N32 Triode or 3N21 Tetrode Transistor Average Collector Characteristics . . . Jan.
 Socket Positions For Three Types of Audio Transistors Available for Portables . . . July
 Transistor Collector Characteristic Displacement (Tetrode-Pentode) . . . Jan.
 Two-Station Installation of UHF Filter With Pair of Tied-In Antennas . . . July
 TV Antenna Gain Chart (Relation of Signal Voltage Above Reference Dipole to DB Gain) . . . Jan.
 TV Troubleshooting Guide Chart Featuring Use of Scope and Square-Wave Patterns . . . Oct.
 Vertical-Horizontal Oscillators (and Tubes) Used in Vertical Chassis . . . Nov.
 Voltage-Power Ratio Equivalents in Db . . . Nov.
 Yagi Polar Radiation Patterns . . . Dec.

CIRCUIT DIAGRAMS

AF Contact Potential Bias Circuit . . . Jan.
 AF Grid Circuit Altered to Reduce RF Voltage Feed . . . Feb.
 AF Grid Circuit Modified to Minimize RF Signal Detection . . . Feb.
 Adjustable Phase Shift Network . . . Sept.
 Admiral 20AX5A/20AX5E2 Revised AGC . . . Sept.
 Admiral 20 Colpitts Oscillator . . . Aug.
 Admiral (Model 18XP4B2) Horizontal Oscillator . . . Nov.
 Antenna Input of 2-Band Receiver Using Crystals . . . Sept.
 Audio Amp Power Supply Critical Component Replacements . . . May
 Audio Frequency Amplifier Response Setup . . . Sept.
 Audio-Frequency Reference-Level Adjustment Circuitry . . . Sept.
 Audio-System Measurement . . . Mar.
 ATR Combination 6-12 V DC Input Vibrator Pack . . . Apr.
 ATR Filament Circuitry for Model 2600 TV Chassis . . . Oct.
 ATR 41-Mc 21-Inch TV Chassis . . . Oct.
 ATR 6-V DC Inverter . . . May
 Battery AC/DC Filament Circuitry . . . Mar.
 Battery-Chassis Biasing . . . June
 Battery-Operated Basic Schematic . . . June
 Battery-Radio Autotransformer-Power Supply . . . June
 Beat-Frequency Oscillators: Hartley . . . Colpitts, Tuned-Grid-Tickler, Pierce . . . Jan.
 Berliner Audio Multimeter *(Cover)* . . . June
 Ilogen J623 Battery/AC Phono-Amplifier . . . June
 Blonder-Tongue MAGC Automatic Gain Control *(Cover)* . . . Apr.
 Blonder-Tongue MLA VHF Distribution Amplifier . . . Apr.
 Bridge Rectifier Circuit for Test Set . . . Nov.
 Capehart CX-13 Color-TV Chassis B-Selenium Power Supply . . . Sept.
 Capehart CX-13 Color-TV Receiver . . . Sept.
 Capehart CX-13 Color-TV Set IF Filament String . . . Sept.
 Capacity Bridge . . . Sept.
 Cardwell PC-4 Printed Circuit 41-Mc IF Strip *(Cover)* . . . Mar.
 Cathode Bias in Duo-Diode-Triode Detector and Amplifier . . . Jan.
 Cathode-Coupled MV in Vertical Oscillator . . . Sept.
 CBS-Columbia 700 *(Hartley)* Oscillator . . . Aug.
 CBS-Columbia (Model 1603) Horizontal Oscillator . . . Nov.
 CBS-Columbia (Model 1603) Vertical Oscillator . . . Nov.
 CBS-Columbia Model 205 Color Chassis (Block Diagram) . . . Feb.
 Ceramic Cartridge Low-Frequency Equalization Circuit . . . June
 Circuits Designed to Provide Variation of BFO Output Power . . . Feb.
 Circuit Illustrating Resistive Overload Problems . . . June
 Circuitry For Speakers in Same General Area and When They Are Far From Each Other . . . Aug.
 Circuitry Illustrating How Damping Factor of Amplifier is Determined . . . July
 Color-TV Automatic Chroma Control; RCA *(Cover)* . . . Nov.
 Color-TV Color-Bar Generator; RCA WR-61A . . . Nov.
 Color-TV Crystal-Controlled Reactance-Tube Oscillator (Midland MC-103C) . . . Jan.
 Color-TV Dot-Bar Generator; RCA . . . Nov.
 Color-TV Dot-Bar Generator; RCA WR-36A . . . Nov.

(Continued on page 26)

*See Instrumentation For Additional References.

**See Instrumentation For Additional References.

Garry Moore

NOW SELLING

CBS TUBES ON THE

CBS TELEVISION

NETWORK

“Women! . . . bless 'em, catch on to good things fast. So I'm telling them on my Friday morning show . . . **there are no better tubes made than CBS tubes . . . the tubes with the Good Housekeeping Guaranty Seal.** More and more women will be asking you for CBS tubes.”

Garry Moore



Be sure YOU have
CBS tubes in your tube caddy.

“I'll be on the CBS Television Network selling CBS tubes and your expert service every other Friday, 10:30 to 10:45 a.m., E.S.T.”

CBS-HYTRON, Danvers, Massachusetts . . . A DIVISION OF COLUMBIA BROADCASTING SYSTEM, INC.

SERVICE, DECEMBER, 1955 • 25

ANNUAL INDEX

(Continued from page 24)

CIRCUIT DIAGRAMS

Color-TV Simplified Dot Generator Schematic; RCA Nov.

Color-TV Vertical/Horizontal Sweep Circuits (RCA) Nov.

Colpitts BFO (Electron-Coupled) for IF of About 450 Kc Feb.

Colpitts Oscillator Aug.

Collins 75 A-2 Hartley Electron-Coupled Oscillator Feb.

Community TV Distribution System Sept.

Community-TV Line Equalizer for 1000' of RG-11/U May

Community-TV Trunk System; Line Amps, Pads, Drops May

Community-TV Two-Way Line Splitter May

Communications Receivers; Common Variety and Advanced Type Jan.

Converted Triode BFO for Electron-Coupled Operation Feb.

Coronado 15TV4 First Video IF June

DC Voltage Measurement Circuits Mar.

De Wald Autotransformer TV Power Supply Dec.

De Wald Models J-215-17/212A Autotransformer Powered TV Dec.

Direct-Coupled Amplifiers Use in Industrial Electronic Equipment Jan.

Dual Frequency BFO Feb.

Dual-Frequency BFO Circuit Mar.

Du Mont RA 109/119 Inputuner Oscillator Aug.

E-V Circotron A-20-C 20-Watt Amplifier (Cover) Jan.

E-V Circotron A-30 Line Amplifier Jan.

E-V Circotron Feedback-Proportioning Circuit Jan.

E-V Circotron Driver Stage Jan.

83 Mercury-Vapor Full-Wave Rectifier Circuits Modified for 5Z3 Feb.

Eight-Speaker Audio System Operating from Single Amp Source May

Electron-Coupled Colpitts BFO for IF of About 455 Kc Mar.

Emerson Chassis Circuit Change to Eliminate Video Overload May

Emerson 838 Transistor-Tube Pocket Radio July

Emerson 120174 Ultrahigh Oscillator Aug.

Emerson 1202200 Horizontal Sweep Nov.

Fault-Alarm Circuit May

Four-Speaker System for Remote Audio Installation Apr.

Four Typical PA Setups Using Combination Phono-Amps and Amplifiers Only July

Fourteen Speaker Hookup May

G.E. A1-901 Record Filter May

G.E. 4ER24A/B11/B12 Two-Frequency Receiver Sept.

G.E. 409 FM Tuner Feb.

G.E. Six-Coil 290-Kc IF Amp for 2-Way Receiver Oct.

G.E. (Model 24C01) Electron-Coupled Oscillator Nov.

G.E. 675 Transistor Pocket Radio (Cover) Oct.

G.E. 17C113 Hartley Oscillator Sept.

G.E. 24C101 Horizontal Oscillator Sept.

G.E. Portable TV M-Line Chassis; Models 147007/8/9/10 Sept.

G.E. Progress Receiver for 2-Way Use Oct.

Grounded-Grid Cathode-Coupled Circuit Feb.

Hallcrafters Tuned-Grid BFO Oscillator Jan.

Hallcrafters (Model 1850) Vertical Oscillator Nov.

Hartley Oscillators; Triode and Electron-Coupled Jan.

Intercom Auxiliary Volume Control Feb.

Intercom Privacy Schematic Feb.

Intercom System Feb.

Intercom System Line Hookups Feb.

Industrial Intercom Booster Amplifier Mar.

Industrial Intercom Remotes Mar.

Industrial Intercom Standby Switching Mar.

Leaky Capacitor Evaluation Circuit Nov.

Magnavox AM/FM/Preamp Chassis; Imperial and Modern Symphony Dec.

Magnavox Imperial Symphony and Modern Symphony 30-W Amp Dec.

Magnavox 105L Vertical Oscillator Sept.

Magnavox Modified Treble Filter Circuit to Improve HF Response Jan.

Magnavox 10-Kc Filter (204/211/231) With Switch to Kill Filter and Extend Amp Range Jan.

Metal-Clad Multisection Resistor Circuitry Aug.

Metallic Rectifier Circuit for Test Instrument Nov.

Modified Autronic-Eye Circuit Oct.

Modified BFO (For Tuning Range) Feb.

Motorola HS-487 (models 56R1-4) Table Model Radio Dec.

Motorola 121.95-Kc Fixed-Tuned Transistorized Receiver Aug.

Multi-Range AC/DC Test Instrument Circuitry Nov.

Operation of A Damping Factor Control July

Ohmmeter Check for Transistors July

Outboard BFO Connections Feb.

Pentode Front-End Stage May

Pierce Electron-Coupled Dual Crystal Beat-Frequency Oscillator Apr.

Power Supply and Relay Switching for In-Can Switching Mar.

Power Supply for 2-Way 450-Mc Receiver (G.E.) Nov.

Push-Pull Amplifier Modified to Include Negative Feedback Feb.

Push-Pull Oscillator Aug.

Push-Pull Output Stage and Circuit Components May

Quarter-Wave/Half-Wave TV Antenna Stubs Jan.

RCA 3-BX-5 Portable Filament Circuitry; Original and Revised Feb.

RCA KCS-83 Sound-IF Amp Stage Modified to Minimize Oscillation May

RCA 6-B 4A/4B 6-B-5 Battery-Operated Personal Set June

RCA 630 Tuned-Plate Push-Pull Oscillator Aug.

RCA 6-JSH-1 Three-Speed Record Changer System Using Variable-Reluctance Cartridge and Click Filter July

RCA 21-Inch Color Chassis CTC4 or CTC4A; Color and Power-Supply Circuitry (Cover) July

RCA SA-32A 30-Watt Amplifier Sept.

RCA SRT-1 Amplifier for Two-Speed Tape Recorder-Reproducer (Cover) May

RCA Three-Speed Portable Player Dec.

RCA WG-388-A 'Scope Vertical Amplifier Aug.

RCA WO-88A 'Scope Vertical Amplifier for Wide Band Use Aug.

RF HV Supply Using Tickler and Clamp Feedback May

Resistive Pads for Adding Loss to Coax-Cable Amplifiers May

Resistor-Capacitor Substitution Box for 'Scope May

'Scope Connection for Audio Input-Output Sept.

Sweep-'Scope Detector Probe Mar.

Sentinel Remote Control; Models 21101, 21121, 21145 Nov.

Series-Ted Hartley Oscillator Aug.

Series-Parallel Array of 8 Speakers Apr.

Series-Parallel AC/DC TV Chassis Heater-Filament Line Jan.

Series-Parallel Speaker Arrangements June

Series-String Filament Checker Aug.

Shunt-Fed Hartley Oscillator Aug.

Single-Ended Amplifier With Feedback from Output Transformer Primary Feb.

Source of Intermittents in Capacitor Circuitry May

Stromberg-Carlson AK-11 Tone Control June

Stromberg-Carlson AK-12 Remote Volume Control June

Stromberg-Carlson AV-52 Preamp June

Stromberg-Carlson 21-22 TV Focus Socket July

Strong Unmodulated-Signal Feed Setup to Check Defective Parts May

Sylvania 620 600-Ma Constant-Current Circuit (Cover) Aug.

Sylvania Transistorized Dynamic Microphone June

Sylvania Transistorized Preamp June

Sylvania 302 VTVM Circuitry Feb.

Sweep Generator Converted to 60-cps Square Wave Use May

Tape Recording-Playback Signal Path Schematics (Webcor) Nov.

Three-Speaker Crossover Network Apr.

3-Way Portable Series-Filament String Using Wire-Wound Resistors Oct.

Transistor (Tetrode) Gating Amplifier Jan.

Transistor (Tetrode) Bistable Circuit Jan.

Transistor Two-Input Mixer Jan.

Transistor, Tube, Diode Flip-Flop Circuitry Apr.

Triax Speaker System Aug.

Triode-Pentode Equalizer-Preamp Circuits for Three-Speed Changer to Obtain Orthophonic Reproduction July

Triode Stage at Front End of Amplifier May

Tube Oscillator/Converter; Equivalent of Transistor Circuit Oct.

TV Antenna Portable Field-Strength Meter Plug Connections May

TV Antenna Pad Circuits Feb.

TV Video-Output Stage Illustrating Use of Resistors Oct.

UHF 2-Channel Dual-Antenna Coupler Filter July

Ultraudion Oscillator Aug.

Variable Equalizing AGC Amplifier July

Vertical Blocking Oscillator Sept.

Video IF Gain-Control June

Visual Monitoring to Determine Types of Intermittents May

Voltage Regulator for + or - 300 Volt Output Sept.

Voltage-Regulated System Switching Relay Operated as Free Rider Mar.

VTVM Application in Tuned Amplifier Mar.

VTVM Circuitry Aug.

VTVM Circuitry Refinements July

Walsco PC-9 Four-Stage Stagger-Tuned Printed Circuit IF (Cover) Feb.

Walsco PC-9 Sync Separator-Horizontal Phase Discriminator Feb.

Wide-Band Chroma Amplifier in Demodulator Probe Preamp Oct.

Zenith Flash-Matic Photocell Remote Control Aug.

Zenith Flash-Matic TV-Chassis Photoelectric Remote Control July

Zenith Flash-Matic Thyatron and Motor Control Circuits Aug.

COLOR-TV

Capelhart's 21-Inch Color-TV Receiver (Cover); Ray S. Guichard Sept.

Chart Analysis of Wide-Band Chroma Signal Amplifier for Color-TV; G. S. Ryan Oct.

Color-TV Antenna System Frequency-Response Considerations; Edward M. Noll May

Color-TV Alignment Hints; Robert E. Ricketts May

Color-TV Bar Generator Applications; Jesse Dines Mar.

Color-TV Circuitry Developments; Chris Stormley Jan.

Color-TV Test Equipment Specifications; Robert G. Middleton Feb.

Color-TV Progress Report: Automatic Chroma Control Circuitry (Cover); W. W. Cook Nov.

Color-TV Progress Report: Test Equipment for Color Receivers; Dot-Bar and Color-Bar Instruments; E. R. Klingeman and S. Wlasuk Nov.

Color-TV Progress Report: The 21-Inch Tricolor Picture Tube; W. W. Lenz, Jr. Nov.

Color-TV Reception in Strong Signal Areas; T. L. Gilford Mar.

Color-TV Troubleshooting With a Bar Generator; Jesse Dines Feb.

Color-TV Tubes; The 6B7J Triple Diode; G. C. Church Jan.

RCA 21-inch 26-Tube Color-TV Receiver (Cover); W. W. Cook July

Wide-Band 'Scope Circuitry for Color-TV Troubleshooting; Wyn Martin Aug.

COMMUNITY TV*

Connecting the Cable in the Community TV System; T. C. Masters May

Community TV Antenna Design and Installation (Site Testing ... Signal Measurement Methods); T. C. Masters Jan.

Community TV Cable Networks; T. C. Masters Feb.

Community TV Coax Temperature-Variation Control; F. E. Huggin July

Community TV Conference Report (TV Reception Far Beyond Line of Sight ... Preventive Maintenance) June

Community-TV Convention (Fourth Annual) Preview; Wyn Martin May

Community-TV Preventive Maintenance; Caywood C. Cooley, Jr. Sept.

Detection and Prevention of Radiation in Community TV Systems; T. C. Masters June

Final Stages in a Community TV Installation (Securing Messenger Cable to Pole ... Matching Transformers ... Tap-off Design and Applications); T. C. Masters Apr.

Horn Antennas for Community TV Installations; Jack Beevor June

Installing the Community TV System (Coax Cable Splicing ... Metal Tower Installation Hints); T. C. Masters Mar.

The NCTA Western Regional Conference (A Preview Report); F. M. Randolph Oct.

Troubleshooting Community-TV Systems; Ralph G. Peters Oct.

COMPONENTS

Audio Amp Component Replacements; Norman Croxhurst May

Color Bands, Codes and Components; Esmond E. Johnson Feb.

Evolution of the Modern Radio; George Hatherson Dec.

Leakage Resistance in Capacitors; G. S. Ryan Nov.

Molded-Composition and Wire-Wound Resistors; Esmond E. Johnson June

Power Wire-Wound Resistors; Esmond E. Johnson October

Replacement of Metal-Clad Resistors in the Field; Fran Chamberlain Aug.

* See TV Antennas for Additional References.

(Continued on page 28)



TELCO SCOUT 3 ANTENNA
Eight elements; for low channels.
No. A-180 NET \$3.30



TELCO DOUBLE V ANTENNA
Adjustable UHF & VHF... Channels 2-83.
No. A-9010 NET \$3.75

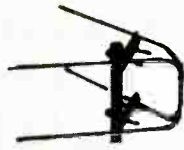

TELCO U-TYPE DOUBLE V ANTENNA
Adjusts to any V angle; VHF-UHF.
No. A-9017 NET \$3.57



TELCO DOUBLE V WINDOW-TENNA
UHF-VHF; mounts on window frame.
No. A-9057 NET \$5.37

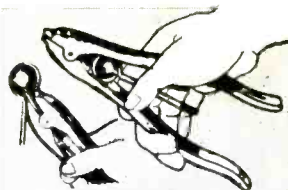

TELCO STAND-OFF "EYE-OPENER"
Handy tool for faster installing
No. 8450 NET \$0.75

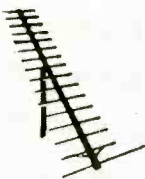

TELCO UHF GOLDEN YAGI
16-element style, cut to channel.
No. A-325 NET \$4.92

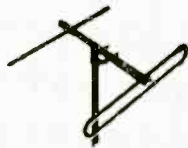

TELCO HI-LOW DIPOLE ANTENNA
Pre-assembled; VHF chs. 2-13.
No. A-250 NET \$5.22



TELCO E-Z STAND-OFF
UHF-VHF; 3 1/2" machine screw.
EZ-8031 NET \$4.80/C

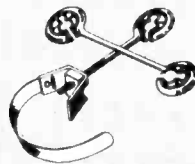

TELCO E-Z KANT-STRIP STAND-OFF
7 1/2" 3-way; 9" stainless strap.
EZ-8396 NET \$0.33



TELCO E-Z DRIVE-IN STAND-OFF
Hardened metal 3 1/2" drive.
EZ-8751 NET \$0.15



TELCO DUPLEX STAND-OFF
7 1/2" in-line duplex wood screw.
No. 8225 NET \$0.15

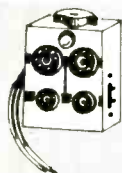

TELCO POCKET TUBE CHECKER
Series fil. and continuity tester.
No. 9270 NET \$2.75

Ask For These

SERVICE AIDS

...at Your Jobber

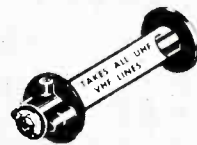

TELCO UNIVERSAL LEAD-IN TUBE
Fits 3/4" hole, 14" wall; brown.
No. 8958 NET \$1.17



TELCO TV SET ROLL-AROUND
Fits all sets, easy to install.
No. 8957 NET \$5.97



TELCO TRIPOD TOWER BASE
Supports 10' masts without guys.
No. 9063 NET \$4.17

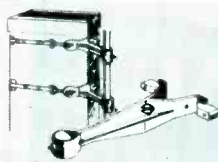

TELCO CHIMNEY MOUNT BRACKETS
Cast alum. pair for 1 1/2" masts.
No. 8001 NET \$4.05

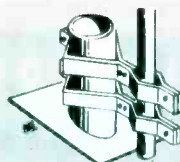

TELCO VENT MOUNT
Holds mast to 2" to 4" vents.
No. 8802 NET \$1.35

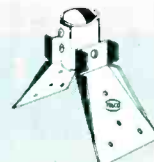

TELCO UNIVERSAL RIDGE MOUNT
Adjustable to peaks, flat roofs.
No. 8906 NET \$1.17

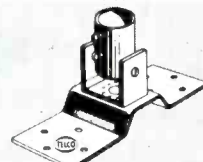

TELCO FITZ-ALL MOUNT
Use anywhere; masts to 2".
No. 8804 NET \$1.77

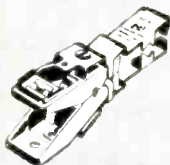

TELCO 3-WAY TV LINE KLIP
For straight, side, plug-in (RCA).
No. 9015 NET \$0.13

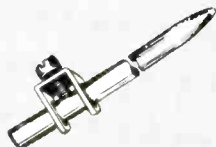

TELCO GROUND ROD
4 ft. long; 3/8" diameter.
No. 8929 NET \$0.81



TELCO UNIVERSAL LIGHT. ARRESTOR
UL approved; UHF and VHF.
No. 9242 NET \$0.45



TELCO ACRYLIC SPRAY-KOAT
Fast-drying outdoor-indoor use.
No. 8665 NET \$1.19

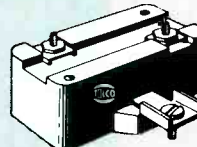

TELCO SPECIAL LIGHT. ARRESTOR
For 300-450-ohm open line; UL.
No. 8640 NET \$0.60



TELCO DELUXE LIGHT. ARRESTOR
For all types TV lines, VHF & UHF.
No. 8642 NET \$0.75



TELCO RIGID-TYPE TV BASE
Smart wrought black finish.
No. 9082 NET \$3.57

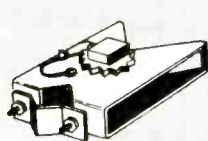

TELCO RATCHET CHIMNEY MOUNT
Galvanized straps; masts to 1 1/4".
No. 9218 NET \$2.37

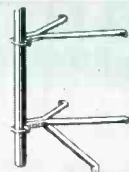

TELCO TUBULAR WALL MOUNT
15" mount; masts to 1 1/2".
No. 9243 NET \$3.00

FREE!

Your copies of all current TELCO Catalogs. Send postcard today!



TELEVISION HARDWARE MFG. CO.

Division of General Cement Mfg. Co. • 901 TAYLOR AVENUE • ROCKFORD, ILLINOIS

NEW

114-096
Four Bay
POWERAY
\$69.75 list

POWERAY

fringe area antenna

REVOLUTIONARY Sleeve Dipole Principle...

POWERAY is an outstanding new antenna design for fringe and deep-fringe areas. Based on a unique variation of the sleeve dipole principle, **POWERAY** provides better TV pictures miles away from the station. The sleeve dipole principle is based on resonance of the overall length at a low frequency and resonance of a 3-wire transmission line section at a high frequency. Only this new design properly balances high gain, directivity and exact impedance match for better fringe area reception.

PREASSEMBLED

POWERAY is preassembled for less install-time on the job. Easily and quickly put up, **POWERAY** provides superior performance for years.

For complete customer satisfaction and full profit margins—it's **POWERAY**, AMPHENOL's exceptional fringe area antenna

114-095
Two Bay
POWERAY
\$34.75 list

AMERICAN PHENOLIC CORPORATION
chicago 50, illinois
AMPHENOL CANADA LIMITED
toronto 9, ontario



Annual Index

(Continued from page 26)

NATIONAL SCENE REPORTS

SERVICE . . . The National Scene . . . Jan.-Dec.

* See TV Antennas for Additional References.

INSTRUMENTATION*

Audio Amplifier Measurements (Practical Setups for Audio Signal Generators to Check Gain and Response; *Norman Crowhurst* Sept.
Audio Instrument Scale Readings; *Norman Crowhurst* June
Audio Multitester (to Check Microphones, Cables, Phono Pickups, Line-Power Amps, Patch Cords and Speakers (Cover); *Oliver Berliner* June
Behind the VTVM Controls (Chart-Analysis of Vacuum-Tube Voltmeter Circuitry and Relation to Panel Adjustments and Receivers Being Checked); *G. S. Ryant*. Aug.
Making and Interpreting AC Measurements; *Norman Crowhurst* March
Behind the Capacitance-Bridge Controls (Bridge Circuitry and Relation to Instrument Adjustments and Components Being Checked.); *G. S. Ryant* Sept.
Interpreting VOM Measurements; *Norman Crowhurst* Nov.
Scope Resistance-Capacitance Substitution Box Applications in Video Work; *Robert G. Middleton* May
Series-String 600-Ma Heater Tube-Checker Circuitry (Cover); *William Drummer*. Aug.
Use of AF Signal Generator to Check System Output; Nov.
VTVM Circuitry; *W. H. Breese and J. E. Snook* Feb.

RADIO-TV SERVICING HELPS

Beam-Current Adjustments
Removing Intermittent Horizontal Sync.
Troubleshooting Switch-Type VHF Tuners
Antenna Rod Repairs
AGC Adjustments Sept.
Blooming; Causes and Cures Nov.
Cures for Horizontal Instability
Remedies for Arcing Troubles
Improving the Scope Sweep Horizontal Linearity
Color TV Receiver Damper Tube Substitutions
Removing Top of Picture Foldover
Vertical Oscillator Tube Changes
Reducing Horizontal Pull May
Horizontal Instability Cures
Series-String Chassis Repair
Troubleshooting AGC Circuits
Demagnetizing Color Picture Tubes July
Phase-Splitters Feb.
Minimizing AC Hum in Radio Chassis
Adjusting AGC to Remove Snow Conditions
Servicing Series-Tube Chassis Aug.
Modified Circuitry for Automatic Auto-Headlight Control
Curbing 90° Deflection Problems
Vertical Hold Improvements Oct.
Transistorized Portable Printed-Circuit Board Repair Notes Apr.
Troubleshooting Heater-Filament Lines.
Jack Darr Jan.
Testing and Repairing Battery-Operated Receivers; *Jack Darr* June
Troubleshooting Radio Intermittents; *Leo G. Sands* May
Troubleshooting Signal-Seeking Chrysler and G-M Auto Radios
Servicing 19-inch Color Tubes June
Stepping Up Tank Vacuum Pressure For Chassis Cleaning Dec.
Troubleshooting Noisy Auto Radios Dec.

SERVICE ENGINEERING

Beat-Frequency Oscillators in Communications Receivers; *Ronald L. Ives* Jan.
Communications Receiver BFO Servicing; *Ronald L. Ives* Feb.
Home Movie Sound-System Repair
Vibrator-Pack Maintenance and Servicing; *Maxwell Alberts* May
Industrial Intercom System Problems and Solutions; *Leo G. Sands* March
Installation, Maintenance and Repair of High-Band Receivers for 2-Way Systems; *Albert R. Sinclair* Oct.

* See Color-TV for Additional References.

Maintenance and Servicing of Low-Band 2-Way Equipment; *George W. Vass*...Sept.
 Photoelectric Systems for Supervisory Control; *Maxwell Alberts*...July
 Portable Vibrator Power Supplies; 6.3/12.6 V Inputs; *Maxwell Alberts*...Apr.
 Repairing Sound Head...Film Transport of Home Movie Equipment; *Maxwell Alberts*...June
 Servicing Industrial Electronic Equipment; *Henry A. Schwartz*...Jan.
 Servicing Communications Receiver BFO Circuits; *Ronald L. Joes*...Mar.
 Servicing of 450-Mc Communications Gear; *George A. Switek*...Nov.
 Tailored Intercom Installation, Servicing and Maintenance; *Leo G. Sands*...Feb.
 TV Chassis Photoelectric Remote Tuning-On/Off Control System; *Maxwell Alberts*...Aug.

SERVICE SHOP FIELD REPORTS

Direct Schematic to Chassis Servicing; *C. R. Cantowine*...July
 Independent Servicing in Sonora, Calif.; *Duncan K. Caldwell*...Nov.
 The Independent Service Man In Jamestown, New York; *George Carlson*...Sept.
 The Independent Service Man in the Rural Areas; *Jack Darr*...Oct.
 Streamlined Test Bench Design; *George F. Steg*...Apr.
 TV Repairs in the Home; *M. Martynec*...July
 The Village Independent Service Shop; *Herman G. Sechusen*...Dec.

TUBE NEWS*

Electronic Voltage Regulators Using Beam-Power Series Tubes...Crystal Diodes in TV Receivers; *A. M. Kelwood*...Sept.
 Nine Pin Miniatures for 600-Ma Series-String TV Chassis; *A. M. Kelwood*...May
 Replacing Obsolete 83 Mercury-Vapor Rectifiers with 5Z3; *Michael Machas*...Feb.
 UHF-TV Microminiature Ceramic Tubes...TV RF Pentodes...Nov.
 Wide-Angle Deflection Trend in Picture Tubes; *Dwight V. Jones*...Dec.

TRANSISTORS

G.E. 675 Transistorized Printed Circuit Pocket Radio (Front Cover); *Wyn Martin*...Oct.
 Low Level AF Transistors...TV Check Tube; *A. M. Kelwood*...Mar.
 Tetrode and Pentode Transistor Applications; *W. F. Palmer*...Jan.
 Transistors in Amplifiers; Preamps...Dynamic Microphone Units; *A. M. Kelwood*...June
 Transistor Noise Figure Measurement; *A. M. Kelwood*...Apr.
 Transistor-Tube Circuitry for Pocket Radios; *A. M. Kelwood*...July
 Transistor-Tube Developments; *A. M. Kelwood*...Aug.
 VHF/UHF Transistors; *A. M. Kelwood*...Oct.
 Audio Transistors...Nov.

TV ANTENNAS—SYSTEMS**

Broad-Band VHF Distribution Amplifier with AGC (Cover); *M. W. Percy*...Apr.
 Broad-Band Yagi Design; *Jan Kobler*...Dec.
 Double Diamond Phasing for VHF Antennas; *Ralph Peters*...Apr.
 Dual-UHF Antenna Installations Using Filter-Couplers; *Louis E. Raburn*...July
 Field and Lab Tests Used to Evaluate TV Antenna Performance; *G. N. Carmichael and J. F. Guernsey*...Nov.
 Fringe-Antenna Tower-Installation Field Notes; *Ralph G. Peters*...Aug.
 Fringe Area Installation Notes; *Harry Chaney*...Jan.
 Highlights of Antenna-Installation Rules Now Being Considered by the Insurance Companies to Curb Damage Due to Storms; *Ralph G. Peters*...Sept.
 In-line Helical Yagi Construction and Operation; *Douglas H. Carpenter*...Mar.
 Multiple Set Linear-Coupling Antenna-Amplifying Systems; *Ralph G. Peters*...Feb.
 Portable Vibrator-Pack Power Supply for Field-Strength Meter; *Jack Darr*...May

*See Transistors.

**See TV Antennas For Additional References.

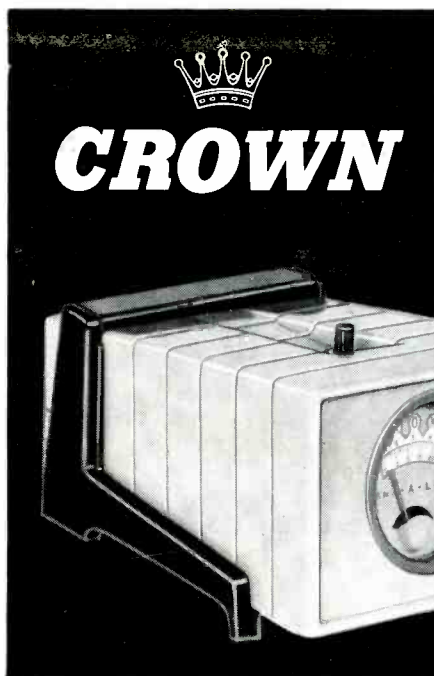

the most
RUGGED and
Dependable
 Antenna
 Rotator
 on the
 Market!

Model CAR6B in combination with Crown's exclusive Tenn-A-Liner Planter—an excellent item for an entirely new approach to antenna rotator promotion.



Crown's ruggedness and dependability assure long, trouble-free service... smooth, constant performance even under adverse weather and operating conditions. In fact, only 1.06% of all Crown units sold require service... a unique record of quality and satisfaction.

Crown Tenn-A-Liner Rotators have lifetime lubricated capacitor motors which operate on 115 volts... built-in roller thrust bearing with 175 lbs. weight capacity... 365° rotation... automatic brake prevents coasting or windmilling. Protected by Crown's exclusive "Weather-Guard" design. UL and Canadian Standards Association listed.

CROWN TWO SET COUPLER

Operates two TV sets from same antenna with excellent results on any combination of channels. No printed circuits! Low in cost... easy to install... it pays off in extra "over-the-counter" sales. Get the complete story on the highest profit line in the TV antenna rotator field—Crown Tenn-A-Liners and the complete line of Crown TV accessories... Write us today!



CCG

CROWN CONTROLS Co., Inc. NEW BREMEN, OHIO

Canadian Subsidiary Crown Controls Mfg. Ltd. Export Division, 15 Moore St., New York, N. Y., Cable—"Mithorne"

SERVICING HELPS

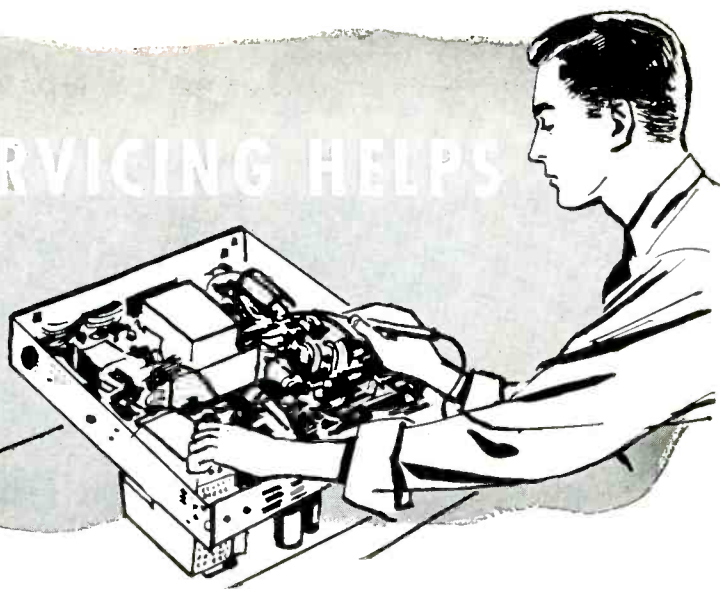

Stepping up Tank Vacuum Pressure for Chassis Cleaning . . . Troubleshooting Noisy Auto Radios

ALTHOUGH CHASSIS can be cleaned with standard vacuum cleaners, the job is never a really good one, for the blower pressure just isn't high enough to get all the dust out of corners and the variables, and the standard hose is too stiff for convenient use in close quarters.

The problem can be solved by taking the motor (which is in running order) out of a defunct tank-type vacuum cleaner, stripping out the dust bag, screens, and dust baffles, and providing a new high-flexibility hose.

In making these changes, you'll have to clean up the impellers, which are usually caked with dirt. This can

be done by boiling them in water with a detergent. Then the motor and impellers can be reassembled.

Now the intake end of the case should be sawed off, allowing sufficient length for the motor and impellers, and the intake cap and toggles should be reseated. A strong handle should be mounted on top, for convenience in use, allowing adequate hand clearance. A Stanley No. 3 door pull, mounted above the case on a 1" aluminum block at the inner end, and a bracket at the outer end, over the power plug, works well.

The motor should then be reinserted, and, after checking perform-

ance, outlet cap installed. The bottom skids should be shortened and replaced in their holders. The large outlet hole should then be filled with a fiber cap, taken from the intake; then a reducer should be made from standard hose fittings so that a $\frac{3}{8}$ " rubber tube can be fastened to the outlet. A $\frac{3}{8}$ " soft rubber tube about 3' long should then be attached to this reducer, and a nozzle, made from $\frac{3}{8}$ " copper tubing, mounted to the other end, using standard copper tubing (Weatherhead) fittings. Rubber tubing is held to the fittings by use of small clamps, to keep it from blowing off at inopportune moments.

The general appearance of a chassis cleaner made in this manner is shown in Fig. 1. Because of its small size, it has been found ideally suited for use in electronic rack bays and other crowded locations. Air pressure developed by the model shown has been found to be about 38 pounds, sufficient to lift a 6-32 hex nut out of a chassis, and to blow effectively lint and dust out of a variable capacitor.

Troubleshooting Noisy Audio Radios†

The noise that can be generated inside of an auto radio can be broken down into five categories: Noisy when jarred, noise on rough roads, microphonism, oscillation, hash and hum. The first step is to determine under which category the defect falls.

Oscillation is perhaps one of the most frequent troubles encountered. Its most common symptom is a series of whistles or tweets across the band corresponding to stations. An open *arc* bypass capacitor, output electrolytic or screen bypass capacitor could be at fault here. An open tweet filter in the second *if* transformer might also be causing the trouble.

In signal-seeking radios, the .002-mfd capacitor from pin 1 of the 12AU7 to ground should be checked for an open.

An open suppressor grid or tube socket shield center post, especially on the *if* tube frequently prove to be a source of trouble. The blue relay lead on SST radios may be lying too close to the *if* tube socket. The possibilities of tube defects should not be overlooked, especially in the *if* amplifier tube.

Motorboating also comes under the oscillation heading. It is generally caused by an open screen bypass or

(Continued on page 40)

Fig. 1. Chassis cleaner made from defunct tank-type vacuum cleaner.

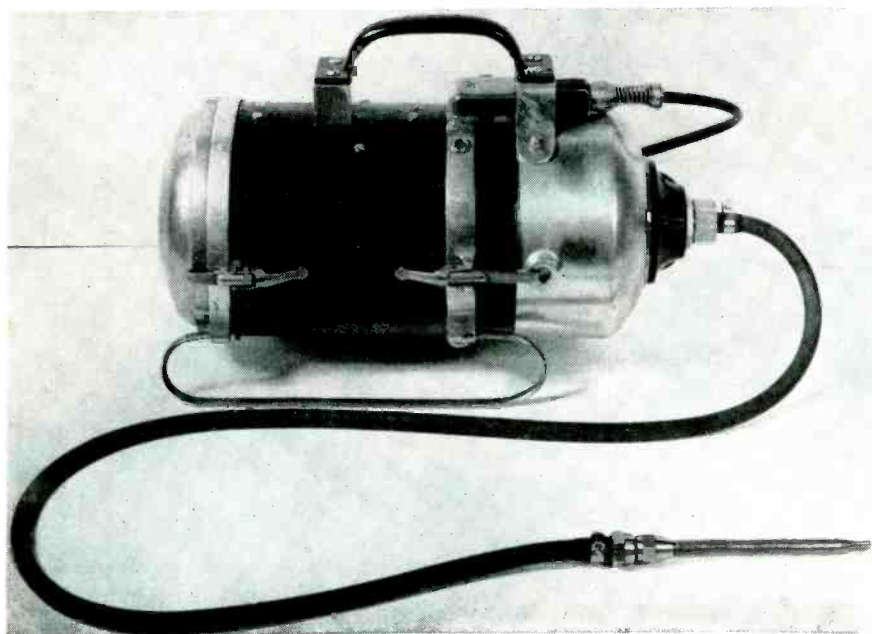

†Based on copyrighted data appearing in *Delco Radio Training Manual 551*.

Superior's New Model TV-60

ALLMETER

The most complete all-purpose 20,000 Ohms per Volt Multimeter ever designed!

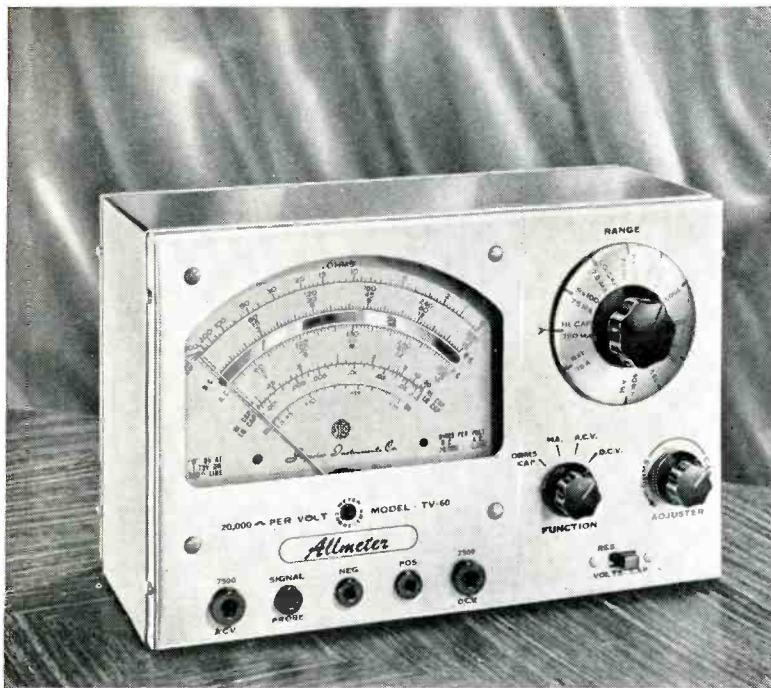

FEATURES

- ✓ Giant recessed 6½ inch 40 Microampere meter with *mirrored* scale assures accuracy and easy-reading. All calibrations are printed in large easy-to-read type. Fractional divisions are easily read with the aid of the mirrored scale.
- ✓ The line cord, used only when making Capacity measurements, need be plugged in only when using that service. It is out of the way, stored in its plicofilm compartment at all other times.
- ✓ A built-in Isolation Transformer automatically isolates the Model TV-60 from the power line when the capacity service is in use.
- ✓ Selected, 1% zero temperature coefficient metalized resistors are used as multipliers assuring *unchanging* accurate readings on all ranges.
- ✓ Use of the latest type of *printed circuit* guarantees maintenance of top quality standard in the production runs of this precise instrument.
- ✓ A new *improved* type of high-voltage probe is used for the measurement of high voltages up to 30,000 Volts. This service will be required when servicing color TV receivers.
- ✓ Simply plug-in the R.F. probe and convert the Model TV-60 into an efficient R.F. SIGNAL TRACER permitting the measurement of stage-gain and cause of trouble in the R.F. and I.F. circuits of A.M., F.M., and TV receivers.
- ✓ Plug in the Audio probe and convert the Model TV-60 into an efficient AUDIO SIGNAL TRACER. Measure the signal levels and comparative efficiency of hearing-aids, public-address systems, the amplifier sections of Radio & TV receivers etc.

- ✓ A sensitive, accurate Volt-Ohm-Milliammeter with *giant* meter and *mirrored* scale.
- ✓ An accurate direct-reading Capacity meter.
- ✓ A Kilovoltmeter.
- ✓ An R. F. Signal Tracer.
- ✓ An Audio Signal Tracer.

SPECIFICATIONS

- 8 D.C. VOLTAGE RANGES: (At a sensitivity of 20,000 Ohms per Volt) 0 to 15/75/150/300/750/1500/7500 30,000 Volts.
- 7 A.C. VOLTAGE RANGES: (At a sensitivity of 5,000 Ohms per Volt) 0 to 15/75/150/300/750/1500/7500 Volts.
- 3 RESISTANCE RANGES: 0 to 2,000/200,000 Ohms, 0-20 Megohms
- 2 CAPACITY RANGES: .00025 Mfd. to .3 Mfd., .05 Mfd. to 30 Mfd.
- 5 D.C. CURRENT RANGES: 0-75 Microamperes, 0 to 7.5/75/750 Milliamperes, 0 to 15 Amperes
- 3 DECIBEL RANGES:
 - 6 db to + 18 db
 - + 14 db to + 38 db
 - + 34 db to + 58 db

R. F. SIGNAL TRACER SERVICE:

Enables following the R.F. signal from the antenna to speaker of any radio or TV receiver and using that signal as a basis of measurement to first isolate the faulty stage and finally the component or circuit condition causing the trouble.

AUDIO SIGNAL TRACER SERVICE:

Functions in the same manner as the R.F. Signal Tracing service specified above except that it is used for the location of cause of trouble in all audio and amplifier systems.

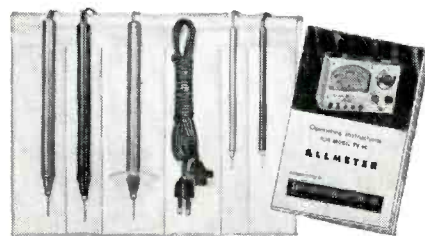

Model TV-60 comes complete with book of instructions; pair of standard test leads; high-voltage probe; detachable line cord; R.F. Signal Tracer Probe and Audio Signal Tracer Probe. Plicofilm bag for all above accessories is also included. Price complete. Nothing else to buy. Only **\$52.50**

SHIPPED ON APPROVAL NO MONEY WITH ORDER — NO C.O.D.

Try it for 10 days before you buy. If completely satisfied then send \$12.50 and pay balance at rate of \$8.00 per month for 5 months. **No Interest or Finance Charges Added!** If not completely satisfied return unit to us, no explanation necessary.

MOSS ELECTRONIC DISTRIBUTING CO., INC.
Dept. D-192, 3849 Tenth Ave., New York 34, N.Y.
Please rush one Model TV-60. I agree to pay \$12.50 within 10 days and to pay \$8.00 per month for 5 months. It is understood there will be no finance, interest or any other charges, provided I send my monthly payments when due. It is further understood that should I fail to make payment when due, the full unpaid balance shall become immediately due and payable.

Name _____

Address _____

City _____ Zone _____ State _____



SYLVANIA SILVER SCREEN 85

No. 1 in independent survey among servicemen



"Fewer returns" votes for "Silver Screen 85" were more than twice that of No. 2 and No. 3 brands combined

Best quality and consumer demand important reasons why servicemen make "Silver Screen 85" their No. 1 choice.

Servicemen gave "Silver Screen 85" the highest vote of confidence paid any picture tube in a national survey recently conducted by an independent research corporation. "Silver Screen 85" took top honors in answer to the key question, "what picture tube do you consider *best regardless of price?*"

FEWER RETURNS

"Fewer returns" were experienced with "Silver Screen 85" than with the No. 2 and No. 3 brands combined. "Best quality" and "better picture" were highest among reasons servicemen gave for voting "Silver Screen 85" No. 1.

PUBLIC DEMAND

Consumer demand was one of the factors of importance servicemen credited to "Silver Screen 85" according to the survey. When asked why they specified brand to their distributors, more servicemen named public demand as their reason for "Silver Screen 85" preference.

In fact, among the top four reasons why servicemen specified brand, "Silver Screen 85" again took 1st place.

You, like the servicemen who offer its high praise, can profit from "Silver Screen 85's" success story. Make "Silver Screen 85" your good-will leader. Feature it; promote it; you'll develop strong customer relations and high word-of-mouth recommendations. Your business will flourish and so will profits.



SYLVANIA®

SYLVANIA ELECTRIC PRODUCTS INC.
1740 Broadway, New York 19, N. Y.
In Canada: Sylvania Electric (Canada) Ltd.,
University Tower Bldg., Montreal

LIGHTING • RADIO • ELECTRONICS • TELEVISION • ATOMIC ENERGY

ness
trater
Al
able
per
ne
ject
er
y

AUDIO
INSTALLATION AND SERVICE

Phono • Tape • PA
Cartridges • Needles • Amplifiers • Speakers

Six Vital Areas in Radio-TV-Phono Speakers That Deteriorate With Age and Make Periodic Replacement Imperative

A LOUDSPEAKER'S performance resembles that of a tube; it usually continues to work for a long time but it does not continue working with exactly the same quality as it did when it was new because of deterioration problems.

Broadly speaking, there are two kinds of loudspeakers. One type is a multiple-unit affair, with electrical crossovers and acoustically designed enclosure, employing a large low-frequency unit, a moderate-size middle-frequency unit, and some kind of tweeter. The other is a single unit, normally about 8 inches in diameter, which carries the full frequency band.

The magnet assembly, that many assume will last forever, is extremely susceptible to deterioration.

To obtain a wide-frequency response, a strong magnetic field is necessary in the air gap to produce a tight electromagnetic coupling between the movement of the voice coil and the electrical circuit of the ampli-

fier. Early loudspeakers used a very large magnetic assembly and had to be energized by *dc* flowing through an energizing winding on the magnet to get sufficient flux for satisfactory performance.

However, magnetic material research has produced magnetic structures which achieve a very much stronger magnetic field in the air gap with a considerably smaller magnet. All of these fine magnetic materials employ molecular orientation; this is achieved during magnetization by special processing. Some of the earlier attempts at producing improved magnetic materials resulted in phenomenal properties, but they only held for a short period of time and rapidly deteriorated due to instability in the molecular structure of the steel.

Further research added additional elements and more closely controlled the processes of manufacture to achieve a higher degree of stability, so that the magnet would retain its

properties as it aged. But notwithstanding these high-efficiency magnet-steel improvements, progressive deterioration with age still obtains. This is due to the fact that the magnet is inevitably subjected to vibrations which result in continuous shock to its molecular structure. Although the modern materials are really highly stable, compared with earlier materials, they are all affected by some sort of fatigue and eventually deteriorate.

This means that when a loudspeaker's magnet gets to be several years old, the magnetic field which it produces in the air gap for the voice coil is not as strong as it was when the loudspeaker magnet was new. The result of the deterioration on a speaker's frequency response is illustrated in Fig. 2.

Deterioration in the magnetic field of the air gap reduces the degree of damping which the amplifier can transfer to the low-frequency fundamental resonance of the loudspeaker system. This means that the loudspeaker has begun to lose its frequency control; it no longer can offer a defined performance. The currents in the voice coil do not exert the rigid control on the diaphragm movement. This usually results in increased intermodulation distortion and deterioration of high frequencies.

The voice coil assembly is also vulnerable, because it is subject to extremely high stresses in driving the diaphragm. The driving force is provided by the audio currents flowing in the turns of the coil, which have to be transmitted to a coil former by means of an adhesive compound used to secure these turns; the former drives the cone or diaphragm of the speaker.

The material employed in virtually welding the voice coil turns to their coil former served as the subject of considerable research in the early days of speaker design. Often, it was

(Continued on page 34)

Figs. 1 and 2. A cross-section of a typical loudspeaker highlighting vulnerable parts is illustrated in Fig. 1. The effect of magnet deterioration on loudspeaker performance is shown in Fig. 2. Dashed-line represents curve of loudspeaker when new, with magnet strength high; solid line shows result when magnet deteriorates.

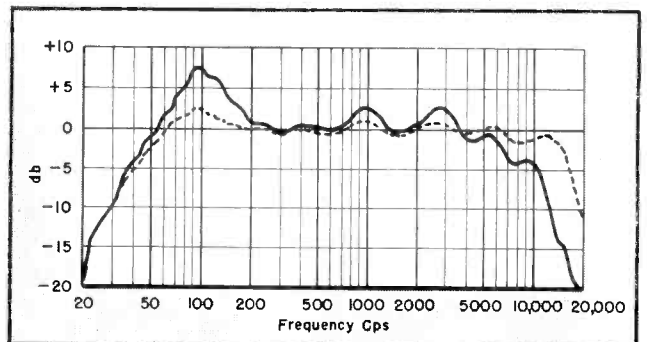
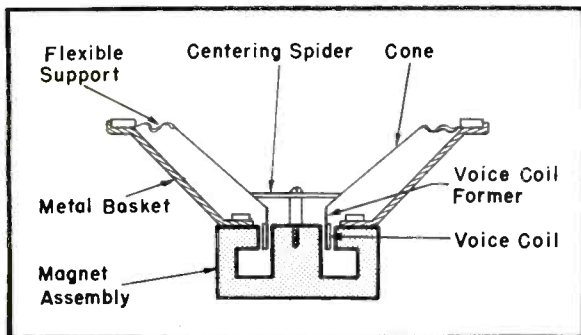

ERIE 413

HIGH VOLTAGE CERAMICONS®

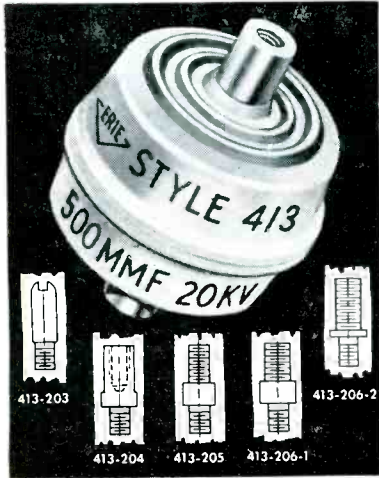

THE REPLACEMENT for high voltage TV filter applications

The ERIE 413 High Voltage Ceramicon is an innovation in capacitor design and has had wide acceptance by servicemen everywhere.

Now, for even greater convenience, each body is individually packaged with 7 terminals in 5 different styles. With a minimum stock the serviceman is now able to supply the correct replacement terminals for practically any receiver rated at 20 KV or lower. Inventory is reduced, service time is reduced, profits are increased. The illustrations on the left tell the story.

ERIE components are stocked by leading electronic distributors everywhere.

ORDER NOW
From Your
ERIE
DISTRIBUTOR



ERIE ELECTRONICS DISTRIBUTOR DIVISION

ERIE RESISTOR CORPORATION

Main Offices: ERIE, PA.

Factories: ERIE, PA. • LONDON, ENGLAND • TRENTON, ONTARIO

NOW!
**Identify ANY Needle
By Phono Manufacturer!**

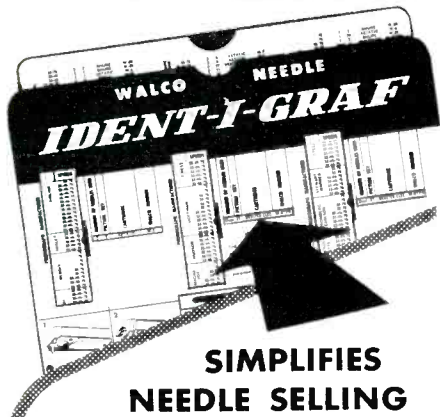

SIMPLIFIES NEEDLE SELLING

All you need is the name of the phono-graph manufacturer and the Walco Ident-I-Graf gives you positive needle identification in 3 seconds! Saves time and sales. Builds big needle profits. Throw away your complicated wall charts, Rube Goldberg selectors and other gimmicks. Learn how easy it is to sell needles with the Walco Ident-I-Graf. Available FREE to Walco dealers.

Walco E. ORANGE, N. J.

FIGHT POLIO March of Dimes January 3—31, 1956

ASK FOR SPRAGUE BY CATALOG NUMBER

Know what you're getting... get exactly what you want. Don't be vague... insist on Sprague. Use complete radio-TV service catalog C-610. Write Sprague Products Company, 61 Marshall Street, North Adams, Massachusetts.

DON'T JUST SAY CAPACITORS SAY

SPRAGUE®

WORLD'S LARGEST CAPACITOR MANUFACTURER

Audio

(Continued from page 35)

speaker has a characteristic like this.

The frequency at which the hole occurs is not usually a fundamental frequency, but a harmonic of various lower frequencies. The result is that this particular harmonic is removed from certain notes lower down in the scale, and we have different tone qualities for various notes that are sub-harmonics of the *hole* frequency. This does not appear as a resonance or peak but it still does distort the reproduction.

Another part of the cone assembly that is subject to deterioration is the centering spider. The spider's purpose is to keep movement of the voice coil parallel to the walls of the air gap without rubbing, and to keep it working within the gap, instead of wandering outside, either way.

When new, the spider's relaxed position is flat, to which position it will return the voice coil. And, it will exert a restoring force proportional to the voice coil movement away from this position, and dependent upon the properties of the material of which it is made.

As the spider ages, the restoring force may change, due to material fatigue or aging caused by weather conditions. A particularly bad flaw that can develop is spider stretching. In this condition, the spider's relaxed position will not be flat, but we will have two positions of relaxation, one either side of flat. This will result in an *oil-can* effect, causing serious harmonic distortion, often not correctly traced to the loudspeaker.

From the foregoing, it will be evident that the part of the speaker most susceptible to deterioration is the diaphragm assembly. Thus some manufacturers make replacement diaphragm assemblies that can be assembled on the same magnetic assembly and frame. If this operation is undertaken, one must be sure to clean the magnetic air gap in which the voice coil travels, and center accurately, according to the instructions issued with the replacement.

In the course of time, particles adhere inside the magnetic gap, particularly fine particles of iron dust, which come from everywhere. Ordinary dust may usually be removed by means of a brush or a blast of air through the gap. But magnetic particles cannot be removed so easily from a position where there is such an intense magnetic field. The air blast will normally blow these particles from one side of the gap to the

other, where they still hold on, or the brush will move them about in the gap without completely removing them.

Modeling clay has been found to offer one solution for air-gap cleaning. The clay must be formed into a strip not much thicker than the width of the air gap and pressed down into the gap. After pressing the clay down into the gap, it can be withdrawn; the magnetic particles will adhere to the modeling clay.

Many tweeters use metal diaphragms; such as the small horns, to provide high-frequency dispersion. It would seem that this type of unit would be completely free from any of the troubles discussed. The magnet problem is not too acute, because usually the speaker unit is much smaller, and thus it is easier to provide a liberal magnet design and loss of magnetic field does not matter too much.

However, anchorage of the turns to the voice-coil former still represents a point that can deteriorate and this can develop into quite a problem at the high-frequency end of the tweeter's spectrum. Also the metal diaphragm itself often suffers from metal fatigue due to diaphragm vibrations. These diaphragms are usually initially treated to achieve maximum rigidity or hardness, consistent with light construction.

One method features use of an aluminum diaphragm that is anodized to produce surface hardening. This also represents a useful and efficient means of anchoring the turns of the voice coil to the former. When the voice coil is new, it is apt to move uniformly like a piston, but as it ages, it has a progressive tendency to break up into Chladni patterns and no longer move as it should. This action is progressive because, as soon as one part of the diaphragm tends to flex about another part, the metal develops a *memory* in its molecular fatigue and so continues to emphasize this vibration. So, as the diaphragm gets older, the effect becomes more pronounced.

The important fact about progressive loudspeaker-performance deterioration is that the deterioration is gradual, but insidious. At no point along the line does the loudspeaker's performance change sufficiently rapidly for one to observe a difference in performance. Unless there is some serious mishap such as a burned-out voice coil, most are of the impression that the speaker still performs as good as new, however old it may be.

QUAM
the Quality line

When you specify Quam products you are assured of components that are carefully checked and tested for top performance and dependability . . . delivered when you need them . . . at the right price.

manufacturers of

QUAM Adjust-a-Cone[®] Speakers for television, radio, high fidelity, public address, outdoor use, replacement and many other applications.

QUAM Focalizer Units for TV picture tube focusing . . . use Alnico V permanent magnets . . . eliminate troubles inherent to wire-wound focusing devices.

QUAM Ion Traps for any size or type of TV picture tube.

QUAM Tru-Match Output Transformers, designed to get the best performance from your speaker.

QUAM-NICHOLS CO.
232 Marquette Road and Prairie Avenue
Chicago 37, Illinois

Although the customer may not readily believe that the speaker in his TV, radio or phono has lost its pep, his reproducer no longer is performing as well as it did, when it was new some years ago. One should also remember that since manufacturers are continuously improving their products, new speakers will always sound better than the model replaced, even though the new one appears to be exactly the same as the original.

FIBERGLAS DROP CLOTH

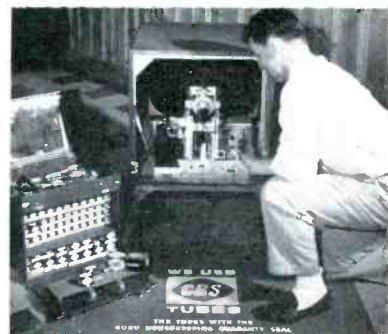

Fibreglas drop cloth (37" x 48") to protect floors and rugs now being made available to Service Men through CBS tube distributors. Drop cloth is said to be fire-resistant.

RECORD-PLAYER Service Tips

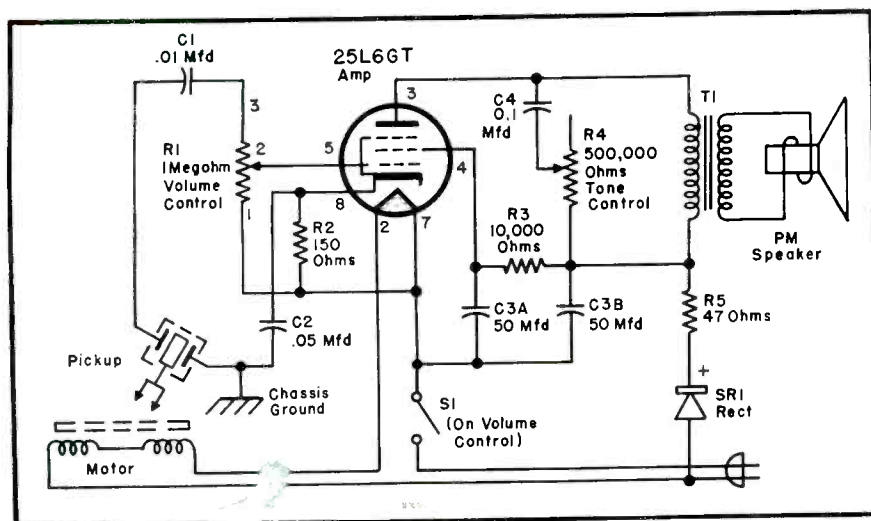

Fig. 1. Schematic of portable three-speed record player, with series connection of the 25L6GT heater and phono motor. (RCA model 6-EMP-2A.)

IN RECORD PLAYERS, as in a number of radio and TV chassis, manufacturers have reduced overall size to meet consumer demand for smaller packages. Such units have a reduced complement of parts and novel circuitry for the smaller quantity of components. This range of record players often presents many servicing problems.

An example of a streamlined record player, a three-speed portable* using a unique heater circuit, is illustrated in Fig. 1. Here, the motor, placed in series with the amplifier tube heaters, serves as a voltage dropping resistor; the motor is designed to operate at the reduced voltage with a current of .3 ampere as required by the tubes.

Aside from the unusual heater circuit, the amplifier circuit is typical, with a medium-output crystal cartridge driving a 25L6GT directly.

The turntable in this model is rim-driven by an idler which is moved vertically to contact the proper diameter step on the motor shaft to select the desired speed.¹ A large spindle for playing 45 records is recessed into the center of the turntable. It is brought to the play position by lifting it and turning it counterclockwise; it then seats in the raised position. A turn clockwise permits it to drop into the turntable for playing 33 1/3 or 78 rpm records. This spindle eliminates the nuisance of special adapters for the 45 rpm discs.

The turnover-style pickup is equipped with two osmium tipped styli, one of 1-mil radius for 33 1/3 and 45 rpm records, and another of

3-mil radius for 78-rpm records. A common complaint with this record player would be distorted sound resulting from worn styli. The needles can be replaced by pulling the old stylus straight out and pushing in a new stylus. The one-mil stylus can be recognized by the red-dot color coding; the 3-mil stylus is uncolored. In many cases the use of one stylus will greatly exceed the use of the other stylus; either one can be replaced alone.

The other principle complaint—nothing happens when the set is turned on—is normally due to an open filament 25L6GT. The tube can be replaced through an opening in the motorboard under the turntable. The retaining washer must be removed from the spindle and the turntable removed. The tube will then be accessible. More trouble can be expected in explaining how a bad tube can stop the motor, than in servicing the unit.

In many 45 portables,** which use a two-stage amplifier, heaters and motors are also in series. Here a 6AT6 provides extra gain for good volume from a medium-output pickup. The power switch is on the motor board, with the reject button.

Battery operated 45 radio-phonos,*** that are becoming increas-

*RCA models 6-EMP-2A/2B.

**RCA models 6-EY-3A/3B.

***RCA models 6-BY-4A, and 6-BY-4B.

¹SERVICE, *Audio Maintenance-Service Tips*; October 1955.

ingly popular, also have many circuitry, motor and receiver features. These models use 4 flashlight cells to operate a 6-volt phono-motor (which draws 30 ma) for approximately 150 hours of intermittent operation; a conventional *ab* pack operates the radio or amp for about 100 hours.

The receiver, a battery superhet, uses a 1R5 converter, 1U4 *if* amplifier, 1U5 second detector and audio amplifier, and a 3V4 audio output amplifier. A ferrite rod antenna is mounted close to the battery pack. Alignment instructions note that the battery has considerable effect on the inductance of the rod and must be properly located when the antenna trimmer is adjusted. A 3-mmf neutralizing capacitor has been included in the *if* to permit high gain without oscillation.

In the *phono* position, the audio amplifier and output stages operate, but filament power is removed from the converter and *if* amplifier stages. Because the battery drain for the first two stages is eliminated, a slightly higher output power of 200 milliwatts is available in the *phono* position, compared with 170 milliwatts in the *radio* position.

A common record player complaint is *wow* (turntable speed variations). There are a number of possible causes for this in rim-drive units. When the unit has recently been serviced, a good possibility is grease or oil on the inner rim of the turntable or on the idler wheel. Both surfaces should be cleaned with a solvent such as carbon-tet or one of the newer and safer solvents which are replacing carbon-tet. The solvent must not be a type which will soften the idler tire.

Other possible causes of *wow* include defective bearings, bent motor mounts, a bent turntable rim, an idler out of round, or weak springs which do not apply enough pressure on the idler. When the idler pressure is suspected as the trouble, one should check the support plate that has not been oiled. In many units, oil or grease produce more friction than the dry bearing. This is especially true when the oil has collected dust; the support plate may even bind tight. The cure for this condition is, of course, to clean the surfaces with solvent, and to leave them dry unless the manufacturer specifically advises lubricating them.

BLACK AND WHITE TV

COLOR TV

TRANSISTOR RADIOS
FM RADIOS
AM RADIOS

AMPLIFIERS AND TUNERS
AUTO RADIOS
RECORD CHANGERS



WHAT'S YOUR SERVICE PROBLEM?

PHOTOFACT HELPS YOU SOLVE IT

FASTER, EASIER, BETTER, MORE PROFITABLY!

**THE WORLD'S
FINEST SERVICE DATA**



THESE GREAT FEATURES ARE EXCLUSIVE IN PHOTOFACT—THEY HELP YOU EARN MORE DAILY, HELP INSURE CUSTOMER SATISFACTION

PHOTOFACT Service Data is the *only* service information based upon first-hand examination of the actual production-run receivers and equipment. It is authentic, uniform data developed through actual study and analysis by service engineers in the Howard W. Sams Laboratories. PHOTOFACT is the *only* data prepared from the practical point of view of the Service Technician.

Thousands of Service Technicians use PHOTOFACT daily for time-saving, profit-boosting service operations. If you've never used PHOTOFACT, you've never realized your full earning power—you've never given such complete customer satisfaction. So get the proof for yourself. Try PHOTOFACT—use it on any job. Your Parts Distributor has the Folder Sets you need for any of the 17,000 TV and radio receivers, changers, recorders, etc., covered in PHOTOFACT. Once you use this great service, we know you'll want the complete PHOTOFACT Library.

FREE Send for the PHOTOFACT CUMULATIVE INDEX IT'S VALUABLE!



Send for it! Your guide to virtually any model ever to come into your shop; helps you locate the proper PHOTOFACT Folder you need to solve any service problem on any model. Once you have the make and chassis number, it takes just 60 seconds to find the applicable PHOTOFACT Folder. Send coupon now for your FREE copy of the valuable Cumulative Index to all the PHOTOFACT Folders you need.

FREE

HOWARD W. SAMS & CO., INC.

Howard W. Sams & Co., Inc., Dept. 5-M5
2201 E. 46th St., Indianapolis 5, Ind.

Send FREE Photofact Cumulative Index.

Name.....

Address.....

City.....Zone...State.....

EASY-PAY PLAN TO FIT YOUR BUDGET

Ask your PHOTOFACT Distributor... he'll show you how you can now own the PHOTOFACT Library through a unique Easy-Pay Plan that exactly fits your needs. Pays for itself as you EARN MORE.

FULL SCHEMATIC COVERAGE

1. Famous "Standard Notation" uniform symbols are used in every schematic.
2. The same standard, uniform layout is used for each schematic.
3. Diagrams are clear, large, easy to read, easy to handle.
4. Wave forms are shown right on the TV schematics for quick analysis by 'scope.
5. Voltages appear on the schematics for speedy voltage analysis.
6. Transformer lead color-coding is indicated on the schematic.
7. Transformer winding resistances appear on the schematic.
8. Schematics are keyed to photos and parts lists.

FULL PHOTOGRAPHIC COVERAGE

9. Exclusive photo coverage of all chassis views is provided for each receiver.
10. All parts are numbered and keyed to the schematic and parts lists.
11. Photo coverage provides quicker parts identifications and location.

ALIGNMENT INSTRUCTIONS

12. Complete, detailed alignment data is standard and uniformly presented in all Folders.
13. Alignment frequencies are shown on radio photos adjacent to adjustment number—adjustments are keyed to schematic and photos.

TUBE PLACEMENT CHARTS

14. Top and bottom views are shown. Top view is positioned as chassis would be viewed from back of cabinet.
15. Blank pin or locating key on each tube is shown on placement chart.
16. Tube charts include fuse location for quick service reference.

TUBE FAILURE CHECK CHARTS

17. Shows common trouble symptoms and indicates tubes generally responsible for such troubles.
18. Series filament strings are schematically presented for quick reference.

COMPLETE PARTS LISTS

19. A complete and detailed parts list is given for each receiver.
20. Proper replacement parts are listed, together with installation notes where required.
21. All parts are keyed to the photos and schematics for quick reference.

FIELD SERVICE NOTES

22. Each Folder includes time-saving tips for servicing in the customer's home.
23. Valuable hints are given for quick access to pertinent adjustments.
24. Tips on safety glass removal and cleaning.

TROUBLE-SHOOTING AIDS

25. Includes advice for localizing commonly recurring troubles.
26. Gives useful description of any new or unusual circuits employed in the receiver.
27. Includes hints and advice for each specific chassis.

OUTSTANDING GENERAL FEATURES

28. Each and every PHOTOFACT Folder, regardless of receiver manufacturer, is presented in a standard, uniform layout.
29. PHOTOFACT is a *current* service—you don't have to wait a year or longer for the data you need. PHOTOFACT keeps right up with receiver production.
30. PHOTOFACT gives you complete coverage on TV, Radio, Amplifiers, Tuners, Phonos, Changers.
31. PHOTOFACT maintains an inquiry service bureau for the benefit of its customers.

HELPS YOU EARN MORE DAILY

test and rejuvenate your CRT's with the

TELETEST REJUVAESTER

An unbeatable combination . . . a CRT tester and rejuvenator in one small, compact, featherweight, low-cost unit. Simple to operate with one-knob control, a large, easy-to-read 4½-inch meter and a neon tube short indicator. And it weighs less than 4 pounds!

Cut operating costs by saving time and money on trade-in reconditioning and on-call CRT vitalizing. Restore normal CRT performance in 90% of cases!

TESTING

- checks cathode beam current
- locates hot and cold inter-element shorts
- checks resistance leakages as high as 5 megohms
- checks gas content and loss of brightness

REJUVENATING

- removes contamination from cathode surface
- corrects gassy (soft) picture tubes
- restores and improves emission quality
- Cathode activity is constantly metered during the rejuvenation process, thereby preventing permanent tube damage

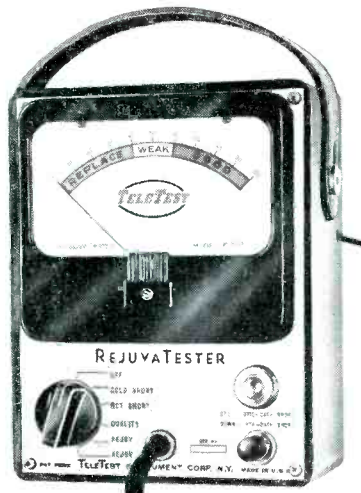

Model RT-203

1-YEAR FACTORY SERVICE GUARANTEE

only \$49⁹⁵

TELETEST
INSTRUMENT CORP.

See your local jobber, or write TODAY:

31-01 Linden Place, Dept. S-12, Flushing 54, N. Y.

AM/FM/Phono

(Continued from page 18)

local supply sources when replacement is required.

Both the treble and the bass amplifiers have a flat response from 20 to 20,000 cps and incorporate separate inverse feedback networks from individual output transformers, eliminating the possibility of distortion feedback possible in systems feeding loudspeakers through a frequency-divider network.

The bass amplifier drives 12" and 15" speakers with magnet weights of 1.5 and 2.4 pounds, respectively. The output of the treble amplifier feeds two high-frequency horns specially designed for the application.

TV Antennas

(Continued from page 21)

gain up to approximately 5 db over the single antenna.

The proximity of the parasitic element to the driven element, along with its shape and dimensions, results in an impedance transformation, which combined with the close coupling has the effect of reradiating and inducing a current in the driven element of much higher amplitude than the original out-of-phase current. The net in-phase current is therefore substantially equal to the current in the outer halfwave portions of the dipole as shown in Fig. 10 (p. 21). The polar radiation pattern that it has been found possible to obtain for such an array with the parasitic phase-reversing element is shown in Fig. 5 (p. 21). An antenna which employs this principle* is illustrated in Fig. 6.

*Walsco Wizard; patent applied for.

Servicing Helps

(Continued from page 30)

output electrolytic capacitor in the *rf*, oscillator-modulator or *if*.

In radios with a phase inverter stage the proximity of the output pad to the phase inverter grid should be checked. In radios using an inverse feedback circuit, one should check for an open output pad, or in case of output transformer replacement, for reversed primary leads.

If a continuous squeal occurs, one should check for an open oscillator grid resistor; in sets that use an oscillator-tilt resistor.

If hum only occurs on station, the *if* tube should be replaced or a check made for a short between the cathode and filament on the *if* amplifier tube socket.

WRITE FOR THIS

FREE LIFETIME HI-FIDELITY Sales Kit

DEALER SALES KIT MAKE BIG HI-FI PROFITS

Sell the finest HI-FI Units for custom building or in BEAUTIFUL CABINETS . . . Sell BELOW REGULAR WHOLESALE PRICES with full dealer mark-up and with price protection.

TRANSVISION Hi-Fi Equipment is SOLD THRU SELECTED DISTRIBUTORS

TRANSVISION, INC., NEW ROCHELLE, N. Y.
In Canada: 1338 Queen St. W., Toronto 3, Ont.

TRANSVISION, INC., New Rochelle, N. Y. S-12
Rush FREE Dealer SALES KIT on HI-FI and name of nearest distributor.

State _____

Circuit Diagrams In This Issue

Motorola HS-487 (Models 56R1-4) Radio	12
DeWald Autotransformer TV Power Supply	14
DeWald (Models J-215/16/17-212A) Autotransformer TV Chassis	15
Magnavox 30-W Amp For Imperial Symphony AM/FM/Phono (Cover)	18
Magnavox AM/FM Chassis With Pre-Amp	19
RCA Three-Speed Portable Phono Amp	38

DON'T Just say capacitors

Ask For Sprague By Catalog Number
Know what you're getting . . . get exactly what you want. Don't be vague . . . insist on Sprague. Use complete radio-TV service catalog C-610. Write Sprague Products Company, 61 Marshall Street, North Adams, Massachusetts.

SPRAGUE

WORLD'S LARGEST CAPACITOR MANUFACTURER

Modern Radios

Continued from page 12)

tuned to the incoming signal by a tuning capacitor. The signal, together with *avc* voltage from the detector, is applied to the third grid of the converter tube.

The local oscillator section of the converter tube utilizes the cathode and first grid in a cathode-feedback oscillator. Three windings are employed: the tuned inductance, the feedback and a third winding, with a connection to only one end, which actually couples capacitively to the tuned circuit. This circuit, and the equally popular Hartley-oscillator circuit, in which the cathode is tapped onto the tuned circuit, have not changed in years. However, the 6BE6 converter tube (item 2; p. 12) provides slightly higher conversion trans-conductance with lower current drain than did the 6SA7.

The 455-kc *if* output from the converter tube passes through the *if* transformer to the grid of the *if* amplifier. Changes in the *if* transformer (item 3) account for much of the improved sensitivity of the modern simple superhiet. The slug-tuned transformer is smaller and has a higher impedance and *Q* than the pre-war air-core unit. Therefore, the gain from converter grid to *if* amplifier is greater. The *avc* voltage is applied to this *if* amplifier stage by a 3.3-megohm shunt-feed resistor. This is one of the variations from the basic circuit for which one must be alert when servicing. The use of a shunt feed does not, however, change the basic operation of the receiver.

The *if* amplifier (item 4) in modern miniature receivers utilizes a 12BA6, which has about twice the transconductance and therefore twice the gain of a 12SK7. The transconductance also decreases more rapidly with bias in the 12BA6; therefore *avc* is more effective. Another change required by the 12BA6 is an unby-passed cathode resistor, which not only protects the tube, but also reduces the effects of changing tubes and of tube aging.

The second *if* transformer (item 5) is also slug-tuned as was the first. Again a further increase in the *if* gain selectivity is possible because of the higher impedance and higher *Q* of the newer transformer.

The detector is a simple half-wave diode in the same envelope with the audio amplifier. This tube (item 6) is a 12AV6 having nearly the same characteristics as the 12SQ7, which was so popular for years. Another tube, which sometimes serves as a

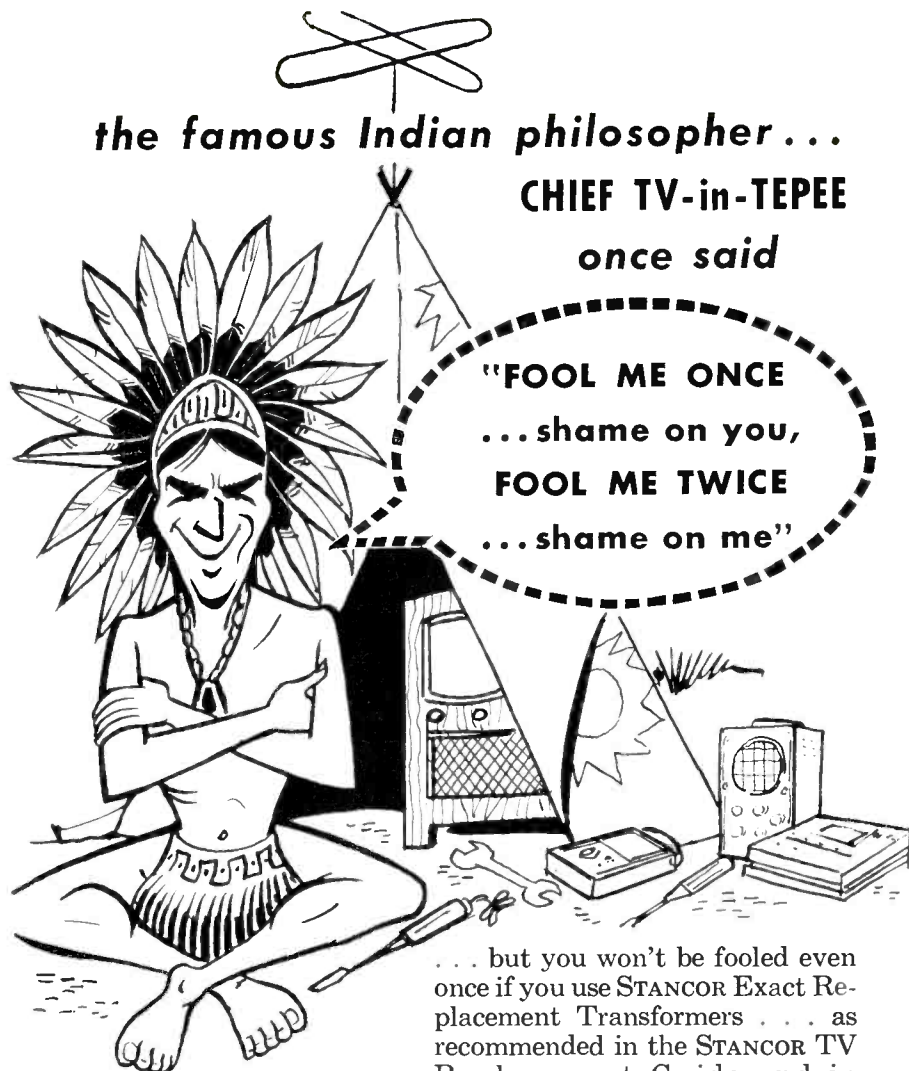

the famous Indian philosopher . . .

CHIEF TV-in-TEPEE
once said

"FOOL ME ONCE
... shame on you,
FOOL ME TWICE
... shame on me"

. . . but you won't be fooled even once if you use STANCOR Exact Replacement Transformers . . . as recommended in the STANCOR TV Replacement Guide and in Counter-Facts . . . because every unit is a VERIFIED exact replacement, designed from the original manufacturer's specifications and tested by actual installation and operation in the recommended chassis.

FREE—54 page STANCOR TV GUIDE. Lists over 8000 TV models and chassis and over 150 exact replacements. Available from your STANCOR distributor or from Chicago Standard.

EXPORT SALES:
Roburn Agencies, Inc.
431 Greenwich St.
New York 13, N. Y.



**CHICAGO
STANDARD
TRANSFORMER
CORPORATION**

3588 ELSTON AVENUE • CHICAGO 18, ILLINOIS

detector and audio amplifier, is the 12AT6; it has a lower amplification factor. The greatest change in this stage of the receiver is the use of the miniature, rather than the octal base, tube. The automatic-volume-control voltage developed across the load is filtered by a 3.3-megohm resistor and .05-mfd capacitor, and applied to the converter and to the *if* amplifier. The load resistance is also the volume control. In this receiver its value is 1 megohm; in many receivers it is 250,000 or 500,000

ohms. The audio amplifier is operated with contact bias, requiring a grid resistor of at least several megohms. This bias is about one volt.

The coupling circuits for the audio amplifier are now usually in a single printed circuit; item 7.

The power amplifier tube (item 8) a 50C5, is almost identical to the 50L6, except that it is a miniature tube. Again the circuit is the same as in receivers of years ago.

[To Be Continued]

anchor

C-202

two-set

TV COUPLER

1 antenna
for 2 TV sets

- Safe, easy to install
- Completely insulated
- Solderless connections

Top performance is yours on all channels when you install the new Anchor **MODEL C-202** 1 for 2 TV Coupler. This highly efficient High Frequency Transformer type Coupler with matched impedance of 300 ohms, will effectively transfer the signal from antenna to two TV sets with negligible signal loss to each and at the same time provide maximum isolation between sets to minimize interference.



ASK ABOUT OTHER **anchor** QUALITY PRODUCTS



anchor products co.

MANUFACTURERS OF ELECTRONIC COMPONENTS

2712 W. MONTROSE AVENUE • CHICAGO 18, ILLINOIS

for service and lab. work

Heathkit

PRINTED CIRCUIT

OSCILLOSCOPE KIT

FOR COLOR TV!

① Check the outstanding engineering design of this modern *printed circuit* Scope. Designed for color TV work, ideal for critical Laboratory applications. Frequency response essentially flat from 5 cycles to 5 Mc down only 1½ db at 3.58 Mc (TV color burst sync frequency). Down only 5 db at 5 Mc. New sweep generator 20-500,000 cycles, 5 times the range usually offered. Will sync wave form display up to 5 Mc and better. Printed circuit boards stabilize performance specifications and cut assembly time in half. Formerly available only in costly Lab type Scope. Features horizontal trace expansion for observation of pulse detail — retrace blanking amplifier — voltage regulated power supply — 3 step frequency compensated vertical input — low capacity nylon bushings on panel terminals — plus a host of other fine features. Combines peak performance and fine engineering features with low kit cost!

Heathkit TV

SWEEP GENERATOR KIT

ELECTRONIC SWEEP SYSTEM

② A new Heathkit sweep generator covering all frequencies encountered in TV service work (color or monochrome). FM frequencies too! 4 Mc — 220 Mc on fundamentals, harmonics up to 880 Mc. Smoothly controllable all-electronic sweep system. Nothing mechanical to vibrate or wear out. Crystal controlled 4.5 Mc fixed marker and separate variable marker 19-60 Mc on fundamentals and 57-Mc on calibrated harmonics. Plug-in crystal in-Blanking and phasing controls — automatic amplitude output circuit — efficient attenuation — maximum RF output well over .1 volt — excellent linearity. Easily your best buy in this class.



MODEL
0-10
\$6950.
Shpg. Wt.
27 lbs.



MODEL
TS-4
\$4950.
Shpg. Wt.
16 lbs.

Heath

COMPANY

A SUBSIDIARY OF DAYSTROM, INC.
BENTON HARBOR 11, MICH.

WRITE FOR FREE CATALOG
...COMPLETE INFORMATION

Ser-Cuits

(Continued from page 14)

supplied to the *rf* and the first two *if* amplifiers for automatic gain control.

The video and intercarrier sound signals are amplified by the pentode section of the 6AN8. The sound signal is trapped from the plate circuit of the video amplifier and supplied to the sound *if* amplifier, while the video is applied to the cathode of the picture tube. No *dc* restorer is included. Contrast is controlled by an adjustable resistor in the cathode circuit of the video amplifier, while brightness is set by a potentiometer in the picture-tube cathode circuit.

The intercarrier sound signal trapped from the video amplifier is applied to the grid of the pentode section of the 6U8, which drives the ratio detector; this detector utilizes two diodes of a 6T8. The triode section of the 6T8 amplifies the audio and drives the 12L6 audio output stage.

The sweep circuits receive their synchronizing signal from the resistive part of the video amplifier load. The triode section of the 6U8 serves as a first sync-clipper; the triode section of the 6AN8 serves as a second sync clipper and amplifier. The signal amplitude is halved by the voltage divider in the plate circuit, and is applied to both vertical and horizontal sweep circuits.

The vertical oscillator is a blocking oscillator, receiving its synchronizing signal through a printed-circuit integrating network. One half of a 12BH7 operates as the vertical oscillator; the second half is the vertical output amplifier. An autotransformer is employed in the output to convert the deflection yoke impedance to the proper impedance for the amplifier. The vertical controls include the vertical hold control, which sets the natural blocking-oscillator frequency by changing the resistance in the grid circuit of the blocking oscillator, the height control which limits the charging rate of the .057-mfd vertical sweep capacitor, and the vertical linearity control which changes the portion of the output-amplifier cathode resistance, which is capacitively bypassed.

The retrace-blanking circuit employed in this chassis is particularly interesting, because of its simplicity. A resistor is required in series with the vertical-sweep capacitor to provide a large negative pulse to the grid of the output amplifier for fast retrace and linear sweep. This resistor, a 6800-ohm unit, is in series with a .047-mfd sweep capacitor.

ask the
"Man-on-the-Roof"
 why he prefers
South River

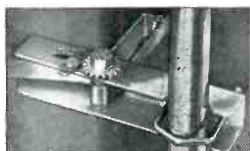

**TWO
 TO A
 SET**

**RATCHET TYPE
 CHIMNEY MOUNT**

Model RT (Galv. Banding)
 Model RT-ST (Stainless Banding)
**FASTEST, SIMPLEST, MOST
 CONVENIENT EVER
 MANUFACTURED**

Mounts in 2 simple steps. Completely factory assembled with no eyebolts, banding clips, nuts, etc., to handle. Furnished with flat-lay, non-coiling banding, heavy gauge embossed, welded steel construction. Forged, heat treated Alum. ratchets.

Write for Our Latest Catalog

SOUTH RIVER
 METAL PRODUCTS CO., INC.
 South River, New Jersey

*pioneer &
 outstanding
 producer of
 finest line
 of antenna
 mounts*

RICE'S RESALE PRICE GUIDE

THE FIRST ISSUE of a pocket-sized pricing digest containing current list or suggested resale prices on radio, TV, audio and electronic components, has been published by the Electronic Publishing Co., Inc., 180 N. Wacker Drive, Chicago 6, Ill.

Book, priced at \$2.50, with over 300 pages, covering more than 6000 items, features an alphabetical listing of manufacturers and products, with type or part numbers arranged numerically.

The guide has been designed to simplify and expedite reference to resale prices, and provide official proof to set owners that component prices quoted on repair jobs are in order.

Revised editions will be published four times a year.

FIBERGLAS COLORED AUTO ANTENNAS



Morris Gren (left), president of Almo Radio Co., Inc., Philadelphia distributors, and Dick Morris, Snyder sales manager, looking over new Snyder fibreglas auto antennas, which are available in three colors: sea green, oriental red and caribbean blue. Antennas can be installed on top cowl on the front of the car, or on the rear deck (with an extension to the standard 48" cable that comes with antenna).

PERSONNEL

BRUCE VINKEMULDER has been appointed distributor sales manager of Centralab, 900 E. Keefe Ave., Milwaukee 1, Wisc.; he will also supervise ad and export departments.



Bruce Vinkemulder



Jack Whiteside

JACK WHITESIDE, general manager of Simpson Electric Co., has been promoted to vice president of the parent company, American Gage and Machine Co., in charge of the Simpson Electric Division.

ARTHUR B. SHESSER has been appointed director of sales of Haydu Brothers of New Jersey. . . . FRANK G. FERDINAND is now sales manager of the cathode-ray tube division.



Arthur B. Shesser



F. G. Ferdinand

MARTY BETTAN has been named district sales manager for the five boroughs of New York City and Westchester County by Channel Master Corp., Ellenville, N. Y.



Marty Bettan



S. D. Gurian

SEYMOUR D. GURIAN has been named sales manager of the engineering products division of Radio Receptor Co., Inc., Brooklyn, N. Y.

be a
 man
 in the
 know



at no cost!

"THE CAPACITOR" comes prepaid direct to your home every month—12 times a year. 16 to 24 pages, including a complete full length technical or constructional article—AND the "TRADING POST" section for your ad.

Yes, as a subscriber to the CORNELL-DUBILIER monthly magazine "THE CAPACITOR", you can use its famous "TRADING POST" section to run an advertisement (no cost to you), to SELL—SWAP—or BUY all sorts of equipment and services helpful in your business.

A service of
CORNELL-DUBILIER
world's largest manufacturers of capacitors



Editor—"The Capacitor"
 CORNELL-DUBILIER ELECTRIC CORP.
 Dept. S-125, South Plainfield, N. J.
 Yes Sir! Put me down for a FREE Subscription to Cornell-Dubilier's "THE CAPACITOR"

name _____
please print

address (home) _____

city _____ zone _____ state _____

my occupation or job title is _____

This is the

2-Set TV COUPLER

Rated No. 1

••• by a nationally known independent product quality rating group as the result of tests made on 10 leading two-set couplers for:

- IMPEDANCE MATCH
- SIGNAL TRANSFER
- TWO-SET ISOLATION

MOSLEY 902



List Price \$3.95

Rated **FIRST** in overall quality for weak signal reception means; the MOSLEY 902 Dual Match 2-Set TV Coupler can be sold and installed in practically any TV area with full confidence that your customers will be completely satisfied!

Available at Radio and Television Parts Distributors — coast-to-coast.

Mosley
Electronics, Inc.
8622 ST. CHARLES ROCK ROAD
ST. LOUIS 14, MISSOURI

Associations

PRMSA

AT A RECENT MEETING of the Philadelphia Radio Service Men's Association, RCA was awarded a plaque in recognition of their cooperation with the radio and TV service industry.

Presentation of the award was made by **Richard G. Devaney**, PRMSA president. **Charles M. Odorizzi**, RCA executive vice president, accepted the plaque in behalf of RCA.

In accepting the award, Odorizzi asserted that his company would continue to work closely with independent Service Men as a means of improving service standards.

FRSAP

A RESOLUTION, calling for a review of the possibilities of self-licensing on a local level, but channeled through the state federation, was passed at a monthly meeting of delegates of the Federation of Radio Service Men's Association of Pennsylvania.

Three committees were appointed by **B. A. Bregenzer**: Newsletter, plaque and lecture.

Group-insurance programs were also reviewed at the session.

Charles M. Odorizzi, RCA executive v-p, accepting PRMSA plaque for his company at a recent meeting from association proxy, Richard G. Devaney.



TESA, Ohio

A GROUP OF NINETEEN delegates from local associations met recently in Columbus, Ohio, and formed the Television Electronic Service Association of Ohio.

Officers elected were **Richard E. Miller, Sr.**, president; **Marvin A. Miller** (RTA, Springfield, O.) first vice president; **Vern B. La Plante** (ETAT, Toledo) second vice president; **Harry L. Hakes** (SORTTA, Hillsboro, O.) third vice president, and **John P. Graham** (ARTSD, Columbus) secretary-treasurer.

Delegates unanimously agreed that TESA should become an affiliate of NATESA.

TEN YEARS AGO IN SERVICE

MULTI-ELEMENT MINIATURES appeared for the first time in the majority of radios announced as the year ended. Some models featured push-button tuning. A number of automatic phonos using the small tubes with crystal pickups were unveiled, too. Belmont released a 10-ounce pocket-size receiver using subminiatures. . . . Service associations programmed series of lectures and clinics to familiarize members with these developments. . . . **Oden F. Jester** was named general sales manager of the radio and phono division of Maguire Industries, Inc. . . . *The Representatives of Radio Parts Manufacturers, Inc.*, announced a 130-page *Radio and Electronic Industry Buyers' Guide*. . . . Allied Radio Corp. adopted the Raytheon Bonded Electronic Technician Program. . . . A remote-control rotator-operated TV-antenna system was developed by Farnsworth to eliminate ghosts in large cities and mountainous areas. . . . A 7" TV picture tube, 7EP4, was announced by Allen B. Du Mont Laboratories, Inc. . . . A drive-belt display stand was made available by General Cement Manufacturing Co. . . . A mutual-conductance tube tester was developed by Simpson.

WUERTH TUBE-SAVER

Guaranteed to Triple Life of All Tubes!



Amazing new invention saves all tubes from starting surges by Thermal Cushion action. Tests by leading laboratory show tubes last up to 7 times longer. Used by Armed Forces. U.L. Approved.

See Your Jobber or Write Us for Prices

WUERTH ENTERPRISES
Box 126, 512 West Avenue
Jenkintown, Pa.

Sure Sale with Every Service Call —and Every Set Sale. LIST \$795

MOST WANTED TV ACCESSORY

WHEN YOU CHANGE YOUR ADDRESS

Be sure to notify the Subscription Department of SERVICE at 52 Vanderbilt Avenue, New York 17, N. Y., giving the old as well as the new address, and do this at least four weeks in advance. The Post Office Department does not forward magazines unless you pay additional postage, and we cannot duplicate copies mailed to the old address. We ask your cooperation.

BENCH-FIELD TOOLS . . .

CHEMCLEAN CHEMICAL WIRE STRIPPER

A chemical wire stripper, *Chemclean* 493, for removing Formvar, Formex, Isonel and baked enamel coatings from wire, has been introduced by Chemclean Products Corporation, 610 Warren St., Brooklyn 17, N. Y.

Wire is said to be uniformly coated when dipped; bond between wire and insulation is broken and insulation can be wiped off.

ESICO LUGER SOLDERING GUN AND TIPS

A *Luger* soldering gun, designed to handle seven interchangeable tips, has been announced by Electric Soldering Iron Co., Inc., Deep River, Conn.

Tips include angled 45°, 90°, straight and 1/16" v-shaped point types. Tips, of special alloy, it is said, will not anneal, bend or develop surface residue. Gun is available in two models: single heat, 1.2 amp, and dual heat, 1.2 to 1.5 amp. Both models feature 10 v focused twin spotlights to illuminate work area.



G-C TEST SOCKET ADAPTOR KIT

A set of test socket adaptors, 9250, designed for rapid measurement of voltages (audio and video) and resistance in TV sets from either the top of the chassis or the base of the pix tube, has been announced by General Cement Manufacturing Co., 400 S. Wyman St., Rockford, Ill.

Included are four socket adaptors; pix tube, 7 and 9-pin miniatures and 8-pin octal. All have extended test tabs allowing use of alligator clips or test prods. Units are also available separately.

PHALO POWER SUPPLY PLUG

A female type circular plug, *F-1018*, designed for power supply cords on heavy duty equipment, has been developed by Phalo Plastics Corp., 25 Foster St., Worcester, Mass.

Receptacles are factory-molded into plug head and to power supply cord. Made of molded polyvinyl chloride composition in pastel colors.

KESTER

Absolutely non-corrosive and non-conductive, KESTER "RESIN-FIVE" CORE SOLDER contains an activated type of resin that gives you that fast, positive action on all your jobs . . . including the most difficult.

KESTER SOLDER COMPANY
4448 Wrightwood Avenue • Chicago 39, Illinois
Newark 5, New Jersey • Brantford, Canada

SOLDER

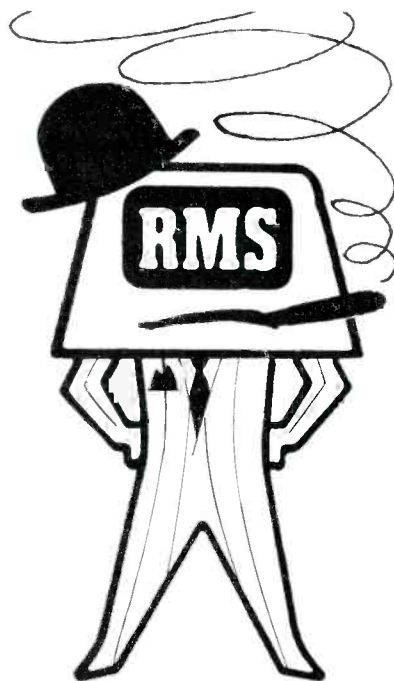

LOOK FOR

the "BIG SHOT"

RADIO MERCHANDISE SALES • N. Y. 62, N. Y.

New! COLOR & BLACK & WHITE LAB & TV SERVICE 5" SCOPE

KIT \$79.95
Factory Wired \$129.50

460

- Flat from DC to 4.5 mc to reproduce 3.58 mc sync burst and oscillator signals in color TV sets.
- V amplifier direct-coupled and push-pull thru-out; gradual roll-off beyond 4.5 mc, useful at 10 mc.
- High V sensitivity: 25 mv/in.
- Choice of direct coupling (DC) or capacitive coupling (AC).
- 4-step frequency-compensated attenuator in both AC and DC positions.
- Built-in calibrator permits peak-to-peak voltage measurement.
- Automatically syncs anything visible on the screen.
- Pre-set TV V & H sweep positions (30 cps & 7875 cps).
- Edge-lit lucite engraved graph screen with dimmer control, filter; standard bezel fits standard photographic equipment.
- 5U1 CR1.

Prices 5% Higher on West Coast
EICO Write for Name of Distributor & FREE New 1956 CATALOG S-12

84 Withers St. • Pklyn 11, N. Y.
NOW IN STOCK AT YOUR NEIGHBORHOOD DISTRIBUTOR—ORDER NOW!

Problem:

2 TV Sets
1 Antenna

Answer:



2-SET COUPLER

Model TV-42
Approved for Color TV
UHF, VHF and FM



Cost: ONLY \$2⁹⁵ LIST

Features:

- Matched resistive circuit
- Flat response—0 to 900 megacycles
- 12db inter-set isolation
- Easy to install
- Couples 2 TV sets without ghost or smear

Application:

In class A signal areas the B-T 2-Set Coupler provides the ideal low cost solution to the problem of operating two receivers from one antenna. There are other applications. For example, the TV-42 can couple a TV set and FM receiver to one antenna—or it can be used, in reverse, to couple or mix 2 antennas to one receiver.

Write for FREE BOOKLET—"TV for 2 or 3... or More"
Covers all types of Multiple TV Systems

Sold by Radio-TV Parts Distributors and Jobbers

BLONDER-TONGUE LABORATORIES, INC.
Dept. LM-8 Westfield, New Jersey



Manufacturers of TV Cameras,
TV Amplifiers, Boosters,
UHF Converters, TV Accessories
and Originators of the Masterline
and 'Add-A-Unit' Master TV Systems.

INSTRUMENTS

TAMPA VIDEO PICTURE TUBE REACTIVATOR

A picture tube reactivator, *Dyna-Beamer*, for restoring cathode emission while set is operating, using the sweep method, has been developed by Tampa Video Service, Inc., 6105 Interbay Blvd., Tampa 9, Fla.

Unit is said to indicate whether no raster or dim raster is due to bad pix tube or improper grid bias in set.

ELECTRONIC TEST PIX TUBE VOLT CHECKER

A tester, *Ma-Chek*, designed to check voltages applied to various pix tube elements, has been introduced by Electronic Test Instrument Corp., 13224 Livernois Ave., Detroit, Mich.

Tests bias (to see whether brightness or contrast control is working), first anode and filament, sets with low focus voltage from 400 to 1000 or with high focus voltages from 1000 to 3000.

JACKSON TUBE TESTER

A tube tester, model 49, whose meter and power supply can be used for other purposes, has been introduced by the Jackson Electrical Instrument Co., Dayton, O.

Tester features a number of plug-in accessories: A high-resistance shorts tester, which measures inter-element leakage to 2 megohms, heater-current tester and a selenium rectifier checker. Soon to be made available are a signal tracer, rf oscillator and capacitor tester.

PRECISION BATTERY-OPERATED VTVM

A battery-operated *vtm*, model 78, equipped with a 5 1/4" meter and using standard batteries (one 477, 67 1/2 v and two 950, 1 1/2 v), is now available from Precision Apparatus Co., Inc., 70-31 84th St., Glendale 27, N. Y.

Instrument has 6 true-zero-center *dc v* ranges at 13 1/3 megohms constant input resistance... 0-1 1/2, +6, +30, +150, +600, +1500 v; 5 resistance ranges... 0-1000 and 100,000 ohms, 0-1, 100, and 1000 megohms; 5 extra-high-impedance *rms ac* ranges at 8-megohms input resistance and 67-mfd input capacitance... 0-3, 12, 60, 300, 1200v.

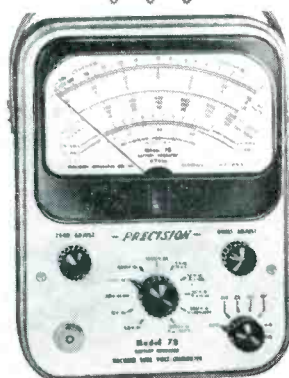

FIRST METER

DESIGNED FOR
GENERAL TV SERVICING

a professional instrument
designed for testing a T.V.
ABOVE and BELOW
chassis!

THE VIDEO PROBE METER!

Saves TWO HOURS PER
DAY when used in shop
for under chassis work.



With the attachable pick-up loop, (where sufficient signal is available) the Probe Meter can detect and indicate radiation of signal thru I.F. and video amp tubes. (Simply slide loop over tube being tested.) Where internally shielded tubes are encountered, remove tube and insert probe tip into grid pin of socket.

Model V-1
indicates
gain
per stage



List Price
\$31.50

Can accurately trace and indicate the following T.V. circuits,—(from tuner to pix tube) R.F., I.F., Det., Video, Sync., local osc., Hz. osc., Hz. Drive, audio output, sound I.F. (Signal tracing radios.)

EXCELLENT FOR TRACING AND COMPARING
COLOR T.V. CIRCUITS
ADDITIONAL FEATURES

Voltmeter, 0-500V. D.C., 20,000 Ohms/volt

Fully Guaranteed

If your dealer cannot supply you, order direct. Full purchase price refunded if not satisfied.

DEALERS AND REPS.: INQUIRIES WILL
RECEIVE IMMEDIATE ATTENTION

Research Inventions & Manufacturing Co.
617 F St., N. W., Washington 1, D. C.

Coming Events

IRE National Convention-
Radio Engineering Show
Kingsbridge Armory, N. Y. C.
March 19 to 22, 1956

Ask for Sprague By Catalog Number

Know what you're getting...
get exactly what you want.
Don't be vague... insist on

Sprague. Use
complete radio-TV service
catalog C-610. Write
Sprague
Products
Company,
61 Marshall Street,
No. Adams,
Mass.

DON'T
JUST SAY
CAPACITORS

SPRAGUE®
WORLD'S LARGEST CAPACITOR MANUFACTURER

ADVERTISERS IN SERVICE

DECEMBER, 1955

CATALOGS-BULLETINS

GRAMER - HALLDORSON TRANSFORMER CORP., 2734 N. Pulaski Rd., Chicago 39, Ill., has released catalog G-25, listing more than 400 replacement transformers. Included are flybacks, vertical outputs, deflection yokes, linearity or width coils, horizontal and vertical blocking-oscillator transformers and power transformer.

INTERNATIONAL RESISTANCE CO., 401 N. Broad St., Philadelphia 8, Pa. has issued a 4-page data bulletin, B-1, with information on tests, applications, specifications, tolerance, range, performance and dimensions of deposited carbon resistors.

KENWOOD ENGINEERING CO., INC., Colfax Ave., Kenilworth, N. J., has published an illustrated 16-page catalog listing TV antenna mounts and accessories.

ALPHA WIRE CORP., 430 Broadway, New York 13, N. Y., has released catalog 55, with specifications, descriptions and illustrations of over a thousand electronic wire items.

CINEMA ENGINEERING CO., 1100 Chestnut St., Burbank, Cal., has issued an 8-page catalog, 17-SE, covering instrument type switches. Includes a code-system outline and complete specifications.

HARMON-KARDON, INC., 520 Main St., Westbury, N. Y., has published an illustrated 17-page brochure covering hi-fi tuners, amplifiers, tuner-amplifier combinations and accessories.

B&K MANUFACTURING CO., 3726 N. Southport Ave., Chicago 13, Ill., has released illustrated bulletin 104, describing models 400 and 200 picture tube rejuvenator-testers.

ORRADIO INDUSTRIES, INC., 120 Marvyn Rd., Opelika, Ala., has issued a 4-page illustrated pamphlet detailing how magnetic recording tape is manufactured.

CHANNEL MASTER CORP., Ellenville, N. Y. has prepared a comprehensive design-application report on the K.O. antenna developed to eliminate co-channel interference and venetian blinds.

ALLIED RADIO CORPORATION, 100 N. Western Ave., Chicago 80, Ill., has announced the release of a 100-page rotogravure booklet, No. 151, on high fidelity.

THE ENGINEERING PRODUCTS DIVISION, RCA, Camden, N. J., has published three four-page catalog sheets describing 30- and 15-watt power amplifiers. One catalog, S.3027, covers a 30-watt amplifier with four microphone inputs and one phono input. Another, catalog S.3026, covers a 30-watt amplifier with two microphone inputs and one phono input. The third, catalog S.3023, details a 15-watt amplifier with two microphone inputs and one phono input.

	Page
American Phenolic Corp.....	28
Anchor Products Co.....	42
Argos Products Co., Inc.....	2
Atlas Sound Corp.....	34
Blonder-Tongue Labs.....	46
Bussmann Mfg. Co.....	6
CBS-Hytron (Div. Columbia Broadcasting System).....	25
Channel Master Corp.....	4, 5
Chicago Standard Transformer Corp.....	41
Cornell-Dubilier Electric Corp., Inside Front Cover, 43	43
Crown Controls Co., Inc.....	29
Allen B. DuMont Laboratories, Inc.....	13
Electronic Instrument Co., Inc.....	45
Electronic Publishing Co., Inc.....	48
Erie Resistor Corp.....	36
General Cement Mfg. Co.....	27
General Dry Batteries, Inc.....	3
The Heath Co.....	42
JFD Mfg. Co., Inc.....	16
Jensen Industries, Inc.....	34
Kester Solder Co.....	45
Littelfuse, Inc.....	1
P. R. Mallory & Co., Inc. Inside Back Cover	
Moss Electronic Dist. Co., Inc.....	31
Mosley Electronics, Inc.....	44
Oxford Electric Corp.....	35
Quam-Nichols Co.....	37
The Radiart Corp..... Inside Front Cover, 43	
Radio Corporation of America 7, Back Cover	
Radio Merchandise Sales, Inc.....	45
Raytheon Mfg. Co.....	9
search Inventions & Mfg. Co.....	45
ward W. Sams & Co., Inc.....	39
pson Electric Co.....	47
Snyder Mfg. Co.....	48
South River Metal Products Co., Inc.....	43
Sprague Products Co.....	36, 40, 46
Superex Electronics Corp.....	34
Sylvania Electric Products, Inc.....	32
Teletest Instrument Corp.....	40
Television Hardware Mfg. Co. (Div. General Cement Mfg. Co.).....	27
Transvision, Inc.....	40
Walco.....	36
Wuerth Enterprises.....	44



**a Volt-Ohm
you can carry in
your shirt pocket!**

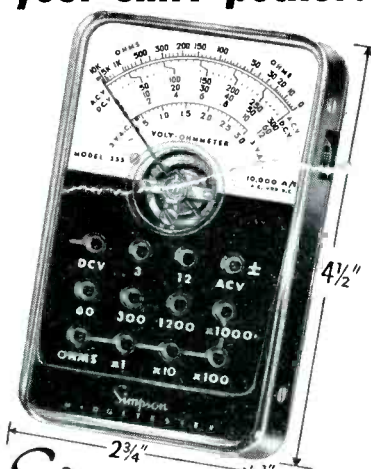

**Simpson
MIDGETESTER**

MODEL 355
SELF SHIELDED!

\$29.95
including
probe leads

The world's first practical shirt-pocket volt-ohm-meter. Rugged and accurate. Not affected by any outside magnetic influences. 10,000 Ohms per volt AC and DC! Fourteen ranges: 5 for AC voltages, 5 for DC voltages, and 4 for DC resistances.

See your Parts Distributor

**Simpson
ELECTRIC COMPANY**
WORLD'S LARGEST MANUFACTURER
OF ELECTRONIC TEST EQUIPMENT

5200 W. Kinzie St., Chicago 44, Ill.
ESTebrook 9-1121

IN CANADA: Bach-Simpson, Ltd., London, Ontario

Snyder
PHILADELPHIA

Auto Antennas

WORLD'S MOST COMPLETE LINE

40 MODELS +

JOTS and FLASHES

A TV DRIVE-IN service where motorists can register for rooms by means of a closed-circuit DuMont TV system is now in operation at the Temple Hotel in Pendleton, Oregon. Cars, driving to a curbside booth at one side of hotel, trigger a signaling device which alerts a room clerk inside hotel. At the same time, the car enters field of vision of two-way closed-circuit network, which flashes a picture of driver to a screen inside hotel so that clerk may see him; picture of room clerk is relayed to a TV screen in curbside booth so that the driver may see him. The two may talk and make room arrangements by means of an audio system. A bellboy brings registration sheet to car, gives guest a room key, takes guest's baggage and directs him to a free parking space in the hotel's garage.

A 40-hour course in color TV, designed to train 20,000 Service Men throughout the country, has been inaugurated by Philco. As the initial step in the school, Service Men representing all Philco distributors are being brought to Philadelphia factory headquarters in groups of not more than twenty. After these distributor reps have been trained in servicing and methods of teaching, they will return to their respective areas to conduct local color TV schools for qualified Service Men through the Philco factory supervised service program.

A year-long celebration marking the silver anniversary of the founding of the Snyder Manufacturing Co., is being planned for '56. . . . Frank J. Bingley, executive engineer of Philco Research Laboratories, has been awarded the IRE '56 Vladimir K. Zworykin television prize for his color TV contributions. . . . The Insuline Corporation of America, Manchester, N. H., has become a subsidiary of the Van Norman Company, Springfield, Mass. Samuel J. Spector continues as president and chief executive officer, Bernard L. Cahn, as vice president for sales. . . . Sylvania Electric Products, Inc., will soon construct a multi-million dollar plant in Altoona, Pa., for the production of receiving tubes. . . . The JFD Manufacturing Co., Inc., recently announced the opening of a Canadian manufacturing and sales division; JFD Canada, Ltd., located at 51 McCormack Street, Toronto 14. . . . George Zimmerman is now chief engineer of the transformer division of Oxford Electric Corp. . . . Electronic Instrument Co., Inc., 84 Withers St., Brooklyn 11, N. Y., recently celebrated its tenth anniversary at a birthday luncheon, during which Harry R. Ashley, founder and president of the company, was honored by industry leaders. . . . The Cornell-Dubilier Electric Corp. has moved its mid-west sales office to 5247 West Diversey Ave., Chicago 39, Ill. . . . E. H. Applegate has been named distributor sales manager of Regency Division, I. D. E. A., Inc., 7900 Pendleton Pike, Indianapolis 26, Ind.; he will continue to serve as ad manager. . . . Samuel Yurman has been named sales manager of Kenwood Engineering Co., Inc., Colfax Ave., Kenilworth, N. J.

1st with all prices

Pricing Digest answers a need long-felt by Servicemen—List or resale prices for every replacement part or component at your fingertips.

Over 200 pages, covers more than 60,000 items

Compiled like a telephone book (1) alphabetical by Manufacturer (2) Alphabetical by Product Category (3) Numerical by Part Number. Price and identify any replacement item in seconds—as easy as 1-2-3.

9 3/4" long by 3 3/4" wide . . . convenient for counter, pocket, tool box or tube caddy.

1st in savings

Time and money savings—no wasted effort—no calls to your distributor to check prices. No undercharges—no overcharges when you price your tubes and parts from the Official Pricing Digest.

PRICE \$2.50 PER COPY—will pay for itself many times over by giving you CORRECT PRICES where and when you need them. Publication dates are October, January, April and July. Completely revised prices will be current on each publication date.

Available exclusively thru your parts distributor.

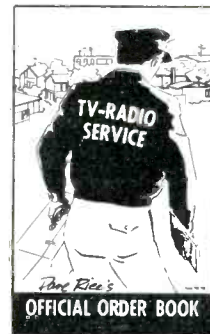

Dave Rice's OFFICIAL TV-RADIO SERVICE ORDER BOOK

Best Service Order Book because it's the only form providing for all types of service on TV-Radio, Phono or Hi-Fi equipment. **Best service order book** because it's the only form providing separate listings for tubes, parts and components, plus space for picture tube and serial number.

Best service order book because it's the only form clearly separating labor and parts and allowing all state and local taxes to be added.

Best Service order book because its handy size is 5 1/2" wide by 8 1/2" long. Each book contains 50 orders (in triplicate). Original white bond, duplicate yellow, triplicate pink. Numbered consecutively in sets. Two sets of carbons bound into each book. The only form packaged in dustproof boxes of ten—keeps stock clean until you need it.

Sold by parts distributors at 75c per book or \$6.50 per box of 10.

Electronic Publishing Co., Inc.
180 North Wacker Drive
Chicago 6, Illinois

P. R. MALLORY & CO. INC.
MALLORY
APPROVED PRECISION PRODUCTS

P. R. MALLORY & CO. INC.
MALLORY
APPROVED PRECISION PRODUCTS

P. R. MALLORY & CO. INC.
MALLORY
APPROVED PRECISION PRODUCTS

P. R. MALLORY & CO. INC.
MALLORY
APPROVED PRECISION PRODUCTS

P. R. MALLORY & CO. INC.
MALLORY
APPROVED PRECISION PRODUCTS

Always right ...either way

Whichever way you prefer Dual Controls, Mallory can supply you with Exact Duplicates.

GET THEM READY-TO-USE . . .

completely assembled in all the combinations of resistance values, tapers, taps, switches and shaft lengths to fit most of the popular TV sets.

GET THEM AS SUB-ASSEMBLIES . . .

and combine factory-made sections, switches and shaft tips to match the job at hand. You don't need much stock . . . a small inventory equips you to make 10,000 different combinations. And you don't need much time . . . assembly takes less than five minutes.

SUIT YOURSELF, AND SUIT YOUR CUSTOMERS

Either way, Mallory dual controls give you an exact match of the electrical and physical characteristics you need . . . plus qualities of precision, quiet operation and long life that equal or exceed the original equipment control.

Your Mallory distributor carries Mallory Exact Duplicate Dual Controls in the style you like. Order from him today.

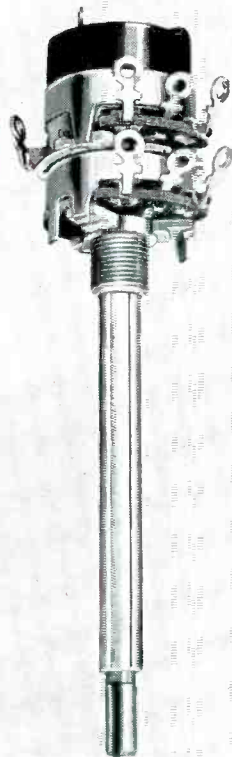
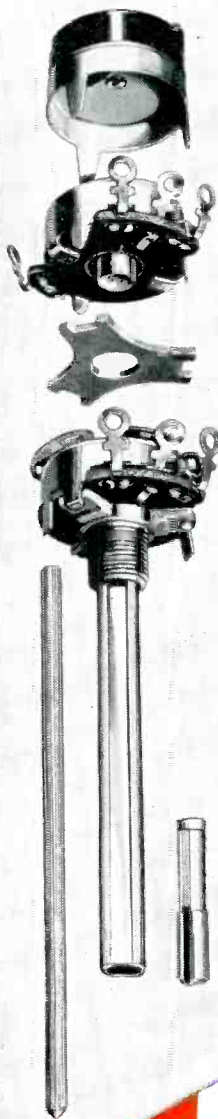

P. R. MALLORY & CO. INC.
MALLORY

CAPACITORS • CONTROLS • VIBRATORS • SWITCHES • RESISTORS
RECTIFIERS • POWER SUPPLIES • FILTERS • MERCURY BATTERIES
APPROVED PRECISION PRODUCTS

P. R. MALLORY & CO. Inc., INDIANAPOLIS 6, INDIANA

How to sweeten a sour video amplifier . . .

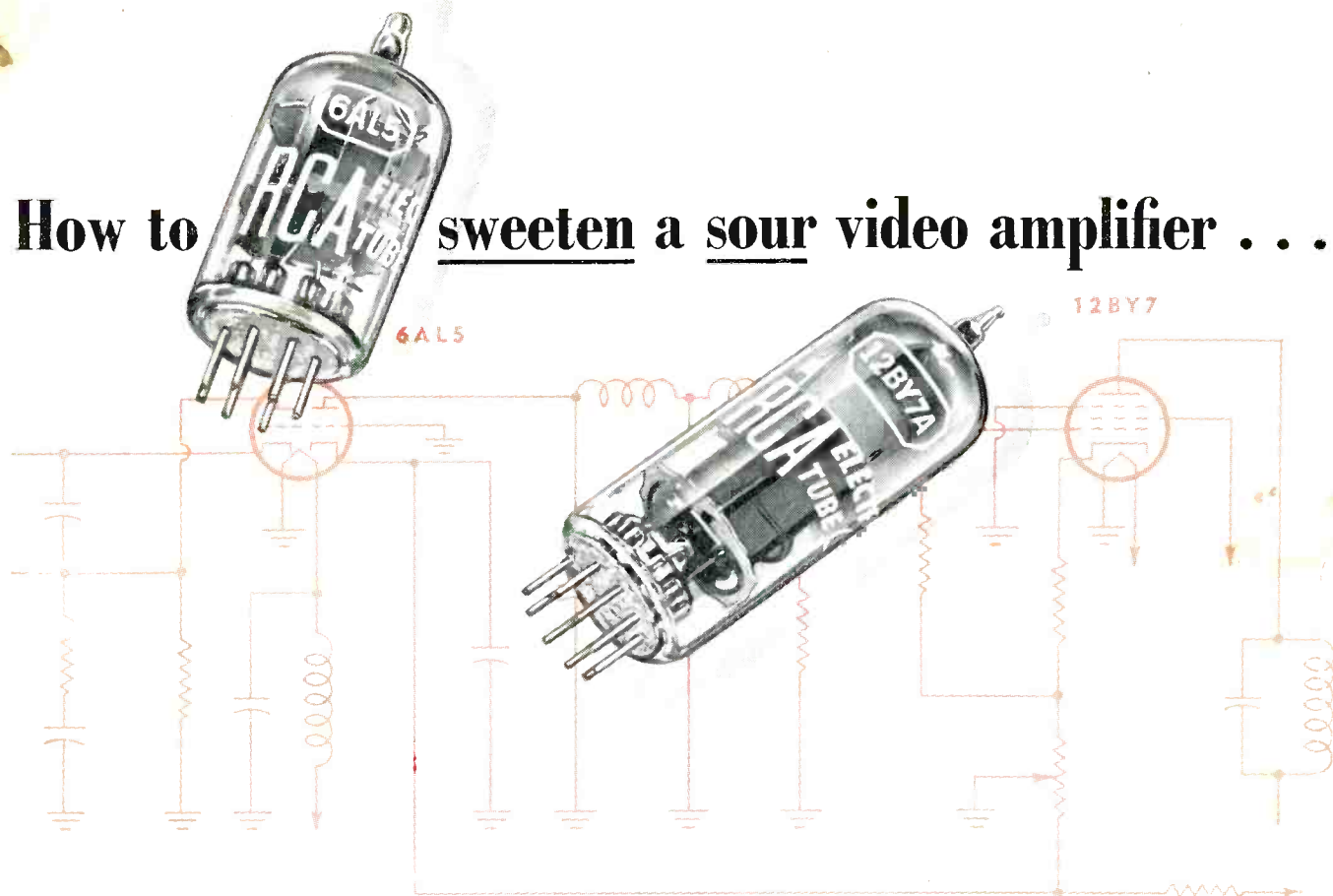

Use RCA Tubes with Built-In Quality!

In 2nd picture detectors and video amplifiers, a "sour" 12BY7-A or 6AL5 can wash out or smear a picture and make a.g.c. ineffective. In video amplifiers with critical requirements, fine performance depends on good tubes in the sockets. Strict quality control and selected materials used in the manufacture of RCA tubes give you replacement tubes conforming to TV set manufacturers' requirements for top performance—your assurance of better picture and sound fidelity.

In circuits so vital to clear, sharp pictures—use only long-lasting top-quality tubes—that means RCA TUBES. Your customers will see and hear the differences.



RADIO CORPORATION of AMERICA
ELECTRON TUBES

HARRISON, N. J.

First choice for TV circuits . . . dependable RCA Tubes.