

SERVICE

AUGUST
1951

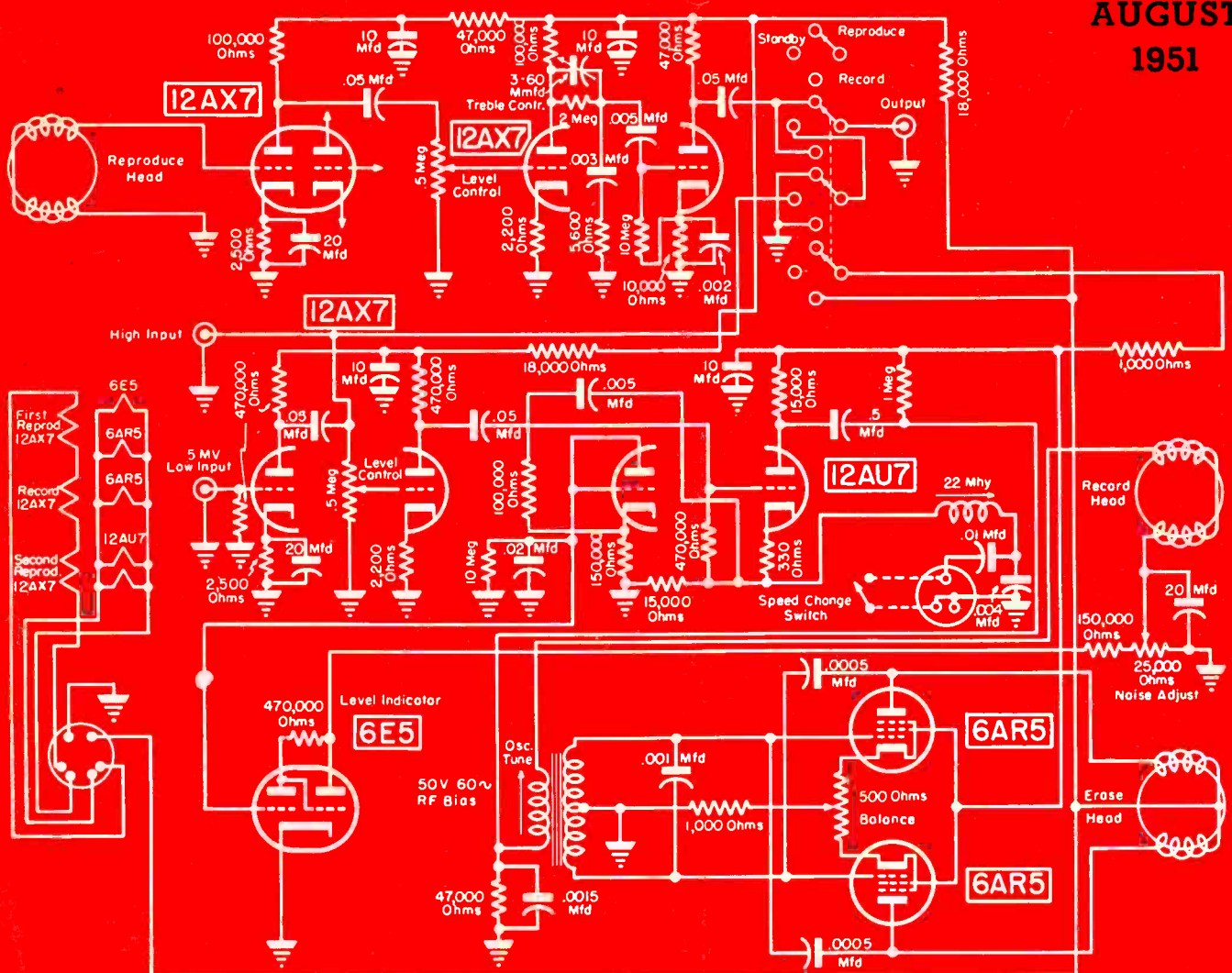

Magnetic-type recorder and playback amplifier system, employing 12AX7 dual hi-mu triodes in cascade in recorder to drive a final 12AU7 stage.

[See page 2]

There Are **36,292,000** Automobiles In The U.S.A.

18,100,000 Of Them Have Radios...



FOR *Each* OF THESE 18,100,000
 RADIOS THERE IS A
Correct
RADIART
REPLACEMENT
VIBRATOR
This Is Big Business For You...

These 18,100,000 automobile radios require vibrator replacement at one time or another. Good servicemen everywhere install and recommend RADIART VIBRATORS in EVERY CASE... because there is a correct Radiart replacement vibrator... to ORIGINAL SPECIFICATIONS... for most every need! No "guess work"... no "next best type"... Radiart gives your customers the best... assuring you they'll keep coming back... always satisfied. Jobbers everywhere carry all popular types in stock... or can get quickly any number wanted from the 86 precision engineered types manufactured.



AND... TWO-WAY MOBILE COMMUNICATIONS... REPRESENTS BIG VIBRATOR REPLACEMENT BUSINESS!... Continuous-duty service in taxicabs, police cars, etc. - frequently 'round-the-clock' - means 3 to 6 vibrators replaced per year... See your jobber for the latest issue of RADIART FORM F 781 for complete listings... or write direct to—



THE RADIART CORPORATION CLEVELAND 2, OHIO
 VIBRATORS • AUTO AERIALS • TV ANTENNAS • ROTATORS • POWER SUPPLIES



CHICAGO, ILL.—Harold W. Chambers, Chambers Radio and Appliance Co., says: "We had to lick call-backs before they licked us. So we made quality tubes a 'must' at Chambers—principally G-E tubes, the brand every serviceman respects. Now TV service shows a steady profit on our books. Consequently, all of us here are strong for General Electric tubes—boost them every chance we get."

BROOKLYN, N. Y.—Joseph F. Lauinger, President, Conlan Electric Company, says: "Call-backs can wipe out profits. Quality tubes mean fewer call-backs—protect income. That's why, with 40,000 owners on our contract list, we feature G-E tubes. We know that when one of our men installs a G-E picture tube or receiving type, chances are that customer will *stay satisfied!*"

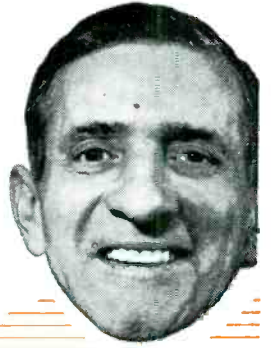

HERE'S PROOF THAT G-E TUBES CUT CALL-BACKS!

CINCINNATI, O.—COVINGTON, KY.—Everett Caudill, Manager, Tel-Rad Center, says: "To cut costs, we had to cut call-backs! They tied up our repairmen—wasted valuable working time. The trouble was mostly tube failures. We had to stop that in its tracks—and we did, by going over 100-percent to quality tubes. When we say 'quality tubes' at Tel-Rad Center, we mean, first of all, G-E tubes!"



WASHINGTON, D. C.—Mike Filderman, Vice-president, Phillips Radio Company, says: "Our call-back expense scared us, for customers' sets kept giving trouble. That was before we standardized on quality tubes—G-E tubes. They've done away with our most common cause of receiver trouble, tube failures. Believe me, that saves plenty, when you're servicing about 15,000 TV sets on yearly contract!"



Thousands of dealers, the country over, echo what these leading servicemen say about G-E tubes . . . For quality tubes to cut down YOUR call-backs, see your General Electric tube distributor today!



GENERAL  ELECTRIC

181-KAB

FOR HIGH EFFICIENCY SOUND REPRODUCTION



MODEL VH-91



MODEL VH-15



MODEL VH-20



MODEL VH-24

Jensen *Hypex* PROJECTORS

Jensen Hypex Projectors for indoor and outdoor PA and sound reinforcement are highly efficient, sturdy, weather-proof, corrosion resistant loudspeakers with many exclusive advanced features. For example, the Hypex (hyperbolic exponential) flare formula—patent 2,338,262—provides the most effective acoustic loading right down to 1. f. cut-off. Special plastic diaphragm driver unit gives powerful reproduction with a "punch"—yet free from unpleasant harshness. And soundly engineered adjustable mounting facilities make installation a pleasure.

JENSEN MANUFACTURING COMPANY
Division of The Muter Company
6601 S. Laramie Ave., Chicago 38, Illinois
Phone: PORTSMOUTH 7-7600.

LEWIS WINNER
Editor

SERVICE

F. WALEN
Assistant Editor

Registered U. S. Patent Office
Including *Radio Merchandising and Television Merchandising*

	Page
Accelerated Testing Techniques. By Philip Greeley	38
Association News	48
Audio Installation and Service (Phono Arms—Audio Definitions). By Kenneth Stewart	30
Color Television (Conversion Circuits). By Philip Selvaggi	20
Magnetic-Tape Recorder Circuitry (Cover). By Wyn Martin	36
Master-Antenna System Installations. By John B. Ledbetter	18
Plug-In TV Booster. By Jack Grand	22
Ser-Cuits (Continuous and Turret-Type TV Tuners). By M. W. Percy	24
Service . . . The National Scene	15
Servicing Helps. By M. A. Marwell	44
Ten Years Ago in Associations	49
Tubes News (Vertical-Deflection Amplifiers). By L. M. Allen	42
Views and News. By Lewis Winner	13

AUDIO INSTALLATION AND SERVICE

Application of Damping to Phono Arms	30
Audio Definitions	34
Non-Directional Mike Design	32
Preamp Design	32
Portable-Type Players	32

CIRCUITS

Auxiliary B-Power Supply	40
Belmont Vertical and Horizontal Circuits Altered for Color TV	20
Belmont 7-Inch Electrostatic-Tube Vertical and Horizontal Sawtooth Generators	20
Blocking Oscillator with Switch for Color Pickup	69
Concertone 1401 Tape Recorder (Cover)	36
Concertone 1401 Tape-Recorder Power Supply	36
Emerson TV Chassis Continuous-Type Front End	26
Emerson TV Chassis Turret Tuner	24
Hallicrafters T-54 Revised for Color TV Operation	21
Hallicrafters T-54 Vertical and Horizontal-Sweep Circuits	20
Impedance Meter Setup for Capacitance Testing	38
Phono Reproducer Arm-Pickup Cartridge Circuitry	30
Plug-In TV Booster	22
Raytheon TV Chassis Continuous Tuner	26
RCA 630TS Dual-Frequency Synchrolock Horizontal-Scan Circuit	69
RCA 9T246 Dual-Frequency Synchroguide Scanning Circuit	79
RCA 9T246 Modified for Color	68
Stromberg-Carlson TV Chassis Gain-Reduction Modification	44
Sylvania 1-387 Revision for Vertical-Trace Suppression	45
TV Color Circuitry Modifications	21
VTVM Designed for Leakage Testing	38

COVER

Magnetic Tape Recorder (Concertone 1401)	36
--	----

SERVICING HELPS

Admiral Service Aids:	
Elimination of Intermittent Contacts on Color TV Socket	47
12H6 Substitutions	47
15.75-KC Radiation Control	47
Air-King Chassis Hum and Buzz Removal	47
Electrostatic-Tube Focusing	44
Packard-Bell Alignment Notes	46
Sentinel Horizontal-Hold Improvements	47
Stromberg-Carlson Service Notes:	
Correcting Picture Bending	46
Interlace Improvements	46
Removing Buzz or Whistle in HV Supply	45
Sync Modification to Eliminate Picture Pulling	46
Westinghouse V-2171/2172/2176/2177 Tube Substitution Charts	46

Index to Advertisers

Manufacturers	80
Jots and Flashes	80
News	62
New Parts . . . Tools . . . Instruments	60
Rep Talk	58
TV Parts . . . Antennas . . . Accessories	50



Entire contents Copyright 1951, Bryan Davis Publishing Co., Inc.

Published monthly by Bryan Davis Publishing Co., Inc.

52 Vanderbilt Avenue, New York 17, N. Y.

Telephone MURRAY Hill 4-0170

Bryan S. Davis, Pres. Paul S. Weil, Vice-Pres., Gen. Mgr. F. Walen, Sec. A. Goebel, Cir. Mgr.
Mid-West Representative: Stuart J. Osten, 333 N. Michigan Ave., Chicago 1, Ill. Telephone: Dearborn 2-3507
East-Central Representative: James C. Munn, 2253 Delaware Dr., Cleveland 6, Ohio. Telephone: ERLEW 1-1726
Pacific Coast Representative: Brand & Brand, 1052 W. Sixth St., Los Angeles 14, Calif. Tel.: Michigan 1732
Suite 1204, Russ Building, San Francisco 4, Calif. Telephone: SUTTER 1-2251

Entered as second-class matter June 14, 1932, at the Post Office at New York, N. Y., under the Act of March 3, 1879. Subscription price: \$2.00 per year in the United States of America and Canada; 25 cents per copy. \$3.00 per year in foreign countries; 35 cents per copy.

**GET THIS
REVISED**

*up-to-the
minute*

TUBE MANUAL NOW!



*"New durable
plastic
fiber cover!"*



*New snap-open
loose-leaf binder...
makes it easy to
add new tube
data sheets*

Yours for **\$2.00**

Offers complete reliable tube data . . . required by radio and television technicians and electronics engineers.

In these days of television, new tube types are introduced nearly every week. Here at last is a tube manual that will keep you always up-to-date.

It's the 8th edition of Sylvania's famous "Technical Manual" in the same convenient 5½" x 9½" size BUT WITH A BRAND NEW PLASTIC FIBER COVER AND SNAP-OPEN LOOSE-LEAF BINDING.

More than 80 new tube types have already been added to this new 8th edition, including all current TV picture tubes.

Typical pages show tube base diagrams, give physical specifications, ratings, typical operation data and curves, application and design details. Tubes listed in numerical order for quick, easy reference.

Bound in durable plastic

New, convenient loose-leaf plastic binder enables this

manual to open easily and lie flat on your bench. Quick, snap-open feature permits insertion of additional data sheets. These sheets . . . already punched for your book . . . are periodically mailed to you FREE as inserts in "Sylvania News," Sylvania's free monthly magazine.

Your Sylvania Distributor has these Manuals NOW. Get your copy from him today or mail the coupon with \$2.00 for each copy ordered.

Here are just a few of the New Tube Types added to the 1951 Manual

OA3	6AS6	6BG7	25W4
IN60	6AX6	12AU7	1274
5AX4	6BA5	12BN6	5642
6AB4	6BF7	19BG6	5692
6AJ5	6BQ7	25AU5	5719

Sylvania Electric Products Inc.
Department R-2608-A
Emporium, Pa.

Enclosed please find \$2.00 for a copy of the new Sylvania Technical Manual.

Name _____

Street _____

City _____ Zone _____ State _____



SYLVANIA



IN TUNE WITH THE TUNER!

NEW...IMPROVED

"STANDARD
TV
BOOSTER"

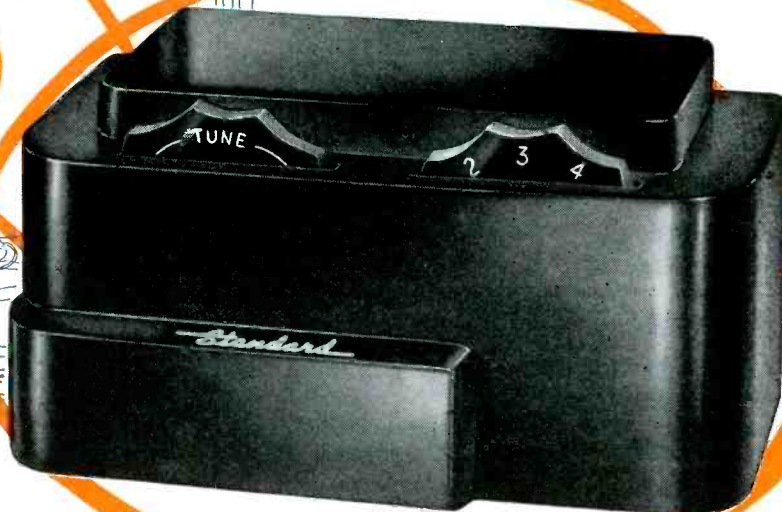

MODEL B-51

Millions of "Standard Tuners"

Now In Use

Used by over 75
TV Set Manufacturers



The new "Standard Booster" will increase the TV signal strength to a degree that will make possible "city" reception in areas remote from the TV transmitter. It reduces the "snow" or noise and interference to give a clearer, sharper picture and improved sound reception. It also makes possible receiving a picture in very remote areas or "blind" areas in close-to-transmitter locations where the TV set alone will not — makes a TV set a real enjoyment!

SEE US AT THE
PACIFIC COAST
SHOW

Standard COIL PRODUCTS CO. INC.
CHICAGO • LOS ANGELES • BANGOR, MICH.

To Servicemen... Who want to protect their future in Television Servicing

MEN who are interested in continuing their careers as TV service technicians and desire to increase their earnings, will find the information in this page calls for serious thought—and for action.

Your future, the future of your business in television servicing depends on what you do about it.

LICENSING OF SERVICEMEN IS A GOOD REASON WHY YOU SHOULD ACQUIRE TECHNICAL KNOWLEDGE NOW

In New York City, it is proposed that licenses and permits be required of TV contractors, subcontractors, service shops, technicians and apprentices. Once licensing becomes law in New York City this requirement is sure to spread to other municipalities. Licensing and permits mean passing a technical examination. Stiff penalties are cited in the licensing bill upon conviction of a violation. The required technical knowledge can easily and quickly be learned through study of the RCA Institutes Course in Television Servicing. One of the advantages of the RCA Institutes Course, to you as a working serviceman, is that you can study this course at home, in your spare time, and still keep working on your regular job. Now is the time to prepare for license examinations and protect your future in TV servicing.

TELEVISION SERVICING IS SPREADING TO NON-TV AREAS

The Federal Communications Commission recently announced plans for setting up 1,807 new TV broadcasting stations, most of them in the new UHF channels. This will open up areas that have never been touched by television. Radio servicemen in those locales should take a

lesson from servicemen in areas now served by television. In these areas, TV servicing has substantially replaced radio servicing as a means of income. Practical experience in radio servicing is not the important qualification for a successful and profitable career in TV servicing. Practical radio experience *plus* the technical training of the RCA Institutes Home Study Course in Television Servicing, will put you on the right track to be successful in TV servicing.

PRACTICAL, PRE-TESTED DATA MAKES TV SERVICING EASY

The RCA Institutes Home Study Course in Television Servicing is a "down-to-earth" course in the underlying principles of television. It is printed and illustrated in easy-to-understand, non-mathematical language. You learn pre-tested "How-to-do-it" techniques interwoven with "How-it-works" information. The course is based on the actual experience of the RCA Service Company in servicing thousands of home television receivers. You learn the "short-cuts" in TV trouble-shooting that enable you to do a good job in less time, saving you many hours of on-the-job labor. *This up-to-the-minute course contains material on the latest developments in color TV and UHF.*

APPROVED BY LEADING SERVICEMEN'S ASSOCIATIONS

Such well-known associations as—National Appliance & Radio Dealers Association; Television Contractors Association; National Alliance of Television & Electronic Service Associations—are already using the RCA Institutes course for upgrading the standing of their members. *Tell the Secretary of your local or State association to write us for low rates for group enrollment.*

RCA Institutes conducts a resident school in New York City offering day and evening courses in Radio and TV Servicing, Radio Code and Radio Operating, Radio Broadcasting, Advanced Technology. *Write for free catalog on resident courses.*



RCA INSTITUTES, INC.
A SERVICE OF RADIO CORPORATION OF AMERICA
350 WEST FOURTH STREET, NEW YORK 14, N.Y.

Send for FREE BOOKLET

Mail the coupon—today. Get complete information on the RCA INSTITUTES Home Study Course in Television Servicing. Booklet gives you a general outline of the course by units. See how this practical home study course trains you quickly, easily. Mail coupon in envelope or paste on postal card.

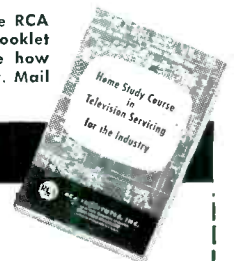

MAIL COUPON NOW!

RCA INSTITUTES, INC.
Home Study Department, S-851
350 West Fourth Street, New York 14, N.Y.

Without obligation on my part, please send me copy of booklet "RCA INSTITUTES Home Study Course in TELEVISION SERVICING." (No salesman will call.)

Name _____ (Please Print)

Address _____

City _____ Zone _____ State _____

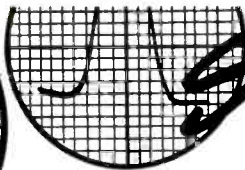
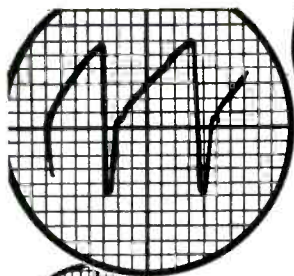

See YOUR ANSWER

WITH THE

PRECISION ES-500A

HIGH SENSITIVITY—WIDE RANGE

5" OSCILLOSCOPE

PUSH-PULL VERTICAL AND HORIZONTAL AMPLIFIERS

20 MV PER INCH "V" SENSITIVITY—150 MV PER INCH "H" SENSITIVITY

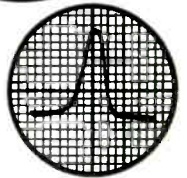
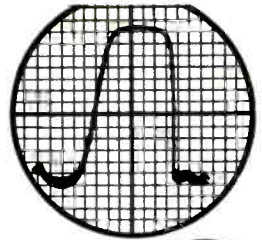
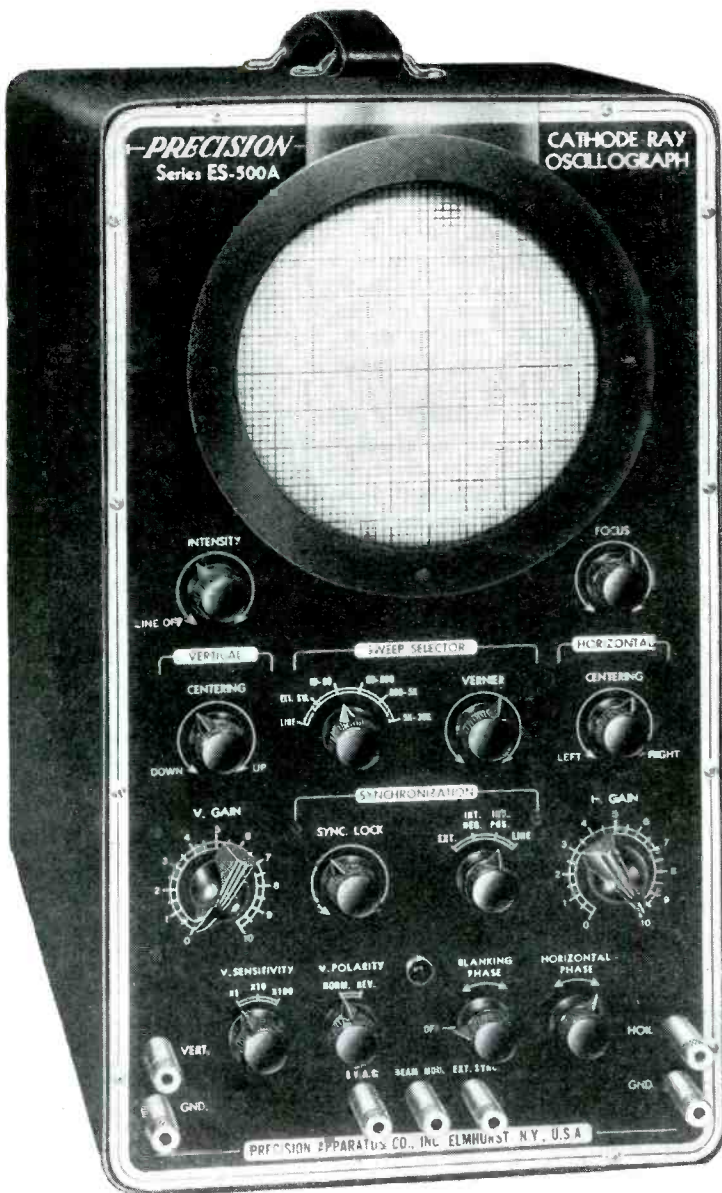

SERIES ES500A affords the ultimate in performance, visibility and operational flexibility at moderate cost. "Precision" engineers have incorporated every necessary basic feature which they have found to be required to meet the needs of the rapidly advancing art of electronics, A.M., F.M., and TV.

The new Series ES-500A provides an unparalleled combination of high sensitivity, extended frequency range and other essential operating features specifically desired for experimental and commercial visual circuit analysis.

SUMMARY OF IMPORTANT FEATURES

- * **High Sensitivity, Extended Range, Voltage Regulated Push-Pull Vertical Amplifier**—20 MV (.02 V) per inch deflection sensitivity. 10 cycles to 1 MC response. 2 megohms input resistance. Approx. 22 mmd. input capacity.
- * **Frequency Compensated Vertical Input Step Attenuator**—X1, X10, X100 plus continuous variable gain control in cathode follower input stage.
- * **Vertical Phase-Reversing Switch** permits inversion of all patterns at will. Non-frequency discriminating.
- * **Extended Range, High Sensitivity Push-Pull Horizontal Amplifier**—150 MV (.15 V) per inch high deflection sensitivity adequate for most all "H" drive purposes. 10 cycles to 1 MC response at full gain. 1/2 megohm input resistance. Approx. 20 mmd. input capacity.
- * **Linear Multi-Vibrator Sweep Circuit**—10 cycles to 30 KC plus line and external sweep.
- * **Amplitude Controlled, 4-Way Synch. Selection**—Internal Positive, Internal Negative, External and Line.
- * **"Z" Axis Modulation** input facility for blanking, timing, etc.
- * **Internal, Phasable 60 cycle Beam Blanking** for elimination of alignment retrace, clean display of synch. pulses etc.
- * **Sweep Phasing Control** for sinusoidal line sweep usage. Wide angle bridge circuit.
- * **Direct H and V Plate Connections** and Audio Monitoring phone jacks at rear. All four plates accessible.
- * **High Intensity CR Patterns** through use of adequate high voltage power supply with 2X2 rectifier.
- * **The Circuit and Tube Complement**—6C4 Vertical input cathode follower. 6CB6 first "V" amplifier. 6C4 "V" phase inverter. Push-Pull 6AU6's vertical CR driver. 7N7 first "H" amplifier and phase inverter. Push-Pull 6AU6's horizontal CR driver. 7N7 Multi-vibrator internal linear sweep oscillator. 5Y3 low voltage rectifier. 2X2 high potential rectifier, VR-150 voltage regulator. SCPI/A CR Tube.
- * **7 Four-Way Lab. Type Input Terminals**—Take banana plugs, phone tips, bare wire or spade lugs.
- * **Light Shield and Mask** removable and rotatable.
- * **Extra Heavy-Duty Construction** and components to assure "Precision" performance.
- * **Heavy Gauge, Etched-Anodized, No-Glare, Aluminum Panel.**
- * **Fully Licensed** under Western Electric Co. patents.

* **Series ES-500A** in louvered, black ripple, heavy gauge steel case. Size 8 1/4" x 14 1/2" x 18". Complete with light shield, calibrating mask and instruction manual.
NET PRICE \$169.50

See the new ES-500A Oscilloscope on display and available at leading Radio Parts & Equipment Distributors.

AM • FM • TV



PRECISION APPARATUS CO., INC.

92-27 Horace Hording Boulevard, Elmhurst 6, New York

Export Division: 458 Broadway, New York, U.S.A. • Cables—Morhanex
In Canada: Atlas Radio Corp., Ltd., Toronto, Ontario

Convenient "PRECISION" Purchase Terms can be arranged with your local favorite authorized "PRECISION" Distributor.

AM • FM • TV

MERIT

Merit TV full-line* Components For Conversion or Replacement

MDF-30—new 70° "full focus" distributed winding "cosine" yoke—complete with network. For direct drive tubes up to 24".



HVO-8—air core "flyback" for direct drive systems.



BURTON BROWNE ADVERTISING

Merit TV full-line* Components For Conversion or Replacement

Merit... HQ for TV Service Aids

Keep ahead of TV conversion and component replacement service problems — write MERIT . . . HQ for TV Service Aids. . .

Ask for your free copy of MERIT TV Repl. Guide; Merit 1951 Complete Catalog No. 5111; Merit Auto Vibrator Transformer Dealer Sheet and Repl. Guide, No. 3; Merit Output Transformer Chart, No. 4; Merit TV Booster & Repl. Guide No. 6. Write: Merit Transformer Corporation, 4425 North Clark Street, Chicago 40, Illinois.

These 3 Merit extras help you:

Exclusive: Tapemarked © with specs. and hook-up data.
Full technical data packed with every item.
Listed in Sam's Photofacts.

*Merit is meeting the TV replacement component and conversion demand with a line as complete as our advance information warrants!

*“I want to see
Americans save . . .”*



JOHN L. COLLYER
President, The B. F. Goodrich Company

“I want to see Americans save for their own personal security, and I want to see them, as stockholders in our government, urge economy in all phases of our national life in order to provide national security against aggression.”

By their rapidly mounting participation in the Payroll Savings Plan, Americans are saving for their personal security, fighting the menace of inflation and making a major contribution to America's defense against aggression. In Mr. Collyer's own company 80% of the 38,000 employees throughout the company have already enrolled in the Plan, with two large divisions still to report.

As Chairman of the Ohio Payroll Savings Advisory Committee, Mr. Collyer knows what is being accomplished by leaders of industry, top management and labor in their joint effort to step up the Payroll Savings Plan. A few recent figures should be interesting to those not so familiar with the national picture:

- In the steel industry campaign, Carnegie-Illinois Steel Corporation (now U. S. Steel Company), recently raised its payroll participation from 18% of 100,000 employees to 77% . . . Columbia Steel Company of California went from 7.9% to 85.2% . . . American Bridge Company signed 92.8% of the workers in the large Ambridge plant . . . 87%

of Allegheny-Ludlum Steel Corporation's 14,000 employees are now on the Payroll Savings Plan . . . Crucible Steel Company of America, reinstating its plan, signed up 65% of its 14,500 employees.

- In the aviation industry, Hughes Aircraft Company went from 36% to 76%; Boeing Aircraft enrolled 10,000 new names before Christmas.

Some dollars and cents figures? In the last quarter of 1950, sales of \$25 E Bonds—the denomination so popular with payroll savers—increased 2.5% by 245,000 bonds more—over the last quarter of 1949.

If you do not have The Plan That Protects the personal security of your employees, the national economy and our country's defense, phone, write or wire to U. S. Treasury Department, Savings Bonds Division, Washington Building, Washington, D. C. Your State Director is ready to help you install a Payroll Savings Plan or step-up your employee participation.

The U. S. Government does not pay for this advertising. The Treasury Department thanks, for their patriotic donation, the Advertising Council and

S E R V I C E



it's revolutionary!

The New

du mont

*Selfocus
Teletron*

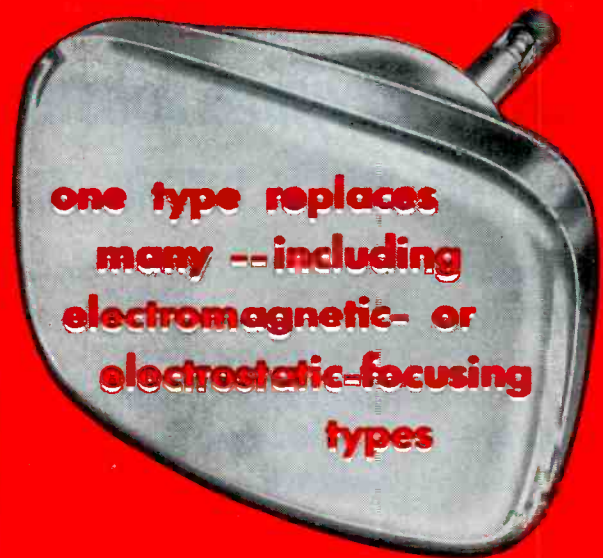

write for complete information:
CATHODE-RAY TUBE DIVISION,
ALLEN B. DU MONT LABORATORIES, INC.,
CLIFTON, N. J.

DU MONT
*Teletrons**



MODEL TVB-2B

The New Improved NATIONAL TELEVISION BOOSTER MAKES THIS MUCH DIFFERENCE!

The new, improved National Television Booster adds a true stage of RF amplification to any TV set.

If the signal is low, but perceptible, this booster will greatly increase brightness, contrast and definition — open up whole new areas to good TV reception! Housed in a smart metal cabinet finished in special wear-resistant mahogany enamel.

\$39.95 list

COMPARE THESE FEATURES:

- (1) Turret tuner with individually-tuned set of coils for each channel. (2) Removable polystyrene coil-mounting contact panels. (3) A single 6AK5 for maximum gain with minimum noise level.
- (4) Built-in power transformer (not AC-DC). (5) Selenium rectifier for long life.
- (6) Fine tuning control in addition to channel selector. (7) Pilot light illuminates selected channel.



HOW RMS HI-GAIN * TRANSMISSION LINE HELPS YOU SELL SETS!

With new improved RMS HI-GAIN LINE, clear television pictures can be obtained where normal line losses might otherwise deteriorate reception.

This means your *fringe area prospects*, for whom TV reception has been unpractical, can now get signals through the Hi-Gain line *with virtually no loss!*

In these installations, Hi-Gain is comparable in cost to 300 ohm twinex. Thus Hi-Gain helps you overcome the main deterrents to set ownership in extreme fringe areas.

*Reg. TM—Hi-Gain Line, Cat. No. HG 450 is an improved open transmission line with a steel core within the copper wire, to prevent stretch and breakage of the line.

Loss is 1/6 that of 300 ohm twinex.

Ask your jobber for RMS HI-GAIN LINE—or for complete details write:

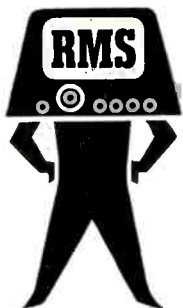

RADIO MERCHANDISE SALES, INC.

1165 SOUTHERN BOULEVARD • NEW YORK 59, NEW YORK

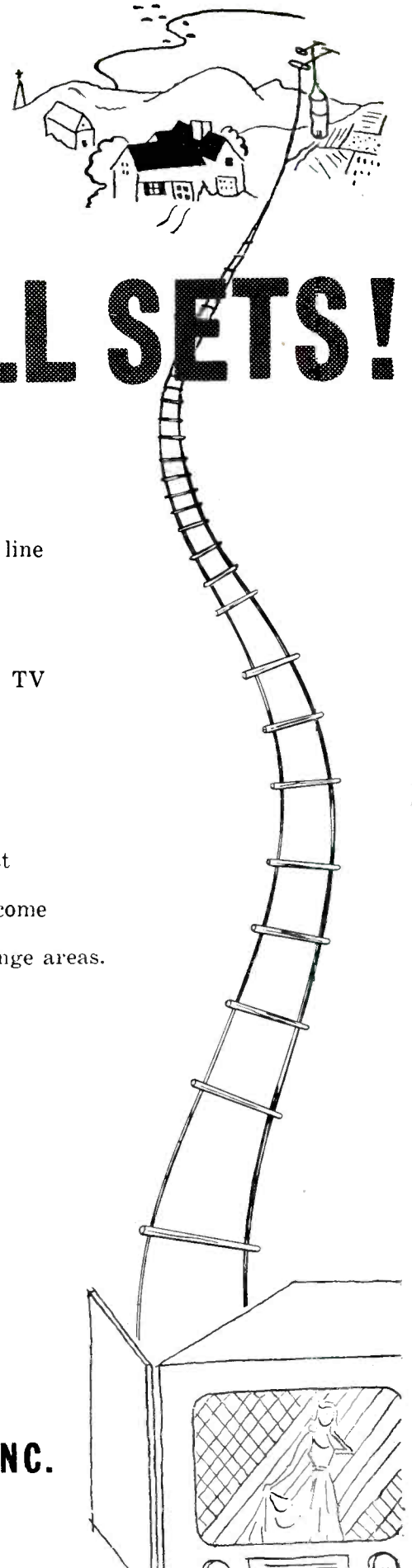



You're Out, Pop!

**The New RAYTHEON TV Picture Tube Warranty Policy
Fans Father Time for Distributors and Service Dealers**

RAYTHEON TELEVISION PICTURE TUBES are warranted for 6 months from the date they are installed in the customer's Television set!

This means that a Raytheon Tube Distributor or Service Dealer can stock Raytheon Picture Tubes now without fear that the warranty will expire while the tube is in stock.

**HERE'S HOW THIS EASY TO USE RAYTHEON
TUBE WARRANTY POLICY WORKS!**

Upon installation, a Tube Warranty Registration card (see picture) is filled out and

mailed to RAYTHEON. That's all the Dealer has to do. RAYTHEON records the necessary data and mails a Tube Registration Certificate to the user. Tubes in use less than 6 months failing to give satisfactory service are returned to RAYTHEON with the warranty certificate and receive immediate adjustment.

Add this simple, easily operated Tube Warranty Policy to the superior quality of Raytheon Television Picture Tubes and you'll readily realize why the combination means *no more tube warranty trouble for you.*



Right for Sight!



RAYTHEON MANUFACTURING COMPANY

Receiving Tube Division

Newton, Mass., Chicago, Ill., Atlanta, Ga., Los Angeles, Calif.

Excellence in Electronics

RADIO AND TELEVISION RECEIVING TUBES, CATHODE RAY TUBES, SPECIAL PURPOSE TUBES, SUBMINIATURE TUBES, MICROWAVE TUBES

COPYRIGHT 1951



New Horizons for TV

WITH DOUBLED and in, some instances, tripled and quadrupled power grants raced by the government's ether guardians to dozens of stations throughout the land, as the first step in a freeze-lift program, providing sparkling new viewing areas for hundreds of thousands around the country, and the telephone service company announcement that there'll be east-to-west television service in the early fall, one of the brightest phases of the sight-and-sound era now looms ahead for every Service Man.

The higher powers, already allotted to many popular stations in metropolitan areas, have spread viewing possibilities to thousands of communities who had about given up all hope of seeing airplane pictures, until perhaps the ultrahighs came their way. As a result, countless new trading areas have appeared, providing brimming opportunities. Many resourceful Service Men have already struck out to survey these new sites and prepare for the installation of the assortment of antennas and accessories, such as towers, boosters and rotators, that will be required in many locations.

Some of the boys have prepared extensive direct-mail campaigns to enlighten future purchasers on the fascinating aspects of viewing in their own home. In some instances, there have been suggestions for personal visits to permit discussions of not only installation costs, but the location of the antenna; preliminary steps which have been found in the past to eliminate those hours of delay, so annoying when the receiver arrives and everyone is so anxious to look and listen.

In many towns, Service Men and dealers have combined their efforts to sell television to the new fringe spots, dealers supplying Service Men with the names of prospects so that they can follow up the shop demonstration and assist in bringing the sale to a

close. The Service Man's complete familiarity with the technicalities involved in TV pickup have always been quite helpful in providing the right answers to those knotty questions buzzing around every home. During such visits it is always possible to study the room in which the receiver might be placed, and the roof, window or backyard where the antenna will eventually have to be set up. Detailed comments on these important points are always welcomed by prospective buyers, particularly if he can be assured that reception in his house will be satisfactory.

Where the Service Man is not too familiar with a terrain, and thus might be in doubt as to the pickup possibilities within the area, portable setups have been found very effective in evaluating field-strength conditions. As a matter of fact, many Service Men have adopted the field-strength-judgement approach as a basic technique, to be employed in all pre-installation surveys. The instruments are compact, lightweight, and can provide the required information very quickly. The use of this equipment also serves as a medium of impression, not only because of its intriguing appearance, but because of the professional manner in which it is used, and the accurate answers it provides.

Not only has the increased power created new fields of activity in the fringes, but in areas close by the transmitter, where it has been found the supergain can drench some of the circuits with too much signal. As a result, there have been complaints of picture pulling or tearing, erratic operation of the brightness and contrast controls, blooming, etc. Thus, Service Men have found themselves quite busy modifying circuits to remove the faults caused by excessive signal. Incidentally, many set manufacturers have begun to issue bulletins

with circuit alteration data designed to cure these rather odd conditions. Some of these suggestions appear in this issue in the *Servicing Helps* section, and many others are scheduled to be published in the near future.

In New York City, the shifts to high power and the operation of several stations from one tower, created another new activity for the Service man, involving not only the problem of too much gain, but of antenna re-orientation. The trouble was caused by a shift in transmitting towers several blocks, from a northeast to a southwest position. This situation will probably become increasingly acute when two more stations in this area also begin transmitting from the tallest building in the country.

A National Problem

While this condition is currently a New York City problem, it will become one of national import as other stations alter their tower positions, either to a multiple antenna site or elsewhere in an effort to improve reception. Orientation will be quite important not only to the setowner, but to the broadcaster, too. The Service Man who is alert and follows these trends very carefully will be in a position to serve his community and establish himself even more firmly as a technical specialist in his home town.

The Coast-to-Coast Plan

The coast-to-coast program which will provide links to Denver, Salt Lake City and San Francisco, will provoke a stirring national interest, and arouse even greater enthusiasm for viewing, an enthusiasm which will mean increased set sales and more installation and service work.

Truly, there are bustling days ahead, teeming with new horizons in TV, for all Service Men.—L.W.



*These three braves
scalp TV Capacitor
problems!...*



SANGAMO'S TV TRIO

Used as original equipment Tops for replacement needs

Sangamo offers three top television capacitors that you can use with confidence. You'll like these tested, *proved* performers for their quality, their small size and their stability.

The **REDSKIN** is a plastic molded paper tubular that is easy to work with—on production line or on the bench—because its strong, tough casing stands rough handling and the flexible leads can't pull out! It gives long life at 85° operation.

The **CHIEFTAIN** is a dry electrolytic that fits anywhere! Tiny, but durable, it is ideal for application in tight spots beneath a chassis. Bare tinned-copper wire leads make it easy to mount. Maintains uniform capacity when subjected to heat and high ripple currents.

The **SIoux** is a 6,000 volt paper television capacitor with a new standard of permanence. Designed to withstand continuous operation at 85° C, it is mineral oil impregnated to provide longer life and more stable performance over a wide range of operating temperatures.

A trial of these replacement capacitors will convince you. See your Jobber . . . if he can't supply you, write us.



Your Assurance of

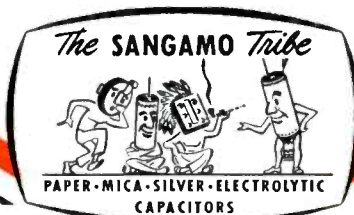

Dependable Performance

SANGAMO ELECTRIC COMPANY
SPRINGFIELD, ILLINOIS

IN CANADA: SANGAMO COMPANY LIMITED, LEASIDE, ONTARIO

9C30-7D

SERVICE...The National Scene

GENERAL SERVICING LICENSING BILL FAVORED BY PENNSYLVANIA SERVICE MEN--Over 3000 members, representing nine chapters of the Federation of Radio Servicemen's Associations of Pennsylvania, voted unanimously recently to support legislation, which would license radio and TV Service Men. According to the measures, presented before the General Assembly, at least two years of on-the-job activity, or an equivalent in school training, would be generally required to qualify for license-exam registration. Many may not have to take the exam, however, if they can produce properly documented evidence of knowledge and training, plus two years of experience, which would be equivalent to the standards "normally evidenced by successful passing of the exam." However, cites the bill, should it become necessary, the board may, at its discretion, still require a petitioner to take an exam within the 2-year period. A fee of \$25.00 has been set as the charge for the examination. Any applicant who shall fail to pass the first exam, may take additional tests on payment of a \$15.00 fee. License renewals, granted yearly, will cost \$15.00. Fees for registration as an apprentice shall be \$5.00. The bill also stipulates that all employers of service personnel will have to register with a special licensing board, and in addition, these employers will be required to pay an annual registration fee of \$10. Applicants or licensees whose licenses are refused, suspended or revoked by the board will have, according to the bill, 30 days in which to appeal to a court of common pleas, where the matter shall be heard without a jury, the action of the court being final. Those violating any provisions of the measure will be subject to a fine of not less than \$25 and not more than \$100. In default of payment of these fines and court costs, the bill provides for a jail sentence of not less than 30 days and not exceeding 90 days. . . . In a subsequent issue of SERVICE, a comprehensive review on all of the bill's provisions will be published.

FCC PROBING COMMON-CARRIER ASPECTS OF COMMUNITY ANTENNAS--Believing that the new crop of community antennas, providing pickup of stations beyond the normal receiving range, actually may be a common-carrier service, thus operating as an interstate medium, the FCC have begun to survey the situation. Some members of the Commission have indicated that the feeding of signals to receivers on a subscription basis may be a hired service and accordingly subject to government regulation. Others have voiced the opinion that the system is nothing more than a means of extending coverage, providing pickup to those who individually could not afford to set up the required super-sensitive antenna-amplifier system. Thus far, community-antenna provisions have been included in nearly 20 areas in Pennsylvania, about half a dozen in New York, several in California, Maryland, Maine, Kentucky, West Virginia, Tennessee, Arkansas and Texas. Manufacturers are particularly keen about the advantages offered by the mountain-top antennas; noting that it provides them with new market areas.

NON-PROFIT TV SERVICE PLAN INITIATED--A unique plan, described as a non-profit venture, in which Service Men will work on consumers' receivers at cost, has been introduced in Brooklyn, N. Y. The scheme provides for an annual membership fee of \$10, payable by the consumer, for service rendered at a Service Man's rate of pay, plus expenses. The cost schedule, issued by this non-profit group, indicates a charge of \$2.35 for a home service call; \$2.85 per hour for shop labor; \$3.90 per hour for antenna and installation. Parts used on service and installation will be sold at a 20 per cent discount to members of the plan. Those who join the group, it is said, receive a decal, to be applied to the set, disclosing the date of entrance into the plan, service expiration date, the set's serial number, etc. According to the organizers of the idea, the preliminary response has been very encouraging.

SERVICE...The National Scene

FACTORY-GUARANTEED TV-SERVICE-CONTRACT PLAN ACCEPTANCE GROWING--Service contracts between the consumer and the plant, offered through dealers in conjunction with TV service contractors, with fees paid directly to the factory, who in turn compensates the installer when he returns contract coupons received in payment for calls, are reported becoming quite popular. In the method, originated by Sylvania, which incidentally is known as the pay-back plan, 1-year and 90-day contracts are available. The 90-day contract can be converted to a 1-year affair at the owner's option, at any time previous to the expiration of the 90-day contract. The conversion can be made by application to the factory and the remittance of an amount equal to the difference between the 90-day rate and the 1-year rate, plus a \$2.00 conversion fee. On expiration date, any unused coupons are redeemable in cash by the plant in accordance with rate schedules. It is said that maximum refunds have been as high as 42 per cent of the entire service-contract cost. According to the Sylvania procedure, if it is necessary to provide more service calls than the coupons issued permit, no charges are made, provided a defective condition exists warranting such calls. Ninety-day contracts are being sold at \$26.00, with 2 coupons available for service calls. The 1-year contract, selling at \$55.00, contains 5 service-call coupons. Both of these cover table-model sets. Console-combination contracts are \$6.00 more for the 90-day agreement with 3 service-call coupons, and \$12.00 more for the 1-year contract, plus a total of 7 service-call coupons.

W.U. TO SERVICE ALL SETS--An announcement from Western Union Services has disclosed that their recently introduced service department is now set up to install and service all standard makes of TV receivers. The present servicing territory has been extended to include Bergen and Hudson counties, and accordingly will cover five of the largest counties in northern New Jersey. According to W.U., service calls will be answered regardless of whether or not the setowner has a contract with the company. For nights and Sundays, a telephone answering service will be used to receive and relay calls to the service center for action on the following business day.

MILWAUKEE TV SERVICING LEGISLATION NOW BEING STUDIED--TV Service Men of Milwaukee may soon be required to obtain a certificate from a licensing committee to operate their shops, according to a recent ordinance submitted to the Common Council. Stiff fees of from \$100 to \$500 have been suggested as the cost of the license, a price which has been bitterly criticized as exorbitant by many local and national groups. Members of one association declared that licensing in Milwaukee is unnecessary since legitimate operators are completely cognizant of their responsibilities and are making every effort to carry them out. Fly-by-night shop owners are gradually disappearing, and a strong conscientious group of operators are now in the majority, the association spokesman announced. It is expected that the City Council, which is now in summer recess, will offer its reply to the proposed legislation as soon as it convenes in the early part of September.

TV-FM ANTENNA SAFETY MEASURE HANDBOOK--An extremely informative booklet describing the recognized electrical and fire code standards which should be followed in the installation of TV and FM antennas, has just been released by the National Fire Protection Association in Boston. Detailed are specifications for grounding, lightning arresters, and the proper mounting of single, stacked, rotary and master antennas. A detailed report on this timely report will appear in an early issue of SERVICE. Watch for it!--L. W.

Take off the *blinders* and **EAT** again!



ANCHOR BOOSTERS

make it possible!

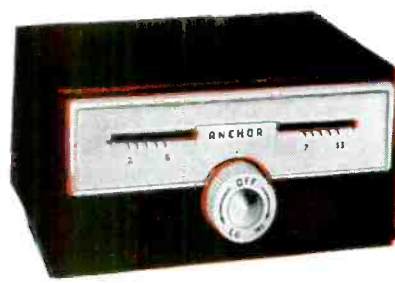

THE ANCHOR *Suburbanite*
For Intermediate Reception

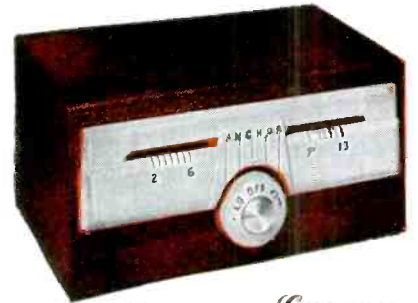

THE ANCHOR *Granger*
For Fringe Arc Reception

ANCHOR RADIO CORP.
2215 SOUTH ST. LOUIS AVENUE • CHICAGO 23, ILLINOIS

Master-Antenna

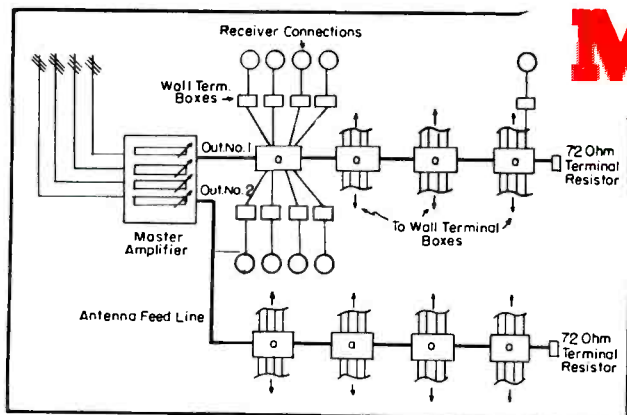

Analysis of Methods Used in Installing Multiple-Receiver Links in Apartment Houses, Garden-Court Developments, Hotels, Stores, etc.

(Above, left)

Fig. 1. General layout of apartment-house antenna system. In this plan each terminal box is shown feeding both 72-ohm and 300-ohm receivers without a matching transformer. It is recommended that RG59/U coax cable be used to connect both types of receivers to the outlets. The reduction in noise pickup and radiation will be found to more than offset any mismatch. Since the lead from the distribution box (a) to the receivers is only 4' to 10', the drop in transfer efficiency will be very slight. (Courtesy Jerrold)

(Left)

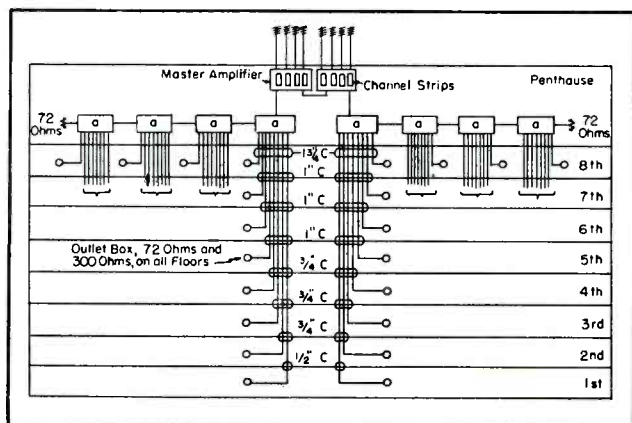

Fig. 2. Centralized system fed through coax to apartments. (Courtesy Jerrold)

UNTIL RECENTLY, one of the most difficult problems confronting the independent Service Man has been the installation of TV antennas in hotels, apartment buildings, and other multiple dwellings. While the usual practice of installing a separate antenna for each receiver involved is certainly acceptable in duplex homes or small apartments, serious problems often occur when this practice is applied to larger building installations.

Grouping of several antennas on a common roof has been found to cause element interaction between antennas, reradiation pickup from adjacent antennas, loss in long lead cables, violation of local safety laws or fire ordinances, and the possibility of extensive property damage due to installation procedure, subsequent storms, etc.

Element interaction between a number of adjacent antennas has been found to change the characteristic impedance, operating efficiency, and field patterns to such an extent that serious picture degradation has resulted. This has been particularly noticeable when the affected antenna is adjusted to a weak or high channel station.

Reradiation interference can be caused by the particular position or orientation of one or more antennas. (This condition has been found to be prevalent in localities where channels 2 and 5, 3 and 6, 7 and 11, or 9 and 13 are assigned and where one or

more of the receivers concerned has a strong tendency toward oscillator radiation).

Ghosts can occur when strong reflected signals from nearby objects are deflected from a certain antenna in the group. This trouble often is difficult to locate or correct, since the short time element between the direct and reflected signals may be such that no appreciable image displacement can be seen. Instead, the result usually is loss of sharpness or picture definition.

Since the only practical place for the antenna is on the roof or highest projection of the building, the length and efficiency of the lead-in must be considered. While line losses are of little or no consequence in receivers situated near the antenna location, they assume major proportions in lower-floor locations because of the long lead-in (and usually circuitous route) required to reach the receiver. Noise, hum pickup, excessive mismatch, and high-signal loss are factors which must be eliminated in these cases.

The possibility of *property damage*, especially in buildings equipped with slate, shingle, or metal roofs has been found to increase in direct proportion to the number and size of antennas, masts, guy wires, etc. A maze of antennas on an apartment roof or hotel not only detracts from its appearance but often, in a large number of com-

munities, is in direct violation to safety regulations, fire codes and building ordinances. In addition, such installations increase the owner's liability risk and often result in his reluctance or flat refusal to permit any type of roof-top installation to be made.

The Master TV Antenna System

The installation of a master antenna system, whereby all receivers in the building are fed (through suitable distribution boxes) from a high-gain antenna system, has been found to be a practical solution to the foregoing problems.

At present, there are several types of master TV distribution systems in general use¹. The systems normally employ a master antenna, master amplifier, channel amplifier strips (one for each desired station), and receiver distribution boxes.

Planning the Installation

To guarantee a perfect installation, it is necessary to make a careful analysis of the building plan. If the realtor or building superintendent has no copy of the original plan, one can be drawn up with reasonable accuracy, showing

¹Jerrold, Taco, RCA, Lynmar, Electric-Voice, etc.

System Installations

by JOHN B. LEDBETTER

Engineer, WKRC-TV

the location and number of master amplifiers, distribution boxes, receiver outlet boxes, conduit or leaders, etc. In this way, much time and effort, not to mention costly changes and oversights, can be avoided.

There are seven major factors which must be kept in mind when drawing up the block diagram: (1) antenna and antenna location; (2) location of master amplifier; (3) type and length of downlead; (4) location of the receiver distribution boxes; (5) length of cables connecting these boxes to each apartment; (6) the location and relative distances of each receiver terminal box, and (7) the size and length of conduit sections.

In Fig. 1 appears the general layout of an apartment-house system.² This basic diagram can be applied to

elevator-type buildings, hotels, hospitals, garden court developments, etc., and can be modified, if necessary, to meet dealer and department store requirements.

In this layout, four separate yagi antennas are shown, for illustration, each being cut for one particular channel to insure maximum efficiency. (The number of antennas depends, of course, on the total number of TV or FM stations desired or available in your community). The antennas may or may not be mounted on the same mast, depending on whether the maximum strength from each channel is received at the same point on the roof. The antennas to a master amplifier³ shielded 72-ohm coax cable connects to a master amplifier³ which includes four channel amplifiers⁴. The signals of

all stations received are mixed in the output of the master amplifier and fed over two feed lines to the various antenna distribution outlets.

Locating the Master Amplifier

In fringe or weak-signal locations where it is absolutely necessary to keep the antenna downlead as short as possible, the master amplifier must be mounted on the roof, penthouse, or top floor of the building (as close to the antenna as 115-volt power supply will allow). If the equipment is installed on the roof, it must be protected by a weather-proof dog-house. In local or strong-signal areas, the master amplifier can be installed closer to the receivers, as long as the downlead does not exceed the recommended lengths indicated in Fig. 4. In all cases, the amplifiers must be located in a well-ventilated spot. Installation of the equipment in a closet or other closely confined area must be avoided.

In some installations, all of the amplifiers and distribution equipment can be centralized and connected to various apartments by coax cables. A typical example of this procedure appears in Fig. 2, representing an installation in a 64-unit 8-story Long Island apartment house. For reception of all New York TV stations, eight antennas were used, four on each mast. Two master amplifiers were mounted on the inside of the fire-tower wall and interconnected. Since the total distance between the antennas and any distribution box did not exceed 500', RG59/U cable could be used throughout. Eight distribution boxes also were mounted inside the fire-tower wall. All leads, from the distribution boxes to receiver terminal boxes, were run through conduit, the conduit size decreasing from 1 1/4" to 1/2" as the number of cables going from the eighth floor to ground decreased.

In other installations, the master amplifier can be mounted on the roof, in a penthouse, or on a middle floor of the building, with the antenna distribution boxes located on each floor. In garden court developments, such as the one shown in Fig. 3, (a 36-

(Continued on page 76)

²Designed for Jerrold Mul-TV system.

³Jerrold MC-1.

⁴Jerrold CA.

Fig. 3. A garden-court master-antenna installation. (Courtesy Jerrold)

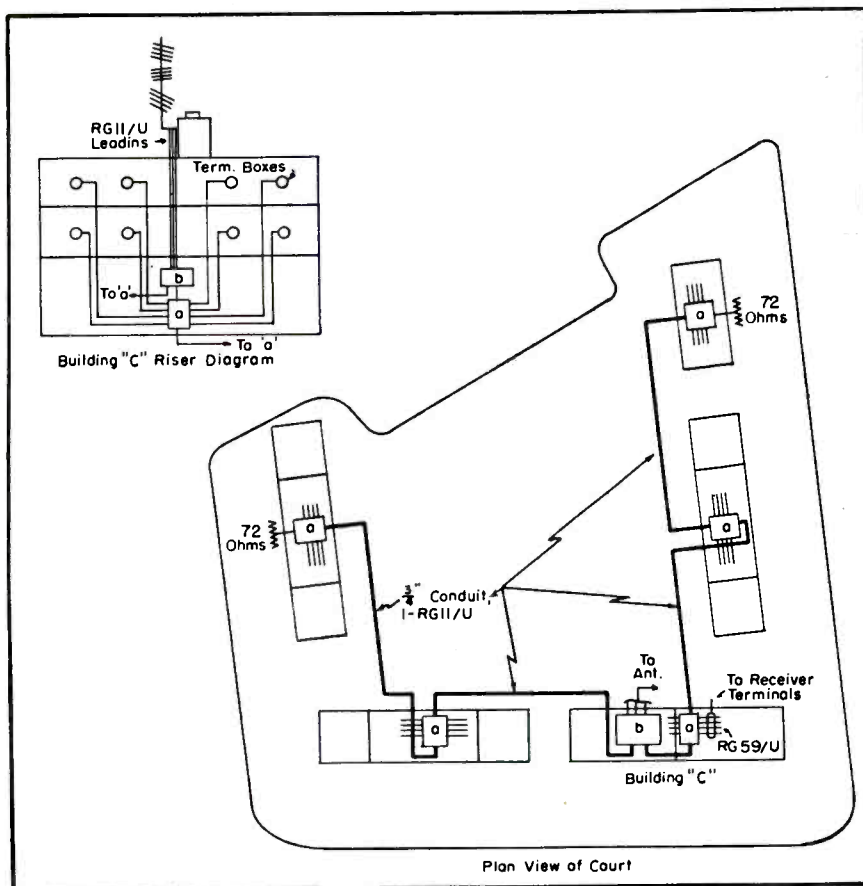

COLOR

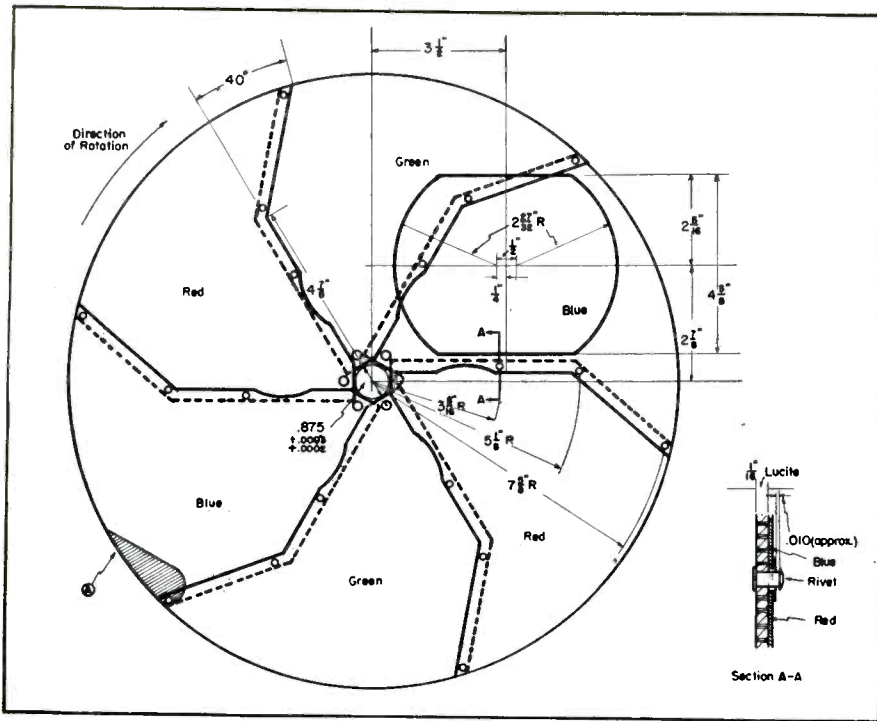

Detailed drawing for 15½-inch color disc. Area represented in *A* may be used for counterweights phased 60° apart near side. Filters are normally mounted on far side, with overlap as shown in *AA*. Two types of plastic filter material are recommended by CBS: 1/16" high-temperature plexiglas or boillable lucite; produced by Monsanto (filter *E* for all colors or 4/3 density No. 61 for green) and Eastman-Kodak (½ density No. 47 for blue and No. 26 for red).

IN CONVERTING a monochrome receiver for CBS color, it is necessary to be familiar with the problems and limitations involved in the alteration. First, it must be remembered that the quality of color pictures at present cannot be compared with black and white reproduction, as far as bright-

ness, size and detail are concerned. In color receivers substantial light is lost by absorption in the color filters. Secondly, the mechanical apparatus used to recombine the various colors is limited in size for mechanical reasons, thus limiting the size of the set to be converted. Third, there is

some loss in the detail obtainable with the disc color system, because of the 405-line system involved.

In sets with electromagnetic deflection and flyback transformers there are additional technical problems. The complexity of the entire horizontal sweep circuit requires an altered switching arrangement. The flyback transformers and yokes in the standard monochrome receivers are designed to operate most efficiently at a horizontal frequency of 15750 cps, and will not work as well at the new 29160 cps level.

Conversion Procedure

The smaller electrostatic receivers will be found to be the easiest types to convert. The smaller size screen is more suited to the use of a color wheel. Electrostatic deflection also avoids the problems connected with the horizontal driving circuits, when the horizontal frequency is changed from 15750 to 29160 cps. In most sets, the timing for the vertical and horizontal sweep frequencies is determined by some form of a blocking oscillator or multi-vibrator. Either one of these two types of circuit runs at a frequency lower than desired, and they are synchron-

Fig. 1 *a* and *b*. Vertical sawtooth generator used in the Belmont 7-inch electrostatic type chassis is shown in *a*. The horizontal sawtooth generator used in this model appears in *b*.

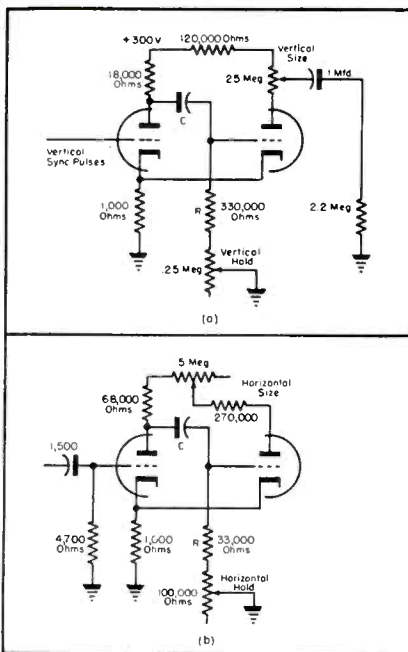

Fig. 1 *c* and *d*. Belmont chassis vertical (*c*) and horizontal (*d*) circuits altered for disc system pickup.

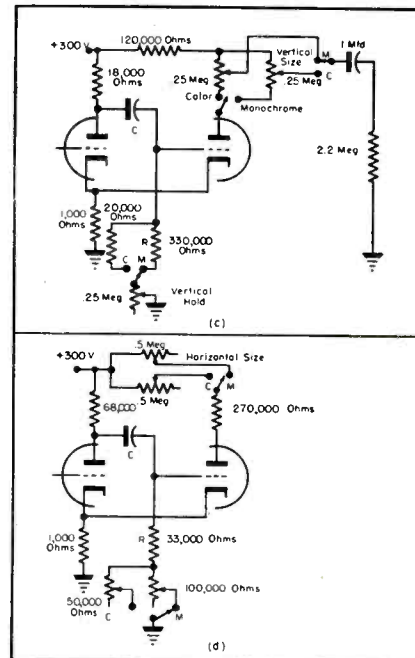
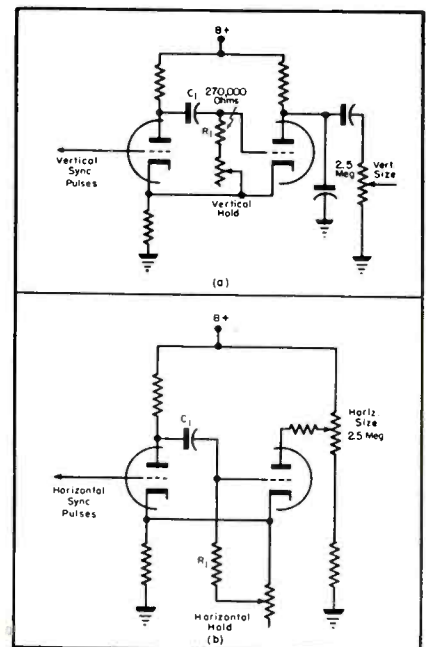

Fig. 2 *a* and *b*. Vertical (*a*) and horizontal sweep (*b*) circuits used in the Hallicrafters T-54 chassis.



TELEVISION

by PHILIP SELVAGGI

Part II... Circuit Changes Involved in Converting Electrostatic and Electro-magnetic-Type Receivers to Color-Wheel System for Black and White, and Color Pickup.

ized by the incoming vertical or horizontal sync pulses.

In both of these circuits the circuit element which controls the frequency is usually a combination of resistor and capacitor. An increase in the resistor-capacitor combination will decrease the sweep rate, while a decrease in the values of this rc combination will result in an increase in the sweep rates. In the color-wheel scheme the vertical sweep has to be brought from 60 cps to 144 cps, an increase of 2.4 times. The rc combination in the ver-

tical circuit for black and white reception thus becomes 2.4 times the value of the rc combination required for color. In the horizontal sweep circuit this rc value has to change by approximately $29160/15750 = 1.85$, when switching from color to black and white.

In making a conversion it will be necessary to provide a separate switching arrangement.

Then, a new set of rc time constants will have to be installed. The ratio of the black and white time constants to the color time constants should be approximately 2.4 for the vertical and 1.85 for the horizontal. The size controls usually have sufficient range for color and monochrome presentation, so that it will be sufficient to duplicate the existing size control. Fortunately, there is a great deal of similarity in many of the timing circuits which do not use *afc* circuitry.

Examples of Electrostatic Conversions

A typical horizontal and vertical oscillator, used in a Belmont 7" receiver, is illustrated in Fig. 1. In this case the frequency determining rc combination consists of a 1-mfd capacitor and potentiometers. For conversion, a switch with dual hold and size controls must be incorporated. Resistors limit the highest frequency obtainable from this circuit. In the color position the resistor's value becomes much smaller so that the multivibrator can operate at the higher frequencies required by color.

Whenever a change is made from the lower to the higher sweep frequency the amplitude of the sweep voltage usually decreases. Under these circumstances the picture will be smaller and the size control will have to be adjusted. To avoid the inconvenience of adjusting the size control with program selection, dual size con-

trols must be provided with a switch. A trouble which may arise, when changing amplitude in this fashion is that of non-linearity. If a set has a linearity control it would be wise to incorporate dual linearity controls operated by a third part of a ganged switch.

Another conversion example appears in Fig. 2; vertical and horizontal sweep circuits of a Hallicrafters T54. In this chassis the timing of the vertical and horizontal sweeps is deter-

(Continued on page 68)

(Left)

Fig. 3 *a*, *b* and *c*. Circuits illustrating color-system changes required: In *a*, capacitor value has been altered to change sweep frequency; sweep frequency modification appears in *b*, with frequency-limiting resistance being changed; hold-control alteration to change sweep frequency appears in circuit in *c*.

(Below)

Fig. 4. Suggested changes in Hallicrafters T-54 vertical (*a*) and horizontal circuits (*b*) for color-wheel operation.

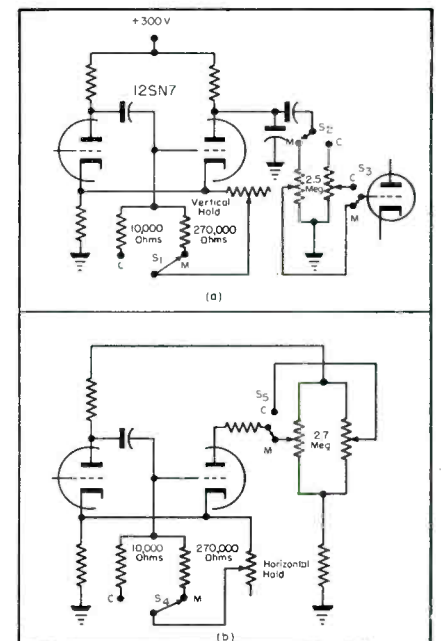
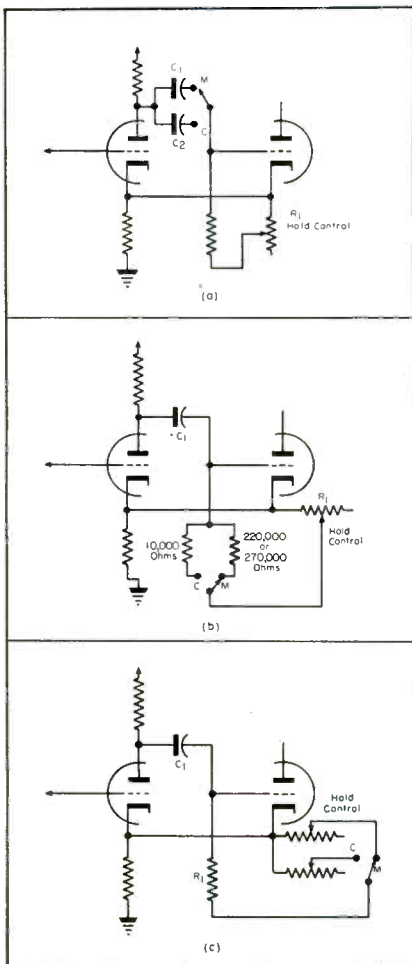

Plug-In TV Booster

by JACK GRAND

One-Tube Unit, Installed in TV Chassis, Can be Used to Provide Additional IF Stage to Video or Sound System.

Fig. 1 (left): Typical booster installation. The lower tube represents the original stage in receiver, while the upper one is the added booster stage.

BOOSTERS OR PREAMPS, originally considered to be, at best, experimental accessories whose definite values were problematical, have completely shed this doubtful status, and proved themselves extremely useful and reliable members of the TV family, and in a versatile manner. In the main, boosters have been found necessary where the TV sets could not compensate for some of the conditions that cause poor reception. Some of these problems have been found to be the fault of the chassis. However, the bulk of the difficulties have been found to be due to poor locations and poor antenna installations. Specifically, boosters have

been designed to correct some of the following conditions:

- (1) Weak signals, and the corresponding need for greater *rf* sensitivity in areas of weak signal (such as fringe areas) or poor antenna facilities (such as indoor antennas and lack of antenna height).
- (2) Lack of gain in older sets.
- (3) Poor noise figure in the first *rf* stage. In some cases the signal-to-noise ratio can be appreciably improved by the boosters.

Two types of boosters have been developed to correct some of the fore-

going difficulties; tunable and automatic, the latter striving to achieve automatic operation and concealed installation.

Recently, there has been developed a plug-in type booster¹, that actually adds an *if* stage to either the video or sound section of the TV set. A view of this booster, installed, appears in Fig. 1; the lower tube is the one originally used in the set, while the upper tube is the new additional stage. No rewiring of the socket is required, a plug serving as a duplicate of the replaced tube. Plate and screen supply voltage is obtained from the former screen connection. The output is coupled to pin 5, as in the instance of the original single tube. All other components are connected to the upper socket.

Fig. 2. Circuit of the plug-in booster. Gain of the tube is added in cascade.

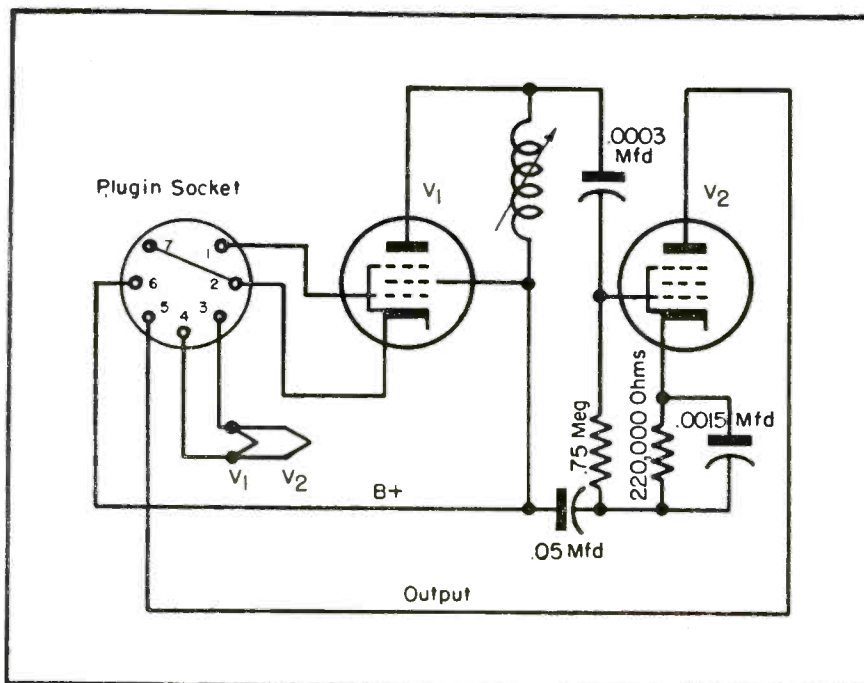

Since the booster represents an *if* stage, it is not necessary to tune it each time different channels are selected by the set. It is automatically turned on and off, with the other tubes. Further, it is a concealed installation.

If the filaments of a TV chassis are hooked up in parallel, then a 6AG5, 6AU6, or 6BC5 can be used. If the filaments are hooked up in series, then either a 6BH6 or a 6BJ6 can be used.

Great care has to be exercised in the placement of the ground lead. Where oscillation occurs, the booster should be shielded by placing it inside a metal shield. This metal container can be either a partial or a total shield. Adding a stage to the *if* strip will cause the overall bandwidth to be decreased, a result which may be found objectionable in some installations. In many trial tests made, the narrowed

¹Grayburne.

(Continued on page 55)

Snyder
PHILADELPHIA

Directronic*

MOTORLESS

TV AERIAL SYSTEM

360° ELECTRONICALLY SWITCHED BEAM

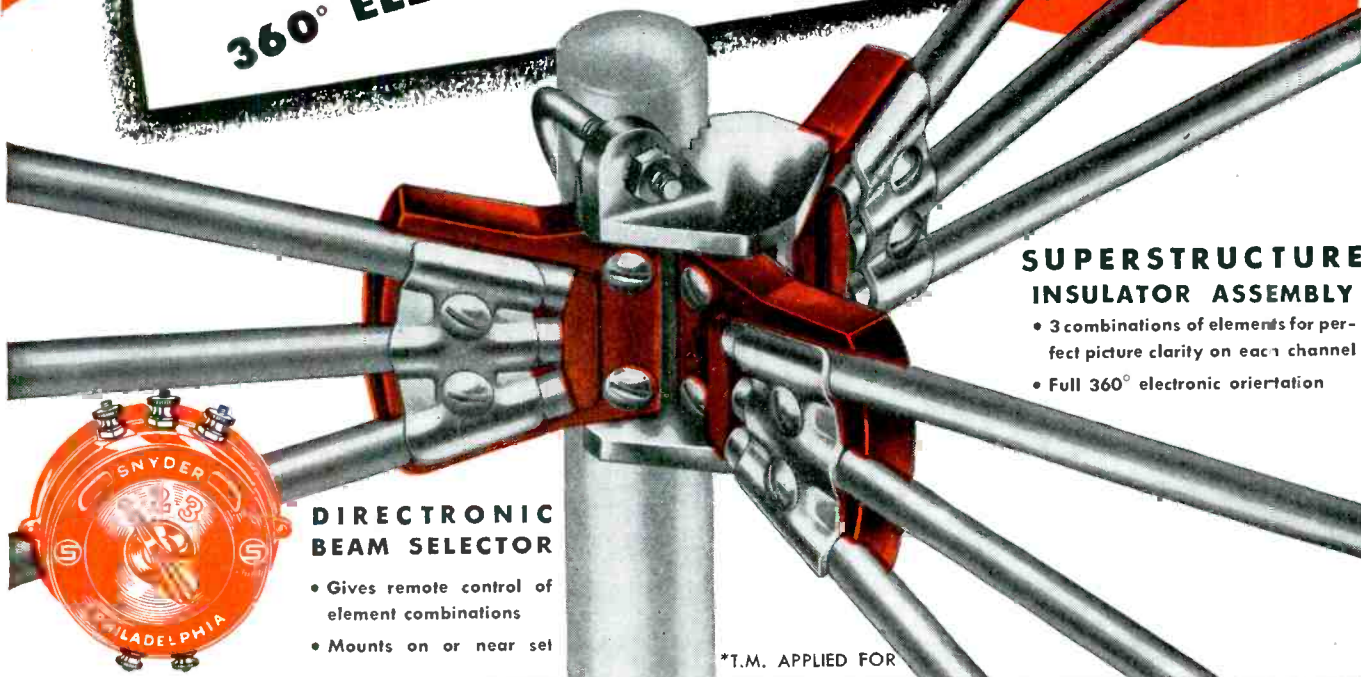

SUPERSTRUCTURE INSULATOR ASSEMBLY

- 3 combinations of elements for perfect picture clarity on each channel
- Full 360° electronic orientation

DIRECTRONIC BEAM SELECTOR

- Gives remote control of element combinations
- Mounts on or near set

*T.M. APPLIED FOR

<p>NO MOTORS OR MOVING PARTS</p>	<p>NO ROOF ORIENTATION</p>	<p>NO ELECTRIC POWER</p>	<p>NO GHOSTS</p>
---	---	---	-----------------------------

SNYDER MFG. CO.

ANTENN - GINEERS

PHILADELPHIA 40 • U. S. A.

EXPORT : ROBURN AGENCIES, INC., NEW YORK 7, N. Y.

P. S. ONLY ONE LINE TO INSTALL

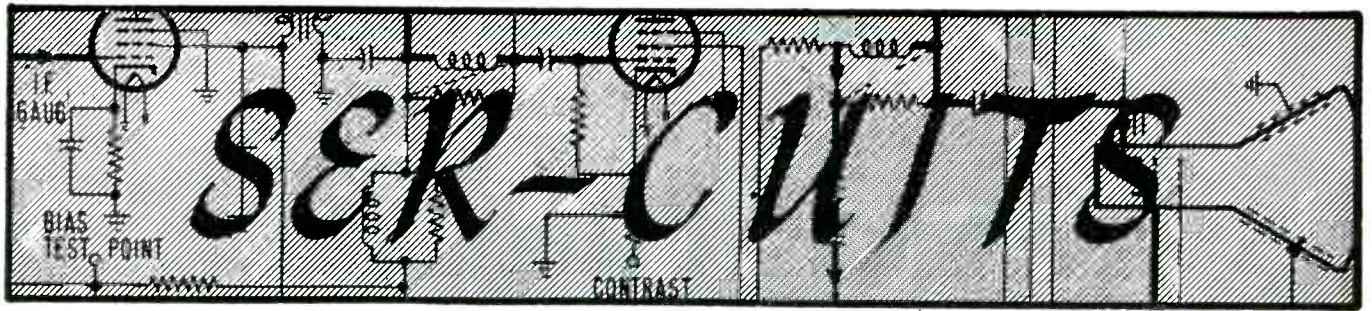

by M W . P E R C Y

Analysis of Circuitry Used in Continuous and Turret-Type TV Chassis Tuners.

IN THE DEVELOPMENT OF CHASSIS for standard broadcast, FM or TV, the input section has always been a focal point of interest, since it is here that the all-important signal gain factor can be initiated. In all systems, the tuning techniques have played a major role, providing a means of amplification adjustment, coupling control and frequency selection. In TV, two types of tuning have been favored; continuous and turret. Some chassis lines have featured use of one type in one run and the other in other models.

In the Emerson chassis, for instance, there are sets using continuous type or capacity-tuned TV tuners (470662), covering channels 2 through 6 in the first (*lo*) range and 7 through 13 in a second (*hi*) range. To facilitate tuning, a certain amount of additional coverage above the highest and below the lowest tunable channel in

each range is provided. A two position switch, actuated by a knob concentric with the fine tuning shaft, is used to switch all circuits.

Two tubes are employed in the system: a 6CB6 *rf* amplifier and a 6J6 oscillator-mixer.

A four section 180° rotation gang capacitor is used for tuning, a mechanical drive ratio of approximately 5 to 1, being provided between the main tuning and the gang shaft.

Four circuits are tuned in both ranges: antenna, *rf* plate, mixer grid, and the oscillator plate-grid. A split stator design is incorporated in the gang section used for tuning the oscillator. All circuits track continuously through both the *hi* and *lo* ranges.

The overall *rf* response from the antenna terminals to the mixer grid is determined in each range by the combined selectivities of a single tuned

antenna circuit and a double tuned over-coupled interstage transformer circuit.

The antenna stage transformer consists of a tuned secondary suitably coupled to a primary designed to match a 300-ohm line. In the *lo* range the entire secondary inductance is tuned. In the *hi* range, by means of a tap, only a part of the secondary inductance is tuned in conjunction with a suitable inductance shunt. The primary is common to both the *hi* and *lo* ranges. An electrostatic shield is provided between the primary and secondary to minimize the asymmetrical capacitance coupling which generally impairs the balance to unbalance response of an antenna input system.

Two overcoupled double-tuned interstage transformers are provided, one for the *lo* and a second for the *hi* range. In each transformer low side mutual inductance is employed to pro-

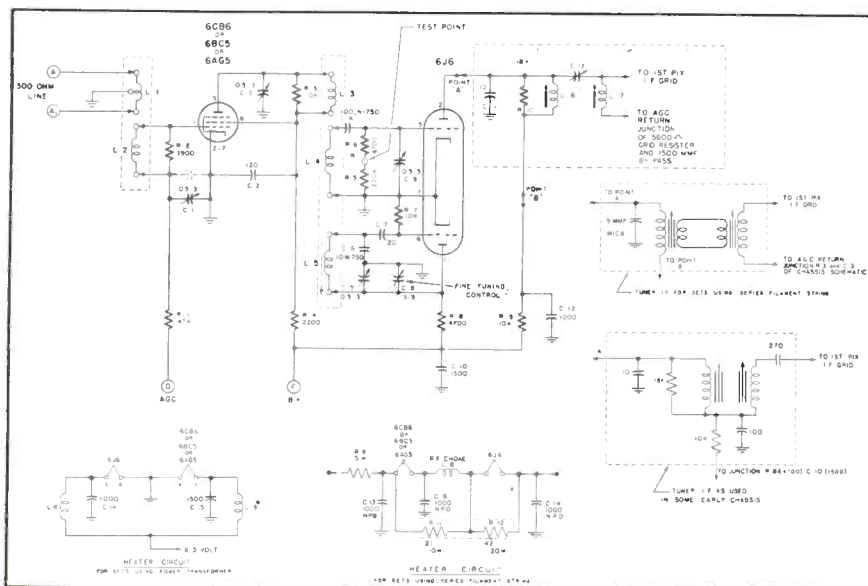

(Left)

Fig. 1. Schematic of turret-type tuner used in Emerson TV models.

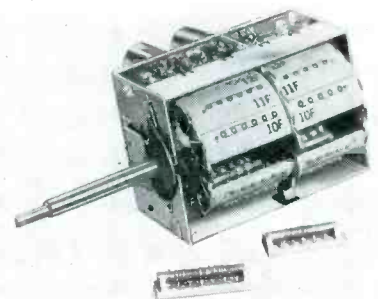
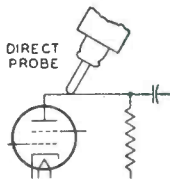

Fig. 2. Standard type turret tuner, similar to unit diagrammed in Fig. 1, which can be adapted for *uhf* reception, by removing *vhf* coil segments illustrated in foreground and replacing with ultrahigh assemblies.

Now...a NEW Junior VoltOhmyst* ...the WV-77A

For all regular measurements and specialized measurements as illustrated.



MEASURES AC VOLTS ... such as signal voltage on plate of af tube.

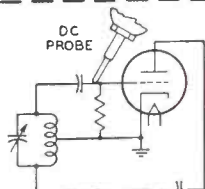

MEASURES DC VOLTS ... such as oscillator grid bias. One-megohm resistor in probe prevents circuit loading.

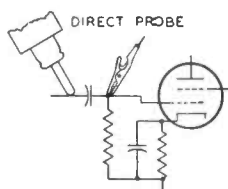

MEASURES RESISTANCE ... such as leakage in coupling capacitor up to 1000 megohms.



Just one probe cable and one slip-on probe handle all measurements.

Check these important features...

- ✓ Accurate laboratory calibration.
- ✓ Meter electronically protected against burn-out.
- ✓ Metal case shielding... extra stability in rf fields.
- ✓ Sturdy 200-microampere meter movement.
- ✓ Carbon-film 1% multiplier resistors... dependability plus.
- ✓ Zero-center scale... for discriminator alignment.
- ✓ Frequency response flat from 30 cps to approximately 3 Mc.
- ✓ High ac input resistance for greater accuracy.
- ✓ Constant dc input resistance... 11 megohms on all scales.
- ✓ Negative feedback circuits for greater over-all stability.
- ✓ Ohms cable always positive... for quick leakage measurements of electrolytic capacitors.
- ✓ Polarity reverse switch... eliminates cable switching.
- ✓ $\pm 3\%$ over-all accuracy on +dc scales, and $\pm 5\%$ on ac and -dc scales.

An all-electronic ac-operated vacuum-tube volt-ohmmeter by RCA ONLY \$47.50.

Includes DC probe, AC direct probe and cable, ground lead, and alligator clip.

The RCA WV-77A VoltOhmyst* provides the extra features you have tried to find in an inexpensive VTVM. Using the famous Volt-Ohmyst electronic bridge circuit, 200-microampere meter movement, and carbon-film multiplier resistors, the WV-77A incorporates features you would expect to find only in more expensive instruments. Sturdily built... calibrated against laboratory standards... and backed by a 12-month warranty... the WV-77A has the durability, versatility, and accuracy to please discriminating customers such as service technicians, engineers, amateurs, and military personnel.

As a DC Voltmeter it measures dc from 0.05 volt to 1200 volts in five ranges. Uses 1-megohm resistor in isolating probe; probe has less than 2-uuf input capacitance. Has 11-megohm input; useful for measuring high-resistance circuits such as oscillator, discriminator, and avc.

As an AC Voltmeter it measures ac from 0.1 volt to 1200 volts rms in five ranges.

Uses high-impedance diode tube as signal rectifier. Frequency range is more than adequate for measurement of power line, audio, and ultra-sonic frequencies.

As a wide-range Ohmmeter the WV-77A measures resistance from 0.2 ohm to 1 billion ohms in five ranges. Requires only 1.5-volt battery as burn-out protection in measuring such low-power elements as battery-type tube filaments.

The all-new RCA WV-77A VoltOhmyst comes completely equipped with probes and cables as illustrated. For complete details, see your RCA Test Equipment Distributor today... or write to RCA, Commercial Engineering, Section 56HX, Harrison, N. J.

Accessories Available on Order

The WG-289 High-Voltage Probe and WG-206 Multiplier Resistor extend the dc range of the WV-77A to 50,000 volts.

The WG-264 Crystal-Diode Probe extends frequency range of the WV-77A to 250Mc.

*Reg. U. S. Pat. Off.

Available from your
RCA Test Equipment
Distributor



RADIO CORPORATION of AMERICA
TEST EQUIPMENT
HARRISON, N. J.

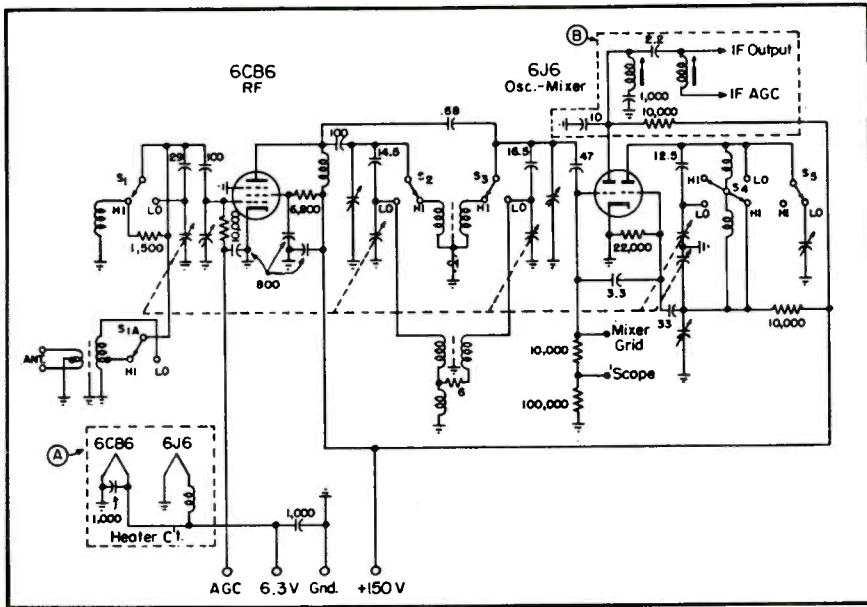

Fig. 3. Emerson TV set continuous-type front-end.

vide the coupling necessary to obtain the required bandwidth. A .68-mmfid high side coupling capacitor is employed to oppose the low side mutual inductive coupling and thereby minimize variations of bandwidth as a function of operation frequency.

In the tuner, a slight amount of inductance has been intentionally introduced in series with the screen bypass capacitor to neutralize partially the input grid conductance in the high channels, thereby reducing the loading on the antenna transformer secondary. The inductance takes the form of about $\frac{3}{8}$ " of wire in each connecting lead of the bypass capacitor.

The oscillator stage utilizes one triode section of the 6J6 in a stable low drift Colpitts circuit. Sufficient oscillator injection is provided to the mixer stage to accommodate power-line voltage fluctuations and variations in *B+* caused by *agc* action in normal receiver applications. The oscillator operates above the signal frequency in both ranges.

The mixer circuit uses the second triode section of the 6J6, its grid being tuned by a section of the gang capacitor.

Emerson Turret-Type Tuner

The turret tuner, employed in some Emerson models, contains the *rf* amplifier, converter, and oscillator stages. Tuning and tracking adjustments for all twelve channels currently in use are provided. The tuner serves to select, amplify, and convert to *if*, the desired signals. No separation of the intermediate frequencies is made, and the complete signal is fed to the first video *if* stage.

The tuner uses a rotary turret carrying individual coils for each tuned circuit, for each channel setting. A type 6AG5 (or 6BC5 or 6CB6) serves as the *rf* amplifier and a type 6J6 as mixer and oscillator. The *rf* amplifier is a wideband, tuned stage whose output is inductively coupled to the mixer. The oscillator operates in a Colpitts type circuit. Individual slugs provide for alignment of the oscillator of the various channels. A variable-dielectric type capacitor is used for fine tuning of the oscillator. The plate of the mixer is connected to a double-tuned first *if* transformer.

A center-tapped primary of the *rf* coil, is designed to match a balanced 300-ohm line. The secondary is tuned by the input capacity of the *rf* amplifier in series with the parallel combination of a trimmer and a fixed capacitor. In some tuners the fixed capacitor has been omitted and the

(Continued on page 28)

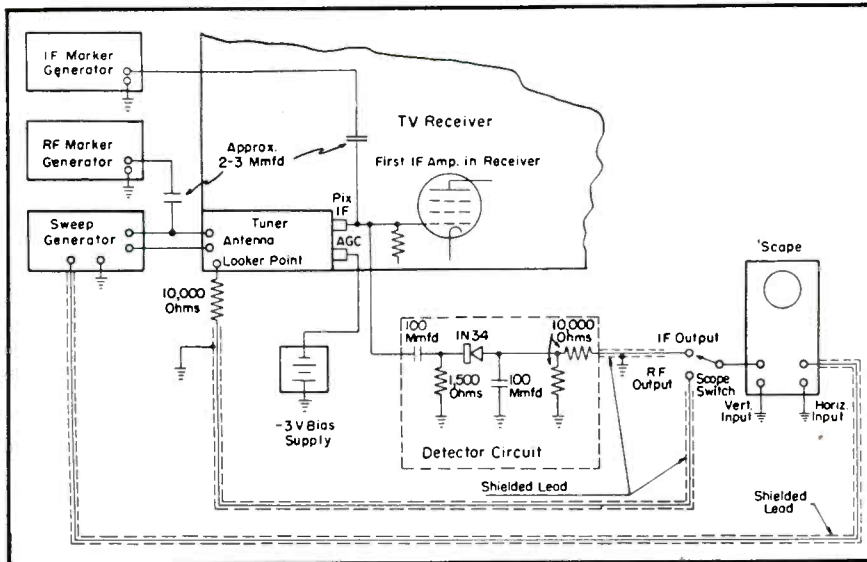
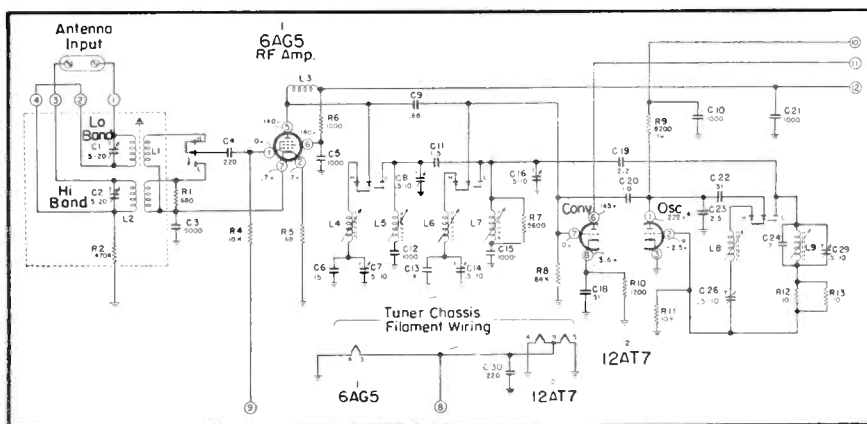
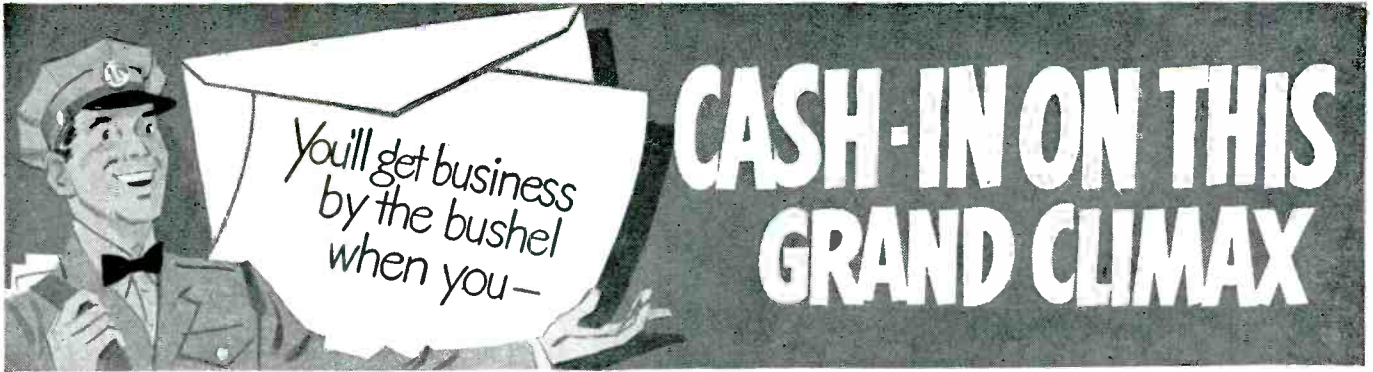

Fig. 4. Alignment setup for continuous tuner illustrated in Fig. 3

Fig. 5. Circuit at Raytheon continuous tuner.





CASH-IN ON THIS GRAND CLIMAX

of Sylvania's big brilliant campaign for Service Dealers

Now begins the second half of Sylvania's greatest and most appealing ad campaign ever offered to Service Dealers.

Featuring 2 famous celebrities, Paulette Goddard and Patrice Munsel, this campaign ties in with big ads soon to appear in the Saturday Evening Post, Lock, Life, and Collier's magazine, and is backed by the nation-wide weekly TV show, "Beat the Clock."

Everything included

Here's everything you need for a record harvest of fall service business. You get big, smashing life-like displays of the famous stars. You get counter cards, streamers, direct-mail pieces . . . even radio spot announcements.

Remember, you pay only one cent each for the mailing pieces. All the rest is FREE! So don't let another minute go by without calling your nearest Sylvania distributor . . . or mail the coupon NOW.

SYLVANIA

RADIO TUBES; TELEVISION PICTURE TUBES; ELECTRONIC PRODUCTS; ELECTRONIC TEST EQUIPMENT; FLUORESCENT TUBES, FIXTURES, SIGN TUBING, WIRING DEVICES; LIGHT BULBS; PHOTOLAMPS; TELEVISION SETS



Sylvania Electric Products Inc.
Dept. R-2608B, Emporium, Pa.

Please send me full details about Sylvania's great Fall 1951 Service Dealer Campaign.

Name _____

Street _____

City _____ Zone _____ State _____

Proved Combination for FINE TV RECEPTION

AMPHENOL

— IN LINE —*

ANTENNA

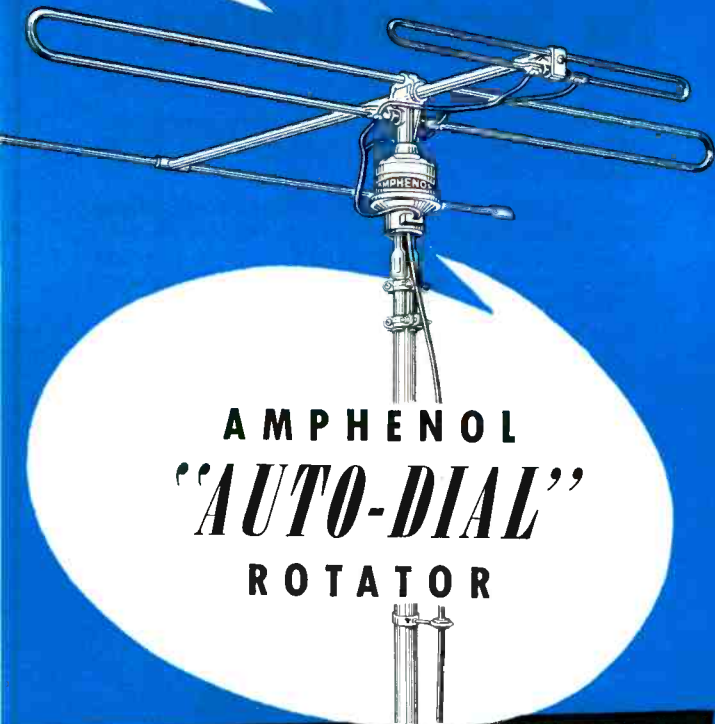

AMPHENOL
"AUTO-DIAL"
ROTATOR

*Reissue Pat. No. 23,273

There's nothing equal to it . . . for perfect picture reception . . . the performance-proven design of Amphenol's patented "In-line" Antenna and the Amphenol "Auto-Dial" Rotator. The proved combination for the ultimate in television reception.

BUT—don't wait until the Fall rush. Check your future needs now to insure the best equipment for Fine TV Reception. Specify Amphenol "In-line" Antenna and "Auto-Dial" Rotator . . . a proved picture quality combination.

AMERICAN PHENOLIC CORPORATION
1830 SOUTH 54th AVENUE • CHICAGO 50, ILLINOIS

AMPHENOL

Ser-Cuits

(Continued from page 26)

range of the trimmer increased proportionately. The output coil of the *rf* amplifier is also tuned by a trimmer, and the output capacity of the tube. The grid coil of the mixer ($\frac{1}{2}$ of a 6J6) is tuned by a variable capacitor and the input capacity. Both coils form an overcoupled circuit, with the output coil loaded with a 10,000-ohm resistor, to provide the proper band pass. The oscillator coil is wound on the same form as the output and grid coils to provide oscillator injection to the mixer grid. The initial oscillator frequency is fixed by permeability tuning of the oscillator coil and preset .5 to 3 mmfd trimmers. Frequency is varied by means of fine tuning controls (3 to 5 mmfd trimmer) which consists of a spiral shaped dielectric disc rotating between fixed stator plates.

Raytheon's Ray-Dial TV Tuner*

A continuous-type tuner is featured in Raytheon chassis. The tuner is a small separate sub-chassis, independent of the TV chassis, except for acquiring its filament and *B* voltage. The subchassis consists of two tubes performing as an *rf* amplifier (6AG5) and converter-oscillator (6J6 in some chassis and 12AT7 in others) separate high and low-band core-tuned coils, separate high and low-band trim-

*From manual prepared by Ken Kleidon, technical writer engineer, Belmont Radio Corp.

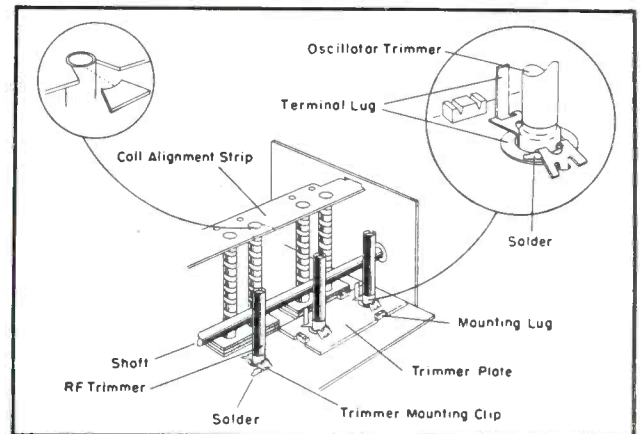
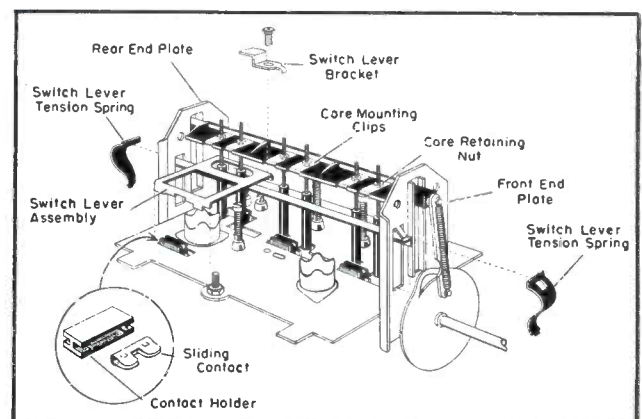

Fig. 6. Replacing coils and trimmers on Raytheon tuner.

Fig. 7. Switch-contact replacement on Raytheon continuous tuner.



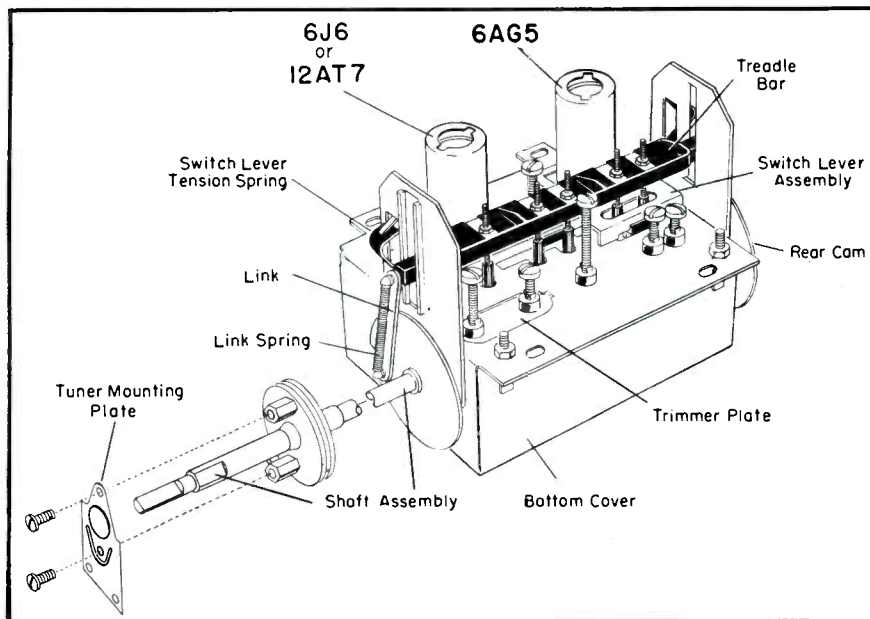

Fig. 8. Continuous Ray-Dial tuner used in Raytheon TV receivers.

mers and an automatic switching device to change bands.

The tuner is used in the present Raytheon 16, 17 and 20 inch receivers.

Raytheon Tuner Service Hints

After a tuner has been in operation for a considerable length of time, dust and dirt will accumulate especially at the points lubricated at the factory. These points will require lubrication to insure proper mechanical operation. Before lubrication is applied, these points should be cleaned with carbon tet.

Lubricant should be applied between: Rear cam and switch lever assembly; front cam and switch lever assembly; rear bushing and chassis frame; front bushing and chassis frame; rear end plate and chassis frame; front end plate and chassis frame; switch lever bracket and switch lever assembly; and discs of planetary mechanism.

Microphonic-Erratic Operation

Microphonic or Erratic Operation: A copper bonding strap connects the tuner frame to the TV chassis to eliminate the possibility of erratic or microphonic operation. The bonding strap should, if broken, be replaced or repaired. Loose tuner mounting screws or bottom cover nuts may also cause the same condition. Shaft end play or a bent cam may also cause erratic operation. A bent cam or end play may not produce enough leverage on

the switch lever assembly to permit proper switching.

Part-Replacement Rules

Replacing Parts: Since the tuner is small and compact and very high frequencies are involved, replacement of parts must be given very special attention. Substitution of parts is not recommended. Extreme care should be taken to insure obtaining the exact replacement part. When replacing components it is important to maintain the same lead length and dress the component in the same original position.

Trimmers can be replaced by first unsoldering the connecting leads to the trimmer. The trimmer mounting clips should be unsoldered from the chassis on the *rf* trimmers. The top spring of the trimmer mounting clip should be bent toward the trimmer insulation to allow removal from the bottom side of the chassis.

Soldering Trimmers

Trimmers should not be overheated with the soldering iron as the insulation material will melt.

When replacing trimmers, the trimmer body should be wrapped tightly with a damp cloth to prevent overheating while soldering. The bottom of the trimmer mounting clip must be soldered to the chassis on the *rf* trimmers and to the terminal lug on the oscillator trimmer.

Coils should only be replaced when damaged or when the ribbon is broken. A majority of suspected defective coils

can be repaired by placing a soldering iron at the coil solder connections to insure good connection. When replacement is necessary, the tuner shaft should be turned until the cores are as far out of the coils as possible. With a coping saw blade, the coil alignment strip should be cut out, very carefully. The coil should be grasped with pliers and carefully broken loose and removed. Glue should be scraped from mounting hole at chassis base. If necessary the bottom of the replacement coil should be filed to enable fitting in hole at chassis base. Then the coil should be carefully inserted and secured with glue at the outer sides of both the top and bottom ends. Coil leads should then be soldered to proper terminals.

Oscillator-Coil Replacement

If replacement of the high-band oscillator coil is necessary, it is important to be sure that the end of the coil with bunched or closely spaced windings is placed in the mounting hole at the chassis base.

Binding Causes

Lubricant should never be applied to the iron cores if they tend to bind in the coil. Binding is caused by either the core retaining nuts being too tight or because of glue between the core mounting clips and the core-retaining nuts.

Iron-Core Replacements

The iron cores, preset at the factory, have glue applied at the underside of the treadle bar between the core threads and the core mounting clips and at the top of the treadle bar between the core retaining nuts and the core threads. If the cores remain intact and are properly glued, no service is required. When replacement is necessary, it is important to be sure that the core retaining nuts are reinstalled and glue is applied at the proper points after core is properly adjusted. The core retaining nuts should not be tightened securely, tightening only enough to allow a slight amount of play between the core mounting clips and the treadle bar. Excess glue should be avoided and care exercised not to cement core retaining nuts to the core mounting clips or the core mounting clips to the treadle bar.

All the iron cores are colored at the bottom with paint, either white, orange, blue or brown. They must be replaced with the same color core.

AUDIO *installation and service*

Phono-Tape-Wire-PA-Amplifiers-Speakers

by KENNETH STEWART

Application of Damping to Phono Arms . . . Audio Definitions . . . Preamp Design . . . Portable Tape Recorder Features.

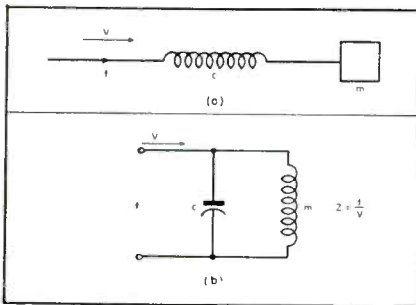

Figs. 1a and b. The mechanical schematic of a conventional reproducer arm and cartridge at low frequencies, appears in a: c is the needle suspension compliance of the reproducer cartridge; m is the effective mass of the arm and cartridge assembly, referred to the stylus tip; f is the force developed at the stylus tip; and v is the velocity of motion of the stylus tip. The electrical equivalent of a appears in b. Z is the mechanical impedance at the stylus tip.

IN PHONO REPRODUCTION, the arm and its components constitute a key factor in the playback operation. Particularly important in the link is the stylus-bearing force which must be small to limit the bearing pressure to reasonable values. It is this force which is called upon to hold the stylus in contact with the groove, against the dynamic forces developed at the stylus point at arm resonance, and to move the reproducer arm about its vertical pivot along the spiral path which the record groove presents. Damping in both the horizontal and vertical pivots provides a reduction of the resonant force, improves resistance to external shock and protects against damage from accidental release of the reproducer head.

Discussing this all-important phase of disc reproduction at the annual IRE convention, during a session of the professional group on audio, William Bachman, of Columbia Records, noted that at low frequencies, below 500 cps,

the mechanical system of a phono reproducer arm and pickup cartridge may be represented by a mass suspended on a spring. This point is illustrated in Fig. 1a, where m represents the effective mass of the arm and cartridge assembly, referred to the stylus point, and c represents the compliance (the reciprocal of stiffness) of the stylus suspension.

Below the resonant frequency of the system, which is often in the 30 to 60-cps region, it was pointed out, the motion of the mass corresponds to the motion of the driving point. In other words, the arm and cartridge follow the slow progress of the spiral groove. Above the resonance the system becomes mass controlled, and the arm does not follow the rapid undulations which the modulated groove imposes upon the reproducer stylus. This difference in motion between the stylus and the arm, said Bachman, provides the stimulation of the pickup, to which the output voltage is proportional.

Reporting that the operation of the system may also be described in electrical terms (Fig. 1b), the Columbia audio specialist declared that the mass is analogous to inductance, compliance to capacitance, force to voltage, and velocity to current. The unidirectional motion which describes the radial motion of the arm in following the spiral groove corresponds to dc in the electrical system. Thus, it was noted, the alternating velocity imparted to the stylus by the groove modulation corresponds to ac in the electrical network. Above the resonant frequency this velocity (or current) divides between the compliance, c , and mass, m , practically all of it admitted by the compliance in the useful range of the reproducer. The output voltage was described as proportional to the velocity

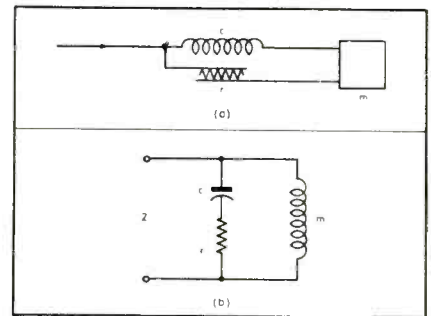

Figs. 2a and b. A mechanical schematic of a phono reproducer arm and cartridge, with damping in the needle suspension, is shown in a; r is the effective mechanical resistance resulting from the dissipation in the needle suspension. In b is illustrated the electrical equivalent of a. Above resonance, the impedance at the needle point, Z , can never become lower than r .

to which the compliance is subjected in a magnetic type of reproducer, or to the integral of this velocity in a displacement-sensitive reproducer.

At the resonant frequency of the circuit of Fig. 1b, the impedance, Z , reaches very high values, limited only by the Q of the system. The Q of the mass element is very high. However, Bachman said, there is usually some dissipation in the suspension compliance, but its value must be limited if the midrange impedance of the system is not to be made too high.

It has been usual practice to increase arm mass to move the resonant frequency farther below the desired transmission band. This, it was pointed out, reduces the incidence of arm resonance excitation by program material, but the resonant impedance is thereby increased, which further increases the susceptibility to jumping as a result of accidental mechanical shock.

The proper functioning of the system in the useful signal frequency

*Largest
Selling Booster*

AT ANY PRICE!



Regency

**SIGNAL
BOOSTER**

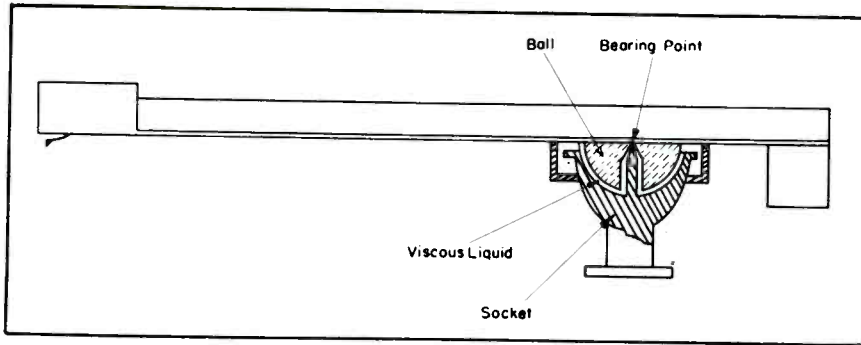

Fig. 3. Cross-sectional view of phono reproducer arm having viscous film damped pivot.

range depends upon all of the imposed motion, v , being accommodated by the spring, c . Only below the resonant frequency is the motion of m significant. Bachman noted that, putting the resistance in this position does mean that it will have to carry the dc , or, in other words, accommodate the motion imposed by the slow radial progress of the spiral. The velocity of this spiral is quite low.

From the mechanical schematic in Fig. 2b, it will be noted that the mechanical resistance element must be installed between the arm and the motorboard. It could be applied against any part of the arm, or at its pivots, or elsewhere, was described as particularly opposed to the usual concept of a reproducer arm. In fact, it was pointed out, failure of many arms to operate satisfactorily at the low bearing forces which lp micro-groove records impose can be traced to excessive pivot friction. This friction was noted as being quite different from the desired mechanical resist-

Non-directional, high-impedance inconspicuous-type microphone, whose frequency range is said to have a rising characteristic between 2,000 and 5,000 cps. Output level is approximately -55 db. The unit is available with or without an off-on switch. Crystal element has a moisture-proof coating. (Model DK-1; Astatic Corp.)



ance. Friction does cause energy to be dissipated as heat, as does mechanical resistance. The big difference, it was noted, was that pure mechanical resistance does not change in value as the velocity is varied. In rubbing friction, the resistance offered varies violently with the imposed velocity. One example appears in the difference between starting friction and running friction, observed in bearings. As an example of linear mechanical resistance, Bachman offered the case of a boat, floating in water. The resistance it offers is easily demonstrated by the work the engine has to do to move it at constant speed through still water and dead air. Yet this same boat may be moved, slowly, of course, with a surprisingly small force in still water and dead air. The friction of the boat moving through the water was cited as being linear, assuming that the velocity range did not extend into turbulence of the water. The friction behaves as true mechanical resistance, in which the velocity of the motion is proportional to the applied force.

According to Bachman, a more attractive method of obtaining linear mechanical resistance is through the use of viscous liquids. The resistance may be obtained by moving an impeller through a liquid, forcing the liquid through an orifice, or by utilizing the viscous fluid as a film in shear. One difficulty to which these methods

Preamp which features a *dynaural* noise suppressor which is said to reduce record surface noise without losing musical quality, a preamp for low-level magnetic pickups, a variable turnover control to compensate for different recording characteristics, an adjustable record-distortion filter, and an input level adjustment for use with the noise suppressor and external automatic loudness controls. (Model 112-B Dynaural Preamp; Hermon Hosmer Scott, Inc., 385 Putnam Ave., Cambridge 39, Mass.)

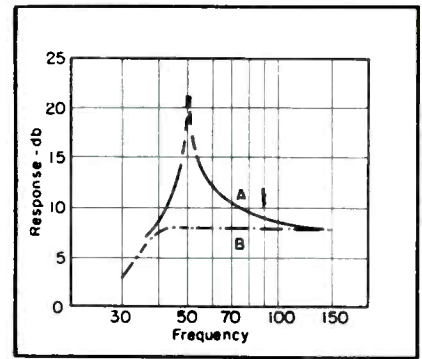

Fig. 4. Response of experimental arm with and without damping; Curve A, no damping; curve B, with damping.

are subject is the change of viscosity with temperature. While this effect is large with most petroleum oils, the effect is much smaller in silicon oils. Since the specific value of the mechanical resistance is not critical in this application either type of oil was said to be useful over a reasonable temperature range.

The mechanical resistance obtained by fluid films has been found to be proportional to the area of the film and approximately inversely proportional to the film thickness. It has been observed that with thicker films and higher viscosity liquids a significant amount of compliance appears along with the resistance. If this compliance were too large, it would serve to uncouple the resistance element from the system. Small values of compliance, on the other hand, are helpful in that they permit the arm to follow severely warped or eccentric records readily.

It is interesting to note, said Bachman, that the amount of mechanical resistance used in this reproducer arm is not a critical value. The upper limit

Portable Tape Player available with or without self-contained amplifier, in either 7½" or 3¾" per second speeds. All models feature double track operation. Model PB-1 with preamp plugs into any existing amplifier, radio or TV set. Frequency range said to be 50 to 8000 cycles at 7½" per second. Playing time one to two hours. Model PB-A1, complete with self-contained 5-watt amplifier and 5¼" Alnico V speaker. Frequency range said to be 50 to 8000 cycles at 7½" per second. Playing time one to two hours. (The Pentron Corp., 221 East Culbertson St., Chicago 16, Ill.)

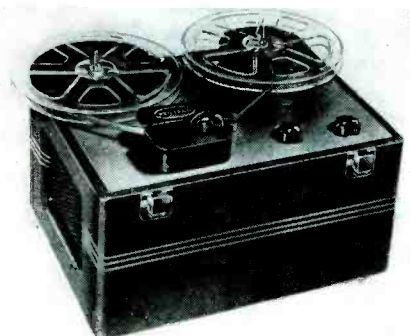



Here's how YOU can sell more Picture Tubes *WITH* **HYTRON'S NEW** **EASY BUDGET PLAN!**



GUESS YOU NEED A NEW PICTURE TUBE - THAT'LL COST YOU ABOUT \$50.00.

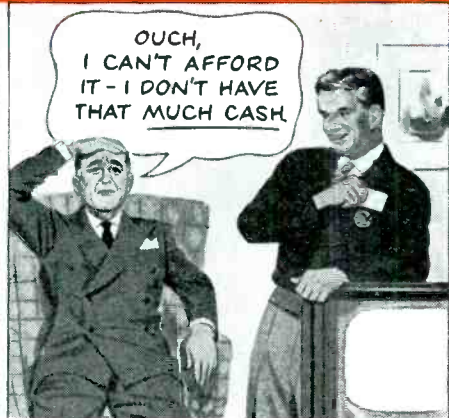

OUCH, I CAN'T AFFORD IT - I DON'T HAVE THAT MUCH CASH.

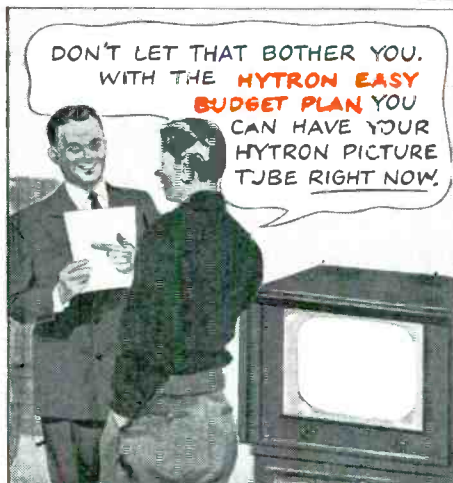

DON'T LET THAT BOTHER YOU. WITH THE **HYTRON EASY BUDGET PLAN** YOU CAN HAVE YOUR HYTRON PICTURE TUBE RIGHT NOW.

ANOTHER HYTRON FIRST FOR YOU!

No need to miss that profitable picture-tube sale — just because the customer doesn't have the cash. The original Hytron Easy Budget Plan saves the sale. Gives you a competitive edge. Hytron has arranged the details for you. A national credit organization, with facilities in all TV areas, stands ready to serve you.

Find out how *you* can put this wonderful, timely Hytron plan to work right now! Write for complete information today.



WHAT A WONDERFUL PLAN. WE'VE GOT OUR PICTURE TUBE... AND UP TO TWELVE MONTHS TO PAY.

ANOTHER HELPFUL SERVICE FOR YOU FROM...



MANUFACTURERS OF RECEIVING TUBES SINCE 1921
HYTRON
RADIO AND ELECTRONICS CO.
A DIVISION OF COLUMBIA BROADCASTING SYSTEM INC.
MAIN OFFICE: SALEM, MASSACHUSETTS

Hytron Radio and Electronics Co.
Salem, Massachusetts

Please rush me details on the Hytron Easy Budget Plan.

Name
(please print)
Street
City..... State.....

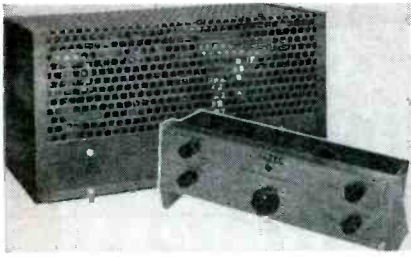

(Above)

Preamp (right) and power amplifier (left) system which features three-step selection of record crossover frequencies, control of the rise and drop in both treble and bass, equalization for variable reluctance pickup, filter for 33 $\frac{1}{3}$ recording characteristic rise, a three-input selector switch and a continuously variable volume control. The frequency response is said to be flat to +0 and -1 db from 20 to 20,000 cps. It is claimed that the system will deliver 27 watts of audio power at less than 5% harmonic distortion; 20 watts at less than 2% harmonic distortion and 15 watts at less than $\frac{1}{2}$ % harmonic distortion. (A-433A preamp and A-333A power amplifier; Altec Lansing Corp., Beverly Hills, Calif.)

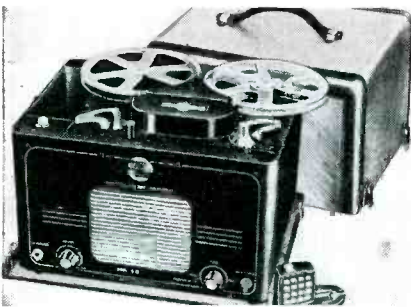

(Above)

Dual-speed dual-track magnetic tape recorder which records at speeds of either 3.75 or 7.50 inches per second. Recordings can be made at both speeds on the same track. Dual track permits two-hour recording on a 7" reel. Has provision for headphone or speaker monitoring from built-in or external speaker, and recording from built-in or external radio. (Model D-37; Masco.)

(Below)

Radio-phono cabinet (36" h x 16" d x 24" w), in which the top panel can accommodate FM-AM tuners, and the middle pull-out drawer, mounted on ball-bearing slides, can house automatic record changers. Associated accessories, such as preamp, amplifier, power supply, etc., can be housed in the bottom compartment. (Model RP; Standard Wood Products Corp., 43-02 38th Street, Long Island City 4, New York.)



of resistance is reached when it interferes with tracking of records having reasonably small values of eccentricity or warpage. With the usual values of suspension compliance and mass, this would occur at several times the amount of resistance necessary to damp critically the arm resonance. At the other extreme, where the resistance approaches zero, it was said, the arm merely reverts to a conventional one, in which there is very low pivot friction. If the design is such that the resonance of the arm and suspension compliance occurs below the desired transmission band, the variation in resonant response, resulting from change in the mechanical resistance, is of little importance. Between these extremes a wide range of improved performance exists. Even a resistance in the order of 1/6 of the critical value was described as contributing to a cut in the Q of the resonant system significantly, with a corresponding improvement in stability as a result.

Fig. 4 illustrates the performance of an experimental arm similar to the one shown in Fig. 3. It was said that a light arm, having approximately 20 gms effective mass at the stylus tip was used with a crystal cartridge whose compliance was approximately $.5 \times 10^{-6}$ cm/dyne. The light arm and stiff cartridge were chosen so that the resonant frequency would be high enough to avoid errors due to pointer vibration in the indicating instruments. Without damping, the dynamic forces developed near resonance were so large that the stylus was forced out of the groove. For this reason it was not possible to measure the true resonant rise, and the curve, therefore, shows, with dashed lines, an estimated response in this region.

The application of linear mechanical resistance to the pivots of phono reproducer arms was described as an effective means of providing damping of the low-frequency arm resonance.

Audio Definitions

Continuing the presentation of the series of audio definitions, recently released by IRE*, we find that the term *available power* of a linear source of electric energy has been defined as the quotient of the mean square of the open-circuit terminal voltage of the source, divided by four times the resistive component of the impedance of the source. (The available power would be delivered to a load impedance that is the conjugate of the internal impedance of the source, and is the maximum power that can be de-

livered by that source.)

The available power of a sound field, with respect to a given object placed in it, can be the power which would be abstracted from the acoustic medium by an ideal transducer having the same dimensions and the same orientation as the given object. The dimensions and their orientation with respect to the sound field must be specified. The commonly used unit is the *erg* per second, but the available power may also be expressed in watts.

Articulation (Per Cent Articulation) and Intelligibility (Per Cent Intelligibility): The word *articulation* is customarily used when the contextual relations among the units of the speech material are thought to play an unimportant role; the word *intelligibility* is customarily used when the context is thought to play an important role in determining the listener's perception.

Baffle: A shielding structure or partition used to increase the effective length of the external transmission path between two points in an acoustic system, as for example, between the front and back of an electroacoustic transducer. (In the case of a loudspeaker, a baffle is often used to increase the acoustic loading of the diaphragm.)

Bidirectional Microphone: A microphone in which the response predominates for sound incidences of 0° and 180°.

Class-A Push-Pull Sound Track: A class-A push-pull photographic sound track consist of two single tracks side by side, the transmission of one being 180° out of phase with the transmission of the other. Both positive and negative halves of the sound wave are linearly recorded on each of the two tracks.

Class-B Push-Pull Sound Track: A class-B push-pull photographic sound track consists of two tracks side by side, one of which carries the positive half of the signal only, and the other the negative half. During the inoperating half cycle, each track transmits little or no light.

Conical Horn: A horn whose cross-sectional area increases as the square of the axial length.

Constant Velocity Recording: A mechanical recording characteristic wherein for a fixed amplitude of a sinusoidal signal, the resulting recorded amplitude is inversely proportional to the frequency.

Crossover Frequency: As applied to electric dividing networks, the crossover frequency is the frequency at which equal electric powers are de-

*Standards on electroacoustics (51 IRE 6, S1), published by the Institute of Radio Engineers, 1 E. 79th Street, New York 21, N. Y.

(Continued on page 52)

**LOOKING FOR A NEEDLE
IN A HAYSTACK?**



THEN YOU'D BETTER SWITCH TO

PERMO
long-life
PHONO NEEDLES



COMPLETE

Facts

MAKE THE DIFFERENCE!

**YOU GET COMPLETE INFORMATION
—MANUFACTURER-BY-MANUFACTURER**

—when you use Permo Long-Life Phonograph and Needle Facts. It's fast—easy—no fumbling—no failures—no guesswork. Permo "Facts" tell you what needle goes where! Current releases cover Admiral, Columbia and Philco sets; giving **EXACT, COMPLETE** information regarding record changers, cartridges and needles used in those sets.

PLUS THESE "EXTRAS" TO HELP YOU SELL!

Permo Long-Life Needle Replacement Kits for all Admiral or Philco models are yours for less than \$6.50. Here's what you get: (1) Admiral, Columbia or Philco Section, Permo Long-Life Phono and Needle Facts. (2) Complete opening stocks of superb Permo Long-Life Phono Needles—to fit all post-war Admiral and Philco sets. (3) Convenient display cards that fold to fit into handy pocket-size packets. (4) Needles are individually packaged with *installation tools* where necessary, and *spare parts* (nuts, screws, etc.) This kit is bound to make you a best seller of replacement needles!

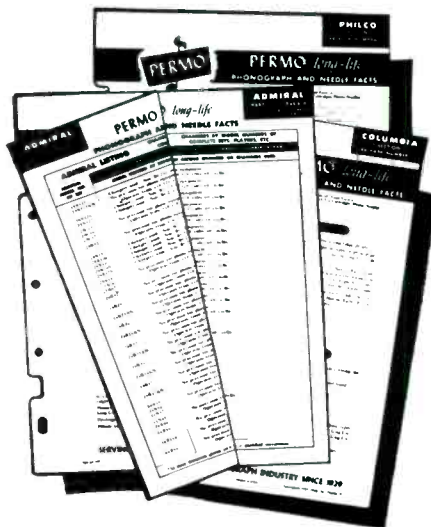

Admiral, Columbia and Philco "Facts" now available. Write for your **FREE** copies. Additional "Facts" covering other manufacturers will be released progressively. Get your profit by selling Permo Long-Life replacement needles!



PERMO, INC. *Champion of Perfection*

6401-33 N. RAVENSWOOD AVE.

CHICAGO 26, ILLINOIS

Fig. 1. Power-supply system for the tape recorder illustrated on the cover.

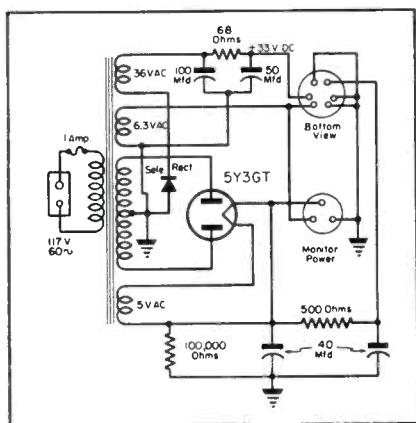

MAGNETIC RECORDING systems, with their specialized requirements for frequency response, speed, magnetization and erasing, have called for the application of many circuitry innovations. Tape units, for instance, have featured the use of recording and playback amplifiers and bias oscillators for erasing, the latter providing 60 kc for biasing the record head and for erasing of previous recording. In addition, novel switching arrangements have been incorporated for record, standby and playback operations. On the cover, this month, appears the circuit of a recently-developed tape recorder* featuring not only the foregoing, but many other interesting magnetic-circuit developments.

Switching

In the switching arrangement, included to permit use of the unit in a custom music system, the *record* position controls the screen voltage on the oscillator tubes, causing them to generate *rf* current. Plate voltage is applied to the final record amplifier tube. The output of the playback amplifier is connected to the *output* jack.

Standby-Position Operation

In the *standby* position the oscillator and final record tubes are disabled. The low gain *input* jack is connected straight through to the *output* jack, enabling the power amplifier to be used for normal listening. With the tape recorder shut off, it is merely a shorted link in the music system. With the recorder left turned on, the microphone channel is still *hot* and will feed amplified microphone output into the external power amplifier for monitoring purposes. With the switch in the *playback* position, the oscillator and final record tubes are also disabled,

Magnetic-Tape Recorder Circuitry

by WYN MARTIN

[See Front Cover]

Eight-Tube Unit, With Separate Heads for Record and Playback, and High-Frequency Erase Using a Self-Balancing Push-Pull Power Pentode Erase Circuit, Features Instantaneous Choice of 7.5 or 15-Inch Per Second Tape Speeds, and Provision for Simultaneous Monitoring While Recording.

but the playback amplifier output is connected through to the *output* jack.

Record Amplifier

The amplifier is composed of a 12AX7 dual hi- μ triode in cascade arranged to drive a 12AU7 final record current stage. The first two stages are of standard high-gain design without equalization. The cathode of the first stage is heavily bypassed with an electrolytic capacitor to reduce hum and noise disturbances. Gain per stage for the first and second stages has been found to be approximately fifty.

The 12AU7 is used for two jobs: To provide equalized record current for the record head and in addition as a record current level indicator. The cathode return of one-half of the 12AU7 record amplifier stage is through a 15,000-ohm resistor bypassed by an inductance-capitance resonant circuit. At lower frequencies a negative feedback voltage is developed (series feedback) across this resistor that reduces the stage gain by over 20 db. The feedback also has the effect of reducing the distortion in that stage to a negligible amount. As the frequency increases, the bypassing action of the shunt *lc* circuit increases, thereby reducing the amount of negative feedback, and increasing the stage gain. When the frequency of resonance is reached, there is very little feedback and the stage gain is maxi-

mum. The frequency of resonance varies with the position of the speed switch on the right side of the machine. When the unit is operating at 15 inches per second, the *lc* circuit is tuned to 15 kc. When the machine is turned to a 7½-inch speed an additional .01-mfd capacitor is connected into the *lc* circuit, making it resonant to approximately 8 kc.

The second half of the 12AU7 is connected as a diode to provide a rectifier for the record-level circuit. Voltage from the record current amplifier is fed to the cathode of the diode section while the diode plate return is through a 10-megohm resistor and a .02-mfd capacitor. When a sudden voltage appears across the diode, the .02-mfd capacitor takes a charge and builds up a negative voltage rapidly. The negative voltage is fed to a 6E5 eye tube which varies its shadow pattern to indicate relative voltage. The capacitor charges rapidly through the diode but discharges slowly through the 10-megohm resistor. The result of this is a floating action that is not fatiguing to the operator *riding* gain.

A 5-millivolt signal, fed into the *high gain* input has been found to be sufficient to cause full eye closure. When a crystal microphone is used, a 470,000-ohm resistor provides a return path for the grid. If a microphone is not being used with the recorder, the *high gain* input must be shorted to reduce thermal noises to a minimum, while recording from a radio or other *high-level* sources. The low-gain in-

*Concertone 1401; Berlant Associates.

(Continued on page 53)

260

260

260

260

260

260

260

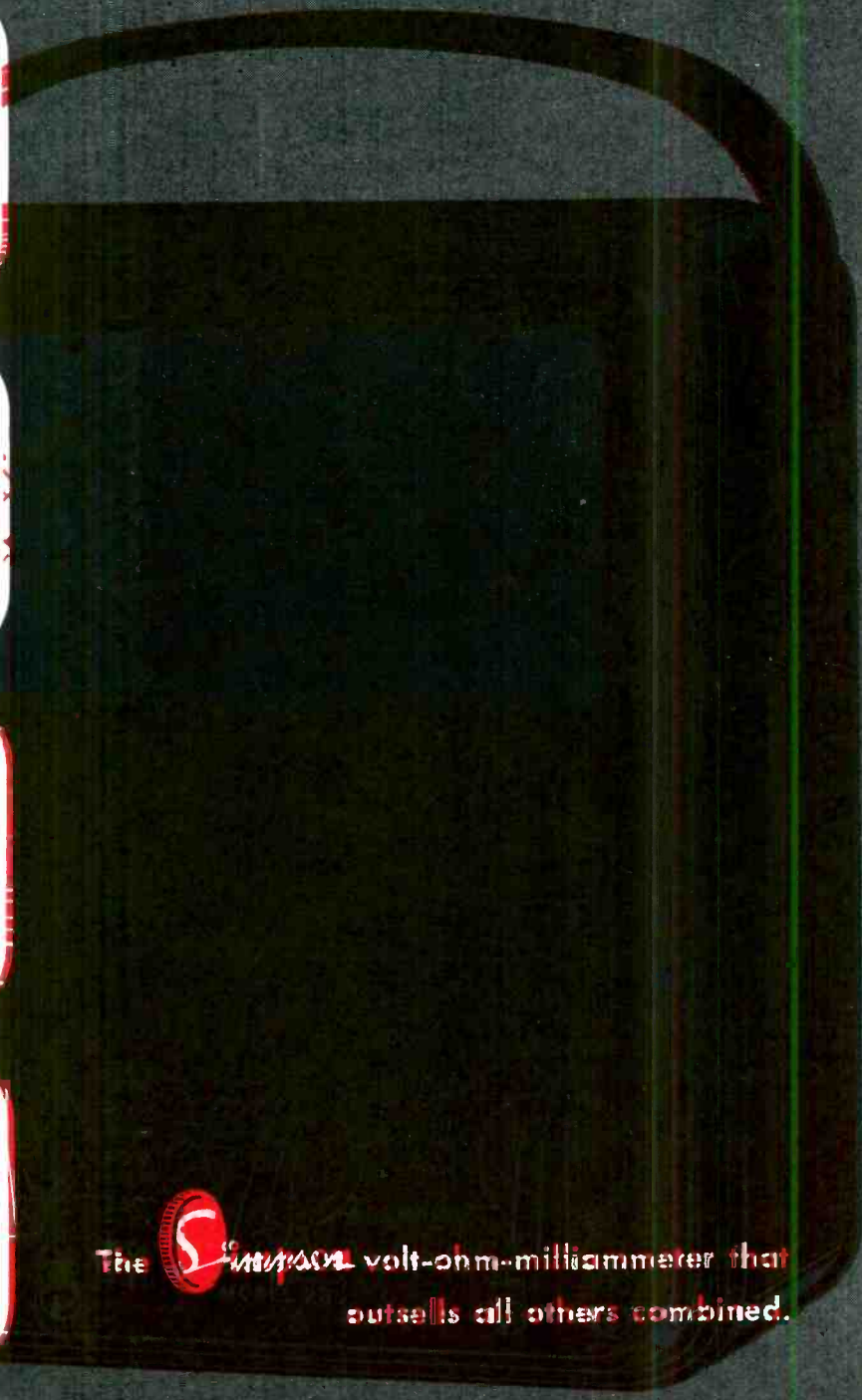

The  **SIMPSON** volt-ohm-milliammeter that outsells all others combined.

Fig. 1. Circuit of vtvm designed for leakage testing.

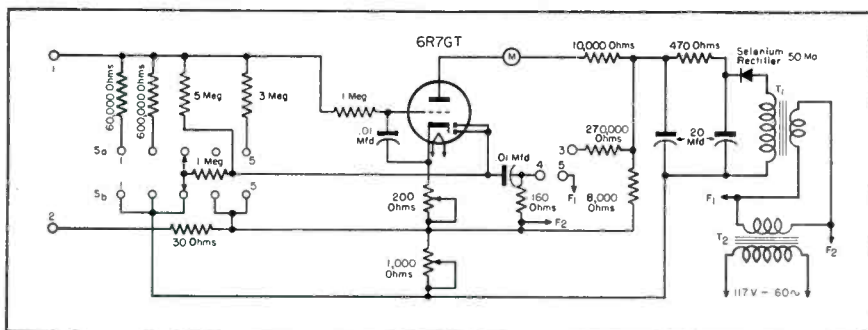
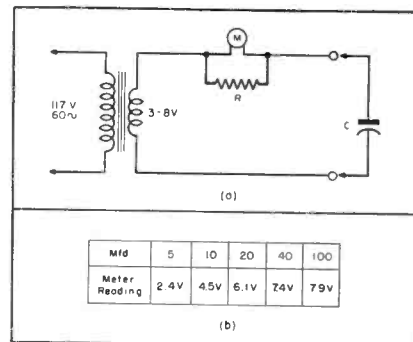

Fig. 2. Impedance-meter setup for capacitance testing. Meter is ac type, with range of from 3 to 8 volts.



ACCELERATED TESTING Techniques

by PHILIP H. GREELEY

**Paper-Capacitor Leakage Tests With a VTVM . . .
Circuit-Continuity and Leakage Checking with
Streamlined Setups . . . Comparison Component
Testing . . . Use of Supplementary Power Supply
for Auto-Radio Servicing.**

POOR APPARATUS PERFORMANCE is often caused by leaking coupling capacitors used in audio and video circuits. It is valuable, in practical service work, to be able to check capacitors for leakage as suggested with the use of a vtvm and an auxiliary power supply while the capacitors are left connected in their circuits. It is also important to be able to quickly precheck replacement capacitors to avoid repeat work when a leaky new part is installed. Satisfactory leakage testing requires a fairly high test voltage of at least 1/5 of the rated capacitor working voltage. High resistance leakage paths may have minute breaks or gaps that can be bridged only by an adequate voltage.

Most of the standard volt-ohmmeters use only a 3- to 6-volt battery for driving the ohmmeter. This has not been found too effective for leakage tests. However, it does not appear to be advisable to make changes in a fairly costly calibrated vtvm to improve leakage tests, because these tests can be rough on the meter with chance of damage. A very simple vtvm designed for leakage testing can be made. Use of precision resistors and calibra-

tion are unimportant in a leakage tester, but a high sensitivity giving a full scale meter deflection of around 40 megohms is required, in order that sizeable and easily noted deflections will be given on a resistance of 300 megohms or more. Good coupling and bypass capacitors in the value range of from .1 mfd to .005 mfd, will have a leakage resistance well above 300 megohms, with a little more leakage being tolerable in higher value capacitors and those employed only in low voltage circuits.

In reality, a leakage tester is merely an ohmmeter having a driving voltage of perhaps 120 volts, instead of the usual 3 to 6 volts, and a corresponding sensitivity increase of some 20 or more times. The tester must be so designed that it limits temporary meter current to perhaps twice normal rated current and prevents too rapid throw-over of the meter pointer against its stop by the charging current taken by a capacitor when tested.

A vtvm designed for leakage testing is shown in Fig. 1. Other rough duty vtvm uses can be provided, including the equivalent of the impedance type

capacitance meter of Fig. 2, at the small additional cost of a switch and a few extra resistors, capacitors and terminals. For operation of a reasonably rugged 3 or 5-ma meter, M, a 6R7GT or 6SR7 may be used, or a 6J5, if the capacitor test is omitted. The meter range is not critical, but circuit values of R₁, R₂ and R₃ may require a change if the meter is not somewhere in the 4-5 ma range.

Assuming that meter M has five main scale divisions, as from 0 to 5 ma, the tester can be designed to read upward from near zero to about 4½ divisions on resistance and leakage tests, and to read downward from 4½ divisions on capacitance tests and alignment indications on AM receivers. A 2-pole, 5-position wafer switch, S_a and S_b, serves to control the resistance range and action of the tester. Switch setting 3, shown, is the highest or most sensitive resistance and leakage range. Switch settings 2 and 1 reduce the resistance and leakage ranges, and on leakage tests can be used to greatly reduce the capacitor charging time where capacitors of .05

**KESTER
SOLDER**

Give top quality TV service with Kester "Resin-Five" Core Solder

**MADE ONLY FROM NEWLY MINED
GRADE A TIN AND VIRGIN LEAD**

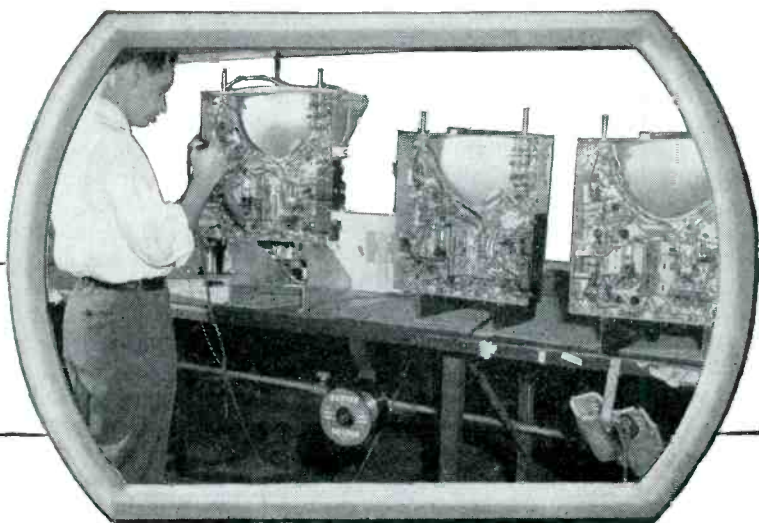

TV—the nation's fastest growing business demands the nation's number 1 solder. Kester "Resin-Five" Core Solder, formulated especially for TV, will out perform any solder of the rosin-core type. It easily solders such metals as brass, zinc, nickel-plate, copper, and ferrous alloys.

'Resin-Five' Core Solder

non-corrosive . . . non-conductive

Kester... Standard for the TV and Radio Fields

"Resin-Five" flux is more active and stable than any other rosin-type flux. Yet it is absolutely non-corrosive and non-conductive.

**FREE SOLDERING BOOKLET—Send for Your
Copy of—Soldering Simplified**

Kester Solder Company
4248 Wrightwood Avenue • Chicago 39, Illinois
Newark, New Jersey • Brantford, Canada



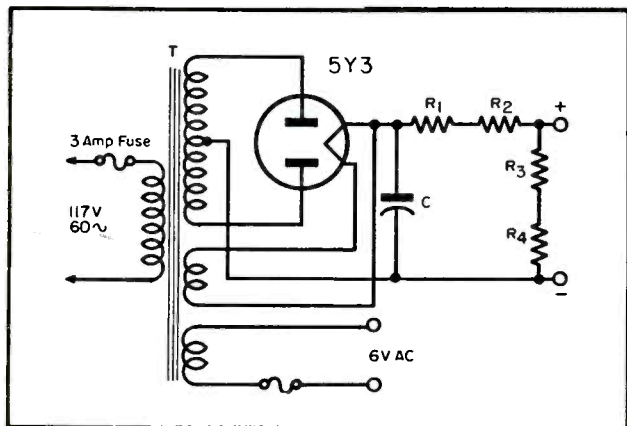

Fig. 3. Auxiliary B-power supply which can be used for auto-radio servicing.

mfd and larger are checked. After charging a capacitor on setting 2 or 1, the switch can be moved back to setting 3 for final leakage test.

Two small 6-volt filament transformers, T_1 and T_2 , having about 1-ampere rating may have their filament secondaries connected together at F_1 and F_2 , so that the (normally) primary of T_1 serves as the high-voltage winding. In the power supply is a 50-ma selenium rectifier, SR , followed by a simple filter comprising a dual 20-mfd 150-volt electrolytic and a 470-ohm 1-w resistor. The power drain of this tester is so small, 4 to 5 watts, that it may be kept in operation continuously whenever bench work is being done.

VTVM Operation

The tester can be adjusted by first shorting pin jack terminals 1 and 2 and setting 200-ohm resistor for $4\frac{1}{2}$ -ma reading on a 5-ma scale. Then it will be necessary to remove the short and set the 1000-ohm resistor so that it cuts down tube plate current to low value of .2 or .3 ma. Exact up and down settings are unimportant except that a major portion of the meter scale should be used. A voltage of near 10 is developed across this resistor which is applied negatively to the grid of the tube on switch positions 1, 2 and 3 through the resistors in series, and serves to nearly cut off tube plate current unless this voltage is reduced by connection of a resistor across terminals 1 and 2 or a leakage resistance across terminals 1 and 3.

Circuit continuity and resistance checks work in a range from 20,000 ohms to 20 megohms, much higher than the range of a simple battery type ohmmeter or circuit tester. Switch setting 1 will read about half scale when a 60,000-ohm resistor is connected across terminals 1 and 2; setting 2 will be half scale on .6 megohm, and setting 3 half scale on 6 megohms. Calibration has been found unimpor-

tant for fast preliminary testing, and it is practicable at any time to check a resistance reading against the reading on a spare resistor of known value. Equal resistors will read exactly the same. However, from day to day in this simplified test circuit, which is neither balanced or voltage stabilized, a particular value resistor may read at slightly different points on the meter scale with variations in line voltage or other change in operating condition.

Leakage tests are similar to resistor tests except that the sensitivity is increased at least 10 times by inserting test leads in pin jacks 1 and 3, instead of 1 and 2. Pin jack 3 will be found to be at a potential of about 120 volts positive through a protective resistor of 270,000 ohms. In reality the grid of the 6R7 is driven slightly positive until the effective resistance between pin jacks 1 and 3 rises to a high value. Capacitors under test for leakage pass current until fully charged, and the meter pointer is driven over against its stop during this charging time by excessive tube plate current, but this excess current is limited, to avoid meter damage, by resistor R_3 . Switch setting 3 is the most sensitive leakage range and the meter pointer will read near mid-scale on 70 megohms and will return to its open circuit position only on leakage resistance values of 1,000 megohms or more. Switch setting 2 or 1 may be used to shorten the charging time, where capacitors larger than .05 mfd are tested with a return to setting 3 for final leakage indication.

By comparison testing of capacitors of different makes, the Service Man can readily determine which grades uniformly show a very high leakage resistance. By making a first test on a capacitor and repeating after a delay of a few seconds, a lack of meter kick will show that the capacitor has held its first charge without an appreciable leak-off. This leakage test is quite useful also in checking insulation resistance as between the windings of a

transformer or to frame, speaker field coil to frame, etc.

On switch positions 4 and 5, the negative voltage derived from the 1000-ohm unit is removed from the 6R7 grid and the meter pointer initially will read about 4.5 on a 5-ma scale. Pin jacks 1 and 2 can now be used for test leads, preferably with a resistor of 1 to 2 megohms in a probe on lead 1, for noting *avc* voltage on common AM radios, where alignment is made for maximum downward swing of the meter. Switch range 4 is most useful with provision of range 5 for *avc* voltages above about 10. This same test can be readily employed in noting oscillator action, by connecting across the oscillator grid resistor, and for checking across grid resistors in audio and other *rc* coupled circuits. The resistor probe of terminal 1 must always be used on a grid or *avc* circuit, and the meter should read downward on an operating oscillator or *avc* circuit, and should never go upward appreciably on an audio coupling circuit, where the coupling capacitor does not leak and the tube is not gassy.

By setting the switch on range 4 and using pin jacks 4 and 5 with low resistance test leads, an impedance type checker for electrolytic capacitors similar to that of Fig. 2 is provided. The diode plates of the 6R7, in this instance, rectify a portion of the filament voltage, F_1 - F_2 , appearing across the 160-ohm resistor when a capacitor is connected from 4 to 5; this rectified voltage is applied negatively to the tube grid with a corresponding reduction of meter current.

A substantial amount of auto radio servicing can be done with the auxiliary power supply of Fig. 3. All the true radio section repair work such as *rf*, converter, *if* and audio, which normally takes most time, can be done conveniently with *ac* filament and *dc* plate power. The rectifier tube and buffer capacitor should always be checked. It is generally obvious, if a vibrator has been working, before the radio is removed from the car. If desired, the Service's Man own auto may be equipped with a battery connector and antenna for final quick check of a repair job.

The idea of comparison testing has been found to be very helpful in checking components. Some components, such as electrolytics, have a wide value tolerance, and data on leakage tolerable in capacitors of various types and values is not too readily available. A used component which fails, in an important degree, to pass any test given a new unit of equal rating, should be rejected.

NEW PARA-CON ANTENNA COMBINES PARABOLIC & CONICAL PRINCIPLES



Barbara Lee—Rising TV Star, WEWS Cleveland

Sight Sells It

After all, people buy TV sets to enjoy the picture. It just makes sense that the antenna bringing in the best picture brings in the best entertainment and the most customer satisfaction. Hook a Para-Con onto any set and you'll agree—it sells on sight.

Solves 9 out of 10 Installation Problems—Challenges Comparison

Two best features are incorporated into one BEST antenna. The praiseworthy features conical type aerials possess for supplying full audio and full video bandwidth reception are used with a parabolic design that gives the Para-Con a concentration of signals. Para-Con is engineered to concentrate the maximum wave energy on the antenna by providing all-around, unmatched performance . . . perfect picture clarity . . . long customer satisfaction.

Any TV Set Performs Better With a Para-Con Antenna

Every set performs better when conditions are better. Install Para-Con when older sets are starving for a stronger signal. Install a Para-Con when any set is being drowned in a sea of local interference. In the majority of set installations, Para-Con makes both old and new sets perform at their peak. To be on the safe side every time, install the sensationally performing new Para-Con antenna and forestall TV troubles at both the reception and the service end.

Proved in Thousands Of Installations

Spectacular success has been achieved in practically every installation. Even in locations far removed and in difficult terrain where other more elaborate arrays were tried and failed, PARA-CON aerials not only bring in brighter, clearer pictures but seize and channel in stations where dependable reception has not been possible with an ordinary antenna. Ward's new PARA-CON Antenna has been field tested in thousands of installations . . . proved far and away better.

Singles Out The Stations High Front to Back Ratio

The new Para-Con design achieves an unusual capacity to obtain sharp directivity over all the television spectrum. Para-Con principles afford greater power and less interfering noise on each channel.

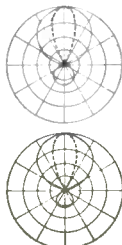

One Antenna Covers All Channels

The Para-Con antenna reaches out and grasps all channels. The Ward Para-Con has an exceptionally low standing wave ratio combined with a spectacular high gain advantage on all channels.

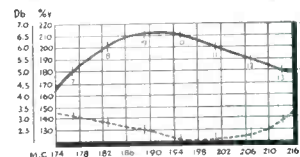
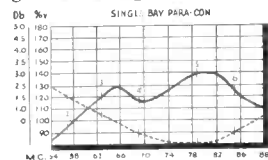

No Ghost Hunts

No more skeletons in your customer's TV closets. Scientifically determined direct impedance matching characteristics eliminate many ghosts. Para-Con's revolutionary design transfers the maximum power from the antenna to the receiver with a minimum of reflections.

Profit-Wise Dealers Prefer Para-Con*

The antenna is one of the most important and critical components of a TV receiver. Nearly 20% of all TV service calls result from faulty antennas. The general all-around, high performance of Ward's Para-Con antenna gives customer satisfaction right from the initial installation. Expensive call-backs due to antennas are slashed. Ruggedly built for long lasting trouble-free service Para-Con withstands winds and weather. Easy to handle and quick to install . . . saves time and expense.

See your distributor for Ward's answer to your antenna problems. *Trade Mark

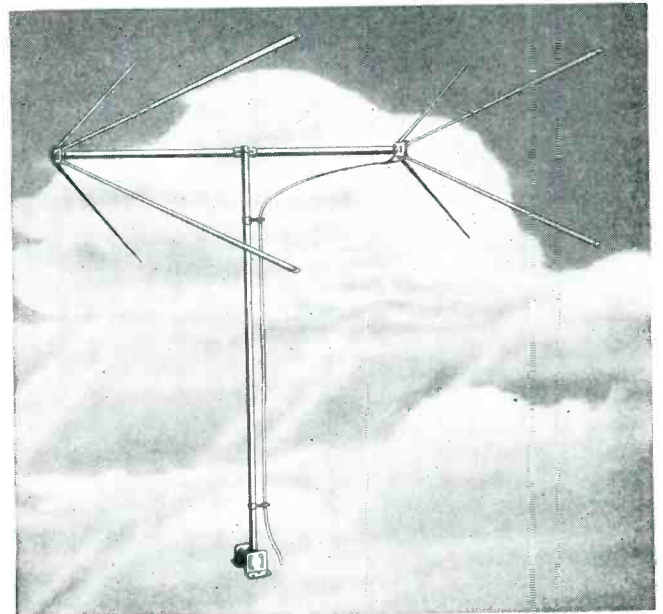

The First In TV To Use Parabolic Principle

Parabolic antennas have long been used in special applications for concentrating weak signals onto driven elements. The brilliant results of Ward Para-Con are now setting new performance standards on all channels and in most every area. Ward's Para-Con Antenna is different. It's new. Now it is possible for one antenna to meet and solve many of the local problems of installation and reception.

Ideal For All Band Fringe Areas

In fringe areas where selection of a number of channels is available, Ward's stacked Para-Con models provide the ideal compromise antenna for maximum results on all bands. Stacked in either two or four bay arrays, the Parabolic design reflectors reach out, gather and concentrate maximum energy on the antenna elements.

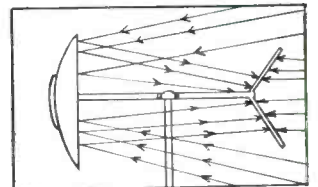

Diagrammatic sketch showing how parabolic reflectors gather in and concentrate energy on conical elements.

WARD

PARA-CON

(Combining Parabolic and Conical Principles)

ANTENNAS

THE WARD PRODUCTS CORPORATION, Division of The Gabriel Co.
1523 E. 45th Street, Cleveland 3, Ohio
IN CANADA: ATLAS RADIO CORP., LTD., TORONTO, ONT.



TUBE News

by L. M. ALLEN

Minimizing Pulse Voltages in TV Vertical-Deflection Amplifiers* . . . Use of Phosphors in Picture-Tube Production . . . Automatic Focus Picture-Tube Design Features.

IN MAGNETIC-DEFLECTION PICTURE-TUBE SYSTEMS the pulse voltages generated in the output of vertical-deflection amplifiers, and developed by the rapid change of current in the vertical-deflecting coils during vertical retrace, must be kept small to minimize the possibility of failure in the vertical-output transformer, the vertical-output tube, and the tube socket.

The minimum theoretical pulse voltage developed in a yoke during retrace is a function of retrace time; a longer retrace period permits a lower pulse voltage. There are, however, several successive factors imposing a maximum limit on the duration of vertical retrace. The fundamental limitation is that retrace must be completed during vertical blanking or the picture will be folded at the top. TV standards specify that vertical blanking last between five and eight per cent of the field period, which is 16,667 microseconds. A further limitation arises from the fact that conventional vertical oscillators do not permit retrace to begin before the arrival of the vertical synchronizing pulse, which follows the beginning of blanking by an interval approximately equal to one per cent of the field period. A receiver, therefore, must have a retrace time of less than four per cent of the field period (665 microseconds). Finally, provision must be made for an even shorter retrace

because tube and component variations will cause production variations. Fortunately, pulse voltage may be limited to a reasonable value without a retrace period of three per cent of the field period (500 microseconds) being exceeded.

The magnitude of pulse voltage is determined not only by duration of retrace but also by the waveshape of the voltage in the vertical-deflecting coils. Minimum pulse amplitude can be obtained if the coil voltage pulse is made rectangular. The rectangular pulse is achieved when the retrace is slightly faster at the start. The values of theoretical minimum pulse voltage obtained with this ideal rectangular waveform are most conveniently used when expressed as a function of peak-to-peak sawtooth voltage and retrace

time. This relationship enables the data to be applied universally to any vertical-deflection circuit and permits quick comparison between the ideal and the practical circuit. The corresponding ratio of pulse to sawtooth voltage in an actual circuit can be measured for comparison purposes with a 'scope, either at the vertical-deflecting winding or at the plate of the vertical-output tube.

Adjustment of Retrace Time

The minimum retrace time is determined by the resonant frequency of the deflecting winding and its associated components. The retrace time may be made longer than this minimum by proper adjustment of the damping resistance applied during retrace. When triodes are used as vertical-output amplifiers, the tube itself is used as the damping resistance and the damping is adjusted by the *peaking* portion of the grid signal to the vertical-output tube. The best method of adjusting the retrace time is to make the duration of the peaking pulse equal to the desired retrace time.

The duration of the peaking pulse depends solely upon the conduction period of the discharge device in the sawtooth-generating circuit. Generally, the conduction period, in turn, depends upon the duration of the pulse on the grid of the tube in the discharge cir-

(Continued on page 56)

James B. Lindsey, vice president in charge of engineering and development at Thomas Electronics and Robert E. Burrows, sales manager, with recently developed automatic-focus electrostatic-picture tube, which it is said does not require a focus coil or potentiometer.



*Based on copyrighted information prepared by the RCA tube department.

3 Important Rauland Policies

...Are they
paying off for you?

1 Did you know that Rauland's Replacement Picture Tube Warranty and Adjustment Policy provides a 6 months warranty from the date of purchase by the consumer? And that all Rauland replacement tubes now carry a triple registration card providing protection for jobber, dealer and consumer?

2 Did you know that Rauland provides a full 120-day price protection on distributor inventory of replacement picture tubes? That Rauland distributors can carry a stock adequate for their territories without risk of loss through price adjustment?

3 Did you know that Rauland offers valuable premium points for the prompt return of warranty registration cards? Each card returned promptly entitles dealer and distributor to premium points redeemable in valuable merchandise prizes.

• • •

If you have not received full details on all of the above, write, phone or wire your distributing contact on Rauland tubes. If you have not received your prize merchandise catalog, use the coupon below today.

THE RAULAND CORPORATION



Perfection Through Research

4245 N. KNOX AVE. • CHICAGO 41, ILLINOIS



The Rauland Corporation
4245 N. Knox Ave., Chicago 41, Illinois

Please rush premium merchandise catalog and full information on:

Earning Premium Prizes 6 Months Warranty
 Distributor Price Protection

Name _____

Address _____

City _____ State _____

Servicing Helps

by M. A. MARWELL

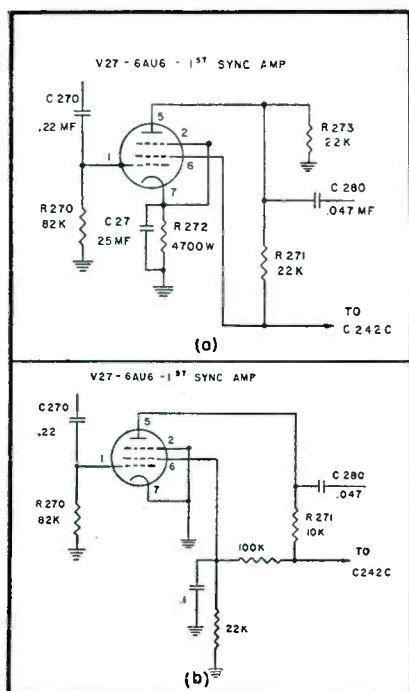

Fig. 1 (a and b). Before (a) and after (b) modifications in Stromberg-Carlson chassis providing a gain reduction to minimize picture pulling in strong areas.

Focusing Electrostatic Tubes*. Stromberg-Carlson Service Helps: Removing Buzz or Whistle in HV Supply . . . Sync Modification to Improve Picture-Pulling Conditions . . . Improving Interlaces . . . Reducing Picture Bending. Admiral Service Hints: Eliminating 15.75 KC Radiation in Metal-Cone Picture Tube Chassis . . . 12H6 Substitution Procedures . . . Checks for Intermittent Contacts on Color TV Socket . . . Hum Buzz Elimination in Air King Sets. Sentinel TV Notes: Eliminating Critical Horizontal-Hold Control Action . . . Minimizing Distorted or Weak Sound . . . Packard-Bell Field Alignment Techniques.

SETTING UP AND FOCUSING electrostatic picture tubes requires slightly different techniques than were used on magnetically focused tubes. Adjustment of the brightness control, centering magnet, ion-trap magnet and the focus potentiometer, all have some effect on spot size and shape, and consequently influence focus voltage. The ideal condition is reached when the tube is focused with the lowest possible focus anode voltage; when best test pattern vertical wedge resolution occurs simultaneously with the best raster line focus; when good focus is obtained at high and low brightness levels, and when focus is obtained well within the range of the focus control.

In the focus procedure, there are five steps:

(a) The brightness control should be set for average brightness.

(b) The focus pot should be set slightly counterclockwise from the best focus position.

(c) The ion trap magnet should be adjusted for maximum brightness. Within the range of maximum bright-

ness, a region of best focus will occur. The ion trap magnet should be set within this region of best focus. The ion trap magnet must not be used as a centering adjustment.

(d) The picture should be centered by adjustment of the centering magnet.

(e) The foregoing procedure should be repeated until no further improvement is obtained.

In checking for vertical and horizontal resolution, with the brightness control set for average brightness, the focus pot should be adjusted for maximum resolution in the vertical wedges of a test pattern. The raster lines should be clearly visible at this point. If the raster lines are not in focus, the focus pot should be turned until they are in best focus. This should occur within a very few degrees of rotation of the focus pot and without appreciable loss of definition in the vertical wedge. In some instances, a slight compromise may be necessary for final

focus adjustment. With the brightness control set for average brightness, it is then necessary to focus on the test pattern and favor the vertical wedge resolution as long as the raster line structure is visible.

Checking for focus with a change of brightness requires, first, that the brightness control be turned for low picture brightness. Best focus should occur in the center of the picture. Then the brightness control can be turned for maximum usable brightness. Best focus should now occur near the edge of the tube with the center only slightly out of focus. This condition gives the best average focus.

If vertical and horizontal resolution do not occur simultaneously, it may be due to the centering magnet. The following change should be tried: If, for example, the tab nearest the yoke is 45° clockwise from the rear tab, the tab nearest the yoke, should be moved to 45° counterclockwise from the rear tab, and then the entire centering magnet assembly should be rotated approximately 180° around the

*From RCA service notes.

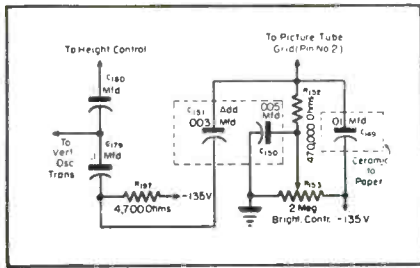

Fig. 2. Revised circuitry of Sylvania I-387 (chassis code CO3) which permits suppression of vertical retrace lines. Components in dotted portion are those which have been added; C156, a .01-mfd ceramic, has been omitted.

neck of the tube until the picture is again centered.

Centering Magnets

One type of centering magnet, currently employed, consists of two magnetic rings with four tabs, two attached to each ring. A second type consists of two small bar magnets attached to two discs of metal with an off center hole for the neck of the tube. This second type magnet should be assembled with the cardboard sleeve toward the yoke, the tabs upward and the tab closer to the yoke counterclockwise from the rear tab. This position appears to give the most nearly circular spot and best focus in the majority of cases. If the tabs on this second type centering magnet are approximately 90° apart, to obtain proper centering and if good focus cannot be obtained by the procedures outlined, then it may be advisable to replace the centering magnet.

If the picture focuses at the extreme counterclockwise end of the focus control, it may be due to leakage in the picture tube. If the picture focuses at the extreme clockwise end of the focus control, it may be due to leakage external to the picture tube or to a defective 1V2. If difficulty is experienced in centering the picture on the screen, it may be desirable to rotate the picture tube 180°.

Stromberg-Carlson Service Notes

Model 17 Series . . . Buzz or Whistle in High-Voltage Power Supply: Notes from the field indicate that cases of buzz or whistle in the high-voltage power supplies on these models can often be traced to vibration of the bakelite terminal board on the horizontal output transformer when part No. 161040 is used. These cases can usually be cured by tightening the long brass screw which clamps the assembly together. Apparently with age, the rubber washers used in assembly change resilience and allow the
(Continued on page 46)

Stimulate More Sales for BURGESS BATTERIES



USE THESE NEW BURGESS PROFIT AIDS IN YOUR STORE!

Highlight your Summer Fun



BURGESS BATTERIES
in your Portable Radio
CHROME PROTECTED For Longer Listening Pleasure

EYE-CATCHING WINDOW BANNER MAKES CUSTOMERS OUT OF PASSERS-BY!

This attractive new Burgess window streamer gets immediate customer attention—ties in with Burgess advertising in big national magazines and newspaper supplements with national circulation—reminds customers to buy fresh Burgess portable radio batteries for summer fun. Colorful red, black, yellow on durable stock.

Highlight your Summer Fun



BURGESS BATTERIES
IN YOUR Portable Radio
CHROME PROTECTED For Longer Listening Pleasure

ATTENTION-GETTING COUNTER CARD REMINDS TO BUY!

Folks just browsing through your store, and customers for other purchases, are reminded to buy Burgess when they spot this colorful red, black, yellow counter card. Printed on heavy cardboard stock with sturdy easel.

COUNTER MERCHANDISER SELLS THE PRODUCT!

This handsome little counter display takes up little space and displays portable radio battery XX45. This model is most used in the popular smaller portable radios. Consumer benefit printed at top prompts sales. Red, yellow and black.

Contact your jobber now for this material.



BURGESS BATTERIES

BURGESS BATTERY COMPANY • FREEPORT • ILLINOIS

has been necessary to standardize on an average developed *agc* voltage of 2.8 volts for all *if* alignment.

This level of injection voltage makes the factory alignment useable in most areas, without too much change in the overall curve due to varying signal levels. It is recommended that enough sweep voltage be used to develop 2.8 volts of *agc*. Most signal generators will have enough output on the *if* frequency range.

Admiral Service Hints

15.75 kc Radiation (Horizontal Oscillator): Whistles throughout the broadcast band can be caused by radiation from the horizontal sweep circuit of a television receiver using a metal-cone picture tube. These tubes do not have an *aquadag* coating on the inner and outer surfaces of the cone, as glass tubes do; these coatings act as an additional filter for the second anode supply and reduce radiation.

The addition of a 500-mmfd, 20-kv capacitor from the second anode lead to ground (after the filter capacitor in the *hv* housing) will reduce the radiation appreciably on receivers using metal cone tubes. Connections between the second anode lead and the bypass capacitor should be made carefully to avoid corona. Additional attenuation of the radiation can be obtained in some cases by installing a .1-mfd, 600 -v capacitor from each side of the *ac* line to ground.

12H6 Substitutions: Type 12H6s were used in 21B1 series chassis, and service replacements may be difficult to obtain, since this tube is no longer being manufactured. A 6H6 may be used in place of the 12H6 if the following changes to the heater circuit are made:

- (1) The wire from pin 7 of the 12H6 (V_{401}) socket, should be removed.
- (2) The wire should then be taped to prevent it from shorting to chassis.
- (3) A wire should then be connected from pin 7 of the 12H6 to pin 7 of the V_{401} socket.

Intermittent Contacts On Color TV Socket: Intermittent contact between the color plug and socket can cause no sound, or no sync or no picture, sound or raster. If the socket is suspected, the plug should be removed and the socket contacts tightened with a pair of pliers.

Hum-Buzz Elimination

According to field reports some Air King 700-93 chassis have been found

to have a considerable amount of hum or buzz. This can be cured by putting a shield over the glass 6SQ7, providing the 6SQ7 is of the metal ring base type. Substitution of a metal 6SQ7 will also have the same effect.

Critical Horizontal-Hold Control Action

Critical horizontal-hold control action or inability to adjust horizontal hold on Sentinel chassis have in some cases been traced to a leaky .05 mfd 600-volt feedback coupling capacitor, causing several resistors to change

value. These resistors are the 4,700-ohm type used in series with the capacitor, the 27,000-ohm unit used in the cathode of the 6AL5 phase detector, and the 5,600-ohm type used in the plate circuit of the horizontal oscillator tube.

High resistance leakage in the .05-mfd capacitor will place $B+$ on the 4,700-ohm and the 27,000-ohm resistors causing them to change value. The phase-detector circuit then places a greater amount of positive bias on the grid of the horizontal oscillator (Continued on page 58)

**Bendix
Television**

OR
6AC5
V13

**PRODUCT OF
Bendix
AVIATION CORPORATION**

TIME = PROFIT

The Bendix "Long-Range" Chassis is not only a powerful fringe area receiver but also a dependable unit. It was designed to provide all the time-saving, profit-making advantages of easy accessibility to controls, chassis and component parts.

The super-sensitive circuits, which provide the "Long-Range" chassis with peak performance and maximum operating efficiency of both picture and sound, are fully illustrated and described in the new Bendix Technical Data Handbook. Clear, concise schematics plus complete data provide quick, easy reference to all circuits, component parts and controls.

Designed to give the finest in TV reception, the Bendix "Long-Range" chassis assures greater profits by minimizing service problems.

FREE POCKET-SIZE TECH DATA HANDBOOK

It's yours for the asking . . . a new combination handbook and memo pad containing schematics and technical data covering both the Bendix Standard and "Long-Range" chassis.

Send me free schematics and tech data about BENDIX TV

Name _____
Company _____
Address _____
City, Zone, State _____

Fill Out This Coupon, Paste It To
Penny Postal Card, Mail It To
SERVICE DEPT. 88, BENDIX RADIO
BALTIMORE 4, MARYLAND

ASSOCIATIONS



ARTSNY

MEMBERS of the Associated Radio-Television Servicemen of New York have been notified that the classified telephone directory will list members under the ARTSNY trademark with semibold identities for name, address and telephone numbers, each listing costing \$1.50 a month.

Response to the plan has been enthusiastic.

PR SMA

ACCORDING TO A REPORT from James T. Daly, prexy of the Philadelphia Radio Service Men's Association, plans are being made to hold a convention and show, very similar to the type conducted last year.

Further details are expected to be released very soon.

RTTG, Florida

A NOTE from Thomas Middleton, serving as public relations chairman of the Radio and Television Technicians Guild of Florida, has disclosed that Bob Collins is president of the association. Other officers are: Orville Smith, vice president; A. Edward Stevens, treasurer, and Steven J. Petruff, secretary.

Coop Ad Campaign

Recently the group advertised in the *Miami Herald* in a cooperative venture. The advertisement contained the names of all of the members of the association, and noted the reliable service each member has pledged to provide.

TCA

AT A RECENT MEETING of the Television Contractors Association of New Jersey, held in East Orange, N. J., Gus Friedman of Argus Television and Radio, Newark, N. J., was elected president, and Lester Palmer of Palmer Television Service, West Orange, N. J., was named vice president. Ralph Terbush of Tele-Brothers, East Orange, N. J., was named executive secretary.

The meeting featured a discussion of a proposed advertising campaign which would educate the public on the complete facilities available in the shops of members of the association, and the ethical procedures employed in the conduct of the member's businesses.

Florida RTTG coop ad which appeared in a recent issue of the *Miami Herald*.

**THIS EMBLEM IS
YOUR ASSURANCE
OF RELIABILITY**

**ORGANIZED & CHARTERED
APRIL 28th, 1950**



MEMBERS OF THIS ORGANIZATION ARE PLEDGED TO RENDER QUALITY SERVICE AT FAIR & REASONABLE PRICES.

FOR THE BEST IN RADIO & TELEVISION SERVICE LOOK TO THIS EMBLEM IN YOUR SERVICE DEALER'S WINDOW.

DADE COUNTY CHAPTER

BELOW IS THE DEALER IN YOUR NEIGHBORHOOD WHO SUBSCRIBES TO THE ETHICS AND STANDARDS AS SET BY THE RADIO & TELEVISION TECHNICIANS GUILD OF FLORIDA, INC.

A & M APPLIANCE CENTER
129-36 N.W. 7th Ave.
Ph. 78-8920

O. J. BALIK RADIO & APPLIANCE
15 N.W. Le Jeune Rd.
Ph. 48-3664

COLLINS RADIO & SOUND CO.
2082 Grand Ave.
Ph. 48-3668

EDDIE'S RADIO SERVICE
3209 N.W. 7th Ave.
Ph. 3-6564

KESSLER'S RADIO TELEVISION & APPLIANCES
1521 S.W. 8th St.
Ph. 3-6811

LAWRENCE RADIO & ELECTRIC
2422 Ponce de Leon Blvd.
Ph. 48-3458

RAND RADIO
3117 N.W. 27th Ave.
Ph. 82-2088

SABAL PALM TELEVISION CO.
"Television Service Unlimited"
5253 N.E. 2nd Ave.
Ph. 64-1725

"ACCURATE" RADIO & TELEVISION SERVICE
3203 N.W. 17th Ave.
Ph. 2-6994

BEACH RADIO & TELEVISION SHOP
422 Espinola Way
Ph. 58-1188

DAVIS RADIO SALES & SERVICE
3203 N.W. 17th Ave.
Ph. 9-4888

GILBERTS RADIO & TELEVISION
15 N.W. 17th Ave.
Ph. 2-2717

LACKMAN RADIO—T.V. SERVICE AGENCY
2093 S.W. 67th Ave.

LOCKHART RADIO & T. V. SERVICE
11600 N.W. 12th Ave.
Ph. 78-9621

RYAN RADIO & TELEVISION CO.
1555 S.W. 8th St.
Ph. 2-4137

SHAN—THE RADIO MAN, INC.
119 N.W. 12th Ave.
Ph. 3-4930

ARMOR RADIO & SOUND SER.
220 - 12th St., M.B.
Ph. 58-1627

BUENA VISTA RADIO
86 N.W. 36th St.
Ph. 9-4216

DIETEL RADIO SERVICE
715 N.E. 125th St.
Ph. 7-4845

HAIGLER RADIO & TELEVISION
2316 S.W. Red Road
Ph. 87-1621

LEO'S RADIO SERVICE
714-16 5th St., M.B.
Ph. 58-0233

MIDD'S RADIO & T. V. SERVICE
2191 N.W. 89th St.
Ph. 7-4981

TED REINER RADIO & T.V.
"Ring Reiner for Radio"
3604 W. Flagler St.
Ph. 83-1342

DICK SMITHEY JR. RADIO SALES & SERVICE
3630 N.W. 2nd Ave.
Ph. 9-5869

TRAIL RADIO & TELEVISION
5805 S.W. 8th St.
Ph. 87-5550

ARROW TELEVISION
755 41st St., M.B.
Ph. 5-7664

BILL'S RADIO & APPLIANCE SERVICE
3243 S.W. 8th St.
Ph. 48-4691

EAGLE RADIO CO.
2286 N.W. 36th St.
Ph. 2-5210

HENSHAW RADIO SERVICE CO.
431 W. Flagler St.
Ph. 2-5293

LATTA RADIO
3052 E.W. 8th St.
Ph. 48-7434

PETRUFF RADIO SALES & SERVICE
588 N.W. 44th St.
Ph. 7-4386

ROSS RADIO & TELEVISION SERVICE
1164 S.W. 17th Ave.
Ph. 9-6350

UNITED RADIO & TELEVISION
8265 N.W. 7th Ave.
Ph. 7-6173

NETSDA

DAVE KRANTZ, representing PRSMA, has been named chairman of the publicity committee for the National Electronic Technicians and Service Dealers Associations, whose headquarters are at Dorchester House, Washington, D. C.

Currently NETSDA represents over 5000 radio and television Service Men and dealers affiliated with

(Continued on page 55)

TEN YEARS AGO

From the Association News Page of SERVICE, August, 1941

EMIL J. MAGINOT was honored at an RTG testimonial dinner at the Hotel Manger in Boston, and received a bronze plaque from Al Saunders on which was engraved: "Life Member, Radio Technicians Guild, Boston Chapter, Emil J. Maginot, 1941." It was also announced during the dinner that Maginot had been appointed technical sales engineer for National Union. . . . The Lawrence, Mass., chapter of RTG held their fourth annual outing with over 150 members in attendance. Those in charge of the event were: John Seditini, president; Howard C. Parker, committee chairman; and Robert C. Bingham, James A. Mulligan, Romuald Bernard, Herbert Stadler, Abraham Hyder, Almeric Dussault, and Herbert Grosser. . . . The third annual clambake of the Allentown, Pa., chapter of RSA was held at Feilbach's Grove. . . . F. S. Moiser was elected president of the Danville chapter of RSA. Others elected were: Ben Williamson, vice prexy; Evard Welch, secretary; Earl Drollinger, treasurer; Harry Longer, membership; G. R. McKinney, examiner; Lyal Cummings, advertising; Owen McArdle, program; and Cal Stapp, editor of the *Servicemen's Dirt* Ray B. Mould was elected president of the La Porte, Ind., chapter of RSA. Stanley A. Kubit was elected secretary-treasurer. . . . Clifford E. Denton, chairman of the radio educational commission of the advisory board on vocational education, delivered a talk on training Service Men in preparation for an emergency, before the Metropolitan New York chapter of RSA. . . . Ken Vaughn, the newly elected national president of RSA, attended a meeting of the Pittsburgh, Pa., chapter. . . . Robert Pickerell was elected president of the Tri-County, Pa., RSA chapter. Others elected were: Sam Miros, vice president; Christ Ashcraft, treasurer; and Blair Ressler, secretary.

FIRST IN LONG-RANGE PERFORMANCE!



REACH OUT FARTHER... AND BRING 'EM IN STRONGER!

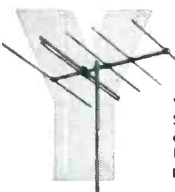

No. 5Y2-No. 5Y6

5-Element Low Band YAGI No. 5Y2-No. 5Y6 Series. Custom-cut to exact channel wave length, delivers more powerful forward gain.

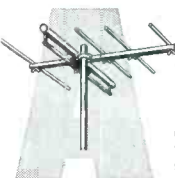

No. 5Y7-No. 5Y13

5-Element High Band YAGI No. 5Y7-5Y13. Breaking long distance records across the country. Outperforms! Out-sells!

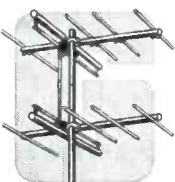

No. 5Y7S-No. 5Y13S

5-Element Stacked High Band YAGI No. 5Y7S-5Y13S. 1/4 wave-length stacked to produce still higher gain and reduced noise interference.

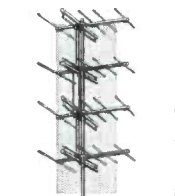

No. 5Y7DS-No. 5Y13DS

5-Element Double Stacked High Band YAGI No. 5Y7DS-5Y13DS. Designed to deliver ultra-high gain in "impossible" reception areas! Transposed 1/2 wave length jumper harnesses sharpen horizontal pattern.

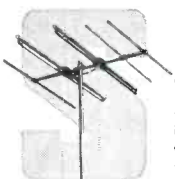

No. 5Y45

5-Element YAGI for Channels 4 and 5 No. 5Y45. Unique in performance! Economical in price. Provides 10 db gain on both channels 4 and 5. Compact in construction.

"Sky-Ranger" YAGIS are also available in most 4-element and 3-element array designs. Write for illustrated catalog No. 160 describing the complete JFD Sky-Ranger YAGI Line.

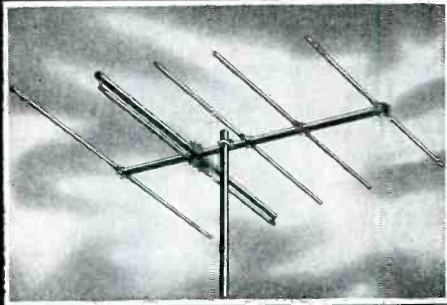

Completely pre-assembled!



- 1** 5-element beam custom-cut to exact channel wave-length affords unsurpassed forward gain.
- 2** Ruggedly constructed of heavy-wall, corrosion-resistant aircraft aluminum. 1" od driven element and crossarm.
- 3** Stepped-up driven element provides direct match to 300-ohm impedance.
- 4** Narrow beam width pin-points distant stations and delivers high signal-to-noise ratio.
- 5** Special jumper harnesses permit stacking on all low band channels.

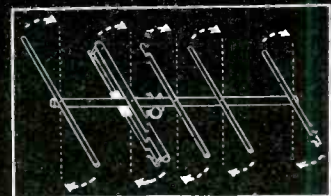

Snap "Quik-Rig" elements into position and tighten wing nuts for instant assembly.

See us at Booth No. 113-115 at the NEDA Show



JFD MANUFACTURING CO., Inc.
6109 H 16th Avenue, Brooklyn 4, N. Y.

FIRST in Television Antennas and Accessories

New TV Parts...Accessories

PERFECTION ELECTROSTATIC-TUBE CENTERING ASSEMBLY

A picture-centering device, the *Kine-Center*, for electrostatic picture tubes, which use no focus coil, has been introduced by the Perfection Electric Co., 2635 South Wabash Ave., Chicago, Ill.

Unit consists of two metal rings, which can be rotated independently to adjust picture and center it. Rings are mounted on a form that can be clamped to the neck of the tube. Rings are said to be stabilized magnetically.

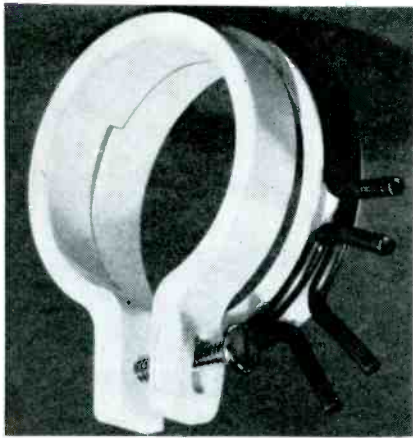

* * *

RAM TRANSFORMERS FOR COLOR TV

A line of flyback transformers and deflection yokes for use with the field-sequential color system, has been announced by Ram Electronics Sales Co., South Buckhout St., Irvington-on-Hudson, N. Y.

* * *

E-V AUTOMATIC TV BOOSTER

An automatic, all-channel TV booster, model 3010, the *Tenna-Top* that mounts at the antenna top ahead of the lead-in, has been announced by Electro-Voice, Inc., Buchanan, Michigan.

Featured is a junction control box that may be concealed behind the TV receiver and plugged in between receiver and electric outlet. Can be used with or without an antenna rotator.

Includes four 6J6 rf amplifiers. Unit is $7\frac{1}{4}'' \times 7\frac{1}{8}'' \times 6''$. Junction box is $6\frac{3}{4}'' \times 3\frac{1}{8}'' \times 4\frac{3}{4}''$.

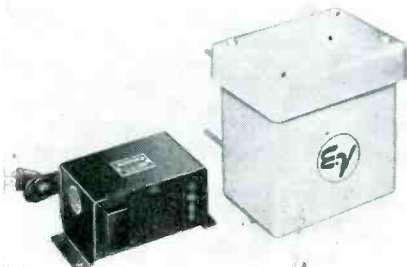

SUPERIOR TV BAR GENERATOR

A TV generator that throws a bar pattern on a receiver screen, has been announced by the Superior Instruments Co., 227 Fulton St., New York 7, N. Y.

Unit provides a linear pattern to adjust vertical linearity, height and centering as well as horizontal drive, width, peaking, linearity and centering. Vertical sweep signal permits adjustment and synchronization of vertical oscillator discharge and output tubes. Also provides a vertical signal to replace the vertical oscillator to check vertical amplifier operation.

Horizontal sweep signal can be used for adjusting and synchronizing the horizontal oscillator *afc* and output tubes, and to check the *hvc* section of fly-back and pulse operating power supplies. Tests are said to be possible when no station is on the air.

Unit supplies twelve fixed vertical lines, four to twelve variable horizontal lines, vertical sweep output of 60 cycles and horizontal sweep output of 16,750 cps.



* * *

FINNEY CO-LATERAL TV ANTENNA

A TV *co-lateral* type antenna, model 400, that is said to provide all-channel coverage in remote fringe areas of up to 100 miles or more, has been announced by the Finney Corp., 4612 St. Clair Ave., Cleveland, Ohio.

Featured is a co-linear arrangement of elements consisting of twelve driven and twelve parasitic on the high band and eight driven and four parasitic on the low band, that is claimed to produce narrow patterns with high gain and high signal-to-noise ratio.

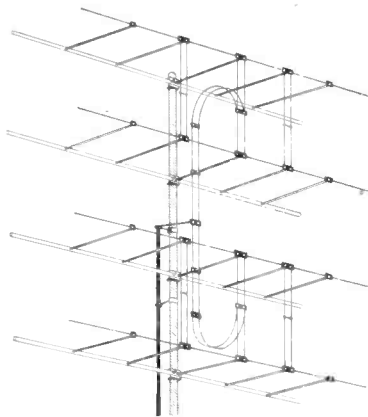

STANCOR HORIZONTAL DEFLECTION-HV TRANSFORMER

A TV replacement unit, the *A-8130* horizontal deflection output and high voltage transformer, that may be used for conversion, has been announced by the Standard Transformer Corp., Chicago, Ill.

Unit is for use in pulse-operated single-rectifier power supplies to deliver up to 14,000 volts of anode potential with a sweep for horizontal scan of 65-70° picture tubes having up to 24-inch screens. Requires 3-27 mh width control coil. Overall height of the unit is $4\frac{1}{8}''$ with a base area of $2\frac{7}{8}'' \times 2\frac{1}{8}''$.

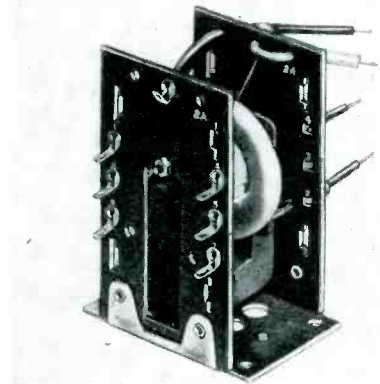

* * *

MERIT COSINE YOKES

Cosine yokes, *MDF-70* and *MDF-30*, are now available from the Merit Transformer Corp., 4427 N. Clark St., Chicago, Ill. Yokes are equipped with network and leads.

MDF-70 has a distributed winding for edge-to-edge picture focus, and a ferrite core for use with all picture tubes up to and including 24" where they require 70° deflection. Recommended for use with *HVO-6* and *HVO-7* ferrite core flybacks.

MDF-30 is of the same design as *MDF-70*, but has high-horizontal and low-vertical inductance for use with *HVO-8* air core flyback in direct drive systems.

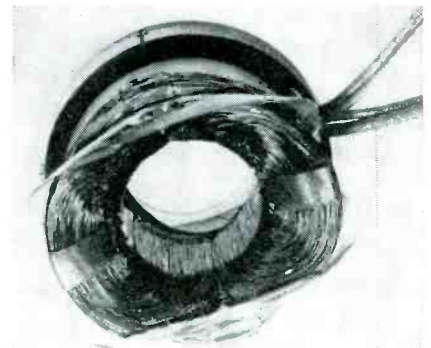

WARD PARA-CON ANTENNA

An antenna, *Para-Con*, that is said to combine parabolic and conical designs in one antenna, has been developed by Ward Products Corp., Cleveland 3, Ohio.

Antenna features parabolic reflectors which are claimed to pick up and concentrate additional energy onto the driven elements. High front-to-back ratio eliminates co-channel interference.

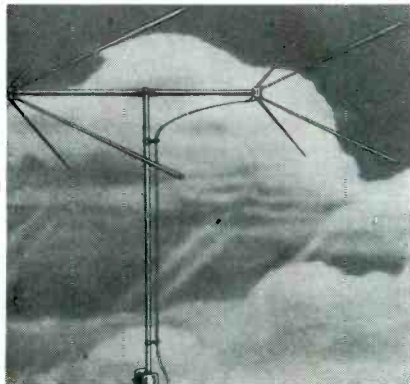

* * *

JFD TV PICTURE CLARIFIER

An E-Z picture clarifier that is said to filter out FM image and amateur harmonic interference, has been announced by JFD Manufacturing Co., Inc., 6101 Sixteenth Ave., Brooklyn 4, N. Y.

Clarifier is installed by connection to the input terminal of set and adjusted until picture clears.

Four models are available: *BR120-10-30*—filters out amateur harmonic interference from 14 and 28-mc bands; *BR120-80-110*—filters out FM image interference; *BR120-30-60*—filters out amateur harmonic interference from 30 to 60 mc, and *BR120-60-90*—filters out diathermy interference from 60 to 90 mc.

* * *

INDUSTRIAL TV ANTENNA CLIP

A clip, the *Tenna-Clip*, which provides contact to standard screw-type 300-ohm line antenna posts, is now available from Industrial Television Inc., 359 Lexington Ave., Clifton, N. J.

* * *

EASY-UP LEADIN TESTER

A device for locating breaks in 300-ohm twinline leadins, the *Twin-Test*, has been announced by Easy-Up Tower Co., Racine, Wis. Unit is said to indicate the exact location of the break by means of a light, while connected to any type of antenna, in opened or closed circuit.

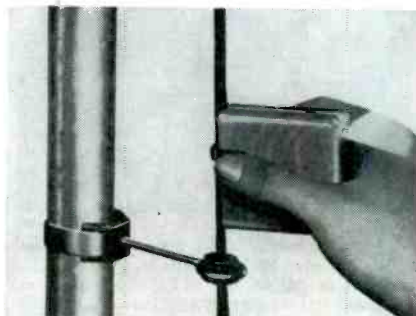

[Additional new-product news on pages 70 and 71.]

Introducing... SHURE BROTHERS, INC.

Direct Drive

A new SHURE family of crystal and ceramic fine-groove and standard cartridges

SPECIAL CRYSTAL MODEL W31AR and Ceramic Model WC31AR are unsurpassed for replacement of RCA "45" R.P.M. Changer Cartridges (ideal for 33 1/3 R.P.M. too!)

Unique needle design provides the easy needle replacement everybody has been looking for—and protects cartridge from mechanical shock.

THESE NEWLY DEVELOPED CARTRIDGES PROVIDE:
Easy Cartridge Installation • Maximum Fidelity • Easy Needle Replacement

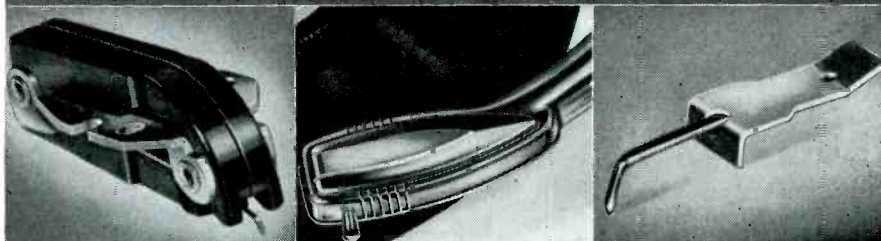

Universal, light-weight aluminum mounting ears will fit either 1/2" or 3/8" mounting.

Response-frequency characteristic designed to complement record response for maximum fidelity and minimum noise.

New, specially designed needle with broad shank and finger-nail grip bar. Long-life osmium point.

THIS NEWLY DEVELOPED SERIES OF CARTRIDGES

is the last word for first-place reproduction at low cost. So easy to install, the Serviceman will ask for them over and over again. High vertical compliance of the especially designed needle protects the crystal and ceramic elements from "drop-shock" damage.

Model	Type	List Price	Output Voltage	Needle Force	Shure Needle No.	Code
W31AR	Crystal 33 1/2 & 45 R.P.M.	\$6.50	2.1 V	7 grams	A53MG	RUGEB
WC31AR	Ceramic 33 1/2 & 45 R.P.M.	6.50	.65 V	7 grams	A53MG	RUGED
WC33B	Ceramic 78 R.P.M.	6.50	.75 V	9 grams	A52A	RUGEL
W36B	Crystal All-Purpose	6.50	2.5 V	9 grams	A56U	RUGEN
WC36B	Ceramic All-Purpose	6.50	.7 V	9 grams	A56U	RUGER

Shure Patents Pending.
Licensed Under Patents of Brush Development Co.



SHURE BROTHERS, Inc. ★

Manufacturers of Microphones and Acoustic Devices

225 W. Huron St., Chicago 10, Illinois • Cable Address: SHUREMICRO

another

JENSEN NEEDLE

first...



The JENSELECTOR

FOR FAST, EASY, REPLACEMENT
NEEDLE SELLING



PICKS THE PROPER NEEDLE

This new Jensen Needle Guide will give the exact replacement needle number for any type record player without knowing the model or cartridge number. See your distributor or write to Jensen for your "Jenselector."

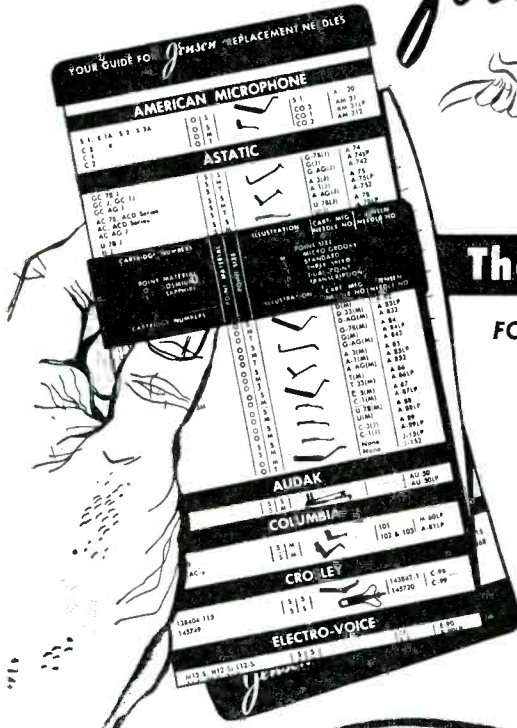

JENSEN NO. 32 DEALER PACK gives you a balanced assortment of 32 best proven sellers. Packaged in an attractive, useful plastic box that contains an automatic inventory feature.

Jensen INDUSTRIES, INC.
331 S. Wood Street, Chicago 12, Illinois

CANADIAN BRANCH
1200 Bay Street, Toronto 5, Ontario



Audio

(Continued from page 34)

livered to each of the adjacent frequency channels when all channels are terminated in the loads specified.

Cutter: An electromechanical transducer which transforms an electrical input into a mechanical output, typified by mechanical motions which may be inscribed into a recording medium by a cutting stylus.

DC Erasing Head: In magnetic recording, one which uses *dc* to produce the magnetic field necessary for erasing. *DC* erasing is achieved by subjecting the medium to a unidirectional field. Such a medium is, therefore, in

a different magnetic stage than one erased by alternating current.

Directivity Factor: (a) The directivity factor of a transducer used for sound emission is the ratio of the intensity of the radiated sound at a remote point in a free field, on the principal axis, to the average intensity of the sound transmitted through a sphere, passing through the remote point and concentric with the transducer.

(b) The directivity factor of a transducer used for sound reception is the ratio of the square of the electromotive force produced, in response to sound waves arriving in a direction parallel to the principal axis to the mean

square of the electromotive force, that would be produced if sound waves having the same frequency and mean-square pressure were arriving at the transducer simultaneously from all directions with the random phase.

Doppler Effect: The phenomenon evidenced by the change in the observed frequency of a wave in a transmission system, caused by a time rate of change in the effective length of the path of travel between the source and the point of observation.

Frequency-Response Equalization: The effect of all frequency discriminative means employed in a transmission system to obtain a desired over-all frequency response.

Gradient Microphone: A microphone, the output of which corresponds to a gradient of the sound pressure. (Gradient microphones may be of any order as, for example, zero, first, second, and so forth. A pressure microphone is a gradient microphone or zero order. A velocity microphone is a gradient microphone of order one.)

Mathematically, from a directivity standpoint for plane waves, the *rms* response is proportional to $\cos n\theta$, where θ is the angle of incidence, and n is the order of the microphone.)

Magnetic Powder-Coated Tape (Coated Tape): A tape consisting of a coating of uniformly dispersed, powdered ferromagnetic material on a non-magnetic base.

Magnetic Tape: A magnetic recording medium having a width greater than approximately 10 times the thickness. This tape may be homogeneous or coated.

Magnetic Wire: A magnetic recording medium, approximately circular in cross section.

CASH-CARRY SERVICE SHOP

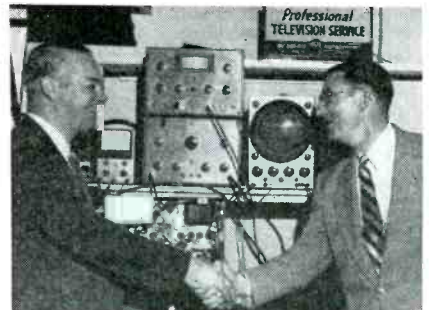

Mort Farr, Philadelphia TV service shop operator, being greeted by Vic Williams (right), RCA renewal sales rep in the Philadelphia area, as he installs test equipment in Farr's cash and carry shop. Farr services TV sets dropped off by owners on their way to work in the morning, and strives to have them repaired and ready for pickup the same evening.

Tape Recorder

(Continued from page 36)

put requires approximately .25 volt for full eye closure. Heater current for the first two stages is filtered *dc* to keep hum to a low level.

Playback Amplifier

The playback amplifier consists of one-half of a 12AX7 high-gain stage, feeding another 12AX7 cascade amplifier with both low frequency and treble equalization. The gain control is located between the first and second stages. Due to the extreme deficiency of low frequencies in the output of magnetic tape the gain must be much greater at the lower frequencies. To accomplish this, an *rc* network consisting of a 2-megohm resistor, .003-mfd capacitor and 5600-ohm resistor is used to alter the response curve of the amplifier. A small trimmer capacitor across the series resistor (2 megohms) allows for fine adjustment of the high-frequency gain.

The output stage is a modified cathode follower with considerable cathode degeneration. This reduces the distortion, and with the addition of the cathode bypass capacitor (.002) helps make the output insensitive to capacitive loading, by the shielded cable used to connect the unit to the power amplifier.

The output voltage is between 1 and 2 volts *rms* as measured with a high-impedance *vtvm*.

The heaters are energized with filtered *dc* to keep hum to a minimum. Microphonics due to tubes are minimized by a shock suspension holding the amplifier into the recorder.

The plate resistor used in the first stage plate circuit is of a special low-noise type. Other resistors used in the amplifier, while not of the *low-noise* type, must be reasonably quiet, due to the very high gain inherent in a tape machine.

If the amplifier-noise output increases after a period of use or storage, it is important to check the tubes first, and then the resistors. A noisy resistor can be detected by an irregular frying noise of a generally lower pitch than that due to tube hiss. Some tube hiss is always present in a normal amplifier and should not be mistaken for defective components. A leaking capacitor can cause a resistor to appear noisy due to the abnormal direct current allowed by the leaking capacitor. The .003-mfd capacitor in the *rc* equalizer circuit is the most critical

(Continued on page 54)

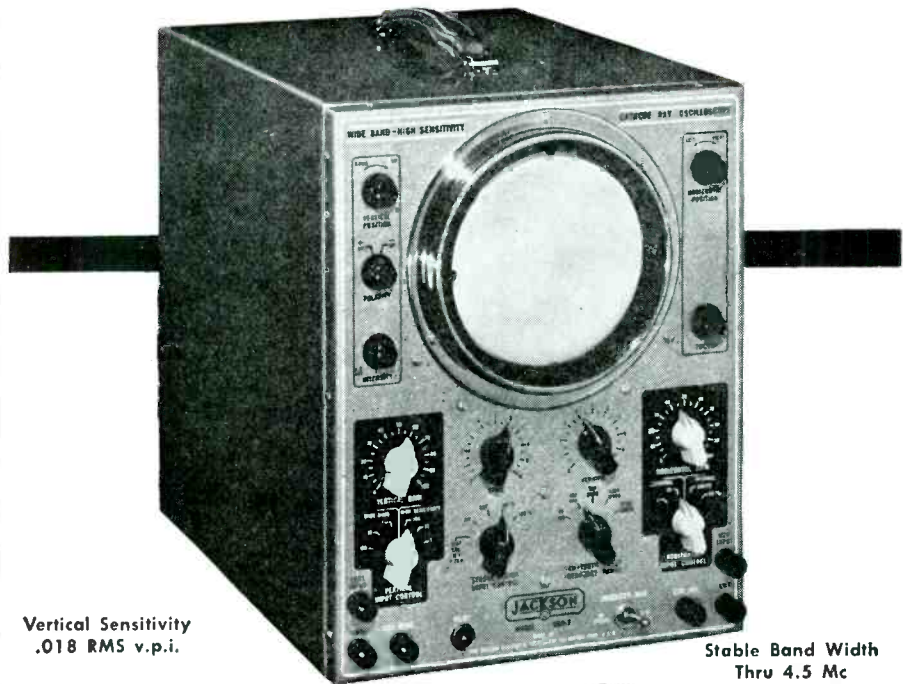

Vertical Sensitivity
.018 RMS v.p.i.

Stable Band Width
Thru 4.5 Mc

JACKSON Oscilloscope gives you "dual service"

This is a high-quality, laboratory-grade 5" Oscilloscope that provides the "dual service" of both high sensitivity and wide band width.

specifications

Vertical Amplifier—Video-type frequency compensation provides flat response within 1.5 db from 20 cycles thru 4.5 Mc, dropping smoothly to a still useful value at 6 Mc.

Sensitivity Ranges—With a band width of 20 cycles thru 100 Kc, the sensitivity ranges are .018, .18, 1.8 RMS volts-per-inch. The wide band position 20 cycles thru 4.5 Mc has sensitivity ranges of .25, 2.5, 25 RMS volts-per-inch.

Horizontal Amplifier—Push-pull with sensitivity of .55 RMS volts-per-inch.

Input Impedances—Vertical: 1.5 megohms shunted by 20 mmfd. Direct to plates, balanced 6 megohms shunted by 11 mmfd. Horizontal: 1.1 megohms.

Linear Sweep Oscillator—Saw tooth wave, 20 cycles to 50 Kc in 5 steps. 60 cycle sine wave also available, as well as provision for using external sweep.

Input Voltage Calibration—Provides a standard voltage against which to measure

voltages of signal applied to vertical input.

Vertical Polarity Reversal—For reversing polarity of voltage being checked or for choosing either positive or negative sync. voltages.

Return Trace Blanking—Electronic blanking provides clear, sharp trace to prevent confusion in waveform analysis.

Synchronizing Input Control—To choose among INTERNAL, EXTERNAL, 60 CYCLE, or 120 CYCLE positions.

Intensity Modulation—60 cycle internal or provision for external voltage for intensity modulation uses.

Additional Features—Removable calibration screen—Accessory Model CR-P Demodulation Probe for Signal Tracing—All-steel, gray Ham-R-Tex cabinet. Total net weight only 26 pounds. Same height as other Jackson TV instruments: 13" H x 10 1/4" W x 15 1/8" D.

Prices: Model CRO-2, Users' Net \$197.50.
Model CR-P Probe, Users' Net \$9.95.

TWO OTHER FINE JACKSON INSTRUMENTS

Model 655 Audio Oscillator



Sine-wave 20 cycles to 200,000 cycles. Less than 5% harmonic distortion between 30 cycles and 15,000 cycles. Frequency calibration accurate within 3% or 1 cycle. Hum level down more than 60 db of maximum power output. Output impedances of 10, 250, 500, 5000 ohms or Hi Z resistive output.

Model TVG-2 TV Generator



Sweep Oscillator in three ranges from 2 Mc thru 216 Mc. all on fundamentals. Reversible sweep direction. Sweep width variable. 1 Mc thru 18 Mc. Marker covers 4 Mc thru 216 Mc. Crystal Oscillator to use as Marker or Calibrator. Video Modulation, from external source for using actual video signal for check, or for use with Audio Oscillator to produce bars for linearity checks.

See your electronics distributor for more information, or write

JACKSON ELECTRICAL INSTRUMENT CO. • DAYTON 2, OHIO

"Service Engineered" Test Equipment
IN CANADA: THE CANADIAN MARCONI CO.

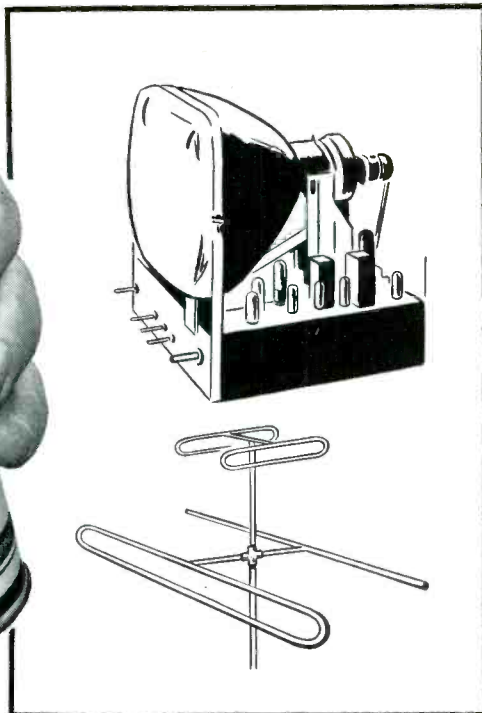

PREVENT CORONA

in high voltage circuits with



ACRYLIC SPRAY

Advertised in
The SATURDAY
EVENING POST

Spray on antenna and lead-in terminals, too; Krylon prevents corrosion and pitting

Krylon is an acrylic spray — not a vinyl plastic. Spray it, right from the 12 oz. aerosol can, on the high voltage coil and insulation... in the socket of the high voltage rectifier... on component parts of the high voltage rectifier circuit. Krylon dries in a few minutes to form a permanent protective coating of high dielectric strength.

Both inside the set and on the antenna, Krylon seals and protects... makes TV sets perform better, longer... cuts down service calls... builds customer good will. Two types — clear (list \$1.95) and nonconducting aluminum (list \$2.25). Also in gallons for application by brushing or dipping. See your jobber, or write direct.

KRYLON, Inc. Dept. 610
2601 North Broad St. Philadelphia 32, Pa.

Tape Recorder

(Continued from page 53)

and should be suspected first in case of noise.

Equalization

Unequalized output of a tap-reproducing head is proportional to frequency up to the point of optimum output (around 3 kc at 15 kc per second) and inversely proportional to frequency above that point. To secure flat overall response, it is necessary to use amplifiers with drastically altered characteristics. Most of the treble

boost required appears in the record amplifier and the bass boost in the playback amplifier. This system has been found to work out very well in practice as the drooping playback curve attenuates the hiss inherent in the tape output and thermal noise in the amplifier.

The bass boost built into this unit's playback amplifier (around 30 db) will not vary appreciably with time and wearing heads and has therefore not been made adjustable. The treble response, on the other hand, is something liable to change for various reasons, including head wear and has therefore been made adjustable over a

wide range in the playback amplifier.

There are three magnetic heads in the apparatus, mounted by adjustable saddles, to allow for azimuth correction.

Frequency Checks

In music, substantially all frequencies above 4000 cycles are overtones of fundamental notes of lower frequency. These overtones are of greatly diminished amplitude. The amount of equalization required in a recording amplifier to correct for tape characteristics is considerable. Consequently it becomes necessary to run frequency checks at very low input levels so that this full equalization can be realized within the limits of the overall gain of the amplifier.

In checking this recorder for frequency response it is necessary to use a signal generator known to be of constant output voltage, 20 to 15,000 cps, with a good signal-to-noise ratio at .003 to .005 volt output or one properly attenuated to give this output. Also required is a db meter capable of indicating accurately —20 db or lower to +3 db or higher; a monitoring amplifier of flat response from 20 to 15,000 cps, with a terminating resistor of low value across the output transformer and voice coil, to dampen the effect of resonances in the speaker; and low-loss shielded leads between units which do not affect the readings 20 to 15,000 cps.

In application, the output of the signal generator (.003 to .005 volt) should be connected to the high input, making sure that the low input jack is shorted. Then the output should be connected to the input of the monitoring amplifier, and the db meter connected across the resistor, which is across the output transformer of the amplifier and also across the voice coil of the speaker.

Now, the record-standby-playback switch is set on record, the record control is set full on, and the playback control full on. Next, a 15-inch speed is selected and the signal generator set to 500 cycles output, .003 to .005 v.

The equipment is then placed in operation and the monitoring amplifier control set to give audible output; record 500 cycles for about 30 seconds. Recording should follow for about 10 seconds each of the following frequencies: 20, 50, 60, 75, 100, 200, 500, 1000, 3000, 5000, 7000, 9000, 10,000, 12,000, 13,000, 14,000 and 15,000 cps. Then the recorder should be stopped and the record-standby-playback switch set to playback position. Tape should be rewound and the recorder placed in operation again with output set on 500 cycle note first recorded to zero db output on db meter. Each of the

other tones recorded should be identified and reading of db meter noted.

Readings should not vary more than ± 2 db from 500 cycles zero level. Reading at 2500 cycles should be zero to +1 db if treble control is adjusted properly. Frequency check on $7\frac{1}{2}$ -inch speed should be made in exactly the same way, but only to 10 kc.

Plug-In-Booster

(Continued from page 22)

bandwidth was not found to affect the receivers' efficiency.

If a set needs additional gain in either the video or sound *if* strips, it is possible that this booster will supply the gain required. It must be remembered that boosters must be selected to correct a particular complaint. What might be the cure in one case would cause no improvement in others. The Service Man must evaluate the situation carefully and provide the best remedy. In many instances, the plug-in booster will provide an effective solution.

Associations

(Continued from page 49)

the following associations: The Federation of Radio Servicemen Association of Penna., Empire State Federation Radio Servicemen Association, Philadelphia Radio Servicemen Association, Mid-State Radio Technicians Association, Lackawanna County Radio Technicians Association, Allied Television Technicians Association of South Jersey, Belair County Association Radio Service Engineers, Television Associates of Washington, D. C., Associated Radio and Television Servicemen of New York City, Long Island Radio Technicians Guild, Southern Tier Chapter of Radio Servicemen Association of Binghamton and the Endicott Technicians Association.

RCA SERVICE COMPANY BRANCHES HONORED



Frank M. Folsom (third from right), president of RCA, awarding *president's cup* trophies to four television service branches of the RCA Service Co., for *extraordinary achievement* in maintaining customer satisfaction during a three-month campaign recently concluded: R. L. Barnes, Easton, Md.; K. D. Hallberg, Omaha; O. H. Bowers, Toledo; and T. M. Hermida, Flushing, N. Y. At left, E. C. Cahill, president of the RCA Service Company.

*Your complete needs
in two cartridges!*

The **NEW**
two-needle, three-speed
replacement
cartridge . . .

model
AX

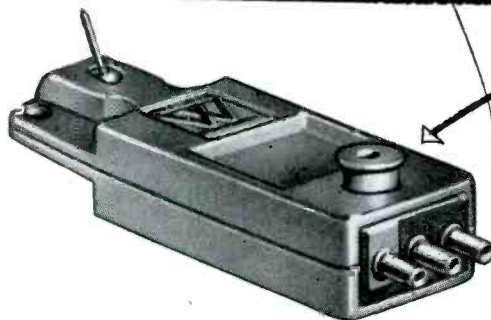
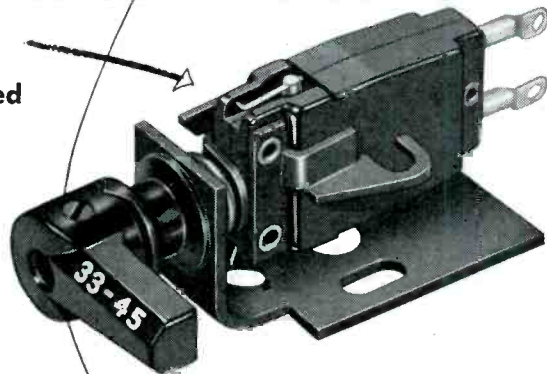

The 78 RPM
replacement cartridge
"Featheride"
model **WS**

The model **AX**

Replaces 90% of today's two-needle, three-speed cartridges. It is a complete unit, including twist mechanism, cartridge, needles and instructions for installing in any standard $\frac{1}{2}$ " mounting. Model AX twist mechanism is easily removed when cartridge is to be installed in tone arms in which such mechanism is an integral part. Double-protected against moisture by the Dri-Seal crystal and Dri-Pack packaging.

This one two-needle, three-speed replacement cartridge ends the need for replacement charts and big inventories.

Write for descriptive folder to Webster Electric Company, Racine, Wisconsin. Established 1909.

The model **WS**

Here's the cartridge that replaces more than 100 different types for 78 RPM records. It can be installed on any $\frac{1}{2}$ " standard RMA tone arm. The one cartridge develops either $1\frac{1}{2}$ volts or 4 volts at $\frac{3}{4}$ ounce tracking pressure. The Model WS is furnished complete with rest button, terminal clips, extra needle screws, a factory-tested, osmium-tipped removable needle and instructions for installing. The Dri-Seal protected crystal and the exclusive Dri-Pack container assure a cartridge always ready to deliver peak performance.

Featheride cartridges are made by Webster Electric Company, Racine, Wisconsin. Established 1909.



WEBSTER ELECTRIC
RACINE ♦ WISCONSIN

"Where Quality is a Responsibility and Fair Dealing an Obligation"

ONE STANDARD - *The best that can be made -* For Initial Equipment and Replacement



TUNG-SOL
RADIO, TV TUBES, DIAL LAMPS

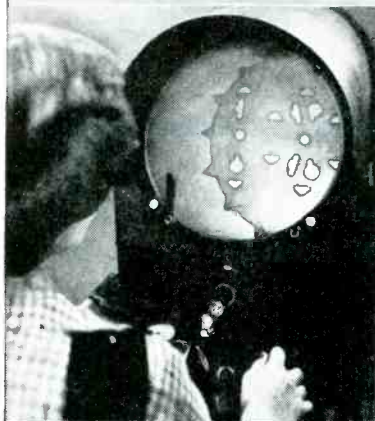

Optical comparator is used to check mica disc specifications to thousandth-inch accuracy.

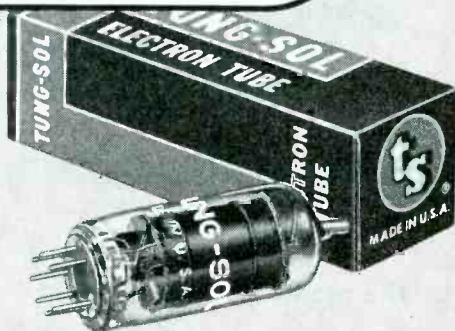

TUNG-SOL LAMP WORKS INC., Newark 4, N. J.

Sales Offices: Atlanta • Chicago • Dallas • Denver • Detroit • Los Angeles • Newark

Tube News

(Continued from page 42)

cuit. In the blocking-oscillator discharge circuit, the duration of the grid pulse is a function of the resonant frequency of the blocking-oscillator transformer. This resonant frequency can be lowered by adding external capacitance across the transformer, although redesign of the transformer would be desirable to maintain a high l to c ratio. If capacitance is added, some shunting resistance may be required to lower the Q of the coil so as to pre-

vent *double triggering* of the blocking oscillator.

Adjustment of Peaking Amplitude

The theoretical value for minimum retrace pulse can be approached only if the duration of the peaking pulse equals the desired retrace time and if the amplitude of peaking is properly adjusted. Amplitude variation should not be used to adjust retrace time. The amplitude of the peaking has some effect upon retrace duration, but when the amplitude is varied to obtain a desired retrace time, the minimum theoretical voltage corresponding to that

retrace time can not be approximated.

The shape of the waveform at the yoke or plate of the vertical-output tube is a good criterion for the adjustment of peaking amplitude. Alternatively, the point of correct adjustment may be judged through observation of the picture-tube raster. When the peaking is properly adjusted, the spacing of the first few lines at the top of the raster is practically equal to the spacing of the next few lines below. Wider spacing indicates too much peaking; cramping or fold-over at the top of the raster indicates too little peaking.

Effect of Peaking Waveform

The ideal condition for minimizing the pulse voltage is to make the retrace slightly faster at the beginning than near the end. Most conventional circuits tend to cause this type of non-linearity. Blocking oscillators, in fact, normally cause the retrace to be too nonlinear. Waveforms, obtained with a conventional blocking oscillator, show that the peaking pulse has a greater amplitude at the beginning of peaking. This greater amplitude reduces the damping on the vertical-output transformer and permits the retrace to be very fast at the beginning with the result that the retrace pulse is much larger than it should be. The shape of the peaking pulse in a circuit containing a blocking oscillator results from the fact that, during conduction, the *resistance* of the blocking-oscillator tube is varying. The variation is caused by the excessive slope of the voltage waveform at the grid. This slope may be reduced by inserting a resistor of approximately 100,000 ohms in series with the grid of the tube. It may be desirable to insert this resistor at the tube socket to minimize electrostatic coupling to the grid circuit and possible loss of interlace.

Picture Tube as Aid to Adjustment

Observation of the vertical-retrace lines in the picture can be useful in circuit study in a number of ways. For instance, the retrace time can be accurately measured by counting the retrace lines. Because each line represents one horizontal-scanning period, the number of retrace lines divided by 525 and multiplied by 100 yields the retrace time in per cent of the vertical-scanning period. The raster should be interlaced for this measurement. In addition, the relative spacing of the retrace lines is a good indication of the linearity of vertical retrace. The retrace should appear quite linear. The degree of nonlinearity requisite for minimum pulse voltage is not sufficient

to be readily visible to the eye on the picture.

Picture-Tube Phosphors*

Phosphors have the unique property of converting ultraviolet rays, fast-moving electrons, and alpha, beta, and gamma radiations into visible light. In fluorescent types of phosphors this conversion is practically instantaneous; in phosphorescent types, the exciting energy is stored within the phosphor crystal and released as light over an appreciable time interval. This storage phenomenon is termed persistence. Other important characteristics of phosphors are stability, efficiency of energy conversion, particle size, and luminescent color. These characteristics are present in varying degrees in an extensive variety of phosphors.

Phosphor Application Techniques

Four methods of applying phosphors are in general use, namely, settling, spraying, silk screen, and flow.

In the settling method, a suspension of the phosphor material in water is used.

Spraying Method

In the spraying method, a suspension of the phosphor material in a solution containing an organic binder, such as nitrocellulose or acrylic resins, is used. This method is particularly useful when the luminescence is viewed from the excited side. The spraying method may also be used for the application of silicate phosphors onto a cathode-ray tube screen, provided contrast is not an important requirement.

Automatic, Self-Focusing Electrostatic Picture Tube

A self-focusing electrostatic TV picture tube is now available from Thomas Electronics, who have announced that the tube operates on a low voltage, is unaffected by normal line voltage changes or anode voltage fluctuations and will not drift out of focus.

Tube is said to be directly replaceable with any tube presently in use. Using a standard five pin socket, it operates at the same tube ratings and operating conditions as the standard electromagnetic type.

CORRECTION

THE ILLUSTRATION which appeared with a description of the Taco isolation box in the July issue of SERVICE, actually represented a channel converter, developed to convert a highband channel to a lowband channel in the master-antenna amplifier systems, recently announced by the Technical Appliance Corp., Sherburne, N. Y.

You may wonder why
I'm sending you this . . .

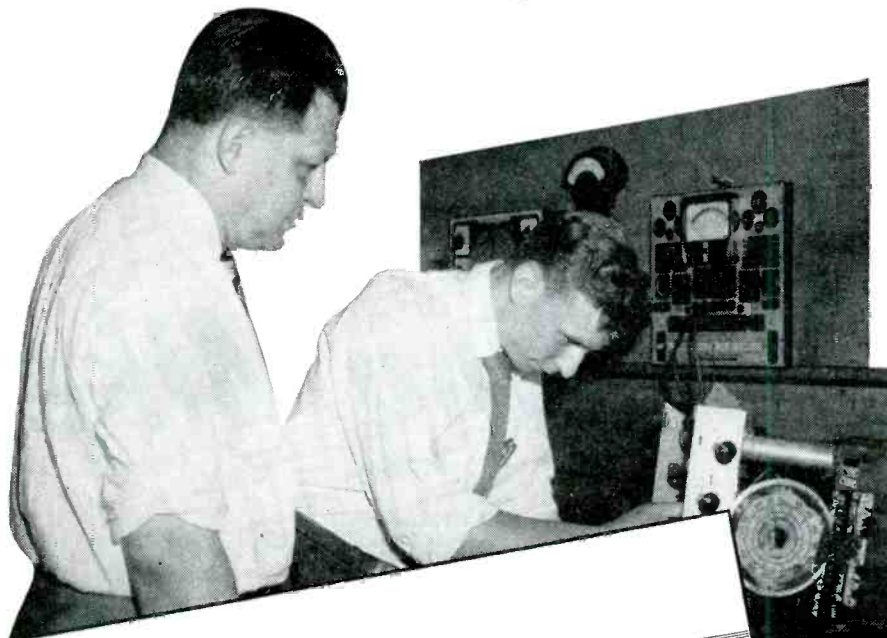

RADIO - TELEVISION
Repairs and Installations TELEPHONE
HYACM 7-5506

MADLINGER • 299 DEVOT ST.
BROOKLYN, N. Y. February 13, 1951

Workshop Associates, Inc.
135 Crescent Road
Needham 94, Massachusetts

Gentlemen:

Ever since you first advertised your DUBL-VEE antenna, I've been installing nothing else after I saw the results. In quite a few fringe areas the reception I received was a little short of perfect. As you know, channel 9 and 13 are generally the toughest stations to receive in the Metropolitan area. However, after installing this antenna I had no difficulty. The clarity and definition received on 9 and 13 was as good as any channel on the air. I doubt whether there is an antenna on the market today which can compare with your DUBL-VEE.

You may wonder why I'm sending you this complimentary letter. Well after using the antenna so often and getting the same excellent results, I can't help but tell you the engineering genius I see in this antenna.

Sincerely yours,
W. Madlinger
William Madlinger

We might add that the Workshop DUBL-VEE is the original patented DUBL-VEE antenna. For outstanding TV reception be sure to specify it.

The WORKSHOP ASSOCIATES

DIVISION OF THE GABRIEL COMPANY

Specialists in High-Frequency Antennas

135 Crescent Road, Needham Heights 94, Massachusetts





C-D's Tiny Mike

—the ceramic with the
million dollar body!

Never before such uniformity, such dependability in ceramic capacitors! TINY MIKE is C-D through and through. Even the ceramic body is made by C-D, in its brand new ceramic body plant, electronically controlled at every stage!



Write for Catalog Dept. S-81
Cornell-Dubilier Electric Corp.
South Plainfield, N. J.

CONSISTENTLY DEPENDABLE CORNELL-DUBILIER CAPACITORS

Plants in South Plainfield, N. J., New Bedford, Worcester and Cambridge, Mass.; Providence, R. I.; Indianapolis, Indiana; Fuquay Springs, North Carolina, and subsidiary, The Radiart Corporation, Cleveland, Ohio.

Servicing Helps

(Continued from page 47)

tube, resulting in increased current through the 5,600-ohm plate resistor which changes its value.

Distorted or Weak Sound

Early Sentinel models (419, 420, 423, 424, 425 and 428) have been found to suffer from distortion or weak sound occurring after set has been in operation approximately a week or ten days. It has been traced to drifting of the discriminator transformer.

The discriminator drift can be cor-

rected by adjusting the discriminator secondary trimmer screw located on top of discriminator coil shield can. The discriminator secondary adjustment screw should be adjusted for both minimum buzz and clearest sound. It is important to be sure that this position is between the two maximum buzz peaks that will be noticed when the adjusting screw is turned to the right or left of the minimum buzz position.

In current and future models discriminator transformers are receiving an additional impregnation and baking to eliminate the possibility of discriminator drift.

Rep Talk

THE GEORGE E. ANDERSON CO., 1901 Griffin St., Dallas, Texas, has been appointed rep for the Radion Corp, Chicago, Ill., in the states of Texas, Arkansas, and Louisiana. . . . *Massey Associates, Inc.*, 1 Thomas Circle, N.W., Washington, D. C. (southern New Jersey, eastern Pennsylvania, District of Columbia, Maryland, Delaware and Virginia), *Kay Sales Co.*, 3760 Broadway, Kansas City 2, Mo. (Iowa, Nebraska, Kansas and Missouri) and *Logan Sales Co.*, 530 Gough St., San Francisco 2, Calif., (northern California and Nevada), have been appointed reps for Cleveland Electronics, Inc., Cleveland, Ohio. . . . *Samuel K. MacDonald*, 1531 Spruce St., Philadelphia 2, Pa., has incorporated his business. Other branch offices are at 3308 14th St., N.W., Washington, D. C. and 335 Fifth Ave., Pittsburgh 22, Pa. . . . *Jas. J. Backer*, 2321 Second Ave., Seattle, Seattle, Wash. (Washington, Oregon, Idaho and Montana), *Kay Sales Co.*, 3760 Broadway, Kansas City, Mo. (Missouri, Iowa, Kansas and Nebraska), and *V. Avis McCorvey Co.*, 212 Mimosa Dr., Decatur, Ga., have been named reps for the Astron Corp., 255 Grant Ave., East Newark, N. J. . . . *Earl T. Champion*, 6459 N. Sheridan Rd., Chicago 26, Ill., rep for Centralab, is now covering central and southern Wisconsin and northern Illinois. . . . *Maury Farber*, 167 Hartwell Rd., Buffalo, N. Y. (New York state), *Bloom Friedman*, 521 Fifth Ave., New York City (Trenton, N. J. south Pennsylvania, Virginia, Maryland, Delaware, Washington, D. C.), *B. J. Fitzner Co.*, 1409 Kales Bldg., Detroit, Mich. (Michigan), *Jack Heimann Co.*, 1215 Harmon Pl., Minneapolis, Minn. (Minnesota, West Wisconsin, Iowa, Nebraska, N. and S. Dakota), *Mel Pearson Co.*, 1011 S. Josephine St., Denver, Colo. (Colorado, Utah, east Idaho, New Mexico, Wyoming), *Dave Lee and Co.*, 819 Thomas St., Seattle, Wash. (Washington, Oregon, west Idaho, British Columbia), *Perlmuth-Colman and Associates*, 1335 S. Flower St., Los Angeles, Calif. (California and Arizona) and *Texport Co.*, 5004 Ross Ave., Dallas, Texas, have been appointed reps for Ram Electronics Sales Co., Irvington-on-Hudson, N. Y. . . . *Thomas Scott*, 15709 Turner Ave., Detroit 21, Mich. has been named a rep for The Workshop Associates, Division of the Gabriel Co., in Michigan. . . . *JKM, Inc.*, 510 N. Dearborn St., Chicago 10, Ill. (Illinois, Indiana, Wisconsin, Kansas, Missouri), *John T. Butlers*, 4924 Oleander Dr., Wilmington, N. C. (N. and S. Carolina, Tenn., Miss., Alabama, Georgia), *Henry Feldman Co.*, 400 W. Pico Blvd., Los Angeles 15, Calif. (southern California and Arizona), *Gordon C. LeRoy*, 29 Bancroft Dr., Rochester 16, N. Y. (New York State), *Nickerson and Rudat*, 381 Brannon St., San Francisco 7, Calif. (northern California and western Nevada) and *C. B. Parsons and Co.*, 119 Belmont Ave. N., Seattle 2, Wash. (Washington, Oregon, Idaho, Montana, British Columbia, Alaska), have been named reps for Hermon Hosmer Scott, Inc., Cambridge 39, Mass. . . . *T-V Prod-*

ucts Co., Brooklyn, N. Y. have appointed *Henry W. Burwell Co.*, as reps covering Mississippi, Alabama, Florida, Georgia, Tennessee and N. and S. Carolina. The *G. G. Willison Co.* has been named to cover Texas, Louisiana, Arkansas and Oklahoma. . . . *Burlingame Associates*, New York City, will cover New England for *Brach Manufacturing Co.* . . . *Herb Erickson Co.*, Hendersonville, N. C., (Tennessee, N. and S. Carolina, Mississippi, Alabama, Georgia, Florida), *Harry Estersohn*, Philadelphia, Pa. (eastern Pennsylvania, southern New Jersey, Delaware, Maryland and Virginia) and *Bill Bartleson*, Minneapolis, Minn. (Minnesota, N. and S. Dakota), have been named reps for *Permoflux Corp.* . . . *Jane Drucker*, known in private life as Mr. John J. White, who for the past three years devoted fulltime as public relations counsel to *The Representatives*, has retired. Coincident with Miss Drucker's retirement, *The Representatives* have established national headquarters offices at 600 S. Michigan Avenue, Chicago 5, Ill. . . . *Phoenix Electronics, Inc.*, Lawrence, Mass., has appointed the *Earl Goetze Co., Inc.*, Kansas City Merchandise Mart, 2205 Grand Ave., Kansas City 8, Mo., as its rep in the states of Neb., Ia., Mo., and Okla. . . . *Lee Roche* has announced the founding of *The Newhope Corp.*, 6 E. 39th Street, New York 16, N. Y., to operate as a manufacturer's rep, covering metropolitan N. Y. C., N. J., and government agencies in Washington, Philadelphia, etc. Newhope currently represents American Television and Radio Company (ATR), St. Paul, Minn. . . . *Gordon C. LeRoy*, 29 Bancroft Drive, Rochester 16, N. Y., has been named rep for Standard Wood Products Corporation, 43-02 38 St., L. I. C. 4, N. Y. . . . *The Les A. Morrow Co.*, 3123 W. 117th St., Cleveland, O., is now representing The Turner Company, Cedar Rapids, Ia., in Ohio Kentucky, western Pennsylvania and West Virginia. . . . *John B. Guenther* is now a Planet Manufacturing Corp., rep in Texas, Oklahoma and Ark. Guenther maintains headquarters at 7322 Marquette Ave., Dallas, Texas. . . . *Berlant Associates*, Los Angeles, has appointed *Vern Maynard* as its rep for eleven Western states, with headquarters at 6274 W. Manchester Blvd., Los Angeles. *John Maynard* has been named Berlant rep for Texas, Oklahoma, Arkansas and Louisiana, with headquarters at 4507 Shenandoah, Dallas 5, Texas. . . . The *Philson Mfg Co., Inc.* 60-66 Sackett St., Brooklyn, N. Y., has named *S. H. Stover* as their western Penna and W. Va., rep. . . . Elected to associate membership in the Reps were: *Jack and Jim Logan* (California), *George S. Shirk, Jr.* (Wolverine), *Joseph Farber* and *Gordon C. LeRoy* (Empire State), *Charles Silvey* (Los Angeles), and *Austin L. Wright* (Mid-Lantic). . . . *Wesley L. Wilson*, 2750 West North Avenue, has been named by John F. Rider, Inc., as a rep in metropolitan Chicago and Northern Illinois. . . . *Bloom-Friedman Associates*, 521 Fifth Ave., N. Y. 17, are now national reps for Ever-Quiet. . . . *Edward T. Connolly* is now a G. E. tube division district rep with headquarters in Cleveland, Ohio. He will be responsible for the sale of electronic tubes, test equipment and component parts in northeastern Ohio, northern West Virginia and western Pennsylvania. . . . *Robert E. Giannini* has been appointed district rep for the G. E. tube divisions with headquarters in Los Angeles. He will cover southern California and Arizona areas.

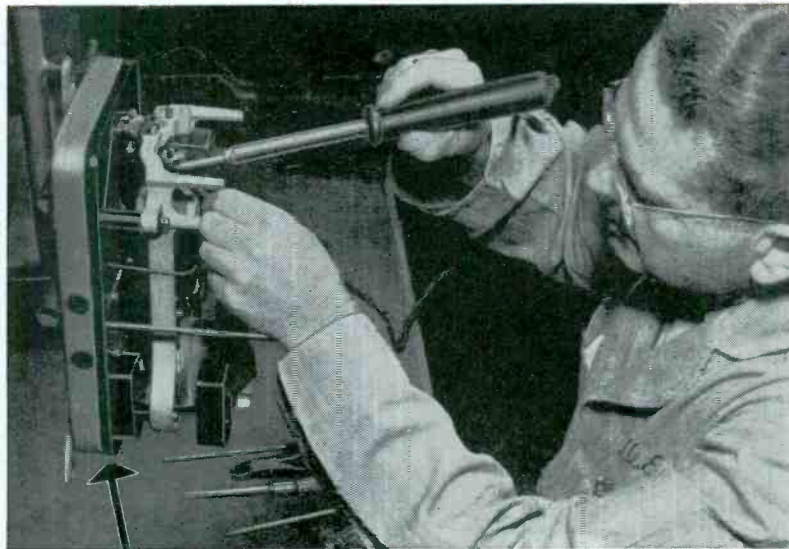

from
INSTRUMENTS
to
ARMATURES

American Beauty

SOLDERING IRONS
for PRODUCTION JOBS
LARGE or SMALL!

For descriptive catalog pages write Dept. S-2



DEPENDABLE • DURABLE • EFFICIENT • SINCE 1894

AMERICAN ELECTRICAL HEATER CO.
DETROIT 2, MICH.

ANASTIGMATICALLY

CORRECT

UNIFORM FOCUS

UNIVERSAL TV DEFLECTION YOKES

FOUR MODELS DIRECTLY REPLACE
IN 80% OF ALL TV RECEIVERS

CLETRON Yokes include the latest advances in design to simplify replacements and large picture tube conversions. Excellence in quality and workmanship combine to give the finest possible performance in a TV receiver.

Anastigmatically corrected coils are used in all units to insure sharp focus over the entire picture area.

High-temperature insulating materials provide for widely varying conditions without breakdowns.

Quadruple formvar insulation affords maximum protection from high voltage failures.



See our new TV Yoke, Lightning Arrester and complete CLETRON Speaker line. Booth No. 619, August, Pacific Electronic Exhibit in San Francisco. Booth No. 326, September, N.E.D.A. show in Cleveland.

Write today for complete information.

CLEVELAND ELECTRONICS, INC.

6618 Euclid Ave. • Cleveland 3, Ohio

MORHAN EXPORTING CORPORATION

458 BROADWAY, NEW YORK



New Parts • •
Instruments •
Tools • • • • •

MALLORY VIBRATOR TESTER

A vibrator tester that provides direct reading on *good-bad* conditions of doubtful vibrators, has been announced by P. R. Mallory & Co., Inc., Indianapolis, Ind.

When rectifier tube is plugged into the front panel, interrupter type vibrators can be tested in conjunction with the same rectifier tube used in the car radio. Tester may be used with the filtered rectifier power supplies, or will operate from a 6-volt *dc* source.

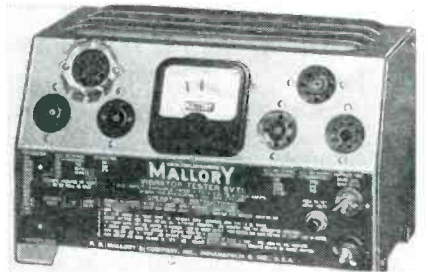

* * *

RADELCO AUTO ANTENNA

A *screw ball* auto antenna is now being marketed by Radelco Manufacturing Co., 7580 Garfield Boulevard, Cleveland 25, Ohio. A universal model, it is said fit any make of automobile.

Also available are a TV conical, the *Ace*, and quick mounting, pre-assembled yagis, custom cut to individual channels.



* * *

INTERNATIONAL RECTIFIER
SEALED SELENIUM CELLS

A line of hermetically sealed selenium cartridges has been developed by International Rectifier Corp., 6809 S. Victoria Ave., Los Angeles 43, California. Rectifiers are assembled in half-wave cartridges with current ratings from 300 microamperes up to 60 milliamperes. The individual cartridges accommodate up to 400 cell elements with *dc* voltage ratings up to 8,000 volts per cartridge. The outside diameters vary from 3/16" up to 1/4" depending upon current rating.

PERMOFLUX AUTO-EXTENSION
SPEAKERS

Two rear-seat auto-extension speaker assemblies (model *RS46A*, 4" x 6" and *RS69J*, 6" x 9") have been announced by the Permoflux Corp., 4904 W. Grand Ave., Chicago 39, Ill.

Featured is a three-way switch that is prewired at the factory. Assembly includes mounting hardware and a metal grille.

* * *

VIDEO PRODUCTS 630 CHASSIS FOR
LARGER PICTURE TUBES

A 630-type chassis, model *K24*, for use with the 24-inch picture tube, has been developed by Video Products Corp., 2061 Broadway, New York 23, N. Y. Chassis is said to feature a 16-kv voltage supply.

EICO RF-AF SIGNAL GENERATOR

An *rf-af* signal generator, model 322, in both kit and factory-wired form, is now available from the Electronic Instrument Co., Inc., 276 Newport St., Brooklyn 12, N. Y. Featured is a five-step switching arrangement that is said to provide pure *rf*, modulated *rf* or pure *af* outputs.

Unit has a Hartley oscillator that is claimed to produce fundamentals from 150 kc to 34 mc, with harmonics to 102 mc, and Colpitts audio oscillator that generates a 400-cycle sine-wave voltage.

**LITTELFUSE MINIATURE FUSE
EXTRACTOR POST**

A fuse extractor post for 3AG fuses is now available from Littelfuse Inc., 4757 N. Ravenswood, Chicago, Ill.

Featured are a reduction of behind-the-panel distance by one inch (overall length of 1 11/16"); bakelite construction with wide threads; leaf-spring tension lock in the knob of the post that is said to reduce voltage drop between the knob contact and the fuse; all-purpose terminal; bottom contact that is said to cut through any surface accumulation on the fuse cap to assure low resistance electrical contact; and a one-piece side terminal and the internal metal ring.

Fuse may be tested without removing it, there being a hole for a test prod at the top of the knob.

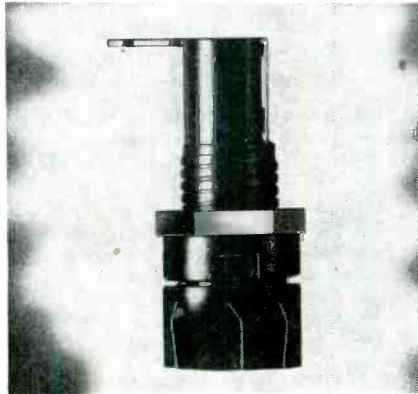

* * *

**CENTRALAB MINIATURE ROTARY
SWITCHES**

Miniature rotary switches in multi-pole, multi-position, multi-section types and in combination with *ac*-line switches and variable resistors, have been introduced by Centralab, 900 East Keefe Ave., Milwaukee, Wis.

Available are *series 20*, a bolted construction with phenolic or grade L-5 steatite insulation and staked construction with a maximum of two sections in phenolic insulation that can be supplied with an *ac* line switch substituted for the rear section on the bolted or staked type; and *series 30* miniature switch, with dual concentric shaft, staked construction. Has a variable resistor in front, rotary switch in between and an *ac* line switch in the rear. *Series 30* is also available with variable resistor and an *ac* line switch in the rear, the rotary switch section in front, and with phenolic insulation.

* * *

PLOMB TOOL CONTAINER LINE

A *Proto* master tool chest, 9997, and two socket-set boxes, 5295 and 5495, have been announced by the Plomb Tool Co., Los Angeles, Calif.

Tool chest measures 27" x 12" x 15" high, and has two 2 3/4"-deep two-compartment drawers, four 1 1/4"-deep three-compartment drawers, a top section partitioned into three compartments, and a 21 3/4"-wide tote tray with three compartments. Hinged to and inside the top is a drop front that covers all drawers when the chest is closed and permits locking. A tumbler lock is said to provide three-way holding protection.

Socket wrench boxes for 3/8" and 1/2"-drive sets, respectively, feature rounded corners and use a drawn one-piece construction without laps for the top and bottom.

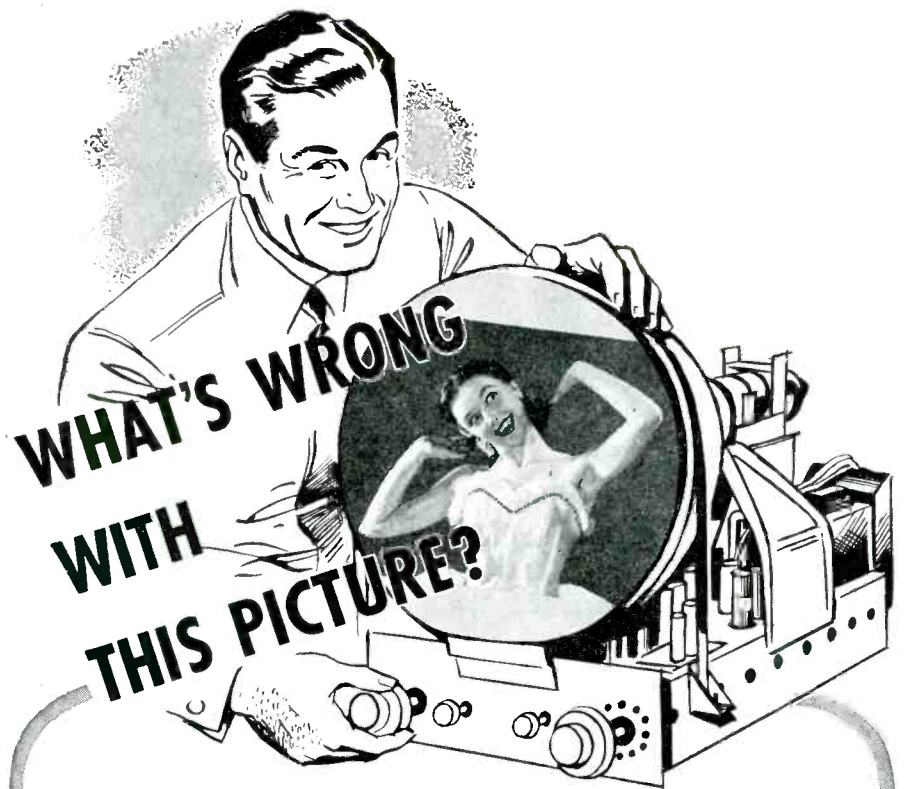

There's nothing wrong, *yet*. The set's just out of the shop and everything *seems* A-1 . . . but wait until chassis heat goes to work on the paper tubulars. Then it's "out of sync" and another costly call-back for the service technician.

Sprague Black Beauty Telecap Molded Tubulars are a positive guarantee against this sort of trouble. Made by the same "dry process" as expensive metal-encased oil capacitors, they are stable and retrace consistently, unlike ordinary cardboard-cased or "wet process" molded tubulars. And this extra quality is yours at no extra cost!

Black Beauty Telecaps are a *must* for every TV replacement job.

Write for Catalog C-607-61.

SPRAGUE
Black Beauty
TELECAPS®

Ask for them by name

SPRAGUE **SPRAGUE PRODUCTS COMPANY**
(Distributors' Division of Sprague Electric Co.)
North Adams, Massachusetts

PIONEERS
IN ELECTRIC AND ELECTRONIC DEVELOPMENT

**We Proudly Present
the New
SCREW BALL
ANTENNA**

THE EASIEST, QUICKEST OF ALL AERIALS TO INSTALL. ONLY ONE MAN NEEDED AS ALL MOUNTING WORK IS DONE FROM TOP OF COWL OR FENDER.

Here's all you do!

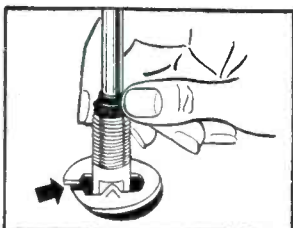

Insert one edge of split-washer into hole . . . twist . . . and en- fire bottom of mounting base slips into position beneath cowl or fender.

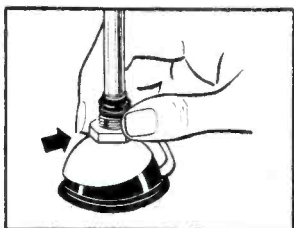

Slide ball-top into place over mounting hole . . . adjust antenna to proper angle . . . tighten . . . and the mounting job is done. Quickly! Easily!

Model EZ-3 \$4.95
List

PLACE ORDER AT ONCE
WITH YOUR NEAREST
PARTS JOBBER!



**7580 GARFIELD BLVD.
CLEVELAND 25, OHIO**

NEWS

AEPEM NAMES CASHMAN CHAIRMAN

John H. Cashman, president of The Radio Craftsmen, Inc., Chicago, has been elected chairman of the Association of Electronic Parts and Equipment Manufacturers.

Francis F. Florsheim, president of Columbia Wire and Supply Co., Chicago, was named vice chairman, and Helen Staniland Quam, of Quam-Nichols Co., Chicago, treasurer. Kenneth C. Prince, Chicago, was reappointed executive secretary of the association.

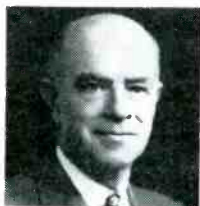

John H. Cashman

* * *

CLEARBEAM MOVES TO NEW PLANT

Clearbeam Antennas, Burbank, Calif., has moved into a 16,000 square-foot plant, at 100 Prospect Ave. Operations of Clearbeam's subsidiaries, TV Wire Products and Tempo Products, will be centered in the new plant, also.

Peter S. Wald is president of Clearbeam.



* * *

HYTRON NOW A CBS DIVISION

Hytron Radio and Electronics Co., Salem, Mass., has become a division of the Columbia Broadcasting System, Inc. Management and general policies of Hytron will remain the same as before the acquisition.

* * *

CENTRALAB PRINTED CIRCUIT GUIDE

A manual entitled, *Printed Electronic Circuit Guide No. 1*, has been published by Centralab, 900 E. Keefe Ave., Milwaukee 1, Wis.

Guide lists 269 printed circuit plates as used by 69 manufacturers. Includes a cross-reference chart which designates the Centralab catalog number for a given manufacturer's part number.

* * *

MAGNECORD CATALOG

A catalog describing magnetic tape recorders has been released by Magnecord Inc., 360 North Michigan, Chicago, Ill.

Catalog details conversion and adaptation equipment and contains a description of special accessories such as switches, spooling mechanisms and adapter panels.

**Presenting
THE NEW
Mueller
NEEDLE CLIP**



Actual Size

**PIERCES INSULATION
TO MAKE QUICK
CONTACT**

Solid bronze, non-corroding. Wire centers itself in notched jaw. Teeth on sides of jaw allow use for many other applications.

— USED IN —

- Electric and radio service shops
- Telephone and power company testing and maintenance
- Laboratory test work
- Hooking up truck trailer lights
- Field telephone and signal work

SEND FOR FREE SAMPLE AND CATALOG 810

Mueller Electric Co.
1565 E. 31st St., Cleveland 14, Ohio

**C-D TWIST-PRONG ELECTROLYTIC
MANUAL**

A manual listing over 400 TV twist-prong electrolytics, *Television Replacement Guide TVR 7*, has been released by Cornell-Dubilier Electric Corp., South Plainfield, N. J.

One section lists alphabetically the names of 68 TV set manufacturers, their set model numbers and chassis numbers arranged numerically. Over 1,000 models are noted with original capacitor specifications and rotational stock numbers. Appearing are letter codes showing whether unit is a single, dual, triple or quadruple section capacitor, and the recommended twist-prong electrolytic replacement.

Another section lists twist-prong electrolytic replacements in their numerical order, rotational stock numbers, recommended replacement in the sets by model and chassis, and the number of sets in which any one unit can be used.

A third section provides a compilation of the physical and electrical characteristics of over 400 recommended electrolytic replacements in single, dual, tripple and quadruple section units. The last section includes a cross-index of former twist-prong electrolytics and their present equivalent part numbers, and rotational stock numbers.

Guide is priced at \$.50 and is available from C-D authorized jobbers or direct from the company.

I.D.E.A. APPOINTS KIRK ASST. S-M

Earl H. Kirk, formerly manager for Van Sickle Radio Supply Co., Indianapolis, Ind., has been appointed assistant sales manager for the Regency Division of Industrial Development Engineering Associates, 55 N. New Jersey St., Indianapolis, Ind.



Earl H. Kirk

* * *

LITTELFUSE TV FUSE GUIDE

A TV fuse guide that lists brand name, model numbers and corresponding fuse requirements on TV chassis, is now available from Littelfuse Inc., 4757 N. Ravenswood, Chicago, Ill.

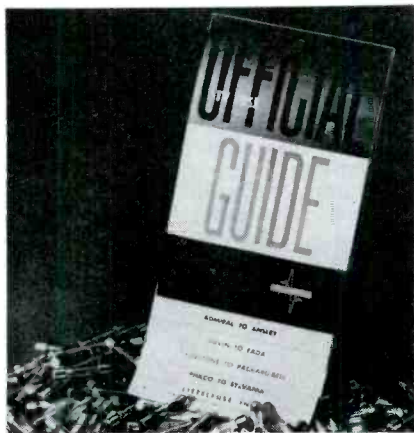

* * *

DUMONT CONVERSION INSTRUCTIONS

Instructions for converting small-screen TV receivers to larger sizes are now available from the electronic parts division of Allen B. Du Mont Laboratories, Inc., East Paterson, N. J.

Covered are popular makes and models of TV receivers with instructions for installing *Inputuner*, deflection yoke, horizontal output and *hv* transformer and linearity and width controls. Further details are available from Edwin B. Hinck.

* * *

HENRICHS NOW SUPERVISOR OF SYLVANIA EQUIPMENT SALES SERVICE

Luther C. Henrichs, formerly a sales account specialist for the radio tube division, has been named supervisor of equipment sales service of Sylvania Electric.



Luther C. Henrichs

* * *

ERIE RESISTOR ELECTS GORDON GROTH EXECUTIVE V-P

Gordon Groth, formerly president of the Electra Manufacturing Co., has been appointed executive vice president of the Erie Resistor Corp., Erie, Pa.

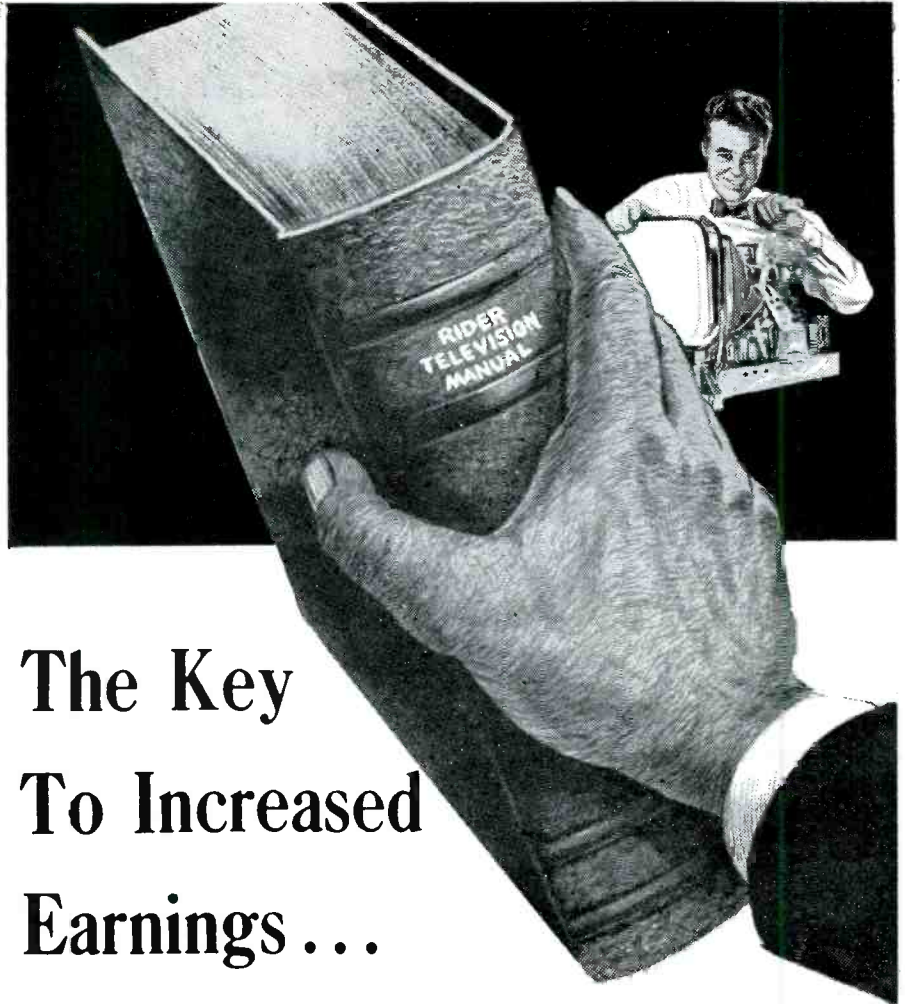

The Key To Increased Earnings ... Is At Your Fingertips

Now, more than ever before, your knowledge of every phase ... every detail ... of servicing each set in the manufacturer's line really pays off. And there's only one source that gives you *all* you must know. It's Rider Radio & TV Manuals. The only complete, authoritative service data on television and radio in the world!

Here you'll find the answers to all your servicing questions. From complete unpacking and installation data to complete factory parts lists. With Rider's accurate, factory-authorized information at your fingertips you'll spend less time per call ... and do a better job! The result is greater profits. Ask your jobber to show you the latest Rider Manual — today!



JOHN F. RIDER Publisher, Inc.
480 Canal Street, New York 13, N. Y.

... if you are commercially or professionally interested in TV, you must read

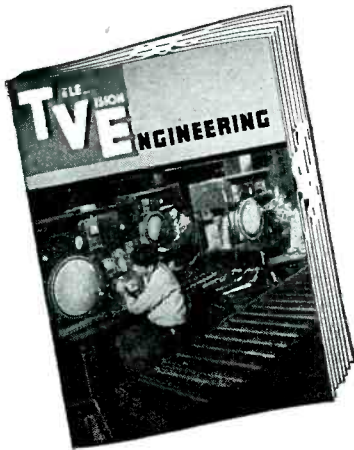

TELEVISION ENGINEERING every month!

Devoted exclusively to TV Research . . . Design . . . Production . . . Operation . . . Instrumentation

TELEVISION ENGINEERING is the *only* trade publication which directs its *entire* editorial content to executives and engineers who design, manufacture, operate and maintain television receiving and transmitting equipment—both commercial and educational.

Every issue is chock full of timely and thorough TV articles, authored by outstanding specialists. You'll find practical, carefully prepared reports and papers on such vital subjects as . . .

Color TV Systems . . . Ultrahigh Receiver-Transmitter Design Problems . . . Tube Production-Line Techniques . . . TV Broadcast Equipment . . . Camera Tube Research . . . Glass, Plastics and Metal in TV . . . TV Test Equipment in the Plant . . . Film Recording . . . Flying Spot Scanners . . . Tone Amplifiers for TV Films . . . Compact Motors for TV . . . TV Component Design . . . Mechanical Design Factors in Antennas . . . Quality Control Charting . . . Microwave Relays . . . Receiver and Transmitter Servicing . . . Production Aids . . . Instrument Activities . . . TV Sound Systems . . . Studio Lighting.

Enter your subscription NOW . . . Fill out the coupon below
(Not sold on newsstands)

MAIL COUPON

TeleVision Engineering
82 Vanderbilt Ave., New York 17, N. Y.

Here is my remittance for my subscription to **TeleVision Engineering** at the **SPECIAL RATE . . . 3 years (36 issues) only \$5.**

(1 year subscription \$3.)

NAME

ADDRESS

CITY ZONE STATE

For our confidential records, open only to the Audit Bureau of Circulation, please supply the following information:

Occupation Title

Department in which employed

Operation

Production

Research

Employed by

Nature of Business

(State if TV Manufacturer, TV Broadcast Station, etc.)

TEL-A-RAY PURCHASES NEW BUILDING

A new building, containing 75,000 square feet of floor space, has been purchased by Tel-A-Ray Enterprises, Inc., Box 332, Henderson, Kentucky.

This building will replace the old plant which was totally destroyed by fire in the early part of this year. Production is expected to begin immediately on counter-balanced antenna towers, automatic boosters, etc.



* * *

LUCAS NOW WITH JERROLD ELECTRONICS

Edmund D. Lucas, Jr., formerly publicity manager for the Philco Corp., has been appointed manager of advertising and public relations of Jerrold Electronics Corp., 121 North Broad St., Philadelphia 7, Pa.

Sidney J. Mass, who has been director of advertising and sales promotion for the company during the past year, has been named sales manager.



E. D. Lucas, Jr.



Sidney J. Mass

* * *

SPRAGUE CATALOG

A 16-page catalog, C-607, has been issued by Sprague Products Company, North Adams, Mass. Provided are data on capacitor types for radio and TV service, amateur radio, experimental, laboratory and other needs.

Included are details on wire-wound resistors, interference filters, capacitor mounting hardware and a universal capacitor and resistor analyzer. Detailed listings of molded tubular capacitors, prong mounting dry electrolytics, disc ceramics, multiple ceramics, *doorknob* high-voltage ceramics are also provided.

* * *

GOLDMAN OF GTC HONORED

Stuart A. Goldman, secretary-treasurer, General Transformer Co., was among 65 Chicagoans to complete recently the University of Chicago's seventh executive program and receive certificates at a special ceremony in Leon Mandel Hall, Chicago.

* * *

MARKEM SERVICE SYSTEM BULLETIN

A four-page bulletin describing the operation of a streamlined servicing system has been published by Markem Printing Co., 145 Hudson St., N. Y. 13, N. Y.

Illustrated and described are special forms used, which include master card, office master, customer's contract and expiration tickler.

FIELDS NOW WITH VEE-D-X

Malcolm V. Fields has been named head of the special products division of The LaPointe Plascomold Corp., Windsor Locks, Conn.



M. V. Fields

* * *

RADIO RECEPTOR PROMOTES MANN

Martin Mann has become assistant sales manager of the Seletron Rectifier Division of Radio Receptor Co., Inc., 84 North 9th St., Brooklyn 11, N. Y.

* * *

SOUTH RIVER NOW IN NEW PLANT

South River Metal Products Co., Inc., South River, N. J., has started producing its line of antenna mounting brackets in a new plant on the South River, N. J., Turnpike.

Max Cohn is president of South River. South River will exhibit at the NEDA show in booth 302.



* * *

THOMAS SIX-MONTH PICTURE TUBE GUARANTEE

Thomas Electronics Inc., 118 Ninth St., Passaic, N. J., has announced that its picture tubes will now be guaranteed against defects in materials and workmanship for a period of six months from the date on which the tube goes into the set.

Guarantee, which accompanies each tube and is printed on a 2-fold card, consists of a dealer's copy, a user's copy and a user's registration copy. The registration copy is for mailing, postpaid, to the factory.

If the tube should be replaced within the six-month period, the replacement is also guaranteed for a six-month period.

* * *

COPPERWELD TO EXHIBIT AT NEDA SHOW

The Copperweld Steel Company, Glassport, Penna., will exhibit at the September NEDA show and display ground rods, grounding wire, antenna wire and guy strand. An added feature will be a display of Copperweld fine wire used in twinlead, coax cable, tube leads, grid supports and hookup wire.

Copperweld products, made by the molten-welding process, have a thick copper covering which is cast around and inseparably welded to a preheated steel billet. The weld is said to be so perfect that the combined metals act as one, and can be reduced to rod and wire sizes by hot rolling and cold drawing without altering the original proportions of copper and steel.

Mr. Serviceman:
BOOST YOUR REPUTATION AS A TROUBLE-SHOOTER

R from **GRAYBURNE**

STOP Major TV-AM INTERFERENCE TROUBLES - Fast, at Low Cost

with these new **GRAYBURNE SPECIFICS**

TV IF SIGNAL BOOSTER

Model TSB-1

Precision-engineered complete IF stage, specifically designed for extra gain. Can often replace broad-band and tunable boosters—at only 1/3 the cost!

- Increases video output up to 20% - sharpens contrast.
- Eliminates separate tuning for each channel.
- Quick permanent installation *inside* the cabinet.

\$9.95 List, less tube



DUAL TUNABLE INTERFERENCE FILTERS

4 precision-engineered models, each specifically designed to help eliminate a *specific* type of TV interference, i.e., Amateur Harmonic Interference: 14 to 28 mc, and 30 to 54 mc; Diathermy; and FM Image Interference.

- Photo of interference-pattern on package shows which type of interference each model removes.
- Dual tunable feature for maximum interference rejection.

\$2.75 List

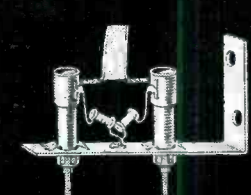

Clear-Pix TV INTERFERENCE ELIMINATOR

Specifically designed to filter out 80-110 mc interference - most common source of trouble. Easily installed - just attach to antenna input terminals.

\$1.98 List



FERRI-LOOPSTICK

The most sensitive Small Radio Antenna in the world! Specifically designed to increase sensitivity over conventional loops, particularly on higher frequencies.

- Ferri-Loopstick Q averages 275 against 125 for conventional loops. Increases signal-to-noise ratio.
- Omni-directional: no orientation of loop necessary.

75c List

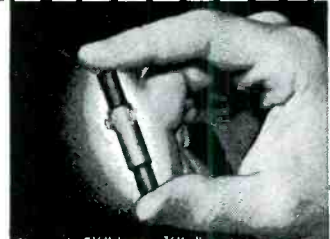

Size: only 2 1/4" long x 1/8" diameter.

Liberal Trade Discounts

Professional Service-Dealers! Your Profits and Professional Prestige depend on giving your customers more TV and AM enjoyment - fast, and at low cost! GRAYBURNE *service-engineered* SPECIFICS improve set performance so amazingly, your customers will call you their **ELECTRONICS WIZARD!** For full technical data and name of your local Grayburne Distributor, write NOW for Catalog S-8.

Grayburne Means
 Quality Electronic Components

GRAYBURNE CORPORATION
 103 LAFAYETTE STREET
 NEW YORK 13, N. Y.



**VEE-D-X
"JC"
YAGI**

**VEE-D-X
Outboard
BOOSTER**

**MOST
POWERFUL
COMBINATION
for
SINGLE
CHANNEL
RECEPTION**

VEE-D-X

THE LaPOINTE-PLASCOMOLD CORPORATION
Windsor Locks, Conn.

N.U. TUBE CASE

A carrying case for receiving tubes and small hand tools has been announced by the National Union Radio Corp., Orange, N. J.

Fabricated of 1/4" plywood throughout, the case measures 19 5/8" long x 9 3/8" wide x 14 1/4" high, and is said to support 350 pounds. Between 180 and 225 tubes can be carried in the case. Two compartments in the hinged top are available for tools having a length as great as 19". A removable tray has a small compartment with a hinged cover that is suitable for such small items as fuses, panel-lamps, etc. Case is available through N. U. distributors.

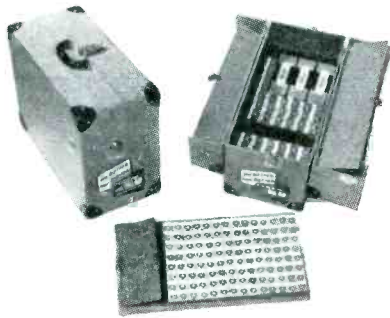

* * *

**RAY SPARROW ELECTED MALLORY
EXECUTIVE V-P**

Ray F. Sparrow has been elected executive vice president of P. R. Mallory & Co., Inc., Indianapolis. Sparrow has been vice president in charge of sales for many years, having joined Mallory as a vice president in '31 when the Yaxley Manufacturing Co., of which he was an official, was consolidated with Mallory.

Harold C. Buell, Mallory sales manager since '45, has been promoted to vice-president in charge of sales to succeed Sparrow.

* * *

**SNYDER DIRECTRONIC TV ANTENNA
CONSUMER CAMPAIGN**

A consumer campaign in newspapers, slanted towards replacements, in major metropolitan markets throughout the country, advertising the *directronic* motorless TV antenna has been announced by the Snyder Manufacturing Co., Philadelphia.

According to Dick Morris, sales manager, the major television centers of the country are expected to be blanketed through the medium of big-circulation newspapers.

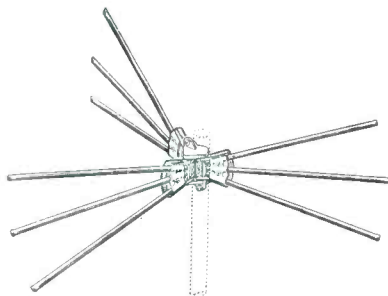

Snyder directronic antenna

**The ONLY
truly high-fidelity high-
performance tape recorder
in the popular price
field!**

**Concertone
RECORDER**



Model
1401

**"just like
being there"**
Has every feature
of the most expensive
professional equipment. Ready for
console instal-
lation. Write for
\$345.00
Bulletin #107. USER'S NET COST

Manufactured By
Berlant Associates
4917 W. Jefferson Boulevard
Los Angeles 16, California

LEW BONN TO CELEBRATE 25TH YEAR

Lew Bonn Co., 1211 La Salle Ave., Minneapolis, will celebrate their 25th year as a distributor with a 3-day *Sell-ebriation*, September 26, 27 and 28 in the grand ballroom of the Leamington Hotel, Minneapolis. Invitations have been issued to 4,000 dealers, industrial accounts and amateurs.

Visitors will be shown *What's New for '52* in the radio, electronics and television fields. There'll also be 50 displays by manufacturers which will show visitors *How to Sell It*.

Booths will be manned by manufacturers' reps.

Plans also include a buffet table and cocktail party following each day's booth demonstrations.



Lew Bonn (left) and W. Heisel,
Bonn general manager

SYLVANIA TUBE MANUAL

The eighth edition of the *Sylvania Technical Manual* in a *snap-open* loose-leaf format has been published by Sylvania Electric Products, Inc., Emporium, Pa.

Manual provides technical data on more than 500 receiving tube types, standard TV picture tubes, as well as 84 pages of general information on vacuum tube operation.

Engineering data section includes text on fundamental electrical laws, fundamental properties of vacuum tubes, definitions of common radio terms, general tube and circuit information, tube dimensions, use of curves, resistance-coupled amplifier data, information on obsolete tube types, tube base diagrams, and data on panel lamps, ballast tubes and plug-in resistors. Also contains data on sixty new receiving tube types and all standard TV picture tubes. Priced at \$2.00; available from Sylvania distributors or direct from advertising department.

* * *

TV TUNER REPAIR SERVICE

A service for installation companies involving the repairing and rebuilding of defective front-end tuners has been announced by Tuner Repair Exchange, 9-21 119th St., College Point, N. Y. All work is said to carry a ninety-day guarantee.

Fred J. Krell is prexy of the new company and Robert Miller, service manager.

* * *

STANCOR CATALOG

A catalog, listing 441 transformers and related components, is now available from Standard Transformer Corp., Chicago, Ill.

Described are transformers, and television components, including electrical specifications, dimensions and weight. Illustrations show each mounting type in detail.

Sixty-five classifications ranging from audio chokes to vibrator transformers, and covering TV; high fidelity; input, output; interstage; driver; modulation; power; filter chokes; filament; plate; isolation and autotransformers, are detailed.

* * *

GUTHMAN OPENS INDIANA PLANT

A 55,000 square-foot, one-story plant in Attica, Indiana, has been opened by Edwin I. Guthman & Co., Inc., Chicago, Ill.

At present Guthman produce *if* transformers, antenna coils, oscillator coils, loop antennas, shield cans, dual compression trimmers, compression type mica trimmers, metal frame padders, magnet and litzendraht wire, *rf* tuners, horizontal output transformers, and yokes.



MOSLEY Low Loss TV Accessories . . .



provide **BETTER TV PICTURES**
through more efficient installation!

HANDY, EFFICIENT PLUGS, SOCKETS AND CONNECTORS FOR 300 OHM FLAT TRANSMISSION LINE

MOSLEY Transmission Line Plug. No. 301. The Plug of 1,000 Uses! FM and TV installations, Factory test benches, Experimental labs, Ham shacks, Dealer demonstrations, Mobile and field equipment, etc. Use indoors or out. Fits all MOSLEY sockets as well as 1/2" crystal holder and octal tube sockets. Low loss acrylic plastic with large non-rusting screws. Solderless. List \$.48.

MOSLEY Transmission Line Socket. No. 311. Mates with No. 301 above for constant impedance connection. List \$.48.

MOSLEY Polarized Connector. No. 321. Made of same material and similar in construction to No. 301 and 311 but designed so that 2 conductor line cannot be reversed. Use in pairs. List (per pair) \$.92.

MOSLEY Tap Socket. No. 331. Install several MOSLEY Tap Sockets along an extended 300 ohm line and TV set can be connected at different places in the room. Handy in dealer display rooms. Made of low loss acrylic plastic with non-ferrous metal parts. Installed without cutting line. Solderless. List \$.58.

MOSLEY Base Socket. No. 341. Neat, efficient. Mount on baseboard, metal chassis, anywhere! No solder needed to install. Furnished with nickel-plated machine screws and nuts as well as wood screws. List \$.84.

MOSLEY Input Adapter. No. 304. If TV set has terminal strip for antenna connection, install MOSLEY adapter on strip and use MOSLEY No. 311 Socket on lead-in for convenient, low loss connection. Adjustable lugs. 1/2" pin spacing. List \$.30.

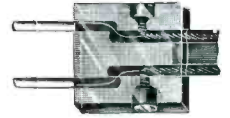

301



311



321



331



341



304

MOSLEY

W O F Q Y

Electronics

2126 LACKLAND OVERLAND, MISSOURI

A SINGLE SOURCE OF SUPPLY

MOSLEY ELECTRONICS manufactures the only complete line of antenna transmission line connectors, plugs, sockets and other accessories. MOSLEY products are solderless and designed for maximum electrical efficiency. Install MOSLEY accessories with complete confidence. Write for new Catalog No. 50-51.

DUMONT NAMES PHILLIPS ASST. S-M

W. C. Phillips, formerly manager of the purchasing department, has been named assistant sales manager of the electronic parts division, Allen B. Dumont Labs, Inc., East Paterson, N. J.

* * *

(Right)

Bill Barron (right), sales manager of the Merit Transformer Corp., discussing an advertising and merchandising campaign, which will feature answers to TV servicing problems, with members of their agency, Burton Browne Advertising. From left to right: Agency art director, Norman Harris; Burton Browne, president; James Cody, account executive, and Bill Barron.

TV SERVICING AD CAMPAIGN PLANS



there's only ONE
APPROVED POWER SUPPLY

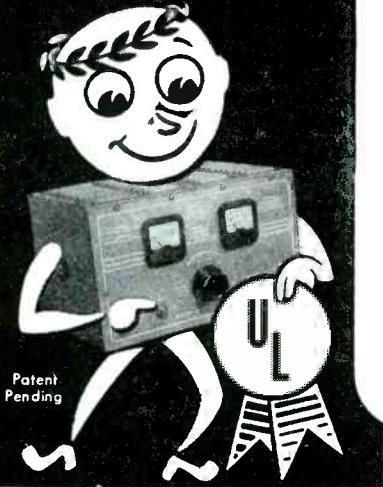

**New Low Cost "BJ" JUNIOR
SAVES TIME, MONEY
SERVICING DC EQUIPMENT**

Demonstrate and test car and marine radios . . . relays, 'phone circuits, instruments, other low voltage devices. End costly storage battery failures with Electro's dependable filtered power supply. Exclusive conduction cooling doubles rectifier power rating, assures lowest cost per ampere output over any other type, and dissipates over 3 times the heat. Quality components withstand high overloads. 6 volts, 1 to 12.5 amps. continuous output.

Model "B" 6 Volt DC Power Supply, 1 to 20 Amps, for Heavy Duty Applications

**OVER 2 MILLION
Battery Radios Offer
Huge PROFIT Market!**



**CONVERT BATTERY
RADIOS TO ALL-ELECTRIC**
Now is the time your customers want dependable all-electric hum-free performance . . . tap this big timely market now! Operates any 1.4 volt 4 to 6 tube battery radio from 115 volt 50/60 cycle source. Uses less than 1/4 the power of the cheapest AC radio. Guaranteed 3 years.



SEND COUPON
ELECTRO PRODUCTS LABS.
4501-BS Ravenswood Ave., Chicago 40, Ill.
Send literature, name of nearest jobber.
Name
Address
City..... Zone.... State.....
In Canada: Atlas Radio Corp., Limited, Toronto

Color TV

(Continued from page 21)

mined by the capacitor C_1 , the fixed resistor R_1 , and the potentiometer in series with R_1 ; The sweep rate depends upon the rc product of the grid circuit where $C = C_1$ and $R = R_1$, plus the resistance of the pot. To change the vertical frequency this rc product must be divided by 2.4. Either the R or the C could be divided by this value. For the horizontal sweep the rc product must be divided by 1.85. Fig. 3 (p. 21) shows three different ways of obtaining this division. In *a* is illustrated the method used to switch a capacitor in or out, as the set is switched from color to black and white. For monochrome the vertical capacitor must be 2.4 times the color capacitor and the horizontal capacitor 1.85 times the color capacitor. The disadvantage of this method is that it may not be easy to find capacitors with the values to satisfy the necessary ratios. The basic principle is illustrated, however, and the method can be used when the right capacitors are available.

Fig. 3*b* shows a method in which the value of the resistance is reduced by the right factor. In this case, the frequency limiting resistor has been changed: If we call the pot resistance, R_1 , then the ratio of $R_1 + 220,000$ ohms/ $R_1 + 10,000$ ohms = 2.4 for the vertical frequency and $R_1 + 270,000$ / $R_1 + 10,000 = 1.85$ for the horizontal frequency. This circuit is the simplest and the cheapest to install.

Circuit Defects

The circuits in *a* and *b* do have one defect. They both have just one ad-

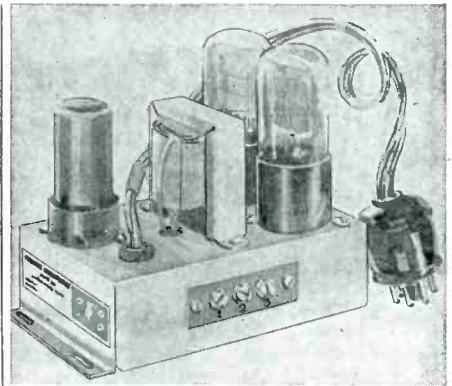

\$14.95 NET

**HIGH FIDELITY SOUND
FOR YOUR T.V. SET**

Simply remove output tube and plug into socket. This superbly engineered High Fidelity Push Pull Amplifier flat within 1.5 DB from 80 to 20,000 cycles.

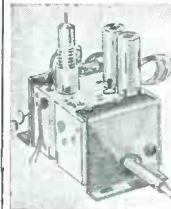

**HAVING TROUBLE
INSTALLING STAND-
ARD TUNERS IN
PHILCO RECEIVERS?**

Remove the old tuner and install the new simply by using four screws with these SPECIALLY DESIGNED brackets—Saves 75% of installation time.

\$1.00 net
Minimum Order, 3 Sets

Send money order or check with order and save C.O.D. fee and postage.

VIDAIRE ELECTRONICS MFG. CO.

Dept. TV

576 WEST MERRICK ROAD, LYNBROOK, N. Y.

justment for both color and monochrome. If, as the set ages, this setting changes for one presentation or the other, it will be necessary to adjust the potentiometer each time the receiver is switched from color to monochrome. One way to solve this difficulty is illustrated in *c*. The resistance is again changed by the right ratio, but instead of changing the fixed re-

Fig. 5. Vertical-deflection circuit of RCA 9T246 modified to provide correct scanning for field-sequential color.

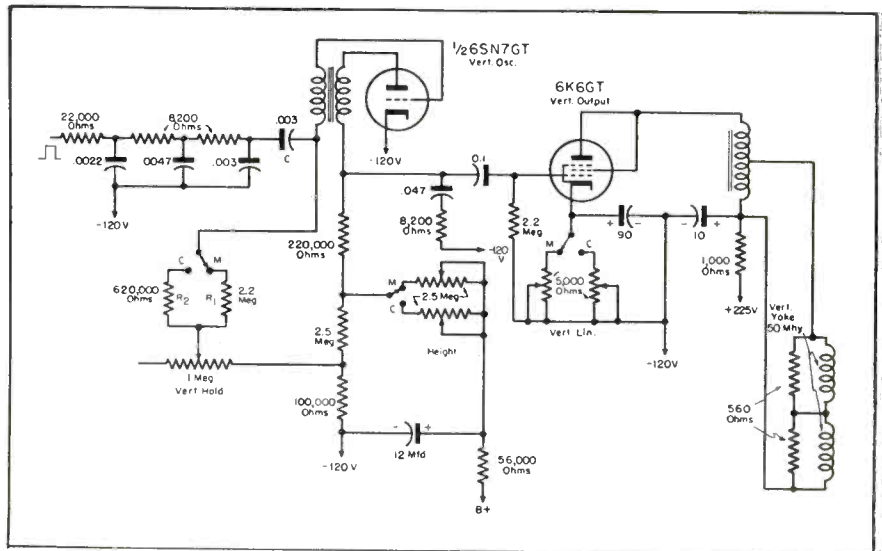

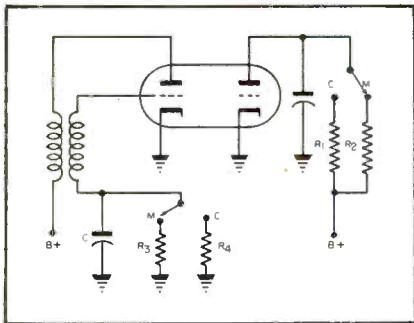

Fig. 6. Blocking oscillator with switch for color and black and white reception.

sistor, an additional potentiometer is inserted in the color position. Thus, there can be adjustments for either color or monochrome without interfering with the other operating conditions. This method is expensive, requires more space, and demands more effort to install.

Hallicrafter Set Conversion

A method which can be used to convert the vertical and horizontal size control for color appears in Fig. 4. (p. 21). In both cases 2.5-megohm potentiometers have been placed into the circuit in suitable positions to be switched into operation as the color switch is operated. In these two instances the existing pots were duplicated for the color section. In any case, where a potentiometer which is used as a frequency or size control can cover the range required for color and monochrome, it is only necessary to duplicate the pot in the color scheme and adjust it for proper size in each position of the color monochrome switch. It should be noted that only a *dpdf* switch is required to change the sweep circuits.

Blocking Oscillator Circuit

A blocking oscillator circuit, of the type used in the RCA 9T246, appears in Fig. 5. In this case the capacitor *C*, in conjunction with resistors, *R*₁ or *R*₂, determine the frequency of the blocking oscillator. A 2.2-megohm resistor can be used for the 60-cps vertical sweep of black and white, while a 620,000-ohm resistor will serve for the 144 cps required for color. In one alteration, the vertical size of the original potentiometer was duplicated as it had enough range. Fig. 6 shows another type of blocking oscillator where the *rc* combination in the grid circuit

Fig. 7. Typical dual-frequency synchrolock horizontal-scan circuit applied to RCA 630TS.

(Continued on page 75)

most everyone prefers a V-M tri-o-matic*

sell these V-M tri-o-matic RECORD CHANGERS



Cash in on a potentially great market, with the V-M tri-o-matic 950—the practical 3-speed replacement unit for obsolete one- and two-speed record changers!

V-M tri-o-matic changers play automatically all records, all speeds, all sizes, and shut off automatically after the last record plays.

(Automatic intermix for 10" and 12" records of same speed, too.) Minimum mounting space, 13³/₁₆" wide x 11⁷/₈" deep, over-all height 7¹/₄". Pre-cut mounting boards available.

Simple installation in any cabinet.



The V-M tri-o-matic 955 rounds out the home entertainment picture! Beautifully styled to harmonize with any cabinet, the tri-o-matic 955 plays through the amplifying system of any TV set

or radio. The exclusive, patented tri-o-matic Spindle offers POSITIVE RECORD PROTECTION, since records are LOWERED — NOT DROPPED — on the spindle shelf. Equipped with 6-foot AC cord and a 4-foot sound cord and plugs.

FOR FULL DETAILS, SEE YOUR REP OR JOBBER
Registered, Spindle Design Patented



V-M CORPORATION • Benton Harbor, Mich.

*the phono in most top-brand radio-phono combinations

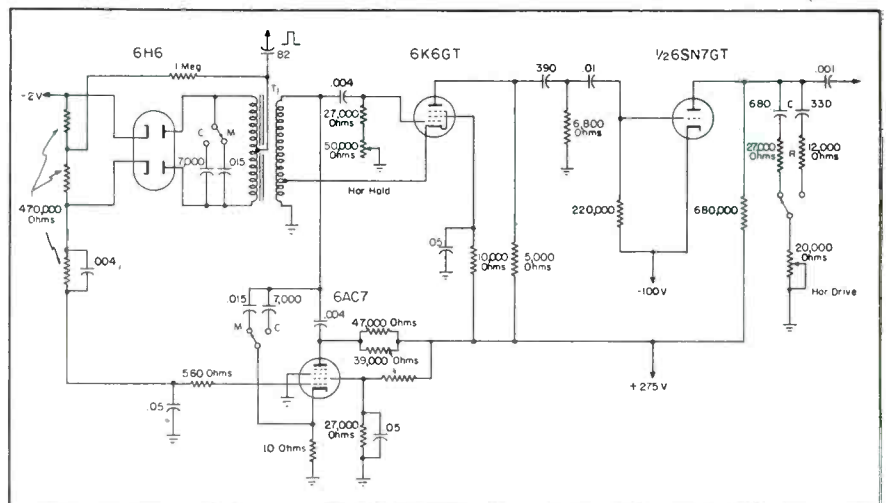

EICO

gives you Laboratory Precision at
Lowest Cost!

NEW **EICO**
Instruments and **KITS**

... with a complete line

Over 50,000 servicemen have bought one or more EICO Kits and Instruments. That's the proof of EICO's leadership in value to the serviceman!

For latest precision engineering, finest components, smart professional appearance, lifetime performance and rock-bottom economy—see and compare the EICO line at your jobber's today before you buy any higher-priced equipment! You'll agree, with over 50,000 others, that only EICO Kits and Instruments—no other—give you the industry's greatest values for the industry's lowest costs!

Read the full story on the complete EICO line. Write today for your free latest Catalog S-8.

221K VTVM Kit \$25.95
Wired \$49.95

625K Tube Tester Kit \$34.95
Wired \$49.95

320K Sig. Gen. Kit \$19.95
Wired \$29.95

145K Sig. Tracer Kit \$19.95
Wired \$28.95

315K Deluxe Sig. Gen. Kit \$39.95
Wired \$59.95

HV Probe \$6.95

IRF Probe Kit \$3.75
Wired \$5.95

1040K Battery Elim. Kit \$25.95
Wired \$34.95

425K 5" Scope Kit \$44.95
Wired \$79.95

511K VOM Kit \$14.95
Wired \$17.95

360K Sweep Gen. Kit \$34.95
Wired \$49.95
C-5 5mc Crystal \$3.95

ELECTRONIC INSTRUMENT CO. Inc.
276 NEWPORT STREET, BROOKLYN 12, N. Y.

Due to unsettled conditions, prices and specifications are subject to change without notice.
Prices 5% higher on West Coast

SPECIFY BLACO
(formerly BLACKBURN)

A-1 Ground Clamps
Fit 3/8" to 1 1/4" Pipe

ASK YOUR JOBBER
BLACO MANUFACTURING CO.
(formerly Blackburn Specialty Co.)

6525 EUCLID AVE., CLEVELAND 3, OHIO

BUYING POWER
for your products!

The more than 28,000 professional radio and TV service technicians who read **SERVICE** every month.

TUBES

Every Critical Type

Fully Guaranteed • Brand New • Immediate Delivery

1U5	1R5	1B3GT	1X2
5U4G	1U4	3Q4	5V4G
5Y3GT	3S4	6AG5	6AH6
6AU6	3V4	12AU7	6BC5
6BE6	6AL5	12SA7GT	6BG6G
6J5GT	6BA6	12SK7GT	6BQ6G
6K5GT	6SA7GT	12SN7GT	6CD6
6K6GT	6SK7GT	12SQ7GT	6J6
6W4GT	6SN7GT	35L6GT	6T8
35W4	6V6GT	50L6GT	12AT7
35Z5GT	6X5GT		
	12BH7		

ALL TYPES NOT LISTED—
60% OFF STANDARD LIST PRICE

TERMS: Orders for less than \$25.00, add 10% to above prices. 25% with order, balance C.O.D. All merchandise subject to prior sale, F.O.B. New York City.

TeleVision Materials Corp.
114 LIBERTY ST., NEW YORK 6, N.Y. • COrtlandt 7-4307

INDUSTRIAL TV CASCADE AUTOBOOSTER

A cascade *Autobooster*, IT-90A, featuring an input amplifier of the low-noise cascade (Wallman circuit) type using a 6BQ7 dual triode has been developed by Industrial Television Inc., 359 Lexington Ave., Clifton, N. J. The resulting low-noise factor of the amplifier is said to make it effective as a preamp for any high-gain antenna system. Separate antenna inputs for high and low band antennas, or a single high-low antenna, are provided. Gain controls to adjust the amplifier gain on the high and low channels *independently* are provided. These controls are to be set by the installer for best overall performance, and are not operating controls for the user.

A feed-through switch is incorporated which permits the *Autobooster* to be removed from the circuit.

* * *

JACO NYLON ALIGNMENT TOOL

A nylon alignment tool, for use where high voltages are involved, has been produced by the Jaco Products Co., Cleveland, Ohio.

* * *

BLONDER-TONGUE AUTOMATIC BOOSTER

An automatically-operated TV booster, the *B-T Antensifier*, covering high and low TV bands, is now available from Blonder-Tongue Laboratories, 38 North Second Ave., Mount Vernon, N. Y. Features a four cascaded-tube circuit, with four dual-triodes. Has a bypass switch which cuts booster out of circuit on strong signal inputs.

* * *

TRIO ROTATOR

A TV rotator and direction indicator, have been announced by the Trio Manufacturing Co. Griggsville, Ill.

Rotator uses two 24-volt motors, one for clockwise and the other for counter-clockwise rotation, and stops at both ends of 360° turns. Featured are a cast *Tensalloy* aluminum mast holder and a 1/16" strut shaft that is said to withstand 4500 pounds bending movement, automatic electro-mechanical brake, all aluminum case, numbered terminals boards on rotator and indicator and ball-bearing end thrusts on shafts.

Rotator turns 1 rpm and can be fastened to any pipe up to 2" od.

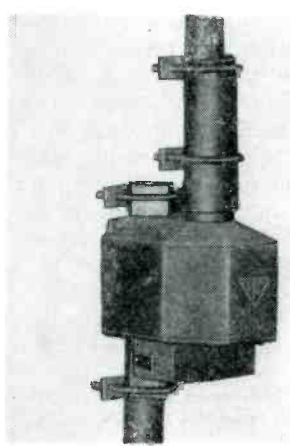

[Additional TV Product News on pages 50-51]

PHOENIX UNIVERSAL MOUNT

A universal antenna mount, model PAM-3, has been introduced by Phoenix Electronics, Inc., Lawrence, Mass. It is said to provide for installation on flat, peaked and sloping roofs of any pitch. Clamps hold poles from 1" to 1½" in diameter.

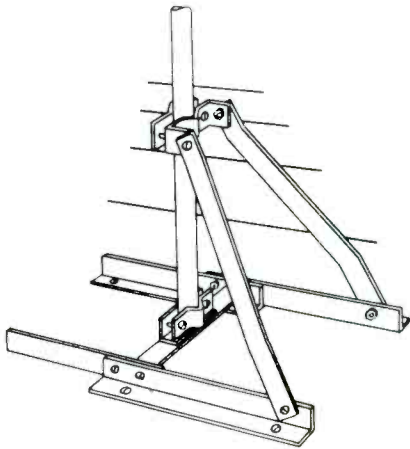

* * *

TACOPLEX SYSTEM AGC STRIP

An *agc* strip (No. 1562-*) for use with the Tacoplex system has been announced by the Technical Appliance Corp., Sherburne, N. Y.

Strip is said to compensate for changing signal strength automatically by means of a detector and filter, developing a bias voltage proportional to the signal output. This bias voltage is fed to a four tube amplifier strip which is connected to the antenna. The strips come tuned for any one of the 12 TV channels or FM band.

* * *

SPOT ILLUMINATED TV ALIGNMENT TOOLS

Alignment tools which cast a spotlight along the shank of the tip to the working area are now available from Spot Tools, Inc., Morris Plains, N. J.

Lucite holder is said to accommodate interchangeable aligning tips of two diameters, ⅛" and 7/32". Tool has one tenite tip 6" long and an overall length of 12" when assembled.



Spot tools.

*Save Time
Save Money
with these...*

New
**STANCOR
REFERENCES**

The big new Stancor 1951 Mid-Year Catalog lists 441 Stancor transformers ... the most complete catalog line in the industry. All transformers, including television components, are classified and indexed so you can easily locate the unit you need. Each listing includes electrical specifications, dimensions, weight and list price. Clear illustrations show each mounting type in detail.

* * *

The 8th Edition of the Stancor Television Catalog and Replacement Guide provides you with quick, easy-to-read replacement information on 1511 TV models and chassis made under 79 brand names. All manufacturers are listed alphabetically and the models and chassis are listed in numerical order. A separate section lists all Stancor TV transformers and related components by part number.

Both of these up-to-date references are now stocked by your Stancor distributor, or write Stancor directly for your free copies.

* * *

AUDIOPHILES—Use Stancor transformers to build the famous Williamson High Fidelity Amplifier. Circuit diagrams and complete parts lists are available in Stancor Bulletin 382 at your Stancor distributor.



*Most Complete Line
in the Industry*

STANDARD TRANSFORMER CORPORATION

3588 ELSTON AVENUE, CHICAGO 18, ILLINOIS

EICO DECADE BOX KIT

A resistance decade box, model 1171, in factory wired or kit form, has been produced by Electronic Instrument Co., Inc., 276 Newport St., Brooklyn 12, N. Y.

Unit is said to supply resistance values from 0 to 99,999 ohms with ½% precision. Featured is a separate comparator position, which, with its binding posts, permits substitution of an equivalent component for the resistance value indicated by the decade box.

(Right)

Illuminated window display of A. R. Spartana Co., 239 N. Gay St., Baltimore, Md., featuring picture-tube promotional material furnished by the G.E. tube divisions.

PICTURE-TUBE DISPLAY

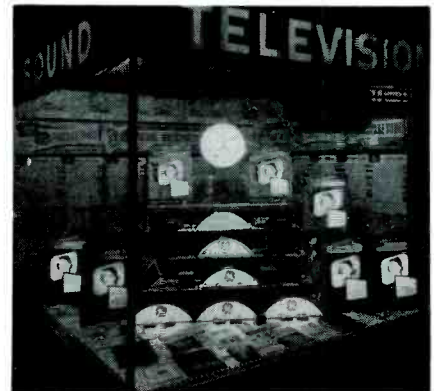

"They're worse than PINK ELEPHANTS"

say TV owners of the *vertical black bars* which appear when Barkhausen Oscillation occurs in the horizontal sweep output tube (such as the 25BQ6, 6BQ6, 6EV5, 25EV5, 6AU5, or 25AU5, etc.).

GET RID of BARKHAUSEN OSCILLATION with the B. O. ELIMINATOR!

Because it brings a concentrated magnetic field near the source of the Barkhausen Oscillation—namely the screen grid—the Perfection B. O. Eliminator usually stops the oscillation. *Easy to Install.* Just slip over the tube, move down or up, or turn until the dark vertical bars disappear.

Order today from your supplier!

PERFECTION ELECTRIC COMPANY
 2637 South Wabash Avenue, Chicago 16, Illinois
 MAKERS OF PERFECTION SPEAKERS AND TELEVISION COMPONENTS

RESERVE SPACE NOW FOR SEPTEMBER SERVICE
 Mailed to the radio and TV servicing industry's buying power mid-September, the start of the FALL BUYING SEASON. Last forms close Sept. 1.

TUBES Price Slashed!
 Receiving & Transmitting

RMA Guaranteed—Standard Brands		TV Picture Tubes BLACK FACE
0Z4 .. \$.59	6V6 .. \$.89	10BP4 \$22.50
1R5 .. .89	7C4/	12LP4 23.50
5U4 .. .79	1203A .89	14BP4 24.50
5V4 .. 1.39	12AT7. 1.19	16GP4 32.50
5Y3 .. .49	12AU7. 1.19	16HP4 32.50
6AC7 . 1.29	12BH7. 1.19	17BP4 32.50
6AG5 . 1.29	12SA7. .79	19AP4 36.50
6AL5 . .79	12SK7. .79	20CP4 39.50
6AU6 . .79	12SQ7. .69	24AP4 74.50
6BC5 . .89	35A5 . .98	
6BG6 . 1.89	35L6 . .89	
6BN6 . 1.39	35W4 . .69	
6BQ6 . 1.59	35Y4 . .89	
6K7 .. .59	35Z5 . .59	
6SA7 . .69	50A5 . .98	
6SN7 . 1.09	50B5 . .98	
	5CL6 . .75	

FREE: Write for catalog . . . tubes, parts and accessories for radio and TV! Also special electronic instruments catalog.

Minimum order; \$5.00. 25% deposit with order, balance C.O.D. Include postage with order. All merchandise subject to prior sales, F.O.B. New York, N. Y.

SPEAKERS Sensational Savings!

ALL ALNICO V—Priced Extra Low

4" PM	\$1.59	4" x 6" 1,500 ohm	\$1.69
5" PM	1.69	8" Auto 4-6 ohm.	2.89
4" x 6" PM	1.79	8" PM	3.25
6" PM	1.89	12" PM	6.69
6" 62 ohms with output trans.			2.79

SPECIAL OFFER!
 DEDUCT 5% from the price of any speaker in lots of 10 or more. Can be assorted.

GENUINE MOLDED CONDENSERS
 Fresh Stock—All Mineral Oil Filled
 100° Centigrade—Meets Jan C91 Tests
 ALL 600 VOLTS

Cap.	Per 10	Per 100
.001	\$.79	\$6.90
.00279	6.90
.00579	6.90
.0189	7.90
.0289	7.90
.05	1.09	9.90
.1	1.25	11.50

ELECTROLYTIC CONDENSERS

	Ea.	Lots of 10
20 x 20—150V.	\$.39	\$3.70
40 x 40—150V.45	4.30
50 x 30—150V.45	4.30
25—25V.19	1.50
20—25V.29	2.59
8—450V.39	3.69
10—450V.39	3.69
16—150V.59	5.69

All Guaranteed Fresh Stock!

The ROSE Company
 102 PARK PLACE Cortland 7-6195 NEW YORK 7, N. Y.

JFD ACQUIRES SITE FOR NEW PLANT

A site for the construction of an additional 120,000 square-foot plant has been acquired by the JFD Manufacturing Co., Inc., 6101 Sixteenth Ave., Brooklyn 4, N. Y. Also purchased was a factory for the specific manufacture of electrical plugs and other components.

* * *

VACO SCREWDRIVER CATALOG

A 32-page screwdriver catalog-handbook has been published by Vaco Products Co., 317 East Ontario St., Chicago 11, Ill. Featured are a screw chart and screw reference data.

Included are pages detailing handle and blade quality standards, round and square blade screwdrivers, Phillips amberyl handle and Phillips offset screwdrivers, clutch head screwdrivers, klipxon screw-holding screwdrivers, non-sparking and non-magnetic screwdrivers, offset screwdrivers, neon flash-tester screwdrivers, lucite lens flashlight screwdrivers, etc.

* * *

UNITED CATALOG ISSUES OPS SUMMARY

A 2-page summary of ceiling price regulations as they affect the distributor has been issued by United Catalog Publishers, Inc., 106-110 Lafayette St., New York 13, N. Y.

Summary covers GCPR, CPR-22, CPR-30 and SR-39 orders. Included is a commentary on the relationship of *United Catalog's pricing service* to the entire price control situation.

* * *

ALPROD CO NAMES FRED GOSSARD S-M

Fred Gossard, formerly credit manager of G. E. Credit Corp., has been appointed sales manager of Alprodco, Inc., Kempton, Ind.

* * *

MILLER NEEDLE SELECTION LEAFLET

A leaflet entitled, *How to Select the Proper Needle for Your Phonograph*, has been released by the M. A. Miller Manufacturing Co., 1165-69 East 43rd St., Chicago 15, Ill. Available through jobbers, leaflets available in a padded form simplifies selection of proper needle replacement. Forms are retained by the Service Man as a permanent record, to facilitate future ordering of needles.

* * *

CARTER MAINTENANCE MANUAL

A maintenance manual and parts catalog, 351, for Genemotors has been published Carter Motor Co., 2644 W. Maplewood Ave., Chicago, Ill.

Contents include maintenance recommendations, service notes, list of replacement parts for popular Genemotor models, and a bulletin covering the line with illustrations and specifications. The manual presents servicing procedure covering all vital parts of the Genemotor, such as armatures, commutators, bearings, brushes, etc.

[Additional News on pages 62 to 67.]

JAMES VIBRATOR REPLACEMENT GUIDE

A 4-page vibrator replacement guide, the *James Blue*, has been published by the James Vibrapowr Co., 4036 North Rockwell Ave., Chicago 18, Ill. Covers the firm's complete line of vibrators, and offers detailed cross-reference information. Also included are complete base wiring diagrams.

* * *

RADIO APPARATUS CORP. APPOINTS DICK MITCHELL S-M

Dick Mitchell has been appointed sales manager for Radio Apparatus Corp., 310 Fountain Square Bldg., Indianapolis, Ind., manufacturers of police-alarm and monitoradio systems.

Mitchell is also sales manager for I.D.E.A.



Roy True, prexy of Radio Apparatus Corp., and Dick Mitchell.

* * *

RIDER'S TV MANUAL 7 AVAILABLE

Distributors of John F. Rider Publisher, Inc., 480 Canal St., New York 13, N. Y., have received a supply of TV manual, Vol. 7.

The productions of 74 manufacturers are included in this volume; 776 models produced during the fall of '50 to summer '51 are presented. All pages, the equivalent of 2,352 (8½x11) are prefiled.

Volume contains schematics, chassis views, voltages, resistance readings, alignment procedures, test patterns, waveforms, parts lists and parts values, boosters, tuners, and up-to-date manufacturers' changes on previously published information. Instructional circuit action descriptions and unpacking and installation data complete the contents of the manual. Priced at \$24.00.

* * *

HARRY FETIG NOW MAGNECORD SERVICE STATION DIRECTOR

Harry E. Fetig has become director of Manufacturers Electronic Service, Santa Monica, California, approved Magnecord west coast service station.

Fetig was formerly with Altec Service Corp., serving as installation engineer, service inspector, technical inspector and field manager. In the latter capacity he supervised theater work, installation and maintenance of naval gunnery trainers, centralized radio systems, public address systems, and announcing, inter-communication and music systems.

* * *

SAMS TV TUBE LOCATION GUIDE

Volume 2 of *Television Tube Location Guide*, published by Howard W. Sams & Co., Inc., Indianapolis, is off the press and now being shipped to distributors.

The new volume shows the position and function of tubes in hundreds of television receiver models.

Guide is pocket size, 5½" by 8½" and contains over 220 pages, including coverage of TV models produced in 1949-50.

Price, \$2.00.

It's SENSATIONAL!

CLEARBEAM'S NEW ALL-CHANNEL

RHOMBIC

ELECTRICALLY ENGINEERED for LONG DISTANCE (DX) RECEPTION and SHARP DIRECTIVITY over the entire TV SPECTRUM

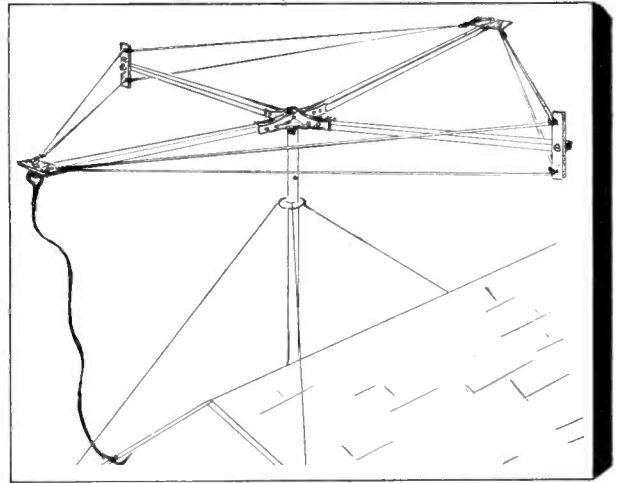

"Remember the Rhombic" has long been the phrase used by electronic engineers wherever the problem involved long distance (dx) and sharp directivity. Now, for the first time, Clearbeam has engineered this all-time favorite in an exclusive design to cover the entire high and low TV band—bringing you a Horizontal, Multi-Wire Rhombic TV Antenna with exceptionally high gain for low signal areas, and unusually sharp directivity to rid reception of ghosts! For picture-perfect long distance all-channel reception, remember the Rhombic—specifically "CLEARBEAM"!

SENSITIVE
7-Strand copper receiving elements

STURDY
Heavy-duty Alum casting frame. Alum reinforced structural grade waterproof Douglas Fir.

PREASSEMBLED
for ease in installation.

A COMPLETE LINE OF QUALITY ANTENNAS & ACCESSORIES FOR EVERY RECEPTION REQUIREMENT

Clear Beam TV ANTENNAS & ACCESSORIES

NOW IN OUR NEW HOME: 100 PROSPECT AVENUE, BURBANK, CALIFORNIA
ROckwell 9-2141 • CHARleston 0-4886

ARRL LICENSE MANUAL

The 1951 edition of the *Radio Amateur's License Manual* has been published by the American Radio Relay League, West Hartford, Conn. Expanded to 96 pages, it contains ten chapters covering the six classes of amateur licenses, general information on amateur licensing, portable and mobile operation, overseas licensing, international regulations, and U. S. regulations. Each chapter on the individual licenses includes full information on the scope of the examinations, together with sample questions (and their correct answers) typical of those that will be found on the actual FCC examinations. Readers will also find an examination schedule covering all FCC examination places and dates, and a full-page map of U. S. amateur call areas. Price, 50 cents.

REVISED BOOK ON RCA TV COMPONENTS NOW AVAILABLE

A revised and amplified version of the book *Television Components*, is now available to Service Men through RCA distributors. Heretofore, distribution of the book has been restricted to distributors.

The revised book (*CTV-1011-A*) contains vital data on more than 60 such components.

Book presents, with each component listed, such information as electrical ratings and characteristics, terminal connection diagrams, outline drawings, typical circuits, associated components, and recommended installation procedures.

Available at a suggested list price of twenty-five cents.

Before Any Other Consideration

Integrity of Circulation

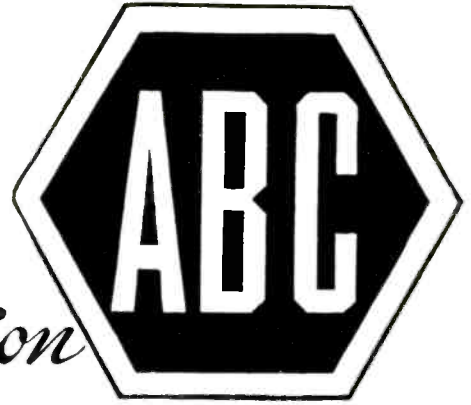

OF THE several factors that enter into the use of published media, the distribution of the advertisers' sales messages, as governed by the selection of media, can of itself decide the success or failure of the advertising investment. That is why integrity of circulation is the first consideration with experienced space buyers.

The emblem shown above stands for the FACTS that make it possible for advertisers to select the right media and to know what they get for their money when they invest in publication advertising. It is the emblem of membership in the Audit Bureau of Circulations, a cooperative and nonprofit association of 3300 advertisers, agencies and publishers.

Working together, these buyers and sellers of advertising have established standards for circulation

values and a definition for paid circulation, just as there are standards of weight and measure for purchasing agents to use in selecting merchandise and equipment. In other words, A.B.C. is a bureau of standards for the advertising and publishing industry.

A.B.C. maintains a staff of specially trained auditors who make annual audits of the circulations of the publisher members. Information thus obtained is issued in A.B.C. reports for use in buying and selling space. All advertising in printed media should be bought on the basis of facts in these reports.

This business paper is a member of the Audit Bureau of Circulations because we want our advertisers to know what they get for their money when they advertise in these pages. Our A.B.C. report gives the facts. Ask for a copy and then study it.

SOME OF THE AUDITED INFORMATION IN A.B.C. BUSINESS PAPER REPORTS

SEND THE RIGHT MESSAGE TO THE RIGHT PEOPLE

Paid subscriptions and renewals, as defined by A.B.C. standards, indicate a reader audience that has responded to a publication's editorial appeal. With the interests of readers thus identified, it becomes possible to reach specialized groups effectively with specialized advertising appeals.

- How much paid circulation.
- How much unpaid circulation.
- Prices paid by subscribers.
- How the circulation was obtained.
- Whether or not premiums were used as circulation inducements.
- Where the circulation goes.
- A breakdown of subscribers by occupation or business.
- How many subscribers renewed.
- How many are in arrears.

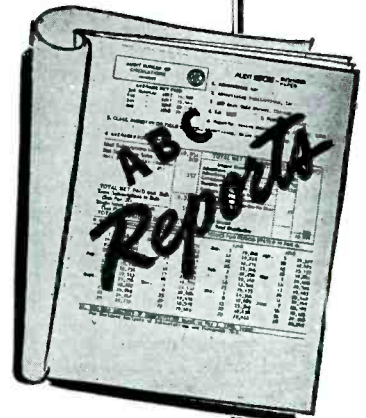

SERVICE

A.B.C. REPORTS — FACTS AS THE BASIC MEASURE OF ADVERTISING VALUE



**VISUALLY IDENTIFIES
TROUBLE IN ANY SECTION
OF A TV RECEIVER**

The HICKOK Model 650 Videometer is the first instrument of its kind to accurately and rapidly solve your servicing problems with the necessary tests to visually identify trouble in any section of a TV receiver.

FEATURES:

- An all-purpose video generator. Provides an electronically accurate bar or dot pattern on the screen of any TV receiver— independent of station operation.
- Can be used as a TV transmitter to simultaneously transfer a program to any number of TV receivers—on any desired channel.
- RF output, directly calibrated in microvolts for sensitivity measurements.
- Substitute Video Amplifier with gain of 0 to 10.
- Crystal controlled timer for greater accuracy.
- Fast, accurate, the ideal instrument for all area servicing.
- Increases TV maintenance profits—allows you to trouble shoot many more installations per day.
- Built only by HICKOK. Contains highest quality components throughout for lasting accuracy and dependability.

Write for the new, complete Hickok Test Instrument Catalog today.

**THE HICKOK ELECTRICAL
INSTRUMENT COMPANY**

10321 Dupont Avenue • Cleveland 8, Ohio

Color TV

(Continued from page 69)

determines the frequency. Again a smaller resistor and a switch were incorporated to make the circuit adaptable for color.

Flyback Conversion Problems

Receivers which employ flyback transformers for the high-voltage supply and those that use horizontal *afc* systems are not as easy to convert, as the smaller electrostatic types.

AFC Circuit Difficulties

The *afc* circuit has been found to make the conversion process somewhat
(Continued on page 78)

Color wheels for field-sequential colorcasts announced by Deitz Sales Co., 120 South Orange Ave., Newark, N. J. Available for 7-, 10- and 12-inch sets. Solid one-piece product, 1/100" in thickness, that is said to be balanced to prevent vibration. Supplied with pre-drilled mounting holes for assembly to either spindle or hub.



AT MILLER PARTS-SHOW BOOTH



Phil M. Spink, assistant sales director of M. A. Miller Manufacturing Co., Chicago, Ill., presenting prize won on Miller jackpot machine to W. Laforet of the Bowman-Anthony Company, Toronto, Ontario, during the recent Chicago parts exhibit. Twenty prizes were awarded, with winners receiving from \$50.00 in cash or \$100.00 worth of Miller and Carillon dynamic needles.

**PHOTOFACT Users
Write Our Best ADS!**

Hundreds of unsolicited letters tell what the world's finest Radio & TV Data means to Service Technicians

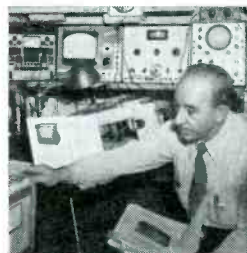

Albert B. Corideo
51 Ridgefield Ave.
Waterbury, Conn.

"I have been using PHOTOFACT ever since the first copy and will keep on as long as it is available. It has the most complete information and best diagrams I have ever seen, and it has been more than useful to me."



Joseph A. Ciskie
Le Center, Minn.

"I have PHOTOFACT complete to date and can honestly say that every Radio & TV service man who wants a better shop should have your service."

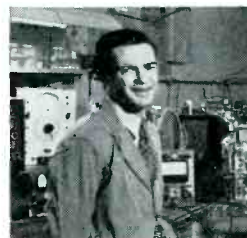

Dale H. Miller
4004 E. Anaheim St.
Long Beach, Calif.

"PHOTOFACT is great . . . and the literature contained in the PF Index is the most interesting and constructive we have found."

NOW! GET THE PROOF FOR YOURSELF!

FREE

**We'll Send You a FREE Photo-
fact Folder on any postwar re-
ceiver listed in the PF Index.**

Learn for yourself—at our expense—how PHOTOFACT pays for itself by earning bigger repair profits for you! Ask for a FREE Folder covering any postwar AM, FM or TV receiver listed in the PHOTOFACT Cumulative Index. Examine it. Put it to work at your bench—then judge for yourself!

WRITE FOR FREE FOLDER TODAY!

HOWARD W. SAMS & CO., INC.
2201 East 46th Street • Indianapolis 5, Indiana

HEATHKITS OFFER UNMATCHED ADVANTAGES

Heathkit
OSCILLOSCOPE
KIT
\$39.50

Heathkit
TUBE CHECKER
KIT
\$29.50

Heathkit
VACUUM TUBE
VOLTMETER
KIT
\$23.50

Heathkit
ELECTRONIC
SWITCH
KIT
\$19.50

Heathkit
TV ALIGNMENT
GENERATOR
KIT
\$39.50

Heathkit
SIGNAL
TRACER
KIT
\$19.50

Heathkit
AUDIO
GENERATOR
KIT
\$34.50

Heathkit
CONDENSER
CHECKER
KIT
\$19.50

Heathkit
IMPEDANCE
BRIDGE
KIT
\$69.50

Heathkit
RF SIGNAL
GENERATOR
KIT
\$19.50

Heathkit
BATTERY
ELIMINATOR
KIT
\$22.50

Heathkit
HANDTESTER
KIT
\$13.50

**HEATH COMPANY
BENTON HARBOR 11, MICHIGAN**

EXPORT AGENT: ROCKE INTERNATIONAL CORP., 13 EAST 40th STREET, NEW YORK CITY 16

You'll find unmatched advantages in HEATHKITS—the most complete line of test equipment in kit form. Careful engineering and extensive laboratory testing in the development of each kit, coupled with the use of only highest quality components give you RUGGED, DEPENDABLE, and ACCURATE test equipment. You SAVE MONEY when you build your own because all expensive factory wiring and construction costs are completely eliminated. . . . All kits are COMPLETE and a real pleasure to build—Every part necessary is furnished—and the clear, detailed instruction manual makes construction easy and educational. (And, the finished kits are truly professional in appearance.) Order your HEATHKIT today and enjoy these tremendous advantages!

in the basement, directly underneath the antennas. A distribution box was also located in the basement of each of the other buildings. (Basement locations were chosen because of the availability of *ac* power). The distribution boxes were connected with RG11/U run in conduit between buildings. (In similar projects, it may be satisfactory and less expensive to run the interconnecting coax overhead on a messenger cable instead of using conduit). RG59/U cables were dropped through the walls from each apartment to the distribution boxes in the basement. (Conduit is not required in buildings of this construction).

In the foregoing type of installation, where units and outlets are spread out over considerable distances, the following factors must be observed: (1) cable lengths from the master amplifier (through the distribution box) to the furthest receiver must *never* exceed 700' in strong-signal areas and 500' in fringe areas. (2) RG11/U should be used between distribution boxes whenever the distance between these units exceeds 50'. (3) If the buildings are so far apart that cable lengths exceed the foregoing requirements, then two, three, or more separate systems should be installed to cover the area. (For example, in a 933-unit garden development in Wilmington, Del., covering two square miles, ten separate systems were used). (4) In fringe areas, antenna lead losses to the master amplifier *must* be kept to a minimum. If the antenna lead is over 25' long, RG11/U must be used.

Antenna Installation

In the installations outlined 4-element yagis or equivalent, cut for each channel, mounted 15' to 20' above the roof are recommended. Up to four may be mounted on the same mast, which should accommodate approved-type lightning arrestors. The masts should be grounded with at least No. 8 aluminum wire.

Download Installation

After the location of the master amplifier has been determined, the download should be run, with a physical length as short as possible. Not only should kinks or sharp bends be avoided in the cable, and but it should be protected with tape or metal sleeving wherever sharp corners, rough surfaces, or building protrusions are encountered. If possible, the cable

Master Antenna

(Continued from page 19)

unit affair in Pottstown, Pa., consisting of five 2-story buildings) the amplifiers and the first antenna distribution box can be located in the central building, with the remainder of the antenna

distribution boxes located in the basements or attics of the remaining buildings.

The antennas in the Fig. 3 installation were mounted on a single mast and installed on the most centrally-located building. The master amplifier and distribution box were placed

Fig. 4. Cable-length chart. Between antenna distribution boxes RG59/U should be used. In extremely strong-signal areas (25,000 microvolts or more on low channels or 50,000 microvolts on high channels), RG59/U can be used in practically all cases, regardless of lead lengths. Incidentally, under no circumstances should RG59/U with a soft center conductor be used. (Courtesy Jerrald)

Area	Cable from Antenna to Master Amplifier				Cable from Master Amplifier to First Distribution Box	
	Channels 2 to 6		Channels 7 to 13		Use RG59/U	
Local (More than 5,000 μ V Signal)	400 ft. or Less	400 ft. or More	200 ft. or Less	200 ft. or More		
	RG59/U	RG11/U	RG59/U	RG11/U		
Fringe and Weak Sig. (Less than 5,000 μ V)	200 ft. or Less	200 ft. or More	100 ft. or Less	100 ft. or More	200 ft. or Less	200 ft. or More
	RG59/U	RG11/U	RG59/U	RG11/U	RG59/U	RG11/U
Extreme Fringe Sig. (Less than 500 μ V)	Use RG11/U				50 ft. or Less	50 ft. or More
					RG59/U	RG11/U

Scrap Shortage May Cause Mill Use Of Steel Strapping Restricted In Future **DON'T GET CAUGHT!**

In 9 out of 10 cases, the present overloaded inventories won't last more than a few weeks when Fall business booms! Smart jobbers and dealers are preparing now to lick the coming squeeze on materials. Protect yourself by ordering today...and don't get caught!

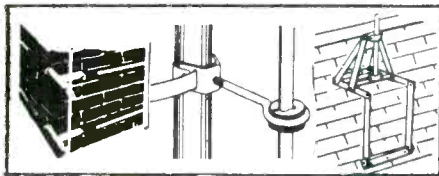

Bro... Allocation

**TO DO BUSINESS
TOMORROW, ORDER
PHOENIX
Speed-Tennas
AND
Speed-Mounts
TODAY!**

**PHOENIX ELECTRONICS
INC. LAWRENCE, MASS.**

TELEVISION ENGINEERING

if you are commercially or professionally interested in TV, read
for news of all that's NEW in the lab, plant and station involving design, manufacture, operation and maintenance of TV equipment for research, production, testing, receiving and transmitting.

Special Rate: 3 yrs. (36 issues) \$5

Bryan Davis Publishing Co., Inc.
(Publishers of SERVICE)

52 Vanderbilt Ave., New York 17, N. Y.

should be run through conduit or supported at intervals with metal rings.

Antenna Distribution Outlets

The distribution units can be mounted either on the wall or base-board behind the receiver. No attempt should be made to space the boxes equally. The use of random or unequal lengths of cable connecting each outlet box to the next has been found to be preferable, also. It is important to use care in cutting the cable and in installing cable fittings. An improper connection at any point can cause serious trouble later.

When all antenna distribution boxes have been connected, the last unit on the string must be terminated with a 72-ohm resistor. Otherwise, operation of the entire unit will be affected.

Credits

The author is grateful to Jerrold, and Jerry Kilroy in particular, for his assistance in preparing this article.



At a recent training session for technical representatives of distributors of Jerrold Multi-TV master antenna systems.

SYLVANIA COORDINATED TV-RADIO SERVICE CAMPAIGN



Point-of-sale material covering continuing national advertising and TV campaign promoting Service Men, now available from Sylvania: Six-color 36" window displays; six-color 18" counter cards; two-color 26" window streamers; TV-radio Service Men's fluorescent day-glow emblems for use on doors, windows or trucks (supplied in 8" and 12" diameters). Also available are rolls of dealer service stickers and a 60-page book of suggested spot announcements for use with local TV and radio stations. Direct mail material (6" x 9" post cards, shipping tag mailers, etc.) in kit form available from the advertising department of Sylvania at Emporium, Pa., at a charge of one cent per mailing piece ordered.



FIXED CAPACITORS

The three popular types here illustrated are specified by leading set makers, and they fit as perfectly into the SERVICE scheme. They are small... adaptable... the product of lifetime experience in Capacitor engineering. Use them with complete assurance of maximum satisfaction through, high standards of quality control.



MINIMATE—Metal tubular dry electrolytics—Compact, hermetically sealed capacitors with exceptionally low leakage—capable of withstanding high surge voltage—exceptionally long shelf life—ideally suited for under chassis mounting.

EY—Twist prong dry electrolytics—most popular type used by television and radio set manufacturers; simple to mount, specially processed for long-life operation at ambient temperatures up to 85° C.; Centrifuge electrolyte impregnation; spot welded cathode tabs; excellent stability; low leakage.

AM—Molded paper tubulars—designed for continuous operation at 85° C.; molded in high temperature, heat resistant plastic compound for perfect seal against most severe humid conditions; won't cold flow at 100° C.

WRITE FOR CATALOG AC-2

ASTRON CORPORATION

255 Grant Ave., East Newark, N. J.

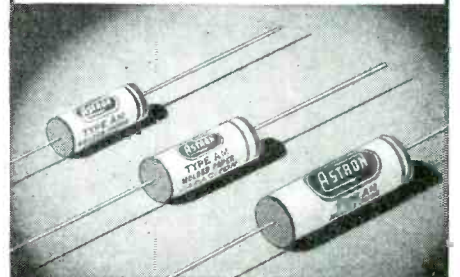

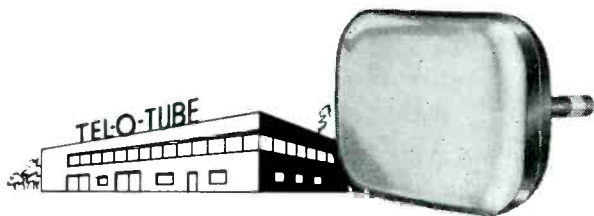

TEL-O-TUBE

The World's Finest Television Picture Tube

10 to 20 inches Round and Rectangular

Electrostatic Focus Tubes

Send Today For Complete Specifications

TEL-O-TUBE CORPORATION OF AMERICA

E. PATERSON NEW JERSEY

Sales Office: Tel-O-Tube Sales Corporation

580 5th Ave. New York 19, N. Y.

SERVICE

Edited exclusively for professional independent Radio and TV service and sound men, service organizations and the service departments of established dealers.

Readership represents 100% buying power for manufacturers of tubes, test equipment, components, accessories, sound and intercom equipment, TV antennas, tuners, boosters, etc.

Advertising in **SERVICE** pays dividends

WHEN YOU CHANGE YOUR ADDRESS

Be sure to notify the Subscription Department of SERVICE at 52 Vanderbilt Avenue, New York 17, N. Y., giving the old as well as the new address, and do this at least four weeks in advance. The Post Office Department does not forward magazines unless you pay additional postage, and we cannot duplicate copies mailed to the old address. We ask your cooperation.

Color TV

(Continued from page 75)

involved because the number of points to be switched over are more numerous. It does have circuit constants which can be altered for color; the tuning elements of the oscillator circuit can be changed to permit horizontal synchronization at 29160 cps.

Synchrolock Adaption

Fig 7 (p. 69) shows the changes that are required to adapt a synchrolock *afc* circuit for color. The 6K6 with a transformer comprises a Hartley oscillator which is tuned close to 15750 cps by means of the capacitor across the secondary winding. This capacitor must be changed from .015 to .007 to make the oscillator operate close to 29160 cps. The same change is required in the frequency-controlling capacitor in the reactance tube. Since the correct timing is obtained from the tuning of the oscillator in conjunction with the proper setting of the reactance tube, it is not necessary to modify the hold circuit in this case. It was

found necessary, however, to modify the *rc* circuit in the horizontal-drive circuit.

Dual-Type Transformer Use

These modifications indicate that a total of three switching points are required in the *afc* circuit alone. If no more switching points were required, the situation would not be so bad. As was mentioned previously, however, the flyback transformer, designed to operate with best efficiency at 15750 cps, must be replaced with one providing sufficient drive and linearity at 29160 cps. A dual-type transformer has been designed to supply sufficient drive for

the color picture. This transformer, together with the necessary changes in the driving circuit, are shown in Fig. 8. In the color position there are additional turns on the secondary winding to obtain more drive. In addition, it was found necessary to reduce the screen dropping resistor in the 6BG6GT from 100,000 to 17,000 ohms, thereby increasing the screen voltage and the gain of the 6BG6GT. In one arrangement the transformer has been mounted on a conventional square ferrite output transformer core, with the winding positions placed similar to those of an ordinary flyback transformer.

Circuit Changes Required

The changes necessary to adopt the synchroguide *afc* circuit for dual reception are also illustrated in Fig. 8. The synchroguide circuit has more adjustments and tuning elements, the total number of switching points adding up to five. The values of new variable capacitors, for use with color, are indicated in the horizontal lock and the horizontal frequency controls. The horizontal drive has to be converted again while the horizontal hold

Myron J. Greenwald (left), vice-president of Celomat, describing Celomat color wheel to Leopold M. Kay, vice-president in charge of engineering of CBS-Columbia, Inc.

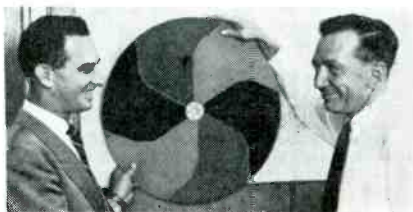

THREE TYPES OF
TWIN LINE CONNECTORS GIVE
YOU A CHOICE FOR ANY
INSTALLATION
PROBLEM!



No. 14-0
A general purpose polarized
connector.



No. 14-1
Attaches directly to re-
ceiver terminals.
Eliminates cutting line
to install a connector.

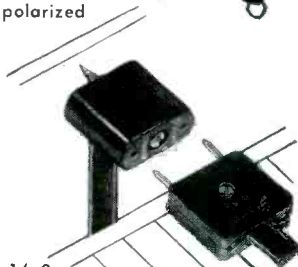

No. 14-2
A baseboard connector; serves as junction for antenna lead-in and inside lead to set. Mount them in parallel to accommodate the receiver in various locations.

Grayhill

4532 W. Madison Street

GET DETAILS—Write for
the Grayhill Catalog
NOW

Chicago 24, Illinois

Seletron SELENIUM RECTIFIERS

May be up your alley, too!

... AS THEY ARE FOR
THE BRUNSWICK-BALKE-
COLLENDER COMPANY

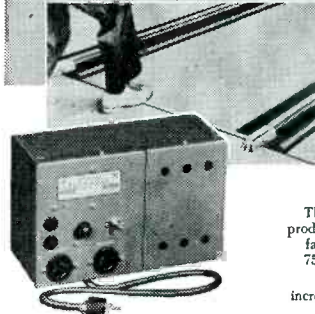

Illustrated above is the "Tel-E-Foul" control box. When the bowler oversteps the foul line the electronic beam conveys an impulse causing a light to flash above the alley. A 75 MA SELETRON miniature is built into the control box on each bowling lane.

The new "Tel-E-Foul," photo-electric Foul Indicator produced by The Brunswick-Balke-Collender Company, famous manufacturer of bowling equipment includes 75 MA SELETRON miniatures in its electronic circuits.

SELETRON Selenium Rectifiers are the choice of an increasing number of manufacturers in diversified fields because they are so thoroughly dependable under all types of grueling conditions. SELETRON is available in the miniature sizes required for radio, TV and other electronic circuits, all the way up to heavy duty power stacks used in a wide range of industrial applications.

Whenever you meet up with a power conversion problem, no doubt SELETRON engineers can be of substantial assistance in recommending the right rectifier for your needs. Write us today!

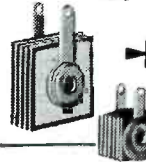

Seletron

SELETRON DIVISION

RADIO RECEPTOR COMPANY, Inc.

Since 1922 in Radio and Electronics

Sales Dept.: 251 W. 19th St., New York 11, N. Y. • Factory: 84 N. 9th St., Brooklyn 11, N. Y.

remains the same. The complexity of the problem for sets with *afc* and fly-back transformers are quite obvious from this schematic, there being eight points which have to be changed and

switched over, in addition to the replacement of the flyback transformer.

(In the next discussion, there will appear an analysis of the color wheel,

and its phasing problems with manual and automatic systems. There will also appear a review of the tricolor tubes and a description of the latest color receivers.)

Fig. 8. Dual-frequency synchroguide scanning circuit as applied to RCA 9T246 chassis. Horizontal output transformer required for modified system features a primary with 800 turns of No. 10 or 14 litz; a *hv* winding, also with 800 turns of No. 10 or 14 litz, and a secondary with three sections of 100, 200 and 250 turns, respectively, using No. 28 *bse* wire. According to CBS, secondary should be wound first; second, primary for 6BG6G; and third, *hv* primary for 1B3, all being wound on a square-type ferrite core with a 15-mil gap in each leg. A ferrite-type yoke is also recommended for use with the circuit.

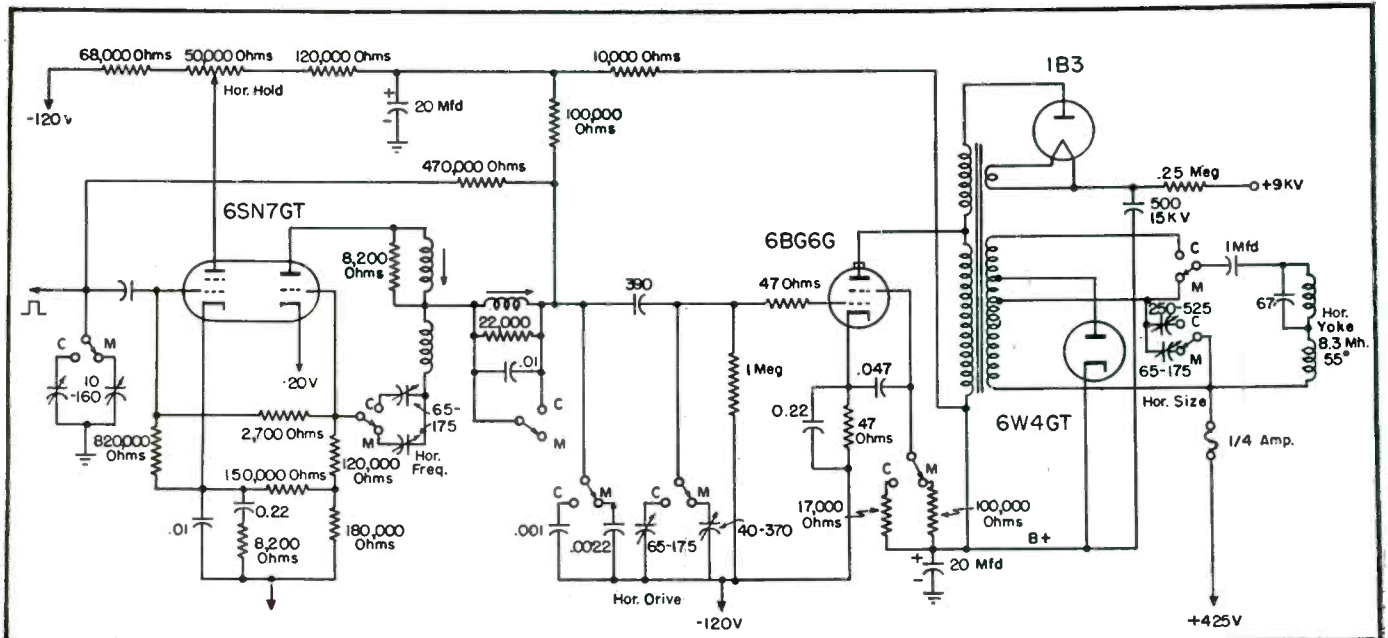

For AC CURRENT ANYWHERE
NO MAGIC just use
ATR INVERTERS

ATR

STANDARD AND HEAVY DUTY INVERTERS



For Inverting D. C. to A. C.

Specially Designed for operating A. C. Radios, Television Sets, Amplifiers, Address Systems, and Radio Test Equipment from D. C. Voltages in Vehicles, Ships, Trains, Planes and in D. C. Districts.

NEW MODELS **NEW DESIGNS**
NEW LITERATURE

"A" Battery Eliminator, DC-AC Inverters
 Auto Radio Vibrators

See your jobber or write factory



AMERICAN TELEVISION & RADIO CO.

Quality Products Since 1931

SAINT PAUL 1, MINNESOTA-U. S. A.

JOTS AND FLASHES

COMMUNITY ANTENNA SYSTEMS, which for quite a while were simply experimental ideas, during the past few months have become major installation projects throughout the country. In Hazard, Ky., 90-airline miles from the nearest television station, and in a valley ringed by hills, a community antenna mounted 1000' above the town has been found to provide a sound solution to reception difficulties. According to G.E., three antennas have been installed to pickup channels 4, 5, and 7, with signals being fed to amplifiers at the base of the tower, and fed down the mountain by 3000' of open-wire lead. Amplifiers have also been installed along the way to compensate for any loss of signal strength. At the base of the mountain, signals are fed to coax cables mounted on poles of the local lighting company. From the poles, smaller coax carries signals into the local homes. . . . Fluorescent lighting has become a feature of TV receivers, Sylvania having announced development of a cold light mounted behind a white plastic mask surrounding the picture tube. The light receives its power from a transformer by way of a resistor-series network. Complete details on this unusual installation will appear in an early issue of SERVICE. . . . The sixth bound volume of *RCA Victor Service Data*, which provides service and technical data on all 1950 models of RCA television sets, as well as radio receivers and phonos, is now available to Service Men through RCA distributors.

. . . . An illuminated *Professional Television Service* sign has been made available to TV Service Men through RCA distributors by the RCA tube department. . . . *Ed Hinck*, jobber sales manager of the electronic parts of DuMont Labs, East Paterson, N. J., has returned from a sales tour which covered the west coast. . . . *Dr. C. J. Breitwieser*, formerly chief of electronics and head of the engineering labs at Consolidated Vultee Aircraft Corp., has been named executive assistant to *Dr. F. R. Hensel*, vice prexy in charge of engineering, at *P. R. Mallory & Co., Inc.* . . . The 3-story building and basement occupied by *Milo Radio & Electronics Corp.*, 200 Greenwich St., New York, 7, has been air-conditioned. . . . The third edition of *Milton Kaufman's Radio Operator's License Q&A Manual*, published by John F. Rider Publisher, Inc., 480 Canal St., New York 13, N. Y., is now available at jobbers. . . . *Newark Electric Co.*, 323 W. Madison St., Chicago 6, Ill., has released its 1951 catalog. . . . Advertising and public relations for the Celomat Corp., is now being handled by Art-Copy Advertising Agency, 104 East 40th St., N.Y.C. . . . *Sylvania Electric Products, Inc.*, observed the 50th anniversary of its founding on July 31. Nearly \$10,000,000 will be spent for new plants and equipment in '51, according to Sylvania prexy *Don G. Mitchell*. . . . Operadio Manufacturing Co., St. Charles, Ill., has changed its name to *Dukane Corp.* . . . *Lincoln N. Kinnicutt* has been appointed advertising manager of the LaPointe-Plascomold Corp., Windsor Locks, Conn.

ADVERTISERS IN SERVICE—AUGUST, 1951

AMERICAN ELECTRICAL HEATER CO.	59	NATIONAL COMPANY, INC.	10
Agency: Dudgeon, Taylor & Bruske, Inc.		PERFECTION ELECTRIC CO.	72
AMERICAN PHENOLIC CORP.	28	Agency: Scantlin & Co.	
Agency: Burton Browne, Advertising		PERMO, INC.	35
AMERICAN TELEVISION & RADIO CO.	80	Agency: William Hoffman & Associates	
Agency: Firestone-Goodman Adv. Agency		PHOENIX ELECTRONICS, INC.	77
ANCHOR RADIO CORP.	17	Agency: Milton Richards Adv. Co.	
Agency: Symonds, MacKenzie & Co.		PRECISION APPARATUS CO., INC.	6
ASTRON CORP.	77	Agency: Shappe-Wilkes Inc.	
Agency: Hart Lehman, Advertising		RCA INSTITUTES, INC.	5
BENDIX RADIO TV & BROADCASTING DIV.		Agency: J. Walter Thompson Co.	
BENDIX AVIATION CORP.	47	RAD-ECO MFG. CO.	62
Agency: MacManus, John & Adams		Agency: Lehman Wood	
BERLANT ASSOCIATES	66	THE RADIART CORP.	Inside Front Cover
Agency: Mann Adv. Co., Inc.		Agency: Stern and Warren	
BLACO MFG. CO.	70	RADIO CORPORATION OF AMERICA	25, Back Cover
Agency: C. F. Peters & Associates		Agency: J. Walter Thompson Co.	
BURGESS BATTERY CO.	45	RADIO MERCHANDISE SALES, INC.	11
Agency: Ruthrauff & Ryan, Inc.		Agency: Teled Associates	
CLEAR BEAM TV ANTENNAS	73	RADIO RECEPTOR CO.	29
Agency: A. James Rouse Co.		Agency: Walter J. Zimmerman & Assoc.	
CLEVELAND ELECTRONICS, INC.	60	THE RAULAND CORP.	43
Agency: The White Adv. Co.		Agency: MacFarland, Aveyard & Co.	
CORNELL-DUBILIER ELECTRIC CORP.	58	RAYTHEON MFG. CO.—RECEIVING TUBE DIV.	12
Agency: Reiss Adv. Agency		Agency: Burton Browne, Advertising	
ALLEN B. DUMONT LABORATORIES, INC.	9	REGENCY DIV. I. D. E. A., INC.	31
Agency: Austin C. Lescarboura & Staff		Agency: Burton Browne, Advertising	
ELECTRONIC INSTRUMENT CO., INC.	70	JOHN F. RIDER PUBLISHER, INC.	63
Agency: H. W. Hauptman Co.		Agency: Cont'l Adv. Agency, Inc.	
ELECTRO PRODUCTS LABORATORIES, INC.	68	THE ROSE CO.	72
Agency: Gotsch Associates		Agency: A. D. Adams Adv.	
GENERAL ELECTRIC	1	HOWARD W. SAMS & CO., INC.	75
Agency: Maxon, Inc.		Agency: George Brodsky, Advertising	
GRAYBURNE CORPORATION	65	SANGAMO ELECTRIC CO.	14
Agency: H. W. Hauptman Co.		Agency: Arthur R. Mogge, Inc.	
GRAYHILL	79	SHURE BROTHERS, INC.	51
Agency: Merchandising Advertisers, Inc.		Agency: Casler, Hempstead & Hanford, Inc.	
HEATH COMPANY	76	SIMPSON ELECTRIC CO.	37
Agency: G. Dean Arend, Adv.		Agency: Burton Browne, Advertising	
HICKOK ELECTRICAL INSTRUMENT CO.	75	SNYDER MFG. CO.	23
Agency: The White Adv. Co.		Agency: Brooks and London	
HYTRON RADIO & ELECTRONICS CO. A DIV. OF COLUMBIA BROADCASTING SYSTEM, INC.	33	SPRAGUE PRODUCTS CO.	61
Agency: Bennett, Walther & Menadier, Inc.		Agency: The Harry P. Bridge Co.	
J. F. D. MFG. CO., INC.	49	STANDARD COIL PRODUCTS CO., INC.	4
Agency: Shappe-Wilkes, Inc.		Agency: Frank G. Nahser, Inc.	
JACKSON ELECTRICAL INSTRUMENT CO.	53	STANDARD TRANSFORMER CORP.	71
Agency: The Parker Adv. Co.		Agency: Burnet-Kuhn Adv. Co.	
JENSEN INDUSTRIES, INC.	52	SYLVANIA ELECTRIC PRODUCTS, INC.	3, 27
Agency: Frank C. Nahser, Inc.		Agency: Cecil & Presbrey, Inc.	
JENSEN MFG. CO.	2	TELEVISION MATERIALS CORP.	70
Agency: Burton Browne, Advertising		TEL-O-TUBE CORPORATION OF AMERICA	78
KESTER SOLDER CO.	39	Agency: Salow Adv. Agency	
Agency: Frank C. Nahser, Inc.		TUNG-SOL LAMP WORKS, INC.	56
KRYLON, INC.	54	Agency: E. M. Freystadt Assoc., Inc.	
Agency: Gray & Rogers		U. S. TREASURY DEPT.	8
THE LA POINTE-PLASCOMOLD CORP.	66	V-M CORPORATION	69
Agency: The F. W. Prella Co.		Agency: Mivard Sales & Adv. Counsel	
P. R. MALLORY & CO., INC.	Inside Back Cover	VIDAIRE, INC.	68
Agency: The Altkin-Kynett Co.		Agency: Goldman & Gilbert	
MERIT TRANSFORMER CORP.	7	WARD PRODUCTS CO.	41
Agency: Burton Browne, Advertising		Agency: The Hubbell Adv. Agency	
MOSLEY ELECTRONICS	67	WEBSTER ELECTRIC	55
Agency: Rudolph Bartz, Advertising		Agency: Mivard Sales & Adv. Agency, Inc.	
MUELLER ELECTRIC CO.	62	THE WORKSHOP ASSOCIATES, INC.	57
		Agency: Larcom Randall, Adv.	

In Volume Controls, too... fast, sure fit is important

In a survey of hundreds of servicemen, the importance of fast, sure installation was emphasized time after time in connection with volume controls. If you want a control that lets you do the job fast . . . and do it right . . .



Make Sure! Make it Mallory!

When you use the Mallory Midgetrol*, you get a combination of features that can't be matched.

First, you get a *permanently fixed, tubular brass shaft* that can be adapted for split-knurl or flatted type knobs in a few seconds by inserting one of the steel shaft ends supplied in every package. This means utmost convenience without sacrificing the stability of permanent, two-point shaft suspension.

Second, you get the convenience of AC switch design that permits secure attachment, *without*

removing the control housing. Positive indexing assures proper position.

Third, you get exceptionally accurate resistance values and taper curves.

Fourth, you can be sure of years of quiet, satisfactory service life through extremes of humidity and temperature.

Make it Mallory and make sure! Ask your distributor to show you the time-proved Mallory Midgetrol with the new features that make installation faster and simpler than ever.



*Depend on your Mallory Distributor
for precision quality at competitive prices*

Dual concentric Mallory Midgetrols can be made up easily by combining factory-assembled front and rear sections of desired resistance values. Ask your Mallory Distributor for details!

*Reg. U. S. Pat. Off.

P. R. MALLORY & CO. Inc.
MALLORY

CAPACITORS • CONTROLS • VIBRATORS • SWITCHES • RESISTORS
• RECTIFIERS • VIBRAPACK® POWER SUPPLIES • FILTERS

*Reg. U.S. Pat. Off.

APPROVED PRECISION PRODUCTS

P. R. MALLORY & CO., Inc., INDIANAPOLIS 6, INDIANA

You get *all five* ...with *RCA Batteries*

1. **Completely rounded line**

(one source for both fast-moving and hard-to-get types!)



2. **Radio trade distribution**

3. **Radio-engineered quality**

4. **Greatest array of selling aids**

5. **Top brand acceptance**

 **No other radio battery line offers you as much as RCA!** You get a *complete line* . . . *one source* for both fast-moving and hard-to-get types. Seven batteries are designed to minimize your stock requirements . . . meet most of today's demand. The complete line provides a type for almost every portable and farm radio need!

You get **radio trade distribution**, too, which builds your volume through greater repeat sales. Remember, *RCA Battery distribution always steers customers back to radio dealers and servicemen* . . . away from the non-radio outlets!

You get radio-engineered quality . . . top performance and long-lasting power. Every sale means a satisfied customer for you!

You get the **greatest array of selling aids in battery sales history!** Signs, displays, merchandisers, and servicing aids . . . all designed to make your selling easier.

And, you get **top brand acceptance** with "the greatest name in radio . . . RCA" . . . for faster, more profitable sales.

Call your local RCA Battery Distributor *today* for complete details on how you can join the radio trade switch to RCA Batteries . . . and greater battery sales!



RADIO CORPORATION of AMERICA
RADIO BATTERIES

HARRISON, N. J.