

are prospects for **C-D QUIETONES**

***MOST MAN-MADE INTERFERENCE** can be eliminated — but your customers don't know it.

Tell them . . . show them — using their own sets as demonstrators . . . and you'll discover that C-D Quietone Noise Filters are the surest-selling, steadiest-moving accessories in the entire radio repair and service field.

Shown above are only four of the units which make up the complete C-D line. One of them is sure to solve any *average* radio interference problem you encounter. And for those toughies — such as the short-wave fan who simply must have his ultra-violet ray treatments — there are special C-D Quietones which will bring background noise down to the level of a rabbit's bark. *Take advantage of this big profit opportunity NOW!* Mail coupon below for free copy of Catalog No. 195A. Cornell-Dubilier Electric Corporation, Dept. S10, South Plainfield, New Jersey. Other large plants in New Bedford, Worcester and Brookline, Mass., and Providence, R. I.

*87 out of every 100 listeners are unable to hear favorite programs clearly from certain stations because of man-made interference. *A large majority of these listeners are unaware that this radio interference can be eliminated.*

FREE! "THE CAPACITOR" Is The Serviceman's Magazine. Here is the ideal magazine for servicemen.

Articles are down-to-earth, brief, factual — dealing with situations you face every day.

Mail coupon and your subscription will start at once.

1910 1948



CORNELL-DUBILIER
WORLD'S LARGEST MANUFACTURER OF
CAPACITORS

See your local classified telephone directory for nearest authorized C-D Distributor.



MICA • DYKANOL • PAPER • ELECTROLYTIC

CORNELL-DUBILIER ELECTRIC CORPORATION, Dept. S10
South Plainfield, New Jersey

*I can use those ideas for servicemen. Please start
The Capacitor coming my way at once — FREE.
Please send copy of Catalog No. 195A.*

Name.....

Address.....

City..... Zone..... State.....

I am a serviceman amateur experimenter

other classification.....

"KEN-RAD TUBES STAND UP!"

"Nobody can tell me about Ken-Rad tubes—I've been using them for 14 years!

"When you've used them as long as I have, you know you can depend on them.

"I don't know any tube that stands up better than Ken-Rad tubes. They're quality through and through.

"Customers like them. This means repeat business—better business.

"Ken-Rad tubes do the trick all right!"



W. B. STYLES of Styles & Appleton, Oakland, California, one of thousands of reliable servicemen who depend on Ken-Rad tubes to build repeat business.



JAMES E. CAMPBELL, Foreman, Quality Control Section, who oversees the quality sampling inspection (below) before tubes are accepted into warehouse. Ken-Rad tubes are constantly being tested to assure dependable performance, long life.



"KEN-RAD TUBES MUST STAND UP!"

"They have to stand up—through test after test.

"This comprehensive testing results in dependable tubes that satisfy your customers, increase your business.

"Ken-Rad tubes are factory-tested for noise, microphonics, static, life, shorts, appearance, gas, air and hum.

"No wonder they're tops in quality, stamina and endurance. No wonder they're customer-pleasers, profit-makers."

KEN-RAD Radio Tubes

PRODUCT OF GENERAL ELECTRIC COMPANY

Schenectady 5, New York

178-GA11-8950

The
Serviceman's
Tube



RADIO · TELEVISION · ELECTRONIC
SERVICE

LEWIS WINNER
Editorial Director

F. WALEN
Assistant Editor

ALFRED A. GHIRARDI
Advisory Editor

	Page
Association News	36
Increase Your 'Scope Sensitivity. By J. B. Farnum and Jack Najork	30
Magnetic Wire Recorder-Playback (Cover)	28
Ser-Cuits (Complete Analysis of Admiral 301A TV Model)	22
Servicing Helps. By P. M. Randolph	32
Sound Powered Communication in TV Installation Work. By K. I. Donald	26
Ten Years Ago in Associations	37
TV Receiver Visual Alignment Techniques. By Lester L. Libby	14
TV Interference . . . Causes and Remedies. By Ira Kamen	20
TV Sync and Inter Sync Systems. By Edward M. Noll	34
Views and News. By Lewis Winner	13

CIRCUITS

Admiral 301A (Complete TV Circuit)	23
Admiral 301A (Block Diagram)	25
G. E. Variable Reluctance Preamp Circuit	30
G. E. Preamp (Revamped to Increase 'Scope Gain)	30
G. E. 901/910 (High Voltage and Picture Tube Circuit)	40
RCA MI-12775 (Cover)	28
Sound Powered Communication Systems	48
Sync Separator Circuits (Diode, Triode, and Pentode)	34
Tele-Tone TV 149	19

COVER

Magnetic Wire Recorder-Playback (RCA MI-12775)	28
--	----

SERVICING HELPS

Clock Movements for Program Selection and On-Off Control	32
Servicing Notes on Philco, RCA, Detrola, Emerson and Stromberg Carlson	43
TV Picture Tube Parts	32
Vibrator Testing with a 'Scope	45

Index to Advertisers

56

Manufacturers

New TV Parts . . . Accessories	51
New LP Products	52
New Instruments . . . Components	53
News	54
Jots and Flashes	56

Entire contents Copyright 1948, Bryan Davis Publishing Co., Inc.



Published monthly by Bryan Davis Publishing Co., Inc.
52 Vanderbilt Avenue, New York 17, N. Y. Telephone MUrray Hill 4-0170



Bryan S. Davis, President

Paul S. Weil, Vice Pres.-Gen. Mgr.

F. Walen, Secretary

A. Goebel, Circulation Manager

Cleveland Representative: James C. Munn, 2233 Delaware Dr., Cleveland 6, Ohio. Telephone: Erieview 1726

Pacific Coast Representative: Brand & Brand, 1052 W. Sixth St., Los Angeles 14, Calif. Telephone: Michigan 1732

Suite 1204, Russ Building, San Francisco 4, Calif. Telephone: SUTter 1-2251

Entered as second-class matter June 14, 1932, at the Post Office at New York, N. Y., under the Act of March 3, 1879. Subscription price: \$2.00 per year in the United States of America and Canada; 25 cents per copy. \$3.00 per year in foreign countries; 35 cents per copy.

Thousands Switch to PHOTOFACT for Quicker, Easier, More Profitable Servicing!

Thousands of Radio Service Technicians are *right!* They've found the way to quicker, easier, more profitable servicing. Join these thousands of successful money-making Servicemen who have switched to PHOTOFACT Service Data. Learn for yourself how this accurate, easy-to-use, practical data saves you time, makes your work easier, helps you earn more. PHOTOFACT gives you 100% useful service data—every photograph, every diagram, every bit of information helps you do a *complete job.* You owe it to yourself to switch to PHOTOFACT. There'll be a big difference in the time you save and the bigger profits you'll earn every single working day.

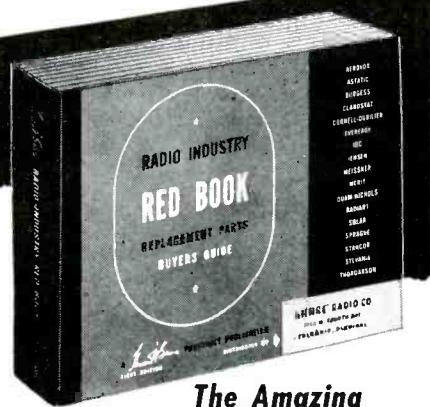

The Amazing Radio Industry RED BOOK Replacement Parts Buyer's Guide

NOW—stop wasteful hunting through dozens of incomplete parts manuals. The RED BOOK tells you what you need to know about replacement parts for approximately 17,000 sets made from 1938 to 1948. Includes complete, accurate listings of all 9 major replacement components—not just one. Lists correct replacement parts made by 17 leading manufacturers—not just one. Covers original parts numbers, proper replacement numbers and valuable installation notes on: Capacitors, Transformers, Controls, IF Coils (including Peak Frequencies), Speakers, Vibrators, Phonocartridges. *Plus*—Tube and Dial Light data for each receiver, and Battery replacement data. *Get all the right answers* in the RED BOOK. 440 pages, \$3.95 8½ x 11; sewed binding. **ONLY . . . \$3.95**

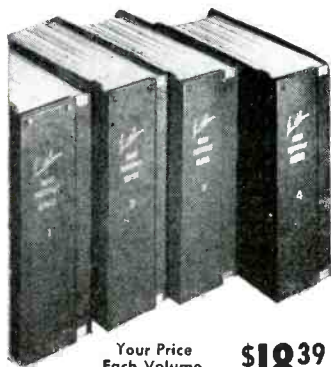

Your Price
Each Volume,
In DeLuxe Binder **\$18.39**

PHOTOFACT VOLUMES The Preferred Service Data

Bring your file of post-war receiver Service Data right up to July, 1948! Here's the most accurate and complete radio data ever compiled—preferred and used daily by thousands of Radio Service Technicians. Includes: Exclusive Standard Notation Schematics; photo views keyed to parts lists and alignment data; complete parts listings and proper replacements; alignment, stage gain, circuit voltage and resistance analysis; coil resistances; record changer service data, etc. Order Volume 4 today—keep your Photofact library up-to-date—it's the *only* Radio Service Data that meets your *actual* needs!

- Vol. 4. Covers models from Jan. 1, 1948 to July 1, 1948
- Vol. 3. Covers models from July 1, 1947 to Jan. 1, 1948
- Vol. 2. Covers models from Jan. 1, 1947 to July 1, 1947
- Vol. 1. Covers all post-war models up to Jan. 1, 1947



1947 Record Changer Manual

Nothing like it! Complete, accurate data on over 40 post-war models. Exclusive exploded views, photos from all angles. Gives full change cycle data, information on adjustments, service hints and kinks, complete parts lists. **PLUS**—for the first time—complete data on leading Wire, Ribbon, Tape and Paper Disc Recorders! 400 pages; hard cover; opens flat. Order now! **ONLY . . . \$4.95**



Receiver Tube Placement Guide

Shows you exactly where to replace each tube in 5500 radio models, covering 1938 to 1947 receivers. Each tube layout is illustrated by a clear, accurate diagram. Saves time—eliminates risky hit-and-miss methods. 192 pages, completely indexed. **ONLY . . . \$1.25**



Dial Cord Stringing Guide

The book that shows you the *one right* way to string a dial cord. Here, in one handy pocket-sized book, are all available dial cord diagrams covering over 2300 receivers, 1938 through 1946. Makes dial cord restringing jobs quick and simple. **ONLY . . . \$1.00**

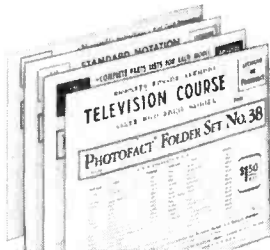

Subscribe Regularly to PHOTOFACT Folder Sets

Here's the most accurate and complete Radio Data ever compiled—issued regularly two sets per month. Keeps you right up-to-the-minute on all current receiver production. Packed with extra help—full PHOTOFACT data on Automatic Record Changers—communications receivers—amplifiers—*plus* new PHOTOFACT Television Folders—exclusive, uniform coverage of popular Television Models, data proved best by actual service clinic experience. Subscribe at your Jobber today, for regular monthly issues. **PER SET, ONLY . . . \$1.50**

FREE Cumulative Index

Send for the FREE Cumulative Index to PHOTOFACT Folders covering *all* post-war receivers up to the present. You'll want this valuable reference guide to the Radio Service Data preferred and used by thousands. Helps you find the Folders you want quickly. Get this Index at your Jobber or write for it today.



BOOST YOUR EARNING POWER!

Mail This Order Form
to HOWARD W. SAMS & CO., INC.
2924 E. Washington St., Indianapolis 7, Indiana

My (check) (money order) for \$.....enclosed.

- Send the RED BOOK. \$3.95 per copy.
- Send PHOTOFACT Volumes in DeLuxe Binder:
 - Vol 4. Vol. 3. Vol. 2. Vol. 1 (\$18.39 each).
 - Automatic Record Changer Manual, \$4.95.
 - Tube Placement Guide, \$1.25.
 - Dial Cord Stringing Guide, \$1.00.
 - Send FREE Photofact Cumulative Index.

Name.....

Address.....

City.....State.....

HOWARD W. SAMS & CO., INC.
INDIANAPOLIS 7, INDIANA

a new family joins the sangamo tribe...



New Dependability, New Long-Life Performance

Meet Sangamo Electrolytics, the newest family to become linked with the Sangamo Tribe. Introducing, from left to right on the opposite page, are illustrations of the "Chieftain", "Tomahawk", "Warrior", "Apache", and "Mohican". These newcomers now join the established tribe of Sangamo Micas, Silver Buttons, Papers, and Plastic Tubulars. Their heritage of dependability and long-life

performance stems from being built in a factory which was constructed *especially* and *exclusively* for the manufacture of contamination-free electrolytics. Their performance will meet and exceed the most stringent requirements of electronic applications. Yet, these new, high-quality capacitors are competitive in every respect from a standpoint of design, construction, and price.

Your own trial-use will convince you that new standards of dependability and longevity have been built into Sangamo Electrolytics. Order from the new Sangamo Electrolytic Capacitor Catalog No. 825C, which is yours for the asking, and without obligation.



Micas

Silver Buttons



Papers

Plastic Tubulars





SANGAMO

electrolytic

CAPACITORS

Chieftain



Tomahawk

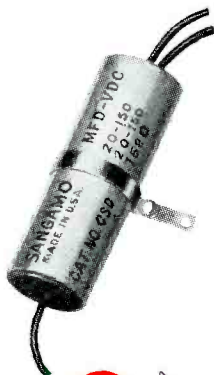

Warrior



Apache

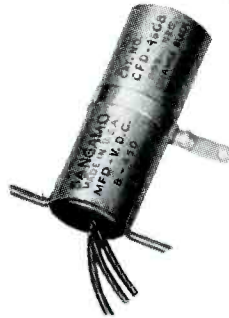

Mohican



SANGAMO

ELECTRIC COMPANY

SPRINGFIELD, ILLINOIS

Are you Building a Business ... or Burning your Bridges?

Would you patronize a dentist who filled your teeth with plaster of Paris?

Would you trust your children's lives to a doctor who prescribed cut-rate pills?

Your business, too, is built on *customer confidence!* And your reputation is too valuable to risk with inferior or unknown products. The cost of the parts you use in the average repair job is insignificant com-

pared with your investment in *your reputation.*

That's why we say—**YOUR CUSTOMERS AND YOUR REPUTATION CAN AFFORD ONLY THE BEST! . . . SPRAGUE.**



CAPACITORS

SPRAGUE

*KOOLOHM
RESISTORS

* T.M. Reg.
U. S. Pat. Off.

SPRAGUE PRODUCTS COMPANY, North Adams, Mass.

JOBGING DISTRIBUTING ORGANIZATION FOR PRODUCTS OF SPRAGUE ELECTRIC CO.

Reach for a **SPRAGUE** and Know You're Right!

The superiority of the new Sprague type TM High-Temperature Molded Paper Capacitors didn't happen by chance. You can use this better unit in your work today only because of more than four years of intensive research and one of the largest retooling programs in Sprague's history. That's why we can say "*The First Truly Practical Molded Paper Tubulars are Sprague TM's*"—and it is also the reason you can use them on any job with confidence and pride.

- Highly Heat Resistant
- Conservatively Rated
- Moisture Resistant
- Small in Size
- Non-inflammable
- Mechanically Rugged
- Completely Insulated

**UNCONDITIONALLY
GUARANTEED!**

You can stake your reputation on Sprague replacement parts. If used at rated capacitance and voltage, they are **UNCONDITIONALLY GUARANTEED** to give satisfactory performance. Insist on Sprague and Get the Best!

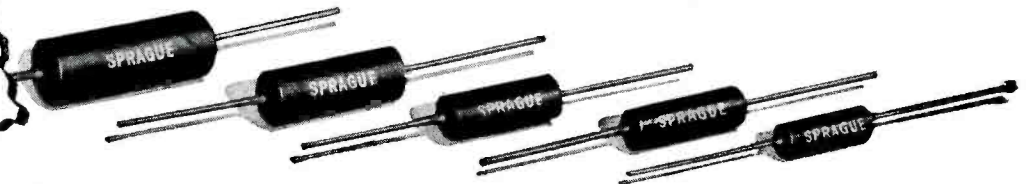

Build YOUR OWN TEST EQUIPMENT

Heathkit ELECTRONIC SWITCH KIT DOUBLES THE UTILITY OF ANY SCOPE



\$34.50

Gives two separately controllable traces with individual inputs on any scope. See both the input and output traces, locate distortion, phase shift, etc., immediately. Individual gain controls and positioning control. Coarse and fine sweeping rate controls. Complete Heathkit matches others, with 5 tubes. All metal parts are punched, formed and cadmium plated. Complete with tubes, all parts, detailed blueprints and instructions. Shipping Wt. 13 lbs.
Nothing ELSE TO BUY

HEATHKIT CONDENSER CHECKER KIT

\$19.50

Nothing ELSE TO BUY



A condenser checker anyone can afford to own. Measures capacity and leakage from .00001 to 1000 MFD on calibrated scales with test voltage up to 500 volts. No need for tables or multipliers. Reads resistance 500 ohms to 2 megohms. 110V 60 cycle transformer operated complete with rectifier and magic eye indicator tubes. Easy quick assembly with clear detailed blueprints and instructions. Small convenient size 9" x 6" x 4 3/4". Wt. 4 lbs.

HEATHKIT SIGNAL GENERATOR KIT



\$19.50

NOTHING ELSE TO BUY

Every shop needs a good signal generator. The Heathkit fulfills every servicing need, fundamentals from 150 Kc. to 30 megacycles with strong harmonics over 100 megacycles covering the new television and FM bands. 110V 60 cycle transformer operated power supply.

400 cycle audio available for 30% modulation or audio testing. Uses 6SN7 as RF oscillator and audio amplifier. Complete kit has every part necessary and detailed blueprints and instructions enable the builder to assemble it in a few hours. Large easy to read calibration. Convenient size 9" x 6" x 4 3/4". Wt. 4 1/2 lbs.

HEATHKIT SIGNAL TRACER KIT

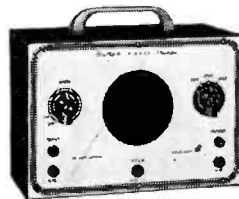

\$19.50

Nothing ELSE TO BUY

Reduces service time and greatly increases profits of any service shop. Uses crystal diode to follow signal from antenna to speaker. Locates faults immediately. Internal amplifier available for speaker testing and internal speaker available for amplifier testing. Connection for VTVM on panel allows visual tracing and gain measurements. Also tests phonograph pickups, microphones, PA systems, etc. Frequency range to 200 Mc. Complete ready to assemble. 110V 60 cycle transformer operated. Supplied with 3 tubes, diode probe, 2 color panel, all other parts. Easy to assemble, detailed blueprints and instructions.

Small portable 9" x 6" x 4 3/4". Wt. 6 pounds. Ideal for taking on service calls. Complete your service shop with this instrument.

HEATHKIT SINE AND SQUARE WAVE AUDIO GENERATOR KIT

The ideal instrument for checking audio amplifiers, television response, distortion, etc. Supplies excellent sine wave 20 cycles to 20,000 cycles and in addition supplies square wave over same range. Extremely low distortion, less than 1%, large calibrated dial, beautiful 2 color panel, 1% precision calibrating resistors, 110 V 60 cycle power transformer, 5 tubes, detailed blueprints and instructions. R.C. type circuit with excellent stability. Shipping weight 15 pounds.

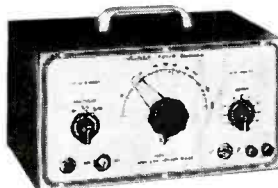

\$34.50

Nothing ELSE TO BUY

THE NEW HEATHKIT VACUUM TUBE VOLTMETER KIT

The most essential tool a radio man can have, now within the reach of his pocketbook. The Heathkit VTVM is equal in quality to instruments selling for \$75.00 or more. Features 500 microamp meter, transformer power supply, 1% glass enclosed divider resistors, ceramic selector switches, 11 megohms input resistance, linear AC and DC scale, electronic AC reading RMS. Circuit uses 6SN7 in balanced bridge circuit, a 6H6 as AC rectifier and 6 x 5 as transformer power supply rectifier. Included is means of calibrating without standards. Average assembly time less than four pleasant hours and you have the most useful test instrument you will ever own. Ranges 0-3, 30, 100, 300, 1000 volts AC and DC. Ohmmeter has ranges of scale times 1, 100, 1000, 10M and 1 megohm, giving range 1 ohm to 1000 megohms. Complete with detailed instructions. Add postage for 8 lbs.



\$24.50

Nothing ELSE TO BUY

HEATHKIT FM AND TELEVISION SWEEP GENERATOR KIT



\$24.50

NOTHING ELSE TO BUY

THE BASIC FM AND TELEVISION SERVICE INSTRUMENT

At the lowest cost possible, anyone can now service FM and television receivers. The Heathkit sweep generator kit operates with oscilloscope and covers all necessary frequencies. A few pleasant hours assembling this kit puts any organization in position to share the profits of the FM and TV boom.

Every part supplied — grey crackle cabinet, two color calibrated panel, all metal parts punched, formed and plated. 5 tubes, complete detailed instructions for assembly and use. Shipping weight 6 lbs.

The NEW 1948 HEATHKIT 5 INCH OSCILLOSCOPE KIT

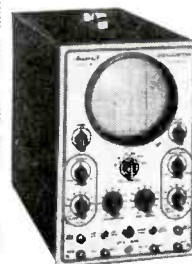

\$39.50

NOTHING ELSE TO BUY

New improved model of the famous Heathkit Oscilloscope. Building an oscilloscope is the finest training for television and newer servicing technique and you save two-thirds the cost. All the features and quality of instruments selling for \$100.00 or more. Supplied complete with cabinet, two color panel, 5B1 tube, 2 5Y3 tubes, 2 6SJ7 tubes and 8B4 sweep generator tube. Power transformer supplies 1000V negative and 350 volt positive. Sweep generator 15 cycles to 30 M. cycles. Has vertical and horizontal amplifiers. Oil filled filter condensers for long life. Complete blueprints and instructions included.



The **HEATH COMPANY**

... BENTON HARBOR 11, MICHIGAN

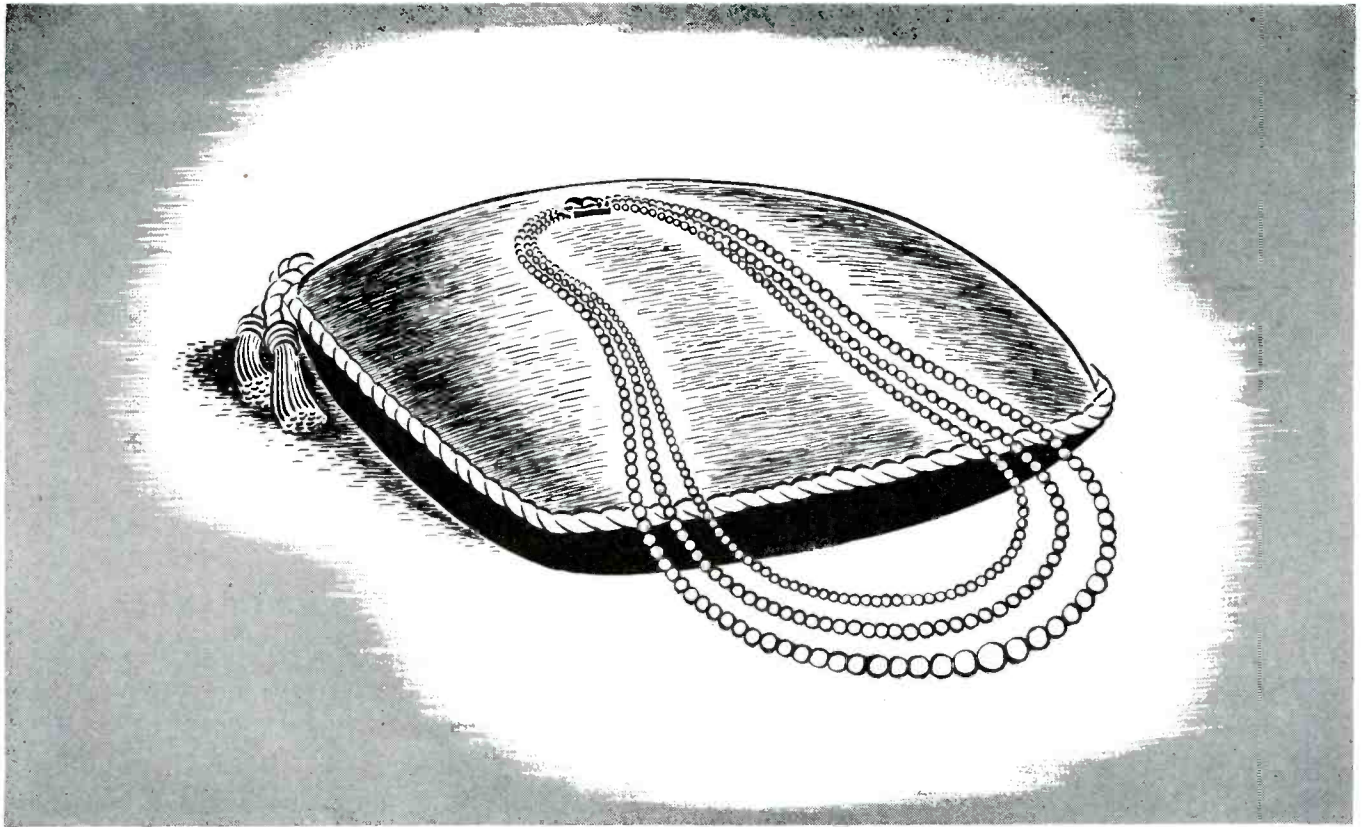

Quality

The intangible beauty in a string of pearls that makes them more outstanding is the quality they naturally possess. And so it is in vibrators. The RADIART VIBRATOR is the peak of quality, not by mere chance, but because efforts have been made to make them, always, top quality! The RADIART VIBRATOR is a product of finest materials . . . expertly manufactured . . . and built up to a standard . . . not down to a price! That is why, Radiart means quality — that is why Radiart leads the field in sales . . . preferred everywhere by servicemen who choose to serve their customers needs best.

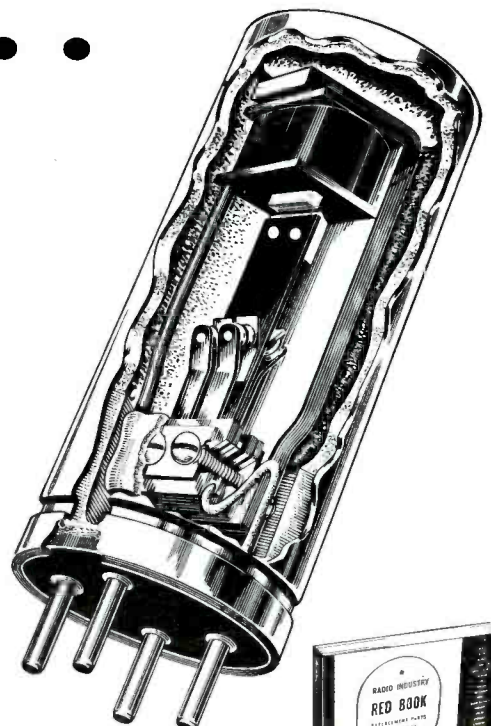

THE ONLY VIBRATOR LINE TO BE LISTED IN SAMS RED BOOK

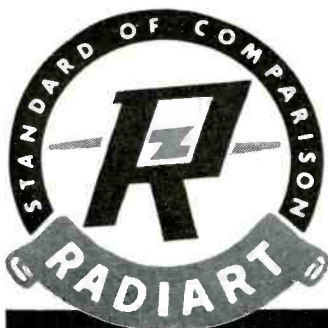
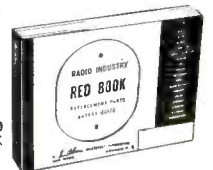

The Radiart Corp.

CLEVELAND 2, OHIO

Export-Scheel International Inc., 4237 N. Lincoln Ave., Chicago 18, Ill.



Model 266
Vacuum Tube
Voltmeter
for TV, FM, AM

RANGES: Volts: (A.C. and D.C.) 0-1, 5, 10, 50, 100, 250, 500, 1000, 5000

Milliamperes: (D.C.) 0-1, 5, 10, 20, 100, 250, 500
Amperes: (D.C.) 0-10

Ohms: 0-100 10 ohms center)
0-10,000 100 ohms center)
0-100,000 1000 ohms center)
0-1 megohm 10,000 ohms center)
0-10 megohms 100,000 ohms center)
0-100 megohms 1 megohm center)
0-1000 megohms 10 megohms center)

Size: 8 1/2" x 9 1/2" x 8". Dealer's Net Price complete with Operator's Manual.....\$94.50



Model 330 RCP
Mutual Conductance
Tube Tester
for TV, FM, AM

The Simpson Model 330 tests tubes in terms of PERCENTAGE of rated DYNAMIC MUTUAL CONDUCTANCE, a direct indication of tube performance with reference to the manufacturer's STANDARD MICROMHO rating. Shows tubes as good, fair, weak or definitely bad. When you have finished a tube test ONE BUTTON returns all switches to the normal position ready for the next test.

Size: 15 1/2" x 9 1/2" x 6 1/4"

Dealer's Net Price, complete with Operator's Manual.
\$132.50



Model 415-A Signal Generator for FM and AM. Incorporates built-in sweep circuit for modern FM servicing. Frequency modulated signal with a sweep of 1 megacycle, more than adequate for all FM alignment. Internally modulated at either 60 cycles or 400 cycles or modulated from an external source. A 120 cycle saw-tooth voltage is available as scope synchronization or as actual scope sweep. AM bands cover complete frequency range from 75 KC to 130 MC.
For 105-130 volts, 50-60 cycle
Size: 5 7/8" x 11 3/8" x 15 1/8"
Dealer's Net Price, complete with Operator's Manual..... **\$145.00**

for
TV, -FM, and AM
servicing

— your 3 finest basic testers

On Model 266 Vacuum Tube Voltmeter, note these distinguishing Simpson features: the 1 volt range, for full scale deflection, necessary in low R.F. voltage measurements; the zero center switch provided for discriminator circuit alignment, a feature which embraces all D.C. voltage ranges. D.C. volt input resistance ranges from 50 megohms to 200 megohms. The low input impedance at 60 cycles is 40 megohms. The low input capacitance of the probe (approximately 4 micro-microfarads) insures the accuracy essential for the high frequencies encountered in servicing FM and television receivers.

Ask
your
jobber
or send for
literature.

SIMPSON ELECTRIC COMPANY
5200-5218 W. Kinzie St., Chicago 44, Ill.

In Canada: Bach-Simpson, Ltd., London, Ont.

Simpson
INSTRUMENTS THAT STAY ACCURATE

As here!

The NEW General Electric Variable Reluctance Cartridge for Long Playing Records

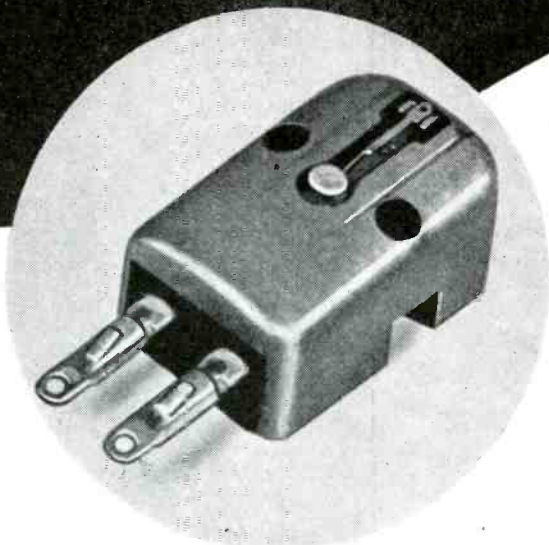

- Specifically designed for the new long playing records...high compliance...low mass stylus assembly
- Equipped with 1 mil tip radius sapphire stylus
- Can be used with standard G-E preamplifiers

Place your order today!

*General Electric Company, Electronics Park,
Syracuse, New York*

You can put your confidence in—

GENERAL  **ELECTRIC**

168-G10

ONE OF THESE 5 WILL BEST FILL YOUR V.O.M. REQUIREMENTS

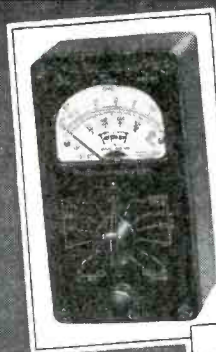

MODEL NO. 630

MODEL NO. 666-HH

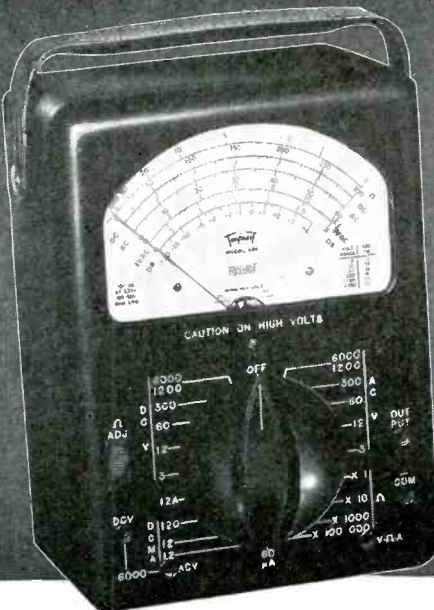

MODEL NO. 625-NA

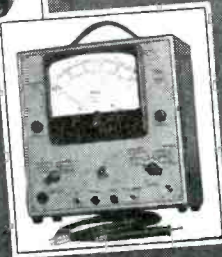

MODEL NO. 2451

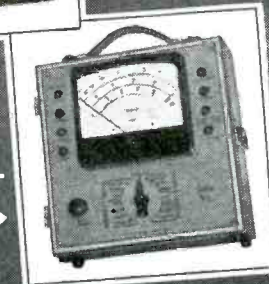

MODEL NO. 2405-A

MODEL 630. Outstanding Features: (1) The new Triplett Molded Selector Switch with contacts fully enclosed . . . (2) Has Unit Construction with Resistor Shunts, Rectifier Batteries in molded base . . . (3) Provides direct connections without cabling . . . no chance for shorts . . . (4) Big easily read 5 1/2" Red • Dot Lifetime Guaranteed Meter.

TECH DATA

D.C. VOLTS: 0-3-12-60-300-1200-6000, at 20,000 Ohms/Volt
 A.C. VOLTS: 0-3-12-60-300-1200-6000, at 5,000 Ohms/Volt
 D.C. MICROAMPERES: 0-60, at 250 Millivolts
 D.C. MILLIAMPERES: 0-1-2-12-120, at 250 Millivolts
 D.C. AMPERES: 0-12, at 250 Millivolts
 OHMS: 0-1000-10,000, 4.4 Ohms at center scale on 1000 scale; 44 Ohms center scale on 10,000 range.
 MEGOHMS: 0-1-100 (4400-440,000 at center scale).
 DECIBELS: -30 to -4, -16, -30, -44, -56, -70.
 OUTPUT: Condenser in series with A.C. Volt ranges.

MODEL 630. U.S.A. Dealer net price \$37.50
 Leather Carrying Case, \$5.75. . . Adapter Probe for TV and High Voltage Extra.

MODEL 666-HH. This is a pocket-size tester that is a marvel of compactness and provides a complete miniature laboratory for D.C. and A.C. voltages, Direct Current and Resistance analyses. Equally at home in the laboratory, on the work bench or in the field . . . its versatility has labeled it the tester with a thousand uses . . . housed in molded case . . .

TECH DATA

D.C. VOLTS: 0-10-50-250-1000-5000, at 1,000 Ohms/Volt
 A.C. VOLTS: 0-10-50-250-1000-5000, at 1,000 Ohms/Volt
 D.C. MILLIAMPERES: 0-10-100-500, at 250 Millivolts
 OHMS: 0-2,000-400,000, (12-2400 at center scale)

MODEL 666-HH. . . . U.S.A. Dealer Net Price . . . \$22.00
 Leather Carrying Case, \$4.75.

MODEL 625-NA. This is the widest range laboratory-type instrument with long 5.6" mirrored scale to reduce parallax. Special film resistors provide greater stability on all ranges. Completely insulated molded case. Built by Triplett over a long period of time, it has thoroughly proved itself in laboratories all over the world.

TECH DATA

SIX D.C. VOLTS: 0-1-25-5-25-125-500-2500, at 20,000 Ohms/Volt
 SIX D.C. VOLTS: 0-2.5-10-50-250-1000-5000, at 10,000 Ohms/Volt
 SIX A.C. VOLTS: 0-2.5-10-50-250-1000-5000, at 10,000 Ohms/Volt
 D.C. MICROAMPERES: 0-50, at 250 Millivolts
 D.C. MILLIAMPERES: 0-1-10-100-1000, at 250 Millivolts
 D.C. AMPERES: 0-10, at 250 Millivolts

TRIPLETT ELECTRICAL INSTRUMENT COMPANY • BLUFFTON, OHIO, U.S.A.

In Canada: Triplett Instruments of Canada, Georgetown, Ontario

OHMS: 0-2000-200,000, (12-1200 at center scale)
 MEGOHMS: 0-40, (240,000 at center scale)
 SIX DECIBELS RANGES: -30 +3.0, +15, +29, +43, +55, +69.
 (Reference level "O" DB at 1.73 V. on 500-Ohm line.)
 Six Output on A.C. Volts ranges.

MODEL 625-NA. . . . U.S.A. Dealer Net Price . . . \$45.00
 Carrying Case, \$5.50. Accessories available on special order for extending ranges.

MODEL 2405-A. This instrument combines ultra sensitivity with a large 5 3/4" scale meter and is housed in a rugged metal case. . . It is furnished with hinged cover so that it can be used for service bench work or for portable field service. Gives A.C. Amperes readings to 10 Amps.

TECH DATA

D.C. VOLTS: 0-10-50-250-500-1000, at 20,000 Ohms/Volt
 D.C. AMPERES: 0-10, at 250 Millivolts
 D.C. MILLIAMPERES: 0-1-10-50-250, at 250 Millivolts
 D.C. MICROAMPERES: 0-50, at 250 Millivolts
 A.C. VOLTS: 0-10-50-250-500-1000 at 1000 Ohms/Volt
 A.C. AMPERES: 0-0.5-1-5-10, at 1 Volt-Ampere
 OHM-MEGOHMS: 0-4000-40,000 ohms—0.4-40 megohms (self-contained batteries)
 OUTPUT: Condenser in series with A.C. Volts ranges
 DECIBELS: -10 to +15, +29, +43, +49, +55. (Reference level "O" DB at 1.73 V. on 500-ohm line.)
 CONDENSER TEST: Capacity check of paper condensers is possible by following data in instruction book.

MODEL 2405-A. . . . U.S.A. Dealer Net Price . . . \$59.75

MODEL 2451. Electronic Volt-Ohm-Mil-Ammeter . . . is easy to use in complicated testing . . . A must in F.M. and TV work in any sensitive circuit where low current drain is a factor . . .

TECH DATA

D.C.-A.C.-A.F. VOLTS: 0-2.5-10-50-250-500-1000
 R.F. VOLTS: 0-2.5-10-50
 D.C. MILLIAMPERES: 0-2.5-10-50-250-500-1000
 OHMS: 0-1K-10K-100K
 MEGOHMS: 0-1-10-100
 INPUT IMPEDANCE: 11 Megohms on D.C. Volts.
 4.8 Megohms on A.C.-R.F. Volts

MODEL 2451. . . . U.S.A. Dealer Net Price . . . \$76.50
 External high-voltage probe available on special order. See the Triplett V.O.M. line at your local Radio Parts Distributor or write

Precision first . . . to Last





MADE TO SELL YOU AND YOUR SERVICE

3 NEW SYLVANIA AIDS!

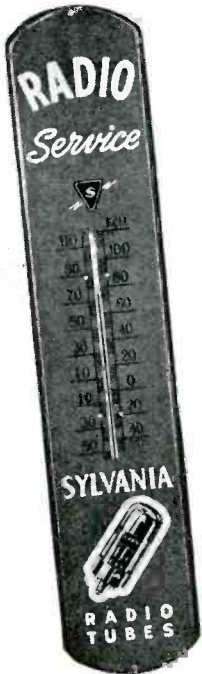

Big, handsome, eye-catching! That's the new Sylvania 38¾" high and 8¾" wide metal thermometer! Put this green, black and white business aid outside your shop—call attention to the service you offer and the merchandise displayed in your windows!

You can obtain this sales-catcher from your Sylvania Distributor! See him today!

only **\$2⁹⁵**

Here's the new Sylvania Service Kit now available to service dealers—a prestige-building and practical addition to your service business!

Made of laminated plywood covered with brown plastic fabric with the appearance of fine leather, this kit has a tube capacity of over 75 tubes. The interior measures only 18" x 11¾" x 5½". The tool section in the lid is designed to hold the most commonly used tools for on-call service. Ask your Sylvania Distributor for this wonderful new, low-priced Service Kit. Get that added professional touch that means so much.



(Tools shown not included)

only **\$9⁹⁵**



only
\$4⁵⁰

And here's the new Sylvania illuminated shadow box sign that's ready for hanging in your window, on your wall, or on any strategic flat surface in your window. Two eyes in the top of the sign are for hooks or chains.

The big, bright red letters "Radio Service" tell your message in no uncertain terms to every passerby. The sign's face is glass; the background translucent yellow. The red letters are outlined in black, while the bottom half of the sign is black with yellow lettering. The brown metal case is chrome trimmed. Size: 18¾" long, 8¾" high, 3¾" deep. Seven-foot cord provided.

At Sylvania Distributors everywhere! Sylvania Electric Products Inc., Advertising Department, Emporium, Pa.

SYLVANIA ELECTRIC

RADIO TUBES; CATHODE RAY TUBES; ELECTRONIC DEVICES; FLUORESCENT LAMPS, FIXTURES, WIRING DEVICES; PHOTOLAMPS; ELECTRIC LIGHT BULBS

RADIO • TELEVISION • ELECTRONIC
SERVICE

The New York Town Meeting

TELEVISION was quite a headline item at the four-session Town Meeting of Radio Technicians held during the latter part of September in the Astor Hotel, New York City.

Tv antennas, circuitry and instruments required for installation and servicing, were among the major topics discussed by industry experts.

Analyzing the problem of antennas, Ira Kamen, author of the series of tv antenna articles appearing in *SERVICE*, pointed out that there are quite a few types of antennas which can be used in primary signal areas: dipoles, dipoles and reflectors, folded dipoles, wideband arrays, unipoles, stacked dipoles (straight and folded), fanned elements, conical, and indoor antennas.

The dipole and dipole-reflector antennas are usually mismatched to 300-ohm transmission lines to obtain a broad-band (50-200 mc) response characteristic. The impedance of a dipole antenna at resonance is 73 ohms and somewhat less when a reflector is added, depending upon the spacing of the reflector with respect to the dipole. Kamen pointed out that this antenna impedance increases at those frequencies above and below the resonance frequency so that at some off-resonant point, the antenna will match the transmission line, which compensates for the inefficiency of the dipole at the off-resonant frequency. Folded-dipole arrays have an impedance of four times a straight dipole and thus approximately matches a 300-ohm balanced line. Stacked arrays have a higher gain than the single array types and can be furnished for connection to 73-ohm coax and 300-ohm transmission lines. Kamen also covered the problem of reflection, multipath, signal-to-noise, and high-band antennas, analyses of which have appeared in *SERVICE* articles by Kamen.

In an interesting discussion on how to conduct yourself in the consumer's home, Errol Jones of Amie Associates listed twenty-five relevant factors: Courtesy, friendliness, willingness, appearance, serviceability, tact, intelligence, adaptability, sincerity, imag-

ination, patience, memory, alertness, enthusiasm, forcefulness, honesty, industrious, concentration, self-confidence, initiative, health, loyalty, ambition, cooperation and dependability.

In another extremely informative talk on instruction of the customer in television receiver operation, Marvin Kaplan of Video Television revealed how the various controls on a television set can be compared with the controls on the receiver to simplify operation. He said that the technician can explain that the volume control, on-off switch, and tone control are identical with those on the standard house set and the channel selector switch and fine tuning control can be compared to a carpenter making a shelf—the first rough cut of the board to size and then the trim and sandpaper operation for the fine and exacting finish. He pointed out that the contrast control can be explained as a form of volume control, but instead of regulating the volume of sound, it regulates the volume of picture. The brightness control, he said, could be described as a means of adjusting the background brilliance of a picture, so that the contrast or ratio of black to white in the picture is pleasing to the viewer. Continuing, Kaplan pointed out that the horizontal and vertical hold controls can be explained as a means of locking in the picture to prevent it from moving up or down or side. And the focus control, he said, can be compared to a pair of binoculars, the simple knob adjustment being used to sharpen the picture which is being viewed.

In a discussion of the equipment required to service a television set, Carl Quirk of DuMont Labs, listed seven basic items for test work: Vacuum-tube voltmeter (preferably one with an r-f probe for h-f measurements); 'scope; voltage calibrator to be used with the 'scope; sweep generator (with a self-contained marker system); traveling detector or probe (the traveling detector can consist of a 1N34 crystal detector with a filter built into a small probe-like case); tube checker; and a high-voltage meter capable of testing up to 15 or possibly 30 kv.

Quirk also discussed various trou-

bles which are found in tv receivers and offered ten common faults and their possible causes: (1) hum in horizontal sweep.....open filter in the power supply; (2) sound in picture.....misalignment of the i-f strip; (3) picture size decreased both horizontally and vertically.....reduction of B+ to both sweep circuits; (4) picture will not hold horizontal sync.....bad-reactance or sync-discriminator tube; (5) picture size reduced to approximately one-half original height.....possibly one-half of the vertical-deflection amplifier (6SN7) is out; (6) same as (5) but linearity is also bad.....open cathode bypass or open plate decoupling capacitor in vertical deflection amplifier; (7) no horizontal or vertical sync.....bad sync separator stage; (8) picture rolls vertically.....bad vertical sync amplifier; (9) picture becomes large and the entire raster disappears.....defective high voltage supply; and (10) no raster.....no high voltage, due in many receivers to a lack of horizontal sweep.

Highlights of other papers presented at the Town Meeting will appear in subsequent issues of *SERVICE*. Watch for these digests.

Preventive Maintenance

THE PREVENTIVE MAINTENANCE plan, originally scheduled for introduction in September, will be conducted in November in a regional test program by 60 members of the Harrisburg Chapter of the Federation of Radio Servicemen's Associations of Pennsylvania.

There'll be an intensive direct mail, window display, newspaper and on-the-air promotional campaign. Several leading manufacturers have agreed to cooperate in this all-important effort to remind the consumer that it is wise to have receivers inspected and essential repairs made *before* the receiver becomes completely inoperative and exceptionally costly to service.

Good luck to you gentlemen in your pioneering work, which we know will be beneficial to everyone—consumer, Service Man and industry.—L. W.

TV Receiver Visual

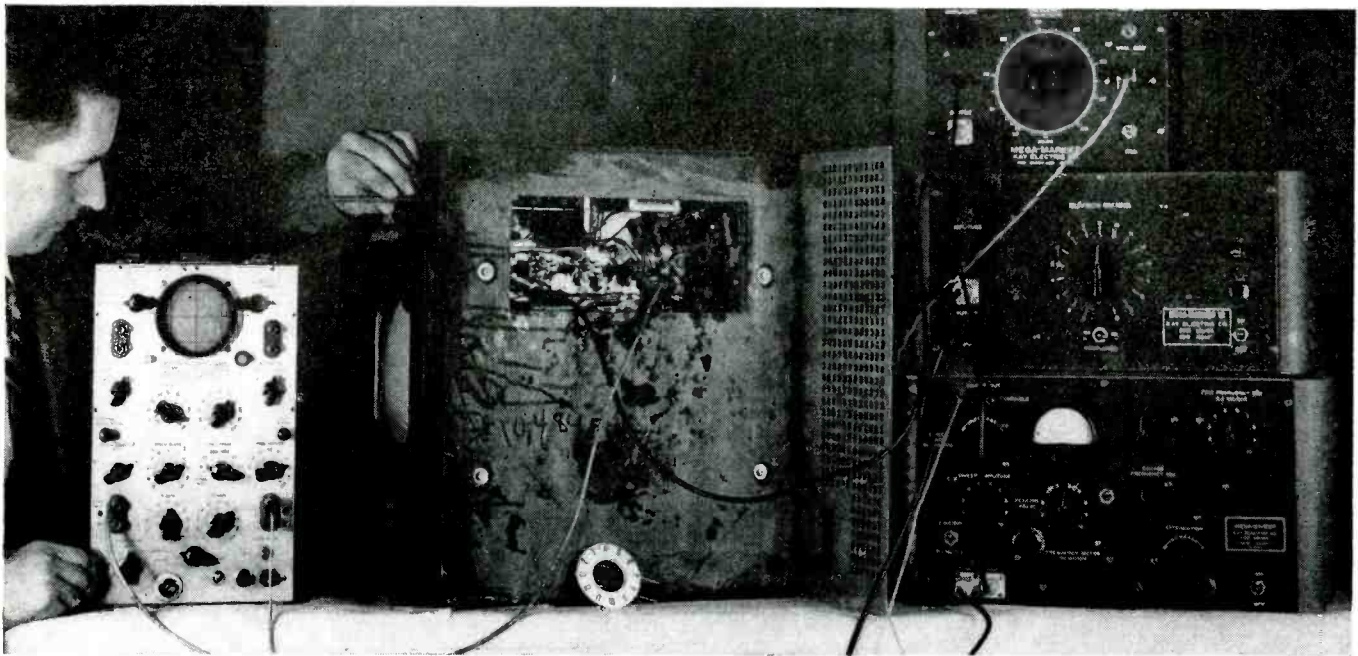

Fig. 1. Aligning the Tele-Tone TV-149 receiver with a 'scope and sweep and marker generator.

IT IS WELL RECOGNIZED that the alignment of the i-f and r-f circuits of tv receivers is best accomplished by the use of precision and foolproof visual alignment instruments and techniques. With the correct type of wide-range sweep oscillator and precision frequency marker generators used in conjunction with a 'scope, the alignment procedure becomes a routine operation of but a few minutes duration. Otherwise, it is a hopelessly complicated task, beset with many pitfalls.

The most common deficiencies which the Service Man should guard against when choosing a sweep generator are:

(1) Inadequate sweep width (at least 20 to 30 mc should be available).

(2) Output signals at other frequencies in addition to the one being used, giving spurious effects.

(3) Possible future obsolescence of sweep generator when new high-band tv channels are allocated.

(4) Fixed 60-cycle sine sweep, with its attendant retrace and phasing difficulties, and its inability to show up hum in the circuit being tested.

Of the four items enumerated the latter three are self-explanatory. The first one is important because it is very often desirable to compare the relative gains of several adjacent r-f channels quickly in order to spot bad r-f coils, switch contacts, etc. When a sweep generator having as much as 30 mc of sweep excursion is used, it is necessary merely to rotate the receiver channel switch through several positions rapidly and observe visually the relative

amplitudes of the band-pass response patterns on the 'scope, without changing any adjustments on the sweep generator.

Once the Service Man has equipped himself with the right instruments and tools for tv receiver alignment and repairs, he can feel confident of being able to do his work rapidly and efficiently, with consequent high profit. Of course, it goes almost without saying that he must also acquire for himself a good basic understanding of tv receiver circuit principles and operating characteristics, since no tool or instrument can be completely effectual when used to check circuits about which the user does not have the proper *know how*.

Alignment Setup¹ For Tele-Tone TV-149

The TV-149 is a transformerless table model tv receiver with a 7" 7JP4 electrostatic deflection picture tube; Fig. 3, page 19.

Alignment can be facilitated if circuit familiarity prevails. Accordingly, a circuit analysis* will be presented as a prelude to alignment procedure.

The TV-149 uses the inter-carrier system on video and sound i-f, wherein the picture and sound carriers are both sent through a single i-f string and are separated *after* the second detector. The sound is taken off the plate of the

video amplifier and fed through a 4.5-mc trap into a 4.5-mc i-f amplifier and then through a ratio detector. The synchronization circuits use ordinary triggered sync into a multivibrator sweep oscillator. The vertical and horizontal sweep systems are very much the same, the main difference being in the frequencies involved.

Tuner

The tuner in this model covers 12 channels (2 to 13). The local oscillator is tuned to the high side on all channels and is adjusted to provide a picture carrier i-f of 37.3 mc and a sound carrier i-f of 32.8 mc. The tuning inductance for channel 2 is across the oscillator at all times, while tuning inductances for channels 3 to 13, respectively, are shunted across the channel 2 inductance as these channels are selected. In aligning the receiver channel 2 must first be adjusted and channels 3 to 13 then adjusted. Misalignment of channel 2 will detune the other channels. Appreciable readjustment of channel 2 may require retuning of several of the low frequency channels. This effect is of less importance on channels 7 to 13. Alignment should be attempted only after the receiver has been operating for five minutes.

R-F Amplifier

The antenna is fed between the grid and cathode of the r-f amplifier. The

¹Features of instruments used in setup appear in Appendix A.
*Courtesy of Tele-Tone Radio Corp.

Alignment Techniques

First Of A Series Of Articles Providing Practical Information On The Alignment Of Popular Models Of TV Receivers, With Setups Of Instruments Best Adapted For Each Receiver And Methods of Achieving Properly-Aligned Response Characteristic. Offered In This, The Initial Installment, Are Alignment Data For The Tele-Tone TV149.

input circuit of this stage is not tunable. The r-f stage output circuit is tuned by what is, electrically speaking, a single tapped inductance. Mechanically, this inductance takes the form of several individual coils which are cut in or out of the plate circuit by the band switch. These coils as well as the mixer coils rarely need touching.

Mixer

The output of the r-f amplifier and the local oscillator is capacitor fed into the control grid of the mixer stage. This circuit is tuned in much the same manner as the output of the r-f amplifier.

Oscillator

The r-f oscillator is fairly straightforward in operation. Its main feature is that the coil for channel 2 is permanently parallel to all other oscillator coils from 3 to 13. It is therefore necessary, when aligning the oscillator, to align channel 2 first and the rest of the coils in any order thereafter. The coils are tuned by brass slugs accessible from the outside of the cabinet by removing the *station selector* knob and the channel escutcheon. Channel 2 is found at the top of the right-hand slot and the others follow in regular order in a clockwise direction, finishing with channel 13 at the top of the left-hand slot. The use of the inter-carrier system in this receiver precludes the necessity for providing a *fine tuning* control on the oscillator.

Video I-F

Each video i-f transformer has only one adjustment, a powdered iron slug accessible from the top of the chassis. The video i-f string is stagger-tuned to two frequencies. The first and third i-f transformers are tuned to 34.8 mc, the second and fourth being tuned to 36.9 mc. The response curve is fairly

by LESTER L. LIBBY

Chief Engineer

Omega Laboratories and Kay
Electric Co.

flat topped and should produce a picture with good definition.

Video Amplifier

The output of the video amplifier is fed to three separate circuits. It is here that the separation of picture and sound takes place. It supplies (1) the picture tube with picture intelligence and blanking, (2) the grid of the sync separator with the incoming sync pulses and (3) the 4.5-mc trap with the sound carrier. A cathode circuit potentiometer is used for controlling the picture contrast.

Sync Separator and D-C Restorer

The sync pulses fed from the plate of the video amplifier to the grid of the sync separator are taken off the plate of the sync separator (at which point they are of negative polarity) and are used to trigger the sweep oscillators in much the conventional manner. There is a sufficient amount of limiting action to remove whatever impulse noise interference may ride in on the sync pulses. The d-c restoration voltage is developed across the cathode resistor of the 6AU6 sync separator/d-c restorer and fed to the control grid of the cathode-ray picture tube.

Sweep Oscillators and Amplifiers

Both the horizontal (15,750 cps) and vertical (60 cps) sweep oscillators and amplifiers are quite similar in general operation. The oscillators are of the multivibrator type and the amplifiers are 12SN7's (twin triodes) operating push-pull. Centering in both cases is accomplished by varying the d-c voltage on one of the picture tube

deflection plates and maintaining a constant d-c potential on the opposing plate.

Sound System

The sound carrier is taken off the plate of the video amplifier by a 4.5-mc trap and fed through a 4.5-mc amplifier to the ratio detector, and then to the audio amplifier, audio output stage and speaker.

High-Voltage Power Supply

The high voltage power supply is of the r-f type. The oscillator therein is free-running and is independent of other circuits in the set. It is not a fly-back power supply. The oscillator is essentially a tuned-plate type of circuit with tickler coil feedback, operating into a typical rectification and filter network. The oscillator is a 12SN7 and the rectifier a 1B3/8016.

AGC

The receiver uses an *agc* circuit operating on the r-f and first two i-f stages. While it is quite effective in most locations, the receiver may overload in regions of very high field intensity. The contrast can generally be adjusted for a normal picture under such conditions but spurious beats, jagged vertical lines (i. e., poor resolution) and a *moire* pattern may appear. For this reason a resistor-network attenuator pad has been included in the antenna circuit of the set, connected between the *distant* and the *local* input terminals and providing an attenuation of between 10 and 15 db.

General Data

The filaments (with the exception of the high voltage rectifier) are hooked up in three series banks. Two of the filament banks are connected in parallel to one another and both are in series with the third bank. A selenium rectifier, a 25Z6 and a 6X5 (doubler)

**NEW
LOW
PRICES**

On RCA Top



**RCA 15-watt
DE LUXE AMPLIFIER MI-12295**

**NOW
ONLY
\$87⁵⁰**

List price
complete with tubes

● You've never seen a value like this distinctively styled RCA 15-watt All-Purpose Amplifier. You can't beat it for high quality performance, compactness, beauty, and simplicity of operation under all sorts of operating conditions.

Electronically engineered to give top performance. Frequency response (30 to 15,000 cycles). Two high impedance microphone input channels 116 db. gain (RMA), each with individual volume control. Two hi-impedance phono channels, one for hi-level and one for low-level pickups. Can be used with popu-

lar low output magnetic pickups. Phase inversion and inverse feedback used to obtain low distortion and uniform frequency response for various load conditions. Unique balanced tandem tone control circuit. Choke filtered power supply for minimum hum and uniform regulation. Large functionally designed control knobs. Accessible output terminal board and replaceable cartridge type fuse conveniently located in rear. Set of locking-type 3 pin Cannon plugs and receptacles for each microphone input. Also available with 2 low impedance inputs (250 ohms).

15 watt push-pull Output—
Noise-free electronic mixing—
Switch for high-low power
output requirements — Under-
writers-approved.

Additional Unparalleled
Amplifier Values

RCA 50-watt De Luxe Hi-Impedance Amplifier MI-12293 \$197⁵⁰
Complete with RCA Tubes Now only

RCA 30-watt De Luxe Hi-Impedance Amplifier MI-12296 \$115⁰⁰
Complete with RCA Tubes Now only



SOUND PRODUCTS
RADIO CORPORATION of AMERICA
ENGINEERING PRODUCTS DEPARTMENT, CAMDEN, N.J.

In Canada: RCA VICTOR Company Limited, Montreal

Quality Sound Equipment

COMPARE...BE CONVINCED!

**More business for you because it's RCA...
More profit because of these new values**

RCA SPEAKER

MI-12422



12-inch high efficiency, Alnico V, Cone Type Mechanism. Special cone provides a selected listening characteristic—a result of thousands of listeners' reactions over the past 10 years. 10-watt capacity. 15 ohm voice coil.

\$12⁵⁰

Also available with matched 10-watt multi-tap line transformer as MI-12421.

\$18⁰⁰



RCA MOLDED SPEAKER BAFFLES

Molded Plasticized Fibre Baffle with attractive gray hammeroid finish and contrasting grille cloth, 12" x 15" x 5½", sloping front, strong, moisture-resistant, and non-warping. Available for 5", 6½" and 8" mechanisms as MI-6378, MI-6379, and MI-6380, respectively.

\$3⁷⁵

Similar baffles for 5", 6½", 8", 10" and 12" mechanisms also available in molded Bakelite and wood.

All prices shown are suggested list prices subject to normal dealer discounts.

RCA VARACOUSTIC MICROPHONE

MI-6204-G



Three microphones in one. Here you have the popular cardioid microphone (uni-directional) *plus* standard velocity microphone (bi-directional) *plus* standard pressure microphone (non-directional) all in one general purpose unit. Variable characteristic obtained by ingenious slider mechanism on rear of housing. Quality and performance found heretofore only in more expensive polydirectional Broadcast Microphones. High sensitivity, shock mounted, high impedance. 30 feet of cable.

\$67⁵⁰

Make the RCA
Sound Products Distributor
in your area your
SOUND HEADQUARTERS.

NEW BANTAM VELOCITY MICROPHONE

MI-12080-B

Smaller than a pack of cigarettes. First used at all 1948 political conventions. Broadcast quality. Built-in voice-music switch. 15 feet of cable.



\$60⁰⁰

MAIL THIS COUPON FOR FREE CATALOG



BUY
THE BEST
FOR LESS

84 pages of sound products—microphones, amplifiers, speakers, recorders, intercoms, portable P.A. and numerous other profitable items. Send for your FREE copy today.

RCA SOUND PRODUCTS (Dept. 110-J)
Radio Corporation of America
Camden, N. J.

Please send me free copy of RCA's new Catalog on complete line of matched sound products *and price list*.

Name _____

Company _____

Type of Business _____

Address _____

City _____ State _____

are used to supply all circuits with the *B* voltages: +400, +120 and -140 volts with respect to ground (chassis), and +250 volts with respect to the hot side of the a-c line. This latter voltage is fed solely to the high voltage power supply.

Precautions

No tube should be removed before first disconnecting the receiver from the power line, as damage to other tubes may result. On this model the chassis is returned to one side of the a-c line. Care should be taken to avoid grounding the receiver. As the antenna terminals are isolated from the chassis no damage will result if the antenna is grounded. Where severe line noise is encountered, reversing the a-c line plug may be advantageous. When testing or aligning this receiver, a separate, short clip-lead should be connected between the chassis of the receiver and the test instruments. However, the test instruments must have transformer-type power supplies, and there should be no external ground lead connected to any of the chassis.

Alignment Procedure

(1) Video I-F Alignment: A typical setup of the instruments used for i-f and r-f alignment of the Tele-Tone receiver is shown in Fig. 1.

An adequate signal can be fed through the video i-f string by feeding the (combined) output of the sweeping oscillator and marker generator into a tube shield placed over the 6AG5 mixer tube. Care must be taken that this shield is *not* grounded. The ground side of the coaxial output cable

from the alignment instruments can be connected to the grounded shield of the adjacent oscillator tube, 6J6. This method will be found to be convenient and practicable, especially where a simple jig has been prepared. As a substitute arrangement, a small (0.25 mmfd) coupling capacitor to the grid of the first i-f tube may be used.

The 'scope should be connected between the grid electrode of the 6AU6 video amplifier and ground, preferably by means of a shielded lead, and the sweeping oscillator should be adjusted to sweep between the limits of approximately 28 and 44 mc.

The desired video i-f response or selectivity characteristic is shown in Fig. 2. To arrive at this shape, the marker oscillator is set first at 34.8 mc and the first and third video i-f transformers adjusted for the proper response at this lower or sound end of the curve by tuning these slugs for maximum deflection (from the base line) of the marker *birdie*. Then the marker generator is set at 36.9 mc and the second and fourth i-f transformers similarly adjusted for proper response at the high-frequency or picture end of the selectivity curve.

This complete sequence of adjustments must be repeated a few more times to work out any interaction which may exist between the two sets of adjustments. Then the 37.3-mc picture carrier point should be checked with the marker oscillator to see if the response characteristic is approximately 50 to 60 per cent of maximum at this frequency, and the 32.8-mc sound carrier point should be checked to see if the response is approximately 5 to 10 per cent of maximum here.

Slight readjustments of the i-f transformer slugs may be necessary to arrive at a satisfactory compromise characteristic. The final curve shape may be anything within the limits of the dotted lines of Fig. 2 and still give satisfactory overall performance.

(2) Sound Alignment: The sound alignment of this receiver is best done with a 4.5-mc signal source and a vacuum tube voltmeter. The 4.5-mc crystal-controlled signal from the crystal oscillator section of the marker generator is designed specifically for use in this type of application.

With the sweep and marker generators inter-connected in the same fashion as was used for the video i-f alignment operation, but with the sweep generator output turned off (by turning the peaking control of either klystron oscillator to a point where the tube is in a non-oscillating condition), the coaxial output cable is then connected between the grid (pin 1) of the 6AU6 video amplifier tube and ground. The video gain (i. e., picture contrast) control is set at maximum, and the *vtvm* is connected between pin 7 of the 6AL5 ratio detector tube and ground and is set up to measure negative potentials of the order of 4 volts. The 4.5-mc trap inductor and the primary of the ratio detector transformer are each adjusted to produce a maximum reading on the *vtvm*. In both cases the output amplitude control of the marker generator is adjusted so that the reading on the *vtvm* is between -3 and -4 volts when the tuning adjustments are peaked up.

The *vtvm* should then be connected across the .0015-mfd capacitor which precedes the .02-mfd coupling capacitor to the audio volume control. The secondary of the ratio detector transformer should then be adjusted for zero reading on the *vtvm*. (Note: The primary adjustment slug of the ratio detector transformer is found on the underside of the receiver chassis, the secondary on top.)

After the foregoing adjustments have been completed, the *vtvm* is disconnected and the 'scope connected in its place across the .0015-mfd capacitor. The sweep generator is then adjusted to sweep approximately ± 2 mc around the 4.5-mc center frequency, and the resultant discriminator curve displayed on the 'scope screen is examined for symmetry, linearity of center portion and any spurious kinks or other effects. This visual examination permits checking for proper overall performance of the sound i-f system under substantially dynamic condi-

(Continued on page 46)

Fig. 2. Video i-f amplifier response curves of the Tele-Tone tv receiver.

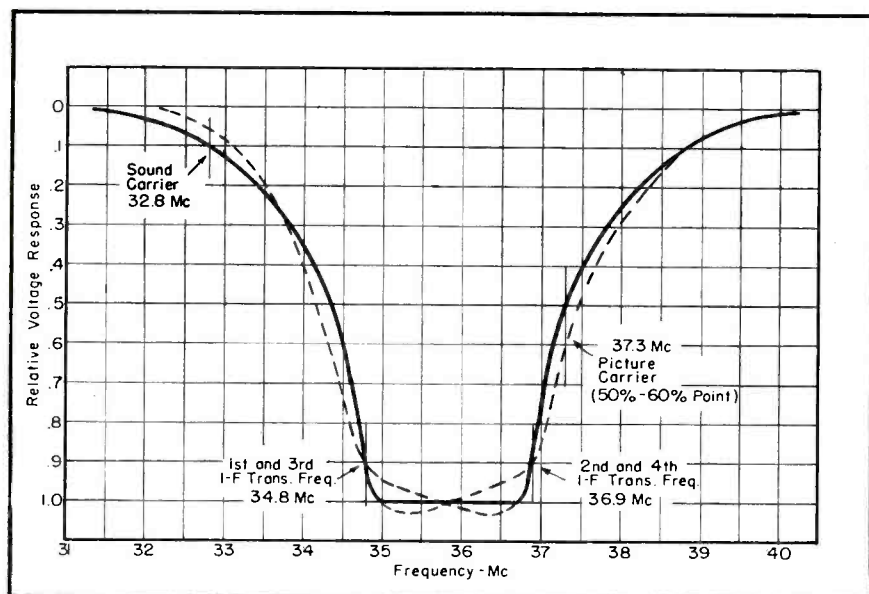

TV Interference . . . Causes And Remedies

Comprehensive Analysis of Nine Sources of Interference (F-M Stations, F-M Receivers, TV Receiver Local Oscillators, TV Receiver Video Circuits, TV Receiver Sweep Circuits, Prewar Diathermy Equipment, Electromedical And Industrial Apparatus, Hams And Man-Made Devices) And Solutions Which Have Proved Effective.

TELEVISION'S PRESENT INTERFERENCE problems are growing pains and will probably be under industry control within the next few years. In the interim developmental period, during which the tv receivers are being redesigned, i-f frequencies shifted, etc., the Service Man has the field responsibility of solving tv interference problems on those tv receivers being manufactured in accordance with current standards.

Television interference is transmitted from: (1) F-m stations; (2) f-m receivers; (3) tv receiver local oscillators; (4) tv receiver video circuits; (5) tv receiver sweep circuits; (6) prewar diathermy equipment; (7) electromedical and industrial apparatus; (8) radio amateurs, and (9) man-made devices.

Television interference is also a result of tv receivers having such design defects as *poor image rejection*, *high level local oscillator radiation*, *insufficient shielding*, and *poor selectivity*.

Analysis of Causes of Interference

To solve any interference problem, the nature of the interference must be thoroughly understood.

(1) **F-M Stations:** The second harmonic of the f-m band, 88 to 108 mc,

by **IRA KAMEN**

Manager, Television Antenna Dept.
Commercial Radio Sound Corp.
New York City

lies in the upper tv band, 174 to 216 mc. Some of the present f-m transmitters do not have sufficient f-m second harmonic suppression and are a serious source of trouble which cannot be eliminated as the interference is on the same frequency as the tv station. F-m transmitter engineers are working on this problem feverishly, but until this problem is solved at the source,

Fig. 1. Typical r-f interference pattern on picture-tube screen. (Courtesy Belmont Radio.)

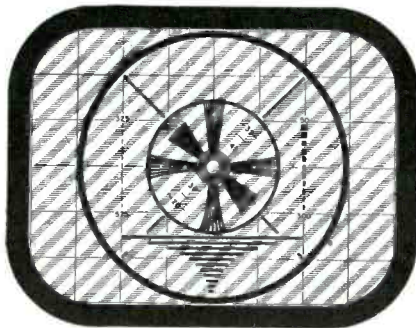

the tv set user will have to bear with the situation.

The only action the Service Man can take to discriminate against this *on station* f-m interference, is to install a directional antenna which can be adjusted so that the f-m station is not in the receiving pickup angle of the antennas.

(2) **F-M Receivers:** The f-m receivers manufactured to date have their local oscillators set below the incoming 88- to 108-mc frequencies. This means that the local oscillators of the f-m receivers tune through channels 5 and 6. The local oscillators of the f-m receivers have been known to radiate interference into tv receivers located 1,000' away from the f-m antenna. This *on station* f-m interference is a serious problem which will be with us for a number of years, until f-m manufacturers exercise better control over their designs.

An expensive method of preventing the f-m local oscillator signal from climbing the transmission line and radiating from the f-m antenna, is to install an r-f amplifier (f-m booster) between the f-m receiver and the transmission line. This amplifier will prevent the local oscillator signal from going into the transmission line and



(a)

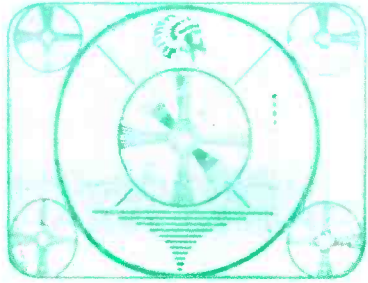

(b)

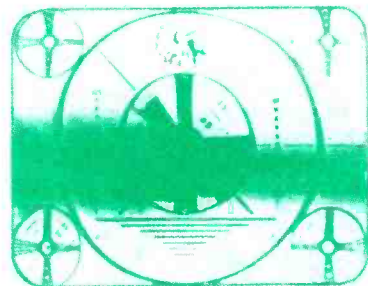

(c)

Fig. 2. Three types of interference are shown here. In *a* appears a weak picture affected by r-f pickup on the antenna. Weak diathermy interference is shown in *b*, and in *c* we see the results of strong diathermy or hum in the video i-f, detector or video output. (Courtesy G.E.)

boost the f-m signal input to the f-m receiver.

(3) TV Receiver Local Oscillators:

Whenever tv receivers are tuned to channels 2, 3, 7, 8 and 9, their local oscillators are operating on channels 5, 6, 11, 12 and 13, respectively. This condition exists because the local oscillator frequency is on the high side and is equal to the incoming frequency, plus the i-f frequency; e. g., channel 2 (54-60 mc) plus 27 to 21 mc (i-f frequency) leaves the local oscillator at approximately 81 mc which is on the channel 5 band (76-82 mc). Similar examples can be set up to show how the local oscillator of a tv receiver tuned to channels 3, 7, 8, 9 transmits a signal on channels 6, 11, 12 and 13, respectively.

The tv industry is considering new i-f frequencies in their 1949 produc-

tion to preclude this interference problem. An r-f preselector will also prevent the tv local oscillator signal from entering the antenna circuit. If the tv receivers are located adjacent to each other in a dealer's establishment the local oscillator interference problem can only be kept under control by judicious tuning of the tv receivers. When the tv receivers are close to each other, they couple directly through chassis radiation from their local oscillators. Therefore tv receivers being demonstrated must not be tuned to any combinations of channels where the interfering signals are developed.

(4) TV Receiver Video Circuits: The tv receiver video circuits must reproduce currents varying from 60 cps to 4.5 mc. In the frequency range of 60 cycles to 4.5 mc, we have the broadcast band which is .54 to 1.5 mc. It is therefore obvious that if the tv receiver video circuits or components were to radiate, they would induce interference signals into broadcast receivers in the neighboring area.

This video interference manifests itself in two ways:

(A) Background noise of variable signal strength which rides along behind broadcast stations. When the broadcast signals are weak, this background interference may be severe enough to mask the station program.

(B) *Beeps* of variable intensity which rides all over the broadcast band. These *beeps* are a result of the video signals beating with the steady broadcast station frequencies.

Most of the tv manufacturers are aware of this problem and are taking many wiring and shielding precautions to preclude radiation of interfering video signals. The Service Man can make an inexpensive shield from window screen material and completely shield the radiating tv receiver by pushing the screening between the chassis and the cabinet, so that the chassis is completely enclosed in the screen material. The screen material must be grounded to the chassis.

When making *custom* installations, care should be taken in shielding the video cable which connects the video amplifier output to the *picture* tube. Failure to shield this cable can result in high level induction fields which can radiate interference in a mile radius.

(5) TV Receiver Sweep Circuits:

The tv receiver sweep circuits have saw-tooth wave forms which are rich in harmonics. The horizontal sweep frequency of 15,750 cps harmonics produce *beeps* in the broadcast band



(d)

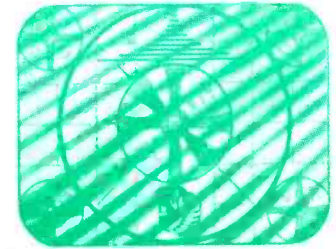

(e)

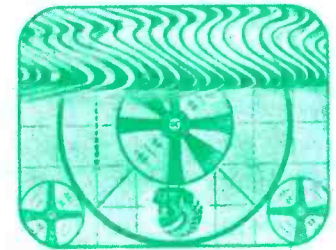

Fig. 3. Three other types of interference which may disturb a tv picture. In *d* appears the results of interference from electromedical equipment. The view in *e* shows s-w transmitter interference and in *f* we have automobile ignition interference. (Courtesy Admiral.)

when they beat with the broadcast station carriers.

Big picture tubes with their large sweep yokes are the worst offenders. In some dealer establishments where the a-m broadcast signals are weak, the *beeps* from the tv receivers makes a-m reception impossible on loop-operated receivers.

In addition to shielding, serious consideration should be given to locating the tv receiver, as far as possible from the a-m receiver picking up the interference. A shielded external a-m antenna will raise the a-m signal to *beep* ratio, so that the *beeps* will be lost in the background.

(6) Prewar Diathermy Equipment:

The prewar diathermy equipment which is leased by many companies who sell diathermy treatments, is a constant source of interference. These diathermy equipments vary in frequency, have raw a-c on their plates, and in general act as low-powered transmitters whose fundamental or

(Continued on page 46)

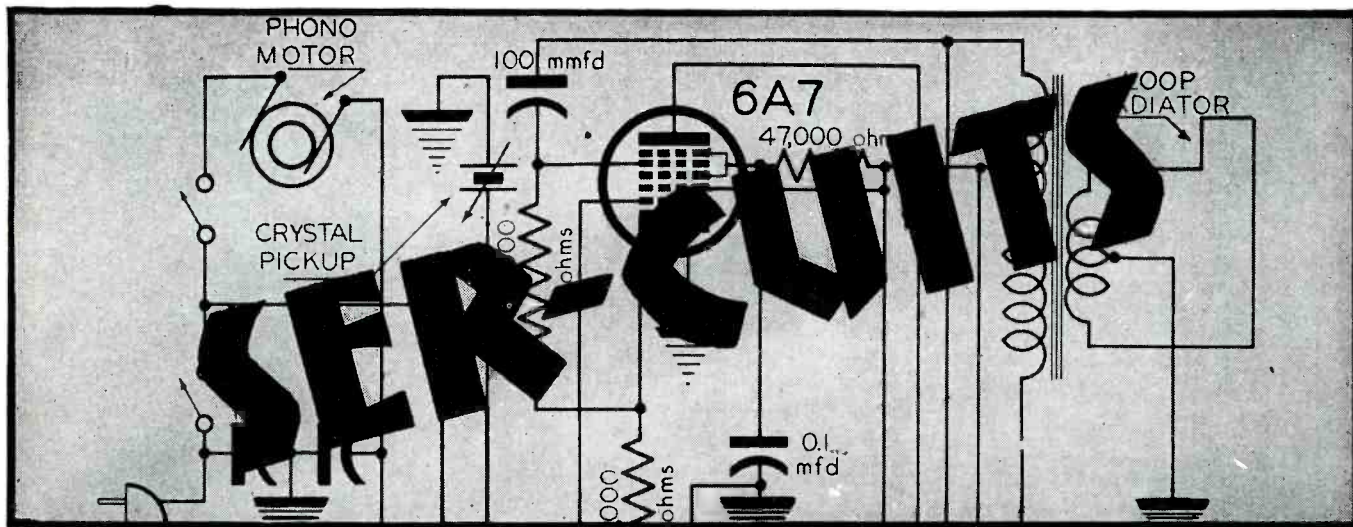

Complete Circuit Analysis Of The Admiral 301A TV Chassis. Additional Circuit Data On The G. E. 901/910 And Philco 48-2500 Projection Receivers.

IN RESPONSE to many requests, our tv circuit-analysis coverage is continued this month, with complete details on the Admiral 301A, which uses the RCA A1582 tuner. Additional data on the G. E. 901/910 and Philco 48-2500 projection receivers are also presented.

Admiral 301A

In this model (Figs. 1 and 2) we have an r-f section which amplifies the audio and video carriers and converts them to their respective intermediate frequencies. The audio portion (section 2 in Fig. 1) consists of a conventional i-f f-m ratio detector and audio amplifier circuit. The video section (3 in Fig. 1) consists of a stagger-tuned broadband i-f amplifier, video detector and video amplifier circuit. The sweep section (4 in Fig. 1) contains the horizontal and vertical sweep generators and the sync circuits. The power supply section (5 in Fig. 1) supplies the necessary voltages for operation of the various tubes and circuits.

R-F Amplifier (6J6): An f-m interference trap is connected across the 300-ohm balanced input of the receiver. This trap, which consists of L_{184} , L_{185} , C_{121} and C_{122} , is adjustable throughout the frequency range from 93 to 109 mc.

A center-tapped choke (L_{127}) and two coupling capacitors (270 mmfd) form a high-pass filter for the input of the receiver. This is done to improve the rejection of low-frequency interference signals. Such interference

signals in the range of the intermediate frequencies of the receiver might otherwise be very troublesome.

Two 150-ohm resistors are used in the grid return circuit of the push-pull r-f amplifier. They also serve as a load to match the 300-ohm input circuit in order that standing waves will not appear on the transmission line. Contrast control bias is supplied to the common return of these resistors to control the gain of the stage. Neutralization, provided by a pair of 1.5-mmfd capacitors, is necessary since a triode tube is used as an r-f amplifier.

The equivalent of a quarter-wave line, made up of inductances L_{101} to L_{120} , is used to tune the plate circuits of the r-f amplifier. A switch (S_{101A}) is used to short out sections of the line to tune it to any one of the thirteen channels. Three capacitors (C_{107} ...2.2 mmfd, C_{108} ...4.7 mmfd, and C_{109} ...68 mmfd) provide capacitive coupling between the r-f amplifier plate line and the tuned line in the converter grid circuit. The 2.2-mmfd unit is connected between opposite sides of the two tuned lines to improve the symmetry of the circuit on the three lower channels. An inductive coupling link, L_{183} , provides additional coupling on the six lower channels.

Converter (6J6): An equivalent quarterwave line (L_{120} to L_{124}), is used to tune the push-pull grid circuit of the converter. This tuned line is similar to the one used in the r-f amplifier plate circuit. Both the r-f amplifier and converter tuned lines (as well as the tuned line in the oscillator circuit)

are assembled on the wafers of the channel switch. Their close proximity to each other results in mutual coupling. Added capacitive and inductive coupling is used as described previously. Over-coupling, plus the loading effect of a 10,000-ohm resistor (R_{108}) on the eight lowest frequency channels, results in the required 6-mc bandwidth in the r-f and converter circuits.

A 1-megohm resistor (R_{107}) furnishes grid-leak bias due to the oscillator injection voltage. The high resistance value of this resistor makes the converter grid circuit susceptible to interference signals at the audio and video intermediate frequencies. A series trap consisting of coil L_{128} and a 22-mmfd capacitor (C_{110}) is connected across the 1-megohm resistor to reject such interference signals.

The converter plates are connected in parallel and feed the primary of the i-f transformer. The primary is tuned to the video i-f pass-band. Capacitive coupling via a 270-mmfd capacitor (C_{111}) is used between the primary and the first video i-f grid. The secondary is tuned to the audio i-f and directly coupled to the first audio i-f grid. Transformer T_{101} performs the first separation of the audio and video i-f signals. Audio i-f rejection traps are still necessary in the video i-f amplifiers.

Oscillator (6J6): An equivalent quarter-wave line, consisting of inductances L_{130} to L_{181} , is used as an oscillator tank. A split-stator capacitor is effectively connected across the plate end of the oscillator-tuned line and

TV and HYTRON go together!

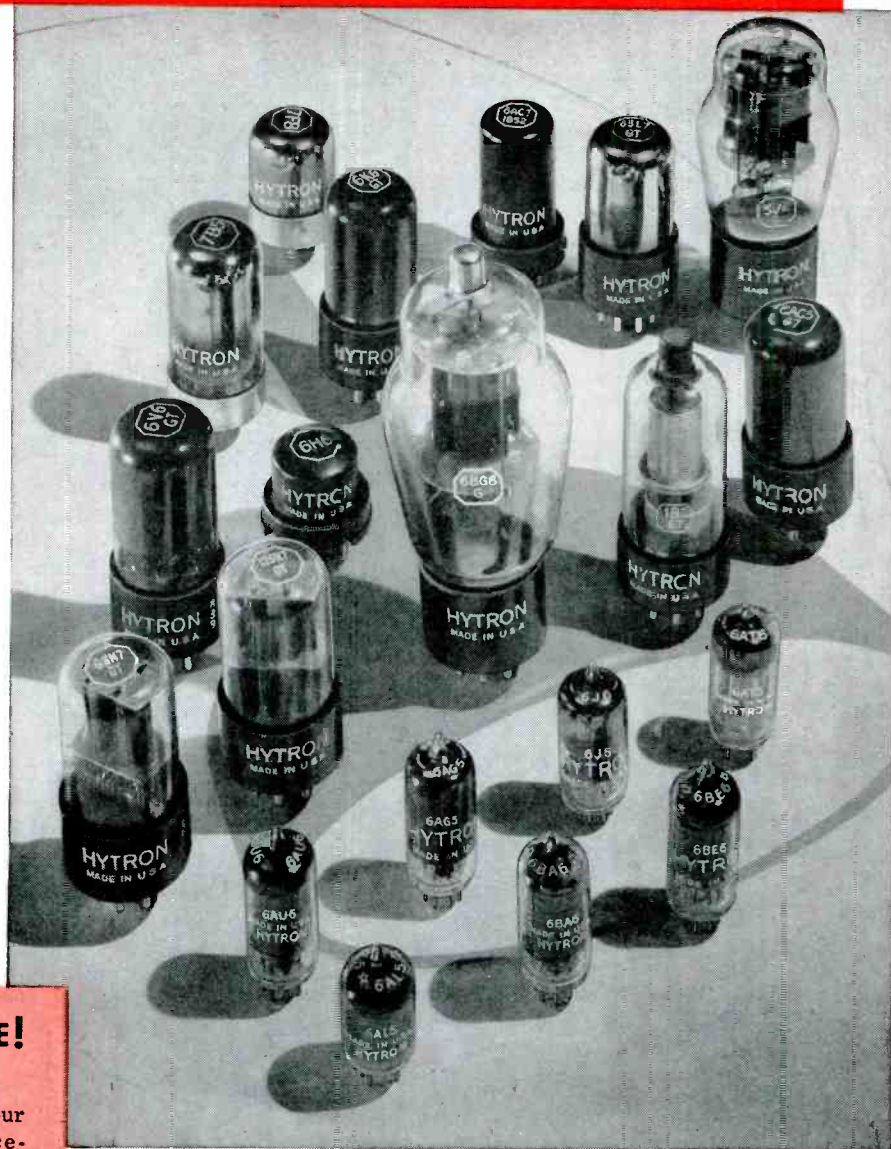
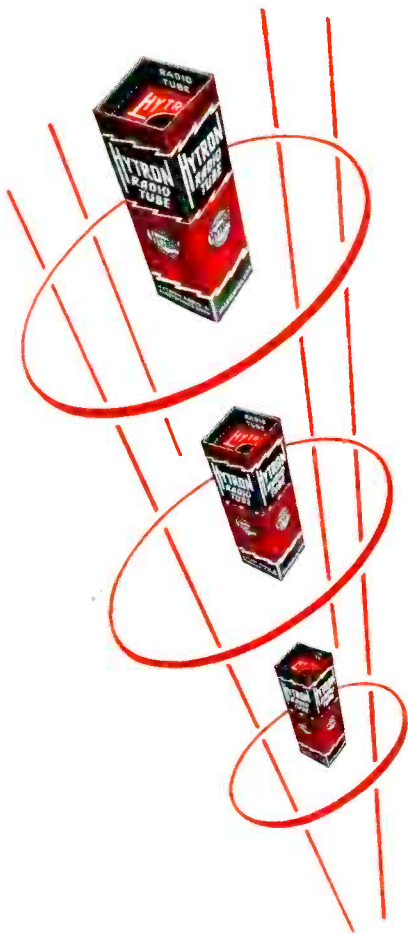

GOING...GOING...GONE!



Last prizes in your Hytron serviceman's contest going-going-gone. Grand prize winner soon to be announced. Contest over. *BUT* the results are just beginning. We are now up to our necks in "hot" ideas. Two swell new shop tools are already scheduled for production. Many more coming. Don't miss a single one. And thanks a million for your cooperation in the contest. We are doing our darndest to make your efforts pay off for you.

TV and tubes go together. A heck of a lot of tubes. Lots of kinds of tubes. Miniature, GT, G, metal, and lock-in. In TV you find all varieties of receiving tubes.

To replace them, you need dependable tubes and a wide range of types. Dependable—because the complex TV tube chain is no stronger than its weakest link. A wide choice of types—to match the ingenuity of TV set designers.

Hytron gives you both. All kinds of tubes—and the same dependable Hytron tubes which keep company with the best of TV set makers. Service *your* TV sets with Hytron tubes; you'll find that TV and Hytron go well together.

SPECIALISTS IN RADIO RECEIVING TUBES SINCE 1921

HYTRON

RADIO AND ELECTRONICS CORP.



MAIN OFFICE: SALEM, MASSACHUSETTS

cient bias is used to provide noise limiter action in this stage.

Video Output (6K6GT): A pentode power amplifier is used in the video output stage. Fixed bias is obtained from the -8-volt bias supply. Cathode bias is also used and the cathode bypass capacitor is omitted to introduce inverse feedback. A constant K type of filter is also used as a plate load for this stage. The coupling between this plate load circuit and the grid of the picture tube is a modification of the usual circuit. This is due to the d-c restorer diode (one section of the 6AL5) and the circuit for sync pulse output to the sync and sweep circuits of the receiver. The sync is taken from a 3,300-ohm resistor (R_{331}). A 10,000-ohm resistor (R_{335}) is used to isolate the coupling circuit as well as to attenuate the higher video frequencies.

The d-c restorer diode (one section of the 6AL5) is across the 3,300-ohm resistor. The video signal appearing across a 47,000 ohm resistor (R_{335}) contains an accentuated sync pulse due to the action of the d-c restorer diode. This provides the input signal for the sync amplifier.

Horizontal Oscillator (6V6GT): A beam tetrode tube is used as an electron-coupled horizontal oscillator. A horizontal oscillation transformer (T_{401}) is slug-tuned, the slug adjustment being the horizontal lock control.

The plate current of the 6V6GT is driven to cut-off and saturation giving a *squared* output waveform. This squared output is fed to a differentiator made up of a 8,200-ohm resistor and 350-mmfid capacitor (R_{425} and C_{419}) which delivers a peaked waveform.

Horizontal Discharge (6SN7GT): The peaked waveform from the differentiator is used to trigger discharge $\frac{1}{2}$ of the 6SN7GT. A 25,000-ohm horizontal drive control (R_{420}) and 8,200-ohm resistor (R_{138}) are connected in series with a 680-mmfid discharge-tube capacitor (C_{419}) to give a large negative grid swing during the retrace interval.

Horizontal Output (6BG6G): A beam tetrode is used in the horizontal output amplifier to obtain the required driving power for the horizontal deflection coils and a 9-kv rectifier circuit. The circuit is conventional with the exception of the plate load circuit.

The output of the horizontal amplifier is transformer-coupled (by T_{402}) to horizontal deflector coils, T_{403A} . Width control L_{101} shunts a portion of the output transformer (T_{402}) secondary, making the inductance variable for width control.

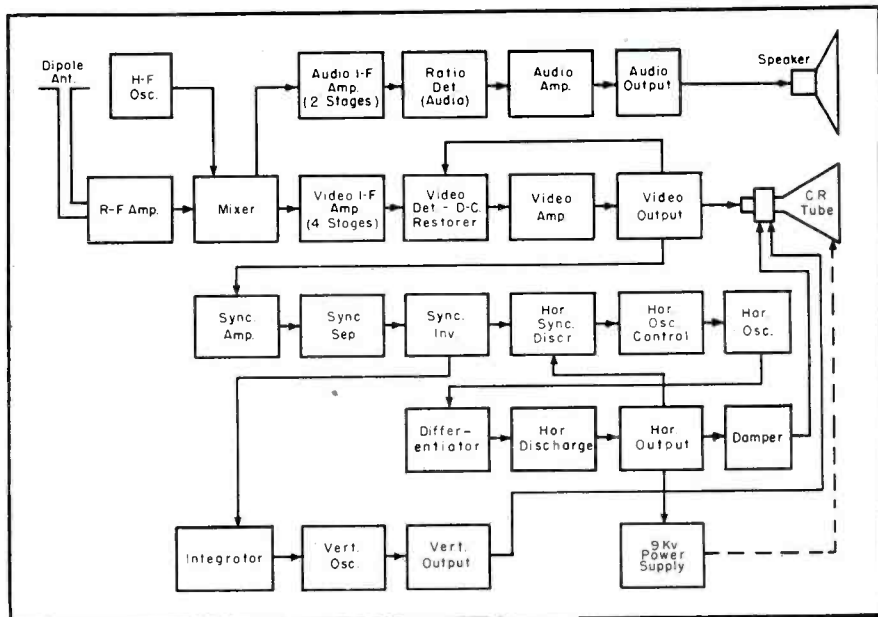

Fig. 2. Block diagram of the Admiral 301A tv receiver.

A 5V4G damper is connected in such a way as to give an effective increase in the plate voltage of the 6BG6G horizontal output amplifier. The plate current of this tube flows through the 5V4G for the major portion of the trace. Two capacitors of .035 and .05-mfd value (C_{121} and C_{125}) are fully charged during this period and supply the 6BG6G current during the time the 5V4G is not conducting. An average voltage due to damper tube current is developed across a network composed of the .035 and .05-mfd capacitors and the horizontal linearity adjustment, L_{402} . This voltage gives approximately 60 volts boost to the plate voltage of the 6BG6. The network provides linearity control by adjusting the cathode waveform (bias) of the damper tube.

A 5-mmfid blocking capacitor (C_{120}) prevents d-c flow through deflection yoke T_{402} .

9-KV Power Supply: The 6BG6G horizontal output amplifier is the source of power for the 9-kv power supply. The plate voltage for the rectifier (1B3GT/8016) is obtained from a horizontal output transformer (T_{402}) by auto-transformer action. A separate secondary winding supplies filament power to the rectifier tube.

Due to the high-frequency power source and the relatively light load, an RC filter is sufficient for filtering. The external coating of the picture tube serves as the output filter capacitor.

Vertical Oscillator (6SN7GT): A cathode coupled multivibrator is used as a vertical oscillator. A 1-megohm vertical hold control (R_{121B}) is a variable resistor in the grid circuit of the

discharge section of the multivibrator. A 2-megohm and 470,000-ohm resistor (R_{149} and R_{150}) form a voltage divider circuit, the 2-megohm unit being a potentiometer which permits plate voltage adjustment on the discharge section of the multivibrator, and also serves as a height control adjustment.

Vertical Output (6K6GT): A triode-connected pentode tube is used as a vertical output amplifier. A 5,000-ohm variable resistor (R_{155}) is in the cathode circuit and serves as a vertical linearity control. The plate of this stage is transformer-coupled to the vertical coils of deflection yoke T_{402} . Damping resistors are connected across the vertical coils in the deflection yoke.

Sync Amplifier (6BA6): The sync amplifier is an RC coupled circuit with fixed bias supplied by a selenium bias rectifier. An RC plate decoupling filter consisting of a .1-mfd capacitor and a 10,000-ohm resistor provides low-frequency boost. High-frequency attenuation results from a 200-mmfid plate bypass. Low-frequency boost and high-frequency attenuation in the sync amplifier plate circuit removes some of the unwanted video and noise from the sync pulses. Further noise limiting occurs in the grid circuit.

Sync Separator (6AU6): An RC coupled circuit is used in this circuit. Fixed bias is supplied by the selenium bias rectifier. The use of a sharp cut-off pentode tube, low plate voltage and a rather high bias voltage results in plate clipping of the negative (video) portions of the input cycle. All traces

(Continued on page 38)

Receiving instructions via a sound powered phone at the antenna point. (Courtesy RCA.)

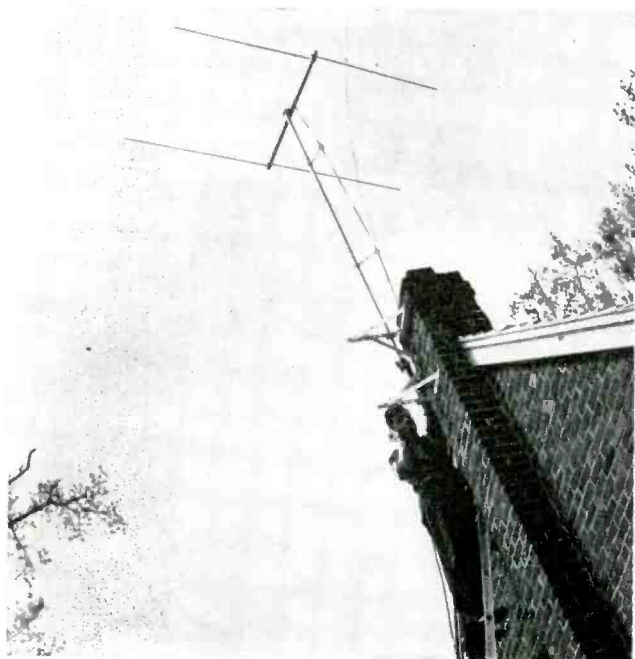

Relaying antenna-position instruction via a sound powered phone in the home. (Courtesy RCA.)



Sound Powered Communication In TV Installation Work

Design And Application of Sound Powered Telephones, Which Generate Their Own Transmitting Power, And Are Extremely Handy In Maintaining Roof-To-House Contact During Antenna Installations.

THE ADVENT OF TV has introduced a new and important installation tool in the Service Man's kit, the sound powered phone.

In making critical tv antenna adjustments it is necessary that one installation man be stationed at the antenna and that his movements be directed by another man at the receiver. It is important that these two men be able to communicate with each other freely in adjusting the antenna for best pictures on the receiver screen.

Sound powered telephones are the preferred devices for this application as they generate their own transmitting power. All other types of field telephones require cumbersome batteries which must be continually replaced. The current for the sound powered telephone is developed by the armature, in the sound powered telephone mouthpiece, which is located between the poles of a permanent Al-

by **K. I. DONALD**

nico magnet whose magnetic lines are across a fixed coil. The armature in the mouthpiece is, of course, driven by



voice power, and the output of the mouthpiece transmitter drives the receiver diaphragm in the ear piece of a sound powered phone connected in the circuit.

The frequency response of a typical sound powered telephone is shown in Fig. 1. It will be noted that the narrow band frequency response eliminates those frequencies which generate background noise and develops signals in the voice range only. While the harmonics of speech which enables one to recognize the speaker are not generated the frequency response is sufficient to carry on a clear conversation provided both parties speak distinctly and directly into the mouthpiece.

Fig. 2 shows several circuits used by manufacturers of sound powered (Continued on page 48)

View of a typical sound powered telephone. (Courtesy U. S. Instrument Corp.)

*For those who
Demand the
Finest...*

Meissner

**PRESENTS PRECISION
ENGINEERED PERFORMANCE**

FM RECEPTOR



Now, the incomparable beauty of FM reception is available to all with the Meissner model 8C FM Receptor. Here is the full scale fidelity of FM reception, unbelievably free from static, interference or fading. The new FM band is 88 to 108 MC; power supply is 105 to 125 volts, 50 or 60 cycles AC; consumption is 35 watts. Audio Fidelity, flat within plus or minus 2 db, from 50 to 15,000 CPS. For the best FM reception, remember MEISSNER, it's the finest.

AM-FM TUNER AND AMPLIFIER

If you appreciate quality—you'll want MEISSNER. The Meissner Model 9-1093 AM-FM Tuner and Amplifier has a frequency range of 535 to 1620 KC (AM Band) and 88 to 108 MC (FM Band). It has a power output of 18 watts at less than 2% harmonic distortion, and a hum level, 65 db below full output. It's delivered complete with tubes, two antennas and all hardware required to mount the chassis units in the cabinet. The antennas consist of a low impedance 12" x 16", noise reducing loop for AM broadcast and an indoor type folded dipole, 300 ohm, for FM broadcast. Insist on the finest, insist on MEISSNER, it's yours for more listening pleasure.

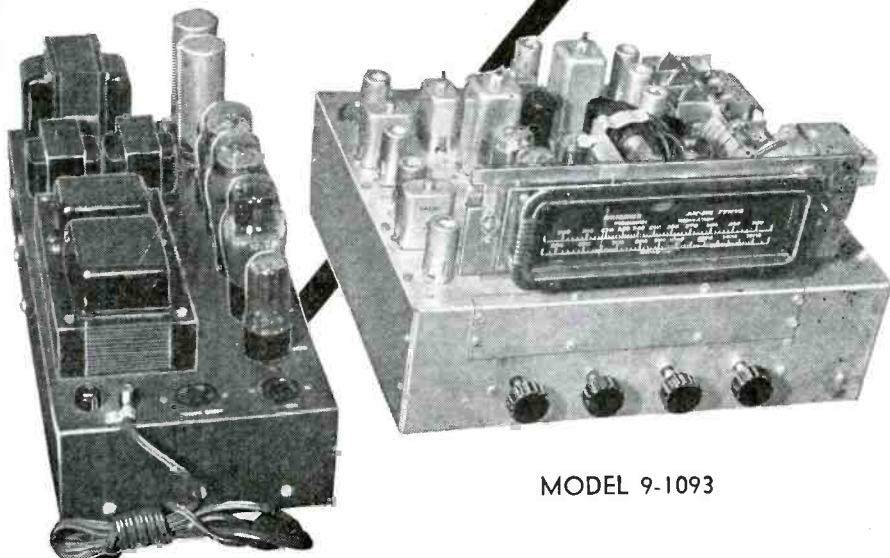

MODEL 9-1093

M **EISSNER MANUFACTURING**
DIVISION OF MAGUIRE INDUSTRIES, INC. MT. CARMEL, ILL., U. S. A.

Magnetic Wire Recorder-Playback

IN THE EARLY MODELS OF MAGNETIC wire recorders, several disadvantages were inherent. First, the velocity of the wire increased as the take-up drum received more wire and its effective outside diameter increased. This feature made quality recordings rather difficult to obtain. Second, the hum level and noise pickup were apt to be rather high unless expensive counter-measures were employed. Another disadvantage lay in the inability of the wire material to exhibit good frequency response.

In present-day wire recorders the above disadvantages have largely been overcome. Quality and dependability are such that program material recorded on wire recording systems of even the most inexpensive type are acceptable for most applications. Even the old bugaboo of wire breakage on fast rewinds has been minimized by synchronizing braking action on both drums and increasing the ten-

[See Front Cover]

sile strength of the wire. Breakage usually is due to incorrect adjustment of the braking mechanism and can be corrected accordingly.

The RCA MI-12875

It is often desirable to play back a program immediately after it has been recorded. It is on this point that wire recorders (and tape recorders) are at a disadvantage when compared to disc-type recorders. Even with the fastest rewind speed available in commercial recorders, several minutes time must be consumed in rewinding before the program can be played back. A practical limit in rewind speed is necessary in order to prevent excessive wire

¹From data submitted by John B. Ledbetter of WKRC.

breakage and possible damage to the recorder rewind mechanism.

A novel approach to this problem has been made in the recorder/playback unit shown on the cover this month; RCA MI-12875. Instead of employing the usual fixed wire drum mechanism, this recorder features a special wire cartridge which contains two 15-minute lengths of wire and two reels for each wire length. The two sets of wires and reels are so arranged that when one wire is being wound on its take-up reel, the other wire is being rewound on its supply reel. With this system, programs of any length up to 30 minutes can be recorded and made ready for playback immediately, simply by recording the first half on one wire, and switching to the second wire for the last half of the program. As the second portion is being recorded, the first reel is automatically rewound on its supply reel. In this way the first part is *cued* and ready for use as

Television
'HOW IT WORKS'

Just out. Here is practical theory on the biggest development since the introduction of radio. Deals with transmission and reception of television signals, giving clear overall picture. Goes into frequency standards, antennas, and describes the various parts of a television receiver. Covers portions of a television Manual. If of Vol. 1 Rider Television Manual. If you order the Manual (\$18.00) you automatically get this book.

Even if television is not yet in your area it will be soon. You need to know about it now.

- Manufacturers: Here is the textbook you can use in training your servicemen.

Over 200 pages
Illustrated . . . **\$2.70**

UNDERSTANDING
VECTORS AND PHASE

Provides easy understanding of vectorial presentations so you will get more benefit from radio articles and books.

160 Pages Cloth bound . . . \$1.89
Paper bound . . . 99c

BROADCAST OPERATORS' HANDBOOK
by H. E. Enns, Station Engineer, WIRE

Tells how to operate a radio station and keep it in operation. Covers transmitter operation and maintenance, what to do and how to operate control room, master and remote controls.

288 Pgs.—Profusely Illus.—**\$3.30**

LEARN RIGHT
WITH RIDER!

FM
TRANSMISSION & RECEPTION

by John F. Rider and Seymour D. Uslan

Included among the "100 Best Technical Books of 1947 and early 1948" by the "Library Journal" this book has been adopted with equal enthusiasm by schools, colleges, engineers and radio servicemen.

Latest in theory, method of operation, high and low power, antennas, methods of alignment, solutions of servicing problems—everything needed.

416 Pages
Cloth Cover. \$3.60

OTHER
RIDER BOOKS

Inside Vacuum Tube 424 Pgs. \$4.50
Servicing by Signal Tracing 360 Pgs. 4.00
Cathode Ray Tube at Work 338 Pgs. 4.00

Send for Complete Catalog of titles

BY THE PUBLISHER OF
RIDER MANUALS

Order From Your Jobber
or write direct
to us.

JOHN F. RIDER Publisher, Inc.
404 FOURTH AVENUE, NEW YORK 16, N.Y.
Export: Rocke-International Corp.
13 E. 40th Street, New York 16, N.Y.

**More manufacturers use
more advertising space in**

RADIO · TELEVISION · ELECTRONIC

SERVICE

than in any other radio service paper!

•

Thousands of professional radio-television-electronic Service Men pay for their subscriptions to SERVICE—men who stock, sell and use the great percentage of all replacement parts and accessories, test equipment, sound apparatus, antennas, radio hardware, etc.

For Buying Power —
For Responsive Readership —
For Complete Market Coverage —
Advertising in SERVICE is a MUST —

MEMBER
MEMBER

soon as the second half is finished. On playback, the same system is employed, the playback switch being thrown to the second wire position as soon as the first is through.

Operation of System

Fundamentally, the idea is extremely simple. The entire cartridge plugs into the front of the recorder and its mechanism engages the shaft of the recorder motor. Use of plug-in type cartridges eliminates the need of threading wire for each recording.

As in all recorder systems, caution should also be observed in setting the proper recording level. Excessive modulation may cause the wire to be so magnetized that complete erasure may be difficult and sometimes impossible. A neon modulation indicator built into the recorder is intended to prevent this occurrence if properly followed.

Erasing-Recording

If for any reason it is desired to erase the wire in either or both reels without recording other material simultaneously, the selector switch is turned to the proper *record* position

and the entire reel of wire is allowed to pass through the recording head with the volume control turned to its minimum setting.

Tone Control

The tone control is connected in the circuit only on *play*; it is not used in the *record* positions. Two indicators are mounted on the front panel of the recorder. These include a green pilot lamp in the upper left-hand corner of the speaker grille which indicates when power is on, and a neon lamp in the opposite corner of the speaker grill which gives indication of the correct recording level.

Recording Procedure

In actual recording the usual procedure is followed. The volume control is adjusted until the neon indicator flashes on *stressed* syllables. To prevent the possible loss of a small portion of the recording on playback, it is best to switch from the first reel to the second just *before* the limit switches are operated. (These switches are in the motor circuit and are automatically operated just before the end of the reel has been reached).

This point of operation occurs when a numeral 15 has been reached. On rewind the reel is allowed to run until the dial reads exactly the same as it did at the start of the recording. It is then ready for playback.

Maintenance

Since the rubber idler wheels which operate the cartridge reels may be dented by contact with the motor shaft during periods of inoperation, the cartridge must be either removed entirely from the compartment or pulled out far enough to disengage the rollers from the driving shaft. At the back of the compartment which normally houses the wire cartridge are two slots in the recording head. These should be cleaned occasionally with a small stiff brush.

Frequency Response

Frequency response of the recorder is good for a unit of this type. At 50 cycles the response is down only 3 db. Above 1,000 cycles a gradual rise to plus 4 db at 4,000 cycles is exhibited, with a gradual drop to -2 db at 10,000 cycles.

(Data courtesy RCA.)

NOW! YOU CAN GET IMMEDIATE DELIVERY ON 1/2- AND 1/4-TON PANEL TRUCKS!



THAMES TRUCKS
FORD PRODUCTS
MADE IN ENGLAND



1/4-Ton. 65 cu. ft., Interior length 51", width 48", Height 40". Wheelbase 90". Curb weight 1550 lbs.

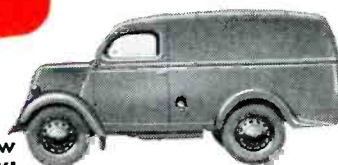

1/2-Ton. 120 cu. ft., Interior length 79", width 54", Height 45 1/2". Wheelbase 90". Curb weight 2160 lbs.

PRICED AS LOW AS \$1,247
PAINTED YOUR CHOICE OF COLORS

Sign up today and drive one away. Take delivery on a new Thames Panel Truck . . . not next month, not next week, but NOW! The Thames is the largest selling light duty truck in England. It is a Ford product made in England.

AMPLE LOAD SPACE . . . With a capacity of 120 cubic feet for the 1/2-ton Truck and 65 cubic feet for the 1/4-ton, there is ample load space for light deliveries.

EASY HANDLING . . . A 90-inch wheelbase makes the Thames an exceedingly easy truck to handle, easy to park. Turning circle of the 1/2-ton is 36 ft., 1/4-ton, 34 ft. 9 in.

POWER WITH ECONOMY . . . One-third the displacement of the average 1/2-ton engine, the 4-cylinder Thames consumes much less gas. Curb weight of 2160 lbs. on the 1/2-ton, 1550 lbs. on the 1/4-ton also helps gas mileage. The engine is especially suitable for non-premium fuels.

AMPLE POWER . . . The sturdy precision built engine is more than adequate to meet load requirements.

BIG ADVERTISING VALUE . . . The unique appearance of Thames Trucks builds prestige for your business.

NATIONWIDE SERVICE . . . Selected Ford Dealers carry a complete supply of parts and Ford Dealers everywhere will service Thames Trucks.

FORD MOTOR COMPANY
2780 Schaefer Road, Dearborn, Michigan

Please send me more information about Thames Panel Trucks.

Name

Address

City State

Increase Your 'Scope Sensitivity

Modified Reluctance Pickup Type Preamp Used With 'Scope Provides Voltage Gain of Ten.

by J. B. FARNUM and JACK NAJORK

Specialty Division
General Electric Co.

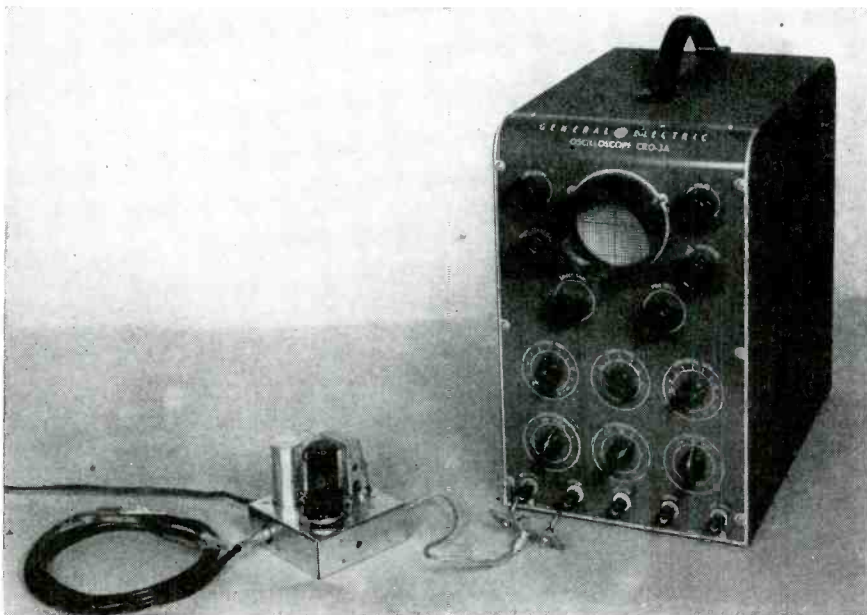

Fig. 1. Preamp used to increase sensitivity of 'scope.

Fig. 2 (below). Original circuit of preamp.

Fig. 3 (right). The revamped portion of the preamp which permits its use with a 'scope to increase its gain.

'SCOPE SENSITIVITY is a mighty important item in servicing work, particularly for the alignment of f-m and tv receivers. If you have a 'scope that does a good general job, but just lacks that extra gain needed for those v-h-f jobs, a small preamp such as is used with the variable reluctance phono-

graph pickup can be called in to lend a hand. Two simple changes in this preamp transform it into a self-powered unit which can be used with almost any 'scope to provide a voltage gain of approximately ten. If your present 'scope has fairly good sensitivity of about 0.3 volt per inch, addition of the preamp will give you one inch of deflection with an input of approximately .03 volt.

The beauty of the preamp is that it is self-powered by an a-c supply, so there are no hot line or chassis problems; you can connect or disconnect it, depending upon the sensitivity you need for various jobs. Your original 'scope remains in one piece. You don't even have to take it out of its cabinet, because this is strictly an external addition.

The schematic diagram (Fig. 2) shows the original circuit of the preamp.¹ For use as a 'scope preamp, its input impedance is much too low. To correct this, the 6,800-ohm input resistor, R₁,* is removed, and a voltage divider consisting of two, one megohm,

(Continued on page 49)

*This resistor is omitted on some production units to increase high-frequency response of the preamp.
¹G. E. UPX-003.

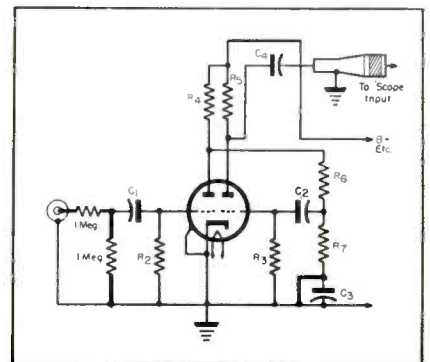
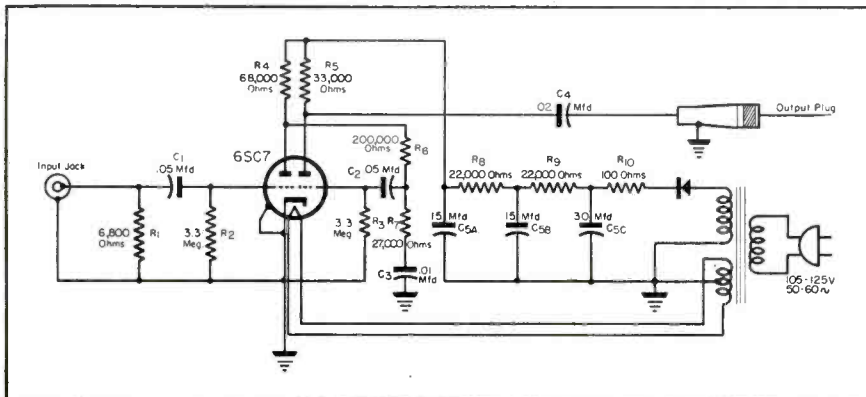

TV Test Equipment that covers all present and future bands.

IN GOOD COMPANY

The Mega Sweep, a high quality instrument, is now being used by these and other leading manufacturers.

FADA Radio

ANACONDA

Samuelson Radios

Users



Federal Telecommunication Laboratories, Inc.



BELL TELEPHONE LABORATORIES

E. I. DU PONT DE NEMOURS & COMPANY



GENERAL ELECTRIC COMPANY BELMONT RADIO CORPORATION

THE MEGA-SWEEP



THE MEGA-PIPPER

Precise crystal positioned marker generator. Used with the Mega-Sweep, the Mega-Pipper generates four sharp marker pips which are displayed on the response curve on the oscilloscope. These pips appear simultaneously at sound and picture i.f. carrier and adjacent sound and picture i.f. carrier frequencies. Pips are applied directly to oscilloscope and do not disappear when tuned into traps. Fast, precise tuning of traps and positioning of i.f. characteristics possible. Plug in crystals make it possible to change Mega-Pipper to any i.f. frequency in the RMA bands.
Price \$150.00 f.o.b. factory



THE MEGA-SWEEP

Expert opinion says, "Yes, you must have a Sweeping oscillator to do TV service work." Why not buy the best and assure the best quality work. The Mega-Sweep is the only sweep capable of operation in the UHF-TV bands now being discussed. Wide Sweep (up to 30 mc) continuously variable attenuator with flat frequency response, low amplitude modulation while sweeping. The sawtooth type sweep is entirely electronic. Only one r.f. sweeping voltage in output. No spurious signals, no phasing or synchronizing problems.
Price \$395.00 f.o.b. factory



THE MEGA-MARKER

Experts say, "A marker is essential for use with your sweeping oscillator." The Mega Marker is a precision variable oscillator (accuracy 0.25%) which operates with the Mega-Sweep. Crystal oscillator (4.5 mc) included for calibrating instrument's variable oscillator and supplying accurate marker for lining up video sound trap and intercarrier i.f. and discriminator. Includes output amplitude control, provision for mixing Mega-Sweep and Mega-Marker outputs for application to the receiver under test.
Price \$60.00 f.o.b. factory



THE MEGA-MARKER SR.

This unit provides a crystal controlled high accuracy (0.01%) sound r.f. carrier for each of the twelve television channels. The carriers can be used tone modulated or unmodulated by setting a panel switch. Includes amplitude control and switched channel tuning. Contains independent power supply and can be used either with Mega-Sweep or as an independent test instrument for tuning TV receiver local oscillator on all twelve channels.
Price \$195.00 f.o.b. factory

FREE SCHOOL

We are conducting a series of free one day schools at our factory to instruct in the operation and application of our equipment. Write department S for dates and enrollment.

WRITE FOR FULL SPECIFICATIONS

KAY ELECTRIC CO., 19 Maple Ave., Pine Brook, N. J.

Servicing Helps

Clock Movements For Program Selection And On-Off Control. Picture Tube Parts. Service Notes On Philco, RCA, Detrola, Emerson, And Stromberg-Carlson Receivers. Vibrator Testing With A 'Scope.

THE USE OF CLOCK movements in receivers to control *on-off* operation or program selection at pre-selected times has become quite a popular idea, and as a result several types of *radio clocks* have been developed.

A circuit for one type¹ is shown in Fig. 1. The unit used here has hour/minute/second hands. The length of play, when in the alarm position, is set at 1 hour and 15 minutes, plus or minus 15 minutes. Tolerances for the *on* time are approximately 3 minutes previous to the set time to 1 minute late. Control is thus provided for use as an alarm or as a selector for programs. The duration of the alarm period insures complete reception of programs up to one hour with the op-

by P. M. RANDOLPH

tion of turning to the *on* position if further play is desired.

On-off selector switch included in this system permits the use of the clock feature or bypasses this to permit playing regardless of dial setting.

The clock has an enclosed motor field, and thus no shielding is required to prevent interference.

TV Picture Tube Components

MANY SERVICE MEN have inquired as to the types of components actually employed in a typical magnetic picture-

¹Types SK859, 1107 and 1108 made by Haydon Mfg. Co., Inc.

²Available from receiver division, G. E.

tube system. In Figs. 2 to 8 appear the parts² involved in a 10-inch picture-tube system requiring 50° magnetic deflection at an accelerating voltage of 9,000: horizontal output transformer, horizontal size control, horizontal linearity control, deflection yoke, focus control, centering device, mounting bracket and ion trap. (See pages 43 and 44.)

The focus coil is a combination permanent and electromagnet affair. The horizontal transformer is polyethylene molded and hermetically sealed. Overall length of the deflection yoke, centering device and focus coil assembly is 4 $\frac{3}{8}$ " ; maximum diameter of the assembly is 3 $\frac{3}{4}$ ".

Service Notes³: Philco 46-1201/1203, 47-1201

ANY OF THESE SETS using a voltage-doubler may be suspected when the volume goes down and the tone goes off. The two 15-mfd 150-volt electro-

(Continued on page 43)

³From Service notes prepared by Jack Darr.

Fig. 1. Circuit for automatic clock system. Switch *on*, manual contacts closed, permits control by receiver switch. With switch *on* and automatic radio switch *on*, automatic operation is provided.

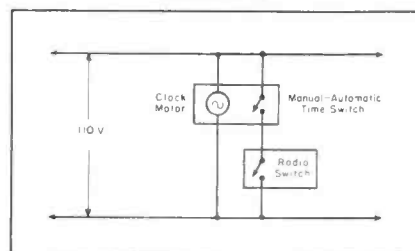
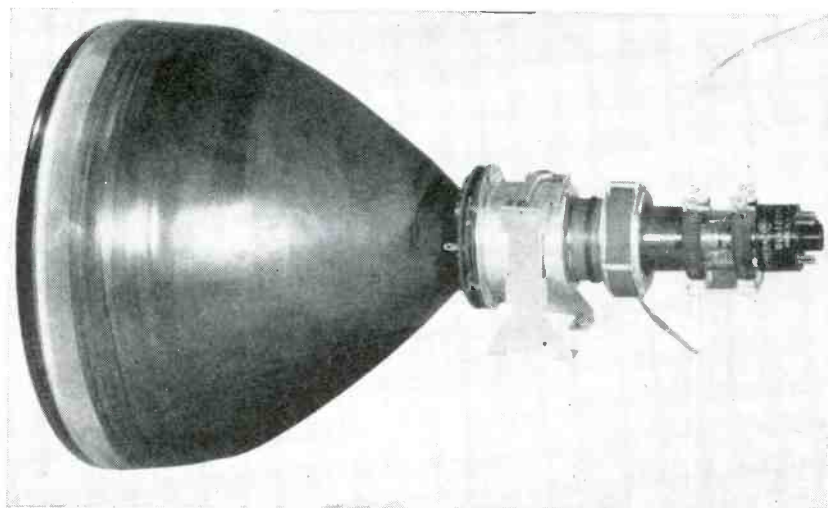

Fig. 2. View of an electromagnetic type television picture tube with the deflection yoke, focus coil and ion trap in position. (G.E.)



WANTED

**Economical, Positive,
Tube and Battery Tester**
combined with
**complete 20,000 ohms per volt
circuit testing facilities.**

Must handle all modern tubes with
full anti-obsolescence features.
Must test all up-to-date A.M.-F.M.
and TV circuits.

Now Available!

THE NEW PRECISION SERIES 654

COMBINATION

Cathode Conductance Tube Tester
Dynamic (Under-Load) Battery Tester
High Sensitivity A.C. and D.C. Circuit Tester
(20,000 ohms per volt D.C.)

Ranges to 6000 Volts*, 120 Microamperes,
12 amperes, 60 Megohms, + 70 DB
*(30,000 Volts with Series TV-2 Super
High Voltage Television Test Probe.)

Series 654 is a rugged, complete, compact, high sensitivity Service Laboratory designed to meet the specific needs of the modern electronics service-maintenance technician, with utmost practical economy — conforming fully to the "Precision" high standards of quality, workmanship and performance!

TUBE AND BATTERY TESTING FEATURES

- Tests all modern tube types including Noval 9 pin, dual capped H.F. tubes, and TV amplifiers, via time-proven RMA-recommended, emission test parameters.
- Filament voltages — 3/4 to 117 V.
- Absolute Free-Point 10 element lever selection for both short and merit tests.
- Dual short-check sensitivity.
- Individual Tests of Multi-Section Tubes.
- Ballast Unit Tests.
- Micro-Line adjustment.
- Pilot and signal light tests.
- Noise and Condenser test jacks.
- Dynamic "under-load" test for all popular radio A, B, and C dry batteries.
- Built-in, brass geared roll chart.
- Anodized, etched, easy reading, heavy gauge aluminum panel.
- Fuse Extractor Post.
- Telephone type cabled wiring using plastic-insulated, moisture resistant hook-up wire.

CIRCUIT TESTING FEATURES

- 5 D.C. Voltage Ranges: — 20,000 ohms per volt.
- 5 A.C. and Output Voltage Ranges: — 1000 ohms per volt
0-12-60-300-1200-6000 volts
also 0-30,000 volts via optional TV-2 Television Test Probe.
- 6 D.C. Current Ranges: — 0-120 microamperes.
0-1.2-12-120 MA
0-1.2-12 Amperes
- 3 Wide Resistance Ranges: — 0-6000-600,000 ohms; 0-60 megohms.
(No A.C. power required)
- 5 Decibel Ranges from —12 to +70 DB.

- ★ Fully Rotary Selective Ranges and Functions.
- ★ Only 2 pin jacks for all standard ranges.
- ★ 50 microampere, 4 5/8" Wide-Angle meter.
- ★ 1% Wirewound and film-type resistors.
- ★ All circuits isolated from power line.

SEE this new "Precision" Test Instrument on display at leading radio parts and equipment distributors. Write directly for the latest Precision catalog describing the full Precision line of quality Electronic Test Instruments for all phases of A.M., F.M. and TV.

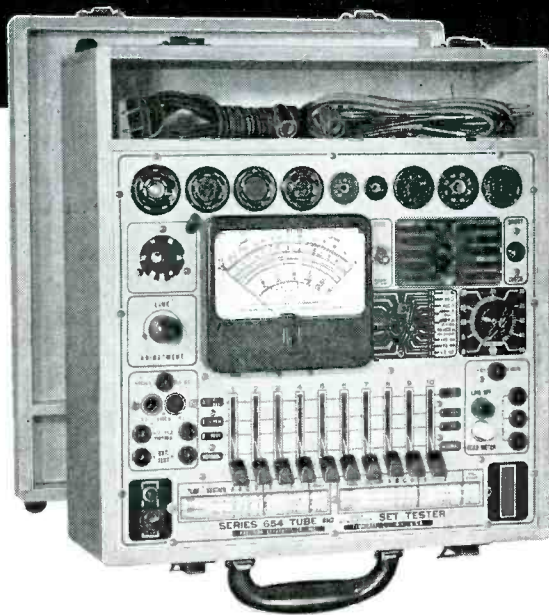

Series 654 is available in 4 distinctive models to suit individual application requirements.

★ 654-P . . . PORTABLE . . . In hardwood portable case, with tool compartment and hinged removable cover. Size 12 x 13 x 6".

Complete: — \$106.40

★ 654-MCP . . . LAB. PORTABLE . . . Open style Metal Case Portable. Fine dull black ripple finish on heavy gauge steel. Size 10 1/2 x 12 x 6"

Complete: — \$103.55

★ 654-PM . . . PANEL MOUNT . . . In standard size panel mount, size 12 1/4 x 19", with dust cover. For rack, cabinet or wall mount.

Complete: — \$106.40

★ 654-C . . . COUNTER . . . In modern, chrome-trimmed counter cabinet. Fine black ripple finish on heavy gauge steel. Size 16 x 13 1/2 x 7" slopes to 3" at front.

Complete: — \$108.90

Coming Soon—Watch for
Official Announcement
—Worth Waiting For:
The New Series E-400
WIDE RANGE SWEEP GENERATOR
The New Series ES-500
MULTI-PURPOSE 5" OSCILLOSCOPE



PRECISION APPARATUS CO., INC.

92-27 HORACE HARDING BOULEVARD • ELMHURST 6, NEW YORK

Export Division: 458 BROADWAY, NEW YORK CITY, U. S. A. • Cables: MORHANEX

TV Sync And

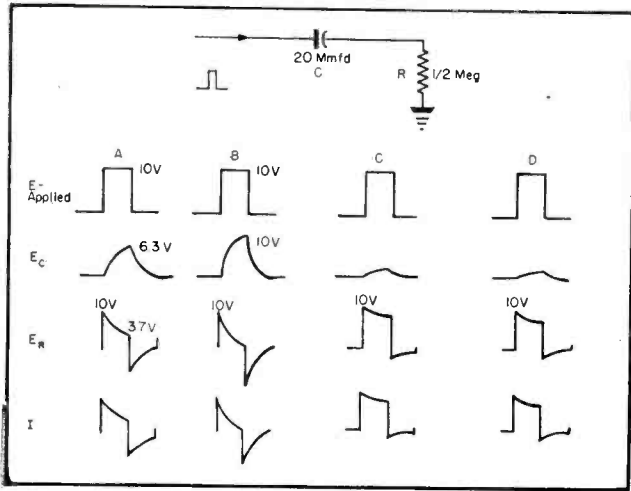

Fig. 1. Time constant and coupling pulses. At A we have a 10 microsecond pulse; B, 50 microsecond pulse; C, 2 microsecond pulse and D, 50 microsecond time constant. (For circuit shown, $t_{\mu sec} = R_{meg} \times C_{mfd}$ or $t = .5 \times 20 = 10$ microseconds)

Fig. 2. Pulse distortion as the low frequency response becomes progressively poorer.

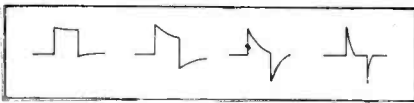

Fig. 3. Time constant circuit and plots illustrating the time constant and pulse distortion, when the steepness of the leading edge is lost. At A is a .05 microsecond time constant and at B, a .5 microsecond time constant.

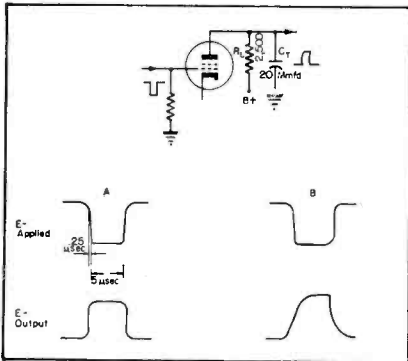
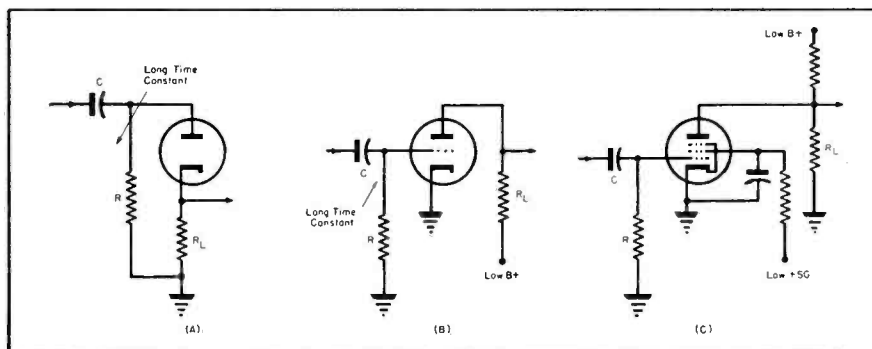

Fig. 4. Extent of pulse distortion as the high-frequency response becomes progressively poorer.



Fig. 5. Typical sync separators using diode, triode and pentode tubes.



IN OUR discussion of rectangular pulses last month it was pointed out that the rectangular sync pulse consists of a base frequency and a number of low-order and high-order harmonics, which are vested in the leading and trailing edges of these pulses and constitute fast changes in voltage per unit time, while the low-order harmonics are vested in the duration or flat-tops of the pulse which represent a slow change in voltage per unit time.

It was then shown that the flat top of a pulse represents a low frequency because it is a sustained voltage level which must be held constant for the duration of the pulse. Therefore, the duration of the pulse determines the low-frequency response requirements, because the longer the pulse the longer the time interval the voltage must be held at a level value.

Now, the exact method in which to interpret the response of a circuit to a pulse is in relation to the time constant of such a circuit. In this interpretation the pulse is considered to be a d-c voltage which is cut on and off at specific intervals for specific durations. In a simple rc combination, Fig. 1, the time required to put a 63% charge on the capacitor is termed the time constant (exponential rise of voltage on the capacitor,

charging toward the applied voltage level). The time constant in seconds is equal to the product of the resistance in ohms, and the capacity in farads. For practical use in tv circuits time constant is most often in microseconds and is equal to the product of the resistance in megohms and the capacity in micromicrofarads. Thus, if a 10-microsecond pulse is applied to a circuit with a ten-microsecond time constant, the capacitor will charge to 63% of the applied pulse amplitude at the end of the 10-microsecond pulse, as illustrated in Fig. 1. If the pulse is applied for five time constants or is five times longer in duration than the time constant of the circuit, the charge on the capacitor at the end of 50 microseconds will be almost the peak amplitude of the applied pulse. If the time constant of the circuit is made five times longer than the pulse duration, the charge on the capacitor at the end of the pulse will be relatively low.

The instant the pulse is applied, and before the capacitor begins charging, the voltage across the resistor is maximum and equal to the peak amplitude of the pulse. At this time, the current flow is maximum because there is a current circulating around the circuit which will attempt to charge the capacitor to the peak value of the applied voltage. As the charge builds up on the capacitor this potential subtracts from the potential of the applied voltage and the current in the circuit therefore is reduced. The voltage drop across the resistor, as shown in Fig. 1, is reduced a corresponding amount. Therefore, as the charge builds up on the capacitor, the current flow gradually reduces and voltage drop across the resistor decreases. Thus if a 10-volt pulse is applied, at the end of the first time constant, 6.3 of the original 10 volts will appear on the capacitor and 3.7

Inter-Sync Systems

Part II of Series . . . Explanation of Time Constants . . . Uses of Square Pulses . . . Sync Clipping . . . Sync Separators (Diode, Triode And Pentode) . . . Function of D-C Restorers . . . Difference Between Separator And Restorer Systems And Their Relation To TV Receiver Operation.

across the resistor. At the end of six time constants the capacitor will have been fully charged and therefore the current flow will be zero and the voltage drop across the resistor will not decrease an appreciable amount. If the pulse is applied for a duration, much shorter than the time constant, or if the time constant is increased to have it much larger than the pulse duration, the charge on the capacitor will be very slight and consequently the voltage across the resistor will not decrease an appreciable amount. It is evident, therefore, if the capacitor and resistor we are talking about were the coupling capacitor and grid resistor of an inter-stage coupling circuit, the pulse would appear across the resistor with the best fidelity when the time constant of the circuit is much greater than the duration of the pulse.

Actually, to maintain an absolutely linear flat-top on our pulse, it is necessary that the time constant of the grid-capacitor, grid-resistor combination be almost 100 times the duration of the pulse. Likewise, the longer the duration of the pulse the larger the time constants become in order to maintain this ratio.

A pulse is often used to check the frequency response of the video amplifier because the extent of the taper of the flat top is an indication of the low frequency response of the amplifier. The poorer the low-frequency response the more decided the pulse is distorted, as shown in Fig. 2, which shows the pulse distortion as to the low frequency response becomes progressively poor.

Time Constant and the Leading Edges of a Pulse

We have noted that the presence of the distributed capacity across the plate load resistor of the video stages causes a loss of high frequencies. Likewise, this very same capacity across the plate load will cause distortion of the leading edges of a pulse, because actually the leading edges of the pulse are made up of h-f compon-

by **EDWARD M. NOLL***

*Instructor in Television
Temple University*

ents. A better understanding can be obtained if we think in the light of time constants. Thus, if a pulse is applied to a parallel resistor-capacitor combination and the leading edge of that pulse rises from minimum to maximum in one-quarter micro-second, it is necessary that the distributed capacity be capable of charging up to that level in the same amount of time. If the time constant of the plate resistor and distributed capacity combination is long, the capacitor will not assume the maximum charge in the $\frac{1}{4}$ microsecond allotted and will continue to charge during the flat top portion of a pulse. Consequently, the pulse will be distorted, Fig. 3, and this steepness of the leading edge will be lost. If the time constant is made very short in comparison to the rise of the leading edge it will have no difficulty following the sharp rise of the voltage at the beginning of the pulse. Thus, to sustain the fidelity of the leading and trailing edges of all pulses it is necessary that the shunt time constant be short in comparison to the rate at which the pulse climbs. If this is not so, the lag imposed by the long time constant of the shunt rc combination will cause the steepness of the leading edge to be lost and the pulse will fold over. To keep this time constant short the size of the plate resistor must be relatively low and the distributed capacity must be kept at a minimum, the same requirements imposed on a video amplifier.

A squared pulse, therefore, can also be used to check the h-f response of a video amplifier because a loss in h-f response means a long time constant shunt combination, which means the steepness of the pulse will be lost in

accordance with the extent of the high frequency loss. Fig. 4 reveals the extent of the pulse distortion as the h-f response becomes progressively poorer.

Sync Clipping

Before the sync pulses are shaped for application to the horizontal and vertical oscillator circuits the sync as an entirety must be separated from the composite television signal. The sync separator or clipper must separate that portion of the composite television signal above the blanking or black level. The three signals present above the blanking level are the horizontal sync, the equalizing sync block and the vertical sync block. The leading edges of all the sync pulses are used to keep the horizontal sweep in synchronism and the vertical sync block is used to synchronize the vertical sweep. The actual separation occurs in a circuit which holds all portions of the signal below the blanking level at cut-off. Most sync separators are signal biased; that is, the current drawn in the input circuit at the peak of the sync tip supplies the bias for the stage. This current and resultant bias is sufficient to hold all portions of the signal below the blanking level at a cut-off value.

Three typical sync separators are shown in Fig. 5, using a diode, triode and pentode tube. In the diode separator of *A*, positive-going composite signal is applied to the plate of the diode. The peak of the sync tip draws maximum diode current and therefore capacitor *C* is charged to peak value during the sync tip interval of the composite signal (capacitor charges quickly because of the short time constant formed by *C* and low resistance of conducting diode). The charge placed on *C* by the peak diode current flowing through *R* is sufficient to prevent conduction of the tube until the signal amplitude is near the blanking level. Consequently, the only portion

(Continued on page 50)

*From a forthcoming book, *Television for Radiomen*, to be published by Macmillan.

ASSOCIATIONS

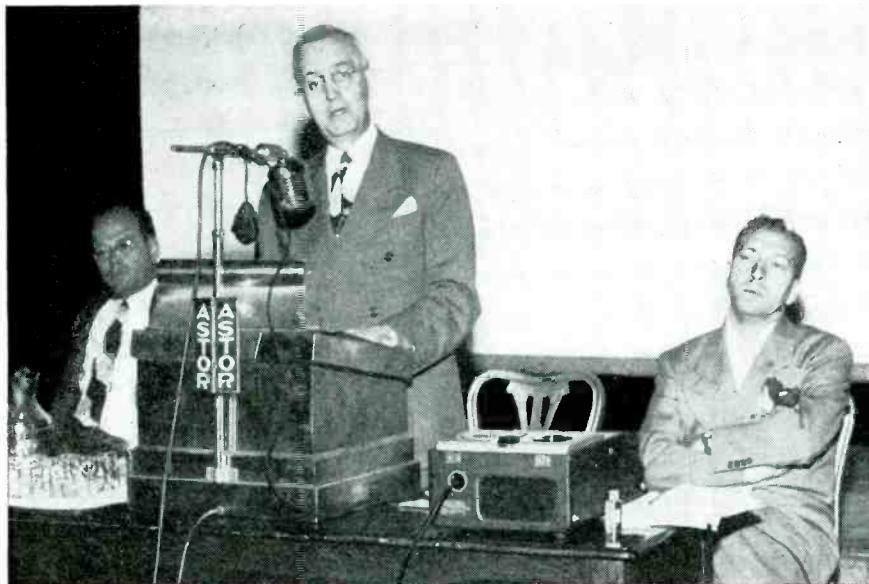

At the first session of the Town Meeting of Radio Technicians, held during the latter part of September in the grand ballroom of the Hotel Astor in New York City. Left to right: Harry A. Ehle, chairman of the Town Meetings, who presided; Max Balcom, president of RMA, who presented the initial talk on the purpose of the Town Meeting; and ye editor, who served as moderator.

ARSD, Columbus, Ohio

A REPORT from the Associated Radio Service Dealers Association of Columbus discloses that Bill Hensler and Paul Wendel of Howard W. Sams Company presented a talk on television during a recent meeting covering in part the text of the Saunders tv course. Hensler and Wendel discussed the service problems commonly met in the field as well as specialized installation problems. According to ARSD, Howard Sams is considering

the production of a 16-mm film for use at service meetings.

At a subsequent meeting in September Al Saunders offered one of his interesting lectures on television. The talk was presented at the Masonic Auditorium in Cleveland.

The Saunders Tour

PAUL WENDEL has dropped us a note detailing the recent association tour of Al Saunders, of the Saunders Radio-Electronics School, and an active as-

Speakers at the Town Meeting session, left to right: Ira Kamen, who spoke on tv antenna installation; Marvin Kaplan and Errol Jones who participated in a symposium on tv installation in the home.



sociation man in New England, who is lecturing for Howard W. Sams. Saunders appeared in Seattle and Tacoma, Washington; Portland and Medford, Oregon; San Francisco, Oakland, Los Angeles, and San Diego, California; Dallas and Fort Worth, Texas; Indianapolis, Indiana, and Detroit, Michigan. Wendel states that at Seattle the attendance exceeded 400, at Tacoma there were about 250 in the auditorium and in Portland over 300 appeared. A standing room sign was set up at the meeting in Oakland and in 'Frisco over 500 came to listen to Saunders.

ARSNY, New York City

THAT THE SERVICE MEN of New York and New Jersey are tv conscious was quite evident during the three day *Town Meeting of Radio Technicians* held at the Hotel Astor in New York City, in which ARSNY participated as a cooperating agency. The huge grand ballroom, where the meeting was held, was jammed.

At the opening session, Ira Kamen covered the all-important subject of tv antenna installations. And in a symposium on tv installation in the home, Marvin Kaplan, Errol Jones and Irving Winston covered three vital topics: *Instructing the Customer in Set Operation, Instructing the Customer in Performance Eccentricities and How to Conduct Yourself in the Customer's Home.*

During the second session Eugene Ecklund discussed television servicing in the home with existing test equipment, and Harold Suss covered a case history of a tv service shop.

On the third day, during which two sessions were held, one in the afternoon and one in the evening, two extremely interesting technical topics were discussed by Carl Quirk and Murray Goldstein: *Television Service in the Shop, and RF and IF Systems and FM Conversion Systems.*

In the evening session John F. Rider discussed sweep generators.

At all four sessions business papers were also offered on credit, the securing of loans, advertising and public relations, and general topics on the future of television.

A report on these papers appears on the editorial page of this issue.

ACCORDING TO A RELEASE from Max Leibowitz, president of ARSNY, a twelve lecture schedule has been set up for the fall and winter-spring seasons of '48-'49. Subjects to be discussed include antennas, front ends and i-f systems, video amplifiers, horizontal and vertical sync circuits, low and

TEN YEARS AGO

From the Association News Page of SERVICE, October, 1938

RSA PRESENTED A GUARANTEE service plan covering the work and material rendered by individual members. . . . Allentown, Pa., and Hartford, Conn., voted to affiliate with RSA. . . . The Green Bay Chapter received its charter from RSA and the Holyoke Chapter received its charter too. . . . A dinner meeting was held by the Alton Chapter during which Joe Marty, Jr., executive secretary of the RSA presented a charter to the group. A. G. Mohaupt of the National Speakers Bureau of the RSA spoke on "Test Instruments and Their Uses." . . . More than 350 Service Men attended the Chicago Chapter test equipment meeting which was sponsored by fifteen test equipment manufacturers. . . . Bill Akers of Philco described the *Philco mystery control* at a meeting of the Cleveland Chapter. . . . A talk on automatic frequency control was presented before the Danville Chapter. . . . The Duluth Chapter held its annual get-together at the Hotel Spaulding. At the speaker's table was the Mayor of Duluth, Joe Marty, Jr., John Potts, and many others. . . . Several special committees were set up by the metropolitan New York Chapter of the RSA. A. E. Rhine was named chairman of the membership committee; E. Bendheim, chairman of the grievance committee; E. P. Mandeville, chairman of the education and technical committee; Charles H. Yocum, chairman of the special relations committee; and Fred Horman, chairman of the library committee. Sidney Bloch, Frank Cassidy, Vincent Campbell, and Joseph Breyer were elected to the governing board. . . . The southern New Hampshire Chapter held an outing at Lake Sunapee. . . . A preview of a lecture course on tv was given by Dr. Lester Reukema before the Radio Service Association of California, Inc. . . . An educational program guided by Frank Dunningan was planned by the Associated Radio Technicians of Spokane. Dunningan was vice president of ART.

high-voltage power supplies, cathode-ray tubes and circuits, alignment and test equipment, and servicing and test equipment. The lectures will be presented in October, November, December, January, February, March, April and May.

3 BASIC TYPES REPLACE OVER 150 STANDARD MODELS

**Revolutionary Discovery
Simplifies Replacement—
Greatly Improves
Record Playing**

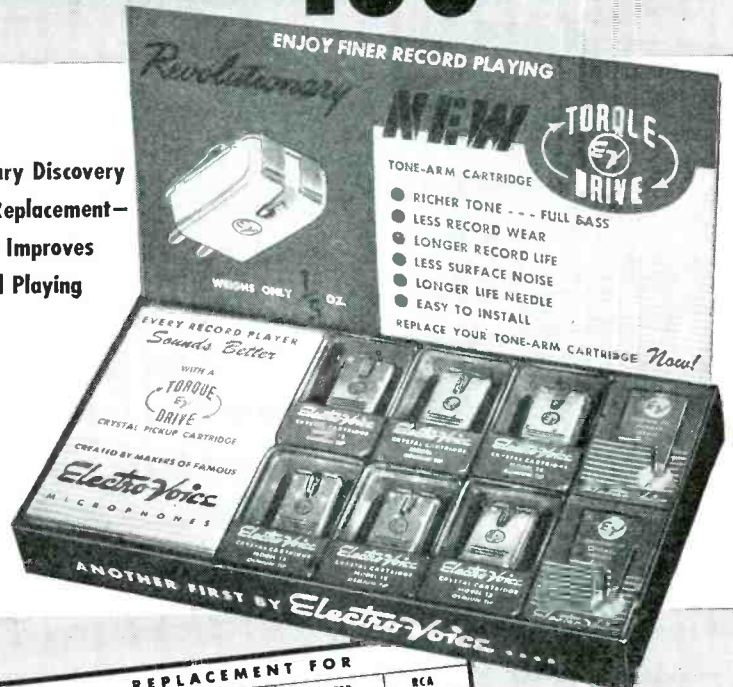

		REPLACEMENT FOR					
ELECTRO-VOICE	ASTATIC	SHURE		WEBSTER		RCA	
MODEL M12 Medium Voltage (Red)	L-22A	L-76S	P30	P93C	E4	N4	31050*
	L-25A	L-76AS	P30B	P93D	E4-1	N6	31156*
	L-26A	LT-M	P30C	P93E	E-9	N6P	32632*
	L-27A	LT-MA	P30D	P93S	F1	N6P-4	33122*
	L-32A	LT1-M	P30E	P94	F1P	N8	33217*
	L-70	LT1-MA	P30S	P94B	F2	N8P	33905*
	L-70A	LT2-M	P87	P94E	F2P	N9	34225*
	L-70S	LT2-MA	P87B	W42A	F3P	N11	34307*
	L-70AS	LT3-M	P87S	W57A	F4P	N11P	34710*
	L-71	1-J	P90B	W57AN	F5		35171*
	L-71A	1-M	P90C	W58A	F5P		37158*
	L-71S	401-A	P90D	W60A	F6		39686*
	L-71AS		P90S	W60B	F6P		
L-76		P93	W60HS	N2			
L-76A		P93B	W61B	N3			
MODEL H12 High Voltage (Blue)	L-24A	L-72S	P88	W56A	C-2†		CR1A
	L-36A	L-72AS	P88S	W59A	C-3†		CR2A
	L-46A	L-82	P89	99-180	C-6†		S2
	L-50A	L-82A	P89S	99-181	N-10		
	L-72	L-82V	W40A	W41A	N-10P		
L-72A	M-23			N-10P-1			
MODEL L12 Low Voltage (Yellow)	L-40A	LP-6	QC	QT-3JA	C5†		71173
	L-41A	LP-21	QT-J	QT-3M	F3		70339
	L-75	LP-23	QT-M	QT-3MA	F7P		70338
	L-75A	MLP-1	QT-2J		N3		
	L-75S	MLP-1J	QT-2M		N5		
	L-75AS	MLP-2	QT-3J		N7		

Use "A" mounting plate furnished with cartridges (1/2" hole centers) for all replacements except those marked with an * or †. *Use "B" mounting plate furnished (3/8" to 13/16" hole centers). †Use "C" mounting plate furnished (Webster Side Flange). All Model 12 Cartridges equivalent to ASTATIC "A" type except Tone Arm Rest Button is not supplied. It is recommended that the lower voltage cartridge consistent with volume level be installed. NOTE: Models M12, H12 and L12 have Osmium-Tip Needle. For Cartridge with Sapphire-Tip Needle, specify Model M12-S, H12-S, or L12-S.

New Torque Drive Crystal Pickup Cartridge achieves clean, clear tone definition and fidelity that are truly amazing! You can hear the difference! Gives new life to every record library.

AUTHORIZED DISTRIBUTORS EVERYWHERE

Write for Replacement Chart Bulletin No. 146

New Model L-14 Microgroove Crystal Cartridge, and New Model 20 Magnetic Cartridge for Regular or Microgroove records also available.

E-V Pat. Pend. Licensed under Brush Patents

ELECTRO-VOICE, INC.
BUCHANAN, MICH.
Export: 13 East 40th St., New York 16,
U.S.A. Cables: Arlab

IT PAYS TO REPLACE WITH

Electro-Voice

New **DUAL SPEED** **PHONOMOTOR**

FOR 78 R.P.M. OR 33 $\frac{1}{3}$ R.P.M.

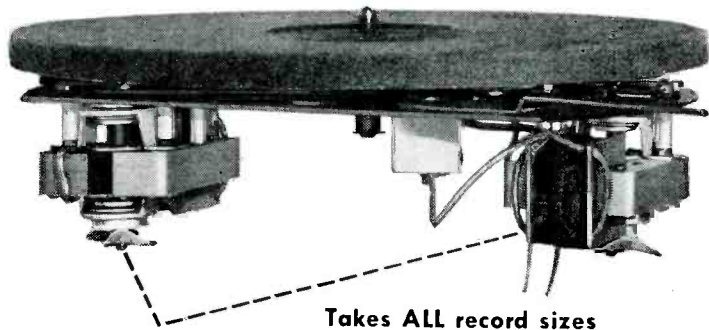

Takes ALL record sizes

TWO turntable speeds—78 or 33 $\frac{1}{3}$ r.p.m. are optional with the new Alliance Dual-Speed Phonomotor! With a simple "flick" of the control, you select either speed at will.

A dual version of the famous Model 80, this complete, new record player assembly gives the same kind of high quality "wow-free" performance required for commercial transcriptions!

Make the Alliance Dual-Speed your answer to the growing demand for slow-speed, long-play micro-groove records!

And remember—The new Alliance Dual-Speeds will be just as dependable as the millions of Model 80 Phonomotors now in use!

Radio service shops and retailers will find the new Alliance Dual-Speed Phonomotor is the ideal turntable drive for record players consoles, table models, combinations and portables. Each unit is individually boxed. Place your orders with your regular jobber now!

WHEN YOU DESIGN . . . KEEP
alliance motors
IN MIND

ALLIANCE MANUFACTURING COMPANY • ALLIANCE, OHIO
Export Department: 401 Broadway, New York 13, N. Y., U. S. A.

Ser-Cuits

(Continued from page 25)

of the video signal are removed from the sync pulses by this stage.

Sync Inverter (6SN7GT): A triode sync inverter circuit is used to obtain a push-pull feed for the horizontal sync discriminator.

A tap on the cathode load of the

sync inverter provides a feed to the integrator for vertical synchronization. The vertical integrator consists of a three-section, RC filter network (R_{441} , R_{442} , R_{443} , C_{428} , C_{429} , C_{430}).

Horizontal Sync Discriminator

(6AL5): The sync discriminator is also an RC coupled circuit. A push-pull, sync signal input is supplied by the sync inverter. An RC voltage divider circuit (R_{416} , R_{418} , C_{109}) is used to supply a portion of the horizontal sweep output voltage to the horizontal sync discriminator. A 1,000-mmfid capaci-

tor (C_{409}) used in the divider circuit, is needed for d-c blocking.

The discriminator delivers a d-c output voltage that is proportional to the phase difference between the sync pulse and horizontal sweep voltage inputs. When the frequency and phase relationship between these two voltages is correct, the discriminator circuit develops its normal output voltage. This voltage, combined with cathode bias voltage, is equal to the normal operating bias of the horizontal oscillator control tube. When the horizontal sweep circuit in the receiver is not locked in with the transmitter, the frequency or phase relationship between the sync pulses and the horizontal sweep voltage is abnormal. The d-c output of the horizontal sync discriminator changes accordingly.

The d-c output of the horizontal sync discriminator is fed to the grid of the horizontal oscillator control through an RC filter network. The filter is necessary to keep sync pulses and noise from reaching the grid of the horizontal oscillator control tube.

Horizontal Oscillator Control (6J6):

A triode reactance modulator circuit is used for horizontal oscillator control. A .015-mfd horizontal oscillator tank capacitor is returned to the cathode of the oscillator control tube. This control tube input voltage is out of phase with and leads the oscillator tank voltage by approximately 90°. Due to the inverted input circuit, the signal on the plate of the control tube also leads the oscillator tank voltage by the same amount. Coupling this amplified leading voltage back to the oscillator tank makes the horizontal oscillator control tube appear as a shunt inductance across the oscillator tank. The oscillator tank is made to resonate at the correct sweep frequency with this shunt inductance effect.

The d-c output of the horizontal sync discriminator supplies a portion of the bias for the horizontal oscillator control tube; the other source of bias being a 33-ohm cathode resistor. Any shift in phase difference between the transmitter sync pulses and the horizontal sweep voltage in the receiver causes the sync discriminator d-c output to change. This changes the bias on the horizontal oscillator control tube and changes the amplitude of the reactive voltage appearing in the plate circuit. The effective shunt inductance across the horizontal oscillator tank then changes. This, in turn, shifts the horizontal oscillator phase sufficiently to correct for the original phase shift. The horizontal hold cir-

cut in the receiver is actually an automatic frequency-control circuit.

G. E. 901/910

In discussing this projection-type tv model last month, we pointed out that the video i-f amplifier consists of a four-stage band-pass amplifier using four 6AC7s. Transformers are over-coupled and then loaded with resistance to give adequate band-pass frequency characteristics. A winding added to two of the transformers is tuned to trap out the adjacent audio and tuned for audio take off respectively. One trap is tuned to 27.9 mc to provide rejection of the adjacent channel audio i-f, while the three other traps are tuned to 21.9 mc to provide rejection of the same channel audio. A series trap is also used to tune out the associated audio interference.

Now let us study the clipper and sync amplifier circuitry in this model.

Clipper and Sync Amplifier

A 6SH7 pentode tube is used to separate the sync pulses from the composite video signal taken off at the video load resistor. The clipper tube is operated at very low plate and screen voltages and its bias is derived by grid rectification of the positive polarity video signal applied to the grid. Thus, conduction will occur only during the sync pulse intervals which are the most positive components of the video signal.

One-half of a 6SN7GT serves as a horizontal synchronizing amplifier which operates into the *afc* input transformer. This transformer, by virtue of a center-tapped secondary, permits both positive and negative horizontal sync pulses, when used in combination with the output sawtooth voltage from the sweep transformer and phase detectors, 6SL7GT, to form the control voltage which is amplified by one-half of a d-c amplifier, 6SL7GT, and applied to a 6SN7GT horizontal multivibrator.

The vertical synchronizing amplifier tube, 1/2 of a 6SL7GT, receives the sync pulse at its grid through a three-section integrating circuit. This integrating circuit accepts the wide vertical sync pulses and shapes them for triggering purposes while the horizontal sync pulses do not have sufficient energy to charge the integrating circuit and are, thereby, attenuated. A positive going vertical sync pulse is developed in the plate circuit of the 6SL7GT which is used to

(Continued on page 40)

TRANSVISION



NEW Television Kits, and Equipment

Important Advances in TV Reception and Servicing!



MODEL 10 BL TV/FM KIT

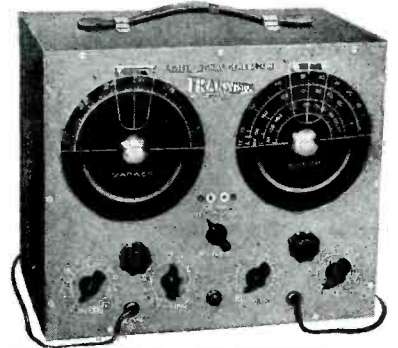

SWEEP SIGNAL GENERATOR

FLASH! New BIG VALUE KIT: Model 10A, 10" Electromagnetic Kit, 52 sq. in. picture, with amazing new continuous tuning on all 12 channels (less cabinet) NET \$199.00
MODEL 10BL, TV/FM Kit, gives 115 sq. in. picture; complete FM Radio; receives all channels; streamlined cabinet NET \$269.00
Roto-Table for Model 10BL, gives full 180° visibility NET \$23.50
MODEL 10CL Same as model 10BL, but gives 150 sq. in. picture with all angle lens mounted on 10BP4 tube. Complete with cabinet and all-angle lens NET \$299.00
MODEL 7CL, TV Kit, gives 60 sq. in. picture; console cabinet with Roto-Table; streamlined design. Receives all 12 channels; continuous tuning NET \$199.00
MODEL 7BL, same as 7CL except that it is a table model NET \$189.00
 All prices include cabinets, tubes, all-channel double folded di-pole antenna, and 60 ft. of lead-in wire.

NEW . . . TRANSVISION SWEEP SIGNAL GENERATOR for Television and FM
 Complete frequency coverage from 0-227 MC with no band switching. . . . Sweep width from 0-12 MC completely variable. . . . Accurately calibrated built-in marker generator.

OUTSTANDING FEATURES: (1) Frequency range from: 0-227 MC. . . . (2) Dial calibrated in frequency. . . . (3) Sweep width from 0-12 MC completely variable. . . . (4) Self-contained markers readable directly on the dial to 5% or better. (No external generator required to provide the marker signals). . . . (5) Crystal controlled output makes possible any crystal controlled frequency from 5-230 MC. . . . (6) Plenty of voltage output—permits stage-by-stage alignment. . . . (7) Output impedance 5-125 ohms. . . . (8) Directly calibrated markers, 20-30 MC for trap, sound and video IF alignment. . . . (9) IRP for alignment of traps for IF channels when a DC volt meter is used as the indicating medium. . . . (10) Unmodulated IF signal to provide marker pips simultaneously with the main variable oscillator. . . . (11) Markers can be controlled as to output strength in the pip oscillator. . . . (12) Power supply completely shielded and filtered to prevent leakage. . . . (13) All active tubes are the new modern miniature type. . . . (14) Phasing control incorporated in the generator. **MODEL NO. SG Net \$99.50**



NEW ALL-CHANNEL BOOSTER



NEW REMOTE CONTROL UNIT KIT

TRANSVISION ALL-CHANNEL TELEVISION BOOSTER
 To assure television reception in weak signal areas, or areas which are out of range of certain broadcast stations, Transvision engineers have designed this new booster. It increases signal strength on all 13 television channels. Tunes all 13 television channels continuously. Can be used with any type of television receiver. Unusually high gain in upper television channels. LIST \$39.95
Model B-1

TRANSVISION REMOTE CONTROL UNIT KIT
 Will operate any TV receiver from a distance. Turns set on, tunes in stations, controls contrast and brightness, turns set off. Ideal for installations where the television receiver is inaccessible. Tuner unit is a high gain, all-channel unit with about 50 micro-volt sensitivity. Easy to assemble in about an hour. LIST \$49.00
Model TRCU, with 25 feet of cable \$47.00
 Without cabinet

NEW 8-PAGE CATALOG showing complete Transvision line now available at your distributor, or write to:

TRANSVISION, Inc. Dept. S New Rochelle, N. Y.
 In Calif.: Transvision of California
 8572 Santa Monica Blvd., Hollywood 46
 All prices 5% higher west of Mississippi; all prices fair traded.
 All Prices Subject to Change Without Notice

Radiomen . . . you can

GET INTO THE
**TELEVISION
 BUSINESS**

In a BIG WAY with the
**TRANSVISION
 DEALER PLAN**

Write for details now!

of the current and make use of a capacity-inductance filter. Another 5U4G, whose output is added to that of the other 5U4Gs is used to supply higher B + voltage of approximately 480 volts for operation of the horizontal and vertical sweep output tubes, the vertical sweep generator, and screen grid of the picture tube.

The Picture Tube

A 5TP4 projection tube makes use of electrostatic focus and magnetic deflection at the high voltage anode potential of 27 kv. An inner conducting surface on the bulb extending down into the neck is connected to the high voltage anode cap to act as the anode element. The external outer surface of the tube from the high voltage anode terminal to the neck is covered with a special insulating coating to reduce the possibility of voltage breakdown, from high humidity. *This surface must not be handled during service adjustment.* A very thin layer of sprayed metal on the inner screen surface is used to prevent ions from destroying the screen, making an ion trap in this tube unnecessary.

Philco 48-2500

In the August issue, features of the circuits used in this projection receiver were presented, with a few details on the micro-lens system. This month additional data on the optical system are offered.

A correcting lens is located at the center of curvature (radius of curvature is approximately 11") of the spherical mirror. The surface of this lens is flat on the side toward the mirror, and is curved on the opposite side so that any spherical aberration (focus error) introduced by the spherical mirror is corrected by an aberration of equal value but of opposite sign. The light emitted axially from the front of the picture tube should not be permitted to be reflected back from the mirror to the tube face or the contrast of the picture will be reduced. To prevent this condition, the center of the spherical mirror is painted black.

As the picture is projected on the reflecting portions of the spherical mirror, the effect is as though the picture were reflected by thousands of tiny mirrors at different angles. As these rays pass through the corrector lens, the focus error caused by the spherical mirror is corrected, and these rays are directed onto a flat mirror and reflected to a focus on the surface of the screen. Since the projection

(Continued on page 42)

CURRENT CONVERSION

ATR "A" BATTERY ELIMINATORS



for DEMONSTRATING AND TESTING AUTO RADIOS

New Models . . . Designed for Testing and Operating Auto Radios and D. C. Electrical Apparatus from 110 Volt A. C. Lines. Equipped with Meter, Voltage Control, and Selenium Rectifier, Assuring Noiseless, Interference-Free Operation, and Extreme Long Life and Reliability.

New Models

AUTO RADIO VIBRATORS

A Complete Line of Vibrators . . .

Designed for Use in Standard Vibrator-Operated Auto Radio Receivers. Built with Precision Construction, featuring Ceramic Stack Spacers for Longer Lasting Life.

New 34 page VIBRATOR GUIDE FREE

New Models

STANDARD AND HEAVY DUTY INVERTERS

For Inverting D. C. to A. C. . . . Specially Designed for operating A. C. Radios, Television Sets, Amplifiers, Address Systems, and Radio Test Equipment from D. C. Voltages in Vehicles, Ships, Trains, Planes and in D.C. Districts.

AMERICAN TELEVISION & RADIO CO.
Quality Products Since 1931
 SAINT PAUL 1, MINNESOTA-U.S.A.

✓ NEW MODELS
 ✓ NEW DESIGNS
 ✓ NEW LITERATURE
See your jobber or write factory

★ For over 35 years—the finest in electrical and electronic instruments.

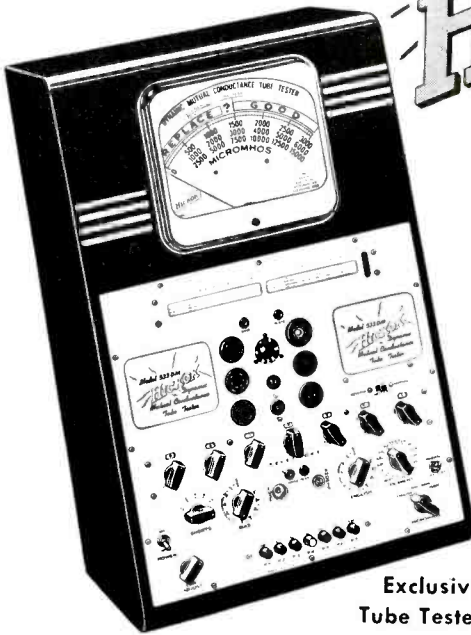

HICKOK

World Famous

TUBE TESTERS

Choice of the experts!

Television receivers **MUST** have good tubes. You can depend on HICKOK Tube Testers to reject all weak tubes quickly and accurately.

Exclusive features that have put HICKOK Tube Testers far in the lead are:

1. Tests **FUTURE** life of tubes!
2. Tests all tubes **ACCURATELY!**
3. Reads micromhos **DIRECTLY**—the only true test of a tube!
4. Tests tubes for gas content—more important now than ever before!

533 DM (illustrated above) Dynamic Mutual Conductance Tube Tester

The popular and effective selling-aid model, designed for quick customer-convincing, counter demonstration and test. Incorporates the new HICKOK test feature that foretells future tube life. Large 9" scale, reading directly in micromhos, also indicates "GOOD", "?" and "REPLACE". 17" x 26³/₄" x 11". 110-130 VAC.

The HICKOK line of Tube Testers is **COMPLETE**. They are available in portable, counter and display cases. Also with self-contained, high sensitivity multimeters and with specially designed professional features.

HICKOK has long been the choice of leading technicians and electronic manufacturers the world over.

See your jobber or write for free catalog.

THE **HICKOK**

ELECTRICAL INSTRUMENT COMPANY
10521 DUPONT AVENUE • CLEVELAND 8, OHIO

other on the edges of the projection tube. An iron-pole piece (curved to fit the sides of the tube) is attached to each magnet, and is used to produce a strong concentration of field to deflect the electron beam upward near the tube face. The oppositely polarized ends of the magnets, farthest from the tube face, cause a lesser and downward deflection of the beam before it is deflected upward. The result is the same as that which would be produced if the face of the tube were tilted inward; the distance the beam travels to the bottom of the picture is reduced, and the distance to the top is increased. This action creates the trapezoidal pattern. The keystone magnets are adjusted for the proper keystone pattern by moving them toward (parallel with the tube neck) or away from the tube (at right angles to the tube neck). Perfect keystoneing is obtained when the pattern has a 2³/₈" top, a 2¹/₈" bottom, and slant sides of 2¹/₈". Normally, a slight amount of pincushioning (upward bowing of the bottom of the screen pattern) results. However, this effect is so slight that it can easily be corrected by aligning the magnets above or below the center line of the tube. When projected on the screen, a properly keystoneed picture appears with straight edges, as if no predistortion existed.

Optical System Throw

The optical system has a throw of 33.5" (distance from corrector lens to screen). By utilizing the efficiency of front projection (picture is reflected from front of screen) and the directional characteristics of the screen (secured by slight grooving and cylindrical shaping), a gain in illumination of 17.2 is obtained. The directivity of the screen is concentrated within a vertical angle of 10° and a horizontal angle of 30° each side of center. The principal direction of light is tilted about 2° above horizontal. The directional characteristic of the screen produces a viewing cone of approximately two feet in the vertical plane at a distance of ten feet from the receiver, and approximately four feet at a distance of twenty feet from the receiver.

Screen Composition

The Philco screen is made of metal with random vertical grooves and is coated with a special material. This construction reduces the effect of random light.

[Data based on copyrighted material prepared by Philco.]

Ser-Cuits

(Continued from page 41)

tube is located out of the field of these rays, the effect is to produce a picture unshadowed and, to all appearances, unaffected by the physical presence of the tube in the center of the projection system.

Since the optical system is mounted at an angle and projects on the screen at an angle, a rectangular picture pro-

jected from the face of the picture tube would appear on the screen as a trapezoid (pattern with sloping sides and bottom smaller than top). Conversely, when a trapezoid is projected from the face of the picture tube, it appears on the screen as a rectangle. Trapezoid (keystone) projection is used in the Philco system. Forming of the trapezoid pattern (keystoneing) is achieved by applying a magnetic field at right angles to the electron beam. To produce this magnetic field, two oppositely polarized permanent magnets are mounted diametrically opposite each

Servicing Helps

(Continued from page 32)

lytics used as doubler capacitors should be checked. The original units gave quite a bit of trouble. Both should be replaced at once, using 16-mfd units, matched on a capacitor tester for the best performance. While you're there, to insure continued performance, it would be wise, too, to replace the coupling capacitor feeding into the power tube. This is an .01, located on the right end of the chassis, upside-down, knobs toward you. It would also be a good idea to replace the plate bypass on the same tube, an .03, tucked away under C₂₀₂, a 2-mfd unit. These fail often and replacement will probably save a call-back.

If the record player on the 1201 makes a squeaking noise and runs slow, an inspection of the cabinet is essential. The cabinet should be opened by tripping the latches inside the record door, at sides, and the two locating-rollers, which position the record correctly when inserted, checked. If these touch the record, when playing, it will slow the turn-
(Continued on page 44)

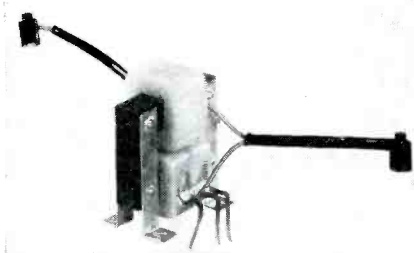

Fig. 3. Horizontal output transformer used in tv receivers.

Fig. 4. Horizontal linearity control.



Flexibility makes

"the Service Man's Line"

Brach antennas . . . long known for dependability . . . maximum reception . . . trouble-free operation . . . durability and ease of installation . . . now feature an added extra . . . Flexibility. Unique construction features aid the service man in making a more rapid installation to which future additions or modifications can be easily made.

1. FLEXIBILITY A complete line designed with basic antenna parts which are convertible to more complex arrays as required by location and reception problems.

2. COMPLETE KITS Each antenna model is independently designed and furnished in a completely packaged kit containing all necessary hardware, downlead (when desired) and the Universal Base Mount . . . ready for installation.

3. PRE-ASSEMBLY Each antenna is factory pre-assembled as far as possible, ready to erect. Complete and simple installation instructions. Saves valuable man-hours on the roof.

4. MECHANICAL STRENGTH Weather - tested for durability, Brach Antennas feature a husky steel mast, rigid connections, sturdy base mount, neat appearance. All parts corrosion resistant.

5. SUPERIOR RECEPTION Designed with engineering "know-how". All Brach antennas are factory pre-tuned, matched for 300 ohm transmission line with large diameter aluminum elements for better signal pick-up. Directivity patterns and standing wave ratios available upon request.

New! Tops in TV! HI-LO ROTATABLE Antenna

Here it is! A rotatable antenna to provide peak performance with any station at any time. Brach introduces the new "Superview" Rotatable, covering both high (174 MC to 216 MC) and low (88 MC to 108 MC) TV bands. High band extension available for easy addition to standard dipole array for separate orientation. No more multiple images. No more "weak" stations. Brach's Superview HI-LO assures television reception that's tops. Make sure and investigate the new Superview line today.

Write for Free Brach catalog showing complete line of TV and FM antennas and accessories.

SEND FOR CATALOG No. S304



L. S. BRACH MFG. CORP.

200 CENTRAL AVENUE, NEWARK, N. J.

WORLD'S OLDEST AND LARGEST MANUFACTURERS OF RADIO ANTENNAS AND ACCESSORIES

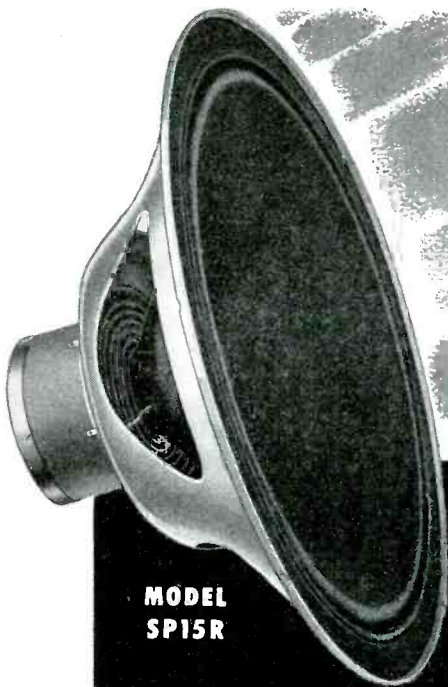

**TREMENDOUS VOLUME
FOR SPECIAL USES**

**MODEL
SP15R**

**THE
*Ultimate***

**IN SOUND
REPRODUCTION**

UTAH'S PUBLIC ADDRESS SPEAKER

CAPACITY CROWDS . . . large and noisy . . . are easily blanketed with sound when you install Utah's new SP15R in the PA system. It is a speaker outstanding for its heat dispersing 2 inch voice coil and 31.6 ounce Alnico V permanent magnet which make it capable of handling 30 to 40 watts power. These advantages plus amazing fidelity throughout the tonal range establish the Utah SP15R among the finest single unit sound speakers. Speakers are finished in gold-hammered lacquer and are now available for delivery.



UTAH RADIO PRODUCTS

HUNTINGTON, INDIANA
DIVISION OF INTERNATIONAL DETROLA CORPORATION
EXPORT DIVISION: MORHAN EXPORTING CORP., N. Y. C.

QUALITY • FIDELITY • POWER

Servicing Helps

(Continued from page 43)

table. Under the pickup arm, at the right, you will find a $\frac{1}{4}$ " nut, with an eccentric bushing. This should be adjusted for clearance with a record on the turntable. Incidentally, this gadget is not shown on the service information for this set.

**RCA 55XF and All 1942-1943 Battery
Or Small A-C/D-C Models**

IF THESE SETS lack volume, and the last (diode) i-f trimmer is very flat,

the output i-f should be replaced. The combination i-f trimmer/r-f filter gadget in this transformer has shorted out. Attempts at repairing these have led to the conclusion that the best way is to replace the whole thing.

Stromberg-Carlson 1210

IF THE F-M BAND on these 11-tube sets is weak, and doesn't start to work as quickly as it should, the 6BE6 converter tube should be replaced. The original tubes seem to lose their punch

Fig. 8 (right). Horizontal size control.
(All illustrations courtesy General Electric)



Fig. 5. Deflection yoke.

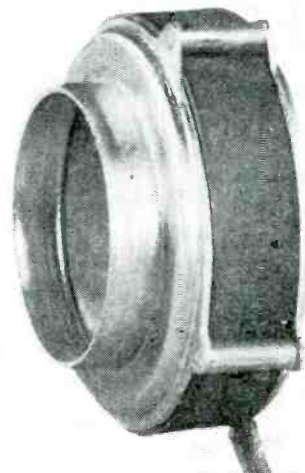

Fig. 6. Focus coil.

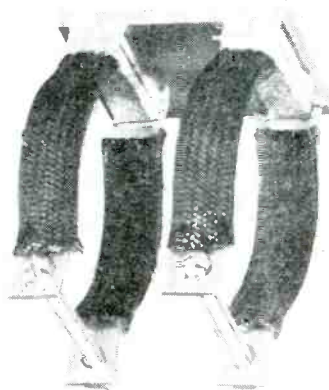

Fig. 7 (above). Ion trap.



after a short period of use, with the result that they refuse to oscillate at the high frequencies necessary for f-m.

Selenium Rectifier A-C/D-C/Battery Models

IF PERFORMANCE IS WEAK OR non-existent on a-c on these little jobs but good on batteries, the selenium rectifier should be checked for correct output. First, of course, the input capacitors should be checked for proper capacity. If this isn't the trouble, the rectifier should be replaced. A check of the total voltage on the filament string is a good test.

Firestone 4-A-61, etc.

THESE SMALL A-C/D-C sets seem to suffer from loose solder joints, especially around the oscillator socket. Noise when jarred is a good indication of this trouble. If one bad joint is found, the whole set should be checked from one end to the other. Four bad spots were found in one set.

Philco 46-350, 47-350

SMALL PORTABLES and others of this type, using a 1S5 as a second detector/first a-f have a habit of going weak and becoming distorted. The 3.3-megohm resistor used as a screen-grid resistor should be checked. This is usually of the *match-stick* type, and opens up, or increases in value. No voltage at all on a vtvm is a sure sign of trouble. The bypass might also be replaced for protective reasons.

A-C/D-C/ Sets Using 50L6, Cathode for Filament Source

THESE MODELS MADE BY DETROLA and Emerson, with a filament string supplied from the cathode-current of the 50L6, 117L7, etc., often have leaky coupling capacitors or gassy tubes which cause an increase in plate current that soon paralyze one or all of the battery-type tubes.

Vibrator Testing with 'Scope

ANY 'SCOPE, even a small one, is a very handy item for auto-radio work. To use, the vertical leads across primary points on the vibrator should be clipped, a check made for a good square waveform. Try it out on a few good ones first, and you will soon learn to recognize the correct waveform. Extremely long *pips* at leading edges, or distortion of wave, indicates bad buffer, point bouncing, etc. Substitution of a new vibrator will show up the difference. This is a good customer-convincer, too. He can easily see the difference between his old vibrator and the new one.



It's the shape of the shimmy that counts!

CERTAIN audio frequencies cause considerable vibration in the filament and lead-in wires of a dial lamp. In old style lamps, this vibration produced a whipping action which eventually tore the filament apart.

By "matching" these frequencies in G-E dial lamps, General Electric engineers let the filament vibrate without whipping and eliminated a common cause of failure.

For information on G-E miniature lamps, call your nearest G-E Lamp office. Or write General Electric Co., Div. 166S-10, Nela Park, Cleveland 12, Ohio.

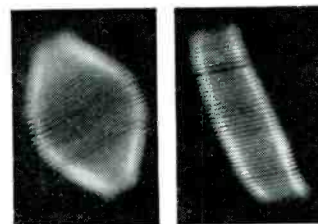

Old Filament New Filament

1. Dependable, trouble-free performance.
2. High level of maintained light output.
3. Low current consumption.
4. Long life.
5. Profitable to handle.
6. Greater dealer acceptance.

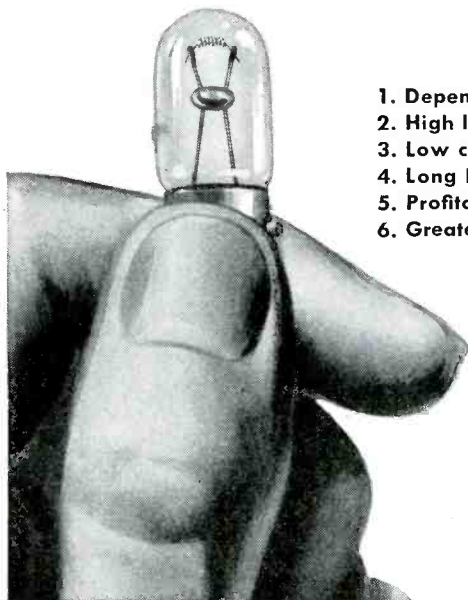

G-E LAMPS

GENERAL  ELECTRIC

New practical ELECTRICAL guide



... For easier, better work, and more profits on down-to-earth electrical jobs—new handbook gives hundreds of useful facts, data, and methods, in handy form, at low price of

only \$2.50

Just Out! ELECTRICIANS' POCKET COMPANION

By BENJAMIN GOLDBERG

Formerly Electrical Inspector, New York City
375 pages, 4 1/4 x 7, hundreds of illustrations, charts, diagrams and tables

Here, at your fingertips is a comprehensive selection of the important facts, figures and data the electrician needs to know about modern electrical work. The Electricians' Pocket Companion answers your questions; gives needed information based on the National Electrical Code and Underwriters' requirements; supplies diagrams, tells what to do. It covers the entire range of subjects from motors, meters and transformers to lighting, wiring, and literally hundreds of others. In addition, it contains a clear explanation of electrical fundamentals and mathematics. The author is a practical electrician of broad experience and has made a good choice of the most helpful practical material—and the price is much less than that of other handbooks. While smaller and more convenient, the Electricians' Pocket Companion presents all tables, diagrams, etc., in large, easily read size. Four different indexes give quick access to any fact needed in your work. Read it for 10 days—at our risk. Use coupon.

Save Time—Work More Efficiently

... With helpful data, diagrams and tabulations on subjects like these:

Electrical Fundamentals; Meanings of Terms Commonly Used in Electrical Work; Electricians' Tools; Methods of Work; Electric Meters; Transformer Connection Schemes; Electric Motors; Typical Control Schemes for AC Starters; Lighting and Signal Circuits; Insulation Resistance Testing; Electrical Equipment Troubles; Illumination Values; Residence Wiring Systems; Electrical Symbols and Abbreviations; Electrical Formulas and Their Applications; Electrical Code Tables, Diagrams and Examples; Standards for Electrical Materials, Equipment and Installations; Domestic Heating System Controls; Safety Cautions and Emergency First Aid ... and many more.

TEN DAYS' TRIAL

Dept. S-108, MURRAY HILL BOOKS, Inc.
232 Madison Ave., New York 16, N. Y.

Send me books checked below for 10 days' examination on approval. In 10 days, I will pay for books plus a few cents postage, or return them postpaid. (Postage paid on cash orders; same return privilege. Books sent on approval in U. S. only.)

- Electricians' Pocket Companion, \$2.50
 Electric Motor Repair, \$5

Name
Address
City, Zone, State.....
Occupation

TV Interference

(Continued from page 21)

harmonic frequencies are liable to operate on the tv, i-f or r-f band.

The FCC is considering action to limit the use of these illegal equipments.

(7) **Electromedical and Industrial Apparatus:** The electromedical and industrial equipment manufacturers have been assigned and are using 26.96 to 27.28 mc for the fundamental frequency of their apparatus. This band lies directly in the tv i-f band. Whenever any of these equipments operate in the area of tv receivers using the current i-f frequencies, r-f or diathermy type interference are noted on the tv pictures.

The Service Man can minimize or eliminate this interference by installing a simple i-f trap in the antenna circuit. These traps are now commercially available and are simple capacitor-coil type series-resonant circuits which are in a shielded container and installed directly across the antenna terminals.

(8) **Radio Amateurs:** Much of the interference credited to hams is caused by items 1-7, although interference is possible from two ham bands: 21-21.5 mc (i-f interference) and 50-54 mc (spills over into channel 2).

The 21-21.5 mc problem can be minimized by filtering in the manner described under 7, while the 50-54 mc interference should be referred to the local office of the FCC for appropriate action.

(9) **Man-Made Devices:** The worst interference from man-made devices is from the *little transmitter* in the automobile ignition system, the spark plug. The *bright spot* in solving this problem is the development of a *resistor spark plug*.* This *resistor spark plug* reduces the radiated interference signals so that it is under 35 microvolts from .54 to 150 mc at 50' from the spark plug. When all automobiles utilize this type of spark plug, the *floating-specks* will be washed from the tv screens.

Other devices as neon signs, ultraviolet lamps, motor sparking, etc., can all be suppressed at the source in the same manner as radio interference.

The final success of the tv industry in realizing full consumer acceptance will be dependent upon the satisfactory solution of the tv interference problem.

*Auto-Lite.

GREYLOCK

A Dependable Name in

RADIO TUBES

GT, Glass and Miniature Types
All Tubes in Individual Cartons

6A8GT	12AT6	1R5
6AT6	12BA6	1T4
6BA6	12BE6	1U4
6BE6	12K7GT	1S5
6K7GT	12Q7GT	354
6Q7GT	12SA7	304
6SA7GT	12SK7	3V4
6SK7GT	25Q7	12AU6
6SQ7GT	25L6GT	12BF6
6V6GT	25Z6GT	35B5
6X4	50B5	35L6GT
12A8GT	50L6	35Z5GT

39¢
each

SPECIAL OFFER!

All 39¢ Tubes may be purchased in lots of 100 assorted, at \$35.00 per 100.

6A7	6AU6	6G6G
6AC5	6BH6	6SN7GT
6AK5	6BJ9	12AU7
6AQ5	6C6	25Z5
6AQ6	6D6	75
6AJ5	6SL7GT	11Z73
1H5GT	19T8	11L7L
1N5GT	70L7	6L6GA
32L7	84	53

49¢
each

59¢
each

SPECIAL!! 6BG6G \$.89

Standard Replacement VOLUME CONTROLS.
all sizes, 1 1/2" shaft, less switch, each..... .24
With SPST switch, each..... .34
With DPST switch, each..... .39

PM SPEAKERS Less Trans.
4" with Alnico V Magnet..... \$1.14
5" with Alnico V Magnet..... 1.14
6" with Alnico V Magnet..... 1.49
3" PM with plastic cone, and 8-oz. Alnico V Magnet..... 1.35
6"x4" PM with Alnico V Magnet..... 1.19
WEBSTER AJ1 Pickup, plastic arm..... 1.49

SELENIUM RECTIFIERS
100 Ma.59
75 Ma.49

TERMS: Net C.O.D., F.O.B. N.Y.C. 35¢ Handling Charge on all orders under \$5.00.

Write for Bargain Catalog S-10

GREYLOCK ELECTRONIC SUPPLY CO.
30 Church Street New York 7, N. Y.

TV Alignment

(Continued from page 19)

tions. The marker output level is reduced to its minimum value for this test and the 4-mfd electrolytic capacitor across the detector load resistors is temporarily disconnected.

Appendix A

Mega-Sweep: This as a sweeping oscillator which in conjunction with any standard scope can be used to display the response characteristic of broad-band circuits over a range of from below 100 kc to above 500 mc. It is a beat-frequency type of oscillator employing two X-band reflex klystrons which operate at approximately 10,000 mc. One klystron oscillator operates at fixed frequency while the other is tunable and frequency modulated or swept. The outputs of these two oscillators are fed into wave guides where they are mixed and detected by a crystal rectifier. The resulting difference frequency is applied to a coaxial output connector on the panel of the instrument. Suitable buffers, matching devices and a directional coupler are used in the wave guides to minimize direct coupling between the oscillator and reaction of the load on the output. A precision absorption type of microwave frequency meter indicates the output frequency by measuring the frequency of each klystron. A continuously variable, broad-band microwave attenuator adjusts the output level. The variable frequency oscillator is swept by a sawtooth voltage generated in the

A Remarkable NEW LINE

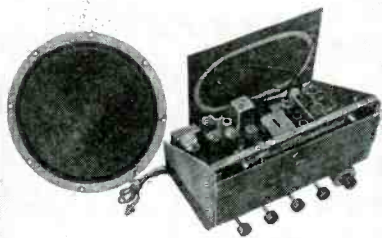

Espey Model 511

High QUALITY High POWER Custom-Built AM-FM CHASSIS

Like every other model in the complete ESPEY line of replacement receivers, and FM Tuners, the Model 511 AM-FM chassis (illustrated) is the last word in modern engineering in the electronics field. Featuring 12 tubes plus Rectifier and Tuning Indicator, it is Drift Compensated, and is supplied complete with all antennas, 25 watt speaker, and all hardware. Its low price assures high profits for you in the growing replacement field. Write today to Dept. N-10 for complete details of this expanding profitable market!

ESPEY MFG. CO., Inc.
528 EAST 72nd ST., NEW YORK 21, N. Y.
"Established 1928"

instrument. This voltage is available at output posts for horizontal deflection or synchronization of a standard 'scope. Controls are provided for peaking each klystron oscillator to maximum output as indicated by a panel meter, for tuning the center frequency of the variable oscillator to the desired point and for setting the frequency deviation (0 to 30 mc) and sweep rate (50 to 100 cps) by adjusting the sawtooth voltage amplitude and repetition frequency. The frequency stability of the klystron beating oscillators is maintained by an electronically regulated power supply of very low ripple output.

Mega-Marker: This is a marker oscillator unit which provides a *birdie* type of frequency marking signal for use on a displayed response characteristic of a

television i-f amplifier in conjunction with the *Mega-Sweep*. The unit contains two oscillator sections, one of which is continuously variable over the television i-f band and the other of which is fixed frequency crystal-controlled. The crystal-controlled section is used to check the calibration accuracy of the variable oscillator section, and permits adjustment of the variable oscillator inductive and capacitive trimmers against specific crystal harmonics so that accuracy to 0.25% is available over the complete dial. The crystal oscillator section serves the further useful purpose of providing a 4.5-mc signal for alignment of the sound i-f coils and discriminator transformer of inter-carrier sound i-f types of tv receivers. The *Mega-Marker* is made in two models, the first of which has its variable oscillator tunable from 19 to 29 mc and the second of which has its variable oscillator tunable from 29 to 39 mc. The unit obtains its power from a take-off cable connected to the *Mega-Sweep* which has an electronically-regulated power supply.

Mega-Marker, Sr.: This instrument is a crystal-controlled, twelve-channel television r-f sound carrier generator with a crystal-controlled oscillator and multiplier circuit followed by a germanium crystal diode harmonic generator circuit and a twelve-channel output frequency band pass circuit. In addition, an r-f output amplitude control and a coaxial cable mixing and matching network are included. The latter permits feeding without mis-match the combined output of this generator and sweep unit to the input of the receiver under test, thus giving a visual display of the response characteristic with the super-imposed marker *birdie* at the sound carrier point of the particular television channel being aligned. A front panel switch and associated circuit permit the r-f output for any channel to be amplitude modulated by an identifying tone, thus permitting the local oscillator of the receiver to be adjusted aurally for correct tuning when a visual-alignment setup has been determined to be unnecessary. The instrument has a self-contained power supply, and provides sound carrier frequencies (channels 2 to 13) to an accuracy of 0.01%.

Mega-Pipper: This test instrument, designed for use with the sweep generator, in the alignment of television i-f amplifiers, provides four precise simultaneous *pips* at particular alignment frequencies along the 'scope display, marking the associated picture and sound i-f carrier points and the adjacent i-f sound and picture carrier points. The instrument consists of a broadly-tuned input buffer amplifier, crystal-controlled local oscillator, mixer, dual crystal bridge intermediate circuit, detector-amplifier output stage and power supply. Signal from the sweep generator is fed into the *pipper* to a tap-off control and then out again to the receiver circuit under test. The tapped-off signal is connected to the input of the broadly-tuned amplifier and thence to the mixer stage where it is heterodyned against the signal from the crystal-controlled local oscillator. The input amplifier is tuned broadly to permit it to pass signals within ± 4 mc of the RMA recommended i-f sound carrier frequency range of 21.25 to 21.9 mc, and acts primarily to isolate the crystal-controlled oscillator signal from the tv receiver circuit under test.

[To Be Continued]

Built for Service



Servicemen's choice!
in...

ARKANSAS

• Arkansans know that it takes a tall lot of traveling to find a better tube than Cunningham. That's because Cunningham tubes are built to deliver long life and top performance in any radio. That's why, if *you* campaign for Cunninghams whenever new tubes are called for... you'll harvest an *extra* crop of customers as dependable as Cunninghams themselves!

See your
CUNNINGHAM DISTRIBUTOR
Lavender Radio Supply Co.
Texarkana

Cunningham Tubes

A product of
RADIO CORPORATION OF AMERICA
Harrison, N. J.



★ Yes sir, a brand new member of the well-known Clarostat family of controls. Type 47 or 15/16" diameter miniature control is smaller, handier, yet just as tough as its bigger brother, Type 37 composition-element control.

It's a beauty. Note the trim lines. It includes the famous Clarostat stabilized element you can bank on. Nothing sacrificed by way of electrical and mechanical sturdiness in attaining smaller size. Available with (factory-equipped) or without switch. Available with one tap. Choice of tapers.



Available from your Clarostat jobber. Ask for this tiny-but-mighty Type 47!

Controls and Resistors

CLAROSTAT MFG. CO., Inc., DOVER, N. H.

In Canada: CANADIAN MARCONI CO., Ltd. Montreal, P.Q., and branches

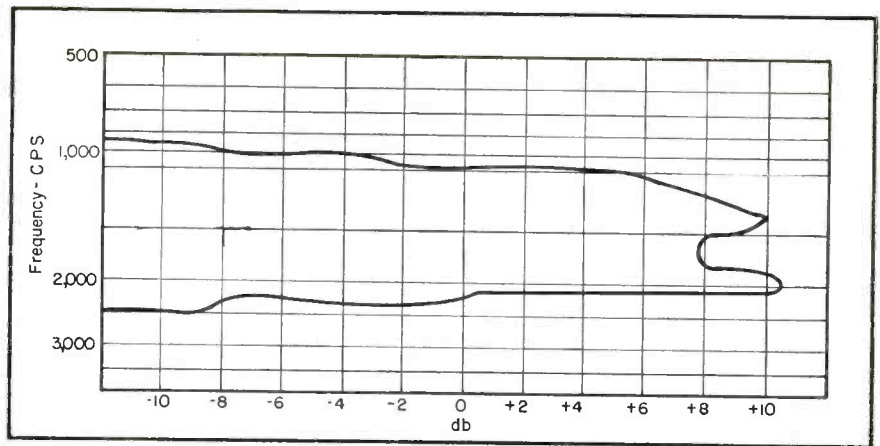

Fig. 1. Typical frequency response curve of sound powered telephone handsets.

Sound Communications

(Continued from page 26)

phones at 1,000 cycles varies from 500 to 1,000 ohms depending on manufacturers' specifications.

The rough duty of tv installations is a natural for the phones as they were developed and manufactured during the war for marine and other field applications. These units are rugged, weatherproof, and in many cases they have been treated with anti-fungus compounds.

Fig. 3 shows the technique of using a coaxial shield and a pipe ground on the roof of a building to effect communication without affecting the adjustments of the tv antenna and the necessity of running connecting cable between sound powered phones. It is not recommended that the sound pow-

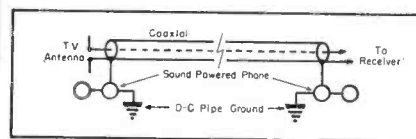
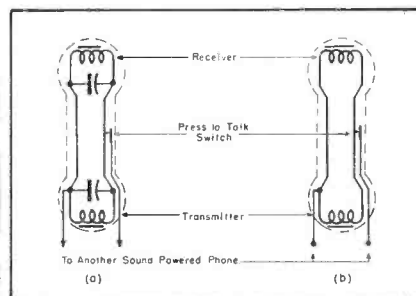

Fig. 3. Connection of sound powered phones to coaxial shield and d-c ground of pipe to establish communication without using additional wires.

Fig. 2. Circuits of typical sound powered phone systems in operating position.



ered phones be connected across the antenna or transmission line, as the capacity load of the sound powered phones may impair the efficiency of the tv antenna circuit. When using the sound powered phones the installer can save himself the fatigue of pressing the switch on the hand grip of the phone when he wants to contact the line for talking and receiving, by either taping the line switch so that it is pressed at all times or he may remove the switch assembly and permanently short it with a jumper wire.

FREE! send for our

RADIO BUYING GUIDE

a complete and diversified line-up of:

- electronic equipment
- sound systems
- recording equipment
- amateur gear
- television components and kits
- replacement parts
- laboratory and service test equipment

Save time and money—buy direct from distributor! Consult the NEWARK radio buying guide, featuring all standard makes... a value-packed listing of 20,000 essentials for expert servicemen, engineers, soundmen, experimenters, teachers, hobbyists, amateurs!

24 HOUR SERVICE ON ALL ORDERS
Free technical advisory service!

JUST MAIL THIS COUPON TO GET YOUR CATALOGUE

Newark Electric Co., Inc., Dept. 12
242 West 55th St., New York 19

Please send me the FREE Newark Buying Guide of fine radio equipment.

Name _____
Address _____
City _____ State _____



3 GREAT STORES
115 W. 45th St. & 212 Fulton St., NEW YORK
and 323 West Madison Street in CHICAGO

MAIL ORDER DIVISIONS
242 West 55th Street, NEW YORK 19, N. Y.
323 West Madison Street, CHICAGO 6, ILL.

Send for a sample and see

HOW TO MAKE BETTER TV AND FM ANTENNA INSTALLATIONS

INSTALLED
IN 5 MINUTES BY
ONE MAN WITHOUT
SPECIAL TOOLS

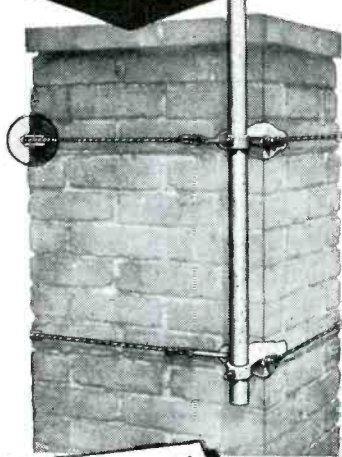

Mastercraft
ANTENNA MOUNT
PAT. PENDING

ONLY THE NEW MASTERCRAFT HAS ALL THESE EXCLUSIVE FEATURES!

1. PAYS FOR ITSELF IN TIME SAVED! No holes to drill. Fits all size chimneys. (May also be mounted on any rectangular part of building.)
2. ONLY ONE SET NEEDED FOR EACH ANTENNA because units can be spaced according to height of mast.
3. NO CHAFING. UNIQUE CORNER SLEEVES attached to cable prevent contact with chimney.
4. THOROUGHLY FIELD TESTED. Strong—lightweight (2 lbs. per set)—Rustproof—Inconspicuous from street.
5. PROTECTED BY PRODUCT INSURANCE covering property damage (\$1000.) and personal injury (\$20,000.)

MAXIMUM
DEALER
AND JOBBER
DISCOUNTS
\$7.50
per set
LIST

RUSH \$4.50 FOR POSTPAID SAMPLE.
JOBBERs—Write today for descriptive literature and discounts.
Dept. B

Mastercraft PRODUCTS CO.
60 South Street, Boston 11, Mass.

'Scope Sensitivity

(Continued from page 30)

one-half watt carbon resistors is substituted. This change raises the input impedance to approximately two megohms which is about the value found in most 'scope amplifiers.

Since the variable reluctance pickup has a rising high-frequency response, the preamp is designed to boost the lower frequencies. We don't need this accentuated bass response for our purpose, so that is removed by shorting out C_3 with a piece of bus wire. You can leave C_3 in the unit, just in case you some day decide to use the preamp for phono work. Fig. 3 shows the revised schematic diagram. The bottom view of the preamp in Fig. 4 shows just where the changes are made.

To permit rapid connection and disconnection, you may want to make some form of plug and socket arrangement such as shown in Fig. 1, which will fit the input terminals of your 'scope. For the input cable to the pre-amplifier, make up a piece of shielded coaxial cable or microphone lead with a standard phono plug at one end and clip leads at the other. Shielding is important here because the gain is high. If you use an unshielded input cable, stray hum pickup will override the signal and make the entire unit useless.

The modified preamp will take an input of about .2 volt before overloading. This is an adequate input limit because most 'scopes have sufficient gain by themselves to give good patterns with input voltages above .2 volt.

The frequency response of the modified preamp is flat from 40 or 50 cycles to 10 kc. There is, however, slight phase shift at the lower frequencies. This is of no particular disadvantage unless the input impedance of your 'scope is low, of the order of $\frac{1}{2}$ megohm or less. In this case, phase shift can be reduced somewhat by increasing

(Continued on page 50)

Fig. 4. Bottom view of preamp showing where changes are made to permit its use with the 'scope.

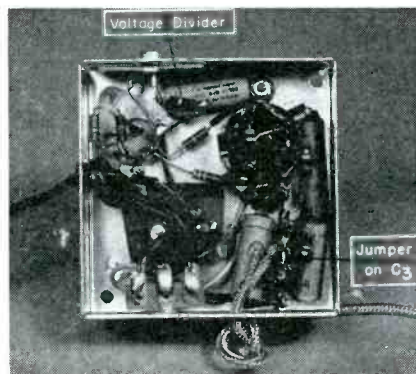

Built for Service



Servicemen's choice!
in...

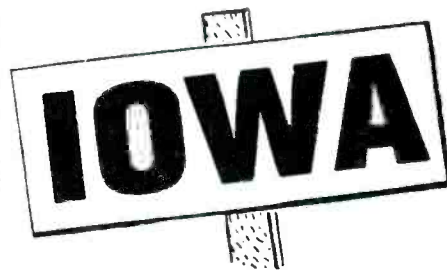

• Iowa does more than furnish fine food for American homes... and Cunningham tubes do more than furnish top performance. Cunninghams are *first-line* tubes... built for long life and trouble-free service. That's why you should elect to replace with Cunninghams when new tubes are called for.

See your
CUNNINGHAM DISTRIBUTOR

Radio Trade Supply Des Moines

Cunningham Tubes

A product of
RADIO CORPORATION OF AMERICA
Harrison, N. J.

TV Sync Systems

(Continued from page 35)

of the signal which is developed across the diode load resistor occurs when the diode is conducting and the diode conducts for only signal amplitudes which are higher in level than the blanking level and only the sync pulse itself is higher in level.

The charge placed on C during the sync tip interval by the peak diode current is held at a constant value by the long time constants of R and C . Actually, the capacitor is recharged to peak value approximately every 60 microseconds and the time constant of R and C must be sufficiently long to hold this charge level between recharging intervals. Thus the time constants of R and C are much longer than the interval between sync tips and is, in most all cases, in excess of 25,000 microseconds.

In some cases external bias is also supplied to the diode to make certain that the diode will be clipped off at the blanking level and will not remain cut-off until the peak of the sync tip. As shown in Fig. 6, the sync separator can be wired to accept either a positive or a negative-going composite signal just by changing the electrode to which the composite signal is applied. An interesting fact about the charge and discharge cycle of capacitor C is made evident. During the charge of capacitor C the diode is conducting and consequently the time constant of the conducting diode's d-c resistance and the capacitor C determines the fast rate at which the capacitor reaches peak value. During the discharge cycle the diode is cut off and the discharge is through the large resistor R . Consequently, the capacitor quickly charges during the sync tip interval because the time constant is short and is able to sustain a fixed charge during the remainder of the line interval because of the long time constant of C along with R . Thus we find the diode

Fig. 6. Circuits of diode separators arranged for positive and negative signal phase operation.

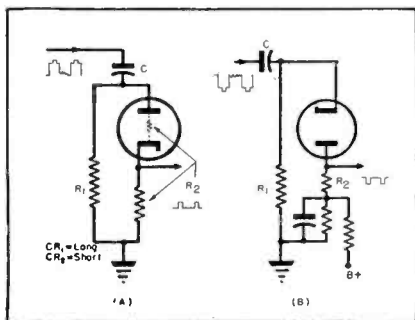

Speed Up TELEVISION INSTALLATIONS

WITH
U. S. I.
SOUND
POWERED
TELEPHONES

PRECISION
BUILT for
FULL QUALITY
TRANSMISSION



SET AERIAL DIRECTION QUICKLY

No yelling out of window or inside the customer's house. . . . Best of all there are no batteries to lug around. . . .

Clip these sound powered telephone hand sets on to each end of the lead in either paired or co-axial type or use a separate line.

In a few minutes, with a quite workmanlike conversation between the set and aerial location, you can set the direction "on the beam." . . .

Write for prices and address of nearest distributor.

**UNITED STATES
INSTRUMENT CORPORATION**
SUMMIT NEW JERSEY

sync separator very similar to the d-c restorer with the exception that the d-c restorer only conducts at the very peak of the sync tip, while the diode separator conducts between the blanking and the sync tip levels.

It would be possible to operate a diode separator with external bias alone by making certain that the bias applied would not permit the diode to conduct until the amplitude of the blanking level was overcome. This means that a certain level signal would have to be applied at all times.

[To Be Continued]

'Scope Sensitivity

(Continued from page 49)

the value of the output coupling capacitor (C_1) to 0.5 mfd.

You can determine the input impedance of any 'scope by connecting it to a sine wave source, the amplitude of which is adjusted to produce a given deflection. Then insert resistance in series with the sine wave source until the deflection is reduced by one-half. The value of resistance required to produce this fifty per cent reduction is equal to your 'scope input impedance.

ELECTRIC SOLDERING IRONS

that are sturdily built for the hard service of industrial usage. Have plug type tips and are constructed on the unit system, with each vital part, such as heating element, easily removable and replaceable. In 5 sizes, and from 50 watts to 550 watts.

American Beauty

TEMPERATURE REGULATING STAND

This is a thermostatically controlled device for the regulation of the temperature of an electric soldering iron. When placed on and connected to this stand, iron may be maintained at working temperature, or through an adjustment on bottom of stand, at low or warm temperature.

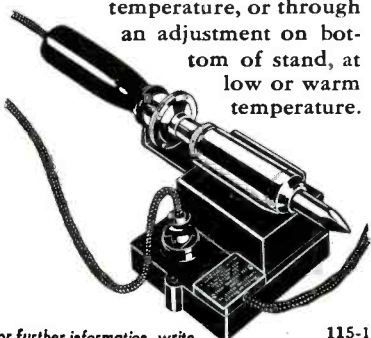

For further information, write

115-1

**AMERICAN ELECTRICAL
HEATER COMPANY**
DETROIT 2, MICHIGAN
established 1894

TECH BENCH

Now Available
for the

RADIO TECHNICIAN



"Everything in its place, and a place for everything . . ." Engineered for convenience and workability . . . designed to give 100% working efficiency and sturdily built for long and practical use.

CHECK THESE OUTSTANDING TECH-BENCH FEATURES . . .

- Eighteen well proportioned drawers, eight of which can be used for complete material systems or small tools.
- Stops on all drawers to prevent spilling.
- Hardwood finished top with durable, lustrous finish.
- Two conveniently located internally wired electric sockets for electrical tools and equipment.
- Handy catalog and chart space.
- Reinforced canvas apron of generous size.
- Top surrounded three sides with guard rail and has grooved slot.
- Made of corrosion resistant non-magnetic aluminum.
- Foot rest placed for comfortable working position.
- Either left-handed or right-handed model.

STANDARD SPECIFICATIONS

Length 40", Depth 20", Height 38"
Shipping Weight, 90 Lbs.

only \$74.95 F.O.B.
HOUSTON

Order from your Radio Supply Dealer or for further information write directly to

The DE MARIA COMPANY
711 Main Street Houston, Texas

New TV Parts... Accessories

VISION RESEARCH TV PREAMP

A 3-stage tv preamp, Telebooster model TVZ, featuring continuous tuning over all channels and adjustable gain, has been announced by Vision Research Laboratories, 87-50 Lefferts Blvd., Richmond Hill, N. Y. Has four tuned circuits.

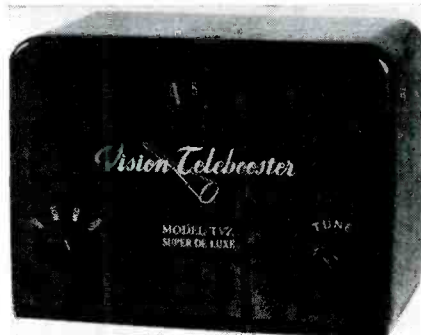

JFD ADJUSTABLE CHIMNEY ANTENNA MOUNT

An adjustable chimney antenna mount has been developed by the JFD Manufacturing Co., Inc., 4120 Fort Hamilton Parkway, Brooklyn 19, New York.

Held with two 12' lengths of heavy-duty galvanized steel bands.

Constructed in two separate sections, the mount is said to permit unlimited spacing between brackets, which achieves maximum support of antenna masts.

Brackets are said to firmly hold any size mast from 1/2" to 1 1/2" O.D.

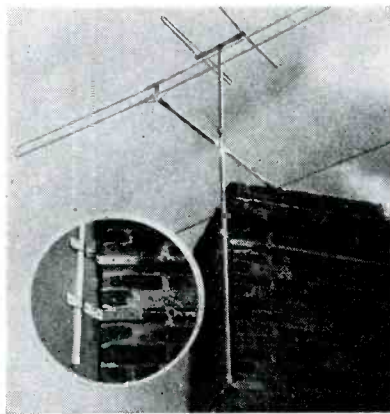

LA POINTE TV ANTENNA

A tv antenna, DGA-12, Sky Monitor, designed for use in prime and near fringe tv areas, has been announced by the La-Pointe Plascomold Corporation, Unionville, Connecticut.

Provides a tunable Q section for matching line impedance. Polyethylene is used for insulation at all points of high frequency.

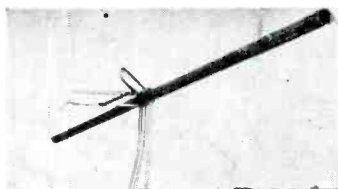

Built for Service



Servicemen's choice!
in...



• Since 1915, thousands of set owners in Maryland have voted for Cunningham tubes . . . because they're good for long terms of public service. That's why Cunninghams enjoy such a high reputation today. Cast your vote for Cunninghams when new tubes are called for, and more customers will vote for you!

See your
CUNNINGHAM DISTRIBUTOR

Radio Electric Service Co. Baltimore

Cunningham Tubes

A product of
RADIO CORPORATION OF AMERICA
Harrison, N. J.

Sharp, Clear Television Reception at 100 MILES AND OVER

You can be assured of the finest television reception at more than double the normal range with a Workshop 6-element Super High-Gain Antenna. Weak, remote "signals" come in strong and steady to produce pictures sharp in detail and contrast. This antenna is *actually* opening up new television areas.



List Price \$45.00

Write for
Television Antenna Catalog

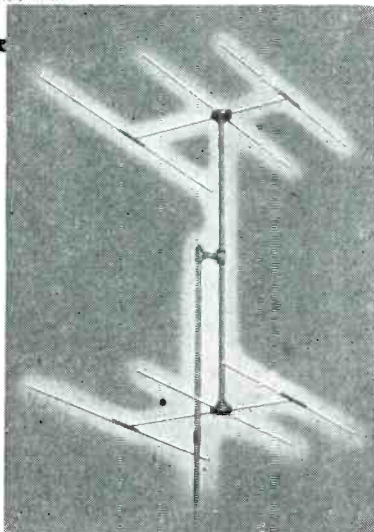

THE WORKSHOP ASSOCIATES INCORPORATED

67 Needham Street, Newton Highlands 61, Mass.

AMPERITE

Studio Microphones at P.A. Prices

Ideal for BROADCASTING

- RECORDING
- PUBLIC ADDRESS

"The ultimate in microphone quality," says Evan Rushing, sound engineer of the Hotel New Yorker.

- Shout right into the new Amperite Microphone—or stand 2 feet away—reproduction is always perfect.
- The only type microphone that is not affected by any climatic conditions.
- Guaranteed to withstand more "knocking around" than any other type mike.

Special Offer: Write for Special Introductory Offer, and 4-page illustrated folder.

AMPERITE Company, Inc.

561 BROADWAY • NEW YORK 12, N. Y.

In Canada: Atlas Radio Corp., Ltd., 560 King St. W., Toronto

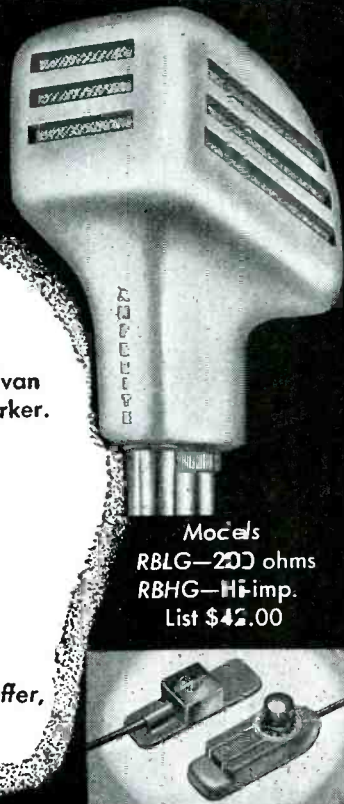

Models
RBLG—200 ohms
RBHG—Hi-imp.
List \$42.00



"Kontak" Mikes
Model SKH, 1st \$12.00
Model KKH, 1st \$18.00

New LP Products

ALLIANCE DUAL-SPEED PHONOMOTOR

A *Dual-Speed* Phonomotor, providing 33 $\frac{1}{3}$ and 78 rpm speeds, has been announced by the Alliance Manufacturing Company, Alliance, Ohio. Two motors, instead of one, are mounted below the standard 10" or 12" turntable. The new unit is a complete record player assembly.

A single control in the form of a lever changes the turntable speed to 33 $\frac{1}{3}$ or 78 rpm as desired. The device is so controlled that only *one* motor is in the electrical circuit at a time.

When the control lever is operated, the desired motor is electrically switched into the circuit; turntable speed is changed to 33 $\frac{1}{3}$ or 78 rpm; device disengages the idler tire from the turntable rim and the motor pulley through linkage which is completely apart from the idler system when the motor is in play position, and neutral position switches off both motors when not in service.

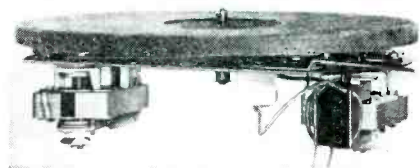

CALIFONE SLOW SPEED RECORD PLAYER

A 33 $\frac{1}{3}$ rpm record player, for use with the *lp* fine groove vinylite records, has been announced by the Califone Corp., 1041 North Sycamore Avenue, Hollywood 38, Calif.

Unit has a *feather* pickup which exerts needle pressure of less than 6 grams. Matched base and pickup are available in two finishes, models 2B and 2D, blonde or dark walnut.



WEBSTER-CHICAGO LP CHANGER KIT

A kit consisting of an automatic record changer, designed for the 33 $\frac{1}{3}$ rpm records, amplifier and speaker, has been announced by the Webster-Chicago Corp.

The record changer in the kit has a seven gram pickup and one mil radius tip, while the amplifier and speaker is an 8-watt output model with separate volume and tone controls. It will play up to four hours in one loading.

AUDAX LP PICKUP

A series of *Tuned-Ribbon* reproducers, type LM, for the long-playing discs, has been announced by the Audak Company, 500 5th Ave., New York 18, N. Y. Operate with a point pressure of about 6 grams and said to be capable of a range of from 40 cps to over 10 kc.

New Instruments... Components

FTR MINIATURE SELENIUM STACKS

Two selenium stacks, RS 400 and RS 500, with current ratings of 400 and 500 ma, have been developed by Federal Telephone and Radio Corp., East Newark, N.J.

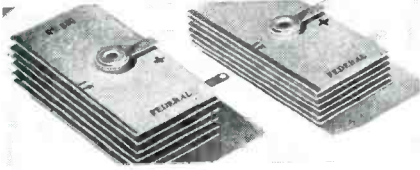

**SHOOTS TROUBLE
FASTER!** Makes more money
for you on job or
at service bench!



PRICE
\$9.95
at distributor
or postpaid,
direct. *Barry*,
no COD's.
Ohioans add
3% State Sales
Tax.

Signalette

MULTI-FREQUENCY GENERATOR

In radio service work, time means money. Locate trouble faster, handle a much greater volume of work with the SIGNALLETTE. As a trouble shooting tool, SIGNALLETTE has no equal. Merely plug in any 110V. AC-DC line, start at speaker end of circuit and trace back, stage by stage, listening in set's speaker. Generates RF, IF and AUDIO Frequencies, 2500 cycles to 20 Megacycles. Also used for checks on Sensitivity, Gain, Peaking, Shielding, Tube Testing. Wt. 13 oz. Fits pocket or tool kit. See at your distributor or order direct.

Clippard INSTRUMENT
LABORATORY
Inc.

DEPT. S, 1125 BANK STREET
CINCINNATI 14, OHIO

QUALIFIED JOBBERS WRITE,
WIRE FOR DETAILS.

HICKOK DISPLAY TUBE TESTER

A display tube tester, model 533 DM, with a 9" illuminated scale which reads *Replace, Doubtful and Good* has been announced by The Hickok Electrical Instrument Co., 10521 Dupont Avenue, Cleveland 8, Ohio.

Incorporates the Hickok dynamic mutual conductance circuits. Uses rectified current to energize plates and grids of two rectifiers. Meter shows micromho ranges of 0-3000, 0-6000, 0-15,000. Has roll chart in panel. Gas test provision.

Size: 26 3/4" high x 17" wide x 11" deep.

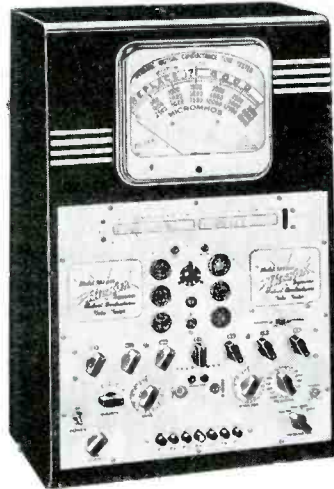

IRC DEPOSITED CARBON RESISTORS

Deposited carbon resistors, DCF and DCH, for applications up to 1 and 2 watts, respectively, have been announced by International Resistance Co., 401 N. Broad St., Philadelphia, Pa.

Resistors are designed to provide high stability and low voltage coefficient, and to assure low capacitive and inductive impedance in h-f applications. Available in 3 tolerances: 1%, 2% and 5%.

Resistance ranges are: DCF, 200 ohms to 5 meg.; DCH, 500 ohms to 20 meg.

Comprehensive data are in bulletin B-4.

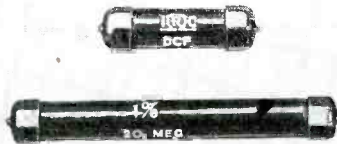

Servicemen's choice!

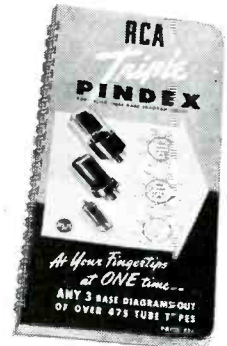

... Triple PINDEX Tube Base Diagram Guide

Here's the service tool you've been waiting for... the *Triple Pinindex Tube Base Diagram Guide*. Now you can select *ANY three* tube base diagram in a flash... and have *all three* in front of you to work from—at the same time! It's actually three identical books spiral-bound into one... so designed that you can turn the pages in each section individually. Here's a time- and temper-saver if there ever was one... and it contains base diagrams for over 475 tube types in *each book!*

The cost? Only 75 cents! Get yours today from your *Cunningham Distributor*—Order Form 2F366.

Cunningham Tubes

A product of
RADIO CORPORATION OF AMERICA
Harrison, N. J.

Permoflux SPEAKERS

YOUR JOBBER CAN SUPPLY YOU!

Permoflux quality and dependability—the same as supplied to the major set manufacturers—is your assurance of complete customer satisfaction. You'll find Permoflux Speakers easy to install and readily available in both PM and Electrodynamic types. You'll find too, that it pays to give your customers "tops in tone" with a Permoflux Replacement Speaker.

TWO COMPLETE
FACTORIES TO SERVE YOU

PERMOFLUX

WRITE FOR
FREE BULLETIN

PIONEER MANUFACTURERS OF PERMANENT MAGNET DYNAMIC TRANSDUCERS

PERMOFLUX CORPORATION

4900 WEST GRAND AVE., CHICAGO 39, ILLINOIS
236 SOUTH VERDUGO ROAD, GLENDALE 5, CALIFORNIA

Keep high voltage off your test instruments!

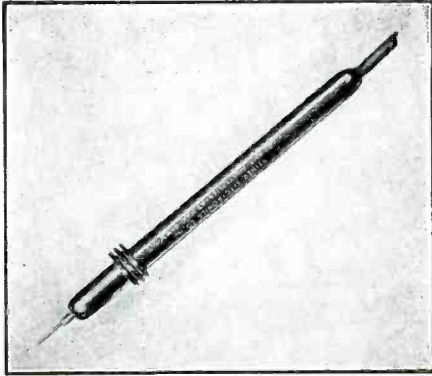

use **REINER** **HIGH VOLTAGE** **MULTIPLIER** **LEADS**

accurate within 2%

You can make high voltage and television measurements on a low voltage multimeter with complete safety if you use these Reiner H. V. M. leads. They have special high-voltage type resistors built into the prod handles. The entire voltage drop is virtually complete

before the wire lead of the cord is reached, leaving the tip of the lead relatively "cold". Supplied in standard scale ranges from 5,000 to 30,000 volts and in sensitivities of 5,000 to 25,000 ohms per volt. Write for price and application chart—bulletin #111.

REINER H. V. M. LEADS are available in the necessary ranges for all popular V. T. Voltmeters. Special ranges and sensitivities can be supplied on order. WRITE FOR BULLETIN #111.

Reiner

ELECTRONICS CO., INC.
152 West 25th St., New York 1, N. Y.

FULL 13 CHANNEL TV-FM COVERAGE!

It's Here...
NEW JFD
Super-Beam HI-LO
Duo-Orienting Array

FEATURES!

- ✓ JFD All-Angle Steel Mounting Bracket for erection of masts anywhere.
- ✓ Corrosion-proof 7½' mast.
- ✓ Frequency Range 44-216 mc. and + 4.2 DB gain.
- ✓ Minimized ghost effects.
- ✓ U-Bolt Clamp securely attaches array to mast, provides unlimited spacing of bays and allows them to be oriented independently.
- ✓ Unbreakable polystyrene Rotolock insulator insures high frequency insulation.
- ✓ Lightning-fast assembly time — no hardware bag.

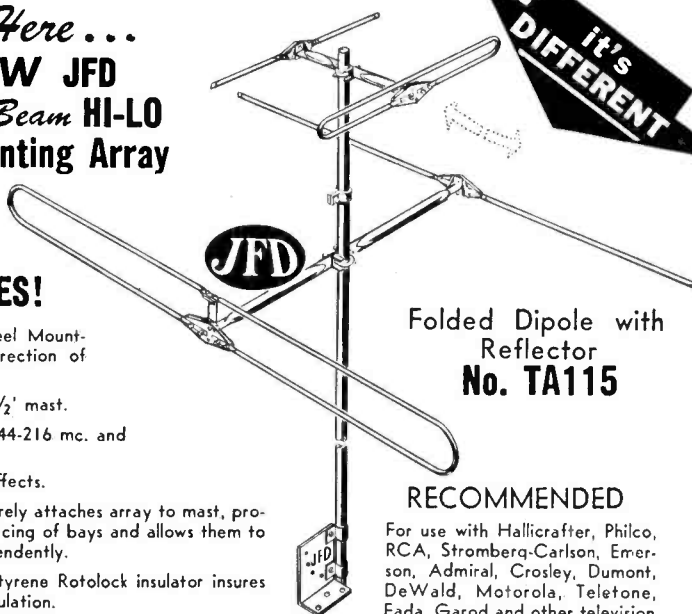

Folded Dipole with
Reflector
No. TA115

RECOMMENDED

For use with Hallicrafter, Philco, RCA, Stromberg-Carlson, Emerson, Admiral, Crosley, Dumont, DeWald, Motorola, Teletone, Fada, Garod and other television sets.

Write for the New
JFD 16-page Super-Beam
Catalog, No. 7810S.

JFD

MANUFACTURING CO. Inc.

4111 Ft. Hamilton Parkway, Brooklyn 19, N. Y.



E. A. FREED NOW MANAGER OF RCA ELECTRONIC PARTS SALES

Edwin A. Freed has been appointed manager of electronic components sales to equipment customers of the RCA Tube Department.

Mr. Freed was formerly equipment sales rep. for the New York and New England territories.



E. A. Freed

* * *

ALLIED 1949 CATALOG

A 180-page catalog (No. 117) with listings of radio and electronic parts, test equipment, batteries, p-a systems, receivers phono, tv sets and components, recording equipment and accessories (including wire, tape, and disc recorders), changers and other playback equipment for the 33¼ rpm lp records, phono motors, etc., has been released by Allied Radio Corporation, 833 West Jackson Boulevard, Chicago 7, Ill.

Section on p-a equipment covers systems from 7 to 60 watts, intercom units, microphones and pickups, speakers, and baffles, phono motors, cables and connectors.

* * *

1949 PARTS SHOW NEWS

William O. Schoning, of Lukko Sales Corp., Chicago, has been elected president of the Radio Parts and Electronic Equipment Shows, Inc., sponsors of the annual Radio Parts Show. Robert C. Sprague, Sprague Electric Co., North Adams, Mass., is now vice president; John L. Robinson, Croname, Inc., Chicago, secretary and Walter W. Jablon, Espey Mfg. Co., New York, treasurer.

Schoning represents NEDA on the board, while Sprague represents RMA; Robinson, the association of Electronic Parts and Equipment Manufacturers and Jablon, the sales Managers Club, Eastern Division.

Other directors elected include Jerome J. Kahn, Standard Transformer Corp., Chicago (RMA); Les A. Thayer, Belden Mfg. Co., Chicago (EP&EM); Aaron Lippman, Aaron Lippman & Co., Newark (NEDA); Charley Golenpaul, Aerovox Co., New Bedford, Mass. (SMED) and Lew Howard, Triad Transformer Co., Los Angeles (WCEMA).

There'll be a four-day show in 1949 at the Hotel Stevens, Chicago, to run from Tuesday, May 16 through Friday, May 19. On Thursday, May 18, the Show Corporation will join with RMA in an all-industry dinner to honor RMA's twenty-fifty anniversary.

The board also voted to recommend to the sponsoring groups that the 1950 trade show be held at the Hotel Waldorf-Astoria in New York.

C-D TO MARKET VIBRATORS

Light and heavy duty vibrators, and vibrator power supplies are now being distributed by Cornell-Dubilier Electric Corp., South Plainfield, New Jersey. The light duty vibrators are a development of the C-D engineering laboratories.

By the purchase of the business, goodwill, trademark, patents and inventory of The Electronic Laboratories, Inc., 24 West 24th Street, Indianapolis, Indiana, C-D acquired a recently improved and new design of heavy duty vibrator and vibrator power supply, which are now being marketed by C-D.

CLAROSTAT MOVES TO NEW HAMPSHIRE

The Clarostat Manufacturing Co., Inc., are moving their office, warehouse and plant facilities to a new five-story block-long building in Dover, N. H.

* * *

MARINO INDOOR TV ANTENNA DATA

A bulletin describing an indoor television antenna, *Telebeam*, with a universal positioning swivel, has been released by the Marino Radio Co., 203 Greenwich Street, New York 7, N. Y.

Antenna length charts for the tv and f-m bands, and 108 to 114 and 300 to 1000-mc bands also appear in the bulletin.

* * *

OXFORD ELECTRIC SPEAKER CATALOG

An eight-page catalog, covering 2", 3", 4", 5", 6", 8", 10", 12" and 15" p-m speakers, is available from Oxford Electric Corp., 3911 South Michigan Ave., Chicago, Ill.

* * *

SAMS' AMPLIFIER MANUAL

A 352-page manual, *Audio Amplifiers and Associated Equipment Manual* (AA1), has been compiled and published by Howard W. Sams & Co., Inc., Indianapolis 7, Indiana.

Manual of *Photofact Folders* includes data on amplifiers, f-m tuners and recorders, covered by *Photofacts* since the end of the war. Covers post war models produced by 31 manufacturers.

Volume also includes complete material on the Brush Sound Mirror, and the Webster models 79 and 80 wire recorders.

Priced at \$3.95.

* * *

DUMONT CATHODE-RAY TUBE PRIMER

A non-technical discussion of the c-r tube and its functions presented in a 63-page book entitled *The Cathode-Ray Tube and Typical Applications*, has been published by the Instrument Division, Allen B. Du Mont Labs., Inc., 1000 Main Ave., Clifton, N. J. Primer priced at 50c per copy.

Available to schools at \$2.50 per dozen copies.

TV ANTENNA PATTERN TESTS

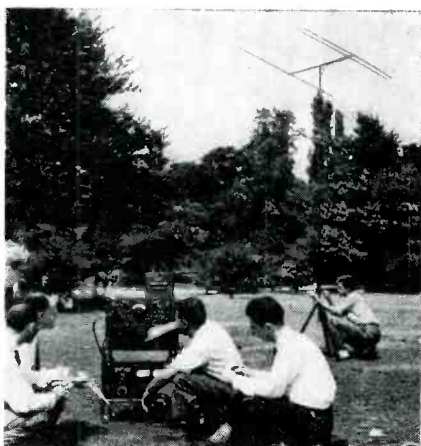

Ward Products engineers conducting pattern and response curve tests on Ward TV antenna (TVH-9) at Gordon Park, Cleveland, Ohio: J. Fine, research; Jim Finneburg, chief engineer; Milt Friedburg, assistant chief engineer; Bob Weiss, test engineer and Ray Jaracz.

THIS SIMPLE BENCH TEST

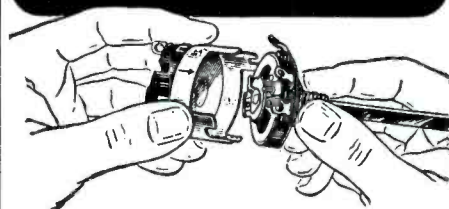

proves you're right

Remove the cover from an IRC control, and from any other reputable control. You'll immediately see the superior IRC construction. Features that insure long dependable performance. Point by point, compare IRC's design to that of any other control and you'll know you're right when you ask for IRC!

Notice—the terminals are riveted assuring *positive* electrical contact. Gliding "5-finger" contactor provides *smooth gradation* of volume. *Silent* Spiral Spring connector eliminates principal source of control noise. Resistance material bonded to bakelite base gives an even, *long wearing* element.

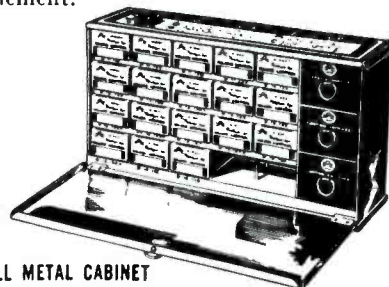

ALL METAL CABINET

Add *time-saving convenience* to the other features of IRC controls by buying a practical stock in this handsome all-metal cabinet. With this minimum investment of 18 Type D Controls plus switches and special shafts, the sturdy cabinet is furnished at no extra charge. You pay only the standard net price of the merchandise. Fast moving control stock in this IRC cabinet services 90% of the Howard Sams RED BOOK listings.

IRC INTERNATIONAL RESISTANCE CO.

401 N. Broad St., Phila. 8, Penna.
In Canada: International Resistance Co., Ltd.
Toronto, Licensee

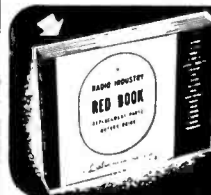

Yes! We're listed in the RED BOOK

Looking for the correct IRC replacement controls for any receiver manufactured from 1938 to 1948? Just refer to The Radio Industry RED BOOK.

RADIO TUBES

25Z6 6AV6 } 29¢ ea.
6T8 35W4 }
19T8 39/44 }

1S5 3S4 } 39¢ ea.
1U5 5Y3GT }

12SA7 6F6GT } 43¢ ea.
12SK7 6K6GT }

Individually boxed. Standard 90-day guarantee. (This refers to tubes listed above)

Standard Brand 8 mfd. 450 v. cond.

24c ea., lots of 10.

Rated accounts—10 days. All others—C.O.D. Less than 50 tubes 5¢ per tube extra. Orders of 200 tubes or more assorted 5% additional discount.

Write for Complete List of Tubes and Parts

PREMIER RADIO TUBE COMPANY
Dept. SE

1802 Winnemac Avenue, Chicago 40, Illinois
Phone: LONgbeach 4429

FREE ALLIED'S NEW 1949 RADIO CATALOG



Everything for the Radio Service Technician . . .

SEND FOR THIS 180-PAGE BUYING GUIDE NOW

Radiomen! Here's the new 1949 ALLIED Buying Guide that brings you everything you need in radio and electronic equipment. Get everything that's newest and finest from the world's largest stocks—test instruments, sound systems and P.A. equipment, thousands of parts, tubes, tools, books—all at lowest money-saving prices, ready for instant expert shipment. Send for your FREE copy of the new 180-page ALLIED Catalog—today!

ALLIED RADIO

ALLIED RADIO CORP., DEPT. 23-K-8
833 W. Jackson Blvd., Chicago 7, Ill.

Send FREE New ALLIED Catalog.

Name.....

Address.....

...Help end spark plug INTERFERENCE

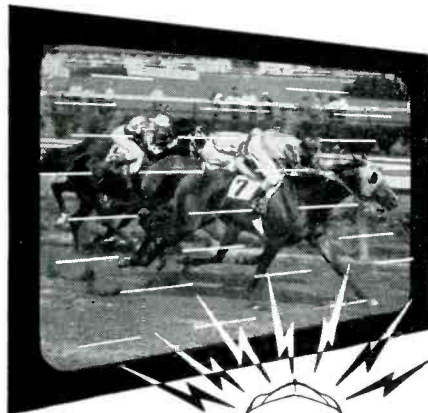

Spark Plugs are miniature broadcasting stations, send signals that interfere with radio reception, distort television. The New Auto-Lite "Resistor" Spark Plug reduces this interference.*



Recommend **NEW** **AUTO-LITE** *Resistor* **SPARK PLUG**

Here's How It Works to End Interference

The "Resistor" acts to dampen the spark plug radio signal to an acceptable level* while still delivering the full high voltage discharge required to ignite the fuel.

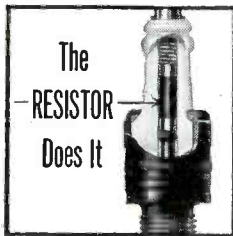

Auto-Lite Ignition Engineers, working with leading automotive manufacturers, have developed the new Auto-Lite "Resistor" Spark Plug with this built-in resistor that reduces spark plug interference.* Remember, the "Resistor" also helps deliver smoother idling, improved economy, longer electrode life. Dealers are being supplied as rapidly as possible. Write for Booklet M-1186 for full information.

THE ELECTRIC AUTO-LITE COMPANY
Toronto, Ontario Toledo 1, Ohio

*Under 35mv/m from 540 k.c. to 150 m.c. at 50 ft.

Tune in "Suspense," Thursdays, 9:00 P. M., E. T., CBS

JOTS AND FLASHES

TV RECEIVER PRODUCTION will reach the 100,000-a-month mark by the last quarter of '48, recently predicted James H. Carmine, vice president in charge of distribution for Philco. He reported that in New York City alone tv receivers are being installed in private homes at the rate of 1,000 a day. "Philco television production, already running well over 4,000 receivers a week or 200,000 a year, will step up to 8,000 a week or 400,000 a year by the latter part of '48," Carmine predicted. . . . The monthly RMA report showed that the tv production spurt was really on. In August RMA member-companies made close to 65,000 receivers, an increase of almost 10,000 over July.

Five more stations have joined the CBS TV Network. They are WIVO in Detroit, WAGA-TV in Atlanta, WSPD-TV in Toledo, WTMJ-TV in Milwaukee and WEWS in Cleveland. The RMA *Silver Anniversary* and the *Annual Parts Show* will be combined for a gala celebration during the week of May 15, 1949, at the Stevens Hotel in Chicago. The decision to combine the two big events was made recently by the RMA board of directors and the directors of the Radio Parts and Electronic and Equipment Shows, Inc., which operates the parts show. Parts manufacturers selling to jobbers will exhibit in the Stevens Hotel Exhibition Hall and industrial exhibitors will have exhibition rooms on the 5th and 6th floors of the hotel. . . . A. J. Nelson, Denver, Colorado, will cover the states of New Mexico, Colorado, Wyoming, Montana, Idaho, Utah and the trading area of El Paso, Texas, for Air King Products Company, Inc., Brooklyn, New York. Sylvania Electric will begin the manufacture of tv picture tubes at a new plant in Ottawa, Ohio. . . . Amy, Aceves & King, Inc., 11 West 42nd Street, New York City, have received a contract to install tv outlets in 3,008 apartments of the Fresh Meadows Rental Housing Development, Flushing, Queens. . . . Walter T. Hannigan, 40 Leon Street, Boston, Mass., is now the New England rep. for the Electronics Division of Erie Resistor Corp., Erie, Pa. . . . Willis C. Toner has been named plant manager of the Sylvania Electric picture tube plant at Ottawa, Ohio. . . . John Frazier, 764 Grosvenor Road, Rochester 10, New York, now represents the Sterling Manufacturing Co., 9205 Detroit Avenue, Cleveland, Ohio, in the New York state area, except metropolitan N. Y. . . . Erwin A. Larson has become distributor sales rep for the metropolitan New York area for the renewal tube department, Radio Tube Division, Sylvania Electric. . . . Joseph G. Howland is now advertising and sales promotion manager of Motorola, Inc., Chicago. He succeeds Victor A. Irvine who has retired because of ill health. . . . Robert J. Flanagan, who was assistant to Mr. Irvine has been promoted to the position of assistant advertising and promotion manager of Motorola. . . . Charles K. Krolek, Russell J. Weber and Charles C. Kayhart have been named district reps to supervise the nationwide tv service work of the Magnavox Company. Krolek will be in charge of the western district, with offices in San Francisco; Weber will cover the central district, with offices in Chicago; and Kayhart will have headquarters in New York City.

ADVERTISERS IN THIS ISSUE

SERVICE INDEX—OCTOBER, 1948

ALLIANCE MFG. CO.	38
Agency: Foster & Davies, Inc.	
ALLIED RADIO CORPORATION	55
Agency: George Brodsky, Advertising	
AMERICAN ELECTRICAL HEATER CO.	50
Agency: Dudgeon, Taylor & Bruske, Inc.	
AMERICAN TELEVISION & RADIO CO.	41
Agency: Firestone-Goodman Adv.	
AMPERITE CO.	52
Agency: H. J. Gold Co.	
L. S. BRACH MFG. CORP.	43
Agency: A. W. Lewin Co.	
CLAROSTAT MFG. CO., INC.	48
Agency: Austin Lescaurba and Staff	
CLIPPARD INSTRUMENT LABORATORY	53
Agency: The S. C. Baer Co.	
CORNELL-DUBILIER ELECTRIC CORP.	Inside Front Cover
Agency: Reiss Advertising	
THE DEMARIA CO.	51
ELECTRIC AUTO-LITE CO.	56
Agency: Ruthrauff & Ryan, Inc.	
ELECTRO-VOICE, INC.	37
Agency: Henry H. Teplitz, Advertising	
ESPEY MFG. CO., INC.	47
Agency: Chas. B. Tighe Advertising, Inc.	
FORD MOTOR COMPANY	29
Agency: J. Walter Thompson Co.	
GENERAL ELECTRIC COMPANY	10
Agency: Maxon, Inc.	
GENERAL ELECTRIC LAMP DEPT.	45
Agency: Batten, Barton, Durstine & Osborn, Inc.	
GREYLOCK ELECTRONIC SUPPLY CO.	46
Agency: Bergman-Jarrett Co.	
HEATH COMPANY	7
Agency: Paxson Advertising	
HICKOK ELECTRICAL INSTRUMENT CO.	42
Agency: White Adv. Co.	
HYTRON RADIO & ELECTRONICS CORP.	24
Agency: Henry A. Loudon, Advertising	
INTERNATIONAL RESISTANCE CO.	55
Agency: John Falkner Arndt & Co.	
KAY ELECTRIC CO.	31
Agency: George G. Felt	
KEN-RAD DIV. GENERAL ELECTRIC	1
Agency: Maxon, Inc.	
P. R. MALLORY & CO., INC.	Inside Back Cover
Agency: Aitkin Kynnet Co.	
MASTERCRAFT PRODUCTS	48
Agency: Bilton Brothers, Inc.	
MEISSNER MFG. DIV. MAGUIRE INDUSTRIES, INC.	27
Agency: Ohio Adv. Agency	
MURRAY HILL BOOKS, INC.	46
Agency: The Harry P. Bridge Co.	
NEWARK ELECTRIC CO., INC.	48
Agency: The Chernow Co., Inc.	
NEWCOMB AUDIO PRODUCTS CO.	40
Agency: Gail Hall Advertising	
PERMOFLUX CORPORATION	53
Agency: Turner Adv. Agency	
PRECISION APPARATUS CO., INC.	35
Agency: Shappe-Wilkes Inc.	
PREMIER RADIO TUBE CO.	55
Agency: Sander Rodkin Adv. Agency	
RADIART CORP.	8
Agency: Ohio Adv. Agency	
RADIO CORPORATION OF AMERICA	16, 17, 47, 49, 51, 53. Back Cover
Agency: J. Walter Thompson Co.	
REINER ELECTRONICS CO., INC.	54
Agency: Reiss Advertising	
JOHN F. RIDER PUBLISHER, INC.	28
Agency: Lansford T. Kling, Advertising	
HOWARD W. SAMS & CO., INC.	3
Agency: George Brodsky, Advertising	
SANGAMO ELECTRIC CO.	4, 5
Agency: Arthur R. Mogge, Inc.	
SIMPSON ELECTRIC CO.	9
Agency: Kreischer & Maloan, Inc.	
SPRAGUE PRODUCTS CO.	6
Agency: The Harry P. Bridge Co.	
SYLVANIA ELECTRIC PRODUCTS INC.	12
Agency: Newell-Emmet Co.	
TRANSVISION, INC.	39
Agency: H. J. Gold Co.	
TRIPLETT ELECTRICAL INSTRUMENT CO.	11
Agency: Western Adv. Agency, Inc.	
UNITED STATES INSTRUMENT CORP.	50
Agency: George G. Felt	
UTAH RADIO PRODUCTS DIV. INT'L DETROLA	44
Agency: Bonsib Adv. Agency	
THE WORKSHOP ASSOCIATES	52
Agency: Larcum Randall, Advertising	

When the Heat is On . . .

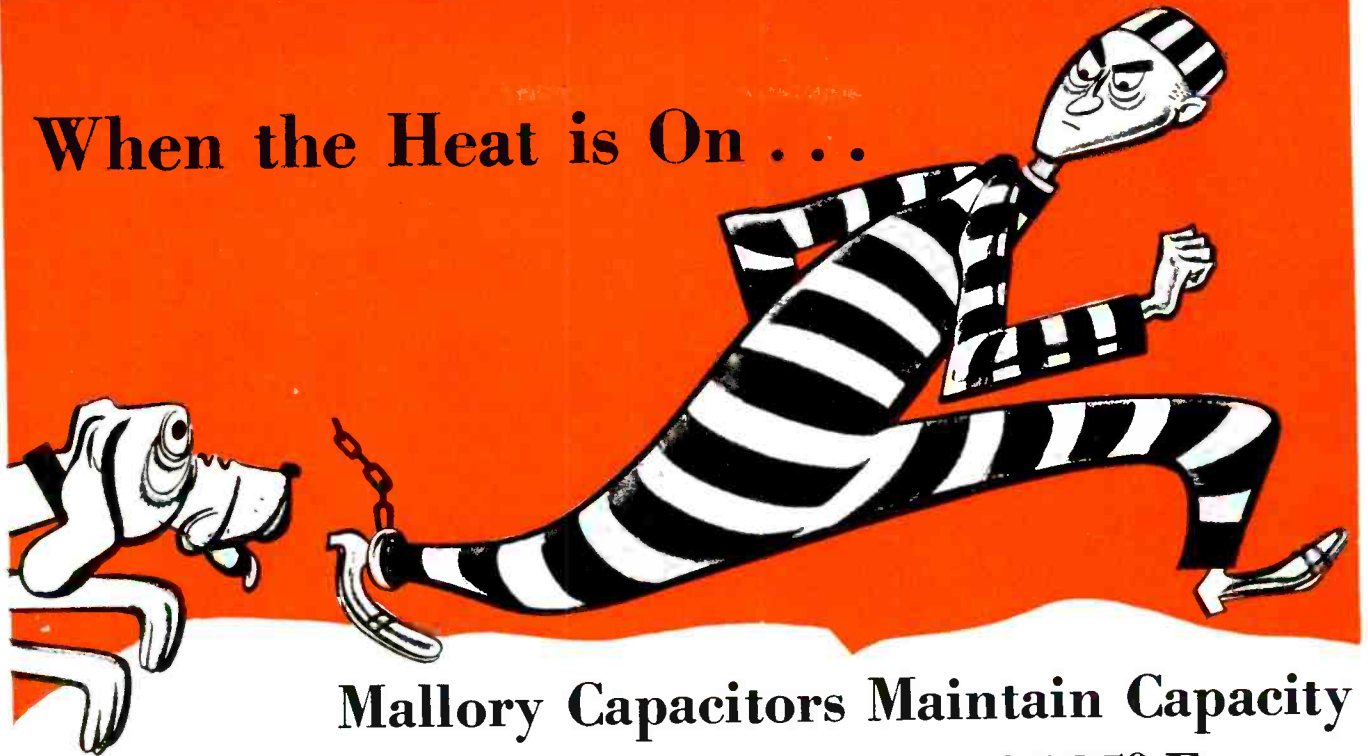

Mallory Capacitors Maintain Capacity Even at Temperatures of 185° F.

You will probably never intentionally install a capacitor to operate continuously at a temperature of 185° F. Still it's reassuring to know that Mallory capacitors have, among other plus values, the quality to take over 2,000* hours of operation at that heat with no loss of capacity.

It's also reassuring to know that Mallory capacitors are ahead of your expectations on most of the points you look for in a capacitor. The carefully guarded purity of materials and protection against contamination during manufacture assure you long shelf-life without reaging, longer life in an inactive set,

low RF impedance, and the ability to withstand high ripple current.

Service men as well as set manufacturers appreciate the year-in-year-out quality of Mallory capacitors—and realize it's due to the same care in manufacturing that justifies the name "Mallory Precision Products."

THE MALLORY "GOOD SERVICE FOR GOOD BUSINESS" PLAN

will increase business and profits in your shop.

A unique follow-up file makes it easy to keep customers.

You tie in with Mallory acceptance to develop new business—ask your distributor about it.

*2,000 HOURS OF OPERATION

An actual test of Mallory capacitors operated in an oven at 185° F. and 450 volts DC, plus 10 volts of 120 cycle ripple, showed them still going strong and with increased capacity at the end of 2,000 hours. Typical results:

At Start of Test		After 2,000 Hours	
Capacity	Resistance	Capacity	Resistance
20.9 mfd	6.16 ohms	23.5 mfd	6.5 ohms
20.1 mfd	6.5 ohms	23.4 mfd	6.55 ohms

BUY MALLORY ASSURED QUALITY AT REGULAR PRICE LEVELS

P. R. MALLORY & CO. Inc.
MALLORY

CAPACITORS . . . CONTROLS . . . VIBRATORS . . .
SWITCHES . . . RESISTORS . . . RECTIFIERS . . .
VIBRAPACK* POWER SUPPLIES . . . FILTERS

*Reg. U. S. Pat. Off.

APPROVED PRECISION PRODUCTS

P. R. MALLORY & CO., Inc., INDIANAPOLIS 6, INDIANA

Concentrated Distribution

...in
the
Radio
Field



You can sell more RCA Batteries because—

1. RCA Batteries are sold primarily through radio dealers and servicemen—this means more *repeat* business for you.
2. RCA provides the greatest array of selling aids in battery history . . . all geared to the *radio trade!*
3. Eight warehouses are strategically located to assure you of quick delivery on fresh stocks of RCA batteries through your local RCA Distributor.
4. RCA's completely rounded line covers virtually all of the requirements of the radio and electronics field.
5. Smart packaging, competitive prices, and "the greatest name in radio" add up to overwhelming customer acceptance.
6. RCA batteries are *radio engineered* for extra listening hours.

See your RCA Distributor about RCA Batteries today.

SELL RCA BATTERIES—THE COMPLETE LINE FOR THE RADIO AND ELECTRONIC TRADE

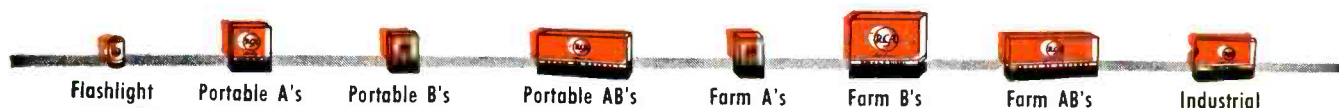

RADIO CORPORATION of AMERICA

HARRISON, N. J.