

# SERVICE

September  
1948

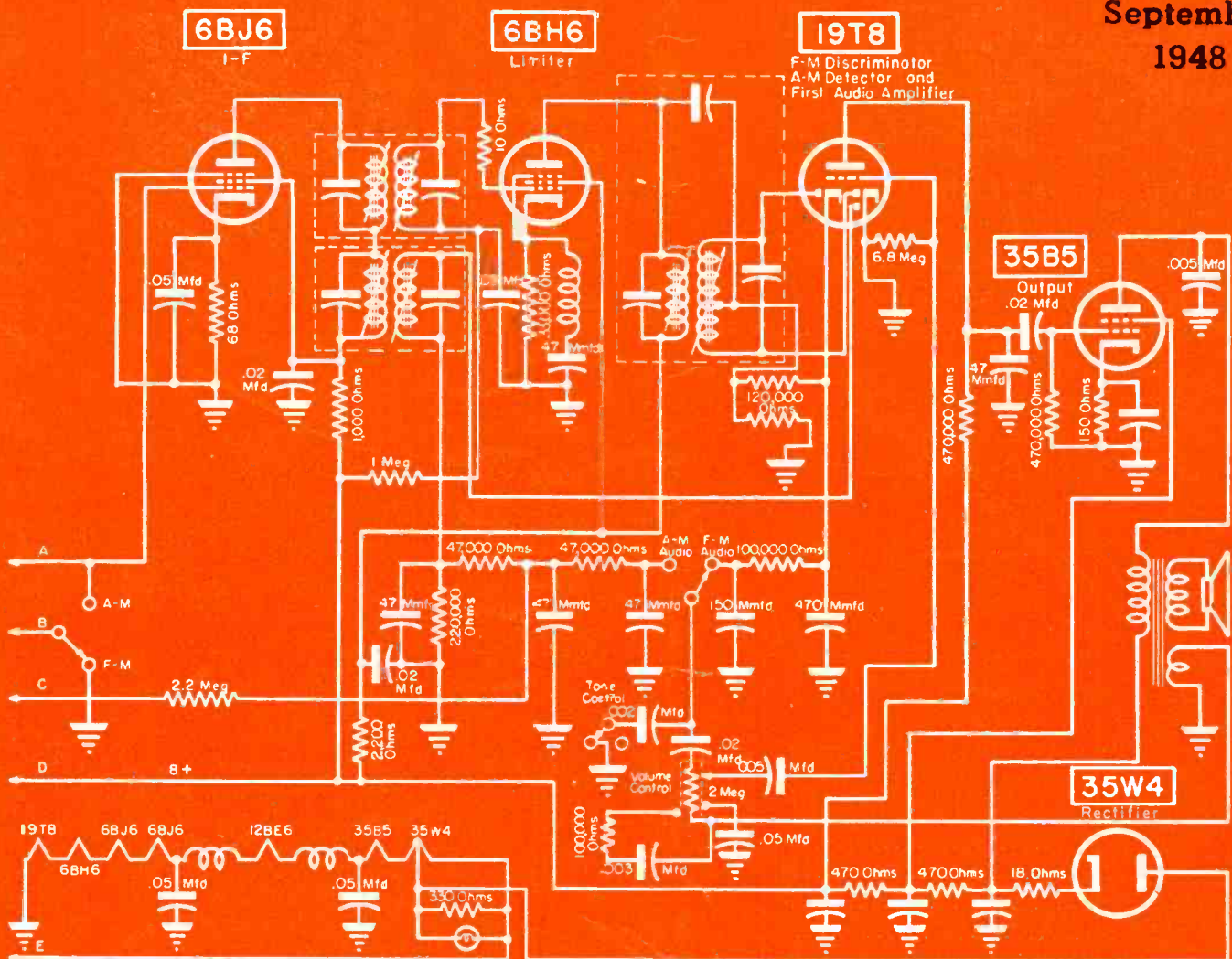

I-f, limiter, f-m discriminator a-m detector first a-f, output and rectifier stages of seven tube a-c-f-m a-c-d-c table model, with a reflex f-m circuit.

See page 21

save 1,000 service hours  
with this complete, up-to-date

# c-d capacitor manual

For Radio Servicing

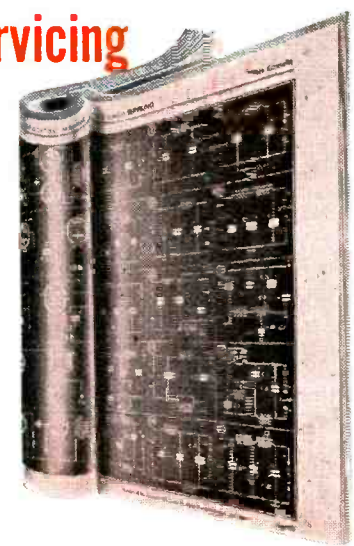

4th Edition by popular request!  
**OVER 400 PAGES!**

Pocket Size—Accurate Parts Tables—Easy Circuit Diagrams

Why hunt and peck for the right capacitor replacement? This complete manual shows you the correct unit at a glance. Simplified tables and diagrams help you service any new or old radio set *faster, easier, more profitably*. You can save 1,000 hours or more in service time. Call your Cornell-Dubilier jobber now or mail coupon for your copy. List price \$1.00. Cornell-Dubilier Electric Corporation, Dept. S9, South Plainfield, N. J. Other Plants in New Bedford, Worcester, and Brookline, Mass., and Providence, R. I.

FOR RADIO SERVICING

Manufacture and Model No.	Cap. Type	Cap. Value	CAPACITY WDF					V. W. VOLTS	E. C. No.	T. C. No.	P. C. No.	P. C. No.	P. C. No.
			10	20	50	100	250						
ALLIED RADIO CORP. 100-1000	100-1000	10					450	400					
100-1000	100-1000	10					100	100					
100-1000	100-1000	10					250	250					
100-1000	100-1000	10					100	100					
100-1000	100-1000	10					100	100					
100-1000	100-1000	10					400	400					
100-1000	100-1000	10					100	100					
100-1000	100-1000	10					100	100					

**CORNELL-DUBILIER • WORLD'S LARGEST MANUFACTURER OF CAPACITORS**

**FILL IN — MAIL COUPON TODAY!**

Cornell-Dubilier Electric Corp., Dept. S9  
South Plainfield, New Jersey

Please rush my copy of the new C-D Capacitor Manual for Radio Servicing. I am enclosing \$1.00  
money order ( ) check ( ) stamps ( )

my jobber is.....

Name.....

Shop.....

Address.....

City..... Zone..... State.....



mica  
dykanol  
paper  
electrolytic

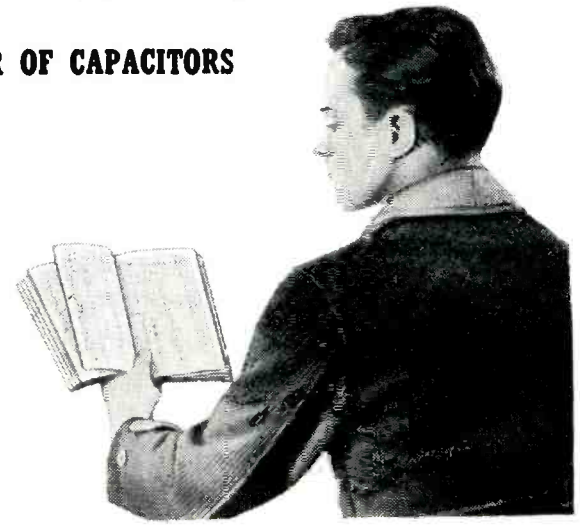

ACCLAIMED FROM  
COAST TO COAST



**GENERAL**  **ELECTRIC**  
FIRST AND GREATEST NAME IN ELECTRONICS

RADIO • TELEVISION • ELECTRONIC  
**SERVICE**

**LEWIS WINNER**  
Editorial Director

**F. WALEN**  
Assistant Editor

**ALFRED A. GHIRARDI**  
Advisory Editor

	Page
Association News	24
Dynamic Noise Suppressors. By Herman Hosmer Scott	16
Electric Power Required for Sound Systems. By E. L. Kendall	12
High Frequency TV Antenna Installations. By Ira Kamen	10
Ser-Cuits (Single Side Band Selectors, TV Projection Models)	32
Servicing Helps. By P. M. Randolph	26
Table A-M/F-M (Cover)	38
Ten Years Ago in Associations	24
The Reactance Modulator. By Douglas H. Carpenter	21
TV Sync and Inter-Sync Systems. By Edward M. Noll	22
Views and News. By Lewis Winner	9
 <b>CIRCUITS</b>	
Coax To 300-Ohm Input Circuit	10
G. E. YRS-1 Single Sideband Selector	32
G. E. 210/211/212 (Cover)	38
H-F and L-F Noise Suppressor Gate Circuits	16
Reactance Modulator Circuit	21
TV Stub Attenuation Control Circuit	10
TV Time Constant Circuits	22
 <b>COVER</b>	
Table A-M/F-M (G. E. 210/211/212)	38
 <b>SERVICING HELPS</b>	
Service Notes: General Television 51	26
Grunow 701 (Chassis 7A)	30
Packard-Philco Auto Radio P-1835	30
Philco Auto Radio 938K	30
Philco 41-608	50
Sonora WAU-243	50
TV Picture-Tube Size Guide Chart	26
 <b>Index to Advertisers</b>	 52
 <b>Manufacturers</b>	
New TV Parts . . . Accessories	43
New LP Products	45
New Instruments . . . Components	47
News	48
Jots and Flashes	52

Entire contents Copyright 1948, Bryan Davis Publishing Co., Inc.



Published monthly by Bryan Davis Publishing Co., Inc.  
52 Vanderbilt Avenue, New York 17, N. Y. Telephone MUrray Hill 4-0170



Bryan S. Davis, President      Paul S. Weil, Vice Pres.-Gen. Mgr.      F. Walen, Secretary      A. Goebel, Circulation Manager

Cleveland Representative: James C. Munn, 2253 Delaware Dr., Cleveland 6, Ohio. Telephone: Erieview 1726

Pacific Coast Representative: Brand & Brand, 1032 W. Sixth St., Los Angeles 14, Calif. Telephone: Michigan 1732  
Suite 1204, Russ Building, San Francisco 4, Calif. Telephone: SUTter 1-2251

Entered as second-class matter June 14, 1932, at the Post Office at New York, N. Y., under the Act of March 3, 1879. Subscription price: \$2.00 per year in the United States of America and Canada; 25 cents per copy. \$3.00 per year in foreign countries; 35 cents per copy.

# added sales punch for the

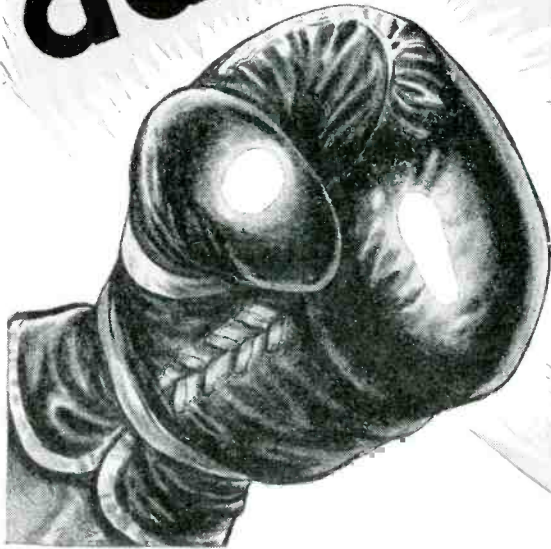

## FASTEST SELLING AUTO AERIAL LINE



● The NEW Radiart Auto Aerial line is the talk of the country! NOW . . . here is ADDED sales appeal for these fast sellers! This colorful counter display card will draw attention of your customers to these top quality aerials . . . and that means ADDED profitable sales for you! The Radiart aerial line has everything! Finest quality chrome plating . . . easy speedy one man installation . . . they replace almost all factory equipped aerials . . . give unequaled performance . . . and they all have the finest interchangeable lead ins of any auto radio aerial.

## The Radiart Corp.

CLEVELAND 2, OHIO

Export: Scheel International, Inc., 4237 N. Lincoln Avenue, Chicago, Ill.

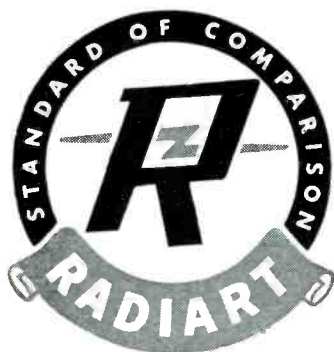

MANUFACTURERS OF THE FAMOUS RADIART "RED SEAL" VIBRATORS

Why Your RAYTHEON Tube Distributor\* Recommends

# The New RAYTHEON BANTAL TUBE



## It's Easier to STOCK

At the same price as ordinary tubes one Raytheon *Bantal* takes the place of *two*—cuts your stock problem in half! The Bantal 12SK7GT, for example, replaces, without shielding, either the GT or metal equivalent. Fast turnover, less money tied up in stock, more profit on your investment.

\*Your Raytheon Distributor sponsors the famous Bonded Dealer-Service Program. Ask him for full details on this business building plan.

## It's Easier to SELL

All these advantages at  
NO EXTRA COST

**Rugged Eight-Pillar Construction** — Short pillars direct to elements; low grid-plate capacitance—greater stability.

**Completely Shielded Internally** — No external shielding hardware or installation labor. Increases your service profit.

**Glass Button Stem** — Low Loss.

**Glass-To-Glass Seal** — Permanent Vacuum.

**Wide Lead Spacing** — No Electrical Leakage.

**Strong Non-Flexible Leads** — No Base Shorts.

**Glass-To-Dumet Vacuum Seal** — No Air Leaks.

**EIGHT POPULAR TYPES** — 6SA7GT — 6SJ7GT — 6SK7GT — 6SQ7GT — 12SA7GT — 12SJ7GT — 12SK7GT — 12SQ7GT.

**SUPERIOR FOR HEAVY DUTY SERVICE** — Recommend Raytheon Bantals particularly for replacements in sets or equipments requiring tubes of long life and greater dependability. Their superior performance assures customer satisfaction and repeat business.



**RAYTHEON MANUFACTURING COMPANY**

RADIO RECEIVING TUBE DIVISION

NEWTON, MASSACHUSETTS • CHICAGO, ILLINOIS • LOS ANGELES, CALIFORNIA

RADIO RECEIVING TUBES • SUBMINIATURE TUBES • SPECIAL PURPOSE TUBES • MICROWAVE TUBES

# Buy WHERE YOU SEE THIS BANNER ... because IT'S BETTER FOR YOU!



### SPRAGUE TM TUBULARS

The first truly practical MOLDED Paper Tubulars! Now in stock—ready for your use—See your SPRAGUE Distributor.

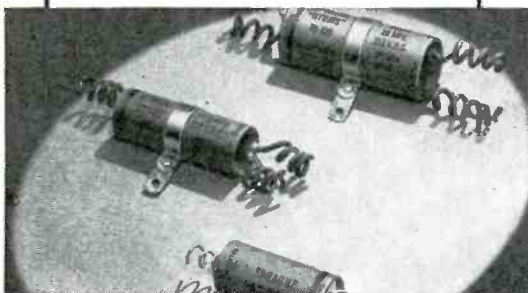

### SPRAGUE ATOMS—DRY ELECTROLYTICS

You can make up virtually any required capacity-voltage combination with a small stock. Keep a representative supply in your shop. **SAVE TIME—SAVE MONEY—SAVE SPACE!**

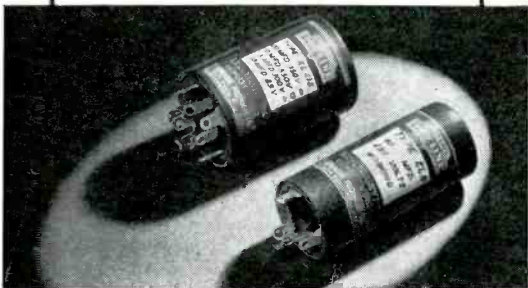

### SPRAGUE EL SELF-MOUNTING MIDGET CAN CAPACITORS

No other Dry Electrolytic gives so much dependability in so small a space! Tinned, Twist-Prong Tabs for easy soldering; quick, universal self-mounting. **SAVES TIME—SPEEDS RELIABLE SERVICE!**



Yes, its better for you *and your business* to buy where this banner is displayed because the SPRAGUE BANNER identifies a Distributor who agrees that *"It's foolish to play penny-ante when your business is at stake!"*

Your Sprague Distributor is a successful business man. He knows the parts business intimately—and he knows that to really build a bigger, more successful service business, you should use only the best replacement parts. That's why he features Sprague Capacitors and \*Koolohm Resistors. His business depends on your success and he wants you to remember that **YOUR REPUTATION AND YOUR CUSTOMERS ARE TOO VALUABLE TO RISK FOR THE FEW PENNIES "SAVED" BY BUYING INFERIOR OR UNKNOWN "BARGAINS"!**

Reach for a **SPRAGUE**  
and Know You're Right!



CAPACITORS

# SPRAGUE

\*KOOLOHM  
RESISTORS

\*T.M. Reg. U.S. Pat. Off.

Yes! We're Listed in the **RED BOOK**

Looking for the correct Sprague replacement capacitors for any receiver manufactured from 1938 to 1948? It's easy—just refer to The Radio Industry RED BOOK . . .





**HERE IS HEAVEN SENT HELP**

*Says* **LYMAN A. ABBOTT**  
 THE IOWA FLYING SERVICEMAN

"To any organization such as ours, installing and servicing PA systems, the new Rider PA Manual is heaven sent help. It is a typical Rider Manual. What more need be said."

"... of course we have all 17 RIDER MANUALS."

"... and attribute a good bit of our success in producing a quantity of work in a minimum of time to their always dependable, complete, factory information. We will have Volume XVIII as soon as it is published."



**You, TOO—NEED ALL 17 RIDER MANUALS**

Volume XVII . . . . .	\$16.50	Abridged Manuals I to V (one volume) . . . . .	\$19.80
Volume XVI . . . . .	8.40	Record Changers and Recorders . . . . .	9.00
Volume XV . . . . .	19.80	Master Index, covering Manuals, Vols. I to XV	1.50
Volume XIV to VII (each volume) . . . . .	16.50		
Volume VI . . . . .	12.50		

**VOL. I RIDER Television MANUAL**  
 1400 Pages, PLUS separate "HOW IT WORKS" and Index, \$18.00. Everything that must be known about the 1946-47 television receivers (complete and kit) of 34 manufacturers. Separate "How It Works" covers theory of television; transmission and reception, frequency standards, antennas, various portions of receivers.

**Television "HOW IT WORKS" Available Separately**  
 If television is not yet in your area, it will be soon. Here is theory you want. 208 pages . . . . . \$2.70

VOLUME 1  
**RIDER PA MANUAL**  
*Just Out*

**Covers 145 Manufacturers' Amplifiers, from 1938 to Date**

Bigger and better than even we had anticipated, the scope and thoroughness of this first industry-wide PA service manual makes it an essential piece of equipment for any shop doing PA work. It covers public address systems, outdoor announcing, musical instruments and phonographs, theatre and church hearing aids, electronic megaphones, intercommunications systems, theatre and home motion pictures, school, hotel and hospital sound systems, mobile and portable sound systems.

- It provides schematics, voltage and resistance tables, tube and chassis layouts, Installation notes, operational instructions, impedance matching.
- Separate "HOW IT WORKS" book explains the theory of various designs employed in different types of amplifier systems, the servicing of PA systems, using the sine wave and square wave means of checking, methods of rapidly locating faults. Everything you need.

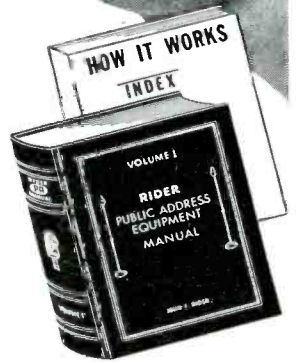

**2000 Pages in this new RIDER FIRST plus separate "HOW IT WORKS" and INDEX . . . . . \$18.00**  
**ORDER YOURS TODAY!**

**RIDER MANUALS**  
**MEAN SUCCESSFUL SERVICING**

**JOHN F. RIDER, PUBLISHER, Inc., 404 Fourth Avenue, N. Y. 16**  
 Export Agent: Rocke International Corp., 13 E. 40th St., N.Y.C. Cable ARLAB

NOTE: The Mallory Radio Service Encyclopedia, 6th edition, makes reference to only one source of radio receiver schematics—Rider Manuals.  
 ANOTHER NOTE: The C-D Capacitor Manual for Radio Servicing, 1948 edition No. 4, makes reference to only one source of receiver schematics—Rider Manuals.



# Tube Testers for Today and Tomorrow...

SPECIFY  
**TRIPLETT**

## UP and DOWN

### Lever Switching Connects Each Tube Pin to Proper Circuit

- 1. ALL ELEMENT CHECK** — Thorough conclusive test of tube elements, shields and taps. The only commercial tester to get at each tube pin and make an open and short check.
- 2. NO HUNTING FOR SOCKETS** — No plugging into wrong socket. Circuit flexibility requires only one socket for each type of tube base.
- 3. CIRCUIT CLARITY** — Lever switch numbering corresponds to RMA tube pin numbers, connected to bring out each active tube element. A simple up or down motion of the lever instantly makes the connection.
- 4. OPERATION SIMPLICITY** — Minimum of control settings plus straightforward arrangement of this outstanding emission circuit. Generally not more than five of the 10 lever switches need be set.
- 5. "PICTURE" YOUR CIRCUIT** — Assures confidence in tests and enables special tube checks for balanced circuits, special loads, etc. "Trick" switching circuits make it more difficult for the serviceman to "picture" his test circuit.
- 6. SET UP YOUR OWN TEST FOR NEW TUBES** — The "pictured" circuit and straightforward test procedures enable the user to set up data for new tubes. A feature rarely found in commercial type tube testers.
- 7. INDIVIDUAL CONTROL FOR EACH TUBE ELEMENT** — Takes care of roaming elements, dual cathode structures, multi-purpose tubes, etc., in addition to standard value tests.

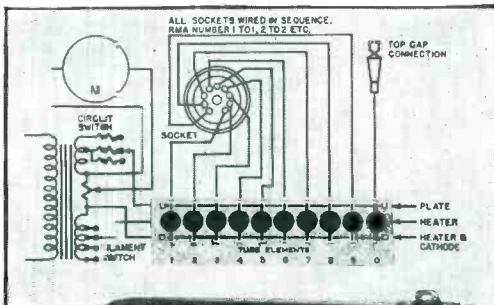

#### TUBE TESTER MODEL 3413

Triplett lever switching circuit arrangement has 7 distinct advantages contributing to maximum flexibility, simplicity of operation and anti-obsolence.

**NET DEALER \$66.75 PRICE**



### ... Combination

#### Volt-Ohm-Mil-Ammeter Model 3480

This tester combines the Tube Tester Model 3413 with complete facilities for voltage current and resistance analyses . . . a real economy for those shops requiring a combination tube tester and volt-ohm-mil-ammeter . . . Attractive two tone metal case with detachable hinged cover . . .

#### TECH DATA

D. C. Volts: 0-3-12-60-300-1200, at 10,000 Ohms/Volt.  
 A. C. Volts: 0-3-12-60-300-1200, at 2,000 Ohms/Volt.  
 D. C. Amps: 0-12, at 250 Millivolts.  
 D. C. Milliamps: 0-1.2-12-120, at 250 Millivolts.  
 Ohms: 0-1000-10,000 (10-100 at center scale).  
 Megohms: 0-1-50 (10,000-500,000 Ohms center scale).  
 Output: Output Jacks, Condenser in series with A. C. Volt ranges.  
 Scale: 5.6" long on top scale arc. 0-1000 Ohms and 0-50 Megohms on top arc.  
 0-12-60-300 A. C. and D. C. Volt figures are on four separate arcs. Scale markings are black on white except A. C. are red on white; 0-1K Ohms scale is green on white.

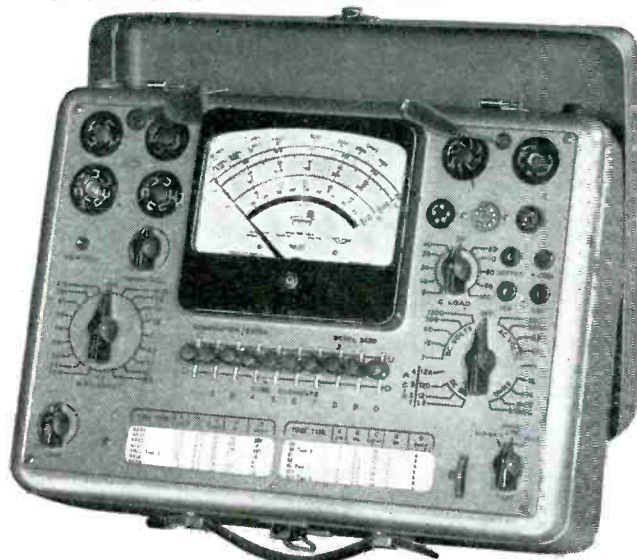

MODEL 3480 **\$98.75** . . . U.S.A. Dealer Net

SEE AT YOUR RADIO PARTS DISTRIBUTOR OR FOR MORE INFORMATION . . . WRITE

**TRIPLETT ELECTRICAL INSTRUMENT COMPANY • BLUFFTON, OHIO, U.S.A.**

In Canada: Triplett Instruments of Canada, Georgetown, Ontario

*Precision first... to Last*





**SYLVANIA  
RADIO TUBES...**



**... MAKE THE SERVICE  
DEALER HAPPY...**

**W**hether a replacement job calls for miniatures, standard tubes or the famous Lock-Ins, you can install Sylvania Tubes with complete confidence. You know they'll give the kind of performance that builds good will among your customers!

And... don't fail to cash in on Sylvania's national advertising. Make full use of the Radio Serviceman's decal—your decal—featured in every single one of Sylvania's national ads!



**... BECAUSE THEY KEEP  
SET-OWNERS HAPPY!**

**DISPLAY THE DECAL THAT  
BRINGS CUSTOMERS  
TO YOU!**

# SYLVANIA ELECTRIC

*Radio Tube Division, Emporium, Pa.*

MAKERS OF RADIO TUBES; CATHODE RAY TUBES; ELECTRONIC DEVICES;  
FLUORESCENT LAMPS, FIXTURES, WIRING DEVICES; ELECTRIC LIGHT BULBS

Sylvania Electric Products Inc.  
Radio Tube Division  
Advertising Dept., Room R-1509  
Emporium, Pa.

Gentlemen:

Please send, FREE, the following quantities of the Sylvania Serviceman's decals:

..... 8-inch size ..... 12-inch decals

Name .....

Company .....

Street Address .....

City ..... Zone # .....

State .....

RADIO · TELEVISION · ELECTRONIC  
**SERVICE**

### Outdoor TV Antennas

THE INDOOR-OUTDOOR TV antenna debate has become quite a hectic affair prompting many strongly-worded comments from industry specialists, stressing the need for outdoor installations particularly for high-band television.

The experts have declared that although indoor antennas will operate satisfactorily on the low bands, in line-of-sight high-signal areas, performance falters on the high bands. Commenting on this problem in this issue (page 10) Ira Kamen declares that . . . "Most indoor antennas fail to operate satisfactorily at the high frequencies due to increased signal loss, a result of the narrow bandwidth of indoor antenna construction, and the high attenuation and reflection of the transmitted h-f signals caused by building materials."

In another stand on the subject, involving a purported statement by a Chicago real estate agency official that "indoor television antennas are adequate in 95 per cent of the Chicago areas," Gardiner G. Greene of Workshop Associates declared that this is certainly not the case. He noted that television might be satisfactory with an indoor antenna in an apartment on one side of the building, while on the other side, a strong outdoor system would be absolutely necessary.

"Indoor antennas," he said, "are sensitive to a person moving about, turning on of the lights and to other motions, all of which may fade the tv picture. Maximum reception is possible therefore, in a great majority of the cases, only with an adequate outdoor antenna."

In another review of the problem, Jerome J. Kahn of Standard Transformer Corporation and an RMA director, said that the industry faces a serious condition in what appears to be a concerted drive by the nation's real estate boards to discourage tenants from erecting outside television antennas.

Kahn declared that this is a problem which can be solved only on a nationwide basis.

"First, the industry must bring into the open what is obviously a careful organized campaign against antenna installations," he emphasized, "and then we must either meet the objec-

tions of the real estate groups which have instigated this opposition and provide assurances of installations which will protect their property or otherwise put an end to this covert but serious obstacle to television sales."

### TV Receiver Shipments Climb

TELEVISION RECEIVER SHIPMENTS by RMA member-companies were 50 per cent greater during the second quarter of 1948 than in the first quarter, with total postwar shipments as of June 30 more than 425,000.

TV sets were shipped to 31 states and Washington, D.C., during the second quarter of this year as compared with 26 states and Washington, D.C., during the first quarter. Installations have been made in over 60 cities in the east, middle west, south, southwest and far west areas.

### TV Alignment

ONE OF THE MOST IMPORTANT phases of television servicing is *alignment*, a procedure which, as we have indicated many times, requires a keen familiarity with receiver circuitry and instruments required for the job. As an assist in this all-important activity, Les Libby, chief engineer of Kay Electric and Omega Laboratories, has prepared an extremely detailed series of articles on *TV alignment* for *SERVICE*, the first of which will appear in the October issue.

In the initial installment there'll appear an extremely thorough analysis of instrument uses and the specific circuit features with which the Service Man should be well acquainted to affect best alignment. Complete block diagrams of test setups, alignment curves and circuits of the leading tv receivers will be offered.

Don't miss this and subsequent installments, which we believe will be one of the most interesting and useful sets of articles ever offered to the Service Man.

### Simple Explanation of F-M/A-M

A SIMPLE YET EFFECTIVE explanation of f-m and a-m has been received from B. Diener, who is in the engineering department of Hoffman Radio.

Diener says: "A-m, or standard

broadcast, is a fixed frequency with an instantaneous variation in the amplitude of the signal. F-M is a fixed amplitude with an instantaneous variation of frequency, these variations corresponding to the music or voice being transmitted by the station. Since noise is essentially an amplitude phenomena, an f-m set which does not respond to a-m will materially reduce the amount of noise received."

Short and complete!

### RMA Service Committee

AN EXPANDED 22-MEMBER industry Service Committee which will project improved servicing techniques was announced recently by the RMA.

The committee will continue to direct the RMA plan adopted last year to encourage receiver owners to call for qualified and franchised Service Men, maintain liaison with Service Men associations and campaign against any municipal licensing of Service Men.

A. T. Alexander of Motorola, Inc., was named chairman of the new group, and former chairman W. L. Parkinson of General Electric, was appointed vice chairman. Other members include R. A. Chesnut, Noblitt-Sparks Industries, Inc.; George Cohen, Emerson Radio and Phonograph Corp.; W. J. Cooper, Stewart-Warner Corp.; Harry A. Ehle, International Resistance Company; F. L. Granger, Stromber-Carlson Company; K. L. Granger, International Detrola Corp.; Robert Herr, Philco Corp.; B. G. Hickman, The Sparks-Withington Company; W. L. Jones, RCA Service Company; Harry Kalker, Sprague Electric Company; Bruce R. Lafferty, The Hallicrafters Company; M. W. McKnew, Westinghouse Electric Corp.; H. A. Newell, Crosley Division; Avco Mfg. Corp.; F. B. Ostman, Farnsworth Television and Radio Corp.; Don J. Phelps, General Instrument Corp.; E. A. Pool, Wells-Gardner Corp.; J. O. Renskers, Belmont Radio Corp.; Frank E. Smolek, Zenith Radio Corp. and M. R. Weissman, Kings Electronics Co., Inc.

Congratulations RMA on the selection of so able a group, which we know will be eminently successful in their work.—L. W.

# High-Frequency

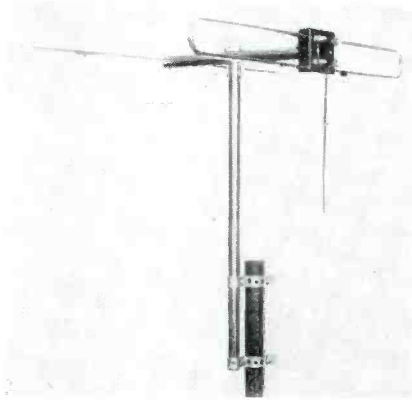

Fig. 1. A h-f attachment with a divider network which isolates the attachment from the l-f antenna. (Courtesy Vertron.)

Channel	Starting Length of Stubs	
	Open	Shorted
2,3	45"	90"
4	40"	80"
5,6	35"	70"
F-M	30"	60"
7-13	16"	32"

Fig. 2. Table of lengths of stubs used to eliminate cross modulation and f-m interference.

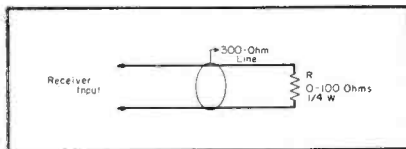

Fig. 3. Connection of resistor to control attenuator effect of stub.

Fig. 4. Typical r-f interference pattern on picture-tube screen. (Courtesy Belmont Radio.)

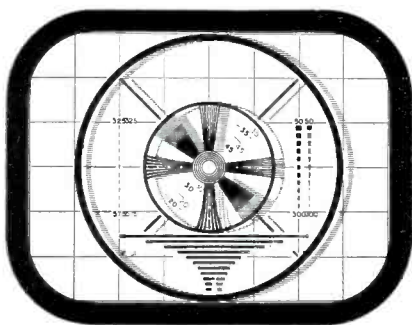
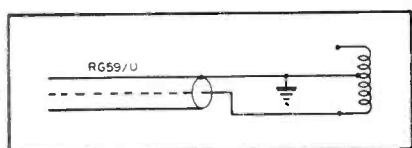

Fig. 5. Circuit illustrating the connection of coax cable to 300-ohm tv receiver inputs.



THE HIGH-FREQUENCY TV channels have introduced many new installation problems.

These new problems may be divided into four categories:

(1) Inefficiency of satisfactory low-frequency tuned indoor and outdoor antenna systems on the high-frequency channels.

(2) Mal-effects at the 7-13 channels of stub filters and other devices required in antenna circuit to solve channel 2-6 tv interference or cross-modulation problem.

(3) Tv receivers with inefficient front ends on the high-frequency channels or excessive local oscillator interference reradiation on the high-frequency channels.

(4) Fundamental deficiencies in earlier tv receiver designs.

Analyzing those antenna systems which are not efficient at high frequency channels, we find:

(a) Three-element arrays (dipole, director and reflectors) when adjusted for operation on the 2-6 channels, are very inefficient at the high frequency channels because of their very narrow bandwidth.

(b) High-Q folded dipoles, adjusted for the low frequency channels, also have a very narrow bandwidth. These antennas have narrow dipole tubing which raises their Q. Large size tubing used for folded dipoles lowers the Q and broadbands the antenna.

(c) Straight dipoles, adjusted for the low frequency channels, matched into 50-75 ohm coaxial lines, are very inefficient at the high-frequency channels because of the severe mismatch of the antenna to the low-impedance coaxial line at its off-resonant frequencies. The solution, of course, where high-frequency reception is required from a single antenna array, is the use of a high-frequency attachment, installed in accordance with the technique outlined in the previous installment<sup>1</sup> of this series. Best adjustment is usually obtained with a high frequency attachment that has a divider network which isolates the attachment from the low frequency antenna, as

shown in Fig. 1. These attachments (with or without divider networks) should be installed above the low-frequency arrays, so that ground capacities have a minimum influence in the high-frequency element.

## Indoor Antenna Problems

Most indoor antennas fail to operate satisfactorily at the high frequencies due to increased signal loss, a result of the narrow bandwidth of indoor antenna construction and the high attenuation and reflection of the transmitted high-frequency signals caused by building materials. There is also considerable consumer resistance to installing more than one indoor antenna to cover all the tv channels.

The advent of the high-frequency channels has also minimized the effectiveness of indoor antennas in multiple dwellings. Adjustable window mounted antenna rods described in a previous article<sup>2</sup> are the most practicable units for multiple dwellings where roof-top antennas are not permitted, or where a master antenna system has not been installed.

Coaxial cable, used in antenna system, has considerably more loss at the high-frequency channels than in the low-frequency band. In all tv installations, where coaxial cable runs of RG59/U exceed 100' and the high-frequency channel signal is weak, the installation of RG11/U will provide a noticeable improvement.

Tv installers should avoid surplus cable unless adequate test facilities are available to check cable attenuation. Many reels of cable, on the surplus market, have an attenuation characteristic much higher than the present commercial standards for new coaxial cable.

## Interference Eliminators

In most cities, the low frequency channels were the first ones placed in operation. Many devices were installed as interference eliminators in the antenna circuits of these l-f channel receivers. The most common device installed to eliminate interference from strong adjacent tv channels and f-m station signals which appeared in tv patterns was the stub, a piece of 300-

<sup>1</sup>Kanien, August, 1948, SERVICE.

<sup>2</sup>Kanien, July, 1948, SERVICE.

# TV Antenna Installations

**Antennas And Installation Procedures Which Afford Best Results. Solving Major H-F Installation Problems Facing Service Men, Involving L-F Tuned Indoor And Outdoor Antennas, Stub Filters Used For Curbing Interference In The 2 To 6 Channels, Local Oscillator Interference, Resistors At H-F, Interfering Frequencies And Metal Backs of Receivers Which Act As Antennas.**

by **IRA KAMEN**

*Manager, Television Antenna Dept.  
Commercial Radio Sound Corp.  
New York City*

ohm twin-lead which could be used open or shorted to attenuate an unwanted tv or i-m signal.

In Fig. 2 appears a table of *stub* lengths. It will be noted that the lengths are called *starting lengths*. This term has been applied because it is usually necessary to reduce the lengths specified an inch at a time with sidecutters until the *stub* filter is at its most efficient length. In the case of the strong adjacent tv channel, where channel 2, for example, appears behind a channel 4 pattern, a 45" (open) or 90" (shorted) piece of transmission line is reduced in length until the channel 2 signals are eliminated from the channel 4 pattern.

The larger shorted type of *stub* is preferred where the attenuation must be controlled. For example, the interfering adjacent tv station should not be so severely attenuated that it cannot be used when the station selector of the tv receiver is tuned to that channel. Attenuation levels can be controlled if a 100-ohm  $\frac{1}{4}$ -watt resistor is installed in the *stub* filter circuit; Fig. 3.

All adjustments on these *stubs* must be made in the location where the *stub* is to be finally installed. Surroundings have a considerable influence on the *stub*. It is better to lay on the floor underneath or behind the tv receiver and cut the *stub*, than to push the receiver away from its installed position for a more comfortable adjustment which may not be satisfactory when the receiver is returned to the installed position.

While these *stubs* do their job well at the low-frequency channels, f-m and the high-frequency channels, many of the *stubs* adjusted for low-frequency channels seriously degrade the pictures on the high-frequency channels. The only way to solve this problem is to connect the *stub* to the tv receiver through a high-frequency anti-capac-

ity transfer switch. The switch will remove the *stub* from the antenna circuit, when the receiver is tuned to the high-frequency channels.

As a general procedure, when installing h-f attachments at the antenna end, the receiver should be checked to make certain the receiver input is free of *stubs*. A *stub*, which loads the transmission line, can produce ghosts in the picture. The *stub* can be inserted after the h-f attachment is installed, a check being made to determine its effect on the new h-f channel or channels.

When a wide-band array is installed and a new h-f channel goes on the air, reception should be checked without *stubs* at the receiver input.

In the h-f channels, we are faced with another unusual factor:

A resistor is not a resistor at the h-f tv channels.

Resistance values change more than 25% (decrease) from their d-c reading at 200 mc. A resistor's lead inductance (need only be an inch or so) at 200 mc may have a considerable effect on a value of less than 100 ohms. Many matching pads are not what they are supposed to be because of these h-f effects. When buying resistors for coaxial matching and attenuation pads, it is a good idea to specify that the resistance value be furnished for 50 to 200-mc operation. All leads from the resistors should be kept as short as possible when assembling resistive pads.

#### **R-F Gain Problems**

Many of the tv receivers installed to date have considerably less sensi-

tivity at the h-f channels due to reduced r-f stage gain. Lack of adequate test equipment in 1946 made it difficult for some manufacturers to measure the gain of their tv receivers at the h-f channels and as a result, many receivers which have 50-75 microvolt sensitivity at the 2 to 6 channels require more than 250 microvolts on channels 7 to 13. New design practice in tv receivers is to make the sensitivity at channels 7 to 13 greater than for channels 2 to 6 because antenna and transmission line losses are higher at the h-f channels and therefore less input signal is available.

Reradiation from the local oscillator of most tv receivers is considerably higher at channels 7 to 13 than at the 2 to 6 channels. This reradiating signal starts from the tv receiver local oscillator, couples into the r-f input, climbs the transmission line, and radiates from the antenna. Interfering signals have been picked up over 1000' from an offending tv receiver on the h-f channels. The interfering signal manifests itself in straight or slanting lines on the tv pattern, as shown in Fig. 4.

Adjacent tv receivers have been found to block each other when one receiver is tuned to channel 7, another is operating on channel 6 and still another is operating on channel 11. The local oscillator in the receiver *tuning in* channel 7 is transmitting a signal on channel 11. To solve this serious problem, the industry is considering a change in i-f frequencies, so that the local oscillator will always radiate in a frequency range which will be above or below the adjacent tv channels in any specific area. Most 1949 models will have less reradiation on all tv channels. FCC chairman Wayne Coy has warned the

(Continued on page 51)

# Electric Power Required For Sound Systems

**Major Sound Factors . . . Location (Room Acoustics, Echoes And Reverberation), Types of Program (Indoor and Outdoor), Acoustic Power Requirement, Acoustic Noise Level And Loudness Efficiency . . . Evaluated In Series of Curve Charts, Serving As Extremely Useful Guide For the Sound Man. Typical Examples Offered.**

by E. L. KENDALL

INFORMATION FROM WIDE, practical, application experience has made it possible to prepare data\*<sup>1</sup> which relates the acoustic levels required and the electrical power capabilities for sound systems for indoor volumes and outdoor areas.

For the determination of required electrical power requirement, the following factors must be taken into account:

- (1) Location to be covered (indoors or outdoors).
- (2) Type of program material to be reproduced.
- (3) Acoustic power capacity required.
- (4) Acoustic noise level in the location to be covered.
- (5) Loudness efficiency of the loudspeakers being used.

## Location

If the location is an outdoor one, the distance to be covered must be known; Fig. 2. The necessary angle of coverage with respect to the point of location of the loudspeaker or loudspeakers must also be known. If the location is an indoor one, the volume to be covered must be known; Fig. 1. (The information which follows will be ade-

quate for the volume to be covered if the reverberation time at 512 cycles per second is within the limits of one-half to twice the average times for reproduced sound.)

**Room Acoustics:** The purpose of a sound system is to supply sound throughout a room at the proper volume and quality. It should never be considered as a remedy for the acoustic defects of a room. Although there are cases where a sound system helped improve listening conditions in a room which was poor acoustically, there are other cases where the increased loudness of sound made it more difficult to understand. It is therefore important that careful consideration be given to the acoustic conditions of a room in which a sound system is to be installed.

(The determination of the proper acoustical treatment for a room is a job for an expert. The following data are intended as an aid in judging the acoustical condition of an existing

*\*From a report prepared by the Operadio Manufacturing Co., in cooperation with the RMA engineering department.*

*<sup>1</sup>Data are offered as an interim method of determining required electrical power, pending more exact information.*

room, no attempt being made to include all the data required in making recommendations for necessary improvements.)

**Echoes:** When a surface of a room is so situated that a reflection from it is outstanding and is heard by the listener an appreciable length of time later than the direct sound, it will appear as a distinct echo and will be disturbing. If the surface is concave, it may have a focusing effect and concentrate reflected sound energy at one locality. Such a reflection may be several db higher in level than the direct sound and its arrival at a later time will be particularly disturbing.

In such cases there are three possible remedies. The offending surface can be covered with absorbing material to reduce the intensity of the reflected sound; it can be changed in contour and thus send the reflected sound in another direction; or some improvement may be obtained by changing the loudspeaker to a new position. The best method of solving any particular problem will depend on local conditions.

**Reverberation:** One of the most common acoustic defects encountered in an

auditorium is that of excessive reverberation. Reverberation is the persistence of sound due to the multiple reflection of sound waves between the several walls of the room. Some of the sound energy is absorbed at each reflection; the rest remains in the room as audible delayed images of the original source. The longer the time interval between reflections (the larger the room), and the lower the absorbing efficiency of the reflecting surfaces, the longer will be the time that this residual sound will persist. The result is an overlapping of the original sound and its images.

### Reverberation Problems

This reverberation causes a general confusion which is detrimental to speech intelligibility. At the same time, it increases the loudness of the sound in the room, which is beneficial to intelligibility. Consequently, there is an optimum amount of reverberation for any room, determined by a balance between the loss in intelligibility due to confusion and the increase in intelligibility due to the increased loudness. In the case of music, a certain amount of reverberation is required to give pleasing quality and brilliance. Reverberation which would be ideal for music is somewhat in excess of that which would be best for speech and, since most auditoriums are used for both speech and music, a compromise is usually made.

Reverberation in a room is expressed quantitatively by the *reverberation time*, which is the number of seconds required for a sound to decrease 60 db from its initial value, after the source has been stopped.

In general, the time will be different for different frequencies, and the reverberation time for a room is usually given for a frequency of 512 cycles.

The reverberation time at other frequencies is just as important as at 512 cycles. In fact, it is fully as important to have the proper relation between reverberation time and frequency, as it is to have the optimum reverberation time at any one frequency. The desirable relation between reverberation time and frequency varies with room volumes.

### Type of Program

**Indoors:** The greatest sound pressure level is required for the reproduction of concert music. For this type of reproduction, *curve A* of Fig. 1 should be used. For the average sound system used to reproduce speech, vocal music, dance music and the like, *curve*

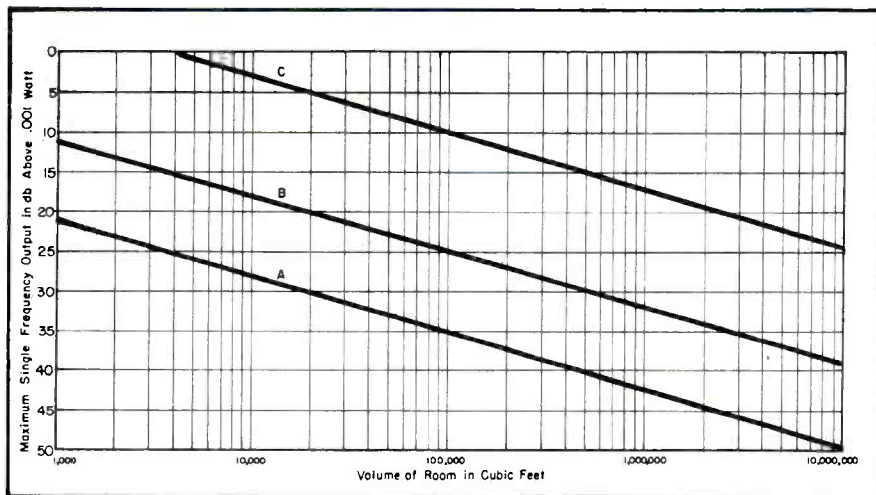

Fig. 1. Acoustic power requirements, indoors. The *A* plot shows the maximum requirements for concert music; *B*, normal public address requirements for music; *C* normal requirements for speech.

*B* should be used. For a system intended to reproduce speech only, *curve C* should be used.

speech program material in outdoor applications.

### Acoustic Power Requirement

#### Outdoor Programs

More power is ordinarily required to produce the desired sound pressure levels outdoors because the sound is not reinforced by reflections from walls and ceiling. The levels required are based on the maximum distance from the loudspeaker at which the sound is to be heard. For outdoor applications, the curve in Fig. 2 should be used. The coverage angle is 30° for the information contained in this figure. Speech levels are used, as music is ordinarily incidental to

The acoustic power requirement of a sound system is the maximum rms acoustic power which the system is required to reproduce on a steady tone without exceeding the distortion and power handling ratings of the components of the system.

The required acoustic power requirement for the conditions of use stated, is obtained from Figs. 1 or 2. In using these data, the following considerations also enter:

- (a) A loudspeaker arrangement is assumed which will distrib-

Fig. 2. Acoustic power requirements, outdoors.

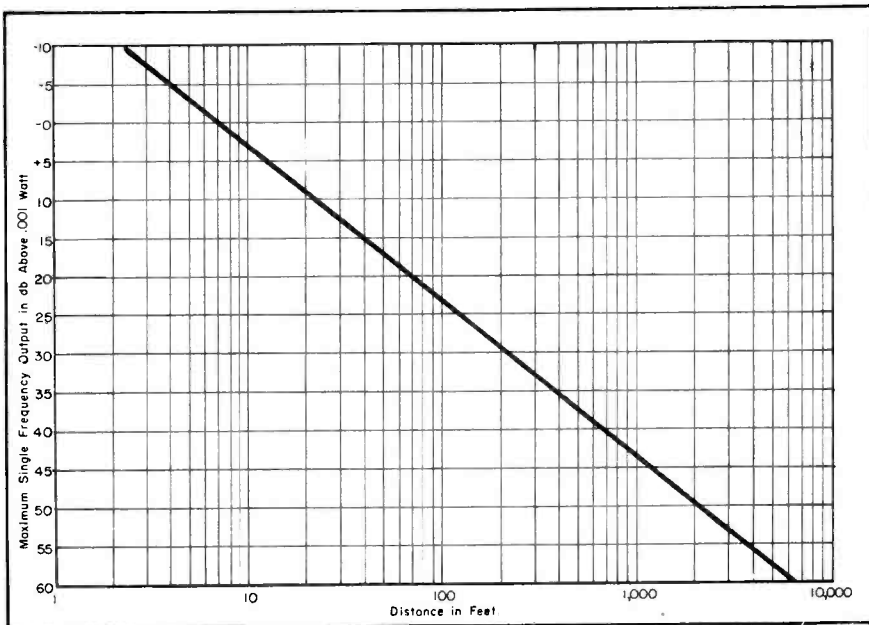

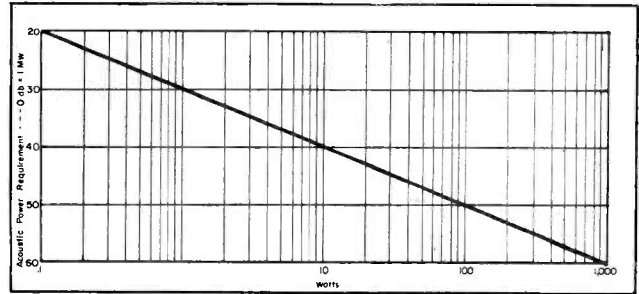
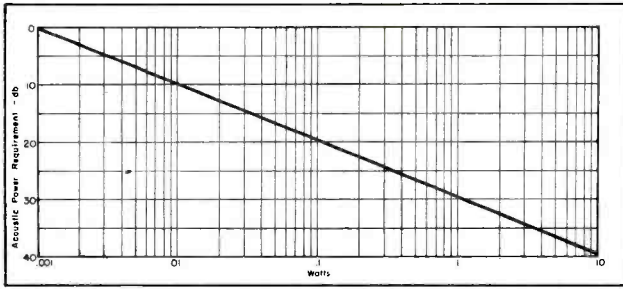

Fig. 3 (left) and 4 (right). Amplifier power capability characteristics are illustrated in these plots.

ute sound properly throughout the space (room or area) to be covered.

- (b) The use of the information given is not recommended for rooms of odd shapes, such as very long, narrow rooms.

Systems providing the acoustic power capacity indicated on Figs. 1 and 2 will produce average sound pressure levels approximately, as follows, on steady tones at the rated power:

Curve A (Fig. 1), Concert music indoors, 105 db.

Curve B (Fig. 1), Average music indoors, 95 db.

Curve C (Fig. 1), Speech only indoors, 80 db.

Curve (Fig. 2), Speech outdoors, 80 db.

#### Acoustic Noise Level

The information contained in Figs. 1 and 2 is based on the assumption that the locations being covered are quiet locations. Should the acoustic noise level be higher than 70 db, the required acoustic power capacity of the sound system must be increased by the number of db that the noise is higher than 70 db for curve in Fig. 2 and curve C in Fig. 1. When music is to be reproduced and the noise level is higher than 70 db, the same considerations apply. In addition, each case is a special problem involving subjective factors such as distraction of listeners due to the wider dynamic range existing in music than in speech. Therefore, no general rule can be applied safely.

#### Loudness Efficiency of Loudspeakers

The loudness efficiency of a loudspeaker is the figure which when applied to the electrical power capacity of a sound system gives the acoustic power capacity. Thus it is the loss factor to be used in converting from

electrical to acoustic power. The following efficiency values should be used:

Type of Loudspeaker	Tentative Efficiency Values	
	Percentage	Db Loss Factor
Small direct radiators (10" and smaller)	2%	17 db
Large direct radiators (12" and over)	5%	13 db
Horn type loudspeaker	15%	8 db

In addition, it will be necessary to add a correction for outdoor coverage if the actual coverage angle of the loudspeaker used is other than 30°. This correction in db is:

$$\text{db} = 10 \log_{10} \frac{S^\circ}{30^\circ}$$

where  $S^\circ$  = the horizontal angle of coverage of the speaker being used in degrees.

#### Typical Examples

To illustrate the application of the foregoing data in determining required electrical power requirement, two typical examples are offered:

**Indoor example—Known...** Room dimensions: 80' long, 40' wide, 20' high. (Volume 64,000 cubic feet.)

Direct radiator loudspeaker to be used, 12" diameter.

Reverberation time at 512 cps, 1.2 seconds.

Noise level, 65 db.

Speech and dance music to be reproduced.

Then... From Fig. 1, curve B:

The acoustic power capacity for 64,000 cubic feet is 23.5 db above .001 watt.

Noise level is 65 db. Therefore no additional capacity is required on this account.

For 12" direct radiator add 13 db. Then the electrical power ca-

capacity required for the amplifier is 36.5 db above .001 watt. Therefore, amplifier power capacity required is 4.5 watts (36.5 db above .001 watt).

#### Outdoor Example

**Known Factors...** Distance from loudspeaker to be covered, 200'. System primarily for speech reinforcement.

Included angle to be covered, 70°. Horn type loudspeakers to be used. Horizontal coverage angle of each, 40°.

Noise level, 72 db.

Then... From the curve in Fig. 2: the acoustic power capacity for 200' distance is 29.2 db above .001 watt.

Noise level is 72 db. Therefore, 2 db must be added (72-70) to 29.2 to obtain required acoustic power capacity or 29.2 + 2 is 31.2 db above .001 watt.

For a horn type loudspeaker 8 db must be added. Then the electrical power capacity required for a single horn type speaker is 39.2 db above .001 watt.

The horn being used covers 40° but the curve is based on 30° coverage. Therefore a 1.3 db correction is required ( $10 \log_{10} \frac{40}{30} = 1.25+$ ) or electrical power capacity of 40.5 db above .001 watt.

Finally each speaker covers only 40° but an included angle of 70° is to be covered.

Therefore, two speakers are required, so twice the electrical power capacity or 43.5 db above .001 watt is required.

Therefore, amplifier power capacity required is 22.5 watts (43.5 db above .001 watt).



**DANGER  
HIGH  
VOLTAGE**

# SAFE..SIMPLE

**HIGH VOLTAGE TV Tests to 30,000 VOLTS**

WITH THE NEW

## PRECISION SERIES TV

**Super High Voltage Safety Test Probes**



- ★ Extended high dielectric anti-leakage paths.
- ★ Multi-channelled guard barrier.
- ★ Full handle length internal arc-back shield directly grounded.
- ★ External arc-back barrier directly grounded.
- ★ Fully shielded instrument connecting cable.
- ★ All critical high potential and ground connections within the probe are positively accomplished via high compression contact springs.
- ★ Special helical film-type cartridge multiplier, developed specifically for very high potentials.
- ★ Custom molded polystyrene probe head, bakelite handle and barrier. Specially machined and tooled lucite internal components.
- ★ "Application Engineered" to meet the exacting requirements demanded by its intended field of usage.

NOW . . . the TV high voltage test problem solved with safety and operational confidence. A super high voltage test probe, "Application Engineered" for the job . . . tested on the job . . . approved for the job. Custom designed for YOUR safety FIRST, and providing the accuracy, dependability and reliability you expect from products bearing the "Precision" name.

★ Convenient (Tool-less) means for rapid removal and interchange of the special cartridge style high voltage tubular multiplier permits a single TV probe to be employed with more than one, high sensitivity, multi-range test set, via purchase of the appropriate cartridge.

Series TV High Voltage Test Probes are now on display at all leading radio parts distributors and are available as follows:

★ Series TVP  
High Voltage Test Probe LESS multiplier cartridge.

Net Price \$12.35

★ Series TV-1  
Model TVP with cartridge for Precision Series EV-10VTVM.

Net Price \$15.45

★ Series TV-2  
Model TVP with cartridge for Precision (or any) 20,000 ohms per volt test sets having a built-in 6000 volt DC range.

Net Price \$15.45

★ Stock value and special value multiplier cartridges are available to match most popular high sensitivity test sets.

Series TV High Voltage Test Probes provide direct kilovoltmeter facilities with your present high sensitivity test set, and vacuum tube voltmeter such as the "Precision" instruments illustrated below.

◆ See them on display at all leading radio equipment distributors along with the complete Precision line of modern electronic test instruments for all phases of AM-FM-TV service and maintenance. ◆



**Model 85**  
Laboratory Type 20,000 ohms per volt AC-DC test set. Full rotary range and function selection. 34 self-contained ranges to 6000 volts, 60 megohms, 12 amperes, + 70 DB. 4½" full vision meter.

Net Price \$38.75

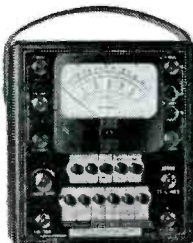

**Model 858-L**  
20,000 ohms per volt Multi-Master. High Speed, Wide Range, push button operated AC-DC V-O-M. 54 ranges to 6000 volts, 600 megohms, 12 amperes, + 70 DB. Full vision 4½" meter.

Net Price \$54.10

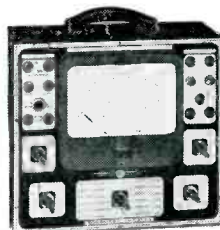

**Model EV-10 MCP**  
Multi-range, high sensitivity, zero-center VTVM plus complete AC-DC V-O-M facilities to 6000 volts, 2000 megohms, 12 amperes, + 70 DB with extra large 7" meter.

Net Price \$89.95

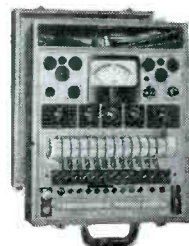

**Model 10-54-P**  
Combination Electronic Tube Tester, and 20,000 ohms per volt AC-DC V-O-M. Self-contained rotary selective ranges to 6000 volts, 12 amperes, 60 megohms, + 70 DB. 4½" full vision meter.

Net Price \$134.40

## PRECISION APPARATUS COMPANY, INC.

92-27 Horace Harding Boulevard • Elmhurst 6, New York

Export Division: 458 BROADWAY, NEW YORK CITY, U. S. A. • Cables: MORHANEX

Fig. 1. Typical characteristics of a dynamic noise suppressor. A, B and C indicate conditions of maximum expansion, intermediate suppression and maximum suppression at the h-f end. D, E and F illustrate corresponding l-f curves.

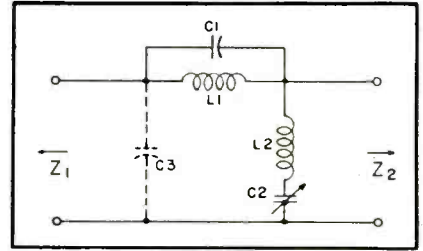
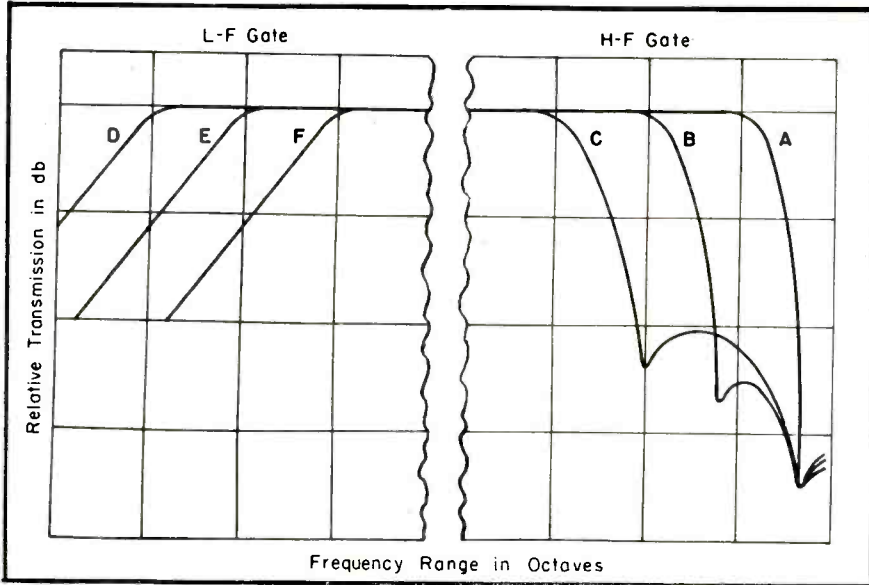
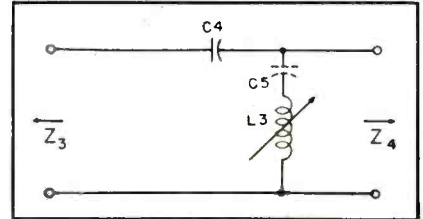

Fig. 2. A typical h-f gate circuit. C2 represents a reactance tube.

Fig. 3. A low-frequency gate circuit.



# Dynamic Noise Suppressors

## Classification of Noise Reducing Systems For Recordings . . . Gate Circuit Characteristics . . . Application Data.

by **HERMAN HOSMER SCOTT**

Herman Hosmer Scott, Inc.

THE PAST FEW YEARS have seen recorded music not merely re-establish, but actually exceed, its former popularity. This has naturally resulted in a great increase in interest in all systems for improving the reproduction of phonograph records.

The reduction of noise in phonograph music is particularly important since even the best records have noticeable noise levels, and the worst are intolerable if played on wide-range equipment. Many systems have been proposed for reducing phonograph noise.

### Classification of Noise-Reducing Systems

Noise-reduction systems may be classified in two ways: They all consist of some means of varying the transmission of a system in accordance with some characteristic of the signal. When the response of such systems

under different signal conditions are plotted, a family of curves will be obtained; and the systems range between two extreme classes, those in which the variation is vertical as, for instance, the volume expander, and those in which the variation is horizontal as, for instance, the *dynamic noise suppressor*.<sup>1</sup> Consequently, systems may conveniently be classified as *horizontal* or *vertical* or, of course, some intermediate type.

Another classification concerns the instantaneous amplitude characteristic, and convenient terminology may be borrowed from amplifiers. A class *A* system is one, except for any filtering action, in which the output wave-form is a replica of the input wave-form. A class *C* system is one non-linear with respect to a single cycle of the applied wave-form. Such systems tend to attenuate low-level signals or

<sup>1</sup>Scott system.

noise because of the kink in the amplitude characteristic. Such a device, however, introduces harmonic and intermodulation distortion, some but not all of which may be removed by means of filters. Important intermodulation products remaining are  $2f_1-f_2$ ,  $2f_2-f_1$ , etc. The *dynamic noise suppressor* is a class *A horizontal* system.

In order for a noise-reduction system to be entirely effective, it is desirable to control the transmission characteristics in accordance with some features of the signals not present in the noise. This is possible only in class *A* systems where the control function which usually resides in grid biases, etc., may be divorced entirely from the controlled circuits. In a class *C* system, the transmission in a controlled range is a function of any voltage in that range whether noise or signal; hence a class *C* system does

(Continued on page 39)

**ALL  
NEW**

P. R. MALLORY & CO. Inc.  
**MALLORY  
Midgetrol**

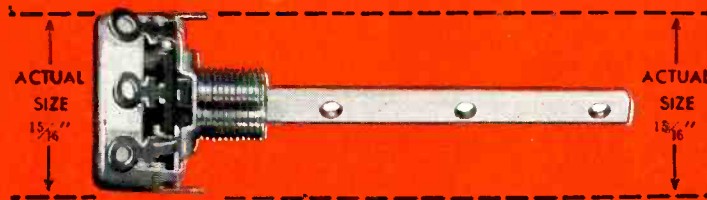

*The Little Volume Control  
with BIG Advantages*

**Bigger  
Market**

The small size of the Mallory Midgetrol lets you service portables, auto radios and small AC-DC receivers which require  $15/16''$  controls.

**Simpler  
Installation**

The unique shaft design of the Mallory Midgetrol saves installation time with *all* types of knobs.

**Simpler  
Stocking**

Electrical characteristics let you use the Mallory Midgetrol to replace  $1\frac{1}{8}''$  as well as  $15/16''$  controls. Stocks are further reduced because no special shafts are needed.

The Mallory Midgetrol is quietest by actual tests—and tests prove it stays quiet, too. In addition, it has nine big features that are *all new*.

- NEW SIZE
- NEW DESIGN
- NEW SHAFT
- NEW EXTENSION
- NEW SWITCH
- NEW ELEMENT
- NEW CONTACT
- NEW TERMINAL
- NEW TWO-POINT SUSPENSION

*It's the NEW Standard in Carbon Controls. See your Mallory Distributor.*

P. R. MALLORY & CO. Inc.  
**MALLORY**

CAPACITORS . . . CONTROLS . . . VIBRATORS . . .  
SWITCHES . . . RESISTORS . . . RECTIFIERS . . .  
VIBRAPACK\* POWER SUPPLIES . . . FILTERS

\*Reg. U. S. Pat. Off.

**APPROVED PRECISION PRODUCTS**

**P. R. MALLORY & CO., Inc., INDIANAPOLIS 6, INDIANA**

**NEW  
LOW  
PRICES**

*On RCA Top*



**RCA 15-watt  
DE LUXE AMPLIFIER MI-12295**

**NOW  
ONLY  
\$87<sup>50</sup>**

List price  
complete with tubes

● You've never seen a value like this distinctively styled RCA 15-watt All-Purpose Amplifier. You can't beat it for high quality performance, compactness, beauty, and simplicity of operation under all sorts of operating conditions.

Electronically engineered to give top performance. Frequency response (30 to 15,000 cycles). Two high impedance microphone input channels 116 db. gain (RMA), each with individual volume control. Two hi-impedance phono channels, one for hi-level and one for low-level pickups. Can be used with popu-

lar low output magnetic pickups. Phase inversion and inverse feedback used to obtain low distortion and uniform frequency response for various load conditions. Unique balanced tandem tone control circuit. Choke filtered power supply for minimum hum and uniform regulation. Large functionally designed control knobs. Accessible output terminal board and replaceable cartridge type fuse conveniently located in rear. Set of locking-type 3 pin Cannon plugs and receptacles for each microphone input. Also available with 2 low impedance inputs (250 ohms).

15 watt push-pull Output—  
Noise-free electronic mixing—  
Switch for high-low power  
output requirements — Under-  
writers-approved.

**Additional Unparalleled  
Amplifier Values**

RCA 50-watt De Luxe Hi-Impedance Amplifier MI-12293 **\$197<sup>50</sup>**  
Complete with RCA Tubes . . . . . Now only

RCA 30-watt De Luxe Hi-Impedance Amplifier MI-12296 **\$115<sup>00</sup>**  
Complete with RCA Tubes . . . . . Now only



**SOUND PRODUCTS**  
**RADIO CORPORATION of AMERICA**  
ENGINEERING PRODUCTS DEPARTMENT, CAMDEN, N.J.

In Canada: RCA VICTOR Company Limited, Montreal

# Quality Sound Equipment

## COMPARE...BE CONVINCED!

**More business for you because it's RCA...  
More profit because of these new values**

### RCA SPEAKER

MI-12422



12-inch high efficiency, Alnico V, Cone Type Mechanism. Special cone provides a selected listening characteristic—a result of thousands of listeners' reactions over the past 10 years. 10-watt capacity. 15 ohm voice coil.

**\$12<sup>50</sup>**

Also available with matched 10-watt multi-tap line transformer as MI-12421.

**\$18<sup>00</sup>**



### RCA MOLDED SPEAKER BAFFLES

Molded Plasticized Fibre Baffle with attractive gray hammeroid finish and contrasting grille cloth, 12" x 15" x 5 1/2", sloping front, strong, moisture-resistant, and non-warping. Available for 5", 6 1/2" and 8" mechanisms as MI-6378, MI-6379, and MI-6380, respectively.

**\$3<sup>75</sup>**

*Similar baffles for 5", 6 1/2", 8", 10" and 12" mechanisms also available in molded Bakelite and wood.*

All prices shown are suggested list prices subject to normal dealer discounts.

### RCA VARACOUSTIC MICROPHONE

MI-6204-C

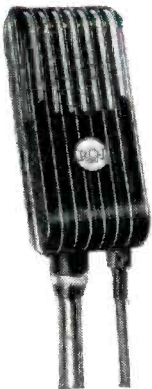

Three microphones in one. Here you have the popular cardioid microphone (uni-directional) *plus* standard velocity microphone (bi-directional) *plus* standard pressure microphone (non-directional) all in one general purpose unit. Variable characteristic obtained by ingenious slider mechanism on rear of housing. Quality and performance found heretofore only in more expensive polydirectional Broadcast Microphones. High sensitivity, shock mounted, high impedance. 30 feet of cable.

**\$67<sup>50</sup>**

These and many other profitable items of sound equipment are available through your RCA Sound Products Distributor.

### NEW BANTAM VELOCITY MICROPHONE

MI-12080-B

Smaller than a pack of cigarettes. First used at all 1948 political conventions. Broadcast quality. Built-in voice-music switch. 15 feet of cable.

**\$60<sup>00</sup>**



MAIL THIS COUPON FOR **FREE CATALOG**



**BUY THE BEST FOR LESS**

84 pages of sound products—microphones, amplifiers, speakers, recorders, intercoms, portable P.A. and numerous other profitable items. Send for your **FREE** copy today.

RCA SOUND PRODUCTS (Dept. 110-1)  
Radio Corporation of America  
Camden, N. J.

Please send me free copy of RCA's new Catalog on complete line of matched sound products and price list.

Name \_\_\_\_\_

Company \_\_\_\_\_

Type of Business \_\_\_\_\_

Address \_\_\_\_\_

City \_\_\_\_\_ State \_\_\_\_\_



# Tests any tube -

... regardless of base connections  
or internal connections of its elements

This is today's outstanding tube tester in simplicity of operation. It is engineered to test all tubes for present radio receivers and any that may come to market within the foreseeable future.

Using the basic RMA recommended circuit, it is possible to test any tube regardless of its base connections or the internal connections of its elements through the use of the new exclusive Simpson three-position lever-operated toggle switches. These new Simpson toggle switches use a molded rotor carrying silver plated contacts which are self-cleaning through their wiping action.

Sockets are provided for all receiving tubes, including the latest nine pin miniature tubes, and the sub-miniatures. Flexible individual element switching arrangement takes care of any future tube developments. Special Simpson acorn tube socket with floating contacts assures positive contact with insurance against damage to the delicate prong construction. Tests can also be made on gaseous rectifiers, pilot lamps and continuity of ballast tubes.

No adapters or special sockets are required. Model 555 is properly fused and provides for line adjustment from 100 to 230 volts with smooth vernier control.

SIZE: 16 $\frac{3}{4}$ " WIDE x 12 $\frac{1}{2}$ " HIGH x 6" DEEP

Dealer's Net Price, complete with test leads  
and Operator's Manual . . . . . \$69.85

*\* Handsome styling for  
quick, accurate operation*

- Panel—Beautiful modern styling in the shining silver and black of highly polished, enduring anodized aluminum.
- Meter—Large, in modern design, facilitates quick observation in tube testing operations. One of the special features is the jewel-like molded Lucite block above the dial opening. This block houses the Neon bulb which glows to indicate shorts and inter-element leakages. Another feature is the projection of the line adjustment control through the meter cover just below the dial opening for ease in observation and adjustment of the line voltage.
- Case—Sturdy plywood with heavy fabricoid covering, slip type hinges and compartment for accommodating line cord and grid cap lead.

With Simpson *No-Backlash* Roll Chart

Ask your jobber, or write for descriptive literature

SIMPSON ELECTRIC COMPANY  
5200-5218 W. Kinzie St., Chicago 44, Ill.  
In Canada: Bach-Simpson, Ltd., London, Ont.

# The Reactance Modulator

**Analysis of Circuit, Employing Capacitive Change, Being Widely Used In F-M Receiving and Test Equipment.**

by **DOUGLAS H. CARPENTER**

THE REACTANCE MODULATOR is one of the most common and least understood methods of accomplishing frequency modulation. This method has found universal acceptance in sweep generator design, and, of course, is the means of providing *afc* in receiving equipment.

The circuit to be described in this article employs a capacitive change, although other types (inductive/push pull inductive-capacitive) have found application in special circuits.

Illustrated in Fig. 1 is a simple two-element oscillator. If we change the setting of the capacitor,  $C_1$ , the frequency of the oscillator must also change. If we connected the shaft of the variable capacitor,  $C_1$ , to a motor the capacitor would be rotated and the oscillator frequency changed, or fre-

quency modulated, at the rate of the driving mechanism. Although this method serves only as a basic illustration, it was actually used in earlier equipment. The reactance modulator simply substitutes for the variable capacitor, and causes the frequency of the oscillator to vary when a modulating voltage is applied.

The first requirement in replacing the capacitor by an electronic system is that it *looks* the same electrically when shunted across the oscillator tank circuit. This, of course, means that it must cause the current to lead the voltage by  $90^\circ$ , the same as a pure capacitor.

Fig. 1a represents the reactance modulator circuit, where we note that

(Continued on page 41)

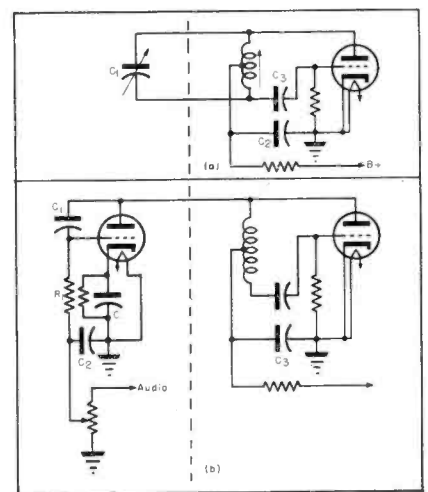

Fig. 1. In (a) we have a circuit of a simple triode oscillator with  $C_1$  representing the tuning capacitor across the inductance.  $C_2$  places the tap at r-f ground potential, and  $C_3$  is used to isolate the control grid from  $B+$ . In (b) the tuning capacitor of the (a) circuit has been replaced by its electronic equivalent, a reactance modulator.

Fig. 3. A plot illustrating how a sine wave modulating voltage applied to the grid, causes a variation of plate current and changes in oscillator frequency. Here we note that the highest frequency is determined by the peak of the negative portion of the modulation sine wave.

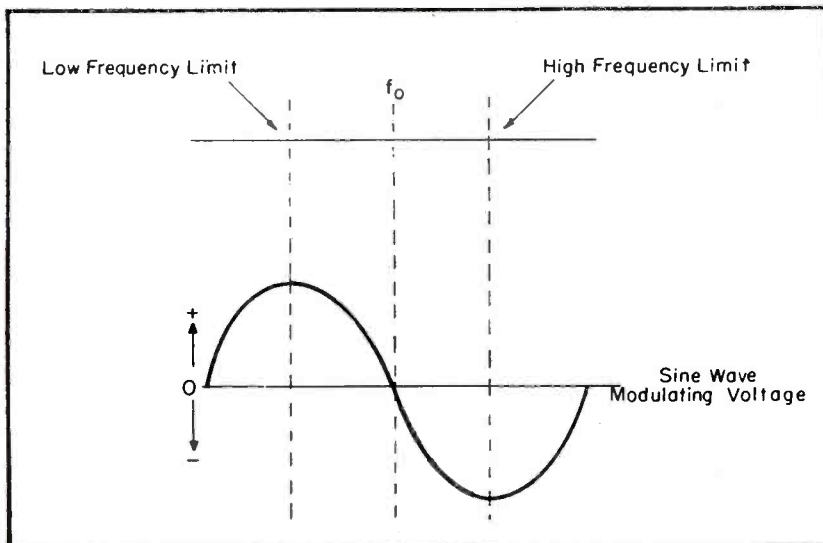
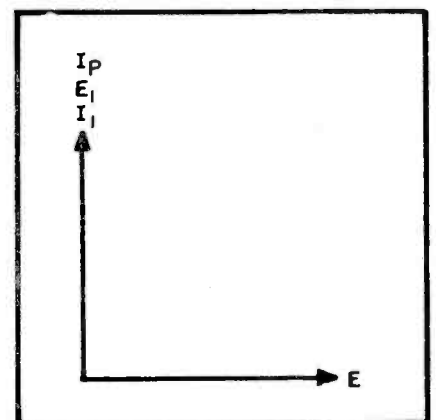

Fig. 2. A simple vector illustrating the relationship of voltage and current.



# TV Sync And Inter-Sync Systems

## TV Receiver Pulse Techniques Analyzed, With Operational Data on Rectangular Pulses and Time Constants.

TELEVISION PICTURE information is not transmitted continuously but is interrupted at intervals for insertion of the rectangular sync and blanking pulses. These pulses which are being transmitted, approximately 20% of total frame time, are the pulses which lock the transmitting and receiving tube scanning beams together and prevent the appearance of spurious signals on the tv image during the synchronizing period.

Before the sync pulses can be used to synchronize the horizontal and vertical sweep generators, two operations must be performed. First the sync pulses as an entirety must be segregated from the composite television signal and then vertical and horizontal components of the sync must be shaped for proper application to the sweep oscillators and to prevent interaction between vertical and horizontal components. A composite signal from which the sync can be extracted is generally taken off in the video output stage or at some earlier stage in the video amplifier. In some receivers a separate sync detector is employed. The picture and blanking

by **EDWARD M. NOLL\***

*Instructor in Television  
Temple University*

components of the composite signal are then removed leaving only the composite synchronizing signal. The synchronizing signal itself then is shaped into vertical and horizontal components.

Synchronization of the horizontal and vertical sweep of the tv receiver is also performed by rectangular pulses similar to the blanking pulses but of shorter duration. Instead of using the synchronizing pulses in the same form in which they are received, these pulses are shaped in accordance with their application, as vertical or horizontal synchronization. The three synchronizing pulses, equalizing, horizontal, and vertical, are respectively two-and-one-half, five, and approximately twenty-five microseconds in duration. Actually the vertical sync block consists of six spaced vertical

sync pulses to form a total duration of approximately 190 microseconds. The leading edges of the horizontal and vertical sync pulses synchronize the horizontal sweep; the pulse width or duration of the vertical sync block locks in the vertical sweep. The leading edges of the equalizing pulses also synchronize the horizontal oscillator and sustain the rigidity of the interlace.

### Rectangular Pulses

The rectangular sync pulse, Fig. 1 consists of a base frequency and a number of low-order and high-order harmonics, which are vested in the leading and trailing edges of these pulses and constitute fast changes in voltage per unit time while the low-order harmonics are vested in the duration or flat-tops of the pulse which represent a slow change in voltage per unit time. For example, the leading and trailing edges of the sync pulses, horizontal, equalizing, and vertical, must rise from minimum to maximum in approximately  $\frac{1}{4}$  microseconds and must fall from maximum

(Continued on page 51)

\*From a forthcoming book, *Television for Radiomen*, to be published by Macmillan.

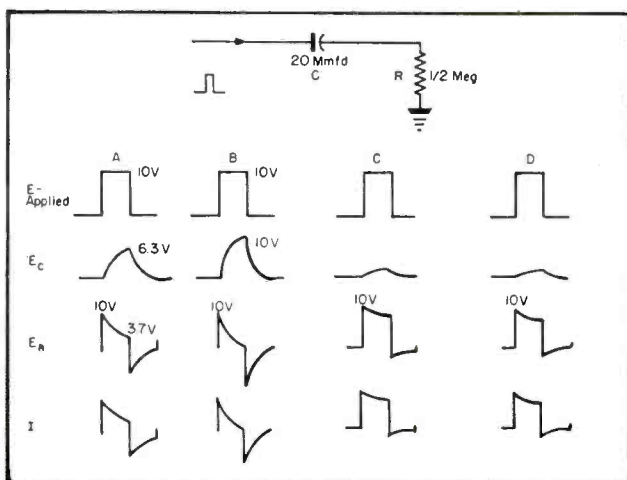
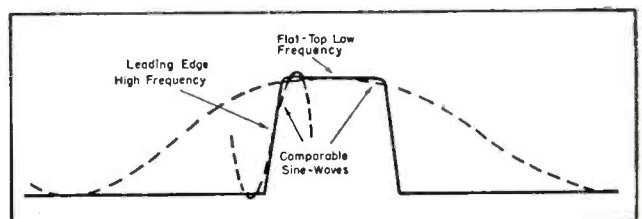

Fig. 2. Time constant and coupling pulses. At A we have a 10 microsecond pulse; B, 50 microsecond pulse; C, 2 microsecond pulse and D, 50 microsecond time constant. (For circuit shown,  $t_{\text{usec}} = R_{\text{meg}} \times C_{\text{mfd}}$  or  $t = .5 \times 20 = 10$  microseconds)

Fig. 1. High and low frequency sections of a pulse.





# Build YOUR OWN TEST EQUIPMENT

## Heathkit ELECTRONIC SWITCH KIT DOUBLES THE UTILITY OF ANY SCOPE

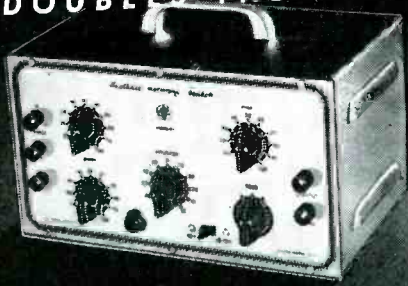

**\$34.50**

Provides two separately controllable traces with individual inputs on any scope. See both the input and output traces, locate distortion, phase shift, etc., immediately. Individual gain controls and positioning control. Coarse and fine sweeping rate controls. Complete Heathkit matches others, with 5 tubes. All metal parts are punched, formed and cadmium plated. Complete with tubes, all parts, detailed blueprints and instructions. Shipping Wt. 13 lbs.  
**Nothing ELSE TO BUY**

## HEATHKIT CONDENSER CHECKER KIT

**\$19.50**

*Nothing ELSE TO BUY*

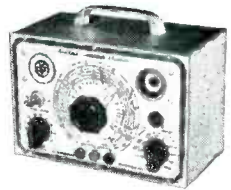

A condenser checker anyone can afford to own. Measures capacity and leakage from .00001 to 1000 MFD on calibrated scales with test voltage up to 500 volts. No need for tables or multipliers. Reads resistance 500 ohms to 2 megohms. 110V 60 cycle transformer operated complete with rectifier and magic eye indicator tubes. Easy quick assembly with clear detailed blueprints and instructions. Small convenient size 9" x 6" x 4 3/4". Wt. 4 lbs.

## HEATHKIT SIGNAL GENERATOR KIT

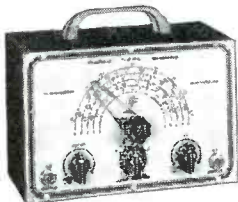

**\$19.50**

**NOTHING ELSE TO BUY**

Every shop needs a good signal generator. The Heathkit fulfills every servicing need, fundamentals from 150 Kc. to 30 megacycles with strong harmonics over 100 megacycles covering the new television and FM bands. 110V 60 cycle transformer operated power supply. 400 cycle audio available for 30% modulation or audio testing. Uses 6SN7 as RF oscillator and audio amplifier. Complete kit has every part necessary and detailed blueprints and instructions enable the builder to assemble it in a few hours. Large easy to read calibration. Convenient size 9" x 6" x 4 3/4". Wt. 4 1/2 lbs.

## HEATHKIT SIGNAL TRACER KIT



**\$19.50**

*Nothing ELSE TO BUY*

Reduces service time and greatly increases profits of any service shop. Uses crystal diode to follow signal from antenna to speaker. Locates faults immediately. Internal amplifier available for speaker testing and internal speaker available for amplifier testing. Connection for VTVM on panel allows visual tracing and gain measurements. Also tests phonograph pickups, microphones, PA systems, etc. Frequency range to 200 Mc. Complete ready to assemble. 110V 60 cycle transformer operated. Supplied with 3 tubes, diode probe, 2 color panel, all other parts. Easy to assemble, detailed blueprints and instructions. Small portable 9" x 6" x 4 3/4". Wt. 6 pounds. Ideal for taking on service calls. Complete your service shop with this instrument.

## HEATHKIT SINE AND SQUARE WAVE AUDIO GENERATOR KIT

The ideal instrument for checking audio amplifiers, television response, distortion, etc. Supplies excellent sine wave 20 cycles to 20,000 cycles and in addition supplies square wave over same range. Extremely low distortion, less than 1%, large calibrated dial, beautiful 2 color panel, 1% precision calibrating resistors, 110 V 60 cycle power transformer, 5 tubes, detailed blueprints and instructions. R.C. type circuit with excellent stability. Shipping weight 15 pounds.



**\$34.50**

*Nothing ELSE TO BUY*

## THE NEW HEATHKIT VACUUM TUBE VOLTMETER KIT

The most essential tool a radio man can have, now within the reach of his pocketbook. The Heathkit VTVM is equal in quality to instruments selling for \$75.00 or more. Features 500 microamp meter, transformer power supply, 1% glass enclosed divider resistors, ceramic selector switches, 11 megohms input resistance, linear AC and DC scale, electronic AC reading RMS. Circuit uses 6SN7 in balanced bridge circuit, a 6H6 as AC rectifier and 6 x 5 as transformer power supply rectifier. Included is means of calibrating without standards. Average assembly time less than four pleasant hours and you have the most useful test instrument you will ever own. Ranges 0-3, 30, 100, 300, 1000 volts AC and DC. Ohmmeter has ranges of scale times 1, 100, 1000, 10M and 1 megohm, giving range .1 ohm to 1000 megohms. Complete with detailed instructions. Add postage for 8 lbs.



**\$24.50**

*Nothing ELSE TO BUY*

## HEATHKIT FM AND TELEVISION SWEEP GENERATOR KIT

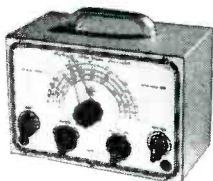

**\$24.50**

**NOTHING ELSE TO BUY**

### THE BASIC FM AND TELEVISION SERVICE INSTRUMENT

At the lowest cost possible, anyone can now service FM and television receivers. The Heathkit sweep generator kit operates with oscilloscope and covers all necessary frequencies. A few pleasant hours assembling this kit puts any organization in position to share the profits of the FM and TV boom.

Every part supplied — grey crackle cabinet, two color calibrated panel, all metal parts punched, formed and plated. 5 tubes, complete detailed instructions for assembly and use. Shipping weight 6 lbs.

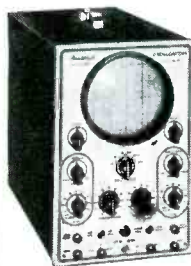

## The NEW 1948 HEATHKIT 5 INCH OSCILLOSCOPE KIT

**\$39.50**

**NOTHING ELSE TO BUY**

New improved model of the famous Heathkit Oscilloscope. Building an oscilloscope is the finest training for television and newer servicing technique and you save two-thirds the cost. All the features and quality of instruments selling for \$100.00 or more. Supplied complete with cabinet, two color panel, 5B1 tube, 2 5Y3 tubes, 2 6SJ7 tubes and 884 sweep generator tube. Power transformer supplies 1000V negative and 350 volt positive. Sweep generator 15 cycles to 30 M. cycles. Has vertical and horizontal amplifiers. Oil filled filter condensers for long life. Complete blueprints and instructions included.



The **HEATH COMPANY**

... BENTON HARBOR 11, MICHIGAN

# ASSOCIATIONS



TEN YEARS AGO

From the Association News Page of  
**SERVICE, September, 1938**

## RTG, Rochester

ED FISK, chairman of the publicity committee of the Radio Technicians Guild of Rochester, reports that programs for the fall, winter and spring of '49 have been prepared.

On September 14 there was a talk by a Better Business Bureau rep.

October 9 will see a fall banquet at Locust Lawn, Ionia, N. Y. On October 12 Al Saunders will talk on tv for Howard W. Sams.

The November 23 meeting will be sponsored by J. F. D. Mfg. Co., with Al Freidman addressing the boys.

The annual Christmas party will be held on December 10 at Potter House, Fairport, N. Y. Sam Shirer of Philco Corp will give a talk on December 14.

The '49 program includes a continuation of the tv school with classes scheduled, thus far, for January 9, February 13, and March 13.

At the annual picnic, held at Durand Eastman Park, about 24 members attended with their families and friends.

## ARSD, Columbus, Ohio

J. P. GRAHAM, editor of the *Associated Radio Service Dealers' News* has forwarded an interesting report on their July meeting and other ARSD activities.

The forthcoming television school was discussed by Fred Colton at the

meeting. The technical committee was requested to initiate a television class following the reception of the current Sams' television lesson.

Four new members were received at the meeting: Emswiler Electric Co., 85 E. Long St., Ober-Lee Electric Co. 2120 N. High St., Seddon & Son Appliances, 3250 N. High St., Clyde Stapf Radio Service, 1420 E. 19th Ave., and Danna Young Radio Service, 1501 Cleveland Ave.

Former ARSD president has been appointed *Authorized Distributor of Delco Radio Parts*.

Ray Horney of Central Radio has become a grandpop.

Mr. and Mrs. Chas. Dykes played host to Dave Sears, John Graham and their better halves recently, when the three couples went to Cincinnati in Charles' new auto, to visit the 50-kw tv transmitter and studio of WLWT. Mr. and Mrs. Jim Julian were already at the transmitter. They had come down a day ahead and Jim really paved the way for a visit behind the scenes, which revealed that the studio and installation cost over \$600,000. The main studio 30' by 40' by 100', is one of the largest in the world. The tower is 571' high, including the antenna, and is 1,400' above sea level.

Graham reports that the tube situation in Columbus is peculiar. He says that every mail brings ads from

(Continued on page 50)

F. M. Miller of General Electric discussing television before members of the Mid-State Service Men's Association of Pennsylvania at a recent meeting in the William Penn High School.

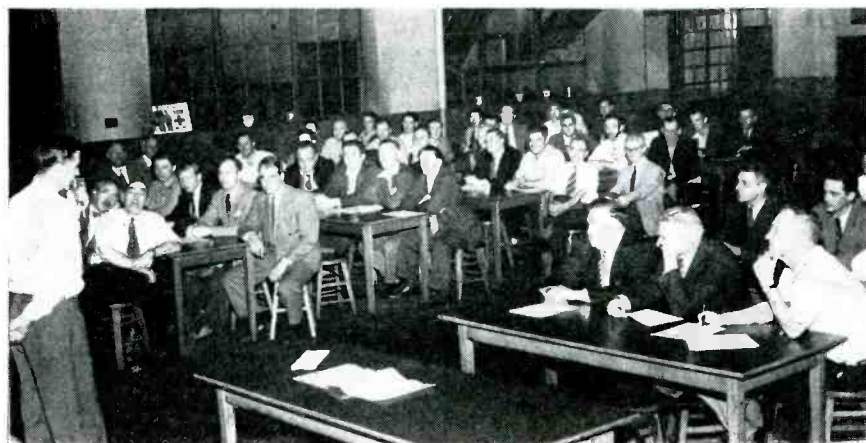

THE NATIONAL OFFICE OF RSA announced that 48 chapters had been approved. . . . Ed Donnelly, treasurer of the Binghamton Chapter, was married. A series of technical meetings were in swing at the Chapter. Subjects discussed included "Scope Alignment of AFC Circuits," "Mathematics for The Service Man" and "Methods of Cost Accounting for Service Men" . . . J. Cummins, service manager of Appliance Wholesalers, demonstrated alignment of high fidelity receivers at the meeting of the Buffalo Chapter. . . . A test equipment show and round table discussion was sponsored by the Chicago Chapter at the Stevens Hotel, with John F. Rider, Walter Weiss, O. J. Morelock and Paul Jackson serving on a panel. . . . The Cleveland Chapter held its annual picnic at Hagg's Grove, Palma, Ohio. . . . Round table discussions of "Cathode Ray Tube Applications in Service Work" were scheduled for the fall meetings of the Danville Chapter. . . . Walter Weiss of Hickok was scheduled to give a talk on test equipment before the Decatur Chapter. . . . Walter Jones of Hygrade Sylvania spoke before the Detroit Chapter. . . . A Service Men's jamboree was held by the Duluth Chapter. . . . A G. Mohaupt of the Radio Training Association addressed the Freeport Chapter on "Applications of the All-Wave Signal Generator in Modern Service Work" . . . Mohaupt also addressed the Fremont Chapter on the same subject . . . The Green Bay Chapter organized in July at the Radio Doctors elected George Thelen, chairman; Harry Dole, secretary; and Fred Olsen, treasurer. . . . Ralph Galasso was elected president of the Tri-County Chapter, Johnstown, Pa. D. L. Kaufman was elected vice president; George Martin, treasurer; and Ken Vaughan, secretary. . . . Cecil Rich was appointed chairman of a committee on by-laws of the Lansing Chapter. Other members of the committee were Ed Bloom, Earl Budd, Ralph Keyes and Max Huntoon. . . . The Radio Dealers' Association of Minneapolis joined the RSA. Group was under direction of executive secretary, Harry Cory. . . . The first annual outing of the Radio Service Men of New Jersey was held at Farchers' Grove, Union, New Jersey. . . . John F. Rider discussed the uses and advantages of the Chanalyst at a meeting of the Westchester Chapter.

Howard W. Sams

presents the amazing  
**RADIO INDUSTRY  
RED BOOK**  
REPLACEMENT PARTS  
BUYER'S GUIDE

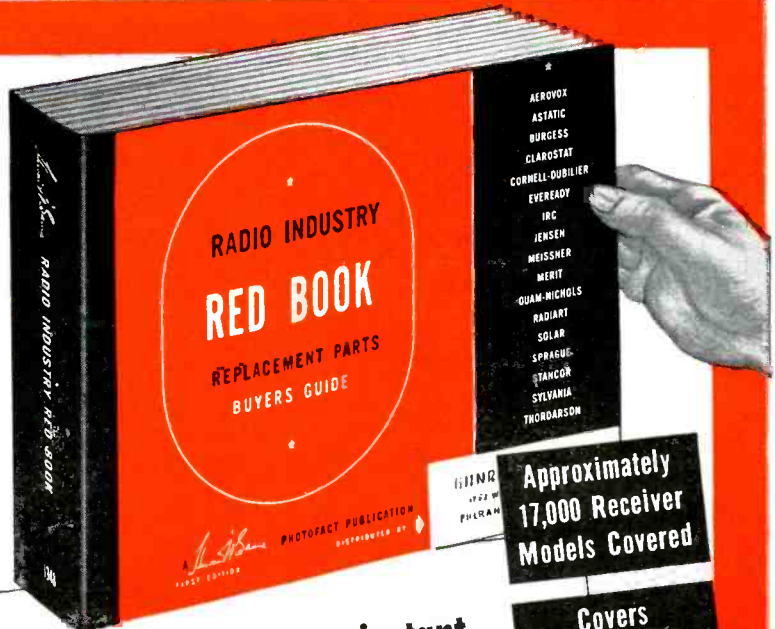

Approximately  
**17,000 Receiver  
Models Covered**

Covers  
**Ten Years:  
1938 to 1948**

**Easy to Use:  
All Data  
Quick to Find**

**440 Pages  
Smyth-bound  
Opens Flat**

**NOW**—a SINGLE authoritative volume that gives you instant reliable data on ALL replacement parts for thousands of popular radio receivers... more useful data than in all other replacement parts guides and manuals COMBINED...

**COMPLETE!**

The First Cooperative Industry Effort in Behalf of the Radio Service Technician

FOR THE FIRST TIME IN RADIO HISTORY!

All 9 Major Replacement Components Listed

(not just 1 or 2 components)

17 Leading Parts Manufacturers Represented

(not just 1 manufacturer)

**COMPLETE DATA ON ALL RECEIVER REPLACEMENT PARTS — ALL IN THIS ONE GREAT BOOK!**

Save time! Stop wasteful hunting! Get ALL the parts data you need—quickly—from this single book.

NOW—for the first time—have all the replacement parts data you need—ALL in one single, authoritative volume. No more waste of valuable time searching through dozens of incomplete manuals and catalogs. The RED BOOK, first and only complete parts guide ever produced, covers approximately 17,000 radio models made from 1938 through 1947—10 full years. Lists parts made by 17 leading manufacturers—not just one! Gives you complete, accurate data on all 9 major replacement components—not just one or two! Clear, concise, easy-to-use—over 440 pages (8½" x 11") bound in a sturdy sewed cover, arranged alphabetically by manufacturer and model number for quick reference. Does away with confused collections of separate books and manuals—gives you complete information—PLUS data that cannot be found in any other source—at a fraction of the price you'd pay for the books it replaces. There's never been anything like it—absolutely indispensable for every service shop!

Only the RED BOOK gives you ALL this invaluable data. Here's everything you need to know about the replacement parts for the receivers you service daily. The RED BOOK gives you original manufacturers' parts numbers, proper replacement parts numbers and valuable installation notes on *Capacitors, Transformers, Controls, IF Coils* (including Peak Frequencies), *Speakers, Vibrators* and *Phono Cartridges, Tube and Dial Light* data includes number of tubes in each chassis, with type number for each tube, plus dial light numbers. *Battery* data includes replacement numbers on A, B, and AB packs. The following leading replacement parts manufacturers are represented in the RED BOOK:

- |                  |            |
|------------------|------------|
| AEROVOX          | ASTATIC    |
| BURGESS          | CLAROSTAT  |
| CORNELL DUBILIER | IRC        |
| EVEREADY         | JENSEN     |
| MEISSNER         | MERIT      |
| QUAM-NICHOLS     | RADIART    |
| SOLAR            | SPRAGUE    |
| STANCOR          | SYLVANIA   |
|                  | THORDARSON |

18 months in preparation—over \$90,000 to produce. The RED BOOK is the product of thousands of man-hours spent in laboratory research and in cooperation with 17 participating manufacturers to produce the most complete, accurate, authoritative parts replacement guide ever published. Every bit of information in this amazing book has been painstakingly checked to insure maximum accuracy and usefulness. Over \$90,000 was spent to prepare the RED BOOK—the only book that brings you everything you need to know—every bit of replacement parts data you want to make your work easier and more profitable. You can't afford to be without the RED BOOK. It's the indispensable guide you'll use profitably every single day. Stop hunting for the right answers now—order your copy today.

THE INDISPENSABLE **\$3.95**  
RED BOOK... ONLY...

Mail This Order Form to Your Parts Jobber Today or send directly to HOWARD W. SAM'S & CO., INC., 2924 E. Washington St., Indianapolis 7, Ind.

My (check) (money order) for \$..... enclosed.  
 Send..... RED BOOK(S) at \$3.95 per copy. (I understand that delivery will be made to me in September.)

Name.....

Address.....

City.....State.....

**BE SURE TO ORDER YOUR RED BOOK TODAY**

HOWARD W. **SAM'S** & CO., INC.  
INDIANAPOLIS 7, INDIANA

# Servicing Helps

MANY SERVICE MEN are often confronted with the problem of illustrating and describing the size of a tv picture tube used to provide a certain number of square inches in picture size. To facilitate these explanations,

by **P. M. RANDOLPH**

the chart shown in Fig. 1 has been prepared. Presented are the tube di-

ameters, their picture areas and the picture length and height.

**Service Notes: General Tel. 51**  
*Modulation hum and insensitive:* Cause was in a .1-mfd/400-volt capacitor  
 (Continued on page 30)

Fig. 1. The tv picture tube size guide chart.

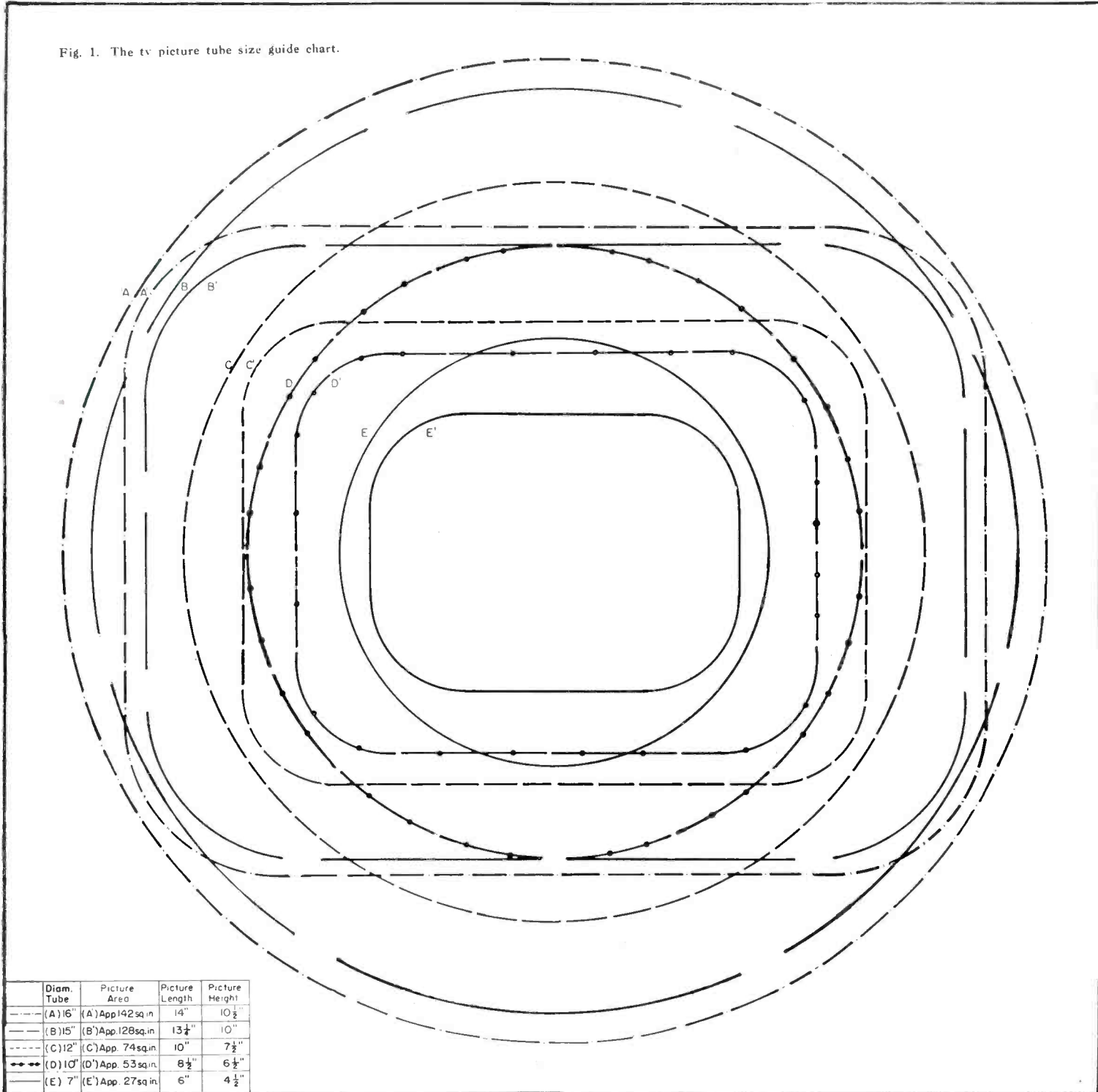

**Specify the**



**1201**

**DELUXE ALNICO 5  
LOUDSPEAKER**

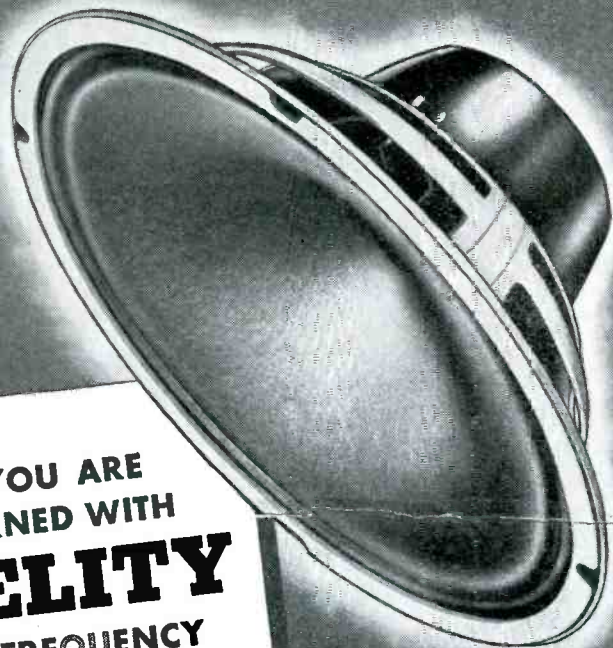

WHEN YOUR  
JOB DEMANDS  
**POWER**

25 WATTS  
POWER HANDLING  
CAPACITY

WHEN YOU ARE  
CONCERNED WITH  
**FIDELITY**

BROAD FREQUENCY  
CHARACTERISTIC  
50—13,000 CYCLES

EQUIPPED WITH  
THE FAMOUS  
**GENERAL ELECTRIC  
ALUMINUM FOIL BASE  
VOICE COIL**



**P**OWER, fidelity and a price that will amaze you for a speaker of this exceptionally high quality—it's the G-E 1201.

It's a wide range speaker with the frequency response stretched out at both ends of the curve to give intense realism, smooth, full lows and "high fidelity." A curvilinear cone is employed to provide this extended frequency response. Alnico 5, 14½ ounces of it, gives high sensitivity and smooth response.

The moving parts in the speaker assembly are ruggedly designed to take high power without damage to the speaker in any way.

Note: Frequency response 50—13,000 cycles.

For complete information on this outstanding speaker write: *General Electric Company, Electronics Park, Syracuse, New York.*

**GENERAL**



**ELECTRIC**

160-25

a new family joins the sangamo tribe...



## New Dependability, New Long-Life Performance

Meet Sangamo Electrolytics, the newest family to become linked with the Sangamo Tribe. Introducing, from left to right on the opposite page, are illustrations of the "Chieftain", "Tomahawk", "Warrior", "Apache", and "Mohican". These newcomers now join the established tribe of Sangamo Micas, Silver Buttons, Papers, and Plastic Tubulars. Their heritage of dependability and long-life

performance stems from being built in a factory which was constructed *especially* and *exclusively* for the manufacture of contamination-free electrolytics. Their performance will meet and exceed the most stringent requirements of electronic applications. Yet, these new, high-quality capacitors are competitive in every respect from a standpoint of design, construction, and price.

Your own trial-use will convince you that new standards of dependability and longevity have been built into Sangamo Electrolytics. Order from the new Sangamo Electrolytic Capacitor Catalog No. 825C, which is yours for the asking, and without obligation.



SC488

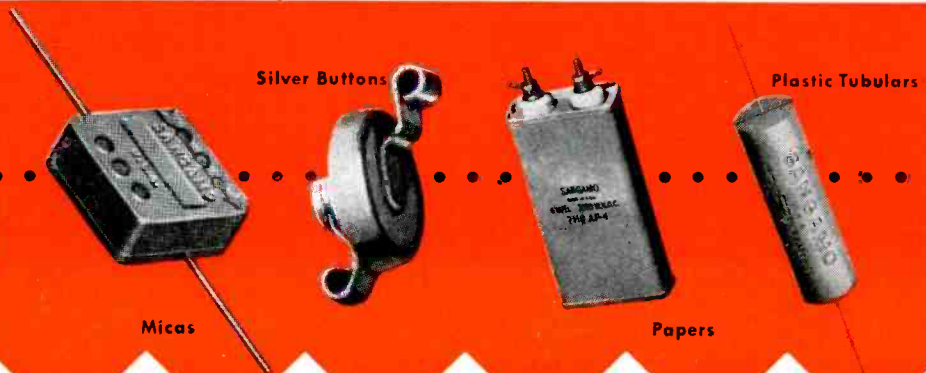



**SANGAMO**

# electrolytic

## CAPACITORS

*Chieftain*



*Tomahawk*



*Warrior*



*Apache*

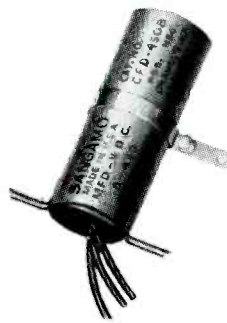

*Mohican*



**SANGAMO**

**ELECTRIC COMPANY**

**SPRINGFIELD, ILLINOIS**

# THE NEW DU MONT TYPE 274-A OSCILLOGRAPH IS EVEN BETTER FOR

**RADIO and  
TELEVISION  
Servicing**



**TWICE THE BAND WIDTH!  
THREE TIMES THE  
SENSITIVITY!**

★ With several notable improvements over its predecessor, the Du Mont Type 274, this new Du Mont Type 274-A is an even finer instrument for the job of radio and television servicing.

An improved vertical deflection amplifier offers a sensitivity of better than 0.2 rms volt/in., and a range (within 30%) of 20 cps to 100 kc in frequency response.

As a result, in your servicing of both radio and television receivers, you can now look at *more parts of more*

*circuits with still greater accuracy and therefore better results.*

For example, you can see *lower level* signals and you can handle *more parts* of the detector and i-f circuits. You can now minimize "hum" troubles more easily, and you can do a better job on sync circuits as well as on other circuits of television receivers.

In fact, with the new Type 274-A, you can't miss doing an all-around, bang-up, more satisfactory and therefore more profitable job. And remember, the new Type 274-A still has the big, 5-inch tube!

Cat. No. 1420-A with 5BP1-A . . . . . \$136.50

Cat. No. 1422-A with 5BP11-A . . . . . \$139.25

**DU MONT**

*for Oscillography*

ALLEN B. DU MONT LABORATORIES, INC., PASSAIC, N. J.  
CABLE ADDRESS: ALBEEDU, NEW YORK, N. Y., U. S. A.

## Servicing Helps

(Continued from page 26)

connected across the power line, which was found to be open. Replacing it with a similar capacitor but rated at 600 volts was found to be the cure. The sensitivity can be boosted by disconnecting the antenna, which is molded into the line cord, from the a-c plug. This disconnect also eliminates the danger of a short, should the capacitor in series with the antenna lead ever short and the line plug be reversed in the outlet.

### Grunow Model 701 (Chassis 7A)

*Intermittent operation:* This is often caused by the two .1-mfd/600-volt capacitors mounted in a can under the r-f coil shield can. These will open intermittently, and even though only one is at fault in most cases, it is best to replace both to avoid callbacks. A good way to check these capacitors is to heat them up with an electric heater, and with the set on, pry on the leads. The faulty unit will show up.

### Packard—Philco Auto Radio Model P-1835

*Set dead and blows fuses:* If wax drips from the chassis it is certain that the buffer capacitor is shorting out against the chassis. Before replacing the buffer it is wise to check to see that no damage was done to either the transformer or the vibrator. The faulty unit should be replaced with a .005-mfd/1,600-volt capacitor and mounted so that it will not drop against the chassis again.

### Philco Model 938 K Auto Radio

*Weak and sometimes dead:* The volume control will often cause this and must be replaced with Philco part No. 8306 because of the special shaft used. On replacing the control, the set was found to play well until it was jarred, resulting in oscillations. The cause was an intermittently open .05-mfd/400-volt capacitor, No. 7 on the schematic, and connected from the *avc* bus to ground.

*Motor tuning will not always bring in stations correctly:* To remedy this, it is necessary to note whether the wire that grounds one side of the push button switch contacts is grounded. If not it must be soldered to the lug which is riveted to the case. Many Service Men will leave the wire un-

(Continued on page 50)





# Safety . . . . .

The cop on the beat that protects your home . . . guides children across the street — he offers an important factor of safety in community life! And so it is with the patented construction feature of the RADIART VIBRATOR — the mica stacks! Because of this mica detail, sudden shifts in load peaks to high voltages are taken in stride, because they are designed to carry an overload! The resulting longer life and more dependable, longer performance means more satisfied customers for you . . . and yet this expensive feature costs no more! Just another factor that has helped build RADIART VIBRATOR superiority, and made them the fastest selling in the field.

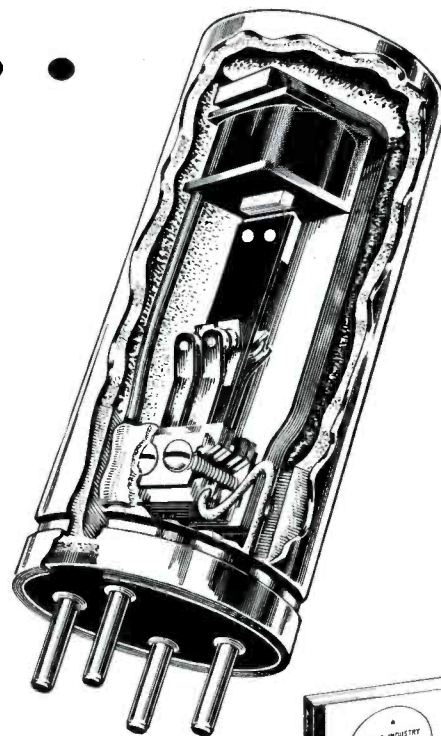

THE ONLY VIBRATOR LINE LISTED IN SAMS' RED BOOK

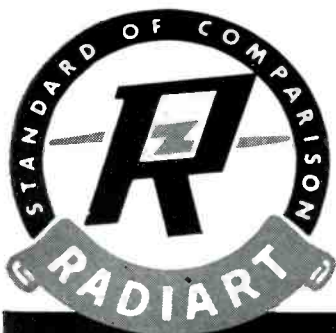

## The Radiart Corp.

CLEVELAND 2, OHIO

Export-Scheel International Inc., 4237 N. Lincoln Ave., Chicago 18, Ill.

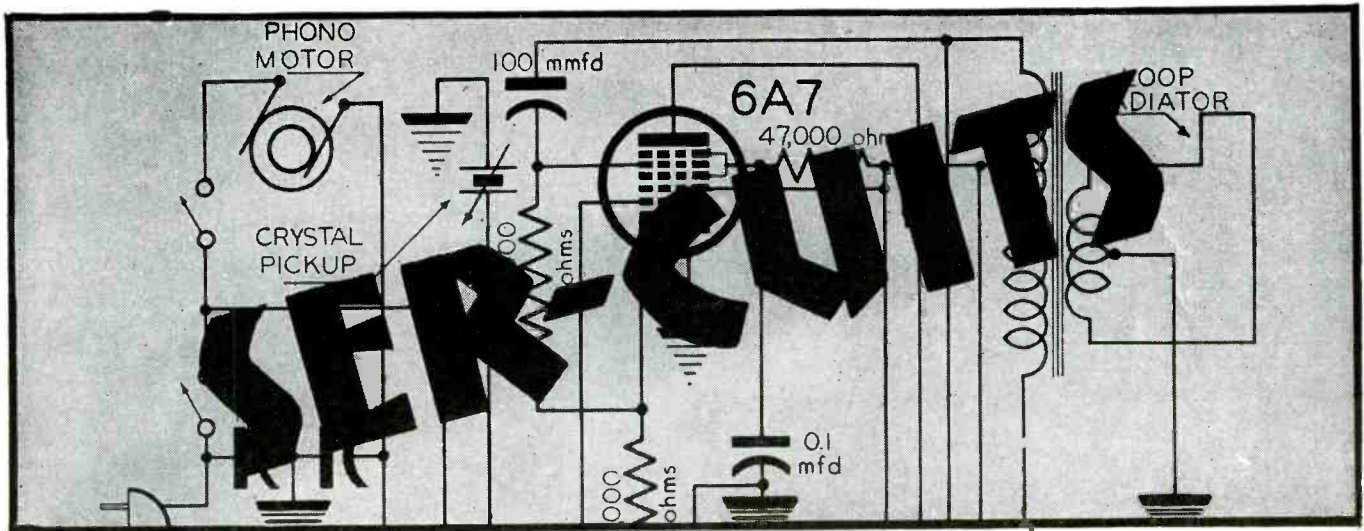

## Circuit Features of the G. E. YRS-1 Single Sideband Selector And G. E. 901/910 TV Projection Receiver.

RECENT ADVANCEMENTS in single sideband practice<sup>1</sup> have resulted in the development of several interesting circuits. An excellent example of this type of circuitry appears in the G. E. YRS-1 single sideband selector.

When connected and aligned to a superhet-receiver having an i-f of approximately 455 kc, this device permits single sideband reception of either modulated or unmodulated signals. Either sideband can be accepted or rejected to cope with existing interference conditions, this selection being made manually by means of push buttons. The unit can also be used for carrier-reinforced double sideband reception, a condition which reduces distortion caused by selective fading. A fourth operating condition permits the receiving system to function in the normal manner.

Although rejection of an undesired sideband range is accomplished by a system which provides the effect of extreme selectivity, the quality of modulation contained in the accepted sideband is not impaired in any manner and is generally restricted only by the i-f pass-band of the particular receiver in use. This is because the audio frequency response of the unit is

<sup>1</sup>IRE Report, COMMUNICATIONS; March, 1948.

Figs. 1, 2, 3 and 4. Fig. 1 illustrates an a-m signal with symmetrical side bands A and B. In Fig. 2 we see the result of an interfering carrier on the signal. Fig. 3 is a typical selectivity curve imposed on the heterodyned signal of Fig. 2. Fig. 4 illustrates an extremely sharp straight-sided response curve.

in excess of 70 to 7000 cps, whereas the overall frequency response of the

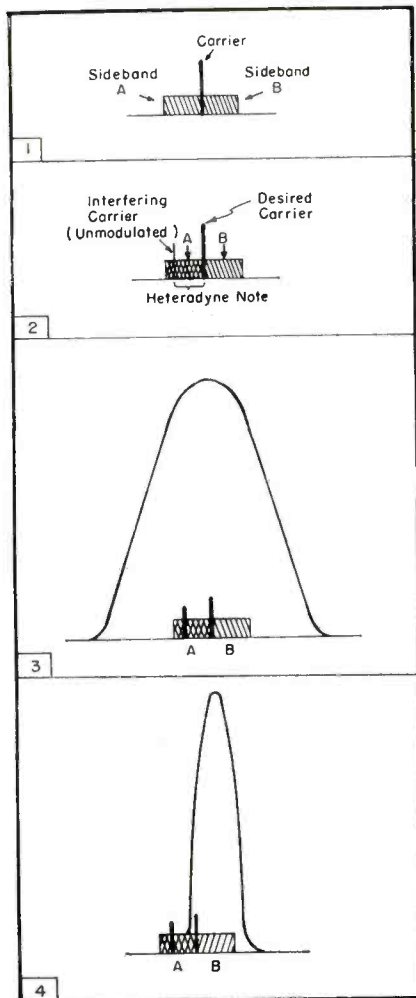

average communications receiver falls off considerably above approximately 5000 cps due to sideband cutting in the intermediate frequency amplifiers.

To illustrate the unit's operation, let us consider an amplitude modulated signal as shown in simple form in Fig. 1. The modulation process creates two sidebands, A and B, which are symmetrically located on either side of the carrier and represent the modulating component. If an interfering carrier of almost the same carrier frequency is superimposed, as shown in Fig. 2, the result will be a heterodyne whose frequency will be equal to the difference frequency of the two carriers. Normally, if the amplitudes of the two carriers are approximately equal, the resulting heterodyne will be of sufficient amplitude to partially or completely mask the intelligence contained in both sidebands of the desired carrier, because conventional communications receivers cannot discriminate between the two carriers and may demodulate sidebands A and B against the interfering carrier. This is illustrated in Fig. 3, where a typical selectivity curve has been imposed on the heterodyned signal of Fig. 2. It will be observed that the curve is sufficiently broad to encompass both sidebands. Even if the receiver is tuned slightly off the carrier in an attempt to discriminate against the heterodyne, the flaring of the skirts of the curve

(Continued on page 34)

# Your HYTRON SERVICEMEN'S Contest

## A REPORT TO YOU

### THE EDITOR-JUDGES COMMENT

"Judging the contest is fun, and I'm learning something from it . . . am impressed with both quantity and quality of the entries . . . contributors took genuine interest in a challenge to their American ingenuity . . . hard to make a choice . . . it is evident that servicemen have found it necessary to devise for themselves special tools . . . no designer sitting off at a distance can possibly anticipate their needs so well . . . basis of a fine exhibit . . . would like to print . . . will result in valuable additions to serviceman's tool kit."

### FIRST PRIZE WINNERS

May

Harry L. Smith, Long Island City, N. Y., was picked by the judges as the lucky winner of the DuMont Type 274 Five-Inch Oscillograph.

June

To lucky Gerard P. Diaz, Parkville, Missouri, went the RCP Model 665-A "Billionaire" vtvm and Model 705-A Signal Generator.

Heartiest congratulations to them both, as well as to the other winners.



FIRST PRIZE  
SEPT.  
Jackson 641  
Universal  
Signal Generator

Second prize — each month, \$50 U. S. Savings Bond.  
Third Prize — each month, \$25 U. S. Savings Bond.  
Grand Prize, \$200 U. S. Savings Bond — to contestant whose idea is judged to be best of the 6 winning monthly first prizes.



FIRST PRIZE  
OCT.  
Weston 769 H-F  
Electronic Analyzer

## AN INVITATION TO YOU

Come on in, servicemen! The contest's fun — and easy, too. Many prizes left. Only one thing to worry about — time's a-wasting. Pick up an entry blank today at your Hytron jobber's. Or drop us a penny postal. The easy-to-follow entry blank will help you do the rest.

Just describe briefly your proposal for a simple, economical shop tool like the Hytron Tube Tapper or Miniature Pin Straighteners. Enter in any or all monthly contests. Mail to Hytron Contest Editor. Then make room on your bench for one of those deluxe first prizes.

SPECIALISTS IN RADIO RECEIVING TUBES SINCE 1921.



# HYTRON

RADIO AND ELECTRONICS CORP.

MAIN OFFICE: SALEM, MASSACHUSETTS



# NOW! UTAH TRANSFORMERS



*Tested*

## PERFORMANCE

UTAH announces a new group of replacement transformers designed especially for use with Utah Speakers. They're engineered and built for peak performance under severe climatic conditions . . . each transformer must pass moisture and operational tests. Utah construction assures complete vacuum impregnation, the use of cellulose acetate insulation, and other fine materials. Three types . . . Universal Output, Universal Line, and Single Output . . . in eight sizes, are available for immediate delivery.



**UTAH RADIO PRODUCTS**  
 HUNTINGTON, INDIANA  
 DIVISION OF INTERNATIONAL DETROLA CORPORATION  
 EXPORT DIVISION: MORHAN EXPORTING CORP., N. Y. C.

**UTAH QUALITY RADIO PRODUCTS**

### Ser-Cuits

(Continued from page 32)

indicate that an appreciable portion of the heterodyne will still be passed.

If the receiver possessed an extremely sharp, essentially straight sided response curve, as shown in Fig. 4, fairly good separation of the sidebands would be possible. Such selectivity, while desirable from the standpoint of communications, might seriously restrict the audio fidelity because the higher and lower audio fre-

quencies would be clipped off along with the heterodyne. This is the reason signals lose intelligibility when a crystal filter is switched into the i-f amplifiers of a communications receiver.

#### Selector Features

The *single sideband selector* combines the advantages of the broad response curve for audio fidelity, and the sharp response curve for selectivity, without the disadvantages of either. This is accomplished by special de-

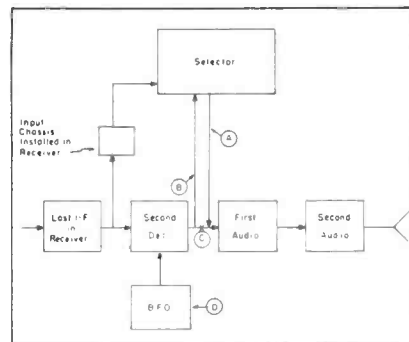

Fig. 5. Block diagram of a typical installation of the selector in a communications receiver setup. Points A and B indicate the a-f in and out positions, while C indicates the point at which a break is made for installation of the selector. The beat frequency oscillator shown at D is not used when the selector is in the circuit.

selector circuits which split the received signal into two components, which when shifted in phase and added or subtracted, reject undesired interference in one sideband or the other. This makes possible the reception of signals which normally would be unreadable because of heterodyne interference.

#### Fourteen Tubes in Unit

There are 14 tubes in the selector: a pair of 6SJ7s as a reactance tube and oscillator, a pair of 6H6s as detectors, four 6SL7GTs as phase shifters, a 6AK6 in a high-impedance input stage, a 6V6GT as a d-c valve, another 6SJ7 as a voltage regulator amplifier, a 6C4 for a-i, 5Z4 rectifier and VR-105 voltage regulator.

As shown in block form in Fig. 5, the selector functions as a complete second detector and beat frequency

Fig. 6. How a selector is connected into the circuit of the Hammarlund SP400X, points A, B and C indicating where the connections are made and D showing where the break is made in the circuit to provide for the installation of the selector.

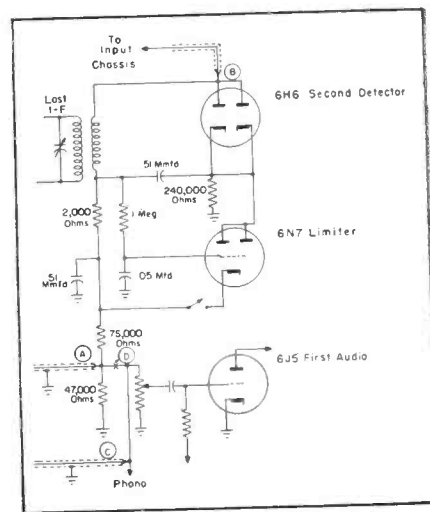

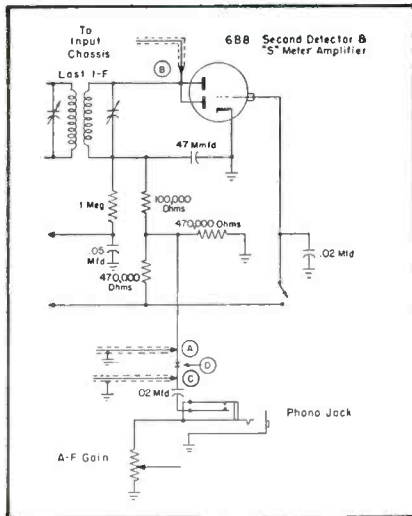

Fig. 7. Circuit of the Hallcrafters SX28A with indications where a selector can be connected (points A, B and C, and the break at point D.)

oscillator and these circuits are, therefore, not used in the receiver when the selector is switched on. Since the receiver's *bfo* is normally turned on and off from the front panel, it is not necessary to make changes in this circuit. The i-f voltage from the last i-f stage in the receiver is fed into the selector, where detection and phase shifting takes place, and the resultant audio voltage is then fed back into the input of the receiver's audio system. Although the receiver's second detector is not called upon to deliver audio voltage when the selector is used in the *sideband and locked oscillator* positions, in some cases it does supply receiver *avc* voltage and operate the *S* meter. The connection between the receiver's second detector and audio system must be broken, as shown, otherwise, audio output from the second detector will feed into the audio system at all times and render the selector useless.

To minimize circuit loading of the last i-f stage in the receiver, a small chassis containing a high impedance input stage for the selector is installed in the receiver at a convenient location which results in minimum lead length to the i-f voltage point. This input chassis employs a miniature tube. Regardless of the location of the input chassis in the receiver, the coaxial lead connection to the i-f voltage point has to be cut as short as possible to minimize capacitive loading of the i-f transformer secondary.

The i-f voltage for the input stage can usually be picked off most conveniently from the diode plate of the second detector and in most cases this connection can be made from the top

(Continued on page 36)



**Each Resistor is CLEARLY MARKED to show Resistance, Wattage and OHMITE Trade Mark**

Guesswork's gone . . . when you use genuine Ohmite Little Devil insulated composition resistors. Each unit, in all three sizes— $\frac{1}{2}$ , 1, and 2 watts—is color-coded and individually marked for quick, sure identification.

Millions of these superior quality resistors are being used today by manufacturers, servicemen, and amateurs. They meet joint Army-Navy Specification JAN-R-11, including salt-water immersion cycling and high humidity tests. They can be used at their full wattage ratings at 70 C (158 F) ambient temperature. Little Devil resistors dissipate heat rapidly . . . have low noise level and low voltage coefficient.

Ratings for maximum continuous RMS voltage drop are high: 350 volts for the  $\frac{1}{2}$ -watt unit, 500 volts for the 1-watt unit, 1000 volts for the 2-watt unit. All units have high insulation breakdown voltage.

Little Devils are completely sealed and insulated by their molded plastic construction. Leads are soft copper wire, hardened immediately adjacent to resistor body, strongly anchored, and hot solder coated. They're light, compact, easy to install.

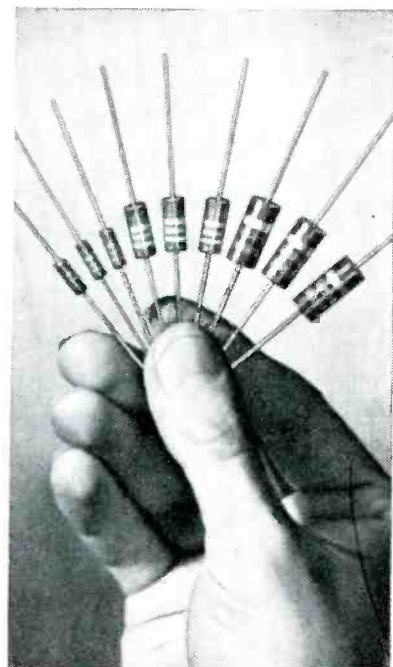

Little Devils are available in Standard RMA values . . . 10 ohms to 22 megohms. Tol.  $\pm 10\%$  and  $\pm 5\%$ . Values to 2.7 ohms available in 1-watt size,  $\pm 10\%$  tolerance.

### OTHER OHMITE PRODUCTS

**BROWN DEVIL RESISTORS**—Rugged, dependable, wire-wound, vitreous-enameled. Easily mounted by tinned-wire leads. Tol.  $\pm 10\%$ . 5-, 10-, 20-Watt sizes. **DIVIDOHM ADJUSTABLE RESISTORS**—Used as multi-tap resistors or voltage dividers. Provide odd resistance values quickly. Vitreous-enameled. See your distributor for these and other Ohmite products.

**OHMITE MANUFACTURING CO.**  
4878 Flournoy Street • Chicago 44, Ill.

Be Right with  
**OHMITE**

RHEOSTATS • RESISTORS • TAP SWITCHES





*Improve the picture*

\* with

**AMPHENOL**

**TV ANTENNA**

and genuine **TWIN LEAD TRANSMISSION LINE**

*All Channels* **HIGH AND LOW BAND**

You are really a picture producer . . . customers expect a perfect picture when they purchase a TV set. Why not protect yourself and customer from expensive service and repair calls by installing the finest antenna at the start? Amphenol's TV Antenna and Twin-Lead Transmission Line have been carefully engineered to fill all demands made by modern television. Sturdy and rugged to withstand the rigors of winter weather. Amphenol antennas also are ultra sensitive and so assure perfect reception of both high and low bands and in all channels. All unbiased tests show Amphenol's 114-005 to be by far the finest TV antenna available.

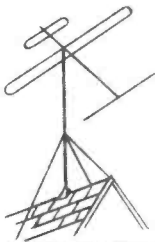

**AMPHENOL**

**AMERICAN PHENOLIC CORPORATION**

1830 South 54th Avenue, Chicago 50, Illinois

COAXIAL CABLE AND CONNECTORS, INDUSTRIAL CONNECTORS, FITTINGS AND CONDUIT, ANTENNAS, RADIO COMPONENTS, PLASTICS FOR ELECTRONICS

### Ser-Cuits

*Continued from page 35)*

of the receiver chassis by means of a small lug attached to the proper pin of the second detector tube. The connection between the receiver's second detector and audio system can usually be broken most conveniently at the audio volume control. In each connection, the shielded outer braid on the cables should be grounded to the receiver chassis to prevent hum pickup. The length of these audio leads is not critical.

The efficiency of the selector in re-

jecting unwanted sidebands and in passing desired sidebands depends, to a great extent, upon correct alignment of the i-f channel in the receiver. If the alignment of the i-f channel is questionable, it is recommended that these stages be carefully realigned. In any event, it is necessary to check the tuning of the secondary of the last i-f transformer and compensate, if necessary, for any additional capacity introduced by the input stage. Some receivers such as the Hammarlund SP400X employ fixed-tuned secondaries and in such cases no adjustment is possible or required. If a complete

i-f alignment is attempted, visual alignment employing a scope and a sweep frequency generator is preferred. If such instruments are not available, alignment can be carried out with the conventional amplitude modulated signal generator and output meter. Some types of receivers employ variable bandwidth i-f channels which, in the *broad* or high fidelity position, yield a double-humped and sometimes unsymmetrical response curve. *I-f alignment should not be carried out at this bandwidth setting.*

The unit requires a substantially stable receiver. The most troublesome source of instability in many receivers is the tunable oscillator which heterodynes the incoming signals to the intermediate frequency. Instability in this oscillator may fall into one or more of the following classifications:

(1) Moderately slow drift in frequency, usually stabilizing within two hours of operation. This drift is caused by temperature readjustment as the receiver reaches a stable operating temperature.

(2) Erratic jumps in frequency. This may be caused by line voltage changes, sudden release of stress due to thermal changes as the receiver warms up, poor sliding contacts on the oscillator tuning capacitor, or poor voltage regulation in the plate power supply. Poor voltage regulation may cause the frequency of the oscillator to change with the setting of the manual (r-f) gain control or with *avc* action.

(3) Frequency modulation of the oscillator at power line frequency or harmonics.

G.E. 901/910

In response to many requests circuit data on the recently produced G.E. projection type tv receiver, models 901/910, are offered this month.

There are 43 tubes in this model: 6AU6 tv r-f amplifier; 7F8 tv converter-oscillator; four 6AC7s in first, second, third and fourth video i-f amplifiers; 6H6 video detector/d-c restorer; 6AG7 video amplifier; 5TP4 projection-type picture tube; 6SH7 clipper; 6SN7GT horizontal sweep amp/vertical sweep generator; 6SL7-GT horizontal phase det/vert. sync amplifier; 6SL7GT horizontal phase det/d-c amplifier; 6SN7GT horizontal sweep generator; 6SN7GT horizontal inverter/cathode follower; 6L6G vertical sweep output; 6SG7 tv audio i-f; 6SV7 tv audio limiter; 6H6 tv audio discriminator; 6AG5 radio r-f amplifier; two 6AK5s as radio oscillator

and converter; 6SG7 radio first i-f amplifier; 6SV7 radio second i-f amplifier; 6SV7 radio a-m detector/f-m limiter; 6AQ7 f-m discriminator/audio cathode follower; 6SL7GT audio amplifier; four 6V6GTs for audio output; 6AL7GT tuning indicator; 6SC7 phono preamplifier; three 5U4G rectifiers; two 6BG6Gs in horizontal sweep output; 6A7G for horizontal damping; and four 1B3GT high voltage rectifiers.

**Tv R-F Amplifier, Converter and Oscillator**

The r-f amplifier makes use of a 6AU6 connected as a triode grounded-grid amplifier. The antenna is connected into the cathode circuit so as to provide a substantially constant input impedance of 300 ohms to the antenna at all frequencies.

The r-f amplifier is coupled to the converter tube by a wide band transformer. The windings are self-tuned by the distributed and tube capacities to provide optimum gain. On channel 2, the transformer is triple tuned to prevent the image frequencies of the 88 to 108-mc f-m band from interfering with these two channels. The triode converter is one section of a 7F8 dual triode tube.

The oscillator makes use of the remaining half of the 7F8 and is inductively coupled to the converter grid by locating the oscillator coil on the same coil form as the converter grid coil. The oscillator is a modified Colpits oscillator, the oscillation being produced by the cathode-to-grid, and the cathode-to-plate interelectrode capacities of the oscillator tube. A choke provides a d-c path to ground to the cathode of the oscillator but maintains the cathode off-ground at the r-f frequencies. The oscillator operates on the high frequency side of the r-f signal on all bands.

**Tv Video and Sound I-F Amplifiers**

The video i-f amplifier consists of a four-stage band-pass amplifier using four 6AC7s. Transformers are over-coupled and then loaded with resistance to give adequate band pass frequency characteristics. A winding added to two of the transformers is tuned to trap out the adjacent audio and tuned for audio take off respectively. One trap is tuned to 21.9 mc to provide rejection of the adjacent channel audio i-f, while the three other traps are tuned to 21.9 mc to provide rejection of the same channel audio. A series trap is also used to tune out the associated audio interference.

[To Be Continued]

# CURRENT CONVERSION

## ATR "A" BATTERY ELIMINATORS



**for DEMONSTRATING AND TESTING AUTO RADIOS**

**New Models . . .** Designed for Testing and Operating Auto Radios and D. C. Electrical Apparatus from 110 Volt A. C. Lines. Equipped with Meter, Voltage Control, and Selenium Rectifier, Assuring Noiseless, Interference-Free Operation, and Extreme Long Life and Reliability.

**ATR**

New Models

**AUTO RADIO VIBRATORS**

*A Complete Line of Vibrators . . .*

Designed for Use in Standard Vibrator-Operated Auto Radio Receivers. Built with Precision Construction, featuring Ceramic Stack Spacers for Longer Lasting Life.

**ATR VIBRATOR GUIDE**  
*a complete line*

New 34 page VIBRATOR GUIDE FREE

**ATR**

New Models

**STANDARD AND HEAVY DUTY INVERTERS**

*For Inverting D. C. to A. C. . . .*

Specially Designed for operating A. C. Radios, Television Sets, Amplifiers, Address Systems, and Radio Test Equipment from D. C. Voltages in Vehicles, Ships, Trains, Planes and in D.C. Districts.

✓ **NEW MODELS**  
 ✓ **NEW DESIGNS**  
 ✓ **NEW LITERATURE**  
*See your jobber or write factory*

**AMERICAN TELEVISION & RADIO Co.**  
*Quality Products Since 1931*  
 SAINT PAUL 1, MINNESOTA-U. S. A.

GET INTO THE  
**TELEVISION  
 BUSINESS**  
 IN A BIG WAY  
**NOW**  
 WITH THE NEW  
**TRANSVISION**  
**DEALER  
 PLAN**

It brings you a sure-fire means of doing a **BIG** and **PROFITABLE** business in Television Receivers

*It's simple . . . but it's great!*

- NO FORCED PURCHASES
- NO "TIE-IN" DEALS
- NO CAPITAL PROBLEM
- NO INVENTORY PROBLEM

Get the **FACTS** about this amazing new **Transvision Dealer Plan** which will give you a big stake and big future in television.

FILL OUT AND MAIL THIS COUPON NOW!

Transvision, Inc., New Rochelle, N. Y.

- ( ) Rush all the information on your special new Dealer Plan.
- ( ) I want to attend your Special Dealer Television Meeting.

Name .....

Address .....

My distributor is .....

# Table A-M/F-M

(See Front Cover)

THE REFLEX CIRCUIT, a feature of many old-time receivers, is being revived in current receiver design, particularly in a-m/f-m table model types. An example of this circuitry appears on the cover this month and in Fig. 1.

In this receiver, the G.E. 210/211/-212, a 6BJ6 acts as both an r-f amplifier and first i-f amplifier. The r-f signal is fed into the grid of the 6BJ6 through the secondary of the first f-m i-f transformer, amplified by the 6BJ6 and tuned at the converter grid by an inductance-capacitor-resistor combination. In the converter the r-f is changed to 10.7 mc i-f and fed into the primary of the first f-m i-f and again inserted into the grid of the 6BJ6 which now acts as an i-f amplifier. The i-f signal is then fed from the plate of the 6BJ6 through a choke into the second i-f transformer. To eliminate any i-f signal from the antenna circuit to prevent interference, a 10.7-mc wavetraps is used in the f-m antenna circuit. A 3-mmfd capacitor and inductance in the f-m antenna circuit are designed to peak at 98-mc with strays to increase the f-m r-f sensitivity. At the f-m r-f frequencies, the capacitor in the primary circuit of the first f-m i-f offers little

series impedance to the r-f signal. A 10-mmfd capacitor and inductance in the primary circuit of the second f-m i-f and switching input to the grid of the 12BE6 converter form a high pass filter to pass the f-m r-f signal into the converter grid and shunt the f-m i-f frequency into the primary of the second f-m i-f transformer.

The f-m oscillator coil is actually a section of a 300-ohm line shorted at one end to form a one-turn loop.

A coil and a 47-mmfd capacitor in the cathode circuit of the limiter tube are series tuned to 10.7-mc to effectively ground the cathode for i-f. A 33,000-ohm resistor in the cathode circuit of the 6BH6 limiter provide a highly degenerative condition for any amplitude modulation applied to the limiter grid. The cathode bias developed by this resistor is approximately 50 volts, which makes it necessary to insert onto the grid of this tube from B+ 50 volts, through a one-megohm resistor.

In this receiver a 12BE6 is used as an oscillator-converter, 6BJ6 as i-f amplifier, 6BH6 as a limiter, 19T8 as a f-m discriminator/a-m detector/first audio amplifier, 35B5 as a power tube and a 35W4 as a rectifier.

Fig. 1. R-f/i-f, converter and reflex circuit of the G.E. f-m/a-m receiver.

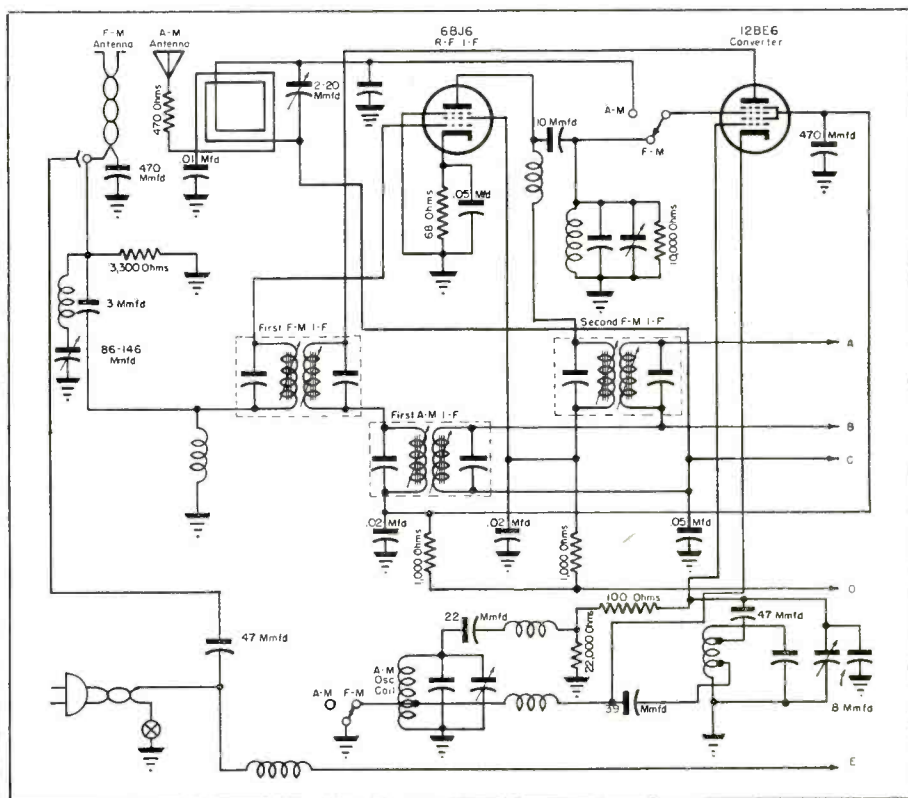



# Noise Suppressors

(Continued from page 16)

not suppress noise above a certain definite amplitude, nor can it discriminate to any degree between noise and signal.

In order to minimize, so far as possible, any undesirable effects caused by the superposition of noise on the signal in the loudest passages, the bandwidth should be limited at any instant only to that required by the signal. This is possible only in a *horizontal* type of noise suppressor.

Two difficulties often encountered in noise-reduction systems are *fuzz* and *swish*, the former being caused by the superposition of noise on the signal, during loud noise, and the latter representing the hangover of the noise after the notes. Obviously the *horizontal* type of noise-reducing system is much less susceptible to these effects than the *vertical* type, since the actual pass-band is limited at any instant only to that required by the music; while in the *vertical* type, the transmission in a wide range of frequency band increases or decreases as a unit. With class *A* systems, the transient characteristics can be adjusted to prevent opening of the system on loud *clicks* and to provide the best compromise between *swish* and loss of high-frequency reverberation. This is not possible in the class *C* system which operates instantaneously.

From a theoretical standpoint then, the *horizontal* class *A* system provides the best potentialities for high noise removal with a minimum effect upon audible quality.

## Gate Circuits

Fig. 1 shows typical characteristics for a *dynamic noise suppressor*. *A, B* and *C*, represent, respectively, conditions of maximum expansion, intermediate suppression and maximum suppression at the high-frequency end. *D, E* and *F* are corresponding low-frequency curves. Of particular importance is the steepness of the cutoff in the high-frequency gate since high-frequency noise is random in its characteristics and, accordingly, tends to be proportional to bandwidth. A typical scale for this figure would be 10 db per horizontal line, although in some suppressors the attenuation may be greater. It is not necessary to have the low-frequency gate as sharp, but the curve should be

(Continued on page 40)

# TRANSVISION



## NEW Television Kits, and Equipment

Important Advances in TV Reception and Servicing!

Transvision makes television more enjoyable, more profitable!

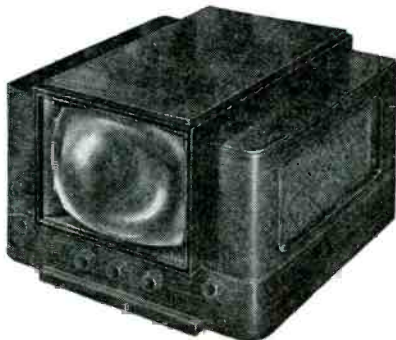

MODEL 10 BL TV/FM KIT

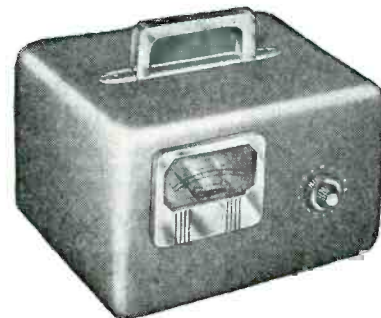

NEW . . . FIELD STRENGTH METER

TRANSVISION manufactures the most extensive line of high quality *Television Kits, Cabinets, Components, and Special Equipment*. Illustrated and listed here are only a representative few of Transvision's leading values. See your distributor.

MODEL 10BL, TV/FM Kit, gives 115 sq. in. picture; complete FM Radio; receives all channels; streamlined cabinet. Roto-Table for Model 10BL, gives full 180° visibility. . . . NET \$269.00  
 MODEL 7CL, TV Kit, gives 60 sq. in. picture; console cabinet with Roto-Table; streamlined design. Receives all 12 channels; continuous tuning. . . . NET \$23.50  
 MODEL 7BL, same as 7CL except that it is a table model. . . . NET \$199.00  
 All prices include cabinets, tubes, all-channel double folded di-pole antenna, and 60 ft. of lead-in wire.

## NEW . . . TRANSVISION FIELD STRENGTH METER . . .

Improves Installations! Saves 1/2 the Work! Has numerous features and advantages, including—(1) Measures actual picture signal strength. . . (2) Permits actual picture signal measurements without the use of a complete television set. . . (3) Antenna orientation can be done exactly. . . (4) Measures losses or gain of various antennas and lead-in combinations. . . (5) Useful for checking receiver reradiation (local oscillator). . . (6) 13 CHANNEL SELECTOR. . . (7) Amplitudes of interfering signals can be checked. . . (8) Weighs only 5 lbs. (9) Individually calibrated. . . (10) Housed in attractive metal carrying case. . . (11) Initial cost of this unit is covered after only 3 or 4 installations. . . (12) Operates from 120 volts, 60 cycles.  
 Transvision Field Strength Meter. MODEL FSM-1, complete with tubes. . . . NET \$99.50



NEW ALL-CHANNEL BOOSTER

TRANSVISION ALL-CHANNEL TELEVISION BOOSTER . . . To assure television reception in weak signal areas, or areas which are out of range of certain broadcast stations, Transvision engineers have designed this new booster. It increases signal strength on all 13 television channels. Tunes all 13 television channels continuously. Can be used with any type of television receiver. Unusually high gain in upper television channels.  
 Model B-1 . . . . . LIST \$39.95

TRANSVISION REMOTE CONTROL UNIT KIT . . . Will operate any TV receiver from a distance. Turns set on, tunes in stations, controls contrast and brightness, turns set off. Ideal for installations where the television receiver is inaccessible. Tuner unit is a high gain, all-channel unit with about 50 micro-volt sensitivity. Easy to assemble in about an hour.  
 Model TRCU, with 25 feet of cable. . . . LIST \$49.00  
 Without cabinet . . . . . \$47.00

NEW 8-PAGE CATALOG showing complete Transvision line now available at your distributor, or write to:

**TRANSVISION, Inc.** Dept. S New Rochelle, N. Y.  
 In Calif.: Transvision of California  
 6572 Santa Monica Blvd., Hollywood 46

All prices 5% higher west of Mississippi; all prices fair traded.  
 All Prices Subject to Change Without Notice



NEW REMOTE CONTROL UNIT KIT

Radiomen . . . you can

GET INTO THE  
**TELEVISION  
 BUSINESS**

In a BIG WAY with the

**TRANSVISION  
 DEALER PLAN**

# RADIO TROUBLESHOOTER'S HANDBOOK

ELIMINATES USELESS TESTING  
... on 4 jobs out of 5



...YOUR COMPLETE PRACTICAL RADIO SERVICE LIBRARY ...in two giant books



## MODERN RADIO SERVICING

A complete guide to troubleshooting, instruments, circuit analysis, repair.

## LEARN TO WORK BY MODERN PROFESSIONAL METHODS

Train for the big pay jobs!

**1** Ghirardi's MODERN RADIO SERVICING is a complete 1 vol. course in all phases of professional radio-electronic repair. Tells how to make preliminary trouble checks on difficult jobs; how to analyze any circuit and its components; how, when and where to use all types of test instruments and interpret their readings to track down the trouble—even how to start a service business of your own. Everything is explained simply and thoroughly. 706 clear illustrations and 725 self-test review questions make study easy. Complete 1300-page book only \$5—or see special combination price offer below.

## CUT TIME IN HALF ON COMMON SERVICE JOBS

**2** Work faster—make more money

Almost 4 out of 5 radio repair jobs can be handled as easily as falling off a log! Just look up the model of the set to be fixed. Chances are Ghirardi's RADIO TROUBLESHOOTER'S HANDBOOK tells exactly what the trouble is, exactly how to fix it. Gives common troubles, their symptoms and remedies for over 4800 radios by 202 manufacturers. Hundreds of additional pages contain tube data; transformer trouble listings, alignment charts and dozens of diagrams, etc., for faster, better service on any radio ever made. Only \$5—or see special combination offer.

## MONEY-SAVING OFFER!

Let Ghirardi's RADIO TROUBLESHOOTER'S HANDBOOK save time, help you make more money on common service jobs. Let MODERN RADIO SERVICING train you in truly scientific servicing that can pave your way to the big money jobs. Get BOTH big books at the special price of only \$9.50 for the two (\$10.50 foreign). Read these helpful books for 10 days at our risk.

**10-DAY EXAMINATION COUPON**

Dept. S-98, Murray Hill Books, Inc.,  
232 Madison Ave., New York 16, N. Y.

Send me the Ghirardi Books checked below for 10-days examination on approval. In 10 days I will pay for the books, plus a few cents postage, or return them postpaid. (Postage paid on cash orders; same return privilege. Books sent on approval in U. S. only.)

- MODERN RADIO SERVICING \$5 (\$5.50 outside U.S.A.)
- RADIO TROUBLESHOOTER'S HANDBOOK \$5 (\$5.50 outside U.S.A.)
- SPECIAL MONEY-SAVING OFFER Both of above big books only \$9.50 (\$10.50 outside U.S.A.)

Name .....  
Address .....  
City & Zone ..... State .....

# Noise Suppressors

(Continued from page 39)

steeper than can be obtained with a simple  $rc$  or  $lr$  circuit.

### H-F Gate Circuit

A typical high-frequency gate circuit is shown in Fig. 2 in which  $C_2$  is actually a reactance tube. Such a circuit resembles a combination of a series-derived and a shunt derived filter, having one point of high attenuation controlled by the resonances between  $C_1$  and  $L_1$ , and another point of high attenuation controlled by the resonances between  $L_2$  and  $C_2$ . This latter point of high attenuation shifts back and forth with the cutoff frequency as  $C_2$  is varied, thus providing a sharp cutoff with a higher degree of attenuation immediately above cutoff. The capacitor,  $C_3$ , is used to restrict transmission at extreme high frequencies well above the normal operating range and may, in more elaborate versions, be replaced by a second reactance tube. The shape of the cutoff under conditions of maximum suppression is controlled to a considerable extent by the impedance,  $Z_1$ , and under conditions of maximum expansion by the impedance,  $Z_2$ ; hence it is possible to obtain dynamic band-pass characteristics having substantially identical or practically any desirable shape over a wide range of operating conditions. A similar circuit as used for the low-frequency gate is shown in Fig. 3,  $L_3$  being actually a reactance tube.

### Reactance Tubes

In actual practice the reactance tubes in the gate circuits are controlled by means of rectifiers which may be diodes enclosed in the same envelope as the reactance tubes or other tubes in the circuit. The high-frequency gate is controlled mainly by energy below the control range, and the response of this control circuit has a characteristic similar to that of the normal human ear. Since musical tones at extremely high frequencies are always harmonics of lower tones, this feature may be used to distinguish between noise and music. The opposite is true for the low-frequency gate where the response to low-frequency fundamentals is controlled

mainly by harmonics of those fundamentals present in the music. The sensitivity characteristics of the low-frequency control circuit are similar to those for the high-frequency control circuit, but have less sensitivity at a somewhat lower frequency. The general result is a system having a pass-band tending to conform to the instantaneous requirements of the music and maintaining tonal balance under conditions of high noise suppression.

### Tubes in Suppressor

The simplest dynamic noise suppressors when added to existing amplifiers require only two additional tubes—one for the high-frequency gate, and one for the low-frequency gate, plus two diodes which may be contained in these tubes or in other tubes of the amplifier. For extended-range applications, a second reactance tube is added to the high-frequency gate.

**SAVE 50% ON KITS!**

**25 WATT P.P. 6L6 HI GAIN AMP. KIT**  
A wonderful buy! Make up an amplifier worth \$50 to you. Powerful enough for auditoriums seating 1500 people. Separately controlled Mike & Phono inputs. All parts incl. drilled chassis, hardware, solder, circ. dia., etc.

LESS TUBES **\$11.95**

**UNIVERSAL TROUBLE SHOOTER KIT**  
Locates every service trouble. Guaranteed to do everything we say. Aligns padder. Locates dead spots, weak spots, defective parts. Checks gain. All parts incl. case, test leads, plug. 2 1/4" x 6" x 3" **\$3.95**

**PHONO OSCILLATOR 2 TUBE KIT**  
Hi-gain with microphone jack and all parts including Tubes. **\$2.95**  
Free data, circuits designed by ROBT. G. HERZOG.

**Universal/general corp.**  
365 CANAL STREET, DEPT. K  
N. Y. 13, N. Y. Walker 5-9642

**GREYLOCK**  
A Dependable Name in  
**RADIO TUBES**  
GT, Glass, and Miniature Types  
ALL TUBES IN INDIVIDUAL CARTONS

39c.	39c.	39c.	49c.	49c.	59c.
6A8GT	12AT6	25L6GT	1R5	6AK5	6X4
6K7GT	12BA6	25Z6GT	1T4	6AC5	25Z5
6Q7GT	12BE6	35W4	1U4	6AQ5	6A7
6SA7GT	12K7GT	45	1S5	6BE6	6C6
6SK7GT	12Q7GT	46	384	6BA6	6D6
6SQ7GT	12SA7	47	3Q4	6AU6	75
6V6GT	12SK7	50B5	3V4	6BJ6	11Z73
12A8GT	12SQ7	50L6			32L7

Webster A11 Pickup, plastic arm.....\$1.49  
TERMS: Net C.O.D. No order accepted for less than \$5.00  
Write for Bargain Catalog S-9  
**GREYLOCK ELECTRONIC SUPPLY CO.**  
30 CHURCH STREET NEW YORK 7, N. Y.

## Reactance Modulator

(Continued from page 21)

the total oscillator voltage is applied across the series circuit  $C_2, R_1$ . The reactance of  $C_2$  is made small at the oscillator frequency so the low end of  $R_1$  may be considered at r-f ground. The reactance of  $C_3$  is also small, so that the reactance modulator is actually across that portion of the tank coil between center tap and plate. The reactance of  $C_1$  is made about ten times as large as the value of  $R_1$  at the operating frequency, so that  $R_1$  has no effect on the phase change across the series combination.

When the oscillator is operating the voltage generated between the plate and the r-f ground point ( $C_3$ ) is, in turn, applied across the series combination  $C_1, R_1$ . Since  $C_1$  has an impedance ten times that of  $R_1$  at the oscillator frequency, it will cause the current to lead the voltage by  $90^\circ$ . This current causes a voltage drop across  $R_1$ . This voltage being created by the leading current must, of course, be in phase with it. Since the plate current of the reactance modulator must be in phase with the grid voltage, it follows that this must also be  $90^\circ$  ahead of the oscillator voltage. Since we have satisfied the requirements of a  $90^\circ$  phase shift, we have simulated electrically the shunt of a fixed capacitor across the oscillator circuit. It is now only necessary to vary the magnitude of the effect to vary the frequency of the oscillator. The relations of voltage to current are shown in the simple vector of Fig. 2.

The amount of apparent capacity change, or the amount of frequency shift of the oscillator may be described as a change in the capacitive reactance across the circuit. Since we know that capacitive reactance is determined by the ratio of voltage to current, we can vary the magnitude or the effect of our simulated capacitor by changing either of the values in the simple formula  $XC = EAC/IAC$ . Since the voltage in our case is fixed we may vary the current to derive the frequency change required. If, for instance, it is possible to vary the bias on the reactance modulator grid, it becomes possible to change the value of total plate current and thus the apparent value of capacity across the oscillator tank circuit.

The universal method of accomplishing this apparent capacity change is to apply a sine wave modulating voltage to the reactance modulator grid. In the resting, or no modulation condition, the bias on the reactance modulator is determined by that sup-

# New **DUAL SPEED** **PHONOMOTOR**

**FOR 78 R.P.M. OR 33 $\frac{1}{3}$  R.P.M.**

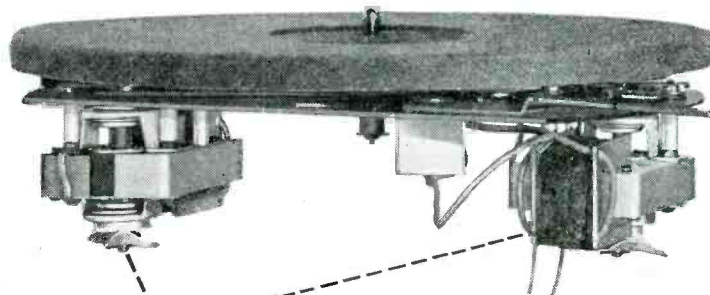

Takes ALL record sizes

**TWO** turntable speeds—78 or 33 $\frac{1}{3}$  r.p.m. are optional with the new Alliance Dual-Speed Phonomotor! With a simple "flick" of the control, you select either speed at will.

A dual version of the famous Model 80, this complete, new record player assembly gives the same kind of high quality "wow-free" performance required for commercial transcriptions!

**Make the Alliance Dual-Speed your answer to the growing demand for slow-speed, long-play micro-groove records!**

And remember—The new Alliance Dual-Speeds will be just as dependable as the millions of Model 80 Phonomotors now in use!

Radio service shops and retailers will find the new Alliance Dual-Speed Phonomotor is the ideal turntable drive for record players consoles, table models, combinations and portables. Each unit is individually boxed. Place your orders with your regular jobber now!

WHEN YOU DESIGN . . . KEEP  
**alliance motors**  
IN MIND

ALLIANCE MANUFACTURING COMPANY • ALLIANCE, OHIO

Export Department: 401 Broadway, New York 13, N. Y., U. S. A.

plied by the voltage drop across  $R_1$ , supplemented by the steady cathode bias. This is carefully adjusted to bias the tube to the center of the straight portion of the plate current characteristic. When a sine wave modulating voltage is applied to the grid, the amount of plate current is varied and the oscillator frequency changes accordingly. If we consider Fig. 3 this is apparent. The zero line represents the state of no modulation or the resting frequency of the oscillator. As the sine wave varies from zero to the positive direction, more current flows in

the reactance modulator plate circuit. As determined by the simple formula, the capacitive reactance has decreased because the voltage is fixed, and the current has increased. If the capacitive reactance has decreased it is the same as if the capacity had been increased. The effect on the oscillator is therefore to lower its frequency. The oscillator reaches its lowest frequency at the crest of the positive excursion of the modulating sine wave. As the sine wave varies from positive to negative less plate current flows in

(Continued on page 42)

# Learn RADIO TELEVISION, ELECTRONICS

by  
**SHOP METHOD  
HOME TRAINING**



You receive all parts, including tubes, for building this fine modern Superheterodyne Receiver. This and other valuable standard equipment is yours to use and keep.

Let NATIONAL SCHOOLS of Los Angeles, a practical Technical Resident Trade School for almost 50 years, train you for today's unlimited opportunities in Radio.



These **FREE** Books will tell you how

Trained Radio technicians are in constant and growing demand at excellent pay—in Broadcasting, Communications, Television, Public Address Systems, Research Laboratories, Home Radio Service, etc. We can train you

in your own home. This practical training has been developed and tested in our own Shops and Laboratories, under the supervision of experienced engineers and Instructors. A free sample lesson is yours upon request—use coupon below.

**You Learn by Building Equipment with Standard Radio Parts We Send You**

You learn by doing. We send you complete standard equipment of professional quality for building various experimental and test units and the receiver shown above. You build many types of circuits, signal generator, low power Radio transmitter, audio oscillator, etc.

**Professional Multitester Now Included**

This versatile testing instrument is portable, complete with test leads and batteries. Simple to operate, accurate, dependable. You will be able to quickly locate trouble, adjust the most delicate circuits.



**APPROVED FOR VETERANS**

**Both Home Study and Resident Training Offered**

Check Coupon Below:

**NATIONAL SCHOOLS**  
1535 S. GARDEN ST. LOS ANGELES, CALIF. 90015  
**MAIL OPPORTUNITY COUPON FOR QUICK ACTION**

National Schools, Dept. SV-9 (Mail in envelope or paste on postcard)  
4000 South Figueroa Street  
Los Angeles 37, California

Mail me **FREE** the books mentioned above including a sample lesson of your course.

NAME ..... AGE.....

ADDRESS .....

CITY ..... ZONE..... STATE.....

Check here if veteran of World War II

(Continued from page 41)

the reactance modulator plate circuit, and the opposite effect is true. The capacitive reactance in this case is increasing, and the effect on the oscillator is as though the capacity were decreasing. The oscillator frequency therefore varies from its lowest to highest frequency. The highest frequency is of course determined by the peak of the negative portion of the modulation sine wave. This is shown graphically in Fig. 3.

The amount of frequency change that can be obtained by the reactance modulator method is determined by a number of conditions. The ratio of the amount of apparent capacity change to the value of fixed capacity in the oscillator circuit must be taken into consideration. It is desirable to use only the distributed capacity of the circuit to determine oscillator frequency when the capacitive system is used. For this reason most commercial circuits slug tune the oscillator coil with no fixed capacitance where maximum frequency swing is desired. The reactance modulator tube itself must be of a high transconductance type so that a large plate current change may be realized.

### Sweep Rate

It is interesting to note that the rate of frequency change of the oscillator or the *sweep rate* is twice the rate of the modulating voltage. The *sweep rate* may be described as the number of times per second that the oscillator carrier is varied through any given point in its excursion. The oscillator frequency may be varied from the lowest to highest frequency points as the modulating voltage changes from the positive to negative crest. If we consider the center or resting frequency point as the reference the carrier has been swept through this point once. The time involved, so far as the modulating voltage is concerned, is one-half cycle. The same thing happens in the opposite direction as the modulating voltage varies from negative to positive. The total time consumed is one cycle of modulating voltage for both sweeps. The *sweep rate* therefore is always twice the modulating rate when a sine wave is used.

### System Advantages

The reactance modulator system of producing a frequency modulated wave has some disadvantages, such as non-

## For Replacements

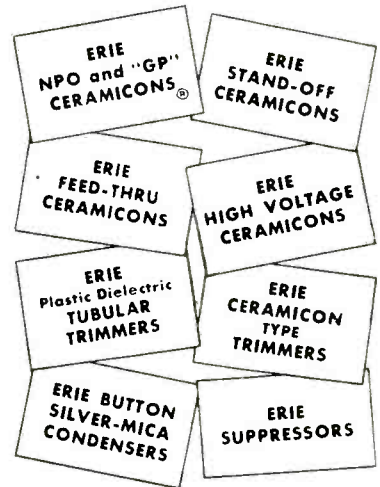

### Rely on these ERIE RESISTOR components

For years many leading set manufacturers have used ERIE RESISTOR components. When repairs call for replacement—replace with ERIE RESISTOR. If your distributor can not supply you, write us for information. New catalog on request.

Electronics Division  
**ERIE RESISTOR CORP., ERIE, PA.**  
LONDON, ENGLAND      TORONTO, CANADA.

## RADIO TUBES

6AV6	25Z6	} <b>29¢</b> ea.
6T8	35W4	
19T8	39/44	
1S5	3S4	} <b>39¢</b> ea.
1U5	5Y3GT	
12SA7	6F6GT	} <b>43¢</b> ea.
12SK7	6K6GT	

Individually boxed—standard 90 day guarantee. Rated accounts—10 days. All others—C.O.D. Less than 50 tubes 5¢ per tube extra. Orders of 200 tubes or more assorted 5% additional discount.

Write for Complete List of Tubes and Parts  
**PREMIER RADIO TUBE COMPANY**  
Dept. SE  
1802 Winnetka Avenue, Chicago 40, Illinois  
Phone: LONgbeach 4429

linearity of frequency change versus modulating voltage change. It is also difficult to get much frequency change at lower oscillator frequencies. The advantage of obtaining a f-m wave by a reliable non-mechanical method more than outweighs these objections however, and this system is thus finding wide utilization in present-day sweep generator equipment, and a host of other applications.

# New TV Parts... Accessories

## OAK RIDGE ANTENNA ACCESSORIES

Antenna accessories . . . *Steel Stand-Offs, Wall Mounts and Chimney Mount Conversion Units*, are now being produced by Oak Ridge Antennas, manufacturing division of Video Television, Inc., 239 East 127 St., N. Y. City.

The *Steel Stand-Offs* (pat. pending) will clamp any of the popular size coaxial or twin-lead cables. Universal application of insulators obtained by reversing either of the half sections of the grommet.

*Wall Mounts* are made of 1/8" steel and cadmium plated. Available in 6" or 12" lengths. Have slotted ends for alignment of mast.

*Chimney Mount Conversion Unit* features a solid steel mount. Applied by wrapping a perforated metal strip around the chimney and taking in the slack with a take-up bolt.

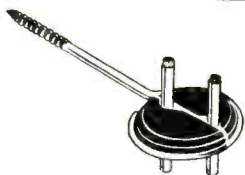
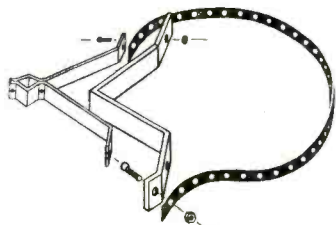

Bottom, Steel Stand-off; Top, Wall Mount and Chimney Mount Conversion Unit

\* \* \*

## VISION RESEARCH TV BOOSTER

An all channel tv booster, model TVA, has been announced by Vision Research Laboratories, 87-50 Lefferts Blvd., Richmond Hill, N. Y.

Unit has two r-f stages on high-frequency channels.



# PHOTOFACT Publications HELP YOU TO SUCCESS!

These are the indispensable service data books you'll use profitably every single working day . . .



Your Price  
Each Volume,  
In Deluxe Binder **\$18<sup>39</sup>**

## NOW! PHOTOFACT VOLUME 4 Includes First Three TV Course Installments

Bring your file of post-war receiver Service Data right up to July, 1948! Here's the most accurate and complete radio data ever compiled—preferred and used daily by thousands of Radio Service Technicians. Includes: Exclusive Standard Notation Schematics; photo views keyed to parts lists and alignment data; complete parts listings and proper replacements; alignment, stage gain, circuit voltage and resistance analysis; coil resistances; record changer service data, etc. Order Volume 4 today—keep your Photofact library up-to-date—it's the *only* Radio Service Data that meets your *actual* needs!

**Vol. 4.** Covers models from Jan. 1, 1948 to July 1, 1948  
**Vol. 3.** Covers models from July 1, 1947 to Jan. 1, 1948  
**Vol. 2.** Covers models from Jan. 1, 1947 to July 1, 1947  
**Vol. 1.** Covers all post-war models up to Jan. 1, 1947



### 1947 Record Changer Manual

Nothing like it! Complete, accurate data on over 40 post-war models. Exclusive exploded views, photos from all angles. Gives full change cycle data, information on adjustments, service hints and kinks, complete parts lists. PLUS—for the first time—complete data on leading Wire, Ribbon, Tape and Paper Disc Recorders! 400 pages; hard cover; opens flat. Order now! **ONLY.....\$4<sup>95</sup>**



### Receiver Tube Placement Guide

Shows you exactly where to replace each tube in 5500 radio models, covering 1938 to 1947 receivers. Each tube layout is illustrated by a clear, accurate diagram. Saves time—eliminates risky hit-and-miss methods. 192 pages, completely indexed. **ONLY.....\$1<sup>25</sup>**



### Dial Cord Stringing Guide

The book that shows you the *one right* way to string a dial cord. Here, in one handy pocket-sized book, are all available dial cord diagrams covering over 2300 receivers, 1938 through 1946. Makes dial cord restringing jobs quick and simple. **ONLY..\$1<sup>00</sup>**

## THE FIRST TELEVISION FOLDER APPEARS IN PHOTOFACT SET NO. 46 DON'T MISS IT!

Now—PHOTOFACT brings you a new kind of Television Service Data—a complete, accurate analysis of a popular Television receiver—based on actual examination of the set in the Sams' laboratories. This is the beginning of a series of uniform, accurate, authoritative Television Folders, exclusively PHOTOFACT—plus the \$500 Television Course—at no extra cost to you! Don't miss Set No. 46—at your local jobber now!

**STAY AHEAD OF THE GAME —  
SUBSCRIBE REGULARLY TO  
PHOTOFACT FOLDER SETS**

HOWARD W. **SAMS** & CO., INC.  
INDIANAPOLIS 7, INDIANA

## METALACE ANTENNA BASE

An all-steel base for chimney mounting of 3/4" to 2" tv, f-m or ham antenna masts, has been announced by Metalace Corporation, 2101 Grand Concourse, Bronx, New York.

Mount consists of an 8" by 8" by 1/8" thick flanged cadmium steel plate with two standoff clamps, attached turnbuckles, and two 12' lengths of perforated steel strap. Installation is made by attaching straps to loops, bending straps around the chimney, and taking up slack by tightening the turnbuckles. The mast is then inserted in the vice type clamps and held by 1/4" retaining bolts.

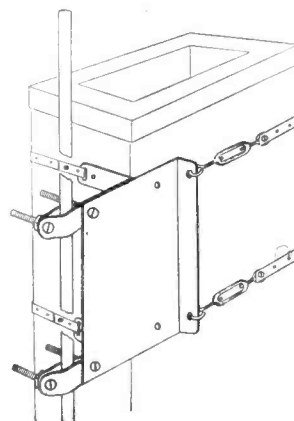

# Presenting DURANITE

## the SUPERIOR CAPACITOR



Immune to Moisture Penetration

Unaffected by Temperatures of **250° F.**

Several sizes — 11/32" to 21/32" dia. 1 1/8" to 2" long.

• An entirely new tubular capacitor—featuring Aerolene, the new impregnant; new processing methods; new DURANITE casing.

Such is DURANITE—the toughest tubular yet offered for use in stay-put assemblies. Therefore don't confuse DURANITES with conventional molded tubulars. DURANITES are different.

Drop, bang, scratch—no damage to the permanent, non-varying, rock-hard DURANITE casing. Unaffected by high temperatures—nothing to melt or burn. Thoroughly moistureproof. No shelf deterioration. Pigtailed won't pull out. And so on.

Order DURANITES from your Aerovox jobber. Popular capacities, 200 to 1600 v. D.C.W. Try them. You'll be amazed!



**FOR RADIO-ELECTRONIC AND INDUSTRIAL APPLICATIONS**

AEROVOX CORP., NEW BEDFORD, MASS., U.S.A.  
Export: 13 E. 40th St., New York 16, N.Y. • Cable: 'ARLAB'  
In Canada: AEROVOX CANADA LTD., Hamilton, Ont.

### TACO H-F TV ANTENNA ADAPTER

A h-f tv antenna adapter, type 445, comprising a half-wave folded dipole with reflector as well as a quarter-wave connecting link with the existing antenna, has been announced by Technical Appliance Corp., Sherburne, N. Y. The matching network is said to be so designed that instead of the usual loss that occurs when loading one antenna with another, a gain is actually the result over the low band.

Antenna adapter is supplied with an aluminum tubular mast extension which mounts to the mast of the existing low-frequency antenna assembly, by means of a coupling clamp.

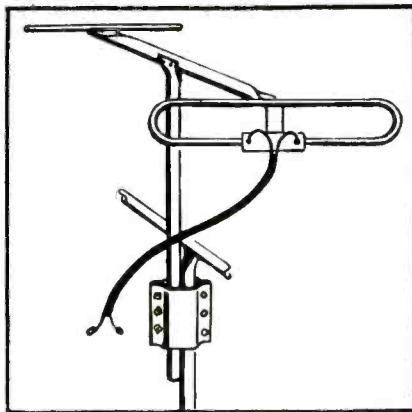

\* \* \*

### TELEVISION INDUSTRIES TV UNITS

A picture i-f and sound i-f strip, and front-end unit have been announced by Television Industries Co., 540 Bushwick Ave., Brooklyn 6, N. Y.

Available also are Du Mont inputuner, Bausch and Lomb projection lens, r-f power supply, deflection coils, etc.

\* \* \*

### WARD STACKED ARRAY

A stacked array, model TV S-6, has been announced by Ward Products Corporation, 1523 E. 45th St., Cleveland 3, Ohio.

Antennas are stacked one above the other, with 1/2 wave spacing.

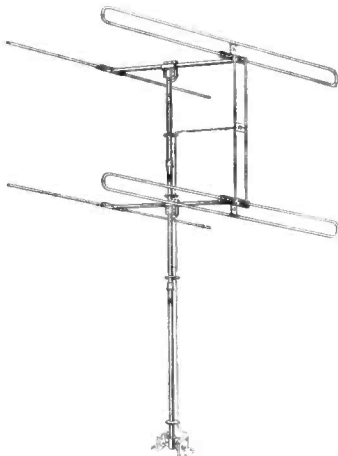

## Mueller (THE CLIPPER) ANNOUNCES THE NEW No. 22 "TWIN-CLIP"

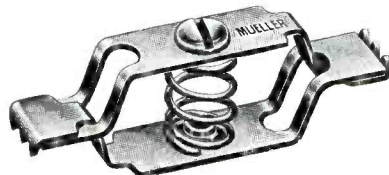

### HAS JAWS ON BOTH ENDS Something New and Different!

Both jaws may be opened at the same time by pressing the center of the clip, or either jaw may be opened separately without disturbing the grip of the other.

Two inches long, made of cadmium plated steel. Has screw connection.

The Twin-Clip is a real time-saver in many electrical and mechanical applications. May be used to make a quick splice, temporary repair hookup, hanging and racking various articles for display or industrial processing, holding identification and record cards, etc.

SEND FOR FREE SAMPLES  
AND COMPLETE CATALOG 810

**Mueller Electric Co.**

1565 E. 31st St., Cleveland 14, Ohio

### RCA VIDEO PICTURE MAGNIFIER

A television picture magnifier has been announced by the RCA Tube Department.

An oil-filled plastic lens, it enlarges the images received on a seven-inch or ten-inch picture tube to the approximate equivalent in size and brilliance of those produced by a 15" picture tube.

Picture magnifier (model 203P2), measures 14 1/2" high, 17 1/2" wide, and has an optical aperture 12" by 15".

\* \* \*

### TELEVISION ASSEMBLY PROJECTION KIT DEMONSTRATION

A projection kit, providing a 20"x26" picture, was demonstrated during August by Television Assembly Co., 540 Bushwick Avenue, Brooklyn 6, N. Y., at the St. Moritz Hotel, N. Y. City.

The kit features a 5TP4 tube, Bausch and Lomb F/1.9 lens, Eastman-Kodak screen, pre-wired and pre-tuned i-f picture and sound strip (pat. pending) and pre-wired DuMont inputuner.

\* \* \*

### JFD TV/F-M ANTENNA INSTALLATION SERVICE

A tv/f-m installation department has been announced by J. F. D. Manufacturing Co., Inc., 4110 Fort Hamilton Parkway, Brooklyn 19, New York.

The department will offer free advice to all Service Men in the analysis and solution of their tv/f-m antenna installation and reception problems.

Inquiries should be addressed to the JFD TV/F-M Antenna Installation Service Department.

# Here's a SENSATIONAL BUY!

## COMBINATION INTERCOM & RADIO

### Customers Say—

"Intercom alone is worth your low price. You get free a 6 tube radio in this deal plus real utility!"

A REAL MONEY MAKER FOR YOU

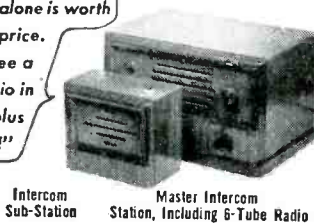

Intercom Sub-Station      Master Intercom Station, Including 6-Tube Radio

Combines a top-quality 6 tube superhet receiver, plus office or home intercom system in handsome walnut-veneer cabinets. Hi-Amplification 3 tube intercom permits instant communication between radio-master and up to 4 remote sub-stations. Any remote station can call the master while radio is playing; call can be returned to any remote station. Operates on 110 volts AC or DC.

It's handsome—It's easy to install—It's easy to use!

Price Includes Radio Master, 1 Remote, 50' wire

Original retail price was \$84.50 with 4 remotes. Buy from RSE and SAVE OVER 50%.

Brand new—only 400 available.

**\$29.95**

Extra Remotes—\$3.95

## MIDGET I.F. TRANSFORMERS

Back again—by popular demand!



RSE scores again with a new and better I. F. I. 400-500 KC range—1 1/4" square x 3" high—ceramic based mica trimmers—high gain iron cores—pep up old receivers, ideal for new construction—and now available in either input or output types—for peak performance! Individually boxed in the colorful RSE carton. List price \$2.10. LRI—input; LR2—output;

Specify Type.

Each	Matched Pair	Dozen	Egg Crate of 100
36c	69c	\$3.95	\$29.00

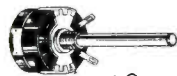

## VOLUME CONTROLS

• Our own private brand—made by a nationally known manufacturer. • The same kind that net for \$1.09. • Noise-free carbon construction, standard shaft and bushing. • Individually boxed in our colorful carton carrying the RSE equality seal of approval. • Complete with switch, full range of sizes.

10 M ohms	100 M ohms	each	<b>59c</b>
15 M ohms	250 M ohms		
25 M ohms	500 M ohms	per 10	<b>\$5.50</b>
50 M ohms	1 Meg ohms		
2 Meg ohms		asstd.	
500 M Knurled Shaft			
500 M ohms less switch, 39c each, 100 for \$35.00			

## TUBES

### "The All-American Five"

Here they are—the fastest movers ever made—at RSE's long discount. Brand new, tested top-grades with regular RMA guarantee. Individually boxed in eye-appealing cartons. Know your supplier—his reputation. Shoot us an order today—watch your profits zoom tomorrow!

12SA7GT...65    12SK7GT...65    12SQ7GT...59  
35Z5GT...49    50L6GT...65

"All-American Kit", one each of above...\$2.98



## ORDER INSTRUCTIONS

Minimum order—\$2.00. 25% deposit with order required for all C.O.D. shipments. Be sure to include sufficient postage—excess will be refunded. Orders received without postage will be shipped express collect. All prices O.B. Detroit.

Demand This Seal of Quality

**RADIO SUPPLY & ENGINEERING CO., Inc.**  
86 SELDEN AVE. DETROIT 1, MICH.

## New LP Products

### WEBSTER ELECTRIC MICROGROOVE PICKUP

A lightweight *Featheride* tone arm and crystal cartridges for reproduction of microgroove records have been announced by Webster Electric Company, Racine, Wisconsin.

The tone arm, of stamped aluminum construction, is balanced to maintain 7-gram tracking pressure for LP requirements.

Crystal cartridge, model F12, is for use with LP records, playing at 33 1/3 rpm. Another model, F11, is a double needle, combination cartridge that plays either microgroove or standard records.



F11



F12

\* \* \*

### DJOTONE LP NEEDLES

*Star Sapphire* and *Shockproof Nylon* needles, with a one mill radius for the LP records have been announced by the Duotone Company Inc., New York.

\* \* \*

### ASTATIC LP PICKUPS

A pickup, FL-33, and crystal replacement cartridge, LP-33, for use with the long playing microgroove discs have been developed by The Astatic Corporation, Conneaut, Ohio. Crystal cartridge has a permanent sapphire needle with .001-inch tip radius. Is readily interchangeable with a companion cartridge LP-78 for playing conventional 78 rpm records.

LP-78 cartridge has a needle tip radius of .003". FL-33 pickup has a needle pressure of five grams, output of approximately .5 volt, and frequency range of 30 to 10,000 cps.



\* \* \*

### PICKERING MICROGROOVE CARTRIDGE REPRODUCER

A pickup, model D-140S, designed for the microgroove, fine-line slow-speed, recordings, has been announced by Pickering and Co., Inc., Oceanside, Long Island, N. Y. Sharp diamond stylus radius is .001".

Cartridge tracks the recordings with a stylus pressure of 5 grams, or approximately 1/6 of an ounce.

Has a *Keystone Clip Mounting* which permits conversion from the standard cartridge to model D-140S.

## Built for Service



Servicemen's choice!  
in...



• Cunningham tubes assay high in esteem in Montana—because Cunninghams measure high in quality and performance. They're built to give long life and trouble-free service. When new tubes are called for, replace with Cunninghams, and you won't have to go prospecting for new customers.

See your  
CUNNINGHAM DISTRIBUTOR  
**George Steele & Co.**  
Butte

**Cunningham Tubes**

A product of  
RADIO CORPORATION OF AMERICA  
Harrison, N. J.

*Now* Small Size, Heavy Duty, Trouble-Free

# 5-WATT VITROHM

## Wire Wound Fixed Resistors

Now . . . for extra reliability in many installations . . . for longer service and steadier performance . . . you can use this compact, low-wattage Type 5F resistor. Resistance wire is insulated and protected by WARD LEONARD's own Green Vitreous Enamel of exclusive formula developed in the WL laboratories. Tough, hard, moisture and acid resistant. Quickly conducts away generated heat. Easily mounted by its wire leads.

**WARD LEONARD ELECTRIC COMPANY**  
Radio and Electronic Distributor Division  
53-E West Jackson Blvd., Chicago 4, U. S. A.

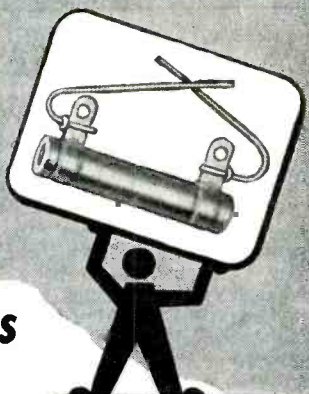

**TYPE 5F • 5 WATTS**  
1" long x 5/16" diam.  
Available from stock in resistances from 1 ohm to 5000 ohms.  
*Made available only by WARD LEONARD thru Authorized Distributors everywhere*

**WARD LEONARD**  
RELAYS • RESISTORS • RHEOSTATS  
Electric control devices since 1892

Send for Catalog D-30

Gives handy data and information on various types of Resistors and Rheostats available from stock.



# FULL 13 CHANNEL TV-FM COVERAGE!

*It's Here . . .*  
**NEW JFD Super-Beam HI-LO Duo-Orienting Array**

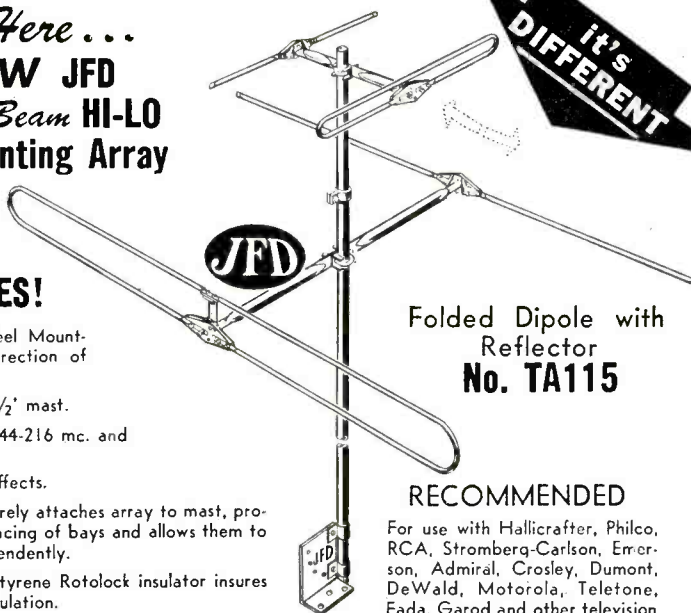

### FEATURES!

- ✓ JFD All-Angle Steel Mounting Bracket for erection of masts anywhere.
- ✓ Corrosion-proof 7 1/2' mast.
- ✓ Frequency Range 44-216 mc. and + 4.2 DB gain.
- ✓ Minimized ghost effects.
- ✓ U-Bolt Clamp securely attaches array to mast, provides unlimited spacing of bays and allows them to be oriented independently.
- ✓ Unbreakable polystyrene Rotolock insulator insures high frequency insulation.
- ✓ Lightning-fast assembly time — no hardware bag.

Folded Dipole with Reflector  
**No. TA115**

### RECOMMENDED

For use with Hallicrafter, Philco, RCA, Stromberg-Carlson, Emerson, Admiral, Crosley, Dumont, DeWald, Motorola, Teletone, Fada, Garod and other television sets.

Visit our Booth #41 at Los Angeles Electronic Convention, Sept. 30 to Oct. 2

Write for the New JFD 16-page Super-Beam Catalog, No. 7810S.



**MANUFACTURING CO. Inc.**

4111 Ft. Hamilton Parkway, Brooklyn 19, N. Y.

### ELECTROVOX MICROGROOVE RECORD NEEDLES

Needles, with sapphire and osmium alloy tips, for the microgroove long-playing records have been announced by Electrovox Company, Inc., 66 Franklin St., East Orange, N. J.

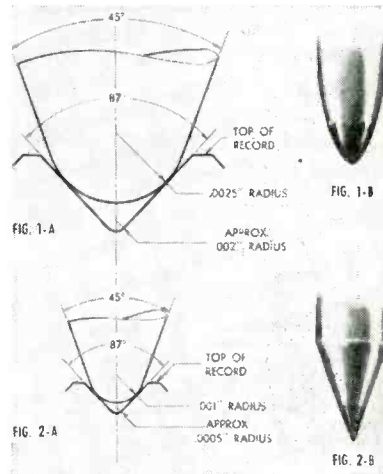
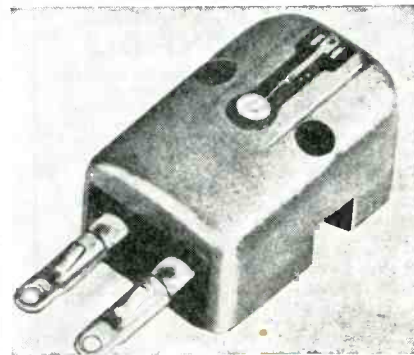

Fig. 1A. Diagrammatic view of conventional needle in record groove. Fig. 1B. Conventional needle point. Fig. 2A. Diagrammatic view of microgroove needle in record groove. Fig. 2B. microgroove needle point.

### G. E. LONG-PLAYING RECORD CARTRIDGE

A variable reluctance cartridge, designed for the *lp* records, has been announced by the receiver division of G. E. The cartridge, which features a low mass stylus assembly and high compliance, is one-third smaller than previous models.

The stylus of the cartridge is a sapphire, measuring one mil in diameter as required by the new microgroove recordings.



### TRANSPARENT MIRROR TV SET



A tv receiver using a mirrored surface lens over picture tube. Mirror does not affect picture image. (Courtesy Sightmaster Corp.)





## The Toast of the Trade!

It is rather remarkable how, year after year, so many of the largest and finest radio and electronic manufacturers depend on Quam for their speaker requirements.

This should be of especial significance to the serviceman. For one thing, it means that these receivers are designed with Quam Speakers as a component part and, when replacements are required, another Quam Speaker should be used to maintain the same high quality of performance.

And it also indicates the confidence these manufacturers place in Quam, and their dependence on the consistently high quality of Quam engineering and production.

Take a tip from the people who buy speakers by the thousands, always specify Quam for your replacement job!

Write for Catalog of Quam  
Adjust-a-Cone Speakers

**QUAM NICHOLS COMPANY**  
526 East 33rd Place, Chicago 16, Illinois

QUAM SPEAKERS ARE LISTED IN  
THE RADIO INDUSTRY RED BOOK

## New Instruments... Components

### SIMPSON ELECTRIC ROTO-RANGER VOLT-OHM-MILLIAMMETER

An a-c/d-c volt-ohm-milliammeter, equipped with the *Roto-Ranger* principle, model 221, has been announced by Simpson Electric Co., Chicago, Ill. In operation, as the selector switch is moved to the range desired, the proper scale for that range is brought into place behind the meter window.

Measures a-c diode balancing circuits, grid currents of oscillator tubes and power tubes, bias of power detectors, a-c diode currents, rectified r-f current, high mu triode plate voltage, etc. D-c sensitivity is 20,000 ohms per volt.

Ranges: Volts, a-c, 2.5, 10, 50, 250, 1000, 500; volts, d-c, 2.5, 10, 50, 300, 1000, 5000; ma, d-c, 10, 100, 500; microamperes, d-c, 100; amperes, d-c, 10; output, 2.5, 10, 50, 250, 1000; ohms, 0-2000, (12 ohms center), 0-200,000 (1200 ohms center), 0-2 megohms (12,000 ohms center).

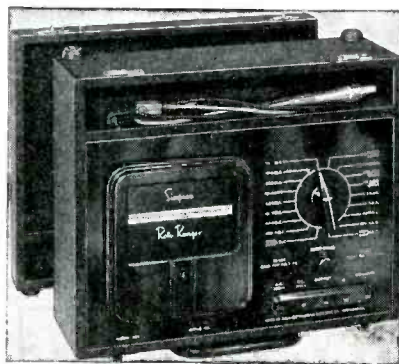

\* \* \*

### ACADEMY ELECTRICAL PLUG CAP

A *Lifetime Automatic Attachment Plug Cap* which is said to require no stripping or slitting has been announced by Academy Electrical Products Corp., 4849 Broadway, New York 34, N. Y.

Plug molded of Plaskon, comes in a variety of modern pastel colors. No screws, soldering or crimping is used to attach plug. Connection is accomplished by metal points incorporated in swivable blades.

Has automatic wire-gripping device, all-angle finger grip.

*Built for Service*

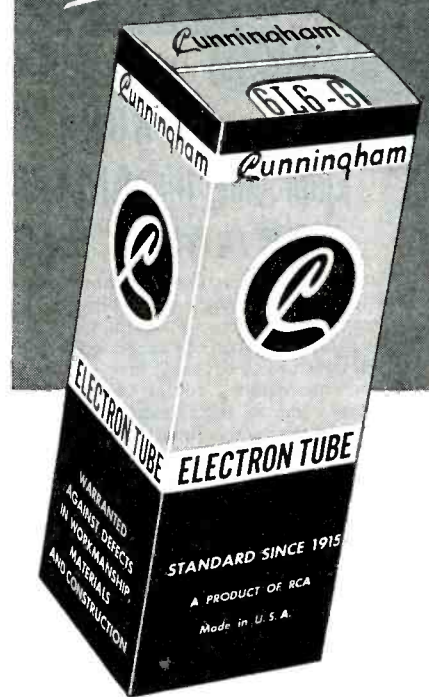

**Servicemen's choice!**  
in...



• Up where the salmon run, Cunningham tubes are a big catch, too ... because Cunninghams have a quality and performance you can't beat. They've been satisfying particular customers since 1915. They'll bring more satisfied customers *your way*.

See your  
CUNNINGHAM DISTRIBUTOR

Northwest Radio Supply Co., Inc.  
Portland

United Radio Supply, Inc.  
Portland

**Cunningham Tubes**

A product of  
RADIO CORPORATION OF AMERICA  
Harrison, N. J.

*For Originality*

LOOK TO



THE QUALITY SCREWDRIVERS YOUR WORK DEMANDS!

Good work requires good tools! That's why it pays you to say "XCELITE" when you get a screwdriver, nut driver or nut driver set. Ask your dealer to show you the whole line—packed with original features to make your job easier.

BLADES are precision-formed of top grade tool steel, as sturdy and accurate-gripping as you'll find.

HANDLES are genuine XCELITE clear amber plastic—shaped to the hand for snug gripping—heat and shock resistant and TOUGH for years of punishing usage.

\*Originators—Not Imitators

PARK METALWARE CO., INC.

Dent. V Orchard Park, New York

**Quality Tools** **PREFERRED BY EXPERTS**

\*FIRST TO USE PLASTIC FOR SCREWDRIVER HANDLES

**ASTATIC PIONEERED THE FIRST CRYSTAL DEVICES**

*Again Astatic takes the lead*

**with MICROPHONES**

**and PHONOGRAPH PICKUPS**

**Employing the AMAZING PIEZOELECTRIC CERAMIC ELEMENTS**

Astatic again assumes a pioneer role . . . in making available, for the first time, the unique physical advantages of the amazing, piezoelectric ceramic element, in a microphone and phonograph pickup cartridge of advanced quality and fidelity. Unaffected by heat, moisture or dryness, they can go virtually anywhere . . . provide transcription quality reproduction, troublefree service, in tropical climates, under exposure to direct sunlight, heat from klieg lights or automotive interiors, when subjected to the many other conditions that threaten damage or impaired performance to other type instruments. These, plus other important advantages, combine to assure an immediate, enthusiastic reception for Astatic ceramic devices.

**NOW AVAILABLE** Astatic has incorporated ceramic elements in two of its most popular product designs—the convertible "Velvet Voice" Microphone and the "Quiet Talk" series pickup cartridges. Now moving through Astatic production lines, they are immediately available.

Write for prices, specifications

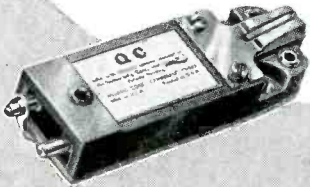

**THE Astatic CORPORATION**  
 ASTATIC CONNEAUT, OHIO  
IN CANADA: CANADIAN ASTATIC LTD. TORONTO ONTARIO



**RIDER P-A MANUAL NOW ON PRESS**

A *Public Address Manual* containing the products of 147 p-a equipment manufacturers, will soon be available from John F. Rider, Publisher, Inc. 404 Fourth Ave., New York 16, N. Y.

The manual will contain 2024 pages describing products produced since 1938. Price of the manual, which is loose-leaf, is \$18.00. Accompanying the manual will be a *How It Works* book describing the theory of the special circuitry found in numerous p-a systems.

\* \* \*

**RCA TRIPLE PINDEX TUBE BASE REFERENCE**

A tube-base reference booklet *Triple Pindex*, which permits simultaneous study of any two or three tube base diagrams out of over 475 types, has been prepared by the RCA Tube Department.

Guide contains three complete and separate base-diagram booklets, joined in a single cover with a spiral wire binding. All three diagrams are available on the same three-in-one page.

Listings are arranged in alphabetical-numerical order, according to tube types.

Diagrams may be located as entries are found in a dictionary or a telephone directory. Uncommon tube types are listed on a back page of the book, together with a key to appropriate diagrams in the book.

Booklet measures a handy 4" by 8".

*Triple Pindex* is available from RCA tube distributors at a price of 75 cents.

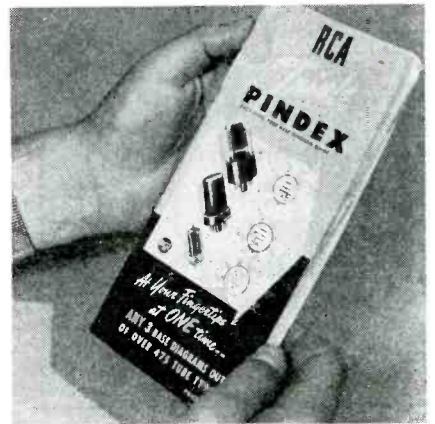

\* \* \*

**MUELLER CATALOG**

An 8-page catalog describing *Universal* battery and test clips, ground clamps, battery charging jumpers, etc., has been prepared by the Mueller Electric Co., 1583 E. 31 St., Cleveland 14, Ohio.

\* \* \*

**TRANSVISION EXHIBIT**

An exhibit of tv kits, cabinets, components and accessories, was held by Transvision, Inc., at the Waldorf-Astoria in N. Y. City during August.

On demonstration were 10", 12" and 15" tv kits, projection models, custom-built cabinets, field strength meters, remote controls, enlarging lenses, antennas, and Sightmaster *Sight-Mirror* tv receivers.

**NEW AND UNUSUAL!**

**VERTROD INTRODUCES A NEW AND UNUSUAL TELEVISION ANTENNA TO COVER ALL TV and FM CHANNELS**

Model FRM employs a high gain 3-element beam array for channels 6 to 13, thereby offering considerably higher gain than the conventional 2-element devices now in use for these channels.

The lower array employs a Hairpin/Reflector Principle. This method offers an excellent combination for primary receiving areas where signal is normally poor on upper channels and satisfactory on lower channels.

*The efficiency of this antenna is superior to any other of similar appearance.*

Dealers price **\$16.50**

Model FRM List \$27.50

No Other Antenna of Equal Efficiency Available at This Low Price.

Catalog available on request

DEPT. S-98  
 11 PARK PLACE  
 NEW YORK 7, N. Y.

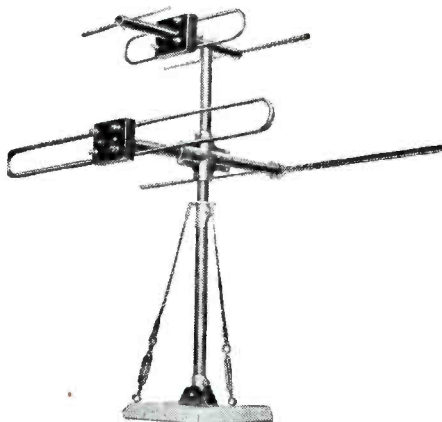

# ATTENTION Service Dealers

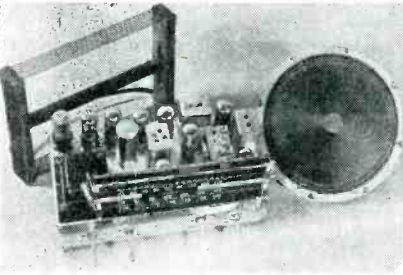

Mr. Servicedealer:

Are you reaping the full advantage of the tremendous replacement market that exists today? Most of your customers are in need of a modern AM-FM radio receiver chassis. They will select ESPEY because ESPEY chassis are the finest available on the market today—at the lowest price.

Head and shoulders above the crowd, from an engineering, design, manufacturing and quality standpoint. All features that are needed in a modern receiver are included, together with all hardware, speakers, and antennas required to make your installation job quick and easy.

There are millions of console sets in existence today whose owners are now aware how easy it is to install a modern AM-FM ESPEY chassis. This large market is growing bigger every day, as more and more owners decide that they want FM. And this opportunity is reserved for YOU.

For further information about this terrific potential, drop a line today to Dept. N-9.

## ESPEY MFG. CO., INC.

528 East 72nd Street

New York 21, N. Y.

"Established—1928"

## SECOND HYTRON WINNER

The second Hytron contest award (for entries made during June) was won by Gerard P. Diaz, 12 W. 7th St., Parkville, Mo. He received a RCP 665-A Billionaire and a 705-A signal generator.



Gerard P. Diaz, who won the June prize in the Hytron Service Men's Contest; Merle Applebee, Burstein-Applebee Co., 1012 McGee St., Kansas City, Mo., Hytron jobber and W. T. McGary, Hytron field representative.

\* \* \*

## RADIART COUNTER CARD

Counter cards to help promote the Radiart antenna line have been prepared by the Radiart Corp., Cleveland, Ohio.



\* \* \*

## WCEMA SHOW NEWS

A thirty-two page booklet of exhibitors at the West Coast Electronic Mfg. Association show at the Los Angeles Biltmore, (Sept. 30, Oct. 1 and 2) with a list of officers, is available to out of towners from George Davis, show manager, at 1406 South Grand Ave., Room 216, Los Angeles 15, Calif.

## CORRECTION

IN THE *Electronic Baby Light* circuit, which appeared in the August issue of *SERVICE*, the grid resistors in the 6SC7 stage should have been 10-megohm units, and the grid resistor in the 6J5 stage should have been a 1-megohm resistor.

*Built for Service*



**Servicemen's choice!**  
in...



For quality in jewelry and textiles, it's Rhode Island... and in Rhode Island it's "Cunningham" for quality tubes. For 32 years, Cunningham tubes have been noted for their top performance and long service life. Vote to use Cunninghams exclusively in *your* work.

See your  
CUNNINGHAM DISTRIBUTOR  
**WILLIAM DANDRETA & CO.**  
Providence

**Cunningham Tubes**

A product of  
RADIO CORPORATION OF AMERICA  
Harrison, N. J.

## HIGH OUTPUT CRYSTAL CONTROLLED FM-AM SIGNAL GENERATOR



World Famous  
**HICKOK**

MODEL  
288X

The most popular FM-AM generator.  
• High FM output. • Fundamental frequencies to 110 MC. • FM frequencies to 160 MC. • Two sweep frequencies—30 KC and 50 MC. • Self contained decibel meter. • Audio frequencies 0 to 15,000 cycles. • Plus many other features.

See Your Jobber Today or Write for Literature.

THE HICKOK ELECTRICAL INSTRUMENT CO.  
10521 Dupont Avenue • Cleveland 8, Ohio

Ask For Model 288X

## NON-DIRECTIONAL FM ANTENNA

### Solves FM Reception Problems

**GIVES COMPLETE COVERAGE . . .** This field pattern prepared by a leading radio laboratory proves HI-PAR receives signals from any direction with uniform efficiency — no dead spots!

**MEANS CORRECT MATCHING . . .** 1/4 wave matching section — superior grade of standard 300 ohm twin-lead colinear line insure perfect matching — increased signal strength.

**ASSURES LIFETIME USE . . .** No plastics to deteriorate. Nothing to rust or corrode. One-piece insulator of special low-loss porcelain. Collector rods of high-strength aluminum. Impregnated hardwood support. No metal to absorb signal strength.

**ASSEMBLES EASILY, QUICKLY.** No orientation necessary. No guy wires. One-piece heavy-cast mounting base.

**HI-PAR PROVED BEST  
BY COMPARISON TEST.**

**Compare performance — compare cost.**

**YOU CAN SELL THE DIFFERENCE!**

**HI-PAR PRODUCTS CO., FITCHBURG, MASS.**

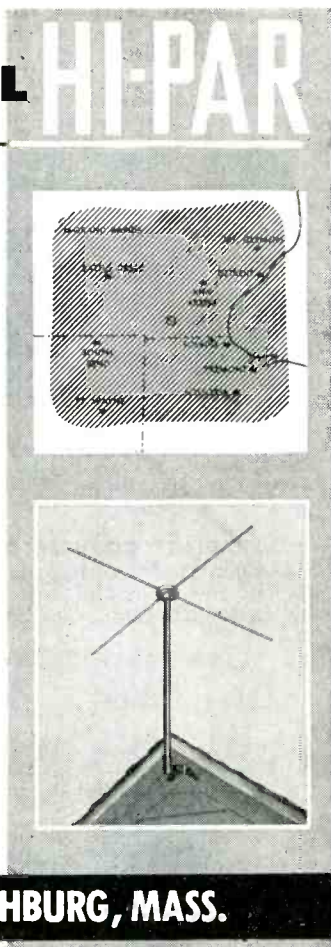

## Servicing Helps

(Continued from page 30)

soldered after working in the control head, which results in poor tuning. Another cause of the same condition is pitted contacts in the push-button switches. A little cleaning and lube will cure trouble here.

Incidentally, if the complaint is weak and distorted reception on these models, the speaker plug should be checked to see that it has not loosened.

### Philco Model 41-608

*Weak on phono and radio, accompanied with distortion:* Replacing the 12-mfd/400-volt section of the filter will cure the trouble. After replacement it will be noticed that the phono exciter lamp will show a marked increase in brilliancy.

During this type of service call it's usually a good idea to replace the exciter lamp, photo cell, and mirror assembly in the phono pickup. The customer will probably be more than happy to cover the additional expense on hearing the improved phono reproduction.

### Sonora Model WAU 243

*Set is inoperative:* Tubes are cold but check okeh. This is caused by a burned-out 82-ohm, 2-watt resistor, which is in the filament string. The power rating of the original was much too small and in replacing a 5-watt resistor should be used. An even better method is to solder a jumper across the terminals to which the resistor was connected and substitute a 50L6GT for the 35L6GT. This trouble will be experienced soon after the set has been in use.

<sup>1</sup>Submitted by John W. Findarle.

## Association News

(Continued from page 24)

out of town distributors of standard tubes, offering big discounts on these tubes, any quantities from one on up. Yet in Columbus, if you want one special tube (a slow mover) you must take the *experimenters* short discount, even if during the same month your tube purchases may amount to several hundred tubes.

Don Blazer will edit the next issue of the *ARSD News*.



### This ATTRACTIVE ALL-STEEL STORAGE DISPLAY CABINET FREE

with purchase of 12 most popular types  
HALLDORSON vacuum-sealed  
TRANSFORMERS.

Assortment includes input, output  
and power transformers as follows (see  
Halldorson catalogue):

1-D4-600	1-T-341	1-B5-853
1-D4-604	1-B5-816	1-S-66
1-K4-800	1-A4-777	1-S-67
1-D4-602	1-A4-775	1-S-40

Dealer Net \$24.90

Just the thing for your service bench or can be mounted on the wall . . . an all-steel storage-display cabinet that holds 12 most frequently used Halldorson vacuum-sealed transformers as per list above . . . You pay only for the transformers . . . the cabinet is included in the deal at no extra cost to you . . . saves trips to distributor's counter . . . makes stock keeping easy . . . Good for limited time only. Act now . . .

SEE YOUR RADIO PARTS DISTRIBUTOR OR WRITE  
The HALLDORSON COMPANY 4500 Ravenswood Ave. Chicago, Ill.

# Halldorson

Vacuum Sealed Transformers

## H-F TV Antennas

(Continued from page 11)

industry that unless the situation improves the FCC will control reradiation by directive.

Balanced 300 ohm-lines appear to have a poorer signal-to-noise ratio at the h-f channels than coaxial line. It thus appears that the balanced line is unbalanced because the two halves of the common 300-ohm input coil cannot be made with equal characteristics in the 200 mc band. Some manufacturers have already discovered this condition and are designing their 1949 models for unbalanced coaxial cable inputs.

It is possible to connect coaxial cable to the r-f input of a tv receiver as shown in Fig. 5. Care must be taken in soldering the coax to the r-f input as the r-f coil is delicate and opens easily. A solder gun or 40-watt iron will usually do the job, without damage. The spotlight feature of one type of solder gun is of greater value in making this coax connection in table model tv receiver chassis.

Television receivers with metal backs or grills, which are fastened to wood cabinets, have been in trouble at the h-f channels. The metal backs are resonant at the h-f channels and act as antennas which induce direct signal pickup into the tv receiver input that may be out of phase with the signal from the external antenna. This direct signal pickup manifests itself as a *leading ghost*.

While removing the metal backs from the tv receiver alleviates this condition, the fire hazard possibilities increase unless wood or asbestos board take place of the metal.

The Service Man's field reports on h-f channel reception will greatly influence the 1949 design of tv receivers.

## Sync Systems

(Continued from page 22)

to minimum in the same time. A comparison with a sine wave tells us that the frequency of any sine wave, which must rise from minimum to maximum in  $\frac{1}{4}$  microseconds, is a 2-mc wave because the period of a 2-mc wave is  $\frac{1}{4}$  microsecond and therefore this 2-mc wave rises from minimum to maximum in  $\frac{1}{4}$  of a microsecond. This approximation tells us the frequency response requirements of any stage which must pass the leading and trailing edges of the television synchronizing pulses.

### Uses of Squared Pulse

The flat top of a pulse represents a low frequency because it is a sustained voltage level which must be held constant for the duration of the pulse. Therefore, the duration of the pulse determines the low-frequency response requirements, because the longer the pulse the longer the time interval the voltage must be held at a level value. To sustain an absolutely flat flat-top the period of a comparable sine wave would have to be many times longer than the duration of the pulse, because the pulse itself is a constant voltage level, while the comparing sine wave rises and falls sinusoidally and only maintains its peak value for a small percentage of the total period of the sine wave. It is evident, therefore, that the frequency response requirements of any stages which must pass the pulse with fidelity is dependent on the steepness of the leading edge of the pulse for its high-frequency limit and the duration of the pulse for its low-frequency limit. It is also this very characteristic of a pulse which permits segregation of components of the pulse into horizontal and vertical sync.

[To Be Continued]

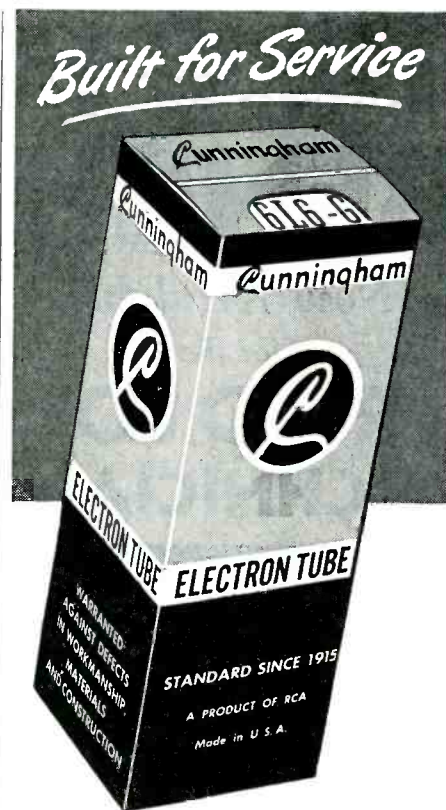

**Servicemen's choice!**



## Cunningham "FIRE BALL" Fluorescent Sign

● Here's a sign so brilliant—so penetrating—that it will sell your service day and *night!* In store or window, it's an immediate eye catcher... and it associates your business with Cunningham tubes... the "standard since 1915."

Of heavy steel construction with chrome trim, and measuring 26" long by 3½" deep, the sign has an orange and white fluted glass panel and a 6-foot hanging chain. Comes equipped with a 20-watt fluorescent lamp, ready to plug into any 110-120 volt, 60 cycle AC line.

Get your "Fire ball" sign today. Ask your Cunningham Distributor for order form 2F685.

# Cunningham Tubes

A product of  
RADIO CORPORATION OF AMERICA  
Harrison, N. J.

## Permoflux SPEAKERS



**YOUR JOBBER CAN SUPPLY YOU!**

Permoflux quality and dependability—the same as supplied to the major set manufacturers—is your assurance of complete customer satisfaction. You'll find Permoflux Speakers easy to install and readily available in both PM and Electro-dynamic types. You'll find too, that it pays to give your customers "tops in tone" with a Permoflux Replacement Speaker.

TWO COMPLETE  
FACTORIES TO SERVE YOU

**PERMOFLUX**

WRITE FOR  
FREE BULLETIN

PIONEER MANUFACTURERS OF PERMANENT MAGNET DYNAMIC TRANSDUCERS

**PERMOFLUX CORPORATION**  
4900 WEST GRAND AVE., CHICAGO 39, ILLINOIS  
236 SOUTH VERDUGO ROAD, GLENDALE 5, CALIFORNIA

# TECH BENCH

Now Available  
for the  
**RADIO  
TECHNICIAN**



"Everything in its place, and a place for everything . . ." Engineered for convenience and workability . . . designed to give 100% working efficiency and sturdily built for long and practical use.

### CHECK THESE OUTSTANDING TECH-BENCH FEATURES . . .

- Eighteen well proportioned drawers, eight of which can be used for complete material systems or small tools.
- Stops on all drawers to prevent spilling.
- Hardwood finished top with durable, lustrous finish.
- Two conveniently located internally wired electric sockets for electrical tools and equipment.
- Handy catalog and chart space.
- Reinforced canvas apron of generous size.
- Top surrounded three sides with guard rail and has grooved slot.
- Made of corrosion resistant non-magnetic aluminum.
- Foot rest placed for comfortable working position.
- Either left-handed or right-handed model.

### STANDARD SPECIFICATIONS

Length 40", Depth 20", Height 38"  
Shipping Weight, 90 Lbs.

only **\$74.95** F.O.B.  
HOUSTON

Order from your Radio Supply Dealer or for further information write directly to

**The DE MARIA COMPANY**  
711 Main Street Houston, Texas

## JOTS AND FLASHES

RULES FOR THE CITIZENS RADIO service have at long last been proposed by FCC. In the rules two classes of stations are described; Class A station, permitted to operate through the 460 to 470-mc band and class B to operate on 465-mc only. A maximum input power of 50 watts would be provided for class A stations and 10 watts for class B. Licenses would be limited to those 18 or over; however the station, except one using telegraphy, could be operated by any other person authorized to do so by the licensee. Fixed and mobile locations would be allowed. Opening of this new service on a regular basis will depend largely on the adoption of these proposed rules, which it appears might go into effect the early part of next year. . . . The August issue of *Sylvania News* contains an interesting analysis of electromagnetic C-R tubes and a discussion of the repairing of marred radio cabinets. . . . Auto radio suppressors and wax molded paper capacitors are described in two bulletins recently prepared by Solar Capacitor Sales Corp. . . . A bulletin (No 139) describing the improved Cardyne cardioid dynamic microphones has been issued by Electro-Voice, Inc., Buchanan, Michigan. . . . Al Pollack is now chief production supervisor of the J. F. D. Manufacturing Company, Inc., 4117 Ft. Hamilton Parkway, Brooklyn 19, N. Y. . . . The Mueller Electric Company, 1583 East 31st Street, Cleveland 14, Ohio, recently celebrated its 40th anniversary. Ralph S. Mueller, founder and senior partner, reported that the company will very soon produce its 200,000,000th clip. . . . Mr. and Mrs. Ken Burcaw recently became the parents of a boy, Robert Joseph. KB is sales manager of the jobber division of Cornell-Dubilier Electric Corporation. . . . Irving Frisch has been named advertising and sales manager of Tech-Master Products, 123 Prince Street, New York, manufacturer of Sound-View 10" tv kits. . . . A. D. Sobel is now vice president in charge of television engineering of the Franklin Airloop Corporation, Long Island City. . . . Charles J. Nesbitt has been appointed advertising manager of the Hallcrafters Company, Chicago, Illinois. Nesbitt was formerly with Montgomery Ward. . . . Harry N. Kreitzer, formerly section manager, Electronic Tube Sales Department, Westinghouse Electric, is now with Gawler-Knoop Inc., 1060 Broad Street, Newark 2, New Jersey. He will cover the Maryland, District of Columbia and Virginia areas.

## ADVERTISERS IN THIS ISSUE

### SERVICE INDEX—SEPTEMBER, 1948

AEROVOX CORPORATION . . . . .	44
Agency: Austin C. Lescarboursa & Staff	
ALLIANCE MFG. CO. . . . .	41
Agency: Foster & Davies, Inc.	
AMERICAN PHENOLIC CORP. . . . .	36
Agency: Burton Browne, Advertising	
AMERICAN TELEVISION & RADIO CO. . . . .	57
Agency: Firestone-Goodman Adv. Agency	
THE ASTATIC CORPORATION . . . . .	48
Agency: Wearstler Advertising, Inc.	
CORNELL-DUBILIER ELECTRIC CORP. . . . .	Inside Front Cover
Agency: Reiss Advertising	
THE DeMARIA CO. . . . .	52
ALLEN B. DuMONT LABS., INC. . . . .	30
Agency: Austin C. Lescarboursa & Staff	
ERIE RESISTOR CORP. . . . .	42
Agency: W. S. Hill Co.	
ESPEY MFG. CO. . . . .	49
Agency: Chas. R. Tighe Advertising, Inc.	
GENERAL ELECTRIC CO. . . . .	1, 27
Agency: Maxon, Inc.	
GREYLOCK ELECTRONIC SUPPLY CO. . . . .	40
Agency: Bergman-Jarrett Co.	
HALLDORSON CO. . . . .	50
Agency: Western Adv. Agency	
HEATH COMPANY . . . . .	21
Agency: Paxson Advertising	
HICKOK ELECTRICAL INSTRUMENT CO. . . . .	49
Agency: White Adv. Co.	
HI-PAR PRODUCTS CO. . . . .	50
Agency: Cory Snow, Inc.	
HYTRON RADIO & ELECTRONICS CORP. . . . .	33
Agency: Henry A. Loudon—Advertising	
J. F. D. MFG. CO., INC. . . . .	40
Agency: Bergman-Jarrett Co.	
P. R. MALLORY & CO., INC. . . . .	17
Agency: The Aitkin-Kynett Co.	
MUELLER ELECTRIC CO. . . . .	44
MURRAY HILL BOOKS, INC. . . . .	40
Agency: The Harry P. Bridge Co.	
NATIONAL SCHOOLS . . . . .	42
Agency: The Mayers Co., Inc.	
OHMITE MFG. CO. . . . .	35
Agency: The Fensholt Co.	
PARK METALWARE CO., INC. . . . .	47
Agency: Melvin F. Hall Agency, Inc.	
PERMOFLUX CORPORATION . . . . .	41
Agency: Turner Adv. Agency	
PRECISION APPARATUS CO., INC. . . . .	15
Agency: Shappe-Wilkes, Inc.	
PREMIER RADIO TUBE CO. . . . .	42
Agency: Sander Rodkin Adv. Agency	
QUAM NICHOLS CO. . . . .	47
Agency: Triangle Adv. Agency, Inc.	
RADIART CORP. . . . .	3, 34
Agency: Ohio Adv. Agency	
RADIO CORPORATION OF AMERICA . . . . .	18, 19, 45, 47, 49, 51, Back Cover
Agency: J. Walter Thompson Co.	
RADIO SUPPLY & ENGINEERING CO. . . . .	45
Agency: Claude E. Whipple	
RAYTHEON MFG. CO., RADIO RECEIVING TUBE DIV. . . . .	4
Agency: Walter B. Snow & Staff	
JOHN F. RIDER PUBLISHER, INC. . . . .	6
Agency: Lansford F. King, Advertising	
HOWARD W. SAMS & CO., INC. . . . .	25, 43
Agency: George Brodsky	
SANGAMO ELECTRIC CO. . . . .	28, 29
Agency: Arthur R. Mogge, Inc.	
SIMPSON ELECTRIC CO. . . . .	20
Agency: Kreicker & Melvan, Inc.	
SOLAR CAPACITOR SALES CORP. Inside Back Cover	
Agency: O. S. Tyson & Co., Inc.	
SPRAGUE PRODUCTS CO. . . . .	5
Agency: The Harry P. Bridge Co.	
SYLVANIA ELECTRIC PRODUCTS INC. . . . .	8
Agency: Newell-Emmett Co.	
TRANSVISION, INC. . . . .	38, 39
Agency: H. J. Gold Co.	
TRIPLETT ELECTRICAL INSTRUMENT CO. . . . .	7
Agency: Western Adv. Agency, Inc.	
UNIVERSAL GENERAL CORP. . . . .	40
Agency: Gelles Adv. Agency, Inc.	
UTAH RADIO PRODUCTS DIV. INT'L DETROLA . . . . .	34
Agency: Bonsib Adv. Agency	
VERTROD CORP. . . . .	48
Agency: Schacter & Fain, Inc.	
WARD LEONARD ELECTRIC CO. . . . .	40
Agency: Henry H. Teplitz, Advertising	



# DRY ELECTROLYTICS FOR TELEVISION RECEIVERS



**...stand up under 85°C operation**

Solar's new Type DY-TV series of dry electrolytic capacitors assures dependable operation under the severest conditions found in television receivers.

An especially developed Solar processing technique makes possible small yet sturdy capacitors designed for high temperature operation with no sacrifice in long life or electrical characteristics.

Because of the remarkable film stability of Solar's DY-TV series of electrolytics, there is but an extremely small change in power factor and leakage current from room temperature to 85°C.

Type DY-TV capacitors, with their special film formation, do not "run away" when voltage is applied after idling under no-voltage conditions at 85°C. These characteristics are retained even after extended shelf life.

Investigate this remarkable achievement in capacitor design today! Write today for catalog.

**SOLAR CAPACITOR SALES CORP.**  
NORTH BERGEN, NEW JERSEY

**SOLAR CAPACITORS**  
"Quality Above All"



Special  
RADIO MIX...



RCA VS-099 Farm Pack and RCA VS-036 "A" Batteries

## ... super-powered for longer life

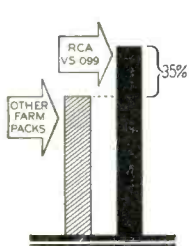

It's RCA's special "Radio Mix" in these super-powered radio batteries that gives them longer service life *at less cost per hour!*

RCA VS-099 Farm Pack will power the average 4-tube, battery-operated receiver 35 per cent longer than the ordinary type of farm pack—at least a full season's service!

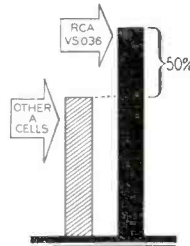

RCA VS-036 "A" Battery has *twice* the service life of average cells . . . 50 per cent more life than standard "long life" types in *heavy drain* portable radio receiver service.

What's more, the RCA VS-099 and VS-036 are *leak-resistant, swell-proof, and climate-proof*—because they're sealed in steel. They stay powerful and fresh!

SELL RCA BATTERIES—THE COMPLETE LINE FOR THE RADIO AND ELECTRONIC TRADE



TUBE DEPARTMENT

**RADIO CORPORATION of AMERICA**

HARRISON, N. J.