

SERVICE

June
1946

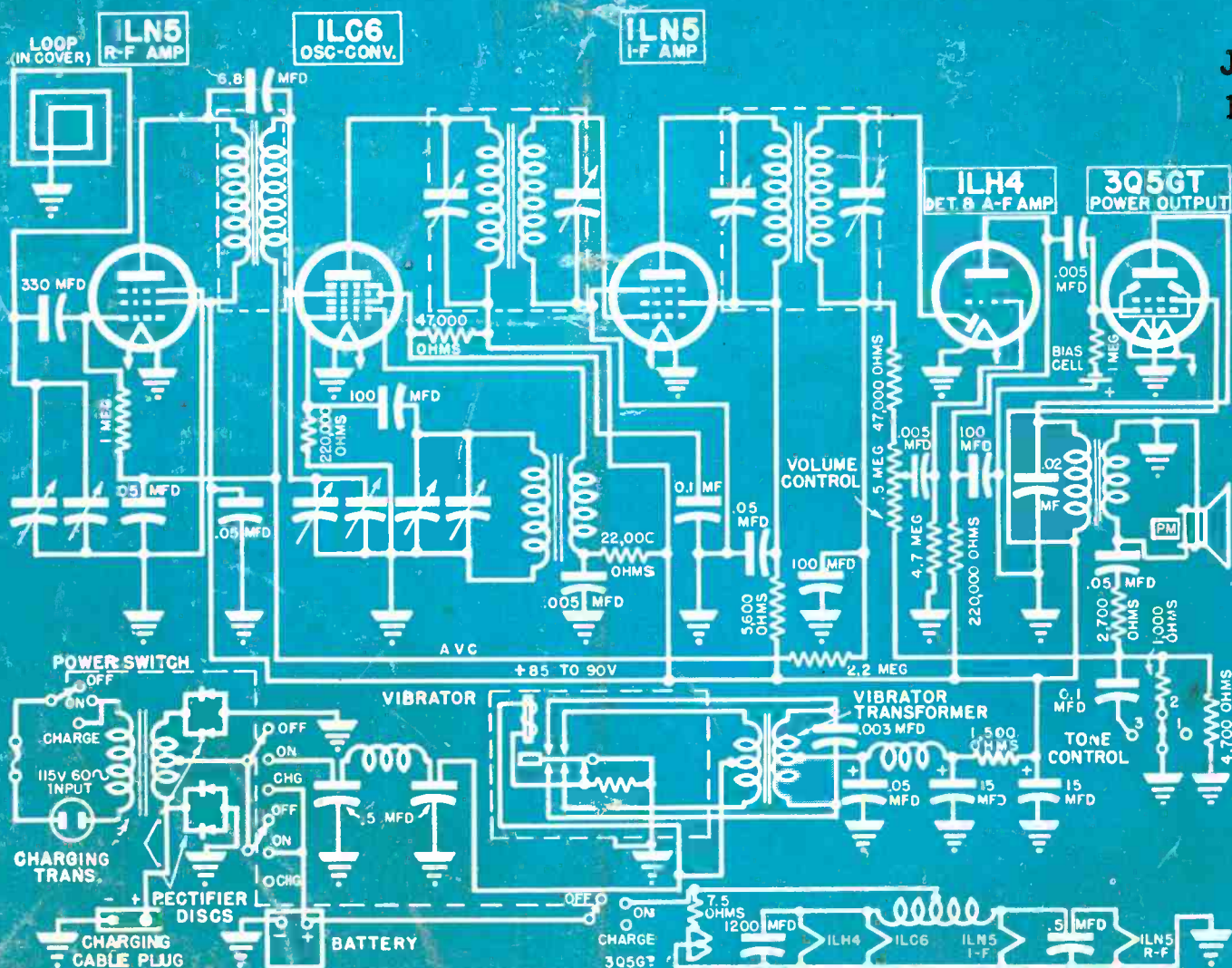

Five-tube 2-volt rechargeable portable with a disc-type battery charger. (see page 22)

THE TECHNICAL JOURNAL OF THE RADIO TRADE

I'm the real radio quiz kid

Sure, the "C-D Capacitor" puts me hep to a lot of things I want to know about servicing short-cuts and methods of increasing profits. It's a handy pocket-size magazine containing the latest data on radio repair, parts, shop maintenance, and many other helpful hints. The first issue alone showed me how to save many dollars on test equipment. Am I smart? You bet — I sent for the "C-D Capacitor" right away, and get this handy compilation of service data, free!

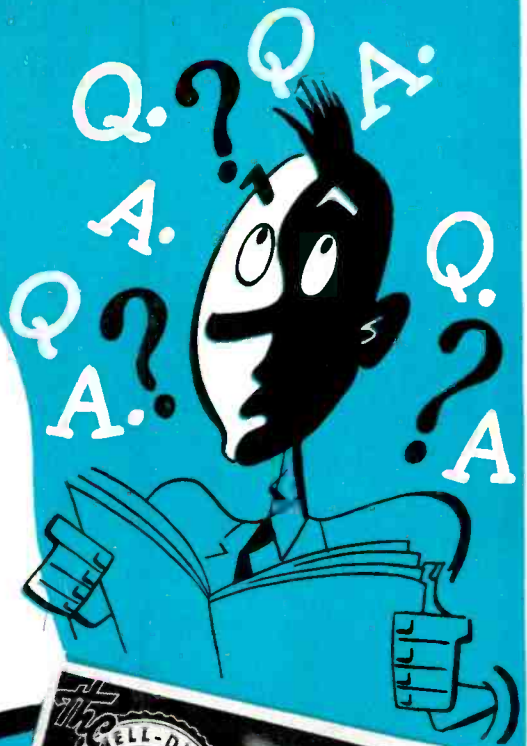

50,000 RADIO MEN NOW READ THE "C-D CAPACITOR"

The cream of the crop of Radio Articles from the radio press . . .
Trading Post Columns for Buyers, Sellers, Swappers

FREE! send for it now! →

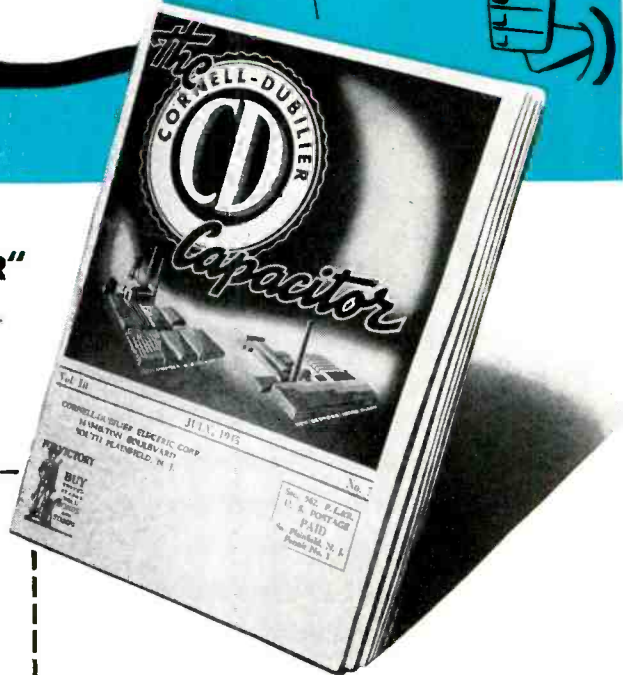

All these sales aids help to make your shop headquarters for radio service in your community.



- Newspaper Mats
- Match Books
- Counter Cards
- Stationery
- Decals
- Shipping Labels
- Pastcards
- "C-D Capacitor"
- Catalogs

let yourself grow! See your local C-D jobber today and order these powerful sales builders. Most of them are free. Get on the "C-D Capacitor" mailing list now, write direct to: Cornell-Dubilier Electric Corp., South Plainfield, N. J. Other plants at New Bedford, Worcester and Brookline, Mass., and Providence, R. I.



MICA • DYKANOL • PAPER • ELECTROLYTIC

CORNELL-DUBILIER
WORLD'S LARGEST MANUFACTURER OF
CAPACITORS

KEN-RAD RADIO TUBES

SELL!



USE!

Promotion Aids Like These, Spell P-R-O-F-I-T-S for You as a Ken-Rad Tube Dealer

Ken-Rad doesn't expect you to "go it alone." Ken-Rad *helps you help yourself*—to a generous slice of the local market for radio tubes! For the asking, you can have colorful Ken-Rad display material that will stop tube buyers in stride, causing them to enter your store to *buy*. The large window-card and other pieces at the right are typical of the wide display selection. . . . Ken-Rad also makes it possible for you to keep in touch *by mail* with the hundreds of radio owners in your neighborhood who buy tubes. Imprinted blotters, letter-head and envelopes, other postage-borne items with your name, address, and message on them—these will work for you as canvassers who are never rebuffed. . . . The Ken-Rad franchise is powered for volume sales, to a market which Ken-Rad guides straight to your door. Increase your profits *the easy way* by handling Ken-Rad radio tubes!

176-E6-8850

● For pictures and descriptions of the Ken-Rad complete group of dealer aids, write for "Sales Helps" Folder ETR-4. It's free!

KEN-RAD

DIVISION OF GENERAL ELECTRIC COMPANY
OWENSBORO, KENTUCKY



Display card, 21" by 32"



Wall Plaque



Decalomania



Personalized blotters



Personalized stationery

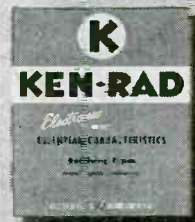

Tube Characteristics book

All of the pieces shown above are in pleasing, effective colors. There also are numerous other Ken-Rad display and promotion items.

EDITORIAL

CIRCUIT IMPROVEMENTS are now beginning to appear in more and more of the newer receivers. When the first runs of the postwar receivers were made, the models were substantially the same as those produced when production was halted by the war. However, as development time became available, interesting advantages were completed, and now we are beginning to see some of these developments in the newer models. Incidentally, many of the prewar developments used in several runs of the last prewar receivers, such as degeneration, hum bucking and iron-core tuning, are now appearing in many of the postwar receivers.

In some instances, prewar circuit developments have been refined. In one receiver, for instance, a hum-bucking potentiometer is used in a 50L6 power stage with the ripple voltage in the plate supply lead fed to the cathode through a resistor. Bypassing of the cathode bias resistor has been eliminated. Thus the ripple can be amplified and appear in phase opposition to the plate hum voltage, neutralizing the hum delivered from the B supply.

In one postwar receiver development, an antenna resistance and capacitor has been included to eliminate resonance in the antenna. Thus i-f or image interference is minimized.

The extensive use of aluminum in wartime equipment has introduced another postwar feature. A portable receiver, recently announced, uses a die-cast aluminum chassis and cabinet with components in chassis channels for improved shielding.

Most postwar receivers now are featuring extra heavy filtering, larger speakers with Alnico 5, and improvements in the antenna systems and i-f, r-f, oscillator and audio stages to provide increased sensitivity, selectivity and improved audio output.

CONGRATULATIONS TO R. C. COSGROVE upon his re-election as president of the Radio Manufacturers' Association. Mr. Cosgrove's outstanding service to RMA has won him the plaudits of the industry.

IN RESPONSE TO MANY REQUESTS, a series of articles featuring *Trades of Sound* will appear in the July issue of SERVICE. Discussions will cover speakers, amplifiers, turntables, microphones and accessories, all prepared by industry specialists. Watch for this outstanding issue!

RADIO TELEVISION ELECTRONIC SERVICE

Reg. U. S. Patent Office

Vol. 15, No. 6

June, 1946

LEWIS WINNER

Editorial Director

ALFRED A. GHIRARDI

Advisory Editor

F. WALEN

Managing Editor

	Page
At the 1946 Radio Parts Show in Chicago	46
Checking Dead Receivers (Trouble Shooting Filament Circuits in A-C/D-C Models). By S. Heller	12
Communications Receivers As Service Instruments. By Thomas T. Donald	9
New Models	35
Old Timer's Corner	28
Oscillator Circuits in Television Receivers. By R. B. Carwood ..	10
Ser-Circuits. By Henry Howard	18
Servicing Helps. By Frank C. Keene	14
Tools and Accessories for the New Service Shop. By Alfred A. Ghirardi	16
CIRCUITS	
Arvin 444, 444A	20
DuMont 180X (Television Oscillator)	33
Emerson 502	18
Emerson 508	20
GE 225B (Television Oscillator)	32
GE 250/260 (Cover)	22
RCA TRK 90 (Television Oscillator)	11
COVER	
5-Tube Rechargeable 2-Volt Portable (GE 250/260)	22
SERVICING HELPS	
Determining Ratings and Current-Carrying Capacities of Transformer Windings	14
Connecting Speakers and Headphones in Parallel	14
Index to Advertisers	48
Manufacturers	
News	36
New Products	42
Jots and Flashes	48

Copyright, 1946, Bryan Davis Publishing Co., Inc.

Published monthly by Bryan Davis Publishing Co., Inc.
52 Vanderbilt Avenue, New York 17, N. Y. Telephone MUrray Hill 4-0170



Bryan S. Davis, President
Paul S. Weil, Vice Pres.-Gen. Mgr.



A. Goebel, Circulation Manager
F. Walen, Secretary

James C. Munn, 10515 Wilbur Avenue, Cleveland 6, Ohio; Telephone SWEetbriar 0052

Pacific Coast Representative: Brand & Brand, 1052 W. Sixth St., Los Angeles 14, Calif.; Telephone MICHigan 1732

Entered as second-class matter June 14, 1932, at the Post Office at New York, N. Y., under the Act of March 3, 1879. Subscription price: \$2.00 per year in the United States of America and Canada; 25 cents per copy. \$3.00 per year in foreign countries; 35 cents per copy.

ANOTHER NEW

Jensen *Coaxial*

The most significant postwar loud speaker development yet announced is the new Jensen family of Type H Articulated Coaxial Speakers. The latest member is Model HNP-51, an all *ALNICO 5* design - in which low-frequency and high-frequency speakers are employed coaxially in an articulated assembly. The 15-inch l-f cone acts as an extension of the h-f speaker horn. The two loud speakers are electrically and acoustically coordinated into a system achieving brilliant and natural response through the entire useful frequency range (l-f performance depends upon the baffle or enclosure used). Frequency-dividing network has variable control in range above 4,000 cycles.

HNP-51 is recommended for FM receivers, high quality phonograph reproduction, television, review rooms, monitoring and home and public entertainment generally.

Coaxial Models HNP-50 and HNF-50 (for manufacturers) and HNP-51 (for general use), are now nearing quantity production. All Type J Jensen Coaxials (3 models) are now in production. Write for complete information.



JENSEN RADIO MANUFACTURING CO., 6621 S. Laramie Ave., Chicago 38, Ill.
In Canada: Copper Wire Products, Ltd., 137 Oxford Street, Guelph, Ontario

Specialists in Design and Manufacture of Fine Acoustic Equipment

TYPE H SPECIFICATIONS

MODEL HNP-51 (15" cone with *ALNICO 5* in both l-f and h-f units. Power rating, 25 watts maximum in speech and music systems. Input impedance, 500 ohms. List price approximately \$125.

MODEL HNF-50 (15" cone *ALNICO 5* design h-f unit, field coil in l-f unit; otherwise same as HNP-51. List price approximately \$75.

COMPLETE REPRODUCERS. Model HNP-51 Speaker is offered in 2 cabinet models to form complete reproducers. Model "CR" Reproducer employs beautiful Jensen Imperial Walnut cabinet. Model "FA" Reproducer employs attractively finished general utility cabinet.





The
14 VOLUMES of
RIDER MANUALS
cover the 60 million
receiving sets now
in American
Homes

16 YEARS of PROVEN LEADERSHIP

During the past sixteen years Rider Manuals have maintained their position of unchallenged leadership because they have consistently demonstrated their reliability, their accuracy and their unquestioned value as time-savers in the localizing of troubles in faulty receivers. In the fourteen volumes of Rider Manuals will be found such vital material as receiver schematics, voltage data, alignment data, resistance values, chassis layouts and wiring, and trimmer connections.

The sixty million sets issued previous to 1942 are the sets most likely to develop faults, find their way to your bench — and Rider Manuals provide the only single source upon which you can depend for accurate, complete, authoritative servicing data covering the important receivers issued from 1929 to 1942.

Volume XV is now in preparation; it will have the greatest number of pages in any volume yet issued. Its increased size will result from the in-

clusion of extra servicing information, additional data that are not ordinarily available on manufacturers' schematics. It will be necessary and useful information that will save a serviceman hundreds of hours a year.

In the meantime be sure you have all fourteen volumes. Check the list below and order from your jobber today.

JOHN F. RIDER PUBLISHER, INC.

404 FOURTH AVENUE, N. Y. 16, N. Y.

Export Division: Rocke-International Electric Corp., 13 E. 40th Street, New York 16, N. Y.

RIDER MANUALS (14 volumes)	
*ABRIDGED VOLUMES J-V	\$17.50
VOLUME VI	11.00
VOLUME VII	15.00
VOLUME VIII	15.00
VOLUME IX	15.00
VOLUME X	15.00
VOLUME XI	15.00
VOLUME XII	15.00
VOLUME XIII	15.00
VOLUME XIV	15.00
RECORD CHANGERS & RECORDERS	9.00

*Originally published as individual
Volumes: I, II, III, IV and V

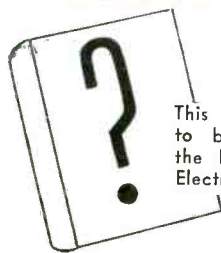

This new Rider Book, soon to be announced, will be the book of books for the Electronic Maintenance Man.

The Cathode Ray Tube at Work
Accepted authority on subject 4.00

RIDER RADIO BOOKS KEEP YOU UP TO DATE

- Frequency Modulation
Gives principles of FM radio \$2.00
- Servicing by Signal Tracing
Basic Method of radio servicing 4.00
- The Meter at Work
"An elementary text on meters 2.00
- The Oscillator at Work
How to use, test and repair 2.50
- Vacuum Tube Voltmeters
Both theory and practice 2.50

- Automatic Frequency Control Systems
— also automatic tuning systems \$1.75
- A-C Calculation Charts
Two to five times as fast as slide rule 7.50
- Hour-A-Day-with-Rider Series —
On "Alternating Currents in Radio Receivers"
On "Resonance & Alignment"
On "Automatic Volume Control"
On "D-C Voltage Distribution" 1.25 each



CABLES

**For Use
in Transmission of
High Frequencies**

CONNECTORS

● Amphenol Twinax and Coax RG cables, produced to standards that surpass the high Army-Navy specifications for critical wartime uses, are ideal for the myriad of peacetime applications in all phases of the rapidly expanding electronic industries. Rigid laboratory tests and notarized affidavits on every shipment give final assurance of extra quality and dependability.

● Amphenol special low-loss V.H.F. connectors are available in a complete line for all practical applications of RG cables and other uses. Mechanically efficient and electrically correct, these easily assembled connectors and adapters provide the utmost efficiency in circuits in which they are used.

AMPHENOL ASSEMBLY SERVICE

An important part of Amphenol service to users of cables and connectors is a complete Assembly Service. Rigid specifications and performance requirements, plus thorough scientific testing of each part and process, assures users of satisfactory service. For cables, connectors and complete assembly service, look to the world's largest producer — Amphenol.

AMERICAN PHENOLIC CORPORATION

CHICAGO 50, ILLINOIS

IN CANADA

AMPHENOL LIMITED • TORONTO



AMPHENOL

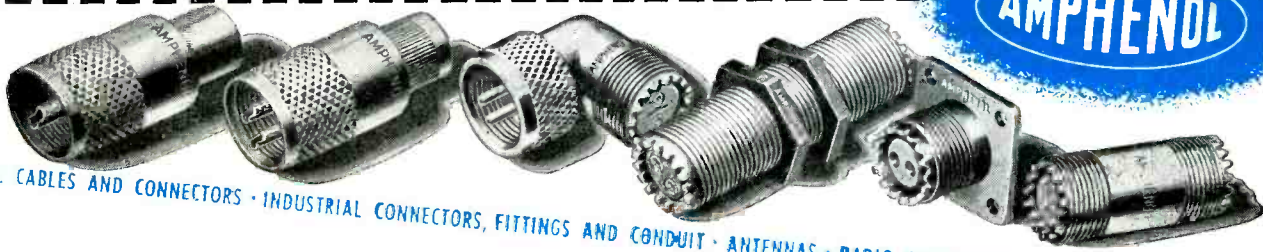

COAXIAL CABLES AND CONNECTORS • INDUSTRIAL CONNECTORS, FITTINGS AND CONDUIT • ANTENNAS • RADIO COMPONENTS • PLASTICS FOR ELECTRONICS

To help increase "Take-Home Savings"

THE Treasury Department has published two new booklets to help you and your employees realize the utmost benefit from your Payroll Savings Plan—benefits proportioned to the extent your employees add to "take home savings" by buying and holding U. S. Savings Bonds.

"Peacetime Payroll Savings Plan" for key executives offers helpful suggestions on the conduct of the Payroll Savings Plan. In addition, it quotes leaders of Industry and Labor and their reasons for supporting the Plan.

"This Time It's For You" is for distribution to employees. It explains graphically how this convenient, easy thrift habit works. It suggest goals to save for and how much to set aside regularly in order to attain their objectives. If you have not received these two booklets, or desire additional quantities, communicate with your State Director of the Treasury Department's Savings Bond Division.

See your Payroll Savings Plan through to maintain your share in America's future. It is sound economics and a powerful force for good today—and tomorrow—as a safeguard for stability and a reserve of future purchasing power—money that is kept within your community.

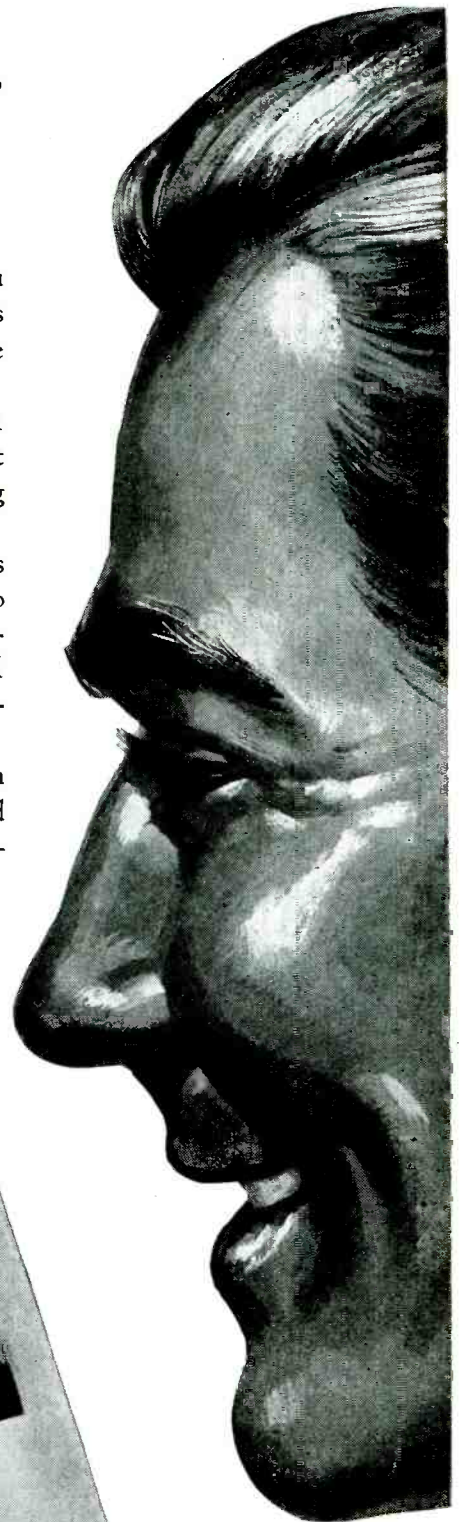

The Treasury Department acknowledges with appreciation the publication of this message by

SERVICE

This is an official U. S. Treasury advertisement prepared under the auspices of the Treasury Department and Advertising Council

From the precision of the Airlines

Flyers know the name Lear well. They've seen it on the radios in their airplanes for more than sixteen years. • Building aircraft radios calls for particular understanding, and far more than usual skill. It takes full knowledge of every new development. • This is the kind of manufacture Lear knows.

It is the kind that now, for the first time, is given to a home radio—the Lear Home Radio. • As soon as you can hear a Lear Radio. Whether it is the set illustrated, or the console combination with television, tape recording, FM and short wave at about \$500; or the compact table model at about \$199.95, you'll find you get something extra in value and performance. • LEAR, Incorporated, Home Radio Sales and Merchandising Division, 110 Ionia Avenue, N. W., Grand Rapids 2, Michigan.

comes the *LEAR* Home Radio

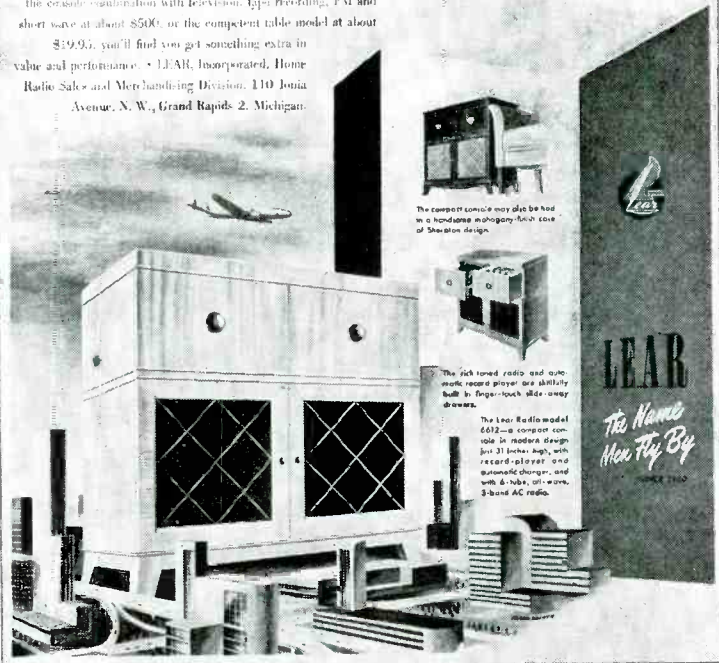

You should see this May Lear advertisement in four colors. That's the way it appears in The Saturday Evening Post.

It's one of the series in the Lear campaign running in national magazines. This campaign tells the Lear story more than 80,000,000 times. And it's sending eager customers into Lear dealers' showrooms to see these truly postwar radios.

This is one of the reasons that the Lear Franchise has "oomph." There are more you should know about. When you do, you'll see why the Lear Franchise is one of the most valuable in the industry. For full details write LEAR, Incorporated, Home Radio Sales and Merchandising Division, 110 Ionia Avenue, N. W., Grand Rapids 2, Michigan.

LEAR RADIO

SYLVANIA NEWS

RADIO SERVICE EDITION

JUNE Prepared by SYLVANIA ELECTRIC PRODUCTS INC., Emporium, Pa. 1946

"CARRY THE TUBES THAT BUILD GOODWILL" IS THEME OF SYLVANIA TUBE QUALITY STORY

**SYLVANIA
SERVICEMAN
SERVICE**

by
FRANK FAX



Carrying the *complete* line of Sylvania receiving tubes is one of the best ways to build goodwill for your business.

You can be sure of this because of the public's recognition of Sylvania's high quality. Extensive national advertising has helped promote this recognition — and acceptance. **QUALITY CONTROL** backs up this story of Sylvania quality.

Before Sylvania tubes can be shipped to your distributor, they must first pass a series of stiff tests conducted by an efficient Quality Control Department. Only those tubes that are proved to be electrically and mechanically perfect ever reach you.

Sylvania makes its own tube parts — over forty-five million a month. Even the fine tungsten wire filaments for Sylvania tubes are *Sylvania-made* to safeguard the quality of this vital tube element.

As a result, Sylvania can keep a close check on every tube — from raw materials straight through to the finished product.

Remember the story of Sylvania quality! It is one reason why carrying Sylvania tubes means you will receive a lot extra in the way of *goodwill*.

SEE YOUR SYLVANIA DISTRIBUTOR

For full information on the complete line of Sylvania receiving tubes — and the long list of valuable business and technical aids for you — call on your local distributor.

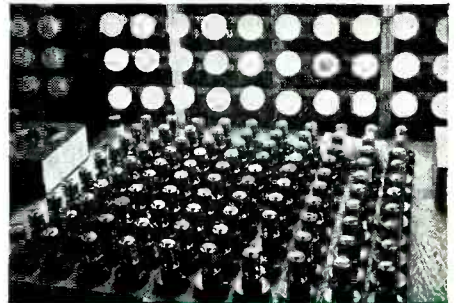

Completed tubes are being "aged" to stabilize characteristics. Then they get continuity, short and noise tests.



Tubes are here being given the Life Test — as another check on design, quality and dependable service.

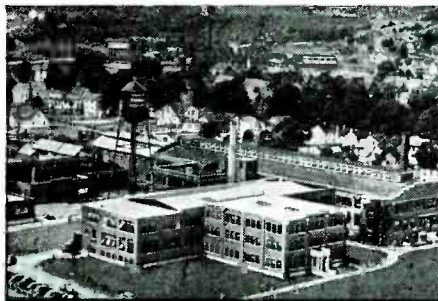

Part of the Emporium, Pa., Tube Plant, where pleasant surroundings help keep employees tuned to quality workmanship.

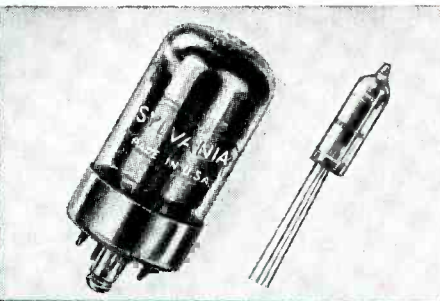

Quality products—the Sylvania Lock-In tube, and the tiny T-3 tube of proximity fuze fame.



This operation gives a percentage of all previously tested tubes a thorough going-over—just as a "double-check."

SYLVANIA ELECTRIC

Emporium, Pa.

MAKERS OF RADIO TUBES; CATHODE RAY TUBES; ELECTRONIC DEVICES; FLUORESCENT LAMPS, FIXTURES, WIRING DEVICES; ELECTRIC LIGHT BULBS

SERVICE

Communications Receivers as SERVICE INSTRUMENTS

by

THOMAS T. DONALD

A GOOD COMMUNICATIONS type receiver is quite an asset to the Service Shop, for it not only serves as an excellent receiver, but as a bench servicing instrument. Although a broadcast receiver may be similarly employed, the added features of the communications receiver as b-f-o, wide-band coverage, tuning meters, avc, on-off switch, variable band width, etc., permit a greater multiplicity of applications.

The communications receiver is particularly useful in checking the output and alignment of a signal generator, especially in the higher frequency bands. Tuning to WWV, the Bureau of Standards station, located in Washington, D. C., is quite helpful in this work. This station transmits standard signals at frequencies of 2.5, 5, 10, 15, and 20 megacycles which are correct to 2 parts in 20 million. These signals are alternately modulated and unmodu-

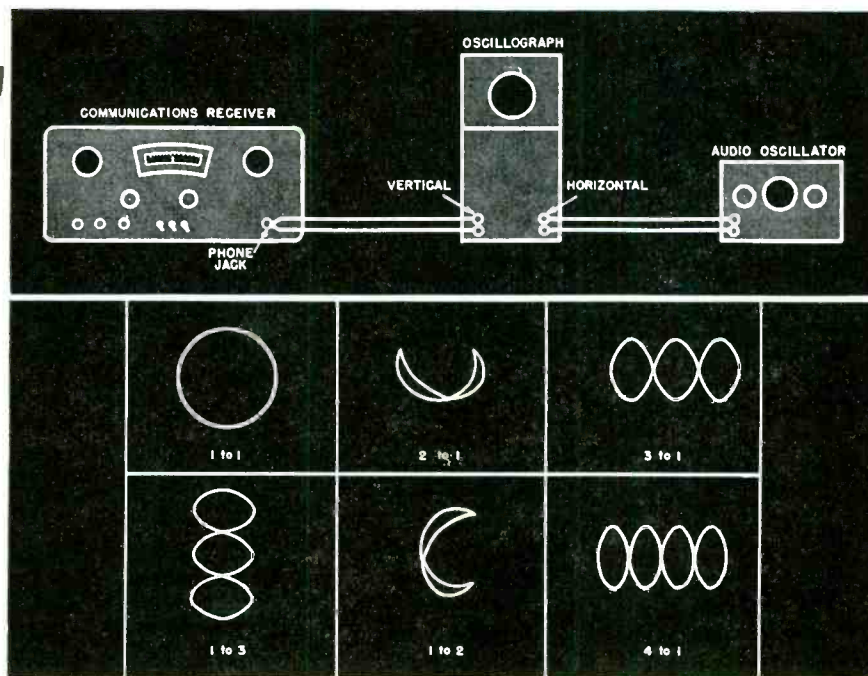

Fig. 2. Hookup for aligning an audio oscillator with WWV audio signal. Some typical Lissajous figures are also shown to demonstrate harmonic relationships as observed on the oscillograph.

lated, the modulating frequency being 440 cps. To pick up this signal at useful volume level, and to reduce the noise background, a high-sensitivity, high-selectivity receiver is necessary. In addition, the problem of tuning in the station properly is met by the use of the tuning meter and bandspread dial.

To use this standard signal to realign the signal generator, the signal from WWV is picked up on the receiver at the frequency to be checked. The signal generator is then fed into the same receiver at the same frequency. Some idea of the frequency stability of the signal generator may be gained

by permitting the two signals to zero beat over a period of time, and noting the frequency drift. In addition, dial drag may be checked by noting if resetting the signal generator brings its dial marking to the same point.

The same method may be used to check any frequency on the signal generator which is either a multiple or subharmonic of a WWV signal. For example, the generator may be checked at the second, third, and fourth subharmonic of any WWV signal. Most signal generators will not produce a harmonic of sufficient strength beyond its fifth. By turning up the gain on the signal generator, it may be checked at 1000 kc, the fifth harmonic being used to beat against the 5-mc WWV signal.

To check a multiple of WWV's signal, say 25, 30, 35, or 40 mc, the b-f-o

(Continued on page 40)

STATION	FREQ.	SUB HARMONICS		HARMONICS
WMCA	570	285Ⓞ	190Ⓞ	1140Ⓞ
WEAF	660	330Ⓞ	220Ⓞ	1320Ⓞ
WOR	710	355Ⓞ		1420Ⓞ
WJZ	770	385Ⓞ		1540Ⓞ
WNYC	830	415Ⓞ		1660Ⓞ
WABC	880	440Ⓞ	220Ⓞ	1760Ⓞ
WPAT	930	465Ⓞ	310Ⓞ	1860Ⓞ
WAAT	970	485Ⓞ		1940Ⓞ
WINS	1010	505Ⓞ		2020Ⓞ
WHN	1050	525Ⓞ	350Ⓞ	2100Ⓞ
WNEW	1130	565Ⓞ		2260Ⓞ
WLIB	1190	595Ⓞ		2380Ⓞ
WFAS	1240	620Ⓞ	310Ⓞ	2460Ⓞ
WHBI	1280	640Ⓞ	320Ⓞ	
WBBR	1330	665Ⓞ		
WBNX	1380	690Ⓞ	460Ⓞ	345Ⓞ
WBNY	1430	715Ⓞ		
WHOM	1480	740Ⓞ		
WOXR	1560	780Ⓞ	520Ⓞ	360Ⓞ
WRWL	1600	800Ⓞ	400Ⓞ	6400Ⓞ

Fig. 1. Chart of broadcast stations in the New York City area with their assigned frequencies, subharmonics, and harmonic frequencies. Circled numbers indicate the harmonic relationship. Blocked figures are exact frequencies often used in set alignment.

OSCILLATOR CIRCUITS in

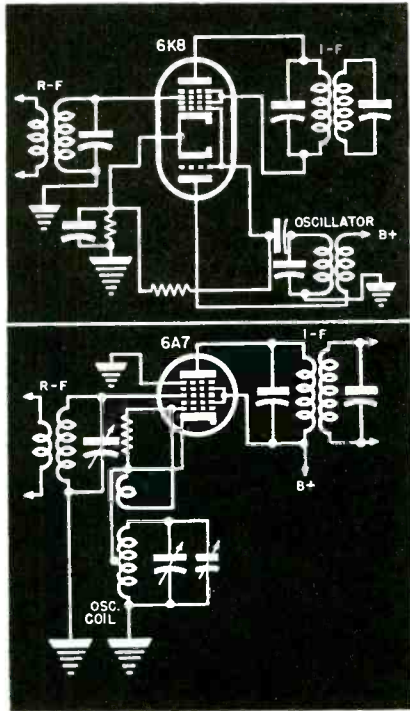

Fig. 1. Two typical converter circuits. In *a*, a 6K8 is used for converting the signal to i-f frequency. This tube is actually two tubes in one envelope, and is suitable for frequencies up to 60 mc. In *b* we have the converter type used in broadcast receivers. At frequencies above 30 mc frequency instability prevents its use.

MOST TELEVISION RECEIVERS use separate oscillator and mixer tubes in place of the conventional converter tube, as in broadcast receivers. This procedure is necessary in view of the high frequency operation, and the rigid frequency stability requirements.

Two typical converter circuits used in broadcast receivers are shown in Fig. 1. Actually, Fig. 1*a* is a two tube combination of mixer and oscillator, since the 6K8 is a triode-hexode in one envelope. The 6A8 of Fig. 1*b* is the true converter tube, since its elements operate *in line*, to modulate the cathode stream and produce frequency conversion. The 6K8 is employed in receivers featuring high frequency ranges as in all-wave or f-m models.

At high frequencies, the converter type has been found unsatisfactory because of its frequency instability, and its inability to produce constant output. Although the 6K8 is sometimes used in the smaller picture television receivers, general practice calls for the use of a separate oscillator tube.

Typical Television Oscillator Circuits

Fig. 2 shows some typical oscillator circuits used in television receivers

These are standard versions of oscillator circuits that are used for broadcast reception. In *a* we have a Hartley oscillator, with the cathode tapped up on the oscillator coil, and the plate at r-f ground potential. This type of circuit is used in many broadcast receivers for the oscillator portion of the converter tube. In *b* appears the same circuit with the cathode at r-f ground potential, and the feedback circuit between the plate and control grid. It should be noted that an additional capacitor and resistor, C_1 and R_1 are required in the later version of the Hartley, which accounts for the preference of the circuit in *a* of Fig. 1 in broadcast receivers. The only electrical difference between *a* and *b* in Fig. 1 is that different tube elements are at ground potential. The circuit in *c* of Fig. 2 is the familiar tuned grid-plate feedback type, also popular in broadcast receivers. In another version of the same circuit the tuned circuit is placed in the plate feed, and feeds back energy to the untuned control grid.

Most broadcast receivers use the tuned grid circuit, since the stator of the variable tuning capacitor can thus be connected directly to the chassis. These points are stressed to illustrate why alternative oscillator circuits are not used in broadcast receivers. In television receivers, the same factors do not apply, since fixed tuned circuits are used in pushbutton arrangement, and anything which may contribute to frequency stability is used in preference to less expensive, but more unstable systems.

The method of feeding the oscillator signal to the mixer stage may take one of two forms. It may be fed either inductively, Fig. 3*a*, or by capacitive coupling, Fig. 3*b*. The method of feed is not critical. Capacitive coupling is usually used since it is the easier and cheaper method of the two. The oscillator signal is injected into the control grid circuit of the mixer tube, and, for capacitive coupling, will affect the resonant frequency of this stage. It can be seen from Fig. 3*c* that the oscillator tuned circuit and the mixer grid circuit are in parallel, through the coupling capacitor. Therefore, any variations in either circuit will affect the frequency of the other. In this respect, the circuit of Fig. 3*a* is superior, since this effect is kept at a minimum by the use of the inductive-coupling system. Any changes in the lead length of the coupling capacitance, or its relative position on the chassis would tend to

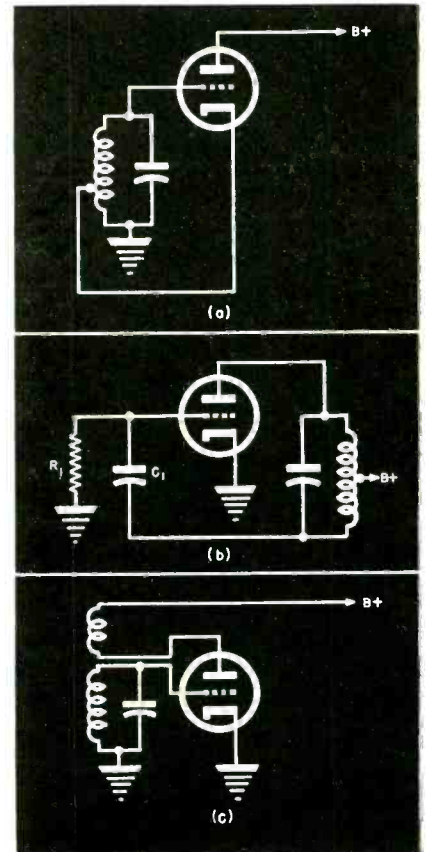

Fig. 2. Three types of oscillator circuits popular in television receivers. In *a* and *b* are two versions of the Hartley oscillator, while in *c* is the tuned-grid plate-feedback circuit.

detune both circuits. While detuning of the r-f stage would be negligible, its effect on the oscillator might be appreciable.

Oscillator Trimmer

There is one important addition to the conventional oscillator circuit. This is the fine tuning control, which is brought out to the panel as an operating control. The tuning capacitor is in effect a trimmer, used to adjust the oscillator frequency for best video and audio response. A typical circuit is shown in Fig. 4. In this circuit, both the tuning capacitance and the trimmer, or fine tuning control, are connected in parallel. In another method Fig. 5, the fine tuning control is connected to ground, while the other capacitance is connected directly across the inductance. This has been done to facilitate wiring and prevent hand capacitance affecting the tuning control.

Frequency Control

Two methods are used for switching the oscillator frequency from band

TELEVISION RECEIVERS

by R. B. CARWOOD

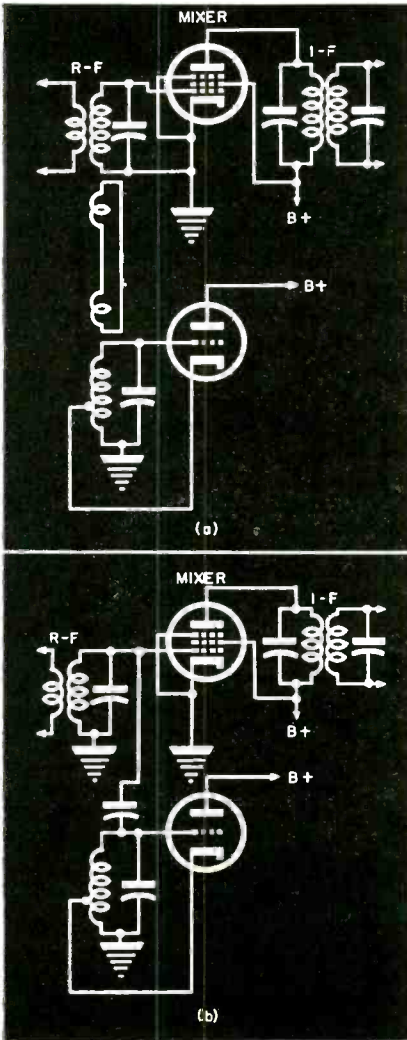
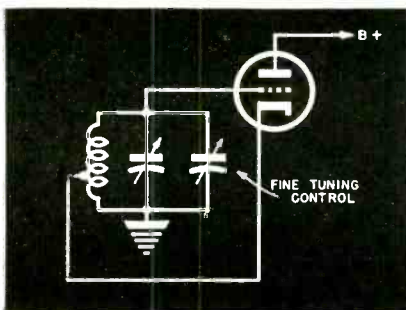

Fig. 3. Two methods of feeding the oscillator frequency to the mixer stage. In *a*, the inductive method is shown, while in *b*, the capacitive method is illustrated. Most television receivers use the capacitive method.

to band; one is inductive, the other capacitive. Sometimes, a combination of the two methods is used to keep the *LC* ratio of the oscillator tuned circuit at closely related values. Another

Fig. 4. The fine tuning control circuit, illustrated here, is essentially a trimmer capacitor across the oscillator circuit. It is brought out to the front panel to permit adjustment of both video and audio signals.



method uses separate *LC* combinations for each band. The latter procedure has the advantage in that any drift on one band will not affect the others. Its disadvantage lies in the space required, and the cost. For these reasons the former method is used in most receivers.

Since the band coverage involves frequencies from 50 to 100 mc, if the same inductance were tuned by a number of capacitances, the *LC* ratio would vary considerably affecting the frequency stability and output. The same would be true for a fixed capacitance with variable inductance values for frequency changing. In the circuit shown in Fig. 5 (oscillator of RCA TRK90), both the inductance and capacitance are varied so as to maintain a fairly uniform *LC* ratio. The receiver covers 5 channels from 44 to 84 mc. The basic oscillator circuit is the portion enclosed in the dotted lines. The inductance is a simple strap-type coil tuned with a fixed negative temperature coefficient capacitance of 80 mmfd. In shunt with this circuit is a fine tuning control and a split inductance.

Fig. 6a shows the oscillator circuit for position 1, where the oscillator frequency is 58 mc. An iron-core tuned coil, T_1 , has its split portions joined by a 5.6-mmfd capacitor, while an additional tuning capacitance of 2.5 to 18 mmfd is connected in much the same way as the fine tuning control.

Fig. 5. Oscillator circuit of the RCA TRK90. The portion enclosed in the dotted lines represents the basic oscillator whose frequency is varied by the addition of inductance, capacitance, or both.

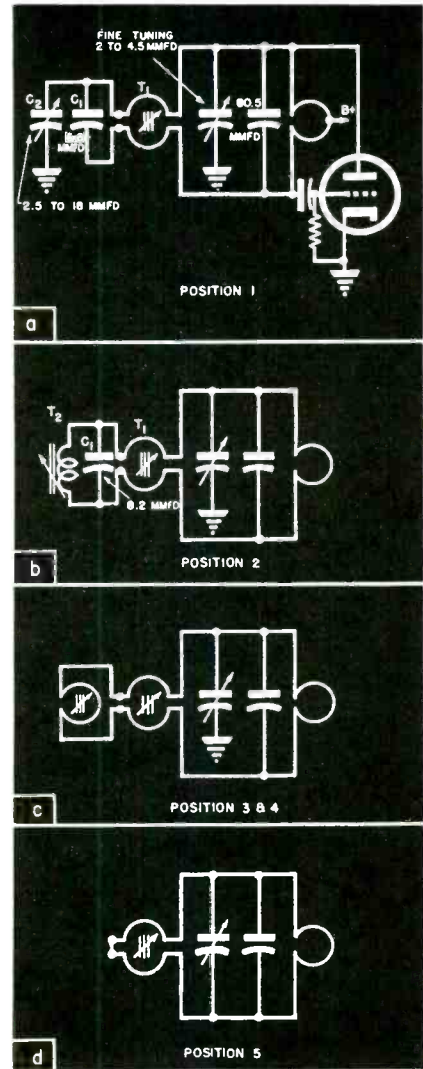
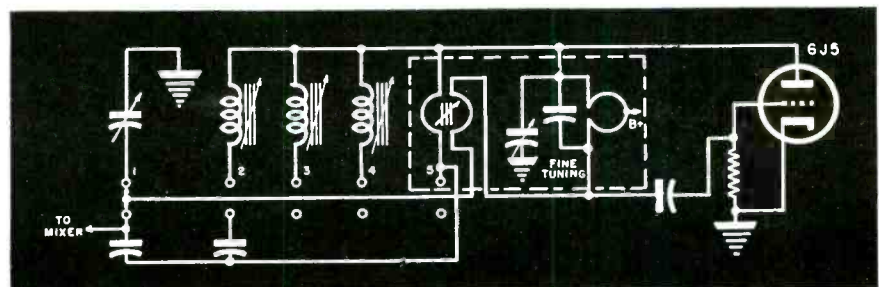

Fig. 6. The oscillator circuit of the RCA TRK90 with the five positions of the band switch. In *a* appears the circuit for the lowest channel, in which additional tuning capacitance has been added. In *b*, the circuit for position 2 is shown. Here, inductance has been shunted across the basic circuit to increase the frequency. In *c*, positions 3 and 4 are illustrated, while in *d*, position 5 is shown. A split inductance has been joined to add an inductance in shunt with the oscillator circuit.

Fig. 6b shows the same circuit for position 2, where the oscillator frequency is 64 mc. Here, the tuning capacitor has been replaced by an iron-core coil, and the shunt capacitance

(Continued on page 32)

CHECKING DEAD RECEIVERS

IT IS GENERALLY SIMPLER to service a dead set than one with any other symptoms. In some cases, however, the source of trouble is an unexpected one and not readily located. This is particularly true where we have a dead set in which one or more tubes do not light up. A methodical procedure will save much time in locating such trouble.

If a fuse blows when an a-c/d-c receiver is turned on, a short between both ends of the line is obviously present. On an a-c set, this is often due to a defective power transformer being burned out by being plugged into a d-c power supply. On an a-c/d-c set, a shorted bypass capacitor connected from the plate of the half-wave rectifier to ground is frequently responsible. On both types, a shorted plug or line cord will, of course, blow a fuse.

Speaking of shorted plugs, a nasty burn may be inflicted on the unwary radio Service Man's hand, if the short is a hot, rather than a cold one—i. e., if a gap present between the two ends of the line is small enough to be jumped by an arcing current when the plug is inserted into the female outlet.

Not infrequently, a filament resistor on an a-c/d-c set becomes shorted to chassis through its casing, causing a fuse to blow. Where the filament resistor is mounted on a bolt, rather than welded to the chassis, the trouble may be due to insulating washers that permit the resistors to short to ground through the bolt.

To check for line short, the power supply should be disconnected, and a test made for the lowest resistance reading between ground and various points in the high side of the line circuit; Fig. 1. When the point at which the lowest reading is found, the various components attached to that point should be disconnected one at a time, repeating the ohmmeter test. When the short reading is present, only when a certain unit is connected into the circuit, and absent when it is disconnected, that unit is the guilty one.

If no fuse blows, the tubes should be checked for filament lighting. If no tube lights, the external power supply may be off, due to an open fuse, or the female outlet may be defective. A neon tester lamp, or an a-c voltage test, will quickly detect these troubles.

If the power supply and outlet check okeh, the set's male plug should be inspected. On open-type plugs, the weld

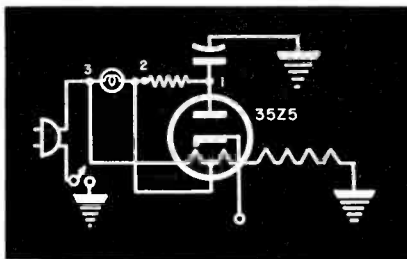

Fig. 1. Checking for line shorts. Tests are made between points 1, 2, 3 and ground, with switch open.

joining the prongs to the base often loosens, resulting in a poor contact when the plug is placed into the outlet.

If the male plug appears to be good, one or more tube filaments may be open. If the set is an a-c type, and only one tube does not light, the trouble is readily apparent. If no tube lights, the power transformer secondary should be tested for filament voltage supply. Then the primary should be checked for 110-120 v a-c.

If any of the present transformer windings read open, and a burnt odor is present in the immediate vicinity of the power transformer, the unit is probably defective, and should be replaced. If no burnt odor can be detected the leads of the winding should be carefully inspected, since power transformers rarely develop open windings merely from long use.

Sometimes a lead becomes nicked and broken by constant wear against the edge of a chassis hole through which it feeds. Cases also occur where twin pairs of leads are present. If the twin leads are not soldered together, the winding may read open, although it is actually perfect.

A similar condition is met when twin lead center-tappings are present. If the twin wires are not soldered together, the winding will be open-circuited.

When the tubes in an a-c/d-c model do not light, tube filaments, plug, line or resistor cord and switch should be checked in the order listed. On closed-type plugs, pulling on each of the wires at the point where they enter the plug will generally reveal an open, if it exists, the end of the loose wire pulling out. Resistor cords frequently develop an open at the plug, where the fragile resistor wire breaks off from the rectifier plate lead to which it is attached. Since the break is not readily visible, the resistor wire should be carefully

unwound until the open is located. Generally only a few windings have to be removed before the break is revealed.

Sometimes tube filaments, resistor cord and switch will test perfect, but the tubes will not light. A reversal of plate and negative leads of the resistor cord should be checked; Fig. 2. The filaments will not light when the resistor cord leads are reversed, since they are connected to only one side of the line, not both.

At times an error of this sort may be encountered on a voltage-doubler power supply. Many are puzzled as to where the negative lead of the resistor cord goes. Regardless of the circuit, this lead must go to the last tube filament exit point; Fig. 3.

Infrequently, a set will come off the assembly line incorrectly wired. Tracing out the filament hookup will be necessary to find the errors. In one recent case, matters were somewhat complicated by the owner's report that an a-c/d-c midget had been playing until recently. Inspection showed that the 50L6 had been wired so that the leads that should have gone to prong 1 went to prong 2 and those that should have gone to 2 went to 3, etc. The filament circuit was thus open, and the set couldn't possibly play. In spite of this, the lady swore on her honor that the set had been performing perfectly before it went bad!

A shorted tube on an a-c/d-c set may cut off filament current from several other tubes. Let us suppose that the shorted tube, and the tubes deprived of filament voltage are metal types, whereas the lighted ones are glass; Fig. 4. The lighted glass tubes often mislead, suggesting that the filament circuit is okeh. Thus long, useless tests of plate, screen, grid and other circuits are made, since the filaments are generally the very last to be suspected and tested. To avoid such a time-wasting procedure, low-voltage metal tubes should be felt for heat as a rough, quick check on the presence of filament voltage.

When metal tubes feel warm and the glass tubes in an a-c/d-c set don't light up or when glass tubes light up and metal tubes feel cold, a shorted tube is probably present. In the latter case, it should be noted that the glass tubes usually light far more brightly than usual.

When high-voltage tubes, such as the 50L6, develop shorts between their

Fig. 2. Reversing plate and negative leads of resistor cord will disconnect filament circuit.

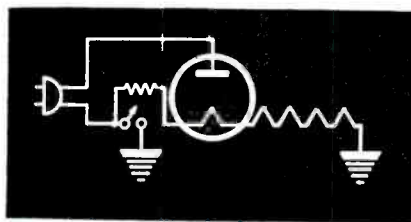

Fig. 3. Proper resistor cord hookup in a voltage-doubler circuit; 1 is a plate lead; 2, a filament resistor; 3, negative lead.

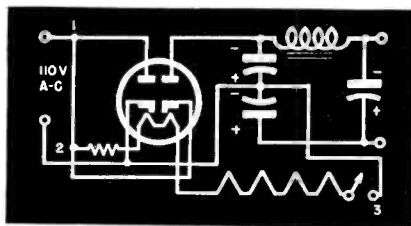
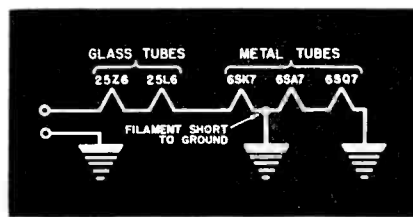

Fig. 4. Short from arrow point to ground will prevent filament current flow to the metal 6SA7 and 6SQ7 tubes. The glass tubes will remain lighted in this case, and the filament circuit will therefore not be suspected.



Troubleshooting Filament Circuits in A - C / D - C Models

by S. HELLER

filaments and other tube elements, the cathode resistor of the tube generally smokes, due to the excessive plate current. This clue should lead to quick detection of the trouble. It may be difficult to locate this type of defect quickly, when the short is of the *hot* type, and does not show up in the tube tester. Substitution of another tube, and observing whether the cathode resistor still overheats, constitutes the best test in these cases.

Series-connected tubes in a-c/d-c sets sometimes may not light because one of them may have been incorrectly forced into its socket. If the tubes are not withdrawn for testing, this type of trouble may not be obvious. Even when they are withdrawn and checked, they may be incorrectly re-inserted because . . . the *key* hole in the socket has been enlarged or the tubes have been replaced while the chassis is in the cabinet with insufficient light to guide during the operation. An ever-present alertness is the only guard against the time-wasting tests that result when this happens.

Tubes may have been incorrectly inserted into their sockets because their *key* sections have been broken off.

Filaments may not light because the tubes are in the wrong sockets. This generally occurs only when a detector tube like the 6SQ7, with filament prongs located at 7 and 8, has been interchanged with a tube whose filaments are the more usual 2 and 7.

Since the detector tube socket will have filament connections leading from the other tubes to contact 7 and 8, the trouble may be readily located and corrected.

Defective grounds may prevent a set from lighting. On some old t-r-f models, the last tube in a series-connected filament string returns to ground through a weld-joining socket to chassis. If the weld becomes rusty, the contact may become open circuited.

The most frequent cause of intermittent lighting is a defective plug. When an enclosed, rubber plug is suspected, it should be moved around in the outlet to note if the tubes light intermittently. The line cord should be checked next, by moving one section about, while holding the other section still.

To illustrate this test, suppose we choose a point, say, 10" from the plug on the line cord, and call this point X. The cord should be held at point X firmly, so that the 10" section of wire between X and the plug does not move. The rest of the wire should be shaken. If the tube filaments continue going on and off, the section between X and the plug has been eliminated as the source of trouble, and a new point, Y, to say 20" from the plug's end, may be chosen, with similar tests made, un-

til the troublesome section of wire is located.

One might ask why we should go to such extremes to locate the exact point of the trouble, when the line cord may be quickly and cheaply replaced. Well, not until we are sure of exactly where the defect lies, can we be certain that it is present in the line cord at all.

Socket contacts sometimes loosen, causing intermittent lighting. The best procedure to follow here is to wiggle all the tubes about, noting where the intermittent occurs. If the lights are put out, sparking will locate the defective contact. Socket contacts may also be short to ground and cause intermittent lighting. Socket lugs bent over, and resting near the chassis, are usually the cause of the trouble.

Intermittent filaments in a-c/d-c sets are quite common. Tube testers are generally inadequate in locating this type of defect. When the tubes have temporarily gone out, the a-c section of the voltmeter should be placed across each of the filaments in turn. When the full line voltage reading occurs, temporarily or permanently, the defective filament has been found. This reading is available because the voltmeter is in series with the tubes when it is placed across the open filament. Since the resistance of the voltmeter is much higher than that of the filaments, practically all of the line voltage is dropped across it.

SERVICING HELPS

HOW can the ratings and current carrying capacities of various windings of transformers of unknown ratings be determined?—G. W. Lilienthal.

Two methods may be used to determine power transformer ratings.

The first is a cut and try method, in which loads are imposed on the various windings to determine their maximum carrying capacities. Thus primary is connected to a 115 volt a-c line, and the secondary windings are loaded, as shown in Fig. 1. Heavy wires indicate filament windings, and the lightest wire size is usually the high voltage winding. The primary winding will be of a wire size between the two.

To determine the current rating for a filament winding, a resistive load is placed across the winding and its value decreased until the filament voltage, as measured with an a-c voltmeter, reads at some rated filament voltage. For example, a 6.3-volt winding, unloaded, will read about 7.5 or more volts. A load is then placed across the winding until the voltage reads 6.3. If the load is a resistor, the rating may be determined by the application of Ohm's law. For example, if a two-ohm resistor is required to bring the voltage down to 6.3, then the rating of the winding will be 3 amperes. If a low-resistance high-wattage resistor is not available, tubes and tube sockets may be similarly used. The current rating of the winding is then computed from the number of tubes, and their current consumption necessary to reduce the filament voltage to 6.3 or 2.5, depending on the initial voltage.

The same method may be used to determine the required rectifier tube. When the current rating of the recti-

Fig. 1. (Lilienthal query). Loading secondary windings to determine winding ratings.

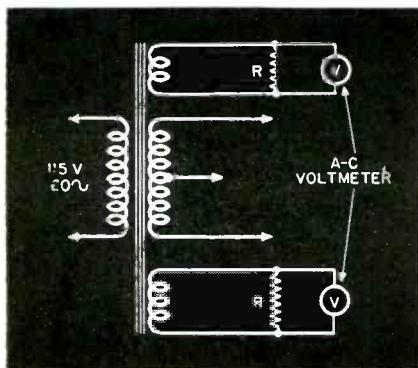

by **FRANK C. KEENE**

Wire Sizes	Current Carrying Capacity Under 50 Watts (Amperes)	Current Carrying Capacity Over 50 Watts (Amperes)
12	6.5	4.3
14	4	2.6
16	2	1.3
18	1.5	1.0
20	1.0	.65
22	.6	.4
24	.4	.27
26	.25	.17
28	.16	.1
30	.1	.07
32	.06	.04
34	.04	.027
36	.025	.017

Fig. 2. Table of wire sizes and current-carrying capacity.

fier tube has been determined, this will indicate to some extent the current rating of the high voltage winding. For example, if the rating of the rectifier filament is found to be 3 amperes at 5 volts, reference to a tube chart will show that the rectifier is probably a 5Z3. This tube delivers a maximum of 225 ma. Therefore, the permissible B current would be high.

Power transformer current ratings may also be computed from the wire size used for the various windings. Wire size in power transformers is determined on a basis of 1000 circular mils-per-ampere for transformers of less than 50 watts, and 1500 circular mils for transformers of more than 50-watts rating.

For example, if the high-voltage secondary winding uses No. 28 wire,

which has a circular mil area of 159.8, the permissible current drain would be 160 ma for a small transformer, or 105 ma for a larger one.

The wattage rating of a transformer may be determined by measuring and determining the wire size used for the primary winding. Thus, if the primary wire size is found to be No. 18 wire, using 1500 circular mils as the determinant, the transformer would be rated at 100 watts.

An approximation of the wattage rating of a transformer may also be made by weighing the transformer. Roughly, the wattage rating is approximately one watt per .1 pound.

A table of wire size and current carrying capacity appears in Fig. 2. Two ratings are shown, one for power transformers under 50 watts, the other for transformers of more than 50 watts rating.

Transformers usually have a transfer efficiency of approximately 90%. If the secondary voltages and currents have been determined, the wattage rating of the transformer may be determined in this manner.

WE have a radio system, consisting of a radio and amplifier, that feeds several hundred headphones and a few speakers. All are connected in parallel. How can we arrange the system so that shorting or grounding of the phone terminations will have no effect on the system?—P. T. Bauman.

Fig. 3 shows a typical system used to supply any number of headphones, in parallel. To prevent grounding of (Continued on page 31)

Fig. 3. (Bauman query). Multiple phone arrangement. Fig. 4 shows an outlet arrangement that will avoid shorting troubles if phone terminals are shorted or grounded while the system is in operation.

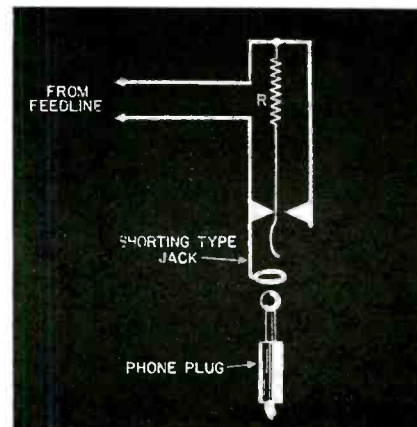
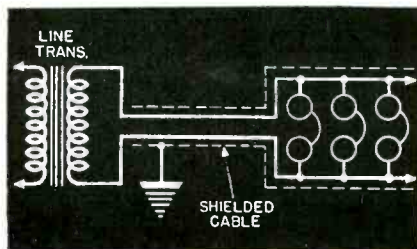

BYQUIST (Kansas City)

GARRETT (Chicago)

SHAFFER (Cincinnati)

GALLAGHER (Cleveland)

KEARNEY (Syracuse)

MARTIN (Boston)

ALLEN (New York City)

SIMON (San Francisco)

BERSCHE (Los Angeles)

FLEMING (Memphis)

WRIGHT (Dallas)

DITTMAN (New York City)

WILLIAMS (Lancaster)

FRISBEE (Charlotte)

SHANAFELT (Atlanta)

15
Cunningham
FIELD SPECIALISTS
bring more business your way

THROUGHOUT the country, 15 Cunningham Field Representatives are teamed up to help you sell more—provide better service. It's their job to keep their ears to the ground—compare notes on merchandising and servicing trends—pass on such information to your local Cunningham Tube Distributor so that he, in turn, can serve you to the best possible advantage.

And backing up these 15 Cunningham Field Specialists is a corps of technical and merchandising consultants ready to lend aid in solving selling and servicing problems in the field.

What's more, the Cunningham Field Representative in your region is ready at all times to set up service meetings, arrange for top-flight guest speakers, and aid in the institution of special sales and advertising campaigns through your Cunningham Tube Distributor.

That's why your Cunningham Tube Distributor is better advised and better able to serve you in all matters pertaining to your business—that's why you should turn to him for the sort of technical and merchandising information that will bring more business your way.

Listen to "THE RCA SHOW," Sundays, 4:30 P. M., EDT, NBC Network

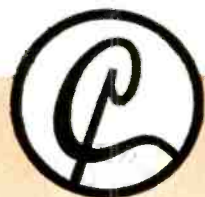

**A QUALITY PRODUCT FOR RADIO SERVICE-DEALERS
 BY THE RADIO CORPORATION OF AMERICA**

TOOLS And ACCESSORIES

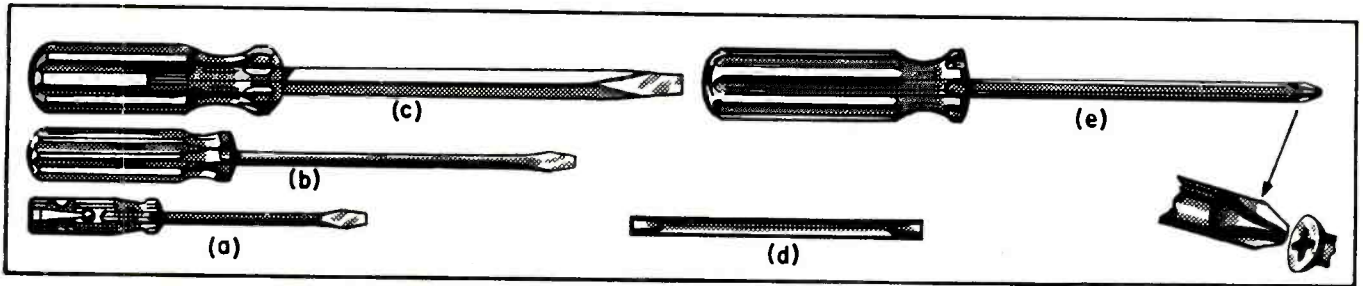

Fig. 1. Basic screwdriver equipment. (Courtesy Vaco Products Co.)

A DISCUSSION OF BASIC TOOLS is continued in this installment. In the previous article a description of the assorted types of screwdrivers required in the Service Shop today was offered. We pointed out that for light-duty work such as setting the set-screws of dials and knobs, variable tuning capacitors, etc., a small screwdriver with $\frac{1}{8}$ " x 3" blade and provided with a pocket clip, shown in Fig. 1 (A) is recommended. Many Service Men make a habit of wearing one of these.

For screws of intermediate size a $\frac{3}{16}$ " x 4" or $\frac{1}{4}$ " x 5" slender round-blade screwdriver, of the type shown at (B), will be found very useful.

Where larger size screws must be turned with more force than the (B)-type screwdriver permits, the larger $\frac{1}{4}$ " x 8" square-blade screwdriver shown at (C) may be used.

When adjusting the alignment-adjusting screws of r-f, oscillator and i-f trimmers the use of an ordinary metallic screwdriver often is bothersome. The metal of the blade may have a detuning effect, or it may be difficult to prevent it from shorting the plate trimmer to the coil shield or chassis. This may be prevented by using one of the special double-ended screwdrivers made of bakelite or other suitable insulating material. One of these,

7" long and made especially for this purpose, is illustrated at (D).

The increasing use of Phillips recessed-head cross-slot screws in radio assemblies makes it necessary to have at least one size of the Phillips-type special screwdrivers at hand in the basic tool kit. One that accommodates screws between the No. 5 and No. 9 size is recommended. A screwdriver of this type is shown at (E), accompanied by an inset illustration to show how the point fits into one of the special Phillips-head screws. Since the cross-cuts in these screws are tapered, an ordinary screwdriver will not fit into them properly for driving.

Socket Wrenches

The quickest method of loosening or running up nuts or screws is by means of socket wrenches that have screwdriver type handles (and work like screwdrivers), as shown at (A) of Fig. 2.

Socket wrenches of this type are available in two styles. In one, there is a different complete wrench for each nut size, a suitable number of these wrenches being assembled to make a set to cover all hex-nut sizes usually encountered. A typical set of seven popular sizes of such wrenches designed especially for the shop is shown at (B). The wrenches are in place in a stand designed especially for them. This set covers hex-nut sizes from $\frac{3}{16}$ " to $\frac{1}{2}$ ". In one make, each socket wrench has a different colored handle to facilitate size selection.

The other type of socket wrench is made up as a combination set using a single handle with a set of interchangeable

able snap-on-sockets of the different sizes required. (One of these sets is illustrated in Fig. 5). The combination units take up less room in a tool kit and are lighter for portable use, but the separate-unit types of Fig. 5 are faster to use. When purchasing socket wrenches be sure that they are deep enough to handle two nuts.

End Wrenches

A set of inexpensive stamped end wrenches, at left in Fig. 3 is an example, is desirable for tightening or removing hex nuts or cap screws that cannot be reached with the usual socket wrenches. A set for hex nuts ranging in size from $\frac{1}{4}$ " up to 1" will take care of practically all requirements. The stamped variety are thin and inexpensive and are adequately strong.

A small adjustable end wrench of the type illustrated at right will be very useful for the odd-sized nut that so often turns up, but don't expect it to take the place of the socket wrenches and fixed end wrenches. One whose jaws open up to a maximum of about 1" will be satisfactory.

Tin Snips or Scissors

Tin snips (also called shears) come in handy for cutting sheet metal, thin sheets of insulation, etc. A small pair—10" or 12"—will be satisfactory. Snips* are made in four styles for different types of cutting. The *standard pattern* (see Fig. 4) is the most generally used type and is designed for cutting straight lines or circles of fairly large radius.

If a pair of scissors having good cutting edges is at hand they may be used

*The terms *right* or *left-hand snips* and *right* or *left-hand cut* are often confused. A *right-hand snip* has a *left-hand cut*, i.e., it cuts to the operator's left of the top blade, thus enabling a right-handed operator to see the line of cut. The reverse is true of *left-hand snips*. A pair of right-hand snips should be bought if you are right-handed; *left-hand snips* if you are left-handed.

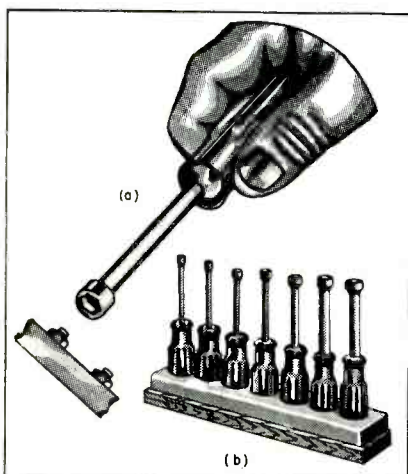

Fig. 2. Screwdriver-type socket wrench used for hex nuts. A set of seven wrenches accommodates all nuts from $\frac{3}{16}$ " to $\frac{1}{2}$ ". (b). (Courtesy Stevens Walden, Inc.)

For the **NEW SERVICE SHOP**

by

ALFRED A. GHIRARDI

Advisory Editor

[Part III . . . BASIC TOOLS]

Fig. 3. An inexpensive set of end wrenches (left) and adjustable end-type wrench (right). These are useful for use on nuts where the socket wrench cannot be conveniently applied. (Courtesy Crescent Tool Co.)

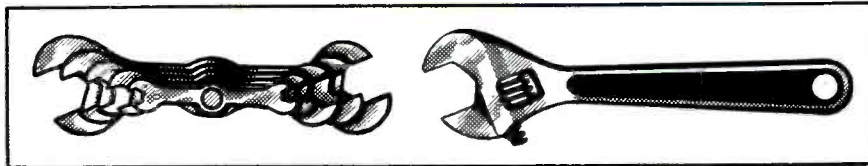
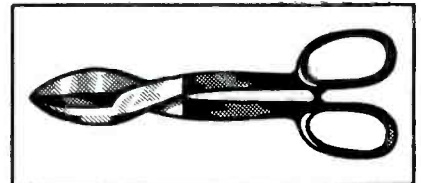

Fig. 4. Standard pattern tip snips. These are especially useful for cutting thin sheet metal in the shop. (Courtesy Crescent Tool Co.)



instead of snips for all cutting of paper, cabling twine, dial cable cord, etc.

Knife

A good knife is a handy little tool to have around the shop. A simple dime-store variety of paring knife, such as that used in kitchens, is satisfactory for general wire-scraping or the other typical jobs where a knife is needed, but where a more durable, compact knife is wanted, something of the *Boy Scout* jackknife or *electrician's* jackknife type with good steel blades, is desirable. The jackknives also contain various combination blades, such as a screwdriver, awl, etc., that can be used for many purposes in emergencies. The screwdriver blade of the electrician's jackknife is provided with a lock which prevents the blade from accidentally

snapping shut while it is being used, thus protecting the user.

Miscellaneous Small Useful Tools

Certain other small tools are either so frequently used, or so difficult to do without, that they belong on the basic list.

A scratch awl for scribing the location of holes to be drilled or cut out, laying out panels, etc. (or an ordinary icepick used for the same purpose) is handy. An excellent pocket scriber made for this purpose and having reversible points is illustrated at (A) in Fig. 5. It is made of knurled steel tubing and is equipped with a screw-chuck which locks the points in open or closed position.

A center punch should always be used to "spot" and start holes to be

drilled with a twist drill, so that the drill will not slide away from the desired spot. A popular type is shown at (B).

One or two small tapered solid punches of different sizes will come in handy for punching small holes in metal, driving out small pins or rivets, etc. One is illustrated at (C).

A small cape (cold) chisel having a 1/2" wide tip will frequently be found useful where a piece of metal must be spread or cut away. One is illustrated at (D).

One or two small ignition breaker-point type files, shown at (E), will be found to have many uses for fine work. Contact points of various kinds may be cleaned with them, just to mention one example. In addition, it would be well

(Continued on page 24)

Fig. 5. Miscellaneous small useful tools: (a), pocket scriber; (b), center punch; (c), tapered solid punch; (d), cape chisel; (e), ignition-type file; (f), flat-hand file; (g), crocheting needle; (h), combination alignment tool.

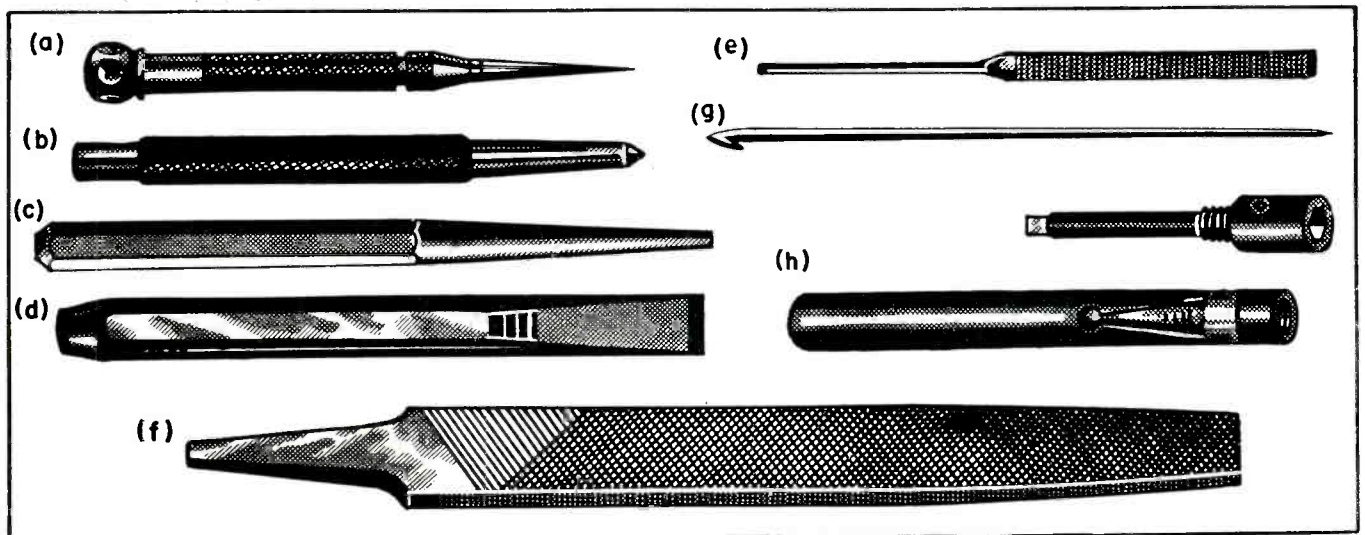

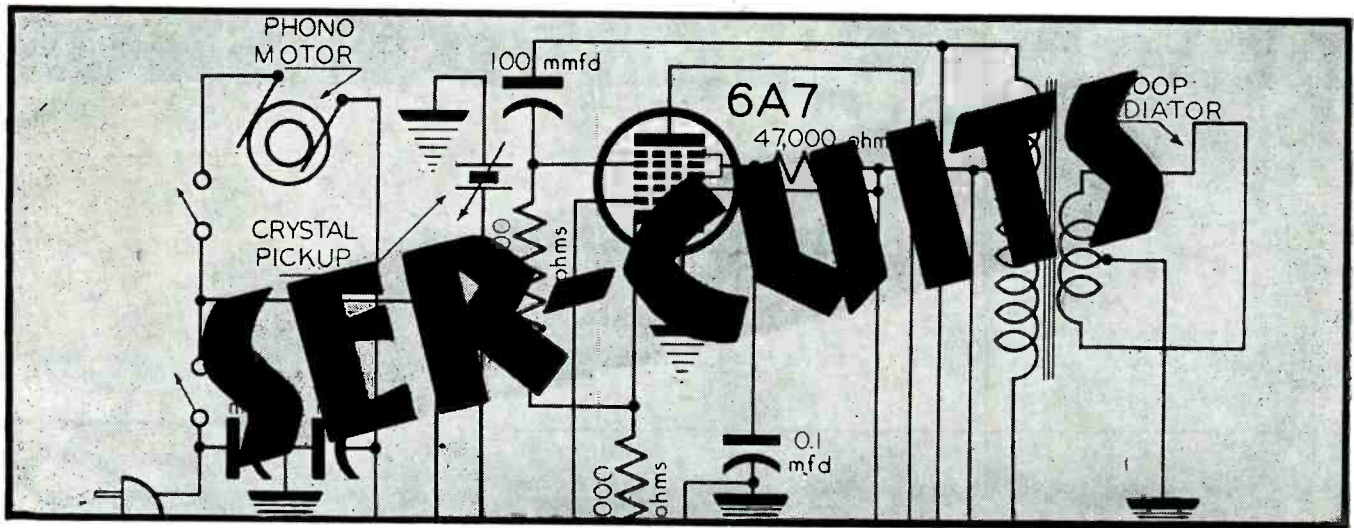

by HENRY HOWARD

CONTINUING OUR ANALYSIS of the new models now coming off the production line, we offer data on Emerson table model and pocket models and Arvin 3-tube receivers.

Emerson 502

A 4-tube and rectifier model, Emerson 502, with several interesting features is shown in Fig. 1. A bi-filar winding on the oscillation transformer with sufficient capacitance, serves as a grid

capacitor. A 15-megohm resistor between the oscillator grid and the avc bus provides an initial bias independent of signal strength. One of the 12SQ7 diodes is also directly connected to the bus.

A tapped output transformer, with the B voltage fed at the tap, is loaded with the 50L6 plate at one end and the

50L6 screen and the balance of the receiver at the other end, through a 1,000-ohm resistor. This is a hum-reducing feature which permits the 50L6 plate to be supplied directly from the 35Z5 rectifier output. The pilot lamp, usually connected across terminals 2 and 3 of the rectifier, has 10 ohms in series for limiting the surge when the set is turned off and on while

Fig. 1. Emerson 4-tube and rectifier with a bi-filar winding on the oscillation transformer with sufficient capacitance to serve as a capacitor. (See list of parts on page 22)

(Continued on page 30; Additional circuits on page 20)

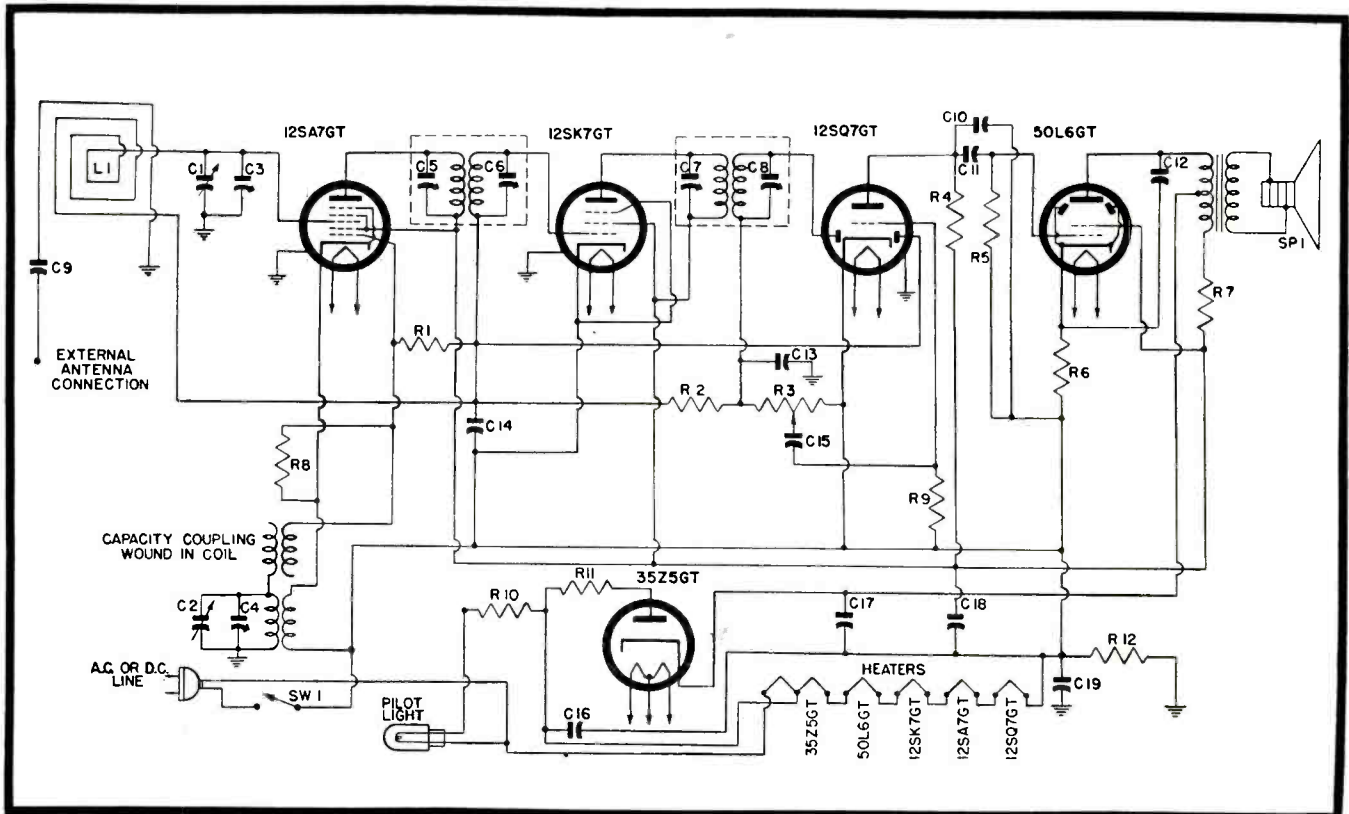

DuMont proudly presents the
NEW Type 274
CATHODE-RAY OSCILLOGRAPH



SPECIFICATIONS

INPUT IMPEDANCE: Vertical-direct 5 meg. 60 μ f; amp. 1 meg. 70 μ f; Horizontal-direct 5 meg. 80 μ f, amp. 5 meg. 30 μ f.

FREQUENCY RANGE: Sine wave response (at full gain) uniform within $\pm 20\%$ from 20 to 50,000 c.p.s., down less than 50% 100,000 c.p.s.

DEFLECTION SENSITIVITY: Amplifiers at full gain 0.65 r.m.s. volt/in., direct ± 18 r.m.s. volts/in.

LINEAR TIME BASE: Variable from 8 to 30,000 c.p.s. Synchronization from vertical amplifier or external signal.

POWER SUPPLY: 115 volts, 50 to 60 cycles a.c. Power consumption app. 50 watts.

TUBES: All tubes, including 5BP1-A CRT, included.

PHYSICAL: Green wrinkle-finish steel cabinet with plastic carrying handle. Modern design green front panel. White characters, black knobs. Height 14"; width 8 5/8"; depth 19 3/4". Weight 35 lbs.

- ★ 5-inch cathode-ray tube.
- ★ linear time-base, 8 to 30,000 c.p.s.
- ★ identical vertical and horizontal amplifiers—20 to 50,000 c.p.s.
- ★ provision for intensity modulation.
- ★ modern design cabinet and panel.

Everything you want in a
general-purpose oscillograph

◆ It's here—Du Mont's new Type 274 Oscillograph—our post-war answer to a long-standing need for a good instrument for routine laboratory and production testing, and for radio servicing—at a low price of only **\$99.50**

Send for descriptive literature!

© ALLEN B. DUMONT LABORATORIES, INC.

DUMONT Precision Electronics & Television
 ALLEN B. DUMONT LABORATORIES, INC., PASSAIC, NEW JERSEY • CABLE ADDRESS: ALBEEDU, PASSAIC, N. J., U. S. A.

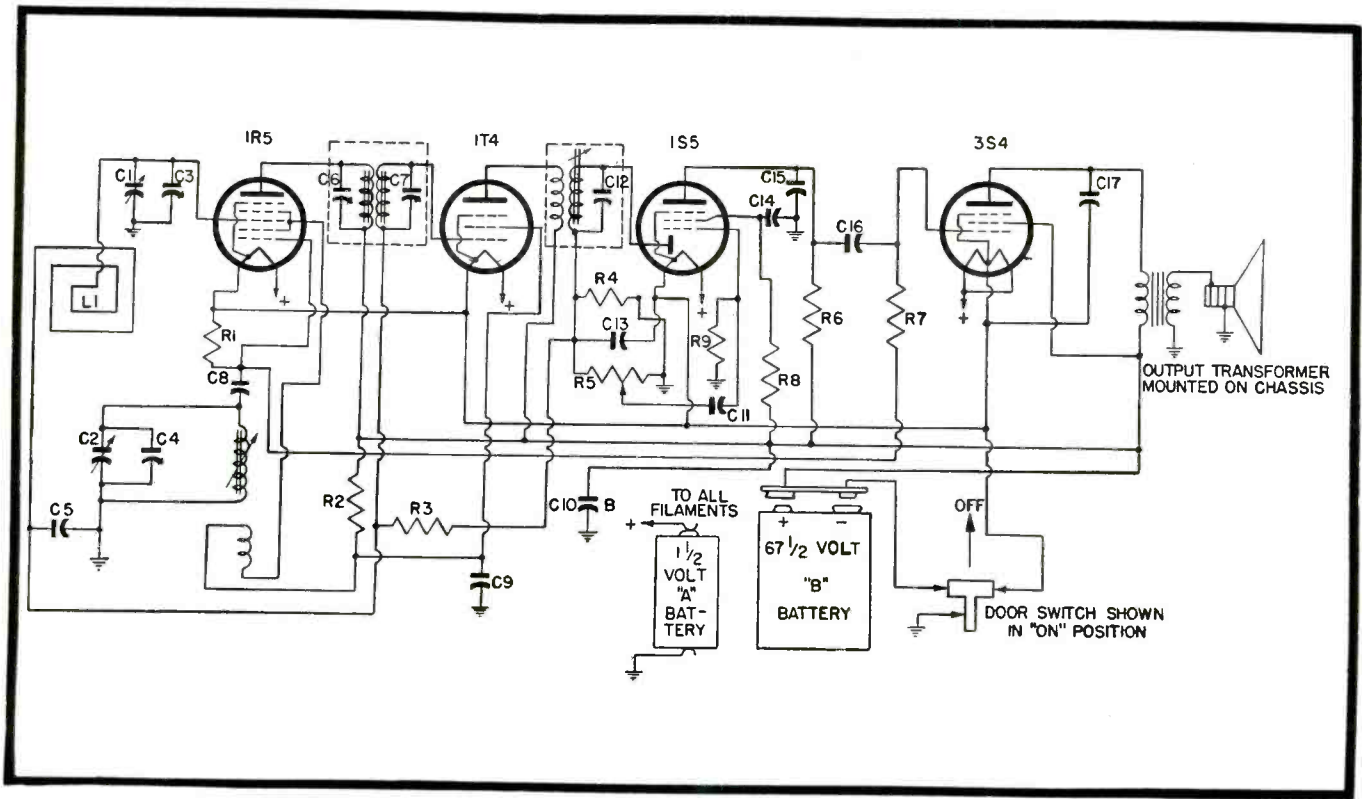
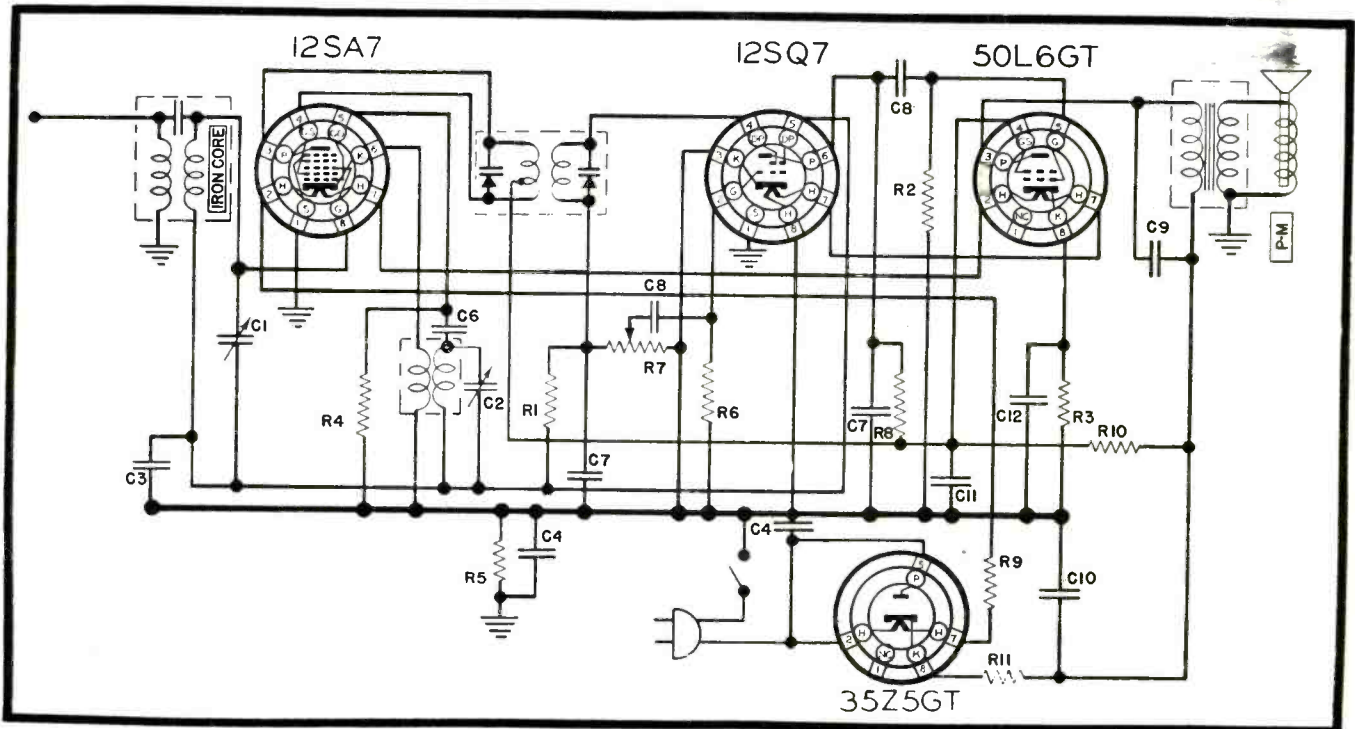

Fig. 2. Pocket-type Emerson 508 with iron-core adjusted oscillator.
(See list of parts on page 22)

R	OHM	W	C	CAPACITY	VOLT
1	4.7 M	1/4	1	Two Gang	
2	1 M	1/4	2	Variable	
3	150	1/4	3	.05	200
4	22 K	1/4	4	.05	400
5	330 K	1/4			
6	15 M	1/4	6	.00005	500
7	2 M	V.C.	7	.0001	500
8	470 K	1/4	8	.002	500
9	47	1	9	.01	400
10	2200	1	10	40 MFD	150
11	15	1/4	11	20 MFD	150
			12	20 MFD	25'

Fig. 3. Arvin 444, 444A three-tube and rectifier with a 20-foot antenna hank to boost gain; list of parts at right.



SUPPRESS RADIO NOISES FROM FLUORESCENT LAMPS!

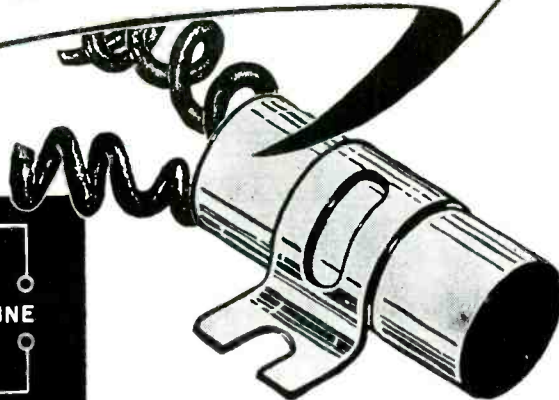
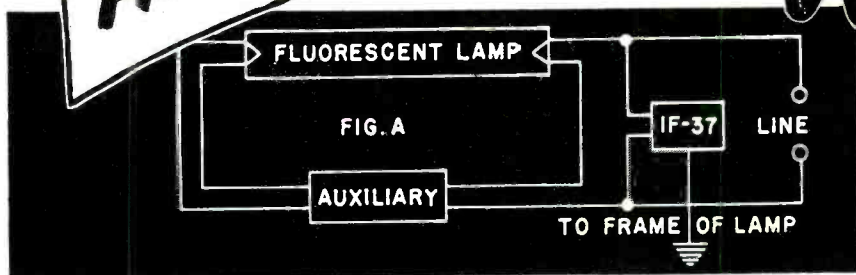

EASILY INSTALLED — HIGHLY EFFECTIVE

The most serious radio interference from fluorescent lamps is that which is conducted down the power line to receivers at remote points. Such interference cannot be avoided merely by placing the lamp at a safe distance from the radio antenna circuit. Nor can it be avoided by using shielded lead-in wire, as in cases where interference is caused, either by direct radiation from the lamp bulb itself or by radiation to the radio antenna circuit from the electric supply lines.

Yet interference conducted down the power line to remote receivers should, and CAN, be reduced.

The really effective method is to connect Sprague IF-37 Filters directly to each fixture as indicated in the above diagram. These filters are

specifically designed for fluorescent lamp interference suppression. They are recommended for single lamp fixtures, connected as shown in figure "A". One filter is required for each auxiliary.

Type IF-37 Filters are EASY to install. Inexpensive, too—only \$1.11 each, net.

RADIO DEALERS! REMOVE INTERFERENCE IN YOUR OWN STORE

The use of Type IF-37 Filters in your own store will help you sell more radios through better demonstration. Your sets may be perfect, but if your own fluorescent lamps interfere with reception your customers may assume the radio is at fault.

*Don't let noise spoil
your sales!*



WRITE

for your copy of the new Sprague Catalog No. C-306. It's the first Sprague Catalog in five years devoted to civilian radio service. In it you'll find new capacitor types and outstanding resistor improvements. Write for your new catalog today!

SPRAGUE PRODUCTS CO.

NORTH ADAMS, MASS.

Jobbing Distributing Organization for Products of the Sprague Electric Co.

PARTS LISTS FOR SER-CUITS

(See pages 18 and 20)

ITEM	DESCRIPTION
C1, C2	TWO GANG VARIABLE CONDENSER
C3	TRIMMER
C4	TRIMMER
C5, C6	TRIMMERS
C7, C8	TRIMMERS
C9	.002 MF 600 VOLT
C10	.0005 MF 600 VOLT
C11	.02 MF 400 VOLT
C12	.02 MF 400 VOLT
C13	.00022 MF MICA
C14	.1 MF 200 VOLT
C15	.002 MF 600 VOLT
C16	.05 MF 400 VOLT
C17	30 MF
C18	50 MF 150V DUAL DRY ELECT CAP
C19	.2 MF 200 VOLT
L1	LOOP ANTENNA
R1	15 MEG 1/4 W.
R2	3.3 MEG 1/4 W.
R3	.5 MEG VOLUME CONTROL
R4	470,000 OHMS 1/4 W.
R5	470,000 OHMS 1/4 W.
R6	150 OHMS 1/2 W.
R7	1000 OHMS 1 W.
R8	22,000 OHMS 1/4 W.
R9	15 MEG 1/4 W.
R10	10 OHMS 1/2 W.
R11	15 OHMS 1W WIRE WOUND
R12	220,000 OHMS 1/4 W.

Above, list of parts for Emerson 502. Below, list of parts for Emerson 508.

ITEM	DESCRIPTION
C1, C2	VARIABLE CONDENSER
C3	TRIMMER
C4	TRIMMER
C5	.02MFD 100VOLT ROLL TYPE
C6	TRIMMER
C7	TRIMMER
C8	.0002 MFD MICA .0002 MFD CERAMIC
C9	.02 MFD 100VOLT ROLL TYPE
C10	.8MFD 100VOLT DRY ELECTROLYTIC
C11	.003MFD 150VOLT ROLL TYPE
C12	CONDENSER
C13	.0001 MFD CERAMIC
C14	.02 MFD 100VOLT ROLL TYPE
C15	.0001 MFD CERAMIC
C16	.001MFD 100VOLT FLAT ROLL TYPE
C17	.003 MFD 150 VOLT ROLL TYPE
L1	LOOP ASSEMBLY
R1	100,000 OHMS 1/4 WATT
R2	8200 TO 22,000 OHMS 1/4 WATT <small>SELECTED IN PROD.</small>
R3	3.3 MEG 1/4 WATT
R4	1 MEG 1/4 WATT
R5	VOLUME CONTROL
R6	47 MEG 1/4 WATT
R7	1 MEG 1/4 WATT
R8	4.7 MEG 1/4 WATT
R9	10 MEG 1/4 WATT

5-TUBE RECHARGEABLE 2-VOLT PORTABLE

(See Front Cover)

THE POSTWAR MODEL, type 250, of the G. E. 5-tube broadcast-range rechargeable 2-volt portable is shown on the cover, this month. The battery, a leak-proof airplane type in a transparent lucite case, will operate the receiver for about 20 hours without recharging. The receiver may be used while charging; a built-in charger operates off the a-c line and draws approximately 10 watts. Charge is indicated by a built-in indicator. Receiver drain is 3.5 watts, 2.1 volts at 1.65 amperes.

The loop, located in the cover to minimize chassis absorption, is resistance coupled to a 1LN5 tuned r-f amplifier through a 330-mmf capacitor across a 1-megohm grid leak. An iron core r-f coupling transformer, aided by 6.8-mmf of direct capacity coupling feeds the tuned converter, a 1LC6. The oscillator section uses an iron-core transformer with screen grid (plate) feedback.

A decoupling filter (22,000 ohms and .005 mfd) keeps oscillator voltage out of the B supply.

A pair of iron core transformers with the 1LN5 i-f amplifier provides plenty of i-f gain. A decoupling filter is also used in this stage (5,600 ohms and .05 mfd).

A 1LH4 detector first a-f delivers avc to the r-f and first detector tubes. The detector load consists of a 47,000-ohm resistor and a 1/2-megohm control. The tone control and components of a degenerative feedback network provide additional impedance.

A 3Q5 power amplifier with parallel filaments obtains C bias from a bias cell in series with a 1-megohm resistor. The feedback tap is taken from a network across the voice coil and fed to the low side of the volume control. The network consists of a .05-mfd capacitor, 2700-ohm and 4700-ohm resistors in series. A 3-position tone control shunts a .1-mfd capacitor and a 1000-ohm resistor across the feedback tap.

The speaker is a 5 1/2" p-m type using alnico 5.

B Voltage Source

B voltage is obtained from a synchronous vibrator and transformer through a r-f and a-f filter consisting of .05-mfd capacitor and a r-f choke for the r-f filter, and 1500 ohms and a

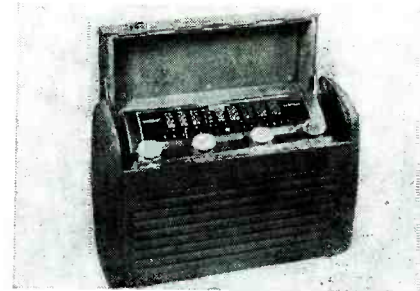

Above, single-band 2-volt portable, type 250. Below, six-band (broadcast and five s-w) model, type 260.



pair of 15-mfd capacitors for ripple filtering. A generous amount of filtering is also provided in the vibrator input and filament circuits. A dual .5-mfd capacitor and r-f choke are in the A+ vibrator input; the split r-f choke feeds two sets of filaments with a .5-mfd capacitor on one side and a 1200-mfd capacitor across the other side (containing the 1LH4 first audio filament). The 3Q5 is supplied separately through a 7.5-ohm resistor, additional filtering being unnecessary.

The line charger uses a 5.8-volt center-tapped transformer with two pairs of paralleled dry-rectifier discs. The battery may also be charged from a 6-volt auto battery by using a special charging cable.

Another model, 260, covers the broadcast bands and five s-w channels. Push-button tuning is available in this model. Both models feature a die-cast aluminum chassis with shielding compartments.

from **RADIO NEWS**

For the **RECORD.**

BY THE EDITOR

MUCH has been said and reams have been written about the necessity for the service engineer to apply modern scientific techniques and sound business practices to assure his success in the post war era. It takes no crystal gazer to predict that with the tremendous increase in varieties of radio models the need will be acute for some new short cut to accurate well organized service data. In the past the serviceman needed information on the products of only 36 receiver manufacturers whereas more than 1000 models of 212 radio and phonograph manufacturers will soon be on the market.

One company has already taken cognizance of this complex problem and is producing a radically different, high efficiency technical reference service. The radio service engineer who acquires this service will be provided not only with exhaustive technical data on radio receivers but will have access to the knowledge of a board of 30 specialists in radio, radar and radio servicing to help him solve problems relating to parts selection, shop operation, promotion, accounting and business methods.

The forward thinking of this organization assures servicemen of a pipeline to the two springs of knowledge requisite to their business success; practical well organized technical information and sound business practices. O.R.

JUNE ISSUE RADIO NEWS

Here's
YOUR
problem

Here's
OUR
answer

Save Up to 50% in Servicing Time!

**In Each
PHOTOFACT FOLDER
You Get:**

- ✓ From 2 to 12 clear photos of the chassis, identifying each component part for immediate checking or replacement.
- ✓ Complete specifications on each component, including manufacturer's part number, available replacement type or types and valuable installation notes.
- ✓ A keyed reference alignment procedure for the individual set, with adjustment frequencies and recommended standard connections.
- ✓ Complete voltage analysis of receiver.
- ✓ Complete resistance analysis of receiver.
- ✓ Complete stage gain measurement data.
- ✓ Schematic diagram.



If you think it's going to be easy to service the 1,000 or more radio sets soon to come off production lines, read no further! The Sams PhotoFact* Service is designed for men who *know* there's a tough time ahead—who need and *want* better service information.

The Sams PhotoFact Service provides such information in the form of reliable, fact-filled, illustrated folders that can save as much as 50% of your servicing time. Every post-war radio is visualized in photographs . . . every part listed and numbered . . . every servicing shortcut and installation fact fully set down! No matter how complicated the set, or how new the components, you have the whole story right in front of you.

You get a set of from 30 to 50 PhotoFact Folders at a time. Each set of folders

comes to you in a handy envelope at a cost of only \$1.50 for each group. They cover all new receivers as they reach the market.

Think of it! An absolutely fool-proof visual method of giving you the exact information you want, where you want it, when you want it, for as little as three cents per new radio model! And every bit of information is compiled by experts from an examination of the actual receiver itself — *not from standard service data!* PhotoFact Folder Set No. 1 is being published June 15. Others will follow closely. Reserve yours now!

Also, Membership in
HOWARD W. SAMS INSTITUTE

Answers to hard service problems! Economical shop practices! How to get more customers! These and many other subjects covered by 30 top notch specialists! Complete facts with PhotoFact Set No. 1.

**Trade Mark Registered*

Cut This Out and Mail It to Your Distributor! If you do not know his name and address, send it directly to Howard W. Sams & Co., Inc. 2924 East Washington Street, Indianapolis 6, Indiana, and we will see that your nearest distributor gets it.

CHECK ONE SQUARE

PLEASE PRINT

Yes, by all means reserve every issue of the Sams PhotoFact Folder Service for me.

Send complete information and reservation card.

My (check) (money order) (cash) for \$1.50 is enclosed for PhotoFact Folder Set No. 1. (Publication date, June 15, 1946). (If you send cash, be sure you use registered mail.)

Name _____ Address _____

City _____ Zone _____ State _____

Company Name _____

My Distributor's Name _____ City _____

HOWARD W. **SAMS** & CO., INC. **RADIO PHOTOFACT SERVICE**



Simple fool-proof action

PICKUP ARM MAY BE MOVED IN CHANGE CYCLE

WEBSTER

Automatic Record Changer



MODEL
56

other important features

Another "extra" on the Webster Model 56 is a protection against thoughtless handling of the record changer. The pickup arm can be moved while the machine is in change cycle, without damage. This is one more reason why Webster changers gives such long-lived and outstanding performance

- Shuts itself off — after the last record has played.
- Velocity trip — changes more types of standard records than the usual changer.
- Protects finest records but will change many old, badly worn — yet cherished — records.
- Feather-touch pickup.
- Fast change cycle.

The Choice of Music Lovers Everywhere

WEBSTER CHICAGO

5610 Bloomingdale Avenue, CHICAGO 39, ILLINOIS

32 years of Continuous Successful Manufacturing

these tools are now available to make alignment on all makes of receivers easier. An alignment tool¹ suitable for most jobs, is shown at (H). It consists of an insulated screwdriver with metal nib, $\frac{5}{16}$ " hex wrench, $\frac{1}{4}$ " hex side wrench, and $\frac{1}{4}$ " hex end wrench slotted. Additional types will be discussed in a later article.

Useful Accessories

Certain accessory items make a great difference in the ease and efficiency with which some repair jobs can be completed, and so they should be included in the Service Man's supply of basic tools.

A small camel's hair brush, for example, is very useful in cleaning off most of the dusty chasses when they come in for repair.

In any chassis probing work, a suitable electric light is essential. A large, ordinary electric light is too bulky in many cases, so that a small flashlight of the *pen-lite* type is very useful. These are obtainable in most corner drug stores and hardware stores.

Centering of voice coils in loudspeakers is a job which calls for shims of the right thicknesses and material. A handy kit of these, Fig. 7, containing five sizes of shims in a snap case may be had for less than a dollar.

A small pocket-type carborundum sharpening stone will prove helpful for sharpening the knife and some of the other cutting tools around the shop.

A small tube of Duco household cement should be kept on hand at all times for general cementing jobs. A

¹General Cement Co. No 5016.

Fig. 6. Two types of metal tool boxes. The trays in (a) swing out automatically when the box is opened. The tray in the box at (b) must be lifted out.

TOOLS

(Continued from page 17)

to purchase an 8" flat hand standard-cut file, of the type shown at (F), for all general filing work. A standard file handle should be provided for it.

Another tool, that is extremely useful in dial-cable replacement work, is a hook similar to a crocheting needle, as an aid in the threading job. One is illustrated at (G).

At least one alignment tool is necessary, although many different types of

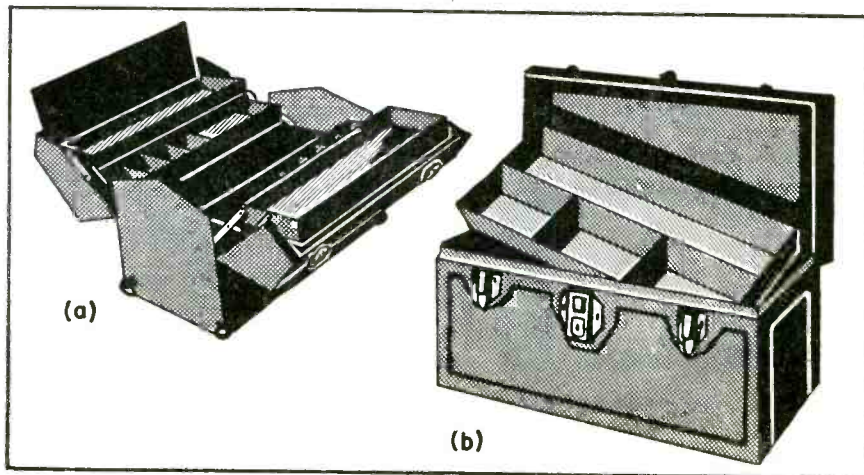

variety of additional special cements for various special purposes will be described in a subsequent article.

Such miscellaneous accessories as light machine oil in a squirt can, a roll of friction tape, rosin-core solder, and non-corrosive soldering paste or fluid flux should also be on hand.

Tool Kit

Some Service Men use their shop tools for outside service jobs also; others find it more convenient to maintain a less complete separate set of tools to take along on outside service calls. Many prefer to have these outside-job tools divided into two groups—a kit of the small *essential* tools that is carried into the house, and a group of the larger *reserve* tools kept in a tool box or bag that is left in the car unless needed.

A convenient, compact kit containing a selected group of small hand tools designed to facilitate the mechanical work on outside service calls is illustrated in Fig. 8. This kit is carried into the home. It contains a master chuck-type handle designed to take a 1/2" reamawl, three screwdrivers of different sizes, and seven Spintite hexagonal socket wrenches ranging from 1/8" to 1/2" size. Also included in the list are an insulated neutralizing and alignment wrench, a pair of diagonal side-cutting pliers and a pair of long-nose pliers. All roll up compactly in a leatherette roll.

Tool Box or Bag

Whether one of the ordinary metal tool boxes having compartment trays, or a fibre tool bag similar to those used

(Continued on page 26)

Fig. 7. A handy kit containing five sizes of speaker voice-coil shims. (Courtesy General Cement Co.)

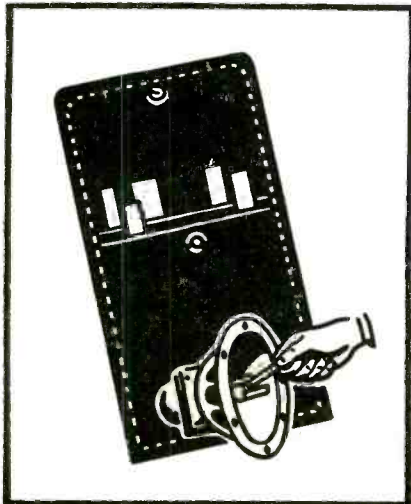

HANDLE MORE JOBS IN A LOT LESS TIME!

THE GREATEST TIME SAVER IN SERVICING HISTORY

Radio servicemen everywhere say that A. A. Ghirardi's **RADIO TROUBLESHOOTER'S HANDBOOK** helps them **TURN OUT TWICE AS MUCH WORK IN A GIVEN TIME!** Four times out of five, it tells exactly how to repair a set—without any elaborate testing whatever! Actually, this big 4-pound, 744-page manual-size Handbook is a complete guide to quick, easy repairs on **PRACTICALLY EVERY RADIO RECEIVER NOW IN USE.**

Covers 4800 Different Home and Auto Radio Models

Its 404-page Case History Section gives full details on common trouble symptoms, their causes and remedies for **OVER 4,800 DIFFERENT RADIO MODELS.** It describes the trouble exactly, tells exactly what to do to repair it. It eliminates much testing—helps you do **TWO OR MORE** jobs in the time normally required for one—repair cheap sets profitably—train new helpers, etc. Equally important are hundreds of other pages specifically geared to today's needs—dozens of hints on the proper substitution of tubes and parts; i-f alignment peaks for over 20,000 superhets; transformer troubles, etc. and hundreds of graphs, tube charts, data, etc.—all carefully indexed so you can find what you need in a hurry. Price only \$5 complete (\$5.50 foreign) on our **5-DAY MONEY-BACK GUARANTEE!**

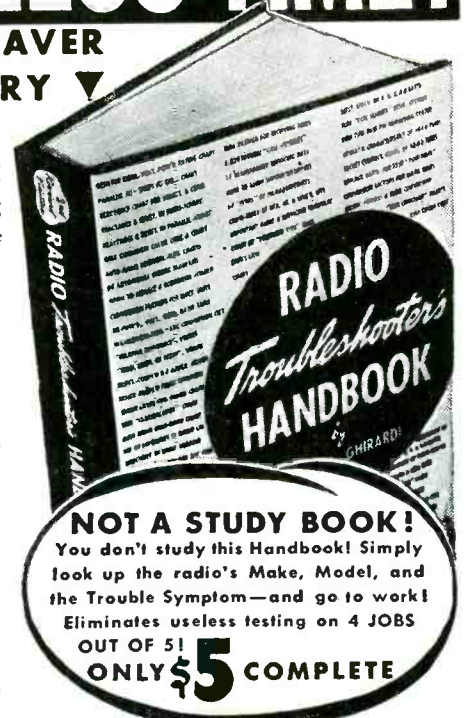

Ghirardi's Complete Guide to Modern Professional RADIO SERVICE WORK



TEST INSTRUMENTS, TROUBLESHOOTING, REPAIR

Once in a blue moon a technical book is written that is so important, so complete, and so easy to understand that it is used and recommended universally by members of a profession! A. A. Ghirardi's **MODERN RADIO SERVICING** is that kind of book—AND MORE!

ELIMINATES GUESSWORK!

Actually, it is the only single, inexpensive book giving a complete course in modern Radio Repair work in all its branches. Explains all necessary test instruments... even how to build your own; how to troubleshoot ALL makes of receivers, analyze their circuits, test components; make adjustments; repairs, etc.—all step-by-step. Used for reference, it serves as a beautifully cross-indexed volume for "bushing up" on any type of work that may puzzle you. 1300 pages, 720 self-testing review questions, 706 illustrations and diagrams. \$5 complete (\$5.50 foreign). **5-DAY MONEY-BACK GUARANTEE.**

See Money-Saving Offer in Coupon!

5 DAY MONEY-BACK GUARANTEE

EVERY CONCEIVABLE SERVICE SUBJECT!

Millimeters, ammeters & voltmeters; Methods and instruments for measuring resistance; ohmmeters; How to build your own instruments; Tube checkers; Set analyzers; Point-to-point testing; Test oscillators; Preliminary trouble checks; AVC and QAVC circuits; Troubleshooting; Testing components; Obscure radio troubles; Aligning and neutralizing; Auto radios; All-wave radio servicing; Marine radio; Interference reduction; How to start and operate a Radio-Electronic service business, etc., etc.

Dept. S-66, Technical Division
MURRAY HILL BOOKS, Inc.
232 Madison Avenue, New York 16, N. Y.

Enclosed find \$..... for books checked (send postpaid) or send C.O.D. (in U.S.A. only) for this amount, plus postage. If not fully satisfied, I may return the books in 5 days for full refund.

- RADIO TROUBLESHOOTER'S HANDBOOK \$5 (\$5.50 foreign)
- MODERN RADIO SERVICING \$5 (\$5.50 foreign)
- MONEY-SAVING COMBINATION**—Both books (over 2040 pages of invaluable service data) for only \$9.50 (\$10.50 foreign).

Name

Address

City & Dist. No. State

Please print or write plainly.

INDIVIDUALLY MARKED

for Quick Identification of Resistance and Wattage

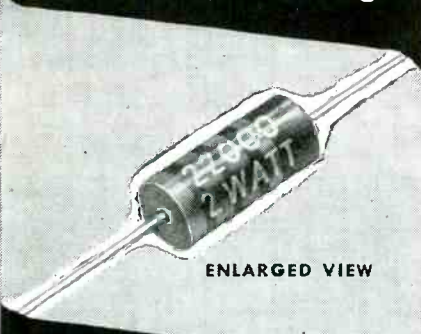

ENLARGED VIEW

1/2 Watt • 1 Watt • 2 Watt

OHMITE
Little Devil
INSULATED COMPOSITION RESISTORS

NOT ONLY are these new *Little Devils* tops in performance and service . . . but you never have to guess about the resistance and wattage of any unit. Every *Little Devil* is individually marked for quick, positive identification in your resistor stock or servicing kit. In addition all units are color coded. Available in Standard RMA values from 10 ohms to 22 megohms, $\pm 10\%$ tolerance.

Available only from Ohmite Distributors

OHMITE MANUFACTURING COMPANY
4877 Flournoy St., Chicago 44, U. S. A.

Type	Size Length	Diam.	Resistance Range	Maximum Volts	List Price
1/2 Watt	3/8"	3/64"	10 Ohms to 22 Meg.	500	13c
1 Watt	1/2"	7/32"	10 Ohms to 22 Meg.	1000	17c
2 Watt	1 1/16"	5/16"	10 Ohms to 22 Meg.	3500	25c

Be Right with

OHMITE

RHEOSTATS • RESISTORS • TAP SWITCHES

TOOLS

(Continued from page 25)

by electricians, plumbers, etc., is to be used for carrying the service tools and miscellaneous supplies on outside jobs, is a question the individual Service Man will have to decide for himself. The writer prefers the fibre tool bag for the following reasons: (1)—It does not bang around in a car. (2)—Tools do not rust as readily. (3)—It does not scratch furniture, polished floors, etc., when brought into the home.

Since the size tool box or tool bag to purchase will naturally depend on the number, type and size of the tools and supplies to be taken on the job, it is best to defer its purchase until you have accumulated all this material and can determine how large a box or bag will be required.

A large variety of metal tool boxes is available. In some, the trays are of the sliding-drawer type; in others they swing out automatically when the cover is opened, as shown in the box at (A) of Fig. 6; in others the trays must be lifted out, as shown in the box at (B).

This completes the *basic* group of tools for the new Service Shop. Many additional desirable tools that will aid greatly in expediting mechanical work in the shop will be described in next month's discussion. As many of these

there is
NO SUBSTITUTE

for GOOD communications and industrial wire. We are shipping you more and more of it now . . .



WIRES

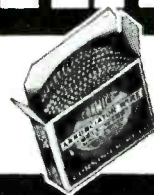

cornish

WIRE COMPANY, INC.

15 Park Row, New York 7, N. Y.

"Made by Engineers for Engineers"

as the tool budget will allow should be purchased.

(To Be Continued)

Fig. 8. A tool kit with a complete set of *essential* tools to facilitate outside service work. This kit case rolls up into a compact form. (Courtesy Stevens Walden, Inc.)

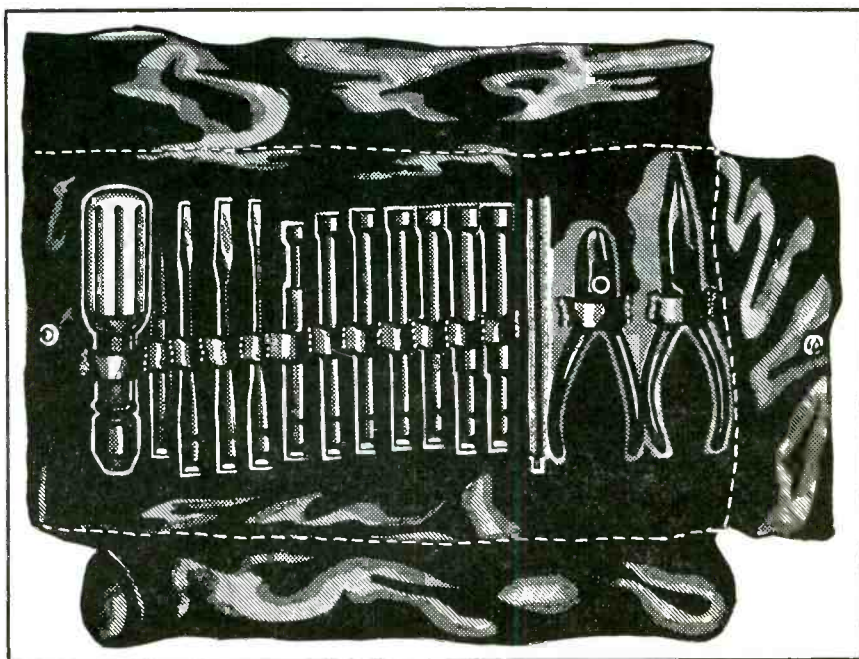

ENGINEERING



DEVELOPMENT

Since its inception, the designs of the UTC Engineering Department have set the standard for the transformer field.



Hum Balanced Coil Structure: Used by UTC in practically all high fidelity designs. . . . Hum balanced transformers are now accepted as standard practice in the transformer field.

1
9
3
3



Ultra-Compact Audio Units: A complete series of light weight audio and power components for aircraft and portable applications. Ultra-Compact Audio units are hum balanced . . . weigh approximately six ounces . . . high fidelity response.

1
9
3
5



Ouncer Audio Units: Extremely compact audio units for portable application were a problem until the development of the UTC Ouncer series. Fifteen types for practically all applications . . . range 40 to 15,000 cycles.

1
9
3
7



Plug-In Audio Units: These units are a modification of our Ouncer series, incorporating a simple octal base structure. Fifteen standard items cover all applications.

1
9
3
9



Light Weight Aircraft Filters: RRF-5 Radio Range Filters and other special filters for light weight applications embody unique size and weight saving features. A typical unit, made by another source with 32 lb. weight, weighed 1 3/4 lb., after UTC design.

1
9
4
1



Torsoidal Wound High Q Coils: UTC type HQA and HQB Coils afford a maximum in G . . . stability . . . and dependability with a minimum of hum pickup. Standardized types available for all audio requirements.

1
9
4
3



Sub-Audio and Supersonic Transformers: Embody new design and constructional principles, for special frequency ranges. 1/2 to 60 cycles for geophysical, brain wave applications . . . 8 to 50,000 cycles for laboratory service, 200 to 200,000 cycles for supersonic applications.

1
9
4
5

1
9
3
4

Linear Standard Audio Units: Flat from 30 to 20,000 cycles . . . A goal for others to shoot at.

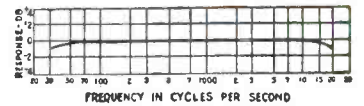

1
9
3
6

Tri-Alloy Shielding: The combination of Linear Standard frequency response and internal tri-alloy magnetic shielding is a difficult one to approach. Used by G. E., RCA, Western Electric, Westinghouse, M G M, Walt Disney, NBC, etc.

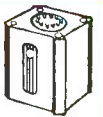

1
9
3
8

Universal Equalizers: The UTC Universal Equalizers, Attenuators, and Sound Effects Filters fill a specific need of the broadcast and recording field. Almost any type of audio equipment can be equalized to high fidelity standards.

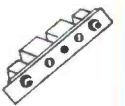

1
9
4
0

Sub-Ouncer Units: A series of 1/3 ounce miniature units with non-corrosive—long life construction for hearing aid, miniature radio, and similar applications. Five types cover practically all miniature requirements.



1
9
4
2

Hermetic Seal Pioneering: Realizing the essentiality of hermetic sealing for many applications, UTC pioneered a large number of the terminals and structures for hermetic transformers . . . now available for commercial use.

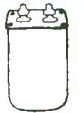

1
9
4
4

Standardized Filters: UTC type HPI, LPI, and BPI (low pass, high pass, and band pass) Filters are standardized to effect minimum cost and good delivery time. Available for frequencies throughout the entire audio range.

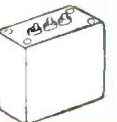

1
9
4
6

New Items: The UTC Research Laboratory is developing new items and improving standard designs in 1946. While some of these developments will be described in our advertisements, many are applied to customers' problems.



MAY WE COOPERATE WITH YOU ON YOUR PROBLEM?

United Transformer Corp.

150 VARICK STREET

NEW YORK 13, N. Y.

EXPORT DIVISION: 13 EAST 40th STREET, NEW YORK 16, N. Y.,

CABLES: "ARLAB"

New! Complete!
FREE CONCORD
Radio
Catalog



RADIO SETS
AMPLIFIERS
RADIO PARTS
Electronic Equipment

For the newest, the latest, and the best in radio sets, parts, amateur kits, test equipment, tools, books . . . mail coupon for your free copy of Concord's first post-war Catalog. Contains huge storehouse of thousands of top-quality, standard line items . . . ready for same-day shipment from CHICAGO or ATLANTA. Includes most-talked-about line of exclusive Concord Multiamp ADD-A-UNIT Amplifiers in America—new-design throughout, offering startling innovations in flexibility, fidelity, power, and economy . . . new high standards of performance almost beyond belief. Mail coupon below for full details . . . and for "everything that's new in radio and electronics."

CONCORD
RADIO CORPORATION
LAFAYETTE RADIO CORPORATION
CHICAGO 7 ★ ATLANTA 3
901 W. JACKSON BLVD. 265 PEACHTREE ST.

Concord Radio Corporation, Dept. S-66
 901 W. Jackson Blvd., Chicago 7, Ill.
 Yes, rush **FREE COPY** of the comprehensive new Concord Radio Catalog.

Name.....
 Address.....
 City..... State.....



OLD TIMER'S
CORNER

by **SERVICER**

I WAS SITTING AROUND the shop waiting for my wife to come by with the weekend groceries and the youngsters, to take them home when Ralph walked in. He looked as if he had lost his last friend, as he sat down on the edge of the service bench and pulled his pipe from his pocket.

"Know what?" he started, "business is getting worse and worse! Seems that with every passing week I get less and less of the business in this town. Yet most of my competitors, including you, are going great guns. What's the matter with me?"

"Don't take it so hard, Ralph," I countered. "Maybe it's just conditions. They have not been in top form lately."

"It's not conditions, unless you want to call the highly specialized ones only affecting me," Ralph went on, "but I just don't seem to be able to get out of the rut. I repair the sets pretty well, but not only don't I make any money when the week is over, but as a rule the customers stay away from me in droves when it comes to coming back with something else to repair."

"Well, Ralph," I said, "I'm expecting the wife and the kids any minute, so I can't go into your problem right now, but I will come over to your shop in a day or so and then talk it over. Perhaps I can put the frigid digit on the hot spot of your failure."

The wife and youngsters walked in at that moment and I had to go. But a few days later, and around ten in the evening, the return from a service call took me past Ralph's *Universal Radio Store* and, chancing to see a light, I led Oldsie (the 19xx vintage car that has served me as delivery truck and family conveyance) gently to the curb and rapped smartly on the window.

Ralph came out, sweating, and puffing that rank-smelling pipe of his.

"Swell of you to drop by," he said, grinning. "Been going over the books and I sure missed again. This week we took in a lot *less* than we spent, if you count the overhead and the salaries of the help. So if you can ferret out what's the trouble I'll be your debtor for life. And the wife will thank you, too!"

I followed Ralph back into the store. It was well-appointed and laid out. Some new products gleamed on the shelves, and the advertising matter of the various lines was tastefully arranged so as to be unobtrusive, yet effective. Ralph had installed the latest fluorescent lighting, and the place fairly exuded opulence and good business. I could see at a glance that Ralph's trouble did not lie here. He had a modern and up-to-date shop, and barring overpayment for the fixtures or the lines, he was doing okeh.

"This dress looks fine, but where's the

WE
BELIEVE

the
HOWARD W. SAMS
RADIO
PHOTOFACT
SERVICE

as described on page 23 of this issue is an absolute "MUST HAVE" for your service department.

Mail the Howard W. Sams Photofact order blank on page 23 directly to us TODAY.

CRABTREE'S
WHOLESALE RADIO

2608 ROSS AVENUE, DALLAS, TEXAS

Here's a New
POWER CUTTER KIT
 with a cutting range of
 5/8" to 2 1/2"



Only
\$7.85
 Complete

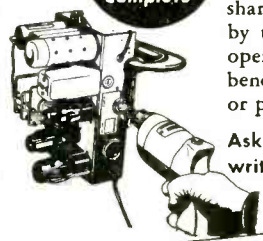

Two Bruno Adjustable Hole Cutters in one convenient kit. High speed steel blades cut clean, fast holes in metal, wood, plastics. Quickly adjustable and easily sharpened. Designed by tool engineers to operate efficiently in bench drill, drill press or portable drill.

Ask your jobber, or write Department S-6

POWER CUTTER KIT CONTAINS			
MODEL	SHANK SIZE	EXPANSION	PRICE
100	1/4" st. shank	5/8"—1 1/2"	\$3.00
101	3/8" st. shank	1"—2 1/2"	\$5.00
790 KIT	5/8"—2 1/2"		\$8.00*

*Fair Trade Minimum \$7.85

BRUNO TOOLS
 9330 Santa Monica Blvd.
 Beverly Hills, Calif.

equipment?" I asked, pointing to an empty but clean service bench.

"Don't believe in extensive equipment," Ralph said. "I have been repairing sets with these two instruments for the past fifteen years and still get out a better job than most fellows with a full test bench," he concluded.

"Show me your two famous, or should I say infamous, units," I said quizzically.

"Here they are," said Ralph, taking two small units from the bench drawer. He produced a volt-milli-ohmmeter which had seen its best days at least 10 years ago, and a cracked pair of old Brandes-make earphones which, instinctively, I knew had been his ham receivers in 1924. It seemed unbelievable that a man should have such a modern store in the front, and be so antiquated in the back! Yet here was the old truth that he who will not keep up with the tide generally drowns.

"Ralph, my old friend," I started mildly, "is *this* all you have? Sure you are not kidding the Old Timer?"

"Well, I have an output meter and a few odds and ends, like a tuning wand and some gadgets here and there. But for the main instruments these are what I use. And so does Jake, my assistant. See, it's this way. There really isn't anything that I can't fix with these instruments. Sure, the new test equipment may do it faster, but it is a whole lot more complicated, and I find that I can do just as good a job with this, even if it takes only a little while longer. So I have never 'gone for' that new stuff. Who ever heard of the old-time Service Man using anything else than his brains augmented by a pair of earphones and an ohm-sifter?"

"Want to know why you aren't making money, Ralph?" I asked. "You have just told me yourself. Have you forgotten that you overhead goes on and on and on, even when you are not in the store and when you are home? There is one expense that you can't cut down no matter how much you try. You must pay rent, light and heat. While the lights are only on when you are here, you have to keep the heat going. Then there's the electricity you use for heating the irons and running the tests. The longer that runs the higher your overhead. In addition to that you have to consider that *you* are the only person in your store, the executive. You should be spending your time making new customers, getting new sales, and talking your business up. Instead of that you are pouring over a service bench. How many times, and be strictly honest with yourself, have you had to go over and over the same chassis thinking that you had the trouble licked only to find that you still had more work to do? How many times have you worked far into the night sweating over a chassis, when you should have been at the *Odd Fellows* meeting, or at your lodge making contacts?"

"Sure it's true that you can repair most any set with the instruments that you have shown me. But what you cannot do, is to repair a set as fast as you can with the aid of the newer and better test equipment. Don't turn out to be one of those boys who says what was good enough for his Dad is good enough for me. If that were true we would never have had airplanes, cars, or even radio! Always be willing to listen to the fellow with the bright new idea. There is the barest

(Continued on page 30)

"The Conneaut"

Another Excitingly New CRYSTAL MICROPHONE

by *Astatic*



Standard in Three Models:

MODEL 600

—is equipped with interchangeable plug and socket connector for use with different stands and cable lengths.

MODEL 600-S

—is standard with the modern and convenient Type S On-Off Switch, as illustrated.

MODEL G-600

—is standard with Astatic's popular Grip-to-Talk Desk Stand for remote control of transmitters and amplifiers.

Because of its streamlined attractiveness, its desirable characteristics and its grand performance, Astatic has proudly given the name "Conneaut" to this new-model crystal microphone, in honor of Astatic's new home location in the historically important Ohio community of Conneaut. Here is a semi-directional crystal microphone with a relatively high output and wide frequency range, making it especially desirable for public address systems in night clubs, dance halls, public auditoriums and similar applications; for paging systems in offices, factories and hotels; for amateur rigs and countless other communications uses. The overall frequency response of this new microphone is exceptionally smooth up to 10,000 c.p.s. and will satisfy the most critical demands for high fidelity performance. In the finishing of this microphone, Astatic's engineers have combined, for the first time, the use of bright chrome and blond plastic, resulting in a degree of beauty heretofore unparalleled in microphone construction. The "Conneaut" is destined to go places. Its faithful performance insures its ready acceptance.

See Your Radio Parts Jobber

You will find it wise, during this transition period, to keep in touch with your parts jobber, who will be first to have new products as they become available.

*Astatic Crystal Devices manufactured
under Brush Development Co. patents*

THE
Astatic
CORPORATION
CONNEAUT, OHIO

IN CANADA: CANADIAN ASTATIC LTD., TORONTO, ONTARIO



A TOP-FLIGHT PORTABLE THAT YOU CAN HAVE RIGHT NOW!

Tops in Performance - Tops in Value

For years, radio servicemen have been "itching" to get this instrument. Here it is . . . with all the unique features of construction and design that beats anything of its type. More versatile performance than a three-ring circus! More value per dollar than a bank vault! You need it now—so come and get it now. See your jobber today for the best instrument buy of the century.

COMPARE THESE FEATURES!

- Self-contained battery operated ohmmeter, high range of 10 megohms with center to full scale ratio of 125.
- Low ohm scale reads 5 ohms at center with 0.1 ohm for each of the first ten divisions.
- Shunts and multipliers individually calibrated to a tolerance of 1%.
- Basic meter movement—400 microamps. Full scale. Sensitivity: 2500 ohms per volt.
- Compensated suppressor type copper oxide rectifier for A.C. measurements.

RANGES

D.C. VOLTS: 0/2.5/10/50/250/1000 • A.C. VOLTS: 0/10/50/250/1000 • D.C. MILLIAMPS: 0/10/50/250/1000 • OHMS: 0/500/100,000 ohms. 1/10 meg-ohms • DECIBEL: -10 to +15, -4 to +29, -18 to +43, -30 to +55 • Db. range calibrated for a line of 500 ohms impedance. For other impedances, correction charts are provided.

Model 424A portable in hardwood case with handle, removable cover, test leads and batteries. Price \$33.50.

Get more for your instrument dollar—
Insist on RCP

RADIO CITY PRODUCTS COMPANY, INC.
127 West 26th Street, New York 1, N. Y.

OLD TIMER'S CORNER

(Continued from page 29)

chance that he just might have something which would make you another dollar, or be able to do your work faster than you could with your old-fashioned ideas and equipment.

"Remember that your customers are impressed by the fact that you are as modern and up-to-date in the repair department as you are in the beautiful layout in the front of the store. Sure, they appreciate your fixing their radios, and sometimes they don't care that you did it with a hairpin and a piece of cotton. But more often than not they like the shiny test equipment and the man who uses it with that certain indefinable air of knowing what makes a radio click.

"There is nothing like putting about four prods to a set and reading the meters of a piece of modern test equipment, and then announcing with conviction: 'Mr. Jones, your second i-f stage is open. It will cost about \$7.50 to replace it, and you can have your set next Saturday.'

"That sounds well. And the customer goes out of the store shaking his head and thinking: 'That Ralph is sure one smart feller. Guess I'll have to see him about that new radio or washing machine. He'll sell me a good one.'

"There's your trouble, Ralph. Get yourself some test equipment, and I'm sure that you'll do well," I concluded.

P. S.—Ralph now has the most modern test equipment in his repair shop that this town has ever seen. And do you know what, I'm not at all sure I was so smart when I told him what I did. You see I have to get some myself if I'm to keep up with him!

SER-CUITS

(Continued from page 20)

hot. This greatly prolongs the life of the lamp, but at a sacrifice in brilliance.

Emerson 508

A pocket-type receiver powered by batteries only, Emerson 508, is shown in Fig. 2. This model has an iron-core adjusted oscillator with a screen-grid tickler feedback circuit and high-gain iron-core i-f transformers. Bias for a 3S4 power amplifier is economically obtained from an oscillator grid leak, eliminating the usual *B* resistor and filter from *B*—to ground and saving this voltage for the *B* supply proper. No r-f filter is used for this purpose, a 1-megohm grid leak permitting sufficient isolation from the oscillator r-f. The oscillator grid leak is a 100,000-ohm type.

Arvin 444, 444A

Three-tube and rectifier a-c/d-c models, Arvin 444, 444A (Noblitt Sparks) are shown in Fig. 3. These models use

(Continued on page 31)

For Soldering in
Tight Places . . .

DRAKE

No. 400 Soldering Iron

Smallest Industrial Iron
Ever Designed

60 Watts — 1/4 in. Tip
Only 9 in. long. Wt. only 8 oz.

This mighty mite is backed by DRAKE's 25 years of soldering iron manufacturing experience. The high quality and long-service of DRAKE Soldering Irons have made them outstanding favorites with all types of radio men everywhere. The DRAKE No. 400 is an outstanding value at



Only \$4.50

List

Drake Has an Iron
for Every Purpose.
Ask Your Radio
Parts Jobber

DRAKE ELECTRIC WORKS, INC.

3656 LINCOLN AVE., CHICAGO 13, ILL.

IMMEDIATE DELIVERY
SUPERIOR MODEL PB-100
VOLT-OHM MILLIAMMETER

\$28.40

RANGES:

DC Volts: 0 to 5/
25/50/250/500/
2500.

AC Volts: 0 to
10/50/100/500/
1000.

Output Meter
Ranges: 0 to
10/50/100/500/
1000 volts.

DC Current: 0 to 10/250 Ma. 0 to 2.5 Amp.
Resistance: 0 to 10,000/100,000 ohms. 0-1 Meg.
Decibels: -10 to +15; 0 to +35; +30 to +55.

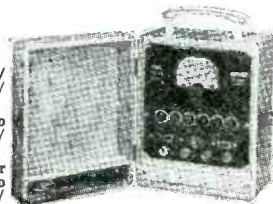

New SUPERIOR
Model CA-11
SIGNAL TRACER

Net
Price \$18.75

Only one connecting cable . . .
no tuning controls.

Highly sensitive . . . uses an
improved vacuum tube volt-
meter circuit.

Signal intensity readings are indicated directly on
meter.

Provision is made for insertion of phones.

Tube and resistor capacity network are built into the
Detector Tube.

Portable. Measures only 5 x 6 x 7". Weighs only
5 lbs.

Write for Catalog

Equipment, parts, supplies . . . hundreds of new and
wanted items for service men and dealers. Ask for
latest bulletin.

Lifetime
SOUND EQUIP. CO., Dept. 80
911-913 JEFFERSON AVE., TOLEDO 2, OHIO

SER-CUITS

(Continued from page 30)

a 12SA7 converter, 12SQ7 detector-first audio and 50L6 output.

To boost the gain, in the absence of an i-f amplifier, a 20-foot antenna hank (no loop) is fed into an iron-core transformer. In addition, there is screen regeneration in the i-f transformer primary, a high-value grid leak, plate load in the 12SQ7 first a-f and bypassed bias resistor in the power stage.

A floating chassis is grounded through a 0.33-megohm resistor and .05-mfd capacitor in parallel. In the filter are a 15-ohm surge resistor, 40-mfd capacitor to the 50L6 plate; and a 2,200-ohm resistor and 20-mfd capacitor to the screen and other tubes.

Power output is 0.8 watt undistorted, 2.5 watts maximum. Avc is used in the 12SA7 circuit.

SERVICING HELPS

(Continued from page 14)

the system, both feed lines should be brought up to the outlet in a shielded cable, with the shield grounded, and both legs ungrounded.

To maintain uniform load, and prevent shorting of the system, the type of outlet shown in Fig. 4 should be used. A single-pole, double-throw jack is used here. When the plug is inserted, the resistor is shorted out of the circuit, and the phones are connected across the line. Removing the plug puts the resistor across the circuit. The value of resistance is determined by the rated impedance of the phones. Since with the plug out, the outlet is already shorted, additional shorting will have no effect. If all the plugs are connected so that the same wire is connected to the external portion of the receptacle, shorting of the receptacle to ground will only ground one side of the feed line, which will have no effect on the system.

TWO-WAY S-H-F SYSTEM



W. C. White, right, electronics engineer of G. E. conducting a two-way conversation on the 2300-2450 mc ham band between two buildings in Schenectady. George H. Floyd, at controls, developed the transceiver used in the test.

Just a few of the thousands of Radio Parts manufactured by INSULINE

You will find the best in radio parts, stampings, chassis, cabinets, and auto-radio antennas in the new I.C.A. catalogs. Be sure to send for your copies as soon as possible.

Address Dept. D-2, Insuline Corporation of America, Insuline Building, Long Island City, N. Y.

insuline
CORPORATION OF AMERICA
INSULINE BUILDING • LONG ISLAND CITY, N. Y.
More than a quarter-century of Quality production.

**Attention
GI JOE!**

Here's Your Opportunity to be First to
**Start Your Own
RADIO SERVICE
SHOP**

Complete Starting-in-Business
Package Stocks of

**TEST EQUIPMENT
TUBES, PARTS, TOOLS**

\$350 up

Act quickly! Meet the pent up demand for radio service. Turn your special service training into a profitable business of your own. No fuss. No worry. Here's everything you need—\$350 up. Details upon request! Write, wire or phone

RCP 448

"POCKET" VOM
A.C.—D.C. Volts
0-5-50-250-1000
D.C. Mills
0-.5-10-100-1000
Ohms
0-2,000-20,000-200,000-
2 Meg.
Size 3"x5 7/8"x2 1/2"

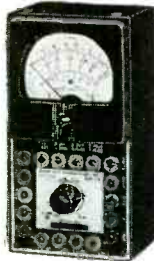

\$24.50 net

RECORD CHANGERS

UTAH-DETROLA #550C \$18.27
WEBSTER-CHICAGO #56 27.20

HALLICRAFTERS SX-28A

\$223



SUPER DEFIANT SX25 \$94.50
SKY CHAMPION S20R 60.00
SKYRIDER MARINE S22R 74.50
S40 NEW MODEL Approximately 79.50
SKYRIDER JR. S41 33.50

HAMMARLUND HQ-129-X \$129

TRIPLETT 625-N

20000 ohms per volt D.C.
10000 ohms per volt A.C.
5" Scale-TOPMOST QUALITY
(12) D.C. Volt Ranges to 5000
(6) A.C. Volt Ranges to 5000
(3) OHM Ranges 0-400-50000-
10 Meg.
(5) D.C. Current Ranges 1 Ma.
to 10 Amp.
PLUS OUTPUT and DB.
RANGES

\$45.00 with test leads.

PHILCO BEAM OF LIGHT

Selenium Cell only, no holder **1.80**

20% deposit required on all C.O.D. orders. 2% transportation allowance on orders of \$25.00 or more accompanied by payment in full.

RADIO SUPPLY & ENGINEERING CO., Inc.
126 SELDEN AVE. DETROIT 1, MICH.

Write for
FREE CATALOG

TELEVISION

(Continued from page 11)

across the split coil has been increased to 8.2 mmfd. It should be noted that at high frequencies the delineation between capacitance and inductance is not fine, so that all inductances may also be considered capacitances, and vice-versa. For positions 1 and 2 the shunt effect of the split inductance which is negligible when considered as an inductance, has been a function of the series capacitance C_1 . Therefore, increasing the value of C_1 increases the capacitance across the tuned circuit. However, the tuning capacitance of position 1, C_2 has been replaced by the coil T_2 . The net effect of all these capacitances and inductances has been to increase the frequency, by adding both inductance and capacitance of the proper value.

Fig. 6c shows the oscillator circuit for position 3 and 4, for frequencies of 80 and 92 mc. An iron-core coil has been added in parallel with the tuned circuit to increase the frequency. This circuit is identical to that of Fig. 6b, except for the capacitance C_1 , which is not used.

Providing a True Inductance

In Fig. 6d we have the oscillator circuit for position 5, where the oscillator frequency is 98 mc. The two ends of the split inductance have been joined, making it a true inductance in parallel with the basic tuned circuit. When a small inductance coil is placed in parallel with another inductance, the effect is similar to parallel resistors, in that the sum inductance will be lower than the lowest inductance value

Fig. 7. Oscillator circuit of the GE 225B. A twin triode 6F8G is used for a combination mixer and oscillator. Since the input and output frequencies of the mixer stage are different, no feedback results. The oscillator circuit is known as the center-tuned type. Frequency is changed by changing the coil size between points A and B.

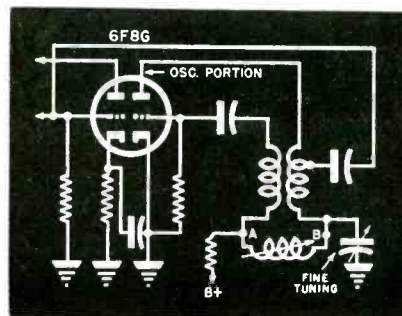

**RAD-EL-CO
HOLDS
THE
LINE**

No Price Increase
Highest Quality
5-Minute Installation
Noise Reducing
Better Reception
Free Displays
6 Different Models

**RAD-EL-CO
HAS
THE
LINE**

RAD-EL-CO MFG. CO.
CLEVELAND 3, OHIO

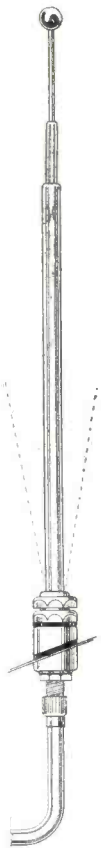

**TWO COMPLETE LINES
of Newcomb Quality
AMPLIFIERS**



Deluxe K Series

Newcomb now offers the first truly "post-war" amplifiers, of a quality heretofore not available to the public address field. Designed to fill a growing demand for the finest possible amplification equipment, their flawless operation signals an outstanding achievement of modern electronic research.

"Not Merely as Good as the Others
... But Better than All Others."



Write
for
Information

Standard # Series

THE SOUND OF QUALITY
Newcomb
AUDIO PRODUCTS CO.
MANUFACTURERS
DEPT. E. 2815 S. HILL STREET
LOS ANGELES 7, CALIFORNIA

used. Thus, in position 5, the highest frequency may be attained.

G.E. HM225B Circuit

Fig. 7 shows the oscillator and mixer circuit of the G.E. television receiver model HM225B. One section of a 6F8G is used for the oscillator, the other for the mixer portion. The oscillator shown is known as the center-tuned type, where the frequency of oscillation is changed by switching the appropriate coil between points A and B.

DuMont 180X

Fig. 8 shows the oscillator circuit used in the DuMont model 180X. Here, a Hartley is used, with the plate at r-f ground potential. The circuit is similar to that of Fig. 2a, with some modifications. Frequency changing is accomplished by switching in LC combinations, between points A and B, in the grid circuit of the oscillator tube. In Figs. 5, 6, and 7, the oscillator frequency was determined by tuning the plate circuit, whereas in Fig. 8, the grid circuit is tuned. There is some disagreement as to which type is more stable, but the trend seems to be toward plate-tuned circuits.

In the oscillator circuit the controlling factor in its design is not that it is being used in a television receiver, but that the frequency of operation is high. Component values are much smaller than at broadcast frequencies, and capacitances of one micromicrofarad and inductances of one microhenry represent a considerable portion of the tuned circuit. For this reason, wiring, sockets, layout, tubes, etc., exert a great influence in the design. For example, if the capacitance or inductance displayed by component parts represent an appreciable portion of the tuned-circuit inductance and capacitance, instability results. In repairing

(Continued on page 34)

Fig. 8. Oscillator circuit of the DuMont 180X. This is a modification of the Hartley oscillator. The frequency of oscillation is changed by switching the LC combination, in shunt with the inductance, in the control-grid circuit.

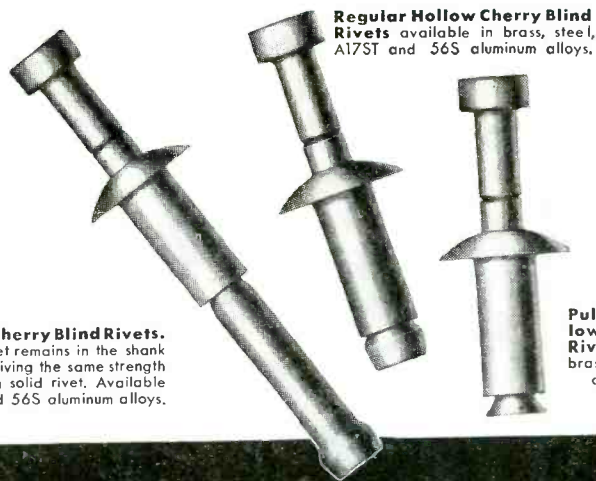
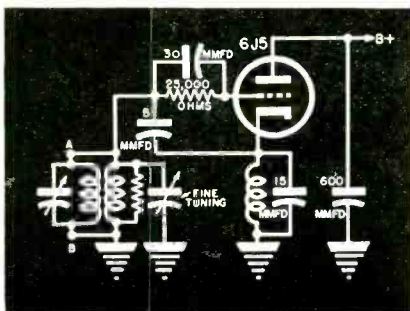

Regular Hollow Cherry Blind Rivets available in brass, steel, A17ST and 56S aluminum alloys.

Self-plugging Cherry Blind Rivets. The stem of this rivet remains in the shank after installation, giving the same strength characteristics as a solid rivet. Available in brass, A17ST and 56S aluminum alloys.

Pull-through Hollow Cherry Blind Rivets available in brass, steel and A17ST aluminum alloy.

Cherry Blind Rivets

ARE NOW AVAILABLE IN

BRASS • STEEL • ALUMINUM

Cherry Blind Rivets in brass and steel have been added as standard items to our original line of aluminum rivets.



G-40 Pneumatic Gun

This expansion of the Cherry Rivet line has been made in answer to demands from many industries requiring a blind rivet in either brass or steel, having the same installation advantages of aluminum alloy Cherry Blind Rivets.

The same Cherry Rivet Guns will install brass, steel or aluminum rivets. Pneumatic and hand-operated guns in several types to meet your particular requirements are small, light, easy to handle.

These new rivets have the same design as the aluminum rivets and are applied with the same pneumatic or manually-operated guns. They are installed by one operator working from one side of the job. They have generous tolerance in hole size and material thickness, unusually broad shank expansion and high clinching action—the same characteristics which have made the aluminum Cherry Blind Rivets so successful.



G-35 Manual Gun

The three standard types of Cherry Rivets shown above are made in several head styles and grip lengths. Standard diameters are 1/8", 5/32", 3/16", 7/32", 1/4" and 9/32". Special head styles and grip lengths are made to order.



For more details, get your copy of Manual D-45, free on request from your jobber or from the Cherry Rivet Co., Dept. A-268, 231 Winston Street, Los Angeles 13, Calif.

CHERRY RIVETS. THEIR MANUFACTURE & APPLICATION ARE COVERED BY U. S. PATENTS ISSUED & PENDING

Cherry Rivet

Company

LOS ANGELES 13, CALIFORNIA



OHM CHEST

packed with
100 Insulated Resistors

A tremendous value! This handsome Chest has twenty compartments—10 in the base and 10 in a removable tray. Walnut finish; brass hinges and fastener. Contains 100 resistors stamped with resistance values, 5 ohms to 20 megohms, 1/2 watt to 2 watts, color coded. Every size is popular. No war surplus resistors in this Ohm Chest!

only
\$4.95
complete
POSTPAID

ORDER NOW for immediate delivery.

Free!

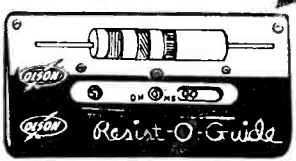

With each Ohm-Chest ordered, we send our "Resist-O-Guide" free. Revolving wheels in color show all resistance values.

CLIP AND
Mail
today!

This offer good only in U. S. A.

Write for our monthly BARGAIN CATALOGS —they're free!

OLSON RADIO WAREHOUSE
73 E. Mill St., Dept. 37, Akron, Ohio

Send me _____ Ohm-Chests with 100 Insulated Resistors in each, @ \$4.95. "Resist-O-Guide" free with each Chest. I enclose \$_____ Send C. O. D.

NAME.....
ADDRESS.....

TELEVISION

(Continued from page 33)

high-frequency receivers, wiring layout should never be changed, nor should substitute type tubes be used in the r-f and i-f portions.

Switching Contact Problems

R-f switching contacts also represent a service problem. Since lead length is important, any variations in contact may cause wide frequency changes. In addition, the change in resistance due to poor circuit contact, with a consequent change in circuit Q , will cause both a frequency departure and loss in circuit gain. Therefore, switches should always be checked for clean and positive contact.

Oscillator Frequency

The frequency of the oscillator is dependent to some extent on the applied voltage. If the voltage is unstable, the frequency will vary, this condition being particularly noticeable on the higher ranges. It is therefore important to check the B voltage to see that voltage regulation is good. Particular attention should be paid to the rectifier tube and the filter capacitors.

I-F Stage Checks

When checking r-f stages for voltage gain with vacuum-tube voltmeters, it should be remembered that the shunt capacitance of the v-t-v-m is usually on the order of 10 mmfd. This, then, represents an appreciable portion of the tuning capacitance, and wide frequency changes will result. A v-t-v-m should only be used for a rough check when measuring stage gains. Incidentally, stage gain in the r-f portion of television receivers is often unity, and r-f transformer gains often less than unity. For example, in the G.E. model 225B, the gain in the r-f transformer is 2, while the gain in the converter is 1/2, resulting in a total stage gain of unity. The gain of television receiver r-f stages will be found to vary from unity to five. The amplitude of the oscillator r-f voltage influences this gain, and the oscillator tube should be carefully selected. There is a wide variation in the ability of oscillator tubes of the same kind to oscillate. A tube checker will not indicate this. Thus the only check is to try them in the receiver. In general, television receiver oscillator troubles are the same as in broadcast receivers, with the added problems of high-frequency of operation.

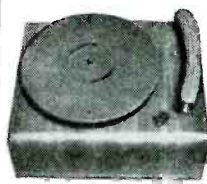

IMMEDIATE DELIVERY

RECORD PLAYER KIT suitable for easy attachment to any radio. Consists of beautiful ready-cut walnut cabinet, new self-starting heavy duty Alliance or G.I. type phono motor with turntable. Astatic crystal pickup arm and volume control. Assembling time 5 or 10 minutes. Complete with instructions for assembling. Your net.....\$11.95 each

NEW POST WAR 5-TUBE SUPERHETERODYNE RADIO KIT featuring built-in loop antenna, automatic volume control and using 12SA7, 12SK7, 12SQ7, 50L6 and 35Z5 tubes. All parts brand new and perfectly matched. Complete, including beautiful brown plastic cabinet and full instructions for assembling, less solder, hook-up wire and tubes. Approximate size, 9x6x5. Your net\$13.75 each
Lots of 3\$12.95 each
Kit of 5 matched tubes (12SA7, 12SK7, 12SQ7, 50L6, 35Z5)\$4.95 each

3-TUBE AC/DC PHONO AMPLIFIER completely assembled, using 12SQ7, 50L6 and 35Z5 tubes. Approximate size, 5 1/4 x 3 1/4 x 1 1/4. Your net (less tubes)\$4.75 each

3-TUBE PHONO OSCILLATOR KIT using 6SQ7, 6SA7, 6H6 tubes, with separate microphone and phono inputs each independently controlled. A real broadcast station in miniature. All necessary parts including instructions for assembling. Your net including tubes.....\$7.55 each

25Y5 RADIO TUBES — direct replacement for 25Z5 — fully guaranteed. List price \$2.35. Your net\$1.46 each

TERMS: At least 25% with order, balance C.O.D. Our complete bargain parts catalog is free for the asking!

WRITE! WIRE! PHONE! Tivoli 2-6015
NATIONAL RADIO DISTRIBUTORS
1029s East 163rd Street
New York 59, N. Y.

ECHOLESS ROOM

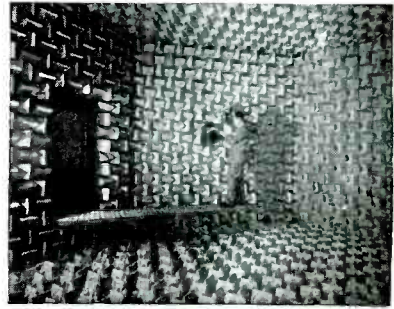

Room without echoes, designed and built by Permoflux engineers. Outer room is built of concrete; floor, walls and ceiling. Inner room is built of Celotex and is set on damping pads, the walls being spaced from the outer concrete room by 4" of air all around. This inner Celotex room is lined with 4" of rock wool and then 10" of fibre glass in the form of thousands of closely fitted wedges, each covered with muslin. Room is somewhat similar to those in the Electro-Acoustic Laboratory at Harvard University.

CHICAGO SURFACE LINES 2-WAY

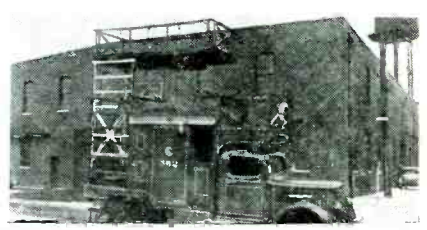

Two-way f-m equipped underground cable repair truck of the Chicago Surface lines. System also uses 15 two-way radio-equipped utility department emergency trucks, 18 supervisor 2-way cars and 8 superintendent receiver-equipped cars. (Courtesy Motorola)

NEW MODELS



Above Hallicrafters S-38 six-tube four-range superheterodyne. Provides continuous coverage from 540 kc to 30 mc. Features an automatic noise limiter and c-w beat oscillator. Below, Hallicrafters personal plane transmitter-receiver, Skytone CA-2. Weighs less than eight pounds. Covers frequencies of radio ranges, control towers and beacons for navigational purposes, and includes a broadcast band.

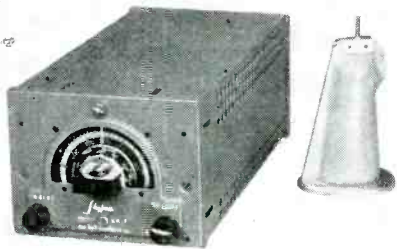

Fibre-based Motorela automatic wireless record player, WR8 (13' x 8½' x 14'). Handles ten 10" or eight 12" records. Has tangent tone arm, crystal pickup, automatic reject button, manual play position, rim-drive turntable and spring-operated locating pin for playing home recordings.

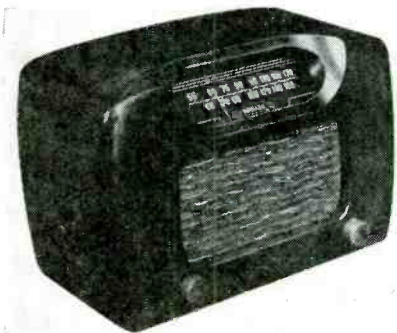

Premier Laboratories 5-tube a-c/d-c super. Has an Alnico 5' p-m speaker.

DETECTS SMALL LEAKS



Condensers with even the slightest leakage will not get by this compact, modern tester. You get positive indication on the electron ray tube and the correct reading on the easy-to-read expanded scale.

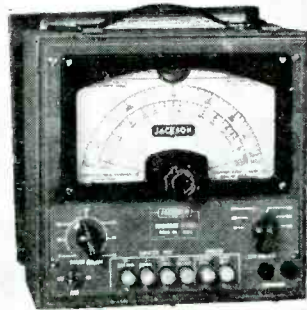

CONDENSER TESTER MODEL 650-A

Range—.00001 to 1,000 mfd.

Automatic Push Button Controlled— Amazing in speed and simplicity of use. Capacity readings almost instantaneous! Leakage test by just pressing a button.

The Model 650 is a modern accurate and complete instrument for detecting faulty condensers—Electrolytic, Paper or Mica. New method for Leakage

Test reveals otherwise unnoticed condenser defects.

Scale is Glass Enclosed and is equipped with the new Jackson Scale Expander indicating pointer—doubles effective scale length.

Measures All Values—Direct reading in Microfarads.

Ranges

.00001 to .001 mfd.	.1 to 100 mfd.
.001 to .1 mfd.	50 to 1000 mfd.

Measures Power Factor on direct reading dial. Power Factor range calibrated from 0 to 60%.

Complete Selection of Test Voltage. 20 volts to 500 volts.

Electron Ray Tube indicates exact balance or shows if leakage is present.

Instantaneous Leakage Indication— Counting of flashes eliminated. No other guess-work with this modern tester. Has special built-in amplifier stage which actually responds to slightest leakage, if present. Thus all leakage defects may be located.

JACKSON

Fine Electrical Testing Instruments

JACKSON ELECTRICAL INSTRUMENT COMPANY, DAYTON, OHIO

SERVICE, JUNE, 1946 • 35

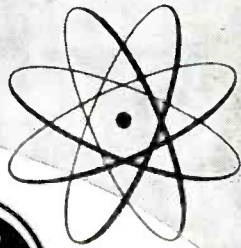

OSCILLOSCOPE CRO-3A

EVERY service man needs this portable oscilloscope for accurate and rapid service work on AM, FM and Television receivers. We list only a few of the many uses that make it indispensable in the modern service shop: study wave shapes and transients; measure modulation adjustment of transmitters; check receiver alignment; determine peak voltages; trace electronic tube characteristics. The CRO-3A gives a sharp, clear picture and is equipped with a screen for easy daylight viewing. Write today: *Specialty Division, Electronics Department, General Electric, Syracuse, New York.*

Electronic Measuring Instruments

GENERAL ELECTRIC

177-D4

PHILADELPHIA CABS TRY 2-WAY UNITS



Two-way f-m 152-162 mc system being tested by the Yellow Cab Company in Philadelphia.

Tests conducted will be studied to determine how widely two-way radio may be utilized in the cab company's 1,172 taxicabs and 15 cabulances.

Mobile equipment in use consists of a small control box and a telephone hand set, installed on the dashboard of the cab; a 40-watt f-m transmitter, a dynamotor transmitter power supply unit, and an f-m receiver, in the cab's baggage trunk; and an 18" antenna mounted on the cab roof.

Station equipment includes a 45-watt f-m transmitter, f-m receiver, console loudspeaker and control box, and either a small microphone or a telephone hand set at the dispatcher's desk. The station antenna, mounted on a mast on the roof of the 10-story Aldine Trust Building, is of the ground plane or *Whirling Joe* type, with four 18" lateral segments.

In operation, when the dispatcher dials the number assigned to a given cab, a bell rings in that cab only and the driver picks up the hand set. If the driver wishes to call the dispatcher, he lifts its hand set and presses a button.

(Courtesy RCA)

AIRCRAFT STATIC ELIMINATOR



Ten-inch whip static eliminator adopted by United Air Lines for its fleet of twin-engined and four-engined planes. The whips, attached at strategic points on the trailing edges of the wing and tail, discharge static before it has a chance to build up interference in the plane's radio.

METAL LENS ANTENNA

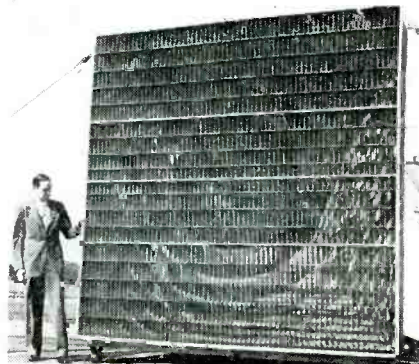

Dr. Winston E. Kock of Bell Telephone Labs with his metal lens (see IRE report, February, 1946, *COMMUNICATIONS* for complete data) used in microwave relay systems.



STOECKER NOW HEAD OF RCA REPLACEMENT PARTS SECTION

Marshall R. Stoecker has been appointed manager of the replacement parts section of the RCA Victor division.

Mr. Stoecker will be responsible for the development and merchandise planning of all replacement parts.

Mr. Stoecker was formerly manager of the radio department of the Chevrolet division of General Motors.



* * *

UNIVERSAL MICROPHONE CATALOG

An 8-page catalog has been published by the Universal Microphone Co., Inglewood, Calif.

A description of microphones, stands and accessories appears.

* * *

HARMAN BECOMES BOGEN SALES MANAGER

Sidney Harman has been appointed sales manager of the David Bogen Company, Inc., 663 Broadway, New York City.

Mr. Harman, recently returned from the Signal Corps where he served as Lieutenant, succeeds Haskel A. Blair, who will devote his full time to Blair-Steinberg Company, sales representatives.



* * *

HABER NAMED RCA TUBE AD MANAGER

Julius Haber has been appointed as advertising and sales promotion manager of the RCA Victor division tube department. He will be located at Harrison, N. J., headquarters for RCA's tube activities.



* * *

JFD DIAL BELT MANUAL

A 64-page belt manual with dial-belt replacement data for over 1,500 models, has been published by the JFD Manufactur-

ing Company, 4111 Fort Hamilton Parkway, Brooklyn, New York.

A special section on drive cables and cords has also been included and is supplemented with data on rubber drives and dial springs.

* * *

DON G. MITCHELL ELECTED PRESIDENT OF SYLVANIA

Don G. Mitchell, former executive vice president of Sylvania Electric Products, Inc., has been elected president. Walter E. Poor, who has been president since 1943, has become chairman of the board of directors.



W. E. Poor * * * Don Mitchell

WALSCO CATALOG

A 16-page catalog, No. 64, has been released by Walter L. Schott Company, Department 113, Beverly Hills, California. Catalog contains a description of hardware items, adhesives, solvents, polishes and other chemicals.

* * *

S. L. OLSON NOW PURCHASING AGENT FOR OLSON RADIO

Sidney L. Olson has been appointed chief purchasing agent of Olson Radio Warehouse, 73 E. Mill Street, Akron 8, Ohio. Mr. Olson is a partner in the company.



* * *

NEWS OF THE REPRESENTATIVES

Fred Ellinger, of Chicago, was elected national president at the recent convention in Chicago. Leslie DeVoe, of Indianapolis, was elected vice president and William McFadden, secretary-treasurer. Dave Sonkin has retired after ten years as secretary-treasurer.

Three new members have been added to the New England chapter: William A. Holliday, 176 Federal St.; William S. Gibson, 1018 Commonwealth Ave.; and Harold A. Chamberlain, 31 Milk St., all in Boston, Mass.

Henry P. Segel was recently elected secretary of the chapter.

Five associate members were recently added to the Mid-Lantic chapter: George C. Scarborough; Malcolm A. Peckham, 130 S. Fairview Ave., Upper Darby, Pa.; John F. Orsi, 1123 Real Estate Trust Bldg., Philadelphia, Pa.; and Howard J. Fairbanks, 401 N. Broad St., Philadelphia 8, Pa. Mr. Fairbanks transferred his

(Continued on page 38)

Burlington

'DONUT' TRANSFORMERS



These transformers are designed for use with vane type ammeters which are used on frequencies from 25 to 133 cycles.

Maximum accuracy is obtained at 70% of full scale value and is dependent upon the number of primary turns used. Accuracy is directly proportional to the number of primary turns.

These transformers are designed for a capacity of two volt-amperes and the secondary windings are of such size as to allow in excess of 800 CM/ampere at maximum rating.

Insulation resistance is such that 4500 volts can be applied without breakdown.

Burlington Bulletin DT gives full information. Write for a copy today.

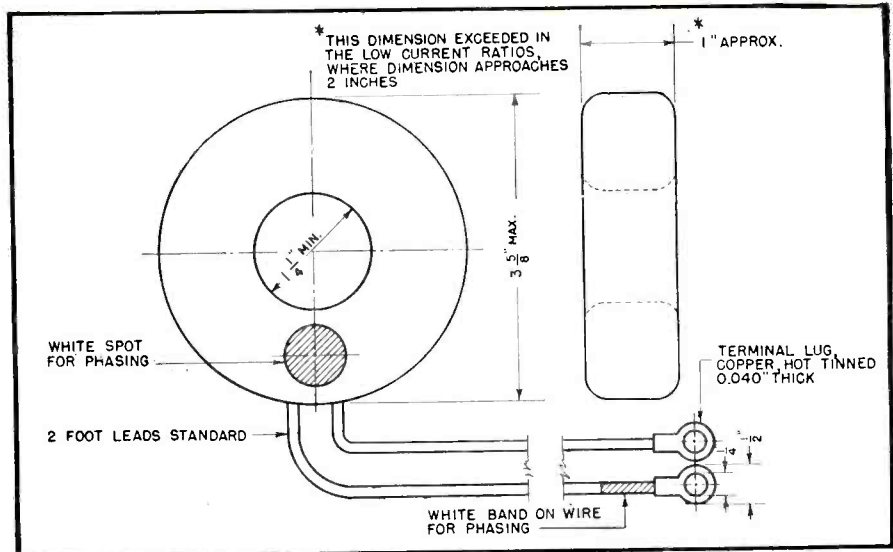

BURLINGTON INSTRUMENT CO.
 405 FOURTH STREET BURLINGTON, IOWA

RAYTHEON
MANUFACTURING COMPANY

Excellence in Electronics
RADIO RECEIVING TUBE DIVISION
NEWTON, MASSACHUSETTS CHICAGO

"...and put Raytheon tubes in my set please." That's the customer specifying "Raytheon"—a name he knows to be synonymous with quality and dependability. Stock Raytheon tubes to keep your customers happy; to keep your business growing.

Superior
RADIO DIAL BELTS

ITS ROUGHNESS ASSURES SMOOTH PERFORMANCE

Made of buna S rubber (#3 thin single) with smooth rubber cover on outside and rough finish on inside. Standard equipment with set manufacturers—resistant to atmospheric changes—more pliable and rougher—insuring positive grip on shafts and pulleys. Its popularity has made it the largest selling Radio Dial Belt in the U.S.A.



FREE Just pay for the belts and get this metal container

B25A	Service-men's Assrt.	25 Belts
B50A	"	50 "
B100A	"	100 "

Use the Belts the Manufacturers use in their original equipment.

Ask your jobber for this handy, durable ALL METAL service-man's sliding drawer cabinet.

J · F · D · MANUFACTURING CO.
4111 FT. HAMILTON PARKWAY • BROOKLYN 19, N. Y.

NEWS

(Continued from page 37)

membership from the New York chapter. The Chicagoland chapter recently added five regular members and six associate members to its roster. New members are: Claude Booth, 2911 N. Central Ave.; Bruce Cumming, 201 N. Wells St.; L. C. McCarthy, 9 So. Clinton St.; Edward Singer, 1722 W. Arcade Place; and Oren H. Smith, 225 W. Huron St., all in Chicago, Ill. The associate members are: William E. Burgoyne, 9 So. Clinton St.; E. F. Classen, 612 N. Michigan Ave.; Frank Gassner, 201 N. Wells St.; Harper D. Roth, 21 E. Van Buren St.; Arthur H. Peterson, 600 So. Michigan Ave.; and Frank O. Glaubitz, of the same address, all in Chicago, Ill.

George D. Norris, secretary of the Northwest chapter, recently moved his office to 2407 First Ave., Seattle 1, Wash.

* * *

SPRAGUE CATALOG

A 40-page catalog with data on Koolohm resistors, Sprague capacitors, test equipment and radio interference filters, has been published by Sprague Products Company, North Adams, Mass.

Among the units cataloged are: Sprague LM universal vertical chassis mounting replacement capacitors; Filterol, for reducing man-made radio noises; mica capacitors ranging from the tiny *toothpick* types to giant potted-case units; transmitting capacitor developments, etc.

* * *

CONCORD RADIO TO OPEN CHICAGO LOOP STORE

Plans are now being made by Concord Radio Corporation to move to 227 West Madison St., Chicago, within the next 60 to 90 days, when alterations are completed.

Concord's general offices, assembly warehouse and shipping departments will be retained in the present quarters at 901 W. Jackson Blvd., Chicago.

* * *

IRC RESISTANCE-RANGE GUIDE

A pocket-size RMA resistance-range guide, Resist-O-Guide, has been announced by the International Resistance Company, 401 North Broad St., Philadelphia 8, Pa. By turning three wheels to correspond with the color code on composition type resistors, standard RMA ranges are indicated. Wheels can also be operated to indicate the correct color coding. The guide, available at IRC distributors, are priced at 10 cents.

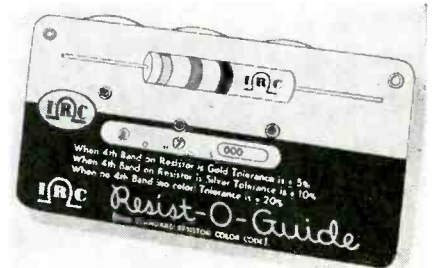

* * *

PANADAPTOR HANDBOOK

A 36-page handbook describing the design and application of the Panadaptor.

has been released by the Panoramic Radio Corporation, 242 West 55th Street, New York 19, N. Y.

Featured in the handbook are circuit details, typical c-r tube patterns and installation notes.

The handbook is available at 50 cents a copy.

MOTOROLA PROMOTIONS

Tim Alexander has been named manager of the service and parts department of Motorola.

Mr. Alexander joined Motorola in 1937 as home set service manager and in 1940 became assistant to Walter Stellner, vice president of the Motorola home products division.

Lt. J. M. Tuttle, recently of the U. S. Navy, has been appointed Motorola regional sales manager for the west coast and inter-mountain territory.

John Paul Jones has returned to his post as Motorola district representative for the southern California territory.



Tim Alexander

ROBERT H. BISHOP NAMED SYLVANIA SALES DIRECTOR

Robert H. Bishop has been named director of sales for all divisions and subsidiaries of Sylvania Electric Products Inc.

Mr. Bishop will be responsible for the coordination of selling policy in all divisions of the company as well as its subsidiaries, Colonial Radio Corporation and Wabash Corporation



DURSTS CATCH A MARLIN

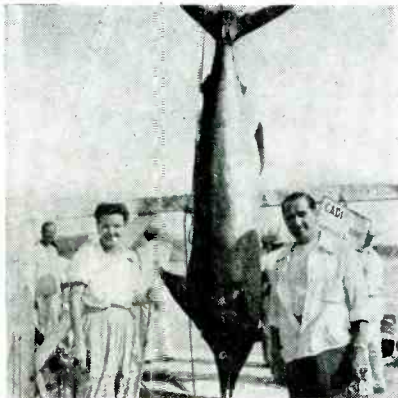

Mrs. Grace Durst and Raymond W. Durst, executive vice-president of the Hallicrafters Company, with the 9'4" 268-pound blue marlin Mrs. Durst landed off Acapulco, Mexico.



MR. RADIOMAN:

Here's How Capitol Radio Can Prepare You Now for a Better Job and a Secure Career in Radio-Electronics . . . !

Add CREI Technical Training to Your Present Experience—Then Get that Better Radio Job You Want—More Money and Security!



CREI home study training in Practical Radio-Electronics Engineering equips you with the ability to go after—and get—a better job in radio-engineering that offers security, advancement and importance.

We are now entering a period where employers can once again afford to be "choosy" in selecting the best-qualified men for the important jobs to be filled.

In our proved course of home study training, you learn not only how . . . but why! Your ability to solve tough problems on paper, and then follow with the necessary mechanical operation, is a true indication that you have the confidence born of knowledge . . . confidence in your ability to get and to hold the type of radio job you want.

CREI courses have been studied by more than 10,000 professional radionien—so don't say YOU haven't the time. CREI courses are designed to be studied in the most crowded schedules—without interfering with your present work, yet helping you as you progress lesson by lesson.

Now you can read what these typical CREI students have to say. They are men who had the initiative to get started on their own betterment program toward better jobs and more money. You have the same opportunity. It costs you nothing but a moment's time to send for complete details in free book.

"I give CREI full credit for my securing the position as Asst. Chief Engineer. . . ." —W. H. Meiners, 420507

"In the past 7 months I have received 3 increases in salary and a promotion that can be partly credited to CREI. . . ." —C. B. McKnight, 401101

"There are many times where what I am studying in the course works right in with the immediate problems of my job. . . ." —C. I. Carpenter, 411024

CREI Training for Veterans is Approved Under the "G.I." Bill.

JUST OFF THE PRESS!



WRITE FOR FREE 36-PAGE BOOKLET

"Your Opportunity in the New World of Electronics"

If you have had professional or amateur radio experience and want to make more money, let us prove to you we have something you need to qualify for a better radio job. To help us intelligently answer your inquiry—PLEASE STATE BRIEFLY YOUR BACKGROUND OF EXPERIENCE, EDUCATION AND PRESENT POSITION.

CAPITOL RADIO ENGINEERING INSTITUTE

E. H. RIETZKE, President

Dept. S-6, 16th and Park Road, N. W., Washington 10, D. C.

New York (7): 170 Broadway

San Diego (1): 316 C Street

Member: NATIONAL HOME STUDY COUNCIL • NATIONAL COUNCIL OF TECHNICAL SCHOOLS

Chicago (2): 30 N. LaSalle Street

San Francisco (2): 760 Market Street

Member: NATIONAL HOME STUDY COUNCIL • NATIONAL COUNCIL OF TECHNICAL SCHOOLS

RADIONIC EQUIPMENT COMPANY

APPROVED ELECTRONICS
SIGNAL GENERATOR

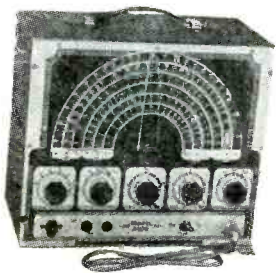

A 100
\$47.00

100 Kcs to 52 Mcs
In 8 Bands. Internal
or external modu-
lation continuously
variable from 0-
100%. Phase shift
audio oscillator.
Cathode follower-
output.

A COMPLETE
SIGNAL
GENERATOR



VOMAX
\$59.85

57 RANGES

One instrument to
satisfy every measure-
ment need. Stable.
Accurate. Dependable.

MEISSNER "ANALYST"

For the speediest and surest method of
locating trouble. Beautifully designed,
sturdily constructed and accurately cali-
brated. 12 tubes. A superb instrument.

\$110.70

SUPREME 546—Oscilloscope	\$87.70
SUPREME 562—Audolyzer	126.17
(Above subject to OPA approval)	
WESTON 697 V.O.-M	35.36
WESTON 779 Analyzer	101.94

Standard make universal output trans. 6 watts	\$1.20
Stancor P6010—5 tube pwr. trans. 40 mil.	2.65
Stancor P6011—7 tube pwr. trans. 70 mil.	3.38
Stancor P6012—9 tube pwr. trans. 90 mil.	3.82
Astatic L72A curved arm pick-up	2.50
Meissner Coil Kit, 456 Kcs.	1.99
(Shielded input and output trans. Unshielded osc.)	

Ant coil, 530 to 1640 Ke with 385 mmf cond.	.50
12" PM 20 oz. speaker	6.25
Meissner Choke Coil Kit (10 assorted chokes)	.49
Cat Whiskers, kit of 3	.05
EL Vibrators, 1703—2041—2088	2.09
2089—Auto and Farm Sets	3.50
EL Vibrator Pwr. Supply, 300V @ 100 ma., 6V Input	14.97
Rub-R-Lite Flashlights, less batts.	1.85
Rub-R-Lite Flashlights, less batts. In lots of 12.	1.35

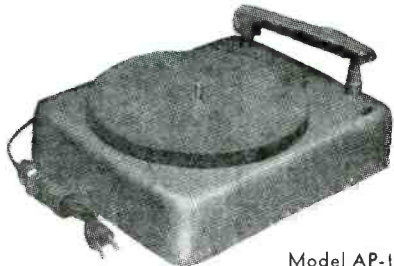

Model AP-1

CHANCELLOR RECORD PLAYER

11.7 AC motor—Shure crystal pickup—hammered brown
lacquer baked finish—one-piece aluminum case—plastic
turntable, felt covered—30" amplifier leads, pin plugs—
entirely hum-free—Standard RMA guarantee.

\$17.95 list in lots of three \$11.58

MASCO SOUND SYSTEMS

25 watt Amplifier with Tubes	\$42.51
25 watt Complete Portable System	87.85
35 watt Amplifier with Tubes	52.04
35 watt Complete Portable System	97.37
50 watt Amplifier with Tubes	68.24
50 watt Complete Portable System	143.09
35 watt Amplifier with Record Changer Top, with Tubes	90.02

TERMS—Payment with order or 25% deposit,
balance C.O.D.—F.O.B. our Warehouse.

Write Dept. 7S for FREE CATALOG
of Radio Parts, Sound Equipment
and Accessories

RADIONIC EQUIPMENT CO.

"Chancellor Radio"

170 Nassau St., New York 7, N. Y.

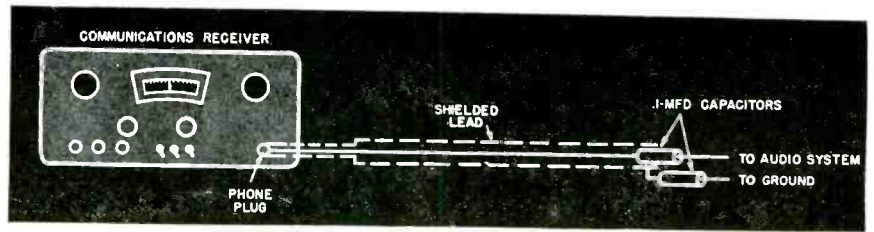

COMMUNICATIONS
RECEIVERS

(Continued from page 9)

is brought into play. Most communica-
tions receivers designed with a broad-
cast band will tune this high. To check
the multiple signal the signal genera-
tor is tuned to zero beat against
WWV at its fundamental frequency,
say 20 mc. The second harmonic of
the signal generator is then picked up
at 40 mc, by means of the b-f-o, and a
zero beat is obtained between these
two signals. The generator is then re-
set to the 40-mc frequency, and the
two signals adjusted for zero beat
again. In this manner, any multiple of
the WWV signal may be checked on
the signal generator.

Broadcast stations maintain their
assigned frequency within a few
cycles. These signals may also be used
to check signal generators at the lower
frequencies. Both harmonics and sub-
harmonics of the broadcast signal may
thus be checked. To gain some idea of
how many points may be checked, a
chart of the stations in the New York
area has been prepared; Fig. 1. This
chart presents the harmonics and sub-
harmonics that may be checked. From
this list it may be seen that almost any

Fig. 4. Shorting plug system used in the Halli-
crafters S-40. A unit consisting of a plug, choke,
and two filter capacitors, wired as shown in a,
permits the use of this receiver's power supply
system for external applications.

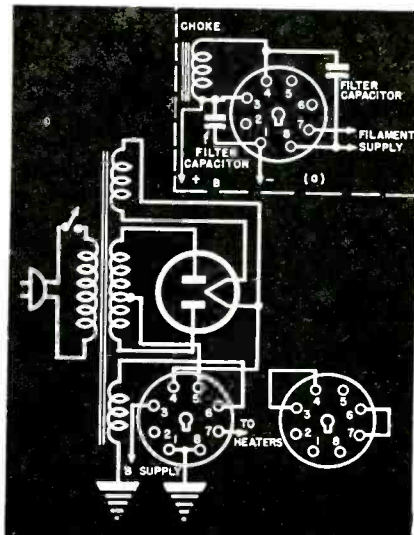

Fig. 3. By attaching a shielded probe to the
headphone jack on the communications receiver,
the prod may be used for checking audio systems.

frequency may be checked accurately.
Sub-harmonics of broadcast-station
harmonics may also be checked by
using the b-f-o method. Let us suppose
that it is desired to check 700 kc on
the signal generator. First, the loca-
tion of WHN's second harmonic, 2100,
is located on the dial by the b-f-o
method. The third harmonic of the
signal generator is then beaten against
the b-f-o for zero beat, at this point.

When WWV is using the 440-cps
signal modulation, this signal may be
used to check audio signal generators
by using an oscillograph with the com-
munications receiver. In this test, the
signal generator is fed into the hori-
zontal amplifier of the oscillograph,
and the audio signal from the receiver
is fed into the vertical amplifier. The

18 YEARS IN RADIO

Get This New Catalog
By This Old Firm

Latest developments in
radio and electronic parts
and devices, newest ham
gear, gadgets to delight
the heart of the
experimenter,
bargains in war
surplus supplies.



- Buy from B-A
- Save Time
- Save Money
- Get the Newest
- Deal with This Old House



It's
FREE
To You

MAIL COUPON TODAY

Don't delay, get your copy of this book.

BURSTEIN-APPLEBEE CO.,
1012 McGee, Kansas City 6, Mo.

Send me FREE new catalog. SERVICE

I AM _____
STATE CONNECTION IN INDUSTRY
NAME _____
ADDRESS _____
TOWN _____ STATE _____



Lissajou patterns at harmonics and sub-harmonics of the 440-cps signal may then be used for point-frequency spotting. The signal from the receiver may conveniently be obtained from the headphone jack which is usually a part of all communication receivers. In Fig. 2 appears an arrangement of the equipment and some resultant Lissajou figures.

The avc on-off switch permits the use of the receiver in output measurements of a signal generator. In this test, it is necessary to make a study of stage gain data. With the avc supply to the r-f and i-f section removed, the developed avc voltage of the detector will follow almost a straight-line function for input. For example, if it has been previously determined that the gain of the receiver at 1000 kc is 100,000, from antenna to detector, an input of 10 microvolts should develop approximately 1 volt at the detector. This is a d-c voltage, and may be checked with a v-t-v-m. Actually, the voltage will be slightly higher. At any rate, a signal of 20 microvolts should produce an avc voltage of 2 volts, and other inputs proportionate voltages. Higher values of input may be checked by feeding the signal in at other points in the receiver, such as the converter

(Continued on page 42)

IT'S NEW . . .

Send for your copy of catalog D2

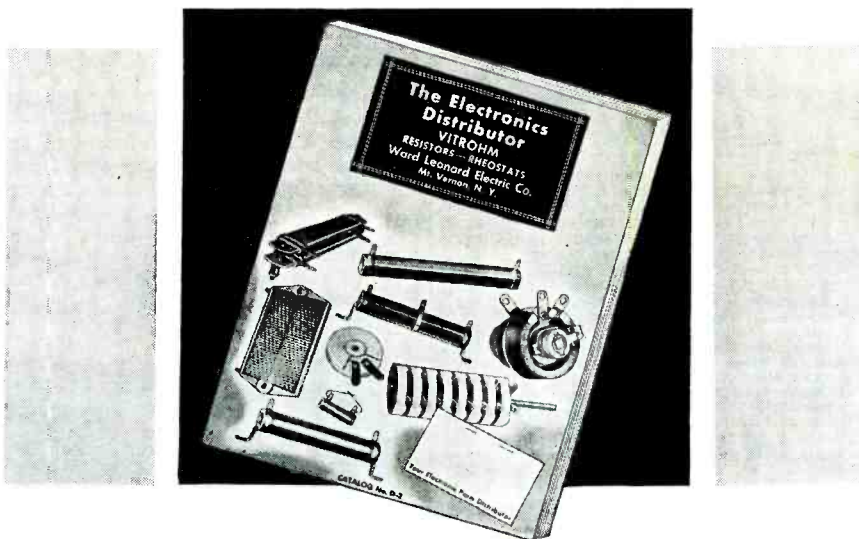

WARD LEONARD

RELAYS • RESISTORS • RHEOSTATS

Electric Control Devices Since 1892

WARD LEONARD ELECTRIC COMPANY

Radio and Electronic Distributor Division

53 E WEST JACKSON BLVD., CHICAGO, ILL.

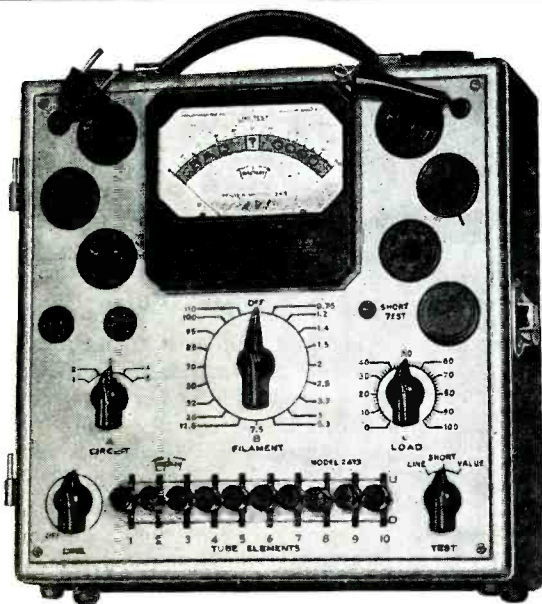

The New Speed-Chek Tube Tester

MORE FLEXIBLE • FAR FASTER • MORE ACCURATE

Three-position lever switching makes this sensational new model one of the most flexible and speediest of all tube testers. Its multi-purpose test circuit provides for standardized VALUE test; SHORT AND OPEN element test and TRANSCONDUCTANCE comparison test. Large 4" square RED • DOT life-time guaranteed meter.

Simplicity of operation provides for the fastest settings ever developed for practical tube testing. Gives individual control of each tube element.

New SQUARE LINE series metal case 10" x 10" x 5½", striking two-tone hammered baked-on enamel finish. Detachable cover. Tube chart 8" x 9" with the simple settings marked in large easy to read type. Attractively priced. Write for details.

Model 2413

is another member of
the **NEW TRIPLETT**
Square Line

Additional Features

- Authoritative tests for tube value; shorts, open elements, and transconductance (mutual conductance) comparison for matching tubes.
- Flexible lever-switching gives individual control for each tube element; provides for roaming elements, dual cathode structures, multi-purpose tubes, etc.
- Line voltage adjustment control.
- Filament Voltages, 0.75 to 110 volts, through 19 steps.
- Sockets: One only each kind required socket plus one spare.
- Distinctive appearance makes impressive counter tester.

*Precision first
...to last*



Triplett

ELECTRICAL INSTRUMENT CO. BLUFFTON, OHIO



Highest Quality
**RADIO & ELECTRONIC
TESTING EQUIPMENT**

**IMMEDIATE
DELIVERY
FROM STOCK
GUARANTEED**

R.C.P. Model 448 Pocket Multitester.....	\$24.01
R.C.P. Model 424A Volt-Ohm Milliammeter...	28.91
R.C.P. Model 461A Sensitive Multitester.....	38.71
R.C.P. Model 664 Electronic Voltmeter.....	45.00
R.C.P. Model 705 Signal Generator.....	48.51
R.C.P. Model 802N Tube & Set Tester.....	58.31
R.C.P. Model 448A Multitester.....	70.07
R.C.P. 668 V.T. Volt-Ohm-Capacity Meter.....	73.01
R.C.P. Model 805 Tube & Set Tester.....	87.71
R.C.P. Model 665A V.T. Volt Ohmmeggor In-	
sulation Tester.....	92.61
Monitor Crystalliner Signal Generator.....	57.50
McMurdo Silver Model 905 "SPARX" Dy-	
namic Signal Tracer.....	39.90
McMurdo Silver Model 904 Capacitance Resist-	
ance Bridge.....	49.90
McMurdo Silver Model "Vomax".....	59.85
Reiner Model 530 Squarewave Generator.....	95.00
Reiner Model 451 V.T. Volt-Ohm Milliammeter	150.00
Superior Model CA-11 Signal Tracer.....	18.75
Superior Model 1553 Volt-Ohm Milliammeter	24.75
Superior Model 680 Volt-Ohm Milliammeter	27.65
Superior PB-100 Volt-Ohm Milliammeter.....	28.40
Superior Model 450 Tube Tester.....	39.50
Superior Model 650 Signal Generator.....	48.75
Superior 720 Multi-Range AC Ammeter.....	49.50
Superior Model 400 Electronic Multi-Meter.....	52.50
Superior Model 800 Tube and Set Tester.....	62.50
SHALLCROSS Decade Resistance Boxes.....	13.50
SHALLCROSS Portable Galvanometers.....	27.50
SHALLCROSS Model 630 Wheatstone Bridge	75.00
SHALLCROSS 637 Kelvin-Wheatstone Bridge	100.00
SHALLCROSS 638-2 Kelvin-Wheatstone Bridge	120.00
VM-Model 200-B Record Changer.....	
List Price \$37.50.....	net 22.50
Maguire ARC-1 Record Changer.....	
List Price \$47.41.....	net 24.50
Lots of 6 or more.....	each 22.90

**The New REINER
Model 333
MASTER TESTER
NET PRICE \$27.50**



Lifetime guaranteed meter is at the optimum angle for easy reading and visual accuracy. Meter is hermetically sealed—positively dust-proof and moisture-proof. Includes 2 Meter fuses.
6 D.C. VOLTAGE MULTIPLIERS 1% ACCURACY: 0-5-10-25-100-250-300 Volts.
6 D.C. CURRENT SHUNTS: 0-5-10-25-100-250-300 milliamperes.
Basic ranges of 0-120 millivolts and 0-1 milliamperes.

**The New REINER
Model 334
MASTER TESTER**

Identical to 333 but has in addition SIX AC Voltage ranges. Each AC and DC range is at a sensitivity of 1000 ohms per volt. AC measurements free from temperature and frequency errors throughout a range of 25 cycles to 1 megacycles. New Germanium rectifier used. Basic motor sensitivity 400 microamperes: full scale. Net Price **\$32.50**

*Write for Our Free
New Post-War Catalog*

**Metropolitan
ELECTRONIC & INSTRUMENT CO.**
Dept. SE 6 MURRAY STREET
NEW YORK 7, N. Y., U. S. A.
Phone: BArlay 7-5556
Cable Address: METRONICS

**NEW
PRODUCTS**

BRUNO ADJUSTABLE CIRCLE CUTTERS

An adjustable circle cutter that is said to cut holes from 1/8" to 8" through 1/4" thickness in steel or other metals and up to 1 1/2" in plastics, fibre or wood, has been announced by Bruno Tools, 9330 Santa Monica Boulevard, Beverly Hills, California. The tools are designed to operate in any standard drill press, wood-working machine, or suitably mounted spindle machine.

Cutter consists of a combination drill and pilot. Has a Wedge-lok cutting blade holder that permits cutting edge to recede or yield from work while maintaining steady pressure and feed.

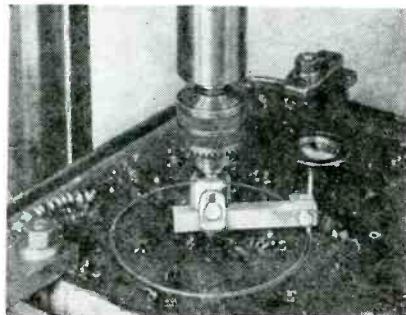

**SYLVANIA PENTODE VOLTAGE
AMPLIFIER**

A semi-remote cut-off pentode amplifier, 1LG5, for portable battery and a-c/d-c receivers has been announced by the radio tube division of Sylvania Electric Products, Inc., 500 Fifth Avenue, New York 18, N. Y.

Filament is rated at 1.6 volts maximum for battery operation and has a design center of 1.3 volts for a-c/d-c operation.

Typical operating conditions and characteristics with 45-volt plate supply in class A1 amplifier service, with suppressor grid connected to negative filament at socket, are: filament voltage, d-c, 1.4; filament current, 0.05 ampere; plate voltage, 45; screen-grid voltage, 45; control-grid voltage, 0; control-grid resistance, 2.0 megohms; plate current, 1.5 ma; and screen-grid current, .45 ma.

CENTRALAB CAPACITORS

Transmitting capacitors, silver micas and other types have been added to the line of Centralab, 900 E. Keefe Avenue, Milwaukee 1, Wisconsin.

The transmitting group includes types 850S, 853S, 854S and 855S. Features are said to include low-power factor, stable retrace characteristics and maximum flashover commensurate with physical size. Plates are pure silver fired to the ceramic surface. Capacity tolerance is $\pm 10\%$.

High-accuracy capacitors are another addition to the line. Coefficient is said to be maintained within ± 10 parts per million. Standard working voltage is 500 volts d-c, capacity tolerance is $\pm 5\%$. Types available are the 841S in 200, 350 and 500 mmfd and 950S in 500, 1,000 and 2,000 mmfd.

High-dielectric constant ceramic tubulars, HDC, are also available now. Power
(Continued on page 43)

TELEVISION

**HOME STUDY
COURSE**

**FOR THE RADIO TECHNICIAN AND
SERVICEMAN ONLY**

Television is not an incomprehensible subject—instead, it is a giant orientation study which a well-organized, clearly-written home-study course can very clearly present. An understandable, practical presentation has been a paramount consideration in the preparation of Reading Television Laboratories' television course.

The television text consists of three major sections as follows:

Section One—Radio Review, Slanted for Television.

Section Two—Television I, The Complete Television System and General Functions.

Section Three—Television II, Transmitter and Receiver Television Circuit Details.

Write Today for Literature!

**READING TELEVISION
LABORATORIES, INC.**

**HATBORO, PA.
(Suburban Philadelphia)**

**COMMUNICATIONS
RECEIVERS**

(Continued from page 41)

or i-f stages. If the stage gain is known, the remainder of the test can be followed through easily.

Alignment Uses

The fact that most communications receivers are accurately aligned makes them very useful for aligning receivers on their high-frequency bands. Alignment instructions usually contain information as to whether the local oscillator frequency should be set above or below the incoming signal. By picking up the local oscillator on the communications receiver by use of the b-f-o, its exact frequency may easily be determined.

Proved Applications

Many other uses for the communications receiver will suggest themselves to the Service Men, once it is placed on the bench. The suggestions cited have actually been used proving that the communications receiver has proved its worth in practice.

Order from LAKE!

Now Available
Postwar
2-Post
Record
Changer



With luxurious brown leatherette portable case, 15" L x 15" W x 10" D. Latest electronic developments make

this modern record-changer the finest on the market today! List price \$49.95. **\$29.97**
Dealer's net

DE LUXE RECORD-CHANGER and AMPLIFIER CASE

De luxe changer case with ample room for amplifier. Overall dimensions: 20" long x 16" wide x 10" high. Sturdily built of 3/4" plywood, de luxe brass hardware throughout. Inside dimensions: 15 1/2" long x 14 3/4" wide x 9 1/2" high. Net..... **\$12.95**

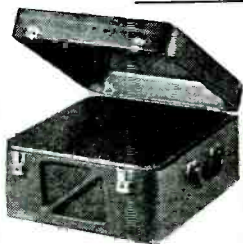

DeLuxe PHONO CABINET

Covered in luxurious, genuine brown leatherette, has de-luxe brass hardware throughout, made completely of plywood with plastic handle, has padded top and bottom. Motor board 14" x 14 1/2". Overall dimensions 16" long by 15" wide by 8" high. **\$8.95**
Your special net price.....

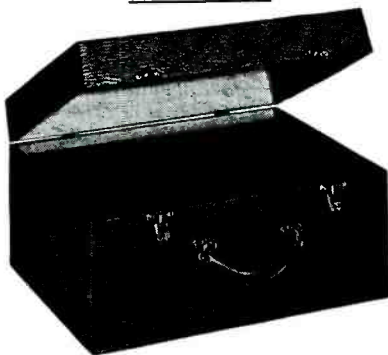

Portable Phonograph case, of sturdy durable plywood, in handsome brown leatherette finish. Inside dimensions: 16 1/2" long, 14" wide, 9 1/2" high. Has blank motor board. As illustrated above, specially priced. **\$6.95**
at

Also blank table cabinets of walnut veneer in the following sizes, with speaker opening on left front side:

(Note: *7 has center speaker grill.)					
#1	8 1/4"	L x	5 1/2"	H x 4"	D \$1.95
#2	10 1/4"	L x	6 3/4"	H x 5"	D \$2.75
#3	13 1/4"	L x	7 3/4"	H x 6 1/4"	D \$3.25
#7*	10 1/4"	L x	7"	H x 5 1/2"	D \$2.50



All types of radio cabinets, equipment and parts are available at Lake's lower prices. A large stock is listed in our catalog.

SERVICEMEN!
Join our customer list today.

Order Our New Catalog Today!
Get on our mailing list!
Dept. D

Lake Radio Sales Co.

615 W. Randolph Street
Chicago 6, Ill.

factor is approximately 2.5% at 1 kc, recommended working voltage 350, d-c; test voltage 700, d-c. Units are available in 1,000, 5,000 and 10,000 mmfd capacities.

Silver micas, 830S to 834S, for high-frequency applications have working voltage of 350, d-c, or 250, a-c. Leakage resistance is said to be more than 10,000 megohms.

Complete information appears in catalog 25.

* * *

G-C PHONO TURNTABLE SERVICE STAND

An 18" high phonograph-turnstile stand, adjustable to fit any size turntable, has been announced by General Cement Mfg. Co., Rockford, Illinois.

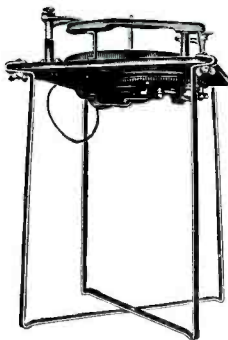

* * *

IDEAL ROTARY FILE AND DIE GRINDER

A 6 1/2" x 1 1/2", one-pound pneumatic file and die grinder has been announced by the Ideal Industries, Inc., 4035 Park Avenue, Sycamore, Illinois.

The motor is a vane type. Dust and chips that may be formed are blown away by the exhaust of air from ports at the chuck end of grinder.

Collet chuck is of the double grip type. The standard chuck, as furnished, is made for tools having 1/4" shank or flexible sleeve may be obtained for 3/8" or 1/2" shank. Available with either lever or button-type control. Handles wheels up to 1 1/2" maximum diameter.

Rated at 1/4 h-p.

* * *

BENDIX ELECTRONIC PHONOGRAPH PICKUP

An electronic pickup that is said to use direct action has been announced by the Bendix radio division of the Bendix Aviation Corporation.

In operation, mechanical undulations are transmitted from the record groove by a filament which introduces them directly into an electron stream within a vacuum tube.

Record wear is said to be minimized since less than two-thirds ounce pressure is exerted on the record.

* * *

AMPENOL RAILROAD ANTENNA

A broadband 160-megacycle ground-plane antenna for two-way communications between train and fixed station and end to end service, has been announced by American Phenolic Corporation, 1830 South 54th Avenue, Chicago 50, Illinois.

Antenna utilizes the metal top of the car for its ground plane. It is fed by armored 52-ohm coaxial transmission line. The gain of the antenna is said to be 0.5 decibel less than a dipole.

Assembly is constructed of steel, heavily cadmium plated and has an overall height of 14 1/2". It is secured to the car by three 1/4"-20 bolts.

(Continued on page 44)



For those tight spots calling for heavy-duty capacitors, you can always count on Aerovox Type -89 oil-impregnated oil-filled tubulars. They are especially ideal for use in vibrator applications; coupling and by-pass functions in transmitters; high-voltage amplifiers; in r.f. by-pass circuits; interference eliminators for motors and generators; and in test equipment. Briefly:

AEROVOX TYPE-89

Hermetically-sealed metal-can container fully sealed against oil leakage and moisture penetration.

Case is insulated, or not connected with the capacitor section.

Center mounting strap and outer insulating tube supplied.

In 400, 600, 1000 and 2000 volt D.C.W. ratings. Choice of popular capacity values.

Sizes from 1/2 x 1-7/16" to 1-1/16 x 2-3/16".

Ask Our Jobber . . .

When you require such heavy-duty ultra-compact oil capacitors, just ask your Aerovox jobber for Type -89. Ask for latest catalog containing listings. Or write us direct.



FOR RADIO-ELECTRONIC AND INDUSTRIAL APPLICATIONS

AEROVOX CORP., NEW BEDFORD, MASS., U.S.A.
Export: 13 E. 40th St., New York 16, N.Y. • Cable: 'ARLAB'
In Canada: AEROVOX CANADA LTD., Hamilton, Ont.

TRANSFORMERS

INbuilt Quality for
OUTstanding Performance

A Superior Product

S
N
C

A Noteworthy Policy

Characteristic Quality

See Your
Nearest Distributor

SNC MANUFACTURING COMPANY

WEST LAKE-ST. • GLENVIEW, ILL.

Export Agents: Scheel International • 4237 N. Lincoln Avenue • Chicago, U.S.A.

TRENDS IN SOUND

featured in the JULY issue of SERVICE

Advertising forms close July 5th
20,000 CIRCULATION GUARANTEE

The **40** Line

Designed to fit the radio man's needs. Over 200 items of Electronic Hardware items needed by every radio man, laboratory technician, experimenter and ham. Every item packed in attractive cellophane bags and priced at 40c list.

A partial list of "40" line items include:

Dial springs, grommets, spade lugs, trimounts, insulating washers, grid caps, C washers, rubber feet, lock washers, bolts, nuts, soldering lugs, snaphole plugs, etc.

Write TODAY for the new Walsco Catalog
No. 46 Dept. 6D

WALSCO products
Help The Radio Man

WALTER L. SCHOTT CO. BEVERLY HILLS, CALIF. CHICAGO 5, ILL.



NEW PRODUCTS

(Continued from page 43)

An armored transmission line may be mounted from the top of the base or brought up through car roof and antenna base.

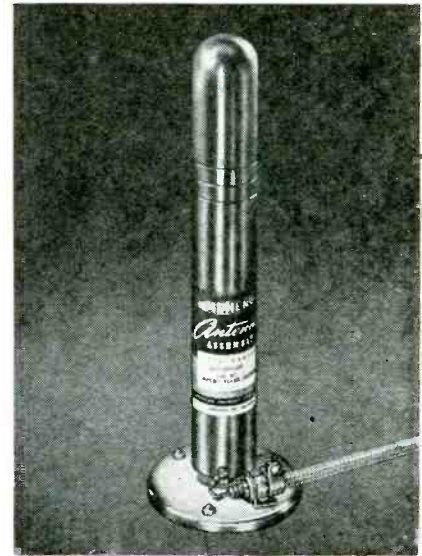

ALDEN'S SHIELD PLUGS AND SOCKETS

Shielded plugs, type 800, and sockets, type 410, in one- to five-prong styles have been developed by the Alden Products Company, Brockton, Mass.

BELL SOUND PHONO P-A SYSTEM

A 25-watt portable phono p-a unit has been developed by Bell Sound Systems, 1183 Essex Avenue, Columbus 3, Ohio.

Has a dual-speed turntable for both 16" transcriptions and commercial recordings; two individually-controlled microphone inputs; bass tone control; 12" p-m speaker; adjustable impedance line transformer; and desk-type crystal microphone.

Case is 13" x 19" x 20".



EBY SOCKETS

Lock-in, octal and non-microphonic type sockets have been announced by Hugh H. Eby, Inc., 18 West Cheltenham Avenue, Philadelphia, Pa.

CHERRY RIVET LIGHT-DUTY BLIND RIVET GUN

A one-hand, plierlike tool, Cherry, Jr. Riveter, that is said to install a rivet with a simple pull, has been developed by Cherry Rivet Company, 231 Winston Street, Los Angeles 13, California. It installs a 3/8" diameter blind rivet, provided in three grip lengths.

SCHMIDGALL HAMMERS WITH PLASTIC HEADS

A hammer with a hard plastic double-

**IT'S EXCLUSIVE!
LOW PRICED!**

**WRL GLOBE TROTTER
TRANSMITTER KIT**



**READY NOW!
LEO'S
Sensation
of the Year!**

\$59.95

40 WATT INPUT Cat. No. 70-300
Complete including all parts, chassis panel, streamlined cabinet, less tubes, coils, and meter.

Cat. No. 70-312 Kit same as above, wired by our engineers\$75.00
All necessary Accessories\$13.85 extra

Here is the latest, most outstanding transmitter value on the market today. The WRL Globe Trotter is capable of 40 watts input on C.W. and 25 watts input on phone on all bands from 1500 KC through 28 Megacycles. Incorporates the Tritet Oscillator using a 20 meter X-tal and providing sufficient drive at 10 meters for the 807 final; Heising choke modulation; three bands, all pre-tuned; 10, 20, and 80 meters; metering provided for both oscillator and final stages; two power supplies, one for 807 final and modulator tubes, one for speech amplifier and oscillator stage.

EXTRA SPECIAL RECEIVER BUY!

New BC 348Q Surplus Receiver. 8 tubes, 200 to 500 Kilocycles. Weather, aircraft, and all ham bands except 10 meters. Cat. No. 35-61, less speaker. **ONLY\$85**

Here are just a few of the many well-known receivers offered by Leo:

Hallcrafters S38	.39.50	Hallcrafters SX46	..\$115
Hallcrafters S40	79.50	Hallcrafters SX42	..\$250
RME 45186.	Hallcrafters S41G	33.50
RME 84\$98.70	Hammarlund HQ-129X	129.
National NC 2-40C225.		

Use our liberal trade-in and easy terms.

SERVICE DEALER NEEDS



WRL MULTITESTER
Steel case with 30-60% angle
Cat. No. 16-491
Less Leads .. **\$1875**

Handles AC DC Voltmeter, DO Milliammeter, high and low range Ohmmeter. 3" meter with sturdy D'Aronson movement. Size 5 1/2 x 8 x 3 1/4.

A complete stock of tools, replacement parts, test equipment, intercom and public address systems . . . everything for the progressive service dealer.

TUBULAR CONDENSERS!

Immediate Delivery!

Small type, Standard Tubular By-Pass Condensers. Waterproof, Long-Life, Phenolic wrapped and Phenolic end fill. Also double waterproof seal. Manufactured to same high specifications used in the famous VT fuse. Genuine lead non-inductive foil condensers.

Unconditionally Guaranteed.

Cat. No.	Cap. 100 Mfd. 400V		Single Lots		Cat. No.	Cap. 100 Single Mfd. 600V	
	Mfd.	Lots	Lots	Lots		Mfd.	Lots
27-837	.002	5.40	.06	27-853	.0025	6.30	.07
27-839	.0025	5.40	.06	27-855	.005	6.30	.07
27-841	.005	5.40	.06	27-857	.01	6.30	.07
27-843	.02	5.40	.06	27-859	.02	6.30	.07
27-845	.025	6.30	.07			1000V	
27-847	.05	6.30	.07	27-861	.0025	7.20	.08
27-849	.1	7.20	.08	27-863	.0035	7.20	.08
27-851	.2	8.10	.09	27-865	.005	7.20	.08

On quantities of 500 or over condensers may be assorted to obtain an additional 5% discount with a minimum quantity of 100 of each type.

GET OUR LATEST FLYER FREE!



Packed with real buys in radio, electronic, and general merchandise.

Giant Radio Map (size 3 1/2 ft. x 4 1/2 ft.)...15c
Handy Tube-Base Calculator...25c
Address: Dept. S-6
Council Bluffs, Iowa

World Radio Laboratories
INCORPORATED
Formerly Wholesale Radio Laboratories

head, Kant-Mar, has been announced by the Schmidgall Manufacturing Company, 307 Cass St., Peoria 2, Illinois.

The head is die cast and is said to be non-breakable, fireproof and acidproof. The base of the head is machined from light-weight aluminum alloys. The handle is hickory.

Made in three sizes.



G.E. AUTO RADIO ANTENNAS

Auto radio antennas for all types of mounting have been announced by the specialty division of G. E.

Available in sizes ranging from 56" to 100"

Antennas are made of admiralty brass and chrome plated. Mounted with ceramic chrome-trimmed stanchions. Silver-to-silver contacts.

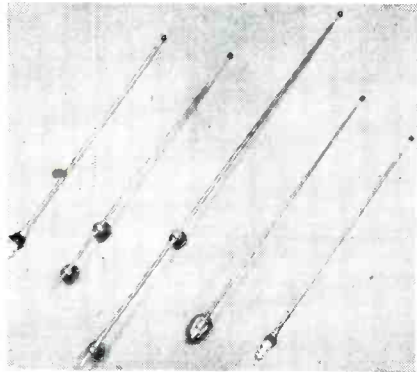

NORD MOLDED TUBULAR CAPACITORS

Molded tubular capacitors in capacities from 0.001 mfd to 0.1 mfd and up to 1000 volts d-c have been developed by the Nord Manufacturing Co., Inc., Bridgeport, Conn.

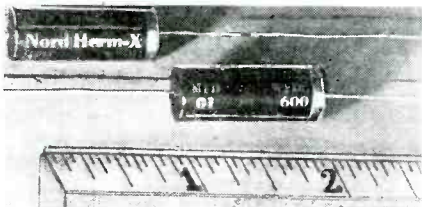

STACKPOLE MIDGET CAPACITORS

Midget capacitors, type GA, for use where required low capacities have frequently been obtained in the past by makeshift "gimicks" constructed of two short insulated wires twisted together, have been announced by the electronics division of the Stackpole Carbon Company, St. Mary's, Pa.

Standard capacities include 0.68; 1.0; 1.5; 2.2; 3.3 and 4.7 mmfd. Standard tolerance is ± 20%.

Can be used for neutralization; capacity coupling in antenna, r-f and i-f coils; feedback; r-f bypass; injection of r-f and audio voltages, etc.

SUPREME

TESTING INSTRUMENTS

AFTER A GREAT WAR RECORD

BACK AGAIN!

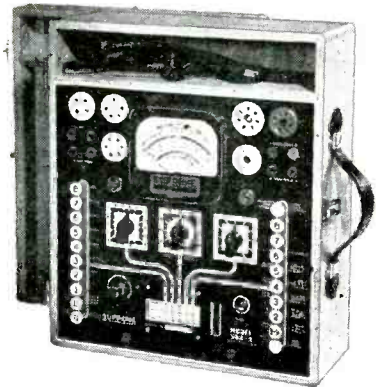

SUPREME MODEL 504-A TUBE AND SET TESTER

SUPREME regrets that war necessitated an interruption of service to its customers and friends. We are genuinely glad to get back into peacetime production—production for YOU.

MANY SUPREME INSTRUMENTS NOW AVAILABLE

—But not enough to take care of all orders at one time. Demand for accurate, dependable SUPREME equipment is such that we suggest you make arrangements for your needed new SUPREME models without delay.

SEE YOUR NEAREST SUPREME JOBBER NOW!



SUPREME INSTRUMENTS CORP.
GREENWOOD, MISS.
U. S. A.

Export Department:
THE AMERICAN STEEL EXPORT CO., Inc.
374 Madison Ave., New York 17, N. Y.

At the 1946 RADIO PARTS SHOW in Chicago

A VARIETY OF INTERESTING test instruments were shown by RCA. These included an audio oscillator with a 20 to 17,000 cps continuous sweep and an improved Rider chanalyst for circuit tracing. A store-planning service was also described by RCA. Exhibited during this discussion were floor plans, counter and sales displays. . . . Webster-Chicago was host to a group of representatives, suppliers and trade specialists at their plant. They demonstrated their record changers. . . . Littelluse, Inc., Chicago, displayed a line of neonized screw drivers, terminal assemblies, fuse retainers, low-voltage testers and flush-lites with neon tubes. . . . Dale Instruments, a division of Electronic Development Co. of Omaha, Nebraska, exhibited small panel instruments. . . . Potter and Brumfield Sales Co., Chicago, showed an assortment of relays, which included plate-circuit types; multiple-leaf, heavy and medium-duty power and standard-type relays for general application. . . . Portable electric megaphones were displayed at the Taybern Equipment Company, N. Y. C. booth. . . . A comparison-limit bridge and a 60-cycle filter were exhibited by the Freed Transformer Co. of New York. . . . Electronic Labs, Indianapolis, showed their line of vibrator replacements and their battery eliminator for test purposes in the shop. Electronic Labs also had on display a vibrator power supply for amateur use and vibrator power supplies for farm and d-c application. . . . Magnetic paper recorders were shown by Brush. Streamlined crystal phonograph

pickups and cutters were also on display. . . . The Hickok Electrical Instrument Co., Cleveland, exhibited their dynamic mutual conductance tester and an all-purpose tube and set tester. . . . A 30-watt amplifier was on display at the booth of the J. M. I. Sales Corp., Chicago (John Meck Industries Sales Co.). . . . Ward Leonard Electric Co. of Mt. Vernon, N. Y., showed a number of relays for antenna changeover, band switching, keying, remote control, etc. Their line of fixed and variable resistors were also on display. . . . The postwar line of Supreme Instruments, Greenwood, Miss., included a mutual conductance tube tester, tube and set tester, signal generator, a-f and r-f oscillators, 3" and 5" type oscilloscopes, audio generators, vacuum-tube voltmeters, multi-meters and panel instruments. . . . Automatic record changers were on display at the booth of the Erwood Company, Chicago. . . . A variety of dial light assemblies were exhibited by the Dial Light Co. of America, N. Y. C. . . . British-type Multicore solder with Ersin flux were shown at the booth of the British Industries Sales Corp. of New York. . . . The Telegraph Apparatus Co., Chicago, displayed a line of speed and hand keys, phone oscillators, plugs, jacks, phone tips, etc. . . . In another display of British equipment, Garrard automatic record changers were shown by the Garrard Sales Corp. of New York. A turn-over type record changer, providing playing of both sides of the record, was also displayed. . . . Antennas for television and

f-m were displayed at the booth of the Workshop Associates, Newton Highlands, Mass. . . . Centralab's line of controls, capacitors, trimmers, switches and switch hardware were also on exhibit. . . . A line of auto radio antennas for side cowl, underhood mounting or fender mounting was exhibited by the Insuline Corp. of America, N. Y. Also shown at this booth were f-m and television antennas, window antennas, carbon-type suppressors, capacitors for motor-noise eliminators, tuners, knobs, etc. . . . Rider manuals and books were on display at the booth of John F. Rider, N. Y. Among the books shown were "Automatic Record Changers and Recorders," "Inside the Vacuum Tube," etc. Two new books will be published by Mr. Rider during the next few months; "Understanding Microwaves" and "Radar—What It Is." . . . Rad-El-Co Mfg. Co., Cleveland, Ohio, exhibited straight cowl, side cowl, top cowl and torpedo cowl auto antennas. . . . Amplifiers of the 12-, 20-, 40-, 60- and 80-watt type were exhibited by Mark Simpson Mfg. Company, Long Island City, N. Y. . . . Crystal pickup cartridges with rapid disconnect features were shown by the Astatic Corp., Conneaut, Ohio. . . . A complete line of cements, chemicals, paints, varnishes, cabinet repair kits, grill cloths, phonograph needles, dial cables, switches and hardware accessories were on display at the booth of the General Cement Mfg. Company, Rockford, Illinois. . . . The American Phenolic Corp., Chicago, showed their dielectric coaxial cables, plugs, sockets, plastic components and a twin-lead transmission line encased in a polyethylene insulating bond. . . . Micro-switches were exhibited by the First Industrial Corp., Freeport, Ill. . . . Universal Microphone

TUBES—PARTS

RADIO DEALERS—SERVICEMEN

Send for our list of available tubes and repair parts.
Sylvania, Tung-Sol, Ken-Rad.

M. V. MANSFIELD CO.
937 LIBERTY AVE. PITTSBURGH 22, PA.

J. V. Duncombe Co.

WHOLESALE DISTRIBUTOR

ELECTRONIC EQUIPMENT, TUBES and PARTS

1011 West 8th Street Erie, Pa.

Phone: 23-546

ERIE'S OLDEST AND LARGEST EXCLUSIVELY WHOLESALE
ELECTRONIC SUPPLY HOUSE
All Nationally Known Lines Are In Our Stock.

IMMEDIATE DELIVERY

ON TEST INSTRUMENTS!

McMURDO-SILVER "Vomax".....\$59.85	SIMPSON 260 v.o.m.....\$33.25
RADIO CITY 705 sig. gen.... 49.50	SIMPSON 305 tube tester..... 39.50
RCP 802-N tube & set tester... 59.50	SIMPSON 2" v.o.m..... 26.50
APPROVED R.F. sig. gen..... 47.00	TRIPLETT 2413 tube tester... 49.50
DUMONT 3" oscilloscope.....105.00	TRIPLETT 2432 sig. gen..... 88.50
DUMONT 5" oscilloscope.....235.00	TRIPLETT 666-H v.o.m..... 20.00

Also, many other types available. Send for latest circular

25% deposit should accompany C.O.D. orders

SCENIC RADIO & ELECTRONIC CO., 53 Park Pl., New York 7

Ted McElroy
World's Largest Manufacturer of
Wireless Telegraphic Apparatus
COMPLETE CENTRAL OFFICE EQUIPMENT
McElroy Manufacturing Corp.
22 Brookline Avenue • Boston, Massachusetts

SERVING NORTHERN NEW ENGLAND

EVANS RADIO

18 N. Main

Concord, N. H.

ALMO RADIO COMPANY

509 Arch Street

Philadelphia 6, Pa.

PHILADELPHIA'S NEW DISTRIBUTOR
FOR RADIO AND ELECTRONIC PARTS

Serving Servicemen and the Industrial Trade

WRITE FOR OUR NEW CATALOG—READY SOON.

Co., Inglewood, California, showed their microphones, floor stands and constant-velocity frequency records. . . . Antenna mounts that can be installed on any rooftop and used with all types of antennas were shown by Shur-Antenna-Mount, Inc., Sea Cliff, N. Y. Also on display were dipoles for f-m and television. . . . Phonograph motors were exhibited by Spirling Products Company, Inc., N. Y. C. . . . V-M Corporation, Benton Harbor, Michigan, showed a record changer that plays twelve 10" or ten 12" records. . . . A complete line of microphones and floor stands were displayed by Electro-Voice, South Bend, Indiana. . . . Advance Electric & Relay Company, Los Angeles, Calif., exhibited a variety of relays for receiver, transmitter and commercial communication applications. . . . Stamford Electric Products Company, Inc., Stamford, Conn., displayed transformers for r-f, a-f and other allied receiver purposes. . . . Hi-Q wire-wound resistors and ceramic capacitors were exhibited by Electrical Reactance Corp., Franklinville, N. Y. . . . A three-core (tri-core) rosin-core solder wire was exhibited by Alpha Metals, Inc., Brooklyn, N. Y. . . . Gothard Mfg. Company, Springfield, Ill., displayed their complete line of pilot-light assemblies. . . . Sensitive, polarized, time-delay, snap action and selector-type relays were shown by the Price Electric Corp., Frederick, Md. . . . Plastic film capacitors were on view at the booth of the Condenser Products Company, Chicago, Ill. . . . A full line of replacement transformers were shown by the Merit Coil Transformer Corp., Chicago. . . . Relays for antenna keying, time delay, remote locking, and other applications were exhibited by the Guardian Electric Mfg. Company, Chicago. . . . Miniature paper capacitors were displayed by the Dumont Electric Corp., New York. . . . Intercommunication equipment using a conical type design was displayed by Sound, Inc., Chicago. . . . Reiner Electronics Company, Inc., N. Y., showed their vacuum-tube

voltmeters, master testers, high-voltage test leads and other allied Service Shop test instruments. . . . Dynamic and crystal microphones were exhibited by the Turner Company, Cedar Rapids, Iowa. Also on display at this booth were magnetic pickups for musical instruments, lapel microphones and hearing-aid units. . . . The Triplett Electrical Instrument Company, Bluffton, Ohio, displayed a line of test instruments, which included volt-ohm-milliammeters, pocket-type volt-ohm-milliammeters, dynamic mutual conductance tube tester, roll-chart tube-testing attachment, counter and portable tube testers, signal generators, etc. . . . An eight-watt portable sound system which includes a 10-watt amplifier, crystal microphone and phono assembly for 12" records, was displayed by the Bell Sound Systems, Columbus, Ohio.

NAVAR TRANSMISSION



Long-range navigation system proposed by engineers of Federal Telecommunication Laboratories, involving the use of transmission stations within 1500-mile ranges located strategically on the earth's surface. About 75 stations would be needed to cover all areas. Stations are omnidirectional type which would enable a pilot to determine horizontal angle relative to station and also true bearing relative to north. Bearings are obtained from dials on the instrument panel. Ground station equipment uses scope projectors which cast dual images; a small one of the face of a Navaar scope and a large figure on a large map-of-the-area screen on a wall, the Navascreen.

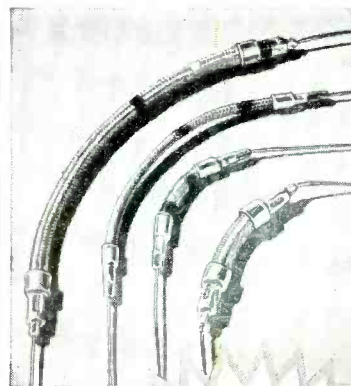

GLASOHM
flexible
resistors

★ Exclusively Clarostat! These flexible glass-insulated wire-wound resistors spell tougher components for tighter spots. Fiberglass core and fibre-glass braided covering. Nothing to char or burn. Self-supporting when soldered in place. Especially handy for point-to-point wiring. Ideal for attenuators or step-by-step controls. Truly midget power resistors.

Type FYG rated at 2 watts. 1" body length. 1/8" dia. 2" pigtail leads.
Standard values from 5 ohms to 2000 ohms.
Patented "Clinch-Grip" ferrules and pigtail leads will not work loose.
RMA color coded. Silky tan finish.
Available in longer lengths, especially as miniature heating elements, on special order.

★ Ask Our Jobber . . .

Ask him for these Clarostat exclusives—handy Glasohms. Ask for the latest No. 46 Catalog—or write us for your copy.



CLAROSTAT MFG. CO., Inc. • 285-7 N. 6th St., Brooklyn, N. Y.

SPEED UP REPAIRS WITH THESE G-C AIDS!

G-C is HEADQUARTERS for RADIO PARTS and SERVICE AIDS



All Types of Radio Cements, Chemicals, Coil Dopes, Compounds.



Dial Cables, Dial Belts, Packaged Hardware, Cabinet Repair Kits

Speedex Wire Strippers

Alignment Tools Ne-O-Lite Testers

G-C leads the field in supplying Radio - Electronic Manufacturers and Service Men with Parts, Tools, Radio Cements, Chemicals and Compounds. Insist on Genuine G-C Quality.

Order from Your Jobber — Send for G-C Catalog



GENERAL CEMENT MFG. CO.
ROCKFORD, ILLINOIS

A RECORD SMASHING BARGAIN!

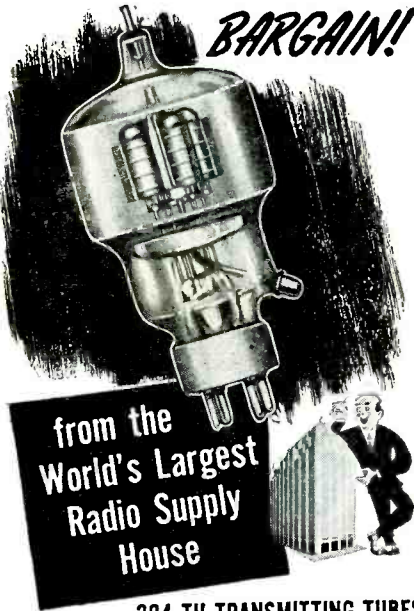

from the
World's Largest
Radio Supply
House

304 TH TRANSMITTING TUBES

Here is a typical money-saving offer from R.W.T. A versatile medium-mu triode now being sold at 5 times R.W.T.'s cost to you—slashed to the sensationally low price of \$9.95! Another R.W.T. achievement! Use it as a modulator—an oscillator—an amplifier! Filament: 5.0 or 10 volts. DC Plate Voltage: 3000 volts (max.). DC Plate Current: 900 ma. (max.). Plate Dissipation: 300 watts. Limited quantity only!

Now being sold at
\$50.00 elsewhere!
Your cost **\$9.95**
at R.W.T.

No matter what you need in radio parts or equipment—order from R.W.T. We have a complete assortment of over 10,000 top-quality parts at lowest prices. Write us your needs and watch our superspeed service!

FREE!

Send today for the latest bargain flyer which includes best buys in nationally known communications receivers, ham transmitting tubes, test equipment, phonograph equipment and hundreds of others.

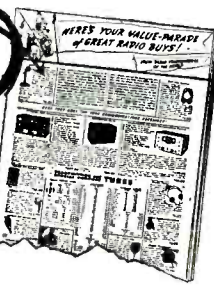

Originators and marketers of the World Famous **Lafayette Radio**

Radio Wire Television Inc.

CUT OUT THIS COUPON NOW!

NEW YORK 13 • BOSTON 10 • NEWARK 2

R.W.T. Dept. FF-6
100 Avenue of the Americas, New York 13

Enter my order for Xmitter tube(s)
 Check enclosed Money Order Send C.O.D.
 Send me FREE copy of your latest Bargain Guide C37 and place my name on list for your New Super Catalog.

Name
Address
City Zone State

Paste on Penny Postcard. Mail Today!

JOTS AND FLASHES

WITH THE 8% PRICE BOOST to receiver manufacturers OPA approved, the retail price of receivers will now be about 5% more. To maintain the pricing pattern, percentage margins have been slightly lowered. The new ruling does not affect receivers in stock or being shipped. . . . OPA still has not ruled on the tube-price increase which is being absorbed by the neighborhood Service Shop. It is expected that an equitable compromise pricing arrangement will be announced soon. . . . The color dynamic paint system (similar to the methods described in the March issue of SERVICE) has been adopted by John Meck in his plant to expedite production and minimize accidents. . . . Two catalogs describing automatic record changers, record players and phonograph motors have been released by the Micro-Sonic Corporation, 44 W. 18th Street, New York. . . . Electro-Tone Corporation is now producing manual and automatic changer portables as well as table model radio phonographs. Albert Saphin is president and Alfred Landes is general sales manager. Monarch Sales Company, 13 E. 16th Street, New York City, is the national distributor. . . . J. C. Belden, Jr., has been elected secretary of Belden Manufacturing Co., Chicago. . . . Cornell-Dubilier has purchased an eight-story plant in Worcester, Mass. . . . A sixteen-page catalog describing signal generators, tube testers, signal tracers, etc., has been released by the Metropolitan Electronic and Instrument Company, 6 Murray Street, New York City. . . . Harley R. Wall has been named home-receiver sales manager for International Detrola Corporation. . . . Ara, Inc., 5655 Wilshire Blvd., Los Angeles 36, California, record manufacturers, are now issuing franchises to independent distributors throughout the country. . . . Malcolm Ferguson has been named president of Bendix Aviation Corp. He succeeds Ernest R. Breech who has become vice president and director of Ford Motor Company. . . . Commander Henry Sheve has returned to Stromberg Carlson and been named staff engineer. . . . R. B. Albright has been appointed principal engineer of the Bendix Radio Division of Bendix Aviation. Mr. Albright will head the laboratory division of Bendix. . . . John L. Brown has been appointed sales manager of the replacement tube department of Raytheon Mfg. Co., Newton, Mass. Mr. Brown was a lieutenant commander of the U. S. Navy in World War II. . . . A twenty-page catalog, No. 25, describing transmitting and receiving capacitors, volume controls, power rheostats, trimmers, switches and switch kits, has been issued by Centralab, 900 E. Keefe Avenue, Milwaukee 1, Wisconsin. . . . General Instrument Corporation will merge with Emerson Radio according to a joint announcement by Benjamin Abrams, president of Emerson, and Abraham Blumenkrantz, president of General Instrument. The merger will also include F. W. Sickles Company, now a GI subsidiary. . . . S. L. Capell, vice president and general manager of Philco Corporation of Canada, Ltd., has been elected president of the Canadian RMA. F. R. Deakins, president of RCA Victor Co., Ltd., was named vice president.

ADVERTISERS IN THIS ISSUE

SERVICE INDEX—JUNE 1946

AEROVOX CORPORATION	43
Agency: Austin C. Lescarboura & Staff	
ALMO RADIO COMPANY	46
AMERICAN PHENOLIC CORPORATION	5
Agency: Burton Browne, Advertising	
AMPERITE COMPANY	28
Agency: H. J. Gold Company	
THE ASTATIC CORPORATION	29
Agency: Wearstler Advertising, Inc.	
BRUNO TOOLS DIV. ROBERT H. CLARK COMPANY	28
Agency: West-Margolis, Inc.	
BURLINGTON INSTRUMENT COMPANY	37
Agency: Weston-Barnett, Inc.	
BURSTEIN-APPLEBE COMPANY	40
Agency: Frank E. Whalen Advertising Company	
CAPITOL RADIO ENGINEERING INSTITUTE	39
Agency: Henry J. Kaufman & Associates	
CHERRY RIVET COMPANY	33
Agency: Dana Jones Company	
CLAROSTAT MANUFACTURING COMPANY, INC.	47
Agency: Austin C. Lescarboura & Staff	
CONCORD RADIO CORPORATION	28
Agency: E. L. Brown Advertising Agency	
CORNELL-DUBILIER ELECTRIC CORP.	Inside Front Cover
Agency: Reiss Advertising, Inc.	
CORNISH WIRE COMPANY, INC.	26
Agency: Hart Lehman, Advertising	
CRABTREE'S WHOLESALE RADIO	28
DRAKE ELECTRIC WORKS, INC.	30
Agency: William Hoffman & Associates	
ALLEN B. DUMONT LABORATORIES, INC.	19
Agency: Austin C. Lescarboura & Staff	
J. V. DUNCOMBE COMPANY	46
ELECTRO VOICE, INC.	Inside Back Cover
Agency: Henry H. Tepletz, Advertising	
EVANS RADIO	46
GENERAL CEMENT MANUFACTURING COMPANY	47
Agency: Turner Advertising Agency	
GENERAL ELECTRIC COMPANY	36
Agency: Maxon, Inc.	
INSULINE CORPORATION OF AMERICA	31
Agency: S. R. Leon Company	
J. F. D. MANUFACTURING COMPANY	38
JACKSON ELECTRICAL INSTRUMENT COMPANY	35
Agency: Kircher, Helton & Collett, Inc.	
JENSEN RADIO MANUFACTURING COMPANY	3
Agency: Burton Browne, Advertising	
KEN-RAD DIV. GENERAL ELECTRIC CO.	1
Agency: Maxon, Inc.	
LAKE RADIO SALES COMPANY	43
Agency: Sander Rodkin Advertising Agency	
LEAR, INC.	7
Agency: Kuder Agency, Inc.	
LIFETIME SOUND EQUIPMENT COMPANY	30
Agency: The Miller Agency Company	
MCELROY MANUFACTURING CORPORATION	46
Agency: Shapne-Wilkes, Inc.	
M. V. MANSFIELD COMPANY	46
METROPOLITAN ELECTRONIC EQUIPT. CO.	42
Agency: Mitchell Advertising Agency	
MURRAY HILL BOOKS, INC.	25
Agency: The Harry P. Bridge Company	
NATIONAL RADIO DISTRIBUTORS	34
Agency: Burke & Wayburn Advertising Co.	
NATIONAL UNION RADIO CORPORATION	Back Cover
Agency: Hutchins Advertising Company, Inc.	
NEWCOMB AUDIO PRODUCTS COMPANY	32
Agency: Gail Hall Advertising	
OHNITE MFG. CO.	26
Agency: Henry H. Teplitz, Advertising	
OLSON RADIO WAREHOUSE	34
Agency: Jessop Advertising Company	
RAD-EL-CO MANUFACTURING COMPANY	32
RADIO CITY PRODUCTS COMPANY, INC.	30
Agency: Reiss Advertising, Inc.	
RADIO CORPORATION OF AMERICA	15
Agency: J. Walter Thompson Company	
RADIO SUPPLY & ENGINEERING COMPANY	32
Agency: Karl G. Hehr Advertising Agency	
RADIO WIRE TELEVISION, INC.	48
Agency: Reiss Advertising, Inc.	
RADIONIC EQUIPMENT COMPANY	40
Agency: Hirschon-Garfield Company	
RAYTHEON MANUFACTURING COMPANY	38
Agency: Burton Browne, Advertising	
READING TELEVISION LABORATORIES, INC.	42
JOHN F. RIDER, PUBLISHER, INC.	4
Agency: Lansford P. King, Advertising	
S N C MANUFACTURING COMPANY	44
Agency: Duane Wanamaker	
HOWARD W. SAMS, INC.	23
Agency: The Aitkin-Kynett Company	
SCENIC RADIO & ELECTRONICS COMPANY	46
WALTER L. SCHOTT COMPANY	44
Agency: Ross, Gardner & White	
SPRAGUE PRODUCTS COMPANY	21
Agency: The Harry P. Bridge Company	
SUPREME INSTRUMENTS CORP.	45
Agency: O'Callaghan Advertising Agency	
SYLVANIA ELECTRIC PRODUCTS, INC.	8
Agency: Newell Emmett Company	
TRIPLETT ELECTRICAL INSTRUMENT COMPANY	41
Agency: Western Advertising Agency, Inc.	
U. S. TREASURY DEPT.	6
UNITED TRANSFORMER CORPORATION	27
Agency: Shapne-Wilkes, Inc.	
WARD LEONARD ELECTRIC COMPANY	41
Agency: E. M. Freystadt & Associates	
WEBSTER-CHICAGO CORPORATION	24
Agency: William Hoffman & Associates	
WORLD RADIO LABORATORIES, INC.	45
Agency: Pfeiffer Advertising Agency	



Electro-Voice ANNOUNCES THE CARDAX

A NEW Cardioid Crystal Microphone

with Revolutionary New MECHANOPHASE* Principle of Unidirectionality . . . Dual Frequency Response . . . High Output . . . and other big features!

**EXCLUSIVE NEW
MECHANOPHASE*
PRINCIPLE
DEVELOPED BY
Electro-Voice**

Utilizes a phase shifting diaphragm to produce a high degree of unidirectionality at all frequencies. Gives true cardioid characteristic by nullifying back pick-up. Unlike any previous method of obtaining unidirectionality and has many important advantages.

*Patents Pending

Here, for the first time, you get *all* these features in *one* microphone! With amazing flexibility, new CARDAX efficiently serves many applications . . . easily solves everyday problems of sound pick-up and reproduction!

★ **TRUE CARDIOID POLAR PATTERN** New E-V Mechanophase* principle gives wide-angle front pick-up in true cardioid pattern over wide frequency range. Sound at rear *dead zone* cancels out and is not reproduced.

★ **STOPS FEEDBACK—CUTS BACKGROUND NOISE AND REVERBERATION PICK-UP** Permits nearly double usable loud speaker volume. Simplifies microphone and speaker placement. Assures finer reproduction of just the sound wanted.

★ **DUAL FREQUENCY RESPONSE** Screw control on back gives (a) Wide range flat response for high fidelity sound pick-up or (b) Wide range with rising characteristic for extra crispness of speech or high frequency emphasis.

★ **HIGH OUTPUT LEVEL** —57 db for flat frequency response. —48 db for rising frequency response.

★ **VOICE AND MUSIC PICK-UP EXACTLY AS DESIRED** Ideal for public address, recording, remote broadcast, communications . . . indoors and outdoors.

★ **FULLY EQUIPPED FOR CONVENIENT OPERATION** Tilting head. Built-in "On-Off" switch. Dual frequency range selector switch. Cable connector. 20 ft. cable. Bimorph crystal. 5/8"-27 thread. New modern functional design. Satin chrome finish. CARDAX Model 950, List Price \$37.00

Licensed under Brush Patents. Electro-Voice Patents Pending.



SEND FOR BULLETIN NOW
Get full facts about amazing new CARDAX! Describes Mechanophase. Shows how dual frequency response selector works. Includes diagrams and response curves.

No Finer
Choice Than

Electro-Voice

MICROPHONES

ELECTRO-VOICE, INC., 1239 South Bend Ave., South Bend 24, Indiana
Export Division: 13 East 40th St., New York 16, N. Y., U.S.A.—Cables: Arlab

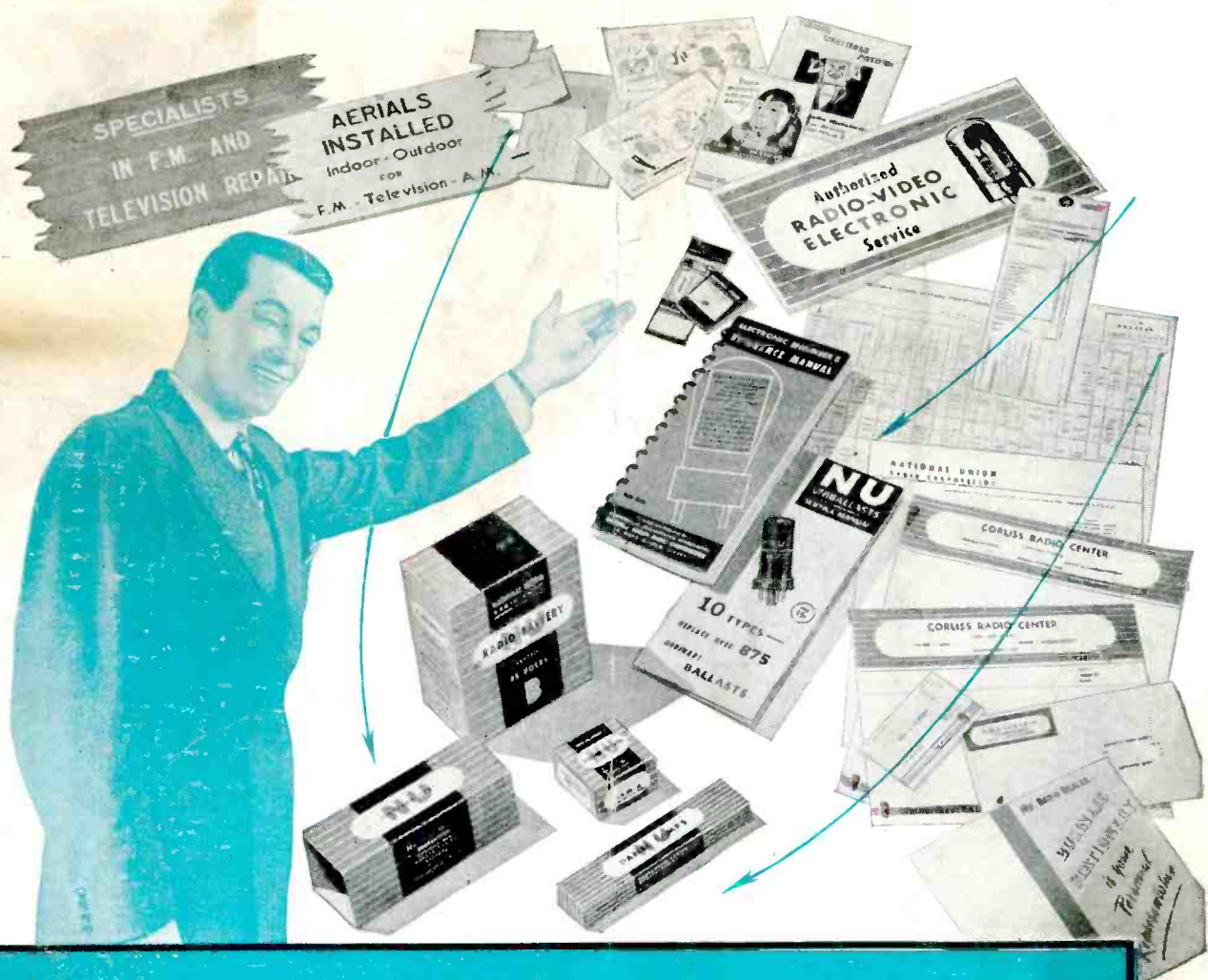

Keep Your Name in Front with N. U. BUSINESS-BUILDERS

One of the largest and finest assortments of dealer helps and sales promotional material ever offered to radio service dealers is now available from National Union Distributors. Here are business-builders for practically every need of the radio service engineer. All are smartly designed in the most modern styles. Many are offered with personalized imprint of your name and address. Let N. U. help you advertise *your* business, find new customers and increase your sales.

Ask Your N. U. Distributor Today!

National Union Radio Corp.
Newark 2, New Jersey

NOW AVAILABLE

BUSINESS-BUILDERS

- Window Decals
- Book Matches
- Dummy Cartons
- Stationery
- Job Tickets
- Embosograf Signs
- Newspaper Ad Mats
- Telephone Ad Mats
- Cartoon Cards

- Trouble Finder Folders
- Battery Cross-Indexes

TECHNICAL HELPS

- Electronic Engineers Reference Manuals
- Service Engineering Bulletins
- Uniballast Manuals
- Visual Aid Vacuum Tube Charts

COMING

- Window Displays
- Outdoor Signs
- Indoor Signs
- Imprinted Scotch Tape
- 4 Purpose Tube Decals
- Shop Coats

Transmitting, Cathode Ray, Receiving, Special Purpose Tubes • Condensers • Volume Controls • Photo Electric Cells • Panel Lamps • Flashlight Bulbs