

SERVICE

A MONTHLY DIGEST OF RADIO AND ALLIED MAINTENANCE

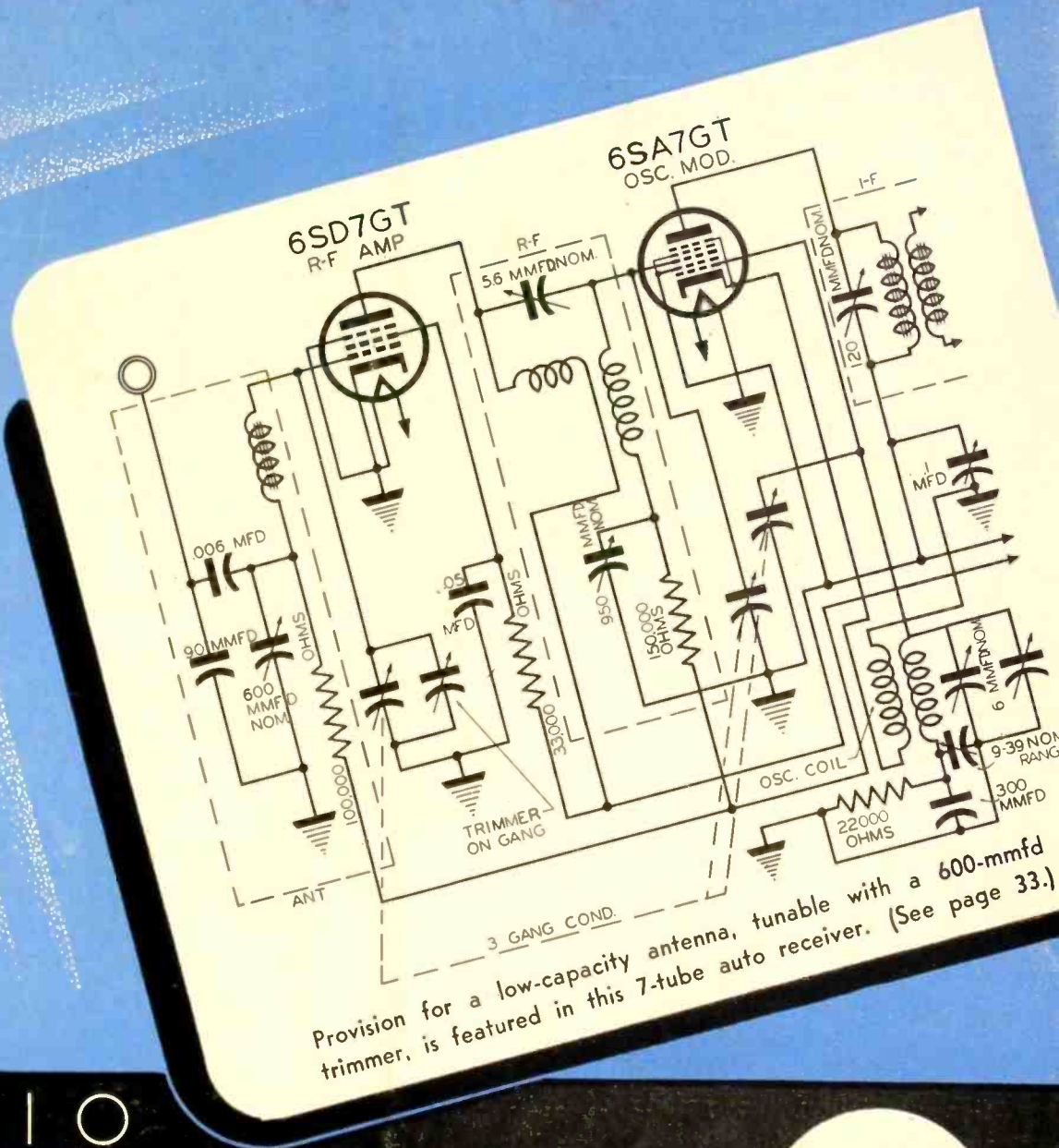

★ RADIO
★ TELEVISION
★ ELECTRONICS

December
1944

HYTRON has made them all!



The march of Hytron receiving tube progress down through the years is fascinating. One looks back on tubes, tubes, and more tubes: battery, AC, AC DC, diodes, triodes, pentodes, beam tetrodes, multiple purpose types, G's, MG's, BANTAM GT's — and now the miniatures. Price and size have been drastically cut; quality and performance, amazingly improved.

Hytron has made them all. Its long and varied experience is priceless in a complex industry where probably never will all the answers be known. In making radio tubes, painfully acquired practical experience must supplement the formulae of science.

With an eye to present and future, Hytron is concentrating its production of receiving tubes on preferred BANTAM GT types needed for war — for today's civilian replacements — and ultimately for post-war. Its wartime activities are teaching Hytron new techniques of miniature production. Many potentially popular Hytron miniatures are in development. Typical American dissatisfaction with anything but perfection continues; the parade of Hytron receiving tubes marches on.



OLDEST EXCLUSIVE MANUFACTURER OF RADIO RECEIVING TUBES

HYTRON CORPORATION

ELECTRONIC AND RADIO TUBES

MAIN OFFICE: SALEM, MASSACHUSETTS
PLANTS: SALEM, NEWBURYPORT, BEVERLY & LAWRENCE

HYTRON HIGHLIGHTS

YOU ARE GETTING MORE THAN YOU THINK

Hytron is shipping you Hytron distributors more MR receiving tubes than you realize. WPB rulings on mandatory exchange of MR tubes between tube manufacturers is not on a tube for tube basis, but on a percentage basis. In other words, Hytron's receiving tube production must be utilized in large measure to maintain percentages for other manufacturers.

For every Hytron branded MR tube, you are also receiving quarterly approximately two and a half times that amount of Hytron tubes under other manufacturers' brands. In short, Hytron is not holding back. When Government regulations are withdrawn, you will instantly become aware of the large Hytron receiving tube production which is serving you.



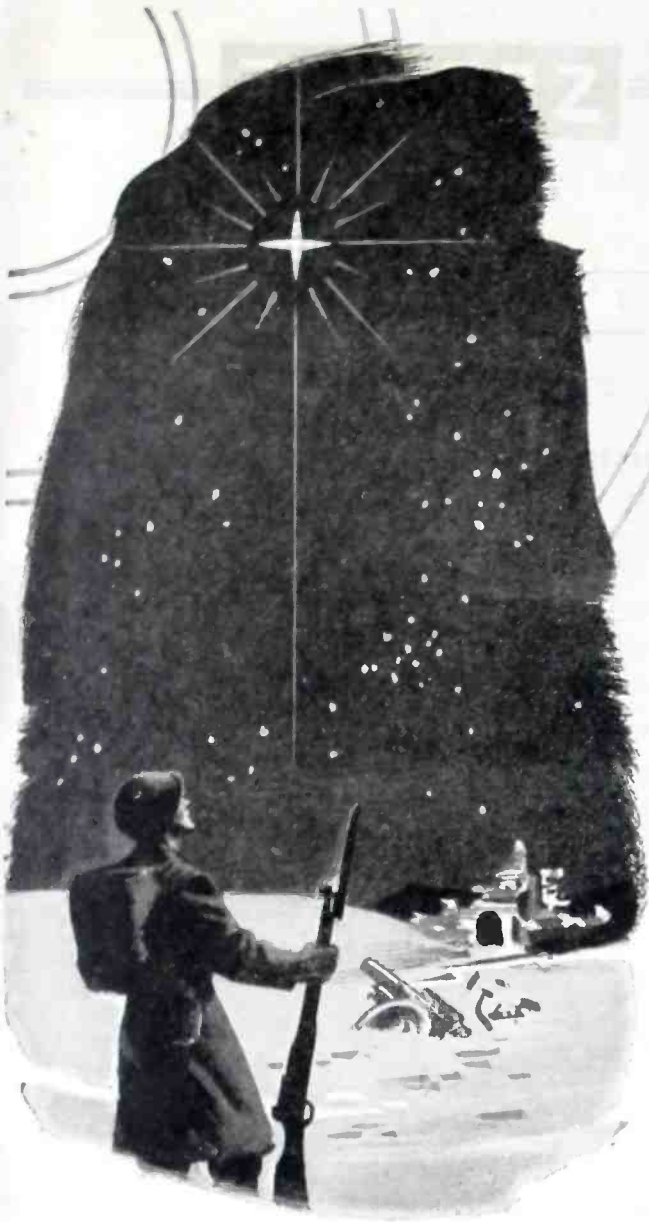

"In times like the present, men should utter nothing for which they would not willingly be responsible through time and in eternity."

Abraham Lincoln, 1861

*a Merry Christmas
and Happy New Year*

Jensen

Jensen Radio Manufacturing Company
6601 S. Laramie Ave., Chicago, Ill.

EDITORIAL

SERVICE

A Monthly Digest of Radio
and Allied Maintenance

Reg. U. S. Patent Office

Vol. 13. No. 12

December, 1944

LEWIS WINNER

Editorial Director

ALFRED A. GHIRARDI

Advisory Editor

F. WALEN

Managing Editor

STREAMLINED business practices appear to have won a favored spot on many Service Men's shop programs. Reports from scores indicate that these new methods are bringing more dollars in the till. While the maintenance of records has never been too popular, many Service Men now find that such record-keeping not only simplifies work scheduling, but avoids unnecessary operations, provides more money-making time and eliminates many a personal service debate. A Service Man from Wisconsin reported recently that the issuing of claim checks more than proved the merit of record-keeping. Previously he was unable to identify repaired receivers rapidly, depending solely upon the owners personal identification. This practice led to confusion and many times loss of receivers. Now this Service Man keeps a record of every receiver serviced, against which claim checks are issued. This record includes the model and serial number. Where the serial number is not available, other specific data identifying the receiver are included in the record. With this system, it is thus impossible for other than the rightful owner to claim the receiver. The record also provides a means of establishing time, cost and parts used in repair. The latter information is helpful in maintaining inventory.

Accurate records are also helpful in disposing of repaired receivers that have not been called for after the necessary calling date has expired. It is necessary to keep within State regulations on this calling date and unless records are kept, it is impossible to establish the date of receipt and sale. Since such sales come within a second-hand material classification, it is also necessary to abide by OPA price regulations. Here again, therefore, records are essential in establishing material cost, type and value of receiver on date of receipt.

Keeping records will be found profitable at all times!

A Simple Vacuum-Tube Voltmeter. By Harry R. Evans	11
Electronic Controls. By S. J. Murcek	31
Electronic Musical Instruments. By Willard Moody	15
High Fidelity and Tone Control. By Edward Arthur	14
Old-Timer's Corner	31
Postwar Trends in Service Equipment. By Raymond Soward	11
Ser-Cuits. By Henry Howard	27
Circuits	
Belmont 796	31
Farnsworth BC-83	27
Gibson EH 150	15
Motorola 40-F (Cover)	33
Philco C-1808	31
Vega 180	16
Cover	
Motorola 40-F	33
Servicing Helps	
Philco 42-380	33
Philco C-1908	33
Stewart Warner 05-5L1	33
Stewart Warner A6S	33
Stewart Warner 206GA	33
Zenith 91-92	33
Zenith 5662 and 5666	33
Index to Advertisers	40
Manufacturers	
News	36
New Products	38
Jots and Flashes	40

Copyright, 1944, Bryan Davis Publishing Co., Inc.



Bryan S. Davis, Pres.
F. Walen, Secretary



Paul S. Weil, General Manager
A. Goebel, Circulation Manager

James C. Munn, 10515 Wilbur Avenue, Cleveland 6, Ohio
Pacific Coast Representative: Brand & Brand, 816 W. Fifth St., Los Angeles 13, Calif.; Telephone, Michigan 1732

Entered as second-class matter June 14, 1932, at the Post Office at New York, N. Y., under the Act of March 3, 1879. Subscription price: \$2.00 per year in the United States of America and Canada; 25 cents per copy. \$3.00 per year in foreign countries; 35 cents per copy.

**The Best
Show
On the Air
Saturday
Night!**



"MEET YOUR NAVY"
Now Carries the RAYTHEON Name
into 3,500,000 Radio Homes Each Week!

Free!

Ask your Raytheon distributor
for colorful, attention-getting
"Meet Your Navy" display to
tie in with this great program.
Easel-mounted, 17 1/2 x 20 1/2"



Every Saturday Night
ENTIRE BLUE NETWORK
Coast to Coast 181 Stations



RAYTHEON MANUFACTURING COMPANY
Waltham and Newton, Massachusetts



All Four Raytheon Divisions
Have Been Awarded Army-
Navy "E" with Three Stars

RAYTHEON
High Fidelity



ELECTRONIC AND RADIO TUBE
DEVOTED TO RESEARCH AND THE MANUFACTURE OF TUBES AND EQUIPMENT FOR THE NEW ERA OF ELECTRONICS

SERVICE, DECEMBER, 1944 • 3

THE SET THAT

never slept

10,800 Continuous Hours

Fifteen months of continual service, 10,800 continuous hours, night and day with the switch never once turned off—and no repairs or replacements needed. That's the record established by a Hallicrafters SX-28 in use testing crystal standards at Scientific Radio Products Co., Council Bluffs, Iowa.

Equal to Five Years' Use

Witness to this amazing performance was Myron C. Jones, resident inspector in charge. Day after day he watched "the set that never slept" in continuous action between January 5, 1943 and April 10, 1944.

Inspector Jones writes:

"This is what I call punishment. It surpasses five years of ordinary use, with no new parts needed. This war plant had many more Hallicrafters receivers, all performing outstandingly. You can't beat Hallicrafters for endurance, sensitivity, selectivity, tone, ease of operation and all around performance."

"The Radio Man's Radio"

This is only one more significant notch in Hallicrafters' record. Men who know radios inside out, men who depend on them when life itself is at stake and when there can be no compromise with quality, specify Hallicrafters, "the radio man's radio."



BUY A WAR BOND TODAY!



hallicrafters RADIO

THE HALLICRAFTERS CO., MANUFACTURERS OF RADIO
AND ELECTRONIC EQUIPMENT, CHICAGO 16, U. S. A.



History of Communications. Number Twelve of a Series

COMMUNICATION BY THE BLINKER

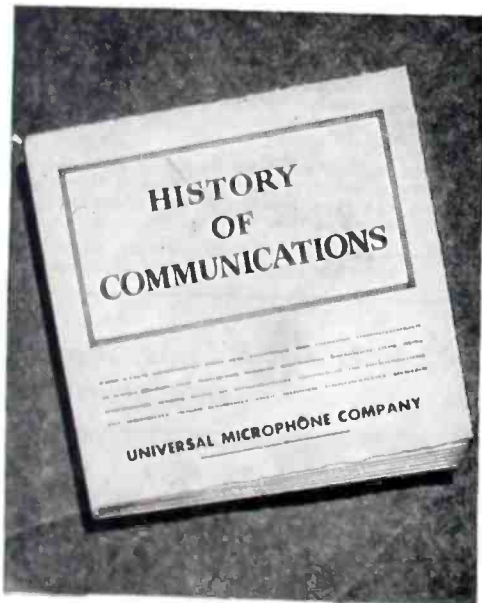

The Blinker, an adaptation of the Heliograph with its own source of light, has been found invaluable for night and day Naval Communications. While limited by "line-of-sight" transmission and the elements of weather, it has been an aid to our cautious convoys during "radio silence."

When Victory is ours and the days of "radio silences" are gone forever, private citizens again will have electronic voice communication equipment for their yachts and other pleasure craft. With the release of civilian radio bands Universal will again offer the many electronic voice components for use in marine craft.

< *FREE—History of Communications Picture Portfolio. Contains over a dozen pictures suitable for office, den, or hobby room. Write for your "Portfolio" today.*



UNIVERSAL MICROPHONE COMPANY
INGLEWOOD, CALIFORNIA



SPRAGUE TRADING POST



A FREE Buy-Exchange-Sell Service for Radio Men



...from all of us to all of you!

To all our friends, old and new, to those in the armed forces, to all who have entered war work, and to those still on the job at the old stands...

Our best wishes for the 1944 Yuletide and our sincere hope that the year 1945 will see the dawn of a peaceful, better, happier world.

SPRAGUE PRODUCTS CO.

FOR SALE—Webster Chicago #1140 de luxe record changer with Astatic Lp-6 cartridge, \$50; also Jensen 860 ohm #A12 speaker, \$12. F. Christian, 819 Blair St., Flint 4, Mich.

FOR SALE—National NC-100XS communications type receiver with general coverage coils, including broadcast band, with crystal filter and Rola G-12 hi-fi speaker, in A-1 shape, \$150. F. Craven, 2216 S. 7th St., Philadelphia 48, Pa.

URGENTLY NEEDED—New or slightly used tubes; 1-6A8, 1-35L6, 2-25Z5, 1-6U5 or 6G5, and 1-6Q7; also other tubes, miscellaneous radio parts and used test equipment. Henry C. Loftland, H-16 Navy Way, Washington Terrace, Orden, Utah.

FOR SALE—Panel transmitter, phone and C.W.; also good assortment of transmitting parts, tubes, etc. Write for list. Pedro Rodriguez, Radio MOFW2, 1432 N. 7th St., Philadelphia, Pa.

WILL TRADE—V-O-M multimeter, 5000 ohms per volt; Precision tube checker #432; set of 12SA7, 12SK7, 12SQ7, 50L6, and 35Z5; Zenith ac-dc portable #5G-401M; and Westinghouse ac-dc #WR165. Urgently need Junior voltohmmyst, sig. generator, late model tube checker, and Rider manuals 9-12. Butler and Sporek, Suffolk Sanatorium, Holtsville, L. I., N. Y.

WILL EXCHANGE—All purpose set tester #048, in neat carrying case for AC operated sig. generator. Robert McMaster, P. O. Box 293, Live Oak, California.

FOR SALE—Radio parts, instruments, and tubes, including 12SK7, 12SQ7, 80 and 6SA7. Send for big list. John Trowbridge, Dept. SPC, 7936 Parnell, Chicago 20, Ill.

URGENTLY NEEDED—A.T.R. radio inverter #6-RSA or equivalent; also good recorder mechanism. Robert T. Hawk, Box 263, Dechord, Tenn.

FOR SALE—Meissner 17-tube television receiver #10-1153 in A-1 shape, \$150, less cabinet and tubes. Lester T. Grove, 400 White Horse Pike, Egg Harbor, N. J.

WANTED—Complete stock of tubes for radio service shop. What have you? K. C. Radio Service, 1127 Third St., S. E., Cedar Rapids, Iowa.

FOR SALE OR TRADE—P. A. horns and units 35 w. amplifier, 12 w. amplifier, C.B., CRA scope, Aerovox #75 bridge, Rider manuals 12 and 13, and crystal mike. Need VT voltmeter, 300 ohm P-P to speaker, trans. 80 w. capacity, and scarce tube types. Leo L. Bowman, Leo's Radio and Electric Service, Lewistown, Mont.

WANTED—Small portable radio and a pair of earphones. John Teglas, 613 Grant St., Niles, Ohio.

WANTED—Public address systems and speakers. Charles A. Govier, Merna, Neb.

URGENTLY NEEDED—Up-to-date all-wave sig. generator, tube tester for all tube types, and Philco dynamic signal tracer #930. Ray Fulton, Mohall, N. Dak.

FOR SALE—Weston 2" meters 0-1 MA., Weston 3" 0-50 microamp. RCA 885 tubes, 6L6 metal—all new. Regent Radio Shop, Inc., 800 Lexington Ave., New York 21, N. Y.

WANTED—Automatic device to turn radio on and off at a given time. Joseph R. Sidelko, 30 Main St., Luzerne, Pa.

FOR SALE OR EXCHANGE—Superior #1230 sig. generator, or will trade for two Rider manuals. Green Radio Service, 1127 W. 17th St., Muncie, Ind.

FOR SALE—Pair of 100 mfd. Hammarlund var. condensers, \$2; pair of Sylvania #210 tubes, \$2. Bou Radio Service, 3131 N. Percy St., Philadelphia, Pa.

URGENTLY NEEDED—Hallcrafters Sky Buddy, Sky Champion, Echophone, or Sky Traveler. H. Schneider, R. K. San., Plymouth, Wis.

WANTED—Radio oscillator and large V-O-M, 6 or 7. J. A. Brown, 315 Santa Fe St., Wynoka, Okla.

POSITION WANTED—Young man, 21, with 4 years electrical-radio training and still taking N.R.I. radio course, wants position in radio repair work in New York City. F. Telcher, 717 E. 175th St., New York 57, N. Y.

FOR SALE—Tube tester—set analyzer—volt-ohm-milliammeter—condenser tester. Supreme 385; like new. Also signal tracer volt-ohm-milliammeter. DC vacuum tube AC voltmeter; Hughes Mitchell X-EC frequency control unit. J. N. Blair, 600 City Bank Bldg., Kansas City 8, Mo.

WILL TRADE—Clough Brengle OM frequency modulated oscillator, perfect condition, value \$60, for straight sig. generator of equal value. Fred Sugbenal, c/o F. & J. Radio Shop, 6 W. Church St., Newark, Ohio.

WANTED—#30 tube. Will pay cash, or swap for any two of my RCA metal tubes or Philco glass tubes. D. Hartman, 410 W. Grace St., Richmond 20, Va.

FOR SALE—Supreme #502 analyzer. G. S. Bennage, Marlionville, Mo.

FOR SALE—Never-been-used Triplett #1230 r.f. sig. generator in original carton, battery operated, covering 100 kc through 18 mc, modulated or unmodulated by 400 cycle note. B. W. Wolfgram, c/o O. T. San., Battle Lake, Minn.

WANTED—Late model tube checker or combination tester for the repair of P.A. equipment. Rev. O. F. North, C. M., 7300 Weil Ave., St. Louis 19, Mo.

WANTED—68-w master beam power amplifier with crystal microphone, Jensen 18" high fidelity speakers, tandem turn tables; must be complete, in good working condition. John D. Foss, Box 1972, Oklahoma City, Okla.

FOR SALE—Two pairs of double headphones, \$1.35 each. Clifford Bryant, 1017-A West 37th St., Savannah, Ga.

FOR SALE—New HY815 and 9002 radio tubes. Fox Sound Equipment Co., 435 S. 5th St., Richmond, Ind.

FOR SALE OR EXCHANGE—3 new RK-51, 2-RCA 805, 8-VR 150, 6-VR 105, 2-RCA 812, 2-HK 24, 1-8" new Simpson D.C.M.A. 0-250, 1-0-300, 1-10 v. samp. fl. XFMR. Need 2-TZ-20 or 40; also 11Q-120X or NC-100 type receiver. N. V. Winton, 28 Columbia ave., Binghamton, N. Y.

WILL TRADE—12-0Z4 tubes, in original sealed cartons for good 35Z5, 35L6, 50L6, 25Z6 and 117Z6 tubes. Send list of tubes you need and suggestions for trade deal. Joe Bourgeois, Box 401, Port Orchard, Wash.

FOR SALE OR EXCHANGE—RCA #155A 3" cathode-ray oscilloscope—\$72 cash, or will trade for Precision EV-10 V.T. multi-tester, Hickok #202 multimeter, or RCP #4194 push button analyzer. Don Y. Yen, 343 Louis St., Rockford, Mich.

WANTED—Supreme 571 oscillator, Supreme 504-A or Precision 920 tube and set tester, 162-C Rider chalanalyt, a good V-O-M, and complete set of Rider manuals. Will consider late model substitute instruments of good make. G. I. Condrey, Route 8, Box 231, Richmond, Va.

FOR SALE—Complete parts for building a 100 w. transmitter, including Taylor tubes, 1-RK49 osc., 40 and 20 meter coils, crystals, etc.; also parts for 600 v. power supply. Bou Radio Repairs, 3131 N. Percy St.

WANTED—Late Hallcrafters SX-24, SX-25 or SX-28. Douglas Gregory, 4030 Lugo Ave., Bywood, Calif.

FOR SALE—New tubes in factory sealed cartons: 14-1LH4; 4-1D7G; 6-6L6G; 6-6SJ7GT; 10-6SK7GT; 5-14A7/12B7; 6-14H7; 4-1LA6. Want to sell lot intact. L. R. Beorden, Box 52, Llanos, Texas.

TO SELL OR SWAP—Rider manuals, Vols. 1 to 8, in good condition. Want good V-O-M meter with at least 10 meg scale. V. D. Walker, 716 North St., Pittsfield, Mass.

WANTED—A-1 sig. tracer of standard make, complete with instructions; also good condenser tester. A. C. Torstenson, 67 Hickory St., Harahan, La.

FOR SALE—Used Onan 110 v. AC 300 w. generator, 1800 r.p.m., \$30; small quantity new Sylvania Ken Rad tubes, 6N7, 1LH4, 7H7, 897J7, 7N7, 7V7, 6SC7, 12AH7, 12A5, 12SH7, 26, and 6L6G. Will swap popular types for 50L6, 35L6, and 35A5. Domangue Radio, P. O. Box 934, Houma, La.

WANTED—About 40 ft. shielded single-conductor rubber-covered cable; also good pickup—Audaux D-27E or equivalent. What have you. John R. Butler, 2630 Park Place, Madison 5, Wis.

YOUR OWN AD RUN FREE!

This is Sprague's special wartime advertising service to help radio men get needed parts and equipment, or dispose of radio materials they do not need. Send your ad today. Write **PLAINLY OR PRINT**—hold it to 40 words or less.

Different Trading Post ads appear monthly in Radio & Television Retailing, Radio Service-Dealer, Service, Radio News, and Radio Craft. Sprague reserves the right to reject ads which do not fit in with the spirit of this service.

When buying Capacitors—please ask for Sprague's by name. We'll appreciate it! **HARRY KALKER, Sales Manager**

SPRAGUE PRODUCTS CO., DEPT. S-124, North Adams, Mass.

(Jobbing distributing organization of products manufactured by SPRAGUE ELECTRIC COMPANY)

SPRAGUE CONDENSERS

* KOOLOHM RESISTORS

Obviously, Sprague cannot assume any responsibility, or guarantee goods, services, etc., which might be exchanged through the above advertisements

TRADEMARK REG. U. S. PAT. OFF.



ESMERALDA COPE HAS TWO JOBS . . .

Esmeralda Cope is one of many hundreds of women workers in the Detrola Radio Division who now are building land mine detectors, FM signal generators and other electronic war equipment. This job continues until Victory. But without detracting from this primary task, many of these workers are being acquainted also with their post-war assignments on the same production lines. Thus they will be ready to build hundreds of thousands of fine radio receivers, automatic record changers, television receivers and other products to enrich the life of a world at peace. Yes, Esmeralda Cope has two jobs. And International Detrola's creed of highest quality rules them both.

BUY WAR BONDS TILL VICTORY

DETROLA RADIO

DIVISION OF INTERNATIONAL DETROLA CORPORATION • BEARD AT CHATFIELD, DETROIT 9, MICH.

C. RUSSELL FELDMANN  PRESIDENT

Official U.S.
Marine Corps
photo



ATTACK . . .



calls for
ENDLESS SUPPLIES

Official U.S. Coast Guard photo

LET'S FINISH the fighting at the earliest possible moment. Let's back-up our fighting men with a never-ending flow of supplies—supplies purchased with your day-in and day-out sales of War Bonds.

Retailers of America, you can do a twofold job for the men who are fighting to protect your future.

By selling more War Bonds than before, you can help to save the lives of fighting men by making

them the best supplied fighters in the world.

By selling more War Bonds than before, you can help to build up the purchasing power needed to provide jobs for our fighters in the post-war period.

Remember, our fighting men will have earned a full share in post-war America. Earn yours. Drive your War Bond Sales to an all-time high.

Don't ease up—until the war is won!

The Treasury Department acknowledges with appreciation the publication of this message by

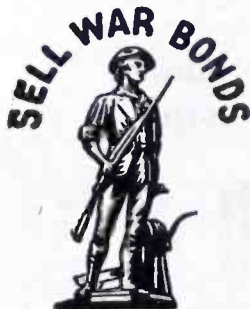

Back the Attack!
SELL MORE THAN BEFORE!

SERVICE

This is an official U. S. Treasury advertisement—prepared under the auspices of Treasury Department and War Advertising Council.

WHERE BUT MT. CARMEL

WOULD YOU EXPECT TO FIND
SKILLS LIKE THESE?



Sure, deft, hands—No compromise with quality here at Meissner as "precision-el" produces vital electronic war equipment.



Precisioneer—The years of experience this Meissner veteran brings to his job are just another reason why the Meissner products you use will do your job better.

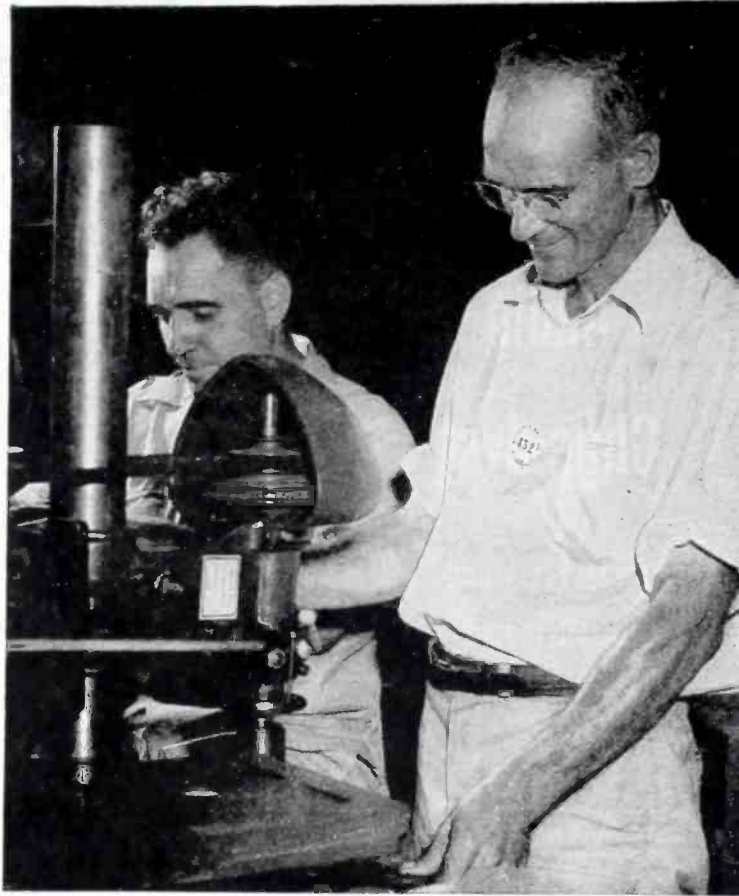

Concentration with a smile—One more reason for the precision performance of Meissner products. It's a smile of pride in a job well done that helps make personnel "precision-el."

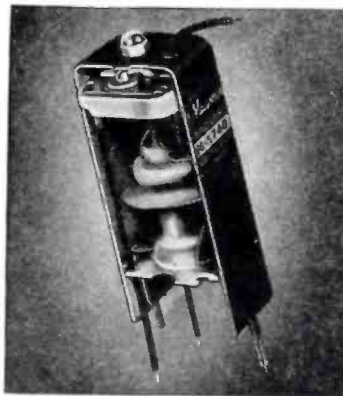

Easy Way To "Step Up" Old Receivers!

Designed primarily as original parts in high-gain receivers, these Meissner Ferrocart I. F. Input and Output Transformers get top results in stepping up performance of today's well-worn receivers. Their special powdered iron core permits higher "Q" with resultant increase in selectivity and gain. All units double-tuned, with ceramic base, mica dielectric trimmers, thoroughly impregnated Litz wire, and shield with black crackle finish. Frequency range, 360-600. List price, \$2.20 each.

MEISSNER

MANUFACTURING COMPANY • MT. CARMEL, ILL.

ADVANCED ELECTRONIC RESEARCH AND MANUFACTURE

Export Division: 25 Warren St., New York; Cable: Simontrice

RCA's New 170-A

Audio Chanalyst

Tests Everything
from Microphones
to Multiple Speakers



THE new 170-A Audio Chanalyst is a combination testing unit which includes the famous Voltohmyst circuit, a new diode flat through the audio range, a B.F.O. signal source, a gain calibrated amplifier, and speaker and line output connections.

The various channels of the RCA Type 170-A can be used independently or in unison to check

all common defects in audio amplifiers and sound systems. Polarity indication and a.c. can be determined instantly with the new electronic indicator, without danger of overload!

A pamphlet containing full description and specifications of the 170-A Audio Chanalyst will be sent gladly, on request.

Please use this coupon ↘

BUY MORE WAR BONDS



Test & Measuring Equipment, Dept. 97-87K
Radio Corp. of America, Camden, N. J.

Please send the bulletin describing the new RCA 170-A Audio Chanalyst to:

Name
Position
Company
Street City.....

RADIO CORPORATION OF AMERICA

RCA VICTOR DIVISION • CAMDEN, N. J.

In Canada:

RCA VICTOR COMPANY, LTD., MONTREAL

POSTWAR TRENDS

IN

SERVICE EQUIPMENT

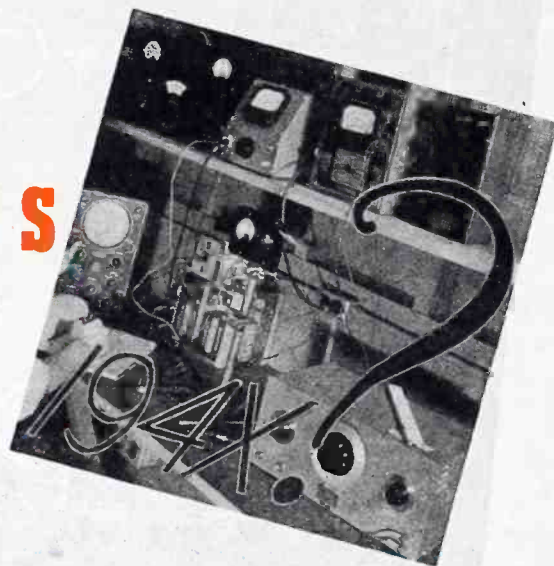

by **RAYMOND SOWARD**

Chief Engineer

Supreme Instruments Corporation

RECENTLY published statements* of service managers of many of the larger set manufacturers have indicated that soon after f-m and television equipment is made available to the public, the Service Man will be confronted with repair and maintenance problems far more difficult than any which he has had up to now. This need not mean that the Service Man should throw up his hands in dismay and decide that it all is getting beyond his ability to understand, and keep up with new circuits and equipment. But it will mean that he will have to devote more and more of his time to the study of data furnished on various receivers by the manufacturers, as well as methods of securing increased efficiency from the new test equipment which will be built.

For the past three years the Service Man has been unable to obtain needed service equipment, and there is probably not one service shop which does not need at least one new piece of equipment. Some need two, some need every piece of equipment replaced. Every Service Man is trying to make his present equipment last by makeshift repairs and substitution of repair parts until the *go-ahead* signal appears for manufacturers to release new equipment.

Most Service Men have been wondering what type of equipment will be offered and just what type of equip-

ment should be bought to handle the repair work. It is a certainty that both television and f-m will be introduced first in the metropolitan areas such as New York, Chicago, San Francisco and other large cities. Service Men in these areas naturally will be called upon first to service and install this new equipment. Gradually then, f-m will appear in other cities and perhaps a year or two after V-Day f-m will appear in the smaller towns. As for television, unless some hitherto unrevealed relay system is used, its reception will be possible only in the larger and medium size cities for several years to come. This will be mandatory because of: (1) the considerable expense involved in the installation and maintenance of proper studio facilities; (2) the limited coverage of the television signal, inherent to the frequencies assigned to it; and (3) the need of an area of high listener concentration to justify the sponsor expenses.

The Service Man, in deciding upon the equipment he will need then, should consider his location. If he lives in one of the small towns he will not find it necessary to buy the *whole book* being offered him. It may be several years before television will be avail-

able in his town and *specialized* equipment for servicing television equipment therefore would not be too essential for his immediate work. On the other hand some of the equipment he does buy can be selected so it will not only do the job on hand, but serve f-m and television sets when they do appear.

In the following paragraphs appear a projected outline of the type of equipment which will be best suited to service the new receivers. No hard-and-fast-rules are intended in this presentation.

Present A-M Receivers

Very little need be added to what has already been said concerning proper test equipment to use on present receivers. It is felt, though, that there are two instruments which have not been used to the best possible advantage in rapid location of trouble. They are the electronic voltmeter and the oscilloscope. This is probably due to their limited manufacture. In addition, the operation and use of these instruments have not been understood well enough by the Service Men except for visual alignment of the larger receivers. It has been found that the use of the electronic voltmeter greatly speeds the location of incorrect operating voltages (and at the same time defective parts), because the indication which

(Continued on page 28)

VACUUM-TUBE VOLTMETER

Built With Parts Around Shop

ohms for the *zero* resistor be used. With these approximate values the meter pointer is set at zero or center scale of the normal zero-left instrument. Then the check switch is thrown to the *test-cal* position. If you are the only lucky fellow in the world the meter will indicate 1.1 volts on the 5-volt scale. However, if you are only human it will be necessary to make a few adjustments. The calibrating resistor (cathode resistor) is increased slightly in value. Then the meter is again adjusted for zero position (the check switch having been placed in the *vm* position first). Then the check switch is thrown to the bias cell and the reading checked. From the value of this reading it can be easily determined whether the calibration is approaching the correct value or going the wrong way and corresponding changes made in the cathode resistance. It must be remembered that in every case of the slightest change in the cathode resistor the zero setting resistor must always be reset. It is suggested that the cathode resistor be mounted within the cabinet or a slotted shaft be used so that it cannot be inadvertently changed. Double weight photographic paper makes an excellent material for a new dial and black India ink flows well on this paper.

To extend the usefulness of the instrument, an a-c rectifier probe was constructed by using an old tube socket and base as connectors, together with a type 6C6 as rectifier. A recent article concerning adaptors for the *voltohmyst* suggested the modernization of this portion of the instrument. The 6H6 is used as a diode, one section rectifying the incoming voltage and the other section rectifying the noise voltage or providing enough voltage to *wash out* the effect of the contact potential of the tube. The

Fig. 2. Front view of the shop-built instrument. Probe is at left. While parts and values described offered excellent results, it is possible to apply other combinations of parts that may be on hand, provided their values are in accordance with circuit requirements.

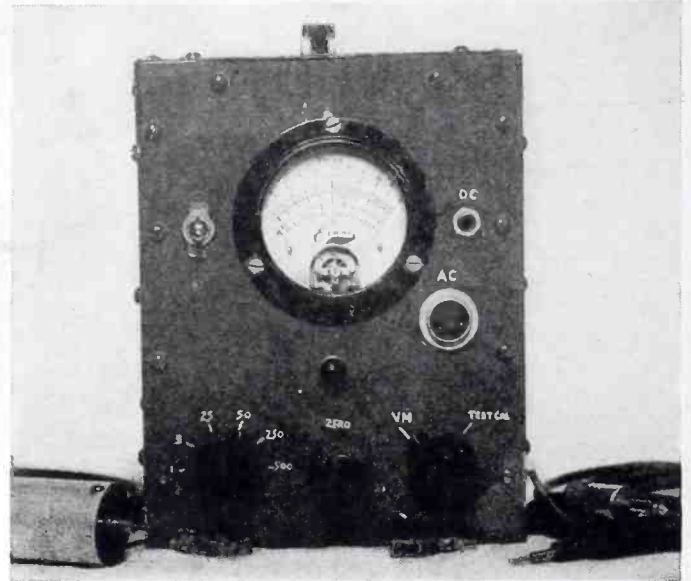

value found most suitable was 35,000 ohms. When the probe was first hooked up a variable 50,000-ohm unit was wired in and adjusted until the meter reading was zero. This value was found to be about 36,000 ohms; however, the 35,000 fixed resistor did the job.

It may be that the ranges selected in this instrument would not be satisfactory to all. An explanation of the method used to determine the multiplier values might be of interest. One should first decide upon the R/v , the type tube to be used and the necessary limit to the applied E_k to permit working over the straight portion of the I_p curve. A 6J5 type was selected because it would be satisfactory and also because it was on hand. The R/v decided upon was 12.5×10^6 or 12.5 megohms-per-volt. This high value was convenient in computing values of the divider. In addition, this would introduce very little loading upon the circuit to be checked. Ohm's law is the only formula used in computing the values of the resistances. Since I

is in milliamperes and R and E are in units, it becomes necessary to multiply the values by 1000 or 10^3 and our equations become

$$(a) R = \frac{E}{I} \times 10^3 \text{ and } (b) I = \frac{E}{R} \times 10^3.$$

$R(\text{total})$ then is 125×10^7 or 12.5 megohms.

The value of the first multiplier is found by dividing the applied voltage by the current in the circuit. The current in the circuit is found by dividing the voltage by the total resistance of the divider, and in each case the result is multiplied by 10^3 . When this value of I is substituted in (a), the resultant R becomes the value of
(Continued on page 30)

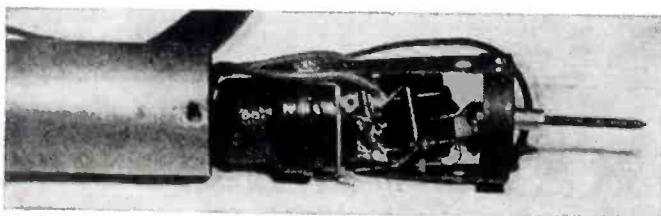

Figs 2 (left) and 3 (right). Fig. 2, the a-c probe. Fig. 3, interior of vacuum-tube voltmeter.

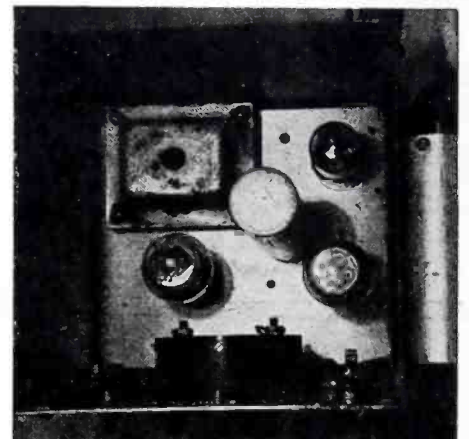

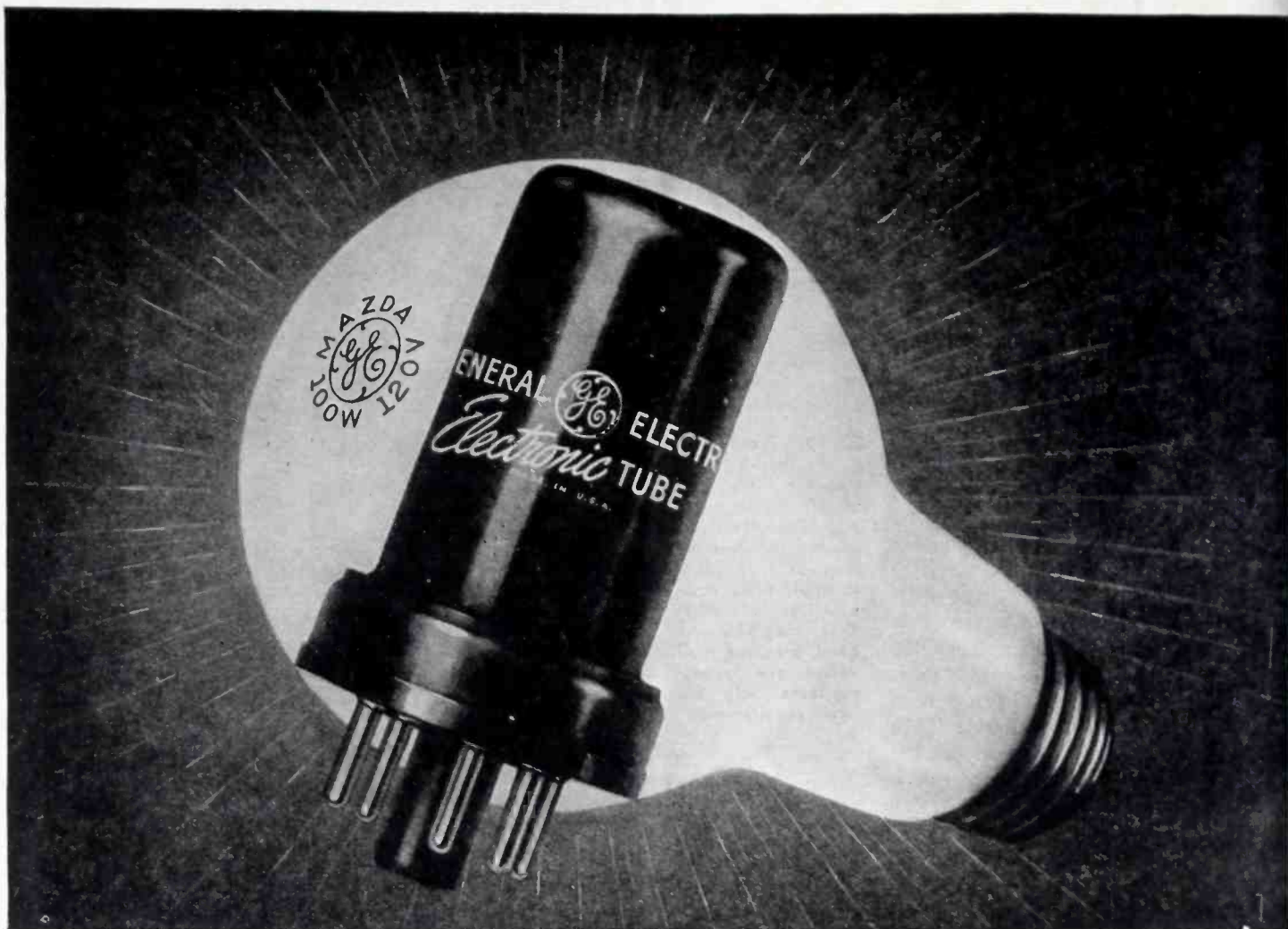

YOUR COMING BEST SELLER!

— a forecast of your future electronic tube business



A little G-E symbol goes a long way—into the homes, stores, factories and farms of millions—into the confidence of a buying America that has learned to depend on G-E MAZDA lamps as it does on sunlight.

General Electric Research stands back of the quality which has built the wide public acceptance for G-E MAZDA lamps. And it is also at work on G-E

electronic tubes. The same effective advertising is carried to consumers through national advertising media. Consequently, G-E electronic tubes are earning the same consumer confidence now given to the famous G-E MAZDA lamps.

Today, the market for electronic tubes in communications and industry is growing rapidly. Tomorrow, these growing markets will combine with FM broadcasting, Television and electronic appli-

cations to vastly increase your replacement-tube market.

Plan now to profit from this growing demand by selling the complete line of G-E electronic tubes. *Electronics Department, General Electric, Schenectady 5, N. Y.*

Tune in General Electric's "The World Today" and hear the news from the men who see it happen, every evening except Sunday at 6:45 E.W.T. over CBS network. On Sunday evening listen to the G-E "All Girl Orchestra" at 10 E.W.T. over NBC.

There's a G-E Electronic Tube for Every Purpose

GENERAL  ELECTRIC

176-C7-0850

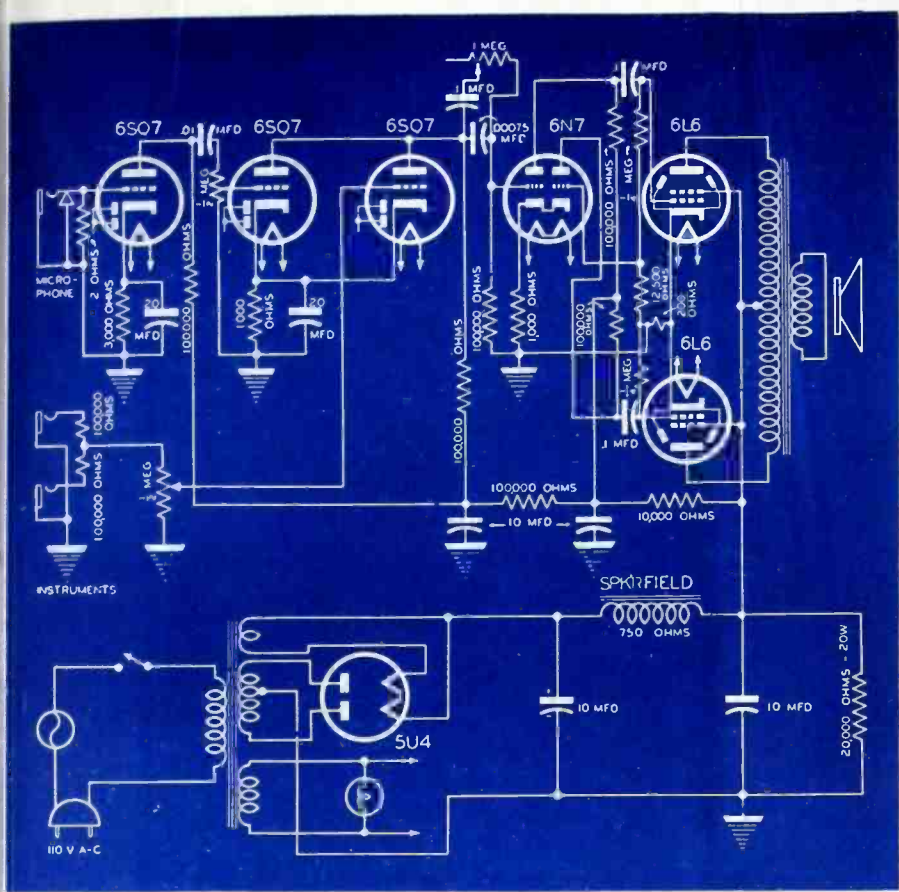

Fig. 1, below. Functional diagram of electronic system used to build up musical instrument volume.

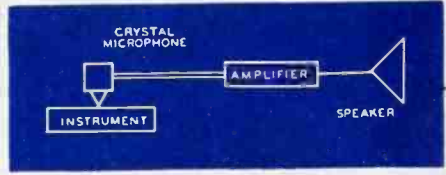

Fig. 2, left. Gibson EH-150 musical instrument amplifier, with many flexible features. Low level of crystal microphone may be increased by 6S07 pre-amplifier, which drives a 6S07. Output level of microphone may be -50 db. Electronic mixing is also possible; one volume control being used for microphone level and another for instrument level.

ELECTRONIC MUSICAL INSTRUMENTS

by WILLARD MOODY

STRING instruments employing pickups and audio amplifier-speakers for reproducing sound, have many unique mechanical and electronic features of particular interest to Service Men. One of the most popular of these *electronic* instruments is the *electronic guitar*.

The basic arrangement used is shown in Fig. 1. A pickup, which may take the form of a small crystal mike designed expressly for such service, is fitted to the guitar. The light weight of the mike is an advantage since it does not interfere with the handling of the instrument and is small in size. Electromagnetic pickups and carbon button mikes have been used, but both have disadvantages. The carbon but-

ton type is noisy, while the electromagnetic type has a low impedance, requiring a transformer to match the amplifier input impedance. Weights of both are not too desirable either.

An amplifier of modern design, Gibson EH-150, is illustrated in Fig. 2. Three input jacks are provided. The low level of a crystal mike may be built up by the 6S07 pre-amplifier which drives a succeeding 6S07 having a volume control in the grid circuit. The output level of the mike may be of the order of -50 db with reference to standard level of .006 watt. Electronic mixing is possible, since the amplifier has two volume controls, one to control mike level and the other to control instrument level. Thus, it is possible to fade down an instrument, make an announcement and then bring up the instrument gain for the musical part of the program. Artistic effects may also be worked

out in vocal-instrument combinations. The 6S07 plates work into the 6N7 which functions as a combined voltage amplifier and phase inverter. The 6L6 tubes in push-pull class A have plenty of undistorted power output. A husky 5U4 is used as a rectifier. Large values of capacitance are used in the 6L6 grid circuits to provide bass notes response. The tone control, too, is somewhat better than average. A .1-mfd condenser is in series with a variable 1-megohm resistance. With the resistance at maximum value, a high pitched tone thus is provided, and as the resistance is reduced in value the shunting of the .1-mfd unit becomes more effective, allowing more of the audio frequency energy to get through to the 6N7 grid circuit.

Another type of amplifier, Vega 180, is illustrated in Fig. 3. Three input jacks are provided. Here, again, elec-

American OUT IN FRONT!

Whether it's the philharmonic, oratory, news, public address, sportscast or commercial, the quality of the program that goes through depends **first** on the microphone **OUT IN FRONT!**

D5



D5-DYNAMIC—An ideal microphone for general use, due to its versatility and dependability. Microphone contour and diaphragm protective grille designed to minimize wind noise and sound field distortion. Recommended for close talking as well as distant sound source pick-up.

D9A UNIDIRECTIONAL DYNAMIC—A pressure-velocity combination microphone, will pick-up from front only, broad frequency response and high output, should fill the majority of requirements. Especially recommended for indoor use due to feed-back reduction and elimination of extraneous pick-up.

D9A

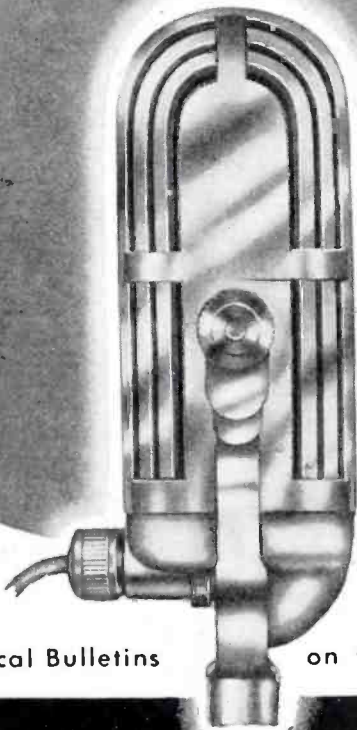

There it stands, unattended, with the whole show going on. It just **has** to be dependable. It just **has** to have full range for the job.

D3

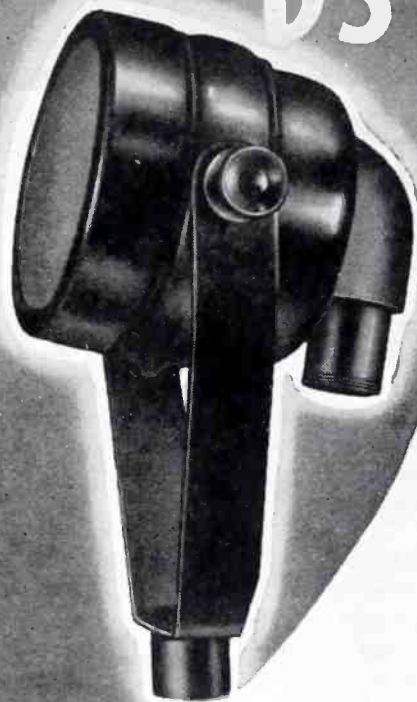

D3 DYNAMIC—Recommended for those microphone applications where high fidelity (uniform response from 50 to 10,000 cps) is of prime importance. Attention to detail in design and construction of each microphone insures stable operation and optimum performance for all types of audio pick-up.

Write for Comprehensive Technical Bulletins

on these and other American Microphones.

American MICROPHONE CO.

1915 So. Western Avenue, Los Angeles 7, California

H I G H F I D E L I T Y

AND

T O N E C O N T R O L

by EDWARD ARTHUR

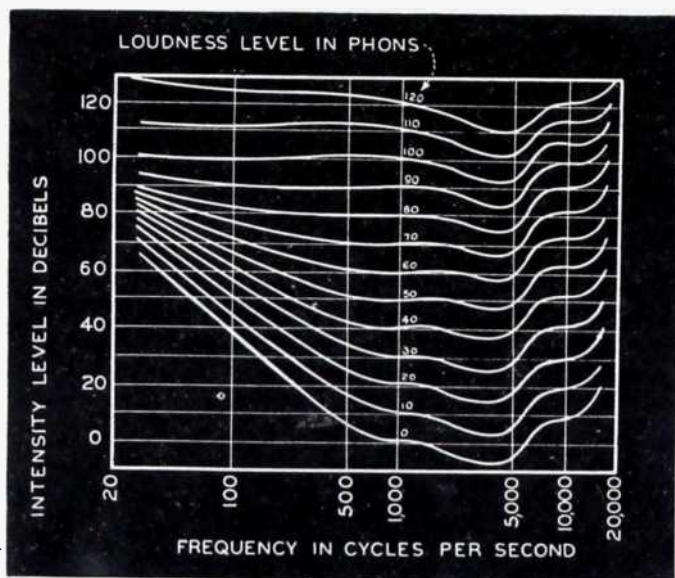

Fig. 1. Chart of relative frequency response of the ear for varying sound levels. Note poor response for both extremes of audio spectrum.

(Feltcher-Munson, J.A.S.A., Oct. 1933)

POSTWAR receiver plans indicate that tone quality will be quite a major feature. F-m, of course, will contribute its share toward tone quality emphasis. The projected interest in this phase of receiver design will prompt many problems that only a substantial knowledge of sound will solve. A review of some of the basic principles of sound and application data that would be of assistance in solving these problems therefore appears to be a *must* on the Service Man's program.

To assist in this important program, a brief review of the essentials are offered in this article. In our approach we will review the physical aspects of sound from the time it originates in the broadcast studio, trace its path through the transmitter and receiver into the sound reproducer, the room in which the receiver is installed, and, finally, the ear of the listening public. In addition, design methods of tone control will be discussed, as well as an analysis of some commercial systems.

Any audio frequency has two important characteristics, its frequency and its amplitude, or volume level. For high fidelity, it is important that the final signal contain all the audible frequencies of the original signal transmitted at their relative amplitudes. Again, frequencies not present in the original, should not appear in the final signal. For *best* or *ideal* reproduction of both speech and music, a frequency range of 30-15,000 cps is essential.

The relative amplitude range at the

point of transmission varies from 70 watts for a full orchestra, to .05 watt for a triangle. However, the limitations imposed by the components involved in both transmission and reception, limit both the frequency range and the amplitude range.

A highly fidelity a-m broadcast station is limited in its audio frequency range of transmission to 30-90,000 cps, because of federal regulations limiting the side band transmission by ten kc. In addition, the amplitude range must be compressed, since background noises would override the low intensity audio signals, and the high amplitude levels would tend to overmodulate the transmitter, creating serious audio distortion, or causing possible station failure. Other factors influencing the fidelity of transmission are the particular microphone used by the studio, the studio from which the transmission takes place, and the attenuation factor and frequency characteristic of the lines over which the signal is piped from the studio to the transmitter.

F-m transmitters have a *possible* audio range of transmission of 30-15,000 cps. Because of the limited action of the f-m receiver, the signal-to-noise ratio is better than in a-m systems, and the signal distortion less than 2%.

A-m receivers limit the ultimate

audio-frequency response. Detuning effects in the r-f and i-f sections of the receiver due to variations in signal amplitude, AVC action, and the voluntary limiting of side-band response to reduce monkey chatter, or cross talk, create signal distortion even before detection takes place. In f-m receivers, the r-f distortion is reduced so as to be a negligible factor.

Audio amplifiers may be designed to have a flat-response characteristic from 30-15,000 cps, so that distortion in this part of the circuit can be ignored. Modern diode-detector circuits can be controlled, so that the distortion in this part of the receiver is also a negligible factor.

The loud speaker and its associated equipment, such as the cabinet in which it is mounted, or the sound diffusers used with it, is the final unit associated with the electrical system of sound reproduction. The fidelity of this unit can be controlled within fairly narrow limits by design and construction. Multiple speakers, to give adequate response to the entire audio spectrum, or sound diffusers incorporated in the cabinet design to permit more uniform distribution of energy, are essential components of all high-fidelity systems.

The final factors involved, are the room in which the loud speaker has been installed, and the hearing ability of the person or persons listening.

The furniture, rugs, and draperies in a room, the size of the room, the position of the listener with reference to the sound source, all exert a great in-

AFTER VICTORY

Cunningham Radio Tubes



**STANDARD
SINCE 1915**

*PREFERRED BY SERVICE MEN
FROM COAST TO COAST*

63-6731-24

A QUALITY PRODUCT OF THE RADIO CORPORATION OF AMERICA

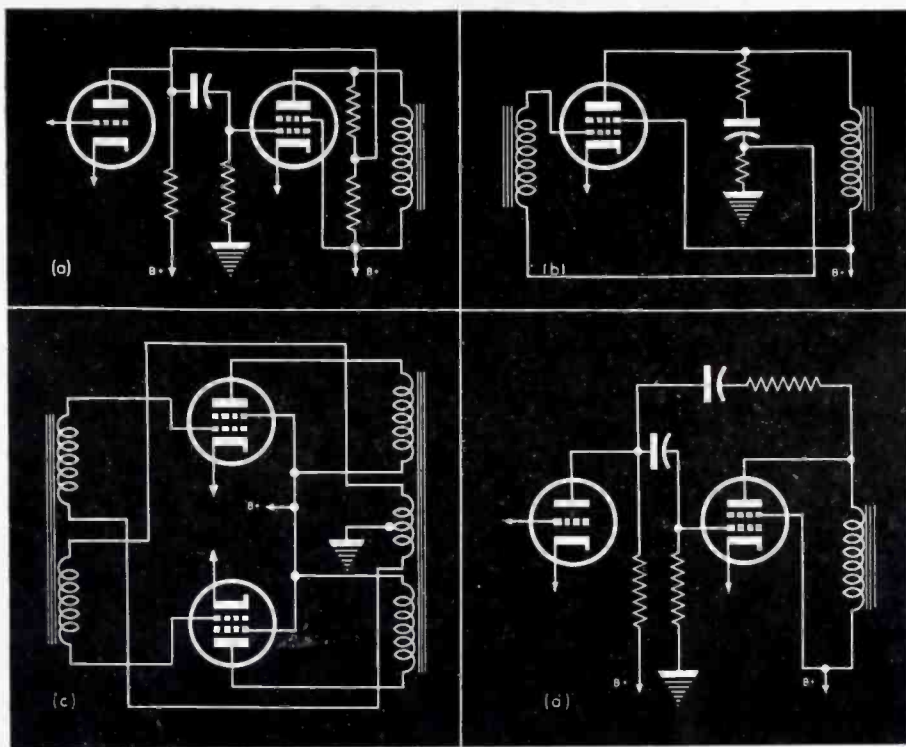

Fig. 2. Various systems of inverse feedback. Most of these systems operate in the final stage of the a-f amplifier.

cps for the lower end, and 9,000 and 10,000 cps for the upper end. A note should be made that satisfactory *speech* reproduction limits are 200-3,000 cps.

Harmonic distortion may also be tolerated within limits. These limits depend, to some extent, on the frequency bandwidth being used. A narrower bandwidth permits more harmonic distortion, since not only are the higher frequencies removed, but the harmonics of the lower frequencies present in this upper range are also silenced. For high fidelity, the total harmonic distortion (that is, 2nd, 3rd, . . . 6th) should be less than 5%. This range may vary to 10 to 12% for fair fidelity.

Amplitude distortion is not necessarily an evil, since it is a function of tone control. As shown in Fig. 1, the ear responds unequally to both ends of the tone scale, depending on the amplitude. Since most music is produced at higher levels than it is reproduced, it becomes necessary to compensate for the frequency characteristic of the ear with a change in level. It is important that we do *not* overemphasize the non-linear ear reaction at a particular reproduction level, since the reaction of the ear to the original signal would have the same non-linear frequency characteristic. Therefore, it should be borne in mind that the difference in audibility for both extremes of the audio range accompanying a change in level, is the most important characteristic of the ear.

It is an anomaly that for high fidelity, it is necessary to have an amplifier with a flat response characteristic to the audio range, and then proceed to distort it with tone control. Tone control, in other words, is a method for compensating for:

- (1)—The non-linear ear characteristic.
- (2)—Amplitude distortion inherent in both the transmitter and receiver.
- (3)—The room in which reproduction takes place.
- (4)—The individual hearing ability and taste of the listener.

A flat-response characteristic is obtained by proper design of the audio components. To facilitate this design, and reduce harmonic distortion, negative or inverse feedback is often employed, Fig. 2. This is accomplished by feeding back a portion of the output of a tube to the input of that
(Continued on page 22)

fluence on the audibility of various portions of the audio spectrum. It should be noted that the relative amplitude of the various audio frequencies is here involved, and not the fidelity of the frequencies themselves. In general, it may be said that more uniform response is obtained when the sound source is installed in a corner facing the center of the room.

One factor not previously discussed, and possibly the most important, is the hearing ability of the listener. Individual abilities vary widely. There is a progressive deterioration of hearing ability with age. This is particularly true of the ear response to the upper registers. A surprisingly large percentage of people are tone deaf in varying degrees.

Given a person of normal hearing, the response of the ear to frequencies between 30-15,000 cps varies, so that maximum response seems to lie between 3,000 and 4,000 cps. The second and more important factor in relation to receiver design, is that this variation in ear response is a function of volume level, Fig. 1. From this empirical chart, it can be seen that hearing response is poor at low frequencies at low levels, and improves as the amplitude is increased. High-frequency response likewise improves with amplitude, but not as rapidly.

A third factor is the influence of the duration of listening. Hearing acuteness decreases with time, due to fatigue.

The enumeration of these problems is not intended to discourage, but rather to point out the obvious need for some system of audio-amplitude

control, which would control the relative response of the various portions of the spectrum, in order to overcome these problems.

It is quite difficult to determine just what high-fidelity reproduction means, since there are so many factors affecting a signal between the time it first is produced at the studio, and finally arrives to the listener. Two facts should be noted. Poor fidelity tends to tire the listener. Again, the listener, individually, is the final judge of whether the reproduction is good or bad. Here, the hearer may be influenced, since he will recognize better fidelity when it is compared to poor tone.

There are three factors that influence fidelity:

- (1)—The percentage of the frequency range of the original present in the final signal.
- (2)—The frequencies not present in the original, but found in the final signal (harmonic distortion)
- (3)—The relative amplitudes of the various frequencies in the original, and their relative amplitudes in the final signal.

As previously stated, *perfect* reproduction involves a frequency range of 30-15,000 cps. However, the extreme frequencies may be eliminated, and satisfactory reproduction will still be obtainable. To gain some idea of this, 95% quality may be obtained in orchestral music with a frequency range of 70-10,000 cps, 90% with a range of 90-8,000 cps. Authorities differ, but the limits for good reproduction would seem to lie between 90 and 100

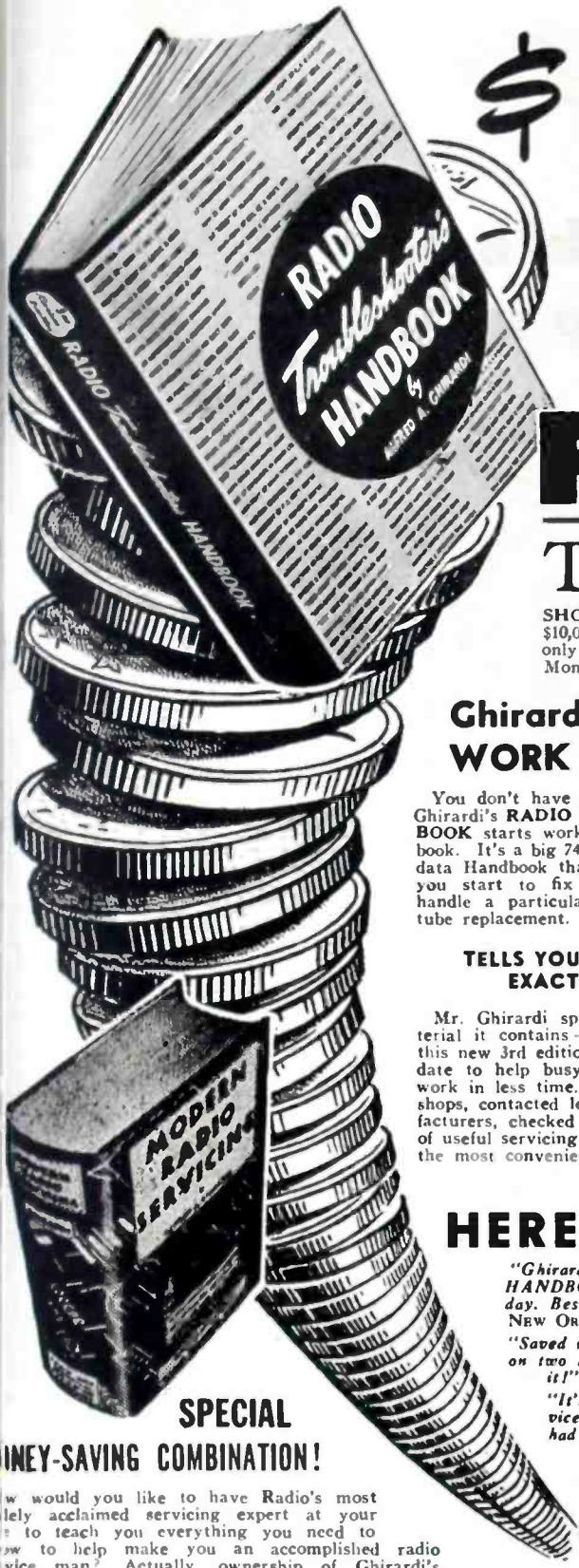

\$ 10,000 WORTH OF HELP FOR YOU!

THE kind of practical, down-to-earth help busy servicemen need these days doesn't grow on trees. It takes plenty of time and money to produce! Actually well over \$10,000 in cash plus months of work by A. A. Ghirardi, Radio's foremost servicing expert, went into this new 3rd Edition of A. A. Ghirardi's **RADIO TROUBLESHOOTER'S HANDBOOK**—before a single book was printed! Just think of it! Over \$10,000 of the finest time-saving servicing helps money can buy—and you get them all for only \$5 complete (\$5.50 foreign). What's more, you can see the book first! Our 5-day Money-Back Guarantee is your absolute protection!

Ghirardi Helps You SPEED UP! . . . DO MORE WORK in Less Time . . . MAKE MORE MONEY!

You don't have to spend hours of study before Ghirardi's **RADIO TROUBLESHOOTER'S HANDBOOK** starts working for you. It isn't a "study" book. It's a big 744-page manual size, "on-the-job" data Handbook that you turn to **FIRST** whenever you start to fix some particular radio set, or handle a particular type of trouble, or parts or tube replacement.

reference . . . all thoroughly indexed! Nine times out of ten the Trouble Case Histories in Ghirardi's Handbook will tell you **exactly** what is wrong with an ailing receiver and **exactly** how to repair it promptly and directly—usually without any testing whatsoever. Over 400 pages are devoted to these Trouble Case History compilations alone! 4,820 models are covered!

TELLS YOU JUST WHAT TO DO—EXACTLY HOW TO DO IT

Mr. Ghirardi spent years in collecting the material it contains—plus months more in revising this new 3rd edition and bringing it strictly up-to-date to help busy wartime servicemen do better work in less time. He visited hundreds of service shops, contacted leading receiver and parts manufacturers, checked carefully on every available bit of useful servicing information—and prepared it in the most convenient possible form for quick, easy

reference . . . all thoroughly indexed! Going far beyond this, however, you'll find hundreds of additional pages of charts, diagrams, compilations, tables, tube or part substitution data or bits of information you require in your daily work. Most servicing problems that you face are covered in this **ONE** convenient Handbook.

MONEY-BACK GUARANTEE

In brief, the Handbook is so extensive, so complete, we much prefer to have you see it and judge for yourself for 5 days. Send the coupon today! Then if you are not more than satisfied, we'll gladly return your money and no questions asked. What could be fairer than that?

HERE'S PROOF!

"Ghirardi's **RADIO TROUBLESHOOTER'S HANDBOOK** paid for itself the very first day. Best book I ever bought!" C. G. ROBERT, NEW ORLEANS.

"Saved more than the price of the Handbook on two different jobs. Wouldn't be without it!" B. J. ABELL, DETROIT.

"It's a treasure storehouse for any serviceman! I quickly found information I had been looking for for two days and

solved a tough job. Ghirardi is a star!" R. E. LOCKE, CALAIS, ME.

"Cuts servicing time in half!" C. VAN HOLLAN, SUPERIOR, WIS.

"The first day I got the Handbook, it helped me to repair four radios within 3 hours—radios which I couldn't ordinarily fix in 3 days." M. J. PENCZAK, LAWRENCE, MASS.

"This book is a 'MUST' for every serviceman—just what I have been searching for. It would take me years to accumulate the information that is now at my fingertips!" JOHN E. MORGAN, DORCHESTER, MASS.

SPECIAL MONEY-SAVING COMBINATION!

How would you like to have Radio's most highly acclaimed servicing expert at your side to teach you everything you need to know to help make you an accomplished radio service man? Actual ownership of Ghirardi's **MODERN RADIO SERVICING** means just about that!

The Only Complete Book of Its Kind

This famous 1300-page book is the only single, inexpensive volume giving a thorough course in modern Radio service work—explanation of the workings of all Test Instruments; Receiver Troubleshooting procedure; Circuit Analysis; Testing and Repair of Component Parts; Installation; Adjusting; Maintenance, etc. Contains 706 illustrations, 720 self-testing review questions, 766 different topics. Sold singly for only \$5 (\$5.50 foreign)—or sold on our special Money-Saving Combination Offer with the above **RADIO TROUBLESHOOTER'S HANDBOOK**—a big \$10 value for only \$9.50 (\$10.50 foreign). Use coupon today before the paper shortage limits available supply!

FEATURED BY LEADING RADIO JOBBERS

5-DAY FREE TRIAL OFFER

RADIO & TECHNICAL DIVISION of Murray Hill Books, Inc.
 Dept. S124, 232 Madison Ave., New York 16, N. Y.

Enclosed find \$5 (\$5.50 foreign) for Ghirardi's 3rd Edition **RADIO TROUBLESHOOTER'S HANDBOOK** postpaid; or send C.O.D. (in U.S.A. only) for this amount plus postage. If dissatisfied in any way, I may return the book at the end of 5 days and receive my money back.

MONEY-SAVING COMBINATION—Check here if you wish to buy both the **RADIO TROUBLESHOOTER'S HANDBOOK** and **MODERN RADIO SERVICING**. \$9.50 enclosed (\$10.50 foreign) or send both books C.O.D. (in U.S.A. only).

Name

Address

City (and Dist. No.) State

REPAIR ANY KIND OF RADIO EQUIPMENT—Easier—Better—Faster!

★ In Your Behalf ★

A dependable OSCILLOGRAPH

R. F. O.-5

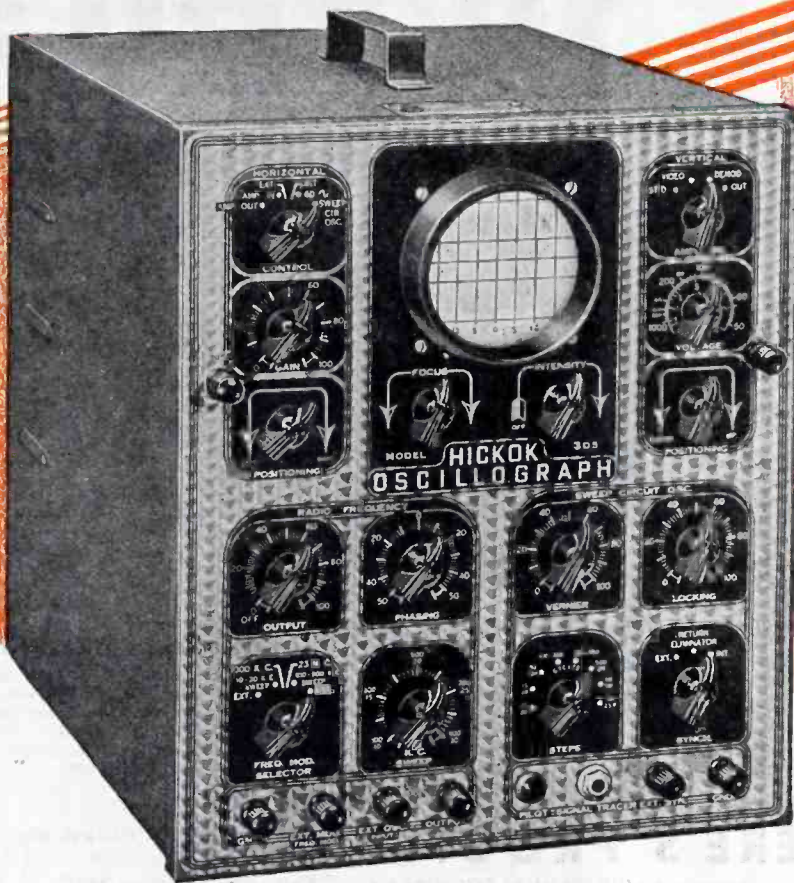

The HICKOK OSCILLOGRAPH R.F.O.-5 is especially designed for frequency modulated, amplitude modulated, and television service. This is your instrument for COMPLETE VISUAL ANALYSIS.

Self-contained Wide Band and Narrow Band F. M. Oscillator, Demodulator, Video Amplifier, Signal Tracer, Visual A.C. Vacuum Tube Voltmeter. It features high sensitivity amplifiers, returns trace eliminator, calibrated screen, variable width frequency modulated oscillator, pilot light and phasing control.

Power supply, 110 to 120 volts, 50-60 cycles. Size, 11" x 13" x 15 1/4". Finished in baked crackle lacquer. Shipping weight, 55 lbs. Shipped on WPB authorization 3243. Otherwise, orders must be accepted for shipment after WPB restrictions are removed. Advise whether you wish New METER Catalog or New RADIO SERVICE EQUIPMENT Catalog.

THE HICKOK ELECTRICAL INSTRUMENT COMPANY
10521 DUPONT AVENUE CLEVELAND 8, OHIO

THE STANDARD OF QUALITY
FOR A THIRD OF A CENTURY

HICKOK

(Continued from page 20)
tube in such a manner as to cancel, buck out, a portion of the input driving power. It is usually employed in the final stage. The benefits to be derived from this procedure are, most uniform frequency response, reduction of stage hum and harmonic distortion and reduction of *hangover effect*. A secondary result is the reduction of stage gain, which is not necessarily detrimental, since most receivers have more than ample output. This latter effect is usually overcome by increasing the driving power to that stage. (The average radio is operated in the home at a volume level of less than 1 watt, and generally, less than 1 watt.)

Hangover effect is due to a speaker cone resonating at its natural period. It is most prevalent when the output tube has a high plate resistance. Since inverse feedback also reduces the apparent plate resistance, the shunting or loading effect of the tube is increased, with a consequent reduction in hangover or speaker boom. Some receivers use transformer coupling for inverse feedback, Fig. 2c. The theory is still the same; feeding back a cancelling voltage out of phase with the input voltage. Bass compensation, to give a rising characteristic to the low frequencies, may be incorporated in the feedback circuit, by the proper proportioning of the resistive and capacitive elements, Fig. 2d.

Bass boost, as differentiated from bass compensation, is the accentuating of frequencies in the range of 60-250 cps. Most bass-boost systems involve the use of inductance to give a sharply rising characteristic to those frequencies below 250 cps. This is necessary, particularly at low volume settings, because of the ear response.

Bass or treble compensation for low level operation is usually incorporated in the volume control, Fig. 3a,b. The particular point on the volume control where it is installed is a function of the level of the incoming signal, and is determined from tests conducted by the design engineers. For this reason, it is important that an identical control be used where replacement is necessary. Fig. 3a shows a bass compensation system, and Fig. 3b a more ideal system for both bass and treble compensation.

Tone controls may be divided into two classes. One is the fixed type where point switching changes the response; the other is the continuously variable type where potentiometers are used to regulate the amount of bass or treble compensation. Console models sometimes use one or the other or a combination of both methods.

Tone control circuits are a combination of resistance, capacitance, and in-

distance, in such relation, that their damping effect on a circuit varies with frequency, Fig. 4.

resistors, at audio frequencies, display no frequency characteristic; that is, their resistance remains constant over the frequency spectrum.

condensers vary in reactance (a-c resistance) inversely with frequency; that is, their resistance increases as the frequency decreases.

inductances vary in reactance directly with frequency; that is, their reactance decreases as the frequency increases.

Since the gain of an amplifier stage is a function of the load across the output of that stage, it is possible to vary the stage gain for various portions of the audio spectrum by the appropriate association of resistance, capacitance, or inductance. The above is true where the control is in parallel with the load. By the same reasoning, the transfer characteristic of an audio stage may be made non-linear by the introduction of capacitive and inductive elements, in inverse position to their parallel operation. This is demonstrated in Fig. 4, where the function of an inductive element in parallel operation is duplicated by a capacitance in series operation.

Fig. 4 shows six basic types of tone control. It will be noted that all of these types are lossier systems. That is, the boosting is accomplished by reducing the level of the unwanted frequencies. The resistors act as variable controls to influence the amount of bass or treble boost desired. The same circuits may, by inverse reasoning, also be designated as damping circuits; a bass-boost may be called treble damper. A tone circuit designation is a function of the frequency characteristic of the amplifier. For example, a bass-boost system may actually be a treble control, if the bass-boost position is the zero spot on the control. An advance of the potentiometer may introduce resistance into the circuit, reducing the bass effect of a condenser, thereby increasing the treble response.

The circuits shown in Fig. 4 are basic, and are usually present in one form or another in the tone-control systems of most receivers.

Incidentally the values associated with a tone-control system are a function of the tube input and output impedances. Since the action of a tone control is a function of constant voltage, the load presented by the tone circuit must be several times as great as the plate resistance for a triode, or the plate-load resistance for a pentode. In Fig. 5 appear some typical examples of tone-control systems. Fig. 6 shows the tone control system em-

Fig. 3. Two methods of bass compensation are shown in a and b. Method shown in a is a popular method; b method offers both treble and bass compensation.

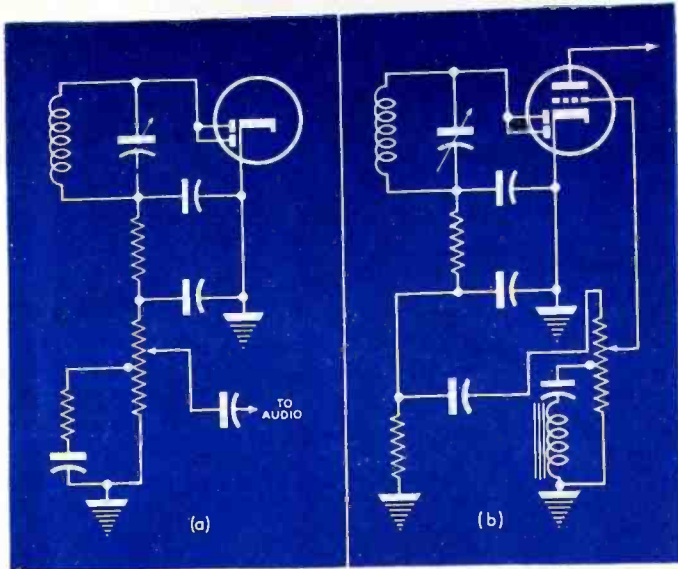
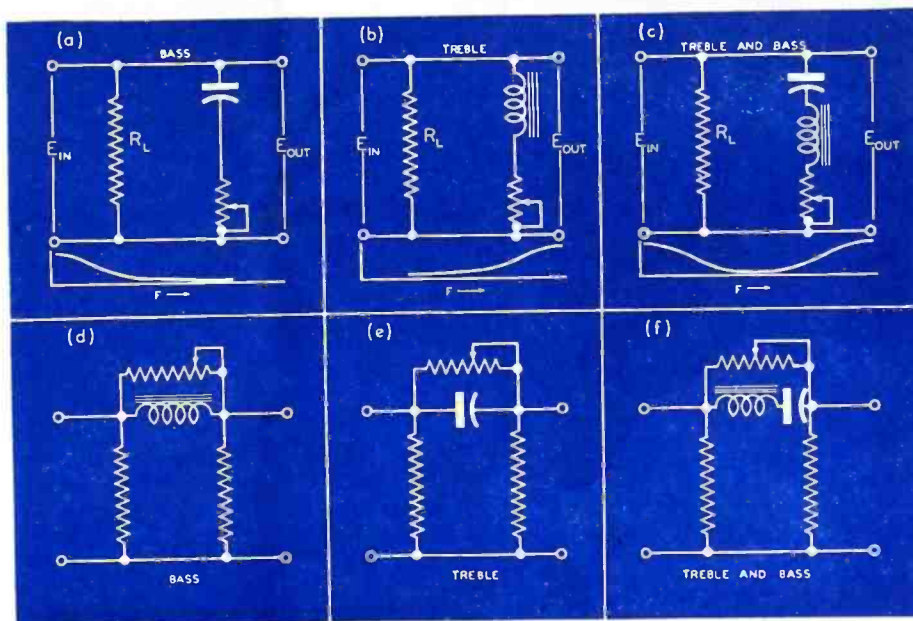

Fig. 4. Six basic methods of tone compensation are illustrated here. Frequency response curves of methods shown in a, b and c also appear. All of these systems are of the lossier type, with boosting provided by reducing level of unwanted frequencies.



ployed by G. E. in their model 35. In position 1, the circuit is normal; that is bass compensation is operating in the volume control and bass boost in the audio. This might be compared with the system shown in Figs. 3a and 4a. In position 2, R_2 is shorted, and the treble is further attenuated by having the full effect of C_2 from plate to ground. Position 3 grounds C_1 removing the bass boost in the volume control. Position 4 grounds C_2 and shorts out C_1 , thereby attenuating both ends of the audio spectrum. These positions are called: 1—brilliant; 2—bass; 3—treble; 4—mellow.

Fig. 5b shows a system used by Zenith in model 8S647. In this diagram S_1 to S_6 represent six tone switches in their normal or off positions. When S_1 is opened, bass boost is applied for low

Fig. 5a. Tone-control system used in General Electric 35 receiver. Point switching is used for tone control. Circuit is normal in position 1, with bass compensation operating in the volume control. This position is called brilliant.

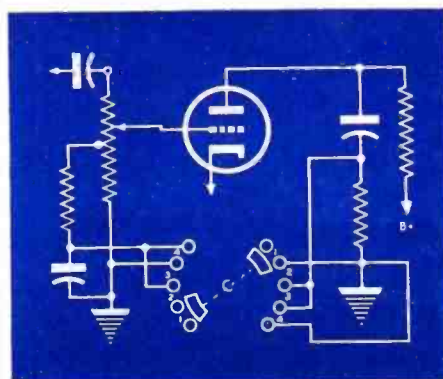

CONCORD Service!

NONE BETTER IN AMERICA FOR RADIO AND ELECTRONIC PARTS AND EQUIPMENT



Sure! Swift! Satisfactory! That's the story of Concord Radio Corporation's service. Twenty-two years of "delivering the goods" have made us a top supplier of radio and electronic merchandise to industry, government and the trade. Two strategically located "supply bases"—CHICAGO and ATLANTA—are as close to you as a letter, a telephone call, a telegram, or a message on the teletype. Here is what Concord can offer you:



Weston 2 1/2" Model 506 Milliammeter D.C. 0-100



IRC Dual Potentiometer 1 1/4" diameter—1 1/4" deep 1/4" shaft—3/4" long Your Cost 89c

Weston 2 1/2" Model 506 Milliammeter D.C. 0-200

Your Cost, either type \$4.95



25 mfd. .25 volt condenser in aluminum can. Your Cost 29c



Micro-Switch, Type Z, S.P.S.T. Normally closed. Aero-Switch, similar to above but normally open. Your Cost, either type, 79c

- The finest merchandise from the best manufacturers
- Large and complete stocks of components and equipment
- A seasoned selling staff of radio and electronic experts
- Consultant radio technicians and engineers
- Same-day shipment, wherever humanly possible
- Super-speed "special service" for military and industrial needs



FREE! Special Supplement! "Hard-to-Find Radio and Electronic Parts and Equipment" . . . Sixteen pages, jammed to the margins with such items as condensers, wire, switches, volume controls, relays, resistors, test accessories, speakers, etc. There's not another listing like it anywhere in the country today.

CONCORD RADIO CORPORATION
901 W. Jackson Blvd., Chicago 7, Ill. Dept. No. S124

Please rush me the new 16-page "Special Supplement" by Concord Radio Corp

NAME _____

ADDRESS _____

CITY _____ STATE _____

CONCORD RADIO CORPORATION
Lafayette Radio Corporation

901 W. Jackson Blvd. CHICAGO 7, ILL. 265 Peachtree Street ATLANTA 3, GA.

volume settings; compare this with circuit of Fig. 3a. When S_2 is closed, C_2 is applied across the volume control, acting as a high-frequency shunt; compare with Fig. 4e. When S_3 is closed, this effect is further pronounced. With S_4 opened, the shunting effect of C_5 is removed, thereby increasing the treble response. Opening S_5 boosts the bass, and opening S_6 boosts the treble. There are two-boost networks involved in this system. One consists of R_1 in association with condensers C_2 , C_3 , C_6 , and C_7 . The other consists of R_2 in association with C_1 . The third element is the plate shunt condenser, C_5 . It can be seen from the action of these circuits that bass or treble boost is a matter of relative level.

Fig. 5c illustrates an inverse feedback circuit used in Pilot FM 12, that also acts as a tone control circuit. Audio voltage from the voice coil is fed back to the cathode of T_1 resulting in high attenuation of high intensity voltages, and lower attenuation of low intensity voltages, providing more uniform gain. The tone control is a two-section affair, one section using the inverse feedback network, and the other the input to the inverter grid. By a combination of these circuits acting simultaneously, a sharp high-frequency cutoff is effected. This is an excellent feature, since it reduces the high fidelity response when signals of limited

Fig. 1. Fig. 5b. Tone-control system in Zenith 85647. This type of control is used in most of their console models. When the switch S_1 is opened, bass boost is applied for low volume settings.

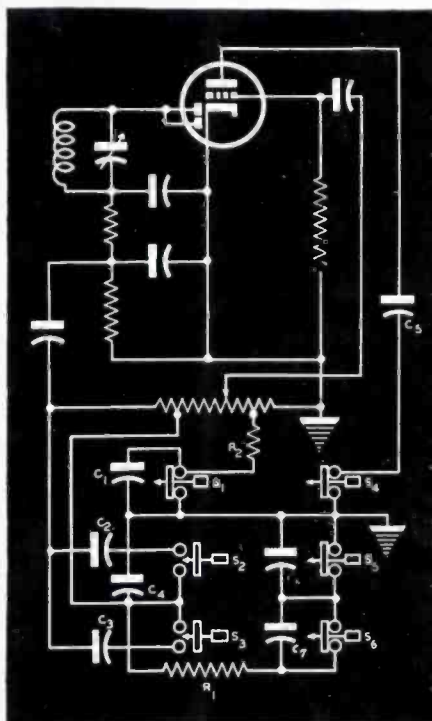

Got Any LAME DUCKS?



Try Our INSTRUMENT

REPAIR SERVICE

Hard to get new testing instruments? Let our well-equipped Service Shop put your instrument in tiptop condition. For the duration. All makes; all repairs by experts.

PRECAUTION—Before you ship, be sure to tell us make, model and serial number, also age of instrument, and what's wrong . . . thank you.

Authorized Supreme Service Station

BURLINGAME ASSOCIATES

Service Division 34

11 Park Place New York 7, N. Y.

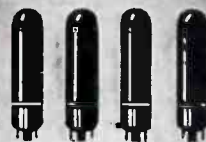

4 STANDARD TYPES

of Amperite Regulators replace over 400 types of AC-DC Ballast Tubes now in use.

Amperites are real REGULATORS . . . have patented Automatic Starting Resistor which prevents initial surge and saves pilot light . . . Ask Your Jobber.

AMPERITE

THE *Simplest* WAY TO REPLACE

BALLASTS

WRITE FOR REPLACEMENT CHART

AMPERITE Co. 551 BROADWAY, NEW YORK, N. Y.

BIG VALUES IN TECHNICAL PERFECTION

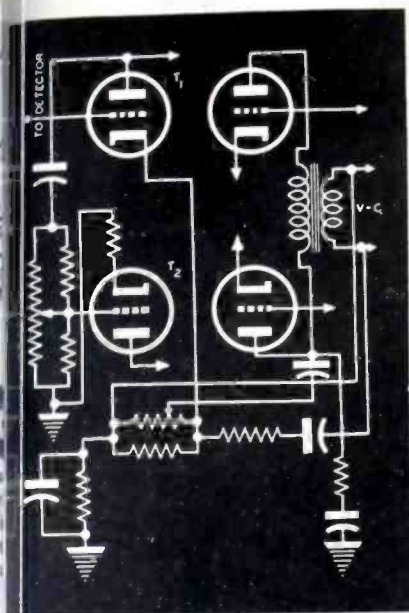

Fig. 5c. Tone-control method used in f-m model 12 of Pilot. Inverse feedback is incorporated to provide high-fidelity response.

frequency range are being received, thereby reducing background noises.

A tone-control system used in the Stromberg Carlson 935 is shown in Fig. 5d. The treble control is quite simple; compare with Fig. 4a. While most tone networks would designate this as a bass compensation system, when acting in reverse, it may be considered as a treble control. It then is a function of the original response curve without tone compensation, which may show a marked high—or low—frequency characteristic instead of a flat one. In this particular case, increasing the resistance in series with C_1 increases the treble response. The network consisting of R_1 and C_2 (compare with Fig. 4c) is a treble-boost network. Since the a-c resistance of con-

(Continued on page 34)

Fig. 5d. Stromberg-Carlson model 35 tone-control system. Bass-boost inductor and RC network coupling system is featured.

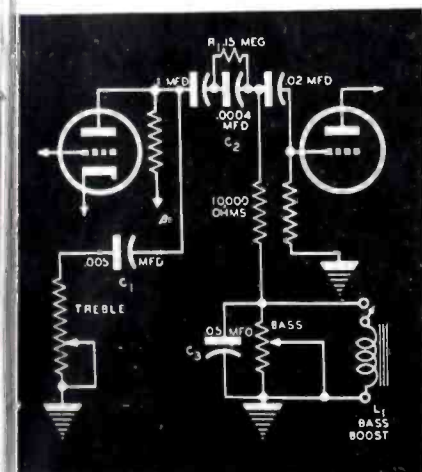

RCP TUBE TESTER NEW MODEL 314

This new tube tester is simple to operate, flexible and speedier for testing Octal, Loctal, Bantam Jr., Miniature, Midget and all acorn tubes. Designed to test all present filament voltages from 1.1 to 117 volts—a range that anticipates voltages of the near future. Has sockets for all receiving tubes; no adapters required; individual connections for each element.

Lever type switching controls each tube prong, checks roaming filaments, dual cathode structures and multi-purpose tubes. Separate plate tests on diodes and rectifiers. Neon short tests detect leakage between elements while tube is hot. 4" square meter with "Poor-Good" scale. Pilot Lite indicator; double fused plug protects transformer. Durable Oak carrying case—14¼"x13"x6". Weight: 12¼ lbs. Complete ready to operate—Price: \$48.50—60 cycle 110 V; \$49.95—50 cycle 220 V. Code: ATLAS.



POCKET MULTITESTER MODEL 420

"Pocket" size, yet rugged, with accuracy same as larger RCP models—only 6½"x3½"x3"—(open face) weighs only 25 ounces. Meter movement accurate within 2%. Voltage multipliers are accurate to 1%. AC and DC voltmeter up to 5,000 volts at 1,000 ohms per volt sensitivity. D.B. meter, output meter, milliammeter and ohmmeter. Total 23 ranges. Code: LIYOR. Complete, ready to operate, with batteries—\$19.95.

These are only two out of the complete line—the RCP line that built a reputation for quality and value before the war. Today it's packed with still greater technical advancements, better engineering, smarter design . . . the up-to-the-minute instrument line. Want the facts? Write today for Catalog No. 128 of standard commercial models.

RADIO CITY PRODUCTS COMPANY, INC.

127 WEST 26th STREET



NEW YORK 1, N. Y.

MANUFACTURERS OF PRECISION ELECTRONIC LIMIT BRIDGES — VACUUM TUBE VOLTMETERS
VOLT-OHM-MILLIAMMETERS — SIGNAL GENERATORS — ANALYZER UNITS — TUBE TESTERS
MULTI-TESTERS — OSCILLOSCOPES — AND SPECIAL INSTRUMENTS BUILT TO SPECIFICATIONS

LOW PASS (TYPE L.P.I.)
HIGH PASS (TYPE H.P.I.)

FILTERS

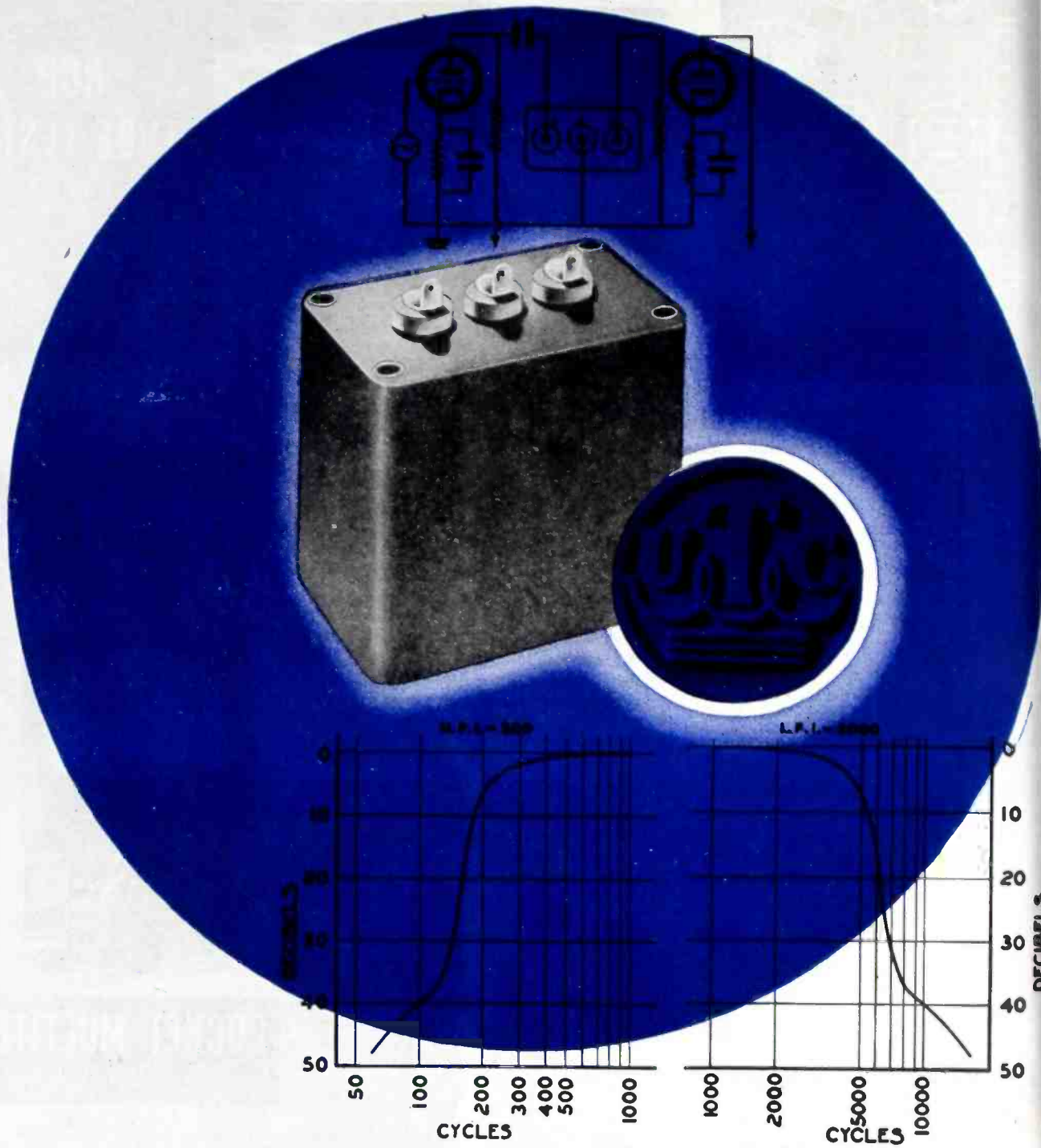

New additions to the UTC Interstage Filter family are now available in the type HPI and LPI units, respectively high pass interstage and low pass interstage filters.

The units are designed with a nominal impedance of 10,000 ohms to be used in a circuit as illustrated. Typical curves obtainable are shown above. Loss at cutoff frequency is less than 6 DB. At .75 times cutoff or 1.5 cutoff frequency respectively, the attenuation is 35 DB, and at one-half or twice cutoff frequency respectively, the attenuation is 40 DB.

These units employ a dual alloy magnetic shield which reduces inductive pickup to 150 Mv. per gauss. The dimensions in hermetically sealed cases are 1½" x 2½" x 2½". Filters of the HPI and LPI type can be supplied for any cutoff frequency from 200 to 10,000 cycles. Specify by type followed by frequency, as: LPI-2500.

May we cooperate with you on design savings for your application . . . war or postwar?

United Transformer Co
150 VARICK STREET NEW YORK 13, N. Y.

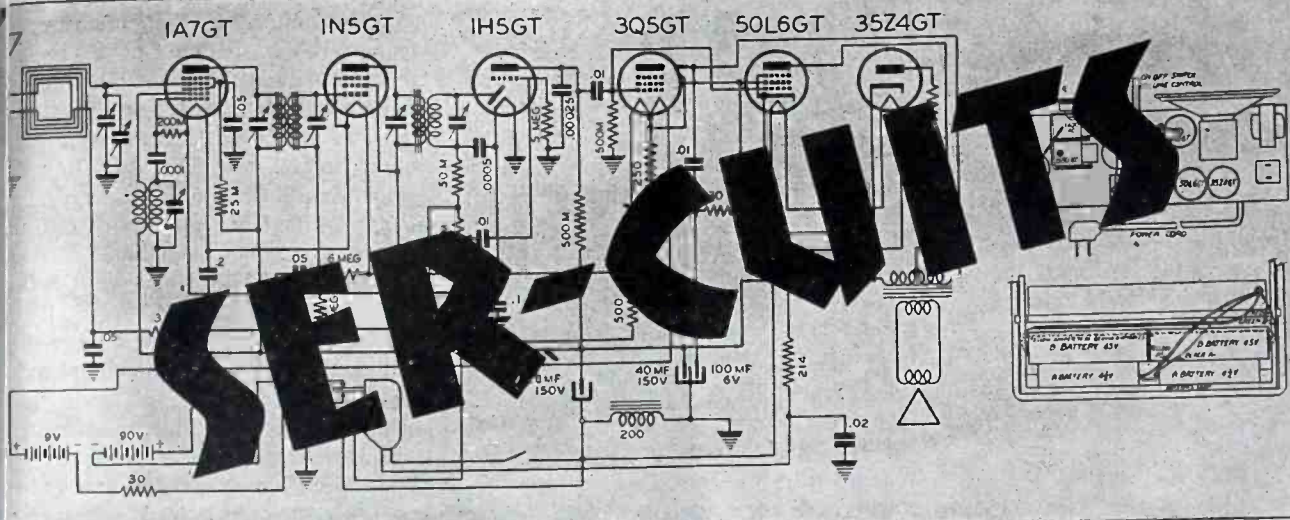

by HENRY HOWARD

SOME of the multi-band, 8-tube or-more type receivers have had many unique simplification features included in their design. An example of this type of design appears in Fig. 1, Farnsworth BC-83. This is an 8 tube, 8-band unit with a single filament winding, made possible by the use of a cathode-type rectifier, 6X5.

A separate 6J5 oscillator in a shunt-fed feedback circuit is coupled to grid 1 by direct grid-to-grid coupling. The cathodes of all tubes, r-f and a-f, are grounded. A voltage divider and delayed avc system assure the proper

bias voltages. A 1600-ohm speaker field coil and a 47-ohm resistor develop the bias voltage. They are placed between the high-voltage center tap and ground. The drop across the 47 ohms is utilized for initial r-f and i-f bias, being supplemented by avc. A shunt circuit parallels the speaker field for supplying the 6K6 power-tube bias. The first audio bias is obtained from a 10-megohm grid leak.

Two .01-mfd line bypass condensers from the a-c line to chassis do a better job than the usual one. A fixed-

Fig. 1. Farnsworth BC-83, using a separate 6J5 oscillator in a shunt-fed feedback circuit coupled to grid 1 by direct grid-to-grid coupling.

tune first detector allows the use of a 2-gang tuning condenser. Note that the plate load of the 6SK7 r-f amplifier consists of a 1500-ohm resistor in series with a choke. An i-f wave trap is also included.

There are two output circuits from the 6SK7 i-f amplifier, the usual i-f transformer feeding a diode detector and, then, the first audio, and also an impedance-coupled dual diode for avc. The detector diode tied in with the C supply, is coupled to the i-f plate through a 25-mmfd condenser and connected to the avc diode through a 1-megohm resistor. A 2.2-megohm resistor connects the first and second

(Continued on page 31)

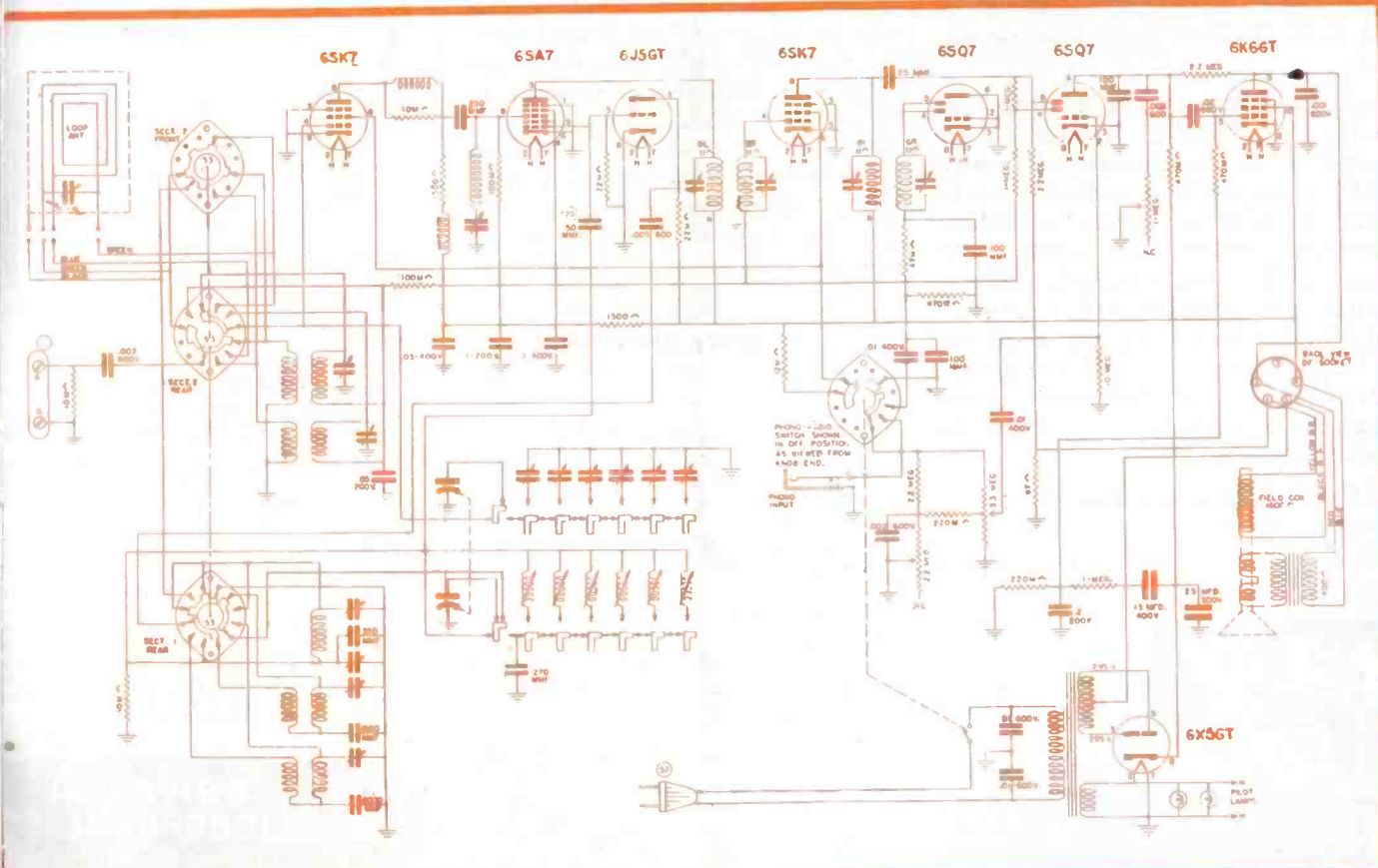

Ready for
Bigger
things...



PLUG IN ELECTROLYTICS

• There's more to those Aerovox plug-in electrolytics than just another type. Actually, those plug-ins facilitate the checking, replacement and servicing of capacitors in continuous use and in vital equipment. They are truly symbolic of the ELECTRONIC AGE now dawning.

Yes, Aerovox invites you to get ready for BIGGER things. Your scope is being increased many fold. Soon you'll be called upon to build as well as service countless electronic devices in addition to more and better radios, phonograph combinations, and, of course, television. And Aerovox is all set to help you not only with the necessary capacitors, but with practical information as well. Bank on Aerovox!

• Free Subscription . . .

Ask your local Aerovox jobber about a free subscription to the monthly *Aerovox Research Worker*. It will help you get ready for the Electronic Age. Order your immediate servicing requirements from him now.



AEROVOX CORP., NEW BEDFORD, MASS., U. S. A.
In Canada: AEROVOX CANADA LTD., HAMILTON, ONT.
Export: 13 E. 40 ST., NEW YORK 16, N. Y. Cable: 'ARLAB'

(Continued from page 11)

the Service Man reads on the instrument is actually the voltage present. Thus it isn't necessary to make mental calculations of the error due to potential drop caused by the voltmeter. This, of course, is more noticeable where we have higher circuit resistances. It is probable that the use of the 1,000 ohms-per-volt sensitivity voltmeter will rapidly diminish as manufacturers start supplying test data on the use of the electronic voltmeter. It is not believed that the higher sensitivities of 20,000 or even 25,000 ohms-per-volt will substitute for the electronic voltmeter, since even these meters have little use when reading voltages in circuits whose resistance is several megohms. The electronic voltmeter should have provisions made for reading a-c voltage at the end of a probe so that the correct voltage will be given even when the frequency is as high as 150 to 200 mc. An instrument of this type then can be used to measure the gain of a stage, either r-f, i-f, or a-f very rapidly, since if properly designed, it will detune even a very critical circuit a negligible amount. As for the oscilloscope, it can be used very advantageously for the location of hum and the cause of bad tone quality. Using the 'scope, a definite location of the trouble can be made in half the average time taken by *hunt-and-try methods*. It is believed that the 'scope will be used more and more.

Another instrument which will be very useful, would have several channels available, with an indicator in each channel to indicate the presence or change in a signal at the point it is connected. These sections should be removable so the Service Man might buy two, three, four or as many as desired for connection to different circuits in a receiver to locate an intermittent.

Frequency Modulation

For the proper repair and maintenance of f-m sets some new equipment will be essential. The signal generator appears to be the first instrument to consider. Two types of signal generators are presently available for servicing a-m receivers. These are amplitude modulated only, and a combination of amplitude and frequency modulated. Few have had an upper range of more than 20 megacycles. They are necessary for alignment of the tuned circuits. Although f-m signal generators have been in many radio shops for some time, it is believed that relatively few Service Men have ever aligned even the very expensive receivers with the frequency modulated

generator, feeling it is worth the time needed to connect up the generator and 'scope. When the new f-m sets are introduced the only proper method to use in their alignment will be a visual one and this will necessitate a wide-band f-m generator and 'scope. The generator should have a frequency range of approximately 100 kc to 200 mc and be frequency modulated at approximately 100 kc above and below mid-frequency. It should have all the other characteristics associated with a good signal generator; good amplitude-modulated waveform; relatively high output and yet have attenuation to a level which will allow alignment of even a sensitive receiver at a very low level; good stability; high accuracy in frequency; and resetability. While the usual 'scope can be used in the alignment of these sets, an all-purpose 'scope would be better. This point is covered in the following paragraphs. Obviously, too, the electronic meter can be used to marked advantage here as in a-m sets.

It is in the servicing of television receivers that the Service Man will meet his biggest problems. Many Service Men who bought an oscilloscope when they were first put on the market and then set it up on the



Available from local dealers or by writing factory direct.

UNIVERSAL STROBOSCOPE

This handy phonograph turntable speed indicator, complete with instructive folder, is now available gratis to all phonograph and recorder owners through their local dealers and jobbers. As a recorder aid the Universal Stroboscope will assist in maintaining pre-war quality of recording and reproducing equipment in true pitch and tempo. Universal Microphone Co., pioneer manufacturers of microphones and home recording components as well as Professional Recording Studio Equipment, takes this means of rendering a service to the owners of phonograph and recording equipment. After victory is ours—dealer shelves will again stock the many new Universal recording components you have been waiting for.



UNIVERSAL MICROPHONE CO.
INGLEWOOD, CALIFORNIA

self to gather dust with the mental reservation that it was no good or at least too complicated to use, will now be confronted with an instrument which is a specialized receiver connected to a grandiose oscilloscope. Now is the time to get that 'scope down and learn how it works, because anything learned about this 'scope can be used to advantage in servicing television receivers.

Servicing the audio section of the television receiver will be identical to the procedure used on a-m and f-m equipment and the test equipment needed will be the same. However, equipment needed for servicing the video section will be quite different than any required up to now. It will be necessary to have a scope whose amplifiers, vertical, horizontal and i-axis, have a range up to 4 or 5 mc. A high-frequency sweep will also be essential. In addition it will be necessary to have provision for switching in a monoscope tube. Thus a standard test pattern for feeding into the television receiver will be available without relying upon the local television station for a signal. Required too, will be a pulse generator to properly test amplifier circuits in the television receiver. This generator will provide flat top pulses of various time durations from a fraction of a micro-second to a few per second. The electronic voltmeter will also play a major role in television receiver servicing.

Servicing receivers in the shop, an important trend, developed by war conditions should be continued by the Service Man. The professional standing of the Service Man will improve if only a very minimum of service has to be done in the home. Home servicing lowers the professional standing of the Service Man. It also prevents a professional arrangement of equipment in the shop since the equipment must be kept portable at all times. There appears therefore to be a definite trend toward better display of test equipment in suitable attractive work benches, which will in turn convince customers that Service Men's activities are of a highly technical nature, and special equipment is necessary for such work.

The Service Man will, upon the introduction of f-m and television, be confronted with complex problems. However a careful selection of equipment will provide the tools which will make the solution of those problems much easier. Service Men must realize that day by day their work is becoming more technical and specialized. The man who begins to prepare himself today, will be the man who will be ready when V-Day comes.



PACKAGED SUPERIORITY

In every Freed package is a transformer that guarantees maximum performance, that meets all your service requirements.

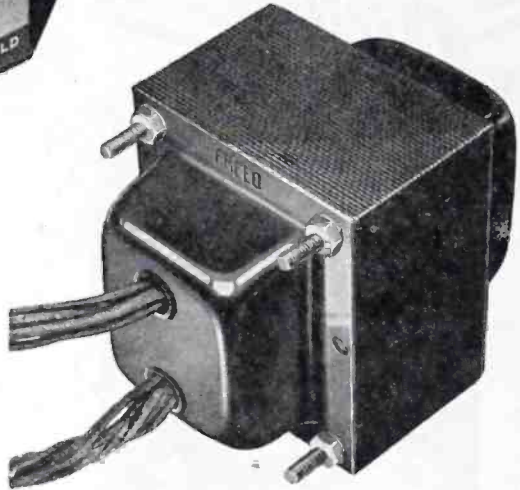

Send in your name now and we will reserve a copy of the latest Freed catalogue for you.

Each package contains a transformer of marked superiority which has passed rigid inspections. The Freed line contains all types of transformers: power, interstage, isolation, step-down, band pass filters and reactors. Available in sizes for all requirements and made to exacting specifications for continuous performance at specified frequencies. Installation is simplified by mounting centers die-stamped to precision accuracy. To give the best service, use the transformers of performance. Use Freed!

FREED TRANSFORMERS
 FREED TRANSFORMER COMPANY
 74 SPRING STREET, NEW YORK CITY

FOR ACCURATE ALIGNMENT

ACCURATE ALIGNMENT

Test Oscillator



SUPREME MODEL 571

- Simple Operation— all ranges read on two basic scales.
- Dual Tuning Ratio. One for speed—one for vernier adjustments.
- Electron coupled circuit giving greatest stability. Iron core coils.
- Ladder Attenuator.
- Double shielding minimizes leakage.
- Golden Oak carrying case.

SPECIFICATIONS

R.F. RANGES:

65-205 KC; 205-650KC;
650-2050 KC; 2050-6500 KC;
6.5-20.5 MC. Harmonics to
82 Megacycles.

AUDIO FREQUENCY:

400 cycles available for external testing.

INTERNAL MODULATION:

R.F. Carrier modulated at approximately 30% and 70% at 400 cycles. Modulation level selected by toggle switch.

EXTERNAL MODULATION:

Jack provided for external audio modulation.

ACCURACY:

1/2 of 1% on first three bands. 1% on last two bands.

SIZE:

9-1/2"x8-11/16"x7-3/8"

POWER SUPPLY:

115 volts 60 cycles—Special voltage and frequency on request.

SUPREME

SUPREME INSTRUMENTS CORP.
Greenwood, Miss., U. S. A.

(Continued from page 13)

the multiplier resistance to that point. This procedure is followed for each multiplier. However, in each case the actual value of the added resistance is determined by subtracting the total R already in the circuit from the computed value of R to that point. The object in each multiplier is to lose all but one volt before the grid is reached, or in other words to provide an IR drop such that only one-volt maximum is applied to the grid of the tube at any point on the multiplier.

The following computations for this divider will straighten out any perplexities in the above statements and readily show how other ranges can be determined.

$$(a) R = \frac{E}{I} \times 10^3 \quad (b) I = \frac{E}{R} \times 10^3$$

$R_1 = 1.25 \times 10^7$ ohms.
First multiplier (5 volts)

$$(b) I = \frac{5}{1.25 \times 10^7} \times 10^3 = 4 \times 10^{-4} \text{ a.}$$

$$(a) R_1 = \frac{5 - 1 \text{ (voltage drop)}}{4 \times 10^{-4}} \times 10^3 = 1 \times 10^7 \text{ ohms} = 10 \text{ megohms.}$$

Second multiplier (25 volts)

$$(b) I = \frac{25}{1.25 \times 10^7} \times 10^3 = 2 \times 10^{-3} \text{ a.}$$

$$(a) R_2 = \frac{25 - 1}{2 \times 10^{-3}} \times 10^3 = 12 \times 10^6 \text{ ohms}$$

$R_2 = 12 \text{ megohms} - 10 \text{ megohms (already in circuit)} = 2 \text{ megohms.}$
Third multiplier (50 volts)

$$(b) I = \frac{50}{1.25 \times 10^7} \times 10^3 = 4 \times 10^{-3} \text{ a.}$$

$$(a) R = \frac{50 - 1}{4 \times 10^{-3}} \times 10^3 = 12.25 \times 10^6 \text{ ohms}$$

$R_3 = 12.25 \text{ megohms} - 12 \text{ megohms (already in circuit)} = .25 \text{ megohm} = 250,000 \text{ ohms.}$

The fourth and fifth multipliers are calculated in the same manner. In determining the value of R_4 we know that the total bleeder resistance is 12.5 megohms and at R_4 the total value is 12.475 megohms. Therefore, subtracting this value from the total R of bleeder gives the value of

$$R_4 = 25,000 \text{ ohms.} \quad R_5 = 25,000 \text{ ohms.}$$

$$R_4 = 200,000 \text{ ohms.}$$

There are countless important uses for an instrument of this type. The writer found a new application (to him at least) just recently. Many of us have attempted to check frequency

of a transmitter. In looking for some visual means to show the zero beat, the electron-ray tubes such as 6U5/6G5 were tried. They were found to require further amplification of the signal in order to get the angle to close sufficiently. This necessitated additional equipment and was therefore discarded. It was decided to rectify the IR drop across the headphones. The ordinary a-c voltmeter and rectifier type voltmeter were not satisfactory, but the answer was the a-c rectifier probe of this vtm. When clipped across the phone terminals the meter pointer followed the pulsations as zero beat approached until on exact zero the pointer would remain stationary. The ears determined the approach to zero beat and the eyes on the vtm determined the exact zero beat. The 1 and 5 volt scales were used, determined by the strength of the received carrier.

Such an instrument is also very useful in alignment of receivers. It is practically a *must* on some of the newer and more sensitive f-m receivers. The defective or low gain stage can also be readily determined.



WIRES

MADE BY

Engineers FOR
Engineers

VICTORY

concentrating upon

for the duration

cornish

WIRE COMPANY, INC.

15 Park Row, New York City, New York



INSTRUMENTS

(Continued from page 16)

may be made adjustable, if desired. A number of condensers of various sizes may be connected to a selector switch, the capacitance being varied at will, to select different resonant frequencies.

Electronic music has become quite an important factor. And the post-war era will undoubtedly see a substantial increase in its use.

Fig. 6. Bass boost and resonant circuits to increase amplifier flexibility. Effect of resonant circuit can be controlled by R . When resistance is lowered in value, circuit Q is reduced and response curve broadens.

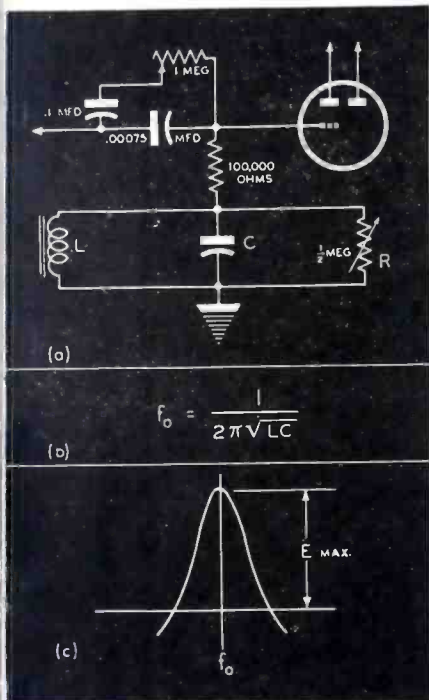

SER-CUITS

(Continued from page 27)

a-f stages plate-to-plate for voltage regeneration to improve quality.

Philco C-1808

A Philco auto receiver, C-1808 Dodge-Plymouth, with a permeability-tuned unit with pushbuttons and an r-f stage with resistance-impedance coupling to the converter tube, appears in Fig. 2. A complex i-f wave trap is included in the coupling circuit. An 850-ohm sensitivity control is used as a cathode-bias resistor for the r-f stage and converter. The 7A7 i-f amplifier

(Continued on page 32)

Fig. 2. Philco C-1808 auto set with a unique i-f wave trap circuit in the coupling circuit.

KEN-RAD *Metal Tubes*

The weight and space saving advantages of Ken-Rad "self-shielding" metal tubes have long been recognized. Their sturdy ruggedness under severe service conditions in fighters and bombers is a matter of record.

Write for your copy of "Essential Characteristics" the most complete digest of tube information available

TRANSMITTING TUBES
CATHODE RAY TUBES
SPECIAL PURPOSE TUBES
RECEIVING TUBES
INCANDESCENT LAMPS
FLUORESCENT LAMPS

KEN-RAD

EXECUTIVE OFFICES
 OWENSBORO · KENTUCKY
 EXPORTS 15 MOORE STREET NEW YORK

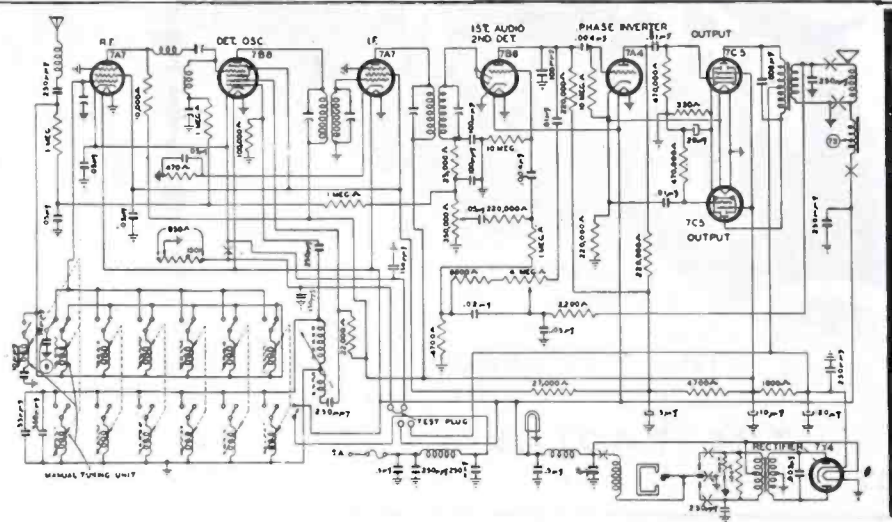

HERE'S THE POPULAR G-E UNIMETER

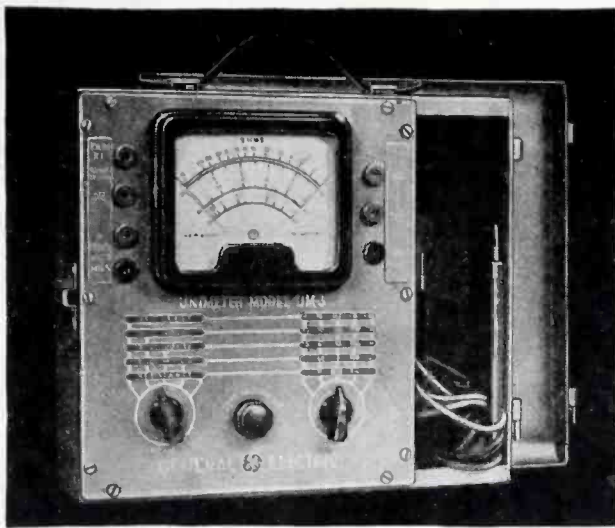

LIKE so many servicemen, you'll want to work with this completely portable all-around utility instrument. Large meter calibrated and protected by unique switching arrangement. Reduces error possibility, easy to read.

Other G-E units available for testing electronic circuits and component parts are: audio oscillators, oscilloscopes, condenser resistance bridges, signal generators and other utility test instruments.

It's a new G-E line—developed by G-E engineers—to help you do a better service job. *Electronics Dept., General Electric Co., Schenectady, N. Y.*

GENERAL  ELECTRIC
164-C7
ELECTRONIC MEASURING INSTRUMENTS

Radiart

Wishes You A

MERRY AND A CHRISTMAS HAPPY NEW YEAR



Latest W P B Information is . . . No permission to make auto antennas until Germany surrenders.

THE RADIART CORPORATION
3571 W. 62nd Street Cleveland 2, Ohio

(Continued from page 31)

uses fixed bias and no avc. The oscillator is tuned by adjusting shunts on the grid-coil. No change is made in the plate tickler coil.

This set has quite a volume-control tone control. A degenerative feedback network feeds back from the voice coil through 2,200 ohms and a 4-megohm tone control, and a 1-megohm resistor to the 7B6 first audio grid. A .05-mfd bypass condenser in the feedback loop kills most of the highs, leaving the feedback mostly to the lows. This is equivalent to a high boost. The tone control is limited by a 6,800-ohm fixed resistor for cutting lows and operates in series with a .01-mfd condenser to the first audio plate for attenuating highs.

Belmont 796

Another phono receiver, Belmont 796, is shown in Fig. 3. This model uses a 6J5 cathode-driver type inverter in which the first power tube is fed as in a conventional audio amplifier. However, because of the very high cathode resistance, there is very little gain produced. The second power tube is fed from a 6J5 input circuit by taking a tap on the cathode resistor 100,000 ohms from ground and 5000 ohms from the cathode. The 6J5 grid return is to the junction. Thus the cathode bias resistor is 5000 ohms.

Voltage degeneration is introduced around the entire audio amplifier by feeding back a voltage from the voice coil to the volume control circuit that feeds the first audio 6SQ7.

Fig. 3. Belmont 796, with a 6J5 cathode-driver type inverter. First power tube is fed as in a conventional audio amplifier. Feedback of voltage from voice coil to volume-control circuit that feeds 6SQ7 provides voltage degeneration.

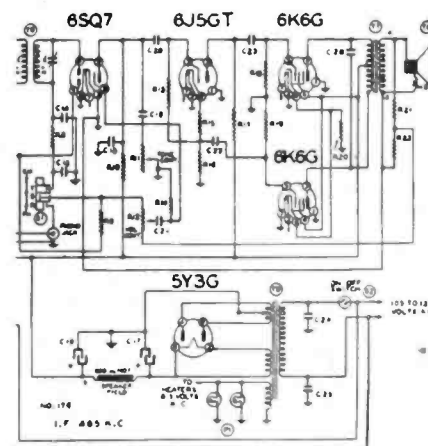

MOTOROLA 40-P

(See Front Cover)

A NOVEL, effective antenna system has been provided in the Motorola receiver, appearing on the cover, this month. This model, 40-P, is designed to operate with a low capacity antenna. Provision is made for an antenna with an effective capacity between 25 and 250 mmfd which is tunable with a 600-mmfd trimmer. The antenna is capacity coupled across a 90-mmfd condenser, and a trimmer with a 6000-mmfd series condenser. An iron-core antenna coil is directly connected to the control grid of a 6SD7 r-f amplifier.

A complex inductive-capacitive interstage coupling unit delivers the signal to the signal grid of the 6SA7 converter. A tunable bypass condenser is at the low end of the grid coil instead of the usual .05-mfd tubular. This trimmer, as well as the antenna trimmer, is set during installation. Avc is supplied to all tubes handling r-f. The oscillator uses a tuned grid-cathode feedback circuit, with the grid leak and condenser at the low potential end of the grid coil instead of the usual position right at the grid. A 300-mmfd condenser is used; the leak is 22,000 ohms.

The remainder of the circuit is conventional, with an iron core 6SK7 i-f stage, 6SQ7 detector-audio and 6U6 pentode output. A voltage divider supplies audio grid bias.

SERVICING HELPS

Philco 42-380

Rectifier 6X5G often shorts between the filament and cathode causing power transformer to burn out. Best to fuse power line on receiver so that when tube shorts, the secondary of transformer is saved. Use of 0Z4 in place of 6X5G will also eliminate the trouble. No modifications are necessary when using the 0Z4 tube.

Philco C 1908

Before reception is obtained after first turning on set, a terrific rushing and crackling noise is heard. This is usually due to a defective 7B8 tube.

Zenith 91-92

Intermittent reception: Often caused by condenser 22-110, a canned affair nice-

RIDER VOLUME XIV COVERS 1941-42 RECEIVERS



That's me three years ago. The first program I carried was Frank Sinatra—back in the days when a bobby sock was something worn by a London policeman.

My, how we 1941 models have worked since then. For most of us it's been too much and many of my contemporaries are now piled up in overcrowded service shops.

There is one bright spot however. Rider Manual Volume XIV is now off press. Carrying complete authorized servicing information on 1941-42 sets, we ailing sets are sure of correct diagnosis and quick painless repair.

But please be patient if your jobber's supply of Volume XIV is inadequate. He, and the Rider folks will get you your volume as fast as present WPB limitations permit.

RIDER MANUALS (14 VOLUMES)	
Volumes XIV to VII . . .	\$11.00 each volume
Volumes VI to III . . .	8.25 each volume
Abridged Manuals I to V	
[1 volume]	\$12.50
Automatic Record Changers and Recorders	6.00
OTHER RIDER BOOKS YOU NEED	
The Cathode Ray Tube at Work	
Accepted authority on subject	\$3.00
Frequency Modulation	
Gives principles of FM radio	1.50
Servicing by Signal Tracing	
Basic Method of radio servicing	3.00

The Meter at Work	
An elementary text on meters	1.50
The Oscillator at Work	
How to use, test and repair	2.00
Vacuum Tube Voltmeters	
Both theory and practice	2.00
Automatic Frequency Control Systems	
—also automatic tuning systems	1.25
A.C. Calculation Charts	
Two to five times as fast as slide rule	7.50
Hour-A-Day-with-Rider Series—	
On "Alternating Currents in Radio Receivers"—	
On "Resonance & Alignment"—	
On "Automatic Volume Control"—	
On "D.C. Voltage Distribution"	90c each

JOHN F. RIDER PUBLISHER, INC.
Export Division: Roctec-International Electric Corp.

404 Fourth Avenue, New York 16, N. Y.
13 E. 40th Street New York City Cable: ARLAB

RIDER MANUALS *are complete* IN 14 VOLUMES

ly hidden between the variable condenser and the tube shield box.

Edward Goldschmidt.

Stewart Warner 05-5L1

Weak and oscillates: Check 100 mfd, 10-volt condenser in filter circuit for open or low capacity.

Stewart Warner A6S "Air Pal"

Poor tone and hum, when set is warmed up: Caused by heat warping speaker cone. Recenter cone and check 70L7GT tube for hum; also check antenna condenser mounting about speaker for loose lead. Will cause set to cut out.

Stewart Warner 206GA

Poor tone and weak: Check filter con-

denser for low capacity. Mount new condenser away from filament resistor which gets hot and dries up condenser.

* * *

Zenith 5662 and 5666

Noisy and oscillates: I-f and tube shields not grounded properly due to loose mounting studs at base of shields. Use a self-tapping screw on shields and ground with wire to speaker frame.

In districts where live voltage is high, I found that a 15 or 20-ohm 1-watt resistor in series with the filament will reduce tube burn outs.

A 70L7GT tube will substitute very well for 50L6 tube, if a jumper is placed between 8 and 6 pins on tube socket. Cut 8 pin off on the 70L7 tube.

Milton Trakes.

STONE SYSTEMS

(Continued from page 25)

denser C_2 decreases with frequency high frequencies pass more readily than low frequencies. The network consisting of R_1 , R_2 , and C_2 is a bass-boost system (compare with Fig. 4a) with the control across the condenser instead of in series. The addition of the inductance across this circuit introduces a resonant network that is quite broad in response. This increases the low-frequency response quite rapidly at very low frequencies.

Tone controls associated with phono pickups are similar in action to receiver tone systems, and component values again are a function of the input impedance, in this case, the pickup. Magnetic pickups are generally low-impedance devices, and crystal pickups high-impedance sources. Additional factors in the design of phono-tone controls and compensation systems are the frequency range of recording and the amplitude contraction

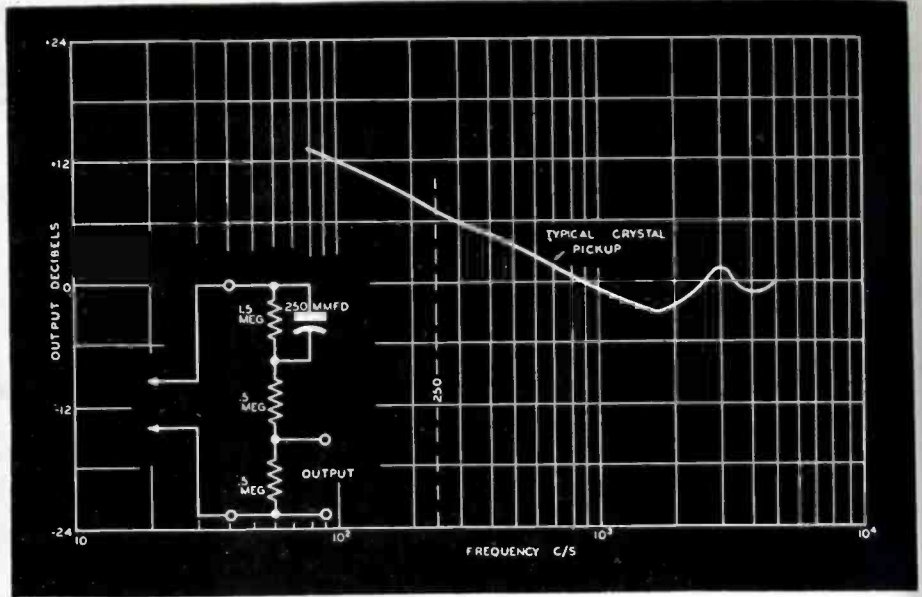

Fig. 6. Typical response curve for a crystal pickup and tone compensation system used with the pickup.

(Courtesy Radiotron Designer's Handbook)

(as opposed to expansion) practiced by the recording studio.

In recording, the low-frequency response is attenuated rapidly to prevent needle jumping and distortion at high amplitude levels. For this

reason, pickup tone control circuits are generally heavily bass boosted. The highest recording frequency for general sale records is in the neighborhood of 8,500 cps, and varies with the manufacturer. Pickups also have frequency characteristics. Therefore most phono-tone systems are characterized by sharp bass boost and sharp cutoff above 8,500 cps.

The response of an average crystal pickup is shown in Fig. 6. It will be noted that the rise in amplitude toward the low-frequency end starts at 900 cps. This response is too gradual for good bass response. In order to flatten the response curve, Stromberg Carlson uses system shown in insert of Fig. 6. It is a version of Fig. 4e, in that it is a treble-boost system. Bass boost below 250 cps is then accomplished in the receiver tone system.

ELECTRONIC CONTROLS

THE gauge circuit at left, is so adjusted by means of calibration potentiometer 13, so that indicator lamp 21 and lamp 22 are dark when height of the measured unit 1 is at the correct value. A subsequent decrease in the height of the measured unit will then result in the illumination of the lamp 21. Also, an increase in the height of the measured unit from the dark value causes indicator lamp 21 to light. If an element is placed in the position 1, here, lamp 21 will indicate, if illuminated, that the element height is too great. Illumination of lamp 21 will indicate that the gauged height is short. Again, failure of either lamp to remain illuminated when the measured object is placed into the gauge cradle indicates that the object is of the correct height.

—S. J. Murcek

(See November SERVICE, for further details.)

A precision production gauge circuit, of the conventional go-no-go electronic control type.

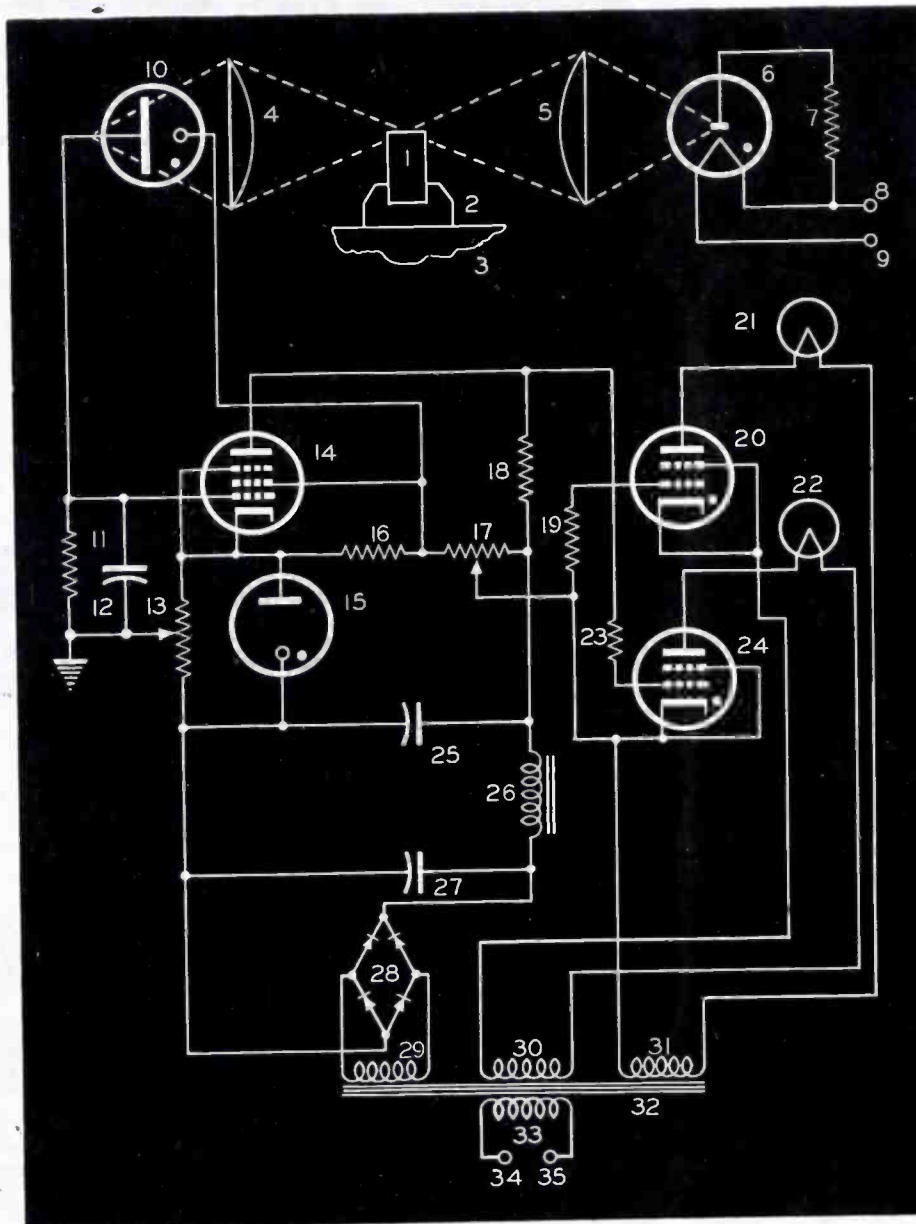

by SERVICER

ST around with some of the boys who had returned from the war, at the *Olde Radio Shoppe*. The question before the house was what sort of a name to pick for the store. Some thought that the name being used was just the thing to attract the women of the neighborhood. Others opined that something more masculine was the thing. I told them that I remembered that in the good old days there were *radiotricians*, *radio doctors* and *radiomen*, and *radio stores* and *radio repairs*. All had made money depending on how the proprietor did his business.

And it seemed to me that there was too much stress being laid on what you should call yourself, and not nearly enough on how you did business. Somehow or other, it never appealed to me to get myself a fancy name and a bad reputation. So I told them that the best name that they could pick was a simple *Radio Man* written out as two words to distinguish it from the term *radioman* which might mean a radiotelegraph operator.

Business Methods

It drifted into how to handle the business, and I told them that I had been lucky to see Mr. Downes who has been in the hardware business with his dad for over fifty years in this town. Seems that as far as old man Downes is concerned, there just ain't any war. Never tell his customers: "There's a war on, you know!" And so he has kept his customers happy and coming to his store. My times he didn't have what they wanted, yet he always was "just out of it, and never turned them away without at least trying to locate the pesky part for them at some of his competitors. Never to a customer that way either.

So it seems to me that when you can't give the customer that tube, or when that resistor has to be replaced with something that just is not available, it will pay handsomely to take over an hour, figuratively, to tell the customer why you can't give it to him. Apologize for your inability to help him and explain to him just how you believe you can make a substitute work as well. After the war is over, your customers will remember the places where they got that "Don't you know there's a war on?" whipped up on their respective faces, and will stay away from them in droves.

Confidence

A couple of nights ago I wandered into Fred's place. Fred is a mighty smart orator who has been helping out in the war effort by teaching some of the local boys and girls the rudiments of radio repair, to bring their work up in the local radio war plant in the town. Doing a good job of it too. Well, some of the boys had a jimmied chassis which they were sure Fred couldn't repair. The symptoms were extreme distortion of all signals, and the braying of the am-

NOW AVAILABLE —

NEW CATALOG, DESCRIBING THE COMPLETE LINE OF

Electro-Voice

COMMUNICATIONS
MICROPHONES

Electro-Voice Differential Microphone, Lip-Type Model 245 for applications where background noise elimination, free use of hands and high articulation are required.

Electro-Voice Differential Carbon Microphone, Hand-Held Model 205-S, an ideal microphone for aircraft, industrial, railroad, police and emergency services.

Electro-Voice Carbon Microphone, Model 210-S, a single button microphone which embodies all of the latest developments required for military use.

Electro-Voice Dynamic Microphone, Hand-Held Model 600-D, designed for high fidelity speech pick-up in those locations where the ambient noise does not exceed 100 db.

ELECTRO-VOICE CORPORATION
1239 South Bend Ave., South Bend 24, Ind., Dept. S-12
Please send us your new "Electro-Voice Communications Microphones Catalog."

NAME OF COMPANY _____
ADDRESS _____ STATE _____
CITY _____
ATTENTION OF _____

Electro-Voice MICROPHONES

ELECTRO-VOICE CORPORATION • 1239 SOUTH BEND AVENUE • SOUTH BEND 24, INDIANA
Export Division, 13 East 40th Street, New York 16, N. Y., U. S. A. Cable: Arleb

plifier was pretty bad. Fred, sweating over the chassis, and using a voltmeter probe, was taking down the socket readings. Throughout the set it seemed that the voltages were oke. Fred then decided to try his output meter. Testing all the cathodes he found that on the first audio stage he got a reading. He took out the bypass condenser, replaced it with another of proper value and the trouble was cleared up. Then he took the bad condenser apart only to find that the boys had just stuck two wires into the cartridge and that the condenser was therefore really open. This led Fred to tell us one of the little-known tests for open cathode con-

densers. When this occurs, the cathode will show a-c or audio. Of course, if the condenser had been functioning properly, we'd have bypassing of a-c to ground. The boys regretted that they had doubted Fred's ability. But I knew Fred would find the trouble because he had taken the time to study his business and knew it well. Told me that he read about 15 minutes every night before turning in, and that over a period of years he had read and digested a whale of a lot of radio manuals and books. Yep, that's the only way to keep up with this fast-moving trade! Might be a good idea for all you young fellers . . . it could pay out, you know.

SPEED UP REPAIRS WITH THESE G-C AIDS!



FREE
STEEL
CABINET

G-C Dial Belt Kits

Exact replacement woven fabric belts. Easy to install — no stretching — no adjustments — a perfect fit every time. Kits come with 25, 50, 100, 200 or 300 belts.



Automatic Wire Stripper

Strips insulation from all types of wire. Does the job instantly, easily, perfectly. An ideal tool for radio men, electricians and sound men.



G-C Contact Service Kit

Contains special contact cleaner and corrosion resistant lubricant. You can clean noisy controls nine times out of ten without dismantling chassis or control unit. Pays for itself over and over.

Order From Your Radio Parts Jobber
ALWAYS ASK FOR G-C PRODUCTS



GENERAL CEMENT MFG. CO.

ROCKFORD, ILLINOIS

Establish and maintain an efficient system of cost controls and operating budgets so as to be able to provide high quality service on a profit basis.



RAYTHEON TUBE BOOK

A radio tube book and substitution chart with data, outline drawings and diagrams of receiving tubes, hearing aid tubes, special purpose tubes, and radio panel lamps, has been published by the radio receiving tube division, Raytheon Manufacturing Company, Chapel Street, Newton 58, Mass.

A large portion of this book is also devoted to a chart of simplified interchange information, including over 1,600 substitutions.

CONCORD RADIO HOLDS ATLANTA CONFERENCE

Executives of the Concord Radio Corporation, 265 Peachtree St., Atlanta, Ga., met with Southeastern manufacturers' representatives recently to study future policy regarding purchasing, and merchandising and postwar plans.



At the Concord Radio dinner-conference (seated left to right): William Hopper (Malory); Elmer Eades (RCA); E. Hollingsworth (Hollingsworth & Still); Edward Berliant (General manager, Concord, Atlanta); Mrs. A. Burwell (Henry W. Burwell, Inc.); Maitland K. Smith; L. C. Still (Hollingsworth & Still). Standing left to right: Henry Wald (store manager, Concord Radio); M. McKinney (Anso, Binghamton, N. Y.); Ed Hulse (manager, Concord Camera Dept.); Paul Witte (industrial sales manager, Concord); V. Hutto (purchasing agent, Concord); James Millar (James Millar Co.).

UNIVERSAL MICROPHONE ADVERTISEMENTS IN PORTFOLIO FORM

The series of full page Universal Microphone Co., advertisements depicting various stages in the advancement of communications through the ages that have appeared in *SERVICE* during the past year will soon appear in a pictorial portfolio.

The illustrations have been used by schools and colleges for classroom study. Several army posts have also requested permission to use them for research work.

The pictures, by Los Angeles artist Keith Thomas, cover the early days of the Phoenician and Greek runners and include a modern drawing from World War II.

The portfolio will be distributed without charge from the Inglewood plant of the company.

SOWARD NOW CHIEF ENGINEER AT SUPREME INSTRUMENTS

Raymond Soward has returned to Supreme Instruments Corporation, Greenwood, Mississippi and will serve as chief engineer. Mr. Soward, from 1936 to 1938 was employed as design engineer. In 1942

STANCOR Transformers

THE STANDBY OF SERVICEMEN

Call your nearest Stancor Jobber—or write us for his address

STANDARD TRANSFORMER CORPORATION

1500 NORTH HALSTED STREET • CHICAGO



TRUESDELL NAMED BENDIX HOME RADIO G-S-M

Leonard C. Truesdell, former sales manager of Crosley Corporation's radio and appliance division, has been appointed general sales manager for the home radio division of Bendix.

A four-point program of pre-planning to prepare the nation's radio service business for the strongly competitive postwar situation that it will face in common with the radio manufacturing industry, was outlined by Mr. Truesdell at a recent meeting of the Philadelphia Radio Service Men's Association.

New opportunities, he said, will be enlarged by a large trade-in-market. Resale of used radios, he said, probably will constitute for the service industry a large

portion of its immediate postwar business. This will offset the shrinking volume of repair and maintenance business which will come with production and sale of new radio equipment which will require considerably reduced servicing due to higher quality and new war-born precision manufacturing techniques.

The program recommended by Mr. Truesdell stated: (1)—Start now to assemble the additional *know how*, modern facilities, equipment and personnel which will be needed to keep pace with newest developments in the radio field. (In this connection Mr. Truesdell urged study of the valuable and timely information, suggestions and ideas contained in the industry's trade papers); (2)—Absorb into the service industry the highly trained ex-Service Men whose advanced military training in radio will fit them to make valuable contributions to this field; (3)—Sell the radio service industry's technical knowledge, services and facilities with soundly conceived advertising, conveniently located places of business and orderly, attractive surroundings; (4)—

became a radio engineer in the signal corps in Atlanta, Georgia. Assisting Mr. Soward at Supreme will be Robert H. Streeter, as design engineer.



Raymond Soward



Robert H. Streeter

* * *

SCHOTT CATALOG

A 20-page 1945 catalog has been published by Walter L. Schott Company, 806 Santa Monica Boulevard, Beverly Hills, California.

The first half of the catalog is devoted to radio chemicals. The second part of the catalog covers radio and electronic hardware.

* * *

"E" AWARDS

Clarostat Mfg. Co., Inc., Brooklyn, N. Y., has been awarded a second white star for its "E" flag.

The Sharon works of the Westinghouse Electric and Manufacturing Company and plant two of the Solar Manufacturing Corporation have received the fourth white star for the "E" pennant.

* * *

HAST HEADS LEAR HOME SET UNIT

Nate Hast has joined Lear, Incorporated, as merchandising manager in charge of styling and marketing Lear home radio sets.

Headquarters are at 230 East Ohio Street, Chicago, Illinois.

Mr. Hast was formerly national sales manager for Emerson Radio.



SYLVANIA BOND-PRIZE CONTEST



The bonds being offered as prizes by Sylvania in the retail radio store and Service Men's section of a national window display contest will now total \$11,000; \$1,000 in war bonds being offered to jobbers in a special contest.

**YOU CAN
DEPEND
UPON**

Smooth Power

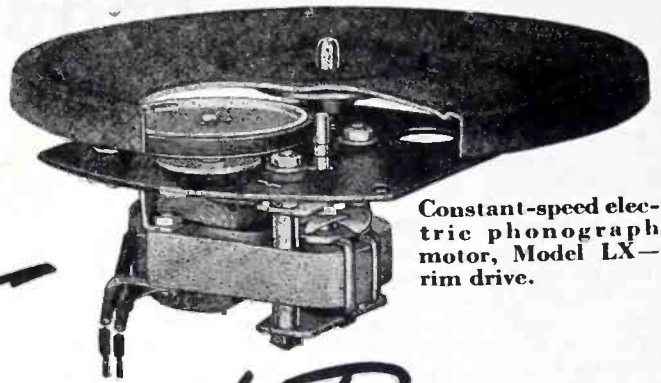

Constant-speed electric phonograph motor, Model LX—rim drive.

The same *Smooth Power* motors that drive General Industries recorders, turntables and record-changers are now being used in a large number of wartime devices where dependability is the most important requirement.

Their quick pickup, unvarying speed and velvety smoothness in operation have made them long-time favorites for phonograph and radio use where accuracy of recording and fidelity of reproduction are essential.

So, if you want such devices for postwar use, we suggest you start your planning now. From our long and proven line of equipment, you can probably

select a standard design to meet your needs. Or, our engineers will adapt one for your specific requirements.

You can save time by starting discussions now, followed by detailed planning when the end of our war work is in sight. We'll welcome your inquiries.

THE GENERAL INDUSTRIES CO.
DEPT. M • • • ELYRIA, OHIO



BURLINGAME PROVIDES INSTRUMENT REPAIR SERVICE

Burlingame Associates, 11 Park Place, New York City, have instituted a special instrument repair section, under the supervision of William E. Adams.

Service Men and experimenters are asked to write to Burlingame first, and state make of equipment and other pertinent facts before forwarding.

Burlingame is an authorized service station for Supreme Instruments.

* * *

CLAROSTAT INTERIM LINE CATALOG

An *Interim Line* catalog listing such items as composition-element and wire-wound controls, switches, constant-impedance attenuators, universal metal-tube plug-in resistors, power rheostats, power resistors, voltage regulators, and glass-

insulated flexible resistors has been issued by Clarostat Mfg. Co., Inc., 285-7 N. 6th St., Brooklyn, N. Y.

* * *

LITTELFUSE APPOINTS HUGHES EASTERN S-M



Jack D. Hughes has been appointed Eastern division sales manager of Littelfuse (Continued on page 39)

**HUMIDITY PROTECTION ON ALL
SPRAGUE KOOLOHMS**

Humidity protection formerly obtainable only on special order, has been adopted for standard Sprague koolohm wire-wound resistors.

This construction includes a glazed ceramic outer shell and a new type of end seal.

Type numbers of the resistors remain the same except for the fact that the letter "T" has been added to the old designation.

LANGEVIN LOUDSPEAKER

A cast aluminum-unit loudspeaker, 26-B, designed to operate through high noise levels and with uniform distribution over horizontal angles of 120 and vertical of 40, has been announced by the Langevin Company, 37 W. 65th St., New York 23. It can be used for voice reproduction by itself or as an h-f component to a wide-range system.

The unit handles power input of 40 watts when equipped with 2 Jensen U-20 drive units. It is 22" wide, 14½" deep, 20" high.

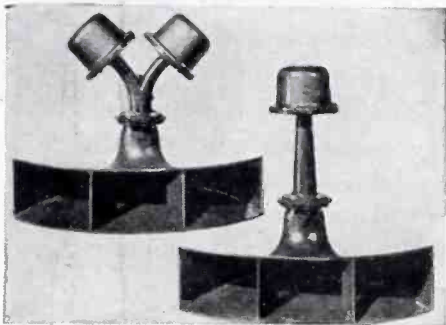

G. E. PHOTOMETER

A transmission photometer for measuring the amount of light transmitted through very small areas of spectrographic plates, has been announced by the special products division of G. E. The new photometer is desirable for use whenever spectrographic analysis is employed,

**NEW
PRODUCTS**

such as in the metal fields, and also for microcolorimetric and microchemical analyses.

Uses a constant power supply of 6 volts, a-c or d-c, with an approximate capacity of 30 amperes. Consists essentially of a light source, an optical system, a galvanometer, a light-sensitive cell, and a mechanical stage for accommodating the plate. This stage has a three-point, ball-bearing suspension, and is movable in three directions.

DU MONT FERROGRAPH

Comparisons of ferrous materials as to analysis and heat-treatment are provided by the Ferrograph, a metal-testing instrument, announced by Allen B. Du Mont Laboratories, Inc., Passaic, N. J.

The Ferrograph utilizes the transformer principle of operation. A 23-cycle exciting current is fed into the primary coil while the output of the secondary is controlled by the magnetic characteristics of a metal sample introduced into the coil. The voltage from the secondary is filtered and the fundamental 23-cycle wave is impressed on the horizontal axis of the cathode-ray tube. The third harmonic is viewed on the vertical axis of the instrument.

The low-frequency exciting current is said to have an advantage over the use of 60-cycles in that the reversals of magnetizing flux are slow enough to give some appreciable effect from residual magnetism. A long-persistence screen is used in the cathode-ray tube to avoid flicker from the low frequency used. A relay turns the cathode-ray beam off automatically unless there is a sample in the test coil. The flux in the test coil can be varied widely.

Calibrated scale provides ten divisions

per inch, with the 10th division accentuated. Instrument operates on 115 volts, 40-60 cycles. Dimensions: 12½" w, 17¼" h, 23¾" d; weight, 100 pounds.



**UNIVERSAL MICROPHONE D-20
MICROPHONES**

A dynamic microphone, D-20, that is said to have a response of 50 to 8,000 cycles, has been announced by Universal Microphone Company, Inglewood, Calif. Will be modeled in a brushed satin chrome finish case with Universal's micro-adjust swivel. Dust-proof hood and twenty-five feet of cord will be included. Will be supplied in four impedances.

Universal will also resume production on other microphone models including the dynamics, KD and 15MM; dynamic handi-mike 200 series, and X-1 and XX, both carbons.

**STACKPOLE CARBON PILE
RHEOSTATS**

Continuously adjustable carbon rheostats formed of carbon disc piles have been produced by Stackpole Carbon Company, St. Marys, Pa. Simply by changing the pressure applied to these piles, many resistance values are made available without opening the electrical circuits in which they are connected. The pressure to vary the resistance may be applied

The Service Man's Best Friend
WARTIME RADIO SERVICE
\$3.00
SUPPLEMENT NUMBER ONE
\$1.00
About 1,200 tube substitutions and much other important information.
We have IN STOCK, adapters to make more than 100 of these substitutions. Quick, convenient, low priced. Ask for list airmail.
CITY RADIO COMPANY
504-6 E. Washington St.
PHOENIX, ARIZONA

Radio
AND
**ELECTRONIC
DEVICES**

BURSTEIN-APPLEBEE CO.
1012-1014 McGee St. • Kansas City 6, Missouri

• *Ted McElroy*
World's Largest Manufacturer of
Wireless Telegraphic Apparatus
COMPLETE CENTRAL OFFICE EQUIPMENT
McElroy Manufacturing Corp.
32 Brookline Avenue • Boston, Massachusetts

TUBES - PARTS
RADIO DEALERS - SERVICEMEN
Send for our list of available tubes and repair parts.
Sylvania, Tung-Sol, National Union.
M. V. MANSFIELD CO.
937 LIBERTY AVE. PITTSBURGH 22, PA.

NEED PARTS?

National can supply you quickly with most of these hard-to-get parts at exceptional prices. Take a look at these bargains—

TUBE SPECIALS

All fully guaranteed.
 Type 27 (Pear Shape) 33c ea.
 100 for \$24.90
 Types UX200, 31, 89 39c ea.
 Types 39, 6F8G, 6SN7GT, 4S, 55 49c ea.
 Types 6SL7GT, 6Z5, 1T4, 3S4 59c ea.
 Types 7H7, 7N7, 22 69c ea.
 Only these types available, while they last, do not ask for others.

6 ft. Electric Cord Sets, high grade, soldered, molded, rubber plug at one end, stripped and tinned at other.
 Each, 29c; 10 for \$2.75; 100 for \$24.60

3,000 m.f.d. at 3v F.P. Condenser in aluminum can 1 1/2" D X 2 1/8" H. Fresh stock. Special, while they last. Each \$1.39
 10 for \$11.89

A Superior Mike Cable, single conductor, shielded, and pre-war natural rubber cover.
 13c per ft.; 100 feet, \$9.90

CONTINENTAL CARBON RESISTOR
 KIT No. C6 Assortment, 100 RMA coated 1/2 and 1 Watt resistors (1/2's are one watt). Unusual bargain at \$3.35

AERIAL KIT containing aerial wire, rubber coated lead-in, insulators, ground clamp, window strip, etc. Each, 89c

20 MFD 150 WV Tubular Pigtall Electrolytic, One Year Quar. Each, 35c; 10 for \$3.30

10 MFD 450 WV Tubular Pigtall Electrolytic, One Year Quar. Each, 43c; 10 for \$3.95

Deluxe assortment of 50 Bakelite Set Screw Knobs for 1/4" Shaft. Kit, \$4.19

50 MFD 150 WV Tubular Pigtall Electrolytic, One Year Quar. Each, 49c; 10 for \$4.45

ASSORTMENT OF 147 FIRST LINE 600 WV TUBULAR BY-PASS CONDENSERS CONSISTING OF 64 .01-600WV, 32 .02-600WV, 24 .06-600WV, 27 1-600WV, One Year Guarantee. List Price, \$33.30. **\$11.95**
 Your cost only.....

Assortment of 200 pcs. Special Radio Hardware including Tube Sockets, Terminal Strips, Grid Caps and Plugs. Kit, \$1.49

20x20/150WV Tubular Electrolytic, First Line Condenser, One Year Guarantee. Each, 61c; 10 for \$5.60

BALLAST TUBES—K42B, K42C, K49B, K49C, K55B, K55C, L49B, L49C, L55B, L55C.
 Each, 45c; 10 for \$3.99
 100-37, 100-70, 100-77 and 100-79.
 Each, 59c; 10 for \$5.45

Continental Bakelite Suppressors—819A (Straight type with Rajah spring snap-on connector, fits all makes of spark plugs. Terminal nut cable connector.) Each, 18c; 10 for \$1.65

HI-TEMP RUBBER PUSH BACK WIRE—Solid and Stranded (#20)
 100 Ft. Roll, 71c; 10 for \$6.50

LOCTAL SOCKETS—(Metal Supporting Ring.)
 10 for \$1.10; 100 for \$9.99

10 MFD 50WV Tubular Pigtall Electrolytic Condenser, One Year Quar. Each, 28c; 10 for \$2.45

10x10/450WV Tubular Electrolytic, First Line Condenser, One Year Guarantee. Each, 74c; 10 for \$6.90

Assortment of 25 Muter Candohm Wire Wound Resistors (All are 7 to 15 W, 15 or more are between 100 and 500 Ohms.) ... Assortment, \$4.99

20% deposit required on all C.O.D. orders. Don't forget L-285 or AA-3 Certificates. Orders of \$25.00 or more, accompanied by payment in full, will be shipped prepaid.

Free Bulletin No. 1100 lists hundreds of other radio parts and supplies. Write for it today!

NATIONAL ELECTRONIC SUPPLY

77 W. Washington Blvd. Chicago 2, Ill.

electrically, mechanically, centrifugally or hydraulically. Uses range from both generator and line-voltage regulator applications to speed control through governed field current on motors.

Stackpole supplies carbon piles in practically any length pile and diameter required.

Carbon disc pile 1 1/2" long composed of dises. 432" in diameter permits a resistance range of from 60 ohms with 1 ounce pressure to .3 ohms at 32 pounds pressure.

BMP TUBE EXTRACTOR

For extraction of standard size metal tubes, the BMP Company, Boonton, N. J., have designed a metal tube extractor. Constructed of one-piece steel, plain, zinc or cadmium plated.

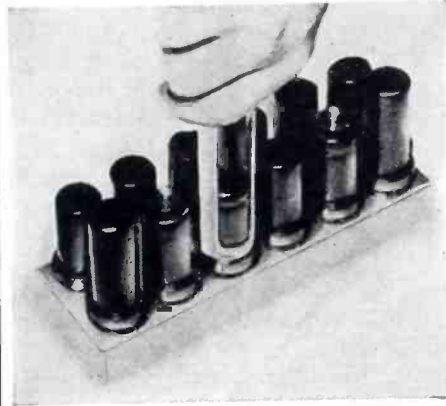

NEWS

(Continued from page 37)

fuse. He will make his headquarters in New York City.

R. J. HIGGINS BECOMES TURNER REP

Royal J. Higgins, 600 South Michigan Avenue, Chicago, Illinois, has been appointed Chicago area representative by The Turner Company, Cedar Rapids, Iowa.

Mr. Higgins was formerly advertising manager of the Hallicrafters Company.

GOLDER NOW G. I. SPEAKER UNIT HEAD

Leon Golder, former secretary and sales manager of Rola, has become manager of the new speaker division at General Instrument Corporation, Elizabeth, N. J.

The speaker business will be conducted by the General Apparatus Corporation, a G. I. subsidiary.

HINKLE ACQUIRES ADIRONDACK RADIO SUPPLY

Ward J. Hinkle of Amsterdam, New York has purchased the Adirondack Radio Supply parts distributing firm of Gloversville, New York.

Mr. Hinkle is moving the headquarters of the company to 68 Lincoln Avenue, Amsterdam, New York where he will continue to feature National Union Radio tubes and parts; Sprague, Solar, IRC, Centralab and other nationally known lines.

NEED A SUPPLY OF MATCHES?

SYLVANIA SERVICEMAN SERVICE

by

FRANK FAX



Book matches, imprinted with your name, are one of the best and most economical ways to advertise your business.

Sylvania has prepared a new style of book match for your use.

Supplied to you for cost, with your name handsomely imprinted:

1,000 .. \$3.25 5,000 .. \$14.90
 2,500 .. 7.50 7,500 .. 22.40

Plus 40 cents per thousand Federal Tax. Orders under 7,500 are shipped FOB Shipping Point; over 7,500, FOB your address.

Order from your local Sylvania distributor, or send your order to Frank Fax, Sylvania, Emporium, Pa.



SYLVANIA

ELECTRIC PRODUCTS INC.

RADIO DIVISION



Plug in
METAL TUBE RESISTORS

★ To facilitate the servicing of those AC-DC sets equipped with plug-in metal-tube resistors, CLAROSTAT offers 10 Universal Types which replace 90% of the original numbers.

Note particularly: A Clarostat "Universal Type" operates within voltage ranges specified on tube, regardless of what pilot current is drawn or of any pilot light combination. It operates regardless of burnt-out pilot lights, operating well within the .3 ampere range required for tube filaments. Also, the tube operates efficiently regardless of line-voltage variation. And above all, remember that Clarostat introduced, pioneered, and has produced the bulk of such resistors in daily use.



★ Ask Our Jobber . . .

Ask for latest Clarostat "Interim-Line" catalog which includes listing of these Universal Metal-Tube Resistors, as well as standard types replaced. Or write direct.



CLAROSTAT MFG. CO., Inc. • 285-7 N. 6th St., Brooklyn, N. Y.

JOTS AND FLASHES

FIRST annual television broadcasters conference, recently held in New York, a tremendous success . . . better study up on the subject starting now . . . for successful post-war servicing, you'll have to be *in the know* on television . . . third White Star awarded to Meissner Mfg. Co., for addition to their "E" pennant . . . J. A. Clancey named manager of National Union Radio Corp.'s plant in Lansdale, Pa. . . "E" awarded for fifth time to Motorola . . . Winter technical meeting of Institute of Radio Engineers to be held January 24-27 at Commodore Hotel, New York City . . . Western Electric Co. plans to manufacture television transmitting equipment after the war . . . Radio & Appliance Agency in Chattanooga, Tenn., made RCA-Victor distributor . . . D. E. Bursell and R. G. Chermack, 2233 University Ave., St. Paul, Minn., appointed factory representatives for Universal Microphone Co. . . Motorola names Edward L. Pinus district sales manager for Middle Atlantic states with headquarters in Philadelphia . . . congratulations to John F. Rider, nationally known radio authority, on his promotion to Lieutenant-Colonel, U. S. A. . . Army-Navy "E" awarded to United Transformer Corp. for excellence in war production . . . Edward R. Hanslip, Jr., named district manager by Bendix Home Radio with headquarters in Kansas City . . . 4th "E" award to the West New York, N. J., plant of Solar Mfg. Corp. . . Paul S. Ellison, advertising director of Sylvania Electric Products, Inc., was elected vice chairman of A. N. A. at its 35th annual meeting . . . third Army-Navy "E" award to Clarostat Mfg. Co., Inc. . . regret to report death of Mrs. James R. Fouch, wife of founder of Universal Microphone Co. . . starting next month your magazine, SERVICE, will be graced with a new and really outstanding cover . . . you'll like it . . . 1945 will bring many new opportunities for radio Service Men . . . new servicing techniques will be demanded for television and f-m . . . SERVICE will try to keep you thoroughly posted on all new developments . . . again, let us remind you to secure and carefully read all literature made available by manufacturers . . . work closely with your distributor . . . he can be of plenty assistance . . . send interesting case histories and servicing short cuts to our editors . . . we'll pay you for those published . . . in addition, you'll get plenty of satisfaction of helping other Service Men who will profit from your experiences . . . here's wishing you all a very Happy and Prosperous New Year.

**ADVERTISERS IN THIS ISSUE
 SERVICE INDEX—DECEMBER, 1944**

AEROVOX CORPORATION	28
Agency—AUSTIN C. LESCARBOURA & STAFF	
AMERICAN MICROPHONE CO.	17
Agency—KEMMERRER, INC.	
AMPERITE CO.	24
Agency—H. J. GOLD CO.	
BURLINGAME ASSOCIATES	24
Agency—HARP LEHMAN, ADVERTISING	
BURSTEIN-APPLEBEE CO.	38
Agency—FRANK E. WHALEN ADV. CO.	
CITY RADIO CO.	38
CLAROSTAT MFG. CO., INC.	40
Agency—AUSTIN C. LESCARBOURA & STAFF	
CONCORD RADIO CORP.	24
Agency—SHAPPE-WILKES INC.	
CORNISH WIRE CO.	30
Agency—HART LEHMAN, ADVERTISING	
DETROLA RADIO DIV., INT'L. DETROLA CORP.	7
Agency—ZIMMER-KELLER, INC.	
ELECTRO-VOICE MFG. CO., INC.	35
Agency—SHAPPE-WILKES INC.	
FREED TRANSFORMER CORP.	29
Agency—FRANKLIN ADV. SERVICE	
GENERAL CEMENT MFG. CO.	36
Agency—TURNER ADV. AGENCY	
GENERAL ELECTRIC	32
Agency—MAXON, INC.	
THE GENERAL INDUSTRIES CO.	14, 37
Agency—FULLER & SMITH & ROSS, INC.	
HALLICRAFTERS CO.	4
Agency—BURTON BROWNE, ADVERTISING	
HICKOK ELECTRICAL INSTRU. CO.	22
Agency—WHITE ADV. AGENCY	
HYTRON CORP.	Inside Front Cover
Agency—HENRY A. LOUDON, ADVERTISING	
JENSEN RADIO MFG. CO.	1
Agency—BURTON BROWNE, ADVERTISING	
KEN-RAD TUBE & LAMP CORP.	31
Agency—ALLEN, HEATON & MacDONALD, INC.	
McELROY MFG. CORP.	38
Agency—SHAPPE-WILKES INC.	
M. V. MANSFIELD CO.	38
MEISSNER MFG. CO.	9
Agency—GARDNER ADV. CO.	
NATIONAL ELECTRONIC SUPPLY	39
NATIONAL UNION RADIO CORP.	Back Cover
Agency—HUTCHINS ADV. CO., INC.	
RADIART CORP.	32
Agency—KENNETH H. KOLPIEN	
RADIO CITY PRODUCTS CO., INC.	25
Agency—REISS ADVERTISING, INC.	
RADIO CORPORATION OF AMERICA	10, 19
Agency—KENYON & ECKHARDT, INC.	
RADIO & TECHNICAL DIV. MURRAY HILL BOOKS, INC.	21
Agency—THE HARRY P. BRIDGE CO.	
RAYTHEON MFG. CO.	3
Agency—BURTON BROWNE, ADVERTISING	
JOHN F. RIDER PUBLISHER, INC.	33
Agency—LANSFORD F. KING	
SOLAR CAPACITOR SALES CORP.	Third Cover
Agency—O. S. TYSON & Co., Inc.	
SPRAGUE PRODUCTS CO.	6
Agency—THE HARRY P. BRIDGE CO.	
STANDARD TRANSFORMER CORP.	36
Agency—BURNET-KUHN ADV. CO.	
SUPREME INSTRUMENTS CORP.	30
Agency—O'CALLAGHAN ADV. AGENCY, INC.	
SYLVANIA ELECTRIC PRODUCTS INC.	39
Agency—ARTHUR KUDNER, INC.	
U. S. TREASURY DEPT.	8
UNITED TRANSFORMER CO.	26
Agency—SHAPPE-WILKES INC.	
UNIVERSAL MICROPHONE CO.	5, 28
Agency—RALPH L. POWER AGENCY	

CHECK on this "QUICK-CHECK" Feature of the Solar Capacitor Analyzer . . .



THE SOLAR MODEL CE Capacitor Examiner speedily locates common defects in capacitors without disconnecting condensers—often eliminating further tests. This saving of time and labor is accomplished by the unique Solar "QUICK-CHECK" feature.

In this *single* instrument are combined the simplest, most convenient methods for examining the true condition of every capacitor in ordinary use . . . shorts, opens, intermittents, high R.F. impedance and high power factor.

Catalog IN-1 illustrates and describes features of all models. Send for your copy today.



Solar Mfg. Co.

ANOTHER HELPFUL SOLAR SERVICE

SOLAR CAPACITOR SALES CORP.
285 Madison Avenue, New York 17, N. Y.

Please send me a copy of Catalog IN-1 on Solar CAPACITOR ANALYZERS.

Name

Title

Company Name

Street Address

City State

SEND THIS COUPON IN—TODAY



After The war, MORE than before!

COUNT ON THE FAMOUS N. U. EQUIPMENT PLAN

Of course, you'll need new shop equipment to cope with the vastly increased peacetime demand for radio, television and industrial electronic service. You'll want fine, modern instruments, tools, meters. And you'll want them, as before, on the easy-to-get basis provided by the famous N. U. Equipment Plan.

Fifty thousand times this plan was Ok'd by service dealers who used it to equip their shops in the years before the war. So plan now to re-equip for peacetime service, the exclusive N. U. way.

**NATIONAL UNION RADIO CORPORATION
NEWARK 2, NEW JERSEY**

Factories: Newark and Maplewood, N.J.; Lansdale and Robesonia, Pa.

**NATIONAL UNION
RADIO AND ELECTRONIC TUBES**



Transmitting, Cathode Ray, Receiving, Special Purpose Tubes • Condensers • Volume Controls • Photo Electric Cells • Panel Lamps • Flashlight Bulbs