

SERVICE

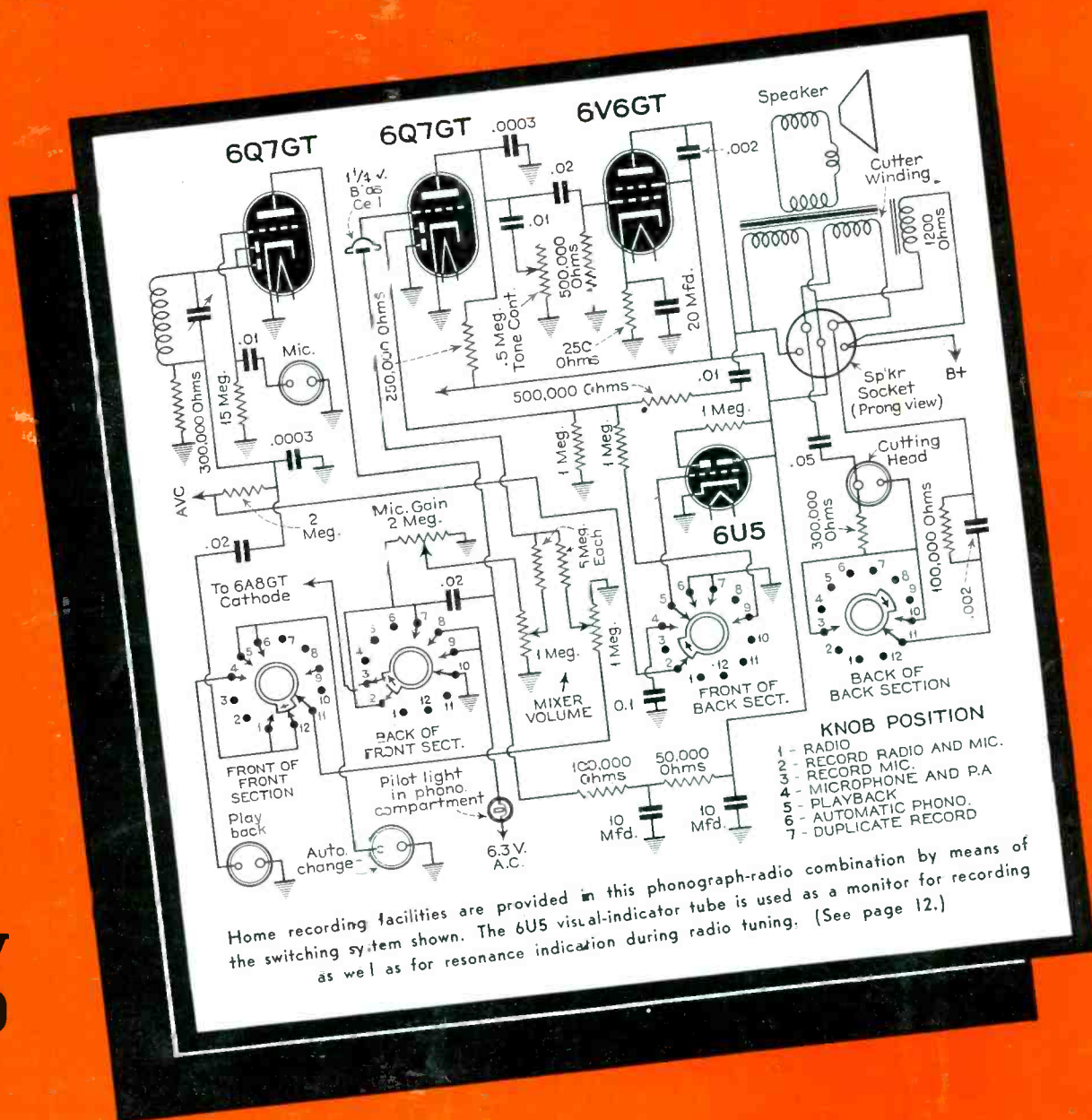

May
1940

P. R. MALLORY & CO., Inc.

MALLORY

The *One* Line That Gives You *All* The Answers On Condenser

Mallory gives you every answer to condenser replacement because the entire line has been developed around an exhaustive study of millions of condensers now in use...and the experience gained in supplying millions of condensers to leading manufacturers for use as original equipment.

It is no idle boast to say that no manufacturer gives you a condenser line with wider replacement possibilities.

For inexpensive, compact receivers Mallory provides Tubular Condensers with over 50 ratings to choose from... with common anode, common cathode and separate sections too.

Mallory FP (Fabricated Plate) Capacitors bring a new high in efficiency and performance. Millions are in use as original equipment. FP Capacitors give you

Replacement

features not duplicated in any other condenser. Smaller sizes, unusually low R.F. impedance, surge-proof construction, improved seal against heat and humidity... these are just a few.

Mallory Type TP (paper)... and Mallory Wet Electrolytic Condensers are equally dependable...equally adapted to efficiently meet the service requirements for which you need such replacements.

Decide now to solve your condenser replacement problems by depending on Mallory. It costs no more. You'll get tops in service from Mallory selected, nation-wide distributor setup.

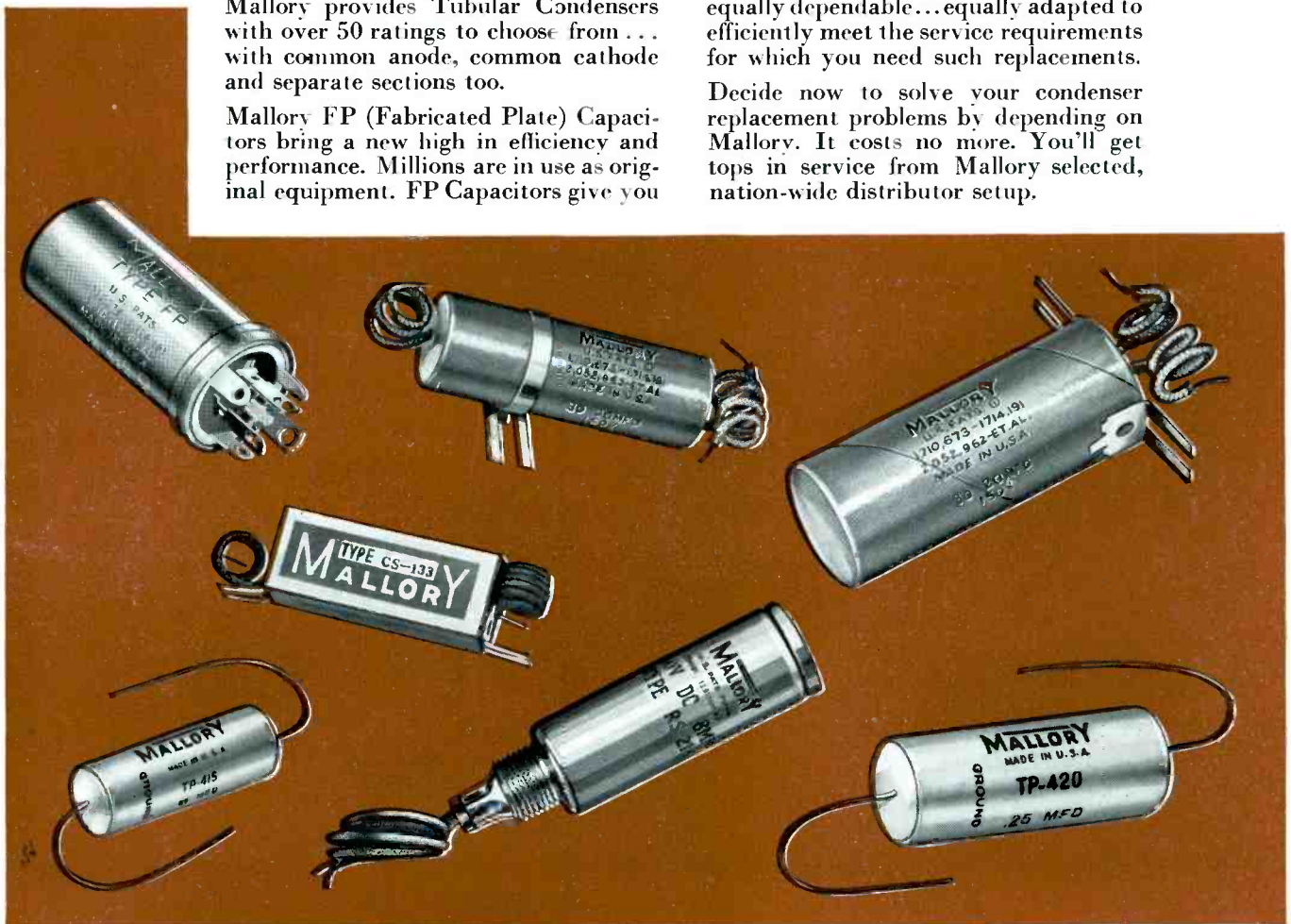

Use
P. R. MALLORY & CO., Inc.
MALLORY
APPROVED
PRECISION PRODUCTS

P. R. MALLORY & CO., Inc.
INDIANAPOLIS INDIANA
Cable Address—PELMALLO

\$2.30 LIST*

Jensen
REPLACEMENT
SPEAKER

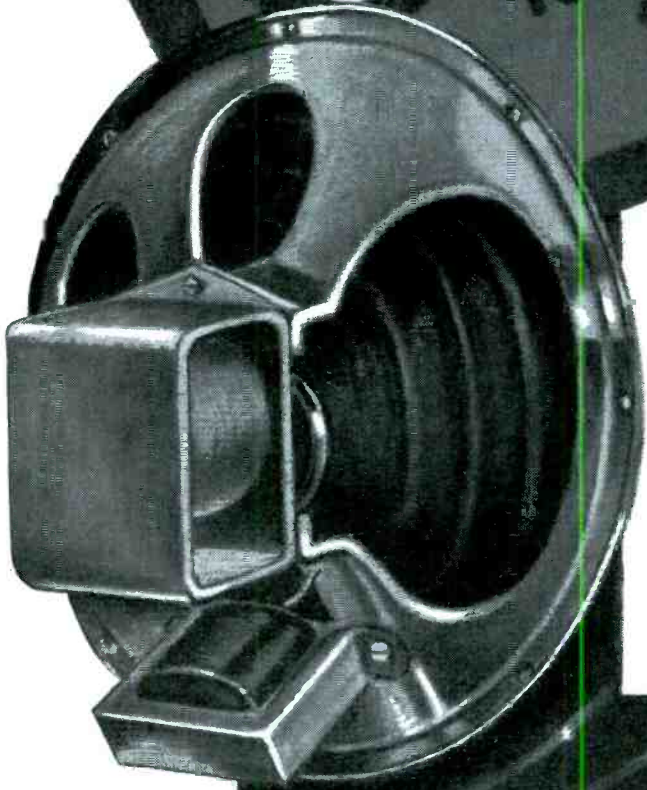

With a **JENSEN** replacement speaker *you know you are giving your customer the best there is.*

Yet you can sell genuine **JENSEN** replacements at prices so low that *your customer pays no premium for JENSEN quality.* So there really isn't any reason to use anything but the best.

** Subject to your usual trade discounts.*



SEEMS as if the postman has been working overtime of late. If we ever get out from under the huge stacks of contest letters he brought, we will announce the winners and distribute the prizes.

The response has indeed been gratifying. The contestants sent in some very excellent ideas which should help us all. We only wish that we could give each and every one a prize.

The prize winning ideas will be published, as space limitations allow, on the pages of SERVICE. We will also attempt to publish certain other good ideas submitted by non-prize winning contestants.



THIS is the time of the year when we raise up our trumpets to herald the approach of the Radio Parts National Trade Show. It will be held this year, as it has been for the past few years, at the Stevens Hotel, Chicago, Tuesday, Wednesday, Thursday and Friday, June 11 to 14, inclusive.

Each year has brought a show which was bigger and better than all previous shows. Present indications definitely point to a great show this year. At this writing all the exhibition booths have already been taken and preregistrations exceed those for the same time last year.

The manufacturers are putting forth their best efforts to make their displays interesting and instructive. The exhibits will be well worth seeing; the technical sessions worth attending. Readers of SERVICE are invited. There is no admission charge.

And don't forget to visit our booth in the registration lobby, Stevens Hotel, Chicago.



EACH day frequency modulation gains momentum. New stations apply for license, receiver manufacturers announce their intentions to manufacture f-m models or additional public interest is aroused. For you f-m is a reality. Sets are already in the homes of listeners. Some already require servicing. You should study all about this new art. Read up on it now!

CONTENTS

	Page
Auto-Radio Installation in 1940 Cars. <i>By Edward H. Barry</i>	8
Auto-Radio Interference Elimination Chart.....	8
Home Recording. <i>By Henry Howard</i>	12
Large Screen Television.....	29
New Tubes.....	25
New Tube Characteristics Chart.....	25
Signal Substitution. <i>By G. N. Goldberger</i>	14
Sound Profits in a Small Town.....	18
Tolerances. <i>By Jack Avins</i>	5
Associations	30
Auto-Radio	
Auto-Radio Installation in 1940 Cars. <i>By Edward H. Barry</i>	8
Auto-Radio Interference Chart.....	8
Circuits	
Avc Filter Network.....	6
Block Diagram Ball Park P-a System.....	18
Bridge T Trap.....	6
Howard 302R, RA, RT Radio Recorder Switching.....	Front Cover
I-f Stage.....	7
Lafayette S53 Radiocorder Switching.....	13
Lafayette BB96 Radiocorder Shielded Preampifier.....	12
Lafayette BB96 Radiocorder Switching.....	12
Precision E200 Signal Generator.....	15
Radio City 308 Tube Tester.....	24
Typical Superheterodyne Circuit.....	14
Wilcox Gay A72 Output and Level Indicator.....	13
Cover Diagram	
Home Recording. <i>By Henry Howard</i>	12
Index to Advertisers	32
Highlights	23, 29, 31
Manufacturers	31
Public Address	
Home Recording. <i>By Henry Howard</i>	12
Sound Profits in a Small Town.....	18
Test Equipment	
Signal Substitution. <i>By G. N. Goldberger</i>	14
Television	
Large Screen Television.....	29

Copyright, 1940, Bryan Davis Publishing Co., Inc.

BRYAN S. DAVIS
President

JAS. A. WALKER
Secretary

Chicago Office:
608 S. Dearborn Street
C. O. Stimpson, Mgr.
Telephone: Wabash 1903

Published Monthly by the
**Bryan Davis
Publishing Co.**
Inc.
19 East 47th Street
New York City
Telephone: PLaza 3-0483



PAUL S. WEIL
Advertising Manager

A. GOEBEL
Circulation Manager

Wellington, New Zealand:
Tearo Book Depot

Melbourne, Australia:
McGill's Agency

Entered as second-class matter June 14, 1932, at the Post Office at New York, N. Y., under the Act of March 3, 1879. Subscription price: \$2.00 per year in the United States of America and Canada; 25 cents per copy. \$3.00 per year in foreign countries; 35 cents per copy.

when
batters
step up
to the
plate

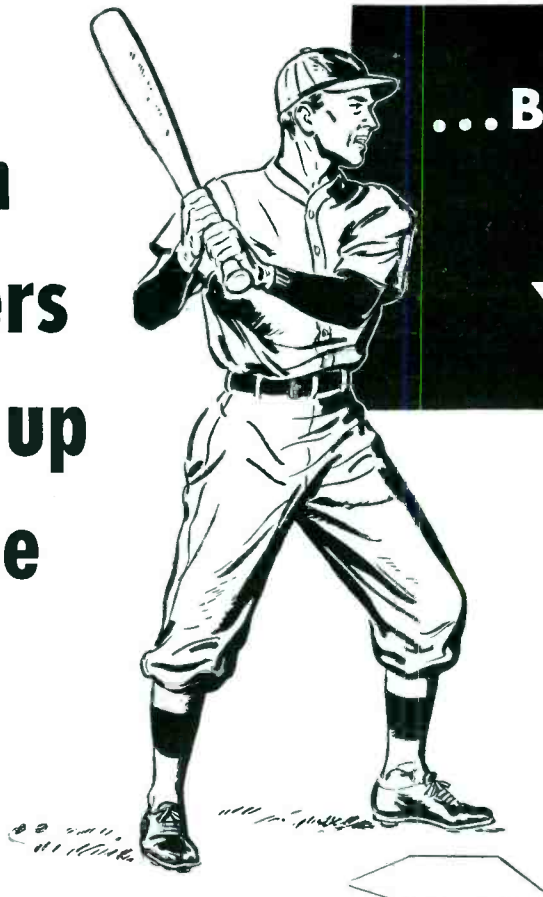

... BATTERY CUSTOMERS
STEP UP TO
YOUR COUNTER!

Baseball season is portable radio season... when portable sets start working overtime—and replacement buying of batteries swings into high.

To get your share of this replacement demand be ready to stock and push the sensational "Eveready" "Mini-Max" "B" battery—the battery that makes portable sets really portable!

The "Eveready" "Mini-Max" "B" battery has set a brand new standard for portable "B" battery size and performance. Combining minimum size and weight with maximum power it delivers twice the service life of any other "B" battery of equal size. That's why approximately 30 leading manufacturers have designed portable sets using this remarkable battery.

Be sure you have enough "Eveready" "Mini-Max" "B" batteries on hand to take care of demand that's starting now. Order today for extra profits tomorrow!



These leading radio manufacturers have designed sets to use the "Eveready" "Mini-Max" "B" battery—

ARVIN	MOTOROLA
AUTOMATIC	NAMCO
COLONIAL	PACKARD BELL
CROSLY	PILOT
DETROLA	RCA
DEWALD	SENTINEL
EMERSON	SONORA
FADA	SPARTON
FARNSWORTH	STEWART WARNER
GAROD	STROMBERG CARLSON
GENERAL ELECTRIC	TELEX
GENERAL TELEVISION	TRAV-LER
GILFILLAN	TROY
HOWARD	WARWICK
KADETTE	WESTINGHOUSE
MAJESTIC	WILCOX-GAY
MISSION BELL	<i>And Others!</i>

NATIONAL CARBON COMPANY, INC.

General Offices: New York, N. Y.
Branches: Chicago and San Francisco
Unit of Union Carbide and Carbon Corporation



The words "Eveready" and "Mini-Max" are registered trade-marks identifying products of National Carbon Company, Inc.



N.U. SIXTY DAY SPECIAL

Limited May 1 to June 29

only **\$12**

DEALER DEPOSIT
 You receive delivery at once.
 Your deposit is rebated on completion of 650 purchase points.

Model 303 P5

Regular Dealer Price **\$24.90**

DACO TUBE TESTER

MODEL 303 P5 FEATURES

- Enclosed in Portable Leatherette Case
- Extra Large, Full Vision Meter
- Standard R.M.A. Circuit
- Snap-Switch Control
- Neon Short-Leakage Test
- All Filament Voltages from 1 to 117 volts
- Provisions for Latest Tube Types
- Spare Sockets for New Types, Preventing Obsolescence
- High Quality Parts Used Throughout
- Complete, Easy Reference Tube Chart
- Ruggedly Constructed Throughout
- Simplified Operation
- Tests Pilot Lights
- Tests Ballast Tubes

SEE YOUR N. U. DISTRIBUTOR OR SEND COUPON

Get It **FREE** the N. U. Way

You get this Daco Model 303 P5 Tube Tester by depositing only \$12.00 with your N. U. distributor. By buying N. U. Tubes, Condensers, and Batteries, you earn purchase points, and on completion of 650 purchase points in 2 years, your deposit will be rebated.

Join thousands of other N. U. dealers; have the best equipped shop in town. Over 50,000 completed deals in our 10 years of successful operation of this plan.

NATIONAL UNION RADIO CORPORATION
 57 State Street, Newark, N. J.

NATIONAL UNION RADIO CORPORATION
 57 State St., Newark, N. J.

S-540

- Please reserve one for me.
- Please have your salesman show it to me.

Name

Address

City State

TOLERANCES

By JACK AVINS

ONE OF the most important ideas which all engineers acquire at an early stage in their training is the concept that nothing in this world is exact. That everything, no matter what it is, is subject to a certain amount of variation or error. As the engineer's education progresses, he learns to look inquiringly at every single job . . . at every part into which a job can be broken down . . . and to ask this important question: "How accurately must I make this in order to get satisfactory results?" Service Men would do well to ask the same question with respect to each and every one of the many operations which they are called upon to perform. It would enable them to do their job more intelligently and much more efficiently.

nothing in nature is exact

Our experience has shown that the first stumbling block which the Service Man encounters is the notion that absolute accuracy is required in order to obtain satisfactory performance. Let us attempt to destroy this false notion immediately by pointing out that there is not a single thing in this entire world which can be measured or adjusted with perfect accuracy. Even in the scientists' work of setting standards and making measurements, and in the engineers' work of making things, it is possible to achieve only a certain maximum degree of accuracy which cannot be exceeded.

Although we shall never be able to achieve perfect accuracy in anything, scientists have gone a long way toward this ultimate goal. To take an illustration which is familiar to all of you, let us consider how accurately frequency measurements can be made. This should be of interest to you because you are called upon to work with many signals of different frequencies in the course of servicing.

Frequency measurements have been made to an accuracy of 1 part in 10 million. This accuracy is so great that we might almost be tempted to say that there is no error. For all practical purposes, most certainly as far as servicing

would mean a maximum error of less than 1/20 of a cycle in 456,000 cycles.

To go to the opposite extreme, we are all familiar with test oscillators which when set to 456 kc may be off by as much as 10,000 cycles or more, instead of by 1/20 of a cycle as in the above illustration. Between these two extremes there lies a wide range of possible variation in accuracy with which you are confronted. It goes without saying that an accuracy of one part in ten million is not required, but at the same time the i-f peak, to go back to our example, should certainly be within 5 or 10 kc of the specified value.

Similar problems relating to accuracy

come up in almost every phase of servicing. Take the matter of resistor accuracy, for example. Here you are all familiar with the fact that resistors are commonly available which have an accuracy of better than 1% to an accuracy which is poorer than 20%. Just as stable oscillators can be made to produce a highly accurate frequency, so resistors can be made which are highly accurate to within about one part in a million. You can form some idea of this accuracy by realizing

that a 1-meg resistor which has this accuracy would be off by less than 1 ohm out of the total of one million ohms! Similarly, a 10,000-ohm resistor of this accuracy would be off by less than 0.01 ohm.

In the preceding illustrations we have emphasized the point that very high

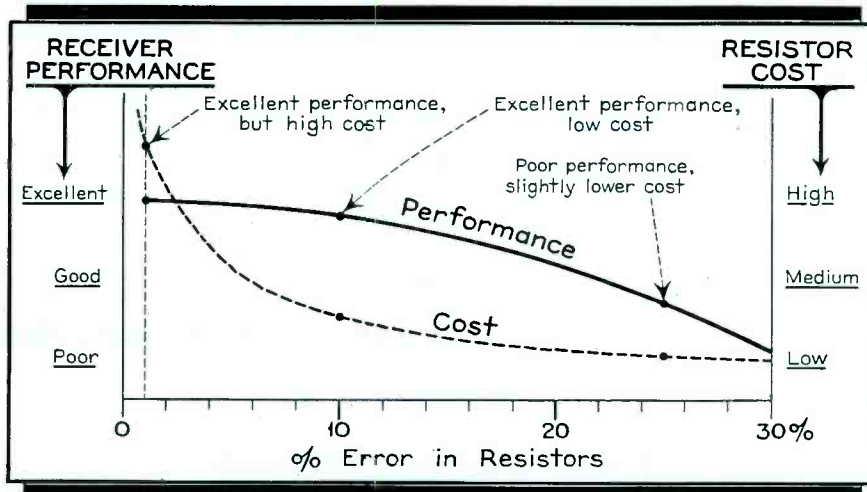

Fig. 1. The performance and cost of a receiver depend upon the accuracy of the parts used. It would seem from these curves that a tolerance of about 10% provides best performance per dollar of cost. If only 1% tolerance were allowed, there is only a very slight improvement in performance, but an enormous increase in cost. For resistors which have a tolerance wider than 10%, the performance drops quite rapidly although the cost does not decrease very much.

is concerned, such a measurement might well be considered perfect. It means that in the case of a 10-mc oscillator, the possible frequency error is less than 1 cycle per second out of a total of 10,000,000 cycles per second! In the case of a 456-kc signal such as you use for alignment, this degree of accuracy

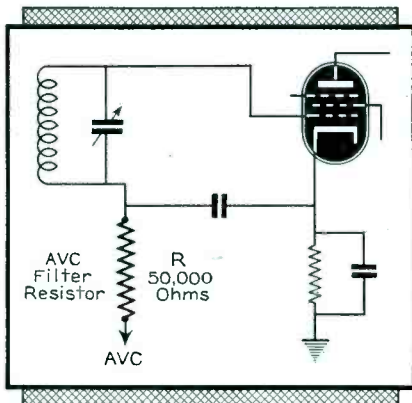

Fig. 2A. The 50,000-ohm resistor used in the conventional avc filter circuit, as shown above, does not require close tolerance. Compare with 2B.

accuracy can be attained but we did not discuss just how it is attained. As you can well imagine, a frequency measurement which is accurate to within one part in ten million is not made simply by reading the dial of a signal generator. On the contrary, it involves elaborate and expensive instruments and the cooperation of a great many scientists. The fact that the assistance of an astronomer is required to make frequency measurements of this degree of accuracy (because such measurements by definition involve an exact knowledge of the element of time) illustrates only one of the many difficulties which are encountered.

As you would expect, all this has an important bearing on the cost. The more accurately a measurement is made, or the more accurately any job is done, the more time it takes, the more elaborate and expensive is the equipment which must be used, and the more money it costs.

goal is best performance per dollar

In any job you are faced with the problem of deciding how accurately it should be done. To illustrate how this important question is answered, let us consider a particular example of interest to you directly. We have in mind a schematic in which the cathode resistor of the r-f tube is identified as 300 ohms. Our general question of accuracy applied to this example results in the specific questions: What error is permissible in this cathode resistor? Should this resistor be accurate to within 1% (3 ohms), 5% (15 ohms), or 20% (60 ohms)? Although it is true that the answer which the design engineer makes is more important because his answer determines the performance of many thousands of receivers, while your replacement influences the performance of only one receiver—still it will be worthwhile considering some of the basic reasons underlying the question of accuracy in this specific instance.

The first thing the design engineer does is to determine the *nominal* value of the cathode resistor. He does this on the basis of the gain which is required in the r-f stage. For the design or experimental receiver model, which is operated at standard line voltage of 117 volts, and in which all the other component parts are of average or rated value, he determines that the best performance is obtained when the cathode resistor is 300 ohms.

But he does not stop at this point. He must still find out how *inaccurate*

In other words, a 20% variation, either plus or minus, from the nominal or rated value of 300 ohms does not materially affect the performance of the receiver. However, the tests show that if the resistor drops much below 240 ohms, the receiver tends to become regenerative and unstable because of the high gain. Similarly, the tests show that if the resistor value is much above 360 ohms the gain is reduced appreciably and the overall sensitivity of the receiver is lowered appreciably. On the basis of these tests the design engineer makes a tentative notation that a plus or minus 20% variation is permissible in this resistor.

Actually the design engineer does not allow this full variation because he must recognize that in production the variations in other components in the receiver reduce the amount of permissible error or tolerance which is required in any one part. Thus in the case of our cathode-resistor illustration, it might happen that all the cathode resistors in a particular receiver might be low by the maximum amount, so that each would be 240 ohms instead of 300 ohms. At the same time the tubes in this particular receiver might have an unusually high mutual conductance, and to make matters still worse, the climate might be very dry, and the line voltage high. All of these effects would tend to raise the gain of the receiver and to cause instability and possibly oscillation. To prevent cases of this sort arising in production, the design engineer reduces the amount of permissible variation in each of the component parts. In the case of the cathode resistor, he might decide for a particular receiver that a variation of $\pm 20\%$ was too great and fix the allowable error or *tolerance* of this resistor at $\pm 10\%$ or $\pm 15\%$. Which value he would choose would of course

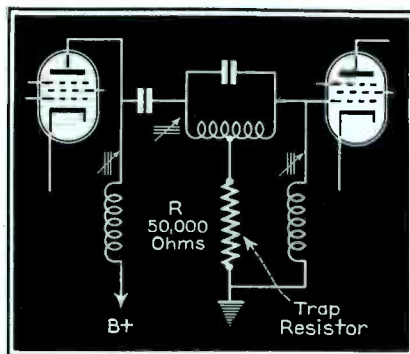

Fig. 2B. The 50,000-ohm resistor used in the Bridged-T network indicated above, however, requires much greater accuracy. Compare with 2A.

the resistor may be without interfering materially with the performance of the set. To do this the engineer obtains information which shows him what happens to the receiver performance as the cathode resistor is increased above 300 ohms, or decreased below 300 ohms. Suppose he finds that there is no noticeable difference (as far as the user is concerned) so long as the cathode resistor is not off by more than 60 ohms in either direction.

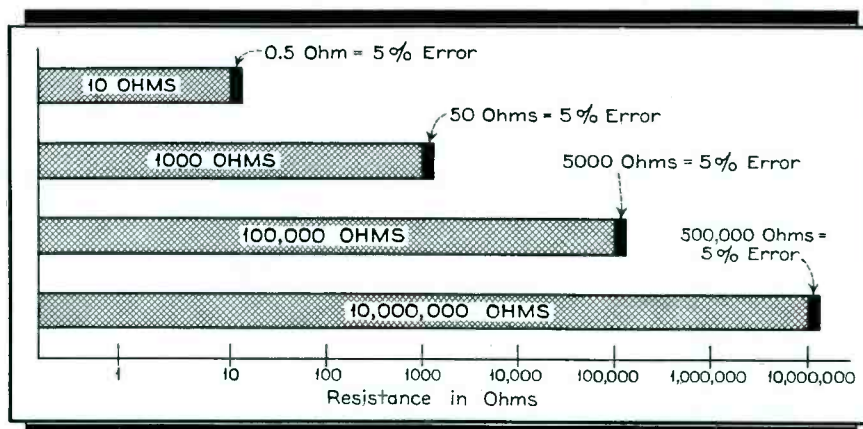

Fig. 3. Each of the four resistors pictured in this illustration has the same percentage error of 5%. Although the relative accuracy of these resistors is the same, note that the error in ohms is proportionally greater for the large resistors. However, an error of 500,000 ohms, in a 10,000,000-ohm resistor, is no more significant or important than an error of 0.5 ohm, in a 10-ohm resistor. Because a logarithmic scale is used the 5% error in each case occupies the same space on the scale.

depend upon the difference in cost between $\pm 15\%$ resistors, say, and $\pm 10\%$ resistors. If there were only a small difference in cost, he would probably decide to stay on the safe side and avoid the possibility of a small percentage of the production receivers having low sensitivity and a small percentage being regenerative. On the other hand, if there were a wide difference in cost, he might decide that it would be cheaper to take care of these relatively few receivers by putting them aside and giving them special attention so as to bring their performance to the normal or average level.

accuracy and your service work

Now that we have given you a brief description of how the resistor came to be coded as a 300-ohm resistor and the significance of this value, let us see how all this is related to the job of servicing. Clearly it provides you with the necessary information for taking care of any matter which has to do with this cathode resistor. On the basis of this discussion you know that there is no need in service work to measure this resistor accurately, that so long as it is within $\pm 10\%$ (between 270 and 330 ohms) it is not responsible for defective operation of the receiver. There is no point in bothering to read your ohmmeter carefully, although we have seen some Service Men do everything but use a magnifying glass on their meter scale so as to be able to read the resistance value accurately. What is the point in taking the time to find out that the resistor value is 289.5 ohms when it can be anything within the range from 260 to 340 ohms without causing any trouble?

We should mention here that in any receiver which comes in for service the allowable variation in any part is usually greater than the accuracy specified in manufacture. In our cathode-resistor example, for instance, you will find that a wider variation than $\pm 10\%$ will usually not impair the operation of the receiver. As we pointed out previously, the production tolerance is usually closer to take care of the relatively few cases when all the parts are off in the same direction.

On the other hand, some receivers will occasionally come in for service in which a 300-ohm cathode resistor does not seem to work out satisfactorily. This may be the result of a number of factors which combine to raise the gain of the receiver. A simple remedy here, provided that some one defective condition such as an open by-pass condenser is not at fault, is to increase the cathode resistance to say 400 ohms; this will decrease the gain and restore stable operation.

performance and cost vs. accuracy

This description of the manner in which the value of a part such as a cathode resistor is arrived at, is generally applicable to a wide variety of components and operations. In each case the engineer must determine the minimum or lowest accuracy which will result in satisfactory performance. Put rather crudely, the engineer's job is to determine how inaccurately he can make and do things and still "get by." This of course is no reflection on the engineer,

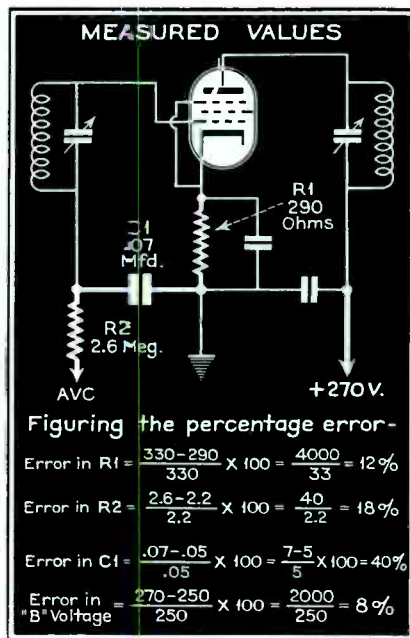

Fig. 4B. The measured values for the stage indicated at A. The percentage differences or errors are computed as shown. Permissible variations are shown which will not generally interfere with receiver performance.

since it means that he is making available to the largest number of people the best possible reception at the lowest cost. The application to servicing is of course similar and requires no elaboration.

Fig. 1 shows in a general way the relation between the three factors that we have been discussing. To make the situation more concrete, we have assumed that the cost and performance of a particular receiver model are measured under a number of different conditions with respect to the accuracy of the resistors, ranging from resistors accurate to within a fraction of 1% to resistors subject to a variation of as much as 30%. Of course in actual practice a receiver would never be designed with the same tolerance for all resistors; however, this fact will not affect the usefulness of our illustration.

If $\pm 1\%$ tolerances are used throughout the receiver, the cost is extremely high, although the performance of the receiver is not materially better

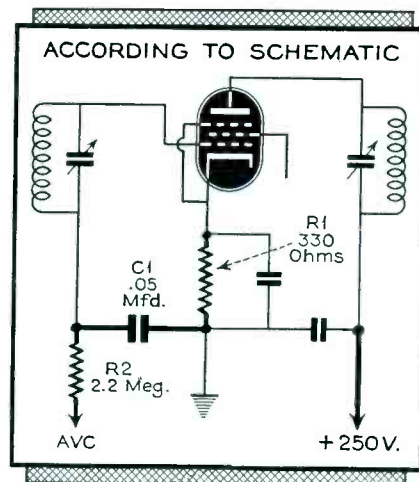

Fig. 4A. The partial schematic shows the nominal or rated values of several parts in a typical stage. The measured values are indicated at 4B.

than when $\pm 10\%$ tolerances are used. You can form some estimate of the difference in cost by noting that 1% accuracy costs from 3 to 20 or more times as much as 10%, that will do the job just as well from the standpoint of receiver performance.

If we use resistors that are off by more than 10%, the curves show that the cost is reduced, although not much, and at the same time the performance of the average set drops noticeably. This of course is to be expected, because some sets will be unstable because of high gain, some will have short tube life because of excessive voltages, some will have poor sensitivity, and so on.

An examination of these curves shows that a tolerance or accuracy of $\pm 10\%$ represents the best compromise because it is accurate enough to give excellent receiver performance and at the same time allows sufficient variation so that the cost is not excessively high.

knowledge of tolerance important

In radio servicing it is not possible to say flatly that everything must be done to an accuracy of $\pm 1\%$, $\pm 10\%$, or to any other degree of accuracy which you might mention. The components used in receivers and the operations required in servicing are both subject to a wide range of permissible variations ranging from a small fraction of 1% to as much as 20% or more. A good Service Man knows approximately how much variation is permissible in every part of the receiver; consequently he knows when to measure things accurately (or approximately), and how to interpret his measurements to tell whether a given condition is responsible for defective operation.

To illustrate the wide variation in permissible error which is found in receivers, take the case of a 50,000-ohm
(Continued on page 21)

AUTO-RADIO INSTALLATION

in 1940 Cars†

By **EDWARD H. BARRY**
SERVICE EDITOR OF MOTOR MAGAZINE

WHEN installing an auto-radio receiver be sure to select an aerial which will give the best results with the set being used, for auto-radio sets, being very sensitive, often are designed to operate with a certain type of aerial. Some sets have separate connections for different types of aerials while on others an adjustment must be made to compensate the set for the aerial being used. It is also easier to install some types of aerials on certain cars and following the manufacturer's recommendations will save time and eliminate difficulties in making an installation.

The recommended list of where the installation of the suppressors, condensers, ground straps and static collectors will normally result in clear reception on each car is shown in the accompanying table. After they have been installed as described the set should be tested to see if they sufficiently eliminate interference. Conditions may vary on two cars of the same model and in some cases additional interference elimina-

† Courtesy, *MoTor*, The Automotive Business Magazine.

tors may have to be installed. The heads of the table suggest additional places where the installation of a condenser or ground strap may do some good. To make a test, connect the lead of a by-pass condenser with a capacity of 0.5 mfd. to the hot side of the suspected unit. Ground the condenser case or the second lead on a metal part of the car. When the position is found where the condenser clears up the interference, make the installation of the condenser permanent.

When installing a condenser or ground strap all dirt or paint must be cleaned from the contacting surfaces and the connection must be tight. When a condenser is installed on a generator be sure to connect its lead to the generator armature terminal for should it be connected to the field terminal it will cause pitting of the voltage regulator points which will prevent the unit from operating properly. When installing static collectors in the front wheels, the inside of the dust caps and the center of the front wheels spindles must be clean and free from grease to give good results.

The installation of the receiver and speaker depends upon the make and type of set being used and the radio manufacturer's recommendations should be followed, bearing in mind of course that on most every car there is some accommodation already in the car for the receiver.

Buick

Insert a suppressor in the high tension lead to the center of the distributor block. Connect the lead from a condenser to the outside terminal, not the field terminal, on the generator and mount it on the generator cable clamp screw. Remove the cover from the ignition coil by inserting a thin blade tool under the edge of the cover about 1 in. to the left of the container seam. Push the tool between the lock and its recess, twist the end of the cover and lift off the cover. Solder one lead of the condenser to the case and connect the other lead to the terminal inside the cover. Do not attempt to connect this condenser to the terminal on the outside of the coil as it will result in damaging the distributor points and will cause erratic engine performance. Install static collectors in the front wheel dust caps. The center of the collector supplied with Buick sets is made of self-lubricating material. To fit the collector in the larger dust caps used on Buick 80 cars it will be necessary to straighten out perfectly flat the sharp, pointed prongs on the collector.

Cadillac, LaSalle

Install a suppressor in the high tension lead in the center of the distributor block. Remove the air scoop from the generator and insert the lead from a condenser through the rubber grommet for the generator wires on the generator and connect the lead to the armature terminal. Mount the condenser on the generator ground screw. Install a condenser on the ignition coil as described for Buick. Peen the distributor rotor insert to lengthen it or install a radio rotor bar. Install static collectors in the front wheels on models 50, 52, 60S, 62 and 72 making sure that the cotter pin is bent around the nut so that it will not interfere with the static collector. Bond the throttle control cable and the oil line to the dash with a ground strap and a self tapping screw.

Chevrolet

An elbow suppressor and an adapter should be installed in the center ter-

INTERFERENCE ELIMINATION CHART	Battery terminal grounded	Distributor suppressor	CONDENSERS										GROUNDS							
			Water temperature gauge	Oil pressure gauge	Ignition coil	Generator	Ignition switch	Voltage regulator	Armature	Gasoline gauge	Distributor	Clock	Circuit breaker	Front wheels	Cylinder head	Hood	Dash controls	Muffler	Steering column	Heater hose
Buick	N	39		12	6										36					
Cadillac	P	37		12	4										36		33			
Chevrolet	N	39			6	14		21							36	29		30		
Chrysler	P	39			5					16							31	32		
DeSoto	P	39			5					16							31	32		
Dodge	P	39			5					16							31	32		
Ford	P		25				7				11									
Graham	P	40			3	*														
Hudson	P	38	17		2	13				15					*					
LaSalle	P	39		12	4									36		33				
Lincoln-Zephyr	P		18	23				8	15	10	26									
Mercury	P		25				7			11										
Nash	P	38			5											31				
Oldsmobile	N	37			6				19					35						
Packard	P	38			5	*			*		22									
Plymouth	P	39			5					16						31	32			
Pontiac 6	N	37			6					20				36	27					34
Pontiac 8	N	37			6					20				36	28					34
Studebaker Champ	P	38			1					16							32		*	
Studebaker Comm.	P	40			1															
Studebaker Pres.	P	40			1						9									
Willys	N	38		24	6															

Numbers refer to illustrations on following pages.

Star * indicates unit is used but not illustrated.

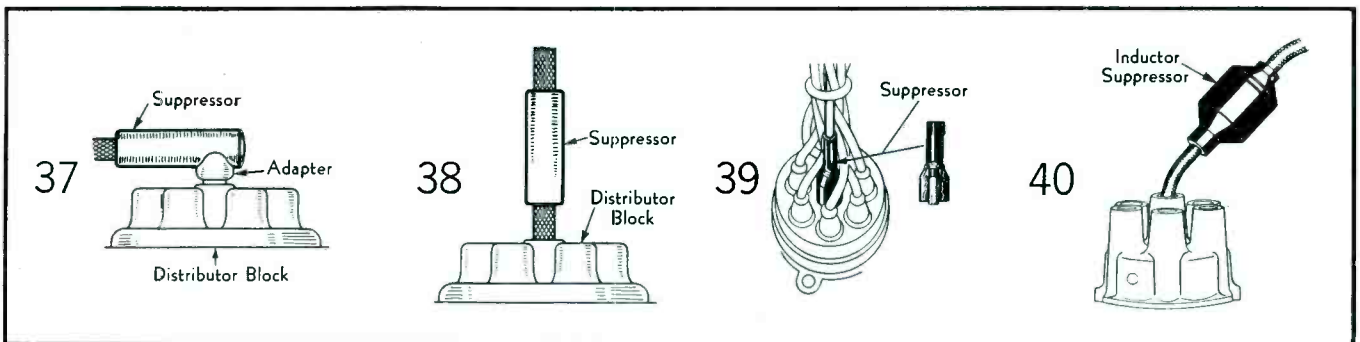
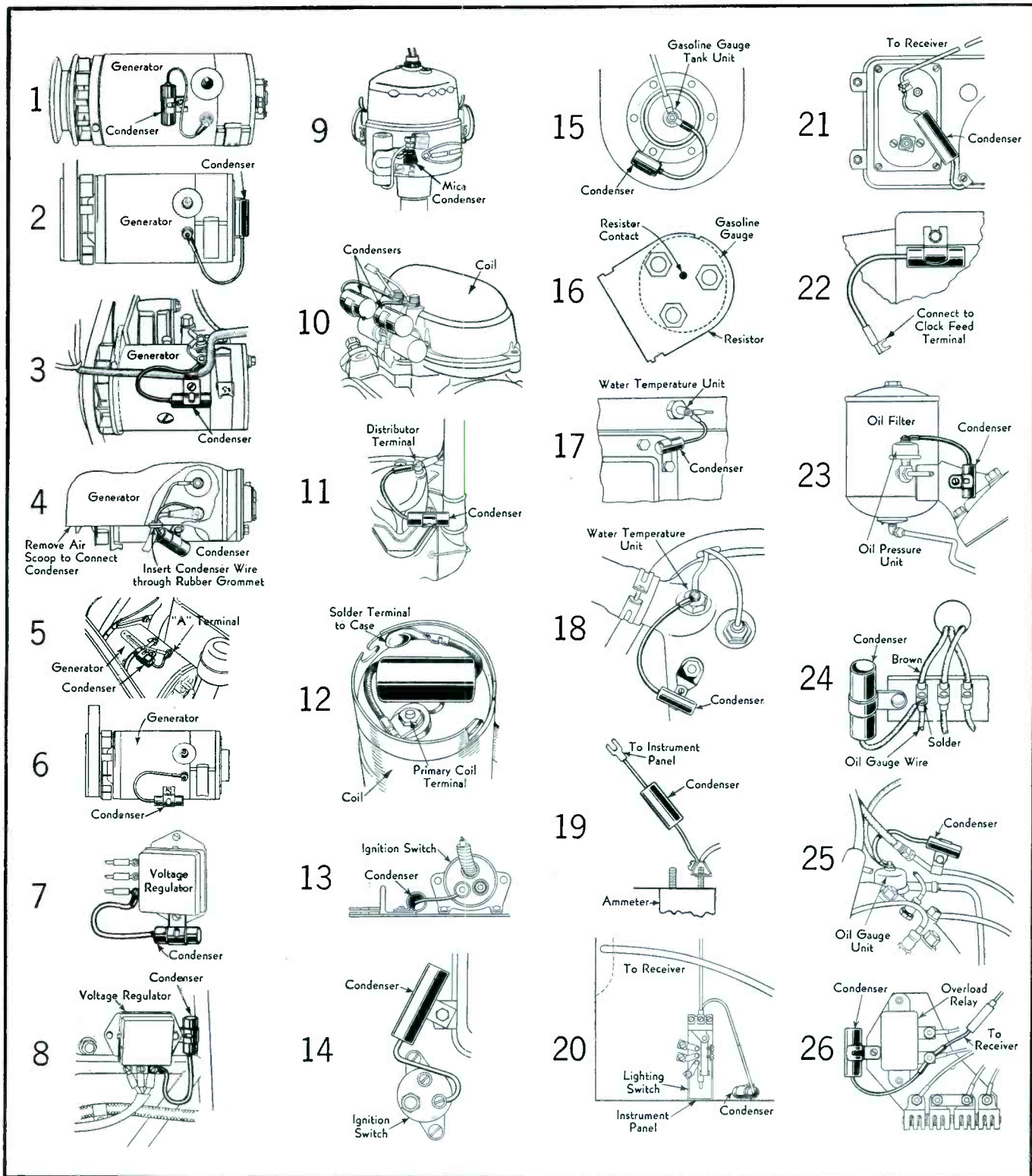

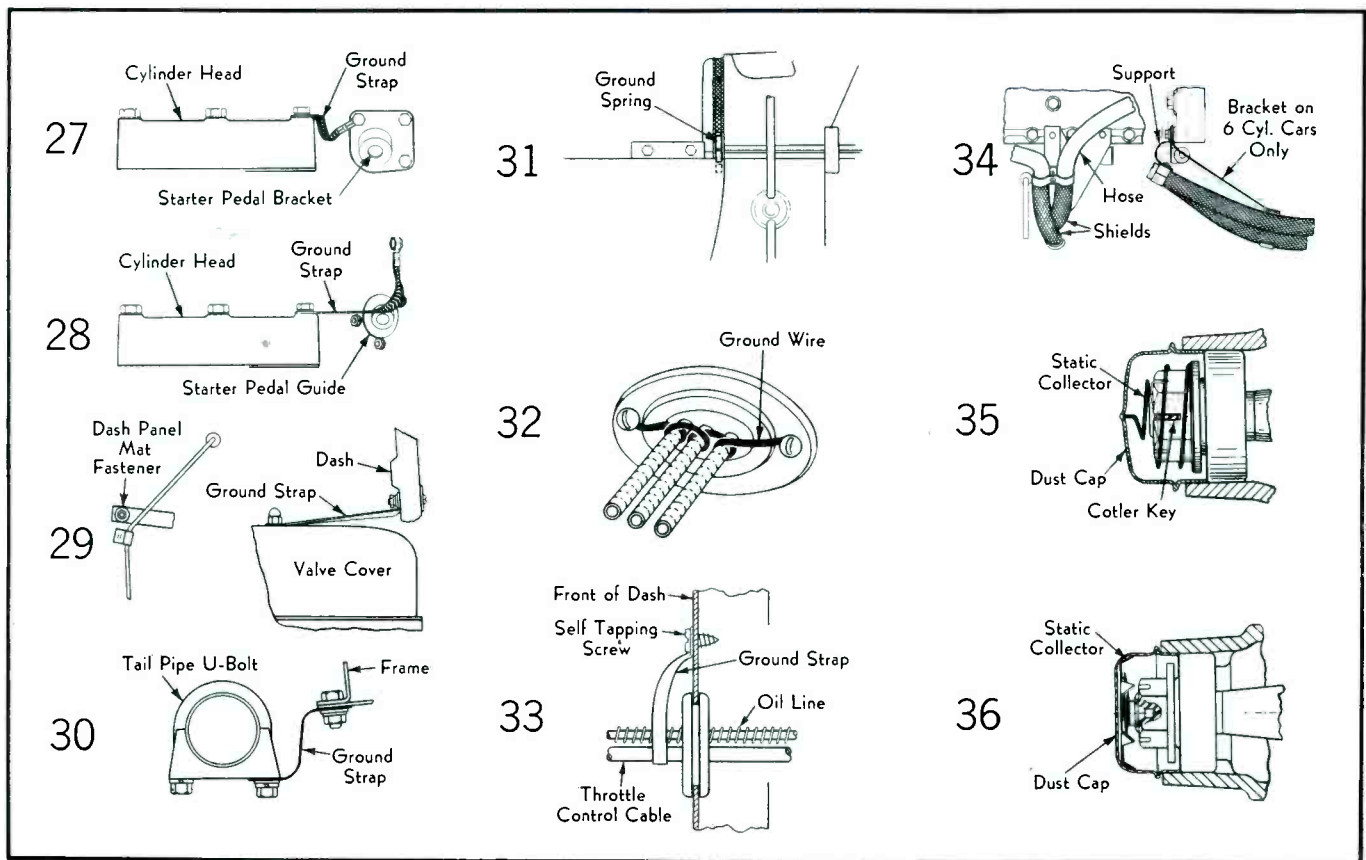

terminal of the distributor block and attached to the high tension wire leading to the terminal. Mount a condenser on the generator frame and connect its lead to the generator armature terminal. Mount a condenser on the flange of the instrument panel near the ignition switch and connect its lead to the ignition switch. Connect the lead from another condenser to the spring clip at the end of the fused lead from the dash unit with a self tapping screw and attach this clip to the discharge terminal of the ammeter. Ground the free end of the ammeter condenser to a convenient mounting bolt on the under side of the instrument panel. Connect a ground strap from the frame to the muffler tail pipe U-bolt. Install another ground strap from the rear valve cover nut to the dash. Then install static collectors in each front wheel, making sure that the cotter pin is bent around the nut so that it will not interfere with the static collector.

Chrysler, DeSoto, Dodge, Plymouth

Screw a suppressor on the center high tension lead to the distributor block and plug the suppressor into the distributor cap. Mount a condenser under the generator ground lead screw and connect its lead to the A terminal on the generator. Remove the three terminal nuts and wires on the back of the gasoline gauge dash unit and assemble a resistor in place. Then replace the wires and nuts. Bond the hand brake

cable, heat indicator tube, oil line, throttle, choke, and speedometer cables where they pass through the dash. Loosen the grommet holder screws and fasten a braid around the tubes and screws. Loosen the hood side panel bolts on the left side and pry out the lower hood lacing screw. Attach a hood grounding clip spring with a self-threading screw using the hole from which the screw was just removed. Then drill another hole with a No. 29 drill and insert a screw. This grounds the top and side of the hood to the cowl.

Ford, Mercury

Mount a condenser on the voltage regulator fastening screw and connect its lead to the bottom terminal of the regulator. Mount another condenser with a special bracket on the distributor and connect its lead to the distributor terminal nut. Connect the lead from another condenser under the center terminal on the oil gauge engine unit and mount it on the line. In some cases it may be necessary to move this condenser to the instrument board and connect the lead to the bar between the oil gauge and the fuel gauge indicators.

Graham

Cut the high tension lead to the center of the distributor block about 1 in from the distributor and insert an inductive type of suppressor. Mount a

condenser on the generator under the screw holding the wiring harness and connect its lead to the armature terminal of the generator. Mount another condenser under the screw which secures the steering column bracket to the instrument panel and connect its lead to the ignition switch.

Hudson

Clamp a condenser under the rear left nut holding the ventilator handle guide assembly and connect its lead to the "AM" terminal of the ignition lock. Attach another condenser under one of the gasoline gauge tank unit mounting screws. Attach its lead to the gauge unit terminal. Mount another condenser on the upper rear cap screw in the engine water manifold plate and connect its lead to the terminal of the water temperature gauge unit. Another condenser should be mounted on the rear of the generator with a machine screw. Connect its lead to the generator armature terminal. Install a suppressor in the high tension lead to the center of the distributor block. Mount a ground strap between the left rear cylinder head bolt and the dash, fastening it to the dash with a metal screw and a lock washer.

Lincoln Zephyr

Install two condensers with special brackets on the distributor and con-

(Continued on page 27)

* Step Out

to the **TRADE SHOW**
and step up your profits

June 11, 12, 13, 14

Stevens Hotel, Chicago



You have to be alert these days to get the business and reap the profits . . . You have to be right up to date on all activities of your industry . . . You have to look ahead and be prepared to take full advantage of the new trends in products and merchandising plans.

That's why you should be at the Trade Show. That's where you will get the "low-down" on what's ahead . . . That's where you will meet with hundreds of others and get ideas that are vital to the successful operation of your business.

Step Out to the Trade Show and Step Up Your Profits!

JOBBER DAYS

Tues., Wed., Thurs., June 11, 12, 13

*Open on these days to Jobbers,
Manufacturers, Manufacturers' Agents, and
Manufacturers' Engineers*

OPEN HOUSE

Friday, June 14

*Trade Show open on this day to entire
Radio Trade*

Radio Parts National Trade Show

*Sponsored by Radio Manufacturers Association and Sales Managers Club
Executive Office • 53 WEST JACKSON BOULEVARD • CHICAGO*

HOME RECORDING

(See Front Cover)

By HENRY HOWARD

THE increasing popularity of home recording is bound to be a boon to the wide-awake Service Man. Requiring a good deal more technique than operating a radio receiver, it should give ample opportunities for adjustment and instruction even when no actual troubles exist. Then there is often a chance to sell accessory equipment such as an additional microphone, mike cables and fittings, besides pushing your favorite record blanks.

For good recording, 1.5 to 3 watts, minimum, should be available for the cutter, although the cutter itself may actually require only about 0.6 watt for maximum amplitude. The additional power is necessary because of transformer losses, mismatch, and the inclusion of special pads and equalizers with series resistance and resistance-capacity combinations for the purpose of flattening the response of the amplifier and cutter. The amplifier must have adequate gain and very low hum and noise level for operation with low level mikes. A strong motor developing high torque and having a husky turntable is a must requirement in order to avoid wows. One or more pins are provided on the turntable to securely anchor the record to prevent slippage. 78 rpm is the standard speed for all the recorders, although an additional speed of 33½ rpm is available in the higher priced semi-professional equipment. Low motor and gear noise is imperative. Otherwise the vibration set up is transmitted to the recording head. Rim drives are practical, being smooth and quiet. A power-level indicator, having a clearly

defined overload point, is essential.

Both magnetic and crystal cutters are being widely used and in about equal proportions. The magnetics usually match the speaker voice coil impedance while the crystals are fed from an extra 60,000-ohm transformer winding. All present-day recorders are designed to make their own grooves by means of a lead screw located either above or below the turntable. At present the pitch seems to lie between 90- and 120-grooves-per-inch.

The record blanks have an aluminum, celluloid or paper base coated with cellulose nitrate or acetate. Due to extensive research in this field, however, this situation may change at any time. The Underwriters' Laboratories will not approve records of inflammable material such as cellulose nitrate.

The depth of cut is very important. If too shallow, the reproducing needle will not remain in the groove and the noise level will be high. If too deep, there will be crossovers—one groove breaking through to the next—although, before this happens, there will be obvious overmodulation and blasting and a strong tendency toward a change in speed (wow) on sustained low notes, the lows having the greatest amplitude. Wilcox-Gay gives the following information in their service bulletin on the Recordio (Models A70-A81-A82): "For correct depth of cut, the grooves will appear to be about as wide as the spaces between them. This may be seen by holding the record in such a position that a light is reflected from the grooves. The correct depth of cut will produce a thread out from the record surface that is firm, although neither

coarse and stiff nor light and fluffy. Provided a new cutting stylus, or one known to be in perfect condition, is being used, the correct depth of cut may be gauged by permitting the cuttings to remain upon the record until completed, then rolling the cuttings into a hard ball. The size of the ball thus obtained should be approximately ⅜ inch in diameter, for the 6½-inch record."

In the instructions accompanying the Lafayette Radiocorder (Radio Wire Television, Inc.) we find the following data on depth of cut: "With proper adjustment the thread removed from the record will be slightly thicker than a coarse human hair, and should be relatively straight and shiny. Examination of the record under a good light should show the width of the grooves to be approximately the same as the width of the uncut space between them. The ideal cut will give a groove that is slightly wider than the uncut space, the accepted standard being a ratio of six to four in relative width." (See Fig. 1.)

Some new jobs have a single head which serves as both cutter and reproducer. Of course, each function has its

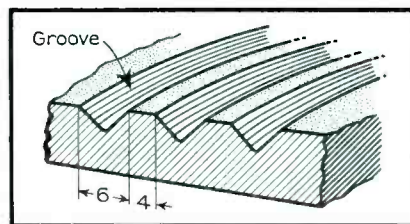
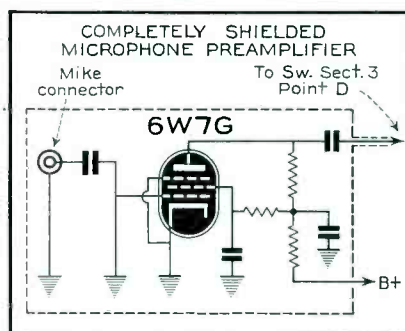
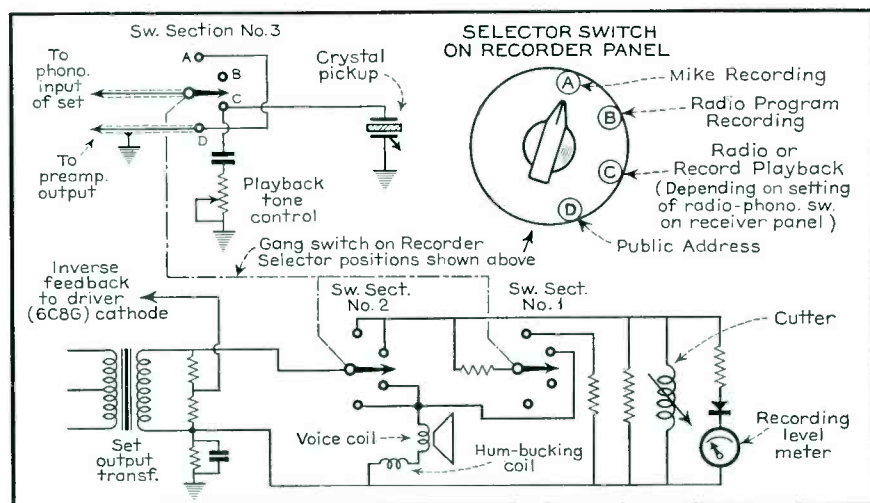

Fig. 1. (Above) The ideal cut will give a groove that is slightly wider than the uncut space. Fig. 2. (Below) Lafayette BB96 incorporates a completely shielded preamplifier stage.



own needle. The pressure used for cutting is only 1½ ounces which is not too heavy for play back. Formerly, the threads or chips would frequently get caught in the cutting stylus, necessitating constant brushing toward the center of the record. Now, special cutting needles are used which have clearance for the chips and the thread is guided towards the center automatically. Another new type of needle designed for reproducing has a curved shank, giving a flatter angle and less record wear. Everyone is aware of the care required in handling pickups. Even greater care

Fig. 3. Lafayette BB96 Radiocorder performs any one of four functions.



SIGNAL SUBSTITUTION

By G. N. GOLDBERGER

PRECISION APPARATUS COMPANY

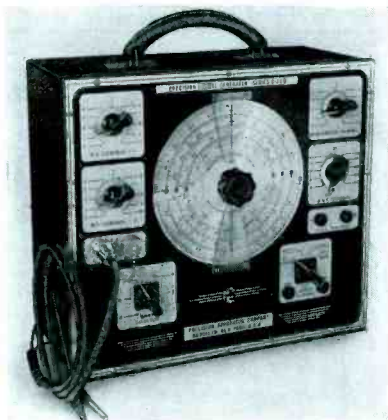

Fig. 2. Variable modulation control, incorporated in the E200, allows increased r-f audibility without r-f overload and provides a means for checking demodulation capabilities of the second detector.

It is surprising to note that, although the average Service Man may be well equipped with modern test apparatus and is well versed in the operation of his instruments, not as much attention has been given, as should be, to the systematic application of these same units to other than their most obvious intents. This seems to be particularly true of the signal generator.

This one instrument is capable of forming the foundation of a complete servicing technique or system which will allow the localization of almost any receiver trouble. A signal generator of proper design can perform amazingly more useful functions than as a mere variable frequency source for alignment.

No claim is made that the system de-

scribed in this article is radically new or revolutionary. It is simply well grounded technique and application based on a few everyday principles. No additional equipment is required than what would normally be on hand in the average service shop . . . a signal generator, multimeter and a tube tester. The

system is, on the whole, an orderly accumulation of many methods which you or the next man may have at one time or other employed in the solution of puzzling radio problems. What is to follow is only a small idea of the possibilities of this servicing method, and confined to but a few examples. The system is founded on fundamental factors and its application is limited only by the operator's own knowledge, ability and confidence in what he is doing.

For the sake of simplicity let us confine ourselves to a common superheterodyne receiver, such as that shown in Fig. 1. The same system of attack, however, is applicable to all receivers regardless of variations. This receiver, let us say, has been brought to us for service with no more of a lead as to the nature of the trouble other than "Fix it, it doesn't work."

Tube Testing

It is a good policy to test all the tubes first. The immediate isolation of a shorted tube (or the finding of a very weak oscillator) is at times the entire solution to the problem. The fact, however, that all the tubes have passed this initial test does not always definitely

eliminate them as a possible source of trouble. No tube tester available to the Service Man is infallible and actual try-out in the receiver is the final determining factor.

Power Supply

Many an oscillator tube can pass both emission and dynamic types of tests and still not function in a receiver, especially if the oscillator circuit accidentally or intentionally requires a tube with high hop. Gassy tubes, on the other hand, will initially test perfectly, but if allowed to operate in the receiver or tube tester, will start to draw grid current or otherwise go sour.

If the tubes test ok in the tester, we can temporarily eliminate them as possible sources of trouble and proceed to the next part of the test. The use of an ordinary multirange meter in conjunction with manufacturer's specifications will allow immediate determination as to whether the proper voltage is available at the power supply and at points A and B (Fig. 1). If the proper voltage is not obtainable, i.e. no reading, excessive reading or below normal, the type of reading obtained will indicate the nature of the trouble. Little difficulty is ever experienced in cases so simple as this. However, should the difficulty not be directly associated with the power supply, and should the operator not desire to make a systematic stage by stage voltage test, the trouble will definitely appear during the systematic signal analysis.

Audio Stages

Let us now set our signal generator for the 400-cycle sine-wave output and start the analysis right at the output transformer. The instrument employed must have sufficient signal output of good wave form to allow direct application at the point C (Fig. 1). At this point both the audio output transformer and the speaker are simultaneously tested. By starting with a sine-wave signal a speaker deficiency such as a slight rubbing of the voice-coil frame to pole piece, with consequent distortion, is readily detected. At the same time the output transformer is tested directly. In all these tests (and in those which follow) the return probe is connected to the receiver chassis.

Moving the audio probe to D requires a reduction in the signal generator a-f attenuator proportionate to the gain of the output tube. No signal (as evidenced by a silent speaker, monitored by the multimeter) localizes the difficulty, the exact nature of which can be readily detected by a multimeter test in this small portion of the receiver. It could

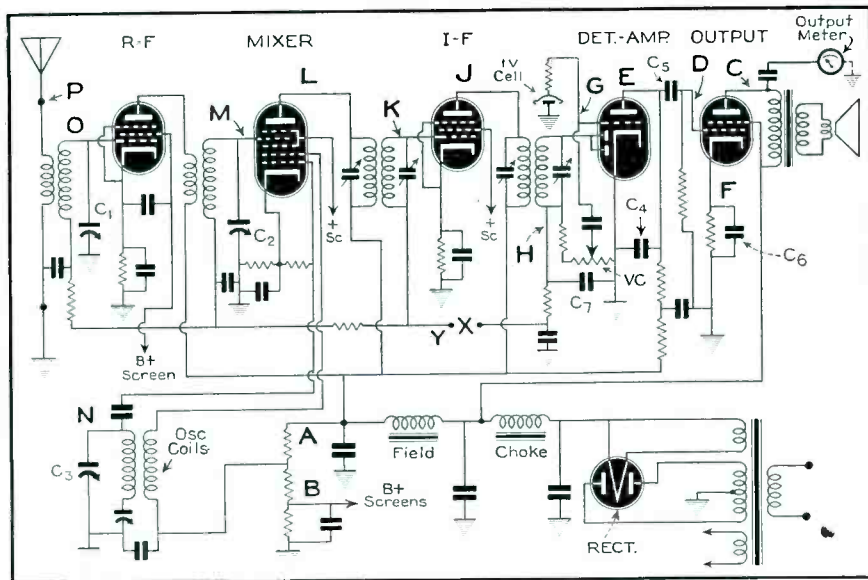

Fig. 1. Signal substitution provides a servicing technique for the systematic location of receiver faults.

eliminate them as a possible source of trouble. No tube tester available to the Service Man is infallible and actual try-out in the receiver is the final determining factor.

SERVICING by S-S-S

With "PRECISION" BASIC TEST EQUIPMENT

"S-S-S" == "SERVICING BY SIGNAL SUBSTITUTION"*

● It is the modern, **ECONOMICAL** key for the solution of your daily service problems . . . there is nothing complex to learn, no need to wish for a third arm and hand, no extraneous equipment to purchase . . . a new systematic method of true **DYNAMIC SIGNAL ANALYSIS** based entirely on simple fundamentals . . . employing **ONLY BASIC TEST EQUIPMENT** as is normally absolutely required in the service laboratory; a reliable dynamic mutual conductance type tube tester such as **PRECISION Series 910**, an accurate wide-range sensitive multi-tester such as **PRECISION Series 852**, and the **PRECISION Series E-200** laboratory Signal Generator, **SPECIFICALLY DESIGNED** for the purposes of "SERVICING BY SIGNAL SUBSTITUTION."

"S-S-S" with **PRECISION Basic Test Equipment**, provides a new high in simple rapid localization and determination of receiver troubles . . .

"S-S-S" is **UNIVERSAL** . . . the same simplified approach applies equally as well to all receiver types regardless of age, make, design, number of tubes, etc. . . .

"S-S-S" gives you unsurpassed dollar value and service from **BASIC TEST EQUIPMENT ONLY!**

"S-S-S" in a single systematic dynamic attack, completely covers the entire problem, with the receiver in **ACTUAL OPERATION** . . .

"S-S-S" provides complete stage-by-stage check-up, trouble shooting and alignment directly from the speaker to antenna post, in one consecutive series.

To mention only a few of the innumerable features of "S-S-S" . . . ● **DIRECT R.F. AND I.F. gain-per-stage measurements** . . . ● **Finds uncoupled, dead or mistracking oscillators** . . . ● **Quickly locates shorted or open I.F. and R.F. transformer turns** . . . ● **Picks out open R.F. or audio by-pass and coupling condensers** . . . ● **Immediately tells necessary direction of I.F., R.F., and oscillator trimmer or padder alignment, etc.**

FREE Now in preparation and **FREE** (as soon as off the press) to all **PRESENT OWNERS and FUTURE PURCHASERS** of Series E-200, a new illustrated text describing this amazingly economical and simplified speed approach to receiver adjustment problems, "Servicing by Signal Substitution."

*"Servicing by Signal Substitution" Copyright 1940 by Precision Apparatus Co., Brooklyn, New York.



PRECISION TEST EQUIPMENT

Standard of Accuracy

SEE

PRECISION APPARATUS COMPANY • 647 Kent Avenue, Brooklyn, N.Y.

SIGNAL SUBSTITUTION

BASIC TEST EQUIPMENT

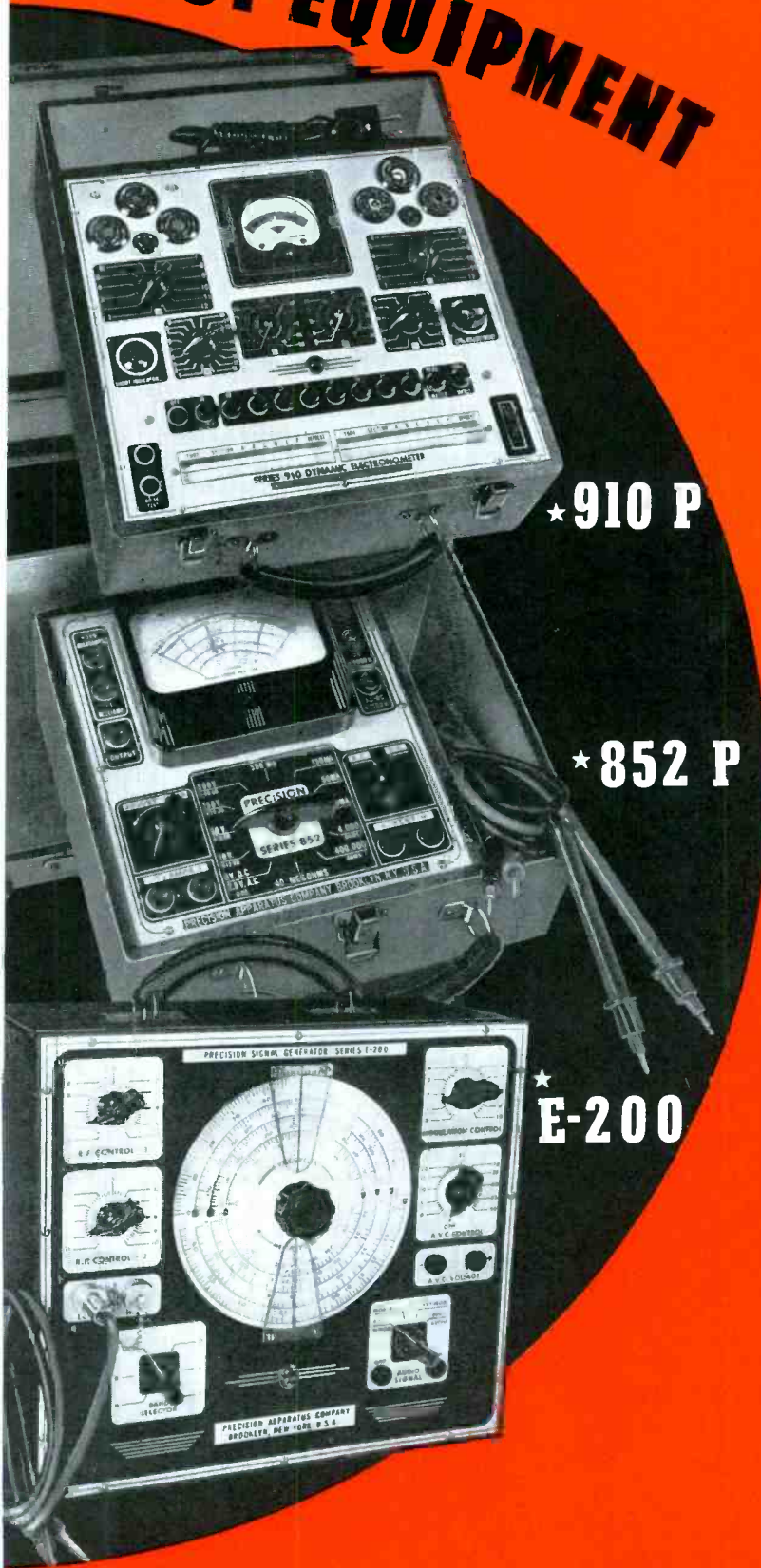

★Series 910

DYNAMIC MUTUAL CONDUCTANCE TUBE TESTER

The first step in "S-S-S" is the rapid, unfailing selection and elimination of defective tubes. The PRECISION series of Dynamic Mutual Conductance Type Tube Testers. (Series 910, 912, 915, 920 or 922) will permanently and efficiently remove the "Question Mark" from your tube test problems.

QUICK FACTS:

- A DYNAMIC MUTUAL CONDUCTANCE TYPE TUBE TESTER, which in one operation, effectively tests all radio receiving tubes for both MUTUAL CONDUCTANCE and CATHODE STRUCTURE • TESTS ALL LATEST TUBE TYPES and ALL FILAMENT VOLTAGES • AUTOMATIC PUSH BUTTON SYSTEM for non-obsoluscent free-point tube analysis • DUAL FREE-POINT FILAMENT TERMINAL SELECTION • VISIBLE FILAMENT CONTINUITY TESTS • SPECIFIC INDIVIDUAL LOAD AND VOLTAGES: APPLIED TO EACH ELEMENT OF TUBE UNDER TEST • VARYING A.C. SIGNAL applied to control grids • METER READS IN PLATE CIRCUIT • OPEN ELEMENTS: Instantly shows up any tube having an open element • INDIVIDUAL TESTS for each section of multi-section tubes • HOT CATHODE LEAKAGE TESTS • HOT INTER-ELEMENT SHORT TESTS • NOISE TESTS • BALLAST TESTS • PILOT LIGHT TESTS • BUILT-IN DOUBLE WINDOW ROLLER TUBE CHART. New charts furnished at no charge • MICRO-LINE ADJUSTMENT, no arbitrarily tapped transformer • PILOT LIGHT (ON-OFF) INDICATOR: FUSED LINE PLUG • TELEPHONE CABLED WIRING EMPLOYED THROUGHOUT • ACCURACY closely maintained by use of factory adjusted and sealed individual calibrating controls • GUARANTEED for ONE FULL YEAR.

PRECISION Series 910P, (illustrated), housed in attractive, removable hinged cover, hardwood, walnut finished carrying case, with built-in tool compartment; also available in counter or standard panel mount. Dealer net price, \$33.95

Series 910MCP, housed in fine dull black wrinkle finished, open face metal cabinet, same as illustrated for Series E-200; dealer net price **\$29.95**

★910 P

★Series 852

SUPER-SENSITIVE TESTER

39 Range A.C.-D.C. volt-ohm-decibel-milliammeter-ammeter . . . Including ranges to 5000 volts A.C.-D.C., 50 microamperes, 10 AMPERES AND 40 MEGOHMS.

The high sensitivity of 20,000 ohms per volt D.C. affords reliable measurements in modern radio and television circuits wherein only minute current drain of the measuring instrument can be tolerated.

A single Master Rotary Range Selector permits simplified rapid check of voltage, current, resistance, etc., in troublesome stages, quickly localized through "S-S-S".

QUICK FACTS:

- SEVEN D.C. voltages ranges at 20,000 ohms per volt to 5000 volts • SEVEN A.C. voltage ranges at 1000 ohms per volt to 5000 volts • EIGHT E.C. current ranges: 0-50 microamps to 0-10 AMPS • THREE RESISTANCE RANGES to 40 MEGOHMS powered by self-contained batteries • SEVEN DECIBEL RANGES FROM -12 to + 69DB • SEVEN OUTPUT RANGES to 5000 volts • METER: Large, modern 4 1/2" "PRECISION," square meter with cobalt magnet; accurately machined soft-iron pole pieces; double jeweled D'Arsonval 50 microampere movement • WIRE-WOUND SHUNTS AND METALLIZED MULTIPLIERS BOTH OF 1% ACCURACY.

PRECISION Series 852P (illustrated) housed in attractive, removable hinged cover, hardwood walnut finished carrying case with built-in tool compartment; dealer net price (complete with batteries and test leads) \$41.95

Standard panel mounted Series 852PM (complete with batteries and test leads), \$42.95
Series 852L, housed in hardwood open, face, walnut finished carrying case; dealer net price (complete) **\$39.95**

★852 P

★Series E-200

LABORATORY SIGNAL GENERATOR

The key to "S-S-S" . . . the simplified method of dynamic receiver analysis, employing ONLY BASIC TEST EQUIPMENT.

Not only an unsurpassed, efficient, laboratory Signal Generator for purposes of alignment but also SPECIFICALLY DESIGNED as the heart of "Servicing by Signal Substitution" and priced easily within the reach of every progressive radio service engineer.

QUICK FACTS:

- SIX BANDS: Full coverage from 110 K.C. to 72 M.C. Direct reading. • ACCURACY: Uses the new 6SJ7 in the "PRECISION" developed "UNIT OSCILLATOR"—buffer amplifier construction, insuring MAXIMUM 1% DEVIATION ON ALL BANDS • LARGE FULL VISION 6 INCH DIAL with ball-bearing drive system • 1000 POINT VERNIER SCALE plus Twin Engraved Hair-Line Indicators afford readings free from parallax • POSITIVE DUAL R.F. NON-REACTING ATTENUATORS . . . CALIBRATED for direct gain measurements in "S-S-S" • COAXIAL OUTPUT CABLE . . . provides low-loss connections for all "S-S-S" requirements • 4 SIGNALS: Unmodulated R.F.; Modulated R.F.; Externally Modulated R.F. (Freq. or Amp.); 400 Cycle Audio Output • 400 CYCLE SINE-WAVE OSCILLATOR MODULATOR . . . Independently Controlled, providing zero to over 60 volts audio signal for all "S-S-S" purposes • VARIABLE MODULATION CONTROL . . . provides 0-100% modulation AT WILL • THE A.V.C. SUBSTITUTION NETWORK . . . overcomes serious alignment troubles by supplying its OWN DIRECTLY CALIBRATED A.V.C. VOLTAGE • HAND CALIBRATION: Each instrument INDIVIDUALLY calibrated against precise laboratory standards • FULLY LICENSED UNDER PATENTS OF AMERICAN TELEPHONE AND TELEGRAPH COMPANY.

PRECISION Series E-200 (illustrated) housed in attractive fine dull black wrinkle finished, open face heavy gauge metal cabinet. Dealer net price (complete with tubes and coaxial output cable) **\$35.95**

Also available in standard panel mount—complete. . . . \$31.95

More than 40 models in the PRECISION 194G LINE . . . 15 Mutual Conductance Tube Tester and Set Tester models ranging in price from as low as \$29.95 . . . 16 Multi-Range Tester models from as low as \$10.95 . . . Signal Generators from \$24.95 . . . etc. See them at your local distributor . . . Ask for the PRECISION TEST EQUIPMENT 194G CATALOG.

BEST EQUIPMENT

THEM AT YOUR JOBBER

Export Division: 458 Broadway, N.Y.C., U.S.A., Cables: MORHANEX



SOUND PROFITS in a small town

Fig. 1. The scene of the Cooperstown installation as viewed from the grandstand with the temporary bleachers visible in the outfields.

THE accompanying layout and photographs should be of special interest at this time of the year, when sound men are going in strong for outdoor installations, because of several rather unusual features involved.

The installation was the work of the Cooperstown Electric Co., Cooperstown (N. Y.), at Doubleday Field, and was for the occasion of the celebration last summer of the Centennial of Baseball; a sport born at Cooperstown.

While this job has all the earmarks of a permanent set up, it was actually a rental proposition, notwithstanding an appreciable amount of conduit and BXL employed.

The contractor had assurance of equipment rental for at least several games during the period of the celebration and evidently felt that permanent installation of the main wiring was justified by the time it would subsequently save in setting up and dismantling his equipment for each of these games, but particularly in the insurance it provided against damage by the milling crowds, with possible service interruptions.

Obviously continuity of service was of the utmost importance because the celebration was one of national interest with a number of nationally prominent people participating in the speech-making. All of this put the town more or less on its mettle and it was up to the sound man to do his bit to help uphold the honor of the town by providing the most perfect possible sound service. Then, too, with officials and businessmen of many surrounding communities present, a good, clean-cut job would provide profitable advertising for his company's newly established sound business.

Every possible step was taken to insure against mishap. In addition to the permanent protection of the wiring in conduit, the line to the speaker group was duplicated, a reserve amplifier was ready to be instantly cut into the circuit should occasion arise, spare microphones were on hand. In short, every part of the system was doubly safeguarded with the exception of the speakers and four of these were grouped in a single cluster, so if one did go ampie coverage could still be provided by the others.

Competitive conditions do not always permit such extensive precautions

to be taken on rental jobs. However, it is a wise sound man who will insist on a price that will permit reasonable safeguards in the way of fool-proof wiring and reserve equipment. Otherwise a serious breakdown means dissatisfaction and adverse publicity which even a solidly established sound business can ill afford.

Although the equipment used in this instance was mostly purchased in preparation for this job, Raymond Kniskern, one of the proprietors and the sound specialist of the Cooperstown Co., states that subsequent rental jobs on which it has been used have made



Fig. 3. Microphone lines were brought right to the announcer's box where duplicate mikes provided for both a regular and a guest announcer.

both the equipment and the precautionary measures a distinctly good investment.

Doubleday Field normally seats about 3500. The modern concrete grandstand accommodates about 800 and the bleachers the balance. But for the period of the celebration additional

Fig. 2. Although the system was a rental job, speaker and microphone lines were protected in conduit and BXL to avoid any mishap which might have reflected unfavorably on the Cooperstown Elec. Co.

temporary bleachers as shown in Fig. 1, completely encircled the field and brought the seating capacity up to about 15,000. Although the Cooperstown Co. had never before undertaken a sound contract of such magnitude, they had done smaller jobs. By taking full advantage of the free consulting service offered by Clarion Institute of Sound Engineers, of which they were members, it was possible to plan all details of the installation so successfully in advance that everything went off without a hitch, not only in the ball park but in a considerable amount of miscellaneous mobile sound service provided in connection with the celebration.

The Clarion sound system in the ball park included a 70-watt main amplifier; 30-watt reserve amplifier; four Cinaudagraph Type HWAW air-column speakers, each rated at 25-watts continuous duty; and three microphones. For the miscellaneous services outside the park a Clarion Model C32 portable 20-watt, 6/110-volt amplifier with built-in record player was employed.

The layout of the main installation is shown in Fig. 2. The two amplifiers were located in a small room in the rear of the grandstand. From this point the output circuits were carried in conduit to the end of the grandstand, thence underground in BXL to the point where the group of four speakers was mounted above the bleachers, and in a conduit riser up to the speaker position. Although one pair of wires fed the entire speaker group, a spare pair was included in the conduit as a precautionary measure.

Input circuits, also in conduit, extended from the amplifier position to the grandstand box behind home plate. Here a 4 x 9-in outlet box provided connections for the microphones. In this system two lines were included. The announcer's position was in the front of the grandstand behind home

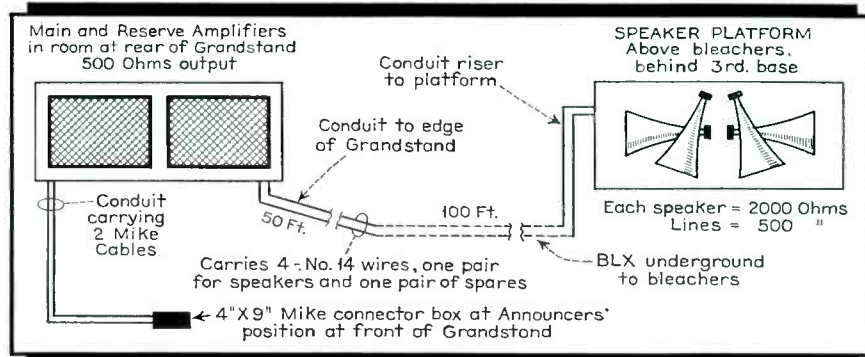



UTC
TROPICAL type
wetproof AUDIOS...

ARE designed to stand up under the most adverse conditions of excessive moisture, salt air and humidity. These TROPICALS have been subjected to unusual frigid and torrid temperature changes in the UTC laboratory TORTURE CHAMBER over a period of eighteen months. To complete our control tests, a representative batch of TROPICAL audios, with the new WETPROOF process of mould sealing the coils, have been sent out to customers in the swampy and coastal regions of the United States, Philippines, South America, India, China, and South Africa. These TROPICALS are still to be heard from and they are out more than a year. The UTC TROPICALS are specially vacuum-pressure treated followed by the UTC MOULD-SEAL process of wetproofing. THEY COST NO MORE.

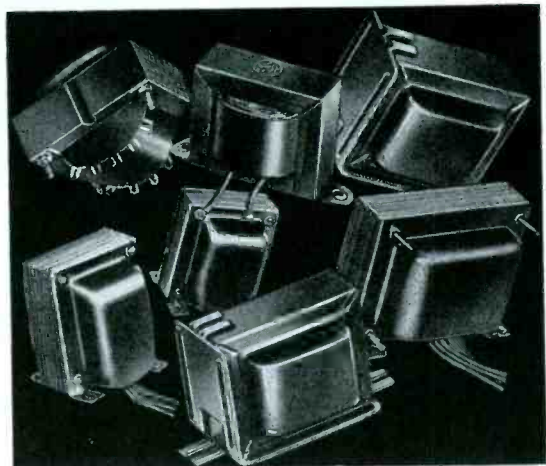

Channel Frame TROPICAL AUDIOS

Type No.	Application	Description	Net Price
R-33	1 plate* to 1 grid	4:1 ratio	\$.72
R-34	1 plate* to 2 grids	2:1 ratio	.75
R-35	Mike to 1 grid	17:1 ratio	.90
R-53	Plate and mike to grid	3:1 and 17:1 ratio	.99
R-56	1 plate to 2 grids	2:1 ratio	.90
R-57	1 plate to 2 grids	2½:1 ratio	1.50
R-36	Driver	30, 49, etc. to class B 19, 49, 79, 89 grids	.90
R-37	R.F. Output	Class B 19, 49, 79, 89 plates to 3,500 and 5,000 ohms	.96
R-58	5 watt Universal output	Any single tube to any voice coil .1 to 30 ohms	.66
R-38A	6 watt Universal	Any tubes up to 6 watts to any voice coil .1 to 30 ohms	.75
R-59	10 watt Universal	Any tubes up to 10 watts to any voice coil .1 to 30 ohms	.84
R-60	15 watt Universal	Any tubes up to 15 watts to any voice coil .1 to 30 ohms	.90
R-39	10 watt line Matching Transformer	250, 500, 1,500 ohms to 2, 8, 15 ohms	.96
R-40	25 watt line Matching Transformer	250, 500, 1,500 ohms to 2, 8, 15 ohms	1.50

*Will match tubes like 27, 37, 56, 6C6 triodes, 6C5. Can be used with high mu triodes with loss in low frequencies.

Ask your distributor to show you these New TROPICAL WETPROOF Audio and Power Components

NEW Microphone Cable Transformers

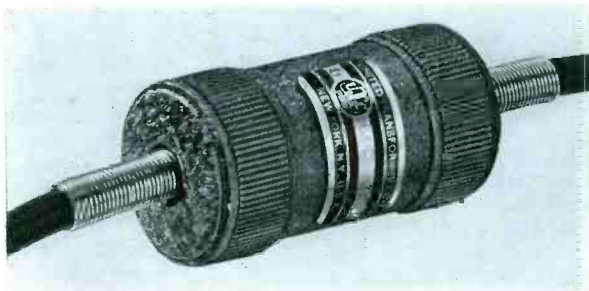

The UTC cable transformers are designed to be inserted in the cable circuit, and are ruggedly constructed to withstand mechanical abuse. The cable connections (supplied less cable) are made through the spring strain relief to terminal boards inside the end caps. These units may be located any place on the cable within twenty-five feet of the amplifier. 1½" diameter . . . 2½" long . . . 1 lb.

Type MC-1—primary tapped 30/50 and 200/250 ohms, secondary to grid, standard fidelity. **Net \$4.50**

Type MC-2—primary tapped 30/50 and 200/250 ohms, secondary to grid, high fidelity. **Net \$6.00**

Type MC-3—crystal microphone to 50/200 ohm line. **Net \$6.00**

UNITED TRANSFORMER CORP.

150 VARICK STREET ★ NEW YORK, N. Y.
 EXPORT DIVISION: 100 VARICK STREET NEW YORK, N. Y. CABLES: "ARLAB"

NON-OBSOLESCENCE VIBRATOR TESTER

TRIPLET

MODEL 1671

Push Button Operated

- ★ Tests All Standard 6-Volt Vibrators
- ★ Easy to Operate — Roll Chart Shows Button Settings
- ★ Uses Standardized 5,000 Ohms - 8 Mfd. Load
- ★ RED•DOT Lifetime Guaranteed Instrument
- ★ Flexible Push-Button Switching Permits Placing Proper Voltages on Each Reed, Guarding Against Obsolescence



Another anti-obsolence feature is the special adapter with leads, included with accessories, with which it is possible to check new vibrators without waiting for instructions from the factory. It also permits checking vibrators not suited for present socket hookups or base arrangements. Model 1671 has a three-scale instrument: 0-10 volts scale shows input voltage to vibrator for start or running tests. . . . Two-zone, two-color merit scale shows vibrator condition as GOOD or BAD. . . . 0-100 scale permits inter-compari-

son of vibrator output under standardized input conditions. Tester is fused against shorted vibrators.

\$39.84

NEW ROTARY SWITCH VIBRATOR TESTER
Model 1672 is the same as model 1671 but has rotary switch control. New speed roll chart simplifies settings. Has anti-obsolence features similar to Model 1671. A real buy at **\$29.84**
—DEALER NET PRICE

The New 1940-41 Line of Triplet Test Equipment Will Be Displayed in Booths 619-621 — Chicago Radio Parts Show

Write for Catalog — Section 175, Harmon Drive

THE TRIPLET ELECTRICAL INSTRUMENT COMPANY

Bluffton, Ohio

plate. Here on a small table were located two microphones to serve the regular and guest announcers. This arrangement is shown in Fig. 3.

The four speakers were installed on an elevated platform at the rear of the bleachers, behind third base, as shown in Fig. 4. By fanning them in an arc of approximately 150 degrees every part of the seating areas was covered. Their elevation and the directional characteristics of the air-column baffles helped to prevent the output from being uncomfortably loud for those sitting near by. Each speaker was equipped with a universal line-to-voice coil transformer adjusted for 2000-ohm input. These were then connected in parallel across the 500-ohm line.

The portable, 6/110-volt amplifier equipment was used mostly in a car, as shown in Fig. 5. It was used almost continuously during the days of the featured ball games, advertising these games, clearing the path for the preliminary parades, and aiding in the direction of the unusually heavy traffic experienced on these occasions.

This amplifier and the two dome-baffle speakers were arranged for quick mounting in the coupe used for mobile operations. A padded wood platform resting on the roof was guyed down with cables in such a manner as to require no mutilation of the roof surface

for permanent anchoring fixtures, yet the whole structure could be placed and removed in a couple of minutes. This is a highly practical arrangement for speaker mounting where a sound man's



Fig. 5. A sound car was provided to advertise the games. It also participated in various phases of the celebration outside the ball park.

car is used for both pleasure and business.

At the conclusion of the celebration, the permanent wiring was donated to the ball park. Normally, with attendance at regular baseball and football games averaging only about 1000, there is little need for sound service. But when special events do require such service it is more than probable that the record established by the Coopers-

town Co. during the celebration will again bring it the contract.

Just after the close of the Centennial celebration, Raymond Kniskern wrote: "Due to the vast crowds here on all days of the big games some very valuable advertising was accomplished which will ultimately result in the use of our equipment at various fairs, sports and social functions in this vicinity." A recent check-up discloses that enough business has developed from this source in the seven months that have elapsed since then to make the equipment investment a profitable one—and the active 1940 summer season is still ahead!

An interesting and illuminating angle of this case is that Cooperstown in

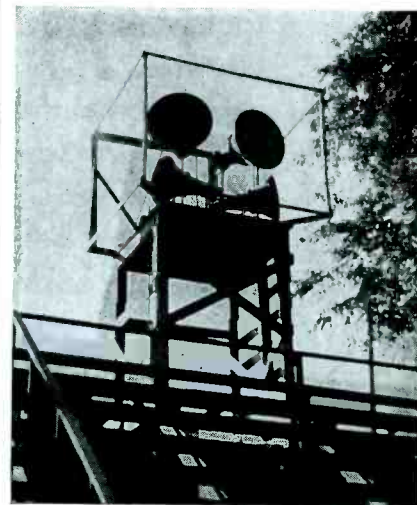

Fig. 4. A group of speakers behind third base covered the field and were sufficiently distant from the announcer's box to avoid feedback problems.

1930 Census had a population of only 2900 and therefore definitely falls in the small-town classification. Yet through good business judgment and careful planning which insures complete success on every job the Cooperstown Electric Co. is building up a sideline of sound which is not only in itself profitable but which provides contacts and advertising in neighboring communities that are helpful in the company's primary business, which is that of selling and servicing radio and electrical equipment.

It isn't every small town that can find such a special object of celebration as did Cooperstown. But many towns do stage special celebrations on July 4th, Decoration Day and at Election time, drawing large numbers of holiday visitors from surrounding areas. Every one of these provides the sound man, whose equipment is used, with an opportunity for business-building publicity—direct and indirect advertising which brings his name to mind whenever future need for p-a service arises.

TOLERANCES

(Continued from page 7)

resistor which is used as an avc filter resistor and compare it with a 50,000-ohm resistor which is used in a video i-f transformer as part of the sound i-f trap circuit. These applications are shown in Figs. 2A and B. The avc filter resistor is undoubtedly the more familiar one because it is commonly used in all receivers. On the other hand, the so-called bridged-T trap circuit has been used only in television receivers, although it may find some future application in radio receivers.

As many of you know, the performance of the circuit shown at (A) will not be impaired in the slightest if the resistor should be 40,000 ohms or perhaps 60,000 ohms instead of the specified value. The only difference will be a slight change in the time constant of the avc circuit which is so small that it cannot be detected.

In the trap circuit shown at (B), however, the situation is entirely different. Here a 20% error in the value of R will seriously impair the effectiveness of the trap circuit. It is not our purpose here to explain how this trap circuit functions, except to point out that the value of R must be held within relatively narrow limits in order to make the trap effective.

To summarize, here we have two applications in which a 50,000-ohm resistor is used and in which widely different tolerances are present. In the case of the bridged-T circuit an error of more than several percent will impair operation, while in the avc circuit an error of considerably more than 20% will have a negligibly small effect.

If we take items other than resistors, we encounter a much wider variation in tolerance. For example, the frequency of the oscillator in an all-wave receiver operating at 30 mc must be stable to within a few kc in 30,000 kc, or approximately 1/200 of 1%. This means that mechanically and electrically the various components in the oscillator circuit must be stable enough so that the drift in the oscillator frequency is less than this value.

To go to the opposite extreme, a by-pass condenser or a filter condenser may vary by almost any amount provided that the capacitance is higher than a certain minimum value. For example, usually when a 0.05-mfd by-pass condenser is specified in a schematic, a 0.25-mfd condenser will also function satisfactorily. However, the smaller value is used because it provides sufficient by-passing, is more compact and is cheaper.

different degrees of accuracy

So far our illustrations have dealt largely with the tolerance of the various components in the receiver. The same arguments apply equally well to the various operations which are required in adjusting a receiver. For example, in aligning a receiver all of the adjustments do not require the same degree of accuracy and care. For example, the oscillator trimmer requires a more careful adjustment than the detector or r-f trimmer. Similarly, the rocking adjustment of the oscillator padder need not be made with great care; usually the response is broad enough so that the padder can be left in the position which gives the best dial calibration at 600 kc, without any appreciable loss in sensitivity.

A much better illustration is the contrast between the accuracy required in the ad-

and I'm the guy they
used to call a "WORRY
WART"



But That Was Before I Learned How To Get the Most out of RIDER MANUALS

"I used to have more worries than Carter has liver pills! But that was before I started to use Rider Manuals as they should be used. I had a few of them, but it seemed that most of the sets that came in for service were the very ones that weren't covered in my Manuals. So, I worried about finding the trouble . . . worried about taking so long to do the job . . . worried about not getting new customers . . . worried about not making any money. Man a day! I just worried *all* the time!

"Then I realized that I ought to have Rider Manual data on *every* set . . . so I got me the *complete set of ten Manuals*. They gave me everything I needed to know to service *any* set . . . data on alignment, I-F peaks, operating voltages, parts lists and parts values, voltage ratings of condensers, wattage ratings of resistors, coil resistance data . . . etc. Right away my worries began to melt away! I turned out *every* job a lot faster . . . had time to get some new customers . . . had fewer complaints . . . and, best of all, began to make *real* money.

"Yes sir, I learned by experience that having only a *few* Rider Manuals is almost as bad as not having *any*! And, believe me, I've got my order in for Volume XI. It's out in June, you know. Why *any* service man tries to get along without all the Rider Manuals is a mystery to me! Maybe he has to learn the hard way . . . like I did."

MAKE SURE YOU HAVE ALL ELEVEN RIDER MANUALS

Volume	Price	Covering
XI	\$10.00	Up to June, 1940
X	10.00	1939-40
IX	10.00	1938-39
VIII	10.00	1937-38
VII	10.00	1936-37
VI	7.50	1935-36
V	7.50	1934-35
IV	7.50	1933-34
III	7.50	1932-33
II	7.50	1931-32
I	7.50	1920-31

ORDER YOUR COPY FROM YOUR
JOBBER TODAY!



JOHN F. RIDER, PUBLISHER, Inc.

404 FOURTH AVENUE, NEW YORK CITY

Export Division: Rocke-International Elec. Corp., 100 Varick St., N. Y. C. Cable: ARLAB



*So much
for
SO LITTLE...*

- Originally introduced by others as a purely price proposition, the miniature-can electrolytic has become the practical and dependable DANDEE. Adequate dry electrolytic section; true hermetic sealing; proper safety venting; spun-over jacket ends to eliminate grounding or shorting of leads; polarity-indicating colored end washers; conservative ratings—these AEROVOX features have justified these general-utility electrolytics for normal-duty service.
- Now available in double-section units as well as single. Center strap provides common negative terminal. 25 to 450 v. D.C.W. 8-8, 8-16, 16-16, 10-10 and 20-20 mfd.
- Single-section DANDEES, introduced two years ago or more, have by now won universal acceptance as general-utility electrolytics. 25 to 450v. D.C.W. 4 to 100 mfd. An additional line of 6, 12 and 15 v. units provides 1000, 2000 and 3000 mfd. in unbelievably small bulk.



Ask Your Jobber . . .

- He can show you DANDEES. Order a few popular values and have them on hand for emergency repairs or for compact assemblies. Ask for our new 1940 catalog—or write us direct.



adjustment of the primary and secondary circuits of a discriminator transformer such as is used in all afc and f-m receivers. Proper operation of the discriminator requires a highly accurate adjustment of the secondary circuit, whereas the primary circuit may be off resonance to a considerably greater degree without impairing the performance of the receiver. The relatively greater accuracy required in the case of the secondary circuit should be readily apparent to anyone who has ever adjusted one of these transformers. The very critical nature of the secondary adjustment and the marked effect which it has on the crossover characteristic is in itself the best indication that a careful adjustment is required. So important is this secondary adjustment that a shift of only about 20 kc in 2100 kc may result in distorted reception as against high-fidelity reception with the secondary trimmer adjusted for proper crossover within several kilocycles. On the other hand, if the primary trimmer is off by 20 kc, there will be practically no effect on the performance of the receiver.

percentage error important

In any operation we have seen that a certain degree of deviation from the ideal condition is permissible without interfering with normal operation. Usually this permissible error is measured by referring to the *percentage* variation from the desired condition or value, rather than by the *actual* variation or error. Fundamentally, the percentage error is of much greater significance than the absolute or actual error because it is the percentage error which indicates whether the operation will be impaired.

We shall illustrate this very important point by applying the principle to the permissible errors in several different resistors. Suppose, then, that we have an accurate ohmmeter which enables us to check the values of a number of different resistors extending over a wide range of values.

First let us start with a resistor which the color code indicates is equal to 10 ohms. We measure this resistor, and we find that its resistance is actually equal to 10.5 ohms.

Now let us check a resistor which according to the color code has a value of 1,000 ohms. This resistor measures 1,050 ohms.

Now let us go to a resistor which is much higher in value, say a 10-meg resistor. Here the measurement shows that the resistor is not equal to exactly 10,000,000 ohms, but is equal to 10,500,000 ohms.

From your practical servicing experience you know that each one of these resistors—the 10-ohm resistor, which is off by 0.5 ohm; the 1,000-ohm resistor, which is off by 50 ohms; and the 10-meg resistor, which is off by 500,000 ohms—is entirely satisfactory for use in any receiver where the indicated value of resistance is specified. Thus the 10-ohm resistor would do very nicely in a grid-bias supply circuit, even though its resistance value was low by 0.5 ohm. And similarly, the 10-meg resistor would function perfectly as the grid leak in a 6Q7 stage which was operated at zero bias—in spite of the fact that its resistance value was off by 500,000 ohms.

The important thing to note about these representative resistors (see Fig. 3) is that the error in ohms is proportionately greater as the value of the resistor itself is increased. Thus the 10-ohm resistor is off by only 0.5 ohm while the 10-meg

resistor is off by 0.5 meg. Now just because the 10-meg resistor is off in value by 500,000 ohms, whereas the 10-ohm resistor is off by only 0.5 ohm, definitely does not make the 10-ohm resistor a more accurate resistor.

The percentage error in the case of the 10-ohm resistor is 5%, because 5% of 10 ohms is equal to 0.5 ohm. Similarly the percentage error in the case of the large resistor is also equal to 5%, because 5% of 10,000,000 ohms is equal to 500,000 ohms. In other words, the percentage of relative error is exactly the same for both the large and small resistors.

This example illustrates the important point that we cannot be guided only by the actual amount of the error, but we must consider the percentage of the entire value which is represented by the error. In our illustration of the resistors, the actual error measured in ohms is larger for the larger resistors, but the relative or percentage error is substantially the same for all three of the resistors.

We could go on with countless illustrations to show that it is not the actual amount of the error which is almost invariably the important factor, but rather the percentage of the error taken of course with reference to the required value. This holds true regardless of whether the matter concerns resistors, coils, or condensers, whether it has to do with money, with the measurement of the horsepower of an engine—with almost any conceivable thing that you can think of, it is almost invariably the percentage error which is the important consideration and not the actual amount of the error.

Because this percentage idea is so important, it is worthwhile for us to spend some time in considering just how errors are represented in the percentage form. As the word "percent" implies—percent means "by the hundred"—the percentage error is always computed by determining how large the error is with respect to the whole unit divided into 100 parts. For example, to compute the error in a resistor, we assume that the resistor represents a whole or unit of 100 parts, and we then determine how many of these 100 parts is represented by the error.

Suppose that you measure a 200-ohm resistor and find that it is actually 182 ohms. The resistor is thus off by 18 ohms in a total of 200. To find the percentage error, you must find out how far off the resistor is on the basis that the resistor represents a total of 100 parts. In this case the resistor is off by 18 parts in a total of 200 parts, or by 9 parts in 100. The percentage error of the resistor is thus 9%.

Let us take a more complicated problem to illustrate this same point. A condenser which is marked 0.004 mfd or 4,000 mfd is tested on a capacity bridge and its value is found to be 4,200 mmfd instead of the nominal value of 4,000 mmfd. What is the percentage error. First, let us get the approximate answer by inspection, and then show how it can be determined more closely.

The condenser is off by 200 parts in a total of 4,000. However the percentage error must be computed on the basis of 100 parts. Clearly, if the condenser is off by 200 parts in 4,000, it is off by only 20 parts in 400, and by only 5 parts in 100. Thus by inspection the percentage error is readily computed as 5%. It is valuable to be able to determine the percentage error by inspection in this way because in service work there is never any necessity for determining the percentage error to any great degree of accuracy. Usually it

is sufficient to know that the percentage error is 1%, 3%, 10%, 20% or thereabouts. There is no point whatsoever in computing the percentage error and finding that a resistor is off by say 5.19%. This is a sheer waste of time since it is entirely sufficient to know that the resistor is off by approximately 5%. This applies to anything that is measured, regardless of whether it is a resistor, condenser, coil, frequency, etc.

A simple formula which can be used to determine the percentage error in any case is given below:

$$\text{Percentage error} = \frac{\text{Actual numerical error}}{\text{Marked value}} \times 100$$

The following examples will illustrate the application of this formula to the previous example of the 4,000-mmfd condenser which measured 4,200 mmfd. To find the percentage error, we must substitute the actual error and the labelled value in the above formula. In this case the actual error is 4,200 mmfd—4,000 mmfd, or 200 mmfd, and the nominal or marked value is equal to 4,000 mmfd. Thus, substituting, we find

$$\text{Percentage error} = \frac{200 \text{ mmfd}}{4,000 \text{ mmfd}} \times 100 = 5\%$$

Note that this checks the value of 5% which we obtained mentally without an actual substitution in the formula for the percentage error.

The following typical relations should be clearly understood: An error of 1 part in 100 represents a percentage error of 1%; an error of 5 parts in 100 represents an error of 5%; and similarly an error of 20 parts in 100 represents an error of 20%. Usually the quantity being measured does not contain 100 units; however, the percentage error can always be determined by finding the number of parts represented by the error when the quantity is considered as consisting of a whole which contains 100 parts. You can either do this mentally, as we did first in the case of the 4,000-mmfd condenser, or else you can use the formula for determining the percentage error. As we previously pointed out, however, the percentage error need practically never be found to more than one place.

Before we leave this subject of computing the percentage error, we show in Fig. 4 a number of typical examples which crop up frequently in service work. These examples show how a determination of the percentage error tells you whether or not a defective condition exists.

In this article we have been able to cover only the more important features of the fact that everything is subject to a certain permissible amount of variation. We have seen that the more accurately a job is done, or the more accurately a part is made, the greater is the cost involved. We have tried to bring out the important consideration that high accuracy for the sake of high accuracy is not something to be sought after. On the contrary, the best job is not the most accurate one, but is always the one which accomplishes satisfactory performance with the smallest expenditure of time and money. This is what is meant by a job "well done."

KENYON CATALOG

Kenyon Transformer Co., Inc., 840 Barry St., New York City, have issued a 24-page catalog illustrating and describing their line of chokes and transformers. Several handy Ken-O-Graphs are also included in the catalog. Copies may be obtained directly from Kenyon.

Hot off the Press....

This New 52-Page RCA SOUND CATALOG!

★
Get a copy today
from your nearest
RCA Sound
Distributor!



Here are the contents of this catalog

ACCESSORIES • AMPLIFIERS: Cables for Amplifier Remote Controls, Input Transformer, Mixer and Mixer Pads, Panels for Amplifier Cabinet, Remote Control Devices, Signal Mixer Units • ANTENAPLEX (Multi-Wave) • ANTENAPLEX (Standard) • BAFFLES • CARILLON (Electric Bells) • COMPLETE SOUND SYSTEMS • CONTROL CABINETS • HEARING AIDS • INTER-OFFICE COMMUNICATING SYSTEMS ("Telekoms") • MASTER CONTROL SYSTEMS (De Luxe) • MASTER CONTROL SYSTEMS (Junior) • MICROPHONES • MICROPHONE STANDS • MOBILE SYSTEMS • PORTABLE ADDRESS SYSTEMS • PUBLIC ADDRESS SYSTEMS (Series Systems) • RECORDING EQUIPMENT: Recording Blanks • 16 m.m. PROJECTOR • SOUND POWER TELEPHONES • SPEAKERS: Baffles, Field Supply Units, Housings, Matching Transformers • TURNTABLES • VOLUME CONTROLS

Any sound system sounds better equipped with RCA Radio Tubes



Commercial Sound

RCA Mfg. Co., Inc., Camden, N. J. • A Service of Radio Corporation of America

SAVE \$1.00 !!!

- The Group Subscription Plan for *Service* enables a group of service men, dealers or jobbers to subscribe at one-half the usual yearly rate.
- The regular individual rate is \$2.00 a year. In groups of 4 or more, the subscription rate is \$1.00 a year. (In foreign countries, \$2.00.)
- Each subscriber should print his name and address clearly and state his occupation—whether a dealer, jobber, independent service man, service organization, etc.

Remember this Group Plan when Your Subscription Expires

HOW CAN YOU MISS
the Big Money
in P.A.
WITH CLARION?

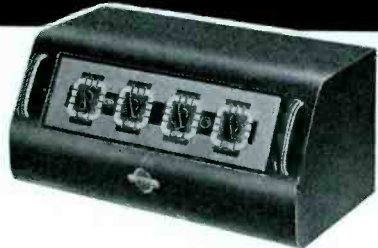

READ WHAT THEY'RE SAYING! ★

- ★ Our most successful year in public address due to your cooperation.
- ★ Thank you for the advice given to me by your Engineering Department . . . for the leads referred to me by your Sales Department.
- ★ You are doing us fellows in the field a favor.
- ★ Your engineers deserve great credit.
- ★ One of the best Christmas presents I received was the renewal of our agency contract.

LOOK WHAT CLARION'S DONE!

New functional design now strengthens Clarion buy-appeal with eye-appeal. The Clarion line for 1940 looks like no other sound amplifying equipment on the market. Individual, distinctive—it's easy to recognize Clarion P.A. on the job. Clarion goes on selling for you after you've banked your first profit . . . attracting the eye, impressing the prospect with its originality of design.

CASH IN ON THIS PROFIT PLAN!

More than great engineering advances make Clarion the BIG MONEY line in P.A. As a member of the Clarion Institute of Sound Engineers (nation-wide Clarion reps), you enjoy factory purchasing power; exclusive sales territory; free engineering service; the backing of national advertising plus local sales promotion. It costs nothing to become a C.I.S.E. distributor; it will pay you big dividends in prestige and profits!

Send for application form NOW!

Only one Clarion representative to a territory. Here's your chance to join the big money-makers in P.A. Act now—get the full facts. Send for application form today!

- ★ From actual letters received at our Sales Office. Photostatic copies will be forwarded on request.

Complete Clarion Line Will Be Displayed At Chicago Trade Show

For complete details, write

TRANSFORMER CORP.
OF AMERICA

69 WOOSTER ST. • NEW YORK, N. Y.

RADIO CITY 308 TUBE TESTER

WHILE this instrument is available in four different types of housings, the test unit and meter are identical in each. These types include one for vertical mounting on a counter, a similar one for horizontal mounting, one with hinged cover and carrying handle, and one for bench use in which the meter is permanently mounted in the case but the compact test unit is removable so that it can be moved about on the bench as needed.

The meter used has an actual face diameter of 7½ inches. Its scale is marked off into the conventional green "Poor" and red "Good" ranges and in addition, in conjunction with a built-in 6H6 diode, provides for direct reading line voltage adjustment. The scale also has a separate range for diode testing.

The test unit consists of a matte-silver finished panel with all embossed scales, knobs and sockets in contrasting black. Ten sockets are provided in all. Eight of these accommodate close to 600 tube types, including the new miniatures, but to take care of future developments spare standard and miniature sockets are provided, to be wired in later as the need develops. In addition provision is made for testing all pilot and auto headlight lamps.

All standard filament and heater voltages from 1 to 117 are available through the filament selector switch, and any line voltages in the range of 95 to 130 volts can be adjusted to standard value by means of the "L. V. Adjustment" control and the provision for direct indication of line voltage on the meter.

The five positions of the "Test Selector" switch offer tests of line voltage, shorts, filament tubes, heater tubes and cold cathode tubes. The different loads required for

various types of tests, i. e., regular, diode, short, and battery operated tubes, are obtainable by means of a 4-position switch. Provision for testing all types of ballast tubes is incorporated in the filament voltage selector switch. A neon indicator is employed for all short and ballast tube tests.

The "Tube Selector" switch, a development of the Radio City Products laboratory, is a 7-position 2-circuit switch. To its seven terminals are connected the individual elements of all test sockets (except the heaters) and the mechanical arrangement is such that in standard tube tests the meter may be connected in series with any one of these while a conductive segment of the switch parallels all others, applying standard test voltages to these. For normal tests of heater tubes the switch is set to place the meter in the cathode circuit of the tube under test, regardless of what pin number this happens to be in this particular tube type. The regular test voltage is then automatically applied to the other elements. In short-circuit tests each individual element can be tested, the neon indicator being connected in the circuit of one element after another as this control is swung through all its positions.

An unusual feature is the provision of jacks for headphones to be used in making critical noise tests. This test is made after completion of the quality test. Tapping the tube with the fingers, the "Tube Selector" switch is rotated and if the tube is inclined to be noisy in the circuits of any of its elements the condition will be evidenced by a clicking sound in the phones.

The four different types of cases in which this instrument is available are all of approximately the same size except that the depth of the portable model is increased by the addition of the cover. This size is 19 in. long by 11¼ in. wide by 7½ in. deep at one end, the panel sloping down to make the depth 5 in. at the other end. The cases are covered in black imitation leather while the panel is of steel, crackle finished to match the case.

The tube tester shown is available in any one of four different housings for portable, counter or rack and panel use.

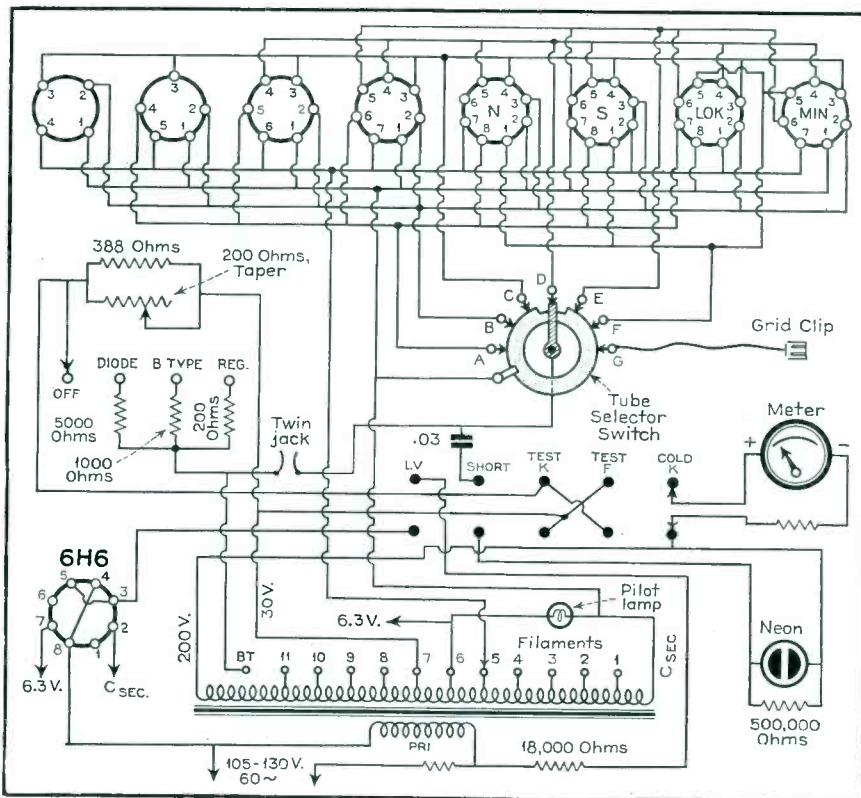

NEW TUBES

THE chart below lists the tentative characteristics of several new types recently introduced. Some are merely older types in new envelopes, others give added characteristics not generally available previously.

The type 1LB4 is a loktal power-output pentode designed especially for service in low-drain battery operated receivers. The filament current is only 50 ma but a power output of 200 milliwatts may be secured under Class A conditions operating with a B supply of 90-volts. 35 milliwatts

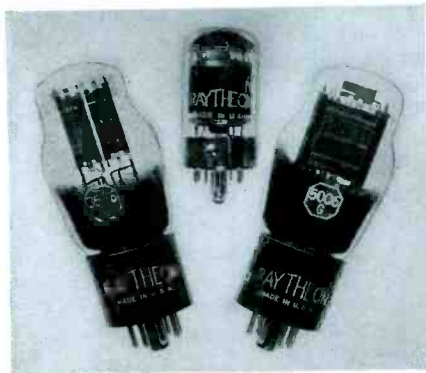

are available when the plate and screen are operated at 45 volts.

The 6AB5/6N5 is a high-vacuum type of tuning indicator tube designed to replace the types 6AB5 and 6N5. A T9 bulb is used and the electrical characteristics have been designed to retain the sensitivity of the 6AB5 together with the extended cutoff of the 6N5.

The 7H7 is a high-mutual conductance type pentode which has been designed to have as wide a cutoff as is consistent with a good ratio of mutual conductance to plate current. This tube has a 2-watt cathode used in place of the usual 3-watt cathode used in other high mutual conductance amplifier tubes and hence may be used in series with other 2-watt cathodes. The new type will find application in untuned r-f circuits, wide-band high-frequency amplifiers and other equipment where high mutual conductance characteristics are desirable.

The 35Z6G is a twin diode rectifier designed for use in voltage doubler circuits and a-c, d-c receivers. It is characterized by a plate current rating of 110 ma, which is somewhat higher than for similar voltage doublers.

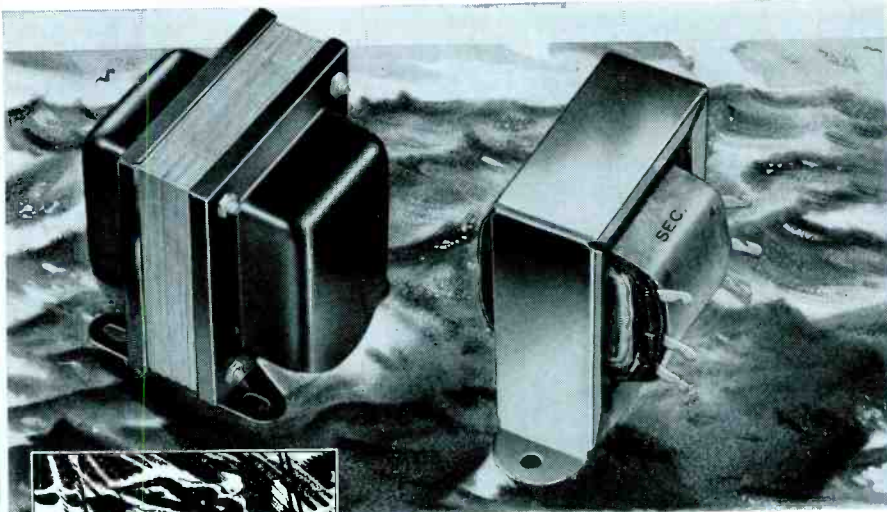

UTAH TRANSFORMERS ARE "Dressed" FOR ROUGH WEATHER

"The weather-resistance of a skipper on a fishing smack"—that's what they say about Utah Transformers.

A non-corrosive, protective film of cellulose acetate provides absolute insulation—prevents breaking down, even under extremely high humidity and other atmospheric conditions which are so frequently destructive to ordinary transformers. The high safety factor of their insulation is proven by the extra hours of satisfactory performance of the Utah transformers which are standard equipment in millions of receivers throughout the world.

Precision manufacturing and the use of other

scientifically selected materials such as high silicon content steel, used in all laminations, make Utah Transformers uniformly dependable. These fully guaranteed transformers are individually boxed, with complete instruction sheets.

Utah Transformers are sold through parts jobbers everywhere. If you do not have your copy of the new Utah illustrated catalog containing complete information about the transformer line and other Utah products—write for it today—there is no obligation. **UTAH RADIO PRODUCTS COMPANY**, 816 Orleans Street, Chicago, Illinois. Canadian Office: 560 King Street West, Toronto. Cable Address: Utaradio, Chicago.



TRANSFORMERS

VIBRATORS • SPEAKERS • UTAH-CARTER PARTS

NEW TUBE CHARACTERISTICS (TENTATIVE)																										
TUBE TYPE	Service	Base	Pin Connections †								Filament			Plate Volts	Negative Grid Volts	Screen Volts	Plate Mc	Screen Ma	Plate Resist Ohms	Mutual Conduct Micro-mhos	Ampl. Factor	Ohms Load for Rated Output	Undist. Power Output Milliwatts	TUBE TYPE		
			1	2	3	4	5	6	7	8	CAP	Volts	Amps												Type	
1G4 GT	Triode	Octal	NC	F	P	NC	G	-	F	NC	-	1.4	.05	F	90	6	-	2.3	-	10,700	825	8.8	-	-	1G4 GT	
1LB4	Pwr Output Pentode	Loktal	F	P	NC	NC	G	NC	SP	F	-	"	"	F	"	9	90	5.0	1.0	0.2 Meg	925	-	12,000	200	1LB4	
6AB5/6N5	Visual Indicator	6-Pin	H	P	G	T	K	H	-	-	6.3	.15	H	180	For 10	Target 100 to 150	0.5	Target 2	-	-	-	Series 0.25 Meg	-	-	6AB5/6N5	
6AC5 GT	Triode	Octal	NC	H	P	-	G	-	H	K	-	6.3	0.4	H	250	0	-	32	-	36,700	34,000	125	7000	3.7	6AC5 GT	
6H4 GT	Diode	"	NC	H	-	P	-	-	H	K	-	"	.15	H	100 Max	-	-	4 Max	-	1000 at 0.25 Ma	-	-	-	-	6H4 GT	
6P5 GT	Triode	"	NC	H	P	D ₂	D ₁	-	H	K	-	"	0.3	H	250	13.5	-	5.0	-	9500	1450	13.8	-	-	6P5 GT	
6SJ7 GT	Pentode	"	NC	H	Sp	G	K	Sg	H	P	-	"	"	H	"	3	100	3.0	0.8	1.5 Meg	1650	2500	-	-	6SJ7 GT	
7H7	Semi-Remote Cutoff Pentode	Loktal	NC	H	P	Sg	Sp	Sh	G	K	H	-	7.0	.32	H	"	2.5	150	9.0	2.5	1.0 Meg	3500	-	-	7H7	
25A6 GT	Pwr Output Pentode	Octal	NC	H	P	Sg	G	-	H	K	G ₃	-	25.0	0.3	H	160	18	120	3.3	6.5	42,000	2375	-	5000	2200	25A6 GT
25D8 GT	Diode-Triode Pentode	"	K	H	Pp	Sg	G _T	Pr	H	Dp	Gp	"	.15	H	100	1.0	3.0	100	0.5	-	1100	-	-	-	25D8 GT	
35Z6G	Voltage Doubler	"	NC	H	Pr	K _R	PL	-	H	KL	-	35.0	0.3	H	117 RMS Per plate	-	-	110 d.c. Per plate	-	-	-	-	-	-	35Z6G	
40Z5/45Z5GT	Half-wave Rect.	"	NC	H	H _T	-	P	-	H	K	-	45.0	.15	H	125 RMS Per plate	-	-	100 Mc D.C. or 60 with panel lamp conn	-	-	-	-	-	-	40Z5/45Z5GT	

† RMA PIN NUMBERS ARE USED
D = DIODE PLATE

NC = NO CONNECTION

F = FILAMENT
Gp = GRID, PENTODE SECTION, etc

H = HEATER

P = PLATE

G = GRID

Sg = SCREEN

Sp = SUPPRESSOR

G_T = GRID, TRIODE SECTION, etc

ONE TEST INSTRUMENT You know is a VALUE!

RCP Model 308
(Series D)
ONLY \$25.95
DEALER NET



It's called the Sales Promoter, so you know it means business. And it's built by RCP, so you know it's a value! But never in RCP Test Equipment history has appearance counted for more . . . never has engineering reached a stage so advanced . . . never has value-giving been greater. You have only to check the features and low price of Model 308 (Series D), compare it with other equipment, to discover how much more for your money RCP offers.

JUST LOOK AT ALL THESE MONEY-MAKING FEATURES!

- ★ Extra-large 9-inch Jumbo meter
- ★ Famous Dynoptimum Test Circuit
- ★ Tests the new miniature tubes
- ★ Spare sockets for new developments
- ★ Checks pilot lights, headlights, miniature lights
- ★ Rapid, simple tests for quality, shorts, etc.
- ★ Individual tests of all sections of rectifiers and multi-purpose tubes
- ★ Noise and hum tests for tubes showing "good"

SERVICEMEN EVERYWHERE are making more money with RCP Test Equipment. And saving money, on the initial cost! By all means, buy quality, but be smart and get value. Ask for RCP Test Instruments. If your jobber cannot supply you, send at once for new FREE Catalog No. 122.

RADIO CITY
PRODUCTS CO. INC.
88 PARK PLACE, N. Y. C.

SIGNAL SUBSTITUTION

(Continued from page 15)

the avc threshold, it will not be functioning with optimum performance under normal conditions.

If we were to substitute a fixed bias in place of the varying avc voltage, and were able to adjust this fixed bias to any desired value equal to that which normal local signals develop in the diode, we could then align and test this receiver under practically true operating conditions, and without detrimental avc interference.

The signal generator employed in

developing this article furnishes a variable bias voltage between zero and fifty volts specifically for avc substitution. All that is required is to open the avc circuit at X, and connect the substitute bias with the negative end toward Y. Alignment of the receiver can then be carried out as if no avc were present.

With the probe at K, the i-f stage can be analyzed, the output section of the i-f transformer adjusted and the diode winding alignment rechecked. By-pass condenser efficiency can be determined in the manner suggested for the audio stages, and shorted turns can be detected readily as mentioned above.

At the same time i-f and r-f gain per stage measurements may be made if the generator employed is provided with a calibrated output control.¹ This is done briefly as follows: With the r-f probe at J, set the r-f attenuators and modulation control to give some arbitrary reading on the output meter near the middle of the scale. Note the attenuator setting. Shift the probe to K. Reduce the attenuator setting until the output meter indicates the same reading as that obtained when the probe was at J. Again note the attenuator setting. The ratio of the two settings indicates the gain of the stage directly.

The probe at L tests the transfer of signal through coil to K, just as the probe at J checks the signal through to the diodes. Placing the probe at M, and still employing the 456-kc signal, allows complete alignment of the input i-f transformer and also allows check of operation of the first detector at the intermediate frequency.

R-F and Oscillator Stages

We are now ready for a complete test and adjustment of the first detector and oscillator. Set the receiver dial to the high end of the broadcast band, about 1500 kc, and apply the r-f probe to M with the generator set for 1500 kc, 400-cycle audio modulated, output. If the oscillator is oscillating and tracking, the audio tone should be heard from the set's speaker. If no signal is heard the oscillator should be checked first. It should be oscillating at 456 kc plus the dial reading (456 plus 1500) or 1956 kc. If the oscillator is oscillating but not tracking, the signal should be heard from the speaker when the generator dial is rocked around the 1500-kc position. If the oscillator is not oscillating at all, regardless of what generator setting is used, no signal will be heard in the speaker.

To check this, connect the generator probe at N and an antenna at M, switch off the generator's audio modulation

¹"Gain Measurements in R-F and I-F Stages," by Jack Avins, SERVICE, May, 1937, p. 273.

and tune it to approximately 1956 kc. Attempt to tune in a station in this manner using the signal generator as a substitute for the set's oscillator stage.

In some cases, where a receiver employs a separate oscillator tube coupled to the first detector through a small condenser, the condition of this condenser can be determined by placing the probe before and after the condenser. If the condenser is open or a lead broken the signal will appear only when the probe is at the mixer side of the condenser.

Once having ascertained that the first detector and oscillator are working, the probe may then be advanced to O where the 1500-kc signal is again applied and the first-detector trimmer adjusted. The r-f stage gain may be measured, if desired, in the same manner as outlined for the i-f stage. If no further difficulties exhibit themselves during this test, the probe is finally placed at P, and if the antenna coil, leads, etc., are continuous and no turns shorted, we proceed with the low-frequency padder adjustments and our set is complete.

It is realized that, as presented, things may appear rather sketchy, however, space limitations do not permit extended treatment. Nevertheless, it is hoped the reader has been able to formulate in his own mind the extensive application to which basic test equipment may serve, and how one's problems can thereby be systematically approached and solved.

HOME RECORDING

(Continued from page 13)

a bias cell. The mike gain control is in the plate of the preamplifier. Note the mixer circuit; one side is fed from the mike gain control and the other from deck No. 1 bringing in radio programs from the diode detector or phonograph. A conventional tone control is used.

The Lafayette S53, a 9-tube push-pull combination radio recorder (see Fig. 5) switches to any one of 5 functions by means of a 5-position, 4-deck rotary switch. A 6SQ7 preamplifier is used for microphone recording and p-a applications. The 6U5 visual indicator tube is used both as a resonance indicator and as a level indicator during recording.

In p-a applications it is possible to reduce, or even eliminate acoustic feedback by providing avc in the audio amplifier. Too much avc will spoil the quality and cause excessive volume compression, but a certain amount will help obtain a proper input level.

Automatic record changer phonographs are coming out with recorder

combined in the near future. The present market consists mainly of consoles, although the number of table models is growing fast. Among these are the Federal recording radio and the Air King radiocorder Model 5000 with a 2-band, 6-tube, a-c superhet. Then there are a number of recorders without radio chassis which are suitable for playback and p-a work. These include the Wilcox-Gay Model A72 (Fig. 4), the Western Sound & Electric Laboratories portable, the Presto Jr. portable, the model C12 Leach recorder put out by Electrical Industries Mfg. Co.

There is a knack to this recording business which must be mastered for real high-quality records; not that it is especially difficult to get fairly good results at once, but it's like the kid with a new camera—he's going to waste a few good rolls of film before he's sure of himself. The entire field of acoustics, proper mike placement, room reverberation, tonal balance for musical instruments, sound intensity, etc., are all involved in making records.

Percussion instruments are the most difficult to record, so the beginner would do well to try other things first to avoid preliminary disappointment. Where the volume range to be recorded is considerable, it is desirable that the operator ride gain, which means increasing the gain on low passages and cutting the gain slightly on the strong passages. This produces a degree of volume compression which may not seem desirable, yet it is standard practice in both broadcasting and professional recording and is the alternate to enduring a high background level. To do this, the operator must be familiar with the piece being played.

Crystal cutters, reproducers and microphones being used extensively in recorders, a few words regarding temperature will not be amiss. Crystals suffer permanent damage when subjected to temperatures above 120° F. Keep them away from radiators! Low temperatures cause no permanent damage; yet, they have an undesirable effect in that they stiffen the crystal, causing a reduction in high frequency response and a loss in all-around efficiency.

AUTO RADIO INSTALLATION

(Continued from page 10)

nect the leads under the terminal nuts. Install a condenser on the overload relay which is mounted on the dash inside the car and over the steering column. Connect its lead to the same terminal on the relay as the battery lead of the radio set is connected. Mount a condenser on the rear of the oil filter bracket and connect its lead to the terminal on the oil gauge. Mount another



THESE *Sylvania* "STOCK BOY" CABINETS CAN HELP YOU SELL

**Ask Your Jobber
How You Can Get Them**

For neat and handy storage of tubes and parts the cabinet on the right has everything—space for over 250 tubes; drawers of 21 compartments; another 4 compartments; and storage bin at bottom. All-steel, 59½" high, 22" wide, 12" deep. The folding cabinet below holds 240 tubes; is 18" high, 21¾" wide and 11½" deep when closed. See your Sylvania jobber about getting one of these cabinets . . . today.



S Y L V A N I A
SET-TESTED RADIO TUBES
Hygrade Sylvania Corp., Emporium, Pa.

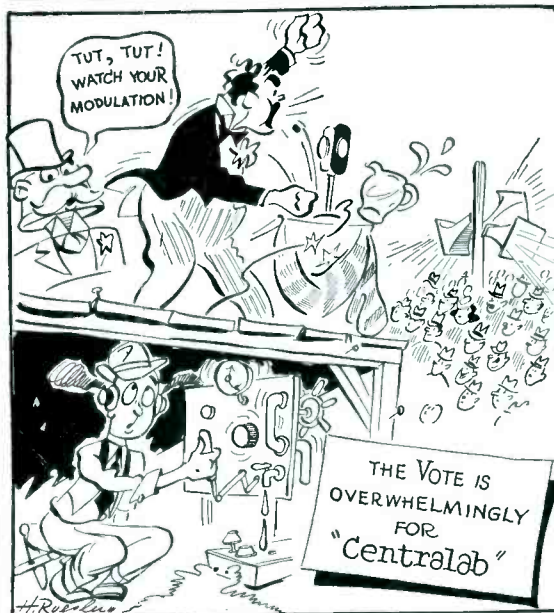

"always specify

Centralab"

DIVISION OF GLOBE UNION, INC.
900 E. KEEFE AVENUE
MILWAUKEE, WISC.

CENTRALAB plays no Favorites

A thoroughly democratic gent is Old Man Centralab . . . for he keeps his "promises" no matter what "system" you use. Whether you are talking to a handful of listeners or to a frenzied football field . . . Centralab parts stand up under all decibel deluges. An overwhelming majority of the boys vote for
CENTRALAB
VOLUME CONTROLS
CENTRALAB
RESISTORS
CENTRALAB
SWITCHES

YOU HAVE TO "KEEP UP" THESE DAYS!



**Rider's Latest Book
FREQUENCY MODULATION**
The most talked of subject of the moment, Rider offers this introduction to frequency modulation with special attention to F-M receivers and the problems they will present to the serviceman. Get this now—be ready. 136 illustrated pages—only \$1.00.

THE CATHODE RAY TUBE AT WORK

By John F. Rider
This is the most complete and practical book ever written on the subject—the only one prepared especially for the radio serviceman. New applications of the cathode ray tube during the past five years require that servicemen know its operation. 336 pages—over 450 illustrations—\$2.50.

AN HOUR A DAY WITH RIDER BOOKS

On Resonance and Alignment . . . On Automatic Volume Control . . . On D-C Voltage Distribution in Radio Receivers . . . On Alternating Currents in Radio Receivers. 60c each.

JOHN F. RIDER PUBLISHER, Inc., 404 Fourth Ave., New York City
Export Div.: Roeca-Int. Elec. Corp., 100 Varick St., N. Y. C. Cable: ARLAB

Read RIDER BOOKS
BANISH BEWILDERMENT—INCREASE PROFITS

A service man has to "keep up" with the new developments these days, if he wants to hold on to his business. These books will give you an understanding of subjects vital to the success of your business . . . today! Start now! Turn your spare time into usable, money-making knowledge.

SERVICING BY SIGNAL TRACING

By John F. Rider
Use the system of servicing which is proved and endorsed—fastest—most modern—the system you can apply to all receivers regardless of age, type or make. Servicing by Signal Tracing operates independently of every limiting factor heretofore encountered. In this new book you learn how all receivers are brought to a common servicing level. You learn how components receive a functional check while the circuits are in an operative condition. Over 360 pages—hard covers—only \$2.00.

NEW! By John F. Rider OSCILLATOR AT WORK

Get your money's worth—KNOW! This new book tells all about ALL oscillators. Explains theory by means of simple illustrations, diagrams and curves. Gives you practical facts. Get your copy TODAY! 256 pages—illustrated—\$1.50.

AUTOMATIC FREQUENCY CONTROL SYSTEMS

With Automatic Frequency Control Circuits in most new higher priced models, knowledge of "AFC" means money in your pocket! Learn the practical facts, from these easy-to-understand explanations. Get your copy today. Cash-in on profitable "AFC" work. Hard covers—144 pages—\$1.00.

SOLAR
Sealtdite
WAX-MOLDED
Tubular Paper Capacitors . . . molded in hard wax . . . no moisture can enter . . . much longer life . . . buy from your jobber in factory-sealed cartons.
Write for Catalog
SOLAR MFG. CORP. Bayonne, New Jersey

A GOOD NAME GOES A LONG WAY
Ken-Rad makes dependable tubes—the top-performing tubes that every radio user wants. Specify Ken-Rad on your next order.
KED-RAD TUBE & LAMP CORPORATION
Owensboro, Kentucky
KEN-RAD
DEPENDABLE RADIO TUBES

condenser under one of the gasoline gauge tank unit bolts and connect its lead to the gauge terminal. This is accessible under a metal cover beneath the spare tire in the rear compartment. Mount another condenser with a special bracket under one of the cylinder head bolts and connect its lead to the water gauge terminal. Another condenser should be fastened to the voltage regulator mounting bolt and its lead connected to the "BATT" terminal.

Nash

Insert a suppressor in the high tension lead to the center of the distributor block. On Ambassador cars it will be necessary to insert a suppressor in both center leads. Mount a condenser under the generator ground lead screw and connect its lead to the generator armature terminal. Attach two hood grounding clip springs under one of the hood lining screws to ground the top and side of the hood to cowl.

Oldsmobile

An elbow suppressor and an adapter should be installed in the center terminal of the distributor block and attached to the high tension wire leading to the terminal. Mount a condenser on the ground lead screw on the generator frame and connect its lead to the "A" terminal on the generator. Attach the

lead from another condenser to the ammeter terminal to which the radio set wire is connected and ground the condenser with another lead to the upper flange of the instrument panel. Install static collectors in the front wheels, making sure that the cotter pin is bent against the nut so that it will not interfere with the collector.

Packard

Cut the high tension lead to the center of the distributor and insert a suppressor in it. Mount a condenser under the ground lead screw on the generator and connect its lead to the generator A terminal. Mount a condenser on the instrument board flange and connect its lead to the feed line on either the ignition switch or the ammeter, depending upon where it does the most good. Interference from an electric clock can be eliminated by connecting an additional condenser to its ammeter terminal.

Pontiac

An elbow suppressor and an adapter should be installed in the center terminal of the distributor block and attached to the high tension wire leading to the terminal. Mount a condenser under the head of the ground screw on the side of the generator case and connect its lead to the generator armature terminal. Mount another condenser

under the left hand instrument board mounting stud nut and connect its lead to one of the accessory terminal screws at the extreme front end of the lighting switch. Install static collectors in the front wheel inner dust caps, making sure that there are no burrs around the center hole in the wheel spindle which would cause excessive wear of the contact button. Bolt a ground strap to the cylinder head with a special screw and lock washer. On the 6 cylinder cars connect the other end of the ground strap to the dash under the upper starter pedal bracket to dash screw. On the 8 cylinder cars drill a 0.199 in hole through the dash 2½ in above the upper starter pedal guide screw and connect the other end of the ground strap to the dash at this point with a self-tapping screw. Spot face around the hole to obtain a good ground connection. If the car is fitted with a "Fore-n-aft" underseat heater it will be necessary to install a heater hose shielding. To make an installation, slip two pieces of braided metal loom over the hose and stretch them lengthwise until they are tight on the hose. Remove the clamp bolt from the double clip which supports the hose at the cylinder head and scrape away all paint and dirt from between the support and the clip and between the support and

clamp bolt nut to form a good ground.

Studebaker Champion

Cut the high tension lead to the center of the distributor block and install a resistor type of suppressor in it. Mount a condenser under the generator ground lead screw and connect its lead to the generator armature terminal. Remove the three terminal nuts and wires on the back of the gasoline gauge dash unit and assemble a resistor in place. Then replace the wires and nuts. Ground the controls that pass through the two rubber grommets in the dash by using a braided shielding. Place one end of the shield under the screw on one side, make a turn around each cable and fasten the other end of the shielding under the other screw. Drill a $\frac{1}{8}$ in hole in the steering column jacket just outside the engine bulkhead. Also drill a $\frac{1}{8}$ in hole through the bulkhead just above the steering column and fasten a ground strap between the two points with self tapping screws.

Studebaker Commander

Cut the high tension lead to the center of the distributor and install a resistor type of suppressor in it. Mount a condenser under the generator ground lead screw and connect its lead to the generator armature terminal.

Studebaker President

Cut the high tension lead to the center of the distributor and install a resistor type of suppressor in it. Mount a condenser under the generator ground lead screw and connect its lead to the generator armature terminal. Connect one side of a small mica condenser to the battery terminal on the distributor and ground the other terminal of the condenser under the distributor condenser mounting screw.

Willys

Install a suppressor in the center terminal of the distributor block and connect the high tension lead to it. Mount a condenser on the generator ground lead screw and connect its lead to the generator armature terminal. Attach

another condenser under a junction block mounting screw and solder its lead to the terminal of the brown wire leading to the oil gauge. Be sure that the floor board bolt heads are tight enough to make a good electrical contact.

NATIONAL UNION DEAL

National Union Radio Corp., 57 State State St., Newark, N. J., announce a deal on a new Model 633 Battery tester made by the Triumph Mfg. Co., Chicago. The tester is provided with a switch for setting the proper battery voltages and a meter which shows percentage of useful life. Full information may be obtained directly from National Union.

SHURE SALES PLAN

A complete Shure plan, sent to sound men and Shure distributors tells who the prospects for replacement sales are, where to find them, and how to sell to them, it is said. It includes special post cards for the sound man to mail to his prospects, a handy sales manual to help him sell, a sound engineers honor award, advertising in trade magazines and in magazines read by sound system users and owners. If you are without a copy of Shure Replacement Sales Plan, write to Shure Brothers, 225 W. Huron St., Chicago.

N. U. TO SELL ERWOOD SOUND

Announcement has been made of a contract entered into by the Erwood Sound Equipment Co., Chicago, and the National Union Radio Corp., Newark, N. J., whereby National Union becomes the exclusive sales agent in the U. S. for Erwood Sound Systems. National Union will handle all matters pertaining to sales, sales promotion, credit, collections and so forth. The Erwood line will be merchandised through jobbers and dealers independently of the National Union line.

WEBBER BOOKLET

"Blue-Book of Instrument Values" an 8-page booklet discussing 1940 radio servicing instruments has been prepared by the Earl Webber Co., 4358 W. Roosevelt Rd., Chicago. Readers of SERVICE may obtain copies directly from Earl Webber.

MECK BOOKLET

"How to Match Speaker Systems" a booklet discussing the proper layout and connection of speaker systems has been prepared by John Meck Industries, Randolph at Elizabeth Sts., Chicago. Readers of SERVICE may obtain copies directly from John Meck Industries.

A theatre type television system was demonstrated recently by RCA. The apparatus used consists of three parts. One contains the newly developed kinescope projection tube and optical system. Another contains the high voltage power supply and the third houses the electrical circuits, amplifiers and controls. A laboratory model, it projects images $4\frac{1}{2}$ by 6 ft. which are said to compare in brightness with motion pictures.

DEALERS AND SERVICEMEN

Cash in Now!
ON
**WARD'S FINEST
AERIAL LINE**

...**ALL THESE FEATURES**
at **NO EXTRA COST**

- Trimount model with extra brackets for Underhood-Alligator-Hinge.
- Uni-Plug Silver to Silver contacts. Fits all Motorola and Bayonet.
- High-Q, low capacity, low loss, water-proofed, non-kink leads.
- Flex-Angle Model — fits all body contours, 16 degree adjustment — Chrysler and Torpedo.
- Time saving installations with Ward's new EZ-IN plug, silver contact.
- The only auto aerial with ceramic stanchions.

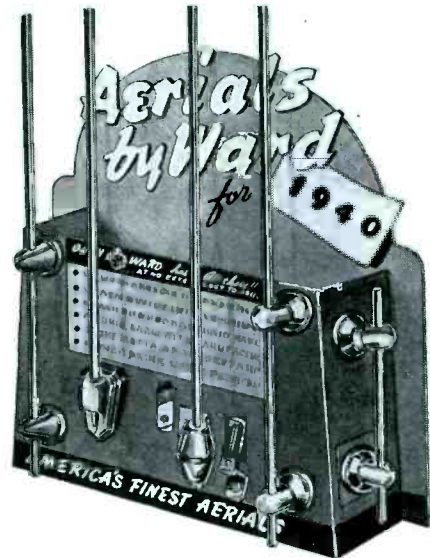

● DISPLAY WA78

A new Dealer display by Ward that is a truly efficient silent salesman.

**BE SURE TO SEE WARD AT THE SHOW
IN CHICAGO, BOOTHS 922-924**

The
WARD PRODUCTS
Corp.
WARD BUILDING CLEVELAND, OHIO

SERVICE, MAY, 1940 • 29

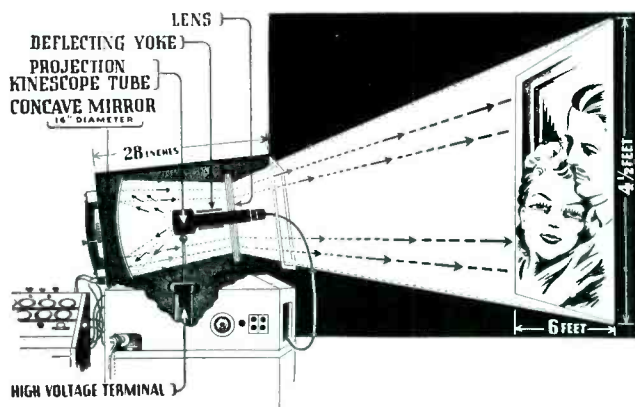

Chippewa Valley
RADIO
SERVICEMEN'S
Assoc.

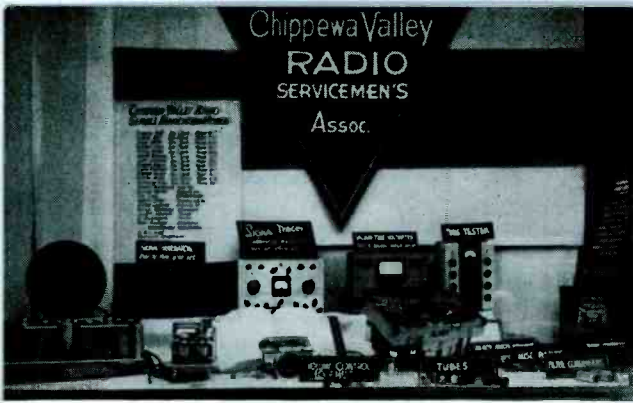

The display is intended to stimulate interest in the newly organized Chippewa Valley Servicemen's Association and attracted much attention from passersby. The main parts of the display, shown here in the Eau Claire, Wisconsin, business district, were also taken to other nearby cities where members of the association are located.

Radio Servicemen of America
INCORPORATED

hereby presents to
Service Magazine
New York, N.Y.

this
Certificate of Honorary Membership
for cooperative endeavors in behalf of the
Radio Servicemen of America

Given at Chicago, Illinois, this first
day of September, 1939

Signature
President

Signature
Secretary

Signature
Executive Secretary

This holder of this Certificate is entitled to the use of the name and insignia of this organization in any manner not inconsistent with our policies.

RADIO SERVICEMEN OF AMERICA

RADIO Servicemen of America announces its Third Annual Convention at the Stevens Hotel, Chicago, Friday, June 14. The Convention will open at 2:00 p. m. of that day with a membership meeting, to be followed with the RSA Extension Course, which consists of a collection of lectures and round-table discussions. A group of engineers will first take up the matter of present-day circuits with comments pertaining to their maintenance. Another group of engineers will discuss future trends and developments. The Extension Course session will end with a general treatment of the problems as they relate to the service industry as the representatives of the trade press see them.

F-m, a subject that is of vital interest to everyone in the industry, will be the topic of a lecture to be delivered at 8:00 p. m., by an outstanding engineer. A complete demonstration will accompany the lecture.

The Exhibition Hall in the Stevens where the 1940 Radio Parts National Trade Show will be in progress will be open throughout the entire day from 10 o'clock in the morning until 10:00 p. m.

Cleveland

Cleveland Chapter is well on its way with their Spring meetings and have a rather heavy schedule ahead with the recent acquisition of G. E.'s television course. It is the aim of the technical papers committee to devote some time each meeting to the subject of Television and its ramifications.

L. Vangunten, Reporter

Danville

Television instruction started April 12, and there was much discussion as to how it should be handled. A campaign was also started to eliminate local radio interference, in cooperation with the local newspaper,

broadcasting station and the power company.

Carl Stapp, Secretary

Newark

The Newark Chapter has been quite busy, of late, with preparations for taking an active part in the Joint Industry Promotion Campaign under the Guaranteed Service Plan. Committees have been so occupied that we have had to forego several of our technical meetings.

Philip C. Sanguinetti

Stuebenville

The membership of the Stuebenville Chapter wish to offer to Mr. and Mrs. Richard Harris their deepest sympathies on the death of their first-born child. Our sincere hope for Mrs. Harris' speedy recovery.

Mrs. Emma Levinson deserves a vote of thanks for the delicious spaghetti dinner she served after the meeting April 16. We all had an exceptionally enjoyable time.

Leonard Roberts Jr., Secretary

THANK YOU DISTRIBUTORS

We appreciate the hundreds of new subscriptions to SERVICE that you have been sending in. To have your service customers read the magazine each month means that they will keep fully acquainted with all new technical developments in the industry. Advertising, too, will influence their buying habits and create a greater demand for those nationally advertised lines you carry. Keep up the good work.

TRADE SHOW

THE Radio Industry Special, carrying Eastern Radio Trade Representatives to the Show, will leave New York City on Sunday

afternoon, June 9, and arrive in Chicago Monday morning, June 10.

As in previous years, the party will leave the train at Englewood, Chicago, and go to the Stevens in a caravan under motorcycle escort.

Anyone desiring to join the party on the Special should contact Perry Saffler, 53 Park Pl., New York City, Rector 2-5334.

Reports received from all sections of the country indicate that the attendance at the Show will exceed that of former years.

Every available booth is already under contract. Of the 169 booths 160 of them will be occupied by 128 manufacturers, while the remaining 9 booths will be occupied by trade papers and associations that participate in the Show activities.

This is the first time in the history of the Trade Show that the space has been entirely taken up so far in advance of the opening date. It presages a Show that will surpass the record exhibitions of the past years.

A Radio Veterans Organization will be formed at the time of the Show. The formation of this Old Timers Club has been under discussion for more than two years, but, during recent weeks, John Olsen, a manufacturer's agent in Pittsburgh, started the ball rolling to get the Club formed this year.

Definite plans will be announced in the Trade Show Directory and Program. It is not anticipated that the club will engage in any particular activities at the 1940 Trade Show, but will lay plans for a general get-together of those who have been engaged in Radio, in a commercial way, for fifteen years or more at future Trade Shows.

It is believed that these reunions of the Old Timers will be of considerable interest. Watch for the announcement at the Show.

D. R. Bittan, President of "The Representatives," announced a change in the scheduled meeting of the organization. Plans are being made for a luncheon meeting, but the exact time is not yet available to manufacturers' agents.

Mr. Radio Serviceman:
WE WANT TO SEE YOU -- At the 3rd Annual RSA Convention • June 14 • Stevens Hotel • Chicago

- ★ Meet leading figures in the industry.
- ★ Attend Technical lectures in each subject.
- ★ Hear and See the F. M. Lecture and complete Demonstration.
- ★ Attend the R. S. A. Extension School to be held Friday 2:00 to 5:00 P.M., June 14.

- ★ R. S. A. is the only national organization for radio servicemen, and is accepted and endorsed throughout the industry. The R. S. A. record of achievement is noteworthy. Meet with us and hear our plans for the future.

Write for Your Advance Copy of the Program of the 3rd Annual RSA Convention

MAIL THIS COUPON NOW!

RADIO SERVICEMEN OF AMERICA, INC.
304 S. Dearborn St., Chicago, Ill.

Name

Address

City State.....

I am interested in R.S.A. Membership. Tell me about it.

I am enclosing \$4.00 for National dues and initiation. Covers dues up to Jan. 1, 1941.....

(Does not include Local Chapter dues where Local Chapters are organized.)

S 540

*Let's Grow Together
in 1940!*



**RADIO SERVICEMEN
OF AMERICA, Inc.**

JOE MARTY, JR., EXECUTIVE SECRETARY
304 S. DEARBORN STREET, CHICAGO, U.S.A.

BELDEN PROMOTION

Whipple Jacobs, president of Belden Manufacturing Co., Chicago, announces the election of Herbert W. Clough as vice-president in charge of sales. Belden manufactures antenna kits, wire and cable.

SIMPSON ANALYZER

For measuring electrical loads in servicing or production testing, Simpson Electric Co., 5216 W. Kinzie St., Chicago, announce a new kit set, 3 small matched



meters in a portable carrying case. This kit set is an outgrowth of Simpson's new line of 9 Micro testers and is available in combinations to measure current, voltage and resistance for practically every requirement, it is said.

Additional information may be obtained directly from Simpson.

SPRAGUE MOUNTING STRAP

The Sprague Type ST metal mounting strap, supplied free with the purchase of Sprague condensers, is said to be strong enough to hold any combination of Sprague Atoms into one compact assembly. This provides an answer for those hard to get exact duplicate replacements where different capacities and voltage ratings are required in a single unit.

A new Sprague catalog showing this development in detail can be obtained directly from Sprague Products Co., North Adams, Mass.

PHILCO ADAPTOR

Philco has recently announced an adaptor for testing tubes of the new high vol-

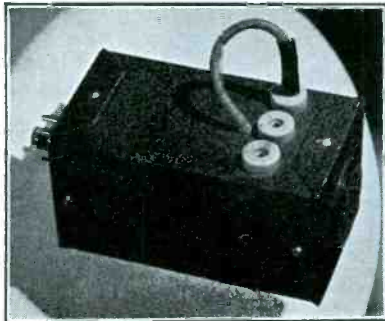

tage types; such as, 117-Z6, 70-L7, etc. The adaptor provides filament voltages of 50, 70, and 117 volts. These different ranges are obtained by means of pin jacks which can be inserted in the proper position to provide the correct filament voltage

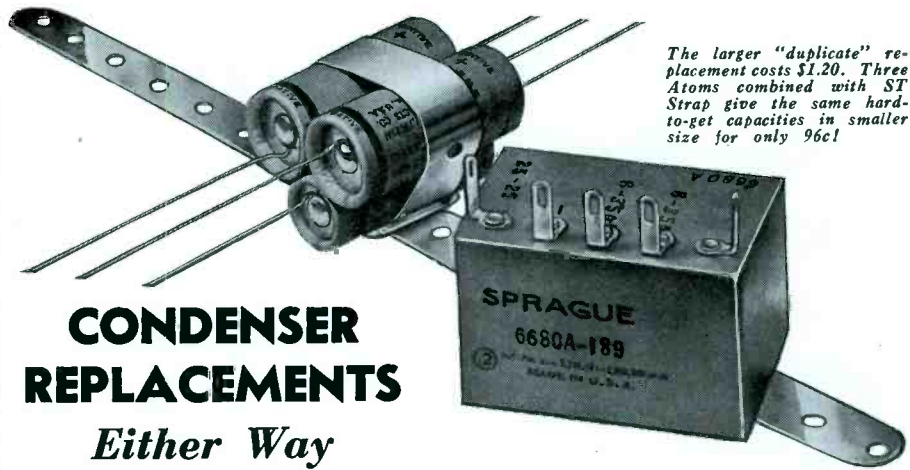

The larger "duplicate" replacement costs \$1.20. Three Atoms combined with ST Strap give the same hard-to-get capacities in smaller size for only 96¢!

CONDENSER REPLACEMENTS
Either Way

It pays to try Sprague for any exact duplicate condenser requirement. As leading suppliers to the largest set makers, we can supply almost any needed unit promptly—and identical to the original specifications.

But don't forget, you can save on most hard-to-get replacements, simply by combining several Sprague Atom midget dries. Just strap 'em together (see picture) with Sprague ST Mounting Straps—supplied free—and you have a smaller, better unit and actually at less cost than an exact duplicate! Using ST Straps, you can make up almost any combination of capacities and voltages using standard Sprague Atoms stocked by every Sprague jobber. Big new catalog of Sprague Condensers and Koolohm Resistors FREE.

NEW MANUAL ON RADIO INTERFERENCE

Just the book you've been looking for. Complete—fully illustrated—tells what to do, how to do it to eliminate all types of man-made radio noise. 25c net.



SPRAGUE

CONDENSERS
KOOLOHM RESISTORS
TEST EQUIPMENT

SPRAGUE PRODUCTS CO. NORTH ADAMS, MASS.

for the tube under test. Additional information may be obtained directly from Philco Radio & Television Corp., Tioga & C Sts., Philadelphia, Pa.,

BRACH ANTENNA KITS

L. S. Brach Manufacturing Corp., Newark, N. J., have announced two new antenna kits. By means of automatic iron-core self-selecting frequency transformers, the antennas may be used on broadcast, standard short-wave and frequency-modulation channels, it is said. The FM12AR kit is of the dipole type, and the FM6VR is of the vertical type. Both kits are supplied with upper and lower couplers and a new type low loss transmission line. Additional information and prices may be obtained directly from Brach.

SOLAR CAPACITOR ANALYZER

The Solar Model QC capacitor analyzer checks condensers while they are at work



in the circuit, it is said. The Model BQC, in addition, incorporates a Wein bridge which gives separate capacity measurements from 0.00001 to 70 mfd. Complete data on these

and other Solar products may be obtained by addressing Solar Mfg. Corp., Bayonne, N. J.

WEBBER TUBE TESTER

Earl Webber Co., 1313 W. Randolph St., Chicago, have added the model 150 low-priced tube tester to their line of service test instruments. A complete technical description of this and other Webber instruments may be secured directly from Webber.

PLUG-IN ELECTROLYTIC

A plug-in electrolytic condenser which permits removal for testing or replacement, has been made generally available by Aerovox Corp., New Bedford, Mass. Developed primarily for the U. S. Signal



Corps, the plug-in unit has offered advantages in aircraft, police-radio and sound systems where continuity of service is of paramount importance.

Plug-in electrolytics are available in either etched foil or plain foil in a wide variety of capacity and voltage ranges.

OHMITE

Brown Devils

stand by you

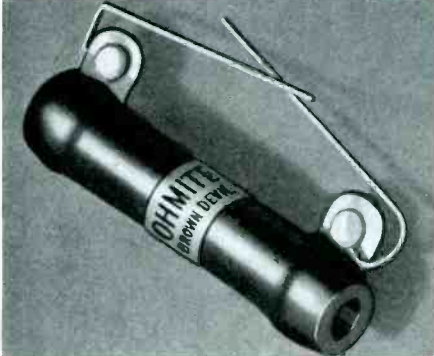

Thru thick and thin—you can depend on these popular, extra sturdy Brown Devils to “Stand the gaff!” Time-proved, wire-wound resistors for voltage dropping, bias units, bleeders, etc. Permanently protected by Ohmite Vitreous Enamel. 10 and 20 watt sizes; resistances from 1 to 100,000 ohms. See your jobber.

Visit Ohmite Booth 119 at the Radio Trade Show

MAIL COUPON

OHMITE MANUFACTURING CO.
4878 Flournoy Street, Chicago, U. S. A.
SEND FREE CATALOG 17

Name
Address
City State



WHEN YOU CHANGE YOUR ADDRESS

Be sure to notify the Subscription Department of SERVICE at 19 E. Forty-seventh St., New York City, giving the old as well as the new address, and do this at least four weeks in advance. The Post Office Department does not forward magazines unless you pay additional postage, and we cannot duplicate copies mailed to the old address. We ask your cooperation.

Index to Advertisers

	Page
A	
Aerovox Corp.	22
Amperite Co.	Third Cover
C	
Centralab	27
Clarion Institute of Sound Engineers	24
H	
Hygrade Sylvania Corp.	27
J	
Jensen Radio Mfg. Co.	1
K	
Ken-Rad Tube & Lamp Corp.	28
M	
Mallory & Co., P. R.	Second Cover
N	
National Carbon Co., Inc.	3
National Union Radio Corp.	4
O	
Ohmite Mfg. Co.	32
P	
Precision Apparatus Corp.	16, 17
R	
RCA Mfg. Co., Inc.	23, Back Cover
Radiart Corp., The.	32
Radio City Products Co., Inc.	26
Radio Parts National Trade Show..	11
Radio Servicemen of America, Inc..	30
Readrite Meter Works.	32
Rider, John F., Publisher.	21, 28
S	
Solar Mfg. Co.	28
Sprague Products Co.	31
T	
Transformer Corp. of America.	24
Triplett Elec. Inst. Co., The.	20
U	
United Transformer Corp.	19
Utah Radio Mfg. Co.	25
W	
Ward Products Corp., The.	29
Y	
Yaxley Mfg. Division.	Second Cover

RADIART AERIALS
The Line that has EVERYTHING
Get Aerial Catalog 640-B
Vibrator Catalog 5540
THE RADIART CORP. CLEVELAND



Big Value...
TUBE TESTER COMBINATION

ONLY
\$26.85
DEALER NET

With RED DOT Lifetime Guaranteed Meter



Readrite RANGER

MODEL 432-A-742
The new 1940-41 Line of Readrite Meters and Testers Will Be Displayed in Booth 618 — Chicago Radio Parts Show

- Model 432-A-742 is a combination Tube Tester and Volt-Ohm-Milliammeter.
- Complete Volt - Ohm - Milliammeter, 16 Ranges • Sockets for All Tubes • Filament Voltages from 1.1 to 110—A Safeguard Against Obsolescence • Precision Indicating Instrument with Two Highest Quality Sapphire Jewel Bearings • Separate Line Control Meter • Neon Shorts Test • Approved RMA Circuit • Portable Black Leatherette Covered Case—Professional in Appearance. Etched Panel. Complete, less batteries . . . \$26.85 . . . Dealer Net Price.

Write for Catalog! Sec. 517 College Ave.

READRITE METER WORKS, Bluffton, Ohio

AMPERITE Announces the **BIGGEST ADVANCE**
in the Dynamic since its Inception!

P.G.
PRESSURE GRADIENT
DYNAMIC

- **UNI-DIRECTIONAL.** NEW SUPERIOR ELIPSOID PICKUP PATTERN
- **ELIMINATES FEEDBACK TROUBLE** BECAUSE IT HAS LOWEST FEEDBACK POINT OF ALL DIAPHRAGM TYPE MICROPHONES
- **FLAT RESPONSE.** FREE FROM ANNOYING PEAKS, GIVING STUDIO-QUALITY REPRODUCTION.

The P.G. diaphragm follows air particle velocity where amplitude is a GRADIENT of the PRESSURE. In ordinary dynamics amplitude is restricted from following air particle velocity.

The P.G. DYNAMIC is a radical improvement in this type of microphone. You can actually hear the difference. Case is designed according to modern acoustic principles. Rugged, not affected by temperature, altitude or humidity. **HAS UNUSUALLY HIGH OUTPUT, -55 DB.**

MODEL PGH (PGL, 200 ohms). Excellent for high fidelity P.A. installations, broadcast studio, and professional recording. With switch, cable connector, 25' cable. Chrome finish, LIST \$32.00 (40-10000 C.P.S.)

MODEL PGAH (PGAL, 200 ohms). For speech and music. 70-8000 C.P.S. Switch, cable connector, 12' cable. Chrome, LIST \$25.00

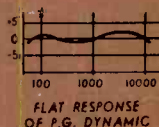

COMBINATION VELOCITY-DYNAMIC ACHIEVED WITH ACOUSTIC COMPENSATOR

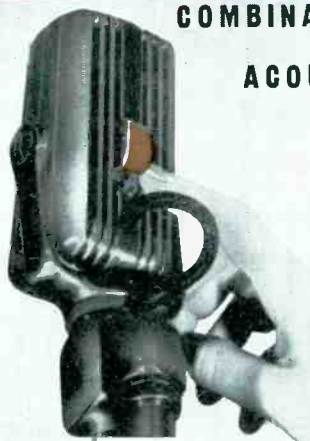

An exclusive Amperite feature: By moving up the Acoustic Compensator you change the AMPERITE VELOCITY to a DYNAMIC microphone without peaks. At the same time you reduce the back pick-up, making the microphone practically UNI-DIRECTIONAL.

WITH ACOUSTIC COMPENSATOR: MODEL RBHk; RBMk (200 ohms) with switch, cable connector. Chrome, LIST \$42.00

RSHk; RBSk (200 ohms). Switch, cable connector, Acoustic Compensator. Chrome or Gunmetal. LIST \$32.00

AMPERITE KONTAK MIKE
Puts Musical Instruments Across



So beautiful is the tone produced with the Kontak Mike, that it was used in the Philadelphia Symphony to amplify a mandolin solo. Gives excellent results with any amplifier, radio sets, and record players.

- MODEL SKH (hi-imp) LIST \$12.00
- MODEL KKH, with hand volume control. LIST 18.00
- Plug extra List 1.50
- FOOT PEDAL, for making beautiful crescendos LIST 12.00

WRITE FOR FREE SALES AIDS

AMPERITE Co. 561 BROADWAY, N. Y. U. S. A.

Specify **AMPERITE** 

PROFITABLE ANSWER

TO THOSE



HEADACHE JOBS!

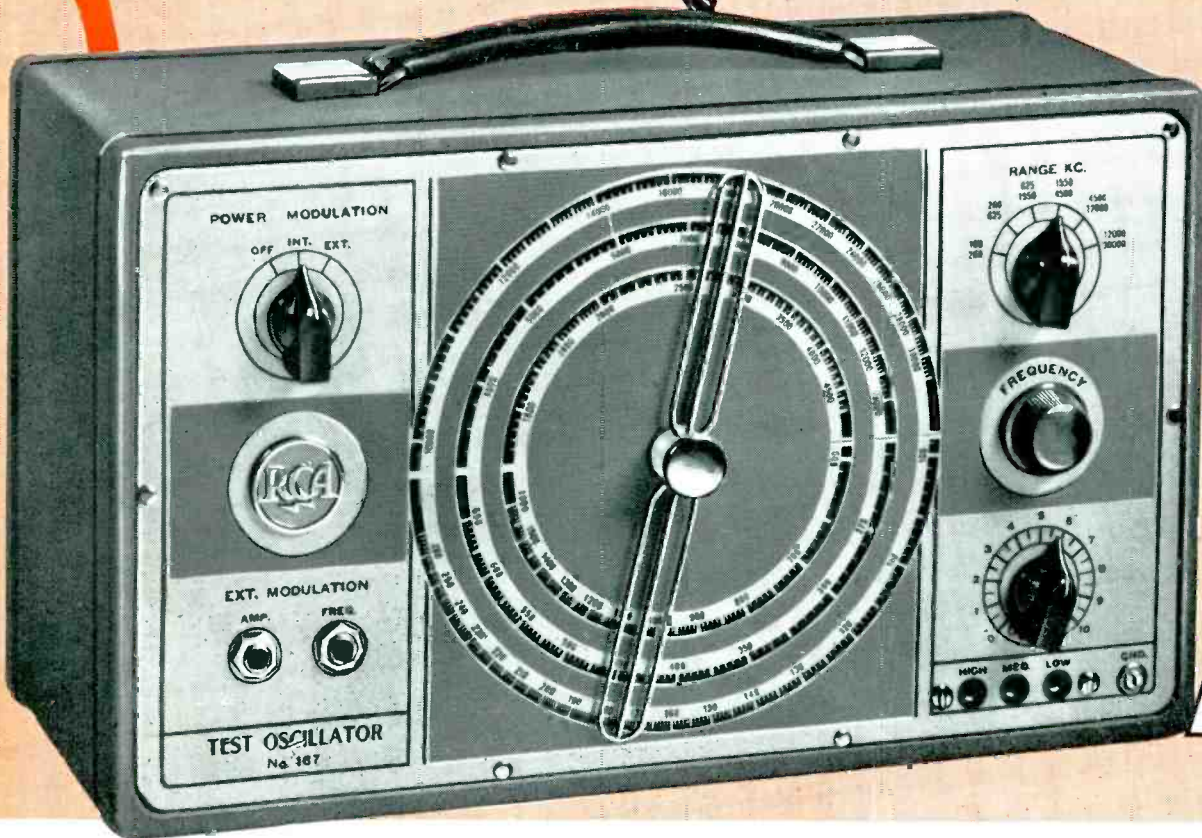

ACCURATE, EASY-READING DIAL

1.0 VOLT R. F. MAXIMUM OUTPUT

100-30,000 K. C. FUNDAMENTALS

Check These RCA Value Features!

- ✓ 6 Ranges: 100 to 30,000 K. C.
- ✓ Harmonics of 6th Band for U. H. F.
- ✓ Metal Tubes; Compact, Stable
- ✓ 400-cycle 8-volt Audio
- ✓ Internal Modulation
- ✓ Snap-up Handle
- ✓ Complete Shielding
- ✓ Jack for External Modulation—both Frequency and Amplitude
- ✓ Precision, new-type Dial
- ✓ 2% Accuracy
- ✓ Smooth, Wide-range Attenuation

Over 335,000,000 RCA radio tubes have been purchased by radio users... in tubes, as in parts and test equipment, it pays to go RCA ALL THE WAY.

NEW RCA TEST OSCILLATOR No. 167

Easy to Look at...to Use...to Own!

DO MODERN, complex receivers make you rant and rave? Go modern yourself—with this modern new test-oscillator that makes the tough jobs simpler! Full 100-30,000 K.C. fundamental range. Harmonics of sixth band for ultra-high-frequency testing. Its 1.0 Volt R.F. maximum Output permits single-stage alignment—and easy adjustment of sets misaligned completely. Its brand-new big dial scale makes settings and readings certain, accurate... The RCA No. 167 is easy to use!

It's easy to look at, too! Servicemen who are good business men appreciate the No.

167's trim, professional appearance. Its blue-grey wrinkle-lacquer case and attractively reverse-etched, brushed chrome panel will help impress customers—build up their confidence in you.

Best of all, it's easy to own! At only \$34.50, the No. 167 is a sound, money-saving investment for the years to come. Minimized Obsolescence—because it's made by the men who know the trends in receivers. Ask your jobber to show you—you'll agree that the No. 167 is a honey.

\$34⁵⁰
with output cable



Test Equipment