

# SERVICE

A Monthly Digest of

# RADIO

and Allied Maintenance

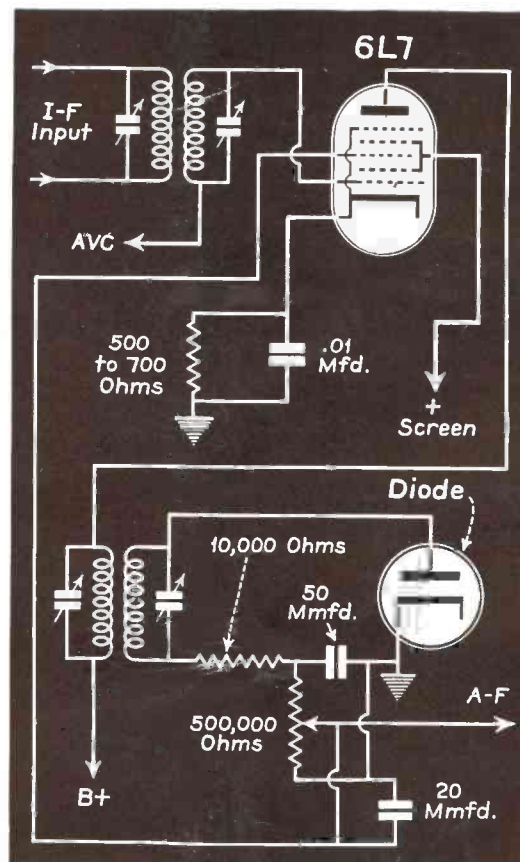

Unusual Connection  
for 6L7

(See page 34)

PER COPY  
25 CENTS

MARCH  
1938

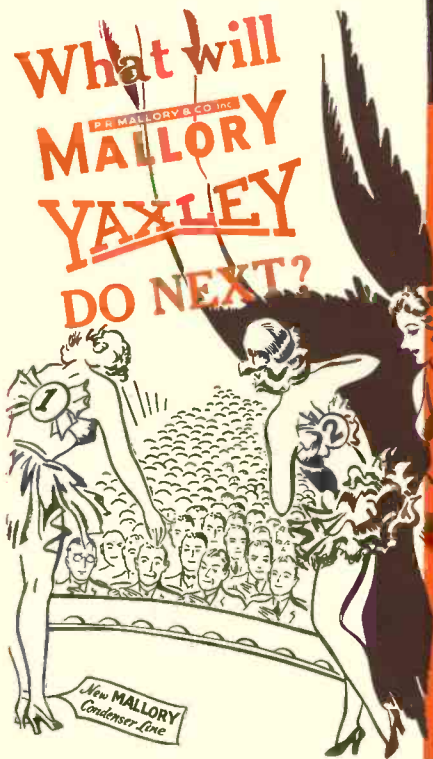

HERE'S ANSWER NO. 2

A complete new line of

P. R. MALLORY & CO. Inc.  
**MALLORY  
 YAXLEY**

**MIDGET  
 UNIVERSAL REPLACEMENT  
 VOLUME CONTROLS  
 with PLUG-IN SHAFTS**

(Pat. Applied For)

**NOW 56 New Volume Controls  
 give you the range of  
 over 1000 exact replacements**

Now—your problem of how to make a wide range of volume control replacements quickly and economically is definitely solved.

No large stocks to carry. No more delays that lose business and customer good-will! No more sending away for "exact replacement" controls you don't have when you need them.

Through the development of the new Yaxley Midget Volume Controls and the introduction of the new Yaxley Plug-In Shaft, Mallory-Yaxley offers the greatest advance in volume control servicing ever known in radio history.

Yaxley Midget Volume Controls—plain, single tap, double tap and duals—are available in resistance values from 5,000 ohms to 3 megohms inclusive and in all necessary tapers. They have flexibility—adaptability—universality—and snap-on switches! But—overshadowing all these advantages is the Yaxley Plug-In Shaft!

A single set of Yaxley Plug-In Shafts multiplies

the usefulness of any one of these controls by 17—or more.

**For Example**—10 new Yaxley Midget Controls plus 17 shafts give you the servicing equality of 170 ordinary Exact Replacement Controls with fixed shafts.

Now—let's go a step further! Multiply seventeen or more exact replacement possibilities by the fifty-six known basic type controls. To cover such a service range with fixed shafts (so-called "specials") would mean you would need *one* each of 952 individual controls. Yaxley Midget Volume Controls with Yaxley Plug-In Shafts provide the same service stock with only 56 controls and 17 Plug-In Shafts. And—the fact of the matter is that 90% of your replacements will be covered by about 12 of these 56 types of controls plus 6 or more of the 17 Yaxley Plug-In Shafts!

Now you can replace controls *exactly, easily* and *quickly* because Yaxley Plug-In Shafts reduce the required investment and multiply the usefulness of *every control* 17 (or more) times.

Order Yaxley Midget Volume Controls—and Yaxley Plug-In Shafts—from your distributor today!

● **WHAT WILL MALLORY-YAXLEY DO NEXT?**

*Watch for further important announcements!*

Use

P. R. MALLORY & CO. Inc.  
**MALLORY**  
 REPLACEMENT  
 CONDENSERS...VIBRATORS

**P. R. MALLORY & CO., Inc.**  
 INDIANAPOLIS INDIANA  
 CABLE ADDRESS—FELMALLO

Use

**YAXLEY**  
 REPLACEMENT  
 VOLUME CONTROLS

# SERVICE

A Monthly Digest of Radio and Allied Maintenance  
Reg. U. S. Patent Office. Member, Audit Bureau of Circulations

EDITORS

MARCH, 1938

Ray D. Rettenmeyer

W. W. Waltz

VOL. 7, NO. 3

## EDITORIAL CONTENTS

<b>FEATURES</b>	<b>HIGHLIGHTS</b> .....	46
A "Break" for Service Men.....	10	
*"Fading" By James J. Reeves.....	5	
<b>ANTENNA</b> .....	2	
<b>ASSOCIATION NEWS</b> .....	36	
<b>AUTO RADIO</b>		
*Nash-Philco N-1514.....	19	
*Trav-Ler 710, 711.....	20	
<b>FRONT COVER DIAGRAM</b>		
Unusual Connection for 6L7.....	34	
<b>GENERAL DATA</b>		
*Howard 318 and 325.....	12	
*RCA Victor 94X, 94X1, 94X2.....	15	
*Zenith 9S (204, 232, 242, 244, 262, 263, 264) (Chassis 5905).....	18	
	<b>MANUFACTURERS</b> .....	38
	<b>RECEIVER CASE HISTORIES</b>	
	Crosley 516.....	31
	G. E. 105.....	31
	Halsen 05.....	31
	Majestic 490.....	32
	Philco 600C.....	32
	Zenith 8S-154.....	32
	<b>SOUND SERVICE</b>	
	Some Acoustic Properties of the Velocity Microphone By A. Barbieri.....	22
	<b>TEST EQUIPMENT</b>	
	Testing Ballast Tubes with the Electronometer	24

\* Indicates that a circuit accompanies the text.

BRYAN S. DAVIS  
President

JAS. A. WALKER  
Secretary

Chicago Office—608 S. Dearborn St.—C. O. Stimpson, Mgr.  
Telephone: Wabash 1903

Published Monthly by the  
Bryan Davis Publishing Co., Inc.  
19 East 47th Street  
New York City  
Telephone: PLaza 3-0483



SANFORD R. COWAN  
Manager

PAUL S. WEIL  
Advertising Manager

A. GOEBEL  
Circulation Manager

Wellington, New Zealand—Tearo Book Depot.  
Melbourne, Australia—McGill's Agency.

Entered as second-class matter June 14, 1932, at the Post Office at New York, N. Y., under the Act of March 3, 1879. Subscription price \$2.00 per year in the United States of America and Canada; 25 cents per copy. \$3.00 per year in foreign countries; 35 cents per copy.

# THE ANTENNA . . .

## SOUND EQUIPMENT INSTALLATIONS NEED GOING OVER—NOW!

THIS IS the time of year when the owners and operators of outdoor amusement enterprises start to think about next summer's crowds and how they can be enticed to come and spend money. Last year's headaches are forgotten and ambitious plans are under way.

It is an ideal time to approach these people on the idea of checking over the sound systems with which many of these parks, swimming pools, dance halls, etc., are equipped. The system, in all probability, hasn't been used for months; it should be gone over and carefully inspected to see what is needed either in the way of repairs or perhaps modernization. Arrangements can be made with the operators to have the system set up, and then a complete test can be made.

In doing this, be sure to check such points as the lines between the amplifiers and the speakers—these may be more or less permanent and should be gone over carefully for shorts and opens. Also, contact points will have become dirty; speaker baffles may be warped or broken; amplifier parts (transformers, condensers, etc.) may be corroded due to exposure to dampness. These, as well as many others which are self-evident to the sound man, should be covered conscientiously.

On the modernization side can be suggested, increased power, additional speakers, compressor-expander units, and so on.

## USED CARS

THE WEEK of March 5th to 12th was designated as Used-Car-Week. Although no figures were available at the time this was written, it is safe to say that at the very least the country has become used-car conscious.

There are plenty of opportunities for Service Men in that field. We need hardly point out that any used car that is equipped with a receiver should have the set gone over before a new purchaser takes possession—the man to talk with is the one who has the car to sell. He wants to have his cars in as good condition as possible, and the car radio is such an essential these days that the dealer can't afford to let one go out without a check up. So there's one point on which to talk.

There is another, and perhaps even greater opportunity for work with the used-car dealer. The cost of a radio set, installed, doesn't add much to the overall price of the car—and above everything else, a radio in the car, *included in the selling price*, will aid tremendously in decreasing sales resistance.

Then, there is the ever-present possibility of obtaining a list of prospects from the dealers who have stocks of used cars and who are moving them. Even if the dealer doesn't want to consider radios for the cars while they are in his stock, knowing who bought the cars will give you the necessary entree so that your sales efforts can be directed toward those who have just bought some of these older cars—from a psychological standpoint alone, they may feel the need of something new, and a radio ought to fill the need beautifully.

## NOISE

IT WOULD BE interesting to know the percentage of all service calls in which the complaint is that every indefinite trouble, noise. Every Service Man in the country knows what a terrific source of headaches these complaints can be, especially as everything not easily understood by the average radio user is more or less automatically classified as noise.

So, the call comes in, "Noise." And the Service Man loads his instruments and goes out on the call, only to find that while he was on the way the set cleared itself. In a lot of cases, that's the end of it as far as the Service Man is concerned. The next time it happens, the user is going to figure that since it cleared up once, it'll do the same thing again.

Suppose, though, that the Service Man gets a chance to look over the set and make his tests; and suppose the noise turns out to be one of those things that no instrument or meter on earth will detect. Suppose further that on taking the set to the shop the trouble just can't be made to turn up. You return the set confidently explaining that it's quite OK—and then within a few hours, or even as long as a day or so you're called back and told a few things about yourself and your ability as a Service Man, none of them very complimentary.

The next time you find one of these things that can't be traced to anything—seemingly—try this. Get permission from the user to walk around the house or apartment, and while doing that keep a sharp lookout for electrical outlets to which lamps or appliances may be connected. While taking your walk, have the set operating. Examine every outlet, even to the extent of removing the metal or bakelite cover plate. Take an insulated screwdriver or aligning tool and poke around carefully inside the outlet box. Shake wires and examine terminal screws.

It is amazing, especially in the large cities where inspection of all electrical work is required by law, to find how many otherwise innocent-looking electric outlets are in bad condition. The same applies to the cords and plugs used with lamps and appliances; in many cases, the good old hairpin and adhesive-tape repair work is responsible.

Further inspection should be made of the house wiring if this is at all practicable. City inspections to the contrary notwithstanding, any number of cases can be found where the BX is poorly grounded—if at all—and where junction-box grounds are notable by their absence. Any one of these or similar points can raise enough racket in a sensitive receiver to make listening unbearable.

Service Men aren't supposed to be experienced electricians in addition to their other accomplishments, but it seems as though it might be necessary, in view of the above remarks. However, if you can definitely trace the noise source to the wiring system, let the owner of the building worry about it from that point. You can't be expected to correct a sloppy wiring job—and if you tried it you'd be sure to get in a jam with someone.

(Continued on page 44)

# The Dictionary TELLS IT BEST

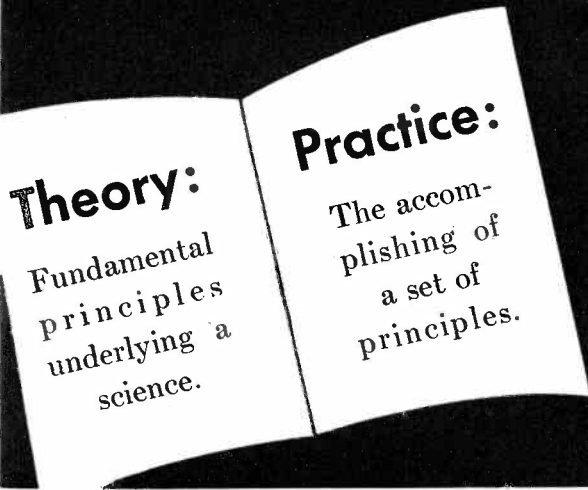

FIRST came theory, then practice. In the service industry successful practice depends upon a proper knowledge of theory. Theory is the root! Practice—the tree! Successful servicemen realize the advantages of learning theory first and are never troubled by new circuit changes or the complicated problems of modern service work. They depend upon Rider Books for basic theory and Rider Manuals for specific circuit information on American radio sets.

You Need Theory if you are to succeed in Practice . . . .

Rider Books ground you with a thorough knowledge of the basic theories underlying the ever-mounting number of new radio developments. They contain fundamental facts which will keep you ahead of radio, not forever catching up with it. No serviceman can afford to ignore the importance of

## RIDER BOOKS for theory

### The Cathode-Ray Tube at Work

With introduction of new, cheaper Cathode-Ray Tubes, this book is even more indispensable for its complete practical information on Oscillographs, etc. 336 pp. 450 ill. Price . . . . . \$250

**Servicing Superheterodynes** Changes, changes, changes! That has been the history of the superheterodyne circuit. Make repairs quickly by analyzing the different parts of the circuit quickly. Rider shows you how. 288 pp. profusely ill. Price . . . . . \$100

### Aligning Philco Receivers

This new book presents authentic and complete instructions for fast and accurate alignment operation on ANY Philco receiver. Every trimmer is located for you. 176 pp. Hard cover. Only \$100

### Servicing Receivers By Means of Resistance Measurement

Tells how to take guess-work out of servicing by using an ohmmeter. This method is in line with continuity data being furnished by set manufacturers. 203 pp. 93 ill. \$100 Price . . . . .

## "AN HOUR A DAY WITH RIDER" BOOKS

### ON RESONANCE AND ALIGNMENT

A clear, easily understood explanation of what happens when a circuit is tuned to resonance. You need this! 96 pp. 48 explanatory figures . . . 60c

### ON AUTOMATIC VOLUME CONTROL

In Rider's personalized style. Check-full of information to make your AVC work easier—more profitable. 96 pp. 65 ill. Hard covers . . . . . 60c

### ON D.C. VOLTAGE DISTRIBUTION IN RADIO RECEIVERS

Theory and practice of d-c voltages—how they are led through various types of networks to the tube elements—calculation of resistances, etc., etc. 96 pp. 69 ill. Hard covers . . . . . 60c

### ON ALTERNATING CURRENTS IN RADIO RECEIVERS

Illustrated with drawings and diagrams. . . . . 60c

## RIDER MANUALS for practice

For practical application of your knowledge, Rider Manuals are indispensable. The eight volumes contain complete and authoritative circuit data on American-made radios and are in every-day use by thousands of servicemen as a time-saving and profit-making guide through the most complicated receiving sets. They form the most comprehensive compilation of service data available to the industry, indexed and cross-indexed to guarantee finding desired information in the least possible time.

### VOLUME VIII—COVERING 1937-1938—\$10.00

1650 pages, plus 128-page index, plus 64-page "How It Works" section.

Rider Manuals are a part of any successful service business. Make sure you have all eight. If not, order the missing ones today.

- Vol. VIII—\$10.00—1937-38
- Vol. VII — 10.00—1936-37
- Vol. VI — 7.50—1935-36
- Vol. V — 7.50—1934-35
- Vol. IV — 7.50—1933-34
- Vol. III — 7.50—1932-33
- Vol. II — 7.50—1931-32
- Vol. I — 7.50—1920-31

### ORDER TODAY

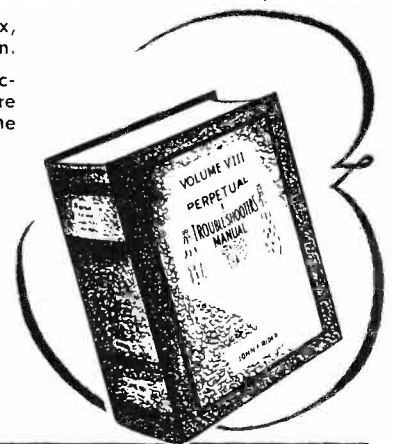

**JOHN F. RIDER, Publisher**  
1440 Broadway, New York, N. Y., U. S. A.

YOU NEED ALL 8  
*Rider*  
MANUALS

# THE SWEETEST CONDENSER EVER DEVELOPED FOR THE SERVICEMAN!

CARRY A CARTON  
OF TEN TO TAKE CARE  
OF EVERY SERVICE  
*Requirement*



THE C-D  
<sup>36</sup> *Beaver* <sup>99</sup>  
TYPE BR ETCHED  
FOIL ELECTROLYTICS

Type BR etched foil electrolytic capacitor is the smallest... and just about the "sweetest"... filter condenser ever developed. Study these features and see if you don't agree that the smart thing to do is to carry a stock of ten "Beavers" with you.

- 1 SMALL... one-fifth the size of corresponding types for similar capacity and voltage range. Will easily fit into most confined space.
- 2 A cinch to hook-up. No mounting brackets, no pal nuts, riveting or similar assembly operations. Just wire in... as you would a tubular condenser. Avoid headaches, delays, and eliminate exact duplicates.
- 3 Both terminals carefully insulated; protective cardboard sleeve supplied with unit. Polarity clearly indicated. Hermetic seal assures long life.
- 4 Available in single capacity units only. Capacities 4, 8, 12, 16, 20 and 40 mfd., 150 volts, D.C., and up to 8 mfd., at 450 volts, D.C.

Ask your local C-D distributor to show you a handy carton of ten "Beavers." Now at EXCEPTIONALLY ATTRACTIVE PRICES.

Get set for maximum profits... Stock up with Type BR.

Cable Address: "CORDU"

**CORNELL**  **DUBILIER**  
**ELECTRIC CORPORATION**

1026 Hamilton Blvd., So. Plainfield, N. J.

# SERVICE

A Monthly Digest of Radio and Allied Maintenance

FOR MARCH, 1938

## "FADING"

By JAMES J. REEVES

PROBABLY THE MOST annoying time killer for the radio Service Man is the receiver with an intermittent condition. Be it spells of fading, distortion, hum or what have you, it takes anyone a certain definite time to locate.

But most vexing of all is the lengthy intermittent fader, which, after fading a few times in the shop, refuses to fade any more. After pounding on tubes, thumping on what-nots, and replacing all coupling and bypass condensers, the set is marched back to the customer, tongue in cheek, with the hope that "we got it." Procedure of this sort was fairly successful for the old-time sets, not a bad idea and usually didn't cost so much. For the more popular models, information and ideas could be had from "Service Hints" published in magazines and tube manuals.

### THE V-T VOLTMETER

Most Service Men, using the vacuum-tube voltmeter for the first time, and not knowing exactly what to expect, are disappointed in the seemingly crazy and irresponsible readings obtained, and consequently discard the meter as too sensitive for practical service work. Let's see what should be expected.

The modern Service Man, particularly if he has been a reader of SERVICE, should be fully informed on different vacuum-tube voltmeter circuits and how to calibrate them. A circuit that works well is illustrated in Fig. 1. A blocking condenser C1 and resistor R1 are used on all a-c measurements, the condenser to block any d-c voltages that may be in the circuit under measurement, and the

resistor to keep the grid circuit closed, making it possible to take r-f, i-f, or a-f voltage measurements across any circuit. While the 0.002 microfarad blocking condenser may seem to offer a large impedance when used on a-f circuits (200,000 ohms for 400 cycles), the amount of Xc voltage drop is negligible compared to the drop across R1 (4%). Keeping this condenser small lowers the condenser time charge across R1 when measuring a-c across high d-c voltages, so that excess current does not pass through the plate meter for too long a period; also, it is less likely to disturb the circuit when a set has faded.

It is advisable to use leads with small insulated alligator clips, keeping the length of the leads to about ten inches to keep the extra capacity as small as possible. A neat trick is to use a short

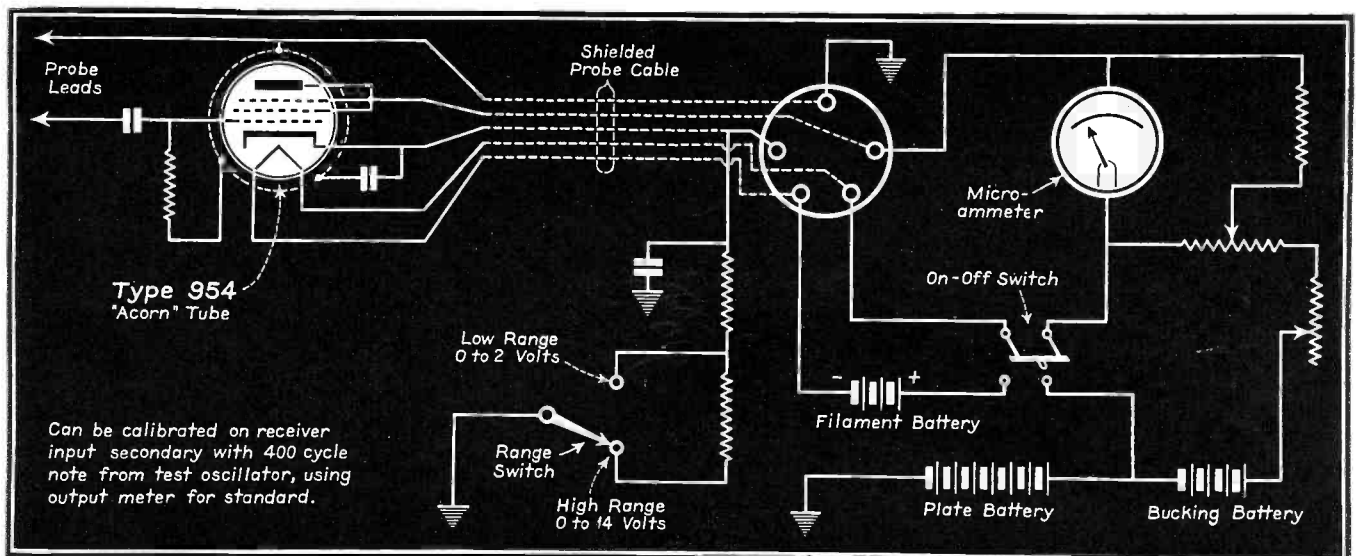

Fig. 1. Circuit of a vacuum-tube voltmeter of the type used for the measurements described in the accompanying text.



The test bench in the author's shop.

ground lead with a heavy clip to support the probe on the edge of the chassis and then lengthen the grid lead slightly, using a stiffer wire so the lead can be bent in an upward arc away from other wires. Now to proceed—

The customer's set is brought to the shop, extra care being taken with intermittent cases not to jar the set, for conditions should be exactly as in the customer's house. Nothing is tested, not even the tubes. The problem to be known, and known for peace of mind, is just what is defective. Too many times in the past has the Service Man, fussing around with testing this and that, temporarily cured the trouble without knowing it, thinking it was the last bypass replaced. A small electrical shock in some circuits will cure the trouble possibly for weeks, and then the set is bounced back by an irate customer.

#### LOCALIZING

Let's assume that the customer's set is a model 630X Philco. Wanting to know whether the trouble lies in either the a-f, i-f, oscillator or r-f section, the probe lead is placed to measure the rectified output of the diode plates, in this case, across the diode load resistor. Connecting a modulated oscillator to the antenna post or lead-in transformer terminals (as used in customer's house), the output attenuator is adjusted until a fair deflection shows on the low scale of the vacuum-tube voltmeter—then await results. As soon as the set fades, notice the meter. If the needle stays steady, it of course would indicate that the set is performing satisfactorily up to that point and the trouble must lie after that point, or in the a-f section between the meter and speaker. If, on the other hand, the meter needle goes

down with the fade, that would indicate the trouble as being in any of the previous stages.

To eliminate the r-f and oscillator stages, merely connect the modulated oscillator output to the first detector grid, adjust the i-f output to a level that gives a fair reading on the low meter scale; again await results. If the needle goes down with the fade, the trouble is in the i-f section or its associated a-v-c system. If the needle remains steady, the trouble lies in either the oscillator or r-f stage.

Testing the oscillator is easy. Using the high meter scale, the probe lead can be connected to either of two places to get an indication of the oscillator voltage—either to the suppressor grid or No. 2 anode grid. Connecting to either place, it will be noticed that the extra capacity of the leads and internal capacity of the vacuum-tube voltmeter

tube detune the set considerably, and either the test oscillator or the set's gang condensers will have to be reset to hear the signal again. Watching the meter dial, if the needle drops with the fade the trouble is with the oscillator; if not, then there is nothing left to suspect except the r-f stage.

To double check this finding and test the r-f circuits individually, the test oscillator is left connected to the antenna circuit, connecting the probe lead to the first detector grid. On doing this, the volume will practically drop out because of the added capacity of the vacuum-tube voltmeter tube and leads, so the trimmer on that particular gang condenser will have to be adjusted to compensate for this. It will be found that the attenuator has to be turned quite high to get an indication on the low scale because of the a-v-c governing the gain of the r-f section. Again, results are awaited. When the needle goes down with the fade, it proves definitely that the trouble lies there. A fade in this stage or the oscillator stage is usually accompanied by tube noise hiss as the a-v-c on the i-f stages increases gain to try to compensate for the lower signal input.

Now that it has taken a maximum of four fades to find in which section of the set the trouble is, the same methods can be continued to find out what stage, and finally what part.

#### AUDIO

Suppose that on the first fade it is found that the trouble lies in the a-f section of the set. Connecting the meter probe lead to the plate circuit of the first a-f stage, it is found that the signal up to there is still steady with the second fade. Moving the probe lead quickly to the other side of the coupling

Fig. 2. Audio-amplifier circuit.

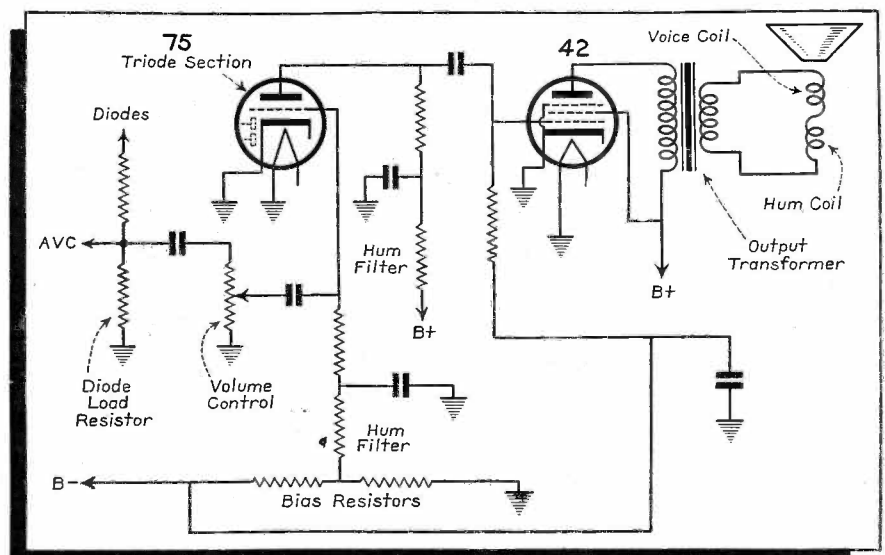



condenser, a reduction in signal is found. Knowing that a coupling condenser should transfer the full signal across to the next circuit, it is obvious that here is the trouble. With no guessing or doubting, the coupling condenser is replaced, resulting in the set being properly fixed.

A word of caution here! On a long fade, when transferring the meter probe from a plate circuit to a grid circuit, such as when testing coupling condensers, it is wise to discharge the meter probe coupling condenser to ground merely by touching the lead to ground, so that when you apply the lead to a grid circuit the discharge won't be applied across the grid and disturb the circuit; and vice versa, when changing from a grid circuit to a plate circuit, charge the meter coupling condenser to about the same potential as the plate by touching the lead to any point of the "B" supply.

Thus, testing in the audio section is an easy matter. Following the rectified signal through the amplifier with the meter probe, you can not help but run into a tube or part that ceases to help couple the signal along. If the signal fades in the plate circuit of a tube and the signal is steady to the grid of that tube, there is nothing else to blame but the tube or its cathode circuit. Replacing the tube for a check will determine which is at fault, or by placing the probe lead across the cathode condenser and resistor, if the needle indicates any a-f voltage at all when the set fades, it indicates that the bypass is not working properly and is at fault. If the trouble is a defective speaker voice coil, it will be noticed that the signal will increase considerably if the coil is opening (because of no-load condition across output secondary), or decrease considerably if the coil is shorting.



Telling the world (Staten Island) of Reeves service.

### I-F

In testing the i-f amplifier, it has to be determined whether the fault lies in the a-v-c biasing system or the amplifier itself. Since a defect in either circuit interacts upon the other to lower the signal, such as measured across the diode load resistor, the simplest and easiest method to determine which is at fault is to disconnect the a-v-c system altogether.

This is best done by disconnecting the a-v-c lead at the diode load resistor and reconnecting to some convenient chassis ground. In doing this, the grid return condensers and resistors are made part of the i-f amplifier, and any defect there will show up. In some a-v-c systems, part of the bias is taken from a tapped diode load resistor, so it should be made sure this lead is also removed and grounded. In making this test, the test

oscillator is connected to the grid of the first detector tube. If the signal can travel through the i-f amplifier now without fading, the trouble must be in the disconnected a-v-c.

But let's assume, however, that the signal did fail somewhere in the i-f amplifier. As a suggested procedure, follow the signal from the test oscillator through stage by stage with the meter until we come to a circuit where the signal fails. Investigation of the different parts with the assistance of the vacuum-tube voltmeter and an ordinary voltmeter, will disclose the trouble.

For instance, putting the meter probe on the first detector plate, it is found that the signal is steady on the first fade. Shifting the probe to the secondary grid circuit, the signal is still steady on the second fade. Again the probe lead is shifted, now to the plate circuit of the next stage, and here it is found that the signal goes down with the fade.

Figuring the possibilities that could cause the signal to drop in the plate circuit, there are several items that can be considered—defective bypass condensers, tube, voltage supply, or the primary circuit itself. When it is known what circuit the trouble is in, waiting for those fades to come along isn't so tiresome, as several of these tests can be made at the same time.

Testing a bypass condenser is easy. Put the meter probe to the circuit and when the set fades, if there is a reading at all it shows that the condenser is opening, and not bypassing the signal drop to ground; therefore, it should be replaced.

If the tube is suspected, tap it gently to see if it will make the set fade or come out of the fade. If a tube is defective enough to cause a fade without being annoyed, then it won't need much

Fig. 3. I-F amplifier.

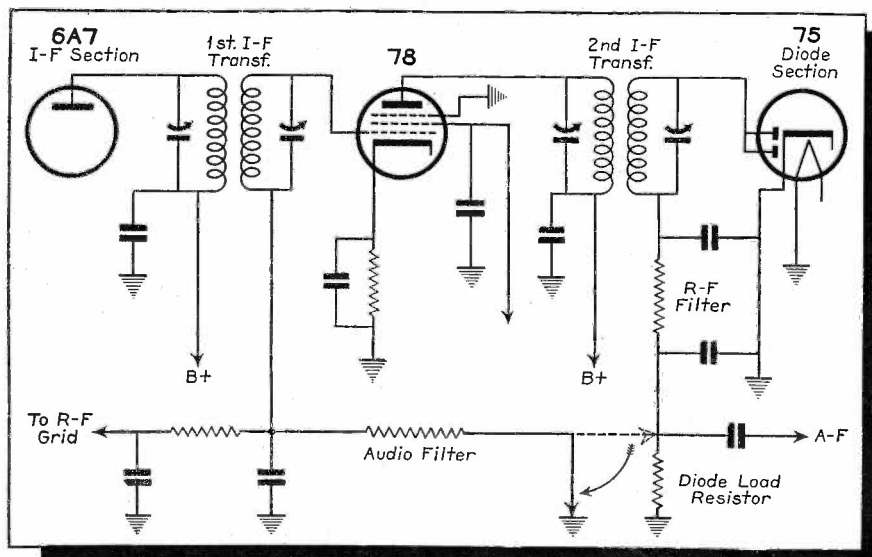

of a tap to cause more fading. Rough thumping here can cause temporary repairs, so take it easy. To be on the safe side replace with a new tube and see if the set fades any more, interchanging back and forth with the old one to see if it will fade only with the old tube and not the new. It is certainly surprising the number of new sets that have this type of trouble, particularly auto sets.

Voltage supply tests with an ordinary voltmeter at the prongs of the tube ascertain the continuity of resistors used in the power supply, at the same time indicating any shorted conditions. Also don't forget the filaments. As a suggestion, use alligator clips on the end of the test prods so that you won't have to hold them.

Testing the i-f primary coil and trimmer is a matter of connecting a very low scale d-c voltmeter with short leads across the combination. Readings obtained will vary from 0.2 volts to sometimes as high as 5 volts and must be watched very carefully for the slightest variation.

When the signal fades, watch to see whether the d-c voltage drops (indicating a shorting trimmer) or if the d-c voltage goes up (a poor soldered connection to the coil may be increasing the resistance thus broadening the tuning and lowering signal gain, or the coil itself may be defective). If the d-c voltmeter does neither then it's possible that the soldered connections to the trimmer are poor, causing it, in effect, to act as if open.

If the signal had been traced to a grid circuit and the trouble was found in that stage, although there are not as many possibilities, it can be investigated in the same manner.

#### SOME POINTERS

A point that can be brought out at this time will help trace trouble in grid circuits, is the fact that when measuring signal voltages across the primary of a transformer, be it i-f or a-f, if the secondary is intermittently opening, whether due to bad connections or de-

fective coil or trimmer in the tuned circuit, it reflects a higher or infinite impedance load to the primary circuit, thus boosting the voltage across that circuit. Thus if the signal shows a gain on the vacuum-tube voltmeter when measuring a primary circuit when actually the set is fading, the trouble can be in the secondary circuit.

It will be noticed that as the meter probe lead is put across any tuned i-f coil, the volume drops. This is not because the meter is materially robbing any power from the circuit, but because of the detuning effect of the added capacity of the leads and tube. It is best not to disturb the trimmers to compensate for this until the trouble has been found. Increasing the attenuator control on the test oscillator until an appreciable reading is shown on the meter is sufficient for testing.

Also when placing the probe lead across the first detector plate circuit you will get some odd crazy readings from r-f voltages present unless the oscillator voltage in the set is killed in some manner, such as gently shorting the oscillator gang condenser with a coin or pen-knife blade.

When testing through to the secondary diode coil or coils, there is considerable step-down in signal voltage from that measured on the primary, but since this is a step-down transformer, that is to be expected.

There is also an odd effect obtained when testing the first r-f filter condenser in the diode r-f filter circuit. It seems that whatever capacity is used there for r-f filtering is just sufficient for that purpose without robbing too much audio from the circuit. When the capacity of the probe and tube is added, audio signal is decreased. If this r-f filter condenser should open up (to cause a fade such as it did before) the volume will now increase again as the capacity of the probe and tube are just sufficient for r-f filtering.

#### A-V-C

If it had been found previously that

the trouble was in the a-v-c system, the a-v-c lead can be reconnected to the diode load resistor where it belongs so the set can be heard to fade while hunting for the trouble. Because the a-v-c is primarily a d-c voltage supply system, the fade must be for some d-c reason. So disregard the probe coupling condenser, either shunting it with a piece of wire or shifting the lead directly to the grid of the tube, thus making it a d-c measuring instrument with a very high impedance.

In testing the a-v-c system, the probe lead can be connected across the diode load resistor; adjust the test oscillator for a fair deflection on the low scale of the meter and read it as d-c negative bias. It will be noticed that the meter reads backward because of the negative voltage being measured, so either reverse the leads or adjust the meter so that it reads full scale with no signal (adjust with the plate bucking battery control) and then read backwards with the signal. Accuracy is not required as it's the indication that is looked for.

With the probe across the diode load resistor the meter is watched carefully as the set begins to fade. Knowing that

Fig. 4. A-V-C circuit.

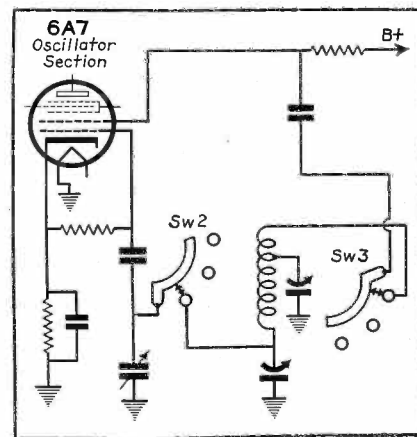
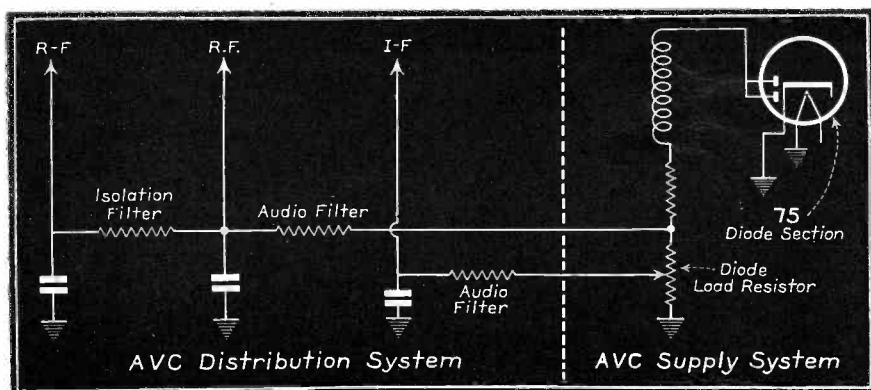

Fig. 5. Oscillator circuit.

the only way the a-v-c supply system in itself can make a set fade is by increasing the negative bias supply, if the meter shows a gain of negative bias when the set fades, the trouble can be localized to the supply circuit.

As a practical example, one of the older model Zenith sets uses a type 24A tube for a-v-c. The customer's complaint was erratic fading for at least an hour after the set had been turned on. Trouble was traced to the a-v-c circuit where the d-c bias was noticed to increase with the fade. Since this tube is operated at a low plate voltage, and hence on the erratic portion of its Ep-*I*p curve, it was thought perhaps a new tube, being more stable, would be the cure, but with no success. Curious further, the low range of an a-c voltmeter was placed across the filament and sure

enough the filament was varying from 2.3 to 2.45 volts. Investigation with a microammeter in the plate circuit showed an increase of from 10 microamps at 2.3 volts filament to 25 microamps at 2.45 volts. This varied the bias from 5 volts to 12.6 negative. Curing this was a matter of wiring in a more up-to-date though similar type of a-v-c system.

This type of trouble can also be traced to a defective a-v-c tube with erratic emission, or a change in load resistance, particularly with old and cheap volume controls used as a load resistance.

If, on the other hand, the negative bias decreases as the signal fades, the fault can be attributed as lying somewhere between the connection to the diode load resistance and the grid returns. Partial and erratic mending of leaky bypass condensers in the grid fil-

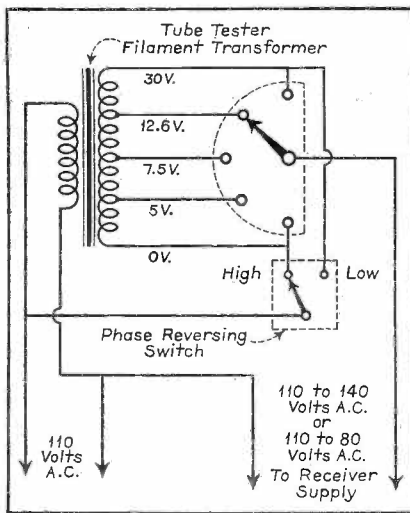

Fig. 6. Variable voltage supply system.

ter circuits and the a-v-c audio filter are the chief sources of trouble here.

This type of trouble can easily and quickly be located with the vacuum-tube voltmeter, particularly so when the set is not fading, as the condenser leakage is then greatest, causing the bias voltages applied to be less negative. As the condenser mends itself or opens temporarily, the drop becomes less and more of the negative bias is applied to the tubes, causing the fade. Moving the probe lead along the resistor-condenser network will show which is at fault, namely, that condenser having the lowest voltage across it.

#### OSCILLATOR

We can test the oscillator stage, as previously mentioned, by placing the meter probe across either the oscillator grid or No. 2 anode grid; if the generated voltage drops during the fade, we blame the oscillator circuit, of course.

Now, there are several things that must be understood about the oscillator before it can be serviced properly. First

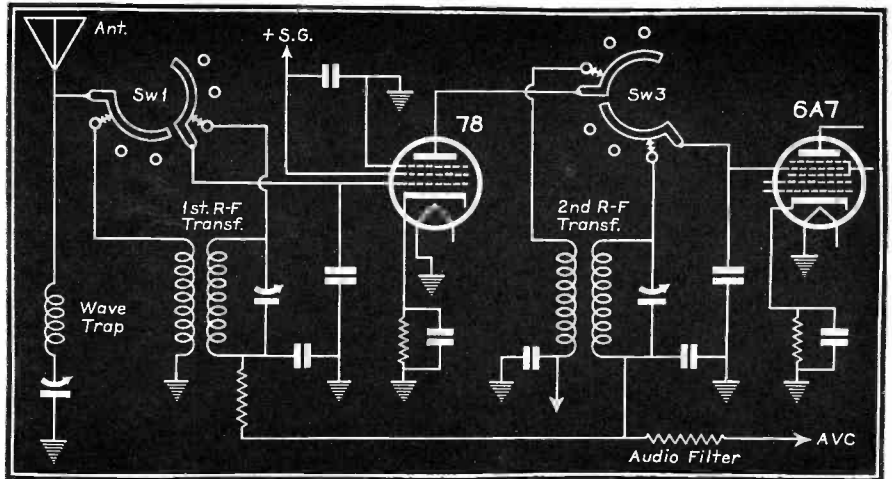

Fig. 7. R-F Amplifier.

of all, the oscillator tube should be regarded as primarily a triode regardless of whether the elements are included in the same glass envelope with another type tube or not (such as in pentagrid converter tubes where No. 2 anode grid can be considered as the plate of the oscillator and the suppressor grid as the grid of the oscillator circuit).

Because of the high voltage and close proximity of the anode grid to the cathode, considerable anode current flows unless the circuit is oscillating and thus providing negative bias to the grid (suppressor grid in type 6A7 tube). To keep the cathode emission down to a safe value if the circuit should stop oscillating or when the oscillator voltage developed is low, thus causing the negative bias on the grid to become less, a resistor of from 10,000 to 20,000 ohms is inserted in the anode grid circuit as a safety precaution so that when this anode current becomes high, the voltage drop across the resistor automatically regulates the current to a safe value.

Now, in the more up-to-date circuits this resistor is also used to shunt-feed the oscillator, that is, the r-f voltage drop across this resistor is fed to the oscillator circuit by a small r-f coupling condenser (250 micromicrofarad) so as to keep the high voltage away from the all-wave switching contacts, reducing arcing and dirty contacts. So if one of the older type oscillator circuits, where the high voltage passes through the switch contacts, comes in for service, a predominate trouble maker is these dirty and arcing contacts that with the slightest resistance will stop the circuit from oscillating, although "B" voltage may be measured on the anode grid.

A very low range ohmmeter is best used to check switch contacts, but do not put it directly across the contacts themselves as pressing against them to get good contact for the test prods will temporarily cure the trouble, sometimes. Follow the connecting leads out to the

other end and test from there. It isn't safe to turn the all-wave switch around, either, as when the broadcast contacts are made again the contacts may be making better than before and the set won't fade again for some time.

This type of trouble isn't so predominate in the shunt-fed oscillator circuits, but shouldn't be overlooked. Sometimes replacing with a newer tube will develop a slightly higher oscillator voltage that will temporarily override the resistance of these contacts and work, but not for very long. Unless the oscillator voltage drops or varies when the tube is jarred or tapped slightly it is best to leave the original tube in.

Another trouble, but infrequent, in the shunt-fed circuits, is the partial opening or opening of the r-f coupling condenser, thus reducing or cutting out the oscillator voltage. When this happens there is usually sufficient capacity left to couple the higher frequencies, so shifting the set dial quickly to the high end of the frequency band to see if the set will start oscillating again, will usually determine this trouble, or the condenser can be replaced temporarily for a trial.

Loose soldered joints and poor grounds are bad offenders. Tested with a low-range ohmmeter, a little wiggling on the wires will usually show this up. A frequent offender on some type sets is a bad gang condenser rotor ground. Again it is cautioned not to test directly, at the pointed suspected, with the ohmmeter, but at some remote point common to it. A good idea is to use alligator clips on the test prods to avoid pressing.

#### R-F

In testing the r-f amplifier, it is a good idea to disconnect and ground the common a-v-c lead. If any leakage had been in the a-v-c system up to this point, it would have showed up in the previous

(Continued on page 34)

# A "BREAK" FOR SERVICE MEN

**Service Men in areas covered by the REA are being given the opportunity to cooperate in getting radios into farm homes. Aside from participating in the initial sales, the increased servicing possibilities add an element of interest.**

IT WILL PROBABLY come as an extraordinary surprise to most radio dealers and Service Men throughout America that during the past two years the farmers of the nation have bought in the neighborhood of 120,000 cabinet radio receiving sets, and that the Government expects them to buy at least as many more during the fiscal year that ends on the last day of next June. If you are a radio dealer in a town that serves a rural community, and if you have not obtained your share of this business, it will interest you to know that the Government is ready and eager to help you get your share.

As a matter of fact, the Government, which has furnished the funds and the credit that have enabled the farmers to buy so many electrical radios, supplies the wherewithal on the condition that the radios be purchased in the vicinity of the farmers' homes. There is no hard and fast rule, and there is no absolute prohibition that interferes with the farmer's freedom of action in making his purchases, but the Government makes it clear that it strongly approves of the purchase of the merchandise and the servicing within 30 or 40 miles of the point where the farm is located. Obviously this policy has been adopted in order to spread widely and evenly over the nation the funds the Government is lending to the rural citizens.

Another interesting item, in these days of slump news, is the fact that this is the best year the farmers throughout the nation have had since 1929. Their total cash income exceeds nine billions of dollars, which is practically equal to their income in 1929, and the farm income in 1929 constituted an all-time high. This year the situation is even better than it was in 1929, because the farm income is more evenly distributed throughout the farm States of the nation than has ever been the case since the Department of Agriculture kept records.

It is plain, of course, that this market for radio receiving sets follows the installation of wiring for electricity by the REA—the abbreviation in Wash-

ington for the Rural Electrification Administration. A further antidote to "recession" blues should be the statement that the REA expects at least two million farm homes will be wired for electricity during the next eight years, and that the program of both public and private utilities is definitely organized for a minimum of installations of this number. Moreover, these two million homes will still leave four million farm homes, as presently enumerated, unsupplied with electricity; and the estimate does not take into account the natural increase in farm homes.

The officials of the Government have found that the farmer wants an electric radio receiving set almost as quickly as he wants the wiring brought into the house. It is a matter of record with the REA that between 70 and 80 percent of the farmers buy radios during the first four weeks after their houses are wired. If the farmer has any reluctance about buying, that hesitation is immediately attacked by the REA. Almost immediately after the house is wired the farmer receives a communication from the Government emphasizing the utility and value of the radio. The

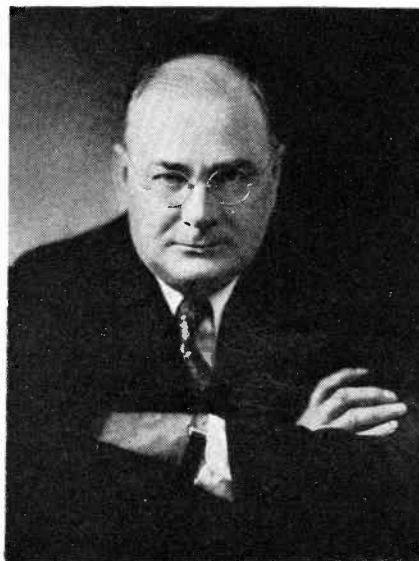

**JOHN M. CARMODY**  
Administrator of the Rural Electrification  
Administration.

announcement points out the varied high-class entertainment that is available, stresses the value of news programs, accurate crop reports, weather reports, the Farm and Home hour, the many home economics programs, and the multifarious programs offered by long and short wave. One exceedingly interesting sales argument offered by the Government is a scientific exposition by Department of Agriculture technologists demonstrating that a radio receiving set in a cow barn means more milk and richer milk. And it is interesting to discover from Government records that the battery sets, which hitherto have been the farmer's radio reception, are fixed on the tractors where they play while the farmer is at work in the fields.

Various parts of the Government help in bringing the radio receiving set to the farm home, but it all begins with the REA. This institution began business in 1935 with a fund of \$15,000,000, to which the RFC quickly added \$46,500,000. During the past year it received an additional sum of \$30,000,000. And for the next eight years it is scheduled to receive between \$30,000,000 and \$40,000,000 annually. The REA primarily was organized to bring electricity into farm homes which have been unable to secure service from the privately-owned public utilities. Where it is possible it hooks up its wires with existing utility facilities. But most of its operations have been initiated in connection with Government-sponsored plants. There are now 18 such generating plants in existence with 350 substations.

Aside from financing the wiring and transmission of electricity to farm homes, the REA may expend its funds and utilize its credit to install plumbing in the homes. It is not permitted to directly finance any other form of home improvement or equipment. But it works closely in cooperation with the Electric Home and Farm Administration, a Government unit created to provide many different kinds of facilities and improvements for the farm homes that utilize electricity to ease the labor of the farm

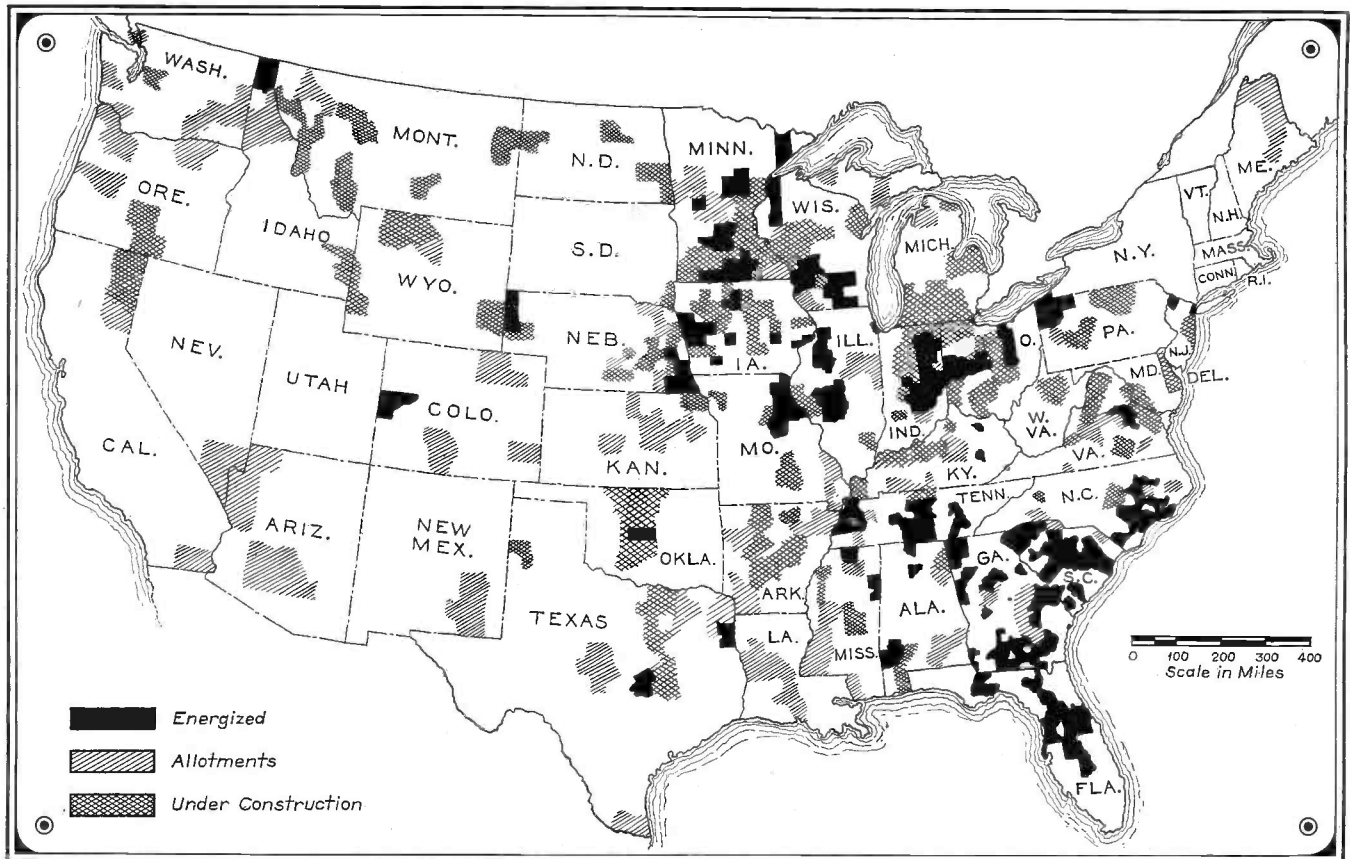

Map showing REA activities, proposed, under construction, or in service.

family. Its specific function is "to purchase conditional sale contracts or other evidences of indebtedness covering retail purchase of electric appliances. Funds for this purpose are obtained by the EFHA from private banks at standard commercial rates of interest. It may also borrow funds from the Reconstruction Finance Corporation.

"Small down payments (10 percent on radios), unusually low monthly payments spread over periods of from two to four years, a flat 5 percent financing charge, and the convenience of paying installments along with the electric service bill, make it possible for families in all brackets to buy."

The agreement between the EFHA and the utility, private or Government, provides that the utility, as agent for the Authority, shall collect the monthly installments. The utility is reimbursed for its service. In addition the utility may, if it elects, purchase the EFHA customer contracts from authorized dealers. That means dealers may present their retail customer sales contracts to the utility and receive cash for the unpaid balance. The funds, of course, are repaid to the utility by the EFHA.

If, for any reason, the utility cannot cash the dealer's sales contract the dealer, under a pre-arranged plan, may forward the customer contracts directly to the EFHA, and the EFHA will pay directly to the dealer the selling price

of the radio set, minus the down payment. In practically all cases the utility collects the unpaid installments.

All radio receiving sets to be financed under this plan must be approved by the EFHA. Manufacturers whose products have not yet been approved for financing, and who desire to participate, are welcomed by the EFHA at Washington. The principal requisite apparently is that the merchandise will be able to stand a rigid test. Radios thus far approved include: Continental, Admiral, Sonora, Aeronautic, Crosley, Emerson, Fairbanks-Morse, GE, Grunow, Gilfillan, Majestic, Arvin, Packard-Bell, Philco, RCA, Sparton, Stewart-Warner, Stromberg-Carlson, American Bosch, Westinghouse and Zenith.

Dealers, anywhere, wishing to obtain approval under the plan are requested to communicate with the Electric Farm and Home Authority at Washington, D. C. Application forms are forwarded to the dealer. These he executes in triplicate, and are validated by the EFHA promptly. The dealers are furnished by the Government, without charge, purchaser contract forms and time payment charts. It is obligatory to use these forms and to comply with these charts in order to sell the purchaser's contract to the EFHA.

The maximum contract periods applicable to radios are: for a radio priced at \$100 or less, 12 months; and for

radios priced over \$100, 18 months. The minimum down payment is 10 percent of the cost of the set. The minimum unpaid balance (retail price, less down payment) financed by the EFHA is \$40. The routine of purchasing and financing under the EFHA plan is not unlike any other plan of deferred payments. Service Men, radio dealers, department stores, any electric equipment shop, utilities, and all others who are in the business of retailing electric radios and other electrical appliances and supplies and services are qualified to participate in the program.

Both the REA and the EFHA have requested the correspondent of SERVICE to invite all radio distributors and manufacturers to become participants in the program. Upon request it will provide these merchandisers with regular notification of its activities. It will provide them with notice of all allotments for wiring six months in advance of the beginning of such work, and will send them approximately once every week a list of construction contracts closed. This service will be provided to readers of SERVICE without charge. It is obvious that this advance information about territories and individual customers, which are strong potential markets for radio receivers, is invaluable to the dealer and the Service Man who is up on his toes. Those who wish these ad-

(Continued on page 33)

# General Data . . .

## Howard 318 and 325

THESE RECEIVERS use the same model chassis, the difference being in the cabinets only.

Tuning: Manual

Ranges: 550-1700 kc; 1.7-5.5 mc;  
5.5-18 mc

Tubes:

R-F: 6K7

1st Det: } 6A7

Osc: } (2)

I-f: 6K7 (2)

A-v-c: } 6Q7G

2nd Det: } (2)

1st A-f: }

Ph Inv: 6J5G

Pwr Amp: 6V6G (2)

Rect: 80

Tun Ind: 6U5

Power Supply: 115 volts, 60 cycles.

I-f: 465 kc

Speaker: Electrodynamic

Field Res: 1000 ohms (when hot)

Phono Connection: Terminal board

### ALIGNMENT PROCEDURE

The following alignment instructions are given with the assumption that the Service Man has a signal generator

Fig. 2. Bottom view of chassis, Howard 318 and 325.

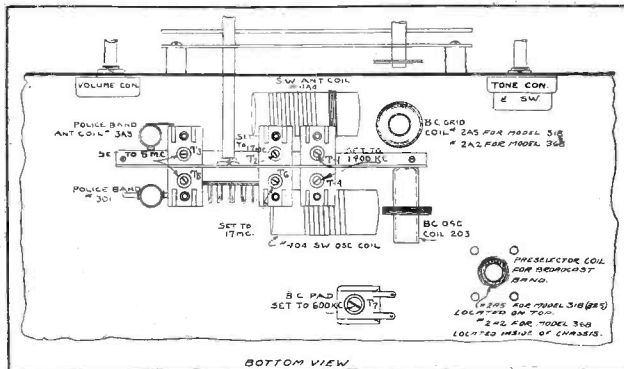

capable of accurately covering the range of the receiver.

The apparatus necessary in addition to a signal generator is a meter connected in the output stage to indicate resonance. This can be a 0 to 3 volt a-c meter connected across the voice coil of the speaker or an output meter connected in the plate circuit of the power tubes in series with an 8 mfd paper condenser.

465 kc into the grid of the 6A7 mixer tube.

The two trimmers in each of the i-f cans should be very carefully peaked to resonance as they are very critical and will greatly affect the performance of the set.

Always use as low an output as possible from the signal generator when making the various adjustments.

### I-F STAGES

The intermediate-frequency stages are aligned in the usual manner by feeding

### SHORT-WAVE BAND 5.5 TO 18 Mc

First check the position of the dial hand by rotating the condenser shaft to the left to full capacity. At this point

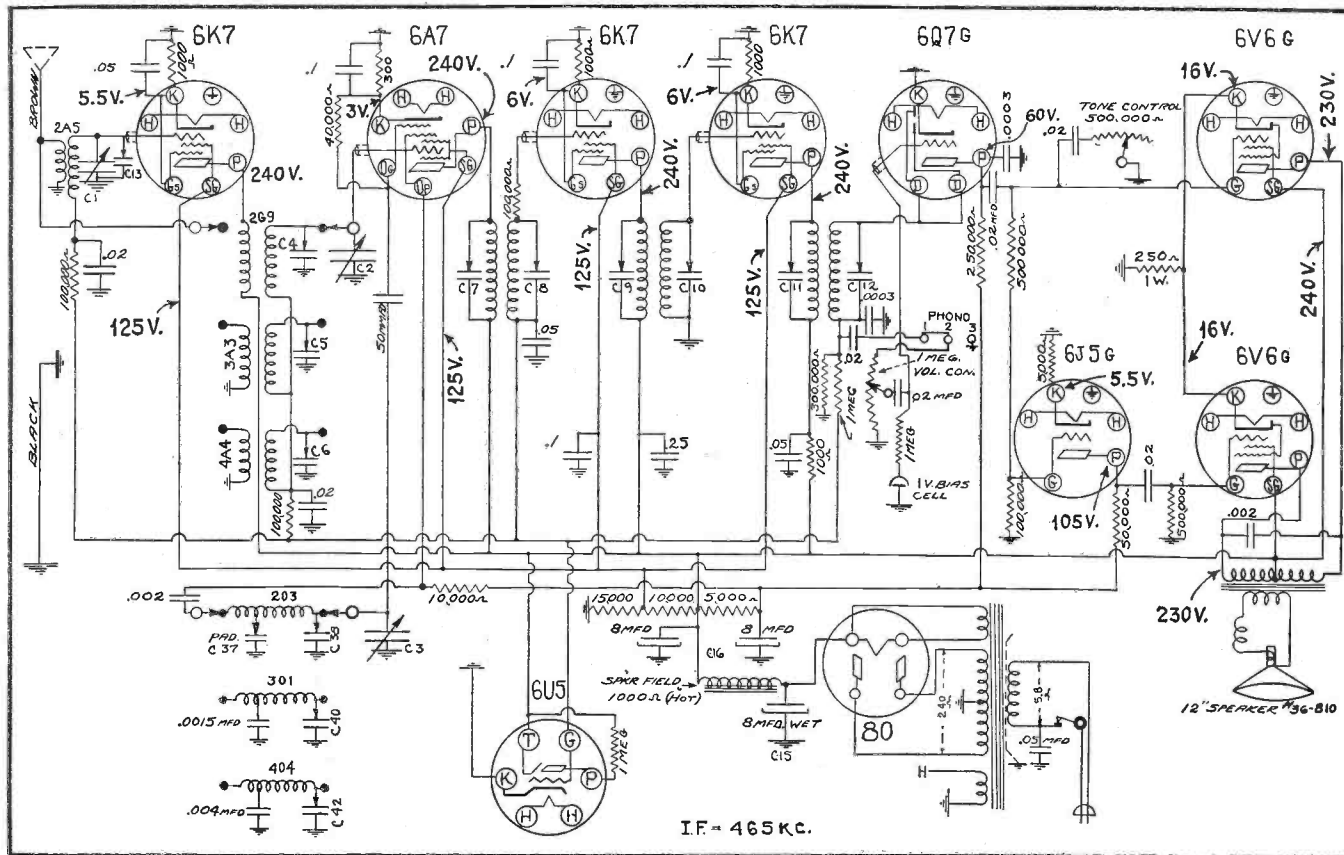
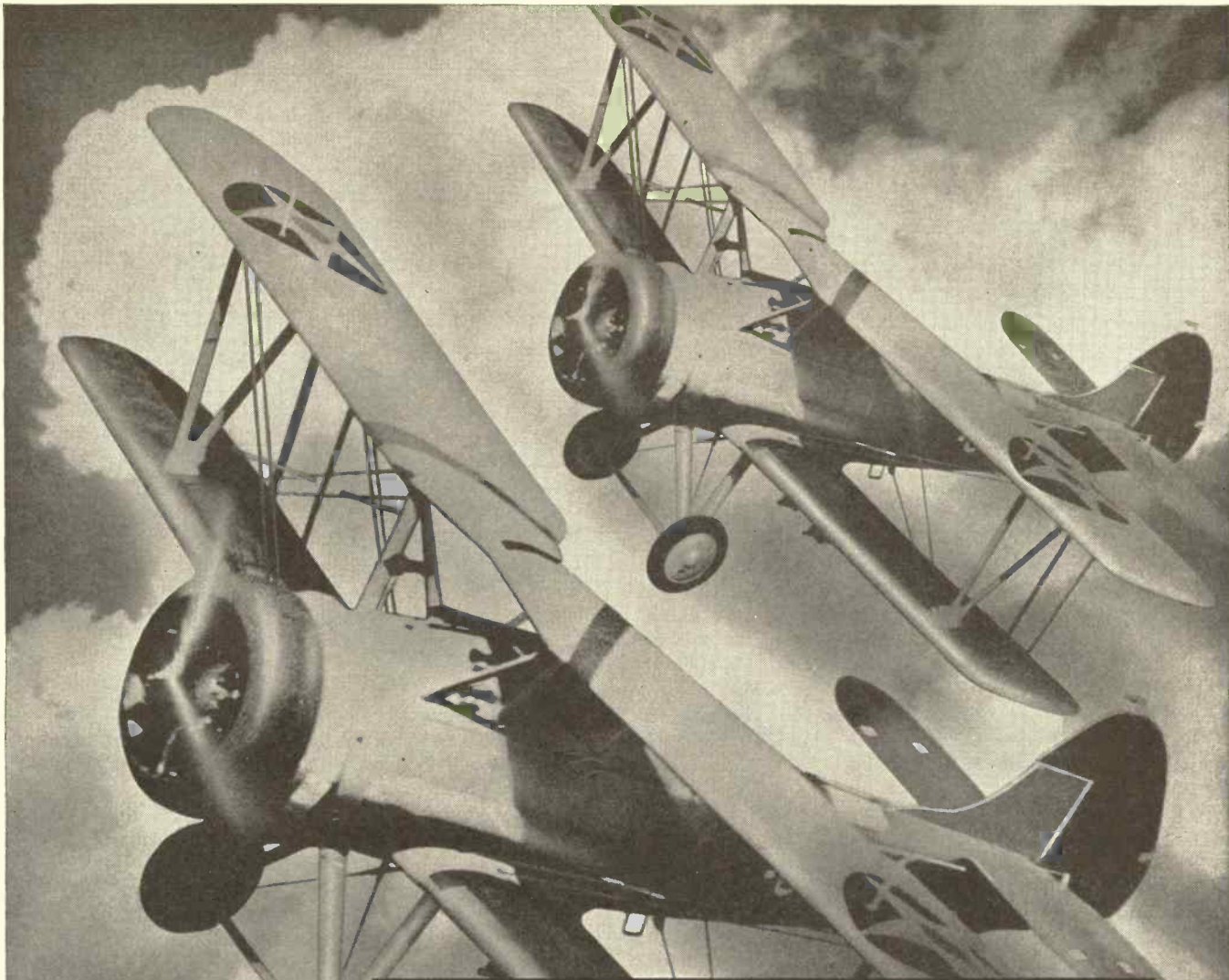

Fig. 1. Circuit diagram of Howard 318 and 325.



**IN THE U. S. AIR CORPS, TOO,  
RAYTHEONS  
DO THEIR "BIT"!**

Zooming through the air at breath-taking speed with machine guns barking, communications between the U. S. air fleets, and ground headquarters *must go through!* To weather such gruelling tests a tube *must* be sturdy... *must* be designed and tested to perform consistently and smoothly under all circuit conditions! This is the punishment Raytheons take *every day* in the U.S. Aviation service—and still render efficient and dependable performance!

These potent reasons helped convince engineers of many leading licensed set manufacturers that these same Raytheon tubes are *the* best for *their* sets. Profit from the combined experience of these men who know.

Choose Raytheons for *your* replacements and enjoy greater permanent tube profits!

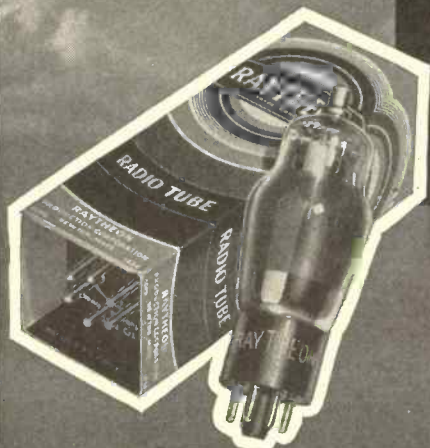

**RAYTHEON**

CHICAGO    SAN FRANCISCO    NEW YORK  
ATLANTA    NEWTON, MASS.

**"WORLD'S LARGEST EXCLUSIVE RADIO TUBE MANUFACTURERS"**

GENERAL DATA—continued

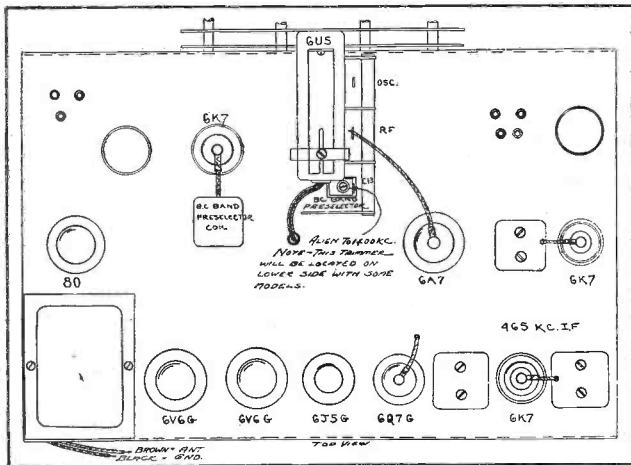

Fig. 3. Howard 318 and 325, top of chassis.

the dial hand should be straight across in line with the lines dividing the scale in half. If the hand is off position it can be lined up by removing dial glass and setting hand with screw in center of dial.

Set the test oscillator to 17 mc.

Turn waveband switch all the way to right for highest s-w band, and set dial hand to 17 mc.

Peak trimmer condenser (T6) of the oscillator coil to resonance with 17 mc fed into antenna.

Adjust antenna trimmer (T2) to same frequency after the above mentioned oscillator trimmer has been set.

After adjusting the two high bands at 17 mc and 5 mc the test oscillator input to antenna should be increased and re-

ceiver dial advanced to 0.9 mc lower; note if test oscillator signal is heard.

In case there is no response, the oscillator trimmers have been pulled down too tightly. The trimmers should be released until this condition exists; then go back to original point of alignment—reduce antenna input voltage and correct the trimmer adjustment.

POLICE BAND 1.7 TO 5.5 MC

Set the test oscillator to 6 mc.

Turn waveband switch to the middle position for Police Band, and set dial hand to 6 mc.

Peak trimmer condenser (T5) of the oscillator coil, Fig. 2, to resonance with 6 mc fed into antenna.

Adjust antenna coil trimmer (T3) to same frequency after the above mentioned oscillator trimmer has been set.

BROADCAST BAND

Turn waveband switch all the way to left and dial hand set to 1400 kc (the top scale)

Peak oscillator trimmer (T4) to 1400 kc and antenna trimmer (T1) to same frequency. Likewise C13 trimmer on the gang condenser.

Set dial hand to 600 kc and adjust oscillator padding condenser (T5) to 600 kc.

Recheck dial at 1400 kc.

Points in the middle of the dial may be checked and if necessary the plates of the front section of variable condenser may be bent for alignment.

NOTES

Seal all trimmers after their final adjustment.

Be sure that the settings are being made to the true fundamental signal from the oscillator and not on a harmonic or image frequency.

It is advisable to check the position of the tuning eye tube to make certain that it is not pushed against the inside of the dial card. With the adjustment screw on the bracket, allow a small amount of clearance between the end of the tube and the dial to avoid any possibility of the heat from the tube affecting the dial card.

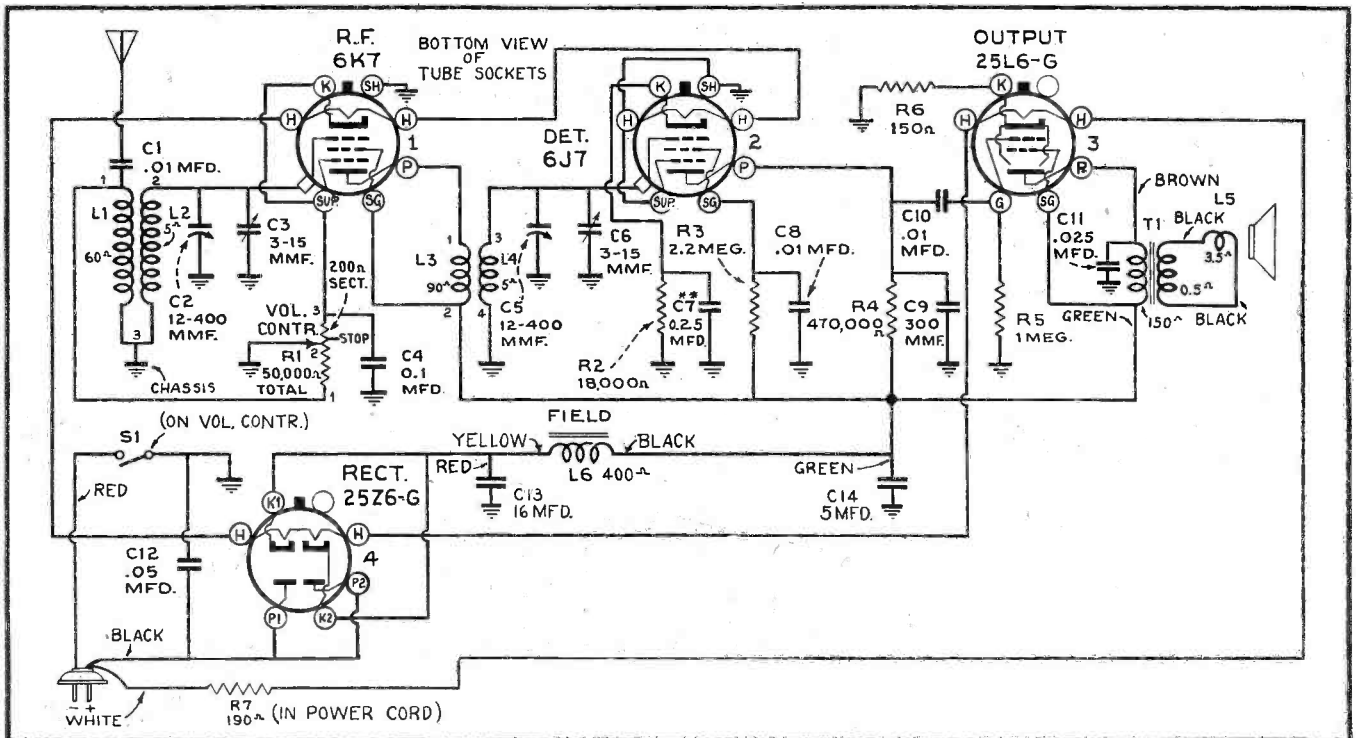

Fig. 1. Schematic diagram, RCA Victor 94X.



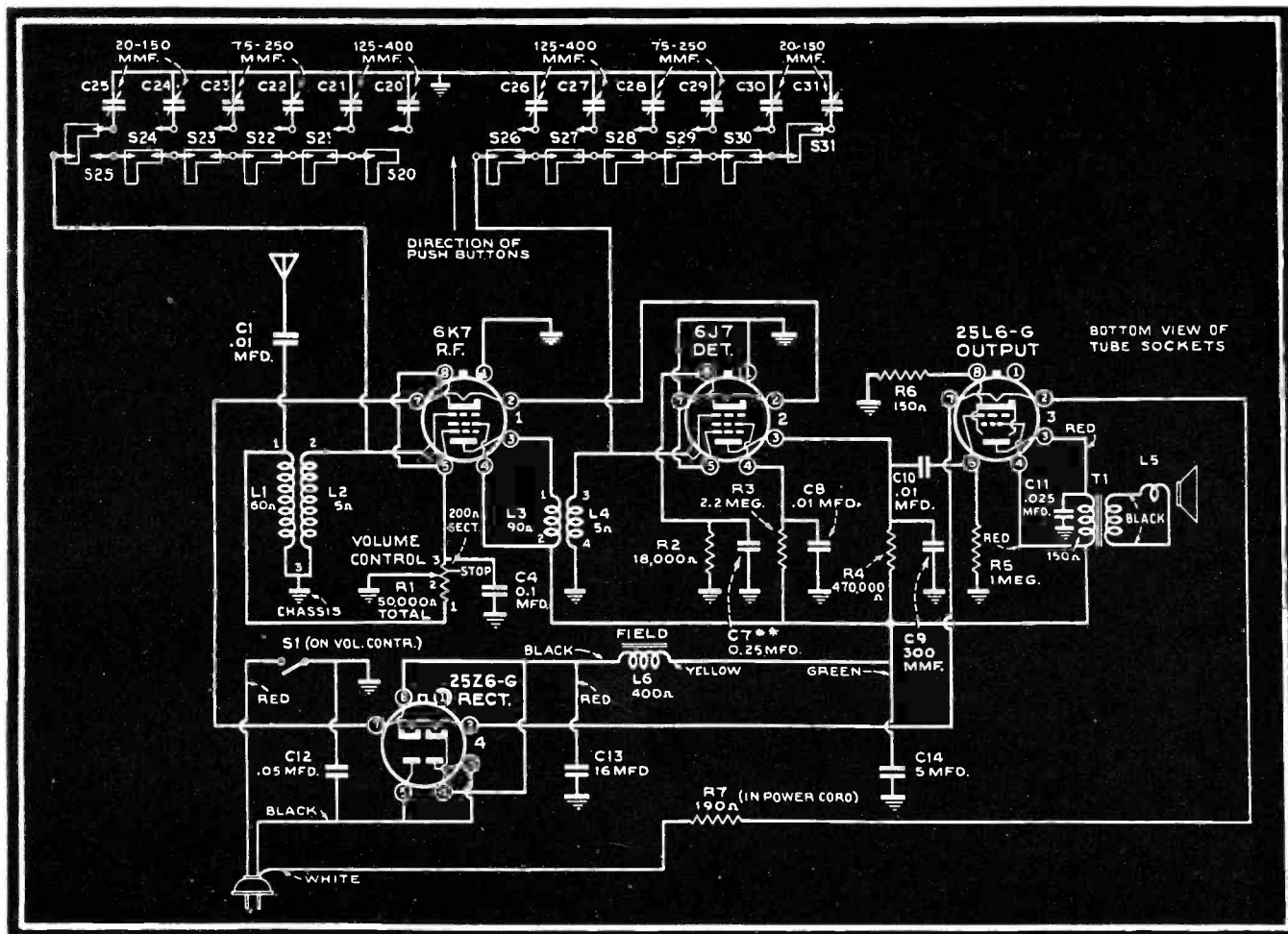

Fig. 2. Circuit schematic, RCA Victor 94X1 and 94X2.

**RCA Victor 94X, 94X1, 94X2**

Cabinet: Table

Tuning: 94X, manual; 94X1 and 94X2, push-button

Range: 530-1800 kc

Tubes:

R-f: 6K7

Det: 6J7

Power Amp: 25L6G

Rect: 25Z6G

Power Supply: 105-125 volts, 50-100 cycles a-c, and 105-125 volts d-c

Speaker: Electrodynamic

V-c Imp: 3 ohms at 400 cycles

Field Res: 400 ohms

**SERVICE NOTES, ALL MODELS**

Some sets have a three-section capacitor pack (C7, C13, C14). In other sets, the pack contains only two capacitors (C13, C14); a separate 0.25 mfd. capacitor being used as C7. The pack furnished for replacement (No. 30873) is a two-section pack and does not include C7. Therefore, when an original three-section pack is replaced by No. 30873, it is necessary to connect a No. 30965,

200-volt 0.25 mfd capacitor from the cathode of the 6J7 to the ground lug at the output transformer. This capacitor should be dressed close to the front of chassis.

94X: Voltages shown on the chassis drawing are between the point indicated and chassis unless otherwise noted. Measurements made with set tuned to quiet point, volume control at minimum, using 1000-ohm-per-volt meter, having ranges of 10, 50, and 250 volts. (Use nearest range above the specified measured voltage.) Values should hold

within approximately 20% for 117-volt 60-cycle a-c supply. On d-c, voltages are approximately 10% lower, except heaters, which remain the same. Values with asterisk are operating voltages. Values not starred are actual measured voltages.

94X1 and 94X2: Measurements made to chassis unless otherwise indicated. Measurements made with all station buttons out, volume control at minimum, using 1000-ohm-per-volt meter, having ranges of 10, 50, and 250 volts. (Use nearest range above the specified measured voltage.) Values should hold within 20% for 117-volt 60-cycle a-c supply. On d-c, voltages are approximately 10% lower, except heaters, which remain the same. For convenience in making measurements at the socket contacts, it is advisable to remove the trimmer and switch assembly, and make a temporary connection from the chassis to the bottom lug on L4. This connection is required in order to complete the detector grid circuit. Values with asterisk are operating voltages. Values not starred are actual measured voltages.

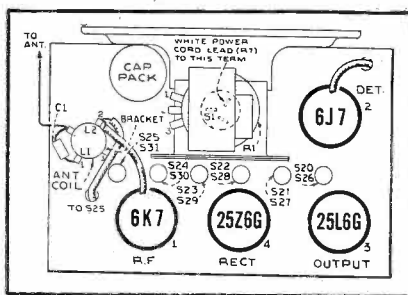

Fig. 3. Chassis layout, RCA Victor 94X, 94X1 and 94X2.

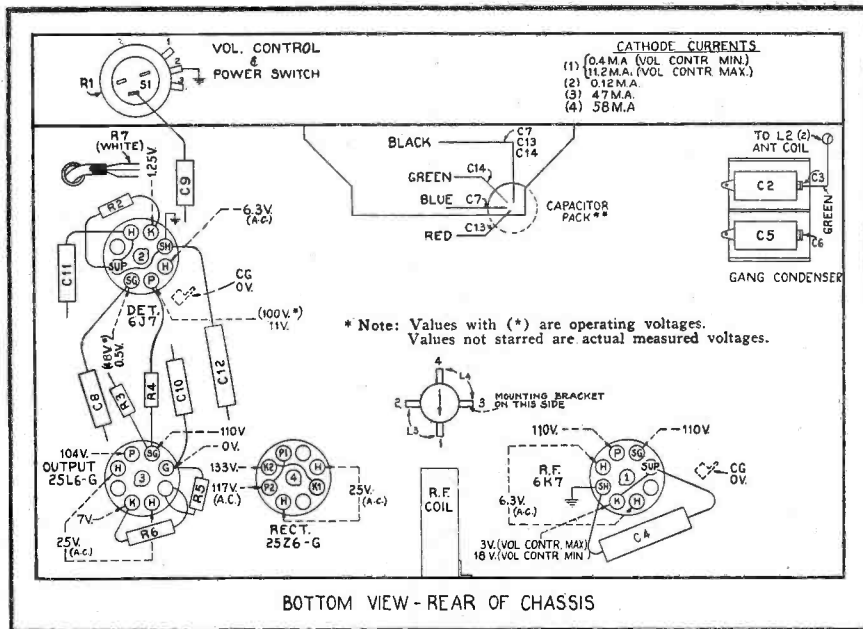

Fig. 4. Bottom chassis layout, RCA Victor 94X.

Removing chassis from cabinet: Remove back plate and volume-control knob. Pull the push-button knobs off their shafts. Remove the 25L6G output tube. Remove the four chassis screws (bottom of cabinet). Lift the chassis and slide it out at an angle to clear the shaft holes in the top of cabinet.

Removing trimmer and switch assembly: For convenient access to the sockets and parts, it is advisable to remove the trimmer and switch assembly. This is a simple operation, accomplished as follows: Remove the two brackets from bottom of chassis, unsolder the three leads that connect to the assembly, remove the two nuts that hold the assembly to the chassis, and lift out the assembly.

In reassembling, dress the leads to prevent rubbing against the push-button shafts.

**Caution:** The chassis is connected to one side of the power supply. Avoid contact of chassis or parts to external ground when servicing.

ALIGNMENT, 94X

Remove dial pointer by pulling it carefully off the pointer shaft. Remove chassis from cabinet.

**Caution:** The chassis is connected to one side of the power supply. Avoid contact of chassis or parts to external ground when servicing.

Reel up the antenna wire, and connect the high side of test oscillator through an 80 mmfd capacitor to the antenna terminal on the antenna trans-

former. Connect low side of oscillator to receiver chassis through a 0.1 mfd capacitor. Turn gang condenser to minimum (full out), tune oscillator to 1800 kc, connect an output meter across the voice coil, and turn volume control to maximum.

Adjust the two trimmers (C3 and C6) on side of gang condenser for maximum output, using lowest possible output from test oscillator.

Assemble chassis in cabinet and press the pointer on the shaft. Turn pointer, while holding tuning knob, so that the

pointer is horizontal and pointing to low-frequency end when the gang condenser is at maximum. Check pointer adjustment on a station.

ADJUSTMENT OF TUNING CAPACITORS 94X1 AND 94X2

The preferable and quickest method of adjusting the tuning capacitors for six different stations, is to employ a test oscillator, as described below:

Make a list of the desired six stations, arranged in order from low to high frequencies.

Determine the correct settings of the test oscillator for these six frequencies. This is accomplished as follows: Tune in each of the six stations on any standard receiver; zero-beat the test oscillator against each station, and note the exact setting of the oscillator in each case.

Reel up the antenna wire. Connect the high side of test oscillator through a 60 mmfd fixed capacitor to the end of the antenna wire. Clip the low side of the oscillator through a 0.1 mfd capacitor to one of the chassis-mounting screws on the bottom of the cabinet. Tune the oscillator to the previously determined point for the lowest frequency station, and adjust for a strong output.

Turn the volume control of the push-button receiver full clockwise, and push in the left-hand end button. Using an insulated screwdriver, peak capacitors C20 and C26, at the same time reducing the output of the oscillator in order to

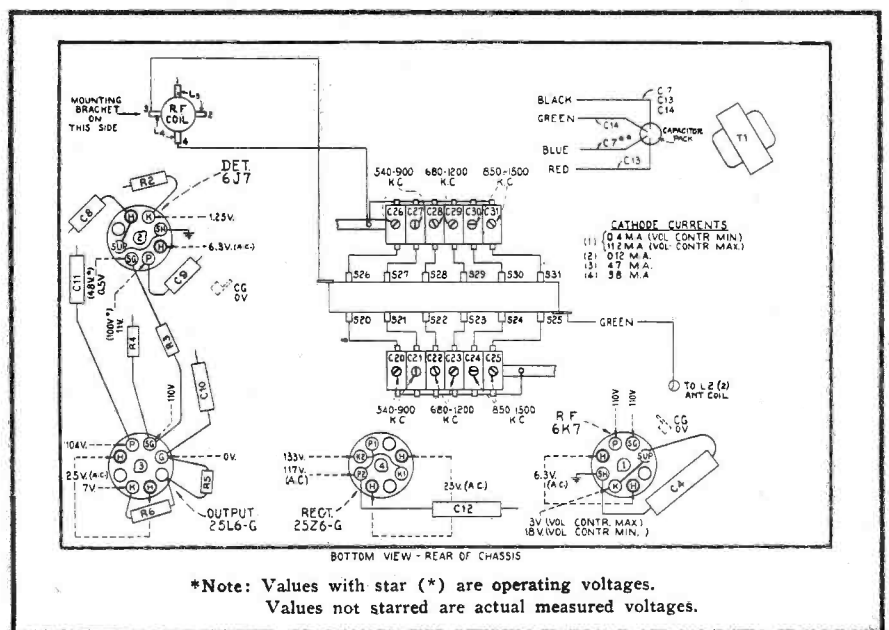

Fig. 5. Bottom view of chassis, RCA Victor 94X1 and 94X2.

# AMPERITE

offers  
**"ADJUSTABLE RESPONSE"**  
 (HIGHER OR LOWER PITCH WITH THE SAME MICROPHONE)

... made possible by  
**THE ACOUSTIC COMPENSATOR**  
 (pat. pend.)

Here is an improvement of great value at no extra cost! Exclusive with Amperite, the Acoustic Compensator gives you these advantages:

- (1) With the flip of a finger, you can now lower or raise the response of the microphone—without introducing any peaks or other undesirable effects. (Not a volume control. Gradually changes operation of the microphone from constant velocity to constant pressure.)
- (2) Permits adjustment of the microphone for most desirable response for close talking or distant pickup.
- (3) Makes the system immediately adjustable to any "taste" room condition, or equipment.

MODELS RBHK, RBMk, with Acoustic Compensator. Frequency range 40 to 11000 CPS. Output, -65 db. Complete with switch, cable connector and 25' of cable. . . \$42.00 LIST. Chrome, \$43.00 LIST  
 MODELS RBHn, RBMn, without acoustic compensator, \$42.00 LIST

PUSH UP TO INCREASE HIGHS; PUSH DOWN TO INCREASE LOWS



**IMPROVES ANY "LOW-COST" INSTALLATION ON 4 COUNTS!**

P. A. Men, you can improve those "price" jobs by using the popular Amperite Model RAH (or RAL). You will get better results because (1) it is excellent for both speech and music; (2) has flat response without undesirable peaks; (3) reduces feedback; (4) stands up under rough handling, changes in temperature, pressure or humidity. . . . Frequency range 60

to 7500 cps. Output, -68 db. MODEL RAH (Hi-imp.) with 12' of cable; MODEL RAL (200 ohms) with 8' of cable. . . . ONLY \$22.00 LIST

## NEW LOW-PRICED CONTACT MICROPHONE . . \$12.00 LIST

The success of our Model KTH (\$22.00 List) has created a demand for a popular-priced Amperite Contact Microphone. The new model listed below can be used on most radio sets made since 1935 and on all P.A. systems. It "makes an ordinary violin sound like a Strad" . . . gives a small piano the tone of a Grand. And yet, there is no distortion. No unnatural effects. No "fingering noises." Installation is simple . . . no changes in strings or instruments . . . attached without tools.

Operates with either high or low gain amplifiers. Has frequency response of 40 to 9000 cps. Output, -40 db. 20' of cable.

MODEL SKH (Hi-imp); SKL (200 ohms) \$12.00 LIST  
 SKH or SKL with foot-operated volume control . . . . . \$20.00 LIST  
 Professional Model KTH (or KTL) . . . . . \$22.00 LIST

## "TOPS IN MIKES"

Station KVOL, of Lafayette, La., writes us, unsolicited: ". . . the Amperite mikes have been in service here for almost three years, and have proven themselves to be "tops" in mikes. They have broadcasted in the rain and in the hot sun. They have even been dropped, but they always came through in fine shape . . ." The Amperite Studio Velocity Model SR80n now has -56 db output. Frequency range 40 to 15000 cps. Triple shielded, fitted with switch, (optional), cable connector, and 25' of cable. MODEL SR80n (200 ohms); \$80.00 LIST  
 MODEL SR80Hn (Hi-imp.) . . \$80.00 LIST



**Sales Aids for the P. A. Man** Amperite offers the following co-operation to P.A. Men.

- (1) FREE Window Decal advertising your Sound Service. Size 5 1/4 x 9 1/4, finished in 4 striking colors.
- (2) FREE Window Display, 11 x 17.
- (3) Special Sound Equipment Letterheads. Samples and prices on request.
- (4) FREE use of cut for printing business cards, etc.

Write for these valuable sales helps, and new Illustrated Bulletins, today!

**AMPERITE Co.** 561 BROADWAY, N. Y. U. S. A.

CABLE ADDRESS  
 ALKEM, NEW YORK

*Better Systems Specify Amperite*



VELOCITY

**AMPERITE**

MICROPHONES

# GENERAL DATA—continued

secure a sharp peak. (Clockwise adjustment of the capacitors tunes the circuits to lower frequencies, and counter-clockwise adjustment tunes the circuits to higher frequencies. The range of each trimmer is three full counter-clockwise turns from the tight position. Do not unscrew more than three turns.)

Push in the second button from left, and adjust C21 and C27 for peak output with the oscillator tuned to the frequency of the second station.

Proceed in this manner to adjust each pair of capacitors for the desired frequencies.

Final adjustment may be made in actual reception of the stations.

RCA Mfg. Co., Inc.

## Zenith 9S (204, 232, 242, 244, 262, 263, 264) (Chassis 5905)

Tuning:	Manual
Ranges:	Broadcast; Police; S-w
Tubes	
R-f:	6K7
1st Det:	6L7
Osc:	6J5
I-f:	6K7
A-v-c	6H6
2nd Det:	
1st A-f:	6F5

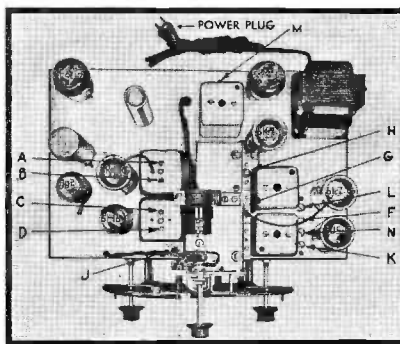

Fig. 1. Chassis of Zenith 9S (Chassis 5905).

Pwr Amp:	6F6
Rect:	5Y4
Tun Ind:	6T5

### ALIGNMENT PROCEDURE

Connect signal generator to grid of first detector through a 0.5 mfd condenser; set generator to 456 kc; band-switch setting, broadcast; receiver dial set to 600 kc; adjust trimmers A, B, C, and D for maximum output.

Connect signal generator to antenna post through a dummy antenna of 200 mmfd; set generator to 1500 kc; band-switch setting, Broadcast; receiver dial

set to 1500 kc; adjust trimmer F to bring set oscillator to scale.

Signal generator connection and setting remain as above; receiver dial remains at 1500 kc; band switch, Broadcast; adjust trimmers G and H for alignment of antenna and detector circuits.

Signal generator connection as above; generator set to 600 kc; band-switch, Broadcast; rock receiver dial (around 600 kc) and at the same time adjust trimmer J for maximum output.

Repeat oscillator and antenna-detector circuit lineup for best results.

Connect signal generator to antenna post through a dummy antenna of 400 ohm resistance; set generator to 18000 kc; receiver band switch set to Short-Wave; receiver dial, 18000 kc; adjust trimmer K to set oscillator to scale.

Generator connection remains the same, set generator to 16500 kc; band switch remains set at Short-Wave; receiver dial at 16500 kc; adjust trimmers L and M (while rocking dial) for maximum output.

Generator connection as above; generator setting 5500 kc; band-switch setting, Police; receiver dial 5500 kc; rock dial while adjusting trimmer N for maximum output.

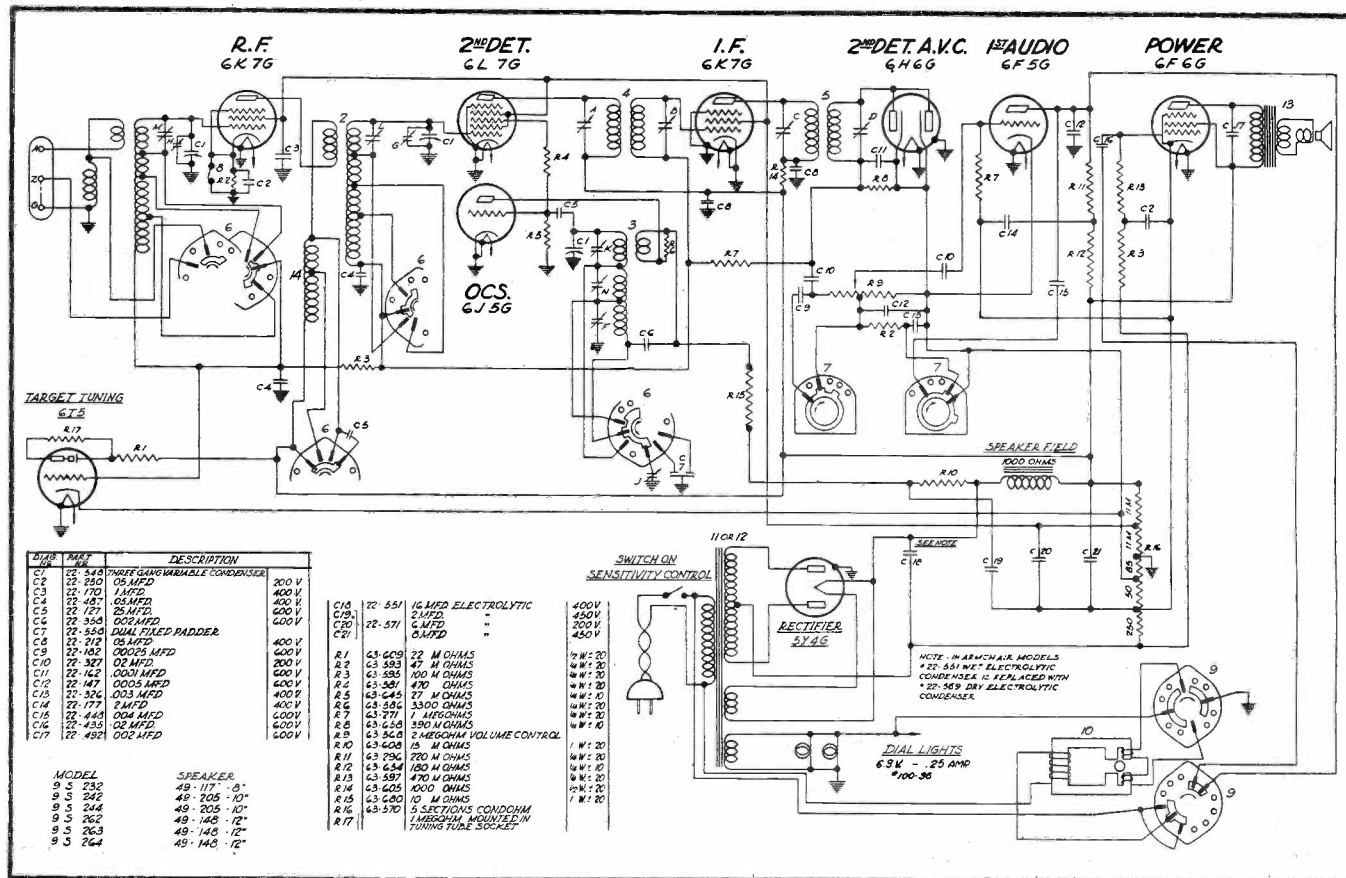

Fig. 2. Schematic diagram, Zenith 9S (Chassis 5905).

# Auto-Radio

padding the i-f stages remove the generator lead from the 6A7 tube.

Set the signal generator at 1,550 kc and then connect the generator lead to the grid cap of the 78 r-f tube in series with a 0.1 mfd condenser (without re-

## Nash-Philco N-1514

All padding adjustments are carefully made at the factory and ordinarily no readjustments are necessary. However, when required, the procedure given below should be followed in detail.

### ALIGNMENT PROCEDURE

**Output Meter**—The output meter must be connected by means of an adapter to the plate of the type 41 output tube and to the receiver chassis.

**Signal Generator**—With the receiver and signal generator set up for operation at the prescribed frequency, turn the receiver volume control on full and set the signal generator attenuator so that a half scale reading is obtained on the output meter. The signal in the speaker should be audible but not loud.

The shielding on the signal generator output lead must be connected to the receiver housing.

**I-F**—Set the signal generator at exactly 260 kc.

Connect the generator lead to the grid cap of the 6A7 tube in series with a 0.1 mfd condenser (without removing

Fig. 2. Chassis layout —top.

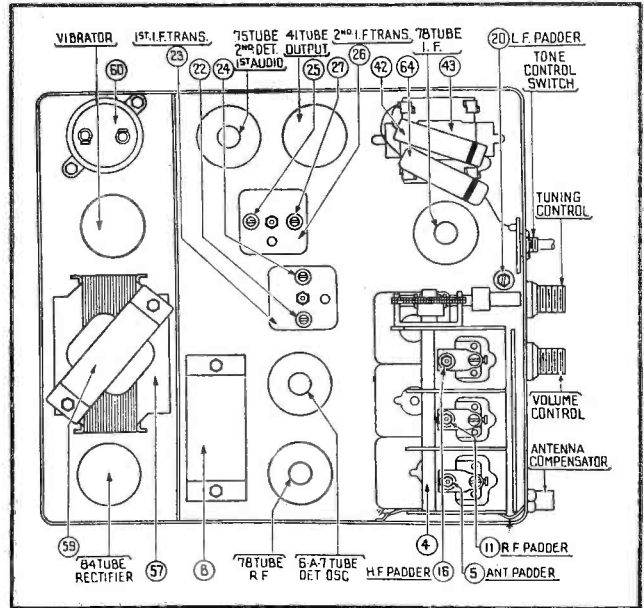

the grid clip). Adjust padders 22, 24, 25 and 27 on the first and second i-f transformer for maximum reading on the output meter.

**High-Frequency and R-F**—After

moving the grid clip).

Turn the tuning condenser out of mesh as far as they will go.

With the tuning condenser in this position, adjust the high-frequency

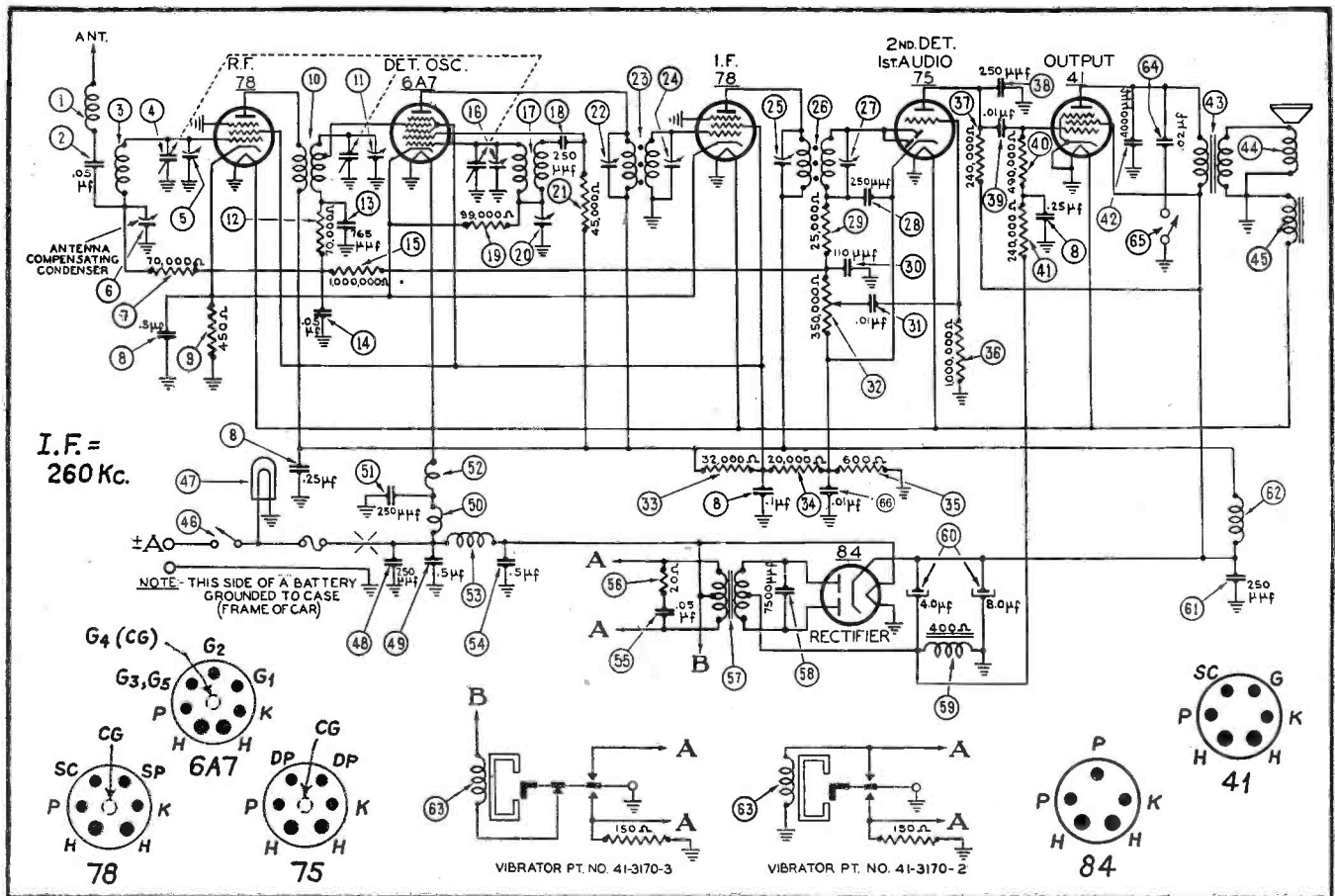

Fig. 1. Nash-Philco N-1514 circuit diagram.

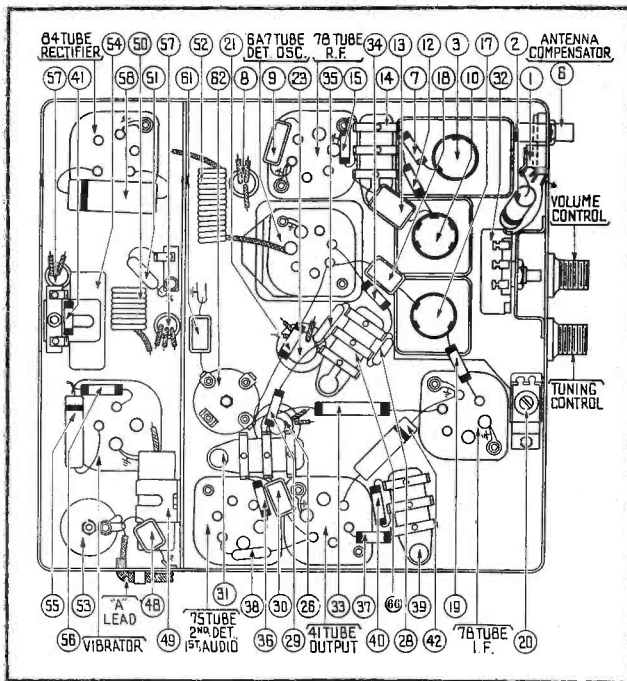

Fig. 3. Underside of chassis, Nash - Philco N-1514.

padder 16 and the r-f padder 11 until the maximum reading is obtained on the output meter. This is the true setting for the 1,550 kc, 155 on the dial scale.

**Low-Frequency**—Turn the tuning condenser plates in mesh to approximately 580 kc, 58 on the dial scale and set the signal generator at 580 kc. Roll the tuning condenser and adjust the low-frequency padder screw 20 for maximum reading on the output meter.

**High-Frequency Readjustment**—Turn

the tuning condenser plates out of mesh to 1,550 kc and set the signal generator at 1,550 kc. Then adjust the high-frequency padder 16 again for maximum reading on the output meter.

Remove the generator lead from the 78 r-f tube.

**Antenna**—When padding the antenna stage it is extremely important that the proper dummy antenna be constructed and used.

Connect the signal generator lead to

the antenna connector on the receiver using an antenna lead, Part No. L-2665, and a 25 mmfd condenser in series between the two leads.

Turn the tuning condenser in mesh to 600 kc and adjust the signal generator to 600 kc. Adjust the antenna compensating condenser 6 for maximum reading.

Turn the tuning condenser to 1,400 kc and set the generator at 1,400 kc. Adjust the padders 11 and 5 for the maximum reading on the output meter.

When the antenna stage adjustment is made with the receiver installed in the car, the receiver antenna lead must be connected to the car antenna in the usual manner. Connect the signal generator output lead to a wire placed near the car antenna but not connected to it.

Trav-Ler 710 and 711

These receivers are seven-tube super-heterodynes employing an r-f stage. Model 710 has a 6½-inch electrodynamic speaker; Model 711 uses an 8-inch electrodynamic speaker. Either the internal speaker or a combination of internal and external (overhead) may be used without changes in wiring. The additional speaker is simply connected by inserting a plug in the socket provided.

The shielded antenna lead is plugged into the socket provided for it on the (Continued on page 30)

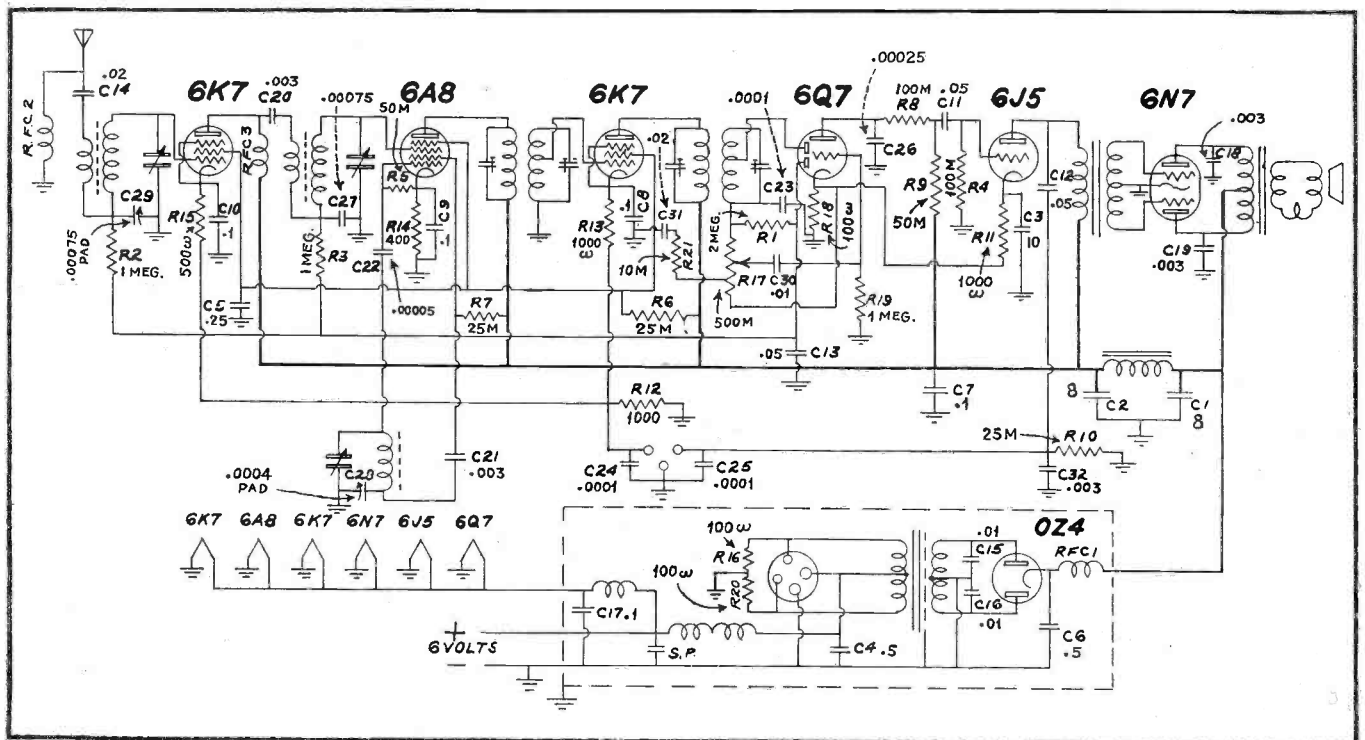
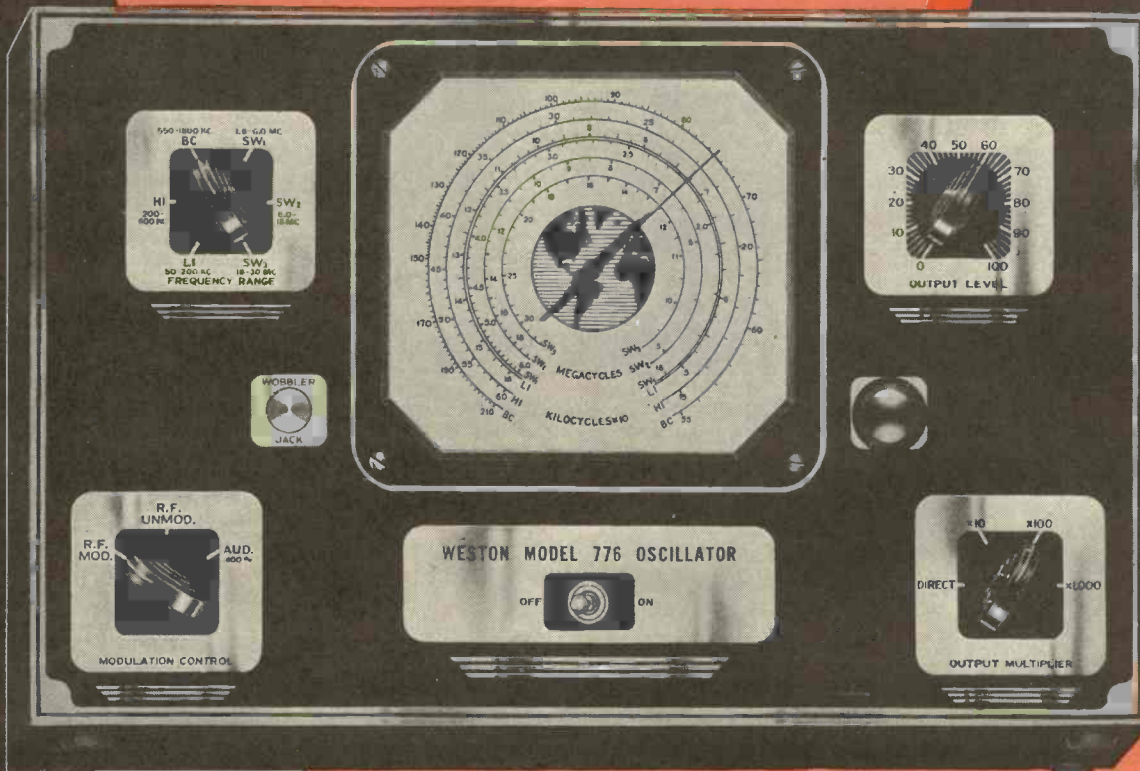

Fig. 3. Schematic diagram, Trav-Ler 710 and 711.

# ONLY THIS NEW WESTON OSCILLATOR

gives you **ALL** these features!

Constant signal level at all frequencies (A.A.C.)  
 . . . Constant frequencies—no padders—no trimmers . . . Guaranteed accuracy at all frequencies ( $\frac{1}{2}\%$  on I.F.—B.C.)—(1% on Short Wave) . . . Constant impedance attenuator (100 ohms) . . . Permanent hand calibration—large  $330^\circ$  fully visible dial . . . Output readings directly in microvolts . . . Signal strength 100,000 microvolts . . . Fundamental frequencies fifty kc—30 meg.—6 individually hand calibrated scales . . . Freedom from drift and feedback . . . For use with all standard oscillographs and frequency modulators . . . Rapid band selection . . . Accurate alignment . . . Fifty percent modulation on all bands . . . Stable operation.



**WESTON**  
*Instruments*

Weston Electrical Instrument Corp.  
 604 Frelinghuysen Ave., Newark, N. J.  
 Send me bulletin describing Model 776 Oscillator.

Name.....  
 Address.....  
 City..... State.....

# Sound Service . . .

## SOME ACOUSTIC PROPERTIES OF THE VELOCITY MICROPHONE

By A. BARBIERI\*

*P-a men are frequently in doubt about the characteristics of the microphones they use. Herein, a manufacturer of velocity "mikes" gives his ideas on that type.—*  
EDITORS.

NATURAL REPRODUCTION without peaks or distortion and zero pickup in the plane of the ribbon, are two well-known claims for the velocity microphone, but the exact reasons for these are not always understood. Once understood, the operation and reason for the new acoustic compensator will be apparent.

All existing microphones can be divided into two groups—(1) pressure operated and (2) velocity or pressure gradient operated.

In a velocity operated microphone, the moving element is so light that it follows practically every vibration of the moving air. It has the same motion that it would have if it were actually made of air. Technically, we might say that the mass of the ribbon itself is lighter than the mass of air that sets it in motion. This vibration is shown in Fig. 1A. Note that at the lower frequencies the amplitude is much greater than at the higher frequencies. The reason for this is as follows: sounds of all frequencies having the same volume travel at the same (or constant) velocity; this is explained in Fig. 1B. If a particle is suspended in mid air and carried by the motion of air vibrating at 60 cps, it would move along the sinusoid AB. CD is the path travelled by the same particle vibrating at 180 cps. The distance AB and CD must be travelled in the same time.

\*Amperite Corp.

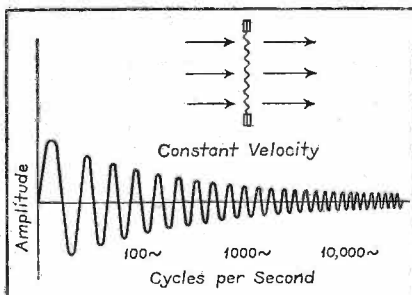

Fig. 1A. A constant-velocity wave train.

The amplitude of the 60 cps note must therefore be much greater. This can be observed on a violin; the G or lowest string vibrates with such a large amplitude that it can actually be seen to vibrate, while the vibrations of the E or highest string are hardly visible.

If the moving element of a microphone is to reproduce naturally all audible frequencies, it must be capable of following the air vibrations as they oscillate with large amplitude at the lower frequencies, and small amplitude at the higher frequencies. The ribbon used in a velocity microphone is usually less than 0.0002" thick and is made of

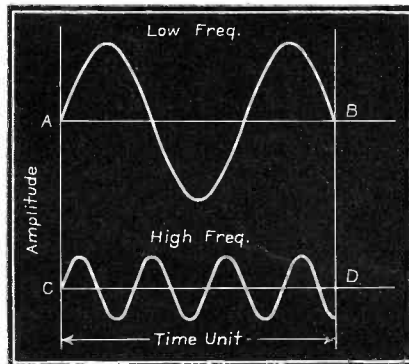

Fig. 1B. Showing the relationship between amplitude and velocity for a constant-velocity wave.

duraluminum. Its natural period of vibration is approximately 10 cps. The ribbon is suspended at both ends and corrugated in such a way as to permit it to vibrate freely with the air particles moving at any audible frequency.

All other microphones fall into the category of constant-pressure or constant-amplitude devices. The so-called ribbon microphone is constant velocity as shown above. The moving elements of all constant-pressure microphones offer some resistance to the moving air particles, the amount of resistance depending upon the stiffness of the diaphragm and the air chambers behind it.

The diaphragm vibrates to the same amplitude with all sound frequencies of the same volume. This might be compared to a riveting machine held against a steel plate. The plate can be vibrated to

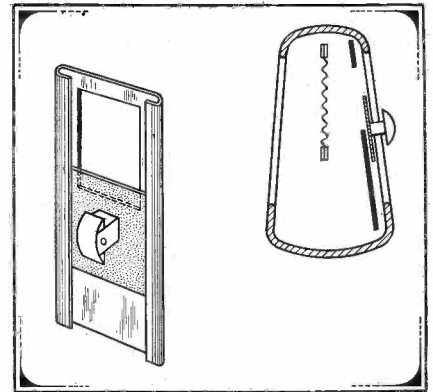

Fig. 3. The acoustic compensator.

an amplitude of 0.010" with a few hard blows, or a rapid succession of lighter blows. In other words, the average pressure of a few heavy blows is equal to the average pressure produced by a great many light blows.

By comparing Fig. 1A and Fig. 2, it will be noted that the greatest difference between a constant-velocity and constant-pressure microphone appears to be in the frequencies below 1000 cps. A natural low-frequency response is important for proper reproduction of music. It is also important in picking up a performer at a distance of 1 foot or more. Without a good low-frequency response the reproduction gets very thin on distant pickup (1 foot or more). It may not be desirable to bring up the lower frequencies with filters, or tone controls, because of the possible introduction of harmonic distortion and other effects.

When the performer hugs the microphone, as is often the case, it is usually best to attenuate the lower frequencies. This can be done by inserting a condenser in series with the velocity microphone, but undesirable effects may result. It can also be done in the design of the velocity microphone transformer without introducing any peaks or undesirable effects.

In order to preserve the low-frequency response of the velocity for the reproduction of music and distant pickup and to attenuate the lower frequencies for close talking, the acoustic compen-

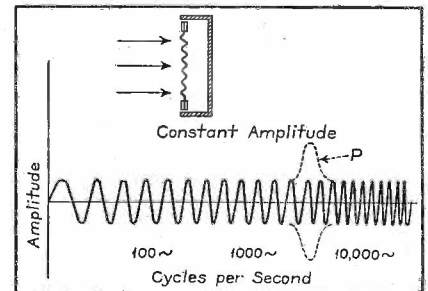

Fig. 2. A constant-amplitude wave train.



sator—instead of electric compensator—was developed. The acoustic compensator permits gradual closing of the back of the velocity. By closing the back, an air cushion is formed behind the ribbon causing the ribbon to vibrate at constant amplitude instead of constant velocity. It can readily be seen that the cushioning effect of the air would be greater at the lower frequencies because of the naturally larger amplitudes of the sound waves and ribbon. The acoustic compensator, as shown in Fig. 3, can be gradually closed—the microphone is thus gradually changed from constant velocity to constant amplitude. Any desired response can therefore be obtained. When the compensator is all the way up the microphone becomes a constant amplitude device—similar to a dynamic—and still has a moving element having a natural period of approximately 10 cps.

In Fig. 2 it was assumed that the constant-pressure device had no natural period of its own. This is, of course, practically impossible because even the smallest diaphragm has a greater mass than the surrounding air and it also has stiffness. The stiffness may cause one peak in the audible range, the mass

another; a peak such as shown at "P" will be experienced in a microphone not properly corrected. In the best types of pressure microphones the peaks are made negligible by the use of resonating chambers resonating tubes, and damping materials.

The acoustic compensator described above makes the ribbon microphone immediately adjustable to any room condition, close or distant pickup, and various types of sound systems. Then there is the matter of taste—some prefer a system that sounds low pitched, others prefer high-pitched systems. A short crooner wants a low-pitched system to make him sound like a big fellow, etc.

The type of speaker and baffle used will make quite a difference. The latest types of good speakers have an excellent high-frequency response and will sound better with a microphone having more "lows." A high pitched microphone will make such speakers sound too high pitched.

All modern microphones can also be classified as directional or non-directional. In the latter group we have those where the sound collecting element is a diaphragm accessible to sound on one side only, as shown in polar curve

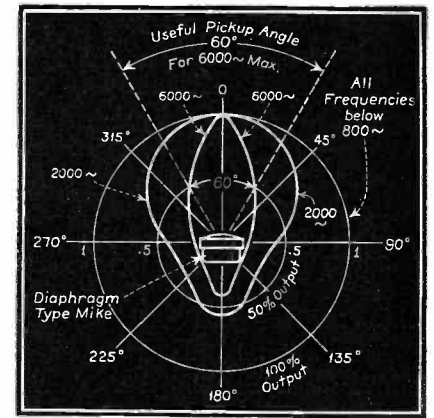

Fig. 4. Polar curve for microphone having directional characteristics.

Fig. 4. Note how the pickup changes at different angles. It is extremely directional to the higher frequencies, while at very low frequencies the response is practically constant for any angle.

The useful range of a microphone is considered as that angle in which all frequencies are reproduced with no greater variation than 2 db. In a diaphragm microphone this angle may be approximately 60 degrees. At high frequencies the angle rapidly becomes smaller; diaphragm microphones do not have a zero angle of pickup.

In the case of a directional microphone such as the ribbon velocity, we have the response as shown in Fig. 5. It can be seen that the difference in pickup between 30 and 9000 cycles is exceedingly small. The useful angle in front or back is 120°. This explains why a single velocity is often used to pickup an entire symphony orchestra. We also have two dead zones at 90 degrees from the faces of the microphone. The width of this angle is from 15 to 20 degrees. Any sound originating within this narrow angle will not be picked up. Of course, strictly speaking this condition holds true only outdoors. Indoors a sound originating in this angle might be picked up from a reflecting wall; in most installations this reflected sound is usually small or can be minimized by rotating the microphone.

By facing the zero angle of pickup of the velocity microphone towards the loud speaker, feedback can be reduced to a minimum. Feedback is usually caused by the microphone picking up sound from the speakers and reamplifying the pickup. If a microphone has a peak, it will feedback much more easily at the peak frequency; in that

(Continued on page 32)

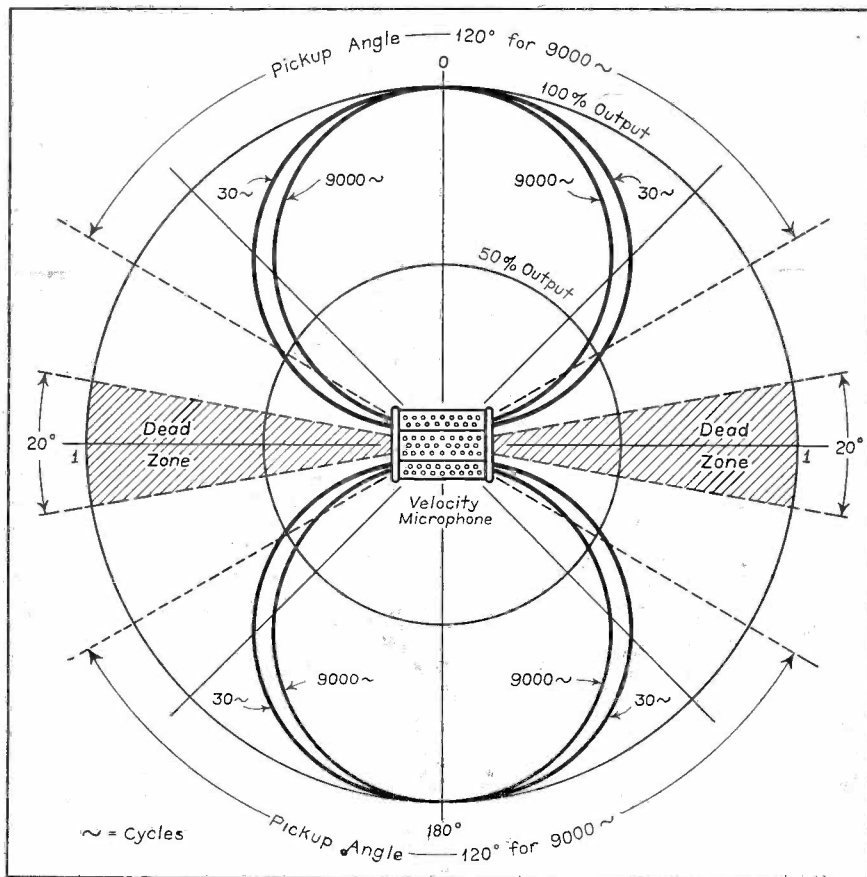

Fig. 5. Type of field curve for velocity microphone.

# Test Equipment . . .

## TESTING BALLAST TUBES WITH THE ELECTRONOMETER

THE FOLLOWING information will enable present owners of Precision Series 500, 500A, 600 and 700 tube testers to make the necessary minor changes to accommodate the testing of ballast tubes.

### WIRING CHANGES

*Electronometer 500, Serial Nos. below 572 (except Nos. 356 and 531).* Looking at the underside of OCTAL SOCKET M-1, and using the RMA numbering system as a guide, with the shell (SH) position as being contact No. 1 and continuing clockwise, interchange wires of that socket as follows:

PRESENT CONNECTION	CONNECT TO
Move wire from No. 1 and No. 2	No. 8
Wire removed from No. 8	No. 1 and No. 6
Wire removed from No. 6	No. 4
Wire removed from No. 4	No. 2
Move wire from No. 3	No. 7
Wire removed from No. 7	No. 5
Wire removed from No. 5	No. 3

Connect eleventh contact position of FILAMENT CONTROL to green lead on G toggle-switch.

Note: The rearrangement of wiring of Socket M-1 outlined above, aside from accommodating all octal type ballast tubes for test purposes, also provides for the additional testing of the octal type full wave rectifiers 5X4 and 5Y4 in the M-1 Socket. The control settings for these two tubes are as follows:

FILAMENT CONTROL at 5  
LOAD CONTROL at 12  
SHUNT CONTROL at 30

TEST POSITION toggle-switch C for first plate and toggle-switch E for second plate.

*Electronometer 500 and 500A, (Serial Nos. 572 to 1285 inclusive); Electronometer 600 (all Serial Nos.); Electronometer 700 (bearing Serial Nos. below 4575).*

Make wire connection from contact No. 1 (shell position) of OCTAL SOCKET M-1 to blue lead on toggle switch F.

Make wire connection from eleventh contact position of FILAMENT CONTROL to green lead on toggle switch G.

### BALLAST TUBE TYPE RESISTOR CODE

A sample and interpretation of the code appearing on standard octal type and replacement type ballast tubes are as follows: RMA Standard Octal Type, BK49AG, Replacement Type, BKX-55AG.

The first letter B on both types, if used, indicates ballast action.

The letter K on both types indicates type of pilot lamp.

The letter X or Y or Z immediately following the pilot lamp designation denotes a particular series of base wiring and appears only on replacement type ballast tubes.

The numerals 49 and 55 appearing on the respective types, indicate the total voltage drop produced by the resistor tube including the pilot lamp.

The letter A or B, C, D, E, E1, F, G, H, J, appearing on both types and immediately following the voltage drop numerals, designates the particular base wiring circuit used.

The letter G on both types, if used, indicates octal base glass unit.

A letter J following the base wiring designation such as K55CJ, refers to

an internal jumper between pins 3 and 4. (See TEST PROCEDURE.)

Where the letters P or PR appear after the base wiring designation, such as K55CP or K55CPR, this indicates an additional resistor section is employed for the rectifier plate circuit. (See TEST PROCEDURE.)

For standard RMA octal-type ballasts, the base wiring designation as shown above is the only information necessary for test purposes.

For replacement-type ballasts, the X, Y or Z series and base wiring designation as shown above is the information necessary for the testing of these types.

### BALLAST TEST PROCEDURE

The neon lamp short check circuit (in conjunction with the line check indication on meter) of the Series 500, 500A, 600 and 700 is used to obtain the following tests on ballast units.

(1) Point to point continuity test of each tapped section of multiple section ballasts.

(2) Tests for loose elements.

(3) Tests for leakage between separate sections of multi-purpose ballasts.

The OCTAL SOCKET M-1 is used to accommodate all octal base type ballast tubes. Any attempt to employ the M-2 octal socket will produce erroneous neon lamp indications.

(1) Rotate FILAMENT CONTROL to the No. 11 position. No specific LOAD or SHUNT CONTROL setting is necessary for ballast testing.

(2) With all toggle switches in NORMAL POSITION, throw instrument switch to "ON" position and obtain LINE CHECK indication on METER.

This operation automatically allows

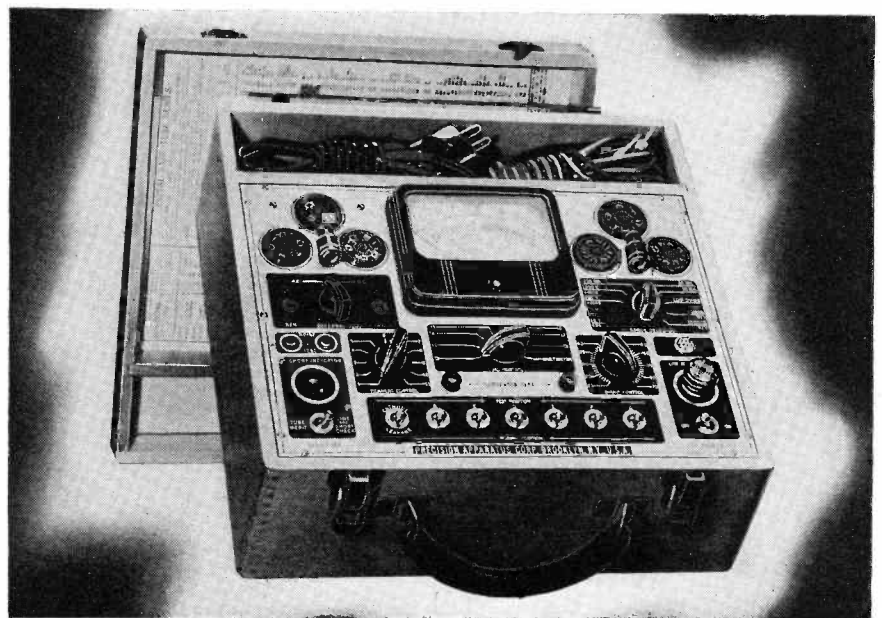

The Electronometer.

Centralab conquers 8 months  
of **RAIN!**

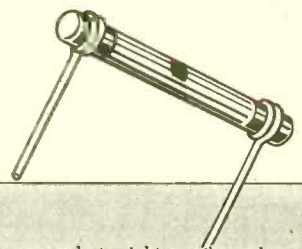
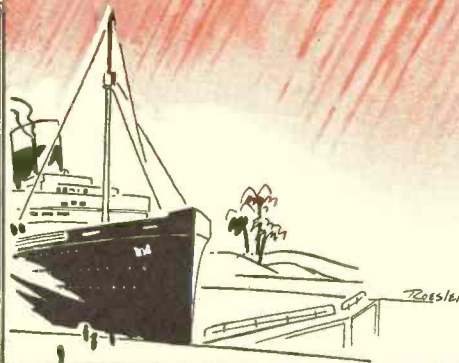
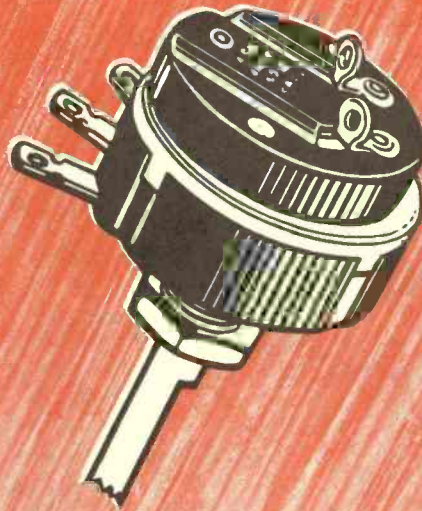

"Since using Centralab Controls... we have not replaced more than three. Centralab has remedied our troubles due to 'comebacks' of noisy controls, and we are proud to recommend them 100%."

*H. W. Wright*

General Manager  
DAY & NIGHT GARAGE  
Panama City, Rep. of Panama

Down in the Canal Zone where the rainy season lasts eight months and plays havoc with radio receivers Mr. H. W. Wright has been "laughing at the rain" since he changed to Centralab controls and Fixed Resistors. Rain . . . cold . . . heat vibration . . . abuse . . . Centralab parts are built to "Take it on the chin". No wonder set manufacturers, experimentors, and amateurs everywhere "SPECIFY CENTRALAB".

CENTRALAB, Division of Globe-Union Inc., Milwaukee, Wisconsin

**Centralab**  
CRL

BRITISH CENTRALAB, LTD.  
Canterbury Rd. Kilburn  
London, N. W. 6, England

FRENCH CENTRALAB CO.  
118 Ave. Ledru-Rollin  
Paris XI, France

Bill - the  
This is the  
oscillator  
I spoke of  
you always  
It's a honey  
JAMES SMITH  
2024 MAIN STREET  
CITY  
PHONE  
RAD.

- 1% Accuracy to 3,000 K.C.
- 2% for Higher Frequencies
- Range 110 to 20,000 K.C.

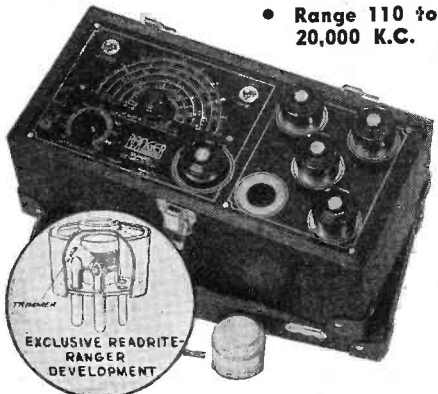

Model 557 Complete  
DEALER PRICE  
Only \$ 18.90

# ACCURACY

GUARANTEED  
IN THIS LOW PRICE  
SIGNAL GENERATOR

• Wherever you go you will hear praise for Model 557 Direct Reading Signal Generator. Continuous use day in and day out has clearly demonstrated its remarkable accuracy and reliability.

Model 557 Direct Reading Signal Generator uses plug-in type coils. Five frequency bands are covered from 110 to 20,000 K.C., all fundamentals. Completely shielded for static and magnetic fields. Attenuation and stability are outstanding features. Strong signals both modulated and unmodulated are furnished.

Each individual coil is separately calibrated by an exclusive method of peaking with trimmer condensers. Furnished complete with batteries and accessories.



**READRITE METER WORKS**  
317 College Ave., Bluffton, Ohio

Please send me more information on Model 557.

Name .....

Address .....

City..... State.....

## TEST EQUIPMENT—continued

the neon short check system to become effective for ballast tests.

Note: Although the neon short check system is employed for both radio tube and ballast tests, the manipulation or operation of the lettered switches for obtaining ballast tests is entirely different than when employing these switches for radio tube inter-element short tests.

(3) Refer to the test data list below for the lettered toggle switches called for. Select the proper base wiring designation of the ballast tube to be tested and insert ballast unit into its respective socket.

Note: The letter A, (as noted in the TEST POSITION column of test data list) refers to toggle switch A. In the case of the Series 500A and 700 tube testers, this letter refers to the CATHODE LEAKAGE toggle switch.

The lettered toggle switches called for are thrown to the TEST POSITION one at a time in the order indicated and each switch thrown remains in the TEST POSITION. All switches are returned to the NORMAL POSITION only after all of the tapped sections of a ballast unit have been tested.

A continuous neon lamp glow after each consecutive lettered toggle switch, called for, is thrown to the TEST POSITION indicates that the section is not open. An open section (anywhere in the chain) will cause neon lamp to become extinguished when that section lettered toggle-switch is thrown to the TEST POSITION.

It is advisable to tap the ballast unit after each of the toggle switches called for is thrown to the TEST POSITION. In this manner, loose elements can be ascertained by noticing any flickering of neon lamp.

Where letter J follows the base wiring designation such as K55CJ, it is necessary to include toggle switch C for test purposes and it should be the last one to be thrown to TEST POSITION.

Where letters P or PR follow the base wiring designation, such as K55-CPR or K55CP, it is necessary to include toggle switch E for test purposes and it should be the first switch to be thrown to TEST POSITION.

The circuits of the base wiring designation F, G, H and J, such as M42H, consist of two multi-purpose sections in one unit. Each section is tested separately as if one unit and the necessary lettered toggle switches for either section.

(Continued on page 28)

# TRANSDUCER

leads again with

## A NEW DYNAMIC BALL SHAPE MIKE

Transducer pioneered the streamlined dynamic microphone field with the famous 'Bullet' models. Now, added to this great line of quality leaders is the new Ball Shape 'Bullet' dynamic, model MK35. The same care in design and manufacture which has put Transducer 'Bullets' out front have been applied to the new Ball type. See it! Hear it! Put it through its paces! Free catalog of the entire 'Bullet' line on request. Write.



Model MK 35 Priced from \$19.50 to \$90

### 'BULLET' MICROPHONES

Made only by

**TRANSDUCER CORPORATION**  
30 Rockefeller Plaza, New York, N. Y.

*Now!*

A Balanced Assortment of

**50 Ten Watt WIRT RESISTORS**

Save \$2.00 and get the NEW

FOR ONLY \$10 VALUE \$12

### Lifetime CABINET absolutely FREE

Resistors are all FIRST QUALITY, WIRT WIRE WOUND, protected from injury by Wirt PHENOCOTE, the non-absorbent, non-hygroscopic coating and laboratory tested for humidity and accuracy.

The cabinet is made of well seasoned bass wood rubbed to a beautiful natural finish—6 drawers of three-ply wood—24 compartments—removable partitions. Order yours NOW from your jobber. If your jobber cannot supply you send in the coupon below, with your jobber's name.

**WIRT COMPANY**  
Makers of DIM-A-LITE 5221 Greene St. Philadelphia, Pa.

Please send me your balanced assortment of 50 TEN-WATT WIRT RESISTORS and your new LIFETIME CABINET. If I decide to keep them I pay only \$10.00 by check or money order. If I am not perfectly satisfied I will return them within 10 days.

Name .....

Address .....

Town..... State.....

P.S. You may also send me information on  carbon composition resistors and  Wirt Auto Radio Ignition Suppressors.

# Listen RADIO SERVICEMEN!

For a long time there had been a real need for a Radio Servicemen's Organization that could band together the competent radio servicemen in a democratic, self-governing association without subsidy from or control by any other division of the radio industry.

Radio Servicemen of America, Inc., has this as its prime objective.

But to achieve this end and win a place for the service group as a recognized factor in this complex industry, four things are necessary:

- A. The selection of only qualified members.
- B. A direct voice in the affairs of the association by every individual through elected, regional representatives.
- C. The insistence upon rigid ethical professional standards that will earn a right to the confidence and cooperation of manufacturers and publishers.
- D. A quality of service that will earn the respect and patronage of the public.

These objectives are assured in the newly completed plan of Radio Servicemen of America, Inc. **HERE'S WHY!**

- 1. There are 20 districts, each of which is represented by elected representatives, for all the affiliated chapters in that district.
- 2. Qualifications for membership are determined by local chapters.
- 3. Local membership in a local chapter where such local chapters exist, is necessary to full membership in the national organization.
- 4. Quality, **not** quantity is the membership aim.

**BUT SERVICE TO ITS OWN MEMBERSHIP IS A BIG PERSONAL REASON WHY YOU SHOULD HAVE A MEMBERSHIP IN RADIO SERVICEMEN OF AMERICA, INC.**

Regular mailings of advance information on new circuits. . . . A monthly house organ, exclusively for members. . . . A publicity program in newspapers, trade publications and on the air. . . . Free, expert technical information. . . . A National Speakers' Bureau to provide authoritative speakers for local chapters. . . . An educational program in the interest of better servicing. . . . Membership costs only **\$2.00 A YEAR** for **national dues** for 1938.

**DON'T WAIT!**

Fill out the application. We will send you full details of the organization, more application blanks . . . everything you need to join this new and important effort to organize servicemen for better servicing and more profit. Mail the blank today with your check to

**Radio Servicemen of America, Inc.**

*(Incorporated Not for Profit)*

304 South Dearborn St., Chicago, Ill.

**APPLICATION FOR MEMBERSHIP**

Gentlemen:

I hereby make application for membership in the Radio Servicemen of America, Inc.

Affiliated with Local Chapter in.....

Personal Name .....

Home Address .....

City ..... State.....

Firm Name .....

Address .....

Telephone (home)..... (firm).....

Years Experience..... Age.....

Membership in other Associations.....

Whole or Part Time Radio Serviceman.....

If Part Time, what portion is devoted to Radio Servicing (1/4, 1/2, 3/4, etc.).....

What are your other duties.....

Education other than Radio.....

Radio Training or Courses.....

Testing Equipment .....

It is my sincere desire to become a member and adhere to your principles of fair competition and ethics and if accepted do solemnly swear (or affirm) that I will faithfully fulfill my obligation as a member of the Radio Servicemen of America, Inc.

Signed .....  
Applicant

Approved: Chapter Secretary.....

Executive Secretary .....

Enclosed check ( ); Money-Order ( ); Cash ( )

**RADIO SERVICEMEN OF AMERICA, Inc.**

*Joe Marty, Jr., Executive Secretary*

**304 S. Dearborn Street**

**Chicago**

**Sponsored by RMA and Sales Managers Clubs**

# DuMONT

## TELEVISION DEMONSTRATED with OSCILLOGRAPHS

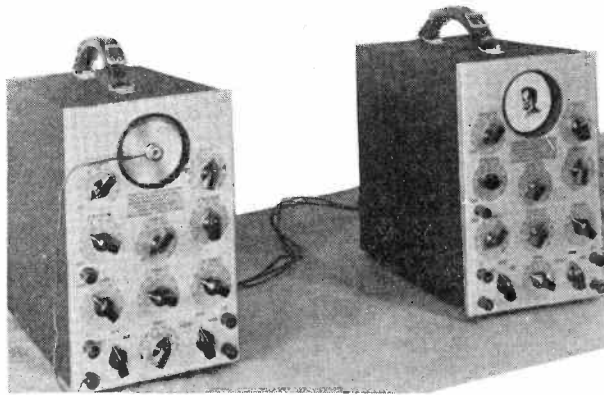

### PROOF OF QUALITY TUBES AND INSTRUMENTS !

This Demonstration is made with two DuMont Oscillographs with minor circuit changes. The same Type 164 Three Inch Service Oscillograph which sells for \$54.50, now faithfully serving the progressive Service Engineers here and abroad.

The DuMont Phasmajector Type No. 1 supplies the video signal transmitted by one Type 164 and received on a DuMont Type 34-7-T Teletron employed in the other oscillograph. With this equipment definition equivalent to approximately 660 lines can be observed, considered as a portion of a regular picture seen on a fourteen inch tube.

FOR FURTHER INFORMATION, WRITE

## ALLEN B. DU MONT LABORATORIES, INC.

UPPER MONTCLAIR

Cable Address:  
WESPEXLIN, NEW YORK

NEW JERSEY



**METAL TUBES?  
THEY MAKE A  
RADIO MODERN!**



Yes—and CUNNINGHAM METAL TUBES are the service man's special—designed, engineered, manufactured expressly for him!

Metal Tubes offer EXTRA advantages. Some of these "extras" include:

1. The elimination of noises arising from external tube shielding—and you can prove this with a demonstration.
2. They assure better performance because of perfect self shielding.
3. Sturdier construction that makes them "vibration proof."
4. They're easier to change.

Besides, Metal Tubes offer many other proofs of merit—all summed up in this statement: They make a radio modern because they give modern performance.

**FREE! \$500.00 WORTH of RCA  
TEST EQUIPMENT**

For full details and entry blanks, see the March issue of RCA Radio Service News... a local Cunningham distributor... or write to the "Modernization Contest Editor," RCA Mfg. Co., Inc., Camden, N. J.

Over 90,000,000  
Cunningham  
Radio Tubes have  
been sold for  
replacement  
service work.  
A product of the RCA Mfg. Co.

# Cunningham Radio Tubes

STANDARD SINCE 1915

## TEST EQUIPMENT—continued

tion are enclosed in brackets as noted on test data list.

### LEAKAGE TESTS

Tests for leakages between sections of multi-purpose ballast units having base wiring designations F, G, H and J (as noted above) are accomplished by throwing both toggle switches BC to TEST POSITION with all other toggle switches in NORMAL POSITION.

A neon lamp glow will indicate leakage between the two independent sections and unit should be rejected as being defective.

Where letter J follows the multi-purpose type ballasts base designation F, G, H, J such as K49JJ or K49HJ, etc., it is necessary to include toggle switch C when testing the second section of such ballasts. This additional toggle switch should be the last one to be thrown to TEST POSITION when testing this section.

Leakage tests on above types are made by throwing toggle switches BCE to TEST POSITION with all other toggle switches in NORMAL POSITION. A neon lamp glow will indicate leakage between the two independent sections.

All ballast tube resistors (used in battery and a-c, d-c receivers) having a single resistance element across the filament prongs of their respective bases, may be accommodated for test purposes by employing toggle switch A, and unit inserted in proper socket. The M-1 socket can only be used to accommodate octal type units.

### TEST DATA LIST

Series	Base Wiring	Test Position
RMA	A	A
X	A	A
Y	A	G
Z	A	A
RMA	B	AG
X	B	AC
Y	B	GF
Z	B	AE
RMA	C	AG
X	C	AC
Y	C	GF
Z	C	AE
RMA	D	AGB
X	D	ACB
Y	D	GFB
RMA	E	AGBE
RMA	E1	AG
RMA	F	(A) (B)*
RMA	G	(A) (B)*
RMA	H	(AG) (B)*
RMA	J	(AGE) (B)*

\*Check for leakage between section as noted in operating instructions heading LEAKAGE TESTS.

SEE THESE AT YOUR DISTRIBUTOR OR WRITE FOR CATALOG NO. 38-S

# THE MODERN LINE



*Portable Type*

*Counter Type*

*Panel Type*

## ELECTRONOMETER SERIES 700

A complete laboratory of compact size for thorough tube analyzing and point to point set testing that has been endorsed and used by leading engineering concerns, broadcast stations, service organizations and institutions. The Series 700, in addition to modern radio tube analyzing features, also incorporates 22 ranges for measurements of A.C. and D.C. voltages, current, resistance, decibel and output. Accuracy is guaranteed by use of wire wound shunts of 1% tolerance and matched resistors of 1% tolerance.

**\$49.95**

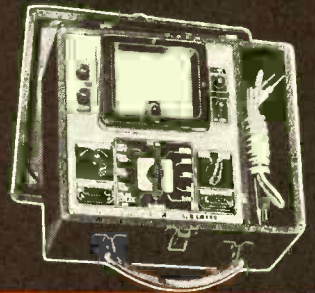

**SERIES 850P** A.C.-D.C.  
Volt-Ohm-Decibel-Milliammeter  
20,000 OHMS PER VOLT D.C.



**SERIES 840L** A.C.-D.C.  
Volt-Ohm-Decibel-Milliammeter  
22 RANGES — 2% ACCURACY



**ELECTRONOMETER  
SERIES 500**  
FOR MODERN TUBE ANALYZING

**SERIES "C"**

FREE POINT  
ROTARY  
SELECTORY  
UNIT



**SERIES  
840C**

COMBINATION OF MODELS 840 and "C"  
AVAILABLE AS 850C WITH 850 and "C"

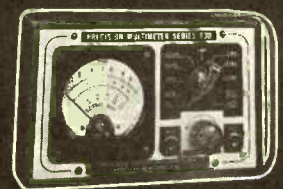
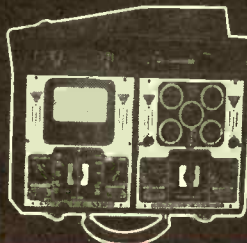

**SERIES 830**  
D.C. Volt-Ohm-Milliammeter  
11 RANGES — 2% ACCURACY

**PRECISION** Apparatus Corporation  
821 EAST NEW YORK AV., BROOKLYN, N. Y.

*All the Latest Features* FOR QUICK, ACCURATE SET TESTING

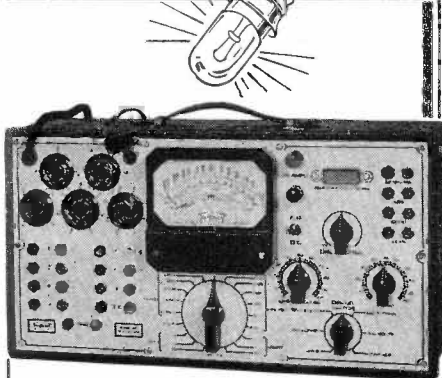

**MODEL 1601**  
DeLUXE SET TESTER  
\$45.33 IN METAL CASE

**Has modern front illuminated instrument . . .**

A great advance in Set Testers is achieved by Triplet's new De Luxe Model 1601 . . . has all the latest features, including many exclusive with Triplet . . . Plug-in type Copper-Oxide Rectifier . . . 25,000 ohms per volt D.C. . . . Large 4-inch square instrument with front illumination (a great aid for more accurate readings).

- D.C. Volts at 25,000 Ohms per Volt. A.C. Volts at 1,000 Ohms per Volt. Reads to 2,000 Volts A.C. and D.C. in 6 Ranges.
- Resistance Measurements to 20 Megohms. Condenser Tester to 30 Mfd.
- 50 Microamperes to 20 Amperes in 9 Ranges.
- New Single Zero Adjustment for Ohmmeter. All A.C. Operated—No Batteries Used.

Also available in attractive leatherette case with compartment for accessories. Net price . . . \$49.33



THE TRIPLET ELECTRICAL INSTRUMENT CO.

173 Harmon Drive, Bluffton, Ohio.

Please send me more information on Model 1601

Name . . . . .  
Address . . . . .  
City . . . . . State . . . . .

**AUTO-RADIO—continued**

right side of the case. The black lead extending from the open end is connected to the antenna lead of roof or suitable undercar or other type of antenna.

The connection to the "A" battery is made by the fused lead which is part of the volume and switch assembly control and is connected to the battery side of the ammeter. This will be indicated by any discharge being shown on the ammeter when the set is turned on. Another lead from the volume and switch assembly connects to the "A" lead from the set. This lead is brought out on the left side.

**ELIMINATION OF MOTOR NOISES**

Recent models of cars will require less attention than will those which have had time to become loosened at body joints. The elimination of generator ripple, which is distinguished by a high-pitched whirring sound, is accomplished by means of a condenser from the generator output to ground. In the case of a roof antenna, a condenser should be connected from a point on the lead that connects to the dome light, where it passes through the left or right side channel of the car, to ground. Make sure that the shielding is continuous

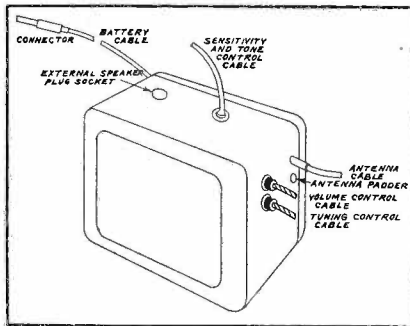

Fig. 1. External view of Trav-Ler 710 and 711, showing various connections and control cable.

from the end of the antenna cable as far up to the antenna proper as is possible; large diameter shielding is preferable. In stubborn cases, use a distributor suppressor. This is inserted in the distributor head or in the ignition coil spout or any place along the high-tension lead. In some cases where motors are mounted on rubber it is necessary to bond the engine to the chassis by means of heavy metal braiding.

**ALIGNMENT INSTRUCTIONS**

Set the variable condenser with rotor plates in full open position; set signal generator to 456 kc; connect generator lead to grid cap of 6A8 through a 0.1 mfd condenser for dummy antenna. Adjust i-f trimmers for maximum out-

MADE BY *Engineers FOR Engineers*



Antenna systems, P-A cables, hook-up wires bearing the nationally identified CORWICO diamond trademark are produced in an adequately equipped plant to do their job 100 per cent.

The illustrious NOISE-MASTER all-wave antenna illustrated above, licensed by A.A.&K., is warranted to eliminate man-made static on broadcast as well as shortwave lengths . . . and to improve reception in any locality.

Write for complete information regarding this and other CORWICO products, made by engineers for engineers.  
**CORNISH WIRE CO., Inc.**  
30 Church St., New York City



**RADIO-WIRE**  
*products*

**The Replacement Parts Market Is Thriving . . .**

Distributors of Parts and Accessories and the Servicing Trade of the country are doing business, plenty of it.

Get your share by advertising in April SERVICE. Forms close the fifth.



put, reducing generator output as point of alignment approaches.

Set signal generator to 1620 kc; connect through a 0.00025 mfd condenser to antenna lead of set. Rotate oscillator trimmer until signal is picked up. Set generator to 1400 kc, pick up signal by turning variable condenser, then adjust r-f and antenna trimmers for maximum output.

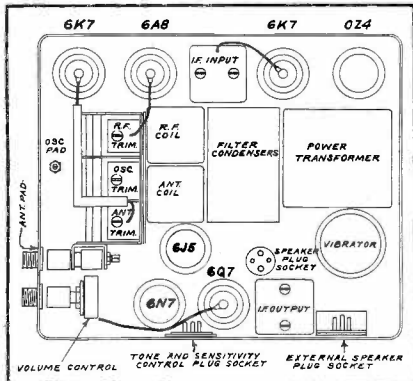

Fig. 2. Tube and chassis layout, Trav-Ler 710 and 711.

Set signal generator to 600 kc, rotate variable condenser to pick up signal then adjust oscillator padder, while rocking variable condenser, for maximum output.

Recheck alignment at 1620 and 1400 kc.

When set is installed, antenna circuit may be tracked to car antenna by adjusting antenna padder located just below antenna socket.

**Crosley 516**

*Intermittent operation with sputtering and chattering that sounds like off-center cone.* Due to broken leads to voice coil. Have had considerable trouble with voltage dividers. Correct values are: feeder 8500 ohms, bleeder 25,000, 2 watt and 1 watt respectively.

*Francis C. Wolven*

**G. E. 105**

*Transformer hum and overheating:* Connect 500-ohm 10-watt resistor in series with center tap of power transformer. Loosen transformer bolts and insert piece of cardboard between transformer and chassis; tighten bolts.

*Willard Moody*

**Halsen 05**

*Broad tuning:* Detector coil grid return goes to chassis ground. Remove wire and resolder directly to pigtail contact on tuning condenser. Realign set and sharpness is improved.

*Willard Moody*



PRESENTING

**THORDARSON AMPLIFIERS**

**NEW**

**DESIGN APPEAL  
CONSTRUCTION  
PERFORMANCE**

- Solid Walnut Cabinet
- Illuminated Dials
- Protected Controls
- Window Visibility Dials
- Low Distortion at all audible frequencies
- Dual Tone Control
- Multiple inputs with individual controls
- Universal output impedance selected by convenient "plug-in" connectors

*Spectacular* is the word which best describes the many features of these new amplifiers. *Spectacular* is the word which best describes their recent announcement by nationwide "Telephone Broadcast" to the trade in principal cities all over the country. *Spectacular* is the word which best describes the new sales appeal of this line. Check the features above and see just how much Thordarson amplifiers give you to sell. Be the first in your territory with the latest, in fact most advanced, amplifier on the market.

**Engineered—Styled—Modernized**

**"They Speak for Themselves"**

See your jobber or write the factory direct for new FREE Catalog No. 600-C.

**AMPLIFIER DIVISION OF**

**THORDARSON ELECTRIC MFG. CO.**  
**500 W. HURON ST., CHICAGO, ILL.**

**GET THIS EQUIPMENT ALMOST FREE!**



**.. with Purchases of ARCTURUS TUBES**

**DOWN PAYMENTS AS LOW AS \$3.00!**

Down payments in the Arcturus Deal are without question the *lowest* ever offered—as low as \$3.00 in some cases! On an average you pay only about **ONE-SIXTH** the amounts required by other deals! This means an *actual cash saving* to you.

**AND REMEMBER THIS IMPORTANT POINT:** Under the Arcturus Equipment Deal not one cent has been added to our regular tube prices. You buy standard tubes at **STANDARD PRICES**, less standard discounts. To pay more than these standard prices on a deal probably means you are actually paying cash for the equipment. Think it over! Remember, also, that the Arcturus plan is still further geared to your needs in that required tube purchases are surprisingly low.

**EXTRA PROFIT FOR YOU!**

In short, the **ARCTURUS EQUIPMENT DEAL** brings you the opportunity of a lifetime to modernize your shop with the latest standard equipment—at almost no cost to you. You obtain possession of the equipment **IMMEDIATELY**—and finance it by your purchases of Radio's finest, best engineered tubes. Thus you profit twice from every tube you sell. You can't lose!

**MAIL THE COUPON NOW!**

**ARCTURUS**

ARCTURUS RADIO TUBE CO., Newark, N. J. 8-5  
Without cost or obligation on my part, send details of your new equipment deal.

Name .....

Street .....

City..... State.....

I am a dealer       I am a serviceman

My jobber is.....

For your convenience this coupon can be pasted on a penny postcard

**SOUND SERVICE—continued**

event the volume can be turned up only to the point of feedback of the peak frequency. The low feedback of the velocity is due to the fact that it has no peaks, and also the zero angle of pickup. The dead angle permits the microphone to be placed in a position where it will pick up the speakers or musicians and at the same time discriminate against noises originating in the audience.

We have discussed above frequency response and angle of pickup of the microphone. We now come to the third and though usually overlooked, the most important requirement of present amplifying systems—minimum harmonic distortion. It has been often demonstrated that an audience will not miss the elimination of an entire octave, but will notice a change of only 2 percent in harmonic distortion; above 5 percent distortion becomes unbearable. It is possible at the present time to build amplifiers where distortion is kept at 2 percent of maximum output, but one must be careful not to introduce such distortion through the pickup devices such as microphones, radio tuners or phonograph pickups.

Pushing a diaphragm in, besides overcoming its own stiffness, requires extra energy to compress the air behind it; in pulling it out the vacuum created by relieving the compression aids it. The in and out motion is therefore not symmetrical. Harmonic distortion is caused by the asymmetry in the system. In the velocity microphone the vibrating element is subjected to very little pull or attraction that will distort its natural shape; it vibrates in a magnetic field of constant intensity. There is therefore slight chance of harmonic distortion originating in the microphone itself.

**Majestic 490**

*Stations come in at two points on dial:* Also, distortion with antenna connected. Due to open a-v-c section of second i-f transformer.

*Rocco Costabile*

**Philco 600C**

*Intermittent, with noise:* Bad connections on antenna and oscillator coils. Resolder.

*Rocco Costabile*

**Zenith 8S-154**

*Fading or reduced volume with little action on target tuning indicator:* Due to bad connections on antenna coil. Resolder.

*Rocco Costabile*

**SALES**



**QUICK—EASY XCELITE Screw Drivers**

Xcelite Screw Drivers—for eleven years the industry's quality product—is now furnished in three attractive display assortments. The famous Xcelite handle—beautiful, transparent, breakproof and shockproof—is known throughout the industry. Made in all popular sizes. Use them. . . . Display them. . . . Sell them. Order from your jobber or write for special descriptive circular.

**PARK METALWARE CO., Inc.**  
Orchard Park, N. Y., U. S. A.

**CROWE** INTER-CHANGEABLE

**ON - THE - PANEL CONTROLS**



**EASY TO INSTALL NO-GLARE DIAL**

**DO** you know that over *five and one-half million* auto radios have been sold in the last six years?

Do you know that nearly *four million* of these sets were new within the last three years?

**Your Opportunity!**

Sell Crowe On-the-Panel Controls to reinstall these still-serviceable radios in new cars. Sell them to replace old-fashioned under-dash or steering column controls in owners' present cars.

**See Your Jobber**  
Get a stock of Crowe Controls from your jobber and go after your share of this valuable replacement business.

**ASK FOR BULLETIN**

**CROWE NAME PLATE & MFG. CO.**  
1775 GRACE STREET CHICAGO  
CABLE ADDRESS: CRONAME - CHICAGO

## A "BREAK" FOR SERVICE MEN

(Continued from page 11)

vance notices should write to Rural Electrification Administration, Washington, D. C.

At this writing the REA and EFHA are active in 42 States. As of the 11th of October, generating equipment had been arranged in Alturas, California; Winchester, Illinois; Maquoheta, Iowa; Iowa Falls, Iowa; Pocahontas, Iowa; Welcome, Maryland; Blissfield and Bad Axe, Michigan; Ocracoke, North Carolina; Artesia, New Mexico; Blachly, Oregon; Harrisonburg and Manassas, Virginia; Quinalt, Washington; Moorefield and Clarksburg, West Virginia; Chippewa Falls, Wisconsin, and Freedom, Wyoming. The REA projects, actual and potential, as they were shown on the official map of the Government on October 1st, are indicated on the map furnished by the REA, reproduced herewith.

All agencies of the Government emphasize the point that it is not difficult to sell a radio to the farmer. It has been found that concurrently with the desire for the electric receiving set, the farm family is eager to purchase a good-looking piece of furniture, a set that will be an ornament in the living room. The officials who have been out in the field report that the farmer sells himself the radio he buys. It has been found in many instances that the local dealers are wholly unawake to the market that has been created. The farmer's chief problem is to determine what kind of radio he will buy. He wants a wide range of reception. Government people have observed that the dealer with the largest stock normally makes the most sales. On the other hand, several manufacturers and distributors in various sections have sent demonstrating groups with the installation crews sent out by the REA. These demonstrators have joined other demonstrators of electrical appliances obviously appealing to the farmer with a newly wired home; and in several instances these groups who demonstrate a number of electrical wares have formed what almost constitutes a travelling show. Following the REA crews, they go into a rural town and catch the farm families on a market day. To make sure of an audience they bill the countryside like a circus. And the Government engineers report the turnout of interested farmers and their families is far greater even than the crowds that come for circus day. And they sign on the dotted line. In some districts intelligent dealers lend radios to farmers whose homes are neighborhood centers; or, demonstrate them at the churches, or at dances.

**ANYBODY CAN BUILD  
CHEAP SPEAKERS —  
IT REQUIRES AN EXPERT  
TO BUILD A GOOD SPEAKER  
AT A LOW PRICE!**



**WITH  
ADJUSTABLE  
IMPEDANCE  
TRANSFORMER**

**New  
Jensen**

**SERIES "S"**

**5 INCH**

**6 INCH**

**8 INCH**

## REPLACEMENT SPEAKERS

*are Quality Speakers at Low Prices*

Here is the answer to the problem with which every dealer and serviceman has struggled. A replacement loud speaker at a price the public will pay and with guaranteed quality and reliability.

It is no longer necessary for the reliable radio service dealer to jeopardize his reputation by offering an ill-fitting, poorly designed replacement part or a nondescript complete speaker to meet the owners' demand for low price. The name Jensen insures the quality, and the price of these new speakers is the lowest in history.

**PRICES**

5" Speaker—List Price, less transformer.....	\$2.30
6" Speaker— " " " " .....	\$2.70
8" Speaker— " " " " .....	\$3.90

Add \$.60 for fixed impedance transformers; \$.85 for adjustable impedance transformers. All are available with an assortment of field coils.



JENSEN RADIO MFG. COMPANY S-338  
6601 So. Laramie Ave., Chicago, Ill.

Please send me more detailed information on New Jensen 5", 6" and 8" Replacement Speakers.

Name .....

Address .....

City ..... State.....

S-338

**YOU'LL NEVER  
LOSE A  
CUSTOMER**  
*... by giving him  
the best...*

**IRC**  
INSULATED  
*Metallized* TYPE BT  
**RESISTORS**

Almost any piece of carbon is a resistor . . . but a really good resistor, scientifically designed to meet every requirement of Radio, is something else again. IRC Resistors may cost a little more to buy . . . But they actually cost far less to use in all replacement work. There's no come-back when you use IRC's. They never let you down . . .

*"They Stay Put!"*

**INTERNATIONAL  
RESISTANCE COMPANY**

401 N. Broad St., Philadelphia, Pa.

## UNUSUAL CONNECTION FOR 6L7

(See front cover)

IN ORDER to satisfy some highly special requirements of a customer, J. A. McRoberts of Long Island City hit upon the scheme shown in the front-cover diagram.

The customer wished to listen to an English station (on short-wave, of course) regularly and wanted tone quality at least partially comparable with local reception, especially in so far as fading was concerned.

In the circuit shown, Mr. McRoberts claims that the 6L7 is acting somewhat as a volume expander. As will be noticed, the so-called injector grid of the 6L7 is connected to the "high" side of the manual volume control; note the absence of the filter usually connected in a-v-c circuits. Such a circuit arrangement would impress the a-f component of the diode output, along with the d-c, upon the injector grid.

Examination of the curves for the 6L7 will show that there is a very wide range in transconductance with change in the bias on the injector grid (No. 3); this change in Gm, for a 0-17 volt bias variation, is of the order of 1300 micromhos. In other words, with zero volts on Grid No. 3, Gm will be 1300 micromhos, while with -17 volts on Grid No. 3, Gm will be practically zero.

Obviously, the connection proposed by Mr. McRoberts provides an a-v-c action of a sort. We are inclined to disagree that there is any real volume expansion. There may be "apparent volume expansion" due to the relatively quick action of an a-v-c system such as this, but this would not be expansion—it might *seem* like expansion of the ear.

Mr. McRoberts points out the practicability of this system for short-wave reception only; this is because the bias on the 6L7 would be cut off by a strong local signal.

Any further reports from the experience of others with this circuit will be welcomed.

## "FADING"

(Continued from page 9)

tests and the only concern now is the r-f amplifier itself.

If the probe is placed on the grid circuit of the mixer tube, and the signal is fed to the antenna circuit, when the reading goes down with the fade it proves definitely that the defect is in the r-f section. If the signal is shifted to the first r-f grid stage, thus eliminating the antenna stage and the signal still fades, it proves that the antenna stage is OK. The signal lead can be shifted



## De Luxe RECEPTION!

- TACO Type 210 Antenna System provides for de luxe reception with any set, new or old.
- Maximum signal strength on all wave bands. Minimized background noises.
- Complete kit. Factory assembled, wired, soldered. Just string up. Only \$6.75 list—and a big value at that.

## DATA . . .

- Ask your local TACO jobber for latest data on self-selecting noiseless antenna systems and master antenna systems. Or write us direct.

**TACO**

TECHNICAL APPLIANCE CORP.

Licensed Under A.A.K., Inc., Patents

17 East 16th St. New York City

In Canada: 414 Bay St., Toronto

**RADIO  
IN IT'S  
ENTIRETY**



**COMPLETE STOCKS  
READY FOR YOU**

"B-A" serves the trade with every need in radio. Complete 160-page catalog of radio receivers, public address systems, parts, supplies and equipment is now available. You will find your favorite nationally known lines represented in this big book. "B-A" prompt service will please you—orders shipped same day they are received.

**BURSTEIN-APPLEBEE CO.**  
1012-14 MCGEE ST. KANSAS CITY, MO.

**UP-TO-DATE CATALOG  
NOW AVAILABLE**

to the plate circuit of that tube and if the fade still occurs, the grid circuit must be OK, and so on.

Testing the r-f amplifier is practically the same procedure as testing the i-f amplifier. The only difference is that the stages are eliminated by shifting the test oscillator signal lead instead of the meter probe. Because of the small r-f voltages available, when testing the grid circuit of the mixer tube it is best to shift the probe to the plate circuit of that tube to take advantage of its amplification. The set's oscillator voltage should be stopped by shorting the oscillator gang condenser so it will not be measured with the signal voltage in the mixer plate circuit.

The circuit components are tested in the same manner, that is, the meter probe is placed across bypass condensers, low scale ohmmeter across switch contacts and poor soldered joints, etc.

There are various methods used to force stubborn sets to fade and the method most applicable to the trouble suspected should be used. For instance, if the trouble has been narrowed down as probably being in the oscillator and the set refuses to fade any more, the set voltage can be lowered by placing a 100-or 150-watt lamp in series with the a-c line, thus coaxing dirty contacts or poor soldered joints to kill the lower oscillator voltage and show up as trouble.

If it is thought that a bypass or coupling condenser may be opening, the set can be left in a cool place for a time and then given a quick temperature change by either forcing the set to play with a higher voltage or by turning on the heat from a portable electric heater. The extreme temperature change causes sudden expansion of soldered joints, particularly in the condensers themselves. If a coupling condenser is suspected, play the set at low volume for the best fading results, as any high a-c excitation tends to make the effect less noticeable.

Playing the set at a higher voltage is a matter of using a tube tester filament transformer, phasing the windings in series with the primary so as to add the secondary voltages to the primary voltage, thus using it as an auto-transformer. Such a circuit is illustrated in Fig. 6 with a phase reversing switch added to make the secondary voltage add or buck the primary voltage by whatever amount is selected by the main switch, thus giving a range of from 80 volts to 140 volts a-c.

While there are other methods of obtaining the same results, this method of finding trouble is direct, and radio Service Men like actually to see what is causing the trouble without guessing.

# ★ VARITRAN ★

## VOLTAGE CONTROL UNITS

Reg. U. S. Patent Office



### FEATURES

- ★ Smooth control
- ★ High efficiency
- ★ Excellent regulation
- ★ Low cost

### APPLICATIONS

- ★ Motor control
- ★ Heat control
- ★ Rectifier control
- ★ Light control
- ★ Line voltage control

The UTC VARITRAN makes possible continuously variable output voltage, using a sliding contact riding over the turns of an auto-transformer. Standard units are designed for 115 volts input, 0-130 volts continuously variable output.

- Model V-1. 570 Watts—5 amp. maximum rating, complete with cord, plug and switch, net. . . . . \$10.00
- Model V-2. Same as V-1, but uncased, with terminal strip for rack or panel mounting, net . . . . . \$9.00
- Model V-3. 850 watts maximum rating, 7.5 amps., uncased, with terminal board and provisions for mounting, net. . . . . \$14.00
- Model V-4. 1250 watts—11 amps. maximum rating, uncased, net. . . . . \$20.00
- Model V-5. 2000 watts maximum rating, 17.5 amps., uncased, net. . . . . \$32.00

### Other Sizes

Automatic VARITRANS are available to maintain line voltage constant. Details and prices on request.

Licensed under U. S. Patent No. 2009013

## ULTRA COMPACT HIGH FIDELITY AUDIO UNITS

The UTC Ultra compact audio units represent the acme in small, light-weight units where portability or size is of paramount importance. Through the use of new design methods, high fidelity is obtainable in all individual units, the frequency response being  $\pm 2$  DB from 30 to 20,000 cycles on all units. There is no need to resonate one unit in an amplifier to compensate for the droop of another unit.

All units employ true hum balancing coil structure, which combined with a high conductivity outer case, affords a maximum of inductive shieldings.

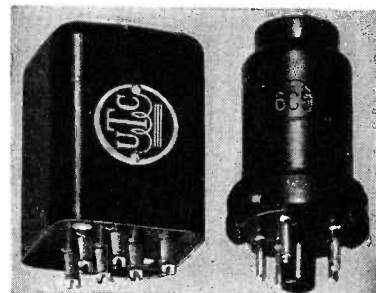

Type No.	Application	Primary Impedance	Secondary Impedance	Your Price
A-10	Low impedance mike, pickup, or multiple line to grid.	50, 125, 200, 250, 333, 500 ohms.	50,000 ohms.	\$6.00
A-12	Low impedance mike, pickup, or multiple line to push pull grids.	50, 125, 200, 250, 333, 500 ohms.	80,000 ohms overall, in two sections.	\$6.00
A-14	Dynamic microphone to one or two grids.	30 ohms.	50,000 ohms overall, in two sections.	\$5.40
A-16	Single plate to single grid.	8,000 to 15,000 ohms.	60,000 ohms, 2:1 turn ratio.	\$4.80
A-18	Single plate to two grids.	8,000 to 15,000 ohms.	80,000 ohms overall, 2.3:1 turn ratio overall.	\$5.40
A-20	Mixing, low impedance mike, pickup or multiple line to multiple line.	50, 125, 200, 250, 333, 500 ohms.	50, 125, 200, 250, 333, 500 ohms.	\$6.00
A-24	Single plate to multiple line.	8,000 to 15,000 ohms.	50, 125, 200, 250, 333, 500 ohms.	\$6.00
A-26	Push pull low level plates to multiple line.	8,000 to 15,000 ohms each side.	50, 125, 200, 250, 333, 500 ohms.	\$6.00
A-27	Crystal microphone to multiple line.	100,000 ohms.	50, 125, 200, 250, 333, 500 ohms.	\$6.00
A-30	Audio choke, 300 henrys @ 2 MA 6000 ohms D.C., 75 henrys @ 4 MA 1500 ohms D.C., inductance with no D.C. 450 henrys.			\$4.20

## UNITED TRANSFORMER CORP.

72 SPRING STREET NEW YORK, N. Y.  
EXPORT DIVISION: 100 VARICK STREET NEW YORK, N. Y. CABLES: "ARLAB"

# ASSOCIATION NEWS . . .

## RSA DOUBLES MEMBERSHIP

We have now affiliated twenty-four local chapters in all parts of the country. Twelve petitions for affiliation from twelve additional local groups are on file in the national office at the present time.

The first issue of our house organ as well as the advance circuit diagrams on the Zenith radios went forward to our members on February 28, 1938.

### Duluth Chapter

The Duluth Chapter in cooperation with the Chief Engineer of KDAL, held a very interesting meeting, at which time the subject of "Broadcasting From the Serviceman's View Point" was discussed.

A second meeting held in February was conducted at one of the night spots in town. Reports were that wives and sweethearts were there. A gala time was reported by all. The credit for this evening should go to John T. Springer, Ed Nys and Gary Kasberg.

### Freeport Chapter

Don Stover and S. A. Frank were chosen as nominees for District Ten.

Local dues were increased to \$5.00 a year—this sum to include national dues and a one year's subscription to a trade publication.

A. G. Mohaupt gave a very interesting lecture on the oscilloscope and its application.

### Flint Chapter

The Flint Chapter is celebrating its first year of existence and its affiliation with RSA, with a dinner and dance.

A membership drive got under way at the last meeting at which time the following officers were elected for 1938: President, Worden Stiles; Vice-President, Harold Wilke; Secretary, James Pugh; Treasurer, Walter Mudge.

### Binghamton Chapter

John Rose was nominated for the office of director from District Nineteen at the first meeting held in February.

The Binghamton Chapter attended in a body a lecture given by Walter Jones of Hygrade Sylvania who spoke at Ithaca, N. Y. Reports reaching the national office also indicate that the chapter attended the tap room in a body afterwards.

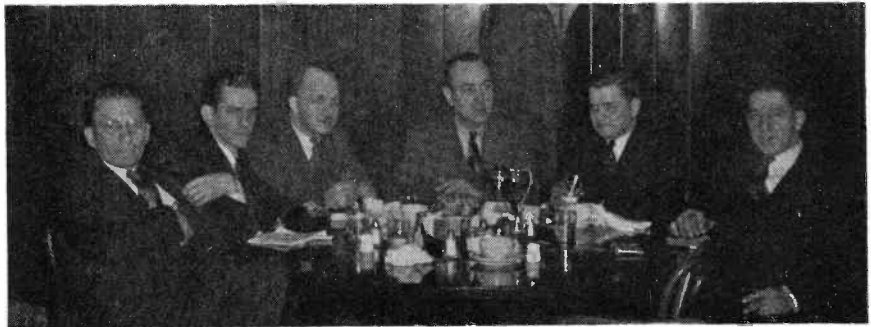

Officers of the Cleveland Chapter, RSA. Left to right, G. H. Roberts, J. R. Trammell, R. L. Kline, L. Vangunten, N. Bear (reporter) and J. Repar.

### Peoria Chapter

A. G. Mohaupt gave a very interesting lecture on the use of the oscilloscope in radio servicing. The members report business good in this territory (excluding house set sales). Car radio sales and service are better than this time last year. Automatic tuning on car radios is going over big.

### Chicago Chapter

The Chicago Chapter held a test equipment show at which eleven manufacturers of test equipment participated.

The Jackson Electrical Instruments Company, sponsored by the chapter, gave a meeting on February 28 to an over-flow crowd of 425 men. One serviceman travelled 500 miles, part of the way on snow shoes, in order to attend this meeting and incidentally apply for membership in the organization.

The committee, appointed by Ray Mason, Chairman, is compiling a list of private brand name receivers in order that the individual members may know what factory makes the receiver when it is brought in to their shops for repair.

A. E. Rodriguez is calling on the various servicemen around Chicago in order to acquaint them with the work that the chapter is doing as well as to gather information for chapter records. The executive committee has decided to limit very strictly the invitations to non-members for future meetings.

### Metropolitan NY Chapter

Meetings are held the second and fourth Monday of each month at the Hotel Victoria. A telephone has been installed in the name of RSA in downtown New York, for the convenience of members and other interested parties.

The Technical Meetings are under the direct supervision of Ed Mandeville. The Chapter officers are: Chairman, George Duvall; Secretary, Selig Rosengarten; Treasurer, J. J. Gonoud.

### Manchester Chapter

At a meeting held on February 1, 1938, a new constitution was submitted and accepted.

An interesting open forum was held on several subjects pertaining to radio at a meeting held February 15, 1938. Advertising was discussed and plans laid to conduct a regular cooperative advertising campaign starting in the late summer and early fall. A committee was appointed to handle all details.

### Davenport Chapter

More than 75 men attended a lecture held by RCA for the chapter in the People's Power Building, Moline, Illinois. The holder of lucky numbers received prizes furnished by the Klauss Electric Company.

Davenport has so far done an outstanding job in the way of new memberships. This chapter has outstripped many other chapters in this respect.

### Boston Chapter

Horace Perry, a local member of the Boston Chapter, conducted a very interesting meeting on February 7th. Mr. Perry gave a fine demonstration of what could be done with good equipment. Radio chassis were provided and the members themselves had a good chance to make all kinds of tests and they were impressed with the fact that the best of equipment is necessary for quality service.

All of the members of the chapter are working together on cooperative advertising and other plans for the betterment of service conditions in the Boston area.

### Detroit Chapter

The Detroit Chapter promises to have John Rider as guest speaker at a large gala turnout in the near future (that is if John can be found before the summer is well advanced). The local broadcasting

(Continued on page 45)



A meeting of the Chicago Chapter, RSA, at the Stevens Hotel. This meeting, held on January 23, was for the election of officers.

**SHOW TIME**  
**JUNE 8<sup>TH</sup> TO 11<sup>TH</sup>**  
**THE ANNUAL**  
**HOMECOMING**  
**OF THE ENTIRE RADIO INDUSTRY**

**Convention Time, Too!**

Starting Tuesday morning, June 7, and continuing through Saturday evening, June 11, the Stevens Hotel, in Chicago, will fairly radiate with radio industry activity.

**CONVENTIONS SCHEDULED**  
 At The Time Of The  
**1938 NATIONAL RADIO PARTS TRADE SHOW**  
 Are Listed Below:  
**RADIO MANUFACTURERS ASSOCIATION**  
**SALES MANAGERS CLUB "REPRESENTATIVES"**  
**RADIO SERVICEMEN OF AMERICA**  
**NAT'L ASSN. OF RADIO PARTS DISTRIBUTORS**

**B C-N U** **RADIO PARTS CITY**  
**STEVENS HOTEL — CHICAGO**  
**June 8, 9, 10 and 11, 1938**  
**RADIO PARTS MANUFACTURERS NATIONAL TRADE SHOW**  
**53 WEST JACKSON BOULEVARD CHICAGO, ILLINOIS**

**Halldorson**  
*Vacuum Sealed*  
**Transformers**

**Two Models**  
**Fit 1250 Receivers**  
 Do You Know eight Halldorson models will take care of all replacement demands for both power and audio transformers in more than 90% of all makes of radio sets?  
 For better, more satisfactory results, specify Halldorson.  
 Ask Your Jobber  
 Write for New Catalog

**THE VARI-VOLT**  
**Exclusively Halldorson**  
 0 to 256 v. in 1-volt steps; 0-128 in 1/2-volt steps.  
 Simplifies radio service work!



**FREE**  
 to Servicemen on Halldorson Deal  
 Please send me—  
 New Catalog  
 Information on Free Vari-Volt Deal.  
 Name \_\_\_\_\_ Address \_\_\_\_\_ City \_\_\_\_\_ State \_\_\_\_\_  
 THE HALLDORSON CO., 4500 Ravenswood Ave., Chicago, Ill. S-338

**SPECIAL OFFER**

a FREE three-month subscription to Sylvania News



**FOR A HAPPY NEW YEAR**

Leading light in the radio industry is Hygrade Sylvania Corporation, which has been making a steady advance in the production and distribution of vacuum tubes and components that are essential to the radio industry. The company's products are known for their reliability and long life, and are used in a wide variety of radio sets, from the simple table-top set to the most sophisticated portable receiver. The company's success is due to its commitment to quality and innovation, and its ability to meet the needs of the radio industry.



More than 55,000 live-wire radio men read each issue of Sylvania News\* . . . and letters keep pouring in from every part of the country, telling how helpful it is.

Join the ranks of the well-informed — get your free subscription to Sylvania News. In every issue you'll find — not only the latest news of the trade — but also a wealth of technical and servicing hints . . . practical merchandising ideas . . . tips on how to improve your business.

Take advantage of this special offer. Mail the coupon below, and your three-month subscription will start with the very next issue. Do it today—time is limited.

\*The official "house magazine" of Hygrade Sylvania Corporation. Hygrade Sylvania also manufactures the famous Hygrade Lamp Bulbs.

**SYLVANIA**  
 Set-Tested Radio Tubes

S-38  
 Hygrade Sylvania Corp., Emporium, Pa.  
 Please send me Sylvania News for the next three months free.  
 Name \_\_\_\_\_  
 Address \_\_\_\_\_  
 City \_\_\_\_\_ State \_\_\_\_\_  
 Serviceman  Dealer  
 Amateur  Experimenter  
 Name of Jobber \_\_\_\_\_

# THE MANUFACTURERS . . .



## CORNELL-DUBILIER ANNOUNCES THE "BEAVER"

Claimed to be extremely small in size for the capacities and voltage ratings listed, the "Beaver" condenser of Cornell-Dubilier is attracting wide attention.

According to Leon Adelman, sales manager of Cornell-Dubilier, the reduction in size is attained through the use of etched foil which gives greater capacity per unit area. Although the etching process has been known for some time, Mr. Adelman states that new methods have produced even greater effective anode areas.

"Beavers" may be obtained in all standard values and ratings.

Among other features of the "Beaver" are hermetical sealing against leakage, insulated aluminum case, and ability to operate in high ambient temperatures. Complete details on these condensers may be obtained from the Cornell-Dubilier Elec. Corp., S. Plainfield, N. J.—SERVICE.

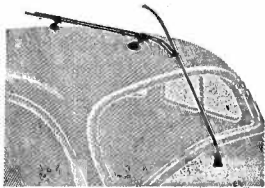

## INSULINE CAR ANTENNAS

A line of antennas for installation on cars has been announced by the Insuline Corp. of America, 23-25 Park Place, New York City. The "Eaglet," illustrated here, is typical of the models offered. All are designed to offer excellent reception and to fit in with the general trends in car styling, according to the manufacturer.—SERVICE.

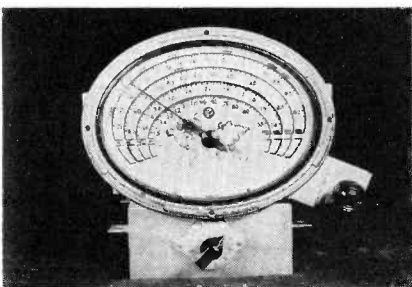

## BROWNING KITS AVAILABLE

Under the guidance of Glenn H. Browning, the Browning Laboratories, Inc., Winchester, Mass., has been formed to engage in the design and sale of kits for the experimenter and amateur. Typical of the models to be made available is the BL-1 4-band tuner, illustrated here.—SERVICE.

## THORDARSON AMPLIFIERS

An entirely new line of amplifiers in moderately styled, solid walnut cabinets has just been announced by Thordarson Electric Mfg. Co., Amplifier Division. Outstanding features are said to be illuminated dials, protected controls, window visibility dials, dual tone control, low distortion at all audible frequencies, inverse feedback, multiple inputs with individual controls, and universal output impedance selected by convenient plug-in connectors.

The full line includes sizes from 8 watts to 60 watts output covering practically every application. Amplifier and speaker carrying cases are available. Free Catalog No. 600-C may be obtained from Thordarson jobbers or by writing the Amplifier Division of the Thordarson Electric Mfg. Co., 500 W. Huron Street, Chicago, Illinois.—SERVICE.

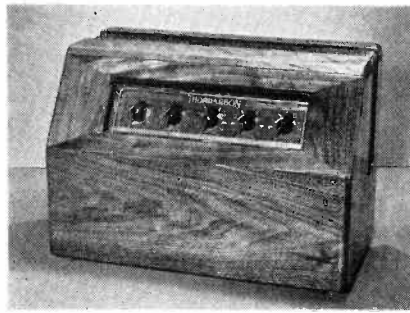

## AUTO-RADIO CONTROL

Star Machine Mfr., Inc., of 1371 E. Bay Ave., Bronx, N. Y., announces their new 1938 Star auto radio control.

This new unit has all ratios self-contained, is adjustable for any opening on instrument panel, and therefore is 100 percent universal for all cars and all radios, according to the manufacturer.

A single unit takes care of any re-installation job regardless of gear ratio or opening on dash, without drilling, cutting, or mutilating instrument panel.

A complete line of custom matched escutcheon plates including the 1938 line is now available with edge illuminated etched glass dials for non-glare illumination.

A four-page illustrated catalog is now being mailed to the trade.—SERVICE.

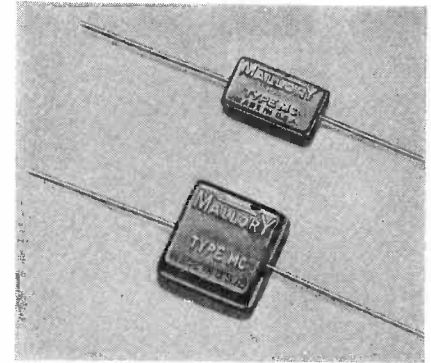
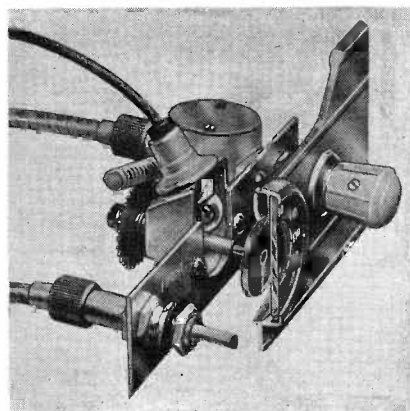

## MALLORY MICA CONDENSERS

Mallory announces a new line of mica condensers—compact, mechanically strong, and moisture proof, made of the best grade of clear India mica. After specially treating the mica-tin foil to exclude moisture, air and foreign matter, it is clamped under pressure to the terminal leads. The junction between the foil and lead terminals assures perfect low resistance contact, preventing the bakelite molding material from affecting this connection. Lead wires are soft tinned metal which may be bent or twisted without breaking. Special catalog on request. Address P. R. Mallory & Co., Inc., Indianapolis, Ind.—SERVICE.

## MIDGET ANTENNA

Hahn-McPherson Laboratories, Hatboro, Pa., have announced a car antenna known as the Police Midget. It is a simplified version of the retractable antenna manufactured by this same organization.—SERVICE.

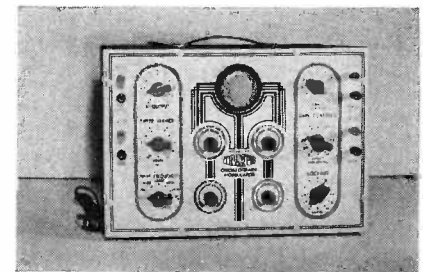

## 2-INCH OSCILLOGRAPH WOBBULATOR

A new Oscillograph Wobbulator, Model 77-2-inch employing the NU 2002, 2-inch cathode-ray tube has been announced by the Triumph Mfg. Co., 4017 W. Lake Street, Chicago, Illinois. The Model 77-2-inch employs a built-in 840 kc frequency modulator automatically synchronized to the linear sweep circuit. Thus complete analysis of r-f and i-f circuits can be made by observing the resonance curve of each tuned circuit, it is claimed.

The Oscillograph proper performs all the standard 'scope functions with a linear sweep of 10 to 45,000 cycles. A pattern locking control assures stable patterns.—SERVICE.

(Continued on page 40)



# VIBRATOR REPLACEMENTS ARE

*Easier, More Profitable*

WHEN YOU USE

# Utah

## VIBRATORS

### HERE'S WHY!

*First* ... They're the Toughest Ever Built!

We give vibrators terrible abuse in our laboratories—then build UTAH's so they can take it! UTAH research is responsible for practically every major improvement in vibrator design. And the 1938 UTAH vibrator, with exclusive patented features, is the finest and toughest ever made. UTAH vibrators can really "take it," and they give greater efficiency besides. Be sure you use UTAH's on your next job.

*Second* ... UTAH VIBRATORS ARE PRICED RIGHT!

Even though UTAH vibrators work better, and last longer, they cost no more. They have earned such popularity through outstanding performance, that quantity production absorbs the cost of their extra features. You get most for your money when you buy UTAH's.

*And*

Because just a few types are needed to service all radios, your jobber has a complete stock. That makes it easy for you to service ANY radio.

Ask your jobber for UTAH Vibrators. Write department S-3 for Vibrator Chart.

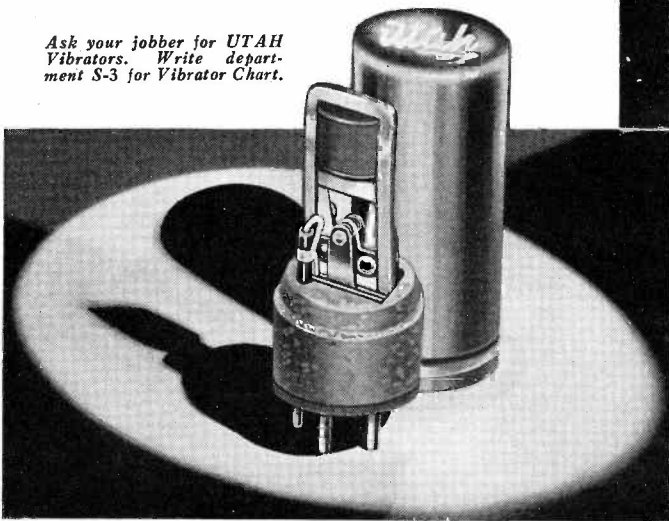

**UTAH RADIO PRODUCTS CO.**  
CHICAGO, U. S. A.

BUENOS AIRES—UCOA RADIO PRODUCTS CO.

**"16 YEARS OF LEADERSHIP"**

MARCH, 1938 •

SAY YOU SAW IT IN SERVICE

# LET'S FACE FACTS

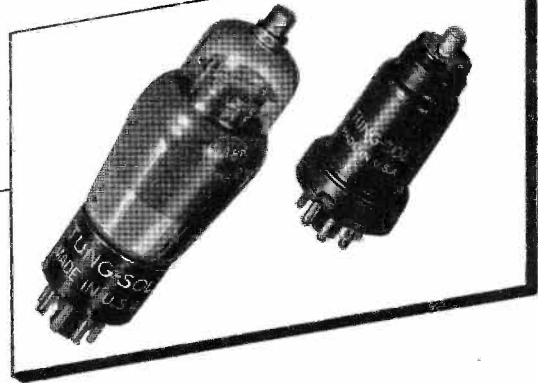

**T**UNG-SOL knows that nothing any manufacturer can do will enable dealers to "get rich" through the sale of radio tubes. Tung-Sol knows, too, that given a fair opportunity, the dealer can make radio tubes one of his most profitable lines. That is why the Tung-Sol consignment plan is offered—not as a gold mine—but as a sound merchandising plan which enables the dealer to make *all* the profit possible from the sale of Tubes.

The plan is simplicity itself. An adequate stock of Tung-Sol dependable tubes is placed in your custody. Once a month you report and pay for the tubes sold. Capital ordinarily tied up in tubes then becomes available for investment in other merchandise. Furthermore, you are protected from cut-price competition as well as losses due to obsolescence or price reductions.

*If you are a responsible dealer, equipped to service radio, you will want the details. Write our nearest Sales Office.*

## TUNG-SOL

One-flow Radio Tubes

TUNG-SOL LAMP WORKS, INC.

Dept. D Radio Tube Division

SALES OFFICES: ATLANTA • BOSTON • CHICAGO • DALLAS  
KANSAS CITY • LOS ANGELES • DETROIT • NEW YORK  
GENERAL OFFICES, NEWARK, N. J.



**SOLAR MINICAP TUBULAR**

A small-size tubular condenser, formerly obtainable only by manufacturers, has been made available to Service Men by Solar Mfg. Corp., 599 Broadway, New York City. According to an announcement by the manufacturer, the condensers are hermetically sealed, and being small in size are adaptable to easy mounting.

Capacities and voltage ratings, as announced, are said to be possible by reason of the use of etched foil which contributes to an increased capacity even with reduction in size.

The "Minicap" is available in voltage ratings of 100, 150, 300 and 450 volts. Capacity ranges cover all of the commonly required values. The electrical characteristics are said to make this condenser comparable with the larger types manufactured by Solar.

Further details may be obtained by writing to the manufacturer.—SERVICE.

**POLICE ADAPTER FOR AUTO RADIO**

A short-wave converter with fixed condenser, for receiving police radio signals, covers the 1500 to 2600 kilocycle bands, is announced by ABC Radio Laboratories, 3334 N. New Jersey St., Indianapolis, Indiana. Two metal tubes are used, one providing r-f amplification of short-wave signals, the other supplies a signal which may be picked up by the radio receiver at 600 to 700 kilocycles.—SERVICE.

**B-L FILTER PAC**

The B-L Electro Manufacturing Company announces a new Automobile Radio Filterpac intended for the demonstration of automobile radios.

The Filterpac is completely self-contained and is no larger than a storage battery. It connects directly to a 110-volt, 60-cycle line and supplies 6 volts direct current for operation of all types of automobile radios on the dealer's display stand. It contains no glass bulbs, liquids, or moving parts, and creates no radio interference. Unlike batteries, it cannot run down at the critical moment when a demonstration is being made. Further details may be obtained from The B-L Electric Mfg. Co., St. Louis, Missouri.—SERVICE.



**NEW PRESTO RECORDING ATTACHMENT**

In response to a broad demand for an inexpensive recording turntable which would make instantaneous recordings and play them back in connection with public address amplifier or radio set, the Presto Recording Corporation of 139 W. 19th St., New York, N. Y., has placed on the market as a separate item the recording turntable furnished as part of their Presto Junior Recorder.

The Presto Radio Recorder consists of a 12-inch, 78 rpm rim driven turntable and motor designed especially for recording, a cutting head and feed mechanism operating from a worm gear on the turntable shaft and a magnetic phonograph pickup. The complete mechanism mounts in a case 15 x 15 x 8 inches. When used with a radio set the pickup is connected to the phonograph input terminals which are a part of all modern radio receivers, and the cutting head is connected across the voice coil of the radio loudspeaker. The pickup impedance is 2,000 ohms and the cutting head impedance 15 ohms. Approximately one-half watt is required to operate the cutting head at full efficiency.—SERVICE.



**MOLDED AUTO RADIO AERIAL**

A radical departure from conventional auto radio aerials, the Airmaster is said to bring to the market a unique new streamlined and fully protected design molded to conform to the contour of the car top.

Only 1½" high, with flexible antenna wire completely encased in molded rubber in a pleasing modern design, the Airmaster meets all requirements of auto radio reception without destroying the contour of the car. Running longitudinally along the entire length of the top and tapering gracefully down over the curved end surfaces, it adds a pleasing streamline effect. Airmaster is being announced by the Renson Products Company of Conshohocken, Penna. Literature will gladly be sent upon request.—SERVICE.

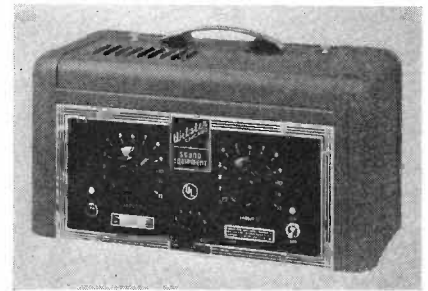
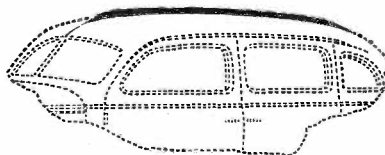

**WEBSTER-CHICAGO AMPLIFIER MODEL 2L-25**

Webster-Chicago have just announced a new 25-watt amplifier Model 2L-25, said to be particularly adapted to critical installation. The following specifications for this amplifier were announced by the manufacturers: distortion, 2½ percent at 25 watts; frequency characteristics, plus or minus 1½ db from 50 to 10,000 cycles; multi-stage degeneration.

Joe Erwood, Chief Engineer, stated: "Our new Model 2L-25 accomplishes many things that even a year ago we thought were impossible. There is no doubt but what it will provide a way to give satisfactory installations under very trying conditions."

Approval has been obtained on this amplifier from the Underwriters' Laboratories.

Further details may be obtained from the Webster Company, 5622 Bloomingdale Ave., Chicago, Ill.—SERVICE.

**OHMITE RHEOSTAT TANDEM ASSEMBLY**

A special type of tandem construction and assembly has been designed by Ohmite engineers for special use with the larger-size Ohmite rheostats. This assembly, like the standard Ohmite tandem assemblies, is used for the control of electrical apparatus where several circuits are to be simultaneously varied, as in the control of the individual phases of a 3-phase line, etc.

This special construction and assembly can be supplied for 2, 3, 4 or more rheostats in tandem, using any combination of Model "N" (300 watt), Model "R" (500 watt), or Model "U" (1,000 watt) units. Standard-type tandem assemblies are available for use with all Ohmite Rheostat models from 25 to 1,000 watts, or with Ohmite Tap Switches. Further details are available from Ohmite Manufacturing Company, 4835 Flournoy Street, Chicago, Illinois.—SERVICE.

*(Continued on page 42)*

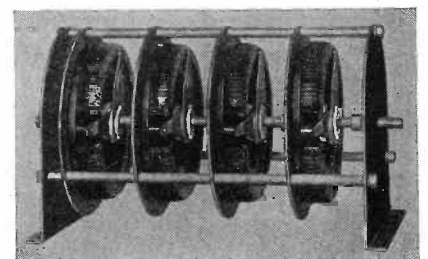

# DUMONT

**ELECTROLYTIC CONDENSERS  
GUARANTEED QUALITY  
NOW AT ATTRACTIVE PRICES**



## MR. SERVICE MAN

Regardless of the prices you pay for condensers, you will find DUMONT QUALITY far superior. Self-healing prevents any possibility of breakdown even if overloaded. This exclusive feature (patented) is found only in DUMONT Electrolytics. Try an assortment today and be convinced. Used by the U. S. Government in large quantities—ample testimony of their true quality.

**—FREE—FREE**

with our kit of 10 electrolytics you get 10 tubulars of 600 and 400 volts absolutely free

Write for name of your nearest jobber

**Dumont Electric Co., Inc.**

514-516 BROADWAY, NEW YORK, N. Y.

U.S.A. RE. No. 19604. Others pending.

"America's Leading Manufacturer of Condensers"



## IT'S THE BEDSIDE RADIO THAT'S BROKEN

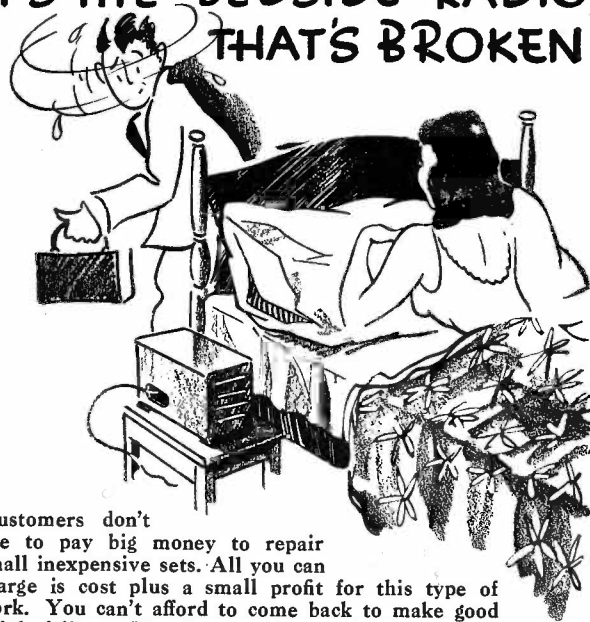

Customers don't like to pay big money to repair small inexpensive sets. All you can charge is cost plus a small profit for this type of work. You can't afford to come back to make good a job failure. Use dependable Ward Leonard Replacement Parts that stand up and keep your job profits.

### WARD LEONARD ELECTRIC COMPANY

36 SOUTH STREET, MOUNT VERNON, N. Y.

Please send me Circular 507.

Name .....  
Address .....  
City ..... State .....  
Jobber's Name .....



RADIART AERIALS  
*are*  
BETTER  
AERIALS

DO YOU KNOW ABOUT RADIART'S  
NEW

*Anti  
Rattler*



FIRST, it was Radiart Styling everyone could SEE that. Then service men learned that Radiart Aerials are quiet, electrically — because built by a manufacturer who has ALWAYS done precision work. Owners found that Radiart aerials don't rust, tarnish or corrode, because Radiart demands, and pays for the highest grade of nickel AND chrome plating on Admiralty Brass. Now comes the latest Radiart betterment — an ANTI-RATTLER (Patent Applied for) which, at last, quiets that maddening noise of long telescopic aerials. Learn about the Anti-Rattler. Learn the whole Radiart Story of quality and profit.

THE RADIART CORP.  
SHAW AVENUE, CLEVELAND, OHIO  
Makers of RADIART VIBRATORS

**It's RADIART  
for AERIALS in '38**

**DO THE JOB  
RIGHT *with*  
OHMITE**

**EXTRA STURDY  
*Vitreous-Enameled*  
BROWN DEVILS**



It's good business to do the job *right*—with OHMITE extra-sturdy Brown Devils, the resistors that put an end to resistor failures.

Built *right* from the core out—sealed tight with glass-like vitreous enamel—Brown Devils give you exactly the same dependable trouble-free construction found in the big Ohmite industrial units.

Ask your Jobber for Brown Devils. They come in values from 1 through 100,000 ohms, in 10 and 20 watt sizes. Priced *right*, too.

Send for Catalog 16.

OHMITE MANUFACTURING CO.  
4827 W. Flournoy Ave., Chicago, U.S.A.

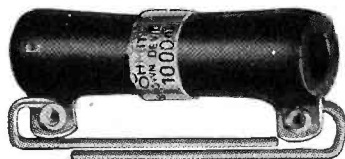

**OHMITE**  
RHEOSTATS RESISTORS TAP SWITCHES

**SERVICE MEN**

... in addition to being our readers, are among our most valued contributors.

Perhaps SERVICE can use an item on that interesting job YOU did yesterday.

**MANUFACTURERS—continued**

**NEW AMATEUR TUBES ANNOUNCED  
BY RAYTHEON**

Raytheon Production Corporation now offers four new RK tubes for use as power amplifiers, oscillators, or frequency multipliers. They were specifically designed for the amateur who wants low cost triodes with long life and the ability to withstand heavy surges. Heavy, thoriated filaments are used to give these tubes extra power.

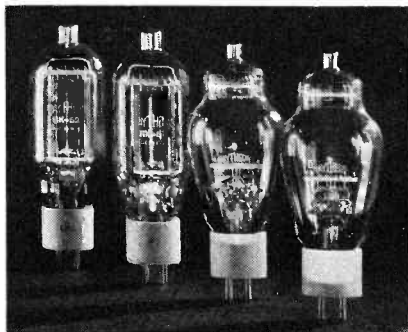

RK-11 is a triode power amplifier having 20 mu. It is designed for use as power amplifier, oscillator and frequency multiplier. RK-12 is a very efficient zero-bias modulator tube offering extremely low distortion—even at 100 watts. Has excellent r-f characteristics, and is said to be particularly suited to buffer amplifier applications. RK-11 and 12 have power outputs of 55 watts each.

RK-51 is a triode type tube designed for use as a power amplifier, oscillator, or frequency multiplier. It has 170 watts output. Amplification factor is 20. RK-52 is a high-mu zero bias triode having low idling current. It is a power amplifier, modulator, oscillator or frequency multiplier. Power output, 135 watts.—SERVICE.

**CARBON MICROPHONE**

A modernly designed carbon microphone, Model 100, has just been announced by Electro-Voice Mfg. Co., 332 E. Colfax Ave., South Bend, Indiana. This microphone has an internal shock absorber, extremely low noise level, combination locking stand and cable connector. It comes furnished with 6 ft. of cable and 5/8"—27 stand coupling. Finished in smooth black and chromium. Button Current (each) 3-5 ma, for close talking or feedback reduction, 12-20 ma, for normal work.—SERVICE.



**Nice  
Work**

... and you can get it when you use

**KENYON  
REPLACEMENTS**

because KENYON insures a better job ... customer satisfaction ... no come-backs.

Write for Catalog

*If you're Profit-wise  
you'll Kenyonize!*



**KENYON**  
TRANSFORMER CO., INC.  
840 BARRY STREET • NEW YORK, N. Y.

*go after*  
**Those Extra Profits**



**MODERNIZE**

THAT OLD RECEIVER  
with the ULTRA NEW

**BROWNING 83**

DX RECEPTION - 4 OVERLAPPING BANDS - HIGH FIDELITY - EXCEPTIONAL SIGNAL TO NOISE RATIO

BROWNING LABS., Inc. SM  
750 Main St., Winchester, Mass.

Please send free circuit diagram and descriptive literature on the Browning 83.

NAME.....

STREET.....

CITY and STATE.....

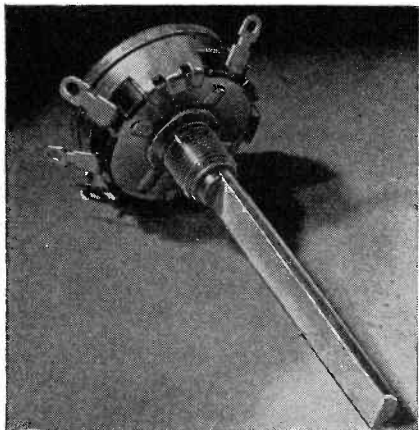

TAPPED AND AUTO-RADIO  
MIDGET CONTROLS

Because of the popularity enjoyed by Clarostat midget composition-element controls since their introduction to the jobbing trade early this year, the line is now being extended to include tapped controls and auto-radio controls.

Further details may be obtained from the 208-page pocket-sized Clarostat Service Manual which may be had from the local jobber or from the manufacturer whose address is 285-7 N. Sixth St., Brooklyn, N. Y.—SERVICE.

## MAKE MORE MONEY WITH WARD AERIALS

(Right) A Real Profit-Maker! WARD'S new Model 5X side-cowl aerial sells at only \$3.50. Features: 3-section, beautiful, bright plate finish, rust-resisting, easily installed.

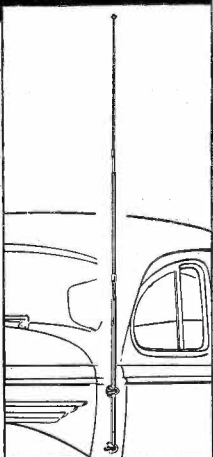

There's big money in selling car aerials — when you sell the WARD line. That's because this "easy-to-sell," "easy-to-install" line is complete, with models at prices to suit every prospect. Write today for complete details on this new money-making opportunity.

**NEW LOW PRICES NOW IN EFFECT!**  
Send today for free catalog showing WARD'S complete line of car and home aerials, with new reduced prices made effective March 1st.

**The WARD PRODUCTS Corp.**  
WARD BUILDING CLEVELAND, OHIO

# Just like that!

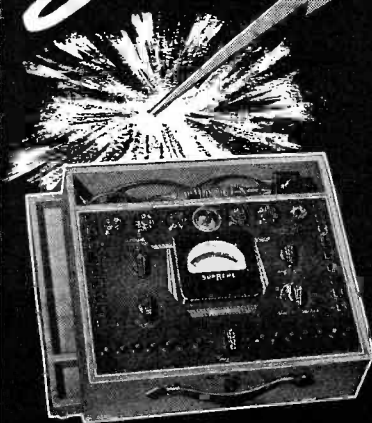

the SUPREME 502 TUBE  
and RADIO TESTER CAN BE

**-Yours  
For Only  
\$5.50  
—DOWN**

Almost as quick as a lightning flash — the Supreme 502 Tube and Radio Tester, or any other Supreme instrument is yours on Supreme S.I.C. terms — the world's easiest installment terms! No long questionnaires! No red tape! Only a few dollars and then a little more than \$1 a week for ten months!

Think of it! The added business alone you will get will surely pay for it! And when you try the 502, you'll be amazed!

Wait until you test its razor-edge accuracy and all its other outstanding features! You'll agree it's the biggest value in the entire instruments industry! Go to your parts jobber — test it — and be your own judge. And when you buy Supreme instruments — not only will you be proud to own them — but you'll have the best equipped, most efficient shop in your community! Write for colorful new 1938 catalog!

### LOOK AT THESE AMAZING FEATURES!

MODEL 502 tube and radio tester is 7 instruments in one! It tests every tube made and electrolytic capacitors on "Good-Bad" scales. It tests electrostatic capacitors for leakage on neon lamp, plus a complete DC volt meter with ranges from 0.2 to 1400 volts in 4 ranges, plus a complete AC volt meter with ranges from 0.2 to 1400 volts in 4 ranges, plus a complete ohmmeter with ranges of 0.1 ohms to 20 megohms (self-contained power supply), plus a 4 range output meter with ranges from 0.2 to 1400 volts AC! Only \$49.95, Cash Price or \$5.50 down and 10 monthly payments of \$4.95.

## SUPREME INSTRUMENTS CORP.

GREENWOOD, MISSISSIPPI • U. S. A.

Export Dept.: Associated Exporters Co., 145 W. 45th St., New York City

Cable Address: LOPREH, New York

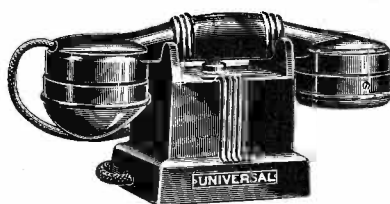

## Two-Way Communication

Inter-'phones, office to office, factory, shipping depts., house to garage and hundreds of other uses. Positive in operation. Simple to install. Modern in appearance. Any number of 'phones on same line.

List Price **\$15** per Station

Dealers and jobbers  
write for discounts.

Microphone Division

**UNIVERSAL MICROPHONE CO., LTD.**

424 WARREN LANE

INGLEWOOD, CALIF., U. S. A.

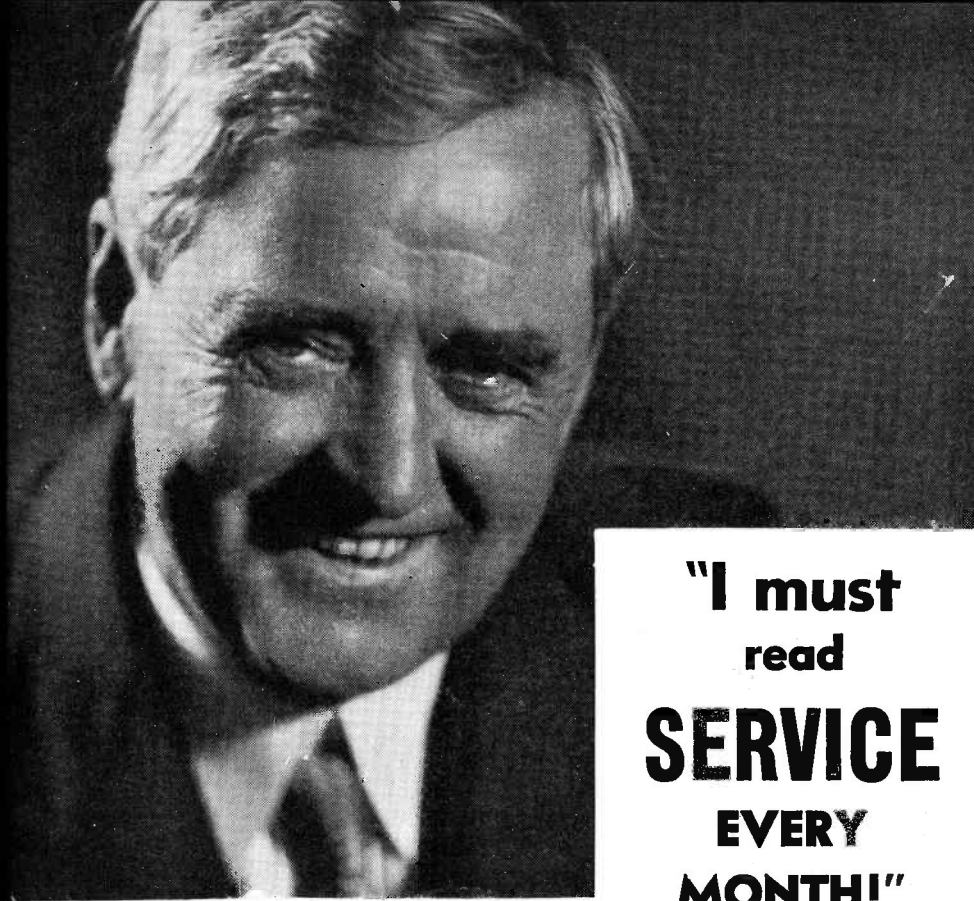

**"I must  
read  
SERVICE  
EVERY  
MONTH!"**

***That's what the leading Servicemen say:***

No other publication even closely approaches SERVICE in the number of technical and semi-technical text pages published exclusively for Servicemen every month.

Time saved represents profits made to a Serviceman. To keep abreast of all the technical progress being made one only has to read SERVICE every month.

Practically all technical data published in SERVICE should be filed for reference guidance during the years to come.

To help every service man, dealer and jobber obtain his own individual yearly subscription to SERVICE for \$1.00 (or one half the regular rate of \$2.00 a year) the Group Subscription Plan was formed. When four or more men sign up at the same time, the subscription rate is only \$1.00 per year each. (The occupation of each subscriber must be given.)

Use the convenient form printed herewith. Your co-workers and service men friends will sign up with you at the half-price rate if you tell them about the "G.S.P." Sign up your group today.

**SERVICE**  
19 East 47th St.  
New York City

## NOISE

(Continued from page 2)

Along about here we meet the question of how the Service Man is to be paid for this work which must, of necessity, be referred to someone else—the electrician—for completion. First of all, the Service Man surely has been reimbursed for his initial call; and if his business methods are on a sound basis, the charge for the call will be sufficient to cover the time spent (surely no more than an hour) in making the inspection of the house wiring. It seems logical to assume that service charges will be based on the possibility of a recall on which no charge can legitimately be made.

There is, however, another means of covering the cost of this electrical inspection—a method which should result in considerably more profit to the Service Man. What we have in mind is the fact that while most people know the names and addresses of their doctors, druggists, and plumbers, electrical trouble is so remote that the local electricians are known infrequently and then chiefly to those who are remodeling or building a house.

The obvious answer is to establish some kind of an arrangement with an electrician whereby you will gain a commission on work referred by you. You can see that if the question of wiring is brought up there will be, on the part of your customer, a certain amount of hesitancy due almost entirely to the fact that he or she doesn't know of an electrician. Your recommendation of the man or firm with which you have a tieup will invariably carry weight.

There are other advantages which will accrue from the association between yourself and one of your local electricians. The greater part of the electrician's work will probably be on new or remodeled buildings, many of them homes. What better prospect can there be for good antenna installations (with concealed wiring, etc.), multiple-speaker jobs, and others which will occur as the situation arises, than the man with a new or remade house?

You needn't confine your references of poor wiring to your electrician; keep on the alert for all jobs of the kind which an electrician would normally handle. Isn't it a fact that many of you are asked about refrigerators, oil-burners, and various other types of equipment which use motors or other electrical parts? Any of these which you yourself may not be equipped to handle, can and should be passed on—always with the understanding, of course, that you are to receive a commission on any work which the electrician may obtain as a result of your "tip."

**SERVICE** | **TEAR OUT AND MAIL**

19 East 47th Street,  
New York City

Servicemen:

Remit \$..... herewith. Please enter 1 year  
subscriptions for the following:

Name .....

Address .....

City-State .....

Occupation .....

Employed by .....

---

Name .....

Address .....

City-State .....

Occupation .....

Employed by .....

---

Name .....

Address .....

City-State .....

Occupation .....

Employed by .....

## ASSOCIATION NEWS—continued

stations in Detroit as well as the newspapers are all set to help the boys put over their program in a big way.

### Newark Chapter

On February 21, the popular Bruce Burlingame gave a lecture to over 100 servicemen.

The chapter has scheduled for March a meeting by RCA and on March 22, Philco will tell them the whys and where-fors of magnetic tuning.

### BUFFALO

A change in the Association meeting dates was discussed at the February 22nd Meeting.

This change, which was favorably voted upon, changes the present meeting dates from the first Monday and the third Tuesday of each month to the first and the third Tuesdays of each month.

This change was made in the interests of efficiency and in the hope that by having all meetings fall on the same night of the week it would be easier for everybody to make arrangements to attend these Association meetings.

At a well attended meeting held Feb. 7, of the Association of Radio Service Engineers, D. C. Shaw, Branch Manager for the United Motors Service Company, spoke on the subject "What Follows Saturation." Mr. Shaw presented his talk in a very effective manner and, judging from the

many complimentary comments that were heard after the meeting, Mr. Shaw was very well liked by all present and many of the members expressed the desire to hear Mr. Shaw again soon.

The Speakers Committee of the Association wishes to take the opportunity at this time to announce that they are doing everything possible to obtain guest speakers of the same caliber for future Association meetings.

February 22 was another very lively Meeting enjoyed by all those present. The large number of servicemen who were present were greatly benefited by Mr. Gerhardt's extremely interesting and timely talk entitled "Servicing Ten Million Philcos."

Upon concluding his talk Mr. Gerhardt answered a great number of questions relating to general service problems which were asked of him by the servicemen present.

### CALIFORNIA

Notes on past, and soon-to-be-held meetings of the Radio Service Association of California. We can't be certain of exact dates in all cases:

Another Chevrolet program of sound motion pictures. These pictures seem to be General Motors way of trying to coax us to buy one of their gas-buggies, but boy! it's plumb enjoyable to be advertised at in this fashion. There's a reel on Ac-

curacy and Precision this time that's a pip.

There must be a new tube for A1 to tell about this time and the technical committee might even have something on the ball, we hope, we hope, we hope.

Good turn-out and good speaker last meeting. George Becker of the Multi-Arc Laboratories spoke mightily interestingly on the trials and tribulations of vacuum tube manufacture, especially special types. Bill Appleton had some very interesting data on the new San Francisco Terminal block signaling system. Wil Styles announced that the budget had been balanced and how, and the chair asked for a couple of new members to cinch that six and a half cents.

Guys who wear topcoats, hats, and other such apparel will be interested in this household hint we ran across the other day. It seems that certain manufacturers take pieces of wire and bend them into odd shapes and call them coat hooks. In fact these may be often found lying around in some drawer along with other such objects d'art. Find one, insert it in the club-room wall, and presto! Simple, isn't it?

Coming up . . . for the meeting of March 7th. Charles F. White of the University of California speaking on Distortion in Diode Detection Circuits. We understand that Mr. White will also have some dope on the new infinite impedance detector.

# ATTENTION Sound Specialists!

## INVENTORY REDUCTION SALE



SPECIAL  
PRICE  
**\$69.50**

Complete

### EAP-2222-6 V. MOBILE SYSTEM

25 Watts output. Featuring famous Electro-Acoustic jar-proof pickup. Rides the record groove no matter how rough the pavement. An Election Year necessity.

**Y**OUR great opportunity to take care of present needs and to anticipate future requirements. The EAP 2222-6 Volt MOBILE SYSTEM is a typical example of the greatest profit opportunity in sound equipment that has ever come your way.

The equipment covered by this special offer is all *new*—licensed under ERPE patents—carries full RMA guarantee. It is standard Electro-Acoustic quality equipment—production over-runs and floor samples.

Systems—amplifiers—accessories—a complete selection for every P.A. requirement—**BUT** the available quantities are small and the time is limited. First come—first served. Don't delay. **WIRE TODAY** for catalogs, specifications and prices.

**ELECTRO-ACOUSTIC PRODUCTS CO.**  
**FORT WAYNE INDIANA**

# HIGHLIGHTS . . .

## THORDARSON ENCYCLOPEDIA

A new supplement No. 243-S to the Thordarson Replacement Transformer Encyclopedia No. 243 has just been released. This covers replacement transformers for all 1937-1938 model home radio receivers listed in Rider's Volume VIII. Based on experience with the Encyclopedia this will prove a valuable aid in radio servicing.

The supplement is free to all registered Encyclopedia owners. The original Encyclopedia and supplement both are available to Service Men free upon registration at their jobbers or postpaid direct from the Thordarson Electric Mfg. Company, 500 West Huron Street, Chicago, Illinois, at a nominal charge.

## RCA ADDS LEAD-IN CABLE TO CAR ANTENNA

The popularity of the new RCA Monogram Auto Antenna has made it possible to include an antenna lead-in cable with the antenna at no increase in the list price, the Parts Sales Division of the RCA Manufacturing Company has announced.

The cable will be packed with the antenna in the same carton, providing a complete installation for the customer. The RCA Monogram Antenna is mounted on the car roof without the necessity of drilling through the top. The lead-in connects with the antenna at the cowl.

At the same time, the prices of two other lead-in antenna cables have been reduced by RCA.

## TACO REPRESENTATIVES

Technical Appliance Corporation has recently appointed two new representatives to handle their lines in the territory of Ohio and Kentucky, Albert M. Baehr of Cleveland, Ohio, and in Upper New York, Harry B. Segar of Buffalo, New York.

## AEROVOX EXPANDS

Fully confident of the lasting soundness of the radio and electrical industries, the Aerovox Corporation of 70 Washington St., Brooklyn, N. Y., announces the leasing of additional floor space for the further expansion of its plant and office facilities.

Already occupying the entire fifth, seventh and eighth floors in the block-square building which forms part of the Gair industrial group at the east end of Brooklyn Bridge, the Aerovox organization has just added the major portion of the sixth floor. After extensive alterations and partitioning, the space includes the concentrated office forces handling engineering, purchasing, production, accounting and sales, as well as the executives. Heretofore, these functions have been handled by scattered offices throughout the plant. Also, the new space is occupied by file and record rooms, reception rooms, material stock department and other features, while the production plant proper gains the space vacated on the other three floors. The rearrangement is aimed at a more unified organization and in anticipation of the heavy volume of business later this year, as well as for a still better service to manufacturing and jobbing accounts.



## WESSNER JOINS WEBSTER-CHICAGO

Absent for a long time on account of ill health, the many friends of Fred Wessner will be glad to welcome him back into the radio business.

Mr. Wessner has accepted the position of Sales Promotion Manager of Webster-Chicago and will be located at the home offices in the Bloomingdale Avenue plant, Chicago. Mr. Wessner was formerly Sales Manager of National Union Radio Corporation, New York.

## CONCISE FACTS ON TEST INSTRUMENTS OFFERED BY WESTON

A new time-saving idea to aid the Service Man in making his purchasing decisions on a factual basis is being put into effect by the Weston Electrical Instrument Corporation, Newark, N. J. A special "quick facts" tag (4x7-inch size) is attached to each unit of test equipment, answering all the questions the Service Man normally asks concerning test equipment of this type. The regular instruction booklet, of course, is still included with equipment. The new tags, however, enable the Service Man to find out what he needs to know for intelligent purchasing at a glance, without having to look through the booklet for it.

Entitled "What It Will Do For You," each tag contains complete data in question and answer form about the particular type of instrument to which it is attached. Information given includes the ranges and scale readings obtainable; guaranteed overall accuracies; functions and fields of application; and numerous other important pointers about the instrument.

## CENTRALAB BULLETINS

Bulletin No. 21 of Centralab, 900 E. Keefe Avenue, Milwaukee, Wis., is entitled "Why Are Volume Controls Noisy?" Included in this bulletin is a data sheet on volume controls.

Available from the same company is an 8-page Engineering Data Book on carbon composition fixed resistors. This bulletin may be obtained on request.

## TRADE SHOW NEWS

No less than five conventions will be held in conjunction with the 1938 National Radio Parts Trade Show at the Stevens Hotel, in Chicago, June 8 to 11, inclusive.

The activities of the week will start on the day preceding the opening of the Trade Show when the annual convention of Radio Manufacturers Association is called to order.

The annual conventions of the Sales Managers Club, "The Representatives," and the National Association of Radio Parts Distributors will open on Thursday, June 9, at 10 A.M.

Throughout the entire four-day period the annual convention of Radio Servicemen of America will feature technical lectures and business sessions. Definite information concerning the activities to be conducted by the engineers and the amateurs are not available at this writing.

By April 1st every radio parts jobber throughout the country should have a liberal supply of free passes to Radio Parts City, the home of the Show.

Each company that contracts for space up to the middle of March is being furnished with 1,000 of these passes for each booth occupied, and general distribution of the tickets should be completed within the month.

## OSCILLOGRAPH PRICE REDUCTION

Widespread popularity with corresponding economies gained by large-scale production activities, is responsible for a marked reduction in the price of the DuMont Type 164 3-inch cathode-ray oscillograph, according to the Allen B. DuMont Labs., Inc., Upper Montclair, N. J.

DuMont also announces the appointment of Vernon C. McNabb of 5105 N. Capital Ave., Indianapolis, Ind., as sales representative for the Indiana and adjacent territory.

## CORNELL JOINS SOLAR

Solar Manufacturing Corporation, manufacturers of fixed condensers, 599 Broadway, New York City, announces an important addition to its executive staff. J. I. Cornell has joined the Solar organization as Consulting and Field Engineer. Mr. Cornell was formerly Chief Engineer of the Magnavox Company; previously he had been Section Engineer in charge of audio components with RCA Mfg. Co., at Camden.

Mr. Cornell is well known among radio industry engineers, and is Chairman of the RMA Committee on Electrolytic Capacitors.

## McBRIDE APPOINTED NU DISTRICT MANAGER

Homer H. Kunkler, General Sales Manager of National Union Radio Corporation, announced from the Chicago Office this week, the appointment of J. J. (Jack) McBride as District Manager of National Union, covering Indiana, Ohio, Michigan, Northern Kentucky and the City of Chicago.



# MILLION ALL-WAVE OSCILLATOR

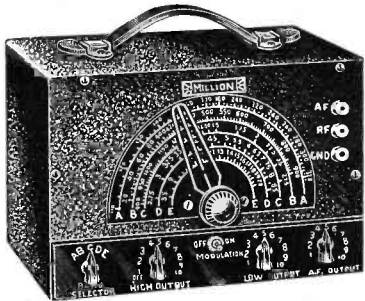

A.C., D.C.  
6 BANDS—100-  
25,000 K.C.  
SEPARATE  
AUDIO  
LINE FILTERS

**19.95**  
NET

Write for literature on our complete line of test instruments.

**MILLION RADIO AND TELEVISION LABORATORIES**  
671 W. OHIO STREET CHICAGO, ILL.

# NEW B9 CRYSTAL MICROPHONE



A small, lightweight, crystal microphone, with good response and high output. It is semi-directional and notably free from feedback. This unit has a wide range of applications, enhanced by the available accessories. The B9 is singular in that it is equipped with a plug at the microphone, thus making cable replacement a simple operation. Chrome finish. Complete with plug and 8' cable. Standard ¼-27 fitting.



List Price

**\$22.50**

All crystal microphones licensed under patents of The Brush Development Co.

Request Catalog No. 27 for Complete Details

**AMERICAN MICROPHONE CO., Inc., Los Angeles, Calif.**

# A GOOD NAME GOES A LONG WAY



Share the prestige of the Ken-Rad name. Customers know that Ken-Rad Tubes give perfect radio reception. This means greater customer satisfaction.

KEN-RAD TUBE & LAMP CORPORATION  
OWENSBORO, KY.

**KEN-RAD**  
DEPENDABLE RADIO TUBES



20 SMART NEW MODELS

# AUTO-RADIO AERIALS

EFFICIENT AS THEY ARE BEAUTIFUL

Toppers - Hinge Whips - Side Cowls - Bumper

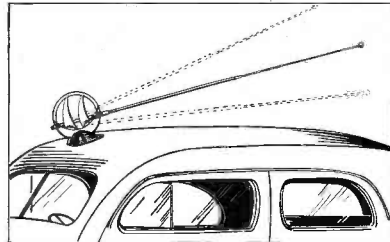

QUALITY antennae, built to furnish better pickup, less static and all-round fine reception. Highest grade materials and workmanship guaranteed.

THE RANGER as shown at left; telescopic; streamlined; perfect insulation; smart ship design; ALL BRASS, triple chromium plate, non-rusting.

Complete illustrated catalogue of Antennae and Auto Radio Accessories will be sent upon request.

INSULINE CORP. of AMERICA  
25 PARK PLACE NEW YORK, N. Y.

## INDEX TO ADVERTISERS

<b>A</b>	<b>I</b>	<b>Radio Parts Mfgs.</b> ..... 37
American Microphone Co., Inc.... 47	Insuline Corp. of America..... 47	<b>Radolek</b> ..... 48
Amperite Co. .... 17	International Resistance Co..... 34	<b>Raytheon Production Corp.</b> ..... 13
Arceturus Radio Tube Co..... 32		<b>Readrite Meter Works</b> ..... 26
	<b>J</b>	<b>Rider, John F., Publisher</b> ..... 3
<b>B</b>	Jensen Radio Mfg. Co..... 33	
Bell Sound Systems, Inc..... 48		<b>S</b>
Browning Labs., Inc..... 42	<b>K</b>	Solar Mfg. Corp..... Third Cover
Burstein-Applebee Co. .... 34	Ken-Rad Tube & Lamp Corp.... 47	<b>Supreme Instruments Corp.</b> ..... 43
	Kenyon Transformer Co., Inc.... 42	
<b>C</b>	<b>M</b>	<b>T</b>
Centralab ..... 25	Mallory & Co., Inc., P. R.	Technical Appliance Corp..... 34
Clarostat Mfg. Co., Inc..... 48	Second Cover	Thordarson Elec. Mfg. Co..... 31
Cornell-Dubilier Electric Corp... 4	Million Radio & Tel. Labs..... 47	Transducer Corp. .... 26
Cornish Wire Co., Inc..... 30		Triplett Elec. Inst. Co., The..... 30
Crowe Name Plate & Mfg. Co... 32	<b>N</b>	<b>Tung-Sol Lamp Works, Inc.</b> ..... 39
Cunningham Radio Tubes..... 28	National Union Radio Corp..... 48	
		<b>U</b>
<b>D</b>	<b>O</b>	United Transformer Corp..... 35
Dumont Elec. Co., Inc..... 41	Ohmite Mfg. Co..... 42	Universal Microphone Co., Ltd... 43
Du Mont Labs., Inc., Allen B.... 28		Utah Radio Products Co..... 39
	<b>P</b>	
<b>E</b>	Park Metalware Co., Inc..... 32	<b>W</b>
Electro-Acoustic Products Co.... 45	Precision Apparatus Corp..... 29	Ward Leonard Elec. Co..... 41
		Ward Products Corp., The..... 43
<b>H</b>	<b>R</b>	Weston Elec. Inst. Corp..... 21
Haldorson Co., The..... 37	RCA Mfg. Co., Inc.... Fourth Cover	Wirt Co. .... 26
Hygrade-Sylvania Corp. .... 37	Radiart Corp., The..... 41	
	Radio Servicemen of Amer., Inc.. 27	<b>Y</b>
		Yaxley Manufacturing Division
		Second Cover

# Advanced

CIRCUIT DESIGN  
PERFORMANCE  
APPEARANCE

## The New BELL 424 P.A. System Meets All These Requirements!

24 watt output and easily portable. Ideal for every type of installation, permanent or temporary. Built to Bell's usual high standard of quality, it embodies features of construction wanted today, and demanded tomorrow, such as: high gain amplifier, Octal series tubes, beam power output tubes, three in-put channels, provision for mixing two microphones and phonograph pick-up, bass and treble compensator controls, new type crystal microphone, twin 12" heavy duty permanent magnet speakers, as well as many other desirable qualities. Simple to operate and easy to service. Attractively priced! Write for details on Bell's complete line of sound equipment and inter-office communicating systems.

**BELL SOUND SYSTEMS, INC.**  
61-62 EAST GOODALE STREET, COLUMBUS, OHIO  
Export Office: 308 W. Washington St., Chicago, Ill.

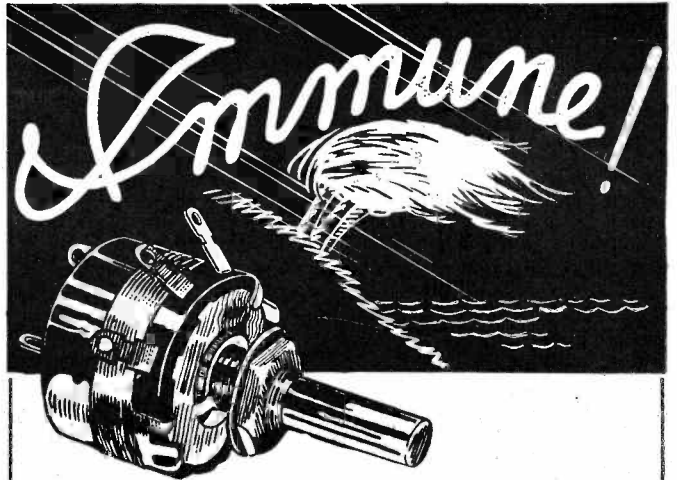
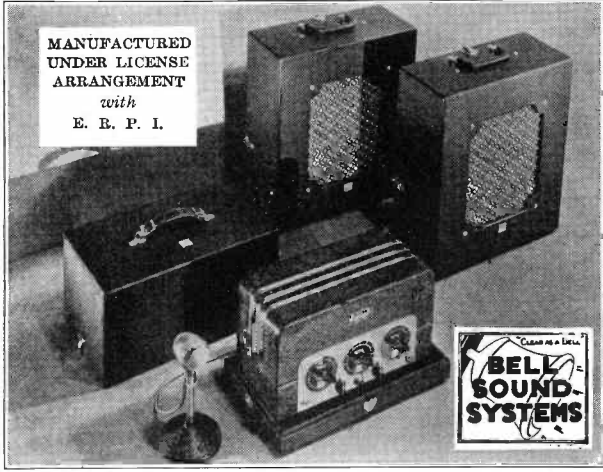

● **SPACE-SAVING**—that's the prime feature of the new **CLAROSTAT MIDGET CONTROL**. Only  $1\frac{1}{8}$ " in dia. by  $\frac{1}{2}$ " (without switch) or  $13/16$ " (with switch). Yet this small control will do everything the large control does, **PLUS** fitting into very tight places. That makes it a more universal control. And ideal for servicemen's requirements.

### New Manual: Pocket-sized. Handy.

Over 208 pages of control and resistor replacements, for all makes and models of sets. Also abundant servicing notes. Free on request—from your jobber or from us direct.

**CLAROSTAT** Manufacturing Co., Inc.

285-287 NORTH SIXTH STREET  
BROOKLYN, NEW YORK, U.S.A.

• OFFICES IN PRINCIPAL CITIES •

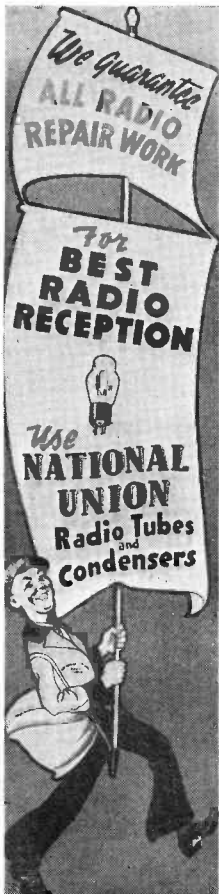

## FREE EQUIPMENT given with purchases of NATIONAL UNION

### Radio Tubes and Condensers

KEEPS THOUSANDS OF  
SERVICE ENGINEERS

## AT THE HEAD OF THE PROFIT PARADE!

You can be up in the front lines for more business, more profits, too. You have to be well equipped to do it though. You need testers, analyzers, circuit data, technical information! These things would cost you lots of money if you had to buy them. Fortunately, you don't... you can get them Free the Easy National Union way. Here's all you have to do. Select what you need. Contract to purchase National Union radio tubes and/or condensers—Make a small deposit which is refunded when your purchase contract is complete. You get the equipment right away... use it while you complete your purchase... then, it's yours free and clear. Easy... isn't it? Why not start on the N.U. free equipment plan... Now?

### N.U. TUBES and CONDENSERS are QUALITY PRODUCTS

Thousands of top notchers in the Radio Service Engineering profession are depending on National Union quality. It's the kind of precision and value that makes good friends for you. National Union quality will never let you down... The National Union guarantee is your assurance.

**NATIONAL UNION RADIO CORPORATION**  
570 Lexington Avenue S-338  
New York City

Who is the nearest N.U. distributor?

Name .....  
Address .....  
City ..... State .....

Send for the NEW 1938 RADOLEK Catalog Now!

Everything you need in radio. It's all in this new **RADOLEK RADIO PROFIT GUIDE**. Every repair part for every receiver. Newest radio receivers. New 1938 model public address amplifiers. outputs for 5 to 100 watts. Test instruments. Technical books. Special equipment. Leading standard brands. Every item guaranteed. It must be right or we make it right. And everything under one roof. You get what you want promptly, and exactly what you want. Radolek's immense stock plus Radolek's efficient organization insures you fastest service. 25,000 service men depend on this service and benefit by Radolek's lowest prices. Send now for your copy of Radolek's Radio Profit Guide. It will help you make more money.

**---RADOLEK---**  
601 W. RANDOLPH, CHICAGO, Dept. R-17  
Send me the Radolek Radio Profit Guide FREE.  
Name .....  
Address .....  
Serviceman?  Dealer?  Experimenter?

# startling



30 M F D . 1 5 0 V W

*Illustration exact size.*

SOLAR MINICAP Dry Electrolytic Capacitors mark much more than an advance in an art. They mean that filters now occupy less space, cost less, have longer life because of permanent sealing, are used in single units to simplify both production and stock-keeping, and are "standard" parts.

Solar engineers have been the pioneers in advanced methods of making radically smaller dry electrolytic capacitors. "little giants," introduced three years ago, were the original ultra-compact dries. Now we announce further size reduction, superior characteristics and outstanding utility in the new *Minicaps*. You will find them in thousands of radio sets,— to stay there.

*Details upon Request.*

**SOLAR MFG. CORP., 599-601 BROADWAY, NEW YORK, N. Y.**



# NOW A Brand-New RCA AC Oscillator AT LOWEST PRICE EVER!

## Giant Dial!... One-Volt Output! RCA Metal Tubes

Attractive blue-gray wrinkle finish case with snap handle. Completely AC operated.

Wide frequency range—100 to 30,000 kcs. Calibration accuracy of 2%. Harmonics of last band may be used for ultra-high frequency testing.

Three attenuator taps plus fine control give continuous control of output from zero to 0.25 volts.

Internal modulation—30% at approximately 400 cycles. Jack provided for external amplitude modulation. Modulation characteristic essentially flat up to 8,000 cycles.

External frequency modulation jack provided for use with sweep condenser for visual i-f alignment.

400 cycle output of 8 volts available for audio circuit testing.

### SPECIFICATIONS

- POWER SUPPLY RATING—Voltage, 110 to 120 volts... Frequency 50 to 60 cycles... Power consumption 30 watts... Fuse protection ½ ampere
- RANGE AND APPLICATION—R. F. frequency 100 to 30,000 kcs. ... 6 bands... Audio modulation frequency approximately 400 cycles ... R. F. output (low, 0.02 volt max.) (medium, 0.25 volt max.) (high, 1.0 volt max.)... Minimum signal 4 microvolts... Leakage negligible... Output impedances (low, 10 ohms) (medium, 750 ohms) (high, 4,000 ohms)
- TUBE COMPLEMENT—RCA 5W4 Rectifier... RCA 6C5 Audio Oscillator... RCA 6J7 R. F. Oscillator
- DIMENSIONS—1 3/4" x 9 1/4" x 6 1/2" deep
- WEIGHT—12 1/2 lbs.

**BROTHER—HERE'S VALUE!** This brand-new RCA Test Oscillator—selling for only \$29.95—not only brings you the extra advantages of unusual precision and speed in your service work—but an array of high quality features as well!

Look at that giant dial! A full 6½" in diameter, it provides a scale length of over 50 inches! High R. F. output, too! One volt! Makes it easy for you to find trouble on sets that won't work—or are completely misaligned. Is essential for single stage alignment work. Incidentally, this oscillator works perfectly with oscillographic method of alignment.

Look at the many features at the left. Imagine how much better, how much easier, this sensational new instrument will make every service job. Then look again at that amazingly low price—and you'll agree that here's a value that you can't afford to pass up! See this fine new instrument on display at your RCA Parts distributor's.

*RCA presents "Magic Key" Sundays, 2 to 3 P. M., E. S. T., on NBC Blue Network*  
Over 300,000,000 RCA radio tubes have been purchased by radio users ... In tubes, as in parts and test equipment, it pays to go RCA ALL THE WAY



# Parts FOR PROFIT

RCA MANUFACTURING CO., INC., Camden, N. J.  
A Service of the Radio Corporation of America