

# SERVICE

A Monthly Digest of

# RADIO

and Allied Maintenance

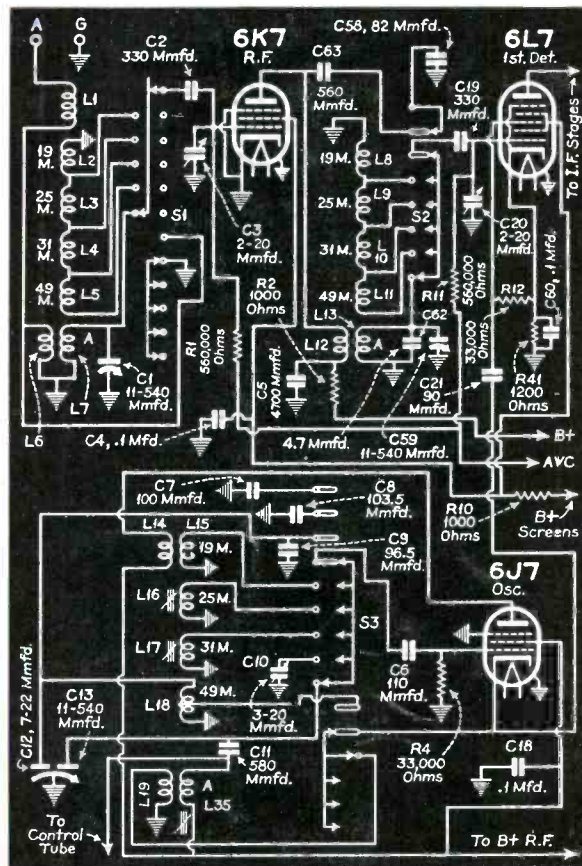

PER COPY  
25 CENTS

SEPTEMBER  
1937

Band-Spread Circuits

(See page 523)

# DO YOU KNOW THESE ESSENTIALS ABOUT VOLUME CONTROLS?

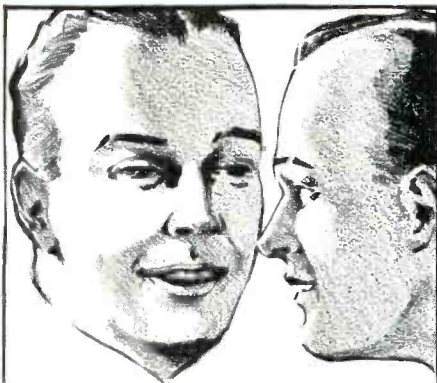

**DO YOU KNOW**

that the resistance value of a volume control is not critical? It is commercial practice to allow a resistance variation of plus or minus 20%. Most circuits will allow even greater variation.

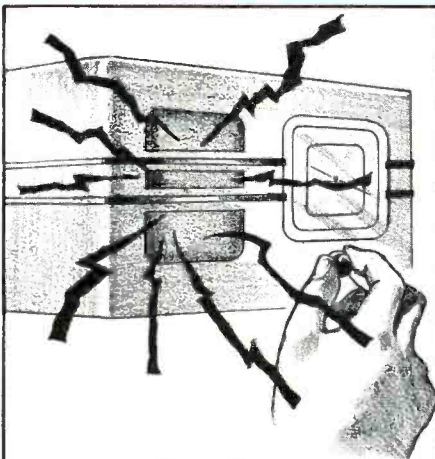

**DO YOU KNOW**

that taper is critical—and if the incorrect taper is employed the volume control action will be sudden and perhaps noisy?



**DO YOU KNOW**

that there are only two kinds of taper necessary for proper volume control operation? The left hand taper used in shunt circuits, and the right hand taper used in series circuits.

YAXLEY No. 4 TAPER (LINEAR)

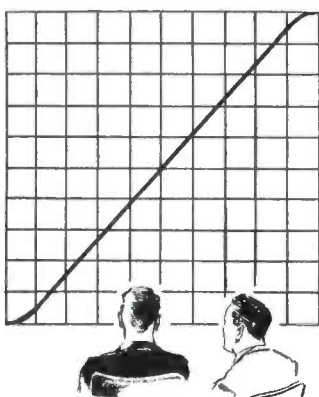

**DO YOU KNOW**

that a linear taper is really not a taper at all—the resistance is uniform over the element? That linear tapers are rarely used except in low resistance values?

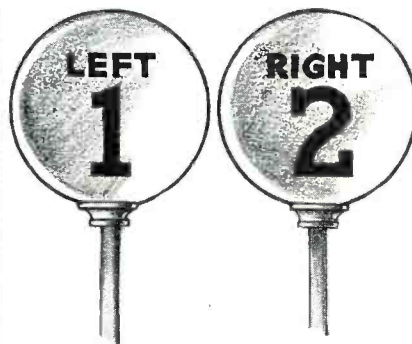

**DO YOU KNOW**

that Yaxley tapers are easy to remember? Left hand is number 1 and right hand is number 2.



**DO YOU KNOW**

that the Mallory-Yaxley Radio Service Encyclopedia completely debunks the subject of volume controls and explains how to easily determine the proper replacement control for any application? See pages 101 to 105!

**DO YOU KNOW** that in developing constant improvements in Yaxley Replacement Volume Controls, Mallory-Yaxley engineering has brought about undreamed of precision in universal application to meet all service needs for over 12,000 different radio receiver models?

*That's worth knowing — if you profit by the knowledge!*

Use

**P. R. MALLORY & CO. Inc.**  
**MALLORY**  
REPLACEMENT  
CONDENSERS...VIBRATORS

**P. R. MALLORY & CO., Inc.**  
INDIANAPOLIS INDIANA

Cable Address—PELMALLO

Use

**YAXLEY**  
REPLACEMENT  
VOLUME CONTROLS



**N**OT in years has there been such a heavy demand for wire in connection with the Serviceman's business. You have noticed it—we have noticed it.

With Public Address going like a prairie blaze and Radio a seething hotbed of activity which promises to be sustained, you will be needing **GOOD WIRE.**

CORWICO Wires are scientifically produced to do their job 100%. Antenna Systems, P-A Cables, Hook-up Wires—made by engineers for engineers. Use CORWICO on your next contract.



No. 14 — (illustrated above) — \$6.75 list

**F**OR broadcast and shortwave frequencies, designed to eliminate "man-made" static and afford better reception. 2 to 6 sets can be operated at the same time with an additional lower transformer for each added unit. Other "Noise-Master" units available. **WRITE FOR INFORMATION.**

## NOISE-MASTER ALL-WAVE ANTENNA

**Eliminates "Man-Made" Static on Broadcast as Well as on Shortwave Bands**

**L**ICENSED by Amy, Aceves & King, engineered with traditional CORWICO care, this masterly aerial system fits every set and every location. Filters out nuisance noises caused by electrical devices. Improves reception generally—widely endorsed by Service men.

*CORWICO Wire Catalog available to Service men.*

*Distribution is exclusively through jobbers.*



**CORNISH WIRE CO., Inc.**  
30 CHURCH STREET  
NEW YORK CITY

# SERVICE

A Monthly Digest of Radio and Allied Maintenance  
Reg. U. S. Patent Office. Member, Audit Bureau of Circulations

SEPTEMBER, 1937

EDITOR  
Robert G. Herzog

VOL. 6, NO. 9

## EDITORIAL CONTENTS

### FEATURES

*Band Spread Circuits (RCA) By K. A. Chittick .....	523	*G. E. Touch Tuning.....	530
*Cathode-Ray Oscilloscope Sweep Circuits By Glenn H. Browning and Francis J. Gaffney .....	560	*RCA Pack-O-Power (CV-8).....	530
Complete Service Laboratories.....	526	*Stromberg-Carlson 229-P.....	536
Fall P-A Markets By H. C. Rolls.....	549	Technical Features of 1938 Zenith Radio Receivers .....	533
*G. E. Touch Tuning.....	530	Wells-Gardner Telephone Dial.....	546
Putting Your Shop Across By Bernard H. Porter.....	525	<b>HIGHLIGHTS</b> .....	574-588-589
*Tapped Transformer Impedances By Maurice Apstein .....	521	<b>MANUFACTURERS</b> .....	580-582-584-586
<b>ANTENNA</b> .....	514	<b>ON THE JOB</b>	
<b>ASSOCIATION NEWS</b> .....	570-572	*Determining Transformer Short By Harold C. Dow.....	522
<b>AUTO RADIO</b>		Extending Speaker Cord for Repairs.....	554
Arvin Auto Radio (Production Changes)...	556	Replacing Pilot Lights.....	548
*Motorola 70.....	540	Replacing Rectifiers in '36 Receivers By J. K. Rose.....	554
*Philco Lincoln-Zephyr L-1424.....	542	Stromberg-Carlson Speaker Data.....	522
*Sparton 676, 686.....	544	Wells-Gardner Telephone Dial.....	546
<b>BOOK REVIEW</b> .....	589	<b>PUBLIC ADDRESS</b>	
<b>GENERAL DATA</b>		Fall P-A Markets By H. C. Rolls.....	549
*Band Spread Circuits (RCA) By K. A. Chittick.....	523	Stromberg-Carlson Speaker Data.....	522
Emerson Automatic Dial.....	534	*Tapped Transformer Impedances By Maurice Apstein.....	521
*Fairbanks-Morse 5CT-3, 6AC-1, 6AC-7, 6AT-4 (Chassis 5C, 6A).....	529	<b>RECEIVER CASE HISTORIES</b> .....	556-558
*G. E. K-66, RCA 220, 222 (Oscillograms, etc.) By Howard J. Surbey.....	558	<b>TEST EQUIPMENT</b>	

An asterisk preceding a listing indicates that a circuit accompanies the text.

BRYAN S. DAVIS  
President

JAS. A. WALKER  
Secretary

Chicago Office—608 S. Dearborn St.—C. O. Stimpson, Mgr.  
Telephone: Wabash 1903

Published Monthly by the  
Bryan Davis Publishing Co., Inc.  
19 East 47th Street  
New York City  
Telephone: Plaza 3-0483

SANFORD R. COWAN  
Advertising Manager  
PAUL S. WEIL  
Eastern Advertising  
Manager  
A. B. CARLSEN  
Circulation Manager

Wellington, New Zealand—Tearo Book Depot.  
Melbourne, Australia—McGill's Agency.

Entered as second-class matter June 14, 1932, at the Post Office at New York, N. Y., under the Act of March 3, 1879. Subscription price \$2.00 per year in the United States of America and Canada; 25 cents per copy. \$3.00 per year in foreign countries; 35 cents per copy.

as simple as A, B, C—



**A**lways  
**B**uy  
**C**ORNELL-  
**D**UBILIER

Just about

**THE BEST RULE YOU COULD FOLLOW IN PURCHASING CAPACITORS**

A generation ago, radio engineers were learning that no condenser would give them the same dependable performance they got from C-D. And the reason for that is quite simple, too. Cornell-Dubilier stood at the head of the class!

Today, on the crest of twenty-seven years devoted to the manufacture of quality condensers exclusively, Cornell-Dubilier is STILL THE NAME FOR DEPENDABILITY. Internationally accepted—you'll find C-D capacitors doing a grand job wherever unfailing service is essential.

**MICA - PAPER - DYKANOL  
WET & DRY ELECTROLYTICS**

Always say "C-D capacitors" and you've learned a good lesson. See them at your local C-D authorized distributor or write for catalog 151A free on request.

Write to  
**CORNELL-DUBILIER ELECTRIC CORPORATION**  
1026 Hamilton Blvd., So. Plainfield, N. J.

**CORNELL-DUBILIER**

*Electric*  
**CORPORATION**

South Plainfield, N. J.



**WORLD'S LARGEST and OLDEST  
MANUFACTURER of CAPACITORS**

# THE ANTENNA . . .

---

## IN THIS ISSUE

**MATCHING LINE AND SPEAKER** transformers to output and input circuits has always been a problem to many p-a Service Men. In his article on the subject, in this issue, Maurice Apstein solves these problems without mathematics. Reading this article may explain why certain p-a installations are not so hot.

With increasing popularity of short-wave reception band spread circuits should prove interesting. K. A. Chittick explains these circuits, as used in a commercial receiver, and discusses the difficulties involved in their design and how these difficulties were overcome in actual practice.

You should be especially anxious to put your shop across. Bernard H. Porter gives you many practical suggestions toward accomplishing this.

The array of handsome service laboratories, pictured on pages 526 and 527 of this issue, should provide sufficient material to help you dress up your bench. When compared with the sloppy bench shown on the page following, they lend truth to the statement "Neatness pays."

P-a equipment will be needed this fall and the opportunities for the enterprising Service Man loom even greater than last year. H. C. Rolls discusses possible markets. Your best bet in this connection, is to look around . . . not just glance here and there . . . but a thorough survey of the situation in your particular neighborhood. After all, Mr. Roll's ideas are not all inclusive. They are just indicative of some of the places which you should investigate as possible users of p-a equipment.

The popularity of cathode-ray oscilloscopes increases with the introduction of each new instrument to the low priced field. Their use would become even more widespread if Service Men were sure they understood how to use them. The article by Glenn Browning and Francis Gaffney should help you understand the operation of sweep circuits in receiver alignment.

Tuning mechanisms have become quite complicated in this year's receivers. We are endeavoring to present material which will simplify the various devices for our readers.

• • •

## HOME RECORDING

**RECORDING OF INDIVIDUAL** sound and voice pictures in the average home has progressed slowly, largely be-

cause of the high cost of the necessary equipment.

This profitable field has now been opened to the Service Man through the introduction of good equipment, at a low price, from several different sources.

You should make every effort to listen to these newer low price recordings. Their quality can compare with commercial records . . . many times superior to those previously obtainable even with higher priced equipment. Don't let past prejudices keep you out of this lucrative field.

• • •

## SERVICE DATA

**WE ARE INDEED PLEASED** to hear so much favorable comment from our readers on the tabular form used for presentation of alignment operations.

Much more can be done toward improving and standardizing service data. The RMA Service Section has appointed a special committee to ascertain your needs and make suggestions accordingly. Improvements depend, largely, upon your requirements. They can come only if you make these requirements known.

Are voltage and resistance measurements helpful to your everyday service problems? What other measurements might be helpful, in your opinion? Do you require a wiring layout or is a clear circuit diagram sufficient.

Jot down your ideas and mail them to us now!

• • •

## NEW YORK TRADE SHOW

**MAY WE AGAIN CALL** your attention to the Radio Parts Manufacturers Fall Trade Show, to be conducted in Commerce Hall, in the Port of New York Authority Building, Fifteenth Street and Eighth Avenue, New York City, October 1 to 3.

Show headquarters and the meetings scheduled during the show will be held at the Hotel Victoria, Fiftieth Street and Seventh Avenue, New York City. The technical sessions will be held at Commerce Hall.

We cannot stress too much the benefits you will obtain by attending the Show. National parts manufacturers will show their wares. Noted personalities will be present. Interesting lectures are scheduled. The hours you spend on the exhibition floor and at the technical sessions will indeed be profitable for you.

We hope to see you at Booth 411.

• SERVICE FOR

# "We unhesitatingly recommend SUPREME test equipment"

SERVICE MANAGER

*J. E. Smolek*  
**ZENITH**



**ZENITH RADIO CORPORATION**  
1400 OGDEN AVENUE  
CHICAGO, U.S.A.      June 8, 1937

Mr. Dulweiser,  
Supreme Instruments Corporation,  
Greenwood, Miss.

Dear Mr. Dulweiser:

After quite an exhaustive check on the merits of Supreme Instruments, we take this opportunity of complimenting your organization on what we believe to be an unusually fine product.

As a radio manufacturer, we must naturally have always at hand a thorough analysis of every type of test equipment, for we are called upon almost daily by jobbers, dealers and service men to offer recommendations. Since it is to the advancement of our product that we give the customer every advantage of skill in workmanship and service technique, we have unhesitatingly recommended the use of Supreme test equipment.

Wishing you continued success in the promotion of highest standards for the service profession, and assuring you that maintenance of fine quality and performance will continue to merit our endorsement, we are

Very truly yours,  
*J. E. Smolek*  
ZENITH RADIO CORPORATION  
Service Manager

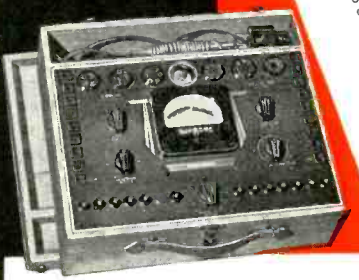

**MODEL 502** tube and radio tester. 7 instruments in one! Tests tubes and electrolytic capacitors on "Good-Bad" scales. Tests electrostatic capacitors for leakage on neon lamp, plus a complete DC volt meter with ranges from 0.2 to 1400 volts in 4 ranges, plus a complete AC volt meter with ranges from 0.2 to 1400 volts in 4 ranges, plus a complete ohmmeter with ranges of 0.1 ohms to 20 megohms (self-contained power supply), plus a 4 range output meter with ranges from 0.2 to 1400 volts AC. Cash Price only \$49.95 or \$5.50 deposit and ten monthly payments of \$4.95.



**MODEL 551** analyzer provides a method of making voltage, current and resistance readings directly from the tube socket without removing the chassis from the cabinet! Can be used either as a set tester or an analyzer, and permits analysis of all voltages from 0.2 to 1400 volts AC in 4 ranges—and 0.2 to 1400 DC volts in 4 ranges at 1000 ohms per volt. Three DC current ranges of 0.7-35-140 mls. 4 output ranges from 0.2 to 1400 volts AC. Self-contained ohmmeter circuit measures from 0.1 ohm to 20 megohms in 5 ranges. Single multi-contact selector switch makes any range instantly available. 20 functions and ranges in all. Cash price only \$38.95 or \$4.25 deposit and ten monthly payments of \$3.86.



**MODEL 546** oscilloscope is a full-size instrument with a 13" cathode ray tube, yet sells for no more than a miniature 1" scope. Has vertical and horizontal Spot Centering Controls on the panel, an Intensity and a Focus Control, Synchronizing Control, Linear Sweep Range Selector, Fine Frequency Adjuster and Horizontal and Vertical Gain Controls. Use with a Signal Generator for complete visual alignment of radio receivers. Cash price only \$59.95 or \$6.50 deposit with ten monthly payments of \$5.95.



**MODEL 501** tube tester will quickly pay for itself in increased tube sales because it will test ALL the new tubes quickly and ACCURATELY on 5 tests: (1) Any open circuit or bad connection in any one tube element. (2) Any short between any two tube elements. (3) Any leakage between any two tube elements. (4) A complete electro-conductance quality test of all elements. (5) A sectional test of each section of multi-section tubes and separate plate tests of full wave rectifiers. Cash price only \$36.95 or \$4.00 deposit and ten monthly payments of \$3.66.



**MODEL 541** set tester is the last word in low priced, versatile testing equipment. Measures all AC voltages from 0.2 to 1400 volts in 4 ranges, all DC voltages ranges from 0.2 to 1400 in 4 ranges at 1000 ohms per volt. Measures DC mls in 3 ranges from 0.2 to 140; includes 4 output meter ranges from 0.2 to 1400 volts AC. Also includes ohmmeter with 5 ranges from 0.1 ohm to 20 megohms and self-contained power supply. Cash price only \$26.95 or \$4.00 deposit with seven monthly payments of \$3.67.

YOUR PARTS JOBBER WILL SELL YOU ANY SUPREME INSTRUMENT ON S. I. C. EASY PAYMENT  
—THE LOWEST TERMS IN THE RADIO BUSINESS

**SUPREME INSTRUMENTS CORP., Greenwood, Miss.**

Export Dept., Associated Exporters Co., 145 W. 45th St., New York City, Cable Address LOPREH, New York



**"BROWN DEVIL" VITREOUS RESISTOR**

Coated with OHMITE specially developed Vitreous Enamel, that protects the coils from moisture. Brown Devils are the ideal resistor for use under humid conditions. 10 and 20 Watt sizes in values from 1 to 50,000 Ohms.

**"RED DEVIL" RESISTOR**

A Wire Wound Resistor coated with high temperature cement, that is famous for its capacity for overloads, 10 and 20 Watt sizes in value from 1 to 25,000 and 30,000 Ohms.



**WIREWATT RESISTORS**

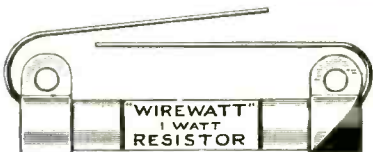

A Wire Wound 1 Watt Resistor with many uses. Built to provide absolute freedom from noise. Small enough to be used anywhere in a radio circuit. Values from 100 to 25,000 Ohms.

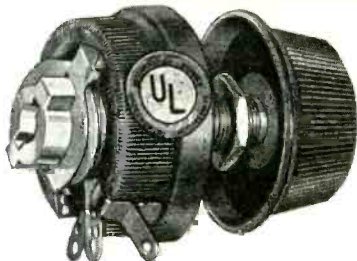

**VITREOUS ENAMELED RHEOSTATS**

Ohmite All-Porcelain Vitreous Enameled Rheostats provide the smooth accurate voltage control that prolongs the life of your transmitting tubes and permits operation at peak efficiency.

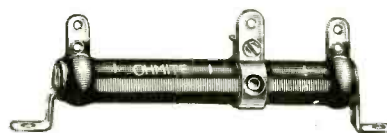

**DIVIDOHM RESISTORS**

A Vitreous Enameled Adjustable Resistor, ideal for experimental work and an excellent voltage divider. Numerous adjustable lugs may be used on one unit. Made in 7 sizes from 10 watts to 200 watts in values from 1 to 100,000 Ohms.

SEE YOUR  
JOBBER

**OHMITE**

WRITE FOR  
CATALOG 16

MANUFACTURING CO.

1827 Flournoy St., Chicago, U. S. A.



FINEST IN QUALITY ... yet COMPETITIVE in price ...

*The*  
**AMPERITE**

**VELOCITY**



PREFERRED by leading P.A. Men the world over!

**FEATURES**

- Compact, streamline, modern, the Amperite Velocity now features ...
1. Output increased 6 DB.
  2. Triple Shielded—against all RF or magnetic fields, entirely eliminating hum pickup.
  3. Eliminates feedback troubles.
  4. Excellent for close talking and distant pickup.
  5. Acoustically designed to eliminate any possibility of cavity resonance.

**LEADING MODELS**

- MODELS RBMn (High Impedance):** RBMn (200 ohms); with Cable Connector and Switch. \$42.00 LIST
- MODELS RBSn, RSHn, streamline design, slightly lower output than above, with switch only.** \$32.00 LIST
- With Cable Connector** \$34.00 LIST
- FINISHES:** All microphones have the new standard gunmetal finish. Chrome or Egg Shell. . . . . Extra \$1.00 LIST
- Other pastel shades. . . . . Extra \$2.00 LIST

The remarkable success of the Amperite Velocity is the result of Amperite's P.A. Policy—to give P.A. Men the finest possible microphones at prices no higher than what they would pay for other mikes. A letter from Ridley's P.A. Systems is typical of the general response of the P.A. industry. It says: "Your Velocity is the finest type of microphone I have ever used. . . . Please duplicate my order."

You, too, will duplicate orders . . . improve installations . . . and enjoy better quality at a competitive price by using Amperite Velocity Microphones. There's a model for every type of installation.

CONSULT YOUR JOBBER NOW!

**NEW! Desk Stand**

New and novel. Ideal for desk, pulpit, footlights, banquets. Microphone can be rotated in the horizontal plane, and used in various positions, as desired. LEAF SPRING SUSPENSION ACTS AS AN EXTRA SHOCK ABSORBER. Unusually stable. STAND ONLY. \$4.00 LIST. Name plate with maximum of 10 letters, \$2.00 LIST.



**NEW! "Ham Mike"**

No peaks! No splashing! Real broadcast quality. Output, —68 db RF Choke Circuit included in microphone. Operates directly into grid of tube. Rugged. Not affected by temperature or pressure changes. MODEL HAM (high impedance); MODEL HAL (200 ohms) . . .

\$22.00 LIST

Price includes new special Ham Desk Stand, call letters, and 3 feet of cable.



**AMPERITE JUNIOR**

A "lapel" Velocity of surpassing quality. Size of a match box. Ideal for lectures and specialty acts. Can be hidden under coat. Output constant with any position of the head. Transformer included in microphone case. MODEL 7J (200 ohms); or MODEL 7J-H (2000 ohms) \$30.00 LIST

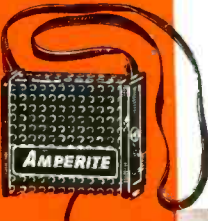

**FREE**

WINDOW DECAL advertising your Sound Service. Size 3 1/4 x 9 1/4, finished in 4 striking colors. WINDOW DISPLAY. 11 x 17, and . . . . . New illustrated bulletins. Write for these valuable sales helps today.

**A POPULAR AMPERITE VELOCITY \$22.00 LIST**

A Velocity Microphone of very high excellence. Built to Amperite standards. Used for both speech and music with great success. No peaks. Flat response over audible range. Output, —68 db; Triple shielded. Fitted with shock absorber and swivel bracket. Model REL (200 ohms) with 8 ft. of cable; Model RAH (2000 ohms) high impedance, with 12 ft. of cable.



**AMPERITE CO.** 561 BROADWAY, N. Y. U.S.A.

Cable Address: Alkem, New York

VELOCITY **AMPERITE** MICROPHONES

# RAYTHEON

*Alone*

IS RESPONSIBLE FOR  
THE SALE OF OVER...

**3,000,000  
FARM RADIOS!**

Over ten years ago RAYTHEON developed and pioneered the 2-volt battery tube. It was the improvement the engineering world was waiting for—to make possible real radio reception in rural localities!

Since then, there has been no outstanding development until the announcement of the new RAYTHEON LOW DRAIN cathode-type tubes which permit AC operation from battery sets without excessive battery drain.

Again RAYTHEON was responsible for tripling the sales of battery receivers! When you buy replacement battery tubes with the name RAYTHEON on the base you are getting tubes made by the engineers who invented them with the added advantage of proven field experience!



# RAYTHEON

445 Lake Shore Drive, Chicago, Ill.  
55 Chapel Street, Newton, Mass.

420 Lexington Ave., New York, N. Y.  
633 Howard St., San Francisco, Cal.

416 Peachtree St., N. E., Atlanta, Ga.

## FOR BETTER RECEPTION

# ★ ACCURACY

★ **Guaranteed In This Low Price Signal Generator**

★ Wherever you go you will hear praise for Model 557 Direct Reading Signal Generator. Continuous use day in and day out has clearly demonstrated its remarkable accuracy and reliability.

Model 557 Direct Reading Signal Generator uses plug-in type coils. Five frequency bands are covered from 110 to 20,000 K.C., all fundamentals. Completely shielded for static and magnetic fields. Attenuation and stability are outstanding features. Strong signals both modulated and unmodulated are furnished.

Each individual coil is separately calibrated by an exclusive method of peaking with trimmer condensers. Furnished complete with batteries and accessories.

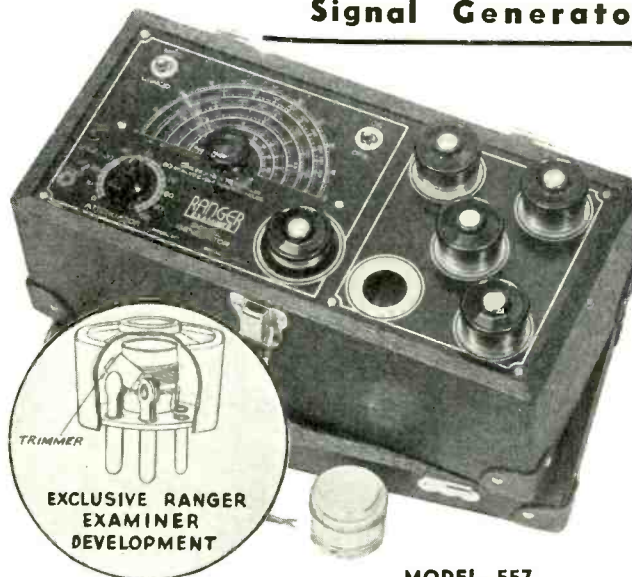

MODEL 557  
COMPLETE DEALER PRICE

Only \$18.90

1% Accuracy to 3,000 K.C. • 2% for Higher Frequencies • Range 110 to 20,000 K.C.

1938 Up-to-the-Minute Tube Tester



\$19.80

Five flush type sockets provide for all tubes. The tester operation is very simple and indicates condition of the tube for dealer and customer on Direct Reading (GOOD-BAD) colored scale of Triplett Instrument. Will also test for interelement shorts and leakages. Complete in attractive, sturdy, quartered-oak case. Sloping etched panel of silver and black. Suitable for portable or counter use.

Combination Volt-Ohm-Milliammeter and Free Point Tester

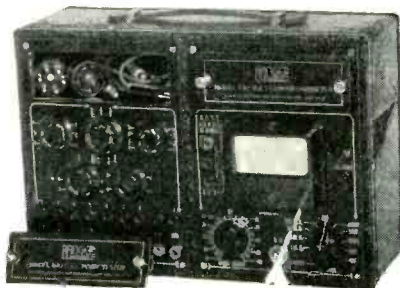

\$28.35

Precision built throughout. Readrite-Ranger Radio Testers need no apology from the highest class servicing shops. In fact, you will find them using these rugged testers on calls because they have been particularly designed to withstand rough field work. Ask your jobber to show you today's values in precision radio testers.

Foundation Oscilloscope with Built-in Sweep



\$11.40

LESS TUBES  
A practical foundation unit for amateurs, engineers, sound and radio servicemen. With proper external additions, it offers facilities for the study and adjustment of countless circuit problems. May be adapted for R-F and I-F alignment, resistor, condenser, vibrator and many other tests.

**TODAY'S BIGGEST VALUES IN PRECISION TESTERS  
SEE YOUR JOBBER . . . WRITE FOR MORE INFORMATION  
SEE OUR DISPLAY—BOOTH 105—RADIO PARTS SHOW—NEW YORK CITY**

**Readrite**  
TESTERS **RANGER** METERS

READRITE METER WORKS  
917 College Drive, Bluffton, Ohio

..... Please send me more information on Model 557.....;

..... Model 430; ..... Model 640-740; ..... Model 840.

Name .....

Address .....

City..... State.....

# SELL

## BEFORE YOU

# BUY

**H**OW would you like to have a good stock of nationally advertised radio tubes on your shelves—without paying a nickel until they're sold?

That's how the Tung-Sol Consignment Plan works for radio dealers who can qualify. You don't pay for the tubes until you've collected your cost and profit. That's worth looking into—to see if you are eligible for this unique plan.

More than 8,000 dealers have

qualified—and are going places in the tube business.

Full profit—no investment—no dead numbers to write off a loss. Easy to sell, because your trade knows that Tung-Sol means top flight tube efficiency.

## TUNG-SOL

*Tone-flow Radio Tubes*

TUNG-SOL LAMP WORKS, INC.

Dept. D Radio Tube Division

SALES OFFICES: Atlanta, Boston, Charlotte, Chicago, Dallas, Detroit, Kansas City, Los Angeles, New York  
General Office, Newark, N. J.

The Tung-Sol franchise is still available to a limited number of dealers who can qualify. Write for the name of your nearest wholesaler.

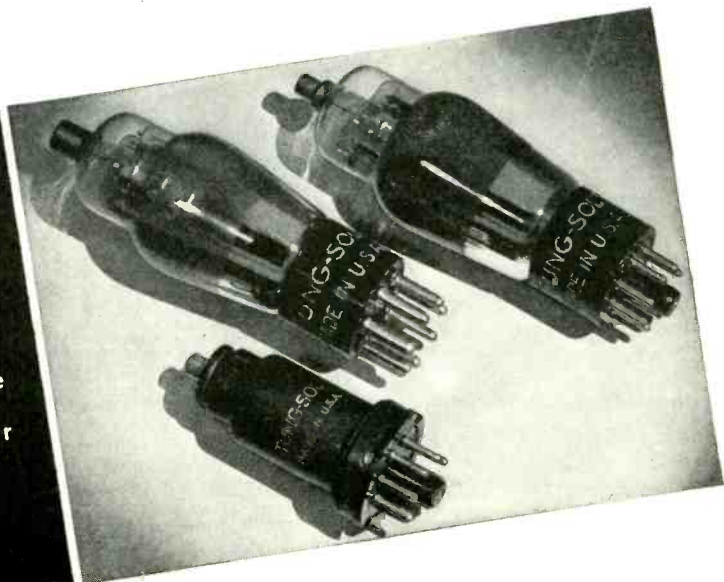

# SERVICE

A Monthly Digest of Radio and Allied Maintenance

FOR SEPTEMBER, 1937

## TAPPED TRANSFORMER IMPEDANCES

By MAURICE APSTEIN

WITH THE ADVENT OF so-called universal output and input transformers, and the general acceptance of the fact that published impedance relationships of several windings of a transformer are more or less flexible, considerable practical material has been published outlining methods for impedance matching, calculation of impedance ratios from experimental voltage readings, and in general, the use of transformers at impedances somewhat different from the manufacturers' ratings.

There seems to have been, however, a complete disregard for one of the most common practical problems with regard to impedance matching which confronts the Service Man or public address installer. It is quite often necessary in the field to determine the impedance of some unknown winding on an output transformer without the necessity of measuring the transformer itself. For instance, a p-a installation man, in adding several additional speakers to an existing system, finds himself with an output transformer tapped at 4, 8, 16 and 500 ohms, none of which values match his speaker network after the additional speakers are added. It would be very handy in such a case to be able to determine what the impedance would be between the 4-ohm tap and the 8-ohm tap, the 8-ohm tap and the 16-ohm tap, the 16-ohm tap and the 500-ohm tap or any other combination of taps available on the transformer.

The usual method for finding these values would be to apply a known a-c to one of the known windings or sections, and measure the voltage across the unknown winding. The unknown

---

**MISUNDERSTANDING OF THE** impedance relationship between the various taps on a transformer winding has undoubtedly caused many headaches to the p-a Service Man. Installations are often ruined and customer confidence lost because of inadvertent mismatching.

The accompanying article gives the impedance relationship between transformer taps. The impedance of a winding is not, as might be imagined, the sum of the individual impedances between the various taps. The actual mathematical relationship is illustrated in Fig. 1.

The chart, Fig. 2, gives solutions of this relationship for commercial transformer windings.

---

impedance is then calculated from the relation,

$$\frac{Z_2}{Z_1} = \left( \frac{V_2}{V_1} \right)^2$$

where  $Z_2$  is the known primary impedance;  $Z_1$  is the unknown impedance;  $V_2$  is the known applied voltage and  $V_1$

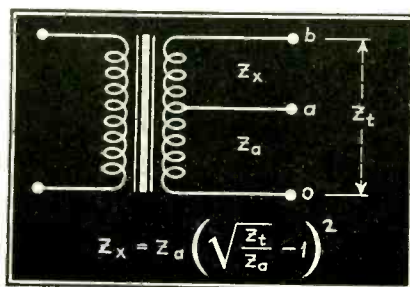

Fig. 1. Illustrating the impedance of an unknown section of a tapped winding in terms of the whole and of the other section.

is the voltage measured across the unknown winding.

The above formula uses assumption that the voltage ratio will be proportional to the turns ratio and that the impedance of a winding varies as the square of the turns, both assumptions are legitimate under the conditions of test for the accuracy desired. Unfortunately, however, the above measurements are made with 60-cycle a-c as the signal source. Unless the transformer under test has very good response at 60 cycles the relationship may introduce serious error. Several small output transformers of the type used to match 6- and 8-inch speakers have been measured using the above method, and reasonable results have been obtained only when the signal frequency was in the neighborhood of 500 to 1000 cycles. At 60 cycles the poor response introduced such serious errors that the measurements were worthless. Another disadvantage of the above method is that it is often awkward to make the measurements required for the calculation, and sometimes impossible because operation of the system would have to be interrupted for a considerable length of time.

### GENERAL FORMULA

At any rate, a general formula which would allow the calculation of the impedance of the unknown section of a winding in terms of the impedances of the known sections would be extremely helpful, and would eliminate the necessity for operating on the amplifier in any way. It would be especially helpful if the formula did not require the primary impedance at all since in many

	2	3	4	5	6	7	8	9	10	25	50	100	125	250	500
2	0	0.097	0.33	0.67	1.07	1.52	2.0	2.52	3.08	12.9	32	73	95	208	436
3	0.097	0	0.064	0.25	0.50	0.84	1.2	1.6	2.0	10.6	29	68	88	198	426
4	0.33	0.064	0	0.058	0.19	0.41	0.66	1.0	1.34	9.0	25	64	85	191	417
5	0.67	0.25	0.058	0	0.05	0.18	0.34	0.58	0.84	7.7	23	61	80	184	405
6	1.07	0.50	0.19	0.05	0	0.049	0.12	0.29	0.51	6.6	22	57	77	181	399
7	1.52	0.84	0.41	0.18	0.049	0	0.034	0.14	0.28	5.5	20	54	72	175	385
8	2.0	1.2	0.66	0.34	0.12	0.034	0	0.029	0.11	4.6	18	51	70	168	381
9	2.52	1.6	1.0	0.58	0.29	0.14	0.029	0	0.023	3.9	16	48	68	164	375
10	3.08	2.0	1.34	0.84	0.51	0.28	0.11	0.023	0	3.4	15	47	63	160	368
25	12.9	10.6	9.0	7.7	6.6	5.5	4.6	3.9	3.4	0	4.2	25	39	116	301
50	32	29	25	23	22	20	18	16	15	4.2	0	8.4	17	77	233
100	73	68	64	61	57	54	51	48	47	25	8.4	0	1.4	33	154
125	95	88	85	80	77	72	70	68	63	39	17	1.4	0	21	125
250	208	198	191	184	181	175	168	164	160	116	77	33	21	0	42
500	436	426	417	405	399	385	381	375	368	301	233	154	125	42	0

Calculated from Formula  $Z_x = Z_a \left( \sqrt{\frac{Z_t}{Z_a}} - 1 \right)^2$

Fig. 2. Approximate impedances between taps of commercial transformers. For example: the impedance between an 8-ohm tap and a 125-ohm tap, as read from the chart, would be 70 ohms.

cases this information is not available. It was with these considerations in mind that the relatively simple algebraic expression was evolved for the impedance of an unknown section of a tapped winding when the impedance of two other sections is known. It is believed to be the first time that the information has been presented in this form.

Considering a typical transformer as indicated in Fig. 1, with unknown primary impedance and an overall secondary impedance of  $Z_t$ , tapped at  $Z_a$ . It is desired to find the impedance between taps a and b, or the impedance  $Z_x$  in terms of  $Z_t$  and  $Z_a$ .

It can easily be shown that this impedance is equal to

$$Z_x = Z_a \left( \sqrt{\frac{Z_t}{Z_a}} - 1 \right)^2$$

As a practical example the original problem may be offered for solution.

Given a 500-ohm winding tapped at 4, 8 and 16 ohms, what is the impedance between the 4- and the 8-ohm taps, between the 8- and the 16-ohm taps and between the 16- and the 500-ohm taps?

To find the impedance between the 4- and 8-ohm taps the whole winding is taken as 8 ohms and the known fraction as 4 ohms. In other words the remaining section of the winding is disregarded for the time being.

Substituting in the formula:

$$Z_x = 4 \left( \sqrt{8/4} - 1 \right)^2 = 0.686$$

Similarly, for the impedance between the 8- and 16-ohm taps:

$$Z_x = 8 \left( \sqrt{16/8} - 1 \right)^2 = 1.37$$

And for the impedance between the 16- and 500-ohm taps:

$$Z_x = 16 \left( \sqrt{500/16} - 1 \right)^2 = 339.$$

Thus without even seeing the trans-

former we can tell that the impedance between the 4- and 8-ohm taps is approximately 0.7 ohms, or that the impedance between the 8- and 16-ohm taps is approximately 1.4 ohms. The impedance of any other combination of taps can be computed in exactly the same manner.

To save the Service Man from the necessity of making troublesome calculations the accompanying chart has been computed for various tap combinations found on commercial input and output transformers. Some caution is necessary in using these values, however, since they apply only to *tapped* windings on the same core. Some of the impedance combinations on universal output and input transformers are obtained by connecting two or more windings in parallel. These exceptions are usually easy to identify since the parallel connections are made externally.

### Determining Transformer Short

A short in the windings of a power transformer can often be determined by connecting a 25-watt electric light bulb in series with the primary as shown in the accompanying diagram. The tubes in the receiver whose transformer is under test should be removed from their sockets during the test. A short in any of the windings of the power transformer will cause the bulb to burn brightly. A normal transformer will produce only a dull red glow.

As an added check, a transformer showing shorted, should be tested again after the secondary leads are disconnected from the receiver. Occasionally the short is found in the wiring and sockets of the receiver chassis.

The most suitable method of determining shorts in a power transformer

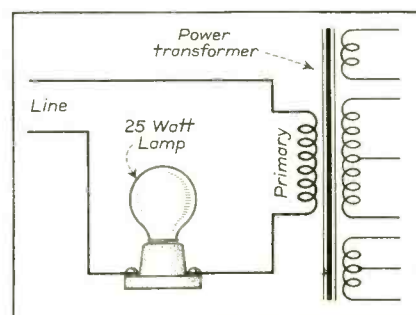

A lamp in series with the primary will show up a short in the secondary.

is through the use of a wattmeter in the primary circuit. A normal transformer usually draws less than 10 watts when it is not connected to a load.

Harold C. Dow

### STROMBERG-CARLSON SPEAKER DATA

Speaker Pc. No.	Cone Pc. No.	Size Ins.	Voice Coil Imp. Ohms	Field Res. Ohms	Used on Models
19209	18746	12	15	635	645 (110 v, d-c)
19210	18746	12	15	3260	645 (220 v, d-c)
19250	18746	12	15	1100	25 (110 v, d-c)
21506	21505	10	15	2500	19, 22, 24
21126	18746	12	15	635	16, 17 (110 v, d-c)
25297	23049	10	15	1950	60 P, R
25683	25730	10	24	7300	No. 3 Spkr. Sys. D-2939
25687	25730	10	24	1050	62, 63, 80 Hi-Fi
26053	26096	6	5	1800	125, 225-H
26170	26250	10	1.5	1050	130-M, 140-K, L, P, M, 145-L, P, 150-L, 160-L, P, 180-L, 230-H, F, 231-R, F, 260
26903	26250	10	1.5	505	E. K. Co's Pc. 16933
27375	27376	12	1.5	1050	230-L
27385	27376	12	1.5	505	240-L, R
27503	25492	8	1.5	505	240-H
27504	26250	10	1.5	505	240-M, P, W, S, 250-L, P, 255-L
27557	25492	8	1.5	1620	228-H
27605	27808	12	1.5	1620	228-L
27827	26250	10	1.5	3425	260
27834	27808	12	1.5	1050	229

NOTE: In the speaker listing which appeared in SERVICE, page 306, May 1937, the following changes should be made: The Speaker Pc. No. 25061 should be Pc. No. 25601; the field coil resistance of Speaker Pc. No. 24777 is given as 1950; this should be 7950.

# BAND SPREAD CIRCUITS

(See Front Cover)

By K. A. CHITTICK\*

THE AVERAGE SHORT-WAVE frequency band covers a spread of 5,600 to 22,000 kc of which less than 5 percent is required by the international entertainment bands at 49, 31, 25, 19, 16 and 13 meters. It is desirable from the standpoint for ease of tuning to spread out each of these bands to the width of the standard broadcast band. To accomplish this and still maintain a continuous all-wave frequency coverage would require 18 to 20 separate bands of 1,000 kc each. Such a design is, of course, impractical and uneconomical for a normal receiver. However, if we select only certain important portions of the short-wave band to be spread for ease of tuning, the design becomes practical.

Several of the new 1938 RCA Victor receivers incorporate this type of spot electrical band spread which brings to the customer four principal short-wave entertainment bands with a greater ease of tuning than on the standard broadcast band. The four bands at 49, 31, 25 and 19 meters are electrically spread approximately 50 times further on the dial scale than on former short-wave receivers. Each band is provided with a separate dial scale as shown in Fig. 1. For example, the 31-meter band now occupies a 10-inch length of dial scale instead of a ¼-inch length as in the usual full coverage short-wave receiver. In addition, the geographical locations by city names of the principal short-

wave stations are printed directly on the dial together with their respective megacycle markings.

Each of the four spread bands is approximately 300 kc in width and covers the frequency ranges (in megacycles) from 5.96 to 6.25, 9.40 to 9.70, 11.67 to 11.93 and 15.07 to 15.38. The 16- and 13-meter bands are not included as spread-band scales.

## THE COILS

The antenna and radio frequency coils each consists of a single tapped inductance which is fixed tuned to the center of each of the four short-wave bands. In this manner, higher inductance antenna and radio-frequency circuits may be used. The antenna stage uses a single primary coil for the four different secondary circuits. A single air trimmer is used to trim all four bands to the proper frequency.

In the radio-frequency stage, the secondary tuned coil is inserted in the plate circuit of the r-f tube in shunt with a high impedance choke which provides a plate voltage connection. A single air trimmer is also used to trim the four r-f circuits to the correct frequency.

The oscillator circuit is tuned over each of the four spread bands by a split section of the variable condenser. This circuit requires separate coils which are mounted directly on the range switch. The coils are trimmed to the correct

frequency in the center of the dial scale by magnetite core inductance adjustments, except on the 49-meter band where an air trimmer is provided for alignment. In this manner each oscillator circuit is aligned to its own dial calibration independent of the other spread bands.

The oscillator circuit used is a compound Hartley with the cathode connection permanently tapped near the center of the 49 meter coil. The other three oscillator coils are progressively shunted across the 49 meter coil as the range switch is turned to the other bands. The cathode tap is thus automatically provided for the higher frequency oscillators. An air trimmer is used to trim the 49 meter band to the correct dial calibration instead of a magnetite core since an inductance change in this coil would affect the inductance of the higher frequency oscillator coils which are connected in shunt.

Fig. 2 shows the arrangement of the coil structure. All coils are mounted directly to the range switch shields which serve as the ground return path for the tuned circuits on each band. A seven-band circuit is shown in Fig. 2 of which four of the bands are spread bands. The remaining three bands are used to cover a continuous frequency range from 530 kc to 22,000 kc.

The length of the high frequency leads external to the coils has been reduced to a minimum. Strap type terminals connect the coils to the range

\*Engineering Dept., RCA Mfg. Co., Inc.

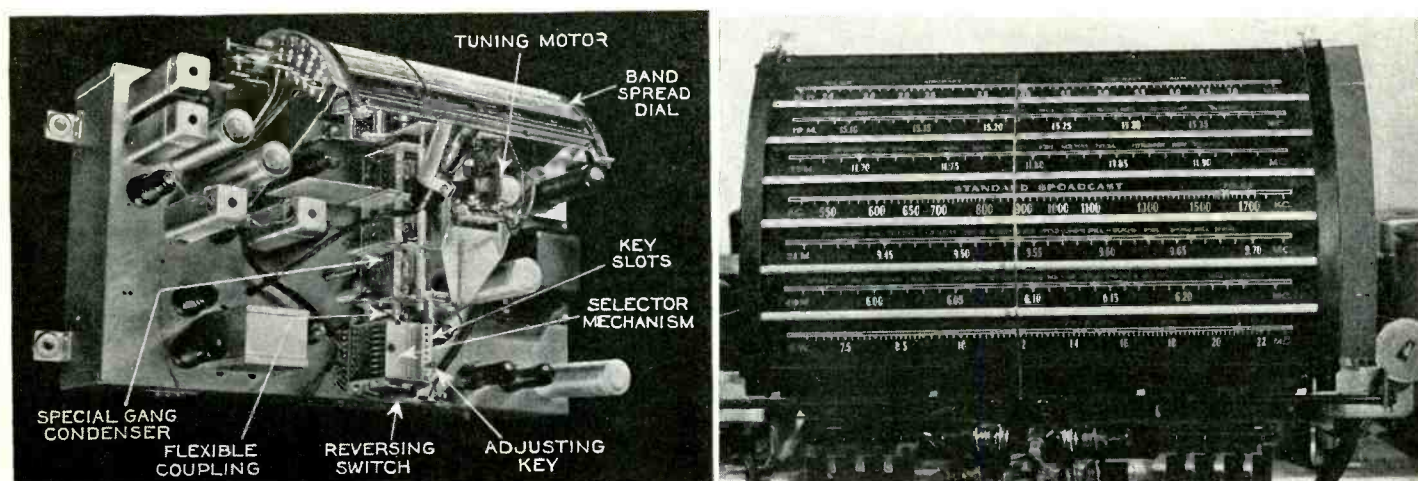

Fig. 1. RCA band spread receiver and dial. Five spread bands and three complete coverage bands are employed.

switch in order to reduce the number of soldered joints. The oscillator tube is cushion mounted to reduce microphonic howl on the wide coverage high-frequency band. This type of mounting is not required on the spread bands since these bands are free from microphonic howl due to the low inductance to capacity ratio used in the circuits.

#### THE CONDENSERS

The split section of the variable condenser which tunes the oscillator over each spread band has a total capacity change of approximately 15 mmfd, and results in a frequency change in each oscillator circuit of about 300 kc. In order to obtain frequency stability with respect to small changes in capacity caused by vibration and motion of leads, a padding condenser of 100 mmfd is connected in shunt with the 15-mmfd variable condenser on the 49-meter band and left connected for the three higher-frequency spread bands. To maintain the same width of tuning range (300 kc) on the higher-frequency bands as on the 49-meter band, additional padding condensers are shunted across the oscillator circuits. A total capacity of 200 mmfd is required for the 31-meter band and 300 mmfd for the 25- and 19-meter bands.

#### FREQUENCY DRIFT

A difficulty encountered in the design of such a spread-band system is frequency drift caused by changes in humidity and temperature. Since each spread band is calibrated in 10-kc divisions, approximately  $\frac{1}{4}$  inch apart on a dial scale 10-inches long, it becomes of importance that oscillator drift be reduced to a minimum. A change of 1 mmfd in capacity will shift the dial calibration 20 to 25 kc or over  $\frac{1}{2}$  inch on the dial scale.

To reduce frequency drift caused by humidity, all oscillator and radio-frequency coils, terminal boards, range switches, r-f sockets, variable condenser terminal boards, etc., are impregnated in a special wax and then cold dipped to form a heavy wax seal. The type of grid and plate resistors for the oscillator circuit are selected for minimum changes in capacity with humidity.

Changes in oscillator frequency caused by the normal temperature rise of the chassis and variations in room temperature presents a problem. The coils expand with an increase in temperature which results in an increase in inductance. The distributed capacity of component parts, including the coils, wiring, and variable condenser also increases. Both of these effects lower the frequency of the oscillator and result in errors in dial calibration. In fact, during the early stages of the develop-



Fig. 3. Temperature drift compensating condenser.

ment, it was not unusual to have a frequency drift equal to the entire length of the dial scale.

To compensate for this decrease in oscillator frequency, the 100 mmfd padding condensers are designed with the proper negative coefficient of capacity as the temperature increases. This capacity correction is in the order of 0.2 percent for each of the four spread bands, over a temperature rise of approximately 250 Centigrade. The oscillator frequency, and therefore the dial calibration, remains fixed after the short initial warm-up of the tubes, over the normal variations in room temperature and the increase in chassis temperature after the receiver has been placed in operation.

The design of the compensating condenser is shown in Fig. 3. It follows closely the standard design of a small mica condenser. Alternate layers of foil and mica are stacked together and clamped with a metal clamp, under certain pressure conditions. The assembled unit then is imbedded in a plastic material under fixed conditions of temperature and pressure. The materials used in the condenser and the type of plastic determine to a large degree the resultant coefficient of capacity with temper-

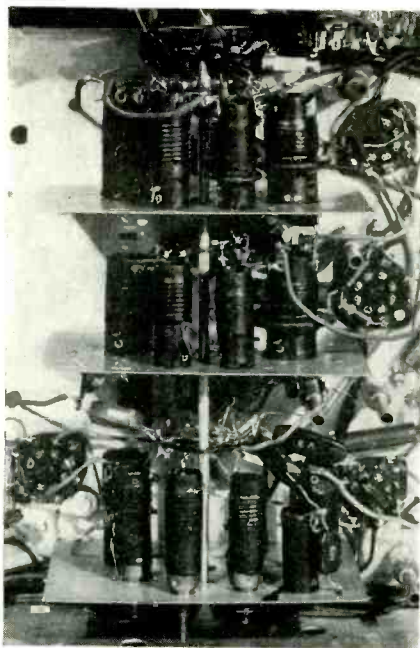

Fig. 2. Band spread coil structure. The coils are grouped about the band switch to reduce the length of wiring.

ature change. The connecting leads of the condensers are welded to the foils instead of soldered, since the molding operation takes place at a higher temperature than the melting point of solder.

The shift of oscillator frequency caused by a change in power line voltage is reduced to a minimum in the spread-band circuits. The use of the separate Hartley type oscillator in conjunction with a low inductance to capacity ratio and the proper choice of the values of the plate and grid blocking condenser results in an oscillation stability which is satisfactory over normal variation in line voltage.

#### THREE-BAND COIL STRUCTURE

The new 3-band coil structure, used in this year's RCA receivers, employs a type of winding for the standard broadcast band known as the accumulative winding. It consists of a universal wound Litz coil which progresses along the coil form instead of building up a narrow coil as in the usual manner. The use of the accumulative winding increases the Q of the circuit approximately  $2\frac{1}{2}$  times over the winding used in last year's receivers.

A large universal winding is used as an antenna primary coil for the broadcast band. The secondary winding consists of the accumulative coil in series with the 2 high-frequency coils. The latter are approximately  $\frac{1}{10}$  of the total inductance and produce only a slight effect on the overall circuit.

For the medium-frequency band extending from 2100 to 6800 kc, the large universal coil is shorted and the accumulative winding is used as the primary. The secondary circuit consists of 2 solenoid windings in series. These windings are wound on a grooved form to eliminate the necessity for inductance adjustment.

On the highest-frequency band extending from 6800 to 22,000 kc, both the universal primary and accumulative winding are shorted. The primary coil is the larger of the solenoid windings and the smaller solenoid is the secondary.

This type of circuit reduces the number of range switch connections, results in efficient performance for all three bands, and simplifies the manufacture of the receiver.

The r-f stage operates essentially in the same manner except that an additional winding is placed between the accumulative coil and the medium-frequency solenoid winding to improve the gain at 49 meters. A high-frequency primary is also used on the highest-frequency band together with the low-frequency primary to improve the performance on this band.



# PUTTING YOUR SHOP ACROSS

SERVICE MEN USING THE promotional aids supplied jointly by the mat makers and manufacturers find that advertising pays. This is particularly the case when intelligent advantage is taken of these services supplemented by an occasional original design.

Contrary to general opinion, the independent Service Man benefits by using the manufacturer's name as it appears on such mats. Rather than advertising the maker in preference to the service retailer, as is the usual claim, the Service Man is in reality identifying himself to his public as a part of a nationally advertised and reliable product. He is, in brief, cashing in on the manufacturer's more costly program of promotion, rather than losing in the reverse order.

## MATS

A number of the larger manufacturers offer a means for reproducing first class advertisements at a few cents a mat. Distributing agencies of these companies often provide them free. These mats (special composition board previously impressed with type of professional copy to form dies for molten type metal) make attractive ads. Decorated with appropriate borders and art work such mats produce effects that cannot be duplicated by the combination of advertising agency, artist and printer for less than thirty-five dollars. Ample space is allowed for the insertion of the name, address and phone number. Moreover, they are available in various sizes in keeping with annual advertising budgets; their special advantage is in the variety of choice that places emphasis on the radio features of national holidays, sports, news and elections. The sales message is also changeable from week to week. Thus all-year-round interest can be stimulated.

Naturally liberties can be taken with the mats. When the mat is duplicated in metal and the resulting piece mounted on wood the printer can cut out any undesired portion and substitute more personalized copy with the usual type letter forms.

Few realize the possibilities of such cutting or adapting cuts for their individual use.

Just as the radio industry has a line of mats for its trade, so the automobile and other lines make similar provisions. The printing plants in every community have, in their offices, a catalog of mat proofs for all classes of advertising. A casual inspection of these will convince one that even the illustration of a satisfied customer walking in a new suit

By BERNARD H. PORTER



Fig. 2. This home-made design is effective and can be used in the classified ad section of newspapers, business cards or blotters.

down the sunny side of a street can be used from the tailor's mat and combined with some catchy copy on the mat of an automobile service ad to form an appropriate sales talk for the Service Man.

For example, Fig. 1 is a simple drawing with captions cut from a magazine and a shop's folder. When mounted on paper, photographed and made into a cut in the usual manner, the result



Fig. 3. Auto dealers remind car operators to change oil, etc. . . why don't Service Men suggest a periodic checkup of receivers?

shown was obtained. In reality, Fig. 1 is a drawing of the result obtained by joining two mats. The bird and accompanying words were salvaged from a mat advertising book, while the radios and reading in the lower right had been used for some time as part of a shop's ad. A printer's saw did the trick.

Creation of attractive cuts need not

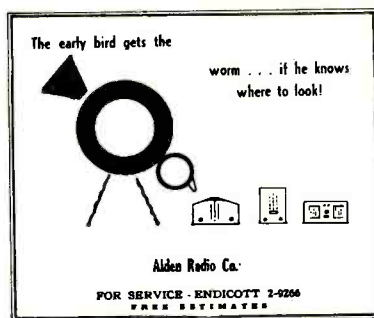

Fig. 1. Eye-catching advertisements can be designed by any Service Man in his spare time.

be confined to the ingenious combination and adoption of mats to individual needs. Pleasing designs can be drawn with India Ink on a good grade of paper and later reproduced at a reasonable price. Fig. 2 is an example of such a design whose dimensions can be varied at will, though appearing at its best advantage when inserted in the solid type copy of classified ad sections. One need not be a finished artist to design this kind of display ad.

A second type of advertising piece can also be made by the average Service Man. It is a seal, or sticker, which, when pasted to the interior of the radio cabinet, provides a service record for both the Service Man and owner. At the same time it is good advertising for the service shop. (A modification of this suggestion is described on page 634 of the December 1936 SERVICE, see "Card Helps Repeat Business.")

## SERVICE QUESTIONNAIRES

Repeat business is the aim of all tradesmen catering to the public. It is to be hoped that through honest dealing, value-for-the-money and good service one's customers will reward him with later calls and purchases. Oftentimes, however, the initial contact has not been established properly. In this case, an invitation (see top card of Fig. 4) addressed to a customer who has not called for some time, will be found useful. The questions referred to are not unlike those shown in the lower card of the same illustration. In addition to gaining comments that will promote better service in the future the shop owner is, if nothing else, reminding the customer that his servicing facilities are still available at the same address. In the center card as shown, the shop is also thanking the customer for his past business. Such messages are usually provided with business reply postage.

A useful questionnaire from the advertising standpoint is that in which the Service Man reverses the procedure and answers customers' questions. This is conveniently accomplished by a column of some 250 words in the local newspaper as supplementing the paid space. Editors will often make this arrangement with a prominent Service Man in a community and, as the column grows in popularity, may even pay for it. Non-technical questions and answers are the more acceptable.

## FOLDERS, BLOTTERS AND CARDS

The repair and sales shops are usually cluttered with manufacturer's folders, (Continued on page 578)

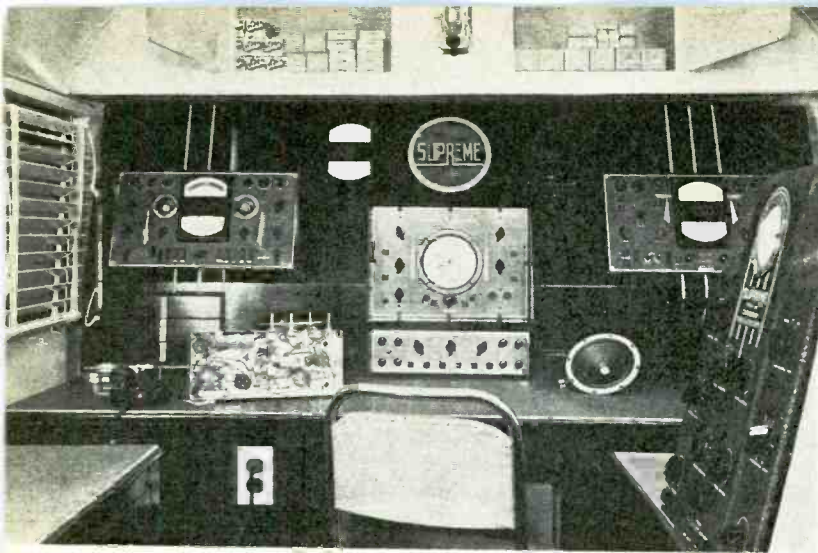

Suggested Supreme service layout.

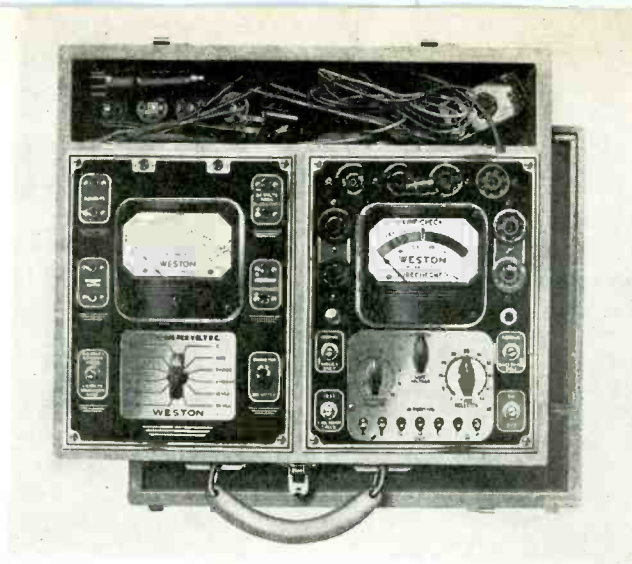

Weston Serviceset.

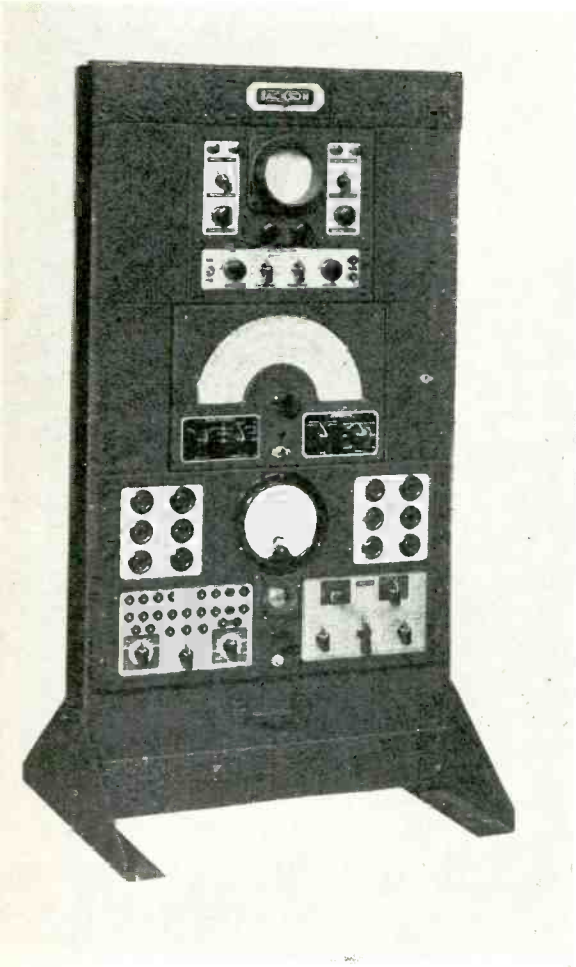

Jackson Servicelab.

## COMPLETE SERVICE

IN AN EFFORT TOWARD giving the Service Man's equipment more eye value the various test equipment manufacturers are featuring complete service laboratories.

Tidy equipment, as shown in the accompanying illustrations, does its part by impressing the clients with the Service Man's reliability and competence. In so doing it helps pay for itself. There are, however, many additional practical advantages favoring such equipment.

In many shops bench space must be carefully conserved to give adequate working room. An assembly of equipment occupies less space on the bench than individual pieces of equipment.

Assembling the various pieces of equipment at one point simplifies receiver analysis and repairs.

The complete equipment installation

is ruggedly assembled; the individual instruments are less liable to damage through accident.

After the Service Man has completed his individual service laboratory he can photograph it and have a suitable cut made for inclusion on all his stationery and advertising. Additional value will thus be obtained.

### SUPREME

The Supreme radio test benches and service laboratories shown among the accompanying illustrations were built from a set of plans and suggestions issued by the Supreme Instruments Corporation.

The panels house several Supreme testing instruments and a loudspeaker. The instruments are a diagnetometer, signal generator and tube tester. An-

Triplett standardized test bench panels.

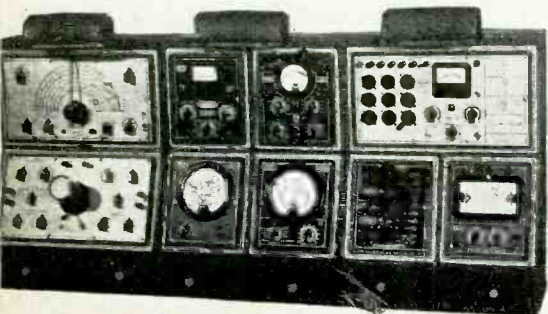

Clough-Bregle service laboratory.



Triplett Model 1404 service panel.

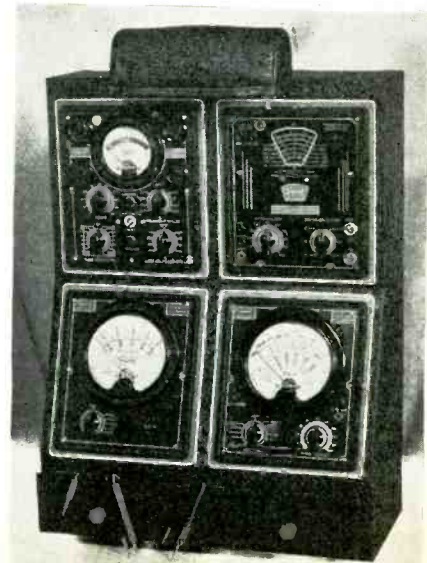

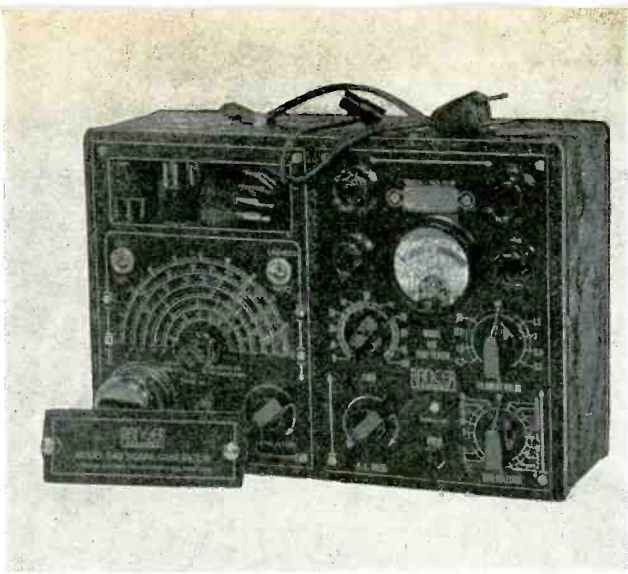

Readrite 440-540 combination.

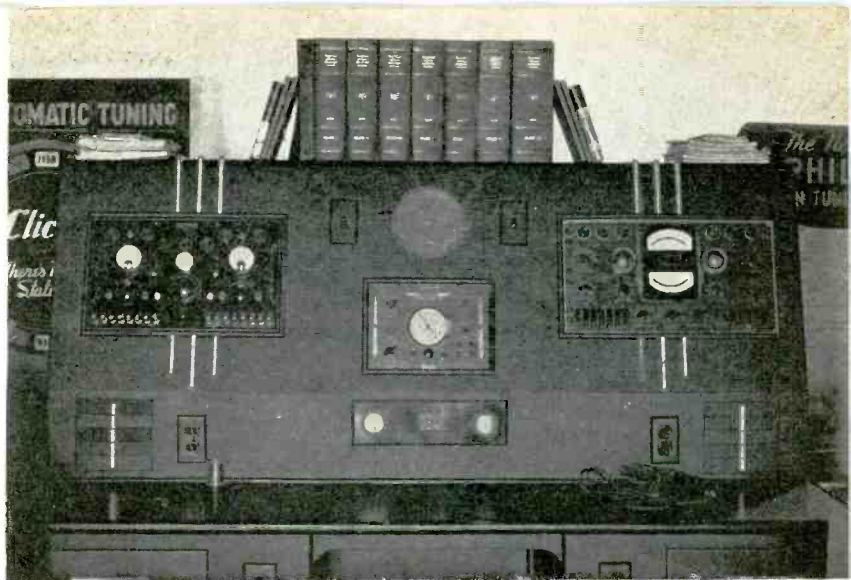

Suggested Supreme service layout.

## LABORATORIES

tenna, ground and power outlets are conveniently located. Parts drawers, tube racks and soldering iron rests are within easy reach. With cabinets and drawers below there is storage space for tools, batteries, etc. The entire bench is made of wood attractively painted. Decorations are accomplished with wood half rounds.

### JACKSON

Jackson Electrical Instrument Company uses a standard relay rack to mount their three section service laboratory.

The lower unit consists of a dynamic analyzer for the purpose of complete tube testing and also for complete receiver testing, including point-to-point tests and component tests.

The central unit in the assembly is a complete frequency modulated signal generator. The instrument may be used for any purpose where a test oscillator is required.

The upper unit in the illustration is a complete cathode-ray oscilloscope incorporating the features required in modern service work.

### TRIPLETT

Laboratory test bench panels, in three cabinet styles with facilities for a complete service laboratory, are offered by the Triplet Electrical Instrument Company. Any Triplet Master or DeLuxe line tester may be installed.

The Model 1403 accommodates one DeLuxe and two Master testers. The 1402 has compartments for two DeLuxe



Earl Webber Official Radio Service Laboratory.

Triumph portable service lab.

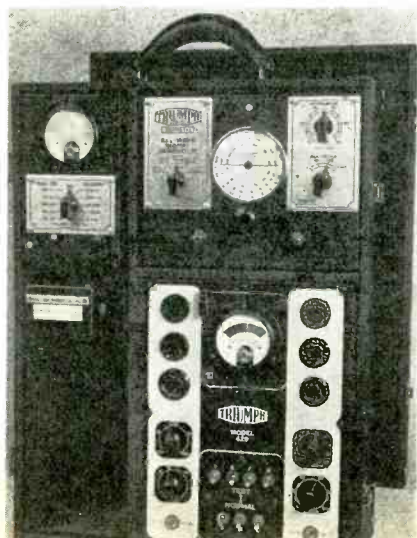

Triplet Model 1403 service panel.

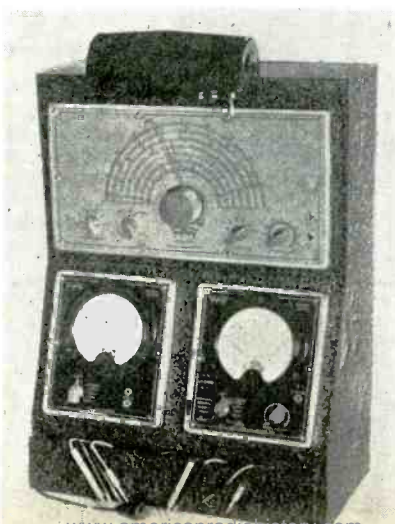

United Motors Service Model 652 service bench.

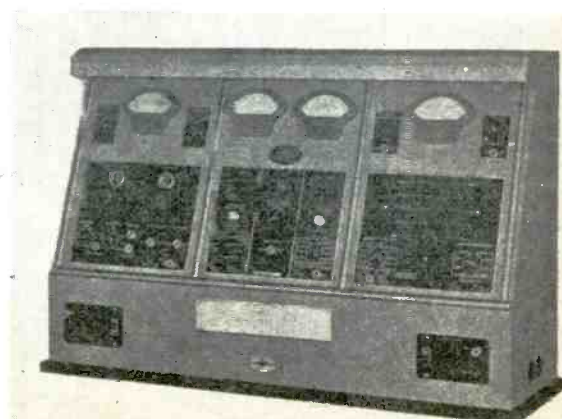

instruments and Model 1404 will hold any four Master units. Installation is such that testers may be easily removed for field use. Any two or more cabinets may be bolted together to form a continuous panel.

The cabinets are constructed of sheet metal and have a black wrinkle finish. The panel front is trimmed in red and white. A large drawer is provided at the bottom for accessories.

#### CLOUGH-BREngle

The Clough-Brengle Company's complete service laboratory is housed on a standard 36-inch rack. Various combinations of Clough-Brengle equipment can be obtained for relay-rack mounting.

The laboratory pictured consists of a model 94 rack; the CRA-R oscillograph, complete with horizontal and vertical amplifiers and sweep circuits; a model 95-R Super-Unimeter for making resistance, capacity, a-c and d-c measurements; a model 79-BR audio oscillator with a range to 50,000 cycles; and a model 110-R modulated signal generator.

Although the equipment shown can be fitted to any standard rack, a special rack is provided with handsome trimmings and convenient lighting facilities.

#### TRIUMPH

Triumph Manufacturing Company offers a portable service laboratory which includes a model 110 signal generator, a model 420 tube tester and a model 300 multirange meter. Similar combinations may be obtained for convenient bench mounting.

#### UNITED MOTORS

The United Motors 652 service panel is divided into three sections. A universal speaker, with a universal output transformer and substitute field ar-

Enclosing the entire work bench in a metal screen helps alignment operations and trouble shooting.



Photo. courtesy Tobe Deutschman Corp.

angement; an output meter calibrated in watts, when used with the universal speaker; a complete vibrator tester; a multirange volt-ammeter tester for point-to-point and radio testing; a signal generator; elaborate power supply circuits and convenient lighting facilities are suitably arranged on the instrument panel.

#### EARL WEBBER

The Earl Webber Company features several complete service laboratories that combine some twenty-three sections for various types of automobile and household radio testing.

Vibrator tests; point-to-point measurements, both a-c and d-c; alignment; speaker substitution; tube tests, etc—everything at the Service Man's elbow for rapid testing and accurate repairs.

#### READRITE

The Readrite Meter Works offer sev-

eral portable combinations to assist the Service Man in testing in the customer's home. The model shown consists of a tube tester and a multirange meter for a-c and d-c measurements.

#### WESTON

The Weston Serviset, consisting of the Model 772, a 20,000-ohm-per-volt voltmeter, and the companion Model 773 tube checker, when placed side by side in the case as illustrated, forms a convenient combination for rapid checking in the field.

A similar combination, together with the Weston signal generator, may be used for bench mounting in the shop. Suitable Weston meters may also be used for line voltage, power, db and other indications.

Although many of the laboratories pictured herewith are obtainable in complete form, they show in general a basis toward which the Service Man may strive. In most cases the various items used to make up the complete panels may be purchased individually from time to time. Pending their arrival, blank panels can be used to fill the empty spaces.

Should the Service Man assemble his own complete laboratory, many optional arrangements will suggest themselves depending on the exact nature of the equipment to be mounted. It is well, however, to remember several points about the installation setup.

Seldom used or obsolete equipment will only occupy space that could be better used by modern, regularly used instruments. Instruments should be arranged for a maximum of convenience. If two instruments are associated in practical use, such as a signal generator and a cathode-ray oscilloscope, they should be mounted adjacent to each other.

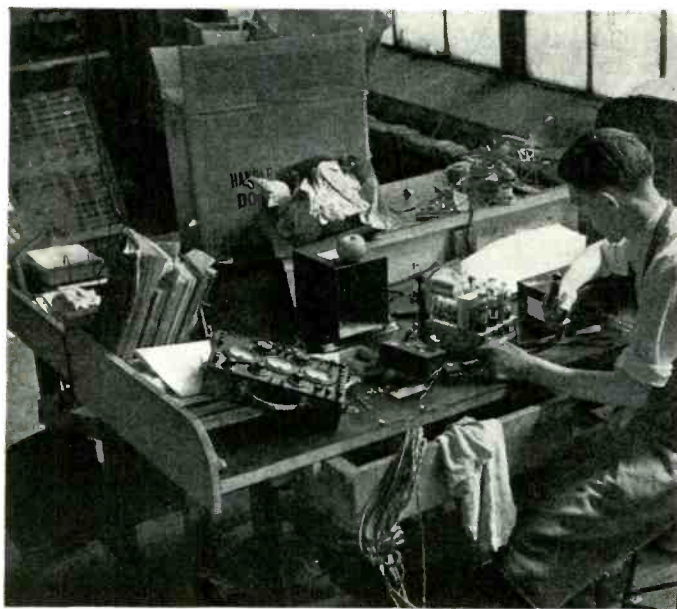

Photo, courtesy RCA Mfg. Co., Inc.

The impression created by a neat, well equipped service bench is emphasized when compared to the other extreme as pictured here.

# General Data . . .

## Fairbanks-Morse 5CT-3, 6AC-1, 6AC-7, 6AT-4 (Chassis 5C, 6A)

THE FAIRBANKS-MORSE MODEL 5CT-3 is a 5-tube receiver using octal-based tubes in a conventional superheterodyne circuit. It is housed in a table-type cabinet. The 6AC-1, 6AC-7, and 6AT-4 employ the same chassis with the addition of a type 6G5 tuning eye. The 6AC-1 is an end-table model, the 6AC-7 a console and the 6AT-4 is a table model.

The frequency range from 540 to 18,300 kc is covered in three bands. A circuit diagram of the chassis is given in Fig. 1, with the tubes used and the various voltages encountered on the socket prongs lettered on the diagram. The voltages are given for a line voltage of 120. A meter having a resistance of a 1000-ohms-per-volt should be used for making the measurements.

### ALIGNMENT PROCEDURE

The aligning capacitors for the i-f circuits are easily accessible through holes in the top of the i-f shield cans. The r-f trimmers are accessible from the front and side of the receiver chassis. (See Figs. 2 and 3.)

A sensitive output meter should be connected across the voice coil or across

the primary of the speaker transformer. In making adjustments the signal-generator output should be reduced to a minimum consistent with a reasonable deflection of the output meter. The receiver volume control should be turned to its maximum position clock-

wise (full on) throughout the entire alignment procedure. The alignment operations are given in the accompanying table. The resistor or condenser listed under dummy antenna should be connected in series with the signal-generator-output lead and the position

### FAIRBANKS-MORSE 5CT-3, 6AC-1, 6AC-7, 6AT-4 (CHASSIS 5C, 6A) ALIGNMENT OPERATIONS

Signal Generator Connection	Dummy Antenna	Signal Generator Frequency	Range Switch	Dial Setting	Trimmer No.	Peak
6A8G Grid	0.1 mfd	456 kc	Broadcast	530 kc	1, 2, 3, 4	I-f trimmers
Antenna	400 ohm	456 kc	Broadcast	530 kc	5	Wave trap
<i>Trimmer No. 5 should be adjusted for a minimum reading on the output meter. It may be necessary to increase the signal-generator output.</i>						
Antenna	400 ohm	5.4 mc	Police	5.4 mc	6	Police osc
Antenna	400 ohm	5.4 mc	Police	5.4 mc	7	Police det
Antenna	400 ohm	1.8 mc	Police	1.8 mc	8	Police osc
<i>The gang condenser should be rocked while making this adjustment. The peak indication resulting from the combined operations should be used.</i>						
<i>Repeat adjustments 6, 7 and 8 until no further change is noted.</i>						
Antenna	200 mmfd	1,500 kc	Broadcast	1,500 kc	9	Brdcst Osc
Antenna	200 mmfd	1,500 kc	Broadcast	1,500 kc	10	Brdcst det
Antenna	200 mmfd	600 kc	Broadcast	600 kc	11	Brdcst Osc
<i>The gang condenser should be rocked while making this adjustment. The peak indication resulting from the combined operations should be used.</i>						
<i>Repeat adjustments 9, 10 and 11 until no further change is noted.</i>						
Antenna	400 ohm	18 mc	Short Wave	18 mc	12	s-w osc
Antenna	400 ohm	18 mc	Short Wave	18 mc	13	s-w det
<i>Check the calibration at 6.0 mc. The padder condenser is fixed.</i>						

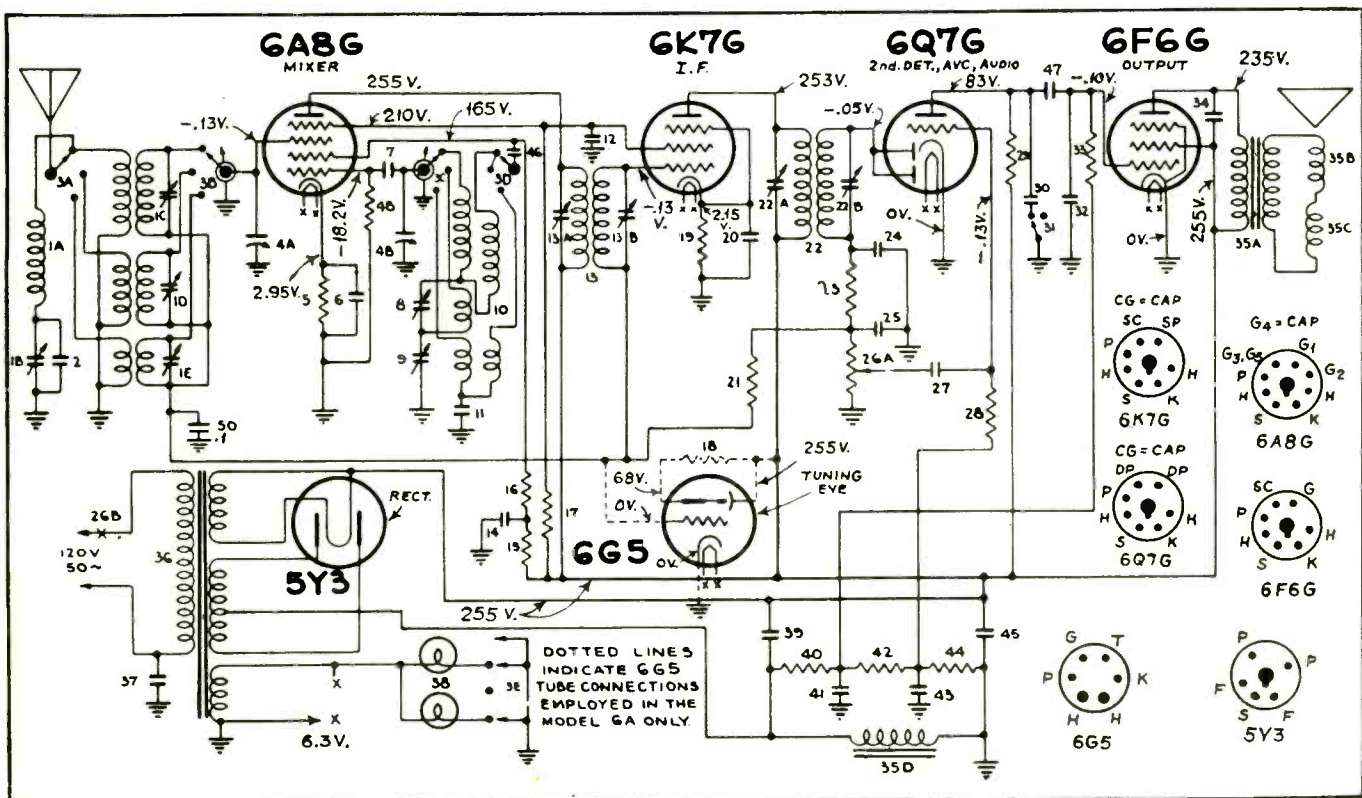

Fig. 1. Fairbanks-Morse 5CT-3, 6AC-1, 6AC-7, 6AT-4 (Chassis 5C, 6A) circuit diagram.

# GENERAL DATA—continued

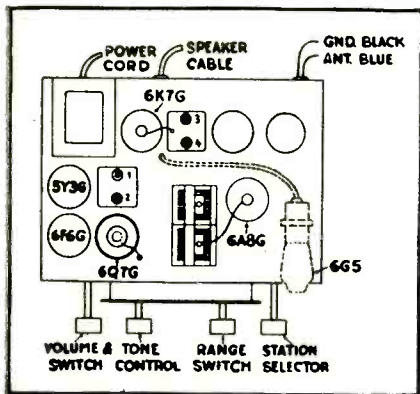

Fig. 2. Fairbanks-Morse tube and i-f trimmer locations.

on the receiver chassis indicated under signal-generator connection.

The alignment instructions must be followed in the order given on the table for proper results. For greater accuracy the entire procedure should be repeated.

## RCA Pak-O-Power (CV-8)

THE RCA MODEL CV-8 Pak-O-Power is a self-contained power conversion unit which operates from a 6-volt storage battery and supplies the A and B power required to operate the RCA Models 85BK, 85BT, 86BK or 86BT receivers.

Four clip leads extend from the cable for connection to the storage battery. Two leads, the brown (—) and yellow (+4 v), supply power for the CV-8

## FAIRBANKS-MORSE PARTS LIST

Item	Condenser Mfd	Item	Resistor Ohms
2	0.00001	5	220
5	0.05		
7	0.0001	15	4,700
11	0.004	16	10,000
12	0.1	17	22,000
14	8.0		
19	0.05	19	220
24	0.0001		
25	0.0001	21	1 meg
27	0.02	23	47,000
30	0.003		
32	0.00025	28	470,000
34	0.006	29	470,000
37	0.01		
39	16.0	33	470,000
41	0.1	40	2.2 meg
43	0.05		
45	8.0	42	330,000
46	0.001	44	47,000
47	0.02		
50	0.1	48	33,000

vibrator; while the remaining two leads, blue (+4 v) and red (+6 v), supply the 2 volts for the receiver tube filaments. It is important that the battery leads be connected correctly as a wrong connection of the red or blue lead will burn out the tubes. Refer to the wiring diagram for proper connections.

The two 4-volt leads, blue and yellow, should make separate connections to the same battery strap to avoid vibrator buzz. The four pairs of twisted leads must each be twisted their full length to avoid vibrator buzz. The seven-con-

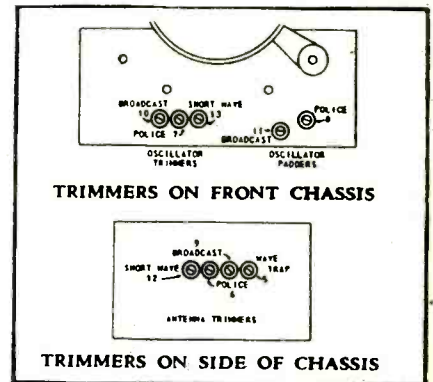

Fig. 3. Fairbanks-Morse r-f trimmer locations.

tact female receptable plugs into the power plug on the rear of the receiver chassis. The battery cable supplied with the receiver is not required.

The seven plug connections are as follows: No. 1, battery side of vibrator switch. No. 2, vibrator side of switch. No. 3, +180 volts for power output tube. No. 4, receiver chassis ground. No. 5, +135 volts for all tubes except power output. No. 6, jumper to No. 4. No. 7, battery side of filament switch.

To check the CV-8 when a receiver is not available, resistors may be used for loading. A 56,000-ohm, 1-watt resistor from contacts 3 to 2; and an 8,200-ohm, 3-watt resistor from contacts 5 to 2 will provide proper loads. It will be necessary to connect a jumper from contacts 1 to 2 to operate the CV-8 without a receiver. Under these conditions the voltage from contacts 3 to 2 should be 180 and from contacts 5 to 2 should be 135.

When operating and servicing the CV-8 chassis should be insulated from the receiver chassis to avoid vibrator buzz.

## G. E. Touch Tuning

THE GENERAL ELECTRIC COMPANY has developed a motor drive for three of their larger sets. The motor is a special 6-volt reversing type using a split phase winding with a capacitor of about 1000 mfd.

### THE MOTOR DRIVE

On the motor shaft (see Fig. 1) is a special friction clutch pulley with two prongs projecting away from the motor and parallel with the shaft. The motor pulley is belted to a larger pulley on a horizontal shaft supported along the front apron of the chassis. This shaft is a double thread 20-pitch screw, 1/8 inch in diameter and about 9 inches long hung in conical bearings. Along

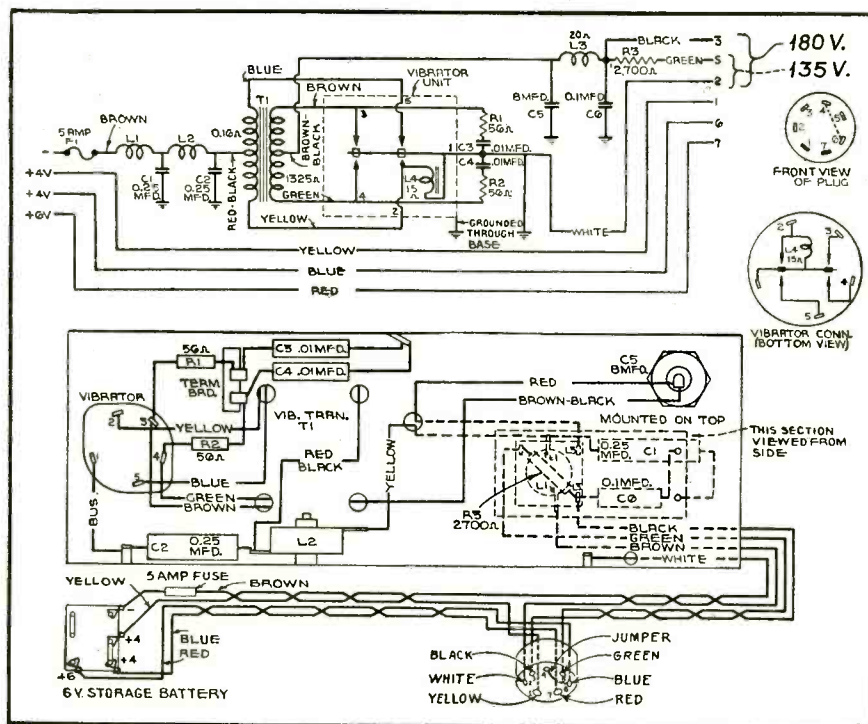

RCA Pak-O-Power CV-8 circuit diagram and wiring layout.

## GENERAL DATA—continued

the screw rides a split nut between two spring bronze holders mounted on a rider which follows a 3/16 inch diameter steel guide. To this rider is welded one end of a rectangular bar whose other end is welded to another smaller rider. Suitable springs prevent rattling and make smooth operation. A piece of bronze cable is fastened to one end of the bar and to a pulley on the tuning condenser shaft through a take-up spring. Another piece is fastened to the same pulley and to the other end of the slider bar. At a suitable point on the bar the adjustable pointer is screwed.

In operation the motor turns the screw and causes the nut to travel from one end to the other and in so doing moves the pointer and rotates the tuning condenser a half turn. A reversing switch operated from the tuning condenser shaft reverses the motor at each end of the run.

For manual tuning the screw is turned by a knob through a reduction gear and right angle drive. The vernier ratio is about 86. During motor operation the manual drive disengages,

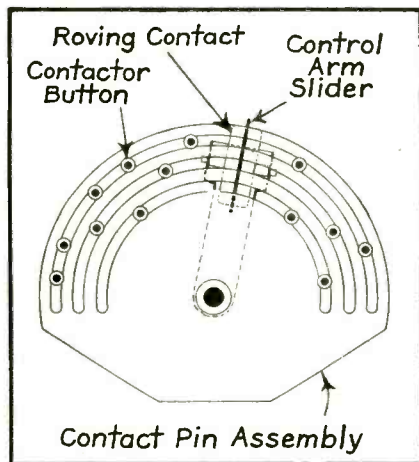

Fig. 3. Contact pin assembly.

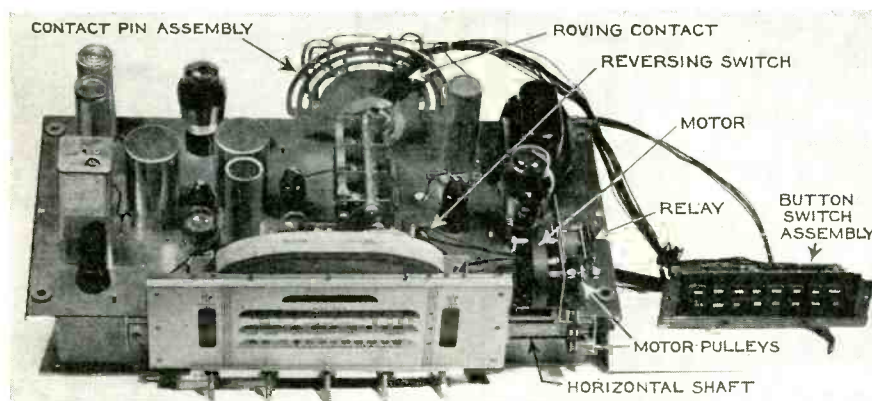

Fig. 1. G. E. receiver chassis showing "Touch Tuning" mechanism and motor.

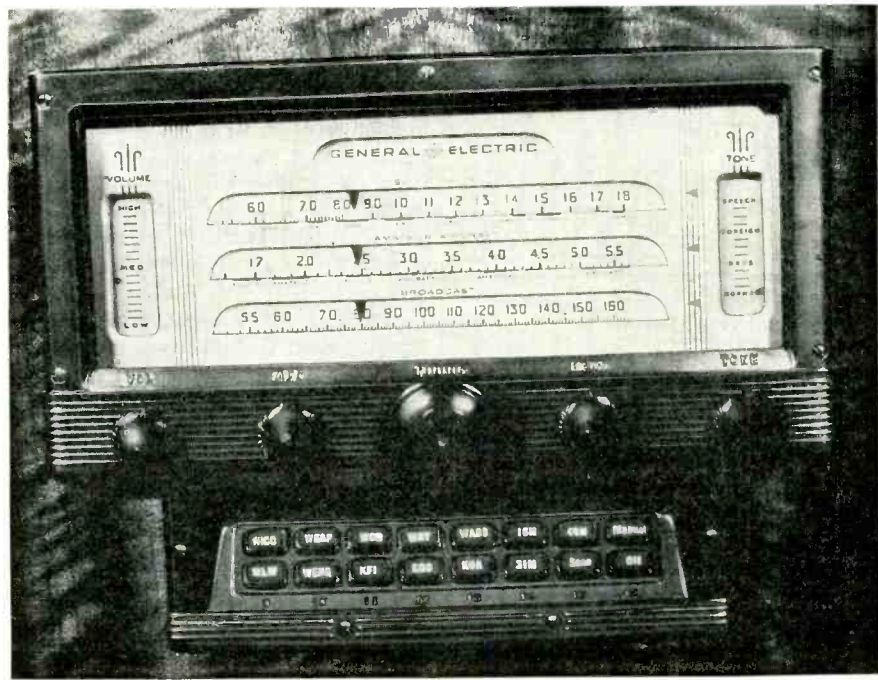

Fig. 2. Front panel of receiver showing louver dial and push-buttons.

hence the knob must be pushed in when tuning manually. This action is so slight and the knob is so shaped that this operation is coincident with turning the knob.

### THE BUTTON ASSEMBLY

Below the control knobs on the "Touch-Tuning" sets, there are two rows of eight buttons each, numbered from 1 to 16. One is for turning the receiver off, one is for manual operation, one for scanning and thirteen are for station selection (see Fig. 2). The thirteen buttons are connected to adjustable contact pins mounted in three semi-circular rows in a die casting at the rear of the tuning condenser (see Figs. 1 and 3). Coupled to the tuning condenser shaft is a roving contact which passes over the pins.

With the receiver turned off, depressing a station button causes it to be turned on and puts the motor in operation. When the roving contact strikes a contact pin connected to the depressed button, a relay mounted at the end of the motor shaft is energized. This successively opens the motor circuit, opens the silent tuning contact, puts the afc in operation and blocks the motor pulley. This last operation stops the tuning condenser instantly and the friction clutch removes any serious jar. Subsequently depressing any other station button releases the relay, grounds the afc, closes the silent tuning contact and starts the motor. Depressing the manual button makes the receiver operative but disconnects the motor for manual tuning. By then depressing the scanning button the set may be motor-tuned, silently, until the button is released. This scanning button does not latch in, nor does it release any other buttons.

### SETTING-UP STATIONS

By adhering closely to the following instructions, the necessary local adjustments of the "Touch Tuning" system may be made a very simple procedure.

List the thirteen most popular stations in the district. Set them down in the order of frequency, *i. e.*, lowest frequency station as No. 1 with next higher frequency as No. 2, etc., up until No. 14 button. As is obvious from Fig. 2, station button No. 8 should be omitted

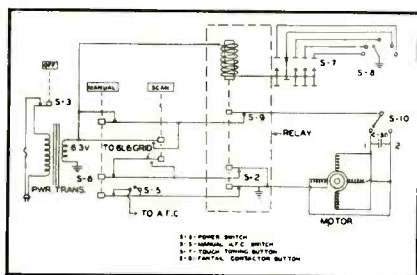

Fig. 4. Circuit diagram of "Touch Tuning" System.

because it is listed as the manual button. Two or three favorite short-wave bands may be substituted for the station letters on the corresponding buttons if preferred.

Set band switch to broadcast band, depress the manual button, turn the afc switch off and set the tone control to the speech position. The speech position allows a more accurate tuning of the station by the manual control knob.

Tune in manually the station listed for the No. 1 button. This should be done very accurately, leaving the selector knob set midway between the points at which a slight hiss is heard. Set the contactor button (see Fig. 3) so that the control arm slider is located in the middle of the button. Tighten the button in place by means of the thumb screw. Do not use any mechanical force to tighten the screw.

Attach the wire from the "Touch Tuning" mechanism marked No. 1 to this button.

Use the same procedure for setting up the No. 2 station button, but, in this case, locate the contact button so that

it is in the center arc and attach lead No. 2 to it. Set up the No. 3 station button and have its contact button located in the outside arc. The No. 4 station button should be located the same as the No. 1 button. By this changing from arc to arc as the stations increase in frequency, stations with only a ten-kilocycle separation in frequency may be located next to each other on the buttons.

Secure from the station letter card supplied with the receiver, the call letters of the stations set up and place them in the "Touch Tuning" buttons. Insert one end of the cardboard into the button, then bow the center slightly, insert the opposite end and press down the center. The small celluloid windows should be inserted over the top of the station indicators in the same manner.

To check the accuracy of the station button set-up the following procedure should be followed: Manually tune the receiver to the high-frequency end of the band. Press button No. 14 and when the pointer comes to rest on the assigned station, turn the afc switch on and off. No noticeable change in response should be noticed. If it appears that the afc switch when turned on improves the tuning appreciably, it will be necessary to reset the contactor button which is connected to the No. 14 lead. This procedure should be followed for all the other station buttons.

Tabs may be inserted for the various short-wave bands such as the "49" and "25" by selecting the proper tab and using them in place of less desirable

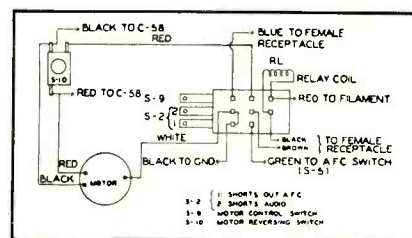

Fig. 5. Motor-relay circuit diagram.

broadcast stations. The contactor button is located in the manner outlined above except that the band change switch is set to the proper band and the contactor button adjusted only to the center of a particular short-wave band as indicated on the dial scale. The desired short-wave station may be readily tuned in manually, once the desired band is located approximately.

MANUAL TUNING

When it is desired to receive stations other than those listed on the thirteen buttons, or to tune in the short-wave bands, the manual button should be depressed. This turns the receiver power on and disengages the automatic tuning mechanism, allowing the operator to tune the set in the conventional manner. The station-tuning knob is the large control knob and is engaged with the tuning mechanism by the slight pressure of the hand required for the normal tuning operation. A (Scan) button controlling the motor drive is incorporated in order to facilitate the manual tuning operation. Press this button until the pointer is near the dial location of the desired station and then tune the station accurately by means of the tuning knob. The (Scan) button, not locking in a depressed position as do the other buttons, allows finger tip control of the motor drive.

Two or more of the automatic tuning buttons may be labeled 49, 31, 25 meters, etc., as indicated above, to facilitate the tuning in of a short-wave station in these bands. If it is desired to tune a station in the 49-meter band, for example, turn the band selector switch to this range of frequencies, then press the 49 meter button. After the pointer automatically comes to a stop on this band, press the manual button and then tune in the desired station by the manual tuning knob.

*Caution:* Do not tune the set manually when any of the thirteen "Touch Tuning" buttons are depressed.

The use of afc eliminates the necessity for accurate tuning by automatically adjusting the radio circuit electrically to the station's correct position. By automatically adjusting for any

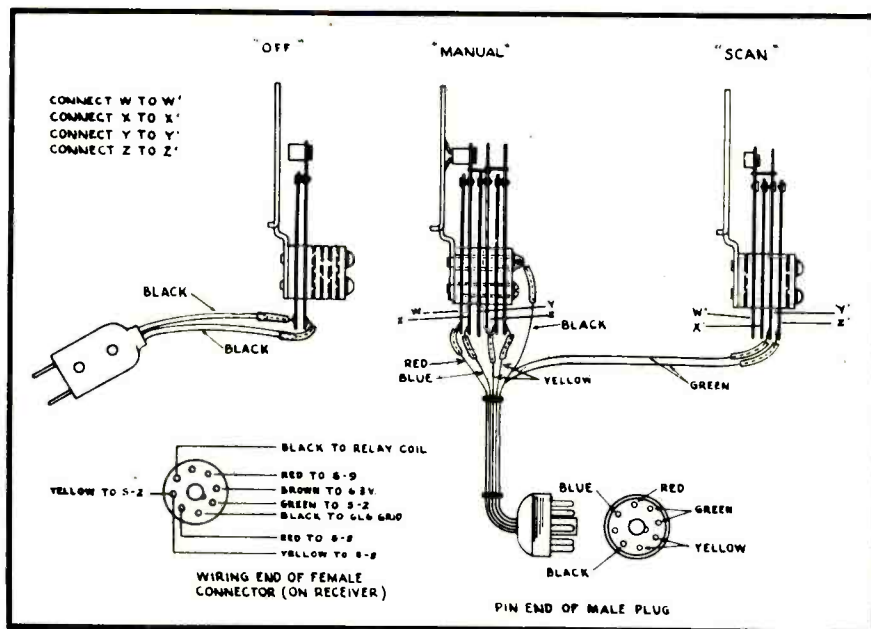

Fig. 6. Circuit diagram of the "Off," "Manual" and "Scan" button switches.





slight tuning deviation that might occur, the highest quality reception is always assured.

When tuning manually, it is recommended that the afc switch be turned off (see Fig. 2) until the station is roughly tuned in, after which, switching to the on position will constitute a final adjustment and no further tuning is necessary. When using any of the thirteen "Touch Tuning" station selector buttons, the afc switch should be in the on position.

The afc switch should be turned off when tuning to a station that has a tendency to fade if there is a powerful station 10 kc from this station. This will prevent the receiver from changing over to the powerful station in preference to the desired station at some instant when extreme fading may occur.

### Emerson Automatic Dial

THE EMERSON RADIO MODELS AT-170, AT-172 and AT-181 employ the device shown in the accompanying illustrations to tune a number of preset stations. The device is called the Automatic Dial.

#### TUNING WITH THE AUTOMATIC DIAL

Tuning with the Automatic Dial is very similar to dialing a telephone except that only one turn of the dial is necessary. Merely push in the button bearing the call letters of the desired station, and, keeping the button pressed in firmly, rotate the dial until it stops with the button near the top. The button may then be released. This procedure automatically tunes in the desired station.

The illustrations, Fig. 1, indicate the proper rotation of the dial for a particular button. The button must always stop near the top of the disc. If the button for the desired station is already at the top, rotate the dial in either direction about a quarter turn and then push the button in and rotate the dial back again until it stops with this button near the top.

#### SETTING-UP THE STATIONS

The bakelite front plate for the dial, packed with the receiver, is to be assembled after all the desired stations are set-up on the dial assembly. Eight cards of station call letter tabs are also packed with the receiver.

The illustrations, Fig. 2 and Fig. 3, show the major parts of the automatic dial. Ten buttons are supplied with each dial. There are eleven button holes in the circular housing. One of these button holes is not used. (See Fig. 3).

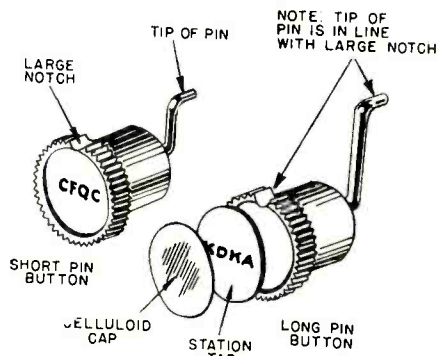

Fig. 4. Details of buttons.

Each of the buttons may be set for a particular station. The stations chosen should be the popular local broadcast stations. The dial cannot be used for automatic tuning of short-wave stations. Each button is adjustable in that it can be rotated in its hole in the housing. This rotation is the means of adjustment for any particular station.

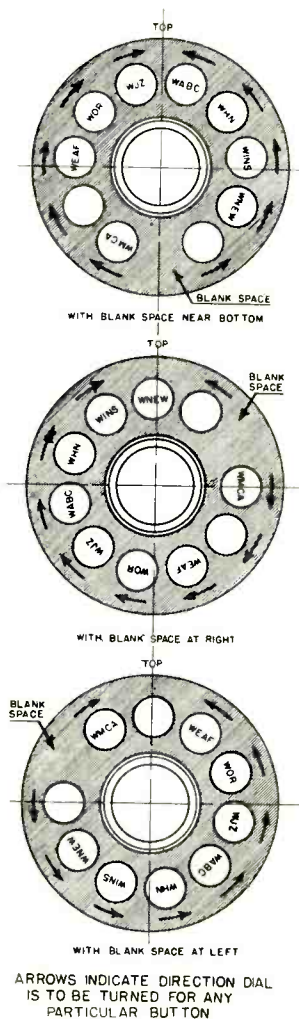

Fig. 1. The proper rotation of the dial for a particular button.

First turn the receiver on. The adjustments should be made with the receiver warmed up. Of the possible ten selected local stations choose five of the more desirable and determine their frequencies. Station frequencies will usually be found listed in newspapers. The station with the lowest frequency of the first five chosen should be adjusted first. Compare the frequency of this station with the frequency markings on the tab inserts in the buttons. The station frequency will be between the frequency limits marked on one of the buttons and that button should be adjusted for that particular station.

Do not remove the thin metal disc which holds the buttons in the housing until this entire procedure is completely finished. Merely loosen the face nut slightly and rotate the disc until its semi-circular notch falls below the first button to be adjusted. See Fig. 2. (When rotating this disc it is necessary to successively hold each button in place as the notch in the disc moves past these buttons.) Tighten the face nut again to prevent the disc from falling off. Take out the first button and remove the celluloid cap and tab insert by prying with a sharp instrument at the large notch on the side of the button.

Tune in the desired station by means of the selector knob on the front of the cabinet. The large notch on the side of the button will indicate the position of the stop pin on the back of the button (see Fig. 4). The tip portion of the stop pin in this drawing is the part that stops against the floating vane. This tip portion in stopping against the vane is the action that locates the station once the button is adjusted (see Fig. 5). The vane is visible between the edge of the button housing and the edge of the hole in the cabinet (see Fig. 3).

With the station tuned in and without moving the circular housing partially insert the button, lining up the tip portion of the stop pin by eye with the center of the floating vane, and then push the button in, engaging the teeth. See Fig. 6. The center joint of the veneer on the cabinet may be used to assist in this lining up since the joint is approximately at the center of the floating vane.

Hold the button in and rotate the thin metal disc a small fraction of a turn, just enough so that it holds the button in place.

It is important that when the stop pin is lined up it is either horizontal or pointing at some angle away from the hub of the housing. This precaution may be observed by locating the large

## GENERAL DATA—continued

notch of the button (which is in line with the tip of the stop pin) outside the dotted circle through the buttons as shown in Fig. 3.

To check if the button has been properly adjusted rotate the entire housing first in clockwise direction so that the button stop pin is clear of the floating vane. Push the button all the way in with a finger and rotate the housing so that the pin travels toward and stops against the floating vane. The desired station should then be heard. Repeat this procedure on the counter-clockwise side of the vane. The station should again be heard.

If the station tunes in perfectly on each side of the vane no further adjustment is necessary. If it does not tune in perfectly, further adjustment should be made by carefully pulling out the button and rotating it one notch in the housing in the direction which will bring in the station more accurately. Check the tuning again. Find the station call letters for this button on one of the cards supplied. Remove the tab from the card and insert in the button by pressing in firmly. Replace the clear celluloid cap over the call letter tab, snapping it firmly in place.

Note: Two of the ten buttons supplied with the dial have long pins. In rare cases a particular station cannot be reached with a short pin button. The

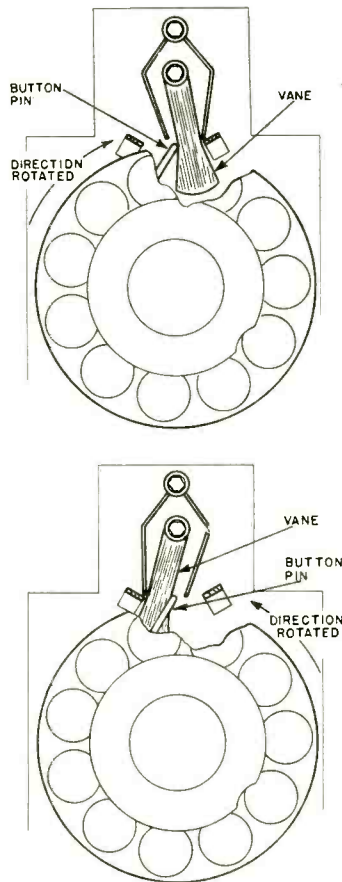

Fig. 5. Showing tip of pin hitting vane from either side when station is tuned.

two long pin buttons are available for this purpose.

Adjust four buttons for the other four selected stations following the procedure outlined above. In adjusting these buttons care should be taken, when rotating the thin metal disc, to keep the other buttons from falling out past the notch in the disc. The remaining buttons, five in number, may be adjusted for any other local stations easily obtainable, or left in reserve for future settings.

After the buttons are all adjusted the thin metal disc should be removed carefully, by unscrewing the face nut, and replaced by the bakelite front plate. Be very careful in removing the thin metal disc that the buttons do not spring out from the housing. The cabinet should be tilted or placed on its back, when placing the bakelite plate on the dial, to make sure that the buttons do not fall out.

Check carefully Fig. 3 and Fig. 7 for aligning the bakelite front plate with the circular housing. The plate must fit in easily and snugly. Care should be taken not to damage the locating pins on the back of the front plate.

### PRECAUTIONS

The long pin buttons, when adjusted, should have the long length of the pin nearly horizontal. If a long pin, after the button is adjusted, interferes with any other part of the mechanism when

Fig. 2. Emerson automatic dial mechanism.

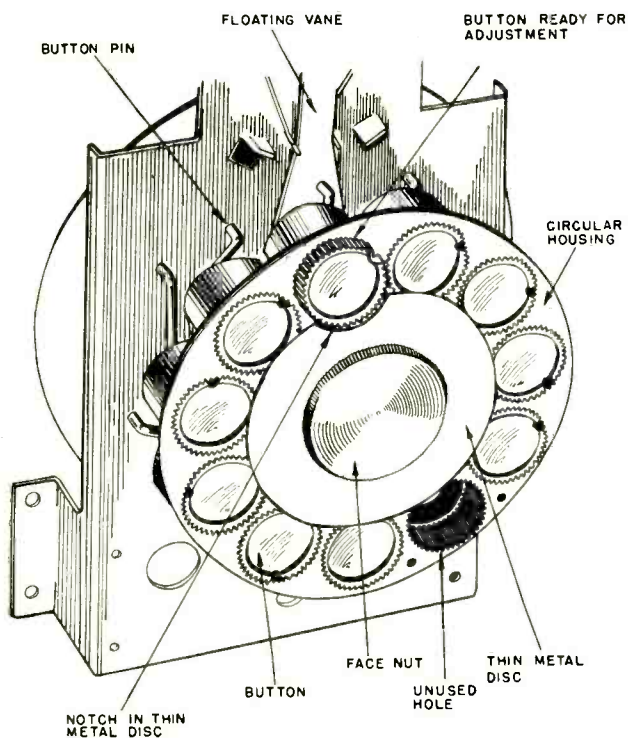
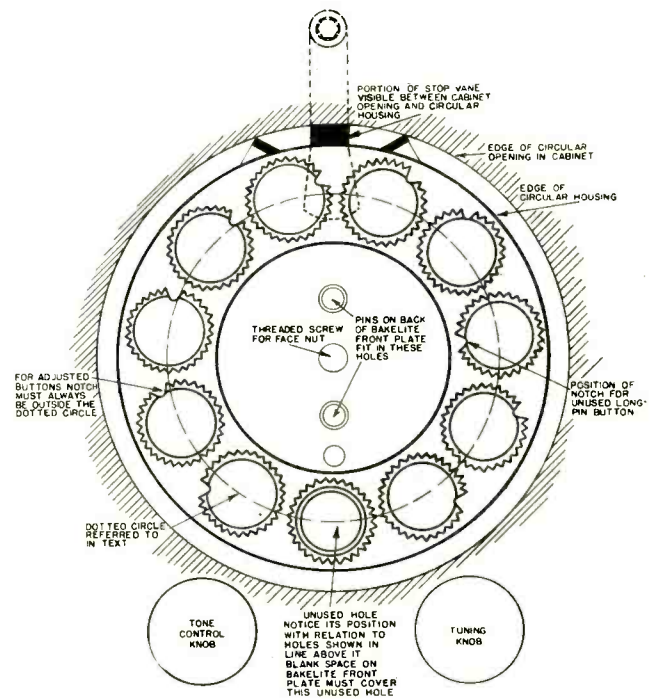

Fig. 3. Front of dial with metal disc removed.



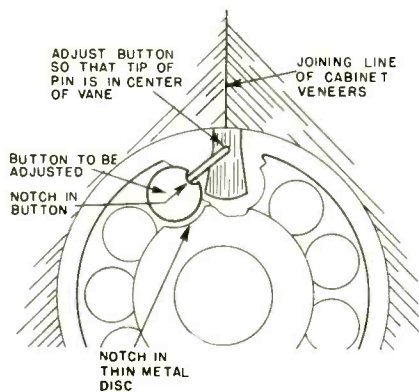

Fig. 6. The center joint of the cabinet is approximately at the center of the floating vane.

the housing is rotated the button cannot be used in that particular hole.

If no special use is found for the two long pin buttons it is preferable to insert these in unused holes with the pins pointing directly toward the hub of the housing.

When loosening the thin metal disc be sure the face nut is unscrewed only enough to allow the disc to turn. During adjustments check this nut frequently to make sure it is in no danger of falling off. It cannot be emphasized too strongly that the utmost care must be taken to prevent this metal disc or the bakelite front plate from falling off and allowing the adjusted buttons to spring out from the housing. When making adjustments, rotate the thin metal disc very carefully to be sure that the adjusted buttons do not fall out of the housing past the notch in the disc.

After replacing the thin metal disc with the bakelite plate, the disc should not be discarded but should be reserved for future use in resetting buttons or in the event the receiver is reshipped. The receiver should never be transported with the bakelite plate assembled.

**Stromberg-Carlson 229-P**

THE STROMBERG-CARLSON MODEL 229-P radio receivers are 8-tube superheterodynes employing metal tubes in the circuit given in Fig. 1. The tubes used and their functions are lettered on the diagram. The receivers have three tuning ranges which cover the frequencies from 540 to 3500 kc and 5600 to 18,000 kc. The total power consumption of the receiver is approximately 90 watts.

The voltages indicated on the accom-

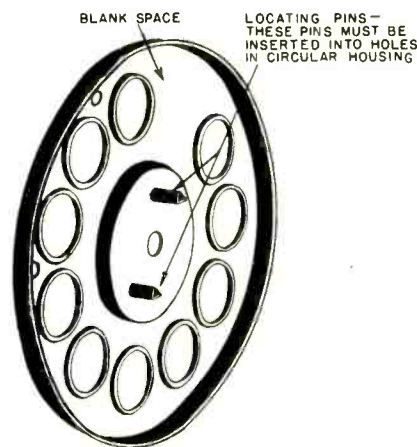

Fig. 7. Rear view of bakelite front plate.

STROMBERG-CARLSON 229-P PARTS LIST

Item	Condenser Mfd	Item	Condenser Mfd	Item	Resistor Ohms	Item	Resistor Ohms
3	0.01 (2)	74	0.1	9	Divider	44	100,000
4	25	75	0.01	19	100,000	47	470,000
5	16	77	0.02	33	330	48	1 meg
6	16	78	0.02	34	270	49	270,000
7	10	79	0.02	35	680	52	400
8	10	80	0.02	36	3,900	127	27,000
16	0.002	81	0.02	37	4,700	137	Control
17	0.0027	82	0.02	38	10,000	138	Control
18	0.0038	83	0.002	39	10,000	139	27,000
65	0.0001	84	0.006	40	27,000	151	270,000
66	0.0001	122	0.002	41	47,000	152	270,000
67	0.0001 (2)	123	0.01	42	47,000	153	1 meg
69	0.001	124	Gimmick	43	100,000		
70	0.00125	133	16				
71	0.1	135	0.001				
72	0.1	136	0.03				
73	0.1	147	0.01				

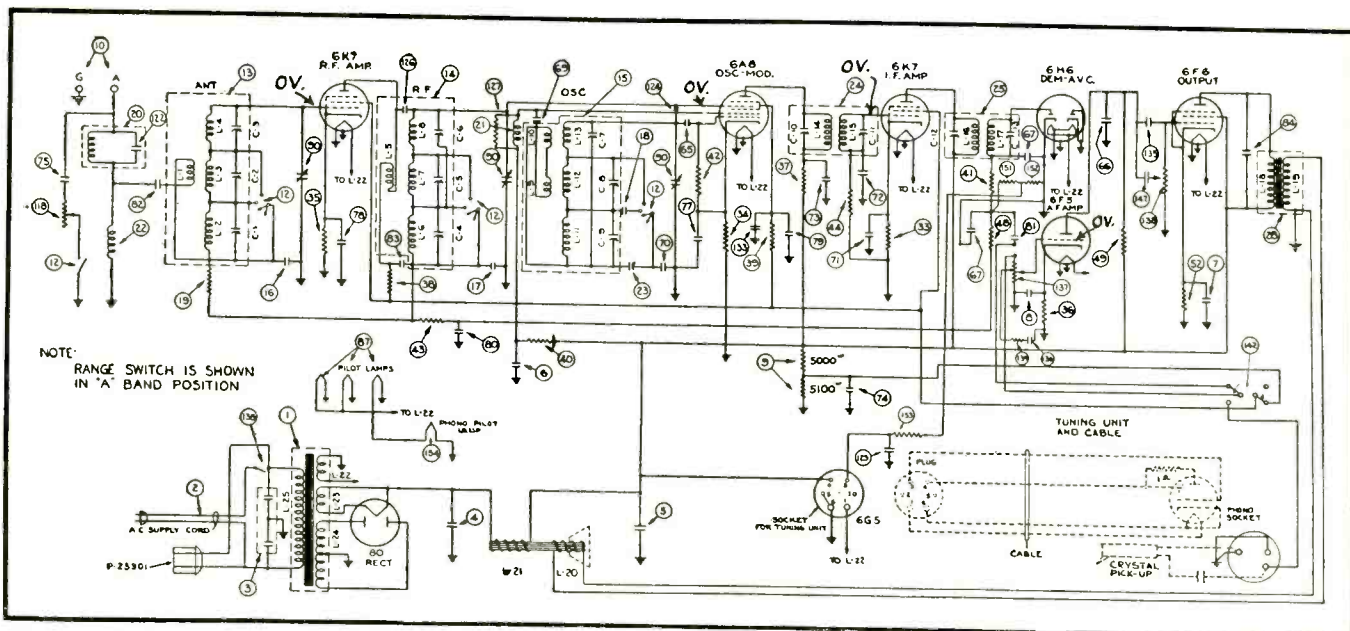

Fig. 1. Stromberg-Carlson 229-P circuit diagram.

# Clicks with them all

## MODEL 775 WESTON SERVISSET

"The most complete, most versatile servicing tool ever offered servicemen."

"This WESTON 20,000 chms-per-volt analyzer is the 'tops', and the new 773 Tube Checker leads them all."

"WESTON quality dependability and long life, at prices we can afford. Big WESTON Meters, too."

"We need high sensitivity, and we trust WESTON to provide it . . . just as they do for all industry."

"These instruments are quickly removed from the combination case and can be used individually for portable, counter or panel use."

"With 772 I can service a<sup>1</sup> receivers . . . measure photo-cell currents and service television as well."

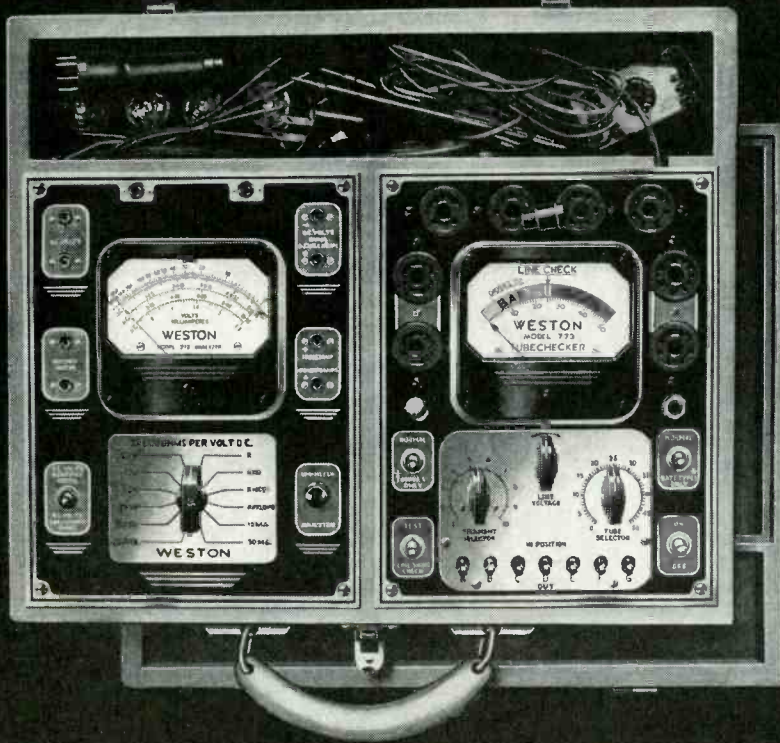

Your profits this fall and winter will depend, to a large extent, on your equipment. See the WESTON Model 775 Serviset today. Examine it carefully. Compare it, feature by feature, with any other equipment the market affords. Then consider that it is WESTON built . . . that it provides the sound engineering, the quality materials, the dependable accuracy and the long, useful life that the name WESTON assures. See the Model 775, as well as all other WESTON instruments for radio use. Visit your jobber today, or send the coupon for complete information.

All WESTON Radio Instruments can be purchased under the WESTON Investment Plan



Model 772 Analyzer also is available in this light-weight, solid-wood carrying case with real luggage handle.



Model 773 Tube Checker in individual carrying case. Also available in attractive, polished, solid-wood counter case.

WESTON  
ELECTRICAL  
INSTRUMENT  
CORPORATION  
604 Frelinghuysen Ave.,  
Newark, N. J.

Send data on Model 775 and other radio instruments.

Name \_\_\_\_\_

Address \_\_\_\_\_

City \_\_\_\_\_

State \_\_\_\_\_

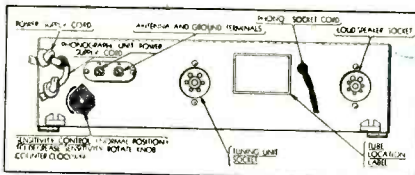

Fig. 2. Rear of chassis showing location of sensitivity control.

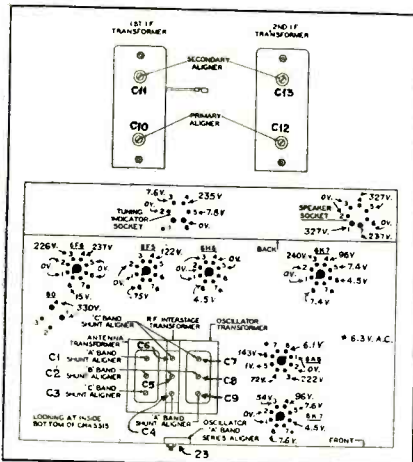

Fig. 3. Tube locations, socket voltages and trimmer locations.

panying diagrams were taken with a 100-ohm-per-volt voltmeter with the volume control on full; the receiver in operating condition but with no signal input. The values given are for a line voltage of 120. Values taken in the field may differ by 15 percent (plus or minus) from those given.

These receivers are equipped with a single record playing phonograph unit which uses a crystal type pickup.

A sensitivity control is provided for use on the broadcast range only. The control knob is located on the rear of the chassis base. (See Fig. 2.) When either the B or C ranges are in operation this sensitivity control is cut out of the circuit by the range switch. The receiver functions at its maximum sensitivity on these two ranges.

Although the tuning indicator tube can be used as a means of indicating resonance, a more accurate adjustment of trimmers is possible through the use of a sensitive output meter connected across the primary of the speaker transformer or across the voice coil. The various trimmers should be adjusted for a maximum indication on the output meter or for a minimum shadow angle on the tuning indicator tube.

Throughout the alignment procedure the volume control on the receiver should be on full and, as the stages are brought into alignment, the signal generator output should be kept low by means of the attenuator provided on the generator. The location of the aligning

STROMBERG-CARLSON 229-P ALIGNMENT OPERATIONS

Signal Generator Connection	Dummy	Generator Frequency	Band Switch	Dial	Trimmer	Peak
I-F ALIGNMENT						
6A8 Grid	0.25 mfd	465 kc	A Band	1000 kc	C-13	Second i-f sec
6A8 Grid	0.25 mfd	465 kc	A Band	1000 kc	C-12	Second i-f pri
6A8 Grid	0.25 mfd	465 kc	A Band	1000 kc	C-11	First i-f sec
6A8 Grid	0.25 mfd	465 kc	A Band	1000 kc	C-10	First i-f pri

Repeat the i-f alignment for greater accuracy.

R-F ALIGNMENT						
Antenna	400 ohms	17 mc	C Band	17 mc	C-7	Osc shunt
Antenna	400 ohms	17 mc	C Band	17 mc	C-6	R-F shunt
Antenna	400 ohms	17 mc	C Band	17 mc	C-3	Antenna shunt
Antenna	400 ohms	3.4 mc	B Band	3.4 mc	C-8	Osc shunt
Antenna	400 ohms	3.4 mc	B Band	3.4 mc	C-5	R-F shunt
Antenna	400 ohms	3.4 mc	B Band	3.4 mc	C-2	Antenna shunt
Antenna	200 mmfd	1.4 mc	A Band	1.4 mc	C-9	Osc shunt
Antenna	200 mmfd	1.4 mc	A Band	1.4 mc	C-4	R-F shunt
Antenna	200 mmfd	1.4 mc	A Band	1.4 mc	C-1	Antenna shunt
Antenna	200 mmfd	0.6 mc	A Band	0.6 mc	23	Osc series <sup>1</sup>

Repeat the 1.4 mc adjustments.

<sup>1</sup> Rock the gang condenser while making this adjustment.

trimmers is given in Fig. 3.

Both the receiver and the signal generator should be allowed at least 15 minutes to warm up before adjustments are attempted.

The alignment operations are given in the accompanying table. The condenser or resistor indicated under

dummy antenna should be connected in series with the generator output lead and the position on the receiver chassis designated under signal generator connection. The alignment operations must be made in the order given. For accurate results the entire alignment procedure should be repeated.

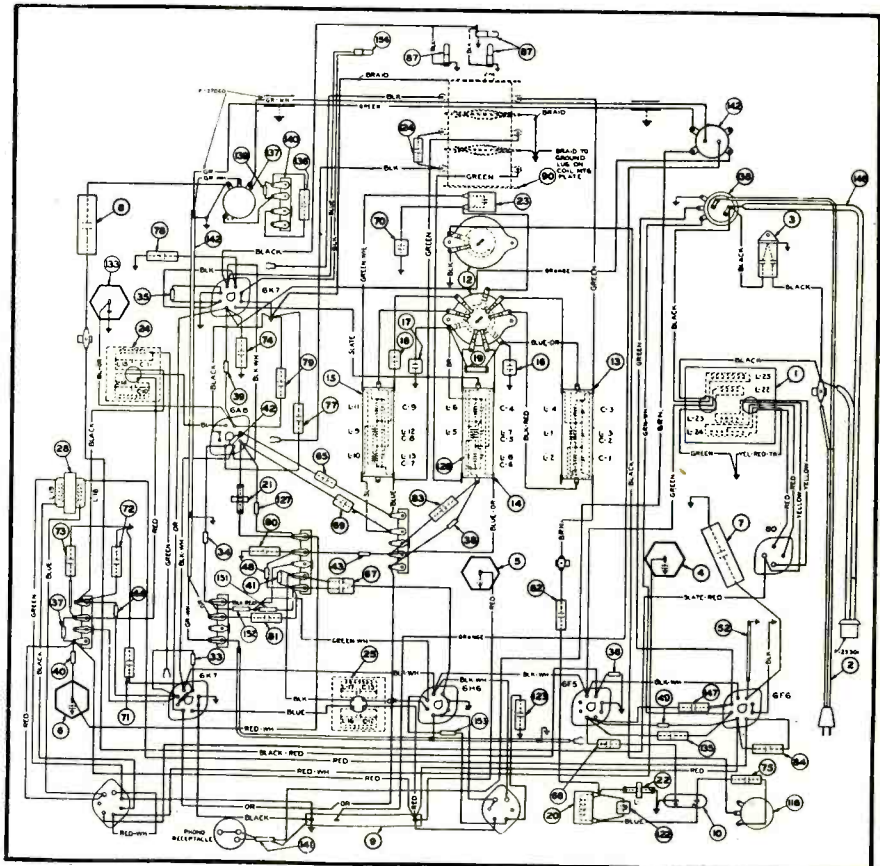

Fig. 4. Wiring assembly.

# NOW TRANSFORMER REPLACEMENT ENCYCLOPEDIA

## DATA IN A FLASH WITH THE NEW

**THORDARSON  
REPLACEMENT  
TRANSFORMER  
ENCYCLOPEDIA**

**COVERS 98.9% OF  
RIDER'S 7 VOLUMES**

Like a flash your eye spots the exact Replacement Transformer needed. Never before has a radio parts manufacturer given the service man such a value. A servicing helper that will make history. Practically every set mentioned in Rider's 7 volumes is cataloged. Eliminate time wasting check-up of wiring or letters to manufacturers. Now it's in this one book under one cover. No more guessing.

**GET YOUR COPY NOW!**  
LIST PRICE—25c  
15c Postpaid direct from factory on request or

**FREE** From Your Distributor Through Registration.  
Ask about it TODAY!

BE SURE TO SEE US AT THE NATIONAL TRADE SHOW  
BOOTH NO. 70—PORT AUTHORITY BLDG.  
OCT. 1-2-3—NEW YORK CITY

**THORDARSON ELECTRIC MFG. CO.**

**500 W. HURON ST., CHICAGO, ILL.**

*Demand "Power by Thordarson"*

# Auto-Radio . . .

## Motorola 70

THE MOTOROLA MODEL 70 is a 6-tube auto-radio receiver employing the superheterodyne circuit shown in Fig. 1. The tubes used and their functions are indicated on the diagram. The total current drain, at 6.3 volts, is approximately 5.5 amperes.

### ALIGNMENT PROCEDURE

In making alignment adjustments on these receivers it will be necessary to remove the chassis from its housing. A metal plate is advised for a good ground to the chassis. The plate should be at least a foot square and one end of the storage battery to be connected to it through a very heavy lead.

A sensitive output meter should be connected across the primary of the speaker transformer or across the voice coil. In making the adjustments the receiver volume control should be kept on full and the reading on the output meter kept below half scale by means of the attenuator on the signal generator.

The receiver may be aligned on the service bench without the acoustinator

control, providing the upper left hand contact of the acoustinator receptacle is grounded to the set chassis. This is the contact nearest the volume control shaft. When this connection is shorted to ground it cuts out the resistor net-

work in the cathode circuit and is equivalent to the acoustinator being set in the "Country" and "Voice" positions, which are the correct settings for alignment.

The alignment operations are given in the accompanying table. The condenser indicated under dummy antenna should be connected in series with the signal generator output lead and the position on the receiver designated under signal generator connection.

The adjustments must be made in the

### MOTOROLA 70 ALIGNMENT OPERATIONS

Signal Generator Connection	Dummy	Generator Frequency	Dial	Trimmer
I-F ALIGNMENT				
<i>Remove grid cap from 6A7 tube. Connect 500,000-ohm resistor from tube's grid to the receiver chassis.</i>				
6A7 Grid	200 mmfd	262 kc	1600 kc	Second i-f
6A7 Grid	200 mmfd	262 kc	1600 kc	First i-f
<i>Repeat i-f alignment for greater accuracy.</i>				
R-F ALIGNMENT				
78 R-F Grid	0.25 mfd	1600 kc	open	Osc 1400
78 R-F Grid	0.25 mfd	535 kc	closed	Osc 600
Ant plug	0.25 mfd	600 kc	600 kc <sup>1</sup>	Ant 600
Ant plug	0.25 mfd	1400 kc	1400 kc <sup>1</sup>	R-F 1400
Ant plug	0.25 mfd	1400 kc	1400 kc <sup>1</sup>	Ant 1400

*The antenna adjusting trimmer located in front of the receiver should be adjusted after the receiver is reinstalled in the car and attached to its normal antenna. The signal generator should be connected to a wire located near but not attached to the car antenna.*

<sup>1</sup> Tune receiver to the signal.

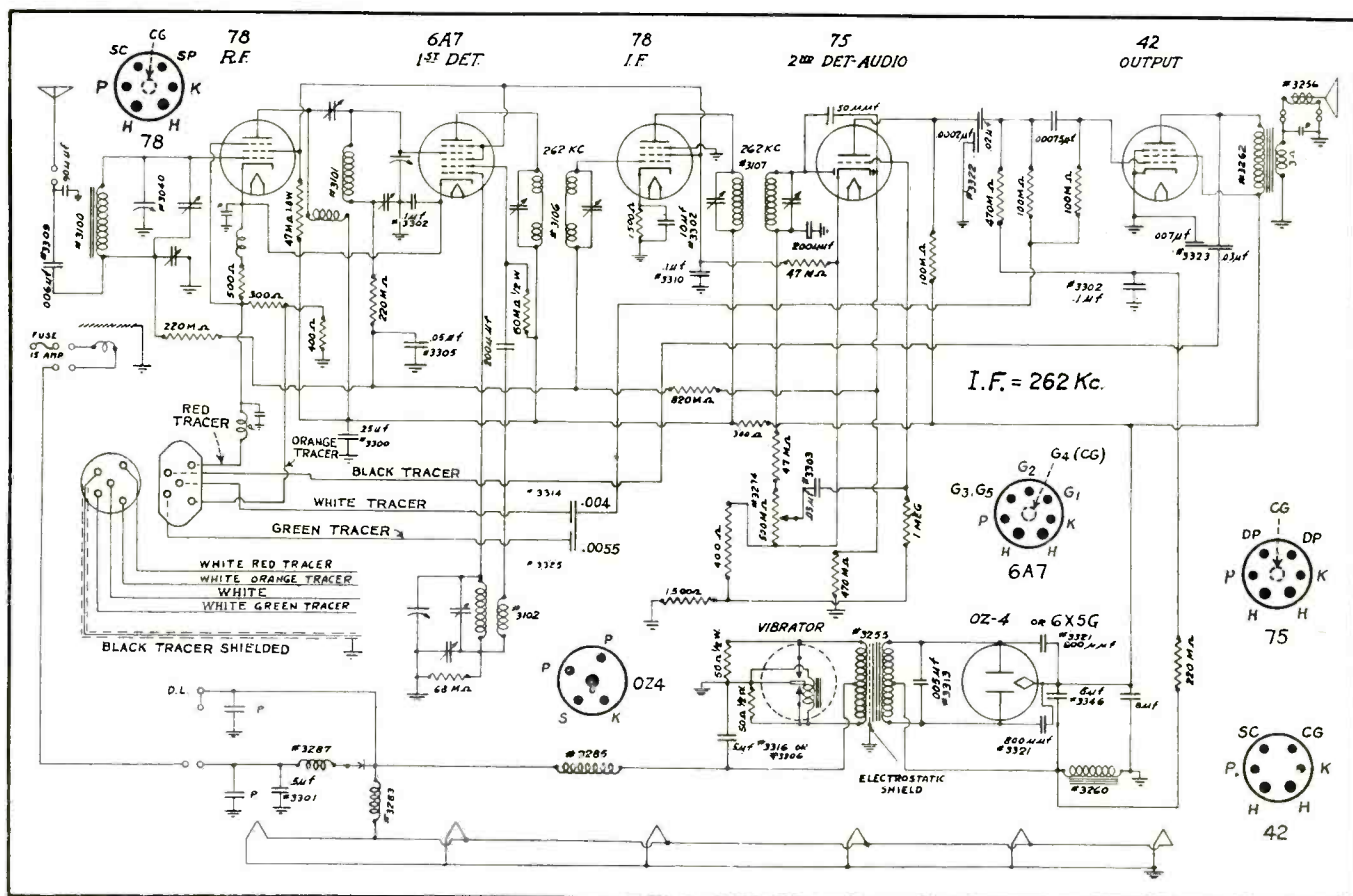

Fig. 1. Motorola 70 circuit diagram.



There's a **'NEW DEAL'**  
in **EQUIPMENT DEALS!**



**QUICK DELIVERY  
TO YOU!**

**SMALL DOWN  
PAYMENT**

**TUBES AT STANDARD  
LIST PRICES**

**ARCTURUS  
HELPS YOU SELL**  
The finest line of dealer helps  
on the market today...  
Write for descriptive catalog.

**ARCTURUS makes it easier than  
ever before to obtain up-to-the-  
minute shop equipment! . . . .**

Here is your chance to keep your shop absolutely up-to-date with standard equipment. The new ARCTURUS PLAN makes it possible for you to get the equipment you need, even the most expensive unit—and get it quickly, with only a small down payment.

AND REMEMBER—when you buy ARCTURUS TUBES under this plan you pay STANDARD LIST PRICES, less standard discounts. We haven't added one cent extra. This means that ARCTURUS offers a sensational Equipment Deal and STILL SELLS TUBES AT STANDARD PRICES!

The small monthly tube requirements make it easy for you to own this equipment. Some deals require the purchase of less than one tube per day! No need to "oversell" yourself on tubes.

Equipment offered includes Tube Testers, Set Testers, Oscilloscopes, Analyzers, Signal Generators, Combination Unit Assemblies, Portable Typewriters, a Genuine Neon Sign and a long list of other high quality shop equipment.

**MAIL THIS COUPON FOR DETAILS**

Arcturus  
Radio Tube  
Co., Newark,  
New Jersey.

Gentlemen:

Send complete details of your new Equipment Deal.

- I am a Dealer
- I am a Serviceman

**ARCTURUS**

**INDEPENDENT TUBES FOR DEALERS WHO  
DO THEIR OWN INDEPENDENT THINKING**

Name.....  
Address.....  
City..... State.....

S-1

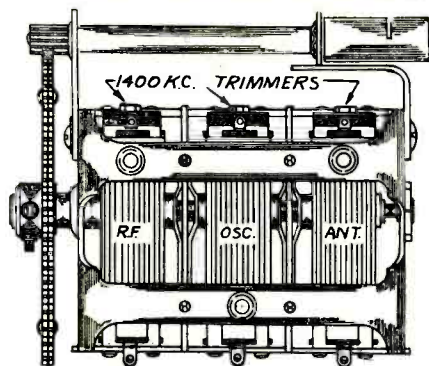

Fig. 2. Motorola 70 trimmer locations.

order given. The proper setting of each trimmer is obtained at the maximum indication on the output meter. For more accurate results the entire alignment should be repeated.

Allow both receiver and signal generator to warm up for at least 15 minutes before attempting adjustments.

**Philco Lincoln-Zephyr L-1424**

THE PHILCO MODEL L-1424 auto-radio receiver is a 7-tube superheterodyne designed especially for use in Lincoln-Zephyrs. A circuit diagram is given in Fig. 1 with the tubes used and their functions lettered on the diagram.

**ALIGNMENT PROCEDURE**

In making alignment adjustments on these receivers it will not be necessary

to remove the chassis from its housing. The adjusting trimmers can be reached after the cover is removed (see Fig. 2).

A sensitive output meter should be connected across the primary of the speaker transformer or across the voice coil. In making the adjustments the receiver volume control should be kept on full and the output meter kept below half scale by means of the attenuator on the signal generator.

The alignment operations are given in the accompanying table. The condenser indicated under dummy antenna should be connected in series with the generator output lead and the position

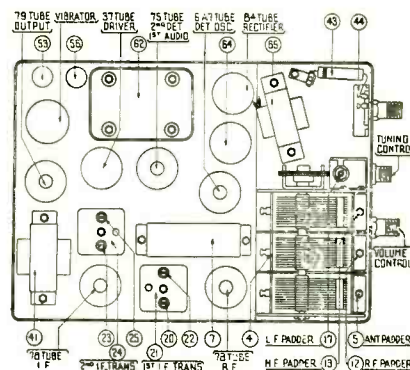

Fig. 2. Philco Lincoln-Zephyr parts layout and trimmer locations.

**PHILCO LINCOLN-ZEPHYR ALIGNMENT OPERATIONS**

Signal Generator Connection	Dummy	Signal Generator Frequency	Dial	Trimmer	Peak
<b>I-F ALIGNMENT</b>					
78 I-F Grid <sup>1</sup>	0.1 mfd	260 kc	1550 kc	25, 23	Second i-f
6A7 Grid <sup>1</sup>	0.1 mfd	260 kc	1550 kc	22, 20	First i-f
6A7 Grid <sup>1</sup>	0.1 mfd	260 kc	1550 kc	25, 23	Readjust
<b>R-F ALIGNMENT</b>					
78 R-F Grid <sup>2</sup>	0.1 mfd	1550 kc	1550 kc <sup>3</sup>	13, 12	H-F
78 R-F Grid	0.1 mfd	600 kc	600 kc	17 <sup>3</sup>	L-F
78 R-F Grid	0.1 mfd	1550 kc	1550 kc	13	H-F
Antenna lead	565 mmfd	1400 kc	1400 kc	12, 5	Antenna

<sup>1</sup> Do not remove the grid cap.  
<sup>2</sup> Using a piece of paper approximately 0.006-in. thick as a gauge between the heel of the rotor plates and the stator plates, turn the rotor plates in mesh until they strike against the paper.  
<sup>3</sup> Rock the tuning condenser while making this adjustment.

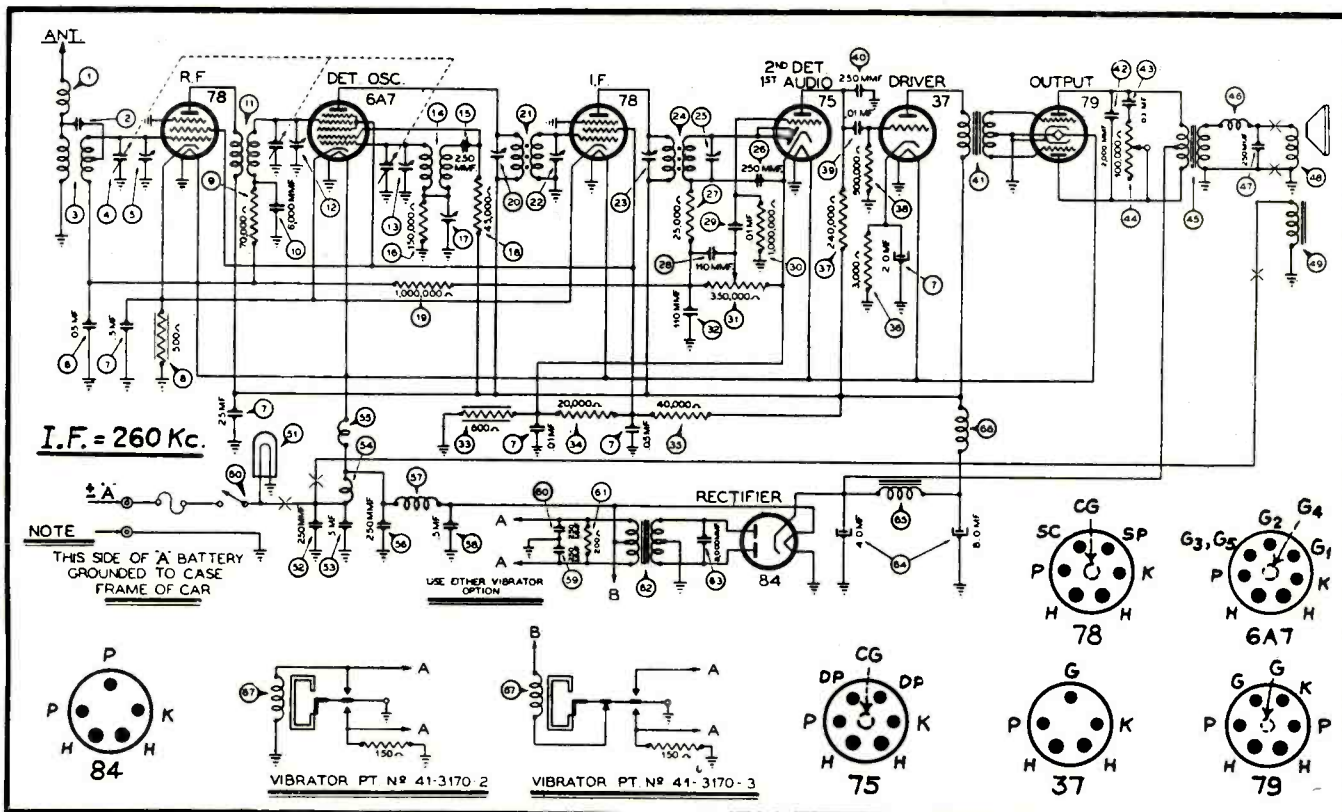

Fig. 1. Philco Lincoln-Zephyr L-1424 circuit diagram.

# Another Contribution to the Art by Jensen The Bass Reflex Principle

☐ Briefly, this new acoustic principle involves the function of an acoustic network through which back-side radiation from the cone type of loudspeaker is made to add usefully to the acoustic output from the front-side. Thus that energy, previously a source of destructive interference and difficult to dissipate satisfactorily in open-back loudspeaker cabinets and baffles, becomes a source of useful acoustic output. And, by suitable acoustic network design this added output occurs through a range of low frequencies not heretofore possible to produce by practical method. In short, one or more octaves of low frequency response range is added to what has previously been accepted as maximum loudspeaker and baffle ability.

This accomplishment not only involves consideration of acoustic networks in simple form but also those of more comprehensive nature which are Jensen developments and which constitute new art. Application of this new *Bass Reflex* principle is practical in every known use of direct radiator loudspeakers and we predict that henceforward consideration of the principle will be mandatory if the best possible acoustic results are to be achieved in treatment of loudspeakers and associated cabinets or baffles.



☐ We offer the details of this new development as a Jensen Engineering Service to those manufacturers who are prepared to incorporate the principle in their manufactured product. The service may either involve consideration of simple acoustic networks or of those more comprehensive ones; the determining factor usually being that of finished product cost against performance objective. Specifications are provided to insure suitably designed cabinet enclosures, loudspeaker design and audio frequency analysis of the receiver itself. Those interested are invited to write and ask for a date at which the work can be undertaken.

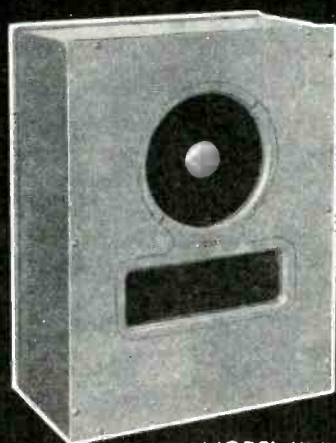

MODEL KM-12

☐ Jensen built *Peri-Dynamic* Reproducers, incorporating *Bass Reflex*, are offered the trade for all manner of applications concerned with the Reproduction and Reinforcement of sound. Models are available with either 8, 10, 12 or 15 inch speaker equipment. List prices range from \$12.50 up. The list price of Model KM-12, illustrated at left, is \$34.25 complete with 12-inch PM12-C speaker.

KM and KV Models are shipped in kit form with enclosure designed for easy assembly in the job. They are ideal for public address, radio and similar uses.

☐ Jensen built *Peri-Dynamic* Reproducers, incorporating *Bass Reflex*, are offered the trade for all manner of applications concerned with the Reproduction and Reinforcement of sound. Models are available with either 8, 10, 12 or 15 inch speaker equipment. List prices range from \$12.50 up. The list price of Model KM-12, illustrated at left, is \$34.25 complete with 12-inch PM12-C speaker.

Models C and D Jensen Imperial Reproducers range up to \$310 list. Some models are with dual speakers and variable filter networks. All incorporate the *Bass Reflex* Principle and are offered in beautiful, modernistic cabinets. For Broadcasting Station monitoring, laboratory reference work, homes, schools, or any use where the best possible quality of reproduction is an essential, these Reproducers are recommended.

Write for complete information on all Models.

JENSEN RADIO MANUFACTURING COMPANY  
6601 SOUTH LARAMIE AVENUE CHICAGO, ILLINOIS

"The Name Insures the Quality"

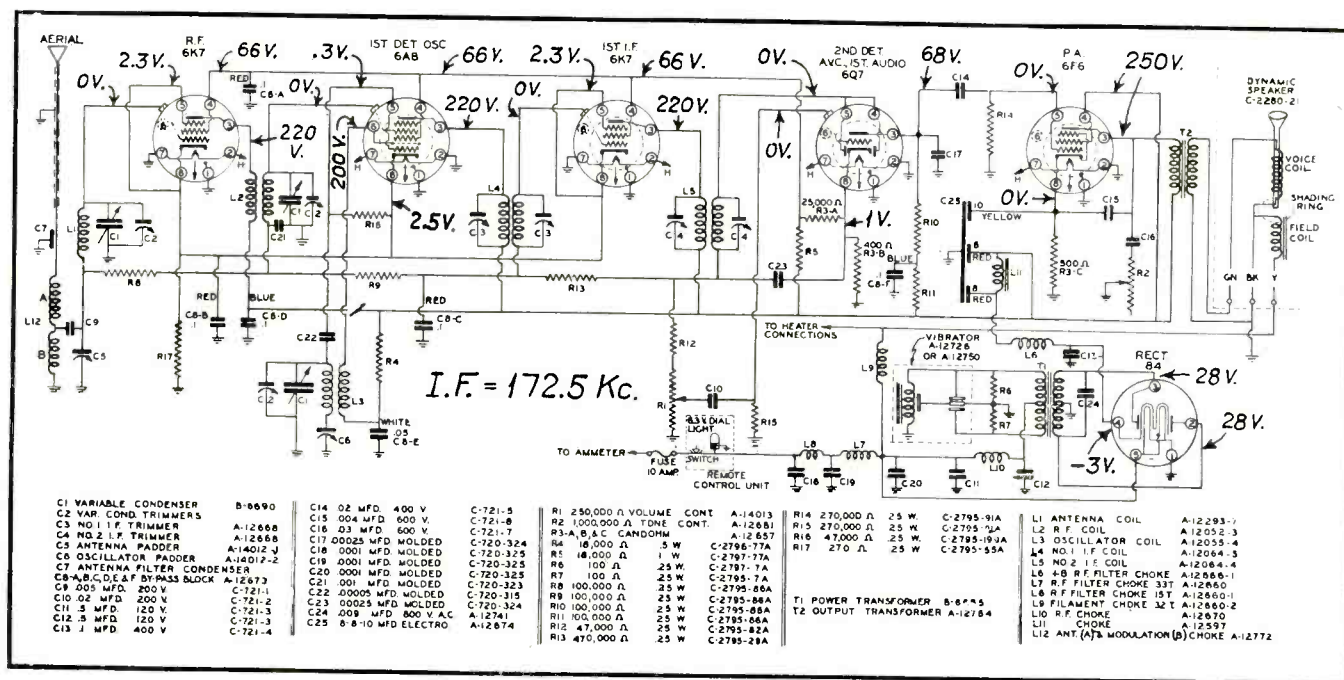

Sparton 676 circuit diagram.

on the receiver chassis designated under signal generator connection. The adjustments must be made in the order given. The proper setting for each trimmer is indicated by a maximum reading on the output meter. For more accurate results the entire alignment should be repeated.

Allow both the receiver and signal generator at least 15 minutes to warm up before attempting any adjustments.

Sparton 676, 686

The Sparton Models 676 and 686 are 6-tube auto radio receivers employing metal tubes in the circuits given in Figs. 1 and 2, respectively. The tubes used, their functions and the various voltages encountered on the socket prongs are lettered on the diagrams. The voltages were measured with a 1000-ohm-per-volt voltmeter with the volume control on full, the antenna shorted to the

chassis and with a battery voltage of 6.3 volts. Actual values taken in the field may vary as much as 15 percent (plus or minus) from those given.

ALIGNMENT PROCEDURE

The necessary operations for alignment of these receivers are given in the accompanying table. The condenser listed under dummy antenna should be

(Continued on page 554)

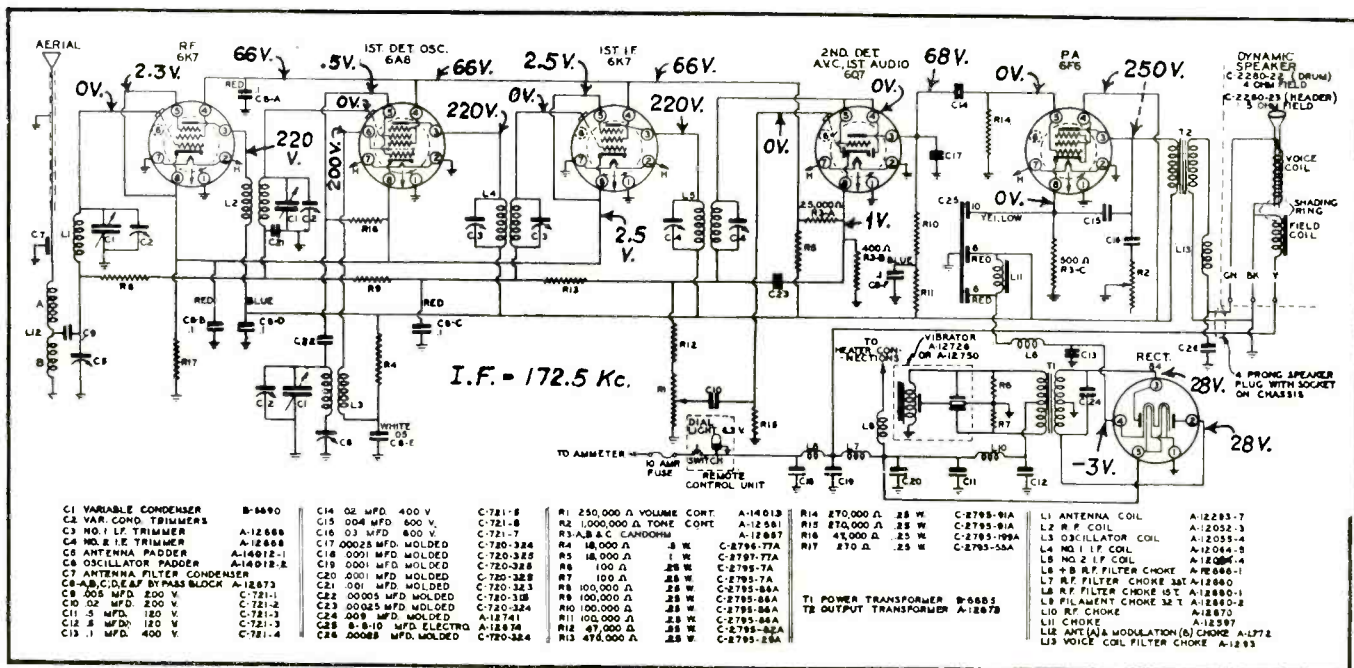

Sparton 686 circuit diagram.

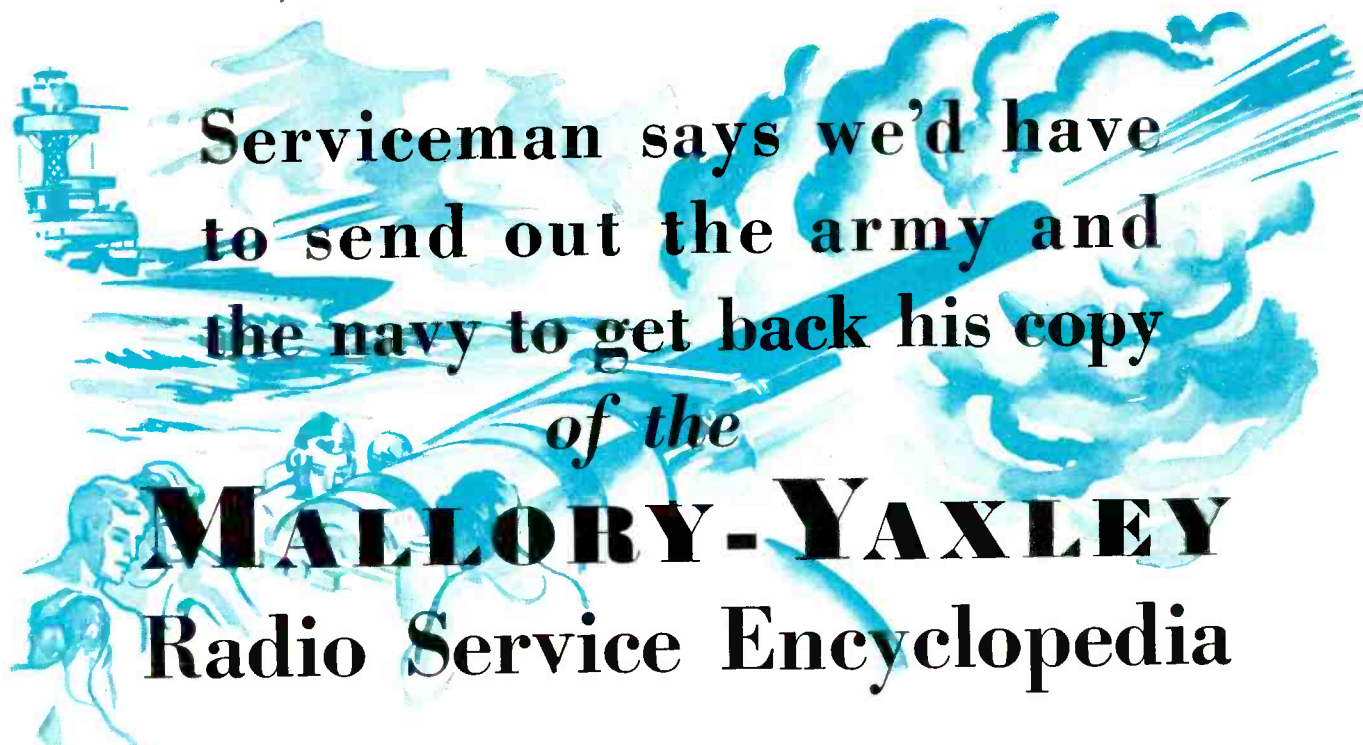

Serviceman says we'd have  
to send out the army and  
the navy to get back his copy  
of the  
**MALLORY-YAXLEY**  
Radio Service Encyclopedia

WHEN Byford Dunn—proprietor of Dunn's Radio Shop at Carrier Mills, Ill.—likes something he doesn't mind saying so.

"A word about your Mallory-Yaxley Radio Service Encyclopedia," writes Mr. Dunn. "It is the last word in 'Labor Saving Machines'. The only way to get mine back would be to trade me a better one—or send out the army and navy! If I had not had that book I would have been up in the air a few days ago. A boy brought in a radio he had taken the old volume control out of and with the wires cut where they fastened in the radio and not on the control. With my Mallory-Yaxley Radio Service Encyclopedia I had it going in a few minutes—and there was the price of my manual!"

F. C. Robinson, of Livingston, Montana, is equally enthusiastic. He writes: "The Mallory-Yaxley Radio Service Encyclopedia is a fine book and well worth much more than was charged for it. It will

help many a serviceman out of a tight place!" Read this . . . from Sanford Helt, Chief Engineer of the American Broadcasting Corp., at Lexington, Kentucky . . . "In my fourteen years of radio, I've never seen anything to equal your Mallory-Yaxley Radio Service Encyclopedia. I bought the volume as soon as it came out as I wanted it in my technical library."

Interesting reading, these comments from other men in the field! But—how about you? When are you going to save those extra hours and make those extra dollars that other men are saving and making with this great book that completely covers Schematics-Circuits, Volume Controls, I. F. Peak Frequencies, Transformer Circuits, Condensers, Tubes and Vibrators? You'll have to act promptly, for there are only a few copies left. See your Mallory-Yaxley distributor right away about this greatest help a serviceman ever had!



Use  
**MALLORY**  
P. R. MALLORY & CO. Inc.  
REPLACEMENT  
CONDENSERS...VIBRATORS

**P. R. MALLORY & CO., Inc.**  
INDIANAPOLIS INDIANA  
Cable Address—PELMALLO

Use  
**YAXLEY**  
REPLACEMENT  
VOLUME CONTROLS

# ON THE JOB . . .

## Wells-Gardner Telephone Dial

THE WELLS-GARDNER CHASSIS Series A1, A2, A3, A4, A5 and A7 employ a telephone dial assembly which provides a means of presetting a number of broadcasting stations and tuning in these stations at any time by depressing a button and rotating the dial to a stop position.

The apparatus is mounted on an assembly attached to the front of the chassis.

A silencer circuit is provided which results in silent tuning between stations when using the telephone dial buttons.

When a telephone dial button is depressed, a circuit is established between the ungrounded end of the volume control and the chassis ground. Referring to Fig. 1, contact is made between the line from the volume control, contact ring, contact washer arm (when button is depressed), spring and pulley ring stud. Since the pulley ring is at ground potential, this grounds the audio voltage and no signal will be heard until the button is released to break the contact.

It should be noted that the contact ring is part of the pulley ring assembly, but is insulated from it.

In the case of powerful local stations a slight amount of signal may be heard when the button is depressed.

### ADJUSTMENTS

*If noise occurs on all buttons:* This is probably due to a poor contact between the flat contact spring and the contact ring. See Fig. 1. Clean the flat contact spring and contact ring to insure a good electrical connection. Ordinary cleaning fluid may be used and will be effective in most cases in cleaning the surface without affecting the plating. If the contact is still not satis-

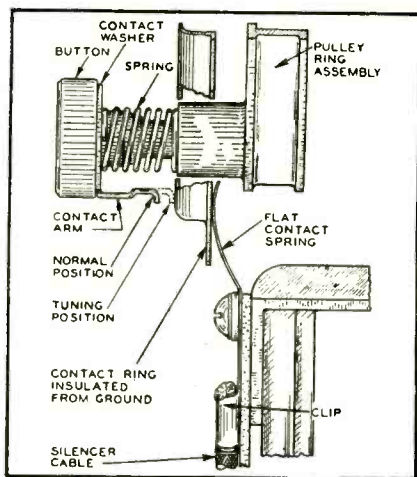

Fig. 1. Silencer assembly.

factory, a piece of fine emery cloth may be used.

*If noise occurs on one button only:* This is due to a poor contact between the pulley ring stud, spring, contact washer, and contact ring. See Fig. 1. Clean all of these items of the particular button, in the same manner as mentioned previously, so as to provide a good electrical connection.

*Drive cord slips:* If the telephone dial drive cord slips on the tuning shaft pulley, this may be remedied by adjusting the drive cord tension pulley. Loosen the tension pulley bracket screw and adjust pulley assembly until the desired tension is obtained.

*Position of stop pin:* When the tele-

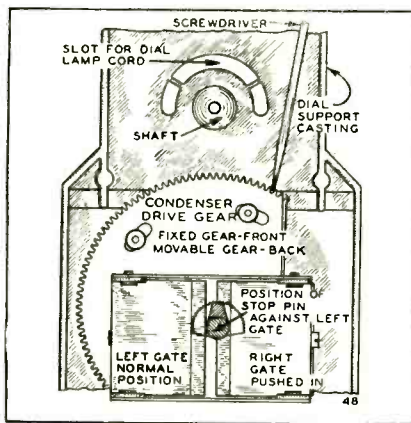

Fig. 2. Replacing pulley ring assembly.

phone dial assembly is on the chassis, the gang condenser rotor should not completely open or close. The travel of the rotor in this respect is controlled by the gang stop pin on the pulley ring. See Fig. 4. This is necessary to protect the gang condenser in case the telephone dial is swung rapidly to either of the extreme positions. When the gang stop pin is properly set, it will serve as the stop at both extreme positions. If the rotor is seen to open completely or close completely, the stop pin should be pulled back and reset to overcome this condition.

*Greasing and oiling:* After a period of time, put some light grease on the pulley ring shaft and on the teeth of the pulley ring. Use light oil on the drive shaft assembly bearing, care being taken not to get any on the drive cord.

### REPLACEMENTS

*Complete dial and condenser assembly:* Remove the grid lead clip from tube grid cap.

Remove silencer cable from the con-

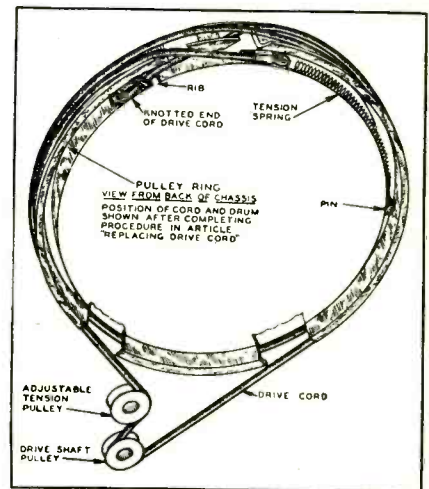

Fig. 3. Drive cord replacement.

tact spring assembly. Unsolder dial lamp lead from terminal of tube socket.

Unsolder the three stator section connections of the gang condenser. Unsolder the three braided shield leads which ground the gang condenser frame to the chassis, taking care not to loosen the connections of any other units which are grounded at these common points.

At the back of the gang condenser is a stud which secures the assembly to an L bracket which is secured to the chassis.

Through this stud is a cotter pin. Remove only the cotton pin, metal washer, and rubber washer.

Viewing the assembly from the back, on the left is a brass bolt which holds the dial support bracket to the chassis—remove this bolt from underneath the chassis.

Grasp the dial support brace and move entire assembly toward the front of the chassis. When the support casting rubber cushions slip clear of the slot in front of chassis, lift entire assembly clear of chassis.

To replace this assembly, reverse the procedure as given above.

*Pulley and button ring assembly:* Remove drive cord.

From underneath the chassis, unsolder the dial lamp lead from prong of the tube socket. Pull this lead through and out to the front of the assembly.

Remove the four escutcheon screws which hold the escutcheon ring and glass crystal in place. The dial scale pointer is removed by unhooking it from the center stud. Unscrew and remove center stud, washers, and dial scale. Slide pulley ring assembly off the center shaft.

On the No. 10 dial, two strips of celluloid between the escutcheon ring and the glass crystal will have to be removed.

To replace the pulley ring assembly, proceed as follows: Lay the assembly face down and adjust the stop pin. The stop pin (Fig. 2) is directly in back of the wide spacer on the dial button ring.

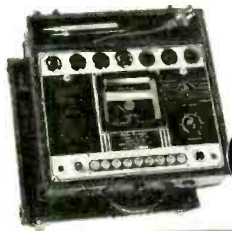

220

## Model 220 Roto Ranger

Tube and Set Tester

In the opinion of hundreds, the Model 220 is the greatest of all analyzing equipment. The "Roto-Ranger" feature places twelve distinct scales at your finger tips. Utilizes latest tube testing circuit. Has filament return selector. Tests all types of condensers on separate scales. Has separate resistance scales of 100 ohms, 100,000 ohms, 100 megohms. Three D.C. scales of 8-300-1000 volts. (2500 ohms per volt.)

Net price **\$62.75**  
Time Price: \$12.50 down and 6 monthly payments of \$9.60 each.



275

## Model 275 Roto Ranger

High Sensitivity Set Tester

With the Roto-Ranger convenience and a sensitivity of 10,000 ohms per volt, this is one of the most outstanding instruments on the market—a new Simpson development. Ranges are D. C. volts 0-10-50-300-1000; A. C. volts 0-8-150-1000; ohms 0-2,000-200,000-20 megohms. Milliamps 0-10-100-500; Microamps 0-100.

Net price **\$42.50**  
Time Price: \$8.50 down and 6 monthly payments of \$6.60 each



201  
202

## Model 201 and 202 Roto Ranger

Volt-Ohm-Milliammeter

A Volt-Ohm-Milliammeter with Roto-Ranger Feature with the following ranges: Model 201 (D. C.) Ohms, 0-20-200-2,000-20,000-200,000-20 megohms; Microamps, 0-200; Milliamps, 0-10-150; Volts, 0-8-300-1,000. Model 202 (A. C. and D. C.) A. C. volts, 0-8-130-1,000; D. C. volts 0-8-300-1,000; D. C. Milliamps, 0-1-8-130; Ohms, 0-100-0-50,000-2 megohms.

Net Price D. C. Model **\$32.50**  
Time Price: \$6.50 down and 6 monthly payments of \$5.00 each  
Net Price A.C.-D.C. Model **\$35.75**  
Time Price: \$7.00 down and 6 monthly payments of \$5.50 each



## Model 210

All-Wave  
Signal  
Generator

A signal generator as accurate as it is beautiful. Heavy aluminum castings give proper shielding. Single rotary selector switch provides modulated, unmodulated and externally modulated radio frequency and 400 cycle audio output. Range: Continuously variable from 94 kilocycles to 26 megacycles—all on fundamentals. Divided into 6 bands, 94-216, 215-550, 550-1500 kilocycles and 1.5-4.0, 4.0-10.0, 10-26 megacycles, selected by means of a 6-position rotary switch.

Calibration: At 6 points with quartz crystal oscillators. Maximum change in original calibration over long periods of time are less than 1%.  
Net Price, A. C. line operated **\$49.00**  
Time Price: \$9.85 down and 6 monthly payments of \$7.50 each  
Battery operated type (Model 211) **\$39.50**

# WHAT SUCCESS!

*In one year*

**H**OW DID IT HAPPEN? How did a line of testing equipment, unheard of one short year ago, move so swiftly into the front ranks of radio analyzing equipment. How, for example, did the Simpson Model 220, unknown only eleven months ago, become the fastest selling instrument in its price class?

Was it because Simpson Equipment brought fresh ideas (long overdue) into the radio testing field? Was it because the Roto Ranger feature marked the greatest single advance in ten years of instrument building? Was it because . . . but why go further?

The answer, we believe, is that this success, like all achievements, was not due to any one thing, but rather to the sum total of **MANY THINGS**. It was the logical achievement of an organization that started afresh and anew, with unsurpassed experience in instrument building to guide it, but with none of the handicaps of old methods, old facilities, or old ideas to hamper it!

A serviceman expressed the big idea in a simple, but forceful way, at the New York Show when he exclaimed, "There **IS** something about these Simpson Instruments that **GETS** you!"

Hundreds of servicemen saw that "something" at the New York Show, and hundreds more saw it at the Chicago Show. They saw the revolutionary advances in Simpson Instruments, and they saw something that is even more significant to the experienced eye—a new beauty of design and workmanship in every outward detail from panel to pointer that gave unmistakable evidence of a watch-like precision which carries into the minutest hidden detail.

The thousands who purchased these instruments have had their first impression eloquently confirmed in truly flawless performance. They have found instruments that do the job better and quicker—instruments that DO "STAY ACCURATE." Look at them here. Notice the range of service they cover, and the better way they cover it. But look at them "in the flesh" too—at your jobber's. You will then know **HOW** it all happened—in **ONE SHORT YEAR!**

**SIMPSON ELECTRIC COMPANY**  
5218 W. Kinzie Street, Chicago, Ill.

*New*

**Model 100 ANAL - O - SCOPE**

A NEW FREE POINT TESTER for use with any Set Tester or Volt-Ohm-Milliammeter. Has five sockets with a complete set of series type jacks connected into the various circuits for measurement of voltage, current and resistance between any tube elements or socket contacts. By selecting a card corresponding to the tube under test and placing it on the ANAL-O-SCOPE a complete picture of the elements and connections is in view while all tests are being made. The cord and plug method of analysis is combined with the "Free Point" method in this modern testing unit. Furnished complete with test prods, adapters and cards covering all popular tubes. Can be kept up to date at low cost.

Net Price **\$17.50**

# SIMPSON

*Instruments that*  
**STAY ACCURATE**

**ASK YOUR JOBBER**

SAY YOU SAW IT IN SERVICE

*All sold on deferred payments*

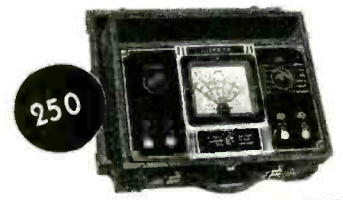

250

**20,000 OHMS PER VOLT**

## Model 250 -- Set Tester

This new Simpson Set Tester sets a new "high" in sensitivity and value. Negligible current consumption (20,000 ohms per volt) means incredibly accurate voltage readings on ranges of 2.5-10-50-250-1,000. Same ranges for A.C. at 1,000 ohms per volt. Current readings from 1 microamp to 500 milliamps. Accurate resistance readings as low as 1 ohm up to 40 megohms. Built and mounted as only Simpson Instruments are built. Send coupon for details covering range of tests. SEE IT!  
Model 250 (20,000 ohms per volt model)—Net Price **\$42.50**  
Time Price: \$8.50 down, 6 monthly payments of \$6.60 each.  
Also built in 10,000 ohms per volt model. Net Price \$32.50

## Model 215

A. C.-D. C. Volt-Ohm-Milliammeter

The first small instrument (only 5 1/2 x 7 x 3") to incorporate a big, 4 1/2 - inch, easily read dial. Ranges: 0-2.5-10-50-250-1,000 volts A. C. or D. C. (at 5,000 ohms per volt D. C. and 1,000 ohms per volt A. C.); Milliamps, 0-10-100-500; Microamps, 0-250; Decibels five ranges—12 to +55; Ohms 0-4,000, 0-400,000, 0-4 megohms.

Net Price **\$25.75**

## Model 205

Volt-Ohm-Milliammeter

Here is Simpson quality and accuracy in a pocket edition. Only 5 1/4 x 2 7/8 x 1 3/4". Highest resistance ranges ever provided in an instrument of this size—0-2000-200,000 ohms-2 megohms; Volts 0-10-50-250-1,000 (D. C. only); Milliamps, 0-10-500.

Net Price **\$13.25**

**Mail This Coupon**

SIMPSON ELECTRIC CO.  
5218 W. Kinzie Street, Chicago

Please send facts covering Simpson Instruments checked:

Model 220    Model 275    Model 201  
 Model 202    Model 250    Model 215  
 Model 205    Model 210  
 Anal-O-Scope

Name .....

Address .....

City ..... State .....

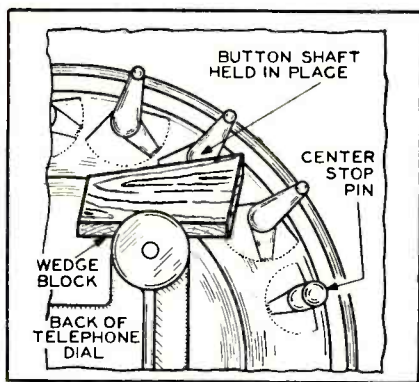

Fig. 4. Holding push-button shaft in place.

Pull this pin back and adjust it to the center position.

Rotate tuning condenser rotor counter clockwise (from front) as far as possible. See Fig. 2.

Place the pulley ring assembly on the shaft with the knot of the dial lamp at the top—do not engage the gears.

Pull the dial lamp lead through the slot in the pulley ring gear and through the long slot in the dial support casting. Then place this lead through the clip under the dial support brace and out through the opening in the back of this brace.

With the gears still disengaged, rotate the pulley ring clockwise (from front) 1/2 revolution until the stop pin passes over the right gate and comes to rest against the left gate. See Fig. 2.

With the condenser rotor fully closed, push the pulley ring on the shaft until the pulley ring gear engages the fixed gear only, front) of the condenser drive gear assembly. Hold the pulley ring assembly and with a fine blade screwdriver, move the movable (back) gear clockwise one tooth relative to the fixed gear. Then push the pulley ring all of the way on, engaging the movable gear.

Now lay the chassis on its back. Replace in the order given the large washer with rectangular hole, dial scale, washers, center stud, dial pointer, glass crystal, and escutcheon. Resolder the lamp lead.

For the No. 10 dial, before putting the escutcheon on, lay the two celluloid strips on the glass crystal with the inside flange facing away from the glass. Then lay the escutcheon on top of the celluloid strips. The section not cut out for station call letters should be at the wide spacer in the button spacer ring. Center the small holes in the celluloid discs in the station call letter openings and then tighten the escutcheon screws.

The stop pin must now be adjusted, as explained above, until the condenser does

not open or close fully. Injury to the condenser will result if allowed to open or close fully.

Replace the drive cord as explained below.

**Gates:** After a great amount of use, one or both of the stop gates may wear, making it necessary to replace the stop gate assembly. This is done by first removing the pulley ring assembly as explained above.

The stop gate assembly is then removed by taking out the two screws at the bottom of the assembly.

**Drive cord:** Remove the old drive cord and tension spring. Rotate telephone dial clockwise (from back of chassis) as far as it will go.

Viewing the pulley ring drum from above and to the back, place the knotted end of the drive cord in the slot provided for it, catching the knot in back of the rib as shown in Fig. 3.

Bring the cord down and around the right side (from back) of the drum at front part of groove in pulley ring drum and under the drive shaft pulley making one-half turn on this pulley. Then bring the cord around the right side (from back) of the adjustable tension pulley and up to the upper left side of the pulley ring drum in front of the cord already on.

Hold the cord in the left hand and rotate the dial counter-clockwise with the right hand. Feed the cord on the drum in such a way that after passing the two openings at the top of the pulley ring drum, it passes to the back of the groove in the drum. After the pulley ring drum makes one complete revolution, place the cord through the left drum opening into the slot and secure the tension spring hook over the pin provided for it. See Fig. 3.

**Dial button or button shaft:** A telephone dial button or button shaft may be replaced without removing the chassis from the cabinet.

Rotate the dial until the button shaft to be replaced is in the position shown in Fig. 4. Using a wooden wedge block or any other wedge, hold this button shaft in place as shown. Remove the clear celluloid disc and the call letter disc with the point of a pin from the button of the shaft to be replaced (No. 10 dial—brown opaque celluloid disc only).

Remove the hairpin spring from the front of this shaft, spreading it with an ice pick or screwdriver. Take off the button, metal washer, molded bushing, and spring. Take out the wedge block, remove the button shaft to be replaced from the back of the dial assembly and

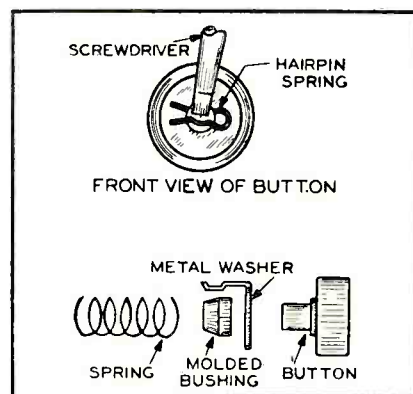

Fig. 5. Placing hair-spring on a push-button shaft.

put in the new one. Then put the wedge block back in place again as illustrated.

Lay the cabinet back down against a chair so that it will be about 30 degrees from the vertical position.

Assemble the spring, molded bushing, metal washer, and button in the order shown in Fig. 5. (Last three items may be in one unit). Push the button and spring assembly over the button shaft with the tab of the metal washer in the normal position. Hold the tab and rotate the button until the flat in the shank coincides with the flat on the shaft. Push the button all of the way on.

Put the hairpin spring in place, as shown in Fig. 5, with the upper part of the slot near the end of the button shaft and the lower part over the end of the shaft. Place the blade of a screwdriver at the center of the lower part of the spring and push down until the spring snaps into place in the slot on the shaft. Remove the wedge block.

### Replacing Pilot Lights

In order to replace pilot lights in inaccessible places the tool shown in the illustration may be used. The pilot light is inserted into the end of a length of rubber tubing. Wetting the bulb will simplify this operation. To help turn the tubing and give it consistency a small glass or bakelite rod may be inserted into the other end.

With the help of this simple tool it

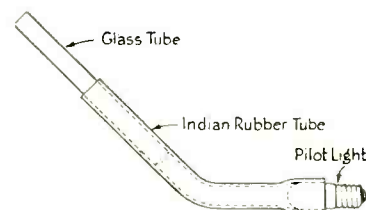

is often possible to screw in pilot lights in the most difficult places without removing the chassis from the cabinet.

RCA Radio Service News



# Public Address . . .

## FALL P-A MARKETS

By H. C. ROLLS

CONTRARY TO WHAT MIGHT be expected the Fall season offers very excellent markets for *outdoor* p-a equipment, markets in which the demand is either weaker or entirely non-existent at other times of the year. The closing months of the year also bring renewed or specialized interest in certain kinds of indoor equipment.

### OUTDOOR STADIUMS

In spite of the shortness of the autumn season athletic fields offer an unusual market. The management will always be found willing to consider a substantial expenditure as summer ends. They want to make certain of attracting the football fans that contribute so large a portion of the total annual income. The approach of their best season makes it possible for them to contemplate expenses that would be unwise at any other time. The managers of school and college stadiums react, in this respect, in much the same way as the managers of commercial fields.

P-a prospects are not confined to those athletic arenas which are still unequipped. Almost any stadium is likely to add more seats from time to time and every increase in seating capacity is an argument for enlarging the existing

p-a system. Every field that was equipped as long as two or three years ago is a logical prospect for modernization. Every field that entertains reasonably large audiences at important games is a prospect for servicing arrangements, including the presence of a competent Service Man during every such game, and inspection and minor adjustments in advance. The service should include the presence in the stadium of all repair and replacement parts—tubes, cable, duplicate speakers and so on—which may be needed in case of a breakdown. The servicing contract may include a reasonable charge for the loan of this equipment, which can be paid for separately if an emergency requires that any of it be actually used.

### SKATING RINKS

Another outdoor p-a market makes its appearance in the very late autumn in preparation for the winter season. Ice skating rinks are now almost invariably equipped with loudspeakers that disseminate musical entertainment. The power needed is rather small, in proportion to the area to be covered, because of the reinforcement provided by reflection from the ice and because of the superior efficiency of cold air in

transmitting sound. The primary function of a rink system is served using a record player or a radio tuner as a source of input, but the management can be persuaded to add a microphone, partly for use on special occasions, and partly to provide a calling system by means of which announcements may be made, etc. P-a systems are used at public as well as private rinks. Park authorities will usually be found receptive when properly approached.

Rink systems already installed can, of course, be modernized or enlarged. Servicing contracts are comparatively easy to arrange. The music is quite important to rink owners since it forms an additional attraction.

Indoor rinks, both for ice skating and for roller skating, take on increased importance in winter. They have very different power requirements. The indoor ice rink needs surprisingly little power. Sound is reinforced not only by reflection from the ice, but by reverberation from the walls and ceiling, which are usually bare and hard. Roller skating rinks, to the contrary, require high power to overcome the noise of skating. Comparatively small roller rinks commonly use as much as 100 watts audio output. Speakers must be scattered for even a high power output originating at one end of the rink may be practically inaudible at the other. Reverberation from the hard floor, walls and ceiling of a roller rink offers no help to the system because it provides equal reinforcement to the noise of skating.

### THE THEATRE

Most movie houses now need a p-a system in addition to their talkie equip-

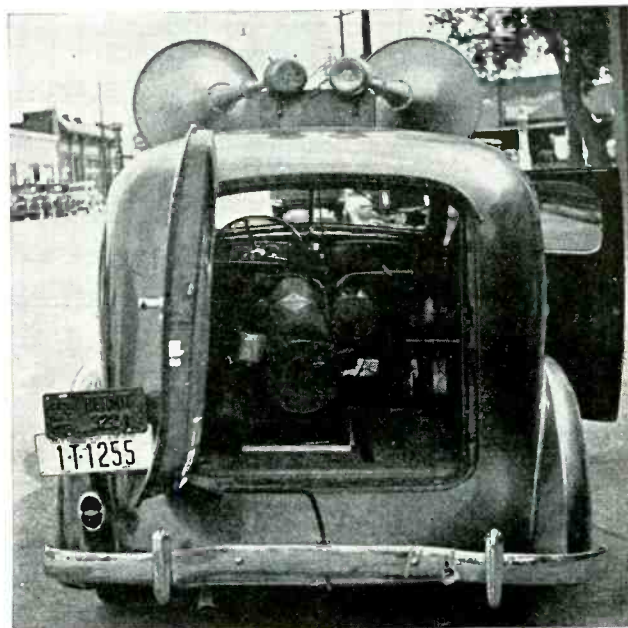

Typical sound truck installation.

# IRC

REG. U.S.

PAT. OFF.

Initiative—Resourcefulness—Cooperation  
to advance the interests  
of the industry

*Metallized* CO

*... Now Available*

## SPECIAL REPLACEMENT TYPE

with  
the  
*First and  
Only*

## SILENT SPIRAL

(Designated in IRC Guide)

*"Because It's Positive"*

For years, servicemen have been looking for better controls—quieter controls for those extremely critical duplicate replacement jobs that cannot be handled with standard types. Today, IRC makes such controls available—backed with all the well-known features of standard Metallized units PLUS the exclusive 5-Finger Silent Element Contact PLUS the exclusive Silent Spiral Connector which is supplied on all of the new special replacement controls listing at \$1.50 and up (not standard types). These special controls are identified by the letter "J" preceding their part number in the IRC Guide. See them at your IRC jobber's today.

### GET THIS NEW GUIDE FREE!

Just off the press! 208 pages! Lists standard and special replacement types for practically every radio receiver. Includes handy control and resistance calculation data, complete IRC Resistor Catalog, etc. Indispensable! Ask your jobber for a copy—or write direct to us.

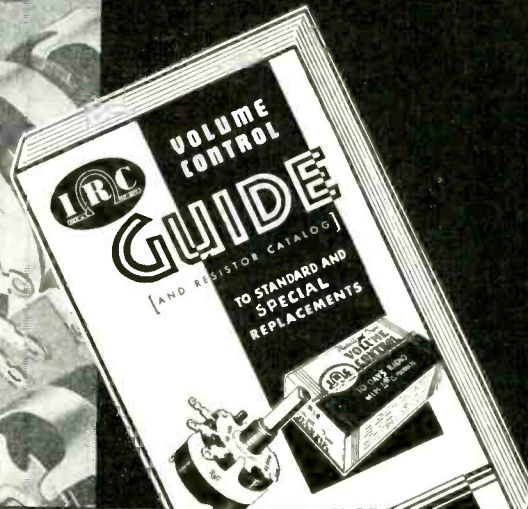

## *Quietest!* BECAUSE OF SLIDING METAL-TO-METAL CONTACT

Factories and Licensees in  
MAKERS OF RESISTANCE UNITS OF MORE TYPES

**CONTROLS**  
*Available in*  
**REPLACEMENT**  
**CONTROLS**

**SILENT SPIRAL**  
**SPECIAL CONNECTOR**

Guide with Prefix "J"— Patent Applied for)

**It's Positively Noiseless!!**

**IT ELIMINATES THE MOST COMMON SOURCE OF NOISE IN *Any* CONTROL**

The outcome of two years of engineering development work, IRC brings you the outstanding control improvement in years—positive and continuous electrical connection between the center terminal and the adjustment arm. This Silent Spiral Connector spells complete elimination of sliding, metal-to-metal contact in the place where most control noises originate. It means that these new IRC Special Replacement Controls are unquestionably quietest, because they are the only controls having this feature.

The Silent Spiral Connector is made of special wire—sturdy and durable—constructed like a fine watch for a lifetime of the quietest service you can imagine.

**NO SLIDE**

**NO FRICTION**

**NO NOISE**

**THEY'RE THE *Only* CONTROLS IN WHICH  
SLIDING METAL-TO-METAL CONTACT HAS BEEN ELIMINATED**

**INTERNATIONAL RESISTANCE COMPANY**

401 NORTH BROAD STREET, PHILADELPHIA, PA.

Canada . . . England . . . France . . . Germany . . . Italy . . . Denmark . . . Australia

DESIGNS, IN MORE SHAPES, FOR MORE DIFFERENT APPLICATIONS THAN ANY OTHER MANUFACTURER IN THE WORLD

ment. Mikes are used on the stage for amateur nights, bank nights, vaudeville entertainment, etc. In addition, the talkie system itself offers frequent opportunities to the p-a Service Man. It is no more than a standard p-a system in which a photocell is the source of input instead of a microphone.

Fall is the traditional season for revival of theatrical activity. That is when the best pictures are released and when management is most receptive to ideas of improvement and change.

Confining the present discussion to movie houses, which are of course the most common form of theatre, every such place of entertainment is a logical prospect for a microphone system. Every theatre already equipped is a good prospect for periodical service visits, provided the matter is tactfully suggested. Approached carefully, with scrupulous avoidance of any appearance of high pressure selling, motion picture exhibitors are good prospects for steady servicing contracts.

The Service Man who gives satisfaction in p-a work may often find it possible to help out in connection with the talkie equipment and thus provide himself with additional income. No talkie apparatus is now sold or leased with compulsory servicing arrangements—the field is open to all comers.

Recent years have seen great improvements in both the recording and

the reproduction of sound pictures. Frequency range has been extended, and now covers 40 to 8,000 cycles; the dynamic or volume range has also been extended. Apparatus only three or four years old is obsolete and cannot do justice to modern recordings. More than half the theatres in the country, many more than half the smaller theatres, need new sound apparatus, and local Service Men can sell it to exhibitors whose confidence they have won. Such equipment can now be obtained from the Service Man's regular parts jobber.

Theatres also make large use of standard p-a systems for advertising. They install loudspeakers in front of the box office. More elaborate tricks are not uncommon; for example, a cardboard cutout of a character whose ear conceals a microphone into which a passerby may speak, receiving an answer through cardboard lips that mask a loudspeaker. Sound trucks are called on to advertise attractions. The Fall months are those in which theatres go in most heavily for advertising of all kinds.

#### P-A IN POLITICS

Political activity offers a special and unusual field, temporary in nature, sometimes hard and sometimes easy to break into; often very profitable.

Political p-a systems are, because of the temporary need, often rented rather

than sold. Political payments are not always reliable; the Service Man who is incautious about collecting before election may find that after the Day the club or party (especially the losing party) is without funds, and unable to meet its obligations until new contributions come in, next year.

In spite of these difficulties political work can be made very profitable. Four types of p-a systems are needed. They are: mobile equipment, mounted in automobiles or trucks; microphone installations in public meeting halls; microphone installations in political clubhouses and battery apparatus for street corner orators. Some of these systems are combined on occasion. The mobile truck apparatus, for example, may serve to attract a following and lead them to a meeting hall or political clubhouse, where (perhaps powered by the a-c line) it is used to reinforce political speeches.

One of the most difficult angles of political work is that of converting rentals into sales. Next year's election is always a long way off. It is not easy to demonstrate that buying equipment is cheaper than renting it. If the savings that can be made in that way seem too large they constitute a clear argument that the rental charge has been excessive. If the savings do not appear very large politicians would rather not buy. One helpful method is to equip a sound truck with convertible apparatus that can also be used from a standard power line. It is then easier to sell the system with the argument that it can be used in the clubhouse as soon as election is over, and will pay for itself by giving year-round service at the club meetings.

#### P-A IN EDUCATION

Every school can use classroom p-a equipment. It serves a wide variety of educational purposes.

School officials can address every student without calling a general assembly—for which the school auditorium is often too small. Special educational programs can be broadcast to all classrooms, or to selected groups of classrooms.

Many radio programs are used by educators. They tune in on official celebrations in Washington, at their state capitals, or at their respective municipal or county governments. Orchestral and other musical broadcasts are used in courses in musical appreciation or training. Lectures by specialists are valuable in courses in history, civics or geography. These and other broadcasts are reproduced in classrooms for which they are appropriate. Phonograph records

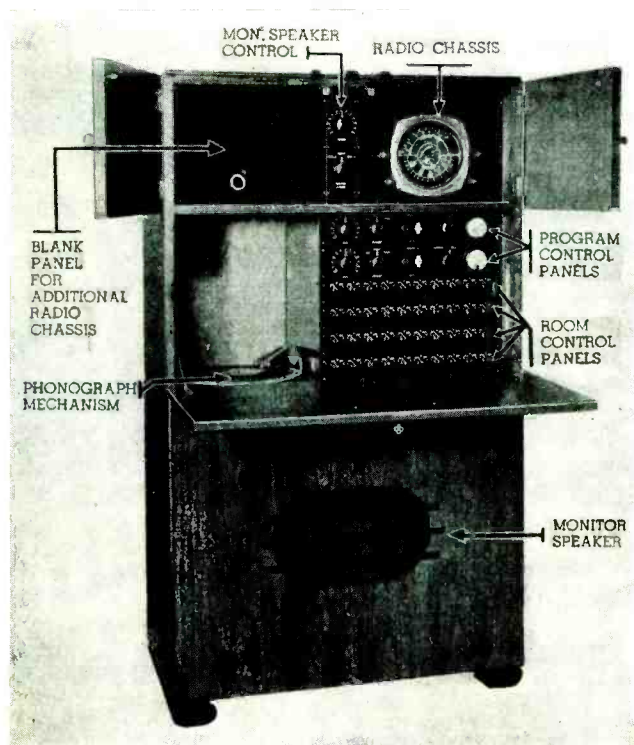

A centralized school p-a system.

# New

## STANDARDIZED TEST BENCH PANELS . . . by



- Triplet is now offering for the test bench, the same kind of standardization that has made Triplet Master models outstanding favorites; A standard size panel to accommodate standard Master and DeLuxe models. Testers may be added as required.
- Testers are held firmly in the panel compartments by flexible rubber retaining gaskets with compression fit. Instant installation or removal of instruments is possible. When in the panel, testers give appearance of being permanently installed.
- Laboratory panel cabinets can be bolted together.
- Cabinets are of metal, black wrinkle finish.

Provision for lamp attachment. Size 22½" x 16" x 5" top, 7¼" bottom.

Price of Cabinets, only \$10.00, Dealer Net, Any Model. Clamp-on Lamp, \$6.67 Dealer Net.

Model 1402 Accommodates Any Two DeLuxe Models  
Model 1403 Accommodates Any One DeLuxe and Two Master Models

Model 1404 Accommodates Any Four Master Models  
(Illustration shows three cabinets bolted together).

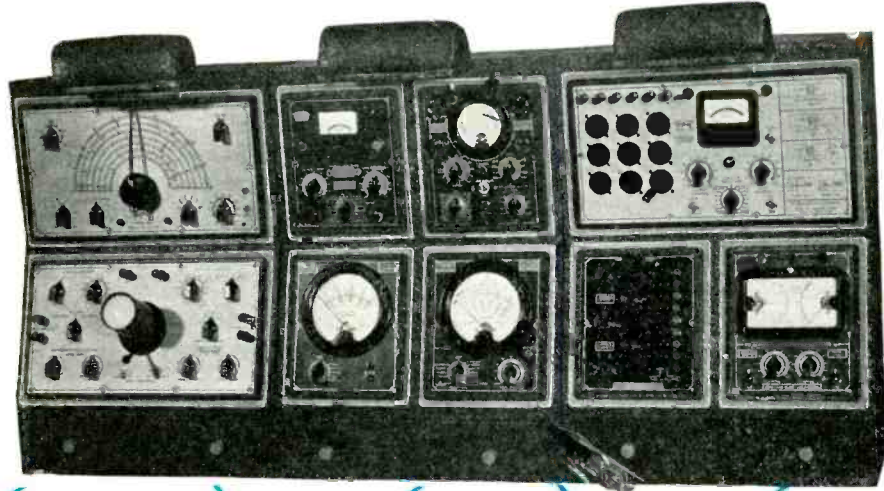

**Model 1402 As Shown Contains the Following Models:**  
1631 Oscillator  
1690 Oscilloscope

**Model 1404 As Shown Contains the Following Models:**  
1210-A Tube Tester  
1209-D D.C. Volt-Ohm-Milliammeter  
1209-A A.C. Voltmeter  
1241 Condenser Tester

**Model 1403 As Shown Contains the Following Models:**  
1250 Vacuum Tube Voltmeter  
1220-A Free Point Tester  
1670 Vibrator Tester

Single Unit Price ..... \$22.00  
Single Unit Price ..... \$20.00  
Single Unit Price ..... \$16.00  
Single Unit Price ..... \$27.50  
Single Unit Price ..... \$36.67  
Single Unit Price ..... \$11.00  
Single Unit Price in Metal Case ..... \$24.00

Any Combinations may be made up using standard Triplet 1200 Master Unit and Triplet 1600 DeLuxe Testers.

Model 1601



### New Triplet DeLuxe Set Tester

Contained in black leatherette case (as shown) with removable cover. Roomy compartment for accessories. Dealer's Net Price, \$49.33  
Also furnished in black wrinkle finish metal case (same as above less black leather carrying case and cover). Dealer Net Price ..... \$45.33

Remember Booth No. 205—Radio Parts Show — New York City. . . . Many New Items in the Ever-Enlarging Triplet Line Will Be Displayed.

SEE YOUR JOBBER — WRITE FOR CATALOG

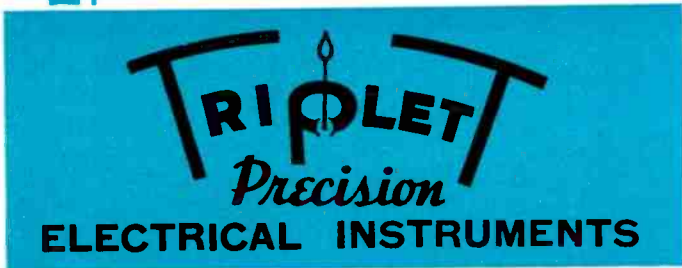

THE TRIPLET ELECTRICAL INSTRUMENT CO.  
179 Harmon Ave., Bluffton, Ohio

Please send me more information on ..... Model 1402;  
..... Model 1403; ..... Model 1404; ..... Model 1601;  
..... I am also interested in .....

Name .....  
Address .....  
City ..... State .....

## PUBLIC ADDRESS—continued

also are played in a central system and selected classroom speakers may be connected.

The same p-a equipment often serves as a communication system. The classroom loudspeaker, doing double duty as a microphone, permits direct two-way communication between each teacher and the principal's office.

The smallest and least elaborate classroom system will consist of a centrally located radio tuner, record player, microphone and amplifier, and speakers in each classroom that can be switched as desired. The larger systems have double or even triple channel amplifiers, double radio tuners, double phono turntables, and a central mike. The switching arrangements permit chosen groups of rooms to listen to different phonograph, radio or microphone programs, while still other classroom speakers are temporarily switched into communicating position and used for exchange of information between teacher and principal.

Additional p-a equipment is often used in language courses. The more elaborate installations include recorders, into which students can speak in a foreign language, and then hear themselves as others hear them. Smaller language systems may consist merely of a half-dozen or a dozen turntables, each equipped

with headphones. Students listen to foreign language records, according to their state of advancement, and write down what they hear. Simple p-a installations sometimes convey to a foreign language class a recording of speech or music, including patriotic or popular songs of the foreign country in question.

Recording systems are extensively used by music students, and by those studying elocution. Phonograph records give dictation in shorthand at any desired speed, either to an entire class, or more usually to selected groups of students who wear earphones.

Most school auditoriums need p-a equipment which is often part of a centralized classroom system of the type mentioned above but may also be an independent installation.

Hearing aid headphones are used in schools for the benefit of those who would otherwise fall behind their classes through aural defects.

Athletic field speakers may be cut into the central school system when the field is located close to the school buildings. Where the athletic field is at a distance and requires its own installation, the commercial considerations already mentioned will be found almost invariably to apply to school stadiums as much as to those run exclusively for profit.

## AUTO-RADIO—continued

connected in series with the signal generator output and the position on the receiver chassis designated under signal generator connection. The adjustments must be made in the order given. For accurate alignment the entire procedure should be repeated.

An output indicating device should be connected across the primary of the

speaker transformer or across the voice coil.

The receiver volume control should be on full throughout the alignment procedure and the output meter adjusted to remain below half scale by means of the attenuator provided on the signal generator. The trimmers should be adjusted for maximum indication on

the output meter.

The alignment of the i-f trimmers may be facilitated by lowering the sensitivity of the receiver. This can be accomplished by connecting a 25,000-ohm resistor and a 250-mmfd condenser in series from the 6K7 i-f grid to ground. The use of this suppressor may aid also in adjusting the remaining trimmers.

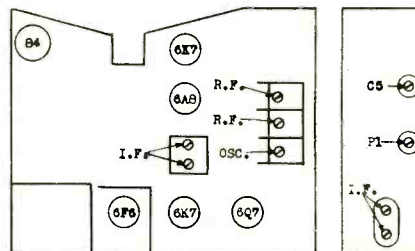

Fig. 3. Spartan 676, 686 trimmer locations.

Both receiver and signal generator should be allowed at least 15 minutes to warm up before attempting adjustments.

### Extending Speaker Cord for Repairs

When a chassis is removed from a cabinet for check or to make adjustments or repairs, it is usually necessary to use a speaker. A spare speaker is not always available which necessitates the removal of the speaker from the cabinet. This has caused a great loss of time to the Service Man, particularly in the models having an enclosed back such as the "acoustical labyrinth," since this must be removed before it is possible to reach the speaker.

In such cases a speaker adapter and extension cord, by which the speaker in the cabinet may be used after the chassis has been removed, should prove a useful device. Sockets and plugs for the purpose may be secured from the set manufacturers and in some cases the completed cable may be purchased.

After the chassis has been removed from the cabinet, the speaker plug is inserted into the adapter and the plug is inserted into the speaker receptacle on the chassis. This will allow you plenty of speaker cord so you may place the chassis in any position desired, on the floor in a customer's home or on your bench in the shop.

*Stromberg-Carlson Telephone Mfg. Co.*

### Replacing Rectifiers in '36 Receivers

In all 1936 receivers using 5Z4MG rectifier tubes it will be advisable to use 5Y3Gs for replacement purposes. The latter is a common tube, easy to obtain and is not subject to the breakdown that was encountered in some of the 5Z4MG tubes.

*J. K. Rose  
WELLS-GARDNER & CO.*

### ALIGNMENT OPERATIONS SPARTON 676, 686

Signal Generator Connection	Dummy	Signal Generator Frequency	Dial	Peak Trimmer
I-F ALIGNMENT				
6A8 Grid	0.25 mfd	172.5 kc	540 kc	Second i-f
6A8 Grid	0.25 mfd	172.5 kc	540 kc	First i-f
R-F ALIGNMENT				
Antenna	150 mmfd	1350 kc	1350 kc	Osc
Antenna	150 mmfd	600 kc	600 kc	Osc paddler (P1)
<i>Rock the gang condenser while making this adjustment.</i>				
Antenna	150 mmfd	1350 kc	1350 kc	Repeat osc
Antenna	150 mmfd	1350 kc	1350 kc	R-f trimmers
Antenna	150 mmfd	600 kc	600 kc	Antenna pad (C5)

*Rock the gang condenser while making this adjustment.  
Repeat alignment procedure.*

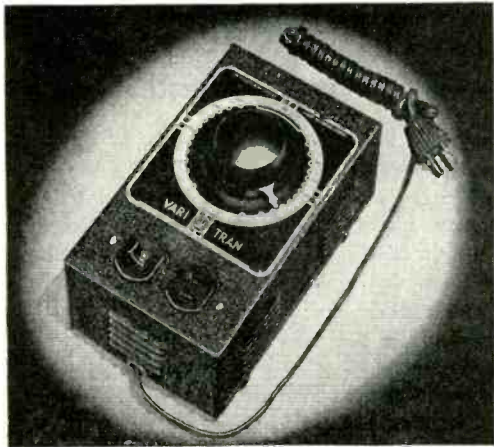

## VARITRAN★ VOLTAGE CONTROL UNITS

### FEATURES

- ★ Smooth control
- ★ High efficiency
- ★ Excellent regulation
- ★ Low cost

### APPLICATIONS

- ★ Motor control
- ★ Heat control
- ★ Rectifier control
- ★ Light control
- ★ Line voltage control

The UTC VARITRAN makes possible continuously variable output voltage, using a sliding contact riding over the turns of an auto-transformer.

Standard units are designed for 115 volts input, 0-130 volts continuously variable output.

Model V-1. 570 Watts—5 amp. maximum rating, complete with cord, plug and switch, net.....	\$10.00
Model V-2. Same as V-1, but uncased, with terminal strip for rack or panel mounting, net.....	\$9.00
Model V-3. 850 watts maximum rating, 7.5 amps., uncased, with terminal board and provisions for mounting, net..	\$14.00
Model V-4. 1250 watts—11 amps. maximum rating, uncased, net .....	\$20.00
Model V-5. 2000 watts maximum rating, 17.5 amps., uncased, net .....	\$32.00

### Other sizes

Automatic VARITRANS are available to maintain line voltage constant. Details and prices on request.

## UTC CATHODE RAY OSCILLOSCOPE



The UTC OSCILLOSCOPE incorporating the new 2" cathode ray tube has every feature required for application in the radio field. It includes linear sweep, audio amplification, brilliance, focus, beam centering and amplitude controls. Grouping of the controls on the simple control panel is such that rapid and simple adjustment is possible.

The entire unit is housed in a black crystal finished carrying case with etched aluminum front panel. The size of this unit is extremely small considering the 2" cathode ray tube and multiplicity of applications.

**NET PRICE, Complete, less tubes \$30.00**

### TYPICAL FEATURES ARE

Large Tube.....	2" screen
Linear sweep .....	15 to 25,000 cycles
Amplifier response .....	30 to 20,000 cycles
High sensitivity.....	.2 volts per inch (amplified)
All controls including beam centering on main panel	
Small size.....	6½ x 10 x 9½ inches overall
A.C. Power Supply.....	115 volts—60 cycles
Tubes used.....	885, 80, 6J7, 6K7, 24-XH
Low hum pickup.....	choke filtered plate supply

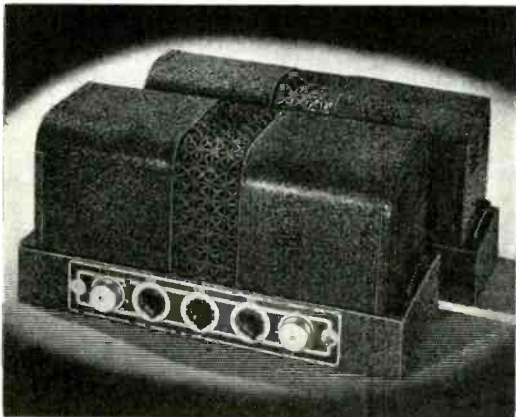

## BEAM POWER AMPLIFIERS

The UTC PAK hits are now acknowledged by the PA field as ideal Universal amplifiers. PAK power amplifier kits are available with outputs of 8, 15, 35, 55, 70, 110 and 250 watts. Stabilized feedback can be used in the PAK-1, PAK-2, PAK-3 and the PA output transformers have special feedback windings for this purpose. There is provision for mixing of two high impedance inputs. An etched panel providing a dual gain, two position mixer with gain links for high or low gain on each position and a VARITONE equalizer control are now standard equipment on these kits.

**PAK-1M** Self bias 35 watt output. Audio and power on separate chassis for rack or cabinet mounting. High impedance input 110 to 120 DB gain. Provision for immediate switchover to 95 DB gain with connections either for triode plate or 500-200 ohm input line. Output transformer impedances 500, 200, 16, 8, 5, 3, 1.5 ohms. Includes all components and accessories such as resistors, condensers, sockets, calibration plate, etched mixer panel, controls and accessories for a dual gain, two position high impedance mixer, chassis, dust covers with handles, hardware—except tubes—all fully mounted. List Price \$80.00. **Your Cost \$48.00**

**PAK-2M** Same chassis layout as PAK-1M but has output of 55 watts in fixed bias. List Price \$85.00. **Your Cost \$51.00**

**PAK-2XM** Same as PAK-2M but has VARIMATCH modulation output. Impedances on 3800 ohms plate to plate 380, 660, 2050, 3740, 4100, 7000, 7500, 8200, 12,000, 15,000, 16,400, 21,500, 29,800. On 4000 ohm plate to plate 237, 1300, 1750, 2700, 3270, 5200. List Price \$85.00. **Your Cost \$51.00**

Tubes required for PAK-1M and PAK-2M kits are 1-6J7, 3-6C5's, 2-6L6's, 1-83.

# UNITED TRANSFORMER CORP.

72 SPRING STREET

NEW YORK, N. Y.

EXPORT DIVISION: 100 VARICK STREET NEW YORK, N. Y. CABLES: "ARLAB"

# RECEIVER CASE HISTORIES

## American Bosch 360, 360-M

*Oscillation:* A distressing and costly service problem, which arose in one of these sets shortly after it was returned to the customer's home, was solved only after hours of diagnosis.

The receiver would intermittently break into oscillation. The first analysis was a defective by-pass condenser. After checking each individual condenser and resoldering all coil terminals, etc., we found the same trouble present.

The tube shields in this model are made of an aluminum composition and the bases are riveted to the chassis. After a period of time this metal becomes slightly corroded and a poor ground results. We found that this was the cause of all our troubles.

By drilling a small hole through the shield, base and chassis and using a self-threading screw the problem was solved.

*RCA Service Tip File*

## Arvin 7

*Production changes:* More recent production of this model auto radio receiver incorporated the following circuit changes:

A 200-ohm,  $\frac{1}{4}$ -watt resistor (R14) has been added in the power pack across the vibrator points.

The 100,000-ohm,  $\frac{1}{4}$ -watt resistor (R3) in the 6A7 No. 1 grid circuit has been changed to 50,000 ohm,  $\frac{1}{4}$  watt (R29).

A bayonet-base pilot light is used instead of the one with a screw base.

A 4-prong speaker-plug socket is used instead of the 3-prong socket.

An ammeter cable and fuse has been added.

It was found necessary to change the mechanical design somewhat to eliminate the possibility for motor noise pickup at the point in the receiver case where the local-distance plug and tone-control plug were attached. This change is made beginning with the sets from which the louvers were omitted.

## Arvin 17, 37

*Production changes:* More recent production of this model auto radio receiver incorporated the following circuit changes:

The 100,000-ohm,  $\frac{1}{4}$ -watt resistance (R3) in the 6A7 No. 1 grid circuit has been changed to 50,000 ohm,  $\frac{1}{4}$  watt (R29).

A 1,000-ohm,  $\frac{1}{4}$ -watt resistor (R24) has been inserted in the 6A7 No. 1 grid circuit.

The 400-ohm,  $\frac{1}{4}$ -watt resistor (R2) has been changed to 500 ohms,  $\frac{1}{4}$  watt (R10). Allowable variation in R2 is from 200 to 600 ohms. Allowable variation in R10 is from 400 to 600 ohms.

The 500-ohm,  $\frac{1}{4}$ -watt resistor (R10) in the cathode of the 78 tube has been changed to 1500 ohms,  $\frac{1}{4}$  watt (R28).

The condensers C12 and C26 have been combined into one dual unit with capacities of 0.006 mfd, 800 volt and 0.25 mfd 400 volt respectively. The lead with the red dot is the 0.006 unit.

A suppression choke (X5) has been added in the A lead. A 0.002-mfd mica condenser (C6) is used ahead of the choke.

A bayonet-base pilot light is used instead of the one with a screw base.

A 4-prong speaker-plug socket is used instead of the 3-prong socket.

An ammeter cable and fuse has been added.

It was found necessary to change the mechanical design somewhat to eliminate the possibility for motor noise pickup at the point in the receiver case where the local-distance plug and tone-control plug were attached. This change is made beginning with the sets from which the louvers were omitted.

## Arvin 27

*Production changes:* More recent production of this model auto radio receiver incorporated the following circuit changes:

The 100,000-ohm,  $\frac{1}{4}$ -watt resistor (R3) in the 6A7 No. 1 grid circuit has been changed to 50,000 ohm,  $\frac{1}{4}$  watt (R29).

A 1000-ohm,  $\frac{1}{4}$ -watt resistor (R24) has been inserted in the 6A7 No. 1 grid circuit.

The 400-ohm,  $\frac{1}{4}$ -watt resistor (R2) has been changed to 500 ohms,  $\frac{1}{4}$  watt (R10). Allowable variation in R2 is from 200 to 600 ohms. Allowable variation in R10 is from 400 to 600 ohms.

The 500-ohm,  $\frac{1}{4}$ -watt resistor (R10) in the cathode of the 78 tube has been changed to 1500 ohms,  $\frac{1}{4}$  watt (R28).

The condensers C12 and C26 have been combined into one dual unit with capacities of 0.006 mfd, 800 volt and 0.25 mfd, 400 volt, respectively. The lead with the red dot is the 0.006 unit.

A suppression choke (X5) has been added in the A lead. A 0.002-mfd mica

condenser (C6) is used ahead of the choke.

A bayonet-base pilot light is used instead of the one with a screw base.

A 4-prong speaker-plug socket is used instead of the 3-prong socket.

An ammeter cable and fuse has been added.

It was found necessary to change the mechanical design somewhat to eliminate the possibility for motor noise pickup at the point in the receiver case where the local-distance plug and tone-control plug were attached. This change is made beginning with the sets from which the louvers were omitted.

Beginning with serial No. D44011H the type 75 tube was replaced with a 6B7; triode connected.

The 0.003-mfd, 600-volt condenser (C25) was changed to 0.006 mfd, 600 volt (C26).

Beginning with serial No. E45219H, the triode connection on the 6B7 was changed to a pentode connection. The changes indicated below were therefore required.

A 0.25-mfd, 400-volt condenser (C12) was added as a screen by-pass from the screen of the 6B7 tube to ground. A 1-megohm,  $\frac{1}{4}$ -watt resistor (R9) was added as a screen dropping resistor from B plus to the screen of the 6B7 tube. The 0.006-mfd, 600-volt condenser (C26) was changed to 0.003 mfd, 600 volt (C25).

Under the conditions outlined above voltages on the 6B7 are approximately: Plate, 60; screen, 30 and cathode, 1.7 volts. A 1000-ohms-per-volt voltmeter was used for these measurements.

## Clarion AC-260, 25-260

*Open i-f transformers:* In cases where the i-f coils in these receivers are open they may be replaced with Majestic 460 type replacement coils.

For improved performance and sensitivity remove the noise-suppression feature by taking the delay bias off the second detector. To accomplish this connect the grid return of the second i-f transformer to a slightly positive point on the voltage divider . . . the a-f cathode tap will give good results.

*Francis C. Wolven*

## G.E. A-64, A-67

*No screen voltage:* This is usually caused by the 8,800-ohm section (R9) in the voltage divider. A 9,000-ohm resistor will make a satisfactory replacement.

*Francis C. Wolven*



*An extra measure of Quality*

**PRECISION**  
TEST EQUIPMENT  
*Standard of Accuracy*

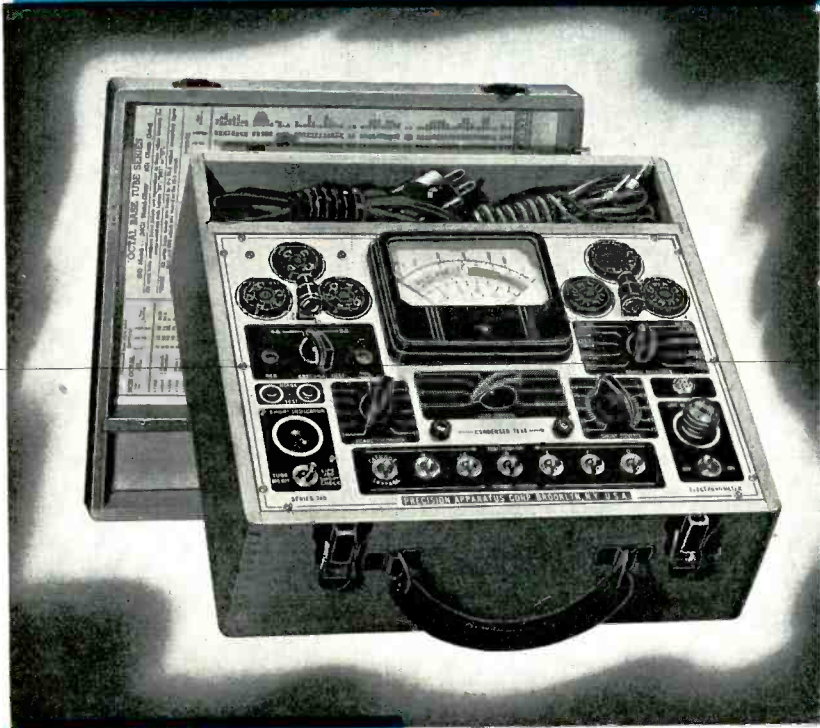

**"Precision" Series 840 L**  
AC-DC VOLT — OHM — DECIBEL —  
MILLIAMMETER, including a 2500-volt range.



Four AC and DC ranges at 1000 ohms per volt 0-2500  
Four D.C. current ranges 0-1000 MA.  
Three resistance ranges 0-10 megohms.  
Five decibel ranges from -10 to +63 DB.  
Large 4 1/2" square meter, wire wound shunts and matched multipliers both of 1% accuracy.  
Net Price **\$19.95**

**"Precision" Series 850 P**  
AC-DC VOLT — OHM — DECIBEL —  
MILLIAMMETER

Super resistive meter 20,000 ohms per volt.  
Six AC and DC voltage ranges 0-1500 volts.  
Six DC current ranges 0-500 MA.  
Three resistance ranges 0-40 megohms.  
Six decibel ranges from -12 to +59 DB.  
Large 3 1/2" square meter. Wire wound shunts 1% accuracy and 1% matched multipliers.  
Net Price **\$39.95**



*New*

## Electronometer No. 700

A MODERN TUBE TESTER COMBINED WITH ADEQUATE AC AND DC VOLTS—OHMS—DECIBEL AND MILLIAMMETER RANGES FOR OBTAINING POINT TO POINT ANALYSES.

A complete tube analyzer and set analyzer in one combination case compact size. Tests all types of octal and nonoctal tubes, including 6Z5—12A5—12Z5 and gas rectifiers OZ3 and OZ4. Electronic tube merit test strictly in accord with standardized R.M.A. specifications. Accurate, flexible and simple to operate. Individual multi-element tests. Load selection. Noise test pin jacks. For set analyses: Four AC and DC voltage ranges from 0 to 1000 volts. Three DC current ranges 0-250 MA. Three resistance ranges 0-10 megohms. Four DB ranges from -10 to +55 DB. Four output ranges 0-1000 volts. Paper condenser tests by neon method. Current leakage measurements of electrolytic condensers.

The 700 Electronometer is the most modern tube and set tester incorporating advanced engineering design. Wire wound shunts and matched multipliers of 1% accuracy are employed. A quality instrument at a popular price.

Available in Portable, Counter or Panel Type. **\$49.95**  
Net Price .....

WRITE FOR OUR NEW 1938 CATALOG

## Electronometer No. 500

The "Precision" series 500 Electronometer incorporates every advanced circuit feature for spotting defective tubes easily.

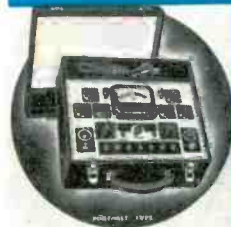

This modern instrument tests tubes in many rigid ways before it can pass as "GOOD." Though the price of the 500 is kept surprisingly low, practically all of the tube analyzing features was incorporated in the higher priced 700 Electronometer are included.  
Net Price **\$39.50**

## "Precision" Series 830

The Precision Series 830 multi-range meter can truly be called a "HANDITESTER." Though small in size, it incorporates eleven adequate ranges:

Five DC voltage ranges at 1000 ohms per volt 0 to 1000 volts.  
Four DC current ranges 0-250 MA.  
Two resistance ranges 0-300000 ohms.  
Incorporates a large 3" square meter and wire wound shunts and matched multipliers both of 1% accuracy.  
Net Price **\$10.95**



SEE THE NEW "PRECISION" LINE AT YOUR FAVORITE DISTRIBUTOR

**PRECISION** Apparatus Corporation

821 EAST NEW YORK AVENUE

BROOKLYN, NEW YORK

## RECEIVER CASE HISTORIES—continued

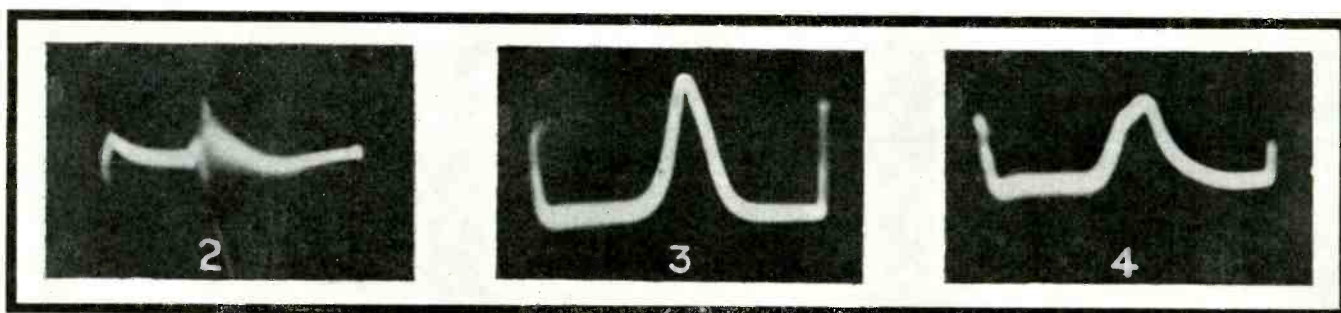

### G. E. K-66

*Distortion, with whistling as stations are tuned in:* In order to view the overall resonance curve the oscillograph and a frequency modulated oscillator were connected. The sweep frequency of the oscillograph was set to 60 and the vertical plates energized from the 60-cycle

No. 2 was the result. The pattern was flickering rapidly. This indication together with the audible symptoms, gave reason to suspect an open condenser.

On checking various condensers throughout the receiver the by-pass condenser on the cathode of the 58 r-f tube showed open. This condenser was

replaced and primary trimmers of the first i-f transformer and a recheck of all i-f adjustments produced oscillogram No. 6.

The test oscillator was connected across the receiver aerial and ground terminals and an overall curve viewed. An improvement over No. 3 was

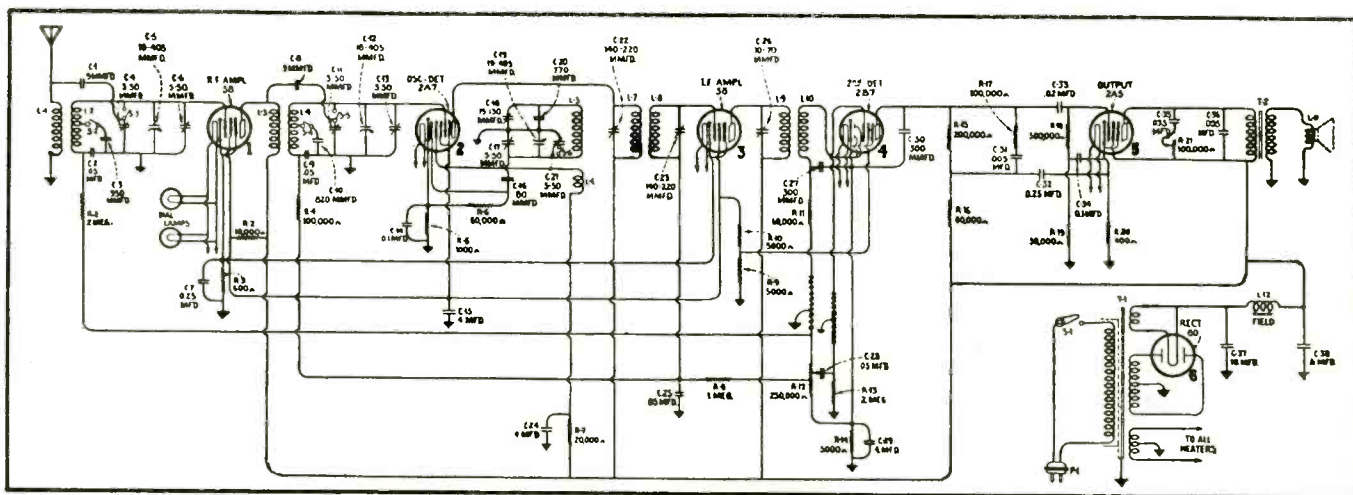

line supply. Adjustments were made until the curve shown in oscillogram No. 1 appeared.

The vertical plates of the oscillograph were connected from the tap on the receiver volume control (R-12 on the circuit diagram) to ground.

After placing the receiver in operation at 1400 kc, the test oscillator's output was placed across the aerial and ground terminals, and adjusted to secure a resonance curve. Oscillogram

replaced and oscillogram No. 3 appeared on the screen. Upon disconnecting the test oscillator the receiver operated in a fairly satisfactory manner.

With the test oscillator connected from the grid of the first-detector tube to ground and adjusted for the i-f (175 kc), oscillogram No. 4 resulted. Adjustment of the second i-f transformer primary trimmer improved this curve as shown by oscillogram No. 5.

Further adjustments of the second-

noted—showing more gain but about the same form.

Adjustments of the gang condenser trimmers, as well as the 600-kc trimmer were made in the order recommended by the manufacturer. Oscillogram No. 7 shows the final resonance curve obtained.

Howard J. Surbey

RCA 220, 222 (see G.E. K-66)

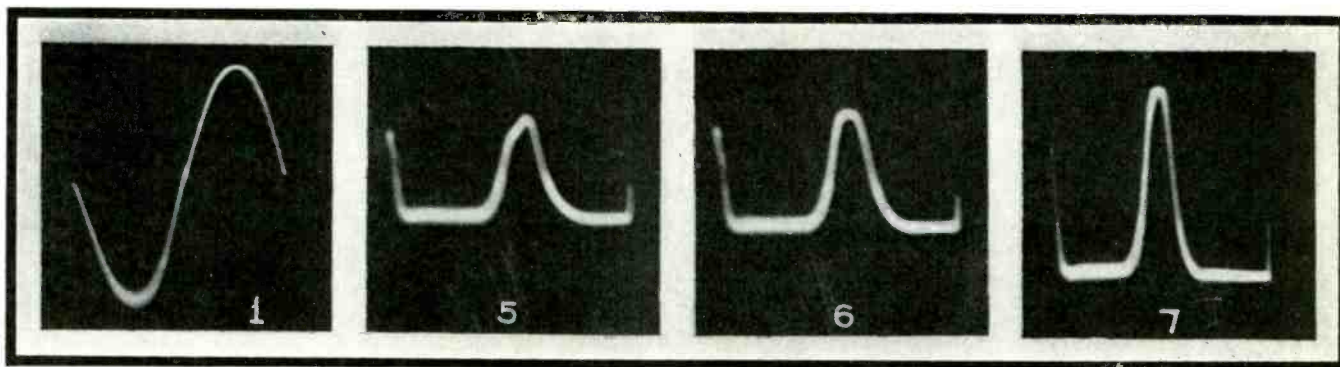

# Announcing THE NEW RIDER MANUAL



## Greatest ADVANCE SALE EVER GIVEN A RIDER MANUAL

Never has a Rider Manual had the enthusiastic reception which Volume VIII enjoys—even before its publication. Never have the advance orders been so great. This is the result of, **FIRST**: The tremendous and ever-increasing popularity of Rider Manuals. **SECOND**: Technicians' recognition of the thorough planning which has gone into this latest volume. For, this is **NOT** just another volume; **RATHER** it is so complete and so well laid out that it actually represents a great *forward stride toward the perfect Manual*.

To deliver the same degree of completeness which has characterized other Rider Manuals it was necessary to make Volume VIII over 1600 pages. Think of it, over 1600 pages chock-full of *dependable* information which will make the radio serviceman's work easier and more profitable—and at no increase over the price of Volume VII! And—in spite of today's rising costs of publishing, each copy of Volume VIII will be supplemented with an *additional*

invaluable section entitled "How It Works." This separate section meets the current need for special technical information on the modern radio set—*outside* as well as *within* the actual radio circuit. Motorized tuning—special automatic frequency circuits—these and other *mechanical* as well as electrical kinks and innovations of the modern set must be understood if the serviceman is to work on the better sets—which pay the bigger profits.

Of course, you need all the preceding volumes of Rider Manuals which cover receivers issued between 1920 and 1937. Check your Rider Manuals with the list below and order any missing volumes when you order your Volume VIII covering the 1937-1938 models.

Vol. VIII . \$10.00 ... 1937-38	Vol. IV . 7.50 ... 1933-34
Vol. VII . 10.00 ... 1936-37	Vol. III . 7.50 ... 1932-33
Vol. VI . 7.50 ... 1935-36	Vol. II . 7.50 ... 1931-32
Vol. V . 7.50 ... 1934-35	Vol. I . 7.50 ... 1920-31

### VOLUME VIII IN TWO SECTIONS

#### "HOW IT WORKS"

A new "plus" service for Rider Manual users. A separate section which goes with every copy of Volume VIII and describes the Technical Features, both *mechanical* and electrical, that servicemen must know to repair the modern set with Automatic Frequency Control systems and motorized tuning devices. You will find this section of great value.

#### MANUAL

Volume VIII contains more than 1600 pages of circuit information on receivers produced by over a hundred different manufacturers. Auto-radio receivers, home receivers, inter-communicating systems, public address amplifiers, electronic musical instruments, etc., are all covered. As to the completeness of the information and the models represented, we suggest your comparing it with any other service now offered. Compare the replacement parts list, the alignment instructions. Compare it for convenience in use, or anything else which would have a bearing on its value to you.

#### INDEX

Check this easy to follow Index. See the tremendous number of sets and models covered. Note, too, that this Index proves what we say—"that information on every set is instantly found." A time saver and a convenience for you. This Index of about 118 pages covers all eight Rider Manuals and goes with every copy of Volume VIII.

**JOHN F. RIDER, Publisher, 1440 BROADWAY, NEW YORK**

**PLACE YOUR ORDER TODAY**

**VOLUME VIII**  
*Rider*  
**MANUAL**  
OUT NOVEMBER 10<sup>TH</sup>

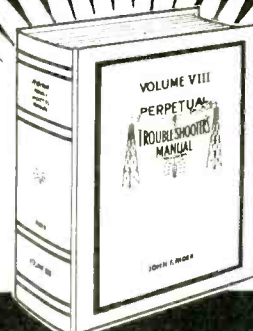

**OVER 1600 PAGES**

PLUS A SUPPLEMENTARY BOOK

# TEST EQUIPMENT..

## CATHODE-RAY OSCILLOSCOPE SWEEP CIRCUITS

By GLENN H. BROWNING and FRANCIS J. GAFFNEY

FUNDAMENTALLY A CATHODE-RAY oscilloscope is a voltmeter, the point of which (the electron beam) has practically no inertia and as a consequence can follow high-frequency variations in voltage. So that the variations in voltage can be plotted on the screen against time (i. e., a curve can be drawn on the screen showing the variations in voltage as time progresses), a horizontal movement of the electron beam is necessary. It is many times desirable to have the movement of the electron beam horizontally across the screen, linear with respect to time, that is, the beam moves equal fractions of an inch for each fraction of a second. In order to obtain such a movement, what is termed a saw-tooth voltage must be applied to the horizontal plates of the cathode-ray oscilloscope, for this saw-tooth wave allows the beam to deflect

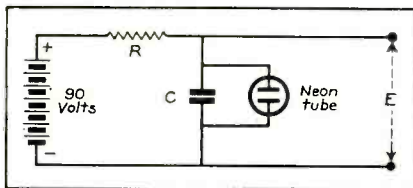

Fig. 1. Simple sawtooth oscillator circuit.

across the 'scope horizontally with time and then return to its original position practically instantaneously.

### THE SAW-TOOTH OSCILLATOR

If a condenser is charged from a voltage source with a resistance connected in series with the condenser, a definite time is taken to charge the condenser to the voltage of the source. The time taken to charge the condenser will depend upon the value of the resistance and the size of the condenser, the charging time is proportional to the product of the resistance and the capacitance. The voltage across the condenser under the above conditions will rise substantially proportional to time during the first part of the charging process. If such a voltage were applied to the horizontal deflecting plates of the cathode ray oscilloscope the cathode ray beam would be deflected proportional to time. However, so that the beam will return to its original position and again traverse the screen proportional to time,

a method of discharging the condenser must be employed.

The simplest method of discharging the condenser would be to use a type of gaseous discharge tube (such as a neon tube) which exhibits practically infinite resistance until a voltage of a given amount is reached, whereupon the gas in the tube ionizes and the resistance of the tube falls to a relatively low value. The circuit of one of the simplest types of saw-tooth oscillators is shown in Fig. 1. The voltage across the condenser will vary as shown in Fig. 2. The circuit consists merely of a battery with a resistance and condenser in series. A neon tube is connected across the condenser. When the voltage across the condenser rises to approximately 50 volts, the neon tube ionizes causing a current to flow which in turn discharges the condenser. The period of such an arrangement does not in general give an absolutely constant frequency; consequently, more satisfactory means have been developed for use with cathode-ray circuits.

The 855 tube is commonly used for producing saw-tooth deflecting voltages of the proper frequency. A schematic diagram of the 855 appears like that of an ordinary triode having a grid, plate, and cathode. The actual operation, however, is materially different. If a negative bias is placed on the grid of the tube and a voltage is impressed between the cathode and the plate, practically no current will flow in the plate circuit until the voltage is raised to a definite value, at which point the tube will ionize and current will continue to flow in the plate circuit regardless of voltage variations impressed on the grid circuit. The grid circuit, then, might be said to have no control over the plate current after the tube has ionized.

However, the grid circuit does have a function, for the amount of the bias on the grid determines to some extent the voltage necessary in the plate circuit to ionize the tube. This function of the grid is very valuable in the case of the cathode-ray oscilloscope for it allows some control of the period with which the beam will sweep horizontally across the screen, and by putting a portion of the signal on the grid, the voltage variations of the signal which it is desired to examine may be made to keep in step with the horizontal sweep.

It should be appreciated that in order to obtain a curve on the screen of a cathode-ray oscilloscope, it is necessary for the actual voltage variations to be

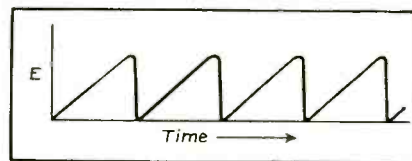

Fig. 2. Voltage variation across the condenser of Fig. 1.

repeated over and over again in exactly the same position on the screen. If they are not, the curve, instead of remaining stationary, will appear to drift across the screen, or if its motion is very rapid, will appear to be a confusion of lines.

For the study of some voltage variations, a sine, or what is commonly known as a harmonic sweep circuit, is more advantageous than the saw-tooth or linear sweep. However, both types of sweep circuits may be used advantageously in obtaining a resonance curve on the cathode-ray oscilloscope.

### AN UNMODULATED SIGNAL

If an unmodulated signal is fed into a radio receiver which is tuned to the frequency of the signal, no sound will be heard in the loudspeaker, for though the r-f and i-f amplifier (if the receiver is a superheterodyne) amplify this unmodulated signal and the detector tube rectifies the resultant voltage, the rectified signal consists only of a series of r-f pulses of equal amplitude smoothed out somewhat by what might be termed a smoothing condenser. As there is no amplitude variation at audio frequencies, the a-f amplifier has impressed on it substantially a d-c volt-

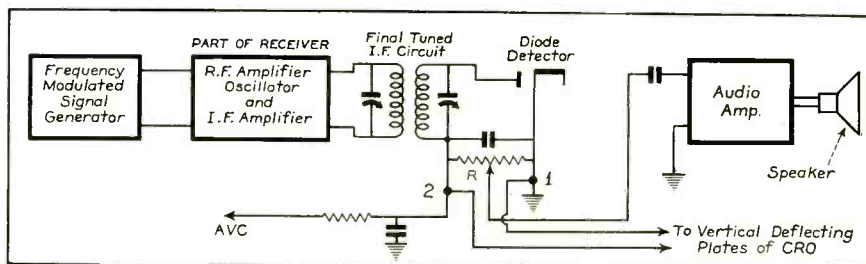
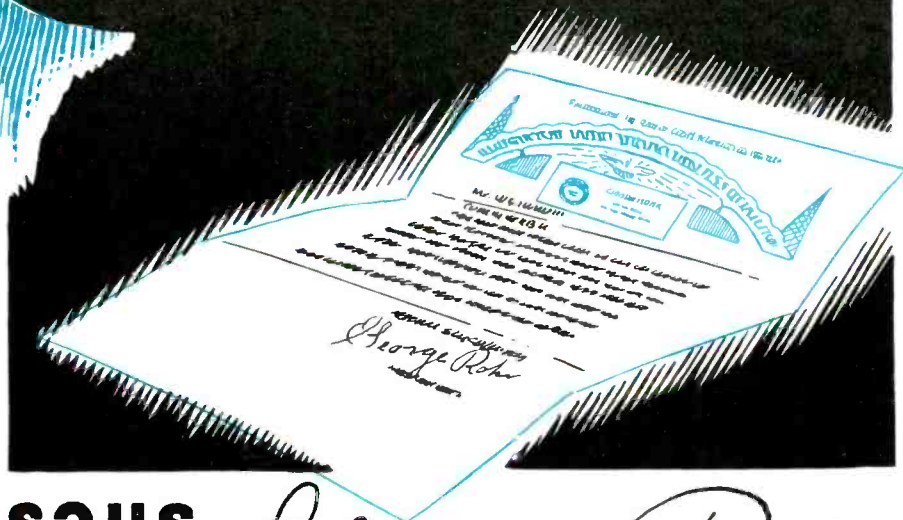

Fig. 3. The setup for connection of the cathode-ray oscilloscope.



*"Centralab is the difference between a satisfied customer and a dissatisfied one."*



**says**

*George Rohr.*

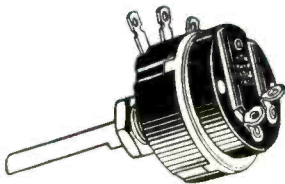

**THE SMOOTH  
CENTRALAB CONTROL**

offers maximum resistor length for case diameter . . . close uniformity between resistors . . . accurate tapers . . . uniform current distribution . . . better power dissipation and longer life.

● Mr. George Rohr of 67 Thorne St., Jersey City, N. J., hands us the above bouquet along with some other very flattering statements in a recent letter! Thanks Mr. Rohr . . . thousands of other radiomen feel the same way about Centralab.

In fact, set manufacturers and experimenters as well as service men have for years shown their preference for Centralab . . . and they have said it with generous orders. We suggest, you too, specify CENTRALAB.

CENTRALAB—Division of Globe-Union Inc., Milwaukee, Wisc.

# Centralab

Canterbury Rd., Kilbourn N.W., England

118 Ave Ledru-Rollin, Paris

age. Such a system is shown in Fig. 3 where a signal generator is connected to a superheterodyne receiver. The r-f amplifier, the oscillator, and a part of the i-f amplifier are depicted in block form while the final tuned circuit in the i-f amplifier is shown schematically. This tuned circuit is connected to a diode detecting system. The rectified voltage is fed into an audio amplifier shown in block form which in turn is connected to the receiver's loudspeaker.

Fig. 4 shows the r-f signal generated by the signal generator, while Fig. 5 shows the rectified series of pulses which are generated across the diode resistor R. The condenser (C) tends to average these pulses so that between points 1 and 2 an average d-c voltage is developed. If this d-c voltage was applied to the vertical plates of the cathode-ray oscilloscope with no amplifier intervening between the deflecting plates and the impressed voltage, the electron beam would take a position on the screen depending upon this voltage E. If the frequency of the signal generator were changed, the voltage E would vary because of the selectivity of the receiver. When the frequency of the signal generator is increased or decreased 10 or 15 kilocycles from the frequency to which the set is tuned, the voltage E would be comparatively small. Consequently, if the frequency of the signal generator is varied over a range so that it increases and decreases from the frequency to which the set is tuned, the spot on the screen of the cathode-ray oscilloscope can be made to move up and down as the frequency of the signal generator is varied. If, at the same time, the electron beam was moved across the screen in a horizontal direction in step with the change in frequency of the signal generator, a resonance or response curve of the receiver would be depicted on the screen.

FREQUENCY MODULATION

An obvious method of obtaining a frequency modulated (varying frequency) signal would be to vary the

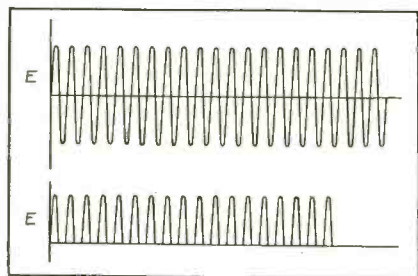

Figs. 4 & 5. The r-f signal generated by the signal generator and the rectified series of pulses appearing across the diode load resistor.

tuning condenser of the oscillator. As the required variation in frequency is over a comparatively small range, only a small variation in the main tuning condenser would be necessary. Therefore it is advantageous to use a small condenser with a single rotating plate connected in parallel with the main oscillator tuning condenser. This single variable plate may be made to rotate with respect to a fixed plate by means of a synchronous motor. A frequency variation with time will result. In order to have a sweep circuit in step with the frequency variation of the signal generator devices may be placed on the rotating shaft of the synchronous motor so that a condenser is charged through a resistance and then dis-

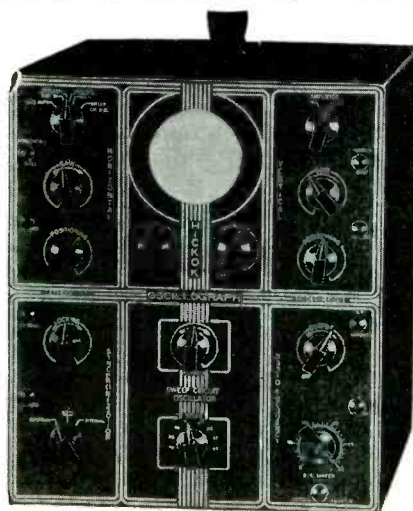

The Hickok cathode-ray oscilloscope is provided with a fixed r-f signal generator which is frequency modulated.

charged at the appropriate point. Thus, a saw-tooth voltage variation is obtained similar to that shown in Fig. 2. Obviously the relationship between the frequency variation and the voltage produced by the saw-toothed oscillator will have a fixed relationship between them as they are mechanically coupled together.

Later investigations have made it possible to vary the frequency of the signal generator by electronic means. Through the use of the 60-cycle a-c power supply as a timing means, in conjunction with a vacuum tube, frequency modulation of an oscillator in a signal generator is obtained. In automatic frequency control of superheterodyne circuits a tube is employed which acts as a variable inductance. (Readers not entirely familiar with the methods employed and circuits utilized for a tube to act as an inductance or capacitance in conjunction with an oscillator circuit are referred to Hubert R. Shaw's

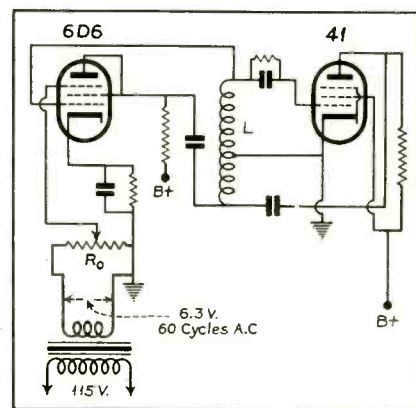

Fig. 6. Frequency modulation by electronic means.

article on Automatic Frequency Control, October, 1936, issue of SERVICE, page 471.)

The circuit shown in Fig. 6 illustrates one method of using a 6D6 tube for tuning an oscillatory circuit. The oscillatory circuit consists of a 41 tube with a grid leak and grid condenser in series with the control grid. The tank circuit is composed of the inductance L and the dynamic capacitance of the 6D6. In the circuit shown the amount of dynamic capacitance of the 6D6 across the inductance L depends upon the voltage impressed on the suppressor grid. The frequency generated by the 41 oscillator tube depends upon the capacitance in the tank circuit (across the inductance L). If an a-c voltage is impressed on the suppressor grid of the 6D6, the frequency produced by the 41 oscillator tube will vary over the cycle of the impressed voltage, it will be highest at the positive peak of the cycle and lowest at the negative peak. Thus, if the frequency of the oscillator is 600 kilocycles, with no voltage impressed on the suppressor grid, frequencies above and below this value would be generated by impressing an alternating voltage on the suppressor grid. The magnitude of this frequency change will depend upon the magnitude of the voltage impressed on the suppressor. Therefore, the amount of frequency variation may be changed by means of the potentiometer R<sub>0</sub>.

The voltage impressed on the suppressor is a 60 cycle voltage since it is obtained by means of a transformer from the power supply. The oscillator frequency is thus made to vary about a center frequency, going through a complete cycle of variation in each sixtieth of a second. Under these conditions the oscillator is said to be frequency modulated. The amplitude of the oscillator voltage will remain sub-

# Going Up!!

## THE PAID CIRCULATION OF

SERVICE has been consistently going up—and this issue is the largest in the magazine's history. Nearly 15,000 copies will be distributed—and will be read by over 30,000 radio men—the largest proved jobber-dealer-servicing coverage in the field.

SERVICE, from cover to cover, is full of essential, reliable, and exclusive technical advice, of definite assistance to all servicemen, parts dealers, and distributors, including the public address field.

SERVICE publishes more material on General Data, New Circuits, Case Histories, Public Address, Automobile Radio, Test Equipment, and New Products than any other trade publication serving the radio industry.

## ADVERTISING PUBLISHED IN

SERVICE shows a steady trend upward—more manufacturers of parts and accessories use it as the backbone of their trade paper campaign than any other publication. SERVICE advertising, month after month, produces the highest ratio of returns at the lowest cost per dollar invested.

If your product can be sold and marketed through radio distributors, dealers, servicing organizations and independent servicemen, advertising in SERVICE will thoroughly blanket the field.

*Further particulars regarding SERVICE circulation, market coverage and advertising rates will be submitted without obligation.*

# SERVICE

19 EAST FORTY-SEVENTH ST.,  
NEW YORK, N. Y.

## Subscribe now save \$1.00

The Group Subscription Plan\* for SERVICE enables a group of service men, dealers or jobbers to subscribe at one-half the usual yearly rate.

The regular subscription rate is \$2.00 a year. In groups of 4 or more, the subscription rate is \$1.00 a year. (In foreign countries, \$2.00.)

### USE THIS CONVENIENT FORM

Name .....

Address .....

City-State .....

Classification .....

Employed by .....

Name .....

Address .....

City-State .....

Classification .....

Employed by .....

Name .....

Address .....

City-State .....

Classification .....

Employed by .....

Name .....

Address .....

City-State .....

Classification .....

Employed by .....

\*Business or professional classifications are required to complete our records. Each subscriber should write one of the following classifications in spaces indicated. Use separate sheet of paper for additional names.

INDEPENDENT SERVICE MAN—DEALER  
SERVICE MAN—DEALER—DISTRIBUTOR

State your classification if not listed.

Bryan Davis Publishing Co., Inc.  
19 East 47th Street New York, N. Y.

## TEST EQUIPMENT—continued

stantially constant while the frequency varies.

### THE RESONANCE CURVE

The cathode-ray oscilloscope is provided with two sets of deflecting plates. One set of plates is used to deflect the electron beam vertically and are referred to as the vertical deflecting plates. Voltages applied to the other set of plates will cause the spot to move back and forth horizontally across the screen. These plates are referred to as horizontal deflecting plates. When no voltages are applied to either the horizontal or vertical deflecting plates the spot should appear in the center of the screen. Centering controls are provided which apply small d-c voltages to the two sets of plates so that the neutral position of the spot may be adjusted. Means are provided within the 'scope, as previously explained, for producing voltages of the proper wave forms to sweep the spot back and forth across the screen with either a harmonic or a linear motion.

The variations in frequency of the frequency-modulated signal generator must have the correct phase relationship to the horizontal deflecting voltage in order to obtain a single resonance curve on the screen of the cathode-ray oscilloscope.

The horizontal deflecting voltage serves merely to deflect the spot in a horizontal straight line back and forth across the screen. Because of the persistence of vision, a straight horizontal line would be seen if this voltage was applied to the horizontal deflecting

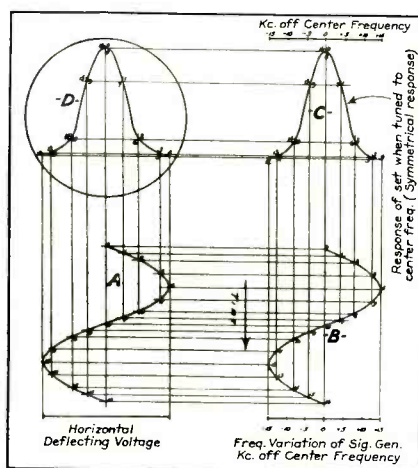

Fig. 7. If a voltage is applied to the vertical deflecting plates which is exactly in step with the voltage applied to the horizontal deflecting plates, a pattern will be traced on the screen.

plates while no voltage was applied to the vertical deflecting plates.

If a voltage is applied to the vertical deflecting plates which is exactly in step with the voltage applied to the horizontal deflecting plates, a pattern will be traced on the screen. Such a voltage may be obtained across the resistor R of Fig. 3 if the frequency applied to the antenna terminals of the set is made to vary as shown by curve B of Fig. 7. Curve B has exactly the same frequency (goes through a complete cycle in the same time) as does curve A. Curve C represents the voltages which will appear across the resistor R under these conditions.

It can be shown that a single curve will be produced on the screen of the oscilloscope if the response of the set is symmetrical about the center frequency of the signal generator. This

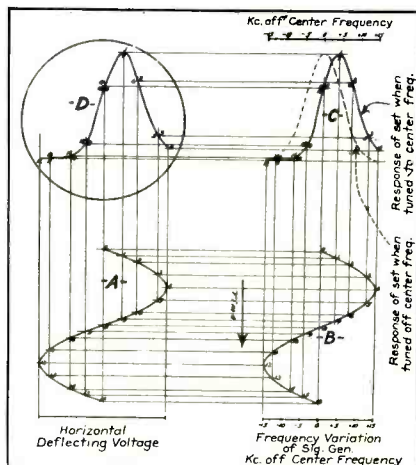

Fig. 8. The conditions which prevail when the set is detuned slightly from the center frequency of the frequency modulated signal generator.

curve will trace itself twice for each complete cycle of horizontal deflecting voltage.

Resonance curves may thus be depicted on the cathode-ray oscilloscope by impressing a frequency-modulated signal voltage on the input terminals of the receiver and impressing the voltage generated in the diode-detector circuit on the vertical deflecting plates of the cathode-ray oscilloscope, as shown in Fig. 3. The horizontal plates of the cathode-ray oscilloscope are connected to either a harmonic or a saw-tooth sweep circuit which moves the beam horizontally across the screen.

The conditions which prevail when the set is detuned slightly from the center frequency of the frequency modulated signal generator are illustrated

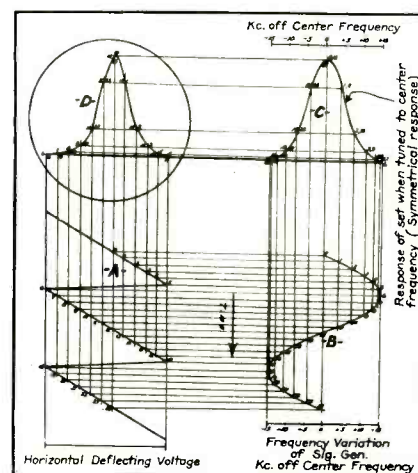

Fig. 9. The manner in which a curve is plotted on the screen of the oscilloscope when the horizontal deflecting voltage is in the form of a saw-tooth wave.

by the curves of Fig. 8. The dotted response curve shown in this figure is exactly similar to curve C of Fig. 7. If the set is tuned to a frequency slightly higher than the center frequency of the signal generator, the response curve which would be obtained during a complete cycle is represented by the solid curve C of Fig. 8. This can be seen by referring to curve B. At point O of this curve the signal generator is producing its center frequency. The set, however, is tuned to a higher frequency than this center frequency so that the response (the voltage developed across R, Fig. 3) is somewhat below the maximum value.

It has been explained that when a sinusoidal voltage is applied to the horizontal deflecting plates the motion of the spot across the screen does not vary linearly with time. For this reason the picture appearing on the screen of the 'scope when the set is detuned from the center frequency of the signal generator will not be symmetrical in shape even though the response curve of the set is symmetrical about the point of maximum response. Further detuning the set in the direction of higher frequency is equivalent to shifting the solid curve C farther to the right; thus point 4 may be made to rise higher and higher as the set becomes farther and farther detuned from the center frequency. It is thus possible to roll the curve appearing on the screen back and forth about its center position if the set is tuned to frequencies higher and lower respectively than the center frequency of the signal generator. In any case, however, only one curve appears on the screen of the oscilloscope if the response



curve of the set is symmetrical about the point of maximum response.

Fig. 9 shows the manner in which a curve is plotted on the screen of the oscilloscope when the horizontal deflecting voltage is in the form of a saw-tooth wave. If a saw-tooth deflecting voltage is applied to the horizontal plates and no voltage is applied to the vertical deflecting plates a straight horizontal line will appear on the screen of the oscilloscope, but the mode of motion of the spot as it traverses the screen will differ from the case of a sinusoidal sweep voltage. Points 6-18 of curve A in Fig. 9 represent one complete cycle of the saw-tooth wave. At point 6, zero voltage is applied to the horizontal deflecting plates. If the horizontal centering control is correctly adjusted the spot may be made to take up a position at the extreme left-hand side of the screen at this instant of time. The spot now moves across the screen with uniform motion (covers equal distances in equal increments of time) until point 17 is reached. It then travels back across the screen from right to left in the small increment of time represented by the distance between the horizontal lines drawn through points 17 and 18. The cycle is then repeated over and over again. Curve A of Fig. 9 shows what might be termed a perfectly formed saw-tooth wave. In actual practice the wave form obtained will have rounded corners and the lines will be curved slightly.

In order to obtain a resonance curve on the screen of the 'scope when the frequency of the signal generator varies sinusoidally with time, it is necessary that the frequency of the saw-tooth deflecting voltage be twice that of the

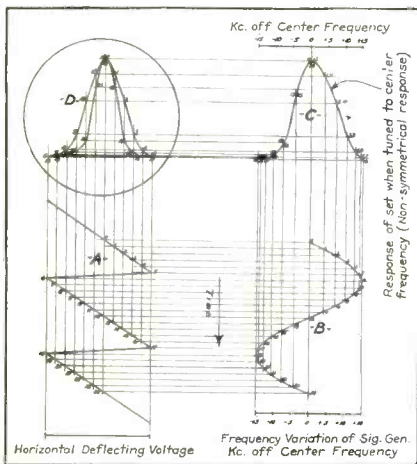

Fig. 10. If the response of the set is not symmetrical about the center frequency produced by the signal generator, two curves will appear on the cathode-ray screen.



## TACO ANTENNA SYSTEMS and make many Extra Dollars



Type 400—Inexpensive. All-Wave. Self-selecting. Kit includes transfer unit, set transformer, 2—30-ft. coils antenna wire, 50-ft. transmission cable, 1 screw-eye, 2 nail knobs, 2 insulators. \$3.75 list.



Type 510—Popular-priced. All-Wave. Self-selecting. Including antenna transformer, set transformer, 2—30-ft. coils antenna wire, 60-ft. transmission cable, 1 screw-eye, 2 nail knobs, 2 insulators. \$4.50 list.



Type 210—Truly de luxe kit. Superlative performance. Includes antenna transformer, set transformer, 2—30-ft. coils antenna wire, 75-ft. transmission cable, 1 screw-eye, 2 nail knobs, 2 insulators. \$6.75 list.

TAKE any set, anywhere, any owner. Equip it with a TACO Antenna System. Presto! Tremendous difference in performance: maximum signal strength; minimum background noise; ideal results on broadcast and shortwaves.

All because TACO Antenna Systems (licensed under A.A.K. Inc. Patents) represent the most advanced engineering design. Latest low-loss-winding transformers. Factory assembled, wired, soldered. Complete kit. Ready to string up. Several models provide for every need and every pocketbook.

There's also the TACO Master Antenna System for apartment house, hotel, hospital, and home with many radio set outlets. Ideal for store demonstration system. Simple. Efficient. New manual tells you how to sell, estimate and install.

### Write for NEW DATA

on the complete TACO line. Meanwhile, ask your jobber to show you these fast-selling, money-making items.



## TECHNICAL APPLIANCE CORP.

Pioneers in Noiseless Antenna Systems

17 EAST 16TH STREET : : : NEW YORK CITY

In CANADA: 414 BAY STREET, TORONTO  
LICENSED UNDER AMY, ACEVES & KING INC. PATENTS

mode of variation of the frequency of the signal generator. Curve B represents the manner in which the frequency of the signal generator varies about its center frequency as time progresses. Curve C represents the response of the set (voltage across the resistor R in Fig. 3) during a complete cycle of frequency variation.

In curve C it has been assumed that the response of the set is symmetrical about the center frequency; that is, equal frequency departures either side of the center frequency produce equal decreases in the output voltage. Thus both halves of curve C are identical in shape so that if the figure were folded about the vertical line drawn through point O, every point of the left-hand side of the curve would fall on the corresponding point of the right-hand side of the curve.

A complete curve is traced on the screen of the oscilloscope while the frequency variation of the signal generator has completed but one-half of its complete cycle. That is, in one complete cycle of frequency variation of the signal generator, the curve D which appears on the screen of the oscilloscope has been traced twice by the moving spot. Only a single curve will be produced on the screen of the 'scope if both halves of curve C are identical, or, in other words, if the set response is symmetrical about the center frequency. Notice that the curve appearing on the screen has a slightly sharper peak than that produced when a sinusoidal sweep voltage was impressed on the horizontal deflecting plates and all of the other conditions remained the same. Of course, the sharpness of the curve depends somewhat on the amplitude of the horizontal sweep voltage, but in general the curve obtained with a harmonic sweep is a more faithful reproduction of the actual response curve than that of Fig. 9.

If the response of the set is not symmetrical about the center frequency produced by the signal generator, two curves will appear on the screen of the 'scope as shown in Fig. 10. In this figure, curve C shows the response of the set as the input frequency departs from the frequency to which the set is tuned. The response of the set falls off much more rapidly as the frequency is decreased away from the center frequency than it does when the frequency is increased.

We have seen that if the set is detuned from the center frequency of the signal generator, when a harmonic sweep voltage is used in obtaining a

resonance curve, only a portion of the complete curve will appear on the screen of the oscilloscope. On the other hand, when the saw-tooth voltage is applied to the horizontal deflecting plates, while the set is detuned from the center frequency, two resonance curves appear on the screen of the oscilloscope and these curves are displaced from each other, an amount depending upon the amount that the set is detuned. This condition is shown in Fig. 11. The dotted curve C of Fig. 11 shows the response which the set would have if tuned to the center frequency. The solid curve which is used in obtaining curve D shows the effect of tuning the set to a slightly higher frequency than the center frequency of the signal generator. By pro-

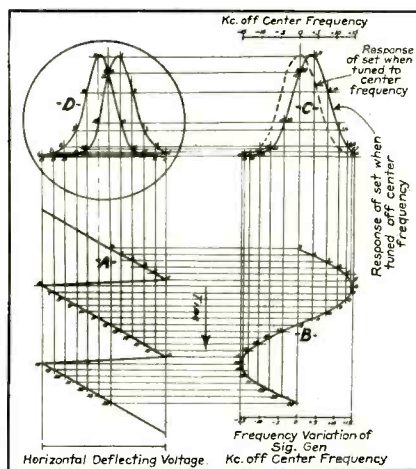

Fig. 11. Two resonance curves appear on the screen of the oscilloscope and these curves are displaced from each other by an amount depending upon the amount that the set is detuned.

jecting lines from the various points the manner in which curve D is traced by the moving spot is made apparent. By following the consecutive points of curve D, it can be seen that the two loops form a single closed figure. As the set is tuned to higher and higher frequencies above the center frequency, the section of curve D represented by line 5-6 will rise higher and higher on the screen, so that the right-hand loop of the curve tends to collapse. At the same time, the left-hand loop of curve D, represented by points 6-17, will become more and more distorted until, when the set is tuned to a frequency sufficiently high or low, the voltage across the resistor R, Fig. 3, will be practically zero and both traces disappear.

#### CONCLUSIONS

From the foregoing analysis it can be seen that the use of the saw-tooth

deflecting voltage provides a good means for tuning the set to the center frequency of the signal generator. The saw-tooth voltage also provides a means of determining whether or not the response of the set is symmetrical about this center frequency. The sinusoidal sweep voltage, however, provides a more faithful reproduction of the actual output curve of the receiver when the receiver is correctly tuned. This is of particular importance in the adjustment of band-pass i-f transformers which are used to obtain a flat top resonance curve. We have seen that the saw-tooth deflecting voltage produces a resonance curve which is somewhat sharper than that actually associated with the set. For this reason, if this type of deflecting voltage is employed in adjusting the band-pass circuit, an adjustment may be made which is too broad.

#### Clough-Bregle III Frequency Modulator

THE CATHODE-RAY OSCILLOGRAPH together with a frequency modulated oscillator has been for some time now the recognized method of examining radio receivers for alignment and shape of resonance curve; the shape of this curve is one of the primary considerations in performance of better grade receivers with respect to fidelity.

#### FLAT-TOPPED I-F IN LOWER PRICED RECEIVERS

Many of the less expensive receivers introduced this season will require alignment by this method because they employ flat-topped response curves in the i-f amplifier in order to accommodate automatic dialing of stations, without employing automatic frequency control. The necessity of using such circuits in these designs is made more apparent by the diagrams in Fig. 1.

Fig. 1a shows the selectivity curve of a radio receiver in which the intermediate transformers are coupled below critical coupling. It will be noted that when the signal is mistuned by 3 kc, the carrier signal on the second detector is reduced to 60 percent of what it would be with perfect tuning. At the same time, some of the sideband energy is of greater amplitude than that of the carrier itself. The result is that the second detector views this as an over-modulated signal, and the poor quality of reception that results is a matter of common experience to everyone who has mistuned a selective receiver having this type of selectivity curve.

Designers of receivers employing

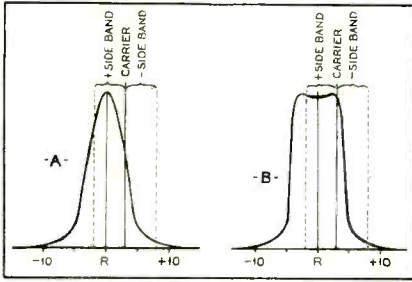

Fig. 1. Typical resonance curves showing the effect of detuning 3 kc.

automatic tuning without afc recognize that this type of mistuning may result from mechanical discrepancies in setting up the stations on the dial mechanism, as well as from subsequent drift of the receiver oscillator due to tube aging, heat, and humidity, and have met these possible situations by overcoup-

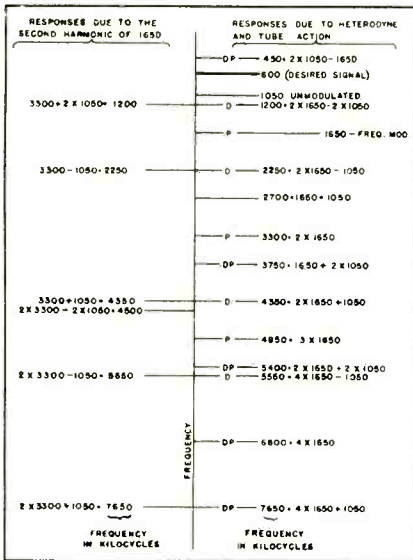

Fig. 3. The various responses that may be encountered in a beat-type signal generator with a fixed-frequency oscillator generating 1650 kc.

ling the i-f transformers so as to produce a curve of the type of Fig. 1b. In this curve, note that the mistuning of the receiver by 3 kc suppresses the side band on one side, but that the side band on the other side does *not* rise to a greater amplitude than the amplitude of the carrier. Thus the detector does not operate on an over-modulated

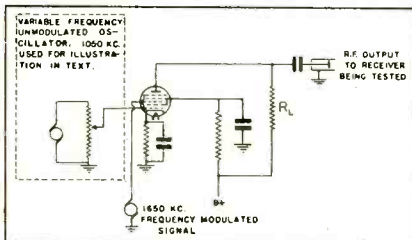

Fig. 2. General principle employed in beat-type signal generators.



# WEBSTER CHICAGO Develops Another BIG "SOUND" MONEY MAKER

## SELECTIVE PAGING SYSTEM WITH TALK-BACK FEATURES



Model FC-7R  
Size 9" x 7 3/4" x 6"

... At UNBELIEVABLY LOW PRICES

• 7 Watts of Power

• Talk to Any Station or All Stations

• Talk Back From Remote Position Thru Speaker

Again Webster-Chicago blazes the trail of Sound Progress... opening a vast new market for the Sound Dealer. Previously a paging or call system consisted of an amplifier, microphone and the required number of speaker stations. Now for smaller factories, hotels, auto stations, departmental installations in larger factories—in fact, for any paging system covering up to 20 to 3,000 sq. ft. of floor space a new low priced design having in addition a selective switch so that the operator can talk to any one station only or can throw the switch so as to talk to all stations at once. *Talk-Back* from positions of 20 to 40 feet can be done from each station. And in doing this, equipment has been greatly simplified; just one small master unit encloses microphone and necessary speech amplification equipment and one specially designed speaker for each station. (Transmitter shown will handle up to 5 stations.)



Model DA-8  
Double End  
Speaker

Example of Low Prices  
Model FC-7R... List... \$70  
Model DA-8... List... \$20

Model FC-7R will accommodate up to 5 speakers, will handle 20 to 30,000 sq. ft. of floor space at average noise level.

# WEBSTER-CHICAGO

... The Complete line of Public Address Systems, Sound Equipment and Accessories ... Popular-Priced Leaders in the Sound Field For Over 12 Years!

★ THE FASTEST MOVING LINE OF SOUND EQUIPMENT

WEBSTER-CHICAGO  
Section S-5, 5622 Bloomingdale Ave., Chicago, Ill.

Please send me more information on:

- Model FC-7R;
- Model DA-8 Speaker;
- Send Catalog.

Name .....

Address .....

City .....

State .....

signal, and although the reception has the nature of single side band reception, the quality of the received signal is perfectly satisfactory.

Many Service Men already recognize the difficulty of tuning overcoupled i-f transformers with an oscillator and output meter. The effect of over-coupling is to make the primary and secondary trimmers of the transformer interlock in such a way that a definite symmetrical alignment is a tedious operation. Cathode-ray alignment will soon be a necessity, even on the less expensive receivers where service costs must be kept consistent with the original price of the receiver. A frequency modulated oscillator which would be as nearly foolproof as possible and would eliminate all guess-work in its application is, therefore, a real service necessity.

DIFFICULTIES IN DESIGN

In designing a frequency modulator, modulating a single wave to a given channel width, and then heterodyning this signal to a mean frequency for testing purposes, was found desirable. The large majority of frequency modulators now offered employ this principle in one form or another. In some instances, the necessary heterodyning frequency is supplied by a variable oscillator within a single instrument, while in others provision is made for the introduction of this heterodyne frequency from an independent unmodulated test oscillator. Irrespective of which mechanical arrangement is used, the basic method is subject to some defects, which not only affect the speed of the servic-

ing or testing operation, but the accuracy of the portrayed selectivity curve as well.

Fig. 2 illustrates the general principle which has been employed in practically all generators to date to accomplish the heterodyning of the frequency modulated signal to the desired test frequency. For illustration, a 6L7 tube is shown as the frequency mixer, and on one of its control grids is impressed a frequency modulated wave of 1650 kc mean frequency, while the other grid is driven by the unmodulated signal from a self-contained or external oscillator. If an output signal of 600 kc is desired, the last-mentioned signal would be set to 1050 kc so that the resultant signal would be the difference frequency (or  $1650 - 1050 = 600$  kc). Equipment designers have recognized that the output will also contain the sum frequency ( $1650 + 1050 = 2700$  kc), but with the ordinary system there are numerous other frequencies produced which are confusing when rapid service work is being attempted. The seriousness of this confusion is given graphically in Fig. 3, which shows that in addition to the 600 kc desired test signal, fourteen other responses may also be present. If a higher frequency signal is desired, the relative frequencies of these undesired responses will shift frequency in a complex manner and are always a confusion to rapid and certain service testing.

Each one of these undesired responses can be ascribed to one or more of the following causes:

(1) The introduction into the frequency changer of harmonics of the

frequency modulated signal, in this case 3300, 4950, etc. (The effects of the second harmonic of 1650 kc, combining with the heterodyne frequency of 1050 kc, are shown at the left of the base line in Fig. 3).

(2) Rectification effects due to derivatives of the rectifier of a higher order than the second. (Marked D above the base line of Fig. 3.)

(3) The firing through of the frequency modulated wave at 1650 kc due to the amplifying action of the tube. This has a practical effect in all frequency modulators because of the overloading effects which may be produced in the receiver due to the high amplitude of this signal. In some receivers this signal may re-combine with other frequencies to produce still other spurious responses within the receiver itself, not shown on the chart of Fig. 3.

All of these effects are more aggravated when attempting to secure high output voltages from the modulator, as this requires driving the heterodyne tube to higher amplitudes.

SOLUTIONS

As a solution to the first fault a filter was designed for the 1650 kc frequency modulator which would attenuate the second and higher harmonics and leave a perfectly pure 1650 kc signal to impress on the heterodyne tubes. Since this signal is frequency modulated it was impossible to use resonant circuits for filtering. This would have caused every receiver tested to include the resonance curve of the filter employed. For this reason, a band-pass design was decided on which is shown in Fig. 4. Fig. 4a is the filter as calculated, with two half-sections of low pass and one section M derived, or anti-resonant section, designed to discriminate sharply against the second harmonic of the oscillator at 3300 kc. In actual construction it was found that these same sections could be duplicated at a moderate cost, using the arrangement shown in Fig. (4b). The 64.5 microhenry shunt element is replaced by the mutual inductance between the two coils of (4b). The general nature of the attenuation characteristics of this filter is also shown in Fig. 4c as having a high attenuation to the second harmonic, which is naturally the strongest, and good attenuation of the higher harmonics. With the filter as constructed it was impossible to detect any harmonic output from the oscillator using a sensitive radio receiver for this test.

Obviously, it is of no avail to care-

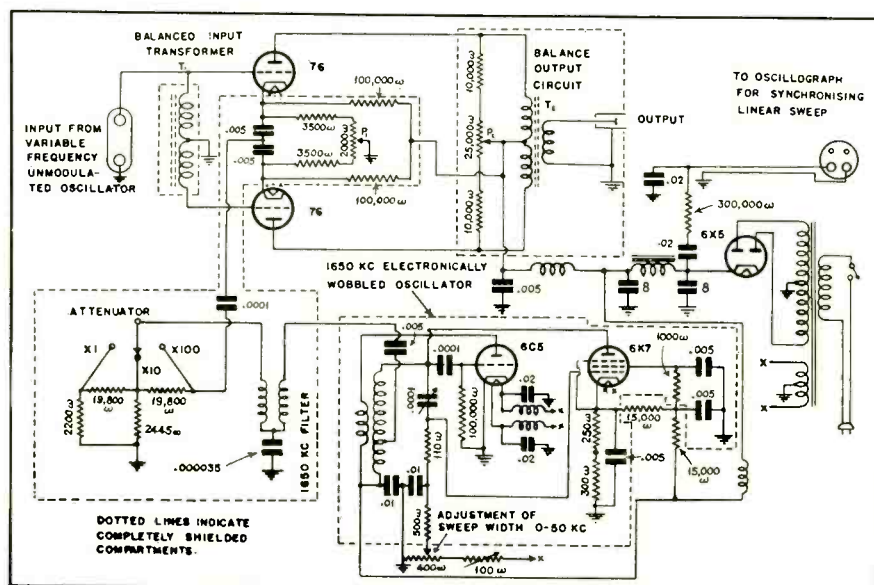

Fig. 7. Clough-Bregle III frequency modulator circuit.

TEST EQUIPMENT—continued

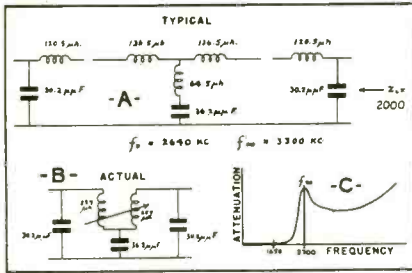

Fig. 4. Typical and actual circuits of the band-pass filter together with a curve showing the attenuation produced.

fully filter the output of the oscillator without carefully shielding the oscillator circuits from the heterodyne tubes and other equipment. This detail has been carried out, as can be seen in the photograph of Fig. 5.

The second fault is due to the plate-current-grid-voltage curve of the tube being more involved than can be ex-



Fig. 5. The complete frequency-modulated oscillator showing the shielding.

pressed by a simple square-law relationship. A square-law relationship between grid voltage and plate current is all that is required for the tube to act as a heterodyne mixer and give the sum or difference of the mixed frequencies in the output. Any higher derivatives result in spurious output frequencies, like those marked D in Fig. 3. For this reason, type 76 tubes were chosen as frequency changers, and were biased to an operating point chosen to be the square-law for the largest applied signals; that is, where the plate current is closely proportional to the square of the grid voltage. This largely sup-

(Continued on page 576)

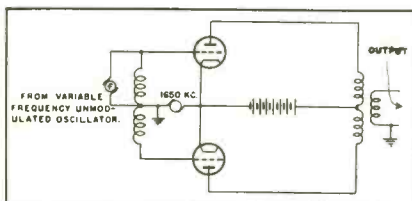

Fig. 6. The push-pull frequency changer circuit.

# ALL IN ONE



**TYPE BH  
INTERCOMMU-PAGING  
SYSTEM**

A PAGING AND INTERCOMMUNICATING SYSTEM

Write for

## BULLETIN NO. 111

## GIVING COMPLETE DETAILS

# OPERADIO

**MANUFACTURING COMPANY**

**PUBLIC ADDRESS EQUIPMENT HEADQUARTERS**

**ST. CHARLES • ILLINOIS**

**EXPORT DIVISION: 145 WEST 45<sup>th</sup> STREET NEW YORK CITY**

# ASSOCIATION NEWS . . .

## NEW YORK TRADE SHOW

Registration for the New York Parts Trade Show will start at 10:00 A.M., Friday, October 1, at Commerce Hall.

The Show will officially open at 2:00 P.M., Friday, October 1.

The Show hours for the three days will be as follows: Friday, October 1—2:00 P.M. to 10:00 P.M.; Saturday, October 2—2:00 P.M. to 10:00 P.M.; Sunday, October 3—12:00 Noon to 6:00 P.M.

Technical lectures will start at 8:00 P.M., on Friday, October 1. The sessions on Friday night, Saturday night and Sunday afternoon and night will be under the auspices of the service associations of the New York area. The Saturday afternoon session will be conducted by the amateur organizations, and will be devoted to amateur activities.

Radio parts jobbers have been receiving advance copies of the "Trade Show Directory" distributed by Radio Parts Manufacturers National Trade Show, and containing the list of companies that had filed their contracts for space.

This advance distribution of the "Trade Show Directory" will permit the jobbers and others planning to attend the show to know who will be in charge of booths and demonstration rooms; and the pages allotted to each of the exhibitors will provide space to make notes of things they want to discuss or investigate.

## RADIO SERVICE MEN OF AMERICA, INC.

Radio Service Men of America, Inc., is the name designated for the new national Service Men's association organized in Chicago.

Basically, it is anticipated that Radio Service Men of America, Inc., will function as a central source for gathering and disseminating information on developments in the radio field, that it will serve as a central liaison between the manufacturer and individual local Service Men's organizations and that it will act as central headquarters for improving and promoting the welfare of the Service Man.

Joe Marty, with the active assistance of the Sales Managers Clubs, both eastern and western divisions, and a number of interested manufacturers has been busy contacting various service organizations in the east and Middle West. Mr. Marty states that every group he has visited and explained the purpose of the Radio Service Men of America, Inc., have assured him it meets with their approval and have promised 100% cooperation. Mr. Marty feels that every local service organization will appreciate the advantages of this central association and will want to become affiliated.

Mr. Marty further states that numerous prominent men of all branches of the radio industry have expressed themselves as being in full sympathy with this movement and have promised their support and cooperation with this new plan.

Local organizations or individual Service Men in cities where there is no organization are cordially invited to write for more details to Joe Marty, Monadnock Block, Room 1533, Chicago.

## SALES MANAGERS CLUB

Arthur A. Berard, President of the Sales Managers Club, Eastern Group, has called a joint meeting of the Eastern and Western Sales Managers Clubs at 10:30 A.M., Friday, October 1, at the Victoria Hotel.

It is the opinion of the committee that the holding of this meeting ahead of the opening of the Trade Show will enable the manufacturers to devote their entire attention to the trade without interruption during the entire show period.

## NATIONAL ASS'N OF PARTS DISTRIBUTORS

Leslie Rucker, President of the National Association of Radio Parts Distributors, has called a meeting of the Regional Delegates at 10:30 A.M., Friday, October 1, at the Victoria Hotel.

A membership meeting of the Association has been scheduled for 10:30 A.M., Sunday, October 3, also at the Victoria Hotel.

## CLEVELAND CHAPTER IRSM

One of our August meetings featured the inner workings of the new RCA push-button tuning. J. W. Wagner of RCA and Jimmie (watch out for your fenders) Hauser, an old time RCA service engineer dating back to the time of the Radiola Grand, covered the subject ably.

Not to be outdone, Philco came to bat with none other than Bill Akers (there's a man for you) with the low down on the new Philco line. He explained the "Concentric" dial and discussed discriminator alignment.

Having recovered from these technical talks we immediately started another headache by holding our Fourth Annual Picnic at Hutters Grove. All attending professed to have had an exceptionally good time. There were plenty of eats, refreshments, games and prizes. The Arcturus ball team took over the TungSol gang, 12 to 5.

Our new technical paper chairman, Maynard Elliot, has outlined a rather extensive fall and winter program. We are scheduled to start off, on September 15, with Floyd Wenger, representing the Triplet Electrical Instrument Co.

We extend a most cordial welcome to every one interested to attend any or all of our meetings. Just drop in on the first Monday and third Wednesday of each month at the Hotel Cleveland.

There will be our usual Trade Show some time in November...

L. VANGUNTEN, *Official Observer*

## RCA SERVICE MEETINGS

Inauguration of a "Technaural" series of service lecture-meetings to be conducted under joint sponsorship with wholesale distributors in more than 100 cities, was announced by E. C. Cahill, Service Manager of the RCA Manufacturing Co.

The first of the new service lecture-meetings will be held in New York City on October 1, to coincide with the annual convention of the Institute of Radio Service Men and the Trade Show. All of the

other meetings will take place during the month of November. Announcements of exact dates and places will be made by RCA wholesalers in each city, who will also issue the invitations to the radio service engineers.

The "Technaural" lectures will include discussions of recent technical developments and trends in the field of commercial sound applications. Special technical material will also be presented on the alignment of band spread receivers using the "Overseas Dial" for improved short-wave reception. A number of interesting demonstrations have been arranged to illustrate the principles of volume expansions and compression and inverse feedback in sound amplifiers.

## RADIO OLDTIMERS CLUB

A Radio Oldtimers Club is in process of formation with the avowed intention of having two events a year in Los Angeles. One will be the annual beer binge and barbeque. The other will be a gala program of pioneer entertainers and will be on the air.

Those who have been in radio for ten to fifteen years will belong. There will be no dues. There will even be enough offices so everybody can have a title.

Prime movers and instigators are Walter Biddick, present radio station representative, and E. K. Barnes, recording engineer. Both were with KHJ in its early days of 1923-'25.

Permanent secretary, nobody else wanting the job, will be Dr. Ralph L. Power, radio counsellor, with offices in the Van Nuys Bldg., Los Angeles. He resigned from a USC professorship in 1922 to become studio manager and announcer for *The Examiner's* radio station and finished up by being radio editor for most all the other local sheets over a period of ten years before opening his own office.

## PR SMA

Snatches from the Philadelphia Radio Service Men's August 15 outing:

Jesse Ehly kept feeding the fishes. No, he wasn't seasick, it was rolls he gave them in the lake.

Bob Thorn in his snappy red suit could have been the sailor's delight, if there had been any sailors!

The first prize, a \$49.75 auto radio, was won by Dave Krantz, but he wasn't there to collect. (Neither was the radio!)

Thanks to Philco, Raymond Rosen, and Radio Electric for donations of prizes.

Bob Thorn tried to sign up everybody in the park. He even called on Stan Meyers for a membership button.

Charley Wrigley must be reading late at night, he had a headache early in the day.

Quinn of Philco has a rather cute little wife.

John Tighe and a friend did very nicely with his fiancée and another Lankenau nurse.

Others who took a merry part in the activities were: Charley Brophy, Langan, Subolonski, and Mrs. Poole and children.

Roy Lowe came late but not too late, and didn't he look just grand all in white.

*From PR SMA News*

*Get ALL These Features!*

SPECIFY

**Utah**

VIBRATORS

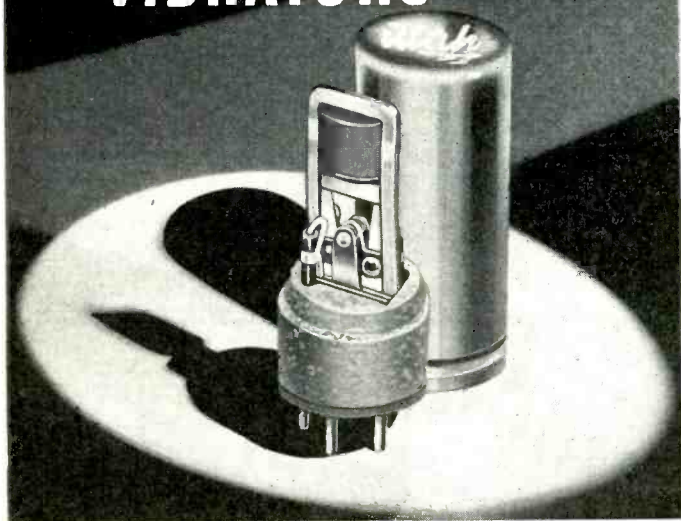

- ✓ Exclusive sulphur-free molded rubber liner eliminates chemical corrosion on metal parts—particularly contact points.
- ✓ Rubber liner consists of two parts beveled to make a closer fit and suppress noise.
- ✓ Lower liner molded to fit in order to hold mechanism in position in center of vibrator shield, supporting leads and preventing undue vibrations.
- ✓ Exclusive flat frame provides simpler construction and more permanently rigid mounting for contact arms.
- ✓ Short leads are clamped and held steady against vibrator frame eliminating vibration and prevent breakage of leads. Reduces radio interference usually resulting from long leads.
- ✓ Tapered reed prevents undue strain and equalizes bending, providing longer reed life.
- ✓ Special design provides right degree of wiping action to keep pure tungsten contact points clean, but not enough to cause excessive wear.
- ✓ Highest grade mica insulators.
- ✓ Stack is held to frame with two screws making a mounting with less likelihood of misalignment.

**UTAH RADIO PRODUCTS CO.**

CHICAGO, U. S. A.

TORONTO BUENOS AIRES  
ONTARIO, CANADA (UCOA RADIO PRODUCTS CO.)

"16 YEARS OF LEADERSHIP"

**NOW READY**

THE NEW SYLVANIA  
CHARACTERISTICS SHEET!



Let It Solve Your Tube  
Characteristics Problems!

No radio service man should be without this complete tube characteristics chart. It contains the very latest tube characteristics information available—information that can be found nowhere else.

**COVERS MORE THAN 180 TYPES**

The Sylvania Tube Characteristics Sheet suits service men to a "T." It covers more than 180 types . . . tube types are numerically listed . . . characteristics are tabulated . . . all characteristics and base diagrams are arranged on one side of the paper—instantly available. Also contains full information on the latest types of glass, metal and "G" tubes. Folds to pocket size—swell for your service kit!

Best of all, it's FREE! Just fill in and tear out the coupon below, and send it to us. You'll get your Characteristics Sheet . . . pronto!

**SYLVANIA**  
SET-TESTED RADIO TUBES

S-97

HYGRADE SYLVANIA CORPORATION, Emporium, Pa.

Please send me a FREE copy of the latest Sylvania Tube Characteristics Sheet.

Name .....

Address .....

City ..... State .....

Dealer  Service Man

Amateur  Experimenter

LIST OF EXHIBITORS

National Trade Show — Commerce Hall, New York City — October 1 to 3, 1937

Exhibitor	Booth No.	Exhibitor	Booth No.	Exhibitor	Booth No.
Aerovox Corporation	20	Hannarlund Mfg. Co., Inc.	615	Readrite Meter Works	105
Alpha Wire Corporation	11	Hickok Elec. Instrument Co.	402	Recoton Corporation	—
American Microphone Co., Inc.	204-A	Hygrade Sylvania Corp.	209-210	SERVICE	411
American Phenolic Corp.	203	International Resistance Co.	9	Shure Brothers	8
Amperite Company	301	J. F. D. Mfg. Company	408	Simpson Electric Co.	12
Arcturus Radio Tube Co.	403	Jefferson Electric Co.	15	Solar Mfg. Corp.	207
Atlas Resistor Co.	715	Kester Solder Co.	66	Sprague Products Co.	302
Belden Mfg. Company	211-212	Kracuter & Co., Inc.	404	Standard Transformer Corp.	10
David Bogen Co., Inc.	14	Lenz Electric Mfg. Co.	305	Supreme Instruments Corp.	24-25
The Brush Development Co.	64	The Lifetime Corp.	5	Technical Appliance Corp.	—
BRYAN DAVIS PUBLISHING COMPANY, INC.	411	Magnavox Co.	309	Thordarson Elec. Mfg. Co.	—
Bud Radio, Inc.	23	P. R. Mallory & Co., Inc.	102-103	Tobe Deutschmann Corp.	6-7
Allen D. Cardwell Mfg. Corp.	307	Meissner Mfg. Company	310	Triplett Elec. Instr. Co.	205
Centralab	22	The Muter Company	314	Tung-Sol Lamp Works, Inc.	27-28
Clarostat Mfg. Co., Inc.	16	National Company, Inc.	311	United Catalog Publishers, Inc.	306
The Clough-Brengle Co.	312-313	National Union Radio Corp. of N.Y.	17-18	United Sound Products, Inc.	412
COMMUNICATIONS	411	Ohmite Mfg. Company	201	United Transformer Corp.	601-602
Continental-Diamond Fibre Co.	21	Operadio Mfg. Company	68	Utah Radio Products Co.	67
Cornell-Dubilier Elec. Corp.	716	Oxford-Tartak Radio Corp.	401	Vulcan Electric Co.	—
Coto-Coil Company, Inc.	206	Pioneer Gen-E-Motor Corp.	106	Ward Leonard Elec. Co.	414
Crowe Name Plate & Mfg. Co.	303-304	Precision Apparatus Corp.	616	The Ward Products Corp.	104
Drake Electric Works, Inc.	101	RCA Mfg. Co., Inc.	701-702	The Webster Co.	208
Hugh H. Eby, Inc.	63	The Radiart Co.	410	Weston Elec. Inst. Corp.	405-406
Electro Acoustic Prod. Co.	308	Radio City Prod. Co., Inc.	213	Wincharger Corp.	—
The General Industries Co.	515	The Radiotechnic Lab.	65	Wirt Company	13
		Raytheon Production Corp.	407		

SHOW PROGRAM

The New York metropolitan groups of Service Men have issued a most cordial invitation to all Service Men to attend the technical sessions to be held in conjunction with the New York Parts Trade Show. The program, provided by Carl Rauber, Secretary of the Program Committee, is complete and comprehensive, covering subjects that are of importance to service men at the present time:

**Friday, October 1**

2:00 P.M.-8:00 P.M.

Registration and viewing of exhibits.

8:00 P.M.

Technical Sessions open.

"New RCA Amplifiers and Speakers," by M. M. Brisbin, RCA Mfg. Co., Inc., Camden, N. J.

9:00 P.M.

"Present and Future Education of the Service Engineer," by John F. Rider, New York City.

10:00 P.M.

"New RCA Test Equipment and Methods of Use," by H. J. Schrader, RCA Mfg. Co., Camden, N. J.

11:00 P.M.

Exhibits close.

**Saturday, October 2**

The Saturday afternoon sessions will be conducted by the amateur organizations.

2:00 P.M.

Exhibits open.

8:00 P.M.

"Transformers and Their Uses," by Robert Kenyon, Kenyon Transformer Co., New York City.

9:00 P.M.

"Application of Amplifiers to Musical Instruments," by Charles Conners, Hygrade-Sylvania Corp., Emporium, Pa.

10:00 P.M.

"Technical Features of Touch Tuning," by Earl Reihman, General Electric Co., Bridgeport, Conn.

11:00 P.M.

Exhibits close.

**Sunday, October 3**

2:00 P.M.

Exhibits open.

2:00 P.M.

"Errors on Sweep Circuits and Their Correction," by Bruce Burlingame, Supreme Instruments Corp., Greenwood, Miss.

3:00 P.M.

"Manufacturing Parts and Paging Systems and Amplifiers," by Percy Collison and John J. Wolfe, Stromberg-Carlson Telephone and Mfg. Co., Rochester, N. Y.

3:30 P.M.

"Receiver Troubles and Their Cures," by Robert G. Herzog, Editor, SERVICE Magazine, New York City.

8:00 P.M.

"Modern Test Equipment," by Kendall Clough, Clough-Brengle Co., Chicago.

9:00 P.M.

"Selling Sound," by Earl Sandwick, Electro-Acoustic Products Co., Fort Wayne, Ind.

9:30 P.M.

"Servicing Automatic Tuning," by Charles Gerhard, Philco Radio and Television Corp., Philadelphia, Pa.

11:00 P.M.

Show closes.



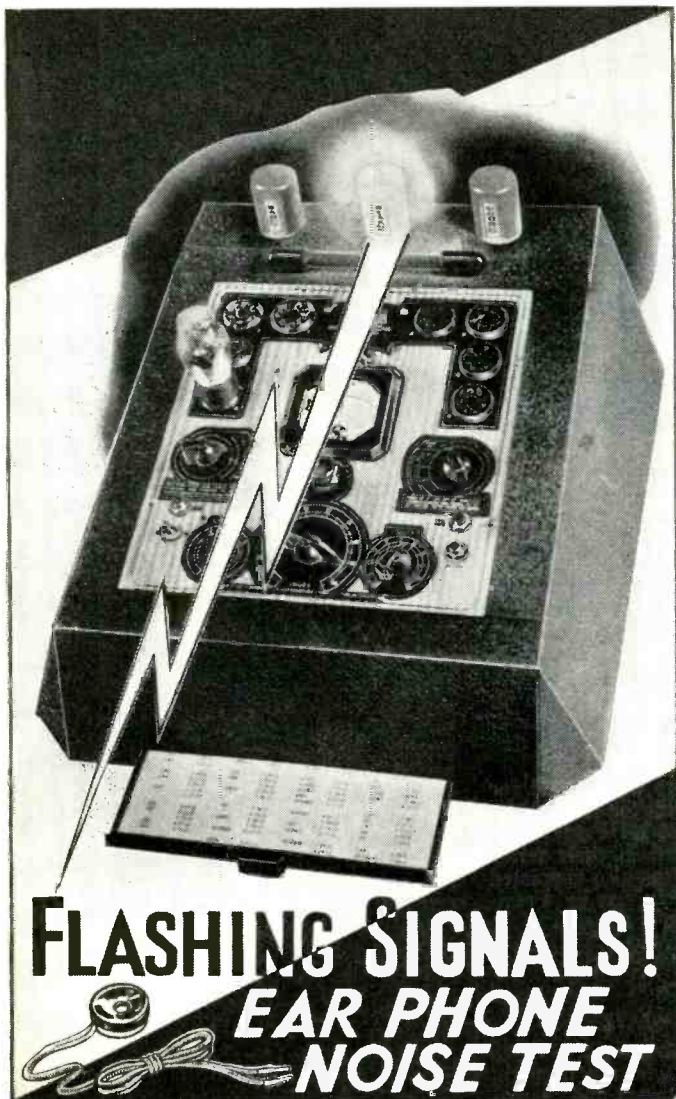

## FLASHING SIGNALS! EAR PHONE NOISE TEST

**F**LASHES a brilliant red signal for a bad tube—amber signal for a weak tube—and a green signal for a good tube.

Signals are translucent ivory until you press the button. The customer listens to the noise test through a permanently attached earphone.

Shorted or leaky tubes cause intense glow, spreading lengthwise in long glass cylinder. Makes test of grid control. Fast and simple to operate.

Crystalline metal case—lustrous chrome panel—steel slide for chart.

Net price to dealers, \$54.00.

[ On demonstration at your jobber's.  
On display, Booth 65, National Trade Show! ]

### THE RADIOTECHNIC LABORATORY

1330 Sherman Avenue  
EVANSTON, ILL.

SEE  
YOUR  
JOBBER

A Complete Line of  
Tube Test Equipment

**RADIOTECHNIC**

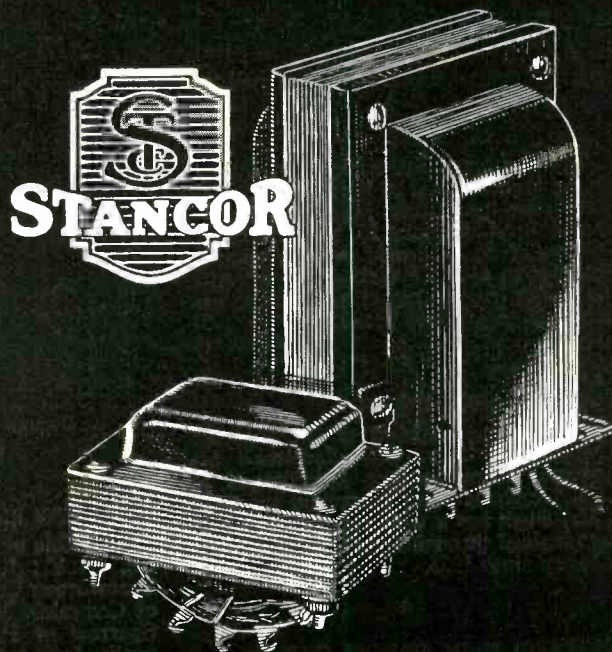

*There's Nothing Finer Than*

## STANCOR TRANSFORMERS

**S**TANCOR has disproved the old bro-mide, "One make is as good as another" . . . for (in a few short years) Stancor has attained a reputation in the industry for **SUPERB QUALITY** . . . achieved through careful engineering, the closest kind of inspection and special manufacturing equipment, much of which was designed in our own plant for exclusive Stancor processes.

*If it's a* **STANCOR** *it's Good*

**STANDARD  
TRANSFORMER  
CORPORATION**

850 BLACKHAWK STREET, CHICAGO

# HIGHLIGHTS . . .

## RADIOJAC CIRCULAR

A new circular illustrating and describing Radiojac, an aid to busy Service Men, is available from Cooks Mfg. Co., 274 Mile Square Road, Yonkers, N. Y. This device consists of 36 hardwood rods, ranging in length from 1½ to 8 inches. By selecting the proper lengths, any chassis can be supported in an inverted position.

## STANCOR APPOINTMENT

J. J. Kahn, President of the Standard Transformer Corp., 850 Blackhawk St., Chicago, announces the appointment of C. L. Pugh as sales promotion manager.

Mr. Pugh has a wide experience in selling obtained through actual practice in the industry since 1923.

## GHIRARDI TWIN GADGET DISPLAY

Radio & Technical Publishing Co., Dept. 18, 45 Astor place, New York City, publishers of Ghirardi's new Twin Pocket Trouble Shooter Gadgets, announce a compact combination counter and wall display stand, which holds six of the Home-Radio Gadgets and six Auto-Radio Gadgets.

The stand is designed so that each set of Gadgets remains in full view, even after some have been sold and removed. These stands are being supplied to those dealers ordering 25 or more Gadgets.

## BELDEN APPOINTMENT

The appointment of Alfred Crossley as special consulting engineer to its engineering staff is announced by the Belden Manufacturing Co., 4689 W. Van Buren St., Chicago.

Mr. Crossley has been active in the radio field for over 25 years. He is known for his past activities as chief engineer of a number of prominent radio manufacturers. He has had extensive service as radio officer in the Navy and has received a number of patents on radio devices.

## ALLIED RADIO

Allied Radio Corporation of Chicago announces the expansion of its facilities immediately to include an additional 10,000 square feet of space in its building at 833 West Jackson Boulevard. This marks the second space increase in the last two years and gives Allied more than 50,000 square feet to house its complete organization.

Allied also announces the release of a new 1938 Catalog. It contains 164 pages and includes more than 12,000 exact duplicate and replacement parts; 61 new Knight radios; amateur receivers, transmitters and transceivers; build-your-own-kits; public address systems; test instruments; books, tools, etc. Unique features of this book are its convenient arrangements of the parts portions and the separate amateurs, public address, test equipment and radio set sections. A free copy may be obtained by writing to Allied Radio Corporation, 833 West Jackson Boulevard, Chicago, Illinois



Dumont 3-inch Oscillographs in production.

## FOUR NEW RMA DIRECTORS

S. I. Cole of the Aerovox Corp., Brooklyn, N. Y.; J. J. Kahn of the Standard Transformer Corp., Chicago; H. E. Osmun of Centralab, Milwaukee, Wis., and R. F. Sparrow of P. R. Mallory Co., Indianapolis, Ind., were chosen by the parts division of the Radio Manufacturers Association as the four new directors from that division.

The four new directors are elected for one-year terms ending with the next RMA Convention in 1938, since all Parts Division Directors are limited in their terms to one year. Mr. Cole was also appointed on the Membership Committee by President Muter.

## SUPREME ISSUES CERTIFICATES

The Supreme Instruments Corp. believes that those Service Men who are properly equipped should be recognized and recommended by the radio industry. As a result this company is conducting an inquiry among its users as to just which Service Men can measure up to a completely equipped shop test. Those who pass the requirements are presented—absolutely free—with an 8½x11 inch certificate which states that the party receiving the certificate possesses and operates certain test equipment in the legitimate pursuit of his radio servicing profession, the ownership and operation of which entitles this Service Man to be recognized as an adequately equipped member of his profession.

The certificate continues, "Therefore, be it declared, that in the opinion of the officials and engineers of the Supreme Instruments Corp., City of Greenwood, County of Leflore, State of Mississippi, U.S.A., he has the necessary technical instruments whereby he may properly perform the duties attending the service and visual alignment of radio receivers and like equipment."

## MAGNAVOX BULLETIN

The Magnavox Company, Fort Wayne, Indiana, have recently issued three interesting bulletins. One bulletin gives data on Magnavox wet electrolytic capacitors, a second is devoted to their Model 305 15-inch dynamic speaker, while the third gives standard specifications of the Magnavox line of dynamic speakers. The bulletins may be obtained free on request.

## SOLAR REPRESENTATIVE

The Solar Manufacturing Corporation announces the appointment of Leo C. McCarthy as representative in the Chicago metropolitan area, for jobbing accounts. Leroy Eschner will continue as senior representative for Northern Illinois manufacturing accounts, while Irvin Aaron, of Milwaukee, will visit Northern Illinois jobbers, outside of Metropolitan Chicago.

The Bayonne, New Jersey, plant of Solar is now in active production of wet and dry electrolytic condensers. The additional production facilities thus made available will almost double the Solar Electrolytic capacity.

## TUBE VOLUME SHOWS INCREASE

A report issued today by the Arcturus Radio Tube Company, Newark, New Jersey, discloses that the company's tube volume for the first half of 1937 shows a marked increase over the corresponding period last year and marks a new high since 1929.

"Every division of our business, comprising manufacturers, jobbers and export sales are running ahead. Additional help has been hired to keep pace with this increasing demand and prospects indicate a record year for 1937," states C. E. Stahl, Vice President and General Manager.

## PRESTO BULLETIN

The Presto Recording Corporation, 139 W. 19th St., New York, N. Y., now have available literature on their new Junior portable sound recorder. This unit is suitable for recording voices or combinations of musical instruments that can be played back immediately, handling any record up to 12 inches in diameter.

## NEW WHOLESALE CATALOG

The Wholesale Radio Service Co., Inc., of 100 Sixth Avenue, New York, N. Y., announces the release of their new 1938 Winter Catalog No. 69. This 180-page catalog, like its predecessors, is distributed free of charge.

Really six big catalogs contained in one, readers will find separate sections devoted to home, farm and auto radios, public-address equipment, ham equipment, replacement parts, tubes, test equipment and a line of electrical appliances.

## DAVEN BULLETIN

Those desiring information on the Daven ladder attenuators, Type No. LA-220, should write to The Daven Company, 158-160 Summit Street, Newark, N. J., for Bulletin No. 533. This literature contains complete information on these units and will be sent free on request.

# NEW! BURTON SERVICE ESTIMATOR

MODEL 26



MODEL 26 is a complete test unit in one case for diagnosing trouble in any radio receiver. Enables the service man to make an accurate and intelligent estimate of repair cost on first service call. Dynamic analysis for all tubes and separate tube elements. Inter-element, leakage or shorts shown hot on a neon tube. A complete resistance analyzer, volt-ohm-milliammeter D. C. and A. C. available in eleven ranges through selector switch. Long scale precision D'Arsonval meter has 1 MA movement. Voltage scales 1,000 ohms per volt. Condenser leakage test through jacks. Genuine quartered oak case is 13" x 13" x 6". Test leads included. Price (115 v. 50-60 cyc.) \$44.95.

MODEL 22 is a PORTABLE TUBE TESTER for determining true condition of all tubes. Each tube element is checked while connected to its proper circuit. Sensitive 1 MA meter with good-bad scale. Leakage test sensitive to 1,000,000 ohms included. Quartered oak case 13" x 13" x 6". Price (115 v. 50-60 cycle) \$34.95.

MODEL 21 COUNTER TUBE TESTER same as above except in sloping counter case. Price (115 v. 50-60 cycle) \$33.95. Write for full details.

**THE BURTON-ROGERS COMPANY**  
755 BOYLSTON STREET BOSTON, MASS.



## STREAMLINED P. A. SYSTEM

Again Bell leads the field by designing a P. A. system that has astonishing tone fidelity, is extra powerful, and has an attractive appearance of which every owner is proud—something new in the industry. Complete system is encased in one unit for easy portability. Equally suitable for permanent or temporary installations. Ultra wide range crystal microphone, heavy duty permanent magnet twin speakers, and beam power output tubes are just a few of the many features embodied in the construction of this modern system. Write for complete details and specifications. No obligation.

### DEALERS:

Cash in on quick sales and profitable rentals. Write for details and information on Bell's complete line of P. A. equipment and communicating systems.

**Specifications:**  
Power Output: 12 Watts.  
Overall Gain: 124 D. B.  
Frequency Response: With in 2 D. B. from 35 to 10,000 cycles.  
Circuit: 4 stage, Class A.  
Resistance Coupled.  
Tubes: Incorporates Beam Power Type.

### Choice of Colors:

So the modern beauty of this streamlined Amplifier unit will harmonize with its surroundings; it comes in either red, blue or black crackle finish.

**BELL SOUND SYSTEMS, INC.**  
61-62 E. GOODALE STREET, COLUMBUS, OHIO  
Export Office: 308 W. Washington St., Chicago, Ill., U. S. A.

**WRITE FOR DETAILS ON BELL'S COMPLETE LINE**

# QUALITY Proven by actual PERFORMANCE



... in the field ... year after year Radio Service Specialists have *proved* the consistent superiority of National Union tubes. It's this kind of testimony from the boys on the firing line that really counts. When a National Union tube goes into a socket the man who puts it there has full confidence that he's used the finest product tube making science can provide.

## FREE SERVICE EQUIPMENT!

### Free Equipment

Let N. U. equip your service shop free with your pick of the latest and best radio testers. Free equipment includes: Tube testers, set analyzers, oscillographs, signal generators, modulators, meters and other servicing instruments. In shop equipment items available include stock cabinets, coats, display signs, electric clocks, etc. All items absolutely free the National Union Way.

### The National Union Way

Through National Union's help, radio service dealers everywhere have been able to set up better equipped shops to do better work; also to obtain sales helps that produce more customers. National Union has constantly put the latest advances in scientific equipment as well as modern selling aids within reach of the service dealer. The National Union Deal calls for a dealer deposit which is rebated when the specified number of tubes have been able to set up better equipped shops to do better dealer should investigate.

**THE ROAD TO BETTER BUSINESS**

**NATIONAL UNION**

1. Full guarantee on highest quality radio tubes.
2. Cut price business not solicited.
3. Price Protection.
4. N. U. jobber stocks are complete...No hunting for odd types.
5. Timely business building aids.

**NATIONAL UNION RADIO CORPORATION**  
570 Lexington Avenue, New York City

S-937

I am interested in the following equipment: .....

Name .....

Address .....

City ..... State .....

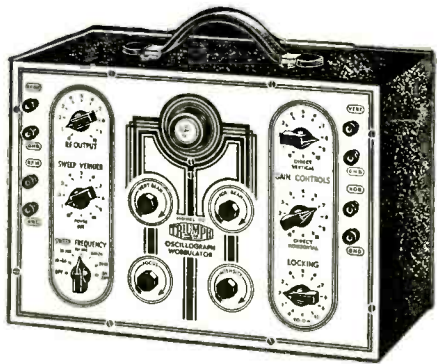

**ONLY \$49.95!**

Radio's finest Electronic Instrument, Triumph Model 77, is not only a complete Cathode-Ray Oscilloscope, it contains a complete frequency modulated electronic wobblator. Used with any good signal generator, the 77 permits accurate visual alignment of r-f, i-f, a-f, and padding circuits. Easy to operate! After the initial adjustments, only one control is used. Complete operating instructions free, in advance, for your examination. Investigate the Model 77 before you buy any oscilloscope! Standard model employs 913 C-R tube. Special model with 2" tube supplied on request, \$10.00 extra. Ask your jobber or write the factory.



### High Resistance Multirange Analyser

Model 350 (5,000 ohms per volt) Multirange Analyser is the latest addition to the Triumph line. Only \$19.95 with a 3" square meter. \$24.95 with a 4 1/2" square meter. Thirteen practical ranges, a.c.-d.c. volts, 0/3/15/150/600, d.c. mills 0/15/150, and 3 resistance ranges, 0/5,000/1,500,000/15,000,000 ohms. Triumph test instruments cost less, look better, last longer, and are most practical for radio service work. Jobbers be prepared with complete data.

**TRIUMPH MFG. CO.**

4019 W. Lake St., Chicago, Ill.

(In Canada, Big A Co., Belleville, Ontario)

Send Catalogs and free Instructions on How to Operate an Oscilloscope Wobblator.

Name .....

Address .....

576

### TEST EQUIPMENT—continued

presses the undesired signals of Fig. 3 marked D.

Two heterodyne tubes are used, rather than one as in previous designs. This permits connections, as indicated schematically in Fig. 6, and allows the 1650 kc modulated signal to be introduced to both tubes in the cathode circuit, while the unmodulated heterodyne signal (f) is introduced push-pull into the grid circuits. The 1650 kc modulated signal opposes itself in the two halves of the output transformer. This prevents the firing through effect of this signal in the manner previously mentioned. In addition, the mathematics of this development, as well as actual tests, show that those modulation products marked P in Fig. 3 appear in opposition in the output winding and are largely canceled out by this balanced circuit construction.

The undesired responses are diminished or balanced out completely by this treatment of the problem, with the result that a frequency modulator is possible which produces simply the sum and difference of the two mixed frequencies. Thus, when aligning a receiver it is unnecessary to look at traces on either side of the desired signal to decide which is the true resonance curve of the receiver. At the same time, a higher output is possible because the designer is not limited by the appearance of more and more spurious responses as the output level is raised. The high output is desirable, for it permits the examination of single stage performance.

#### THE COMPLETE INSTRUMENT

A complete instrument has been built, employing the principles outlined above, with many circuit refinements not previously employed in frequency modulators. The complete circuit diagram is shown in Fig. 7, and the external appearance in Fig. 8. This instrument is made for operation with any good unmodulated oscillator or signal generator for supplying the heterodyne voltage when connected to the terminals marked Input, and then set to a frequency which added to or subtracted from 1650 kc will result in the exact frequency desired for testing. This frequency is fed into a shielded transformer of balanced construction, wound on an iron core. The output of this transformer applies the signal voltage to the grids of the two 76 heterodyne tubes. The 1650 kc frequency modulated signal is fed into the cathode circuit of the 76s through the filter previously described and a three-step ladder

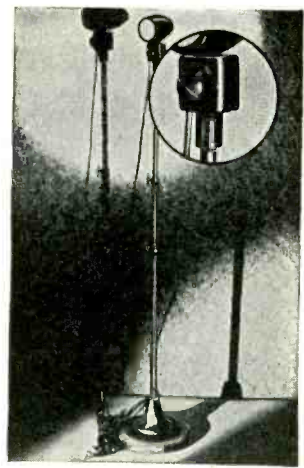

### FINGER-TIP CONTROL *Electar* BULLET MICROPHONE

The ELECTAR Bullet Microphone is a dynamic microphone of the latest type and most modern design with the volume control ON THE MICROPHONE.

The response characteristics are practically uniform from 20 to 9000 cycles, meet all requirements for naturalness of response plus remarkable tone quality.

It is unusually sensitive. . . . No polarizing voltage, batteries, pre-amplifiers or specially designed amplifiers are necessary.

Exclusive with

**EPIPHONE, Inc.**

142 West 14 Street • New York, N. Y.



Visit  
Booth  
715

New York  
Radio Show  
Oct. 1-2-3

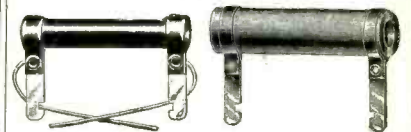

5 and 10 Watt

10-20-25 Watt

Moisture Proof—Triple Insulation—Tolerance within 2%—64 Standard Ohmages—1 to 50000 Ohms

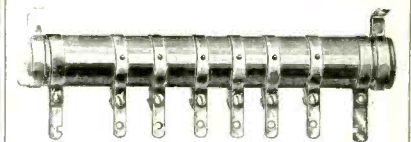

ADJUSTABLE VOLTAGE DIVIDERS



STANDARD REPLACEMENTS

Write for NEW 1938 Catalog

**ATLAS RESISTOR CO.**

423 Broome St. New York

EXPORT DIV., 100 VARICK ST.  
New York, N. Y., U. S. A.

Cable Address: "ARLAB." All Codes

SAY YOU SAW IT IN SERVICE

• SERVICE FOR

attenuator having a ratio of 10 to 1 per step.

In order to equalize both the amplifying and rectifying characteristics of the two 76 tubes, two potentiometers, P1 and P2, are provided as factory adjustments for equalizing the grid bias and plate resistance, respectively. By controlling the balance between the windings of the output transformer, T2, and by adjustment of the potentiometers, P1 and P2, it has been found practical in manufacture to hold the output (at 1650 kc) down to 10 microvolts—with the attenuator cut out of circuit. This is the condition of maximum output signal.

The 1650 kc oscillation is generated by a 6C6 tube in a typical tuned grid arrangement. In addition, a small resistor is inserted in the tuned circuit, the voltage across which is fed to the grid of the 6K7 control tube. This tube returns energy to the oscillating circuit in such phase as to behave as a condenser proportional to the mutual conductance of the 6K7 tube. The mutual conductance of the 6K7 is varied by impressing an a-c voltage from the 60-cycle power transformer within the instrument. Manufacturing control is exercised over the various elements, so that the potentiometer, P3, controlling this voltage may be calibrated directly in terms of sweep width from 0 to 50 kc.

An interesting feature is embodied in this circuit which may have some application to broadcast receiver design. Like most oscillators having small component parts, the frequency generated by the 6C5 tube is normally subject to some shift with operating temperature. In this particular case, the shift is in such direction that it can be eliminated by increasing the bias on the 6K7 control tube in proportion to the temperature of the oscillator. The expedient has been employed of making a portion of



Fig. 8. Clough-Brengle 111 frequency modulator.

# "What The Well-Dressed Service Shop Should Wear"

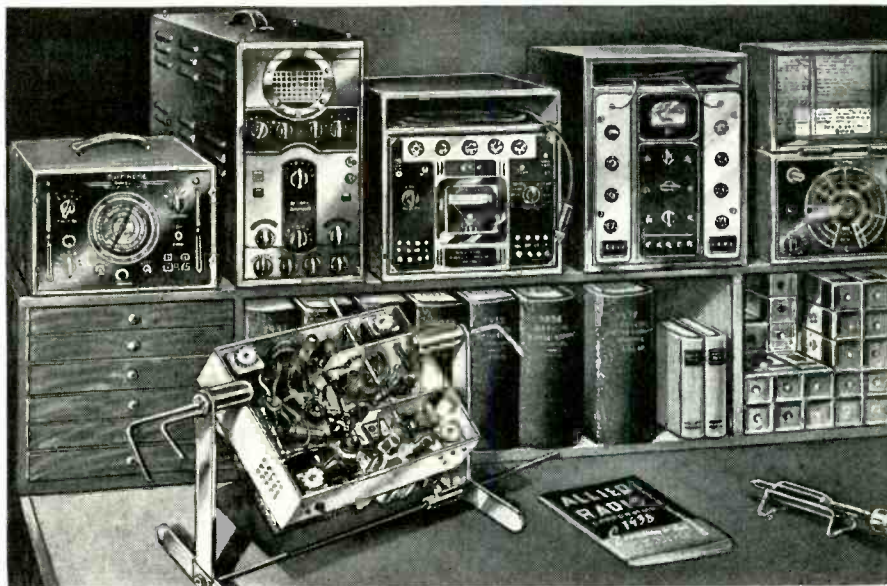

## ALLIED'S NEW CATALOG BRINGS YOU EVERYTHING IN RADIO

Complex circuits and new wrinkles have complicated life for the Serviceman. But with a completely equipped shop you can solve every servicing problem, handle every service job in a jiffy. Shop your ALLIED Catalog for:

- **SIGNAL GENERATOR**—For accurate alignment of all sets. ALLIED offers you the choice of the newest makes—at lowest prices.
- **CATHODE RAY OSCILLOSCOPE**—Indispensable for complete visual checking of modern sets. Latest types in ALLIED's new book.
- **SERVICE ANALYZER**—One good instrument replaces several meters—measures voltages, current, etc. ALLIED offers all famous brands.
- **MODERN TUBE CHECKER**—The new instruments test all metal, octal, and glass tubes quickly and accurately. ALLIED has the one you want.
- **CONDENSER ANALYZER**—Measure all condensers accurately with an up-to-date analyzer. You'll find the finest types in ALLIED's Catalog.
- **HANDY CHASSIS CRADLE**—Leaves both hands free for work. Prevents damage to chassis. See this new aid in ALLIED's Catalog.
- **COMPLETE TOOL EQUIPMENT**—Everything from a soldering-iron to a circle-cutter. ALLIED quotes lowest prices on all radio tools.
- **SERVICE BOOKS**—Up-to-date radio reference books save you time and money. ALLIED stocks every book you'll need. See our listings.
- **BASIC PARTS STOCK**—ALLIED's Catalog is your reliable index to replacement parts for every set—ALLIED stocks more than 12,000 duplicate and replacement parts.
- **YOUR ALLIED CATALOG**—Servicemen say it's their most important help. The new 1938 Catalog is your dependable Buying Guide.

For better work, for satisfied customers, for maximum returns on your investment, bring your Service Shop up to date. Check your bench against this standard list. Shop the ALLIED way for greater value—greater profit! Take advantage of the speedy service, the money-saving prices only ALLIED can offer. Get your copy of the new 1938 ALLIED Catalog today. Address Dept. 19J-8.

**ALLIED RADIO CORP.**  
833 W. JACKSON BLVD. CHICAGO, ILL.

the cathode resistor of the 6K7 out of copper, and properly placing this coil to equalize the normal frequency drift of the circuit, with the result that the frequency can be depended on to within 1 kc under operating conditions.

Shielding of the individual units within the instrument has been employed, in order that a maximum amount of control may be exercised on the circuits at all times and under all conditions.

The controls are simple, at the lower left the binding post for connecting an

external unmodulated oscillator of the service signal generator type (see Fig. 8); at the right the shielded output jack for connection of the concentric cable to the receiver under test; in the center, the usual line power switch and pilot light; at the upper left, the three-step control for the 1650 kc frequency modulated wave; and at the right, the control for sweep width, calibrated from 0 to 50 kc in width.

Kendall Clough  
CLOUGH-BRENGLE Co.

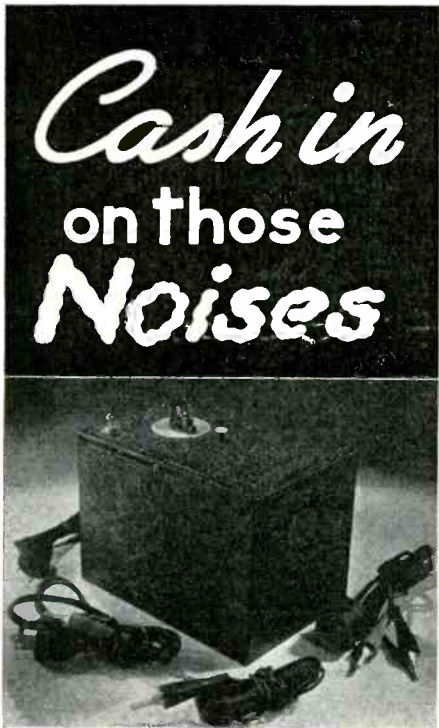

## HERE'S HOW...



First, invest in an AEROVOX Interference Analyzer. Diagnoses any case in a few minutes. Tells what type noise filter to use, and how. Neat. Simple. Portable. Only \$7.50 (Serviceman's Net Cost).



Start handing out the new AEROVOX Noise-Suppression pamphlet. Tells set owners what is man-made static and how YOU can cure it for them.



Then stock a few AEROVOX noise-suppressors. Install them at noise-producing device and at set itself.

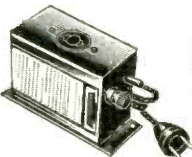

Think, talk, dream and sell noise suppression. Noise means dollars. And you can cash in.

## Ask for Details..

Big 32-page general catalog just issued has entire section on noise suppression. Ask your jobber or write us direct for copy.



## PUTTING YOUR SHOP ACROSS

(Continued from page 525)

advertising bulletins, parts or the like. Invariably one notices that the blank space at the bottom of the last page of such folders is not filled in with the shop's address, or, if it is, the same has been done hastily with an over-inked rubber stamp causing portions of the words to cross into the printing above and to make both unintelligible. Naturally, the preferred way is to have the shop address printed on the folder. Lacking this, one uses the rubber stamp, though it is hoped he does so with only the necessary ink and with due respect to margins. Neatness, like advertising, pays. Rather than leave the space blank and thus lose over half the folders' value to the shop, one can type in the proper identification. In small communities a personal touch is made by writing the name neatly. In any case, it is well to make use of this space.

The blotter has been termed the oldest and most reliable of advertising media for rarely, if ever, does it find the waste-basket without having outlived its usefulness. A combination log and blotter (Fig. 5) when conveniently near the home radio serves most effectively its purpose of blotting, advertising and record-keeping. Each time that the blotter or log is used it presents at least a portion of the sales message. Other designs may be drawn by the Service Man as in Fig. 2.

Good blotting stock, however, can be purchased to perform either one of two purposes, but rarely both. It is made to be printed upon or to absorb ink. When selecting it, therefore, one will do well to pay a little extra for quality's sake and so obtain a material that will give the highest in efficiency of these two

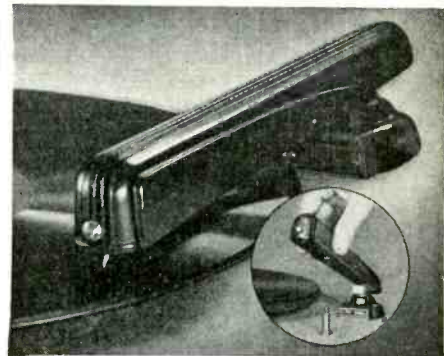

## RECORDS LAST LONGER SOUND BETTER with the Shure ZEPHYR

The Shure ZEPHYR Crystal Record Reproducer combines many new exclusive advancements in pickup design with the inherent advantages of the piezo-electric crystal. It accurately and faithfully reproduces the full frequency range of modern records. Gives you more accurate, more life-like reproduction of the recorded original. High output level gives excellent performance with radio receivers and moderate-gain amplifiers.

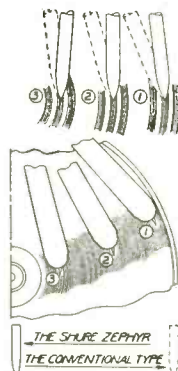

### "Balanced-Tracking"

The illustration at the left shows how accurately the ZEPHYR "tracks" the groove across a 12" record. The enlarged views at the top (looking down at the record) compare the relation of needle to groove for the ZEPHYR pickup (solid line) and conventional pickup (dotted line) at the start (1), half (2) and finish (3) of the record. ZEPHYR "Balanced-Tracking" makes records last longer... gives finer reproduction.

**Model 99B "Aero-Stream"** Shure Zephyr, complete with 3 1/2-ft. cable, mounting screws and drilling template (no arm-rest included). **\$12**  
List Price.....

A new modern Arm-Rest specially designed for the Zephyr is now available. No thumb screws or other adjustments—to lock simply press tone-arm over Arm-Rest... releases when lifted. LIST PRICE, 50c.

Write for Bulletin 143-SB today!

Shure patents pending. Licensed under patents of the Brush Development Company.

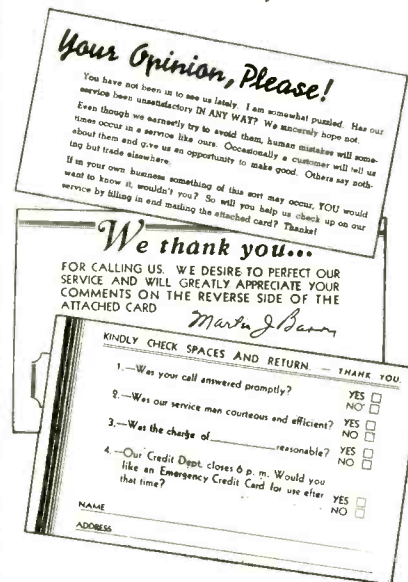

Fig. 4. Cards like these let customers know you are interested in giving the best possible service.

Don't fail to visit the  
Service Booth  
at the NEW YORK  
RADIO TRADE SHOW  
October 1 - 2 - 3  
Port of N. Y. Authority Building  
Eighth Avenue and 15th Street

respects. Otherwise one's blotter becomes like the proverbial pen at the post office and is, in reality, only a poor advertisement.

On proper occasions, mail out seasonal cards to all customers: not the "Merry-Xmas," give-us-a-chance-to-stick-you kind, but rather a sincere sentiment signed simply with the shop's name. Such mailing is not expensive considering how it builds up bonds of friendship between the man at the repair bench and his trade.

To carry out the above suggestions successfully, an up-to-date mailing list is essential. Such a compilation is a tremendous aid in building good-will. It is preferable to list customers' names in a book intended solely for the purpose, rather than to jot them down on the backs of soiled envelopes or business cards, sides of tube cartons, and scraps of paper as such become available at the required moment. It requires only an extra second to locate the customer book and to record the name with related information in the proper order. Likewise, when writing the name, take sufficient time to register a mental picture of your client's face, so that upon later occasions you can associate one with the other. Half a service job is obtained when a customer is spoken to by name; he, of all persons, delights in hearing his own name. Like the greetings idea, it pays.

Finally, remember the customer at least intends to be human and, accordingly, is not just another something to which a repair bill is addressed. He who takes as much pride in these more social matters as he does the technical side of reconditioning will find himself more successful from the start.

#### FREE ESTIMATES

Local	Kiloc.	Your Dial	Distance	Your Dial
WMCA	570			
WEAF	660			
WOR	710			
WJZ	760			
WNYC	810			
WABC	860			
WAAT	940			
WHN	1010			
WRNY	1010			
WLWL	1100			
WOV	1130			

#### Alden Radio

..... BROADWAY Alden Theatre Building

#### FOR SERVICE - ENDICOTT 2-9266

WINS	1180			
WNEW	1250			
WBBR	1300			
WEVD	1300			
WBXN	1350			
WARD	1400			
WBBC	1400			
WLTH	1400			
WHOM	1450			
WCNW	1500			
WMBO	1500			
WWRL	1500			

#### FREE ESTIMATES

Fig. 5. Log for postal card or blotter makes an effective ad.

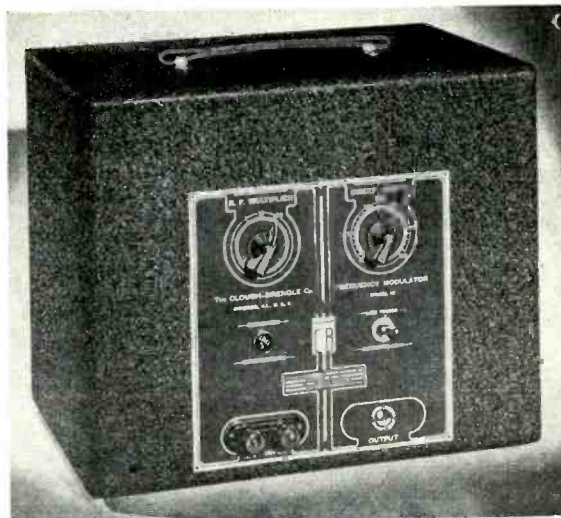

# Now

## A PERFECTED MODULATOR

KENDALL CLOUGH, pioneer of Cathode Ray and Electronic test equipment again scores a sweeping victory. After years of exhaustive study and research Clough-Brengle announce the . . .

### New Model 111 Electronic Frequency Modulator

One Positive—One Negative Beat!! No more! No less! **LOOK INSIDE— THEN DECIDE**  
Unit supplies only the frequency modulation needed to delineate receiver response curves on the Cathode Ray Oscillograph. Balanced circuits, Band Pass Filters, Push Pull Coils and Unit Shielding have eliminated harmonics and spurious repeat points. Low impedance C-B coaxial cable provided with each instrument. Use with any R. F. Oscillator.

**FREE** Write today or see your parts distributor for complete description. **FREE**

**The CLOUGH-BREngle CO.**

2817 WEST NINETEENTH STREET  
CHICAGO ILLINOIS



## VOCAGRAPH Thirty Watts "Hushed Power"

net only **\$39.90**

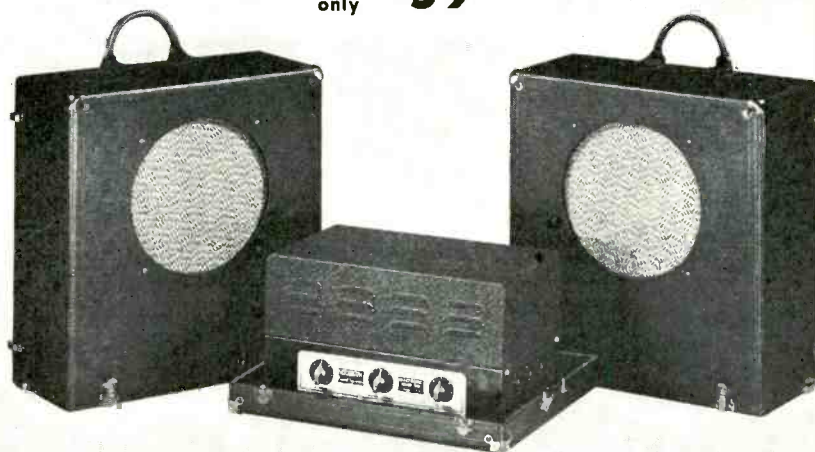

### Compare These STARTLING Sound Values!

See what other leading manufacturers ask for a full thirty-watt, dual high gain input, beam power amplifier! Then ask your own parts supply house to demonstrate this amplifier. Here are a few of the many other VOCAGRAPH values he offers you:

Thirty-watt, fully portable system. Model 30-30PV complete with velocity microphone, three piece case, and two 12-inch p.m. speakers, only \$100.80.

Eighteen-watt, high gain amplifier. Model 30-18C for only \$29.70, or complete with velocity microphone, two 12-inch speakers, and three piece case, etc., only \$85.80.

Ten-watt, high gain amplifier. Model 30-10C for only \$17.70 or complete with velocity microphone and carrying case with 12-inch speaker, only \$47.40.

Whatever your sound needs may be, from ten to ninety watts, get the new VOCAGRAPH catalog. It shows you how to make bigger sound profits.

### NEW 6-v and 110-v Mobile Amplifier

The lowest priced combination 6-v battery 110-volt line operated amplifier ever built, with full rated 30 watts output from generator or a-c pack built in. Phone record player optional. Complete amplifier prices start at \$66.00. Write for full details.

FREE Engineering Bulletin

**VOCAGRAPH SOUND SYSTEMS**

Division of Electronic Design Corp.,  
162-B N. May Street, Chicago, U. S. A.  
Send at once complete data and prices.

Name .....

Address .....

# THE MANUFACTURERS . . .

## IRC VOLUME CONTROL

Elimination of sliding, metal-to-metal contact in volume controls, with resulting elimination of the most common cause of noise, is claimed by the International Resistance Co. in its new line of special replacement Metallized type controls.

By means of a spiral spring wire continuous electrical connection is obtained between the center terminal and the volume adjustment arm. These controls are identified by the letter "J" preceding their part number in the IRC Volume Control Guide.

This new IRC Guide lists the IRC replacements for almost every radio receiver made up to the present time. It also contains volume control information, resistance calculation data, etc.

The Guide is free upon request to the International Resistance Co., 401 N. Broad St., Philadelphia, Pa.

## UNIVERSAL CAR-RADIO CONTROLS

A new idea in merchandising remote-control replacement units for car-radio sets is being introduced by Universal Controls, Inc., Long Island City, N. Y. According to the plan announced by Emil Gartner, sales manager, replacement dials are now supplied for the Universal Control. By stocking only two control heads, one switch-arm, and seven extra dials, any combination of gear ratios can be matched and the set calibrated simply by selecting the proper dial and inserting it in the control head, it is said.

## RCA P-A EQUIPMENT

A new line of public address and sound reinforcement equipment, which includes an electric mixing unit for remote control of sound distribution, has been announced by the RCA Victor Commercial Sound Section.

The new equipment has been streamlined for compactness and trim appearance, includes many new technical features and has been competitively priced, according to W. L. Rothenberger, RCA Commercial Sound Manager.

Included in the new line is a remote electrical mixer and three power amplifiers rated at 6, 12 and 24 watts, respectively.

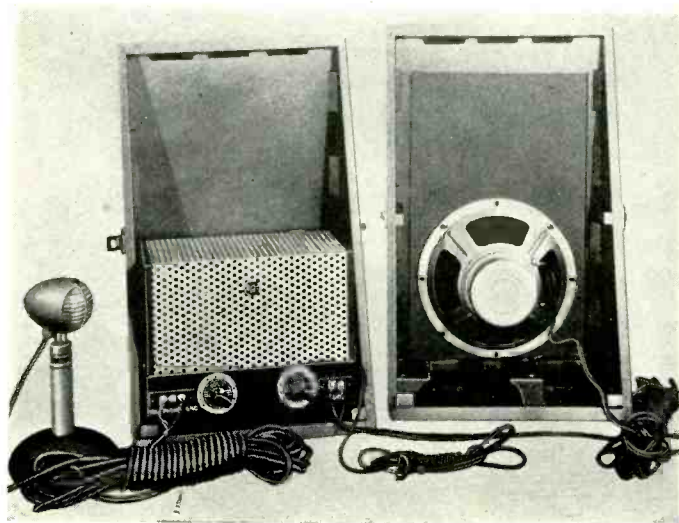

RCA P-A System.

## WEBSTER-CHICAGO PAGING SYSTEM

The Model FC-7R is a 7 watt selective paging system with talk back features introduced by Webster-Chicago, 5622 Bloomingdale Ave., Chicago.

In operation, the master station can call any one of five stations or can call all five stations at once. Any station can reply to the master station. If desired, a separate switch arrangement at the speaker will

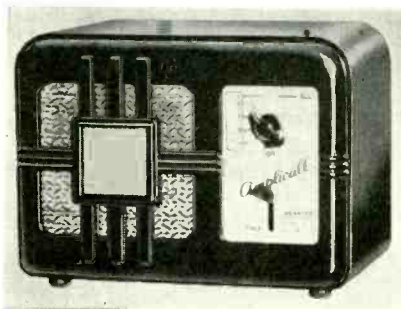

permit that station to call the master station.

System can be installed with master and just one outlying station or any number of

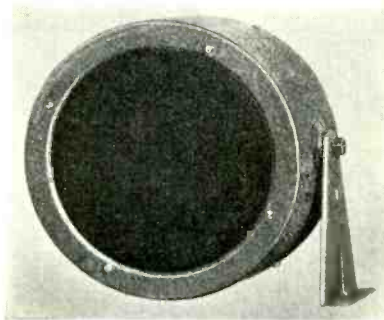

outlying stations up to five. It is powered for factory floor spaces of 20,000 to 30,000 square feet with an average noise level.

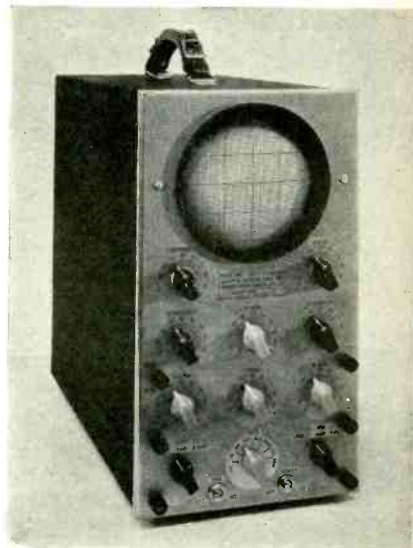

## DUMONT WAVE-EXPANDING FEATURE

The wave-expanding feature as incorporated in the latest DuMont 5-inch all-purpose oscillograph, is valuable in the study of complex waves where it is desirable to spread a small portion of the wave for detailed study. It allows expansion of waves of much higher frequency than the fundamental frequency of the sweep. Million cycle waves can be observed with good detail, and the return trace eliminator, a regular television principle, permits the waves to appear only on the forward linear portion of the sweep.

Additional information may be obtained from Allen B. DuMont Labs., Inc., Upper Montclair, N. J.

## TRANSDUCER MIKE LINE

J. T. Kane, Sales Manager of Transducer Corporation, recently announced that the complete line of Bullet microphones has been redesigned and improved to provide higher fidelity, sensitivity and better all round performance.

The new models are: TR-5, an all purpose mike with sensitivity of 42 db high or low impedance. Available in standard black telephone bakelite. TR-6, substantially the same as TR-5 but adapted for use with exceedingly long lines. Sensitivity—40 db. available in standard black telephone bakelite. TR-7, a non-directional, vertical type. Sensitivity—40 db. available in standard black telephone bakelite. TR-8, custom built mike to satisfy any line or amplifier requirement. Sensitivity—38 db. This job may be had in black or choice of colors and in impedances of 10, 50, 200, 500, 2,500, 50,000, 500,000 ohms. TR-9, a custom built mike furnished with individual laboratory drawn curve. Sensitivity—38 db. available in black or choice of colors and any of the following impedances—10, 50, 200, 500, 2,500, 50,000, 500,000 ohms.

Complete information is available from the manufacturer; address, Radio City, N. Y.



**SMALL INVESTMENT . . .  
LARGE PROFITS** with these



**MOISTURE PROOFED  
TRANSFORMERS**



**D**ON'T waste time scurrying around for a single replacement transformer! Don't tie up a small fortune in stock! Keep on hand a moderate assortment of these GTC units—and be prepared for almost any service requirement, from 4 to 12 tube, current or orphaned model.

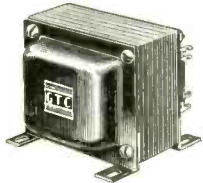

Made in two styles: 2.5 volt double filament winding, and combination 2.5 volt and 6.3 volt single-heater winding. Separate brackets permit mounting flush, horizontal or vertical—eliminates drilling new holes.

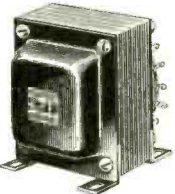

Built with low loss silicon steel core of sufficient stack to provide an ample margin over the highest rating specified for the unit. Moisture-proofed by famous GTC "PULL-PUSH" Process—will give lasting satisfaction under normal operating conditions even in the hottest, most humid sea-coast climate. Ask your jobber or write for FREE Bulletin 41.

**GENERAL  
TRANSFORMER CORP.**

Visit us at the  
New York Show  
BOOTH 202

1266 W. Van Buren St., Chicago

**NEW . . .  
DU MONT TYPE 168  
5 INCH ALL-PURPOSE  
OSCILLOGRAPH**

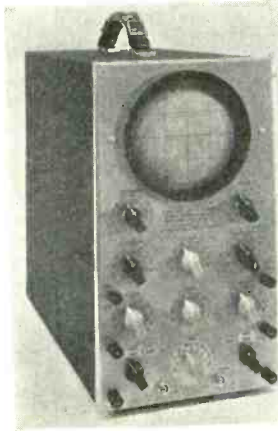

**T**HE new Type 168 is designed for service engineers, experimenters or research engineers. It incorporates all the many advantages of the popular Type 164, 3-inch oscillograph plus a DU MONT Type 54-XH 5-inch cathode ray tube, a two-stage vertical amplifier with a gain of 450 and many other outstanding features.

*If you require the best, ask your jobber about this new 5-inch oscillograph.*

**Allen B. Du Mont Laboratories, Inc.**  
Upper Montclair, New Jersey

**A COMPLETE NEW LINE  
FOR SALES AND PROFITS**

GENERAL  
ELECTRIC  
**PRE-TESTED  
METAL  
TUBES**

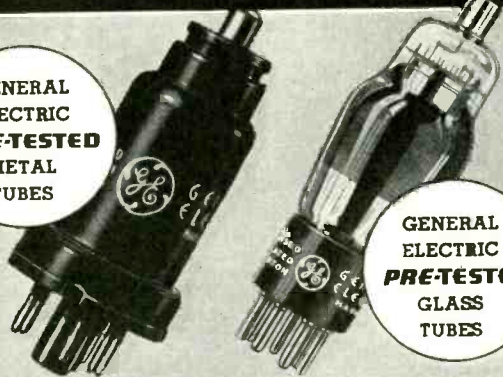

GENERAL  
ELECTRIC  
**PRE-TESTED  
GLASS  
TUBES**

**FOR CUSTOMER SATISFACTION  
Use G-E RADIO TUBES**

Memo to:

**Dealers and Servicemen**  
Ask your G-E Radio Distributor for details of the G-E Radio Tube Merchandising Plan, or write to Radio Tube Sales Section, General Electric Company, Bridgeport, Conn.



**GENERAL  
ELECTRIC**

APPLIANCE AND MERCHANDISE DEPARTMENT  
GENERAL ELECTRIC COMPANY, BRIDGEPORT, CONN.

*Money Talks*



● But so does the Spieler—reels and realms of talk—even expensive printed talk won't make pretty do as pretty says. It's results that count. Play Safe — Buy Exact Duplicate Radiart Replacement Vibrators from your Dependable Radiart Jobber.

## MANUFACTURERS—continued

### AEROVOX CARBON RESISTORS

Carbon resistors with a bakelite molded jacket, providing additional protection against moisture, shorts and other contingencies, are offered by Aerovox Corp., 70 Washington St., Brooklyn, N. Y. These

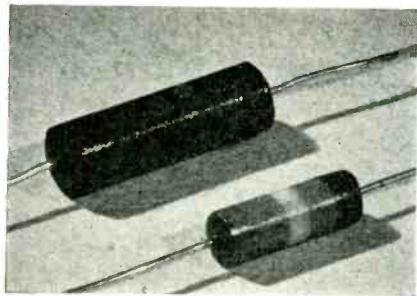

resistors with color-coding lacquer stripes, have 2-in. pigtail leads of tinned copper. Resistance values range from 100 ohms to 10 megohms. The units are offered in 1/2 and 1 watt ratings.

### TRANSDUCER COAXIAL CABLE

Transducer Corp., 30 Rockefeller Plaza, New York City, announce a coaxial cable to meet the demand for antenna leadin, transmission lines and feeders, photo-cell cables, measuring instrument cables, etc.

Additional information may be obtained from the manufacturer.

### SIMPSON PANEL INSTRUMENT

The accompanying illustration shows a new panel instrument with illuminated dial produced by the Simpson Electric Co., Chicago. The dial is made of a non-warping translucent material with a convenient 6-volt lamp which gives a well-diffused lighting.

A feature of the instrument is the bridge type construction and soft iron pole pieces which is claimed by the manufacturer to give it greater accuracy and added stamina to retain its accuracy. It is available in both d-c and a-c voltmeters, milliammeters and microammeters, as well as thermocouple ammeters and milliammeters in all conventional ranges. The rectangular face

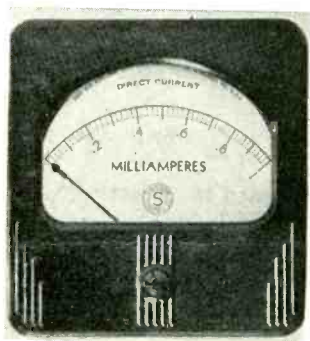

of the instrument measures 3-in. in width and 3 1/8-in. in height. It mounts in a round hole 2 3/4-in. in diameter. The socket and lamp are supplied with the instrument. A bulletin describing the instruments is available from the manufacturer.

### AMPERITE HAND-I-MIKE

Amperite Co., 561 Broadway, are introducing their Hand-I-Mike, a compact complete velocity microphone with output transformer of the high or low impedance type included.

A flat response from 60 to 7,500 cycles with an output only 3 db below standard



sized units is claimed for the Hand-I-Mike.

Additional information may be obtained from the manufacturer.

### ELECTRO-ACOUSTIC AMPLIFIER

The Electro-Acoustic Model AP-1832B is an 18 watt system complete with twin speaker carrying case, two 10-inch speakers, crystal microphone with adjustable floor stand and cables and plugs.

The amplifier has inputs for 2 crystal or velocity microphones and a high-impedance pickup. Outputs are provided for 2 electrodynamic speakers and from 2 to 12 permanent magnet dynamics.

Additional information may be obtained

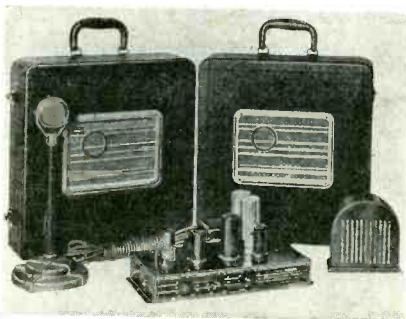

from the Electro-Acoustic Products Co., Fort Wayne, Ind.

### RCA 6Y6G BEAM POWER TUBE

The 6Y6G is intended for use in the output stage of a-c receivers, particularly those in which the plate voltage for the output stage is relatively low. With 135 volts on plate and screen, it is capable of giving an output of 3.6 watts with a maximum signal input of 13.5 volts. Under these conditions, the total distortion is about 9.5 per cent.

Further details of the characteristics and rating of the 6Y6G may be obtained from the RCA Manufacturing Co., Inc., Harrison, N. J.

### CROSLY CHATTABOX

The Crosley Radio Corp., Cincinnati, Ohio, has entered the field of intercommunication systems for use in the home, business and industry with a set called the Chattabox, a two-way loud-speaker

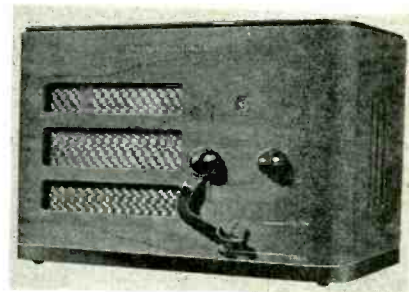

communication system.

There are two methods of operating two or more units. The simpler method is merely to connect the power cord of each unit into the power receptacle. In factory buildings where electrical interference may be transmitted by electric wiring or wherever it is desired to operate the system without the possibility of other units in adjoining offices picking up the conversation, a direct wire connection can be used.

### STAR AUTO-RADIO CONTROL

The Star Machine Manufacturers, Inc., Hunts Point and East Bay Aves., New York City, present their latest audio-radio control. The new control is said to have many improvements over their last year's model.

As in the 1937 model, all ratios are available with a single unit which is also suitable for either clockwise or counterclockwise rotation. Full illumination is possible even on cars with a small dial opening. Backlash has been completely eliminated, it is claimed.

### TRIUMPH MULTIRANGE ANALYZER

The Model 320 Triumph multirange analyzer is designed for voltage, current

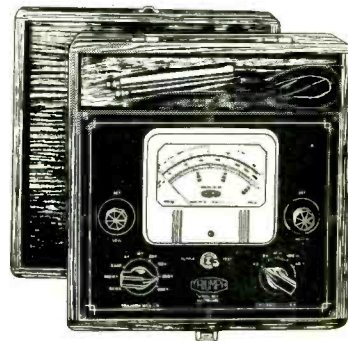

and resistance measurements in both d-c and a-c. The 4- by 4 5/8-inch meter used has a 50 microampere movement.

Additional information may be obtained from Triumph Mfg. Co., 4017 W. Lake St., Chicago.

**AC CURRENT ANYWHERE!**  
In CARS . . On FARMS . . In DC DISTRICTS

With New  
**1938**

**ATR**  
DC-AC  
**INVERTERS**



FOR OPERATING—Standard 110 volt or 220 volt AC Radios, Public Address Systems, Electrical Testing Equipment, etc.

LIST PRICE AS LOW AS **\$20.00\***  
\*Without Filter  
As Low As \$22.50 with Filter (Standard Discounts Apply)

**PROVEN—DEPENDABLE—GUARANTEED**

- OUTSTANDING FEATURES**
- Interference-Free All Wave Radio Operation
  - Improved Long Life ATR Vibrators of new design and construction having dual arms and using eight 1/4" diameter tungsten contacts assuring increased long life and reliable service.
  - Four Point Voltage Regulators make possible the correct output voltage for minimum to maximum loads and also help compensate for input voltages which are lower or higher than normal.
  - 32 Different Types of DC input voltages ranging from 6 to 220 volts and having AC output voltages of both 110 and 220 volts.

**OTHER ATR PROFIT MAKERS**

**ATR AUTO RADIO "A" BATTERY ELIMINATOR**



Specially Designed for Demonstrating and Testing Auto Radio Sets on Regular AC Lines. 105-125 Volts, 50-60 Cycles. Has many other uses. Comes completely equipped with On-Off Switch, Pilot Light Indicator, 10 ampere Fuse, Rubber Mounting Feet, 6 ft. Rubber Cord, Heavy Gauge Metal Cabinet. ATR Standard Model. Rated output 6.3 volts at 6.5 amp. (Without Meter) **\$13.95**  
ATR Heavy Duty Model. Rated output 6.3 volts at 14 amps. (Without Meter) **\$21.00**  
Any of the above models equipped with Dealer's Net indicating voltmeter, add \$1.00 extra. Price Complete



**ATR Auto and Farm Radio Replacement Vibrators**

**A COMPLETE LINE FEATURING** • Longer Life • Precision Construction • Improved Performance • Lower prices Backed by More Than Six Years of Experience in Vibrator Design and Research, Development and Manufacturing.

**ATR Automatic Tapering BATTERY CHARGER**

Keeps Auto Battery fully charged right in the car! Operates from any 110 volt AC 50-60 cycle line. Equipped with a full wave dry disc type rectifier unit. Comes completely equipped.  
Model 400—Maximum charging rate 4 amperes **\$7.95 List**  
Model 600—Maximum charging rate 6 amperes **\$11.45 List**  
(Standard Discounts Apply)

**American Television & Radio Co.** St. Paul, Minnesota, U. S. A.  
Cable Address: "Likex," N. Y.

**Quiet, Insulated and Reliable**  
**RESISTORS**

**CONTINENTAL CARBON**

bakelite insulated resistors are impervious to moisture, conveniently small and noiseless in high gain circuits. They are recommended for use in compact amplifiers and radios.  
M3, 2"x13/16" . . . 3 Watt, \$ .30  
M1, 1"x9/32" . . . 1 Watt, .20  
M 1/2, 5/8"x7/32" . . . 1/2 Watt, .17

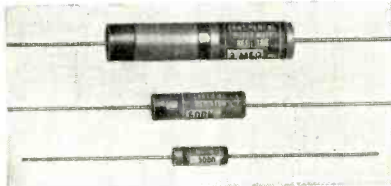

**CONTINENTAL CARBON**

ceramic insulated resistors have withstood the tests of time in actual service. Where space permits, ceramic insulated resistors are recommended for the utmost in stability and long life. In close tolerance applications, these resistors are the choice of leading test instrument manufacturers of precision equipment and meters.

- H5, 3"x9/16" . . . 5 Watt, \$ .50
- E2, 2"x3/8" . . . 3 Watt, .30
- D2, 1 1/4"x1/4" . . . 1 Watt, .20
- G4, 1"x1/2" . . . 1/2 Watt, .17

Send for Bulletins 104B, 105, 103A, and 101A.

**CONTINENTAL CARBON Inc.**

13912 Lorain Avenue Cleveland, Ohio  
Also Toronto, Canada

**To Servicemen and Dealers**

**DO YOU KNOW THAT**

**TRIAD**

**MANUFACTURES OVER 100 TYPES OF**

*Glass and Metal*  
**BALLAST TUBES**

(RESISTOR UNITS)

WHICH ARE AVAILABLE THROUGH YOUR JOBBER—FOR INCREASING REPLACEMENT BUSINESS. . . .

ALSO A COMPLETE LINE OF RADIO RECEIVING TUBES  
**A Profitable Line to Handle**

*Write for Particulars*

**TRIAD MANUFACTURING CO., INC.**  
**PAWTUCKET RHODE ISLAND**

**THE QUALITY NAME IN RADIO TUBES**

**Impervious to moisture . . . .**  
**—they're**  
**Vacuum-Sealed**

The vacuum-sealing is positive in action and insures uniform impregnation of all windings.



Conveniently packaged. Construction and shell assemblies make possible universal mounting.



Make your test bench voltage exactly what you want it.

**VARI-VOLT Transformer**

0 to 256 v. in 1-volt steps.  
0 to 128 v. in 1/2-volt steps.  
Simplifies radio service work.

**FREE** to Service Men on Halldorson Deal.

**Halldorson**  
*Vacuum Sealed* **Transformers**

The Halldorson Company, 4500 Ravenswood Ave., Chicago, Ill. S937

Please send me  
 New Catalog on Halldorson Vacuum Sealed Transformers.  
 Information on how I can obtain Vari-Volt Transformer Free.  
Name .....  
Address .....  
City ..... State .....

## MANUFACTURERS—continued

### TRAV-LER TRAVEL-MATIC TUNING

Trav-Ler Radio & Television Corp., 1036 W. Van Buren St., Chicago, announce a low price superheterodyne, with auto-



matic tuning and button dial, called Travel-Matic.

A descriptive bulletin may be obtained from the manufacturer.

### "GOVE" VERTICAL MIXER

Tech Laboratories, 703 Newark Ave., Jersey City, N. J., have recently announced their Type 214 "Gove" vertical mixer. This attenuator was invented by Edward L. Gove, technical supervisor, WHK and WJAY, Cleveland, Ohio. The unit can be cleaned from the front of the panel by removing the escutcheon and it is completely shielded and dustproof. Narrow construction permits as many as seven mixers in one row on a standard 19-inch rack. Specifications are as follows: noise level, 130-140 db below zero level; range, standard units are furnished with 20 steps at 2 db; circuit, ladder or potentiometer; impedance, 30, 50, 200, 250, and 500 ohms for ladders, and 250,000 ohms for potentiometers.

### RTL TUBE TESTER

The Radiotechnic Laboratory, 1328 Sherman Ave., Evanston, Ill., announce their Model U tube tester.

A unique feature of the Model U is the

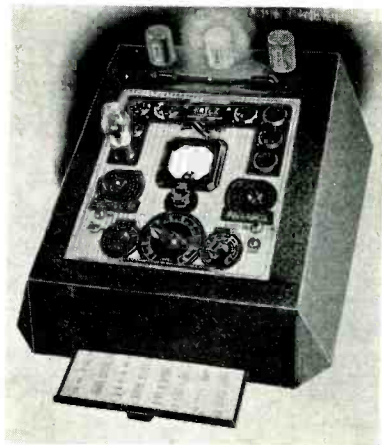

flashing signals which light up during test and indicate the condition of the tube.

Additional information may be obtained from the manufacturer.

### PRESTO RECORDER MECHANISM

Presto Recording Corp., 145 West 19 St., New York City, has placed on the market as a separate item the overhead mechanism supplied with their Model D recorder. The overhead mechanism may be attached to any high grade phonograph turntable to record voice or music from a microphone, or it may be attached to a radio-phonograph combination to record radio programs off the air.

The Presto mechanism cuts the groove as it records the sound on Presto cellulose double coated discs. Steel or sapphire cutting needles are employed. The records may be played with steel needles, as soon as they are recorded, on any phonograph. The Presto mechanism can be furnished to cut either from inside out or from outside

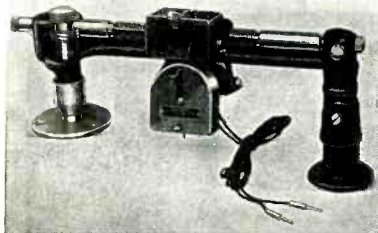

in at 96 grooves per inch.

Literature is available describing the installation of the mechanism on radio phonograph combinations.

### ATTENTION MANUFACTURERS

Mr. G. C. Motwane, managing director of Eastern Electric & Engineering Company, Bombay, is now in the United States. Mr. Motwane is particularly interested in securing data on public-address systems, radio parts, and all kinds of sound apparatus, such as, sound-on-film recorders. He may be contacted at the Hotel Irving, 26 Gramercy Park, East 20th St., New York City.

### AMPLITONE AMPLIFIER

The amplifier pictured is manufactured by the Amplitone Products Co., 152 Wash-



ington St., New York City.

It is powered either from a six volt storage battery source or directly from the 110-volt a-c power lines. A filtered genemotor is used for B power when the unit is operated on a six-volt supply. Additional information may be obtained from the manufacturer.

### JFD DIAL BELTS

The J. F. Distributing Co., 4111 Ft. Hamilton Pkway., Brooklyn, N. Y., announce a line of woven fabric belt replacements for practically all dials. Complete information and prices may be obtained by writing for bulletin 417B.

### LAFAYETTE 20-WATT AMPLIFIER

For all-around public-address requirements, Wholesale Radio Service Company, Inc., of 100 Sixth Avenue, New York City,

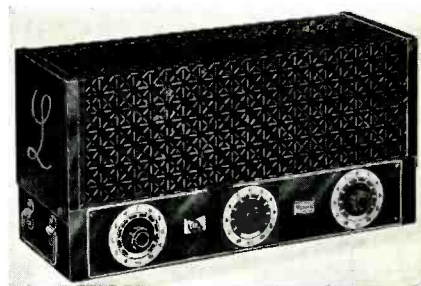

is offering the new Lafayette Model 131-A, 20-watt amplifier. The unit features glowing red neon control dials that can be observed and set in darkened locations; reverse feedback giving only three percent harmonic distortion at the rated output, and economy of use through the inclusion of a 24-watt speaker field supply. Metal tubes, except for the rectifier, are used throughout, providing a sound power of 20 watts when fed into 500 ohms. Two high-gain channels are provided for use with crystal, condenser or velocity microphones while two low-gain channels are included for carbon mikes, phono-pickups, etc. Fading and mixing controls permit flexibility of reproduction when used with orchestras, singers and phono-pickup. Photo-electric cell input can be substituted in place of these with no change in amplifier circuits.

### MERCURY-VAPOR RECTIFIER

The Continental Electric Co., Geneva, Illinois, have announced their new mercury-vapor rectifier tube, which is known as Type 2-RA-15.

This rectifier has the following electrical characteristics: filament voltage, 2.5 volts; filament current, 16 amperes; d-c output (average), 15 amperes; d-c output (crest), 45 amperes; arc drop, 5-8 volts; pickup voltage, 8-11 volts; d-c output voltage, 60 volts max.; crest inverse voltage, 200 volts max.; filament heating time, 2 to 3 minutes; overall length, 8½ inches; overall diameter, 3¾ inches. It is designed for low-voltage applications such as projector arcs,



arc welders and the like. The manufacturer guarantees 2,000 hours' life for this tube when used within the limits shown above.

The manufacturer will gladly send complete details to interested firms.

• SERVICE FOR



## THE BRUSH TRANSFILTER FILLS THE GAP

● The transfilter fills the selectivity gap between the electrically tuned circuit and the quartz filter. A transfilter can be employed in any superheterodyne whose intermediate frequency amplifier can be tuned to 465 kilocycles.

Technical data on request

**The BRUSH**  
Development Company  
3317 Perkins Avenue, Cleveland, Ohio

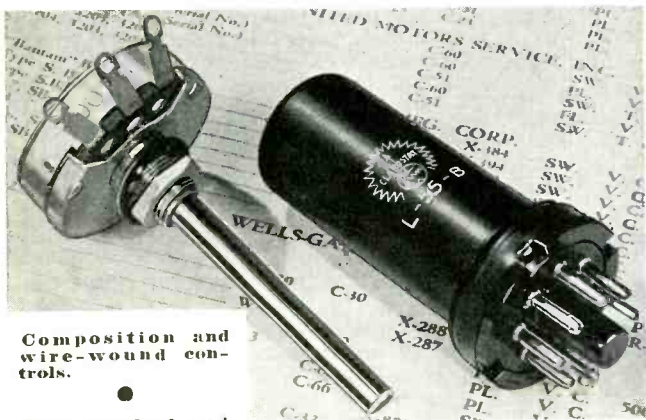

Composition and wire-wound controls.

● Both standard and exact - duplicate units.

● Also metal-tube resistor replacements.

● Most accurate and complete listings insure right choice.

● And your Clarostat Jobber has been selected to serve you best.

## Correct DATA and PARTS

An absolutely free, brand new servicing manual. Over 200 pages. Covers replacements for all sets. Yours for the asking. ● And remember, those listings are backed by the jobber's stock of Exact-Duplicate and Standard Replacements.

**CLAROSTAT** Manufacturing Co. Inc.



285-287 NORTH SIXTH STREET  
BROOKLYN, NEW YORK, U.S.A.

• OFFICES IN PRINCIPAL CITIES •

# METALEX HORNS

A Boon To The  
Sound Engineer



Model 2800

- Steel for Wear
- "Ex" for Objectionable Resonances

The enthusiastic expression we are receiving regarding the Metalex Horn makes us want everyone

interested in public address work, to try one. These efficient exponential horns should not be confused with the so-called parabolic units. Spun from steel and coated with the material "Ex," these Metalex horns give almost unlimited wear and have no objectionable resonances. Stocked in 3 sizes.

The Model N M 2900—12" Nokoil speaker installed in a Metalex Horn gives almost unbelievable reproduction.

Write for interesting literature.  
Wright-DeCoster Distributors are always anxious to cooperate.

## WRIGHT-DECOSTER, INC.

2253 UNIVERSITY AVE. ST. PAUL, MINN.  
Export Dept.: M. Simons & Son Co., New York  
Cable Address: "Simontrice"  
Canadian Representatives:  
Wm. F. Kelly Co., 1207 Bay St., Toronto, Ont., Canada  
Taylor & Pearson, Ltd., Edmonton, Alta., Canada.

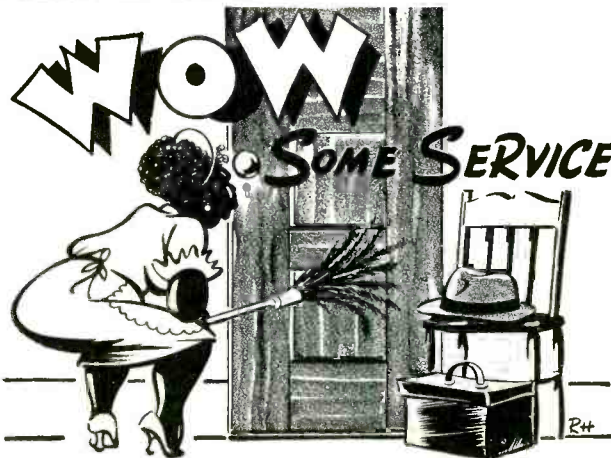

The radio serviceman gives real service when he uses Ward Leonard Replacement Parts. They are honestly rated and made right, therefore work done with them "STAYS DONE." Send for Servicemen's bulletin 507A. It will help you build a permanent business.

See our booth at Radio Parts Manufacturers Show, Port of Authority Bldg., New York, October 1st to 3rd

## WARD LEONARD ELECTRIC COMPANY

36 SOUTH STREET, MOUNT VERNON, NEW YORK  
Please send me free copy of Bulletin 507A.

Name .....  
Address .....  
City ..... State .....  
Jobber .....

## MANUFACTURERS—continued

### MALLORY REPLACEMENT CONDENSERS

In a recent announcement to the trade P. R. Mallory & Co., Inc., Indianapolis, Ind., introduced twenty-one new replacement condensers.

The Mallory replacement condenser line

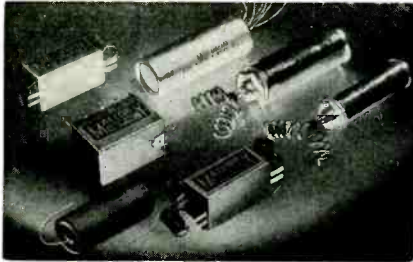

has been expanded to meet new requirements. In addition a number of special universal condensers have been added to the line which are designed for use on receivers requiring parts of unusual mechanical construction.

### WIRELESS INTERCOMMUNICATOR

United Sound Products, 816 W. North Ave., Chicago, announce a line of wireless intercommunicating systems.

An illustrative and descriptive folder may be obtained directly from manufacturer.

### HIGH-SENSITIVITY "ROTO-RANGER"

A high-sensitivity set tester has been announced by Simpson Electric Co. which incorporates the mechanism found in a number of set analyzers and tube testers produced by this company. This mechanism, known by the trade-name, "Roto-Ranger," consists of a rotating drum (containing twelve independent scales) which is geared to a twelve-position range selector switch so that the proper scale automatically comes into view to correspond with the position assumed by the switch.

This new model has a resistance of 10,000 ohms per volt d-c. D-c scales in the new model read 0-10-50-300-1000 volts. A-c scales read 0-8-150-1000 (at 1000 ohms per volt) Resistance ranges are 0-2000-200,000 ohms—20 megohms. Current readings are 0-10-100-500 milliamperes and 0-100 microamperes. A new bulletin describing the tester (Model 275) has been issued, which can be obtained by writing to Simpson Electric Co., 5216 W. Kinzie St., Chicago.

### UNIVERSAL CAL-FON

The Cal-Fon intercommunication system, manufactured by the Universal Microphone Co., Inglewood, Cal., has been augmented



with the addition of several new types.

Besides the ordinary desk mount used in offices and factories, a new model of similar design with the mounted box and the French-style 'phone, but with the addition of wall brackets is available for those who prefer a wall intercommunicating 'phone.

### MICAMOLD RESISTORS

Micamold Products Corp., Flushing and Porter Aves., Brooklyn, N. Y., have announced a line of cement coated resistors in ratings from 10 to 100 watts. The standard line is of conventional construction and dimensions. Both fixed types and semi-variable types with sliders and brackets are available. Special types can be obtained to suit manufacturers' specifications.

Additional information can be obtained from the manufacturer.

### ELECTRO-VOICE MICROPHONE

A small size high-fidelity velocity microphone has been announced by the Electro-Voice Manufacturing Co., 332 E. Colfax Ave., South Bend, Ind. The microphone features: zero-cavity resonance, integral shock absorber and reduced feed back, it is



said. It is claimed to be especially suitable for tropical service.

The manufacturer will be glad to supply a catalog.

### IRC PRECISION RESISTOR

To meet the need for a small precision resistor in values up to  $1\frac{1}{4}$  megohms, the International Resistance Co., 401 North Broad St., Philadelphia, Pa., has introduced a new IRC Precision wire-wound resistor



known as Type WW-5. This is made in ranges from 500,000 ohms to  $1\frac{1}{4}$  megohms.

Additional information may be obtained from the manufacturer.

### HAMMARLUND I-F

A new group of iron core i-f transformers are now being made by the Hammarlund Manufacturing Company, Inc., 424 West 33rd St., New York City.

These new transformers are said to provide high gain per stage together with extremely sharp selectivity. Specially developed finely powdered high permeability magnesium alloy, rust proof and non-corrosive, is used for the core. This core is claimed to afford a great increase in inductance, thus permitting a reduction in the number of winding turns and consequently greatly reducing eddy current losses.

### VOCAGRAPH LOW PRICE LINE

In an announcement to distributors Vocagraph is offering a Series Thirty p-a line in the low price field. Three basic chassis are offered 10 watts, 18 watts and 30 watts.



Complete systems and portable units are also offered.

Descriptions and technical data are available from Electronic Design Corp., 164 N. May St., Chicago.

### ARCTURUS 5W4G TUBE

Arcturus Radio Tube Company, Newark, New Jersey, announces a new 5W4G rectifier for use in a-c receivers. The electrical characteristics of this new Arcturus 5W4G remain unchanged, but the mechanical construction has been altered after considerable investigation and collaboration with several leading set manufacturers.

This change enables a set manufacturer to utilize any chassis arrangement with respect to the rectifier tube and r-f coils. Exhaustive tests in the laboratories of set manufacturers disclosed a general tendency of 5W4G's, when placed next to an r-f coil, to cause noise in the receiver when the tube was vibrated ever so slightly. The new Arcturus construction is said to eliminate this noise regardless of vibration or the position of the r-f coil and results in quiet set operation.

### C-D ETCHED FOIL ELECTROLYTICS

The accompanying illustration reveals the inside story of Cornell-Dubilier's etched foil dry electrolytics. This compact unit, type JR, is first dipped in wax, then encased in an inner cardboard container which is vacuum impregnated. Into the space between the inner liner carton and the condenser section a special asphalt compound which surrounds and hermetically seals the condenser unit is poured. After passing C-D's test requirements, the condenser is sealed in a silvered cardboard



container equipped with universal flanges for mounting.

Additional information on these and other condenser products may be obtained from Cornell-Dubilier Corp., South Plainfield, New Jersey.

## No More Headaches!

This NEW MUTER Chart Simplifies Ballast Tube Replacements.



Jobbers told us, "this ballast tube replacement business is a headache, why doesn't somebody do something about it?" So we did. The new MUTER chart shows the correct replacement unit for every make and model of set. In addition, a cross-reference listing simplifies your inventory. With just a few MUTER ballast tubes, you can meet practically every replacement requirement. No more disappointed customers! No more lost profits! No big slow-moving inventories! And remember, the MUTER line of metal ballast tubes is the sweetest you ever saw. They are standard equipment by many leading set manufacturers. Take this easy step to bigger profits! Get this MUTER Ballast Tube Chart. Your copy is ready. Address Dept. S-9 TODAY!

**THE MUTER COMPANY**  
1255 South Michigan Ave., Chicago, Illinois

Discontinue MUTER Products	
MUTER METAL BALLAST TUBE REPLACEMENT CHART	
Make and Model	MUTER Part No.
PACIFIC	5308
5310	5309
5311	5310
5312	5311

## "ASK ANY MECHANIC" he'll tell you

IF IT'S QUALITY YOU'RE LOOKING FOR, REMEMBER THE NAME KRAEUTER



That's because Krauter Pliers do the job quicker and better. As, for example, the diagonal cutting pliers 4601 shown here, made especially for close cutting and precisely fitted for exact work.

**KRAEUTER & CO., Newark, N. J.**  
(Pronounced KROY-TER)  
Manufacturers of Highest Quality Pliers and Tools Since 1860

## MILLION TUBE AND CONDENSER TESTERS



**MODEL CP**  
Net Cash Dealer **\$13.95**

D'Arsonval Good-Bad meter test all types and leaks, hot with neon. Line voltage adjustment. Bypass and electrolytics.

**MODEL TM**  
Dealer's Net Cash **\$16.95**

Large square meter and continuous line voltage adjustment.

**MILLION RADIO AND TELEVISION LABORATORIES** 671 W. Ohio St. Chicago, Illinois

## Curtis Electrolytic CONDENSERS



A complete line of "Standard," "Blue Ribbon," and Exact Duplicate Condensers to meet all requirements.

Patent No. 1,950,352

Write for complete catalog.

**CURTIS CONDENSER CORPORATION**  
3088 WEST 106TH ST. CLEVELAND, OHIO

## RADIO AMATEUR CALL BOOK

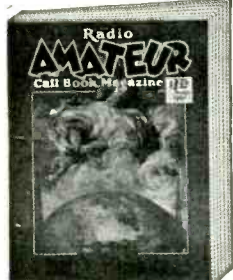

is the only publication listing all radio amateurs throughout the entire world. It also includes a complete list of High Frequency Commercial Stations, International Abbreviations and "Q" Signals, High Frequency Press and Weather Schedules, "Q", "R" and "T" Signals, U.S. Radio Inspection Districts, International Prefixes.

Every radio amateur should have a copy of this valuable book. Always up-to-date, published quarterly, single copies \$1.25, annual subscription \$4.

**RADIO AMATEUR CALL BOOK, Inc.**  
612 So. Dearborn Street Chicago, Illinois

## MORE PROFIT PER SERVICE CALL



**Meissner**  
Dual Universal WAVE TRAP

The only Wave Trap that will eliminate both channels of interference at the same time. Serves two purposes. Suppresses code and noise interference at intermediate frequencies and at the same time eliminates interference from a station in the broadcast or police band. The dual control makes this possible. Note: Beautiful large counter display card furnished FREE. Sold by all leading jobbers.

Cat. No. 8046 . . . . . List Price \$2.65

**MEISSNER MFG. CO.**  
Mt. Carmel - Illinois

## ★ ALWAYS CARRY Ken-Rad Radio Tubes

Ken-Rad genuine all-metal radio tubes are dependable. They give outstanding performance. Write for information.

**KEN-RAD TUBE & LAMP CORP., INC.**  
Owensboro, Ky.

Also manufacturers of Ken-Rad Incandescent Electric Lamp

## BETTER SERVICE MORE PROFIT

A Complete Line of Radio Parts For Service Men Under One Trade Name



Condensers  
Resistors  
Tubes  
Transformers  
Vibrators  
Volume Controls  
Antenna Kits

**SERVICE TO THE RADIO INDUSTRY**

If You Are Handicapped in Rendering SERVICE to Your Customers and or—if You Are Handicapped in Realizing Sufficient PROFIT for Yourself and—if Your Reputation Warrants Our Assistance—  
Send for Details and Application Blank to  
**AMERICAN APPLIANCE ASSOCIATES, INC.**  
Central Terminal Bldg., Albany, N. Y.

**FREE CATALOG**

**THE MOST COMPLETE OF ITS KIND IN THE INDUSTRY**

Every Amateur, dealer, jobber, serviceman needs this brand new catalog . . . *just off the Press!* It's the most complete in its field in the entire Radio Industry! Over 3,000 items are listed including: All-Wave Antennae, Auto Antennae, Master Antennae, Antenna Accessories and Hardware. Insulators of all kinds including X'mitting, Standoff and Feedthru types; sockets, jacks and plugs. A most complete catalog of wires, conductors and cables. A new line of colored insulated test leads, prods, phone tips, etc. A department of Auto Radio Essentials. Keep this big new illustrated catalog handy for it lists all the quality products made by *Birnbach* . . . one of the oldest and most highly respected names in Radio. Address Dept. S-9.

**GET YOUR FREE COPY TODAY**

**BIRNBACH RADIO CO.**  
145 HUDSON ST. BIRCO NEW YORK, N. Y.

**CINAUDAGRAPH**

*Speaker*

**CINAUDAGRAPH Magic Magnet Speakers**

—extensively utilized by all leading radio receiver and P. A. equipment manufacturers—are available in a complete range of sizes from 5½ to 18 inches, to meet your every radio requirement.

If you demand utmost dependability and fidelity of reproduction from your equipment—in-sist on Cinaudagraph P. M. speakers. Carried in stock by all progressive distributors. Free descriptive literature on request.

**CINAUDAGRAPH CORPORATION**  
Speaker Division • Stamford, Conn.

**HIGHLIGHTS—continued**

**UNITED SOUND PRICE INCREASES**

The United Sound Engineering Co., 2233 University Ave., St. Paul, Minn., announce a general increase in prices on their entire line. New price sheets may be obtained upon request.

**CENTRALAB CATALOG**

Centralab has published a twelve-page catalog covering their line of volume controls, fixed resistors, selector switches and auto-radio noise suppressors.

Copies of the catalog may be obtained from Centralab, 900 E. Keefe Ave., Milwaukee, Wis.

**WRIGHT-DECOSTER BOOKLET**

Wright-DeCoster, Inc., 2233 University Avenue, St. Paul, Minn., have released a booklet illustrating and describing their "Talk-Bak" equipment.

Copies of the booklet may be obtained from Wright-DeCoster.

**ATLAS RESISTOR CATALOG**

The Atlas Resistor Co., 423 Broome Street, New York City, have published their latest catalog, No. 8. Copies may be obtained directly from Atlas.

**MASTER ANTENNA MANUAL**

A Master Antenna System Manual may be had by writing the Technical Appliance Corp., 17 East 16 St., New York City. This latest edition covers the profit-making possibilities of the master antenna system as applied not only to apartment houses and other large buildings, but also to individual dwellings wherein many radio set outlets are required. It deals with the theory, installation and operation of such a system, as well as the survey of buildings and estimating.

**CLOUGH-BREngle APPOINTMENT**

Eugene Carrington has joined the personnel of the Clough-Brengle Co., 2817 W. 19 St., Chicago. He will head a newly formed division.

**SPRAGUE BULLETIN**

Sprague Products Co., North Adams, Mass., have issued a bulletin announcing price reductions on their TC tubular condensers.

Copies of the bulletin may be obtained from the manufacturer.

**JEFFERSON BULLETIN**

Bulletin PA-14 describing Jefferson automatic bias for Class "B" modulators has been published by Jefferson Electric Co., Bellwood, Ill. The bulletin contains, besides a general engineering discussion of the principles involved, complete diagrams of circuits and necessary instructions.

**ARCTURUS TUBE DEALS**

A new equipment deal by which dealers and Service Men can obtain shop equipment at practically no cost to them has been announced by the Arcturus Radio Tube Co., Newark, N. J. The full lines of Supreme and Clough-Brengle equipment are available, including tube testers, set testers, oscilloscopes, analyzers, signal generators, combination unit assemblies and many others. A Neon sign and two models of portable typewriters are also included.

Details of the deal may be obtained directly from Arcturus.

*Radiojac*



A new Tool to support your chassis  
Patent Pending

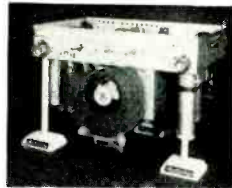

**\$1.60**

plus 10c for Postage

Money Back Guarantee

- Whatever system you are using, how often do you swear in supporting your chassis?
- Here's a NEW TOOL that saves your time, temper and patience. From a handy benchstand, requiring only 2½" x 9" of space, you can readily select any length of support—simply insert the needed rods (which have a spring-tight fit) into respective bases, and presto—you have a substantial support for any chassis without screwing or clamping.
- The only device which will accommodate all sets, old or new, small or large.
- Invented by an old-time Serviceman for the Serviceman.
- Set includes benchstand, 36 hardwood rods, varying in length from 1½" to 8", 1 large and 3 small bases.

Order yours today

(If sent C.O.D. there is a small additional charge.)

**COOKS MFG. COMPANY**  
274 Mile Square Rd., Yonkers, N. Y.  
Distributors—write for particulars.

**UNIVERSAL VELOCITY MICROPHONES**



- 100% Performance
- 100% Appearance
- 100% Satisfaction
- or
- 100% Refund

Made in the following impedances. 33 ohms for dynamic mike lines. 200 ohms to connect to carbon mike inputs. 500 ohms for telephone and remote lines. 10,000 ohms high impedance direct to grid. Not affected by heat, cold or moisture.

**JOBBERS**

Write for refund guarantee plan that will double your sales and satisfy every customer.

MICROPHONE DIVISION  
**UNIVERSAL MICROPHONE CO. LTD.**

422 WARREN LANE  
INGLEWOOD, CALIF., U. S. A.



# BOGEN SOUND SYSTEMS

## ALWAYS FIRST WITH THE LATEST

This organization has not been content merely with keeping abreast of modern trends and developments. Repeatedly we have been

"FIRST WITH  
THE LATEST."

In keeping with this policy, we will present for the first time in commercial sound equipment—

## BINAURAL AMPLIFICATION

AND

## ELECTRONIC TONE CORRECTION

Don't fail to hear these radical and different methods of sound amplification. On display at

**Booth No. 14**  
COMMERCE HALL  
NATIONAL TRADE SHOW  
NEW YORK CITY — OCT. 1-3

**DAVID BOGEN CO., Inc.**  
663 BROADWAY  
NEW YORK CITY

## PIONEERS IN PUBLIC ADDRESS DEVELOPMENT

Make advertising space  
reservations NOW for  
OCTOBER "peak sales"  
issue of

## SERVICE

Last forms close October 5th

## HIGHLIGHTS—continued

### MARCONI MEMORIAL

It has been announced in the press and over the radio that the Veteran Wireless Operators Association has launched a Marconi Memorial Fund, the purpose being to erect a monument commemorative of the ideals and achievements of the inventor of wireless telegraphy, Guglielmo Marconi, number one veteran of their association.

The Fund was started by the contribution of \$100.00 by VWOA's President, William J. McGonigle, for the association. Mr. David Sarnoff, President of the Radio Corporation of America, was the second subscriber with a contribution of \$1000.00. Mr. Alfred J. McCosker, President of Radio Station WOR and Chairman of the Board of the Mutual Broadcasting System, was the third contributor.

In general the Fund will be solicited from organizations engaged in the radio field: communications, manufacturing, amateurs, etc., and their employees—the people most likely to know of his outstanding achievements and desirous of participating, by contribution, in the erection of a "living tribute" to this truly great man.

A committee composed of outstanding men in the radio field will be appointed to pass upon a suitable design and site for the monument. Designs will be solicited from prominent American sculptors. Mr. Sarnoff has expressed his willingness to head this committee.

Contributions and communications should be mailed to the Marconi Memorial Fund, Veteran Wireless Operators Association, RCA Building, 30 Rockefeller Plaza, New York City.

### WARD TROLLEY AERIAL

James Waechter, superintendent of Ward Products Corp., 1740 E. 12 St., Cleveland, Ohio, says, "In introducing the Trolley aerial Ward products has produced its 1,000,000th automobile aerial."

The Trolley aerial is known as the Model E.S.

Descriptive literature on Ward products may be obtained upon request.

### G.E. CAPACITOR CATALOG

The General Electric Co., Schenectady, N. Y., have issued a 6-page folder illustrating and describing their small pyranol capacitors for motors and other equipment.

Copies may be obtained upon request.

### BOOK REVIEW

*SERVICING WITH SET ANALYZERS*, by H. G. McEntee, published by Radcraft Publications, Inc., 99 Hudson St., New York City, 63 pages, price 50 cents.

This book has been written principally for the Service Man and covers the fundamental theory and application of modern set analyzers and associated apparatus. It contains chapters on analyzer principles, trouble shooting with set analyzers and testing equipment. The chapter on "Commercial Testing Equipment" gives data on available equipment. A chart of the RMA socket numbering system is also included.

## New Business for SOUND ENGINEERS

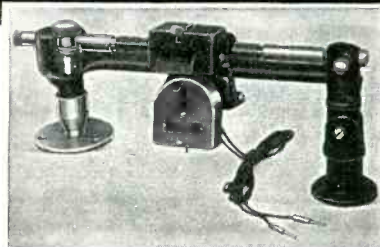

● You can attach the Presto 112-D recording mechanism to any radio-phonograph combination to record radio programs off the air. No pregrooved records needed. The Presto mechanism cuts the groove as it records the sound—makes permanent high quality records that can be played 50 times or more on any phonograph.

*New price to PA and servicemen complete with installation data, \$64.00.*



# PRESTO

RECORDING CORPORATION  
145 West 19th St., N. Y. C.

Be sure to visit  
the  
NEW YORK  
RADIO TRADE SHOW

October 1 - 2 - 3

Commerce Hall  
Port of N. Y. Authority Building  
Eighth Avenue and 15th Street



## FUNCTIONAL DESIGN

"V" Series Velocity Microphones

The smooth trim lines and screen housing are more than just style. They contribute to the top performance that typifies the "V" Series. No side-wall reflection. No resonance.

Priced from \$25 to \$75 list.

Write for catalog. See your jobber.

### ELECTRO-VOICE MFG. CO.

332 E. Colfax Avenue, South Bend, Ind.

Export Office: 100 Varick Street, New York City

## RACON P. M. Units

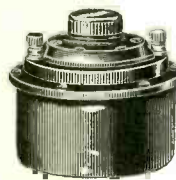

An efficient permanent magnet horn unit requiring no outside excitation. Aluminum nickel steel magnets are used to supply maximum flux density in the air gap. Cast bronze case, completely enclosed, making Unit water tight.

15 ohm impedance at 1000 cycles. Continuous operating capacity 10 watts.

Peak load capacity 30 watts.

RACON'S catalog S-9 describes the complete line of Horns, Electro-dynamic Units and Acoustical Sound Projectors.

### RACON ELECTRIC CO., INC.

52 EAST 19th STREET

NEW YORK CITY

## INSIST ON WARD AERIALS!

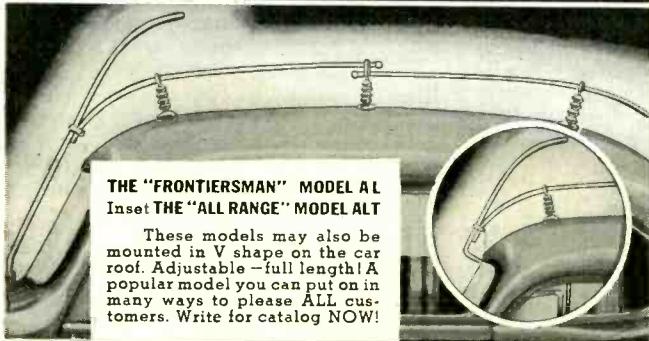

THE "FRONTIERSMAN" MODEL AL  
Inset THE "ALL RANGE" MODEL ALT

These models may also be mounted in V shape on the car roof. Adjustable - full length! A popular model you can put on in many ways to please ALL customers. Write for catalog NOW!

### The WARD PRODUCTS Corp.

WARD BUILDING CLEVELAND, OHIO

## RADIO IN ITS ENTIRETY!



"B-A" serves the trade with every need in radio. Complete 160-page catalog of radio receivers, public address systems, parts, supplies and equipment is now available. You will find your favorite nationally known lines represented in this big book. Orders will be shipped the same day as received.

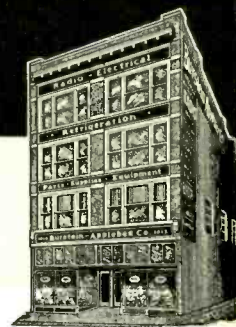

### BURSTEIN-APPLEBEE CO.

1012-14 MCGEE ST.  
KANSAS CITY, MO.

### UP-TO-DATE CATALOG AVAILABLE

## INDEX TO ADVERTISERS

A	H	R
Aerovox Corp. .... 578	Halldorson Co., The ..... 583	RCA Mfg. Co., Inc. .... Fourth Cover
Allied Radio Corp. .... 577	Hygrade-Sylvania Corp. .... 571	Racon Elec. Co., Inc. .... 590
American Appliance Associates, Inc. .... 587		Radiart Corp., The ..... 581
American Tel. & Radio Co. .... 583	I	Radio Amateur Call Book ..... 587
Amperite Co. .... 517	International Resistance Co. .... 550-551	Radiotechnic Lab., The ..... 573
Areturus Radio Tube Co. .... 541	J	Raytheon Production Corp. .... 518
Atlas Resistor Co. .... 576	Jensen Radio Mfg. Co. .... 543	Readrite Meter Works ..... 519
B	K	Rider, John F., Publisher ..... 559
Bell Sound Systems, Inc. .... 575	Ken-Rad Tube & Lamp Corp., Inc. .... 587	S
Birnbaeh Radio Co. .... 588	Kraeuter & Co. .... 587	Shure Brothers ..... 578
Bogen Co., Inc., David ..... 589	M	Simpson Electric Co. .... 547
Brush Development Co., The ..... 585	Mallory & Co., Inc., P. R. Second Cover, 545	Solar Mfg. Corp. .... Third Cover
Burstein-Applebee Co. .... 590	Meissner Mfg. Co. .... 587	Standard Transformer Corp. .... 573
Burton-Rogers Co., The ..... 575	Milton Radio & Tel. Labs. .... 587	Supreme Instruments Corp. .... 515
C	Muter Co., The ..... 587	T
Centralab ..... 561	N	Technical Appliance Corp. .... 565
Cinaudagraph Corp. .... 588	National Union Radio Corp. .... 575	Thordarson Elec. Mfg. Co. .... 539
Clarostat Mfg. Co., Inc. .... 585	O	Trind Mfg. Co., Inc. .... 583
Clough-Brengle Co., The ..... 579	Ohmite Mfg. Co. .... 516	Triplett Elec. Inst. Co. .... 553
Continental Carbon, Inc. .... 583	Operadio Mfg. Co. .... 569	Triumph Manufacturing Co. .... 576
Cooks Mfg. Co. .... 588	P	Tung-Sol Lamp Works, Inc. .... 520
Cornell-Dubilier Electric Corp. .... 513	Precision Apparatus Co. .... 557	U
Cornish Wire Co., Inc. .... 511	Presto Recording Corp. .... 589	United Transformer Corp. .... 555
Curtis Condenser Corp. .... 587		Universal Microphone Co., Ltd. .... 588
D	Q	Utah Radio Products Co. .... 571
DuMont Labs., Inc., Allen B. .... 581	R	W
E		Ward Leonard Elec. Co. .... 585
Electronic Design Corp. .... 579	S	Ward Products Corp. .... 590
Electro-Voice Mfg. Co. .... 590		Webster-Chicago ..... 507
Epiphone, Inc. .... 576	T	Weston Elec. Inst. Corp. .... 537
G		Wright-DeCoster, Inc. .... 585
General Electric Co. .... 581	Y	
General Transformer Corp. .... 581	Yaxley Manufacturing Division Second Cover, 545	

### SOLAR DRY ELECTROLYTICS

High voltage breakdown; low leakage; long life; freedom from corrosion; operate at low and high temperatures . . . . .



### SOLAR WET ELECTROLYTICS

Surge-proof; high effective capacity; remarkable idling characteristics . . . . .



### SOLAR PAPER CAPACITORS

High overload voltage; long life; excellent moisture seal; low R.F. impedance . . . . .

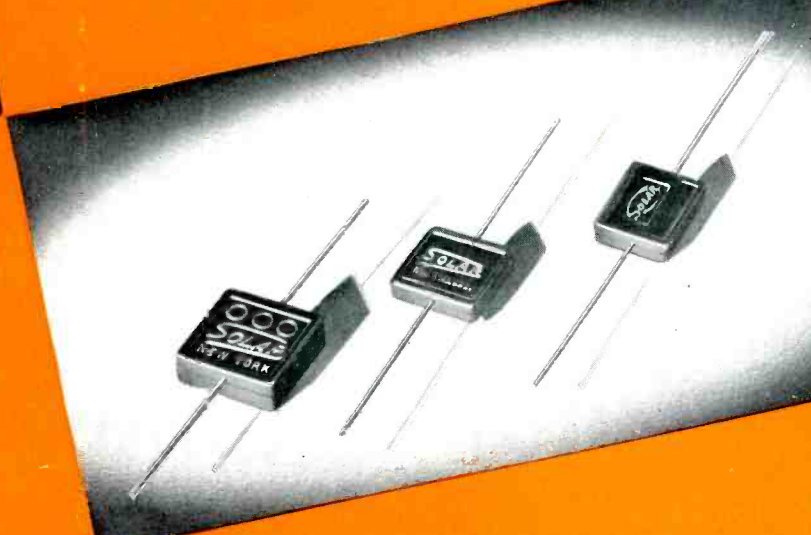

### SOLAR MICA CAPACITORS

Low R.F. losses; capacity stable through wide temperature variations . . . . .

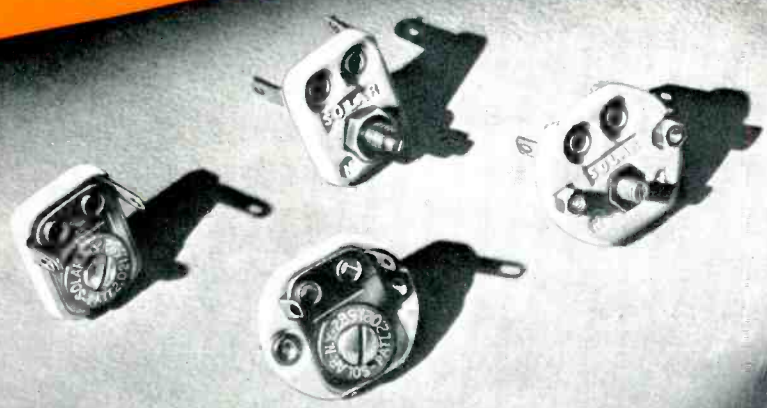

### SOLAR TRIMMER AND PADDING CAPACITORS

Low R.F. losses; constant capacity after setting; smooth adjustment; rugged mechanical construction . . . . .

SOLAR MFG. CORP.  
599-601 BROADWAY, NEW YORK

# GET FAMOUS RCA 3-POINT SERVICE SYSTEM FREE!

ACT NOW! Offer good during September only!

## HERE'S WHAT YOU GET— FREE! an \$8<sup>75</sup> value!



**RCA Radio Service Tip File**  
—to help you solve difficult service jobs

Hundreds of service men sent us radio service tips, telling how they licked difficult jobs. We selected 420 of the Tips, printed them on 3" x 5" cards, and put them in this handsome steel file—for YOU! These Tips have helped hundreds of men in your business to successfully apply the other fellow's experience to their own jobs. Tips contain radio set names, model number, type of trouble and solution—plus diagrams when necessary. Filing case comes complete with 420 cards. Will hold 700 additional. Value, \$5.00



**By JOHN F. RIDER**

and J. Van Newenhizen—"Radio Service Business Methods"—tells how to get most profit from your business

This authoritative book tells you all you want to know about the profitable operation of your business. It goes into great detail, answers all operation queries. Shows you how to run your business. Value, \$3.00



**"101 SERVICE SALES IDEAS"**

—proved ways of getting business!

Every idea has produced business! The ideas were sent to us by dealers and service men who used them successfully. They're all classified—making them easy for you to use. Value, 75¢.

**Plus RCA Victor Receiver Alignment**

—a new book showing how to align with Cathode Ray Equipment.

## AND HERE'S HOW!

All you do to get the valuable and complete RCA 3-Point Service System free, is to buy any *one* of the eight RCA instruments listed below! This generous offer is good only during September. So act NOW! PLACE YOUR ORDER AT ONCE WITH YOUR LOCAL RCA PARTS DISTRIBUTOR.

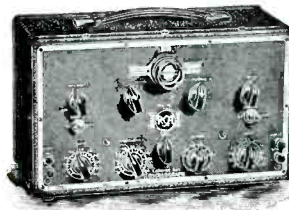

Stock No. 151  
One-Inch Oscillograph  
\$47.50



Stock No. 150  
Electronic Sweep  
Oscillator \$64.50



Stock No. 9633  
Beat Frequency Oscillator  
\$64.50



Stock No. 9545  
Three-Inch Oscillograph  
\$84.50

### NOT ILLUSTRATED

Stock No.		
9558	Frequency Modulator . . . . .	\$27.50
9572	Piezo Electric Calibrator . . . . .	29.95
9595	Test Oscillator (Battery) . . . . .	34.50
9600	Universal AC Bridge . . . . .	49.65



# Parts FOR PROFIT

RCA MANUFACTURING COMPANY, INC., CAMDEN, N. J.  
A SERVICE OF THE RADIO CORPORATION OF AMERICA