

Out the Window with Guesswork!

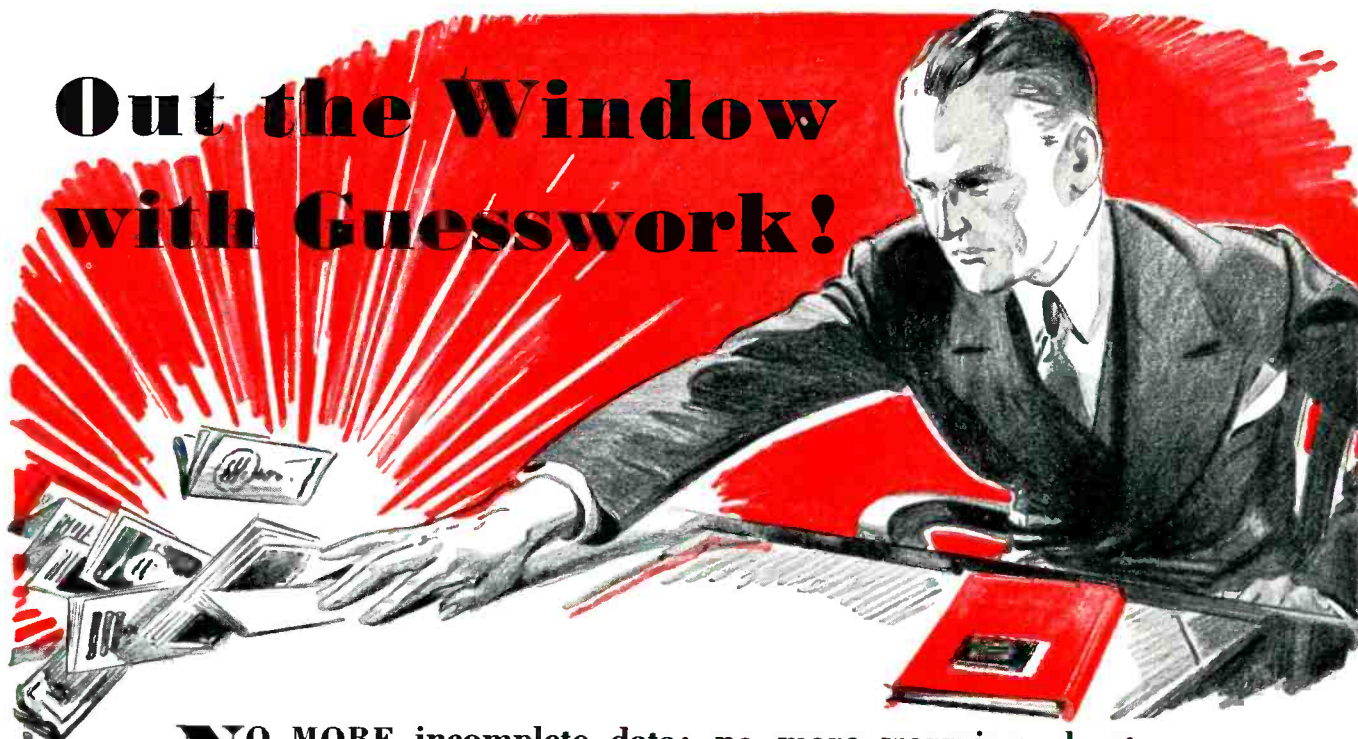

NO MORE incomplete data; no more worrying about inaccuracy; no more frenzied hunting for information you can't find; no more experimenting at your own expense; no more advice to buy from manufacturers long since out of business; no more cross listings that double cross your thinking. No more—

But what's the use! It's just a case of no more guesswork, no more time wasting when you get your copy of the new—

MALLORY-YAXLEY Radio Service Encyclopedia



Here for the first time—under one cover—is concise, complete, authoritative information on *all* repairing of *all* sets. Chuck-full of notes on tricky installations—*all* the references anyone can need—conveniently and simply arranged.

Thousands of servicemen who have bought their copies say "the book is a life saver"—the finest help they have ever had. They are tickled to death with this "All in One" Book—all the information on Circuits—Schematics, I. F. Peak Frequencies, Transformer Circuits, Condensers, Volume Controls, Vibrators and Tubes—in *one* book, on one page, on one line for any receiving set.

Over 200 pages of exact information. Bound in waterproof, washable cloth and printed on paper that stands the gaff...it is a permanent working reference.

We have prepared this Encyclopedia for you. Your Mallory-Yaxley distributor has your copy ready for you to examine. Your share of the cost is a trifle. Buy the book—if in a week it does not pay its way, if you would part with it for twice what you paid for it—return the book and get your money back. But act today; the edition is limited.

Use
P. R. MALLORY & CO., Inc.
MALLORY
REPLACEMENT
CONDENSERS...VIBRATORS

P. R. MALLORY & CO., Inc.
INDIANAPOLIS INDIANA
Cable Address—PELMALLO

Use
YAXLEY
REPLACEMENT
VOLUME CONTROLS

1917

FIRST HIGH-VACUUM TUBES

Following the development of high-vacuum tubes for experimental purposes, General Electric Company received the first commercial order for receiving tubes, to be manufactured in quantity, from the U.S. Government. These vacuum tubes played an important part in the communication systems of the Allies during the World War.

1913

COOLIDGE'S X-RAY TUBE

One of the most important inventions of the G-E "House of Magic." This was the first pure electron device commercially made. It has contributed much to the health and comfort of mankind.

1921

BATTERY RECEIVING TUBES

The perfection and manufacture of Types UV-199, -200 and -201-A by General Electric Company played a large and important part in popularizing radio as a source of enjoyment in the home. These were the first radio tubes known to the public.



1935

ORIGINATED ALL-METAL TUBE

The use of metal to supersede glass in vacuum-tube design and manufacturing technique was another General Electric contribution to the advancement of the radio art. Small and sturdy, "sealed-in-steel," metal tubes produce more stable and finer reproduction—especially on short-wave stations.

1927

SCREEN GRID TUBES

As early as 1924, General Electric engineers turned their attention to the perfection of the screen-grid tube. In 1927 the tube was perfected and regular production started. This tube's high amplification factor, together with its stability of operation, made possible a new era in radio circuit design.

FOR CUSTOMER SATISFACTION, SPECIFY G-E RADIO TUBES

GENERAL ELECTRIC

APPLIANCE AND MERCHANDISE DEPARTMENT, GENERAL ELECTRIC COMPANY, BRIDGEPORT, CONNECTICUT

SERVICE

A Monthly Digest of Radio and Allied Maintenance

Reg. U. S. Patent Office. Member, Audit Bureau of Circulations

EDITOR

Robert G. Herzog

MARCH, 1937

VOL. 6, NO. 3

EDITORIAL CONTENTS

FEATURES

*An A-C, D-C Portable Amplifier By Nathan I. Daniel	170
Extra Dividends for the Service Man By Bernard H. Porter	140
*Inverse Audio Feedback (G.E.)	139
*Modernizing Receivers With P-A Amplifiers By I. A. Mitchell	168
Regulating Electrolytic Condensers By Paul MacKnight Deeley	141
*Servicing With the Test Oscillator By Glenn Browning	137
*The Vacuum-Tube Voltmeter By O. J. Morelock, Jr., and Harold L. Olesen	175

ANTENNA

.....	134
-------	-----

ASSOCIATION NEWS

.....	178
-------	-----

AUTO RADIO

*Arvin "Phantom Filter"	166
*Bosch 838	162
*Zenith 5520 (5-M-191)	164

BOOK REVIEW

.....	191
-------	-----

GENERAL DATA

*Bass Attenuation By E. M. Prentke	177
Checking Alignment	177
*Inverse Audio Feedback (G.E.)	139
Parasitic Oscillations By Francis C. Wolven	177
*RCA 15U	142
RCA 125, 225—Service Note	187
Regulating Electrolytic Condensers By Paul MacKnight Deeley	141

*Servicing With the Test Oscillator By Glenn Browning	137
Stromberg-Carlson 145, 150, 160, 180 Service Note	166
Technical Features of 1937 Sparton Radio Receivers	146
*The Vacuum-Tube Voltmeter By O. J. Morelock, Jr. and Harold L. Olesen	175
Type 5T4 Full Wave Rectifier	139
*Westinghouse WR-315	158

HIGHLIGHTS	190
------------------	-----

MANUFACTURERS	180-182-184
---------------------	-------------

ON THE JOB	177
------------------	-----

PUBLIC ADDRESS

*An A-C, D-C Portable Amplifier By Nathan I. Daniel	170
*Bass Attenuation By E. M. Prentke	177
*Inverse Audio Feedback (G.E.)	139
*Modernizing Receivers With P-A Amplifiers By I. A. Mitchell	168

TEST EQUIPMENT

Checking Tubes By L. Baw	177
Dressing Up the Service Bench By Jim Kirk	177
*Servicing With the Test Oscillator By Glenn Browning	137
*The Vacuum-Tube Voltmeter By O. J. Morelock, Jr. and Harold L. Olesen	175

An asterisk preceding a listing indicates that a circuit accompanies the text.

BRYAN S. DAVIS
President

JAS. A. WALKER
Secretary

Chicago Office—608 S. Dearborn St.—C. O. Stimpson, Mgr.

Telephone: Wabash 1903

Wellington, New Zealand—Tearo Book Depot.

Published Monthly by the

Bryan Davis Publishing Co., Inc.

19 East 47th Street

New York City

Telephone: Plaza 3-0483

SANFORD R. COWAN
Advertising Manager

PAUL S. WEIL
Eastern Advertising
Manager

A. B. CARLSEN
Circulation Manager

Cleveland Office—10515 Wilbur Ave.—J. C. Munn, Mgr.

Telephone: Republic 0905-J

Melbourne, Australia—McGill's Agency.



Entered as second-class matter June 14, 1932, at the Post Office at New York, N. Y., under the Act of March 3, 1879. Subscription price \$2.00 per year in the United States of America and Canada; 25 cents per copy. \$3.00 per year in foreign countries; 35 cents per copy.

**"I'D TRUST WESTON
building a meter 40,000
times as sensitive as
this Neon Lamp!"**



The tiny Neon Lamp in your checker probably is the 1/4 watt size. The meter in the new Model 772 Analyzer consumes only 6 1/4 millionths of a watt . . . almost 40,000 times as sensitive.

THE
WESTON

MODEL 772

**Super-Sensitive
ANALYZER**

50 MICROAMPERES FULL SCALE

\$46⁵⁰
NET

To Dealers In U. S. A.



You can *do more . . . make more . . .* with the WESTON 772 Super-Sensitive Analyzer. With its big, 50 microampere meter . . . its sensitivity of 20,000 ohms per volt, resistance ranges *usable* up to 30 megohms, current measurements as low as 1/2 microampere . . . you can get into and thoroughly check *all* receiver circuits; including those you could not check with former servicing instruments. But, in addition, you can get *extra business—extra profit—servicing* sound movies, P.A. systems, photo-cell circuits, sensitive relay systems, and even television with Model 772. Introduced by WESTON just seven months ago, Model 772 has become standard equipment in most aggressive service shops . . . because

of its wide range of usefulness . . . its time-saving facility . . . its money-making ability . . . *and because WESTON builds it.* Servicemen recognize WESTON's years of experience and leadership in building the highly sensitive instruments for governments, scientific laboratories and for industry the world over, as the best guarantee that even a highly sensitive instrument like Model 772 will *stand up . . . serve dependably and profitably* for many years. Let us send you all the facts. Return the coupon today.

WESTON Instruments can be purchased on deferred payments through the WESTON Investment Plan.

WESTON
Radio Instruments

Weston Electrical Instrument Corporation, 604 Frelinghuysen Avenue, Newark, N. J.
Rush me complete data on WESTON Radio Instruments.

Name _____

Address _____

City _____ State _____

THE ANTENNA . . .

NEW AUTO-RADIO MODELS

THE RADIO MANUFACTURERS throughout the country have announced or are about to announce their newest line of auto-radio receivers. One manufacturer has added automatic frequency control. Others are featuring some form of noise balancing within the receiver circuits. Many have provided antenna couplers for use with the recent innovations in whip and over-the-top auto antennas. Practically all of the higher priced models use two speakers or provide for dual speaker installation. Permanent magnet dynamics are used in many instances.

Iron-core r-f and i-f transformers are also more predominant in the newer models. One manufacturer provides permanent pretuning of the iron-core i-f transformers. Another provides an iron-core antenna transformer with a tapped arrangement for matching to the particular installation.

Beam-power output tubes in metal and G types are quite prominent in several models and, in general, greater output is obtainable.

Controls are generally simpler and more easily adaptable to different automobile models. Practically all feature dash mounting of the remote control.

. . .

AUTO-RADIO SALES

WITH THE FIRST WHIFF of spring air the public turns to motoring in the great outdoors. In an effort to get the most out of the many hours spent on the road, 4,500,000 of the 26,000,000 passenger car owners have installed auto radios in their machines. Of these 2,400,000 have sets over two years old. Thus some 21,500,000 car owners ride without entertainment and, theoretically, there is a potential market for 23,900,000 auto-radio receivers—to say nothing of the continuous influx of new cars, without radios.

We have repeatedly pointed out in these columns that the Service Man is well equipped to make auto-radio sales. The best approach to this sales problem is by direct contact (lists of registered car owners are easily obtainable) or through mail advertising.

Another approach to the sales problem is through friendly local gasoline stations.

. . .

THIS SERVICE BUSINESS

A LONG AND ALMOST ENDLESS list can be given in answer to the question "What's wrong with the service business?" An equally long, if not longer list of so-called cures has been given. However, most of these cures apply to the service industry as a whole. No single Service Man could, in applying the cure, by any action on his part, materially improve his own or the industry's condition.

Alfred E. Teachman, known to SERVICE readers through his article on the impact generator, will offer cures applicable to the individual Service Man in an early issue of SERVICE.

. . .

INTERCOMMUNICATING SYSTEMS

QUITE A NUMBER OF THE manufacturers of amplifiers have added some form of intercommunicating equipment to their line. Because of the importance of this field to the Service Man the next issue of SERVICE will feature details and technical data pertaining to a number of these systems.

To Champion Jobbers' and Dealers' PROFITS

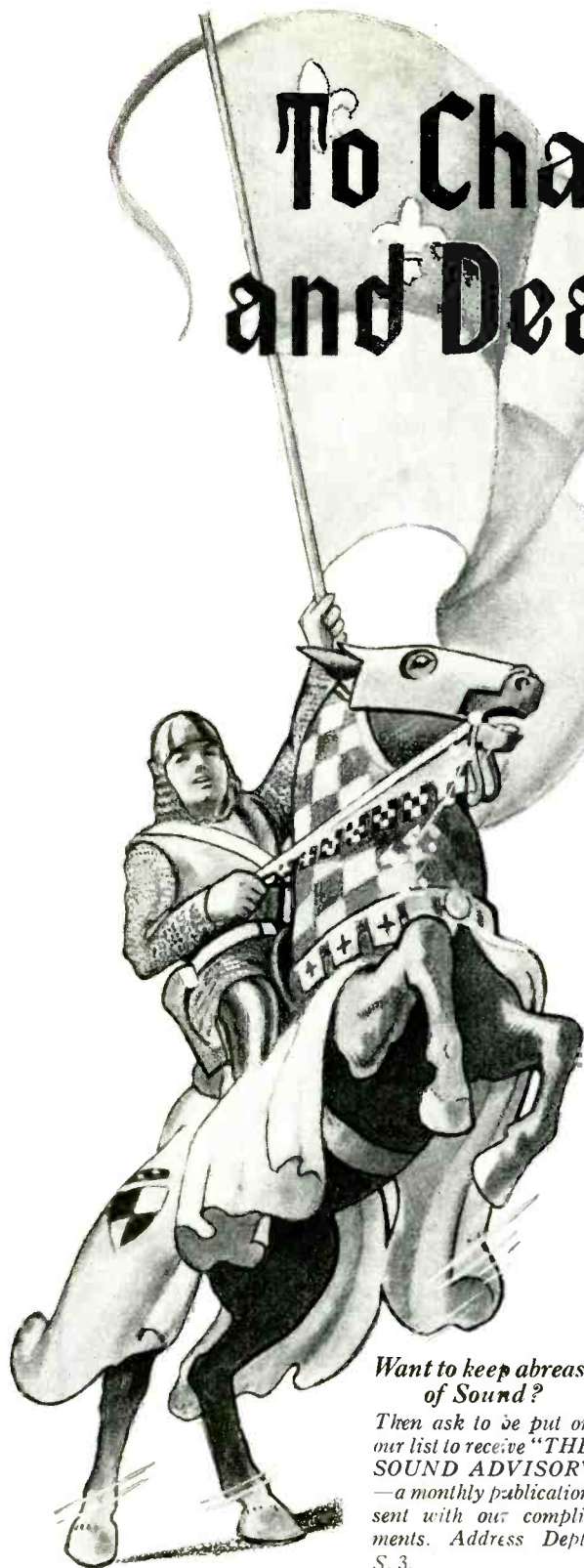

Want to keep abreast of Sound?

Then ask to be put on our list to receive "THE SOUND ADVISOR" — a monthly publication sent with our compliments. Address Dept. S. 3.

... has always been the policy from which we have never deviated. We offer not only a substantial profit to jobbers and dealers, but so conduct our business that you actually *make* those profits.

OPERADIO does not enter into competition with jobbers and dealers by selling direct to the consumer. Neither do we countenance, directly or indirectly, the practice of competing unfairly with our established outlets by selling *everyone* and *anyone* who can purchase our equipment and pay for it.

To maintain a policy which allows for protected profit taking ... to pass by the business of those who operate against our established jobber-dealer setup ... to refuse the business of the "price chiseler" ... those are the principles to which we subscribe.

Mr. Jobber and Mr. Dealer ... we submit that when you sell OPERADIO Sound and Public Address Equipment you make more money because you are dealing with a company who does not sell all comers at your expense.

★ **A NEW LINE?** ... Operadio does not obsolete jobbers' and dealers' stocks by bringing out a new line periodically. To be sure, progress demands that we give you the benefit of new developments as they are proved practical and saleable. Such new developments will be announced shortly.

OPERADIO

MANUFACTURING COMPANY ST. CHARLES ILLINOIS

A NAME LONG KNOWN FOR FAIR DEALING AND QUALITY IN SOUND AND PUBLIC ADDRESS EQUIPMENT

MARCH, 1937 •

SAV YOU SAW IT IN SERVICE

135

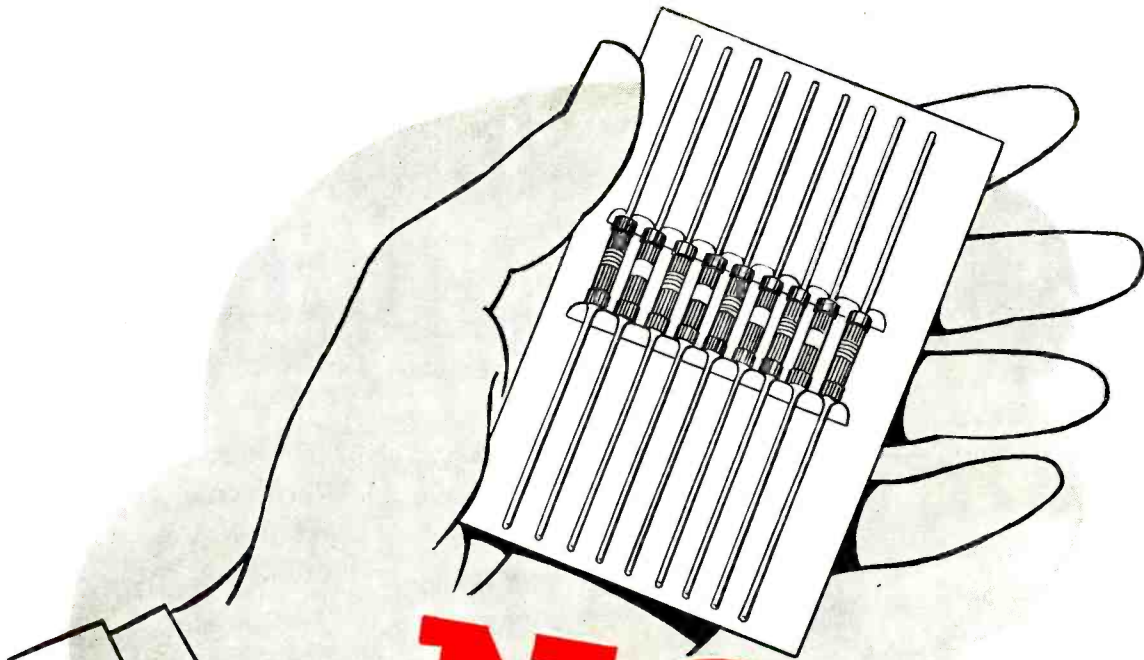

NOW!

SMALL END-LEAD RESISTORS

In a New and Convenient Package

- Still the same ceramic covered resistor, and like all Centralab Resistors, it is thoroughly insulated from all adjacent parts. The end leads permit conservation of space.
- Its smaller mass results in reduced capacity coupling of adjacent parts. • Resistor is 11/16" long, 1/8" diameter and has a rating of 1/2 watt. • Change to CENTRALAB for greater efficiency. » » »

CENTRALAB Division of Globe-Union Inc.
MILWAUKEE

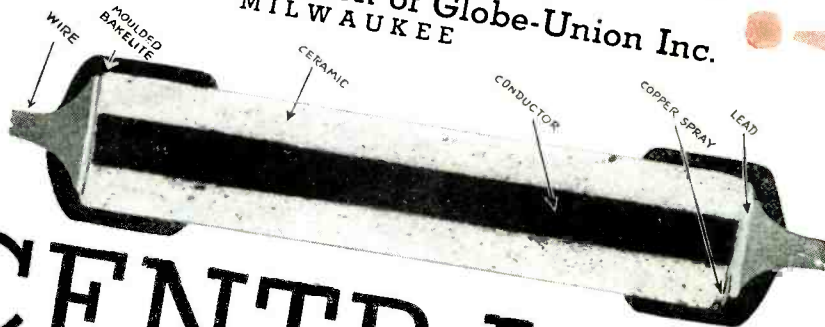

CENTRALAB

SERVICE

A Monthly Digest of Radio and Allied Maintenance

FOR MARCH, 1937

SERVICING WITH THE TEST OSCILLATOR

By GLENN BROWNING

AT this date, it might seem impossible that anything new can be written regarding that most essential of service instruments, the oscillator. However, an intimate contact with hundreds of Service Men, corroborated by the extensive experience of a well-known service editor, would indicate that few Service Men are making the most of this highly versatile equipment. True, every Service Man uses his oscillator for aligning r-f, oscillator and i-f circuits. Unfortunately, few Service Men expect their oscillator to do more.

Even this elementary job cannot be correctly performed, in many instances, without a theoretical and practical understanding of the additional possibilities of an oscillator. Most instructions for alignment warn the operator to keep his signal input way down, in order to prevent the avc action of the receiver from coming into play and making it difficult to peak the circuits accurately. Lack of sensitivity, with good tubes and

WIDELY KNOWN as a consultant and research engineer, the designer of the Browning-Drake and Browning 35 receivers and an instructor in radio servicing at MIT, the author of this article requires no introduction to the readers of SERVICE. It might be mentioned, however, that Mr. Browning's intimacy with prevailing service practices, as revealed in his service classes is largely responsible for these "post-graduate" notes in how to use an all-wave oscillator.

nothing obviously wrong with a receiver, almost invariably suggests the need for realignment. But lack of sensitivity is often due to inoperation of the avc delay circuit—the avc action affecting and cutting down the amplification of



The Hickok OS-10 oscillator used in making the measurements discussed herein.

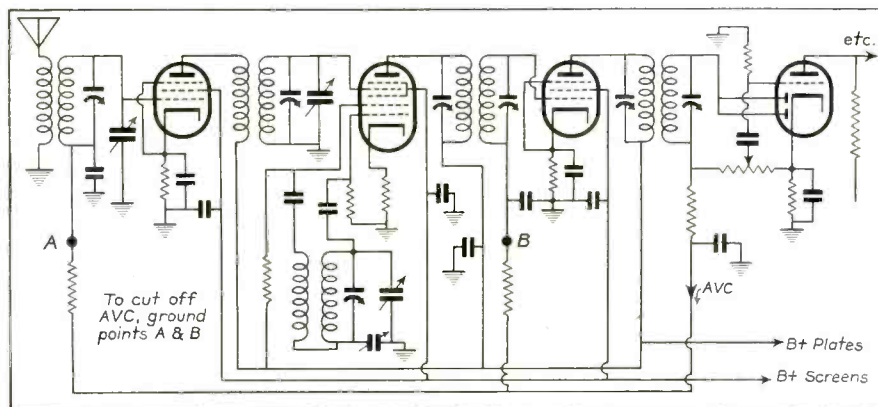

Fig. 2. Cutting out the automatic volume control in a conventional superheterodyne circuit for alignment or avc tests.

even the very weakest signal. When such a condition exists, alignment is next to impossible if the weakness of the input is relied upon to eliminate automatic control—and anyway, the fundamental cause of the trouble would have been overlooked. (It might be desirable to point out here that while a receiver should be aligned with the avc out, any final curves, or other forms of oscillatory inspection, should be made with the automatic volume control functioning. This provides a true picture of conditions as they exist under normal operation.)

CIRCUIT FAMILIARITY ESSENTIAL

It is essential that the Service Man be perfectly familiar with the circuits of his oscillator and output meter and that he study the circuit of the receiver before making tests in which the instruments are directly connected. Where d-c is present in the output, as when the meter is connected from the plate of an output tube to the chassis, a series

Overall Resonance Curve on Superheterodyne with One Stage R.F. and One Stage I.F. Amplifiers
Resonance curve taken at 1000 Kc., ± 4 Kc. AVC connected. Input constant, frequency varied. Output indicated on DB. meter.
Curve A—before proper alignment of antenna and R.F. trimmers.
Curve B—after antenna and R.F. trimmers properly adjusted for maximum output.

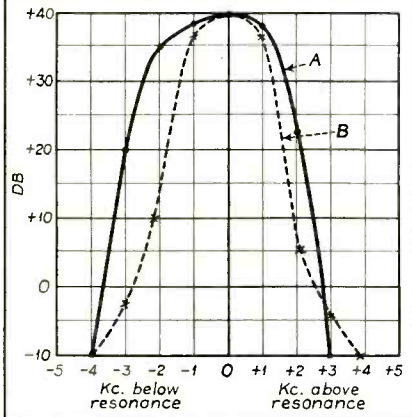

Fig. 3. Overall curves showing before and after alignment—a quick check made by a conscientious Service Man.

condenser should be used. If accurate db readings are desired the output circuits should be properly balanced. This, however, is not necessary for qualitative or for relative measurements.

Input circuits are usually upset when connected directly to the oscillator output due to the shunting over of bias resistors or of condensers and because of variations from normal operating impedance or capacitance. In some instances these effects will be negligible—in others they will give rise to fallacious curves and erroneous conclusions. When connecting to the antenna circuit, a standard dummy antenna should be used, or a satisfactory approximation such as a series 200-mmf condenser for the broadcast bands and a series 400-ohm resistor for the short-wave bands. In many cases it will be satisfactory to connect the high side of the oscillator output to a small antenna—a few feet of

Resonance Curve of I.F. Amplifier.
Resonance curve taken at 456 Kc. ± 5 Kc. AVC connected. Input voltage constant. frequency varied from 456 to 461 and from 451 to 456 Kc.
Note flat top on selectivity curve. This is due to triple-tuned, band-pass I.F. transformers.

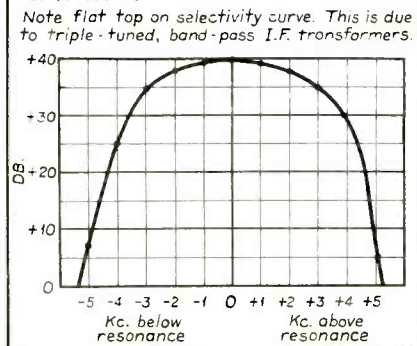

Fig. 4. This curve was made to determine sideband cutting in the r-f or i-f stages.

wire—and ground the low side. The receiver can then be connected to a standard aerial. The oscillator functions as a small transmitter affecting the receiver through normal operating coupling devices—i. e., transmitting and receiving antennae—thus duplicating conditions of actual operation. Reduction in the length of this antenna will provide additional attenuation where necessary.

CHECKING AVC ACTION

The avc action can usually be checked by varying the oscillator output from minimum up. There should be a direct and proportional rise in volume up to a certain point, and then the characteristic levelling off. A more accurate observation can be made by using a db meter or an output meter rather than relying upon the ear. If the automatic volume control seems to be functioning satisfactorily, alignment procedure can then be followed using low outputs from the oscillator—outputs below the point where the avc action began to function. (The above check demonstrates accurately just how much input the receiver can stand during alignment before the avc comes into play and broadens the curve.)

If the avc action is suspicious—or if the receiver has been brought in with a complaint of fading—it will be a good idea to check the set at various inputs, with and without the avc connected. The avc can usually be shorted out by grounding the low side of grid circuits affected by the automatic volume control. Fig. 2 is typical, and points A and B are grounded to eliminate the avc action. The following is a tabulation of such a check made on a representative superheterodyne. A Hickok model OS-10 (Fig. 1) was used to supply the input and the db meter (part of the OS-10) was used to measure the output. Throughout the measurements the sensitivity control on the receiver was on full.

Oscillator Setting	AVC On	AVC Off
X10	db	db
2	-5	-5
4	0	0
6	5	8
8	10	16
10	15	22
X100	db	db
2	18	28
3	20.5	32.5
4	22	26
5	23	20
6	23.5	15
7	25	-4
8	25.5	-4
10	27	-3

Response Curve of a Typical Superheterodyne with One Stage R.F. and One Stage I.F. as the Frequency to which the Receiver is Tuned Varies.

Output from the signal generator left constant, though its frequency was varied. Volume control on receiver fixed. AVC connected but input from signal generator set sufficiently low so that output DB is not affected by AVC action.

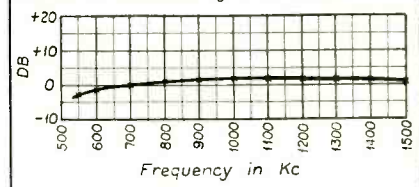

Fig. 5. Typical sensitivity curve over a single band when trimmers are adjusted properly. A visual answer to the customer who complains of "dead spots."

It will be observed that the avc began to function at about 8-X10. Without the avc, overload was noticeable by the change in the audible pitch at 3-X100. The decrease in output with increase in overload is characteristic.

It is suggested, if the above test is made, to take advantage of the "avc off" condition, and align the set at this time as a more satisfactory signal can be used.

CONVINCING THE CUSTOMER

Many customers are cranks—particularly on the matter of how much work was done on their receivers. It is a good idea for your own satisfaction and the client's to plot a resonance curve on a receiver before and after alignment when the symptoms indicate adjustments of this nature. Such curves are shown in Fig. 3, and indicate the improvement which has been effected.

Fig. 4 is a familiar curve—but made,

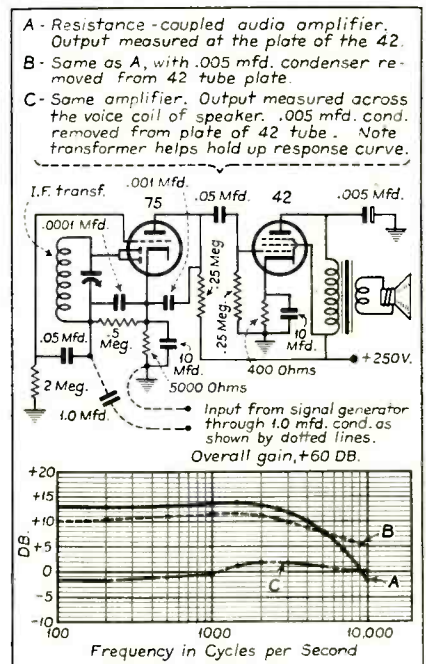

Fig. 6. Audio-frequency circuit analysis with the oscillator will go far toward detecting the more subtle causes of frequency discrimination.

EXTRA DIVIDENDS FOR THE SERVICE MAN

By BERNARD H. PORTER

SCARCELY a day passes when an attentive Service Man, while acting in his usual capacity, does not come in contact with related fields. In such instances general knowledge can be turned to profit. As an example, consider the home where the electric iron sputters or the vacuum cleaner refuses to operate. Perhaps the lady of the house was reminded of these while the Service Man inspected the home power line wiring, fuses, or aerial system. He is asked to examine the defective devices. Usually a burned-out fuse or shorted wire strand has caused the difficulty. The necessary repairs are made readily and charged accordingly. When only a brief time has been spent in locating the trouble, no charges may be made. Such acts, performed in the home while servicing the radio, are charged profitably to good-will.

As these occasions for electrical servicing present themselves, one can gradually stock up on repairs. Later, as a result of experience, study, and increased contacts, the Service Man may build an electrical repair trade of sufficient size to warrant a full line of parts.

AUTO IGNITION SYSTEM

Sideline servicing also exists while installing or checking over an automobile radio for a client. Service Men, wishing to insure the highest degree of automotive and radio efficiency, are acquainted with the automobile ignition system including battery, lights, spark-plugs, indicators, generator, horns and high-tension circuits. Having this knowledge, Service Men can not only install a car radio correctly, but also detect electrical difficulties in the ignition. Certainly he can clean and adjust spark-plugs, points and automatic retarders. Such abilities are convertible to a cash return. They also provide the foundation for a good sideline trade.

Those desiring to develop a sideline ignition service along with the usual auto-radio work will find it advisable to have a supply of distilled water and a battery charger on hand.

WRITING ARTICLES

For the academically-minded Service Man there is considerable satisfaction, if not cash return, to be gained from writing for publication. Some Service Men, perhaps, are not aware that the editors of their own class of journals

The adjectives "wide-awake" are applied to persons who are alert to opportunities. Having found such situations, the aggressive individual takes advantage of them.

By the same definition, a wide-awake Service Man is one who puts his general abilities to the most productive use.

Unlike his colleagues, he knows the remunerative sidelines in reconditioning radios. He does not sacrifice his chosen work for the sake of becoming a jack-of-all-trades, but merely applies himself when the occasion arises.

are interested in purchasing news items, service notes and technical discussions on the very subjects they are qualified to describe. Possibly as a result of special study or interest in some phase of radio, one has carried out extensive investigations and has thereby accumulated specialized knowledge on a particular subject. Moreover, it is possible that the same treatise, formally presented, might be acceptable to the academic publications like the Proceedings of the Institute of Radio Engineers. Similarly, minor items on servicing, new apparatus, testing procedures, and electronic applications can be made a source of income, if properly prepared.

Finally, Service Men located in small communities can write items of interest to readers of the local newspaper by merely keeping themselves informed of the latest information on developments as given in the trade journals and manufacturers' leaflets. More enterprising persons might go so far as to conduct a weekly column in which not only the recent investigations are discussed popularly, but also questions submitted by the local fans are commented upon and answered.

To be sure one's average customer rarely sees this first type of discussion in print, so that the Service Man might well argue any of his efforts (frequently contributed without pay at first) have little direct advertising value for him. On the contrary, the publication of such material establishes a Service Man's position among his fellow tradesmen as an aggressive and well-informed individual whose chief interest in life is his chosen work of radio. The prestige gathered thereby may in time be considerable.

On the other hand, the man located in the smaller cities can establish himself, by the class of writing last mentioned, directly with his fellow towns-

men and potential customers as an expert in the field. For Service Men so situated, it might be advisable for them to present their advertising script to the local paper in the form of interesting writeups or a question-and-answer box. Once the popularity of such writing is obtained, the editor would cooperate gladly by later paying for such a service. Thus it is that in addition to listing one's technical and scholastic affiliations, he may also include on advertising matter the notation, "Contributor to Scientific Journals." In any case, whether the written discussions are gratis or paid for, their later reward to the Service Man means, directly and indirectly, more cash dividends.

PUBLIC SPEAKING

In the same category as writing for publication is the opportunity for the gifted few to speak in public of their industry and its progress. Local social clubs, churches, technical societies and general gatherings offer such possibilities for direct person-to-person advertising of one's profession and interest. The returns from this source are not to be overlooked.

In connection with the above suggestions, mention has been made of keeping one's self informed of recent developments. In all probability there is no other appliance servicing trade requiring as much mental effort and constant study as that of radio. The changes in design and manufacture are made, so to speak, without advance notice; while the rapidity of progress, both commercially and academically, in all branches of the industry is in itself almost breath-taking. The up-to-date Service Man, interested in future cash returns is, therefore, studying continually. Not only do ideas about him alter, but his equipment must be re-

(Continued on page 186)

REGULATING ELECTROLYTIC CONDENSERS

By PAUL MacKNIGHT DEELEY*

DURING the past two years there have been placed into the field some hundreds of thousands of both wet and dry electrolytic capacitors of a comparatively new type known as regulating capacitors.

FUNDAMENTAL DIFFERENCE

Fundamentally, the only difference between the standard non-regulating type of electrolytic capacitors and the regulating type is the relation of leakage current to applied voltage. The difference between the two is illustrated graphically in Figs. 1 and 2.

Fig. 1 shows the relationship between leakage current and applied voltage of a typical 8-mfd, 300-working volt non-regulating type. Fig. 2 shows the curve expressing the relationship between leakage current and applied voltage of a typical 8-mfd, 300-volt regulating type of capacitor.

The regulating type of capacitor has a very definite use in radio receiver design and its primary purpose is to keep all direct-current potentials down to a predetermined level during the warm-up period of the receiver.

These capacitors are usually used because of the saving in initial cost allowed through the use of parts having lower breakdown ratings, although more compact design is also possible since these lower voltage components are usually less bulky. In these lower priced receivers less expensive transformers with poorer regulation (difference between no-load and full-load voltages) can be used.

WARM-UP CONDITIONS

When the receiver is first turned on and until the tubes warm up they draw no current from the rectifier. In the

*Chief Engineer, Electrolytic Division, Cornell-Dubilier Corp.



Fig. 3. Typical regulating condensers.

filter network of the receiver, the capacitors, if of the non-regulating type, must be capable of withstanding the no-load voltages present during this warm-up period. It has been found that in some cases there is a difference of as much as 200 volts between no-load and full-load operating conditions.

In such cases, the employment of capacitors rated at the higher open-circuit, or no-load, voltages represents a material increase in cost over what capacitors rated at the normal operating voltage condition would cost.

This necessary increase in cost, is not only confined to the filter capacitors but applies to the other capacitors in the circuit network, particularly capacitors used as plate and screen by-passes as well as coupling capacitors.

The regulating condenser, as has been stated above, draws considerable leakage current during the warm-up period of the receiver, loading the rectifier and power transformer and preventing excessive voltage on the other components throughout the receiver. The regulating condenser is purposely designed to withstand this temporary overload without detrimental effects to its own life or to the life of the receiver.

By employing properly selected and designed regulating capacitors, the voltages of the power supply may be regulated automatically so that the rated operating voltages of the filter capacitors as well as many other capacitors in the receiver network may be materially reduced thus making the entire capacitor cost of the receiver much less.

This procedure of using the regulating capacitors has become a standard practice in receiver design during the current radio season and it will, no doubt, be only a comparatively short time before these receivers will require servicing.

ADDITIONAL REPLACEMENT FACTORS

It is of importance that the Service Man becomes acquainted with the regulating type of capacitor and begins also to recognize the fact that in the replacement of electrolytic filter sections, such sections should not be replaced purely on the basis of capacity and operating voltage ratings but that care should be taken to ascertain whether the filter capacitors are standard non-regulating types or special regulating units. In order to properly replace a regulating type of capacitor, the degree of regulation should also be ascertained since these units are made with different degrees of regulation to fit the requirements of the receivers in which they are employed.

In some cases, regulating types of capacitors may be replaced with capacitors rated at higher operating voltages but it is very important to note that this type of replacement will not provide the necessary protection for the other capacitors in the receiver.

To make proper selection of regulating capacitors, it may be necessary for the Service Man to ascertain, among other things, open-circuit no-load voltages, total current drain under operating voltages, etc.

In making replacements, especially in the newer lower priced receiver, it is essential to employ the proper regulating capacitors, to prevent breakdown of the other condensers or parts throughout the receiver from excessive no-load voltages.

An additional factor that the Service Man should recognize is the frying noise that is usually present in the speaker during the warm-up period of the receiver employing the regulating type of electrolytics. This noise is not a sign of defective condensers but should rather be taken as an indication of normal operation.

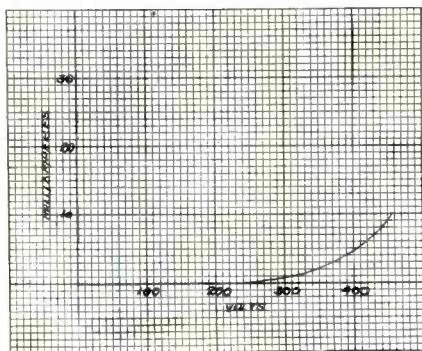

Fig. 1. Applied voltage-leakage current curve of 8-mfd, 300-volt, non-regulating electrolytic condensers.

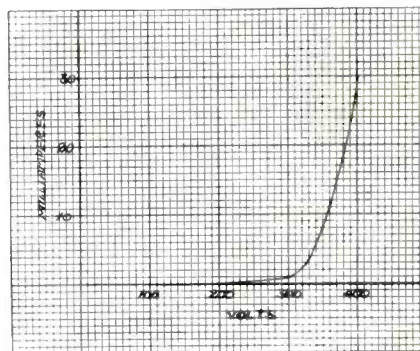

Fig. 2. Applied voltage-leakage current curve of 8-mfd, 300-volt, new type regulating electrolytic condensers.

General Data . . .

RCA 15U

The RCA model 15U is a 15-tube all-wave superheterodyne with 11 metal and 3 glass tubes and a glass tuning eye. The long-wave range from 150 to 410 kc is covered in band X. Four additional bands cover the ranges from 530 kc to 60.0 mc. The radio receiver and amplifier draw 180 watts from the 60-cycle, 115-volt line; the total drain including the phonograph motor is 205 watts. An undistorted power output of 12 watts is available at the 12-in dynamic speaker, with a maximum of 15 watts.

A few of the design features include higher-fidelity reproduction from both records and radio; the dynamic expander; "Magic Brain;" automatic record changer; selector dial; "Magic Voice;" magnetite-core i-f transformers, wave-trap, and low-frequency oscillator tracking adjustments; new plunger-type air trimmers; and a 12-in electrodynamic loudspeaker with aluminum voice coil and high-frequency tone diffuser.

PHONOGRAPH CIRCUIT

The voltage generated in the pickup L41 is applied across the phonograph volume control R36 through the pickup transformer T2 and the compensation pack. The arm of the volume control selects the amount of audio voltage applied to the control grid of the audio expander, 6L7.

In order that full volume range reproduction may be realized from disc recordings, it is necessary that the gain of the audio expander be varied in direct proportion to the intensity of the recorded sound. To accomplish this, the expander control R32 is placed in shunt with the volume control, and the arm of the expander control connected to the control grid of the 6C5 expander amplifier. The audio voltage applied to this tube is amplified and applied to diode plate P2 of the 6H6 expander rectifier through capacitor C79. The rectifier current develops a voltage across resistors R44 and R43. The voltage developed across R44 is applied to the No. 3 grid of the 6L7 audio expander and varies the amplification of this tube so that the gain will be increased for loud passages and decreased for soft passages. The expander bias control R46 is used to adjust the residual bias on No. 3 grid of the audio expander.

The audio output of the 6L7 audio

expander is resistance-capacitance coupled to the audio driver 6C5. The output of this tube is shunt fed to the primary of the interstage transformer T3 by means of reactance L5 and blocking capacitor C11. The audio signal developed across the secondary of T3 is applied to the control grids (push pull) of the 2A3 tubes for final power amplification. Bias for these tubes is developed across the loudspeaker field L38 and applied to the grids through resistance-capacitance filters. The output of the power-amplifier stage is transformer coupled to the voice coil of the loudspeaker.

RADIO CIRCUIT

The conventional type of superheterodyne circuit is used. It consists of a r-f amplifier stage, first detector (converter) stage, separate oscillator stage, two i-f amplifier stages, a diode detector-avc stage, an audio voltage amplifier stage, an audio driver stage, a push-pull power output stage, and a full-wave rectifier stage.

The "Magic Brain" is constructed as a separate, self-contained completely shielded, 5-band, oscillator-detector-antenna-tuning unit which plugs into the main chassis.

The antenna couples to the 6K7 r-f amplifier through a tuned antenna transformer. In the long-wave band, L6 acts as the primary while L5, L4, L3, and L2 act as the secondary. As bands are changed the sections of the coil are changed; the unused portions which

resonate in the particular band in use are shorted out. This arrangement reduces the total number of coils and leads, and results in having a low-loss primary and secondary winding for each band with high efficiency of operation. The ultra-short-wave band employs a separate antenna transformer L13 and L14. The output of the r-f stage is fed to the first detector 6L7 grid No. 1 through a similar r-f transformer. The locally generated (heterodyne) oscillator signal is applied to grid No. 3 of this same tube.

The output of the first detector is fed through the i-f amplifier consisting of two 6K7 tubes and three magnetite core i-f transformers. The first i-f transformer has a third (tertiary) winding L40 which, when placed in series with the secondary L25 by the fidelity switch S4, broadens the i-f amplifier characteristic curve for higher-fidelity reception. The output of the i-f amplifier is detected by the No. 2 diode of the 6H6 twin-diode tube. The audio frequency secured by this process develops a voltage across resistor R20 which is applied across the radio volume control R18 through capacitor C63. The voltage which develops across resistors R19 and R20 is applied as automatic control grid bias to the r-f, first detector, and i-f tubes. The No. 1 diode of the 6H6 is used to supply residual bias to the controlled tubes under conditions of little or no signal. This diode under such conditions draws current which flows through resistors R21, R19, and R20, thereby maintaining the desired operating bias. The sensitivity of the receiver is increased on the three high-frequency bands by reducing the residual bias on the above-mentioned controlled tubes by switch S10 which is actuated by the range-selector control. The arm of the volume control R18 supplies audio signal voltage to the 6C5 first audio stage. The output of this stage is applied to the 6C5 audio driver through a specially designed compensation filter network. The functions from this point on are the same as previously mentioned under "Phonograph Circuit."

The 6E5 cathode-ray tuning tube provides a means of visually indicating when the receiver is accurately tuned to the incoming carrier. A portion of the signal voltage developed across resistors R19 and R20 is used to actuate the grid of the amplifier section of this tube. As the grid voltage increases negatively, the plate current is reduced and the indicating shadow becomes less. The correct point of tuning is indicated by the minimum width of the dark sector on the fluorescent screen.

The various diagrams contain such information as will be needed to locate causes for defective operation if such develops. The values of resistors,

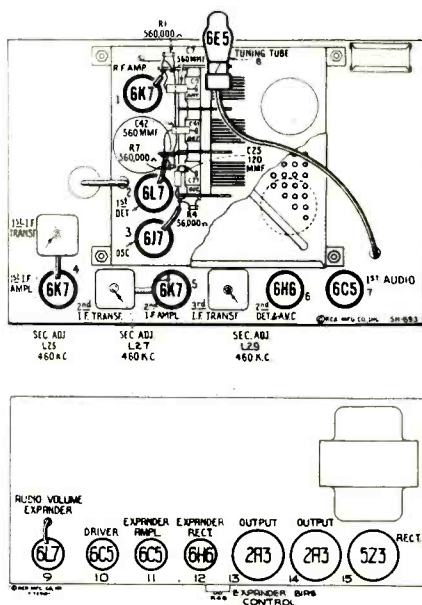

Fig. 2. Tube and i-f trimmer locations.

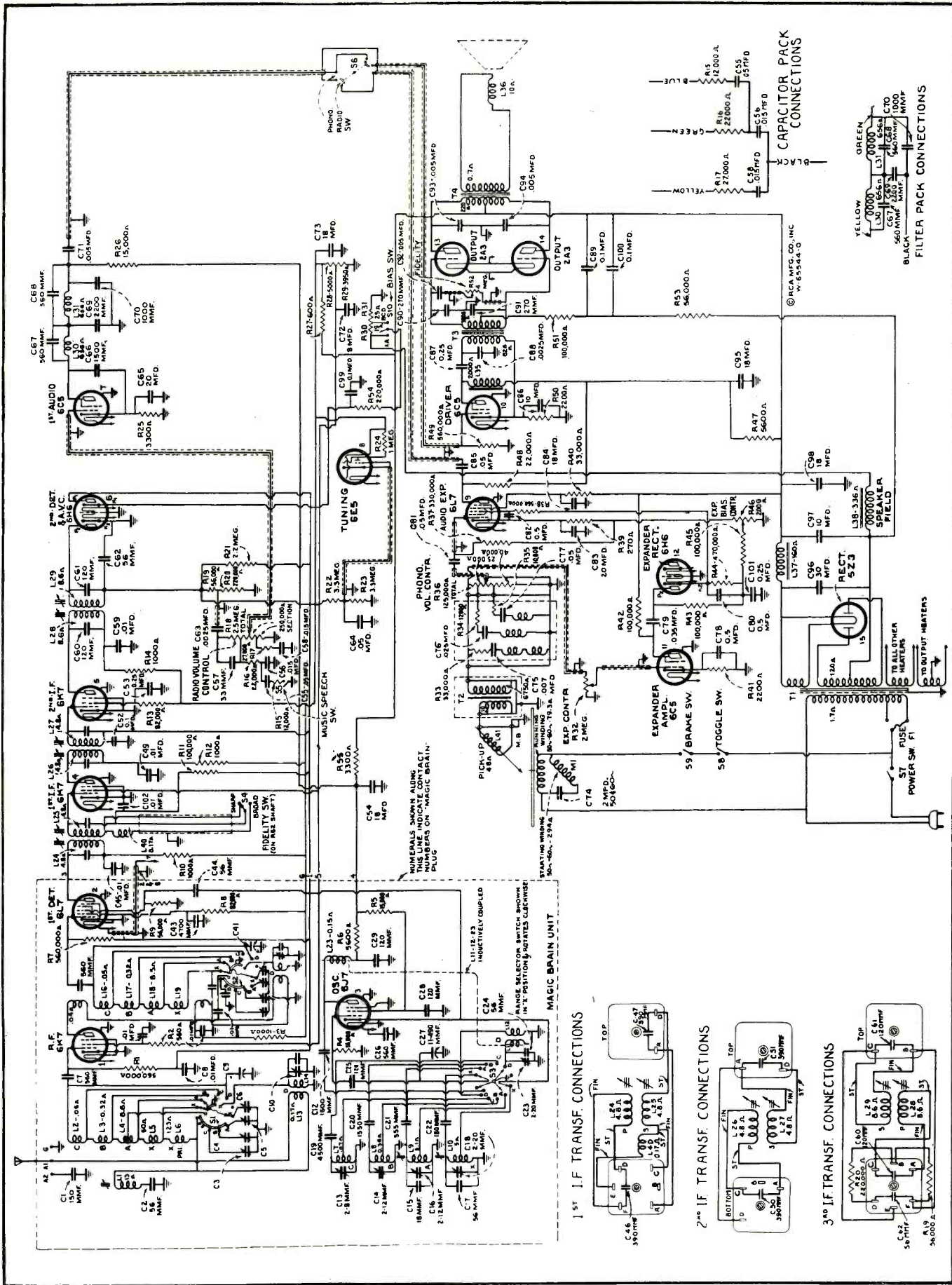

Fig. 1. RCA 15U circuit diagram.

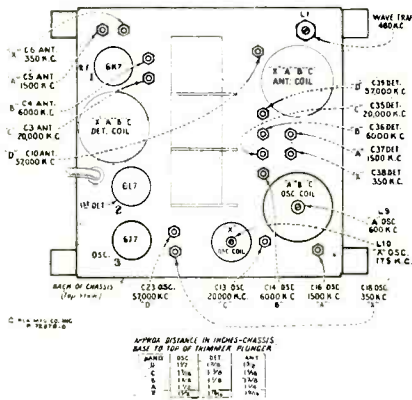

Fig. 4. "Magic Brain" trimmer locations.

capacitors, coils, etc., are indicated adjacent to the symbols signifying these parts on the diagram. Identification titles, such as C1, L2, R1, etc., are provided for reference between the illustrations. The coils, reactors, and transformer windings are rated in terms of their d-c resistance only. Resistance values of less than one ohm are generally omitted.

AUTOMATIC RECORD CHANGER

An improved automatic mechanism,

employing a synchronous motor, is used in these models. It is of the record ejector type, having a record capacity of seven for the 10-inch type, and a capacity of six for the 12-inch type. The turntable speed is fixed at 78 rpm by the design of the drive motor and the intermediate gear mechanism. This speed is invariable and does not vary as long as the supply line frequency remains constant. It is very important that a machine of any particular rating be operated at the voltage and frequency for which it is designed and rated. Attempts to operate on other voltages or frequencies will result in improper reproduction from the phonograph system and possible damage to the equipment. The ejecting mechanism is arranged so that it will trip on various types of records. This is obtained by having a trip mechanism which is actuated by the rate of needle acceleration toward the center of the record.

"MAGIC VOICE"

The instrument is designed with a cabinet incorporating the "Magic Voice." This is accomplished by having

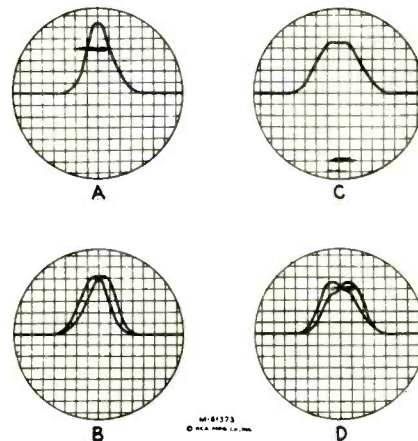

Fig. 5. I-F alignment Oscillograph curves.

the rear of the speaker compartment completely enclosed by a tight-fitting back.

Five metal open-end pipes of equal diameter but of three different lengths are inserted in holes in the cabinet base and extend upward in the speaker compartment. The effect is to cause the lower-frequency waves, reaching the top of the cabinet through the pipes, to arrive approximately in-phase with the sound waves emitted from the front of

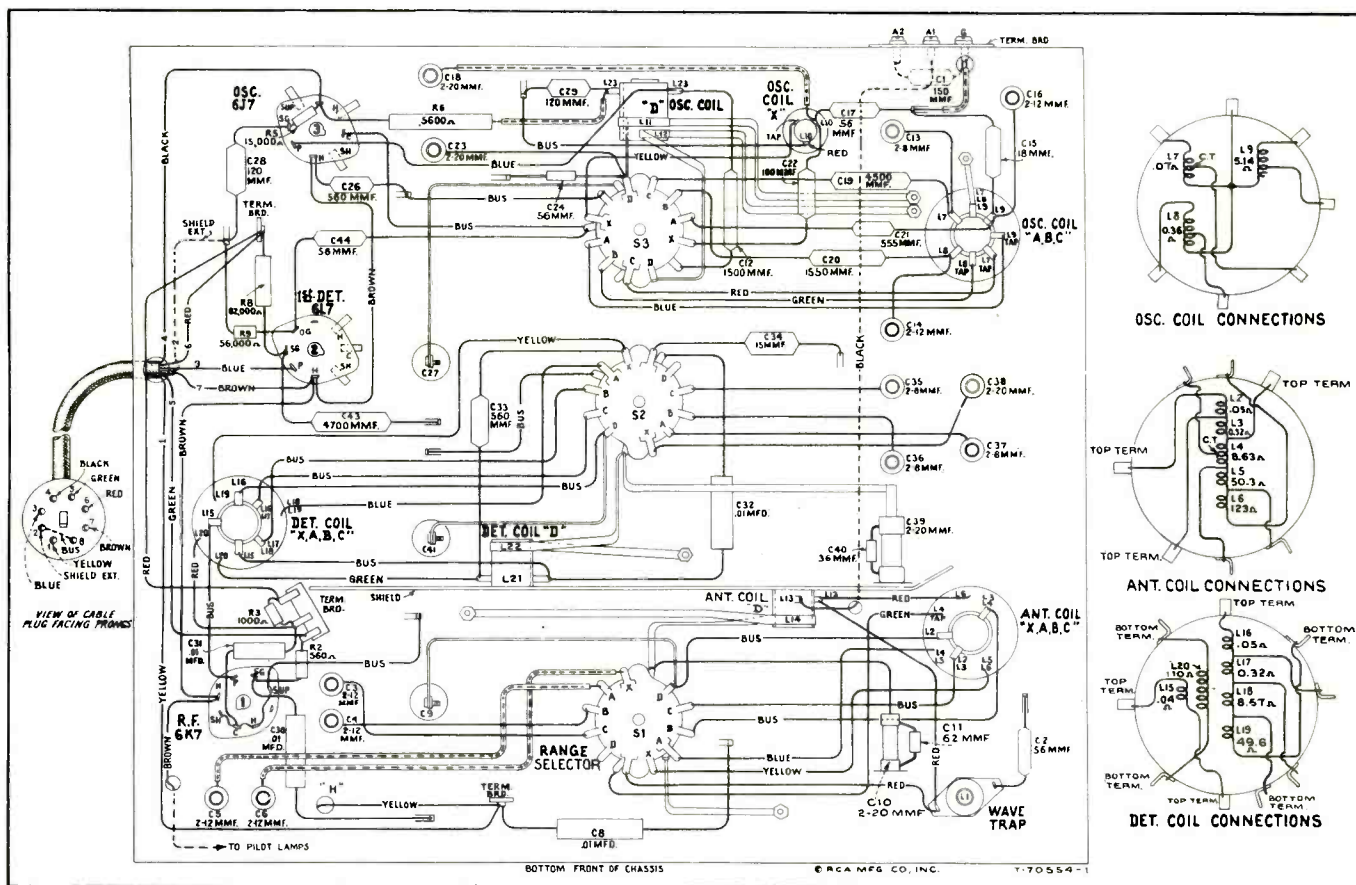

Fig. 3. "Magic Brain" wiring diagram.



Double Profits
FOR SERVICE DEALERS

ARVIN

Phantom Filter
CAR RADIOS



Three powerful radios, two 6-tube sets and a super 7-tube model, with matching panel or universal controls and overhead, separate case or in-the-set speakers. Complete set prices as low as

\$39⁹⁵ LIST

● The Arvin Double-Profit plan on car radios is a business-building opportunity for service dealers. It works this way: You take your first profit on the Arvins you sell—and you take a second profit on installation and service work other Arvin dealers require. To get in on Arvin's two-way profit plan, do this:

Sign up with an Arvin jobber as an Authorized Service Station. Then you will get a comprehensive service manual—complete service information on all Arvin models—factory bulletins to keep you up to date—and the Arvin Authorized Service Station sign. In addition, if you sell Arvins, you get all the sales helps *free* that go along with the Arvin Floor Plan Deal.



This striking Roll-Around Display Demonstrator is only one of many business getting sales helps that go along free with the Arvin Floor Plan Deal.

● The new Arvins include a long line of amazing engineering achievements, headed by the Phantom Filter—a "station booster" that steps up power and brings in more stations more clearly. This and many other exclusive features contribute to the brilliant performance of the new Arvins. They also put new ease in installation and service.

Arvin service dealers can take extra service profits without selling Arvins—but if you're in car radio to make money you can hardly afford to pass up Arvin's double-profit plan. Ask your jobber for full details. NOBLITT-SPARKS INDUSTRIES, Inc., Columbus, Indiana. *Makers also of Arvin Rhythm Radios for the home.*

ASK YOUR JOBBER ABOUT THE NEW ARVIN FLOOR PLAN DEAL

- Technical Features of 1937 Sparton Radio Receivers -

Model No.	517	517B	517W	517X	557	567	527-2	587-2	537	577	617	617X	667	67X	637-6	687-6	727X	727	827X	827XD	977	827	987	1167	1567	1867 ft
Cabinet *	T	T	T	T	T	Ce	T	Ce	T	Ce	T	T	Ce	Ce	T	Ce	T	Ce	T	T	-	T	Ce	Ce	Ce	Ce
Power Supply	A.C.		A.C.		Batt.		Batt.		A.C.		A.C.		A.C.		Batt.		A.C.		A.C.		A.C.		A.C.		A.C.	
No. of Bands	2		2		2		2		3		3		3		3		3		4		4		4		4	
Range (Kc.)	540 - 1720 5900 - 17,500		540 - 1720 5900 - 17,500		-		-		535 - 17,500		535 - 17,500		535 - 17,500		-		535 - 19,500		140 - 420 535 - 19,500		540 - 20,000 535 - 19,500		140 - 420 535 - 19,500		140 - 420 535 - 19,500 20,000 - 60,000	
I.F. Peak (Kc.)	456		456		-		-		456		345		345		-		456		456		456		456		456	
Dynamic Speaker	6"		6"		-		-		8"		10"		10"		-		10" 8"		-		12"		12"		15" 5"	
H.F. Speaker Compensator	/		/		/		/		/		/		/		/		/		/		/		/		/	
Field Res.	1500		1500		-		-		1500		1200		1200		-		-		1000		1600		1000		800	
Phono. Conn.	/		/		/		/		/		/		/		/		/		/		/		/		/	
Tone Control	/		/		/		/		/		/		/		/		/		/		/		/		/	
Wave Trap	Yes		Yes		-		-		Yes		Continuous		Continuous		-		-		Cont.		Cont.		Cont.		Cont.	
Variable Condensers	2		2		-		-		2		3		3		-		-		3		3		3		3	
Number of Tuned Circuits	6		6		-		-		6		7		7		-		-		7		9		7		9	
Viso-Glo	/		/		/		/		/		/		/		/		/		/		/		/		/	
R.F.	/		/		/		/		/		/		/		/		/		/		/		/		/	
1st. Det. Osc.	6A7		6A7		/		/		6A8G		6A8G		6A8G		/		/		6A8		6A7		6A8		6A8	
Intermediate Freq.	/		/		/		/		/		/		/		/		/		/		/		/		/	
2nd. Det. A VC	/		/		/		/		/		/		/		/		/		/		/		/		/	
1st. Audio	/		/		/		/		/		/		/		/		/		/		/		/		/	
2nd. Audio	/		/		/		/		/		/		/		/		/		/		/		/		/	
Output	42		42		/		/		6F6G		6F6G		6F6G		/		/		6N6G		42		6N6G		(2) 45	
Rectifier	80		80		/		/		5Y3G		5Y3		5Y3		/		/		5Y3		80		5Y3		(2) 5Y3	
Expander Amplifier	/		/		/		/		/		/		/		/		/		/		/		/		/	
Expander	/		/		/		/		/		/		/		/		/		/		/		/		/	

NOTE: All models marked X are for export, and have universal power transformers. † The 1867 has 3 speakers and an additional H.F. amplifier consisting of a 6J7G first stage, and a 6F6G output stage. * T = Table, Ce = Console

RIDER MANUALS

Now in SEVEN Volumes

1600 PAGES

VALUE...

that Stands Out

Like a Neon Sign on a dark street Rider Manuals stand out as the greatest manual value ever offered the radio serviceman. Complete information on radio receivers of over 350 different makes—7970 pages chock-full of pertinent service data on the greatest number of models ever compiled in one work—and all presented in a way that makes it easy to find *all of what you want when you want it*. . . . Over a hundred and thirty thousand volumes of Rider Manuals, now in use, testify to the tremendous value of these outstanding books in saving time—increasing profits—and guaranteeing success for the work of the radio serviceman. When you consider that your very next job may require the information contained in the very Rider manual you have “never gotten around to buying”—when you consider that your Rider Manuals can be kept up-to-date for *the profit from one additional tube sale a week*, you can see why we say, “You are taking unnecessary chances trying to ‘get by’ without a complete set of seven Rider Manuals”—the radio serviceman’s most inexpensive necessity.

Volume I—\$7.50—1920-31 Volume III—\$7.50—1932-33 Volume V—\$7.50—1934-35
Volume II— 6.50—1931-32 Volume IV— 7.50—1933-34 Volume VI— 7.50—1935-36

VOLUME VII—1600 PAGES—\$10.00 COVERING 1936-37.

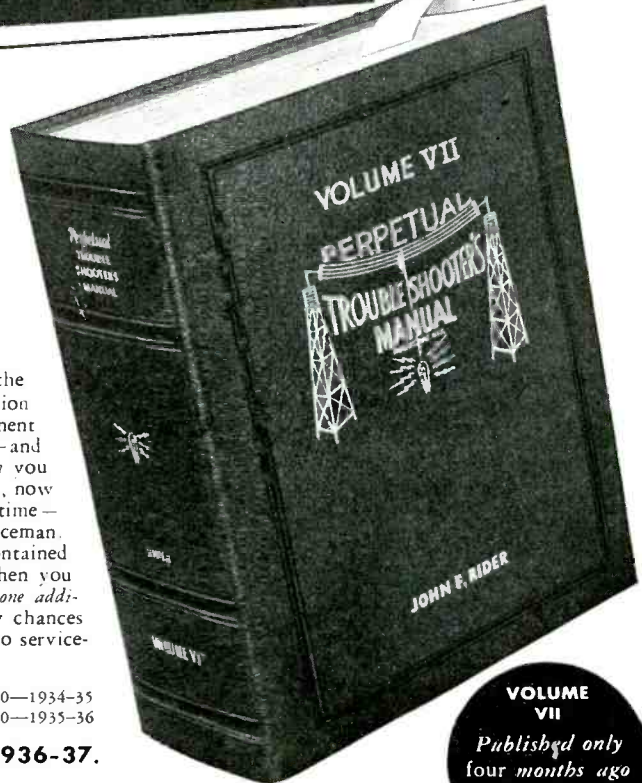

VOLUME VII

Published only four months ago Now in its third printing.

2 *New* RIDER BOOKS YOU NEED!

ALIGNING PHILCO RECEIVERS

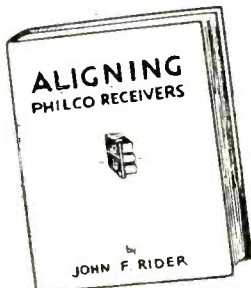

176 PAGES—
HARD COVER—only \$1.00

Well over 8,000,000 Philco radio receivers have been produced. To date 24,000,000 radios of all makes have been bought in this country. So, it is logical to assume that on the average, every third set you service will be a Philco. For this reason, no serviceman should be without this new book which presents authentic and complete instructions for fast and accurate alignment operation on ANY Philco receiver, from the first to the eight-millionth set. Every trimmer is located for you. The order followed on the tables is the same order you use when aligning receivers on the bench.

You Can't Afford to be Without This

—AND ANOTHER
“An Hour a Day With Rider” Book
ON

ALTERNATING CURRENTS IN RADIO RECEIVERS

This new book presents an explanation of the behavior of radio frequency and other currents in radio receivers. Written by John Rider in his simple, easily understood style, and offered at the same price as its companion “Hour a Day . . .” Books—Only 60¢

OUT IN MARCH

JOHN F. RIDER, Publisher, 1440 BROADWAY, NEW YORK CITY

GENERAL DATA—continued

the speaker, giving extended low-frequency response without boominess, or cabinet resonance.

ALIGNMENT PROCEDURE

There are seventeen adjustments required for the alignment of the oscillator, first detector, and antenna-tuned circuits; one adjustment for the wave-trap; and six adjustments for the i-f system. Fifteen of these adjustments are made with plunger-type air trimming capacitors and require the use of a special tool (stock No. 12636 adjusting tool). Each of these capacitors has a lock nut for securing the plunger in place after adjustment. The remaining nine adjustments are made by means of screws attached to molded magnetite cores. These cores change the inductance of the particular coils in which they are inserted to provide exact alignment. All of these adjustments are accurately made during manufacture and should remain in proper alignment unless affected by abnormal conditions of climate or purported alterations for servicing, or unless altered by other

means. Loss of sensitivity, improper tone quality, and poor selectivity are the usual indications of improper alignment. Such conditions will usually exist simultaneously. Correct performance of this receiver can only be obtained when these adjustments have been made by a skilled Service Man with the use of adequate and reliable test equipment.

The extensive frequency range of these receivers necessitates a more or less involved method of alignment. However, if the following directions are carefully applied in the sequence given, normal performance of the instruments will be obtained.

The plunger-type air trimming capacitors have their approximate plunger settings tabulated on Fig. 4. If the plungers have been disturbed from their original adjustments, they may be roughly set to the specified dimensions prior to alignment.

In performing services on the "Magic Brain," the leads should be restored to their original positions, since the lead-dress is important for proper operation and dial calibration.

PRECAUTIONARY DRESSING OF LEADS FOR "MAGIC BRAIN" ALIGNMENT

Band X:

(1) Keep blue lead A of S1 to antenna coil L4-5 dressed away from chassis, and from yellow lead X of S1 to antenna coil L5-6.

(2) Bus lead from C10 to S1 should be as short as possible.

(3) Keep blue lead A of S2 to detector coil L18-19 clear of chassis, coil shield, coil, and other leads.

(4) Keep spaghetti lead C6 to X of S1 apart from spaghetti lead C5 to A of S1, and from chassis.

Band A:

(1) Keep green lead terminal S1 to antenna coil tap L4 away from chassis, coil shield, and coil.

(2) Keep spaghetti lead C5 to A of S1 apart from spaghetti lead C6 to X of S1 and from chassis.

Band C:

Lead from C19 to oscillator coil L7 should be maintained as short and straight as possible.

If the test-oscillator signal cannot be heard as the receiver (heterodyne) oscillator air-trimmer plunger is changed from its minimum-capacity to maximum-capacity position (receiver dial and test oscillator set to the specified frequencies, and the correct oscillator air-trimmer used) it may be an indication that the test-oscillator frequency is outside the range covered by the air-trimmer. Under such conditions, when a more accurate setting of the test oscillator cannot be determined, set the oscillator air-trimmer-plungers to the approximate settings given on Fig. 4. Tune the test oscillator until the signal is heard in the speaker. Each of two test-oscillator settings (the fundamentals or the harmonics of which are 920 kc apart) produce a signal. The lower-frequency test-oscillator setting should be used as this places the test-oscillator (signal) frequency 460 kc below the frequency of the receiver heterodyne oscillator.

Holes are provided in the top of the r-f and antenna coil cans on some models to enable a tuning check with the Tuning Wand. The hole in the top of the detector coil can has a cinch button which must be removed before insertion of the tuning wand. When the brass end of the wand is inserted in the coil, the inductance of the coil is decreased. If this results in an increase of output, the respective air-trimmer capacitance should be decreased (plunger pulled out). If inserting the iron end of the tuning wand causes an increase in output, resulting from an increase of inductance of the coil, the respective

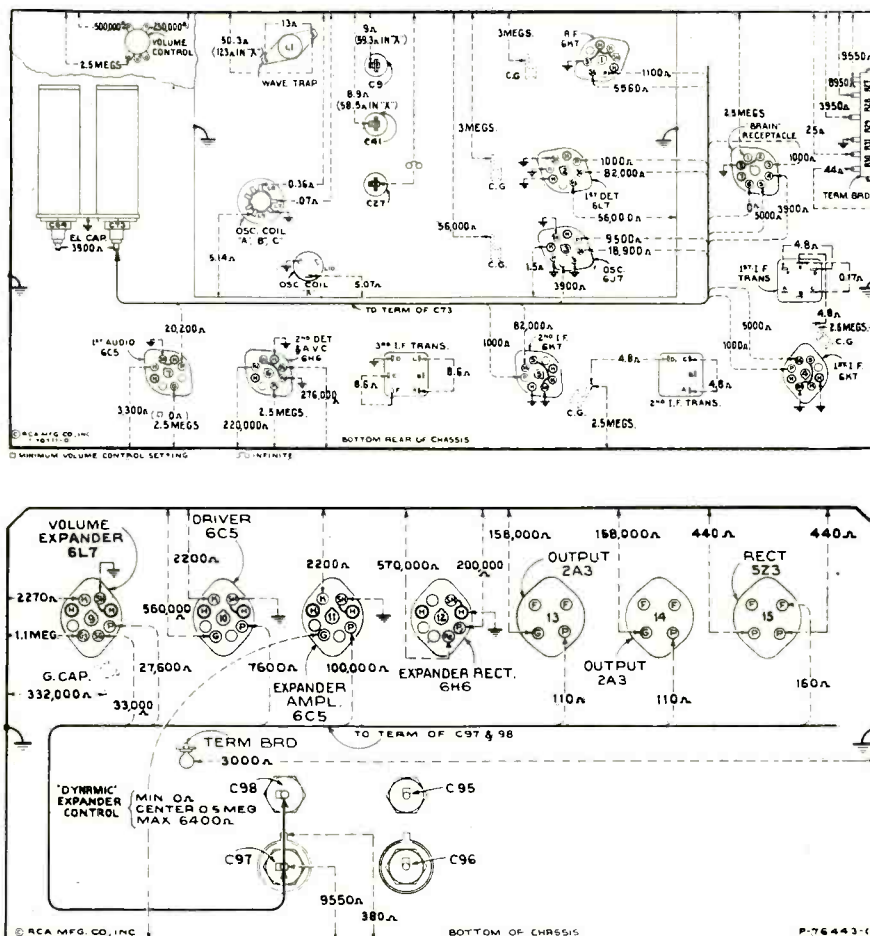

Fig. 6. Underchassis view with resistance measurements for various terminals indicated.

RADIO SERVICE SHOP

Using **SUPREME** *Testing*
Instruments



WRITE FOR DETAILS

Designed by SUPREME INSTRUMENTS CORP. CRISFIELD MISSISSIPPI

air-trimmer capacitance should be increased (plunger pushed in). If the range of the air trimmer is not sufficient to give the desired results, the lead-dress may be changed in the particular circuit being aligned, so as to cause the circuit to resonate within the range of the trimmer. An increase in the capacity-to-ground of the circuit will be required if the iron end of the tuning wand causes an increase of signal output when the air-trimmer plunger is full-in, while a decrease in the capacity-to-ground will be required if the brass end of the tuning wand causes an increase in signal output when the air-trimmer plunger is full-out.

Two methods of alignment are applicable—one requires use of the cathode-ray oscillograph, and the other requires an output meter. The cathode-ray alignment method is advantageous in that the indication provided is in the form of a wave-image which represents the resonance characteristics of the circuit being tuned. This method is preferred because of the i-f characteristics of these receivers. If oscillograph equipment is not available, an approximate alignment may be performed by the output-indicator method. Alignment by this method is similar to the cathode-ray method outlined below except that the receiver volume control should be at maximum, the trimmers adjusted to peak response and the test-oscillator sweeping operations omitted. Either of these methods require the use of a reliable test oscillator.

CATHODE-RAY ALIGNMENT

Make alignment apparatus connections as indicated in the instructions for the particular make of oscillograph and frequency modulator used for the adjustments. Connect the receiver chassis to a good external ground. The oscillograph "high" terminal should be connected to the terminal with the yellow lead connection on the third i-f transformer. The "low" post of the oscillograph should be connected to the receiver chassis.

Set the oscillograph power switch on and adjust the intensity and focus controls to give a clearly defined spot or line on the cathode-ray screen. Set the vertical and horizontal amplifiers on and turn the vertical gain control to the full-clockwise position. Set the timing selector to the position for internal sweep. The synchronizing, frequency and horizontal gain controls should be set to about their mid-positions. For each of the following adjustments, the test-oscillator output must be regulated

so that the image obtained on the oscillograph screen will be of the minimum size for accurate observation. The receiver volume-control setting is optional.

I-F ADJUSTMENTS

(a) Set "Fidelity" control to counter-clockwise position, "Radio - Phono" switch to "Radio," and "Range Selector" to standard-broadcast band. Connect the "Ant." output of the test oscillator to the grid cap of 6K7 second i-f tube (with grid lead in place) through a 0.001-mfd capacitor, with "Gnd." to receiver chassis. Tune the test oscillator to 460 kc and place its modulation switch to "On" and its output switch to "Hi."

(b) Turn on the receiver and test oscillator. Increase the output of the test oscillator until a deflection is noticeable on the oscillograph screen. The figures obtained represent several waves of the detected signal, the amplitude of which may be observed as an indication of output. Cause the wave-image formed (400-cycle waves) to be spread completely across the screen by adjusting the horizontal gain control. The image

should be synchronized and made to remain motionless by adjusting the "Sync." and "Freq." controls.

(c) Adjust the two magnetite core screws L29 and L28 (see Figs. 2 and 7) of the third i-f transformer (one on top and one on bottom) to produce maximum vertical deflection of the oscillographic image. This adjustment places the transformer in exact resonance with the 460-kc signal.

(d) The sweeping operation should follow using the frequency modulator. Shift the oscillograph "Timing" switch to "Ext." Insert plug of frequency-modulator cable in test-oscillator jack. Turn the test-oscillator modulation switch to "Off." Turn on the frequency modulator and place its sweep-range switch to "Hi."

(e) Increase the frequency of the test oscillator by slowly turning its tuning control until two separate, distinct, and similar waves appear on the screen. If only one wave appears, increase the "Freq." control on the oscillograph to obtain two waves. These waves will be identical in shape, totally disconnected, and appear in reversed positions. They

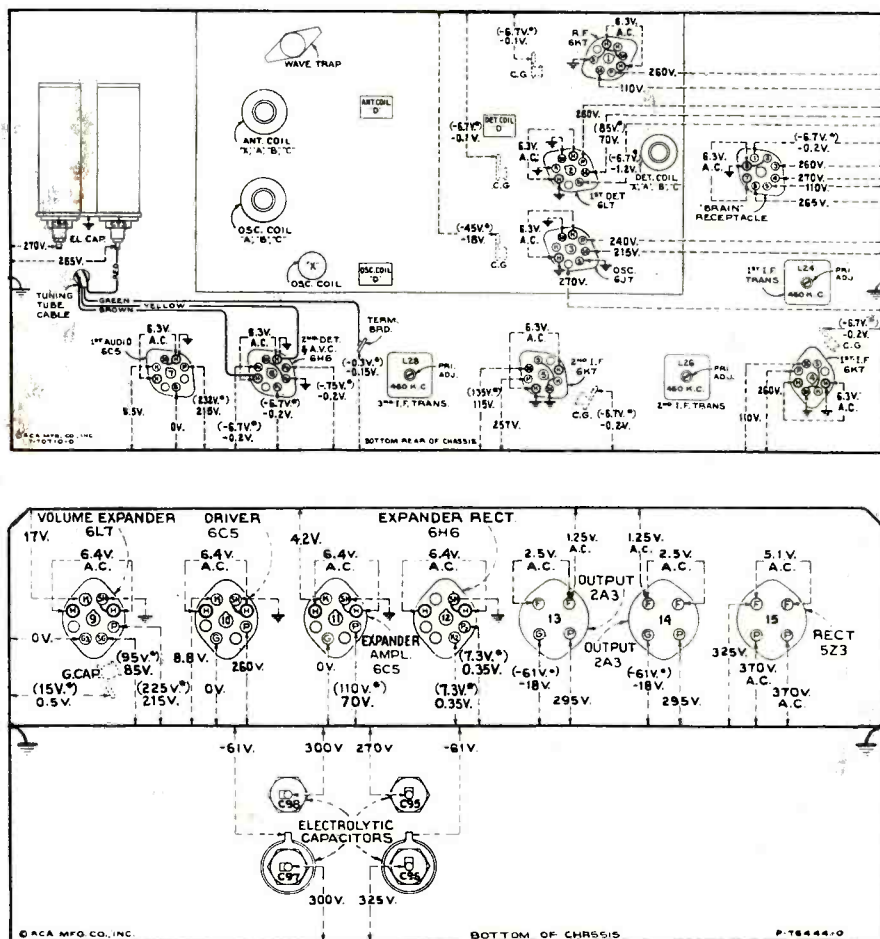

Fig. 7. Underchassis view with voltage measurements for various terminals indicated.

UTC PAK KITS FULFILL ALL POSSIBLE PUBLIC ADDRESS REQUIREMENTS

PAK-1—Self bias amplifier kit. 35 watt operation. Output transformer impedances 500, 200, 16, 8, 5, 3, 1.5 ohms. Includes all accessories except tubes. Fully mounted. Net price..... **\$45**

PAK-1X—Same as PAK-1, but with Vari-match modulation output transformer. Net price..... **\$45**

PAK-2—Fixed bias amplifier kit. 55 watts operating condition. Output transformer with impedances of 500, 200, 16, 8, 5, 3, 1.5 ohms. Includes all accessories except tubes. Fully mounted. Net price..... **\$48**

PAK-2X—Same as PAK-2, but with Vari-match modulation output transformer. Net price..... **\$48**

The UTC beam power amplifier kits are designed to take full advantage of the unusual characteristics of the 6L6 tubes. Some of the unique features of this amplifier are:

HIGH POWER 35 watts self bias, 55 watts fixed bias.

HIGH GAIN 118 DB with provision for immediate change over to 95 DB.

SEPARATE CHASSIS for power supply and audio sections permitting maximum flexibility and minimum hum pickup.

STABILIZED FEEDBACK effects increase in output power and reduction in overall distortion.

EQUALIZER with calibrated control to bring up the low frequency end or to bring up both low and high frequencies simultaneously.

MOBILE OPERATION can be obtained using the audio chassis alone and genemotor. 20 watts available.

RACK PANEL MOUNTING or rack cabinet mounting permissible. Combined overall dimensions 16 1/2" x 12 1/2" x 8".

ELECTRON MIXING can be added to kit with little change.

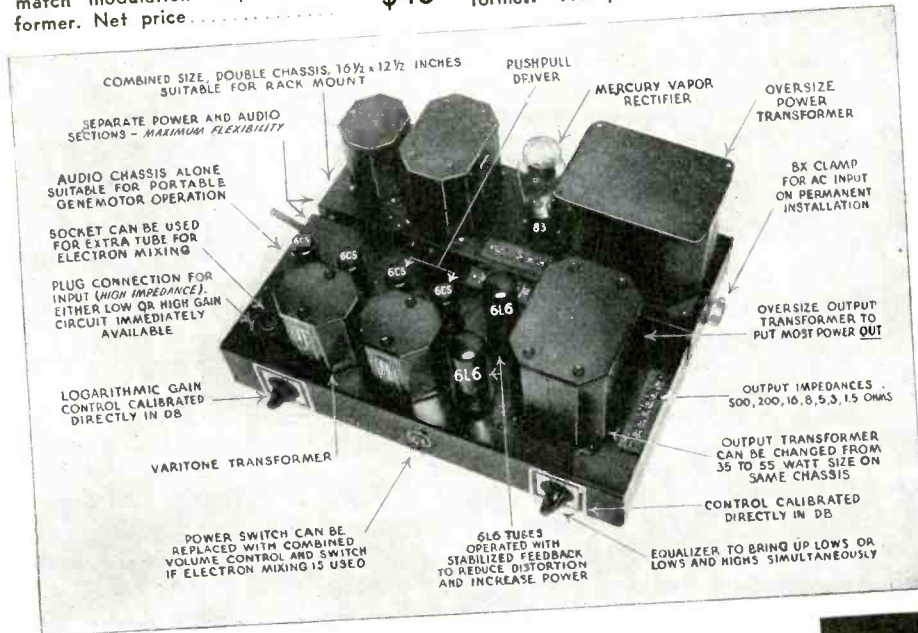

... Name your tubes ...

the new **UTC PA VARIMATCH** transformers will match all of them to a broadcast line or to any voice coil. These transformers never become **OBSOLETE**. They are sure to match new tubes yet to be announced.

The UTC PVM items are companion units to the UTC **VARI-MATCH** amateur transformers which match any modulator tubes to any RF load.

PVM-1
For all audio tubes up to 10 watts audio. Output 500, 200, 15, 8, 5, 3, 1 1/2 ohms. Some typical tubes single or push pull: 19, 31, 33, 41, 42, 43, 45, 47, 48, 49, 53, 59, 71A, 79, 89, 2A3, 2A5, 6A6, 6F6, 6V6, 25A6, 25L6. Net Price..... **\$3.00**

PVM-2
For all audio tubes up to 20 watts audio. Output 500, 200, 16, 8, 5, 3, 1 1/2 ohms. Some typical tubes for single, push pull, or push pull parallel: 19, 31,

33, 41, 42, 43, 45, 46, 47, 48, 49, 50, 52A, 300A, 53, 59, 71A, 79, 89, 841, 843, 1602, 2A3, 2A5, 6A6, 6F6, 6L6, 6V6, 25A6, 25L6. Net Price..... **\$4.80**

PVM-3
For all audio tubes up to 50 watts audio. Output 500, 200, 16, 8, 5, 3, 1 1/2 ohms. Some typical tubes in push pull parallel: 42's, 45's, 46's, 50's, 52's, 300A's, 59's, 2A3's, 2A5's, 6F6's. In push pull self or fixed bias: 6L6's, 10's, 807's, 801's. Net Price..... **\$7.50**

PVM-4
For all audio tubes up to 100 watts audio. Output 500, 200, 16, 8, 5, 3, 1 1/2 ohms. Some typical tubes push pull parallel: 6L6's, 10's, 807's, 801's, push pull 845's, 800's, etc. Net Price..... **\$12.00**

PVM-5
For all audio tubes up to 250 watts audio. Output 500, 200, 16, 8, 5, 3, 1 1/2 ohms. Typical tubes: 211, 242A, 203A, 830B, 852, 838, 4-800's, 4-845's, ZB 120, etc. Net Price..... **\$19.50**

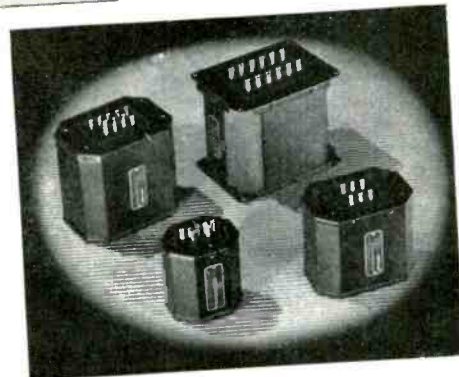

UNITED TRANSFORMER CORP.

72 SPRING STREET

NEW YORK, N. Y.

EXPORT DIVISION: 100 VARICK STREET NEW YORK, N. Y. CABLES: "ARLAB"

will have a common base line, which is discontinuous. Adjust the "Freq." and "Sync." control of the oscillograph to make them remain motionless on the screen. Continue increasing the test-oscillator frequency until these forward and reverse curves move together and overlap, with their highest points exactly coincident.

(f) With the images established as in (e), readjust the two magnetite core screws L29 and L28 on the third i-f transformer so that they cause the curves on the oscillograph screen to become exactly coincident throughout their lengths and have maximum amplitude.

(g) Without altering the adjustments of the apparatus, shift the "Ant." output of the test oscillator to the grid cap of the 6K7 first i-f tube (with grid lead in place), through a 0.001 mfd capacitor. Regulate the test-oscillator output so that the amplitude of the oscillographic image is approximately the same as used for adjustment (f) above.

(h) The two second i-f transformer magnetite-core screws L27 and L26 (one on top and one on bottom) should then be adjusted so that they cause the forward and reverse curves to become coincident throughout their lengths and have maximum amplitude.

(i) Without altering the adjustments of the apparatus, shift the "Ant." output of the test oscillator to the input of the i-f system, i.e., to the grid cap of the 6L7 first detector, (with grid lead in place) through a 0.001-mfd capacitor. Regulate the test-oscillator output so the amplitude of the oscillographic image is approximately the same as used for adjustment (h) above.

(j) The two first i-f transformer magnetite-core screws L25 and L24 (one on top and one on bottom) should then be adjusted so that they cause the forward and reverse waves to become coincident throughout their lengths and have maximum amplitude.

(k) Note width of oscillographic image at a point which is 50% of maximum amplitude. Turn receiver fidelity control to extreme clockwise position. Note width of oscillographic image at a point which is 50% of maximum amplitude. Under normal conditions the latter measurement should be approximately 60% greater in width than the former measurement. The image should also appear slightly double humped. These conditions indicate proper broadening of the band-width of the i-f amplifier. Turn range selector to medium-wave (B) band and note increase of amplitude. The amplitude should in-

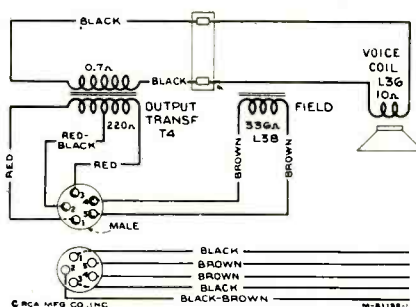

Fig. 8. RCA 15U loudspeaker wiring

crease several times. It may be necessary to decrease output of test oscillator to keep image on screen. Turn receiver fidelity control to extreme counter-clockwise position.

R-F ADJUSTMENTS

Make receiver dial adjustments as outlined under "Selector dial," Fig. 9. Alignment must be made in sequence of wave-trap, ultra-short-wave band, short-wave band, medium-wave band, standard-broadcast band and long-wave band.

Wave-Trap adjustment:

(a) Connect the "Ant." output of the test oscillator to the antenna terminal "A1" through a 200-mmfd (important) capacitor. Remove the plug of the frequency-modulator cable from the test-oscillator jack. Turn test-oscillator modulation switch to "On." Shift the oscillograph "Timing" switch to "Int." Place receiver range selector in standard-broadcast position. Set the receiver dial to a position of no extraneous signals near 600 kc. Tune the test oscillator to 460 kc. Adjust the wave-trap magnetite-core screw L1 to the point which causes minimum amplitude of output (maximum suppression of signal) as shown by the waves on the oscillograph. An increase of the test-oscillator output may be necessary before this point of minimum amplitude, obtained by correct adjustment of wave-trap screw, becomes apparent on oscillograph screen.

Ultra Short-Wave Band:

(b) Connect the "Ant." output of the test oscillator to the antenna terminal "A1" of the receiver through a 300-ohm resistor. Set the receiver range selector to its ultra-short-wave position and its dial pointer to 57,000 kc. Adjust the test oscillator to 19,000 kc. The third harmonic of 19,000 kc is used for this adjustment.

Adjust oscillator air-trimmer C23 for maximum (peak) output. Two posi-

tions, each producing maximum output, may be found. The position of minimum capacitance (plunger near out) should be used. This places the receiver heterodyne oscillator 460 kc higher in frequency than the incoming signal. Tighten lock nut. Adjust the detector air-trimmer C39, while slightly rocking the gang tuning condenser back and forth through the signal, for maximum (peak) output. Two peaks may be found on this trimmer. The peak of maximum capacitance (plunger near in) should be used. Tighten lock nut. Adjust the antenna air-trimmer C10 for maximum (peak) output while slightly rocking the gang tuning condenser back and forth through the signal. Two peaks may be found on this trimmer which produce maximum output. The peak with maximum capacitance (plunger near in) should be used. Tighten lock nut. Check the image frequency by changing the receiver dial setting to 56,080 kc. If the image signal is received at this position, the adjustment of the oscillator air-trimmer C23 has been correctly made. No adjustments should be made while checking for the image signal.

(c) Retune receiver for maximum response to 57,000 kc (not image response) without disturbing test-oscillator adjustments. Change test oscillator to 6,800-14,000 kc range. Tune test oscillator until signal is heard in speaker (should occur at approximately 14,250 kc, fourth harmonic of test oscillator used). Two test-oscillator settings (230 kc apart) will produce a signal at this point. The lower frequency test-oscillator setting should be used, as this places the test oscillator harmonic 460 kc below the frequency of the receiver heterodyne oscillator. Tune receiver for maximum response at a dial setting of approximately 28,500 kc (image should tune in at a dial setting approximately 27,580 kc) without altering test-oscillator adjustment. Test-oscillator second harmonic of 14,250 kc is used for the following check. Check calibration of receiver dial. A receiver-dial reading of less than 28,500 kc indicates that the inductance of the oscillator secondary coil L11 is too low and should be increased. If the receiver dial reading is greater than 28,500 kc, the inductance of L11 is too high and should be decreased. If it is necessary to change the inductance of L11, first remove bottom cover of "Magic Brain" and then set receiver dial pointer to 28,500 kc. To decrease inductance, move the grounded ends (straps) of L11 and L12 (see Fig. 3) nearer chassis. Do



Built on the identical principle employed in the actual making of the Higher Fidelity records. Positive, unfailing, unvarying . . . immune alike to heat and humidity . . . used throughout the world in foremost Broadcast Stations, Theatres and Laboratories. A model for every need, from the humblest midget portable to the most exacting transcription requirements. Write for your copy of "Pickup Facts."

Watch for announcement of an important NEW CUTTING-HEAD development . . . pioneered by Audax.

AUDAX COMPANY, 500 Fifth Avenue, New York

"Creators of High Grade Electrical and Acoustical Apparatus Since 1915"

MARCH, 1937 •

SAY YOU SAW IT IN SERVICE

153

not allow straps to touch chassis except where connected. To increase inductance, move the straps farther away from chassis. Adjust position of straps until maximum (peak) output results. The alignment of the detector tuned circuit should next be checked at 28,500 kc without changing either the receiver or test-oscillator adjustments. An increase of output when the brass end of a tuning wand is brought near L22 indicates that L22 is too high in inductance, while an increase when the iron end is brought near the coil indicates that the inductance is too low. The inductance of L22 may be varied by changing the spacing between the grounded end (strap) of L22 and the strap connected from C41 to contact on S2 (Fig. 3). Adjust the spacing until maximum (peak) output results. Replace "Magic Brain" bottom cover and repeat adjustments in (b) prior to those of short-wave band.

Short-Wave Band:

(d) Set the receiver range selector to its short-wave position and its dial pointer to 20,000 kc. Adjust the test oscillator to 20,000 kc. Adjust oscillator air-trimmer C13 until maximum (peak) output is reached. Two peaks may be found with this circuit. The peak with minimum capacitance (plunger near out) should be used. Tighten lock nut. Adjust detector air-trimmer C35 until maximum (peak) output is reached, while slightly rocking the gang tuning condenser back and forth through the signal. Two peaks may be found with this circuit. The peak with maximum capacitance (plunger near in) should be used. Tighten lock nut. Adjust antenna air-trimmer C3 until maximum (peak) output is reached while slightly rocking the gang tuning condenser back and forth through the signal. Two peaks may be found with this circuit. The peak with maximum capacitance (plunger near in) should be used. Tighten lock nut. Check the image frequency by changing the receiver dial setting to 19,080 kc. The image signal should be received at this position indicating that the adjustment of C13 has been correctly made. No adjustments should be made while checking for the image signal.

Medium-Wave Band:

(e) Place receiver range selector to its medium-wave position with its dial pointer set to 6,000 kc. Tune the test oscillator to 6,000 kc. Adjust oscillator air-trimmer C14 to produce maximum (peak) output as shown by the waves on the oscillograph. Two peaks may be found with this circuit. The peak

with minimum capacitance (plunger near out) should be used. Tighten lock nut. Adjust the detector air-trimmer C36 for maximum (peak) output while slightly rocking the gang tuning condenser back and forth through the signal. Two peaks may be found with this circuit. The peak with maximum capacitance (plunger near in) should be used. Tighten lock nut. Adjust antenna air-trimmer C4 to produce maximum (peak) output. Tighten lock nut.

Standard-Broadcast Band:

(f) Remove the 300-ohm resistor from between the test-oscillator "Ant." post and receiver antenna terminal "A1" and insert a 200-mmfd capacitor in its place. Place receiver range selector to standard-broadcast position with receiver dial pointer set to 600 kc. Tune the test oscillator to 600 kc. Adjust oscillator magnetite-core screw L9 (top of large oscillator coil can) for maximum (peak) output as shown by the waves on the oscillograph screen.

(g) Set receiver dial pointer to 1,500 kc. Tune test oscillator to 1,500 kc (1,500-3,100 kc range) and increase its output to produce a registration on the oscillograph screen. Carefully adjust the oscillator, detector, and antenna air-trimmers C16, C37, and C5, respectively, to produce maximum (peak) output as shown by the waves on the oscillograph screen. Shift the oscillograph "Timing" switch to "Ext." Place the frequency modulator sweep-range switch to its "Lo" position and insert plug of the frequency-modulator cable in test-oscillator jack. Turn test-oscillator modulation switch to "Off." Retune the test oscillator (increase frequency) until the forward and reverse waves show on the oscillograph screen and become coincident at their highest points. This will

occur at a test-oscillator setting of approximately 1,680 kc. Adjust trimmers C16, C37, and C5 again, setting each to the point which produces the best coincidence and maximum amplitude of the images.

(h) Remove the plug of the frequency-modulator cable from the test-oscillator jack. Turn test-oscillator modulation switch to "On." Set oscillograph "Timing" switch to "Int." Tune test oscillator to 200 kc (200-400 kc range). Tune receiver for maximum response to this signal at a dial reading of approximately 600 kc. The third harmonic of the 200-kc signal is used for this adjustment. Shift oscillograph "Timing" switch to "Ext." Insert the plug of the frequency modulator cable in test-oscillator jack. Turn test-oscillator modulation switch to "Off." Retune the test oscillator (increased frequency) until the forward and reverse waves show on the oscillograph screen. This will occur at a test-oscillator setting of approximately 230 kc. Disregarding the fact that the two images may or may not come together, adjust the oscillator magnetite-core screw L9 (top of large oscillator coil can) to produce maximum (peak) amplitude of the images. Shift the oscillograph "Timing" switch to "Int." Remove the plug of the frequency-modulator cable from the test-oscillator jack. Turn the test-oscillator modulation switch to "On." Repeat adjustments in (g) above to compensate for any changes caused by the adjustment of L9 core, tightening lock nuts on C16, C37, and C5, respectively, after each is adjusted.

Long-Wave Band:

(i) Shift the oscillograph "Timing" switch to "Int." Remove the plug of the frequency-modulator cable from the test-oscillator jack. Turn the test-oscillator modulation switch to "on." Place receiver range selector to its long-wave position. Set the receiver dial pointer to 175 kc. Tune the test oscillator to 175 kc and increase its output until a deflection is noticeable on the oscillograph screen. Adjust oscillator magnetite-core screw L10 (located on top of small oscillator coil can) so that maximum (peak) amplitude of output is shown on the oscillograph screen.

(j) Set receiver dial pointer to 350 kc. Tune test oscillator to 350 kc. Adjust the oscillator, detector, and antenna air-trimmers C18, C38, and C6 to produce maximum (peak) output as shown by the waves on the oscillograph screen. Without disturbing the connections, shift the oscillograph "Timing" switch to

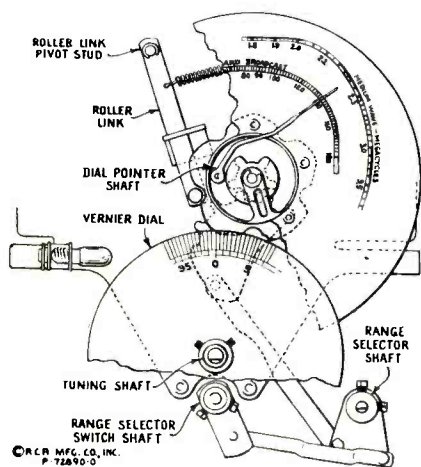
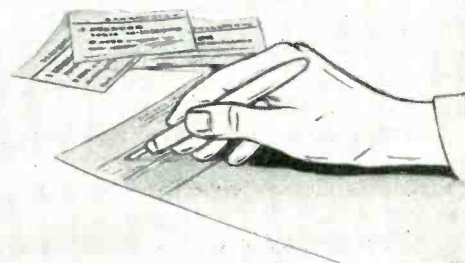
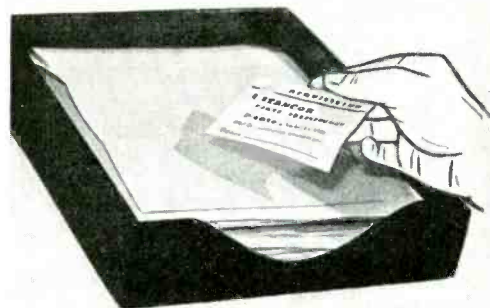

Fig. 9. RCA "Magic Brain" selector dial change mechanism

Let Us keep your
INVENTORY!



for your Convenience

Stancor makes it possible to throw the "want book" in the discard. There need be no more shortage in your transformer stock. . . and no troublesome inventory routine to keep track of what is on the shelves.

The new Stancor label does the trick. Use it as a stock check and you'll never need to say, "Sorry, but we're just out."

**S T A N D A R D
T R A N S F O R M E R
C O R P O R A T I O N**

850 BLACKHAWK ST. • CHICAGO, ILL.

"Ext." Place the frequency-modulator sweep-range switch to its "Hi" position and insert plug of frequency-modulator cable in test-oscillator jack. Turn test-oscillator modulation switch to "Off." Retune the test oscillator (decrease frequency) until the forward and reverse waves show on the oscillograph screen and become coincident at their highest points. This will occur at a test-oscillator setting of approximately 198 kc. This setting places the test-oscillator frequency to 175 kc. The second harmonic is now used for the 350 kc adjustment. Adjust air-trimmers C18, C38, and C6, again, to produce maximum amplitude of the images and best coincidence throughout their lengths.

(k) Retune the receiver to approximately 175 kc so that the forward and reverse waves appear on the oscillograph screen. Adjust the oscillator magnetite-core screw L10 to produce maximum (peak) amplitude of the waves, disregarding the fact that the two images may or may not come together.

(l) Shift the receiver dial setting to 350 kc without altering any other adjustments (frequency modulator still in operation). Adjust air-trimmers C18, C38, and C6, respectively, to produce maximum amplitude and best coincidence of the waves. These adjustments compensate for any changes caused by the adjustment of the magnetite core screw L10. Tighten lock nuts on C18, C38, and C6, respectively, after each is adjusted.

AMPLIFIER ADJUSTMENTS

It is essential that correct voltages and currents exist at the 6L7 audio expander stage in order that the expanding function may take place in the proper manner. A screwdriver adjustment is accordingly provided to regulate the 6L7 control grid No. 3 bias to the correct operating value. Two methods of adjustment are applicable. Either method requires a normal voltage of 300 volts across the filter output. The one to be preferred (a) requires the use of a beat-frequency oscillator, a 100-ohm resistor, a 200-ohm resistor, and a 1,000-ohm-per-volt a-c voltmeter (rectifier-type) having a "low" range of 1.0 volt and a "high" range of 250 volts or greater. The less accurate method (b) requires the use of a split-plate adapter (stock No. 12353), and a suitable d-c milliammeter. Both of these procedures are outlined below. *Caution:* Before using either method, be sure that power-supply fuse is in proper position for the line voltage.

(a) *Preferred Method:* Turn power

switch off. Connect the 200-ohm and the 100-ohm resistors in series between the beat-frequency oscillator terminals (upper "250" and "CT") with the 100-ohm resistor connected to "CT." Calibrate the beat-frequency oscillator, adjust it to 1,000 cycles, and reduce its output. Connect the 1,000-ohm-per-volt a-c voltmeter (1-volt range) to the beat-frequency oscillator terminals (upper "250" and "CT"). Remove the male plug from the receptacle on the shielded cable running between the input transformer T2 and the compensator pack. Connect beat-frequency oscillator terminal CT to the large pin on the male plug. Connect the junction of the 200-ohm and the 100-ohm resistors to the small pin on the male plug.

Adjust beat-frequency oscillator output until the voltmeter reads exactly 1.0 volt. Remove the voltmeter leads from beat-frequency oscillator terminals without disturbing any of the oscillator adjustments. Place the voltmeter to its 250-volt or greater range and connect it between the plate prongs of the two 2A3 power-output tubes. Connection to the tube prongs may be made by stripping approximately 1/2 inch of insulation from the ends of two short leads of rubber-covered wire, wrapping one bare end around each plate prong (being careful to prevent the bare ends from shorting on the chassis when the tubes are placed in their sockets), and connecting the voltmeter to these leads. *Caution:* Do not touch these plate connections after the power is turned on since the potential at these points is rather high and carelessness might result in a serious shock.

Set the "dynamic amplifier" and "fidelity control" to their extreme counter-clockwise positions. Set the phonograph volume control to its extreme clockwise position. Turn on power switch and allow a few minutes for the instrument to become stabilized. Adjust the expander-bias control R46, on rear apron of amplifier, until the voltmeter reads 195 volts. Turn phonograph volume control to extreme counter-clockwise position. Transfer lead from the junction of the 200-ohm and the 100-ohm resistors to the beat-frequency oscillator (upper "250") terminal without disturbing any of the oscillator adjustments. Adjust phonograph volume control until the voltmeter reads 50 volts. Turn the "dynamic amplifier" control to its extreme clockwise position allowing maximum expansion to take place. The voltmeter should now read not less than 150 volts if the expander circuit is operating correctly. Failure to do so in-

dicates a defect in the system and the usual service procedure should be followed.

(b) *Alternate Method:* Turn power switch off. Place split-plate adapter (stock No. 12353) under the 6L7 audio-volume expander. Connect a suitable d-c milliammeter to the adapter. Turn both the phonograph volume and the "dynamic amplifier" controls to their extreme counter-clockwise positions. Turn on power switch and allow a few minutes for the instrument to become stabilized. Adjust expander bias control R46, on rear apron of amplifier to give 1.0 ma of plate current with no signal input to the dynamic amplifier.

LOUDSPEAKER

Centering of the loudspeaker voice coil is made in the usual manner with three narrow paper feelers after first removing the front paper dust cover. This may be removed by softening its cement with a very light application of acetone using care not to allow the acetone to flow down into the air gap. The dust cover may be cemented back in place with ambroid upon completion of adjustment.

ANTENNA AND GROUND TERMINALS

These receivers are equipped with an antenna-ground terminal board having three terminals. These terminals are marked "A2," "A1," and "G," the latter being the ground terminal and should always be connected to a good external ground. The transmission-line leads of an RCA RK-40A antenna system should be connected to terminals "A2" and "A1." The receiver coupling units of the RK-40 and the Spider-Webb antenna systems should be connected to terminals "A1" and "G." Connect a single-wire antenna to terminal "A1."

SELECTOR DIAL

Fig. 9 illustrates the relation of the various parts of the dial mechanism when in its standard-broadcast position with the range switch likewise turned to its standard-broadcast position. In re-assembling the dial after repairs, see that the gears are meshed in accordance with the diagram, at the same time noting that the range switch is in its standard-broadcast position and the lever attached to the range-switch shaft placed in the position shown.

To adjust the dial mechanism, set the range switch to its standard-broadcast position. Place a straight-edge across the center of the dial so that its edge is even with the lower (end) marking at both the low-frequency and high-frequency ends of the dial. Under such

By popular demand...



**ELECTRONOMETER
SERIES 600**

In the design of the Series 600 ELECTRONOMETER, "PRECISION" engineers embodied many advanced circuit features to fill the need of tube analyzing in an extremely accurate, complete and speedy manner; also incorporating adequate radio set analyses measurements of volts, ohms, current and condenser leakages. It is a COMBINATION testing instrument of COMPACT SIZE (12 $\frac{3}{4}$ x 11 $\frac{1}{2}$ x 6), built to withstand "rough" usage, and weighing approximately only 15 pounds. The 600 was designed primarily to eliminate the inconvenience of carrying or the expense of purchasing several testing units.

\$45.75



MULTIMETER No. 830

This 11 range "PRECISION" service instrument contains a large 3 inch D'Arsonval type meter of 2% accuracy. 5 D.C. voltage ranges: 0-10; 0-100; 0-250; 0-500; 0-1000 at 1000 ohms per volt. 4 D.C. current ranges: 0-1 ma; 0-10 ma; 0-100 ma; 0-250 ma. 2 resistance ranges: Low ohms shunt method. 0-500 ohms. As low as 1/2 ohm. High ohms reading. 0-300,000 ohms. Selector controlled throughout. 4 $\frac{1}{2}$ x 7 x 2 $\frac{1}{2}$. Leather finish.

\$10.95



**ELECTRONOMETER
SERIES 500**

There is not a fine tube analyzer feature, not a single advanced and tested refinement omitted from this instrument. Its attractive design to inspire customer confidence and its structural character for long service and flexibility for future tube releases reflect the very best in modern tube analyzer construction. Attractively finished in baked black shrivel. Size 18 x 11 $\frac{1}{2}$ x 6 $\frac{1}{2}$. Approximate carrying wt. **\$39.50** 17 pounds.



**SET ANALYZER
SERIES 829**

The "PRECISION" Series 829 Master Selective Set Analyzer is designed to completely fill the need for servicing in an extremely accurate, speedy and simple manner. Careful consideration has been given to engineering design; for accuracy... flexibility... and ease of control. To insure lasting satisfaction, scrupulous care has been exercised in the selection of the materials that go into its manufacture.

\$44.95

PRECISION Apparatus Corporation
821 EAST NEW YORK AV., BROOKLYN, N. Y.

★ Acclaimed . . . for Their True Amplification Test

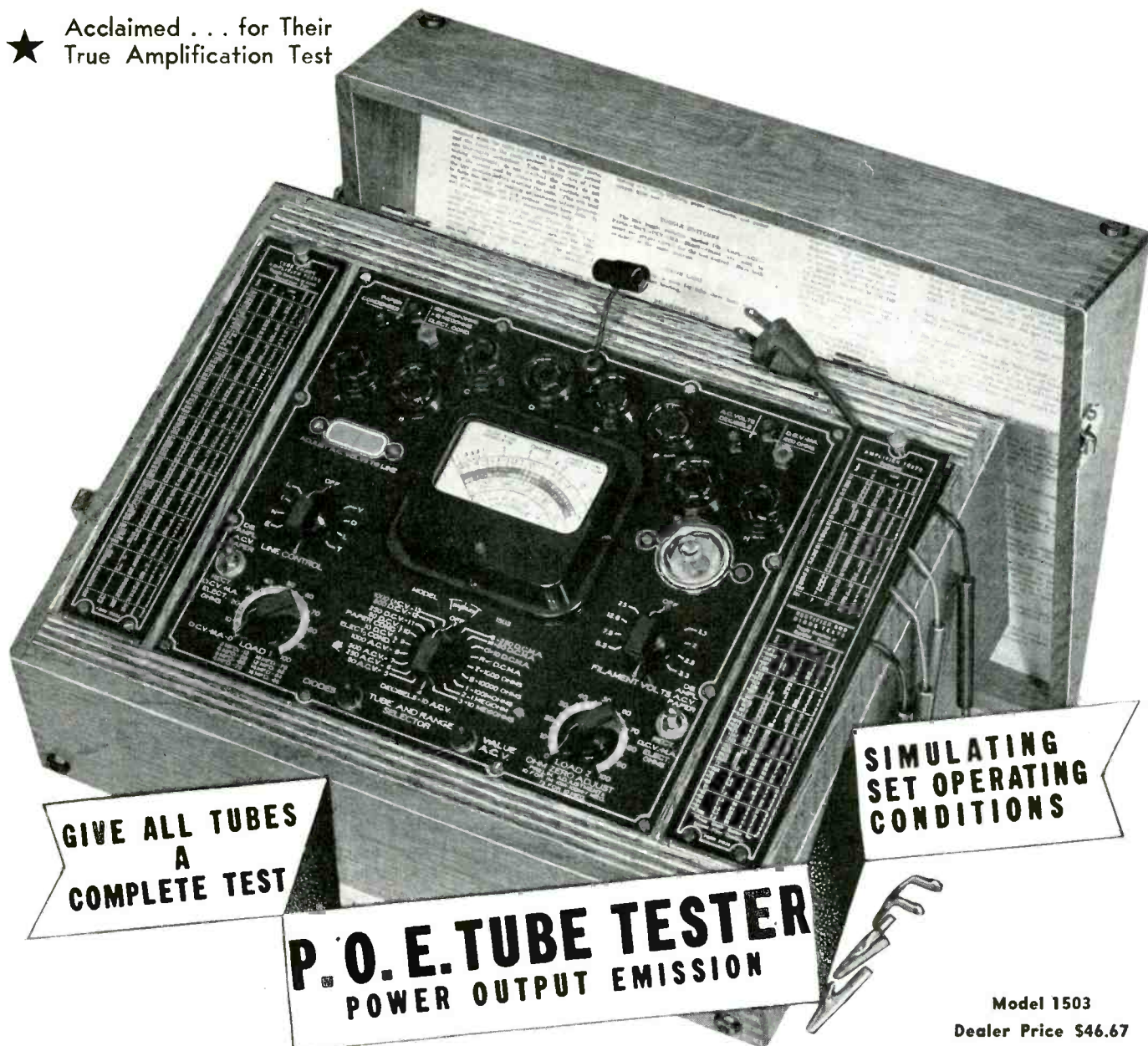

GIVE ALL TUBES
A
COMPLETE TEST

SIMULATING
SET OPERATING
CONDITIONS

P. O. E. TUBE TESTER
POWER OUTPUT EMISSION

Model 1503
Dealer Price \$46.67

MADE IN THREE MODELS

MODEL 1502
P. O. E. Tube Tester has Shadow Graph Line Voltage Indicator. Neon Inter-Element Short Test is made while tube is hot. Complete in Quartered Oak Case. Dealer Price

\$36.67

MODEL 1503
combines with the P. O. E. Tube Tester separate Universal Volt-Ohm-Milliammeter, Condenser Tester and Deebol Meter. In same Case as Model 1502. Dealer Price

\$46.67

MODEL 1504
same as 1503 but also combines Free Point Tester in side panels. Dealer Price

\$56.67

**SEE YOUR JOBBER
WRITE FOR CATALOGUE**

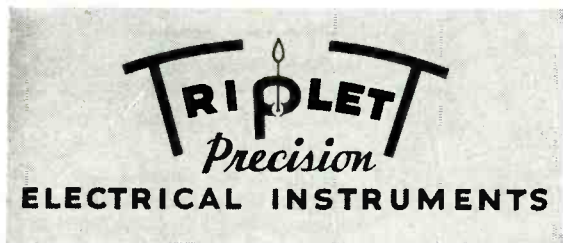

THE TRIPLET ELECTRICAL INSTRUMENT CO.
173 Harmon Ave., Bluffton, Ohio

Please send me more information onModel 1502;Model 1503;
.....Model 1504.

.....I am also interested in.....

Name

Address

City..... State.....

the grid of type 6A8 oscillator-modulator. This tube converts the 465-kc i-f to a second i-f of 100 kc. The automatic frequency control works by automatically changing the frequency of the second oscillator. The double superhetrodyne was described in the January issue of SERVICE.

THE CIRCUIT.

With this type of circuit, when the receiver is tuned to within 7 kc either side of a desired station signal, the signal will be brought into almost perfect tune or in better tune than is usually possible with the eye or ear. This feature will therefore overcome distortion caused by mistuning.

The receiver covers the ranges between 525 and 18,500 kc in three bands with ample overlap. An undistorted power output of 12.5 watts is available with a maximum of 21 watts. The power consumption at 115 volts is 125 watts.

From the output of the (second) oscillator-modulator the signal is fed through a conventional i-f system to the avc, detector and audio system. The signal is also fed from the output of the i-f stages to the type 6K7 limiter tube which is so connected as to give fairly even output regardless of the strength of the station signal at the input of the receiver. This uniform signal is then fed to the discriminator type 6H6 tube which is connected to the grid of the type 6J7 control tube. In the discriminator circuit, voltages are developed either positive or negative depending on which side of resonance the set is tuned. This change of bias on the control tube will cause it to change the oscillator frequency to bring the set into tune.

ALIGNMENT PROCEDURE

Before attempting to align the receiver the Service Man should familiarize himself with the general layout of the chassis, the location of the tubes and

the various alignment condensers. Both the receiver and test oscillator should be allowed to warm up for about a half-hour before adjustments are attempted.

A conventional output meter should be connected across the voice coil or the speaker transformer primary. The sensitivity of the output meter must be sufficient to give a satisfactory reading with a very low input signal. It is also necessary to use an 0.5 microammeter in order to align the discriminator circuits.

I-F ALIGNMENT

(1) Set the volume control on full and turn the bass control to the bass position (immediately after control turns the set switch to its on position).

(2) Connect the output meter across the voice coil of the speaker.

(3) Set the test oscillator to 100 kc, and adjust the output to give a readable deflection on the output meter when the signal is applied to the grid of the 6K7 i-f amplifier tube through a 0.5-mfd blocking condenser.

(4) Connect a 10,000-ohm resistor across the primary winding of the third i-f coil No. 62. This should be connected to terminals marked "A" and "B" in Fig. 2.

(5) Adjust trimmer No. 64 to maximum output, reducing the output of the test oscillator as required.

(6) Remove the 10,000-ohm resistor from the primary side of the i-f coil No. 62 and connect across the secondary winding from terminals marked "C" and "D".

(7) Adjust trimmer No. 63 to maximum output, reducing the output of the test oscillator as required. Remove 10,000-ohm resistor.

(8) Turn switch No. 98 to the left-hand position (viewed from rear of chassis).

(9) Set the output of the test oscillator to a high level.

(10) Connect a 0 to 5 microammeter across resistor No. 149 and adjust trimmer condenser No. 111 to maximum swing of the microammeter, keeping the output of the test oscillator set to a point which will give a deflection of approximately 5 microamperes when condenser No. 111 is tuned to maximum deflection. When the test oscillator is set to this output, do not alter the output of the test oscillator until the alignment of the discriminator circuit is completed.

(11) Adjust trimmer No. 110 until the microammeter reading is reduced exactly to zero.

(12) Turn switch No. 98 to the right-hand position and proceed with the alignment of the i-f.

(13) Apply the test signal to the grid of the 6A8 oscillator-modulator tube.

(14) Connect the 10,000-ohm resistor across the primary of i-f coil No. 50 by connecting it to the terminals marked "E" and "F" in Fig. 2.

(15) Adjust trimmer No. 52 to maximum output, reducing the output of the test oscillator as required.

(16) Remove the 10,000-ohm resistor and connect across the secondary of i-f transformer No. 50. Connect to terminals marked "G" and "H".

(17) Adjust trimmer No. 51 to maximum output, reducing the output of the test oscillator as required.

(18) Remove the 10,000-ohm resistor.

(19) Set the test oscillator to 465 kc, and adjust the control oscillator trimmer No. 92 to maximum output.

(20) Apply the test signal to the grid of the type 6A8 oscillator-detector tube.

(21) Connect the 10,000-ohm resistor across the primary of i-f transformer No. 26 by connecting it to the points marked "J" and "K" in Fig. 2.

(22) Adjust trimmer No. 28 to maximum output, reducing the output of the test oscillator as required.

(23) Remove the 10,000-ohm resistor and connect across the secondary of the i-f transformer No. 26 by connecting it to the points marked "L" and "M" in Fig. 2.

(24) Adjust trimmer No. 27 to maximum output, reducing the output of the test oscillator as required. Remove the 10,000-ohm resistor.

ADJUSTMENT OF BROADCAST BAND

(1) Set the wavechange switch to the white or broadcast band position.

(2) Set the test oscillator and dial indicator to 1600 kc.

(3) Apply the test signal to the antenna terminal of the chassis through a
(Continued on page 172)

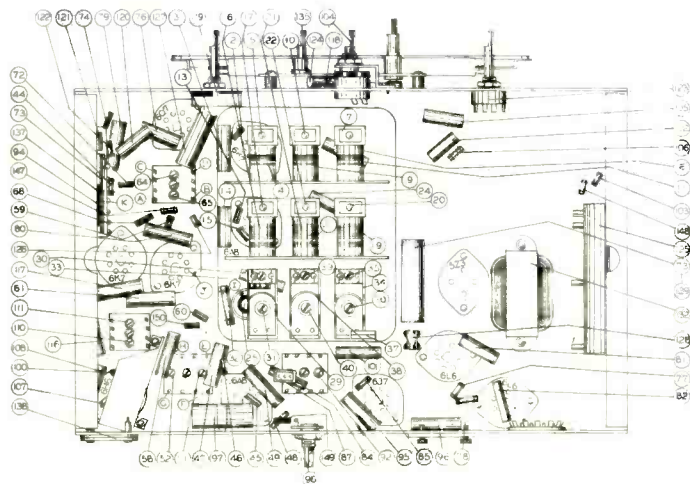
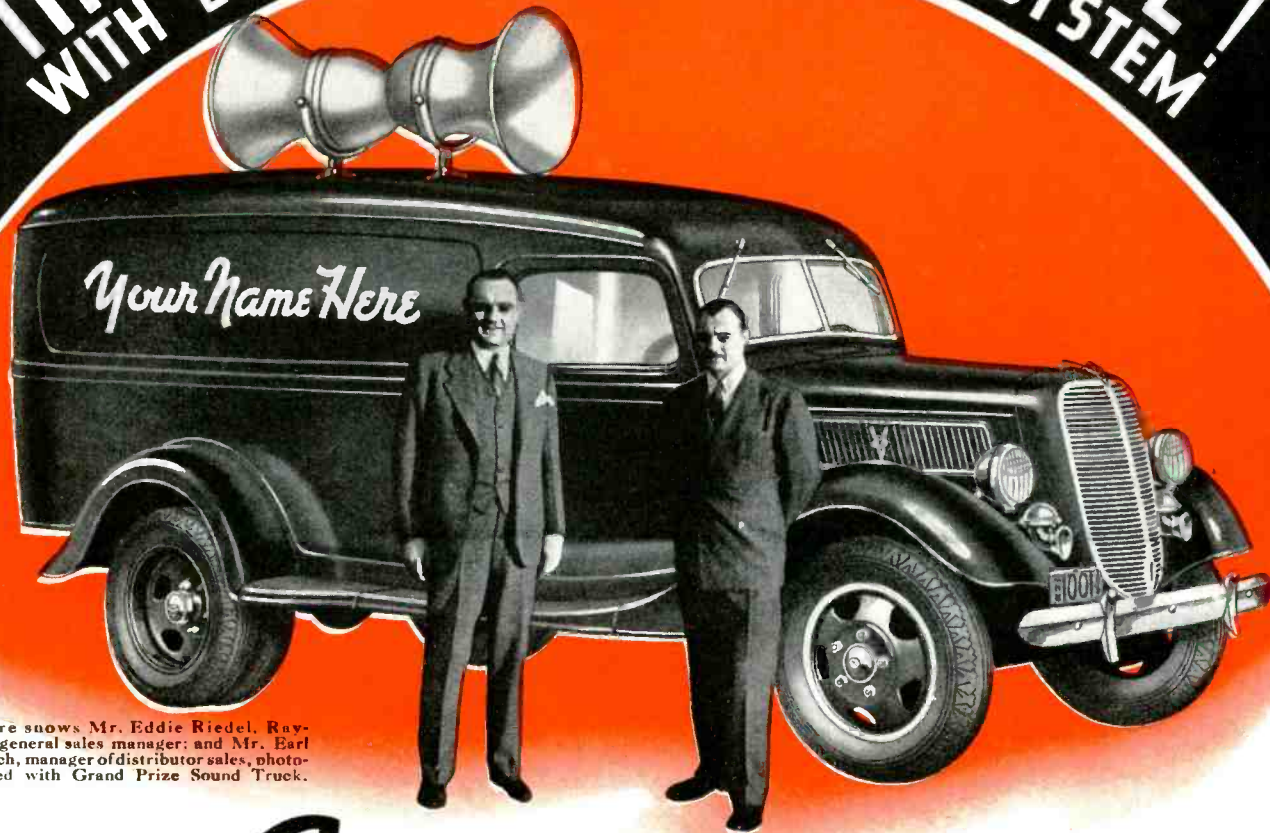

Fig. 2. Westinghouse WR-315 trimmer locations.

THIS SERVICE TRUCK FREE!
 WITH BUILT-IN LOUD-SPEAKER SYSTEM



Picture shows Mr. Eddie Riedel, Raytheon general sales manager; and Mr. Earl Dietrich, manager of distributor sales, photographed with Grand Prize Sound Truck.

WE ARE *Giving It Away!*

ALSO 500 OTHER FREE PRIZES

It's the easiest contest ever! Just answer a simple question—an answer that every serviceman or dealer gives to his customers two or three times a week. It may win for you this new V-8 service truck with a complete built-in sound system—or \$600 Cash! In addition, the first prize winner's name and photograph will appear six weeks after the contest in our advertisement in the Saturday Evening Post! There are 500 other prizes you will find equally desirable! Learn about the Raytheon Contest today! Ask your jobber!

RAYTHEON

RAYTHEON PRODUCTION CORPORATION

420 Lexington Ave., New York, N. Y.
 55 Chapel Street, Newton, Mass.

445 Lake Shore Drive, Chicago, Illinois
 555 Howard Street, San Francisco, Cal.
 415 Peachtree St., N. E., Atlanta, Ga.

RAYTHEON IS THE MOST COMPLETE LINE - ALL TYPES OF GLASS, OCTAL BASE, METAL, RESISTANCE AND AMATEUR TRANSMITTER TUBES

**EVERY
SERVICEMAN
SHOULD OWN**

**This Combination Volt-Ohm-Milliammeter
And Free Point Tester**

**DESIGNED TO WITHSTAND
ROUGH FIELD SERVICING**



Model 640-740

Precision Built

**DEALER
PRICE \$27.00**

NO EXTRA CASES TO BUY

Buy the money saving combination Free Point Tester and Volt-Ohm-Milliammeter installed in one compact carrying case. Just what you need for field use. Every service shop should own duplicate servicing instruments, as protection against rush work, instruments damaged in service, and for taking care of other emergencies.

The Ranger Examiner Free Point Tester with its eight automatic switch type and ten single action jacks makes possible any combination of series or parallel instrument connections through the set sockets to all parts of the circuit. Five sockets handle any type radio tube.

Compare these precision built testers . . . in per-

formance . . . and in price. Made by the oldest manufacturer of radio testers in the country. Model 740 Volt-Ohm-Milliammeter has 3" square Triplett Precision Instrument. Scale readings: 10-50-250-500-1000 A.C. and D.C. Volts at 1000 Ohms per Volt (D.C. accuracy 2%; A.C. 5%); 1-10-50-250 D.C. M.A.; 0-300 low Ohms; High Ohms to 250,000 at 1.5 Volts. Rheostat adjustment for 13½ volts for Ohm readings to 2.5 Megohms. Batteries may be added permitting such readings in 250,000 ohms steps. Low ohms to ½ ohm with 25 ohms in center of scale. Backup circuit is used. Current draw is only 1 M.A. Model 640-740 Portable Free Point Tester and Volt-Ohm-Milliammeter. DEALER NET, \$27.00.



**MODEL 640
FREE POINT
TESTER
ONLY**

\$9.90 FREE
NET TO DEALER

**ALSO AVAILABLE
As
SINGLE TESTERS**

Booklet. Lists 101 most frequent Radio Troubles, How to Detect and How to Cure. Nothing like it before. Greatly simplifies every-day servicing. Send coupon now.

**MODEL 740
VOLT-OHM-
MILLIAMMETER**



**ONLY
\$18.60**
NET TO DEALER



READRITE METER WORKS
317 College Dr., Bluffton, Ohio

..... Please send me more information on Model 640-740;
..... Model 640; Model 740. Free booklet,
"101 Radio Troubles and Their Cures."
..... I am also interested in.....

Name

Address

City..... State.....

ment of the receiver is directly dependent upon it.

Adjust trimmer A to maximum output and then remove the paper gauge.

Set the test oscillator and condenser gang to 1400 kc. Apply the test signal to the grid cap of the 6K7 r-f tube and adjust trimmer B to the maximum output.

Apply the test signal to the antenna lead through a 0.0002-mfd condenser and adjust trimmer C to maximum output. Check sensitivity at several points.

Repeat the r-f alignment if necessary.

Zenith 5520 (5-M-191)

The Zenith chassis 5520 is a 5-tube car radio using either metal or G type (glass tubes with octal bases) tubes in a conventional superheterodyne circuit. It has a frequency range from 540 to 1600 kc and a power output of 3.2 watts. The total current drain with a battery voltage of 6, is 5.5 amperes. The sensitivity at 1 watt output is 5 mv.

THE CIRCUIT

A complete circuit diagram of the

5520 is given in Fig. 1 with the tubes used, their functions and the various voltages encountered on the socket prongs lettered on the diagram. The voltages were measured with an input battery voltage (at the battery) of 6 volts. A 1000-ohm-per-volt voltmeter was used for the measurements. The volume control was turned on full and the antenna was disconnected during the measurements.

A tapped iron-core antenna coil of the auto-transformer type is used to feed the signal to the control grid of the 6A8G modulator-oscillator stage. The rear section of the two-gang tuning condenser and the 200 to 750-mfd padder tune the oscillator coil and maintain the 456-kc frequency difference between the oscillator signal and the station carrier. The padder is also used as the grid condenser for the oscillator section of the tube.

A 6K7G tube is used with two doubly tuned i-f transformers in an i-f stage. One diode of the 6Q7G tube is used as the second detector and the other diode is used as an avc rectifier. The cathodes

of the 6A8G and the 6K7G are grounded and minimum bias is maintained by connecting the avc return to a suitable tap in the negative leg of the voltage divider circuit. This bias is equal to the drop in resistor R8 (40 ohms) connected in series with the filter choke and the chassis.

The triode section of the 6Q7G is resistance coupled to the 6F6G output stage. The bias for the output stage is also taken from the drop occasioned in the negative leg of the voltage supply system and is equal to the combined drop in the choke T4 and the resistor R8.

A vibrator and step-up transformer is used to obtain the high voltage necessary for the power supply circuits. An OZ4 rectifier and a suitable filter network is used to convert the high voltage a-c thus obtained to smooth d-c used in the plate and screen circuits.

ALIGNMENT PROCEDURE

Connect the service oscillator output leads to the control grid of the 6A8G oscillator-modulator tube and to the receiver chassis. Connect an output meter

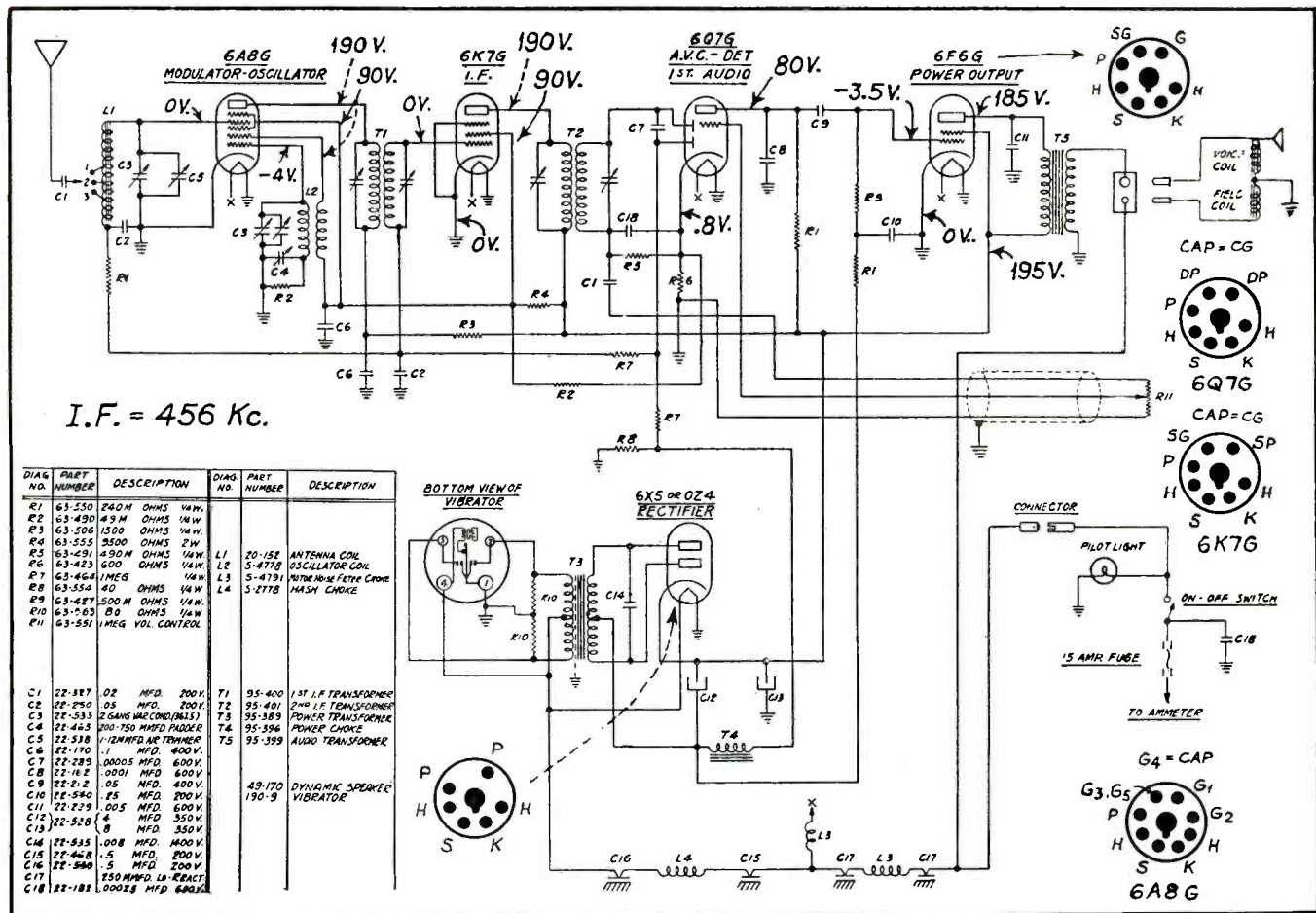

Fig. 1. Zenith 5520 circuit diagram.

Money IN THE BANK...
NOT ON THE SHELF



That's only one of the advantages of the TUNG-SOL CONSIGNMENT PLAN. No outlay for an adequate stock of these high quality tubes. No repeated investments to keep that stock up to the minute. Sell—collect your profit—then remit the cost price. That's "velvet"—for you!

Tung-Sol performance means repeated, full-profit sales. There are still desirable locations for the appointment of reputable dealers..who can qualify. Write for name of your nearest Tung-Sol wholesaler.

TUNG-SOL

Tone-flow radio Tubes

TUNG-SOL LAMP WORKS, INC.
Radio Tube Division

Sales Offices: Atlanta, Boston, Charlotte, Chicago, Dallas, Detroit, Kansas City, Los Angeles, New York. General Office: Newark, N.J.

Don't try to **GUESS**
a radio set into balance!

It's so easy
with this new
Series 3710

\$49²⁵
complete



BENDIX-DAYRAD SCOPE

Make your balancing tests swiftly and surely. You'll get the most out of a receiver in the least possible time with this new Bendix-DayRad Scope. At its low, big-production-price, it's a splendid investment for any radio service department.

Here's What You Can Do With It

1. The alignment of radio receivers. (Built-in amplifiers to adjust for the sensitivity of the receiver).
2. The measuring of peak voltage A.C. with or without amplifiers.
3. The measuring of audio quality in audio amplifiers, thereby locating causes of distortion.
4. The measuring of modulation, percentage of transmitters, or oscillators.
5. Checking phase shifts in various devices.
6. Modulation percentages of received signals by phase shift method.
7. Testing of auto radio vibrators.
8. The adjustment of transmitters.

Brief Specifications:

The Series 3710 has complete controls for adjustment of tube and spot, namely intensity, focus, horizontal, and vertical spot controls. The intensity control is equipped with the AC power switch.

Vertical and horizontal gain controls have switches for connecting the binding posts directly to the ray tube or through the amplifiers.

Maximum peak voltage applied to the binding post input must not exceed 400 volts.

Both amplifiers substantially flat in frequency response from 15 to 100,000 cycles.

The sweep frequency range is continuously variable from 15 cycles to a maximum of 20,000 cycles, and is linear through its entire range.

The sweep frequency step control is variable in ten steps.

The variable sweep control provides a means of interpolation between the frequency ranges.

The synchronization control provides a means of locking in step the sweep tube with the voltage supplied externally to be viewed. This control has three positions, internal lock, line frequency lock, and external lock.

Cabinet is 6 1/4" wide, 8 1/4" high, 10 1/2" long. The handle for carrying is the trim at the top of the case and it is concealed when not in use.

The instrument operates on 110 volts 50 or 60 cycles. 25 cycles at a slightly higher price. Weight complete approximately 15 lbs

Price complete is \$49.25.

Send Coupon below for new Bendix-DayRad catalog

—SEND THIS COUPON NOW!—

BENDIX PRODUCTS CORPORATION, Bendix-DayRad Dept.
(Subsidiary of Bendix Aviation Corporation)
458 Bendix Drive, South Bend, Indiana

Please send full details of the Bendix-DayRad System of Radio Service, including data on Time Payment arrangements, for above, and other Bendix-DayRad units

Name

Address

City State

My Distributor's Name

across the primary of the speaker transformer or across the voice coil.

Turn on the service oscillator and the receiver and allow both at least 15 minutes to warm up before attempting adjustments.

I-F ALIGNMENT

Set the service oscillator to 456 kc and adjust the i-f trimmers to the point giving the greatest output reading, starting with the secondary trimmer on the second i-f transformer and working toward the primary trimmer on the first i-f transformer. These as well as the following adjustments should be made using as small an output from the service oscillator that will give a readable indication on the output meter so that the avc action will be least effective.

Repeat the i-f adjustments to assure greater accuracy.

R-F ALIGNMENT

Change the service oscillator lead from the grid of the 6A8G to the antenna connection. A male Delco-Remy connector may be used in making the connection to the antenna lead.

Set the service oscillator at 1600 kc and rotate the gang condenser until the plates are entirely out of mesh. Adjust the oscillator section trimmer until the 1600-kc signal is tuned to maximum.

Set the service oscillator at 600 kc and rock the gang condenser slowly to and fro through the point where this signal is received, meanwhile adjusting the padder condenser for a setting which gives the greatest output reading.

Repeat the 1600-kc adjustment.

ANTENNA STAGE ALIGNMENT

There is such an extremely wide variation in antenna capacities that it is difficult to match the set to the antenna without some means of variable antenna alignment. To accomplish this, an antenna compensating adjustment is pro-

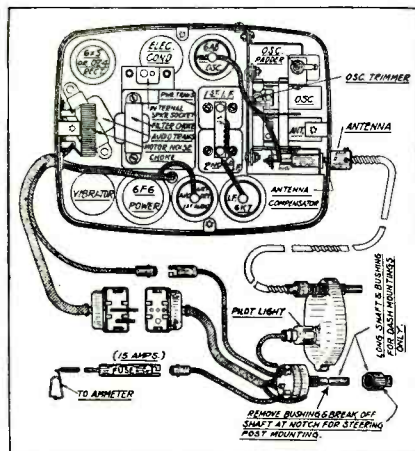
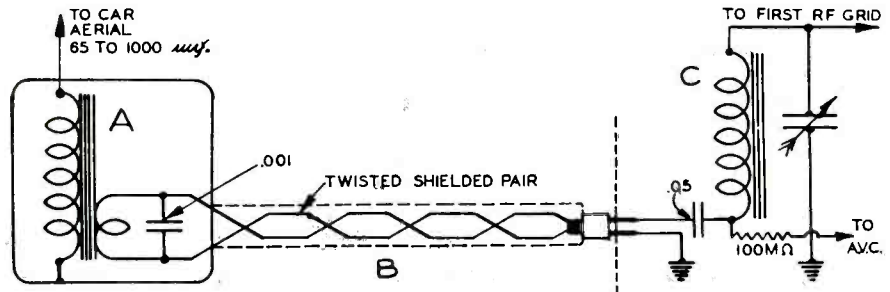

Fig. 2. Zenith 5520 tube and trimmer locations.



Arvin "Phantom Filter" circuit.

vided through the small hole directly above the antenna cable connector on the receiver case. In addition to this, a tapped antenna transformer is also incorporated. The proper method of alignment is as follows: After completely connecting receiver, tune in a signal between 1400 and 1450 kc and adjust the antenna compensator shown in Fig. 2, for either the roof antenna, or single or double under-car antenna. The receiver is shipped from the factory with the antenna tap set to the No. 2 position, and, therefore, need not be changed for either of the two types of antennas mentioned.

For Zenith "Fleet Wing," and "Over the Top Antennas," unsolder the antenna lead from the No. 2 lug, and resolder it to the No. 3 lug. After this is done, tune in a station between 1450 and 1400 kc and adjust the antenna compensator shown in Fig. 2 to resonance.

For high-capacity antennas such as the 1936 Dodge solid steel roof, or the Lincoln Zephyr luggage compartment, drawer antenna, etc., remove the antenna lead from the No. 2 lug, as it comes from the factory, and resolder it to the No. 1 connector. After this is done, the same procedure of tuning in a signal from 1450 to 1400 kc and balancing to resonance with the antenna compensator, as described above, should be followed.

This system of tapped transformer, and variable compensating adjustment gives a flexible means of resonating the receiver to any type of antenna, and it should be noted that the tap need only be changed in two cases. Of course, it is necessary to remove the bottom cover in order to shift the antenna tap where necessary.

SERVICE NOTE

The OZ4 rectifier tube used in this model may be replaced with a 6X5 providing the 6X5 is enclosed in a grounded tube shield. The close-fitting type with a ground clip that connects to the shield pin of the tube is a convenient type to use.

Arvin "Phantom Filter"

The "Phantom Filter" circuit is shown in the accompanying diagram. Essentially it consists of three separate parts: the antenna coupler, the transmission line and the tuned resonance circuit.

The antenna coupler is designed to resonate at 500 kc with an antenna capacity of 75 mmfd. Higher capacities, of course, resonate the input circuit to lower frequencies with a slight reduction in efficiency although performance is quite satisfactory with metal insert top antennae such as used in 1936 Dodge cars.

Energy in the antenna is impressed on the primary of coil A where it is induced into the low-impedance secondary and fed into the matched line B, which is loaded with 1,000-mmfd. capacity at the input end.

Terminating at the antenna coil in the receiver C, the twisted pair is coupled in series with the antenna coil winding and the capacity of the line and loading condenser becomes the automatic volume control condenser.

High-Q construction utilizing the efficiency obtainable by iron-core and double-pie coil design permits an overall gain of from 14 to 24 in the antenna stage.

Stromberg-Carlson 145, 150, 160, 180

Replacing receiver in cabinet: In replacing the receiver in the cabinet in these models it is important that the metal grommets in the rubber cushions at the top of the dial plate, which is held to the cabinet by wood-screws, are in place. If these are not in place, there is a chance that the screws may be driven too far into the cabinet and possibly break through the front. If the grommets are in place and the screw is not turned too hard, there is no danger of this. However, it is perfectly satisfactory to omit the screws. Unless the set is in transit there is no purpose to the dial being screwed to the cabinet.

"ASK ANY MECHANIC" he'll tell you

REPAIRMEN WHO
KNOW THEIR
STUFF KNOW
KRAEUTER TOOLS
ARE "TOPS"



Experts agree that Kraeuter Tools are the highest quality line in the world. And that's not surprising considering the important contributions made during the past 70 years by this company in the hardening and tempering of steel and the introduction of radically new and improved designs and finishes. The more you know about Tools the quicker you will recognize the superiority of the Kraeuter Line.

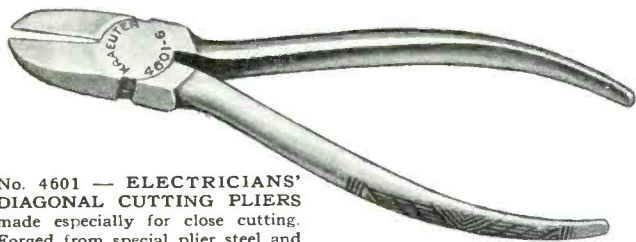

No. 4601 — ELECTRICIANS' DIAGONAL CUTTING PLIERS made especially for close cutting. Forged from special plier steel and precisely fitted for exact work. Sizes 4½" to 7½".

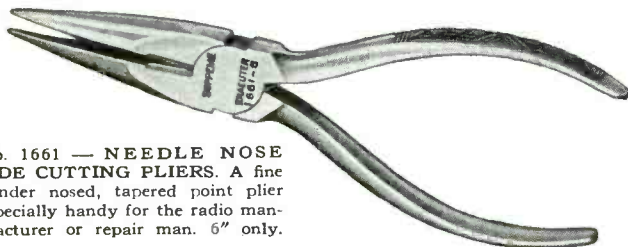

No. 1661 — NEEDLE NOSE SIDE CUTTING PLIERS. A fine slender nosed, tapered point plier especially handy for the radio manufacturer or repair man. 6" only.

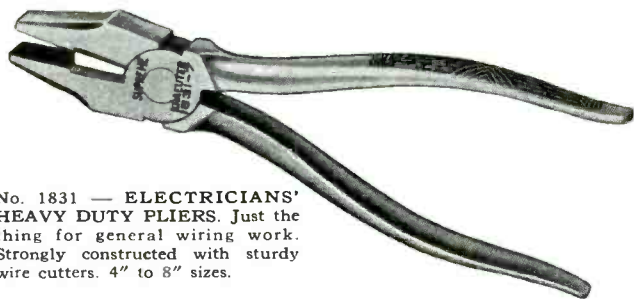

No. 1831 — ELECTRICIANS' HEAVY DUTY PLIERS. Just the thing for general wiring work. Strongly constructed with sturdy wire cutters. 4" to 8" sizes.

KRAEUTER Pliers save time—do the job better. There's a model for every purpose. For full information write Kraeuter & Co., Dept. "S".

KRAEUTER & CO.
(Pronounced KROY-TER)
NEWARK, N. J.

Manufacturers of Highest Quality Pliers and Tools Since 1860

DEALERS... Equip Your Sound Trucks with the *All-Purpose*

SOUND SYSTEM

for 6 Volt D.C. or 110 Volt A.C.

CAN BE USED FOR:

Rentals or Sales.
Portable or for
Fixed Location.
Outdoors or Indoors.
Automobile, Truck
or Ship Work—
6 Volt Operation
if Power Line Not
Available.
Small or Large Audiences.

A sound system that can be used anywhere. For any size audience to 10,000. Has all the latest refinements including tone control, crystal microphone, two heavy duty permanent magnet speakers. All units especially designed with large factor of safety to insure satisfaction under all conditions. System is complete with all accessories including phonograph turntable.

**30
Watts
Output**

Amplifier delivers 30 watts undistorted output. It is a new design using beam type tubes and housed in attractive steel case with japanned finish. Uses 5 tubes on 6 Volt D.C. and 6 tubes on 110 Volt A.C.



**Model
530**

Note:
phonograph
turntable
is built into
amplifier.

Latest type crystal
microphone.



Improved high efficiency Permanent
Magnet Speakers.



- FULLY LICENSED
- STRICT DEALER POLICY
- TIME PAYMENT PLAN

For more information, send coupon, learn all about Webster-Chicago's fast selling merchandise and the money-making possibilities for the Sound Specialist. Get new 1937 Catalog.

SALES PROMOTION HELPS

Webster-Chicago Dealer Helps are showing dealers the enormous possibilities now present in the sound market. The single All-Purpose system is all you need stock at the start. Webster-Chicago manufactures a complete line of Public Address Equipment and Sound Accessories including—

**New AMPLICALL
INTER-OFFICE
COMMUNICATION SYSTEM**

WEBSTER - CHICAGO

WEBSTER-CHICAGO

Section M-5, 3825 W. Lake St., Chicago, Ill.

..... Please send me complete information on the All-Purpose Sound System.

..... Please send me New 1937 Catalog.

Name

Address

City..... State.....

Public Address . . .

Modernizing Receivers with P-A Amplifiers

Those who have followed the progress of radio remember the change-over from the tinny receivers of 1925 to the exaggerated bass of 1929 and the middle ranged sets of 1933. The overall fidelity of the radio receivers manufactured during the last year or so, however, is definitely better than that of their predecessors. The many years of experimentation along these lines have enabled the set manufacturer to produce modern receivers with full depth and naturalness of tone, at a price, although somewhat larger, in accordance with the more prosperous times.

A large percentage of the receivers sold during the depression years incorporated a low power output stage,

in combination with phonograph reproducing devices and represent a large cash investment. Most of the owners of these receivers have an exaggerated idea of the value of these antique models—especially those with the phonograph combinations. This is plainly evident by their inertia in purchasing new receivers.

Undoubtedly a number of these set owners are completely satisfied with the number and separation of the stations received on their present sets and yet are quite dissatisfied with the tone quality of the reproduction. This should prove especially true in cases where the equipment is a phonograph combination. It should be very easy to sell these clients an accessory which will increase the power, improve the frequency response and reduce the harmonic distortion of their reproduction.

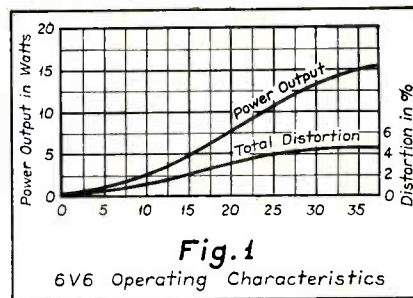

Fig. 1. Beam-power tube characteristics.

The public-address amplifiers described below are adapted for radio receiver modernization.

AN A-C BEAM-POWER AMPLIFIER

Tube manufacturers have recently released the 6V6 (and the 6V6G). This tube is a tetrode power amplifier similar in all respects to the familiar 6L6, but with a medium power rating. Fig. 1 illustrates the operating characteristics of the 6V6 in push-pull class AB. Over 15 watts of audio power can be obtained with only 5 percent distortion, without fixed bias or high power driver requirements. A complete circuit of an amplifier using these tubes is illustrated in Fig. 2. The circuit shown is simple and of conservative design. High-impedance input is used to the 6J7, which is, in turn, resistance coupled to a 6C5 driver tube. The 6C5 is transformer coupled to the push-pull output tubes. A gain of approximately 90 db is obtained from this three-stage setup due to the high power sensitivity of the 6V6 tubes. The input of the amplifier can be operated directly from the output of a radio receiver detector by connection to the detector plate through the 0.1-mfd condenser indicated in the circuit diagram. With the exception of the plate-grid coupling condenser, which should be removed, the receiver circuit can be left intact. If phonograph operation is also desired the switch indicated in the circuit can

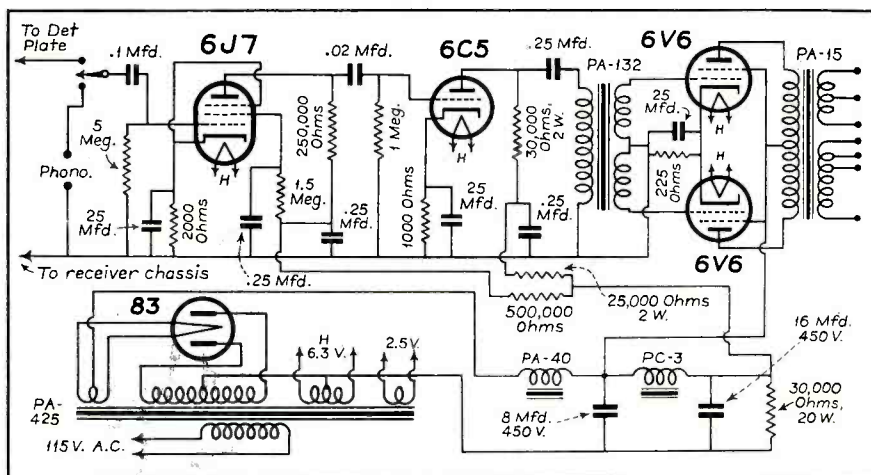

Fig. 2. An a-c beam-power amplifier.

usually only a single pentode, having relatively poor frequency response and comparatively high distortion. Manufacturers were trying to reduce costs and these economical pentodes were the rage. Today push-pull output stages with high fidelity is the order of the day.

PUBLIC AWAKENING TO QUALITY

With the influx of the modern high-fidelity receivers the public is becoming more and more quality conscious. This should suggest an opportunity for the enterprising Service Man.

There are at present some 14,500,000 set owners in the United States with receivers more than two years old. Many of these sets are incorporated in expensive cabinets. Others are in com-

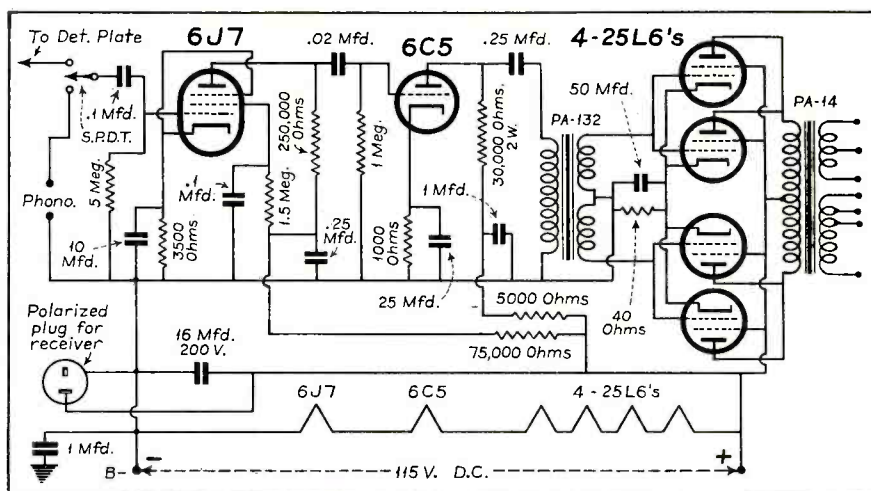

Fig. 3. A power amplifier for d-c receivers.

UTAH VIBRATORS



CAN

Take it!

**EXCLUSIVE UTAH FEATURES MEAN
LONGER LIFE—HIGHER EFFICIENCY**

When you install a UTAH Vibrator—no other serviceman can do a better job. You have given your customer longest vibrator life, freedom from set interference, and peak efficiency.

UTAH Vibrators are TOUGH! We've proved it by gruelling tests. Manufacturers know it too. That's why UTAH Vibrators are original equipment in more than a million sets. And the 1937 UTAH Vibrator is the finest and toughest we've ever made.

Use UTAH Vibrators on your replacement jobs. Prove to yourself they work better, last longer—but cost no more.

Your jobber has UTAH Vibrators for all radios.



THE NEW UTAH P.M. *Dynamic* SPEAKER

brings "better than new" performance to sets using this type of speaker.

UTAH has designed a new Permanent Magnet speaker that sets a new high in performance and long-time efficiency. Ideal for multiple speaker installations. Twenty-two models available in all standard sizes from five to fourteen inches.

Hear them at your jobber's—or write for details.

UTAH RADIO PRODUCTS CO.
CHICAGO, U. S. A.

TORONTO ONTARIO, CANADA BUENOS AIRES (UCOA RADIO PRODUCTS CO.)

"15 YEARS OF LEADERSHIP"

20,000 OHMS PER VOLT!

A new HIGH in Sensitivity and Value

At 20,000 ohms per volt, this new Simpson Set Tester is the most remarkable value ever offered to the serviceman. Negligible current consumption means accurate D. C. voltage readings of 2.5—10—50—250—1000. Same ranges for A. C. at 1000 ohms per volt. Current readings from 1 microamp to 500 milliamps. Accurate resistance readings as low as 1 ohm up to 40 megohms. Ask for new circular covering wide range of tests.



Model 250 (20,000 ohms per volt model)—Net Price... **\$38.50**

Time price: \$8.00 down and 6 monthly payments of \$5.85 each

Model 225 (10,000 ohms per volt model)—Net Price... **\$29.50**

Time price: \$6.00 down and 6 monthly payments of \$4.50 each

Illuminated Dial Tube Tester

Checks all tubes under individual load conditions utilizing latest authoritative circuit. Tube quality shown on illuminated scale. Separate scales for "Diodes" and 0-100 percentage scale for matching tubes. Spare sockets provide for future tube changes. Has neon-tube short check. A beautiful instrument that boosts tube sales.



Model 222 Tube Tester—Counter or portable type—Net Price... **\$39.50**

Time price: \$8.00 down and 6 monthly payments of \$6.20 each

"Roto-Ranger" Tube and Set Tester

"Roto-Ranger" feature places twelve distinct scales at finger tips. Utilizes latest tube testing circuit. Has filament return selector. Tests all types condensers on separate scales. Has separate resistance scales of 100 ohms, 100,000 ohms, 100 megohms. Three D. C. scales of 8—300—1000 Volts. (2500 Ohms per Volt.)

Model 220—Net Price... **\$57.00**

Time Price: \$11.40 down and 6 monthly payments of \$8.75 each

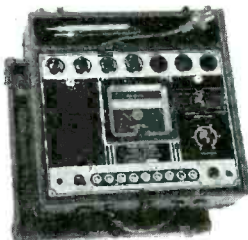

"Roto-Ranger" Volt-Ohm Milliammeter

Incorporates Simpson "Roto-Ranger" feature with twelve separate scales covering all ranges for practical servicing.

Model 201 with D. C. ranges only: Net Price... **\$29.50**

Time Price: \$6.00 down and 6 monthly payments of \$4.50 each

Model 202 (A. C.-D. C. type): Net Price **\$32.50**

Time Price: \$6.50 down and 6 monthly payments of \$5.00 each



**SOLD ON
DEFERRED
PAYMENTS**

SIMPSON
RADIO INSTRUMENTS
AND SERVICE EQUIPMENT

**ASK
YOUR
JOBBER**

COUPON BRINGS FACTS

Simpson Electric Co., 5218 W. Kinzie St., Chicago
Send bulletin describing models checked.

No. 250 No. 225 No. 222 No. 220 No. 201 No. 202
 Send deferred payment application.

Name _____

Address _____

ALL 6L6G's ARE *not*
alike!



HERE'S why the Arcturus 6L6G tube is recognized as being individual by both radio technicians and amateurs. . . .

Months of painstaking research in the Arcturus laboratory have developed a unique testing method which assures exceptionally low grid current for every 6L6G with an absolute minimum of distortion. Every tube is *individually measured* for power output and resulting sensitivity. Two separate noise tests (the last one in an actual radio receiver) bring truly remarkable freedom from noise while the excellent emission life assures maximum power output over a longer period of time.

Guarding and insuring Arcturus efficiency are 137 separate tests and checks that every tube must pass before being shipped. No wonder then, they have earned the reputation. . . .

The Quality Tube Of The Industry

ARCTURUS RADIO TUBE COMPANY
NEWARK, NEW JERSEY

ARCTURUS

**INDEPENDENT TUBES FOR DEALERS WHO
DO THEIR OWN INDEPENDENT THINKING**

Automatic-

★ VOLUME CONTROL
★ VOLUME RANGE EXPANDER

**Exclusive with Wards
Super-Power Amplifiers**

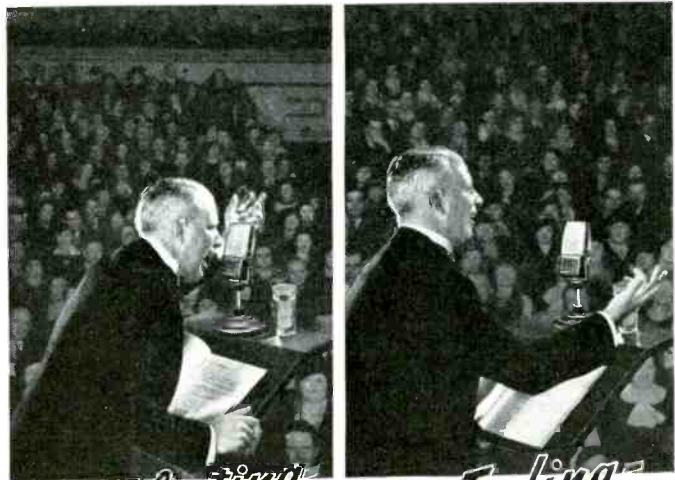

No Blasting

No Fading

Now it is possible to operate a microphone much closer to the speakers without the objectionable howls caused by *feed-back*. This *exclusive* Ward feature also maintains constant volume level whether announcer shouts into mike or speaks softly some distance away. Another great Ward *advantage* is the VOLUME RANGE EXPANDER. Brings amazing new realism to recordings; makes it unnecessary for operator to raise volume at low point of record or raise it at high point. Convenient change over switch permits either the AUTOMATIC VOLUME CONTROL or the VOLUME RANGE EXPANDER to be thrown in or out of the circuit at will.

Both these exclusive features are to be found only on Wards 45 and 100 watt amplifiers. Other models range in power from 5 watts up; in price from \$12.95 up. Of special interest to the serviceman is the 60 watt system that comes complete with 12 tubes, 4 heavy duty speakers, crystal mike and floor stand . . . sells for only \$115. May be bought for only \$10 Down, \$9 a month. Send today for 1937 Radio Catalog giving complete descriptions and monthly terms.

MONTGOMERY WARD

Largest Distributors of Sound Systems in U. S.

CHICAGO - BALTIMORE - ALBANY - KANSAS CITY - ST. PAUL
DENVER - PORTLAND - OAKLAND - FT. WORTH - JACKSONVILLE

Mail coupon to nearest Ward House for your FREE copy of Wards 1937 Radio Catalog. It's the finest ever printed!

MONTGOMERY WARD

Dept. SM-2

Name

Street

City..... State.....

is employed. This impedance is suitable for the microphones and pickups mentioned above, directly for the high impedance types or with suitable matching transformers for the low impedance types. In the case of the crystal pickup, however, the series 400,000-ohm resistor (shown dotted in Fig. 1) is used.

Any combination of two of the above devices may be mixed independently. The operation of the mixer is quite simple. The voltage acting on the grid with a signal introduced in one of the jacks depends somewhat upon the setting of the volume control connected to the other jack. With the values of resistance shown in the diagram the variation in signal level that either control can cause in the signal on the other, over its entire range, is about one-quarter. For any small adjustment of the volume level on one the variation in the other is not noticeable. Thus the result is mixing that is independent for all practical purposes.

THE AMPLIFIER CIRCUIT

A 6J7 metal pentode tube supplies the amplification necessary for the input stage. A 2-megohm series resistor is used to supply the screen voltage from the plate supply circuit.

The second stage is a signal divider using a 6C5 tube. The 180-degree out-of-phase voltages necessary for operation of the push-pull output stages are supplied from this tube. The signal divider circuit is shown in Fig. 2. To completely isolate the grid input signal from the output plate and cathode signals the 370,000-ohm resistor and the 0.25-mfd condenser are used in the grid return circuit. If these were omitted the cathode load resistor would act as a part of the grid load and a portion of the grid signal would be developed across its terminals. This would unbalance that half of the circuit and true push-pull action could not obtain. A complete description of the signal divider circuit was given in the June, 1936, issue of SERVICE.

The four 25L6 beam-power tubes are used in a push-pull parallel stage and, with the fixed C battery bias, deliver 10 watts of audio power to the 12-in dynamic speaker. The C battery bias is used to conserve all the available voltage for plate supply.

Plate current for the 25L6 is taken directly off the 100-mfd filter condenser in the power supply circuit. Although considerable ripple voltage is present at this point, the hum in the speaker is barely audible and modulation hum is absent even on loud signals. This can be attributed to the characteristics of

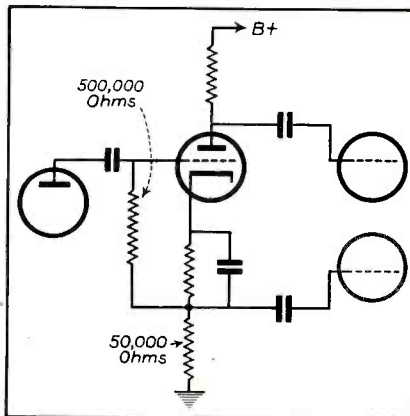

Fig. 2. A type of abbreviated signal divider circuit. The grid return isolation resistor and condenser are omitted. This practice allows part of the grid voltage to be developed across the cathode load resistor.

the 25L6 which (like the 6L6) shows no appreciable variation in plate cur-

rent for large variations in plate supply voltage, over the operating range.

THE POWER SUPPLY CIRCUIT

Three 25Z5 rectifiers are used in a parallel half-wave arrangement. These feed a 100-mfd input condenser which serves a four-fold purpose: as high a B voltage as is possible is obtained when operating the amplifier on a-c; the ripple voltage is reduced over what it would be with a lower capacity input condenser; the regulation is undoubtedly improved and a low impedance plate supply is provided.

Additional filtering for the screens of the 25L6s is provided by a small choke and a 24-mfd filter condenser. Another 8-mfd condenser and the 6000-ohm resistor are used to assure hum-free supply for the input and divider stages.

Nathan I. Daniel,
DANIEL ELECTRICAL LABS.

GENERAL DATA—continued

0.0002-mfd series condenser and adjust the oscillator trimmer condenser No. 30 until the signal is received at a maximum.

(4) Adjust trimmers Nos. 17 and 5 to maximum output.

(5) Set the test oscillator and dial indicator to 570 kc and adjust the oscillator series condenser No. 31 to maximum output, at the same time rocking the condenser gang.

(6) Return both the test oscillator and dial indicator to 1600 kc and check the adjustment of trimmers Nos. 30, 17 and 5 for accuracy.

ADJUSTMENT OF GREEN BAND

Note: In adjusting the two short-wave bands (green and red) a 0.0002-mfd condenser and a 400-ohm resistor connected in series should be inserted in the high side of the test oscillator leads.

(1) Set the wavechange switch to the green band position.

(2) Set the test oscillator and dial indicator to 5500 kc and adjust the oscillator trimmer condenser No. 39 until the signal is received at a maximum.

(3) Adjust trimmer condensers Nos. 22 and 10 to maximum output.

(4) Set the test oscillator and dial indicator to 1900 kc and adjust the oscillator series condenser No. 40 to maximum output, at the same time rocking the condenser gang.

(5) Return both the test oscillator and dial indicator to 5500 kc and check the adjustment of trimmers Nos. 39, 22

and 10 for accuracy.

ADJUSTMENT OF RED BAND

(1) Set the wavechange switch to the red band position.

(2) Set the test oscillator and dial indicator to 17,000 kc and adjust the oscillator trimmer condenser No. 35 until the signal is received.

Note: When adjusting the oscillator trimmer condenser No. 35 it will be possible to secure two peaks. The peak secured with the trimmer screw turned farthest out should be used. When aligned on the correct peak a strong signal will be heard at 17,000 kc and a weaker signal at approximately 16,000 kc. No signal should be heard at 18,000 kc.

(3) Adjust trimmer condensers Nos. 20 and 7 to maximum output.

(4) Set the test oscillator and dial indicator to 6,000 kc and adjust the oscillator series condenser No. 36 to maximum output, at the same time rocking the condenser gang.

(5) Return both the test oscillator and dial indicator to 17,000 kc and check adjustment of trimmers Nos. 35, 20 and 7 for accuracy.

Important: While testing or making repairs on this receiver, the chassis should not be turned upside down or on its side for any long period of time while the set is turned on as the chemicals in the electrolytic filter condensers will come out through the air vents, making the condenser appear to be defective. If left in this position too long the condenser may be injured.

Announcing

TWO NEW P.A. UNITS



60 Watt 6L6 Amplifier by THORDARSON

The Thordarson 6L6 amplifier delivers powerful, brilliant tones at full rated output. 4 beam power 6L6's are used in push pull parallel, eliminating grid current and permitting simple driver requirements at 60 watts output. Performance improved by greater gain and frequency response. Wave distortion at minimum. Tube life increased. Power supply regulation effect reduced by decreased plate current fluctuation. Carefully engineered, perfectly designed and powered by Thordarson transformers including Tru-Fidelity.

NOTE: Radio men everywhere acknowledge these two new P. A. units the finest they have heard. Both of these amplifiers available completely wired or in "Build-it-yourself" style with "Foundation Units."

Now Tru-Fidelity Speaks!

Clear audio reproduction—a marvel of modern transformer and amplifier design. You be the judge! Hear the Thordarson Tru-Fidelity P. A. unit in operation. Delivers absolute linear and distortion free audio power at 10 watt output. Ideal as a recording amplifier—speech amplifier for broadcast purposes—general P. A. or sound reproduction work where moderate output levels are sufficient, and quality reproduction is most essential.

ASK YOUR SUPPLIER FOR BULLETIN SD 269. Lists prices, circuit diagrams, and descriptions of units, or write factory direct using coupon. Get your copy today — FREE.

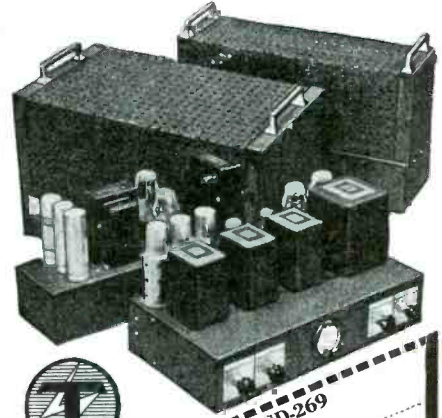

THORDARSON ELECTRIC MFG. CO.

500 W. HURON ST., CHICAGO, ILL.

Dept. S73 Please send me Bulletin SD-269
Name _____ Address _____ City _____ State _____

ACRO CHASSIS CRADLE

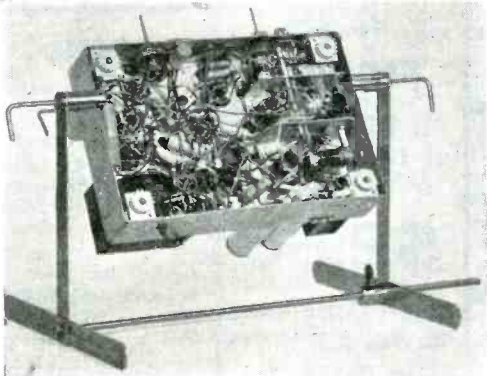

Only
\$4.85
Postpaid

Prevents Damage—Holds Chassis in Any Position

Holds any make or model radio chassis in desired position for testing, aligning, repairing, replacing parts, etc. Special mechanical clamps hold chassis in vise-like grip—no danger of breakage or damage at your expense to coil assemblies, tubes, dial assemblies, etc. Allows both hands free for work. Puts repair jobs on a production basis and increases your income from service. Is very desirable for displaying radio chassis.

Sent postpaid on receipt of \$4.85. Savings and increased earnings pay for it in short time. Made of steel—nicely finished. Order today.

ACRO TOOL & DIE WORKS

1401 Wilson Ave., Chicago, Ill.

Inquiries invited from distributors.

Extra Clamps
Extra set clamps for Acro Cradle are a great convenience. Their use permits rapid handling of chassis on test, etc. Price (per pair) \$2.75.

5000 OHM CONTINENTAL Carbon Spark SUPPRESSORS



Out where the test begins—out where stations are few and far between, your car radio needs all the sensitivity its circuit will permit. CONTINENTAL Carbon's new 5,000-ohm low-voltage-coefficient spark suppressors effectively squelch ignition interference, thus releasing the avc circuit and the full sensitivity of your set.

Make this test—tune in a distant station while driving on a country road at 30 to 50 miles per hour. Shut off your ignition and note if the radio reception is better. If it is better with the motor shut off, you need CONTINENTAL suppressors.

For spark plug suppression select S27, S20A, or S21, in 5,000-ohm resistance. Use T13 or T11 for the distributor in 10,000 ohms; T17 for Ford V-8 distributors. Available from leading radio jobbers.

CONTINENTAL CARBON Inc.

13912 LORAIN AVE., CLEVELAND, OHIO (TORONTO, CANADA)

Please send booklet on Interference, 10 cents enclosed.

Name _____

Address _____

City _____ Jobber _____

**I WAS
KIDDING
MYSELF**

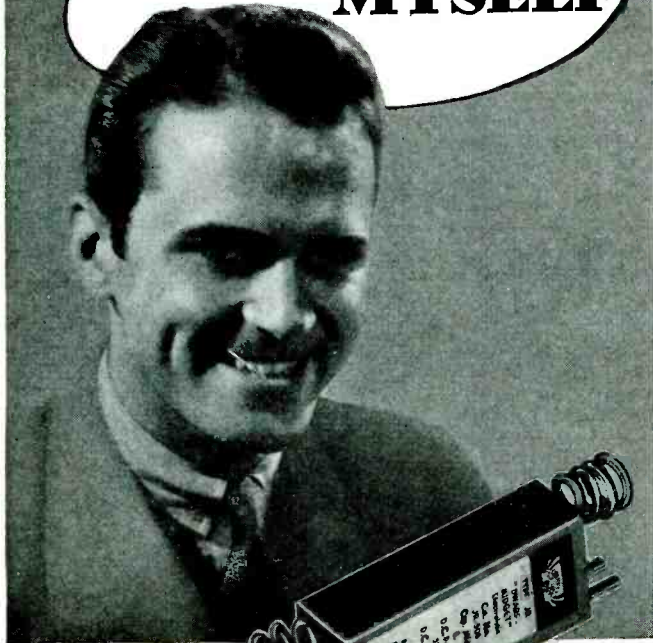

**Now I standardize
on C-D condensers**

"There was a time when I would watch pennies! But the couple of pennies I 'saved' by using low quality replacement parts for servicing proved mighty expensive. Disgruntled customers . . . free repeat calls . . . loss of good-will . . . these are only a few of the results of my 'savings.'

Today I use only the finest replacement parts that money can buy. I have found that I keep my customers longer, get a good portion of my business through recommendations and I don't lose money on free repeat calls.

Yessir! I standardize on Cornell - Dubilier condensers. They're the 'tops.' I don't kid myself any longer—I know that the best is the cheapest in the end."

FOR MORE THAN TWENTY-SEVEN YEARS CORNELL-DUBILIER HAS BEEN THE WORLD'S LARGEST EXCLUSIVE MANUFACTURER OF CONDENSERS.

MICA - DYKANOL - PAPER - WET and DRY ELECTROLYTIC

Send for complete catalog No. 137-A today!

CORNELL-DUBILIER CORPORATION
1026 Hamilton Boulevard South Plainfield, N. J.

CORNELL  DUBILIER

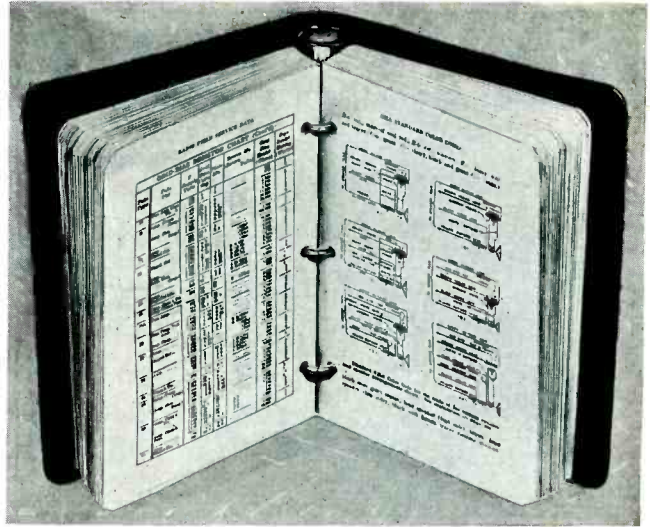

RADIO FIELD SERVICE DATA

Bigger and Better!

The new loose-leaf edition of Ghirardi's handy job data book has *more of everything!* The very dope you need for servicing in the shop or outside. Twice a year **SUPPLEMENT SHEETS** will keep it always up to date for you. *Send coupon today for this great time and money-saver!* **MONEY-BACK GUARANTEE.**

- CASE HISTORIES**
Trouble symptoms and remedies for over 1,500 receiver models.
- I. F.'s**
for 5,424 sheets, including 1937 models.
- AUTO RADIO DATA**
Electrical wiring diagrams, ignition system data and interference remedies for all American cars.
- TROUBLE SHOOTING**
Time-saving chart for spotting possible trouble sources.
- CHARTS AND TABLES**
26 of them! Glass and metal tube data, RMA color codes, wire tables, etc.

**436
PAGES**
81 DIAGRAMS
26 DATA CHARTS
AND TABLES
\$2.50

WITH JAN. & JUNE '37 SUPPLEMENTS
Combination Offer
This great book together with Ghirardi's 1300-page **MODERN RADIO SERVICING — \$6.**

"How's Business?"
Want more business? Want bigger profits? Want more customers? There's a brand-new Ghirardi book that tells you just how to get them — 2,199 practical, money-making **IDEAS** you can use today. Send for Free Circular describing "RADIO BUSINESS PROMOTION AND MANAGEMENT"—the first and only book of its kind!

RADIO & TECHNICAL PUBLISHING CO.
45 Astor Place, New York, Dept. S-37



- Encl. find \$6 for Combination Offer on both servicing books, including January and June '37 Supplements to DATA BOOK. Postpaid. (Foreign \$6.50.)
- Encl. find \$2.50 for RADIO FIELD SERVICE DATA alone, with January and June '37 Supplements. Postpaid. (Foreign \$3.)

Please send free circulars (S) on both servicing books.
 Please send free circular (BB) on new Radio Business book.

Name

Address

S-37

TEST EQUIPMENT...

THE VACUUM-TUBE VOLTMETER

By O. J. MORELOCK, JR. and HAROLD L. OLESEN*

IN all equipment associated with or including vacuum tubes of any kind whatsoever, resonant and other types of high-impedance circuits are always found. Such circuits must be used in order to obtain sufficient amplification from the tubes, which are in themselves high-resistance devices. The impedance for instance, of a r-f circuit such as is used in the first and second stage of a receiver may be as high as 2 or 3 meg when tuned to resonance with an incoming signal.

To make any measurements of potential across such a circuit it is obvious that a meter having a resistance as high as 3 or 4 meg would be required as a lower meter resistance placed across the circuit might change the potential conditions as much as 50%. About the only connection that can be made across a circuit of this type without upsetting the circuit potentials would be that of another vacuum tube, the connection

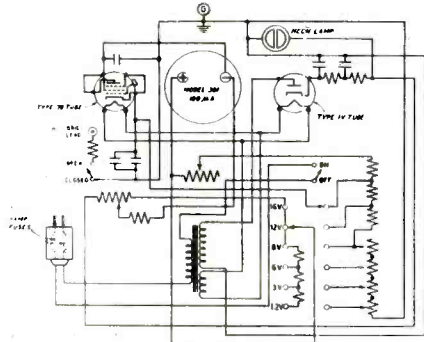

Fig. 1. Weston 669 vacuum-tube voltmeter.

being made across the grid and cathode of said tube.

THE INSTRUMENT

The vacuum-tube voltmeter is, as the name implies, nothing more than a vacuum tube connected through a meter in its plate circuit to a suitable power supply. The grid and cathode of the tube are connected across the circuit to be measured, the potential across said circuit causing a change in grid voltage on the tube and thus, a resultant change in plate current is indicated on the instrument. As the impedance from grid to cathode of the tube is practically infinite, no load whatsoever is placed on the circuit and under normal conditions

the potential will not be altered in any way.

As the vacuum tube is also a rectifier, potentials of any frequency placed across the grid and cathode of the vacuum-tube voltmeter will result in a direct-current deflection on the instrument in the plate circuit. For this reason the vacuum-tube voltmeter can be used for measuring audio as well as radio-frequency potentials provided the circuit is worked out correctly to cover this broad range of frequency.

MULTIPLE RANGES DESIRABLE

Because any given vacuum tube is considerably limited as to the range of potentials, which may be applied to its grid circuit the overall direct range of a vacuum-tube voltmeter is restricted as compared to a standard a-c or d-c voltmeter as such. Further, the scale of a vacuum tube voltmeter is not uniform throughout its entire operating range. These two reasons make it essential that the vacuum tube voltmeter have a number of ranges so that accurate readings may be made over the entire range of the device.

Up to approximately 15 volts the vacuum-tube voltmeter input circuit should be connected directly to the grid of the tube so as to make the input impedance of the device as high as possible, thus placing the least possible load on the circuit under test. For voltages above 15 volts the Service Man may provide himself with a voltage divider. If such a divider is used the resistance of the total divider should be appropriate for the circuit across which it is connected. Obviously, for high-impedance circuits the voltage divider must have considerable resistance and for best results should contain a resistance equal to 10 to 20 times the impedance of the circuit across which it is connected. It should be noted that for practically all normal uses of a vacuum-tube voltmeter the range 0.2 to 16 volts is ample. Only occasional requirements will be encountered for voltages in excess of 16 volts.

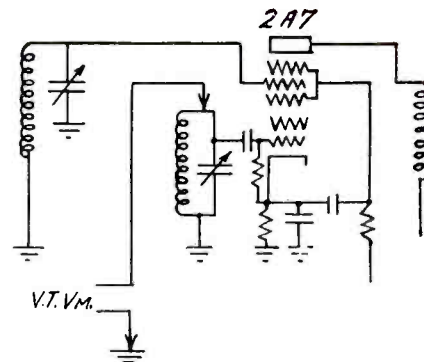

Fig. 2. Testing oscillator performance.

When using a voltage divider in conjunction with a vacuum-tube voltmeter care must be taken to allow for the load introduced on the circuit by the voltage divider since the high impedance of the grid circuit of the vacuum-tube voltmeter is no longer the determining factor.

When taking measurements on circuits where there is no returned path for the grid circuit of the vacuum-tube voltmeter it is necessary to return the grid through a suitable resistor and to connect the vacuum-tube voltmeter to the circuit under test through a suitable blocking condenser. For most vacuum-tube voltmeters, a 3-meg resistor and a 0.00025-mfd condenser will be found satisfactory for this application.

It should be noted that readings taken with the above combination on alternating currents, will be peak values and that to obtain the effective value of the readings a multiplying factor of 0.707 should be used. Since most vacuum tube voltmeter indications are used proportionately it is often unnecessary for the user of the device to reduce peak readings to effective value readings.

It should be noted that when taking measurements across grid circuits that are a-c controlled, or where a d-c grid voltage is introduced between the grid of the receiver tube and the ground, if direct measurements are to be made across this grid circuit, the d-c blocking connector should be used with the vacuum-tube voltmeter. If this precaution is not taken, the d-c bias voltage will be read on the vacuum-tube voltmeter causing extreme errors in reading.

The vacuum-tube voltmeter should be so designed to permit direct access to the grid terminal of the vacuum-tube voltmeter tube so that for high-frequency work the connecting circuit between the circuit under test and the vacuum-

Fig. 3. Checking coils for resonance.

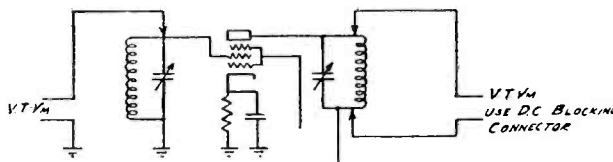

* Weston Electrical Instrument Corp.

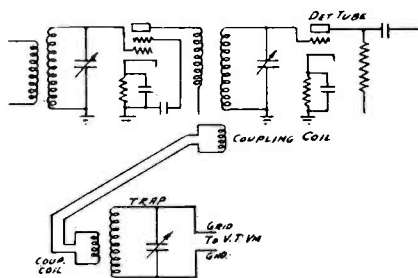

Fig. 4. Resonant trap circuit.

tube voltmeter grid and its cathode, can be as short and free from loss as possible. This precaution becomes increasingly necessary as the frequency is increased over 5 mc.

OSCILLATOR PERFORMANCE

One of the most important measurements that can be made on a superheterodyne receiver is that of oscillator performance. To make this measurement the vacuum-tube voltmeter should be set on its highest range. Connection can then be made from the stationary plates of the oscillator tuning condenser to ground. For this connection it is recommended that the grid be connected to the stationary plate and the ground terminal to the chassis. See Fig. 2.

With the receiver turned on, a reading should be obtained on this range, the usual potential of oscillator circuits running somewhere between 6 and 16 volts. There is no need to use any d-c blocking condenser as the oscillator test circuit is always connected from the grid of the oscillator tube to ground.

It may be found that a better reading will be obtained on one of the lower voltage ranges, and if so, the switch should be turned to one of these ranges, either the receiver turned off or the lead disconnected from it, and the zero setting readjusted if necessary. The receiver can then again be turned on and with approximately a half scale reading the receiver dial should be rotated from one end of the band to the other. The oscillator voltage will vary to some extent but should in all cases maintain a potential of at least 60% of the highest value.

If the receiver is an all-wave type, it should be switched to each of the short-wave bands and operation of the oscillator tube on each of these bands noted. If there are any dead spots or points where the oscillator ceases to function they will be immediately apparent by sudden drops to zero of the instrument pointer. These conditions can then be rectified by inspection of the oscillator circuit, inspection of the tube electrodes and a test of the tube itself. The oscillator cathode biasing resistor and its associated by-pass condenser are often

causes of trouble in this circuit.

These should be inspected carefully and if erratic operation is still apparent either the plate voltage on the oscillator should be increased or the bias resistance dropped in value approximately 10%. An open in the oscillator grid coupling condenser is often the cause of dead spots.

RESONANT CIRCUITS

Each individual coil of the receiver may be checked for resonance with its tuning condenser by referring to the circuit of Fig. 3. The vacuum-tube voltmeter is connected directly across the grid circuit, and the oscillator tuned to the required resonant frequency of the tuned circuit under test. The padder, trimmer or air dielectric condenser should be adjusted until a sharp resonant point is noted on the vacuum-tube voltmeter scale. A definite peak indication should be obtained showing that the

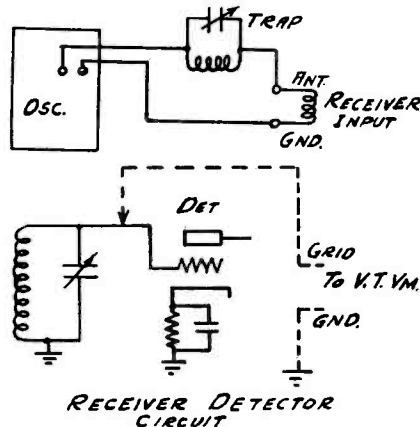

Fig. 5. Checking the trap circuit.

coil actually resonates and is not just passing energy from previous circuits, the resonant characteristic being proof that the coil and condenser are doing their job correctly.

While measurements are made across plate tuned circuits, care should be taken to protect the input of the vacuum-tube voltmeter from the d-c plate potential applied to the tube. The meter should be connected either directly across the plate coil or through the d-c blocking connector to the chassis of the receiver. When making the adjustment for reso-

nance it may be found that a slight readjustment of the trimmer condenser will be required due to the tube capacity of the 78 tube being placed in parallel with the trimmer or the padder condenser. However, this correction can be made by moving the vacuum-tube voltmeter on to the next stage and readjusting the trimmer of the first stage to give maximum reading across the second circuit.

The first requirement for making adjustments of this type is a r-f voltage of sufficient magnitude to give ample readings on the vacuum-tube voltmeter. If the frequency of the circuit to be adjusted appears in the broadcast band, then a t-r-f receiver can be set up and turned on, with the oscillator connected to the antenna and ground terminals. By setting the oscillator control to the frequency required for the resonance of the circuit and tuning the receiver to this frequency, considerable voltage can be built up across the second or third receiver stage.

A RESONANT TRAP

When adjusting the oscillator be sure to set the attenuator at the maximum position using the high output jack. A small coupling coil of 10 to 20 turns having the same diameter as that of one of the tuned r-f coils can be wound up quickly and placed over the end of the receiver tuning coil. With the same number of turns on the other end of this coil circuit brought out at a convenient place on the bench or table, a field can be set up for adjusting the trap circuit. See Fig. 4.

The coil and condenser forming the trap circuit should be connected directly across the input to the vacuum-tube voltmeter with the coil brought out from the receiver coupled closely to the trap circuit. The trap padder should be adjusted for maximum deflection on the vacuum-tube voltmeter. If it is convenient to get at the coils in the t-r-f receiver, the trap circuit can be adjusted by placing it directly in the field of the receiver coil. To make sure that the efficiency of the trap circuit is good, the trap should be tested for continuity at other frequencies. To do this

(Continued on page 188)

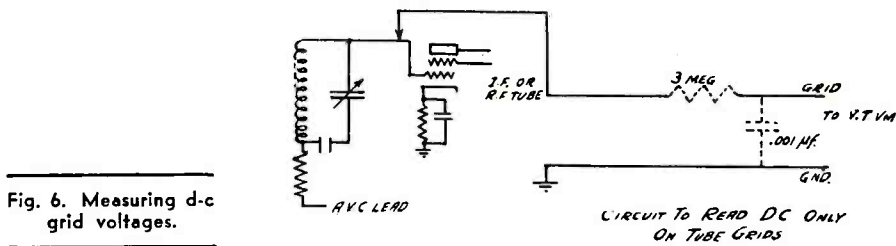

Fig. 6. Measuring d-c grid voltages.

ON THE JOB . . .

Checking Tubes

When checking tubes on commercial tube testers considerable time may be saved by first inserting the tube in its socket with the line switch in the line voltage check position. An open heater or filament will be indicated by the absence of the line voltage dip. This will eliminate the watchful waiting for the tube to heat—only to find that the heater was open.

L. Baw

Dressing Up the Test Bench

Name plates, escutcheons and chart holders improve the appearance of the test bench and add convenience as well. Plates similar to the one shown in Fig. 1 can be purchased in any hardware shop. They are made of brass and can be obtained in almost any desired size. The card may be removed conveniently for making changes, etc. A small piece of celluloid slipped over the card will keep it clean and neat.

Metal shims or washers, $2\frac{7}{8}$ inches

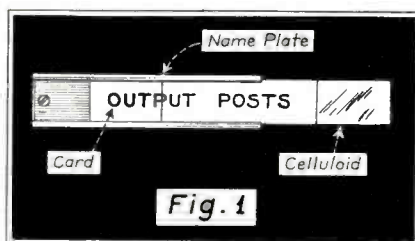

outside diameter, can be obtained at any specialty hardware store. These washers are just the right diameter to use for escutcheons for small bar knobs. (See Fig. 2.) They may be used to hold down a piece of cardboard with markings, protected by celluloid, or the escutcheon may be painted white and the markings made with India ink directly on the escutcheon.

Chart holders, similar to the one shown in Fig. 3, may also be purchased in any hardware store in numerous sizes. They have an opening at the top for the

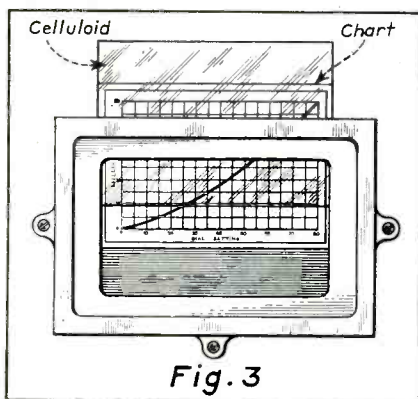
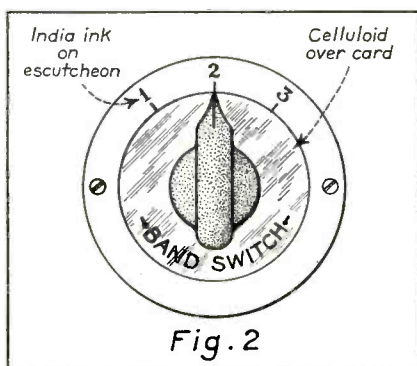

chart and its celluloid protection. The chart may be removed easily and a new one slipped in whenever a change in calibration is made.

These parts usually come in brass, but they may be enameled black to match the panel. For a real ritzy job—have them chrome plated.

Jim Kirk

Checking Alignment

Some Service Men are so anxious to have receivers just right that they make a practice of realigning, or rather checking them, for alignment in almost every instance. When the long distances which receivers have to travel are taken into consideration, there is a slight possibility that alignment may change to a small degree. However, realignment under these circumstances will normally make such a slight difference in the reception that it is of no real value to the ordinary user and could be determined only by a Service Man with proper equipment. We sincerely believe that, in the vast majority of cases, there is no point to realigning receivers. In fact, unless carefully done, some loss might actually be experienced.

When a receiver lacks sensitivity, before making any alignment, first check the tubes and the various voltages to make sure these are correct.

It is recommended that no changes be made in alignment except on receivers which are so badly out of alignment as to actually cause a loss of sensitivity and selectivity which would be readily noticed by even an ordinary user. Cases of this kind are few and far between.

When alignment is required, then refer to the aligning instructions in the service manuals. It is highly important that these instructions be followed strictly if the essential qualities of tone fidelity, sensitivity and selectivity are to be maintained to their standards as set by factory engineers.

Under no circumstances should any changes be made unless the proper instruments are available with which to make alignment tests and adjustments.

Stromberg-Carlson Telephone Mfg. Co.

Parasitic Oscillations

An oscilloscope is not necessary to detect transients, parasitic oscillations, etc., in power stages. Simply place a pickup coil over or near one of the tubes. Connect the coil to the antenna of a good receiver and tune it to a clear channel. The strays will be evident in the form of r-f hash.

Francis C. Wolven

Bass Attenuation

The circuit shown herewith gives a simple method for reducing the bass response of a receiver or amplifier. When listening to speech, or to certain music containing too much bass, some attenuation may be needed for effecting naturalness. All that is required is the insertion of a small condenser in series with the original coupling condenser (or in series with the audio transformer secondary in circuits where this is found) and shunting this new condenser with a 500,000-ohm rheostat. With the latter in such a position that the full 500,000 ohms is across the 0.001-mfd

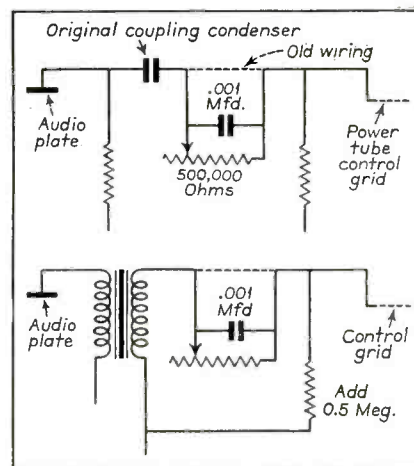

Bass attenuator for receiver or amplifier.

condenser, the effect of the resistance is negligible and the condenser attenuates the low tones due to its high reactance at low frequencies. As the resistance is reduced, the condenser is in effect shorted, and when the resistance is zero the response of the original circuit is unaffected.

E. M. Prentke

ASSOCIATION NEWS . . .

INSTITUTE OF RADIO SERVICE MEN REPORTS

THE IRSM has developed the idea of condensing articles that appear in the professional press in response to comments made by the members from time to time. These digests, prepared by the Institute's editorial staff, pertain only to the matter contained in the original articles. Each digest is an abbreviated version of the author's presentation—a statement of the pertinent facts with descriptive matter eliminated.

The collection is then published in the "IRSM News and Digest" each month.

Ken Hathaway, Managing Editor

Boston Chapter

The following were elected officers of the Boston chapter of the IRSM for 1937: Bernard L. Cook, chairman; William Wells, vice-chairman; Ingvar Paulsen, secretary; Lyman Hodgdon, treasurer; Ralph F. Anderson, service bench committee; Wilbur Paulsen, membership committee; Raymond Wyman, ethical practices committee; Guy Boodry, program committee, and William A. Remick, advertising and publicity committee.

William A. Remick, Publicity Committee

Chicago Chapter

The election of officers for the chapter for the ensuing year was unique in that all officers were elected by a unanimous ballot. Joe Marty, Jr., was chosen as chairman; John Polak, as vice chairman; Robert Clarke, as secretary; and Stanley Gazinski, as treasurer.

A rising vote of thanks was given "Bob" Easterbrooks, the "maestro" at numerous Institute functions, who has served the chapter as its treasurer for three years. He was relieved of his duties as guardian of the local purse-strings at his own request, owing to the fact that he is not certain of his plans for the coming year.

The members of the chapter chose to hold three meetings each month, beginning immediately, only one of which will be an "open" meeting to which guests are invited. Also, at the close of each of the open meetings, the members will remain for a session of their own, to which guests will not be invited, except by special arrangement.

Plans are being laid for social events of various kinds. "Bob" Easterbrooks, August Schwanenberg, and Russ Jimieson are on the committees.

Chapter Chatter

Cleveland Chapter

February brought Allen Nace of Radiart with an oscillographic demonstration of proper buffer condenser applications and what vibrator hash looks like (we all know what it sounds like).

Moock Electric, RCA Victor distributors, held their spring session and invited us all to hear (and see) Jonny Yost do

a grand job of explaining "How to Train Your Ear for Radio Servicing" with gestures and cathode-ray obbligate. Numerous prizes were awarded and refreshments served.

At our next session, Mr. Hunt, First Neon Sign Service, showed us where, why and how to remove the r-f hash emanating from these pretty lights. Maynard Elliott put on a practical demonstration of the new RCA Victor oscillograph and oscillator units which was greatly appreciated by the gang. Mr. Jackson of Moock Electric favored us with a sound film version of "Behind the Broadcast," depicting the scenes behind the magic key programs.

The NRSQP examination is to be held on April 7, at the Case School.

L. Vanquinten, Official Observer

Manchester Chapter

After considerable arrangements, Arthur B. Sanborn, George J. Craig, Jr., Frank E. Allard and a number of the boys from Boston chapter called the first meeting of the Manchester chapter on February 15.

Guy E. Boodry, Bernard L. Cook, Ingvar Paulsen, Ralph F. Anderson, and William Remick (officers of the Boston Chapter) spoke briefly, each outlining some phase of the service industry and the IRSM's place in the industry or of the NRSQP and its significance to the Service Man.

Some thirty-odd Service Men attended the gathering and pressed to have an interesting time until 12:30 a. m., when the meeting was adjourned.

Reading Chapter

At the first meeting held in January, Carl Barbey was elected chairman, and Donald H. Kresge was elected as secretary-treasurer. A program for the ensuing months was laid out and discussed.

On January 19, Mr. George Barbey of the George Barbey Co., discussed two subjects before the chapter, "The Pitfalls of Local Organization" and "Profitable Methods for the Service Business."

On February 2, Mr. D. K. Craig of the Weston Electrical Instruments Corp. spoke on the topic, "Why 20,000 Ohms per Volt." Other meetings definitely scheduled are as follows: March 16, a representative from Supreme Instruments Corp.; March 30, a representative from Clough-Brengle on oscillators and the oscillograph.

Donald H. Kresge, Secretary-Treasurer

Rock River Chapter

Officers elected for the Rock River chapter for 1937 are: Harry Richards, chairman; Lloyd Ward, secretary; Paul Patton, treasurer, and Carl Hand, librarian.

The Clough-Brengle Co. made an oscillograph demonstration for the Rock River chapter on February 2 at the Gas and Electric Building.

Librarian Carl Hand spent the winter

months at Venice, Cal., and incidentally dodged a lot of lippy weather.

Lloyd Ward, Secretary

Staten Island Chapter

The Staten Island chapter elected officers for the coming year at a recent regular meeting. The officers are as follows: John Nisslein, chairman; Frank LaPenna, vice-chairman; James Reeves, secretary-treasurer. George Muccino was chosen as chairman of the welfare committee; Thos. O'Reilly, sergeant-at-arms; J. O'Brien, chairman of the membership committee, and A. Nickel, librarian.

J. O'Brien

Westchester Chapter

The Westchester chapter held its annual election of officers at a meeting held on January 13. Those elected were: Henry Lutters, chairman; Jack Livingston, first vice-chairman; Paul M. Harris, second vice-chairman; Robert Marriott, secretary, and Herman Kuckes, treasurer.

First vice-chairman Jack Livingston was elected chairman of the regional committee recently.

An open invitation is extended to any member of the Institute visiting in Westchester County to drop in at any of the meetings of the chapter. Meetings are held on the second and fourth Wednesday nights of each month at the Veteran's Hall in Mt. Vernon, N. Y.

Paul M. Harris, Second Vice-Chairman

ASSN. OF RADIO SERVICE ENGINEERS

At our meeting held in the Hotel Statler, Buffalo, N. Y., on February 1, the following newly elected officers were installed: T. J. Telaak, president; J. E. Stoffel, vice-president; A. J. Schreiber, secretary; V. E. Ball, treasurer; Frank Bestine, corresponding secretary; H. Keller, librarian, and John Klemens, sergeant-at-arms.

A table model radio and aerial is being offered as a grand prize for the greatest number of active and associate members brought in during our 60-day membership drive now in progress.

During the meeting held February 1 it was decided to start all meetings in the future promptly at 9:00 p. m. instead of at 9:30 or 10:00 p. m. as in the past.

At our February 16 meeting, Mr. Bill Cotter of the Stromberg-Carlson factory was the guest speaker.

Anthony Schreiber, Secretary

RADIO ASSOCIATION OF CALIFORNIA

Mr. Harold W. Lindsay of the Shell Development Co. was the guest speaker at the meeting held March 1, at 921 Harrison Street, Oakland, Cal. He spoke on "The Production and Measurement of High Vacua and its Relation to Electronics."

The production of high vacuum is a fine technical art. The members appreciated learning how this art is applied to their own familiar radio tube as well as to the more general field of electronics.

H. R. Anderson, Secretary

BROWN DEVIL WIRE WOUND RESISTORS



Built to Stand Up
says Bill Fitt

Brown Devils make ideal replacement resistors. They are built exactly like the big OHMITE industrial units . . .

wound on a porcelain core and covered with the specially developed vitreous enamel which insures evenly spaced winding. That's why they eliminate profitless "call-backs."

Tinned lead wires make for easy installation. 10 and 20 watt sizes; resistance values through 100,000 ohms. Ask your jobber or get Catalog 16 — FREE!

OHMITE

MANUFACTURING COMPANY

4827 Flournoy Street, Chicago, Illinois



Manufacturers
of
RHEOSTATS
RESISTORS
TAPSWITCHES

FOR PERFECT DEMONSTRATION OF AUTO AND OTHER D.C. RADIOS



Epc

STORAGE BATTERY ELIMINATOR

REPRESENTS A FULL CHARGED BATTERY THAT NEVER RUNS DOWN

Provides 6 volt-10 amps. filtered D.C. from 110 volt A.C. Assures instant, adjustable current at minimum power consumption. Ends forever the messy battery-charging nuisance. Also efficient as a battery charger. Write for further details.

\$19.75

As Illustrated
Variable Voltage
List Price

\$15.75

Model B
6 volt-5 amps.
Fixed Voltage

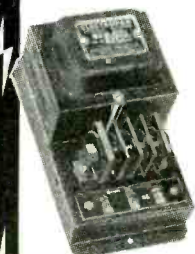

ELECTROPAK

Supplies rectified D.C. for operating relays, solenoids and remote controls. Voltage ranges from 6 to 24 volts, rated at 2 to 15 amps. Operates on 110 volt A.C.

ADAPTOPAK

Operates A.C. radios in D.C. districts and 110 volt A.C. radios in autos and trailers.

ELECTRICAL PRODUCTS CO.

6529 Russell St.

DETROIT, MICH.

QUICK!

SEND FOR THIS PROFIT-MAKER!

It's Worth Dollars-A-Week to You—
Yet Costs Only 15c!



Thousands of money-making service men—who know real value when they see it—are using the new Sylvania Technical Manual on the same sort of jobs you're working on today! Why? Because they've found that this handy pocket manual saves *time* . . . and time is money!

With a 50% increase in contents . . . 184 pages of information, hints and tips . . . its cost to you is still only 15c. It lists 193 types of tubes, with important circuit application information on each—tells all about glass, metal, and "G" type tubes, including those for Majestic receivers—and gives you full information on Sylvania "Ballast Tubes." *You need it* in your business—you'll find a use for it on every job. Don't wait—send for it *now!*

Hygrade Sylvania Corporation, makers of Sylvania Radio Tubes and Hygrade Lamps. Factories at Emporium, Pa.; Salem, Mass., and St. Mary's, Pa.

SYLVANIA

The Set-Tested Radio Tube

HYGRADE SYLVANIA CORPORATION

S-37

Emporium, Pa.

Please send the Sylvania Technical Manual. I enclose 15c in stamps.

NAME

ADDRESS

CITY STATE

THE MANUFACTURERS . . .

SYLVANIA 25L6G

Hygrade Sylvania Corp. announces the 25L6G, a double-grid power output tube designed for use in a-c, d-c and d-c receivers. This tube is a glass counterpart of the metal type 25L6 and is similar to this type in characteristics, providing a high power output at comparatively low plate and screen voltages. The interelectrode potential fields are such that with normal electrode spacings the electron stream is sectionalized in its flow to the plate, rendering it possible to secure high efficiency with resultant increased power output and power sensitivity.

SPRAGUE UNIVERSAL REPLACEMENTS

The Sprague Products Co., North Adams, Mass., announce three universal replacement condensers. The new units are of compact design and are adaptable to various methods of mounting.

Sprague condenser type BT-100 is a rectangular unit having three 8-mfd sections (8-8-8 mfd, 200 volts) and two 5-mfd sections at 25 volts. From the individual sections and leads, numerous combinations such as 8-16 mfd; 12-16; 10-16; 5-20, etc., may be obtained. Also, the 5-mfd sections may be combined as a single 10-mfd unit. This same condenser in a round cardboard casing with mounting lugs is known as type ST-10.

The third new universal replacement condenser is known as type BT-1. This has three 150-volt sections, 5-10-25 mfd. Six leads give any needed combination of these capacities.

A new Sprague catalog will be sent upon request.

RANGER-EXAMINER TUBE TESTER

The Readrite model 440 Ranger-Examiner tube tester uses an emission type of circuit. Only four operations are required for testing the average type of tube. Results are shown on a direct reading good-bad scale of a Triplett model 221 instrument.

A shadow-graph a-c meter is used for line voltage adjustment. In addition to indicating the line voltage setting, this meter serves as a pilot light in showing when tester is connected to the power supply.

Additional information and prices of this



tester may be obtained from the Readrite Meter Works, Bluffton, Ohio.

BELFONE INTERCOMMUNICATIONS

The Bell Sound Systems, Inc., Columbus, Ohio, have announced a new line of intercommunicating equipment. This new Belfone equipment is designed to have a greater field of application. Similar to original Belfone equipment it provides for inter-communication between two or more remotely located stations. Through its ability to be used in connection with loudspeakers it can also be employed as a call system. In this latter case those located at the speaker stations can talk and receive messages when within a 30- or 40-ft. range of the speaker.

Among the various features in the master station equipment are: a rotary selector

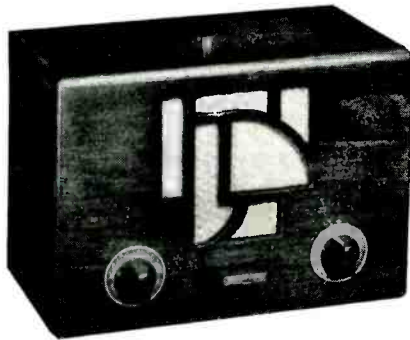

switch which permits the selection of from one to ten stations; a "treadle" type send-receive switch which offers operation with either the left or right hand; a combination volume control and an on-off switch; the control is calibrated to stages of relative volume; a jewel lamp indicator and a volume control on the back of the unit for controlling the volume of outlying speaker stations.

The master unit incorporates an amplifier and a combination microphone speaker in one case.

ASTATIC B-16 PICKUP

The Astatic Microphone Laboratory,

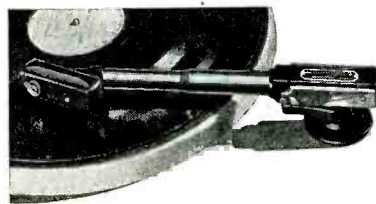

Inc., Youngstown, Ohio, have released their model B-16 crystal pickup. This instrument introduces to the professional field the Astatic offset head design found in the model B pickup recently introduced.

AKRAD "KINK-AIDS"

The Akrad Products Co., 362 Wooster Ave., Akron, Ohio, presents the 1937 edition of "Kink-Aids," a collection of indexed and filed service kinks.

Each kink represents a successfully completed service job and there are kinks to service some 3,500 different models.

A supplement is available for owners of the 1936 edition of "Kink-Aids" to enable them to bring these up-to-date.

WARD LEONARD RELAYS

Ward Leonard radio-frequency relays are available in two sizes: 15-ampere ca-

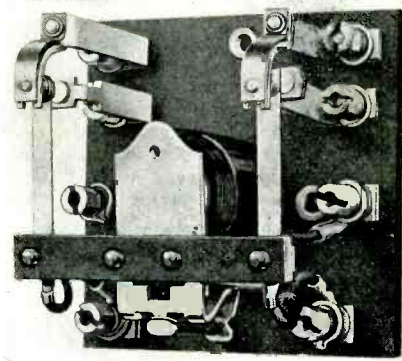

capacity and 4-ampere capacity.

The midget type with 4-ampere contacts arranged for double-pole, double-throw is available for operation on 6- to 8-volt d-c and 110-volt a-c circuits.

A mica-lex insulating base and cross arm and 2-in spacing of contact arms insures against leakage of radio-frequency currents.

These radio-frequency relays are designed for antenna change over and for switching directional antennae. The midget size, 3-inch square base, is adapted for mobile installations such as police or aircraft transmitters. They are also suitable for other high-frequency applications.

ARCTURUS ADDITIONS

The Arcturus Radio Tube Co., Newark, N. J., announces the following additions to their line: The 6J5G, 6K5G, 6U7G, 25L6G and the 950. With the exception of the 950 these are glass tubes with octal bases.

UNIVERSAL PORTABLE RECORDER

The Universal Microphone Co., Inglewood, Cal., announce a portable recording machine. Housed in a black leatherette case, 16 by 22 by 9 in, the equipment weighs about 50 lbs.

The equipment is complete in itself, and includes 25 feet of microphone cable, as well as a light cord for 110 volt a-c operation, a velocity microphone, and orchestra-type folding microphone stand with a six-foot maximum height, and complete recording and playback equipment for instantaneous work.

A high-gain amplifier incorporates the features of the professional type of amplifier. There is a low and high pass filter. The speaker is mounted in the lid, and a carrying compartment for the microphone and stand is provided.

The amplifier is mounted in the base with the controls directly in front of the operator. A neon light is used for volume indication.

Additional information may be obtained from the manufacturer.

TOBE MOUNTING CLIP

A unique mounting clip is now supplied with all Tobe Deutschmann electrolytic condensers. The clip is not permanently affixed to the condenser and may be inserted in spaced slits in the condenser ends.

Brand New and "A Cinch to Sell"

BELfone CALL REPLY SYSTEMS

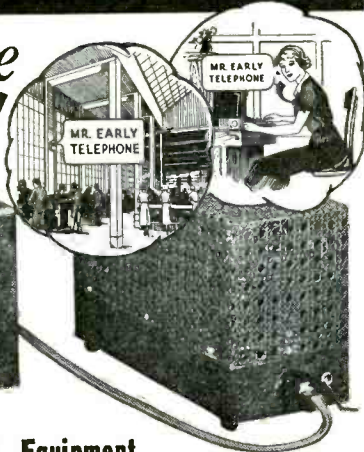
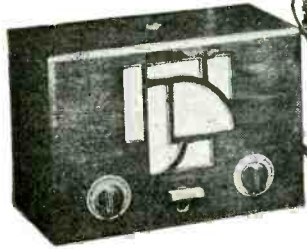

Maker of Famous P. A. Equipment
Opens new fields for Profit!

Here's another BELfone. It's new! It's powerful! Distinctly designed to replace old fashioned call systems . . . buzzers . . . gongs . . . whistles. And every large business needs a call system! But BELfone not only "calls", it is a REPLY system as well. Merely press a key and besides locating your party, BELfone enables

JOBBER'S
Write for full details on this modern money-maker as well as Bell's line of P. A. Equipment.

you to converse with him. This model BELfone has ample power for covering large areas and for any number of stations. It has many distinct features—is easy to install — is highly flexible — is free from care — and is a low cost system. A time saver that is a new money maker for you. Write for details.

BELL Sound Systems, Inc.
61-62 E. GOODALE ST.
Columbus, Ohio
EXPORT OFFICE, 308 WEST WASHINGTON STREET, CHICAGO, ILL.



VITROHM LINE VOLTAGE REDUCER Protects the Set From Over Voltage

The way line voltage is being stepped up it is no wonder that you are getting kicks because resistors, condensers and tubes are burning up. You can not only answer embarrassing questions but can turn them into profit by offering the kicker this inexpensive unit that brings too high voltage down to safe limits. Write today for folder No. 1480 and prices



WARD LEONARD ELECTRIC COMPANY
36 SOUTH STREET, MOUNT VERNON, N. Y.

Please send me Folder No. 1480.

Name
Street
City State
Jobber

MARCH, 1937 •



INSTALLATION IN 1937 CHEVROLET

10 Universal ADVANTAGES

1. PRE-ASSEMBLED, complete units.
 2. Quick and easy installation. No cutting of dash.
 3. No visible bolts or screws.
 4. Fit all car radio sets.
 5. Escutcheon Plates to fit all '37, '36 and '35 car models. Beautiful finish.
 6. Color-matched knobs.
 7. Automatic dial adjustment.
 8. Smooth, easy tuning.
 9. Minimum stock for maximum coverage of jobs.
 10. Priced for your profit.
- PATENTED

PRE-ASSEMBLED REMOTE CONTROLS for all 1937-36-35 CARS and ALL CAR RADIOS

Quicker and better re-installations . . .
Less stock to carry . . . Less work . . .
More money for you!
CLIP AND MAIL COUPON TODAY.

Universal CONTROLS, INC.

21-07 40th Ave., Dept. D
Long Island City, N. Y.

DISTRIBUTORS—Your inquiry will bring our local representative with the complete story.



Please send without obligation your descriptive Bulletin 37-D2 about the 1937, patented UNIVERSAL CONTROLS.

Name
Address
.....-Distributor.....



FREE

New Simpson Set Tester #250 (20,000 ohms per volt) with purchase of 650 National Union Tubes over 2-year period and dealer deposit of \$21.00 for immediate delivery of tester. This instrument would cost you \$38.50 if you bought it.

FREE SIMPSON INSTRUMENTS To National Union Servicemen

By special arrangement, the Simpson line of testers is now obtainable FREE with special deals on

NATIONAL UNION TUBES

. . . a complete line of highest quality tubes in glass, metal and G-type. Note special offers at right (good only in the United States) . . . Coupon will bring further details. Ask your jobber for new booklet, "Your Pocket-Book . . . What About It?"



Other National Union Offers (On Tube Purchases Over 2-Years Over)

Simpson Set Tester #225 (10,000 ohms per volt) — with 500 tubes; deposit, \$15.00.

Simpson Roto-Ranger Tube Tester #220 — with 950 tubes; deposit, \$33.00.

Simpson All-Wave Signal Generator #210 (AC) — with 800 tubes; deposit, \$28.00.

Simpson Roto-Ranger Volt-Ohm-Milliammeter #201 — with 500 tubes; deposit \$15.00.

Simpson Roto-Ranger Volt-Ohm-Milliammeter #202 — with 550 tubes; deposit \$17.00.

National Union Radio Corporation S-337
570 Lexington Ave., New York City
Tell me how to get Simpson Testing Instruments and other FREE equipment.
Name
Address
City State

SAY YOU SAW IT IN SERVICE

"BROWNIE" ALL-WAVE ANTENNA

Porcelain Products, Inc., announce their "Brownie" all-wave antenna. The "Brownie" antenna is of the balanced doublet type, with a single transformer at the receiver.

A descriptive folder may be obtained from Porcelain Products, Inc., Findlay, Ohio.

GHIRARDI SERVICE DATA SUPPLEMENTS

Owners of Ghirardi's "Radio Field Service Data," the 436-page loose-leaf job-data book for radio Service Men, have already received the first of the two semi-annual supplements to be issued in 1937. The January supplement sheets issued, number 32 pages and contain trouble symptoms and remedies for each of the 112 sets described. The Ghirardi Data Book now contains such remedies for over 1500 American and Canadian receivers.

Service Men who have already purchased the Ghirardi Field Service Data Book are receiving this current issue of supplement sheets without charge and will also receive the second set of sheets for 1937 when they are issued in June. Those who now purchase the Data Book will also receive the two supplements free of charge, until this special offer is withdrawn by the publishers, Radio & Technical Publishing Co., 45 Astor Place, New York City.

WRIGHT-DECOSTER AUTO SPEAKERS

Wright-DeCoster, Inc., St. Paul, Minn., have announced two auto-radio speakers; the models 1136 and 596.

The 1136 is a combination of the 980 "Nokoil" reproducer and a new cabinet. The grille covering the front of the new cabinet is entirely open. The screen covering the grille opening is dusted with a velvet fibre giving it a velvet appearance.

The cabinet may be mounted either by a single stud mounting or base mounting.

The model 596 is a combination of the standard model 482 5-inch "Nokoil" reproducer and a small steel cabinet.

These speakers are designed to be used as an added speaker in modern auto-radio installations. The "Nokoil" reproducers are permanent magnet speakers and do not require field current.

Additional information may be obtained from the manufacturer.

DANIEL PORTABLE AMPLIFIERS

The Daniel Electrical Laboratories, 148 W. 46th St., New York City, announce

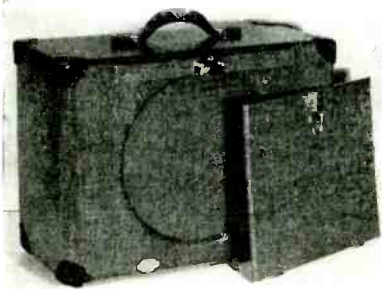

their line of portable a-c and a-c, d-c amplifiers available in several models from 6 to 15 watts.

A descriptive bulletin may be obtained directly from the manufacturer.

HEADPHONE ATTACHMENT KITS

The Trimm Radio Manufacturing Co., 1770 W. Berceau Ave., Chicago, announce headset attachment kits with universal switching—headset or speaker—for radio receivers. The device is designed for connection in the voice-coil circuit of any radio receiver. A variety of models in



both air and bone conduction types is available.

WARD WINDOW ANTENNA

The Ward Products Corporation announces an all-wave window aerial known

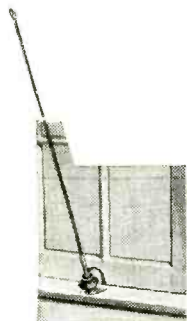

as "Windex." Among its features are that it fastens to the window sill; is plated, rust-resistant for use in homes and apartments. This aerial is telescopic, extending to 8 feet. The "Windex" also features the Ward moulded powerhouse type insulation.

ATR VIBRATORS

The American Television & Radio Co., St. Paul, Minn., has announced a line of replacement vibrators for auto and farm radios. This company has enjoyed more than six years of experience in vibrator



design, research, development and manufacture.

A guide to ATR vibrators is available from the manufacturer, free of charge.

WEBSTER-CHICAGO 2A-30 AMPLIFIER

Webster-Chicago engineers have designed the 2A-30 amplifier with an adjustable frequency characteristic—either the bass or the high-frequency end can be accentuated or attenuated at will, with the result that a new standard of performance can be set by installation organizations as required.

Additional information on the 2A-30 amplifier can be obtained directly from Webster-Chicago, 3825 W. Lake St., Chicago.

"BULLET" MICROPHONE IN COLORS

The Transducer Corp., 30 Rockefeller Plaza, New York City, announce that their "bullet" microphone is now available in black, red or ivory.

Combinations, using one color for the rear section of the "bullet" housing with a contrasting color for the front section, are also available.

A descriptive bulletin describing these dynamic microphones is available directly from the manufacturer.

UNIVERSAL CAR-RADIO CONTROLS

One of the features of Universal's remote-control unit for car radios is that the control head, supplied as a single unit, is designed to fit all recent car models and car-radio sets. Plates and knobs have been styled to fit car models for the years 1935, 1936, and 1937, and to match the finish and color of the dash in accordance with original car equipment. The units are ready for installation without assembly work on the service bench and without cutting of the instrument panel.

Universal's bulletin 37-A, containing a description of the unit and illustrations of typical installations, can be obtained by writing to Universal Controls, Inc., 27-07 40th Ave., Long Island City, N. Y.

UNITED TRANSFORMER CO. AMPLIFIER

The 25L6 beam-power tube has been used in an amplifier announced by the United Transformer Corp., 72 Spring St., New York City. Four of the 25L6s are used in push-pull parallel to provide 8 watts output. Three stages are used providing a total of 85-db gain. The input is high impedance and the output universal line and voice-coil impedances. The audio unit is a single chassis and will operate directly on a d-c line. Another chassis is used for power supply which incorporates a power transformer, full-wave rectifier and 2-stage filter.

PRECISION 830 MULTIMETER

The Precision series 830 Multimeter is an eleven range instrument with a 3-inch bakelite case d'Arsonval type meter. It has 5 d-c voltage ranges with full-scale readings from 10 to 1000 volts; four direct-current ranges with full scales from 1 to 250 ma and two resistance ranges, low ohms from 1/2 to 500 ohms and high ohms to 300,000 ohms.

A rotary switch selects any of the de-

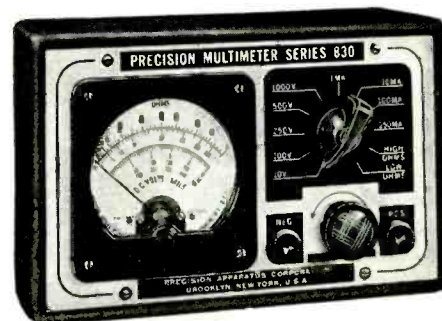

sired ranges and only two binding posts are required on the panel.

A description of this and other Precision equipment can be obtained upon request from Precision Apparatus Corp., 821 E. New York Ave., Brooklyn, New York.

HIGH FIDELITY

is the trend



AR 43\$75.00



BR2S\$37.50

* Brush sound cell construction is a "natural" for high fidelity. Faithful response over a wide frequency range is an inherent feature.

* When Brush microphones are rated as being flat in response, for a given frequency range, they ARE FLAT. . . . No mechanical or electrical compensation is necessary.

* Those facts have been realized and hundreds of sound cell mikes are being used for sound level analysis and calibration purposes . . . Plus the thousands in "P. A." and broadcast applications.

Technical Data on request

The BRUSH
DEVELOPMENT CO.
3317 PERKINS AVENUE
CLEVELAND, OHIO

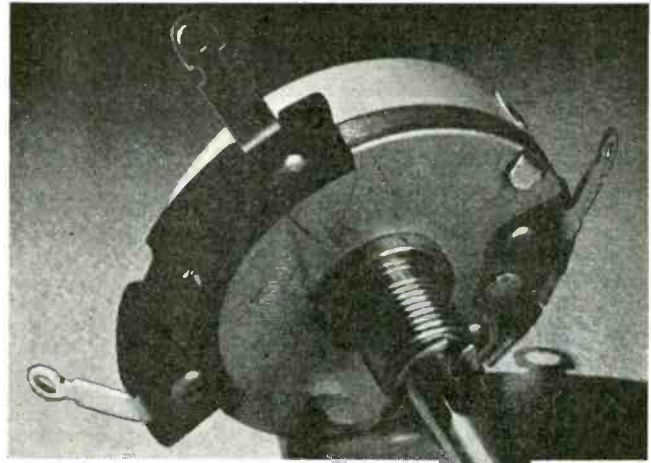

Tapped Controls

• A carefully selected kit covers the replacement needs of most sets using this type. • Minimum inventory. Maximum convenience. • Typical of CLAROSTAT policy of saving you money and time.

Send for **DATA** covering the CLAROSTAT Tapped Control Replacement Kit, as well as other money-saving kits. Meanwhile, count on your local CLAROSTAT jobber for those rush-job replacements.

CLAROSTAT Manufacturing Co. Inc.
285-287 NORTH SIXTH STREET
BROOKLYN, NEW YORK, U.S.A.
• OFFICES IN PRINCIPAL CITIES •

Ready Now! A Great New ALLIED Spring CATALOG

156 PAGES OF INTEREST FOR EVERY DEALER, SERVICEMAN AND SOUND MAN
Send for the new Spring 1937 ALLIED Radio Catalog! 156 big pages packed with Everything in Radio—more than 10,000 parts; newest analyzers, tube testers, tube checkers, oscillographs, etc.; Amateur gear; Build-Your-Own kits; Public Address systems; books, tools, etc. For better work, more satisfied customers, and bigger profits, you'll find everything you need in this great book!

FASTEST SERVICE—LOWEST PRICES
You can buy with confidence from ALLIED—Radio's Leading Supply House! Our tremendous stocks, our central location, our economical merchandising methods and our efficient shipping department mean greater values, faster service and lower prices for you. You'll find that ALLIED is your "Silent Partner"—ready to serve you faster and better.

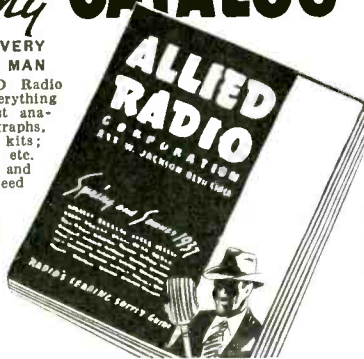

10,000 PARTS
The new ALLIED Catalog includes more than 10,000 exact duplicates and replacement parts for repairing or building any radio circuit. Any part, any size, when you want it!

NEW SOUND SYSTEMS
8-60 watts; permanent, portable and mobile; for 110 volt, 6 volt and universal operation. With "Calibrated Output Indicator," higher fidelity, and greater dependability.

50 NEW KNIGHT RADIOS
Increased, improved and refined—5 to 19 tubes—with Automatic Dialing, AFC, Tone expansion, etc. New plastic Radios; portable battery sets; phono-radio combinations, auto sets, etc.

Mallory-Yaxley Encyclopedia
All the information needed for repairing more than 12,000 radios! Priced amazingly low for only \$1.47

ALLIED
RADIO
CORPORATION
833 W. JACKSON BLVD. CHICAGO

FREE CATALOG

ALLIED Radio Corporation,
833 W. Jackson Blvd.,
Chicago, Ill. Dept. 19-C

Rush me your new Spring 1937 Radio Catalog.

Enclosed find \$1.47 (plus postage) for Mallory-Yaxley Encyclopedia.

Name

Address

QUALITY PLUS ! ! !

ATR REPLACEMENT VIBRATORS

for AUTO and FARM RADIOS
A COMPLETE LINE
FEATURING

- Longer Life
- Precision Construction
- Improved Performance
- Lower Prices

Backed by More Than Six Years of Experience in Vibrator Design and Research, Development and Manufacturing.

Insist on ATR Vibrators—The Best by Test
Mail the coupon TODAY for your FREE copy of the ATR VIBRATOR GUIDE along with the name of your nearest ATR Jobber.

AMERICAN TELEVISION & RADIO CO.
St. Paul, Minnesota, U. S. A. Cable Address: "Likex," New York
Manufacturers of D.C.-A.C. Inverters, "A" Battery Eliminators, Battery Chargers and Inverter Vibrators.

American Television & Radio Co., St. Paul, Minn.
Gentlemen:
Please send me a FREE copy of the ATR Vibrator Guide and the name of my nearest ATR Jobber.

Name

Address

City..... State.....

Check here: Dealer Serviceman Experimenter

DAYRAD DISPLAY

A complete line of devices for inspecting and servicing car radios and ignition systems was displayed at the Automotive Service Industries Show in Chicago by The DayRad Corp., subsidiary of The Bendix Products Corp., 401 Bendix Dr., So. Bend, Ind. A full line of DayRad units which answer any service problem was on display and, it is said, attracted great interest among those who attended the Chicago show.

RADOLEK AMPLIFIER

The 50-60 watt amplifier manufactured by the Radolek Co., 601 W. Randolph St., Chicago, incorporates a flexible output arrangement. By means of a variety of connecting taps and output sockets any combination of from one to four speakers may be used with proper matching maintained through the use of suitable dummy plugs. Field supply for these speakers is also obtainable from the amplifier for one or all of the four speakers.

Complete details of the amplifier can be obtained from the manufacturer.

OPERADIO INTERCOMMUNICATING SYSTEMS

The Operadio Manufacturing Co., St. Charles, Ill., have added a group of intercommunicating systems to their "unit-matched" equipment line.

The type A system is designed for use in an office or organization where two persons or departments wish to be in communication. It allows either person to talk at any time independently of the other.

Type B system consists of a master and a number (up to 10) of outlying stations. It is designed for use where it is necessary for one person to be in communication with a number of other stations. Outlying stations are able to talk back to the master station but cannot call the master station independently or talk to another outlying station.

Type C consists of a multiple number of the intercommunicating units from 3 to a maximum of 11, all connected so that any of the locations can talk to any one of the others at any time. With a ten station installation of this system it is possible to carry on five pairs of conversations simultaneously, without cross-talk or interference, and it is possible at all times for a third person, intentionally or unintentionally, to "talk into" an existing conversation but impossible to "listen in" on a conversation unless it is the desire of the per-

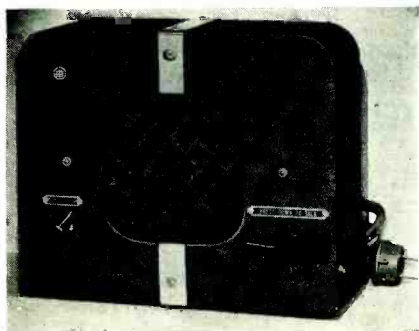

sons talking to have him do so. An illustrated bulletin of these Operadio systems can be obtained directly from the manufacturer.

CLOUGH-BREngle ANALYZER

In addition to offering an array of a-c and d-c voltage ranges, the Clough-Brengle Model 95 "Super-Unimeter" is capable of reading a capacity from 0.00025 to 16 mfd and resistance from 1/2 ohm to 20 megohms on direct reading scales.

Two 4 1/2-in fan type meters with C-B green molded cases are used. The a-c and capacity ranges, with the necessary selector switches and binding posts, are segregated on one panel, while the other panel contains a duplicate meter, selector switch and pair of binding posts for voltage, current and resistance ranges.

Because of this separation greater flexibility and simplicity is obtainable.

Operation is from a built-in power supply.

The Model 95 is offered in both portable



and 19-in relay rack mounting types. Complete information can be obtained from the Clough-Brengle Co., 2815 W. 19 St., Chicago.

AMPERITE MICROPHONE WITH CONNECTOR

A cable connector is now supplied as standard equipment with Amperite velocity



microphones, models RBMn and RBHn, at no extra cost.

The cable connector is of the positive three-pin type. A locking ring eliminates possibility of pulling the connector apart. The body of the connector, holding the cable, is made longer to prevent the leads from shorting.

A descriptive bulletin may be obtained from Amperite Corp., 561 Broadway, New York City.

ELECTRO-ACOUSTIC AMPLIFIER

Electro-Acoustic Products Co., Fort Wayne, Ind., announce a 30-watt beam-power amplifier with provision for mixing three crystal or three velocity microphones and a high-impedance phonograph pickup.

Five controls are incorporated for mixing, fading and tone. A master gain control is

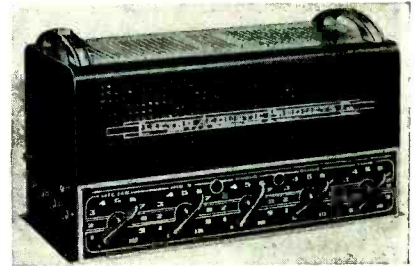

provided for monitoring multi-circuit programs.

Additional information on this and other Electro-Acoustic amplifiers may be obtained directly from the manufacturer.

KEN-RAD 6C8G

The Ken-Rad Tube & Lamp Corp., Owensboro, Ky., has developed a tube known as 6C8G. This tube consists of two similar medium-mu triodes in one envelope with all elements brought out to external connections. This Ken-Rad 6C8G is a voltage amplifier useful as a phase inverter in automobile receivers. Numerous other uses for this tube will undoubtedly appear in all types of receivers and amplifiers. An engineering bulletin describing applications of this new tube will be sent on request.

The Ken-Rad 6C8G is a glass type with an eight-pin octal base.

ANOTHER RIDER BOOK

John F. Rider's 160-page volume "Aligning Philco Receivers" has been placed on the market.

The book represents information on the entire Philco line from the first set produced to the very latest.

The data has been prepared in cooperation with the Philco Engineering Dept. and is authentic and complete. The order followed in the tables is the same that the Service Man uses when aligning the receiver on the service bench, presented in convenient form for rapid and accurate alignment operations.

NATIONAL UNION TYPEWRITER DEAL

R. M. Coburn, general sales manager of National Union Radio Corp., 570 Lexington Ave., New York City, announced the conclusion of negotiations with Royal Typewriter Co., which will enable Service Men to equip themselves with a Royal portable by purchasing National Union tubes.

Two Royal portable models are being made available, the De Luxe portable and model "O." Royal machines were chosen after a survey of the typewriter field, in the belief that these machines are best fitted to the needs of the Service Man.

Mr. Coburn states that typewriters have been added to the list of National Union free equipment offers in response to a demand from the service industry. Service Men have sensed the fact that the efficient appearance of letters, invoices and quotations prepared on the typewriter, lend to their business an air of efficiency and prestige which is lacking when such consumer contacts are prepared by hand.

FOR PUBLIC ADDRESS SYSTEMS

The Model D-2 Astatic Crystal Microphone, shaped and styled like a watch—only 2 1/2" dia. and 1/2" thick—immediately wins the heart of every microphone user wherever public appearance is made. Not only beautiful to look at but does not obstruct performer's face. Essentially a NON-DIRECTIONAL unit with frequency response substantially flat from 50 to 6000 c.p.s. and built to stand shock far beyond ordinary. Equipped with plug and socket connector for immediate interchange with K-2 or D-104 on same stand. List Price \$25. See your jobber or write for D-2 Bulletin.

For finer reproduction of recordings and longer record service the TRU-TAN Pickup is recommended, which features the exclusive Astatic Offset Head Design. List Price, \$17.50. Send for TRU-TAN Booklet or see your jobber.

Astatic Microphone Laboratory, Inc.
Dept. S, Youngstown, O., U. S. A.



PIONEER MANUFACTURERS OF QUALITY CRYSTAL DEVICES

Model D-104

Model D-2

Model K-2

Model L-1

Licensed under Brush Development Co. Patents - Astatic Patents Pending

ASTATIC

ROYAL TYPEWRITER FREE

—To
National Union
Servicemen

National Union and the Royal Typewriter Co. have negotiated a plan to provide free typewriters to National Union servicemen. . . . A choice of either the Royal DeLuxe model (shown here) which lists for \$64.50, or the Royal Model 0 which lists for \$54.50 may be had with—



NATIONAL UNION TUBES

—purchased over a two-year period as follows: 1000 tubes plus \$35.00 dealer deposit secures the DeLuxe Model typewriter. . . . Purchase of 850 tubes, plus \$29.00 dealer deposit gets the Model 0 machine. . . . This is at the rate of only 8 to 10 tubes a week, purchased on the 2-year period—depending on model. . . . Deposit assures immediate delivery of typewriter. . . . Offer good only in U. S. Send coupon below for further details.

Ask your jobber for new booklet, "Your Pocket Book — What About It."

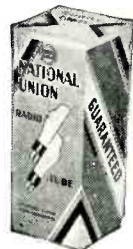

National Union offers a COMPLETE LINE of radio tubes in glass, metal and G-types—the outstanding favorites in the radio service profession.

NATIONAL UNION RADIO CORPORATION
570 Lexington Avenue, New York City S337

Tell me how to get Royal Typewriter and other equipment FREE.

Name
Address
City..... State.....

NOISE-MASTER ALL-WAVE ANTENNA Kills "Man-made" Static

"NOISE-MASTER"
No. 14
List Price \$6.75

Brings in overseas signals stronger, and eliminates "man-made" static on broadcast as well as short-wave band. For better reception in EVERY location.

"NOISE-MASTER"
No. 18
List Price \$3.40

First time at this popular price . . . a SELF-SELECTING antenna of the simple doublet type, designed to clear up short-wave reception.

"NOISE-MASTER"
No. 19
List Price \$4.30

This is another SELF-SELECTING model of the doublet type, with junction-box in the antenna line. Assures finer all-wave reception.



This trademark guarantees the best in antenna and radio wire products.



On Broadcast as Well as on Shortwave Frequencies

Licensed by Amy, Aceves & King, engineered by Corwico . . . every Service Man knows that's plenty to say about any antenna! Try one of these modern units on your next installation . . . a real good will builder for YOU!

Write for descriptive literature

CORNISH WIRE CO., Inc.

30 CHURCH STREET

NEW YORK CITY

Conveniently packaged

FIVE SIZES with flexible shell mounts . . . take care of 90% of demand.

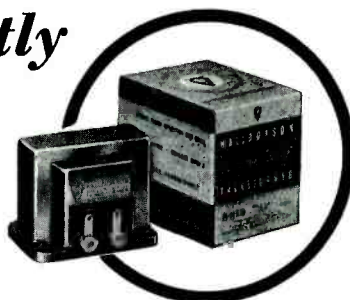

Halldorson has made a detailed study of radio transformer requirements . . . in an effort to reduce types . . . to provide flexibility without sacrifice of efficiency. Send for new catalogue giving complete information.

Remember all Halldorson transformers are vacuum-sealed and, therefore, impervious to moisture. Play safe, follow the lead of old-time service experts who have cured their transformer troubles . . . Insist on

Halldorson Vacuum Sealed Transformers

The Halldorson Co., 4500 Ravenswood Ave., Chicago, Ill. S 337
Please send me your new catalogue of Vacuum Sealed Transformers.

Name
Address
City..... State.....



Bridge Analyzer

to furnish an exact test of
condensers and resistors

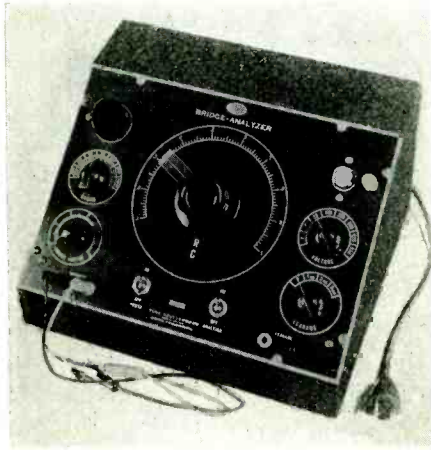

Quick, Accurate Measurements in a single glance!

This direct-reading instrument will show definitely the condition of every condenser, and will measure accurately both condensers and resistors. But the big feature is that it's *quick, accurate, simple!* The main dial of a TOBE Bridge Analyzer is extra-large, uniformly-spaced... practically impossible to make a mistake in reading. One glance at the main dial, multiply its reading by the decade switch factor, and you have the story without other involved types of calculation or reference to calibration charts. Will not become obsolete.

Quickly trace elusive types of receiver trouble, poor power factor, and intermittent open circuits.

100% GUARANTEED

... or your money back!

Don't buy any Bridge which lacks this easy reading feature! Order the TOBE Bridge Analyzer *now*, under the most daring guarantee ever offered! It doesn't cost you a penny if you're not 100% delighted. Full refund guaranteed.

TOBE Bridge Analyzer, complete with built-in power supply for any 110 volt 60 cycle circuit, electric eye with pre-amplifier, neon tube for conventional analyzer service, and complete with 1-6G6, 1-6C6, 1-01A, and 1 neon **\$28.50** tube. Net price

Tobe Deutschmann Corp.

Dept. C-10, Canton, Massachusetts

Please ship one complete TOBE BRIDGE ANALYZER at \$28.50, all shipping charges prepaid, under your **ABSOLUTE SATISFACTION OR MONEY BACK GUARANTEE.** I enclose () Payment in full, () Deposit of \$5.00, balance C.O.D.

Name

Address

Town..... State.....

EXTRA DIVIDENDS FOR THE SERVICE MAN

(Continued from page 140)

vised and improved regularly in order to follow the changing notions of his art.

TELEVISION

Of the subjects now demanding attention, from the viewpoint of long-range or future profits, none seems more important than that of television. During the past year journals and newspapers alike have made their conjectures as to when television should become a commercial reality. Obviously, no one knows the exact date, though one can not help but feel something of major importance will happen during this present year when extensive field tests have already brought television developments out of the laboratories into the studios.

Great Britain officially opened her television programs as broadcast from the Alexandria Palace in London last March and have inaugurated a four-year plan whereby England will erect a network of stations in the populous centers in order to reach at least 70 percent of the people by television waves. In commenting upon the future, British engineers have predicted that "within four years television receivers, available at a price comparable with the present high-grade radio receiver and providing a bright picture of sufficient definition for real entertainment, will occupy the space now devoted in the home to the broadcast receiver."

Regardless of who is the superior in this new communication art, the fact remains that present readers of SERVICE will be installing and repairing, in the not too distant future, television receivers in the homes of clients. The radio profession has agreed unanimously that a national industry comprising the distribution of news, movies and entertainment in a medium of sight and sound will materialize into large proportions within the next 10 years. At that time, the servicing branch of television will be no sideline trade, but rather a specialty in itself.

Meanwhile, aggressive Service Men, wishing to make the new art a part of their future business, are acquainting themselves with all the technical phases of the developments. Those wishing to enter by the ground floor, so to speak, can well afford to peruse manufacturer's data on devices like cathode-ray tubes, transmitting parts, visual-receiver specifications, and the like, as it becomes available. Advances in techniques, as described in foreign periodicals, also constitutes a part of this study program. Likewise, the patents on new

DANIEL AMPLIFIERS



are PORTABLE

and embody the following
outstanding features

SIMPLICITY—Complete in one case. Merely plug in mike or phono or both. Easily sold any place where public address can be used.

APPEARANCE—Just look at the picture. That tells the story.

QUALITY—12" dynamic speaker. Push-pull beam power amplification—unusually wide range.

MODELS—AC 15 watts (2-6L6G), AC-DC 10 watts (4-25L6G), AC 6 watts (1-6L6G), AC-DC 4 watts (2-25L6G).

PRICE—You can get two Daniel amplifiers for what you would expect to pay for one.

Write for literature and prices.

DANIEL ELECTRICAL LABS.
148 W. 46th St. New York



P. A. is Big Business. LAFAYETTE has met this fact with CO-ORDINATED SOUND SYSTEMS. Complete packaged units—pre-tested—ready for easy installation and long faultless operation. Priced right they offer a system for every conceivable P. A. application.

**SEND FOR FREE NEW 116
PAGE SPRING CATALOG NOW!**

WHOLESALE RADIO SERVICE CO., INC.
NEW YORK, N. Y. • CHICAGO, ILL. • ATLANTA, GA.
100 SIXTH AVENUE, 901 W. JACKSON BLVD. • 430 W. PEACHTREE ST., N. W.
BRONX, N. Y. • NEWARK, N. J. • JAMAICA, L. I.
542 E. FORDHAM RD. • 219 CENTRAL AVE. • 90-08 LEVITT STREET
MUTCHICK ROAD

WHOLESALE RADIO SERVICE CO., Inc.
100 SIXTH AVENUE, NEW YORK

Rush FREE Spring Catalog 68-5C7.

Name

Address

City

State

"Ever Tear Open a 'BARGAIN' CONDENSER to See What Makes It So Cheap?"



SPRAGUE
The Standard of Condenser Quality

"Don't buy condensers blind-folded!"

"Take an average or 'bargain' cardboard dry electrolytic for instance. Tear it apart. See if the terminals are embedded—see whether or not the unit is doubly-sealed in a moisture-proof container. See if ordinary wax instead of high quality heat-proof wax is used. Tear open defective condensers to learn exactly why they failed. . . ."

"Nothing will prove more convincing in getting you to standardize on Spragues, as thousands of discriminating servicemen and amateurs have already done. Their solid, honest construction tells its own story of outstanding condenser quality!"

SPRAGUE PRODUCTS COMPANY
North Adams, Mass.

television inventions and procedures offer a fund of useful knowledge.

HONESTY INSURES MAXIMUM PROFITS

In the days when communication consisted of smoke flashes viewed from hilltops and Service Men were merely those individuals who kept the fire burning, it was written that men should do for others as they would have done to them. Today, when some 7.4 millions of radio receivers pass in a single year from factory to home by a cash transfer of 372,700,000 dollars, the same policy obtains.

Unfortunately, however, with the increased temptation for cut-rate servicing and straight-forward gyping by that class of persons seeking a cut on the 33,200,000 receivers now in use and the additional 7,400,000 sets to be sold this year, the reliable Service Man has a serious problem confronting him. Realizing the import of the situation, editors of consumer's reports, newspapers, and popular magazines like "Reader's Digest," are advising the public of radio racketeering practices. For our purposes here, it is not necessary to describe such acts; sufficient it is to say that readers of SERVICE will not participate in them without first considering the consequences. Rather will they rely upon the news of their dependable and honest work to pass from client to client as it most assuredly will.

Similarly, Service Men will affiliate themselves with the local electric light companies and with reputable manufacturers in view of the recent warnings that dependable radio service cannot be wholly evident from the mere inspection of a telephone directory, or perusal of a newspaper advertisement. In other words, he who would be known reliable must actually prove himself so. Moreover, upon completing an assignment, one should be convinced of having performed the best possible service under the conditions. By such a policy, the dependable Service Man can be assured his reputation for honesty will be his greatest asset in the end.

Whether or not the next months of 1937 servicing mean expansion into sideline activities or improvement of present practice and facilities, let it at least be an honest year's work. The extra dividends will take care of themselves.

RCA 125, 225

Slipping dial: Clean friction plate and ball bearings. Increase the tension on the three fingers that grip the clock type gear when the knob is pushed.

E. J. Bancroft

SAY YOU SAW IT IN SERVICE

"Sure! . . . I've even **TORN OPEN SPRAGUES** to see what makes 'em **SO GOOD!**"



CONDENSERS
USE SPRAGUES.. and Note the Difference

"Look inside a Sprague dry electrolytic such as the PTM-8 'Pinhead' Tiny-Mike. Note that both terminals are deeply **IMBEDDED IN HIGH MELTING POINT** pitch. No chance for corrosion here! Note that an inside container is used as a **DOUBLE SEAL** against moisture which so commonly increases leakage and lowers voltages with a consequent rise in heat in ordinary condensers.

"In short, note that Sprague not only makes the finest, most reliable condensers, but also takes every precaution to **keep them as fresh as the day they left the factory.**"

"Yours for long, trouble-free condenser service."

Sincerely,
Harry Walker
Sales Manager,
Sprague Products Co., North Adams, Mass.

Cashing in on
HOME RADIO WIRING



- TACO Master Antenna System means one aerial serving up to 25 set outlets.
- Ideal for apartment house, hotel, hospital, club or even private dwelling.
- An all-wave, noiseless, high-efficiency system at cost within reach of any building owner.
- Neat. Easily installed. Exposed or concealed wiring.

↓ Handy foundation kit. As many outlets as needed. Complete instructions. Engineering collaboration. A neat profit is assured on every job!

Free MANUAL! Just issued. New edition. Describes surveying, estimating, installation, testing, etc. Ask your jobber for your copy or write us.

TACO
TECHNICAL APPLIANCE CORP.
Pioneers in Noiseless Antenna Systems
17 E. 16th St., New York City

"BULLET"
DYNAMIC MICROPHONES



EVERYBODY WANTS ONE . . . EVERYBODY CAN AFFORD ONE!

The All-Purpose "Bullet" Dynamic Microphone is sweeping the 1937 market.

T. R. 3 — New Model "Bullet" . . . smaller than TR 2 but with relatively the same characteristics. List price, any impedance . . . \$24.50.

T. R. 2 — Standard Model "Bullet" . . . the ultimate in dynamic microphone performance. List price, any impedance . . . \$39.50.

Write for circular "S" and technical data

TRANSDUCER CORPORATION
30 Rockefeller Plaza
New York, New York

SUCCESSFUL in
PERFORMANCE.. DESIGN..
CONSTRUCTION.. SALES..
say leading P.A. men

AMPERITE VELOCITY
ACHIEVES
UNIQUE RECORD
IN ACTUAL USE



Featuring..

1. Output increased 6 DB.
2. Triple shielded—against all RF or magnetic fields, entirely eliminating hum pickup.
3. Eliminates feedback troubles.
4. Excellent for close talking and distant pickup.
5. Acoustically designed to eliminate any possibility of cavity resonance.
6. Fitted with switch and cable clamp.

NEW! MODELS RBHn (High Impedance): RBMn (200 ohms) with Cable Connector and Switch

\$42.00 LIST

NEW! MODELS RBSn, RSHn, streamline, slightly lower output and frequency range than above, with switch only

\$32.00 LIST

Models RAL (200 ohms): RAH (2000 ohms). Built to Amperte standards: No peaks. Flat response. Triple shielded. Shock absorber. Swivel bracket.

\$22.00 LIST

Finishes: All microphones have the new standard Gunmetal Finish. Available in Chrome, extra. \$1.00 List.

FREE: WINDOW DECAL, advertising your SOUND SERVICE. Four-color design. 5 1/4 x 9 1/4. Write for it now.

AMPERITE Co. Cable Address: Alton, New York
 561 BROADWAY NEW YORK

AMPERITE Velocity **MICROPHONE**

TEST EQUIPMENT—continued

the trap should be connected as shown in Fig. 5, in series with the test oscillator and with the receiver and oscillator tuned to a frequency other than that to which the trap is adjusted, a reading should be obtained on the vacuum-tube voltmeter. If no reading or a very low reading is obtained, it is obvious that the trap circuit will not pass to a great extent, frequencies on each side of the resonant point. This can be corrected by using a smaller coil and a larger condenser.

The degree of attenuation of the trap circuit on any frequency can be measured by taking a reading with the trap in series with the oscillator and then shorting out the trap circuit and noting the second reading. If the trap circuit is to be designed for frequencies somewhere in the intermediate band then a superheterodyne receiver should be set up and the oscillator connected from the grid of the first detector tube to the chassis. The amplification obtained in the i-f section of the receiver can then be used to build up the voltage as mentioned in the previous paragraphs.

It is quite often found advantageous to connect a trap circuit resonated to the intermediate frequency in series with the antenna connection in the superheterodyne receiver. Such an arrangement will cut down to a considerable extent the image ratio of the receiver or, in other words will limit feedback of the intermediate-frequency potential into the antenna circuit.

AVC INDICATOR

Alignment and adjustment of avc receivers can be handled accurately and rapidly by making use of the vacuum-tube voltmeter as an avc voltmeter indicator. The ground connection should be made directly to the avc lead which carries voltage to the various r-f and i-f tubes with the grid of the vacuum-tube voltmeter connected to the chassis of the receiver. With the test oscillator connected either to the first detector tube or to the antenna and ground posts of the receiver, adjustments of the various trimmers can be made for maximum avc swing on the vacuum-tube voltmeter.

If exact alignment is to be carried out by this method, the r-f stages should be aligned first. As an increase in signal at the input to the second detector tube will result in an increase in avc voltage, exact alignment of all the tuned circuits can be made without changing the position of the vacuum-tube voltmeter.

On some receivers avc amplification is used. In such cases with the oscillator connected to the first detector tube and a signal tuned in, the trimmers that resonate the avc amplifier tube circuits

The **RADIO**
STETHOSCOPE
 ONLY ONE OF 15 R-T-L FEATURES

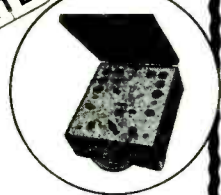

Model M, Series B, Radiotechnic Portable Tube Tester. Counter model tube testers also available.

The RADIO TUBE "STETHOSCOPE," an R-T-L feature, provides an audible check on tube noises caused by loose elements and intermittent shorts. Let your customer listen to the earphone while you watch the neon. He HEARS the noise while you SEE it. Easily the hit of the year in advanced tube selling. JUST ONE OF FIFTEEN R-T-L ADVANTAGES.

The Radiotechnic Laboratory

Dept. S

1328 Sherman Ave. Evanston, Ill.

A Complete Line of
 Tube Test Equipment

RADIOTECHNIC

Birco

All-Wave Antenna



WINNING NEW FRIENDS
 WITH ITS PERFORMANCE

Amazed by its performance—hundreds of satisfied customers are recommending the new, improved BIRCO Switch-O-Matic Antenna. Here at last is an antenna that does what it's supposed to do: clarifies reception! It's easy to install, too, for it is a factory assembled and soldered job which eliminates poor connections. The antenna transformer matches impedance to transmission. There is no signal loss in transmission to the receiver coupler which automatically adjusts itself to the frequency tuned in by the receiver. No switching for short wave or broadcast is required.

No. 375 All Wave Antenna. List ea. \$4.25.
 No. 376 All Wave Antenna for sets with built in aerial selector. List ea. \$3.50.

If your dealer cannot supply you write Dept. S-3 giving name of jobber and we will see that you are supplied.

BIRNBACH RADIO CO.
 145 HUDSON ST. BIRCO NEW YORK, N. Y.

FACTS

on

SERVICE
CIRCULATION

- 70% own their own business.
- 81% carry a stock of tubes.
- 89% carry a stock of parts.
- 78% carry a stocks of sets.

Over 22,500 full-time, professional servicemen read the magazine each month.

Over 800 legitimate distributors of parts and accessories subscribe to SERVICE.

ENTIRELY *New* IN DESIGN
PERFORMANCE * BEAUTY

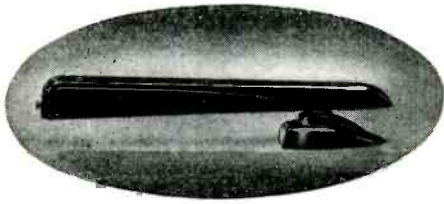

SHURE ZEPHYR
★ *Balanced-Tracking*
CRYSTAL RECORD REPRODUCER

The ZEPHYR marks an important milestone in pickup progress. It brings you basically new improvements of far-reaching significance in electric pickup design. *Exclusive "needle-tilt"* Balanced-Tracking reduces record wear . . . increases record life. Improved wide-range frequency characteristic and better transient response give you higher fidelity . . . more life-like reproduction. "High-Lift" streamlined arm allows plenty of room for easy convenient needle changing. Plays 10 and 12 inch records. Furnished with 3½ ft. shielded cord, mounting screws, and complete instructions. List Price. **\$12**

Order a ZEPHYR now! Let your own tests prove how much better a Shure Zephyr really is.

See your Jobber or write for Bulletin 205S for complete technical data — today.

Licensed under patents of the Brush Development Company. Shure patents pending.

SHURE MICROPHONES
SHURE BROTHERS • MICROPHONE HEADQUARTERS
225 WEST HURON STREET • CHICAGO, U. S. A.

NOW

Make your space reservations for the important
APRIL ISSUE

Final Closing Date
APRIL 5th

TEST EQUIPMENT—continued

should be adjusted for maximum avc voltage, this being indicated directly on the instrument. Voltage readings can be taken directly in d-c circuits with the vacuum-tube voltmeter. The indications must be transferred to d-c volts by reference to calibration curves supplied with the device. Line volts at all frequencies are most important, the instruments are calibrated in a-c with d-c curves supplied.

To make sure that the avc operation of the receiver is correct, the attenuator of the oscillator should be manipulated back and forth with a corresponding change in avc potential indicated by the Model 669 meter. If correct action does not take place the resistors in the avc circuit of the diode detector should be examined, as the drop across these resistors determines the avc potential. If a separate avc amplifier tube is used, this tube and its associated circuit should be examined to make sure that it is functioning properly.

D-C GRID VOLTAGE

Occasionally the resistors connecting from the return circuits of the r-f or i-f coils to the avc control lead become open or the by-pass condensers in the grid return circuits become shorted. Either of these two difficulties will stop avc action on the tube grid. To make sure that this action is taking place directly on the grid of the tube, the circuit shown in Fig. 6 should be used. The condenser across the input circuit of the vacuum-tube voltmeter will short out the radio frequency at that point while the d-c potential applied to the grid of the tube will be indicated by the meter.

INSTRUMENT VERSATILE

The voltmeter can be used in many other circuit measurements including the drop across chokes, resistances, r-f coils and other such circuits. The only general precautions that are to be taken in these cases, is to make sure that no electrostatic pickup is appearing in the grid of the tube or in other words, the reading is determined only by the drop across the circuit component being measured.

The vacuum-tube voltmeter is limited only in its usefulness to the ability of the operator. Many uses beyond those mentioned above can be made of this instrument. As the Service Man becomes more familiar with his vacuum-tube voltmeter he will find it of greater and greater help and will ultimately consider it to be one of the tools without which he cannot function properly.

**Matched
REPLACEMENTS**



- ★ First, the largest listing of exact duplicate condenser replacements for every standard set. No improvisations. No makeshifts. No experimentation.
- ★ Second, an exact duplicate that FITS right, WORKS right, LOOKS right. That means customer satisfaction, prompt pay, and no return calls "to make good."
- ★ That's what AEROVOX Exact Duplicate Replacements mean to you. And you cannot afford to be satisfied with less.



Send for DATA

Our latest catalog lists several pages of exact duplicates. Supplements issued from time to time. Your local AEROVOX jobber carries a representative stock.



HIGHLIGHTS . . .

UTAH RADIO PRODUCTS EXPANDS

Ira J. Owen, president of Utah Radio Products Co., Orleans St., Chicago, an-



IRA J. OWEN,
President Utah Radio Products Co.

nounced their latest expansion program. Several departments will be completely reequipped with automatic machinery of recent design to further increase production and to keep pace with progress in the industry. This new equipment will enable Utah to maintain delivery schedules on their increasing business.

The Utah laboratory will also be expanded with new specially built testing apparatus to maintain Utah standards.

The office efficiency will also be stepped up by the addition of a modern basic standard cost system.

Mr. Owen states that the outlook for the remainder of the year is very promising and indicates an increase in value of business.

NATIONAL TRADE SHOW

Committees of the IRSM headed by Joe Marty, Jr., chairman of the convention committee, have been working on preparations for the fifth annual IRSM convention to be held simultaneously with the National Trade Show at the Hotel Stevens, Chicago, June 10 to 13 inclusive.

Plans are being laid to arrange a program that differs from the usual type of technical session. In addition speakers of renown will talk on various subjects. One of the purposes of the lectures is to instill a greater degree of self-confidence in the attending Service Men.

That the National Trade Show will be a sell-out (of the 130 booths) is assured, according to advices from Ken Hathaway, managing director of the show.

"It is most difficult to have to tell a would-be exhibitor that there is no more space," said Mr. Hathaway, "but that is exactly what I'll have to do in a very short time. We have been literally swamped with contracts, and the Exhibition is nearly a third larger than the goal that we had set originally."

When questioned about the possibility of increasing the space or providing booths elsewhere, the Managing Director stated that no such provision could be made. When the Exhibition Hall, which contains

130 booths is filled, that is the limit to the amount of space that can be utilized at this show.

GRAMER STANCOR VICE-PRESIDENT

Jerome J. Kahn, president of the Standard Transformer Corp., manufacturers of Stancor transformers, univerters and electric fans, announces the appointment of Everett E. Gramer as vice-president in charge of engineering and production.

Mr. Gramer graduated from Armour Institute of Technology with a B.S. in Electrical Engineering. He became associated with Transformer Corporation of America, as an engineer shortly thereafter. He resigned from this organization to become chief engineer of Standard Transformer Corporation. He served in this capacity for three years and then devoted part time to sales in and around the Chicago territory. He continued in this position until recently he became vice-president in charge of engineering and production.

CENTRALAB VOLUME CONTROL GUIDE

Centralab, 900 E. Keefe Ave., Milwaukee, Wis., announce the latest edition of



their volume control guide. The new guide is to have about 83 percent more pages than the last edition with 400 individual types of receivers listed including some 700 models.

The guide also contains data covering the Centralab tone and wavechange switches, midget radiohms, p-a controls and general circuit information.

Copies of this guide may be obtained directly from the manufacturer.

WHOLESALE RADIO CATALOG

The Wholesale Radio Service Co., Inc., of 100 Sixth Ave., New York, N. Y., an-

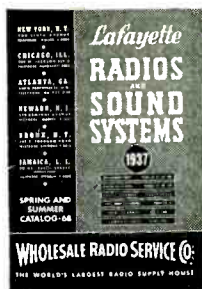

nounces the release of their Spring and Summer 1937 Catalog No. 68. This catalog, like its predecessors, is distributed free of charge. Copies may be obtained upon request.

IRC VOLUME CONTROL GUIDE

The International Resistance Co., 401 North Broad St., Philadelphia, Pa., an-

nounces the latest edition of the "IRC Volume Control Guide." The guide is printed in pocket size with durable covers and is punched for convenience in hanging over the service bench.

Copies of the guide may be obtained, upon request, directly from the manufacturer.

An increase of approximately 25% in manufacturing space with a resultant increase in the production of IRC insulated metallized resistors, metallized volume controls, and precision and heavy-duty wire-wound resistors has recently been made by the company.

CORNELL-DUBILIER CATALOG

The Cornell-Dubilier Corp., South Plainfield, N. J., have released their illustrated catalog, No. 137A, listing replacement electrolytics and paper condensers. It is available to dealers and Service Men.

The sixth of the series of "point of sale" promotional displays has also been released. This latest counter-size placard is printed in three colors. It is available to all jobbers and distributors.

Both the catalog and the display may be obtained directly from the manufacturer.

RCA AUDIBLE SCHEMATIC

Inauguration of a new series of service lecture meetings to be conducted under joint sponsorship with its wholesale distributors in over 100 cities, was announced by the Service Division of the RCA Manufacturing Co., Camden, N. J. The first of the meetings have already begun in some localities and the rest are scheduled to be held throughout March until every section of the country has been covered.

With the aid of the board shown in the illustration, RCA service engineers are able to demonstrate both visually and audibly a variety of conditions pertaining to audio frequency circuits. It's a feature of RCA's new series of service meetings on "Training the Ear and the Eye for Radio Servicing." Behind the board are mounted apparatus, various parts of whose circuits are connected to the switches on corresponding parts of the schematic diagram. Certain effects may be heard

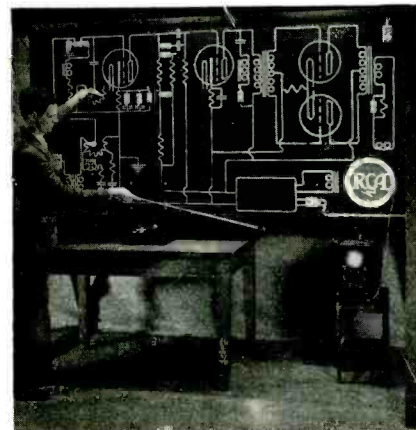

through a loudspeaker concealed behind the monogram and their characteristics studied on a cathode-ray oscillograph.

HIGHLIGHTS—continued

FREE OSCILLOGRAPH DATA

"How to Operate an Oscillograph and Wobbulator" is the title of a 6-page technical bulletin offered free by the Triumph Mfg. Co., 4017 W. Lake St., Chicago. The bulletin describes a number of tests which may be made with the oscillograph, both with and without the wobbulator, that are of particular value to Service Men and manufacturers. It also lists the uses of the Triumph models 77 and 820 oscillographs.

SOLAR CATALOG

Solar Manufacturing Corp., 599 Broadway, New York City, announce their con-



SOLAR CONDENSER CATALOG

denser catalog No. 8-S. Two full pages of the catalog are devoted to each type of condenser.

Copies may be obtained directly from Solar.

INTERFERENCE ELIMINATION BOOKLET

A condensed summary of the subject of eliminating man-made interference in domestic and auto-radio installations is contained in a booklet released by Continental Carbon Inc. Each form of interference is discussed briefly and methods of attacking it are disclosed. The booklet is of vest pocket size, 24 pages, and is illustrated. It may be obtained directly from the factory, 13900 Lorain Ave., Cleveland, Ohio, price 10c postpaid.

BOOK REVIEW

RECEIVING TUBE MANUAL, Technical Series RC-13, published by the Commercial Engineering Section RCA Radiotron Division, RCA Manufacturing Co., Inc., Harrison, N. J., 192 pages, price twenty-five cents.

This manual, like its preceding editions, has been prepared to assist those who experiment or work with radio tubes and circuits, and it is up-to-the-minute on RCA radio receiving tubes. The information presented in this book was selected after careful consideration of its usefulness. In general, the form will be found to follow that of previous editions although many revisions and additions have been made. Of special interest is a four-page tabulation covering the conditions for the operation of resistance-coupled amplifiers. A nine-page circuit section is also given.

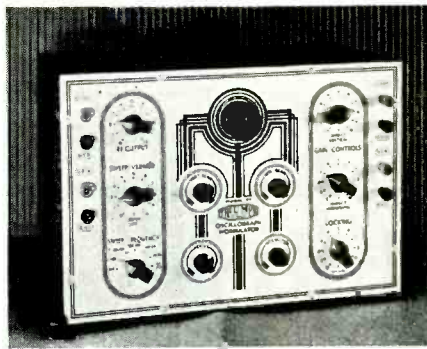

Cathode Ray

**OSCILLOGRAPH
WOBBULATOR**

2 Model 77 Instruments **FOR** the cost of **1**

Model 77 combines in one instrument both an electronic Wobbulator and a 913 Oscillograph. A linear sweep, synchronous locking, horizontal and vertical amplifiers and full beam controls are also included. The combination permits visual alignment of r.f. and i.f. tuned stages, flat topping, and adjustments of AFC and AVC circuit constants.

Model 77 used without the Wobbulator, may be employed to locate audio distortion, the cause of intermittent reception and measure audio gain. It will identify auto vibrator trouble with absolute certainty. Functions of a vacuum tube voltmeter may be performed with this versatile Oscillograph such as measuring transformer ratios, hum voltage, power factor and capacity of condensers, percentage of modulation and phase relationships. Any Signal Generator may be used with the Model 77 Oscillograph Wobbulator.

Model 77 is supplied complete with its six tubes in a portable carrying case, 13 3/4" x 9 1/2" x 8" deep. Wt. 13 lbs. Finished in ivory and black with red pointer knobs and universal, colored binding posts, the Model 77 presents a strikingly attractive appearance. Instructions and circuit diagram available.

A TRIUMPH



Triumph Instruments Cost Less

- Model 820 1" Oscillograph**
with 15 to 35,000 cycle linear sweep, dual amplifiers, synchronous locking, and 4 beam controls. your best buy..... **\$39.95**
- Model 800 3" Oscillograph**
with 15 to 50,000 cycle linear sweep, dual amplifiers, synchronous locking, and 4 beam controls. Lab. style, only..... **63.60**
- Model 180 Electronic Sweep**
test oscillator for use with any type oscillograph. Copied but unbeatable. Triumph Wobbulator..... **46.00**
- Model 120A Signal Generator**
Direct reading dial, calibrated microvolt attenuation, no leakage, 100 k.c. to 75 m.c. 30% Mod..... **29.95**
- Model 420L New Standardized**
Tester checks all types of tubes, makes hot leakage, and performance tests. Accurate, reliable, simple..... **29.95**
- Model 300 Multirange Meter**
official 1000 ohm per volt factory standard. 6 ac-dc volt ranges, 3 ohm and 2 m.a. ranges, portable, handy..... **15.95**
- Model 310 Volt-ohmmeter for**
knock about service. 2 ohm and 3 volt ranges at 1000 ohms per volt..... **7.85**

TRIUMPH MFG. CO.

4019 W. LAKE, CHICAGO, ILL.

Please send catalog and FREE data on "How to Operate An Oscillograph."

Name Address
City State

- The Group Subscription Plan for *Service* enables a group of service men, dealers or jobbers to subscribe at one-half the usual yearly rate.
- The regular individual rate is \$2.00 a year. In groups of 4 or more, the subscription rate is \$1.00 a year. (In foreign countries, \$2.00.)
- Each subscriber should print his name and address clearly and state his occupation—whether a dealer, jobber, independent service man, service organization, etc.

Remember this Group Plan when *Your* Subscription Expires

(Service)

BRYAN DAVIS PUBLISHING CO., INC.

19 East 47th Street

New York, N. Y.

MODEL



836

1937's Most Popular Auto Speaker

The above model is a combination of our new automobile speaker cabinet and the model 682—8-inch Nokoil Speaker which requires no field current, thereby eliminating any drain on the battery.

Those who know the quality of the Nokoil Reproducer can well imagine the performance the model 836 is capable of giving.

The steel cabinet has a single stud attached to it, so that the cabinet carries the speaker. This does away with the old type method of drilling a hole in the pole piece of the speaker, making it carry the entire load, which often forces the pole piece off center. In the bottom of the cabinet, holes are provided so it may be base mounted when desired.

List Price Complete
With Speaker **\$8.36**

Write for literature and prices on other models. Also name of our nearest distributor.

WRIGHT-DeCOSTER, Inc.

2253 UNIVERSITY AVE., ST. PAUL, MINNESOTA

Export Dept.: M. Simons & Son Co., New York

Cable Address: "Simontrice"

Canadian Office: Wright-DeCoster, Inc., Guelph, Ontario.



WE NEEDN'T SHOUT . . .

Radio men who have followed the advancements of condenser and resistor design know that the pioneering work in this field has been done by MICAMOLD, who created:

- * TUBULAR PAPER CONDENSERS
- * MOLDED BAKELITE PAPER CONDENSERS
- * MOLDED BAKELITE MICA CONDENSERS
- * TRIMMERS ON MOLDED BAKELITE
- * BAKELITE MOLDED WIRE WOUND RESISTORS
- * INSULATED BAKELITE MOLDED CARBON RESISTORS



FOLLOW THE ARROW AND YOU FOLLOW THE LEADER

MICAMOLD PRODUCTS CORPORATION

FLUSHING & PORTER AVENUES, BROOKLYN, NEW YORK

INDEX TO ADVERTISERS

A	H	S
Aero Tool & Die Works..... 173	Haldorson Co., The..... 185	Share Brothers..... 189
Aerovox Corp..... 189	Hygrade Sylvania Corp..... 179	Simpson Electric Co..... 169
Allied Radio Corp..... 183		Solar Mfg. Corp., Third Cover
American Television & Radio Co..... 183		Sprague Products Co..... 187
Amperite Co..... 188-194		Standard Transformer Corp..... 155
Arceturus Radio Tube Co..... 171		Supreme Instruments Corp..... 149
Astatic Microphone Lab., Inc..... 185		
Audak Company..... 153		
B	K	T
Bell Sound Systems, Inc..... 181	Ken-Rad Tube & Lamp Corp., Inc. 194	Technical Appliance Corp..... 187
Bendix Products Corp..... 165	Kraeuter & Co..... 167	Thordarson Elec. Mfg. Co..... 173
Birnbach Radio Co..... 188		Tobe Deutschmann Corp..... 186
Brush Development Co., The..... 185		Transducer Corp..... 187
		Trind Mfg. Co., Inc..... 193
		Triplett Elec. Inst. Co..... 159
		Triumph Mfg. Co..... 191
		Tung-Sol Lamp Works, Inc..... 165
C	M	U
Centralab..... 136	Mallory & Co., Inc., P. R. Second Cover	United Transformer Corp..... 151
Clarostat Mfg. Co., Inc..... 183	Melssner Mfg. Co..... 194	Universal Controls, Inc..... 181
Continental Carbon, Inc..... 173	Micamold Prod. Corp..... 192	Universal Microphone Co., Ltd..... 194
Cornell-Dubilier Corp..... 174	Modell's..... 193	Utah Radio Products Co..... 169
Cornish Wire Co., Inc..... 185	Montgomery Ward..... 171	
Curtis Condenser Corp..... 194	Muter Co., The..... 193	
D	N	W
Daniel Elec. Lab..... 186	National Union Radio Corp..... 181-185	Ward Leonard Elec. Co..... 181
	Noblitt-Sparks Industries, Inc..... 145	Ward Products Corp..... 194
		Webster-Chicago..... 167
		Weston Elec. Inst. Corp..... 133
		Wholesale Radio Service Co., Inc. 186
		Wright-DeCoster, Inc..... 192
E	O	Y
Electric Amplifier Corp..... 193	Ohmite Mfg. Co..... 179	Yaxley Manufacturing Division
Electrical Products Co..... 179	Operadio Mfg. Co..... 135	Second Cover
Electro-Voice Mfg. Co..... 193		
F	P	
Fox Sound Equip. Corp..... 194	Precision Apparatus Co..... 157	
G	R	
General Electric Co..... 131	RCA Mfg. Co., Inc..... Fourth Cover	
General Transformer Corp..... 193	Racon Elec. Co..... 193	
	Radio & Tech. Publ. Co..... 174	
	Radio Service Institute..... 194	
	Radiotechnic Lab., The..... 188	
	Raytheon Production Corp..... 161	
	Readrite Meter Works..... 163	
	Rider John F., Publisher..... 147	

VELOCITY

ELECTRO-VOICE

CARBON

MICROPHONES



"V" SERIES

The all-feature microphone. Preferred by Sound and Communication engineers the World over. Three models—\$35.00 to \$75.00, list.

Electro-Voice Mfg. Co.
332 East Colfax Avenue
SOUTH BEND, IND.



"K" SERIES

Genuine quality brought to the low-price field. Three models from \$19.50 to \$29.50, list. Also a Static-Velocity model at \$20.00, list.

SEE YOUR JOBBER
Write for Catalogue



Five popular carbon models priced from \$5.00 to \$25.00, list. Complete repair service on all makes.

TRIAD

THE CHOICE OF SERVICEMEN
BECAUSE THEY ARE USED BY
LEADING SET MANUFACTURERS

TRIAD MANUFACTURING CO., INC.
PAWTUCKET RHODE ISLAND

THE QUALITY NAME IN RADIO TUBES



MOISTURE PROOFED TRANSFORMERS

You can immediately service nearly all models, orphaned as well as current, with half the investment in stock usually required. Type P (half-shell) furnished with brackets for flush, vertical or horizontal mounting, as shown. Ask your jobber or get Bulletin 31—FREE.

GENERAL TRANSFORMER CORP.
502 S. THROOP STREET, CHICAGO

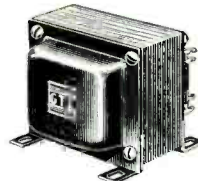
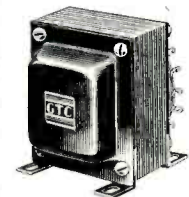

**FREE
1937
RADIO
CATALOG**

FREE TO SERVICEMEN

Selling Nationally advertised Radios is as easy as rolling off a log. We carry R. C. A., Philco, G. E., Zenith, Delco, Bosch, Motorola, Emerson, Detrola, Fada, Grunow and many others. Over

500 sets to select from. The discounts we allow you range up to 50% from manufacturers prices.

Become Our Distributor

in your locality. Write for catalog, descriptive literature and confidential discount sheet to

Modell's

58 CORTLANDT ST. (Wholesale
Dept. R
New York City Since 1889 Division)

HOW DO YOU DO IT?

How do you solve the many servicing problems with which you have to contend . . . what special kinks have you worked out which help you in servicing receivers . . . have you developed shortcut schemes for testing, or built test devices that do the work better and faster?

No matter what the scheme or the device, there are many Service Men who would like to know the how's and why's—just as you would like to know about the schemes and devices employed by others.

All you have to do is give us the outstanding points, and a rough pencil sketch of the device if it happens to be such—and we will do the rest.

Write up those ideas now and send them into the . . .

ON THE JOB DEPARTMENT

RACON PIONEERS AGAIN!

**Permanent Magnet
Horn Units**



These efficient P.M. units require no outside excitation. Available in two types; both the 36% Cobalt steel and the newest high flux Alnico type magnets are used to supply maximum flux density in the air gap.

Cast bronze case, completely enclosed, makes unit water tight. Continuous operating capacity 10 watts. Peak load capacity 30 watts. 15 ohm impedance at 1000 cycles.

Electro-dynamic type units also available in all sizes. RACON'S catalog S-3 describes the complete line of Horns, Electro-dynamic Units and Acoustical Sound Projectors.

RACON ELECTRIC CO., INC.
52 EAST 19th STREET NEW YORK CITY



**A NEW
STANDARD IN
AMPLIFIERS**

INTRODUCING
a new type of amplifier—ultra modern in design and having the professional appearance so necessary for fine installations.

ELAMCO Series "B" amplifiers (illustrated) are built to the most exacting standards and developed around an original and unique type of construction, skillfully incorporated into moderately priced units.

Descriptive Bulletins 7 and 8 sent upon request. Strict Dealer Policy . . . Ethically Engineered by

ELECTRIC AMPLIFIER CORP., 135 W. 25th St., New York

★ ALWAYS CARRY
Ken-Rad
Radio Tubes

Ken-Rad genuine all-metal radio tubes are dependable. They give outstanding performance. Write for information.

KEN-RAD TUBE & LAMP CORP., INC.
 Owensboro, Ky.

Also manufacturers of Ken-Rad Incandescent Electric Lamps



UNIVERSAL
Portable
Recording
Machine

A precision machined, compact outfit that positively eliminates all waver—Records in either direction at 33 $\frac{1}{3}$ or 78 R.P.M.—90, 110 or 130 lines per inch—110 volt AC 100% synchronous motor—Solid 16 in. turntable—Constant speed rim belt drive—Reinforced black leatherette carrying cases—Unequaled value—

Superlative performance—Also stationary machines, cutting heads, special acetate pickup, etc.

UNIVERSAL MICROPHONE CO., Ltd.
 424 WARREN LANE, INGLEWOOD, CALIF., U. S. A.

Meissner
Dual Universal WAVE-TRAP

The only wave-trap that will eliminate both i.f. and broadcast interference at the same time

RANGE	400 to 1900 kc.
DUAL CONTROL	2 channels
HIGH "Q"	Iron Core
ATTENUATION	Minus 40db.

SERVICEMEN:—Every service call is a sale for this unit. Keep a supply in your kit, and you will make a profit out of every call.

SOLD BY ALL LEADING JOBBERS

MEISSNER MFG. CO.
 Mt. Carmel - Illinois

10 **NEW**
WARD
AUTO AERIALS

FOR 1937

SEND FOR CATALOG TODAY

The WARD PRODUCTS Corp.
 WARD BUILDING CLEVELAND, OHIO
 IN CANADA: ATLAS RADIO CORP., TORONTO, ONTARIO
 FOREIGN: LINCOLN EXPORT CO., NEW YORK, N. Y.

MODEL T. A. - The "Tur-rette"—Maximum Efficiency. One of the new 1937 top aerials featured by WARD. NO DRILLING IN TOP

New! **AC-DC AMPERITE**
WITH STARTING RESISTOR!
Prevents Untimely Burnouts

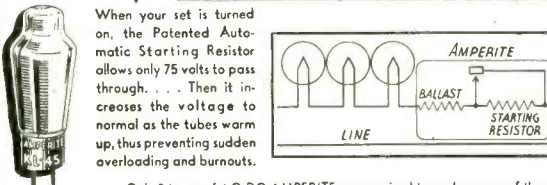

When your set is turned on, the Patented Automatic Starting Resistor allows only 75 volts to pass through. . . . Then it increases the voltage to normal as the tubes warm up, thus preventing sudden overloading and burnouts.

Only 3 types of AC-DC AMPERITE are required to replace any of the 60 types of AC-DC ballast tubes. NEW LOW PRICE: List \$1.00. (Also new low price on replacements for 2-Volt Battery Sets, List \$1.00.)

WRITE FOR CHART CV5-

AMPERITE Company 561 BROADWAY NEW YORK

FOX
SOUND EQUIPMENT
 The Choice of Radio Engineers

Sells on demonstration and stays sold because it "stays on the job," rendering long satisfactory service.

- Fox One-Piece Metal Diaphragm
- Fox Electro Dynamic Unit
- Fox Aluminum Trumpet Horns
- Fox B-5 Universal Baffle Type Horn
- Fox Low Level Speaker

Write for catalog sheets and prices on complete line. It points the way to greater profits.

FOX SOUND EQUIPMENT CORP.
 3121 Monroe St. Toledo, Ohio

Curtis
Electrolytic
CONDENSERS



The Service Man's Friend—Reliable
 . . . Accurate . . . Satisfactory . . .
 Write for complete catalog today.

Patent No. 1,850,352

CURTIS CONDENSER CORPORATION
 3088 WEST 106TH ST. CLEVELAND, OHIO

YOU CAN'T KEEP PACE
 with "Model T" Training



A car ten years old is not more out-of-date today than are many service men. Radio service is becoming not only more technical, but also more highly competitive. The man who hopes to get ahead must have adequate MODERN training now!

Advanced Home Study Training In
RADIO SERVICE & PUBLIC ADDRESS



Free!

Insure your future with RSI home study training in your spare time. Start any time—take up to 3 years to complete. Terms as low as \$5 monthly.

WRITE TODAY FOR YOUR FREE COPY OF "THE KEY TO SUCCESSFUL SERVICING"

RADIO SERVICE INSTITUTE
 Dept. S-3 3308 14th Street, N.W. Washington, D. C.

New Eye-Saver Catalog



A RADICAL DEPARTURE
IN CONDENSER CATALOGS

Mail the coupon
for your copy ...
and a free Domino
Bakelite-molded
condenser sample.

Large photographs, big type, clarity, make it easy for you
to locate any condenser ... Be sure to get your copy! It'll
save your eyesight and your temper ... and will show
you how to save money by buying "Quality Above All"!

SOLAR MANUFACTURING CORPORATION 599-601 BROADWAY, NEW YORK, N. Y., U. S. A.

Free



NAME _____
ADDRESS _____
JOBBER'S NAME _____

New RCA Aerodynamic "Mike" made to order for P. A. use!

Small in size, yet providing superb performance, this new RCA Microphone offers many features for greater efficiency!

HERE'S an aerodynamic microphone "made to order" for P. A. work! Of streamlined, modern design, it's so small it fits easily into the palm of your hand—can be carried without the least trouble. Small in size but an ace in performance!

This new RCA "mike" is of the pressure operated, dynamic type. It gives excellent frequency response, insuring truly natural tone reproduction and clarity of speech. New Alnico permanent magnet assures maximum sensitivity and extra long magnet life. External excitation or power is unnecessary.

These are but a few of this microphone's features. Check the other important features listed in the panel at right. You will find few other "mikes" providing such fine quality at low cost!

This new RCA aerodynamic microphone spells profit to service men in P. A. Order now from your RCA Parts or Sound distributor. *Ask about the two new stands developed by RCA for use with this new "mike".*



Parts FOR PROFIT

RCA MANUFACTURING CO., INC., Camden, N. J.

A Service of the Radio Corporation of America



Stand alone, \$3.75 list price

Quality Features That Mean Extra Value

- Impedance 250 ohms
- Triple Chromium finish
- Small size — light weight
- Good tone quality—high sensitivity
- No external excitation or power required
- Rugged construction—insensitive to mechanical vibration
- Unaffected by changes in temperature, humidity or barometric pressure
- May be operated at distances up to 1,000 feet from amplifier
- Excellent for close talking
- Practically non-directional when faced vertically
- Minimum response to wind
- New Alnico magnet—retains magnetism indefinitely