

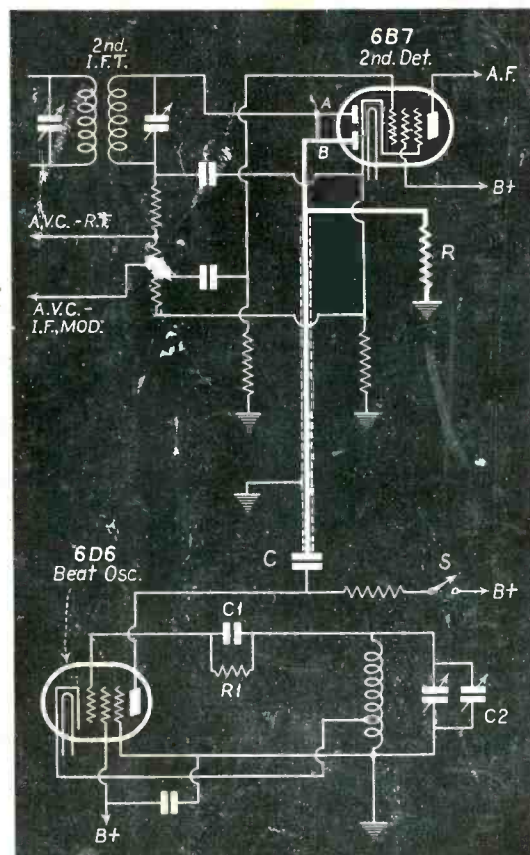

SERVICE

A MONTHLY DIGEST OF
RADIO
AND ALLIED MAINTENANCE



Beat Oscillator Circuit

(See Page 11)

PER COPY
25 CENTS

JANUARY
1935

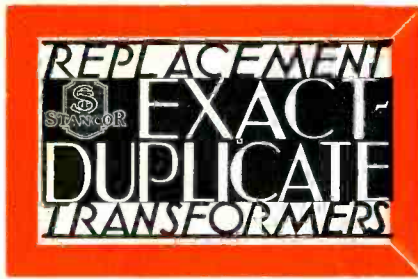

... "he is interested in good products, interested in *why* they are good, and feels obliged to use only the best in his repair work . . . he is exercising his professional ability to the fullest extent."

—SERVICE—DECEMBER 1934

To those **SERVICE MEN** who feel the **OBLIGATION** of their **PROFESSION**



WHICH is one of the reasons for service men preferring **STANCOR EXACT-DUPLICATE** Replacement Transformers so generally.

For **STANCOR EXACT-DUPLICATE** Replacement Transformers came to the service man at a time when the future of his profession was becoming more and more uncertain because of what was expected of him and his inability to get the units with which to accomplish it.

"Post Mortems" held over thousands of burned-out, defective transformers in the **STANCOR** Laboratories; searching, exhaustive probing into the whys and wherefores of, not only the unit, but all the peculiarities of the chassis, positively assures you of an **EXACT-DUPLICATE** Replacement



"**POST MORTEM**s" that guard your reputation and your profits

Transformer identical to the original in every electrical and physical characteristic.

When you use a **STANCOR EXACT-DUPLICATE** Replacement Transformer, the installation is a professional job. There have been no holes to redrill and no rewiring to be done.



Simultaneously, with the development of these units with which to make your work easier, **STANCOR** began the designing and making of Universal Replacement Power Transformers, Audios, Filters and Chokes . . . all bearing the same high-fidelity pledge—the **STANCOR** Trade Mark.

A distributor distribution was built up all over the United States, Canada and our Island possessions, so that these units may be as handy to you as your telephone.

And today, **STANCOR** is recognized by thousands of service men as a completely reliable source of supply for high-fidelity units that never let them down in the job of renewing original performance.

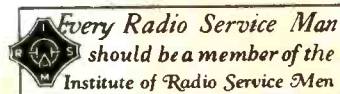

STANDARD TRANSFORMER CORPORATION 866 Blackhawk St. Chicago, Ill.
Every **STANCOR** unit for replacement is "trade-marked" and packed in a distinctive package for your protection against substitution.

Most Accurate Medium-Priced Tube Testers Available



Model A.C. 49

Dynamic Mutual Conductance Display or Portable TUBE TESTERS

NEW . . . In Method, Design, Precision, Performance, Customer Confidence, Simplicity and Merchandising Appeal.

NEW . . . Edgewise Meter with Long Combination English Reading and Direct Reading Dynamic Mutual Conductance Dial in Actual Micromhos not affected by amount of Plate Current.

English Reading Dial for Customer Acceptance, in three colors — GREEN "GOOD" — RED "POOR" — BLACK "DOUBTFUL."

Direct Reading Dynamic Mutual Conductance in Micromhos for Dealer and Servicemen's Precision Test — THE ACCEPTED UNIT STANDARD OF TUBE PERFORMANCE.

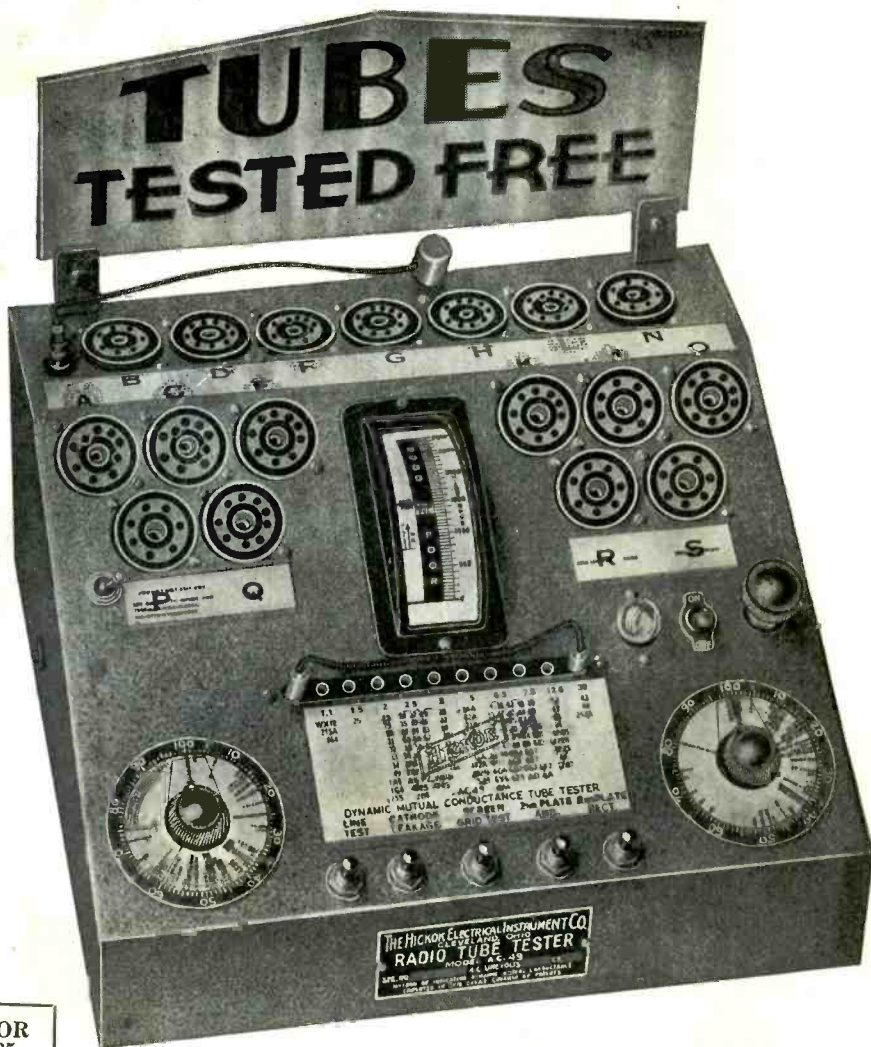

WRITE FOR NEW 1935 CATALOG

No Customer-Confusing Adjustments
ONLY ONE SETTING TO MAKE—NO GRID SHIFT EMPLOYED
Model A.C. 49 Display Unit—Size 14" x 12 1/4" x 12"

TWO WAY SALES FEATURE—Plate Glass Sign—"Tubes Tested Free" and Large Card Holder on Front for Special Use

BETTER TESTERS • BETTER SERVICE • BETTER PROFITS

THE PRODUCT OF RESEARCH AND EXPERIENCE COVERING MANY YEARS IN THE MANUFACTURE AND PIONEERING OF DYNAMIC MUTUAL CONDUCTANCE TUBE TESTERS . . .

PRECISION LINE VOLTAGE ADJUSTMENT INDICATED ON THE LARGE EDGEWISE MUTUAL CONDUCTANCE METER.

Actually DISSECTS Radio Tubes and transposes INTRICATE FACTORS in simple form and in plain view of the customer and operator. CLOSER TESTS—GREATER TUBE SALES.

This NEW EDGEWISE METER APPLICATION facilitates the very utmost in Radio Tube Merchandising Results . . . Tube Sales . . . by indicating closest possible test of actual value of the tube in radio set performance. Not merely "Good"—"Poor" or "Doubtful" . . . But, How Good? How Poor? How Doubtful? All with dependable Hairline Accuracy, that sells tubes.

THE VALUE OF TUBES IS DEPENDENT UPON DYNAMIC MUTUAL CONDUCTANCE. NO OTHER TEST WILL SUFFICE. THE HICKOK METHOD OF INDICATING THIS VALUE AS EMBRACED IN THIS TESTER CONFORMS TO ALL MANUFACTURERS STANDARDS OF PRACTICE FROM WHICH THERE MUST BE NO DEVIATION.

THE HICKOK ELECTRICAL INSTRUMENT CO., 10514 Dupont Ave., CLEVELAND, OHIO
Makers of the first commercial direct reading Dynamic Mutual Conductance Tube Testers

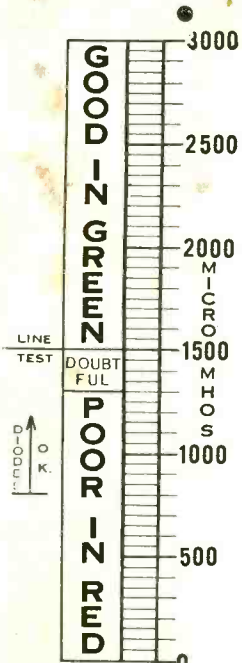

EXACT SCALE
Models A.C. 49 and A.C. 49-P

SERVICE

A Monthly Digest of Radio and Allied Maintenance

Vol. 4, No. 1
JANUARY, 1935

EDITOR
M. L. Muhleman

ASSOCIATE EDITOR
Ray D. Rettenmeyer

EDITORIAL CONTENTS

FEATURES

Beat Oscillator Circuit.....	11
Increasing B Battery Service By L. S. Fox.....	11
Review of Set Testers.....	12
The All-Star Junior.....	9
The Service Men's Side of High Fidelity By I. A. Mitchell.....	24

ANTENNA

1935	6
------------	---

ASSOCIATION NEWS	28
------------------------	----

AUTO RADIO

Colonial Model 182.....	20
-------------------------	----

CIRCUITS

Atwater Kent Model 275.....	15
Beat Oscillator Circuit.....	Front Cover
Colonial Model 182.....	20
Dayrad Series 52 Radio Set Tester.....	12
Equalizer Circuits	24
High Fidelity Audio Amplifier.....	26
Howard Model D All-Wave.....	19
Kadette "Jewel" Model 40 Receiver.....	17
Lafayette Universal Bridge.....	13
Philco Volume-Control Circuit.....	22
Radio City Model 404 Multitester.....	14
Remler Model 42	16
Simple Diode Detector Circuit.....	21
The All-Star Junior.....	9
Weston Model 698 Selective Set Servicer.....	14

FORUM	30
-------------	----

GENERAL DATA

Arvin I-F Peaks	17
Atwater Kent Model 275.....	15
Beat Oscillator Circuit.....	11
Colonial Field-Coil Values.....	18
Dayrad Series 52 Radio Set Tester.....	12
Electrolytic Condenser Ratings.....	18

Howard Model D All-Wave.....	18
Kadette "Jewel" Model 40 Receiver.....	17
Lafayette Universal Bridge By Hubert L. Shortt.....	12
New Colonial I-F Peaks.....	18
Oscillation and Electrolytics.....	18
Radio City Model 404 Multitester.....	13
RCA Victor I-F Peaks.....	17
Remler Model 42.....	16
Weston Model 698 Selective Set Servicer.....	14

HIGHLIGHTS	32
------------------	----

MANUFACTURERS	34-37
---------------------	-------

ON THE JOB

Brace Grip By Frank Bentley.....	23
Emergency Footing Cleats By Frank Bentley.....	22
Making Service Data Handy By E. E. Gilcrease.....	22
Majestic 20 By F. C. Wolven.....	23
Moisture in Philco Models By H. J. Griffin.....	23
Philco V-C Noises By Frank M. Jalln.....	22
Philco 112 Crackling By F. C. Wolven.....	22
Radiola R-11, RAE 26 By F. C. Wolven.....	23
RCA Victor 100 By E. M. Prentke.....	22
Silver Model R By E. M. Prentke.....	22

PUBLIC ADDRESS

The Service Men's Side of High Fidelity By I. A. Mitchell.....	24
---	----

SERVICE-MAN'S NOTEBOOK

Vacuum Tubes and Their Applications, Part I	21
---	----

BRYAN S. DAVIS
President

JAS. A. WALKER
Secretary

Chicago Office—608 S. Dearborn St.—C. O. Stimpson, Mgr.
Telephone: Wabash 1903
Cleveland Office—10515 Wilbur Ave.—J. C. Munn, Mgr.
Telephone: Garfield 0905-J

Los Angeles Office—2743 San Marino St.—J. E. Nielsen, Mgr.
Telephone: Drexel 0718

Entered as second-class matter June 14, 1932, at the Post Office at New York, N. Y., under the Act of March 3, 1879. Subscription price \$2.00 per year in the United States of America; 25 cents per copy. \$3.00 per year in Canada and foreign countries; 35 cents per copy.

Published Monthly by the

Bryan Davis Publishing Co., Inc.
19 East 47th Street
New York City

SANFORD R. COWAN
Advertising Manager

A. B. CARLSEN
Circulation Manager

St. Louis Office—505 Star Bldg.—F. J. Wright, Mgr.
Wellington, New Zealand—Tearo Book Depot.
Melbourne, Australia—McGill's Agency.



AND NOW THE NEWEST 1935 DEVELOPMENT FROM THE UTC ENGINEERING LABORATORIES

THE VARITONE* AUDIO TRANSFORMER

A universal audio input transformer giving continuously variable low end, high end or low and high end equalization.

VT-1—Designed to work from a single plate or low impedance microphone line to one or two grids.

List price . . . \$8.50 Net to dealers . . . \$5.10

* Patent applied for.

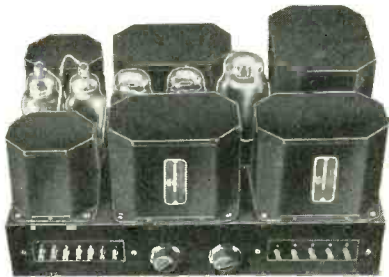

Three stage 45A prime amplifier with VARITONE

The VARITONE is an essential component for High Fidelity theatre and P A amplifiers. Manufacturers of such equipment are invited to write us regarding the application of the VARITONE to their equipment.

Affords 15 D B controllable correction of low frequency response, high frequency response or simultaneous correction of low and high frequency response.

Typical Components for use in a popular priced High Fidelity Receiver Amplifier Using the VARITONE as an input source.

	List Price	Net Price
VT-1 Varitone Input Transformer	\$8.50	\$5.10
PA-132—from single 57 triode plate to push-pull 45 grids	5.00	3.00
PA-245—from two 45 A prime plates to Broadcast and Voice coil lines	7.00	4.20
PA-22 —45 A prime plate and filament supply transformer	10.00	6.00
PA-40 —A prime input choke	4.50	2.70
PA-44 —Output smoothing choke	4.50	2.70
	\$39.50	\$23.70

UTC NIKLSHIELD Audio filter and Power Components are now available in amplifier kits. Quality units that all public address men can afford.

NS-1	1 plate to 1 grid. 3½:1 ratio	\$2.35
NS-2	1 plate to 2 grids, split secondary. 2:1 ratio	2.50
NS-3	Push pull plates to push pull grids. 1.8:1 ratio	2.75
NS-4	Low or high impedance pickup to grid. Pri. 500, 1000, 2000, 4000 ohms	3.00
NS-5	Single or double button mike to 1 grid	2.50
NS-6	Single or double button mike to 2 grids	3.00
NS-7	Ribbon velocity mike to grid	3.50
NS-8	Ribbon velocity mike to 500 or 200 ohms	3.50
NS-9	Mixing carbon mike, 500 or 200 ohm line to 500 or 200 ohm line	3.50
NS-10	Single plate and carbon mike to one or two grids	3.50

CLASS A OUTPUTS

NS-11	Single 250, 245, 59 triode, 71A to 8, 4, or 2 ohm voice coil	\$2.50
NS-12	Single 18, 20, 33, 41, 42, 47, 2A5, 59 pentode or 89 triode plate to 8, 4, or 2 ohm voice coil	2.50
NS-13	Push pull 250, 245, 59 triode or 71A plates to 8, 4, or 2 ohm voice coil	3.00
NS-14	Push pull 18, 20, 33, 41, 42, 47, 2A5, 59 pentode, 89 triode plates, to 8, 4, or 2 ohm voice coil	3.00
NS-15	Push pull 2A3 plates to 8, 4, or 2 ohm voice coil	3.00
NS-16	Push pull 48 plates to 8, 4, or 2 ohm voice coil	3.00
NS-17	Single 250, 245, 59 triode, 71A to 500, 8, 4 or 2 ohms	3.00
NS-18	Single 18, 20, 41, 47, 2A5, 59 pentode or 89 triode plate to 500, 8, 4 or 2 ohms	3.00
NS-19	Push pull 250, 245, 59 triode or 71A plates to 500, 8, 4 or 2 ohms	3.50
NS-20	Push pull 18, 20, 33, 41, 42, 47, 2A5, 59 pentode, 89 triode plates to 500, 8, 4 or 2 ohms	3.50
NS-21	Push pull 2A3 plates to 500, 8, 4 or 2 ohms	3.50
NS-22	Single 250, 245, 59 triode, 71A to 4000 or 2000 ohms	2.75
NS-23	Single 18, 20, 33, 41, 42, 47, 2A5, 59 pentode or 89 triode plate to 4000 or 2000 ohms	2.75
NS-24	Push pull 250, 245, 59 triode, 71A to 4000 or 2000 ohms	3.25
NS-25	Push pull 18, 20, 33, 41, 42, 47, 2A5, 59 pentode or 89 triode plates to 4000 or 2000 ohms	3.25
NS-26	Single 26, 36, 27, 55, 77 triode or 864 plate to 500 or 200 ohms	3.00
NS-27	Push pull 26, 36, 27, 55, 77 triodes or 864 plates to 500 or 200 ohms	3.50
NS-28	Line to speaker audio matching transformer. Input 4000 ohms and 500 ohms. Output 15, 8, 4 and 2 ohms. Will handle up to 15 watts	4.50

CLASS B INPUT TRANSFORMERS

NS-29	Driver plate to 49, 53, 79 or 89 grids	\$2.75
NS-30	Driver 46 or 59 plate to 46 or 59 grids	2.75
NS-31	Push push 49, 53, 79, or 89 plates to 8, 4, or 2 ohms	3.25
NS-32	Push push 46 or 59 plates to 8, 4, or 2 ohms	3.25
NS-33	Push push 49, 53, 79 or 89 plates to 5000 or 3500 ohms	3.50
NS-34	Push push 46 or 59 plates to 5000 or 3500 ohms	3.50
NS-35	Push push 49, 53, or 89 plates to 500, 8, 4, or 2 ohms	3.75
NS-36	Push push 46 or 59 plates to 500, 8, 4, or 2 ohms	3.75

FILTER AND AUDIO CHOKES, FILAMENT TRANSFORMERS

NS-37	Filter choke. 25 henrys 30 MA; resistance 900 ohm	\$2.00
NS-38	Filter choke. 15 henrys 60 MA; resistance 240 ohm	2.00
NS-39	Filter choke. 20 henrys 90 MA; resistance 400 ohms	2.50

NS-40	Filter choke. 30 henrys 75 MA; resistance 350 ohms	3.00
NS-41	Filter choke. 10 henrys 150 MA; 95 ohms	3.00
NS-42	Class B Input choke. Max. D.C. 175 MA	3.50
NS-43	Center tapped audio for push pull triode plates. Resistance 12,000 ohms	2.25
NS-44	Detector plate shunt choke. Max. D.C. 3 MA	1.75
NS-45	Pri. 115 A.C. Sec. 2½ V.C.T. 6A	2.25
NS-46	Pri. 115 A.C. Sec. 6.3 V.C.T. 3A	2.25
NS-47	Pri. 115 A.C. Sec. 2½ V.C.T. 12A	2.25
NS-48	Pri. 115 A.C. Sec. 5 V. 4 A	2.25
NS-49	Pri. 115 A.C. Sec. 7½ V.C.T. 3A	2.25
NS-50	Plate Transformer for small power tubes. Class A and B. Pri. 115 V.A.C. 60 cycles. Secondaries: 300-0-300 at 75 MA; 5 V.C.T. 3A, 6.3 V.C.T. 2½A, 2½ V.C.T. 6A	7.00
NS-51	Plate transformer for push pull power tubes Class A and B. Pri. 115 V.A.C. 60 cycles. Secondaries: 400-0-400 at 125 MA; 2½ V.C.T. 5A, 2½ V.C.T. 10A, 5 V.C.T. 3A	9.00

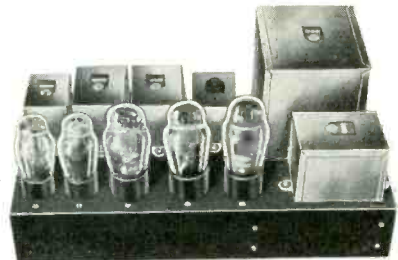

Double push-pull 2A3 amplifier using NIKLSHIELD units

UTC NIKLSHIELD units may be purchased thru your local UTC distributor at regular 40% discounts.

UNITED TRANSFORMER CORP.

Export Division: 15 Laight Street, New York City

264 CANAL STREET NEW YORK CITY

THE ANTENNA . . .

1935

SO, we have a new year to contend with. What will it bring? Is it to be another sad year, with too much struggle to make a decent living and too much viciousness in competition? Who can say?

But this much can be said—the outlook for 1935 appears good. For that matter, the last half of 1934 was not so rotten. There were gradual increases in business, more belt-tightening and more good, old American complaining which is always a bright sign in itself. When Business starts kicking, you may rest assured that it is getting ready to go places and wants to have all roads cleared immediately.

The first reports on the New York Auto Show have come through. The facts are that there is a very healthy increase in sales—much above last year's Show—and a record attendance. "As the Automobile Industry goes, so goes the Nation," is a phrase of political origin, but an apt one and true to the extent that the Automobile Industry is rather a good index of business conditions in the light industries. The more cars sold, the more sold of this, that and the other thing—with always the possibility of these sales eventually increasing sales in the so-called heavy industries.

We're all tied up in this business of sales. Increases in general business are as important to you as they are to men in all other professions. Money flows out in all directions once it is thawed out, and though there is still a great amount of money still frozen in banks in the form of investments and savings, the greenbacks are coming out of their holes into the light of day. If they see no warning shadows denoting a continuance of "freezing weather," they'll stay out and circulate. There may still be a shadow, but it's not frightening, apparently.

It may seem almost treason to say that a depression is more often than not a beneficial condition. The fact remains that for all of the suffering, for all of the underlying pessimism, those left in the run work harder and get more things done. Sheer necessity is the driving force, and when the clouds clear away, we are all surprised at the improvements that have been added to life.

This has been apparent in the radio field. Remarkable advancements have been made in radio receiver design in the past four years. The engineers have kept forging ahead and will continue to do so. Engineering features have been introduced so rapidly that all of us have found it difficult to keep abreast with things. We have been virtually snowed under with complicated tubes and circuits. But who will say that they haven't kept us on our toes—kept our minds keen—and through learning their intricacies, made us better technicians?

By becoming a professional, the Service Man has gained the recognition of the radio industry. True enough, radio servicing itself has become of increasing importance in the past four years, but it has this importance principally because of the men who represent it. Though we do not like the word "slave," so many Service Men have written us with regard to their slaving to make a decent living, we wish to remark that

this slaving on the part of those with sufficient push to keep on, has been their making. These Service Men have cut a place for themselves in the radio industry—and they did it without the use of a chisel!

We are of the opinion that there will be considerable pick-up in the servicing field this year. The "modern" receivers with complicated circuit functions and complicated adjustments will be coming in for servicing in increasing numbers. Not all Service Men will be able to repair or adjust them properly, and with possible "proof of technical ability" becoming a necessary mark of worth, like a doctor's degree, the untrained man may be forced out of the picture with resultant benefit to the trained man. Sooner or later this must come about and from what we hear, the service associations may take things into their own hands so that their members may have ample protection. This may be a better scheme than to let nature take its course. Moreover, a bit of pressure from bona fide Service Men will likely send some so-called Service Men back to the professions from which they originally came. Improved business conditions will hasten the process.

Some of the largest manufacturers in the radio field are taking a keen interest in the Service Man. Their opinion, though unspoken, is that the Service Man will play a very important part in the future of the radio business. Some of these companies are working up ambitious plans which will be of mutual assistance. These plans will be put into effect this year.

What about technical advancements in 1935? We have heard, for one thing, that there will be a new batch of receivers having engineering tricks far outdistancing anything we have seen in the past. We have no inkling as to what they may be but our long guess is—entirely new forms of intermediate-frequency amplification, advanced and more complicated mixer-oscillator systems for all-wave receivers, triple-detection receivers, and new high-fidelity r-f and a-f circuits. There is also the possibility of new automatic control circuits. A circuit arrangement has already been devised which automatically alters the oscillator frequency in a superheterodyne in the event that it shifts. This is controlled entirely by the incoming signal and insures the correct oscillator frequency at all times. Since the oscillator frequency drift in an all-wave superheterodyne is a serious matter, there seems to be little doubt but that some such frequency-control system will be used.

We also anticipate an increased use by the Service Man of the newly developed cathode-ray oscilloscopes. This type of device will eventually prove indispensable with regard to the alignment and adjustment of receivers of the high-fidelity and all-wave type whose satisfactory operation is dependent upon precise adjustment. Other types of servicing instruments may also appear on the scene. The Service Man may require more equipment but there will be more work on higher-priced sets during the year—work that will provide a decent profit.

We believe this year is going to improve with age. It should be a better year for everyone.

MAKE 1935 PROFITABLE

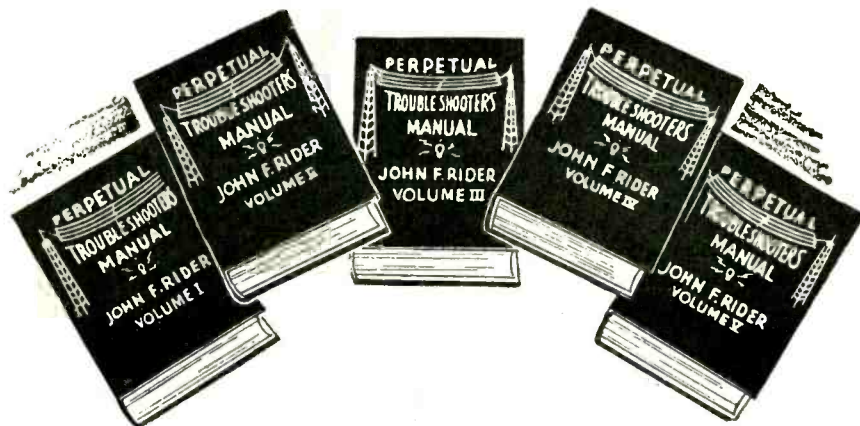

Rider's Manuals are Guaranteed the World's Finest

VOLUME V

In the past various manuals have been offered to the Radio Servicing fraternity, but never before has such a stupendous compilation of technical servicing material been collected between two covers. . . . It is true that Rider's Manuals have established a standard for details which are invaluable to the Serviceman, but even this standard has been surpassed in Volume V. . . . No details were too minute—nothing was deemed too trivial to be omitted, if that information would aid in any way whatsoever a Serviceman in doing his job. . . . The thought of expense was thrown aside in making Rider's Volume V all-embracing in its scope and coverage. . . . All the essential servicing details of over 940 models are presented in a manner that requires superlatives in its description. . . . The new receivers of 1935 have complications galore—not only in their circuits, but in the mechanical features as well and because of that, it is abso-

lutely necessary to have every bit of available information at your finger tips when you need it. . . . And this information is easily found by means of the separate 64-page Index that lists exactly what appears on every page in all five volumes. . . . Everything is simplified to the greatest possible extent for your convenience, so that waste motion can be eliminated with a resulting increase in your profits. . . . Never before has any single manual been offered to the servicing field that contained 1200 pages and that covered the products of 112 manufacturers. . . . These facts are all-important when you are in the market for a manual. . . . Do not take our word for anything—step into your dealer's today and prove to yourself that Rider's Volume V is without doubt the servicing sensation of the year—better than any other manual—THE ABSOLUTE PEER!
1200 pages, \$7.50

VOLUME IV

Receivers manufactured up to March, 1934, are included in this volume. Herein will be found the more complicated superheterodynes with QAVC, noise gates, flasher tuning indicators, duo-diode pentodes used two and three times in reflex circuits, half-wave and full-wave detectors, automatic tone control, bucking bias voltages, elec-

1060 pages, \$7.50

tron-coupled oscillators and all the other refinements that were introduced in this period. The manufacturers and trade names in Volume IV assure you of a real coverage of the radio field. A Special Section of 24 pages explains some of the more complicated receivers. A 40-page Index covers Volumes I, II, III and IV.

VOLUME III

From the middle of 1932 to June, 1933. The Superheterodyne was introduced in this period and these sets are to be found in Volume III.

1070 pages, \$7.50

VOLUME II

This volume covers the period between early 1931 and the middle of 1932. Some early sets are found in this volume that were unavailable when Volume I was published.

800 pages, \$6.50

VOLUME I

This volume covers the period between 1919 and early 1931. The great majority of the old sets are to be found in this volume.

1000 pages, \$7.50

Servicing Superheterodynes

A comprehensive and easily understood explanation of the superheterodyne, which every serviceman should own. The thoroughness of the subject's coverage and the practical service hints given will mean dollars in your pocket in time saved in analyzing trouble. 288 pages, \$1.00.

RIDER'S MANUALS HAVE more schematics . . . more i-f. peaks . . . more alignment data . . . more circuit descriptions. . . . MORE EVERYTHING THAN ANY OTHER MANUALS.

Send for our FREE monthly house-organ, "Successful Servicing"



JOHN F. RIDER, PUBLISHER, NEW YORK, N. Y. 

1440 BROADWAY



HERE'S THE BOOK THAT SAVES TIME AND MAKES MONEY
It's complete It's authoritative It's invaluable

AND YOU CAN HAVE IT FREE

Mallory put information in this manual that will put *money* in the pockets of any man who wants to meet the ever-increasing requirements of the automobile radio industry with greater ease and greater profit! Mallory created a sensation in the vibrator field when it created the famous Mallory Elkonode. Mallory scored again with this remarkable manual which marks a great advance over all former publications. Surely you've heard about it. Certainly you'll want to profit by it —and sending for your copy today is a real move in the direction of *starting the new year right!*

Think of it — 28 big pages of information that will make every working day of 1935 a more profitable day! Get it—read it—use it! Mail the coupon now and get *your* copy of this money-making manual *absolutely free.*



P. R. MALLORY & CO., Incorporated
INDIANAPOLIS, INDIANA
 CABLE ADDRESS—PELMALLO



P. R. MALLORY & CO., Incorporated
 Indianapolis, Indiana
 Gentlemen:
 Please send me a copy of the Mallory-Elkon Service and Replacement Manual—absolutely free.

Name _____
 Address _____

SERVICE

A Monthly Digest of Radio and Allied Maintenance

FOR JANUARY, 1935

THE ALL-STAR JUNIOR

THE All-Star Super Six fabricated receiver introduced last fall was received so well that the same group of manufacturers are now sponsoring a second design—the All-Star Junior—lower in cost than the Super Six, but in some ways superior to the former set.

POSSIBLE PROFITS

The All-Star Junior looks like a good bet for the Service Man interested in

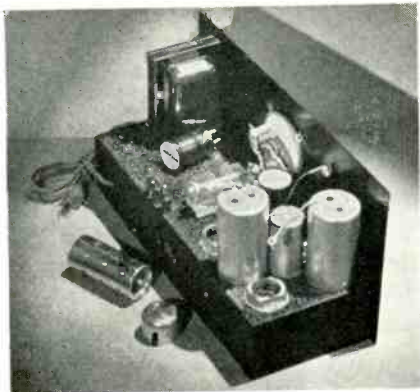

Fig. 3. A rear view of the receiver. The speaker plugs into the socket mounted on the rear wall of the sub-base.

constructing the latest in all-wave receivers for people with thin pocket-books. The actual assembling and wiring job is a cinch as the panel and sub-base are completely drilled and punched to take the standard parts specified. These parts are available on any jobber's shelves and in many cases the Service Man will have a good stock of many of the parts on his own shelves. Moreover, a special cabinet may be obtained for this receiver that it may have the appearance of a finished factory job. The cabinet has a detachable ebony-finished wood cover, has a base length of 18 inches, a height of $9\frac{1}{2}$ inches and a depth of 8 inches.

A five-tube, all-wave superheterodyne, engineered and sponsored by a group of manufacturers, that has electrical band-spreading, a signal beacon, and plenty of gain. Can be assembled and wired in no time. A good "side-line" for the Service Man.

FEATURES OF SET

One of the principal features of the set is the beat-frequency oscillator—not included in the standard All-Star Super Six Receiver—which may be used for the reception of cw signals or used as a signal beacon. This beat-frequency oscillator will indicate the presence of a station by producing a high-pitched note in the speaker when the set is tuned to the station carrier. With this arrangement, and moderately careful tuning, it is next to impossible for one to pass over an unmodulated carrier. A switch is provided so that the beat-frequency oscillator may be made in-operative after a phone station is tuned in.

The next important feature in the

All-Star Junior is the electrical band-spread system. There is provided in both the first detector circuit and the oscillator circuit a band-setting tank condenser and a lower capacity tuning condenser. The low-capacity first detector and oscillator variable condensers are ganged together and mechanically coupled to the main tuning control on the front panel. The high-capacity band-setters or tank condensers are in shunt with the respective low-capacity condensers, but are not ganged. They are controlled by small knobs, with scales, on the front panel and permit large shifts in wavelength or frequency. At the same time—since they are not mechanically coupled—they permit the tuning to exact resonance of both the

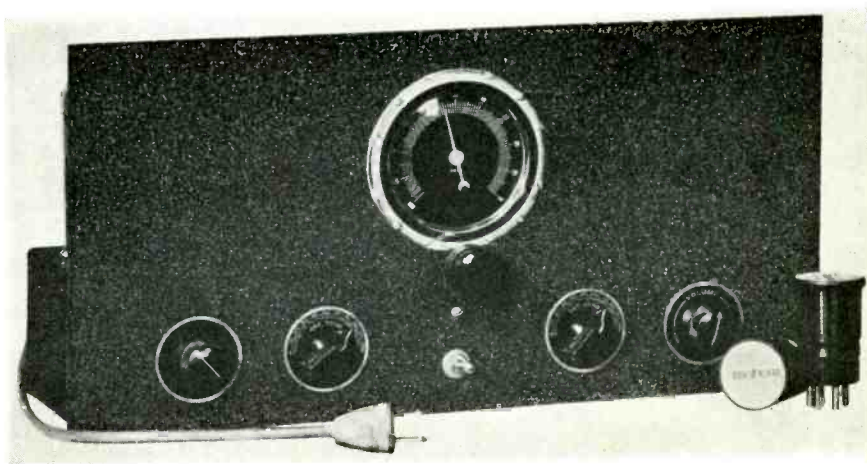

Fig. 2. Front panel view of a completely assembled All-Star Junior. The airplane dial has a 270-degree scale.

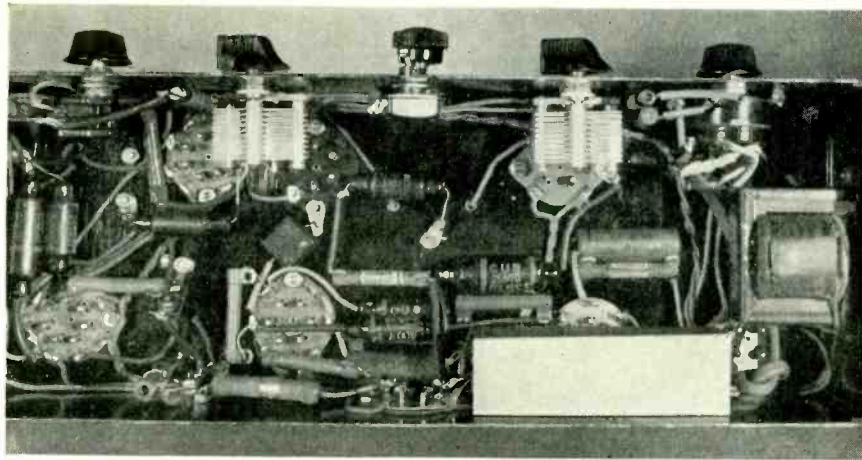

Fig. 4. Bottom view of the receiver chassis, showing wiring and location of parts.

first detector and oscillator circuits for any band of frequencies.

Once the tank condensers have been set to the bottom of some specific frequency band—say, the 49-meter broadcast band—all actual tuning is done with the main airplane-type tuning dial. Since this dial controls variable condensers having very low maximum capacity, the entire 49-meter band is spread out or opened up so as to occupy almost the entire tuning scale rather than just a few degrees on the scale. The band-spread feature is continuous over the entire wavelength range of the receiver. Stations may be accurately logged.

High efficiency is obtained through the use of plug-in coils, which provide low contact resistance and are free from the effects of mutual inductance or dead-end effects. Six pairs of coils are used to cover the range from 10 to 550 meters.

THE CIRCUIT

The complete circuit, with parts values, is shown in Fig. 1. A 6A7 tube is used as first detector and oscillator. The output of the first detector or mixer is fed to a pre-tuned i-f transformer peaked at 370 kc, an intermediate frequency sufficiently high to steer clear of the effects of image frequency.

The input i-f transformer is coupled to the pentode section of a 6F7 tube. The triode section of this tube is used as the beat-frequency oscillator in connection with the shielded coil unit marked "BFO." The "BFO Switch" shorts the oscillator plate to ground when closed, thus making the oscillator inoperative.

The 6F7 i-f pentode is coupled to a second i-f transformer which in turn feeds a high-gain second detector. The output of this tube—a type 77—is resistance coupled to a type 42 power pentode. An i-f filter, consisting of a

choke, RFC, and two condensers, C-7, is included in the plate circuit of the second detector tube to prevent any stray i-f signal voltage from reaching the power tube control grid.

A type 80 rectifier is used in the power supply. The power-supply filter has two sections, the first section being a standard filter choke and the second section being the 1,000-ohm field of the dynamic speaker.

It should be noted that there are three antenna input connections which permit the use of an ordinary aerial or an antenna of the doublet type with transposed feeders.

Volume is controlled by varying the bias on the i-f pentode only. A sensitivity control, or "Local-Distance" switch, is included in the cathode circuit of the mixer tube. When the switch is closed, the resistor R-2 is shorted with the result that the bias on the mixer tube is reduced and the gain consequently increased.

MECHANICAL DETAILS

A front-panel view of the All-Star Junior is shown in Fig. 2. The knob to the extreme left controls the Local-Distance Switch, the next knob controls the Oscillator Tank Condenser. The toggle switch in the center is the Beat-Frequency Oscillator control. To the right of this switch is the knob for the Mixer Tank Condenser and to the extreme right, the Volume-Control knob.

A rear view of the receiver is shown in Fig. 3. This clearly shows the two i-f transformers, with the beat-frequency oscillator unit mounted between them. The mixer and oscillator coils plug in to sockets mounted each side of the band-spread gang condenser.

(Continued on page 11)

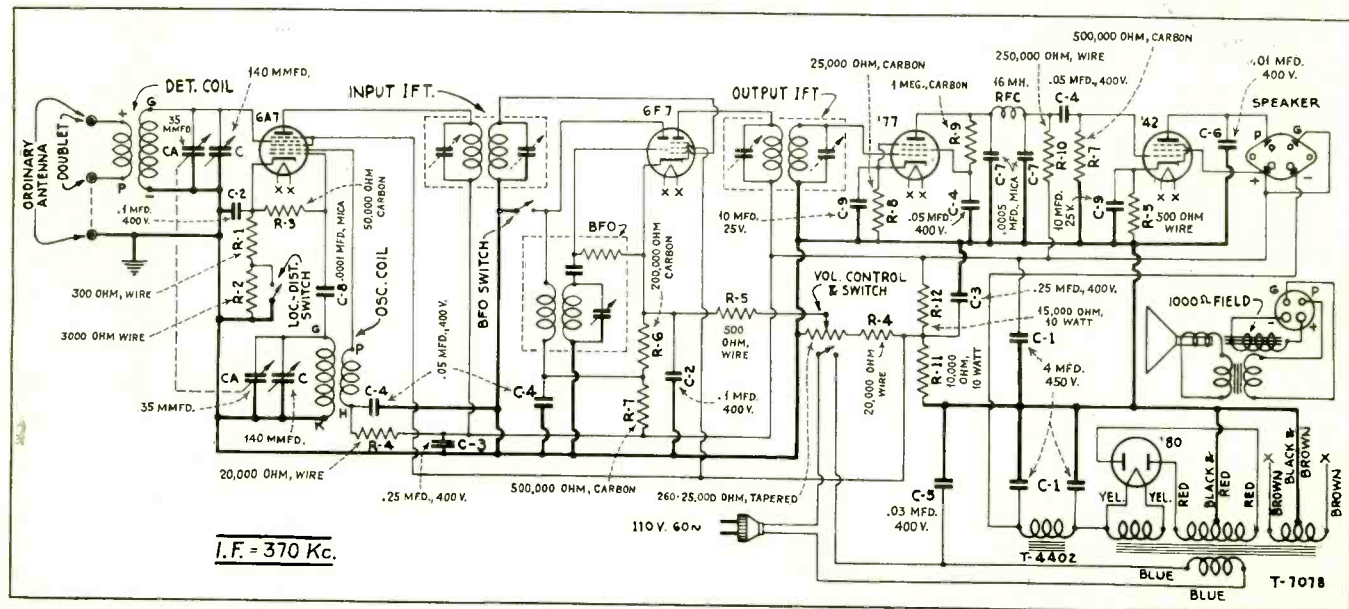

Fig. 1. Complete diagram, with parts values, of the All-Star Junior Receiver. The condensers "CA" are the band spreaders and the condensers "C," in shunt with the band spreaders, are the band setters.

INCREASING B-BATTERY SERVICE

By L. S. Fox*

In battery receivers, the grid-bias voltages are usually obtained from a C battery, and these bias voltages are correct for the corresponding plate voltages obtained from new B batteries. As the B batteries are used up, the plate voltages are reduced, but because no current is taken from the C battery, its voltage remains practically constant. Therefore, while the grid bias will be correct for new B batteries, it will become increasingly excessive as the plate voltages fall. As a result, the performance of the receiver will not be as satisfactory as it would if grid bias could be reduced to a suitable value for the lower plate voltages. When the grid bias is so reduced, it will be found that usually the B batteries are serviceable to lower voltages than without the reduction. In many cases, with receivers having constant grid-bias voltages, where the B batteries had to be replaced when down to 34 volts, the reduction of the grid-bias voltages made it possible to use the B batteries down to 30 volts and in some instances to 24 volts, adding as much as 50 per cent to B-battery life.

C-BATTERY BLEEDER

This grid-bias reduction is accomplished in many modern battery receivers by bleeding the C battery through a shunt resistor which is connected across the battery only when the receiver is in operation.

When short B battery life is reported, the receiver should be examined to see if a C-battery bleeder resistor is used. If not, this battery saving feature can easily be added to most sets. All that is required is a new off-on switch having an additional pair of contacts and the resistor itself. The resistor and switch contacts are connected in series across the entire C battery so that current from the C battery will flow through the resistor only when the receiver is turned on.

RESISTANCE CALCULATION

To calculate the resistance required, measure the total B-battery current of the receiver with B batteries down to 37 volts per 45-volt battery, and divide by 200,000. The result will be the correct value in ohms for a 22.5-volt C battery. For a C battery of less than 22.5 volts, the resistance should be proportionately

less. An actual value to the nearest 500 ohms will be satisfactory.

Where a C-battery bleeder is used, the C battery should always be replaced with the B batteries, so that the B and C voltages will always be in proper proportion. If new B batteries are used with an old, run-down C battery, the grid bias will be too low and, therefore, the plate current will be too high, so that the B batteries will have short life. Where short B-battery service is the complaint, always check to see if new B batteries were used together with an old C battery.

BEAT OSCILLATOR CIRCUIT

(See Front Cover)

The new RCA Victor Model ACR-136 Amateur Communications Receiver utilizes an interesting arrangement of coupling between the i-f beat oscillator and the second detector. The beat oscillator is used principally for the reception of cw signals in this receiver, but also proves of value as a station finder or signal beacon for modulated or unmodulated carriers of phone or broadcast stations.

BEAT OSCILLATOR CIRCUIT

The beat-oscillator, second-detector circuit, of the ACR-136 is shown on the front cover. The beat oscillator uses a 6D6 tube in an electron-coupled circuit, the cathode of the tube connecting to a tap on the oscillator coil. The coil, with its shunt capacity, normally oscillates at the same frequency to which the i-f amplifier of the receiver is tuned. A small vernier condenser, C-2, is shunted across the main oscillator-coil capacity. This condenser may be varied for the purpose of altering slightly the beat-oscillator frequency when certain forms of beat-note interference are encountered. The pitch of the received cw signals may also be varied in this manner.

A switch, S, in the plate circuit of the beat oscillator tube is used for cutting off the plate voltage when the beat oscillator is not in use.

The grid of the beat-oscillator tube is biased by the condenser-leak combination, C-1, R-1.

COUPLING SYSTEM

The 6B7 tube functions as second detector, avc and first a-f. Diode A provides linear rectification and a portion of the voltage developed across a load resistor and the volume-control

potentiometer, is used to bias back the r-f, mixer and i-f tubes. Diode B is used as the coupling medium between the beat oscillator and second detector. It will be seen that the plate of the beat-oscillator tube is connected to this diode through a small coupling condenser, C. The coupling lead is shielded to prevent the i-f voltage from being induced in adjacent circuits.

The diode B is grounded through the load resistor, R. This resistor provides the return connection to the cathode of the 6B7 tube, but it is a question if any current flows in this circuit. Since diode B is at ground potential it assumes a negative bias equal to the voltage drop in the cathode bias resistor. If the beat-oscillator voltage is sufficient to overcome this bias, then current will flow in the circuit of diode B. If the beat-oscillator voltage is maintained at a value lower than the diode bias voltage, no current will be created in the diode circuit from the beat-oscillator voltage. In any event, diode B is coupled to the cathode of the tube and will induce the beat-oscillator voltage in this common circuit. The i-f oscillator voltage therefore beats with the incoming signal voltage.

THE ALL-STAR JUNIOR

(Continued from page 10)

The power transformer is mounted at the far end of the chassis, with the type 80 rectifier socket next to it.

A bottom view of the chassis is shown in Fig. 4. This indicates the relative positions of the mixer and oscillator tank condensers, the volume control, the filter chokes, etc.

THE MANUFACTURERS

The Foundation Unit, together with diagrams and construction details, is being supplied by Thordarson. This company is also supplying the power transformer and filter choke. The fixed resistors are by Ohmite, the tapered volume control by Electrad, fixed condensers by Cornell-Dubilier, variable condensers by Hammarlund, and all r-f and i-f coils by Meissner.

The Crowe Name Plate Mfg. Co. is supplying the airplane dial, the four nameplate dials and the receiver cabinet. The 6-inch dynamic speaker, with 1,000-ohm field, was designed by Oxford. The tube shields are products of the Erie Can Company, and the eight wafer sockets are supplied by the Oak Mfg. Co.

A special wiring kit is being supplied by the Belden Mfg. Co. and the same concern can supply as optional equipment an all-wave aerial kit.

The Service Man need not purchase the complete kit . . . any of the parts may be purchased separately, as most of them are standard.

*National Carbon Company, Inc.

General Data . . .

REVIEW OF SET TESTERS

(A second group of testers will be reviewed in the February issue)

DAYRAD SERIES 52 RADIO SET TESTER

The Dayrad Series 52 Radio Set Tester is a combination of set tester, volt-ohmmeter, capacity tester and point-to-point tester. A schematic diagram of this unit is shown, and all resistor and condenser values have been listed there.

The flexibility of this instrument by use of a combination of selector switches (see diagram) results in the possibility of making a complete test of present radio circuits. A further check of the circuit will indicate that the factor of obsolescence has been considered in the design of this unit, adapting it to possible future circuits.

RANGES

Through the use of the 1-ma, 55-ohm meter the voltage ranges of 0-5-25-125-250-500-1250 volts are available for either ac or dc. The unit may also

be used as an output meter, in which case the same ac voltage ranges as given above are available. And, through further use of the meter milliamperes may be measured from 0-5-25-125-250-500-1250 ma.

Paper-type condensers may be measured from .001 to .1 mfd and from .1 to 10 mfd; while electrolytic condensers having values between .1 and 10 mfd may also be checked.

Without use of external batteries resistances between 0 and 3,000,000 ohms may be read, the instrument reading as low as one ohm.

An additional feature of this set tester may be gained from further reference to the circuit diagram. The meter is isolated from the circuit when no push buttons are pressed.

The Dayrad Series 52 Radio Set Tester is enclosed in a black leatherette carrying case with removable cover.

Test prods, output leads and special chassis connected together with necessary plug adapters are furnished. The instrument weighs 13 pounds and measures 11¼" by 11¼" by 6".

LAFAYETTE UNIVERSAL BRIDGE By Hubert L. Shortt*

With the introduction of more and more complicated all-wave receivers, phonograph-radio combinations and public-address amplifiers, the accurate measurement of resistors and capacitors is becoming increasingly important from the standpoint of the Service Man. For instance, in avc circuits,



The Lafayette Universal Bridge.

where the time action is a function of resistance and capacitance, replacements of defective units cannot be made with confidence unless the true value of the new part is definitely known. In certain amplifiers using phase-inverting circuits to produce push-pull action without the use of transformers, a critical grid resistor must be just right or the amplifier sounds peculiar.

Manufacturing tolerances being what they are, the labels on resistors and condensers cannot always be trusted, and if they should be missing altogether, or if the color bands are charred or faded, the Service Man is just out of luck unless he owns a bridge of some sort.

The usual small "volt-ohm-meter," consisting of a milliammeter in series with a local battery and a "zeroing" resistor, is all right for casual measurements of resistors of medium value, but is admittedly unsatisfactory for either very low or very high values. It is of no value at all for condenser measurement.

WHEATSTONE BRIDGE

To meet these new service conditions, Mr. Gerard Kelly, working in the writer's laboratory, has developed a compact, reliable, universal Wheatstone Bridge that accurately measures resistance from .01 ohm to one million ohms and capacitance from .0001 mfd to 100 mfd. Now the Wheatstone Bridge is one of the classical instruments of the electrical art and has been known for

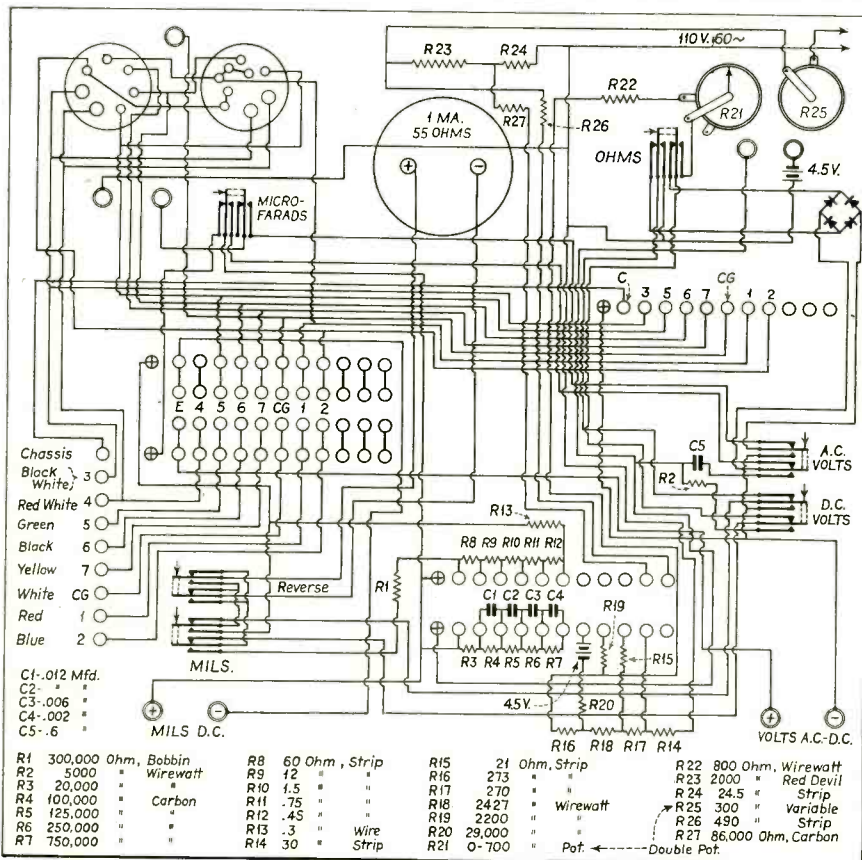

Circuit of Dayrad Series 52 Radio Set Tester.

*Chief Engineer, Wholesale Radio Service Co., Inc.

GENERAL DATA—continued

more than sixty years, but in its laboratory form (as most Service Men remember it from their high-school days) it is a rather unwieldy device and involves mathematical computations for which practical Service Men have neither the time nor knowledge.

The Wheatstone Bridge principle has been expounded in every science text book published since the Civil War, so it hardly need be described at length in a 1935 radio magazine. Almost everybody remembers the familiar diamond-shaped diagram, with three resistors of known value and the resistor to be measured constituting the four arms, and with a meter or other indicating device connected between the outer points of the diamond. When the resistors of known value have been adjusted to give a zero reading on the meter, the value of the unknown resistors can be calculated from a simple formula involving the ratios of the various resistors to each other. This method requires a dc source and a small galvanometer (which is simply a high-priced name for a milliammeter with the 0 mark in the center of the scale instead of at the left side). What the great majority of Service Men do not appreciate is that ac can be used just as readily, and that if it is used, both resistors and condensers can be measured with the same instrument with the same ease. The dc galvanometer is merely replaced by a pair of phones, or, better still, by an output meter such as most Service Men already have in their analyzers.

CONVENIENT READINGS

In the Lafayette Universal Bridge designed by Mr. Kelly, all mathematics other than simple multiplication has been eliminated, and the readings become practically self-indicative. The bridge itself is a small affair measuring only nine inches long, 4½ wide and 3 deep, the container being a strong black enamelled steel box with spot-welded joints. On the top of the panel are eight binding posts, two knobs and a

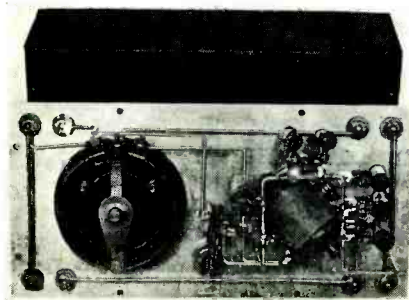

Internal view of Lafayette Universal Bridge.

button. The small knob on the left represents a nine-position switch, the larger knob on the right a husky 400-ohm potentiometer that forms two of the sides of the bridge. (One side from the rotating arm to one end of the winding, the other side from the arm to the other end of the winding.)

The switch knob is marked "Multiply By," and the five resistor positions are marked .1, 1, 10, 100 and 1000; the condenser positions are marked .1, .01 and .001. The potentiometer knob travels over two concentric scales. The inner one, applied against the resistor markings of the switch, reads from .1 to 1000; the outer one, for condensers, reads from .1 to 1000 in the other direction. The fact that there are ten clear and open divisions from .1 to 1 on both scales permits exceedingly accurate measurements to be made. The Service Man will begin to appreciate the value of this accuracy when, for instance, he measures two apparently identical r-f transformer secondaries and finds one reads 3 ohms, as it should, and the other 75 ohms because of a poorly soldered joint.

BRIDGE CIRCUIT

The internal connections of the bridge are simple and are shown in the diagram. The posts marked "External Standard," which are located in the lower left corner of the panel, are normally short circuited by a piece of No. 12 wire. They are provided so that external resistors or condensers of known value may be used for experimental purposes.

The best "voltage source" is a small filament lighting transformer with a single heavy winding giving 2½, 5, 6 or 7½ volts, the actual value being unimportant. This is much better than a dry battery, as the voltage source is practically short circuited when low value resistors or suspected circuits are being investigated. The emf of the battery falls off so quickly under a load of this kind that the bridge cannot be balanced very well. An ac source can be used for both condenser and resistor measurement, while only resistors can be handled with dc.

Under some conditions in the field, in dc districts, for example, a battery must be used. If the Service Man has much of a dc trade, he can still handle condensers with this bridge by merely using an ordinary buzzer to give an interrupted voltage source. The "Press to Read" button cannot be locked down anyway and can be released quickly if the pointer setting indicates an obvious short circuit.

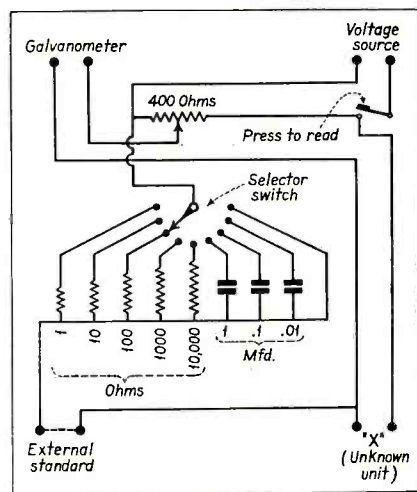

Circuit of Lafayette Universal Bridge.

THE GALVANOMETER

In the absence of an output meter, the 0-1 ma range of the regular analyzer meter can be used as the galvanometer with dc as the voltage source on the bridge. If the analyzer is not already equipped with a pole changer, it can easily be fitted with one in the form of a double-pole, double-throw switch of the telephone type. This is necessary because during the balancing operation current flows through the meter first in one direction and then in the other, balance being indicated by a zero reading. If the meter isn't reversed when the bridge is off balance in the backward direction, the needle is likely to wrap itself around the adjacent stop.

The actual accuracy of the Lafayette Universal Bridge has been measured as 1% for resistors and 3% for capacitors.

RADIO CITY MODEL 404 MULTITESTER

The Radio City Model 404 Multitester is shown in the accompanying illustration. It is a 2000-ohms-per-volt, portable unit for use as an all-around tester; ohmmeter, voltmeter, milliammeter, and microammeter ranges being provided. The multipliers and shunts are hand calibrated for an accuracy of

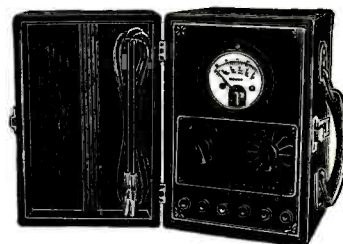

Radio City Model 404 Multitester.

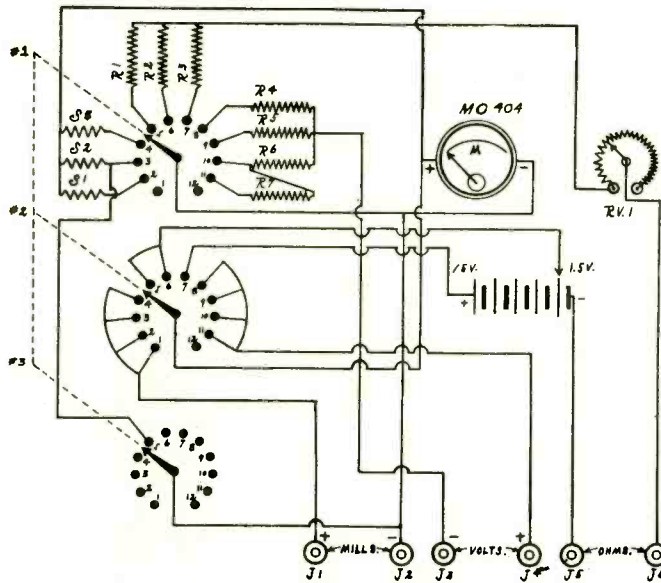

Circuit diagram of the Radio City Model 404 Multitester. A three-section, twelve-position selector switch is used for providing the progressive circuit selections.

1 percent, and the unit is completely self-contained.

AUTOMATIC SELECTOR SWITCH

The possibility of burnouts is provided against by an automatic selector switch (see the accompanying schematic diagram) which connects the meter to the desired circuit and range, and simultaneously disconnects it from all other circuits and ranges. Further safety is provided in having individual jack terminals for each circuit, isolating it from all other circuits.

RANGES

The D'Arsonval meter used in this instrument is 3½" in diameter with a bakelite case. A tapered rheostat affords a smooth zero-adjustment on all ohmmeter ranges.

The triple-range ohmmeter measures

all resistance values from ¼ through 2,000,000 ohms, in the individual ranges as follows: 0-2,000, 0-200,000 and through 0-2,000,000.

The sensitivity of the meter is 2,000 ohms per volt and has the following four individual voltage ranges: 0-5, 0-50, 0-250 and 0-750.

The triple-range milliammeter section of the multitester permits measuring milliamperes in the individual ranges of 0-5, 0-50 and 0-250. For greater accuracy in measuring low-current circuit values in photo-electric cell circuits, special grid circuits, and the like, a microampere scale of 0-500 has been provided.

The Model 404 Multitester is compact and measures 6" by 8½" by 3½". The unit is housed in a leatherette covered case.

WESTON MODEL 698 SELECTIVE SET SERVICER

The Weston Model 698 Selective Set Servicer is shown in the accompanying illustration. It includes a Weston Universal Volt - Ohm - Milliammeter, equipped with a Model 301 instrument, a complete Model 666 Type 1A Socket Selector Set, all necessary leads, and a substantial leatherette carrying case.

SOCKET SELECTOR SET

The Socket Selector Set is designed to prolong the life of the Servicer. The Selector block mounts on top of the instrument, as shown in the illustration by means of two pin terminals on its under side. Future developments in tube-base design can be compensated for by the addition of a selector block or an adapter to accommodate the new type tube base, making alterations to the Servicer unnecessary.

RANGES

The ranges of this instrument can readily be seen from the schematic diagram. These ranges are: 750, 150, 15, 7.5 volts ac and dc, 500,000—5,000 ohms full scale, 3500—35 ohms center scale, and 75 to 7.5 milliamperes. It should be noted that current readings can be had in dc only. Note that plugging in the pair of jacks opposite any terminal serves to operate a self-contained jack switch to open the circuit to that particular terminal and divert its current through the instrument.

Resistances may be measured between any two terminals or between terminal and ground by plugging into the desired terminals on the Socket Selector Unit and the resistance jacks on the instrument. Ground may be brought over to

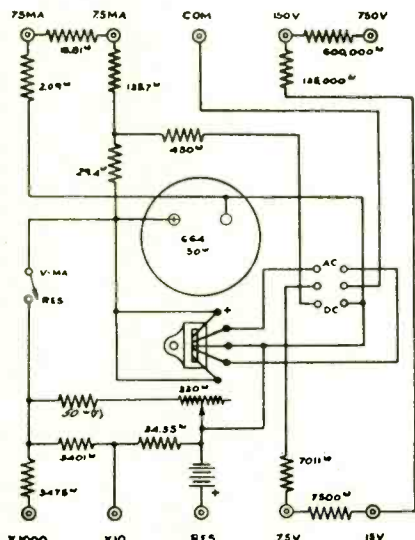

Circuit diagram of the Weston Model 698 Selective Set Servicer.

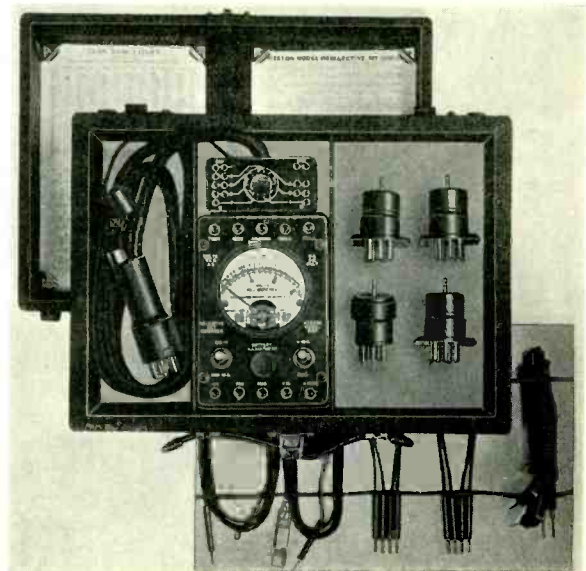

A view of the Weston Model 698 Selective Set Servicer in its carrying case, with cable plug and socket selector set.

GENERAL DATA—continued

the selector by means of the ground lead and resistances to the chassis measured.

This instrument can also be used as an output meter by using the ac, 7.5-volt range across the dynamic speaker terminals.

Voltage, current, resistance and continuity measurements may be made in any radio receiver.

The output of the pentode tube is coupled to the diode plates of the type 75 tube through the condensers C-6. The diode D-1 provides avc voltage for the i-f tube and delayed avc action is obtained by returning this diode circuit to ground through resistor R-6. This places diode D-1 at a negative voltage

with respect to the cathode of the 75 tube, the bias voltage being equal to the drop in the cathode resistor R-8.

BIAS VOLTAGE

Linear detector action is provided by diode D-2. The load circuit of this diode consists of the resistor R-7 and

Atwater Kent Model 275

The circuit of this receiver is shown in Fig. 1. It is seen to be an ac-dc set of the dual-band type. Band selection is accomplished by a single, double-pole double-throw switch which shorts to ground sections of the antenna and oscillator coils. A band-pass pre-selector is used in the antenna stage, the band-pass feature being used in both frequency ranges.

The pre-selector is coupled directly to the 6A7 tube which functions as mixer and oscillator. The 264-kc output of the mixer is fed through one stage of i-f using a type 44 pentode.

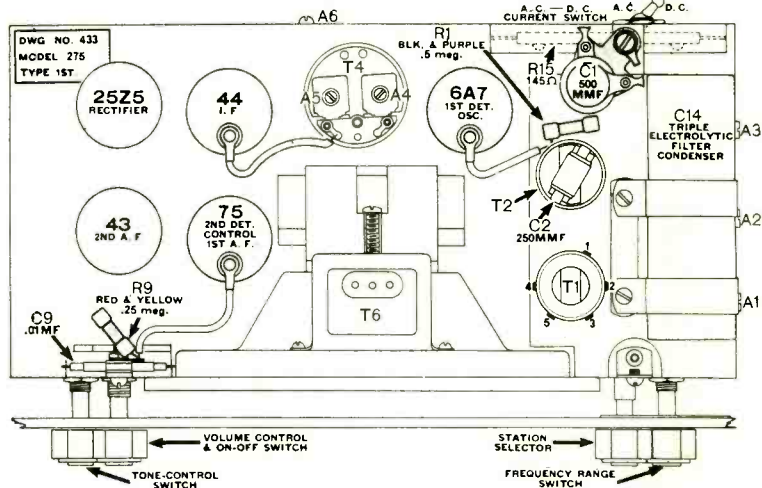

In Fig. 1 (below) is shown the circuit, with voltages and values, of the Atwater Kent Model 275 receiver. In Fig. 2 (above) is the chassis layout showing the locations of the trimmers, i-f transformers, etc.

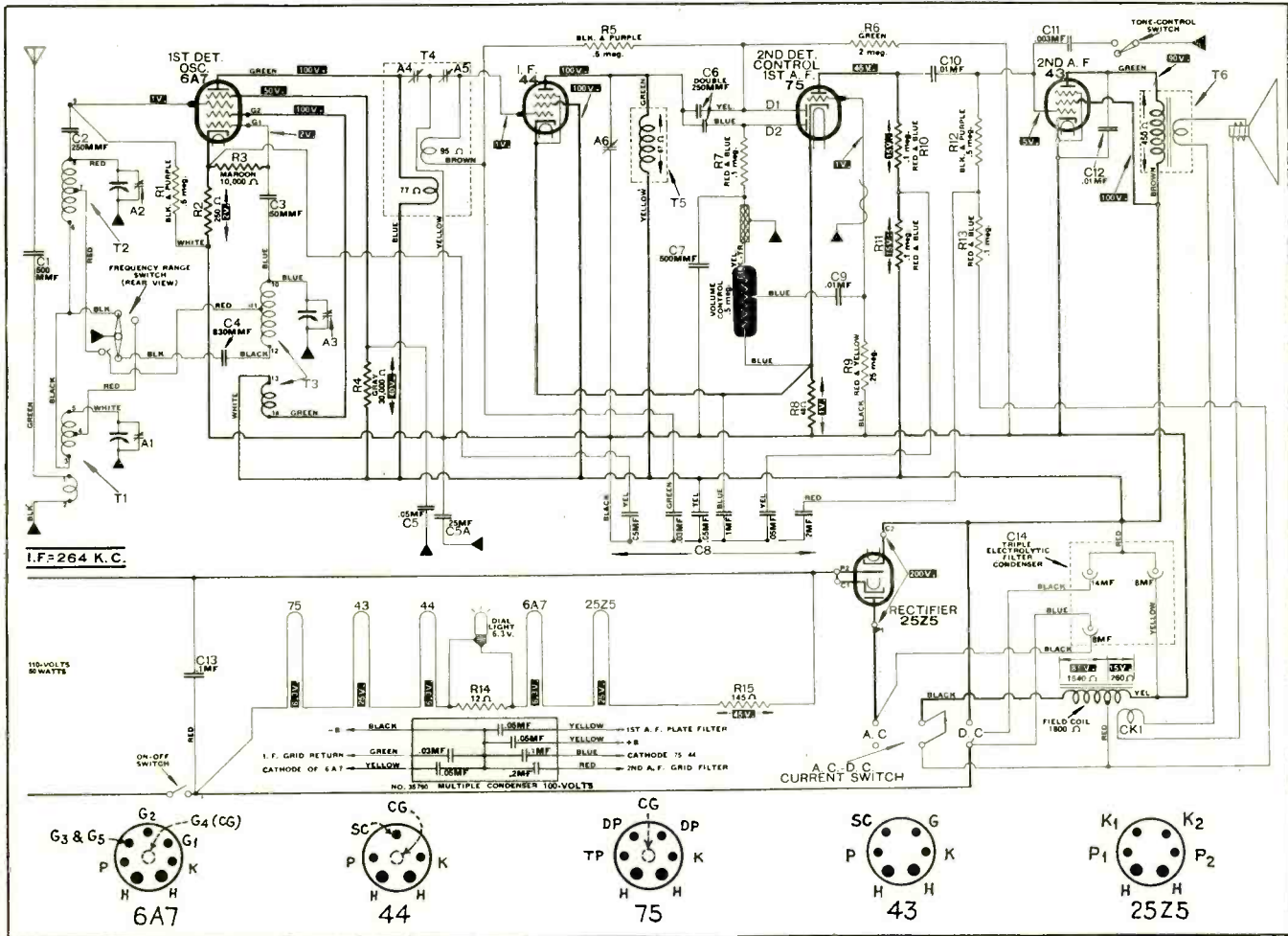

GENERAL DATA—continued

the volume-control potentiometer. The low end of this potentiometer connects to the high end of the cathode resistor with the result that the detector diode is not biased and consequently the diode detector operates at maximum sensitivity at all times. It should be noted at this point that the initial bias for the i-f tube is also obtained from the resistor R-8 in the cathode circuit of the 75 tube. This resistor also provides the bias for the grid of the type 75 triode which functions as a self-biased a-f amplifier. The output of this triode is resistance coupled to the type 43 power pentode. This tube obtains its bias from a tap on the field coils of the dynamic speaker which is seen to be in the negative leg of the power supply.

All tube heaters are connected in series and shunt the power line through voltage-reducing resistors, the resistor R-14 having the correct voltage drop for the pilot light.

An ac-dc switch is provided which, when in the dc position, disconnects plate P-1 of the 25Z5 rectifier tube. In this position the tube acts as a resistance in the circuit. When the switch is thrown to the ac position, the 25Z5 tube functions as a half-wave rectifier. The speaker field is used as the filter choke and hum is further reduced by virtue of the hum-bucking coil CK-1 in series with the speaker voice coil.

SERVICING

All the necessary parts and voltage values are given in the diagram of Fig.

1. Adjustments and alignments are carried out in the usual manner. The locations of the trimmer condensers, i-f transformers, etc., are clearly shown in the sketch of Fig. 2, with each trimmer carrying the same designation as in the schematic diagram.

Remler Model 42

This is a six-tube superheterodyne receiver with avc, tone compensator and separate frequency range covering police signals. It is designed to operate from the usual 110-125 volt, 50-60 cycle line.

THE CIRCUIT

It will be seen from the accompanying diagram that there is a stage of r-f preceding the mixer, this pre-selector stage using a type 6D6 tube. The primary of the antenna coil employs both inductive and capacity coupling in order to provide equal signal voltage transfer over the entire frequency band covered by the receiver. The 6D6 r-f tube has an aperiodic impedance in the plate circuit and this circuit is capacity coupled to the secondary or input coil to the mixer-oscillator tube.

The 450-kc output of the mixer section of the 6A7 tube is fed through an i-f transformer tuned to the same frequency, and thence to the 6D6 i-f tube where the i-f signal is amplified and passed to the parallel diodes of the type 75 tube through a second i-f transformer.

The diode section of the 75 tube func-

tions as a linear rectifier and as the avc voltage source. The rectified voltage appears across the load resistor 18 and the volume-control potentiometer 26. Voltage is taken off from this circuit and fed through the filter resistor 29 to the control grids of the r-f, mixer and i-f tubes. The a-f voltage is picked off by the potentiometer arm and fed to the grid of the triode section of the 75 tube, through the block-coupling condenser 6, where it is amplified and in turn fed to the control grid of the type 42 pentode power tube.

The cathodes of the r-f, mixer and i-f tubes are connected together and are common to the cathode resistor 15, which supplies the initial bias for these three tubes. No bias is placed on the diodes of the 75 tube, but the control grid of the triode section is biased by the voltage drop in resistor 17 which is connected in the negative leg of the power supply. The control grid of the power pentode is biased in the same manner, the bias being equal to the voltage drop in resistors 17 and 21.

Tone compensation may be obtained by closing the switch in the plate circuit of the 75 triode. This throws in an extra capacity to ground, which increases the attenuation of the higher audio frequencies.

SERVICE DATA

The antenna and r-f coils are in the shielding can nearest the front of the chassis, and the mixer coil is in the shield within the chassis. The first i-f transformer and oscillator coils are mounted in the shield between the 6A7 and 6D6 tubes; while the second i-f transformer is located on the underside of the chassis. The oscillator trimmer condenser is nearest the back of the variable gang condenser and the mixer and r-f trimmers are next in order toward the front of the chassis.

Trimmers for the i-f transformers are adjustable through holes in the shield can, and on the i-f transformer within the chassis. Use a weak signal or oscillator input when adjusting the trimmers.

In removing the chassis from the cabinet, pry off the knobs with a wooden screwdriver with a piece of cardboard against the cabinet and pull off the pointer from the condenser shaft.

The voltages are given in the diagram. Due to the current drawn by the voltmeter used, readings of the 75 and 42 grid voltages will be less than those given. The voltage drop across the speaker field is 120.

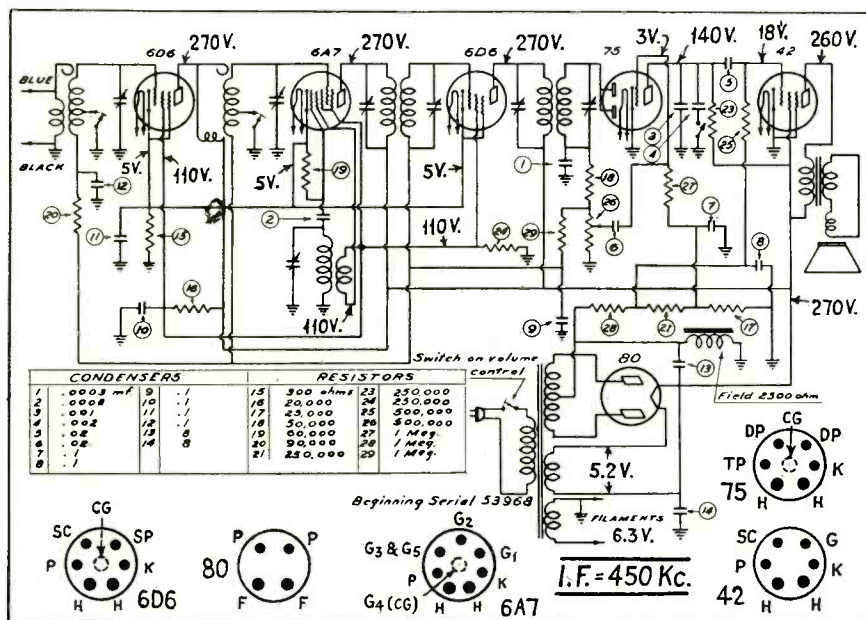

Circuit of the Remler Model 42 dual-wave receiver, with socket connections and voltage values.

GENERAL DATA—continued

Kadette "Jewel" Model 40 Receiver

This three-tube, ultra-midget receiver is a t-r-f job of the universal type, for operation on either an ac or dc line. The heaters of the three tubes are connected in series with a 300-ohm resistor and the circuit so formed shunted across the 110-volt line.

It should be noted from the accompanying circuit of the Kadette Model 40 that the antenna is capacitively coupled to both the primary and secondary of the input transformer, there being no direct connection.

The signal is fed to the first r-f tube, through the antenna transformer, where it is amplified and then fed through an r-f transformer to the type 6C6 detector tube. The output of the 6C6 detector tube is resistance coupled to the pentode power tube section of the 12A7. The output of the pentode feeds the magnetic speaker.

The second section of the 12A7 tube, which consists of a plate and a cathode, is employed as a high-voltage, half-wave rectifier. The high-voltage output from the cathode is filtered by the choke and condenser network.

BIAS AND VOLUME CONTROL

The type 6C6 r-f tube is biased by the voltage drop in the cathode resistance. This resistance is equal to the resultant

value of the combined unit, R-111, and resistor R-257 which is in shunt with it. The actual resistance value is dependent upon the position of the contact arm of the potentiometer section of the unit R-111. This potentiometer permits a variation of the bias on the r-f tube and therefore functions as the volume control. It should be noted, however, that the low end of the potentiometer connects directly to the control grid of the power pentode so that the 550,000-ohm potentiometer also functions as the grid resistor for the power tube. If the arm of the potentiometer is moved towards the low end, the amount of resistance in the cathode circuit of the r-f tube is increased with the result that the negative bias on the tube is increased. This reduces the gain of the tube. Moreover, since the contact arm of the potentiometer is grounded, its movement towards the low end also decreases the value of resistance in the control-grid circuit of the power pentode. This decrease tends to reduce the audio input to the power pentode. Thus, the potentiometer simultaneously increases or decreases both r-f and a-f gain.

The 6C6 detector tube is biased by the voltage drop across the 100,000-ohm resistor in the cathode circuit. A

1,500-ohm resistor in the cathode circuit of the 12A7 pentode provides bias for the control grid.

RCA Victor I-F Peaks

The i-f peaks of the latest RCA Victor receivers are as follows.

Model	I-F Peak
118	460
126-B	460
127	370
128	460
135-B	460
211	460
224	460
235-B	460
262	175
322	460
327	370
341	175

Arvin I-F Peaks

The Arvin Models 10-A and 20-B auto-radio receivers produced in 1933 employ an intermediate frequency of 175 kc, while the Models 20-A and 30-A of the same year have an intermediate frequency of 181.5 kc.

In the Models 15, 16, 25, 35 and 45 of this year a standard frequency of 175 kc is used for the intermediate amplifiers.

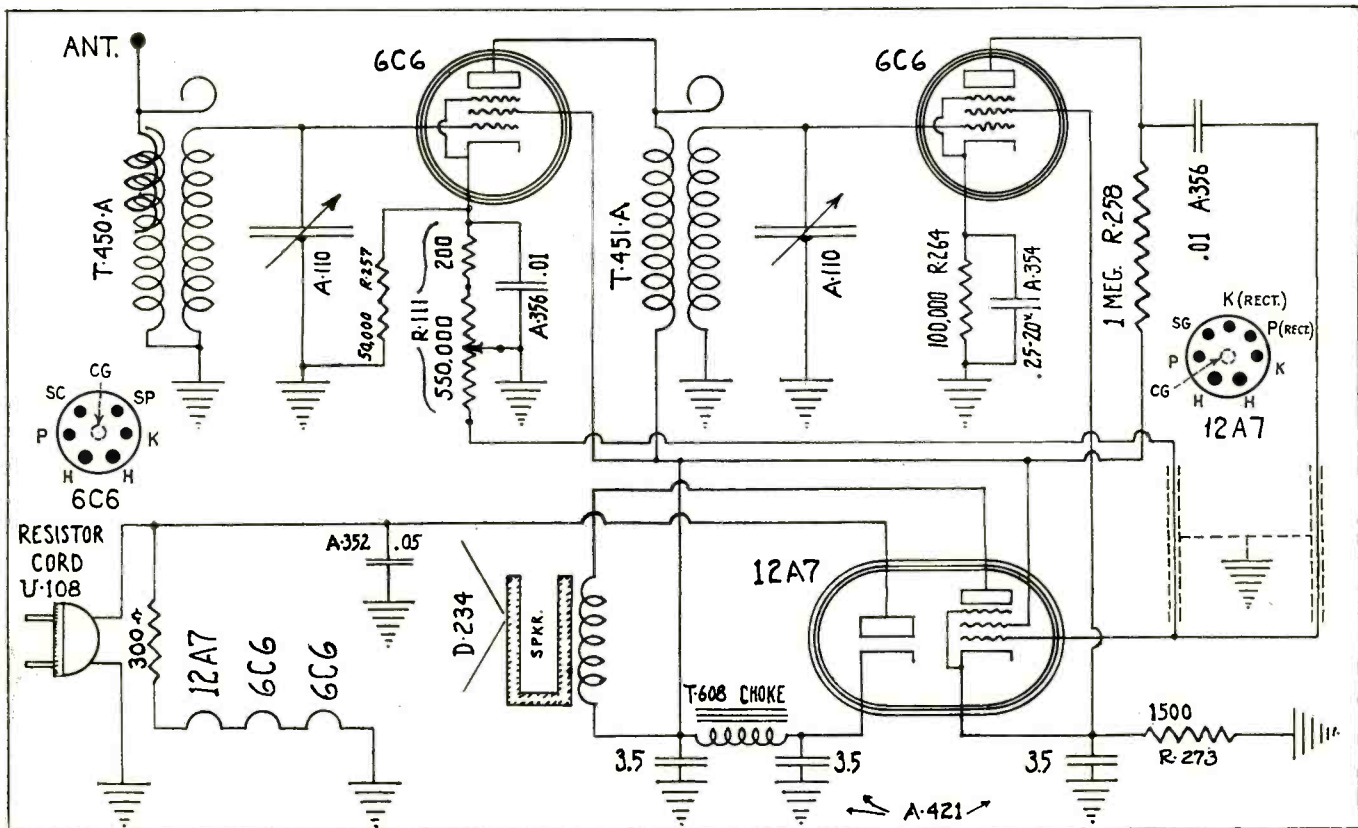

Circuit of the Kadette "Jewel" Model 40 tuned r-f receiver.

GENERAL DATA—continued

New Colonial I-F Peaks

The i-f peaks for the latest Colonial receivers are as follows:

Model	I-F Peak
603	480
604	445
605	175
651	480
652	480
653	480
654	480
655	480
656	175
657	480
658	480
659	175

The Model 659 is a battery-operated receiver, using a 951 tube as mixer and another type 951 as i-f amplifier. This tube is similar in characteristics to the type 32 tube but is not interchangeable with it.

Colonial Field-Coil Values

In the accompanying table are given the field-coil resistance values for the earlier models of the Colonial receivers.

Receiver Model	Resistance in Ohms
36	9000
36P	9000
37	1450
37P	1450
38	9000
39	2500
41	1450
41P	9000
41C	1450
42	1450
46	2500
47	1450
48	1450
49	2500
50	1450

In those models listed having speaker fields with a resistance value of 9000 ohms, the field is used as a bleeder across the power supply.

H. G. D'Arcus, Jr.

Oscillation and Electrolytics

When you have trouble with oscillation in some of the later model sets, especially RCA Victor, employing electrolytic filter condensers, look carefully at the circuit to see what means of r-f bypassing is used in the B supply to the r-f and i-f tubes. Ten to one you will find that the electrolytic is trying to serve as filter and r-f bypass. I use a procedure about as follows: Take all the r-f and i-f leads which go to the electrolytic and separate them from the others, then feed them through a decoupling r-f choke and use a .5-mfd, 600-volt paper bypass. A 500 to 2,000-ohm resistor may replace the choke.

F. C. Wolven.

Howard Model D All-Wave

This is an 8-tube, all-wave super-heterodyne with a frequency range from 540 to 25,000 kc, covered in four separate bands. The band of 540-1500 kc is covered with the band switch in position 4, as is evident from the diagram. Each switch section has two arms so that progressive coil sections are shorted, thus preventing absorption or the effects of mutual inductance. The second range is 1500 to 4000 kc; the third range 4000 to 12,000 kc; and the fourth range, 11,000 to 25,000 kc.

THE CIRCUIT

The complete circuit is shown on the opposite page. The input is so arranged that most any type of antenna system may be used, or two antennas—one for short waves and one for broadcast reception.

A type 78 tube is used in the r-f stage. This tube is tuned-impedance coupled to the 6A7 mixer-oscillator tube. The 465-kc output of the mixer is fed to two stages of i-f using type 78 tubes.

The output of the i-f amplifier is fed to the diodes of the 85 tube. The upper diode is used for detection and the lower diode for supplying avc voltage. The detector diode is not biased, whereas the avc diode is biased by the voltage drop across the 300-ohm resistor in the negative leg of the power supply circuit.

Note that avc voltage is impressed on the grids of the r-f, mixer and i-f tubes, making a total of four circuits under avc control. The grid returns of all these tubes connect to the common avc feed line and this line terminates in the qavc control potentiometer the far end of which is grounded through a separate resistor.

Note that there are no cathode resistors in any of the circuits. Negative bias for all tubes is obtained from the same point; namely, the 300-ohm resistor in the negative leg of the power supply. The amount of negative bias placed on the r-f and i-f tubes is controlled by the qavc potentiometer.

The manual volume control is in the detector diode load circuit. The audio component is picked off and fed to the control grid of the 85 triode. This triode in turn is resistance coupled to a

type 76 a-f tube. The tone control is connected in between these two tubes. The output of the type 76 tube is resistance coupled to the type 42 power pentode. The pentode also obtains its bias from the 300-ohm resistor in the negative leg of the power supply.

VOLTAGE READINGS

Voltage readings are given in the diagram. They are based on a line voltage of 115 and are read from the points indicated to ground.

Electrolytic Condenser Ratings

In order that electrolytic condensers may be properly used rather than unknowingly abused, it is well to have an understanding of their ratings. Thus there are three principal factors involved in the rating of electrolytic condensers, namely: (1) The dc voltage at which they are normally operated; (2) The ac ripple voltage across the condenser; (3) The maximum instantaneous voltage across the condenser at any period of time, as for example at the moment the receiver is turned on. These three factors, according to Howard Rhodes, Chief Engineer for the Aerovox Corporation, are defined as follows:

By *dc operating voltage* is meant the dc potential as measured with a potentiometer or equivalent method.

By *peak ripple voltage or ac component* is meant the maximum instantaneous value of ac voltage across the condenser, due to the ac component in the condenser. This can be measured with a cathode-ray oscilloscope or with a vacuum-tube voltmeter.

By *maximum surge voltage* is meant the maximum potential the condenser will withstand without breakdown or permanent injury, for a period of five minutes when applied to a series combination of the condenser and a resistance, the resistance having a value

$$20,000$$

in ohms equal to $\frac{C}{C}$ where C is the

$$C$$

rated capacity in mfd.

The standard voltage ratings for radio type electrolytics are given in the accompanying table.

DC Oper. Volts	Max. Surge Volts	Mfd.		Max. Peak Mfd	AC Ripple Mfd	Voltage at 120 cycles	Mfd	Mfd
		1, 2, 3	4, 5, 6					
350	400	30	27	25	20	15	10	10
400	450	30	27	25	20	15	10	10
450	525	30	27	25	20	15	10	10
475	600	30	27	25	20	15	10	10
500	600	30	27	25	20	15	10	10

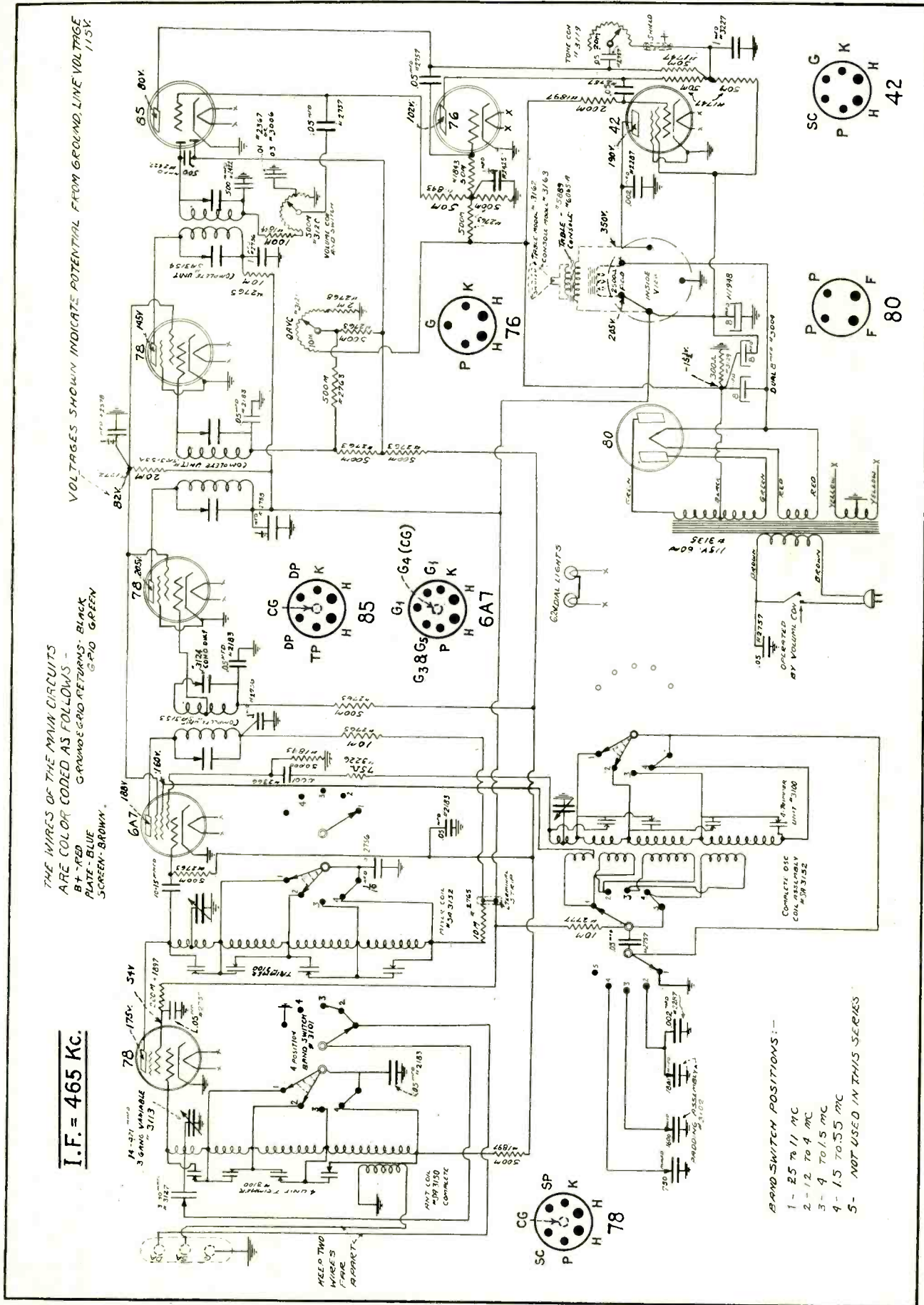

Complete schematic diagram of the Howard Model D All-Wave Receiver, with socket connections, voltage values and parts values. Note the qavc system in this set. The diodes of the type 85 tube are used separately—one for linear detection and one for avc.

Auto-Radio . . .

Colonial Model 182

This is a 6-tube super. A 78 r-f tube feeds the incoming signal to the 6A7 mixer-oscillator. The 175-kc output of this tube is amplified by the pentode portion of the 6F7. This tube provides avc, diode detection and, together with the triode portion of the 6F7, furnishes a-f amplification for the input of the 41 push-pull output stage. The speaker is a separate 8-inch dynamic. A dynamotor furnishes the plate supply, drawing its power from the car's battery.

AVC AND SENSITIVITY CONTROL

The 175-kc output of the 6F7 i-f stage is impressed between the cathode and diode plates of the 6B7, in series with R-12, R-13 and R-14. The diode current flowing causes a voltage drop across these resistors. Only the drop across R-12 is used for avc. Since the grid returns of the 6A7, 78 and 6F7 are connected to R-12, the negative bias across it is impressed upon the grids of these tubes. Increases in signal strength are offset by decreases in tube amplification resulting from this increased negative bias. The effect is to tend to

maintain the output of the 6F7 i-f at a constant value.

Residual bias for the tubes is furnished by R-2. In addition, the residual bias, and therefore the tube amplification, is affected by the setting of the Local-Distance switch. When the switch lever is on contact No. 2, the drop across R-15, due to the plate current of the 6B7, bucks the residual from R-2, decreasing the total negative bias and increasing tube amplification. In the "Local" position, contact No. 1, only the residual from R-2 is applied to the tube grids.

The sensitivity control should be either full clockwise or full counter-clockwise. If allowed to remain halfway between the two positions, R-15 will be shorted, removing the 6B7 bias.

The volume control shunts R-12 and R-13 for audio frequencies. Accordingly, any desired amount of the audio component across R-12 and R-13 can be picked off by the movable arm of the volume control and fed to the control grid of the pentode portion of the 6B7.

THE PHASE-CHANGER CIRCUIT

In any push-pull circuit, the instantaneous voltage on the grid of one of the tubes must be opposite in polarity to the voltage on the other tube's grid. Ordinarily, this polarity difference or phase change is accomplished by the push-pull input transformer. In the Model 182, it is accomplished as follows:

At some particular instant the polarity of the signal voltage on the 6B7 plate will be negative. This negative voltage is coupled through C-18 to the control grid of the upper type 41 tube. This signal voltage on the 6B7 plate also causes a drop (audio frequency) across C-17, R-16, R-10, and C-27, with the polarities becoming increasingly negative toward C-27. Accordingly, the control grid of the triode portion of the 6F7 is driven in a positive direction by the drop across R-10 and C-27. This causes the plate current to increase, which is to say that the plate becomes more positive. This positive potential is coupled through C-19 to the grid of the lower type 41 tube. The result, then, is that the grid of one 41 is going in a positive direction while the other is going negative.

POWER-SUPPLY UNIT

The plate-supply unit is of the rotating dynamotor type. To remove it, take out the three Parker-Kalon screws at (Continued on page 23)

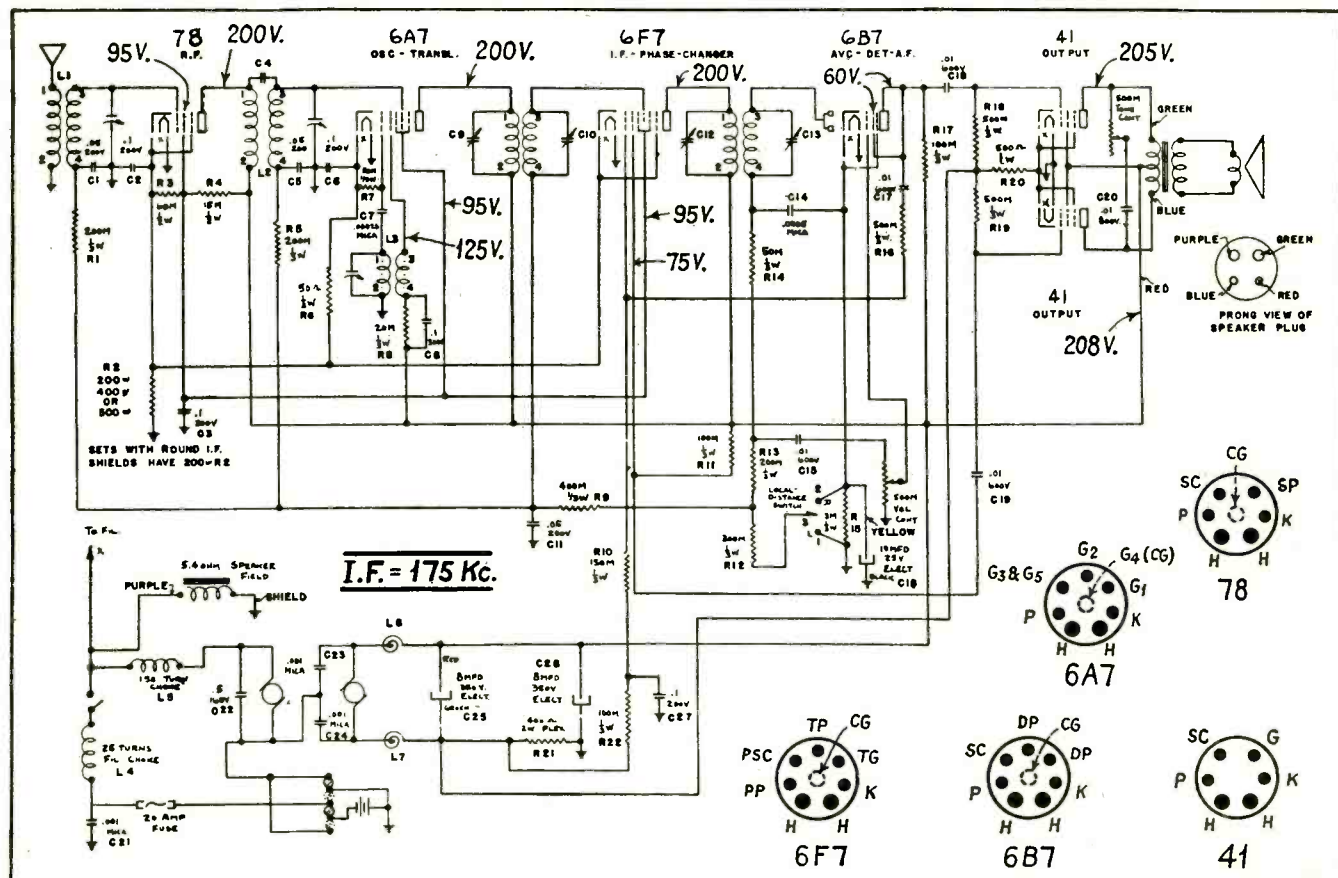

Circuit diagram, with values, of Colonial Model 182 receiver.

Vacuum Tubes and Their Applications

While experimenting with the incandescent lamp in 1873, Thomas A. Edison discovered that a minute current could be made to flow from the lamp filament to another piece of nearby metal, if the latter were biased positively with respect to the filament. This is illustrated in Fig. 1. The circuit is illustrated in Fig. 1-A and the relation of current and voltage between the lamp filament and additional electrode X is illustrated in Fig. 1-B. It is readily apparent that as the voltage on X is increased from some negative value, that no current flows until the potential of X is appreciably positive with respect to the filament. If the voltage is increased still further in a positive direction the current will continue to increase until a voltage of K, Fig. 1-B, is reached, after which further increases in voltage produce no increase in current.

EDISON EFFECT

This phenomenon, which was called the Edison Effect, was studied by a number of physicists for some 16 years before J. J. Thompson discovered that the current was due to the fact that electrons from the filament were attracted to the plate X by virtue of its positive potential. After a further two years study of the matter O. W. Richardson discovered that electrons, which are negatively charged particles of electricity, were boiled out of the lamp filament when it was heated. As a result it was found that the hotter the filament the greater the number of electrons boiled off and the larger the current between the filament and the positively charged electrode. This is equivalent to saying that the saturation current is

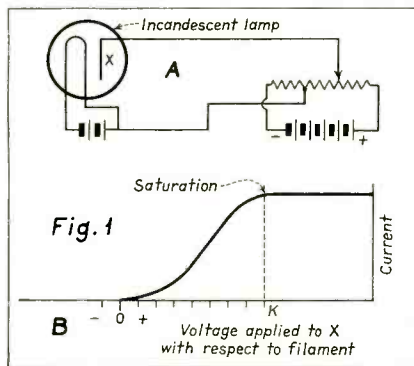

The circuit of A is used for illustrating the Edison Effect. Curve B illustrates the effect of saturation, an increase in voltage above K producing no increase in current.

The first of a series of thumb-nail sketches on the characteristics and functions of vacuum tubes and how they are applied to modern radio-receiver circuits. — THE EDITOR.

higher if the filament is hotter. This is illustrated in Fig. 2, in which the parameters T_1 , T_2 , and T_3 represent different filament temperatures.

It is this saturation current that determines the maximum output of vacuum tubes. As a matter of fact it is common practice in certain types of auto receivers to operate one of the i-f tubes near its overload or saturation value so that the peaks of ignition interference from adjacent automobiles will overload the tube and thus be less annoying when operating in traffic.

DIODE DETECTORS

The first practical use of the Edison Effect was for diode detectors. This

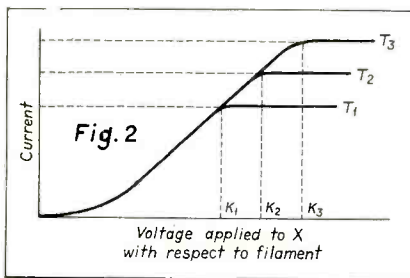

If the filament temperature is increased, the voltage applied to X with respect to filament can be increased with corresponding increase in current.

was done by J. A. Fleming in 1905 and the tube was called the Fleming Valve. Of course the Fleming Valve was invented and used before the days of high vacuum and certain irregularities appeared in the characteristics due to ionization of the gas that remained in the glass envelope. This need not concern us at this point since it will be explained in detail later. It is obviously a short step from the circuit of Fig. 1-A to the diode detector of Fig. 3-A. The battery and potentiometer of Fig. 1 are simply replaced by the source of alternating or fluctuating potential to be rectified.

OPERATION OF DIODE RECTIFIERS

In the usual diode rectifier or detector, the input voltage E is applied to the rectifier and load resistance in

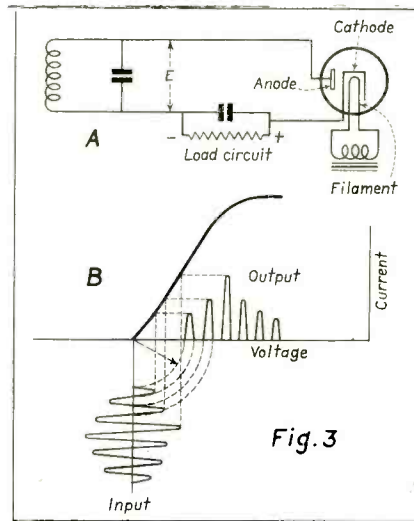

The simple diode detector circuit of A results in the rectification of the input current to that shown on the output side in curve B.

series. When a positive peak of the input signal is applied to the anode or plate, some of the electrons which have been boiled off the hot cathode or filament are attracted to the anode, the number depending on the magnitude of the signal peak. It should be noted that current is generally assumed to flow in a direction opposite to the direction of flow of electrons. This is a hang-over from the theory developed around voltaic cells in which the current was believed to flow from the positive battery terminal through the load to the negative terminal of the cell. As the anode of the rectifier of Fig. 3-A becomes positive, current then can be assumed to flow from the anode to the cathode and so through the load resistor to the return terminal of the input circuit.

When a negative peak of the input signal is applied to the rectifier anode there is no current flow. Only the positive peaks of current will then pass through the rectifier and be applied to the load resistance. This state of affairs is illustrated in Fig. 3-B. This rectified wave may be resolved into a direct current and an audio-frequency current if the input signal is modulated. If only a carrier is applied to the rectifier, of course, only a direct current will flow through the load resistance. The polarity of the resulting dc voltage across the load resistance is indicated in Fig. 3-A.

(To be continued)

ON THE JOB . . .

Emergency Footing Cleats

One very frequently encounters jobs of installation where a good bit of climbing or walking on a sloping roof is necessary.

Various devices, some of them not altogether satisfactory, are generally applied to the shoe or soles to prevent slipping and afford a safe footing. However, nothing can afford better security than cleats. Small boards to temporarily attach as such are not always handy and often easily split.



Large boards or pieces require the use of heavy nails which are not practical to drive into the covering of many roof materials.

Quickly saw off the back of binding portion of a number of old pulp magazines, each one affording a solid block of paper, some 1" thick and about 2" wide. A number of small shingle nails will hold the pieces down firmly and safely for an excellent contact for the sole of the shoe. It will not slip on the tough block of paper which has much more friction than wood of any kind. The smaller nails will not damage the roofing material in any way and the block of paper will not split.

Frank Bentley.

RCA Victor 100

Modulation hum at low volume setting can be corrected by by-passing one side of the primary of the power transformer to ground through a 0.1-mfd, 400-volt condenser. Try reversing the line plug in the socket after this change.

E. M. Prentke.

Making Service Data Handy

How many times has the following come over your telephone: "It's an Atwater Kent radio, but I do not know the model number."

You look on your shelf and there are five Rider Manuals nestling snugly together, and through your mind runs this thought: "She has an AK set to be repaired but what model is it . . . which manual shall I take on the job?" Furthermore, the data on some models is strung out through two or three volumes and those things (manuals) are somewhat bulky to carry around.

Now, the other evening while working on a set, I had three volumes open on the bench (one had the voltage data, another the chassis layout, and the third had alignment and resistance data on one set). I got a bright idea. Pardon my blush as I hand myself a bouquet—why not arrange your data sheets as follows?

Take the AK sheets from all five manuals, put them in volume one, then all of the Balkeit, Crosley, etc., in alphabetical order having all of the data on sets the name of which starts with the letter A together, B together, then if the party has a Majestic radio, model number unknown, all Majestic data is in volume three or four depending on which binder contains the M sheets. And the index still applies to the individual sheets.

Once each year when the new manual is obtained, your sheets must be rearranged, putting the new RCA sheets with the older ones and maybe taking the letter E sheets, for example, from volume one and transferring them to volume two, and the last few letters of the alphabet will be put in the new binder to provide space in the other binders for the new sheets. It will be necessary to punch an additional hole in some of the sheets to fit the older binders with three studs.

E. E. Gilcrease.

Philco 112 Crackling

Crackling or sputtering at high volume, okay at low volume. Usually due to output transformer breaking down. A steady crackling at all volume settings usually means a field coil burning out. Set may operate intermittently. When dead there will be no voltage on any tubes except the power tubes. In both cases, the cause is due to electrolysis.

F. C. Wolven.

Philco V-C Noises

A method of removing so-called noise in volume controls of Philco Models 89, 19, 71, 91, 43. This noise

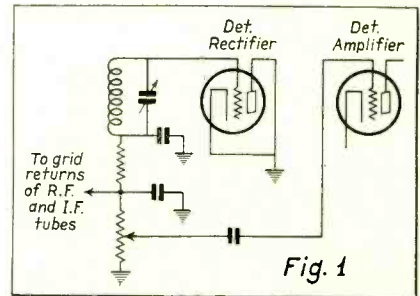

Original volume-control circuit. See changes in Fig. 2.

appears to be in the volume control and is very noticeable on the carrier of a station and at fairly low volume. In some sets it is noisier than others depending upon the sensitivity of the set.

The above sets use the volume control from the grid return of the detector rectifier to ground. The movable arm goes through a coupling condenser to the grid of the audio input tube. The accompanying diagrams illustrate the two connections.

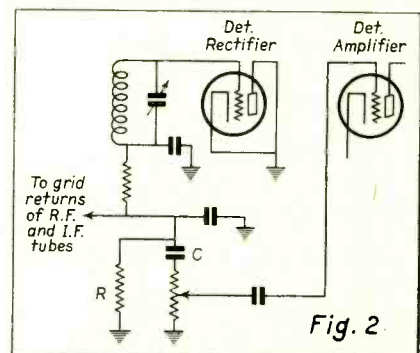

The altered circuit, with condenser C and resistor R added.

This change has been made by the factory for later Models 16 and 17 Philco and the writer found that it works equally as well for Models 89, 19, 71, 91, 43. It may work fine on others where the control appears noisy. However, we haven't had the opportunity to try it on the other models.

Frank M. Jalln

Silver Model R

All voltages O.K. yet set fails to play. These sets seem to get out of alignment so far that the signal fails to get through the intermediate amplifier. Re-align the intermediates at 175 kc.

E. M. Prentke.

Moisture in Philco Models

In this section we are having a great deal of trouble with sets using auto-dyne-type circuits. Due to unusually damp weather, the sets absorb moisture and become inoperative over part or all of the dial. This is especially true with Philco Models 38 and 38A (battery sets) and the Model 19 ac set. All these sets are wired with cloth-covered, hook-up wire.

SYMPTOMS

Symptoms are: first a creeping of calibration on the high-frequency end of the dial, followed by inability to receive the higher frequencies; and as the set absorbs more moisture, there is no reception on any part of the dial. Apparently the type 15 tube fails to oscillate. However, this is not the case. Instead, the frequency of the tube has shifted.

Moisture increases the capacity of the oscillator circuits, thereby lowering the frequency of the oscillator. The frequency difference is not so great at the low-frequency end, but as attempts to tune in higher frequencies are made the frequency difference becomes greater, finally becoming so large that the output of the type 15 tube will not go through the tuned intermediate-frequency stage. In other words, the oscillator fails to track.

REMEDY

Remove the mica strips from the high-frequency compensators, which are mounted on the gang condensers, and replace them with a high-grade, clear mica. Now, using a high-grade, rubber-covered, hook-up wire, remove the first i-f transformer and replace the red lead from the plate of the 15 tube and the first compensating condenser, being careful with the delicate tuned windings.

Next replace the lead from the oscillator-coil assembly to the first i-f compensating condenser. Replace the lead from the oscillator-coil assembly to the low-frequency compensating condenser. Replace the leads to the ganged condenser (both r-f and oscillator sections), and replace the 6,000-ohm first detector-oscillator bias resistor with one of 4,000 ohms. Peak the i-f stages at 460 kc, adjust the low-frequency and high-frequency compensating condensers, and recheck the i-f stages. Now, the set will not be affected by the climatic conditions. However, it might be well to re-center the speaker, as most permanent-magnet speakers drag, giving very poor tone.

In the Philco ac sets, new mica in the gang condenser and a new bias resistor of 10,000 ohms, replacing the 15,000-ohm unit, will usually make the set operate satisfactorily.

All new wiring should be self-supporting and should not be placed against the chassis as the capacity will affect the calibration and adjustments.

H. J. GRIFFIN,
Shelby, N. C.

Brace Grip

The round smooth handle of the common brace is not such an easy thing to grip and hang on to, particularly when working with the hands protected by gloves or mittens. It is practical, too, many times to hold the brace against the body when drilling many holes with the bit in a horizontal position, but the smooth handles slip on the clothing.



Procure an inexpensive soft rubber fruit jar lid remover of the cap type as shown. It snugly but not too tightly fits any ordinary brace handle, does not, however, enlarge it too much, and makes an excellent aid to the grip. Prevents slipping when held against the body. A very handy thing to keep in the tool kit.

Frank Bentley.

Radiola R-11, RAE 26

Oscillation and motorboating is often due to leaking 9-mmfd condenser which feeds the grid of the avc tube. Intermittent fading and lack of pep is often due to either C-18 or C-20 (Rider's Manual Vol. II) leaking and sometimes damaging R-10 or R-11. Replace with 600-volt, 0.1-mfd condenser unit having a very high insulation resistance. It is best to replace these condensers whether they are defective or not, as they never last the life of the set.

F. C. Wolven.

Majestic 20

Often blow 4,125-ohm section of voltage divider causing lack of plate and screen voltages on r-f and i-f tubes. The .022 Acoustic Compensator usually blows if used much.

F. C. Wolven.

COLONIAL MODEL 182

(Continued from page 20)

the bottom edge of the dynamotor housing and then take out the two screws holding the metal can type of condenser to the housing. The housing and dynamotor then can be loosened from the chassis. Unsoldering the leads under the dynamotor and removing the four screws that hold the dynamotor to the housing case permits complete removal of the dynamotor. After considerable use, the dynamotor commutator may need cleaning. Use the finest sandpaper. *Never use emery cloth.*

If the receiver is set up on the bench, outside of its case, be sure to connect a wire from the speaker cable to the chassis to complete the speaker field circuit.

REMOTE-CONTROL UNIT

Data relative to the remote-control unit employed with this receiver will be found on page 225 of the June, 1934, issue of SERVICE.

I-F ADJUSTMENTS

When peaking the i-f transformers, use a low enough output from the test oscillator to render the avc action inoperative.

The first i-f transformer is mounted on top of the chassis, with the adjusting screws accessible through holes in top of the shield can. The second i-f transformer is mounted underneath the chassis, directly to the rear of the gang condenser unit. The condensers C-12 and C-13 are accessible through holes at the end of the shield can furthest from the gang condenser unit.

R-F ADJUSTMENTS

There are three holes at the back of the chassis through which the condenser trimmers are accessible. The unit nearest the control end of the chassis is the r-f unit. The next one is the mixer and the last one the oscillator.

VOLTAGE READINGS

The voltage readings are given on the diagram. Readings should be taken with a 1000-ohms-per-volt meter, from the cathode to the respective elements of each tube. Ordinarily, a 20% deviation from the values given may be allowed.

Public Address . . .

THE SERVICE MAN'S SIDE OF HIGH FIDELITY

By I. A. MITCHELL*

Some facts regarding the frequency characteristics of radio receivers and public-address systems and how these characteristics may be improved by the use of equalizers or their equivalent. The design of a complete high-fidelity audio amplifier is also covered.

THE past few years have effected a great increase in the overall fidelity of audio amplification systems. High fidelity is now not limited solely to the laboratory and broadcast station, but a demand for this type of equipment is being built up with the public. The larger radio organizations are both advertising and demonstrating high fidelity as the newest sales feature in radio. The Service Man can take advantage of this by converting ordinary receivers to higher fidelity.

"FIDELITY"

The word "fidelity" in radio receivers can be covered by three major points insofar as the ear is concerned; namely, wide frequency range, low harmonic distortion and low hum level. While new tubes and circuit developments have aided the progress of radio quality,

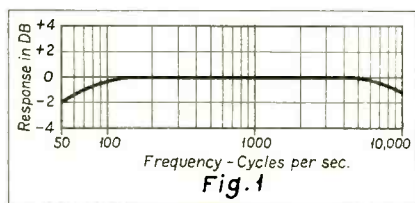

Frequency curve of medium-priced audio transformer.

the keynote of this advance has been the improvement in audio transformers. Fig. 1 illustrates the response of a typical, good transformer in the medium-price range. In many radio receivers, particularly of the t-r-f type, replacement of the ordinary audio transformers with transformers of this type will improve the quality tremendously.

Unfortunately, sound pickup devices such as microphones and record pickups and reproducing loudspeakers have not been perfected to as great an extent as the audio amplifiers associated with them. The cause of this is apparent when one considers the many mechanical features which enter into both pickup and reproducer operation. Compensation for the defects in these

*Chief Engineer, United Transformer Corp.

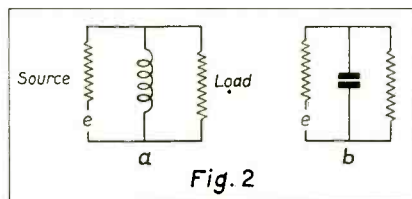

Two equalizer networks, that of (a) using inductance and that of (b) using capacity.

sound source pickups and reproducers is made possible through the use of equalizer networks.

EQUALIZERS

In many receivers the r-f design is such that high frequencies are cut off. This can also be regained through equalization. Equalizers have been used for many years in the broadcast stations for reducing the frequency discrimination of program lines and pickup devices. Due to their high cost, their use has not spread to the p-a and radio-receiver fields to the proper extent.

The simplest form of equalizer consists of a capacitor or reactor so inserted in a circuit that the attenuation bears a definite relation to frequency. In other words, if, as in Fig. 2-a, we shunt a line with an inductor, the impedance of the inductor increases and the loss of the inductor consequently decreases as we go up in frequency. Using a capacitor, as in Fig. 2-b, a directly opposite result takes place; that is, the attenuation increases as the frequency increases. Figs. 3-a and 3-b show typical frequency curves for such equalizers. If the inductor or reactor were thrown in series with the line their respective effects would be reversed.

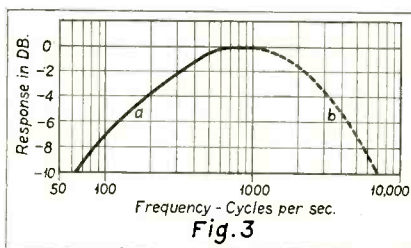

Frequency curves for the equalizers shown in Fig. 2.

This form of equalizer is used in conjunction with the crystal tweeter. Due to the capacitive action of this speaker, the frequency response tends to be rising. By using a matching transformer having correct leakage reactance (this is effectively the same as a series reactor), the frequency response is made uniform.

PARALLEL EQUALIZER

A more common and generally more effective equalizer is the parallel type where an inductor and capacitor are used simultaneously. Fig. 4 illustrates the circuit of this type of equalizer and the frequency response resulting from its use at the low and high end. If this same inductor and capacitor in parallel were connected in series with the line, an absorption circuit would be effected which would attenuate a narrow band of frequencies. Unfortunately, these equalizers as normally used are somewhat complex in design, and expensive. It is necessary that high-Q coils be used to get sharp attenuation and these are generally high in cost. However, recent development work has resulted in an equalization device which is incorporated in an audio transformer structure.

"VARITONE" PRINCIPLE

Fig. 5 illustrates frequency curves obtainable from this type of transformer through the "varitone" principle. A potentiometer control device is used and the curves shown are at maximum control positions. A is with the potentiometer arm at the center and represents the characteristic of the transformer itself. B represents equalization of the low end, C equalization of the high end, and D simultaneous

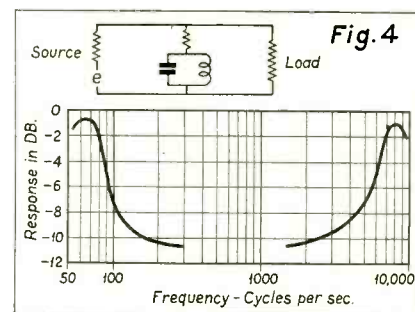

Frequency response resulting from the use of a parallel equalizer.

equalization of both low and high ends. A standard universal audio transformer is available incorporating this feature. The primary of this transformer consists of two windings; one is a high-impedance winding designed to operate from the plate of an amplifier or detector tube. It is also suitable for use with a high-impedance magnetic pick-

• SERVICE FOR

Get This Book

AND INCREASE YOUR PROFITS

...yours for 10c in stamps



● Radio Service men! This book *will* increase your profits, because in it you will find all of the latest technical information that is necessary for your job . . . how to recognize tube and set troubles . . . and most important, how to solve these problems to get fine, sure performance!

This 104-page book is crammed with useful information for every radio service man. It contains complete data on all tubes, including types 15, 18, 255, 25 YS, 2Z2, 46 B1, and 182 B. It also gives descriptions of over 90 types of tubes and 150 cuts and diagrams.

Actually, no radio man can afford to be without this book, because it takes the guesswork out of tube application. . . . A handy pocket manual that furnishes accurate facts and information. Send today for this latest Sylvania service help . . . it's yours for 10c. You'll find it so useful you wouldn't take \$10 for it! Send 10c in stamps today.

Sylvania

REGISTERED U.S. PAT. OFF.

THE SET-TESTED RADIO TUBE

Factories:

SALEM, MASS.
EMPORIUM, PA.
ST. MARYS, PA.
CLIFTON, N. J.



©1934 H. B. C.

Warehouse Stocks In:

Portland, Ore., Atlanta, Georgia,
Philadelphia, Pa., Salem, Mass.,
Denver, Col., Los Angeles, Cal.,
New York, N. Y.

HYGRADE SYLVANIA CORPORATION
Emporium, Pennsylvania

(C-20)

Please send me the new Sylvania Technical Manual.
I enclose 10¢ in stamps.

Name

Address

City State

up. The other winding is a center-tapped, low-impedance winding suitable for use with a single- or double-button microphone, a 200- or 500-ohm line, or a low-impedance pickup. In line with the universal nature of the primary winding, the center-tapped secondary is designed to operate into push-pull grids or a single grid equally as well.

IMPROVING RESPONSE

Through the use of a transformer of this type, many radio receivers and p-a amplifiers can be quickly converted to high fidelity. However, in some cases it is desirable to make other additional changes. Fig. 6-a illustrates the frequency response of a typical midget set. Due to the small baffle area of a midget cabinet, and also frequently the poor electrical characteristics, the low frequencies are sadly missing. To compensate for this and effect a balanced tone, the highs are badly cut off by the set manufacturer. While this type of set has a mellow tone, the brilliant highs and rumbling lows which give life to music are lacking. To equalize this set as it stands and bring it up to the high-fidelity curve shown in Fig. 6-b would be extremely difficult. However, if the curve D of Fig. 5 is compared with this receiver, it is seen that a very marked improvement is possible. Many of the better receivers of 1929 to 1931 had fairly good frequency response, particularly at the low end. Through the use of high-end equalization, the upper end can be brought up and flat response obtained. It is important to note that as equalization is increased, the gain is decreased. If in normal use a set requires the volume control turned well up for good volume, it may be necessary to add another stage of audio to compensate for the equalizer loss.

In some cases it may be desirable to incorporate an entire new audio ampli-

fier so that high power output can be obtained at low distortion level. Fig. 7 illustrates the complete circuit of an amplifier of this type suitable for home or p-a use. The circuit is very simple in nature and uses self bias for all the tubes. The power output is 8 watts at 5% distortion and the gain is approximately 75 db with no equalization. A peak power of 14 watts is available.

The equalizer transformer previously mentioned is used at the input of this amplifier affording provision for microphone, pickup, or tube. The secondary operates into a single 57, triode connected, which is resistance-coupled to another 57 similarly connected. The 500,000-ohm volume control potentiometer is used as part of this resistance coupling. The second 57 is parallel fed and transformer-coupled to a pair of 45's operated A Prime. These are in

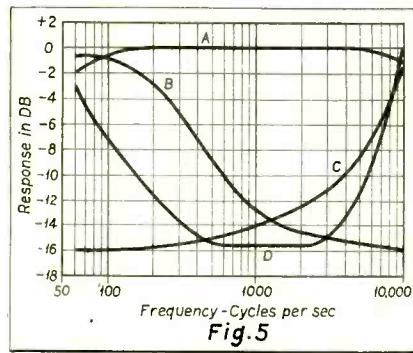

Frequency curves obtainable through the use of a Varitone transformer.

turn coupled through a universal output transformer to either a line or voice-coil combination. The power supply is standard, using the 83-V rectifier for good regulation.

USE OF TWEETER

Most phonograph records, microphones, and some broadcast stations are not as yet up to true high-fidelity stand-

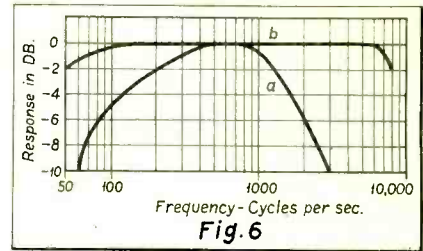

Curve (a) represents response of average midget receiver and curve (b) the curve of a high-fidelity receiver.

ards. The use of the equalization provided on this amplifier makes it possible to bring new life to these sound sources. If an ordinary phonograph record is equalized as in D, Fig. 5, instruments such as castanets and cymbals which are rarely heard normally, come out in their true brilliance of tone. The owners of phonograph combinations can easily be sold on a high-fidelity conversion which will bring veritable "new life" into their music. Where the extreme high frequencies are desired, it is generally desirable to add a tweeter speaker to the receiver or amplifier. An inexpensive unit of this type for the home has just been released. This tweeter has the appearance of a 4-inch magnetic speaker, and is connected to the set through a small matching transformer working across the voice coil winding. The impedance ratio of this transformer is 10/15,000 ohms.

INSTALLATION POINTERS

In addition to the electrical characteristics of a set or amplifier, the trend toward high fidelity necessitates greater care in compensating for acoustic conditions. When installing a set in a home, the set should be placed at least a few inches from the wall, or better yet, place it "catty-corner," otherwise the low-frequency response will be affected. If a number of different set locations are tried in the room, it is possible to determine where best acoustic conditions exist. Due to the directional characteristic of high audio frequencies, deflector plates should be placed in front of a tweeter, if one is used, to disperse these frequencies uniformly.

With proper care, there is no reason why a Service Man cannot build an amplifier system with controlled equalization equal or superior to any on the commercial market. Through the use of tone correction, defects in program fidelity, record fidelity, or acoustic conditions can be practically eliminated. Here is a new market for service work which should mean dollars to those who take advantage of it.

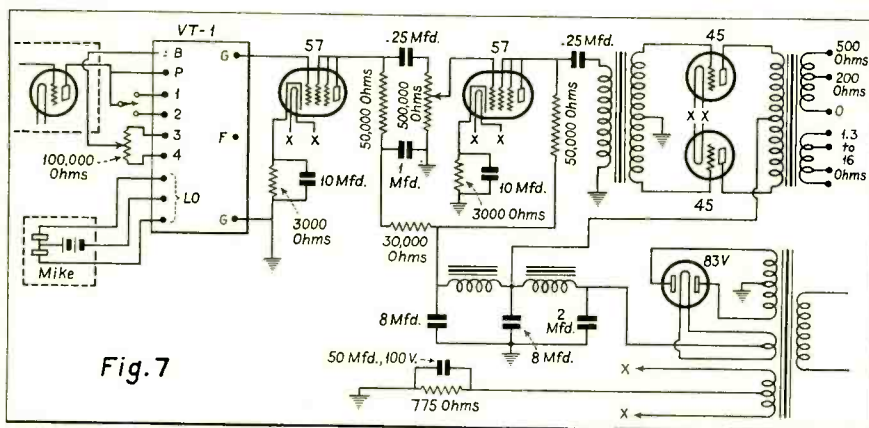

Circuit diagram of power amplifier with excellent frequency characteristics, suitable for public-address or radio-receiver use.

ANOTHER C-D TRIUMPH!

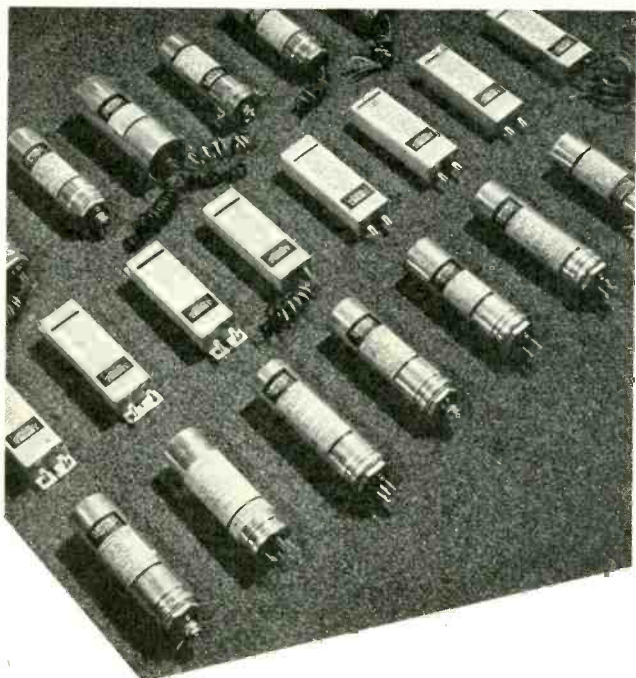

NEW HIGH-FORMATION DRY ELECTROLYTICS

The Condenser Industry's leader scores another triumph! C-D's leading engineers spent months in developing these electrolytics—the finest that have ever been offered the trade. They are intended to afford the utmost in quality and fidelity of manufacture.

3 TYPICAL REASONS WHY

1. Negligible leakage characteristics. 300 microamperes for 8MFD at 450v.
2. Longer life—hermetic sealing
3. Low power factor. Approximately 3%.

Make sure that the condensers you buy bear the C-D label. Then you know that your condensers are guaranteed—by the tremendous prestige of the largest condenser corporation in the world.



New type 8MF in cardboard container.

List price \$ **.95**

New type 8MF unit in metal container

List price \$ **1.05**

LOOK TO C-D IN 1935!

Send for new free Literature!

CORNELL-DUBILIER

C O R P O R A T I O N

4375 BRONX BOULEVARD
NEW YORK CITY

Name

Address

City State

THORDARSON

Replacement Transformers remain

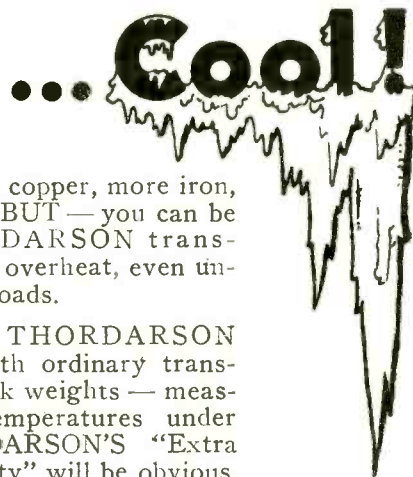

• It takes more copper, more iron, more money — BUT — you can be sure a THORDARSON transformer will not overheat, even under heavy overloads.

Compare a THORDARSON transformer with ordinary transformers — check weights — measurements — temperatures under load. THORDARSON'S "Extra Margin of Safety" will be obvious.

New Transformer Manual

Latest Data for Servicemen Transmitters - Amplifiers

• The most complete transformer manual ever compiled — consisting of three large sections: Servicemen's Guide, Sound Amplifier Manual, and Transmitter Guide. Complete with heavy cover 50c (postpaid). Contains the following sections:

• **Servicemen's Guide**—24 pages of charts, tables, short-cut methods, testing kinks, and other worthwhile information for the radio serviceman. The only manual of its kind.

• **Sound Amplifier Manual**—32 pages of sound amplifier system data—over 19 complete amplifiers — pre-amplifiers—microphone, mixer, and input circuits—speaker output coupling circuits.

• **Transmitter Guide**—32 pages transmitters from 20 to 1000 watts — circuits for the new tubes—r.f. and modulator circuits—grid modulation—Class B—fundamental circuits — tube charts.



Send for Your Copy Today!

THORDARSON ELECTRIC MFG. CO.

500 W. Huron Street Dept. J Chicago, Ill.

Please send me the following new THORDARSON literature:

- THORDARSON Transformer Manual—No. 340-A. (50c enclosed). The above Manual includes the following sections, which can be purchased separately without cover if desired.
- THORDARSON Servicemen's Guide—No. 342-A. Price 10c, postpaid (Catalog 341-A included Free).

THORDARSON Transmitter Guide—No. 344-A. Price 15c, postpaid (Catalog 343-A included Free).

THORDARSON Sound Amplifier Manual—No. 346-A. Price 15c, postpaid (Catalog 345-A included Free).



Name

Address

City

State

ASSOCIATION NEWS . . .

INSTITUTE OF RADIO SERVICE MEN REPORTS

THE Institute of Radio Service Men is celebrating its third birthday with a record of real accomplishment so far as the advancement of the radio service profession and industry is concerned. Starting as they did at a time when the profession was "in the depths of despondency," the members of the IRSM, in three years, have brought recognition of the importance of the radio service profession by the radio industry, and has completed the foundation of stability and security. During 1935 the Institute will build upon the foundation already laid, the first stone of which will be the inauguration of standards of competency—the federal qualification of radio Service Men—as explained below.

Milwaukee

The Milwaukee Chapter elected officers for 1935 at its meeting on December 4. Al F. Braeking is the new Chairman, Joe Zipp is Vice-Chairman, Wm. E. Hough succeeds himself as Secretary, and E. A. Rehoski is the Treasurer.

Ken Hathaway, Executive Secretary of the Institute, attended the meeting, and discussed organization affairs with the new as well as the old officers.

December 18 Meeting

The meeting of the Milwaukee Chapter, held at the University of Wisconsin Extension Division on December 18, was one of the best, if not the best, meeting of radio Service Men ever held in the city. Phil Laeser, Ultra-High-Frequency Engineer of Radio Station WTMJ, delivered a technical lecture on the subject, "High Fidelity, High Frequency, and Facsimile," and gave a demonstration throughout the lecture of the facsimile reproduction used at WTMJ. The demonstration was made by using a radio receiver of the ultra-high-frequency type to which was attached a reproducing device that made impressions on the paper, printing the messages transmitted from the station. The system, while experimental at this time, promises to be one of the ultimate adaptations of the much-talked-of Television.

Ten members of the Chicago Chapter drove to Milwaukee to attend the meeting. Among them were Bennie Zinser, Jos. Roth, Walter Marsh, J. H. Whitfield, Worden Mann, V. A. Parolek, Tom Hogan, and Bob Easterbrooks. Harold Nitze was down from Sheboygan, and E. C. Knight was over from Madison. The get-together after the meeting enabled the members to renew acquaintances and talk over their many problems. Many such affairs are being planned for the ensuing months.

"Flying Squadrons"

Chapters are forming committees known as "Flying Squadrons" to make visits to other Chapters, either for the purpose of organizing or to provide a means for closer association. New York originated the idea of the name, although Rochester had done the same thing for several months past. Chicago has formed its committee and the trip to Milwaukee as reported above was its first trip.

As a result of the work of the New York "Flying Squadron" four new Chapters have

been added to the New York area, and several others are being planned. Rochester likewise reports that it is preparing to get out again shortly after the turn of the year.

Qualification of Service Men

Throughout the entire three years since the IRSM was founded, investigations have been conducted to determine the best course to pursue in the matter of setting up definite standards of competency among radio Service Men so that the radio industry and the public might know who is qualified to do radio service work. The subject has been divided into two phases, the first of which will be inaugurated early in 1935 (the first examinations being planned in conjunction with the Third Annual Chicago Convention and Trade Show to be held in March). While the qualification of radio Service Men is to be done in accordance with a plan developed by the IRSM, the examining and grading will be under the jurisdiction of the National Board of Radio Service Standards, comprising a representative of the broadcast, manufacturing, distribution, and service fields, and a representative of the consumer.

The questions to be used in the examinations are being compiled by the Committee on Professional Status of the IRSM and sub-committees to which have been assigned various classifications. The questions, together with answers, are to be put into published form for loan or for sale (the method has not yet been determined) and should be ready about February 1, 1935.

The Chapters of the IRSM will be supplied with advance proofs of the questions and the answers as the basis for the discussions—preparing them for the qualification examinations that are to come—according to present arrangements.

Boston Chapter

The Boston Chapter is planning a series of trips to the cities in the New England area for the purpose of forming new Chapters. Word has not been received concerning the creating of a "Flying Squadron," but undoubtedly that is the intent. Boston has shown splendidly during the last year, and gives promise of stepping out for some real accomplishments.

Madison Chapter

The Madison Chapter, it was found recently, has been broadcasting over one of the local stations for several months—having developed a special program consisting of a request organ recital. The members of the Madison Chapter agreed to a special assessment to pay for the promotional program which has been worked out on a co-operative basis with the station being used.

Rochester Chapter

Rochester, after intermittently using the facilities of broadcasting for the purpose of public enlightenment in matters relating to service and efficient set operation, has inaugurated a program over two Rochester stations, the continuity being prepared by a Broadcasting Committee and put on with local talent. The Rochester Chapter is fortunate in having in Bernie Cohen one who

is versatile, particularly in dialects, who can take the part of several players. The Rochester programs are dramatizations.

Elmira Chapter

The Elmira Chapter has also been provided with broadcast facilities for several weeks. The local members prepare the continuity and arrange for the presentation.

Chicago Chapter

The RCA Service School meetings came to a close with the meeting held on December 17. The average attendance at the four meetings held in Chicago was well over three hundred. That there was extreme interest in what Charles Herbst had to say was exemplified by the fact that the audience remained intact until after 12:30 at this last meeting.

The Chicago Chapter is planning to hold a party on the night of January 26—the annual Parts Distributors' Party. It is to be a stag and smoker, just a social event when matters of a more serious nature will be laid aside for the evening and everyone will be determined to have a good time. The attendance is being limited to 500.

Several other social events are being planned for the coming months, the Parts Distributors' Party being the forerunner. Such affairs will do much to dispel the gloom that pervades the radio service field.

Board of Trustees Meeting

The Board of Trustees held its December meeting in the Executive Offices in Chicago on Sunday, December 16, at which time many important subjects were discussed and decided upon. A definite program for development during 1935 was laid down, including the plan to examine and qualify radio Service Men as set forth by the Committee on Professional Status.

ASSOCIATION OF RADIO SERVICE ENGINEERS

The Association of Radio Service Engineers of Buffalo, N. Y., held their final meeting of the year on the evening of November 18 at the Hotel Statler. This meeting was climaxed by the election of officers for the coming year. Those elected were: H. M. Sheets, Chairman; F. Hirschweiler, Vice-Chairman; V. W. Olney, Secretary; A. A. Bolm, Treasurer; F. Bestine, Sergeant-at-Arms; L. J. Roberts, Librarian.

The association has as its main objective for the coming year the increasing of membership to include all of the Service Men in Buffalo and surrounding territory who actually depend upon the service business for a living. Allied with this objective will be a stronger endeavor to bring about complete cooperation of the local radio parts jobbers in the restriction of trade discounts to men of that classification.

It is gratifying to note the expression of interest in the development of this Association by Service Men of other localities; namely, Jamestown and Olean. It is understood that plans are under way in these centers to bring about organization similar to that enjoyed by local association members.

ALFRED A. REISER,
Publicity Committee.

(Continued on page 30)

• SERVICE FOR

READ THIS LABEL!



Exact Duplicate

Electrolytic Condensers

are available for all popular receivers at leading jobbers. Save money, time, trouble—and give your customer a workmanlike job using the highest quality, most attractive condenser block.

All TOBE products are stocked by the following jobbers in the state listed below.

(See past issues for other states):

NEW YORK

- Central Appliance Co., 51 Central Ave., Albany.
- Fort Orange Dist. Co., 356 Broadway, Albany.
- Loveless Dist. Co., Bath.
- Broome Distributing Co., Inc., 139 Water St., Binghamton.
- J. F. Distributing Co., 5024 Ft. Hamilton Parkway, Brooklyn.
- Shupack Radio Co., 482 Sutter St., Brooklyn.
- Radio Equipment Corp., 161 E. Genesee St., Buffalo.
- Scheller Radio Parts Service, Inc., 263 Oak St., Buffalo.
- Barker, Rose & Kimball, Inc., Elmira.
- Chanrose Radio Co., 170 Jamaica Ave., Jamaica, L. I.
- Roskin Bros., Inc., 23 W. Main St., Middletown, N. Y.
- Standard Elec. Supply Co., 224 Broadway, Newburgh, N. Y.
- H. L. Dalis, 110 Lafayette St., New York City.
- Federated Purchaser, Inc., 25 Park Place, New York City.
- Fischer Distributing Co., 152 Chambers St., New York City.
- Try-Mo Radio Corp., 85 Cortlandt St., New York City.
- Wholesale Radio Service, 100 Sixth Ave., New York City.
- Howe & Rogers Co., 70 Stone St., Rochester.
- Radio Service Shop, 244 Clinton Ave., N., Rochester.
- Mohawk Elec. Co., 1335 State St., Schenectady.
- Geo. W. Millard, 3 Fourth St., So. Glens Falls.
- W. E. Berndt, 111 S. State St., Syracuse.
- Yates M. Hoag, 277 South St., Utica.

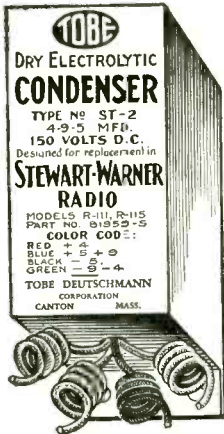

TOBE DEUTSCHMANN CORP.
CANTON, MASSACHUSETTS

ASTATIC

dependability

"TECHNICAL EXCELLENCE AND SUPERIOR PERFORMANCE HAVE LED THOUSANDS TO DEPEND COMPLETELY UPON ASTATIC CRYSTAL DEVICES."

Crystal Microphone D-104



Professional in appearance but rugged in construction, the Astatic crystal microphone is especially adaptable to remote control service and Public Address systems. Built to withstand rough handling without adjustment, the D-104 crystal microphone will give remarkable performance and long service in this field.

Astatic Crystal S-type Transcription Pickup

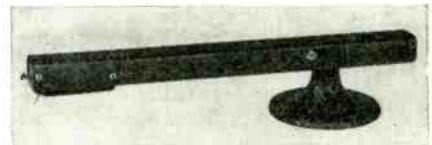

Licensed under Brush Development Co. patents.

This light weight pickup is especially recommended for studio reproduction, and has been found highly satisfactory in the reproduction of transcription recordings.

ASTATIC MICROPHONE LABORATORY, Inc.
Youngstown, Ohio, U. S. A.

WHY

are smart SERVICE organizations stressing ANTENNA again?

• Modern all-wave radio reception without specially designed and carefully installed antenna equipment is anything but good. Foreign stations come in very, very faintly. Their weak energy must be accumulated. Further, "man-made" static, the curse of foreign reception, must be eliminated.

Only strict attention to the antenna equipment can accomplish this double purpose. CORWICO kits, engineered for modern performance, help you Service Men to get out of your customers' sets the satisfactory service they were originally intended to give. We've been at this Antenna job a long time, and we can help you a lot.



USE THIS COUPON

CORNISH WIRE CO. Please place us on your mailing list for information of interest to Service Men.
50 Church St., N. Y. City

Name

Address

City..... State.....



"NOISE-MASTER"

Cat. No. 14, List Price \$6.75

Recommended in locations where there are sufficient "man-made" noises to interfere with radio reception over both the short-wave and broadcast bands. The last word in antenna design, licensed under the Amy, Aceves & King patents Nos. 1,920,162, 1,938,092 and 1,965,539. A highly engineered product which makes one aerial act electrically as two perfect antennas, by automatically selecting the varying frequencies of short-wave and broadcast signals. Two or more sets (preferably not more than four) can be operated at the same time, on the same antenna, by using an additional lower transformer unit on each additional set.

Try "NOISE-MASTER" On Your Next Installation

"Explorer"
Cat. No. 11
\$3.70

ALSO

"Conqueror"
Cat. No. 12
\$3.40

THE FORUM...

THE RIGHT IDEA

Editor, SERVICE:

The following is a message that I wish to address to the gentlemen of the service profession in regard to the question of our status as business men and technicians.

"Gentlemen: We have had the good fortune to be urged by the manufacturers and others in the radio industry during the last few months to wake up from our thoughts of depression and begin to realize our very important position of service and responsibility to the public and to the radio industry.

"Unfortunately, many of the hard-working, serious-minded, conscientious, capable and studious members of our profession have permitted themselves gradually to drift into an almost unbelievable state of mind during the last few years, resulting in a condition in which they allowed unscrupulous and incapable competitors not only to gnaw their subtle way into our business, but even worse, to almost ruin our reputations not to mention our profits.

"To indulge in a little introspection, let us examine the nature of ourselves. We are at heart technicians. During ten or more hours of our day, we are intensely occupied in the three-fold task of servicing radio receivers, p-a systems, etc. First we drive to the home of our client, examine his set and tubes, unfasten the chassis and speaker which, not counting the accumulation of dust, amounts to some fifty or seventy-five pounds to be carried to our 1924 model automobile, also not so clean. Then we make another trip up three flights of stairs to get our tube tester, ohmmeter, oscillator and last year's overcoat. The second task is the testing and delving into the intricate maze of avc, automatic noise suppression, automatic overload prevention, beat-frequency oscillators (Signal Beacon, to you) and miscellaneous eye-straining circuits; after which we perform the delicate operation of bringing several LC circuits into resonance simply by turning a dozen or so little screws with a fibre screw-driver! If our magic brain succeeds at last in producing a receiver that will pass a signal 10-kc wide, it is our next job to deliver the machine and humbly present our bill for \$3.00. This third duty is often the most difficult for our genius of the oscillograph. We just quake as we show the bill, expecting the customer to object to the high service charge. This same customer is perfectly willing to pay \$4.00 or \$5.00 for a mere tuning of his piano, which job requires only about an hour of work, and very simple and inexpensive equipment.

My conclusion is that any self-respecting Service Man who is sure that he understands his work, and who surrounds himself with the latest in signal generators, and has on order a "Radio X-Ray" already has or should have the intelligence to spend a few evenings figuring his recurrent and variable expenses, and reducing these to his cost per hour of operation; and after looking carefully at this amazing figure, should decide on his hourly service charge. I think that any high-grade Service Man has the ability to become a fair business man and must start to be one at once. This means that he must charge enough for his work so that he can main-

tain himself, his car and shop in a truly professional manner. And to demand professional fees, he must inform his client of the trouble and the cost of repair in a convincing and professional tone. After he has begun to operate on a business-like basis, putting aside part of the income for replacement of equipment, service car, etc., it will be his duty to continue to study and improve himself technically, just as any sincere professional man does."

E. M. PRENTKE,
1950 East 105th St.,
Cleveland, Ohio.

SERVICING AND BUSINESS

Editor, SERVICE:

Having just received my copy of SERVICE for December, I was reading some letters in The Forum and from them I find a lot of truth but also a lot of poor business ideas, and so this letter with some of my ideas for what they are worth.

Having been in the business of repairing, building and servicing of radios and sound equipment for over sixteen years, I have had to learn a lot of things in the radio business by a lot of hard knocks and in this district where I live, there are a lot of "gyp artists" whose business it is to get all they can for nothing. We have a good class of people, but not so many.

A Service Man must be a business man as well, or go out of business because a Service Man who doesn't love his work too well but not wisely.

I had to go into business for myself two years ago just when times were the worst and I know that being a business man as well as a Service Man, even if I do not have a store, has paid me better. By that I mean, I make better profit from higher prices. People will pay good prices for work done and good parts used, and when I find people who want price work and not quality work done, I tell them to get some one else, as the profit would be too small and in the second place, most people of that type do not have the money to pay when the job is done, even if you do it. Besides, even if they are willing to pay they sometimes make you wait for your money and by the time you get it, the small profit that you made on the job is gone.

People that I do business with who have \$9.95 radios that go haywire, and I find that the trouble is not a tube, I tell them that it would cost too much to fix, as the first price of the radio was so small. Most people who have that type of radio as a rule have no money or they would have a good set.

Any Service Man who loves his work so well as not to be a business man should work for some company and not for himself as he would not make a success of it. I like to work on radios but I know that if I am not a good business man, I won't make enough profit for me to pay my bills and to eat—and a Service Man won't go far not eating.

In Mr. Cherry's letter, he speaks of shielding the coil on the dash of Pontiac cars as well as the high tension lead but what he forgot to say was that after you shield the coil, use only a piece of shielded loom from the coil to the dash and be sure to insulate it from the shield you

put over the coil. Ground the other end on the fire wall and put one wire-wound suppressor in the high tension lead and the usual condensers and you will in most cases have no noise in the radio in the car. If that does not stop it, shield the low-tension lead, grounding it only on the fire wall.

SERVICE is a very fine magazine and a help to the trade. I have been reading it since the first issue and I have always found something in it to help me on some job.

H. G. D'ARCUS, JR.
1026 Monroe Ave.
Asbury, Park, N. J.

ASSOCIATION NEWS

(Continued from page 28)

P. R. S. M. A. MEETING

The regular monthly meeting of the Philadelphia Radio Service Men's Association was held December 4th, with a special program sponsored by RCA Victor and Raymond Rosen & Company.

The speakers for this meeting were Mr. T. F. Joyce, Manager of the Advertising Department of RCA Victor and RCA Radiotron, who spoke on the Business Side of Radio Service; Mr. W. F. Diehl, of the Engineering Department of RCA Victor, who spoke on the Development of the Cathode-Ray Tube; and Mr. Chester Aiken, who gave a very interesting demonstration of the Proper Application of the Cathode Ray to Radio Service.

At the annual election of the P. R. S. M. A., the following officers were elected: Mr. A. H. Prow, President; Mr. J. C. Courtney, Jr., Vice-President; Mr. F. A. P. Ziesmer, Secretary; Mr. Joseph W. Bishop, Treasurer.

The following men were elected to the Advisory Board: Mr. Ralph Croll, Mr. P. Freed, Mr. D. Wallace.

Appointments to the Advisory Board by the President were as follows: Mr. Jess Eahly, Mr. A. M. Hass, Mr. E. M. Ward, and Mr. E. Koehler.

I. R. S. M. NEW YORK CHAPTER

The New York Chapter of the Institute of Radio Service Men will hold its annual election of officers in the Pennsylvania Hotel on Monday evening, January 28th, at 8 o'clock.

Subject to acceptance by the respective nominees, the executive committee of the chapter have placed the following names in nomination:

Chairman: Fred L. Horman, Edward P. Mandeville, Herbert Zvorist, Matthew Hughes.

Vice Chairman: E. McD. Bendheim, M. Asch, J. D. Hartley, Ludwig Seger.

Secretary: Forrest B. Arnold.

Treasurer: Harold B. Olson.

Librarian: David Salzman.

Additional nominations are to be called for from the floor.

A technical talk is also being arranged for on the subject: "Radio Interference Caused by Automobile Ignition Systems and How to Overcome It," by W. J. Bartlett of Electric Heat Control Co.

F. B. Arnold, Secretary.

*"Here's what I think about
NATIONAL UNION RADIO TUBES"*

Says Fred D. Kerridge
of Minneapolis, Minn.



"So far this year (1934). I have used about 800 of them, and to date, have replaced only two tubes, which is about 400 per cent better than any other tube I have ever used.

"I am personally SOLD on National Union tubes and I am selling only National Union.

"I have taken advantage of five of your shop equipment offers, and they have certainly been a great help in my work... thanks to National Union."

Thousands of alert aggressive Service Dealers have joined the National Union plan for better service business. Why not you?

SEND COUPON TODAY!

National Union Radio Corp.
of N. Y.
400 Madison Ave., N. Y. C.

Tell me about the National Union plan for merchandising radio service, and free shop equipment.

Name.....
Street.....
City..... State.....



S-135



**"YES, MA'M YOU
CAN USE YOUR
BURGESS
BATTERIES
7 OR 8 HOURS
EVERY DAY"**

(A SERVICE MAN OF 1965)

IF THIS young "Service Man" were full grown today, he'd be telling owners of battery operated sets that dry batteries can now be used 7 or 8 hours a day—at no increase in the cost per hour!

EVERY SERVICE MAN KNOWS many battery set owners who believe they will get more hours of service if their batteries are used only 3 or 4 hours a day. This belief is no longer true. BURGESS Engineers have proved, by tests made in our Laboratories and in actual use, that you can now use BURGESS Batteries 7 or 8 hours every day and get the maximum service we've built into them!*

DOUBLE THE ENJOYMENT of your battery set customers by telling them of the BURGESS 8 Hour Day. If you'd like complete, technical information about the BURGESS Power House—the 100% DRY, 400 Hour "A" Battery which retails for \$3.20—or about BURGESS "B" and "C" Batteries, write the BURGESS BATTERY CO., Freeport, Illinois.



*For economical operation of 7 to 8 hours a day, sets should be powered by batteries of proper capacity. Set owners should ask their Service Men to recommend type and size of batteries best suited for their use.

"Multi-Tap"
POWER TRANSFORMERS

(Patents Allowed)

Stock of Only Five (5) Power Transformers

provides Immediate renewal of original performance in case of trouble in the transformer—the heart of the radio—in any of over 50% of all radios—whether "orphaned" or current models.

Exact duplicates **ELECTRICALLY**

The wide range of adaptability of only five models "Multi-Tap" Universal Power Transformers is made possible thru various taps in these units which may be used singly or in combinations. The required current values can be delivered to each of the several leads in the set with any combination of tubes, as accurately as by the original power units. Easily installed.

Universally adaptable **PHYSICALLY**

The extremely wide range of adaptability physically is made possible with the scientifically staggered mounting slots in the several sides of the frame. This is very essential in many installations to avoid redrilling and defacing the mounting panel.

IMPORTANT. Fully shielded for radios having Underwriters Lab. approval. No extra unused leads to become shorted. The above are typical of the GENERAL group of power—audio—input—filament—line—mike—amateur—class "B" transformers, chokes, auto-radio "B" units and vibrators. The most comprehensive line of replacement units from one manufacturing source of supply—service engineers' every need. All GENERAL transformer cores are of low loss, high permeability silicon steel, all coils are high vacuum impregnated, removing all moisture.

"Multi-Tap" Guide, listing 2114 models of radios which you can immediately service with one of only five (5) "Multi-Tap" Power Transformers.

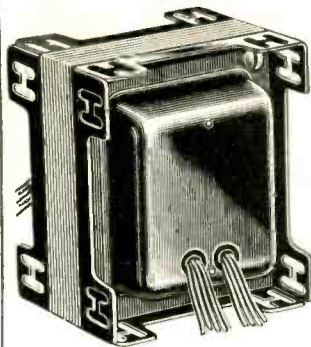

Protects set owners fire insurance policy. The above are typical of the GENERAL group of power—audio—input—filament—line—mike—amateur—class "B" transformers, chokes, auto-radio "B" units and vibrators. The most comprehensive line of replacement units from one manufacturing source of supply—service engineers' every need. All GENERAL transformer cores are of low loss, high permeability silicon steel, all coils are high vacuum impregnated, removing all moisture.

Free for the Asking!

MAIL THIS TODAY

GENERAL TRANSFORMER CORPORATION
502 S. Throop St., Chicago, Ill.

Send me without charge a copy of "Multi-Tap" Guide with name of nearest distributor.

Name.....
Address.....
City..... State.....

BURGESS
BATTERIES AND FLASHLIGHTS

HIGHLIGHTS...

NATIONAL UNION '35 PLANS

In addition to the free radio service shop equipment program, National Union Radio Corporation of New York, plans to help service dealers to effectively sell their radio service work to set owners in 1935, according to an announcement made this week.

Mr. H. A. Hutchins, National Union's Vice-President in Charge of Sales, in commenting on the company's 1935 plan stated: "National Union feels more strongly than ever that its efforts to advance the interest of the radio service dealer by supplying him with modern instruments and service manuals is a program which benefits not only the radio servicing industry but renders a genuine service to set owners everywhere. The instruments and the information having been made available, we are going to make every effort to create goodwill for service dealers and point the way to public confidence in these men as professionals and experts."

FEDERATED FALL RADIO SHOW

With a total attendance of over 15,000 for the four days of its showing, the Fall Radio Show passes into history as one of the most successful exhibitions of its kind. Held at the Exhibition Hall at 25 Park Place, New York City, this show attracted radio Service Men and dealers from all points in the metropolitan area as well as a considerable number from outlying states.

The following exhibitors had on display set-ups of the latest radio parts and equipment: Aerovox Corp., Cornish Wire, Burton-Webber, E. I. Guthman, Universal Microphone, Alpha Wire, Upco Engineering, American Radio Hardware, Porcelain Products, Jackson Electro, Macy Engineering, Pioneer Gen-E-Motor, Shure Bros., Sangamo, Supreme, Hygrade Sylvania, Oxford Radio, R. C. A. Parts, Jefferson Electric, Lang Radio, Acratest Products, Electrical Labs., Amperite Corp., Lynch Mfg., Ohmite Mfg., General Transformer, American Microphone, Fletchthaim, Triplett Meters, Wright-De Coster, Raytheon Production Corp., Hickock Instrument, Clough Brengle, Alden Products, Insuline, Electrad, Radio City Products, John F. Rider, Kester Solder, American Transformer, Acratone Radio.

The Television equipment developed and built by Joseph Lukacs and J. E. Jones proved to be the hit of the show. They demonstrated, quite ably, the possibilities of television as it is developed to its present stage by several demonstrations, one of which was an experiment in radio set repair.

HELPFUL SHORT-WAVE DATA

The Cornish Wire Co., 30 Church Street, New York City, manufacturers of radio antenna products and radio wire, announce the publication of a comprehensive treatise on All-Wave (short-wave) Antenna Kits and Accessories.

A feature of this work is a map of the world, showing the important short-wave stations, with their call letters and kilocycle designations. The reverse side explains the importance of the aerial in modern long-distance and short-wave radio re-

ception, pointing out that the Service Man is the man to do the job of adjusting a customer's radio antenna to local conditions.

The company continues by cataloguing its kits and antenna parts, including an ordinary kit (No. 10) . . . also a kit for the circuit recently patented by Amy, Aceves and King.

The chart is listed at 25c. for consumer distribution, but is free for inspection and distribution by dealers, wholesalers and Service Men, who are invited to communicate with the Cornish Wire Company at once for a supply.

NA-ALD CATALOG

The Alden Products Company, 715 Center Street, Brockton, Mass., have available their 1935, 14-page catalog covering the following Na-Ald (trade mark) products: Analyzer plugs and associate adapters, laboratory test prods and accessories, sockets, cable connectors, microphone cables, plug-in coils, dials, short-wave condensers, victron insulated short-wave and transmitting products.

NEW TOBE MERCHANDISER

The Tobe Condenser Merchandiser, shown in the accompanying illustration, is an all-metal, three-sided display (that may be rotated at will) of Tobe Exact Duplicate Electrolytic Condensers. It contains one each of all of Tobe's various replacement condensers, such as RCA Victor, Crosley, Majestic, Kadette, Emerson, Atwater Kent, Stewart-Warner, etc. It also contains one each of the most popular standard Tobe condensers . . . some 56 condensers in all.

This merchandiser is delivered with all condensers in place, the individual units being held by spring clamps from which

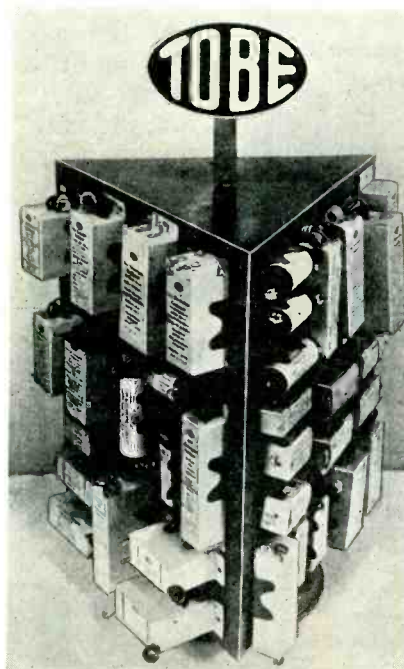

Unique counter replacement-condenser merchandiser with rotating display.

they may be removed when sold. All of the merchandise furnished with this unit is taken from regular stock, and each display place is marked so that the merchandiser may be kept filled from the user's stock.

A deposit, which is refunded when the condenser purchases total a given amount within one year from the date of the invoice, is all that is required on this display stand. The condensers are billed at regular list prices less jobber's discount. The condenser merchandiser is one of the new selling ideas of the Tobe Deutschmann Corporation of Canton, Mass.

INTERFERENCE-FILTER PRICES

In keeping with the far-reaching purposes of the interference-prevention campaign launched by the Radio Manufacturers Association during the recent I. R. E. convention at Rochester, N. Y., a marked reduction in list prices of interference filters is announced by the Aerovox Corporation, Brooklyn, N. Y.

SOLAR SERVICE CATALOG

The Solar Manufacturing Corporation, 599-601 Broadway, New York City, manufacturers of Fixed Capacitors for radio use, announce the issuance of their latest Special Service Catalog No. 6-S.

Features of special interest to the service trade include Ultra-Compact Dry Electrolytics in various voltage ratings, Special Self-Healing Type Wet Electrolytic Condensers, Auto Vibrator and Suppressor Condensers, together with a wide assortment of Paper, Mica, Trimmer and Padding Condensers.

REPLACEMENT CONDENSER CATALOG

Constantly adding to its regular stock of exact duplicate replacement condensers for the more popular makes of sets in current use, the Aerovox Corporation of Brooklyn, N. Y., is issuing supplementary bulletins from time to time in bringing the listings up to date. The latest bulletin just issued carries an impressive array of replacement units. New items are being added to the line as rapidly as the demand warrants an economical production schedule. Types not listed may be obtained by submitting samples of condensers which have failed in service together with data as to the sets in which they are used, capacity and voltage ratings. The exact duplicate replacement condenser bulletins are available on request.

SYLVANIA FLASHING ELECTRIC SIGNS

The Hygrade Sylvania Corporation, Emporium, Pa., are offering for sale a neon flashing electric tube seller. This sign, which is lithographed in five brilliant colors, really features two signs in one . . . the signs being different for the conditions of off and on, the first condition suggesting that the prospective customer have his tubes checked and the second condition advertising Sylvania Set-Tested Tubes. All that is necessary to put the sign to work is plugging it into the socket, it is stated. The actual face size of this display is 14½ x 11 inches.

Leaky Condensers Cause Distortion

noise, unbalanced voltage distribution, incorrect tube operation, and many other common troubles.

Capacity and ohm meters do not indicate these faulty condensers, but the



CONDENSER ANALYZER
will find the defective condenser instantly!

Only \$11.40 net to servicemen.
Order One Today

All TOBE products are stocked by the following jobbers in the state listed below:

(See past issues for other states)

PENNSYLVANIA

Radio Electric Service Co., 1024 Hamilton Ave. Allentown
John V. Duncombe, 1101 W. 8th St. Erie
E. J. J. Gobrecht, 120 E. Chestnut St. Hanover
Radio Distributing Co., 1128 Market St. Harrisburg
Eshelman Supply Co., 214 W. Chestnut St. Lancaster
Elliott & Waddington, 116 N. Mercer St. New Castle
Kratz Bros., Cor. Kohn & Oak Sts. Norristown
Herbach & Rademan, 438 Market St. Philadelphia
M & H Sporting Goods Co., 512 Market St. Philadelphia
Radio Electric Service Co., N. E. Cor. 7th and Arch. Philadelphia
Cameradio Co., 603 Grant St. Pittsburgh
Hamburg Bros., 963 Liberty Ave. Pittsburgh
George D. Barbey Co., 404 Walnut St. Reading
Fred P. Pursell, 403 Olive St. Scranton
Elk Electrical Co., Inc. Fleming Block. St. Marys
Radio Service Co., 50 Hazle Street. Wilkes-Barre
G. A. Hayes, 448 Market St. S. Williamsport
Lincoln Hi-Way Service Station, 624 W. Market St. York

TOBE DEUTSCHMANN CORP.
CANTON, MASSACHUSETTS

HIGH GAIN AMPLIFIER WITH CRYSTAL INPUT



**THE TURNER S-16
PORTABLE PUBLIC
ADDRESS SYSTEM**

Turner high-gain amplifiers are specially designed for crystal microphone input. No pre-amplification necessary. Tube noise reduced to minimum and all hum eliminated. All parts operate with high safety factor.

Illustrated above is the Turner S-16 Portable Outfit complete with the new Turner Type G Crystal Microphone, the ideal instrument for PA work as it requires no energizing current and will withstand rough handling.

Other items in the Turner line include a variety of amplifying units for various purposes, line amplifiers, pre-amplifiers, field supply units, microphones and speakers. Write for descriptive circulars and full information concerning the profit possibilities in this field.

THE TURNER COMPANY
CEDAR RAPIDS, IOWA, U.S.A.

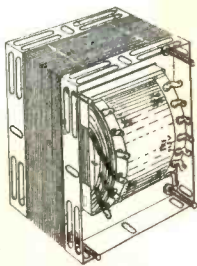

Popular?

Yessir! The Kenyon Standard Line is probably the most popular replacement line used by Servicemen today.

With 5 types in stock you can service practically any standard receiver — efficiently — profitably. Our replacement transformer chart tells you how—get a copy today!

Kenyon makes a transformer for every purpose; Inputs, Outputs, Audio, Line Chokes, Microphone, Filament and Dreadnaught Transmitting Transformers,—also any special transformer or choke—at real low prices.

Kenyon's Free Service Data is extremely valuable to all Servicemen. Get a copy from your distributor or write to us direct, giving his name.

**KENYON
TRANSFORMER CO., Inc.**
840 Barry Street, New York City



"No Radio Can Be Better Than Its Aerial—
No Aerial Is as Good as a LYNCH Aerial"

LYNCH
- HI-FI -

TRADE MARK REGISTERED

High-Fidelity

ANTENNA SYSTEMS

PATENTED and GUARANTEED
For Your Protection • To outperform any other aerial

The only system employing Lynch GIANT KILLER Cable—the king of all transmission lines. You make MORE profit. You gain prestige. Your customers will tell others.

What Are YOU Doing About It?

Servicemen prefer to make LYNCH installations because no mechanical difficulties are encountered; they deliver what is expected from them every time; and as many as 15 receivers may be fed by a single antenna. There is a LYNCH antenna to fit every price and physical requirement.

Full Information on Request

ARTHUR H. LYNCH, Inc., 227 Fulton St., New York, N.Y.
PIONEER OF NOISE-REDUCING AERIALS

THE MANUFACTURERS . . .

NEW RCA CATHODE-RAY OSCILLOGRAPH

A new complete, compact, ac-operated Cathode-Ray Oscillograph has just been announced by the RCA Victor Division of the RCA Manufacturing Co., Inc., Camden, N. J. The unit is shown in the accompanying illustration. This oscillograph has been designed for use by Service Men, for use by amateurs and experimenters, for educational institutions, for radio dealers, and for radio manufacturers.



The Type TMV-122-B Cathode-Ray Oscillograph is complete and ready for immediate use. It includes two power supplies (one for the tube and one for the amplifier), vertical and horizontal amplifiers, synchronizing frequency generator and six tubes, including the RCA-906 Cathode-Ray Tube, which is a 3-inch unit.

Through the use of two wide-frequency-range high-gain amplifiers, the sensitivity is said to be 2 volts dc per inch for both vertical and horizontal deflection. The amplifiers have flat frequency characteristics between 20 and 90,000 cycles \pm 10 percent. The amplifier gain is approximately 40.

NEW VACUUM-TUBE VOLTMETER

Clough-Brengle engineers have now developed a new portable, accurately calibrated, vacuum-tube voltmeter expressly

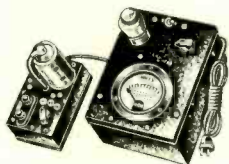

designed for radio service work. The new Model UC, shown, will read potentials as low as .2 volt without drawing any current from the circuit under measurement, it is stated.

The Model UC likewise is designed for measurement of voltage at both radio and

audio frequencies. These properties give it application for uses, such as, measurement of audio and r-f gain, hum level, noise level, locating shorted r-f and a-f coils, and impedance of transformers and speaker voice coils.

The manufacturer has just prepared a new descriptive bulletin which will be mailed on request. Address the Clough-Brengle Co., 1134 W. Austin Ave., Chicago, Ill.

ALLIGATOR CLIP

The Alligator Clip, shown in the accompanying illustration, and manufactured by the Mueller Electric Co., 1583 East 31 Street, Cleveland, Ohio, is a small clip with slender, elongated jaws for radio and electrical test work . . . a clip which is said to combine the design features of their Universal Clip with the advantages of an ordinary alligator clip for getting into tight places.



The following are the exclusive design features claimed for this clip: Meshing teeth on three sides of jaws, both screw and banana terminal connections, unusual strength, handiness, and an insulator (sold separately) to prevent short circuits and electric shocks. An internal recess at the end of the insulator automatically snaps around the tubular barrel holding the clip firmly.

Further information relative to this Alligator Clip, designated as No. 85, may be obtained from the circular 680-L.

NEW LYNCH REPLACEMENT RESISTORS

A new type of resistor, claimed to have important advantages with regard to replacement service, has been announced by the Lynch Manufacturing Co., Inc., 405 Lexington Ave., New York City.

According to the manufacturer, the new design of resistor is the result of a number of years of research and experiment. The type of resistor is said to differ from others in that the background material or basic composition is in itself a resistance



material into which another resistance material of lower value is introduced. The entire mass, after it has been reduced to absolute uniformity, is subjected to tremendous pressure and under such pressure extruded into rods. The result is said to be one solid uniform compact current-carrying mass having a uniformity equivalent to the cross-section of a gun forging.

An idea of the uniformity of these resistors can be gained from the accom-



Fig. 1. Cross-sectional photo of resistor (80-power).

panying micro-photographs of a cross-section of one of the resistance rods. The photo of Fig. 1 was taken under an 80-power microscope and the photo of Fig. 2 under a 600-power microscope.

It is said that further microscopic study under normal and excessive wattage indicated that "light" points, or points of excessive microscopic current density do not exist in the resistors. To maintain these "noiseless" characteristics under practical conditions, a special contact was developed which consists of a metal surface at each end of the resistor over which is placed a solid piece of metal in the form of an end cap to which end cap is integrally attached the pigtail.

According to the manufacturer, cathode-ray tube tests revealed the new resistor to be noiseless and that no unit dropped in value under various loads up to double wattage and voltage up to 288 and above.

(Continued on page 37)



Fig. 2. Cross-sectional photo of resistor (500-power).

Microphone and Line Transformers

Jefferson Quality Design and Construction Improve Performance



For 'phone and Amateur Work

These small but efficient transformers are designed for use with single-button microphones. Unshielded style shown, No. 467-413, for coupling mikes to 200,000 ohms is a low priced unit particularly suited for home and inter-office communications or where voice predominates. No. 467-261 is the shielded transformer of this type—for mikes to work into 500,000 ohms.



Line Transformers

No. 467-177 is for coupling a single triode, 25,000 ohms to 200 or 500-ohm line. No. 467-178 is for coupling either a 200 or 500-ohm line to a single or push pull grid.

Phonograph Pick-up Transformers

The No. 467-181 Transformer gives exceptionally fine reproduction over the entire musical scale. It is designed to work with low-impedance pick-up. In quality it is all the "Jefferson" name implies.



JEFFERSON RADIO FUSES are designed to protect radio sets against damage due to excessive current surges or short circuits. They carry a 10% overload indefinitely and will blow at a 50% overload. Standard packages consist of 100 fuses (20 metal boxes, each containing 5 fuses of one size).

Microphone Transformers

Microphone and Line Transformers in this line include types for every purpose and are engineered to give the utmost in service and performance.

Three shielded and two unshielded transformers are made, in one-button and two-button types. Shielded types in attractive black enameled cases with binding posts, unshielded types with brackets and leads. For accuracy and uniformity, the coils are machine wound and vacuum impregnated.

Designed for coupling the output tube of the preamplifier to a transmission line or pad and matching the impedance of a transmission line to the input of the amplifier. Assembled in black enameled cases equipped with lugs.

These transformers are only part of a comprehensive line, consisting of replacement power transformers of universal design, audio, input, output, filament and amplifier transformers and chokes.

Since the inception of commercial broadcasting, Jefferson Transformers have been the choice of discriminating radio buyers. Superiority of design and operation plus the most advanced constructional features insure a continued preference for Jefferson quality. There is not a more profitable line for the service parts distributor and dealer. Send for Catalog 342-R and latest price schedules. JEFFERSON ELECTRIC COMPANY, Bellwood, (Suburb of Chicago), Illinois.

SEND FOR these up-to-date Amplifier Diagrams:

- 1—2A-3 Amplifier
- 2—Class B "59"
- 3—2B-6 Amplifier
- 4—38 watt Parallel PP Class A Prime

FREE—Use Coupon →

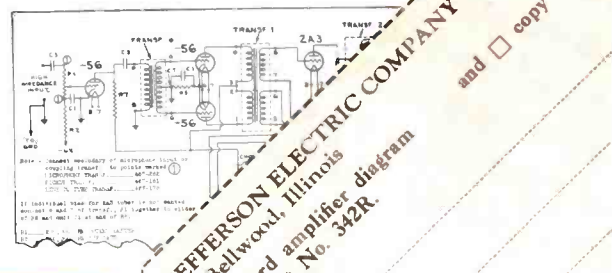

JEFFERSON ELECTRIC COMPANY
Bellwood, Illinois
Please forward amplifier diagram of Catalog Sheet No. 342R.
Name _____
Address _____
City _____
State _____
and copy

JEFFERSON

Radio Transformers

THE
life-time
ANALYZER
now made in
two models

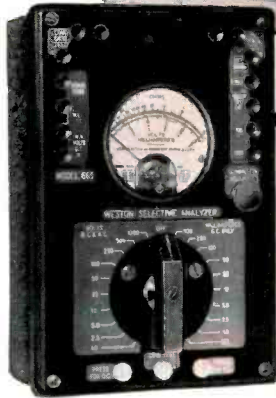

ROTARY SWITCH MODEL



PIN JACK MODEL

Both models illustrated use Weston Socket Selectors

The demand for Weston Selective Analyzers proves conclusively that dealers and service men are finding it highly profitable to use nothing but a quality, life-time analyzer. This selective method of analysis, introduced by Weston, now is standard practice among radiomen everywhere.

To suit all requirements, two types of the famous Model 665 now are available. Type 1 employs a rotary switch for the selection of ranges . . . while Type 2 has a series of pin jacks and is offered at much lower cost.

Both types have the same broad list of ranges, and combined with the Weston Socket Selector Set are truly universal in their capacity to analyze radio receivers. A bulletin is available giving complete information on these life-time analyzers. Return the coupon today . . . Weston Electrical Instrument Corp., 604 Frelinghuysen Ave., Newark, N. J.

WESTON
Radio Instruments



WESTON ELECTRICAL INSTRUMENT CORP., 604 Frelinghuysen Ave., Newark, N. J.
Send bulletin on Weston Radio Instruments.

Name _____
Address _____
City and State _____

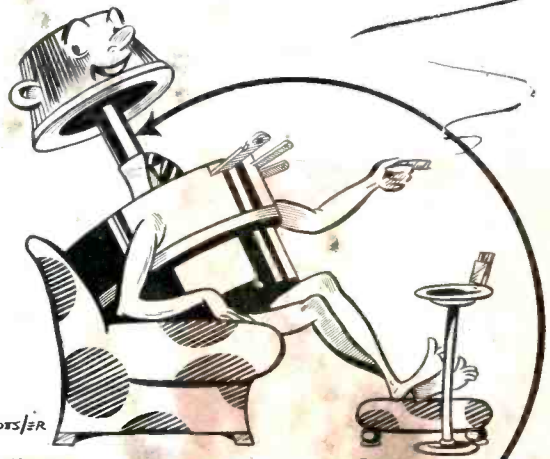

"Pretty Soft"

Not that I'm a softie . . . but with my new shaft of aluminum you can almost "bite" me off with a good pair of pliers . . . in fact a few swipes with a file and I'm down to the required size.

Just another refinement that makes it so much easier to use me in a replacement job. And do I work smooth? . . . ask thousands of servicemen the world over who always use CENTRALAB RADIOHMS for ALL their jobs. Don't say "Gimme a Volume Control." Specify RADIOHMS the next time you stock up.

The new RAD-10HM offers a smoother attenuation because of greater effective length of resistance strip employed.

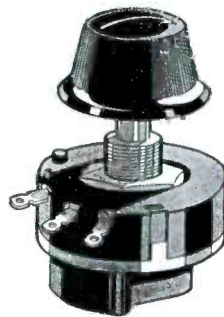

Centralab

Division of Globe-Union Mfg. Co.
MILWAUKEE

Every Radio Service Man should be a member of the Institute of Radio Service Men

Centralab
RADIOHMS

Fixed Resistors Sound Projection Controls Suppressors

NEW ROLA HIGH-FIDELITY SPEAKERS

The Rola Company, Cleveland, Ohio, have just announced a new group of electro-dynamic speakers which they state are designed to meet the industry's requirements for high-fidelity reproduction, greater power-handling capacity and high efficiency. The Model G-12 is a unit suited for use with all types of radio equipment, electro-musical instruments, theatre and public-address systems. The following improvements are claimed for the G-12: New cone designs, a new method of cone suspension, a new spider and clamping means, a new large, high-efficiency, voice coil and



an improved method of balancing the cone and voice-coil assembly.

The Model G-12 is a 12-inch speaker with large field-coil structure (maximum 3½ pounds wire capacity). It is available in either high fidelity (50 to 7500 cycles with variation of response of less than 10 decibels) or general response (50 to 5000 cycles with a variation of response less than 10 decibels) for either ac (any voltage or frequency) or dc, of any field resistance, and with transformer to meet any output-tube requirements.

The Model G-12 ac, shown, is equipped with a standard type 80 rectifier tube, with filter circuit including filter capacitor and hum-neutralizing coil. It is supplied with input transformer or with input direct to 8 ohm voice coil.

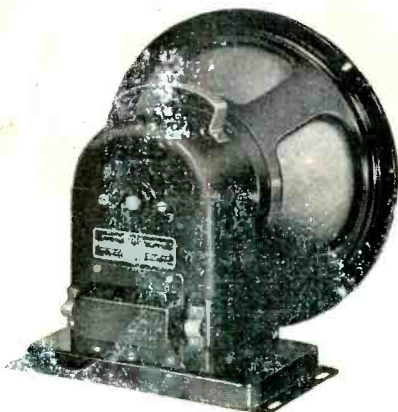

The Model G-12 dc, also shown, is designed for operation from direct current or from conventional field supply from radio set, amplifier, etc. A hum-neutralizing coil is also included as standard equipment.

Further information may be obtained from the above company.

SHURE CRYSTAL MICROPHONE

The Model 70H Crystal Microphone, manufactured by the Shure Brothers Company, 215 West Huron St., Chicago, Ill., is a general purpose instrument, designed for direct mounting on microphone stands and does not require suspension rings or springs.

The unit is of the diaphragm-actuated type. Vibrations of the diaphragm produced by sound waves are transmitted to the crystal element through a "matched-impedance" mechanical-coupling system. This system employs the "cantilever" principle, thus providing efficient transfer of energy from sound wave to crystal element, it is stated.

The crystal and associated mechanical system are mounted in a heavy cast-metal case of bevel-edged design, finished in chromium plate overall. The diaphragm is protected by a heavy, chromium-plated screen.

The Model 70H is said to have the following features: No batteries or power supply required, no hiss or internal noise, excellent frequency characteristic, moderately high output level, remarkably immune to mechanical vibration pick-up, unaffected by ordinary temperatures or humidity, and only moderate care in handling required.

Full information may be obtained from the above company.

MODEL "M" VELOCITY MIKE

The new De Luxe Model "M" Velocity Microphone, shown in the accompanying illustration, has been designed to meet the requirements of broadcasting studios, recording studios, sound-equipment companies and public-address users, states their manufacturer, the Bruno Laboratories, 22 W. 22nd St., New York City.

Two cobalt magnets are used to produce the magnetic field in which is suspended the aluminum alloy ribbon. These magnets are placed vertically, end to end, and the ribbon suspended in the dense portion of the magnetic field. A sound wave striking the ribbon will then continue to travel without impediment and will not be reflected back by the inner portion of the horseshoe magnets as is the case of poorly designed velocity microphones, it is said.

These units are said to possess a rugged construction, a flat frequency-response curve from 30 to 14,000 cps, a directional characteristic enabling the reduction of



acoustic feedback, and are said to not be subject to variations of humidity and temperature. The matching transformers used in these mikes are wound on permalloy cores with an impedance output either 200 or 500 ohms, although other ohmages can be supplied.

NEW TUBULAR CONDENSERS

The Federal Engineering Co., 286 Mercer Street, New York City, have just announced a new line of tubular condensers in all



sizes and capacities. A .5-mfd. 400-volt (working) dc unit is shown in the accompanying illustration.

NEW HOMCHARGER

The New Hi-Rate Homcharger is a unit designed to charge the average car battery overnight and at a total cost, in most localities, of only a nickel, it is stated.

This charging unit starts at approximately 10 amperes, this rate automatically dropping as the battery becomes charged. Since its output is automatically adjusted to the needs of the battery, the unit may be left connected for an indefinite period without resulting harm, it is said.

Detailed literature is available from the Automatic Electrical Devices Co., 324 East 3rd St., Cincinnati, Ohio.

BELL P-A SYSTEM

The Bell Model P. A. 2C Public-Address System, shown, has been developed to meet the increasing demand for a practical, high-quality, light weight and efficient single unit, twin-speaker portable public-address system, it is said. This equipment may be used for public address in auditoriums, funeral homes, night clubs,



hotels, for paging, in ballrooms, theatres, dance bands, for publicity, political speeches, advertising, etc.

The new Crystal Microphone is utilized to make this the most modern sound amplifying system ever offered at a moderate price, it is said. The frequency response is further said to be superior to the best carbon or condenser type of microphone.

Three-stage resistance-coupled, Class A amplifier, has a wide range frequency response. All filter components are built into the amplifier chassis. The tubes utilized are as follows: 1-type 2A6; 1-type 53; 2-type 2A5's and 1-type 80. The power output is 7 watts. The following controls are provided: ac, on-off switch, volume control, tone control, and a two-program selector switch.

The entire system nests into one case 16" by 19" by 13" and weighs 50 pounds.

Manufactured by Bell Sound Systems, 264 North 4th St., Columbus, Ohio.

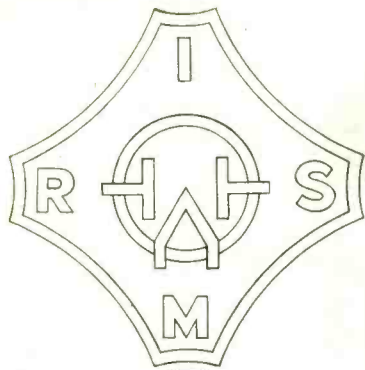

THE EYES OF THE
RADIO SERVICE INDUSTRY

WILL BE TURNED TO

CHICAGO

MARCH 22, 23, 24, 1935

WHEN THE

THIRD ANNUAL CONVENTION

AND

TRADE SHOW

OF THE

RADIO SERVICE INDUSTRY

WILL BE HELD AT THE HOTEL SHERMAN

For RADIO SERVICE MEN, Engineers and Amateurs:

Exhibits of the latest things in Parts, Test Equipment, Public Address, Cathode Ray, Meters, and so forth.

Service Talks by the most outstanding speakers in the Radio Service World—on subjects close to your heart.

Demonstrations of unusual Electronic Apparatus. The opportunity to meet and become acquainted with those that manufacture the products you use every day.

For RADIO PARTS DISTRIBUTORS:

Meeting: Parts division Radio Wholesalers Association to which all Parts Distributors are invited.

For RADIO PARTS MANUFACTURERS:

The opportunity to meet real Radio Service Men. The opportunity to get their direct opinions of your products. The opportunity to effectively promote the sale and distribution of your merchandise.

The Institute of Radio Service Men, Inc. (a Professional Association)

AND

The Institute of Radio Service, Inc. (a Trade Association)

Invites You to Attend

ADMISSION FREE



"E. H. Rietzke SPEAKING!"



Mr. E. H. Rietzke, President of CREI and originator of the first thorough course in Practical Radio Engineering.

The Service Man Who KNOWS More— Is The Man Who EARNS More!

Radio developments change overnight! No other industry today is setting such a fast pace . . . and it takes real *technical training* for the service man to make a success and to keep in stride. It is your efficiency and thorough training that will put you ahead of the other fellow.

Your CREI Diploma Will Prove More Valuable Than Your Tool Kit—

This is the day of the Service "engineer" rather than the service *mechanic*. We provide you with "tools" in the form of knowledge and training, which in the long run will be of far more importance than your "screw-driver."

Don't put it off again—write today for full particulars about our Home-Study and Residence Courses and how easy it is to pay for them.

44-Page Illustrated Booklet Mailed On Request!



Capitol Radio Engineering Institute

Dept. S-1

14th & Park Rd., N.W., WASHINGTON, D.C.



MAKES THE RIGHT TOOLS For the Right Radio Repair Job!

NEUTRALIZING AND ALIGNING TOOL KIT

With carrying case. Includes every possible combination of convenient neutralizing tools which servicemen MUST have. 12 separate and distinct telescoping parts, some of which can be used for several operations. Supplied in black leatherette vest pocket case. List price complete



RADIO SCREW DRIVER KIT WITH INSULOID HANDLE

Five special radio screw drivers. High Grade carbon steel and Insuloid shock-proof handles. Sizes 4 1/2" to 10 1/2" long and blades of 1/8" to 3/16". For all radio needs. List price



FREE CATALOG
Just off the press! Hundreds of latest developments for servicemen. Big selection of S.W. Parts, Kits, etc. Get your FREE copy today!

\$1.75

DISCOUNT of 40% applies on above when purchased from your Jobber or Mail Order House . . . or write us direct and we will see that you are supplied.

INSULINE CORPORATION OF AMERICA
23-25 PARK PLACE Dept. S-125 NEW YORK, N. Y.

TWIN SPEAKER P.A. SYSTEM



MODEL P.A. 2C

Specifications:
2 10-inch electro-dynamic speakers; high fidelity amplifier.
7-watt output.
Crystal Micro-
phone.

Price: \$121.50
(with tubes)

Other models for portable or permanent installation.
Prices from \$59.50 up.

Some valuable territory still available. For details write
BELL SOUND SYSTEMS, Inc.

264 N. FOURTH ST.

COLUMBUS, OHIO

SERVICEMEN!



BUILD THIS Lafayette UNIVERSAL BRIDGE

No Serviceman, Set Builder, Amateur, or Experimenter can afford to be without a Bridge—when the new Model 4AC Lafayette UNIVERSAL BRIDGE is available at so low a price!

The Lafayette UNIVERSAL BRIDGE will measure resistances of from .01 ohm to 1 megohm and capacities of from 100 mfd. to .0001 mfd.—with an overall accuracy within 5%.

Many uses will suggest themselves, for instance: for measuring the accuracy of condensers; checking the resistance of contact switches, etc.

There's no guess work when you have the Lafayette UNIVERSAL BRIDGE . . . and you can save money by building it yourself. Size when completely built: 9" x 4 1/2" x 2 1/2". All scales are etched on front panel in white. Comes complete with full directions for assembly and for use.

Complete Kit of Parts \$10.95

If wanted wired and assembled, add \$1.00

GET THIS AMAZING BARGAIN BOOK



and SAVE MONEY

**NO. 56B
IT'S
FREE**

This brand new catalog—just off the press—is unlike any Bargain Book ever published! It is a supplement

to our Catalog 56 but unlike most supplements every single item listed is a genuine BARGAIN.

Most companies which issue so called Bargain Books list regular items at regular prices . . . with a scattering of real bargains. But here every item from cover to cover is an outstanding value!

And every item is brand new, first quality merchandise . . . up to the high standards set by Radio Headquarters during 14 years of Serving the Radio Industry! Here is an opportunity for every Serviceman to stock up on needed replacement parts, Short wave parts, kits and accessories, testing equipment and many other items among the hundreds listed in this 32-page BARGAIN BOOK.

WHOLESALE RADIO SERVICE CO.
100 Sixth Ave., Dept. S-15
New York City

- Send me the Lafayette UNIVERSAL BRIDGE KIT @ \$10.95.
- Send me above completely wired @ \$11.95.
- Send me your BARGAIN BOOK 56-B.

Name
Address
City State

WHOLESALE RADIO SERVICE CO., INC.
NEW YORK | NEWARK | ATLANTA
100 Sixth Ave. | 219 Central Ave. | 430 W. Peachtree St. N.W.



Ken-Rad Radio Tubes

DEPENDABLE LONG LIFE

Ken-Rad Radio Tubes are made to give clear, dependable reception. They satisfy customers and build good will for dealers. Write for full information.

THE KEN-RAD CORPORATION, Inc., Owensboro, Ky.
Division of The Ken-Rad Tube and Lamp Corporation
Also Mfrs. of Ken-Rad Incandescent Electric Lamps

A hit! The 7-POINT MICROPHONE

THIS

Here's why the Amperite Velocity Microphone gives you the best in quality and value. . . . (1) Wider frequency range. No peaks; no distortion. (2) Directional quality makes it easy to eliminate feedback. (3) Wider area of coverage. One Amperite Velocity Mike will replace several diaphragm type mikes. (4) Not affected by temperature, weather conditions or age. (5) Rugged construction. (6) Best value in mikes, or money refunded. (7) Fully guaranteed for one year against any service costs. Order from your wholesaler. Write for Illustrated Bulletin S-2.

AMPERITE Corporation 561 BROADWAY NEW YORK

AMPERITE VELOCITY MICROPHONE

NOT THIS



SOLAR

WET AND DRY ELECTROLYTIC
PAPER AND MICA CONDENSERS

RECOGNIZED FOR
SUPERIOR QUALITY
IN ALL CLIMATES
THE WORLD OVER

SOLD BY LEADING
JOBBERS EVERYWHERE

SOLAR MFG. CORP.
599 BROADWAY
NEW YORK

BEST BY TEST!

ASK FOR
CATALOG
OF EXTREMELY
COMPACT TYPES
HANDY FOR SERVICE

A FEW GOOD TERRITORIES STILL OPEN

REPRESENT US — THERE IS GOOD MONEY IN IT!

MAKERS OF

**FREE EDGE
CONE AND VOICE
COIL ASSEMBLIES**





**BAKELITE BOBBINS
FIELD COILS FOR
ALL DYNAMIC SPEAKERS**

We also Manufacture Various Types of Magnetic Speakers
We can Supply and Remedy Your Speaker Needs
SPEAKER MANUFACTURERS SINCE 1921

LEOTONE RADIO CO. 63 Dey Street, New York City

Great News for Servicemen

FREE Catalog

184 PAGES of the most versatile
line of radio and equipment of any
Mail Order concern in the country.
SEND FOR YOUR COPY TODAY!

More PROFITS for YOU!

192 PAGES tells how to make BIG MONEY in short-wave and public address paraphernalia. Bound in a sturdy Cardinal Red LEATHERETTE COVER. 50c.

TRY-MO RADIO CO., Inc., 85-SE Cortland St., New York, N. Y.

SERVICE ENCYCLOPEDIA OF ACTUAL RADIO TROUBLES

Bertram M. Freed has compiled all his important service notes into a book consisting of 200 pages and 46 diagrams. It is closely packed with information covering the weak points in over 500 different model receivers with their symptoms and corrections.

Price includes one FREE Supplement which contains over 200 additional Models, Diagrams, and Illustrations. **\$1**

If your regular Jobber or Mail Order House cannot supply you, write direct to—

SERVICEMEN'S PUBLISHING COMPANY
136 LIBERTY STREET NEW YORK CITY



ONE OF THE SUPREME FIDELITY AMPLIFIERS

THREE STAGE HIGH GAIN
PUSH-PULL 2A3
Uses 2-53, 2-2A3 and 1-5Z3 Tubes

15 WATTS OUTPUT **\$24.50**
Less Tubes

WE MANUFACTURE AN
AMPLIFIER FOR EVERY
PURPOSE.

Send for a copy of our new Sound Manual and general catalog.

Wholesale Merchandisers, Inc.
626 Broadway, Dept. E, New York City

Federal REPLACEMENTS EXACT DUPLICATE

↓

"Quality Transformers"

Built to strict specifications as demanded by U. S. Navy requirements and unconditionally guaranteed. Unaffected by severest climatic conditions. Only the highest quality end plates and other parts used. A complete stock of all standard replacements in stock at all times. Prompt delivery.

Also "quality" condenser blocks, I. F. transformers, tubular condensers, oscillators and P. A. Equipment—at surprisingly low prices.

Write for complete catalog of all Federal "Quality" Products. Some desirable territory still open.

Federal Engineering Co., Inc.
286 Mercer St. New York, N. Y.

When Choosing a Radio School

Consider the advantages afforded by the long-established RCA INSTITUTES

The beginner or the experienced man who seeks instruction in any branch of radio will find courses designed for him . . . either at the resident schools in New York and Chicago or in the RCA Institutes Extension Courses for Home Study.

Following Units Especially Recommended to Readers of "Service":
Elementary Radio Mathematics—Advanced Radio Mathematics—Advanced Radio Servicing—Sound Amplification

Resident schools are fully equipped, conveniently located, low weekly tuition rates. Home Study Courses are on the "no obligation" plan. Free post-graduate practical training period at a resident school.



Catalog on Request

RCA INSTITUTES, Inc.
 Dept. SV-35

75 Varick Street, New York
 1154 Merchandise Mart, Chicago

Radio Repair Men . . . Amateurs

Sears, Roebuck and Co., The World's Largest Mail Order Company (in the Radio and Parts business for almost 20 years) announce for restricted distribution a new Wholesale Radio Parts and Amateur Equipment Catalog.

24-HOUR SERVICE

Everything carried in stock—the broadest guarantee ever written—complete satisfaction or your money refunded.

Write today for catalog No. 57S61. We will put your name on our mailing list and send you this big, new catalog as soon as it is off the press.

57S61

Sears, Roebuck and Co., Chicago, Ill.

IT IS only reasonable to expect more from specialists. Whether you are buying a car, a loaf of bread, a room of furniture, or a tube tester—it pays to buy from companies that make a **SPECIALTY** of what you want.

DAYRAD

SPECIALIZES IN RADIO SERVICE INSTRUMENTS

Our research and engineering laboratories are devoted exclusively to development and improvement of radio service instruments. Our business is done entirely with the experts who, like yourself, make a business of radio service.

Write for our catalog.

THE RADIO PRODUCTS CO. 125 SUNRISE PLACE DAYTON, OHIO

this SERVICE GUIDE FREE



You need this new 1935 ALLIED Catalog! Over 100 pages of highest quality standard radio equipment—thousands of exact duplicate parts—all leading makes of test instruments. Before you buy, consult your new ALLIED Catalog—it will help you give better service at bigger profits. Send for this new 1935 Catalog now.

ALLIED RADIO CORPORATION

833 W. JACKSON BLVD., CHICAGO, Dept. N.

Gentlemen:
 Send me **FREE** your New 1935 Radio Catalog which is packed with thousands of highest quality radio parts selected especially for the Radio Serviceman.

Name

Address

City

Supplemented for 1 year free.
STEP AHEAD

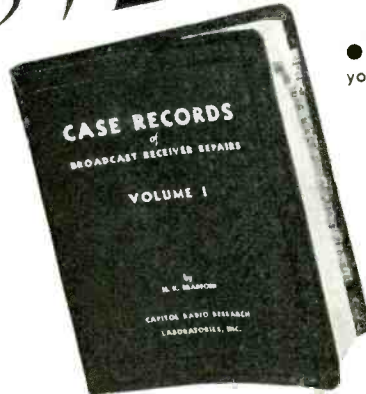

of the rank and file—with "CASE RECORDS" OF BROADCAST RECEIVER REPAIRS

● Add 10,000 hours to your service experience!

● ELIMINATE GUESS WORK IN YOUR SERVICING!

● DON'T PUZZLE YOUR PROFITS AWAY!

Your work has already been done and recorded for you in CASE RECORDS. This 9x12" flexible leatherette binder contains 1,500

alphabetically and numerically arranged CASE RECORDS of successfully completed

service jobs. Each Record tells—symptom—parts responsible—electrical values—location, and best replacement or repair. This Manual introduces the fastest technique known to the service profession. \$4.75 postpaid with supplements.

108 receiver makes listed. 3,000 models.

Capitol Radio Research Laboratories, Inc.

1503 TWENTY-FIRST STREET, N. W., WASHINGTON, D. C.

Originators of Case Record Servicing Technique

Please send me complete information on "CASE RECORDS OF BROADCAST RECEIVER REPAIRS" and your introductory DATA SHEET offer. I understand that this does not obligate me in any way.

NAME

ADDRESS

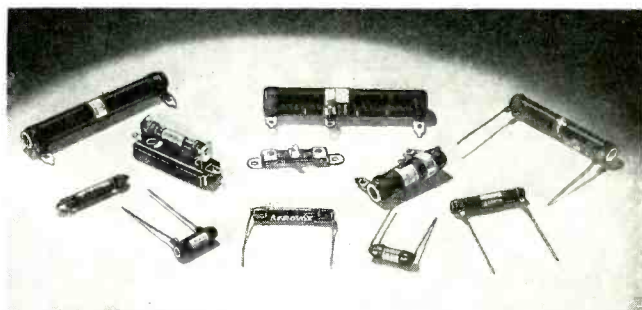

AEROVOX for RESISTORS, Too!

Not only a complete line of condensers, but also a complete line of resistors, is offered by Aerovox:

- Carbon Resistors . . . non-inductive, non-hygroscopic, unaffected by humidity changes . . . choice of sizes, wattages, resistance values.
- Wire-Wound Vitreous-Enamel Pyrohm Junior Resistors . . . no larger than usual carbon types but with wattage ratings of 5, 10, 15 and 20 . . . standard resistance values.
- Adjustable Pyrohm Vitreous-Enamel Wire-Wound Resistors . . . for voltage divider networks . . . for transmitters . . . for industrial needs.
- Wire-Wound Fibre Strip Resistors . . . eyelet terminals . . . also center tapped.
- Vitreous-Enamel Resistors with all types of terminals.
- Lavite Resistors and Grid Leak Resistors . . . also mountings.

Remember this: Aerovox means one source of supply for condensers and resistors . . . one order . . . one bookkeeping entry . . . one check in payment . . . a big saving not to be overlooked!

NEW CATALOG: 1935 Edition just off press . . . sent on request . . . covers entire line of condensers and resistors. Also sample copy of monthly Research Worker.



AEROVOX

CORPORATION

80 Washington St. : : Brooklyn, N. Y.

JOBBER!

Be ready February 10th with all the parts specified for the sensational ALL-STAR JUNIOR. Extensive publicity "breaks" at this time. Get in touch with the 11 Star manufacturers whose parts are used in the ALL-STAR JUNIOR. BELDEN, CORNELL-DUBILIER, CROWE NAME PLATE, ELECTRAD, Inc., ERIC CAN, OAK, HAMMARLUND, MEISSNER, OHMITE, OXFORD, and THORDARSON.

DEALERS!

The ALL-STAR JUNIOR IS A DESIGN sponsored by 11 prominent manufacturers to encourage the use of good quality parts in short wave receivers which are assembled by radio fans. Every detail of the design has been perfected to insure satisfactory performance of the finished set. Your part in the program is to dramatize the set by having a man assemble one in your store window. Display the parts and accessories which your fan customers will want to buy from you. You probably have most of the parts—sell them on this big campaign!

SERVICEMEN!

Learn the circuit of the amazing ALL-STAR JUNIOR. Be ready to help your customers in the assembly of the set and accessories. Sell tested tubes, doublet antenna systems, and cabinets for this fascinating project. The ALL-STAR JUNIOR promotion is a big friendly plan which will bring profit to every phase of the radio industry. Your part of the program is just as important as that of the jobbers and dealers. You are in contact with short-wave fans. BOOST the ALL-STAR JUNIOR. Offer to help in the assembly at your regular service fees. Now is your time to get advance information. WRITE TO

ALL-STAR Jr. Headquarters

360 N. Michigan Ave., CHICAGO, ILL.

BUILD YOUR OWN
ALL-STAR JR.
★ ALL-WAVE Superheterodyne ★

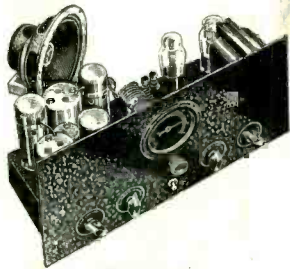

FEATURES
All-Wave Reception
Continuous-Band-Spread
Super-Sensitivity
Latest Type Tubes
High Fidelity Audio System
Pre-Tuned I. F. Coils
Beat-Frequency-Oscillator
All A. C. Operation
Easily Assembled
Low Cost Standard Parts

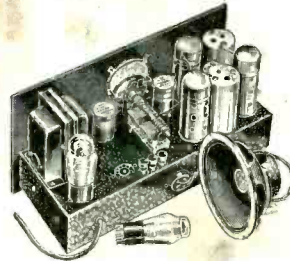

DEPENDABLE Paper Dielectric CONDENSERS

in electrolytic sizes
New Type L

600 Volt peak, 475 working volt.
Supplied in standard replacement capacities.
Physical dimensions comparing in size to equivalent electrolytics.
Metal or cardboard, square or cylinder containers.
Low power factor—will hold a charge for hours proving superiority and lowest possible leakage current!
Non-Polarized, for A.C. or D.C.
Non-Inductive, lowest A.C. resistance.
Superior performance in any capacity.
Long life—no corrosive chemicals to reduce capacity or shorten service.
Lower prices—cost no more than ordinary electrolytic condensers.

Continental Carborite Resistors

Solid Molded CARBORITE Resistors are the choice of leading radio manufacturers and radio test instrument manufacturers. 1000 Volt ceramic insulation covers the ends, as well as the body, of CONTINENTAL CARBORITE Resistors. Eliminate short circuits by using fully insulated resistors in radio service, amplifier construction, and in testing instruments. Jobbers—Dealers, write!

Interesting New Literature Free

CONTINENTAL CARBON Inc.

13912 LORAIN AVE., CLEVELAND, OHIO
TORONTO, CANADA

SPEAKER REPAIR KITS

DEALERS AND
SERVICEMEN

Here is your opportunity to secure a Kit or a complete assortment of Kits suitable to your particular needs. Our own experience in this field has enabled us to design Kits which will simplify your speaker repair work and increase customer satisfaction.

You can't afford to be without it.

MULTIPLEX RADIO SERVICE, INC.

88—4th AVENUE

BROOKLYN, N. Y.

Send
for this
FREE
Attractive
Folder



UNIVERSAL 5-METER HAND SET

A new, 9-ounce, compact hand set—Designed for 5-meter transmitters and 5-meter transceivers—Bent Aluminum rubber-covered handle—2000 ohm telephone receiver—High Output, single button Universal Microphone of 200 ohms—6-ft., 4 conductor cord with color-coded phone tips—List Price \$6.00.

UNIVERSAL MICROPHONE CO., Ltd.

424 Warren Lane

Inglewood, Calif., U. S. A.

INDEX TO ADVERTISERS

Aerovox Corp.	41	Insuline Corp. of America.....	39	Radolek Co., The.....	44
Allied Radio Corp.	41	Jefferson Elec. Mfg. Co.....	35	Rider, John F.	7
All-Star, Jr.	42	Ken-Rad Corp., The.....	40	Sears, Roebuck & Co.	41
Amperite Corp.	40	Kenyon Transformer Co., Inc.	33	Servicemen's Publishing Co....	40
Astatic Microphones Labs., Inc.	29	Leotone Radio Co.	40	Solar Mfg. Corp.	40
Bell Sound Systems	39	Lynch, Inc., Arthur H.	33	Standard Transformer Corp.	
Burgess Battery Co.	31	Lynch Mfg. Co.	Third Cover		Second Cover
Capitol Radio Eng. Inst.	39	Mallory & Co., P. R.	8	Thordarson Elec. Mfg. Co.	27
Capitol Radio Research Labs.	41	Multiplex Radio Service, Inc.	42	Tobe Deutschmann Corp.	29-33
Central Radio Labs.	36	National Union Radio Corp. of		Try-Mo Radio Co., Inc.	40
Continental Carbon, Inc.	42	N. Y.	31	Turner Company, The.	33
Cornell-Dubilier Corp.	27	Ohmite Mfg. Co.	44	United Transformer Corp.	5
Cornish Wire Co.	29	RCA Institutes, Inc.	41	Universal Microphone Co., Ltd.	42
Federal Engineering Co.	40	RCA Radiotron, Division of		Weston Elec. Inst. Corp.	36
General Transformer Corp.	31	RCA Mfg. Co., Inc.	Fourth Cover	Wholesale Merchandisers, Inc.	40
Hickok Elec. Instrument Co.	3	Radiart Corp., The.	44	Wholesale Radio Service Co.	
Hygrade Sylvania Corp.	25	Radio City Products Co.	44	Inc.	39
		Radio Products Co., The.	41	Yaxley Mfg. Co., Inc.	8



RADIO ENGINEERING

Covering the design, production, engineering and test of Radio Receivers, Tubes, Parts, Amplifiers, Recording and Sound Projection Equipment. Published monthly.

Subscription, \$2.00 Yearly
(Foreign, \$3.00)



COMMUNICATION AND BROADCAST ENGINEERING

Covering Radio Communication, Broadcasting, Police, Marine and Aeronautical Radio, Telephony and Telegraphy, Facsimile and Television. Published monthly.

Subscription, \$3.00 Yearly
(Foreign \$4.00)

BRYAN DAVIS PUBLISHING CO., INC.
19 EAST 47th STREET, NEW YORK CITY



Dual Pre-Amplifier and Power Amplifier Combined All A. C. Operated

For every type of P. A. Service—For Audiences up to 10,000 persons or Areas up to 30,000 square feet!

RADOLEK engineers have accomplished the incredible feat of combining two high gain pre-amplifiers with a 36 watt power amplifier and a single power supply circuit—all in one A.C. operated chassis. Input from either pre-amplifier may be used alone or both may be mixed in any proportion before reaching the power stage. Individual mike tone controls govern each input. A master tone control adjusts the output to the acoustical conditions within range of the speakers. Individual microphone volume con-

trols mix either input in any proportion. A master volume control adjusts the output volume to suit the audience. Plug-in connections (also terminals) are provided for two crystal microphones and one phono or radio circuit. One, two, or three dynamic speakers may be plugged in sockets provided for them or connected to terminals provided. Amplifier supplies 40 watts field current. Output transformer is tapped for 3, 6, 9, 15, 250, 500, and 1000 ohms, matching all standard speaker voice coils and line circuits.

FREE

Crystal Amplifier Book! Tells how to make money with this sensational new P. A. Amplifier. Write for your copy.

Restricted Sales Policy

RADOLEK caters to the legitimate radio dealers and radio servicemen. In the March issue of Radio Craft this new amplifier will be featured in a full page advertisement at LIST PRICE. You are protected. You can sell RADOLEK amplifiers and make a legitimate merchant's profit. Readers of Radio Craft are referred to their local radio dealers for further information on the new Crystal Amplifier. Send for your FREE Crystal Amplifier Book. Be ready to make Amplifier sales.

PRICES

Complete outfit as illustrated, including 250 ft. of 4 wire cable, 100 ft. of 2 wire shielded cable, ten tested tubes, 2 Crystal Microphones with ring suspension, and three Oxford Concert Type 12½" Speakers.
List \$250.00
YOUR PRICE.... **\$147.00**

Amplifier with 10 Matched Tubes, and dummy plugs for speaker sockets, but without Cable, Speakers, or Microphones. Complete instructions for installation and operation included
List \$150.00
YOUR PRICE.... **\$88.20**

"THE FIRM THAT PROTECTS YOUR PROFITS"

THE RADOLEK COMPANY

585 WEST RANDOLPH STREET
CHICAGO, ILLINOIS

Send for your 1935 RADIO PROFIT GUIDE

R
C
P
•
R
C
P
•
R
C
P
•
R
C
P

New "RCP" ANALYZERS Lead in Value!

ACCURACY, completeness, fine appearance—plus convenience and provision for future needs—all at the lowest cost.

The new model 5414 Analyzer has a D'Arsonval meter, guaranteed accurate within 2%. Measures resistances of less than ½ ohm. Three-range (0-200—200,000—2,000,000) ohmmeter. Three-range (0.5—50—250 milliammeter). Four-range (0.5—50—250—750) voltmeter, at 2,000 ohms per volt. Individually calibrated shunts and multipliers. Instantaneous automatic selector switches, which make reference charts and jumping of connectors unnecessary. Handsome leatherette carrying case—14½" x 8½" x 4¼". Weight 6 lbs. Complete, ready to use, with 10-wire analyzer, test prods and Sure-Grip-Pull-Out adapters, \$28.95. Kit, \$24.50. Write Dept. S-1 for 1935 Catalog of complete testing equipment.

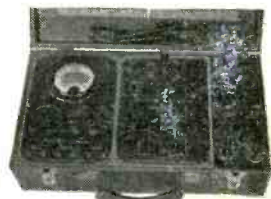

MODEL 5414
Complete, \$28.95
KIT, \$24.50

RADIO CITY PRODUCTS CO.

28-30 WEST BROADWAY

NEW YORK CITY

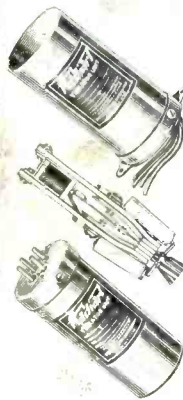

Radiart

The Only Complete Line of
Duplicate Replacement
Vibrators

Cash in on your share of the tremendous auto vibrator replacement business that will be done in the next few months. Radiart leads all others in original equipment.

Available at your jobber or
write for catalog.

THE RADIART CORP.

East 133 at Shaw Ave., Cleveland, Ohio

NOW BOTH 10 WATT AND 20 WATT SIZES



OHMITE Brown Devil Vitreous Enameled Resistors are fit companions for the famous Red Devils. For the service man who prefers vitreous enameled resistors, the Brown Devils are ideal replacement units. They are made in two sizes, 10 watts, and 20 watts, and are furnished with tinned wire leads so that they may be easily soldered in the circuit.

These resistors, along with hundreds of other resistors and rheostats, are described in the NEW Ohmite Catalog Number 11, which has just been released—the coupon below will bring your copy at once.

-----OHMITE-----

MANUFACTURING COMPANY

627 North Albany Avenue Chicago, Illinois
Please send my copy of the NEW No. 11 Catalog.

NAME
ADDRESS
CITY STATE

Announcing an Important Development..



The Improved **LYNCH** RESISTOR

Unretouched photo of Improved Lynch Resistor, taken under 80-power microscope. Note the uniformity which gives greater current-carrying capacity — freedom from heat . . . noise . . . change!

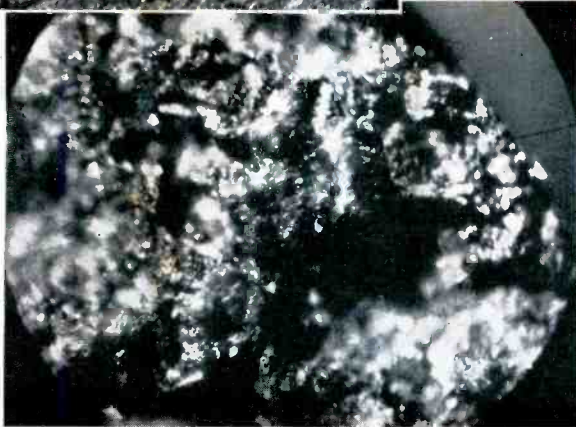

Ordinary resistor under 80-power microscope (unretouched photo) . . . Note rough surface which causes excessive heating—gradual change in resistance.



Another ordinary resistor under 40-power microscope (unretouched photo). Lower current-carrying capacity is due to many voids . . . in such a porous mass, contact is point contact only.



The Most Important Advance in Resistors in more than 10 Years

AFTER more than five years of exhaustive laboratory work and many months of proving in actual service in the field, we are pleased to present a resistor with marked advantages . . . and, at no advance in prices.

Born at dazzling yellow heat, this new ceramic composition possesses the rugged dependability of Gibraltar. Extruded to exacting specification, its uniform texture ensures far greater current-carrying capacity and permanent, noiseless accuracy.

Absolutely guaranteed against open-circuiting or change in resistance value. . . . Moisture-repellent!

We invite you to demonstrate for yourself the great superiority of these Triple-tested Resistors. Connect them into circuit, overload them heavily, as we have done for hours, days, weeks! Then make your own measurements for accuracy; noiselessness. If, after your own tests you are dissatisfied, return the resistors to your jobber, or to us and your money will be cheerfully refunded.

Ask your jobber also for our new low prices on Lynch "Bluejackets" and "Selectohms"—the wire-wound resistors with a reputation.



The Gold Standard
of Resistors

LYNCH MANUFACTURING COMPANY, Inc.

R. A. SAYRES, Pres.

C. G. CULIN, Vice Pres.

L. R. BEARDSLEE, Sec.-Treas.

405 LEXINGTON AVENUE

NEW YORK, N. Y.

Laboratory and Factory, Cranford, N. J.

You Can Earn as Much as **48.7%** Equivalent Compensation on RCA Tubes

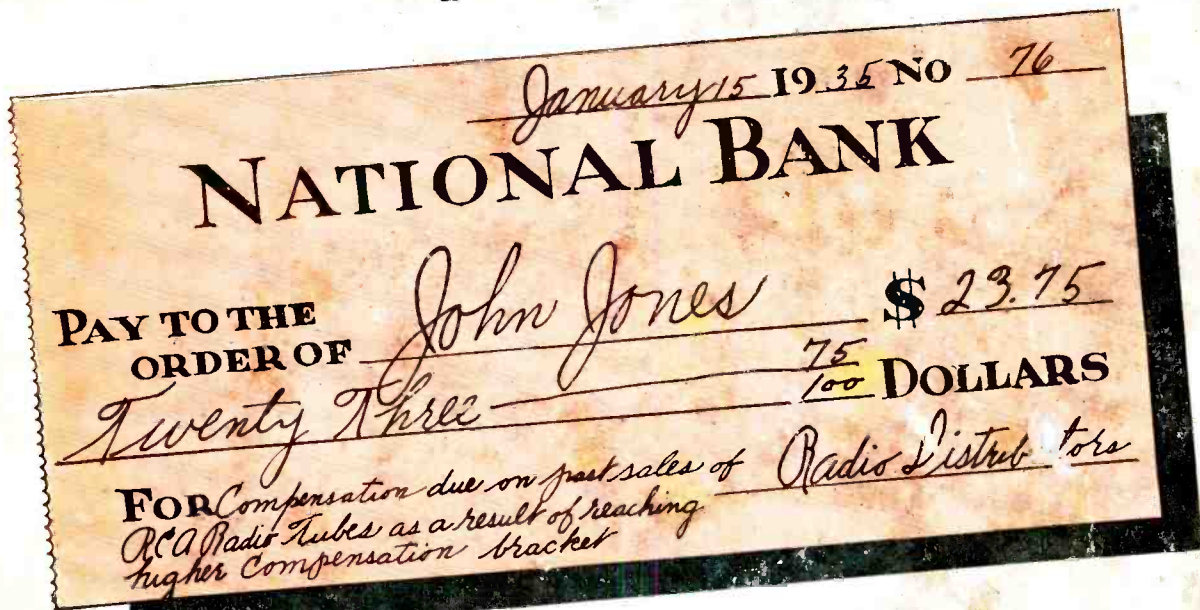

The RCA Radiotron Division believes its Agents should be well compensated. Furthermore, it believes its Agents should be compensated in proportion to the sales they produce. Thus, the compensation schedule now in effect is composed of compensation brackets, or "steps", corresponding to the yearly sales of RCA Radio Tubes by Agents. The total equivalent compensation runs as high as 48.7 per cent. And the sale price is protected!

With short steps between brackets, any RCA Radio Tube Agent can easily boost his compensation to the next higher classification—or even the next higher after that. And he does not have to wait until his Agency Agreement is renewed to earn the higher rate of compensation. It takes effect as soon as his RCA Tube sales reach the figure corresponding to the higher compensation rate.

And—get this—not only does he qualify for this compensation on all future sales, but he is compensated for prior sales

on the same basis. In other words he receives a check or credit covering a additional compensation for past sales... he makes additional money on tubes he has already sold.

Ask your Wholesale Agent how many dollars worth of

RCA Tubes you have sold since the beginning of your Agency Agreement. With the aid of this figure and the table shown you can determine how many additional RCA Tubes you have to sell in order to reach the next higher bracket; also the back compensation and the total additional compensation you receive as a result.

IMPORTANT

The bracket you have reached by the expiration of your first year's Agency Agreement determines your rate of compensation on all sales during the second year's Agreement, regardless of how many tubes you sell the second year. Think it over. It's well worth your while.

Sales Volume	*Compensation	Dollars Credit for Past Sales	**Total Aid (†) Dollars Earned
Under (Aver. sale of less than \$20 mo.)	\$250 35—5	—	—
On reaching (Average sale of \$20 month)	\$250 37—5	\$4.75	—
On reaching (Average sale of \$37.50 month)	\$450 39—5	\$8.55	\$12.35
On reaching (Average sale of \$55 month)	\$650 41—5	\$12.35	\$19.95
On reaching (Average sale of \$75 a month)	\$900 43—5	\$17.10	\$31.35
On reaching (Average sale of \$105 month)	\$1250 45—5	\$23.75	\$50.35
On reaching (Average sale of \$187 month)	\$2250 46—5	\$21.38	\$116.38

*No loss from price changes, no obsolescence, no investment, and assured profit are generally agreed to be worth 3 to 3.5 per cent and should be added to these percentages.
**Includes dollars earned as result of going to higher basis.

RCA RADIO TUBES

RCA Radiotron Division of the RCA Manufacturing Co., Inc., Camden, N. J.