

# SERVICE

A MONTHLY DIGEST OF  
**RADIO**  
AND ALLIED MAINTENANCE



In the White House . . .  
(see page 306)

PER COPY  
15 CENTS

NOVEMBER  
1932

# —because **ELECTRAD KNOWS** the Service Man's **PROBLEMS**

Most radio people admit that ELECTRAD Products are unsurpassed in quality. But some may not know that ELECTRAD quality is superior because of *exclusive* engineering features.

These distinctive advantages insure not only better results, but greater convenience and saving of time and money for service men.

Whatever resistor, volume control or amplifier you are called on to replace, remember that you will find what you need in the new ELECTRAD Catalog, because ELECTRAD knows your problems. *Mail coupon for your copy.*

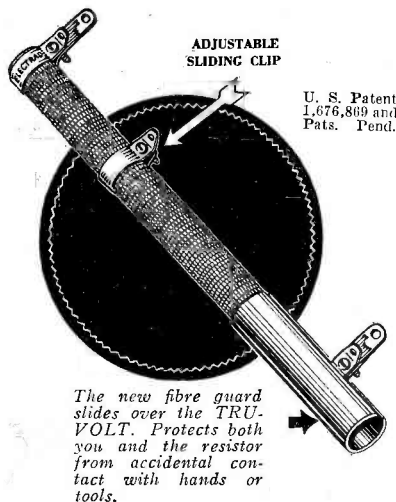

## TRUVOLT Resistors

### *Air-Cooled—Adjustable Clips*

In no resistors, other than ELECTRAD TRUVOLTS, will you find these desirable features:

- 1—Patented construction permits air-cooling, larger wire, greater radiation and longer life.
- 2—Spiral winding permits better electrical contact.
- 3—Sliding clips permit accurate adjustment.
- 4—Full-length fibre guard prevents injury from contact with tools or hands.

## Replacement **VOLUME CONTROLS** with new features

Only five types of ELECTRAD Standard Volume Controls are required for the replacement needs of 799 receiver models. That means convenience and saving of time, labor and money. All types are instantly convertible to use a power-switch, merely by removing the end cover and snapping the switch-assembly in its place.

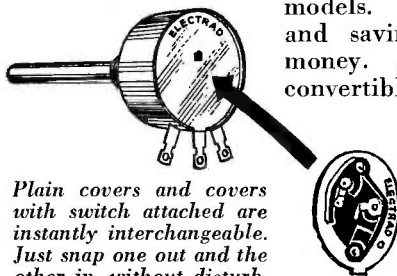

Plain covers and covers with switch attached are instantly interchangeable. Just snap one out and the other in, without disturbing the control connections.

Long, aluminum shafts also—easier to cut to desired length—less time—less trouble.

## AMPLIFIERS *for Every Purpose*

Widely praised for high output, rich tone and economical operation. Four models, covering every private and public amplifier need, from 1.6 watts to 21.9 watts of undistorted power output. List price, \$32.50 to \$195.00, *less tubes.* Write for complete catalog.

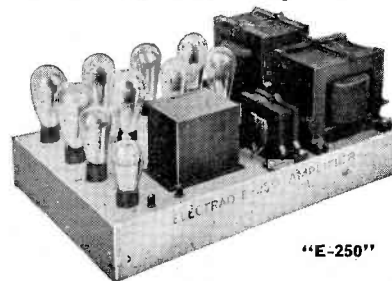

### Resistor Replacement **HAND BOOK**

An accurate, loose-leaf guide to resistor values. The most useful "tool" in the service man's kit. \$1.00 a year, including four supplements.

ELECTRAD, INC., 175 Varick Street  
NEW YORK

Please send me your new catalog of products which make the service man's work easier.

Name .....

Address .....

175 Varick St., New York, N.Y.  
**ELECTRAD**  
INC.

..\$-11

AROUND THE WORLD RECEPTION A CERTAINTY



Every Day  
in the Year

with the New  
15-550 METER

SCOTT  
ALL-WAVE  
Deluxe

SCOTT-TRAVEL to the ends of the earth! Spin the whole globe's wealth of entertainment into your own home with the twirl of a dial. True single dial control does it—no trimmers or auxiliary dials, no fussing with plug-in or tapped coils. Here is performance so perfected that this receiver is GUARANTEED to bring in foreign stations, 10,000 miles or more away, with full loud speaker volume in all seasons, every week throughout the year.

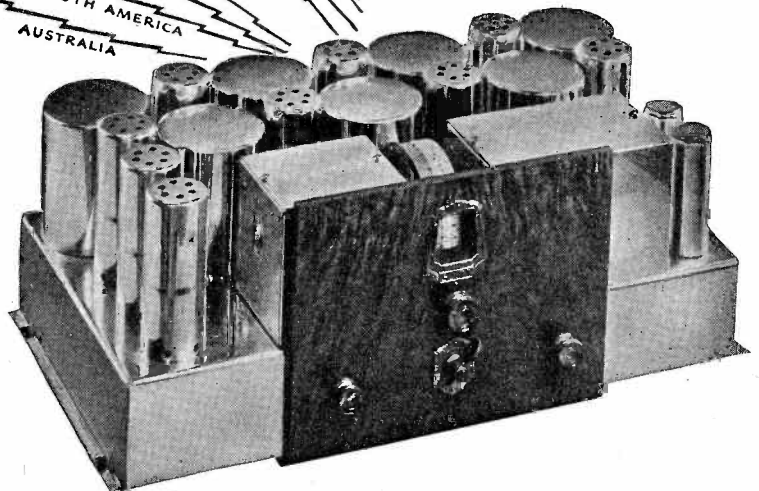

## Guarantee Based on History's Most Impressive Radio Performance Record

Verified Chicago reception, by a SCOTT ALL-WAVE operating under ordinary home conditions, of every scheduled program broadcast over a whole year's time from VK2ME, Sydney, Australia—more than 9,500 miles away . . . more than 19,000 logs of foreign stations submitted by SCOTT ALL-WAVE owners this year . . . are but two of many accomplishments.

It takes advanced, precision engineering—laboratory technique in custom construction—a background of nearly a decade of experience in building superfine receivers—to make such records possible, and to permit such a guarantee.

Yet here it is! Try it yourself. Thrill to the reception of stations in England—France—Germany—Spain—Italy—South America—far-off Australia. Listen in on gabbing telephony amateurs—hear land-to-plane messages—foreign news flashes on the short waves—a dozen and one new radio thrills await you. Get American, Canadian and Mexican stations you've never dreamed were on the air. Get them *all*—even those thousands of miles away—with full loud speaker volume and lifelike fidelity of tone. Tone so perfect

that, in studio tests, music critics fail to distinguish between the actual playing of a hidden pianist, and the SCOTT ALL-WAVE DELUXE reproduction of a pianist's broadcast program.

Such performance results from micrometer-measured accuracy in custom building. It testifies to the incorporation of every worthwhile development in radio, plus many exclusive innovations made by Scott engineers. These betterments include full automatic volume control; visual tuning; the ultimate in selectivity; highest degree of sensitivity ever developed in a radio receiver; lowest known noise level of reception; new Class "A" linear amplification giving tremendous volume without distortion; new-type tubes; many other absorbingly interesting technical achievements.

Still, with all these superiorities, a SCOTT ALL-WAVE DELUXE costs no more than many models of ordinary receivers. And it is the *only* receiver with an iron-clad warranty. Every part (except tubes) is guaranteed for five years against breakage or service failure, instead of the ordinary 90-day period.

Learn about this new wonder of the radio world! The set that not only gets 'round-the-globe reception, but that is used around the world—Scott owners in 75 different foreign countries enjoy this remarkable performance. The whole story of the SCOTT ALL-WAVE DELUXE is the most vitally interesting news of radio quality, performance and value ever published. Get it today! Mail the coupon below for complete information, including technical data, performance proofs, and everything you want to know.

**SEND COUPON NOW FOR PROOF**

E. H. SCOTT RADIO  
LABORATORIES, INC.  
4450 Ravenswood Ave.,  
Dept. S-112, Chicago, Illinois

Send me complete information about the New Scott All-Wave Deluxe Receiver, including technical details, performance proofs, prices, etc. This request is not to obligate me in any way.

Name.....  
Address.....  
City.....  
State.....

**E. H. SCOTT RADIO LABORATORIES, INC.**  
4450 Ravenswood Avenue Dept. S-112 CHICAGO, ILL.

# SERVICE

A Monthly Digest of Radio and Allied Maintenance

NOVEMBER, 1932  
Vol. 1, No. 10

EDITOR  
John F. Rider

MANAGING EDITOR  
M. L. Muhleman

## Editorial Contents

### FEATURES

|                                      |     |
|--------------------------------------|-----|
| Wave Traps and Coil Calculation..... | 305 |
| Review of Set Testers.....           | 307 |
| Biography: J. H. Schmidt.....        | 306 |

|                            |     |
|----------------------------|-----|
| ANTENNA (Do Your Bit)..... | 302 |
|----------------------------|-----|

### AUTO-RADIO

|  |     |
|--|-----|
| Car Aerials.....                         | 322 |
| Crosley Model 95 (Roamio).....           | 321 |
| Ignition Coils.....                      | 322 |
| Majestic for Fords.....                  | 322 |
| Pontiac Ignition Diagrams.....           | 322 |
| Removing Motorola 88 and 61 Chassis..... | 322 |
| Sparton "B" Eliminators.....             | 322 |
| To Be or Not to Be.....                  | 321 |

|                                |     |
|--------------------------------|-----|
| FORUM (The Reader's Page)..... | 328 |
|--------------------------------|-----|

### GENERAL DATA

|  |     |
|--|-----|
| Adjusting Philco Model 43.....             | 315 |
| Adjusting Philco Models 80 and 37.....     | 316 |
| AVC Tube Operation.....                    | 316 |
| Clarion Model AC-240.....                  | 317 |
| Copper Oxide Rectifiers as Detectors*..... | 316 |
| Delco Correction.....                      | 316 |
| Franklin 33-B Set Analyzer.....            | 312 |
| Franklin D-33-A Analyzer.....              | 311 |
| Hickok Ohm Capacity Voltmeter.....         | 308 |
| Jewell 444 Set Analyzer.....               | 309 |
| Keller-Fuller Model F.....                 | 316 |
| Kolster Field Coil Resistance Values.....  | 316 |
| Majestic 55.....                           | 316 |
| Philco 80 Whistles.....                    | 316 |
| Power Transformer Testing*.....            | 316 |
| Readrite No. 1000 Set Tester.....          | 310 |
| Readrite No. 710 Set Analyzer.....         | 310 |
| Receiving Antenna Practice.....            | 314 |
| Shallcross Types 651-652 Set Testers.....  | 308 |
| Sprayberry Set Analyzer.....               | 309 |

|   |     |
|---|-----|
| Stewart-Warner R 104-105.....                       | 318 |
| Stromberg-Carlson Nos. 38, 39, 40 and 41 Sets... .. | 313 |
| Supreme AAA-1 Diagonometer.....                     | 307 |
| Supreme Model 56 Analyzer.....                      | 308 |
| Weston 660 Set Analyzer.....                        | 312 |

|                 |     |
|-----------------|-----|
| HIGHLIGHTS..... | 326 |
|-----------------|-----|

|                                  |     |
|----------------------------------|-----|
| INDEX OF MONTHLY LITERATURE..... | 334 |
|----------------------------------|-----|

### MANUFACTURERS

|                               |     |
|-------------------------------|-----|
| AKAformer System, New.....    | 332 |
| Amperites, New.....           | 332 |
| Brunswick Engineers, Inc..... | 332 |
| Finger-Proof Microphone.....  | 332 |
| Littlefuses for Meters.....   | 332 |
| Multidapter.....              | 332 |
| Solar Inverters.....          | 332 |

### ON THE JOB

|   |     |
|---|-----|
| A Line Voltage Tip,<br>By Martin Wazlahowsky..... | 324 |
| Installation Service,<br>By John J. Birkel.....   | 324 |
| That Additional Speaker,<br>By S. Rider.....      | 324 |

### PUBLIC ADDRESS

|                                     |     |
|-------------------------------------|-----|
| Impedance Matching.....             | 320 |
| Loudspeaker Patching Panel.....     | 320 |
| Pre-Amplifier for P-A. Systems..... | 319 |
| Time Lag Device*.....               | 324 |

### SHORT WAVES

|                                   |     |
|-----------------------------------|-----|
| Clarion Model AC-240.....         | 317 |
| Constant Regeneration.....        | 317 |
| Noise-Reducing S.W. Aerials*..... | 318 |
| Sets for Special Aerials.....     | 318 |
| Stewart-Warner R 104-105.....     | 318 |
| Tunable Hum Elimination*.....     | 318 |
| Useful Information.....           | 318 |

### Advertising Director

ROBERT N. MANN  
1440 Broadway, N. Y. City  
Telephone: CHickering 4-4542

Published monthly by

John F. Rider Publications, Inc.  
1440 BROADWAY  
NEW YORK, N. Y.

### Officers

JOHN F. RIDER,  
President and Treasurer  
M. L. MUHLEMAN,  
Vice-President  
J. SCHNEIDER,  
Secretary

Entered as second-class matter June 14, 1932, at the Post Office at New York, N. Y., under the Act of March 3, 1879. Copyright, 1932 by John F. Rider Publications, Inc. Contents must not be reproduced without permission. Subscription price \$1.00 per year in the United States of America; 15 cents per copy. \$2.00 per year in Canada and foreign countries; 25 cents per copy.

A RADIO SET TESTER

A RADIO TUBE TESTER



List Value with Case, \$265.00

## HICKOK STATIKTESTER—FREE or at a nominal cost to Tung-Sol Retailers

The cost of this equipment depends on the volume of Tung-Sol Radio Tube sales, from Tung-Sol Retailers' **consigned stocks**.

This Statiktester is the latest development in tube testing and set testing equipment combined. In addition to accurately testing tubes for mutual conductance, plate current, shorts and gas content, it supplies a means of measuring every unit in a radio set—tests electrolytic condenser leakage and capacity, all values of inductance and resistance. It incorporates the new point-to-point method of testing.

Ask your Tung-Sol wholesaler for details.

# HICKOK ELECTRICAL INSTRUMENT CO.

CLEVELAND, OHIO

# THE ANTENNA...

## DO YOUR BIT

**R**EGENERATION is on the way back. A few recently announced low priced receivers with few tubes, have made their appearance on the market. The ability to produce four- and five-tube superheterodynes is attained through the use of regeneration. In contrast to the regeneration problems experienced in connection with t-r-f. receivers, the modern superheterodyne simplifies matters. Instead of regeneration control over a fairly wide frequency band, the use of this method of amplification in the second detector circuit, thereby eliminating the need for an i-f. stage, is quite ingenious. By locating the regeneration in this circuit, it is operative at only one frequency; namely, the intermediate frequency. Once adjusted on the job, it stays fixed.

Reports from various sources seem to indicate that regeneration in one form or the other will again become general. It feels good to think of days gone by, 14 or 15 years ago, when all we had to work with was a regenerative detector. We didn't mind three or four regeneration controls so as to get the *nth* amount of regeneration before it spilled over.

• • •

**W**HAT is the service branch of the radio industry going to do about bettering conditions? We think that much can be done—at least we are under that impression.

The first thing to do is to remove whatever bad taste is in your mouth due to the panning we have received from the radio merchandisers. They said that service activities impaired sales. They know this is plain "hooy" and so do we. Let us also forget that a few years back, service operations were said to be so bad that set owners were disgruntled. You might just as well forget the present-day statements that service work is so good that it interferes with set sales. What happened in the past is just so much water over the dam.

No matter how you may feel towards radio dealers, manufacturers, magazines and individuals, service information and the like, there is one thing you must have uppermost in your mind if you are going to stay in the radio service business. Expressed in the simplest language, it is this—the radio receiver industry must get back on a solid footing.

Merchandisers and merchandising magazines have done a great deal of wailing. Dealers have placed the blame upon the receiver manufacturers, have talked prices, installments, too many new models, and a myriad other things. As is usually the case, the man who does the loudest talking makes the least effort to correct matters. We are referring to the thousands of radio set dealers throughout the nation, who are not making any great effort to sell receivers to those people who still have enough money to buy a new set.

All of this is the concern of the merchandiser. Any improvement in the radio industry will improve the status of the service branch. It is our opinion that the service branch can be nationally helpful by stimulating listener interest.

You men who have been sending literature to set owners, asking if their sets are in good condition, should not couch your phrases in the negative. Don't ask if a set is in good condition. Tell a man that his set *must* be in good condition if he is to enjoy the programs being offered. Tell him that he is actually missing information, entertainment—that the family is missing entertainment—by not listening, or by trying to listen with a poor receiver.

There are tens of thousands, if not hundreds of thousands, of receivers inoperative in these United States because the people are no longer interested in radio. The problem at hand is not whether a receiver four or five years old should be serviced, or if a new one should be sold. The important thing is to get the man to use his receiver—to listen to radio programs. If a receiver four or five years old, or older, will not be serviced and the man cannot afford to purchase a new receiver, the industry at large is *losing a listener and a potential customer.*

The problem at hand is to revive listener interest . . . to *get people back on the air.* It would be of inestimable value if manufacturers, radio dealers, broadcast stations, advertisers who use time on the air, and service organizations, combined to revive listener interest. Perhaps the aid which the service industry can give in this direction is small in comparison with all others, but as small as it may be, it still is important.

Don't ask questions in your sales literature. Make definite statements. Try to bear in mind that the only reason people have their radio receivers repaired is because they want to listen to radio broadcasts. If their interest is allowed to diminish, your service activities will diminish. It is highly probable that some of your letters will cause some of the recipients to buy new receivers and you will derive no immediate revenue—unless you make the receiver sale. At any rate, every receiver sold helps the radio industry by that much. Some of the families who receive your letters will buy new sets—some will have their receivers repaired.

A concerted drive of this type by the men who are supposed to represent the necessary evil in the radio industry, will open the eyes of those who are doing nothing but sobbing and wailing.

Getting the nation back onto its feet is not one man's job. No one man can ruin the nation and no one man can make the nation. Each and every individual must do his share. We know as we write these lines that times are tough. Service Men are having trouble deciding upon service charges, meeting gyp competition, finding work, earning respectable salaries. What is the solution? Is it to stand by and hope for the best? Or will you make an effort to get business? Whether the remainder of the members of the radio industry admit it or not—the aid of the service branch—our branch—is required in the national effort to restore the industry to its original basis. We've had depressions before and we'll have them again. National morale has been greatly improved. Business has commenced to show some gain. The opportunity is here to help the radio industry and to help yourself.

*John F. Rider.*

# NATIONAL UNION

## helps thousands of SERVICE MEN to profit . . . come on along . . .

**1.** Volume 1. Valuable Service Manual by John F. Rider, famous radio scientist lecturer, and author. Contains over 2,000 diagrams on voltage, electrical values, etc. Free with small purchase of tubes.

**2.** Volume 2. Also by John F. Rider. Over 700 pages of valuable data. Point-to-point resistance data given, enabling operation of continuity, capacity and resistance tester. Free with small purchase of tubes.

**3.** Oscillator and output meter. Only way to really service super-hets properly! Absolute necessity for up-to-date servicing. Yours free with small tube purchase and small deposit.

**4.** Readrite Tube Tester. Compact, easily carried. Illuminated dial permits reading in even darkest corners! Free with small deposit and purchase of tubes.

**5.** Readrite Resistance Tester. The new readrite continuity, capacity, and resistance tester. No more chassis pulling! With it, you can make every test—continuity, capacity and resistance—without taking the set apart. Yours with a small deposit and purchase of tubes.

**6.** Unameter. Sensational new tube tester . . . easy to operate. Turn the selector, then place tube in the socket, and watch the reading on the meter in English. An aluminum chassis, with bakelite panels, and attractively finished in gold, red and black. One of the finest pieces of equipment ever offered. It is yours free with a moderate purchase of tubes and a small deposit.

*The Standard Tube  
for Standard Sets . . .  
at a Standard Price*

Here's a tube maker that recognizes service work as a profession! NATIONAL UNION understands the service man's problems and offers radio equipment FREE.

**R**IGHT now National Union is doing more for the service man than any other tube manufacturer. We are actually giving away thousands of dollars worth of free equipment to service men everywhere. We are making these costly offers because we understand the problems of modern servicing. And we want to do a real job to help the service man help himself.

Just look at the equipment offered in this advertisement! Read how you can get any one or all of these valuable pieces . . . and think of the opportunity that is given you here.

Of course these offers are very expensive for us. But we honestly believe that by helping the service man we in our turn will be rewarded.

Thousands of coupons have already come to us. Service men have been quick to take advantage of these offers . . . And many have written us telling us just what National Union has meant to them . . . in better service work . . . satisfied customers . . . and increased profits!

And so we want you, too, to own this equipment. And if you haven't already sent in your coupon, send it at once . . . today!

**FREE!** Tube Base Layout Chart compiled by John F. Rider. No obligations—write for one!

**NATIONAL UNION RADIO CORPORATION**  
400 MADISON AVENUE · NEW YORK CITY

Dear Sirs: I am checking the equipment in which I am interested:

8-11-32

|                                      |  |                        |
|--------------------------------------|--|------------------------|
| READRITE                             | OSCILLATOR AND                             | NAME _____             |
| TUBE TESTER <input type="checkbox"/> | OUTPUT METER <input type="checkbox"/>      | ADDRESS _____          |
| VOL. I <input type="checkbox"/>      | RESISTANCE TESTER <input type="checkbox"/> | CITY _____ STATE _____ |
| VOL. II <input type="checkbox"/>     | UNAMETER <input type="checkbox"/>          |                        |

**ASK YOUR  
JOBBER'S  
SALESMAN**



# THANKS

TO THE SERVICE MEN WHO HAVE RESPONDED SO EARNESTLY TO OHIOHM ADVERTISING . . . and, Here is Something for which you may say "Thanksgiving" more Profitably . . .

PLEASE excuse us if we appear to be overly optimistic and "peppy." To us the depression is over. At least, it is not retarding the sale of Ohiohm Resistors considerably.

- Of course we feel that we have a mighty fine product. We know we have the finest service men and dealers in the country using OHIOHMS. The combination should lick any situation.
- This is the season for giving thanks. We are thankful

to the loyal service men in our ranks. We also have something to help your Thanksgiving.

**OHIOHM**  
(50,000 OHMS)  
**SPARK SUPPRESSORS**  
now available  
to fit  
**FORD V-8**

- Automobile radios are gaining in popularity by leaps and bounds. Ohiohm Spark Suppressor Sets fill the bill for eliminating ignition interference. Another step forward is the ability to take care of installations in Ford V-8s with a 50,000 ohm Ohiohm Suppressor. OHIOHM SUPPRESSOR SETS are furnished for 4, 6 and 8 cylinder cars.

## FIRST AID Resistor KIT

Do not be without this kit. Where there's radio trouble OHIOHMS may be the cure. In countless cases improvements in reception can be effected with these resistors. Pocket size, two different types—1-watt and 2-watt kits. Initial order includes free Ohm Dial, Resistor Guide and your own advertising labels.

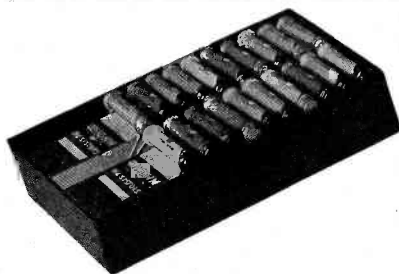

DEALER PRICE . . . \$3.50  
Model B, 1-Watt Kit  
LIST VALUE \$6.00

THE OHIO CARBON CO. • Cleveland, Ohio  
In Canada Ohiohms are made by C. C. Meredith & Co., Ltd., 637 Boy St., Toronto



Something New!

*Cleanaire*

ICE-BOX  
and REFRIGERATOR  
DEODORIZER

a 50c item: Absorbs offensive food odors. Sell this when you give radio service. Write for details.

# OHIOHM



# Wave Traps and Coil Calculation

**W**HILE there is little need for wave traps in receiver installations employing modern radio equipment, there are occasions in which a wave trap is indispensable. So far as we are aware, there are no reliable wave traps commercially available, due probably to the negligible demand. This lack of demand may be due to a lack of knowledge on the part of many as to the fine job a wave trap can do on a receiver with poor selectivity, or in the case of extreme local interference.

In any event, it is a relatively simple matter to build a trap to meet required con-

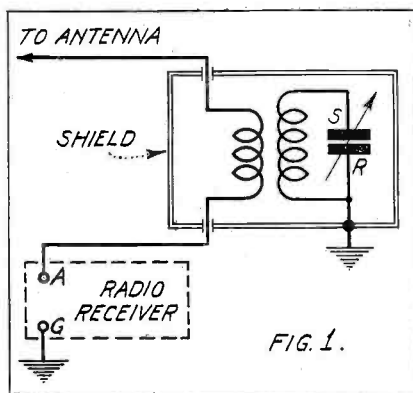

A wave trap should be well shielded, and coupled to the antenna by a primary coil. The shield should be grounded

ditions, but certain precautions are necessary if the trap is to be bang up.

A wave trap can of course be made as selective as conditions require by properly choosing a coil and condenser of sufficiently low resistance, and by properly proportioning the coupling between the trap and the antenna.

## MANNER OF COUPLING

A wave trap should always be coupled to the antenna in the manner shown in Fig. 1. A simple anti-resonant circuit (coil and condenser to you) inserted directly in the antenna circuit is undesirable for a number of reasons, but principally because such an arrangement is quite likely to tune the aerial to some long wavelength, thus decreasing its efficiency in the broadcast band and at the same time increasing the possibility of long-wave interference.

Another thing, a wave trap should be housed in a copper or aluminum box which is securely grounded. The shaft of the condenser, which will generally extend through the wall of the box shield should also be grounded. Moreover, the antenna leads entering the box should be separated an inch or more to prevent capacity coupling around the primary which would tend to defeat the purpose of the trap.

In general the primary winding may be bunched or layer wound, as shown in Fig. 2. It should be wound on one end of the coil form, near the ground end of the secondary, and should be separated from  $1/8''$  to  $1/16''$

from the end of the secondary winding. The primary should have an inductance of 20 to 80 microhenrys, depending on the coupling desired. The inductance of the secondary of course depends on the capacity of the variable condenser employed.

## COIL CALCULATION

Fig. 3 is a chart from which the coil dimensions and turns may be obtained. For example, if a variable condenser of .0005 mfd. is to be used and it is desired that the trap cover the broadcast band, it appears from Fig. 3 that a coil of 150 microhenrys will be required for resonance at 550 meters.

Let's see how this is worked out on the chart. We are to use a variable condenser with a maximum capacity of .0005 mfd. and the highest wavelength we wish to reach is 550 meters. Therefore we take a ruler and connect .0005 on scale C with 550 on the wavelength scale . . . this being represented by line A. This line intersects the scale L at approximately 150, so the coil should have an inductance of 150 microhenrys.

Now, using 150 on scale L as a fixed point, and figuring a coil form with a diameter of, say, 3 inches (i.e.,  $d=3$  inches) we again use the ruler, which now is represented by the straight line B which establishes an index point K. A straight line (line G) drawn through point K and scales  $n$  and 1 indicates the turns per inch and the length of secondary winding. If a length of secondary winding of 3 inches is permissible, then 19.5 turns per inch will be required, or 60 turns total. Referring to the table of Fig. 4, it appears that a close wound coil of No. 18 single cotton covered wire has 19.5 turns

per inch. The secondary is then 60 turns of No. 18 s.c.c. wire wound on a 3-inch form. The form should be about 4 inches long and may be any good high-frequency grade of micarta, bakelite, hard rubber, isolantite, or impregnated paper tubing.

The primary may be any size of wire, say No. 30, and since inductance is approximately proportional to the square of the number of turns, and the primary inductance should be roughly one-half to one-seventh that of the secondary, the primary turns should be one-fourth to one-fifth that of the secondary; i.e., 2 to 15 turns.

For large low-loss coils such as this one, tight coupling is permissible, and 15 turns of No. 30 wire should be satisfactory.

## THE CONDENSER

Now the condenser should be chosen as carefully as the coil if the trap is to be of the best. Isolantite, glass, or mica insulators should be used to support the stator, since the usual bakelite compounds ordinarily employed may cause excessive losses at the shorter wavelengths, especially during damp weather. If a trimmer condenser is attached to the condenser it should be removed. It is important that the space between rotor and stator be as free from dielectric (other than air) as possible. Thick stator supports of a given material are better than thin ones, and narrow ones better than wide ones.

Unless there is a wide separation between the coil and condenser and metal box shield, the inductance of the coil will be decreased and the resistance increased somewhat. A separation at the ends of the coil of one inch, and at the sides of  $3/4$  inch is common

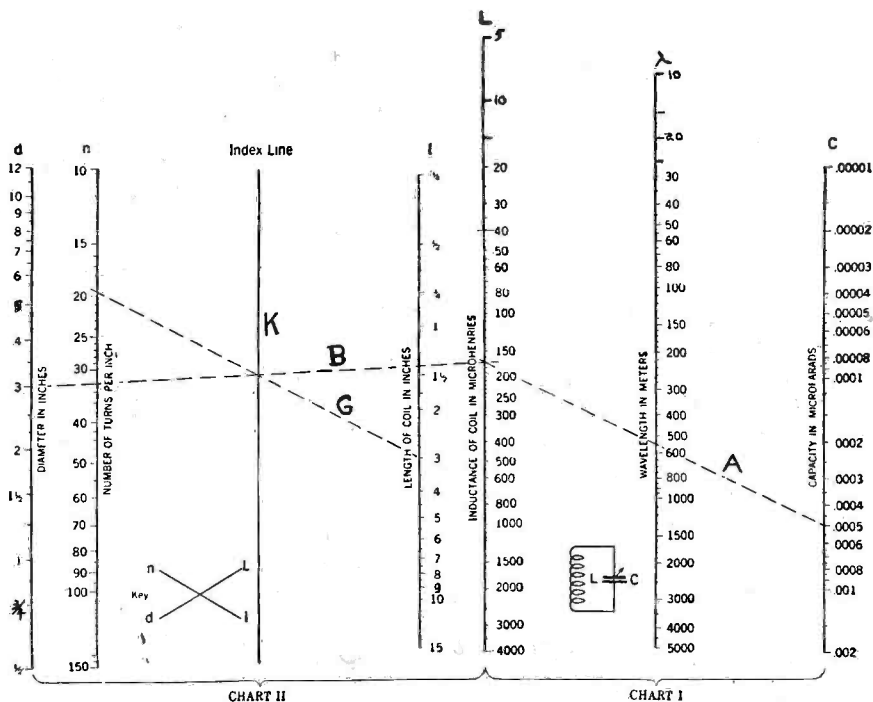
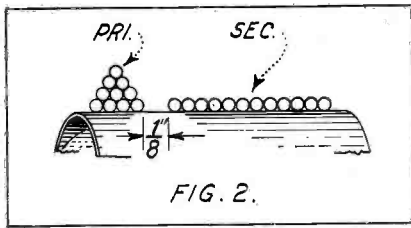

Fig. 3. From this chart it is possible to calculate the inductance and the number of turns of wire required to cover a certain waveband with a condenser of given minimum and maximum capacity. The process may also be reversed



It is preferable that the primary coil of the wave trap be layer-wound, as shown

practice and will not seriously increase coil resistance. In such instances the calculated total turns of the coil should be increased about 5% to allow for the effect of the box.

The coil should be painted with cellulose acetate to prevent moisture being absorbed by the cotton or silk insulation of the wire and thus increasing the losses. Both humidity and temperature will effect the tuning of the trap somewhat. Unless the variations in humidity and temperature are extreme, the tuning should not require re-adjustment over long periods of time.

#### STRAY CAPACITIES

In the usual case, a condenser of about .00025 mfd. capacity and a coil of about 350 microhenrys should be used unless a larger condenser is available. Single layer solenoid coils have a distributed capacity of about .000002 mfd. per inch of coil diameter (i.e.,

for a 3-inch coil the secondary distributed capacity would normally be .000006 mfd.). The type of primary shown might add .000002 mfd., and the wiring about .000006 mfd. more. The average variable condenser has a minimum capacity of about .000015 mfd. to .00002 mfd. Hence, the total minimum capacity of the circuit might be .000035 mfd.

If at minimum capacity the trap is to resonate at 200 meters, then from Fig. 3 it is seen that a secondary inductance of 350 microhenrys would be required. A capacity of .00025 mfd. is required to tune this inductance at 550 meters. If a 2-inch diameter coil is to be used, with a length of secondary of about 3 inches, then 40 turns per inch, or 120 turns total, would be required. To offset the reduction in inductance due to the can add 5%, or 6 turns, making a total of 126 turns, or 42 turns per inch. A reference to the table of Fig. 4 indicates that No. 26 wire can be used.

#### CONNECTIONS

In connecting up the trap, the antenna lead should connect to the primary terminal furthest away from the secondary, the other terminal connecting to the antenna post on the receiver. The end of the secondary winding nearest the primary should connect to the rotor of the variable condenser and to ground, the furthest end of the winding connecting to the stator of the condenser.

The winding of the primary coil should be opposite in direction to that of the secondary winding.

Though the inductance, capacity and physical calculations given have been applied to the design of a wave trap, you should be able to use the chart of Fig. 3 and the table of Fig. 4 to great advantage wherever such calculations are needed.

Fig. 4

| Wire size<br>B&S Gage | Turns per inch<br>S.C.C. wire | Ohms (d-c.)<br>per 1,000 ft. |
|-----------------------|-------------------------------|------------------------------|
| 10                    | 8.6                           | 1.0                          |
| 11                    | 9.7                           | 1.26                         |
| 12                    | 11.25                         | 1.59                         |
| 13                    | 12.0                          | 2.00                         |
| 14                    | 13.0                          | 2.59                         |
| 15                    | 15.4                          | 3.12                         |
| 16                    | 16.75                         | 4.00                         |
| 17                    | 17.75                         | 5.07                         |
| 18                    | 19.5                          | 6.39                         |
| 19                    | 22.75                         | 8.28                         |
| 20                    | 25.75                         | 10.16                        |
| 21                    | 28.25                         | 12.81                        |
| 22                    | 31.00                         | 16.15                        |
| 23                    | 34.5                          | 20.38                        |
| 24                    | 37.00                         | 25.69                        |
| 25                    | 38.00                         | 32.4                         |
| 26                    | 42.00                         | 40.86                        |
| 27                    | 48.00                         | 51.51                        |
| 28                    | 53.25                         | 64.97                        |
| 29                    | 58.00                         | 81.92                        |
| 30                    | 63.25                         | 103.30                       |

## The Man on the Cover

J. H. Schmidt, Service Manager, Kolster Radio, Inc.

HE was born at Omaha, Nebraska, February 11, 1899, practically at the turn of the century, and therefore grew up in that era of electrical progress.

He was interested in "wireless" in the early days, having experimented with its wonders as early as 1914. This interest led him to take the Morse Telegraph course at Boyles Business College in Omaha, in 1917, and with the termination of this instruction he joined the Union Pacific Railroad at Kersey, Colorado, as student telegrapher. This job included the formal functions of ticket agent, baggage man, mail man and collector of freight and express bills.

Possibly the punching of tickets and the hauling of baggage led him to return to Omaha and take a different tack for a change. At any rate, this he did, and until January of 1918, worked in the office of Chief Mechanical Engineer in successive functions of typist clerk, payroll clerk, clerk in charge of drafting room records, copyist draftsman and detail draftsman. Or, as Mr. Schmidt says, he worked as a clerk.

But, with the early wireless experiments in the back of his head, and with war spreading its wings over the land, he resigned his position to enlist in the regular Navy, with rating of Lansaman for Electrician, Radio. In time he was transferred to the Naval Radio School, Harvard University, and after completing his course there was given the rating of Radio Electrician, 2nd Class, and almost immediately transferred to the Instruction Staff as assistant.

Upon the signing of the Armistice, Mr. Schmidt was transferred to the Radio Test Laboratory, Navy Yard, Washington, D. C. In time he became Radio Electrician, 1st Class, U.S.N., and during his enlisted period was also detached

to duty on the President's yacht, *Mayflower*, and also maintained early radio installations at the White House.

Mr. Schmidt was honorably discharged from the Navy September 3, 1919, and re-employed in civilian status two days later. Then came two years' experience in the Design Department where he was Supervisor of tracings, blue prints, photographic records, etc. . . . and what an eyefull he must have gotten. Later he was employed in the capacity of Draftsman on all types of receiving, transmitting and aircraft equipment, and detail draftsman on the same items.

The next two years were spent in the Inspection Laboratory where he was engaged in inspection, test, repair, calibration and installation of all types of radio equipment. Then another two years as Assistant to the District Radio Material Officer, having complete supervision of material purchases and maintenance, and special job order expenditures for all radio, radio compass, pigeon and air-craft transmitting stations in that district.

Mr. Schmidt resigned from Civil Service in February, 1924, to assume the post of Service Manager for old C. Brandes, Inc., manufacturers of headsets and loudspeakers. He was transferred to the Newark Mt. Pleasant Avenue plant at the time of Brandes merger with the Federal Telegraph Company in 1926, to become Assistant Service Manager of that organization. He retained this status when the company became Kolster Radio, Inc., and later became Factory Service Manager. He retained this status during eighteen months receivership, becoming Factory Service Manager for Kolster Radio, Inc., as at present, when the company was purchased by the International Telephone and Telegraph Corporation.

# General Data . . .

## REVIEW OF SET TESTERS

### Supreme AAA-1 Diagonometer

The Supreme AAA-1 Diagonometer serves five definite purposes. It functions as a general analyzer, a tube tester, an oscillator, an ohmmeter-megohmmeter, and a capacity tester.

A complete circuit diagram of the unit is shown in Fig. 1, and a view of the instrument in Fig. 2.

### ANALYZER

The analyzer portion of the instrument uses a single multi-scale meter similar to that used in the Model 56. Both a-c. and d-c. measurements are obtained with the same scale distribution, so that a measurement of 2.5 volts a-c., for example, causes the meter needle to deflect exactly the same number of degrees as is deflected by a measurement of 2.5 volts d-c.

All test circuits and meter ranges are available for external use through insulated pin jacks. Current ranges of 0-2.5, 0-10, 0-25, 0-100 and 0-250 milliamperes and 2.5 amperes are available for external use for either a-c. or d-c.

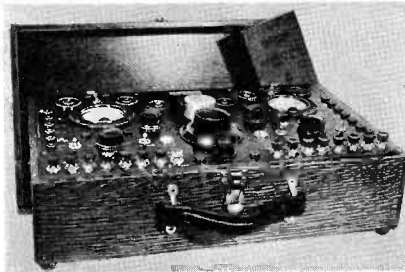

Fig. 1. The Supreme AAA-1 Diagonometer, which includes an oscillator and tube tester

An external d-c. voltage range of 2,500 volts is provided in addition to the external a-c. and d-c. ranges of 0-2.5, 0-10, 0-25, 0-100, 0-250 and 0-1,000 volts. Two 2,500-ohm per volt high-resistance d-c. voltmeter ranges of 0-40 and 0-200 volts are also available through external connections for testing automotive and aeroplane installations.

The instrument is also adaptable for an analytical a-c. voltage, 1,000 ohms per volt,

test up to 1,000 volts on each side of the center-tapped plate-supply transformers through the rectifier tube socket.

The Analyzer requires no panel adapters, and will handle all tubes including the 7-prong tubes, duo-diodes, duo-diode-triodes, etc.

### TUBE TESTER

The tube tester circuits include five tube-testing sockets for accommodating 4-, 5-, 6- and 7-prong tubes, and a-c. power supply potentials ranging from 100 to 240 volts. A "filament heater" selector switch is provided for all tubes. The grid potentials of the tube tester circuits are provided by a biasing arrangement by which the proper controlling grid potential is determined by the plate current load of a tube under test, and the applied bias may be observed with the corresponding plate current readings. In addition, an oscillation test is included for matching tubes for the r-f. stages. The instrument also has a gas test for all amplifier types of tubes, indicating the comparative gas content of the tube under test. Another arrangement is provided for indicating the cathode-heater leakages of the cathode type of tube.

It will be noted from the diagram that a primary selector switch is provided for adjusting the tube tester to line potentials between 100 and 240 volts.

All of the potentials utilized in the tube tester circuits are available at external connections for any other tests desired. A pilot light indicates whether or not power is being applied to the tube testing circuits.

Fig. 2. Complete schematic diagram of the Supreme AAA-1 Diagonometer. Note the oscillator in its separate shield, directly below the power-supply transformer

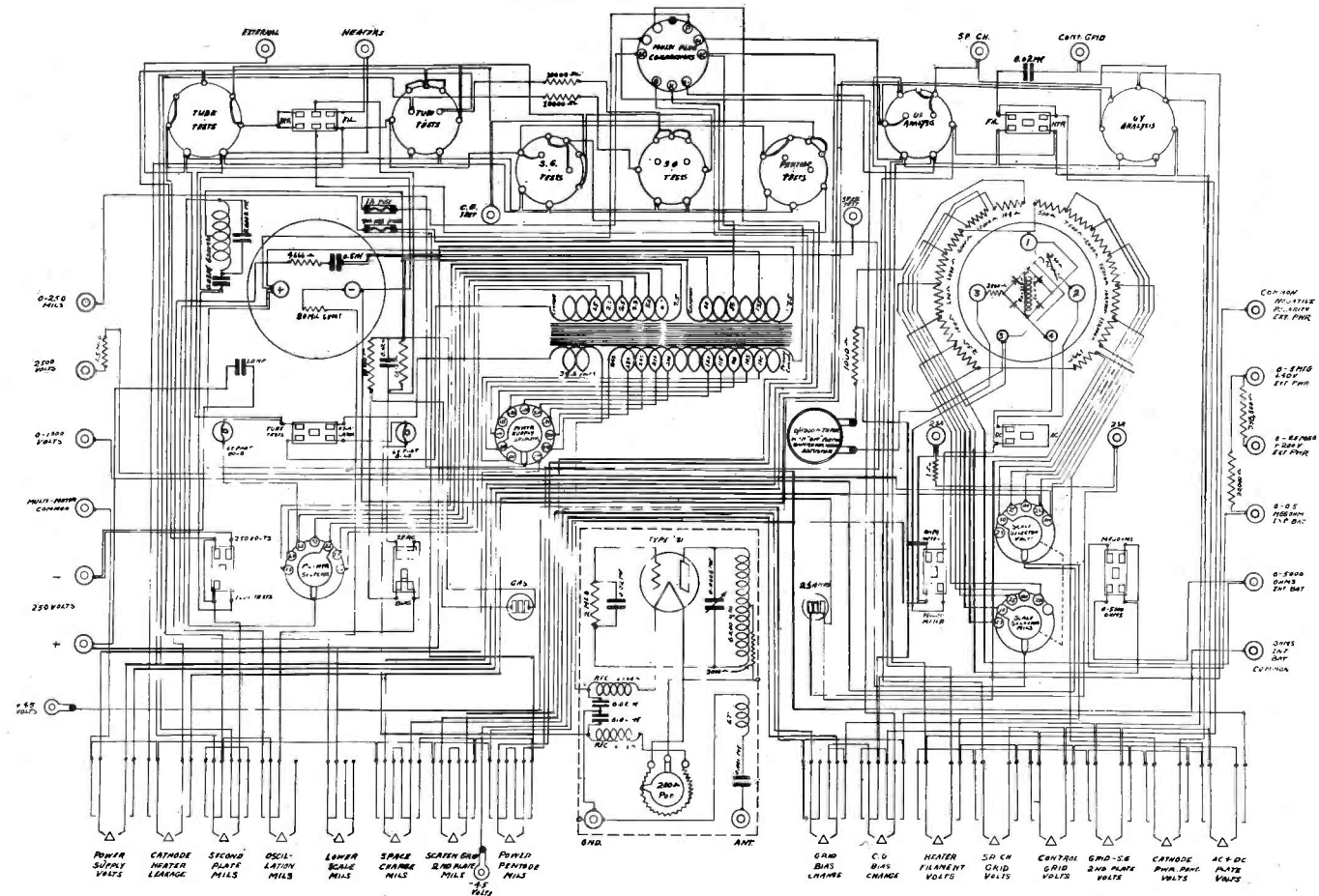

# GENERAL DATA—continued

## THE OSCILLATOR

The oscillator is shielded and a means provided for attenuation. It operates over a range of approximately 90 to 1500 kc.

The oscillator is 100% modulated at the frequency of the power-supply system so that it may be used for r-f. and i-f. adjustments.

For output measurements, the meter in the analyzer can be thrown in series with a self-contained condenser and used as an output meter.

## OHMMETER-MEGOHMMETER

The multi-scale meter when used as an ohmmeter, has a low range of 0 to 5,000 ohms and a high range of 0 to 500,000 ohms. An indicating range of 0 to 5 megohms is available by using an external 45-volt battery. An indicating range of 0 to 25 megohms is available by utilizing the self-contained potential of 250 volts d-c. from the power output circuits. A zero adjuster is provided.

## CAPACITOR TESTER

The Diagonometer has provisions for applying 250 volts d-c. to paper condensers under test, indicating leakages up to 6 megohms. It also indicates capacities from .002 mfd. to 10 mfd.

## Supreme Model 56 Analyzer

The Model 56 Analyzer employs a single meter for all readings. This meter has three scales permitting the measurement of ohms, volts and milliamperes. The circuit is shown in Fig. 3 and the Analyzer itself in Fig. 4.

Six alternating and six direct voltage ranges 0-3, 0-9, 0-30, 0-90, 0-300 and 0-900 volts and five alternating and five direct current ranges 0-3, 0-9, 0-90 and 0-300 milliamperes are provided for all measurements. In addition, three ranges, 0-3, 0-30 and 0-300, are provided for external d-c. voltage measurements with a sensitivity of 2,750 ohms per volt for use in measuring across high-resistance circuits. All current and



Fig. 4. The Supreme Model 56 Analyzer. One meter is used for all measurements

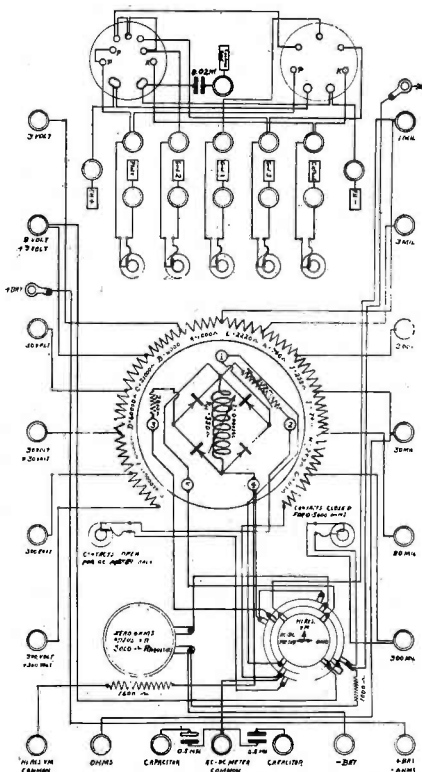

Fig. 3. Circuit of Supreme Model 56 Analyzer. The rectangles between the binding posts at the top indicate leads through analyzer cable to analyzer plug

voltage ranges are also externally available at insulated pin jacks.

An "ohms" scale is provided for indicating resistance values in a low range from 0 to 5,000 ohms and in a high range from 0 to 500,000 ohms. A 4½-volt battery is used when measuring on both resistance ranges.

With ordinary 60-cycle power supply, capacitive measurements may be made between approximately .0002 mfd. and 7.0 mfd. Condenser leakage tests may also be made.

By the use of a condenser connected between the "Capacitor" pin jacks and the "Meter Common" pin jack terminals (see diagram) the unit can be used as an output meter for measuring the a-c. components of the applied output potentials of a radio receiver.

Provisions are also made so that a standard point-to-point resistance analysis can be made between respective tube sockets. 4-, 5-, 6-, and 7-prong tubes can also be tested. A 7-prong socket and a composite socket are mounted on the panel of the Analyzer for this purpose.

## Shallcross Types 651-652 Set Testers

These testers permit the testing of circuits employing 4-, 5-, 6- and 7-prong tubes. The instruments employ only one meter, but with the switching arrangements indicated in the complete tester diagram shown in Fig. 5, permit all the necessary d-c. current and voltage measurements encountered in modern receivers.

The d-c. current and voltage readings available in the two models are as follows:

| Type | Volts            | Milliamperes |
|------|------------------|--------------|
| 651  | 10-100-250-1,000 | 2.5-10-100   |
| 652  | 7.5-30-150-750   | 3-15-75      |

The circuit shown is designed for the Shallcross No. 651 Tester, using the Weston Model 301 D.C., 0-1 MA meter and the Shallcross No. 652 Tester, using the same model Weston meter with a scale of 0-1.5 MA. The only changes between the two are the values of the resistors R1 to R9. The values given in the diagram are for the No. 651 Tester. The values for the No. 652 Tester are as follows:

|    |           |
|----|-----------|
| R1 | 82 ohms   |
| R2 | 4,900 "   |
| R3 | 15,000 "  |
| R4 | 80,000 "  |
| R5 | 400,000 " |
| R6 | 100 "     |
| R7 | 100 "     |
| R8 | 4,000 "   |
| R9 | 800 "     |

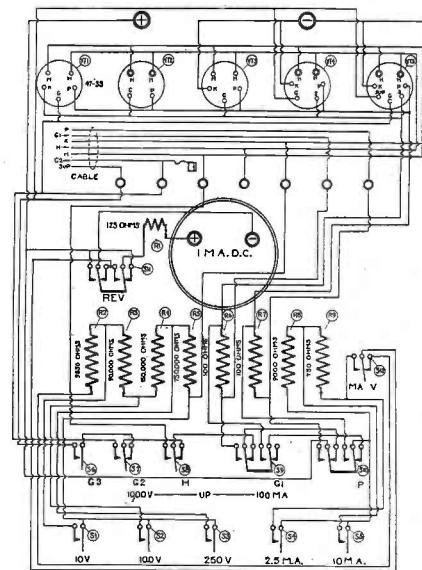

Fig. 5. Circuit diagram of the Shallcross Set Tester. Calibrated resistors are used

The approximate d-c. resistance of the 0-1 milliammeter is 27 ohms, and that of the 0-1.5 milliammeter, 18 ohms.

## Hickok Ohm Capacity Voltmeter

The ohmmeter in this unit is operated from 110-volt, 60-cycle line in conjunction with a rectifier tube, which may be a '01-A, '12-A or '71-A. The capacity meter connects into the same line cord.

The power transformer and filter system for the rectifier is incorporated in the unit, as indicated by the schematic diagram of the complete device shown in Fig. 6.

The range of the ohmmeter is from 5 ohms to 30 megohms. This is made possible by the use of a rectified d-c. voltage of 3 volts on No. 1 ohms scale, to 300 volts on No. 4 ohms scale.

The ohmmeter is equipped with four scales as follows:

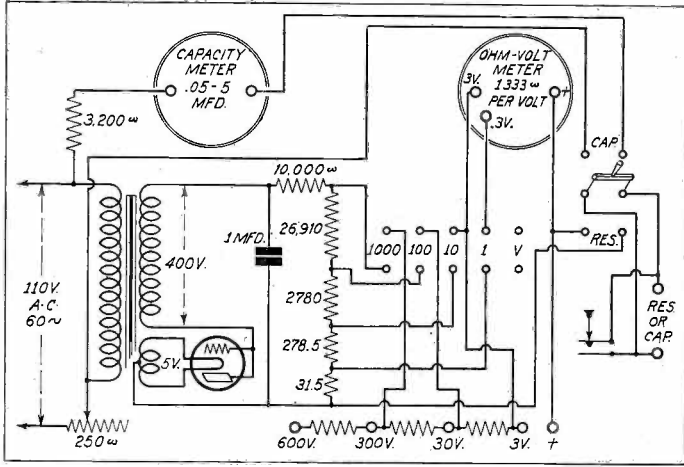

Fig. 6. Schematic diagram of the Hickok Ohm Capacity Voltmeter. The rectifier tube may be most any one with a five-volt filament, such as the '01-A, '12-A or '71-A. The rectifier tube socket is on the panel, as shown in Fig. 7

| Scale | Range              |
|-------|--------------------|
| No. 1 | 5 to 30,000 ohms   |
| No. 2 | 50 to 300,000 ohms |
| No. 3 | 500 to 3 megohms   |
| No. 4 | 5000 to 30 megohms |

The ohmmeter is also used as a voltmeter in which the sensitivity is 1,333 ohms per volt, with ranges as follows:

| Scale | Range    | Resistance   |
|-------|----------|--------------|
| No. 1 | 0-3 V.   | 4,000 ohms   |
| No. 2 | 0-30 V.  | 40,000 ohms  |
| No. 3 | 0-300 V. | 400,000 ohms |
| No. 4 | 0-600 V. | 800,000 ohms |



Fig. 7. The Hickok Ohm Capacity Voltmeter which operates direct from a-c. line

The capacity meter has a scale of 1/4 to 15 mfd. Both capacity and resistance are read by one pair of binding posts, as the diagram indicates, and a switch is provided to make the change from resistance to capacity reading.

A 250-ohm rheostat is included in the a-c. line circuit so that adjustment can be made to meet the standardized voltage conditions.

### Sprayberry Set Analyzer

This analyzer is an assembled job, and is built around a Western rectifier type Model 301 universal voltmeter. The following a-c. and d-c. voltage ranges are available through an eight position switch: 0-5-10-50-100-250-500 and 1,000 volts. There are also three d-c. ranges through a three position switch for current reading, as follows: 0-2.5 ma.; 0-25 ma., and 0-100 ma.

The complete schematic diagram of the Sprayberry Analyzer is shown in Fig. 8. A later model also includes a 7-prong tube

socket, but the wiring of the analyzer remains essentially the same.

All the current and voltage ranges are available at the tube sockets and also externally, through jacks J, J-1 and J-2. Two binding posts are mounted next to these jacks for battery connection when it is desired to employ continuity testing.

The Sprayberry Analyzer will perform all the usual tests necessary to carry out on a receiver, and may also be used as a mutual conductance meter through the use of push buttons included in the circuit. The voltmeter may also be used as an output meter through the jacks J-1 and J-2.

Fig. 8. The circuit diagram of the Sprayberry Set Analyzer. Both a-c. and d-c. ranges are read on a single meter, which is of the rectifier type. External readings may be had through jacks J, J-1 and J-2

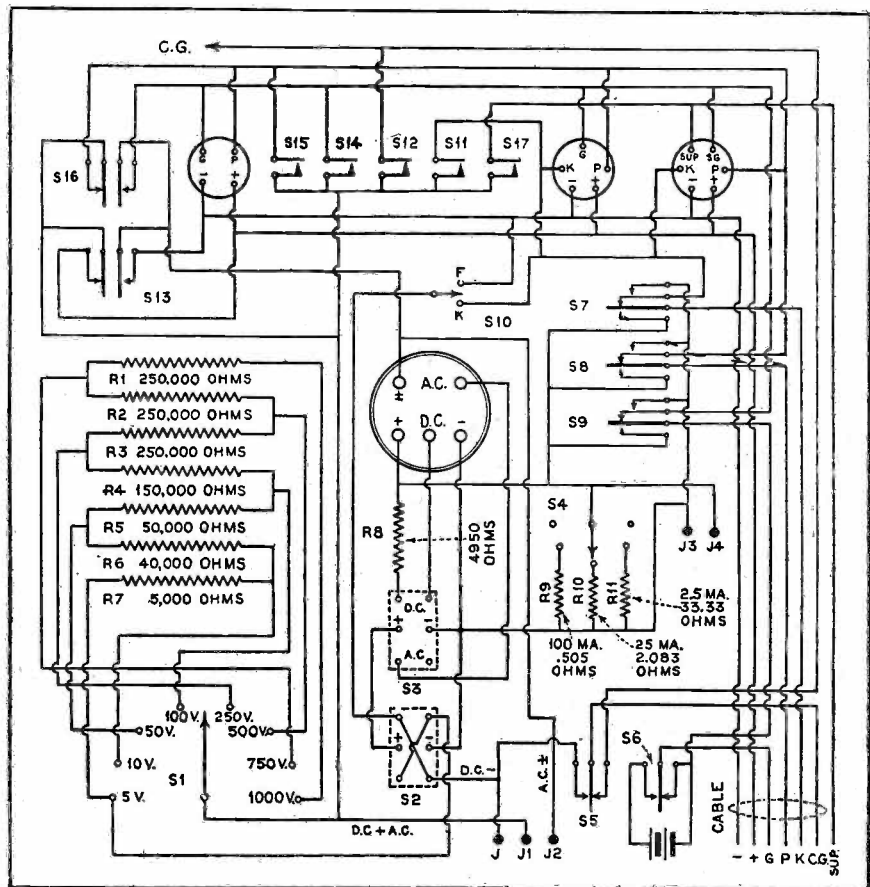

### Jewell 444 Set Analyzer

The schematic diagram of the Pattern 444 Analyzer is shown in Fig. 9, and a view of the instrument in Fig. 10. This is similar in some respects to the Weston 660 Analyzer in that a multiple combination socket moulded into the panel is used for accommodating all tubes including the new 7-prong type.

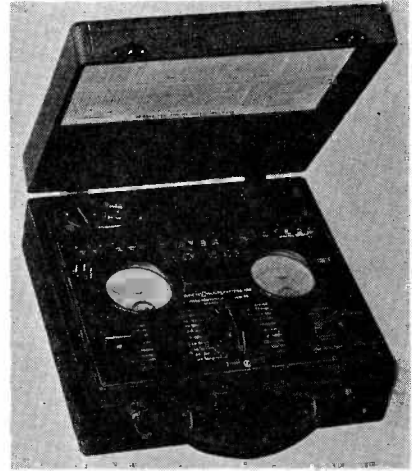

Fig. 10. The Jewell 444 Set Analyzer with 24-range selector switch in center of panel. The circuit is shown on page 310

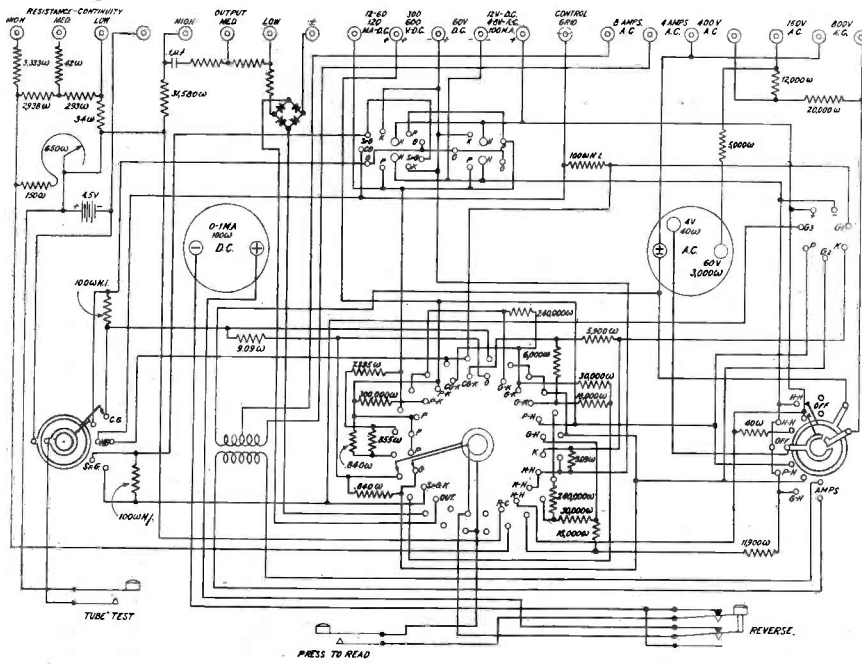

Fig. 9. Schematic diagram of the Jewell 444 Set Analyzer illustrated on page 309

The switching system in the center of the panel provides 24 ranges for external test lead connections. Among these are three output meter ranges and three resistance measuring ranges.

Two meters are used: one a-c. and one d-c. The scale ranges are as follows: A-C. Meter: 0-4-8-160 and 800 volts; 0-12-60 and 120 milliamperes. D-C. Meter: 0-6-12-30-60-120-300 and 600 volts; 0-12-60 and 120 milliamperes; 0-1,000-10,000 and 100,000 ohms.

The ranges available for external use are indicated in the circuit diagram.

### Readrite No. 1000 Set Tester

The No. 1000 Tester, shown in Fig. 11, employs a capacity meter and a multi-scale meter for the measurement of voltage, cur-

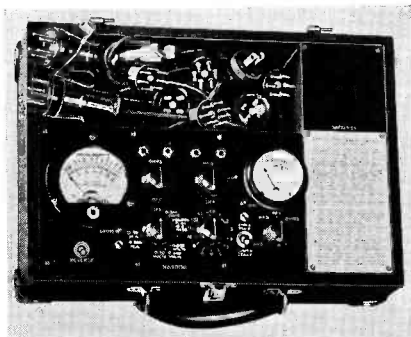

Fig. 11. The Readrite No. 1000 Capacity and Continuity Set Tester. The compartment to the right holds the necessary batteries

rent and resistance. The tester has double test cables and plugs, thereby providing for the point-to-point measurement of resistance between any tube circuit and rectifier. Pro-

visions are also made for straight continuity testing either by the voltage or resistance method.

The capacity meter has two ranges, .08 mfd. to 1.0 mfd. and 1.0 mfd. to 10 mfd. The meter operates from the a-c. line and a 3,000-ohm rheostat permits the necessary zero adjustment. See the circuit diagram of Fig. 12.

The volt-ohm-milliammeter is of the D'Arsonval type and has a sensitivity of 1,666 ohms per volt. The ranges are as follows: 0-500, 0-50,000 and 0-3,000,000 ohms; 0-30, 0-300 and 0-600 volts; 0-30 and 0-300 milliamperes.

A rheostat is also provided for permitting zero adjustment on the voltmeter when used for measuring resistance. The necessary voltages are supplied by batteries enclosed in the instrument.

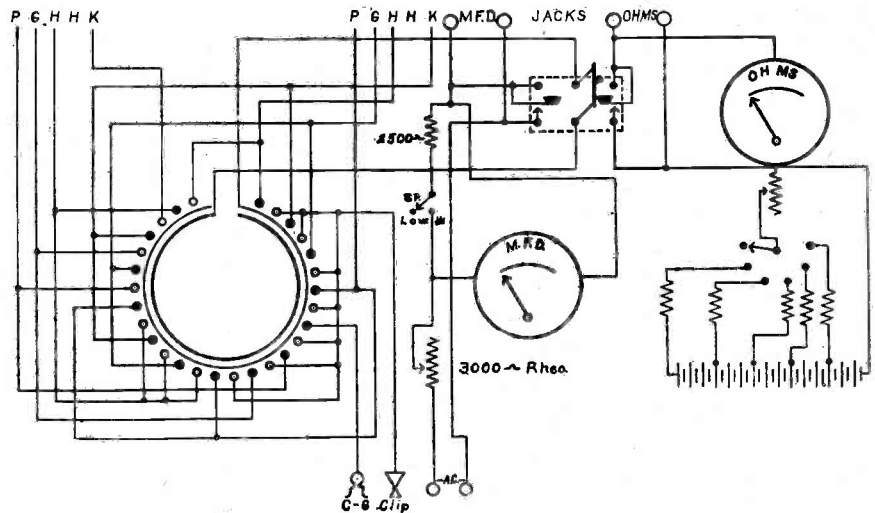

Fig. 12. Schematic diagram of the Readrite No. 1000 Set Tester. The right hand switch determines the resistance ranges of the ohmmeter. Note the zero adjuster variable resistance in circuit with this meter

At the lower part of the panel are two selector switches which are used in conjunction with the test cables. The left-hand selector switch controls the ranges of the meter as heretofore listed, and provisions are made by means of pin jacks so that these ranges are also available for external use.

In using the Tester for point-to-point resistance analysis, the right hand test cable plugs into an amplifier or detector socket and the left hand cable into the rectifier socket. The resistance readings of the various circuits between the tube elements and rectifier are obtained by rotating the selector switch which throws each circuit in in turn.

### Readrite No. 710 Set Analyzer

An illustration and the circuit diagram of the No. 710 Analyzer are shown in Figs. 13 and 14 respectively. It will be noted that three meters are used, a d-c. milliammeter, a d-c. voltmeter and an a-c. voltmeter.

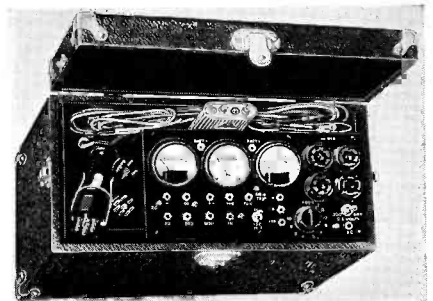

Fig. 13. The Readrite No. 710 Set Analyzer

The d-c. voltmeter has the following ranges: 0-20-60-300 and 600 volts. The a-c. voltmeter has the following ranges: 0-10-140 and 700 volts. The d-c. milliammeter has a range of 0 to 15 and another of 0 to 150 ma.

The d-c. meters are of the polarized vane type, and the a-c. meter of the repulsion type.

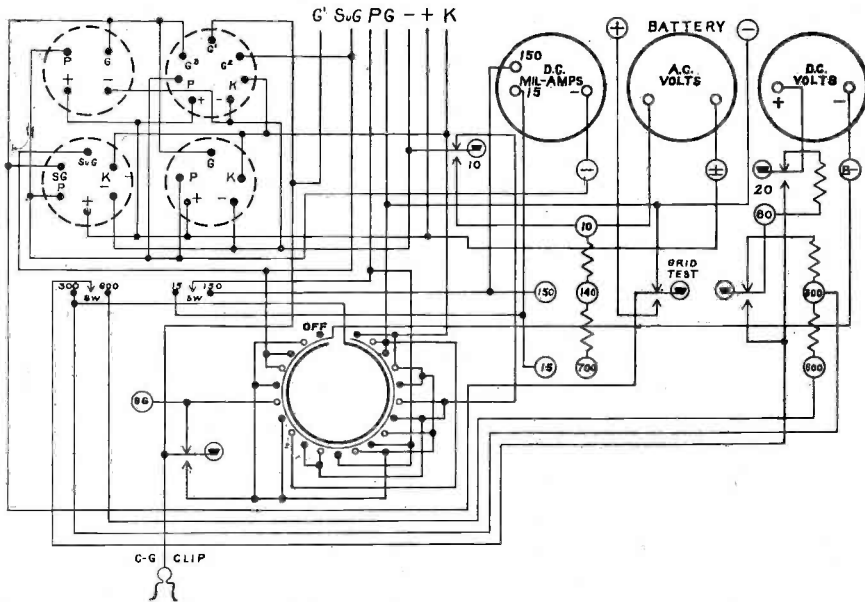

Fig. 14. Circuit diagram of the Readrite No. 710 Set Analyzer shown on opposite page. The wires terminating near the top of the diagram are the cable leads

There are four sockets on the panel of the instrument for accommodating 4-, 5-, 6- and 7-prong tubes.

The type of tests possible are as follows: grid voltage, plate voltage, filament voltage, cathode voltage, suppressor-grid voltage, screen-grid voltage, plate current, a-c. line voltage, tests on secondary of power transformer, and the latest type of r-f. and superheterodyne circuits. All the ranges of the meters are available through tip jacks.

### Franklin D-33-A Analyzer

The circuit of the D-33-A is shown in Fig. 15, and an illustration of the unit in Fig. 16.

This instrument is a combination set analyzer and tube tester, and will accommodate all tubes, including the 7-prong types. Proper meter ranges and desired circuits are se-

Fig. 15. Schematic diagram of the Franklin D-33-A Analyzer. Note that a power transformer is used in conjunction with a selector switch

lected by pressing push buttons on the panel.

In addition to checking all circuits under operating conditions, the following meter ranges are provided for external circuits: A-C. Meter: 0-4-8-16-200 and 1,000 volts; 0-20 and 0-100 milliamperes. D-C. Meter: 0-10-100-400 and 800 volts; 0-10 and 0-100 milliamperes; also 0-5,000 ohms and 0-5,000,000 ohms. There are also provisions for a low and high range output meter for aligning r.f. and superheterodyne receivers.

The tube checker is a-c.-operated, and by means of a tap switch, all standard filament voltages may be selected, including a 6.3-volt and a 30-volt filament position. In addition, an extra tap is provided to accommodate any new filament voltage series which may be announced.

The d-c. meter in the analyzer is equipped with a rectifier, enabling it to be used as an output meter, as mentioned above. The

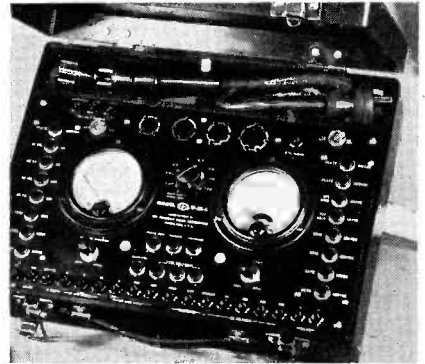
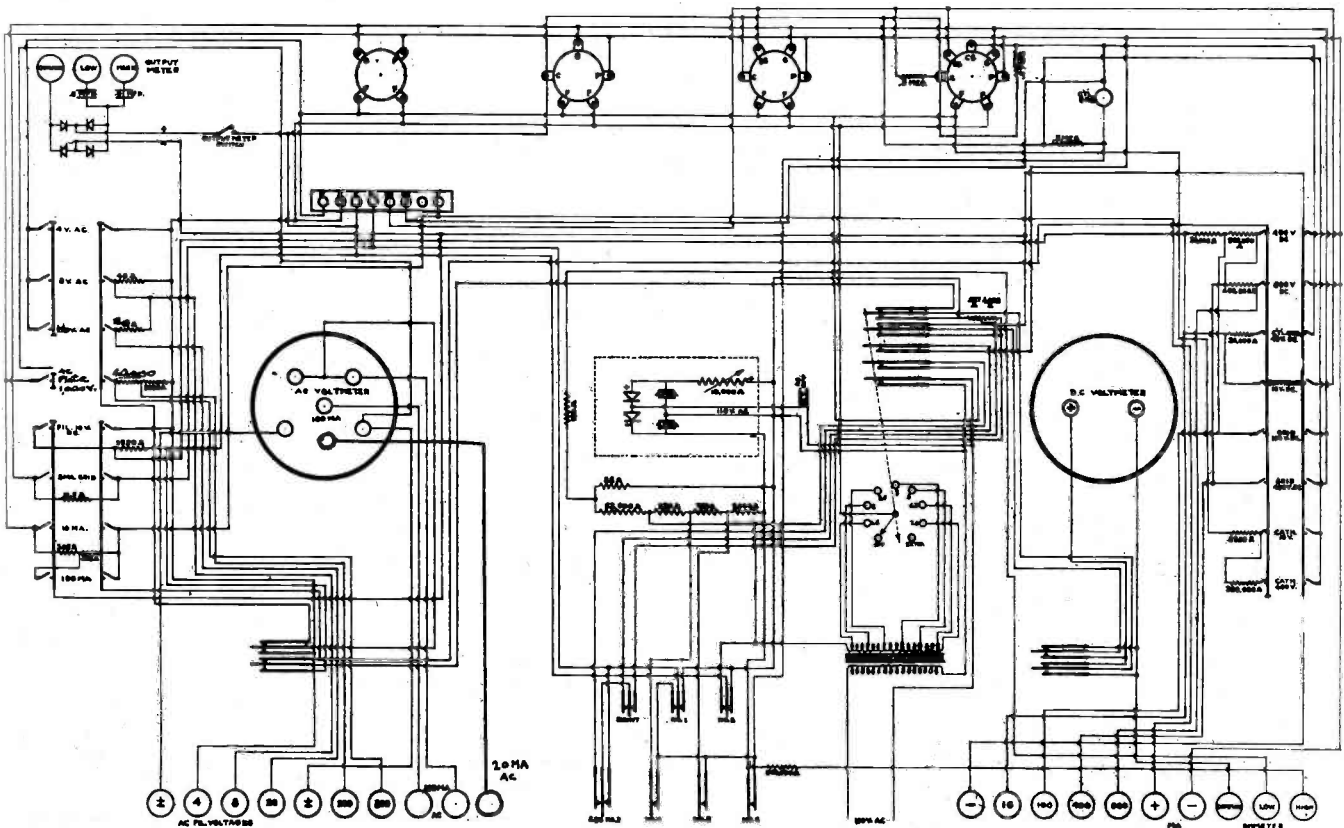

Fig. 16. A view of the Franklin D-33-A Analyzer. Note the series of push buttons along the front of the panel



## GENERAL DATA—continued

output of a receiver may be checked directly from plate to ground of the final amplifier stage, as both scales are provided with d-c. blocking condensers.

The power supply used for the tube checker is also used in conjunction with the voltmeter for resistance measurement.

### Franklin 33-B Set Analyzer

The Model 33-B Set Analyzer uses a single meter in conjunction with a switching arrangement (see Figs. 17 and 18) to provide output tests, sensitivity tests, straight and point-to-point resistance analysis; filament,



Fig. 17. The Franklin 33-B Set Analyzer, with single meter for all a-c. and d-c. readings

plate, grid, screen and cathode voltage measurements, and plate and grid current measurements.

The resistance scales will check up to 1,000 and 1,000,000 ohms. The output meter, being of the rectifier type, has a good degree of sensitivity.

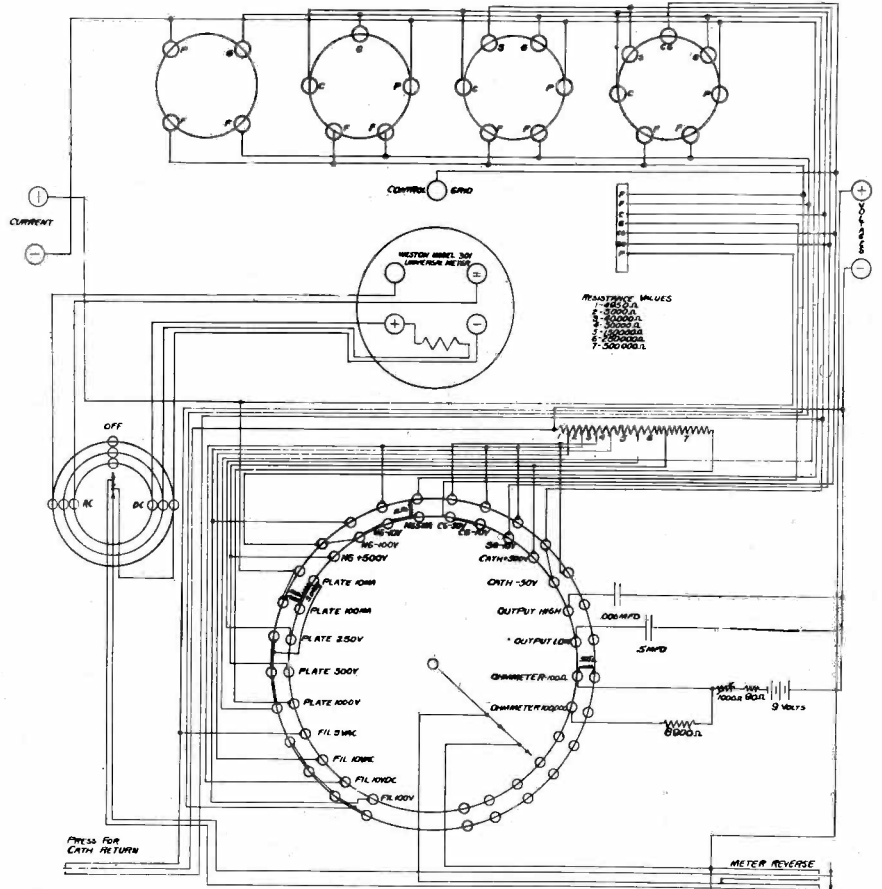
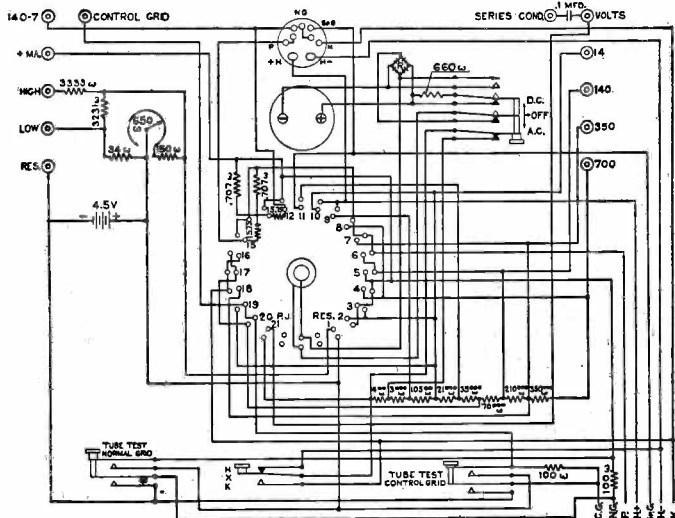

Fig. 18. Schematic diagram of the Franklin 33-B Set Analyzer shown at the left. In this Analyzer a selector switch is employed to break in on the various circuits in the set. The circuit is so arranged that it is also possible to make point-to-point resistance measurements. The resistance values for each section of the tapped resistor are lettered into the diagram just to the right of the meter

The a-c. and d-c. voltage scales are: 0-5-10-250-500 and 1,000 volts. Current scales are: 0-5-10 and 100 milliamperes, and 0-1 ampere a-c. or d-c. All scales are available for testing external circuits.

A switching arrangement is used which enables various scales to be selected without changing pin jacks, as indicated by the diagram of Fig. 1.

### Weston 660 Set Analyzer

The 660 Analyzer uses a single meter in conjunction with an ambitious switching arrangement to provide current, voltage and resistance readings, and for circuit changes.

The meter is of the multi-scale type and

Fig. 19. (left) Circuit diagram of the Weston 660 Set Analyzer, showing how the single selector switch provides all the meter ranges. A separate switch provides for a-c. or d-c. readings

Fig. 20. Front panel view of the Weston 660 Set Analyzer, showing the selector switch and, directly above the meter, the composite tube socket for all tubes including the 7-prongers

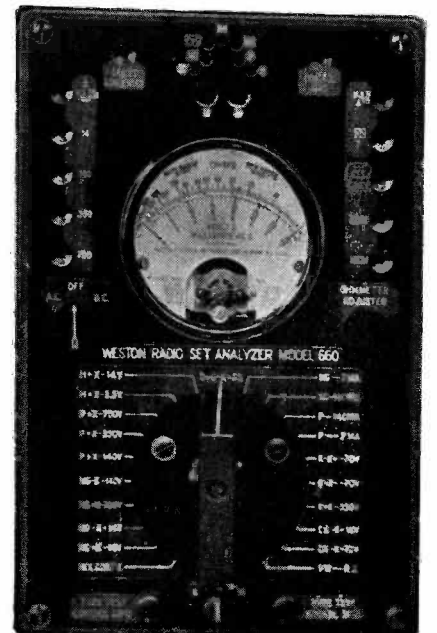





Receiving Antenna Practice

While receiving antennas are comparatively simple structures, there are a few facts relative to their performance that are all too likely to be disregarded. This state of affairs strangely enough has led to a number of misleading statements in recent technical publications. This, therefore, seems an appropriate time to review a few simple facts about receiving antennas, lest this become a lost art.

EFFECTIVE HEIGHT

The effective height of an antenna is the ratio of the voltage induced in the antenna to the strength of the uniform field about the antenna. In other words, it is the voltage in microvolts induced in the antenna by a uniform field of one microvolt per meter. This is of course of more academic than practical interest because the field about a receiving antenna in the average urban localities is seldom uniform. Thus, the effective height of a vertical antenna is approximately equal to one-half its physical height, and that of an umbrella structure to the physical height of the bottom of the

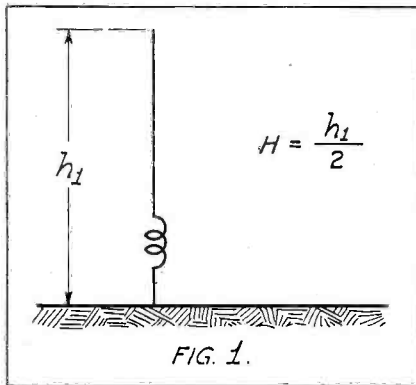

The effective height of a vertical aerial is equal to one-half its physical height

umbrella plus one-third of the total height of the entire structure. Both of these examples are illustrated graphically and mathematically in Figs. 1 and 2.

Now, if a flat top is added to the vertical member it acts to load the structure and thereby increase its effectiveness somewhat.

ELECTRIC FIELDS

To digress for a moment, consider an electromagnetic radio wave traveling over a flat and perfectly conducting surface, as illustrated in Fig. 3. The direction of travel of the wave, the magnetic field, and the electric field are mutually at right angles, as shown. Now the average open type of antenna, such as the L-type illustrated in Fig. 3, consists essentially of a capacity reactance (the inductive reactance usually being 10% or less of the capacity reactance). Thus, its response will be principally due to the electric field and not the magnetic field. Consequently a voltage will be induced in the lead-in or vertical member, which is parallel to the field, but not in the horizontal flat top which is perpendicular to the field. In

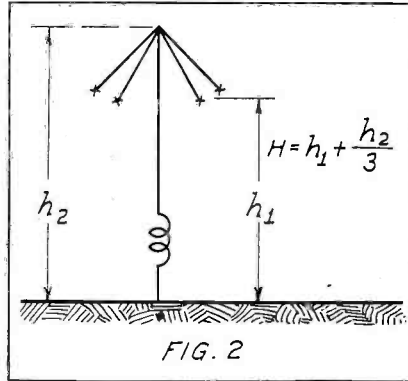

The effective height of an umbrella aerial is equal to the physical height of the bottom of the umbrella plus one-third of the total height

an ideal case, then, the flat top will contribute very little to the voltage induced at the receiver. It does, however, materially reduce the aerial reactance and this loading effect may be of considerable benefit. It is evident then that the best distribution for a given length of aerial is to have the whole length vertical. (See Fig. 4.) Since the height is usually the limiting factor, rather than total length of wire used, the aerial should be as high as possible and the horizontal member as long as practicable up to say 100 feet.

As it so happens, the ideal condition just outlined seldom obtains, and as a result the wave front is not parallel to the surface of the earth. Moreover, the lead-in may not be wholly vertical nor the flat top entirely horizontal. Again, the direction of wave propagation may be naturally altered by nearby steel buildings, etc., and currents induced in nearby wires and metal structures will frequently contribute an appreciable part of the voltage induced in the antenna system. So, the ideal case can only serve as a general guide.

SHIELDED LEAD-INS

For all of the alterations which may take place, the lead-in, or vertical portion of the antenna, is in general the member responsible for most of the induced voltage. If this is the case, it is obviously wrong to extend the shield of a shielded lead-in all the

way up to the horizontal flat top, or to place an antenna transformer of the type used with noise-reducing aerial systems, directly at the flat top. Both of these practices are becoming more or less common, with the result that in some instances the shield placed over the lead-in wire may be the better antenna, due to its large pickup.

These statements should not be taken to indicate that we condemn shielded lead-ins. On the contrary, as pointed out in previous issues of SERVICE, they serve a very useful purpose. However, these statements are intended to leave the thought with you that shielded lead-in and other antenna systems must be installed with care, if the pickup properties of the antenna are to remain unimpaired.

The antenna transformer or shielded lead-in should start near ground or should run only as far along the exposed lead-in as necessary to shield it from nearby sources of interference. Figs. 5 and 6 illustrate representative cases of rooftop antennas with transformers and shielded lead-ins properly installed. If the buildings have metal frameworks or metal lath, this generally constitutes the system ground, and as such tends to shield the antenna somewhat from the interference-producing devices within the building. In cases such as that illustrated in Fig. 5, the only section of the lead-in likely to be effective in signal pickup—and at the same time comparatively free of noise pickup—is that portion tagged A. The remainder may therefore be shielded without material damage to signal intensity as it runs in an enclosed area. On the other hand, the vertical portion A left free will contribute to the induced signal voltage.

A similar arrangement is made in the case of a condition as illustrated in Fig. 6. In this case practically the entire lead-in above the surface of the roof is left unshielded as it is fairly well above the noise area, and being free of conductive obstructions will contribute considerably to the induced signal voltage. Note that in both cases the antenna transformer is at least five feet above the roof.

TRANSPPOSITION LEADS

It is evident that where a lead-in of the transposition type is employed in connection

Showing the disposition of the electric and magnetic fields of a radio wave, and the angle they present to each other and to an antenna

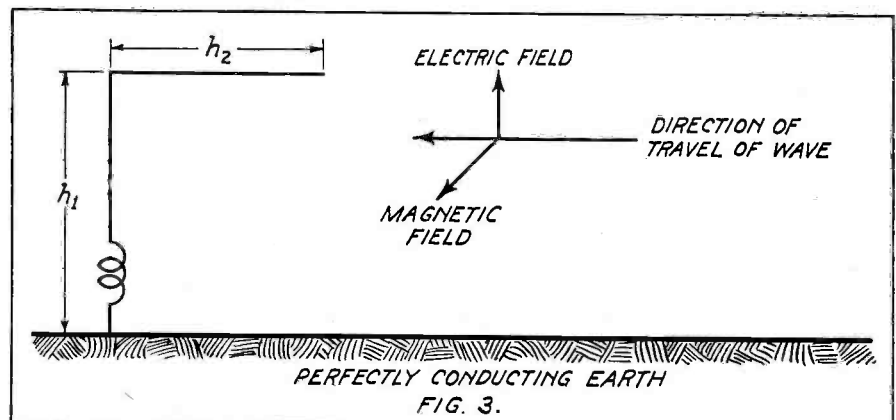

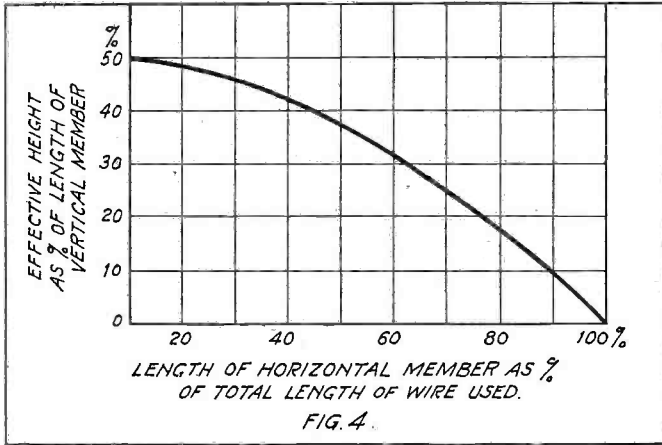

A graph indicating the relative percentages of length of vertical and horizontal wires. Thus, where the whole wire is horizontal (100%) the pickup efficiency is small; whereas if 50% of the total wire is vertical, the efficiency is high

with a horizontal flat top (See page 125, June SERVICE) that the effectiveness of the lead-in as a signal pickup is nil, just as in the case of the common form of shielded lead-in we have been discussing. Here, again, a reduction of the length of transposition may pay dividends in increased signal, though the transposition should be carried all the way to the flat top in the event that the whole length of the lead-in is in a very definite noise area. This is likewise true in connection with the shielded lead-in. In either case, you must use your own judgment.

There is one other point relative to transposed lead-ins which should be clarified. The practice of using transposed lead-in lines is an old one with short-wave transmitters constructed by amateurs who use such lead-in systems for coupling energy to the antenna without affecting the natural frequency or effective lengths of aerials which are generally measured to very close limits. In these cases the transposed leads function independently of the aerial itself and do not alter the natural frequency. The same holds true in reverse—that is, when the aerial is used for reception. Nevertheless, a number of the fellows who have installed transposed aerial systems report a considerable reduction of signal strength. This no doubt is due primarily to the capacitive effect of the twisted lead wires which will in-

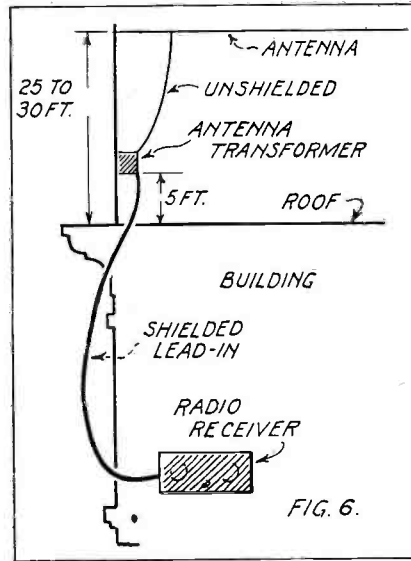

The antenna transformer should be mounted a distance above the roof, and the lead shielded only below

crease the wavelength of the antenna system. Now the average antenna used for broadcast reception has a capacity of about .0002 mfd., and most broadcast receivers are designed in anticipation of aerials of this average value of capacity. It is, therefore, obvious that a directly-coupled aerial of considerably greater capacity would be less satisfactory.

Some of the receiver manufacturers provide their sets with "long" and "short" antenna terminals, the "long" terminal being connected to the "short" terminal through a condenser of about .0002 mfd. Since the joint capacity of condensers in series cannot exceed the value of the smallest capacity, in this case .0002 mfd., the receiver is effectively matched to the aerial, irrespective of its length or capacity. For this reason, it is well to connect transposed lead-in lines to the "long" antenna terminal, if so provided, or to make the connection through a .0002-mfd. fixed condenser if no such condenser is provided in the set proper.

**Adjusting Philco Model 43**

The Philco Model 43 Short Wave Combination Receiver can be adjusted by means of the Philco 095 B or similar oscillator. This

oscillator provides a 450-kc. signal which is used for adjusting the intermediate-frequency amplifier stages, and it also provides 700 kc. and 1400 kc. signals for adjustments in the broadcast range. The other compensating condensers in the short-wave range are of special construction and will not require re-adjustment. Since all gain in the receiver is obtained in the i-f. stages, it is only necessary to make the adjustments of the i-f. compensating condensers, should the set ever become weak. The following procedure should be used:

Remove the control-grid connection from the first detector tube, and substitute the antenna connection from the oscillator. Connect the output meter across the primary of the output transformer.

Set the oscillator in operation at 450 kc. Adjust the i-f. compensating condensers for maximum output meter reading.

Replace the control-grid connection of the first detector tube, and connect the 450-kc. signal to the antenna terminal of the radio set; adjust the wave trap for minimum reading in the output meter.

Change the oscillator setting to 175 kc.

Tune in the fourth harmonic of this signal at 700 kc. and adjust the 700-kc. condenser for maximum output meter reading.

Re-set the dial at 1400 kc. and tune in the eighth harmonic of 175 kc. at 1400 on the bottom scale; adjust the 1400-kc. condenser for maximum output meter reading.

Tune the set to 1400 kc. on the second scale from the bottom and adjust this compensating condenser for maximum output meter reading.

When adjusting the 1400 and 700 compensating condensers (indicated in the accompanying sketch) it may be found that the oscillator signal will be heard 10 kc. or more off the desired dial reading. This can be corrected by alternate adjustments and re-tuning of the tuning condenser, bringing

That portion of a down lead comparatively free from local interference should not be shielded, but used as part of the aerial

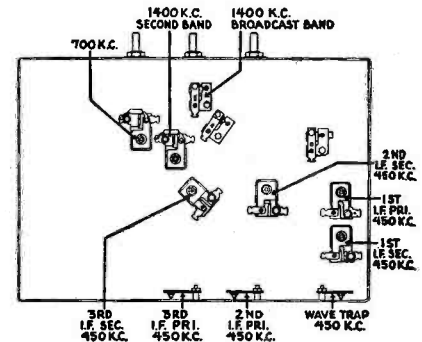
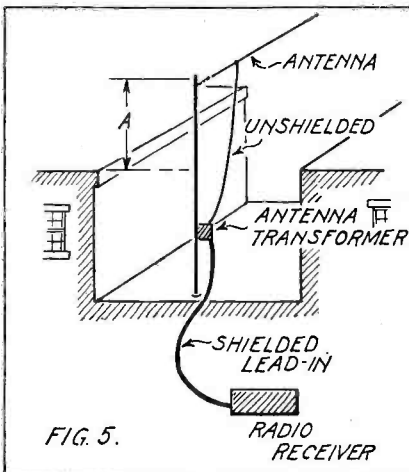

An under-view of the chassis of the Philco Model 43, showing the positions of the trimmer and compensating condensers. The condensers shown are the only ones that should be adjusted

the signal nearer to 700 or 1400 each time until maximum output meter reading is obtained with the correct dial scale reading.

It is important that the wires which connect between the r-f. coils and the wave-change switch be so arranged that they will have maximum separation between them for minimum capacity losses.

### Adjusting Philco Models 80 and 37

The general method of adjusting Philco Models 80 and 37 is the same as that for other Philco models. Adjustment of the compensating condensers is done first. This adjustment is then followed by the adjustment of the antenna, and high-frequency condensers, and finally the low-frequency condenser.

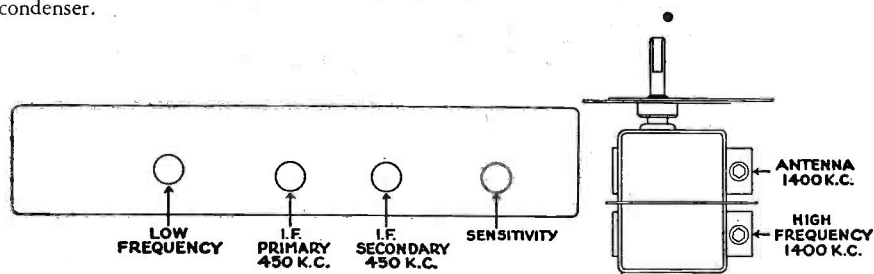

Fig. 1. (Above) Back of Philco Model 80 chassis, showing locations of the compensating condensers. Fig. 2. (Right) Tuning condenser, Model 80 chassis, showing locations of additional compensating condensers. The manner of adjustment is explained in the accompanying text

It is necessary to have an accurately calibrated oscillator signal at 450 kc. (see page 271, October SERVICE) for adjusting the i-f. compensating condensers in the Model 80.

The adjustment of the "sensitivity" compensating condenser in the Model 80 should be done at the time of installation in accordance with the data accompanying the set.

### Keller-Fuller Model F

You may have worked upon two of these jobs some time in the past and looked for a second filament winding. The early production with serial numbers from 10,000 to 10,098 employed a single winding to supply all heater and filament circuits, with the exception of the rectifier tube.

### Delco Correction

Due possibly to the presidential campaign speeches and the new group of mystery sketches placed on the air, we permitted an error to creep into the schematic diagram of the Delco 32-volt d-c. receiver, on page 270 of the October issue. This diagram shows a

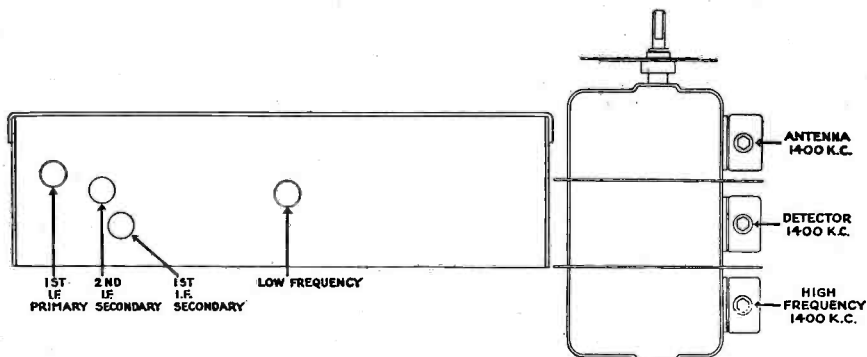

Fig. 3. (Above) Back of Philco Model 37 chassis, showing locations of compensating condensers. The 2nd i-f. secondary condenser is mounted on the front of the chassis, but is accessible through the opening in the back, as shown. Fig. 4. (Right) Indicating the locations of the additional compensating condensers on the gang condenser

The Model 37 intermediate frequency is adjusted at 175 kc.

The accompanying sketches indicate the adjusting positions in the Model 80 and the Model 37.

### Copper Oxide Rectifiers as Detectors

A new type of radio detector has been developed which depends for its action on the rectifying properties of the boundary between copper and cuprous oxide. Small discs are used to form the detector, and it is of the full-wave type.

The circuits developed possess unique advantages in that harmonic distortion is practically eliminated, a stage of audio frequency amplification is eliminated, and automatic volume control of variable mu tubes as well as other tubes is made possible.

(L. O. Grondahl and W. P. Place, Proceedings I.R.E., October, 1932)

ballast tube connected in series with a 175-ohm resistor, the two being shunted across the "A" line. The circuit is quite correct, but the circular gadget is not a ballast tube . . . it is a common pilot lamp. Please mark this before it slips your mind . . . and pardon us for being stupid.

### Power Transformer Testing

Details of a test board for power transformers, on which it is possible to make all the necessary current and voltage measurements under proper load conditions, and to also place the transformers on heat run for any length of time.

The test board is meant primarily for manufacturer's testing, but a similar test board for small work could easily be built to the specifications given.

(R. F. Shea, Radio Engineering, October, 1932)

### Philco 80 Whistles

A glance at the schematic diagram of the Philco 80 (page 267, October SERVICE) will indicate that regeneration is employed in the circuit of the second detector. Regeneration is controlled by the throttle condenser (18) which may be adjusted from the back of the chassis.

It occurs to us that some over-zealous fellows may make this adjustment too critical, instructions to the contrary, with the possibility thereof of calls from owners complaining of birdies in their sets.

If the adjustment of the regeneration is too critical, a change in weather may be sufficient to cause the second detector to spill over into oscillation. A slight readjustment in such a case would fix matters.

So, if you get any birdie complaints, remember condenser (18) and dive for it.

### Kolster Field Coil Resistance Values

There are numerous occasions when checking the voice coils of speakers to determine the degree of continuity, when the actual d-c. resistance would come in handy. The following voice coil data is offered at this time. More will follow at a future date. These figures apply to the voice coils only, disconnected from the transformer.

| Model              | Ohms |
|--------------------|------|
| K 60—K 62 AC       | 3.0  |
| K 70—K 72 AC       | 7.5  |
| K 80—K 82 AC       | 8.7  |
| K 90—K 92 AC       | 8.7  |
| K 83—K 93 DC       | 8.7  |
| K 63—K 73—K 103 DC | 3.0  |
| K 113—K 123 DC     | 3.0  |
| K 133—K 143 DC     | 8.0  |
| K 110—K 112 AC     | 2.8  |
| K 120—K 122 AC     | 2.8  |
| K 130—K 132 AC     | 8.0  |
| K 140—K 142 AC:    |      |
| Large speaker      | 8.0  |
| Small speaker      | 16.5 |

### AVC Tube Operation

If you are working on a receiver which has an automatic volume control and the controlled tubes show greater than normal grid bias without any signal input, more than likely the AVC tube must be replaced. However, before replacement, check the grid bias applied to the AVC tube. If for some reason the grid bias is too low, the AVC tube plate current may reach such proportions as to cause the application of excessive no-signal control-grid bias on the controlled tubes.

### Majestic 55

If this receiver shows signs of buzzing and sputtering after a period of use, check the 100,000-ohm resistor in the control-grid circuit of the output tube. This unit is connected between the control grid and the grid leak. It may be necessary to remove this resistor if the gas content of the output tube is excessive. Oftentimes, changing the output tube obviates the necessity of removing this resistor.

# Short Waves

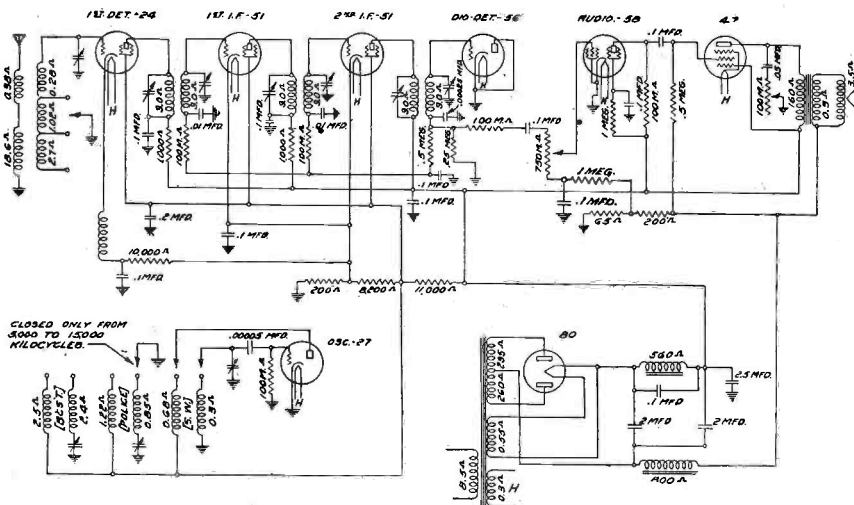

Fig. 1. Complete schematic diagram of the Clarion Model AC-240 short- and broadcast-wave receiver. The 800-ohm coil in the negative leg of the power supply is the dynamic-speaker field winding

## Clarion Model AC-240

This is an AVC short-wave and broadcast band superheterodyne with a frequency range of from 15,000 kc. to 550 kc. The bands are controlled by a three-position switch. In the first position the band covered is 15,000 kc. In the second position the band is 5,500 kc. to 1,500 kc. The third position is 1,500 kc. to 550 kc.

The circuit diagram is shown in Fig. 1. The intermediate-frequency stages are peaked at 490 kc. For alignment, a test oscillator which will tune to 490 kc. is necessary.

An under view of the chassis is shown in Fig. 2 with the parts marked for reference purposes. The adjusting nuts for the ten trimmer condensers used will be found on the upper side of the chassis.

Note that the schematic diagram includes the d-c. resistance values of all units. This is handy for individual tests, though a complete resistance analysis is provided in Table 1. These readings were taken from sockets to ground, with the wave-change switch in the "broadcast" position, volume control in the "full on" position, all tubes and pilot light removed. The tolerance for resistors is ten percent plus or minus. When taking low-resistance readings such as cathode or heater, be very sure you have made good contact at socket and ground or an erroneous reading will almost certainly result.

### VOLTAGE DATA

The voltage data given in Table 2 was taken with volume control "full on," wave-change switch in "broadcast" position, and with a line voltage of 115.

In testing the circuits of the '47 tube, the plate voltage was taken with an external meter connection and on the 250-volt scale, across plate and heater terminals of an adapter into which the tubes are plugged. The space charge grid reading was taken in a like manner. The grid voltage on this tube

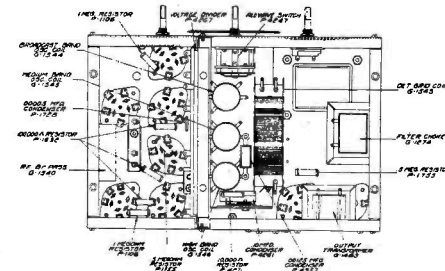

Fig. 2. A bottom view of the Clarion AC-240 chassis. Though this sketch shows the disposition of the units, it does not indicate the positions of the compensating condensers. Such condenser adjusting screws will be found on each of the three i-f. transformers and on the back of the gang condenser

was taken between the ground terminal and the common lead to field and voice coil on the speaker (since the half-megohm grid resistor would prevent a direct reading). The type 58 tube was tested with a five-to-six adapter in the analyzer and six-to-five adapter in the set, with the suppressor grid connected to the cathode terminal on both adapters, thus permitting use of the analyzer plug.

### POSSIBLE FAULTS

**Fading:** Line voltage fluctuations will cause fading due to a consequent change in plate voltage on the oscillator tube. Use a line-voltage regulator.

**Weakness:** The 58 tube in the audio stage may change with use. Change tube and at the same time make sure that line voltage is not above 120. If so, it will cause rapid tube wear.

**Harmonics:** No first r-f. stage is used and commercial stations at about 500 kc. may cause a 1,000-kc. harmonic to be picked up and amplified by the i-f. stages. Use a wave trap for individual cases. (See article on traps in this issue.)

**Image Frequency:** A signal 980 kc. lower than that tuned in, may be impressed on the first (autodyne) detector and amplified. Reduce size of aerial, change its direction, or use a wave trap.

## Constant Regeneration

The difficulties of maintaining maximum regeneration while tuning a short-wave set composed of a single regenerative detector or detector plus tuned or untuned r-f. may be obviated by a bit of simple re-designing. The idea is so good as a matter of fact, that we see no reason for the continuance of the old type tuner.

The stunt is this; use an abbreviated superheterodyne made up of first and second detectors and oscillator—a stage of audio being optional—and make the i-f. second detector regenerative. It may then be set for maximum regeneration and left as is.

The use of a throttle condenser for controlling the regeneration makes things very

TABLE 1

| Tube          | Grid      | Cathode | Heater | Plate   | Screen    | Suppr. | Space  |
|---------------|-----------|---------|--------|---------|-----------|--------|--------|
| 1st Det.....  | 4.0       | 10,300  | 0.15   | 20,400  | 8,400     | ..     | ..     |
| 1st I-F.....  | 850,000   | 200     | 0.2    | 20,400  | 8,400     | ..     | ..     |
| 2nd I-F.....  | 850,000   | 200     | 0.25   | 19,400  | 8,400     | ..     | ..     |
| Dio. Det..... | 250,000   | 0.17    | 0.33   | 0.11    | ..        | ..     | ..     |
| Osc.....      | 100,000   | 0.25    | 0.15   | 8,400   | ..        | ..     | ..     |
| 1st A-F.....  | *infinity | 0.1     | 0.12   | 120,000 | *infinity | 0.1    | ..     |
| Pent.....     | 500,000   | ..      | 0.25   | 20,000  | ..        | ..     | 19,400 |
| Rect.....     | ..        | ..      | 19,900 | 1,320   | ..        | ..     | ..     |
|               |           |         |        | 1,360   |           |        |        |

\* Readings of one megohm and over are given as "infinity." The first three significant figures only are interpreted from the ohmmeter in each reading; the individual resistance in the circuit can be readily checked upon removal of chassis.

TABLE 2

| Tube          | Fil. | Plate | Grid | Cathode | Screen | Plate MA. |
|---------------|------|-------|------|---------|--------|-----------|
| 1st Det.....  | 2.0  | 230   | 8.0  | 10      | 75     | 0.6       |
| Osc.....      | 2.0  | 100   | 0    | 0       | ..     | 7.0       |
| 1st I-F.....  | 2.0  | 250   | 0    | 3.0     | 75     | 2.0       |
| 2nd I-F.....  | 2.0  | 250   | 0    | 3.0     | 75     | 2.0       |
| 1st A-F.....  | 2.0  | 190   | 0.4  | 0       | 25     | 1.0       |
| Dio. Det..... | 2.0  | 0     | 0    | 0       | 0      | ..        |
| Pent.....     | 2.25 | 250   | 16.0 | ..      | 250    | 30.0      |
| Rect.....     | 4.8  | 300   | ..   | ..      | ..     | ..        |

handy, for then the condenser may be mounted on the front panel and the second detector thrown into oscillation when the reception of c.w. signals is desired.

The arrangement has one other advantage; stations can be logged.

A regenerative i-f. second detector gives considerable gain and selectivity. The first detector also provides a bit of gain, particularly if an r-f. pentode is used, and adds somewhat to the selectivity of the job.

It should occur to you that there are many short-wave converters hanging around which have a stage of i-f. They could be made over as per the above arrangement, and possibly give better satisfaction than if they were used in conjunction with broadcast sets, where they are plenty noisy.

A good intermediate frequency to use in any event is 465 kc.

### Stewart-Warner R 104-105

Here is a receiver which S-W admits as being complex. It's a double superhet. In other words, the short-wave section has its own oscillator and the i-f. of the short-wave converter is 1525 kc. The i-f. in the broadcast part is 177.5 kc.

When servicing with the voltage-measurement system, the receiver must be tuned to some short-wave band and the local-distance switch must be pulled out. Voltage test must be made between the socket terminals and the chassis. Set analyzer measurements made with usual plug-cable arrangement will result in readings which will differ widely from the actual voltages present in the receiver.

To align the short-wave tuning adjustments, the broadcast part of this receiver must be perfect; that is, the dial reading must be perfect. To align the broadcast portion, tune to a well-known station operating between 1000 and 1400 kc. Note the dial setting. If it corresponds to the known frequency of the station, the calibration is satisfactory. If not, set the dial pointer to the correct frequency and adjust the fourth trimmer reading from the front towards the rear of the chassis, accessible through the gang condenser housing. This trimmer is fourth from the tuning dial. This completes the calibration and the receiver then must be aligned. Tune the receiver to 1400 kc. according to the dial calibration. Feed a local signal, obtained from a test oscillator adjusted to 1400 kc. to the receiver and adjust the third and fifth trimmers reading from the front towards the rear of the chassis until maximum signal is obtained. The adjustment of these trimmers will require retuning of the receiver. Retune the receiver for maximum response at that frequency and again adjust these trimmers. Very little adjustment will be required. Repeat this procedure until you are certain that the output cannot be increased by further retuning or adjustment.

### ALIGNING SHORT-WAVE I-F. AT 1525 KC.

To align the short-wave i-f. circuit, tune the broadcast receiver to 1525 kc. Then

adjust the test oscillator to 1525 kc. by varying the oscillator tuning until the signal in the receiver is maximum. Then switch to the 80-33 meter range of the receiver. Adjust the test oscillator output to give about  $\frac{1}{4}$  or  $\frac{1}{2}$  full scale output on the output meter. Now adjust the three trimmers located between the tuning condenser gang shield and the transformer cans. Start with the trimmer nearest the front of the chassis. Use a bakelite screwdriver.

### ALIGNING SHORT-WAVE 180-80 METER BAND

This adjustment is critical. Tune the receiver to 800 kc. Adjust the test oscillator so that maximum response is available from the receiver. Shift to the first short-wave band of the receiver and turn the dial pointer to the left as far as it will go. This tunes the receiver to 1600 kc. which is the second harmonic of the test oscillator signal. Now adjust the lower trimmer to the left of the tuning dial support. If static noises interfere with the operation of the AVC tube, substitute a 57 with an open filament or with one filament prong cut off, in place of the AVC tube. Now reset the receiver tuning dial to the broadcast band at 975 kc. and adjust the test oscillator for maximum response on this frequency. Now shift to the first short-wave band and turn the dial pointer to the right as far as it will go. This tunes the receiver to 3900 kc., or the fourth harmonic of the 975-kc. signal. Now adjust the trimmer located nearest the tuning dial and accessible through the gang condenser housing. If it was necessary to change the adjustment of the last named trimmer to a marked degree, repeat the alignment for the 1600-kc. signal as previously outlined.

### ALIGNING 80-33 METER BAND

Set the test oscillator to 925 kc., using the method previously described for 800 kc. and 975 kc. Shift the tuning range of the receiver to the second short-wave band, and turn the pointer as far as it will go to the left. Adjust the upper trimmer located to the left of the tuning dial support, facing the front of the chassis until the response is maximum. The frequency for alignment in this case is the fourth harmonic of 925 kc., or 3700 kc. Now set the test oscillator to 1500-kc. signal, or 6000 kc. Now adjust the second and third trimmers reached through the top of the tuning condenser gang, reading from the front of the chassis towards the rear. Retune the receiver exactly to the fourth harmonic of the 1500-kc. signal and readjust the second trimmer accessible through the condenser shield, and also the trimmer at the right of the dial support. The last trimmer adjustment is not critical.

### Noise-Reducing S. W. Aerials

The man-made noise picked up by aerials used with short-wave sets may be reduced by the use of a well-separated, transposed lead-in, this lead-in to be used preferably with a horizontal doublet antenna.

Under normal interference conditions, the lead wires should be spaced approximately two inches apart, and transposed every fifteen inches. Square insulating blocks are used at the points of transposition. If the interference is severe, the leads should be transposed more often . . . say every ten inches. In any event, the greater the number of transpositions, the less the interference. A point is reached, however, where to accomplish a great number of transpositions the two lead wires must run close together. This obviously increases the capacity of the lead line, which is detrimental.

A chart is provided for determining the proper length of the horizontal wires for different frequency bands. The proper lead-in lengths are also given.

(E. L. Dillard, *Short Wave Crafts*,  
November, 1932)

### Tunable Hum Elimination

Tunable hum in short-wave receivers using "B" eliminators can be effectively eliminated by by-passing the plates of the rectifier tube with .001-mfd. mica fixed condensers. These condensers should connect from the respective plates to the center tap of the filament.

Ordinary mica receiving condensers will stand up if the inverse peak voltage across the rectifier tube elements is not more than 500 volts.

(QST, November, 1932)

### Useful Information

Maxwell House coffee cans (minus the coffee) make fine shields for short-wave plug-in coils. Use the top and all.

### Sets for Special Aerials

One of the many advantages in using an aerial with a transposed lead-in, or one employing an orthodox transmission line, is the elimination of the ground lead.

Any ground lead can pick up interference of one sort or another, but such pick-up is particularly noticeable on the short waves.

Since these special noise-reducing aerials eliminate the ground connection and at the same time use lead-ins that are shielded from pick-up, interference is considerably reduced.

No short-wave receivers to our knowledge are designed for use with aerials of this sort, and few if any are made with provisions for these types of aerials.

If a transposed lead-in, or a transmission line, is to be used, do not fail to disconnect the antenna coil in the receiver from the ground connection or chassis. This coil should connect only to the two leads of the aerial system.

Though the various antenna coils of the receiver do not meet the impedance requirements of these special aerial systems, they will suffice. Otherwise, a special impedance-matching coil should be used and this should be coupled to the secondary of the input coil in the receiver, the primary in each case being dispensed with.

# Public Address . . .

## Pre-Amplifier for P-A. Systems

A simple public-address system may consist of only a single amplifier, a single microphone, and such loudspeakers or headphones as may be required. However, if more than one high quality microphone is to be used for program pickup, two or more amplifiers are usually required, a main or power amplifier and a pre-amplifier.

power supply as the main amplifier, it is good practice to employ a separate supply for each to avoid motorboating and other instability inherent in high-gain multistage amplifiers.

Fig. 2 illustrates schematically a typical pre-amplifier and power supply. Considerable care must be taken in such a circuit to reduce the noise to an absolute minimum. It will be noted that the power filter con-

than one watt. The chokes may therefore be quite small physically and, as a result, relatively inexpensive.

The chokes and power transformer should be separated by at least 6 inches and rotated so that the axes of the three coils are at right angles, or as near to right angles as possible. These precautions are intended to prevent hum pickup which tends to nullify the action of the filter. The low current drain and series filter choke will insure a long life for the rectifier tube.

## POWER UNIT

The power unit may be assembled on the same panel as the amplifier if sufficient care is taken. However, it is good practice to separate the amplifier and power unit several feet, if possible. The filament wiring for both amplifier and rectifier tubes should be twisted wire and the latter should be run in a heavy copper braid securely soldered to ground at only one point. Leads K and L in Fig. 2 should also be twisted and inclosed in heavy copper braid. The power transformer should have a static shield between primary and secondaries which should be connected to ground. It is recommended practice to connect the amplifier filament center-tap to one of the tube cathodes. This connection may not be the most quiet, however, and this lead should be tied at each cathode and to ground in turn to determine the best location for minimum hum. The entire rectifier should be enclosed in a heavy iron box which is separately connected to ground. The box must have a sufficient number of holes to insure good ventilation. A number of small, round holes is best, say  $\frac{1}{8}$ " in diameter.

The respective values of the units are given in the diagram of Fig. 2. In the case of the resistors, the approximate wattage dissipation of the various current-car-

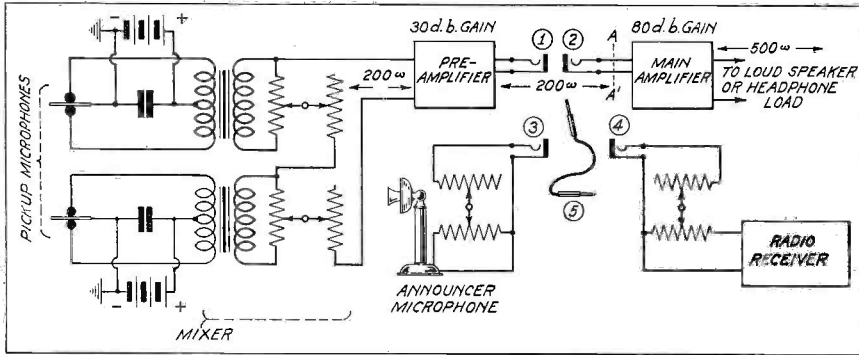

Fig. 1. Layout of a typical P-A. system. The patch cord (5) permits interconnection between units (1), (2), (3) and (4)

As described in the July issue of SERVICE (see page 171), the usual close-talking or announcing microphone has an output level for normal operating conditions of about minus 10 db. to minus 30 db. The high quality carbon microphone or condenser microphone and its associated two-stage amplifier, have output levels of about minus 60 db., while the dynamic and ribbon-type microphones have output levels of about minus 80 db. to minus 90 db. Moreover, if more than one microphone is used simultaneously for program pickup, a mixer circuit is required. The minimum loss in the usual mixer circuit is about 10 db. Thus, a system to supply 6 watts (30 db.) to a loudspeaker load from two high-quality carbon microphones would require  $60 + 10 + 30 = 100$  db. gain to barely meet requirements. It would be usual practice in such a case to employ a total amplification of about 110 db. While it is possible to design a single amplifier having a total gain of 110 db., it is not customary or advisable to do so, because of the very possible resultant instability and lack of flexibility. In general two amplifiers would be and should be used for such an installation, a main amplifier having a gain, in this case, of 80 db. (see page 204, August SERVICE), and an output capacity of 6 watts or more, and a pre-amplifier having a gain of about 30 db. and an output capacity of about one milliwatt.

## LAYOUT AND DIAGRAM

Fig. 1 illustrates a typical public-address system, from which it is evident that two separate amplifiers are desirable from an operating standpoint. It is also evident from this figure that a gain control is not required in the pre-amplifier. While the pre-amplifier may be supplied from the same

sists of two chokes, having a total resistance of about 2500 ohms. The first choke L-1 should have an inductance of about 30 henrys (see page 168, July SERVICE). The second choke L-2 should have an inductance of 50 henrys or more. The wattage dissipation in both chokes will be slightly more

Fig. 2. Complete schematic diagram of the pre-amplifier described in the accompanying article

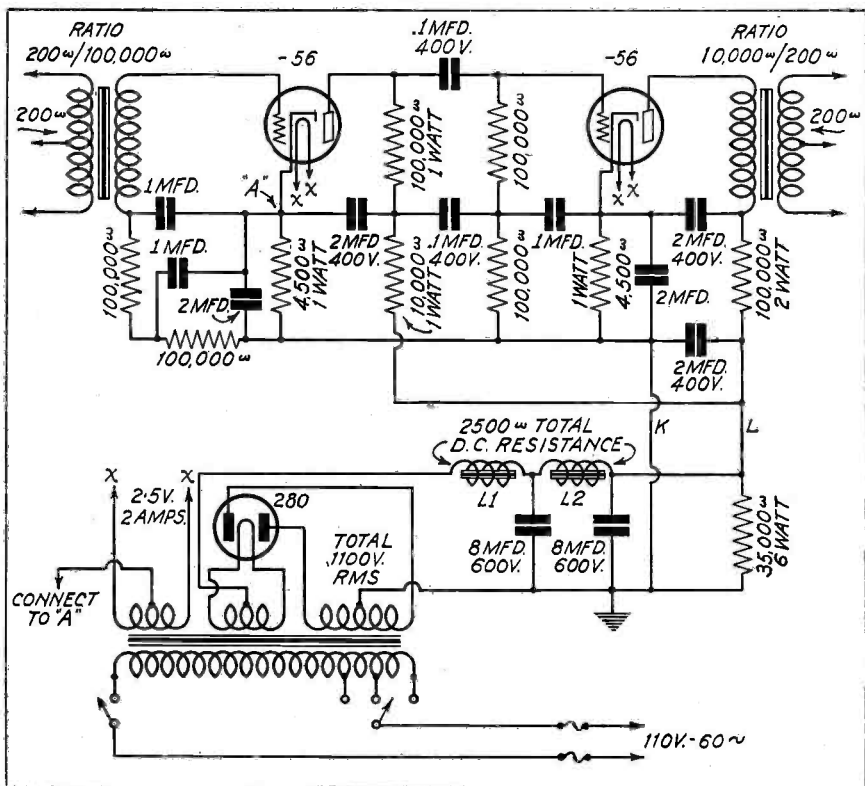

rying elements are also indicated. The rating indicated, or the next larger standard size, should be used.

**PRECAUTIONS**

The amplifier should be enclosed in a heavy copper or iron box which is separately grounded at one point and ventilated in a manner similar to that recommended for the rectifier unit.

Considerable care must be exercised in the choice of both coupling and filter resistances. They must be units which are known to be stable and quiet. Otherwise noisy operation is likely to result. The noise created by poor or defective resistance units sounds very much like ordinary static. Some units produce characteristic crashes while others produce a hissing or frying noise.

It will be noted that neither amplifier tube is operated at maximum plate voltage. This is of no consequence since the bias is such as will insure maximum gain and the additional filtering, although secured at some loss in plate voltage, is very much worth while.

The power output of this amplifier is about 5 milliwatts and the gain about 40 db., which is adequate to meet any conditions likely to be imposed on it. Both input and output circuits of the amplifier should be balanced to prevent noise pick-up in the lines. The input and output transformers should be provided with center-taps, as shown, for grounding when necessary.

**Loudspeaker Patching Panel**

As promised in our last issue, we are giving herewith the details of a simple and inexpensive patching or connecting panel for handling a number of loudspeakers. It is built up from standard N. E. C. wiring devices (regular lighting-type plugs and receptacles) as indicated by the accompanying sketch.

**CONNECTION ARRANGEMENTS**

The number of speakers that may be connected and interconnected and switched hither and yon with considerable ease, is nearly unlimited. The speakers may be connected in series, in parallel and in series-parallel so that most any condition of impedance matching and distribution of sound may be met.

Referring to the sketch, the nine receptacles unmarked are standard duplex plug-in receptacles. The two receptacles in each

duplex device are wired in parallel, and therefore two speaker lines may be plugged in to each device if paralleling is desired, or one speaker line into one receptacle and the other used to patch over to the next group of three, or to put the groups in series, etc. The flexibility of this arrangement will be found very convenient as devices such as level indicators or monitors can be plugged in to check each line.

The receptacles marked A, A-1 and B, B-1 are similar to the regular duplex receptacles except that they are separately wired, that is, they are not connected in parallel. By interposing these receptacles between groups it is possible to place the groups in series or parallel, according to which type of patch cord is used.

**THE PATCH CORDS**

Several different patch cords should be made up with both one and two leads so that prong-to-prong connections can be made. Also several plugs can be fitted with shorting wires so that the prongs in one receptacle can be connected together to complete a series circuit. For example, to make a series-parallel setup, after the speakers have been plugged into the duplex receptacles, the prongs of A-1 would be connected together and also those of B which puts the three groups in series, and two or more speakers in parallel according to how they are plugged into the duplex receptacles.

The complete list of fittings which will be required for making up this connecting panel, with Hubbell catalog numbers, and including armored plugs, is as follows:

Two No. 9572 Receptacles (A, A-1; B, B-1)

Nine No. 7575 Duplex Receptacles

Four No. 7056 Plugs

The output leads from the matching transformer are connected to the binding posts marked 1 and 2. After the load impedance is determined, the proper taps can be selected on the transformer.

The cost of the complete panel should be about fifteen dollars.

**Impedance Matching**

In threshing about for a satisfactory coverage of the problem of impedance matching in a-f. amplifiers, we barged into Lesson 45 which is a part of the Capitol Radio Engineering Institute Course. Therein we

found just what we were after, and here it is:

In all our study of tube operation we hear of the necessity of impedance matching. At radio frequencies we can usually match impedances by changing taps on a coil, varying the coupling, adjusting a variable condenser, etc. At audio frequencies that is not so easy to do. Here we deal with large values of fixed capacities, iron core transformers, etc. It is evident that the impedance-matching requirements must be calculated ahead of time and the apparatus designed accordingly. Impedance matching is usually accomplished by means of a transformer. Just what do we mean by "impedance matching?"

As an example, assume we wish to couple a '45 power tube to a dynamic reproducer. The impedance of the tube is 1,750 ohms; we will assume that the reproducer has an impedance of 15 ohms. We can calculate the turn ratio of the transformer from the equation,

$$\text{Turn Ratio (Step Down)} = \sqrt{\frac{Z_p}{Z_s}}$$

where  $Z_p$  is the impedance across the primary and  $Z_s$  is the impedance across the secondary.

With the values assumed above,

$$\text{Turn Ratio} = \sqrt{\frac{1,750}{15}} = \sqrt{107} = 10.3$$

Since to obtain the maximum undistorted output the tube must operate into a load impedance equal to twice the internal tube impedance, the primary winding should be designed to have an impedance of  $1,750 \times 2$ , or 3,500 ohms at its lowest operating frequency.

Now assume that this same reproducer is to be operated from two '45 tubes in push-pull, the two tube impedances thus being in series and presenting a total load across the primary of 3,500 ohms. Then,

$$\text{Turn Ratio} = \sqrt{\frac{3,500}{15}} = \sqrt{233} = 15.2$$

In the case of the push-pull Class B amplifier output where only one-half of the primary and one tube is operating at a time the primaries must be considered as two separate primaries alternately coupled to the common secondary. Assume that in such a circuit each tube has an internal impedance of 1,500 ohms and that we wish to couple to a 10-ohm reproducer. Then the turn ratio between *one-half* the primary and the secondary will be,

$$\text{Turn Ratio} = \sqrt{\frac{1,500}{10}} = \sqrt{150} = 12.2$$

The primary will then be made up of two windings in series, *each* winding having a turn ratio of 12.2 with respect to the common secondary.

Impedance-matching transformers are very often designed with taps so that a standard telephone line, for example, can be coupled to any one of several circuits of different impedances. For example, the primary may be designed to offer an impedance of 500 ohms for connection to a 500-ohm telephone line, with the secondary tapped for 10, 50, 100, 200, and 300 ohms. Or any other combination can be arranged. It is only necessary

(Continued on page 324)

Details of the patching panel for use with P-A. systems

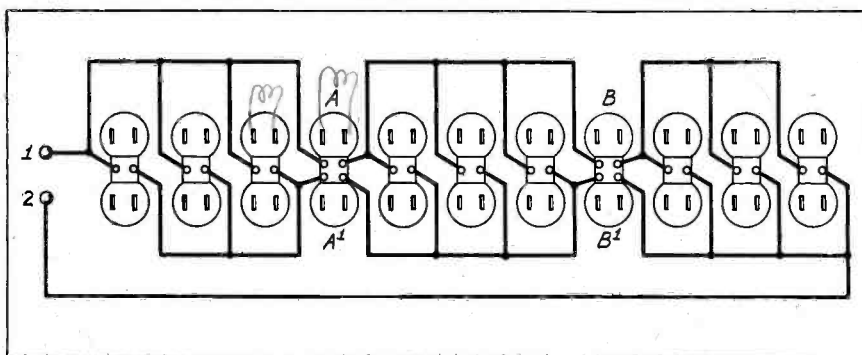



# Auto-Radio

## Crosley Model 95 (Roamio)

The Model 95 is a 6-tube superheterodyne job with a combination oscillator and first detector. The auto series tubes are used and the filament voltages should be about 5.8 to 6 volts.

The complete schematic diagram, including values of the units, is shown in Fig. 1. The location of the aligning condensers is shown in the layout of Fig. 2. This sketch also indicates the location of each tube.

In connection with Fig. 1, it should be noted that the type '37 tube used as second detector is connected as a diode detector and also functions as an automatic volume control. It should also be noted that the output power pentode is a type '41 tube. In some of the chassis a type '38 power pentode is used instead of the '41, in which case the value of the grid leak is 500,000 ohms. Moreover, when the '38 is used the cathode is connected by an 1,100-ohm resistor and a 450-ohm resistor in series to the chassis. In this case, the cathode of the first audio tube is connected to the point between the 1,100-ohm and 450-ohm resistors, thereby receiving its bias through only the 450-ohm resistor.

### CIRCUIT ALIGNMENTS

The primary and secondary of the transformer between the first detector and the first i-f. amplifier, and the secondary of the transformers between the first i-f. amplifier and second i-f. amplifier and between the second i-f. amplifier and second detector must be tuned accurately to 181.5 kc. (See Fig. 2 for condenser locations).

To accomplish this alignment, use a local

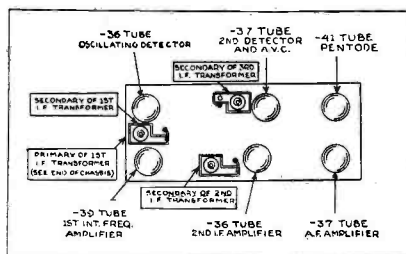

Fig. 2. Chassis of the Crosley Model 95, showing positions of tubes and compensating condensers

oscillator tuned to 181.5 kc. and set the dial of the station selector at 550 kc. Connect the high side of the oscillator output through a condenser of approximately .1 mfd. to the grid of the first detector tube, and the low side of the oscillator to chassis. Do not remove the clip wire from the grid of the first detector tube.

When these adjustments have been made, the i-f. stages will be properly aligned.

The antenna coupling circuit and oscillating circuit should not be aligned until after the i-f. stages have been accurately aligned to 181.5 kc.

For aligning these two circuits, connect the high side of the local oscillator through a .00025-mfd. condenser (a dummy antenna should be used if available) to the antenna lead of the receiver, and connect the low side to chassis, as before. Set both the oscillator and the station selector dial to 1400 kc.

Now adjust the padding condensers on the ganged condenser to give maximum reading on the output meter. The receiver will then be properly aligned.

### VOLTAGE DATA

The approximate voltages are given in the accompanying table. They should be measured with tubes in place and speaker connected. Four 45-volt "B" batteries of rated voltage should be connected to the receiver "B" terminals. Check the voltages with a high-resistance d-c. voltmeter (600 ohms or more per volt).

### CROSLLEY MODEL 95 (ROAMIO) VOLTAGE DATA

| Tube     | Plate   | Screen  | Grid       |
|----------|---------|---------|------------|
| 1st Det. | 160-180 | 70-80   | -7 to -9   |
| I-F.     | 160-180 | 70-80   | AVC only   |
| 2nd Det. | 0       | .....   | 0          |
| 1st A-F. | 80-90   | .....   | -5 to -6   |
| Output.  | 150-170 | 160-180 | -16 to -18 |

Plate and screen voltages measured from element to chassis.

Now adjust the two padding condensers at either side of the first i-f. transformer for maximum reading on the output meter. Then adjust the secondary padding condensers on the second and third i-f. transformers for maximum output meter reading.

### To Be or Not to Be

An interesting problem is arising in the auto radio field. Should the auto ignition man learn what there is to be known about radio receivers, or should the radio Service Man learn what there is to be known about

Fig. 1. Schematic diagram of the Crosley Model 95 (Roamio), with combination oscillator-detector

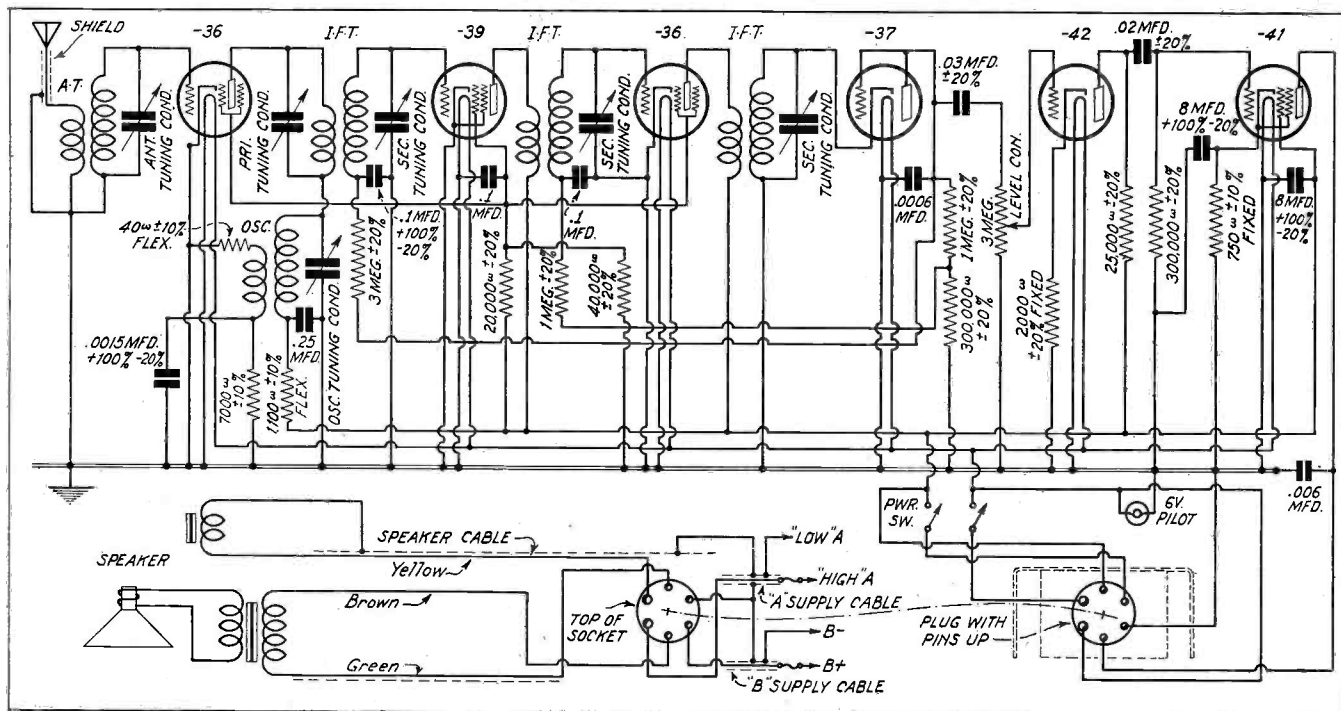

ignition systems in automobiles? By far the latter arrangement is better. The reason for this statement is that the ignition man would be called upon to learn much more than the radio man, particularly so when we realize that the amount of ignition work which would have to be done by the radio Service Man would represent the superficial operations, whereas the ignition man would be called upon to gain an extensive knowledge of radio in general.

**Car Aerials**

Some car aerials are very poor when it comes to signal pickup and at the same time are comparatively free from noise. Some car aerials are good pickups of signal, and also noise. What to do . . .

Well, here are a few slants on the subject: Interference fields are stronger above the car than below. An aerial in the roof of a car will therefore pick up more noise than an aerial mounted under the car chassis.

A roof antenna provides the greatest signal pickup, and if the down lead is well shielded the noise problem may prove no problem at all. However, it is *very important* that the down lead be well shielded and the shield well grounded at one or more points.

Since the interference field is much less below the chassis of the car, because of the shielding effect of the chassis, an antenna of the plate type, or composed of one or more wires strung below the chassis, will in many cases solve the noise problem. However, such an aerial has less sensitivity or signal pickup than a roof antenna, and therefore should be used only in the event that the receiver has a relatively high degree of sensitivity. Here again the lead from the aerial to the receiver should be shielded.

Another thing about the under-car aerials; the nearer the plate or wire is to the ground the greater its pickup. But in your desire to get the best effect, don't lower the aerial so much that it will be wiped off the bottom of the car by road projections.

Mr. L. F. Curtis, of United American Bosch Corporation, suggests as an excellent

arrangement (*Proceedings, I. R. E., April, 1932*) a pair of plates, one on each side of the car (under the running boards is a good place) coupled to a shielded line or lead-in by a properly designed step-down transformer, similar to the arrangements we have described for noise-reducing aerials.

**Sparton "B" Eliminators**

Sparton now has available "B" Eliminators for all Models of Sparton Automobile Radio Receivers. Essential data is given in the accompanying table.

SPARTON ELIMINATOR DATA

| Models Used On                     | Eliminator Part No. | "A" Battery Ampere Drain | Output Voltage | Milliamperes |
|------------------------------------|---------------------|--------------------------|----------------|--------------|
| 34.....                            | C-1240              | 2.75                     | 200            | 40           |
| 40, 40-A, 42.....                  | C-1405              | 2.40                     | 200            | 20           |
| AR-19, 19-A, 41, 41-A, AR-50, 50-A | C-1359              | 1.65                     | 180            | 30           |

All the Eliminators listed in the table will operate at a 20% overload continuously.

The space required for mounting Eliminator C-1240 and C-1405 is 4½ inches by 6 inches by 6¾ inches high. The weight is 13 pounds.

The space required for mounting Eliminator C-1359 is 5 inches by 9½ inches by 5¾ inches high. The weight is 14 pounds.

**Ignition Coils**

Ignition coils which are mounted upon the driver's side of the bulkhead will have to be moved to the motor compartment side. This statement has been made upon numerous occasions, but is being stressed for the reason that numerous installations have been recorded in Lincoln cars and freedom from ignition interference was a problem. After everything was reported as having been tried, it was discovered that the ignition coil position had not been changed.

**Majestic for Fords**

We have received word that Grigsby-Grunow has designed a special set for Ford cars. It is a 6-tube superheterodyne and is complete with a "B" eliminator.

This set has been approved by Ford, and will hereafter be standard equipment for all Ford V-8 cars.

**Pontiac Ignition Diagrams**

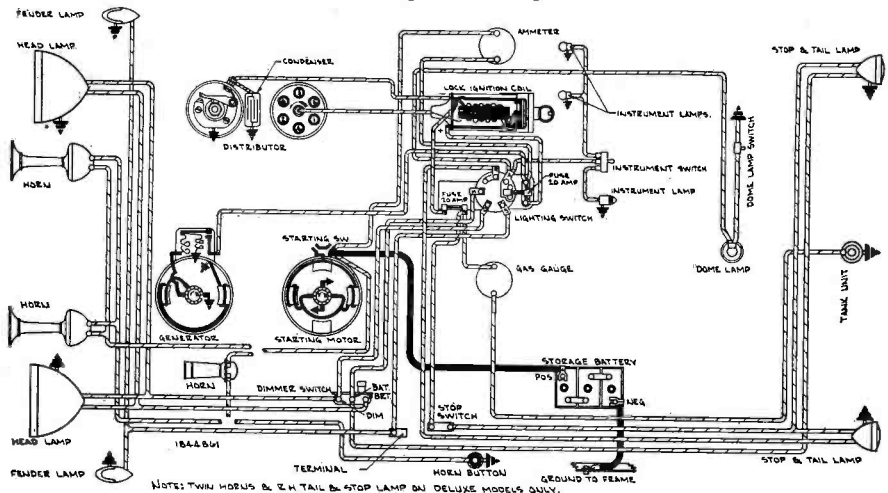

(Below) Wiring of ignition system for Pontiac 1932, Model 302, 8-cylinder cars. Distributor contact opening; .0125"-.0175"

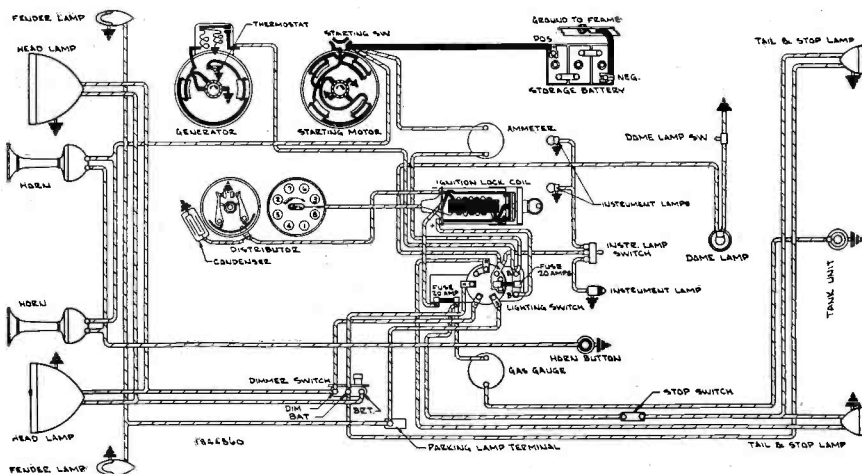

(Above) Wiring of ignition system for Pontiac 1932, Model 402, 6-cylinder cars. Distributor contact opening; .018"-.024". The rotation of the distributor is clockwise when viewing drive end

**Removing Motorola 88 and 61 Chassis**

Here is a simple little trick for removing the radio chassis of Motorola Models 88 and 61. Remove the two No. 10 screws which hold the bottom of the chassis to the housing. Facing the rear of the chassis, grip the outside right hand corner of the shelf, upon which are mounted the tube sockets, with a pair of pliers. Hold the shielding cabinet with the right hand. A sharp jerk will easily remove the chassis from the housing. By operating as named, a "pull" is put upon the chassis in the proper direction to release it from the 9-way plug which holds it in place.

Note: Since resistance tolerances in the sets are plus or minus 10%, and tubes may vary over 20%, your readings may disagree with the above by plus or minus 30%. CL-PZ is also known as CL-47, the latter being the final type number.

| Position | Tube  | Fil. Volts | Plate Volts | Grid Volts | Screen Grid Volts | Cathode Volts | Normal Plate M.A. |
|----------|-------|------------|-------------|------------|-------------------|---------------|-------------------|
| R.F.     | CL-51 | 2.2        | 233         | 3.         | 66                | 3.            | 5.                |
| 1st Det. | CL-51 | 2.2        | 233         | 7.         | 73                | 7.            | 2.3               |
| Osc.     | CL-27 | 2.2        | 80          | 0          | 0                 | 0             | 4.                |
| I.F.     | CL-51 | 2.2        | 233         | 3.         | 77                | 3.            | 5.                |
| 2nd Det. | CL-24 | 2.2        | 162         | 6.2        | 73                | 7.2           | 1.5               |
| Output   | CL-PZ | 2.2        | 228         | 15.        | 233               | 0             | 27.               |
| Rect.    | CL-80 | 4.8        | 300         | 0.         | 0                 | 0             | 50.               |

Volume control position Full. Line Voltage 115.

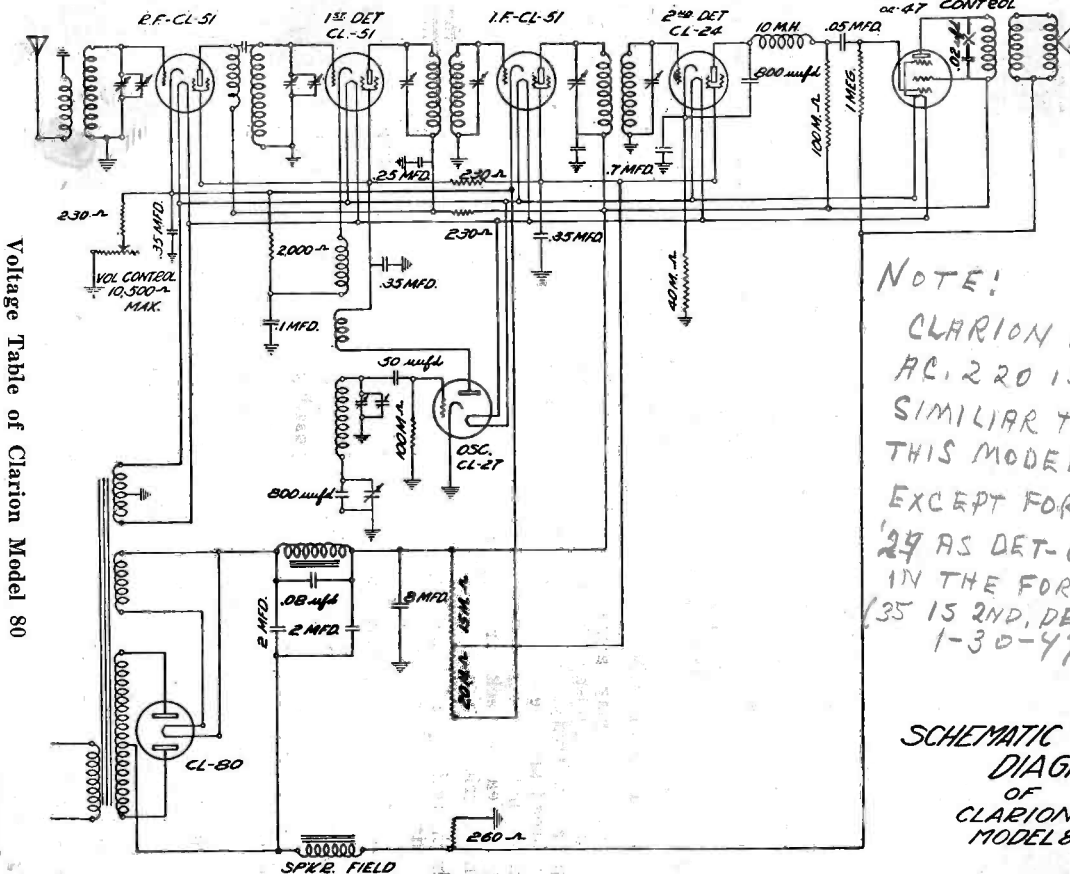

NOTE:  
CLARION MODEL  
AC. 220 IS VERY  
SIMILAR TO  
THIS MODEL 80  
EXCEPT FOR A  
24 AS DET-OSC,  
IN THE FORMER,  
35 IS 2ND. DET.  
1-30-47

SCHEMATIC  
DIAGRAM  
OF  
CLARION  
MODEL 80

these units is great and there may be occasions when your distributor has been unable to keep up with the requests made of him.

For such emergencies the Stancor staff designed the Stancor Universal Replacement Transformer. They accomplish a very satisfactory replacement where an Exact-Duplicate is not available. They are furnished with Stancor adjustable mounting frames that permit an adequate range of mounting adjustments for all practical purposes. Made with customary Stancor quality, the electrical characteristics produce satisfac-

You should have Stancor Universal Replacement Transformers for the same purpose. Put one into the set temporarily. Give your customer immediate service of his radio. Then, when you have the Exact-Duplicate, install it permanently. Your customer will appreciate your service. You'll hold business and build more. The profits increase proportionately.

Have you a copy of the Stancor catalog? If not, ask your distributor. If he cannot give you it, use the coupon or drop us a line. We'll see you get one.

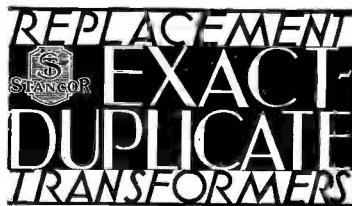

# STANDARD TRANSFORMER CORPORATION

862 BLACKHAWK STREET CHICAGO, ILL

STANDARD TRANSFORMER CORP.,  
862 Blackhawk St., Chicago, Ill.

I am interested in Stancor Universal Replacement Transformers for temporary installations. Send me your complete catalog of Exact-Duplicate and Universal Replacement Transformers.

Name .....  
Address (City and Street) .....

# ON THE JOB . . .

## FIRST PRIZE INSTALLATION SERVICE

By John J. Birkel

My experience in service work has been general, and along with regular repair jobs I do a lot of installation work.

From my experience I have learned that the best way to increase my business is to offer the most complete inspection and installation service in my locality.

When I install a set, I install it to remain sold. The first thing I do is to carefully examine the aerial and ground if they have already been put in. If there are any connections that are poor or may become poor with time, I solder them.

My next job is to inspect all service boxes (meter boxes), light socket switches, electrical appliances, etc., for loose connections, as all of them can prove to be noise makers.

This preliminary inspection of the location is done some time during the day, and the final inspection and demonstration of the radio set is made in the evening between 6 and 7 o'clock when the entire family is present. Then, if there are any complaints, I can clear them up right on the spot.

Another thing; I never fail to tell my customers the truth about the sets—what they can do and what they cannot do—especially the short- and long-wave combinations. In this case, I explain the tuning of the set and inform them as to which wave bands are "live" during the day and night.

Of course, such a procedure takes time, but it pays in the end. My customers stick by me when they require servicing work.

## SECOND PRIZE THAT ADDITIONAL SPEAKER

By S. Rider

Many people would like to have an extra speaker or two for use in other rooms, but very few people know that extra speakers can be added to their radio for such purposes.

Some time ago I designed an attachment which will permit one or more magnetic speakers to be used on most any set. This attachment consists of a small box with input and speaker binding posts, a mounting bracket, and a volume control.

I sell these boxes for \$3.95 each, and I manage to dispose of five or six each week. This has meant just so much found money to me. People have certainly taken to the idea, and it is a simple matter to run leads from the output of the receiver to another room, and there install the control box and extra magnetic speaker.

(In receivers using a single power tube feeding a dynamic speaker, it is easy to break into the plate circuit with an ordinary adapter. In order to prevent the possibility of a shock, it is well to isolate the magnetic speaker from the d-c. plate voltage by the use of a fixed condenser of from 1 to 4 mfd.)

In a push-pull job, two adapters and two

condensers would be used, the condensers being in series with the plates and the speaker terminals. A volume control of the potentiometer type would be best, the resistance element being shunted across the "safe" side of the output—and with one end of the element also connecting to one of the speaker terminals—and the arm of the potentiometer connecting to the other speaker terminal.—Ed.)

## HAVE YOU GOT WRITER'S CRAMP?

*Each month we lay out \$7, \$5 and \$3 in prizes for you to carry off, and then you go to sleep on us.*

*Well, we think we know why you haven't entered this contest. Most every day some of the fellows drop into the office here, and in the course of the conversation they let loose some swell ideas. When we say "There's an idea!" they seem surprised, because they take the stunts as a matter of course.*

*Maybe you think your ideas aren't so hot. Maybe you haven't stopped to consider whether or not any of the stunts you employ in your business are worth anything. Anyway, that's just what some of the fellows thought who sent in ideas, and they were plenty surprised when their names appeared under the word "prize."*

*We are receiving good ideas regularly, but we are anxious to get the vast number we know to exist out from under cover. Your ideas will help someone else and the other fellow's ideas will help you. And a prize is not to be sneezed at.*

*Now, no matter what you may think of your own ideas, why not let us be the judge? Don't be so modest. Write up those little things which have helped to build your business, and send them in pronto. Never mind the frills . . . we have a well-manned Frill Department to take care of your write-ups as well as our own.*

*Well, we're waiting. . . .*

## THIRD PRIZE

### A LINE VOLTAGE TIP

By Martin Wazlahowsky

When you are called upon to service a set against which the chief complaint is weak reception or lack of distance, and you find after checking the tubes that they are okay, take a look at the schematic diagram of the receiver power pack and see if there is a line-voltage adjusting switch.

A great many of the better grade receivers have a switch by means of which it is possible to compensate for differences in line voltage, but as a rule they are located in

such a position that the set owner is not very likely to tamper with it.

If the set has a switch of this type, check the a-c. line voltage and if it is not over 115 volts, change the position of the voltage-adjusting switch, while the set is tuned to a station, and note the difference in reception. Sometimes this will make as much difference as a new set of tubes.

As a rule, a-c. line voltages are much nearer to 100 or 110 volts than 120 volts, except in some metropolitan areas, and therefore it is fairly safe to leave the voltage-adjusting switch in its higher position. Of course, if the voltage fluctuates very much, it is advisable to install some good voltage regulator to take care of the condition.

The next time you are on a "weak reception" job, don't forget the line voltage switch.

## PUBLIC ADDRESS

### Impedance Matching

(Continued from page 320)

that the turn ratio for each tap meet the equation,

$$\text{Turn Ratio} = \sqrt{\frac{Z_p}{Z_s}}$$

And here is another interesting bit of data . . . a tube having a comparatively high amplification constant is more desirable as a Class B audio amplifier than the usual low Mu power tubes because of the large grid excitation swings necessary to obtain maximum power output from these latter types of tubes and the power required to obtain this high excitation voltage. The most desirable type of tube for a push-pull Class B audio amplifier would be one in which the plate current is practically zero at zero grid bias. With such a tube the grids would always be operated positive, the power required from the driver for excitation would be more uniform and the input impedance during the excitation cycle would not vary over such wide limits.

## Time Lag Device

A carbon filament lamp in series with a 50-ohm variable resistor makes an efficient time lag device by placing them in the 110-volt a-c. or d-c. line feeding the solenoid of the relay.

The delay action is contributed by the carbon-filament lamp in series with the relay, and the time can be varied by adjusting the tension of the relay armature spring and by the setting of the 50-ohm variable resistor.

(The idea could well be used with Class B amplifiers where it is advisable to heat the tube filaments before impressing the high voltage.—Ed.)

(N. Holman, *QST*, November, 1932)

**MODERN RADIO Requires**  
**AMPERITE Line Voltage Control**

*Install AMPERITE and  
Do Your Customers a Favor*

**T**HERE is marked *improvement* in the AMPERITE-equipped receiver.

Reception is better, signals are clearer, noises are reduced and volume is more uniform.

In addition, AMPERITE protects tubes and expensive parts from dangerous voltage overloads, due to line variations.

A good service job becomes a better service job when you install AMPERITE—and there's an *attractive profit to you* for the five-minutes' extra work it requires.



**AMPERITE**  
VOLTAGE CONTROL

AMPERITE Corporation  
561 BROADWAY, NEW YORK

Send \$1.40 to  
Dept. S-11 for  
sample and sales  
helps.

**Earn More MONEY!**  
*With*  
**PUBLIC ADDRESS SYSTEMS**

**SERVICE MEN**

**1933 CATALOG**

Alert service men are cashing in on the tremendous interest in Public Address Systems, and Amplifiers! More business on these items—right now—than ever before in radio history! In **WHOLESALE RADIO COMPANY'S** new catalog you'll find the most advanced types of public address equipment and amplifiers—at new low prices.

**NEW CATALOG—Just Out**

**FEATURES REPLACEMENT PARTS!**

Our new 1933 catalog, just out, also contains a complete **REPLACEMENT PARTS** section. We carry a tremendous stock on hand in order to insure speedy delivery. What you want when you need it—at lowest Wholesale prices!

Write for a copy of our new catalog **TODAY**. IT'S ABSO-

**LUTELY FREE!** Everything new in radio—**LAFAYETTE SETS, TRUTEST PARTS, PUBLIC ADDRESS EQUIPMENT, AMPLIFIERS, REPLACEMENT PARTS OF EVERY DESCRIPTION, TUBES, KITS,** etc. The **WHOLESALE RADIO** catalog, issued by the largest concern of its kind in the world, will **FREE** be sent to you. Write us today!

**WHOLESALE RADIO SERVICE CO., INC.**  
100 SIXTH AVE. NEW YORK

**Check New and Old Type Tubes**



**with this Economical**

*Readrite No. 406 Tester!*

(\$25 List)

**Only \$15 Net to Dealer**

*Checks All Types of Tubes  
by Exclusive Readrite Test*

**D**EALERS and service men are enthusiastic about the new Readrite No. 406 Tester. While low in price, it accepts and rejects tubes as efficiently and satisfactorily as testers costing many times more.

With the Readrite Tester No. 406, you can test, **WITHOUT ADAPTERS**, all tubes released up to the present time—including those with 4, 5, 6 and 7 prongs.

**Note These Important Features**

This new tester with 7-prong socket is specially designed for testing of all new-type tubes. Connects to A.C. supply line. A push button provides two plate current readings for determining the conductance and worth of a tube. Another new feature applies the same test to rectifier as well as to all other types of tubes. A separate push button provides for testing both plates of '80 type tubes.

**Illuminated Meter Dial**

Wide range in readings is made possible by a simplified single scale meter. It is connected in tip jacks. A small protecting fuse is attached also. A pilot light, located directly beneath the meter, is used to illuminate the dial. Both lamp and fuse are easily renewed. This tester is an ideal companion to the Readrite No. 1000 Tester for testing voltages, milliamperes, resistances, continuities, short circuits, capacities.

If your jobber cannot supply you, we will ship the No. 406 tester directly to you—when remittance accompanies your order at dealer's net price of \$15.00.

Mail the coupon now—get complete information!

**READRITE METER WORKS**  
30 College Ave., Bluffton, Ohio

READRITE METER WORKS,  
30 College Ave., Bluffton, Ohio

Gentlemen:

Please send information about Readrite No. 406 Tester. Also Catalog of other servicing instruments.

Name .....  
Street Address .....  
City ..... State .....

# HIGHLIGHTS . . .

## Obstinacy

This is about an old lady who is a-ferred o' aerials and refuses under any circumstances to have one on her radio. This old lady claims fear of the possibilities of damage by lightning, but the truth of the matter is that she formerly owned a Radiola portable superhet. with a hidden loop aerial. So, she's just obstinate and won't try to understand why an aerial should be used with the new set.

Well, the new set picks up more noise than program, and the old lady practically wanders the streets asking people what radio company it is "which makes a baffle that takes out all noise." She read about this baffle thing, she says, and she is going to get one because, "my Radiola didn't need an aerial, so why should my new set need one?"

## I. R. S. M. Convention

Big doings at the Hotel Sherman, in Chicago, from January 9 to 11. It will be the First Intersectional Convention of the Institute of Radio Service Men.

The program will be devoted strictly to problems of the service profession, and will be full of technical discussions of such a nature that Service Men can ill afford to forego the opportunities which the convention will bring to them.

This convention will represent the first meeting of an extensive nature and in the exclusive interest of the service branch of the radio industry that has ever been held. In addition to technical discussions, trips to laboratories are being provided for those who desire to obtain first-hand information regarding the workings of the modern radio factory or laboratory.

Arrangements are being made to have field engineers from practically all of the leading radio manufacturing plants discuss special features about the sets produced by the companies which they represent.

We hope you'll be there. We will.

## Radio Tube Exchange

With so many types and makes of tubes on the market, it is not always easy to make the necessary purchasing contacts. To cure this knot in the business of tube distribution, Sam Solar has formed the Radio Tube Exchange of America, with offices located at 123 Liberty Street, New York City.

Tubes such as used in transmission, reception, television, amplification, rectification, etc., are now available through this company.

The Radio Tube Exchange are jobbers for the leading tube manufacturers and thereby are in a position to have all new types of tubes on hand at all times.

## 450%

S. J. Eckenrode, of the Radio Building Co., Richmond, Indiana, informs us that he increased his business 450% last year by the simple process of placing in all private mail boxes twice yearly his particular brand

of service card. Well, 450% is an increase what is an increase. You fellows ought to try the same stunt.

Mr. Eckenrode's card may have a great deal to do with it. The back has a nice listing of radio hints which the average radio listener would have no difficulty in understanding. The hints are simple, and written in non-technical language.

On the front of the card in large type is the following: "SOME DAY THIS CARD WILL SAVE YOU THE PRICE OF A NEW RADIO." That's what we call a good line.

Mr. Eckenrode also states that newspaper advertising never panned out for him. What's your experience?

## Pickup

WASHINGTON—Federal Power Commission, in Supreme Court, wins right to control investments of power companies. Commission now lacks only divine right needed to make A-C. set operate on D-C. circuit. *Algae*—N. Y. *Herald Tribune*.

## Parallel Resistor Chart

Mr. D. T. Siegel, General Manager of the Ohmite Manufacturing Co., 636 N. Albany Avenue, Chicago, gave us a buzz to let us know that said company is now passing out a parallel resistor chart which eliminates calculations arising from the use of resistance units in parallel.

This chart is a simple diagram on which the value of two or more parallel resistances may be read directly without any calculations. A chart of this type is quite often a necessity, both for replacement work and for resistor value determination.

If you want one of these charts, write Ohmite. No charge.

## For Hams

We can't refrain from commenting on the C. W. receiver outlined on page eight of *Modern Radio* for November. We know that many of our readers are Hams, and therefore wish to call this particular receiver to their attention. It should be the berries for the brass pounders.

## Useless Information

The coil on top of a G. E. electric refrigerator is tuned to 150 meters. (*Go ahead and prove us wrong.*)

## Scoop!

The new radio receivers are going to be decidedly more complex than even the present modern sets with their channel controls, muters and complicated AVC. Some of these receivers will be entirely different from any sets as we now know them. We should like to Walter-Winchell on our informers, but for the present, mum's the word. But tighten your belts and get ready for a new load of servicing data about six months hence. Until then, whoopee!

## I. R. C. Catalog

The International Resistance Company have brought out their new resistor catalog. Has a green cover and sixteen pages of data on all the various types of units I. R. C. manufactures. Aside from this, there is a lot of good dope in the back relative to the calculation of resistor values, grid bias resistor calculations, conversion of and extension of ranges of meters, etc.

You ought to have one of these. No charge. Just write International Resistance Company, 2006 Chestnut Street, Philadelphia, Pennsylvania.

## Got Any Stamps?

Ye editor, Mr. Rider, is a confirmed philatelist (stamp collector to you). He specializes in U. S. stamps. Got any swaps?

## Merger

Two magazines for the price of one. The *Radio Call Book Magazine and Technical Review* has been absorbed by *Radio News*—in case you didn't notice.

## "R9"

A new magazine with two issues to its credit . . . a really creditable thing these days. Devoted principally to the interests of the radio amateur. By "interests" is meant his rights to definite sections of the ether. So far the magazine has carried little of a technical nature.

## Don't Push

We know of a family who are going to have their radio serviced for Christmas. The other presents they will receive will be the free samples handed out by radio advertisers.

## Mystery, by Gar!

Scene: Home of well-to-do family.  
Object of Mystery: Electric clock.

Spooks stalk the living room. Once a week the electric clock stops at 9:30 A. M. The great house of Pinkerton is stumped. It took a Service Man to solve it. Answer next month. (Can you wait?)

## Mallory-Elkon Catalog

A complete catalog listing dry electrolytic condensers with full information as to capacity, working voltage, dimensions, price, etc., is made available by P. R. Mallory & Co., Inc., of Indianapolis, Indiana, in their new catalog known as Form S-9.

One interesting feature of this catalog is the replacement data chart for Dry Electrolytic HI-Volt D-C. Condensers showing the proper Mallory-Elkon condenser for all the leading radio sets manufactured during the past few years.

The catalog may be had from Mallory & Co. free of charge.

# GET THE *new*



*free* 50 cents

**•CENTRALAB** Volume Controls for Replacements  
**•CENTRALAB** Fixed Resistors  
**•CENTRALAB** Radio Suppressors

## Centralab

CENTRAL RADIO LABORATORIES  
 930 Keefe Avenue Milwaukee, Wis.

We want every service man to have a **FREE** copy of this valuable book. Illustrated, it contains 64 pages of interesting and necessary information. Priced regularly at 50c, it is yours for the asking.

Write us on your own or your firm's stationery and enclose two 3c stamps for postage and wrapping.

# SHALLCROSS

## No. 651



### RADIO SET TESTER

For 4-, 5-, 6- and 7-prong tubes

This new circuit makes it possible for the service man to construct a light weight and compact, up-to-date, radio-set tester for all tubes and radio sets in general use. It uses a special set of Shallcross Super Akra-Ohm Wire-Wound Resistors.

Send 6c in stamps for Bulletin 161-E containing wiring diagram, construction details, and operating chart.

**Shallcross Mfg. Company**  
 ELECTRICAL SPECIALTIES  
 700 PARKER AVENUE  
 COLLINGDALE, Pa.  
(NEAR PHILADELPHIA)

*Always Super AKRA-OHM ACCURATE* *Accurate NON-INDUCTIVE WIRE WOUND RESISTORS*



# New!

*a totally different*

## Replacement Resistor Guide

*with these important new features*

1. Complete data for over 925 modern receivers.
2. Resistance value and wattage listed for each unit.
3. New simplified system of listings saves time and prevents errors.
4. Complete technical discussion of resistor uses in modern receiver design. Get your copy today! Enclose fifty-cents with the coupon below, or ask your jobber for it. Free with the Continental Replacement Kit.

**End Resistor Troubles This Easy Way**

Why take chances of losing profits and customer goodwill by installing replacement resistors of unknown brand. When buying resistors, look for the green Continental label. Every Continental Resistor is "Certified" accurate, noiseless, and will give years of trouble-free performance.

## CONTINENTAL CARBON Inc.

13900 LORAIN AVE. » CLEVELAND, OHIO  
 Canadian factory » Toronto, Ontario

Enclosed please find fifty-cents, for which I am to be sent, postage prepaid one copy of the new Continental Replacement Resistor Guide.

Name .....  
 Address .....  
 City ..... State .....

# More PROFITS

from

## TRANSFORMER REPLACEMENTS

Use General Transformers! They exactly meet set manufacturers' specifications for electrical characteristics. Because they cost less, you make more in actual cash—plus the good will of your customer earned by a wholly satisfactory job.

### GENERAL TRANSFORMERS

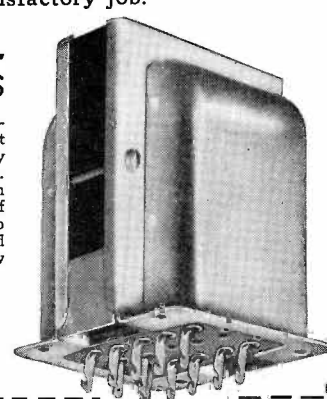

Built of best materials—carefully inspected before shipment—sold tax free—are carried by a live Distributor near you. Send today for Price List on the most complete line of Transformers for every radio use, distributor's name, and FREE Circuit Diagram of new Class "B" Amplifier.

**GENERAL TRANSFORMER CORPORATION**  
 1904 KILBOURN AVE.  
 CHICAGO, ILL.

**FREE CIRCUIT DIAGRAM**

General Transformer Corp., 1904 Kilbourn Ave., Chicago, Ill. Send me Price List, name of Distributor near me, and FREE Circuit Diagram for new Class "B" Amplifier.

NAME .....  
 ADDRESS .....

# THE FORUM . . .

## The Right Idea

Editor, SERVICE:

The Institute of Radio Service Men, of which I am a member, have adopted a Code of Ethics which all *real* Service Men should follow.

If a chassis is examined in detail so that each and every part is individually tested *after* the cause of the original failure of the set to function has been determined and properly repaired; then and only then can the "surgeon" be sure that the set is finally, and without doubt, returned to its original state of operation.

Such a procedure may well take up more time and effort, and even call for an extra part or two not figured in on the original estimate. Therefore, some may complain that this idea is not permissible if for no other reason than on the grounds that the customer is getting something for nothing. Which would be the case generally, but a job should be accepted only if a sufficient payment is to be received to cover cost of parts and to justify full time spent to service a chassis thoroughly to every last detail.

If real Service Men, whose ambitions are to make our profession a life work, would only realize that to merely substitute a condenser or other defective part is just patchwork and nothing more, they could then supply the answer to the reason so many "call-backs" must be made under any form of guarantee they may extend to their customers. And ninety-day guarantees *should* be extended.

It is very difficult to prove that right *here* is the *answer* to the *success* or *failure* of a servicing business, but the above process of reasoning and procedure has caused my business to grow in spite of the depression, and for no other reason than *satisfied customers*. They represent *practically all of my calls*.

Where a fair price cannot be commanded to justify the conscientious program anyone must adopt hereunder, the job must and should be politely refused with the following statement:

"As I guarantee all my work unconditionally, I must receive what your job is worth, for if I accept the job for less money, I must obviously spend less time in going over your set to trace causes of its present condition. To merely replace the unit I have pointed out as defective is considered patchwork in my profession, as it does not trace back to the cause of the trouble. Tracing and rectifying the cause usually takes more time than a mere replacement."

The crowning feature of it all is my pride in being privileged to hand every customer a black and white guarantee which is attached to the set so that it cannot be removed.

It is important to state here that I do not merely guarantee the part which I have replaced, but guarantee to the customer that he will have no repair expense whatsoever for ninety days, unless it be tubes. It is true that I take somewhat of a gamble here, but except in one instance I have *never* re-

ceived a chassis back within ninety days to replace a part in addition to the original part inserted, and this one exception was my own fault. This form of guarantee is made possible by the very fact that I inspect the entire set, and *know* its condition.

You will find that customers see the logic of the little recitation I have given above, and realize that the slight additional cost offers them *real* protection.

Now, as to testing and replacement, I should like to say this: no one will meet success with these methods if he kides himself about any minor detail, such as any resistances which are off value or rating, etc. Units must have their right values and ratings. A "100 percent" would never jump an open section in a voltage divider with a resistor other than the exact value called for and the proper wattage rating.

If I could by any means influence all real, conscientious, principled Service Men to try this plan 100% for a period of six months, I know that I would have done more to make their positions prosperous than any set of rules or agreements could possibly bring to pass.

A. E. RHINE,

RADIO ENGINEERING SERVICE,

New York, N. Y.

*(We believe that Mr. Rhine's own business code could do much for other Service Men, and if practiced generally by responsible individuals, go a long way toward eliminating the irresponsible and the "transient" Service Men.—The Editors.)*

## Re Condenser Tester

Editor, SERVICE:

Have just finished reading your article in the September issue of SERVICE on your new condenser tester.

Personally, I don't like the idea of purchasing a galvanometer. They are expensive and easily damaged. Furthermore, if you use a high-sensitivity type, the damping is poor.

It would appear to me that a better idea would be the use of a simple vacuum-tube voltmeter, especially so in that a heating transformer is used to actuate the oscillator tube.

In reference to the limitation of checking 1-mfd. condensers. Would it not prove feasible to include a 1-mfd. condenser in the testing unit, such extra condenser to be placed in parallel with the unit to be tested?

Some months ago I built the unit described in your Volume II, Trouble Shooter's Manual, and for battery operation. It was placed in a 6 x 6 x 5 box and performs very well with a limitation mentioned later.

The oscillator coil used was a 175 kc. "Delco" with the unused connections clipped close to the can. No results could be obtained until the shielding can was removed from the coil. After this, no further difficulty was noticed.

The limitation mentioned previously is this: One shorts the test prods and notes the reading of the 25 ma. meter. Testing

now starts, but how under the sun can you detect a leaky condenser, because the leaky condenser reads just the same value as the good one, and after all is said and done, unsoldering connections is the rule if one desires to play safe and be sure.

Have you any dope on a testing system for locating leaky condensers? Have tried 1/4, 1, and 2 c.p. neon lamps on 110 volts a-c. Results have been very poor. A discussion with other Service Men brings forth various suggestions. Some state the idea is only practical with 110 volts d-c. Others state that it is necessary to unbase the neon tube and remove the resistance contained in the lamp base cement, and then recheck tube on d-c. to learn the correct ionizing voltage, each tube requiring its particular voltage.

In reference to your thoughts on the resistance method of testing chassis: Personally, this system does not appeal. It may have certain advantages for the "Dealer's Service Man" testing one make of chassis, because under these circumstances one can learn to remember values. It will take much time, however. On the other hand, the "Dealer's Service Man" usually learns after a short time the characteristic troubles of a certain model, and usually spots these troubles with little difficulty.

For the "Man-About-Town Service Man" and handling all makes, it's my personal opinion that the old reliable analyzer method of spotting trouble and then following the trouble back is by far the best and quickest. Certain troubles indicate certain conditions, and if the Service Man is worth his salt, he will know what to look for.

It's a funny old game, isn't it? While you're looking for the trouble you wish to God you had never broken into the game, and after you have found the trouble, you pat yourself on the back and say, "Well, I'll know what to look for the next time and out comes the old thumb-worn notebook of "facts" and down goes the biography. It's a funny twist of psychology that the data you write down you seldom forget, and that which you fail to write down, you always forget.

HARRY W. KRUG,

Rochester, N. Y.

*(Details relative to your questions will appear in a forthcoming issue of SERVICE. Yes, it is a funny old game, but it has its points.—Editor.)*

## Many Thanks

Editor, SERVICE:

Just a few words of praise for the liveliest radio magazine, SERVICE. I think that it is the only magazine that really has truly worth-while information for we Service Men.

Let us have plenty of Point-to-Point Resistance dope. This is one phase of field service that has been very much needed and neglected in the past.

Congratulations to *our own magazine* and the Editors.

L. H. McMURRAY,  
MAC'S RADIO HOSPITAL,  
Rock Hill, S. C.





CLAROSTAT Replacement Volume Controls are "Custom-made" to exactly suit the receivers for which they are offered. Not a makeshift job lot idea.

The resistance, taper, shape and shaft are made according to the proper specifications.

There is no delay in installing them. There are no comebacks when you use CLAROSTAT products.

See the new CLAROSTAT CONTROL HANDBOOK AND CATALOG for 32 pages of dope for servicemen. Send for your FREE copy.



**CLAROSTAT Mfg. Co.**  
285-287 N. 6TH ST. BKLYN. N.Y.

## More Capacity At Less Cost

Latest electro-chemical research by the oldest and largest exclusive condenser manufacturer is reflected in the present large and varied line of



### DUBILIER ELECTROLYTICS

Available in all types—round and square metal cans, cardboard containers, tubular paper wrappings, high-voltage, low-voltage, tapped units, etc. Positively guaranteed for quickest reforming time, lowest leakage, highest working voltage, longest life. And they cost less!

**Write** for literature on Dubilier Electrolytics as well as all other types of condensers for every radio need.



**DUBILIER CONDENSER CORP.**  
4377 BRONX BLVD. NEW YORK CITY



E. H. Rietzke, Pres  
Capitol Radio Eng. Inst.

"... I want to **PROVE**  
the value of my course"

It's written just for men like you  
—who need **ADVANCED TRAINING!** Write for Sample Lesson—  
it's absolutely . . .

# FREE!

## Radio Servicemen—

Here's your chance to qualify for the great opportunities in radio! This interesting lesson will give you an idea of what this course can do for you. It's written for men **ALREADY IN RADIO**, anxious to succeed!

### FREE LESSON:

"Audio Frequency Amplification—Public Address Systems."

Some of the topics covered are:

. . . Calculation of Gain in Decibels. Gain from small -db values to large +db values. The decibel as a unit of power and as a unit of gain. . . Why "Push Pull?" . . . Pentodes or three element tubes? Why and when to use each. . . Class B audio? Problems of design; advantages and disadvantages. . . Impedance Matching—how and why. . . Tone Control; Audio Compensation.

**SEND FOR FREE LESSON!**

### SPECIAL FREE OFFER

**CAPITOL RADIO ENGINEERING INSTITUTE**  
14th and Park Road, N. W. Washington, D. C.

Without obligation, send me **FREE** sample lesson No. 45 showing some of the many subjects covered by your Advanced Training for Experienced Radio Men. SM-11

NAME .....

ADDRESS .....

## OHMITE

Presents a Replacement Resistor Drama  
Entitled  
"THE HEAT TEST"

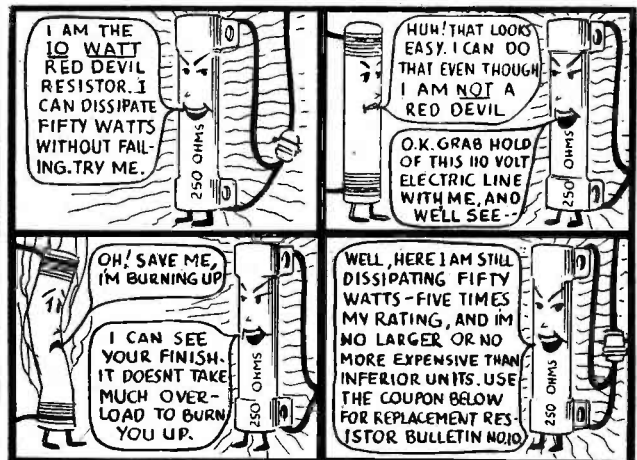

See the Heat Test at your Jobber's. The Red Devil's five-to-one factor of safety eliminates expensive "return" calls for the service man. Resistance values from 1 ohm to 100,000 ohms now carried in stock by most radio parts jobbers.

## OHMITE

Ohmite Manufacturing Company,  
637 N. Albany Avenue, Chicago.  
Please send me your Replacement Resistor Bulletin No. 10.

NAME .....

ADDRESS .....

CITY .....

JOBBER'S NAME .....



SAY PAT - I'M LOOKING FOR THE RESISTANCE VALUES OF THE ATWATER-KENT MODEL 82 - I HAVEN'T GOT IT IN MY MANUAL

I HAVE IT IN MINE - HAVEN'T YOU GOT RIDER'S MANUAL?

SURE BUT IT HAS MUCH MORE DOPE THAN ANY OTHER MANUAL - IT'S WORTH THE PRICE

I HAVE ANOTHER MANUAL - RIDER'S IS MORE EXPENSIVE

ABSOLUTELY! WHEN YOU DO YOU WILL HAVE ALL THE INFORMATION YOU WANT

WELL, IT SEEMS THAT I WILL HAVE TO GET RIDER'S MANUAL.

# "with RIDER'S MANUALS

90% of your problems  
are LICKED" . . . . .

(excerpt from a letter in our files)

- Old sets
- Recent sets
- Power packs
- Eliminators
- Auto-radio
- Chassis layouts
- Voltage data
- Electrical values
- Color coding
- Alignment data
- Trimmer locations
- Socket layouts
- Peak frequencies
- Wiring diagrams
- Resistance data

EVERYTHING you want—  
you'll find in Rider's Man-  
uals. NOTHING has been  
left out.

Rider's Manuals are the  
standard in the radio service  
industry.

### SPECIAL NOTICE

You will find in Volume I and Volume II of Rider's Manuals all the information you need to service those receivers which require servicing today.

When the new sets need servicing—such as those which have been produced during the last four or five months—complete, accurate data will be available through Rider's Perpetual Trouble Shooter's Manual, Volume III.

SEE LIST OF DEALERS ON OPPOSITE PAGE

If there is no dealer near you, write direct to us

## Radio Treatise Co., Inc.

1440 Broadway

New York City

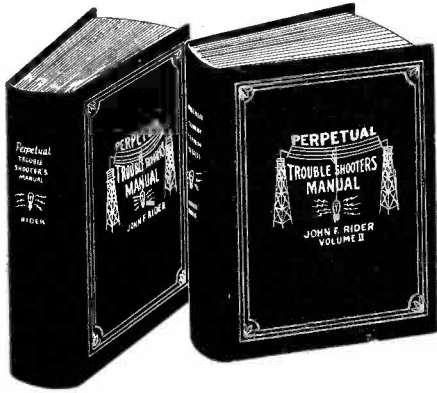

# Recognized by Receiver Manufacturers as Most Complete\*

When you need data on a particular set, you want it now—not sometime in the future. Volumes I and II of the "Perpetual Trouble Shooter's Manual" contain the wiring diagrams and related service data on practically every old and new popular receiver.

When we say these Manuals are complete—we mean complete! . . . Yes sir—complete in listing of the models and complete in information. . . . We know this to be a fact because the calls for service data received at this office from service men who do not have Rider's Manuals are answered by information from these Manuals. We know they are complete because the service men and organizations who have purchased these Manuals from us have told us that they contained all the information they wanted and needed.

Volume II is the companion Volume to Volume I. There is no duplication between the two volumes. . . . Volume II picks up where Volume I left off—and also contains data on those old receivers which were not available when Volume I was printed. . . . Buy both volumes and have the most perfect collection of service information available in the country.

\*"Every radio owner having an all-electric or battery set in his possession continuously since March 1, 1932, or earlier, such set having been made by any manufacturer listed in John F. Rider's "Perpetual Trouble Shooter's Manual," published by the Radio Treatise Co., Inc., New York City, and bearing the maker's name, model number, serial number, is eligible to enter this contest. The above mentioned guide book lists all standard makes of radios."

The above is Rule 1 in the Grigsby-Grunow "oldest-radio" contest, which closed November 1st, 1932. The selection of Rider's "Perpetual Trouble Shooter's Manual" as the guide book in this contest is positive evidence of its completeness.

## Buy from Your Dealer. Sold with a Money-Back Guarantee

|  |   |   |  |
|--|---|---|--|
| <b>Alabama</b><br>Auto Elec. Service Co. . . . . Montgomery      | <b>Kansas</b><br>S. S. Kresge Co. . . . . Topeka            | Sidles-Duda-Myers Co. . . . . Norfolk                                   | United Radio, Inc. . . . . Cincinnati                                    |
| <b>Australia</b><br>McGill's . . . . . Melbourne                 | <b>Kentucky</b><br>P. O. Burkes & Co. . . . . Louisville    | Sidles-Duda-Myers Co. . . . . North Platte                              | Uncle Sam Stores. . . . . Akron  |
| <b>California</b><br>Electric Supply Co. . . . . Oakland         | S. S. Kresge Co. . . . . Lexington                          | Sidles-Duda-Myers Co. . . . . Omaha                                     | <b>Oklahoma</b><br>Brown Electric Co. . . . . Oklahoma City              |
| Radio Mfg. Supply Co. . . . . Los Angeles                        | <b>Louisiana</b><br>Shuler Supply Co. . . . . New Orleans   | Sidles-Duda-Myers Co. . . . . Scottsbluff                               | <b>Oregon</b><br>J. K. Gill Co. . . . . Portland                         |
| Radio Supply Co. . . . . Los Angeles                             | <b>Maine</b><br>Frank M. Brown Co. . . . . Portland         | <b>New Hampshire</b><br>Radio Inspection Service Co. . . . . Manchester | Johnson-Weller Co., Inc. . . . . Portland                                |
| Offenbach . . . . . San Francisco                                | S. S. Kresge Co. . . . . Lewiston                           | John B. Varick Co. . . . . Manchester                                   | Wedel Company . . . . . Portland   |
| Warner Bros. . . . . San Francisco                               | S. S. Kresge Co. . . . . Portland                           | <b>New Jersey</b><br>Bennetts Radio Supply . . . . . Perth Amboy        | <b>Pennsylvania</b><br>Cameradio . . . . . Pittsburgh                    |
| <b>Canada</b><br>T. Eaton Co. . . . . Winnipeg                   | Stern & Co. . . . . Portland                                | Ferry & Smith . . . . . Newark  | Hall's . . . . . Harrisburg  |
| Edwin J. Galloway . . . . . Vancouver, B. C.                     | <b>Maryland</b><br>A. R. Spartana . . . . . Baltimore       | Jacksonfield Radio . . . . . Camden                                     | S. S. Kresge Co. . . . . Allentown                                       |
| <b>Colorado</b><br>Vreeland Radio Corp. . . . . Denver           | Mattson Radio . . . . . Baltimore                           | S. S. Kresge Co. . . . . Morristown                                     | S. S. Kresge Co. . . . . Butler  |
| <b>District of Columbia</b><br>Star Radio Co. . . . . Washington | <b>Massachusetts</b><br>T. F. Cushing . . . . . Springfield | <b>New York</b><br>American Sales Co. . . . . New York City             | S. S. Kresge Co. . . . . Reading   |
| <b>Connecticut</b><br>Hatry & Young . . . . . Hartford           | H. Jappe Co. . . . . Boston                                 | Baltimore Radio Co. . . . . New York City                               | S. S. Kresge Co. . . . . Scranton  |
| S. S. Kresge Co. . . . . New Haven                               | S. S. Kresge Co. . . . . Boston                             | Bian, the Radio Man . . . . . New York City                             | S. S. Kresge Co. . . . . Warren  |
| S. S. Kresge Co. . . . . Stamford                                | S. S. Kresge Co. . . . . Malden                             | Coast to Coast . . . . . New York City                                  | Keystone Radio Co. . . . . Philadelphia                                  |
| S. S. Kresge Co. . . . . New London                              | S. S. Kresge Co. . . . . Quincy                             | H. L. Dalls Co. . . . . New York City                                   | Radio Elec. Service Co. . . . . Philadelphia                             |
| Radio Service . . . . . Hartford                                 | S. S. Kresge Co. . . . . Springfield                        | Federated Purchaser, Inc. . . . . New York City                         | Radio Service Co. . . . . Wilkes-Barre                                   |
| Thomas Brown . . . . . New Haven                                 | Mutty's Radio Labs. . . . . Boston                          | Fl. Orange-Radio Dist Corp. . . . . Albany                              | M. & H. Sporting Goods, Philadelphia                                     |
| <b>Illinois</b><br>Allied Radio Corp. . . . . Chicago            | R. C. A. Institutes . . . . . Boston                        | S. S. Kresge Co. . . . . Dunkirk  | <b>Rhode Island</b><br>W. H. Edwards Radio Svc., Providence              |
| Chicago Radio Apparatus . . . . . Chicago                        | Sager Electrical Supply Co. . . . . Boston                  | S. S. Kresge Co. . . . . Buffalo  | S. S. Kresge Co. . . . . Pawtucket                                       |
| Electric & Radio Supply Co. . . . . Chicago                      | Trade Contact Corp. . . . . Boston                          | S. S. Kresge Co. . . . . Olean  | <b>South Dakota</b><br>S. S. Kresge Co. . . . . Aberdeen                 |
| Grant Radio Co. . . . . Chicago                                  | Tremont Elec'l Co. . . . . Boston                           | S. S. Kresge Co. . . . . Rome   | <b>Tennessee</b><br>J. L. Perry . . . . . Nashville                      |
| Klaus Radio Company . . . . . Peoria                             | <b>Michigan</b><br>S. S. Kresge Co. . . . . Bay City        | S. S. Kresge Co. . . . . Schenectady                                    | <b>Texas</b><br>Service Parts Co., Inc. . . . . Abilene                  |
| S. S. Kresge Co. . . . . Chicago                                 | S. S. Kresge Co. . . . . Detroit                            | S. S. Kresge Co. . . . . Troy   | Southwest Radio Svc. . . . . Dallas                                      |
| S. S. Kresge Co. . . . . Chicago                                 | S. S. Kresge Co. . . . . Grand Rapids                       | Maurice Schwartz & Son, Schenectady                                     | Straus-Frank Co. . . . . Houston   |
| S. S. Kresge Co. . . . . Champaign                               | S. S. Kresge Co. . . . . Highland Park                      | Radio Circular . . . . . New York City                                  | Straw-Frank Co. . . . . San Antonio                                      |
| S. S. Kresge Co. . . . . Springfield                             | S. S. Kresge Co. . . . . Jackson                            | Roy C. Stage . . . . . Syracuse   | Walter Tips Co. . . . . Austin   |
| S. S. Kresge Co. . . . . Peoria                                  | S. S. Kresge Co. . . . . Muskegon                           | West Side Y.M.C.A. . . . . New York City                                | Wilkinson Bros. . . . . Dallas   |
| S. S. Kresge Co. . . . . Freeport                                | S. S. Kresge Co. . . . . Saginaw                            | Wholesale Radio Service, New York City                                  | <b>Virginia</b><br>Johnston-Gasser Co. . . . . Richmond                  |
| S. S. Kresge Co. . . . . Belleville                              | Rissl Brothers . . . . . Detroit                            | <b>New Zealand</b><br>Te Aro Book Depot. . . . . Wellington             | S. S. Kresge Co. . . . . Norfolk   |
| S. S. Kresge Co. . . . . Danville                                | R. & M. Radio Co. . . . . Detroit                           | <b>North Carolina</b><br>Shaw's . . . . . Charlotte                     | S. S. Kresge Co. . . . . Richmond  |
| S. S. Kresge Co. . . . . Decatur                                 | Radio Distributing Co. . . . . Detroit                      | <b>Ohio</b><br>Aitken Radio Corp. . . . . Toledo                        | <b>West Virginia</b><br>Foster-Thornburg Hardware Co. . . . . Huntington |
| S. S. Kresge Co. . . . . Mart.                                   | Radio Specialties . . . . . Detroit                         | Bergman Tool . . . . . Cleveland  | S. S. Kresge Co. . . . . Charleston                                      |
| S. S. Kresge Co. . . . . Chicago                                 | Reno Radio Stores . . . . . Detroit                         | Burns Radio Co. . . . . Dayton  | S. S. Kresge Co. . . . . Wheeling  |
| Newark Elect. Co. . . . . Chicago                                | Wedemeyer Radio Co. . . . . Ann Arbor                       | Goldhamer, Inc. . . . . Cleveland                                       | <b>Washington</b><br>General Radio, Inc. . . . . Seattle                 |
| Radolek Company . . . . . Chicago                                | <b>Minnesota</b><br>Lew Bonn Co. . . . . St. Paul           | Hughes-Peters Elea. Corp. . . . . Columbus                              | Spokane Radio Co. . . . . Spokane  |
| The Swords Company . . . . . Rockford                            | Radio Maintenance Co. . . . . Minneapolis                   | Kladg Radio Labs. . . . . Kent  | Wedel Company . . . . . Seattle  |
| <b>Indiana</b><br>S. S. Kresge Co. . . . . Evansville            | Southern Minn. Supply Co. . . . . Mankato                   | S. S. Kresge Co. . . . . Akron  | <b>Wisconsin</b><br>Harriman Radio Svc. . . . . Appleton                 |
| S. S. Kresge Co. . . . . Fort Wayne                              | <b>Missouri</b><br>Walter Asha Radio Co. . . . . St. Louis  | S. S. Kresge Co. . . . . Cincinnati                                     | S. S. Kresge Co. . . . . Milwaukee                                       |
| S. S. Kresge Co. . . . . Gary                                    | Burstein-Applebee Co. . . . . Kansas City                   | S. S. Kresge Co. . . . . Cleveland                                      | Radio Parts Co. . . . . Milwaukee  |
| S. S. Kresge Co. . . . . Kokomo                                  | S. S. Kresge Co. . . . . Hannibal                           | S. S. Kresge Co. . . . . Columbus                                       | W. A. Roosevelt Co. . . . . La Crosse                                    |
| S. S. Kresge Co. . . . . Lafayette                               | S. S. Kresge Co. . . . . Joplin                             | S. S. Kresge Co. . . . . Lancaster                                      |  |
| S. S. Kresge Co. . . . . South Bend                              | S. S. Kresge Co. . . . . St. Louis                          | S. S. Kresge Co. . . . . Newark   |  |
| S. S. Kresge Co. . . . . Terre Haute                             | S. S. Kresge Co. . . . . University City                    | S. S. Kresge Co. . . . . Toledo   |  |
| S. S. Kresge Co. . . . . Vincennes                               | Van Ashe Radio Co. . . . . St. Louis                        | S. S. Kresge Co. . . . . Sandusky                                       |  |
| Krusse Radio Co. . . . . Indianapolis                            | <b>Nebraska</b><br>S. S. Kresge Co. . . . . Lincoln         | S. S. Kresge Co. . . . . Zanesville                                     |  |
| State Radio Co. . . . . Indianapolis                             | S. S. Kresge Co. . . . . Omaha                              | Lew Stores . . . . . Toledo   |  |
| <b>Iowa</b><br>Iowa Radio Corp. . . . . Des Moines               | Sidles-Duda-Myers Co. . . . . Grand Island                  | Progress Elec. Co. . . . . Cleveland                                    |  |
| S. S. Kresge Co. . . . . Davenport                               | Sidles-Duda-Myers Co. . . . . Hastings                      | Radio Servicemen's Supply Co. . . . . Cleveland                         |  |
| S. S. Kresge Co. . . . . Sioux City                              | Sidles-Duda-Myers Co. . . . . Lincoln                       | Ross Radio Co. . . . . Youngstown                                       |  |
| S. S. Kresge Co. . . . . Waterloo                                |   | Steinberg's . . . . . Cincinnati  |  |
| Sidles-Duda-Myers Co. . . . . Des Moines                         |   |   |  |
| Sidles-Duda-Myers Co. . . . . Atlantic                           |   |   |  |

Note:—All S. S. Kresge Stores are Green Front

If there is no dealer near you, order direct from us

## Radio Treatise Co., Inc.

1440 Broadway

New York City

# THE MANUFACTURERS . . .

## New AKAformer System

Amy, Aceves and King, Inc., have brought out an improved form of noise-reducing antenna system having impedance-matching transformers at both ends of the transmission line, where heretofore but a single transformer was employed. The addition of a second transformer, or AKAformer, at the receiver end permits a much more satisfactory impedance match. Thus, there is a greater transfer of energy from antenna to receiver.

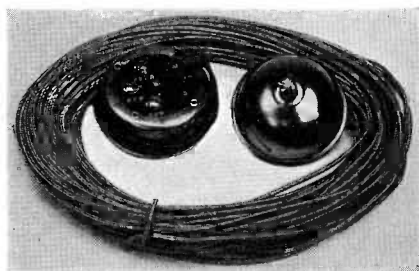

In order to meet the impedance requirements of any receiver, the "receiver" AKAformer is provided with two taps or leads for high- and low-impedance requirements.

Another feature is the incorporation of an optional short-wave connection. By using this tap, the benefits of the noise-reducing qualities of the antenna system may be had down to about 15 meters.

The parts comprising the complete kit are shown in the accompanying illustration.

## Multidapter

As the name implies, the Multidapter is many adapters in one, and can be effectively used in conjunction with any common type of set analyzer, tube tester or similar test instrument.

With the Multidapter, it is possible to test all the new tubes, including types 29, 33, 39, 41, 42, 43, 46, 47, 55, 57, 58, 64, 65, 69, 82, 83, 89, and second plate of 80, etc. Since practically all connections of the Multidapter are interchangeable, the unit is adaptable to any other new tubes which may be announced.



The Multidapter is equipped with a five-prong plug and cable. This is plugged into the five-prong socket on the set analyzer or tube tester. Tube and circuit connections are then taken care of from the top of the Multidapter, which carries a 4-, 5-, 6- and 7-prong tube socket. The various type tubes are adapted by interchanging the positions of "patch cords" in small jacks mounted around the side of the Multidapter.

Obviously, one of the advantages of the Multidapter is that it will take the place of a flock of separate adapters designed for special tubes and purposes.

The Multidapter illustrated is Model 203, which has the five-prong plug mounted on the bottom of the unit. The latest model, the 204, has the plug on the end of a flexible cable which enters the side of the Multidapter.

The Multidapter is manufactured by Radio City Products Company, 48 West Broadway, New York, N. Y.

## Littlefuses for Meters

A new fusible jack has been designed, enabling the user to employ the correct size of fuse for each scale reading on multi-range meters and still be able to shift readily from one range to another. The fusible jack is secured under the binding post of the instrument, and the fuse is enclosed within the bakelite barrel which is merely unscrewed to make fuse renewals. A solderless pin-plug permits installation without the use of tools.

The fuses used in this mounting are Instrument Littlefuses and come in 1/100, 1/32, 1/16, 1/8, 1/4, 3/8, 1/2, 3/4, 1, and 2 amperes capacity. On account of their

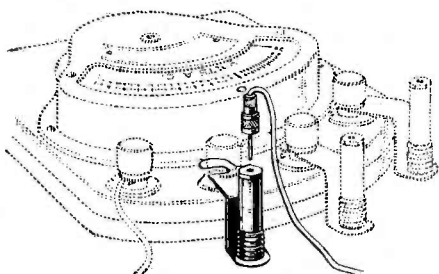

quick acting characteristics, they afford protection to even the most delicate instruments, it is said.

These fuses and mountings are manufactured by the Littlefuse Laboratories, 1772 Wilson Avenue, Chicago, Illinois.

## Finger-Proof Microphone

The open-faced microphone, bugbear of Service Men and repair workers, has given way to the new "super-microphone," or Model "BB" at the plant of the Universal Microphone Co., Inglewood, California.

Factory men claim that fully 90% of repairs are made necessary by the curiously inclined poking a finger in the open-faced microphones. (Did you hear about the woman who ruined a swell mike by spraying its "innards" with antiseptic?—Ed.)

The new-style model at Universal will be fully protected by a new form of grille work.

It is a low-priced two-button type, built to a hair-line precision, according to Universal, and yet is particularly heavy and rugged. BB will be finished in highly polished chrome plate and with three degrees

of sensitivity . . . very sensitive (S); medium, or standard (M); and highly damped (D).

Universal will soon produce a new three-piece microphone floor stand, designed mostly for portable use. It will be an all-nickel plated outfit with three sections and a small base.

## Solar Inverters

The Solar Manufacturing Corporation has brought out a device, known as an Inverter, which will provide 110-volts a-c. from d-c. lines of 110 volts, 220 volts and 32 volts.

The Inverter has no moving parts in the general sense of the word, a special type of

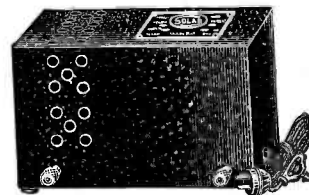

magnetic vibrator being employed in connection with condensers and a filter system, to produce the alternating current.

The Inverter is made in a number of types and sizes to meet various conditions. Complete data may be had free from the Solar Manufacturing Corp., 601 Broadway, New York, New York.

## Brunswick Engineers, Inc.

Brunswick Engineers, Inc., 619 West 54th Street, New York, New York, has assumed all operations of the United Radio Service Co. and the Brunswick Radio Factory Service.

This organization is handling Brunswick replacement parts and service exclusively and all inquiries and correspondence should be sent direct to their New York office.

## New Amperites

There is now available a complete new series of Amperites with the standard screw base.

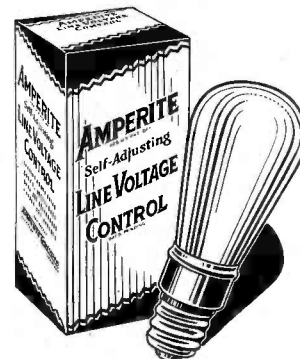

This new type is made in all current capacities and is especially useful in public-address and commercial installations, as well as for the protection of broadcast receivers from line voltage variation.

**STOP RADIO NOISES WITH A**

**TOBE**  
**Filterizer**

PRICE COMPLETE  
**\$ 9.75**



**SERVICE MEN !  
DEALERS !  
RADIO NOISES  
Can Be Eliminated**

*from* Oil Burners—  
Elevated Trains—  
Street Cars—All  
Man-Made Static!  
Elevators—Motors—Sign Flashers  
and All Home Electrical Appliances!

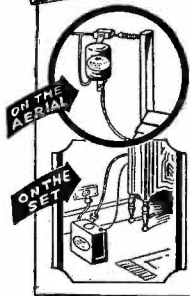

SEND 25% WITH YOUR ORDER—DEALER DISCOUNT  
ALLOWED.

**NEWARK ELECTRIC CO.**

*Distributors of Radio Parts Only*  
**226 W. Madison St. Chicago, Ill.**

**This Man Says—**

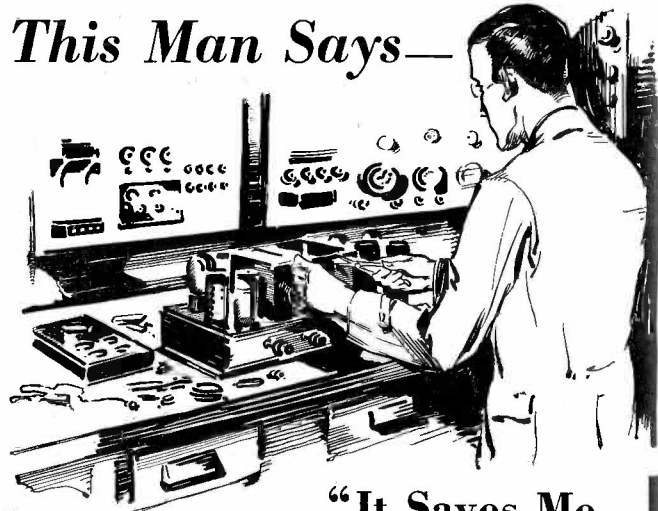

**“It Saves Me  
Time, Money, and Grief!”**

“The RADOLEK PROFIT GUIDE is a big help to me in my service work—I’d hate to be without it.”

“It is the handiest catalog I have because it contains so much valuable radio data. It catalogs practically every item I have need for in servicing standard Radio Receivers and has them arranged in such a manner that I can locate them quickly.”

“It has saved me a lot of time, money and grief by bringing to me the best quality merchandise at the lowest wholesale prices and bringing them to me promptly!”

“Yes, the PROFIT GUIDE is my standby.”

**But How About You ?**

Are YOU profiting by this modern supply service? Many progressive Servicemen are preparing for the big increase in business which is headed in their direction—how about you? There is every indication that the Radio Serviceman is going to have all he can do this season and NOW is the time to prepare for it.

There are many items in the PROFIT GUIDE you will have need for—6 and 7 prong adapters for your Set Analyzers, many new Tools, Resistor and Condenser Kits, and hundreds of other things. If you have not investigated RADOLEK SERVICE do it *to-day!* The sooner you do it the better!

**If You Haven't a Copy of the  
1933**

**PROFIT GUIDE**

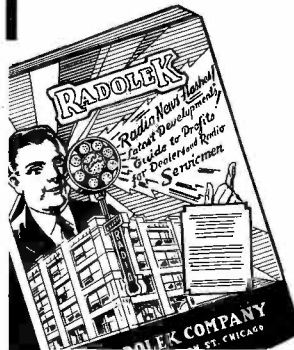

write for you copy mentioning this advertisement. Radolek caters exclusively to Radio Servicemen, Dealers, Laboratories and Manufacturers, therefore you are requested to use your letter head or send us one of your business cards. We restrict the circulation of this Sales Book to protect you and keep your wholesale prices confidential—another example of Radolek's cooperation with the Serviceman.

**601 West  
RANDOLPH  
STREET**

**THE  
RADOLEK  
COMPANY**

**CHICAGO  
ILLINOIS**

**STATEMENT OF THE OWNERSHIP, MANAGEMENT, CIRCULATION, ETC., REQUIRED BY THE ACT OF CONGRESS OF AUGUST 24, 1912**

Of SERVICE—A Monthly Digest of Radio and Allied Maintenance published monthly at New York, N. Y., for Oct. 1, 1932.  
STATE OF NEW YORK } ss.  
COUNTY OF NEW YORK }

Before me, a Notary Public, in and for the State and county aforesaid, personally appeared Robert N. Mann, who, having been duly sworn to law, deposes and says that he is the Business Manager of SERVICE—A Monthly Digest of Radio and Allied Maintenance, and that the following is, to the best of his knowledge and belief, a true statement of the ownership, management, (and if a daily paper, the circulation), etc., of the aforesaid publication for the date shown in the above caption, required by the Act of August 24, 1912, embodied in section 411, Postal Laws and Regulations, printed on the reverse of this form, to wit:

1. That the names and addresses of the publisher, editor, managing editor and business managers are: Publisher, John F. Rider, 1440 Broadway, New York, N. Y.; Editor, John F. Rider, 1440 Broadway, New York, N. Y.; Managing Editor, M. L. Muhleman, 1440 Broadway, New York, N. Y.; Business Manager, Robert N. Mann, 1440 Broadway, New York, N. Y.

2. That the owners are: John F. Rider, 1440 Broadway, New York, N. Y.; Florence Rider, 1501 Undercliff Ave., Bronx, N. Y.; M. L. Muhleman, 1440 Broadway, New York, N. Y.; Robert N. Mann, 1440 Broadway, New York, N. Y.

3. That the known bondholders, mortgagees, and other security holders owning or holding 1 per cent or more of total amount of bonds, mortgages, or other securities are: None.

4. That the two paragraphs next above, giving the names of the owners, stockholders, and security holders, if any, contain not only the list of stockholders and security holders as they appear upon the books of the company but also, in cases where the stockholder or security holder appears upon the books of the company as trustee or in any other fiduciary relation, the name of the person or corporation for whom such trustee is acting, is given; also that the said two paragraphs contain statements embracing affiant's full knowledge and belief as to the circumstances and conditions under which stockholders and security holders who do not appear upon the books of the company as trustees, hold stock and securities in a capacity other than that of a bona fide owner; and this affiant has no reason to believe that any other person, association, or corporation has any interest direct or indirect in the said stock, bonds, or other securities than as so stated by him.

5. That the average number of copies of each issue of this publication sold or distributed, through the mails or otherwise, to paid subscribers during the six months preceding the date shown above is..... (This information is required from daily publications only.)

**ROBERT N. MANN,**  
Business Manager.

Sworn to and subscribed before me this 26th day of September, 1932.  
[SEAL] **JOSEPH NEUMAN,**

(My commission expires March 30, 1934).

# Index of Monthly Literature

## AUTO-RADIO

"B" Eliminators for Auto Radio  
*J. Dunsbeath, Radio Engineering, pp 9, October, 1932*

## BROADCAST

### Amplifiers, A-F.

Causes and Cures of Audio Oscillation  
*L. Van Der Mel, Radio-Craft, pp 343, December, 1932*

Characteristics of Class A, B, and C Amplifiers  
*E. H. Rietzke, "CQ", pp 11, October, 1932*

Heavy-Duty Class B Amplifier (Details)  
*L. Littman, Radio News, pp 355, December, 1932*

Using the New Tubes  
*Robert S. Kruse, Modern Radio, pp 11, November, 1932*

### Amplifiers, R-F.

Characteristics of Class A, B and C Amplifiers  
*E. H. Rietzke, "CQ", pp 11, October, 1932*

Radio Receiver I-F. Frequency Chart  
*Radio-Craft, pp 344, December, 1932*

R-F. Stage Alignment  
*H. L. Olesen, Radio Retailing, pp 32, October, 1932*

Using the New Tubes  
*Robert S. Kruse, Modern Radio, pp 11, November, 1932*

## General

Copper-Oxide Rectifiers for Detection and AVC\*  
*L. O. Grondahl and W. P. Place, Proceedings I. R. E., pp 1,599, October, 1932*

## Receivers

Radio Receiver I-F. Frequency Chart  
*Radio-Craft, pp 344, December, 1932*

Receiver Specifications Chart  
*Radio Retailing, pp 35, October, 1932*

Silver-Marshall B. C. Superheterodyne  
*McMurdo Silver, Radio News, pp 353, December, 1932*

## PUBLIC-ADDRESS

Battery-Operated Portable P-A. System (Construction)  
*C. E. Denton, Radio-Craft, pp 330, December, 1932*

Causes and Cures of Audio Oscillation  
*L. Van Der Mel, Radio-Craft, pp 343, December, 1932*

Characteristics of Class A, B, and C Amplifiers  
*E. H. Rietzke, "CQ", pp 11, October, 1932*

Condenser Microphone (Construction)  
*H. F. Anderson, QST, pp 22, November, 1932*

Condenser Mike Amplifier (Construction)  
*G. E. West, Radio News, pp 340, December, 1932*

Dynamic Microphone Requirements  
*M. Bjorndal, Radio Engineering, pp 21, October, 1932*

Effects of Speaker Baffles, Part 2  
*L. M. Lurie, Radio-Craft, pp 342, December, 1932*

Heavy-Duty Class B Amplifier (Details)  
*L. Littman, Radio News, pp 355, December, 1932*

Heavy-Duty P-A. System, Part 2 (Construction)  
*B. J. Montyn, Radio News, pp 346, December, 1932*

Home Recording Equipment, Part 1 (Construction)  
*Lt. W. H. Weststrom, Radio News, pp 336, December, 1932*

Time-Lag Device\*  
*N. Holman, QST, pp 43, November, 1932*

Voice Recording History  
*S. Y. White, Proceedings Radio Club of America, pp 51, September-October, 1932*

## SHORT WAVE

Band Spreading (Tank Condenser)  
*QST, pp 36, November, 1932*

Hourly Tuning Guide  
*International Short Wave Club Magazine, pp 24, November, 1932*

Noise-Reducing Short Wave Aerials\*  
*E. L. Dillard, Short Wave Craft, pp 412, November, 1932*

Short-Wave Station List  
*Radio News, pp 351, December, 1932*

Tunable Hum Elimination\*  
*QST, pp 39, November, 1932*

## TESTING SYSTEMS

Accurate High-Range Ohmmeter (Construction)  
*Modern Radio, pp 18, November, 1932*

Adapters for Test Equipment, Part 3  
*F. L. Sprayberry, Radio-Craft, pp 346, December, 1932*

Calibration of Harmonic Oscillator  
*H. Bernard, Radio World, pp 4, October 15, 1932*

Crystal Control With Dynatron Oscillators  
*K. A. MacKinnon, Proceedings I. R. E., pp 1,689, November, 1932*

Direct-Reading Mutual-Conductance Meter (Construction)  
*J. H. Potts, Radio-Craft, pp 341, December, 1932*

Neon Tube Oscillator, Part 1  
*D. Pollack, Radio News, pp 342, December, 1932*

Padding  
*J. E. Anderson, Radio World, pp 14, November 12, 1932*

Power Transformer Testing\*  
*R. F. Shea, Radio Engineering, pp 14, October, 1932*

Resistance Meter Calibration  
*H. Bernard, Radio World, pp 4, October 29, 1932*

R-F. Stage Alignment  
*H. L. Olesen, Radio Retailing, pp 32, October, 1932*

Static Analysis of Radio Receivers  
*J. C. Hoover, Journal I. R. S. M., pp 257, August-September, 1932*

Universal Set Analyzer (Details)  
*E. Scribner, Radio News, pp 362, December, 1932*

Visual Test Devices  
*O. H. Schuck, Proceedings I. R. E., pp 1,580 October, 1932*

## TUBES

RCA 48 Power Tube  
*Modern Radio, pp 24, November, 1932*

R-F. Amplifier Tube Chart  
*Modern Radio, pp 7, November, 1932*

Sylvania Types 41, 42, 43, 44  
*Journal I. R. S. M., pp. 24-A, August-September, 1932*

Tubes 48, 262A, 842, 59  
*Louis Martin, Radio-Craft, pp 334, December, 1932*

Using the New Tubes  
*Robert S. Kruse, Modern Radio, pp 11, November, 1932*

Vacuum Tube Chart (Supplement)  
*Electronics, October, 1932*

## MISCELLANEOUS

Photo-Electric Cells  
*G. S. Mitchell, Projection Engineering, pp 7, October, 1932*

Problems of Radio Service Profession  
*K. A. Hathaway, Journal I. R. S. M., pp 266, August-September, 1932*

Running Down Local Interference  
*R. B. Witschen, QST, pp 27, November, 1932*

Service at a Profit  
*John F. Rider, Radio Merchant, pp 27, October, 1932*

Service Charges  
*H. A. Fischer, Journal I. R. S. M., pp 247, August-September, 1932*

All articles listed on this page are cross-indexed for your convenience. Titles given are not necessarily the titles of the original articles, but in each case serve to determine the substance of the article. Listings marked with an asterisk (\*) are abstracted in this issue. The material in each issue of SERVICE is alphabetically indexed on the Contents Page.

# Whatever resistor you need, it's here!

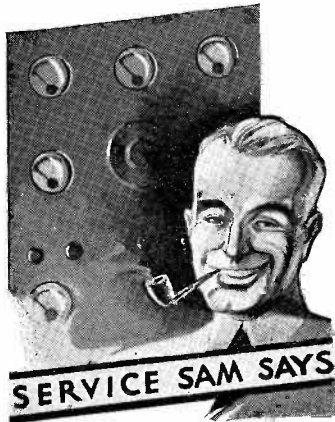

**E**VERY so often someone asks me about the construction of test equipment for a service job. Well, here's the low down. I've had some experience pro and con. I've built units and I've bought units. In both cases I had good experiences and I also realized that I was foolish.

Sure it's possible to build test units, but you've got to be careful. Certain kinds of test gadgets can be built economically and others prove too costly. A set tester can be built with a saving of money. If you're careful you can make a good job of it and you'll be a proud father. Oscillators too can be built, but remember that when completed—that is, finished mechanically—you're only half done. The job must be calibrated—and Mister—calibrated accurately. Calibration can be done at home if you have another accurately calibrated oscillator or an accurately calibrated receiver. For the last arrangement you must know something about harmonics. . . . In addition—you've got to have patience for the first calibration via a receiver and a number of broadcasting stations must be repeated so as to assure accuracy.

An ohmmeter you can make . . . but once more—you have worries about calibration. To calibrate you must know your Ohm's law—also the characteristics of the meter used. In addition the resistors must be damned accurate. You can increase your voltage scales—provided that you use accurate resistors. All of these jobs can be done at a saving when compared with completely assembled and calibrated commercial jobs and they'll stack up with the commercial jobs.

Tube checkers with special calibrated meters such as you will find in the commercial units are better purchased than made. However, if you are satisfied with the simple mutual conductance test and can assign basic values for comparison—okay—build your own checker.

If you think of building anything which requires special meters—you're better off buying the unit complete. Try and remember that you must buy equipment—assemble the equipment—have panels drilled—engraved—leads soldered, etc. In many cases a man thinks it cheaper to build than buy, only to discover that it took two weeks to build and the finished job is not comparable to a commercial job—it's not as versatile.

*Service Sam*

## I R C

### RESISTORS

#### POWER WIRE WOUND

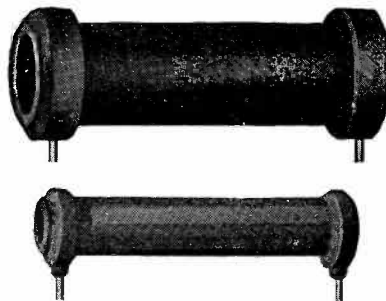

#### MOTOR RADIO SUPPRESSORS



#### PRECISION WIRE WOUND

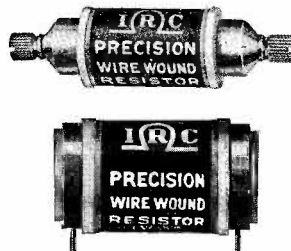

#### Metallized

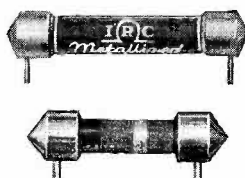

**A complete line—and the only complete line on the market.**

**W**HY shop around to find resistance units for your different purposes? They're all in the I. R. C. line—and all in the new I. R. C. Catalog.

Whether you require Power Wire Wound Resistors, Motor Radio Suppressors, Precision Wire Wound or Metallized Resistors, we manufacture every type you need.

And wherever you are, you can readily buy them. I. R. C. distributors are located in all parts of the country—in virtually every leading city—and in foreign lands. And every resistor bears the quality label known the world over—"I. R. C." **LOOK FOR THIS TRADEMARK.**

Only a glimpse of I. R. C. products is possible in this advertisement. But the full data is yours for the asking in our new catalog, showing resistors, resistor kits, service helps, instructions for making your own apparatus, and technical information on electrical characteristics of all I. R. C. units.

**INTERNATIONAL RESISTANCE COMPANY**  
2006 Chestnut Street, Philadelphia, Pa.  
74 Wellington St., West, Toronto, Ontario, Canada

**Write today for free catalog. Ask for Form 8**



**EXACT  
DUPLICATE  
CONDENSERS**  
For  
**REPLACEMENT  
Service**

**A** COMPLETE replacement service of Duplicate Condensers for practically all radio sets has been offered by The Potter Company for years.

Specifications on hand for over 9000 condensers. *Partial List shown herewith.*

# CONDENSERS

**BY**

**P  
O  
T  
T  
E  
R**

**ATWATER-KENT**

Models: 37, 40, 42, 46, 52, 38, 39, 55, 35.

**AUDIOLA**

All Models.

**BALKEIT**

All Models.

**BELMONT**

All Models.

**BOSCH**

Models: 28, 48-A.

**BRANDES**

Model: B-15.

**BREMER-TULLY**

Models: 8-20-A, 7-70, 7-71.

**CLAGO**

All Models.

**CROSLLEY**

Jewel Box, 55, 56, 77, 54.

**DAYFAN**

5091, 16605, 5582, A-5005, Junior 6.

**ECHOPHONE**

Models: S-4, S-3, S-5, 80, M-60.

**FADA**

Models: 16, 70, 41, 42, 44, 46, 47, 25, 35, 25Z.

**KOLSTER**

Models: K-5, 6-J, 6-K, 6-R, K-20, K-21, K-23, K-24, K-8, K-43, K-44, K-45.

**MAJESTIC**

Models: 70, 72, 90, 90-B, 180, 70-B, 50, 20-21, 22, 32.

**MODERN**

Models: K-12-D, K-12.

**PHILCO**

Models: 87, 531, 77, 76, 86.

**R. C. A.**

Models: Radiola 20, 18, 51, 104 speaker, 16, 17, 41, 50, 60, 62, Radiola 105, AP-947, Victor R-32, RE-45, R-52, 80, 17, 3-KR-8, 30-A, 41.

**SILVER-  
MARSHALL**

All Models.

**SPARTON**

Models: AC-62, AC-7, AC-63, AC-69-A, 79-A, 89, 78-A, AC-5, AC-6, 109, AC-110, 637, 589, 610, 931, 930, 89-A, Jr. 410, 301.

**STEINITE**

Models: 12, 990, 40, 281 Rectifier, 70, 261, 50-A, 261, 23.

**UNITED AIR CLEANERS**

All Models.

**U. S. RADIO & TELEVISION**

Models: 36 Apex, 37 Apex, 41, 46, 47, 48, 41, 32, 99, 7 Gloriatone 26.

**ZENITH**

Models: ZE-17, ZE-10, ZE-8, ZE-9, ZE-6, ZE-5, ZE-11, 12, 14, 70, 12, 15, ZE-18, ZE-7, 52, ZE-4, ZE-70, 70 Jr., 70-X, 2012, A-B-C-D.

**THE POTTER COMPANY**  
NORTH CHICAGO, ILLINOIS

