

SERVICE

—

A MONTHLY DIGEST OF
RADIO
AND ALLIED MAINTENANCE



He amalgamated . . .
(see page 266)

PER COPY
15 CENTS

OCTOBER
1932

IT'S GOT THE STUFF YOU WANT!

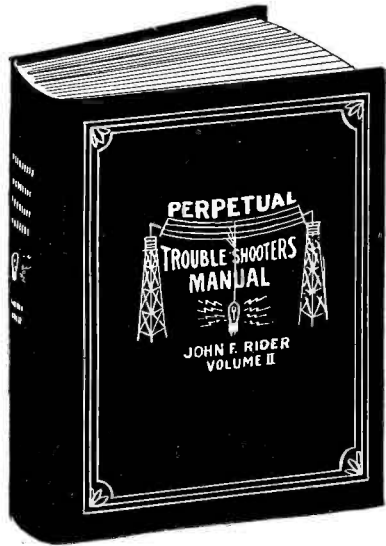

Your job is servicing. You want the information when you need it. Receivers manufactured during the past year are coming into your shop for service. Complete service information on these receivers will be found in Volume II of the "Perpetual Trouble Shooter's Manual."

When we say complete, we mean complete! Electrical values for every receiver in the Manual. Yes sir—even resistance values for every Atwater-Kent receiver listed in Volume II. In addition to the electrical values you will find the wiring diagram—the chassis layout—the voltage data—color coding of the wires—alignment data—intermediate-frequency values—location of trimmers—of all popular commercial radio receivers.

Volume II is the companion Manual to Volume I. If you have Volume I you will want Volume II. It picks up where Volume I left off. Complete index of Volumes I and II will be found in Volume II.

We want you to know that these Manuals are produced with the cooperation of the radio receiver manufacturing industry—that each page is a photographic reproduction of the material supplied by the receiver manufacturers. Each page is accurate—detailed—dependable.

SPECIAL—More Than 50 Pages of Point-to-Point Resistance Data

Buy it from Your Dealer. Sold with a Money-Back Guarantee

Alabama Auto Elec. Service Co.Montgomery	Kansas S. S. KresgeTopeka	Sidles-Duda-Myers Co.North Platte	Oregon J. K. Gill Co.Portland
Australia McGill'sMelbourne	Kentucky P. O. Burkes & Co.Louisville	Sidles-Duda-Myers Co.Omaha	Johnson-Weiler Co. Inc.Portland
California Radio Mfg. Supply Co.Los Angeles	S. S. KresgeLexington	Sidles-Duda-Myers Co.Scottsbluff	Wedel CompanyPortland
Radio Supply Co.Los Angeles	Louisiana Shuler Supply Co.New Orleans	New Jersey Bennetts Radio SupplyPerth Amboy	Pennsylvania CameradioPittsburgh
OffenbachSan Francisco	Maine S. S. KresgeLewiston	Ferry & SmithNewark	Hall'sHarrisburg
Warner Bros.San Francisco	S. S. KresgePortland	Jacksonfield RadioCamden	S. S. KresgeAllentown
Canada T. Eaton Co.Winnipeg	Maryland A. R. SpartanaBaltimore	S. S. KresgeMorristown	S. S. KresgeButler
Edwin J. GallowayVancouver, B. C.	Mattson RadioBaltimore	New York American Sales Co.New York City	S. S. KresgeErie
Colorado Vreeland Radio Corp.Denver	Massachusetts T. F. CushingSpringfield	Baltimore Radio Co.New York City	S. S. KresgeOil City
District of Columbia Star Radio Co.Washington	H. Jappe Co.Boston	Blan. the Radio Man.New York City	S. S. KresgePhiladelphia
Connecticut Hatry & YoungHartford	S. S. KresgeBoston	Coast to CoastNew York City	S. S. KresgePittston
S. S. KresgeNew Haven	S. S. KresgeMalden	H. L. Dails Co.New York City	S. S. KresgePottsville
S. S. KresgeNew London	S. S. KresgeQuincy	Federated Purchaser, Inc.New York City	S. S. KresgeReading
Illinois Allied Radio Corp.Chicago	S. S. KresgeSpringfield	Fl. Orange Radio Dist Corp.Albany	S. S. KresgeScranton
Chicago Radio ApparatusChicago	H. Jappe Co.Boston	S. S. KresgeDunkirk	Keystone Radio Co.Philadelphia
Electric & Radio Supply Co.Chicago	S. S. KresgeBoston	S. S. KresgeBuffalo	Radio Elec. Service Co.Philadelphia
Grant Radio Co.Chicago	S. S. KresgeGrand Rapids	S. S. KresgeOlean	Radio Service Co.Wilkes-Barre
Klaus Radio CompanyPeoria	S. S. KresgeHighland Park	S. S. KresgeRome	M. & H. Sporting Goods, Philadelphia
S. S. KresgeChicago	S. S. KresgeJackson	S. S. KresgeSchenectady	Rhode Island W. H. Edwards Radio Svc.Providence
S. S. KresgeChampaign	S. S. KresgeMuskegon	S. S. KresgeTroy	S. S. KresgePawtucket
S. S. KresgeSpringfield	S. S. KresgeSaginaw	KronsonBuffalo	South Dakota S. S. KresgeAberdeen
S. S. KresgePeoria	Rissi BrothersDetroit	Maurice Schwartz & SonSchenectady	Tennessee J. L. PerryNashville
S. S. KresgeFreeport	R. & M. Radio Co.Detroit	Radio CircularNew York City	Texas Service Parts Co. Inc.Abilene
S. S. KresgeBelleville	Radio Distributing Co.Detroit	Ray C. StageSyracuse	Southwest Radio Svc.Dallas
S. S. KresgeDanville	Radio SpecialtiesDetroit	Sun Radio Co.New York City	Straus-Frank Co.Houston
S. S. KresgeDecatur	Remo Radio StoresDetroit	West Side Y.M.C.A.New York City	Straus-Frank Co.San Antonio
Mid-West Radio MartChicago	Wedemeyer Radio Co.Ann Arbor	Wholesale Radio Service, New York City	Walter Tips Co.Austin
Newark Elect. Co.Chicago	Minnesota Lew Bonn Co.St. Paul	New Zealand To Aro Book DepotWellington	Wilkinson Bros.Dallas
Radiolek CompanyChicago	Radio Maintenance Co.Minneapolis	North Carolina Shaw'sCharlotte	Virginia Johnston-Gasser Co.Richmond
The Swords CompanyRockford	Southern Minn. Supply Co.Mankato	Ohio Aitken Radio Corp.Toledo	S. S. KresgeNorfolk
Indiana S. S. KresgeEvansville	Missouri Walter Ashe Radio Co.St. Louis	Bergman ToolCleveland	S. S. KresgeRichmond
S. S. KresgeFort Wayne	Burstein-Applebee Co.Kansas City	Burns Radio Co.Dayton	West Virginia Foster-Thornburg Hardware Co.Huntington
S. S. KresgeGary	S. S. KresgeKansas City	Goldhamer, Inc.Cleveland	S. S. KresgeCharleston
S. S. KresgeKokomo	S. S. KresgeHannibal	Hughes-Peters Elec. Corp.Columbus	S. S. KresgeWheeling
S. S. KresgeLafayette	S. S. KresgeJoplin	Kladar Radio LabsKent	Washington General Radio, Inc.Seattle
S. S. KresgeSouth Bend	S. S. KresgeSt. Louis	S. S. KresgeAkron	Spokane Radio Co.Spokane
S. S. KresgeTerre Haute	S. S. KresgeUniversity City	S. S. KresgeCincinnati	Wedel CompanySeattle
S. S. KresgeVincennes	Van Ashe Radio Co.St. Louis	S. S. KresgeNewark	Wisconsin Harriman Radio Svc.Appleton
Kruse Radio Co.Indianapolis	Nebraska S. S. KresgeLincoln	S. S. KresgeToledo	S. S. KresgeMilwaukee
State Radio Co.Indianapolis	S. S. KresgeLincoln	S. S. KresgeSandusky	Radio Parts Co.Milwaukee
Iowa S. S. KresgeDavenport	S. S. KresgeOmaha	S. S. KresgeZanesville	W. A. Roosevelt Co.La Crosse
S. S. KresgeSioux City	Sidles-Duda-Myers Co.Grand Island	LeW StoresToledo	
S. S. KresgeWaterloo	Sidles-Duda-Myers Co.Hastings	Progress Elec. Co.Cleveland	
Sidles-Duda-Myers Co.Des Moines	Sidles-Duda-Myers Co.Lincoln	Radio Servicemen's Supply Co.Cleveland	
Sidles-Duda-Myers Co.Atlantic	Sidles-Duda-Myers Co.Norfolk	Ross Radio Co.Youngstown	
		Steinberg'sCincinnati	
		United Radio, Inc.Cincinnati	
		Uncle Sam StoresAkron	

Note:—All S. S. Kresge Stores are Green Front

If there is no dealer near you, order direct from us

Radio Treatise Co., Inc.

1440 Broadway

New York City

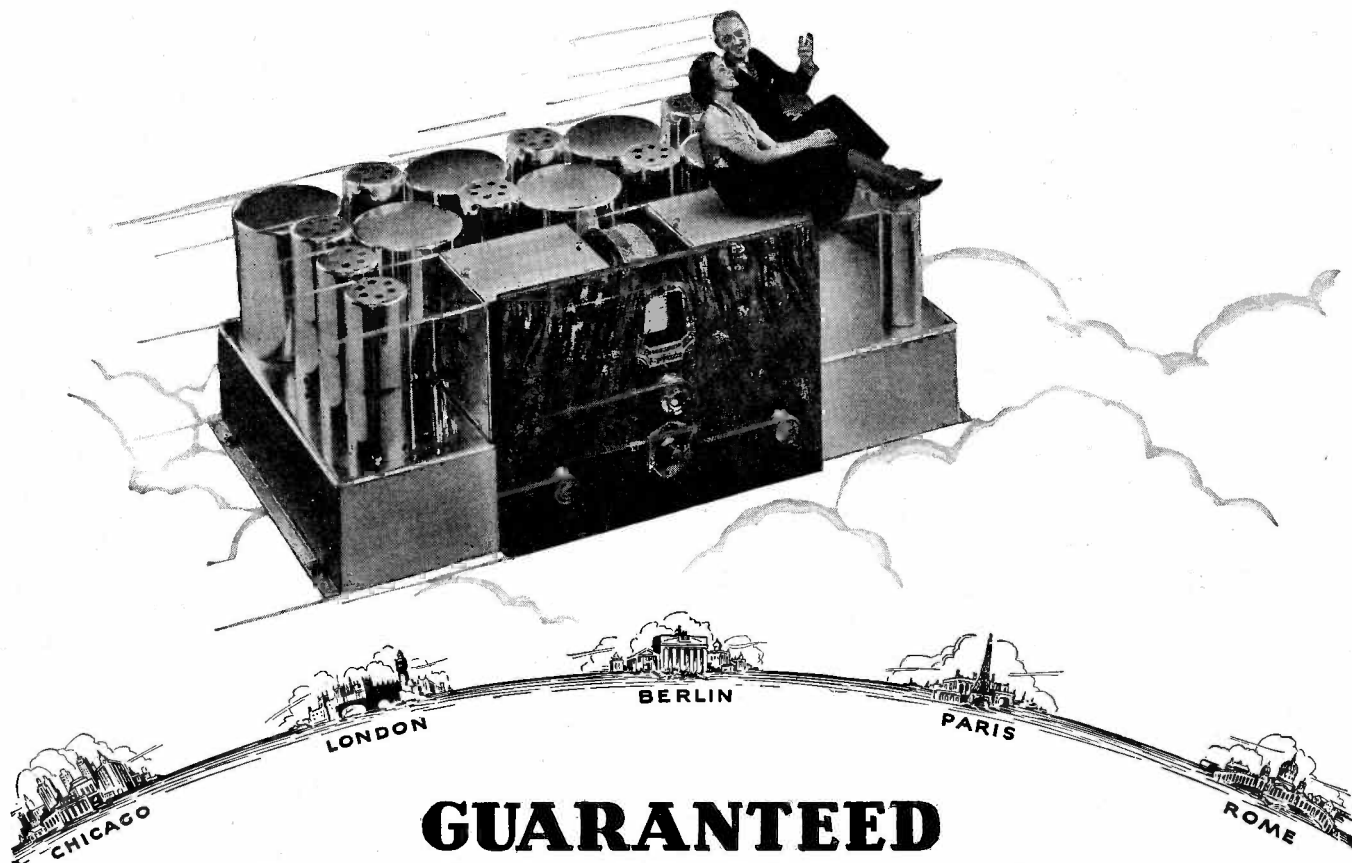

GUARANTEED 'Round-the-World Reception For the First Time in Radio History

JUST turn a switch—and—z-i-p! we're off on a world tour via radio. Because it's a new SCOTT ALLWAVE DELUXE there'll be no fussing and fumbling about—only one dial to tune, no coils to plug in, no trimmers to adjust carefully. Just use the convenient log furnished with the set and the foreign station you want—maybe 10,000 miles or more away—comes in on the dot.

Let's Start to Merrie England!

Let's try G5SW, Chelmsford, England. Get it any day between 3:00 and 6:00 P.M. Hear peppy dance music from the Hotel Mayfair in London (Yes, those Britishers furnish music that's as "hot" as any orchestra in the States!). Then, too, there are world news broadcasts that tell listeners all over the far-flung British Empire the news of the day in the homeland. At 6:00 P.M. (Midnight London time) it's thrilling to hear "Big Ben," in the House of Parliament, strike the hour of midnight in a sonorous voice.

Foreign Reception Every Day in the Year

Tired of the English program, eh? Like something French? That's easy—let's go to gay Páree.

Here's Radio Colonial, Paris, France, and it is on the air for the SCOTT ALLWAVE DELUXE any day between 3:00 and 6:00 P.M. Hear those dulcet tones of a spirited Mademoiselle! What, you can't understand French? Never mind, here's an orchestra and a song. Music is a universal language. This is Monday—that's lucky, for there'll be an hour's talk in English today about the encampment of the Veterans of Foreign Wars to be held in Paris in 1935.

10,000-Mile Distant Stations Guaranteed

Unusual to get such reception? Not at all for this receiver. This new SCOTT ALLWAVE DELUXE is guaranteed to bring it in like that—yes, absolutely guaranteed to bring in foreign stations 10,000 miles or more away, every day of every week in the year, with loud speaker volume.

How can they make such a guarantee? Well, chiefly because the SCOTT ALLWAVE DELUXE is a custom-made receiver. It is built with as much care and

precision as a fine watch. There's skilled designing and engineering behind it too—as well as parts good enough to carry a five-year guarantee against failure.

Most Perfect Tone Quality in Radio

Want to hear some more? Sure! Where do you want to go? Germany? All right. Here's Zeesen. It can be SCOTT-ed any morning between 9:30 and 11:00. From it you will hear about the grandest symphony concerts put on the air any place. You'll be glad your SCOTT ALLWAVE DELUXE has such exquisite tone. And it is exquisite tone! So perfect that, in a studio test, observers were unable to distinguish between the actual playing of a pianist and the SCOTT reproduction of a piano solo from a broadcasting station when the set and the pianist were concealed behind a curtain.



Tired of Germany? Then let's jump to Spain on our "Magic Carpet." Here's EAQ, Madrid. Hear the castanets and guitars? Always typically Spanish music from this station between 7:00 and 9:00 P.M. You'll enjoy EAQ doubly because they thoughtfully make their announcements in both English and their native tongue.

Opera Direct from the Eternal City

Want a quick trip farther south? Here's Rome—1ZRO. The lady announcer's voice is saying, "Radio Roma, Napoli." From here, between 3:00 and 6:00 P.M. daily, you'll hear grand opera with its most gorgeous voices and with the finest accompaniments.

So you want to hear what's doing on the other side of the world now? That's easy, let's get up early and pick up VK2ME, from Sydney, Australia, any Sunday morning between 5:00 and 8:30 A.M., or VK3ME, Melbourne, any Wednesday or Saturday morning, between 4:00 and 6:30 A.M. Hear the call of the famous bird of the Antipodes—the Kookaburra. There'll be

an interesting and varied program, music, and always a talk on the scenic or industrial attraction of the country.

Australian Stations Sound Close as Home

Can I get Australia easily? Why, of course you can! In a test didn't one SCOTT ALLWAVE pick up every regular program from VK2ME in Chicago, 9,500 miles away, over a whole year's time? Quite a record? You bet! And what's more, the programs received were recorded on phonograph records, and one was even played back to Australia over long distance telephone, and they heard it clear as a bell! That's performance!

These are but a few of the more than 200 foreign stations that may be heard by SCOTT owners.

Tired of foreign travel? Well, let's jog about the STATES—or Canada or Mexico—on the regular broadcast frequencies. Wonderful! You bet! There was never finer reception. Or you can eavesdrop on police calls, international phone transmission, gabbing amateur wireless telephony fans. Your fun with a SCOTT ALLWAVE DELUXE is unlimited.

New Values! Prices Lowest Ever!

Too expensive for you? Not at all! A SCOTT ALLWAVE DELUXE won't cost you more than any good model of an ordinary receiver. And it gives so much more in pleasure and satisfaction!

You'd like to know more about it—the technical details, and proofs of those wonderful performances? Easy! Just tear out the coupon below, fill in your name and address, and mail it TODAY.

THE E. H. SCOTT RADIO LABORATORIES, INC.
4450 Ravenswood Ave., Dept. S 102, Chicago, Ill.

Tell me how I can have a SCOTT ALLWAVE DELUXE for a "Magic Carpet" of my own, and send me complete technical details, proofs of performance, and complete information.

Name.....
Address.....
City..... State.....

SERVICE

A Monthly Digest of Radio and Allied Maintenance

OCTOBER, 1932
Vol. 1, No. 9

EDITOR
John F. Rider

MANAGING EDITOR
M. L. Muhleman

Editorial Contents

FEATURES

- Resistor Values Under Test,
By John F. Rider..... 265
Biography: John W. Million..... 266

ANTENNA (Servicing is a Profession)..... 262

AUTO-RADIO

- Chevrolet 1930-31-32 Ignition Systems..... 278
Engines Mounted Upon Rubber..... 278
Gulbranson 062 Series Super..... 277
Low-Tension Wires..... 278
Studebaker 1931 and 1932..... 278

FORUM (The Reader's Page)..... 290

GENERAL DATA

- All-American "B" Eliminators..... 269
Atwater-Kent 90..... 269
Atwater-Kent 82-Q Battery Set..... 273
Delco Appliance 2-Volt Receiver..... 276
Delco 32-Volt D-C. Chassis..... 270
Distortion in 2-Volt Receivers..... 269
Dual-Speaker Installations..... 274
Electrolytic Condensers and Resistance Measure-
ment..... 268
Grigsby-Grunow 210..... 268
I-F. in Atwater-Kent 91 Series..... 269
Kolster-Columbia 940..... 269
Majestic Model 290..... 275
Musette Model 310..... 271
Phasing Voice Coils..... 274
Philco Model 80..... 267
Philco 095 Oscillator for 450 kc..... 271
R-F. Distribution Systems..... 276
Silvertone 1620 and 1622..... 274
Silvertone Model 1640..... 279

- Sparton 14..... 272
Sparton 18..... 276
Sparton 14 and 18 Trimmers..... 272
Speakers in Philco 90..... 268
Stewart-Warner Models R-104-A, B and E..... 272
Stromberg-Carlson 38, 39, 40 and 41..... 276
U. S. Radio & Television 10 Series 1000 Chassis... 269
Volume Controls..... 276

HIGHLIGHTS..... 288

INDEX OF MONTHLY LITERATURE..... 294

MANUFACTURERS

- Acratest Power Amplifiers..... 292
Electrad "T" Pad Attenuator..... 292
Franklin Tube Checkers..... 292
I.R.C. 2-Watt Resistor Kit..... 292
Janette Electric Plants for Sound Trucks..... 292
Ohmite 20-Watt "Red Devils"..... 292

ON THE JOB

- Curing Noisy Volume Controls,
By Ralph W. Cutts..... 288
Point-To-Point Resistance Chart,
By Chas. V. Averill..... 286
Profitable Hints, By E. M. Prentke..... 288
Tube and Service Profit From Rural Homes,
By Jack S. Stanton..... 286

PUBLIC ADDRESS

- Acoustic Power Determination..... 282
Loudspeaker Installations..... 282

SHORT WAVES

- Shielding..... 280
Silvertone Model 1640..... 279

Advertising Director

ROBERT N. MANN
1440 Broadway, N. Y. City
Telephone: CHickering 4-4542

Published monthly by

John F. Rider Publications, Inc.
1440 BROADWAY
NEW YORK, N. Y.

Officers

JOHN F. RIDER,
President and Treasurer
M. L. MUHLEMAN,
Vice-President
J. SCHNEIDER,
Secretary

Entered as second-class matter June 14, 1932, at the Post Office at New York, N. Y., under the Act of March 3, 1879. Copyright, 1932 by John F. Rider Publications, Inc. Contents must not be reproduced without permission. Subscription price \$1.00 per year in the United States of America; 15 cents per copy. \$2.00 per year in Canada and foreign countries; 25 cents per copy.



INDICATING METERS

Laboratory Accuracy—Rugged Construction

COMPLETE LINE OF

A. C., D. C., THERMOCOUPLE, DYNAMOMETER AND RECTIFIER TYPE INSTRUMENTS IN PORTABLE, FLUSH MOUNTING AND SURFACE TYPE—FOR ALL REQUIREMENTS.

MICROAMMETERS — MILLIAMMETERS — AMMETERS — VOLTMETERS — OHM-METERS — VOLT-OHMMETERS — CAPACITY METERS — WATTMETERS.

ACCURATE — RUGGED

Embodying the most advanced principles in instrument engineering. Cases are of molded BAKELITE, combining handsome appearance with mechanical strength.

Available in case body diameters of 2 $\frac{3}{4}$ "", 3 $\frac{1}{2}$ "", 4 $\frac{5}{8}$ "", 6" and 8 $\frac{1}{2}$ "".

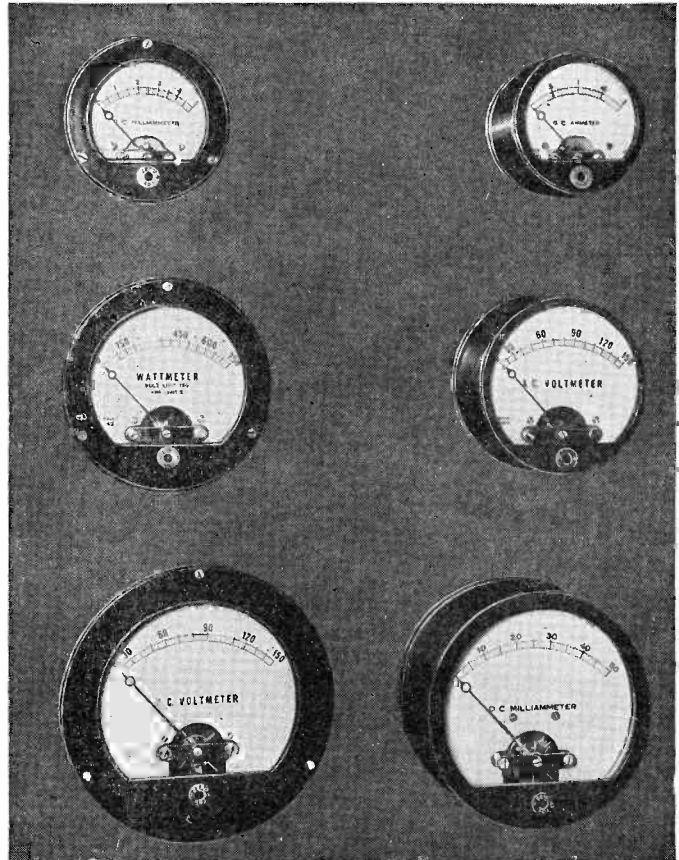

Flush Type

Surface Type

Mechanisms for All Applications Available

DIRECT CURRENT—D'Arsonval movement. Voltmeters have standard resistance of approximately 100 ohms per volt; high-resistance types 1,333 ohms per volt—(full-scale sensitivity, $\frac{3}{4}$ milliampere).

A. C. DYNAMOMETER—This movement is available in all sizes as Ammeters, Voltmeters and Wattmeters, and has many advantages over ordinary iron vane type, and is correct on all commercial frequencies up to 5,000 cycles. The Model 47 A. C. Dynamometer is the smallest type instrument made with this movement.

A. C. MAGNETIC VANE—Represents a new development in this type of instrument. Very accurate, with almost D. C. scale characteristics.

RECTIFIER TYPES—Full-wave rectifiers, capable of carrying 100% overload without injury, are used in the Rectifier, or "X" series. Accuracy 5%.

THERMOCOUPLE TYPES—Vacuum-type Thermo Couples are employed in Milliammeters up to 100 M.A.; above that range air-cooled types are used. Large overload capacity. Accuracy 2%.

ALL MODELS DAMPED APPROXIMATELY 95%, AND ARE DESIGNED TO WITHSTAND LARGE OVERLOADS WITHOUT INJURY TO MOVEMENT OR POINTER.

(Send for Free Catalog No. 20)

THE HICKOK ELECTRICAL INSTRUMENT CO.

10514 DUPONT AVENUE

CLEVELAND, OHIO

Manufacturers of the Statiktester and Other Radio Set and Tube Testing Equipment

BRANCH OFFICES

27 Park Place.....New York City
25 Huntington Avenue.....Boston, Mass.
726 Genesee Building.....Buffalo, N. Y.
572 Macabees Building.....Detroit, Mich.
9 S. Clinton Street.....Chicago, Ill.

2121 N. Alabama Street.....Indianapolis, Ind.
2627 Hale Avenue.....Louisville, Ky.
Red Rock Building.....Atlanta, Ga.
707 Cleveland Street.....Tampa, Fla.
Riggs Bank Building....Washington, D. C.

1408 S. Harwood Street.....Dallas, Tex.
4245 Tracy Avenue.....Kansas City, Mo.
426 Larkin Street.....San Francisco, Cal.
415 Canada Cement Bldg.Montreal, Can.
Clark Building.....Pittsburgh, Penna.

For 20 years manufacturers of the best in electrical indicating meters.

THE ANTENNA...

SERVICING IS A PROFESSION

THE public-address field has had its ups and downs. Today it represents a market with tremendous possibilities. The economic condition of the nation has been responsible for a certain amount of stagnation during the last two years, but the future holds great promise. From where we sit, we can see a tremendous advantage open to the public-address industry if they will but pay more attention to their service facilities.

There was a time—particularly during the early era of the talking movie—when public-address amplifier manufacturers did not have to seek business, or pay a great deal of attention to their equipment once it was sold. Those days are gone, principally because the aspect of the field has changed considerably, and because keen competition has sprung up.

The public-address amplifier manufacturer who cannot see his way clear to giving good service, and guaranteeing service when his equipment is sold, will lose out to those manufacturers who will make the proper national service connections which will permit prompt and efficient service facilities. Such facilities are lacking today yet there are dozens of *trained* Service Men in every community who could handle with ease and promptness any breakdowns in public-address equipment in their vicinity.

To the manufacturers of public-address equipment we say, "Make contacts with Service Men so that you may hereafter guarantee 'factory service' to a customer in *any territory* at the time you attempt to sell him your equipment."

To the Service Man we say, "Communicate with the manufacturers of public-address equipment *now*, and offer your services as a 'factory representative' in your community."

Public-address amplifier manufacturers have been shortsighted in this direction. Salesmen who have been making their livelihoods by selling P-A. units have time and again commented upon the number of sales which have been lost to competitive organizations merely because their own organizations were not in a position to offer to the customer the protection of service facilities.

Public-address manufacturers will find a large number of men in the servicing field who are capable of offering advice to people in their locality relative to public-address installations, and capable of servicing the equipment. Having such men spread over the United States would be a great aid in the form of local representation.

• • •

IT has been said that radio receiver manufacturers instead of making it easy for Service Men are making it more and more difficult to service receivers. That's the bunk. All manufacturers; those who make sets and those who produce parts, have recognized the need for service activity and are doing all that they can to help the radio Service Man. Witness the general publication of electrical values on practically every wiring diagram which is released. There may be one or two manufacturers who are averse to the publication of electrical values on certain grounds. In the near future there will be none. All diagrams will bear all values.

The statement has been made that the construction of the modern chassis makes service work very difficult; that is, the mechanical construction. Perhaps it is true that it is difficult to reach a socket, a pilot light or a resistor.

But, let's look at it from the other direction. The greater the number of sets being sold, the greater the possibility of service and the greater the number of service calls per man; not because the sets are bad, but because there are more of them. Quantity sales depend upon quantity production. To secure quantity production, all units must be placed in such fashion as to expedite wiring of the circuits.

There are more items to the design of a radio receiver than mere accessibility after the chassis is pulled. Of course, the latter counts, but let's be sensible about this thing. Modern receivers are sensitive—sufficiently so that leads and units must be in a certain position in order that the receiver be stable in New York, Chicago, or wherever it may be used. If these units were placed somewhere else, long leads would be required, which no doubt would cause trouble and call for extra shielding. Such an electrical misplacement of units might also call for double wiring. It is evident, then, that should a manufacturer change the positions of a few units, in order to make them accessible, he would destroy the electrical simplicity and at the same time defeat the very purpose for which the units were moved, by having to meet the demand of a more complicated wiring scheme, plus extra shielding.

By designing receivers so that they may be turned out on a production basis, the price can be kept low, and with lower prices greater sales are achieved. *And greater sales mean greater income to the service industry.*

The very fact that the units in a receiver may be difficult to get at keeps the tinkerers and the set owners, who think they know something about radio, from attempting to play around, and *that* helps the radio service industry. There are about 16,500,000 receivers in use. If 20,000 of these were being "serviced" by their owners, and each receiver "fixed" once a year, it would mean a loss on the average of \$40,000 a year to the service industry.

We are wholeheartedly against any movement which would simplify the mechanical and electrical construction of radio receivers to that point where "the boy next door" would be able to service it. Obviously, this is quite impossible, but there appears to be behind this movement a desire to make servicing so easy that the unexperienced, and those who are too lazy to educate themselves, will be able to break in on the profession.

There are too many inexperienced and irresponsible men in the servicing field at present. It is our hope that manufacturers make their receivers so technical and so difficult to "tinker with" that these men will be forced to make a livelihood elsewhere, or buckle down and learn the technicalities of the profession and become responsible. Radio servicing is a profession, not a trade.

John F. Rider.



NATIONAL UNION

pours out modern equipment
to help the SERVICE MAN!

- 1.** Volume I. Valuable Service Manual by John F. Rider, famous radio scientist, lecturer, and author. Contains over 2,000 diagrams on voltage, electrical values, color coding, etc. Free with small purchase of tubes.
- 2.** Volume II. Also by John F. Rider. Takes up where Volume I leaves off. Over 700 pages of valuable data. Point-to-point resistance data given, enabling operation of piece No. 5, the continuity, capacity, and resistance tester. Free with small tube purchase.
- 3.** Oscillator and Output Meter. Only way to really service super-hets properly! Absolute necessity for up-to-date servicing. Yours free with small purchase of tubes and small deposit.
- 4.** Readrite Tube Tester. Voltage tester! Compact, easily carried. Illuminated dial permits reading in even darkest corners! Free with small deposit and purchase of tubes.
- 5.** Readrite Resistance Tester. The new resistance tester. No more chassis pulling! With the new Readrite Tester you can make every test—continuity, capacity, and resistance . . . without taking the set apart! Operates easily, efficiently. And that means you can service more sets better and quicker than ever. Yours free with small purchase of National Union Tubes and small deposit.
- 6.** Latest method of Servicing. Sensational Unameter. Now offered to service men for the first time! Very easy to operate. Turn the selector, then place tube in the socket, and watch the reading on the meter in English. It is a compact, easily carried, sturdy meter. An aluminum chassis, with all panels made of bakelite. And attractively finished in gold, red and black. This Unameter is one of the finest pieces of equipment ever offered. It is yours free with a moderate purchase of tubes and a small deposit.



Join the thousands who have already profited by tying up with **NATIONAL UNION**—the one tube manufacturer that really understands the Service Man's problem.

NATIONAL UNION is doing a real job to help the service man help himself. This year National Union is literally giving away more free equipment than any other tube manufacturer.

Just look at the equipment in this advertisement! Read how you can get any one or all of these valuable pieces . . . and then ask yourself, "What company is doing more to help the service man?"

Of course, these offers are very costly to us. But we honestly believe that, by helping the service man solve his problems, we in our turn will be rewarded.

You'd be amazed to see the thousands of coupons sent in the few months we have been making these offers. But what would really interest *you* are the hundreds and hundreds of letters we have received from dealers and service men everywhere, telling us just how much National Union has meant to them . . . how National Union has helped boost their sales and helped make real profits.

Act quickly! Act now! We know you want to own this equipment yourself. So mail the coupon below . . . today.

FREE! Tube Base Layout Chart compiled by John F. Rider. No obligation. Write for one!

ASK YOUR JOBBER'S SALESMEN



NATIONAL UNION RADIO CORPORATION
400 MADISON AVENUE · NEW YORK CITY

Dear Sirs: I am checking the equipment in which I am interested:

READRITE TUBE TESTER <input type="checkbox"/>	OSCILLATOR AND OUTPUT METER <input type="checkbox"/>	NAME _____
VOL. I <input type="checkbox"/>	RESISTANCE TESTER <input type="checkbox"/>	ADDRESS _____
VOL. II <input type="checkbox"/>	UNAMETER <input type="checkbox"/>	CITY _____ STATE _____

CHECK these Important Points when you consider RESISTORS:

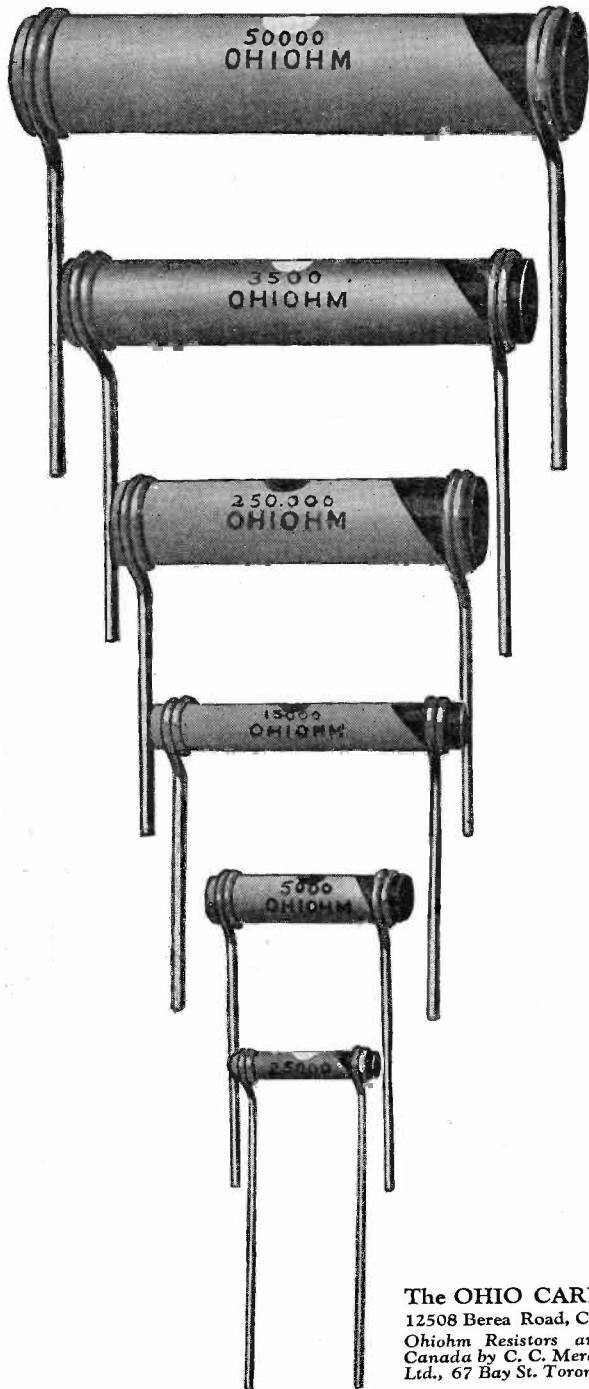

The OHIO CARBON Co.
12508 Berea Road, Cleveland, O.
Ohiohm Resistors are made in
Canada by C. C. Meredith & Co.,
Ltd., 67 Bay St. Toronto

1. **Accuracy** Resistance value within 10% tolerance, the accepted commercial limits. Ohiohms are *guaranteed* to be within this range.
2. **Permanency** Resistance value unchanged by age. The resistance of Ohiohms remains unchanged over an unusually long period of time, whether in use or in stock.
3. **Absence of Noise** Quiet regardless of position in circuit. Many static noises are due to faulty resistors. Ohiohms are noiseless always.
4. **Low Heat Coefficient** Resistance value unaffected despite heating up in service. Ohiohms have an extremely low heat coefficient.
5. **Freedom from Capacity Effect** Resistors should not build up capacity (similar in manner to a condenser) as this often throws the set out of balance. Ohiohms are completely free from capacity effect.
6. **Unaffected by Humidity** In some sections of the country humidity has the effect of altering resistance values in resistors. Ohiohms withstand humidity effects admirably well.
7. **Low Voltage Coefficient** Fluctuations in voltage may vary the resistance of some resistors. Ohiohms, however, have such a low voltage coefficient that the change is practically negligible.
8. **Mechanical Strength** The ability to withstand rough handling. Excessive vibration, dropping resistors or abuse in transit result in some resistors being damaged to the point where they are unfit for service. Some still weaker resistors disintegrate simply with age. Ohiohms can be dropped on the floor or similarly abused without effect.
9. **Appearance** While beauty with resistors, like humans, is only skin deep, nevertheless such factors as straight wire-leads, paint-finish devoid of pores, and other points of appearance are also important from a service and durability viewpoint. Ohiohms challenge comparison for good appearance.
10. **Color Coded, Printed Values and Trade-Marked** Painted according to R. M. A. standards, stamped with the actual resistance value on the piece and trade-marked with the brand name — all are your protection against questionable resistors.

Write For Folder — "SALES RESISTANCE REMOVED FROM THE RESISTOR MARKET"

OHIOHM
RESISTORS



Resistor Values Under Test

By JOHN F. RIDER

WHEN is 50,000 ohms not 50,000 ohms? That may sound foolish, but it is a fact. It is possible in the case of a resistor which indicates a certain value during the measurement and is a different value when it is placed into operation. This problem has been mentioned as one which influences the application of an ohmmeter to metallized and carbon resistors to determine if the unit being tested is fit or unfit for use.

There are certain factors which influence the interpretation of the measured d-c. resistance of a resistor. These are:

1. The accuracy of the testing instrument.
2. The accuracy with which the value indicated upon the test instrument is read by the operator.
3. The accuracy of the ohmic value rating of the resistor as quoted in the table, wiring diagram, etc.
4. The tolerance rating employed by the manufacturer of the unit with respect to any one basic value of resistance.
5. The voltage co-efficient of the resistor.
6. The temperature co-efficient of the resistor.
7. The possibility that the resistance rating as quoted by the receiver manufacturer in his service bulletin or upon the diagram is that representing the conditions under which it is used rather than the value of the unit under test.

Each of these factors will in one way or another influence the judgment of the Service Man when he tests a resistor and measures its ohmic value. We know that commercial ohmmeters are guaranteed to an accuracy of about 2 percent. This does not mean that the instrument may be off 2 percent at all points. It may be more accurate at one point than at another, but the maximum deviation from absolute accuracy is about 2 percent. Since this is a common failing, we might just as well forget about it and use common sense during those times when we discover that the unit being tested is beyond the tolerance limit by the said 2 percent. There is no doubt about the fact that you pay attention to the indication shown upon the meter and that you try to read it as closely as possible, so that while you cannot read to absolute accuracy upon the ordinary form of ohmmeter, you read sufficiently close to make unnecessary the addition of another tolerance figure.

With respect to the third item, we hope that the units are rated accurately. All of us recognize that if a resistor in the plate circuit of a tube is 49,654 ohms, that the resistor will be designated as 50,000 ohms. At the same time, we take for granted that if a resistor is rated at 50,000 ohms, another resistor of identical value will function in normal fashion as a replacement unit.

As to the fourth item, we again must use common sense and recognize that an extremely high order of precision is not required in certain places in a receiver and that all resistors which are within certain limits of the basic value are acceptable. This tolerance limit may be plus or minus from 5 to 10 percent and in a few cases even higher than 10 percent. There are to be found cases where the tolerance is only 5 percent minus and about 10 percent plus. All of this is recognized in the interpretation of the measured

value of resistance; consequently a unit rated at 50,000 ohms is passed as being satisfactory for use when the measured value, assuming correct measuring conditions, is 45,000 ohms or even slightly lower. Naturally the same tolerance applies in the other direction.

VOLTAGE CO-EFFICIENT

The fifth item presents the fly in the ointment, at least it did some years ago, but does no more, and it might be well to elucidate upon this point so as to remove the halo of mystery which surrounds the application of test voltages and the supposedly devastating variations caused when measuring the resistance of a resistor. Every resistor varies in resistance as the voltage across its terminals is changed. A resistor at the time of manufacture may be rated at 50,000 ohms with 200 volts applied across its terminals. If this voltage is changed, the ohmic value of that unit is changed. In the case of carbon and metallized resistors, it may go up and it may go down, depending upon whether the new voltage is greater or less than the voltage applied when the ohmic rating was decided upon. This characteristic is a function of the constituency of the resistor material. Thus, it is possible that 50,000 ohms at 200 volts will not be 50,000 ohms at 4.5 volts.

All of us who have used ohmmeters realize that, as a rule, the testing voltage applied to the majority of resistors measured in the field seldom runs higher than 45 volts. This statement is made in the face of the 200 or 250 volts available in certain ohmmeters, but these voltages are employed to measure resistors rated as high as 20 to 25 megohms and they are seldom found in practice. It is therefore of interest to the service field at large to know something about the tolerance which must be allowed to compensate for the difference in test voltages as employed by the manufacturer and the Service Man, or the difference between the voltage at which the resistor is used and has a certain ohmic rating and the test voltage employed by the Service Man.

In this respect, we can go only by information which is available from resistor manufacturers. The subject was presented to resistor manufacturers by the writer in the Editorial contained in the August issue of SERVICE. Word was received from Electrad, International Resistance, Ohio Carbon, Continental Carbon, Stackpole Resistor and Erie Resistor companies. Information gleaned from the resistors of metallized and carbon types indicates that such resistors may be measured at any value of voltage from about 4.5 to as high as 200 volts, and yet will not change in resistance more than 2 percent maximum, as a result of the voltage applied.

PERCENTAGE CHANGE IN RESISTANCE

If we now consider that resistors checked with modern ohmmeters are not overloaded and that the test voltages are comparatively low, the percentage change in resistance due to the application of the voltage seldom exceeds, if equals, 2 percent. As a matter of fact, considering the present

design of ohmmeters, wherein resistors as high as 500,000 ohms are checked at low values of voltage—around 4.5 volts—and are used at voltages which range from 5 to as high as 100 volts, the variation in resistance would be entirely negligible.

In this connection it is interesting to note that if the testing voltage employed by the Service Man is less than the value at which the resistor is used in the receiver or amplifier, the measured value will be higher than the actual value of resistance when that resistor is used in the receiver. If, on the other hand, the testing voltage is higher than the voltage at which the resistor will be used, the measured resistance will be lower than the actual resistance in the circuit when that unit is placed into operation.

The fundamental voltage co-efficient is expressed in percent change in resistance over a definite range of voltage change. Thus, one resistor rated at .5 watt and 300,000 ohms may have a basic voltage co-efficient of 3 percent for a voltage change of 350 volts. As stated, this figure is determined by the manufacturer of the resistor. Now, if this same resistor is used at 90 volts—which means that .3 milliampere is flowing through it—and it is checked at 4.5 volts, the voltage change between use and test is 85.5 volts. Then the actual co-efficient is

$\frac{85.5}{350} \times 3\% = .7329\%$ and the resistance at 90 volts will be

$$300,000 \times \left(1 - \frac{.7329}{100}\right) = 297,801 \text{ ohms}$$

thus indicating a decrease of about 2,200 ohms from the resistance value measured at the low voltage.

If you consider an exaggerated case, wherein a resistor rated at 1,000,000 ohms and .25 watt is rated basically at a 7 percent voltage co-efficient for a voltage change of 200 volts, and is used at 200 volts and measured at 1 volt, the maximum difference between the value during use and when measured will be less than 70,000 ohms, which condition will not be productive of trouble even if the resistor is okayed, because a resistance of 930,000 ohms instead of 1,000,000 ohms will seldom if ever create a deficient condition. An investigation of receivers shows that high values of resistance when bearing low wattage rating are used at low values of voltage so that the voltage change between use and test is very small. If high voltage is to be applied in practice, the wattage rating of the resistor likewise is high and the voltage co-efficient is low.

TESTING AND OPERATING VOLTAGES

With respect to the condition, when the test voltage is higher than the voltage at which the unit is used in the receiver, such conditions are very infrequent for the simple reason that when checking low values of resistance, low values of test voltage are employed. When checking fairly high values of resistance, the design of the ohmmeter limits the voltage across the resistor to a very low value. In the case of grid filter resistors, the test voltage may be higher than the actual d-c. voltage impressed across the unit in the receiver, but the test voltage seldom is greater, if not lower in practically all instances, than the original test voltage employed by the resistor manufacturer.

As to temperature co-efficient, very little change is encountered when resistors are checked unless the test is made immediately after the receiver has been in operation, in

which case the temperature of the air surrounding the chassis is higher than 20 degrees C., the basic temperature in all such rating operations. The temperature rise due to the load—the flow of the test current through the resistor—is negligible and this condition can safely be neglected.

In sum and substance, the maximum variation in resistance which will be found to exist due to the application of any reasonable test voltage without overloading the resistor will be about 2 percent as the maximum, hence it is not any greater than the possible error in the best of the commercial instruments sold to the service industry.

As to the seventh item, even if the resistor rating is on the basis of the voltage employed in the receiver, the voltage change is small and very little trouble will be experienced from that direction.

From all available information it appears as if the paramount item in connection with the measurement of the resistance of resistors is full and complete knowledge of the tolerance values employed in the selection of resistors for use in any one position of the receiver or amplifier system. There is no doubt but that as the resistance measurement method of service analysis increases in application, there will be general printing and knowledge of the tolerance values employed in receivers and amplifiers.

(See letter on resistance measurement in the "Forum").



The Man on the Cover

John W. Million

Chief Engineer, Audiola Radio Co.

HE graduated from the University of Michigan in June of 1920, and walked out into the world seeking experience. And an odd experience came his way—that is, odd when one thinks of radio—for he "cut his teeth" as Research Engineer for the L. D. Caulk Company, makers of dental amalgams!

Following this unique experience, Mr. Million became Instructor in Mathematics and Physics, at Des Moines University, and during the early months of 1922 he ran a small business of his own, as well as acting as Radio Editor for the *Des Moines Register*.

In September of 1922 he became Research Assistant to the well-known Dr. Arthur H. Compton, at that time head of the Physics Department at Washington University. During that period they verified Dr. Compton's previous experimental results on the Compton effect for which he later shared the Nobel prize.

From 1923 until early 1926, Mr. Million was research engineer at the Bell Telephone Laboratories, first on vacuum tubes, then in circuit development work. His work at that time was mainly on superheterodyne receivers and field strength measuring equipment.

In January, 1926, he became Chief Engineer of the King Hinners Radio Company, later becoming Chief Engineer of the King Manufacturing Corporation as well.

And then in the Fall of 1928, Mr. Million took the office of Chief Engineer of Bremer-Tully, radio manufacturing and design division of the Brunswick-Balke-Collender Company. He then skipped over to the Utah Radio Products Company, as Research Engineer, and in October, 1930, became Chief Engineer of Audiola Radio Company, which position he now holds.

General Data . . .

Philco Model 80

The Philco Radio Model 80 is a four tube superheterodyne, employing a type 36 tube as oscillator and mixer, a type 36 as second detector, and a type 42 pentode as power amplifier. The rectifier is an '80. The intermediate frequency for tuning the i-f. transformer is 450 kc. The power consumption is 46 watts.

SERVICING DATA

Facing the back of the chassis, the compensating condenser at the right with the micarta hex head nut should be adjusted for maximum sensitivity at the time of installation. This adjustment should be done in the following manner.

Place the set in operation and tune to a station near the middle of the dial. Turn the adjusting screw clockwise with a screwdriver until a swishing noise is heard and until a squeal is heard when different stations are tuned in. Now turn the screw counter-clockwise until the swishing sound just ceases. Continue to turn in the same direction about one-quarter revolution beyond this point. Now tune to different stations over the dial to make sure that squeals are not present on any stations received. If such a noise is present at any section of the dial, the adjusting screw should be turned further in a counter-clockwise direction until the noise vanishes. Should the type 36 tube under the metal shield be replaced, this adjustment should be repeated.

Under normal conditions, it will never be necessary to re-adjust any of the other compensating condensers.

The schematic diagram of the Model 80 receiver is shown in Fig. 1 and an under view of the chassis layout is shown in Fig. 2. The necessary resistance data for carrying out a point-to-point resistance test, and voltage data, are given in accompanying tables.

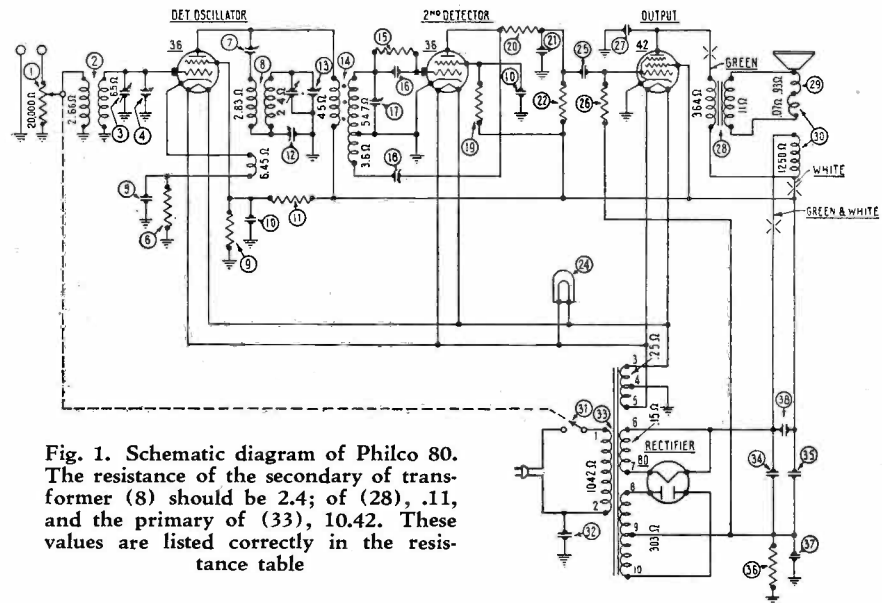

Fig. 1. Schematic diagram of Philco 80. The resistance of the secondary of transformer (8) should be 2.4; of (28), .11, and the primary of (33), 10.42. These values are listed correctly in the resistance table

PHILCO 80 VOLTAGE DATA

Tube	Fil.	Plate	Screen	Grid	Cathode
Det.-Osc.	6.3	245	165	6.4	8.4
2nd Det.	6.3	40	15	.4	0
Output	6.3	240	255	4.0	0
Rectifier	5.0	340 on each anode			

Readings based on a line voltage of 115. Readings should be taken from underside of chassis with test prods. Volume control at max. and station selector turned to low-frequency end.

Fig. 2. Under-view of the sub-base. The numbers correspond to those given in the accompanying tables. The locations of a few of the units have been changed in later production runs. See text for details

PHILCO 80 RESISTOR DATA

Number	Resistance	Power
(36)	325	..
(9)	9,000	1.0
(6) (20)	10,000	0.5
(11)	16,000	5.0
(22)	240,000	0.5
(26)	490,000	0.5
(19)	1,000,000	0.5
(15)	4,000,000	0.5

PHILCO 80 CONDENSER DATA

Number	Capacity
(5)	710 mmfd.
(10) (twin)	.09 mfd.
(16)	50 mmfd.
(20)	1,000 mmfd.
(25)	.015 mfd.
(27)	.006 mfd.
(32) (38)	.01 mfd.
(34) Elect.	8.0 mfd.
(35) Elect.	4.0 mfd.
(37) Dry elect.	10.0 mfd.

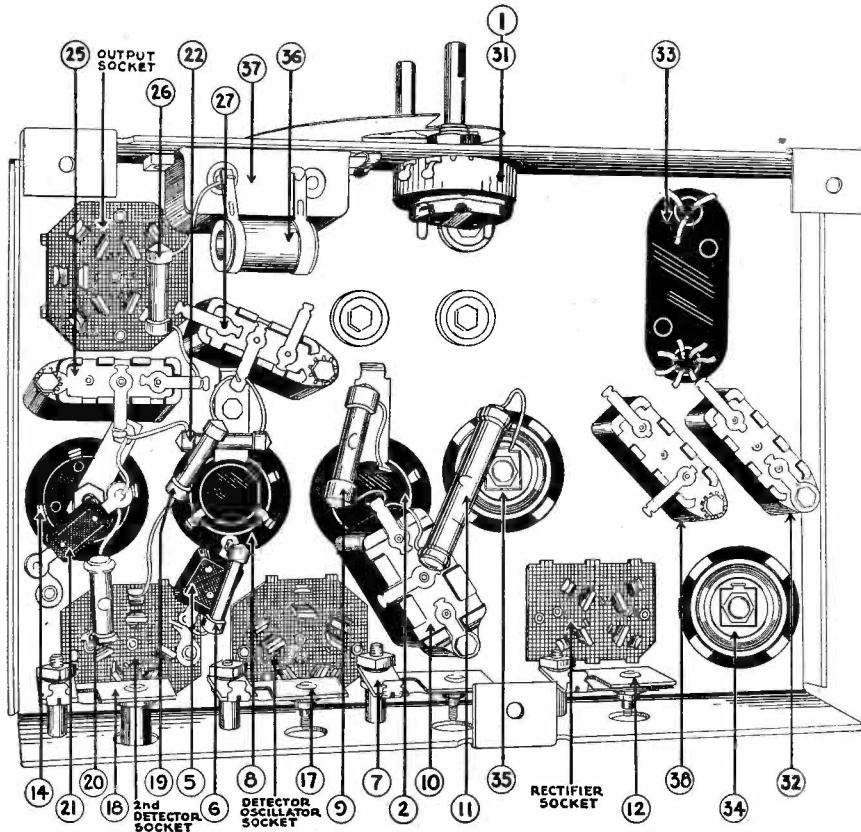

GENERAL DATA—continued

PHILCO 80 RESISTANCE DATA

The measurements below should be made with all tubes removed from their sockets and the speaker disconnected. Unless otherwise clearly indicated, all resistance values are measured between chassis and point stated.

Reference Points	Value in Ohms	Reference Points	Value in Ohms
Aerial to ground (V. C. Min.)	20,000	Amp. control grid	490,325
Aerial to ground (V. V. Max.)	2.66	Amp. cathode	0
Det. Osc. control grid	6.5	Amp. screen	25,000
Det. Osc. cathode	10,006.5	Amp. suppressor	0
Det. Osc. screen	9,000	Amp. plate	25,364
Det. Osc. plate	25,045	Amp. plate to screen	364
Det. Osc. plate to screen	45	Rect. plate to plate	303
2 Det. control grid	4,000,054.7	Rect. each plate	476.5
2 Det. c. grid coil only	54.7	Rect. filament	26,250
2 Det. cathode	0	Across speaker field	1250
2 Det. screen	1,025,000	Across speaker voice and bucking coils	1
2 Det. plate	275,000	Across sec. output trans.	.11
2 Det. plate to screen	1,250,000	Across a-c. plug	10.42
2 Det. plate and grid coil	58.3		

PRODUCTION CHANGES

A number of circuit changes were made on chassis of run No. 5 and above. This run number is rubber-stamped in a star on the back of the chassis. Referring to Figs. 1 and 2, the condenser (27) connects to the B—end of the resistor (26) instead of to ground. The bucking coil—that section of (30) in series with the voice coil—is shorted out. The 10-mfd. dry electrolytic condenser (37) is eliminated, and replaced with a substitute .015-mfd. section combined with (32), part 3793R. The .01-mfd. condenser (38) is eliminated. The positions of (19), (26) and (36) are changed in the chassis from that shown in Fig. 2.

Electrolytic Condensers and Resistance Measurement

It has been said that the presence of an electrolytic condenser in shunt with a fixed resistor, such as a voltage-divider unit or a grid-bias unit, interferes with the measurement of that resistor to determine whether or not it is fit for further use. The contention is that the comparatively low leakage resistance of the electrolytic unit in shunt with the resistor, will very greatly reduce the total d-c. resistance of the shunt combination, thus preventing a test of that circuit and be productive of a misleading reading.

The following figures show a test made in the laboratory of SERVICE. These tests were made with about 50 electrolytic condensers of different manufacture, with capacity values of from 4 mfd. to 50 mfd., and with peak voltage ratings of from 25 to 500 volts. Only good condensers were used, in view of the fact that defective condensers do not enter into the discussion. The resistance values utilized in the tests ranged from 200 ohms to 50,000 ohms. Higher values were not included, because they seldom are associated with condensers within the range quoted. Higher values of resistance and fractional microfarad condensers will be tested this month and reported in the November issue of SERVICE.

The following figures quote the value of the resistor when used alone and the value of the resistor when shunted by condensers

of the capacity and voltage ratings quoted. Recognizing the characteristic of such condensers, about 3 to 5 seconds were allowed before the reading was made. No doubt the value of resistance would have been higher in every case, if longer time were allowed for the condensers to resume their normal state after the application of the testing voltage, which is the charging voltage. In each case, the condenser was connected directly in shunt with the resistor, across the resistor terminals. The polarity of the test voltage was correct in every case.

GENERAL EFFECT

The general summation of these figures is that the presence of a good electrolytic condenser in shunt with a resistor has very little effect. We grant that there is some effect when high values of resistance are employed, but considering the use of certain values of capacity across certain parts of a receiver, particularly resistors, measurement of those circuits is possible and the numerical results should not confuse the operator and cause unjust condemnation of the resistor. At the same time it appears unnecessary to disconnect the electrolytic condenser from the circuit. The last statement is not true in one case; namely, when the test voltage impressed across the resistor being measured, and which is shunted by the electrolytic condenser, is in excess of the voltage rating of the condenser. The results enumerated above were secured with a potential of 4.5 volts applied to a bridge.

The figures quoted represent the average

Resistance in Ohms	Resultant Resistance in Ohms with Condenser in Shunt		
	(25-volt rating)		
	5 mfd.	15 mfd.	50 mfd.
200 ohms			
1,000 ohms	same	990	980
1,560 ohms	same	1,550	1,530
3,600 ohms	same	neg.	3,550
5,000 ohms	neg.	4,940	4,900
10,000 ohms	9,960	9,700	9,600
20,000 ohms	19,800	19,500	19,000
50,000 ohms	45,000	44,000	40,000

(400-500 volt rating, wet and dry units)
4 mfd. 6 mfd. 8 mfd.

of the individual values which were measured for each group of condensers. To properly interpret the figures it is necessary to consider the mode of application of such condensers. At no time is a low-voltage electrolytic condenser of from 5 to 50 mfd. employed to by-pass a high value of resistance; consequently the 4 percent change caused by the presence of a 50-mfd. condenser across the 10,000-ohm unit, is seldom experienced in practice. The same is true of the 20 percent change in resistance due to the presence of a 50-mfd., 25-volt condenser in shunt with a 50,000-ohm resistor. Such combinations are not found in practice.

High values of capacity are invariably employed as bias resistor by-pass condensers in output circuits, particularly pentodes. In such cases, the ohmic value of the bias resistor is low, so that the small change as evidenced in the table is of no consequence. This is especially true of the high capacity connected in shunt with a 200-ohm resistor which is approximately the value used to produce the control-grid bias for a pair of pentode tubes.

The higher values of resistance may be encountered in voltage-divider circuits, in which case the high voltage condensers are used and the percent change at maximum is about 4 percent. It is true that if a resistor which is just within the 5 or 10 percent tolerance, and is low by that figure, will vary still further due to the presence of the condenser, but common sense will dictate whether or not such a variation is sufficient to cause the type of trouble existent in the system being investigated.

Speakers in Philco 90

The speakers supplied with the Philco 90 receivers bearing serial numbers B-32,001 to B-35,000, and above B-53,100, are not interchangeable with the speakers employed with the earlier Model 90 receivers employing a single pentode. The output transformers used with the two pentode tube output circuits are different, consequently a new speaker is required.

Grigsby-Grunow 210

If there is a wavering of output somewhat like slow fading, check the grid leak used in the oscillator stage. Its correct value should be 100,000 ohms. If this unit becomes defective and is reduced in value, there will be a reduction in the output of the receiver.

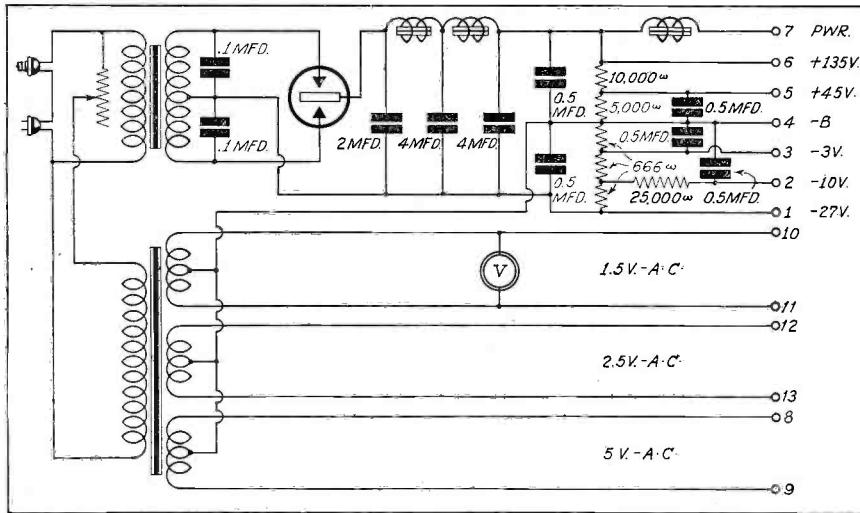

Fig. 1. Schematic diagram of the All-American A-10 "B" Eliminator

All-American B-Eliminators

There have been numerous calls for the circuits and constants of three distinct B-Eliminators manufactured by the All-American Mohawk Corporation during the years 1926 and 1927. The circuits are reproduced herewith.

Fig. 1 shows the circuit for the A-10 Power Unit. Fig. 2 is the circuit for the Type A8 B-Eliminators. Fig. 3 is the circuit used in B-Eliminators Type A-1, A-3 and A-4.

Atwater-Kent 90

In the early production of the Model 90 receivers, the grid returns for the r-f., i-f. and 2nd detector tubes were connected directly to the chassis or ground. In the late productions of this receiver, these circuits return to ground through a red and yellow resistor of 250,000 ohms. A by-pass condenser is connected across this resistor and this condenser, too, has been added to the circuit.

I-F. in Atwater-Kent 91 Series

Although practically every A-K superheterodyne employs 130 kc. as the peak in the intermediate-frequency amplifier, the 91, 91-B and 91-C auto radio receivers employ 260 kc.

Fig. 3. Schematic diagram of the All-American A-1, 3, and 4 "B" Eliminators

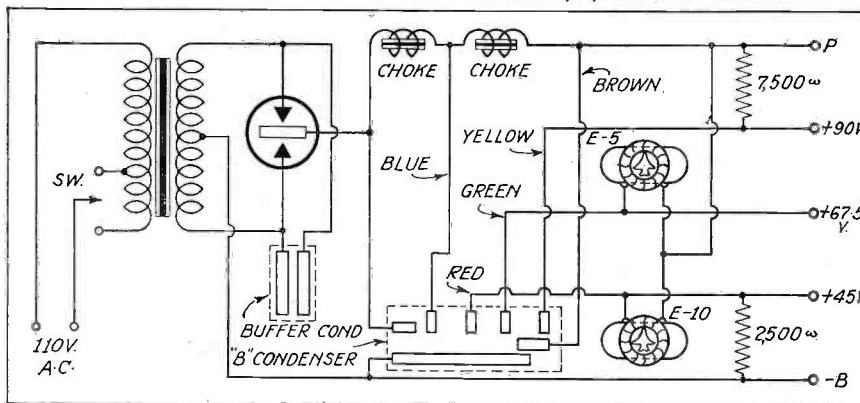

Distortion in 2-Volt Receivers

Quite frequently distortion may be experienced with battery-operated receivers without any obvious reason. In such cases, check the C-battery voltage as well as the filament and plate voltages. The statements made of old, concerning battery receivers are still ap-

rent drain is imposed, thus reducing the C-battery voltage in accordance with the reduced B voltage. In many cases, an old C battery has been found to function better in a receiver which was being operated with partially run-down B batteries. If the B batteries are to be replaced, connect a 200,000-ohm fixed resistor across the C batteries to constitute a load. Such a resistor is suitable for connection across a 22.5-volt C battery and the drain will be just enough to reduce the C voltage in conformity with the reduction in B voltage.

U. S. Radio and Television 10 Series 1000 Chassis

The second detector plate circuit of this receiver contains a 25,000-ohm plate filter resistor. If this resistor is shorted, a pronounced hum will be the result. Because of the low current in this plate circuit and the presence of a 100,000-ohm plate coupling resistor in series with the 25,000-ohm unit, a short circuit across the terminals of the latter unit may not show any variation in the 2nd detector plate voltage and thus not be discernible by voltage measurement. The filter choke in this receiver is shunted by a .06-mfd. condenser. If this condenser is open, a bad hum will result, without any

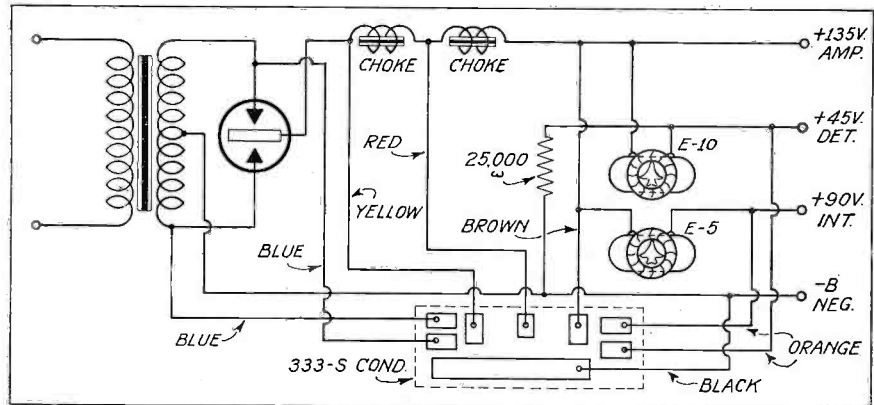

Fig. 2. Schematic diagram of the All-American A-8 "B" Eliminator

plicable. After a period of use the plate battery will run down, whereas the C-battery voltage may remain at practically the original value. Such a condition will cause distortion and can be rectified in what may appear a peculiar fashion . . . place a load upon the C batteries so that a gradual cur-

effect upon the operating voltages. A short across this condenser will naturally cause hum but at the same time it will increase the various plate voltages because the plate choke will be shorted. See that the electrostatic shield in the power transformer is properly grounded. If not, a pronounced hum will be heard.

Kolster-Columbia 940

The following are some resistance values to be found in the Columbia 940 radio and phonograph combination. First a-f. transformer primary, 1,500 ohms. First a-f. transformer secondary, 7,250 ohms. Second a-f. transformer primary, 1,500 ohms and total secondary of this transformer, which is the input, push-pull unit, is 10,800 ohms.

The voltage divider connected directly across the power pack consists of three sections: 2,500 ohms, 45 ohms and 410 ohms. The detector plate-supply resistor is of 50,000 ohms. The grid suppressors in the r-f. stages are of 2,700 ohms each. The bias resistor in the cathode circuit of the first a-f. tube is 1,600 ohms.

GENERAL DATA—continued

Delco 32-Volt D-C. Chassis

The Delco 32-volt d-c. receiver, for use with standard types of 32-volt lighting plants, employs four capacity-coupled tuned r-f. circuits, as seen from the accompanying diagram. Since the use of a comparatively low "B" voltage is anticipated—due to the necessity of using "B" batteries for plate and screen voltages—two type 38 pentodes connected in parallel are used in the power output stage to provide ample volume.

A dynamic speaker is employed. The field of this speaker is shunted across the heaters of the tubes which are connected in series. Therefore, both the heaters and the dynamic speaker field are energized by the 32-volt system. Note that a ballast tube is connected in this circuit.

The volume control consists of a 45,000-ohm variable resistor. This regulates the grid potential by changing the cathode-biasing resistance of the three r-f. tubes. The tone control consists of a 100,000-ohm variable resistor and a .02 mfd. fixed condenser connected in series between the plate terminals of the two type 38 pentodes and ground.

A Local-Distance switch is used, which short circuits the primary of the antenna coil when in the "Local" position.

TRIMMER CONDENSER ADJUSTMENT

A small condenser is located on the top of each of the four tuning condensers. If the selectivity is not normal, it may be necessary to re-align.

The trimmer condensers are adjusted by means of nuts or studs which may be turned with a socket wrench or screwdriver having an insulated handle. They are accessible for adjustment through the four holes in the top of the gang condenser shield.

To adjust the trimmers, tune in a station broadcasting on a frequency of approximately 1,400 kc. Adjust the volume by means of the volume control unit until the station can be faintly but clearly heard.

Starting at the front, adjust each trimmer in order from front to rear. Turn the adjust-

ing nut either from right or left, and leave each in the position in which the loudest signal is received.

SELECTOR DIAL ADJUSTMENT

If the pointers on the dial window do not indicate the frequency of the stations correctly, the dial may be rotated to the correct position. To do this it will be necessary to remove the chassis from the cabinet.

After the chassis is removed, measure the vertical distance from the bottom of the cabinet to the indicating points on the dial window (inside the cabinet). Tune in a station of known frequency, loosen the two

square head set screws which hold the dial and hub assembly to the tuning condenser shaft. Hold the condenser rotor stationary and turn the selector dial on the condenser shaft until the frequency shown on the selector dial of that particular station is the same vertical distance from the bottom of the chassis as that previously measured from the bottom of the cabinet to the indicating points on the dial window inside the cabinet.

The dial light bulb is rated at 6 volts and has a standard flashlight base. It can be removed or replaced easily by lifting the dial light, socket and bracket assembly, up and off of the dial light mounting bracket.

TABLE 1

No.	Body	End	Spot	Ohms	Watts
R-1	Red	Green	Brown	250	0.5
R-2	Violet	Green	Brown	750	0.5
R-3	Red	Green	Orange	25,000	0.5
R-4	Brown	Black	Yellow	100,000	1.0
R-5	Red	Green	Yellow	250,000	0.5
R-6	Green	Black	Yellow	500,000	0.5
R-7	(Wire-wound resistor)			175	6.0

TABLE 3

Tube	Fil.	Plate	Grid	Screen	Pentode	Plate MA.
1st R-F.	6.2	125	1.8	62	..	2.0
2nd R-F.	6.2	125	1.8	62	..	2.0
3rd R-F.	6.2	125	1.8	62	..	2.0
Det.	6.2	75	1.0	8	..	.1
Pentodes	6.0	50	.6	40	10	7.0

TABLE 2

No.	Capacity
C-1	.0005
C-2	.02
C-3	.1-.1
C-4-A	.5
C-4-B	1.
C-4-C	.1
C-4-D	.1
C-4-E	.01

The resistors used in the receiver are color-coded. The corresponding values and wattage ratings are given in Table 1. The condensers carry numbers. The corresponding values are given in Table 2. Condensers C-4-A to C-4-E inclusive, are contained in the by-pass condenser pack.

The voltage readings which may be expected on test are given in Table 3. These are based on a line voltage of 36, and with the volume control on full. Cathode voltage is zero in every case.

Schematic diagram of the Delco 32-Volt D-C. Receiver. The tube heaters are connected in series across the 32-volt line

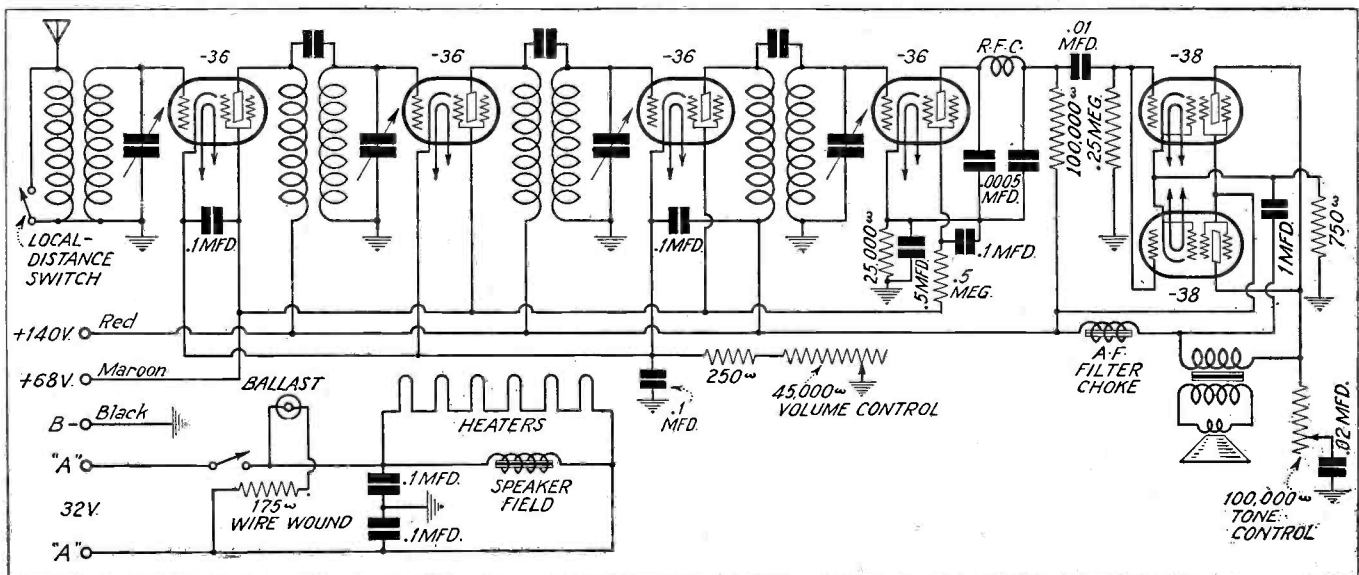

Musette Model 310

The Musette Model 310 is similar to the Musette Models 52 and 53, covered in the September issue of SERVICE, in that constant gain, impedance-coupled r-f. amplifiers are employed. However, in the Musette Model 310, the diagram of which is shown herewith, the plate circuit of one tube is coupled to the grid circuit of the next tube by a single turn of heavy copper wire in the form of a ring, located near the top of the secondary winding. The coupling so formed is principally capacitive.

RESONANCE ADJUSTMENT

Do not attempt to adjust the resonance of this set on a local or powerful carrier. Due to overloading, such signals might be louder if the set were actually thrown out of resonance.

To check resonance, remove the back shield and place it above the tubes, making sure however that it makes a good connection (metal to metal) with the chassis. The trimmer condensers are then accessible and are found directly behind the three screen grid tubes on the variable condensers.

Set the dial so that a signal of low intensity and low wavelength is received and carefully adjust each trimmer to maximum signal strength. Usually the gang condenser will then be in resonance at the higher wavelengths as well, but in some instances when a new condenser has been installed, it may be necessary to warp slightly the two outer plates on each rotor section, which are split for this purpose.

In servicing a set where the volume is insufficient or broadness of tuning is apparent, the antenna stage, or the trimmer nearest the end of the chassis should always be adjusted to the length of the antenna upon which the set is to operate.

VOLTAGE DATA

As very high resistances are used the ordinary set tester will not give correct indications on the following circuits: C bias on the '45 tubes; screen voltages on the r-f. tubes; cathode voltage on third r-f. tube.

Using a voltmeter having 1,000 ohms per volt, and with volume on full, the following approximate voltages will be obtained: (In making these readings the antenna should be disconnected.)

Across speaker field	100-120 V.
Chassis to plate of 1st, 2nd r-f. and '45 tubes	210-230 V.
Ground to cathodes, 2nd and 3rd r-f.	11½-10 V.
Ground to cathode, 1st r-f.	9-10 V.
Filament to filament, all tubes.	2.4-2.5 V.
Filament to filament of '80.	4.8-5 V.
Filament to ground, '80.	210-230 V.

Should the filament-to-ground reading on the '80 tube exceed 230 volts, a grounded electrolytic condenser or an open biasing resistor is indicated; if no reading is obtained, a grounded plate circuit, an open high-voltage secondary, or open speaker field is indicated. If the plate circuit is grounded the speaker field is made to dissipate the '80's entire output and a voltage of 250 to 300

will be obtained across the speaker field terminals.

The bias voltage of the '45 tubes in push-pull is obtained by reading across the speaker field and dividing it by two; this should be approximately 50 to 55 volts. This voltage is dependent upon the two resistors mounted on the electrolytic condenser; if a deflection is had on the voltmeter when reading from ground to the center tap of these resistors, and the voltage drop across the speaker field is from 110 to 120 volts, it may be assumed that the bias on the '45's is correct. A reading of less than 100 volts across the speaker field is indicative of a defective speaker or open resistor somewhere within the circuit.

450 KC. on Philco 095 Oscillator

The Philco Model 095 Oscillator can be altered to provide a suitable 450 kc. signal for adjusting the intermediate frequency stages of the Philco Model 43, or other sets using an i-f. of 450, without interfering with the present frequencies at 175 kc. and 260 kc.

In order to make the necessary alterations, proceed as follows: A Philco compensating condenser, part 04000C and a snap switch, part 3253, should be mounted on the side of the oscillator case. A 3/16-inch hole in the side of the oscillator case should be drilled for mounting the additional compensating condenser, and a second hole 9/16-inch in diameter, 11/32-inch to the left and 7/8-inch above the first hole, to provide an opening for the adjustment of this condenser. Drill a third hole ½-inch in diameter for mounting the toggle switch.

WIRING

The wiring consists of connecting the new compensating condenser and switch in series, and connecting these two across the 260-kc. compensating condenser. To accomplish this, connect a wire between the adjustable plate terminal of the 260-kc. compensating condenser and the adjustable plate terminal of the condenser added. Then connect a wire from the fixed plate terminal of the 260-kc. compensating condenser to one side of the toggle switch added. A wire from the other

terminal of the toggle switch should connect to the fixed plate terminal of the new compensating condenser.

ADJUSTMENTS

The adjustments consist of checking the 260-kc. compensating condenser setting and adjusting the new compensating condenser in the following manner:

Place a radio receiver in operation, tuning it exactly to a reliable station at 780, 1,040 or 1,300 kc. If no station signal is available at any one of these frequencies, tune the station selector of an accurately calibrated radio set to one of these points on the dial.

Without disturbing the dial setting, disconnect the antenna, and substitute the "Antenna" connection from the oscillator. Connect the ground terminal of the set, with the ground wire still connected. Connect the output meter of the oscillator to the loud-speaker connections in the usual manner.

Place the oscillator in operation at 260 kc., with the new switch in the "off" position (open) and adjust the 260-kc. compensating condenser for maximum reading in the output meter.

Now reconnect the antenna in place of the oscillator and tune the set to a station at 900 kc. or 1,350 kc. Again substitute the oscillator for the antenna, placing the 175-260 switch in the "260" kc. position, and the new switch in the "on" position (closed). Adjust the new compensating condenser for maximum reading in the output meter.

This completes the adjustments and the oscillator is ready for use. The fundamental frequency which has been added is 225 kc. The second harmonic of this frequency at 450 kc. is actually employed for making the adjustments to the new Philco receivers. The 900-kc. and 1,350-kc. points used in adjusting the 225-kc. compensating condenser are the fourth and sixth harmonics, respectively, of the 225-kc. signal. When making adjustments to a Philco radio having an intermediate frequency of 450 kc., place the oscillator in operation for 260 kc. and the new switch in the "on" position.

Schematic diagram of the Musette Model 310. Note that this receiver employs constant-impedance coupling in the r-f. stages. The tone control is in the plate circuit of the power detector tube

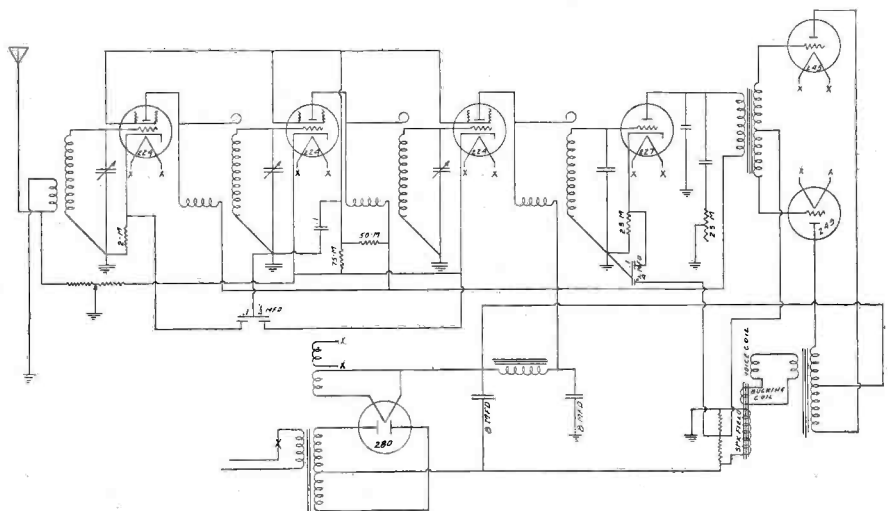

GENERAL DATA—continued

Stewart-Warner Models R-104-A, B and E Receivers

The schematic diagram of the chassis used in the Stewart-Warner Models R-104-A, R-104-B, and R-104-E is shown in Fig. 1. The chassis layout is shown in Fig. 2.

It should be noted that a Wunderlich tube is used as a combination second detector, automatic volume control and audio amplifier. This tube is resistance-coupled to the PZ or '47 pentode output tube.

The intermediate-frequency transformers are tuned to 177.5 kc., both the primaries and secondaries being tuned by trimmer condensers. Alignment may be accomplished in the usual manner, with the aid of a signal generator.

The voltage data is given in the accompanying table. Readings are based on a line voltage of 115 and should be taken with the volume control full on. All d-c. voltages are measured with respect to ground, using a high-resistance voltmeter of 1,000 ohms per volt.

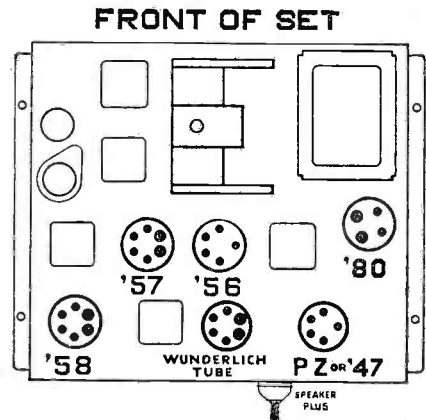
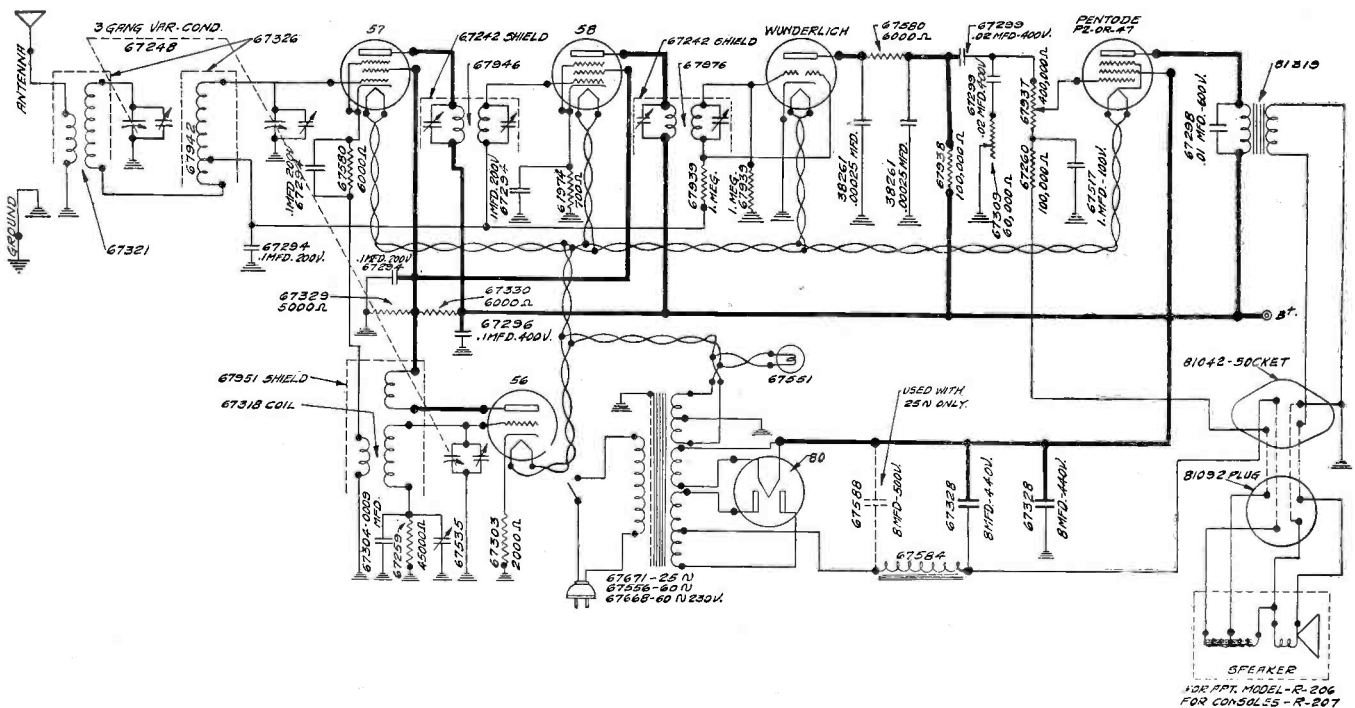

Fig. 1. (below) Schematic diagram of the Stewart-Warner chassis used in Models R-104-A, B and E. Note that a Wunderlich tube is employed as the second detector and automatic volume control. The intermediate-frequency transformers are tuned to 177.5 kc. Fig. 2. (above) Layout of chassis from the top, showing the location of each tube



STEWART-WARNER VOLTAGE DATA

Tube	Fil.	Plate	Screen	Bias
1st. Det.	2.57	256	100	4.5
Osc.	2.57	100	..	7.8
I-F.	2.56	256	100	3.9
2nd Det.	2.56	37
Output	2.56	239	256	15.75*
Rect.	4.9

* This reading obtained between ground and that prong of speaker socket situated furthest from other three. Direct reading from grid to ground or reading taken with a set tester will show about 3 volts because of high resistance in grid circuit.

Sparton 14 and 18 Trimmers

The antenna, r-f. 1st detector and oscillator adjusting condensers in the Model 14 are accessible through the chassis. Facing the rear of the chassis, you will find four holes in the chassis alongside of the r-f. and i-f. transformer shield cans. They are to the right of the cans. Reading from the rear of the chassis, towards the front, the units are as follows: Oscillator equalizing condenser, 1st detector equalizing condenser, r-f. stage equalizing condenser and antenna equalizing condenser. The condenser across the secondary of this i-f. transformer is located towards the front of the chassis at the right hand side, near the speaker cable outlet. This condenser can be reached only after the chassis has been removed. The condenser across the primary of the i-f. transformer is reached through the can which houses this transformer.

In the Model 18, the i-f. transformer condensers are to the left of the transformer cans mounted upon the chassis. Viewing the chassis from the rear and reading towards the front, the first adjustment is for the secondary condenser and the one nearest the front of the chassis is the primary condenser. The aerial, r-f. 1st detector and oscillator

trimmers are within the condenser gang shields. Reading from the rear towards the front, the four adjusting condensers are: antenna equalizing, r-f. equalizing, 1st detector equalizing and oscillator equalizing condensers.

Sparton 14

If the receiver is weak and the oscillator does not appear to function normally, examine the 3000-ohm fixed resistor in the cathode circuit of the 1st detector-oscillator tube. This receiver employs a peculiar type of circuit. One winding of the oscillator is in series with the i-f. transformer primary and the other winding of the oscillator transformer is connected to shunt with the 3000-ohm resistor in the cathode circuit. The suppressor grids in the two type 58 tubes used in this receiver are connected directly to ground and not to the cathodes. The cathodes in these two tubes as used in this receiver are above ground potential. Another suggestion in connection with the oscillator in this receiver is the .002-mfd. condenser connected from one end of the oscillator winding in the cathode circuit to ground. If this condenser is open, the circuit will oscillate feebly, if at all.

GENERAL DATA—continued

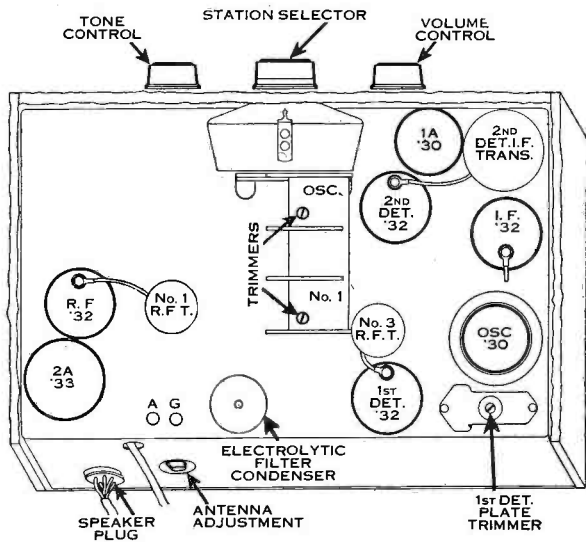

Fig. 1. (below) Schematic diagram of the Atwater-Kent 82-Q battery receiver. The values of the resistors, the color-coding for each being given here, will be found on page 203 of the August issue of SERVICE, where the corresponding color-codings are also given. Fig. 2. (left) Chassis layout of the A-K 82-Q. The trimmer positions are indicated

while the tube voltages are given in the accompanying table.

The intermediate frequency employed in this model superheterodyne is 130 kc. It will be noted from the diagram that a special circuit is added to the input of the first detector for the express purpose of eliminating double-spot tuning.

ADJUSTING DOUBLE-SPOT CIRCUIT

The adjustment of the double-spot circuit requires a modulated oscillator which will provide an extra strong and a normal 1,500-kc. signal. This oscillator should have its output connected to the aerial and ground posts of the receiver and an output meter should be connected across the voice coil of the permanent-magnet dynamic speaker.

With the test oscillator set at the normal 1,500-kc. signal output, adjust receiver to the

Atwater-Kent 82-Q Battery Set

The details given herewith refer to the Model 82-Q (2nd type) above serial number 2550940. The circuit diagram is shown in Fig. 1 and the top view of the chassis is shown in Fig. 2.

The set is designed to receive its filament power from an Air-Cell battery, and its "B" and "C" voltages from the usual dry-cell units. The terminal voltages of these batteries are given in the schematic diagram,

A-K 82-Q VOLTAGE DATA

Tube	Filament	Plate	Screen	Grid
R-F.	2	125	60	-3
1st Det.	2	125	40	-3
I-F.	2	125	60	-3
2nd Det.	2	45	25	-3
1st A-F.	2	55	..	-3
2nd A-F.	2	120	125	-15
Osc.	2	60	..	*

*The measured oscillator grid voltage will vary dependent on several factors. In some cases, no reading will be secured for grid bias. In other cases the reading will be only slight, or it may be as high as 10 volts.

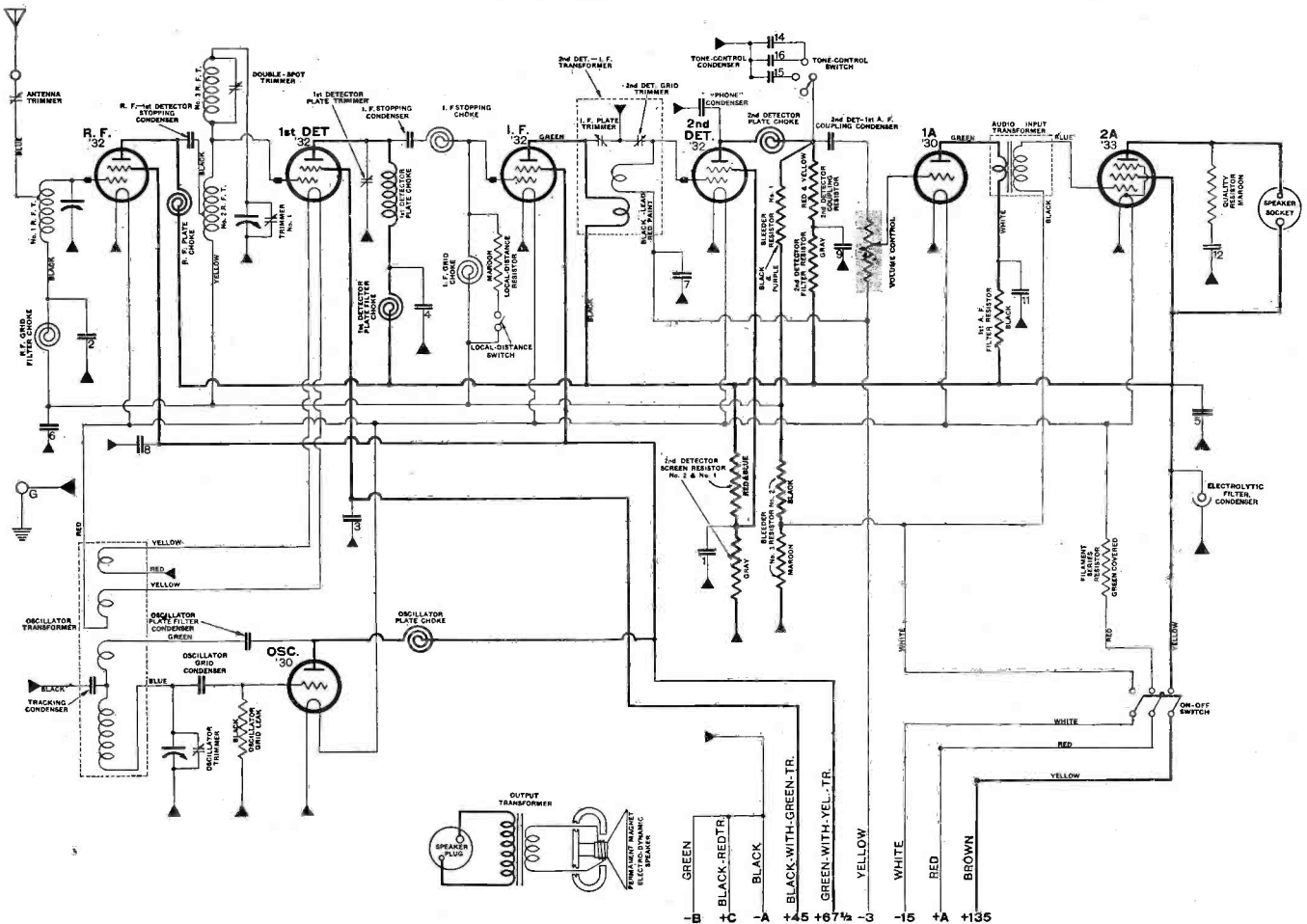

GENERAL DATA—continued

same frequency, and give particular attention to the setting of trimmer No. 1 for a maximum indication in the output meter. Now switch the oscillator to the strong 1,500-kc. signal and tune the receiver to 1,240 kc. Then adjust the double-spot trimmer for a minimum indication in the output meter. Be sure that the minimum indication is reached.

Now change the oscillator back to the normal 1,500-kc. signal, retune the receiver to 1,500 kc. and readjust trimmer No. 1 for maximum output indication. Then tune the receiver to 1,240 kc., set oscillator on strong signal and carefully readjust the double-spot trimmer for minimum indication in the output meter. Repeat these adjustments until further adjustment of No. 1 trimmer does not increase the output of the receiver, and until further adjustment of the double-spot trimmer no longer reduces the output of the receiver at 1,240 kc.

Silvertone 1620 and 1622

The Silvertone (Sears, Roebuck & Co.) Models 1620 and 1622 are battery-operated receivers, as indicated by the common schematic diagram shown in Fig. 1. The total "A" current drain is less than half an ampere and total "B" drain is 22 milliamperes. The dynamic speaker is of the permanent-magnet field type.

By virtue of a filament ballast lamp, the tubes will have proper filament voltage whether a 2-volt Air Cell, a 3-volt Dry Cell Block, or a 6-volt storage battery is used for the "A" supply. Care must be taken that the volume control does not make electrical contact with the chassis, else the ballast lamp will be burned out. It is also important that the switch be off before removing any tubes. Otherwise the voltage

across the remaining tubes will rise, with the possibility of burning them out. Further, the volume control, which is in series with the r-f. filaments, should be advanced slowly since the ballast tube has a slight time lag in its operation.

In some of the models it is necessary to turn the tuning dial to 75 in order that it does not become caught against the loud-speaker when removing the chassis from the cabinet.

when the adjustment is being made, in order that the dial calibration remain correct.

VOLTAGE DATA

The voltage data is given in the accompanying table. The grid, plate and screen voltage readings should be taken between the negative side of filament and respective element, with the volume control set at maximum.

SILVERTONE VOLTAGE READINGS

Tube	Fil.	Plate	Screen	Grid	Plate MA.	Screen MA.
1st R-F.	2.1	135	67	-3	1.7	.125
2nd R-F.	2.1	135	67	-3	1.7	.125
Det.	2.05	27*	13.5*	*	.05	Too low to read
Output	2.05	135	135	*	14.0	4.0

*1-megohm resistor in series.

The receiver is so designed that reception will be satisfactory even though the total "B" voltage drops as low as 70 volts. For best reception the batteries should be replaced when the total voltage has dropped to 100. Readings should be taken with the set in operation.

Should replacement of the r-f. coils or of the tuning condenser be necessary, or if the set suffers from misalignment, the trimmer condensers, accessible through the holes in the tuning condenser cover, should be re-adjusted. This, of course, is best done with an oscillator and output meter, but a fair job can be done by tuning in a broadcast station near 1500 kc. and adjusting the trimmers for maximum volume. The volume control should be kept very low since the ear is more sensitive to slight changes in volume at low volume levels. The dial should be set to the frequency of the station

The control-grid readings should be taken on the 7.5-volt scale of a 1,000 ohms per volt voltmeter; others on the 250-volt scale. Usually, deviations up to 20 per cent are permissible and do not necessarily indicate a fault. Where series grid resistors prevent grid voltage readings, proper plate current at rated plate voltage will serve as an indication of proper grid bias and normal functioning of the tube.

Care must be used when readings are taken with an analyzer since the capacity of the cable may cause the circuit under test to oscillate and give erratic readings. Usually, touching a finger to the grid will stop oscillation.

Dual-Speaker Installations

A drop in volume in dual-speaker installations may be due to some defect in the field coil winding. In contrast to the usual method of employing the field coil in a single speaker installation as the filter choke, quite a few dual-speaker receivers employ the two field windings in shunt with the voltage-divider circuits. Consequently an open in one or the other field winding will not necessarily interfere with the operation of the receiver. In many instances voice coils are connected in parallel. One of these may open without interfering with the operation of the other. With one of a dual combination open, the volume will show a decided decrease.

Phasing Voice Coils

Mention was made recently about proper phasing of voice coils in public-address systems. This condition is of equal importance in dual-speaker installations. If you have occasion to disconnect either one of a pair of voice coils in a dual-speaker job, make certain to mark the proper positions of the respective leads. If you connect one voice coil so that the polarity is wrong, one coil will be moving out as the other moves in when the signal is applied. The volume will drop and distortion will be the result. (See April issue of SERVICE for proper phasing instructions.)

Schematic diagram of the Silvertone Models 1620 and 1622. Note that the volume control is in the filament circuit of the r-f. tubes

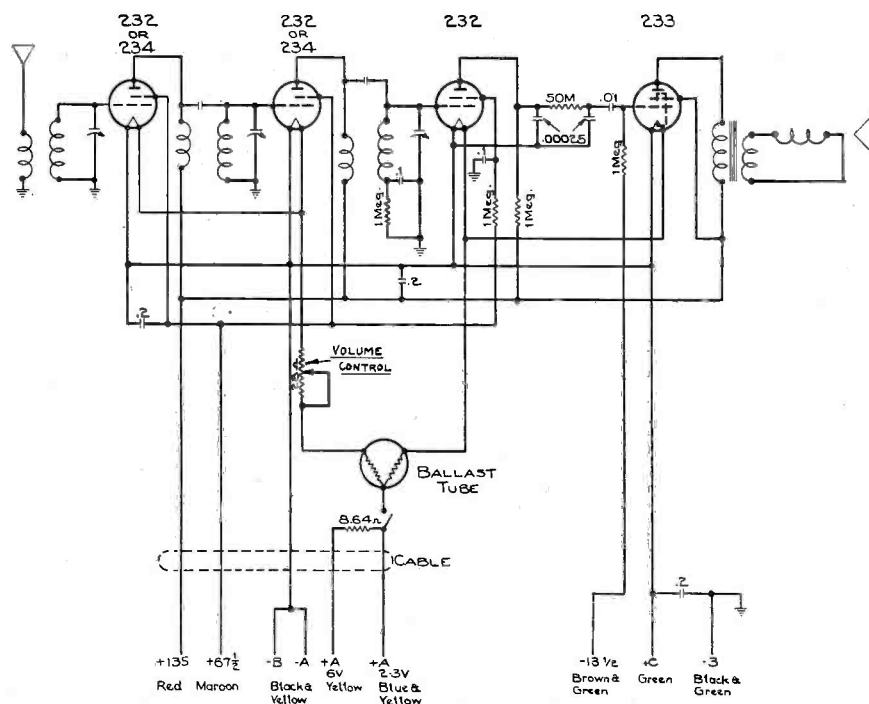

GENERAL DATA—continued

Majestic Model 290

The Model 290 superheterodyne chassis is used in the Madison Model 291, Adams Model 293 and Monroe Model 294 receivers. Fundamentally the Model 290 circuit is quite similar to the Model 200 circuit previously used, though a number of features have been added.

It will be seen from the accompanying schematic diagram that the new type tubes are used in a circuit consisting of a stage of tuned r-f., oscillator, first detector, a stage of i-f., second detector of the duo-diode type, intermediate audio-frequency amplifier, and a single pentode in the power stage. A mercury-vapor, full-wave rectifier is used in the power-supply circuit.

This accounts for all but one tube, a G-58-S, which is referred to as the "Synchro-Silent Tuner" and is a part of the automatic muting system employed. This will be explained later.

SERVICING DATA

Referring to the circuit diagram, the initial bias on the r-f. and i-f. tubes is obtained from resistor R-18. The initial bias on the first detector comes from the resistor R-17. Automatic volume control bias is applied to these three tubes from resistors R-13 and R-14. To secure proper filtering and stability, there are used resistors R-1, R-2, R-4 and R-12. For this same purpose, condensers C-14, C-16, C-17 and C-19 are used. There is also provided an r-f. choke in the center tap lead of the duo-diode i-f. transformer.

The oscillator tube obtains its bias from resistor R-3. The fixed bias on the screen-

grid a-f. tube is obtained from R-16, while the bias necessary for Synchro-Silent Tuning is obtained from resistors R-5 and R-6. Bias for the output pentode comes from resistor R-22.

The manual volume control is a simple audio-frequency potentiometer, R-5, in the grid circuit of the screen-grid audio stage. Automatic volume control effect is exerted on the r-f., first detector and i-f. tubes, due to the voltage drop across resistors R-13 and R-14.

grid circuit of the audio amplifier. The Synchro tube obtains its grid voltage from the automatic volume control circuit. When there is no station tuned in, there is no automatic volume control voltage, and hence the grid of the Synchro tube is approximately at zero voltage. This causes its plate to draw current through resistor R-6. The voltage drop across this resistor biases the a-f. tube so high that the audio amplifier is "blocked out" and hence no noise comes through.

When a station is tuned in, automatic vol-

TABLE 1

Tube	Plate	Cathode	Plate M.A.	Screen	Screen M.A.
R-F.	265	3	4.4	90	.1
Osc.	90	15	1.6	—	—
1st Det.	265	6	.3	.90	.6
I-F.	265	3	5.8	90	1.5
2nd Det.	—	0	—	—	—
1st A-F.	155	90	.6	135	.1
Pwr.	240	—	.28	265	.7
Synchro	85	0	1.4	0	0
Rect.	—	—	—	—	—
Total			70.	—	—

The Synchro-Silent Tuning, or automatic silencing while tuning between stations, is obtained through the combined efforts of the intermediate a-f. tube and the Synchro tube. A type G-57-S tube is used for the first audio stage because of its sharp grid voltage cut-off characteristics. By inserting a high bias in the grid circuit of this tube, it is "blocked out," and no signal will come through it.

To obtain this, a type G-58-S is used as a Synchro tube. This tube obtains its plate supply through resistor R-6, which is in the

ume control voltage develops across resistors R-13 and R-14 and this automatic volume control voltage is impressed in the form of negative bias on the Synchro tube. The plate of the Synchro tube now draws little or no current, and hence the bias across resistor R-6 disappears, leaving nothing but the normal operating bias on the audio amplifier tube. In this condition the entire set is operative, just as though there were no Synchro tube in the circuit.

Because of the variation in antenna and noises in different locations, a potentiometer,

Schematic diagram of the Majestic Model 290. Resistance and condenser values are included below

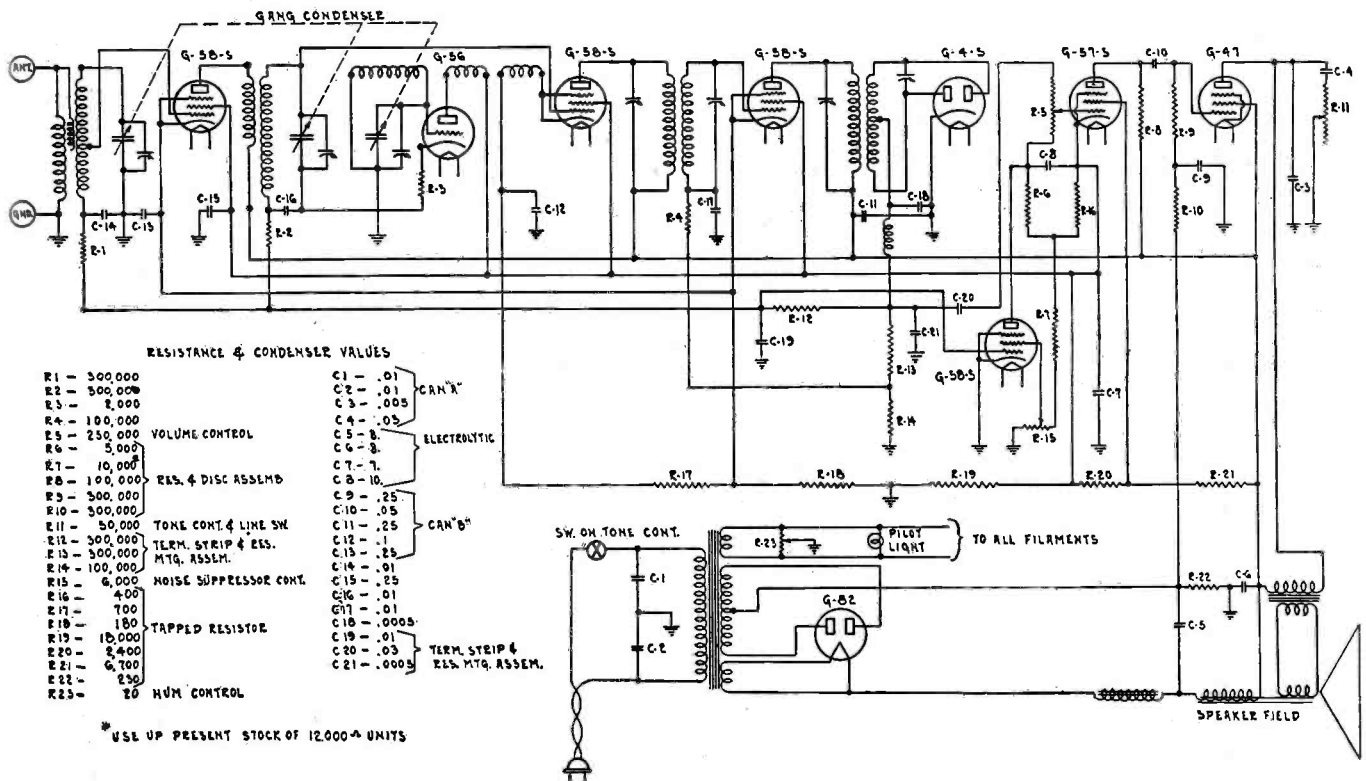

R-15, is included in the screen circuit of the Synchro tube. This control permits an adjustment of the degree of suppression so as to meet the local conditions. Therefore, the following procedure should be carried out to find the proper position for the suppressor control:

1. Set suppressor knob to position of no suppression. (All the way clockwise when facing suppressor control.)

2. Tune receiver to a position off of the broadcasting station, preferably near the low-frequency end of the dial.

3. Turn volume control full on. In this position a great deal of noise will be heard, depending upon the location.

4. Adjust noise suppressor control by rotating counter-clockwise slowly until the noise just stops. It will be found that the noise drops out quite suddenly, and it is desirable that the control be set only to the position required to take out the noise and no further counter-clockwise than necessary.

5. The set is now ready for operation, and it will be found that stations come in with just as much volume as they would if the noise suppressor were not used, but when tuning between stations, the set will be quiet. It may be found that in some particular locations the noise is greater at one end of the dial than the other, so that if the noise suppressor is adjusted to take out noise at the low-frequency end of the dial, some noise may come in at the high-frequency end. In this case, it is perfectly permissible and advisable to readjust the noise suppressor at the high-frequency end of the dial.

It is understood that if maximum distance is desired, without regard to noise between stations, then the Synchro-Silent Tuning Control knob should be rotated as far clockwise as possible—and later returned to its marked position for noise suppression.

The d-c. voltage and current readings for the Model 290 chassis are given in Table 1. These readings should be taken with the silent tuner control set all the way clockwise. The a-c. filament voltage readings on all the tubes, including the G-47 pentode and G-82 rectifier, should be 2.5 volts. All readings in the table are based on a line voltage of 115.

Sparton 18

The oscillator system used in this receiver is like that in the Model 14 mentioned elsewhere in this issue. The same conditions apply. In addition, you may find a peculiar condition when testing between the suppressor grid contact and the cathode or ground for the first r-f. tube. This tube element, when the tube is in the socket, is connected to the control grid of the 1st r-f. tube via the input grid winding. At the same time it connects to the AVC tube plate through a 100,000-ohm resistor and also to the control grid of the 1st i-f. tube through the grid winding of that tube. If you find a low resistance connection to ground and the AVC tube does not function, examine the .01-mfd. condenser connected between the AVC tube plate and AVC tube cathode.

Stromberg Carlson 38, 39, 40 and 41

If you have a call for service on one of these jobs, don't come to a hasty conclusion. There are two versions of these receivers. The first production of this receiver was described in the June issue of SERVICE. You can recognize the early production by counting the number of tubes. Exactly nine tubes were used in the first batch of these receivers. The later production makes use of ten tubes. The two receivers are substantially identical from the aerial to the plate circuit of the i-f. tube, inclusive of the oscillator. The new arrangement uses a trick circuit incorporating two duo-diode triodes (that's a tongue twister we *still* aren't used to) and a pentode as the relay tube. The combination enables quiet tuning between stations by the application of a negative bias to one of the diode tubes during the time that there is no signal carrier in the system. When a carrier is tuned in, the negative bias is overcome and the system is operative.

You'll get more dope on this receiver in November. This announcement is just to advise of the two types of receivers which bear similar model numbers.

Delco Appliance 2-Volt Receiver

The color code of the leads in the cable is as follows:

Red	to + 140 volts on Delco power unit
Black—Red Tr.	to +90 volts on Delco power unit
Maroon	to +68 volts on Delco power unit
Black—Yellow Tr.	to —"B"
Short jumper—	
Black with Yellow Tr.	+ C battery
Long jumper—	
Black with Yellow Tr.	—A battery
Yellow	+ A battery
Green	—3 volts C battery
Black—Green	— 4.5 volts C battery
Black—Green Tr.	—22.5 volts C battery

The trimmer condensers are located atop each condenser in the gang. They are accessible through the holes in the condenser shielding cover. When aligning, set the test oscillator to 1,400 kc. and adjust at this frequency.

Volume Controls

There have been numerous cases mentioned concerning the repeated replacement of a volume control without any remedy, when the original trouble suspected was thought to be in the volume control. If you find that a control appears to go dead when the knob is revolved beyond a certain point and the same thing happens after replacement, it is time to examine the receiver connections adjacent to the control. Time and again, manipulation of the control knob shifts one of the wires so that it either opens or grounds a circuit, with the usual consequences.

R-F. Distribution Systems

A system whereby as many as 3000 radio receiving sets can operate independently on the same antenna without interfering with each other has been perfected by the Western Electric Company. By adding further apparatus, the number of sets can be increased indefinitely without impairing the quality of reception. The sets can be of any make the individual chooses. A city's roofs freed of the fire hazard and the unsightly tangle of innumerable individual antennas thus becomes a scientific possibility.

The system is designed primarily for hotels, apartments and other multiple dwellings and is aimed to overcome the increasing problems which dwellers in such buildings face in obtaining good antenna facilities for their radios at reasonable cost. Modified forms of the system have also been designed to operate a much smaller number of radio sets. The same technical improvements devoted to the large community receiving system are embodied in these smaller forms and are made available on a scale that is suitable even for the individual home owner and his one radio set. All of which should be of special interest to you as a Service Man.

TRANSMISSION LINES

The system was designed by engineers of Bell Telephone Laboratories and employs the principles used in long distance telephone circuits. These principles have for some time shown their effectiveness in the broadcasting end of radio and have become standard there. In this type of construction, the broadcasting transmitter is connected to its antenna by a transmission line several hundred feet long. In the new type of receiving system, the same principles of construction which meet the rigid requirements of the broadcasting station for transmission and for protection from outside interference are, generally speaking, used in reverse order.

The receiving system is protected against "man-made" static, those interferences which the ordinary lead-in wire commonly picks up from sources within a building, such as elevator motors and other electrical devices. The loss in receiving power usually caused by the great length of the lead-in wire and its high capacity to ground is overcome. Every receiving set connected to the system is electrically isolated so that it *cannot put any noises back into the system* to disturb the operation of others on the line.

THE ANTENNA

The first requirement of the system is a properly constructed antenna. With only one antenna involved, the space limitations imposed by crowding many individual antennas on a roof are eliminated and the best principles of construction can be observed. The unit cost of the antenna per receiving set is lowered because of the large number of sets sharing the same facilities.

The antenna is connected to the transmission line through a panel which consists essentially of a suitable lightning arrester, a terminal strip and a repeating coil designed to transfer most efficiently the energy col-

(Continued on page 284)

well grounded at the antenna end to the nearest convenient point on the chassis or metal portion of the car body.

ADJUSTMENT

After the wiring has all been completed and before the chassis is permanently installed, insert the tubes, try out the set, and adjust the antenna trimmer condenser. The correct tube locations are shown in the small sketch in Fig. 2. Put one rubber band around each tube. Do not start the engine of the car.

To adjust the antenna trimmer, tune in a weak signal at the high-frequency end of the

move the second detector tube to make the other readings.

All bias voltages must be read from cathode to ground. The heater voltage in each case should be 6 volts.

Studebaker 1931 and 1932

All models with engines mounted on rubber must have the engine bonded to the bulkhead. Bond from the cylinder bolt to the bulkhead. Use heavy flexible braid. Dome light filters must be installed in all closed models.

Engines Mounted Upon Rubber

In all cases where engines are mounted upon rubber, bonding is required at several points. Use heavy flexible braid and bond at some point near the rear of the engine, at the front of the engine and midway between the two ends. Bond to the frame of the car and to bulkhead. Make certain that the bond is sufficiently flexible so that the floating action of the motor is not hindered.

Low-Tension Wires

In numerous instances, the low-tension wires to the ignition coil pass through the high-tension conduit. In the Ford "V8," the storage battery cables pass through this conduit. In the LaSalle, the primary wire from the ignition coil to the distributor passes through the high-tension conduit. These wires must be removed and if the only available location is adjacent to the high-tension conduit, it might be well to shield these low tension cables.

GULBRANSON VOLTAGE DATA

Tube	Plate	Screen	Grid	Plate MA.
R-F.	177	80	3	3.6
1st Det.	173	76	7*	.9*
1-F.	177	80	3	3.6
2nd Det.	0	0	0	0
1st A-F.	54	77	6	1.2
Output	159	165	15.5	10.0

* Will vary with dial setting.

dial with the manual volume control about three-quarters on. On one end of the chassis is a small metal plate. Remove the two screws holding this plate, and directly under the hole in the chassis is the antenna trimmer condenser screw. Turn this screw up or down until maximum output is obtained.

If the receiver does not work, check the "A" and "B" voltages—but these voltages should be checked only at the sockets in the receiver, or at the "A" and "B" units. Do not check the voltages by removing the cable head and reading them at the multi-point socket, for if the switch is turned on and off with the multi-point socket not connected, the pilot light may be burned out, due to the inductive surge caused by the speaker field.

VOLTAGE READINGS

The voltage data is given in the accompanying table. Before checking the voltages at the sockets, a convenient point, in some cases, to check the applied "A" and "B" voltages is at the speaker terminal strip. A high-resistance voltmeter should be used.

To read the voltages at the sockets, the chassis box, in most cases, will have to be taken off of its mounting. In some instances the cables, which may be attached to the dash or at other points, will have to be taken off. The voltages can be read at the sockets with a long plug or with a pair of long, insulated test prods. If these are not available, it will be necessary to remove the chassis from the box. In the event that it is necessary to do this, the multi-point socket on the cable head is then re-connected to the multi-point plug on the chassis. Considerable care must be taken when the chassis is out of the case in this manner to prevent accidental short circuits of plus "B" or plus "A" points to ground.

All tubes must be inserted and all units connected. A signal will effect the control voltages on the r-f., i-f., and first audio tubes, due to the automatic volume control, so if any are received, ground the antenna and re-

Chevrolet Ignition Diagrams

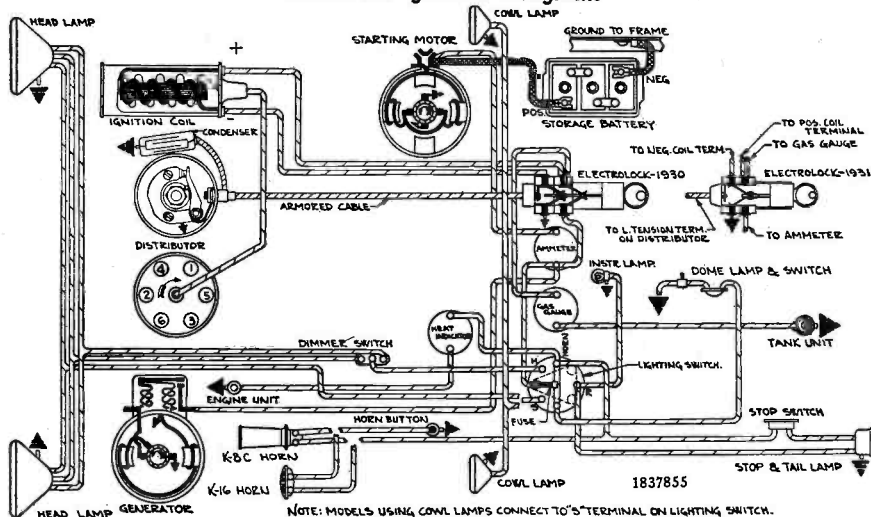

Ignition diagram of Chevrolet cars for the years 1930 and 1931. The generator current is regulated by a third brush; no thermostat. Rotation of distributor is counter-clockwise. Contact opening—.018"-.024"

Ignition diagram of Chevrolet 6-cylinder cars for 1932. Generator and distributor details the same as above. In both cases the negative lug of the storage battery is grounded to the car chassis.

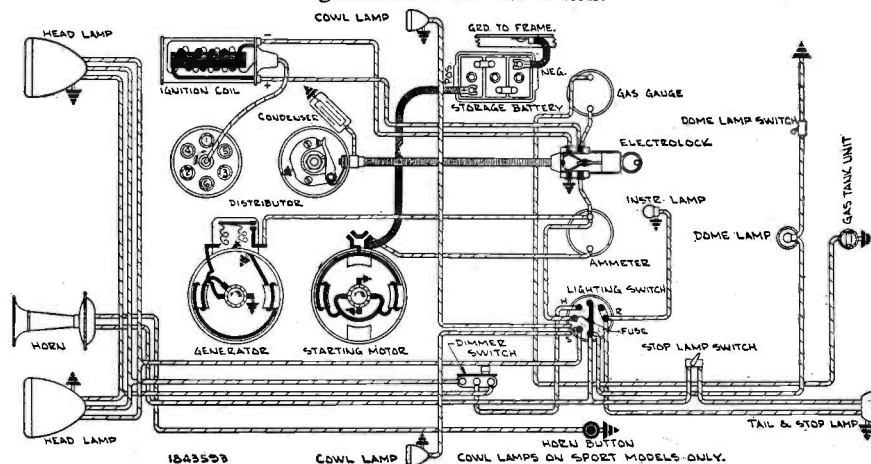

Short Waves

Silvertone Model 1640

The Silvertone (Sears, Roebuck & Co.) Model 1640 is a short- and broadcast-wave superheterodyne employing automatic volume control, "phantom tuning," and "Class B" audio output. The complete schematic diagram is shown in Fig. 1 and the chassis layout in Fig. 2.

The complete frequency coverage is 16,600 kc. to 530 kc. This range is accomplished by three switching positions, which are: No. 1—(Furthest left or counter-clockwise) 16,600 to 5,000 kc.; No. 2—5,000 to 1,600 kc.; No. 3—1,600 to 530 kc. The numbers given are the same as those in the schematic diagram.

The frequency-selecting switch may become noisy in time. The contacts can be cleaned with a piece of absorbent cotton wrapped around a toothpick and dipped in alcohol, carbon tetrachloride, Carbona or similar solvent.

The intermediate frequency employed is 175 kc. Note from the schematic diagram that the second i-f. transformer is variable and functions as the volume control. Being inductive, the control is noiseless.

The first stage i-f. transformer is mounted on the top of the chassis (See Fig. 2) with its adjusting screws accessible through the holes in the top of the shield. The adjusting screws for the second i-f. transformer tuning condensers are accessible through holes in the chassis to the right of the first i-f. transformer, facing the front of the chassis. An insulated adjusting screwdriver must be used since the primary tuning condensers are at high d-c. potential with respect

to the chassis. When peaking the i-f. stages, the AVC and "phantom tuning" must be inoperative. Remove the "phantom" tube from its socket and replace the AVC tube with a dummy; i.e., either a burned-out tube or one with a heater prong sawed off or insulated from its socket contact. Be sure the flexible grid lead is connected to the grid cap of the 57 dummy tube, and the tube shield in place.

The detector is coupled through an auto-transformer to two 46's connected as a "Class A" push-pull driver stage. In turn these feed the "Class B" output stage. The auto-transformer has a high permeability nickel alloy core. If for any reason excessive (25 ma. or more) d-c. flows through this transformer, the permeability of its core and hence the inductance of the transformer may be greatly lowered. As a con-

sequence, tone quality will be impaired and the transformer should be replaced.

It is important, when new a-f. transformers are installed, that their polarity be maintained the same as the original installation arrangement. Reversal of polarity will result in a-f. oscillation or in degeneration with consequent impairment of tone quality.

Tubes that are well matched in their dynamic characteristics will give the best quality of reproduction from the "Class B" stage. Interchange their positions until the best combination is found.

Because of the very low and constant voltage drop in the 83 mercury-vapor rectifier tube, a short circuit across the rectifier output will quickly ruin the tube and possibly damage the power transformer. An '80 tube should be substituted for the '83 when testing, if the trouble involves a complete or partial short of the high-voltage supply.

AUTOMATIC VOLUME CONTROL

A simplified schematic diagram of the AVC and "phantom tuning" circuit is shown in Fig. 3. As to the automatic volume control action, a portion of the signal exist-

SILVERTONE VOLTAGE DATA

Tube	Plate	Screen	Grid	Plate MA.	Screen MA.	Grid MA.
Trans.	190	60	+5	.4	.2	
Osc.	65	..	-10	4.	..	
1st I-F.	170	65	*	3.	.8	
2nd I-F.	200	65	*	4.5	1.	
Det.	170	40(a)	*	.2(a)	(b)	
Drivers	250	250	-10*	18	3.5	
Class B	370	5	+5	21-50(c)	.5-5(c)	1.8-11(c)
AVC	50	80	-10	(b)	(b)	
Phantom	45(a)	65(a)	*	(b)	1.25(d)	
Rect.	390 (max. d-c.)			70.0 (each plate)		

- * High resistance in series.
- (a) Phantom Tuning Control knob full to right.
- (b) Too low to read.
- (c) Latter value when loud signal is being received.
- (d) Phantom Tuning Control knob full to left (but not so far as to switch set off).

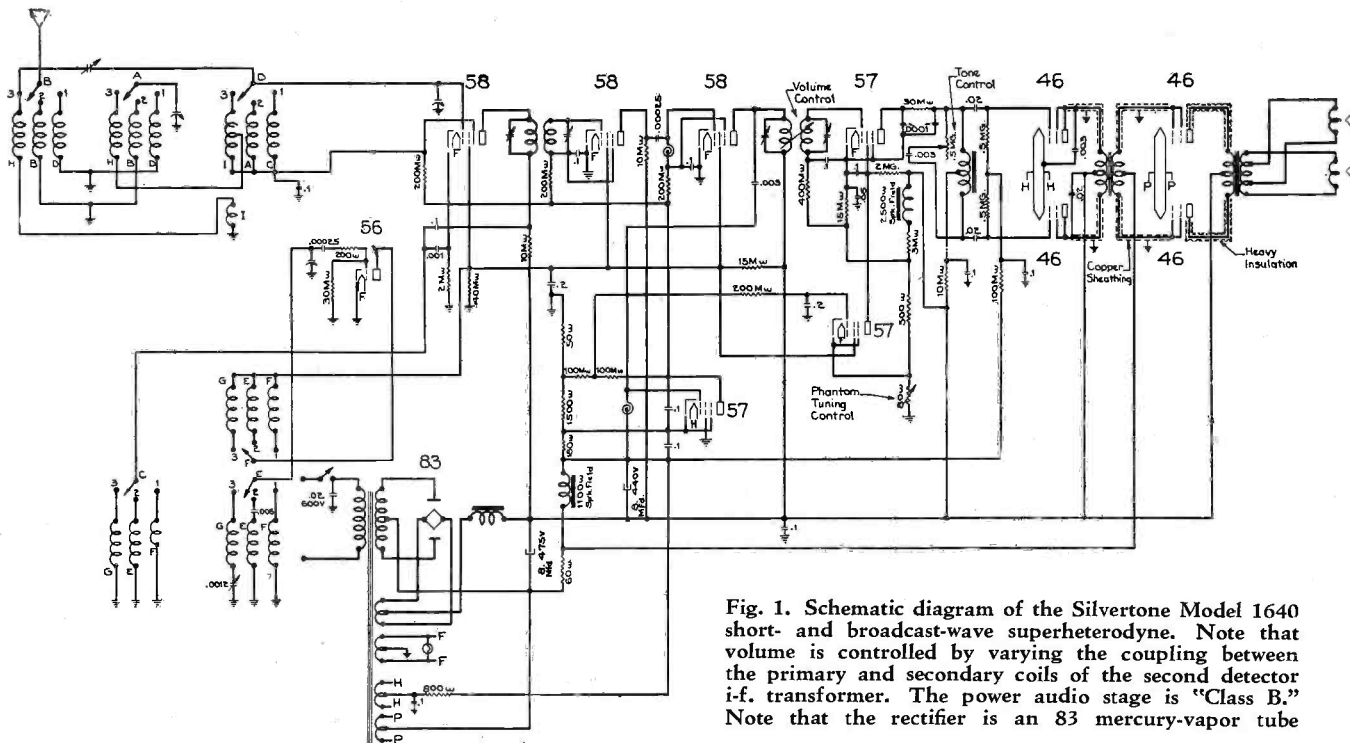

Fig. 1. Schematic diagram of the Silvertone Model 1640 short- and broadcast-wave superheterodyne. Note that volume is controlled by varying the coupling between the primary and secondary coils of the second detector i-f. transformer. The power audio stage is "Class B." Note that the rectifier is an 83 mercury-vapor tube

ing at the plate of the second i-f. tube is impressed on the grid of the type 57 AVC tube. Normally this grid is biased negatively by the voltage drop across R1, and therefore no plate current flows through R3. When the i-f. signal is impressed on the AVC grid, the positive halves of the cycle cause plate current to flow, creating a voltage drop across R3. Since R3 is also in the grid return circuits of the translator and i-f. tubes, the drop across it changes the amplification of these tubes by changing their grid bias. Therefore, the stronger the i-f. signal, the greater the negative bias and the less amplification.

The "phantom tuning" arrangement works hand-in-hand with the AVC, and automatically reduces the gain to zero between stations. Therefore, the receiver remains completely silent until a station powerful enough to insure satisfactory reception is tuned in.

"PHANTOM TUNING" CONTROL

Again referring to Fig. 3, the grid of the 57 "phantom" tube receives its bias from the drop across the adjustable resistor R4 from the drop across R3. The plate of the "phantom" tube and the detector screen are supplied from a common 2-megohm resistor. When a signal is received, the drop across R3 biases the "phantom" tube grid negatively, no plate current flows, and the only drop across the 2-megohm resistor is that due to the very small detector screen current. But, when no signal is impressed on the antenna, and therefore no voltage developed across R3, plate current flows through the "phantom" tube, producing a large drop across the 2-megohm resistor. As a result, the detector screen does not have proper voltage, the detector is made inoperative and there is no response to static and other noises. By adjustment of R4, the sen-

sitivity of the detector with respect to the strength of the incoming signal can be varied. When all the resistance of R4 is in the circuit, it provides bias high enough so that no "phantom" tube plate current flows, even though the received signal is very weak, and hence no drop develops at R3.

There is a condenser connected from one side of the power transformer primary to ground. It is effective in eliminating line noise only when the extension cord plug is in its receptacle in such direction that the condenser connects to the high side of the line. The plug should be tried in both

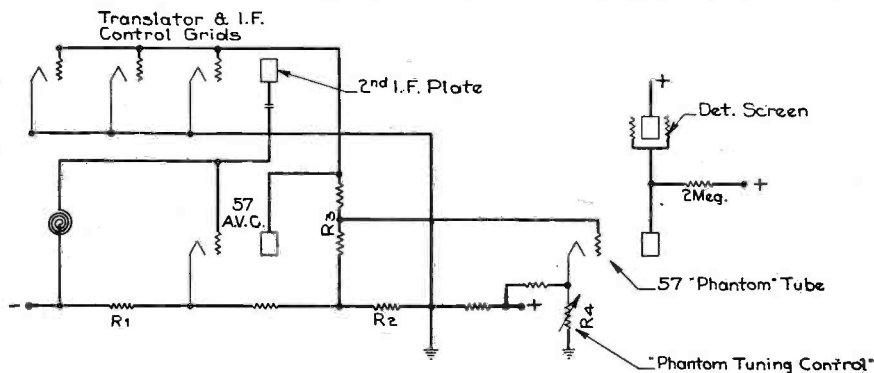

Fig. 3. The skeleton diagram of the automatic volume control and phantom tuning circuits. The operation of this system is explained in the text

Accordingly, the detector will be sensitive and the receiver will respond to weak signals.

The action is very sharp. If the control is set for satisfactory reception from a station of certain strength, the receiver will be silent to a signal of only 2 db. less strength.

In operation, turning the "Phantom Tuning Control" knob to the right increases the resistance of R4. It should not be turned further right than necessary for satisfactory reception of the desired station. However, it must be turned far enough to prevent the desired station from fading in and out abruptly. This happens when the knob position is almost but not quite far enough to the right.

of its possible positions and left in the one affording quieter reception.

VOLTAGE DATA

The voltage and current readings to be expected are given in the accompanying table. Control-grid readings should be taken on the 150-volt scale of a 1000 ohms per volt voltmeter; other readings on the 750-volt scale. These readings should be taken with no signal, except as noted in the table.

Fig. 2. Chassis layout of the Silvertone Model 1640. The locations of the adjusting screws for the 1st and 2nd i-f. transformers are clearly shown. Note from Fig. 1, however, that the first and second i-f. tubes are resistance-capacity coupled

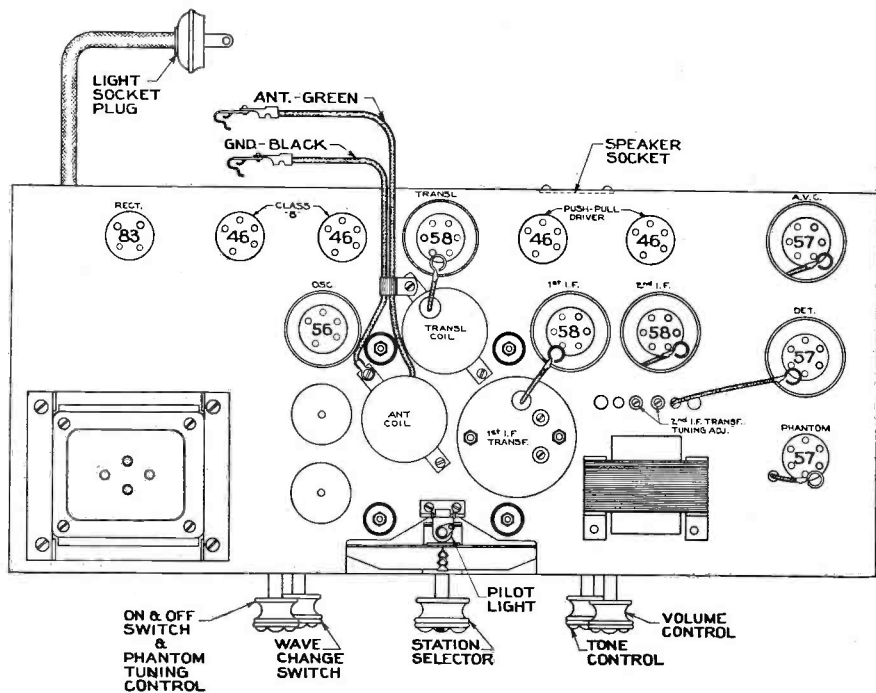

Shielding

Contrary to some recently expressed opinions, short-wave receivers or converters need not be shielded to the nth degree. Shielding is highly important, but is superfluous if carried beyond a certain point.

The reasons for shielding a short-wave unit are as follows: To prevent interaction between circuits; to prevent the pick-up of a-c. hum through induction; to prevent the pick-up by coils and r-f. transformers of both local electrical interference and strong signals.

A reasonable amount of shielding will take care of all the above problems providing said shielding is sensibly handled. The pick-up of strong signals by the coils is hardly ever sufficient to destroy the selectivity of the tuned circuits. Interference by induction is very seldom serious, and electrical equipment in operation near a short-wave receiver will cause more interference through the antenna system than it will through pick-up by the set.

The interaction of circuits is the most serious problem in most cases, and this is taken care of by the shielding of individual circuits. However, the smothering of a complete receiver or converter in a super-shielded metal case is quite unnecessary and in some cases actually detrimental.

Manufacturers have made a careful study of shielding for short-wave units, and the shielding employed is, in most cases, quite adequate.



Section of Reserve Stock of Exact-Duplicate Replacement Transformers

**REPLACEMENT
STANCOR EXACT
DUPLICATE
TRANSFORMERS**

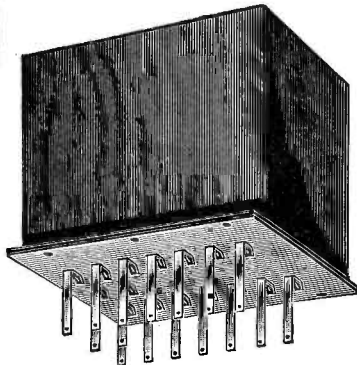
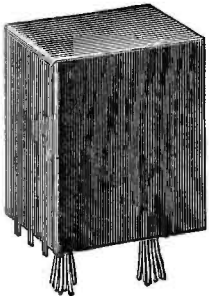
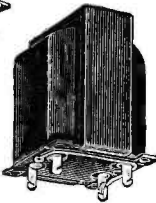
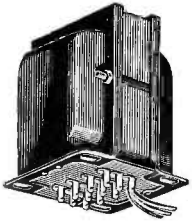
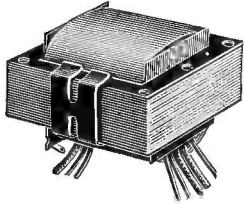
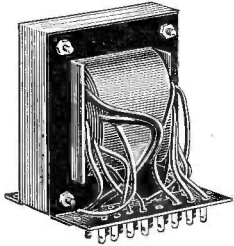
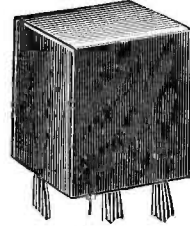

STANCOR ANTICIPATES THE NEW DEVELOPMENT IN THE INDUSTRY

The radio industry has entered that phase of its development when its product must render satisfactory performance over such periods of time as may be dictated by the user.

This inevitably requires that Replacement Parts, authentic in dimensions . . . certain in performance, and priced to permit a good profit be handy to the hand of the service men.

The staff of this organization, associated with the designing and building of high quality transformers since the inception of the radio industry, knew this condition was coming. In consequence there is today a thoroughly reliable source from which your distributor secures the Exact-Duplicate Replace-

ment Transformers necessary for you to be assured of maintaining the original performance of the sets you are called on to service . . . all makes and models.

Stancor Exact-Duplicate Replacement Transformers are made identical to the originals in all physical and electrical characteristics . . . no rewiring or re-fitting. They are distributed by responsible jobbers, distributors and dealers all over the United States.

Write to your nearest distributor for the new Stancor Catalog-Bulletin of Exact-Duplicate Transformers for all makes and models of radio receiving sets. If he cannot get it for you ask us—but he can and he will be glad to.

**STANDARD
TRANSFORMER
CORPORATION**

862 BLACKHAWK STREET

CHICAGO, ILL.

STANDARD TRANSFORMER CORP.,
862 Blackhawk St., Chicago, Ill.

Gentlemen:

Send me by return mail, your catalog of Exact-Duplicate Replacement Transformers, together with price schedule and name of distributor nearest me. Also put my name on your list to receive Catalog-Bulletin No. 3.

Name.....
Address, Street & No.....
City & State.....
Firm and Position.....

Public Address . . .

Acoustic Power Determination

The first consideration in the design of a public-address system should be given to the determination of the acoustic power required to secure adequate coverage of the areas to be served. This, of course, is determined by the acoustic character of the area and by the local noise level.

Fig. 1 is a plot of acoustic power as a function of room volume, taken from a number of sound-picture installations in theatres*. These values are based on experience and are therefore representative of average noise and acoustic conditions in sound-picture theatres. They must therefore be used only as a guide and must be increased to allow for noisy locations or decreased for quiet locations.

The shape of the room or hall cannot be entirely ignored, although unless its average ratio of height to width varies considerably from that of the average theatre of equivalent cubical contents, the difference will not be great. If the height of the ceiling is great compared to the width, less acoustic power may be required, and vice versa.

Acoustic power represents, of course, the actual power delivered to the air by the loudspeakers. To determine amplifier capacity, it is therefore necessary to know the loudspeaker conversion efficiency; that is, the ratio of electrical power delivered to the loudspeaker to the acoustic power it radiates.

A graph from which may be determined the acoustic power required for a predetermined room area

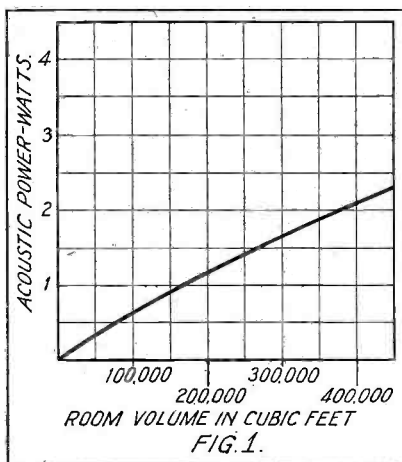

The efficiency of a loudspeaker is not constant with frequency, so that an average figure must be used. This average value is the figure generally quoted by manufacturers. For good baffle-type dynamic speakers, the average efficiency is about 5 percent, and for good horn speakers it may be 20 percent. To determine the required amplifier capacity, then, the wattage of Fig. 1 must be multiplied by 20 for good baffle-type dynamic

* "Loud Speakers for Use in Theatres," By L. G. Bostwick and D. G. Blattner, pp. 161. Feb. 1930, Journal, S.M.P.E.

Watts	DB. Level	Watts	DB. Level
.006	0	.95	22
.009	2	1.5	24
.015	4	2.4	26
.024	6	3.8	28
.037	8	6.0	30
.06	10	9.5	32
.095	12	15.0	34
.15	14	23.9	36
.24	16	37.86	38
.38	18	60.0	40
.6	20		

Figure 2

speakers, and by 5 for good horn-type speakers.

Amplifier gain is usually given in decibels (db.). It is very convenient to extend the use of this unit to the measuring of power levels. It is customary to assume zero level as 6 milliwatts (.006 watt). The table of Fig. 2 shows the relation between power level and decibels (db.) based on .006 watt as zero level.

Now let us work out a specific example. Assume the area of the hall is 200,000 cubic feet, which value we obtain by multiplying together the length, the width and the height. Referring to Fig. 1, we find that the acoustic power in watts required for this hall is 1.2. Now, if a horn speaker is to be used, we multiply 1.2 by 5, which gives us 6 watts as the actual acoustic power needed. Now, referring to Fig. 2, we find that 6 watts is equivalent to 30 db. Therefore, the amplifier to be used must have an output of 30 db., or 6 watts.

If a baffle-type dynamic speaker is to be used, we would multiply the 1.2 previously determined, by 20, which we find to be 24 watts. Since 24 watts is equivalent to approximately 36 db., the amplifier would require this output or power level.

Since music should be reproduced at a level about 6 db. (.024 watt) greater than speech under the same conditions, the system meets the requirements of both. If the system is to be used for speech only, about 19 db. power level in the amplifier would be sufficient when a baffle-type dynamic speaker is used.

If the number of speakers to be used exceeds one, the amount of power delivered to each will be reduced by a specific amount, though the acoustic power will be the same. The determination of the required amplifier power for a given number of speakers was covered in an article appearing on page 171 of the July issue of SERVICE.

Loudspeaker Installations

The companion article in this department on "Acoustic Power Determination" will assist you in computing the requirements for a given installation. The following data, supplied by the Engineering Department of

Racon Electric Company, will assist you in determining the proper connections for loudspeakers and the type of connecting lines to use under a given set of conditions.

To start off with, we must keep in mind that horn-type dynamic speakers (which are pretty general for P-A. work) employ units having an a-c. voice-coil impedance almost

universally standardized at 15 ohms. Since the plate impedances of power tubes are considerably higher than this value — and since we know that even a small impedance mismatch results in a considerable loss of efficiency—it is absolutely necessary to employ an impedance-matching transformer between the output of the power stage and the loudspeaker system.

Amplifier output impedances are also fairly well standardized, they being 4,000 and 500 ohms, and the amplifier output transformer is designed to match the tube output to one or the other of these values. Occasionally both these impedances are obtainable through a cross-strapping terminal arrangement.

Impedances can be matched only at one frequency. This has been generally set at 1,000 cycles and the assumption is usually taken that if the coupled impedances are matched at this frequency an efficient transfer of energy is obtained over the operating audio-frequency band.

CONNECTION METHODS

Taking for granted that separate coupling transformers are used, let us examine various connection methods. Since the voice-coil terminals connect directly to the coupling transformer secondary, we must arrange all matching connections on the primary sides of the coupling transformers which we will take to be 4,000 ohms in this case.

Now, take the case of two speakers. Usually the primaries of the two impedance-matching transformers used with these two speakers would be connected in parallel across the 4,000-ohm output of the amplifier. Obviously, these two 4,000-ohm primaries in parallel are equal to only 2,000 ohms, and therefore there would be a considerable mismatch—a 4,000-ohm output looking into a 2,000-ohm transformer system. The loss should then be considerable, but, strange as it may seem, in this particular instance the impedance relations are such that a fair degree of efficiency, with moderate quality, is obtained with load impedances ranging from 2,000 ohms up to 4,000 ohms. Therefore, when individual coupling transformers are used they can be paralleled in groups of two so that the effective load impedance will always be at least 2,000 ohms.

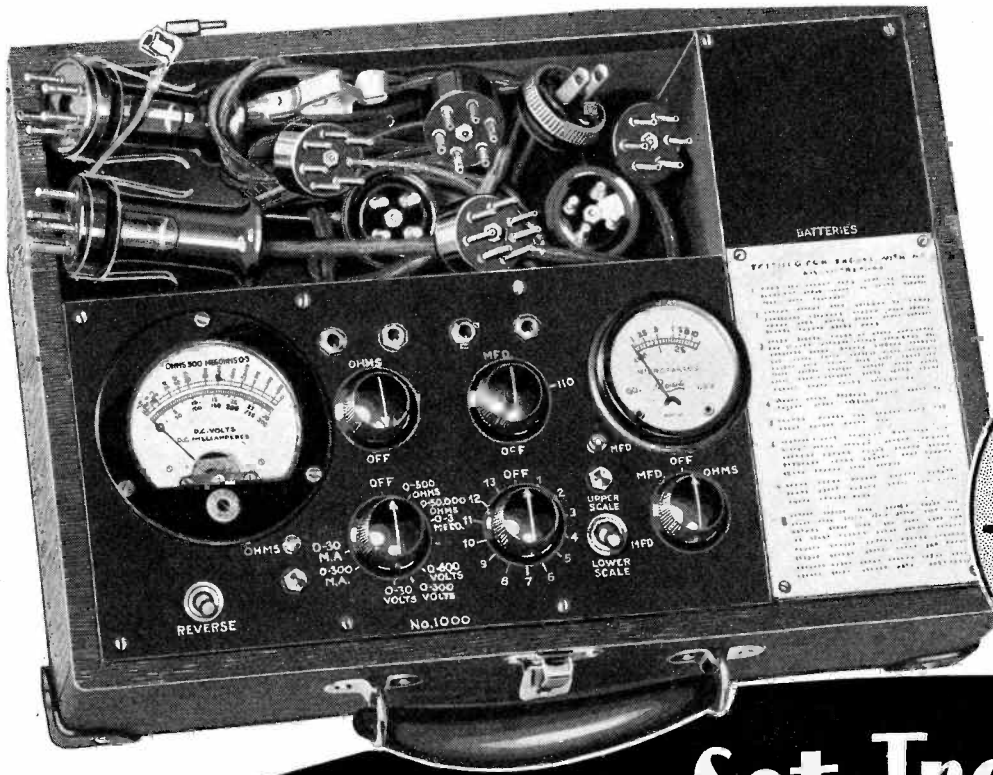

Only
\$33.00 NET
 TO DEALERS AND
 SERVICE MEN
 List \$55.00

NOW!..Locate Set Troubles Quicker and More Precisely!

HERE'S the new Readrite Tester that will make money for you—an instrument that give you a new conception of speed and accuracy—

an instrument that makes possible a new method of servicing. Because sets are becoming more complicated every day, testing socket voltages only is not enough to determine and locate set troubles. This new tester will enable you to quickly and precisely make a complete analysis of the set circuit from the set socket—including resistances, continuities, capacities, and short circuits. It will enable you to test any receiver no matter how complicated the circuit . . . without removing the chassis from the cabinet!

The 3 3/4" D.C. precision meter has full scale deflection of 1 ma. The lower scale is divided into 60 divisions of 0-30, 0-300 and 0-600 D.C. Volts and 0-30, 0-300 D.C. Milliamperes. The upper scale reading is in ohms and megohms. Three scale readings are available for resistance measurements, 0-500 and 0-50,000 ohms, and 0-3 megohms. Can also be equipped to test up to 6 megohms. This scale arrangement insures easy reading and enables resistance tests to be quickly made with extreme accuracy.

The A.C. meter is calibrated for reading directly in microfarads. The lower scale reading is .008 mfd. to .25 mfd. The upper scale reading is .1 mfd. to 10 mfd. Line voltage is also checked with

the A.C. meter. The instrument is calibrated for use on 60 cycles at 110 volts. The rheostat regulates the correct voltage to be applied.

Two plug-in cables and two separate cords are provided enabling testing (through the set socket) the resistance of voltage dividers, series resistors, transformer primaries and secondaries, filter chokes, shorts, opens, speaker fields—also capacities of paper and mica type condensers. Jacks are provided for individual tests separate from the plug connection for all the above, and, in addition, milli-ampere and voltage readings.

The case is strong and covered with fabricoid. The cover is removable. Battery compartment has separate panel. It contains two 22 1/2-volt batteries and one small flashlight cell. There is very small drain on the "B" batteries.

If your jobber cannot supply you, we will ship the No. 1000 Tester directly to you—when remittance accompanies your order at dealer's net price of \$33.00.

- TESTS**
- Voltages
 - Milliamperes
 - Resistances
 - Continuities
 - Short Circuits
 - Capacities

READRITE METER WORKS
 Established 1904
 25 College Avenue Bluffton, Ohio

MAIL COUPON NOW

READRITE METER WORKS,
 25 College Ave., Bluffton, Ohio.

Gentlemen:

Please send me information about Readrite No. 1000 Resistance, Continuity and Capacity Tester. Also catalog of other servicing instruments.

Name

Street Address.....

City..... State.....

It is often practical and economical to run individual loudspeaker lines at voice-coil impedance; i.e., 15 ohms. However, if this is done use no conductor smaller than No. 16 B & S gauge, twisted pair. Also, it is advisable in all cases to run the lines in conduit, with the exception of temporary outdoor systems, which may be run open. The total length of wire on any one group connected to the coupling transformer should not exceed 500 feet, where No. 16 wire is employed. Where No. 14 wire, or larger, is used, a slightly greater length is permissible.

When the speaker or speakers are to be operated at voice-coil impedance, an efficient coupling transformer having an adjustable secondary impedance is a necessity. See Fig. 1. It will be seen that the transformer has a dual-ratio primary of 4,000 ohms and 500 ohms, and four secondary values. From points 1 to 2 the value is 3.75 ohms; from points 1 to 3 the value is 5 ohms, etc.

In the case of two speakers used with this transformer, the voice coils would be paralleled across the terminals 1 and 4 (7.5 ohms) in order to obtain the proper impedance match.

SPEAKER GROUPS

For more than two speakers, various factors must be considered. Nevertheless, wherever possible and practical, speaker voice coils should be connected in parallel. Hence, for three speakers, a parallel connection giving a 5-ohm load impedance would be used ($15 \div 3 = 5$), and the voice coils would then be connected across the 5-ohm taps on the impedance matching transformer. This system will be perfectly satisfactory in all cases where the total length of wire between speakers does not exceed 500 feet.

Four speakers may be connected in two different ways; namely, parallel or series-parallel. With four voice coils in parallel, the impedance would be 3.75 ohms, and therefore they would be connected to the 3.75-ohm taps on the transformer. However, this is rather a low value of impedance with which to work over anything but comparatively short lines and therefore a series-parallel connection should be used. Such a connection gives a load impedance equal to the impedance of a single unit, provided the impedance of the voice-coil units are the same. Therefore, with four speakers in the series-parallel connection, the load impedance would be 15 ohms and the voice coils would connect to the 15-ohm taps on the impedance-matching transformer.

This same series-parallel connection is equally as satisfactory for groups of 9, 16 or 25 speakers. Thus, where either a number of groups are returned to a common distributing point; that is, to a single impedance-matching transformer, or where the groups return to individual transformers grouped together, the series-parallel arrangement can be utilized to obtain a workable load impedance.

The data that has been given above relating to operation at voice-coil impedance applies equally as well to operation of large numbers of speakers where the individual

speaker-matching transformer is used with each unit. A main coupling transformer, similar to the one shown in Fig. 1, but having different secondary impedance values is desirable in this case. The values generally are 600 ohms, 337 ohms, 150 ohms and 37.5 ohms. Generally the primaries of the separate unit transformers should be paralleled in order to obtain a load impedance equal or close to one of the above secondary values. In groups of 4, 9, 16 or 25 as above, the series-parallel arrangement can likewise be used.

SPECIAL CONSIDERATIONS

In planning installations, consideration should be given to the following points: Conductors to each loudspeaker should be twisted and the most satisfactory types are the No. 19 O.G. twisted telephone pair and the No. 16 twisted bridle pair. Single or bunched wires or parallel lay cables should not be used, nor should the BX type of cable.

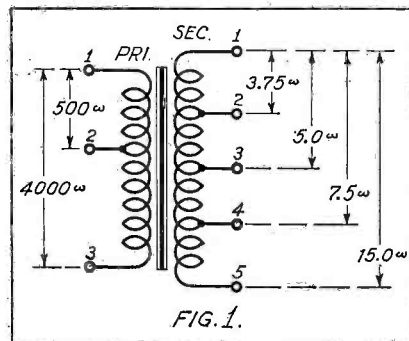

The general details of an impedance-matching transformer to be used between a line or amplifier output, and one or a group of dynamic speakers

For indoor installations, lines should be in rigid iron conduit wherever possible. Where conduit is not practical, or for outdoor permanent installations, a lead-sheathed, rubber-insulated cable is preferable.

The parallel connection of the voice coils of loudspeakers is best, since, aside from line loss, it allows uniform current distribution and avoids overloading in the case of various sized units whose impedances are the same. With the proper coupling transformers, the correct impedance match can be easily obtained, and a parallel further avoids the breakdown of the complete system in the event that one speaker should become open circuited.

When speakers are to be switched on and off individually, both sides of the line should be broken. When switching on the primary sides of the coupling transformers, no balancing impedance is necessary unless more than 25 speakers are on the circuit. While there is a justifiable claim for the use of a balancing impedance, it is more apt to prove itself a liability in power loss and breakdown than an asset in equalizing the load.

Next month we will give you some interesting data on a practical connecting panel which permits the convenient handling of a large number of speakers.

R-F DISTRIBUTION SYSTEMS

(Continued from page 276)

lected by the antenna to the transmission line. The transmission line running from this panel to the amplifiers is one of the vital features of the system. It is a "coaxial conductor," or a conductor within a conductor. This cable, which plays the part of the lead-in wire in the ordinary antenna system, consists of a single strand of No. 18 wire insulated with a special low-capacity rubber compound. Over this, copper braid is woven tightly and then covered with an impregnated cotton braid or, where exposed to the elements, lead sheath. The copper braid itself serves as a conductor. It is grounded and, by picking up outside radio interferences before they reach the inner strand and dissipating them, shields the transmission line itself. This cable can furnish a connection as long as 750 feet from the antenna panel to the amplifiers.

The transmission line terminates in a selective volume control panel. This includes five adjustable filters designed for use with a low impedance radio-frequency line. The filters reduce the signal strength from nearby radio stations to prevent overloading the radio receivers and amplifiers, without reducing the signal strength from other stations. The panel is associated with a power amplifier of the four-stage, untuned, push-pull type. This amplifier has a sufficient gain and power capacity to supply 750 radio sets and the system can utilize four such amplifiers, bringing the total sets to 3,000.

DEGENERATIVE CIRCUITS

Each stage of the amplifier is equipped with an adjustable degenerative circuit for suppressing second order modulation. This circuit prevents the production of "phantom stations" in the amplifier. All vacuum tubes used in these amplifiers are the indirectly-heated cathode type. This prevents the production of power hum usually experienced with filament type vacuum tubes heated directly by alternating current. The amplifier is self-contained with complete power supply. It operates on 50- or 60-cycle alternating current at 103 to 127 volts.

Ten lines issue from each amplifier, each line capable of operating 75 radio sets. The line from the amplifier to the furthest receiving set may be 750 feet long. Thus even in large buildings the entire amplifying equipment may be centralized at one point, such as the basement. The only apparatus needed at the point where each radio set plugs in is a small unit having an attenuator which prevents the sets from re-acting back onto the line.

In one of the smaller forms of the system, special amplifiers are eliminated. This form is designed to work with special radio receivers up to a maximum of 15. Each of these receivers contains its own amplifying equipment. Another of the smaller forms operating up to ten radio sets of any design, requires an amplifier for each set. The amplifiers, however, may be located at a considerable distance from their respective sets and can consequently be grouped together at any convenient point in the building.



15,000 STRONG

A Growing Army of Satisfied Customers

With one bound RADOLEK has sprung into favor with Radio Men everywhere—its Progressiveness, Prompt Service and Fair Dealing are winning and *holding* customers by the thousands!

You can rely on the experience and judgment of this army of Radio Buyers—the same straightforward dealing, fairest prices, civil and obliging service, backed by an alert and intelligent direction and management which has merited *their* loyalty, will please *you* also.

CERTIFIED MERCHANDISE

We are carefully building this great business on the sure foundation of *Satisfaction with Every Purchase*. Having such a purpose it is obvious that we would list nothing in our catalog which does not bear our own stamp of approval and which we can not guarantee. In selecting our merchandise we do not rely too strongly on the word of salesmen—we maintain a special laboratory where the items we list are given a thorough test before being accepted. We look beneath the "varnish and veneer," so to speak. We search for weakness and defects and discard every article we believe would in any way prove unworthy when placed to the test of actual use.

RADOLEK does not deal in reclaimed merchandise! When you place an order with us you get brand-new merchandise, guaranteed to be exactly as described and to fulfill its intended purpose. Remember this: What you get for your money is as important as the price you pay and it isn't exactly pleasant to send several hundred miles for an article only to find that it will not do the work after you have received it.

OUR OVERNIGHT SERVICE

Our location in Chicago, the very center of America and the Radio Industry, insures you better service. We make same day shipment of over 95% of our orders which means that, within a radius of 500 miles you get **OVERNIGHT PARCEL POST DELIVERY** and second day service for practically the entire United States.

A BIG NEW CATALOG NOW READY

Our new 1933 Radio Catalog is just off the press—the handiest and most complete handbook of Radio merchandise and information ever compiled. Every page is full of new items and from cover-to-cover it sparkles with interesting bargains. The Radolek Profit Guide grows from issue to issue—this one being bigger and better than ever before and we expect to do it better as we go along. Right now we have reached a point where we believe that we have accomplished something and we believe that you will agree with us in this when you have examined your copy.

ONLY QUALIFIED PERSONS RECEIVE THE PROFIT GUIDE

We believe that a house which sells at wholesale prices owes something to its customers beyond the mere gathering and selling of merchandise. We believe that we owe them every possible protection of their legitimate profits that we can give them by controlling the circulation of our catalog. We solicit the patronage of Dealers, Servicemen, Laboratories and Manufacturers only and limit the circulation of the Profit Guide strictly to those whom we believe to be entitled to buy at wholesale prices. We ask the cooperation of those who receive our catalog in keeping the prices quoted confidential. Please fill out the attached coupon for your copy if you are not already on our mailing list.

R
Enclose
with This
Coupon a Copy
of Your Letter-
head or One of
Your Business Cards.

PLEASE FILL OUT COUPON IN DETAIL!

Do You Do Radio Service Work?
 Yes No
 Do You Operate from a Store or Shop,
 or from your Home?
 Store or Shop Home
 What Testing Equipment Do You Have?

What Training Course or Experience Have You Had?

PLEASE SEND ME THE NEW RADOLEK PROFIT GUIDE

Name
 Street Address.....
 City..... State.....

THE RADOLEK Co.
 601 W. RANDOLPH ST.
CHICAGO, ILL.
 PHONE MONROE 5434

CONTROLS

Voltage Fluctuations

Automatically!

WHEN you tell your customers about AMPERITE Voltage Control, you do them a favor. When you install AMPERITE, you give SERVICE in its finest sense.

AMPERITE improves radio reception, by automatically controlling voltage variations. AMPERITE also protects tubes and expensive parts from overloading.

Easily installed, in five minutes, in any electric radio.

Help your customers by recommending AMPERITE. An attractive profit, too, for you.



Send \$1.40 to Dept. S-10 for sample and sales helps.



Make More Money

on service jobs!

Learn by advanced training what you can't learn by experience.

Mr. E. H. Rietzke, Pres. Capitol Radio Eng. Inst.

... FREE

This interesting booklet that clearly explains how Advanced Training means more money to you. . . .

Raise yourself above the average, by combining your practical experience with the valuable knowledge offered in this home study course—which gives you the thorough knowledge and ability to intelligently handle the many intricate problems that confront the service man.



MAIL THIS TODAY!

Capitol Radio Engineering Institute
14th and Park Road, N. W., Washington, D. C.

Please send me your Free 28-page booklet, "Practical Radio Engineering," at no obligation to me.

Name

Address

S-10

FREE Brass-Fitted, Leatherette-Covered SERVICE KIT

JUST the thing every service man needs! Easy to carry!—and provides ample space for tools, small parts, 20 assorted tubes, a coil of wire, literature, etc. This kit is sturdily constructed, handsomely finished. It's planned by radio experts for radio experts! Speeds up work, impresses customers with your neatness, efficiency and professional standards.

Get the Sylvania Service Kit FREE! All you do is send us your purchase order for 75 assorted Sylvania tubes—any 75

you want—to be billed through your regular jobber. You will receive your Free Sylvania Service Kit at once.

If you want—order 25 tubes at a time—when you've placed 3 such orders you will receive your kit!

Your customers know that Sylvania tubes have been "tested for a set like yours." When you use Sylvania tubes steady consistent newspaper and radio advertising helps you make quick easy sales!

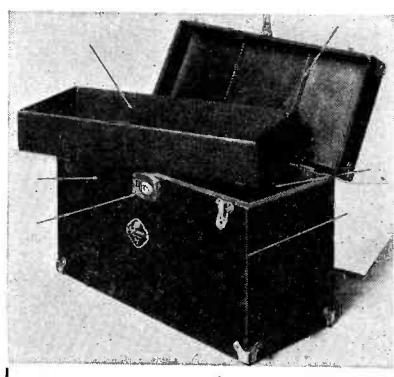

- #### 6 IMPORTANT FEATURES
1. Convenient Tool Tray—plenty of room for aerial wire, etc.
 2. Heavy Brass Finished Lock.
 3. Finished in Black Leatherette.
 4. Elastic Straps for Advertising Material.
 5. Capacity up to 20 Tubes.
 6. Rugged Construction, Professional Appearance, Large Capacity.

Hygrade Sylvania Corporation, Sylvania Division, Emporium, Penna. Date.....

We are anxious to have a Sylvania Service Kit, and attach our purchase order for 75 25 assorted Sylvania Radio Tubes to be billed through

.....
Jobber's Name

Name..... Signed.....
Address.....

S-10-1



HIGHLIGHTS . . .

Movie Accuracy

Let it be known that we are sick of reading notes and publicity blow-ups regarding the extraordinary technical accuracy adhered to in the making of movies.

Claims are continually being made that the movie folks are hounds for detail. No expense is spared to obviate the possibility of offending professional folk, who naturally dislike seeing their pet professions departing from cold fact.

Well, we are sick of all this talk. "The Devil and the Deep," produced by Paramount, left us with the jitters. One scene showed the radio equipment on a British submarine. The equipment consisted of one old Mignon radio receiver, a few coils strung thither and yon, one National Dial . . . and a signalling oscillator employing a Western Electric E tube!

But the crash came when one bad hombre, bound for dirty work, slithered up to the filament wires of the E tube with a pair of cutting pliers. Snip, went one wire under the bite of the pliers, and out went the tube filament. Then—and this fellow was supposed to understand the operation of the equipment—up came the pliers and snip went the other filament wire! Could it be that he wanted to be doubly sure that old man tube would remain dark?

Man, *are we* sick?

Stumped

The Advertising Manager of this here magazine spends a good portion of his evening hours submerged in the short-wave bands. One evening while thus occupied he received a phone call from one of these "trained" advertising investigators who bother you as to what radio program you are listening to.

Said the investigator, "Have you a radio?"

Said our Advertising Manager, "Sure."

"What program are you listening to?" asked the female questioner.

"I'm listening to the short waves," replied our bread winner.

"Oh!" exclaimed the female brain, "so, you *haven't* got a radio" and slammed down the receiver in much disgust.

Mike Monikers

Though b.c. stations, networks and newsreels have used a name plate for their mike stands, the practice has not been so general with Hams, remote installations and public-address systems. But hereafter, unless ordered to the contrary, mike stands of most all types, made by the Universal Microphone Co., Inglewood, Cal., will all be equipped with call-letter name plates. Letters may be painted or cemented on the name plates.

What's Missing?

Bet a lot of you fellows think we run this magazine to suit ourselves. We don't. As a matter of fact, we stay awake nights wondering if we are giving you the sort of data you really need—and wondering at the same time

how many things we may be slipping up on.

After all, this is your magazine, and we would be ever so much obliged if you would tell us occasionally what (or what not) to run. Come on now, what's missing? (*But, no wise cracks, please.*)

A Fact

You'll never lose a customer by courteously answering his fool questions, while he pays for your time.

Now It's Out!

The idea of the 6-pin base is that it permits you to connect several socket terminals together so as to get the effect of a 5- or 4-pin base.

Modern Radio

Easy-Chair Gadgets

When we say "Easy-Chair Gadgets" we mean Radio Convenience Outlets. Yaxley has prepared a treatise on the subject, and even feature the portable control used at The Hague Peace Conference and Geneva League of Nations Conference, those formidable bodies of argumentation.

The treatise is in the form of a bulletin, and also has dope on outlets for radio and public-address installations in single and multiple gang combinations, with selector switches and volume controls included.

Said bulletin is known as Form S-80. Yours for the asking.

ON THE JOB

(Continued from page 286)

the lines are left blank, together with two extra lines at the bottom for inserting additional measurements that the circuit diagram may indicate as desirable. The blank should always be used in connection with such a circuit diagram.

Another feature of the chart is the setting off of the columns for thousands of ohms and millions of ohms with double lines. In the case of a measurement made in megohms, for instance, it is necessary to write only one figure in the proper column. The six ciphers or the abbreviation, "meg." are not needed.

Such charts are reproduced very reasonably in lots of 500 or 1,000, by printers who use the lithotone or offset process of printing. (The chart may be easily reproduced directly from this page, using the process mentioned.—Ed.) A chart of this kind is a real necessity for keeping resistance data in proper shape without loss of time.

THIRD PRIZE PROFITABLE HINTS

By E. M. Prentke

In servicing radio sets, one learns many things which add to his earning capacity as well as to his fame. Here are some ideas which have helped me to earn many extra dollars.

The first is the sale of some small article which is in demand by housewives. I carry

a new type electric appliance plug that has no screws to get loose. It costs 19 cents and sells for 50 cents installed. I have no trouble selling one in each three homes where I call.

And here is an idea I use three or more times a day. It is a card file in which I record the names of customers who are prospects for tubes, service, sets, etc. The headings are as follows: (a) Prospects for repairs; (b) Prospects for new tubes; (c) Prospects for new sets; (d) Prospects for extra speaker; (e) Prospects for ear-aid devices; (f) Radio sets being rented; (g) Customer's used sets and speakers available.

I go through this file often, and telephone the various prospects. It certainly gets the business which might otherwise be forgotten.

The next stunt is the use of Willard "B" Eliminator Solution for replacing the chemical in the rectifiers of Argus radios. There are many of these sets in Cleveland, and the genuine solution is not available here, and is very expensive if purchased from the one company which still has it. I buy 5/16-inch aluminum rods and cut them to size for the anodes. The other electrode is permanent.

The next four items are in the nature of advertising aids, and are: First: when servicing a receiver, TACK one of your cards to the back of the set, and SHOW the customer where it is.

Second: When calling on a person who lives in an apartment, always leave a card or blotter in each mail box on your way in or out of the building.

Third: Take advantage of the advertising aids given free by tube manufacturers. I send out or leave in customers' homes, Program Booklets and Bridge Score Pads which I obtain free of charge from one distributor of radio tubes.

Fourth: Have your name, phone number, and Radio Service title painted in brilliant letters on your portable tube tester or analyzer. This is a fine reminder, as well as protection against theft of valuable instruments.

HONORABLE MENTION CURING NOISY VOLUME CONTROLS

By Ralph W. Cutts

Noisy volume controls in many circuits may be silenced or greatly subdued by shunting them with electrolytic condensers of from 2 to 8 mfd. capacity. The cartridge type dry electrolytics may be used where space is at a premium, paralleling them to secure the necessary capacity.

Care must be taken to give proper polarity and to use sufficiently high voltage ratings for the particular circuit.

We found this a sure cure for screen-grid potentiometers, such as in the Zenith 50, 60 and 70 series, in which we connect the condenser from the arm of the potentiometer to ground.

This arrangement of course cannot be used in some circuits where it would by-pass the signal to ground as, for instance, in circuits where the volume control is in the antenna-ground circuit.

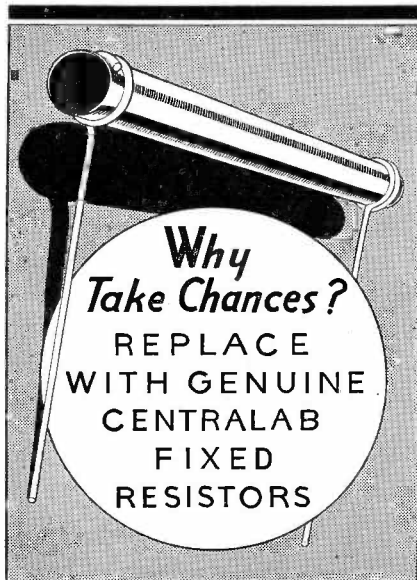

**Why
Take Chances?
REPLACE
WITH GENUINE
CENTRALAB
FIXED
RESISTORS**

**CENTRALAB
FIXED**

RESISTORS are Baptised with Fire in the making and will withstand a greater load than any other composition resistor of equal size.

Packed in handy carton of 10. Your choice of resistance values.

Centralab

Central Radio Laboratories

Milwaukee, Wis.

The CARTER GENEMOTOR

The
Original
"B" BATTERY
ELIMINATOR
for
RADIOS
in
AUTOS
BUSSES
BOATS
PLANES, etc.

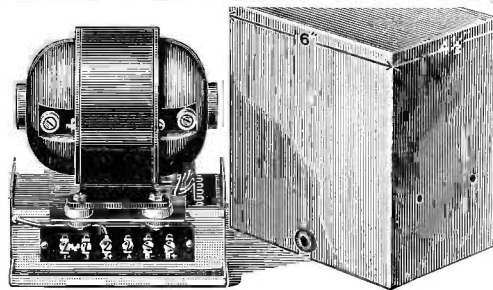

No. 4680A—180 Volt—\$21.00

Single-unit generator and motor eliminates "B" batteries for auto radio. More volume, clearer reception, more stations. No noises; requires no shielded wires. Smallest size—only 4½ x 6 x 6¾"—easily installed. No parts to wear out or replace. Lowest amperage of any eliminator. Guaranteed one year, against electrical and mechanical defects and performance failure. Made by one of radio's pioneers.

SEND NOW FOR PARTICULARS

Successfully operated for three years in Planes, Busses, Pleasure Cars, Sound Trucks, and Police Cars in continuous use. Write today for full particulars—say whether dealer, service man, or individual user.

CARTER GENEMOTOR CORPORATION

361-65 W. Superior St., Dept. 10 Chicago, Illinois

A. J. CARTER, Pres.

**Makes AUTO RADIOS
ALL ELECTRIC**

More Capacity At Less Cost

Latest electro-chemical research by the oldest and largest exclusive condenser manufacturer is reflected in the present large and varied line of



**DUBILIER
ELECTROLYTICS**

Available in all types—round and square metal cans, cardboard containers, tubular paper wrappings, high-voltage, low-voltage, tapped units, etc. Positively guaranteed for quickest reforming time, lowest leakage, highest working voltage, longest life. And they cost less!

Write for literature on Dubilier Electrolytics as well as all other types of condensers for every radio need.



DUBILIER CONDENSER CORP.
4377 BRONX BLVD. NEW YORK CITY



FILTERIZERS



**LICK
YOUR
WORST
ENEMY**



MAN-MADE STATIC

HERE it is! The "something to put on the radio set" that service men have been looking for ever since eruptions of man-made static began spoiling radio reception.

THE Tobe Filterizer Kit keeps radio noise out of the receiver by the simple method of filtering the power input to the set, providing an aerial outside the field of radio noise, and carrying broadcast signals to the receiver thru a FILTERIZED lead-in system.

TO any receiver—anywhere—add the Tobe Filterizer. The result—instant relief from man-made static.

EVERYONE wants relief from radio noise. The Filterizer provides this relief. Tobe's greatly increased appropriations for consumer advertising give you additional assurance of a tremendous demand for this sensational new development.

DON'T be caught napping. Place your orders today for immediate delivery.

Send 25% Deposit With Your Order.

Price \$9.75—Regular Dealer Discount Allowed.

NEWARK ELECTRIC CO., 226 W. MADISON ST., CHICAGO, ILL.

THE FORUM . . .

Wow!

Editor, SERVICE:

Here is a question that I have pondered over a great deal and, no doubt, many readers of SERVICE will be interested in the solution of what seems a deep mystery.

Why was it necessary to invent a color code to designate the value of resistors?

The solution to numerical expression was very nicely evolved by the Arabs several centuries ago, and the Arabic figures are universally used. Why "tip the applectart over" at this late date?

Perhaps there is some esthetic appeal in this writing numbers in color. I can imagine that such a practice would have a profound influence on the postman if such a system were adopted for house numbers. Just imagine the beauty of your letterhead with your address in colors. Then, again, maybe we are just getting into step with other arts. The Chicago Opera, I understand, has developed an organ for expressing music in color.

Anyhow, it doesn't seem possible that our great engineers can find no other satisfactory method of indicating the ohmic value. An imprint or a band ought to be feasible and, certainly a lot easier to read.

The code is not without advantages, though, for much like a doctor's prescription, it prevents the would-be "Mr. Fix-it" from doing the simple jobs and so increases the total income of the service fraternity.

Well, "the world do move," and, no doubt, before long we will need a color code or something for all these new tubes that are endlessly arriving. I suggest hieroglyphics; then no one will understand them except the well-versed initiated.

"A Reader."

Resistance Readings

Editor, SERVICE:

It makes no difference on what side you argue the point—some common sense must be attached to resistance readings. The values given in Table 1, page 233, of the September issue of SERVICE has been compiled from theoretical values. The lists are the result of "electrical bookkeeping," adding the net theoretical resistance from point to point. But when the Service Man measures this resistance, what is he to assume as being an acceptable value?

Let us take a very simple case—the resistance from r-f. control grid to chassis given as 4,000,000 ohms. In tracing through the circuit, we find that it consists of 1,000,000 ohms, 2,000,000 ohms and 1,000,000 ohms, all in series. Suppose we measured it. What would you accept and what would you reject? Let us say that we will measure it with a Wheatstone bridge so there will be little current through the resistors, thus approaching actual conditions. Let us assume that it is a precision bridge so that its error may be neglected. Even under these conditions, would you reject anything differing widely from 4 megohms?

The manufacturers in accepting these resistors for use insist on 10 percent accuracy. Can we say that the final check is 10 percent of 4,000,000 ohms, a deviation of 400,000 ohms? In other words, will we accept as correct any condition between 3,600,000 and 4,400,000 ohms? The truth of the situation is that we are too strict.

In the study of precision measurements we are told that the total deviation is the square root of the sum of the square of the individual deviation. Now, let's go back. The deviation of each 1,000,000-ohm resistor from the 10 percent acceptable figure is 100,000 ohms, plus or minus—for the 2,000,000-ohm resistor, plus or minus 200,000 ohms. What then is the most probable deviation? From the formula expressed above we get:

$$\begin{aligned} \text{Total deviation} &= \sqrt{100,000^2 + 100,000^2 + 200,000^2} \\ &= \sqrt{10^{10} + 10^{10} + 4 \times 10^{10}} \\ &= \sqrt{6 \times 10^{10}} \\ &= 240,000 \text{ ohms} \end{aligned}$$

Thus, the acceptable value would be between 3,760,000 and 4,240,000 ohms. This deviation is less because, in all probability, the overvalues of one resistor will partially balance out the undervalue of the other, etc.

Now, assuming that you use an ohmmeter whose precision when sending current through a carbon resistor may be at least 10 percent. The probable reading will be altered if the error introduced by the meter is 10 percent of the total, or 400,000 ohms. The total possible deviation is:

$$\begin{aligned} \text{Total deviation} &= \sqrt{240,000^2 + 400,000^2} \\ &= \sqrt{5.7 \times 10^{10} + 16 \times 10^{10}} \\ &= \sqrt{21.7 \times 10^{10}} = 470,000 \text{ ohms} \end{aligned}$$

Using an ohmmeter, any value from 3,530,000 to 4,470,000 would be acceptable. You might read a greater deviation but the likelihood is very small.

And when you come to measure resistance in parallel and series combination, the probable deviation is far more difficult to figure.

It is obvious that in many cases the total deviation may be as great as the value of one or more resistors. All this means that the readings taken by Service Men must be tempered by common sense. Either the manufacturers must give the limits of resistance between points or the Service Man must supply the logical reasoning.

JOSEPH KAUFMAN,
Supervisor of Education,
National Radio Institute

(Thank you for this information. The time is not far distant when every wiring diagram will bear specific reference to the tolerance values employed in selecting the resistors. Furthermore, there shall appear in a subsequent issue of SERVICE a résumé of tolerance values applied to resistors as determined by the engineering staffs of the radio receiver manufacturers. As to common sense . . .

the modern Service Technician, as a result of training and practical experience, has acquired this trait and is daily exercising it. The reason for the use of what you call "electrical bookkeeping" is that any such tabulation must of necessity provide a basis for comparison and this basis is the accurate total of the resistance in any circuit, assuming that each and every resistor is accurately rated. If this figure were not given there would be no basis for the tolerance value.—
Editor.)

Favors Flat Rate

Editor, SERVICE:

Your editorial on service charges in the May issue of SERVICE was very timely.

Your request for thoughts from Service Men to help in formulating some plans to acquaint the public with the fact that service charges have become flat rates should meet with hearty approval. There has been more or less chaos in this part of the radio field since its inception as a household necessity.

The flat rate is preferable. Then the customer knows what the cost will be and will not be quite so reluctant in having the work done.

The cost of receivers, as a result of wholesale dumping on the market at extremely low prices—in many cases at less than cost of production in order to make room for new and vastly improved sets—and the parts for these receivers are listed at their original prices, which is way out of line with the cost of the completed receiver, makes servicing of these sets unprofitable.

The Service Man, being in business for profit like everyone else, must charge a fair price for the products he handles. To sell at cost places him in unfair competition with his fellow Service Men.

Any Service Man, even though he has just entered the field, should be able to determine with sufficient accuracy, after the examination of the layout of a receiver, the amount of time necessary to make repairs and the cost to the customer. Of course, the charge must be kept within reasonable limits . . . or if the job is bound to be unprofitable otherwise, not to accept the work.

The working out of any plan in which the public will be served at a reasonable cost and the Service Man will make a reasonable profit commensurate with his training and overhead expenses, will bring about the solution of many complicated problems the factors of which are well known to those associated with the radio industry.

When an analysis is made of what the public wants and is willing to pay for service work, and the competition of the mail order houses is taken into consideration, it becomes obvious that the Service Man has to fight for what he gets.

RUDOLPH POTTKAMP,
St. Joseph, Mo.



CLAROSTAT Replacement Volume Controls are "Custom-made" to exactly suit the receivers for which they are offered. Not a makeshift job lot idea.

The resistance, taper, shape and shaft are made according to the proper specifications.

There is no delay in installing them. There are no comebacks when you use CLAROSTAT products.

See the new CLAROSTAT CONTROL HANDBOOK AND CATALOG for 32 pages of dope for servicemen. Send for your FREE copy.



CLAROSTAT Mfg. Co.
285-287 N. 6TH ST. BKLYN. N.Y.

A MODERN TESTER

Geared to the Times
in
PRICE and VALUE

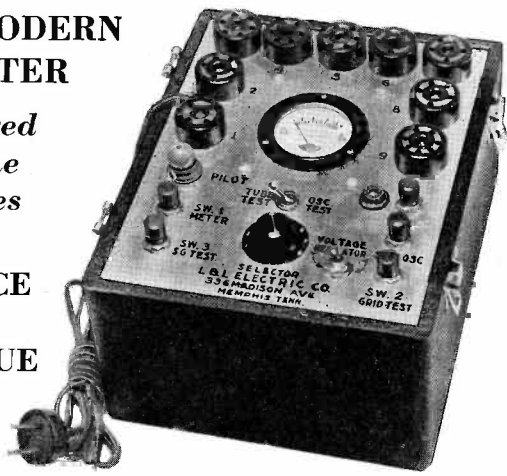

● Model E 33 L & L TUBE TESTER. Tests 4, 5, 6 and 7-prong tubes. No adapters required. IMPROVED AND MODERN. Tests the new 55-56-57-58, the 41-42-43-44, Majestic Duodiode, Speed 295, Wunderlich 5- and 6-prong and BOTH PLATES of 280, 282 and 283 tubes. Has SHORT TEST; GRID CHANGE TEST; OSCILLATION TEST; TOTAL EMISSION TEST and VOLTAGE ADJUSTMENT Line Variation on 90-130 Volts. Provision made for FUTURE TYPE TUBES. WILL NOT BE OBSOLETE. Formica lettered bakelite panel. Mounted in veneer case, imitation leather covered. Top and carrying handle provided.

Net Price to Dealers and Service Men \$19.80

Descriptive circular mailed on request

L & L ELECTRIC COMPANY
336 Madison Avenue Memphis, Tenn.

SERVICE MEN!



NEW 1933 CATALOG
Just off the Press! Be sure to write for FREE COPY

REMARKABLE VALUES ON REPLACEMENT PARTS!

Make "Wholesale Radio" your replacement parts headquarters! We maintain a huge stock of REPLACEMENT PARTS FOR ALL SETS. Brand new factory merchandise at lowest wholesale prices. A guarantee of satisfaction on every purchase. Immediate service.

New Catalog READY!

Write for *Free Copy* of our latest catalog, featuring LAFAYETTE SETS, TRUTEST PARTS, nationally-advertised tubes, kits, speakers, amplifiers, public address systems, etc. Keep in touch with the newest developments in radio by sending us your name and address. *Write today!*

WHOLESALE RADIO SERVICE CO.



100 SIXTH AVE.
NEW YORK, N.Y.



NATIONAL DISTRIBUTORS

- Impedance Chokes for Superheterodynes
- Power Supply
- Input and Interstage
- Filament Supply
- Microphone
- Short Wave Adapter
- Class "B" Amplifier Power and Audio
- Power Amplifier

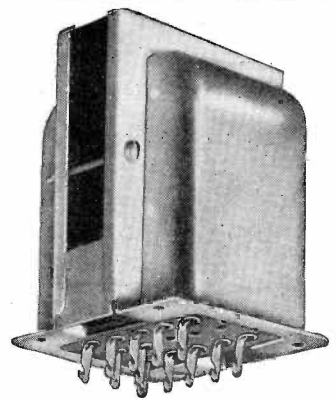

REPLACEMENT TRANSFORMERS

QUALITY at BIG SAVING

A very complete line—in many cases duplicating original specifications—and always guaranteeing equal or better Electrical Characteristics. Precision-made for exacting Service Engineers. All General Transformers are built from finest materials and pass rigid inspection before shipment. Prompt shipment . . . lower cost . . . no sales tax. Send NOW for Price List and FREE Circuit Diagram for NEW Class "B" Amplifier, and name of a Distributor near you.

GENERAL TRANSFORMER CORPORATION
1904 KILBOURN AVENUE, CHICAGO, ILLINOIS

General Transformer Corp., 1904 Kilbourn Ave., Chicago, Ill.
Send me, without obligation, your Price List and include FREE Circuit Diagram for NEW Class "B" Amplifier.

NAME

ADDRESS

THE MANUFACTURERS . . .

J. R. C. 2-Watt Resistor Kit

The International Resistance Company has placed on the market a 20, 2-watt resistor kit. The values enclosed in this kit range from 500 ohms to 1/2 megohm and cover the most popular resistance values used by Service Men in their replacement work.



There is enclosed in each kit an information folder which shows how to obtain thousands of resistance values from these 20 resistors.

Ohmite 20-Watt "Red Devils"

The Ohmite Manufacturing Company, of Chicago, have added fifteen new high-resistance values to the forty-two values now sold. The new units are also of the wire-wound type and range in value from 30,000 ohms to 100,000 ohms in steps of 5,000 ohms.

Because of the greater amount of wire needed to obtain the high-resistance values, the size of the units above 30,000 ohms is slightly larger than that of the lower values, the length being 2 inches and the diameter 7/16 inch. These larger units are rated at 20 watts.

The Ohmite line now consists of "57 varieties" ranging in value from 1 to 100,000 ohms.

Acratest Power Amplifiers

Acratest Products, through their distributor, Federated Purchaser, Inc., have announced two new power amplifiers designed



for universal input and output impedances.

The Model 101 is a three-stage, push-pull 250 amplifier, using 1-58, 1-56, 2-250's and 2-281's. The available input impedances are 200, 500 and 7,500. The available output impedances are 9, 15, 500 and 4,000 ohms. The 9- and 15-ohm windings are isolated from the higher impedances. The amplifier has a built-in volume control with gain plate. The power output is given as 11 watts with less than 4 per cent second harmonic distortion. The gain is given as 87 decibels.

The Model 107 is a two-stage, push-pull Class A prime amplifier, using 2-57's, 2-245's and 1-280 tube. The input impedances and volume control are identical to those of the Model 101 amplifier. The output impedances are 10-15 ohms and 4,000-8,000 ohms. Power output with less than one per cent second harmonic, 4 watts. The gain is given as 78 decibels.

Janette Electric Plants For Sound Trucks

The Janette Manufacturing Co., of 554 West Monroe Street, Chicago, announce a line of gas-engine-driven generators for use with sound truck amplifiers. These units consist of a single-cylinder, 4-cycle, air-

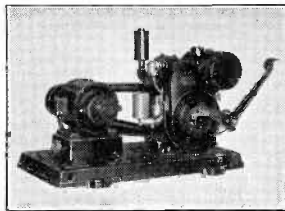

cooled gasoline engine connected to a generator delivering 110-volt, 60-cycle a-c. The entire unit is mounted on a cast-iron base and when ordered for sound truck service comes equipped with filter and shielding.

These Plants are available in five sizes, developing 300, 500, 750, 1,250 and 1,800 watts, respectively.

Franklin Tube Checkers

The Franklin Radio Corporation, of Dayton, Ohio, has brought out two new tube checkers. The model H-33 will test all tubes announced to date, including the 83, 85 and 89. Provision has also been made for testing the 6.3-volt series of six-prong tubes and the 2.5- and 6.3-volt series of seven-prong tubes.

Unlike many tube checkers, the Model H-33 tests tubes under the same conditions as found in a radio receiver, namely, a d-c. rather than an a-c. potential is impressed on the plates and grids of the tubes, and the



recommended voltages are used. The d-c. potential is obtained through the use of rectifiers.

In addition to testing tubes, the Model H-33 checker will make circuit, continuity, and point-to-point tests on radio receivers, and test all types of condensers and resistors.

The Model D-33 checker is identical to the Model H-33 in every respect, except that Model D-33 does not have provision on the end of the instrument case for continuity tests, etc.

Electrad "T" Pad Attenuator

Electrad, Inc., of 175 Varick Street, New York City, are now marketing a group of Constant Impedance "T" Pad controls for the controlling of volume of microphones, electric phonographs, talking-picture amplifiers and other sound amplifying and distribution systems. Constant impedance is maintained throughout the adjustment of the knob. These units may be obtained to work in connection with lines with the following impedances: 15, 200, 500, 3,000 and 5,000 ohms.

WE CAN'T PRINT 'EM FAST ENOUGH!!

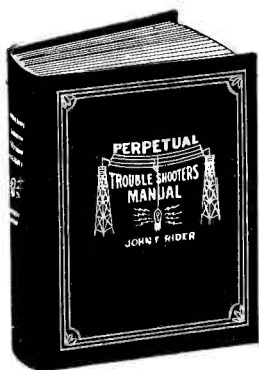

DON'T BLAME YOUR DEALER if he can't supply your Manuals fast enough. We are shipping Manuals as fast as we can print them. All of our print orders have been increased—yes, more than doubled in order to meet the tremendous demand.

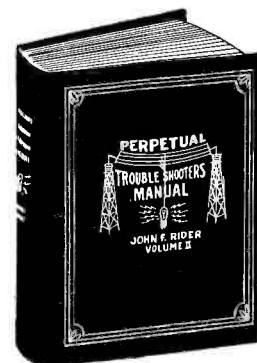

VOLUME I.—THERE IS NO DUPLICATION IN THE TWO MANUALS—VOLUME II.

This Volume is the nucleus for the Perpetual Trouble Shooter's series. It has about 1200 pages of wiring diagrams, chassis layouts, color coding, electrical values, alignment data, etc., covering commercial receivers and power packs manufactured between 1919 and early 1931.

This Volume picks up where Volume I left off. Its contents consist of approximately 800 pages of wiring diagrams, chassis diagrams, socket layouts, color coding, adjustment data, electrical values of all receivers, including Atwater-Kent receivers, intermediate frequencies and point-to-point resistance data.

RIDER'S MANUALS have become the *standard* in the radio service industry. Service Men—service organizations—radio dealers—jobbers—sets and parts manufacturers—schools and libraries are purchasing these volumes in greater quantities than ever. Yes, we know why Service Men and organizations, who in the past, were purchasers of other manuals—have today switched to Rider's "Perpetual Trouble Shooter's Manual" . . . *The men themselves—our customers—have told us.*

SERVICE MEN, service organizations and dealers and jobbers have switched to Rider's Manuals because they have compared—examined the different manuals and have found what they want—what they need—what is really valuable—accurate and essential to a service organization—in the Perpetual Trouble Shooter's Manual.

WE DON'T want you to buy a pig in a poke. Examine the list of dealers on the second cover of this magazine. Go to one of them and examine the Manuals. More than ever before—we want you to compare. Be *critical*—and we know that you will buy Rider's Manual.

YOU'LL BUY Rider's Manual because there is no equal value. Paper is patient. Anything can be printed on paper—every glamorous, descriptive adjective—but—**WILL THE PRODUCT STAND EXAMINATION?** That's for you to decide. That is why we say, "Compare first—then buy." After comparison you will do what tens of thousands have done. Buy right—buy sensibly—economically—Buy Rider's Perpetual Trouble Shooter's Manual.

BUY TODAY and start off on the right foot. During the months and years to come, as your service library increases—through the acquisition of Rider's Manuals (two volumes each year)—you will thank us for having convinced you—because you will have the finest collection of service information available in the entire radio industry. The succeeding issues will keep your proud possession intact and always growing and it will always be the finest.

Gentlemen, you can't lose. Rider's Manuals are sold with a money-back guarantee

SEE LIST OF DEALERS ON SECOND COVER OF THIS MAGAZINE

If there is no dealer near you, write direct to us

Radio Treatise Co., Inc.

1440 Broadway

New York City

Index of Monthly Literature

AUTO-RADIO

Auto Radio Service Station
Radio Retailing, pp 30,
September, 1932

Curing Noises in Auto Radio
F. W. Schor, Modern Radio, pp 12,
October, 1932

BROADCAST

Amplifiers, A-F.

Bias Resistor Values
W. T. Golson, Radio Retailing, pp
40, September, 1932

Power Tube Performance Chart
Modern Radio, pp 10, October, 1932

Amplifiers, R-F.

Balancing Receiving Circuits
D. M. Tennil, Radio Engineering,
pp 17, September, 1932

Bias Resistor Values
W. T. Golson, Radio Retailing, pp
40, September, 1932

Screen-Grid Voltage and Detector
Sensitivity
J. C. Flippen, QST, pp 37, October,
1932

General

Broadcast Station Field Strength
Measurements
Modern Radio, pp 7, October, 1932

Converting A-C. Sets to D-C. and
D-C. to A-C.
M. Chernow, Radio Retailing, pp 38,
September, 1932

Rejctostatic Reception
Lewis M. Clement, Radio News, pp
274, November, 1932

Receivers

Scott All-Wave Superheterodyne
E. H. Scott, Radio-Craft, pp 288,
November, 1932

Silver-Marshall CB-1
Taylor and Dorf, Radio News, pp
286, November, 1932

PUBLIC-ADDRESS

Bias Resistor Values
W. T. Golson, Radio Retailing, pp
40, September, 1932

Buttonhole Microphone, Construction
T. Clifton, Radio News, pp 281,
November, 1932

Heavy Duty P-A. System, Part 1,
Construction
B. J. Montyn, Radio News, pp 282,
November, 1932

Low Cost P-A. System, Construction
Nat Pomeranz, Radio News, pp 288,
November, 1932

Power Tube Performance Chart
Modern Radio, pp 10, October, 1932

Sound Picture Technical Terms,
Part II
Projection Engineering, pp 27,
September, 1932

Turntable Design and Operation
*V. V. Gunsolley, Projection Engi-
neering*, pp 7, September, 1932

Universal P-A. Amplifier, Construc-
tion
L. J. Littmann, Radio-Craft, pp 276,
November, 1932

Vertical Sound Records
*H. A. Frederick, Projection Engi-
neering*, pp 13, September, 1932

SHORT WAVE

Band Spreading
James Millen, Short Wave Craft, pp
332, October, 1932

Harmonic Oscillator
E. Stannard, Radio World, pp 12,
September 24, 1932

Scott All-Wave Superheterodyne
E. H. Scott, Radio-Craft, pp 288,
November, 1932

Screen-Grid Voltage and Detector
Sensitivity
J. C. Flippen, QST, pp 37, October,
1932

Stabilized "B" Supply for A-C. Short
Wave Receivers
D. Dekker and W. Keeman, QST,
pp 18, October, 1932

Ultra Short Wave Converter
James Millen, Short Wave Craft,
pp 350, October, 1932

TESTING SYSTEMS

Analyzer Adapter
H. Bublitz, Radio-Craft, pp 278,
November, 1932

Beat Frequency Oscillator
S. M. Bagno, Radio Engineering, pp
14, September, 1932

Harmonic Oscillator
E. Stannard, Radio World, pp 12,
September 24, 1932

Low Reading Ohmmeter
A. C. Schmitt, Radio Retailing, pp
40, September, 1932

Multimeter
J. E. Anderson, Radio World, pp 5,
October 8, 1932

Pocket Diagonometer, Part 1, Con-
struction
D. L. Van Leuven, Radio News, pp
290, November, 1932

Resistance and Capacity Tester
Jack Grand, Radio-Craft, pp 277,
November, 1932

Tester Adapters, Part II
F. L. Sprayberry, Radio-Craft, pp
280, November, 1932

TUBES

New Material for Radio Tubes
H. C. Todd, Radio Engineering, pp
18, September, 1932

Power Tube Performance Chart
Modern Radio, pp 10, October, 1932

Tubes on Consignment
Radio Retailing, pp 26, September,
1932

Tubes 49, 52, 48, 69, 42
Modern Radio, pp 20, October, 1932

All articles listed on this page are cross-indexed for your convenience. Titles given are not necessarily the titles of the original articles, but in each case serve to determine the substance of the article. Listings marked with an asterisk (*) are abstracted in this issue. The material in each issue of SERVICE is alphabetically indexed on the Contents Page.

IRC Service helps

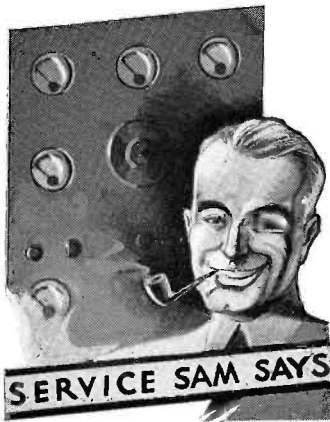

I'M in a reminiscing mood. I've heard some interesting service slants and they may be of some use to you. Maybe you'll agree and maybe you won't.

I spoke with a Service Man about five hours before the writing of these lines. He said that his last three weeks were the busiest in the last two years. That's swell, but the most interesting part of this man's activities is that his service business is prospering by word of mouth advertising—you know, over-the-bridge-table kind.

This man had a tough fight but held his ground. He refuses to compete with cut-price service work and insists upon obtaining his price for his work. If his customer discusses price, he tells him to try the low-priced man. Invariably the customer comes back for a repeat call and the man I know gets the job.

A worthwhile angle in connection with this work is that this man does more than just fix the receiver. After he finishes the job, he gives a 90-day guarantee—the same as the manufacturers do. In the eyes of the customer this means a lot.

I had a chance to talk resistors with this fellow and what he said, struck me as being noteworthy. Due to the fact that he gets his price for his work and does a good job, he feels that he can give the customer real service and go slightly beyond the bounds of pure business. Herein lies the real story.

This man—his name is not very important at this time—will service a receiver and will check each and every part. The resistors are of utmost importance to him. He measures the value of each and every one. If one seems to be "high" or "low"—although it may have nothing to do with the actual trouble in the receiver—he replaces that unit with one of the correct value. If the cost of this replacement runs from about 15c to 25c as his cost, and one or two such resistors are required, the replacement is made and the customer is never told or charged for the change. The change is made in order to assure perfect operation of that receiver and perfect satisfaction to the customer.

Maybe you think this man crazy—a poor business man who gives money away. Nothing of the kind. This chap is building on a solid foundation. It'll pay in the long run. It must pay, because he is successful.

Service Sam

HAVE YOU THE IRC RESISTOR GUIDE?

THE ORIGINAL RESISTOR GUIDE AND STILL THE LEADER

Last year it appeared with 32 pages. Today, the same Guide, selling for the same price, contains 92 pages. No other Resistor Guide on the market will give you one-third the information.

There is no more guesswork, no more groping in the dark, no need to make time-consuming and money-wasting moves when you have this Guide in your kit. All the resistor data you need to know about any popular receiver is contained in this book.

Over four hundred circuits are covered by the IRC Guide. Each page tells you the cause for the defect in the receiver, if caused by a faulty resistor, so that you can immediately recognize what is wrong. It tells the function of each resistor, the points between which it is connected and what points you must contact in order to be able to test the resistor without removing it from the circuit. In addition, the Guide gives the color coding of the resistor and the correct value and correct replacement unit.

In every respect, the IRC Resistor Replacement Guide is an essential and valuable source of definite and accurate service information for the Service Man. The pages are pocket-size so that you can carry the Guide with you on the job. The information is well indexed and concise so that you can readily locate the information you need. The FREE Supplementary Service, which contains four additional pages each month, together with other Service Helps, keeps you up-to-the-minute.

The regular price of the IRC Guide, with free supplements, is \$1.00 if bought alone, but you can get a copy absolutely FREE by ordering 20 IRC Metallized Resistors. Kit No. 1 or Kit No. 2 (20-2 watt resistors).

The 20 IRC Metallized Resistors contained in Kit No. 1 will save you time and grief. The kit has been planned after a careful analysis of the values used most frequently in replacements. It is a convenience you will welcome after you have experienced the satisfaction of having immediately available the correct resistor for the job. This Kit and the IRC Resistor Guide will enable you to solve most of your resistor troubles.



Your cost for Kit No. 1 is \$3.50. Don't be without it.

**They're better
because they're**

Metallized

Resistors for Replacements
Power Wire Wound Resistors
Precision Wire Wound Resistors For Meters and Test Equipment

INTERNATIONAL RESISTANCE COMPANY
2006 Chestnut Street, Philadelphia
74 Wellington Street, West, Toronto, Canada

**EXACT
DUPLICATE
CONDENSERS
For
REPLACEMENT
Service**

A COMPLETE replacement service of Duplicate Condensers for practically all radio sets has been offered by The Potter Company for years.

Specifications on hand for over 9000 condensers. *Partial List shown herewith.*

CONDENSERS

BY

**P
O
T
T
E
R**

ATWATER-KENT

Models: 37, 40, 42, 46, 52, 38, 39, 55, 35.

AUDIOLA

All Models.

BALKEIT

All Models.

BELMONT

All Models.

BOSCH

Models: 28, 48-A.

BRANDES

Model: B-15.

BREMER-TULLY

Models: 8-20-A, 7-70, 7-71.

CLAGO

All Models.

CROSLEY

Jewel Box, 55, 56, 77, 54.

DAYFAN

5091, 16605, 5582, A-5005, Junior 6.

ECHOPHONE

Models: S-4, S-3, S-5, 80, M-60.

FADA

Models: 16, 70, 41, 42, 44, 46, 47, 25, 35, 25Z.

KOLSTER

Models: K-5, 6-J, 6-K, 6-R, K-20, K-21, K-23, K-24, K-8, K-43, K-44, K-45.

MAJESTIC

Models: 70, 72, 90, 90-B, 180, 70-B, 50, 20-21, 22, 32.

MODERN

Models: K-12-D, K-12.

PHILCO

Models: 87, 531, 77, 76, 86.

R. C. A.

Models: Radiola 20, 18, 51, 104 speaker, 16, 17, 41, 50, 60, 62, Radiola 105, AP-947, Victor R-32, RE-45, R-52, 80, 17, 3-KR-8, 30-A, 41.

SILVER-MARSHALL

All Models.

SPARTON

Models: AC-62, AC-7, AC-63, AC-69-A, 79-A, 89, 78-A, AC-5, AC-6, 109, AC-110, 637, 589, 610, 931, 930, 89-A, Jr. 410, 301.

STEINITE

Models: 12, 990, 40, 281 Rectifier, 70, 261, 50-A, 261, 23.

UNITED AIR CLEANERS

All Models.

U. S. RADIO & TELEVISION

Models: 36 Apex, 37 Apex, 41, 46, 47, 48, 41, 32, 99, 7 Gloriatone 26.

ZENITH

Models: ZE-17, ZE-10, ZE-8, ZE-9, ZE-6, ZE-5, ZE-11, 12, 14, 70, 12, 15, ZE-18, ZE-7, 52, ZE-4, ZE-70, 70 Jr., 70-X, 2012, A-B-C-D.

THE POTTER COMPANY
NORTH CHICAGO, ILLINOIS

