

# SERVICE

A MONTHLY DIGEST OF  
RADIO AND  
ASSOCIATED  
MAINTENANCE

August, 1931

SERVICE is a part of John F. Rider's Monthly Supplementary Service. Due deliberation and investigation resulted in the conclusion that while a guaranteed minimum of 80 radio pages represent more material than ever before presented to the radio service industry each 30 days, it nevertheless is not enough to provide full coverage of all items related to service as experienced by the radio service technician. The entry of the home talking movies, electric refrigeration, automobile radio, etc., has greatly increased the number of items which are of interest to the service technician. The purpose of SERVICE is to print the data and discussions covering the items related to the radio industry and directly connected with maintenance.

The number of illustrations in the second issue will be greater than in this, the first. The entire magazine will be type set so as to provide more space for material. We shall present the contents in such fashion that whatever subject is being discussed will be covered in its entirety. Due to the fact that the average service technician does not find a very great amount of time for detailed reading, each subject will be brief and to the point. "Brief and Informative" will be the slogan during the preparation of the text.

#### CONTENTS for AUGUST 1931

Theory of Mechanical Refrigeration	Page 8
Testing Pentodes with Jewell Analyzers	10
Testing New Tubes with Jewell Tube Checkers	11
Manufacturers' Testing Recommendations	12
Some Automobile Radio Facts	16

# Theory of Mechanical Refrigeration

**Editorial Note\*\*\*** The material presented in the next few pages is taken from the "Service Manual for Mohawk Refrigerators with the Duozone Unit", published by the All-American Mohawk Corp.

The theory of mechanical refrigeration is but a part of our knowledge of the physics of heat. A complete knowledge of these scientific facts is not needed by installation men and service men in the execution of their work, but certain things must be thoroughly understood by those men who want to do their work intelligently. They must know, in a general way, what heat is; how it behaves; what it can be expected to do, and what it will do. They must know what the refrigeration unit is; how it functions; what is going on inside the unit; what changes are taking place and the cause of these changes. It is intended—in the following paragraphs—to briefly outline these points.

## Heat is a Form of Energy

Heat and cold are not two different things, but are relative degrees of the same thing. Substances are hot or cold only by comparison with other substances, or with some established standard. No matter how hot or how cold a substance may be, it can absorb heat, thereby becoming hotter, or it can give off heat, becoming colder. A clear distinction must be made between the intensity of heat and the quantities of heat.

## Heat Intensity, or Temperature

Heat intensity, or temperature, is the degree of heat or cold a substance has, as indicated by the thermometer. The generally accepted unit for the measurement of temperature is the degree Fahrenheit (abbreviated °F.). On the Fahrenheit thermometer scale, the melting point of ice is established as 32 degrees, and the boiling point of water at sea level as 212 degrees, so that the unit degree is one one-hundred-eightieth of the difference between melting ice and boiling water.

Temperatures more than 32 degrees below the melting point of ice are spoken of as "below zero," and are indicated in writing by placing the minus sign (—) before the temperature. The "absolute zero," which has never been attained, is calculated to be —459.6°F., and is the theoretical temperature corresponding to the total absence of heat. Thus it appears that even at the lowest temperature attainable, heat is still present.

## Heat Quantity

Heat quantity is the measure of the energy

represented by heat, and, unlike temperature, which is comparative, it is absolute. A given quantity of heat is always the same, whether it is absorbed by or given off from any substance, and regardless of the temperature of the substance. The generally accepted unit for the measurement of heat quantity is the British Thermal Unit (abbreviated B.T.U.), and is the quantity of heat required to raise the temperature of one pound of water, one degree Fahrenheit. Heat quantities cannot be measured directly with a thermometer, but only with a laboratory instrument known as the Calorimeter.

## Sensible Heat

Sensible heat is the heat quantity which produces a sensible or measurable change in the temperature of a substance.

When the temperature of a substance rises, sensible heat has been absorbed; when it lowers, sensible heat has been given off. When an equal quantity of heat is absorbed by two different substances, each having the same weight, one will be found to have a higher temperature rise than the other. This is because different substances have different capacities for absorbing heat.

## Specific Heat

Specific heat is the relative capacity of a substance for absorbing heat. The standard of comparison for heat absorbing capacity or specific heat is water, whose specific heat is, therefore, 1.000. Specific heats of other substances are expressed as a decimal fraction. The specific heat of cast iron, for instance, is .1298, which indicates that it requires but 13/100 of the quantity of heat to change the temperature of a given weight of cast iron through a given range in temperature as would be required to change an equal weight of water through the same range in temperature.

## Latent Heat

Latent heat is the heat equivalent of the energy required to change the state of a substance, either from the solid state to liquid, or from liquid to vapor. These changes take place at constant temperature so that sensible heat is not involved in the change. The latent heat of fusion is the quantity of heat required to melt a solid into a liquid; the latent

\*Note: The Standard Encyclopedia and the Encyclopedia Britannica have been drawn on freely

heat of vaporization is the quantity of heat required to evaporate a liquid into a vapor. Latent heats are expressed in British Thermal Units per pound, and have been determined by experiment for many different substances. Each different substance has its own definite melting and boiling temperatures. The Fahrenheit thermometer scale is based on these two temperatures for water, because water is the one common substance which is familiar in all three states of solid (ice), liquid (water), and vapor (steam). Other substances melt or boil at temperatures higher or lower than water.

#### Effect of Pressure

Effect of pressure on the boiling points of liquids is to change the temperatures at which they boil. Increasing the pressure above atmospheric pressure will raise the boiling point, and reducing the pressure to a partial vacuum will lower the boiling point. It is thus possible to control the boiling temperature, and also the condensing or liquifying temperature, by enclosing the liquid in a container and changing the pressure. There is for each liquid a definite relation between the pressure and the boiling point, and these relations have been determined by experiment for many different liquids.

#### Saturated Vapor

Saturated vapor is a vapor which is in the same container with and in contact with some of the liquid from which it was evaporated. If the heat is added to the contents of the container, without changing the pressure, no change in the temperature of either the liquid or the vapor will take place, but some of the liquid will evaporate and increase the volume of the vapor. If volume cannot be increased, the pressure will increase, and the temperature will increase to the normal temperature for the pressure created. If heat is taken from the contents of the container, without changing the pressure, no change will take place in the temperature of either the liquid or the vapor, but some of the vapor will liquefy or condense, and the volume will decrease. If the volume remains constant, the pressure will decrease, and the temperature will decrease to the normal temperature of the resulting pressure. This relationship holds good just so long as both liquid and vapor are present in contact with one another.

#### Superheated Vapor

Superheated vapor is vapor which is not in contact with the liquid from which it was evaporated, and has absorbed additional heat. Under the condition, heat added is sensible heat, and increases the temperature to some point higher than the temperature corresponding to the pressure which exists. Sensible heat added to a superheated vapor increases the volume by expanding the vapor, or,

if the volume is fixed, increases the pressure. Heat given off by a superheated vapor decreases the volume, or, if the volume is fixed, decreases the pressure. If the process of giving off heat be continued, the vapor will become saturated, and condensation will take place.

#### Heat Transfer

Heat transfer takes place between two bodies having different temperatures in contact with or close to one another. Always the hotter substance will give off heat and the colder will absorb heat. In giving off heat, the hotter substance will have its temperature lowered, or it will condense, or it will freeze, depending upon the circumstances. But in no case will its temperature fall lower than that of the colder substance. In absorbing heat, the colder substance will have its temperature raised, or it will melt, or it will evaporate, depending also upon the circumstances, and in no case will its temperature rise higher than that of the hotter substance. Either of these substances may be the air, but unless the air so heated or cooled is confined to a limited space, its mass is so great and its circulation is so free that there will be no apparent change in its temperature. Heat transfer may take place in three ways, known as "conduction," "convection," or "radiation."

#### Conduction

Conduction is the transfer of heat through, or by means of, a solid substance known as conductor. Conduction takes place more readily through some substances than others. Those substances which transmit heat readily are spoken of as "good conductors," or simply as "conductors"; those which retard the transmission of heat are spoken of as "insulators." Of the common materials of manufacture, copper is the best conductor of heat, and cork is the best insulator. It is therefore natural that those parts of a mechanical refrigeration unit which must transmit heat readily, such as the surfaces of the freezing unit and the condenser coils, should be made of copper; and that the cabinet, which must resist the transmission of heat and so conserve the refrigeration produced, should be made largely of cork; or some other approved insulation.

#### Convection

Convection is the transmission of heat from one substance to another by means of some third substance, either a liquid or a vapor, which conveys the heat from the hotter to the colder substance between which heat transfer takes place. The commonest heat conveyor is the air. The cooling of foodstuffs in a cabinet is accomplished by convection, with the air confined in the cabinet as the conveyor. As the air is cooled, it contracts, becomes denser or heavier, and settled toward the bottom of the cabinet. As it becomes warmed by

absorption of heat from the materials to be cooled, it expands, becomes lighter, and rises toward the top of the cabinet. In this way, a constant circulation of air is automatically kept up and the heat transfer is effected. A second process of convection takes place in the brine solution in the freezing tank, transmitting the heat absorbed on the surface of the freezing tank to the evaporator coil.

### Radiation

Radiation is the transmission of heat through intervening substances without heating these substances. The commonest example of radiation is the heating of things by the sun's rays to temperatures higher than that of the air through which the rays must pass. Radiation plays but a small part in the heat transmission met in refrigeration.

### Rate of Heat Transmission

Rate of heat transmission varies not only with respect to the materials of which surfaces are constructed, as mentioned in connection with conduction, but also in proportion to the thickness of the surfaces. The thicker the surface, the less heat will be transmitted. The conduction of heat through a surface also depends upon the difference between the temperatures on the two sides of the surface. The greater the difference, the more heat will be transmitted. Also, the transmission by convection is greatest when the conveying medium is in free circulation, and less as the circulation is retarded. Several other factors enter into the rate of heat transmission, but they are relatively unimportant in practical electric refrigeration.

### Refrigeration

Refrigeration is the process of cooling things to temperatures lower than that of the surrounding atmosphere. In order that anything may be cooled, it must give off heat. At the same time, the heat so given off must be absorbed by some other substance, the temperature of which must always be lower than the lowest temperature it is desired to produce. For many years, ice offered the only practical solution of the problem of refrigeration. Ice melts at 32°F., and it will absorb heat from anything in contact with it whose temperature is higher than this. The heat thus absorbed by the ice is given off by the things to be refrigerated, and they are, in consequence, cooled. At the same time, the absorption of the heat overcomes the latent heat of fusion, causes the melting of the ice, and the resulting water carries off the waste heat so absorbed.

### Electric Refrigeration

Electric refrigeration is a practical application of the knowledge that liquids absorb heat when they evaporate, or boil, just as ice absorbs heat when it melts. The heat absorbed is the overcom-

ing of the latent heat of vaporization. Not all liquids boil at the same temperature. Water boils at 212°F.; Alcohol boils at 173°F.; Ether boils at 94°F.; Sulphur Dioxide boils at 14°F.; Methyl Chloride boils at 10.65 degrees below zero. Many substances boil at very low temperatures, but only a few have characteristics which enable them to be used as refrigerants. Methyl Chloride is practically usable as a refrigerant, and, as it boils under atmospheric pressure at  $-10.65^{\circ}$  F., it will absorb heat from and thus refrigerate things in contact with it which have temperatures higher than this. This boiling or evaporation changes the Methyl Chloride from a liquid to a vapor, in which form it has no further practical refrigerating value. Because Methyl Chloride costs too much to waste, it must be changed back into a liquid again. It has been shown that when vapors are compressed and cooled off, they will condense or liquefy. This knowledge makes it possible to reclaim the refrigerant and use it over again.

### The Heat to be Removed

The heat to be removed comes from various sources. The largest part is that which continually is conducted through the walls of the cabinet. Food is placed in the cabinet and its surplus heat must be given off. When the doors are opened, cold air flows out of the cabinet and warm air comes in to take its place, and this air must be cooled. Water is placed in the trays to be frozen and this must not only be cooled down to 32° F., but still further heat must be removed from it, overcoming the latent heat of fusion and causing it to freeze. All this heat combines to create the refrigerating load that must be met.

### The Heat is Conveyed

The heat is conveyed to the freezing coil and follows through the tubing and fins to the refrigerant. Heat from the water in the ice cube trays to be frozen is conducted directly from the water to the tray, from the tray to the tray sleeve and through the tubing to the refrigerant.

### The Heat is Absorbed

The heat is absorbed by the liquid Methyl Chloride taking up the latent heat of vaporization, causing evaporation, or boiling. This changes the liquid Methyl Chloride into saturated vapor of Methyl Chloride. In this form, the Methyl Chloride carries all the heat which has been collected from the various sources, but it carries this heat at a very low temperature level. This level is so low that there is no other level available to which it may be given off, so it becomes necessary to raise this heat quantity to some higher level.

### The Heat Level is Raised

The heat level is raised by the compressor, which draws off the Methyl Chloride vapor as it forms in the evaporator coil and compresses it to a

pressure corresponding to a temperature slightly higher than the surrounding air. The work done on the vapor by compressing it superheats the vapor to a high temperature so that the compressor transfers to the condenser superheated Methyl Chloride vapor, which contains all the heat originally absorbed by the liquid Methyl Chloride in the evaporator coil, and also the extra amount of heat added by the work of compression.

#### **The Heat is Given off**

The heat is given off by conduction through the walls of the condenser tubing, into the surrounding air, in which it is dissipated. In giving off heat, the vapor is first changed from superheated Methyl Chloride vapor into saturated Methyl Chloride vapor, and then, as further heat is given off, changed by condensation into Methyl Chloride Liquid.

#### **The Heat Transfer is Complete**

The heat transfer is complete, for it has been seen that the heat to be removed has been absorbed by the Methyl Chloride within the cabinet, and has been given off from the Methyl Chloride to the surrounding air.

#### **The Refrigerating Cycle (Note \*)**

The refrigerating cycle is the definite sequence of movements and changes through which the Methyl Chloride passes in doing its work. In its cycle, it is under low pressure part of the time, and under high pressure part of the time. It is also, at different points in the cycle, a liquid, a saturated vapor, and a superheated vapor.

#### **The Freezing Unit (See Drawing No. 5)**

The freezing unit is automatically supplied with liquid Methyl Chloride. Through its surface the heat is absorbed by the low pressure liquid Methyl Chloride. The absorption of heat changes the low pressure liquid Methyl Chloride into low pressure saturated Methyl Chloride vapor, by overcoming the latent heat of vaporization.

#### **The Compressor (See Drawing No. 3)**

The compressor draws off the low pressure saturated Methyl Chloride from the freezing unit and compresses it into high pressure superheated Methyl Chloride vapor. In doing this, it raises the temperature level at which the absorbed heat

is carried by the refrigerant from the low level of the freezing unit to a level higher than that of the surrounding air.

#### **The Condenser (See Drawing No. 4)**

The condenser receives the high pressure superheated Methyl Chloride vapor from the compressor. The fan—incorporated in the motor pulley—keeps a continuous flow of fresh air pouring over the condenser, and this air takes on the heat which has been absorbed by the refrigerant. As heat is given off, the superheat is removed, and the high pressure saturated Methyl Chloride vapor condenses into high pressure liquid Methyl Chloride, which flows to the receiver at the bottom of the condenser. It is there held in reserve until it is needed to supply the freezing unit again. In passing through the expansion valve into the evaporator coil, it is changed from high pressure to low pressure liquid Methyl Chloride, again ready to absorb heat from the freezing unit.

#### **The Cycle is Complete (Note \*)**

The cycle is complete and constantly repeating. In the freezing unit, the Methyl Chloride changes from a low pressure liquid to a low pressure saturated vapor; in the compressor, it is changed from a low pressure saturated vapor to a high pressure superheated vapor; in the condenser, it changes from a high pressure superheated vapor to a high pressure liquid; in passing through the expansion valve, it is changed from a high pressure liquid to a low pressure liquid, in which form the cycle started.

#### **The Electric Motor**

The electric motor provides the power necessary to operate the compressor, and is the real energy producer in the process of refrigeration. The moving force behind the Methyl Chloride is the compressor. So long as the motor keeps the compressor in operation, the process of refrigeration keeps up. When the compressor is stopped, the refrigerant settles down, the cycle comes to rest and the process of refrigeration ceases.

#### **The Control Unit (See Drawing No. 6)**

The control unit automatically starts the motor when the temperature of the cabinet rises. When sufficient refrigeration has been produced to lower the temperature to its original point, the control unit automatically stops the motor.

#### **NOTE \***

See Drawing No. 1 for picture of Complete Cycle.

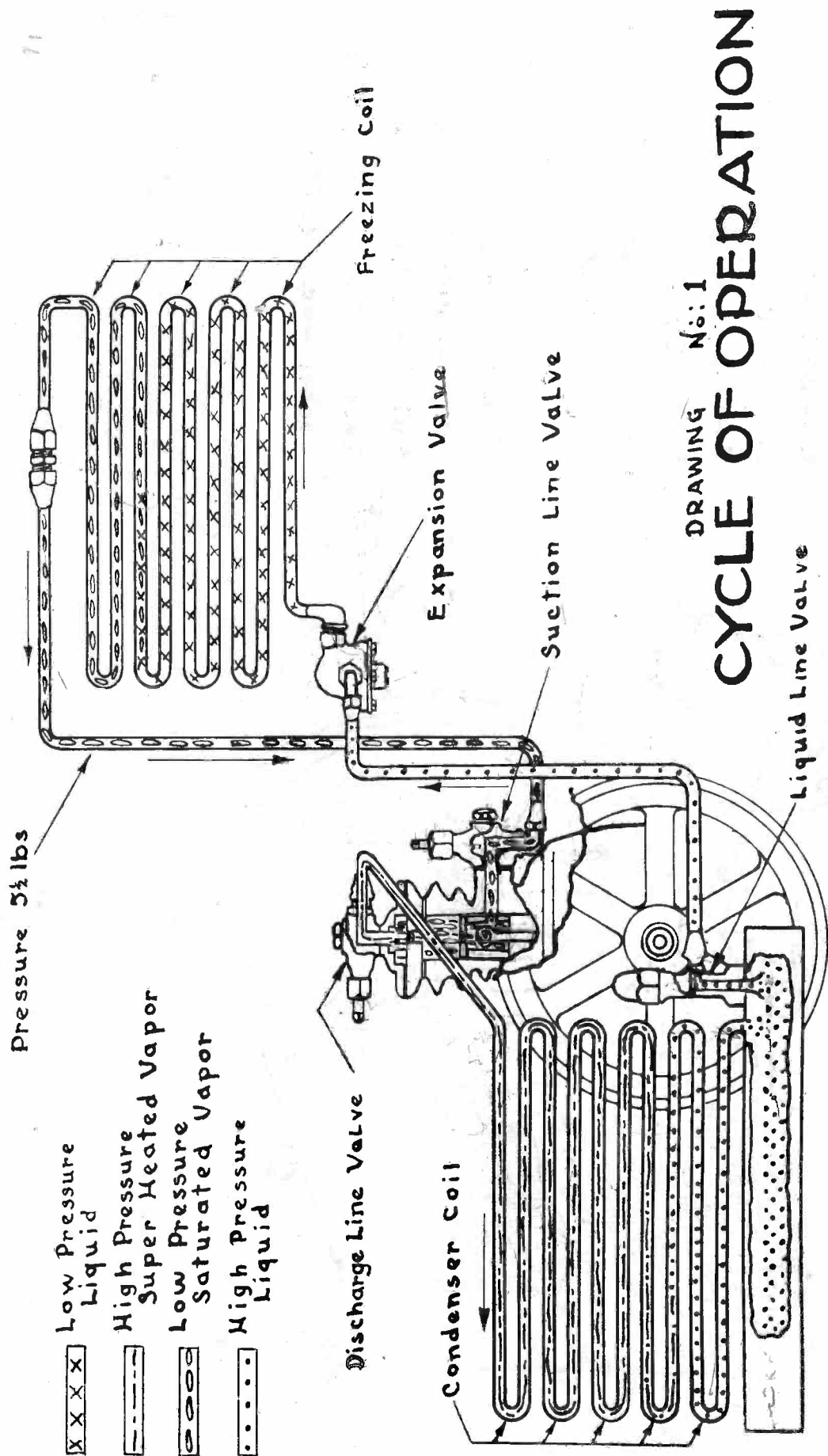

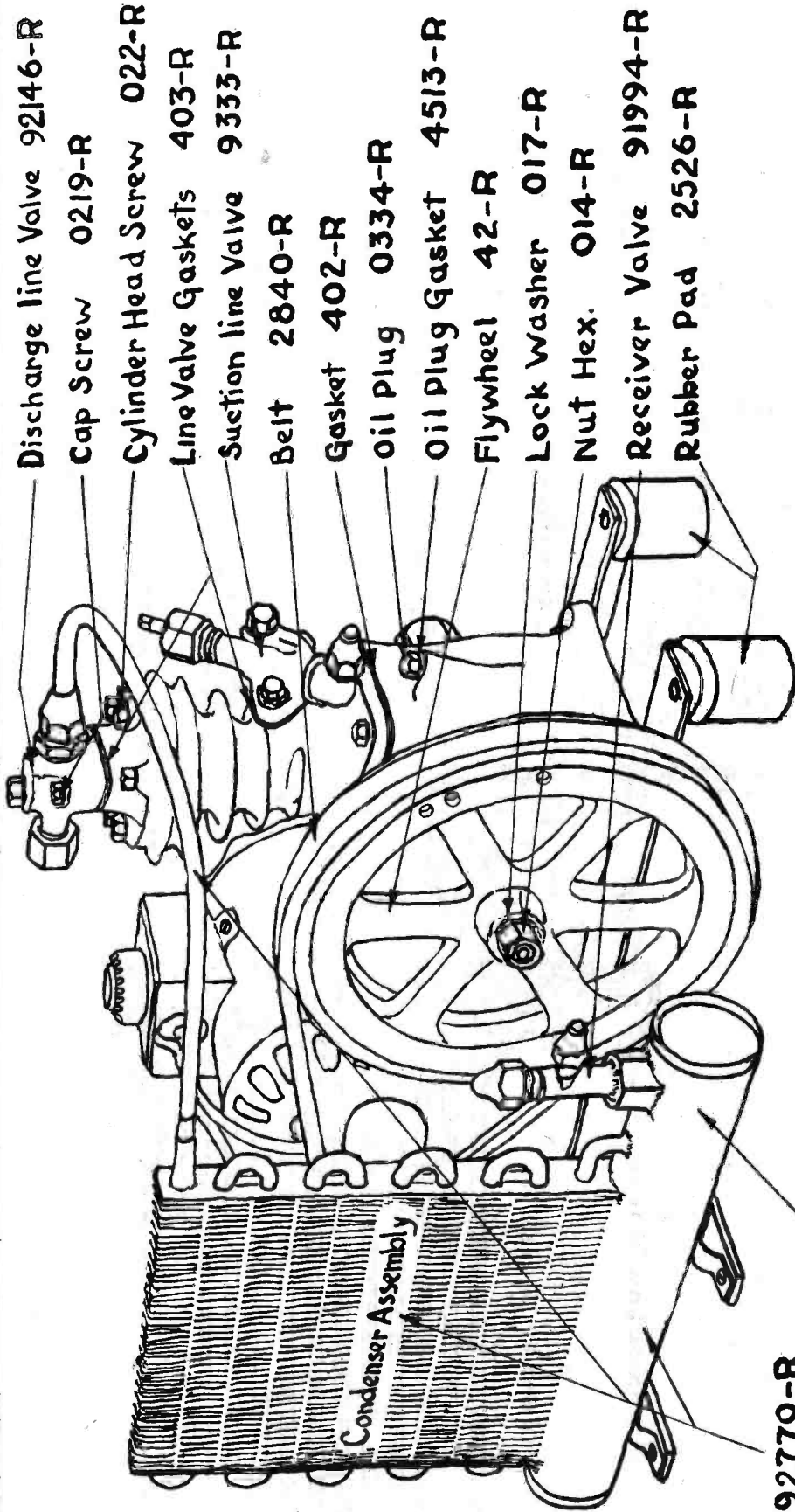

DRAWING No: 2 (With Part Numbers)  
**CONDENSING UNIT**  
 Compressor, Receiver, Condenser, Motor



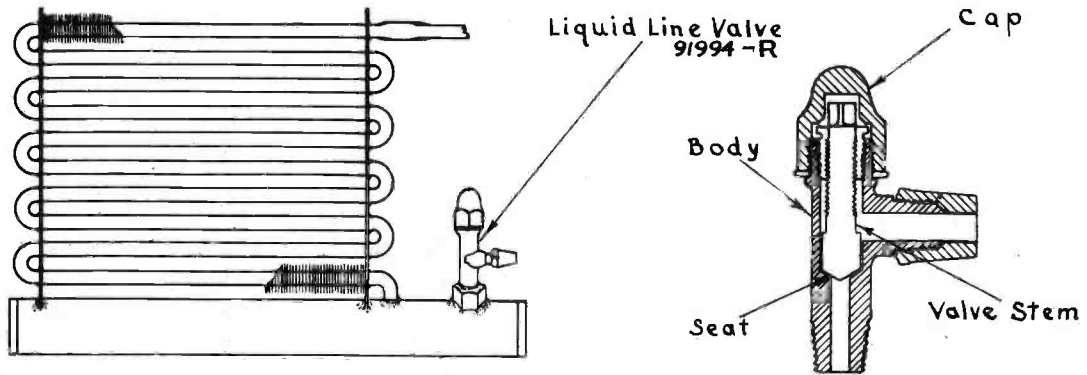

CONDENSER  
AND  
CROSS SECTION OF  
LIQUID LINE VALVE  
DRAWING No:4

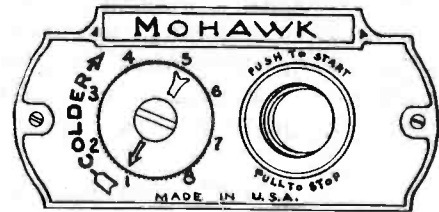
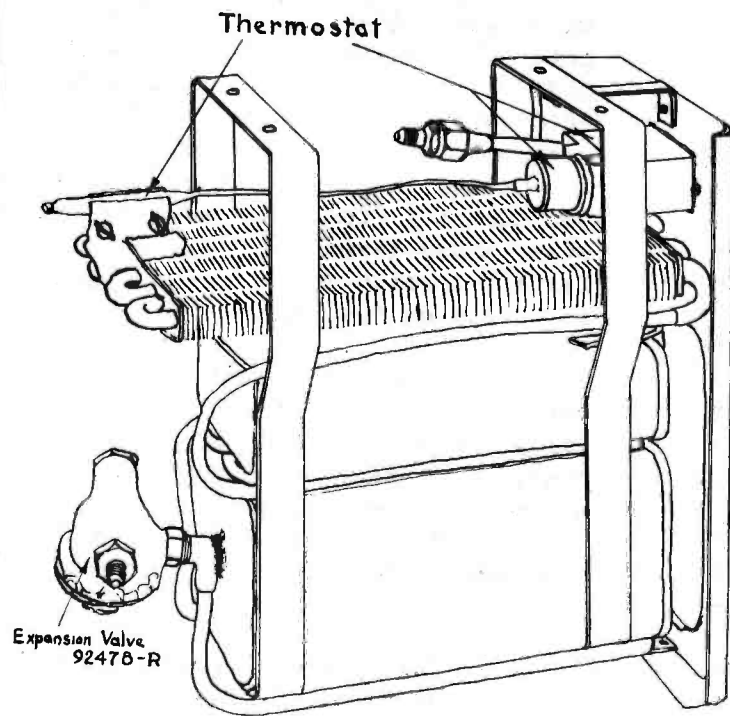

Control  
NOTE: See Drawing No:6

DRAWING No:5  
DUO-ZONE UNIT  
and  
CONTROL

## Testing Pentodes with Jewell Analyzers

A pair of special adapters known as the Pink Ring adapters, designated as #11386 are required if the Jewell models 198, 199, 408, 409 and 579 analyzers and test panels are to be used to test receivers and amplifiers which use the pentode output tube, such as the '33, '47, PZ and GA, which do not have indirectly heated cathodes but are of the filament type. This adapter consists of a five-hole, five-prong adapter with a pink ring connected by a four foot cable to another five-hole, five-prong adapter with a black ring.

Insert the pink ring unit in the pentode socket of the amplifier or receiver and place the plug of the analyzer into this adapter. Insert the black ring unit in the UY socket of the analyzer or control box panel and place the pentode tube into this adapter.

The FILAMENT, PLATE and GRID VOLTAGES may now be read in the normal manner by pressing the proper push buttons on the panel.

To measure the SPACE CHARGE GRID VOLTAGES, it will be necessary to disconnect the analyzer from the receiver and to remove all adapters from both the receiver and the analyzer. Connect a pair of test leads to the 300 Volt D.C. binding posts and press the PLATE 300 V push button. Touch the test prod connected to the positive binding post to the K or cathode socket terminal, which becomes the

space charge grid terminal for these pentode tubes, and touch the test prod connected to the negative binding post to one of the filament socket terminals. The deflection indicated upon the 300 V scale of the instrument will be the SPACE CHARGE GRID VOLTAGE at the tube socket.

Receivers using the type '38 and similar pentode tubes having indirectly heated cathodes may be tested with all Jewell analyzers by treating them exactly as if they were type '24 screen grid tubes. In case the voltages applied to the CONTROL GRID or the SPACE CHARGE GRID elements should cause the instrument to read beyond full scale, it may be necessary to disconnect the analyzer from the receiver and make these tests by means of test leads connected to the proper binding posts on the panel.

Press the push button for connecting the proper instrument range to the binding posts and by means of a pair of test leads connected to these binding posts, make the desired readings by touching the test prods to the proper socket terminals.

The plate current may be read in the normal manner by pressing the proper PLATE MA button. Obviously, the tube test is made with this type of tube by pressing the GRID - TEST CONTROL GRID button instead of the GRID-TEST NORMAL GRID button.

# Testing New Tubes with Jewell Tube Checkers

This data states the methods of using Jewell Patterns 209, 210, 213, 214 and 2, 9 tube checkers for checking the new tubes inclusive of the pentode.

Tube	In Pattern 209 or 219 with or without Pattern 213	In Patterns 210 or 214
Triode '37 5 prong Automobile tube	Use '01A socket Use green ring adapter #8634, 5 holes, 4 prongs Readings, MA 3.5-6.5 Test, 2.0-3.5	Use 5 prong socket No adapter 5 volt filament position Tube units Pattern 210, 36 Pattern 214, 24-36
Tetrode '36 Tetrode '36 5 prong screen grid automobile tube	Use '01A socket Use '01A socket Use green ring adapter #8684, 5 holes, 4 prongs Control grid lead in place Readings MA 0.3-0.4 Test 0.84-1-56	Use 5 prong socket Use 5 prong socket No adapter 5 volt filament position Control grid lead in place Tube units Pattern 210 8 Pattern 214 6-8.5
Pentode '33 5 prong output pentode 2 volt filament battery type	Use '30 socket Use purple ring adapter #11385, 5 holes, 4 prongs Readings MA 8.75-16.25 Test 2.8-5.2	Use 5 prong adapter Use purple ring adapter #11385, 5 holes, 4 prongs 2 volt filament position Tube units Pattern 210, 52 Pattern 214 36-52
Pentode '38 5 prong output pentode with cap on top for automobiles	Use '01A socket Use green ring adapter #8684, 5 holes, 4 prongs Control grid lead in place Readings MA 1.05-1.95 Test 0.7-1.3	Use 5 prong socket No adapter 5 volt filament position Control grid lead in place Tube units Pattern 210 25 Pattern 214 18-25
Pentode '47 5 prong output pentode 2.5 volt filament	Use '45 socket Use purple ring adapter # 11385, 5 holes, 4 prongs Readings MA 7.0-13.0 Test 3.5-6.5	Use 4 prong socket Use purple ring adapter #11385, 5 holes, 4 prongs 2.5 volt filament position Tube units Pattern 210 75 Pattern 214 52-75
Pentode type GA 5 prong output pentode 5 volt filament	Use '01A socket Use purple ring adapter #11385, 5 holes, 4 prongs Readings MA 6.5-12.0 Test 3.0-5.0	Use 4 prong socket Use purple ring adapter #11385, 5 holes, 4 prongs 5 volt filament position Tube units Pattern 210 66 Pattern 214 46-66

## Manufacturers' Testing Recommendations

It might be of interest to spend a little time considering the types of test equipment mentioned in manufacturers' service bulletins. Certain receiver manufacturers have recommended certain changes in commercial test equipment in order that these units conform with the conditions required by the design of their receivers.

Philco is one such concern. As it happens their super heterodyne receivers are peaked at 260 KC and the test equipment, in this case the oscillator, must be capable of producing a signal of this frequency. They recommend the following changes upon the Jewell 560 oscillator, originally designed to produce a 175 KC wave so that it will also provide the test signal at 260 KC. (For that matter this method is suitable for increasing the frequency adjustment to values other than 260 KC.)

The exact change is dependent upon the type of Jewell oscillator in question. This concern made a change in the fixed condenser shortly after the start of production. The condenser referred to, is mounted upon the bottom of the tuning condenser frame. Originally it was .0003 mfd. and was then changed to .00025 mfd. This difference necessitates a variation in the method of wiring in order to accomplish the change. Since the capacity of this condenser is marked, it is a simple matter to determine which one of the two types is at hand. To make the change proceed as outlined.

Remove the four screws from the bottom of the test oscillator case. Remove the cover from the battery box. Disconnect the battery and the oscillator unit can be removed from the box.

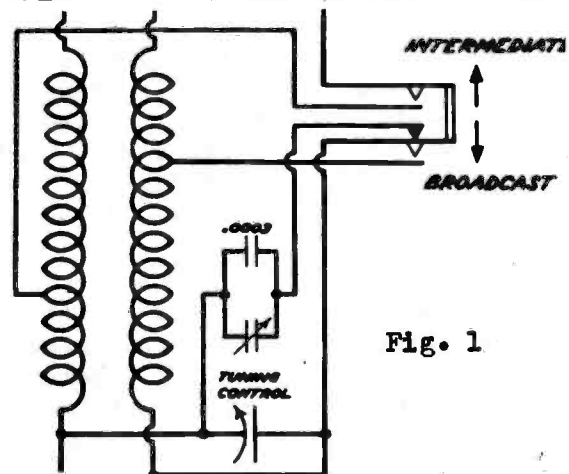

Fig. 1

Remove the four nuts holding the shield in place. Close the plates of the condenser so as to safeguard against injury. If the oscillator makes use of the .00025 mfd. condenser change the circuit as shown in figure 2. Figure 1

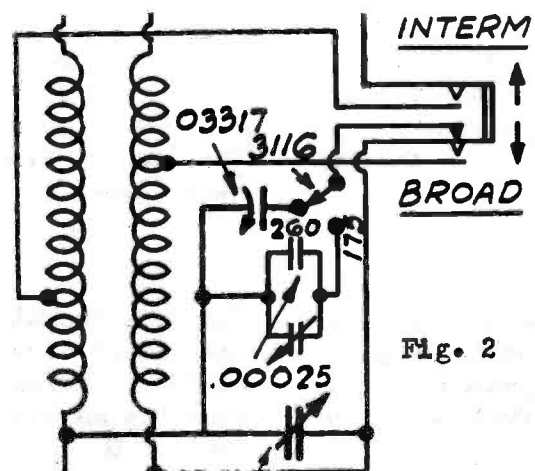

Fig. 2

illustrates the tuning system of the Jewell oscillator. For the complete circuit refer to page 770-A of the 1931 Trouble Shooter's Manual by John F Rider.

Reference to figure 2 illustrates the change made. Note that a single pole double throw switch has been added, and that the original connection from the lower "Intermediate" switch contact has been interrupted. The original lead from the paralleled condenser bank to the lower "Intermediate" switch contact now goes to a switch contact. A condenser is added as shown. If a Philco unit is used it is part number 03317. If not, it may be a midget .0001 mfd. unit. One side of this condenser junctions with the remaining switch terminal, which can be marked 260 KC, to be calibrated later.

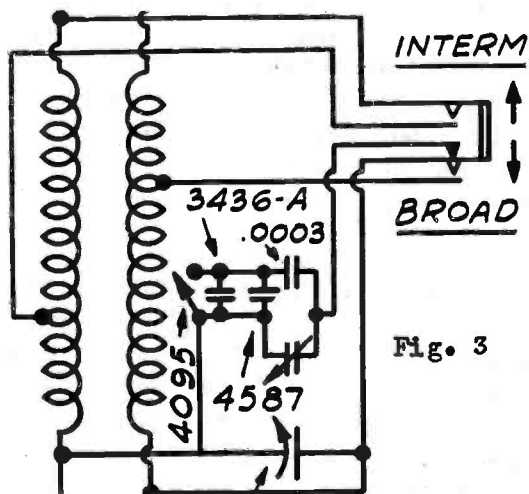

Fig. 3

If the basic oscillator makes use of a .0003 mfd condenser, the circuit is changed as shown in figure 3. The connection to the cam switch is not interrupted. A .00005 mfd condenser is connected in shunt with a neutralizing condenser. If Philco parts are used, the .00005 mfd. condenser is part # 4587 and the neutralizing condenser is part

# 3436-A. If not, a .00005 mfd. condenser will again suffice. Of course it should be a midget of the variable type, so as to enable the required adjustment. The switch whereby the two supplementary condensers are shorted allows for the operation of the complete system at 175 KC without interfering with the calibration at that frequency.

The actual physical placement of the additional units need not be discussed in these pages because that will be evident when the oscillator is opened. If Philco replacement parts are used, the single pole double throw switch is part # 3116 and the single pole single throw switch is part # 4095.

#### CALIBRATION

To calibrate the revamped oscillator, first check the 175 KC setting. This can be done by testing the intermediate of a 175 KC super known to be perfect, or by setting the receiver at say the 4th harmonic of 175 KC, or 700 KC. The signal from the oscillator should be maximum at this point. Varying the setting of the receiver dial should produce a reduction in receiver output both sides of the resonant point. Then readjust the receiver tuning for the 3rd harmonic of 260 KC or 780 KC. Change the position of the switch which has been added to the oscillator, opening the switch for the .0003 mfd. condenser job and resetting the added switch for the .00025 mfd. job. If resonance is not obtained, vary the variable condenser which has been added until maximum resonance is secured. Under no condition should you alter the setting of the oscillator tuning trimmer condenser. This will interfere with the calibrated 175 KC setting. When the proper adjustment has been made the oscillator is calibrated for 260 KC.

A resistance measuring circuit recommended by the Grigsby-Grunow organization for resistance measurements upon Majestic receiving systems is interesting.

As is evident in the diagram, the low voltage source (1.5 volts) is used for the measurement of low values of resistance. This is the LR setting. The two shunts of 3 and 55 ohms provide a means of measuring low values of resistance. See figure 4.

The HR position automatically switches the 1.5 volt unit out of the circuit and switches the 22.5 volt source, with its 25,000 ohm series resistance, into the circuit. This resistor limits the maximum current through the test circuit with the test prods connected to each other.

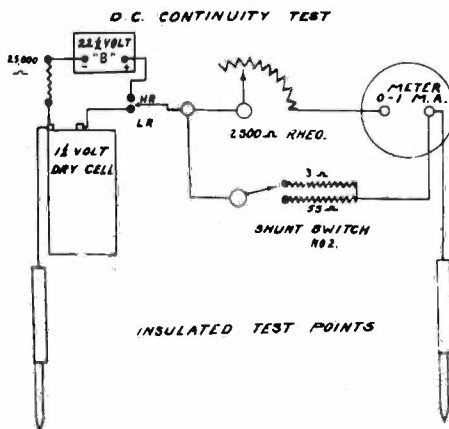

Fig. 4

The 2500 ohm variable resistance is used to adjust the meter for full scale deflection with the test points shorted and switch # 2 open. This is the preliminary test adjustment. This system is capable of checking continuity of units rated from a few ohms to about 800,000 ohms.

#### MAJESTIC 175 KC OSCILLATOR

The 175 KC oscillator suggested by Grigsby - Grunow in their service bulletins is shown

in figure 5. The grid and plate inductances are the windings upon an IF transformer available from Grigsby - Grunow distributors. The color coding shown refers to the IF transformer connections. The RF choke is any conventional unit of about 80 to 250 millihenrys.

The operation of the unit is as follows: The operating volt-

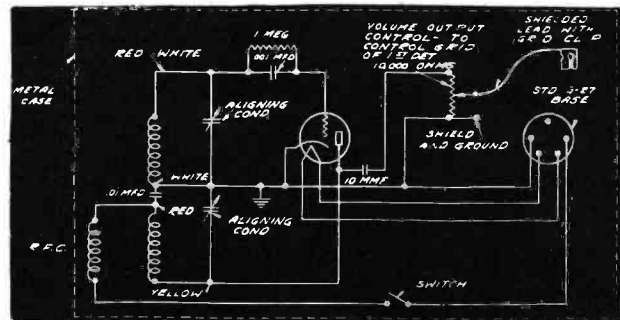

Fig. 5

age is secured from the oscillator socket in the receiver via the five prong plug shown. The circuit illustrated presumes a type '27 tube as the oscillator in the receiver. A five to four prong adapter will convert the system for use with four prong tubes.

Continuing with the '27 tube shown, the '27 tube in the receiver oscillator socket is withdrawn and inserted into the test oscillator socket. The test plug is inserted into the receiver oscillator socket. The grid clip then is connected to the grid of the 1st detector tube, and the oscillator is ready for application.

The simplest means of calibrating the oscillator is to employ the unit with a 175 KC super known to have perfectly aligned intermediates. The oscillator is applied as stated and the oscillator tuning condenser is adjusted for maximum output indication with whatever output system is employed in the receiver.

# Output Measuring Circuit for All Types of Atwater Kent Receivers

In the output measuring circuit, shown, only one speaker, a Type JB, is required in testing any type of Atwater Kent receiver. This eliminates the necessity of tying up four or five electro-dynamic speakers.

This improvement is made possible through the use of a special output transformer, and a series of resistors which take the place of the field coil in the various types of Atwater Kent electro-dynamic speakers.

### OPERATION

(A) Throw S<sub>1</sub> to the right to test for quality on the JB speaker.

Throw S<sub>1</sub> to the left to pick up oscillator signals on the phones when synchronizing variable condensers.

(B) When testing an A. C.-operated electro-dynamic set, move S<sub>4</sub> to the tap that gives the correct resistance to take the place of the field coil in the speaker for that particular set.

- Tap 1 (left) takes place of F-6 field coil.
- Tap 2 takes place of F-4 or N field coil.
- Tap 3 takes place of F-2 field coil.
- Tap 4 takes place of F field coil.

It is NOT necessary to use a "dummy" field load when testing a battery-operated or D. C.-operated electro-dynamic receiver. When testing such a receiver, S<sub>4</sub> may be turned to the 4th tap (right).

(C) MAGNETIC SETS. When testing a magnetic-type set, such as Models 20, 35, 37, 40, etc., connect the two-conductor cord to the speaker-posts on the set being tested. Close both S<sub>2</sub> and S<sub>3</sub> if a reading on the meter is desired; open either S<sub>2</sub> or S<sub>3</sub> to open the meter circuit.

(D) INDUCTOR SETS. In testing a Type Q Chassis, insert the three-conductor plug in the speaker-plug socket on the Q Chassis. Close both S<sub>2</sub> and S<sub>3</sub> if a reading is desired on the output meter. Open either S<sub>2</sub> or S<sub>3</sub> to open the meter circuit.

(E) FIVE-PRONG ELECTRO-DYNAMIC SETS. In testing an L, P, D, F or H Chassis, insert the five-conductor plug in the speaker-plug socket on the chassis, and, if the chassis is A. C.-operated, set S<sub>4</sub> at the correct tap. To get a reading on the meter, close S<sub>2</sub> and S<sub>3</sub>; to open the meter circuit, open either S<sub>2</sub> or S<sub>3</sub>.

(F) FOUR-PRONG ELECTRO-DYNAMIC SETS. In testing a Model 46, 55, 60, 61, 66, 67, etc., insert the four-conductor plug in the speaker-plug socket on the chassis. If the chassis is A. C.-operated, set S<sub>4</sub> at the correct tap. To get a reading on the meter, close S<sub>3</sub> and open S<sub>2</sub>. To operate the phones or JB speaker, close S<sub>2</sub> and open S<sub>3</sub>. To operate both the phones and the meter, close both S<sub>2</sub> and S<sub>3</sub>.

### LIST OF PARTS

(With the exception of fuse ("F") and meter ("G") only standard Atwater Kent parts are used in this circuit.)

T—No. 18911 output transformer. This transformer has an extra winding which couples the speaker or phones to the output circuit of the particular set that is being tested.

- S<sub>1</sub>—No. 13678 toggle switch.
- S<sub>2</sub>, S<sub>3</sub>—No. 9991 toggle switches.
- S<sub>4</sub>—No. 16430 switch.
- R<sub>1</sub>—Four No. 16988 resistors in series.
- R<sub>2</sub>—Three No. 16988 resistors in series.
- R<sub>3</sub>—Four No. 16988 resistors in series.
- R<sub>4</sub>—Five No. 16988 resistors in series.
- F— $\frac{1}{4}$  ampere fuse.
- G—115 ma, thermo-coupled galvanometer.
- 1—No. 14169 double-conductor cord.
- 1—No. 17866 three-conductor cord-and-plug.
- 1—No. 17556 four-conductor cord-and-plug.
- 1—No. 17895 five-conductor cord-and-plug.

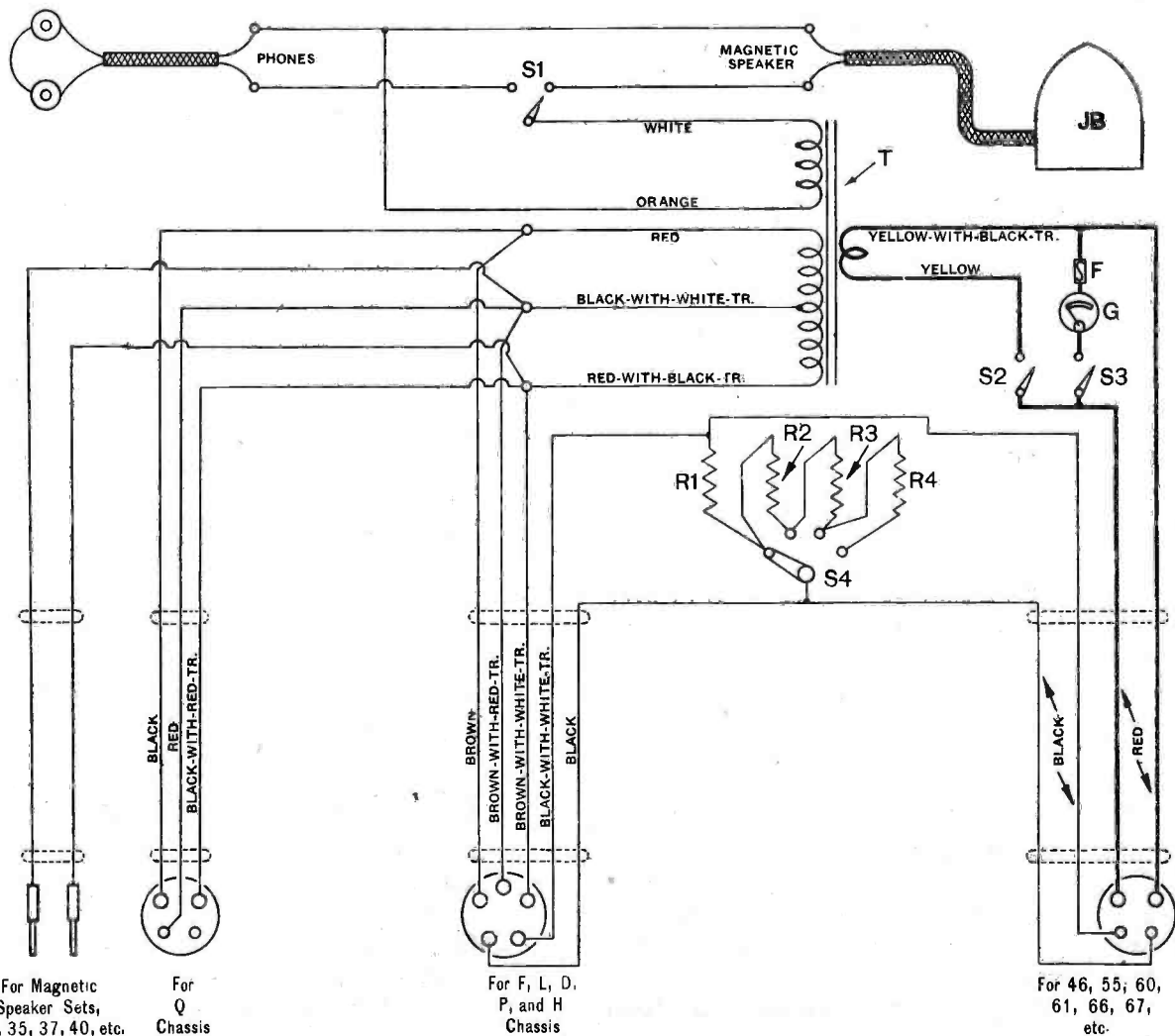

**CAUTION:** USE ONLY ONE OF THESE FOUR CABLES AT ONE TIME.

## Some Automobile Radio Facts

Very few owners of automobiles are familiar with whether or not the car contains an aerial. The following data concerning the presence of an aerial installed at the factory during the time of manufacture should be of aid in the event that the car is equipped with a radio receiver subsequent to its purchase. This data applies to 1931 model automobiles.

All Chrysler "8" and Imperial "80" cars are equipped with an antenna at the factory during the production of the car. The De-Soto "6" and "8" have poultry wire tops, which when disconnected from all grounds can be utilized as the aerial for an automobile radio set. The lead-in connection to the aerial in the Chrysler cars is carried down the front right corner post. In the De-Soto models the connection to the aerial should be made at such a point that the lead-in can be conveniently brought down the front right corner post.

The Studebaker "President" and "Commander" models are factory equipped with antennae. The lead-in is shielded and is brought down the front left corner post.

Where an antenna is to be installed in an automobile, it is good practice to use a shielded lead-in. However the ordinary type of shielded lead-in wire is not satisfactory and should not be employed. The most satisfactory wire is shielded high tension cable or wire known as airpose. When used the shielding should run up to, but not touching the antenna and down

to the receiver housing, with the shielding bonded to the receiver housing.

While upon the subject of shielding, it has been found unsatisfactory practice to shield the high tension cables used in the car ignition system. The shielded high tension cable previously recommended for shielded lead-in purposes is unsatisfactory for use as shielded high tension wires, that is in connection with efforts to eliminate electrical interference.

If the car is not equipped with an aerial, but makes use of a poultry wire top, it is necessary to check every part of this top to locate and remove all grounds before the top is suitable for use as an aerial.

### BATTERY GROUNDS

All cars do not ground the same side of the battery. The accompanying list gives the polarity of the grounded battery lead for some of the 1930 models.

Model	Polarity
Buick 47,47,60	Negative
Chevrolet	Negative
Essex	Negative
Ford A	Positive
Hudson Great "8"	Negative
Hupmobile	Positive
Lincoln	Negative
Pierce-Arrow 132,139,144	Positive
Reo 15,20,25	Negative
Studebaker "Eights" Pres. Comm. Dict.	Positive