

RIDER'S VOLUME XVIII

HOW IT WORKS

AND

COMPLETE INDEX

FOR

VOLUMES XVI, XVII AND XVIII



JOHN F. RIDER PUBLISHER, INC.

480 Canal Street

New York 13, N. Y.

TABLE OF CONTENTS

DETECTOR CIRCUITS IN AM-FM RECEIVERS	1
Admiral Model 9B14-9B16—1. Farnsworth GK-085 and Firestone 4-A-12—2.	
THE LOCKED-IN OSCILLATOR DETECTOR	5
Philco 48-482—5. Circuit Construction—5. Operating Conditions—6. Incoming Signal Changing in Frequency—7. Lock-In Action—7. Incoming Signal Lower Than Center I.F.—8. Incoming Signal Higher Than Center I.F.—8. Obtaining the Audio—9. Suppression of A-M—9. Linearity and Bandwidth—9.	
UNUSUAL I-F AMPLIFIER CIRCUITS	10
Crosley Models 9-119, 9-120 W—10. Philco Model 48-300—10. Philco Model 48-360—11. Philco Model 48-464—11. General Electric Models 210, 211, and 212—12.	
OSCILLATORS FOR F-M SETS	15
GE 210, 211, and 212—16. United Motors Models R-1253, R-1254, and R-1255—17.	
GROUND-GRID INPUT CIRCUITS	19
The Grounded-Grid Circuit—19. Admiral 9B14—20. Noblitt-Sparks 280 TFM—20. Westinghouse H-164—21.	
APPLICATION OF THE PRINTED CIRCUIT	23
Majestic 6FM714, 6FM773—23. What Is a Printed Circuit?—23. The Serviceman's Viewpoint—24.	
AUDIO NOISE SUPPRESSION	25
Philco Electronic Scratch Eliminator—25. Scott "Metropolitan" Receiver—27. Garod 306—29.	

Credit is extended to SEYMOUR D. USLAN and RICHARD F. KOCH for their preparation of the technical material contained herein.

Copyright 1949 by
JOHN F. RIDER

All rights reserved including that of translation into the Scandinavian and other foreign languages.

Printed in the United States of America

DETECTOR CIRCUITS IN AM-FM RECEIVERS

In the production of many combination am-fm receivers, one of the primary problems is the design of those circuits that are intended to perform a dual function — that is, circuits that will operate on f.m. as well as on a.m. Such design problems are encountered in every part of the receiver up to the audio system. R-f, converter, i-f, and detector circuits all have their own individual design problems in combination am-fm receivers.

In some receivers a single tube is capable of performing the function of a-m and f-m detection. Other receivers have separate tubes for a-m and f-m detection, but in some instances one of these detector tubes has another function besides detection. Whatever the type of circuit designed, the important prerequisite is that it function only on a.m. when the receiver is tuned to the a-m broadcast band and only on f.m.

when it is tuned to the f-m band. In this section we will discuss some of the different types of detector circuits that appear in combination am-fm receivers.

Admiral Model 9B14—9B16

The Admiral models 9B14, 9B15, and 9B16 employ a separate tube for both a-m and f-m detection, but the tube employed for a-m detection is also used as the f-m second i-f amplifier. The complete service data for these models appears on *Admiral pages 18-33, 34 through 18-38 in Rider's Vol. XVIII*. A duodiode 6AL5 tube is used on the f-m band in a conventional ratio detector circuit. This tube performs only one function — namely f-m detection. A pentode tube, the 6BA6, serves the dual purpose of f-m second i-f amplifier and a-m detector. The schematic diagram of

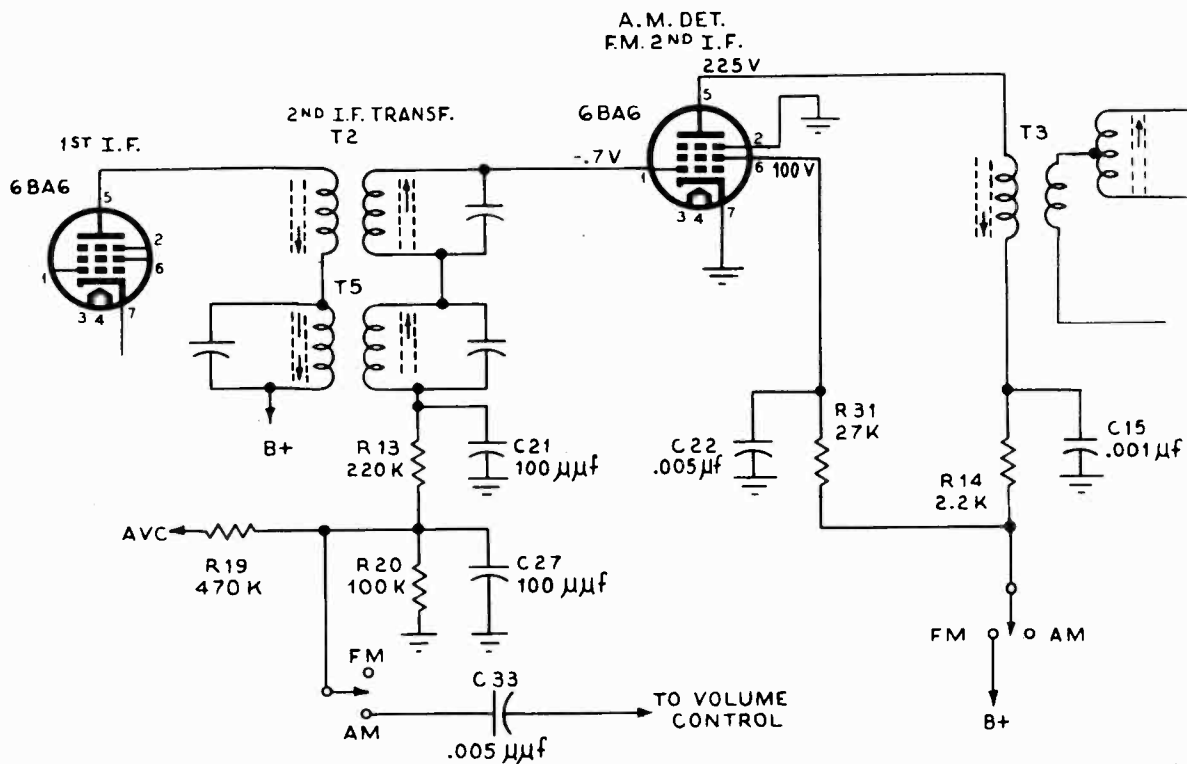

FIG. 1.— The detector and i-f stages of the Admiral models 9B14, 9B15, and 9B16. The second 6BA6 serves as both an fm-if amplifier and an a-m detector.

this circuit is illustrated in Fig. 1. Let us examine this circuit and see how it works when the set is tuned to the f-m band and then to the a-m band.

Although not shown in the drawing, the first a-m and fm-if transformers are in series with each other and precede the first i-f amplifier tube. When the receiver is switched to the f-m band, the primary of the first am-if transformer is shorted and the circuit becomes selective only to the fm-if signal and this signal is fed to the grid circuit of the first i-f amplifier. The output from this tube is coupled to the following stage through the second i-f transformer arrangement as shown in Fig. 1. In this coupling unit *T2* is the fm-if transformer and *T5* the am-if transformer. Since only an fm-if signal is present, transformer *T2* is the active coupling unit due to its being pretuned to the f-m intermediate frequency.

In the f-m position of this set, a switching arrangement in the plate and screen circuits of the second 6BA6 tube enables these electrodes to receive B supply voltage and thus the tube acts as a pentode amplifier to the fm-if signal. The necessary bias for the proper operation of this tube as an amplifier is obtained by the d-c voltage drop across the two series grid resistors *R13* and *R20*. This voltage is about -0.7 volt. The total value of these resistors is high enough to establish this bias with a very small value of grid current.

Although this d-c bias voltage is shown as -0.7 volt, this is only a typical measuring indication. The exact value of the bias depends upon the average signal strength of the incoming signal and thus may be different from the value mentioned. Due to this phenomenon, this bias is a convenient source for avc voltage on the f-m band. The total bias voltage is not used for avc purposes, only part of it, as can be seen in Fig. 1 since the avc lead is connected to the junction of the two grid resistors, *R13* and *R20*. In other f-m receivers that employ a ratio detector, avc voltage is often taken from the negative side of the electrolytic capacitor in the output circuit of the detector.

Now let us examine the circuit when the receiver is tuned to the a-m band. In this position the primary of the first fm-if transformer, although not shown in Fig. 1, is shorted and only the first am-if transformer is selective and passes on the am-if signal to the 6BA6 first i-f amplifier tube. The output from this tube is coupled to the grid of the following 6BA6 tube via the second am-if transformer, *T5*, as shown in Fig. 1. The inductance of the coils of the fm-if transformer *T2* is so low as to have negligible effect on the a-m intermediate frequency, and it is, therefore, not necessary to short the coils of *T2*.

At a quick glance at this circuit one might be puzzled as to how the 6BA6 pentode tube, which previously acted as an fm-if amplifier, now acts as an a-m detector. Upon a more thorough investigation of this 6BA6 circuit, its ability to act as a detector will become readily apparent. First of all, note the plate and screen circuits of this tube. When the set is switched to a.m., the supply voltages are removed from these electrodes, and these sections of the tube are, therefore, inoperative. With these electrodes inoperative, the suppressor grid does not have any effect. Thus the only two electrodes left, the control grid and the cathode, must act as the a-m detector — which they do. They function as a diode detector, with the grid acting as the plate of this diode. The action takes place as in the casual type of diode detector. Avc is also established in the normal manner with capacitors *C21* and *C27* and resistor *R13* acting as a conventional r-f and i-f filter. The audio signal is developed at the junction of *R13* and *R20*. By tapping off at this point and feeding the signal through the proper filters, avc voltage is delivered to the necessary tubes of the receiver.

With the receiver in the a-m position, a switch in this part of the circuit allows the audio voltage to be fed to the volume control of the set via the $0.005 \mu f$ coupling capacitor *C33*, as seen in Fig. 1.

Farnsworth GK-085 and Firestone 4-A-12

At the beginning of this section it was mentioned that in many am-fm receiver combinations a single tube was used to perform the function of detection of both a.m. and f.m. In glancing through the am-fm receivers in *Rider's Volume XVIII*, you will find many such type circuits. In the two receivers to be discussed here such a multi-purpose tube is employed; and, in addition to serving as an a-m and f-m detector, it also has additional electrodes which serve as the first audio amplifier of the unit. The combination receivers that we have in mind are the Farnsworth models GK-084, 085, 086, 087 and Firestone model 4-A-12. The complete service data for the Farnsworth models appear on pages 18-6 through 18-12 of *Rider's Volume XVIII* and the service data for the Firestone model appear on pages 18-7 through 18-10 of the same volume.

The schematic representation for each of these special tubes is illustrated in Fig. 2. Each tube is a triple-diode triode but they have somewhat different constructions even though their functions are the same. The 6S8GT tube, shown in part (A) of Fig. 2, is used in the Farnsworth models and the 19T8 tube

FIG. 2 (A) — Schematic representation of the 6S8GT triode triode tube. (B) The schematic representation of the 19T8 miniature-type tube. Both of these tubes are used for combined a-m and f-m detection.

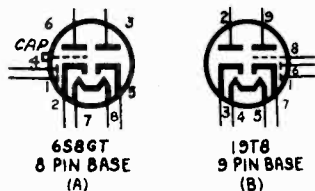

shown in part (B) is used in the Firestone model. The 6S8GT is a regular sized tube with an octal (8-pin) base. Since there are nine electrodes, including the two for the heaters, and only an eight-pin base, connections to the other electrode, the grid of the triode section, is made through the top of the tube by means of a grid cap. The 19T8 tube is a miniature type that employs a nine-pin base and hence there is no need for a grid cap. For this latter tube a special nine-pin socket has to be employed.

The 6S8GT tube requires 6.3 volts operation for its filaments whereas the filaments of the 19T8 tube requires 18.9 volts. The latter tube is more readily usable in ac-dc receivers than the other type. The 6S8GT tube is usually employed in a-c receivers which use a power transformer with a 6.3-volt filament winding. The circuit connections of both tubes are quite similar so we will show only the hookup for the 6S8GT tube in the Farnsworth models. This circuit is illustrated in Fig. 3. Let us now examine this circuit and see how it functions on the a-m and f-m bands relative to its use as an a-m and f-m detector, avc voltage supplier, and audio amplifier.

The schematic representation of the electrodes of the 6S8GT tube are rearranged from that shown in Fig. 2 (A) solely for the purpose of simplifying the drawing. When the receiver is tuned to the f-m band, the fm-if signal is fed through a series of three i-f amplifiers and then coupled to the 6S8GT tube through the ratio detector transformer. The plates and cathodes of pins 2, 3, 4, and 5 are connected in a conventional type of ratio detector circuit as seen in Fig. 3.* Avs for f.m. is taken from the negative side of the 4 μ f electrolytic capacitor in the output circuit of the ratio detector. This point is used because the output voltage there changes in accordance with the varying average strength of the incoming signal.

The 22,000-ohm resistor and 0.003- μ f capacitor in the tertiary winding of the ratio detector transformer forms the de-emphasis network of the receiver. The audio signal output from this circuit is fed to a volume and tone control network through the f-m section of the switch as shown in Fig. 3. The audio signal is finally coupled to the grid of the triode section of the tube through a 0.01- μ f capacitor. The plate, pin 6, and cathode, pin 2, are the other electrodes of the amplifier. Bias for this amplifier is obtained by the d-c voltage drop across the 10-megohm resistor in the grid circuit. The signal output from the plate of this first audio amplifier is then coupled to the grid of the audio power output tube.

Up to this point, the cathode, pin 2, has been used

* For a complete discussion of the ratio detector see pages 313-321 in the text "FM Transmission and Reception" by Rider and Uslan, published by John F. Rider, Publisher, Inc.; 480 Canal St., N. Y. 13, N. Y.

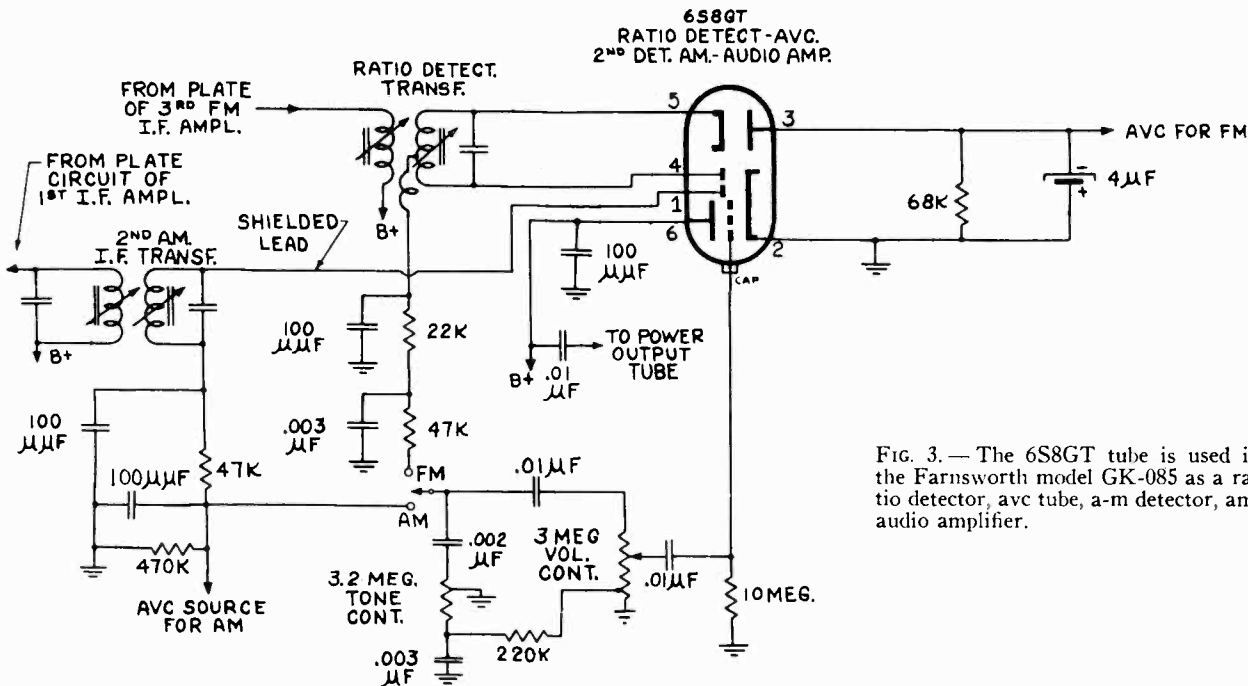

FIG. 3. — The 6S8GT tube is used in the Farnsworth model GK-085 as a ratio detector, avc tube, a-m detector, and audio amplifier.

for two separate applications; one for the ratio detector circuit and the other for the audio amplifier. It also has a third application — that being part of the a-m detector circuit. Let us now examine this circuit when the receiver is tuned to the a-m band. In this position of the im-if signal passes through only one stage of i-f amplification and is then coupled to the plate, pin 1, of the 6S8GT tube through the second am-if transformer. This electrode together with the grounded cathode, pin 2, functions as a conventional diode detector for a-m signals. Since no fm-if signal is present at the ratio detector transformer, the other

electrodes, pins 3, 4, and 5 of the 6S8GT tube, are not operative.

The two 100- $\mu\mu\text{f}$ capacitors and the 47,000-ohm resistor in the secondary circuit of the second am-if transformer serve as an i-f filter. The output signal from this filter is audio and is applied to the volume and tone control circuits of the receiver through the a-m section of the switch, as seen in Fig. 3. This output signal from the i-f filter is used as an avc source for a.m. The avc voltage for the necessary circuits is obtained after the audio signal is properly filtered in the customary manner.

THE LOCKED-IN OSCILLATOR DETECTOR

Practically all of the a-m broadcast superheterodyne receivers today employ the simple method of diode detection. It has been the accepted method of detection for a-m signals for a long time. In f-m the situation is much different. Today there are four methods of f-m detection employed: the limiter-discriminator method, the ratio-detector method, the Fremodyne circuit, and the locked-in oscillator detector. The first three types of f-m detector circuits have been discussed in previous "How It Works" books (see *Volume XV and XVII*) and the latter type of circuit will be discussed now.

Philco 48-482

To date only one manufacturer, Philco Corporation, has employed the locked-in oscillator detector. This circuit has all the necessary features for proper f-m detection, such as negligible response to a-m signals and maximum response and linearity to f-m signals. The locked-in oscillator detector circuit, as its name implies, employs the principle of the locked-in oscillator. A locked-in oscillator utilizing a special tube and circuit construction comprises this f-m detector net-

work. It is used in a number of Philco models but the one to be studied here is model 48-482. The complete service data for this model can be found on *pages 18-91 through 18-107 of Rider's Volume XVIII*. While this f-m detector circuit is more complex than the other three types, the action occurring in the circuit can be understood by careful study of the following analysis.

Circuit Construction

We will first study the individual functions of the associated circuits and then consider the over-all action of the detector under operating conditions. The schematic arrangement for the circuit under consideration is illustrated in Fig. 1. Similar to the ratio detector, a single tube is employed for the process of f-m detection and a-m rejection. In Fig. 1 all the lettered and numbered designations are the manufacturer's except the symbols *L1*, *L2*, *L3*, and *L4* which we have inserted for ease of discussion.

There are three tuned circuits in this network that have to be considered, namely, *L1-C403B*, *L3-C300A*, and *L2-C300B*. The resonant frequency of operation of the latter tuned circuit is also determined by ca-

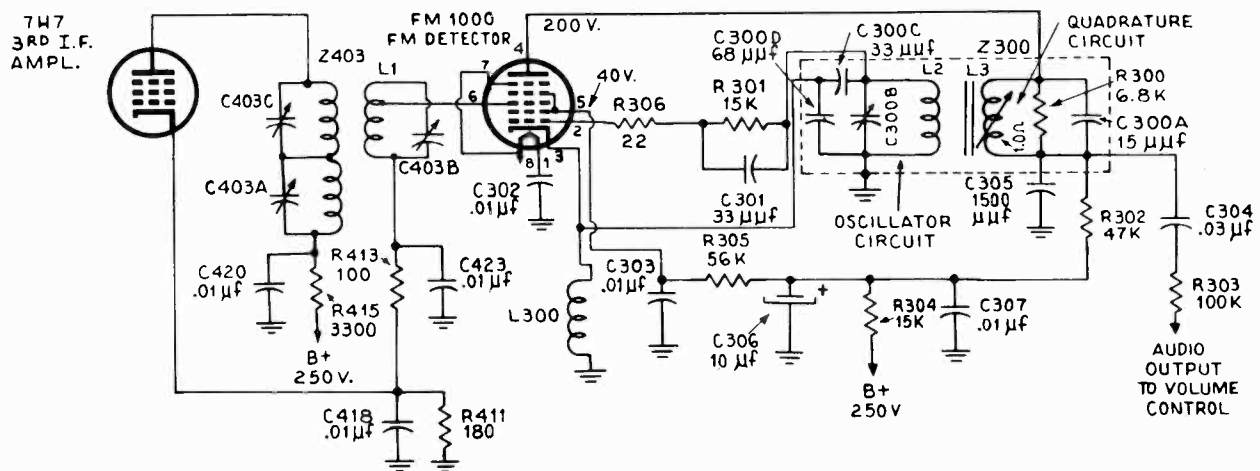

FIG. 1.— The locked-in oscillator detector circuit used in the Philco model 48-482. The FM 1000 tube used in this circuit is a special pentagrid tube.

capacitors C300C and C300D, as well as trimmer C300B. These three tuned circuits are all resonant to the same frequency, which is 9.1 mc, the i.f. of the set. The 7H7 tube is the last i-f amplifier of the receiver. The Z403 designation is for the last i-f transformer of the unit and it contains both a-m and f-m sections. However, only those components that are part of the circuit are shown, consequently the secondary of the a-m section of Z403 is omitted. The primary of this a-m section, which consists of capacitor C403A in conjunction with the coil across it, is illustrated because it is in series with the primary of the fm-if section and constitutes part of the completed f-m signal and d-c path.

The tube used as an f-m detector is designated by Philco as FM 1000 and is of special pentagrid construction, with the second and fourth grids tied together inside the tube and the fifth grid or suppressor connected externally to the filament, pin 8. The first two grids and the cathode of the unit, in conjunction with the associated circuit form a Colpitts oscillator. Components L2 and C300B in connection with C300D comprise the oscillator tank circuit. The parallel circuit arrangement of R301 and C301 forms the grid-leak bias network of the oscillator. The d-c return path from the oscillator grid is through coil L2 to ground. The second grid acts as the oscillator anode. The oscillator signal, which is 9.1 mc, is electron coupled to the plate, pin 4, of the FM 1000 tube. The oscillator anode and the fourth grid, which acts as the screen of the tube, both receive the same supply voltage (because of their internal connections) and they are both at i-f ground potential through the 0.01- μ f capacitor C303.

Coupled to the oscillator tank circuit is the tuned plate circuit composed of capacitor C300A in parallel with coil L3. This circuit, called a *quadrature circuit*, is also resonant to 9.1 mc, the fm-if of the receiver. This tuned plate circuit is called a *quadrature circuit* because it reflects a voltage into the oscillator tank that is 90 degrees out of phase with the oscillator tank voltage. However, the bandwidth characteristics of this circuit are much wider than those of the oscillator tuned circuit because of the parallel 6800-ohm resistor R300. The use of this resistor decreases the Q of the circuit and hence increases its bandwidth. This increase in bandwidth is a desirable factor because for proper operation of the detector the impedance of this plate circuit must not change appreciably over the frequency range of the incoming signal. It must be remembered that the incoming signal is frequency modulated and hence is varying in frequency about a mean. A greater bandwidth can be obtained by using a

smaller value of R300 and hence reducing the Q of the circuit. This further increased bandwidth, although it may be desirable, might result in a complete damping out of the oscillations of the tank circuit. The value of R300 that is used is low enough, nevertheless, to cause the bandwidth of the quadrature circuit to be over five times as great as the width of the f-m signal.

Operating Conditions

Let us now see how the tube functions with the circuit in operation. The oscillator section operates class C and is so designed that its grid, pin 2, is driven positive over a small part of its positive half cycle of signal; hence the r-f current flow in the tube due to the oscillator is in pulses of short time duration.

When there is no f-m input signal to pin 6, these pulses will continue to flow unchanged to the plate circuit of the tube due to the electron coupling between this electrode and the oscillator circuit. Therefore, the same pulses will flow in the quadrature circuit. Due to the transformer coupling between the quadrature and oscillator circuits, some voltage is fed back to the oscillator tank circuit. Since this quadrature network is always in the circuit the voltage fed back in conjunction with the oscillator voltage that would exist without feedback establishes the operating frequency of the oscillator. This feedback voltage, which in reality is a reflected voltage from L3 to L2, is also a factor in establishing the relative phase and magnitude of the plate current pulses.

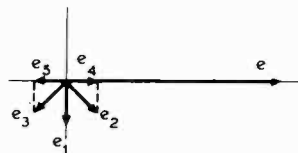

FIG. 2.—The vector diagram indicating the voltage relationships between the signals at the input and oscillator grids of the locked-in oscillator circuit of the Philco model 48-482.

Without any f-m signal applied to the grid, pin 6, but with the proper d-c potentials applied to the FM 1000 tube, the magnitude of these plate-current pulses are constant. However, when an f-m signal is applied to pin 6, the magnitude of these current pulses will vary according to the polarity, or phase, of this incoming signal. If this signal grid swings positive, with respect to its potential before a signal is applied, the magnitude of the current will be increased; that is, there will be an increase in the current flow. On the other hand, if the grid swings negative with respect to its initial potential, there will be a decrease in the amount of current flow. Consequently we see that this signal grid is a controlling factor in the magnitude of the current flow in the FM 1000 tube.

In order to better understand the relationship between the signal at pin 6 and the oscillator voltage with regard to the magnitude of the current, let us study the vector diagram of Fig. 2.* In this drawing vector e represents the oscillator voltage that exists on the oscillator grid, pin 2, and vector e_1 represents the signal voltage that exists on the third grid, pin 6. Since the input to the third grid is an fm-if signal, vector e_1 represents the mean or center frequency of this f-m signal. In this particular case the frequency is 9.1 mc.

You will notice that vector e_1 is shown in quadrature, 90 degrees out-of-phase, with vector e and may wonder why it is drawn in this manner. It is a known fact in the operation of this circuit that when the incoming f-m signal has an instantaneous frequency of 9.1 mc, the center i.f., the pulses of current in the tube remain unchanged. This is the same condition that exists when there is no input signal. Consequently vector e_1 can have no component that is in-phase or 180 degrees out-of-phase with vector e because either component would change the magnitude of vector e . If vector e is changed, the current flow in the tube will vary and we know this is not the case when the incoming signal is exactly equal to the center i.f. Since vector e_1 cannot have any in-phase or 180-degree out-of-phase components with vector e , it is drawn in quadrature.

When the instantaneous frequency of the f-m signal is equal to 9.1 mc, this signal must pass through a zero value when the pulses of plate current (due to the oscillator alone) are at a maximum. This is primarily so because the free frequency of the oscillator, that is, when there is no input to the signal grid, is 9.1 mc, the same as the center i.f.

Incoming Signal Changing in Frequency

Let us now see what happens to the pulse of plate current when the incoming signal is changing in frequency. If there is a phase change between the incoming signal voltage and the oscillator voltage due to a change in input signal frequency, then the two vectors e and e_1 will no longer be in quadrature with each other. This means that the signal voltage vector will either have an in-phase or 180-degree out-of-phase component with vector e . This in turn will mean a change in the magnitude of oscillator pulse current and hence a change in the amount of plate current. But how can the input f-m signal control the amount of

plate current if the magnitude of the f-m signal is constant?

An f-m signal, even though it is undergoing a variation in frequency, also indirectly changes in phase. In Fig. 2 this phase change is indicated by vectors e_2 and e_3 . Vector e_2 indicates the input voltage at some instantaneous point where the frequency has decreased from the center i.f. of 9.1 mc and vector e_3 represents the signal voltage when the frequency has increased. The phase difference between the signal and oscillator voltage has decreased for the case of vector e_2 and has increased for the case of vector e_3 . Resolving both instantaneous signal vectors e_2 and e_3 , into their horizontal and vertical components, we find that voltage vector e_2 has a horizontal component, e_4 , in phase with vector e ; and voltage vector e_3 has horizontal component, e_5 , 180 degrees out-of-phase with vector e . The vertical components of vectors e_2 and e_3 are in quadrature with vector e and thus have no effect upon the magnitude of the oscillator voltage. Since vectors e_4 and e are in-phase with each other they are additive and the magnitude of plate current is said to increase. Conversely, component vector e_5 has to be subtracted from vector e , thereby reducing the plate current flow in the tube.

Therefore, it is seen that when the instantaneous frequency of the incoming fm-if signal is above that of the center i.f. of 9.1 mc, then the magnitude of current pulses decreases; and when the instantaneous frequency is below 9.1 mc, the magnitude of the current pulses increased.

Lock-In Action

Let us now consider the feedback action between the quadrature tank circuit and oscillator tank circuit of Fig. 1. It is known that the feedback voltage is proportional in amplitude to the pulse of plate current and will vary in accordance with the change in plate current. The feedback voltage has a phase lead of approximately 90 degrees with respect to the oscillator voltage that exists without feedback. A change in feedback voltage, which is dependent upon the instantaneous frequency of the incoming fm-if signal, effectively changes the frequency of the oscillator. This frequency change is such that the oscillator will *lock-in* at the same frequency as that of the incoming signal. As the input signal changes in frequency, the frequency of the oscillator will follow accordingly, due to the lock-in effect.

For a more complete understanding of why the frequency of the oscillator changes in accordance with

*For a complete analysis of vector diagrams, what they mean and how to use them, see the text "Understanding Vectors and Phase" by Rider and Usian, published by John F. Rider Publisher, Inc.

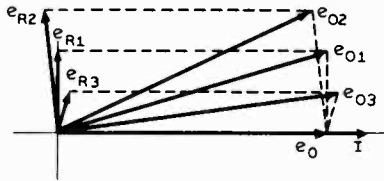

FIG. 3.— The vector diagram indicating the relationships between the reflected voltage from the quadrature circuit and the oscillator voltage in the locked-in oscillator detector circuit.

the incoming signal, let us refer to the vector diagram of Fig. 3. In this diagram vector e_0 represents the oscillator voltage that would exist in the absence of feedback and vector I indicates the current flowing through the oscillator tank circuit. Since the oscillator tank is a resonant circuit, the current flowing through it will be in-phase with the voltage across the circuit at resonance. This is illustrated in the vector diagram of Fig. 3. As mentioned previously, with the circuit operating a feedback voltage exists and the total oscillator voltage is equal to the feedback, or reflected, voltage from the quadrature circuit plus the voltage existing without feedback.

The feedback voltage which is in quadrature leading the oscillator voltage e_0 has the effect of introducing an effective inductance in series with the oscillator tank inductance. This increase in inductance, although small, establishes the operating frequency of the oscillator. If the instantaneous frequency of the incoming signal is equal to the 9.1 mc i.f. of the receiver, or if there is no signal input, a certain amount of voltage is, nevertheless, reflected into the oscillator circuit from the quadrature circuit. This voltage represented by e_{R1} is in quadrature leading the oscillator vector e_0 as shown in Fig. 3. The effective oscillator voltage that exists under these conditions can be found by vectorially adding vectors e_0 and e_{R1} . The resultant oscillator voltage in this case is designated as vector e_{O1} .

Incoming Signal Lower Than Center I.F.

Let us now see what happens to the effective oscillator-voltage vector when the instantaneous frequency of the incoming signal is different from the center i.f. If we assume that the incoming signal decreases in frequency, the pulses of plate current will increase as we have indicated in Fig. 2. Since this current also flows through the quadrature circuit, the increase in current flow will in turn increase the amount of reflected voltage into the oscillator tank. Since the amount of this reflected voltage is increased, then, the

inductance that is introduced in series with the oscillator coil (due to this reflected voltage) is increased from what it was previously. This means that the total effective oscillator inductance is increased and the frequency of the oscillator is decreased accordingly and is said to lock-in with the frequency of the incoming signal. This reflected voltage is illustrated as vector e_{R2} in Fig. 3. It is drawn somewhat longer than vector e_{R1} because of its increase in magnitude. Due to the decrease in frequency of the input signal, the phase lead of vector e_{R2} is slightly greater than that of e_{R1} . When vectors e_{R2} and e_0 are added together, a different resultant voltage, designated as e_{O2} in Fig. 3, appears across the oscillator tank circuit.

Incoming Signal Higher Than Center I.F.

When the incoming signal increases in frequency, the pulses of plate current will decrease. This means that the amount of voltage reflected into the oscillator-tank circuit will likewise decrease. This new reflected voltage is designated as vector e_{R3} in Fig. 3 and is decreased in amplitude compared to vector e_{R1} . Due to the increase in frequency, this reflected voltage vector, e_{R3} , has a phase lead that is slightly less than that of e_{R1} . Because of its decrease in amplitude, this reflected voltage causes a decrease in the effective inductance that is introduced in series with the oscillator coil. This means a decrease in the over-all inductance of the oscillator tank, thereby increasing its frequency of operation. The increase in frequency is such that the new oscillator frequency follows that of the incoming signal and a *lock-in* effect results. Vectorially adding vectors e_{R3} and e_0 gives resultant oscillator voltage e_{O3} .

Glancing at Fig. 3 once more, it can be seen that when the frequency of the incoming signal varies above and below the center i.f., the resultant oscillator voltage also varies in phase. A change in phase is indirectly followed by a change in frequency. The increase in phase of vector e_{O2} over e_{O1} represents a decrease in oscillator frequency and the decrease in phase of vector e_{O3} over e_{O1} represents an increase in oscillator frequency.

The circuit is so designed that the plate current will vary linearly with respect to frequency variations of the input signal above and below the center i.f. The frequency variations of the fm-if input signal are well within the linear limits of the circuit. Although the reflected voltage can be seen to vary in amplitude from Fig. 3, it also varies in phase with respect to the resultant oscillator voltage to maintain the oscillator voltage substantially constant. This is an important

point to remember because if the oscillator voltage were not constant, distortion would result in the output audio signal.

Obtaining the Audio

How does the action of this circuit bring about the detection of the audio modulating component of the input f-m signal? To understand how this occurs is simple, all that has to be remembered is that the *rate* of deviation of the f-m signal is dependent upon the *frequency* of the audio modulating signal and the *amount* of deviation is dependent upon the *amplitude* of the audio modulating signal. Since the rate of change in the plate current is in direct accordance with the rate of deviation, then this rate of plate current variation is in turn dependent upon the frequency of the audio modulating signal. The magnitude of the plate current varies in accordance with the amount of frequency deviation of the f-m signal and hence is indirectly dependent upon the magnitude of the audio modulating signal. Consequently we see that the rate of plate current flow is the same as the frequency of the audio modulating signal and the magnitude of the plate current is proportional to the amplitude of the audio modulating signal.

This plate current flows through its load circuit which consists primarily of the quadrature network, load resistor *R302* and capacitor *C305* as seen from Fig. 1. The audio signal represented by the varying plate current of the tube appears across this load. Part of this audio signal appears across the 47,000-ohm load resistor *R302* and represents an available point from which the audio signal can be taken off. The 1500- $\mu\mu\text{f}$ capacitor *C305* serves as a bypass for any i-f currents. The 0.03- μf capacitor *C304* and the 100,000-ohm resistor *R303* are employed to directly couple the audio voltage appearing across load resistor *R302* to the volume control and hence to the following audio stages.

Suppression of A-M

In the above analysis we have only indicated how the circuit functions as a detector of f-m signals but nothing has been said about suppression of a-m effects which is equally important to the operation of an f-m detector circuit. A-m effects are suppressed in the following manner. If there is a change in the amplitude of the incoming signal, it will tend to change the magnitude of the current pulses. Any change in the magnitude of the current will cause a change in the voltage reflected from the quadrature circuit into the oscillator circuit. This, of course, will tend to cause a

change in the frequency of the oscillator, as we have previously indicated. However, we do know that changes in oscillator frequency are accompanied by phase changes between the pulse current and reflected voltage. This was illustrated by the vector diagram of Fig. 3. Hence, we can conclude that there is a phase change between current pulse and input signal when the input f-m signal undergoes a change in amplitude.

However, the oscillator has only a small frequency change which is considered negligible until it once again locks-in frequency with that of the incoming signal. In other words, it is the lock-in effect of the circuit which is the primary controlling factor in the suppression of a.m. The change in pulse current as caused by a.m. is very small and thus this type of f-m detector circuit is highly insensitive to a.m. The slight sensitivity that it has to a.m. is, like other practical f-m detector systems, far less than the sensitivity it has to f-m signals.

Linearity and Bandwidth

A linear response characteristic is a requirement for the proper operation of f-m detector circuits because, otherwise, distortion would result in the audio output system. With a *minimum* input signal maintained at all times, the response of the circuit under discussion is quite linear. This linearity is over a total bandwidth of 200 kc, or 100 kc on either side of the center i.f. of 9.1 mc. In other words the input fm-if signal to the detector tube can vary between the limits of 9.0 to 9.2 mc and still fall within the linear response of the circuit.

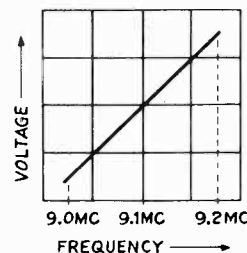

FIG. 4. — Drawing of the f-m detector response of the Philco model 48-482. Note that this curve is linear over a total bandwidth of 200 kc.

This is illustrated by the curve in Fig. 4, which is a drawing of the actual detector response of this model as seen on an oscilloscope. From this drawing it is readily seen that the response characteristic of this circuit is quite linear over a total bandwidth of 200 kc.

If the voltage input to the detector tube is too small, the lock-in effect which is necessary for the proper operation of the detector will not occur; in other words, a certain threshold value of input signal is required at all times. In this receiver the input signal is maintained above its threshold value by providing sufficient i-f amplification preceding the detector.

UNUSUAL I-F AMPLIFIER CIRCUITS

In a highly competitive field such as radio manufacturing, the producers of the equipment are constantly seeking new ways and methods of improving their products. In order to do this, new developments in engineering design are appearing all the time. In this article we will discuss some methods that are being used in current sets to improve the operation of i-f amplifiers in the simplest and most direct possible fashion.

Crosley Models 9-119, 9-120W

In the Crosley models 9-119 and 9-120W, appearing on pages 18-12 and 18-13 of *Rider's Volume XVIII*, the tuning capacitor of the first i-f transformer is returned to r-f ground in an unusual manner. This is shown in Fig. 1. It can be seen that the capacitor is returned to the low side of the oscillator transformer primary, which is at r-f ground. Furthermore, this point is physically and electrically near the cathode of the converter, since the oscillator transformer primary, being tuned to a frequency quite different from

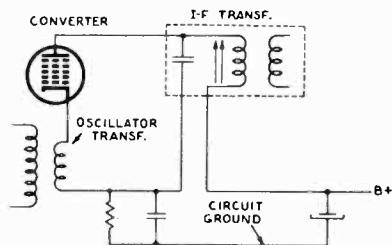

FIG. 1.— Simplified schematic of the converter plate circuit of the Crosley models 9-119 and 9-120W.

the i-f., presents a low impedance to i-f currents in the converter plate circuit. Thus, the i-f currents circulating through the converter and the primary tuning capacitor of the i-f transformer are confined to a very short path. If the capacitor were connected to the low end of the i-f transformer primary, the i-f current would have to return to the cathode of the converter through a rather long ground loop which includes i-f currents flowing in the i-f amplifier grid and plate circuits. Such an intermixing of current paths can easily produce instability in high-gain amplifiers. In this circuit such

instability is avoided by a very simple circuit arrangement which involves no extra parts.

Philco Model 48-300

The i-f amplifier in the Philco model 48-300 portable receiver is conventional in that tuned input and output transformers are used for this stage. As is usual, these transformers are tuned to the same frequency. As a result of this, feedback from the plate to the grid circuit tends to produce oscillation. This feedback is due to several factors, such as the plate-grid capacitance of the i-f amplifier tube, external distributed capacitances between closely placed parts, etc. Another factor is the high gain of the stage, which makes the feedback, small as it is, a potential source of oscillations in the stage.

In order to offset this tendency to oscillate, the stage has been neutralized. Neutralization is a device that is frequently used in transmitter amplifiers, but rarely in receivers. The term "neutralization" is highly descriptive: the tendency to oscillate is produced by positive feedback, so this feedback is cancelled, or neutralized, by negative feedback. For maximum effectiveness, the neutralizing feedback signal should be exactly 180 degrees out of phase with the positive feedback, and of the same amplitude. However, excellent results can be obtained without achieving ideal conditions.

The neutralization of the i-f amplifier in the Philco model 48-300 is shown in simplified form in Fig. 2.

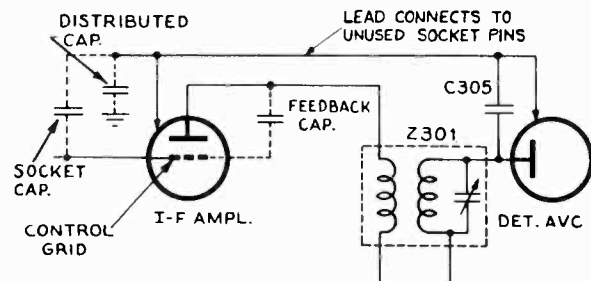

FIG. 2.— Simplified schematic of the neutralized i-f amplifier in the Philco model 48-300.

(The complete data for this model may be found on pages 18-56 through 18-63 of *Rider's Volume XVIII*.) The capacitors shown with dashed leads represent stray capacitances. One of these, labeled "feedback cap," is the source of trouble for it is the path over which positive feedback occurs. It is this capacitance which, if not neutralized, could cause oscillation. Signals traveling over this path arrive at the grid approximately in phase with the plate signal. The i-f transformer, Z301, shifts the signals from the plate of the i-f amplifier by 180 degrees. Therefore, signals fed back to the i-f amplifier grid by way of C305 are 180 degrees out of phase with the plate signals, and, therefore, 180 degrees out of phase with those signals fed back through the dashed-line "feedback cap." C305 is considerably larger than the capacitance which it is intended to neutralize, but because the distributed capacitance to ground acts as a voltage divider with C305, and also because the socket capacitance of the i-f amplifier is in series with it, the amplitude of the signal C305 feeds back to the grid is approximately equal to the signal fed back through the "feedback cap." Thus, two equal signals, of opposite phase, are fed back to the grid. Since they are equal and opposite, they cancel, and thereby provide effective neutralization of the stage.

Philco Model 48-360

In a battery-operated receiver, particularly a portable one, the power available to operate the tubes is much less than in a set operating from a 110-volt line. As a result, tubes used in portables are incapable of providing the sensitivity obtainable from the 6.3-volt heater-type tubes. In order to overcome this handicap to some extent, positive feedback is used in the i-f amplifier of the Philco model 48-360 to increase the gain of this stage.

At this point the reader may well exclaim, "Design engineers are certainly inconsistent! In one set they

go to a lot of trouble to neutralize positive feedback, and in another they take trouble to put it in!" This charge, however, is not well founded; in the model 48-300 the positive feedback is very detrimental to the operation of the set, and *must* be neutralized. In the model 48-360, on the other hand, the positive feedback is controlled and performs a useful and desirable function.

The manner in which positive feedback is obtained in the model 48-360 is shown in Fig. 3. (Complete data for model 48-360 may be found on pages 18-64 through 18-71 of *Rider's Volume XVIII*.) An extra winding, called a tertiary (third) winding, on the second i-f transformer, Z301, applies a signal to the screen grid of the i-f amplifier tube. The signal applied to the screen through the transformer is shifted 180 degrees in passing through the transformer, so that it is in phase with the signal at the control grid. In this way, the screen signal is of such a polarity that it increases the effect of the control grid on the tube. Thus, when the control-grid signal is positive, increasing the flow of electrons to the plate, the screen signal is also positive, further increasing the flow. In addition, the screen-grid signal amplitude is proportional to that on the control grid, so that the effect of the control-grid signal is increased without distorting it. Likewise, when the control-grid signal goes negative, the screen-grid signal goes proportionately negative, increasing the effect of the control-grid swing in this direction.

By a proper choice of turns ratio and coupling between the primary and tertiary of Z301 the positive feedback is maintained at a level insufficient to produce oscillation. Thus, *controlled* positive feedback is used to attain the desired goal of increased gain.

Philco Model 48-464

In an ac-dc radio, B- must either be connected directly to the chassis or bypassed to it so that the B- bus and chassis are at the same r-f and i-f potential. This is particularly important when some components, such as the tuning capacitors, are returned directly to the chassis rather than to the B- bus, and also when a high-gain, two-stage i-f amplifier is used, as in the Philco model 48-464 (see pages 18-72 to 18-79 of *Rider's Volume XVIII*). If this is not done, various undesirable effects, such as instability (tendency to oscillation) of the i-f amplifier, will occur.

In many sets, where the B- bus is not tied directly to the chassis, B- is bypassed to the chassis by means of a capacitor alone or a capacitor and choke in series. When a capacitor and choke are used, they are chosen so as to be series resonant at the intermediate fre-

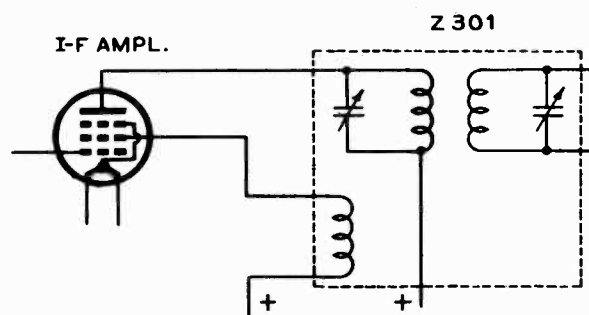

FIG. 3. — Simplified schematic of the i-f amplifier in the Philco model 48-360.

quency. Being resonant at the i. f., they present an even lower impedance to the i. f. than would a capacitor alone.

In order to produce an intermediate frequency, the converter tube is operated on a non-linear part of its characteristic curve. In addition to the production of the i. f. by the mixing action, harmonics of the i. f. will also be generated. Another possible source of harmonic generation is non-linear operation in the i-f amplifiers. Of course, the higher harmonics are usually not very strong, but the second and third harmonics may be strong enough to cause trouble. For this reason, the B- bus in the 48-464 is bypassed to the chassis by the combination of capacitors and chokes shown in Fig. 4.

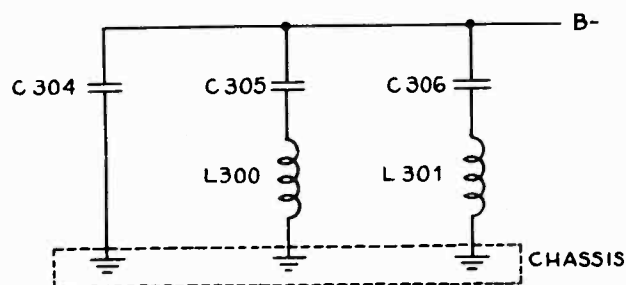

FIG. 4.—Bypassing from B- to ground in the Philco model 48-464 is accomplished by the above circuit.

C305 and L300 are resonant at 455 kc, which is the i. f. C306 and L301 resonate at 910 kc, the second

harmonic of the i. f., and the two capacitors and two chokes resonate together at 1365 kc, the third harmonic of the i. f. Thus these four components provide a very high degree of bypassing at these three important frequencies. C304 takes care of the radio frequencies and the oscillator frequencies. These frequencies, of course, are not fixed, so a fixed-tuned circuit cannot be used to bypass them.

General Electric Models 210, 211, and 212

Two very interesting features are found in the i-f circuits of GE models 210, 211, and 212 (see pages 18-21 to 18-25 of *Rider's Volume XVIII*). These sets are am-fm receivers; the features that will be discussed here are operative features when the sets are used for f-m reception. Starting at the antenna, we find the first unusual circuit to be a reflex amplifier.

In the reflex circuit a single tube is used to amplify both r-f and i-f signals. The advantages in savings of cost and space by the use of one tube instead of two are obvious. This has long been done in the case of converters (combined mixer and oscillator) and combined detector, avc rectifier, and first audio amplifier; both of these combinations are used in these sets.

The reflex amplifier and its associated converter are shown in Fig. 5. The band switch, S1, is in the f-m position. In a good location, f-m signals may be picked

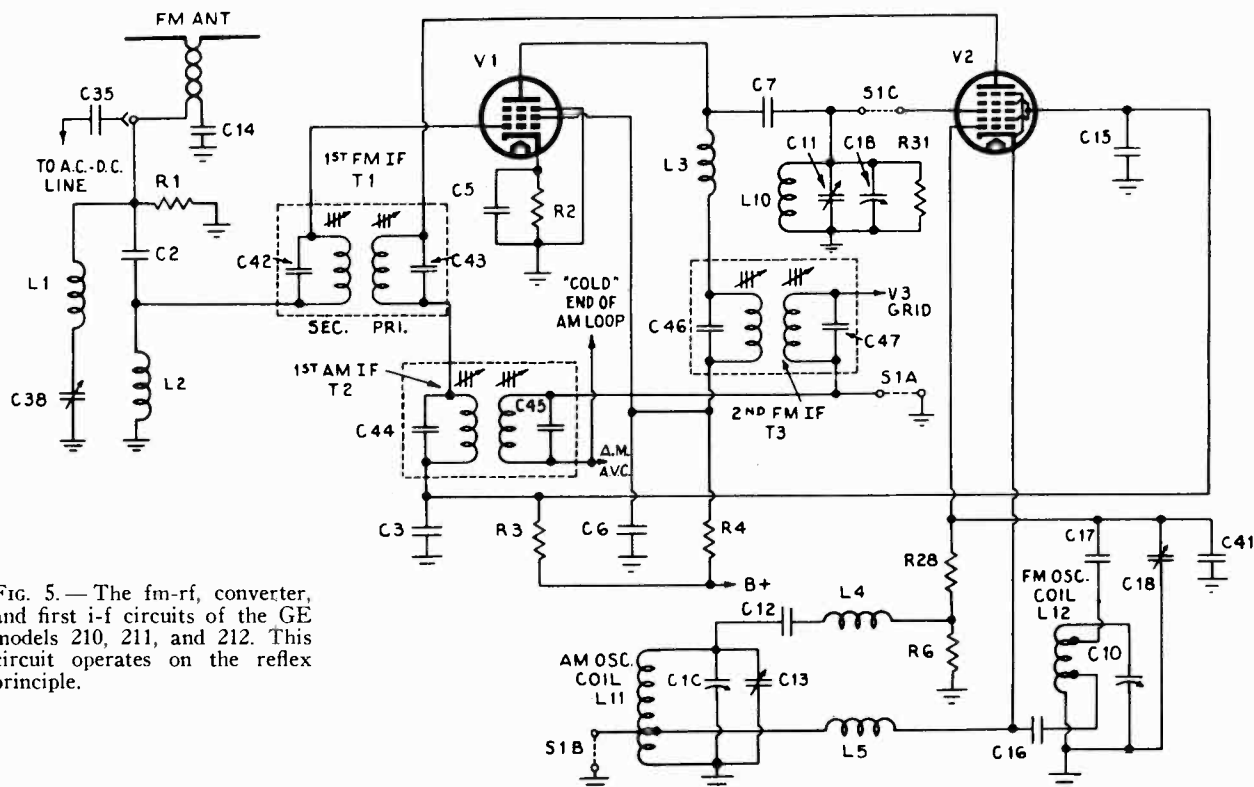

FIG. 5.—The fm-rf, converter, and first i-f circuits of the GE models 210, 211, and 212. This circuit operates on the reflex principle.

off the power line through $C35$; in a poor location, an outside antenna may be used. In the latter case, $C14$ in conjunction with the input to the r-f amplifier, which is single-ended, serves to provide a balanced load for the dipole. $R1$ provides a leakage path to ground for charges which might otherwise accumulate in the antenna circuit. $C2$ and $L2$, together with existing stray capacitances (such as distributed capacitance and lead inductance), are resonant at 98 mc, the middle of the f-m band. Since they are series resonant, the voltage across the choke alone is considerably greater than the voltage across the series combination. This increases the sensitivity of the receiver.

The signal is fed to the grid of $V1$ through the secondary of $T1$. (Because of the unusual circuit that we have here, it is necessary to place the secondary of $T1$ to the left of its primary for the sake of clearness.) The secondary of $T1$ is parallel resonant to the i. f., 10.7 mc, so that it appears like a fairly large capacitance to the much higher radio frequencies, which pass through without any difficulty. $V1$ then amplifies the r-f signals, with $L3$ functioning as the plate load. The "cold" end of $L3$ is bypassed to ground through the series circuit consisting of the primary of $T3$, which is capacitive at the r. f., and $C6$. R-f signals from the plate of $V1$ are fed to the signal grid of the converter, $V2$, through $C7$ and section $S1C$ of the band switch. The particular r-f signal desired is selected by the parallel tuned circuit consisting of $L10$, $C11$, $C1B$, and $R31$; $C1B$ is part of the tuning capacitor gang, and $R31$ is a damping resistor.

The oscillator section of $V2$ operates in a Hartley circuit for both f.m. and a.m., but different tank circuits must, of course, be used. The a-m tank circuit is decoupled from the f-m tank circuit by $L4$ and $L5$, and the cathode tap of the a-m tank circuit is grounded through section $S1B$ of the band switch. A small damping resistor ($R28$) prevents $L4$ from affecting resonance conditions in the f-m tank circuit. There are two interesting points to be observed about $L12$, the f-m oscillator coil; one is that it is made of a short piece of 300-ohm twin lead, shorted at one end and formed into a one-turn loop. The other is that the grid signal is not taken from the top of the tank coil, but is taken from a tap on the coil. The reason for this is to reduce the effect on the tank circuit of variations in the oscillator-grid input capacitance of $V2$. A fuller explanation of this principle is given in *Rider's Volume XV "How It Works"*, page 165.

F-m intermediate frequency signals from the plate of $V2$ are fed through $T1$ to the grid of $V1$. The "cold" end of the primary of $T1$ is bypassed to ground, first through the primary of $T2$ and then through $C3$ and

$C15$. The primary of $T2$, which is tuned to the a-m i.f. acts like a capacitance at the much higher f-m i.f., just as the f-m i-f transformer primaries appear to be capacitive at the still higher f-m r.f. (These relationships hold true for the transformer secondaries as well.) The "cold" end of the secondary of $T1$ is returned to ground through $L2$, which has a very low reactance (about 5 ohms) at the f-m i.f. $C2$ has a reactance of some 50,000 ohms at the f-m i.f., so that not much i-f signal will leak through it. As an added safeguard, however, a series-tuned trap consisting of $L1$ and $C38$ is provided.

$V1$ now functions as an i-f amplifier. The reactance of $C7$ is so high at the i. f., and that of $L3$ so low, that virtually all of the i-f signal available at the plate of $V1$ appears across the primary of $T3$. The signal on the primary of $T3$ is coupled to the secondary in the usual fashion, and is then applied to the control grid of $V3$. The "cold" end of $T3$ is grounded through section $S1A$ of the band switch.

It may appear strange that both $C3$ and $C15$ are used. The reason is that the frequencies used in f.m. and a.m. differ so widely. $C15$ is a mica capacitor which acts as an excellent bypass at the f-m r.f. and even the i.f., but is of too small a value to be satisfactory at the a-m frequencies. $C3$, on the other hand, has sufficient capacitance to be a good bypass at the a-m frequencies. However, it is a paper capacitor, and because of its construction has enough inductance to behave like a choke at the f-m r.f.

When the set is used for a-m reception, $V1$ is not used. R-f signals are fed directly from the "hot" end of the loop antenna (not shown in illustration) through section $S1C$ of the band switch to the signal grid of $V2$. In the a-m position of the band switch, section $S1B$ is open, removing the ground from the cathode tap of the oscillator tank coil. $L4$ and $L5$ have negligible reactance at the a-m oscillator frequencies, and therefore, do not interfere with its operation. $C16$, $C17$, $C18$, and $C41$, on the other hand, have very high reactances at these frequencies; as a result, the f-m oscillator tank circuit does not load the a-m oscillator tank circuit.

A-m i-f currents appear in the plate circuit of $V2$ in the usual fashion. These currents pass easily through the primary of $T1$, since at the a-m i.f. this winding has a very low reactance. A large i-f voltage is built up across the primary of $T2$, the first a-m i-f transformer. This produces a voltage across the secondary of $T2$ which is applied to the grid of $V3$. In the a-m position of the band switch, section $S1A$ shorts the secondary of $T3$, so that a direct path is available from the secondary of $T2$ to the grid of $V3$. The "cold" end of $T2$ is connected to the a-m avc bus; the "cold" end of the a-m

loop antenna is also connected to the avc at this point.

It may be asked why this reflex principle is not used in a-m reception. The answer lies in the frequencies involved. In the receivers we have just discussed the ratio of the f-m r.f. to the f-m i.f. is over 8 to 1, even at the low end of the f-m band. This makes it relatively easy to keep the r-f and i-f signals separate. In the case of a-m reception, however, the r-f to i-f ratio at the low end of the band is not quite 1.2 to 1. If an attempt were made to operate a reflex circuit under these conditions, the separation of the r-f and i-f signals would be very difficult.

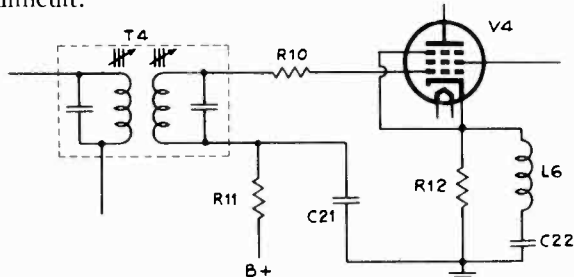

FIG. 6. — Simplified schematic of the limiter in the GE models 210, 211, and 212.

Another interesting aspect of the i-f amplifier in these sets is found in the f-m limiter stage. A simplified schematic of this stage is shown in Fig. 6. This stage not only serves to clip the tops and bottoms of the i-f wave, as is usual in a limiter, but it also introduces a high order of degeneration to any a.m. in the i-f wave. This effect is contributed by the cathode resistor, R_{12} , which has the unusually high value of 33,000 ohms. L_6 and C_{22} are series tuned to the intermediate frequency, 10.7 mc; they, therefore, have a very effective bypassing action for i-f signals. This permits the stage to operate with the normal gain expected from a limiter.

The grid circuit is not very unconventional, although it appears to be so on first glance. R_{10} is a 10-ohm, anti-parasitic resistor. C_{21} and R_{11} are higher in value than usual, and R_{11} is returned to B+ instead of to

ground. The reason for using very high values for these two components is that, speaking colloquially, they do what is usually required of these parts in a limiter, only more so. The usual function of these parts is similar to that of a grid-leak detector, but the parts are ordinarily so chosen that they have a time constant of only a few microseconds.* In the present case, however, the time constant is 50,000 microseconds, a value which is suitable for detection of a-m signals.

With the grid circuit of V_4 acting as an a-m detector, and the cathode resistor of this stage very large in value and unbypassed (to audio), V_4 becomes a highly degenerative amplifier for any a-m signals that may reach it. Thus the stage reduces a. m. in two ways, as an ordinary clipping limiter and as a degenerative amplifier.

R_{11} is returned to B+ instead of to ground because of the high value of the cathode resistor. If the normal plate and screen currents for a limiter stage are to flow here, they will produce an unusually high value of cathode voltage, because of the drop across the cathode resistor. In this case the drop amounts to 50 volts. This requires that the grid be almost 50 volts above d-c ground also, so that the correct operating bias can be obtained. This requirement is met by returning R_{11} to B+. In the absence of an i-f signal, this makes the grid slightly positive with respect to the cathode; only slightly, however, because as soon as the grid starts to go positive, current flows in the grid circuit which produces a drop across R_{11} sufficient to keep the grid voltage very close to the required value.

When an i-f signal is applied, a certain amount of rectification (grid-leak detection) takes place. This establishes a charge on C_{21} of such polarity that the grid becomes negative with respect to the cathode, despite the return of the grid resistor to B+.

* For a complete discussion of limiters, see pp. 277-293 of "FM Transmission and Reception", by Rider and Uslan, published by John F. Rider Publisher, Inc., N. Y.

OSCILLATORS FOR F-M SETS

In an f-m superheterodyne receiver, the function of the local oscillator is naturally the same as that in the more familiar a-m broadcast superhet. However, because the frequencies used in f-m broadcasting are so much higher than those used in a.m., new difficulties are introduced or old ones made worse. One of the major problems encountered is that of frequency drift. This problem has been pretty well solved in a-m sets, but f-m receivers are still sufficiently new so that the solution in their case is not definitely set.

The problem of drift in f-m receiver local oscillators was discussed in the *Volume XV "How It Works"*; however, since the publication of this book enough new tricks have been introduced to make it worthwhile to reopen this subject. Before taking up the technical details, let us briefly review the problem as a whole.

As stated in the *"How It Works"* of *Volume XV*, oscillator drift is likely to be a more serious matter in f-m than in a-m reception, because of the difference in the nature of the signals and the methods of detection. In a.m. the frequency of the carrier is not made to vary under modulation, so receiver oscillator frequency drift does not produce an effect similar to modulation. In f.m., however, oscillator frequency drift does produce an effect that is similar to modulation. Of course, the rate at which drift takes place is so slow that it does not directly produce an audio output, but if the drift is severe it can cause distortion in the audio.

In an a-m receiver, the method of detection is some sort of rectification, which is not in itself frequency sensitive. The rectifying detector is fed from a band-pass i-f amplifier, which is used to avoid reception of any signal but the desired one, and even in this combination severe oscillator drift will cause distortion because of the shape of the i-f pass band. It must be emphasized, however, that the rectifying detector itself will demodulate any a-m wave, regardless of frequency.

In f-m receivers, on the other hand, the detector is a frequency-sensitive device. Although rectification is a part of the process in the operation of both discriminators and ratio detectors, it is not sufficient in

itself. In both these and other methods, frequency-sensitive tuned circuits are a necessary part of the detector. Because of this difference, oscillator drift has a direct effect on f-m detectors which it does not have on their a-m counterparts.

It is possible in both a-m and f-m receivers to make the i-f bandwidth sufficiently great so that some oscillator drift is tolerable. It is much easier to do this in a.m. for two reasons; one of which is inherent in the difference between an a-m and f-m wave while the other is in the difference between the broadcast frequencies employed in each.

The inherent difference lies in the effects produced upon a carrier wave by amplitude and frequency modulation. All types of modulation produce sidebands but the factors that determine the characteristics of the sideband distribution for the various types of modulation are not necessarily the same. In a.m.

FIG. 1. — The spectral distribution of an a-m wave. There are always only two sidebands.

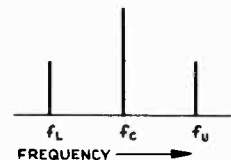

only two sidebands are produced (called the upper and lower sidebands) and the frequency separation of the sidebands from the carrier depends directly upon the frequency of the modulating signal. This is readily seen from the spectral distribution of an a-m wave as shown in Fig. 1. In this figure, f_c , represents the carrier component of the a-m wave and f_u and f_l represent the upper and lower sidebands respectively. The two sideband components are often referred to as one sideband pair. (The amplitudes of the components are of no interest to us in this discussion.) The frequency of sideband component f_u equals the frequency of the carrier plus that of the audio modulating signal and component f_l equals the frequency of the carrier minus that of the audio.

In other words, a high-frequency audio signal will produce sidebands in a.m. that are relatively distant in

frequency from the carrier component and low-frequency audio signals produce sidebands relatively close to the carrier. The distance in separation between f_l and f_u of Fig. 1 determines the operating bandwidth of the a-m wave.

In f.m. the situation is much different. The first and most important factor to consider is that numerous sidebands are possible with f.m. The amount of sidebands is determined by the amplitude and the frequency of the audio modulating signal. The higher the amplitude and the lower the frequency of the audio, the greater the number of sidebands. The spacing of the sidebands are, however, only dependent upon the frequency of the audio modulating signal similar to a.m. The sidebands are distributed equally on either side of the carrier component as illustrated in Fig. 2, the spectral distribution of a typical f-m wave having four sideband pairs (eight sidebands).

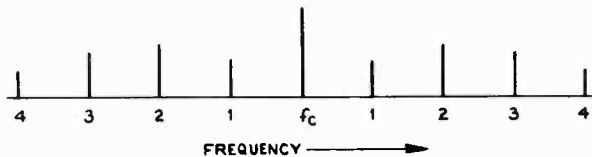

FIG. 2. — The spectral distribution of an f-m wave. There can be numerous sidebands.

In this drawing the sideband pairs are numbered from 1 to 4 with the number 1 components being separated from the carrier component f_c by the frequency of the audio. The frequency separation between each sideband is equal to the audio modulating frequency. In an f-m wave as many as 60 effective sidebands (30 sideband pairs) can exist. The higher order sidebands can be caused by low-frequency as well as high-frequency audio modulating signals. The operating bandwidth of an f-m wave is much greater than an a-m wave even though the audio modulating frequency of the f-m wave is very low as compared to that of the a-m wave.

Consequently in a.m. if sidebands widely spaced from the carrier are lost (which may happen when the oscillator drifts), this will affect only overtones or high fundamental notes, which are not important for intelligibility, and even in musical reproduction are only of secondary importance. In f.m., on the other hand, if sidebands are lost, this may mean distortion of high-amplitude low-frequency (or middle-frequency) modulating signals. Therefore, much less sideband cutting is tolerable in f.m. than in a.m. As a result, all other things being equal, a wider pass band is necessary in f.m. than in a.m. to allow for drift.

The other reason, as we have stated, lies in the

difference between the frequencies employed in f-m transmission and reception compared to those used in a.m. In order to illustrate this difference, let us take some definite figures. Assume an a-m receiver tuned to a station operating at 1000 kc; the receiver has an i.f. of 455 kc, so the oscillator frequency should be 1455 kc. If the oscillator is, say, 0.02% high, then its actual frequency is 1455.291 kc, and the actual i.f. becomes 455.291 kc, an error of only 291 cps. Assume now an f-m receiver tuned to a station operating on 100 mc; the receiver has an i.f. of 10.7 mc and an oscillator tuned below the carrier, so that the oscillator frequency should be 89.3 mc. If the oscillator in this case is also 0.02% high, its actual frequency is 89.31786 mc, producing an i.f. of 10.6214 mc. This is an error of 17,860 cps. If the oscillator were set above the carrier, the error would be correspondingly greater.

To view these two errors in their proper perspective, it must be remembered that the i-f center frequencies in a.m. and f.m. are very different, and that the fm-if pass band is also much wider than that in a.m. In the average of production receivers the ratio of fm-if to am-if pass band widths is of the order of 25 to 1. However, in the numerical examples that we chose, the calculated error for the f-m case is slightly more than 60 times that for the a-m case. This indicates that relatively less drift is permissible in the oscillator of an f-m receiver than in that of an a-m set.

Among the receivers shown in *Volume XVIII* are several illustrating a means of reducing drift that may easily become very common, and at least one employing afc (automatic frequency control) to overcome the tendency of the oscillator to drift.

GE 210, 211, & 212

One of the greatest causes of oscillator drift is changes in the interelectrode capacitances of the oscillator tubes. At the oscillator frequencies used in f-m receivers even the heater-cathode capacitance is important. In addition to its effect on frequency, this capacitance can also be a source of hum leakage from heater to cathode. For these reasons, the cathode is grounded in some oscillators, so that the cathode acts as a shield between the heater and the other elements of the tube, and variations in the heater-cathode capacitance then make no difference. However, it is not always desirable to ground the cathode; this is especially true when a pentagrid converter is used.

One case we have in mind is in the converter section of G. E. models 210, 211, and 212. These models use a miniature type, 12BE6, pentagrid converter

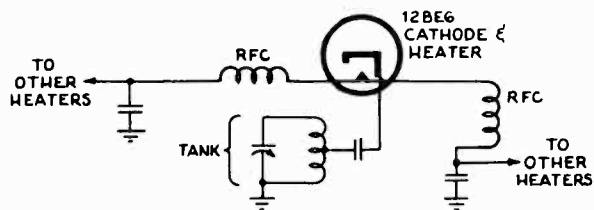

FIG. 3.—Simplified schematic of the converter heater and cathode connections in the GE models 210, 211, and 212. This circuit is designed for f-m oscillator stability.

tube. A simplified schematic of the heater and cathode connections of this converter tube is illustrated in Fig. 3. Complete service data for these models can be found on pages 18-21 through 18-25 in *Rider's Volume XVIII*.

As shown in Fig. 3 the converter heater is isolated from the other heaters in the receivers by r-f chokes and also is isolated from ground by capacitors in addition to the r-f chokes. In addition, the cathode is effectively connected to the heater through the inter-electrode capacitance between the cathode and heater of the tube. This internal heater-cathode capacitance of the 12BE6 tube is sufficient to provide adequate coupling between the two tube elements. Regardless of variations in this capacitance, it still presents a sufficiently low reactance compared to that of the r-f chokes, to keep the heater at the same r-f potential as the cathode, and thereby eliminate any effect these internal capacitance changes might have on the oscillator frequency and hum. The capacitors from the heater line to ground helps keep the oscillator voltage from the heater of the remaining tubes in the receiver.

United Motors Models R-1253, R-1254, and R-1255

An obvious way to overcome the effects of oscillator drift is to retune the oscillator when its frequency changes. It is also obvious that if this chore is forced upon the user of an f-m receiver, he will not take very kindly to the task. However, if the receiver can be made to do the work itself, without any effort on the user's part, a neat solution to the drift problem is obtained. This approach has been taken in a number of f-m sets, including United Motors models R-1253 and R-1254. See pages 18-11, 12 through page 18-19 of *Rider's Volume XVIII* for complete service data on these models.

The circuit that produces automatic retuning of the oscillator when it drifts off frequency is known as an automatic frequency control circuit, usually abbreviated to afc. To operate this circuit it is necessary to obtain a voltage that is proportional to the

extent and direction of the drift of the oscillator. Then this voltage must be applied to an electronic tuning control that will return the oscillator toward the correct frequency. Such an arrangement can not make the drift zero, because a control voltage is necessary to operate it, and the control voltage is generated only when the drift is *not* zero. However, it can reduce the drift very considerably, making it very much less than it would be without afc. (By the addition of certain refinements to the basic system just discussed, an afc circuit can be constructed that will reduce the drift to zero, but these refinements are far too complex for a home receiver.)

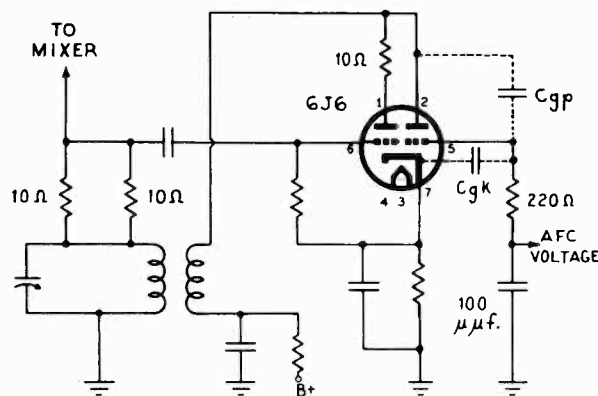

FIG. 4.—Simplified schematic of the oscillator and the reactance-tube circuit used in the United Motors models R-1253, R-1254, and R-1255.

The detector in an f-m receiver must, by the very nature of f.m., respond to frequency changes. Since oscillator drift is a frequency change, the f-m detector can be made to produce an output which indicates this change. This output then serves to control the electronic tuner. In the United Motors models R-1253 and R-1254 an output is obtained from the ratio detector, filtered to remove audio, and then applied to one grid of a 6J6, as shown in Fig. 4.

Fig. 4 shows the oscillator and reactance tube used in these sets. The reactance tube operates as a control for the oscillator and tends to stabilize the oscillator frequency. The diagram has been simplified to show only essentials, and parts values have been shown only for those components that do not perform the ordinary functions found in an oscillator. The 10-ohm resistors are anti-parasitics, to prevent unwanted oscillations. The oscillator is an ordinary tuned-grid feedback type, using one section of a 6J6 duo-triode tube. Since the tube has a single common cathode, and since either positive or negative values of afc voltage may be applied to the grid of the re-

actance tube section, a cathode resistor is used to produce cathode bias. If this were not done, the reactance-tube grid could go positive with respect to the cathode; this would upset the action of the circuit. The cathode resistor is by-passed, bringing the cathode to r-f ground; for this reason the heater can also be operated at r-f ground.

The grid-plate and grid-cathode capacitances of the reactance tube section of the 6J6 have been shown in Fig. 2 because they are very important in the action of this part of the tube. The grid-plate capacitance is approximately $1.6 \mu\mu\text{f}$, and the grid-cathode capacitance $2.2 \mu\mu\text{f}$. These two capacitances act with the 220-ohm resistance to form a phase-shift network between plate and grid. The bottom end of the 220-ohm resistor is grounded to r.f. by the $100\text{-}\mu\mu\text{f}$ capacitor, hence that point and the cathode are effectively tied together. For this reason only the grid-plate and grid-cathode capacitances and the 220-ohm resistor are important in the phase-shifting network. This network produces a shift in the neighborhood of 60 degrees in the 100-mc region. Although this falls somewhat short of the 90 degrees desired ideally for a

reactance tube, it is sufficient to cause the reactance-tube section of the 6J6 to inject a variable capacitance into the oscillator section of the same tube.* Since the reactance-tube section is controlled by the afc voltage, the variable capacitance injected performs the function of returning the oscillator when its frequency drifts. Thus the oscillator frequency is held within sufficiently close limits so that the slight amount of residual drift does not produce distortion in the audio output of the ratio detector.

An interesting point in connection with this afc circuit is the use of a 6.8-ohm resistor (indicated as R57 on the schematic in *Volume XVIII*) in series with the heater of the 6AL5 ratio detector. This resistor drops the heater voltage of the 6AL5 and slightly slows down the rate at which the afc output of the ratio detector follows changes in oscillator frequency. This prevents the afc system from over-compensating, or "hunting". Hunting, in this case, would produce an effect on the audio much like motor-boating.

* For a complete discussion of reactance tube operation, see pages 54 to 62 "FM Transmission and Reception," by Rider and Uslan, published by John F. Rider, Publisher, Inc.

GROUNDED-GRID INPUT CIRCUITS

Today there is really not much of a design problem regarding the antenna and input r-f section of a-m broadcast receivers. Straight pieces of wire and indoor antennas serve adequately well because of the nature of a-m broadcast signals. Impedance matching between the antenna and receiver is not required in such receivers. However, with f-m receivers the situation is quite different. The nature of f-m signals almost invariably requires a special type of antenna construction, whether indoor or outdoor, to be used with f-m receivers. This is necessary in order to achieve the maximum signal pickup by the antenna.

In order to supply the maximum signal from the antenna to the input section of the f-m receiver, these units must be impedance matched to each other. The usual type of f-m antennas have a very low input impedance and for maximum transfer of energy from the antenna to the receiver, the input impedance of the receiver should equal or closely approximate that of the antenna. The correct type of transmission line should be employed to complete the circuit between antenna and receiver and maintain or provide the impedance match.

FIG. 1. — A simplified schematic of a grounded-grid amplifier.

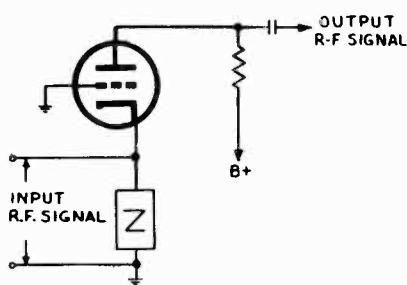

This impedance-matching principle creates a design problem especially when the input signal is fed to the control grid of the first r-f tube because the impedance between grid and cathode is comparatively much higher than the low input impedance of f-m antennas. Such connections require specially designed antenna coupling circuits in order to provide the necessary low input impedance for matching purposes. There are a number of f-m receivers on the market today which simplify this impedance-matching prob-

lem by employing *grounded-grid* r-f amplifiers in the input circuit. Such arrangements as these feed the input signal to the cathode circuit and the grid is effectively grounded as far as r-f signals are concerned.

The Grounded-Grid Circuit

A simplified schematic diagram of a grounded-grid amplifier is illustrated in Fig. 1. The input r-f signal, which is usually secured from the antenna circuit, is applied directly across whatever impedance is in the cathode circuit of the tube. This cathode impedance is represented by Z in the drawing and it may be a resistor, capacitor, or inductor, or any possible combination of these components. With such a system as this, it can readily be seen that almost any value of input impedance can easily be secured by the choice of Z . In this schematic the grid is shown directly grounded in order to simplify the drawing. The grid may, however, be returned to ground through some circuit component as long as it has a negligible impedance value as far as the fm-rf signals are concerned. The grid must also have a d-c return path to ground. The output signal is taken from the plate circuit of the tube.

The fundamental operation of any amplifier circuit depends upon a difference in potential between the grid and cathode of the tube. In the usual amplifier circuit, the cathode is grounded at signal frequencies and the signal fed to the grid. In the grounded-grid circuit, the reverse is true but a difference of potential still exists between the grid and cathode and the tube can function perfectly well in this manner. With such circuits as that shown in Fig. 1, a low input impedance is possible. This means that a grounded-grid type of input circuit can very easily be made to provide a satisfactory impedance match to an antenna.

Besides providing a low-impedance input source, such a circuit is very stable compared to the conventional type of input circuit, especially at the very high frequencies involved in f.m. This highly stable circuit permits the use of triodes as r-f amplifiers without the worry of regeneration causing oscillation. Triodes are

very useful as r-f amplifiers because they have a higher signal-to-noise ratio than pentode amplifiers.

Thus we see that two advantageous features are derived by using a grounded-grid amplifier for the input to f-m receivers; namely, simplification of impedance matching to the antenna and greater stability in the r-f circuit. Let us now study some typical grounded-grid amplifier circuits such as are used in the r-f input circuits of today's f-m receivers.

Admiral 9B14

In the Admiral models 9B14, 9B15, and 9B16 a 6BA6 miniature type pentode is employed as the grounded-grid input tube for the f-m band. The service data for these models appears on pages 18-33, 34 through 18-38 in *Rider's Volume XVIII*.

The schematic diagram for the circuit under discussion is illustrated in Fig. 2. Note that the first r-f amplifier has its screen connected directly to the plate and thus the tube effectively functions as a triode.

The input f-m signal is fed into the cathode circuit of the first r-f tube. Inductance $L4$ is termed the "f-m coupling coil" and inductance $L5$ a "cathode choke". These two components together with the 0.001- μf coupling capacitor $C1$ and the 100-ohm resistor $R2$ comprise the complete load in the cathode circuit of the tube. The r-f voltage across $L4$ is the complete input signal and this voltage is also found across the total series combination of $C1$, $R2$, and $L5$ because the series arrangement of these components is in parallel with $L4$. Glancing at Fig. 2 again, you will note that the cathode of the first r-f tube is connected to the junction point of $C1$ and $R2$. At first it might be thought that only part of this input voltage appears across the cathode because of the voltage divider network of $C1$, $R2$, and $L5$. However, the reactance of the 0.001- μf capacitor $C1$ is so low at the f-m frequencies (being 1.6 ohms at 100 mc) compared to the total series impedance of $R2$ and $L5$ that negligible signal voltage drop occurs across $C1$. Thus, the total available signal voltage is considered as be-

ing applied to the cathode circuit. The total impedance value of the four components in the cathode circuit, as seen by the antenna and its transmission line, has been so chosen that the impedance match will be correct.

Without any signal applied to the cathode circuit but with B plus and heater voltage supplied, a continuous flow of direct current through the tube will result. A d-c voltage drop occurs across the cathode circuit components $R2$ and $L5$ to ground.

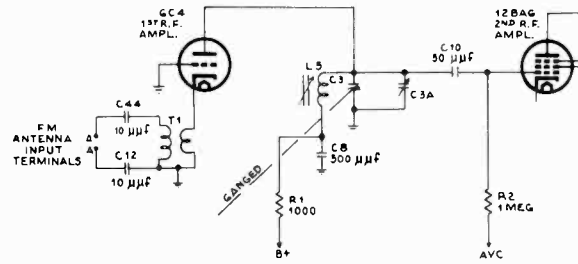

FIG. 3.—A simplified schematic of the r-f section of the Noblitt-Sparks models 280TFM and 281TFM.

Since the grid is directly grounded as seen in Fig. 2, a difference of potential exists between the grid and cathode of this tube, with the cathode being more positive than the grid by the amount of the d-c voltage drop. This establishes the so-called bias of the tube as it does in the ordinary amplifier circuit. When the f-m signal is applied to the cathode circuit, the bias is alternately changed which in turn causes the plate current flowing in the tube to fluctuate in the same manner as this input signal. Consequently the f-m signal appears in the plate circuit of the tube and is coupled to the control grid circuit of the second r-f amplifier via transformer $L6$ as seen in Fig. 2. Only the secondary of this transformer is tuned and the tuning is ganged with the other r-f tuning sections of the set.

Noblitt-Sparks 280 TFM

The f-m section of the Noblitt Sparkes models 280TFM and 281TFM also employs two r-f ampli-

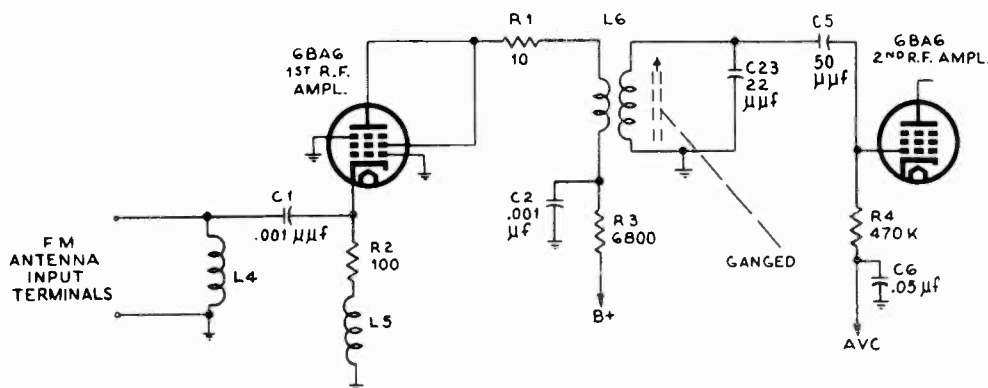

FIG. 2.—The grounded-grid input r-f amplifier of the Admiral models 9B14, 9B15, and 9B16.

fier stages with the first stage being a grounded-grid amplifier. A simplified schematic drawing of this r-f section is shown in Fig. 3. For complete service data for these models see pages 18-8 through 18-12 in *Rider's Volume XVIII*.

A triode tube, the miniature type 6C4, is employed as the first r-f amplifier. In this circuit the grid of the tube is directly grounded, similar to that of the 6BA6 circuit of Fig. 2. The primary difference between the network of Fig. 3 and the previous one is in their cathode circuits. In the circuit under discussion, the input signal is transformer coupled to the cathode via *T1*. Points *A-A* represent the antenna terminal connections. The two 10- μmf capacitors *C12* and *C44* are inserted to balance the input circuit. The actual load in the cathode circuit is the secondary of *T1* plus whatever impedance is reflected from the primary into the secondary. This complete input circuit is so designed that the impedance seen looking into the antenna input terminals is low enough so that an f-m antenna can easily be matched to this input circuit.

An f-m signal appears at the plate of the 6C4 tube in a similar fashion to that described for the previous model. This signal is then coupled to the grid circuit of the 12BA6 second r-f amplifier via the parallel tuned circuit consisting of coil *L5* and capacitors *C3* and *C3A*. Capacitor *C3* is the tuning unit of the circuit and it is ganged to the other r-f tuning capacitors of the receiver. *Avc* is applied to the grid of the second r-f amplifier through *R2*, a one-megohm resistor. In this circuit and the one previously discussed the grid of the first r-f tube is grounded directly and hence does not receive any *avc* voltage.

Westinghouse H-164

In the Westinghouse models H-164, H-166, H-166A, and H-167 a grounded-grid amplifier is also

employed for the input circuit but there are a few interesting details about this circuit arrangement not encountered in the others. See pages 18-12 through 18-19 in *Rider's Volume XVIII* for complete service data of this model. A simplified schematic diagram for the fm-rf section of this receiver appears in Fig. 4.

This r-f section employs the duo-triode 7F8 loctal type tube. Each triode section of this tube is used as an r-f amplifier, the input triode section is a grounded-grid amplifier and the second r-f amplifier is used as a cathode-follower type circuit. Looking at the first r-f amplifier, it is seen that the cathode circuit consists of inductance *L1* in parallel with a 15- μmf capacitor *C30*. The high side of the f-m antenna circuit is attached directly to the coil but across only part of the coil windings. In this manner *L1* acts as an auto-transformer to the incoming signal. Capacitor *C30* in conjunction with the tapped section of coil *L1* offers the correct impedance match to the f-m antenna. This *L1-C30* circuit is fairly selective to f-m signals. The simplicity of such a circuit for impedance matching purposes is readily apparent when it is compared to the ordinary amplifier where the signal is fed to the grid circuit of the tube.

Another interesting feature about this first r-f amplifier is the grid circuit. It was mentioned at the beginning of the section on grounded-grid amplifiers that the grid of the tube in question should be effectively grounded as far as r-f signals are concerned. This is exactly the case in Fig. 4 although it is not immediately apparent from the arrangement of the input circuit. This grid circuit is not tied directly to ground as in the circuits of Figs. 2 and 3.

As noticed from Fig. 4 a 470- μmf capacitor, *C40*, and 470,000-ohm resistor *R17* are attached directly to the grid with the other side of the capacitor grounded. The reactance of capacitor *C40* at the f-m signal frequencies is so low that the grid is considered grounded

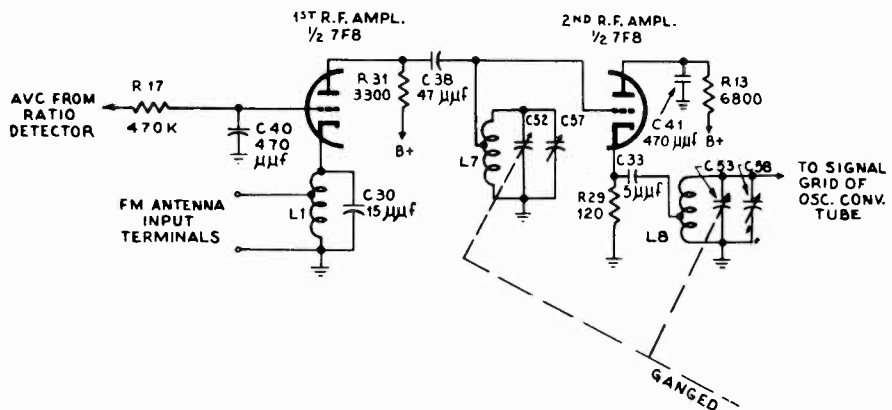

FIG. 4. — A simplified schematic of the fm-rf section of the Westinghouse models H-164, H-166, H-166A, and H-167. The grid of the first r-f amplifier is grounded to r-f signals through the 470- μmf capacitor *C40*.

as far as r-f is concerned. At 100 mc, which is about the center of the f-m band, the reactance of this 470- $\mu\mu\text{f}$ capacitor is 3.4 ohms which is virtually a short circuit. Thus we can see how this triode section of the 7F8 tube functions as a grounded-grid amplifier.

Although not shown in the drawing, the other end of resistor $R17$ is connected to the output circuit of the ratio detector of the receiver. In this manner avc voltage is applied to the grid circuit of this triode. In fact no other tube in these Westinghouse models receives avc voltage on the f-m band. (This is in contrast to the previous models discussed wherein avc voltage was not applied to the grounded-grid amplifiers.) The d-c return path for the grid of the input tube is through $R17$ and the ratio detector load resistors to ground.

The second r-f amplifier of this unit also presents an interesting feature. The output signal from the first r-f amplifier is coupled to the grid circuit of the second triode section via the tuned parallel circuit consisting of $L7$, $C52$, and $C57$. The output signal, instead of being taken from the plate circuit of the tube, is taken from the cathode circuit. Such a circuit is termed a *cathode follower*. The output load on this stage is in the cathode circuit and consists primarily

of the cathode resistor $R29$, to which is coupled capacitor $C33$ and the tuned circuit comprising $L8$, $C53$, and $C58$. Signal currents exist in the cathode circuit of the tube as well as in the plate circuit. The output signal is taken from the high side of the tuned circuit and fed to the signal grid of the oscillator-converter tube. This tuned circuit which has its tuning capacitor $C53$ ganged with the other units of the set, increases the selectivity of the f-m band.

Space does not permit a lengthy theoretical description of a cathode-follower circuit. However such a circuit does offer many advantages even though its gain is less than unity. In other words a loss rather than a gain is the result of such a circuit. One of the chief advantages in such a circuit is that its high-frequency response is excellent which is primarily due to the fact that the circuit has an *equivalent* plate resistance that is very low. The effective input capacitance of a cathode follower tube is less than if the tube were used as an ordinary amplifier. This reduction in input capacitance is advantageous because the frequency response characteristic of the stage preceding the cathode follower is improved. Thus we see that due to the cathode-follower circuit of Fig. 4 the frequency response of both r-f tuned circuits is improved.

APPLICATION OF THE PRINTED CIRCUIT

In the design of radio receivers and other allied electronic equipment, the trend is toward simplification of circuit construction and betterment of performance. Some examples of this have been the design of indoor loop antennas, the design of miniature and subminiature-type tubes, and also the use of selenium rectifiers. These advancements are well known, with the simplified loop antenna dating back over ten years. There have been many other developments—too numerous to mention here. A development that is comparatively new as far as its use in broadcast receivers is concerned will be discussed here.

Majestic 6FM714, 6FM773

This new development is used in Majestic models 6FM714 and 6FM773. It is the resistance-capacitance coupling circuit that exists between the first audio amplifier and power output stage. The circuit in question is the same in each of these models and is illustrated in Fig. 1. Complete service data for model 6FM714 will be found on pages 18-1 and 18-2 and for model 6FM773 on pages 18-3 and 18-4 of *Rider's Volume XVIII*.

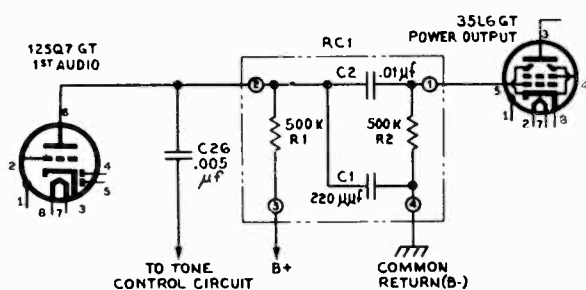

FIG. 1.—The printed circuit that acts as the resistance-capacitance coupling unit between the first audio amplifier and the power output stage is enclosed in the dashed box.

Let us examine the circuit which appears in Fig. 1 and see what the functions of the individual components are. Resistors $R1$ and $R2$ and capacitors $C1$ and $C2$ comprise the so-called coupling circuit between the two tubes. Resistor $R1$ is the plate load for the triode section of the 12SQ7GT tube, capacitor $C2$

is the coupling capacitor which also blocks d.c. from getting to the grid of the power output tube and resistor $R2$ is the grid-leak for the 35L6GT tube. The 220- μf capacitor $C1$, which is attached directly to the plate of the first audio tube, is used to bypass any r-f or i-f signals that might appear at the plate circuit of this tube.

After looking at this circuit, one is likely to ask what is so special about it that warrants discussion. It appears the same as any ordinary resistance-capacitance coupling circuit which exists between an audio voltage amplifier and power output tube. Although it is true that in schematic arrangement the circuit represents the usual type of R-C coupling, the physical construction of this unit is the interesting thing. The audio coupling circuit composed of components $R1$, $R2$, $C1$, and $C2$ is shown schematically enclosed in a dashed box and labeled RC1. The construction of these four circuit elements are in the form of what is known as a *printed circuit*. The manufacturer refers to this RC1 as a "printed circuit plaque" (audio coupling). The lettered designations of these units are ours, not the manufacturer's, and were inserted for ease of discussion. The other components in the receiver, such as $C26$ in Fig. 1, have the manufacturer's lettered symbols.

What Is a Printed Circuit?

Printed circuits are a relatively new phase of electronic engineering and are considered as a wartime development.* Today great advancements have been made in printed circuits; complete transmitters and receivers are now printed in various forms. Before we go too far in telling the advancements made with printed circuits, let us first understand what a printed circuit is and the reasons for its use.

A printed circuit, in brief, is a method whereby wiring and certain circuit components are printed on ceramic or other type surfaces. This printing may be accomplished by stencilling, spraying, or painting on

* For a more detailed discussion of printed circuits see "Printed Electronic Circuits" by C. Brunetti and A. S. Khouri in *Electronics*, April 1946 and "Printed Electronics Circuits," *NBS Technical News Bulletin*, Feb. 1947.

the surface. Resistors, inductors, and capacitors have been successfully printed onto different types of surfaces. There are cases where a complete circuit is printed around the glass envelope of a subminiature type of tube. **Many different types of circuits, from audio amplifiers to high-frequency receivers and transmitters, have utilized the printed circuit technique.

Reduction in the size of certain electronic devices was the original purpose of printed circuits. The savings in space by the use of such circuits are remarkable. In most cases, even though the reduction in size is great, the over-all electrical performance of the unit is as good, if not even better, than that of ordinary type circuits. The same type of frequency response as that of ordinary audio circuits has been obtained from audio amplifiers using printed circuit technique. In certain cases, such as in high frequency circuits, the use of printed circuits has given better performance primarily because of the smaller size of the component required and the smaller values of stray capacitances. Complete units can be made of a number of different printed circuit sheets, thereby enabling easy servicing by replacing the sheet that contains the defective component. This is considered an advantage in service work where time is of the essence and the expense of the extra printed sheets of secondary nature.

The Serviceman's Viewpoint

Now let us return to the circuit of Fig. 1. The circled numbers 1, 2, 3, and 4 indicate the four connections that are made from the printed circuit to the rest of the audio circuit. The use of this printed circuit in the receiver enables the unit to be somewhat more compact. As far as factory assembly is concerned, it is much faster to wire in a single unit (the printed circuit) with four connecting points than it is to wire in four individual circuit components comprising a total of eight connecting points. In the production of printed circuits, the stray and wiring capacitances will be practically the same for every printed unit. Consequently, by the use of such circuits in electronic devices, fewer adjustments in the manufacture and service of receivers will be required.

** See "Printed Circuits," a series starting with October 1948 issue of "The APCO Bulletin."

Let us try to analyze the use of such a "printed circuit plaque" from the serviceman's viewpoint. First of all if the insertion of a new printed circuit can be easily and quickly made then such a feature will benefit the serviceman. This is primarily so because time is one of the most valuable assets of the radio technician. Another important consideration is the cost. If only the coupling capacitor in the printed circuit of Fig. 1 becomes defective, the complete printed unit, RC1, has to be changed. This, of course, is a disadvantage if one feels that the difference in cost between a 0.01- μ f capacitor and the printed circuit is too great. On the other hand, the repairman may find that he has saved enough time by working with the printed circuit to withstand the additional cost.

Another important point that should be considered is the availability of such replacement parts. Most servicemen have a ready supply of resistors and capacitors available in order to fix such common faults as defective coupling capacitors and load resistors. But what of the printed circuit, such as that being discussed here? Such components may be available through parts jobbers, but probably the only way they can be obtained is through the manufacturer, but here the element of time enters into the picture again. The serviceman has to put the set aside, write away for the unit, and wait for its delivery. Requesting a new printed circuit from the manufacturer may be considered in the same manner as ordering any other item, such as an oscillator coil, which is not available from the parts jobber. Whether the time lost in such a transaction makes the use of the printed circuit less valuable is something every serviceman must decide for himself.

Although very few commercially manufactured broadcast radio receivers employ printed circuits in whole or in part, nevertheless, these circuits are definitely here to stay. Exactly what the future will bring in the design and manufacture of receivers is debatable, but it is believed that the use of printed circuits will play a very important role. It is difficult to predict just when printed circuits will be used extensively. It may be 5 or even 10 years from now. Things are changing so rapidly in this modern world of ours that it is impossible to set any precise time for such developments.

AUDIO NOISE SUPPRESSION

A very important problem in the recording and reproduction of sound is the elimination of unwanted sounds, or noise. The art of making disc recordings has advanced to the point today where a brand new pressing has a very low noise level. Unfortunately, this high quality is not permanent; as a record is used and re-used the surface noise, or scratch, increases in intensity. At the same time, the very high treble notes originally pressed on the disc by the manufacturer are gradually erased. As a result, *soft* treble passages are masked by scratch after a record has had some use, *loud* treble passages, of course, are not affected this way. This discrepancy is put to good use in the Philco Electronic Scratch Eliminator and the H. H. Scott Dynamic Noise Suppressor.

Before discussing these two devices, let us recall the simplest type of scratch suppressor. This is the treble tone control, or scratch filter; the former name is usually used when the control is variable, the latter when it is fixed. The effect, in either case, is simply to produce a certain amount of treble attenuation. Even in the case of the variable tone control this amount is likely to be fixed for the duration of at least one record; he is a rare listener who is willing constantly to monitor the treble tone control on his set! As a result, there are two possible conditions: the treble may be cut sufficiently to obscure scratch on soft treble passages, in which case loud treble passages lose naturalness because of the poor high-frequency response; or the tone control may be set to give good reproduction on loud treble parts, resulting in excessive scratch being heard when the treble is soft. The remedy for this difficulty, of course, is to provide an automatic treble control, which will reduce the high-frequency response on soft treble passages and give wide-band response when the treble is loud. Unfortunately, this is more cheaply said than done, so that it has only recently become practical to include such a control in a home-type radio receiver.

The problem that exists with the treble tone control exists also with the base control, but to a much lesser extent. For this reason, the Philco Electronic

Scratch Eliminator operates only in the treble range; but the Scott Dynamic Noise Suppressor, which is somewhat more complex, regulates the bass response as well.

Philco Electronic Scratch Eliminator

The Philco Electronic Scratch Eliminator is used in Philco model 48-1286. (This model is shown on pages 18-165 through 18-179 of *Riders Volume XVIII*.) The basic principle is illustrated in Fig. 1. Here is seen a resistive voltage divider, part of which is shunted by a variable capacitor. In the bass and middle ranges the effect of the capacitor, even at its maximum, is slight, so that all frequencies in these ranges are equally attenuated. Because of the values of resistance used, this attenuation is negligible. In the treble register, however, the reactance of the variable capacitor may be considerably less than one megohm, in which case the highs will be very materially

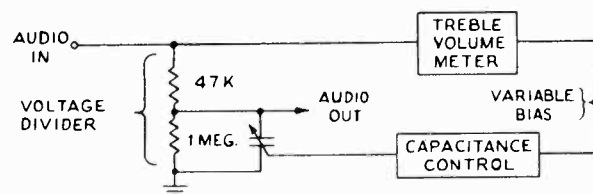

FIG. 1. — The principle of the Philco Electronic Scratch Eliminator is illustrated by this basic circuit.

attenuated by the divider. On the other hand, if the capacitive reactance is made very high, even the highs will suffer no more attenuation than the low and middle tones. In this manner the variable capacitor controls the treble response. The setting of the variable capacitor, in turn, is determined by the level of the treble input to the circuit. The "treble volume meter" shown in Fig. 1 produces a variable bias, rather than an indication on a visual meter, and this bias is applied to a special vacuum-tube circuit which acts as a variable capacitor. This circuit depends for

its action upon the Miller Effect, so called in honor of a research worker for the National Bureau of Standards who first described and analyzed this effect.

In Fig. 2 are two diagrams that illustrate in simplified fashion how this effect arises. Part (A) shows a vacuum tube used as an amplifier, and indicates the grid-plate and grid-cathode capacitances of the tube. In part (B) is emphasized the fact that a capacitive feedback current flows from the plate of the

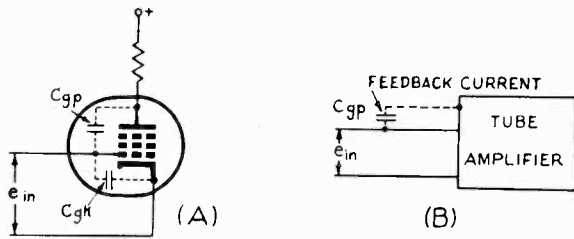

FIG. 2(A).—Simplified amplifier tube circuit showing the interelectrode capacitances which influence the Miller effect. In (B) the feedback circuit which produces the Miller effect is illustrated in block form.

amplifier to the grid, through the grid-plate capacitance. Since this current is generated in the plate circuit, its amplitude depends upon the gain of the amplifier. Now, the effective input impedance of the amplifier is the ratio of the voltage in the input to the current. Therefore, the input impedance depends upon the gain of the amplifier. This impedance consists, of course, of resistance and reactance. If the load of the amplifier is a resistance, the reactive component of the input impedance will be capacitive, since it is determined by the feedback, which is capacitive. Neglecting the effect of the screen grid, the

input capacitance of the amplifier tube in question can be calculated by the formula:

$$C_{in} = C_{gk} + (1 + A)C_{gp}$$

where A is the gain of the amplifier.

If an external capacitor, C, is added from the plate to the grid, in parallel with the existing grid-plate capacitance of the tube, its capacitance is added to the grid-plate capacitance, as in any case where two capacitors are in parallel. The input capacitance then becomes

$$C_{in} = C_{gk} + (1 + A)(C_{gp} + C)$$

If, as in the case of the circuit actually used in the Philco Electronic Scratch Eliminator, the external capacitor is much larger than the internal grid-cathode and grid-plate capacitances of the tube, the effects of the internal capacitances become negligible, and the formula for the input capacitance can be simplified to

$$C_{in} = (1 + A)C$$

Since the gain, A, is easily varied by means of the bias applied to the control grid of the amplifier tube, it is possible to use an amplifier with an external capacitor from plate to grid as an electronic variable capacitor.

This is what is done in the Philco Electronic Scratch Eliminator. Referring again to the simplified diagram of Fig. 1, we see that a variable capacitor is shunted across part of a voltage divider. The variable capacitor in this case represents a vacuum-tube amplifier and its associated network taking advantage of the Miller Effect.

The complete circuit of the Philco Electronic Scratch Eliminator as used in Model 48-1286 is shown

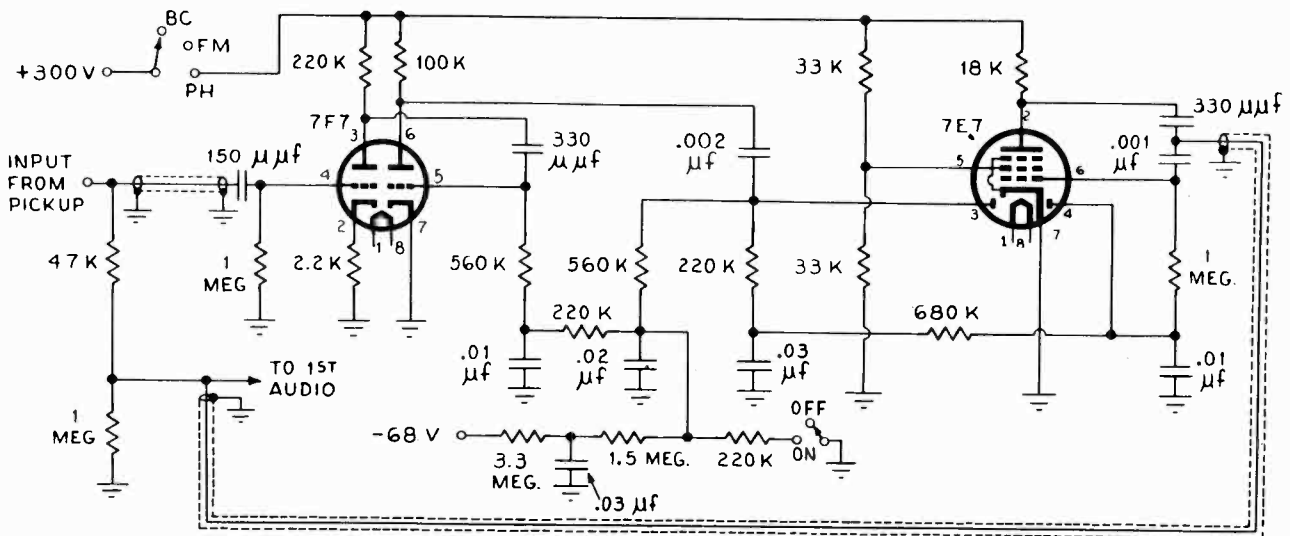

FIG. 3.—The schematic diagram of the Philco Scratch Eliminator as it is used in the Philco model 48-1286.

in Fig. 3. The 7F7 is a twin high-mu triode, providing two stages of amplification of the treble to drive the treble volume meter. These two stages are conventional except in the use of unusually small coupling capacitors. Through the use of these capacitors discrimination of the bass and middle register occurs, but the treble is amplified many times. The output of the treble amplifier feeds one of the diode plates of the 7E7, a duo-diode, remote-cutoff pentode. The rectifying action of this diode provides the variable bias output of the treble volume meter shown in Fig. 1. The variable bias is applied through a decoupling network to the grid of the 7E7, to control the gain of the pentode section of the tube. (The other diode plate, connected to pin 4 of the tube, performs no function in the circuit; this position on the socket of the 7E7 is simply used as a convenient tie point in the wiring of the set.)

A 3300- μmf and a 0.001- μf capacitor are connected in series between the plate and control grid of the 7E7. These components provide the large external capacitance which minimizes the effects of the internal tube capacitances, as explained above, and gives the tube a high variable input capacitance because of the Miller Effect. Only one capacitor is required for the variable capacitance effect, but two are used to isolate the grid, plate, and audio circuits from one another as regards d.c.

Let us review the action of this scratch eliminator: The treble portion of the audio input is amplified by the 7F7, and rectified by one of the diode sections of the 7E7. The resultant d-c voltage is negative with respect to ground, and its amplitude is proportional to the level of the treble in the audio input. Thus, for low levels of treble this negative voltage, which is applied to the control grid of the 7E7, is small, and the gain of the 7E7 is at its maximum. When the treble level is high, however, this bias voltage is also high, and the gain of the 7E7 is much reduced. From the equation for the input capacitance we see that the input capacitance is directly proportional to the gain of the amplifier, being large when the gain is high, and small when the gain is low. As a result, at low levels of treble input, the input capacitance of the 7E7 is high; but when the treble level is high, the input capacitance is low.

As was pointed out at the beginning of this discussion of the Philco Electronic Scratch Eliminator, a large value of capacitance in the voltage divider circuit produces considerable attenuation of the highs; this is what happens when the treble level, to begin with, is low, and record scratch would be objectionably noticeable. On the other hand, when the ca-

pacitance in the divider is small, the attenuation of highs is also small; this is the condition that exists when the treble level in the input is high, and the scratch is masked. Thus an automatic treble tone control action is obtained, which passes the highs when they are desirable, but eliminates them when they are not.

Before leaving this subject, we should consider the actions of the two switches shown in Fig. 3. The three-position switch (a portion of the band switch) is arranged to provide plate voltage to the eliminator only when the phonograph is being used, since it is only then that the eliminator is connected to the audio circuits of the set. The on-off switch provides a means of removing the eliminator from operation, if the user of the set so desires. When this switch is in the "ON" position, grounding the 220K resistor, the voltage at the junction of this resistor and the 1.5 meg. resistor is about -3 volts, providing suitable bias voltages for the second section of the 7F7 and for the 7E7. When the switch is in the "OFF" position, -68 volts is applied through the decoupling networks to these tubes, cutting them off, and preventing the eliminator from operating.

(Note: Shortly before the Second World War the E. H. Scott Radio Laboratories, Inc. used a somewhat similar circuit in several of their receivers. Circuit data and a brief description can be found in *Rider's Volume XIV*.)

Scott "Metropolitan" Receiver

The "Metropolitan" receiver (see pages 18-81, 82 through 18-83, 84, *Rider's Volume XVIII*) made by the E. H. Scott Radio Laboratories, Inc., employs a version of the Dynamic Noise Suppressor developed by Hermon Hosmer Scott, Inc. The operation of this device is based on the same principle as the Philco Electronic Scratch Eliminator, namely, that when the signal level at the ends of the audio band is high, these signals at the two frequency limits are retained, but when the signal levels are low, they are rejected. The reason for this is that the noise level for a given set of conditions (any one phonograph record, say, or album of records) is fairly constant, but the signal level, particularly at the ends of the audio band, varies greatly. Since most noise is at the ends of the audio band, particularly the high end, it is desirable to reduce the audio bandwidth when the audio signal level is low, and to increase it when the level is high, as this mode of operation will maintain a more nearly constant signal-to-noise ratio. The high-frequency end of the audio band contains by far the greater propor-

tion of the noise under most conditions, and particularly when phonograph records are played. For this reason, a device that controls only the treble response will produce considerable reduction in the apparent noise level.

At the same time, the reduction of treble noise tends to produce an apparent increase in bass noise, such as hum. Another objection to audio bandwidth variation at the high-frequency end only is based upon the characteristics of human hearing. It has been found that when the bandwidth of a reproducing system is varied, a natural effect is best preserved by changing the high- and low-frequency responses simultaneously in such a way that the mid-point of the band remains fixed. (If only one end of the band is cut, the middle of the resultant band is effectively shifted toward the other end.) It is therefore desirable on two counts that, when the ultimate in fidelity is a requirement, a noise suppressor should control *both* ends of the audio band.

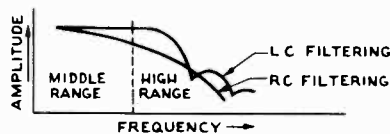

FIG. 4.—The different effects that R-C and L-C low-pass filters have on the frequency range.

A further desirable quality is that the ends of the audio band be more sharply defined than is possible when resistance-capacitance filtering is used. The reason for this is that the gradual change produced by RC filtering must extend into the middle-frequency range if high attenuation is to be obtained at the ends of the audio band. However, when a low- (or high-)

pass filter employing inductance and capacitance is used, a much sharper cutoff can be obtained. The difference between the RC and LC cases for low-pass filtering is shown (somewhat exaggerated for the sake of clarity) in Fig. 4. The quality of sharp cutoff is particularly desirable at the high end, because the noise level is higher here than at the low end. At the same time, though, this sharpness must not be carried too far, or transient oscillations may occur.

Fig. 5(A) shows in block diagram form the Dynamic Noise Suppressor of the "Metropolitan" receiver. (The blocks are numbered to correspond with the tube numbers on the main schematic.) The amplifier is the pentode section of a 6B8, and employs a conventional circuit. The treble and bass rectifiers are the diodes of the same 6B8; they are fed from the pentode section through high- and low-pass RC filters, respectively. Their outputs are applied as bias voltages to the associated "gates", or electronic filters. In this respect, the Dynamic Noise Suppressor is much like the Electronic Scratch Eliminator. However, where the Philco circuit employs the Miller Effect to obtain variable reactance, the Scott device makes use of reactance tubes such as are used in f-m transmitters and r-f generators. (The principles of reactance tubes have been described in many places; see, for example, "FM Transmission and Reception" by Rider and Uslan, pages 54 to 62.)

The output of the amplifier is fed through three gates, two treble and one bass, which act as an audio band-pass filter of variable width. Two treble gates are used, as against one bass, because the amplitude of treble noise is usually greater than that of bass noise, and because greater treble boost than bass boost is available in the main audio amplifier. The circuits of the gates, highly simplified, are shown in Fig. 5(B). The first treble gate employs two series-resonant LC circuits, one of which is fixed, and the other variable by means of reactance tube V10. The two resonant circuits are decoupled by means of the fixed resistors, which prevent interaction. (The grounds shown in Fig. 5(B) are audio grounds, but may not be d-c grounds.) This gate has an amplitude-frequency characteristic similar to that shown for LC filtering in Fig. 4; the position of the first sharp dip is movable, being controlled by V10 and having a minimum frequency of 4 kc (determined by a preset control), while the second dip is fixed at 10 kc (also determined by a preset control). The two dips correspond to the resonant frequencies of the series LC circuits.

The bass gate also depends upon series resonance for its action. The variable inductance required here is produced by reactance tube V11.

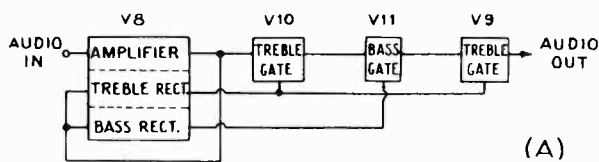

(A)

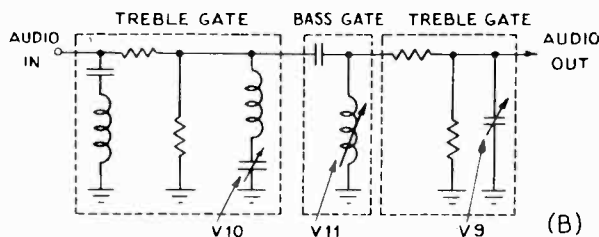

(B)

FIG. 5(A). — The block diagram of the Scott Dynamic Noise Suppressor; in (B), the simplified circuit of this noise suppressor is shown.

The second treble gate does not make use of LC resonance; instead, it uses resistance and capacitance in much the same way as in the Philco circuit. However, the values of resistance used are such that noticeable attenuation begins at a higher minimum-level frequency. The effect of this gate is to produce a more rapidly-falling high-frequency characteristic than would be possible with one gate, without adding more sharp dips, such as are introduced by the first treble gate. In addition, it possesses a frequency characteristic which approximately complements the frequency boost available from the second stage of the main audio amplifier. That is, its frequency response curve is approximately a mirror image of the curve of the treble boost amplifier; when treble boost is used, the response curves upward in the treble region, but the response of the second gate curves downward. In this fashion, the effect of the treble boost is cancelled to a varying extent when there is little desirable signal in the treble register, but the boost is retained when it is desirable. The cancellation is obtained in a smooth manner because of the similar shapes of the boost and gate curves.

A five-position rotary switch (SW-3) provides manual control over the range through which the noise suppressor acts. In one position, it removes the suppressor entirely from the audio path through the set. In the other positions, one section varies the proportion of the audio signal fed to the bass and treble rectifiers; this controls the extent to which the gates will widen the audio pass band during loud passages. At the same time, another section changes the constants in the second treble gate, so that the rate at which this gate attenuates the highs is affected. These two sections are so arranged that under conditions of high noise level the switch may be set to feed relatively small audio signals to the rectifiers, so that even on loud passages the audio pass band is not very greatly expanded; with this same setting, the second treble gate produces relatively high attenuation of the treble. On the other hand, if the noise level is low, the switch can be set to apply a high audio level to the rectifiers, causing the gates to provide a wide pass band even on passages that are only moderately loud. At this setting the second treble gate constants are such that it produces only moderate attenuation of the highs at most. Thus, the effect of the Dynamic Noise Suppressor can be varied through four settings to compensate for conditions of noise that may be only slight, moderate, or highly objectionable.

Garod 306

The previous two circuits were rather intricate in

design. Of course, such circuits are extremely beneficial to the over-all performance of the unit, but they also, nevertheless, add to the cost of the set. In designing phonograph circuits (with or without receivers) in the lower price range, naturally such types of circuits cannot be included without increasing the cost of the set. In many such units it is desired to eliminate certain types of noise which occur at different frequencies. In the phonograph section of the Garod model 306, a simple noise filter is used in the form of a parallel resistor-capacitor combination. The service data for this model appears on page 18-8 in *Rider's Volume XVIII*.

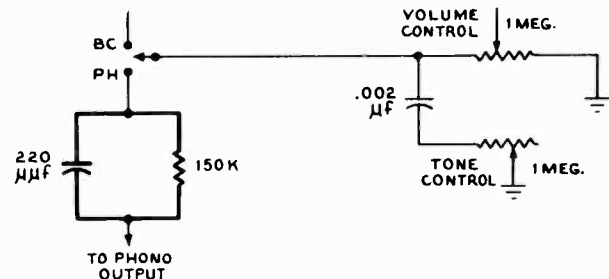

FIG. 6. — The parallel resistor-capacitor combination that is used as the noise filter in the phono section of the Garod Model 306.

A simplified schematic arrangement of this filter is shown in Fig. 6. The filter is located between the output of the phonograph and the phono section of the radio-phonograph switch. The resistor has a value of 150,000 ohms and the capacitor a value of 220 μf . The primary reason for this circuit is to eliminate low-frequency noise, such as rumble in the phonograph unit.

The low-frequency attenuation is not at any one sharply defined frequency but occurs rather gradually. At the low audio frequencies, the impedance of the parallel resistance-capacitance unit is considered to be approximately equal to 150,000 ohms, that of the resistor alone. The reason for this is that the reactance of the capacitor becomes so high at the low audio frequencies that it is considered an open circuit. (At 100 cycles the reactance of 220 μf is approximately 7.3 megohms.) At the high frequencies, however, the reactance of the capacitor decreases, thereby decreasing the over-all impedance of the network — hence providing a ready path for the high audio frequencies.

Many of the small-sized speakers that are used in phonograph circuits or phonograph-receiver combinations have a natural mechanical resonant frequency of a low order — the majority of these frequencies being within the range of 100 to 300 cycles. A low audio-frequency signal equal to or approximating the

mechanical resonant frequency of a speaker will cause the speaker to resonate. If the signal is strong enough, the cone of the speaker will undergo a greater degree of displacement than is usual. The displacement is not gradual but occurs rather suddenly. This is undesirable because the abrupt transportation of the speaker cone is accompanied by an annoying "thumping" sound.

Orchestral recordings have many such low audio-frequency tones and often will cause the undesired

condition described above. To eliminate this annoying characteristic some receivers are designed with a simple resistance-capacitance circuit the same as, or similar to, that shown in Fig. 6. This circuit will attenuate the low audio-frequency output from the phonograph and thus prevent the speaker from breaking into mechanical resonance. Of course, with such a circuit as this a disadvantage exists in that all the low audio frequencies are attenuated a certain amount and not just those frequencies causing the trouble.

INDEX

ADAPTOL
ALLIED

MODEL	FROM	THROUGH	MODEL	FROM	THROUGH
<u>ADAPTOL CO.</u>			<u>AIR KING PRODUCTS CO., INC. (Cont'd)</u>		
CT-1	Misc. 18-1	---	Crown Princess	16-4	---
<u>ADMIRAL CORP.</u>			Minstrel	17-1	---
<u>General Notes For Tilt-Out</u>			Royal Troubador	17-5	---
Chassis	18-1	---		17-9	---
UL5K1 Ch.	17-11	17-12		18-1	18-3
4B1 Ch.	16-10	---	A400, Minstrel, Ch. 470	17-1	---
	16-12	---	A-403 Court Jester, Ch.		
4D1 Ch.	18-2	18-3	470-1, 470-2	16-1	---
4D11, 4D12, 4D13, Ch. 4D1	18-2	18-3	A501, A502, Chassis 465-4	17-2	17-4
5C1 Ch.	18-22	---	A510, Royal Troubador	17-5	---
5F1 Ch.	18-4	18-5		17-9	---
5F11, 5F12, Ch. 5F1	18-9	18-5	A511, A512, Ch. 477	18-1	18-3
5H1 Ch.	16-9	16-10	451-2 Ch.	18-4	18-6
5K1 Ch.	17-11	17-12	458-2 Ch.	16-2	16-3
5N1 Ch.	17-9	17-10	465-4 Ch.	17-2	17-4
6B1 Ch. Early, Late	17-1	17-2	467 Ch.	17-8	17-9
6C1 Ch.	18-6	18-7	470 Ch.	17-1	---
6C11, Ch. 6C1	18-6	18-7	470-1, 470-2 Ch.	16-1	---
6L1 Ch.	16-2	---	477 Ch.	18-4	18-6
	16-11	---	884, 1400	18-7	---
6M1 Ch.	16-1	16-2	4200	17-6	---
	16-11	---	4604D, 4604F, Ch. 458-2	16-2	16-3
6R1 Ch.	18-8	---	4625 Phono	17-7	---
6R11, Ch. 6R1	18-8	18-11	4704 Crown Princess, Ch.		
7A1, 7A1A, 7A1B Ch.	18-23, 24	18-26	451-2	16-4	---
7C1 Ch.	16-3	16-6	4705, 4706, Ch. 467	17-8	17-9
7C60, 7C60UL, Early, Late	17-1	17-2	4706	18-8	18-10
7C62, Ch. 6M1	16-1	16-2			
	16-11	---	<u>AIR KNIGHT</u>		
7C63, Ch. 7C1	16-3	16-6	See BUTLER BROTHERS		
7C64, Ch. 8B1	18-12	18-18	<u>AIRLINE</u>		
7C65, Ch. 7E1	17-3	---	See MONTGOMERY WARD		
	C18-1	---	<u>ALAMO ELECTRONICS CORP.</u>		
7C73, Ch. 9A1	16-6	16-8	Radioette	Misc. 18-1	---
	17-4	17-8	AEC-3RCMB	Misc. 16-1	---
7E1 Ch.	17-3	---	PR-1, Radioette	Misc. 18-2	---
	C18-1	---	PR-2	Misc. 17-1	17-2
7G1 Ch.	18-19	18-21	2RCM	Misc. 16-1	---
7G11, 7G12, 7G13, 7G14,			50	Misc. 17-3	17-4
7G15, 7G16, Ch. 7G1	18-19	18-21	<u>ALDEN, INC.</u>		
7P32, 7P33, 7P34, Ch. 5H1	16-9	16-10	40-1500	Misc. 16-2	---
7RT41, 7RT42, 7RT43, Ch. 6L1	16-2	---	1525	18-1	---
	16-11	---	1561	18-2	18-4
	C18-1	---	1562	17-1	17-3
7T01, 7T01UL, 7T04, 7T04UL,			1600, 1601	17-4	17-5
Ch. 5N1	17-9	17-10	1602L, 1613L	17-6	---
7T03, Ch. 5C1	18-22	---	1636L	18-5	18-6
7T06, 7T12, Ch. 4B1	16-10	---	1755, 1756, 1757, 1758	18-7	---
	16-12	---	1810	18-8	---
7T09-S, 7T09-X, 7C74, Ch.			1815, 1816	18-9	---
7A1, 7A1A, 7A1B	18-23, 24	18-26	1818	18-10	---
7T10, 7T14, 7T15, Ch.			<u>ALGENE RADIO CORP.</u>		
5K1, UL5K1	17-11	17-12	Middie	17-6	17-7
7T12	16-10	---	AR6M	17-1	17-2
	16-12	---		17-6	---
7T14, 7T15	17-11	17-12	AR404, Jr.	17-3	17-5
8B1	18-12	18-18	AR406, Middie	17-6	17-7
8C1	18-27	18-31, 32	<u>ALLIED PURCHASING, INC.</u>		
8C11, 8C12, 8C13, 8C14, 8C15,			(ARTA)		
8C16, 8C17, Ch. 8C1	18-27	18-31, 32	554	17-1	17-3
9A1 Ch.	16-6	---	558	17-4	17-6
	17-4	17-8	571A, 571B	17-7	17-9
	C18-1	---	571X	17-10	17-12
9B1 Ch.	18-33, 34	18-38	572	17-6	---
9B14, 9B15, 9B16, Ch. 9B1	18-33, 34	18-38		17-13	17-16
			579	17-6	17-17
				17-16	
<u>AEROMOTIVE EQUIPMENT CORP.</u>			<u>ALLIED RADIO CORP.</u>		
Air-Com Kit 153AD	18-1	18-2	(KNIGHT)		
<u>AETNA</u>			4B-170	18-1	---
See WALGREEN CO.			5B171	16-1	---
<u>AFFILIATED RETAILERS, INC.</u>				16-6	---
(ARTONE)			5B-175, 5B-176, Ch. 200	16-2	---
R-046, R-1046, R-1046M	17-1	---	5C-185	17-1	---
R-046-U, R-1046M-U,			5C290	17-2	---
R-1046-U	17-2	---	6A-127 Revised	18-1	---
R-146	17-3	17-4	6B-122	16-3	16-5
R-146U	17-5	17-6	6B-127	18-1	---
R-246	17-7	17-8	6B-155, 6B-156	16-6	---
R-546	17-8	17-9	6C-122	18-1	---
R-546A	17-10	17-11	6C-127	18-1	---
R-546-U	17-11	17-12	6C225, 6C226	17-3	17-4
R-727	18-1	18-4	7B-220, 7C-220	17-5	17-8
R-1046, R-1046M	17-1	---	10C-249	18-2	18-6
R-1046M-U, R-1046-U	17-2	---	11B-278, 11C-300	17-9	17-13
			200 Ch.	16-2	---
<u>AIR CASTLE</u>			<u>ALLIED RADIO CORP.</u>		
See SPIEGEL INC.			(KNIGHT)		
<u>AIR CHIEF</u>			4B-170	18-1	---
See FIRESTONE TIRE & RUBBER CO.			5B171	16-1	---
<u>AIR KING PRODUCTS CO., INC.</u>				16-6	---
Court Jester	16-1	---	5B-175, 5B-176, Ch. 200	16-2	---
			5C-185	17-1	---
			5C290	17-2	---
			6A-127 Revised	18-1	---
			6B-122	16-3	16-5
			6B-127	18-1	---
			6B-155, 6B-156	16-6	---
			6C-122	18-1	---
			6C-127	18-1	---
			6C225, 6C226	17-3	17-4
			7B-220, 7C-220	17-5	17-8
			10C-249	18-2	18-6
			11B-278, 11C-300	17-9	17-13
			200 Ch.	16-2	---

**AMBASSADOR
COLLINS**

MODEL	FROM	THROUGH	MODEL	FROM	THROUGH
<u>AMBASSADOR DISTRIBUTOR CORP.</u>			<u>BELMONT RADIO CORP.</u>		
141	Misc. 17-1	---	Boulevard	16-10	---
144	Misc. 17-1	---	B-8AF21	18-1	18-5
<u>AMC</u>			C-10AF21	18-6	18-10
See ASSOCIATED MERCHANDISING CORP.			4B115, Series A	17-1	17-3
<u>ANDREA RADIO CORP.</u>			5C12	18-11	18-16
CO-U15, T-U15	17-1	17-6	5D110, Series A	17-4	17-5
	18-4	---	5D118, Series A	17-6	17-8
JSB	18-1, 2	18-3	5P19, Series A	17-9	---
T-16	16-1	16-3	5P113, 5P116, 5P117, Boulevard	16-10	---
T-U15	17-1	---	6D110, Series A	17-10	17-11
T-U16	16-4	16-5	6D111, Series B	16-1	16-2
<u>ANSLEY RADIO CORP.</u>			6D120, Series A	16-3	16-4
Dynaphone	17-6	17-9	6D121, Series A	17-12	17-13
FM-4, FM Tuner	16-2	16-3	6D127	C18-2	---
WCXR	16-1	---	6D130, Series A	18-17	18-19
32A	C17-1	---	8A150	C18-2	---
53	17-1, 2	17-5	8A5110	C17-9	---
105, Dynaphone	17-6	17-9	11AF21, Series A	16-5	16-9
677, 678	16-4	16-5	5240, Series A	17-14	17-16
5111	16-5	16-6	<u>BENDIX RADIO DIV.</u>		
<u>APEX RADIO & TELEVISION CORP.</u>			PAR-80, PAR-80A	18-1	18-5
25	17-1	17-2	R526M	17-3	17-4
8146, 8347	17-3	17-6	110, 110W, 111, 111W, 112,		
<u>APPROVED ELECTRONIC INSTRUMENT CORP.</u>			114, 115	18-6	18-8
FM Tuner	17-1	17-5	300, 300W, 301, 302	18-9	18-11
<u>ARC RADIO CORP.</u>			416A	17-1	17-2
601	16-1	16-2	613	18-12	18-14
<u>ARCADIA</u>			626A	16-1	16-3
See WELLS GARDNER			697A	17-5	17-6
<u>ARIA</u>			847B	17-7	17-14
See ALLIED PURCHASING, INC.				18-15	18-20
<u>ARTONE</u>			1518, 1519	18-21, 22	18-27
See AFFILIATED RETAILERS, INC.			1521	18-28	18-37
<u>ARVIN</u>			1524, 1525	18-21, 22	18-27
See NOBLITT SPARKS INDUSTRIES, INC.			1531, 1533	18-38	18-40
<u>ASSOCIATED MERCHANDISING CORP.</u>			<u>DAVID BOGEN CO., INC.</u>		
(AMC)			R502	18-3	18-4
125P	18-1	18-2	R601	18-1, 2	---
125Z	18-3	18-4	<u>BREWSTER</u>		
<u>ATLAS SUPPLY CO.</u>			See MEISSNER MFG. DIV.		
NUP, NU6	Misc. 17-2	---	MAGUIRE INDUSTRIES INC.		
<u>AUDAR, INC.</u>			<u>BROWNING LABORATORIES, INC.</u>		
RER-9	18-1	18-3	RJ-12, RJ-14	18-1	18-3
<u>AUTOMATIC RADIO MFG. CO., INC.</u>			RV-10, RV-11	18-4	18-8
(TOM THUMB)			See RADIO & TELEVISION INC.		
Tom boy	17-1	---	<u>BUTLER BROTHERS</u>		
Tom Thumb	C18-2	---	(SKYROVER)		
Tom Thumb Buddy	18-1	18-3	(AIR KNIGHT)		
Tom Thumb Camera	18-4	18-6	RD290	Misc. 18-3	---
Tom Thumb Jr.	17-1	---	RD291	Misc. 18-3	---
A. T. I. P.	16-1	---	<u>CAPEHART</u>		
C-60X	16-1	---	See FARNSWORTH TELEVISION & RADIO CORP.		
F-790	16-3	---	<u>CAPITOL RADIO CORP.</u>		
M10, M20	17-2	17-3	UN61	18-1	---
M86	17-5	---	UN62	18-4	---
P30, P33	18-7	---	UN72, UN72PC	18-2	---
P43, P45	17-4	---		18-3	18-4
127	C18-2	---	<u>CHANCELLOR</u>		
601, 602, Series B	16-2	---	See RADTONE EQUIPMENT CO.		
601, 602, Series C	16-2	---	<u>CHEVROLET DIV. - GENERAL MOTORS</u>		
620	16-3	---	985792	C17-1	---
640, Series B	C17-9	---	986067	16-1	16-4
650	C18-2	---	<u>CISCO</u>		
660, 662, 666, Series C	C17-9	---	See CITIES SERVICE OIL CO.		
677, Series B	17-6	17-8	<u>CITIES SERVICE OIL CO.</u>		
677, Series C	16-4	---	(CISCO)		
720	18-8	---	1A5	17-1	17-2
801, 802, 803	16-4	---	9A5	17-3	17-4
801, 802, 803, Series B	18-9	---	<u>CLARION</u>		
<u>AVIOLA RADIO CORP.</u>			See WARWICK MFG. CO.		
501, 512	16-1	16-2	<u>COAST TO COAST STORES</u>		
509, 518	16-1	16-2	MD28, MD29	Misc. 17-3	---
512	16-1	16-2	<u>COLLINS AUDIO PRODUCTS CO.</u>		
518	16-1	16-2	25-A	18-1, 2	---
	16-5	16-2	25-C	18-3, 4	---

CONCORD
EMERSON

MODEL	FROM	THROUGH	MODEL	FROM	THROUGH
<u>CONCORD RADIO CORP.</u> (LINCOLN RADIO)			<u>DEWALD RADIO (Cont'd)</u>		
6CS1B, 6CS1W	16-1	---	B-511	18-5	18-6
6F26N, Ch. 105	17-1	17-2	JB-523	17-2	---
7E51W	17-3	---	418	18-3	---
7G26C	16-2	16-4	<u>DUAL ENGINEERING CORP.</u>		
105, Ch.	17-1	17-2	(See ELECTRONIC CORP. OF AMERICA)		
1-404, 1-405	18-1	---	<u>ECHOPHONE</u>		
1-506	18-2	---	See HALLICRAFTERS		
1-507, 1-508	18-3	18-4	<u>ECKO</u>		
1-513	18-5	18-6	(See ECKSTEIN RADIO & TELEVISION CO.)		
1-514	18-7	18-8	<u>ECKENROTH CO., INC.</u>		
1-518	18-9	18-11	100, Musagrاند	Misc. 18-4	---
1-601, 1-602, 1-603	18-12	18-15	<u>ECKSTEIN RADIO & TELEVISION CO.</u> (ECKCO-KARADIO)		
1-610	18-16	---	The Airport	17-3	17-7
1-611	18-17	---	The Amateur	17-3	17-7
<u>CORONADO</u>			The International	17-3	17-7
See GAMBLE-SKOGMO INC.			T-5	17-1	17-2
<u>CORONET RADIO & TELEVISION CO.</u>			80A (The Amateur), 80-B (The Airport), 80-C (The Inter- national)	17-3	17-7
Arista	18-1	18-5	<u>EDWARD'S FM RADIO CORP.</u>		
1583	16-1	16-2	FM Tuner	16-1	16-2
1701	16-3	16-4	<u>ELECTROMATIC MFG. CORP.</u>		
1701X Arista	18-1	18-5	A.P.H. 301-A	Misc. 17-5	---
<u>CROMWELL</u>			A.P.H. 301-B	Misc. 17-5	---
See W. T. KNOTT CO.			A.P.H. 301-C	Misc. 17-5	---
<u>CROSLEY DIV.</u> AVCO MFG. CORP.			<u>ELECTRONIC CORP. OF AMERICA</u> (ECA)		
9-101	18-1	18-3	131	17-1	---
9-102, 9-118W	18-4	18-6	132	18-1	18-4
9-103, 9-104W	18-7	18-9	201	Misc. 16-3	---
9-117	18-10	18-11	204	17-2	---
9-119, 9-120W	18-12	18-13	<u>ELECTRONIC LABORATORIES, INC.</u>		
9-201, 9-202M, 9-203B	18-14	18-19	Orthosonic	16-5	16-7
9-302	18-20	18-23	Radio Utiliphone	16-1	16-4
52TC	C18-2	---	76RU, Radio Utiliphone	16-1	16-4
56FC	16-1	16-3	Ch. 2865	16-1	16-4
56TP	16-4	16-6	710PB-AC, 710PC-AC,	17-1	17-4
56PA, 56PB	C17-1	---	710PB-DC, 710PC-DC, Ch. 2887	16-5	16-7
56TD-W	17-1	17-2	710T, Orthosonic, Ch. 2875	C17-1	---
56TN	17-3	17-6	2701, Issue B	16-8	---
56TN-L	16-6	16-9	2811	C18-3	---
56TP-L	18-24	18-26	2865 Ch.	16-1	16-4
56TR, 56TS	18-27	18-29	2875 Ch.	16-5	16-7
56TU-O, 56TV-O	18-30	18-32	2887 Ch.	17-1	17-4
56PA, 56PB	C18-2	---	<u>EMERSON RADIO & PHONOGRAPH CORP.</u>		
56TU	17-7	17-8	BF-169, BF-204, BF-207	C18-3	---
56TX-L	16-2	---	FS Ch.	17-1	17-2
	16-6	---	FS-423, Ch. FS	17-1	17-2
	16-12	16-13	FT	17-3	---
56TY	17-9	17-10	GP Ch.	17-4	17-5
56TZ, 57TC, 1st and 2nd Production	16-6	---	456, Ch. GP	17-4	17-5
56XTA, 56XTW	16-10	16-11	503, 510, 510A, 520, 539, Ch.	16-1	16-3
	16-8	---	120000, 120029, 120030,	16-4	16-5
	16-14	16-15	120032, 120035, 120044	16-5	16-7
	16-19	---	505, Ch. 120020	16-5	16-7
57TK, 57TL	17-11	17-12	505, 523, Ch. 120041	16-8	---
57TC	16-6	16-11	507, 509, 518, 522, 535, Ch.	16-2	---
	16-10	16-11	120004, 120045	16-1	16-3
58TA, 58TL	17-13	17-14	510, 510A	16-1	16-3
58TC, 58TW	17-15	17-16	512, Ch. 120006, 120056	C17-1	---
58TH, 58TH-O	18-33	18-36	513, 514, 534, Ch. 120007	17-6	17-8
58TK	17-17	17-18	515, 516, Ch. 120006, 120056	C17-1	---
58TL	17-13	17-14	518	16-2	---
58TW	17-15	17-16	520	16-8	---
58XA, 58XA-10, 58XA-20,			521, Ch. 120013	16-1	16-3
58YW, 58XW-10, 58XW-20	18-37	18-39	522	17-9	17-10
66CS(O)	18-40	18-43	523, Ch. 120041	16-2	---
	C18-2	---		16-8	---
66CS, 66CSM, 66CS(s)	16-16	16-19		16-2	---
66CT	18-44	18-46		16-1	16-3
66TC-S	16-19	16-22		16-1	16-3
66XTA, 66XTA-10, 66XTA-20	18-47	18-49		16-1	16-3
86CR, 86CS	16-23, 24	16-30		16-1	16-3
86CR Revised, 86CS Revised, 87CC, 88CR	17-19, 20	17-26		16-2	---
88TA, 88TC	18-50	18-60		16-1	16-3
146CS, 146CS(V)	17-27, 28	17-40		16-1	16-3
<u>DAYTON</u>				16-1	16-3
See W. W. GRAINGER CO.				16-1	16-3
<u>DETROLA</u>				16-1	16-3
See INTERNATIONAL DETROLA CORP.				16-1	16-3
<u>DEWALD RADIO</u>				16-1	16-3
A-507	16-1	---		16-1	16-3
A-509	16-2	16-3		16-1	16-3
A-514	17-2	---		16-1	16-3
B-400	17-1	---		16-1	16-3
B-401	18-1	---		16-1	16-3
B-504	18-2	18-3		16-1	16-3
B-506	18-4	---		16-1	16-3

EMERSON
FIRESTONE

MODEL	FROM	THROUGH
<u>EMERSON RADIO & TELEVISION CORP. (Cont'd)</u>		
524, 524-2, Ch. 120011, 120022	16-9	16-13
525, 552, Ch. 120037	16-2	---
	16-7	---
	16-14	---
528, Ch. 120038	18-1	18-6
530, Ch. 120006, 120056	17-11	17-12
531, 532, 533, Ch. 120040	16-15	16-16
534	17-6	17-8
535	16-2	---
	16-8	---
536, Ch. 120036	17-13	17-15
536A, 551A, 553A, Ch. 120053A	17-16	17-18
539	16-1	16-3
540, 564, 572 Ch. 120042,	18-7	18-9
120027, 120065	17-19	17-21
540A, Ch. 120042A	17-9	17-10
542, Ch. 120031	16-2	---
543, 544, Ch. 120046	16-17	---
	16-2	---
543, 544, Ch. 120052	16-18	---
	17-22	17-24
546, Ch. 120049	17-25	17-27
547A, Ch. 120050A	C17-1	---
550, Ch. 120006, 120056	17-16	17-18
551A	16-2	---
552	16-7	---
	16-14	---
553A	17-16	17-18
557, Ch. 120048B	18-10	18-11
558, Ch. 120058	17-28	17-29
559, Ch. 120059A	18-12	---
560, Ch. 120016	17-30	17-32
564, Ch. 120027	18-7	18-9
569, Ch. 120062A	18-13	18-15
570, 574, 580, Ch. 120064	18-16	18-17
572, Ch. 120065	18-7	18-9
574, Ch. 120064	18-16	18-17
577, Ch. 120012B	18-18	18-20
1002, 1003, Ch. 129003	16-19	16-20
120000 Ch.	16-1	16-3
120004 Ch.	16-2	---
	16-8	---
120006 Ch.	17-11	17-12
120007 Ch.	17-6	17-8
120011 Ch.	16-9	16-13
120012B Ch.	18-18	18-20
120013 Ch.	17-9	17-10
120016 Ch.	17-30	17-32
120020 Ch.	16-4	16-5
	16-7	---
120022 Ch.	16-9	16-13
120027 Ch.	18-7	18-9
120029, 120030 Ch.	16-1	16-3
120031 Ch.	17-9	17-10
120032, 120035 Ch.	16-1	16-3
120036 Ch.	17-13	17-15
120037 Ch.	16-2	---
	16-7	---
	16-14	---
120038 Ch.	18-1	18-6
120040 Ch.	16-15	16-16
120041 Ch.	16-5	16-7
120042 Ch.	18-7	18-9
120042A Ch.	17-19	17-21
120044 Ch.	16-1	16-3
120045 Ch.	16-2	---
	16-8	---
120046 Ch.	16-2	---
	16-17	---
120048B Ch.	18-10	18-11
120049 Ch.	17-22	17-24
120050A Ch.	17-25	17-27
120052 Ch.	16-2	---
	16-18	---
120053A Ch.	17-16	17-18
120056 Ch.	17-11	17-12
120058 Ch.	17-28	17-29
120059A Ch.	18-12	---
120062A Ch.	18-13	18-15
120064 Ch.	18-16	18-17
120065 Ch.	18-7	18-9
129003 Ch.	16-19	16-20

EMOR RADIO, LTD.

100	16-1	16-2
-----	------	------

EMPIRE DESIGNING CORP.

55	Misc. 16-4	---
56	Misc. 16-4	---

ESPEY MFG., CO., INC.

FJ-97A, Ch. Revised	16-1	16-2
7B	17-1, 2	17-3, 4
7B, Revised	17-5, 6	17-7, 8
7B1	18-1, 2	---
501	18-3	18-4
5181	16-3	16-6
20516	18-5	---

MODEL	FROM	THROUGH
<u>FM SPECIALTIES, INC.</u>		
Fidelotuner	17-1	17-4
	C18-3	---
Fidelotuner Revised	18-1	18-2

FADA RADIO & ELECTRIC CO., INC.

C33	18-1	---
FM16	17-1	17-11
F711, F750	18-2	18-4
P80	17-12	---
P-80 Late	18-5	18-7
P82	17-13	17-15
P100	17-14	17-16
6A39	17-18	17-20
172	16-1	16-2
368	18-8	18-10
372	17-21	17-23
602	C17-2	---
711, 740	17-15	---
	17-20	---
	17-24	---
1001	17-25	17-27

FARNSWORTH TELEV. & RADIO CORP.
(CAPEHART)

AC-55, Ch. C2-3	C18-3	---
ACL55, ACL56, AKL58, AKL59	C18-3	---
BT-68	16-1	16-2
C-156, C-157, C-193 Ch.	16-3	16-5
C-196 Ch.	17-1	17-3
EF-451, Ch. C-196	17-1	17-3
EK-081, EK-082, EK-083,		
EK-681, Ch. C-156, C-157, C-193	16-3	16-5
EK-263, EK-264, EK-265	C17-3	---
ET-060	C17-3	---
ET-061	C17-1	---
	C17-3	---
ET-063, ET-064, ET-065, ET-066	C17-3	---
ET-069	C17-1	---
	C17-9	---
ET-650BRZ, ET-651BKZ, ET-651BUZ,		
ET-651RDZ, Ch. 171	18-1	18-5
GK-084, GK-085, GK-086, GK-087,		
K-084, K-086, K-287-P	18-6	18-12
GK-100, GK-102, GK-103, GK-104,		
GK-111, GK-112, GK-113,		
GK-114	17-3	17-10
GK-140, GK-141, GK-142, GK-143,		
GK-144	16-6	16-11
	C18-3	---
GK-140, GK-141, GK-143, GK-144	18-15	---
GK-699, GT-699	17-11	17-16
GP-350	17-17	17-18
GT-050, GT-051	17-19	17-20
GT-060, GT-061, GT-064, GT-065	17-21	---
GT-699	17-11	17-16
P-860	18-13, 14	---
19N3, 21N2, 25N2, 26N2, Panamuse	18-17	18-44
100N, 400N Series, Capehart	18-16	18-44
171 Ch.	18-1	18-5
400N Series Capehart	18-16	18-44

FEDERAL TEL. & RADIO CORP.

E1025TB	16-1	16-4
1024TB	17-1	17-3
1030T, 1540T	16-5	16-8
1040TB	17-4	17-6
1540T	16-5	16-8

FERGUSON RADIO CORP.

5X47	Misc. 16-5	---
7X47	Misc. 16-5	---

FERRAR RADIO & TELEVISION CORP.

C81B	17-1	17-4
T61B	17-5	17-7
TA61B	17-8	17-11

THE FIRESTONE TIRE & RUBBER CO.
(AIR CHIEF)

Brilliantone	16-11	---
	16-14	---
Cameo	17-15	17-16
	18-32	18-33
Diplomat	17-8	17-9
Georgian	17-22	17-29
Marlborough	18-34	18-40
Metropolitan	18-34	18-40
Mercury	17-5	17-7
Narrator	18-7	18-10
News-castor	18-24	18-26
Reporter	17-12	17-14
Roamer	16-12	16-13
	16-8	---
S7407-9	17-1	17-4

FIRESTONE
GLOBE

MODEL	FROM	THROUGH
<u>THE FIRESTONE TIRE & RUBBER CO. (Cont'd)</u>		
4-A-1, Mercury	17-5	17-7
	C17-2	---
4-A-3, Diplomat	17-8	17-9
	C17-2	---
4A-10, Reporter	17-12	17-14
4-A-10 Late	18-1	18-3
4-A-11	18-4	18-6
4-A-12, The Narrator	18-7	18-10
4-A-15	18-11, 12	18-23
4-A-17	16-1	16-2
	16-9	---
4-A-26, The Newscaster	18-24	18-26
4-A-27, Cameo	17-15	17-16
4-A-30	18-27, 28	18-33
4-A-37	17-17	17-21
4A-41	17-10	17-11
	C17-2	---
	17-7	---
4-A-42, Georgian	17-22	17-29
	C17-2	---
4-A-61, The Cameo	18-32	18-33
4-A-62, The Marlborough,		
4-A-63, The Metropolitan	18-34	18-40
4-B-6	17-30	17-34
7379-1, 7405-3, 7406-1	16-3	16-5
7383-4	16-6	16-8
7384-2	17-35	17-36
7396-1	16-9	16-11
7402-6, Roamer	16-8	---
	16-12	16-13
7402-4	C18-3	---
7403-1, Brilliantone	16-11	---
	16-14	---
7405-2, 7405-4	17-37	17-38
7405-3	16-3	16-5
7405-4	17-37	17-38
7406-1	16-3	16-5
7423-5	C18-3	---
7423-6	C17-2	---

FONOTALK CORP.

500BI, 500BW	Misc. 18-5	---
--------------	------------	-----

FORD MOTOR CO.

See ZENITH RADIO CORP.

GAMBLE-SKOGMO, INC.
(CORONADO)

7P Series	18-1	18-3
43-5005	17-1	17-7
43-6301	17-8	17-10
43-6321	18-4	18-7
43-7601, 43-7601A, 43-7601B	16-1	16-5
	C17-3	---
43-7602	16-1	16-6
43-7660	18-8	18-14
43-8160	16-7	16-9
43-8177, 43-8178, 43-8179	17-11	17-13
43-8180	17-14	17-16
43-8213	15-1	---
	17-17	17-18
43-8240, 43-8241	17-19	17-22
43-8305	17-23	17-26
43-8312	17-27	17-29
43-8351, 43-8352	17-30	17-33
43-8437	16-10	16-12
43-8470	17-34	17-37
43-8471	17-37	17-40
43-8576	16-13	16-16
	16-2	---
43-9196	17-41	17-42
	17-16	---
43-9201	17-43	17-45
43-9751	17-46	17-47
	17-26	---

GAROD RADIO CORP.

The Companion	16-2	---
The Ensign	16-1	16-2
BP24, BP25	17-1	17-2
3AP, 4AP	17-3	---
4A1, 4A2	17-4	17-5
4B-1	18-1	18-2
5AP1-Y, The Companion	16-2	---
5A1, The Ensign	16-1	16-2
5A2-Y	17-6	---
5A3	18-3	---
5D3, 5D3A	16-3	16-4
5D5	17-7	17-8
5RC-1	17-9	---
6A	17-10	---
6A2	17-11	---
9FMP, 9FMPA, 9FMPU	18-4	18-5
62B	18-6	18-7
306	18-8	---

MODEL	FROM	THROUGH
<u>GENERAL ELECTRIC CO.</u>		
Musaphonic	17-1, 2	17-15
A51, A56	C17-10	---
	C18-3	---
GB-400	17-24	17-25
GD-510, GD-511, GD-512,		
GD-512W, GD-512X, GD-513	18-2	18-3
H-639AC-DC	C18-3	---
LB-673	17-25	17-26
LM1A Charging Cable	18-1	---
L-604	C18-3	---
X-415	18-4	18-12
YRB 60-12	C18-3	---
YRB 79-1, YRB 79-2, YRB 83-1	17-19	17-20
YRB 92-2	C18-3	---
41, 42, 43, 44, 45,		
Musaphonic	17-1, 2	17-15
60, 62	17-16	17-18
102, 102W, 107, 107W, 114,		
114W, 115, 115W	18-13	18-14
	112	18-15
	113	18-16
	140	18-17
	180	17-21
	200, 203, 205	16-1
	202	16-2
	C17-10	18-20
	C18-3	---
210, 211, 212	18-21	18-25
219, 220, 221	C17-10	---
	C18-3	---
230 Kaiser-Frazer	18-26	18-28
233 Kaiser-Frazer	18-29	18-36
250	C17-3	---
254	16-3	16-5
	C18-3	---
260	16-6	16-12
	C18-3	---
280	16-13	16-16
304	18-37	18-39
356, 357, 358	18-40	18-44
417	16-16	16-19
	16-21	16-24
417A	17, 27, 28	17-38
	C17-2	---
502	17-4	17-8
	17-39, 40	17-47
801	16-25, 26	16-38

GENERAL IMPLEMENT CORP.

1A5	17-1	17-2
-----	------	------

GENERAL TELEVISION & RADIO CORP.

4B5	16-1	16-2
5B5	16-2	16-4
9A5	16-2	---
	16-4	16-5
9B6P	18-1	---
20A3A, 20A3P	17-1	---
21A4	18-2	---
22A5C	18-3	---
23A6	16-2	---
	16-4	---
	16-6	---
24B6	16-7	16-8
	16-2	---
	16-4	---
25R5	16-9	16-10
	16-2	---
	16-4	---
26B5	17-2	17-4
27CSL	18-4	---
526, 534, 547, 549, 558,		
588, 591 (Single-ended tubes)	18-5	---
526, 534, 547, 549, 558, 588,		
591 (Double-ended tubes)	18-6	---

GILFILLAN BROS., INC.

Overland,	16-3	---
56A, 56B, 56C, 56D, 56E	16-1	---
58M, 58W	18-3	---
66AM, 66DM	16-2	---
66B, Series 2, Series 3,		
Overland	16-3	---
66DM	16-2	---
66PM	16-4	---
68B, 68D	18-4	---
68F	17-1	17-2
68-48	18-1, 2	---
86 Series	16-5	16-6
108C-M	17-3, 4	17-6
118C-M	17-7, 8	17-10

GLOBE ELECTRONICS, INC.

454	18-1	18-3
-----	------	------

**GOODRICH
MAGNA**

MODEL	FROM	THROUGH
<u>THE B. F. GOODRICH CO.</u> (MANTOLA)		
R-635	16-1	16-4
R655W	C18-3	---
R-661	16-5	16-6
R-685	18-1	18-2
R743-W	17-1	17-2
R75152	17-3	17-5
R76162	17-10	17-12
R76262	17-13	17-15
R-78162, R-78262	18-3	18-10
75434	17-6	17-7
76143	17-8	17-9
92502	18-11	18-12

GOTHAM

See HAROLD SHEVEHS, INC.

W. W. GRAINGER CO.
(DAYTON)

1R73 - See Fonotalk 500BI
1R74 - See Fonotalk 500BW

W. T. GRANT CO.
(GRANTLINE)

MODEL	FROM	THROUGH
300, Series B	17-1	---
405/7	17-2	---
500, 501, Series A	16-1	16-2
	16-5	---
502, 503, Series A	16-3	16-5
510, Series A	16-6	16-8

GRANTLINE

See W. T. GRANT CO.

THE HALLICHAFTERS CO.

Skyranger	16-20	16-28
Skyrider Panoramic	17-1	17-5
Super Skyrider	16-3, 4	16-5
	16-8	16-10
	16-13	16-14
CA-2	18-1	18-5
EC-1B Echophone	16-1	16-2
EC-306, EX-306	18-6	18-9
EC-403, EC-404, Echophone	16-29, 30	16-31
	16-34	16-36
EX-306	18-6	18-9
S-38	C17-3	---
S-39, Skyranger	16-20	16-28
S-40	C17-3	---
S-40A	C18-3	---
S-47	17-17, 18	17-29
SP-44, Skyrider Panoramic	17-1	17-5
	C18-3	---
	C18-4	---
SX-28A, Super Skyrider	16-3, 4	16-5
	16-8	16-10
	16-13	16-16
SX-42	17-6	17-16
	C18-4	---
SX-43	18-10	18-28

HOFFMAN RADIO CORP.
(MISSION BELL)

A202, A309, Ch. 119	16-1	16-2
A700, Ch. 110S	16-4	---
B400, Ch. 118	16-2	16-3
B502, Ch. 113	17-1	17-6
B503, Ch. 115	17-8	17-11
	15-9	---
	17-13	---
B504, Ch. 123	17-1	---
	17-3, 4	17-7
B-508, B-509, B-510, Chassis 129	18-1	18-2
B1000, Ch. 114	17-10	17-13
C1006, C1007, Ch. 131, 132	18-3	18-8
110S Ch.	16-4	---
113 Ch.	17-1	17-6
114 Ch.	17-10	17-13
115 Ch.	17-8	17-11
118 Ch.	16-2	16-3
119 Ch.	17-1	---
123 Ch.	17-3, 4	17-7
129 Ch.	18-1	18-2
131 Ch.	18-3	18-8
132 Ch.	18-3	18-8

HOWARD RADIO CO.

FM-718	17-20	17-21, 22
M901-A	16-1	---
472AC, 472AF	17-4	17-10
472C, 472F	17-1	17-7
474	17-11	17-14
481B, 481C, 481M	18-1	18-6
718, Series X	17-15	17-19
718-FM-5-6	17-23	17-28
901-A	16-1	---
	C17-4	---
901-AP-A	16-2	---

MODEL	FROM	THROUGH
<u>HOWARD RADIO CO. (Cont'd)</u>		
902-A	18-7	18-8
906	16-3	16-4
906C	16-4	16-6
906-S	17-29	17-33
906-SB	18-9	18-11
909-M	17-34	17-37
909 MR	C18-4	---

HUDSON MOTOR CAR CO.
See ZENITH RADIO CORP.

INTERNATIONAL DETROLA CORP.
(DETROLA)

339, 340, 340-1	C18-4	---
582	16-1	16-4
626, with octal tubes	17-1	---
626, with miniature tubes	17-2	---
626, with octal tubes	17-3	---
2744	C18-4	---
7156	17-4	17-6
7270	16-5	16-6
	16-3	---
7901	17-7	17-12

INTERSTATE HOME EQUIPMENT CORP.

68F	Misc. 18-6	---
<u>JEWEL RADIO CORP.</u>		
500	18-1	18-4
505, Clock Radio	18-5	18-7

KAISER-FRAZER

See GENERAL ELECTRIC CO.

KARADIO

See ECKSTEIN RADIO & TELEVISION CO.

KAROLA

See RADIO & TELEVISION PRODUCTS

KNIGHT

See ALLIED RADIO CORP.

W. T. KNOTT CO.
(CHROMWELL)

205	Misc. 17-6	---
-----	------------	-----

LAFAYETTE

See RADIO WIRE TELEVISION

LA MAGNA MFG., CO.
(LAMCO)

Lamco, 3000	18-1	18-3
-------------	------	------

LAMCO

See LA MAGNA MFG., CO.

LAUREHK RADIO MFG. CO.

L-52	Misc. 16-6	---
------	------------	-----

LEANDER ELECTRONICS CORP.

707	17-1	17-3
-----	------	------

LEAR, INC.

565, 565BL, 566, 567, 568	16-1	16-3
662, 663, 665, 6618	16-4	16-6
6610, 6611, 6612, 6610PC, 6611PC, 6612PC, Early production	17-1	17-2
6610, 6611, 6612, 6610PC, 6611PC, 6612PC, Late production	17-3	17-4
6610, 6611, 6612, 6610PC, 6611PC, 6612PC, Early and Late production	17-5	17-6
6614, 6615, 6616, 6619, 6617PC	16-5	16-8
6618	16-4	16-6
6619	16-5	16-8
667PC	Misc. 18-7	---

LINCOLN RADIO

See CONCORD RADIO CORP.

MAGIC TONE

See RADIO DEVELOPMENT & RESEARCH

MAGNA ELECTRONICS CO.

M300-6, M400-6	Misc. 17-7	---
----------------	------------	-----

MAGNAVOX
MONT. WARD

MODEL	FROM	THROUGH	MODEL	FROM	THROUGH
<u>THE MAGNAVOX CO.</u>			<u>MIDWEST RADIO CORP. (CONT'D)</u>		
AMP-101A	17-1	17-2	SG-16	16-4	16-12
AMP-108	17-3, 4	17-6	SGT-12 Ch.	16-1	16-4
AMP-109	18-1, 2	18-3	SGT-16 Ch.	16-4	16-12
AMP-110	17-7, 8	17-10	ST-8	17-4	17-6
AMP-111	18-4	18-7	ST-12	16-1	16-4
CR-190	C17-4	---	ST-16	16-4	16-12
CR-197, CR-197A, CR-197B	16-1, 2	16-7	TM-8	17-4	17-6
CR-198, CR-198A, CR-198B	16-5	16-11	712, Series 12, S-12, SG-12, ST-12, Ch. SGT-12	16-1	16-4
CR-199	16-12	16-16	716, Series 16, S-16, SG-16, ST-16, Ch. SGT-16	16-7, 8	---
CR-200 Series	18-8	18-15	16-4	16-4	16-5
CR-202 Series	18-16	18-25, 26	16-11	16-12	---
CR-203A, CR-203B	17-11, 12	17-17	716A, Series 16, S-16, SG-16, ST-16, Ch. SGT-16	16-6	---
CR-204 Series	18-27, 28	18-37	16-9, 10	16-12	---
CR-207A, CR-207B, CR-207C, CR-207D	17-13	---	16-4	---	---
CR-208	17-18	17-24	<u>MINERVA CORP. OF AMERICA</u>		
CR-208A	17-25, 26	17-28	Portapal	16-1	16-2
	17-13	---	W702	18-1	18-3
	17-29	---	W729, Portapal	18-4	18-6
	17-31	---	729, Portapal	16-1	16-2
CR-208B	17-13	---	<u>MISSION BELL</u>		
CR-208B	17-30	17-31	See <u>HOFFMAN RADIO CORP.</u>		
<u>MAGUIRE INDUSTRIES, INC.</u>			<u>MITCHELL MFG. CO.</u>		
6X	Misc. 18-8	---	Lullaby Bed Lamp Radio	Misc. 18-9	---
<u>MAJESTIC RADIO & TELEVISION CORP.</u>			<u>MOLDED INSULATION CO.</u>		
5A445, 5A445R	16-1	16-2	RS-1	16-1	---
5AK711, Ch. 5B01A	17-1	17-2	RS-1A	16-2	---
5AK731, 5AK780, Ch. 5B05A	17-3	17-4	<u>MONITOR EQUIPMENT CORP.</u>		
5B01A Ch.	17-3	17-4	M-403	16-3	16-4
5B05A, Ch.	17-3	17-4	M-510	16-5	16-6
6B02D Ch.	18-1	18-2	M3070	17-1	17-4
6B11D Ch.	18-3	18-4	RA50	17-5	17-6
6FM714, Ch. 6B02D	18-1	18-2	RAM-47	18-1	18-2
6FM773, Ch. 6B11D	18-3	18-4	TA56M, TC56M, TW56M	16-1	16-2
7B04A Ch.	17-7	17-10	<u>MONTGOMERY WARD</u>		
7C432, 7C447, Ch. 4706, 4707	16-3	16-4	(AIRLINE)		
7JK777R, Ch. 4708P	17-5	17-6	04BR-420B	C18-4	---
7P420, Ch. 4705	18-5	18-7	14WG-635R	C18-4	---
7YR52, Ch. 7B04A	17-7	17-10	54KP-1209B	16-1	16-4
8B06D Ch.	17-11, 12	17-16	54WG-2700A	C17-5	---
8B07D Ch.	17-17, 18	17-22	62-49, 62-68, 62-68X, 62-88	17-1	17-2
8FM744 Ch.	17-11, 12	17-16	64BR-916A	17-3	---
8FM776, Ch. 8B07D	17-17, 18	17-22	64BR-916B	17-4	---
8FM783, Ch. 8B07D	C18-4	---	64BR-1051A	C17-4	---
8JL771A, Ch. 4810A	17-23	17-26	64BR-1051B	C17-4	---
8JL885, Ch. 4810B	18-8	18-10	64BR-1513A, 64BR-1514A, 74BR-1513B, 74BR-1514B	17-5	17-8
8S473	C17-4	---	64BR-1808A	17-9	17-14
12B26E Ch.	17-27, 28	17-33	64WG-1050D, 74WG-1050B	C18-4	---
12FM475, Ch. 41201, 12FM778, 12FM779, Ch. 12B26E	17-27, 28	17-33	64WG-1052B, 74WG-1052B	16-5	16-7
4705 Ch.	18-5	18-7	64WG-1207A, 64WG-1207B, 74WG-1207B	16-8	---
4706, 4707 Ch.	16-3	16-4	64WG-1604B, 74WG-1804B	16-3	---
4708R Ch.	17-5	17-6	64WG-1804C	16-9	16-10
4810A Ch.	17-23	17-26	64WG-1804C	C18-4	---
4810B Ch.	18-8	18-10	64WG-1807B	16-3	---
41201 Ch.	17-27, 28	17-33	64WG-1807B, 74WG-1807B	16-10	16-12
<u>MANTOLA</u>			64WG-2009B	C17-4	---
See <u>THE B. F. GOODRICH CO.</u>			64WG-2010A, 64WG-2010B, 74WG-2010B	C17-5	---
<u>JOHN MECK IND., INC.</u>			64WG-2500B, 74WG-2500B	16-13	16-17
CD-500	18-2	---	64WG-2700A, B	C18-5	---
DE-640, DF-641	18-1	18-2	64WG-2700B	C17-5	---
4D8	18-3	---	74BR-1053A	C18-5	---
4H8	18-3	---	74BR-1053A	17-15	17-17
5G8	18-4	---	74BR-1501B, 74BR-1502B	17-18	17-20
5H8	18-4	---	74BR-1507A, 74BR-1508A	17-21	17-23
<u>MEISSNER MFG. DIV.</u>			74BR-1513B, 74BR-1514B	17-24	17-25
<u>MAGUIRE INDUSTRIES, INC.</u>			74BR-1812A	17-5	17-6
(BREWSTER)			74BR-1812B	16-17	16-21
5A, 574	17-9	---	74BR-2001A	C18-5	---
6D	C17-4	---	74BR-2003A, B	17-26	17-28
6H, 661	17-10	---	74BR-2003C	17-29	17-31
8C	17-1	17-4	74BR-2003C	C18-5	---
9-1053, 9-1054	18-1	18-4	74BR-2702A, B	17-32	17-38
9-1065	16-1	16-3	74BR-2707A	18-1	18-9
9-1091A, 9-1091B	17-5	17-8	74BR-2708A, 74BR-2708B, 74BR-2708C	18-15	18-22
9-1093	18-5	18-8	74BR-2710A	18-5, 6	18-7, 8
10-1193	18-9	---	74BR-2715A, 84BR-2715A, 84BR-2715B	18-10	18-14
10-1199	18-10	18-12	74BR-2717A	18-23	18-30
574	17-9	---	74KR-1210A	18-31	18-34
661	17-10	---	74KR-2706A, 74KR-2706B, 74KR-2713A	17-39	17-41
<u>MIDWEST RADIO CORP.</u>			74KR-2713A	17-42	17-45
P-6, PB-6	17-1	17-3	---	16-4	---
R-8, RM-8, 88, 88A, Ch. RTM-8	18-1	18-3			
R-12, RT-12, RG-12, 8X12, Ch. RGT-12	18-4	18-6			
R-16, RT-16, RG-16, 816, Ch. RGT-16	18-7	18-12			
RGT-12 Ch.	18-4	18-6			
RGT-16 Ch.	18-7	18-12			
RTM-8 Ch.	18-1	18-3			
S-8, ST-8, TM-8	17-4	17-6			
S-12, SG-12, ST-12, Ch. SGT-12	16-1	16-4			
S-16, SG-16, ST-16, Ch. SGT-16	16-4	16-12			
SG-12	16-1	16-4			

MONT. WARD
NATIONAL

MODEL	FROM	THROUGH	MODEL	FROM	THROUGH
<u>MONTGOMERY WARD (Cont'd)</u>			<u>MOTOROLA INC. (Cont'd)</u>		
74WG-1052B	16-5	16-7	PC6	16-7	---
74WG-1054A	C17-5	---		16-9	16-12
74WG-1056A	C18-6	---		16-15	16-17
	17-47	17-49	PD6	16-12	16-14
74WG-1057A	17-50	17-52		16-23	16-28
74WG-1297B	16-3	---		16-6	16-7
	16-8	16-10	PT10, Tuner	18-67	18-69
74WG-1509A, 74WG-1510A	17-53	17-55	PT14, Tuner	18-1	18-3
74WG-1509B, 74WG-1510B	17-56	---	SR7	18-4	18-6
74WG-1801C	C18-5	---	ST-54 Tuner	17-4	17-9
74WG-1801D	C18-5	---	5A1, Ch. HS-6	15-1	---
74WG-1802A, 74WG-1803A	17-57	17-59		17-10	17-13
74WG-1804C	C17-4	---	5A5, Ch. HS-15	15-2	---
74WG-1804D, 74WG-1805A	17-60	17-62		17-10	---
74WG-1807B	C17-10	---		17-14	17-17
74WG-2002A	17-63	17-65	5A7, Ch. HS-62	17-18	17-21
74WG-2004A	17-66	---		17-23	---
	17-58	17-59		17-25	17-26
74WG-2009B	C17-5	---	5A7A, Ch. HS-62A	17-18	17-20
74WG-2010B	16-13	16-17		17-22	---
	16-13	---		17-24	17-26
74WG-2504A, -B, -C	17-67	17-71	47B11	17-27	17-31
74WG-2704A, -B, -C	16-22	16-26	48L11, Ch. HS-113	18-7	18-12
74WG-2505A, 74WG-2705A	16-16	---	55F11	17-32	17-35
	C17-5	---		17-17	---
74WG-2700A	16-27	16-30	56X11, Ch. HS-94	17-36	17-39
74WG-2703A	17-67	17-71	57B61V, Ch. HS-77	17-40	17-51
74WG-2704A, -B, -C	16-16	---	57X11, 57X12, Ch. HS-60	17-52	17-55
74WG-2705A	16-22	16-26	58L11, Ch. HS-114	18-13	18-19
	C17-5	---	65F21, Ch. HS-26	18-20	18-24
74WG-2705B	17-72	17-75	65T21, Ch. HS32, 65T21B, Ch. HS-67	15-62	---
74WG-2709A	C18-5	---		17-56	17-60
74WG-2711	18-35	18-37	67F11, 67F12, 67F12B, Ch. HS-63	17-68	17-74
84BR-1065A	18-38	18-40	67F61BN, Ch. HS-69	17-61,62	17-67
84BR-1503D, 84BR-1504D	18-38	18-40		17-43	17-46
84BR-1507B, 84BR-1508B	18-41	18-43		17-48	17-49
84BR-1515A, 84BR-1516A	---	---	67L11, Ch. HS-59	17-75	17-79
84BR-1815A, 84BR-1816A	18-44	18-46	67T61BN, Ch. HS-69	17-61,62	17-63
84CCR-1062A	18-47	18-48		17-43	17-46
84KR-1209B	18-49	18-51		17-48	17-49
84KR-1520A	18-52	18-53		17-65	17-67
84KR-2510A	18-54	18-56	67X11, 67X12, 67X13, Ch. HS-58	17-80	17-84
84WG-1056B	18-57	18-60	67XM21, Ch. HS-64	18-25,26	18-39
84WG-1060A	18-61	18-63	68L11, Ch. HS-119	18-40	18-46
84WG-1060C	18-64	18-66	75F21, Ch. HS-91	18-47	18-51
84WG-2506A	18-67	18-70	75F31, 75F31A, 75F31B, 76F31, Ch.		
84WG-2704D	18-76	18-78	HS-36, HS-36A, HS-98	18-52	18-72
84WG-2712A	18-79	18-83	PT-10 Tuner	18-67	18-69
	18-85	18-88	77XM21, 77XM22, 77XM22B, Ch. HS-102	18-73,74	18-88
	18-90	---	85F21	17-59	---
84WG-2712B	18-84	---	85K21	17-85	17-91
	18-89	---		17-86	17-88
	17-1	17-3		17-91	17-94
<u>MOTOROLA INC.</u>	17-1	17-3	87T61PN, Ch. HS-70	17-95,96	17-100
Airboy	16-1	16-8		17-43	17-46
AR-96-23, Airboy	16-7	16-11		17-48	17-49
CR6	16-9	16-17		17-66	---
CT6, OE6, PC6	16-15	16-17	402	C18-5	---
	16-12	16-22	405	16-29	---
CT6	16-18	16-7		16-7	---
FD6, NH6	16-6	16-7		16-16	---
HS-6 Ch.	15-1	---		16-33	---
HS-15 Ch.	17-10	17-13	408	16-35	16-36
	15-2	---	505	18-89	18-91
	17-10	17-17		16-7	---
HS-26 Ch.	17-14	18-24		16-16	---
HS-32 Ch.	18-20	18-24		16-30	---
	15-62	17-60		16-33	---
HS-58 Ch.	17-56	17-84	508	16-35	16-36
HS-59 Ch.	17-80	17-79		18-90	---
HS-60 Ch.	17-75	17-55	605	18-92	18-94
HS-62 Ch.	17-52	17-21		16-31	---
	17-18	---		16-7	---
HS-62A Ch.	17-23	17-26		16-16	---
	17-25	17-20		16-33	16-36
	17-18	---	608	18-90	---
	17-22	17-26	705	18-95	18-97
	17-24	17-74		16-32	16-36
HS-63 Ch.	17-68	17-74		16-7	---
HS-64 Ch.	18-25,26	18-39		16-16	---
HS-67 Ch.	15-62	---	708	18-90	---
	17-56	17-60		18-98	18-100
HS-69 Ch.	17-61,62	17-67			
	17-43	17-46	<u>NATIONAL ACOUSTIC PRODUCTS</u>		
	17-48	17-49	WRA-1	Misc. 16-7	---
HS-70 Ch.	17-48	17-100			
	17-43	17-46	<u>NATIONAL CO., INC.</u>		
	17-48	17-49			
	17-66	17-51	HRO-Series	17-7	17-15
HS-77 Ch.	17-40	18-51		17-17	17-20
HS-91 Ch.	18-41	17-39	HRO-M, HRO-MX, HRO-M-RR, HRO-M-TM	17-1	17-3
HS-94 Ch.	17-36	18-88	HRO-5, HRO-SR, HRO-ST	17-4	17-6
HS-102 Ch.	18-73,74	18-12	HRO-SR	17-21	17-34
HS-113 Ch.	18-7	18-19	HRO-SRA	17-4	17-6
HS-114 Ch.	18-13	18-46	HRO-ST	17-16	---
HS-119 Ch.	18-40	16-7	HRO-ST	17-4	17-6
NH6	16-6	16-22	HRO-5TA	17-16	---
	16-18	---	HRO-5-1, Series	17-16	17-17
OE6	16-7	16-12			
	16-9	16-17			
	16-15	---			

NATIONAL
RCA

MODEL	FROM	THROUGH
<u>NATIONAL CO., INC. (Cont'd)</u>		
HRO-7	17-35	17-48
	17-21	---
	17-28	---
NC-57	18-1	18-16
NC-173	17-49, 50	17-62
686S	17-28	---
697	17-21	---
<u>NATIONAL COOPERATIVES, INC.</u>		
R-546	Misc. 16-8	---
6A47WT, 6A47WTR, 6A47WTC, 6AWC2, 6AWC3, 6AFMT, 6AMM	18-1, 2	18-8
<u>NATIONAL UNION RADIO CORP.</u>		
Fraternity	17-1	---
G-517-B, G-517-W, Fraternity	17-1	---
G-613	16-1	16-3
G-615	16-4	---
G-617-SN	Misc. 18-10	---
571	17-2	17-4
<u>NOBLITT-SPARKS INDUSTRIES, INC. (ARVIN)</u>		
RE-200M Ch.	C17-6	---
RE-204 Ch.	C17-6	---
RE-206-2 Ch.	17-16	17-18
RE-209 Ch.	17-1	17-4
RE-228 Ch.	17-5	17-8
RE-233 Ch.	18-1	18-3
RE-237 Ch.	17-9, 10	17-15
RE-243 Ch.	18-6	18-7
RE-248 Ch.	18-4	18-6
RE-253 Ch.	18-8	18-12
140P, Ch. RE-209	17-1	17-4
150TC, 151TC, Ch. RE-228	17-5	17-8
152T, 153T, Ch. RE-233	18-1	18-3
182TFM, Ch. RE-237	17-9, 10	17-15
240P, Ch. RE-243	18-6	18-7
250P, Ch. RE-248	18-4	18-6
280TFM, 281TFM, Ch. RE-253	18-8	18-12
444M, 444AM, Ch. RE-200M	C17-6	---
544, 544R	C17-10	---
544R, 544AR	C17-5	---
552AN, 552N, 555, 555A	16-1	16-4
558, Ch. RE-204	C17-6	---
665	16-5	16-7
6640, Ch. RE-206-2	17-16	17-18
<u>NORTHERN RADIO CO.</u>		
TYPE N600, MODELS AJ, BJ, CJ, EDJ	18-1	18-8
N605-E	16-1	16-4
<u>OLYMPIC RADIO & TELEVISION INC.</u>		
PQ61	18-1	18-2
PTS0, PTS1	18-4	---
6-507	18-5	18-6
6-604V-110, 6-604V-220, 6-604W- 110, 6-604W-150, 6-604W-220, early	17-1	17-4
6-604V-110, 6-604V-220, 6-604W- 110, 6-604W-150, 6-604W-220, late	17-3	17-6
6-604W-110, 6-604W-150, 6-604W- 220, early	17-1	17-4
6-604W-110, 6-604W-150, 6-604W- 220, late	17-5	17-6
6-606U	17-7	17-9
6A-501W-U, 6A-501V-U, 6A-502-U	C18-7	---
6A-606	16-1	16-2
6A-606-U	17-8	17-11
6B-606	16-3	16-4
6-608-110, 6-608-220	18-7	18-10
7-421V, 7-421W, 7-421X	18-2	18-3
7-435V, 7-435W	18-13	18-15
7-526	16-5	16-6
7-724	17-12	17-14
8-618, 8-618-220	18-10	18-12
530	18-16	---
<u>OPERADIO MFG. CO.</u>		
855-AR	Misc. 17-9	---
<u>PACENT ENGINEERING CORP.</u>		
9-R	18-1	18-2
<u>PACKARD-BELL CO.</u>		
Phonocord	17-8	17-13
5DA	16-1	16-2
471	17-1	17-2
568	16-3	16-4
571, 572	17-3	17-4
673A, 673B, 880	18-1	18-3
573	17-5	17-7
771, 771X	18-4	18-6
861 Phonocord	17-8	17-13
872	17-14	17-16
881	18-7	18-9
882	18-10	18-12
1063	18-13	18-16

MODEL	FROM	THROUGH
<u>PACKARD MOTOR CAR CO.</u>		
See STEWART-WARNER CORP.		
<u>PHILCO CORP.</u>		
CR-2, Code 121	16-1	16-3
CR-4, Code 121	16-4	---
	16-6	16-8
	16-5	16-E
CR-6, Code 121	18-1	18-7
UN6-100	17-1	17-5
UN6-450	17-5	17-9
UN6-500	18-8	18-15
UN6-550	16-9	16-11
46-200, Code 125	18-16	18-23
46-1203, Code 125	16-12	16-14
48-141, 48-145	18-24	18-31
48-150	18-32	18-39
48-200, 48-200-I, 48-214, Codes 121, 122, 125	18-40	18-47
48-214, Code 125	17-10	17-13
48-250, 48-251, Codes 121, 122, 126	18-48	18-55
48-300	18-56	18-63
48-360	18-64	18-71
48-460, Code 121	17-14	17-15, 16
	17-19	---
48-461, Code 121	17-17, 18	---
	17-20	17-22
	18-72	18-79
48-464	18-80	18-90
48-472, Code 122	18-91	18-107
48-482	18-108	18-113, 114
48-485	18-115	18-121
48-1201, 48-1260	18-122	18-129
48-1256	18-130	18-137
48-1262, Code 121, 48-1283	18-138	18-145
48-1263	18-146	18-164
48-1270	18-165	18-179
48-1286	18-180	18-198
48-1290	18-199	18-205
49-603	18-206	18-212
49-900E, 49-900I	18-213	18-219
49-901	18-220	18-229, 230
49-905	18-231	18-241, 242
49-909, 49-1101	C17-5	---
80		
<u>PHILLIPS PETROLEUM CO. (WOOLAROC)</u>		
3-1AX, 3-2AX	16-1	16-2
3-5A	17-1	17-2
3-6A	17-3	---
3-12A	17-4	17-5
3-13A, 3-14A, 3-15A, 3-16A	17-6	---
3-17A, 3-18A	17-7	---
3-20A	17-8	---
	17-5	---
3-61A, 3-71A	17-9	17-12
3-62A	C18-6	---
3-63A	18-1	18-2
3-81A	18-2	18-6
<u>PHILHARMONIC RADIO CORP.</u>		
Minuet	18-1	---
99T, Minuet	18-1	---
100, 14B	18-2	---
149C, 200, 249C	18-2	---
400C, 500C	18-3	18-6
<u>PILOT RADIO CORP.</u>		
Pilotuner	17-1, 2	17-6
T-411-U	16-1	16-3
T-521	16-4	16-6
T-530 Series	18-1, 2	18-5
T601 Pilotuner	17-1, 2	17-6
T700	17-7	17-8
T741	17-9	17-12
X203, X205	18-6	---
<u>PORTO-PRODUCTS INC.</u>		
Smokerette	17-1	17-2
PA-510, PB-520	18-1	18-2
SR-600, Ch. 9040A, Smokerette	17-1	17-2
9040A Ch.	17-1	17-2
<u>PURE OIL CO., U.S.A. (PURITAN)</u>		
SD15WG-5015, SD25WG-5025	16-1	16-2
506X, 507X, Ch. 6D15SW, 6D25SW	18-1	18-2
509	17-1	17-2
516, 517	17-3	---
518, 519	17-4	---
<u>PURITAN</u>		
See PURE OIL CO., U.S.A.		
<u>RADIO CORP. OF AMERICA</u>		
Receiver drive cords	C17-5	---
CV-42	17-27	17-28
MI-13174-1, MI-13174-3	18-1	18-2

RCA
RADIO WIRE

MODEL	FROM	THROUGH
<u>RADIO CORP. OF AMERICA (Cont'd)</u>		
Q18, Ch. 477 Second Production	C17-6	---
Q36, Ch. RC-585	16-1	16-2
	16-4	16-7
Q103, Q103-2, Q103A, Q103A-2, Ch. RC-1044	16-8	16-9
	16-11	16-13
Q103X-2, Q103AX, Q103AX-2, Ch. RC-1044B	16-8	---
	16-10	16-13
	18-3	18-10
Q109, Q109X, Ch. RC-602, RC-602A	C17-6	---
Q121, Ch. RC-507U	16-14	16-18
Q122, Q122a, Ch. RC-601, RC-601A	17-1	17-3
	17-6	17-8
Q122X, Q122Xa, Ch. RC-601D, RC-601E	17-3	17-8
	C17-5	---
	C17-5	---
QB12	C17-5	---
QB13, Ch. RC-529A, RC-612	16-19	16-20
	16-23	16-24
	16-7	---
QB55, Ch. RC-563A	C18-8	---
QB55X, Ch. RC-563K	17-9	17-11
QU51C, QU51M, QU55	C17-6	---
QU61	C18-7	---
QU62, Ch. RC-602B	17-12	17-20
QU72, QU72A, Ch. RC-1035	17-21	17-24
RC-474D Ch.	16-25	16-27
RC-507U Ch.	16-14	16-18
RC-529A Ch.	16-7	---
	16-19	16-20
	17-9	17-11
RC-563K Ch.	16-1	16-2
RC-585 Ch.	16-1	16-2
RC-601, RC-601A, Ch.	17-1	17-3
RC-601D, RC-601E, Ch.	17-4	17-8
RC-602, RC-602A, Ch.	18-3	18-10
RC-602B Ch.	17-13, 14	17-20
RC-606 Ch.	16-35	16-39
RC-608 Ch.	16-40	16-43
RC-612 Ch.	16-7	---
	16-19	16-20
	18-55	18-60
RC-613A Ch.	18-15	18-16
RC-615 Ch.	18-17	18-24
RC-616 Ch.	17-27	17-28
RC-1004E Ch.	16-33	16-34
RC-1017A, RC-1017B, Ch.	C17-6	---
	16-31	16-32
RC-1034 Ch.	17-21	17-24
RC-1035 Ch.	18-11	18-14
RC-1040C Ch.	16-8	16-9
RC-1044 Ch.	C17-6	---
RC-1044B Ch.	16-8	16-13
	C17-6	---
RC-1045 Ch.	17-25	17-26
RC-1046 Ch.	17-29	17-30
RC-1046A Ch.	17-29	17-30
RC-1046B Ch.	17-29	17-30
RC-1047 Ch.	16-28	16-30
RC-1050, RC-1050A, RC-1050B Ch.	18-49	18-50
RC-1057A Ch.	18-53	18-54
RC-1058, RC-1058A Ch.	18-51	18-52
RC-1064 Ch.	18-41	18-42
RC-1065, RC-1065A Ch.	18-45	18-46
RC-1066, RC-1066A Ch.	18-43	18-44
RK-117 Ch.	17-44	17-55
RK-121 Ch.	17-31	17-43
RK-121C Ch.	18-25	18-40
RS-123 Ch.	17-31	17-55
RS-123D Ch.	18-25	18-40
RS-1000 Ch.	17-27	17-28
X60, Ch. RC-474D	16-25	16-27
Q55, Q18, Ch. 477 2nd Production	C17-5	---
Q512	C17-6	---
8BX6, Ch. RC-1040C	18-11	18-14
8V7, Ch. RC-615	18-15	18-16
8V112, Ch. RC-616	18-17	18-24
8V151, Ch. RK-121C, RS-123D	18-25	18-40
8X53, Ch. RC-1064	18-41	18-42
8X521, 8X522, Ch. RC-1066, RC-1066A	18-43	18-44
8X541, 8X542, Ch. RC-1065, RC-1065A	18-45	18-46
54B Series	C18-8	---
54B1, 54B2, 54B3	C18-8	---
	C18-9	---
54B5, Ch. RC-1047	16-28	16-30
55F, 66-1	C17-6	---
55U	C17-7	---
55U, 56X, 56X5, 65X	C17-7	---
56 Series, 61 Series	C17-6	---
56X, 56X2, 56X3, Ch. RC-1011, RC-1011A, RC-1011B	C18-8	---
56X5, 56X10, 61-5, 61-10	C17-6	---
56X5, 56X10	C17-7	---
59V1	C17-6	---
61 Series	C17-6	---
61-1, 61-2, 61-3	C17-7	---
61-5	C17-6	---
61-6, 61-7	C17-7	---
61-8, 61-9, Ch. RC-1034	16-31	16-32
61-8, 61-9, Ch. RC-1064	18-47	18-48
61-10	C17-6	---

MODEL	FROM	THROUGH
<u>RADIO CORP. OF AMERICA (Cont'd)</u>		
62-1, Ch. RC-1017A, RC-1017B	16-33	16-34
65BR9, Ch. RC-1045	17-25	17-26
65F, Ch. RC-1004E; CV-42, Ch. RS-1000	17-27	17-28
65X	C17-7	---
65X1, 65X2, 65X8, 65X9, Ch. RC-1034	C17-7	---
66BX	C17-7	---
66X3, 66X4, 66X7, 66X8, 66X9, Ch. RC-1038A	C18-10	---
66X11, Ch. RC-1046A; 66X12, Ch. RC-1046; 66X13, 66X14, 66X15, Ch. RC-1046B	17-29	17-30
66X11, 66X12, 66X13, Ch. RC-1046C, RC-1046D, RC-1046E	C18-10	---
66-1	C17-6	---
67AV1, 67V1, Ch. RC-606	16-35	16-39
68R1, 68R2, 68R3, 68R4, Ch. RC-608	16-39	16-43
68R1, 68R2, 68R4, Ch. RC-608	C18-8	---
75X11, 75X12, 75X14, 75X15, 75X16, Ch. RC-1050, RC-1050A, RC-1050B	18-49	18-50
76ZX11, 76ZX12, Ch. RC-1058, RC-1058A	18-51	18-52
77U, Ch. RC-1057A	18-53	18-54
85T2	C17-8	---
85T8	16-44	16-47
112A	C17-8	---
477 Ch. Second Production	C17-6	---
515	16-48	16-50
612V1, 612V3, Ch. RK-121, RS-123	17-31	17-43
	C18-10	---
	C18-10	---
612V1, 612V3, 612V4, Ch. RK-121	18-55	18-60
710V2, Ch. RC-613A	---	---
711V1, 711V2, 711V3, Ch. RK-117, RS-123; 66X1, 66X2 Ch. RC-1038	C18-9	---
711V2, Ch. RK-117, RS-123	17-44	17-55
	C17-5	---
<u>THE RADIO CRAFTSMEN INC.</u>		
RC-8	18-1	18-5
6-tube kit	17-1	17-2
<u>RADIO DEVELOPMENT & RESEARCH CORP.</u> (MAGIC TONE)		
504	17-10	---
<u>RADIO DISPLAYS CO.</u>		
B-500, C-500, P-500	Misc.18-3	---
<u>RADIO ENGINEERING LABS., INC.</u>		
646, 647, 648	18-1, 2	18-12
<u>RADIO KITS, INC.</u>		
B4	18-1	18-2
S5C	17-1	17-3
210	17-3	17-5
<u>RADIO MFG. ENGINEERS INC.</u>		
VHF 152A	17-1	17-10
84	18-1	18-13
84A	18-2	18-15
<u>RADIO & TELEVISION INC.</u> (BRUNSWICK)		
D-6876, SF-6810, T-4000, T-4000-½	15-1	---
T4400, T4400½	18-1	16-5
T5000	18-3	18-3
	18-3	18-5
<u>RADIO & TELEV. PRODUCTS CO.</u> (KAROLA)		
47602	18-1	18-2
<u>RADIO WIRE TELEVISION</u> (LAFAYETTE)		
A-23	18-1	18-5
A-41	18-6	18-7
B43, BB60, BB61	18-8	---
B80, See WELLS GARDNER Model 71	8-33	---
BP-12	16-1	16-2
C29, See GAROD Model 389	11-4	---
C36, See GAROD Model 4159	10-25	---
C-95	18-9	18-14
C104	18-15	---
CC24, CC25	18-16	18-17
CC58-A	18-18	---
D-13	18-19	18-21
D45, D46	18-22	---
E76, E77	18-23	18-25

RADIO WIRE
SEARS

MODEL	FROM	THROUGH	MODEL	FROM	THROUGH
<u>RADIO WIRE TELEVISION (Cont'd)</u>			<u>SEARS, ROEBUCK & CO. (Cont'd)</u>		
FA-15	16-3	---	4663, 4763, Ch.	101.471	18-9
J4	18-26	---	5372, 5372-B, Ch.	109.371, 109.371-1	18-15
J5	18-27	---	6015, 6016, Ch.	132.820	18-20
J51P	16-4	---	6200A, Ch.	101.800-1; 6203,	---
J62, J62C	18-28	---	Ch.	101.800A	C18-11
JA-328	18-29	---	6686, Ch.	139.151	17-1
JL5	18-30	---	7020, Ch.	101.807	16-1
JS-172, See FADA Model P24-PL72	13-2	---	7021, Ch.	101.807A	16-1
JS-241, See FADA Model 177	13-9	---	7025, Ch.	132.807-2	C18-11
JS-310, See FADA Model 278	13-19	---	7046, Ch.	141.416	18-23
M70, M71	17-1, 2	17-6	7054, Ch.	101.808	16-1
M70A	17-6	17-11	7056	---	C18-11
M72, M73	C18-8	---	7070, Ch.	101.817	17-2
MC-11	16-5	16-6	7080, Ch.	101.809	17-15
<u>RADIONIC EQUIPMENT CO.</u>			<u>SEARS, ROEBUCK & CO. (Cont'd)</u>		
(CHANCELLOR)			(CHANCELLOR)		
Y62W	18-1	18-2	7085, 7102, 8085, Ch.	101.814,	18-26
14B	16-1	16-2	101.814-1A, 101.814-4C	---	18-36
35P	Misc. 17-11	---	7086, 7103, Ch.	110.466, 110.466-1	18-39
240T	16-2	---	7090, Ch.	101.810, 101.810-3	16-1
<u>THE RADOLEK CO.</u>			<u>SEARS, ROEBUCK & CO. (Cont'd)</u>		
35	Misc. 17-12	---	7100, Ch.	101.811	16-4
<u>RAYMOND ROSEN & CO.</u>			<u>SEARS, ROEBUCK & CO. (Cont'd)</u>		
MI-13154	18-1, 2	18-5	7102, Ch.	101.814-1A	16-8
<u>REGAL ELECTRONICS CORP.</u>			<u>SEARS, ROEBUCK & CO. (Cont'd)</u>		
208	C18-11	---	7103, Ch.	110.466-1	18-11
700	17-1	17-2	7105, 7106, Ch.	101.828,	18-26
747	17-3	---	101.828-1A	---	18-36
777	18-1	---	7165, Ch.	101.823,	18-45
800, 801	16-1	---	101.823-1	---	18-48
900	16-2	16-3	7166, Ch.	101.823A,	16-6
1049	16-4	---	101.823-1A	---	16-8
1749	17-4	17-7	7210, Ch.	101.820	17-4
7152	18-2	---	7226, Ch.	101.819A	17-15
7162	18-3	18-4	8000, Ch.	132.838	18-49
7163	18-5	18-6	8003, Ch.	132.818-1	17-6
<u>REMLER CO., LTD.</u>			<u>SEARS, ROEBUCK & CO. (Cont'd)</u>		
MPS-5-3	C17-8	---	8005, Ch.	132.839	17-15
5100	Misc. 16-9	---	8020, Ch.	132.841	18-52
5300B, 5300BI, 5300I	C18-11	---	8050, Ch.	101.813	17-8
5310 Early	Misc. 17-13	18-2	8052, Ch.	101.808-1C	18-56
5310 Late	18-1	18-4	8053, Ch.	101.808-1D	18-58
5400	18-3	18-4	8072, Ch.	101.834	18-57
5410	18-5	---	8085, Ch.	101.814-4C	17-13
5500	18-4	18-5	8086, Ch.	101.814-5C	18-26
5505	18-5	---	8086A, 8086B, Ch.	101.814-6C	18-29
5510	18-5	---	8090, Ch.	101.821	18-31
5515	18-5	---	8092, Ch.	101.810-1A	18-33
5520	18-4	18-5	8102, 8102B, Ch.	101.814-2B	18-44
5530	18-5	---	8102A, Ch.	101.814-3B	18-29
5535	18-4	18-5	8102B, Ch.	101.814-2B	18-31
5560	18-4	18-5	100.156 Ch.	---	18-33
5565	18-4	18-5	101.393 Ch.	---	18-35
<u>REXEL MERCHANDISE CO.</u>			<u>SEARS, ROEBUCK & CO. (Cont'd)</u>		
L-266	16-1	16-2	101.471 Ch.	---	18-1
L-266-A	16-3	16-4	101.800A, 101.800-1 Ch.	---	C18-11
L-266-U	16-5	16-6	101.807, 101.807A, 101.808 Ch.	---	18-9
<u>ROBERT-LAWRENCE ELECTRONICS CORP.</u>			<u>SEARS, ROEBUCK & CO. (Cont'd)</u>		
101-6T, 201W-6T	17-1	17-2	101.808-1C, 101.808-1D Ch.	---	C18-11
102-L-6T	17-3	17-5	101.809 Ch.	---	16-1
201W-6T	17-1	17-2	101.810 Ch.	---	16-4
<u>RYAN SALES CO.</u>			<u>SEARS, ROEBUCK & CO. (Cont'd)</u>		
C5TS3	16-1	16-2	101.810-1A Ch.	---	16-8
<u>SCOTT RADIO LABS., INC.</u>			<u>SEARS, ROEBUCK & CO. (Cont'd)</u>		
Export Receiver	18-1	18-41	101.810-3 Ch.	---	16-1
Imperial, All Wave	16-1	---	101.811 Ch.	---	16-4
SLR-12-A	18-42	18-80	101.813 Ch.	---	C18-11
16A (Metropolitan)	18-81, 82	18-83, 84	101.814, 101.814-1A Ch.	---	17-11
800-B	C17-8	---	101.814-2B Ch.	---	17-15
800-B6	16-2	---	101.814-3B Ch.	---	18-26
<u>SEARS, ROEBUCK & CO.</u>			<u>SEARS, ROEBUCK & CO. (Cont'd)</u>		
(SILVERTONE)			(SILVERTONE)		
3351, 3451, 3551, Ch.	132.802-2C,	---	101.814-4C Ch.	---	18-29
132.802-2D, 132.802-2E	C18-11	---	101.814-5C Ch.	---	18-31
4486, 4586, 4586-A,	18-1	18-8	101.814-6C Ch.	---	18-33
4586-B, Ch.	100.156	---	---	---	18-35
4518, Ch.	101.393	---	---	---	18-29
4586, 4586-A, 4586-B,	C18-11	---	---	---	18-32
Ch.	100.156	18-8	---	---	18-35

**SEARS
STEWART**

MODEL	FROM	THROUGH
<u>SEARS, ROEBUCK & CO. (Cont'd)</u>		
101.817 Ch.	17-2	17-3
	17-15	---
101.819A Ch.	18-49	18-51
101.820 Ch.	17-4	17-5
	17-15	---
101.821 Ch.	18-53	18-55
101.823, 101.823A, 101.823-1,		
101.823-1A Ch.	16-6	16-8
101.828, 101.828-1A Ch.	18-45	18-48
101.834 Ch.	17-13	17-14
109.371, 109.371-1 Ch.	18-15	18-19
110.466, 110.466-1 Ch.	18-36	18-38
132.802, 132.802-2C, 132.802-2D,		
132.802-2E	C18-11	---
132.807-2 Ch.	C18-11	---
132.818-1 Ch.	18-52	18-53
132.820 Ch.	18-20	18-22
132.838 Ch.	17-6	17-7
	17-15	---
132.839 Ch.	17-8	17-10
132.841 Ch.	18-56	---
	18-58	18-59
132.841 Revised Ch.	18-57	---
139.151 Ch.	17-1	---
141.416 Ch.	18-23	18-25

THE SEIBERLING RUBBER CO.

1A5	17-1	17-2
9AC	17-3	17-4

SENTINEL RADIO CORP.

L-2841, L-284NA, L-28N1,		
L-284NR, L-284W	16-8	16-10
IU-248	18-4	18-6
IU284GA	16-6	16-7
	16-19	---
IU285P	16-11	16-13
IU286	C18-12	---
IU293CT	16-17	16-19
IU-309-I, IU-309-R, IU-309-W	17-1	17-3
216J	18-1	18-3
247	16-1	16-2
	16-10	---
248, IU248	18-4	18-6
276P	16-4	16-5
284GA, U284GA	16-6	16-7
	16-19	---
285P, IU285P	16-11	16-13
286P, 286PR	16-14	16-16
	C18-11	---
293CT, IU293CT	16-17	16-19
302-1, 302-T, 302-W	17-4	17-9
309-I, 309-N, 309-R, 309-W	17-2	---
	17-10	---
510	16-20	---

SETCHELL-CARLSON, INC.

408	17-1	---
416	C18-11	---
427	16-1	---
	C18-12	---
437	17-2	---
447	16-2	---

HAROLD SHEVERS INC.
(GOTHAM)

8121 (Gotham)	18-1	18-7
---------------	------	------

SIGNAL ELECTRONICS, INC.

341T	Misc. 16-10	---
------	-------------	-----

SILVERTONE

See SEARS, ROEBUCK & CO.

SKYROVER

See BUTLER BROTHERS

SONORA RADIO & TELEV. CORP

A Ch.	16-1	---
A-11 Ch. A	16-1	---
KBU-168	C18-11	---
RBMU-176	16-2	---
RDA, RDAU	17-1	17-2
RDU-209	C17-8	---
RET	17-3	17-5
RGMF-212, RGMF-230	16-3	---
RK-222, RKU-222	16-2	---
	16-4	---
RMR	17-6	17-8
RMR-219, RMR-220, RMR-245	C18-11	---
RQ-222, RQU-222	16-5	---
RYMU-224	16-6	---
RZLU	17-9	17-10
RZU-222	17-11	17-12

MODEL	FROM	THROUGH
<u>SONORA RADIO & TELEV. CORP. (Cont'd)</u>		
WA-WAU	16-7	---
	16-4	---
WBRU-239	18-1	18-2
WCU-246, WCU-247	17-13	---
WDU	17-14	17-15
WEU-240, WEU-262	18-3	18-4
WGF, WGFL	16-8	---
WJ, WJU	17-16	---
WTRU-254A	18-5	18-7
402A	C18-11	---
100I, 100M	18-8	---
101B, 101B-B	18-9	---
102B, 102G	18-10	---

SOUND VIEW MARINE CO.

Sea Mate	Misc. 17-14	---
----------	-------------	-----

THE SPARKS-WITHINGTON CO.
(SPARTON)

5-16, 5-AW16	17-1	17-2
5-26, 5-26PS, 5-26X	16-1	16-2
6F1	16-3	16-5
6FID	16-5	16-8
6F2D	16-9	16-11
6-26, 6-26PA	16-12	16-14
6-66	18-1	18-2
10 Series, 10-21	17-3	17-6
10-76-PA	17-7, 8	17-14
8435X	17-15, 16	17-22
1005, 1006, 1007, 1008,	18-3	18-10
Ch. 8-57		

SPARTON

See THE SPARKS-WITHINGTON CO.

SPIEGEL
(AIR CASTLE)

G-518	17-1	---
G-521	18-1	18-2
G-722	18-3	18-5
G-724	18-6	18-8
G-725	17-3	17-6
T-2625	16-1	16-3
9	18-9	18-10
77, 770	18-11	18-16
179	18-17	18-19
180	18-20	18-22
770	18-11	18-16
831	16-5	16-7
5000	17-7	---
5000-2	17-8	---
5003	17-9	---
5008	17-10	---
5015	17-11	---
5019	17-12	17-13
5020	16-3	16-4
5021	17-14	---
5024	17-15	---
5025	17-13	---
	17-16	---
5029	18-23	18-24
5030, 5031	17-17	---
5035	18-25	---
5050	17-18	---
5052	17-2	---
6612	18-26	18-29
10001	18-30	---
10002	18-31	---
11305	18-32	18-33
11802	18-34	18-35
108014, 108504	18-36	18-38
11414	18-40	18-42
127084	18-38	18-39
132564	18-43	18-44

STEWART-WARNER CORP.

Packard PA-333915 Early, PA333915 Late,		
PA-333915 (Late Chassis Marked		
R), PA-353832	18-11	18-14
Packard PA-351099, PA-351100	18-7	18-8
Packard PA-351101, PA-351102	18-9	18-10
Packard PA-353832	18-11	18-14
A41T1	17-1	17-3
A51T1, A51T2, A51T3,		
A51T4	17-4	17-6
A61CR1, A61CR2, A61CR3,		
A61CR4	17-7	17-8
A61P1, A61P2, A61P3	17-6	---
	17-9	17-10
A92CR3, A92CR6	17-11, 12	17-21
B72CR1, Code 9038-B	18-1, 2	18-6
R-3271, R-3271C	18-7	18-8
R-3291, R-3291C	18-9	18-10
51T126, 51T136, 51T146, 51T176,		
Codes 9018-C, 9018-F, 9018-H,		
9018-B	18-15	18-16
61TR36, Code 9029-B	C18-12	---
61TR46, Code 9029-H	C18-12	---

STEWART
WALGREEN

MODEL	FROM	THROUGH
<u>STEWART-WARNER CORP. (Cont'd)</u>		
61TR56, Code 9029-J	C18-12	---
61TR66, Code 9029-K	C18-12	---
61TR76, Code 9029-L	C18-12	---
3341, 3341-R Late, 3371	18-11	18-14
9010A	16-1,2	16-8
9013-A	16-8	16-12
9017-A, 9017-B	C17-8	---
9018-B, 9018-C, 9018-F, 9018-H Codes	18-15	18-16
9029-B, 9029-H, 9029-J, 9029-K, 9029-L Codes	C18-12	---
9038-B Code	18-1,2	18-6
<u>STROMBERG-CARLSON CO.</u>		
1105	16-1	16-3
1110	16-4	16-7
1135	16-8	16-9,10
	16-16	16-19
1135A	16-11,12	16-15
1200,1202	18-1	18-3
1204HB, 1204HI, 1204HME, 1204HMG, Ch. 112021	18-4	18-6
1210M2-M, 1210M2-W, 1210M2-Y, 1210PC-M, 1210PG-W, 1210PL-M, Series 10-11	17-1,2	17-7
1235	C18-12	---
<u>SYMPHONY RADIO & TELEV. CORP.</u>		
Biltmore	18-1	18-2
200, 200L-R	18-3	---
260	18-4	---
348	18-5	18-6
<u>TAFFET RADIO & TELEV. CO.</u>		
C47, D47, E47, Series	Misc. 18-15	---
TP41	Misc. 18-15	---
<u>TELECHRON, INC.</u>		
8H59	16-1	16-4
8H67	18-1	18-4
<u>TELECOIN CORP.</u>		
M5TS4	16-1	16-2
<u>TELE-TONE RADIO CORP.</u>		
Dynamite	Misc. 16-11	---
Series H	Misc. 16-11	---
Series N	Misc. 16-11	---
AA, AB Ch.	18-3	---
AD Ch.	18-1	18-2
AE Ch.	18-5	---
AG Ch.	18-6	---
AM Ch.	18-9	---
AN Ch.	18-6	---
AT Ch.	18-7,8	---
AZ Ch.	18-10	---
CA Ch.	17-1	17-2
H Ch.	C18-13	---
R Ch.	17-1	17-2
S Ch.	18-1	---
T Ch.	17-2	17-3
U Ch.	C18-13	---
W Ch.	17-4	---
Y Ch.	17-2	17-3
117, 117A, 118, 119	18-4	---
133, Ch. CA	C17-8	---
135 Dynamite, Series H	17-1	17-2
138 Series N	Misc. 16-11	---
139, 140, 141, Ch. H	Misc. 16-11	---
145, Ch. R	C18-13	---
148, Ch. S	17-1	17-2
149, Ch. H	18-1	---
150, Ch. T	C18-13	---
152, Ch. R	17-2	17-3
152, Ch. W	17-1	17-2
156, Ch. U	17-2	17-3
157, Ch. H	17-4	---
158, Ch. AT	C18-13	---
159 Early, 159 Late, Ch. AA, AB	18-7,8	---
160, Ch. Y	18-3	---
161, Ch. T	18-4	---
163, Ch. H	C18-13	---
164, Ch. H	C18-13	---
165 Early, Ch. AD	18-1	18-2
165 Late, 175, Ch. AG	18-6	---
166 Early, Ch. AE	18-5	---
166 Late, Ch. AN	18-6	---
167, Ch. T	C18-13	---
168, Ch. T	C18-13	---
171, Ch. T	C18-13	---
174, Ch. T	C18-13	---
175, Ch. AG	18-6	---
184, Ch. AM	18-9	---
190, Ch. AZ	18-10	---
198, Ch. AT	18-7,8	---

MODEL	FROM	THROUGH
<u>TEMPLE</u>		
See TEMPLETONE RADIO MFG. CORP.		
<u>TEMPLETONE RADIO MFG. CORP.</u>		
(TEMPLE)		
G-410	18-1	---
G-415, H-415	18-2	18-3
G-418	17-1	---
G-513, G-515, G-5100, G-5101	18-4	18-5
G-521	18-6	18-7
G-522	18-8	18-9
G-612	17-2	---
G-724	18-10	18-12
G-725	17-3	17-6
G-5100, G-5101	18-4	18-5
<u>TOM THUMB</u>		
See AUTOMATIC RADIO MFG. CO., INC.		
<u>THADIO</u>		
L5	17-1	17-2
L-U6	17-3	17-5
TF6	Misc. 18-16	---
T-U6-1	17-6	17-10
<u>TRANSVISION INC.</u>		
7 Inch Kit	16-1,2	16-4
<u>TRAV-LER RADIO CORP.</u>		
SD54 Ch.	18-4	---
5003, 5004, 5005, 5006	16-1	---
5015	17-1	---
5019	16-2	---
5021	18-1	---
5025	18-2	18-3
5027	17-2	17-3
5028	17-3	17-4
5030, 5031	16-3	---
5035, Ch. SD54	18-4	---
5036	18-5	---
5049	18-6	---
5050	17-5	---
5051	17-6	---
5052	17-7	---
5055	17-8	---
<u>TRUETONE</u>		
See WESTERN AUTO SUPPLY CO.		
<u>UNITED MOTORS SERVICE</u>		
R-705	17-1	17-6
Electro-Tuner	18-1	18-5
R-1226	18-6	18-7
R-1227, R-1228, R-1229	16-1	16-2
R-1230, R-1230A, R-1231, R-1231A, R-1232	17-7	17-11
R-1233	18-8	18-10
R-1251, R-1252, X	17-12	17-28
R-1251, R-1252, XX, XXX	17-31,32	---
	17-12	---
	17-15,16	---
	17-21	17-32
R-1253, R-1254	18-11,12	18-19
R-1408, R-1409	16-3	16-4
980690 Revised, 980733, Buick	16-5	16-7
980797, 980798, Buick	18-20	18-21
982399, Oldsmobile	16-8	16-10
982400, Oldsmobile	18-22	18-27
984170, Pontiac	16-11	16-12
984172, Pontiac	17-33	17-35
984247, Pontiac	18-28	18-30
984248, Pontiac	18-31	18-35
986241	18-42	18-46
2233029, GMC	18-36	18-41
7256609, Cadillac	18-47	18-51
<u>U. S. TELEVISION MFG. CO.</u>		
5-16M	16-1	16-2
5-36MPA	16-1	16-2
<u>VIEWTONE TELEVISION & RADIO CORP.</u>		
VP100, VP100A, VP101A	16-1,2	16-4
<u>V-LECTRICAL ENGINEERING CO.</u>		
Z463, Z464P	Misc. 17-15	---
<u>WALGREEN CO.</u>		
(AETNA)		
407, 3 Way Portable	18-1	---
407, 4 Tube Portable	18-2	---
418	18-2	---
505	17-1	17-2

**WARWICK
ZENITH**

MODEL	FROM	THROUGH
<u>WARWICK MFG. CO.</u> (CLARION)		
C110	16-1	---
11011	17-1	17-2
11305	16-2	---
11411-N	17-3	17-4
11801	17-5	17-6
11802V-M	17-7	17-8
12310W 12312M	17-9	17-12
12708	18-1	18-2
12801	17-13	17-14

MODEL	FROM	THROUGH
<u>WATTERSON RADIO MFG. CO.</u>		
420, 424, 425, 440	18-1	---
4582	C17-9	---
4725	Misc. 17-15	---
4782	16-1	---
4790	16-2	---
4801	18-2	---

MODEL	FROM	THROUGH
<u>WELLS-GARDNER & CO.</u>		
35A86-750	17-1	17-4
436A76-670	17-5	17-8

MODEL	FROM	THROUGH
<u>WESTERN AIR PATROL</u>		
W-411 Ch.	18-1	---
W-835 Ch.	17-1	17-2
W-958 Ch.	18-2	---
185AW, Ch. W-411	18-1	---
258, Ch. W-958	18-2	---
587, Ch. W-835	17-1	17-2

MODEL	FROM	THROUGH
<u>WESTERN AUTO SUPPLY CO.</u> (TRUETONE)		
D696	C18-13	---
D1118B	C18-13	---
D1180B	C17-8	---
D1612	18-1	18-2
D-1644	17-1	17-2
D1645, Issue C	C17-8	---
D-1747, D-1748	17-3	17-7
D1752	18-3	18-9
D1835	18-10	18-11
D1836A, D1836B, D1836C	18-12	18-21
E1845A, D1845B	18-22	18-25
E2616	16-1	16-3
D2619	16-3	16-5
D2621	17-8	17-9
D2622	18-26	18-27
D2623	17-10	17-11
D2624, Early, D2630	16-6	---
	16-8	16-10
D2624 Late	16-7	16-10
D2626	18-28	---
D2630	16-6	---
	16-8	16-10
E2634	18-29	18-30
D2640	18-31	---
D2642	17-12	17-13
D2644	16-10	16-11
E2645	16-12	16-14
D2661	17-14	17-15
D2663	18-32	18-33
D2665	18-34	18-36
E2691	17-16	17-19
D2693A	18-37	---
D2693B	18-38	---
D2709	18-39	18-40
D2710	18-41	18-42
D2718, D2718A	17-20	17-23
D2743	18-43	18-44
D2745	17-24	17-26
D2762	18-45	18-46
D2810	18-47	18-48
D2815	18-49	18-50
D3730	17-27	17-29
D3721	17-30	17-32
D3810	18-51	18-53
D4630A, D4630B, D4630C, D4630D, D4630E, D4630F	18-54	18-68
D4832A, D4832B	18-69	18-72

MODEL	FROM	THROUGH
<u>WESTINGHOUSE ELECTRIC CORP.</u>		
H-104, H-105, H-107, H-108	C17-9	---
H-104A, H-105A, H-107A, H-108A	C17-9	---
H-104B, H-105B, H-107B, H-108B, H-110B, H-111B, H-137B, H-138B, Ch. V-2102-3	17-1	17-4
H-104B, H-105B, H-107B, H-108B, H-110B, H-111B, H-137B, H-138B, Ch. V-2102-5	17-4	17-8
H-105	C17-9	---
H-105A	C17-9	---
H-105B, Ch. V-2102-3	17-1	17-4

MODEL	FROM	THROUGH
<u>WESTINGHOUSE ELECTRIC CORP. (Cont'd)</u>		
H-105B, Ch. V-2102-5	17-4	17-8
H-107	C17-9	---
H-107A	C17-9	---
H-107B, Ch. V-2102-3	17-1	17-4
H-107B, Ch. V-2102-5	17-4	17-8
H-108	C17-9	---
H-108A	C17-9	---
H-108B, Ch. V-2102-3	17-1	17-4
H-108B, Ch. V-2102-5	17-4	17-8
H-110, H-111, H-137, H-138, Ch. V-2102-1	C18-13	---
H-110A, H-111A, H-137A, H-138A, Ch. V-2102-2	C18-13	---
H-110B, Ch. V-2102-3	17-1	17-4
H-110B, Ch. V-2102-5	17-4	17-8
H-111B, Ch. V-2102-3	17-1	17-4
H-111B, Ch. V-2102-5	17-4	17-8
H-113, H-114, H-116, H-117, H-119	16-1, 2	16-7
H-122, H-130	C17-9	---
H-133	16-8	---
	16-10	---
H-137B, Ch. V-2102-3	17-1	17-4
H-137B, Ch. V-2102-5	17-4	17-8
H-138B, Ch. V-2102-3	17-1	17-4
H-138B, Ch. V-2102-5	17-4	17-8
H-142, H-163, H-172, H-175	18-1	18-5
H-148	16-9	16-10
H-157	17-9	17-11
H-161, H-168, H-168A, H-168B, Ch. V-2118	18-6	18-11
H-163	18-1	18-5
H-164, H-166, H-166A, H-167	18-12	18-19
H-165	17-12	17-14
H-166, H-166A, H-167	18-12	18-19
H-168, H-168A, H-168B, Ch. V-2118	18-6	18-11
H-172, H-175	18-1	18-5
H-182	18-20	18-22
H-185, H-195	18-23	18-25
H-186, H-187	18-26	18-30
H-195	18-23	18-25
V-2102-1, V-2102-2 Ch.	C18-13	---
V-2102-3 Ch.	17-1	17-4
V-2102-5 Ch.	17-4	17-8
V-2118 Ch.	18-6	18-11
WR-478	17-15	---

MODEL	FROM	THROUGH
<u>WILCOX-GAY CORP.</u>		
6A10, 6A20	17-1	---
6B45B, 6B45M, 6B45W	17-2	---
8J10	18-1	18-2

WOOLAROC
See PHILLIPS PETROLEUM

MODEL	FROM	THROUGH
<u>ZENITH RADIO CORP.</u>		
DB47 Hudson	18-11	18-12
4C54 Ch.	16-1	16-3
4E41 Ch.	17-1	17-2
4G800, Ch. 4E41	17-1	17-2
4K040, 4K040G, Ch. 4C54	16-1	16-3
5C01 Ch.	C17-10	---
5C40, 5C40Z Ch.	16-4	---
5C40ZZ Ch.	16-5	16-6
5C50 Ch.	17-5	17-6
5C51 Ch.	17-3	17-4
5C80 Ch. Crosley	16-7	16-9
5D810, Ch. 5E02	18-1	18-2
5D811, Ch. 5F01	18-3	18-4
5E02 Ch.	18-1	18-2
5F01 Ch.	18-3	18-4
5G003, 5G003Z, Ch. 5C40, 5C40Z	16-4	---
	16-6	---
5G003ZZ, Ch. 5C40ZZ	16-5	16-6
5G036, Ch. 5C51	17-3	17-4
5K037, Ch. 5C50	17-5	17-6
5MX080, Ch. 5C80 Crosley	16-7	16-9
6C06 Ch.	18-29	18-31, 32
6C22Z Ch.	17-12	---
	17-14	---
6C22ZZ Ch.	17-13	17-15
6C40 Ch.	C17-8	---
6C41 Ch.	16-10	16-12
6C50 Ch.	16-13	16-15
6C83 Ch. Willy's	16-16	16-19
6DO Series	C17-10	---
6D815, Ch. 6E05	18-5	18-6
6E02 Ch.	17-16	17-17
	18-19	18-20
6E03 Ch.	18-16	18-18
6E05 Ch.	18-5	18-6
6E40 Ch.	18-7, 8	18-10
6G004Y, Ch. 6C41	16-10	16-12
6G038, Ch. 6C50	16-13	16-15
6G801, Ch. 6E40	18-7, 8	18-10
6MF780, Ford	17-7	17-9
6MH089, DB47 Hudson	18-11	18-12
6MN088, 6MN788, Nash	17-10	17-11

ZENITH
WIREORDER

MODEL	FROM	THROUGH
<u>ZENITH RADIO CORP. (Cont'd)</u>		
6MN790, Mercury	18-13	18-15
6MW083, Ch. 6C83, Willy's	16-16	16-19
6R087Z, Ch. 6C22Z	17-12	---
	17-14	17-15
6R087ZZ, Ch. 6C22ZZ	17-13	17-15
6R880, Ch. 6E03	18-16	18-18
6R886, Ch. 6E02	17-16	17-17
	18-19	18-20
7E02 Ch.	18-21, 22	18-25
7E22 Ch.	18-33, 34	18-36
7H822, Ch. 7E02	18-21, 22	18-25
7ML780, Lincoln, 7ML781, Lincoln Continental	18-26	18-28
7R070, Ch. 6C06	18-29	18-31, 32
7R887, Ch. 7E22	18-33, 34	18-36
8B03 Ch. Lincoln-Zephyr	16-20	16-24
8C01	C17-10	---
8ML692, Ch. 8B03 Lincoln-Zephyr	16-20	16-24
11C21Z Ch.	C18-13	---
12H090, 12H091, 12H092, 12H093, 12H094, Ch. 11C21Z	C18-13	---
RECORD CHANGERS		
<u>ADMIRAL CORP.</u>		
RC-161	RCD. CH. 17-1	RCD. CH. 17-6
RC-161A	RCD. CH. 17-7	---
RC-170, RC-170A	RCD. CH. 16-1	RCD. CH. 16-7
RC-180, RC-181	RCD. CH. 18-1	RCD. CH. 18-9
RC-182	RCD. CH. 18-10	RCD. CH. 18-12
RC-200	RCD. CH. 17-8	RCD. CH. 17-13
<u>AERO METAL PRODUCTS</u>		
46-A	RCD. CH. 16-1	RCD. CH. 16-4
<u>CAPEHART</u>		
See FARNSWORTH TELEVISION & RADIO CORP.		
<u>CRESCENT INDUSTRIES, INC.</u>		
C200	RCD. CH. 17-1	RCD. CH. 17-6
C-250	RCD. CH. 18-1	RCD. CH. 18-6
<u>EMERSON RADIO & PHONOGRAPH CORP.</u>		
819003	RCD. CH. 17-1	RCD. CH. 17-4
<u>FARNSWORTH TELEVISION & RADIO CORP. (CAPEHART)</u>		
P51, P56, P56MP	RCD. CH. 17-1	RCD. CH. 17-16
P51	C17-2	---
P-52, P-57	C17-2	---
P-62	RCD. CH. 18-10	RCD. CH. 18-24
P-72, P-73	RCD. CH. 18-1	RCD. CH. 18-9
41-E, Capehart	RCD. CH. 18-25	RCD. CH. 18-46
<u>GENERAL ELECTRIC CO.</u>		
ER-SP-3	RCD. CH. 17-1	RCD. CH. 17-4
ER-SP-4	RCD. CH. 17-5	RCD. CH. 17-9
P1	RCD. CH. 18-1	RCD. CH. 18-3
<u>THE GENERAL INDUSTRIES CO.</u>		
RC130, RC130L	RCD. CH. 17-1	RCD. CH. 17-9
<u>INTERNATIONAL DETROLA CORP.</u>		
650	RCD. CH. 17-1	RCD. CH. 17-13
7000	RCD. CH. 17-14	RCD. CH. 17-15
<u>LEAR, INC.</u>		
PC-206A	RCD. CH. 17-1	RCD. CH. 17-6

MODEL	FROM	THROUGH
<u>MOTOROLA INC.</u>		
B-27-RC, B-28-RC, B-29-RC, B-31-RC, B-32-RC, B-33-RC, WR6, WR7, WR8, Ch. HS-18	RCD. CH. 18-1 RCD. CH. 18-28	RCD. CH. 18-28 ---
<u>PHILCO CORP.</u>		
D-10, D-10A	RCD. CH. 18-1	RCD. CH. 18-13
M-4	RCD. CH. 18-14	RCD. CH. 18-31
M-7	RCD. CH. 18-32	RCD. CH. 18-45
<u>RADIO CORP. OF AMERICA.</u>		
RP-176	RCD. CH. 17-1	RCD. CH. 17-12
RP-177, RP-177A, RP-177B	RCD. CH. 18-1	RCD. CH. 18-13
RP-178	RCD. CH. 18-14	RCD. CH. 18-23
960001 Series	C18-11	---
960001-1, 960001-2, 960001-3, 960015	C17-5 C18-10	---
<u>RUSSELL ELECTRIC CO.</u>		
C-9	RCD. CH. 17-1	RCD. CH. 17-6
C-10, C-10M	RCD. CH. 18-1	RCD. CH. 18-3
<u>SEARS, ROEBUCK & CO.</u>		
101.204	RCD. CH. 18-1	RCD. CH. 18-5
101.206	RCD. CH. 18-6	RCD. CH. 18-9
<u>J. P. SEEBURG CORP.</u>		
M	RCD. CH. 17-1	RCD. CH. 17-28
<u>STEWART WARNER CORP.</u>		
A-505650	RCD. CH. 18-1	RCD. CH. 18-10
W-504138	RCD. CH. 17-1	RCD. CH. 17-3
VM-504932, VM-504992	RCD. CH. 17-4	RCD. CH. 17-10
VM-505049	RCD. CH. 17-11	RCD. CH. 17-13
VM-505339	RCD. CH. 17-14	RCD. CH. 17-19
VM-506261	C18-11	---
<u>V-M CORP.</u>		
800	RCD. CH. 17-1	RCD. CH. 17-4
<u>WEBSTER CHICAGO CORP.</u>		
70	RCD. CH. 17-1	RCD. CH. 17-9
148	RCD. CH. 18-1	RCD. CH. 18-11
<u>WILCOX-GAY CORP.</u>		
6B40B, 6B40M, 6B42M, 6B42W	RCD. CH. 17-1	RCD. CH. 17-6
6B45B, 6B45W	RCD. CH. 17-7	RCD. CH. 17-12
<u>ZENITH RADIO CORP.</u>		
S-14004, S-14007	RCD. CH. 18-1	RCD. CH. 18-6
WIRE RECORDERS		
<u>MAJESTIC RADIO & TELEVISION CORP.</u>		
7YR752, Ch. 7B04A	WIREC. 17-1	WIREC. 17-4
<u>WEBSTER CHICAGO CORP.</u>		
79	WIREC. 17-1	WIREC. 17-10
<u>WIRERECORDER CORP.</u>		
A-1	WIREC. 17-1	WIREC. 17-8
PA	WIREC. 17-9	WIREC. 17-14

