

Most - Often - Needed

1967

VOLUME TV-26

Television

Servicing Information

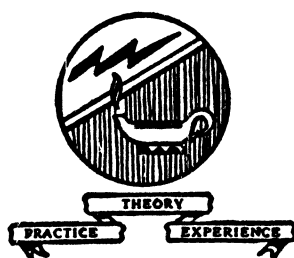

Compiled by

M. N. BEITMAN

SUPREME PUBLICATIONS

PRICE **\$4**

Most - Often - Needed

1967

Volume TV-26

Television

Servicing Information

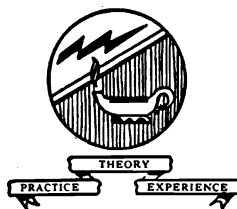

Compiled by

M. N. BEITMAN

SUPREME PUBLICATIONS

SUPREME TV & Radio Manuals

ORDER FORM

SIMPLIFIES TV REPAIRS

These giant TV manuals have complete circuits, needed alignment facts, printed boards, servicing hints, production changes, voltage charts, waveforms, and double-page schematics. Here are your authentic service instructions to help you do expert work quicker; and priced at only \$3 per large annual manual.

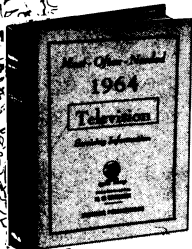

COVER ALL POPULAR SETS

Here is your service data for faster, easier TV repairs. Lowest priced. Best by comparison. *Supreme TV* manuals have all needed service material on every popular TV set. Helpful, practical, factory-prepared data that will really make TV servicing easy for you. Benefit and save with these amazing values in service manuals. Only \$3 per large volume. Used by 184,000 wise servicemen for faster repairs. Join them; begin to make TV repairs easily and quickly.

RADIO DIAGRAMS

Your best source for all needed RADIO diagrams and service data. Covers everything from most recent 1966 radios to pre-war old-timers; home radios, stereo, combinations, transistor portables, FM, auto sets. Only \$2.50 for many volumes. Every manual has large schematics, all needed alignment facts, printed boards, voltages, trimmers, dial stringing, and hints. Volumes are big, 8½x11 inches, about 190 pages. See coupon at right for list of SUPREME popular radio service manuals ▶

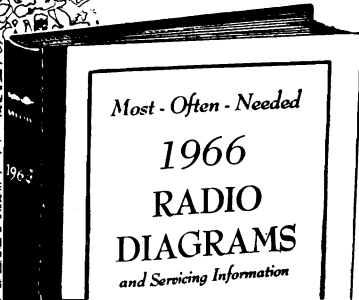

Simplified Radio Servicing by COMPARISON Method

Revolutionary different **COMPARISON** technique permits you to do expert work on all radio sets. Most repairs can be made without test equipment or with only a voltmeter. Many simple, point-to-point, cross-reference, circuit suggestions locate the faults instantly. Plan copyrighted. Covers every radio set — new and old models. This new servicing technique presented in handy manual form, size 8½ x 11 inches, 48 pages. Over 1,000 practical service hints. 26 large, trouble-shooting blueprints. Charts for circuit analysis. 114 tests using a 5c resistor. Developed by M. N. Beitman. New edition. Price only. **\$1.50**



TELEVISION SERVICING COURSE

Let this new course help you in TV servicing. Amazing bargain, complete, only \$3, full price for all lessons. Giant in size, mammoth in scope, topics just like a \$200.00 correspondence course. Lessons on picture-faults, circuits, adjustments, short-cuts, UHF, alignment facts, hints, antenna problems, trouble-shooting, test equipment, picture analysis. Special, only **\$3**



RADIO MATHEMATICS

Explains arithmetic and simple algebra in connection with units, color code, meter scales, Ohm's law, alternating currents, ohmmeter testing, wattage rating, series and parallel connections, capacity, inductance, mixed circuits, vacuum tubes, curves, the decibel, etc., and has numerous examples. Only **25¢**

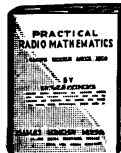

SUPREME PUBLICATIONS

1760 Balsam Rd., Highland Park, ILL.

★ Ship immediately Radio and TV manuals in quantities marked below.

Most-Often-Needed TELEVISION Manuals @ \$3.

QUANTITY	VOLUME #TV	YEAR COVERED
	TV-25	1966
	TV-24	Late 1965
	TV-23	Early 1965
	TV-22	1964
	TV-21	1963
	TV-20	Late 1962
	TV-19	Early 1962
	TV-18	1961
	TV-17	1960
	TV-16	Late 1959
	TV-15	Early 1959
	TV-14	1958
	TV-13	Late 1957
	TV-12	Early 1957
	TV-11	1956
	TV-10	Late 1955
	TV-9	Early 1955
	TV-8	1954
	TV-5	1951

Most-Often-Needed RADIO Manuals @ \$2.50

QUANTITY	VOLUME #R	YEAR COVERED
	R-26	1966
	25	1965
	24	1964
	23	1963
	22	1962
	21	1961
	20	1960
	19	1959
	18	1958
	17	1957
	16	1956
	15	1955
	14	1954
	13	1953
	12	1952
	11	1951
	10	1950
	9	1949
	8	1948
	7	1947
	6	1946
	5	1942
	4	1941
	3	1940
	1	1926-1938

Master INDEX to above manuals, — 25¢

TRAINING BOOKS

- Auto Radio 1964-1965 Diagrams, \$2.50
- Radio Servicing Course, new ed. 2.50
- Simplified Radio Servicing, 1.50
- Radio Mathematics (Self-help) .25
- Practical Radio & Electronics, 3.95
- Answer booklet to above course, .25
- Television Servicing Course, 3.00

- I am enclosing \$ Send postpaid.
- Send C.O.D. I am enclosing \$. . . deposit.

Name: _____

Address: _____

Supreme Publications
Sold by All Leading Parts Jobbers

Admiral

MODELS PG1521, PG1530, PG1535, PG1539, PG1547, using
CHASSIS G21D20-1, -2, G21D22-1, G21D23-1, G21D24-1.

(Material on pages 3 through 6)

IMPROVING FOCUS

The picture tube of these receivers utilizes electrostatic focus in connection with a three position focus adjustment.

For obtaining best overall sharpness of pictures, focus adjustment should be checked at installation and when servicing. Once focus adjustment is properly made, no further need for readjustment is required.

From rear view of chassis on front page, note that there are three focus (pin) connections at top rear of the chassis board, points shown as "A", "B" and "C". To make adjustment, connect plug-in focus lead to either of the three focus pins, whichever provides best focus at central area of picture tube. Important: Focus adjustment should be made with controls set for picture with normal contrast and brightness.

Caution: High B+ potential is present at focus terminals. To prevent electric shock, use care to avoid accidental contact with focus terminals.

HORIZONTAL LOCK ADJUSTMENT

The Horizontal Lock control is set at the factory and seldom requires readjustment. Adjustment need only be made if 8FQ7 tube (V403) has been replaced and the picture cannot be locked-in with slight adjustment of the Horizontal Lock control.

Before proceeding with adjustment, be sure that the picture will sync vertically, as lack of both vertical and horizontal sync generally indicates sync circuit trouble. Lack of only horizontal sync generally indicates trouble in the horizontal sync (phase detector) circuit.

1. Remove cabinet back. Connect interlock cord.
2. Allow a few minutes for set to warm up. Tune in weakest station, set Brightness and Contrast controls for a normal picture.
3. Using a piece of hook-up wire, short pin 2 of V403, 8FQ7 tube, to chassis ground.

4. Adjust Horizontal Lock control at point where picture is in horizontal sync and almost remains stationary with tendency to shift to left or right.
5. Remove wire short from pin 2 of V403. Set Channel Selector to weakest station. Switch Channel Selector on and off channel, picture should remain in horizontal sync.

RASTER TILT ADJUSTMENT

If raster is tilted, loosen deflection yoke clamping screw at rear of yoke. Rotate yoke until raster is straight. Tighten yoke clamping screw. Do not allow yoke to move back on neck of picture tube.

PICTURE CENTERING

The picture may be centered vertically and/or horizontally by moving the centering tabs, which are located on the back of the deflection yoke assembly.

VHF CHANNEL ADJUSTMENT

These sets are provided with a channel adjustment slug for each channel, see illustration. Adjust as follows:

1. Turn receiver on and allow 15 minutes warm up.
2. Set Channel Selector at highest channel to be adjusted. Set Fine Tuning control at center of tuning range, by rotating it one third turn counter-clockwise from full clockwise rotation. Set other tuning controls for normal picture and sound.
3. Remove Channel Selector knob.
4. Using a non-metallic alignment tool, carefully adjust channel slug for best picture. Note: Sound may not be loudest at this point. Repeat procedure for each channel to be adjusted.

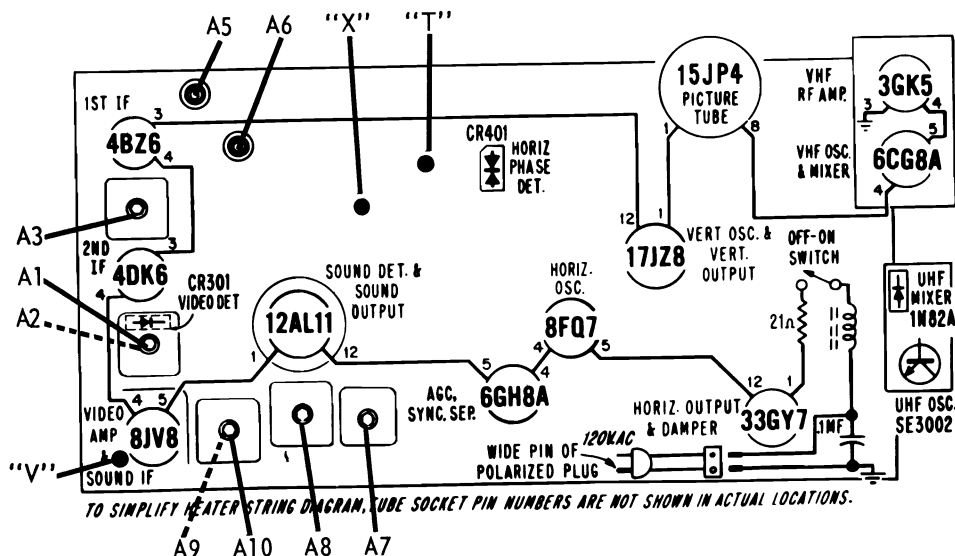
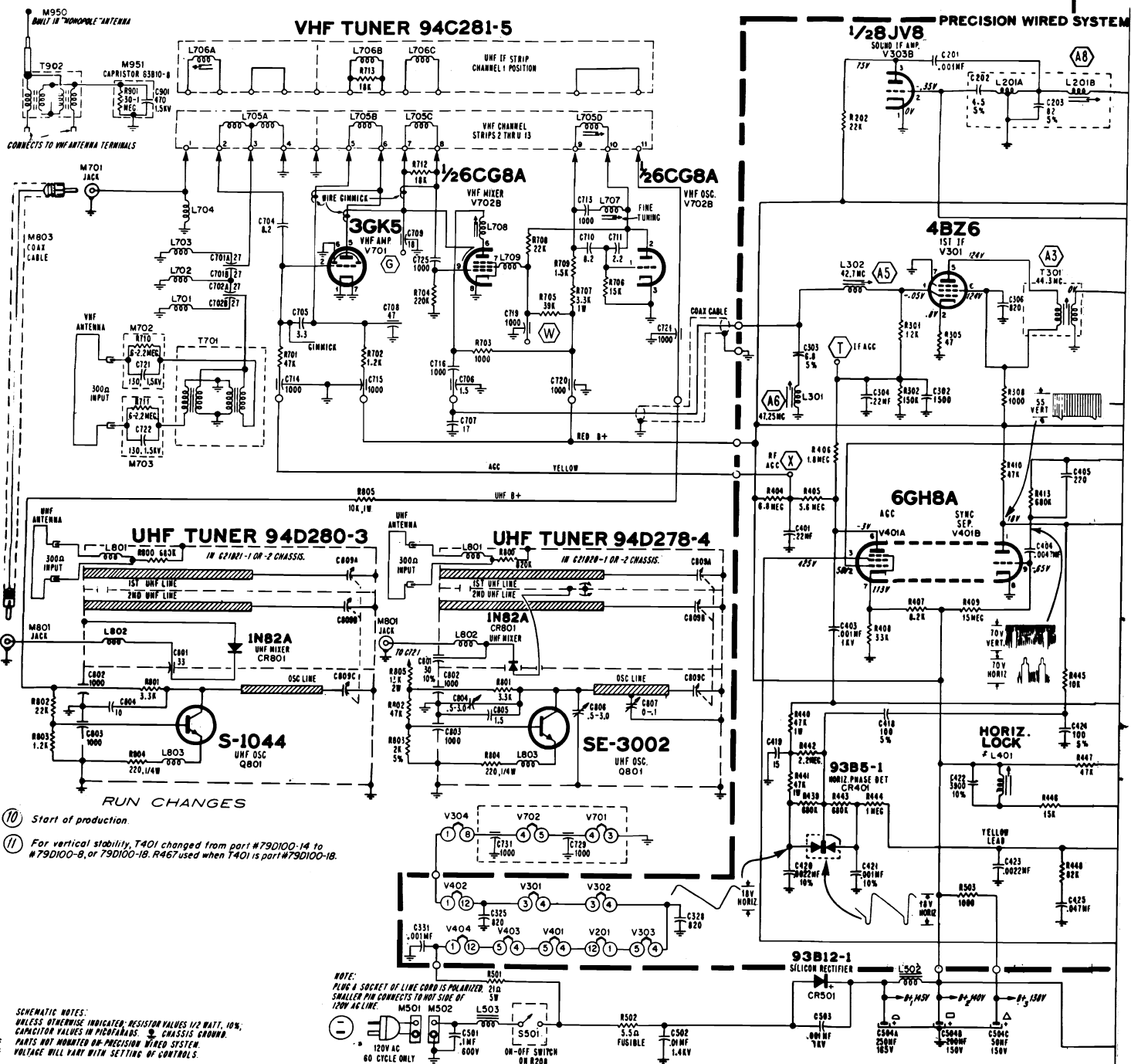

Fig. 1 DRAWING OF TOP OF CHASSIS SHOWING TUBE LOCATION, ALIGNMENT POINTS AND TEST POINTS

ADMIRAL Schematic Diagram Chassis G21D20, etc.



- ⑩ Start of production.
- ⑪ For vertical stability, T401 changed from part #79D100-14 to #79D100-8, or 79D100-18. R457 used when T401 is part #79D100-18.

SCHEMATIC NOTES:
 UNLESS OTHERWISE INDICATED: RESISTOR VALUES 1/2 WATT, 10%; CAPACITOR VALUES IN MICROFARADS. CHASSIS GROUND.
 * PLATE NOT NUMBERED ON PRECISION WIRED SYSTEM.
 † VOLTAGE WILL VARY WITH SETTING OF CONTROLS.

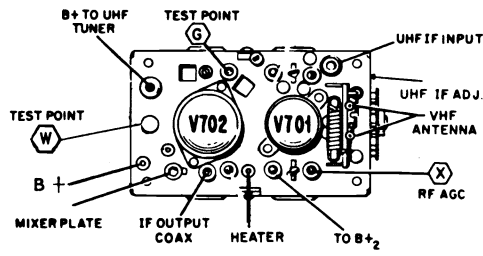

Fig. 2 TOP DRAWING OF VHF TUNER

ALIGNMENT OF UHF IF INPUT USING A TRANSMITTED SIGNAL

Alignment of UHF IF input coil (part of VHF tuner), should be made if UHF reception is poor and after usual causes of poor UHF reception have been checked.

To align UHF IF input coil, tune in UHF channel with normal picture and sound. Using non-metallic alignment tool very carefully adjust slug L706A for best picture, consistent with good sound. For VHF tuner adjustment locations, see figure 2.

ADMIRAL Schematic Diagram Chassis G21D20, etc., Continued

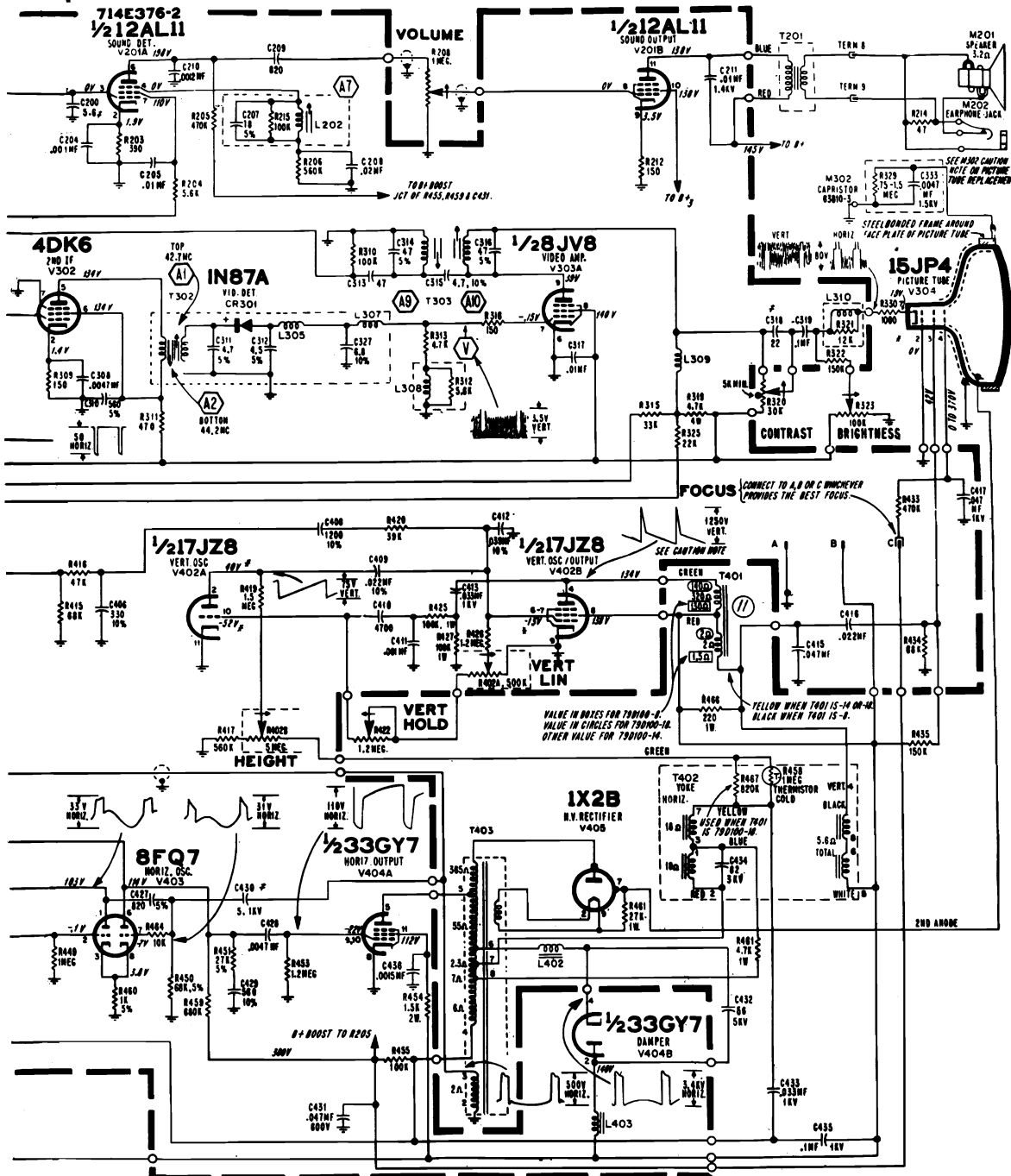

SCHEMATIC DIAGRAM OF G21D20-1, G21D21-1, CHASSIS

IF RESPONSE CURVE CHECK

1. Allow about 15 minutes for receiver and test equipment to warm up.
2. Set VHF tuner to Channel 12. Connect negative of 6 volt bias supply to test points "T" and "X"; positive to chassis.
3. Connect generator to VHF tuner. Test point "G" through the generator matching network of figure 4. Ground low side nearby.
4. Connect oscilloscope high side to test point "V" through a decoupling filter (see figure 5), low side to chassis.

5. The IF curve now obtained should be checked against the ideal response curve (see figure 3). Maintain sweep output at 3VPP as alignment progresses. Keep markers low. A reduction in sweep output should reduce curve amplitude without appreciably altering the shape of the response curve.
6. If the curve is not within tolerance or markers not in proper location, L708 VHF Tuner Mixer Plate Coil should be adjusted for 45.75MC video marker and A1 for rounded curve nose.

IF AMPLIFIER ALIGNMENT

Connect isolation transformer between AC line and receiver. Connect negative of 4 volt bias supply to test point "T" (IF AGC), positive to chassis. See Figure 1.

Using needle nose alligator clip or looped end of hookup wire, connect signal generator high side to test point "G", low side directly to tuner, see Figure 2.

Connect VTVM high side to test point "V" through a decoupling filter, see Figure 5. Connect low side to chassis.

Set Channel Selector to channel 12. (Or other high end channel which does not affect indication). Connect jumper wire across antenna terminals.

Allow about 15 minutes for receiver and test equipment to warm up. Use a non-metallic alignment tool.

IMPORTANT: Before proceeding check signal generator against frequency standard for calibration.

SUGGESTION: Alignment is best accomplished by first removing chassis and reconnecting facing backwards.

1. Set generator at 42.7MC and adjust A1 for maximum.
2. Set generator at 44.2MC and adjust A2 for maximum.
3. Set generator at 44.3MC and adjust A3 for maximum.
4. Connect wire jumper across IF input coil L302.
5. Set generator at 44.8MC and adjust L708 on tuner for max.
6. Remove wire jumper of step 4.
7. Set generator at 42.7MC and adjust A5 for maximum.
8. Reduce bias to -1½ volts.
9. Set generator at 47.25MC and adjust A6 for minimum.
10. Restore -4 volt bias.

11. Disconnect generator and connect sweep generator. Loosely couple marker to sweep connection.
12. Disconnect VTVM, and connect oscilloscope to network.
13. Set sweep frequency at 43MC, sweep width approximately 7MC. Keep marker and sweep outputs at low level to prevent over-loading. A reduction in sweep output should reduce curve amplitude without altering the shape of the response curve.
14. If 45.75MC marker is not within tolerance or markers not in proper location on curve, adjust L708 to position 45.75MC marker. Adjust A1 to correct shape of curve. Avoid reducing amplitude of curve as much as possible.

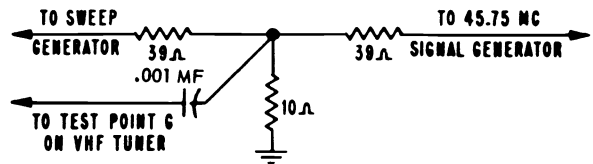

Fig. 4 MATCHING NETWORK

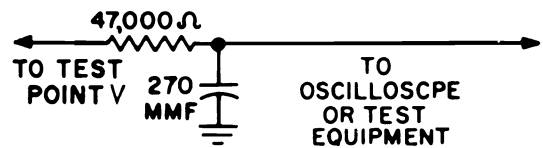

Fig. 5 DECOUPLING FILTER

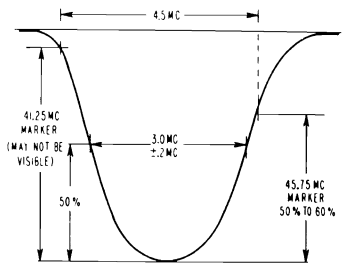
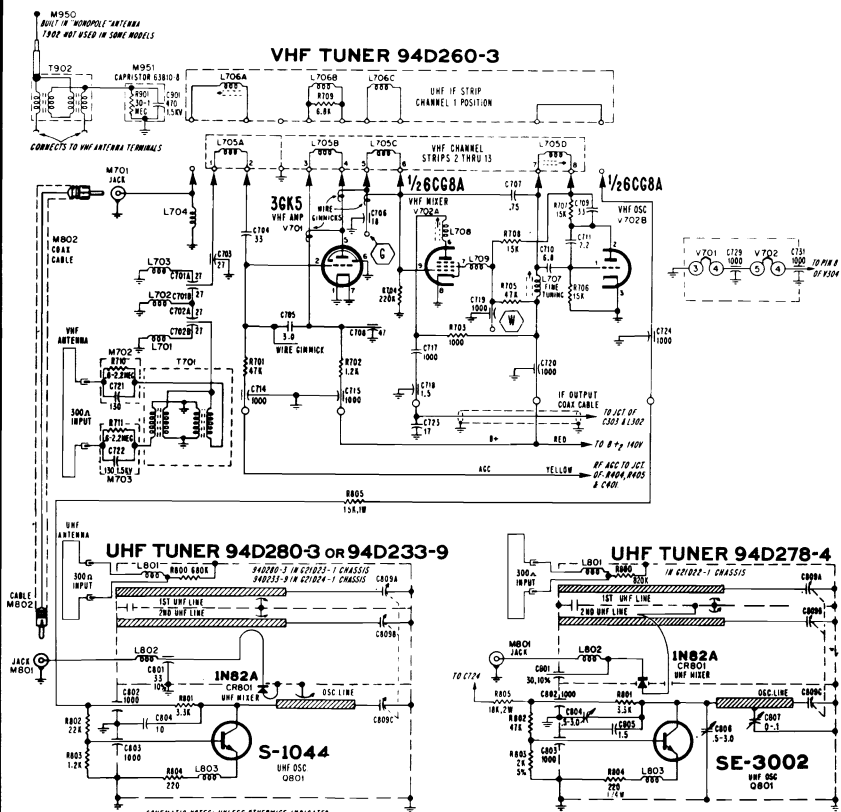

Fig. 3 IF CURVE



TUNING CLUSTER ASSEMBLY FOR CHASSIS G21D22-1, G21D23-1 & G21D24-1

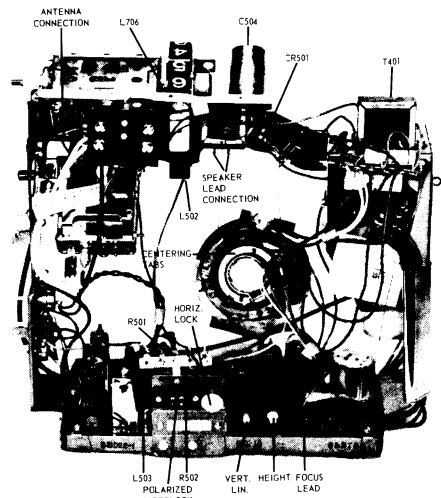

Fig. 6 BACK VIEW OF CHASSIS

Admiral

MODEL CHART

MODEL	NAME	COLOR	SIZE	VHF TUNER	UHF TUNER	CHASSIS
PK1360	Playmate	Black	13"	94C281-7	94C296-4	H1-1A
PK1369	Playmate	White				
PK1377	Playmate	Walnut				
PK1560	Vagabon	Black	15"	94C281-7	94C296-4	H2-1A
PK1569	Vagabon	White				
PK1577	Executive	Walnut				

CHASSIS REMOVAL & SERVICING

1. The chassis can be slid partially out for servicing by:
 - A. Pulling off all of the knobs except the tuner knobs.
 - B. Removing the cabinet back.
 - C. Sliding the chassis back.
2. VHF-UHF tuner assembly removal:
 - A. Remove the tuner knobs and one screw securing the front of the tuner to the front of the cabinet.
 - B. Pull the tuner assembly back and out.
4. High voltage cage access:
 - A. Pry forward on the plastic projections located on the top front of the high voltage cage.
 - B. Lift off the white plastic top.
 - C. Slide the plastic tube cover off.

RASTER TILT ADJUSTMENT

If raster is tilted, loosen deflection yoke clamping screw at rear of yoke. Rotate yoke until raster is straight. Tighten yoke clamping screw. Do not allow yoke to move back on neck of picture tube.

PICTURE CENTERING

The picture may be centered vertically and/or horizontally by moving the centering tabs, which are located on the back of the deflection yoke assembly.

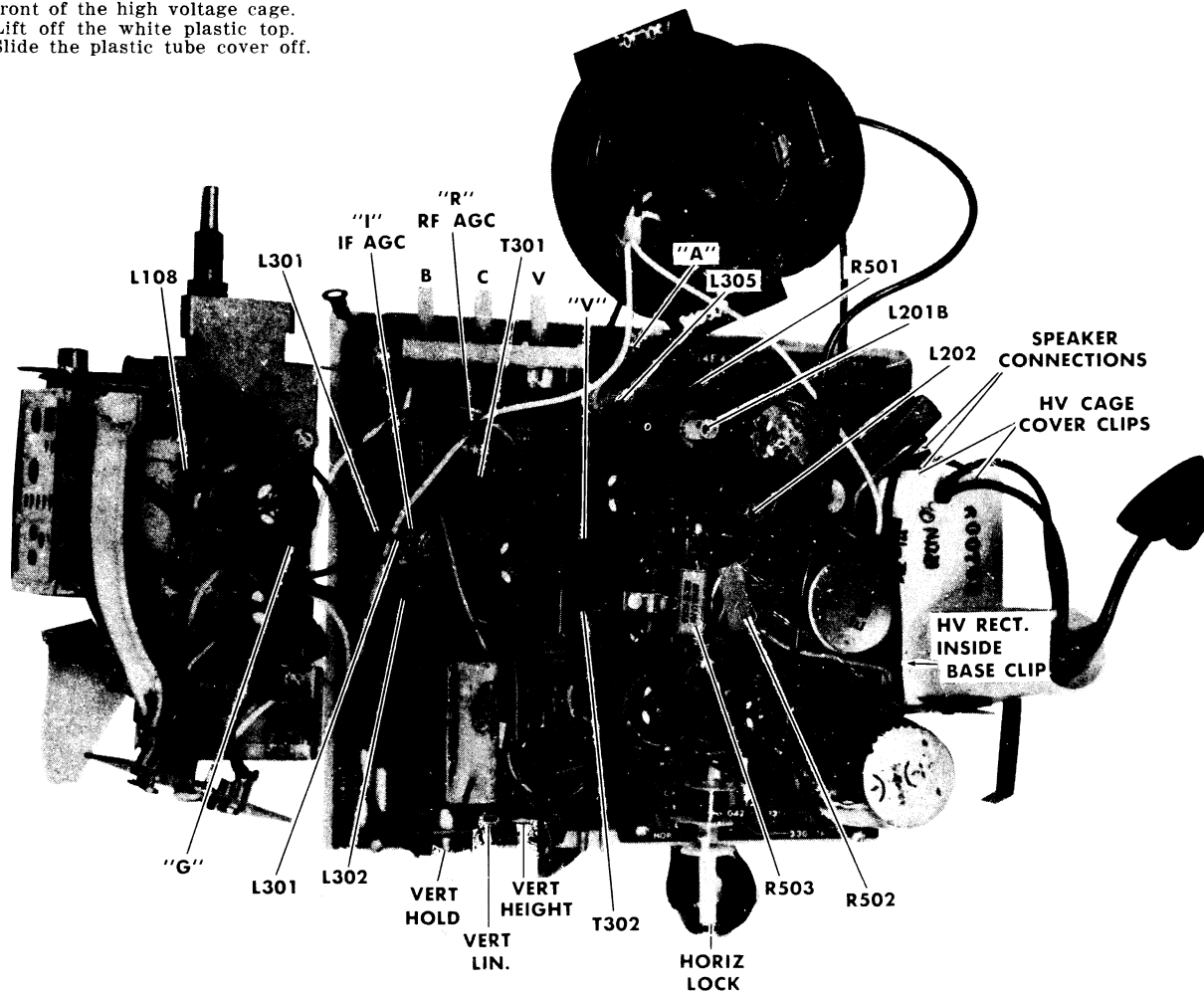

Fig. 1 TOP VIEW OF CHASSIS SHOWING ALIGNMENT & SERVICE ADJUSTMENT LOCATIONS

HORIZONTAL LOCK ADJUSTMENT

The Horizontal Lock control is set at the factory and seldom requires readjustment. Adjustment need only be made if 8LT8 tube (V402) has been replaced and the picture cannot be locked in with slight adjustment of the Horizontal Lock control.

Before proceeding with adjustment, be sure that the picture will sync vertically, as lack of both vertical and horizontal sync generally indicates sync circuit trouble. Lack of only horizontal sync generally indicates trouble in the horizontal sync (Phase detector) circuit.

1. Remove cabinet back. Connect a polarized interlock cord.
2. Allow a few minutes for set to warm up. Tune in weakest stations, set brightness and contrast controls for a normal picture.
3. Using a piece of hook-up wire, ground test point "S" (pin 11 of V401A, 23Z9 tube) through a .12-.15, 600V capacitor to the metal tuner bracket or a metal shield.
4. Adjust horizontal lock control at point where picture is in horizontal sync and almost remains stationary with tendency to shift to left or right.
5. Remove wire short and capacitor from test point "S". Set channel selector to weakest station. Switch channel selector on and off channel, picture should remain in horizontal sync.

HEIGHT AND VERTICAL LINEARITY ADJUSTMENT

If the picture is of incorrect height (vertical size), adjust the Height control. This adjustment may affect the vertical linearity of the picture. If necessary, alternately adjust the Vert. Lin. control and Height control. Note: Upper portion of the picture is affected mostly by the Vertical Linearity control; lower by the Height control.

IF AMPLIFIER ALIGNMENT

Connect isolation transformer between AC line and receiver. Connect negative of 6 volt bias supply to test point "I" (IF AGC), "R" (RF AGC) positive to chassis. See figure 1.

Using needle nose alligator clip or looped end of hookup wire, connect matching network shown in figure 2 to test point "G", low side directly to tuner, see figure 4. Connect signal generator to matching pad.

Connect VTVM high side to test point "V" through a decoupling filter, see figure 5. Connect low side to chassis.

Set Channel Selector to Channel 12, (or other high end channel which does not affect indication). Connect jumper wire across antenna terminals. Set RF generator output to give reading 1-2 volts over residual reading for all IF alignment adjustments.

Allow about 15 minutes for receiver and test equipment to warm up. Use a nonmetallic alignment tool.

IMPORTANT: Before proceeding check signal generator against frequency standard for calibration.

1. Set generator to 47.25MC and adjust L301 for minimum.
2. Set generator at 44.2MC and adjust T302 for maximum.
3. Set generator at 44.8MC and adjust T301 for maximum.
4. Connect wire jumper across IF input coil L302.
5. Set generator at 44.3MC and adjust L108 on tuner for maximum.
6. Remove wire jumper of step 4.
7. Set generator at 43MC and adjust L302 for maximum.
8. Disconnect signal generator and connect sweep generator. Connect marker signals through matching pad connections to test point "G."
9. Disconnect VTVM from decoupling network and connect oscilloscope calibrated for 3 volts P to P to network.
10. Set sweep frequency at 43MC, sweep width approximately 7MC. Maintain 3 volts P to P sweep display by adjusting sweep R.F. Keep marker at low level to prevent overloading. A reduction in sweep output should reduce amplitude without altering the shape of the response curve.
11. If 45.75 MC marker is not within tolerance or markers not in proper location on curve, adjust L108 to position 45.75MC marker. Adjust L302 to correct shape of curve. Avoid reducing amplitude of curve as much as possible.

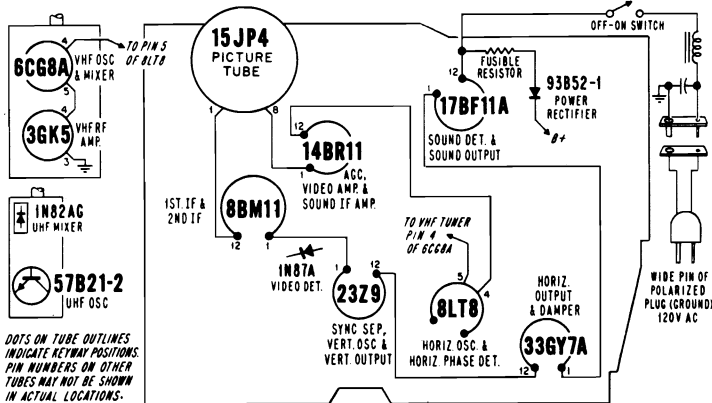

TUBE LOCATION CHART

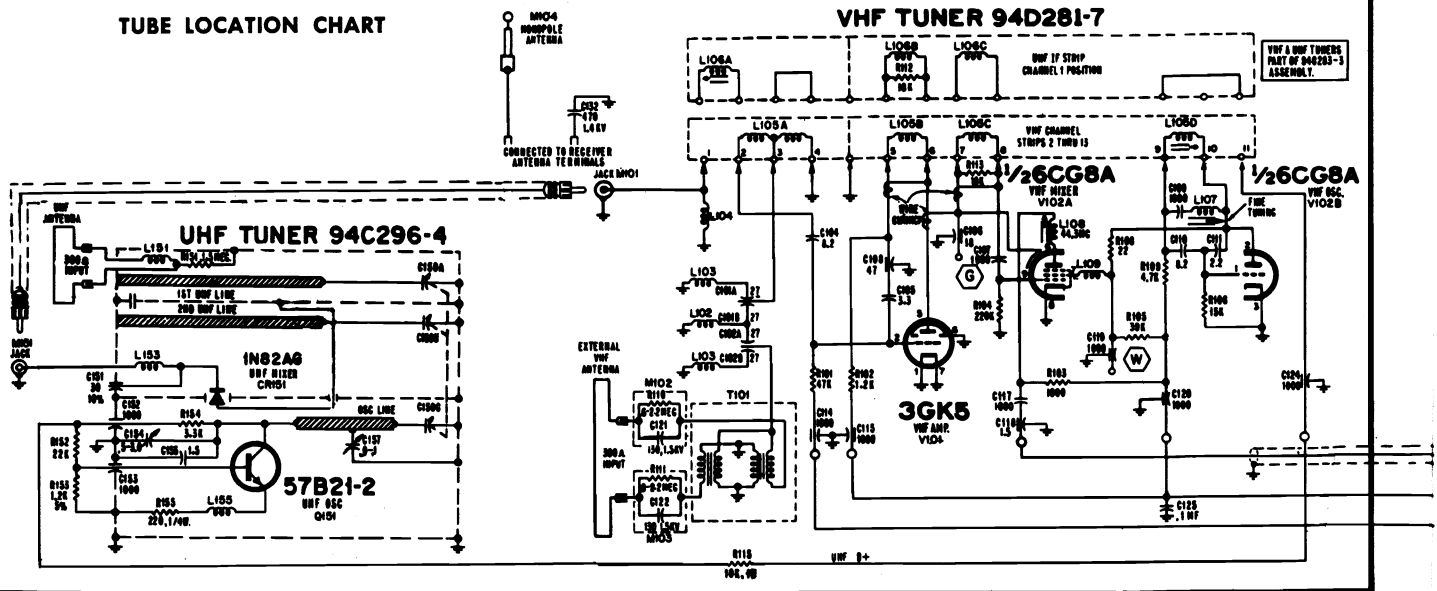

ADMIRAL Chassis H1-1A, H2-1A, Schematic Diagram, Continued

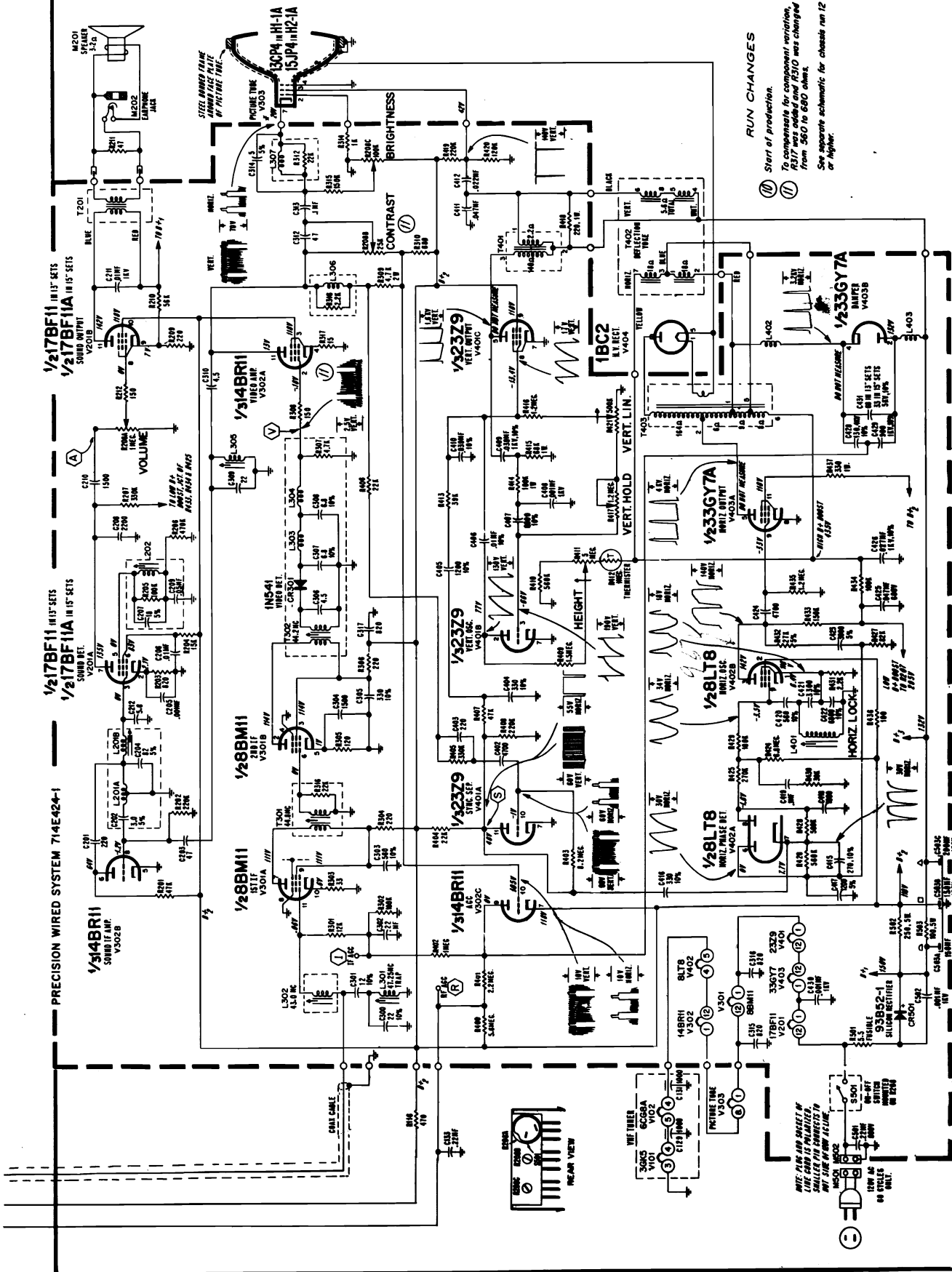

RUN CHANGES
 Start of production.
 To compensate for component variations, R317 was added and R510 was changed from 560 to 680 ohms.
 See separate schematic for chassis run 12 or higher.

SCHEMATIC NOTES:
 CHASSIS COVER PART NOT MOUNTED ON PRECISION WIRED SYSTEM. PRECISION WILL VARY WITH SETTING OF CONTROLS. RESISTOR VALUES OF 50% TOL. CONDUCTOR VALUES OF 10% TOL. UNLESS OTHERWISE INDICATED. CAPACITANCE VALUES IN MICROFARADS UNLESS OTHERWISE INDICATED.

H1-1A & H2-1A CHASSIS SCHEMATIC

IF RESPONSE CURVE CHECK

1. Allow about 15 minutes for receiver and test equipment to warm up.
2. Set VHF tuner to Channel 12. Connect negative of 6 volts bias supply to test points "R" and "I"; positive to chassis.
3. Connect sweep generator to VHF tuner to test point "G" through the generator matching network of figure 4. Ground low side nearby.
4. Connect oscilloscope high side to test point "V" through decoupling filter of figure 5, low side to chassis.
5. The IF curve now obtained should be checked against the ideal response curve, see figure 3. Maintain sweep output at 3V PP as alignment progresses. Keep markers low. A reduction in sweep output should reduce curve amplitude without appreciably altering the shape of the response curve.
6. If the curve is not within tolerance or markers not in proper location, L108 VHF Tuner Mixer Plate Coil should be adjusted for 45.75MV video marker and L302 for rounded curve nose.

OVER-ALL VHF-IF RESPONSE CURVE CHECK

1. Set VHF Channel Selector on channel 12. Connect negative of -6 volt bias supply to test point "R" (IF AGC) and -1.75 volt to test point "I" (RF AGC) positive to chassis. See figure 1.
2. Connect isolation transformer between AC line and receiver. Allow about 15 minutes for receiver and test equipment to warm up.
3. Attach the sweep generator at the VHF tuner antenna terminals, using VHF isolation network. See figure 7.
4. Connect oscilloscope high side to test point "V" through decoupling filter, low side to chassis. Adjust sweep generator for 3 volt peak to peak at test point "V".
5. Compare response curve obtained against ideal curve shown in figure 6.

VHF CHANNEL ADJUSTMENT

These sets are provided with a channel adjustment slug for each channel, see illustration. Adjust as follows:

1. Turn receiver on and allow 15 minutes warm up.
2. Set Channel Selector at highest channel to be adjusted. Set Fine Tuning control at center of tuning range, by rotating it one third turn counter-clockwise from full clockwise rotation. Set other tuning controls for normal picture and sound.
3. Remove Channel Selector knob and VHF indicator.
4. Using a non-metallic alignment tool, carefully adjust channel slug for best picture. Note: Sound may not be loudest at this point. Repeat procedure for each channel to be adjusted.

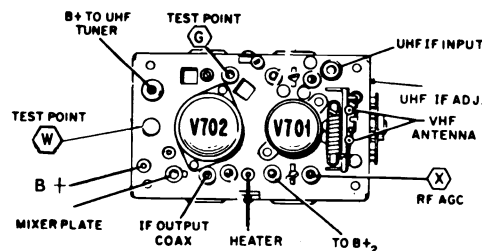

Fig. 2 TOP DRAWING OF VHF TUNER

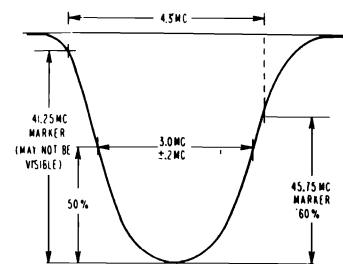

Fig. 3 IF CURVE

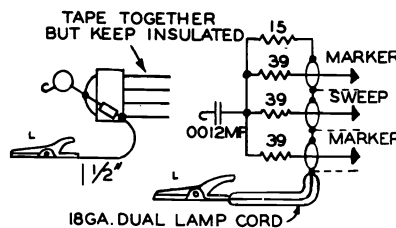

Fig. 4 MIXER GRID MATCHING PAD

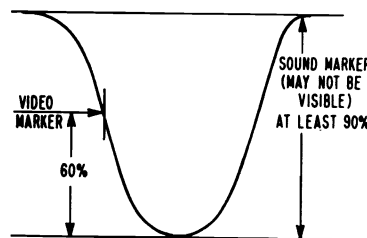

Fig. 6 IDEAL RESPONSE CURVE

ALIGNMENT OF UHF IF INPUT USING A TRANSMITTED SIGNAL

Alignment of UHF IF input coil (part of VHF tuner), should be made if UHF reception is poor and after usual causes of poor UHF reception have been checked.

To align UHF IF input coil, tune in UHF channel with normal picture and sound. Using non-metallic alignment tool very carefully adjust slug L106A for best picture, consistent with good sound. For UHF tuner adjustment locations, see Fig. 2.

VHF AMPLIFIER AND MIXER ALIGNMENT

VHF tuners used in these receivers feature high stability and trouble-free operation. In general, RF and mixer alignment is permanent. However, individual channel oscillator screws or slugs are provided should oscillator adjustment be required after replacement of VHF oscillator tube. For tuner adjustment locations, see figure 2.

4.5 MC SOUND IF ALIGNMENT

1. Tune in normal picture on strongest TV station. Allow about 15 minutes for set to warm up. See figure 1 for adjustment locations.
2. Using non-metallic alignment tool, slowly turn slug "L202" several turns to left until a buzz is heard in sound. Then slowly turn slug "L202" to the right for loudest and clearest sound. NOTE: There may be two points (approx. 1/2 turn apart) at which sound is loudest. The slug should be set at center of second point of loudest sound noted as slug is turned in (toward bottom of coil).
3. Reduce signal to antenna terminals until there is considerable hiss in sound. For best results, use a step attenuator, connected between antenna and antenna terminals. Signal can also be reduced by disconnecting antenna and placing it close to antenna terminals or leads.
4. Carefully adjust slug "L201B" for loudest and clearest sound with minimum hiss. If hiss disappears during alignment, reduce signal to maintain hiss level. Readjust slug "L201B". NOTE: Slug "L201B" should be at end nearest bottom of coil.
5. Carefully adjust slug "L305" for loudest and clearest sound with minimum hiss. If hiss disappears during alignment, reduce signal to maintain hiss level. Readjust slug "L305".
6. If above alignment is correctly made, no further adjustment is required. However, if sound remains distorted at normal volume level (when receiver is tuned for best sound), repeat entire procedure.

NOTE: Do not readjust slug "L202" unless sound is distorted. If "L202" is readjusted, all steps in alignment procedure should be repeated exactly as instructed.

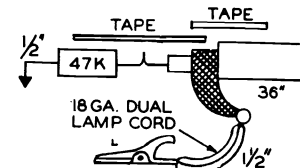

Fig. 5 DECOUPLING FILTER

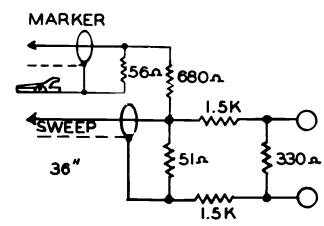
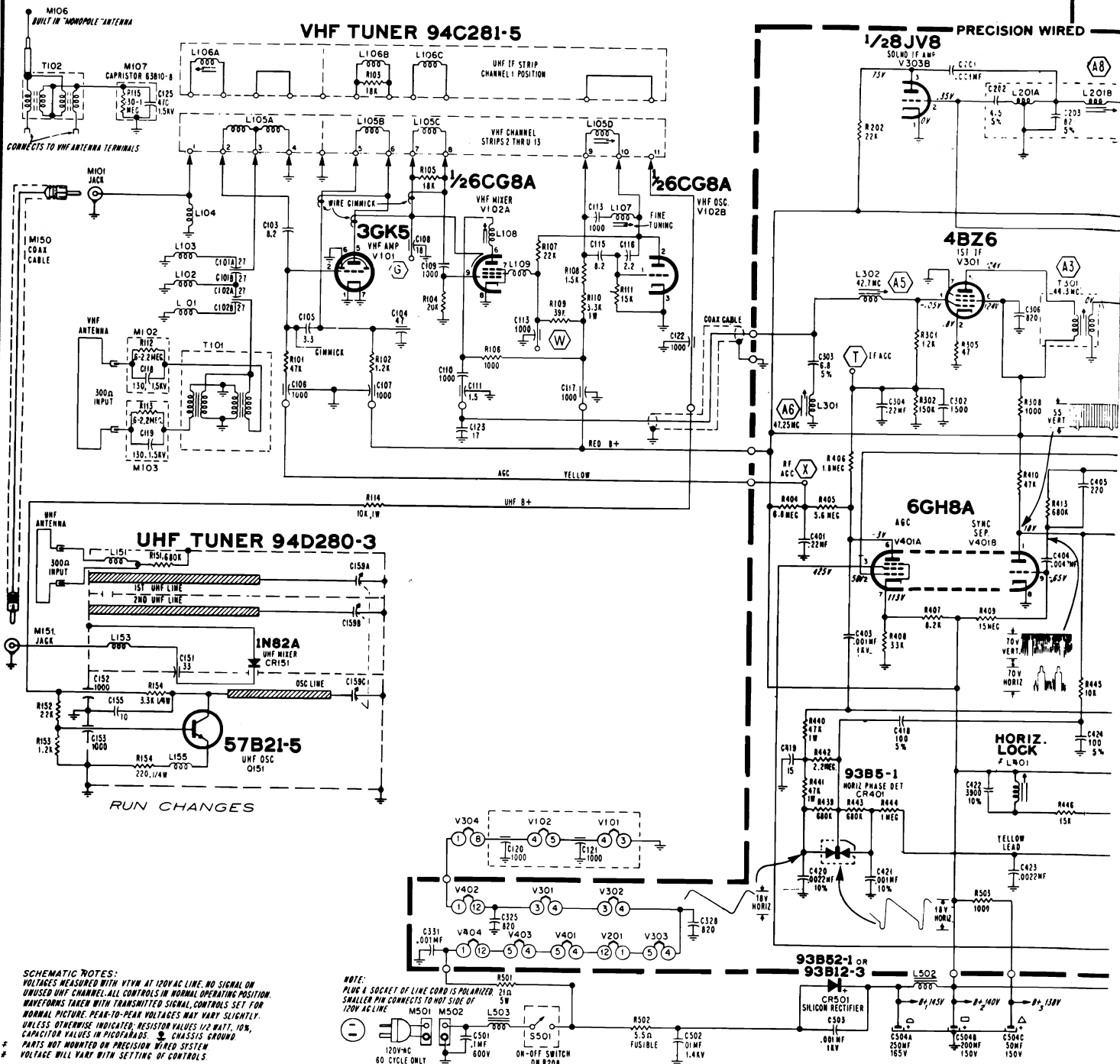

Fig. 7 VHF ISOLATION NETWORK

ADMIRAL Schematic Diagram H21B10-1 Chassis



SCHEMATIC NOTES:
 VOLTAGES MEASURED WITH VTVM AT 120V AC LINE. NO SIGNAL ON UNUSED UHF CHANNEL. ALL CONTROLS IN NORMAL OPERATING POSITION. WAVEFORMS TAKEN WITH TRANSMITTED SIGNAL. CONTROLS SET FOR NORMAL PICTURE. PEAK-TO-PEAK VOLTAGES MAY VARY SLIGHTLY. UNLESS OTHERWISE INDICATED, RESISTOR VALUES 1/2 WATT, 10%, CAPACITOR VALUES IN PICOFARADS. ⚡ CHASSIS GROUND.
 * PARTS NOT MOUNTED ON PRECISION WIRED SYSTEM
 † VOLTAGE WILL VARY WITH SETTING OF CONTROLS.

NOTE:
 PLUG A SOCKET OF LINE CORD IS POLARIZED. ⚡
 SMALLER PIN CONNECTS TO HOT SIDE OF 120V AC LINE.
 M501 M502 L503
 120V-AC 60 CYCLE ONLY
 3.5A FUSIBLE C502 0.1MF 1.4KV
 ON-OFF SWITCH ON R208

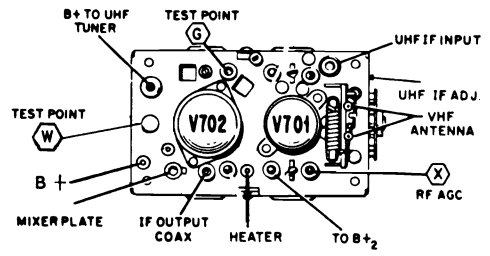

Fig. 2 TOP DRAWING OF VHF TUNER

ALIGNMENT OF UHF IF INPUT USING A TRANSMITTED SIGNAL

Alignment of UHF IF input coil (part of VHF tuner), should be made if UHF reception is poor and after usual causes of poor UHF reception have been checked.

To align UHF IF input coil, tune in UHF channel with normal picture and sound. Using non-metallic alignment tool very carefully adjust slug L106A for best picture, consistent with good sound. For VHF tuner adjustment locations, see figure 2.

ADMIRAL Schematic Diagram H21B10-1 Chassis, Continued

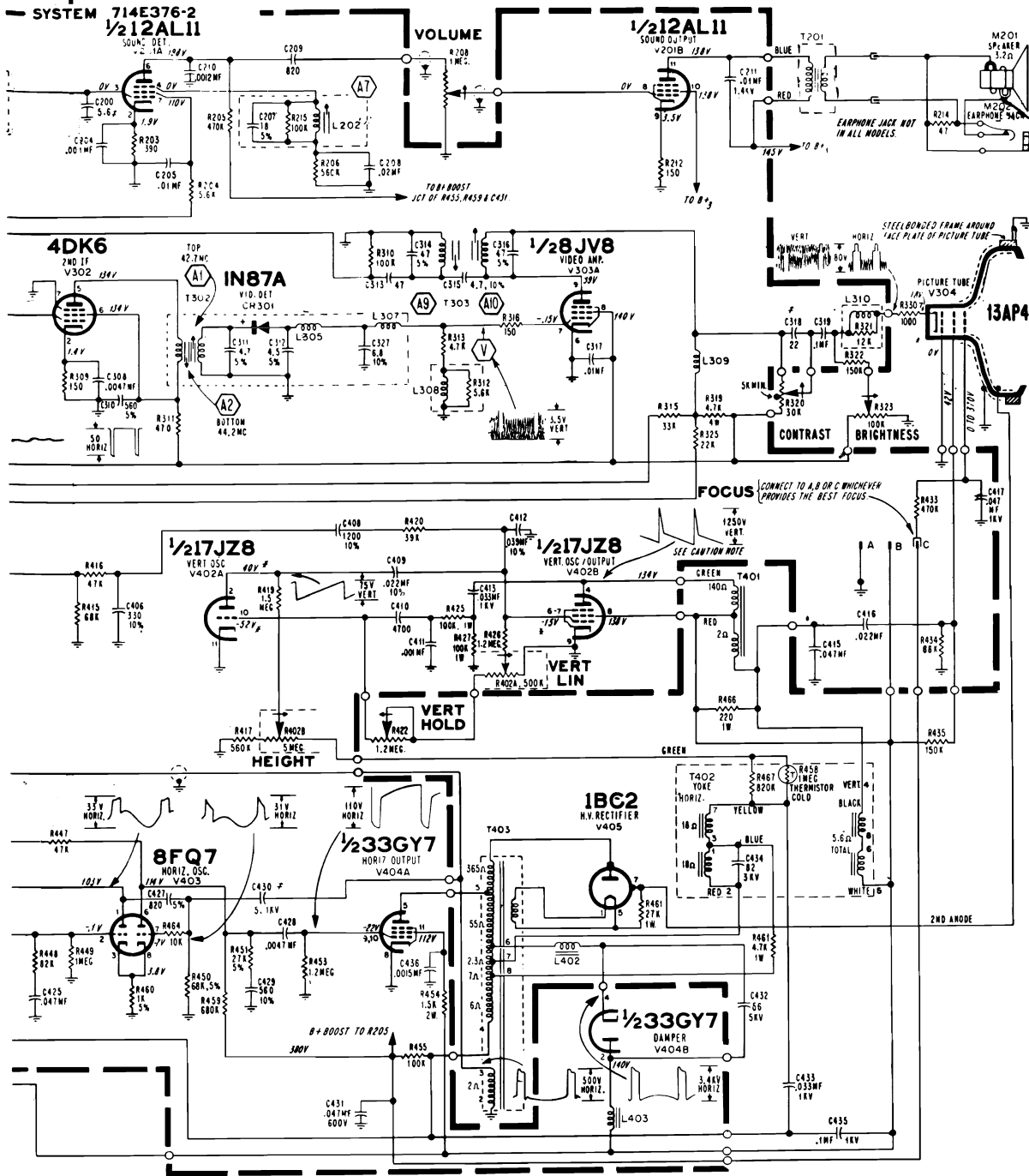

DIAGRAM OF H21B10-1

CONNECTING THE POLARIZED POWER PLUG: As an extra safety feature, this television receiver is equipped with a "polarized" power plug which assures that the metal chassis is properly grounded through the AC power source. This plug is constructed with one wide and one narrow blade so that it fits into a standard AC wall outlet in one direction only. Never attempt to force the plug in the opposite direction.

An "ordinary" extension cord cannot be used with the "polarized" plug. If an extension cord must be used, be sure it is the "polarized" type. Polarized extension cord BP164 is available from your Admiral distributor.

ADMIRAL Chassis H21B10-1 Alignment Information, Continued

IF AMPLIFIER ALIGNMENT

Connect isolation transformer between AC line and receiver. Connect negative of 4 volt bias supply to test point "T" (IF AGC), positive to chassis. See Figure 6.

Using needle nose alligator clip or looped end of hookup wire, connect signal generator high side to test point "G", low side directly to tuner, see Figure 2.

Connect VTVM high side to test point "V" through a decoupling filter, see Figure 5. Connect low side to chassis.

Set Channel Selector to channel 12. (Or other high end channel which does not affect indication). Connect jumper wire across antenna terminals.

Allow about 15 minutes for receiver and test equipment to warm up. Use a non-metallic alignment tool.

IMPORTANT: Before proceeding check signal generator against frequency standard for calibration.

SUGGESTION: Alignment is best accomplished by first removing chassis and reconnecting facing backwards.

1. Set generator at 42.7MC and adjust A1 for maximum.
2. Set generator at 44.2MC and adjust A2 for maximum.
3. Set generator at 44.3MC and adjust A3 for maximum.
4. Connect wire jumper across IF input coil L302.
5. Set generator at 44.8MC and adjust L108 on tuner for max.
6. Remove wire jumper of step 4.
7. Set generator at 42.7MC and adjust A5 for maximum.
8. Reduce bias to -1½ volts.
9. Set generator at 47.25MC and adjust A6 for minimum.
10. Restore -4 volt bias.
11. Disconnect generator and connect sweep generator. Loosely couple marker to sweep connection.
12. Disconnect VTVM, and connect oscilloscope to network.
13. Set sweep frequency at 43MC, sweep width approximately 7MC. Keep marker and sweep outputs at low level to prevent over-loading. A reduction in sweep output should reduce curve amplitude without altering the shape of the response curve.
14. If 45.75MC marker is not within tolerance or markers not in proper location on curve, adjust L108 to position 45.75MC marker. Adjust A1 to correct shape of curve. Avoid reducing amplitude of curve as much as possible.

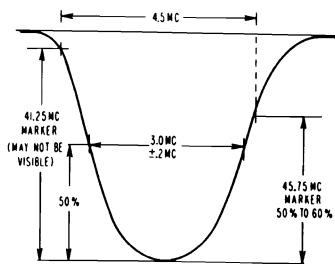

Fig. 3 IF CURVE

IF RESPONSE CURVE CHECK

1. Allow about 15 minutes for receiver and test equipment to warm up.
2. Set VHF tuner to Channel 12. Connect negative of 6 volt bias supply to test points "T" and "X"; positive to chassis.
3. Connect generator to VHF tuner. Test point "G" through the generator matching network of figure 4. Ground low side nearby.
4. Connect oscilloscope high side to test point "V" through a decoupling filter (see figure 5), low side to chassis.
5. The IF curve now obtained should be checked against the ideal response curve (see figure 3). Maintain sweep output at 3VPP as alignment progresses. Keep markers low. A reduction in sweep output should reduce curve amplitude without appreciably altering the shape of the response curve.
6. If the curve is not within tolerance or markers not in proper location, L108 VHF Tuner Mixer Plate Coil should be adjusted for 45.75MC video marker and A1 for rounded curve nose.

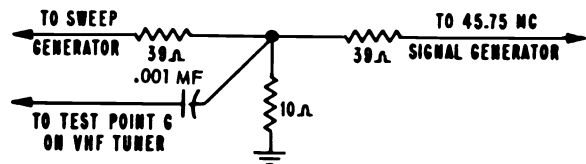

Fig. 4 MATCHING NETWORK

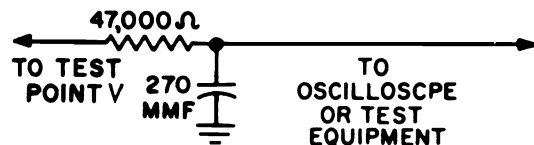

Fig. 5 DECOUPLING FILTER

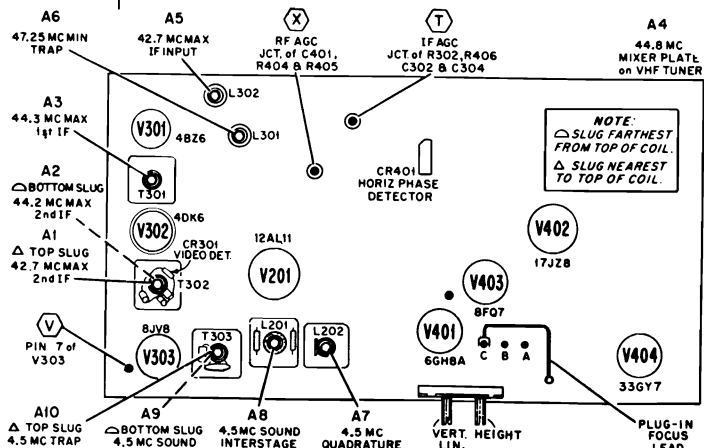

Fig. 6 TOP DRAWING OF CHASSIS SHOWING TUBE AND ALIGNMENT LOCATIONS

Admiral

MODEL CHART

MODEL	COLOR	NAME	SIZE	VHF	UHF	CLUSTER	CHASSIS
PH9515	Green	Barry	19"	94E281-8	94E272-3	HB1956-1	G556-1
PH9516	Ivory	Barry					
PH9527	Walnut	Spaulding					
AH9520	Black	Aurora					
PH9660	Black	Geneva	19"	94E282-10	94E280-7	HB1957-2	G557-2
PH9666	Ivory	Geneva					
AH9677	Walnut	Andover					
PHS9340*	Black	Drake	19"	94E273-10	94E280-3	HB1996-1	5G5 &
PHS9349*	White	Drake				HB1960-51	5H9N & S326AN
PH2101	Brown	Cambridge	21"	94E282-9	94E278-2	HB1958-1	9G558-1
PH2110	Black	Canterbury	21"	94E282-9	94D278-2	HB1958-2	9G558-2
PH2119	White	Canterbury					
PH2127	Walnut	Canterbury					
PH2140	Black	Meredith	21"	94E282-10	94E280-7	HB1957-1	9G557-1
PH2146	Ivory	Meredith					
PH2157	Walnut	Lindsey					
TH3700	Charcoal	Craig	23"	94E281-1	94E278-6	GB2321-1	2G521-1
LH3001	Walnut	White	23"	94E281-1	94E278-6	GB2321-1	2G521-1
LH3002	Mahogany	White					
LH3005	Maple	Belford					
LH3011	Walnut	Belford	23"	94E281-1	94E278-6	GB2321-1	2G521-1
THA9349H†	White	Seaview	19"	94E273-9	94E280-3	HB1960-1	7G560-1
THA9349HC†	White	Seaview					

*Models use Sonar remote control with preset vine tuning. Refer to S1035A for set adjustments.

†Models designed for commercial installations with 72 ohm antenna systems.

The above listed models were originally released, while those listed below were brought out at a later date. Service material on pages 16 through 20.

MODEL CHART

MODEL	NAME	COLOR	SIZE	TUNER CLUSTER	VHF TUNER	UHF TUNER	CHASSIS
PH9511M	Traveler	Brown	19"	HB1956-1 or	94E281-8	94E272-3	G556-1
PH9516M	Traveler	Ivory		HB1967-1 or	94E281-8	94E280-4	G567-1
				HB1969-1	94E281-8	94E296-7	G569-1
PH9650M	Safari	Black	19"	HB1957-2 or HB1968-2	94E282-10 94E282-10	94E280-7 94E278-9	G557-2 G568-2
PH9650W	Safari	Black					
PH9654	Safari	Walnut					
PH9654W	Safari	Beige					
PH9657M	Safari	Walnut					
PH9657W	Safari	Walnut					
PK2104	Cosmopolitan	Beige	21"	HB1958-1	94E282-9	94E278-9	9G558-1
PKC2100	Ambassador	Black					
PKC2101	Ambassador	Brown					
PKC2107	Ambassador	Walnut					
LK3001	Hampton	Walnut	23"	GB2321-2	94E281-1	94E278-6	3G521-2
LK3005	Delaware	Maple					
CK3011	Courtney	Walnut					
CK3012	Courtney	Mahogany					
LK3061	Hamilton	Walnut					
LK3021	Lawson	Walnut					
			23"	GB2321-1	94E281-1	94E278-6	2G521-1

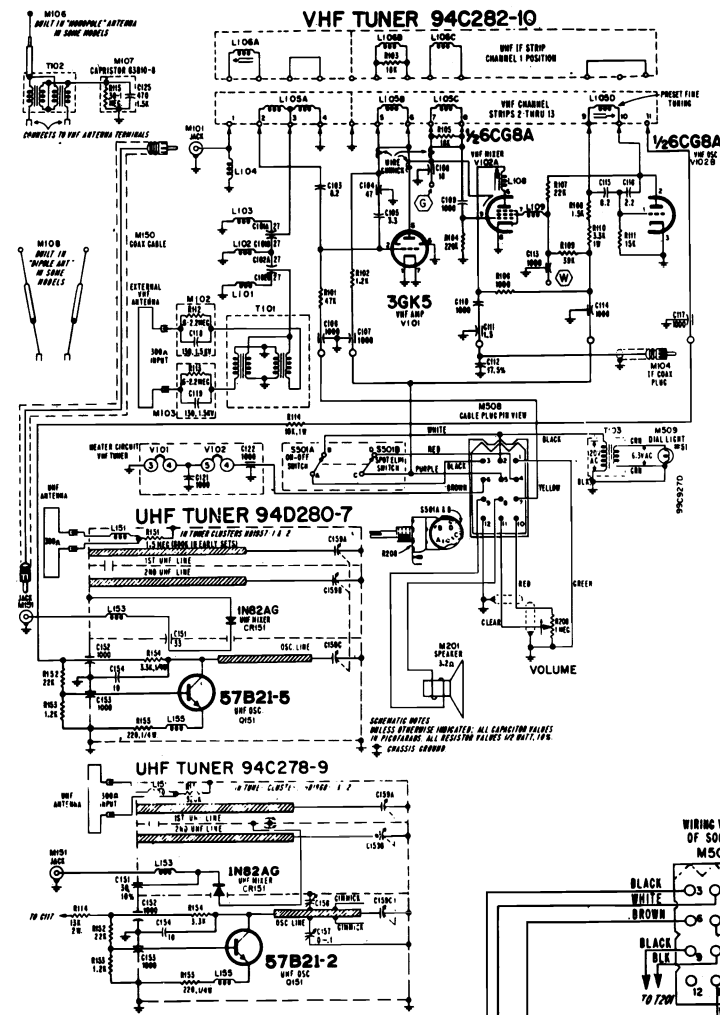

RUN CHANGES

- (10) Start of production
- (11) No service significance

SCHEMATIC NOTES:
 * CHASSIS GROUND
 † PART NOT MOUNTED ON PRECISION WIRED SYSTEM.
 ‡ VOLTAGES WILL VARY WITH SETTING OF CONTROLS, UNLESS OTHERWISE INDICATED. ALL CAPACITOR VALUES IN MICROFARADS. ALL RESISTOR VALUES ARE 1/2 WATT 10%. GS, NS, SCS, TSS & SCS CHASSIS ARE ELECTRICALLY IDENTICAL, EXCEPT FOR VALUES OF C432 & PICTURE TUBE TYPES. SCS CHASSIS, IN SOONER SETS HAVE A SPOT ELM. CIRCUIT, SEE INSET. VOLTAGES MEASURED WITH VTVM AT 120V AC LINE. NO SIGNAL OR UNUSED VHF CHANNEL.
 ALL CONTROLS IN NORMAL OPERATING POSITION. WAVEFORMS TAKEN WITH TRANSMITTED SIGNAL. CONTROLS SET FOR NORMAL PICTURE.
 PEAK-TO-PEAK VOLTAGES MAY VARY SLIGHTLY.

NOTE: DIODE CR502 (IN DASHED LINES), LOCATED IN MAIN CHASSIS ONLY IN SETS WITH NS OR SCS CHASSIS.
 INSTANT PLAT DIODE CR 502
 RESET BUTTON
 M504 CIRCUIT BREAKER
 PLUG AND SOCKET OF LINE CORD IS POLARIZED. SMALLER PIN CONNECTS TO HOT SIDE OF 120V AC LINE.

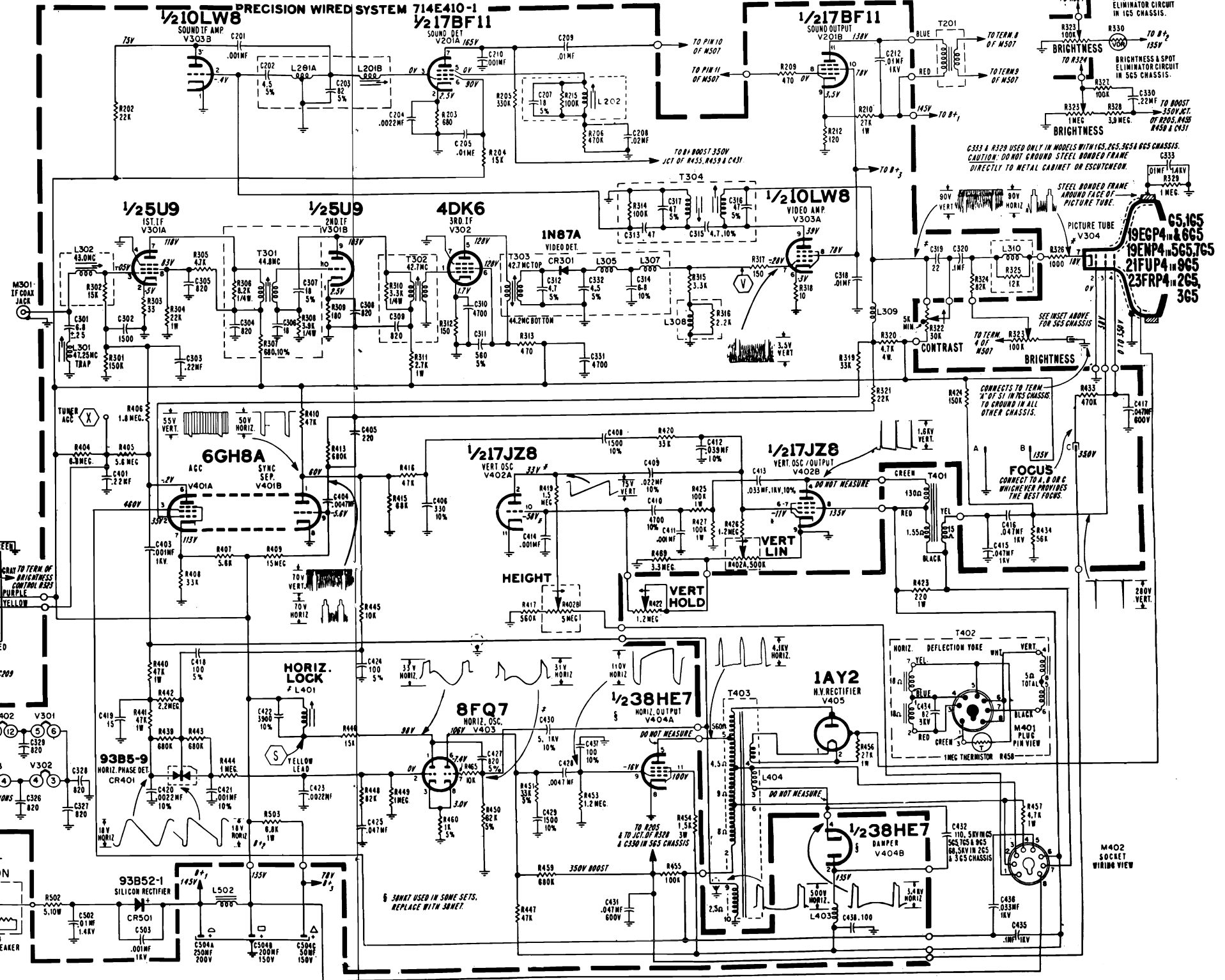

G5, 2G5, 3G5, 5G5, 7G5 & 9G5 CHASSIS SCHEMATIC DIAGRAM

HEIGHT AND VERTICAL LINEARITY ADJUSTMENT

If the picture is of incorrect height (vertical size), adjust the Height control. This adjustment may affect the vertical linearity of the picture. If necessary, alternately adjust the Vert. Lin. control and Height control. Note: Upper portion of the picture is affected mostly by the Vertical Linearity control; lower portion by the Height control.

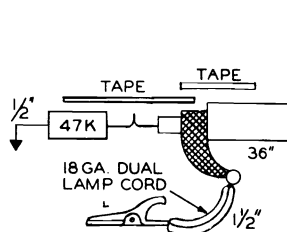

Fig. C DECOUPLING FILTER

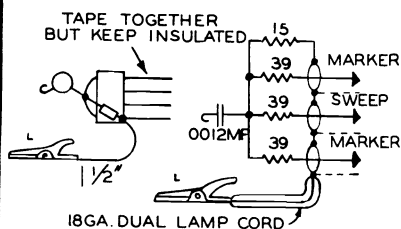

Fig. D MATCHING NETWORK

VHF CHANNEL ADJUSTMENT

These sets are provided with a channel adjustment slug for each channel. Adjust as follows:

1. Turn receiver on and allow 15 minutes warm up.
2. Set Channel Selector at highest channel to be adjusted. Set Fine Tuning control at center of tuning range, by rotating it one third turn counter-clockwise from full clockwise rotation. Set other tuning controls for normal picture and sound.
3. Remove Channel Selector knob.
4. Using a non metallic alignment tool, carefully adjust channel slug for best picture. Note: Sound may not be loudest at this point. Repeat procedure for each channel to be adjusted.

IMPROVING FOCUS

The picture tube of these receivers utilizes electrostatic focus in connection with a three position focus adjustment.

For obtaining best overall sharpness of pictures, focus adjustment should be checked at installation and when servicing. Once focus adjustment is properly made, no further need for readjustment is required.

From rear view of chassis on front page, note that there are three focus (pin) connections at top rear of the chassis board, points shown as "A", "B" and "C". To make adjustment, connect plug-in focus lead to either of the three focus pins, whichever provides best focus at central area of picture tube. Important: Focus adjustment should be made with controls set for picture with normal contrast and brightness.

Caution: High B+ potential is present at focus terminals. To prevent electric shock, use care to avoid accidental contact with focus terminals.

HORIZONTAL LOCK ADJUSTMENT

The Horizontal Lock control is set at the factory and seldom requires readjustment. Adjustment need only be made if 8FQ7 tube (V403) has been replaced and the picture cannot be locked-in with slight adjustment of the Horizontal Lock control.

RASTER TILT ADJUSTMENT

If raster is tilted, loosen deflection yoke clamping screw at rear of yoke. Rotate yoke until raster is straight. Tighten yoke clamping screw. CAUTION: Do not allow yoke to move back on neck of picture tube.

PICTURE CENTERING

The picture may be centered vertically and/or horizontally by moving the centering tabs, which are located on the back of the deflection yoke assembly.

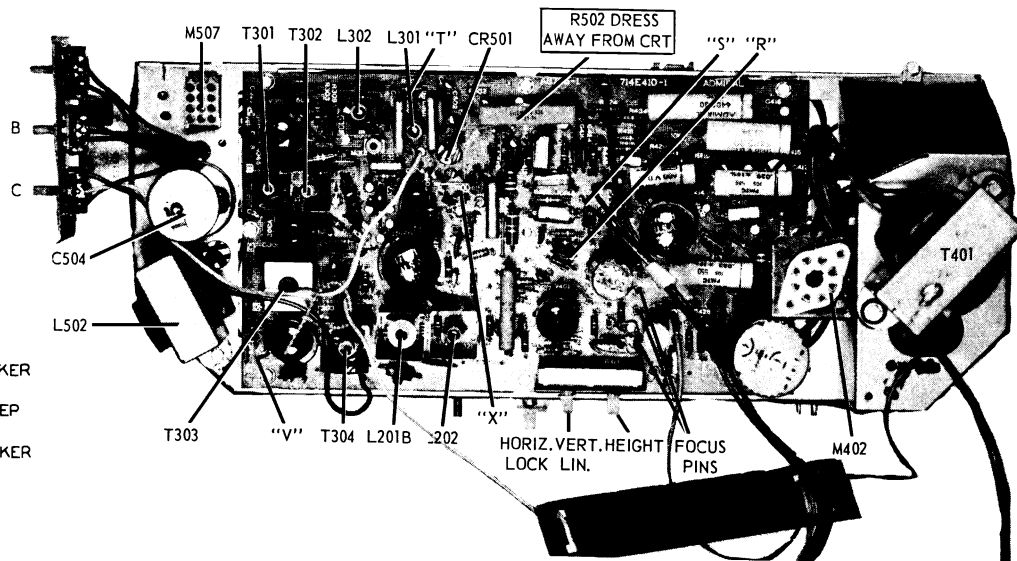

Fig. B TOP VIEW OF CHASSIS SHOWING SERVICE ADJUSTMENTS

Before proceeding with adjustment, be sure that the picture will sync vertically, as lack of both vertical and horizontal sync generally indicates sync circuit trouble. Lack of only horizontal sync generally indicates trouble in the horizontal sync (phase detector) circuit.

1. Remove cabinet back. Connect interlock cord.
2. Allow a few minutes for set to warm up. Tune in weakest station, set Brightness and Contrast controls for a normal picture.
3. Using a piece of hook-up wire, short test point "R" (pin 2 of V403, 8FQ7 tube), to chassis ground. See Fig. B for test point locations.
4. Adjust Horizontal Lock control at point where picture is in horizontal sync and almost remains stationary with tendency to shift to left or right.
5. Remove wire short from test point "R". Set Channel Selector to weakest station. Switch Channel Selector on and off channel, picture should remain in horizontal sync.

IF AMPLIFIER ALIGNMENT

Connect isolation transformer between AC line and receiver. Connect negative of 6 volt bias supply to test point "T" (IF AGC) and "X" (RF AGC), positive to chassis. See Fig. B.

Using needle nose alligator clip or looped end of hook-up wire, connect signal generator high side to test point "G", low side directly to tuner. See Fig. E.

Connect VTVM high side to test point "V" through a decoupling filter. See Fig. C. VTVM voltage should be between 1 and 2 volts above residual while making adjustments. Connect jumper wire across antenna terminals at tuner.

Allow about 15 minutes for receiver and test equipment to warm up. Use non-metallic alignment tools, part no. 98A30-12 and 98A30-14.

IMPORTANT: Before proceeding, check calibration of generator with crystal frequency standard.

ADMIRAL Alignment Information for Chassis 2G521-1, etc., Continued

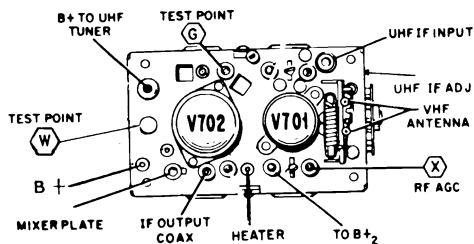
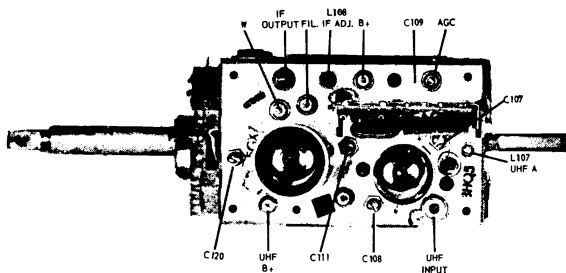

Fig. E TOP DRAWING OF VHF TUNER

1. Connect a jumper wire across L302.
2. Set generator to 44.8MC and adjust L108 in VHF tuner for maximum.
3. Remove jumper wire connected in Step 1.
4. Leave generator set at 44.8MC and adjust T301 for maximum.
5. Set generator at 42.7MC and adjust T302 for maximum.
6. Leave generator set at 42.7MC and adjust the top core of T303 for maximum.
7. Set generator at 44.2MC and adjust bottom core of T303 for maximum.
8. Set the generator to 43.0MC and adjust L302 for maximum.
9. Set generator at 47.25MC and adjust L301 for minimum VTVM reading with the bias set at zero.
10. Return the bias to minus 6 volts.
11. Disconnect the signal generator and connect a sweep generator to test point G on the VHF tuner.
12. Set the sweep generator output so that the response curve on the oscilloscope is 3 volts peak to peak.
13. Response curve should now appear like figure F. If necessary, round the nose of the curve by adjusting the top core of T303. The 45.75MC portion of the curve can be corrected by a slight adjustment of T301.



TOP VIEW OF 94E273 VHF TUNER USED IN REMOTE CONTROL MODELS

OVER-ALL VHF AND IF RESPONSE CURVE CHECK

Set Channel Selector on Channel 12. Connect negative of 3V bias supply to test points "T" (IF AGC) and "X" (RF AGC), positive to chassis. See Fig. B. Maintain 3V peak to peak at Video Detector Test Point "V".

Connect isolation transformer between AC line and receiver. Allow about 15 minutes for receiver and test equipment to warm up.

Attach the sweep generator at the VHF tuner antenna terminals, high side through 1200 ohm resistor, low side through 1200 ohm resistor. Place a 330 ohm resistor across the antenna terminals and a 47 ohm resistor across the generator output. If an external marker generator is used, loosely couple high side to sweep generator lead.

Connect oscilloscope high side to test point "V" through decoupling filter, low side to chassis. See Fig. C.

Compare response curve obtained against ideal curve shown in Figure G. If the curve is not within tolerance, adjust T301 top core to position video marker; adjust T303 to correct shape of curve. It should never be necessary to turn slugs more than 1 turn in either direction. If curve is satisfactory on channel checked, all other channels should be satisfactory. **IMPORTANT:** When sweep output is reduced, response curve amplitude on scope should decrease, but curve shape should remain the same.

VHF AMPLIFIER AND MIXER ALIGNMENT

The tuner is a turret type VHF tuner featuring high stability and trouble-free operation. The inductors of this tuner consist of individual channel strips and in general, RF and mixer alignment is permanent. Individual channel oscillator slugs are provided for each channel, should oscillator adjustment be required after replacement of VHF oscillator tube. See figure E for tuner adjustment locations. If it is definitely determined that complete tuner alignment is required, return tuner to Admiral Distributor for repair or

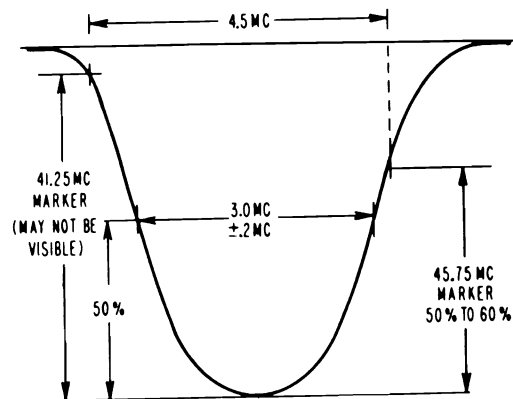

Fig. F Ideal IF Response Curve

replacement. Note: VHF Channel Adjustment can be made from in front of set after removing VHF channel and fine tuning knobs.

ALIGNMENT OF UHF IF INPUT USING A TRANSMITTED SIGNAL

Alignment of UHF IF input coil (part of VHF tuner), should be made if UHF reception is poor and after usual causes of poor UHF reception have been checked.

To align UHF IF input coil, tune in UHF channel with normal picture and sound. Using non-metallic alignment tool very carefully adjust slug L106A for best picture, consistent with good sound. For VHF tuner adjustment locations, see Fig. E

4.5MC SOUND IF ALIGNMENT

1. Tune in normal picture on strongest TV station. Allow about 15 minutes for set to warm up. See figure B for adjustment locations.
2. Using non-metallic alignment tool, slowly turn slug L202 to several turns to left until a buzz is heard in sound. Then slowly turn slug L202 to the right for loudest and clearest sound. **NOTE:** There may be two points (approximately 1/2 turn apart) at which sound is loudest. The slug should be set at center of second point of loudest sound noted as slug is turned in (toward bottom of coil).
3. Reduce signal to antenna terminals until there is considerable hiss in sound. For best results, use a step attenuator, connected between antenna and antenna terminals. Signal can also be reduced by disconnecting antenna and placing it close to antenna terminals or leads.
4. Carefully adjust slug L201B for loudest and clearest sound with minimum hiss. If hiss disappears during alignment, reduce signal to maintain hiss level. Re-adjust slug L201B. **NOTE:** Slug L201B should be at end nearest bottom of coil.

ADMIRAL Service Information for Chassis 2G521-1., etc., Continued

- Carefully adjust slug T304 bottom slug for loudest and clearest sound with minimum hiss. If hiss disappears during alignment, reduce signal to maintain hiss level. Re-adjust slug T304. Caution: Slug T304 is located nearest bottom of coil. Use care so as not to disturb slug nearest top of coil.
- If above alignment is correctly made, no further adjustment is required. However, if sound remains distorted at normal volume level (when receiver is tuned for best sound) repeat entire procedure.

CAUTION: Do not re-adjust slug L202 unless sound is distorted. If L202 is re-adjusted, all steps in alignment procedure should be repeated exactly as instructed.

ALIGNMENT OF 4.5MC TRAP

Alignment of 4.5MC (beat interference) trap T304 top slug requires use of a hexagonal non-metallic alignment tool.

To align 4.5MC trap T304 top slug, tune in television station with beat interference pattern in picture. While closely observing picture, adjust slug T304 top slug for minimum interference pattern.

Note that adjustment T304 top slug is slug farthest from bottom of coil. Use caution so as not to disturb bottom slug, slug nearest bottom of coil, as sound IF alignment will be affected.

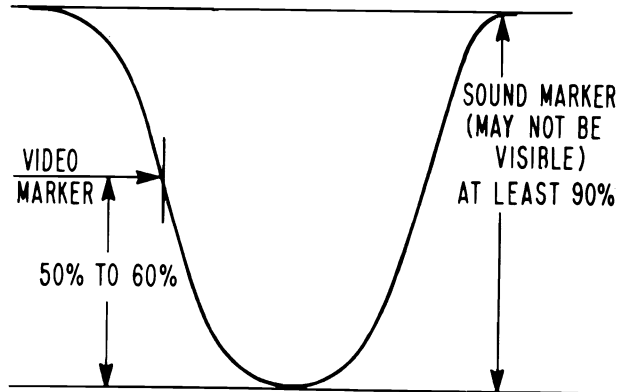
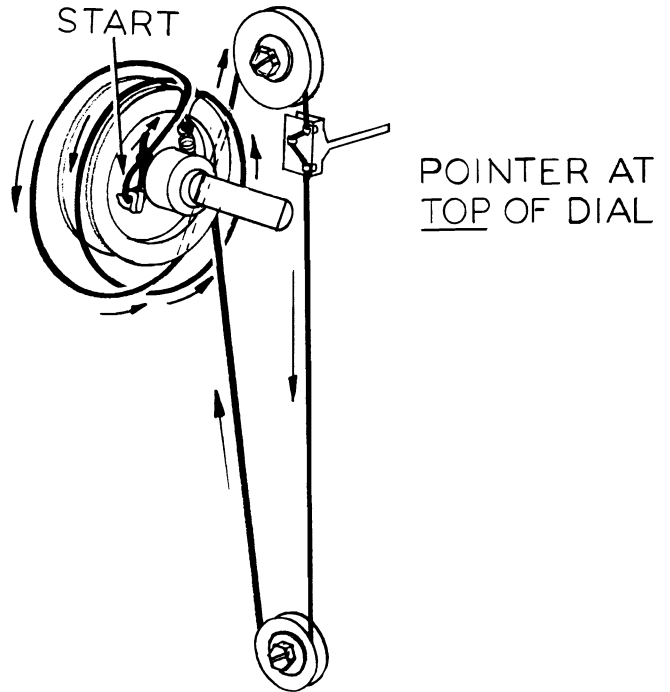

HC1957-1 & -2 TUNING CLUSTER DIAL STRINGING DIAGRAM

Fig. G Ideal Over-all VHF & IF Response Curve

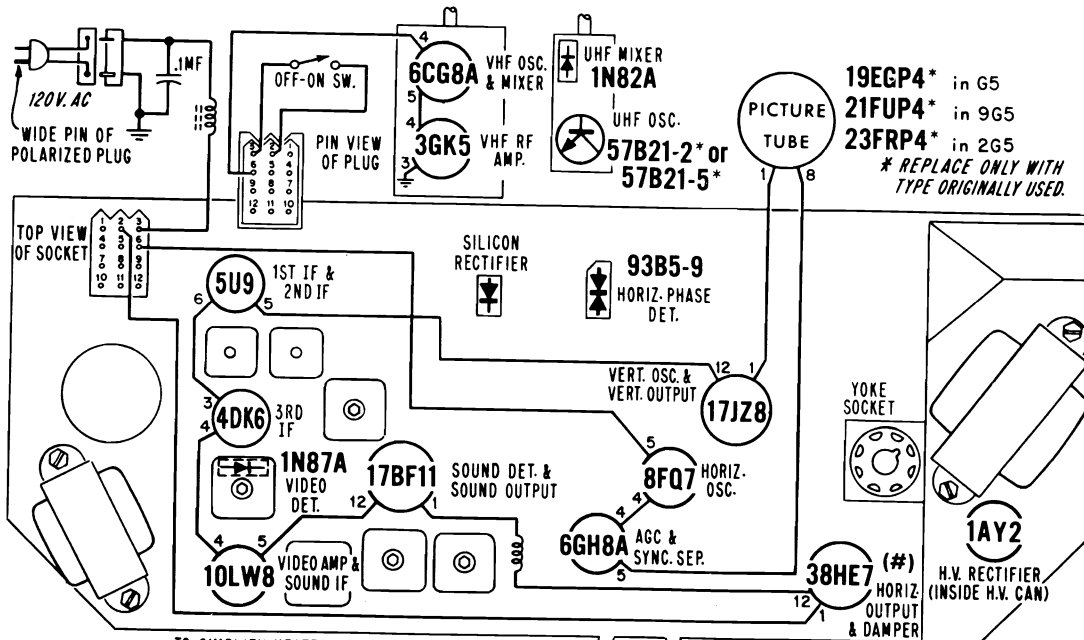

TO SIMPLIFY HEATER STRING DIAGRAM, TUBE SOCKET PIN NUMBERS ARE NOT SHOWN IN ACTUAL LOCATIONS
 (#) TYPE 38HK7 used in some production. TYPE 38HE7 recommended for replacement.

TUBE LOCATION CHART G5, 2G5 & 9G5 CHASSIS

Emerson

MODEL/CHASSIS/CRT CROSS - REFERENCE

Model No.	Chassis No.	CRT Type	
* 13T05	120837-A	23HWP4	
* 13T06	120843-A		
13C16	120839-A		
13C17			
13C18	120841-A	16CMP4	
16P04			
16P06			120840-B,C
16P07			120840-A,B,C
* 19P24	120847-B	19FJP4 or 19FJP4A	
19P25	120842-A		
19P26			
* 19P27			120846-B
19P28	120848-F		

- * 13T05 - Quick-On
- 13T06 - Quick-On & Wireless Remote Control
- 19P24 - Quick-On & Automatic Timer Assembly
- 19P27 - Quick-On

MODEL/CHASSIS/CRT CROSS - REFERENCE CHART

Model No.	Chassis No.	CRT Type
** 15P01	120840-B	16CMP4A
15/16 P08	120840-A,B,C	
** 15/16 P09	120840-A,B,C	
** 15/16 P10	120841-A,B,C	
** 18P01	120842-A,B,F	19FJP4 or 19GJP4
* 19P16	120848-F,Z	
# * 18/19 P24	120847-B	
* 18/19 P28	120848-F,G,H	
18/19 P31	120842-A,B,C,E,F	
** 18/19 P32	120842-A,B	
** 18/19 P33	120848-G	

DU MONT

DuMont models listed below use Emerson chassis as indicated.

Model No.	Model Name	Chassis No.	VHF Tuner	UHF Tuner	CRT Type
43T04	Hudson	120837-A	471669	471674	23HWP4
49P07	Surveyor II	120846-B	471617	471647	19FJP4 or 19FJP4A
49P08	Ranger	120847-B			

CONDITIONS FOR CHASSIS READINGS

VOLTAGES AND WAVESHAPES were taken under actual operating conditions, with normal picture and sound being received. AGC voltage developed on the I-F AGC line (test point C) was minus nine volts. Input voltage to chassis under test was 120 volts, 60-cycle AC. Frequencies indicated for the waveshapes shown are approximate sweep settings for the oscilloscope being used (one-half actual frequency of signal being measured).

RESISTANCE MEASUREMENTS were taken with no power. Where readings are affected by control

settings, both maximum and minimum values are shown.

ALL MEASUREMENTS were taken between points indicated and chassis ground (unless otherwise noted), using an RCA Voltohmyst or equivalent VTVM. A low-capacity probe was used for all waveshapes shown in the schematic diagram. All readings obtained may vary $\pm 10\%$ due to normal component tolerances and strength of input signal to chassis under test.

RESISTANCE READINGS CHART, TV CHASSIS

Ref. No.	Tube Type	Pin 1	Pin 2	Pin 3	Pin 4	Pin 5	Pin 6	Pin 7	Pin 8	Pin 9	Pin 10	Pin 11	Pin 12
V-1	6LN8	*33k	10k	*8.2k	(filament)	*8.2k	220	0	2.7m				
V-2	4DT6A	10	470	(filament)	1.4m	*3.3k	470k						
V-3	17C5/CU5	#180	20 to 1m	(filament)	20 to 1m	*540	*600						
V-4	4EH7	142	100k	142	(filament)	0	*470	*470	0				
V-5	4EJ7	100	0	100	(filament)	0	*220	*220	0				
V-6	8AW8A	0	.5m to 2m	5m to 6m	(filament)	15	90	*2.2k	*4.4k				
V-7	CRT	(fil.)	#3.4k	#440k	0	--	--	150k to 300k	(fil.)				
V-8	6LX8	205k	320k	*0	(filament)	*22k	2.2k	5 to 32k	33k				
V-9	38HE7	(fil.)	*22	--	500k	500k	--	0	560k	--	*1.2k	(fil.)	
V-10	1K3	--	(inf.)	--	(inf.)	--	--	(inf.)					(Plate Cap: 500k)
V-12	10CW5	--	2.2m to 2.7m	22	(filament)	--	*250	--	*0				

NOTES: All resistance readings are in ohms, unless otherwise specified.

"k" denotes kilohms; "m" denotes megohms.

* Asterisk indicates measurements made with common lead of meter connected to junction of L-15 and C-60B (B+ point).

Indicates measurements for 16" and 19" sets only.

Alternate Measurements (23" sets):

V-3, pin 1.... 270 ohms

V-7, pin 2.... 22k

V-7, pin 3.... 60k

EMERSON - DU MONT Chassis 120837A, 120840B, etc., Service Information

GENERAL DESCRIPTION

The models described in this Service Note are 82-channel television receivers, designed for the monochrome reception of all programs telecast within the UHF and VHF tuning ranges. They are equipped with a set of built-in antennae which serve to provide adequate signal pickup in almost all metropolitan area installations, and have provisions for the connection of external UHF and VHF antennae, if desired.

The picture tubes employed in these receivers are equipped with integral implosion protection, which eliminates the possibility of dust deposits becoming settled between the faceplate of the picture tube and a separate safety shield, since this is no longer required. It is important to note, however, that if replacement of the picture tube in any of the models described in this Service Note becomes necessary, that it be replaced with a tube of the same type for continued safety. Do not attempt to utilize a picture tube without integral implosion protection as a replacement.

PERSONAL LISTENING ATTACHMENT JACK

Each of the 16-inch and 19-inch models described in this Service Note (except models 16P06 and 19P25) are equipped with a personal listening attachment jack, designed for use with either a personal listening attachment (part no. 829007) or an under-pillow listening device (part no. 963530). Both of the aforementioned are optional sales accessory items, available through franchised Emerson distributors.

AUTOMATIC TIMER CONTROL

Model 19P24 is equipped with an automatic timer unit (part no. 471324) which can be set to turn the receiver off after a pre-determined interval ranging from ten minutes to three hours. If desired, the receiver may also be operated in a conventional manner, in which case it will remain in operation until the timer switch is returned to its OFF position.

WIRELESS REMOTE CONTROL

Model 13T06 is equipped with a transistorized wireless remote control receiver (assembly no. 471685) which, in conjunction with a hand-held transistorized remote control transmitter (assembly no. 471620), allows the viewer to select channels, choose from any of three different volume levels and turn the set ON or OFF from any point in the room, up to a distance of approximately twenty feet. For details on this wireless remote control assembly, refer to pages 10-12 of this Service Note.

QUICK-ON FEATURE

Models 13T05, 13T06, 19P24 and 19P27 are equipped with the "Quick-On" feature which, when set for operation by means of an auxiliary slide switch provided for this purpose, serves to eliminate the delay usually encountered by the normal warm-up period, by permitting a limited amount of current to flow in the filament circuit even when the set is not operating. An added benefit of this type of operation is that it can serve to prolong the life expectancy of the tubes, by removing the effects of surge currents from all points in the filament circuit. If desired (as may be the case if the receiver is not to be operated for an extended period of time), the "Quick-On" switch may be left in the OFF position, in which instance the normal amount of warm-up time will be required when the receiver is placed in operation.

LEG ASSEMBLY KIT

Models 13T05 and 13T06 are table-model receivers which can be easily converted to console styling by use of specially designed leg assembly kits, part no. 471430A (mahogany) or part no. 471430D (walnut).

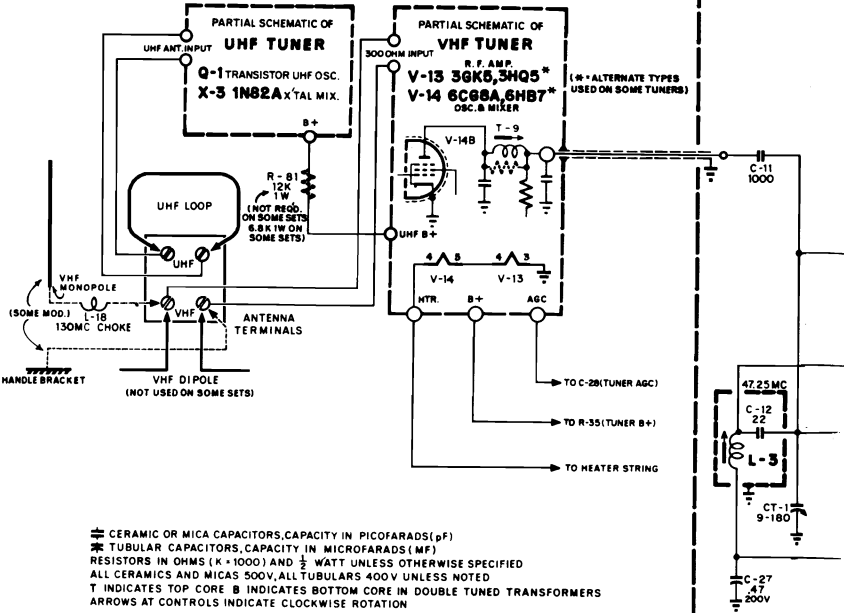

⊃ CERAMIC OR MICA CAPACITORS, CAPACITY IN PICOFARADS (pF)
 ⌘ TUBULAR CAPACITORS, CAPACITY IN MICROFARADS (MF)
 Ⓜ RESISTORS IN OHMS (x 1000) AND 1/2 WATT UNLESS OTHERWISE SPECIFIED
 ALL CERAMICS AND MICAS 500V, ALL TUBULARS 400V UNLESS NOTED
 T INDICATES TOP CORE B INDICATES BOTTOM CORE IN DOUBLE TUNED TRANSFORMERS
 ARROWS AT CONTROLS INDICATE CLOCKWISE ROTATION

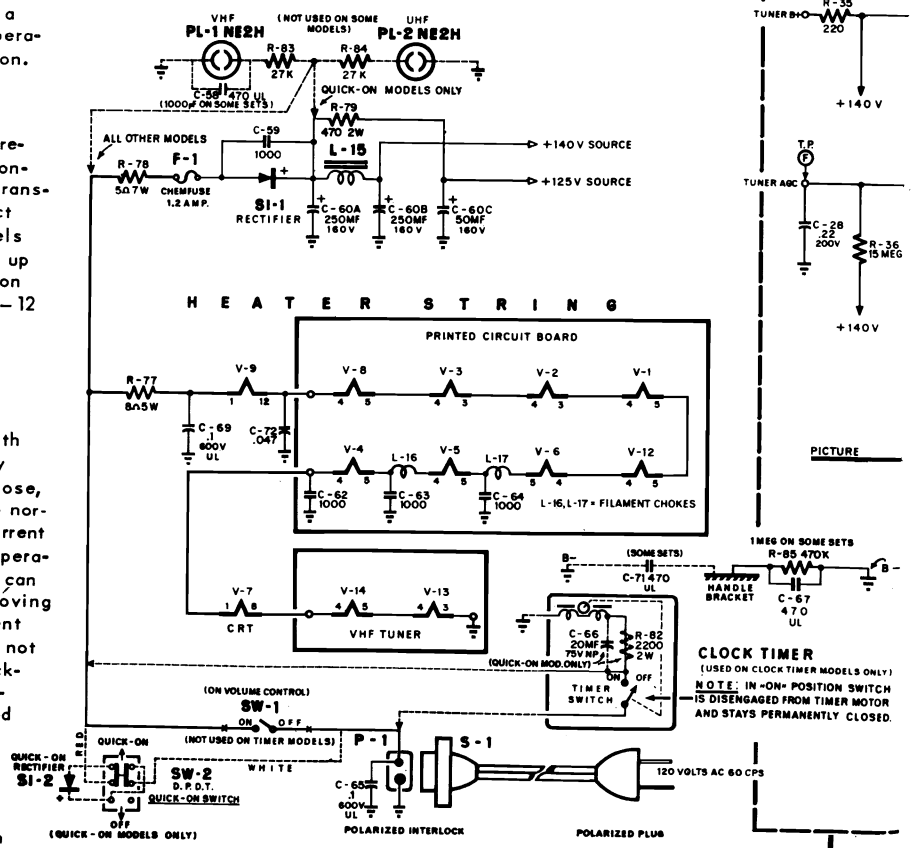

QUICK-ON RECTIFIER S1-2 (QUICK-ON MODELS ONLY)
 QUICK-ON SWITCH SW-2 (NOT USED ON TIMER MODELS)
 P-1 P.D.T.
 S-1 QUICK-ON SWITCH
 POLARIZED INTERLOCK
 POLARIZED PLUG
 120 VOLTS AC 60 CPS
 TIMER SWITCH (USED ON CLOCK TIMER MODELS ONLY)
 NOTE: IN-ON POSITION TIMER SWITCH IS DISENGAGED FROM TIMER MOTOR AND STAYS PERMANENTLY CLOSED.

TV SCHEMATIC - 16 INCH CH. 120840, 120841
 19 INCH. CH. 120842, 846, 847, 848

EMERSON - DUMONT Chassis 120840B, etc., Schematic Diagram, Continued

PRINTED CIRCUIT BOARD

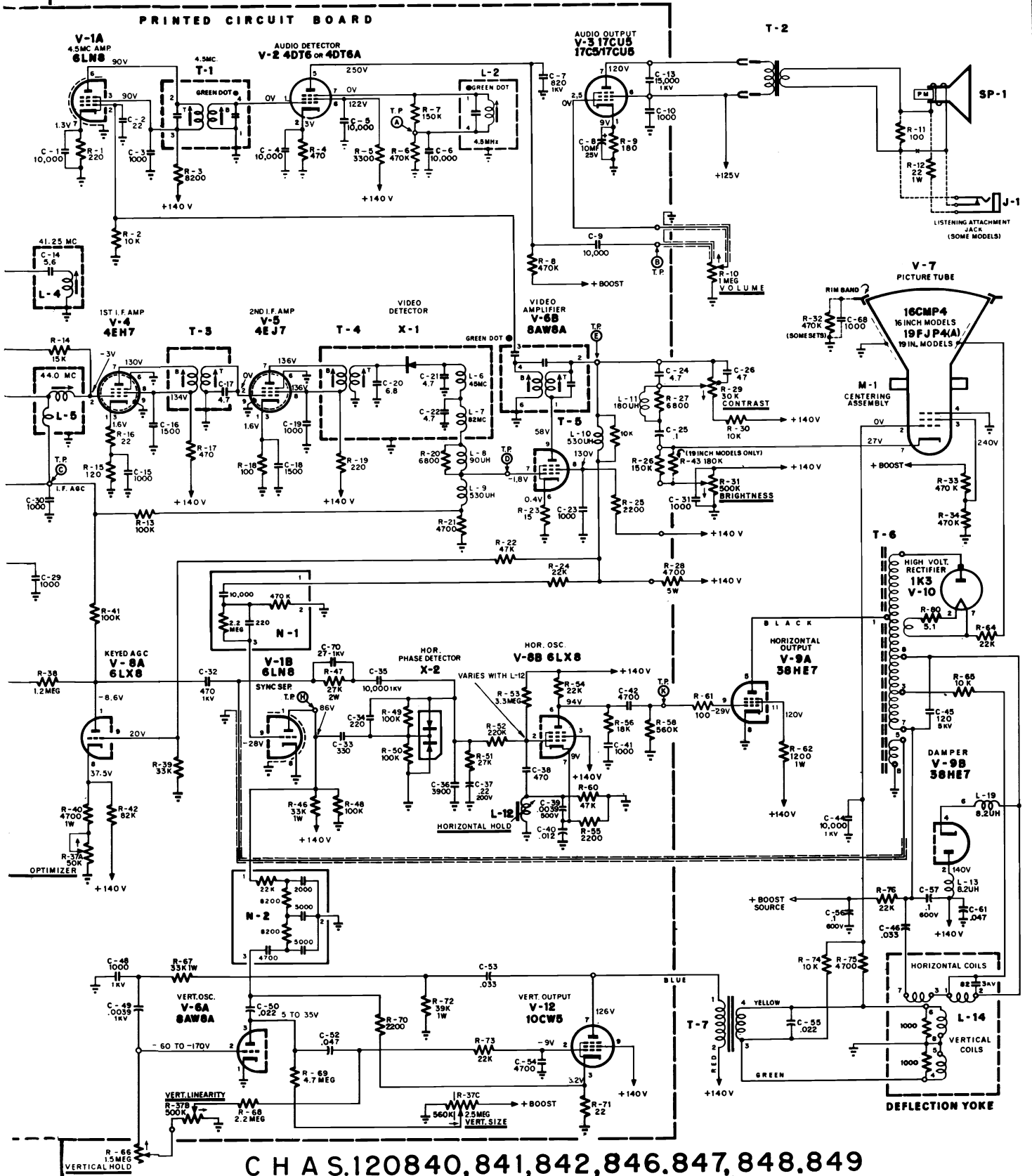

C H A S. 120840, 841, 842, 846, 847, 848, 849

Chassis 120837, 120839, 120843 (using 23HWP4) are practically the same.

ALIGNMENT INFORMATION

ADJUSTMENT PROCEDURE - I-F STAGES, TRAPS AND TUNER OUTPUT COIL

1. Connect an oscilloscope (through a 10k isolation resistor) to pin 7 of V-6B (grid of video amplifier). Scope should be adjusted so that 2 inches of vertical deflection represents approximately 2 volts P-P output.
2. Connect -4.5 volts bias to the I-F AGC test point (Test point "C"), the junction of C-27 and C-30.
3. Connect a terminated sweep generator, adjusted to sweep between 40 and 50 mc, to pin 2 of V-5 (grid of second I-F amplifier) through a 1,000 pf isolation capacitor.
Note: If sweep generator does not have internal markers, a separate marker should be loosely coupled to the output of the sweep generator.
4. Adjust T-4 top and bottom simultaneously for maximum gain and symmetry about the 44.0 mc marker as shown in Fig. 1. (Use core positions nearest outside ends of coil.) With input signal maintained to produce 2 volts P-P output during final adjustment, bandwidth markers should fall between the tolerances indicated.
5. Disconnect generator output leads from grid of second I-F amplifier and connect them to pin 2 of V-4 (grid of first I-F amplifier).
6. Adjust T-3 top and bottom simultaneously for over-coupled response as shown in Fig. 2. (Use core positions nearest outside ends of coil.) With input signal maintained to produce 2 volts P-P output during final adjustment, bandwidth markers should fall between the tolerances indicated.

Note: The correct overcoupled response is indicated when slight rocking of T-3 core settings do not change the amplitude of the 44.0 mc marker, but cause the response to rock or slide about this marker.
7. Reduce the amount of bias applied to the I-F AGC test point (test point "C") to -1.5 volts.
8. Disconnect generator output leads from grid of the first I-F amplifier and couple them to the mixer tube (V-14) of the VHF tuner, using the signal injection shim described below. If this is impractical, connect the generator output leads to the I-F mixer point on the tuner, using the coupling network shown in Fig. 3.

Note: A signal injection shim may be easily constructed by pasting a thin piece of metal foil (approx. 1/2" x 2") on a slightly larger piece of heavy paper. Insert this shim between the mixer tube and its shield in such a manner that the foil side faces the tube, and rotate for maximum signal coupling.
9. Open trimmer CT-1 three turns from its fully closed position and adjust output of generator to produce approximately 2 volts P-P indication on scope.
10. Adjust the tuner output coil (T-9) for maximum gain and symmetry about the 44.0 mc marker.
11. Adjust the 41.25 mc trap (L-4) and the 47.25 mc trap (L-3) for minimum output at these frequencies (as indicated by their respective markers on the 'scope), increasing generator output as required to insure maximum effectiveness of the trap settings.
12. Reduce output of generator to produce approximately 2 volts P-P deflection on 'scope and re-adjust the tuner output coil (T-9) for maximum gain and bandwidth about the 44.0 mc marker.

13. Disconnect oscilloscope from pin 7 of V-6B and connect to pin 7 of V-4 (plate of first I-F amplifier), using a low impedance crystal detector probe as shown in Fig. 8. 'Scope should be calibrated so that 2 inches of vertical deflection now represents approximately 0.2 volts P-P.
14. Reduce output of generator until a usable display is produced on the oscilloscope and again adjust the tuner output coil (T-9), this time tuning for maximum gain midway between the peaks of the band-pass as indicated in Fig. 4. The 44.0 mc marker should fall between the tolerances indicated.
15. Maintain generator output to produce approximately 0.2 volts P-P indication on the oscilloscope (as above) and adjust the grid coil (L-5) to center the 44.0 mc marker on the peak of the response as indicated in Fig. 5, disregarding the tilt of the overall waveshape.
16. Adjust the input trimmer (CT-1) to position the 42.25 and 45.75 mc markers at equal amplitudes and center the 44.0 mc marker with the tuner output coil (T-9), if necessary.
17. With generator output increased to maximum, check the position of the 41.25 mc and 47.25 mc traps (L-4 and L-3), and re-adjust if necessary.
18. Re-adjust generator output to produce a 0.2 volt P-P indication on the scope and observe the response. The curve obtained should conform to Fig. 6.
19. Disconnect the crystal detector probe and connect the oscilloscope to pin 7 of V-6B (grid of the video amplifier) directly through a 10K isolation resistor.
20. Increase bias voltage to -4.5 volts and adjust the oscilloscope so that 2 inches of vertical deflection is equivalent to approximately 2 volts P-P output. Adjust output of signal generator until a 2 volt P-P indication is obtained on the 'scope. Response curve and marker positions should conform to Fig. 7.
21. Remove AGC bias from test point "C". Output signal as indicated on the 'scope should increase, and noise signal on baseline should have an amplitude of at least 1/8 inch.

CAUTION - No attempt should be made to improve a response curve which conforms to that shown in Fig. 7.

- a) To position the 45.75 mc marker adjust T-3, bottom slug.
- b) To position the 42.25 mc marker adjust T-4, bottom slug.
- c) To correct tilt, adjust T-9, the tuner output coil.

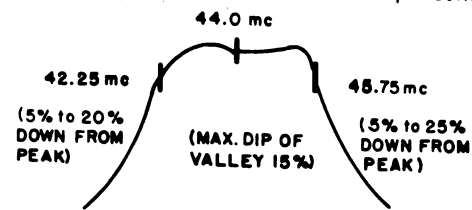

FIG. 1

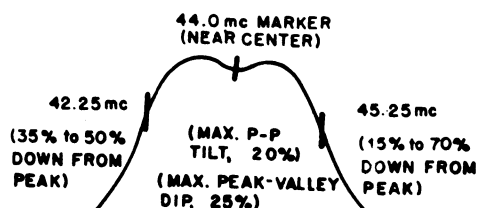

FIG. 2

EMERSON - DUMONT Alignment Information, Continued

ADJUSTMENT PROCEDURE - SOUND TAKE-OFF, SOUND INTERSTAGE, SOUND DETECTOR & 4.5 MC TRAP

1. With antenna connected directly to VHF terminals of receiver, set the channel selector to a strong local station and adjust the fine-tuning control until a 4.5 mc beat is just visible in the picture being viewed.
2. Adjust the 4.5 mc sound trap (T-5, top slug) until the 4.5 mc beat in the picture is either at minimum or is completely eliminated.
3. Adjust the sound quadrature coil (L-2) for loudest sound consistent with minimum buzz, using the second peak from the top of the coil.
4. Using some form of attenuation between the antenna and the VHF input terminals, gradually reduce the

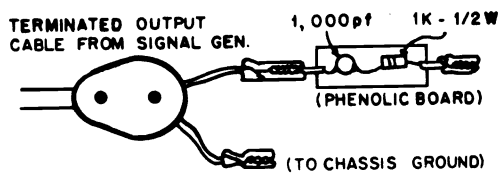

FIG. 3 - GENERATOR COUPLING NETWORK (REFER TO STEP NO. 8)

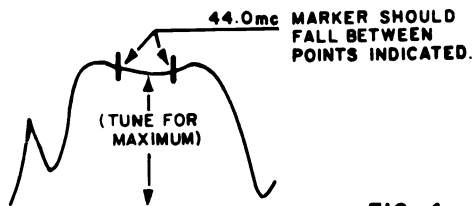

FIG. 4

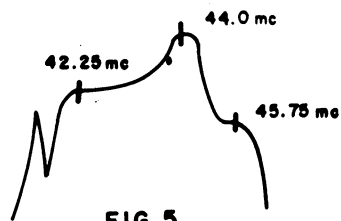

FIG. 5

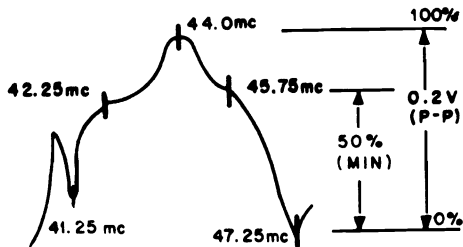

FIG. 6

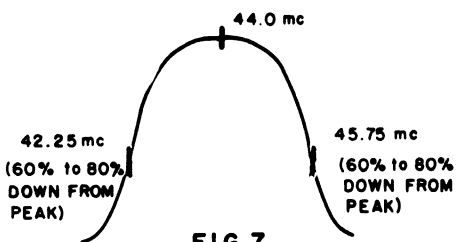

FIG. 7

level of the input signal until distortion is noticeable in the audio output.

5. Adjust the sound take-off transformer (T-5, bottom slug) and the sound interstage coil (T-1) for loudest and clearest sound.
6. Keep reducing the level of the input signal until sound distortion again occurs, and re-tune T-5 bottom slug and T-1 for loudest and clearest sound. Repeat this procedure until no further improvement can be noted.
7. Re-connect antenna directly to VHF terminals of receiver (attenuator removed) and touch-up quadrature coil (L-2) for minimum buzz in sound.

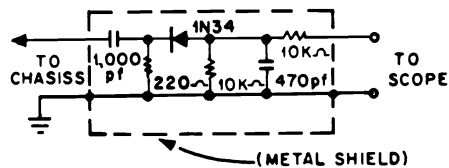
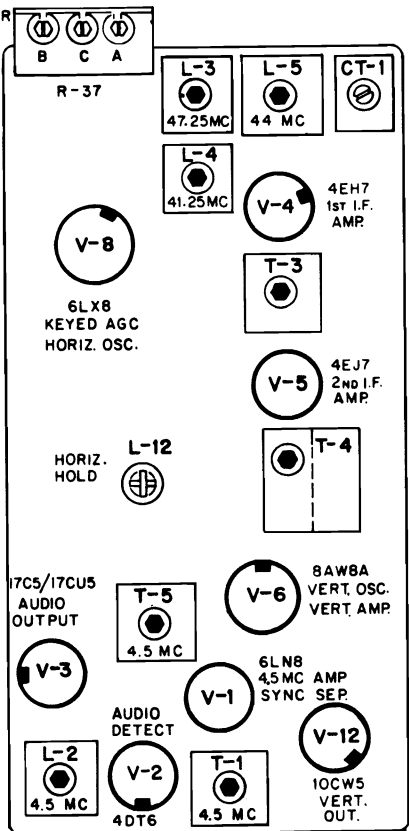

FIG. 8 - LOW IMPEDANCE CRYSTAL DETECTOR PROBE. (REFER TO STEP NO. 13)

(A) PICTURE OPTIMIZER (AGC CONTROL)
(B) VERTICAL LIN.
(C) VERTICAL SIZE



(A) PRINTED CIRCUIT CHASSIS

TUBE LOCATION AND ALIGNMENT POINTS

Emerson

DU MONT

MODEL/CHASSIS/CRT CROSS-REFERENCE

MODEL NO.	CABINET STYLE	TV CHASSIS	CRT TYPE
13C12	CONSOLE	120806-A,B	23GFP4
13C14			
13C15			
* 13K05	LOWBOY	120807-A,B	23GFP4
13T02	TABLE MODEL		
* 13T04			
19P14	PORTABLE	120804-A	19EDP4
19P14A		120805-A,B	or
* 19P15			19DRP4
* 19P21			
* 19P22		120823-B	

*SPECIAL FEATURES:

13K05 AM/FM MPX/Stereo High-Fidelity Combination
 13T04, 19P22 Wireless Remote Control
 19P15, 19P21 Automatic Timer Assembly

CHASSIS AND TUNER CROSS-REFERENCE

CHASSIS NO.	VHF TUNER	UHF TUNER
120804A, 805A, 806A	471616	471619
120805B, 806B		471648
120807A	471623	471619
120807B, 823B		471648

MODEL / CHASSIS / CRT CROSS - REFERENCE

Model No.	Model Name	Cabinet Style	Chassis No.	CRT Type
* 43T02	Sheldon	Table	120807A, B	23GFP4
43T03	Kingston	Model	120806A, B	
43C07	Adams	Consolette		
43C08	Bedford	Console	120806B	
43C09	Francaise			
43C10	Romano			
49P04	Mercury	Portable	120804A, B	19EDP4 (or)
* 49P05	Polaris		120805A, B	19DRP4

* SPECIAL FEATURES:

43T02 - Wireless Remote Control
 49P05 - Automatic Timer Assembly

CHASSIS & TUNER CROSS-REFERENCE

Chassis Number	VHF Tuner	UHF Tuner
120804A, 805A, 806A	471616	471619
120804B, 805B, 806B		471648
120807A	471623	471619
120807B		471648

GENERAL DESCRIPTION

The models described in this Service Note are 82-channel television receivers, designed for the monochrome reception of all programs telecast within the UHF and VHF tuning ranges. They are equipped with a set of built-in antennae which serve to provide adequate signal pickup in almost all metropolitan area installations, and have provisions for the connection of external UHF and VHF antennae, if desired.

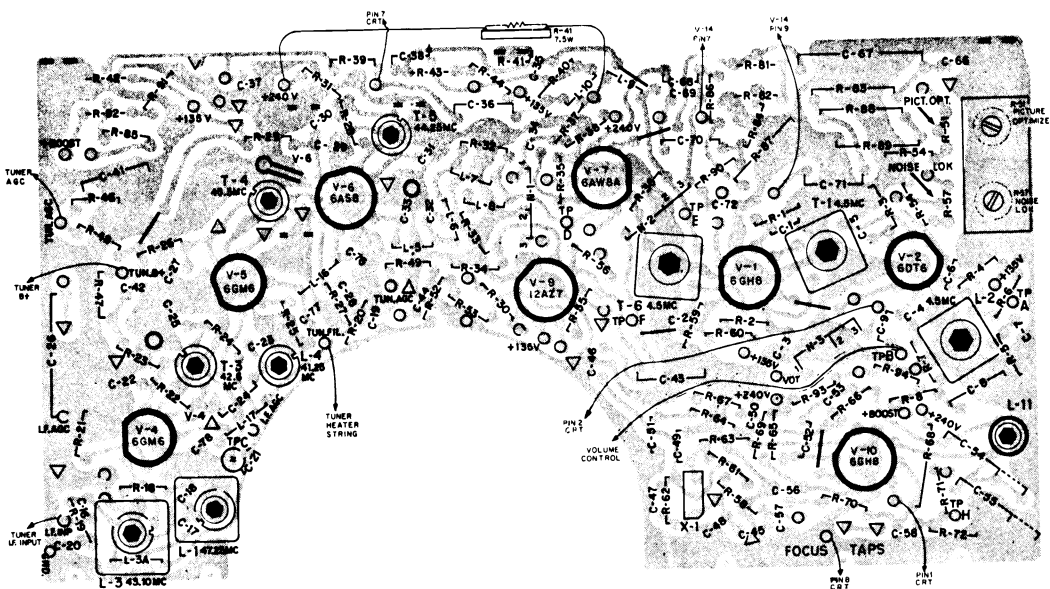

ETCHED PRINTED CIRCUIT BOARD, TOP VIEW

EMERSON - DU MONT Chassis 120804/807 Schematic Diagram, Continued

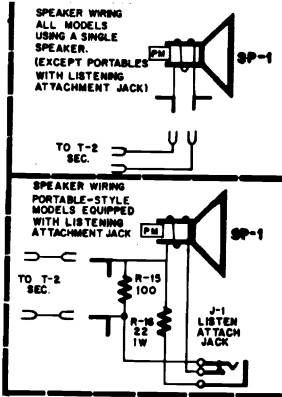
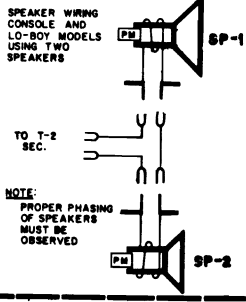

NOTE: PART NUMBERS FOR SPEAKERS LISTENING ATTACHMENT JACKS AND ASSOCIATED ITEMS ARE CONTAINED IN THE CABINET PARTS LISTS

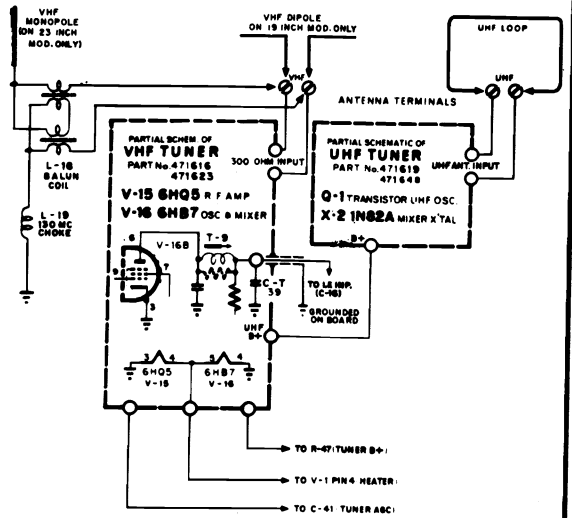

VOLTAGES and WAVESHAPES were taken under actual operating conditions (normal picture and sound). AGC voltage developed at junction of C-19, C-21 and R-20 was minus 4.6 volts. Voltage and waveshape readings obtained may vary $\pm 10\%$ in value due to component tolerances and strength of input signal to chassis under test. Frequencies indicated for waveshapes shown in schematic diagram are approximate sweep settings for oscilloscope used (one-half actual frequency of signal being measured).

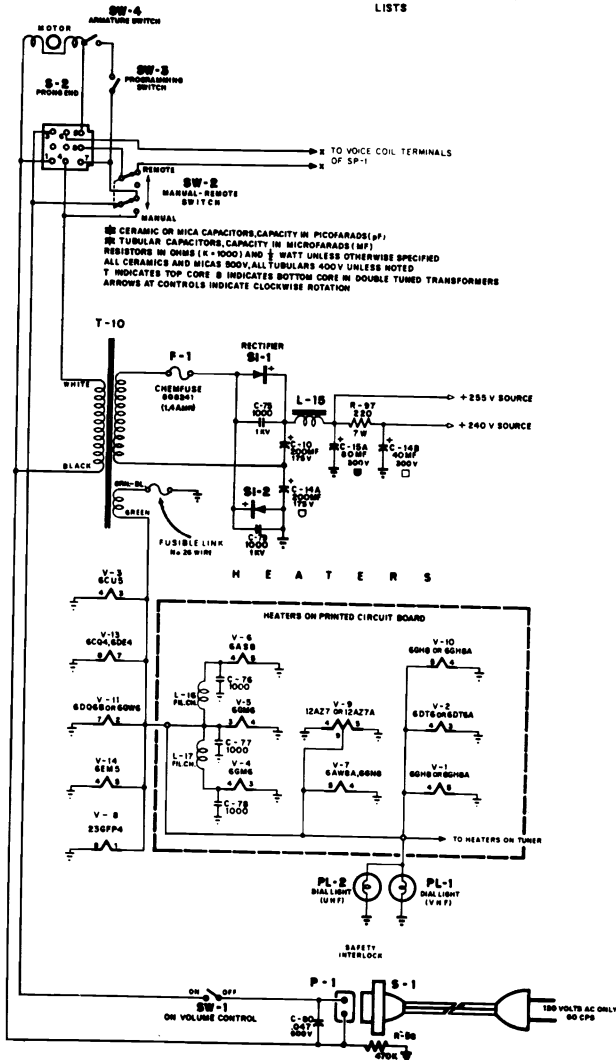

SCHMATIC DIAGRAM (PARTIAL), CH. 120807, 823 AC Input & Motorized Tuning Circuits used with wireless Remote Control.

- SW-2 510237 Manual/Remote Sw. - DPDT
- SW-3 965453 Programming Switch (Part of VHF Tuner)
- SW-4 962755 Armature Switch (Part of Motorassy)

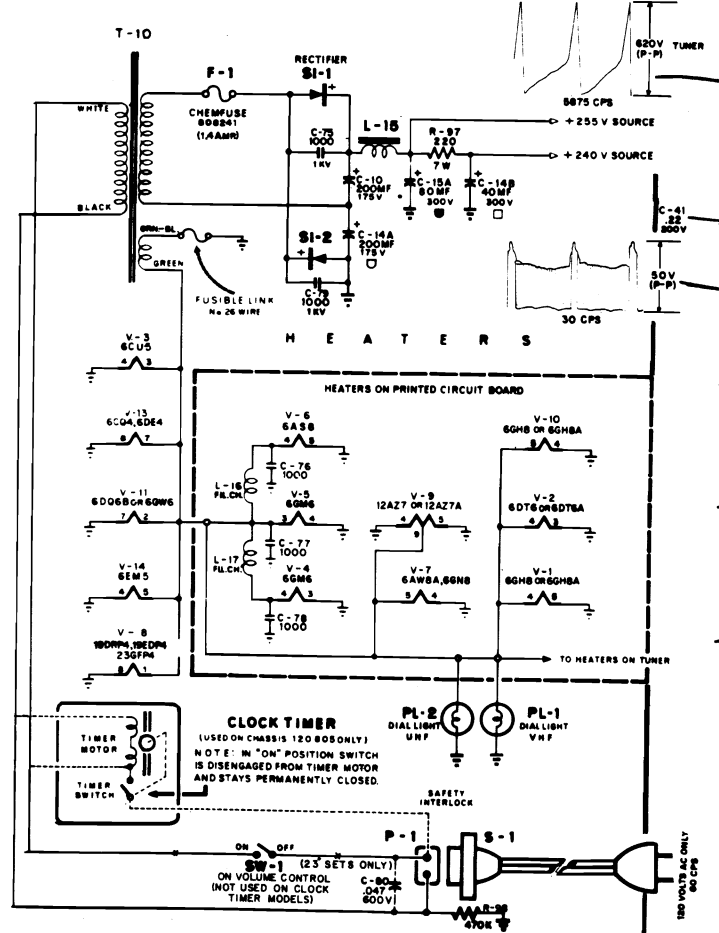

For wiring diagram of AC input and motorized tuning circuits used with wireless remote controlled chassis 120807 and 120823, refer to the partial schematic diagram

EMERSON - DUMONT Chassis 120804/807 Schematic Diagram, Continued

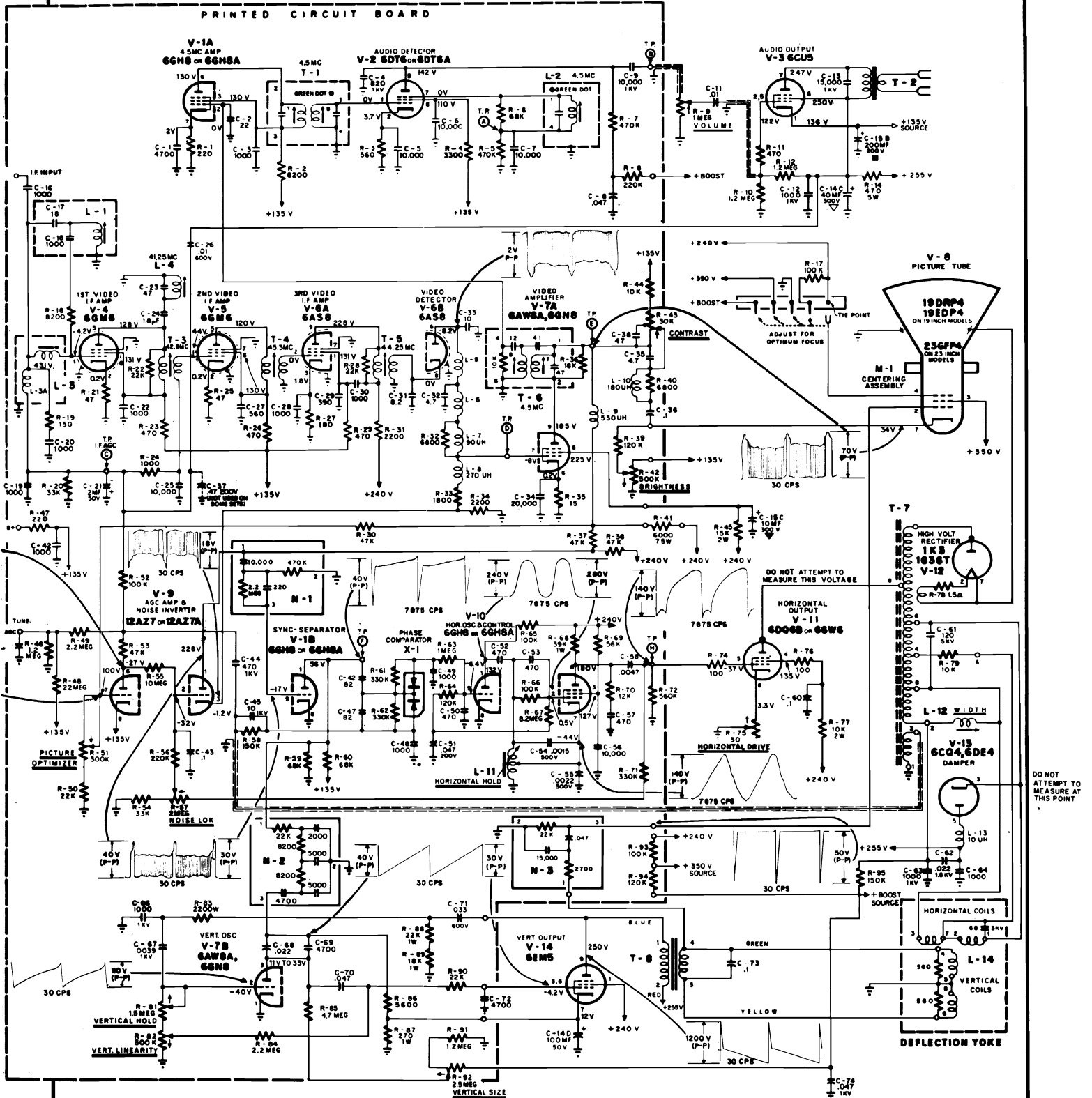

CHASSIS No.120804, 805, 806, 807, 823.

☐ CERAMIC OR MICA CAPACITORS, CAPACITY IN PICOFARADS (PF)
 ☐ TUBULAR CAPACITORS, CAPACITY IN MICROFARADS (MF)
 RESISTORS IN OHMS (K = 1000) AND 1/2 WATT UNLESS OTHERWISE SPECIFIED
 ALL CERAMICS AND MICAS 500V, ALL TUBULARS 400V UNLESS NOTED
 T INDICATES TOP CORE B INDICATES BOTTOM CORE IN DOUBLE TUNED TRANSFORMERS
 ARROWS AT CONTROLS INDICATE CLOCKWISE ROTATION

TV CHASSIS ALIGNMENT INFORMATION

GENERAL ALIGNMENT NOTES:

- Set tuner to highest unused channel and allow both chassis and equipment to warm up for ten minutes or more.
- Connect -3 volts bias through a 10K resistor to the AGC test point (junction of C-19, C-21 and R-20).
- Maintain signal generator output no higher than necessary to produce a reading not to exceed two volts on VTVM and use insulated alignment tools for adjusting.
- Video IF alignment requires the use of a shim for signal injection. This can be easily constructed by pasting a thin piece of metal foil, (approx. $\frac{1}{2} \times 2''$) on a slightly larger piece of heavy paper. Insert this shim between the tuner mixer tube and its shield in such a manner that the foil side faces the tube.

VIDEO IF ALIGNMENT

- Connect high side of signal generator to metal foil on shim, low side to chassis through a .001 mfd. capacitor.
- Place a VTVM (-5 volt range) at video detector test point (junction of L-7 and L-8), common lead to chassis.
- Peak the following for MAXIMUM response at the frequencies specified:
T-5 at 44.25 MC, T-4 at 45.3 MC, T-3 at 42.8 MC
- Tune the following for MINIMUM response, increasing signal generator output as necessary:
L-4 at 41.25 MC, L-1 at 47.25 MC, L-3 at 45.0 MC
- Peak T-9 on tuner for MAXIMUM output at 45.0 MC.
- Set generator at 43.1 MC and re-tune L-3 for MAXIMUM output.

To observe the IF response curve connect an oscilloscope, thru a 10,000 ohm isolation resistor, in place of the VTVM. Inject a sweep signal (40 to 50 MC) along with a loosely coupled marker generator at the mixer tube in the manner described above. Adjust the output of the sweep generator to produce about 2 volts peak to peak curve on the oscilloscope and reduce the marker signal so as not to upset the response curve. The 45.75 MC marker should appear between 55% and 65% down with respect to the peak.

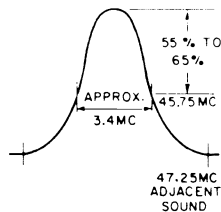

FIG. 5 - OVERALL I.F. RESPONSE CURVE

SOUND IF ALIGNMENT

- Using a strong T.V. transmitted signal, adjust T-6, sound take-off transformer, bottom, and T-1, sound interstage transformer, top and bottom, for the loudest sound.
- Adjust L-2, quadrature coil, for clearest and loudest sound. If two peaks are encountered, use the position where the slug is closer to the circuit board.
- With the antenna loosely coupled to the set, (simulating a weak signal) repeat step No. 1, tuning for maximum volume and minimum distortion.
- If a VTVM is available, measure the voltage across R-5, 470K resistor. Voltages should be between -3 and -10 volts and not vary by more than 3 volts between a strong and weak signal.
- Check sound on all channels and repeat entire procedure if necessary.

4.5 MC VIDEO TRAP ALIGNMENT

- Tune in a local station and adjust the fine-tuning control until a 4.5 MC beat is visible in the picture.
- Adjust T-6 (top) for minimum 4.5 MC beat on screen.

FOCUS ADJUSTMENT

Any one of four different voltages (available at the quadruple terminal strip mounted directly below the Hor. Osc. tube) may be utilized as a focus potential. Remove the insulated clip-lead connector (attached to one of the terminals on this strip) and alternately try connecting it to each possible terminal, leaving it connected to the one which gives the best overall focus.

HORIZONTAL SIZE ADJUSTMENT

The chassis described in this Service Note have been designed to provide proper horizontal sweep under the normal variations usually encountered in line voltages. Should unusually low or high line voltages be encountered, it may be necessary to re-adjust the width control (L-12) for proper horizontal sweep. Turning the control clockwise (inward) will result in increased width, while turning the control counter-clockwise (outward) will reduce the width. When adjusting the width, the Horizontal Drive control setting should also be checked, as outlined below.

HORIZONTAL DRIVE ADJUSTMENT

The horizontal drive control, located just below the horizontal output tube, should normally be in its most clockwise position (minimum resistance in circuit). If overdrive bars (indicated by white vertical lines in the raster) appear at this setting, slowly rotate R-75 in a counterclockwise direction until the lines just disappear.

VERTICAL SIZE AND LINEARITY ADJUSTMENTS

In 19 inch models, vertical size and linearity may be adjusted by inserting a fiber alignment tool into the hollow shafts of the brightness and vertical hold controls, respectively. Insert alignment tool into the hollow brightness control shaft to adjust vertical size, and into the hollow vertical hold control shaft to adjust vertical linearity.

On 23" models the vertical size and linearity controls are mounted on a separate bracket, located at the top right of the chassis, and are accessible through the two openings in the cabinet back.

PICTURE OPTIMIZER AND NOISE-LOK ADJUSTMENTS

- Rotate the Picture Optimizer and Noise Lok controls fully counterclockwise (as viewed from rear of cabinet).
- Tune to the strongest channel and rotate the Picture Optimizer slowly clockwise until the receiver begins to overload (sync instability, sound buzz, kinks in picture), then back off slightly counterclockwise to eliminate overload, continuing an additional approximate ten degrees beyond this point to assure a proper safety factor. If the receiver does not overload when the control has been rotated fully, leave it in this position.
- With the receiver still tuned to strongest channel, rotate the Noise Lok control slowly clockwise until the picture begins to overload (sync instability, sound buzz, kinks in picture), then back off slightly to eliminate this condition. With controls properly set, switch channels to verify setting for strongest signals. This optimizes operation of the Noise Lok for mixed signal conditions (strong and weak). However, in extreme fringe areas it is possible to improve the picture stability by further clockwise adjustment of the control.

PERSONAL LISTENING ATTACHMENT JACK

The 19-inch models described in this Service Note are equipped with a personal listening attachment jack, designed for use with either a personal listening attachment (part no. 829007) or an under-pillow listening device (part no. 963530).

AUTOMATIC TIMER CONTROL

Models 19P15 and 19P21 are equipped with an automatic timer unit (part no. 471324) which can be set to turn the receiver off after a pre-determined interval ranging from ten minutes to three hours. If desired, the receiver may also be operated in a conventional manner, in which case it will remain in operation until the timer switch is returned to its OFF position.

GENERAL ELECTRIC

VIDEO I-F SYSTEM

AM PRE-PEAKING & TRAP FREQUENCIES

L150Min. 47.25 MC	T151Max. 43.0 MC
L135Max. 45.75 MC	T152Max. 45.2 MC
L151Max. 42.50 MC	L153, L154, Max. 44.15 MC

GENERAL: Allow receiver and test equipment at least 20 minutes warm-up.

- Turn volume control to minimum and contrast control fully clockwise. Set channel selector to unused high VHF channel (9-13) and fine tuning fully counterclockwise.
- Short antenna terminals together.
- Connect oscilloscope to Test Point III thru 22,000 ohms resistor not more than 1.5 inches away from Test Point III. Connect -4.5V bias between Test Point II and chassis.
- Inject signals from a properly terminated AM signal generator or sweep generator, through NETWORK shown. To the I-F injection point on the VHF Tuner as shown in the illustration.
- Align the receiver to produce the response curve illustrated.
- All cores are positioned away from printed board.
- Either a speaker or 3.2 ohm 5W load resistor must be connected to speaker terminals.

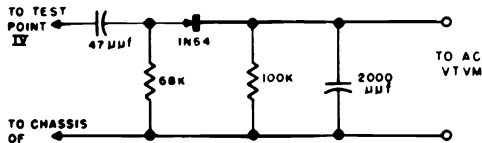

DETECTOR NETWORK

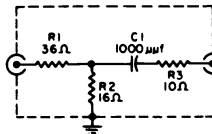

I-F INJECTION NETWORK

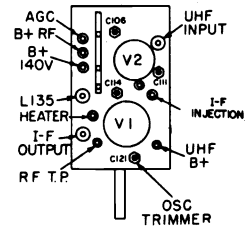

I-F INJECTION

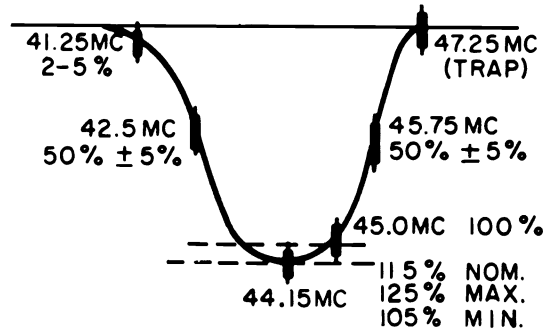

I-F RESPONSE CURVE

AC CHASSIS

- MODELS
M720CMP
M720CWD
M740CWD
M741CWD
M742CMP
M743CCL
M744CPN
M770CWD
M771CMP

- MODELS
M718CWD
M730CMD
M730CWD
M732CMP
M760CMD
M760CWD
M762CMP

VIDEO I-F ALIGNMENT CHART

STEP	SIGNAL FREQUENCY	ADJUST	REMARKS
1	47.25 MC AM	Adjust L150 for minimum scope deflection	Use maximum scope sensitivity and smallest possible signal. Do not retouch this adjustment.
2	38-48 MC sweep generator, with scope calibrated 4 volts peak to peak for 2 inch deflection.	Adjust L154 and L153 in the following sequence: A. Tune L153 core so top of core is flush w/top of coil. B. Tune L154 for max. deflection of 44.15 MC marker. (Do not re-adjust scope) C. Tune L153 for max. deflection of 44.15 MC marker.	Do not retouch these adjustments.
3		L135 (converter plate) for max. deflection of the 45.75 MC marker.	
4		L151 (1st I-F grid) for maximum deflection of the 42.5 MC marker and proper nose shaping.	Symmetry of the nose is important. No portion of the nose should be out of symmetry by more than 3%. Repeat 5, 6, and 7 if necessary.
5		T152 (2nd I-F Plate) to place 45.75 MC marker properly on the curve.	
6		T151 (1st I-F Plate) to place 42.5 MC marker properly on the curve.	
7		L151 if necessary to shape the nose.	

GENERAL ELECTRIC Chassis AC, Servicing Information, Continued

4.5 MC TRAP ALIGNMENT

1. Connect a -7.5V bias to Test Point II, with the positive bias lead grounded to chassis.
2. Turn contrast control to maximum, volume to minimum.
3. Connect the DETECTOR NETWORK shown to Test Point IV and feed its output to an AC VTVM.
4. Apply a 4.5 MC AM signal through a 5µf capacitor at Test Point III.
5. Adjust the top core of T154 for minimum reading on Test Point IV. Two core positions will give an apparent minimum indication, the correct one is the first reached while turning the core from the top end of the coil form toward the circuit board.

NOTE: Retouching of the trap adjustment may be necessary after alignment of the audio takeoff.

AUDIO ALIGNMENT WITH ON-THE-AIR SIGNALS

1. Tune in a strong local signal and set receiver volume to a low audible level.
2. Adjust L301 for maximum undistorted, buzz-free audio output. Start with the core at the outermost position away from the printed board and tune for the second "peak" encountered on the way into the coil form.
3. Connect a variable bias supply (3 to 15V) to the AGC test point with the positive lead to the chassis. Adjust bias until audio signal distorts on peaks slightly, then adjust core of T301 to curb distortion. Repeat this procedure several times at increased bias levels until maximum clarity of audio is obtained.
4. Adjust the bottom core of T154, repeating the bias advances in step 3, to achieve the optimum setting for noise-free performance at low signal levels.

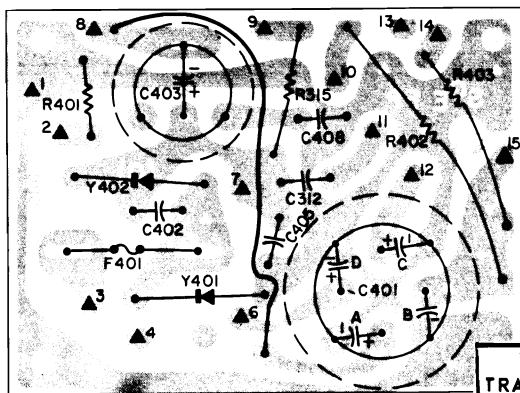

POWER SUPPLY CIRCUIT BOARD

COILS & TRANSFORMERS

- L150-B7
- L151-D7
- L152-B7
- L153-N7
- L154-O7
- L157-P7
- L158-O5
- L160-P7
- L161-O3
- L162-Q4
- L301-C1
- T151-E5
- T152-T7
- T154-M3
- T301-H2

IF BOARD COMPONENT LOCATION

TRIANGLE (▲-O) NUMBERS

REPRESENT WIRE WRAP TERMINALS ON COMPONENT BOARD FOR CONNECTION OF WIRES TO POINTS INDICATED.

- ▲ 1. WIRE TO T302 (SECONDARY)
- ▲ 2. YELLOW AUDIO CABLE WIRE TO R309 (VOLUME)
- ▲ 3. GREY WIRE TO TUNER AGC
- ▲ 4. WHITE SHIELDED CABLE FROM TUNER I-F OUTPUT
- ▲ 5. GREEN AUDIO CABLE WIRE TO R309 (VOLUME)
- ▲ 6. VIOLET WIRE TO ▲-9 ON POWER SUPPLY BD.
- ▲ 7. WIRE TO T302 (SECONDARY)
- ▲ 8. VIOLET WIRE TO ▲-11 ON POWER SUPPLY BD & TO T302 PRIMARY
- ▲ 9. BLUE WIRE TO ▲-15 ON SWEEP BD
- ▲ 10. GREEN WIRE TO ▲-6 ON SWEEP BD.
- ▲ 11. ORANGE WIRE TO ▲-12 ON POWER SUPPLY
- ▲ 12. NO 26 GAUGE (LINK) TO ▲-13 ON POWER SUPPLY
- ▲ 13. BROWN WIRE TO ▲-1 ON SWEEP BD
- ▲ 14. BROWN WIRE TO TUNER FILAMENT SUPPLY
- ▲ 15. ORANGE AND WHITE WIRE TO R169 (CONTRAST)
- ▲ 16. GREEN WIRE TO R169 (CONTRAST)
- ▲ 17. YELLOW WIRE TO PIN 7 OF PICTURE TUBE
- ▲ 18. BLUE WIRE TO R173 (BRIGHTNESS)
- ▲ 19. SHIELDED CABLE GROUND CONNECTION
- ▲ 20. RED WIRE TO ▲-15 ON POWER SUPPLY BD.

CAPACITORS

- C150-C8
- C154-A8
- C155-H8
- C156-E6
- C158-G4
- C159-H6
- C160-H7
- C163-L6
- C164-L2
- C165-M7
- C166-N8
- C167-O8
- C168-N7
- C169-N2
- C172-P4
- C175-K1
- C176-F9
- C178-I4
- C179-M3
- C303-I2
- C304-I3
- C305-F2
- C306-C3
- C307-A3
- C308-C2
- C311-K1
- C318-B2

RESISTORS

- R151-C8
- R152-A6
- R153-E8
- R154-H6
- R157-I8
- R158-B6
- R159-G6
- R160-H6
- R161-M6
- R163-J6
- R166-O2
- R167-J5
- R168-M1
- R171-Q4
- R172-O6
- R174-L2
- R176-F9
- R177-G4
- R178-H5
- R179-O4
- R180-L3
- R182-O7
- R183-H9
- R184-I5
- R185-O5
- R302-I4
- R304-G1
- R305-C4
- R307-D4
- R310-D5
- R312-J1
- R318-B2

TEST POINTS

- II-G9
- III-N5
- V1-L2

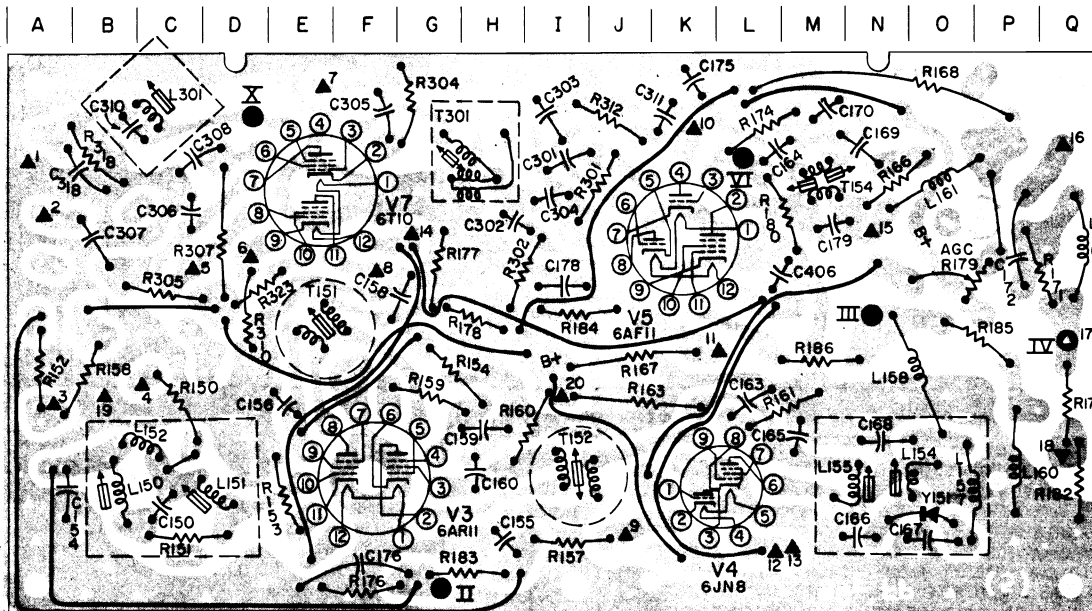

IF CIRCUIT BOARD COMPONENT VIEW

GENERAL ELECTRIC Chassis AC, Schematic Diagram

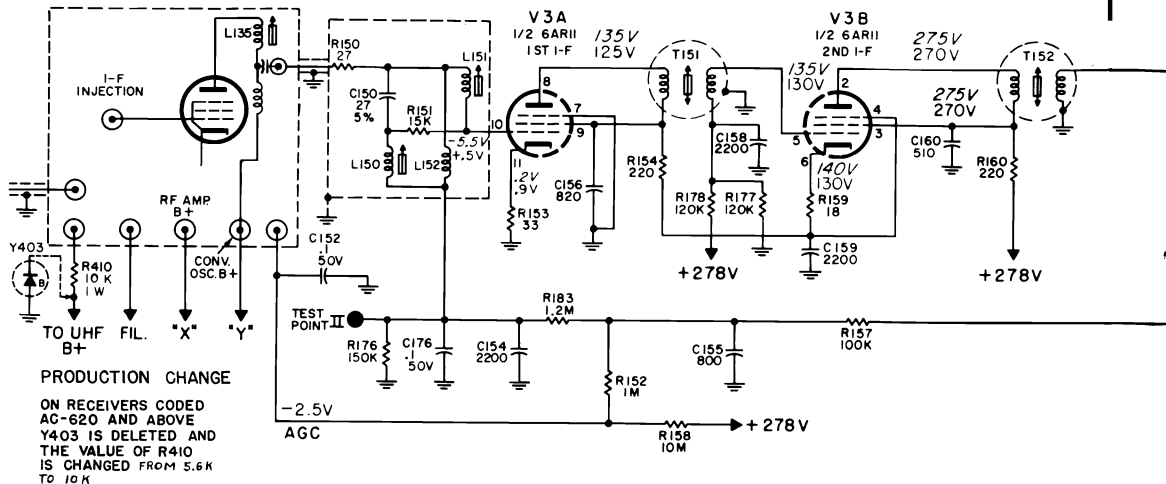

UNLESS OTHERWISE NOTED
K=1000 M=1,000,000
CAPACITORS MORE THAN 1 μ f+pf
CAPACITORS LESS THAN 1 μ f
RESISTORS ARE 1/2 WATT

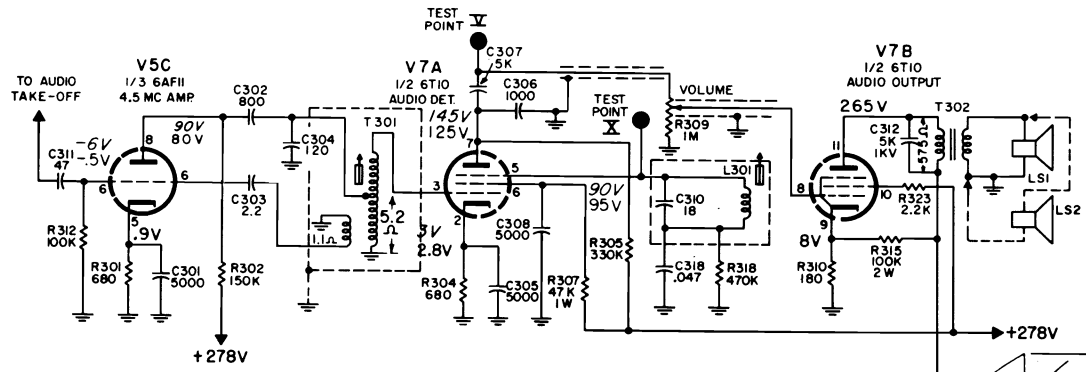

- ALL VOLTAGE MEASUREMENTS MADE WITH A VTVM WITH RESPECT TO CHASSIS GROUND, RECEIVER CONTROLS SET FOR NORMAL OPERATION. MEASUREMENTS MAY DEVIATE $\pm 10\%$ AT 120V AC LINE VOLTAGE
 - WHERE ON-SIGNAL AND OFF-SIGNAL MEASUREMENTS VARY, TWO VOLTAGES ARE SHOWN. ON-SIGNAL VOLTAGE APPEARS IN *ITALICS* OVER OFF-SIGNAL VOLTAGE
ON-SIGNAL VOLTAGES & WAVE SHAPES TAKEN WITH A NOISE FREE SIGNAL PRODUCING -2.5 TO -3.5 VOLTS AGC AT VHF TUNER
OFF-SIGNAL VOLTAGES TAKEN WITH ANTENNA DISCONNECTED & ANTENNA TERMINALS SHORTED TOGETHER ON UNUSED CHANNEL
- INDICATES VARIATION WITH CONTROL SETTING
** - INDICATES SCOPE SYNCHED AT 1/2 VERT FREQ
*** - INDICATES SCOPE SYNCHED AT 1/2 HORIZ FREQ

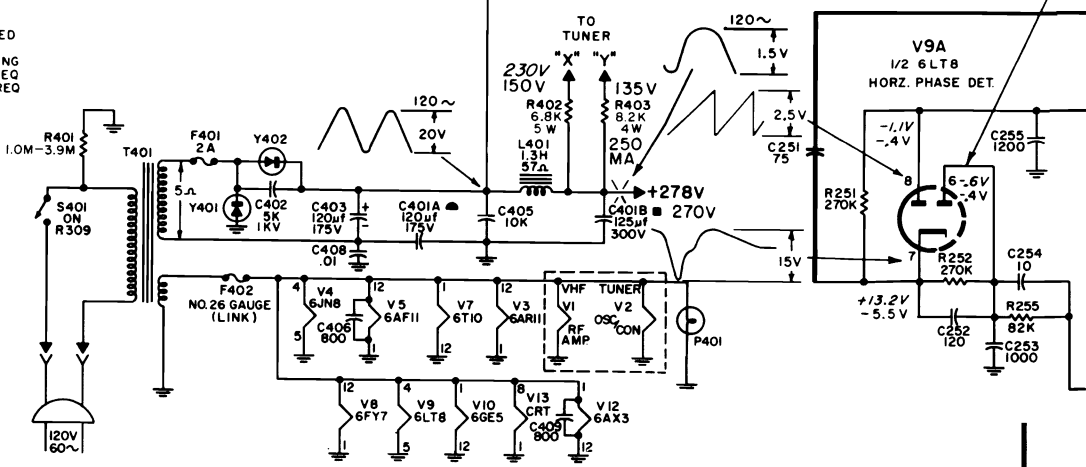

GENERAL ELECTRIC Chassis AC, Schematic Diagram, Continued

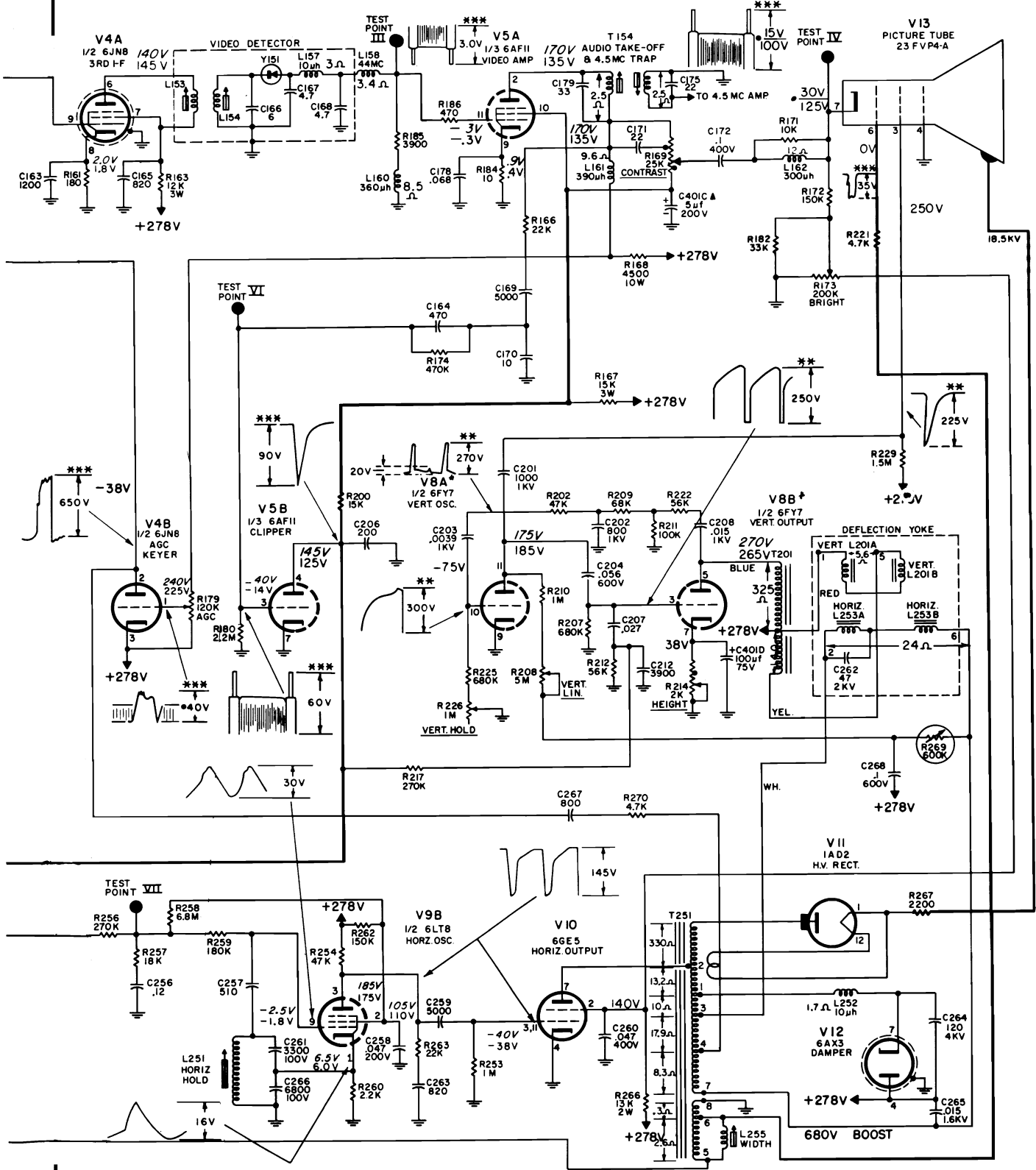

AC CHASSIS SCHEMATIC DIAGRAM

* SOME V8 ARE 6FM7

GENERAL ELECTRIC

DC CHASSIS

MODELS

M400CGR
M401CSD
M402CWD
M403CWD
M403CEB
M403CVY
M405CWD
M407CVY
M407CWD
M423CBG
M425CBH
M425CWD
M452CEB
M454CVY
M454CWD
M503CSD

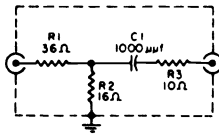

I-F INJECTION NETWORK

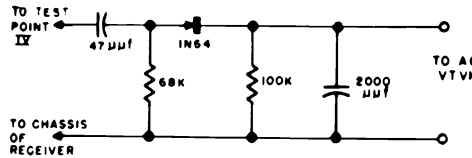

DETECTOR NETWORK

VIDEO I-F SYSTEM

GENERAL: Allow receiver and test equipment at least 20 minutes warm-up. Power the receiver from an isolation transformer.

1. Turn volume control and fine tuning counterclockwise, and contrast control fully clockwise. Set channel selector to Channel 11. Short antenna terminals together.
2. Connect oscilloscope to Test Point III thru 22,000 ohms resistor not more than 2.5 inches away from Test Point III. Connect a variable bias supply (0-20V) between Test Point II and chassis.
3. Inject signals from a properly terminated AM signal generator or sweep generator, through the I-F INJECTION NETWORK shown, to the I-F injection point. This point is accessible at the base of the Converter (V2) on the top deck of the VHF tuner.
4. Align the receiver to produce the response curve illustrated.
5. Position all cores at ends of coils away from circuit board.

AM PRE-PEAKING & TRAP FREQUENCIES

L150 Min. 47.25 MC	T151 Max. 42.8 MC
L160 Min. 41.25 MC	L151 Max. 42.50 MC
L135 Max. 45.00 MC	L154, L153 . Max. 44.15 MC

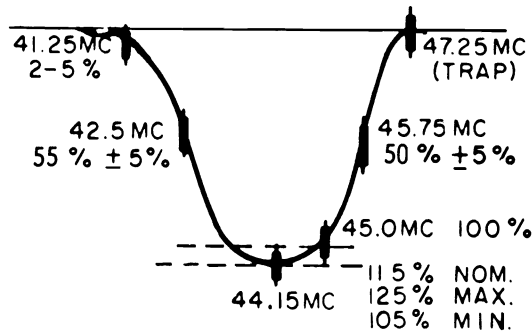

I-F RESPONSE CURVE

VIDEO I-F ALIGNMENT CHART

STEP	SIGNAL FREQUENCY	ADJUST	REMARKS
1	47.25 MC AM (Bias OV)	Adjust L150 for minimum scope deflection	Use maximum scope sensitivity and smallest possible signal for the 47.25 MC AM and 41.25 MC AM adjustments.
2	41.25 MC AM (Bias OV)	Adjust L160 for min. deflection	
3	42.8 MC AM (Bias OV)	Adjust T151 for max. deflection	Position L153 core barely in the top of the coil, then peak L154. Next peak L153. Do not retouch these adjustments.
4	44.15 MC AM (Bias -3.5V)	Adjust L154, then L153 for max.	
5	44.15 MC AM (Bias -3.5V)	L135 for max. at 45 MC and placement of 45.75 MC marker	
6	38-48 MC sweep generator, with scope calibrated 3 volts peak to peak for 2 inch deflection; markers at 41.25, 42.5, 44.15, 45.0 MC & 45.75 MC	T151 for placement of 42.5 MC marker.	Symmetry of the nose is important. No portion of the nose should be out of symmetry by more than 3%. Repeat last four steps if necessary.
7		L151 for max. at 42.5 MC and shaping of nose around 44.15 MC	
8		Knife the coil of L152 if the 42.5 MC marker is above 55% on the curve.	

4.5 MC TRAP ALIGNMENT

1. Connect a -15V bias to Test Point II, with the positive bias lead grounded to chassis.
2. Detune L302 by placing the core at the top of the coil.
3. Turn contrast control to maximum, volume to minimum.
4. Connect the DETECTOR NETWORK shown to Test Point IV and feed its output to an AC VTVM.
5. Apply a 4.5 MC AM signal through a capacitor at Test Point III.
6. Adjust the top core of T154 for minimum reading on Test Point IV. Two core positions will give an apparent minimum indication, the correct one is nearer the top end of the coil form.

NOTE: Retouching of the trap adjustment may be necessary after alignment of the audio take-off.

AUDIO ALIGNMENT WITH ON-THE-AIR SIGNALS

1. Tune in a strong local signal and set receiver volume to a low audible level.
2. Adjust L302 for maximum undistorted, buzz-free audio output. Start with the core at the outermost position away from the printed board and tune for the second "peak" encountered on the way into the coil form.
3. Connect a variable bias supply (3 to 15V) to the AGC test point with the positive lead to the chassis. Adjust bias until audio signal distorts on peaks slightly, then adjust core of L301 to curb distortion. Repeat this procedure several times at increased bias levels until maximum clarity of audio is obtained.
4. Adjust the bottom core of T154, repeating the bias advances in step 3, to achieve the optimum setting for noise-free performance at low signal levels.

GENERAL ELECTRIC Chassis DC, Servicing Information, Continued

MISC.
F401-P4
Y401-S3
V3 -K5
V4 -V9
V5 -V9
V6 -D10
V7 -C3
V8 -V5



COMPONENT VIEW OF CIRCUIT BOARD

† Used on 21" Models Only
Indicates Production Change

TRIANGLE (▲-O) NUMBERS

REPRESENT INTERCONNECTING WIRES ON COMPONENT BOARD FOR CONNECTION TO POINTS INDICATED.

- ▲ 1. I-F INPUT LEAD
- ▲ 2. I-F SHIELD
- ▲ 3. TO T251, PIN 2 (GRAY)
- ▲ 4. TO R167 (CONTRAST)
- ▲ 5. TO R167 ARM
- ▲ 6. TO V10, PIN 7
- ▲ 7. TO TUNER AGC
- ▲ 8. TO R170 (BRIGHT) ARM
- ▲ 9. TO R205 (V HOLD) ARM
- ▲ 10. TO V10, PIN 3
- ▲ 11. TO R205 (V HOLD)
- ▲ 12. TO T251, TERM. 8 & YOKE TERM. 4 (BOOST)
- ▲ 13. TO T201, (BLUE)
- ▲ 14. TO T201 (ORANGE) & L401
- ▲ 15. TO YOKE TERM. 5 & T201 (YELLOW)
- ▲ 16. TO YOKE TERM. 2 (WHITE) & T251 TERM. 5
- ▲ 17. TO R307 (VOLUME)
- ▲ 18. TO R307 ARM
- ▲ 19. AUDIO CABLE GROUND
- ▲ 20. TO SPEAKER
- ▲ 21. TO SPEAKER
- ▲ 22. TO V10, PIN 8
- ▲ 23. TO V10, PIN 1
- ▲ 24. TO TUNER FIL.
- ▲ 25. TO S401
- ▲ 26. TO T251 TERM. 4
- ▲ 27. YELLOW LEAD TO L401
- ▲ 28. ORANGE (+140V) TO VHF TUNER, R167 (CONTRAST) & YOKE TERM. 1
- ▲ 29. To V10, Pin 3 (21" Models only)

COMPONENT LOCATION

RESISTORS	
R150-H4	R263-W7
R151-H6	R264-R2
R152-H2	R265-D4
R153-J2	R267-F11
R154-J1	R217-H7
R155-J4	R218-H9
R156-L3	R202-G9
R157-H1	R203-H8
R158-G2	R204-I7
R159-F1	R206-P11
R160-M3	R207-Q11
R161-M8	R208-R10
R162-N8	R209-F7
R163-P7	R210-C8
R164-O7	R211-C9
R165-L11	R212-E6
R166-O11	R213-G11
	R262-I17

COILS	
L150-G5	L160-I4
L151-I5	L251-F3
L152-H4	L252-V2
L153-M5	L253-W4
L154-O5	L301-S8
L155-L7	L402-N3
L156-K10	
L157-J9	T151-K2
L158-O6	T154-M10
L159-N7	T301-R5

TEST POINTS
II - H2
III - M7
IV - K8
V - F10
VII - X11

CAPACITORS	
C150-H4	C255-D5
C151-H5	C258-E4
C152-H5	C259-E3
C153-H3	C260-C1
C154-J5	C201-F8
C155-L1	C202-T8
C156-L3	C262-B1
C160-M2	C263-B5
C161-N5	C264-O1
C162-O6	C205-G8
C164-M9	C206-G8
C165-N11	C207-E8
C166-J10	C208-F7
C167-J1	C209-B10
C168-G1	C265-W3
	C266-S2
	C267-B4
	C268-E2
	C269-D2
	C301-P10
	C302-Q8
	C303-Q8
	C304-R9
	C305-R8
	C306-T8
	C307-U10
	C308-V10
	C309-W10
	C310-T10
	C311-R10
	C401-R3
	C402-B7
	C404-V8
	C405-M2
	C407-L6
	C408-J6
	C409-Q4
	C301-Q8
	C302-Q8
	C303-Q8
	C252-F5
	#C410-W5

A | B | C | D | E | F | G | H | I | J | K | L | M | N | O | P | Q | R | S | T | U | V | W | X

GENERAL ELECTRIC

SC CHASSIS

MODELS

M150CWH	M156CEB
M151CAV	M156CVY
M151CEB	M157CEB
M152CBN	M503CWH
M152CGL	M507CEB
M152CVY	M509CBN
	M509CVY

VIDEO I-F SYSTEM

1. Turn volume control and fine tuning counterclockwise, and contrast control fully clockwise. Set channel selector to Channel 11 Short antenna terminals together.
2. Connect oscilloscope to Test Point III thru 22,000 ohms resistor not more than 1.5 inches away from Test Point III. Connect a variable bias supply (0-20V) between Test Point II and chassis. Set bias at -3.5V.
3. Inject signals from a properly terminated AM signal generator or sweep generator, through the I-F INJECTION NETWORK shown, to the I-F injection point. This point is accessible at the base of the Converter (V2) on the top deck of the VHF tuner.
4. Align the receiver to produce the response curve illustrated.

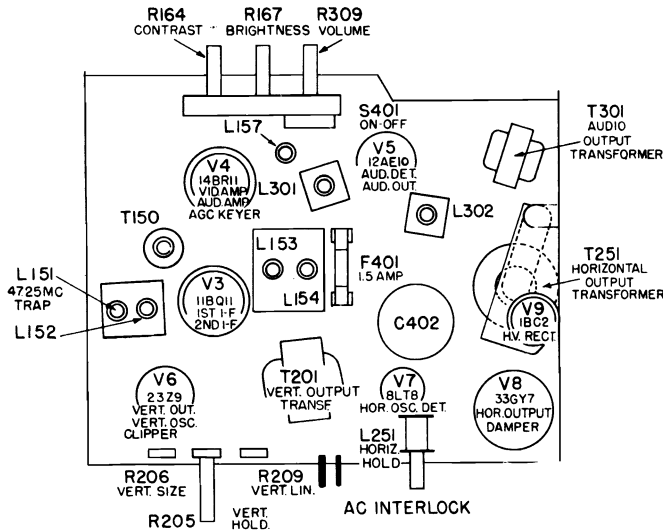

TUBE AND ADJUSTMENT LOCATIONS

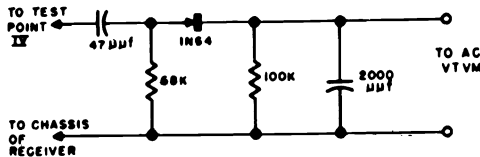

DETECTOR NETWORK

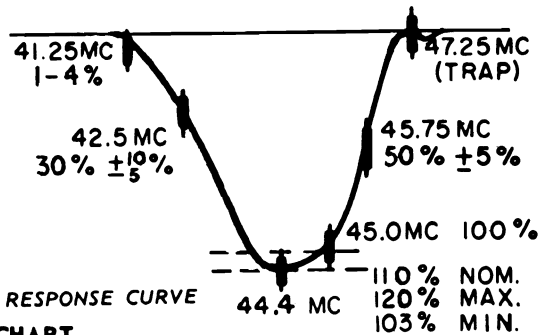

VIDEO I-F ALIGNMENT CHART

STEP	SIGNAL FREQUENCY	ADJUST	REMARKS
1	47.25 MC AM	Adjust L151 for minimum scope deflection.	Use maximum scope sensitivity and smallest possible signal.
2	44.4 MC AM	Adjust L154, then L153 for maximum.	Position L153 core at end of coil nearer circuit board.
3		Align T150 for maximum.	
4		Adjust L135 for maximum deflection of the 45.75 MC marker.	
5		Adjust L152 for proper nose shaping.	
6		Turn L135 core clockwise to place 45.75 MC marker at 50%.	
7	38-48 MC sweep generator, with scope calibrated 3 volts peak to peak for 2 inch deflection; markers at 41.25, 42.5, 44.4, 45.0, 45.75 MC 47.25 MC	Readjust L152 to shape nose around 44.4MC pivot.	Repeat Step 7 to shape nose after Steps 8 and 9.
8		Readjust T150 for proper placement of 42.5MC marker if curve is too narrow.	
9		Spread or knife turns of L150 if 42.5MC marker is above 30% on curve.	

4.5 MC TRAP ALIGNMENT

1. Connect a -10V bias to Test Point II, with the positive bias lead grounded to chassis.
2. .05μf capacitor between Pin 5 of V5A and chassis.
3. Turn contrast control to maximum, volume to minimum.
4. Connect the DETECTOR NETWORK shown to Test Point IV and feed its output to an AC VTVM.
5. Apply a 4.5 MC AM signal through a capacitor at Test Point III.
6. Adjust the L157 takeoff core for minimum reading on Test Point IV. Two core positions may give an apparent minimum indication, the correct one is nearer the top end of the coil form.

NOTE: Retouching of the trap adjustment may be necessary after alignment of the audio takeoff.

AUDIO ALIGNMENT WITH ON-THE-AIR SIGNALS

1. Tune in a strong local signal and set receiver volume to a low audible level.
2. Adjust L302 for maximum undistorted, buzz-free audio output. Start with the core at the outermost position away from the printed board and tune for the second "peak" encountered on the way into the coil form.
3. Connect a variable bias supply (3 to 15V) to the AGC test point with the positive lead to the chassis. Adjust bias until audio signal distorts on peaks slightly, then adjust core of L301 to curb distortion. Repeat this procedure several times at increased bias levels until maximum clarity of audio is obtained.
4. Adjust audio takeoff core, L157, repeating the bias advances in step 3, to achieve the optimum setting for noise-free performance at low signal levels.

GENERAL ELECTRIC Chassis SC, Schematic Diagram

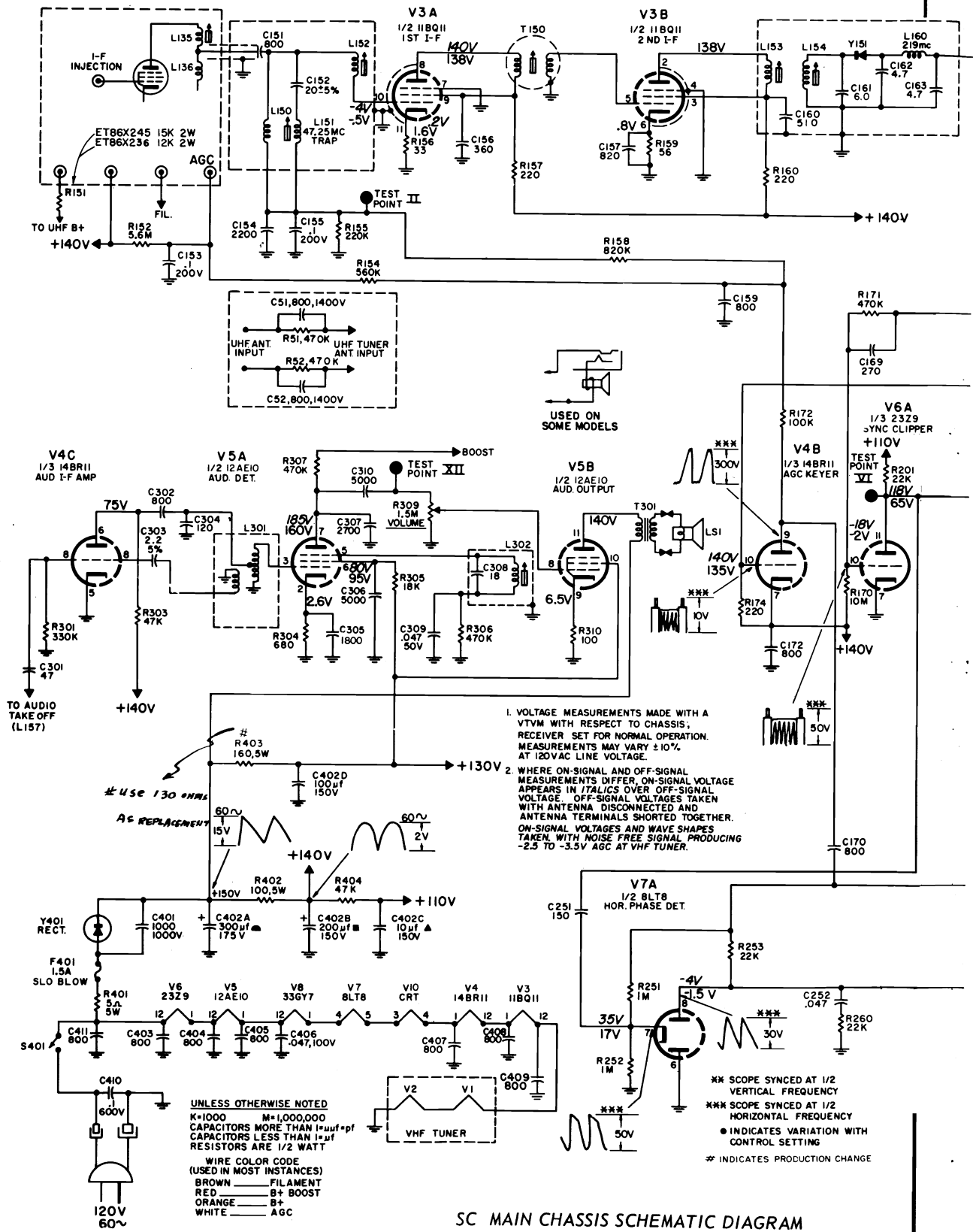

1. VOLTAGE MEASUREMENTS MADE WITH A VTVM WITH RESPECT TO CHASSIS; RECEIVER SET FOR NORMAL OPERATION. MEASUREMENTS MAY VARY $\pm 10\%$ AT 120VAC LINE VOLTAGE.

2. WHERE ON-SIGNAL AND OFF-SIGNAL MEASUREMENTS DIFFER, ON-SIGNAL VOLTAGE APPEARS IN ITALICS OVER OFF-SIGNAL VOLTAGE. OFF-SIGNAL VOLTAGES TAKEN WITH ANTENNA DISCONNECTED AND ANTENNA TERMINALS SHORTED TOGETHER. ON-SIGNAL VOLTAGES AND WAVE SHAPES TAKEN WITH NOISE FREE SIGNAL PRODUCING -2.5 TO -3.5V AGC AT VHF TUNER.

UNLESS OTHERWISE NOTED
 K=1000 M=1,000,000
 CAPACITORS MORE THAN $10 \mu f$ = pf
 CAPACITORS LESS THAN $1 \mu f$
 RESISTORS ARE 1/2 WATT

WIRE COLOR CODE
 (USED IN MOST INSTANCES)
 BROWN — FILAMENT
 RED — B+ BOOST
 ORANGE — B+
 WHITE — AGC

SC MAIN CHASSIS SCHEMATIC DIAGRAM

GENERAL ELECTRIC Chassis SC, Schematic Diagram, Continued

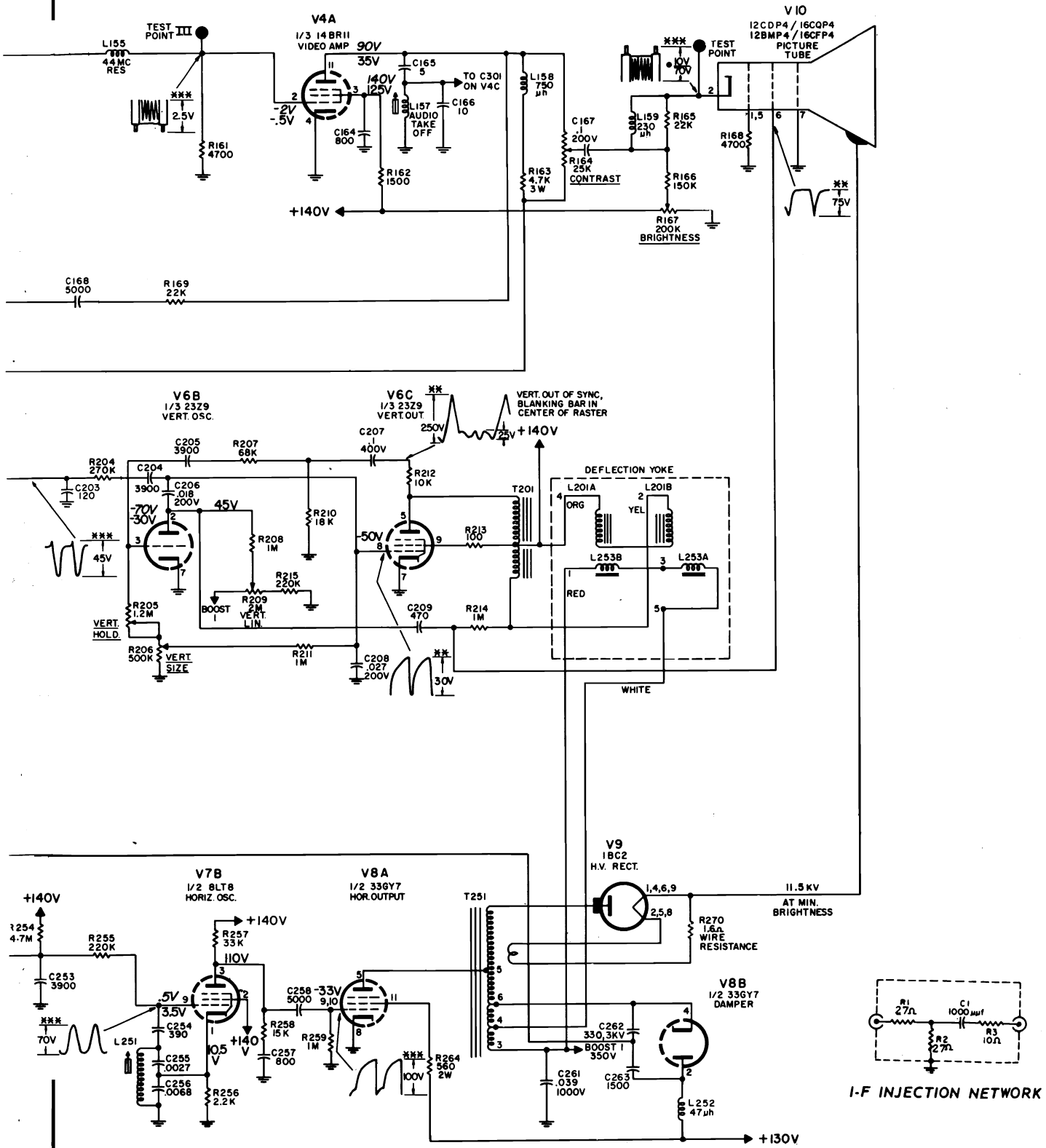

GENERAL ELECTRIC Chassis SC, Servicing Information, Continued

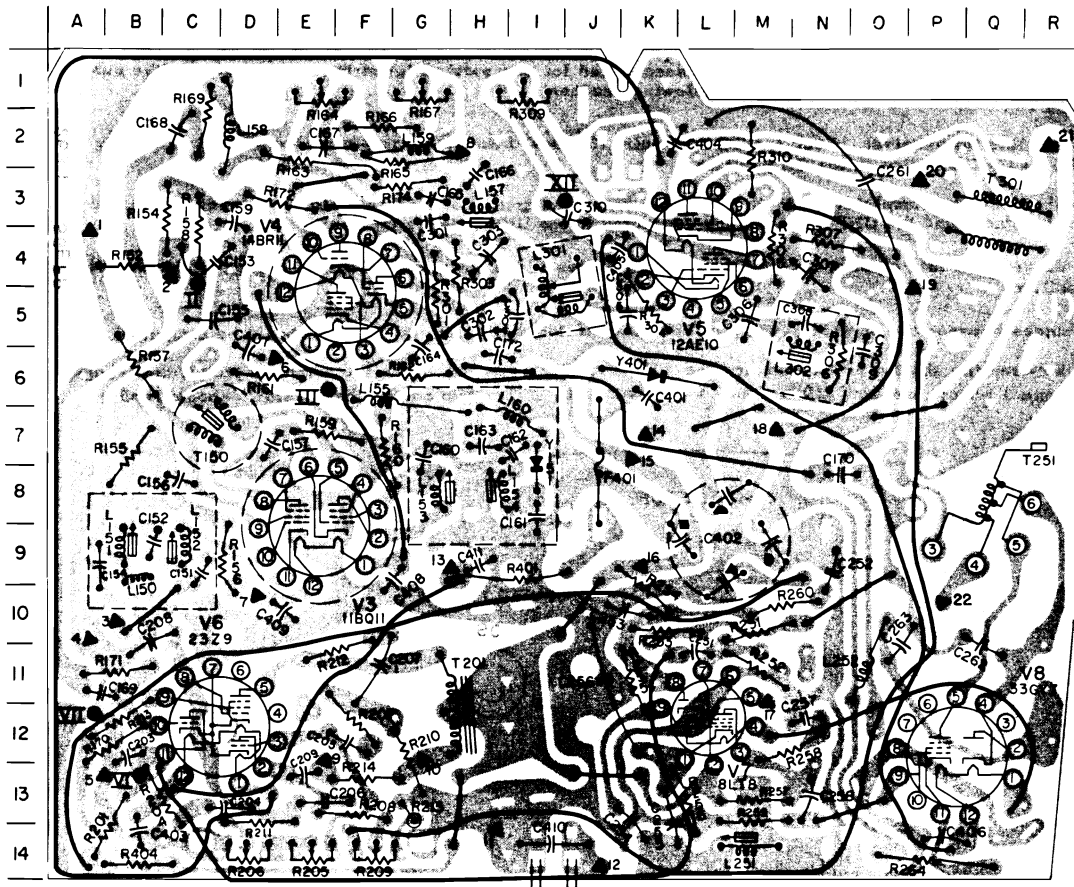

CIRCUIT BOARD VIEWED FROM COMPONENT SIDE

RESISTORS		CAPACITORS		XFMRs
R152-B4	R257-M13	C151-C9	C258-N13	T150-C7
R154-C4	R258-M12	C152-B9	C261-03	T201-H12
R155-B7	R259-M13	C153-C4	C262-Q11	T251-Q8
R156-D9	R260-M10	C154-A9	C263-O10	T301-O3
R157-B6	R264-P14	C155-C5	C301-G3	
R158-C4	R301-G5	C156-C8	C302-H5	
R159-E7	R303-H4	C157-D7	C303-H4	
R160-F7	R304-K5	C159-D3	C304-I5	
R161-D6	R305-M4	C160-G7	C305-K5	
R162-G6	R306-N6	C161-I8	C306-M5	
R163-E2	R307-N4	C162-I7	C307-N4	
R165-G2	R310-M2	C163-H7	C308-N5	
R166-F2	R401-I9	C164-G6	C309-O6	
R169-C2	R404-B14	C165-G3	C310-J3	
R170-B12		C166-H3	C401-K6	
R171-A11	COILS	C167-E2	C402-L9	
R172-E3	L150-B9	C168-C2	C403-B14	
R174-G3	L151-B9	C169-B11	C404-K2	
R201-A14	L152-C9	C170-N8	C405-J4	
R204-C13	L153-G8	C172-H6	C406-P14	
R207-F12	L154-H8	C203-B12	C407-D6	
R208-F13	L155-F6	C204-D13	C408-G9	
R210-G12	L157-H3	C205-F12	C409-D10	
R211-D14	L158-D2	C206-E13	C410-I14	
R212-E11	L159-G2	C207-F11	C411-H9	
R213-B12	L160-I7	C208-B10		
R214-F13	L251-M14	C209-E13	POTS	
R215-G13	L252-O11	C251-L11	R164-E1	
R251-M10	L301-I4	C252-N9	R167-G1	
R252-M11	L302-N6	C253-K10	R205-E14	
R253-K10		C254-K14	R206-D14	
R254-K10		C255-K14	R209-F14	
R255-K11		C256-J11	R309-I1	
R256-L13		C257-N12		

TRIANGLE (▲-0) NUMBERS

INDICATE WIRE CONNECTIONS

- ▲1. ORANGE LEAD TO TUNER B+ SUPPLY (+140V)
- ▲2. WHITE LEAD TO TUNER AGC
- ▲3. SHIELDED LEAD FROM TUNER I-F OUTPUT
- ▲4. SHIELD GROUND
- ▲5. BLACK LEAD FROM TUNER GROUND
- ▲6. BROWN LEAD TO PIN 4 OF PICTURE TUBE
- ▲7. BROWN LEAD TO TUNER FILAMENT SUPPLY
- ▲8. YELLOW LEAD TO PIN 2 OF PICTURE TUBE
- ▲9. GREEN LEAD TO PIN 6 OF PICTURE TUBE
- ▲10. YELLOW LEAD TO TERMINAL 2 OF YOKE
- ▲11. BLACK LEAD TO PIN 7 OF PICTURE TUBE
- ▲12. BROWN LEAD TO S401 ON R309
- ▲13. BROWN LEAD FROM S401 ON R309
- ▲14. ORANGE & BLACK LEAD TO R403 & R402
- ▲15. ORANGE LEAD TO TERMINAL 4 OF YOKE
- ▲16. ORANGE LEAD TO R402
- ▲17. BROWN LEAD TO PIN 3 OF PICTURE TUBE
- ▲18. ORANGE & WHITE LEAD TO R403
- ▲19. RED LEAD TO TERMINAL 1 OF YOKE
- ▲20. TO SPEAKER
- ▲21. TO SPEAKER
- ▲22. WHITE LEAD TO TERMINAL 5 OF YOKE

ROMAN (● VIII) NUMBERS

INDICATE TEST POINTS

GENERAL ELECTRIC

Chassis TC and T-1

Models TR810CTN, TR811TTN-1, TR812CVY, TR814CEB, TR853CEB, TR853CVY

DISASSEMBLY PROCEDURE

CABINET BACK:

- 1.) Remove all leads from the antenna terminals and unplug the power cord from the receiver.
- 2.) Place the receiver face down on a clean, soft pad or cloth.
- 3.) Remove the five Phillips head screws from the back of the receiver — two at the top, one in the center, and two at the bottom.
- 4.) Lift the cabinet back away from the front far enough to reach the 300 ohm UHF antenna lead which connects to the UHF input terminals inside the cabinet back. Unplug the UHF lead and remove the back.

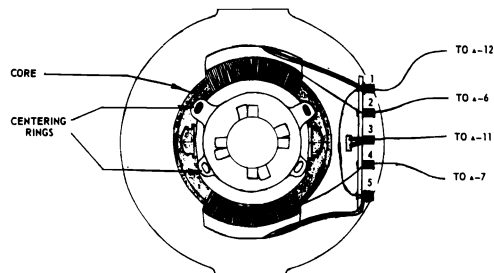

CHASSIS REMOVAL:

Remove the cabinet back and proceed as follows:

- 1.) Remove the control knobs from the front of the receiver.
CAUTION: Use extreme care when performing steps two and three. The pins on the picture tube and the neck of the tube are very fragile.
- 2.) Remove the socket and high voltage anode lead from the picture tube.
- 3.) Slide the corrector Magnet (not used on all receivers) and yoke retaining clamp off the neck of the picture tube, (squeeze the tabs on the yoke clamp together to loosen the clamp for removal) and remove the yoke.
- 4.) Remove the clip contact (attached to the disc capacitor) from the heat sink on the left side of the chassis.
- 5.) Release the retaining clip from the slot in the circuit board (located at midpoint on the right side).
CAUTION: Use care not to break the board retaining clip, as it is an integral molded part of the cabinet front. Slide the board back away from the cabinet front.
- 6.) Remove the speaker leads from the speaker terminals and slide the board out of the slots in the cabinet front.

When reassembling the receiver use care not to crack the circuit board while inserting it into the cabinet slots. Check to be sure the control shafts align with the holes in the front of the cabinet. Do not force the board into the cabinet or damage may result to circuit components.

DEFLECTION YOKE WIRING

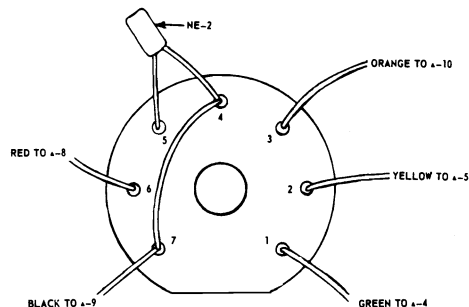

PICTURE TUBE SOCKET WIRING

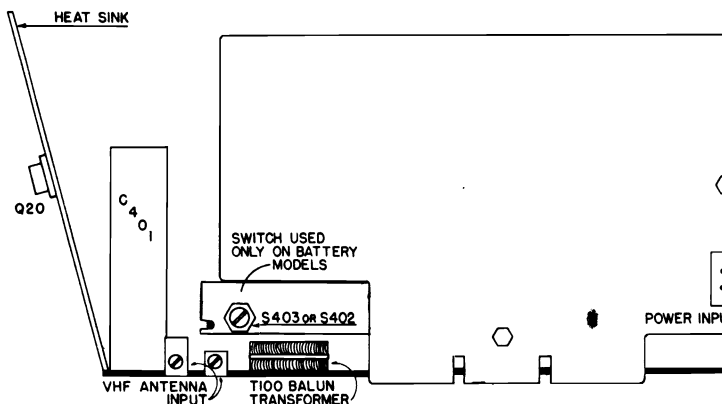
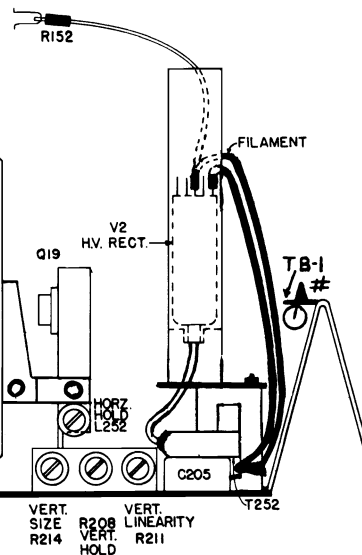

REAR VIEW ADJUSTMENT LOCATION

GENERAL ELECTRIC Chassis TC, Adjustment Information, Continued

ELECTRICAL ADJUSTMENTS

HEIGHT AND VERTICAL LINEARITY: Properly tune the receiver to one of the local television channels. To obtain the best linearity, use a test pattern if one is available.

Adjust R211 and R214 (located at the rear of the receiver) simultaneously for proper vertical size and linearity. The picture should over-fill the screen 1/8" at top and bottom.

HORIZONTAL HOLD: Adjust the horizontal hold control L252 (located at the rear of the receiver) to the point at which the picture remains stable horizontally.

It is advisable to check the operation of the +12 volt power supply before attempting any other electrical adjustments. Malfunction in the power supply can cause faulty operation of the other circuits in the TC Chassis.

REGULATED POWER SUPPLY: Connect the receiver to an AC power source through a variable transformer and adjust for 120 volts AC input to the receiver.

1. On AC-DC models, set the function switch at the rear of the receiver to the AC position.
2. Connect a DC volt meter (0-15 V with 1% accuracy) between Q20 collector and ground.
3. Adjust the regulator potentiometer R405 until the collector voltage of Q20 is exactly +12 volts.
4. Vary the AC line voltage from 112 to 128 volts. The +12 volts at the collector of Q20 should remain constant. This check assures proper operation of the regulated power supply.

CHARGER MODELS: For models which contain the built-in charger circuit, the regulated power supply should be adjusted in the following manner.

1. Connect the receiver to an AC power source through a variable transformer and adjust for 120 volts AC input to the receiver.
2. Set the function switch at the rear of the receiver to the AC position.
3. Connect a DC volt meter (0-20V with 1% accuracy at 12 volts) between the emitter of Q20 and ground.
4. Adjust the regulator potentiometer R405 until the emitter voltage of Q20 is exactly +12 volts.
5. Turn the function switch at the rear of the receiver to the CHARGE position.
6. Adjust the charge potentiometer R406 until the emitter voltage of Q20 is exactly +15.2 volts.

NOTE: Be sure to maintain the AC input voltage to the receiver at 120 volts during these adjustments.

CHARGER CIRCUIT: On AC-DC models which contain the built-in battery charger the following test may be made to check for proper charger circuit operation.

1. A special dual power cord is provided for use with receivers containing a built-in charger circuit. Connect the AC section of this cord through a variable transformer to an AC power source and adjust for 120 volts input to the receiver.
2. Connect a 10 ohm, 1%, 50 watt load resistor in series with a 0-2 amp DC Ammeter (1% accuracy at 1.3 amps) across the output of the DC charger cord. This load should be attached to a socket receptacle of the type used for automobile cigarette lighters. The charger cord is equipped with a special plug end designed to fit this type of socket. Be sure the plug is inserted all the way into the socket, in order to provide the proper socket contact against the tip of the plug.
3. Turn the function switch at the rear of the receiver to the CHARGE position.
4. Connect a DC volt meter (0-20V with 1% accuracy at 15V) between the emitter of Q20 and ground.
5. Vary the line voltage from 112 to 128 volts AC. The ammeter should read a constant 1.26 amps \pm .06 amps. The charger output voltage as indicated on the voltmeter should remain constant at some value within the range of 14.5 and 15.2 volts DC.

AGC CONTROLS:

FIELD ADJUSTMENT: Tune in the strongest available signal and adjust IF AGC Control R140 to the point where the picture overloads. Back off the AGC Control to just beyond the point where the overload condition disappears.

INSTRUMENT ADJUSTMENT:

Set the Contrast Control fully clockwise.

1. Connect the center and one of the outside terminals of a 100 ohm potentiometer directly across the antenna terminals of the receiver. (Do not use any extension leads on the potentiometer.)
2. Set the RF AGC control R133 approximately 1/4 turn from the maximum clockwise position.
3. Connect an external antenna to the VHF input terminals and properly tune to the strongest local TV channel available. Adjust the 100 ohm potentiometer for maximum signal input to the receiver.
4. Connect an oscilloscope to Test Point IV. Sync the oscilloscope at vertical rate and observe at least two vertical sync pulses.
5. Adjust the IF AGC control R140 to produce 65 volts P-P video as observed on the oscilloscope.
6. Connect the positive lead of a DC VTVM to the collector of Q9 and the negative lead to ground.
7. Adjust the 100 ohm potentiometer on the antenna input terminals until the collector voltage of Q9 is 8.3 volts.
8. Adjust the RF AGC control R133 until the voltage at the collector of Q9 just begins to decrease.
9. Remove the 100 ohm potentiometer from the antenna input terminals and recheck for 65 volts P-P video at Test Point IV with maximum signal input.

AUDIO ALIGNMENT

Allow the chassis two minutes and the test equipment 20 minutes to warm up. Prepare the chassis to be aligned in the following manner.

1. Connect an oscilloscope to Test Point V.
2. Connect a DC VTVM between Test Point VI and ground.
3. Place a jumper wire from Test Point II to ground.
4. Feed in a 4.5MC FM signal (400 cycle modulated \pm 7.5KC or \pm 25KC deviation) at Test Point III through a 100pf capacitor.

NOTE: The DC voltage at Test Point VI should be kept at 1.0V throughout the alignment procedure by adjusting the input signal strength from the generator.

5. Adjust T104, T300 and T301 for maximum reading on the VTVM at Test Point VI.

NOTE: The cores should be positioned as follows:

T104 - Away from the circuit board toward the top of coil form.

T300 - Toward the bottom of the coil form near the circuit board.

T301 - The cores should be away from each other, with the bottom (secondary) core near the circuit board, and the top (primary) core near the top of the coil form.

6. Remove the 4.5MC FM signal and apply a 4.5MC AM signal (modulated 600 cycles, 80%) at Test Point III through a 100pf capacitor.
7. Adjust T301 bottom core for minimum AM output observed on the oscilloscope at Test Point V.

PICTURE TUBE ADJUSTMENTS

FOCUS: The proper focus potential for the tube was chosen at the time the set was manufactured. The correction magnet on the neck of the picture tube may be adjusted to provide best overall focus. This magnet is not used with all picture tubes. If the picture tube is replaced it may or may not be necessary to use a corrector magnet on the new tube.

PICTURE TILT: Loosen the yoke clamp by squeezing the tabs on the clamp together and rotate the yoke to correct for tilt.

PICTURE CENTERING: Rotate the two centering rings located at the rear of the yoke assembly until the picture is properly centered.

GENERAL ELECTRIC Chassis TC, Alignment Information, Continued

VIDEO IF SYSTEM

Allow the receiver two minutes and the test equipment at least 20 minutes to warm up before performing the following alignment procedure.

CAUTION: The cores in the IF coils are brittle. Do not use a metal driver when adjusting these cores.

1. Set channel selector to the thirteenth position. (UHF) Set the volume control to a fully counterclockwise position and contrast control to a fully clockwise position.
2. Short the VHF antenna terminals together and leave them shorted throughout the entire video alignment.
3. Connect an oscilloscope through a 10K resistor to Test Point III. Connect the positive terminal of a 4.5 volt bias supply to the IF AGC Test Point II and the negative terminal to chassis ground. Use a battery with the appropriate potentiometer across it as an adjustable, low impedance bias voltage source.
4. Inject signals from a properly terminated AM signal generator or from a 40-50 MC. sweep generator through the network shown to the UHF IF input point on the VHF tuner terminal strip.
5. Align the receiver to produce the response curve illustrated.

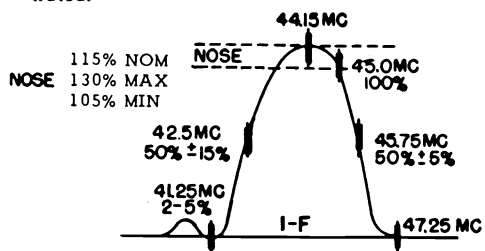

I-F RESPONSE CURVE

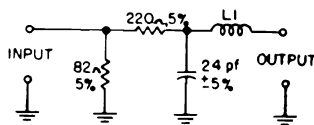

NOTE: Coil L1 is ordered from your General Electric distributor. Catalog number is ET36X733.

I-F INJECTION NETWORK

AM PRE-PEAKING FREQUENCIES

L104.....	Min. at 47.25 MC
L102.....	Min. at 41.25 MC
L56.....	Max. at 45.00 MC
T101.....	Max. at 44.15 MC
T102.....	Max. at 44.15 MC
T103.....	Max. at 44.15 MC
L103.....	Max. at 44.00 MC

TRANSISTOR BASE DIAGRAMS

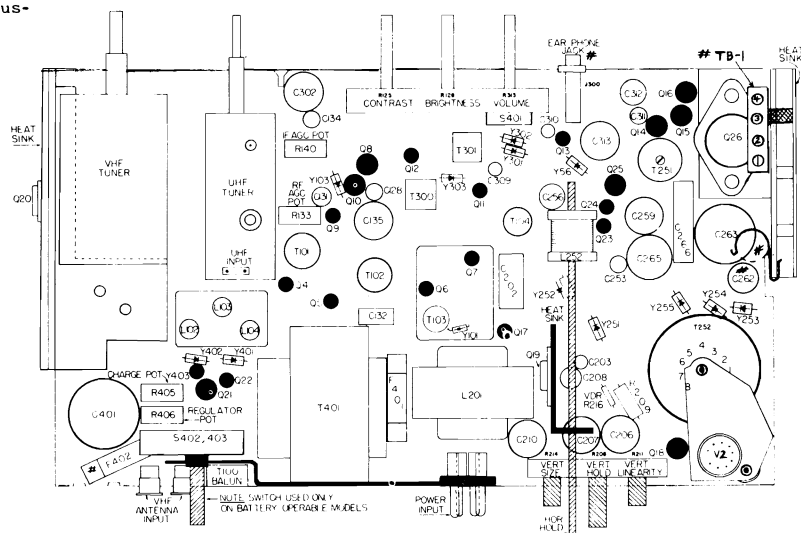
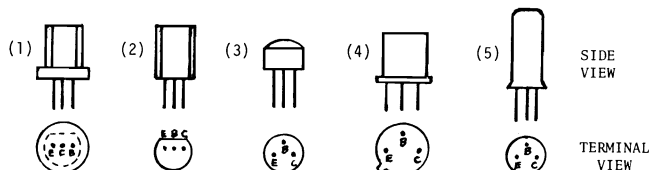

TOP VIEW
MAJOR COMPONENT AND ADJUSTMENT LOCATION

VIDEO IF ALIGNMENT CHART

STEP	SIGNAL FREQUENCY	ADJUST	REMARKS
1.	47.25 MC AM	Adjust L104 for minimum scope deflection	Use maximum scope sensitivity and smallest possible signal for the 47.25 MC AM adjustments
2.	41.25 MC AM	Adjust L102 for minimum scope deflection	Use maximum scope sensitivity and smallest possible signal for the 41.25 MC AM adjustments (core should be toward outside of the coil)
3.	40-50 MCsweep Generator with scope calibrated 1.5 volts p-p for a 2 inch deflection; Markers at 41.25, 42.5, 44.15, 45.00 and 45.75 MC	Adjust L 56 (VHF tuner) for maximum output at 45.0 MC	Use sufficient signal strength to give a 2 inch scope deflection at Test Point III
4.		Tune T101 and T102 for maximum scope deflection at 44.15 MC	T101 and T102 cores should be positioned away from the board marker
5.		Adjust T103 top and bottom for maximum scope deflection at 44.15 MC marker	T103 top core should be positioned away from the board, bottom core will be near the board
6.		Adjust L103 for a compromise between 45.0 MC and a round nose	L103 should rock the nose around a pivot at 44 MC

NOTE: Symmetry of the nose is very important, no position of the nose should be asymmetrical or tilted more than 5%.

GENERAL ELECTRIC Chassis TC, Schematic Diagram

GENERAL ELECTRIC Chassis TC, Schematic Diagram, Continued

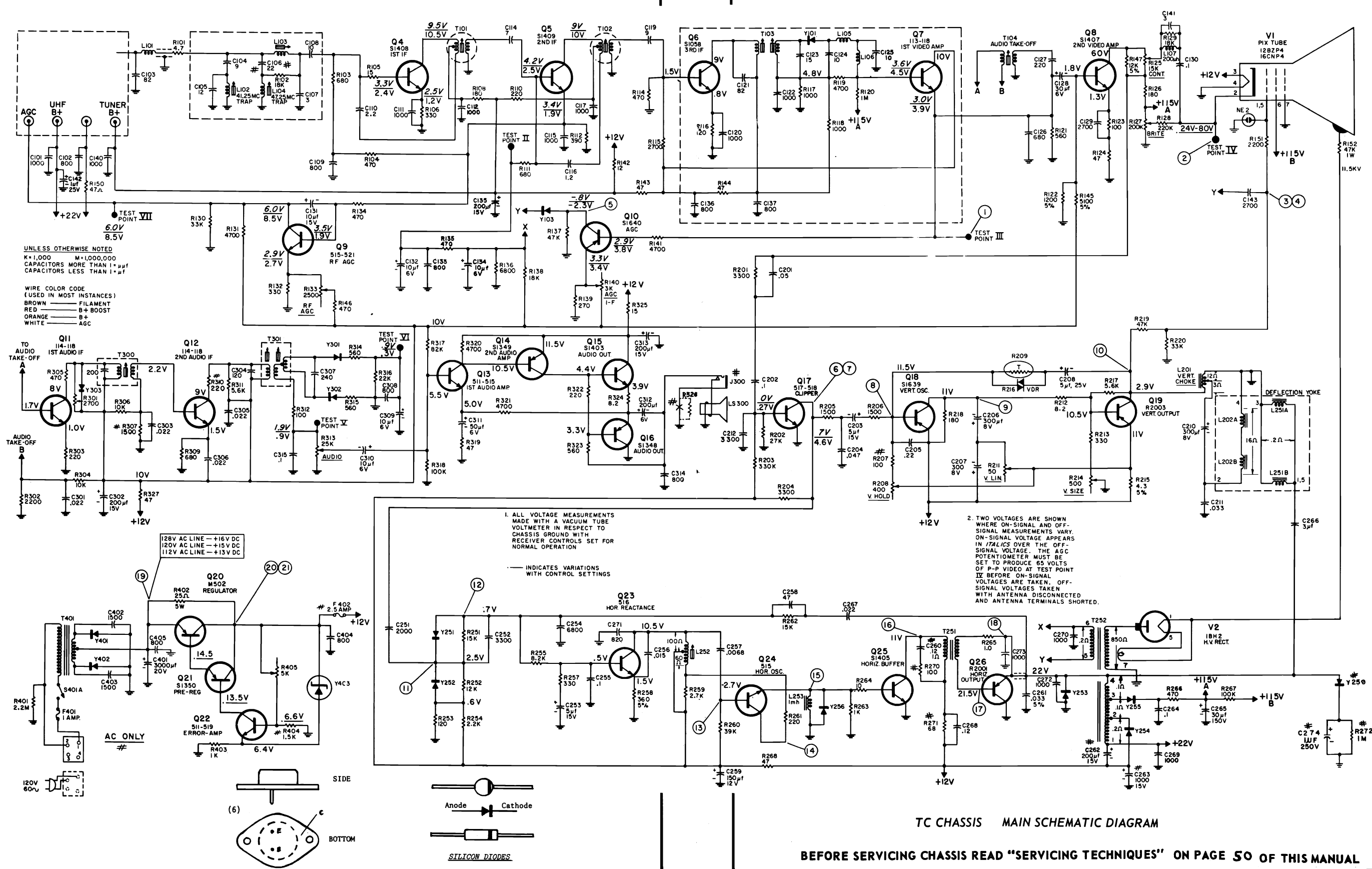

GENERAL ELECTRIC Chassis TC, Continued

SERVICING TECHNIQUES

DONT'S

1. Do not short the anode lead to chassis ground.
2. Do not use a VTVM to measure voltages from one element of a transistor to another. Use VTVM or other AC operated meters with its ground lead connected to the TV chassis. The hum component on the ground lead may be high enough in amplitude to exceed some transistor voltage ratings.
3. Do not replace the transistors with universal types. Use only direct replacements.
4. Do not directly connect any low impedance signal generating devices to circuits other than those outlined under "Receiver Alignment"
5. Do not clip test equipment ground leads to the heat sinks of Q19 or Q20. They are not at ground potential and component damage may result.
6. Do not use an oscilloscope without capacity isolation. Use a low capacity probe (10-15 UUF).
7. Do not use capacity checkers to check the electrolytics used in the TC chassis. The voltage used to test the capacitor could very possibly exceed the voltage rating of the capacitor.

DO'S

1. Know your meter before you use it to check transistors, diodes, capacitor electrolytics. It is very possible the open circuit voltage present on the meter test leads is high enough in amplitude to damage the transistors and the low voltage rated electrolytic capacitors.
2. Use a VTVM to measure circuit voltages. Connect negative lead of meter to chassis ground.
3. Use an oscilloscope whenever possible. It is a very valuable service tool.
4. Use extreme care when soldering transistors and diodes. Use heat sinking devices.
5. Be sure to apply silicone grease to all replacement power transistors. This grease is used for heat conducting reasons.
6. Watch out for extremely warm transistors. They may be defective or have wrong bias voltages on them.

CAPACITORS

C127-L5	C271-N4
C128-I4	C272-S7
C129-I3	C273-R2
C130-H2	C301-L5
C131-H4	C302-G1
C132-I8	C303-J3
C133-I8	C304-K3
C134-G2	C305-K5
C135-I5	C306-J3
C136-K6	C307-L3
C137-K6	C308-M4
C140-D3	C309-L3
C141-H2	C310-N2
C142-E1	C311-P2
C143-G3	C312-P1
C201-M6	C313-O2
C202-M7	C314-O1
C203-N9	C315-K2
C204-N8	C401-B10
C205-R12	C402-E9
C206-Q11	C403-D9
C207-N11	C404-A10
C208-N9	C405-F11

RESISTORS

R255-P7	#R310-J3
R257-P7	R311-K3
R258-N5	R312-L2
R259-M6	R313-M1
R260-O5	R314-N3
R261-N4	R315-M3
R262-O9	R316-M3
R263-N3	R317-M4
R264-Q4	R318-M2
R265-Q3	R319-O2
R266-Q7	R320-P2
R267-M9	R321-O2
R268-P4	R322-Q2
#R270-P4	R323-Q1
#R271-Q4	R324-R1
R301-K4	#R325-P3
R302-L5	R326-O1
R303-L5	R327-F1
R304-L4	R401-K11
R305-K4	R402-E10
R306-I4	R403-E10
R307-J5	#R404-E10
R309-J2	R405-C10

RESISTORS

R201-M6	R127-K1
R202-M6	R128-K2
R203-M7	R129-H3
R204-M7	R130-G4
R205-N8	R131-G3
R206-P10	R132-G4
#R207-P11	R133-G5
R208-Q12	R134-H5
R209-P10	R135-H1
R211-P12	R136-H1
R212-N10	R137-H3
R213-N11	R138-G2
R214-N12	R139-G3
R215-N10	R140-N4
R216-O10	R141-I4
R217-N10	R142-E2
R218-Q11	R143-J6
R219-M9	R144-K7
R220-M8	R145-I3
R221-M9	R146-G4
R222-O7	R147-I2
R252-O7	R150-E2
R253-M6	R151-G3
R254-N7	

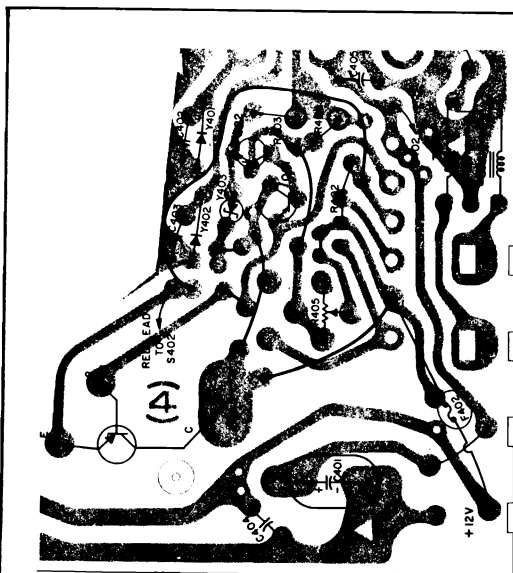

AC-DC(BATTERY) POWER SUPPLY WIRING
COMPONENT SIDE VIEW

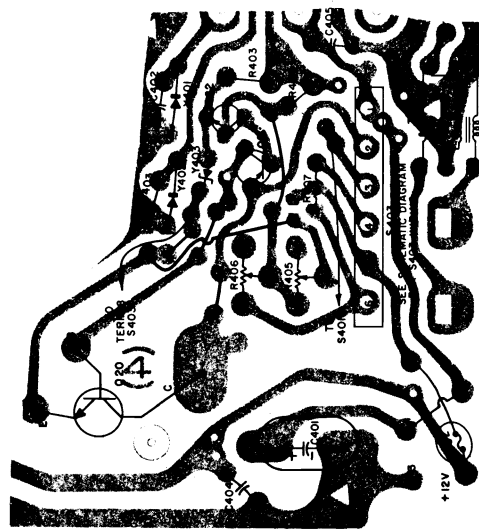

AC-DC-CHARGER POWER SUPPLY WIRING
COMPONENT SIDE VIEW



CIRCUIT BOARD VIEWED FROM COMPONENT SIDE

#-Indicates Production Change

COILS	XFMRs	TEST POINTS	TRANSISTORS	DIODES
L101-D1	T100-E12	II-H1	Q4-E7	Y101-K8
L102-D8	T101-G6	III-K5	Q5-H7	Y103-H4
L103-E7	T102-I7	V-L2	Q6-J7	Y251-O8
L104-F8	T103-J8	VI-L3	Q7-K6	Y252-N7
L105-K8	T104-M5	VII-H5	Q8-I3	Y253-S7
L107-H2	T251-Q3		Q9-H5	Y254-R7
L201-L10	T252-R10		Q10-H3	Y255-Q7
L252-N5	T300-J4	FUSES	Q11-L4	Y301-M2
L253-O3	T301-K2	F401-K10	Q12-J3	Y302-M3
#L254-P4	T401-H9	#F402-B12	Q13-N2	Y303-K4
			Q25-O4	Y401-E9
			Q26-S2	Y402-D9
				Y403-E9

TRIANGLE (▲-O) NUMBERS

- ▲-1 WHITE LEAD TO Q20 EMITTER.
- ▲-2 WHITE LEAD TO Q20 BASE.
- ▲-3 BLACK LEAD TO ANTENNA.
- ▲-4 GREEN LEAD TO CRT SOCKET PIN 1.
- ▲-5 YELLOW LEAD TO CRT SOCKET PIN 2.
- ▲-6 TO YOKE TERMINAL 2.
- ▲-7 TO YOKE TERMINAL 4.
- ▲-8 RED LEAD TO CRT SOCKET PIN 6.
- ▲-9 BLACK LEAD TO CRT SOCKET PIN 4.
- ▲-10 ORANGE LEAD TO CRT SOCKET PIN 3.
- ▲-11 TO YOKE TERMINAL 3.
- ▲-12 TO YOKE TERMINAL 1.
- ▲-13 BLUE LEAD TO Q19 BASE.
- ▲-14 WHITE LEAD TO Q19 EMITTER.
- ▲-15 GREEN LEAD TO SPEAKER.
- ▲-16 BLACK LEAD TO SPEAKER.
- ▲-17 TO "X" ON T252.
- ▲-18 TO "Y" ON T252.
- ▲-19 GREY WIRE TO UHF TUNER
- ▲-20 SHIELDED CABLE TO UHF TUNER
- ▲-21 TO S401
- ▲-22 TO S401
- ▲-23 TO POWER INPUT PLUG
- ▲-24 TO POWER INPUT PLUG
- ▲-25 TO EARPHONE JACK - Late Prod
- ▲-26 GREY WIRE TO TB-1 TERM. 2

REPRESENT TERMINATION POINTS ON COMPONENT BOARD FOR INTERCONNECTING WIRES AS INDICATED.

GENERAL ELECTRIC Chassis TC, Waveforms and Diagrams, Continued

Circled numbers ①, ②, etc., indicate points to observe waveforms shown on the schematic diagram,

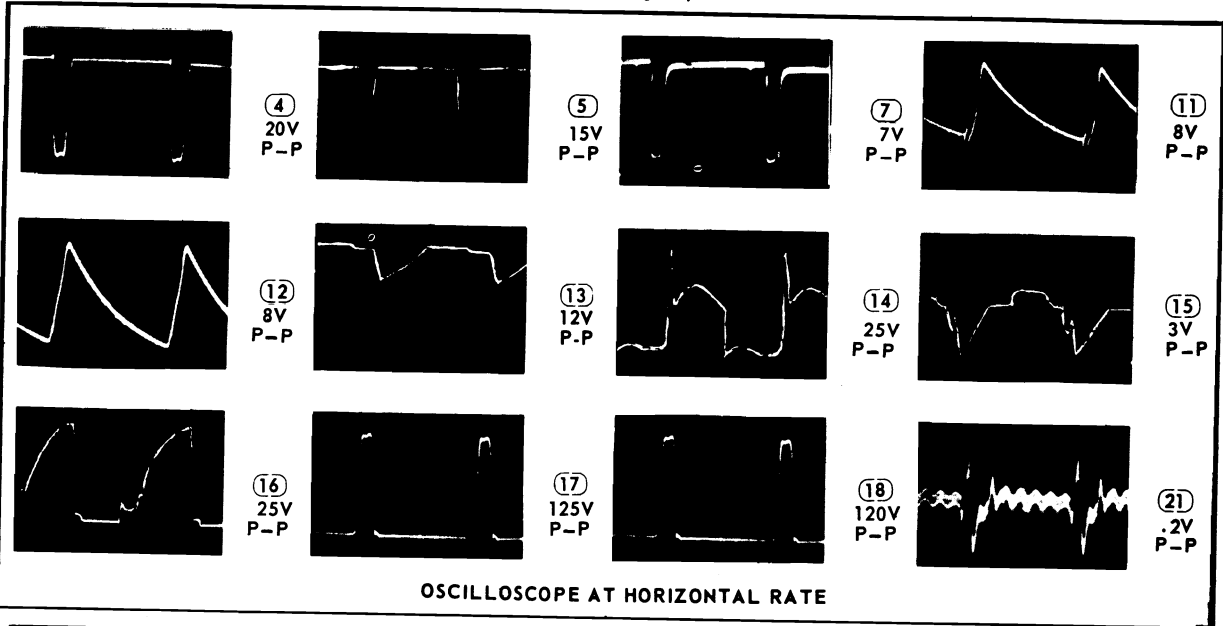

OSCILLOSCOPE AT HORIZONTAL RATE

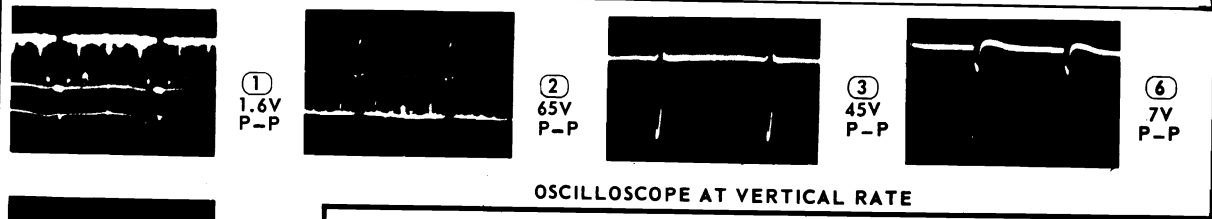

OSCILLOSCOPE AT VERTICAL RATE

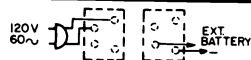
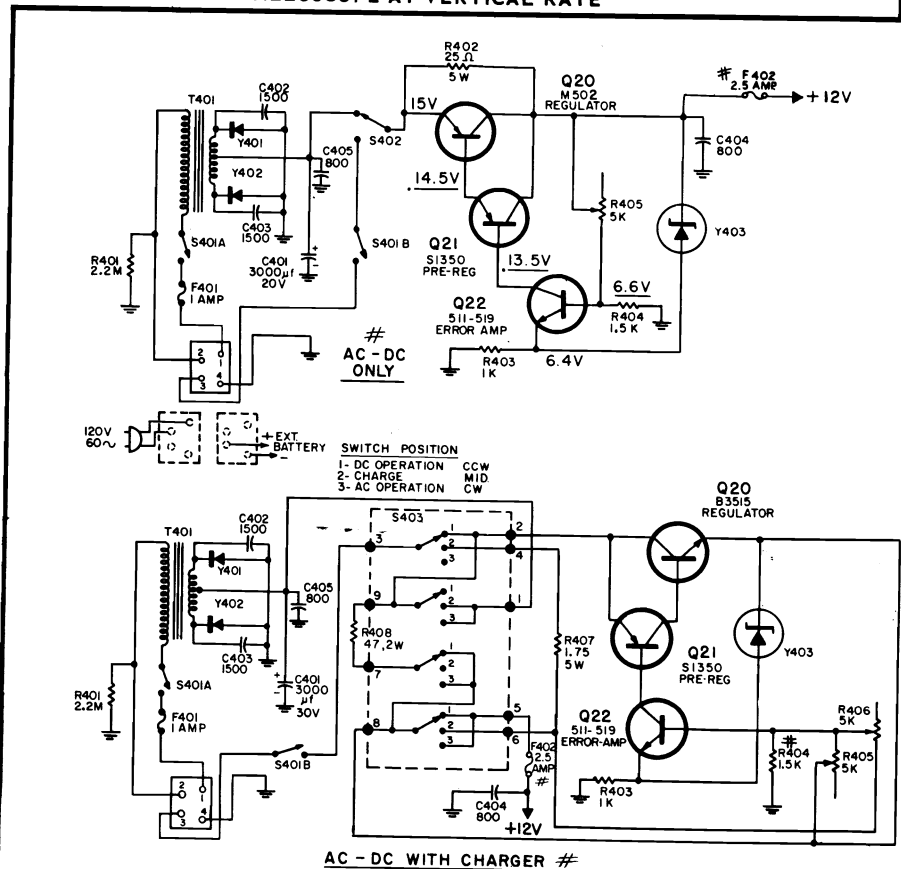
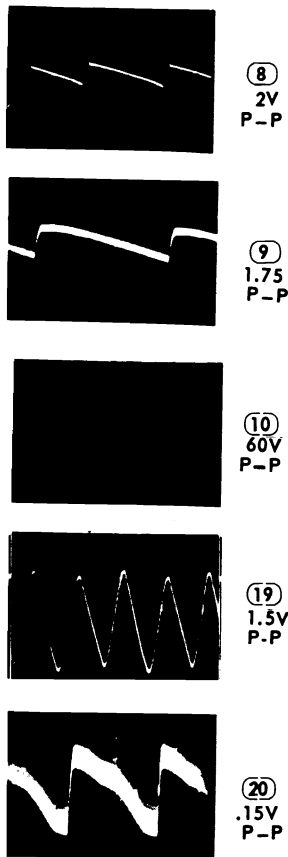

Magnavox

T910 SERIES TELEVISION CHASSIS

The T910 Series Television Chassis are series-filament chassis containing a single circuit board assembly. The majority of the circuit is contained on this one board. As an aid to circuit tracing both sides of this board are "road-mapped" with component identification numbers corresponding to the referenced component on the schematic diagram. These chassis use the bonded face-plate picture tubes, type 19FLP4, 19FTP4 or 17ELP4.

These chassis are identified by a production code sticker located on the chassis. The first three digits (910) identify the basic chassis series. The next two digits (01) identify the version within the series and the last two letters are used to identify any major production changes which might be made during the production of the chassis, (AA) being the original production code.

ADJUSTMENTS

Centering--To center the raster properly, adjust the two centering rings on the rear of the deflection yoke. They should be rotated about the neck of the tube until proper centering is obtained.

Focusing--These chassis employ electrostatic focus picture tube. The focus is accomplished by varying the voltage applied to the Focus Anode (pin 4) of the picture tube. A variable control located on the circuit board is used to select the best focus potential.

Vertical Linearity and Height--Adjust these controls until the picture slightly overfills the mask with the linearity uniform from top to bottom. Adjustment of either of these controls may necessitate adjustment of the vertical hold.

Horizontal Oscillator--The horizontal oscillator coil is also used as the horizontal hold control. Adjust this coil until the picture falls into sync.

VHF Oscillator--The VHF tuner is designed so rotating the Fine Tuning Control, or Fine Tuning Shaft, rotates

the slug in the oscillator coil. All channels should be checked and the Fine Tuning Control set to provide the clearest picture and sound on all channels.

LDR Range Adjust--The procedure outlined assumes that the adjustment must be made under normal lighting conditions where it is not possible to darken the room.

As a preliminary step, set the LDR Range Control to its maximum clockwise position. Adjust the brightness and contrast controls for a normal picture in semi-darkness. If the room lighting cannot be subdued, a semi-darkness condition, insofar as the amount of light striking the LDR, can be simulated by placing your hand over the window of the LDR. Check the contrast to brightness ratio by slowly moving your hand away from the window. If the picture appears too bright under normal lighting conditions, rotate the LDR Range Control slightly counter-clockwise. Repeat this procedure until the contrast to brightness ratio remains the same throughout the variations in room lighting.

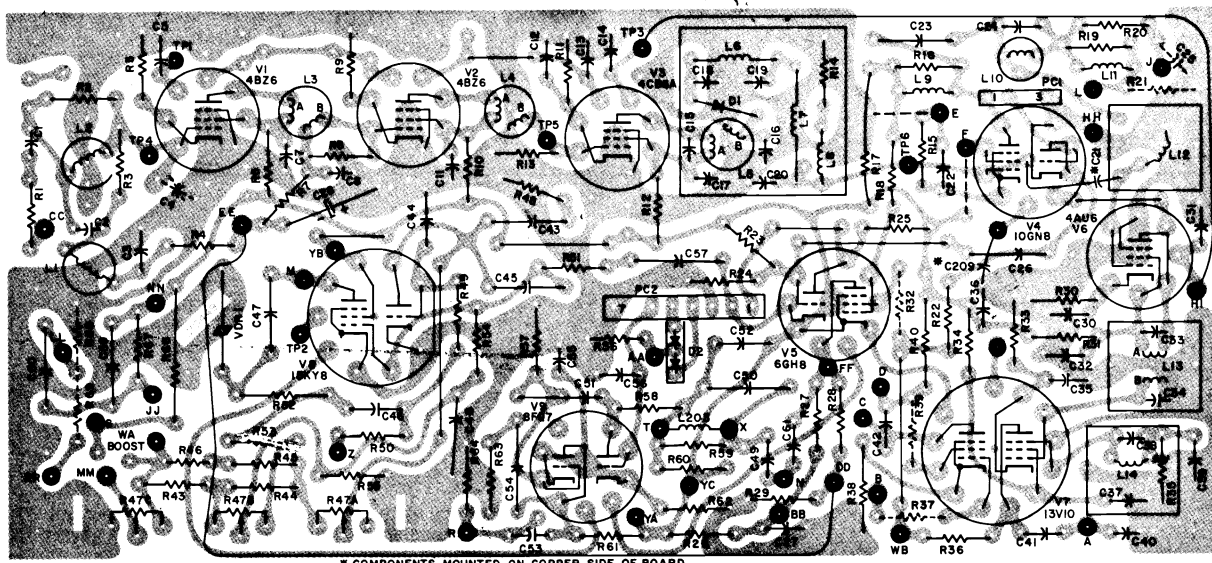

* COMPONENTS MOUNTED ON COPPER SIDE OF BOARD

**CIRCUIT BOARD LAYOUT
(VIEWED FROM COPPER SIDE)**

MAGNAVOX T910 Series Servicing Information, Continued

CHASSIS LAYOUT

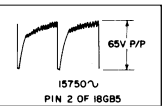
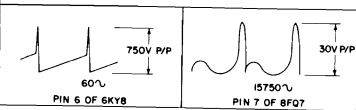
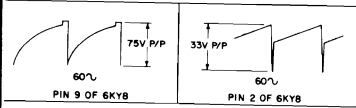
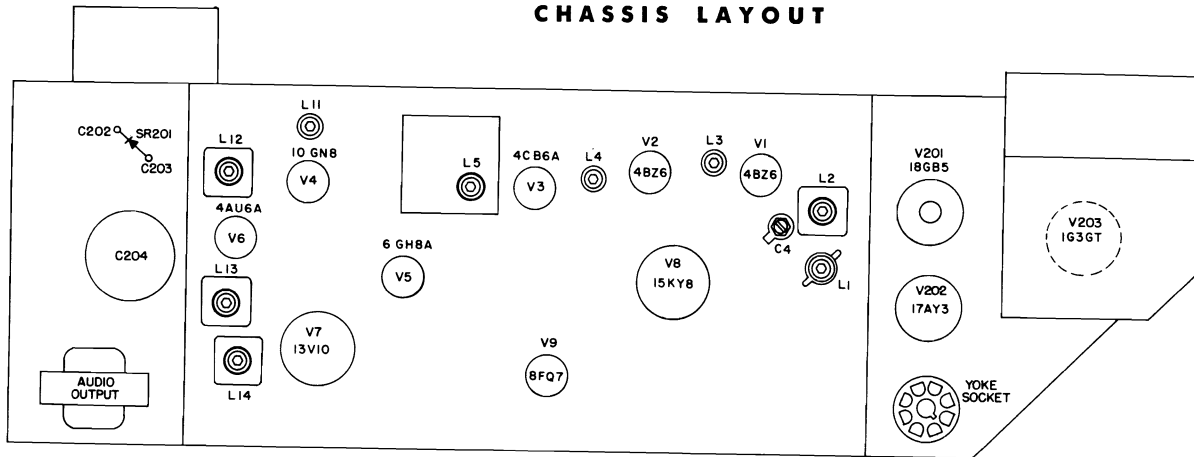

SERIES HEATER CIRCUIT

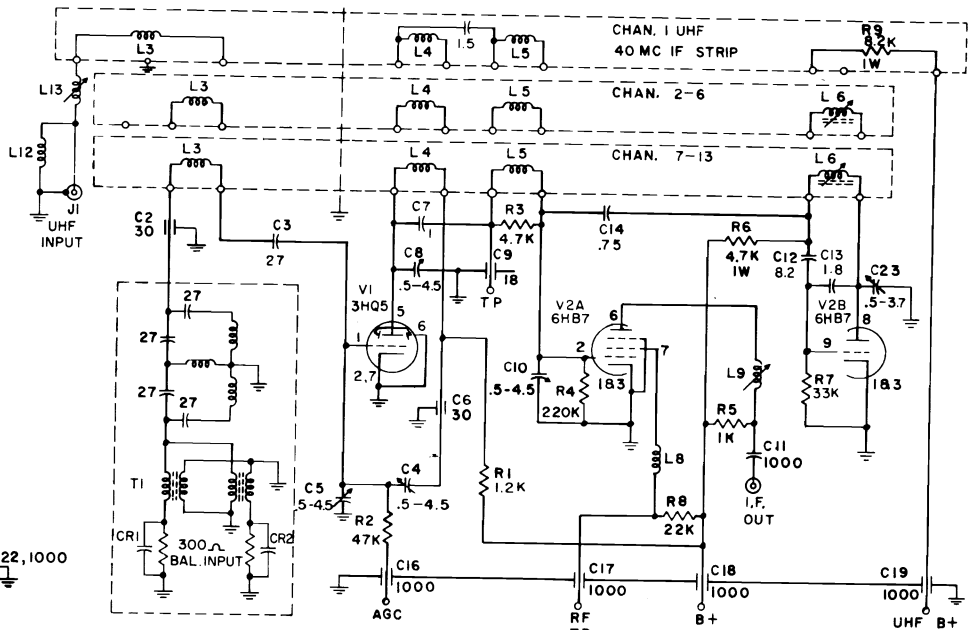
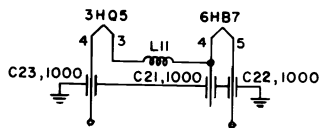

VHF TUNER SCHEMATIC (340078-2, 340082-1 & 340082-9)

NOTE: TUNER TIE POINTS ARE SHOWN ONLY TO COMPLETE SCHEMATIC AND DO NOT SIGNIFY PHYSICAL LOCATIONS

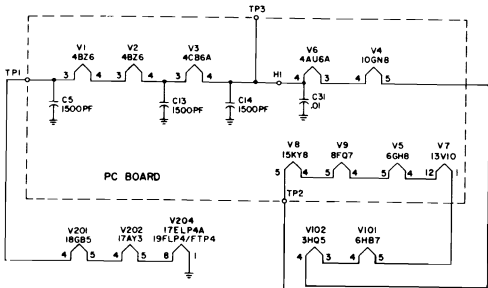

CHASSIS	VHF TUNER	UHF TUNER	C25	R15	C22	R16	R19	R20	C23
910-01-AA	340082-1	340084-2	.01MFD	47,10%	.005MFD	4.7K	15K	220K	.1MFD
910-02-AA	340078-2	340079-1	OMIT	15,20%	.047MFD	4.7K	15K	220K	.1MFD
910-02-AB	340078-2	340099-2	OMIT	15,20%	.047MFD	4.7K	15K	220K	.1MFD
910-03-AA	340078-2	340079-1	.01MFD	47,10%	.005MFD	4.7K	15K	220K	.1MFD
910-03-AB	340078-2	340099-2	.01MFD	47,10%	.005MFD	4.7K	15K	220K	.1MFD
910-04-BC	340082-1	340087-3	.01MFD	47,10%	.005MFD	4.7K	15K	220K	.1MFD
910-05-BC	340082-1	340087-3	.01MFD	47,10%	.005MFD	4.7K	15K	220K	.1MFD
910-06-BC	340078-2	340099-2	.01MFD	47,10%	.005MFD	4.7K	15K	220K	.1MFD
910-07-BC	340078-2	340099-2	OMIT	47,10%	.047MFD	4.7K	15K	220K	.1MFD

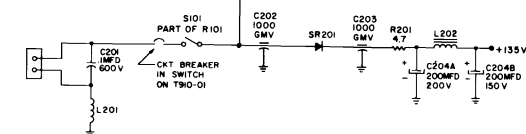
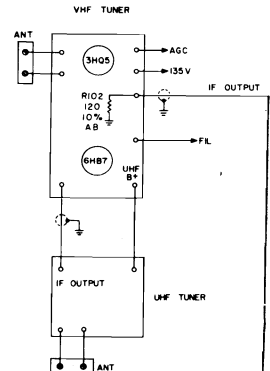

MAGNAVOX T910 Series Schematic Diagram, Continued

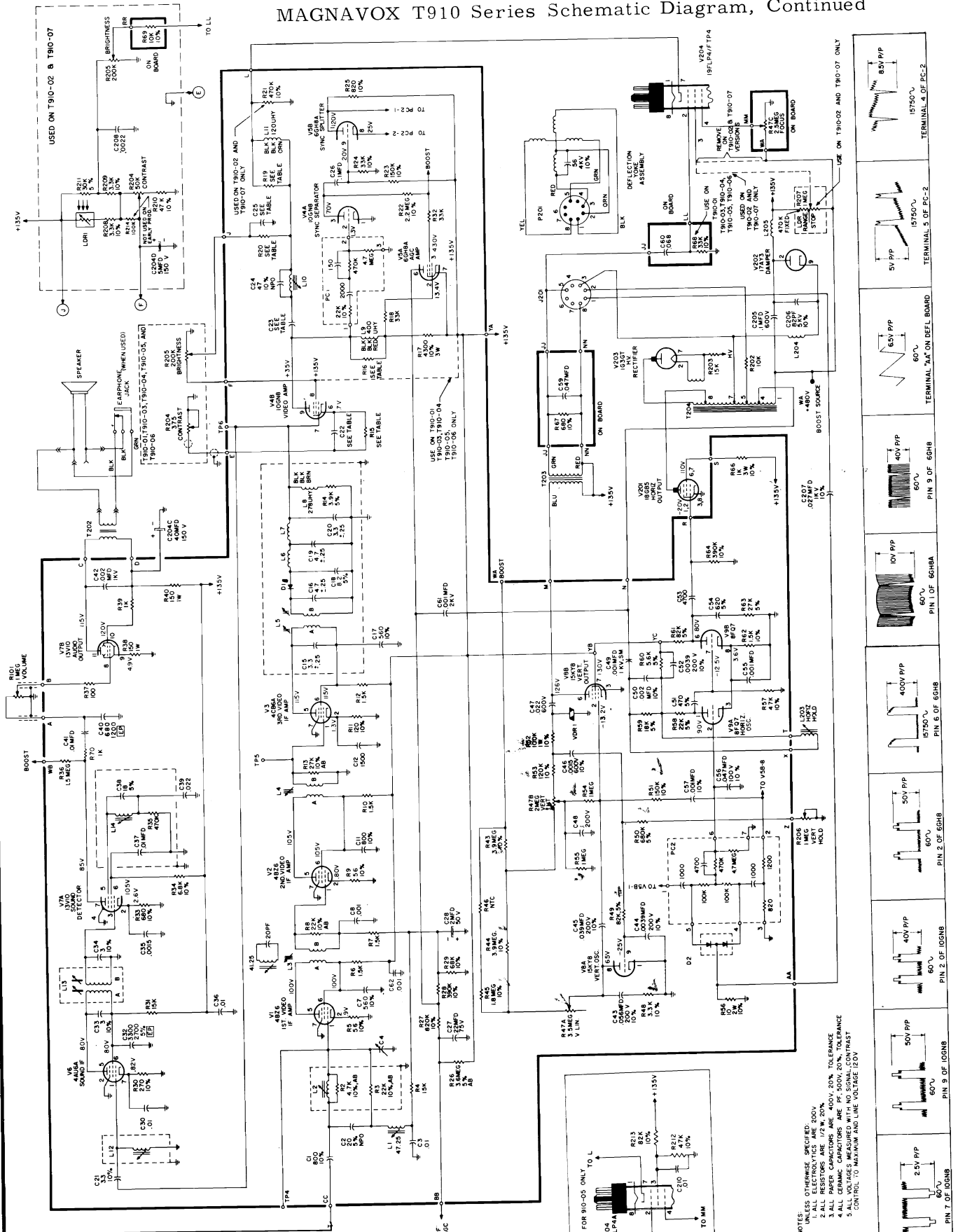

- NOTES:
 1. UNLESS OTHERWISE SPECIFIED, ALL ELECTRONIC COMPONENTS ARE 200V.
 2. ALL RESISTORS ARE 1/2 W, 20%.
 3. ALL PAPER CAPACITORS ARE 400V, 20% TOLERANCE.
 4. ALL CERAMIC CAPACITORS ARE 50V, 20% TOLERANCE.
 5. CONTROL TO MAXIMUM AND LINE VOLTAGE 120V.

MAGNAVOX T910 Series Alignment Information, Continued

ALIGNMENT

1. Use an isolation transformer when aligning and allow approximately 20 minutes warm-up time. Remove the 18GB5 plate cap.
2. Using a low-impedance bias supply, apply a -2.0 volts to BB and a -3.0 volts to EE on the Video IF Printed Board.
3. Connect an oscilloscope through a 10K isolation resistor to Pin 7 of V4.

CONNECT SWEEP AND MARKER GENERATOR	MARKER FREQUENCIES	ADJUST
TP- 5	42.5 MC 45.75MC	Adjust L5, top and bottom, to obtain symmetrical curve with markers at equal amplitude. (See Fig. 1)
TP- 4	41.25MC	Adjust L3 (Top Slug) until marker falls in center of trap suckout.
TP- 4	42.5MC 45.0MC 45.75MC	Adjust L4 until 45.75 marker is at 50% response and L3 (Bottom Slug) until 42.5MC marker is at 50% response. Repeat these adjustments (See Fig. 2).
Tuner Converter Grid	42.5MC 45.75MC	Adjust Tuner Converter Plate Coil for maximum gain between markers.
Tuner Converter Grid	47.25MC	Reduce IF Bias to zero and adjust L1 until marker falls in center of trap suckout. Adjust L2 for maximum attenuation of 47.25MC marker.
Tuner Converter Grid	45.75MC 42.5MC	Reset IF Bias to -3.0 volts and adjust Tuner Converter Plate Coil and C4 for symmetrical curve. (See Fig. 3)

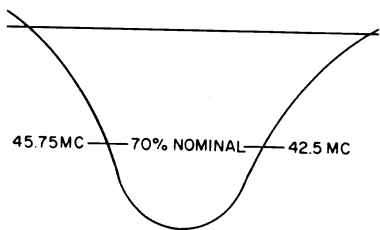

Figure 1

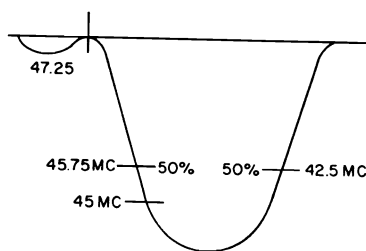

Figure 2

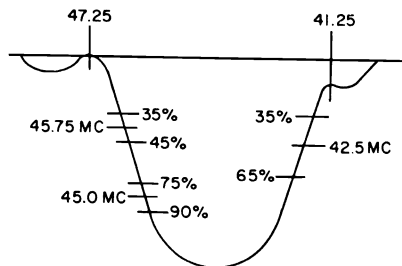
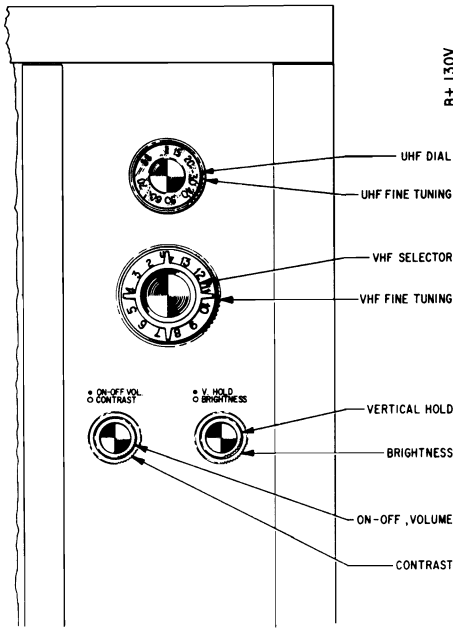

Figure 3

SOUND ALIGNMENT

1. Turn quadrature coil L14 to minimum inductance (core out).
2. Tune receiver to a strong local station (preferably a tone signal or music). Adjust quadrature coil L14 just past the point of maximum sound with minimum distortion.
3. Reduce signal input by removing antenna or placing an adjustable pad across the antenna terminals so that with Volume control set at near maximum, sound is at a low level. Tune the Fine Tuning control through undistorted sound. Set Fine Tuning control to the verge of distortion.
4. Adjust bottom core (grid tuning) of detector drive transformer L13 top core of L13 (plate tuning) and sound take-off coil L12 for minimum distortion.
5. Readjust Fine Tuning control as necessary during adjustment of L12 and L13 to maintain conditions as indicated in step 3 above.

MODELS
GHJ-4097A
GHJ-4147A
GHJ-4157A
GHJ-4017A
GHJ-4447A
GHJ-4457A



CENTERING ADJUSTMENT

If the picture is not centered in the picture opening, it may be centered by removing the cabinet back and adjusting the centering device on the neck of the tube, at the rear of the deflection yoke. Turn the whole device to the right or left. To increase the amount of picture shift, move the two tabs, which project from the device, farther apart. If the picture is tilted at an angle, it may be straightened by loosening the deflection yoke locking clamp and rotating the deflection yoke.

WIDTH ADJUSTMENT

The width may be varied by means of a thin plastic sleeve located between the yoke and the picture tube neck. Adjust sleeve in or out of the yoke for a picture slightly larger than necessary to fill the screen.

Caution: When re-inserting the sleeve, always make certain that the metallic tab is in contact with the picture tube neck.

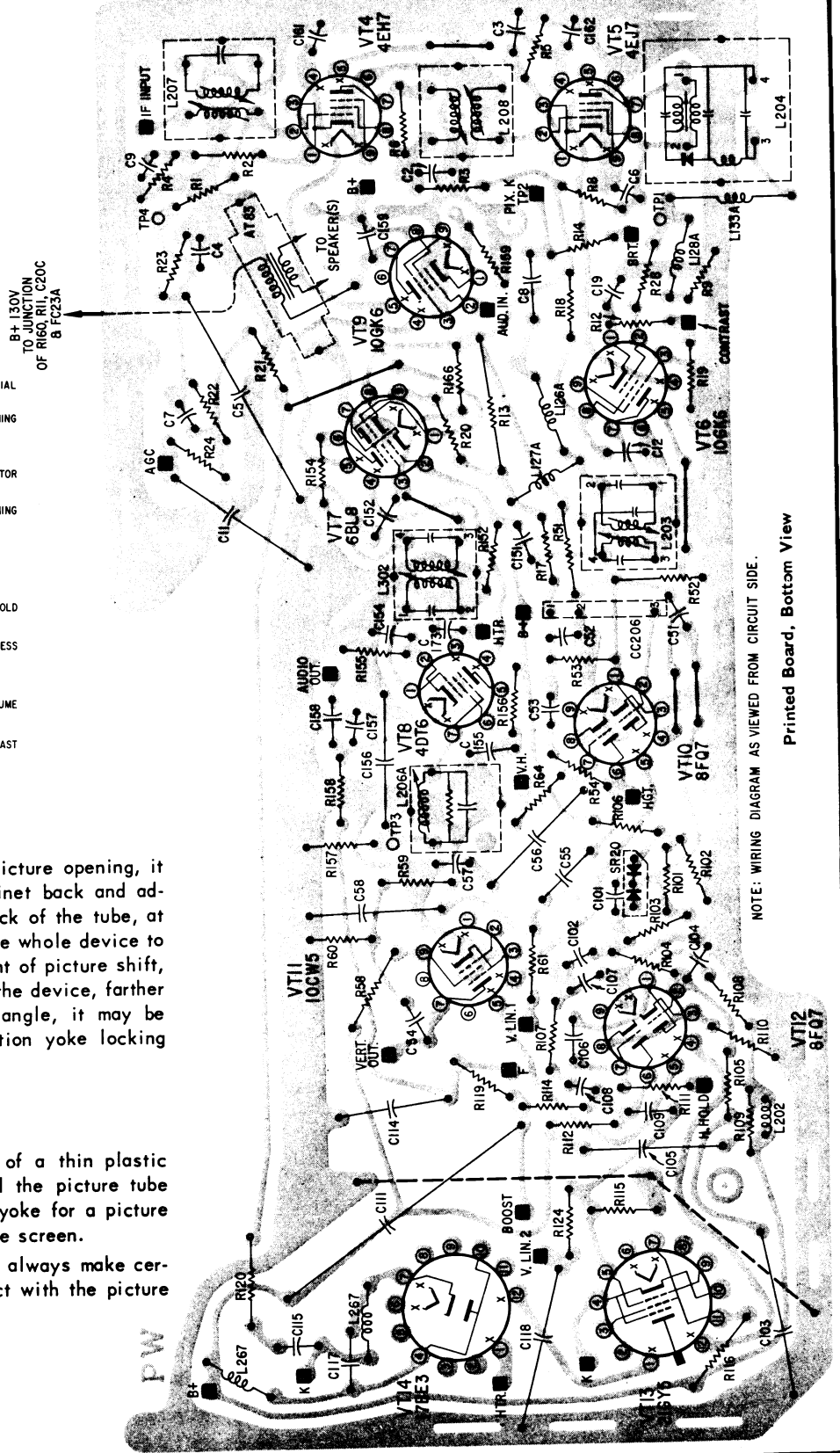

Printed Board, Bottom View

MONTGOMERY WARD Models GHJ-4017A, etc., Schematic Diagram

HORIZONTAL HOLD ADJUSTMENT

If the picture falls out of horizontal sync, the horizontal frequency can be reset by rotating the horizontal hold control located at the rear of the receiver.

HORIZONTAL OSCILLATOR COIL ADJUSTMENT (FIELD)

Should the horizontal hold control fail to bring the picture into sync near the center of its range, center this control and adjust the horizontal frequency coil. This coil is mounted on the printed board and requires a hex head alignment tool for adjustment.

HORIZONTAL FREQUENCY AND OSCILLATOR COIL ADJUSTMENT (SHOP)

1. Turn receiver on and allow adequate warm up at 117 V.A.C. line.
2. Tune in station and set controls for normal operation.
3. Remove SR-20 horizontal AFC selenium diode from socket.
4. Apply direct short across L-202 horizontal oscillator coil.
5. Set R-123 horizontal hold control to mid-range.
6. Adjust R-111 horizontal frequency adjust until picture is nearest to lock-in setting. At this point, the picture will tend to slide slowly horizontally in an upright position.
7. Remove short across L-202 coil and adjust the slug of coil L-202 until the condition described in step 6 is again obtained.
8. Replace SR-20 diode in socket.
9. Check R-123 horizontal hold control for pull-in on either side of center. If necessary recheck adjustment.

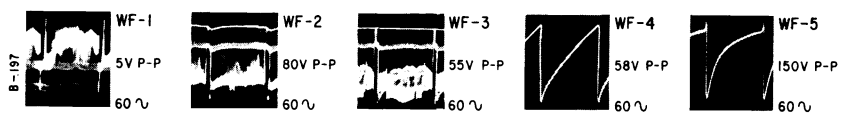
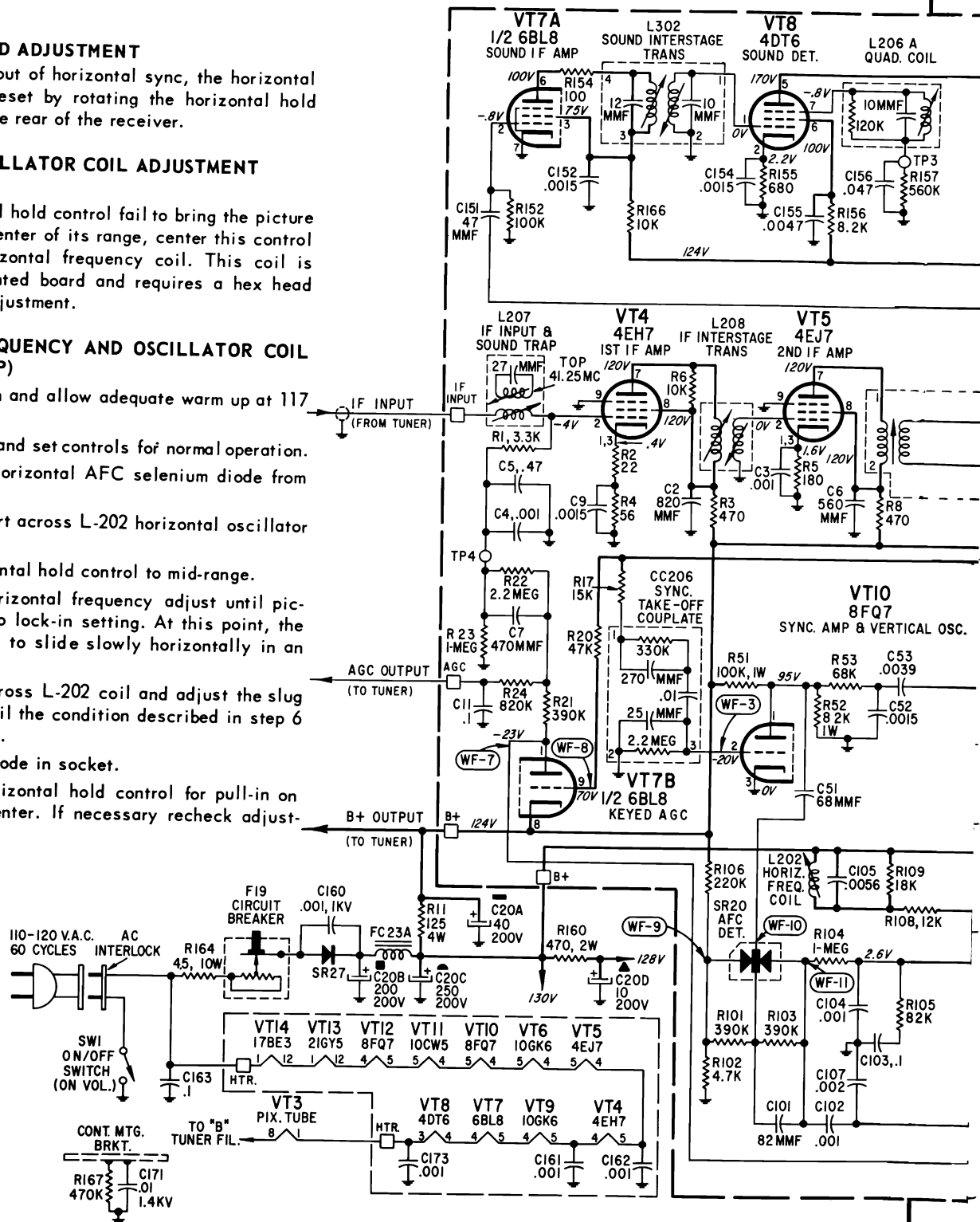

Balloons WF-1 WF-2 etc. shown on schematic indicate points of observation of the waveforms.

MONTGOMERY WARD Models GHJ-4017A, etc., Schematic Diagram, Continued

NOTES:

1. ALL RESISTORS ARE 1/2 WATT, UNLESS OTHERWISE NOTED.
2. CAPACITOR VALUES ARE IN MFD, UNLESS OTHERWISE NOTED.
3. VOLTAGE TOLERANCE MAY VARY $\pm 20\%$.
4. VOLTAGES MEASURED FROM POINT INDICATED TO CHASSIS GROUND WITH "VTVM", AT NORMAL SIGNAL INPUT.
5. WAVEFORMS TAKEN WITH NORMAL SIGNAL INPUT.
6. DOT ON SPEAKER INDICATES PHASE.
7. (*) R56 22K (MODELS: GHJ-4447A, GHJ-4457A). 47K (MODEL: GHJ-4017A)(GHJ4097A, GHJ4147A, 4157A)

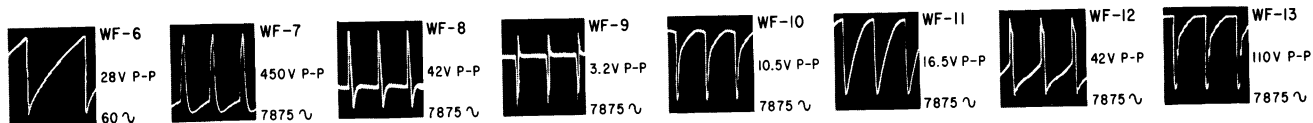
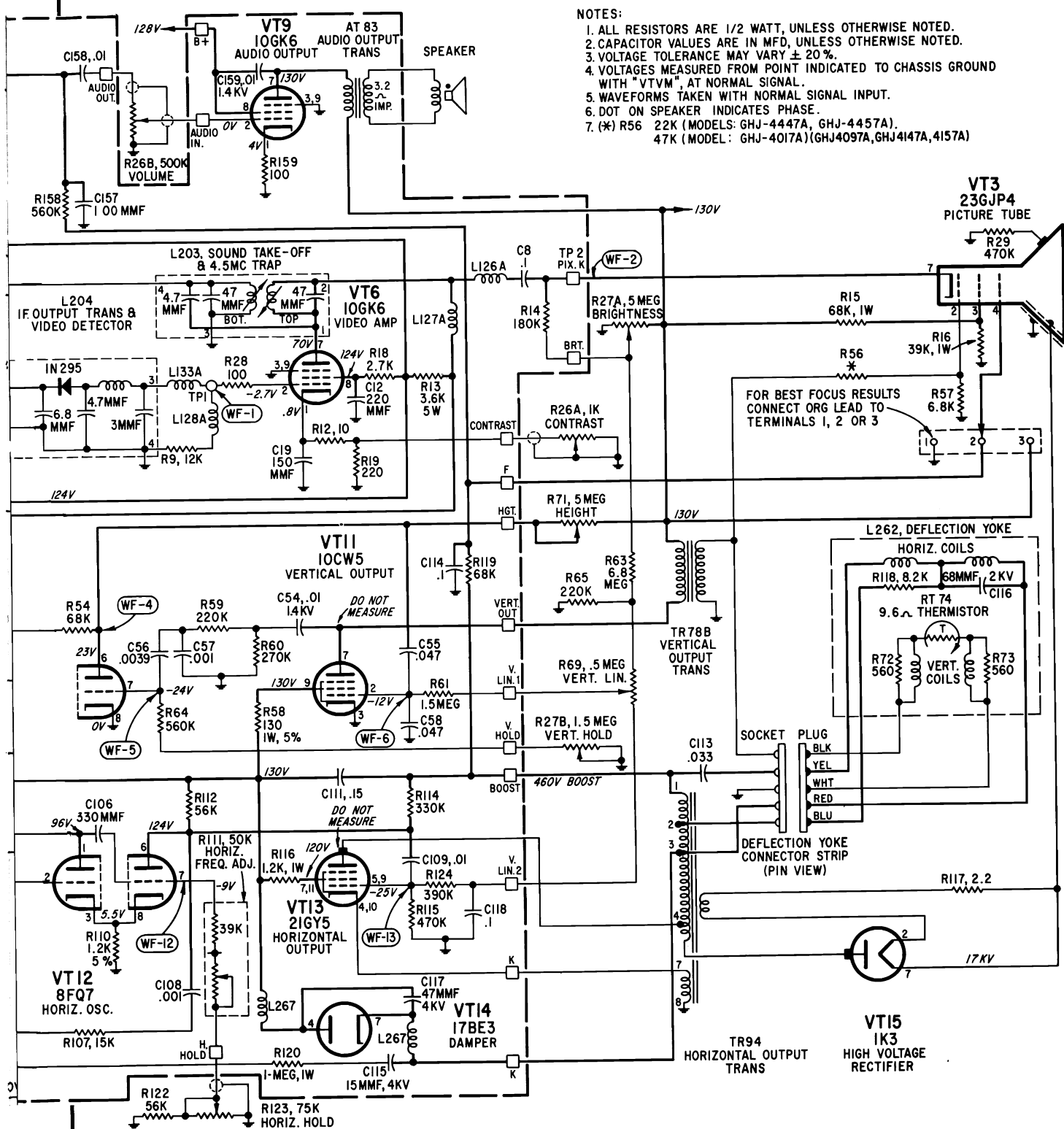

SOUND ALIGNMENT USING FM SWEEP GENERATOR AND OSCILLOSCOPE

1. Connect FM sweep generator set at 4.5 Mc center frequency ± 7.5 Kc deviation to point TP-1 shown on schematic.
2. Connect oscilloscope across voice coil of speaker.
3. Connect VTVM to point TP-3. Set meter to read at least - 5 V.D.C.
4. Adjust generator for a high level output approximately 200 millivolts or greater and set volume control of receiver for an audible level.
5. Adjust L-206A quadrature coil for maximum output on the oscilloscope. Note - during this adjustment, two peaks may occur. It is important to select the peak which gives the maximum voltage. This will normally measure approximately -2.5 V.D.C.
6. Reduce the 4.5 Mc signal from 200 millivolts to a point where the output signal on the oscilloscope starts to break up.
7. Adjust L-203 (bottom) sound take-off coil and L-302 (top & bottom) interstage coil for cleanest maximum output on the oscilloscope.
8. Further reduce 4.5 Mc signal until the audio output signal breaks up again and reset L-203 and L-302 (top & bottom) for cleanest maximum output. Final adjustment of these two coils should be made at that minimum signal level at which undistorted audio output signal is just obtainable.

ALTERNATE SOUND ALIGNMENT USING TELEVISION STATION SIGNAL AND OUTPUT METER

1. Tune in strong air signal.
2. Connect output meter across voice coil of speaker. VTVM to point TP-3 shown on schematic.
3. Adjust L-206A quadrature coil for maximum audio output. Note - during this adjustment, two peaks may occur. It is important to select the peak which gives the maximum voltage. This will normally measure approximately -2.5 V.D.C.
4. Reduce the air signal by disconnecting antenna and/or detuning fine tuning control until audio distortion occurs.
5. Adjust L-203 (bottom slug) sound take-off coil and L-302 (top & bottom) interstage coil for maximum undistorted audio output.
6. Further reduce the air signal level and reset L-203 and L-302 (top & bottom) for maximum undistorted audio output. Final adjustment of these two coils should be made at that minimum air signal level at which undistorted audio output is just obtainable.

7. It may be advisable in some cases to repeat above steps to make certain that the alignment is accurate.

4.5 M.C. SOUND TRAP ADJUSTMENT

1. Connect a signal generator (4.5 Mc, unmodulated) to point TP-1 shown on schematic. Ground side to chassis.
2. Connect VTVM RF probe to point TP-2.
3. Adjust L-203 coil (top slug) for minimum reading.

Note: A diode detector shown in Fig. 4 may be used with the VTVM in place of a commercial RF probe if desired.

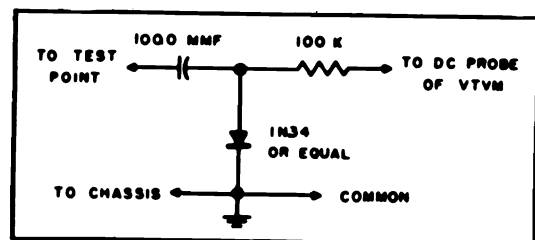

Figure 4 - Diode Detector Detail

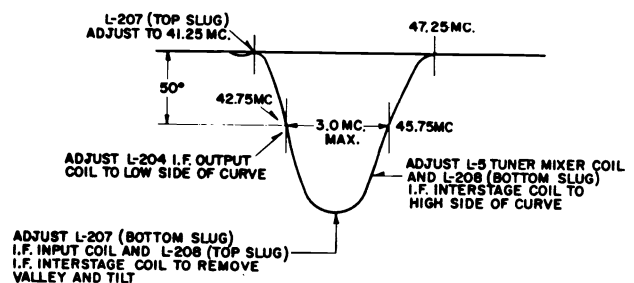

Figure 5 - Video I.F. Phased Pattern

VIDEO I.F. ALIGNMENT

1. Tune receiver to channel 12 or 13, whichever is not assigned.
2. Set the contrast control to maximum clockwise position.
3. Connect the negative side of a 3.0 volt bias supply to point TP-4; connect positive side to chassis.
4. Connect synchronized sweep voltage from sweep generator to horizontal input of oscilloscope for horizontal deflection.

MOTOROLA

CHASSIS TS-461

FOCUSING ADJUSTMENT

To provide for differences in the picture tube gun structure, a focus adjustment is provided by three (3) lugs located on the chassis. They provide a ground potential point, a B+ voltage point and a bootstrap voltage point. Connect the blue lead from the picture tube socket to the lug which provides the best over-all focus, center to edge of screen.

FINE TUNING ADJUSTMENT

The low and high band of the VHF tuner may be adjusted externally from the front of the receiver (see detail). The low band adjustment is made with the channel #6 oscillator adjustment screw located to the right of the tuning shaft (see detail). The high band adjustment is made with the channel #13 oscillator adjustment screw located to the left of the tuning shaft.

Individual oscillator adjustments are provided and are available with the tuner removed from the tuner mounting bracket. If individual os-

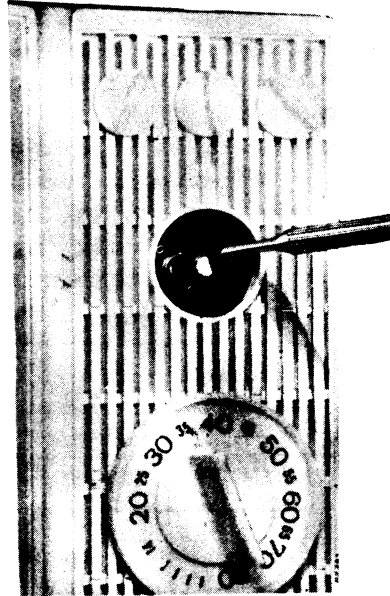

OSCILLATOR ADJUSTMENT

MODEL CHART

MODEL	CHASSIS
BP72BN	12TS-461
BP73BE, BJ, BL, BN	C12TS-461
BP301CN	D12TS-461
BP302CA, CE, CL, CN	E12TS-461

illator adjustment is necessary, the highest available channel should be adjusted first and the remaining available channels should be adjusted in descending order.

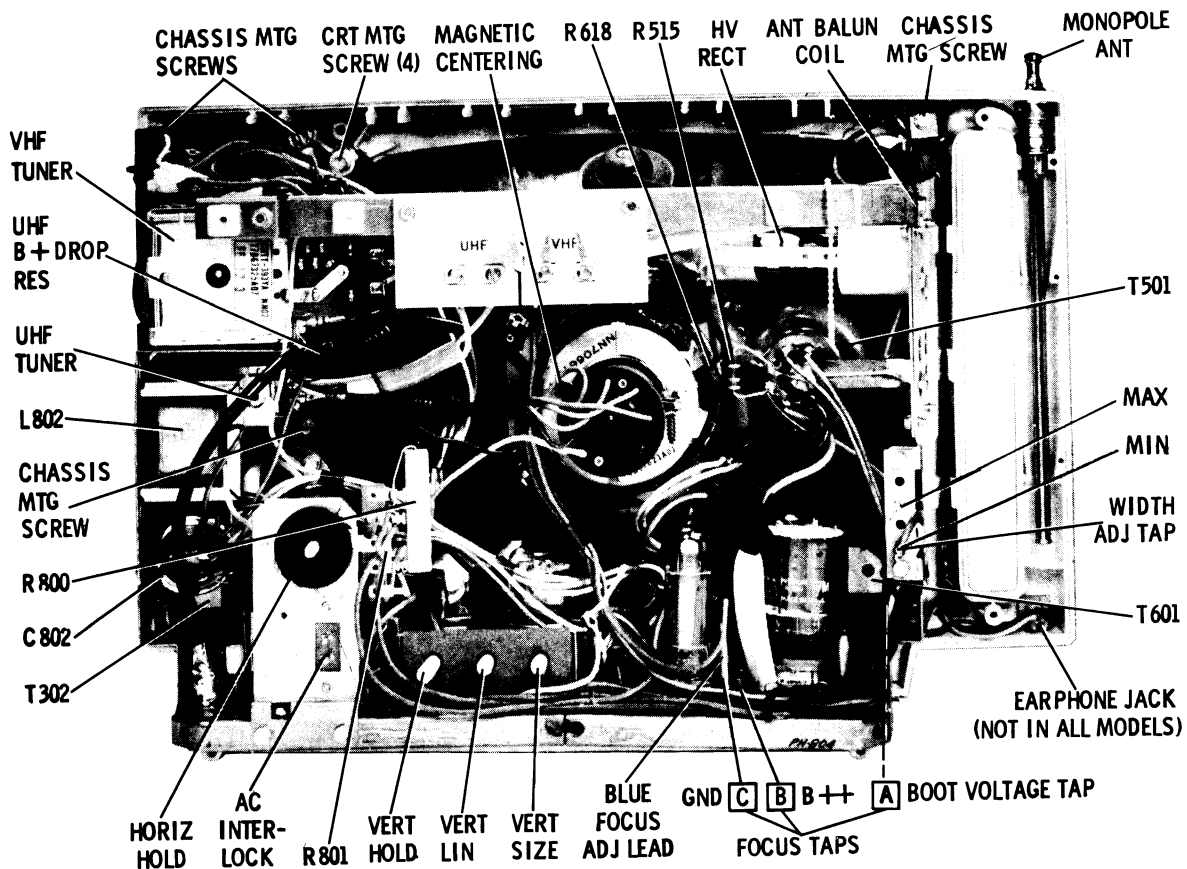

RECEIVER PARTS LOCATION - REAR VIEW

MOTOROLA Chassis TS-461 Servicing Information, Continued

CHASSIS REMOVAL

Seven (7) screws secure the chassis to the cabinet. They are located as follows: Three (3) on the tuner mounting bracket, one (1) at the upper right hand corner and three (3) on the bottom of the cabinet.

PICTURE TUBE REPLACEMENT

Use extreme care in handling the picture tube as rough handling may cause it to implode due to atmospheric pressure. Do not nick or scratch glass or subject it to any undue pressure in removal or installation. Use goggles and heavy gloves for protection.

To remove picture tube, remove chassis as previously described, then remove corner screws securing picture tube to cabinet.

CIRCUIT TRACING

The top (component side) of the chassis board contains a complete legend of the chassis circuit that appears on the bottom and identification of all components by reference numbers that are related to the reference numbers on the schematic diagram. The circuit may be traced from the top of the chassis board and all components can be identified eliminating the need of making any reference to the bottom of the chassis board.

The circuit side (bottom) of the chassis board also contains a com-

plete legend which includes component reference numbers, tube identification, coil terminals and the wiring (jumper wires) is traced in to provide easy circuit tracing of the wiring that appears on the top side of the chassis board.

The tubes are identified by their function as well as the reference number. The first 2 pins are identified by number (i.e., 1, 2) and the tube elements are identified at their respective pins (i.e., K - Cathode, P - Plate, etc.).

The tracing indicates where the wiring (jumper wires) on the top of the chassis board is connected.

Breaks appear in the wire tracing to facilitate the identification of components location. Each wire trace begins and ends with an arrow to indicate where it begins and ends.

To further facilitate circuit tracing of the etched chassis board, a photograph of the chassis board with the pertinent test points identified and related to the schematic diagram is included in this manual.

The test points on the schematic diagram are identified descriptively and/or by number and are blocked in or circled for easy identification. These test points are also shown on the chassis board photographs and serve to pinpoint the physical location of the electrical junction or test point of interest. The descriptive test points such as "AGC, B₊ RF AGC, etc." are included on the chassis as part of the legend.

All other test points may be easily located by circuit tracing from a tube, coil, etc. or any point that is readily identified.

RES-CAP REPLACEMENT AND REPAIR

Res-Cap Repair

If it is desirable to repair a defective res-cap component and the replacement unit is not immediately available, it is possible to repair the existing unit in the following manner. Merely remove the defective component from the circuitry by cutting the appropriate lead(s) and then substitute conventional capacitors or resistors back into the circuitry. When this method is used, it is always desirable to replace the circuitry in such a manner that the defective component is removed entirely from the system. In other words, do not bridge the defective component with the replacement unit. This is to avoid any detrimental effect that the defective component might inject into the system.

Res-Cap Replacement

Provisions are made on the etched board for repair or replacement of the entire res-cap assembly with standard individual components. The components that make up the res-cap are identified by their respective reference number on the top and bottom of the board. Where space permitted, these reference numbers are identified as "ALT

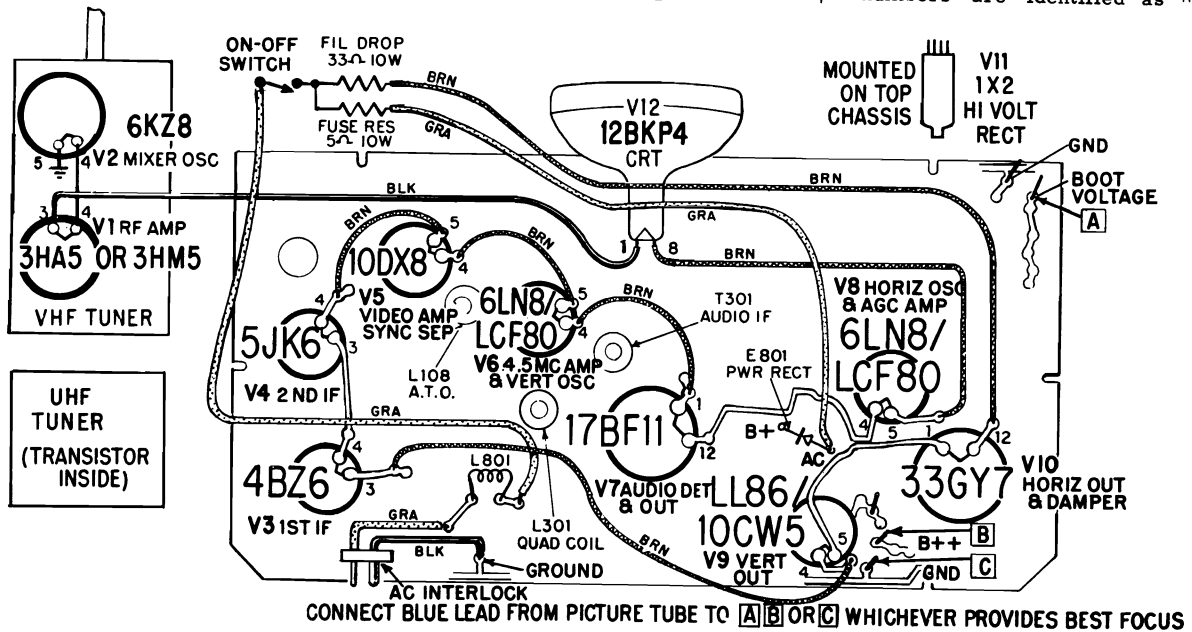

TUBE COMPLEMENT & LOCATION CHART

MOTOROLA Chassis TS-461 Service Information, Continued

R-100", etc. (alternate). In most cases, the alternate positions are located adjacent to their respective res-cap. If the alternate position is not locally located to the respective res-cap, it can be easily located by circuit tracing.

COMPONENT REMOVAL

Removing components from the etched board is facilitated by the fact that the circuitry (plating) appears on one side of the board only and the component leads are inserted straight through the holes and are not bent or crimped.

It is recommended that a solder extruding gun be used to aid in component removal. An iron with a temperature controlled heating element would be desirable since it would reduce the possibility of damaging the board due to over-heating.

The nozzle of the soldering gun is inserted directly over the component lead and when sufficiently heated, the solder is drawn away leaving the lead free from the copper plating. This method is particularly suitable in removing multi-terminal components.

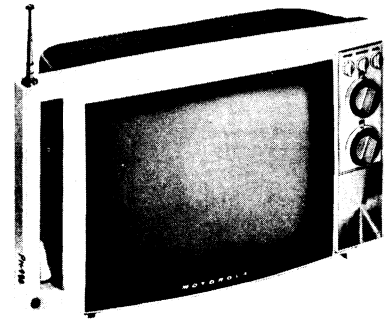

MODEL BP302C

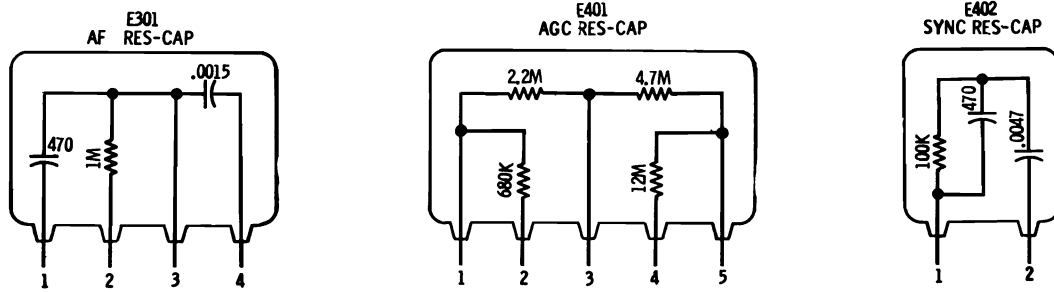

RES-CAP DETAILS

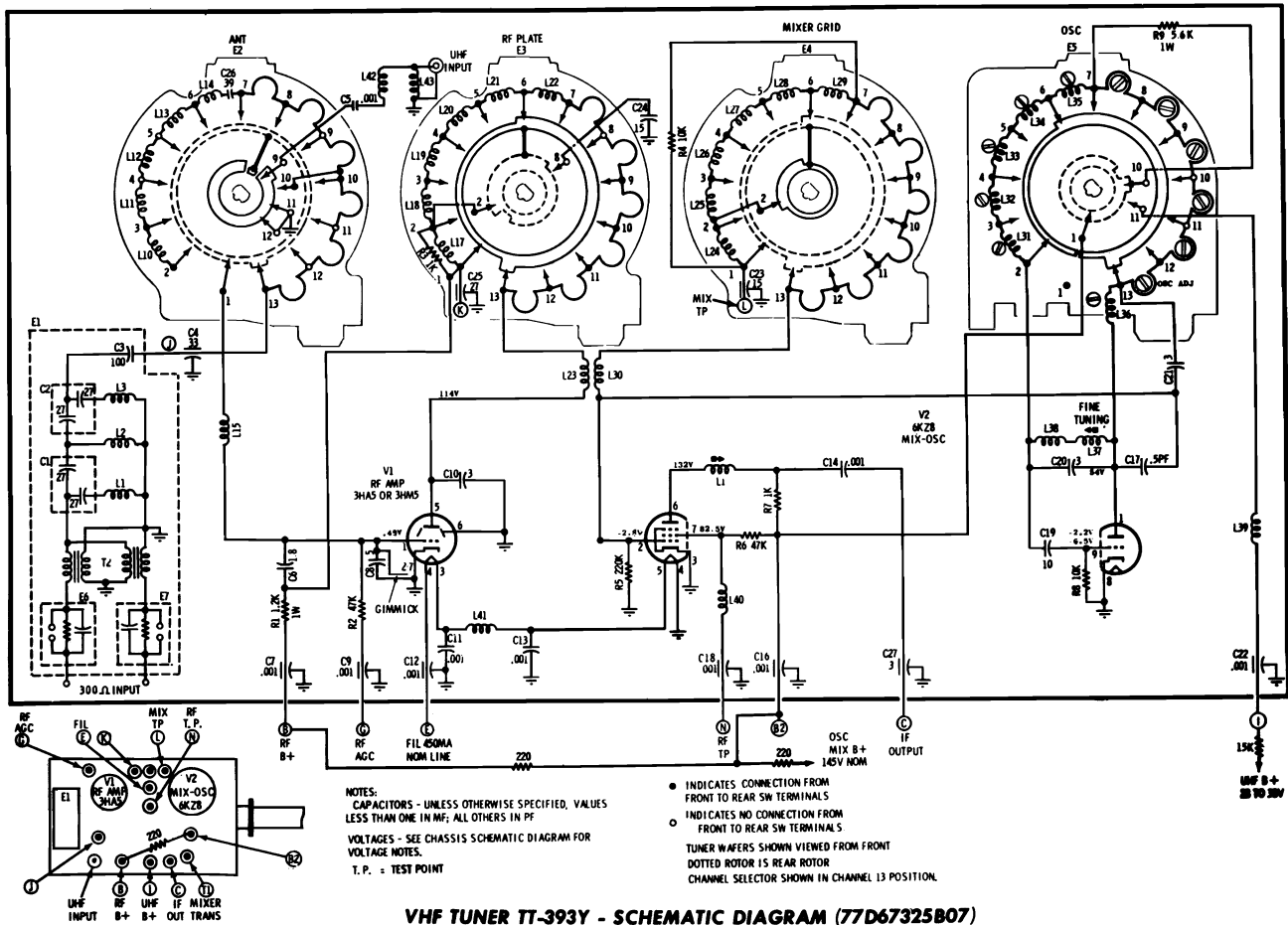

VHF TUNER TT-393Y - SCHEMATIC DIAGRAM (77D67325B07)

VOLTAGE MEASUREMENTS

1. TAKEN FROM POINT INDICATED TO CHASSIS WITH A VTVM. ±20%
2. LINE VOLTAGE MAINTAINED AT 120V AC.
3. TAKEN WITH CONTRAST CONTROL AT MINIMUM AND ALL OTHER CONTROLS IN NORMAL OPERATING POSITION
4. WHERE TWO VOLTAGES ARE SHOWN: VOLTAGE ABOVE BOX-WITH NO SIGNAL INPUT, TUNER ON CHANNEL WITH LEAST NOISE AND ANTENNA TERMINALS SHORTED. VOLTAGE IN BOX-WITH TUNER ON STRONG STATION AND OUTSIDE ANTENNA.

WAVEFORM MEASUREMENTS

1. TAKEN FROM POINT INDICATED TO CHASSIS WITH A WIDE-BAND OSCILLOSCOPE.
 2. OSCILLOSCOPE SYNC'D NEAR SWEEP RATE INDICATED.
 3. TAKEN WITH STRONG SIGNAL, CONTRAST CONTROL AT MAXIMUM: ALL OTHER CONTROLS IN NORMAL OPERATING POSITION.
- * INDICATES VOLTAGE VARIES WITH CONTROL SETTINGS.
 ** INDICATES SPECIAL COMPONENTS, SEE REPLACEMENT PARTS LIST FOR PROPER REPLACEMENT PART NUMBER.

UNLESS OTHERWISE SPECIFIED: CAPACITORS ARE DISC CERAMIC 500V DC, TOLERANCE & CHARACTERISTIC AS NOTED; IF TOLERANCE IS NOT GIVEN CAPACITORS ARE GMV (GUARANTEED MIN. VALUE) TYPE. TUBULAR CAPACITORS ARE 20% 400V DC. DECIMAL VALUES IN MF ALL OTHERS IN PF. RESISTORS ARE ALL 1% 1/2 WATT UNLESS SPECIFIED.

SCHEMATIC DIAGRAM - TS-461A-00

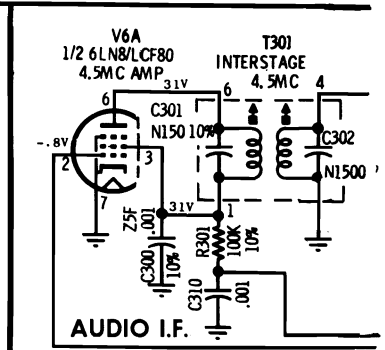
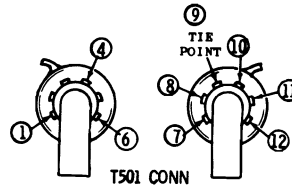

MOTOROLA Chassis TS-461 Schematic Diagram

TUNER PLATE CIRCUIT
SEE TUNER SCHEMATIC

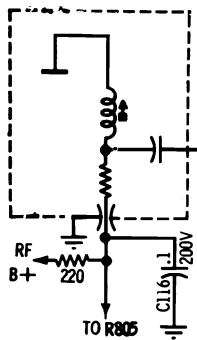

VIDEO I.F.

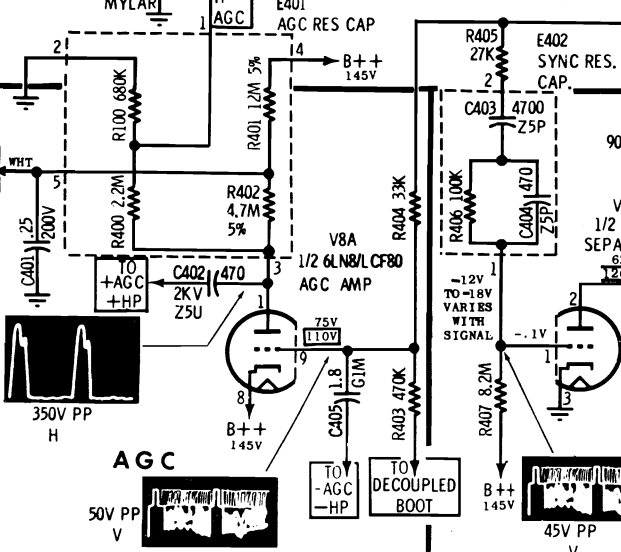
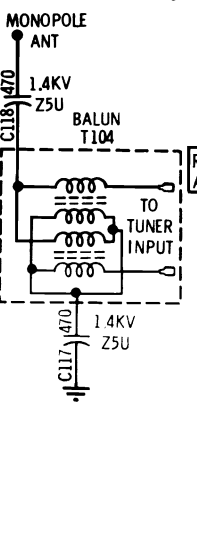
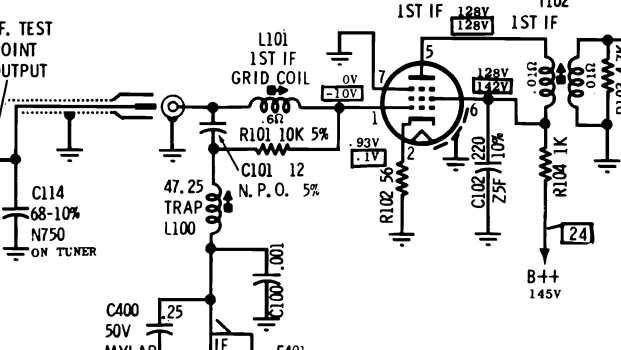

HORIZONTAL

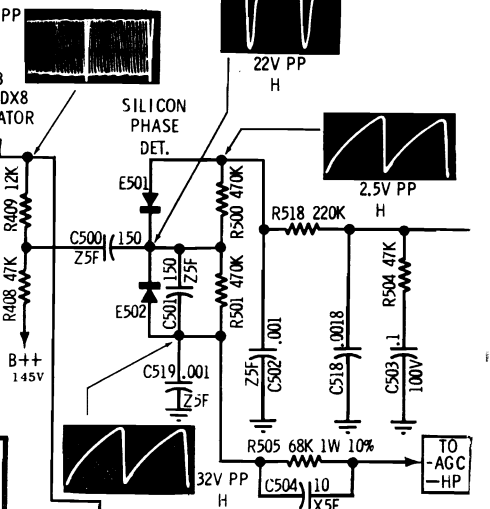

POWER SUPPLY

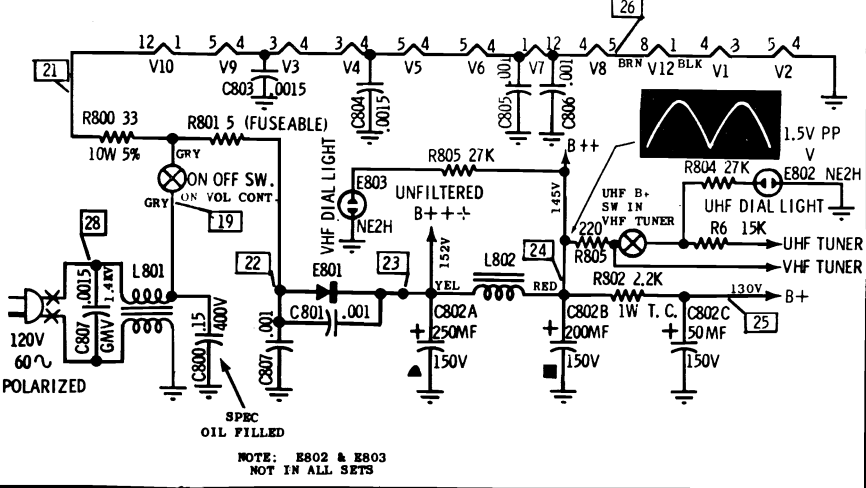

VERTICAL

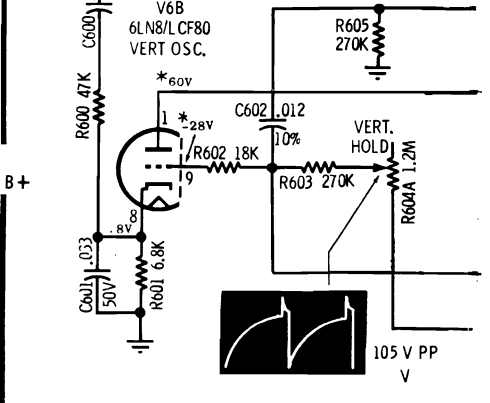

NOTE: E802 & E803 NOT IN ALL SETS

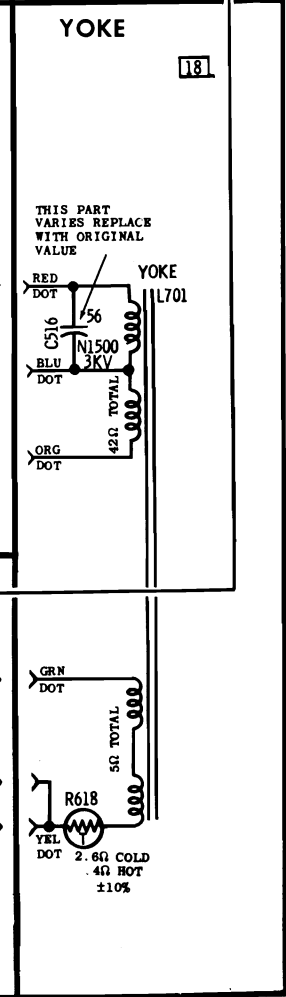
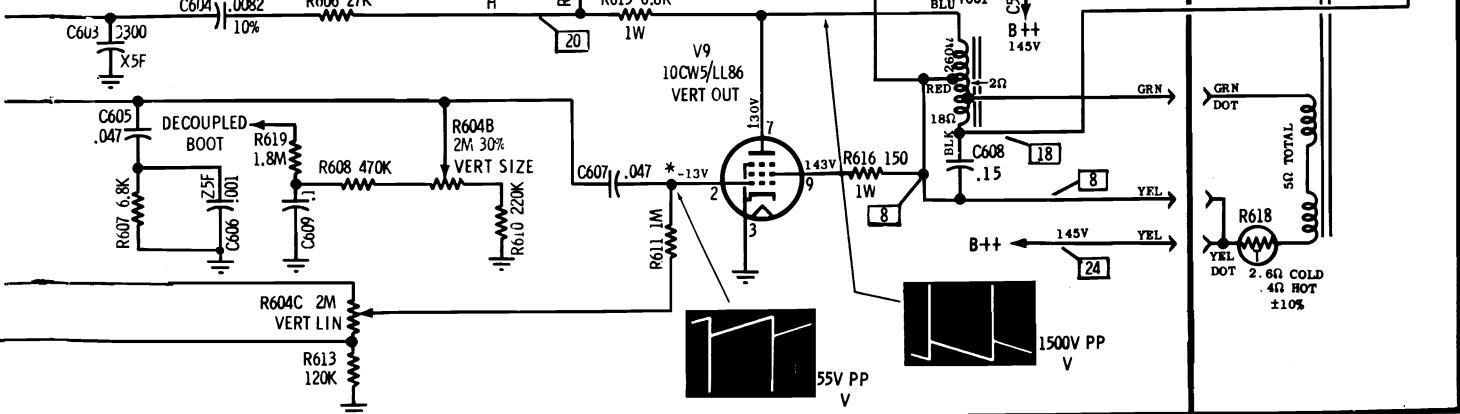
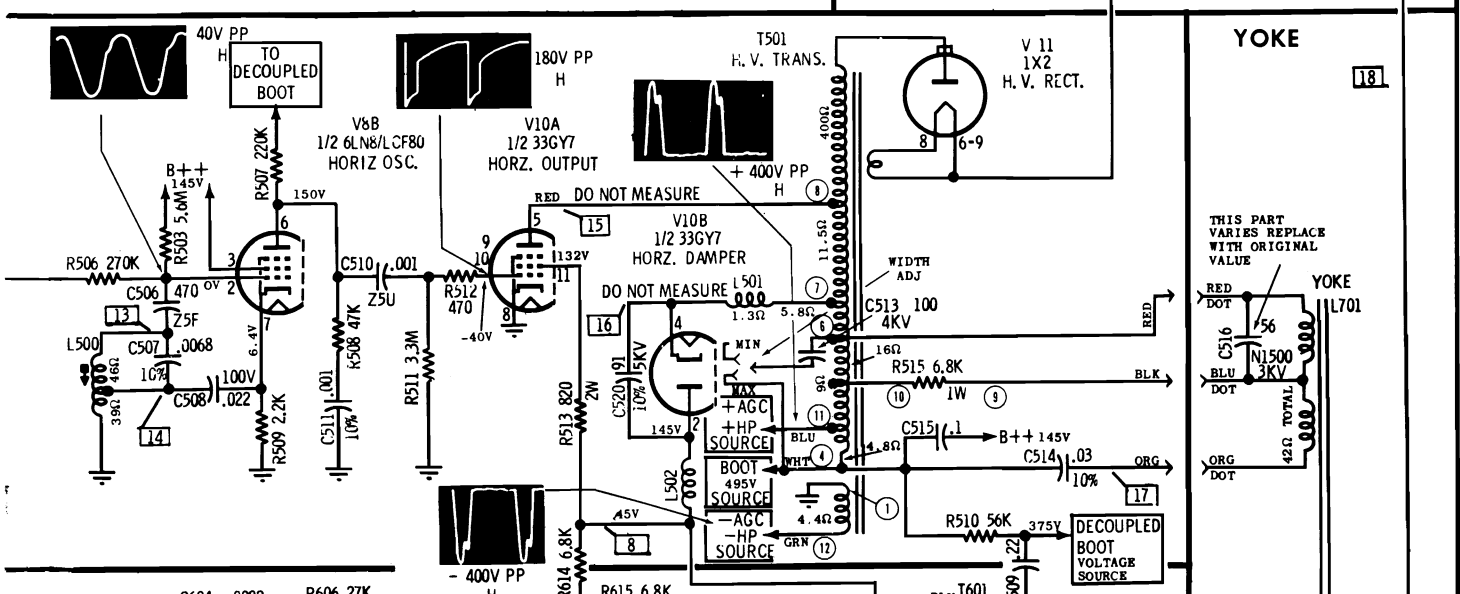
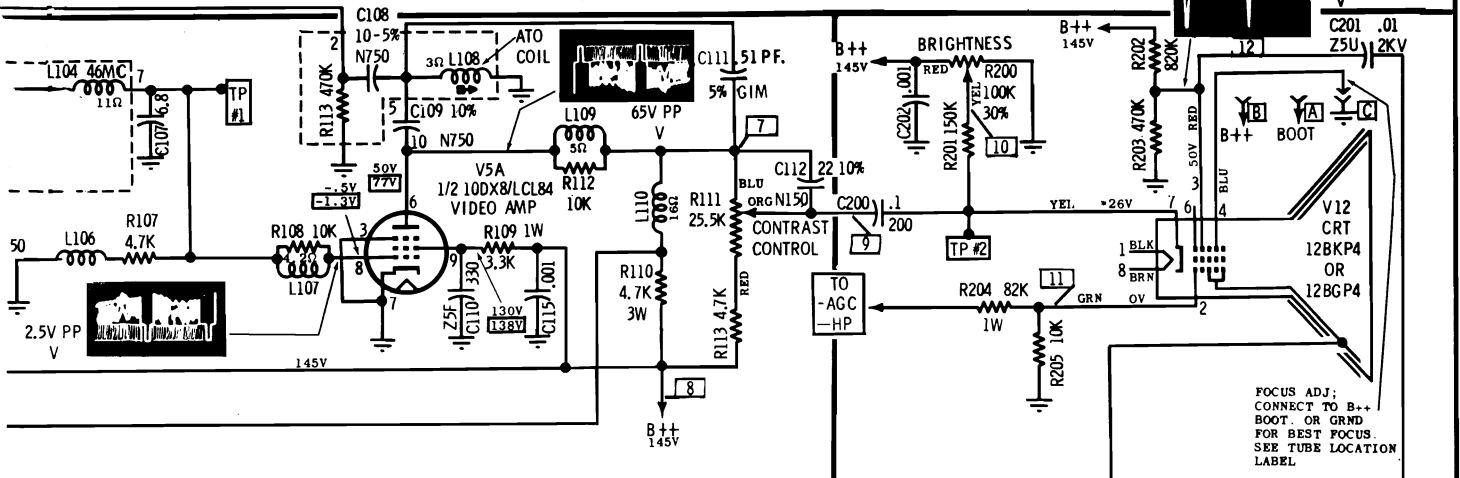
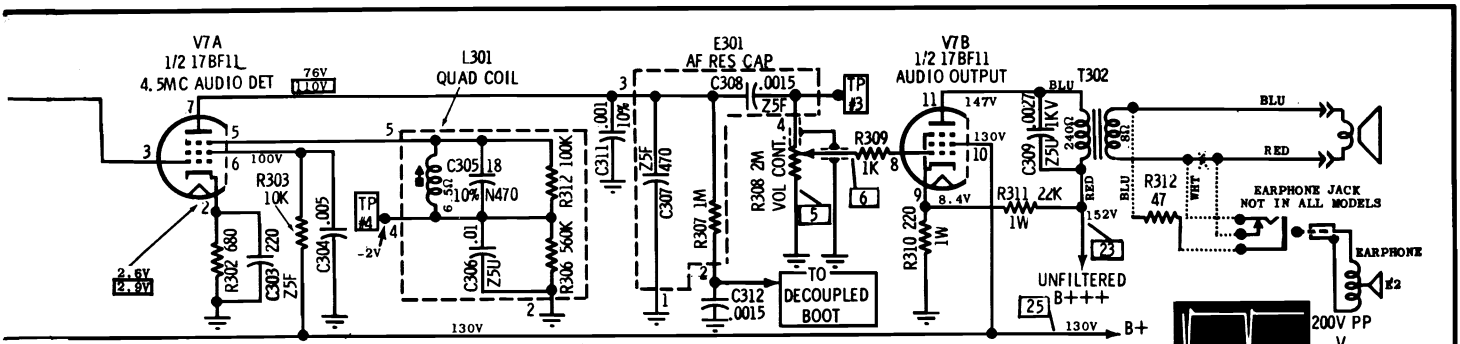

ALIGNMENT PROCEDURE

Pre-Alignment Instructions

Before alignment of the video I.F. section is attempted, it is advisable to thoroughly check the system. If alignment is attempted on an I. F. section in which a faulty component exists, successful alignment will probably be impossible and the entire procedure will have to be repeated when the real cause of the trouble is corrected. Preliminary tests of the system should include voltage and resistance measurements, routine checks for bad soldering connections and visual inspection of the circuits for overheated components as well as for obvious wiring defects.

VIDEO IF & MIXER ALIGNMENT

Pre-Alignment Steps

1. Maintain line voltage at 120 with variac.
2. Remove the two yellow leads from yoke to eliminate RF interference radiation.
3. Disable local oscillator. Ground oscillator grid of mixer-oscillator tube with a piece of bare wire to the tube shield thru hole provided in shield.
4. Apply the negative lead of a 6.0 volt bias supply to I.F. AGC buss, pin #1 of AGC res-cap, E-401, and positive lead to chassis ground.
5. Connect a 750 ohm, 60 watt voltage normalizing resistor from B+ to chassis.

6. Set the contrast control at minimum (extreme counter-clockwise position).
7. Short across tuner input terminals.
8. Maintain 2 volts peak-to-peak at the grid of video amp except when specific values are given in the procedure chart.
9. Refer to "Chassis Alignment Detail" for component and test point locations.

NOTE: To reduce the possibility of inter-action between the two tuning cores in a double tuned transformer or coil, each core should be adjusted for optimum response in the tuning position nearest its respective end of the coil form.

VIDEO IF & MIXER ALIGNMENT PROCEDURE

STEP	SWEEP GENERATOR AND MARKER	INDICATOR	ADJUST	ADJUST FOR AND/OR REMARKS
1.	To grid of 2nd I.F. thru .001mf capacitor. Set sweep to approx 44Mc, markers as required.	Scope to grid of video amp thru 47K ohm resistor.	Both cores of 2nd I.F. transformer (T-103).	Equal peaks and marker placement as shown in curve #1.
2.	To grid (pin #1) of 1st I.F. amp thru .001mf capacitor. Set sweep to 44Mc, markers as required.	Same as Step #1.	1st I. F. transformer (T-102).	Symmetrical curve and proper 45.75Mc marker placement. See curve #2. The 41.75Mc marker should fall between the 10% to 60% of curve as shown.
3.	To mixer T. P. (L) thru .001mf capacitor. Set sweep to 44Mc, markers as required.	Same as Step #1.	47.25Mc trap (L-100).	Minimum response at proper trap frequency. See curve #3. NOTE: Temporary removal of bias and an increase of generator output may be required to see trap clearly.
4.	Same as Step #3.	Same as Step #1.	Mixer plate coil (L-1 on tuner and 1st I.F. grid coil (L-101).	To obtain curve #4. The mixer coil affects the low side and the grid coil affects the high side. Tune coils simultaneously for proper tuning and band-width consistent with maximum gain. If necessary, the 1st I.F. transformer can be touched-up to obtain proper response as shown in curve #4.

SOUND ALIGNMENT (STATION SIGNAL METHOD)

The sound system used in this receiver consists of an audio I.F. amplifier stage, a quadrature grid detector and an output stage. Since this type of sound system is extremely sensitive, relatively small input signal voltage will cause grid current to flow in both the I.F. amplifier and the detector stages. Grid

current through the tuned coils will load them down making the adjustment extremely broad and alignment impossible. For this reason, it is necessary to use a very weak signal when aligning the driver and the detector input coils. Actually, the signal should be well down into the noise level for proper tuning action.

Preliminary Steps

1. Tune in a strong TV station.
2. Adjust all controls for normal picture and sound.
3. Refer to "Chassis Alignment Detail" for coil and test point locations.

MOTOROLA Chassis TS-461 Alignment Information, Continued

SOUND ALIGNMENT PROCEDURE

STEP	STATION	INDICATOR	ADJUST	ADJUST FOR AND/OR REMARKS
1.	Strong signal.	VTVM to point T. P. 4 on quad. coil L-301. (See schematic diagram.)	L-301 (quad. coil).	Maximum deflection (coarse adjustment) of two possible maximum tuning points, use that giving largest voltage reading.*
2.	"	Listening test.	"	Maximum sound with minimum distortion (fine adjustment).
3.	Weak signal.	"	T-301 (inter-stage coil).	Maximum sound with minimum distortion (maintain hiss level).**
4.	"	"	L-108 (take-off coil).	Maximum sound with minimum distortion.

If sound is not clear at this point, repeat the above procedure as necessary.

*The purpose of the top pre-set core is to enable the adjustable core to make the tuning range required while reducing the physical length. If the pre-set core should be mis-adjusted by previous service work, merely re-set near top end of coil and tune for maximum.

**The signal must be weakened considerably either by disconnecting one side of the antenna lead or connecting low value resistors across the antenna terminals until a pronounced hiss appears in the sound. The hiss level must be maintained for proper alignment.

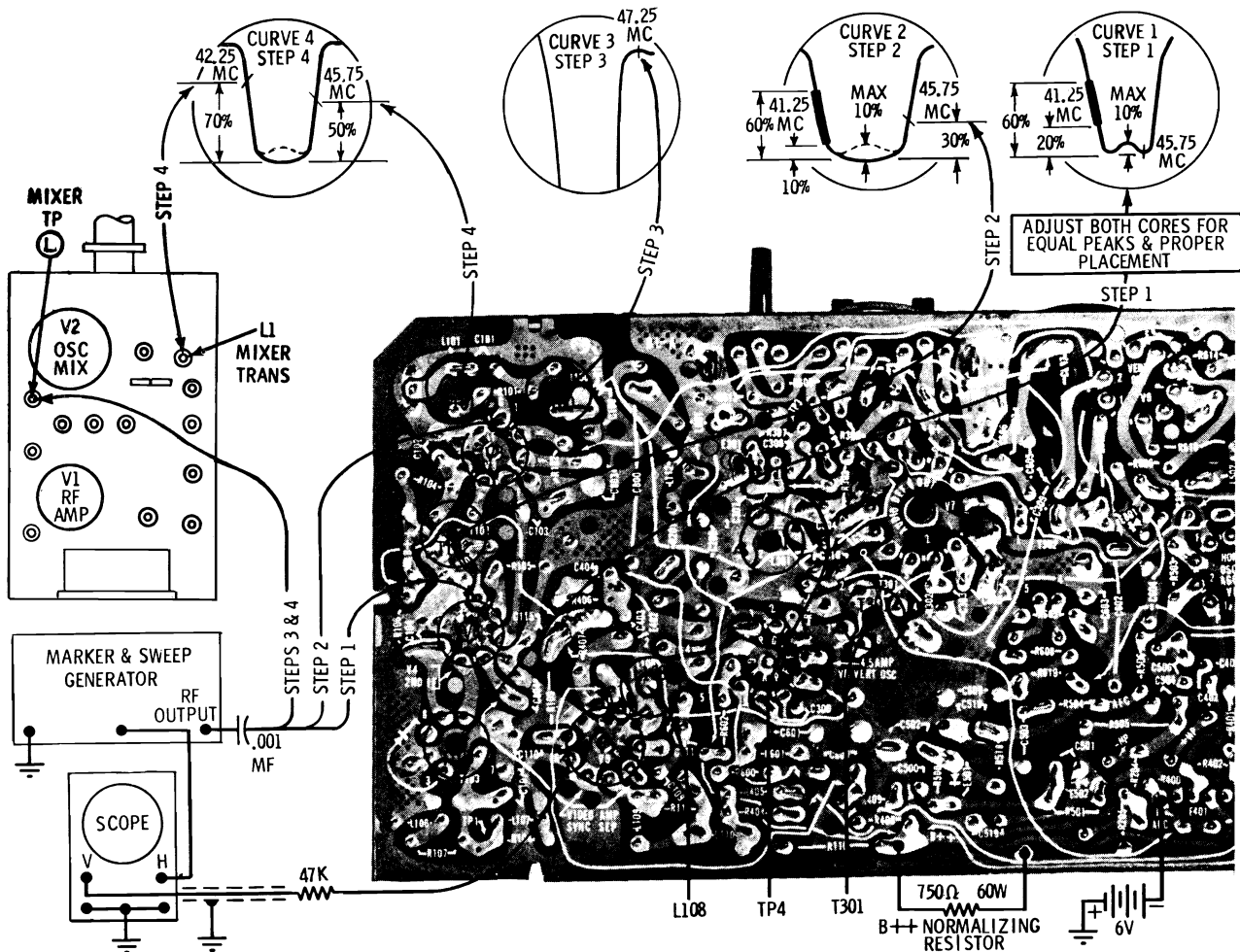

CHASSIS ALIGNMENT DETAIL

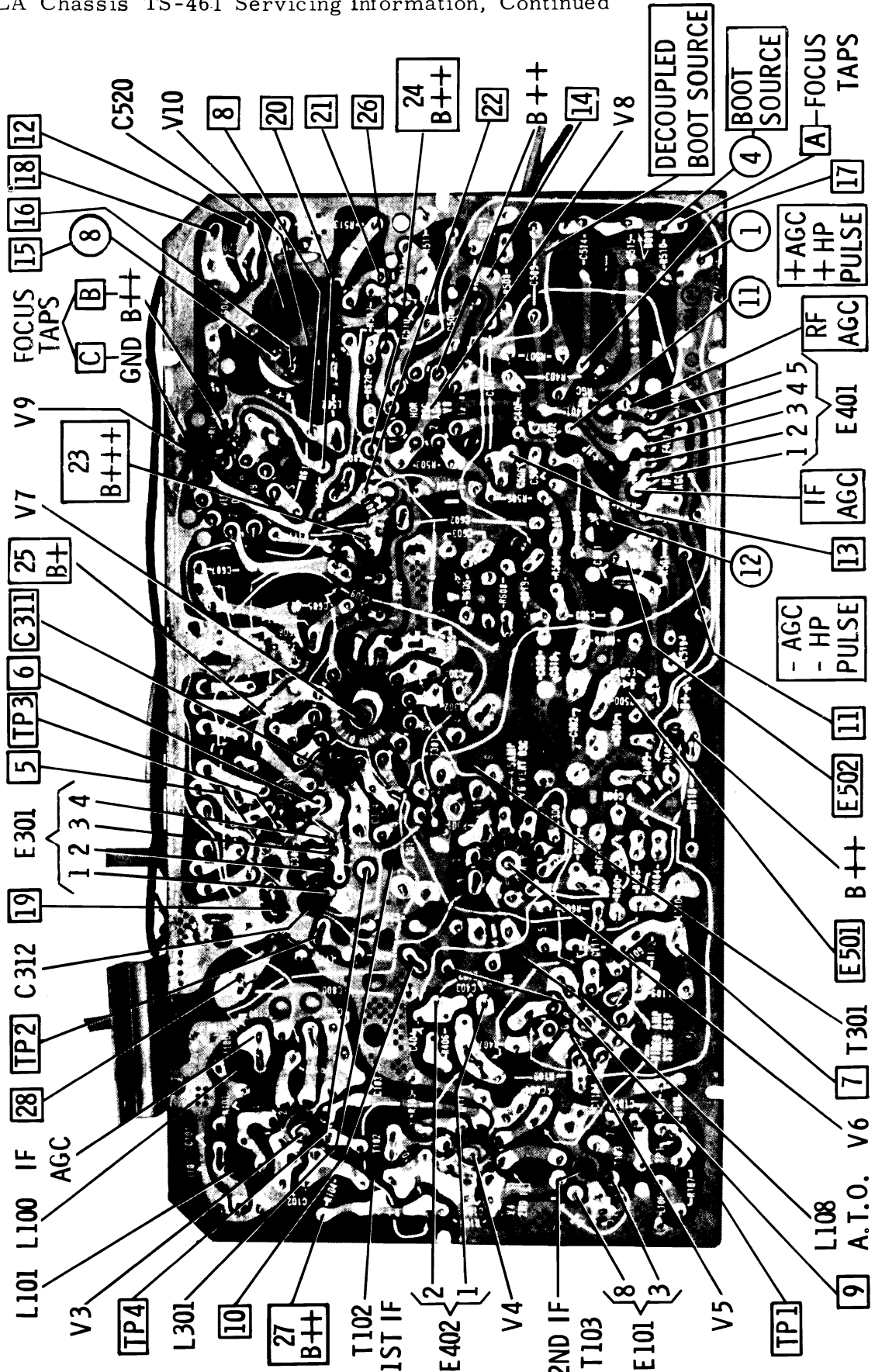

CHASSIS TEST POINT LOCATION

MOTOROLA

CHASSIS TS-597

MODEL BREAKDOWN CHART

MODEL	CHASSIS	VHF TUNER	UHF TUNER	CRT
16BP76BN	CTS-597	CMTT-393Y	KTT-622	16CJP4
16BP77BE, BJ, BL & BN	NCTS-597	CMTT-393Y	KTT-622	16CJP4
BP502CA	C18TS-597	CMTT-393Y	HTT-624 or HTT-627	19GFP4 or 19GEP4
BP503CB, CC & CW	D18TS-597	CMTT-393Y or CPTT-405	HTT-624 or HTT-627	19GFP4 or 19GEP4
BP501CE	18TS-597	CMTT-393Y	KTT-622 or KTT-626	19GFP4 or 19GEP4

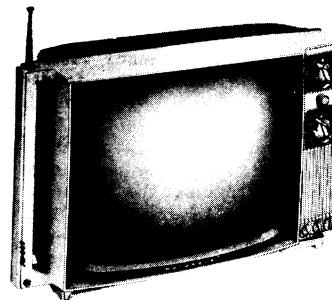

MODEL 16BP77B

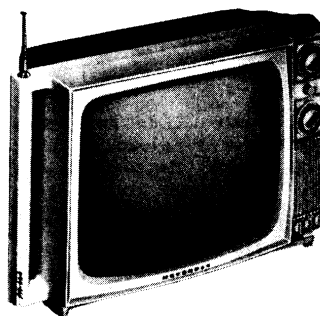

MODEL 16BP76B

FOCUSING ADJUSTMENT

To provide for differences in the picture tube gun structure, a focus adjustment is provided by three (3) lugs located on the chassis. They provide a ground potential point, a B+ voltage point and a bootstrap voltage point. Connect the blue lead from the picture tube socket to the lug which provides the best over-all focus, center to edge of screen.

FINE TUNING ADJUSTMENT

The low and high band of the VHF tuner may be adjusted externally from the front of the receiver (see

Figure #1). The low band adjustment is made with the channel #6 oscillator adjustment screw located to the right of the tuning shaft (see Figure #1). The high band adjustment is made with the channel #13 oscillator adjustment screw located to the left of the tuning shaft.

Individual oscillator adjustments are provided and are available with the tuner removed from the tuner mounting bracket. If individual oscillator adjustment is necessary, the highest available channel should be adjusted first and the remaining

available channels should be adjusted in descending order.

AGC CONTROL

The AGC control is set so as to prevent receiver overload on strong signals. Adjust the control as follows:

Tune in the strongest channel available for best picture and sound. Turn the AGC control clockwise (when viewed from rear of receiver) until picture becomes unstable (rolls or bends, etc.). Then turn control

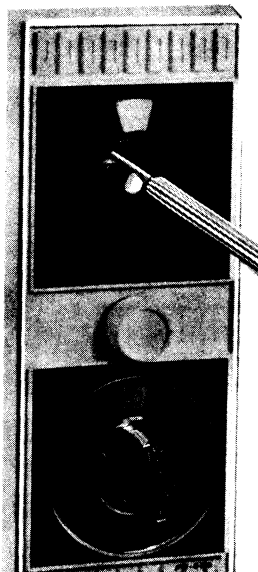
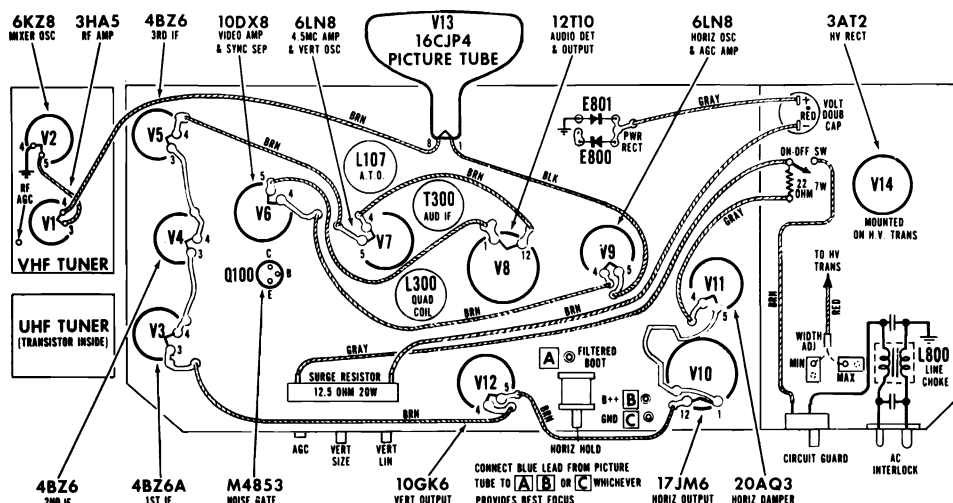

FIGURE 1. OSCILLATOR ADJUSTMENT



TUBE LOCATION AND FILAMENT WIRING DETAIL

MOTOROLA Chassis TS-597 Servicing Information, Continued

counter-clockwise until picture returns to normal. Check all channels; if any are unstable, continue turning control counter-clockwise until the picture is normal on all channels.

HORIZONTAL SIZE CONTROL

To provide for differences in line voltages, either of the two lugs on the terminal strip adjacent to the high voltage transformer may be selected to provide proper horizontal size. The lead must be connected to one of the lugs. Remove power before making adjustment. Refer to the receiver parts location photo for terminal strip location.

CIRCUIT GUARD

The circuit guard is a thermal cut-out type of overload relay. It is in series with the power into the receiver for protection against shorts in the chassis.

The circuit guard will remain in the "closed circuit" state when the current requirements are normal. In the event of a continuous high current overload, the bi-metallic elements of the unit will become heated to the extent of "opening" the contacts and disconnecting the AC power. After the bi-metallic elements have cooled, the circuit guard may be re-set by depressing the plastic re-set button.

The circuit guard is designed to remain "closed" on the higher-than-

normal instantaneous surge currents encountered during the initial warm-up. The circuit guard is unique in the fact that when a short exists in the associated circuitry, power is not re-applied when the re-set button is held depressed.

CHASSIS REMOVAL

Refer to Figures #2. Nine (9) screws secure the chassis to the cabinet. They are located as follows: five (5) on the tuner mounting bracket, one (1) at the upper right hand corner and three (3) along the bottom of the chassis.

RES-CAP REPLACEMENT AND REPAIR

If it is desirable to replace a defective res-cap and the replacement unit is not immediately available, it is possible to repair the existing unit in the following manner. Merely remove the defective component from the circuitry by cutting the appropriate lead(s) and then substitute conventional capacitors or resistors back into the circuitry. When this method is used, it is always desirable to replace the circuitry in such a manner that the defective component is removed entirely from the system. In other words, do not bridge the defective component with the replacement unit. This is to avoid any detrimental effect that the defective component might inject into the system.

COMPONENT REMOVAL

Removing components from the etched board is facilitated by the fact that the circuitry (plating) appears on one side of the board only and the component leads are inserted straight through the holes and are not bent or crimped.

It is recommended that a solder extracting gun be used to aid in component removal. An iron with a temperature controlled heating element would be desirable since it would reduce the possibility of damaging the board due to over-heating.

The nozzle of the soldering gun is inserted directly over the component lead and when sufficiently heated, the solder is drawn away leaving the lead free from the copper plating.

CIRCUIT TRACING

The top (component side) of the chassis board contains a complete legend of the chassis circuit that appears on the bottom and identification of all components by reference numbers that are related to the reference numbers on the schematic diagram. The circuit may be traced from the top of the chassis board and all components can be identified eliminating the need of making any reference to the bottom of the chassis board.

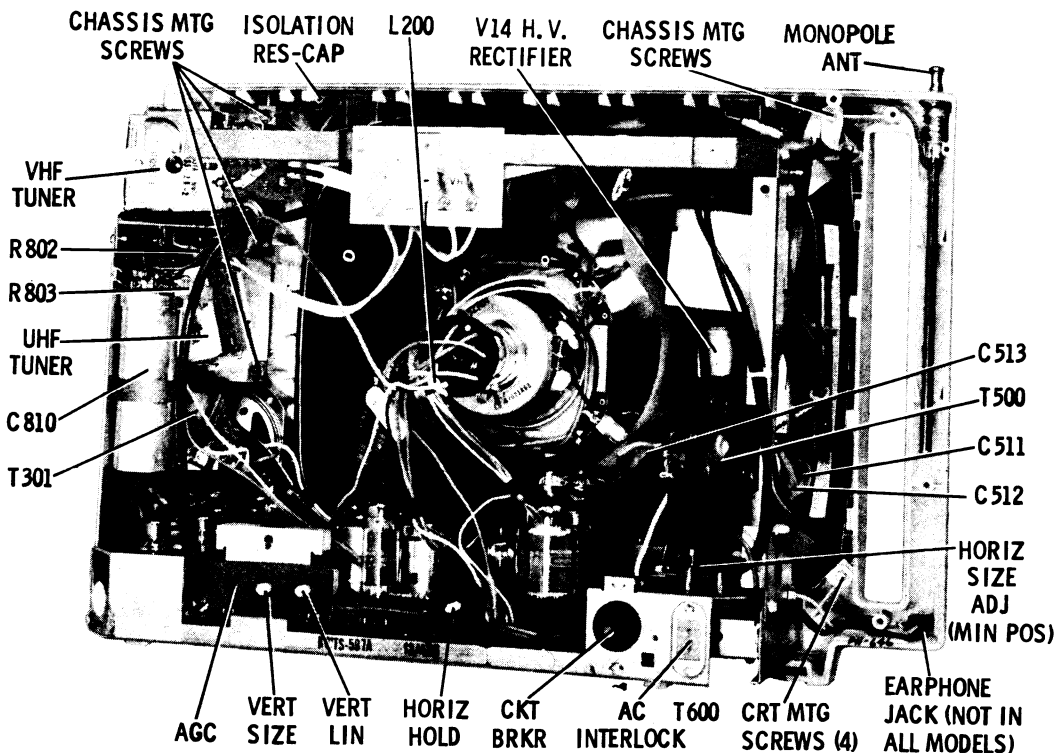
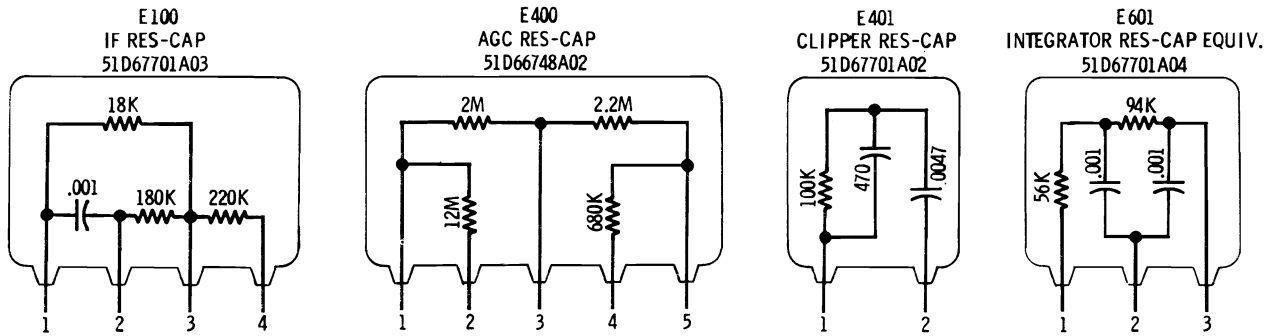

FIGURE 2 RECEIVER PARTS LOCATION

MOTOROLA Chassis TS-597 Servicing Information, Continued



The circuit side (bottom) of the chassis board also contains a complete legend which includes component reference numbers, tube identification, coil terminals and the wiring (jumper wires) is traced in to provide easy circuit tracing of the wiring that appears on the top side of the chassis board.

The tubes are identified by their function as well as the reference

number. The first 2 pins are identified by number (i.e., 1, 2) and the tube elements are identified at their respective pins (i.e., K - Cathode, P - Plate, etc.).

The tracing indicates where the wiring (jumper wires) on the top of the chassis board is connected.

Breaks appear in the wire tracing to facilitate the identification of com-

ponents location. Each wire trace begins and ends with an arrow to indicate where it begins and ends. The test points on the schematic diagram are identified descriptively and/or by number and are blocked in or circled for easy identification. These test points are also shown on the chassis board photographs and serve to pinpoint the physical location of the electrical junction or test point of interest.

CHASSIS CODING CHANGES

Chassis Coding	Chassis Coding Changes	Chassis Coding	Chassis Coding Changes
BTS-597A-01	TO PREVENT DAMAGE TO NOISE GATE TRANSISTOR DUE TO CRT ARCING: Add ceramic disc capacitor .01 mf, +100-0%, Z5U, 2KV, part no. 21S131733 at CRT socket.	BTS-597A-05	TO PREVENT RADIATION FROM HORIZONTAL OUTPUT CIRCUIT: Radiation shield added at rear of flyback transformer.
BTS-597A-02	TO REDUCE INVERSE VOLTAGE ACROSS PHASE DETECTOR AND RE-TRACE BLANKING DIODES E-501 AND E-200: Add ceramic disc capacitors 18 pf, ± 10%, N330, part no. 21S129733 across diode E-200 and 150 pf, ± 20%, Z5F, part no. 21S129730 across diode E-501.	BTS-597A-06	TO PREVENT REGENERATION IN VIDEO IF: B+ lead (blue wire jumper) to 3rd IF stage divided into two sections and mid-point bypassed to ground with 1000 pf 20% Z5F capacitor, C-125. Part Number 21S129821.
BTS-597A-03	DESIGN CHANGE, EARPHONE JACK: Part no. 9P65145A04 replaces part no. 9C67498A03.	BTS-597A-07	MECHANICAL CHANGE: Etched board changed from Part Number 84C68110A02 to 84C68110A03 to accommodate three additional capacitors on top side of board. Capacitors C-203, C-520 and C-125 relocated from bottom to top of board.
BTS-597A-04*	¹ TO REDUCE HORIZONTAL COLLAPSE: Change C-520 from 150 pf, 20%, Z5F to 100 pf, 20%, Z5F (part no. 21S180C18). Change C-500 from 200 pf, 20%, Z5F to 150 pf, 20%, Z5F (part no. 21S129730). Change R-508 from 4.7 meg, 10%, 1/2W to 3.3 meg, 10%, 1/2W. ² RELIABILITY CHANGE: Noise gate transistor, Q-100, changed from type M4852 to M4853 (part no. 48S134853). ³ TUNER CHANGE: Tuner part no. 77D67325A07 replaced by 77D67325B07 (model number of tuner, CMTT-393Y, does not change). *NOTE: Changes #1 and #2 are included in chassis coded A-03 which are used in receiver models with a "-Q" suffix, for example: 16BP76BN-Q. Change #3 is included in chassis coded A-04 used in models with a "-Q" suffix.	BTS-597A-08	RELIABILITY CHANGE: B+dropping resistor R-803 changed from 3.3K, 7 Watt to 3K, 7 Watt, Part Number 17S733877 to raise B+ voltage and increase reliability of neon pilot lights.
		18TS-597A-09, C18TS-597A-09 and D18TS-597A-09	RELIABILITY CHANGE: Added two spark gaps, Part No. 80C68147A01, to prevent damage to power rectifiers in the event of an arc in the high voltage transformer or CRT. One gap is located on the high voltage transformer and connected from the negative AGC pulse winding to ground. The other gap is located at the B++ focus lead tap and is connected from B++ to ground. This change is incorporated in 18" receivers only.

MOTOROLA SCHEMATIC DIAGRAM - TS-597A-00 THRU A-02

NOTES:

VOLTAGE MEASUREMENTS

1. TAKEN FROM POINT INDICATED TO CHASSIS WITH A VTVM $\pm 20\%$.
2. LINE VOLTAGE MAINTAINED AT 120V AC.
3. * VARIES WITH CONTROL SETTINGS
4. ** SPECIAL COMPONENTS, SEE PARTS LIST.
5. TAKEN WITH CONTRAST CONTROL AT MINIMUM AND ALL OTHER CONTROLS IN NORMAL OPERATING POSITION.
6. WHERE TWO VOLTAGES ARE SHOWN, UPPER VOLTAGE - WITH NO SIGNAL INPUT: TUNER ON CHANNEL WITH LEAST NOISE AND ANTENNA TERMINALS SHORTED. LOWER VOLTAGES - WITH TUNER ON STRONG STATION AND OUTSIDE ANTENNA.

WAVEFORM MEASUREMENTS

1. TAKEN FROM POINT INDICATED TO CHASSIS WITH A WIDE-BAND OSCILLOSCOPE.
2. OSCILLOSCOPE SYNCED NEAR SWEEP RATE INDICATED.
3. TAKEN WITH STRONG SIGNAL, CONTRAST CONTROL AT MAXIMUM. ALL OTHER CONTROLS IN NORMAL OPERATING POSITION.

INDICATES PRINTED CIRCUIT BOARD

UNLESS OTHERWISE SPECIFIED, CAPACITORS ARE DISC CERAMIC 500V DC, TOLERANCE & CHARACTERISTIC AS NOTED: IF TOLERANCE IS NOT GIVEN, CAPACITORS ARE GMV (GUARANTEED MIN. VALUE) TYPE. TUBULAR CAPACITORS ARE 20% 400V DC. DECIMAL VALUES IN MF, ALL OTHERS IN PF. RESISTORS ARE ALL 10% 1/2W.

NUMBERS AND LETTERS IN BOXES INDICATE TEST POINTS AND ARE CROSS-REFERENCED TO THE PARTS LOCATION ILLUSTRATIONS.
 O INDICATES WIRE WRAP TERMINAL

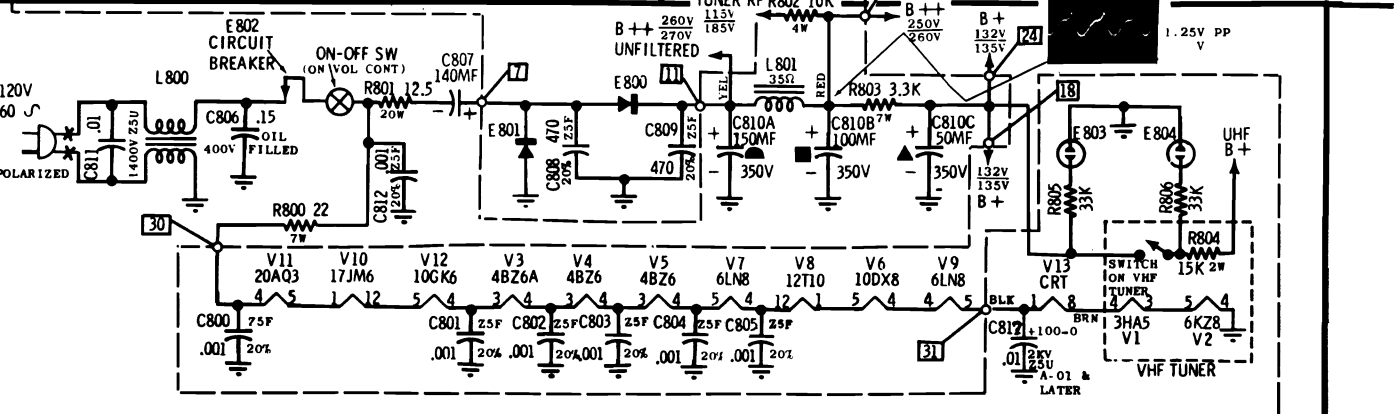
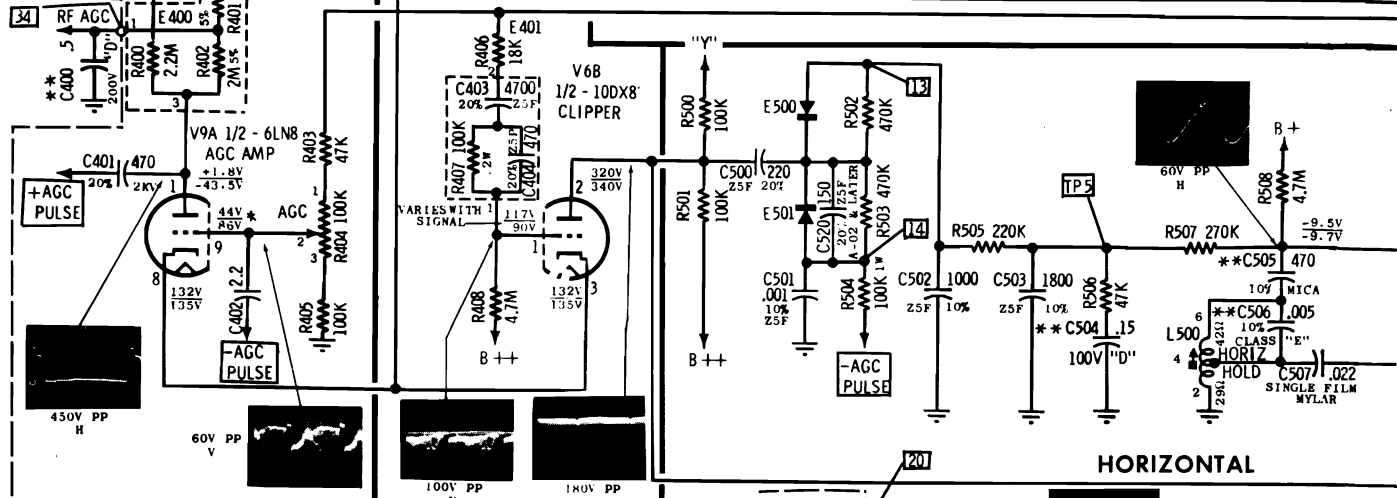
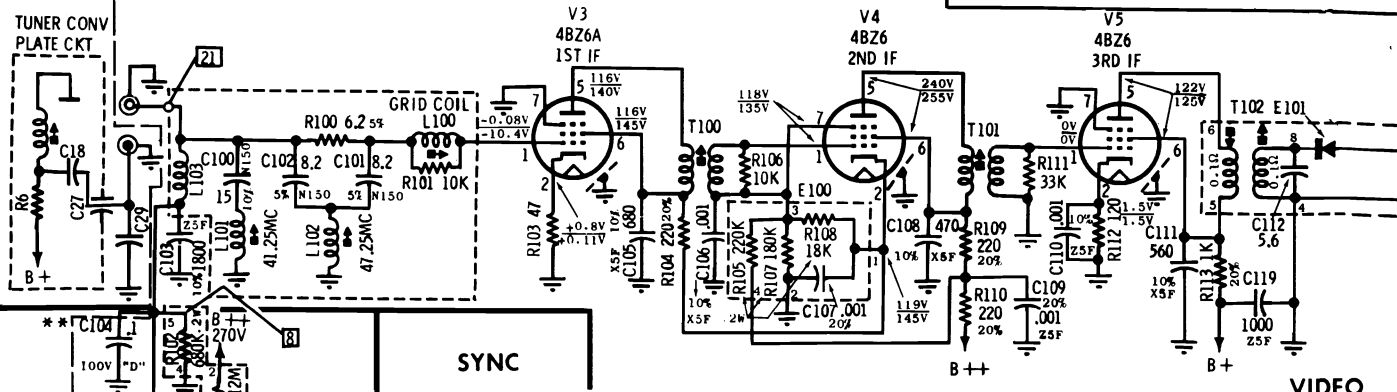
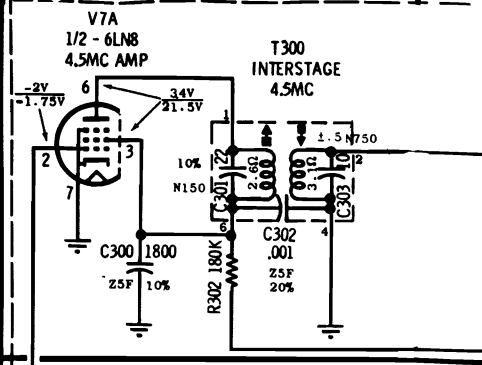
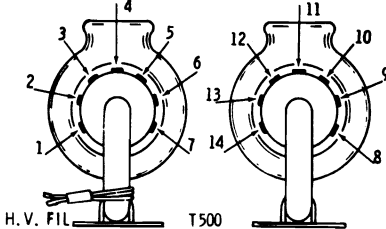

POWER SUPPLY

MOTOROLA Chassis TS-597 Alignment Information, Continued

CHASSIS ALIGNMENT

PRE-ALIGNMENT INSTRUCTIONS

Before alignment of the video I.F. section is attempted, it is advisable to thoroughly check the system. If alignment is attempted on an I.F. section in which a faulty component exists, successful alignment will probably be impossible and the entire procedure will have to be repeated when the real cause of the trouble is corrected. Preliminary tests of the system should include voltage and resistance measurements, routine checks for bad soldering connections and visual inspection of the circuits for overheated components as well as for obvious wiring defects.

VIDEO IF & MIXER ALIGNMENT

Preliminary Steps

1. Maintain line voltage at 120 with variac.
2. Disable horizontal oscillator by unplugging yoke lead(s), removing

tube or using a dummy tube with cathode pin disconnected. Use whichever is applicable to eliminate horizontal radiation interference.

3. Disable local oscillator. Onturret type tuners, set tuner between channels. On switch type tuners, short out grid of mixer oscillator tube with a fine piece of bare wire.

4. Apply the negative lead of a 6.0 volt bias supply to I.F. AGC buss and positive lead to chassis ground.

5. Connect a 1500 ohm, 60 watt voltage normalizing resistor from B+ to chassis.

6. Set the contrast control at minimum (extreme counter-clockwise position).

7. Short across tuner input terminals.

8. Maintain 2 to 5 volts peak-to-peak at the grid of video amp except when specific values are given in the procedure chart.

9. Refer to "Video I.F. and Sound Alignment" detail for component and test point locations.

NOTE: To reduce the possibility of inter-action between the two tuning cores in a double-tuned transformer or coil, each core should be adjusted for optimum response in the tuning position nearest its respective end of the coil form.

4.5MC TRAP ADJUSTMENT (L-107)

1. Carefully tune receiver to local station and advance contrast control.

2. Adjust local oscillator (with fine tuning control) to bring 4.5Mc interference strongly into the picture.

3. Adjust sound trap (L-107) to find the two points of adjustment at which the sound beat is just noticeable on the picture tube screen. Rotate the core toward the center of the two points. Use minimum amount of inductance (core out of coil) that will result in no apparent beat interference.

STEP	SWEEP GENERATOR AND MARKER	INDICATOR	ADJUST	ADJUST FOR AND/OR REMARKS
1.	To grid of 3rd I.F. thru .001mf capacitor. Set sweep approximately 44Mc, markers as required.	Scope to grid of video amp thru 47K ohm resistor.	Both cores of 3rd I.F. transformer (T-102).	Equal peaks and marker placement as shown in curve #1.
2.	To grid (pin #1) of 1st I.F. amp thru .001 mf capacitor. Set sweep to 44Mc, markers as required.	Same as Step #1.	1st I.F. transformer (T-100). 2nd I.F. transformer (T-101).	Proper 42.25Mc marker placement. See curve #2. Proper 45.75Mc marker placement. See curve #2.
3.	To mixer T. P. (M) thru .001mf capacitor. Set sweep at 44Mc, markers as required.	Same as Step #1.	47.25Mc trap, L-102 and 41.25Mc trap, L-101.	Minimum response at proper trap frequency. See curve #3. NOTE: Temporary removal of bias and an increase of generator output may be required to see traps clearly.
4.	Same as Step #3.	Same as Step #1.	Mixer plate coil (L-1 on tuner) and 1st I.F. grid coil (L-100).	To obtain curve #4. The mixer coil affects the center peak and the grid coil affects the two outside peaks. Tune coils simultaneously for proper tuning and bandwidth consistent with maximum gain. If necessary, the 1st and 2nd I.F. transformers can be touched-up to obtain proper response as shown in curve #4.

SOUND ALIGNMENT (STATION SIGNAL METHOD)

The sound system used in this receiver consists of an audio I.F. amplifier stage, a quadrature grid detector and an output stage. Since this type of sound system is extremely sensitive, relatively small input signal voltage will cause grid current to flow in both the I.F. amplifier and the detector stages. Grid current through the tuned coils will

load them down making the adjustment extremely broad and alignment impossible. For this reason, it is necessary to use a very weak signal when aligning the driver and the detector input coils. Actually, the signal should be well down into the noise level for proper tuning action.

Preliminary Steps

1. Tune in a strong TV station.
2. Adjust all controls for normal picture and sound.
3. Refer to "Video I.F. & Sound Alignment" detail for coil and test point locations.

MOTOROLA Chassis TS-597 Alignment Information, Continued

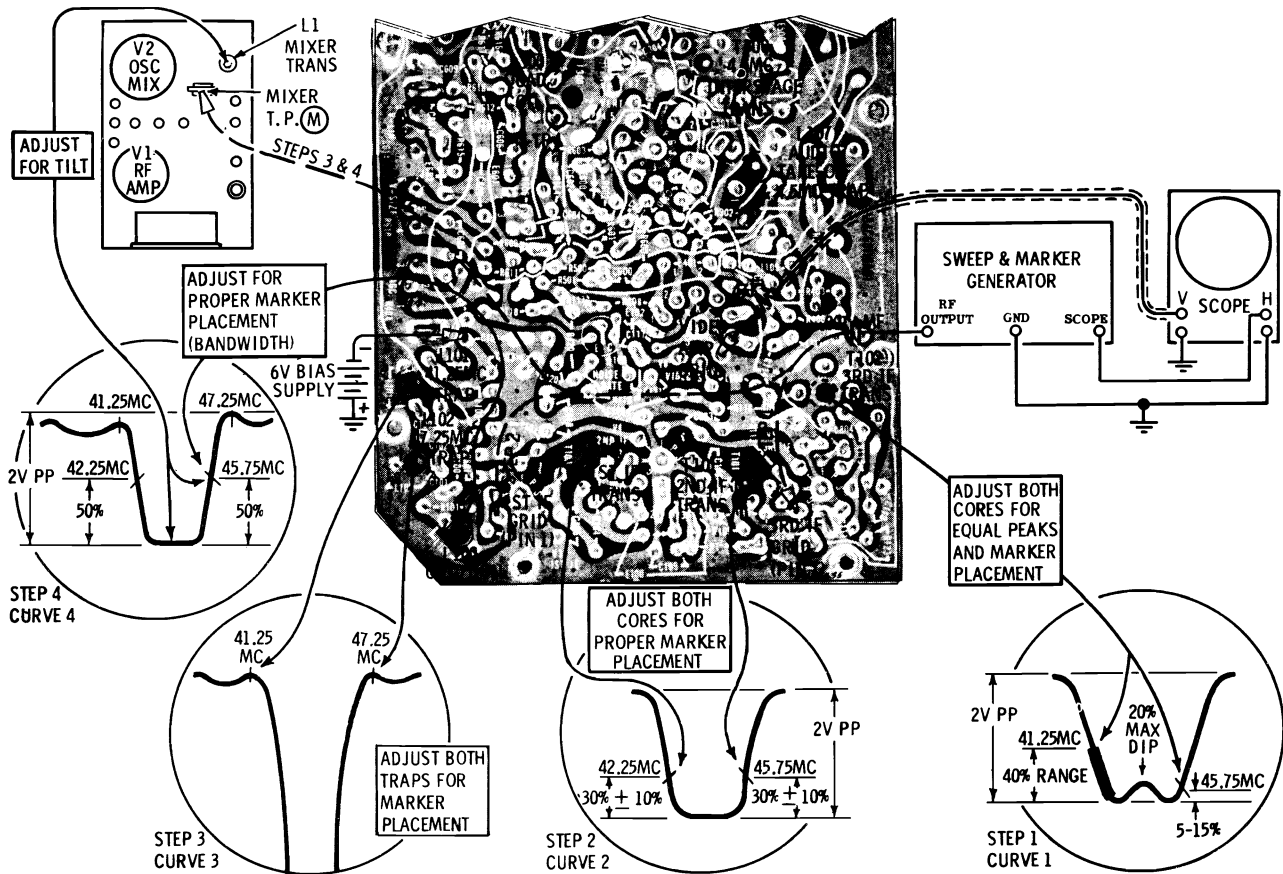

VIDEO IF & SOUND ALIGNMENT DETAIL

SOUND ALIGNMENT PROCEDURE

STEP	STATION	INDICATOR	ADJUST	ADJUST FOR AND/OR REMARKS
1.	Strong signal.	VTVM to TP 4 on quad. coil L-300 (see schematic diagram).	L-300 (quad. coil).	Maximum deflection (coarse adjustment) of two possible maximum tuning points, use that giving largest voltage reading.*
2.	Strong signal.	Listening test.	"	Maximum sound with minimum distortion (fine adjustment).
3.	Weak signal.	"	T-300 (inter-stage transformer).	Maximum sound with minimum distortion (maintain hiss level).**

If sound is not clear at this point, repeat the above procedure as necessary.

*The purpose of the top pre-set core is to enable the adjustable core to make the tuning range required while reducing the physical length. If the pre-set core should be mis-adjusted by previous service work, merely re-set near top end of coil and tune for maximum.

**The signal must be weakened considerably either by disconnecting one side of the antenna lead or connecting low value resistors across the antenna terminals until a pronounced hiss appears in the sound. The hiss level must be maintained for proper alignment.

MOTOROLA Chassis TS-597 Servicing Information, Continued

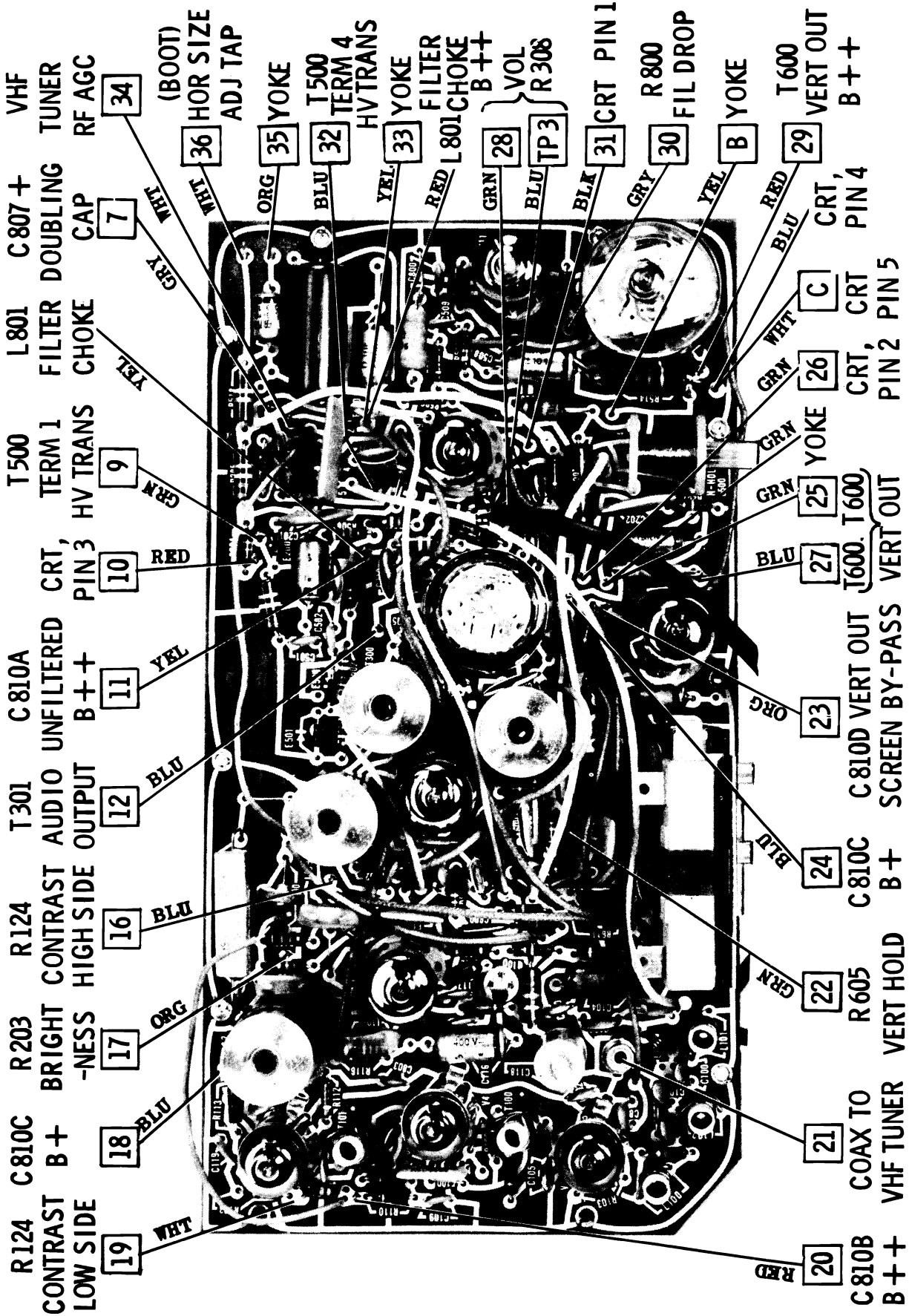

ETCHED BOARD TO CHASSIS INTER-CONNECTIONS

MOTOROLA

MODEL BREAKDOWN CHART

MODEL	CHASSIS	VHF TUNER	UHF TUNER	CRT
BT601CE, CH	JTS-594	OPTT-396	HTT-623*	21FZP4 or 21FVP4
BT602CE, CN	JTS-594	OPTT-396	HTT-623*	21FZP4 or 21FVP4
BT603CH, CS, CW	JTS-594	OPTT-396	HTT-623*	21FZP4 or 21FVP4
BT701CE, CN	22TS-594 or C22TS-594	OPTT-396 or OPTT-404	HTT-624 or HTT-627	23FSP4, 23GXP4, 23HLP4 or 23GSP4
BT702CW	22TS-594 or C22TS-594	OPTT-396 or OPTT-404	HTT-624 or HTT-627	23FSP4, 23GXP4, 23HLP4 or 23GSP4
BU704CW	22TS-594 or C22TS-594	OPTT-396 or OPTT-404	HTT-624 or HTT-627	23FSP4, 23GXP4, 23HLP4 or 23GSP4
BU705CS	22TS-594 or C22TS-594	OPTT-396 or OPTT-404	HTT-624 or HTT-627	23FSP4, 23GXP4 23HLP4 or 23GSP4
BU706CM	22TS-594 or C22TS-594	OPTT-396 or OPTT-404	HTT-624 or HTT-627	23FSP4, 23GXP4, 23HLP4 or 23GSP4
BU707CF	22TS-594 or C22TS-594	OPTT-396 or OPTT-404	HTT-624 or HTT-627	23FSP4, 23GXP4, 23HLP4 or 23GSP4
BU709CM, CW	22TS-594 or C22TS-594	OPTT-396 or OPTT-404	HTT-624 or HTT-627	23FSP4, 23GXP4, 23HLP4 or 23GSP4
BS710CM, CW	22TS-594 or C22TS-594	OPTT-396 or OPTT-404	HTT-624 or HTT-627	23FSP4, 23GXP4, 23HLP4 or 23GSP4
BS711CS	22TS-594 or C22TS-594	OPTT-396 or OPTT-404	HTT-624 or HTT-627	23FSP4, 23GXP4 23HLP4 or 23GSP4
BL712CM, CW	22TS-594 or C22TS-594	OPTT-396 or OPTT-404	HTT-624 or HTT-627	23FSP4, 23GXP4, 23HLP4 or 23GSP4

*HTT-624 or HTT-627 used in some models.

ETCHED BOARD CIRCUIT TRACING

The top (component side) of the chassis board contains a complete legend of the chassis circuit that appears on the bottom and identification of all components by reference numbers that are related to the reference numbers on the schematic diagram. The circuit may be traced from the top of the chassis board and all components can be identified eliminating the need of making any reference to the bottom of the chassis board.

The circuit side (bottom) of the chassis board also contains a complete legend which includes component reference numbers, transistor identification, coil terminals and the wiring (jumper wires) is traced

in to provide easy circuit tracing of the wiring that appears on the top side of the chassis board.

The transistors are identified by their function as well as the reference number. The transistor elements are identified as follows: E - emitter, B - base and C - collector.

The tracing indicates where the wiring (jumper wires) on the top of the chassis board is connected.

Breaks appear in the wire tracing to facilitate the identification of components location. Each wire trace begins and ends with an arrow to indicate where it begins and ends.

To further facilitate circuit tracing of the etched chassis board, a photo-

CHASSIS TS-594

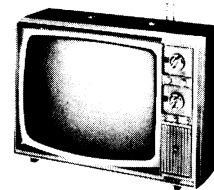

MODEL BT601C

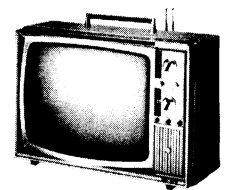

MODEL BT602C

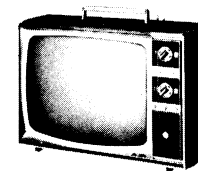

MODEL BT603C

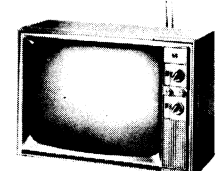

MODEL BT701C

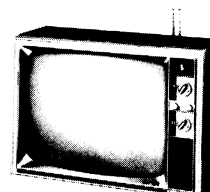

MODEL BT702C

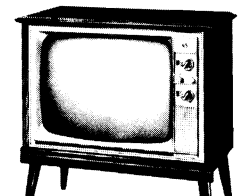

MODEL BU704C

graph of the chassis board with the pertinent test points identified and related to the schematic diagram is included in this manual.

The test points on the schematic diagram are identified descriptively and/or by number and are blocked in or circled for easy identification. These test points are also shown on the chassis board photographs and serve to pinpoint the physical location of the electrical junction or test point of interest.

FINE TUNING ADJUSTMENT

Rotate the fine tuning knob in either direction for best picture and sound on all available channels. Turning the fine tuning shaft to the right or left engages the pre-set gears. The gears, in turn, change the position of the core in the oscillator coil. Individual coils are used for each channel. Therefore, channel pre-set adjustments can be made in any sequence.

MOTOROLA Chassis TS-594 Servicing Information, Continued

COMPONENT REMOVAL

Removing components from the etched board is facilitated by the fact that the circuitry (plating) appears on one side of the board only and the component leads are inserted straight through the holes and are not bent or crimped.

It is recommended that a solder extracting gun be used to aid in component removal. An iron with a temperature controlled heating element would be desirable since it would reduce the possibility of damaging the board due to over-heating.

The nozzle of the soldering gun is inserted directly over the component lead and when sufficiently heated, the solder is drawn away leaving the lead free from the copper plating. This method is particularly suitable in removing multi-terminal components.

COIL SHIELD REMOVAL

The shields on video detector transformer T-100, A.T.O. transformer T-300 and ratio detector transformer T-301 are mounted to the board with spring clips for ease of removal. The shields may be removed by carefully rocking the shield while pulling upward. It may be necessary to pry up shield slightly to start it. Avoid excessive bending of the plated board while removing shield.

FOCUSING ADJUSTMENT

To provide for differences in the picture tube gun structure, a focus adjustment is provided by three (3) lugs located on the chassis. They provide a ground potential point, a B++ voltage point and a bootstrap voltage point. Connect the blue lead from the picture tube socket to the lug which provides the best over-all focus, center to edge of screen.

1ST VIDEO AMPLIFIER BIAS ADJUSTMENT

The bias on the 1st video amplifier is adjusted for the no-signal condition. Proceed as follows:

1. Disable 3rd IF amplifier, Q-3, by shorting base and emitter together.
2. Set optimizer control, R-133, full clockwise (sharp position).
3. Measure 2nd video amplifier, Q-5, collector voltage and adjust video bias control for 50V DC on the collector. Line voltage should be set at 122 volts when adjustment is made.

RF AGC DELAY CONTROL ADJUSTMENT

Adjustable RF AGC delay is incorporated to provide the best possible signal to noise ratio and freedom from overload. The purpose of delaying the RF AGC (which reduces

tuner gain) is to operate the tuner RF stage at high gain until its signal output is greater than mixer noise. The control is adjusted as follows:

1. Short T. P. (B) (junction of R-408 and C-404) to ground.
2. Connect a VTVM to T. P. (A) (junction of R-404 and R-106).
3. Adjust RF AGC delay, R-411, for a +5 volt reading at T. P. (A) while T. P. (B) is grounded.

SERVICING WAFERS

The VHF tuner has been provided with removable wafers for the tuning sections. The major component parts comprising the actual tuning circuits are mounted to the appropriate wafer and changing the wafer replaces most of the components that will affect the tuning.

To remove the tuner wafers, it is necessary to pull the channel selector shaft out the front of the tuner to the extent that the shaft clears the wafer to be replaced or removed for service.

Alignment of a tuner is very seldom needed and, unless unmistakable evidence of tampering is found, should be the last resort.

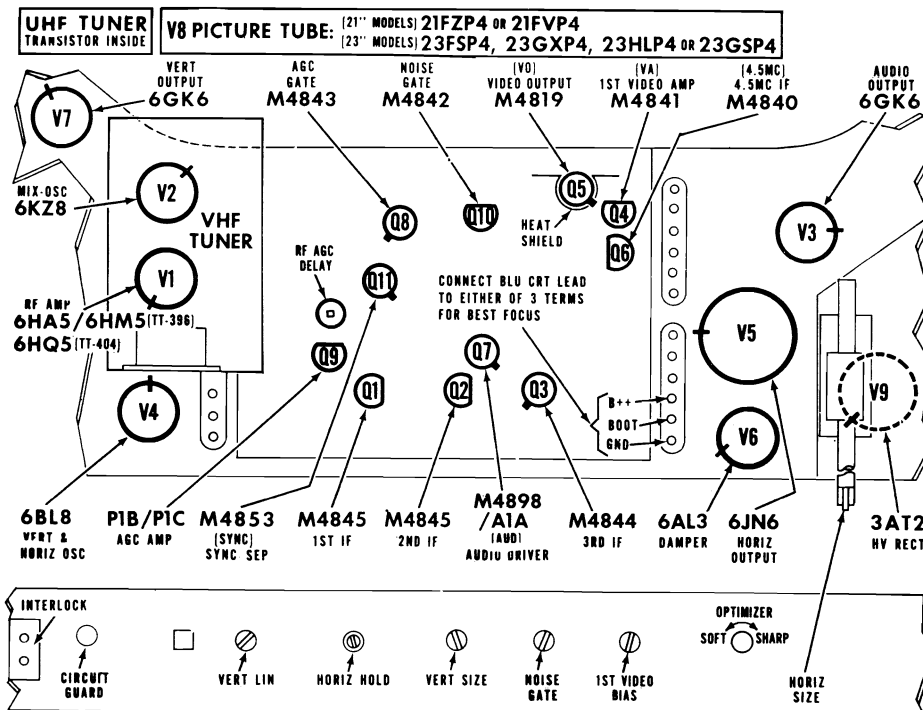

TUBE AND TRANSISTOR LOCATION DETAIL

MOTOROLA Chassis TS-594 Servicing Information, Continued

An alternate method of adjusting the RF AGC delay control is by viewing the picture. Tune in the strongest channel available. Adjust the control and note its effect on the picture. In one range of control setting, the picture will have noise or a busy background and as the control is rotated, the picture will clear up. Further rotation of the control will cause overload on strong signals as evidenced by loss of interlace. Set the control midway between the point at which the noise disappears and the overload point.

OPTIMIZER CONTROL

The purpose of the optimizer control is to reduce the effects of high frequency noise in the picture. If a strong noise-free signal is being received, the optimizer should be set in the clockwise or "SHARP" position to obtain maximum picture detail. However, under noisy signal conditions, the control should be turned toward the "SOFT" position to reduce the effect of noise peaks.

CHASSIS SERVICING

The bottom of the chassis may be completely exposed for servicing by removing the fiber board cover from the bottom of the receiver.

PICTURE TUBE REPLACEMENT

Use extreme care in handling the picture tube as rough handling may cause it to implode due to atmospheric pressure. Do not nick or scratch glass or subject it to any undue pressure in removal or installation. Use goggles and heavy gloves for protection.

CRT REMOVAL

CRT is removed from the rear of cabinet. Remove the chassis retaining screws and yoke. Swing chassis to one side to gain access to the CRT mounting screws.

RES-CAP REPLACEMENT AND REPAIR

If it is desirable to replace a defective res-cap and the replacement unit is not immediately available, it is possible to repair the existing unit in the following manner. Merely remove the defective component from the circuitry by cutting the appropriate lead(s) and then substitute conventional capacitors or resistors back into the circuitry. When this method is used, it is always desirable to replace the circuitry in such a manner that the defective component is removed entirely from the system. In other words, do not bridge the defective component with the replacement unit. This is to avoid any detrimental effect that the defective component might inject into the system.

NOISE GATE CONTROL

The noise gate control is used to adjust the receiver for best hold stability under noise and different signal strength conditions.

To adjust, tune in a channel for best picture and sound. Turn the noise gate control clockwise (when viewed from rear of receiver) until the picture becomes unstable (rolls down or slips, etc.). Then, turn control counter-clockwise until the picture returns to normal. Check all channels; if any are unstable, continue turning control counter-clockwise until the picture is normal on all channels.

CIRCUIT GUARD

The circuit guard is a thermal cut-out type of overload relay. It is in series with the power into the receiver for protection against shorts in the chassis.

The circuit guard will remain in the "closed circuit" state when the current requirements are normal. In the event of a continuous high current overload, the bi-metallic elements of the unit will become heated to the extent of "opening" the contacts and disconnecting the AC power. After the bi-metallic elements have cooled, the circuit guard may be re-set by depressing the plastic re-set button.

The circuit guard is designed to remain "closed" on the higher-than-normal instantaneous surge currents encountered during the initial warm-up. The circuit guard is unique in the fact that when a short exists in the associated circuitry, power is not re-applied when the re-set button is held depressed.

E602
INTEGRATOR RES-CAP EQUIV.
51D65239A22

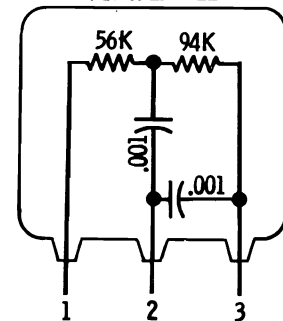

RES-CAP DETAIL

CHASSIS CODING CHANGES

Chassis Coding	Chassis Coding Changes	Chassis Coding	Chassis Coding Changes
TS-594A-01	RELIABILITY CHANGE: To reduce inverse voltage across horizontal blanking diode, E-200, an 18 pf, 10%, N150 capacitor, C-202, is added across the diode.		TO PREVENT REGENERATION: Capacitors C-107 and C-111, the first and second IF emitter by-pass capacitors, changed from .001mf, 10%, X5F (Part Number 21S180B51) to .0033 mf, 20%, X5F (Part No. 21S180B06). Also added C-407, .001mf, 10%, X5F (Part No. 21S180B51) from RF AGC line to ground.
TS-594B-00	RELIABILITY CHANGE: AGC amplifier transistor, Q-9, changed from Part No. 48S134815 (M4815) to 48S134909 (P1B). Horizontal blanking diode, E-200, changed from Part No. 48D67120A02 to Part No. 48D67120A09 for greater inverse voltage rating. TO IMPROVE NOISE GATE OPERATION: R-409 changed from 56K to 100K. TO IMPROVE FRINGE AREA NOISE CHARACTER: Added optimizer control, R-133, 750 ohm potentiometer, Part No. 18D67637A37, in base circuit of second video amplifier, Q-5.		TO IMPROVE TUNER ALIGNMENT: Capacitor C-25 on VHF tuner output cable changed from 47pf, 10%, N150 (Part No. 21S124471) to 68pf, 10%, N750 (Part No. 21S129652). TO IMPROVE TUNING RANGE OF 37.5 AND 41.25MC TRAP ASSEMBLY: On coil assembly, 24D67754A13, core part number changed from 76S735943 to part number 76S738121 for better tuning range.

MOTOROLA SCHEMATIC DIAGRAM - JTS-594 & 22TS-594A-00 THRU B-00

MOTOROLA Chassis TS-594 Schematic Diagram

- NOTES:**
- VOLTAGE MEASUREMENTS**
- TAKEN FROM POINT INDICATED TO CHASSIS WITH A VTVM $\pm 20\%$.
 - LINE VOLTAGE MAINTAINED AT 122V AC.
 - * VARIES WITH CONTROL SETTINGS.
 - ** SPECIAL COMPONENTS, SEE PARTS LIST.
 - TAKEN WITH CONTRAST CONTROL AT MINIMUM AND ALL OTHER CONTROLS IN NORMAL OPERATING POSITION.
 - WHERE TWO VOLTAGES ARE SHOWN: VOLTAGE ABOVE BOX - WITH NO SIGNAL INPUT; TUNER IN BETWEEN CHANNELS AND ANTENNA TERMINALS SHORTED. VOLTAGE IN BOX - WITH TUNER ON STRONG STATION AND SIDE ANTENNA.
- WAVEFORM MEASUREMENTS:**
- TAKEN FROM POINT INDICATED TO CHASSIS WITH A WIDE-BAND OSCILLOSCOPE.
 - OSCILLOSCOPE SYNC'D NEAR SWEEP RATE INDICATED.
 - TAKEN WITH STRONG SIGNAL, CONTRAST CONTROL AT MAXIMUM; ALL OTHER CONTROLS IN NORMAL OPERATING POSITION.
- INDICATES PRINTED CIRCUIT BOARD

UNLESS OTHERWISE SPECIFIED, CAPACITORS ARE DISC CERAMIC 500V DC, TOLERANCE & CHARACTERISTIC AS NOTED; IF TOLERANCE IS NOT GIVEN, CAPACITORS ARE GMV (GUARANTEED MIN. VALUE) TYPE. TUBULAR CAPACITORS ARE 20% 400V DC. DECIMAL VALUES IN MF, ALL OTHERS IN PF. RESISTORS ARE ALL 1/2W.

NUMBERS AND LETTERS IN BOXES INDICATE TEST POINTS AND ARE CROSS-REFERENCED TO THE PARTS LOCATION ILLUSTRATIONS.

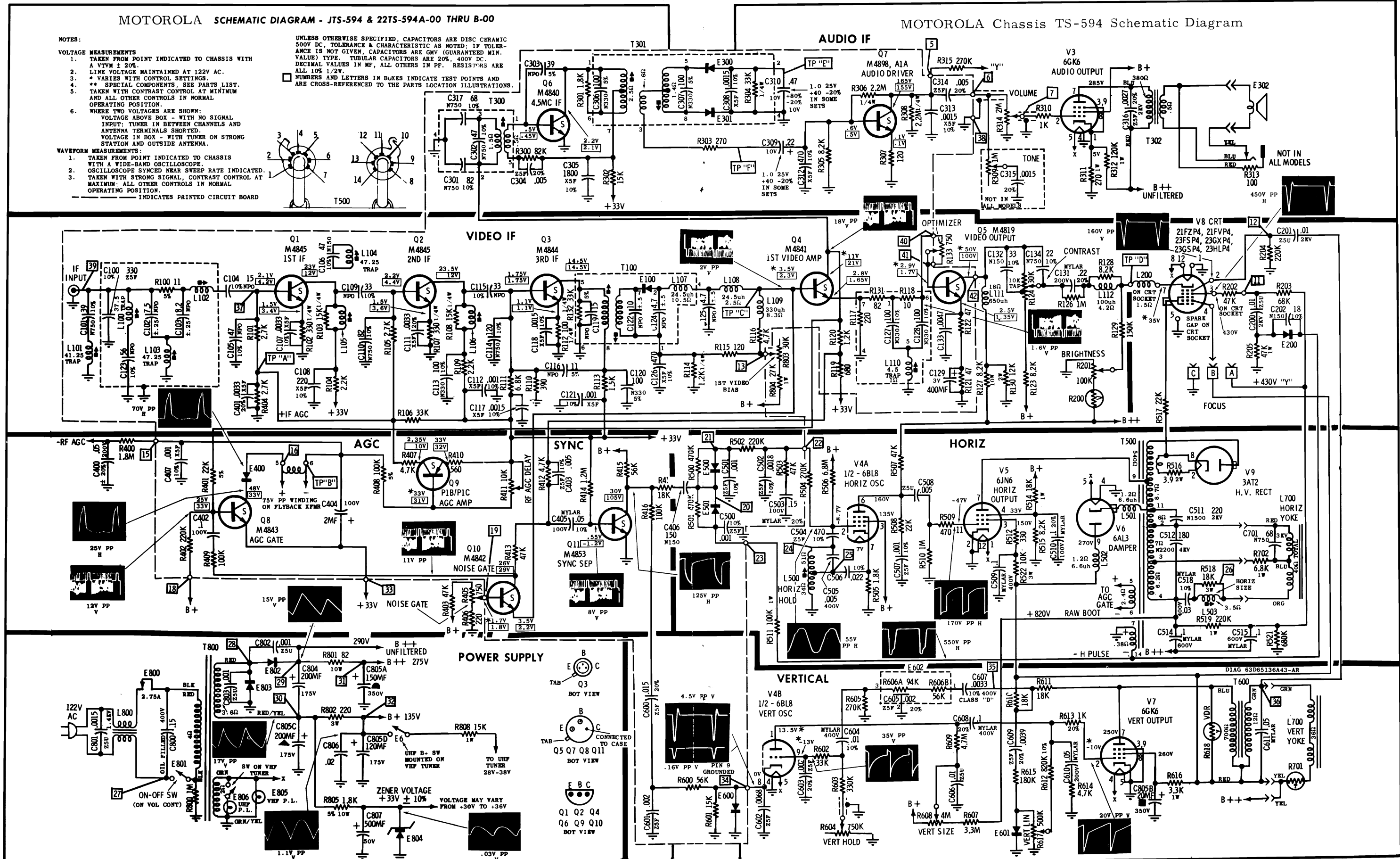
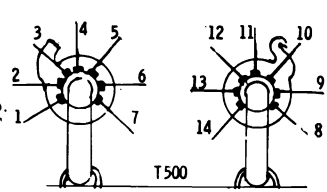

MOTOROLA Chassis TS-594 Alignment Information, Continued

PRE-ALIGNMENT INSTRUCTIONS

Before alignment of the video I.F. section is attempted, it is advisable to thoroughly check the system. If alignment is attempted on an I.F. section in which a faulty component exists, successful alignment will probably be impossible and the entire procedure will have to be repeated when the real cause of the trouble is corrected. Preliminary tests of the system should include voltage and resistance measurements, routine checks for bad soldering connections and visual inspection of the circuits for overheated components as well as for obvious wiring defects.

VIDEO IF & MIXER ALIGNMENT

Preliminary Steps

1. Maintain line voltage at 120 with variac.
2. Disable horizontal oscillator by unplugging yoke lead(s), removing tube or using a dummy tube with cathode pin disconnected. Use whichever is applicable to eliminate horizontal radiation interference.

3. Disable local oscillator by setting tuner between channels or shorting out grid of mixer oscillator tube with a fine piece of bare wire through hole in tuner chassis.

4. Apply the positive lead of a 4.5 volt bias supply to I.F. AGC buss and negative lead to chassis ground.

5. Check for correct 1st video amplifier bias by measuring 2nd video amplifier collector voltage. Voltage should read 50V with no signal input. If necessary, adjust bias according to procedure in "Service Notes".

6. Connect a 1500 ohm, 60 watt voltage normalizing resistor from unfiltered B++ to chassis.

7. Set the contrast control at minimum (extreme counter-clockwise position).

8. Short across tuner input terminals.

9. Maintain 1 volt peak to peak at the base of video amplifier except when specific values are given in the procedure chart.

10. Refer to "Video I.F. and Sound Alignment" detail for component and

test point locations.

NOTE: To reduce the possibility of inter-action between the two tuning cores in a double-tuned transformer or coil, each core should be adjusted for optimum response in the tuning position nearest its respective end of the coil form.

4.5MC TRAP ADJUSTMENT (L-110)

1. Carefully tune receiver to local station and advance contrast control.

2. Adjust local oscillator (with fine tuning control) to bring 4.5Mc interference strongly into the picture.

3. Adjust sound trap (L-110) to find the two points of adjustment at which the sound beat is just noticeable on the picture tube screen. Rotate the core toward the center of the two points. Use minimum amount of inductance (core out of coil) that will result in no apparent beat interference.

STEP	SWEEP GENERATOR AND MARKER	INDICATOR	ADJUST	ADJUST FOR AND/OR REMARKS
1.	To base of 1st IF amp thru 120 ohm resistor in series with .001 mf capacitor. Set sweep to 44Mc, markers as required. Short junction of L-102 and C-104 to ground.	Scope to base of 1st video amp thru 47K ohm resistor (T. P. $\text{\textcircled{C}}$)	Both cores of 3rd IF transformer (T-100)	Adjust for maximum response at 44Mc. See curve #1.
2.	Same as Step #1.	Same as Step #1.	47.25Mc trap, L-104	Minimum response at trap frequency. See curve #2. NOTE: Temporary removal of bias and an increase of generator output may be required to see trap clearly.
3.	Same as Step #1.	Same as Step #1.	1st IF coil (L-105) 2nd IF coil (L-106)	Maximum response at 44Mc. See curve #1. Maximum response at 44Mc. See curve #1. Re-adjust T-100, L-105 and L-106 as necessary to obtain curve #1.
4.	To mixer T. P. $\text{\textcircled{M}}$ thru .001mf capacitor. Set sweep to 44Mc, markers as required. Remove short from junction of L-102 and C-104 to ground.	Same as Step #1.	47.25Mc trap, L-103, 41.25Mc trap, L-101 and 37.5Mc trap, L-100	Minimum response at proper trap frequency. See curve #3. NOTE: Temporary removal of bias and an increase of generator output may be required to see trap clearly.
5.	Same as Step #4.	Same as Step #1.	Mixer plate coil, L-31, on tuner and 1st IF input coil, L-102.	To obtain curve #4. The mixer plate coil, L-31, affects the center peak or tilt and the 1st IF input coil affects the two outside peaks. Tune coils simultaneously for proper tuning and band-width consistent with maximum gain.

MOTOROLA Chassis TS-594 Alignment Information, Continued

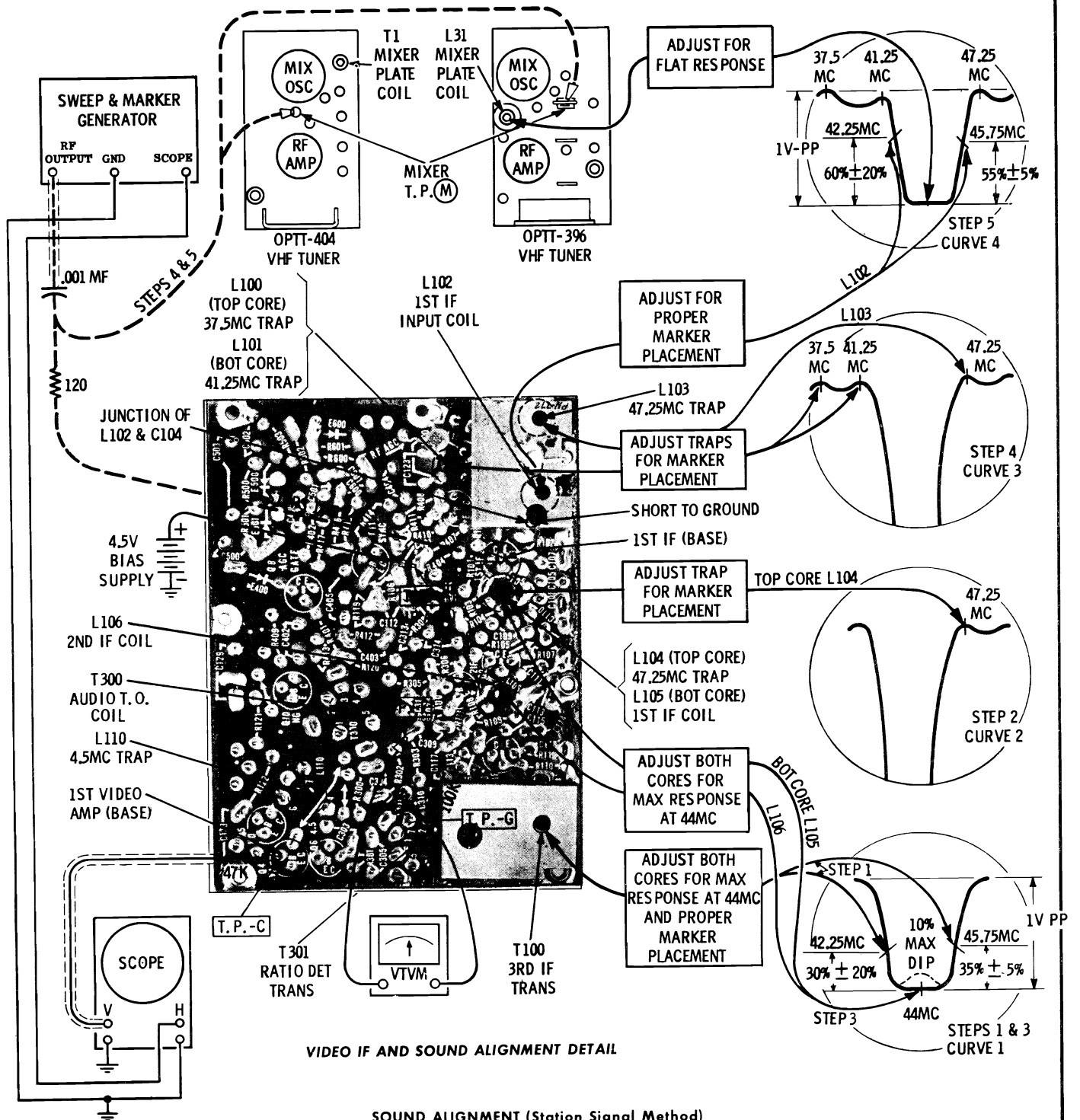

VIDEO IF AND SOUND ALIGNMENT DETAIL

SOUND ALIGNMENT (Station Signal Method)

The 4.5Mc amplifier stage is designed to oscillate at a frequency very close to 4.5Mc. The 4.5Mc input signal controls the frequency of its oscillation. The advantage of having the stage oscillate becomes apparent on weak signals because audio signals too weak to be heard above the noise level are strong enough to control the oscillations

and result in a usable FM output signal.

Preliminary Steps

1. Connect a pair of 100K ohm resistors in series.
2. Connect above resistors across

C-310.

3. Tune in a strong TV station and adjust fine tuning for maximum audio.

4. Refer to "Video I.F. and Sound Alignment Detail" for coil and test point locations.

MOTOROLA Chassis TS-594 SOUND ALIGNMENT, Continued

STEP	STATION	INDICATOR	ADJUST	ADJUST FOR AND/OR REMARKS
1.	Strong signal	One lead of VTVM to junction of two 100K resistors, (T.P. C) other lead to junction of R-303 and C-309 (T.P. F). Set meter to zero center	T-301 ratio det. transformer	Detune secondary (bottom core) to give an indication on the meter. Note direction of meter indication. Leave core in this position.
2.	Strong signal	Same as Step #1	Same as Step #1	Adjust primary (top core) for maximum meter indication in same direction as noted in Step #1.
3.	Strong signal	Same as Step #1	Audio T.O. transformer, T-300	Adjust for maximum output.
4.	Strong signal	Same as Step #1	T-301 ratio det. transformer	Adjust secondary (bottom core) for zero volts (center scale).
5.	Weak signal	Listening test	Audio T.O. transformer, T-300	Reduce signal until considerable noise is present in audio. Signal input can be reduced by tuning into smear or reducing signal input to tuner. Adjust T-300 for minimum noise and best audio as judged by listening to output.

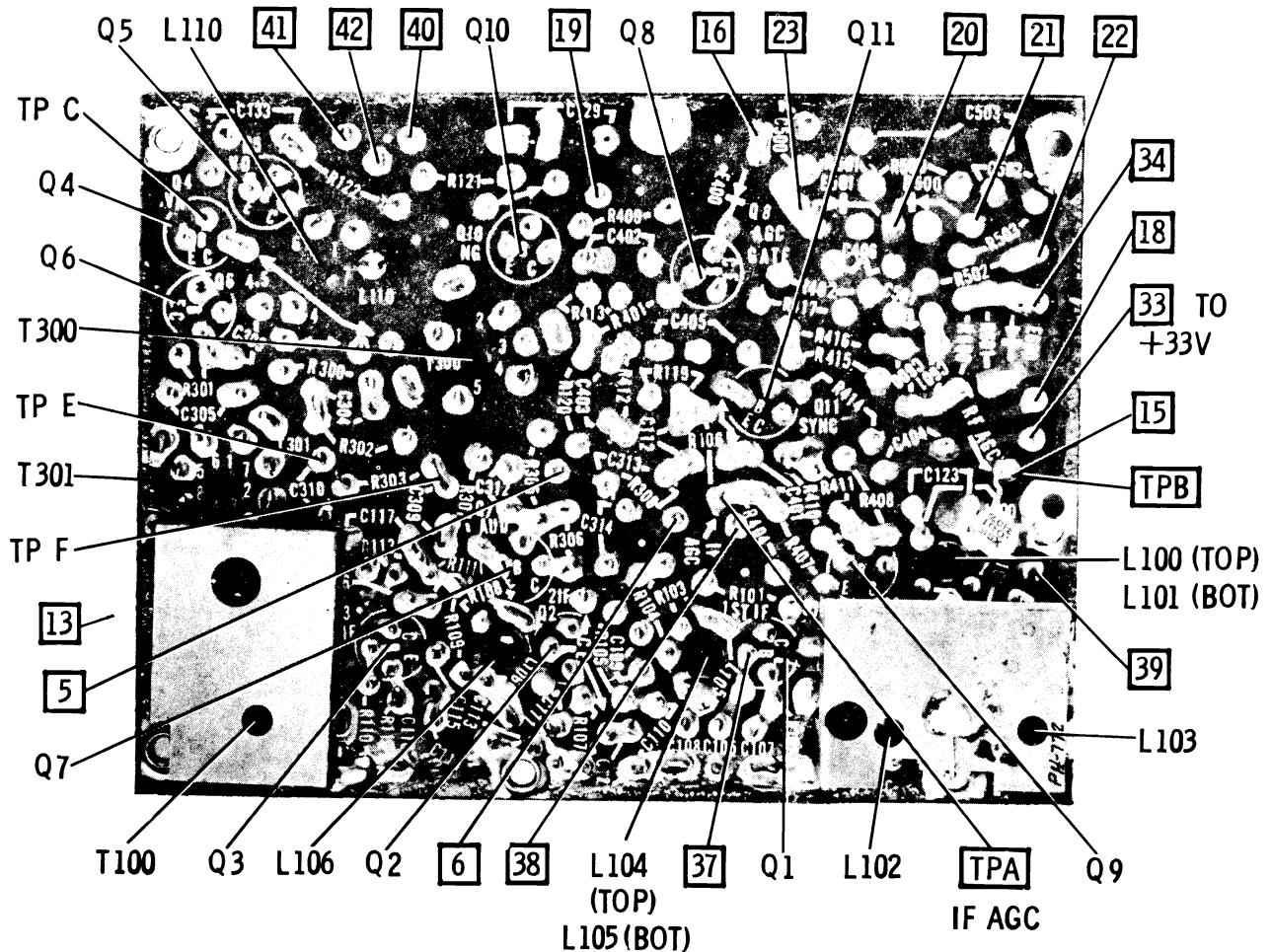

CHASSIS TEST POINT LOCATIONS

PHILCO



Chassis 17C21, A, V, AV, used in Models Q1230BR, BRV, Q1232BK, WH, Q1233WA, Q1234WH, R1228GY. (Material on pages 85 through 90).

17C21, 17C21A, 17C21V & 17C21AV CHASSIS

V1	4CS6	SOUND DET.
V2	10JY8	VIDEO AMP. & GATED AGC
V3	12FX5	AUDIO OUTPUT
V4	6GH8A	SYNC. SEP. & SND IF
V5	17JZ8	VERT. OSC. & OUT.
V6	8FQ7	HORIZ. OSC.
V7	4EH7	1ST VIDEO IF
V8	4EJ7	2ND VIDEO IF
V9	38HE7	HORIZ. OUT. & DAMPER
V10	1K3	H.V. RECT.
CRT	12BUP4/12BQP4	17C21 & 17C21A
CRT	12BUP4	17C21V & 17C21AV

NOTE: 12BUP4 & 12BQP4 CRT'S ARE NOT INTERCHANGEABLE MECHANICALLY

HORIZONTAL OSCILLATOR ADJUSTMENT

FOR ALL CHASSIS

Allow set to warm up. Tune in a picture.

1. Short out horizontal finging by placing a jumper from pin #1 to pin #3 of coil. Add a .1 mfd capacitor from sync. test point to ground.

2. Adjust horizontal hold control to correct horizontal line frequency (to stop picture); it will not be stable. On models with auxiliary horizontal control (17NT45), set horizontal hold control to center of its range and adjust aux. horizontal control to correct line frequency.

3. Remove shorting jumper and adjust ringing coil for the most stable picture. Then remove .1 mfd capacitor from sync test point and picture will be stable in sync.

RESISTANCE CHART

SYM. BOL	TUBE	FUNCTION	PIN NUMBERS													
			1	2	3	4	5	6	7	8	9	10	11	12		
V1	4CS6	Sound Detector	5.5Ω	560Ω	FIL.	FIL.	200K	12K	2.5Ω							
V2	10JY8	Video Amp. & Gated AGC	4.5K	25K	1.8M	FIL.	FIL.	0Ω	3.3K	14K	10K					
V3	12FX5	Audio Output	82Ω	0Ω	FIL.	FIL.	0Ω	16K	14K							
V4	6GH8A	Snd. IF & Sync. Sep.	15K	3Ω	13K	FIL.	FIL.	13K	150Ω	0Ω	1.9M					
V5	17JZ8	Vert. Osc.	FIL.	3.5M	INF.	14K	INF.	1.3M	1.3M	14K	0Ω					
V6	8FQ7	Horiz. Osc.	23K	2.1M	820Ω	FIL.	FIL.	40K	120K	14K	0Ω	150K	0Ω	FIL.		
V7	4EH7	1st Video IF	20Ω	600K	20Ω	FIL.	FIL.	0Ω	14K	26K	0					
V8	4EJ7	2nd Video IF	100Ω	0Ω	100	FIL.	FIL.	0Ω	14K	14K	0Ω					
V9	38EH7	Horiz. Out & Damper	FIL.	13K	NC	8M	8M	NC	NC	0Ω	330K	NC	18K	FIL.		

*Depends on meter polarity

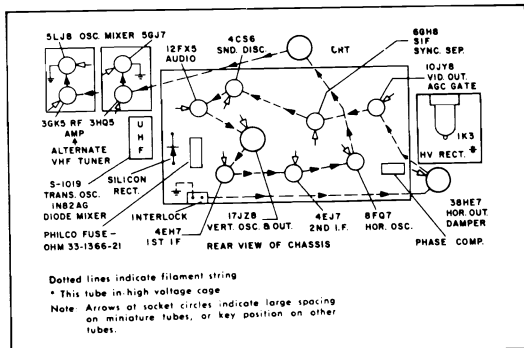

Filament Connections—17C21, A, V, & AV Chassis

OSCILLOSCOPE WAVEFORMS

These waveforms were taken with the receiver adjusted for an approximate output of 4 V p/p at the video detector. Voltage readings taken with raster just filling screen and all controls set for normal picture viewing except for photos 1, 2, and 3 where contrast was at maximum. The voltages given are approximate peak-to-peak values. The frequencies shown are those of the waveforms...not the sweep rate of the oscilloscope.

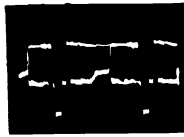

4 Volts p/p, 15,750 cps (max contrast)



4 Volts p/p, 60 cps (max contrast)



90 Volts p/p, 15,750 cps (max contrast)

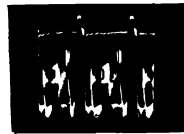

80 Volts p/p, 15,750 cps

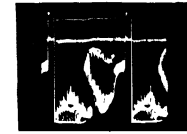

80 Volts p/p, 60 cps



50 Volts p/p, 60 cps



50 Volts p/p, 15,750 cps



48 Volts p/p, 60 cps



60 Volts p/p, 60 cps

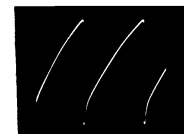

45 Volts p/p, 60 cps

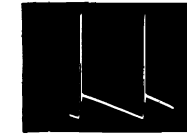

1000 Volts p/p total, 180 Volts p/p, sawtooth, 60 cps

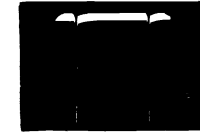

55 Volts p/p, 60 cps



8 Volts p/p, 15,750 cps

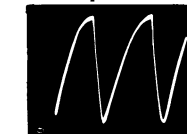

11 Volts p/p, 15,750 cps

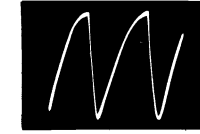

14 Volts p/p, 15,750 cps



11 Volts p/p, 15,750 cps

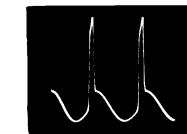

45 Volts p/p, 15,750 cps



45 Volts p/p, 15,750 cps



85 Volts p/p, 15,750 cps

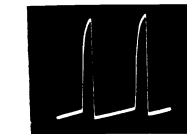

400 Volts p/p, 15,750 cps

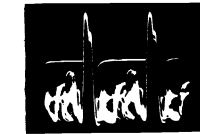

50 Volts p/p, 15,750 cps

PHILCO Chassis 17C21, A, V, AV, Service Information, Continued

17C21, A, V & AV PANEL LUG CONNECTIONS

FROM	TO	FROM	TO
M1	C11T TT-164B, TT-164C	M20	A.O.T. (BLUE)
M2	C6T TT-170	M21	YOKE-#4
M3	VR4-#1	M22	VR5-#1
M4	VR3-#1	M23	SYNC T.P.
M5	VR2-#3 (AUDIO T.P.)	M24	FOCUS +225V
M6	VR4-#2	M25	R57
M7	VR3-#2	M26	C41-C, FOCUS +100V
M8	I.F. TEST POINT	M27	H.O.T.-#1
M9	C17T TT-164B, TT-164C	M28	V9-#9
M10	C8T TT-170	M29	V.O.T. (BLUE) & R57
M11	VR5-#2	M30	V.O.T. (RED)
M12	CRT-#6	M31	HORIZ. OSC. T.P.
M13	L4-1 (SND T.P.)	M32	2ND DET. TEST
M14	CRT-#3	M33	J1T
M15	CRT-#7	M34	V8-#2
M16	V9-#12	M35	CRT-#1
M17	YOKE-#11	M36	C41-B
M18	M37 & C41-A	M37	M16
M19	VR4-#3	M38	WIDTH ADJ. LINK
	N/C	M39	V9-#2
	VR2-#2	M40	V9-#11

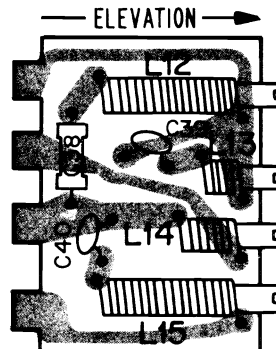

I.F. MODULE "A"
(TRAP)

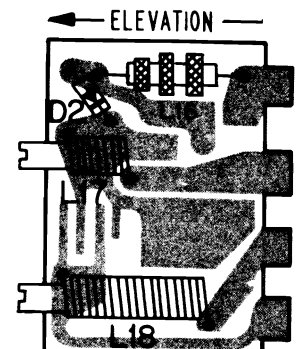

I.F. MODULE "B"
(DETECTOR)

IF Trap & Detector Modules

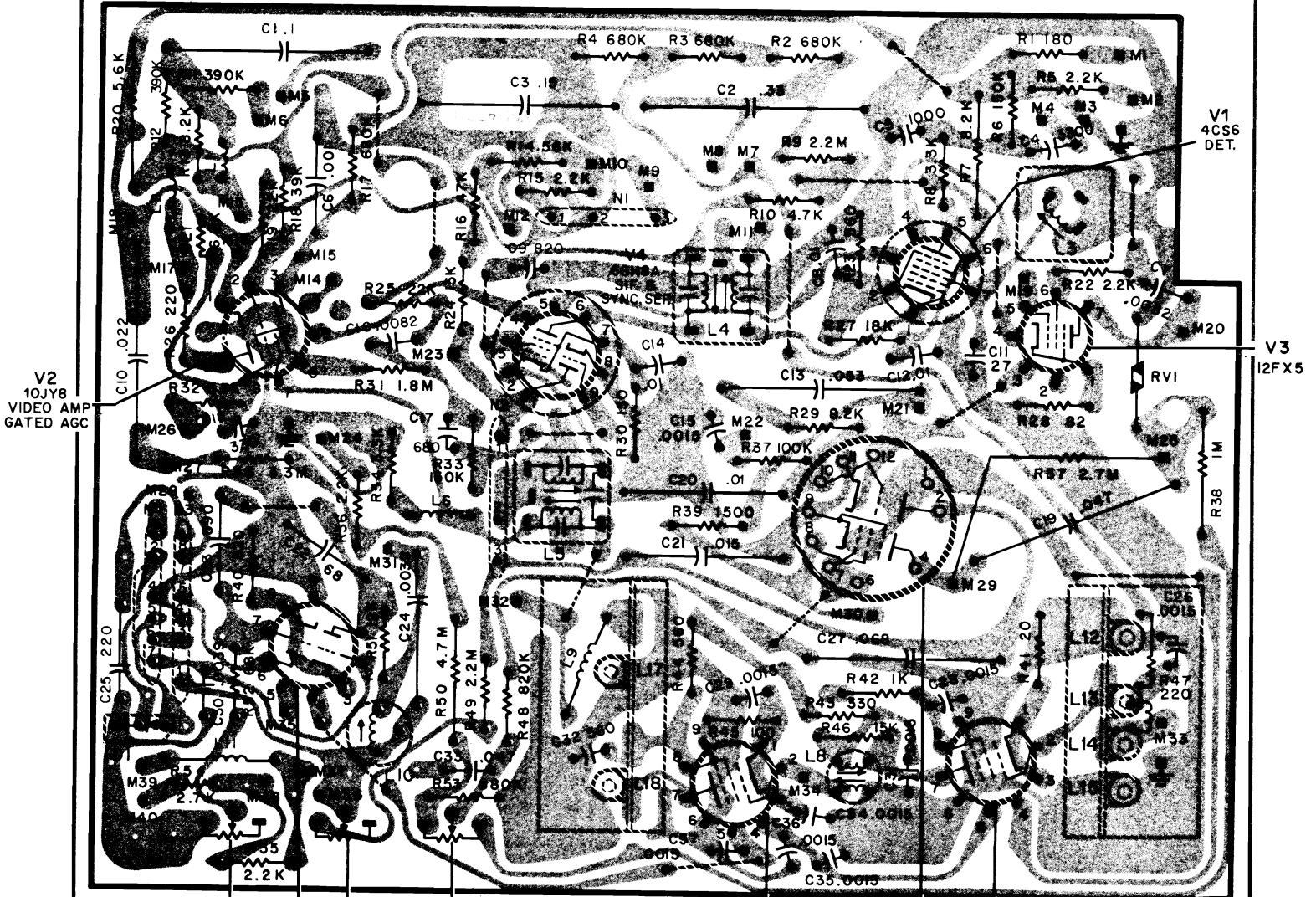

VRIC	V6	VRIB	VRIA	V8	V5	V7
60K	8FQ7	2M	500K	4EJ7	17JZ8	4EH7
HOR	HOR	VERT	VERT	2ND I.F.	VERT	1ST I.F.
HOLD	OSC	LIN	SIZE		OSC	

Bottom View—Perma Circuit Panel 17C21, A, V & AV

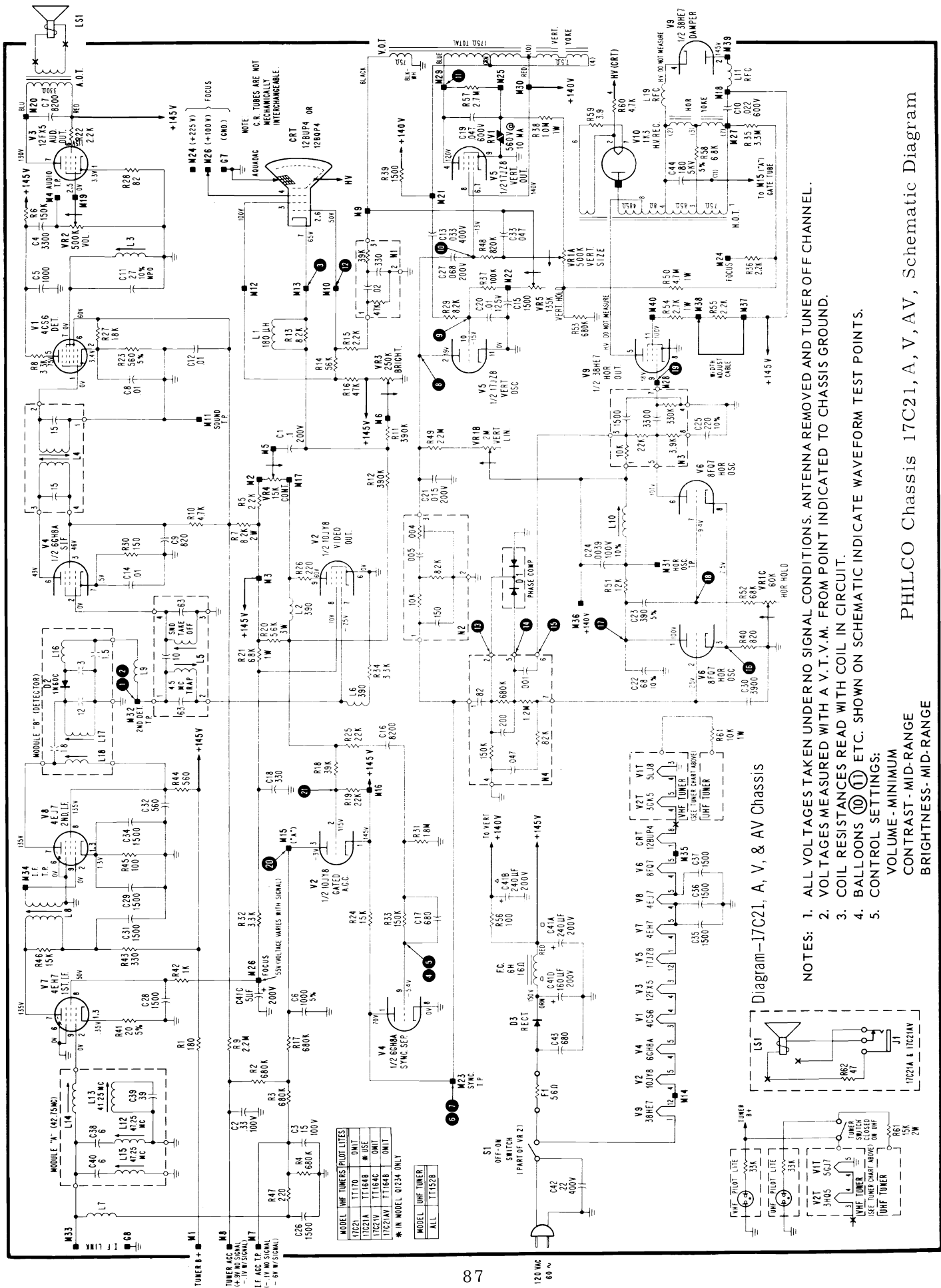

PHILCO Chassis 17C21, A, V, AV, Schematic Diagram

- NOTES:
1. ALL VOLTAGES TAKEN UNDER NO SIGNAL CONDITIONS. ANTENNA REMOVED AND TUNER OFF CHANNEL.
 2. VOLTAGES MEASURED WITH A V.T.M. FROM POINT INDICATED TO CHASSIS GROUND.
 3. COIL RESISTANCES READ WITH COIL IN CIRCUIT.
 4. BALLOONS (⊙) ETC. SHOWN ON SCHEMATIC INDICATE WAVEFORM TEST POINTS.
 5. CONTROL SETTINGS:
 VOLUME - MINIMUM
 CONTRAST - MID-RANGE
 BRIGHTNESS - MID-RANGE

Diagram-17C21, A, V, & AV Chassis

MODEL	UHF TUNER	VHF TUNER	PILOT LITES
17C21	TT1710	OMIT	
17C21A	TT1648	* USE	
17C21V	TT164C	OMIT	
17C21AV	TT1648	OMIT	

* IN MODEL Q1234 ONLY

PHILCO Chassis 17C21, A, V, AV, Perma Circuit Panel Information, Continued

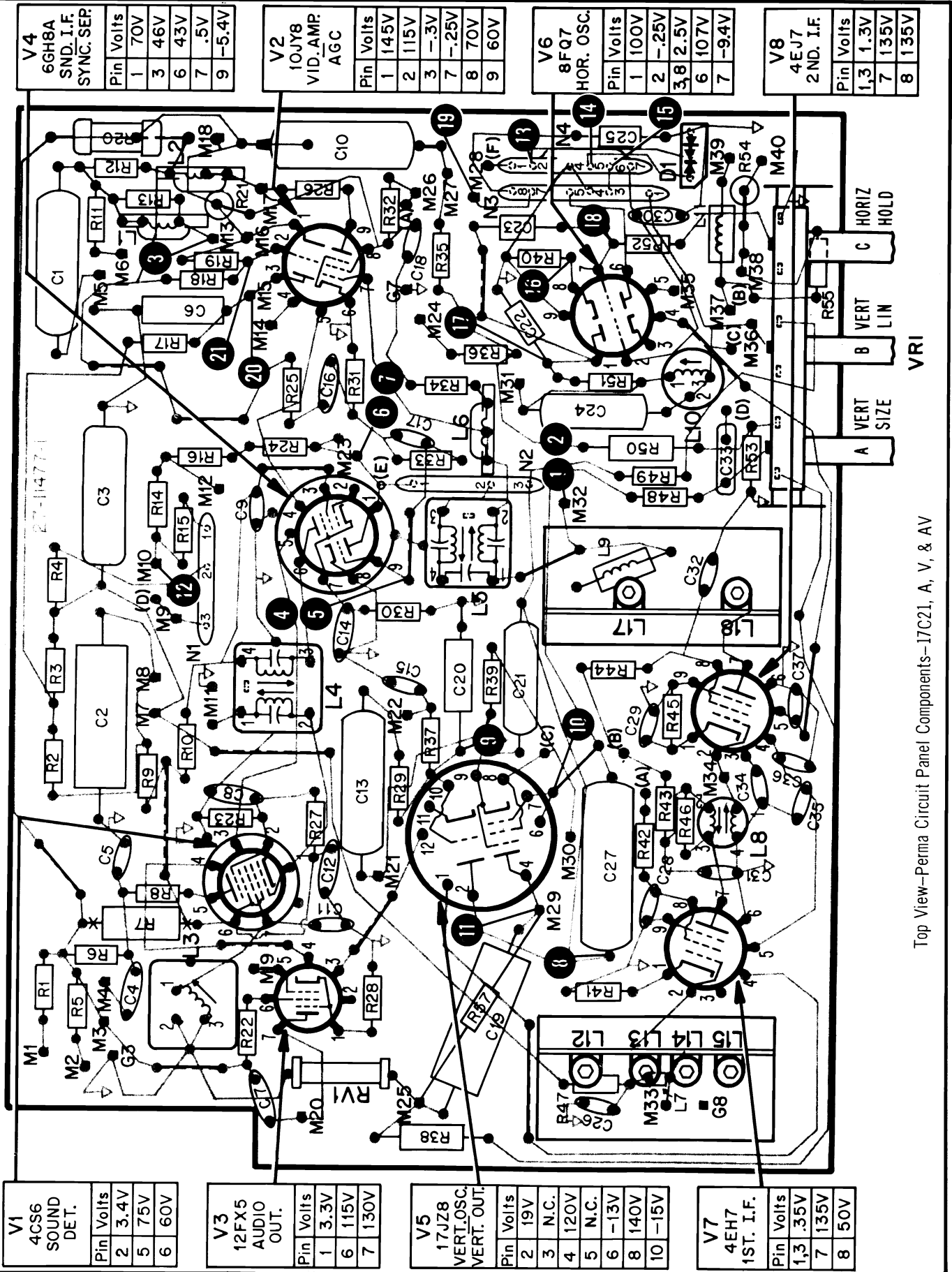

V1	
4CS6 SOUND DET.	
Pin	Volts
2	3.4V
5	75V
6	60V

V3	
12FX5 AUDIO OUT.	
Pin	Volts
1	3.3V
6	115V
7	130V

V5	
17JZ8 VERT. OSC. VERT. OUT.	
Pin	Volts
2	19V
3	N.C.
4	120V
5	N.C.
6	-13V
8	140V
10	-15V

V7	
4EH7 1ST. I.F.	
Pin	Volts
1,3	35V
7	135V
8	50V

V2	
10UJ8 VID. AMP AGC	
Pin	Volts
1	145V
2	115V
3	-3V
7	-25V
8	70V
9	60V

V6	
8FQ7 HOR. OSC.	
Pin	Volts
1	100V
2	-25V
3,8	2.5V
6	107V
7	-94V

V8	
4EJ7 2ND. I.F.	
Pin	Volts
1,3	1.3V
7	135V
8	135V

Top View—Perma Circuit Panel Components—17C21, A, V, & AV

VRI

PHILCO Chassis 17C21, A, V, AV, Alignment Information

17C21, 17C21A, 17C21V & 17C21AV CHASSIS VIDEO I-F AM AND SWEEP ALIGNMENT PROCEDURE

Preliminary Information: (AM ALIGNMENT)

The following video I-F alignment procedure is based upon a tuner with proper bandpass alignment connected to the TV chassis.

1. Allow set to warm up 10 minutes minimum.
2. Apply -7 VDC bias to IF AGC TP lug (M7) & -2 VDC bias to RF TP lug (M8).
3. Connect scope thru a 15K resistor to 2nd detector TP

lug (M32). Calibrate scope for 2V p/p for 100% deflection.

4. Connect AM and marker signal generator thru a .0015 mf capacitor to TP1T (on tuner) I-F test jack.
5. Preset core adjustments
 - a. L12 and L15, six turns out from flush core position.
 - b. L13 fully engaged.
 - c. L17 and L18 two turns out from flush core position.

AM ALIGNMENT CHART

STEP	AM MOD. 400 AT 30%	ADJUST	REMARKS
1	43.5MC	L8 - FOR MAX.	ADJUST FOR FIRST PEAK DOWN FROM FLUSH CORE POSITION.
2	45.25MC	*L1T (ON TUNER) FOR MAX. *L15T (ON TUNER) FOR MAX.	
3	42.75MC	L14 (ON PANEL) FOR MAX.	
4	41.25MC	L13 - FOR MIN.	BIAS MAY BE LOWERED TO PRODUCE SUFFICIENT SCOPE AMPLITUDE.
5	47.25MC 47.25MC	L12 - FOR MIN. L15 - FOR MIN.	BE SURE TO ADJUST L12 FIRST, THEN L15. BIAS MAY BE LOWERED TO PRODUCE SUFFICIENT SCOPE AMPLITUDE.
6	REPEAT STEP 5 UNTIL NO FURTHER IMPROVEMENT IS OBTAINED.		

*L1T (17C21 CHASSIS)-L15T (17C21A, V & AV CHASSIS).

CAUTION: REMOVE AM GENERATOR FROM TP1T BEFORE PROCEEDING WITH SWEEP ALIGNMENT.

NOTE: TO PROPERLY POSITION FINE TUNING FOR SWEEP ALIGNMENT, SET TUNER TO CHANNEL 4 AND INJECT 65.75MC, 30% MODULATED AT ANTENNA TERMINALS. ADJUST FINE TUNING CONTROL FOR MINIMUM SCOPE INDICATION. DO NOT TOUCH FINE TUNING OR CHANNEL SELECTOR FOR BALANCE OF ALIGNMENT.

MARKER INSERTION

If the sweep generator does not have internal markers, an unmodulated signal generator can be used to produce markers. To produce marker using I.F. frequencies connect ground side of generator output cable to subbase by V7 (4EH7) and connect other side of cable directly to a clip that holds from I.F. module shield in place.

To produce marker using R.F. frequencies connect ground side of generator output cable to tuner ground and connect other side of cable to the insulation on the vhf tuner antenna input cable. (See Alignment Equipment setup.)

The marker amplitude should be such that the sweep waveshape is not affected by the marker.

SWEEP ALIGNMENT CHART

Preliminary Steps:

1. Repeat steps 1, 2 and 3 in preliminary information. (AM alignment)
2. Inject low impedance 40MC sweep to lug (M34). Make sure sweep is not in overload. Marker level should be such that output level is not affected.
3. To obtain response curve (Figure B)
 - a. Adjust L18 for marker positions.

b. Adjust L17 to rock response curve.

4. Remove 40MC sweep.

CAUTION: Do not attempt to adjust L17 or L18 after they have been 40MC sweep aligned.

5. Connect sweep generator through a 72 ohm to 300 ohm matching network to antenna terminals.
6. To obtain response curve (Figure A), proceed with steps 7 and 8.

STEP	SWEEP GEN. APPROX. 8 MC SWEEP WIDTH	MARKER GEN. UNMOD. R-F	ADJUST	REMARKS
7	69MC CHAN. 4	45.75MC	*L1T (ON TUNER) *L15T (ON TUNER)	ADJUST COIL INDICATED TO PLACE 45.75MC MARKER BETWEEN INDICATED LIMITS ON VIDEO SIDE OF CURVE (FIG. A). ADJUST SWEEP GEN. LEVEL TO LIMIT SCOPE TO 2V P/P DEFLECTION. KEEP RESPONSE LEVEL WITH L8.
8	69MC CHAN. 4	42.5MC	L14 (ON PANEL)	ADJUST COIL INDICATED TO PLACE 42.5MC MARKER BETWEEN INDICATED LIMITS ON SOUND SIDE OF CURVE (FIG. A). KEEP RESPONSE LEVEL WITH L8.

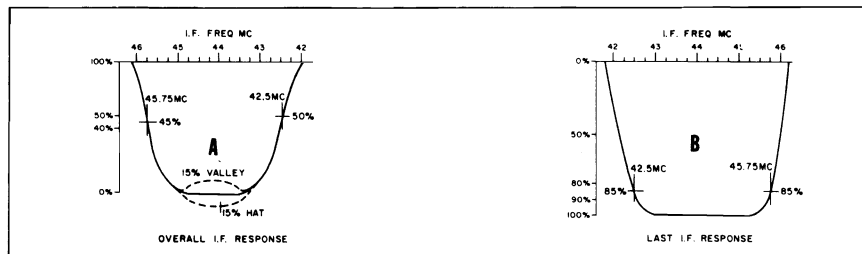

PHILCO Chassis 17C21, A, V, AV, Alignment Information, Continued

4.5MC TRAP, SOUND TAKE-OFF AND INTERSTAGE ALIGNMENT

Preliminary:

1. Set contrast control to maximum.
2. Set volume control to minimum.
3. Apply -15 bias to lug M7.

Equipment:

1. V.T.V.M.
2. AM Generator.
3. RC Network (15K resistor and .01 mfd in parallel).
4. 4.5MC Detector Probe.

STEP	SIGNAL INPUT THROUGH 1500 RESISTOR TO LUG M28	OUTPUT	ADJUST	REMARKS
A	4.5MC AM OR STATION SIGNAL	CONNECT 4.5MC DETECTOR PROBE TO LUG M13. CONNECT VTVM TO 4.5MC PROBE. SET METER TO 2.5V RANGE.	L5 (BOTTOM CORE) FOR MINIMUM OUTPUT INDICATION ON VTVM.	INCREASE SIGNAL INPUT TO GIVE 1/4 SCALE DEFLECTION AT NULL POINT (THIS STEP FOR 4.5MC TRAP ADJ. ONLY).
B	4.5MC AM OR STATION SIGNAL	REMOVE GROUND CONNECTION FROM LUG M11. CONNECT RC NETWORK FROM M11 TO GROUND. PLACE VTVM ACROSS NETWORK. INPUT SHOULD BE ADJUSTED TO KEEP OUTPUT BETWEEN -1V AND -2V.	L4 (TOP & BOTTOM CORES) FOR MAXIMUM INDICATION ON VTVM. (PAD BOTTOM CORE FIRST.)	RC NETWORK CONSISTS OF A 15K RESISTOR AND A .01 MFD CAPACITOR IN PARALLEL.
C	4.5MC AM OR STATION SIGNAL	SAME AS STEP B.	L5 (TOP CORE) FOR MAXIMUM INDICATION ON VTVM.	
D	USE STATION SIGNAL	REMOVE RC NETWORK AND REPLACE GROUND TO LUG M11.	QUAD COIL L7 FOR MAXIMUM SOUND OUTPUT.	THE CORRECT PEAK WILL BE THE SECOND ONE WHEN TURNING CORE INTO COIL.

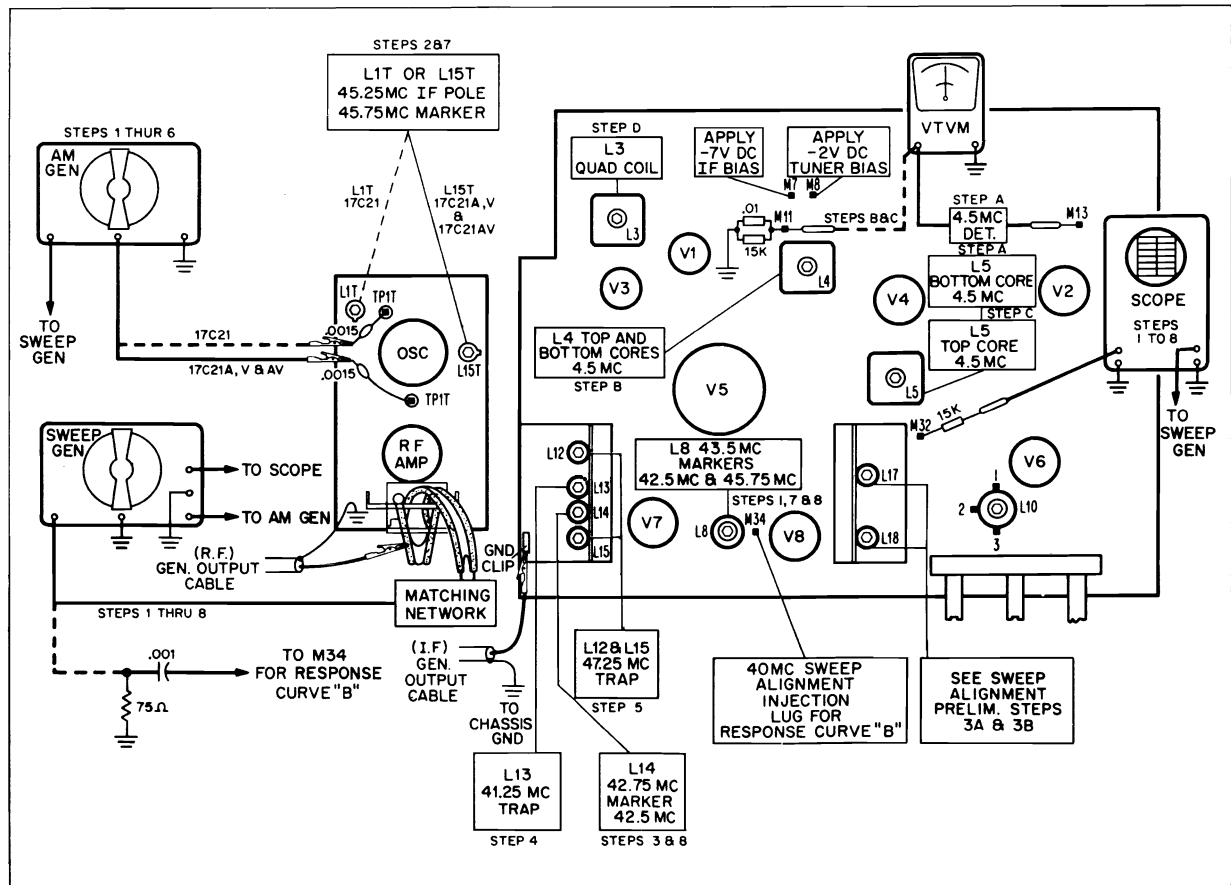

Equipment Setup & Alignment Points—17C21, A, V, & AV



Chassis 17J27, A, used in Models Q3330TN, XTN, Q3332BR, XTN, Q3334WA, Q3336GY, Q3392PE, R3346WA, R3396WA, exact material on pages 91-93 and 96-98. The following additional chassis types are very similar to the type covered and may differ in tuner used, size of picture tube, and other minor details:

Chassis 17H22, used in Models Q2712WH, Q2714WA,
 Chassis 17J25, used in Models Q3562TN, Q3564WA, R3563TN, R3567WA,
 Chassis 17J28, used in Models Q3910WA, Q3912WA.
 Chassis 17N35, used in Models Q4330BK, Q4332MB, WA, Q4334WA, Q4560MB, WA, Q4562MB, WA, Q4564MB, WA, Q4565EA, Q4566SWA, Q4568MC, -2, WA, Q4569WA, Q4570SWA, Q4574EA, MA, Q4584WA, Q4586WA, is also similar and has its schematic shown on pages 94-95.

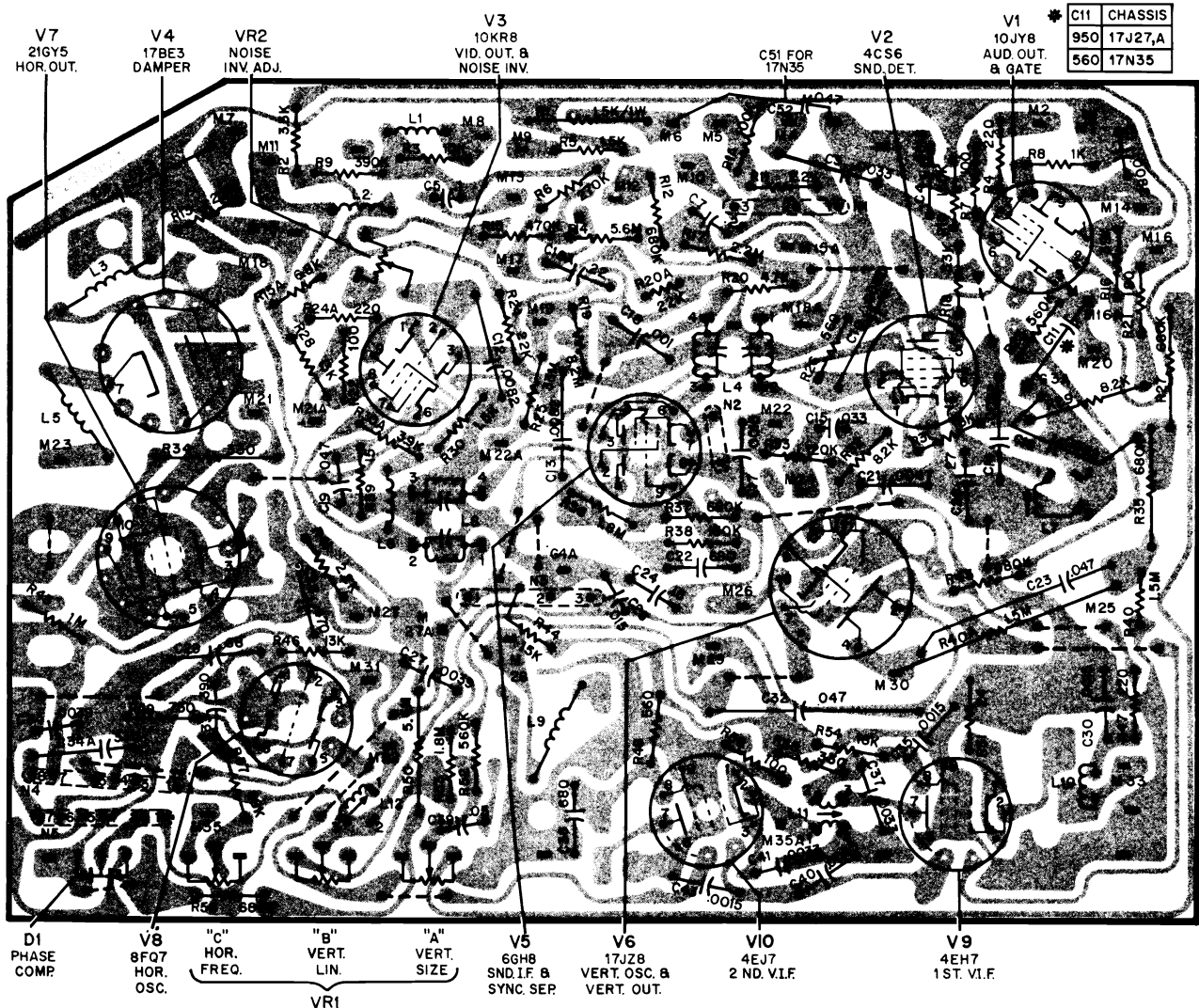

Bottom View Perma Circuit Panel Top Components 17J27, 17J27A

PHILCO Chassis 17J27,A, Schematic Diagram

OSCILLOSCOPE WAVEFORMS

These waveforms were taken with the receiver adjusted for an approximate output of 2.5V p/p at the video detector. Voltage readings taken with raster just filling screen and all controls set for normal picture viewing except for photos 1, 2 and 3 where contrast was at maximum. The voltages given are approximate peak-to-peak values. The frequencies shown are those of the waveforms...not the sweep rate of the oscilloscope. All readings taken with Model PS127 Sencore Oscilloscope.

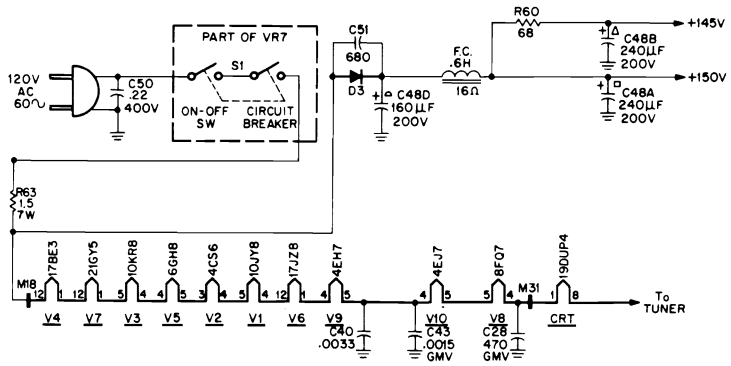
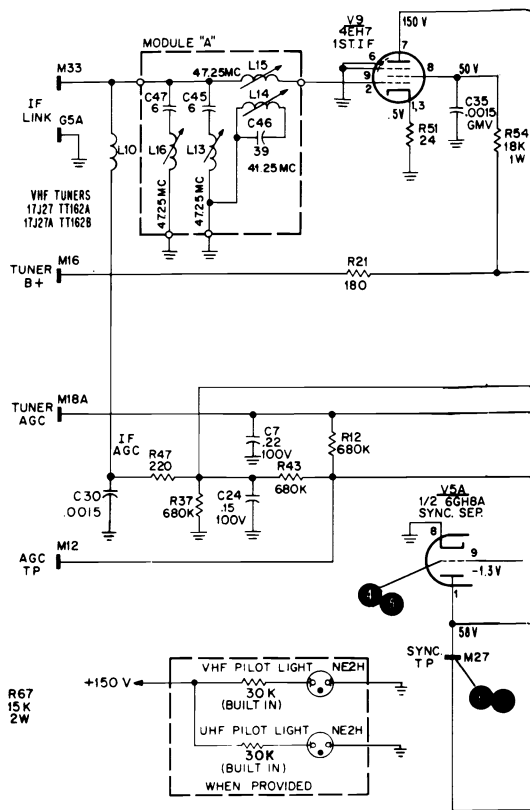
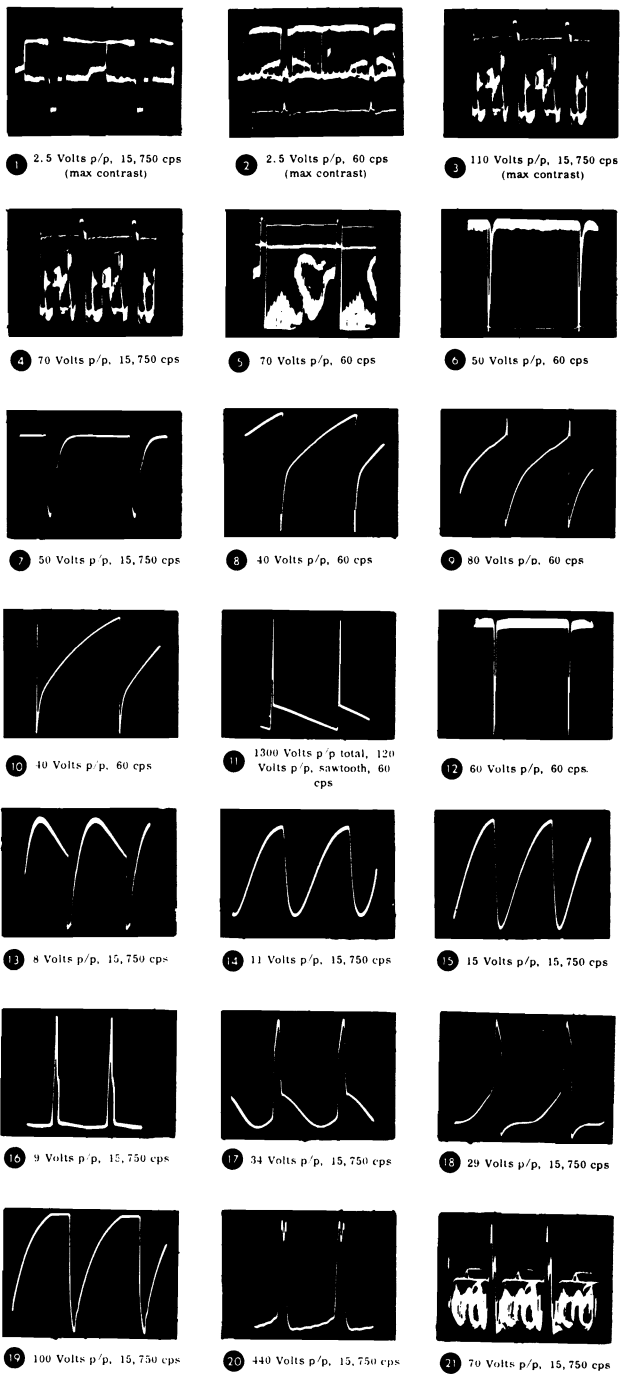

17J27 VOLTAGE AND RESISTANCE CHART

TUBE	USE	PIN NUMBERS											
		1	2	3	4	5	6	7	8	9	10	11	12
V1	Aud. Out. & Gate	150V 12K Ω	83V 36K Ω	-3V 1.3M Ω	FIL	FIL	2.8V 100 Ω	0V 260 Ω	148V 12K Ω	145V 12K Ω			
V2	Sound Detector	0V 6 Ω	3.5V 500 Ω	FIL	FIL	80V 200K Ω	75V 12K Ω	0V 3.5 Ω					
V3	Video Out. & N.I.	.05V 300 Ω	-7.5V 900K Ω	68V 35K Ω	FIL	FIL	.5V 15 Ω	0V 300 Ω	65V 25K Ω	54V 12K Ω			
V4	Damper	FIL	INF	INF	150V 12K Ω	INF	INF	HV 9M Ω	INF	INF	150V 12K Ω	INF	FIL
V5	Snd. IF & Sync. Sep.	58V 12K Ω	0V 2 Ω	60V 12K Ω	FIL	FIL	58V 12K Ω	1V 270 Ω	GND	-1.3V 1.9M Ω			
V6	Vert. Osc. & Output	FIL	21V 3.8M Ω	INF	145V 12K Ω	INF	-17V 1.8M Ω	-17V 1.8M Ω	145V 12K Ω	GND	-21V 200K Ω	GND	FIL
V7	Horiz. Output	FIL	INF	120V 12K Ω	0V GND	120V 300K Ω	120V 12K Ω	120V 12K Ω	120V 12K Ω	-20V 300K Ω	0V GND	120V 12K Ω	FIL
V8	Horiz. Osc.	100V 25K Ω	-1V 2.2M Ω	3.2V 750 Ω	FIL	FIL	120V 45K Ω	120V 95K Ω	3.2V 750 Ω	GND	-9.4V 3.2V	GND	
V9	1st Vid. IF	.5V 24 Ω	0V 420K Ω	.5V 24 Ω	FIL	FIL	GND	150V 20K Ω	50V 20K Ω	GND			
V10	2nd Vid. IF	1.6V 100 Ω	0V	1.6V 100 Ω	FIL	FIL	GND	150V 12K Ω	145V 12K Ω	GND			

PHILCO Chassis 17J27, A, Schematic Diagram, Continued

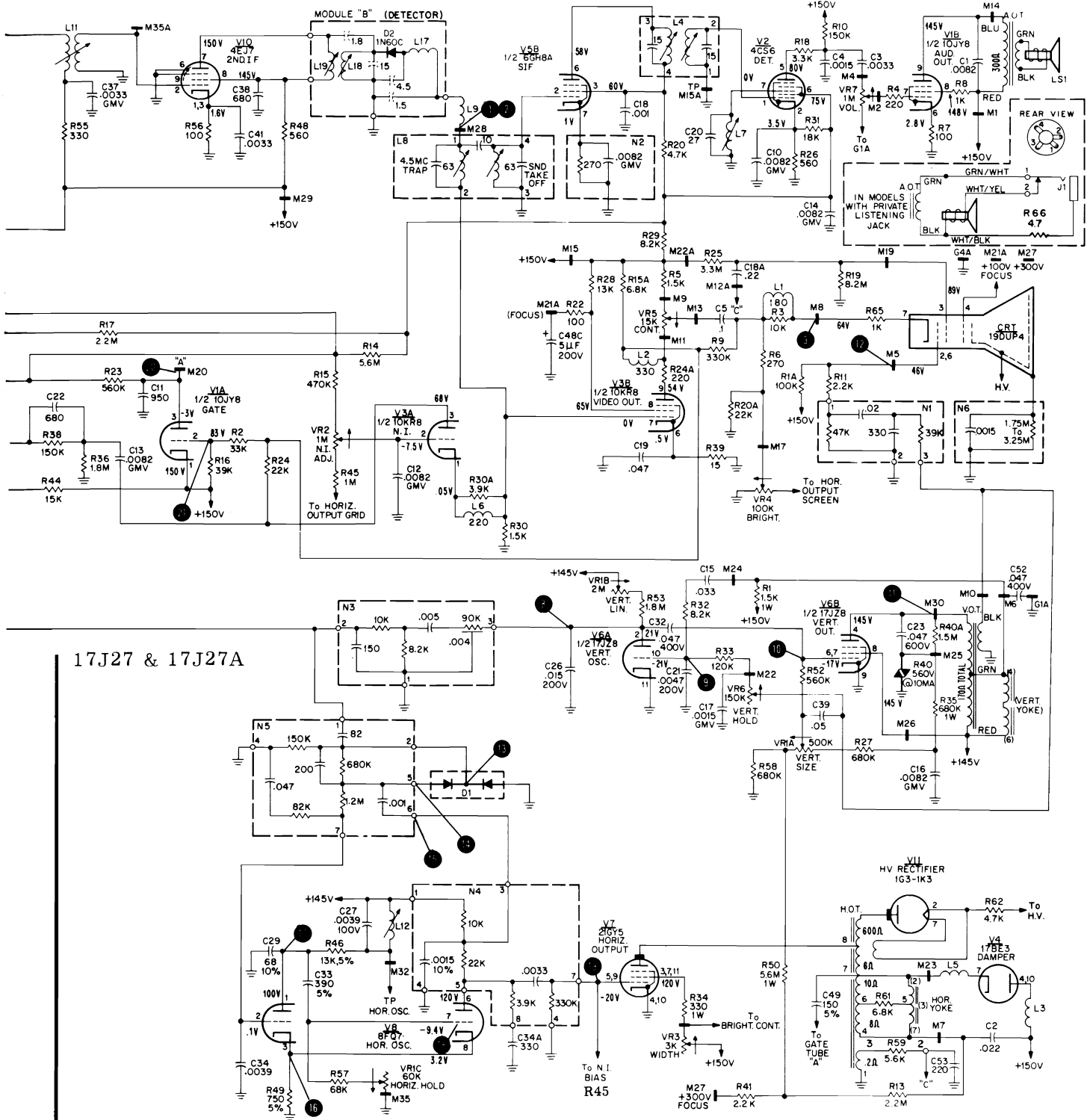

17J27 & 17J27A

- NOTES:
1. ALL VOLTAGES TAKEN UNDER NO SIGNAL CONDITIONS. ANTENNA REMOVED AND TUNER OFF CHANNEL.
 2. VOLTAGES MEASURED WITH A V.T.V.M. FROM POINT INDICATED TO CHASSIS GROUND.
 3. COIL RESISTANCES READ WITH COIL IN CIRCUIT.
 4. BALLOONS 10 11 ETC. SHOWN ON SCHEMATIC INDICATE WAVEFORM TEST POINTS.
 5. CONTROL SETTINGS:
 VOLUME - MINIMUM
 CONTRAST - MID-RANGE
 BRIGHTNESS - MID-RANGE
 ALL OTHER CONTROLS SET FOR NORMAL OPERATION.

PHILCO Chassis 17N35 Schematic Diagram

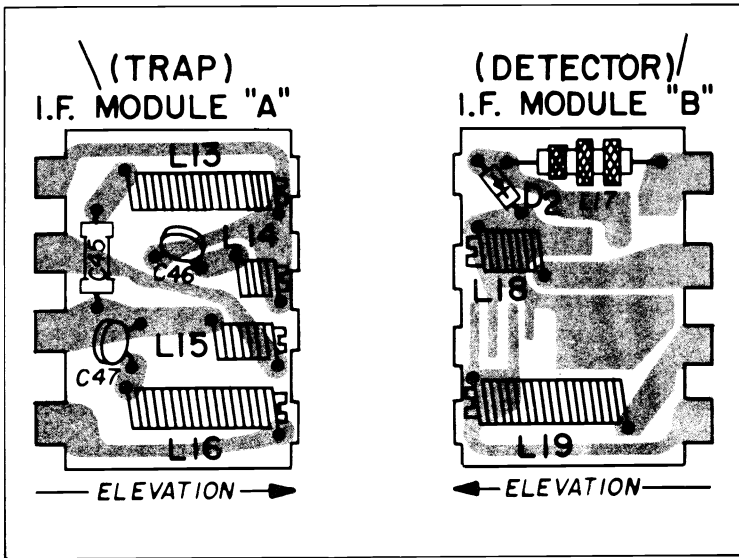

IF Trap & Detector Panel Components 17N35

17N35 VOLTAGE AND RESISTANCE CHART

TUBE	USE	PIN NUMBERS											
		1	2	3	4	5	6	7	8	9	10	11	12
V1 10JY8	Aud. Out. & Gate	150V 12K Ω	83V 36K Ω	-3V 1.3M Ω	FIL	FIL	2.8V 100 Ω	0V 260 Ω	148V 12K Ω	145V 12K Ω			
V2 4CS6	Sound Detector	0V 6 Ω	3.5V 500 Ω	FIL	FIL	80V 200K Ω	75V 12K Ω	0V 3.5 Ω					
V3 10KR8	Video Out. & N.I.	.05V 300 Ω	-7.5V 900K Ω	68V 35K Ω	FIL	FIL	.5V 15 Ω	0V 300 Ω	65V 25K Ω	54V 12K Ω			
V4 17BE3	Damper	FIL	INF	INF	150V 12K Ω	INF	INF	HV 9M Ω	INF	INF	150V 12K Ω	INF	FIL
V5 6GH8	Snd. IF & Sync. Sep.	58V 12K Ω	0V 2 Ω	60V 12K Ω	FIL	FIL	58V 12K Ω	1V 270 Ω	GND	-1.3V 1.9M Ω			
V6 17JZ8	Vert. Osc. & Output	FIL	21V 3.8M Ω	INF	145V 12K Ω	INF	-17V 1.8M Ω	-17V 1.8M Ω	145V 12K Ω	GND	-21V 200K Ω	GND	FIL
V7 21GY5	Horiz. Output	FIL	INF	120V 12K Ω	0V GND	-20V 300K Ω	120V 12K Ω	120V 12K Ω	-20V 300K Ω	0V GND	120V 12K Ω	FIL	
V8 8FQ7	Horiz. Osc.	100V 25K Ω	.1V 2.2M Ω	3.2V 750 Ω	FIL	FIL	120V 45K Ω	-9.4V 95K Ω	3.2V 750 Ω	GND			
V9 4EH7	1st Vid. IF	.5V 24 Ω	0V 420K Ω	.5V 24 Ω	FIL	FIL	GND	150V 12K Ω	50V 20K Ω	GND			
V10 4EJ7	2nd Vid. IF	1.6V 100 Ω	0V 0.7 Ω	1.6V 100 Ω	FIL	FIL	GND	150V 12K Ω	145V 12K Ω	GND			

NOISE CONTROL SETUP

17H22, 17J25, 17J27/A, 17J28 & 17N35 CHASSIS

The noise control adjusts the bias of the noise inverter stage for optimum performance at all signal levels. The procedure for adjustment is as follows:

1. Adjustment should be made on weak signal.
2. Adjust fine tuning control until slight sound beat appears in picture.
3. Adjust noise control (clockwise) until the picture appears watery or shifts sideways. This condition is due to the noise inverter stage clipping sync.
4. Back off noise control (counterclockwise) until picture appears stable, then rotate approximately 30° in same direction for additional safety.

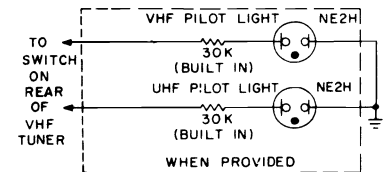
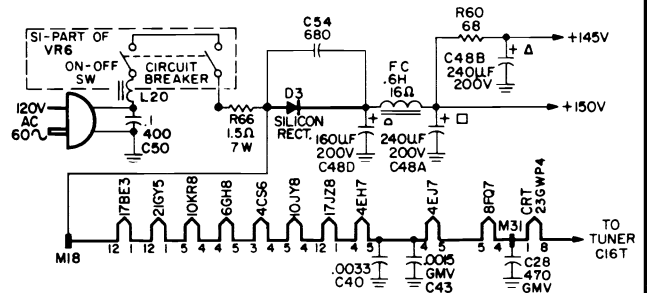
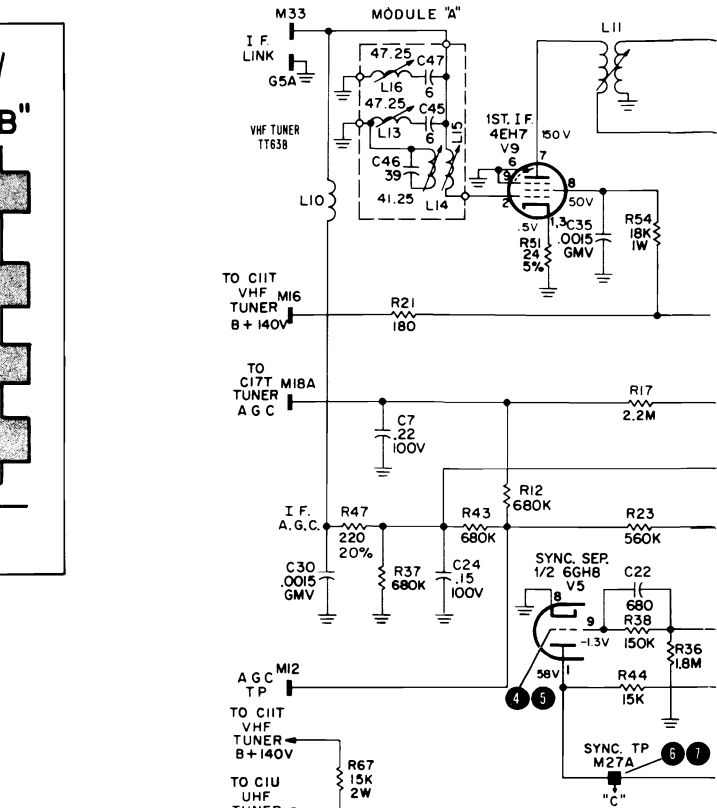

CHECKING THE HORIZONTAL PHASE COMPARER SELENIUM (D1)

When servicing television receivers where the dual selenium diode is suspected, a fast and efficient method of checking them is this:

A 20,000 ohm/volt meter is employed. On the 10K scale, the forward resistance (meter connected in the same polarity as the diode) should be a maximum of 6000 ohms. The ratio of the forward resistances of the two diodes should be less than 2 to 1. On the 100K scale, the back resistance (meter connected in reverse polarity to the diode) should be a minimum of 2 megohms. The center of the phase comparer is the common negative.

PHILCO Chassis 17N35 Schematic Diagram, Continued

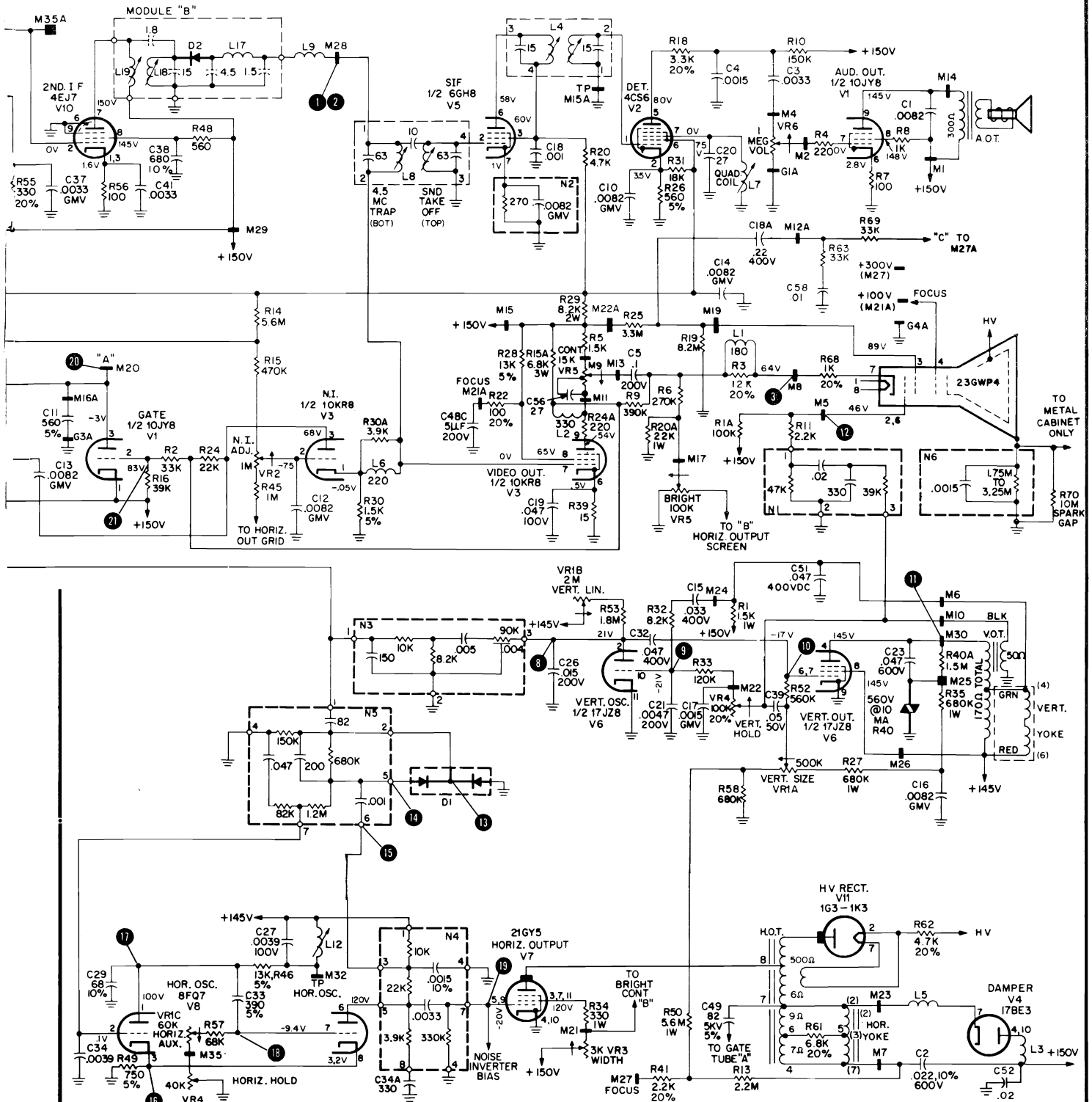

- NOTES: 1. ALL VOLTAGES TAKEN UNDER NO SIGNAL CONDITIONS. ANTENNA REMOVED AND TUNER OFF CHANNEL.
 2. VOLTAGES MEASURED WITH A V.T.V.M. FROM POINT INDICATED TO CHASSIS GROUND.
 3. COIL RESISTANCES READ WITH COIL IN CIRCUIT.
 4. BALLOONS 10 11 ETC., SHOWN ON SCHEMATIC INDICATE WAVEFORM TEST POINTS, SEE PAGE 92.
 5. CONTROL SETTINGS:
 VOLUME - MINIMUM
 CONTRAST - MID-RANGE
 BRIGHTNESS - MID-RANGE
 ALL OTHER CONTROLS SET FOR NORMAL OPERATION.

PHILCO Chassis 17J27, A,
(Continued)

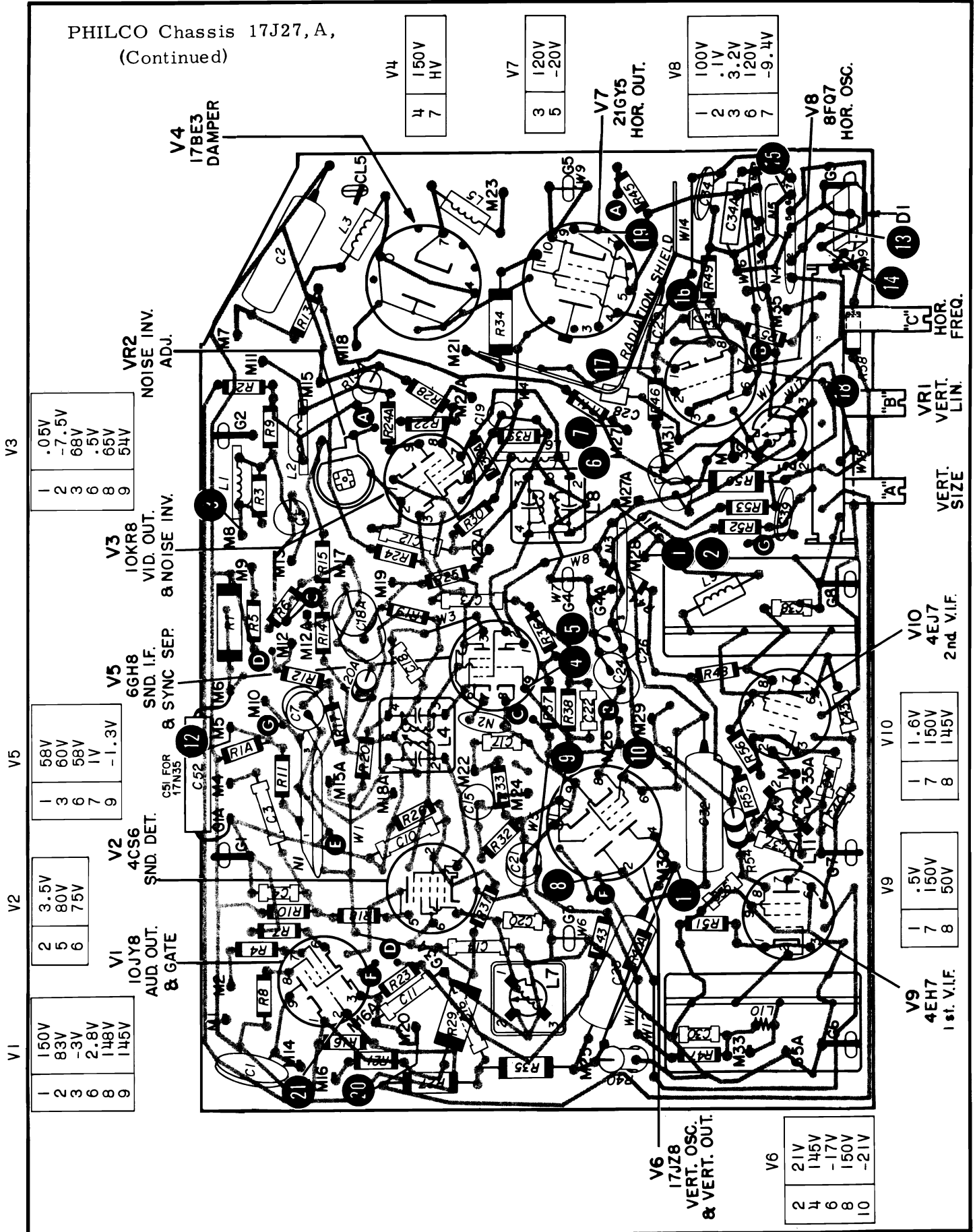

V3

1	.05V
2	-7.5V
3	68V
6	.5V
8	65V
9	54V

V5

1	58V
3	60V
6	58V
7	1V
9	-1.3V

V2

2	3.5V
5	80V
6	75V

V1

1	150V
2	83V
3	-3V
6	2.8V
8	148V
9	145V

V4

4	150V
7	HV

V7

3	120V
5	-20V

V8

1	100V
2	.1V
3	3.2V
6	120V
7	-9.4V

V6

2	21V
4	145V
6	-17V
8	150V
10	-21V

V9

1	.5V
7	150V
8	50V

V10

1	1.6V
7	150V
8	145V

V4
17BE3
DAMPER

VR2
NOISE INV.
ADJ.

V3
10KR8
VID. OUT.
& NOISE INV.

V5
6GH8
SND. I.F.
& SYNC SER.

V2
4CS6
SND. DET.

V1
10JY8
AUD. OUT.
& GATE

V7
21G5
HOR. OUT.

V8
8FQ7
HOR. OSC.

V6
17JZ8
VERT. OSC.
& VERT. OUT.

V9
4EH7
1st. V.I.F.

V10
4EJ7
2nd. V.I.F.

VR1
VERT. LIN.

"C"
HOR. FREQ.

"B"
VERT. SIZE

"A"
VERT. SIZE

Top View Perma Circuit Panel Components 17J27, 17J27A

PHILCO Chassis 17J27, A, Alignment Information, Continued

17H22, 17J25, 17J27/A, 17J28 & 17N35 CHASSIS VIDEO I-F AM AND SWEEP ALIGNMENT PROCEDURE

Preliminary Information

The following video I-F alignment procedure is based upon a tuner with proper bandpass alignment connected to the TV chassis.

1. Allow set to warm up 10 minutes minimum.
2. Apply -15V DC bias to AGC TP lug M12.
3. Connect scope thru a 15K resistor to 2nd detector TP lug (M29). Calibrate scope for 2V p/p for 100% deflection.
4. Connect AM and marker signal generator thru a .0015 mf capacitor to TP1T (on tuner) I-F test jack.
5. Connect sweep generator through a 72 ohm to 300 ohm matching network to antenna terminals.
6. Preset core adjustments
 - a. L13 and L15, six turns out from flush core position.
 - b. L14, L16 and L18 fully engaged.
 - c. L19, two turns out from flush core position.

AM ALIGNMENT CHART

STEP	AM MOD. 400 AT 30%	ADJUST	REMARKS
1	43.5MC	L11 - FOR MAX.	ADJUST FOR FIRST PEAK DOWN FROM FLUSH CORE POSITION.
2	42.75MC	L15 (ON PANEL) FOR MAX.	
3	45.25MC	L15T (ON TUNER) FOR MAX.	
4	41.25MC	L14 - FOR MIN.	BIAS MAY BE LOWERED TO PRODUCE SUFFICIENT SCOPE AMPLITUDE.
5	47.25MC 47.25MC	L13 - FOR MIN. L16 - FOR MIN.	BE SURE TO ADJUST L13 FIRST, THEN L16, BIAS MAY BE LOWERED TO PRODUCE SUFFICIENT SCOPE AMPLITUDE.
6	REPEAT STEP 5 UNTIL NO FURTHER IMPROVEMENT IS OBTAINED.		

CAUTION: REMOVE AM GENERATOR FROM TP1T BEFORE PROCEEDING WITH SWEEP ALIGNMENT.

NOTE: TO PROPERLY POSITION FINE TUNING FOR SWEEP ALIGNMENT, SET TUNER TO CHANNEL 4 AND INJECT 65.75MC, 30% MODULATED AT ANTENNA TERMINALS. ADJUST FINE TUNING CONTROL FOR MINIMUM SCOPE INDICATION. DO NOT TOUCH FINE TUNING OR CHANNEL SELECTOR FOR BALANCE OF ALIGNMENT.

SWEEP ALIGNMENT CHART

1. Repeat steps 1, 2, 3 and 5 in preliminary information.
2. Inject low impedance 40MC sweep to lug (M35A). Make sure sweep is not in overload. Marker level should be such that output level is not affected.
3. To obtain response curve (Figure B),
 - a. Adjust L19 for marker positions.
 - b. Adjust L18 to rock response curve.
 - c. Remove RF sweep before proceeding with 40MC sweep adjustment.
4. Remove 40MC sweep.
CAUTION: Do not attempt to adjust L18 or L19 after they have been 40MC sweep aligned.
5. To obtain response curve (Figure A), proceed with steps 7 and 8.

STEP	SWEEP GEN. APPROX. 8MC SWEEP WIDTH	MARKER GEN. UNMOD. R-F	ADJUST	REMARKS
7	44MC	42.5MC	L15 (ON PANEL)	ADJUST COIL INDICATED TO PLACE 42.5MC MARKER BETWEEN INDICATED LIMITS ON SOUND SIDE OF CURVE (FIG. A). ADJUST SWEEP GEN. LEVEL TO LIMIT SCOPE TO 2V P/P DEFLECTION. KEEP RESPONSE LEVEL WITH L11.
8	44MC	45.75MC	L15T (ON TUNER)	ADJUST COIL INDICATED TO PLACE 45.75MC MARKER BETWEEN INDICATED LIMITS ON VIDEO SIDE OF CURVE (FIG. A). KEEP RESPONSE LEVEL WITH L11.

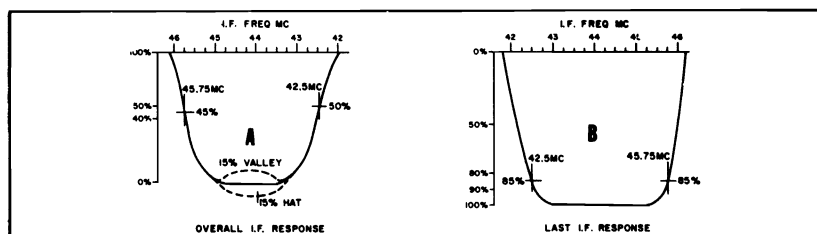

PHILCO Chassis 17J27, A, Alignment Information, Continued

4.5MC TRAP, SOUND TAKE-OFF AND INTERSTAGE ALIGNMENT

Preliminary:

1. Set contrast control to maximum.
2. Set volume control to minimum.
3. Apply -15 bias to lug M12.

Equipment:

1. V.T.V.M.
2. AM Generator.
3. RC Network (15K resistor and .01 mfd in parallel).
4. 4.5MC Detector Probe.

STEP	SIGNAL INPUT THROUGH 1500 RESISTOR TO LUG M28	OUTPUT	ADJUST	REMARKS
A	4.5MC AM OR STATION SIGNAL	CONNECT 4.5MC DETECTOR PROBE TO LUG M4. CONNECT VTVM TO 4.5MC PROBE. SET METER TO 2.5V RANGE.	L8 (BOTTOM CORE) FOR MINIMUM OUTPUT INDICATION ON VTVM.	INCREASE SIGNAL INPUT TO GIVE 1/4 SCALE DEFLECTION AT NULL POINT (THIS STEP FOR 4.5MC TRAP ADJ. ONLY).
B	4.5MC AM OR STATION SIGNAL	REMOVE GROUND CONNECTION FROM LUG M15A. CONNECT RC NETWORK FROM M15A TO GROUND. PLACE VTVM ACROSS NETWORK. INPUT SHOULD BE ADJUSTED TO KEEP OUTPUT BETWEEN -1V AND -2V.	L4 (TOP & BOTTOM CORES) FOR MAXIMUM INDICATION ON VTVM.	RC NETWORK CONSISTS OF A 15K RESISTOR AND A .01 MFD CAPACITOR IN PARALLEL.
C	4.5MC AM OR STATION SIGNAL	SAME AS STEP B.	L8 (TOP CORE) FOR MAXIMUM INDICATION ON VTVM.	
D	USE STATION SIGNAL	REMOVE RC NETWORK AND REPLACE GROUND TO LUG M15A	QUAD COIL L7 FOR MAXIMUM SOUND OUTPUT.	THE CORRECT PEAK WILL BE THE SECOND ONE WHEN TURNING CORE INTO COIL.

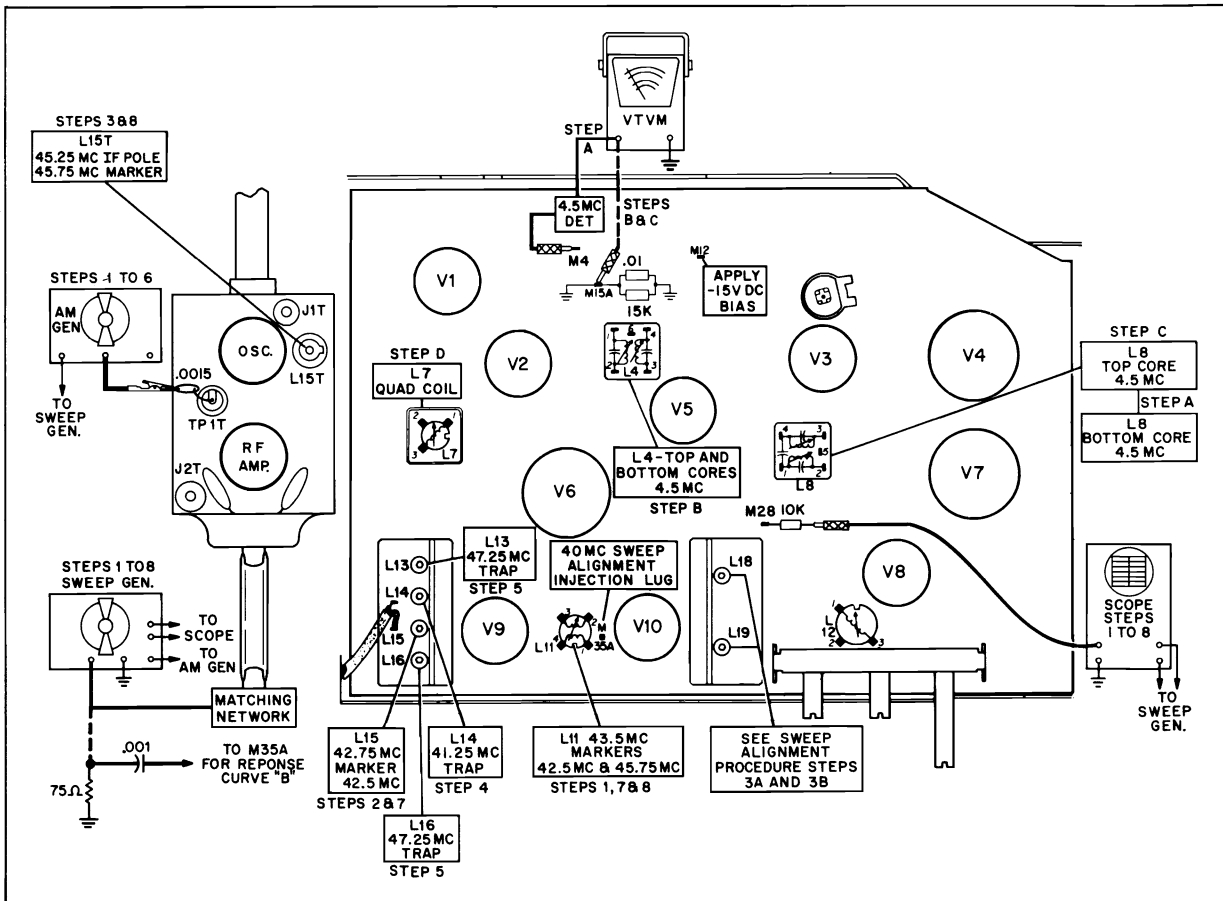

Equipment Setup & Alignment Points

PHILCO

Chassis 17JT41, used in Models Q3572BE, Q3574GY, Q3576WA, has exact service material on pages 99 through 106.

The following additional chassis types are very similar to the type covered and may differ in tuner used, size of picture tube, and other minor details:

Chassis 17LT43, used in Models Q3730GY, Q3734WA,

Chassis 17NT45, used in Models Q4590WA, Q4592MA, Q4594PC, Q4596CH.

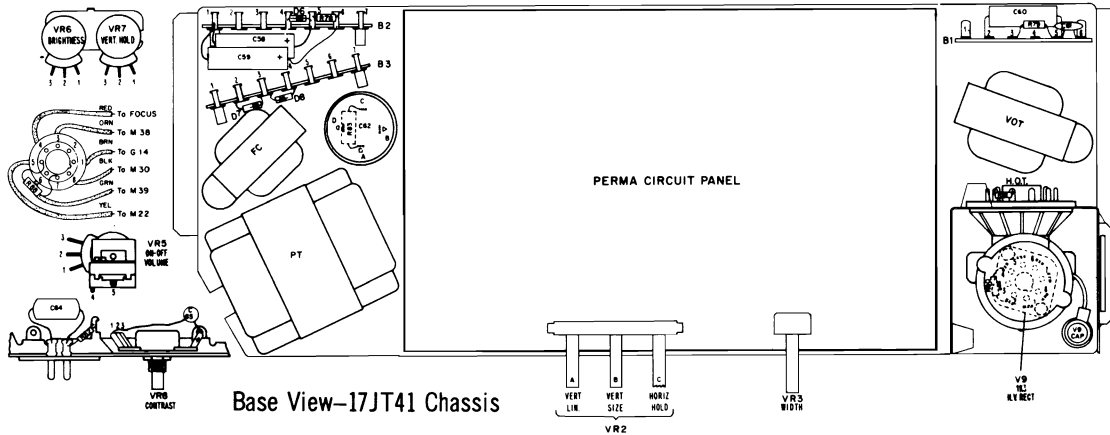

AGC DISTRIBUTION CONTROL ADJUSTMENT (VR1A) - 17JT41 CHASSIS

The AGC Distribution Control (VR1A) is preset at the factory and should not, under normal circumstances, be disturbed. However, if the RF, Mixer, 1st IF or 2nd IF Transistors should be replaced, it may be necessary to reset (VR1A) for optimum signal handling and medium level snow performance.

1. Set the tuner to a channel which will produce a good noise free picture (above medium level signal strength).
2. Reduce signal input by use of Pad (figure 1) until noise (medium level snow) appears in picture.
3. Rotate control (VR1A) clockwise just until noise increases, then stop.

4. Reverse rotation of (VR1A) counterclockwise until noise is just minimized - and stop.

5. Do not rotate (VR1A) any further. Further rotation will not improve medium snow level and will impair higher signal level capabilities.

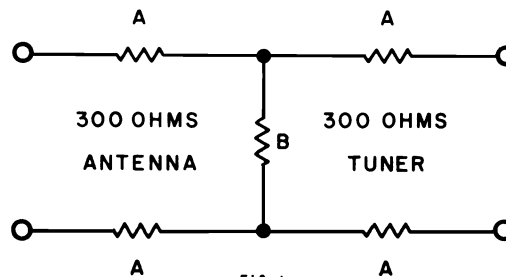

RESISTOR A	RESISTOR B
33 ohm	620 ohm
47 ohm	390 ohm
68 ohm	270 ohm
75 ohm	220 ohm
91 ohm	160 ohm
100 ohm	120 ohm
120 ohm	82 ohm
120 ohm	62 ohm

17JT41 RESISTANCE CHART

TUBE	USE	PIN NUMBERS											
		1	2	3	4	5	6	7	8	9	10	11	12
V1-6KR8	Sync Sep & Vid. Out	*30K	2M	11K	FIL	FIL	15Ω	*40K	8.5K	11K			
V2-6BQ5	Audio Out	NC	150K	100Ω	FIL	FIL	NC	10K	NC	10K			
V3-6BZ3	Damper	FIL	NC	NC	8K	NC	NC	8.5M	NC	NC	8K	NC	FIL
V4-6CB6A	Sound I.F.	3.5Ω	180Ω	FIL	FIL	9K	9K	GND					
V5-6CS6	Sound Detector	6Ω	560Ω	FIL	FIL	10M	9K	3Ω					
V6-6JZ6	Horiz. Out	FIL	GND	14K	GND	330K	NC	NC	330K	NC	GND	NC	FIL
V7-6JZ8	Vert. Osc. & Output	FIL	4M	NC	8K	NC	2.2M	2.2M	8K	GND	200K	GND	FIL
V8-6FQ7	Horiz. Osc.	23K	1.9M	750Ω	FIL	FIL	42K	80K	750Ω	GND			

* WITH POSITIVE LEAD OF VTVM TO GROUND

PHILCO Chassis 17JT41 Schematic Diagram, Continued

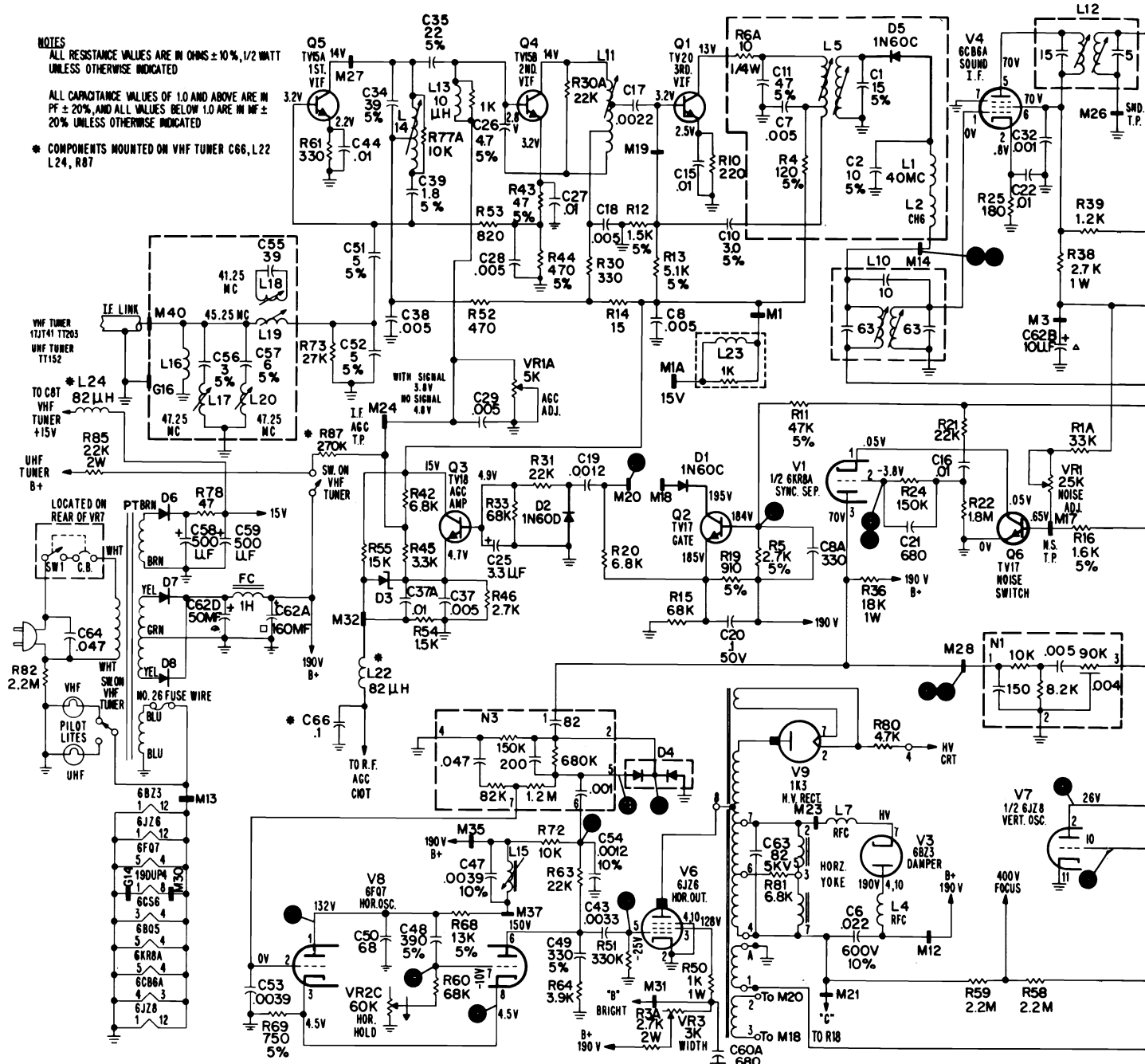

Schematic Diagram-17JT41 Chassis

NOTES:

1. ALL VOLTAGES TAKEN UNDER NO SIGNAL CONDITIONS. ANTENNA REMOVED AND TUNER OFF CHANNEL.
2. VOLTAGES MEASURED WITH A V.T.V.M. FROM POINT INDICATED TO CHASSIS GROUND.
3. COIL RESISTANCES READ WITH COIL IN CIRCUIT.
4. BALLOONS SHOWN ON SCHEMATIC INDICATE WAVEFORM TEST POINTS.
5. CONTROL SETTINGS:
 VOLUME - MINIMUM
 CONTRAST - MID RANGE
 BRIGHTNESS - MID RANGE
 ALL OTHER CONTROLS SET FOR NORMAL OPERATION

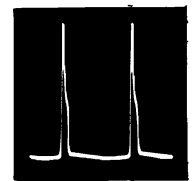

● 14 volts p/p, 15,750 cps

PHILCO Chassis 17JT41 Schematic Diagram, Continued

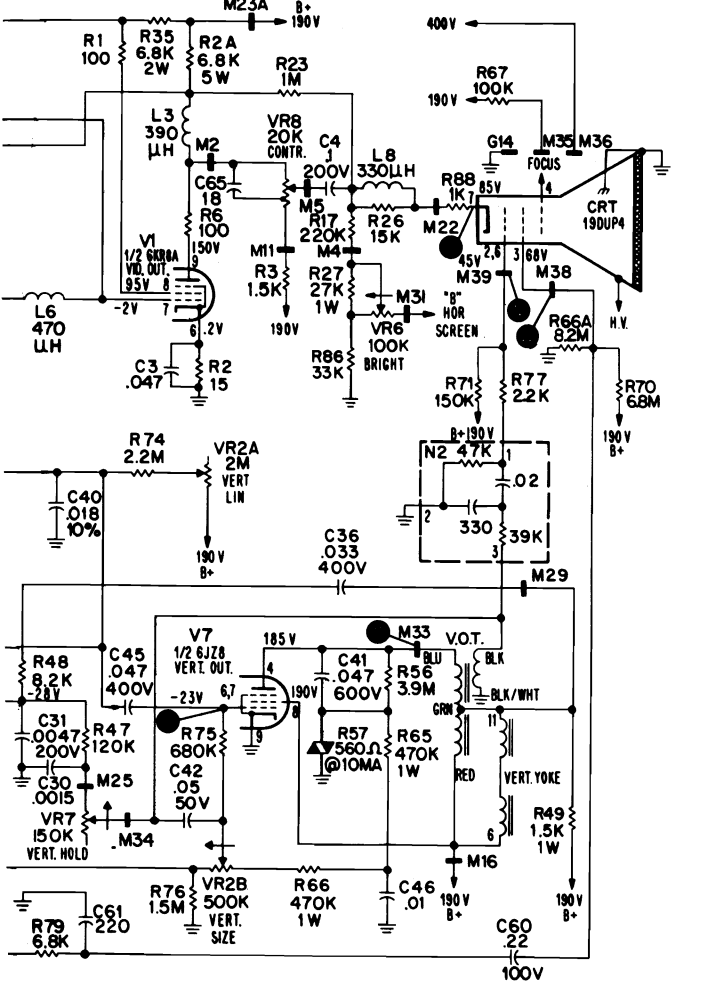
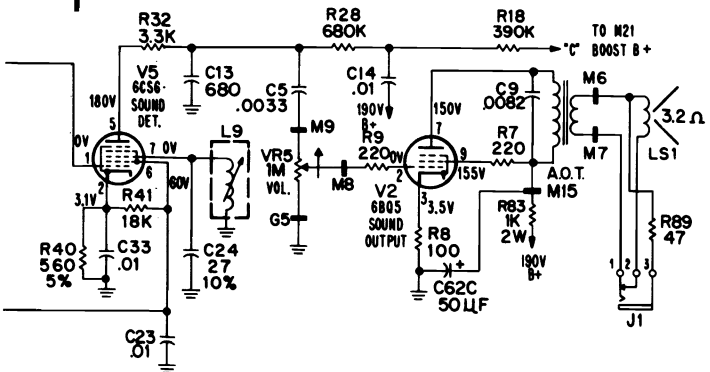

OSCILLOSCOPE WAVEFORMS

These waveforms were taken with the receiver adjusted for an approximate output of 2.5V p/p at the video detector. Voltage readings taken with raster just filling screen and all controls set for normal picture viewing except for photos 1, 2 and 3 where contrast was at maximum. The voltages given are approximate peak-to-peak values. The frequencies shown are those of the waveforms...not the sweep rate of the oscilloscope. All readings taken with Model PS127 Sencore Oscilloscope.

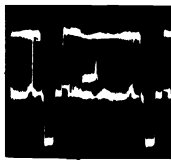

● 2.5 volts p/p, 15,750 cps

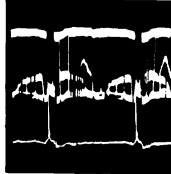

● 2.5 volts p/p, 60 cps



● 115 volts p/p, 15,750 cps



● 100 volts p/p, 15,750 cps



● 100 volts p/p, 60 cps



● 55 volts p/p, 60 cps

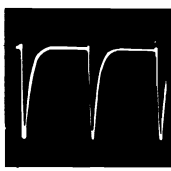

● 55 volts p/p, 15,750 cps

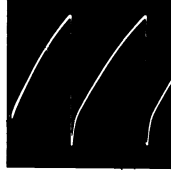

● 50 volts p/p, 60 cps

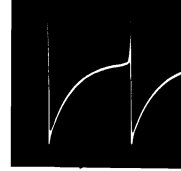

● 85 volts p/p, 60 cps

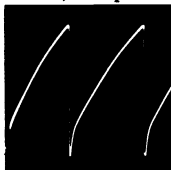

● 50 volts p/p, 60 cps

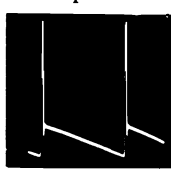

● 1300 volts p/p total, 130 volts p/p sawtooth, 60 cps

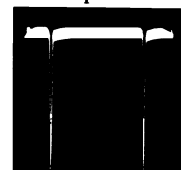

● 115 volts p/p, 60 cps

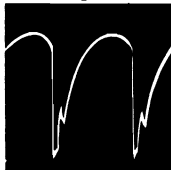

● 11.5 volts p/p, 15,750 cps

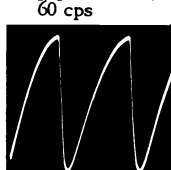

● 15 volts p/p, 15,750 cps

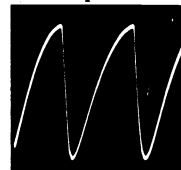

● 21 volts p/p, 15,750 cps

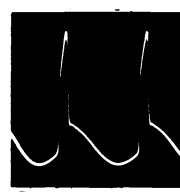

● 48 volts p/p, 15,750 cps

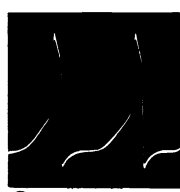

● 42 volts p/p, 15,750 cps

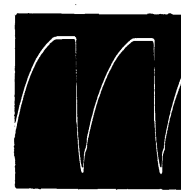

● 140 volts p/p, 15,750 cps

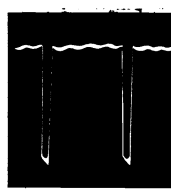

● 22 volts p/p, 15,750 cps

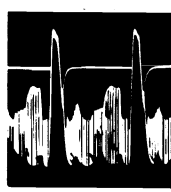

● 12 volts p/p, 15,750 cps



● 90 volts p/p, 15,750 cps

PHILCO Chassis 17JT41, Service Information, Continued

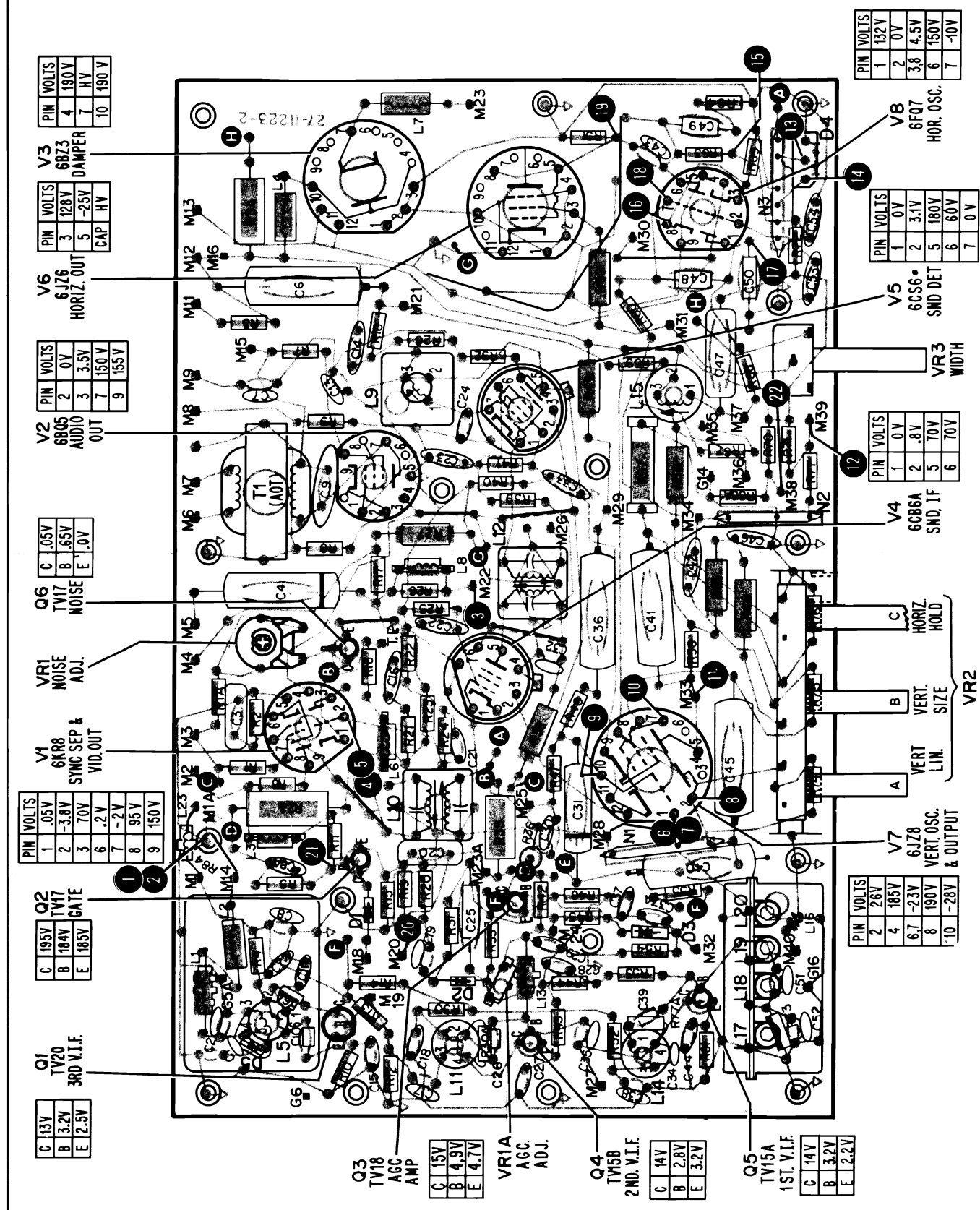

PIN	VOLTS
1	132V
2	0V
3	128V
4	190V
5	-25V
6	150V
7	HV
8	150V
9	150V
10	190V

PIN	VOLTS
1	0V
2	3.1V
3	180V
4	60V
5	60V
6	0V
7	0V

PIN	VOLTS
1	0V
2	0V
3	3.5V
4	150V
5	155V
6	155V
7	155V
8	155V
9	155V
10	155V

PIN	VOLTS
1	0.5V
2	0.5V
3	0.5V
4	0.5V
5	0.5V
6	0.5V
7	0.5V
8	0.5V
9	0.5V
10	0.5V

PIN	VOLTS
1	0.5V
2	0.5V
3	0.5V
4	0.5V
5	0.5V
6	0.5V
7	0.5V
8	0.5V
9	0.5V
10	0.5V

PIN	VOLTS
1	0.5V
2	0.5V
3	0.5V
4	0.5V
5	0.5V
6	0.5V
7	0.5V
8	0.5V
9	0.5V
10	0.5V

PIN	VOLTS
1	0.5V
2	0.5V
3	0.5V
4	0.5V
5	0.5V
6	0.5V
7	0.5V
8	0.5V
9	0.5V
10	0.5V

PIN	VOLTS
1	0.5V
2	0.5V
3	0.5V
4	0.5V
5	0.5V
6	0.5V
7	0.5V
8	0.5V
9	0.5V
10	0.5V

PIN	VOLTS
1	0.5V
2	0.5V
3	0.5V
4	0.5V
5	0.5V
6	0.5V
7	0.5V
8	0.5V
9	0.5V
10	0.5V

PIN	VOLTS
1	0.5V
2	0.5V
3	0.5V
4	0.5V
5	0.5V
6	0.5V
7	0.5V
8	0.5V
9	0.5V
10	0.5V

PIN	VOLTS
1	0.5V
2	0.5V
3	0.5V
4	0.5V
5	0.5V
6	0.5V
7	0.5V
8	0.5V
9	0.5V
10	0.5V

PIN	VOLTS
1	0.5V
2	0.5V
3	0.5V
4	0.5V
5	0.5V
6	0.5V
7	0.5V
8	0.5V
9	0.5V
10	0.5V

PIN	VOLTS
1	0.5V
2	0.5V
3	0.5V
4	0.5V
5	0.5V
6	0.5V
7	0.5V
8	0.5V
9	0.5V
10	0.5V

PIN	VOLTS
1	132V
2	0V
3	128V
4	190V
5	-25V
6	150V
7	HV
8	150V
9	150V
10	190V

PIN	VOLTS
1	0V
2	3.1V
3	180V
4	60V
5	60V
6	0V
7	0V

PIN	VOLTS
1	0.5V
2	0.5V
3	0.5V
4	0.5V
5	0.5V
6	0.5V
7	0.5V
8	0.5V
9	0.5V
10	0.5V

PIN	VOLTS
1	0.5V
2	0.5V
3	0.5V
4	0.5V
5	0.5V
6	0.5V
7	0.5V
8	0.5V
9	0.5V
10	0.5V

PIN	VOLTS
1	0.5V
2	0.5V
3	0.5V
4	0.5V
5	0.5V
6	0.5V
7	0.5V
8	0.5V
9	0.5V
10	0.5V

PIN	VOLTS
1	0.5V
2	0.5V
3	0.5V
4	0.5V
5	0.5V
6	0.5V
7	0.5V
8	0.5V
9	0.5V
10	0.5V

PIN	VOLTS
1	0.5V
2	0.5V
3	0.5V
4	0.5V
5	0.5V
6	0.5V
7	0.5V
8	0.5V
9	0.5V
10	0.5V

PIN	VOLTS
1	0.5V
2	0.5V
3	0.5V
4	0.5V
5	0.5V
6	0.5V
7	0.5V
8	0.5V
9	0.5V
10	0.5V

PIN	VOLTS
1	0.5V
2	0.5V
3	0.5V
4	0.5V
5	0.5V
6	0.5V
7	0.5V
8	0.5V
9	0.5V
10	0.5V

PIN	VOLTS
1	0.5V
2	0.5V
3	0.5V
4	0.5V
5	0.5V
6	0.5V
7	0.5V
8	0.5V
9	0.5V
10	0.5V

PIN	VOLTS
1	0.5V
2	0.5V
3	0.5V
4	0.5V
5	0.5V
6	0.5V
7	0.5V
8	0.5V
9	0.5V
10	0.5V

PIN	VOLTS
1	0.5V
2	0.5V
3	0.5V
4	0.5V
5	0.5V
6	0.5V
7	0.5V
8	0.5V
9	0.5V
10	0.5V

PIN	VOLTS
1	0.5V
2	0.5V
3	0.5V
4	0.5V
5	0.5V
6	0.5V
7	0.5V
8	0.5V
9	0.5V
10	0.5V

PIN	VOLTS
1	0.5V
2	0.5V
3	0.5V
4	0.5V
5	0.5V
6	0.5V
7	0.5V
8	0.5V
9	0.5V
10	0.5V

Top View—Perma Circuit Panel—17JT41 Chassis

PHILCO Chassis 17JT41, Service Information, Continued

17JT41 PANEL LUG CONNECTIONS

FROM	TO	FROM	TO
M1A	R78 (15V. SUPPLY)	M22	CRT #5
M2	VR8-1	M23	H.O.T. #7
M3	C62B	M23A (BOT)	C62-A
M4	VR6-2	M24	R84 (ON TUNER)
M5	VR8-2	M25 (BOT)	VR7-3
M6	SPEAKER	M26	R39
M7	SPEAKER	M29 (BOT)	YOKE #11
M8	VR5-2	M29 (BOT)	V.O.T. (GRN)
M9	VR5-3	M30	CRT #8
M11	VR8-3	M31 (BOT)	VR6-3
M12	C62-A	M32	L22 (ON TUNER)
M13	B2-6	M33 (BOT)	V.O.T. (BLUE)
M14	L10 (SND TRAP)	M34	VR7-2
M15 (BOT)	C62-C	M34 (BOT)	V.O.T. (BLK)
M16	YOKE #6	M35	FOCUS +190V
M16 (BOT)	V.O.T. #3	M36	FOCUS +400V
M18	H.O.T. #3	M38	CRT #3
M20	H.O.T. #2	M39	CRT #6
M21 (BOT)	H.O.T. #4		

PANEL INTERCONNECTING LEADS

- A TO A
- B TO B
- C TO C
- D TO D
- E TO E
- F TO F
- G TO G
- H TO H

PIN VOLTS
4 190V
7 HV
10 190V

POINTS ARE INDICATED BY BALLOONS A, B ETC.

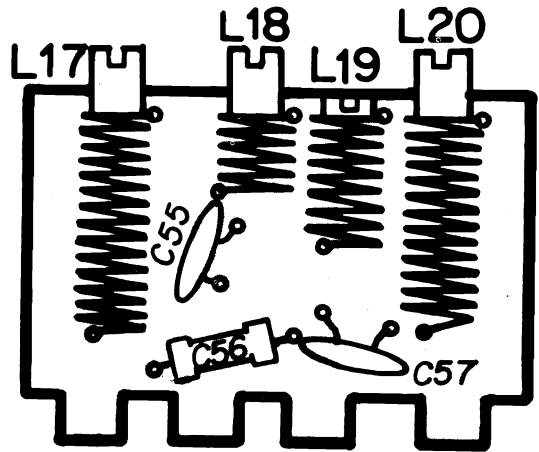

Bottom View, VIF Trap Panel

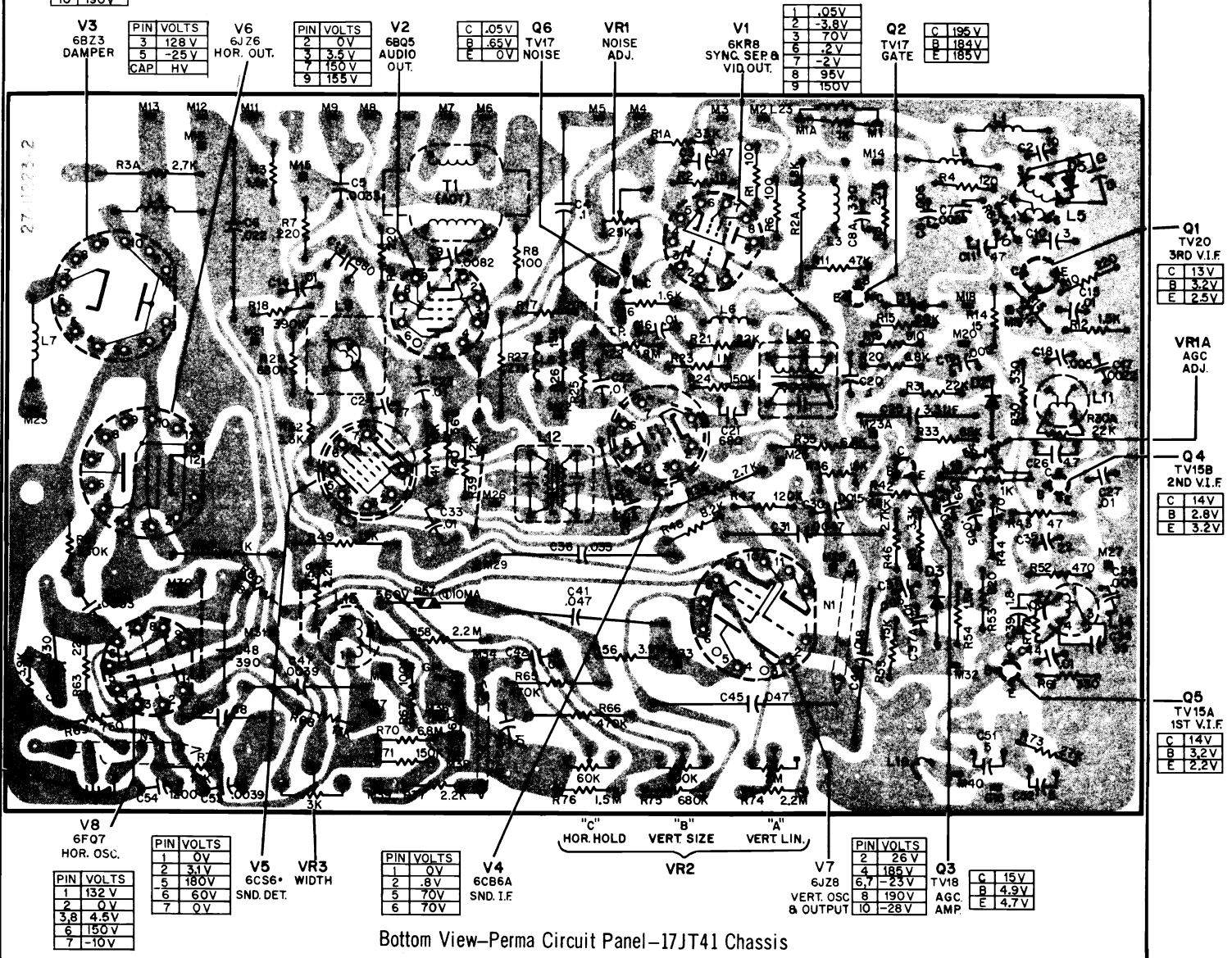

PHILCO Chassis 17JT41, 17LT43, 17NT45, Alignment Information

VIDEO IF AM AND SWEEP ALIGNMENT PROCEDURE

PRELIMINARY INFORMATION

It is recommended that this Video IF alignment procedure be done with the chassis disconnected from the 120V AC line and an external 15 volts DC supply be used to power the Tuner and IF section. This alignment is based upon a tuner with the proper bandpass alignment connected to the chassis.

CAUTION:

To do this alignment with the chassis connected to the 120V AC source the following steps must be taken before proceeding:-

- a. Disconnect the AGC GATE winding leads from lugs M18 & M20.
- b. Connect chassis to 120V AC through an Isolation transformer.

A. Connect external 15 volts DC supply to lug M1A

(omit this step when using 120V AC connected to chassis).

- B. Connect variable external IF bias 4.5 to 6.5 volts DC to lug M24.
- C. Connect external Tuner bias 2.0 volts DC to lug M32.
- D. Connect scope through 10K resistor to lug M14, set scope gain for 2.0 volts p/p deflection.
- E. Allow receiver to warm up 5 minutes minimum.
- F. Set IF bias at lug M24 for 6.0 volts.
- G. Inject low impedance 40MC sweep to lug M19 (3rd IF base) through network (see figure 1). Make sure sweep is not in overload. Marker level should be such that output level is not affected.
- H. Preset core adjustments:-
 - a. L11 & L18 fully engaged (flush with top of coil).
 - b. L17, L19 and L20 set 8 to 9 turns out from flush core position.

I-F SWEEP ALIGNMENT CHART

STEP	SWEEP GEN. APPROX. 8MC SWEEP WIDTH	MARKER GEN. UNMOD. R-F	ADJUST	REMARKS
1	44MC	42.5MC & 45.75MC	L5 BOT.	ADJUST TO PLACE 42.5MC MARKER AND 45.75MC MARKER BETWEEN INDICATED LIMITS SHOWN IN FIGURE B.
2	44MC	42.5MC & 45.75MC	L5 TOP	ADJUST BY ROCKING CURVE TO PLACE 42.5MC MARKER AND 45.75MC MARKER BETWEEN INDICATED LIMITS SHOWN IN FIGURE B.

CAUTION: DO NOT ATTEMPT TO ADJUST L5 TOP AND BOTTOM CORES AFTER THEY HAVE BEEN 40MC SWEEP ALIGNED.

- J. Remove 40MC sweep.
- K. Connect AM and Marker Generator to J2T (UHF input on tuner), set VHF tuner to UHF (ch. 1) position.
- L. Reset IF bias for 5.0 volts.

AM ALIGNMENT CHART

STEP	AM MOD. 400 AT 30%	ADJUST	REMARKS
3	44.0MC 44.0MC	L11 - FOR MAX. L14 - FOR MAX.	ADJUST FOR FIRST PEAK DOWN FROM FLUSH CORE POSITION. ADJUST TO FIRST PEAK DOWN.
4	43.0MC	L1T (ON TUNER) - FOR MAX.	
5	45.25MC	L19 - FOR MAX.	
6	41.25MC	L18 - FOR MIN. (TURN CCW)	BIAS MAY BE LOWERED TO PRODUCE SUFFICIENT SCOPE AMPLITUDE.
7	47.25MC 47.25MC	L20 - FOR MIN. L17 - FOR MIN.	BE SURE TO ADJUST L20 FIRST. THEN L17 BIAS MAY BE LOWERED TO PRODUCE SUFFICIENT SCOPE AMPLITUDE.
8	REPEAT STEP 8 UNTIL NO FURTHER IMPROVEMENT IS OBTAINED.		

CAUTION: REMOVE AM GENERATOR FROM J2T BEFORE PROCEEDING WITH SWEEP ALIGNMENT.

NOTE: TO PROPERLY POSITION FINE TUNING FOR SWEEP ALIGNMENT, SET TUNER TO CHANNEL 4 AND INJECT 65.75MC, 30% MODULATED AT ANTENNA TERMINALS. ADJUST FINE TUNING CONTROL FOR MINIMUM SCOPE INDICATION. DO NOT TOUCH FINE TUNING OR CHANNEL SELECTOR FOR BALANCE OF ALIGNMENT.

- M. Connect sweep generator through 72 to 300 ohms matching network to antenna terminals.
- N. Reset IF bias to get 2.0 volts p/p deflection on scope.

R-F SWEEP ALIGNMENT CHART

STEP	SWEEP GEN. APPROX. 8MC SWEEP WIDTH	MARKER GEN. UNMOD. R-F	ADJUST	REMARKS
9	44MC	42.5MC	L1T (TUNER I-F COIL)	ADJUST L1T TO PLACE 42.5MC MARKER BETWEEN INDICATED LIMITS ON SOUND SIDE OF CURVE (FIG. A). ADJUST SWEEP GEN. LEVEL TO LIMIT SCOPE TO 2V P/P DEFLECTION. KEEP RESPONSE LEVEL WITH L14.
10	44MC	45.75MC	L19	ADJUST L19 TO PLACE 45.75MC MARKER BETWEEN INDICATED LIMITS ON VIDEO SIDE OF CURVE (FIG. A). KEEP RESPONSE LEVEL WITH L14.
11	OBTAIN FRINGE CURVE AS FOLLOWS: A. REDUCE IF BIAS TO 3V DC; TUNER BIAS TO 1.5V DC B. LOWER SWEEP INPUT TO MAINTAIN 2V P/P SCOPE DEFLECTION ADJUST HIGH FREQ. SIDE OF CURVE BY ADJUSTING L14 FOR WAVEFORM "C"			
12	TOUCH UP 47.25MC TRAPS AS FOLLOWS: A. REPEAT AM ALIGNMENT STEPS 7 & 8. MINIMIZE L20 AND A SLIGHT TOUCH OF L17 MAY BE REQUIRED TO ACHIEVE FURTHER NULLING.			

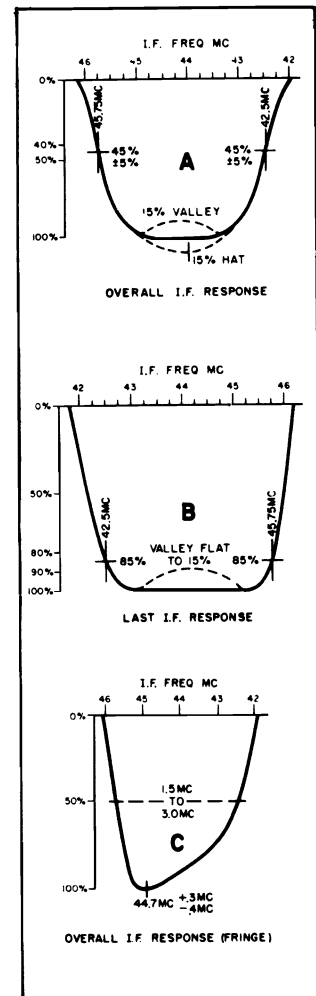

IF Response Curves & Fringe Curve

**17JT41, 17LT43 & 17NT45 CHASSIS
4.5 MC TRAP, SOUND TAKEOFF AND INTERSTAGE ALIGNMENT**

Preliminary:

1. Connect receiver for normal AC operation,
2. Set contrast control to maximum.
3. Set volume control to minimum with power switch "ON".
4. Connect 5.0 volts DC to lug M24 (IF bias).

Equipment:

1. V.T.V.M.
2. AM Generator.
3. RC Network (15K resistor and .01 mf cap. in parallel).
4. 4.5 MC Detector Probe (see section 1).

4.5 MC DETECTOR JIG

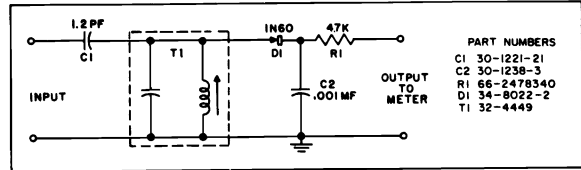

STEP	SIGNAL INPUT THROUGH 1500Ω RESISTOR TO LUG M14	OUTPUT	ADJUST	REMARKS
A	4.5MC AM OR STATION SIGNAL	CONNECT 4.5MC DETECTOR PROBE TO LUG M9. CONNECT VTVM TO 4.5MC PROBE. SET METER TO 2.5V RANGE.	L10 (BOTTOM CORE) FOR MINIMUM OUTPUT INDICATION ON VTVM.	INCREASE SIGNAL INPUT TO GIVE 1/4 SCALE DEFLECTION AT NULL POINT (THIS STEP FOR 4.5MC TRAP ADJ. ONLY).
B	4.5MC AM OR STATION SIGNAL	REMOVE GROUND CONNECTION FROM LUG M26. CONNECT RC NETWORK FROM M26 TO GROUND. PLACE VTVM ACROSS NETWORK. INPUT SHOULD BE ADJUSTED TO KEEP OUTPUT BETWEEN -1V AND -2V.	L12 (TOP & BOTTOM CORES) FOR MAXIMUM INDICATION ON VTVM.	RC NETWORK CONSISTS OF A 15K RESISTOR AND A .01 MFD CAPACITOR IN PARALLEL.
C	4.5MC AM OR STATION SIGNAL	SAME AS STEP B	L10 (TOP CORE) FOR MAXIMUM INDICATION ON VTVM.	
D	USE STATION SIGNAL	REMOVE RC NETWORK AND REPLACE GROUND TO LUG M26.	QUAD COIL L9 FOR MAXIMUM SOUND OUTPUT.	THE CORRECT PEAK WILL BE THE SECOND ONE WHEN TURNING CORE INTO COIL.

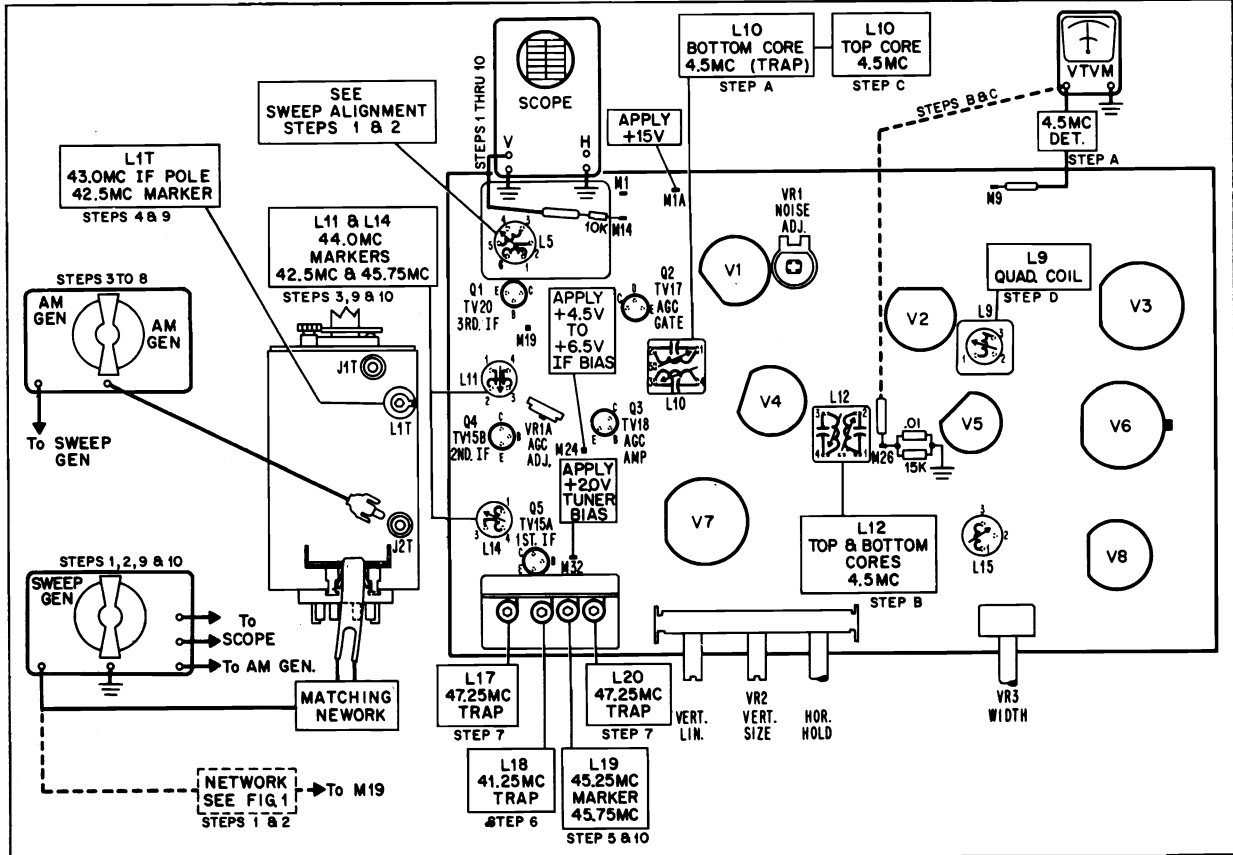

17JT41, 17LT43 & 17NT45 Equipment Setup & Alignment Points

PHILCO Tuners TT164B, C, D, Schematic Diagram

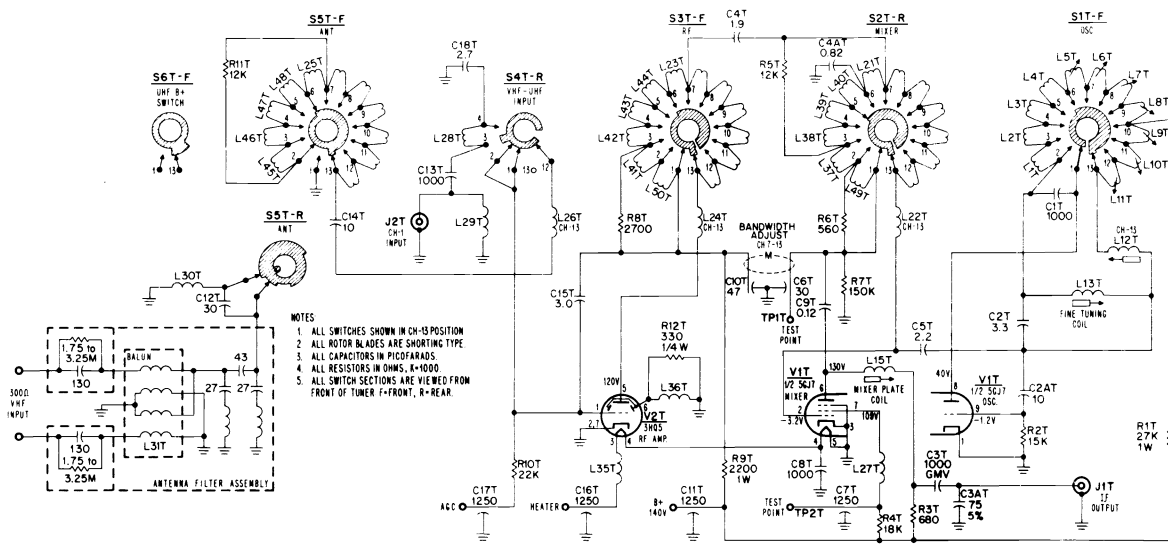

Schematic Diagram--TT164C VHF Tuner

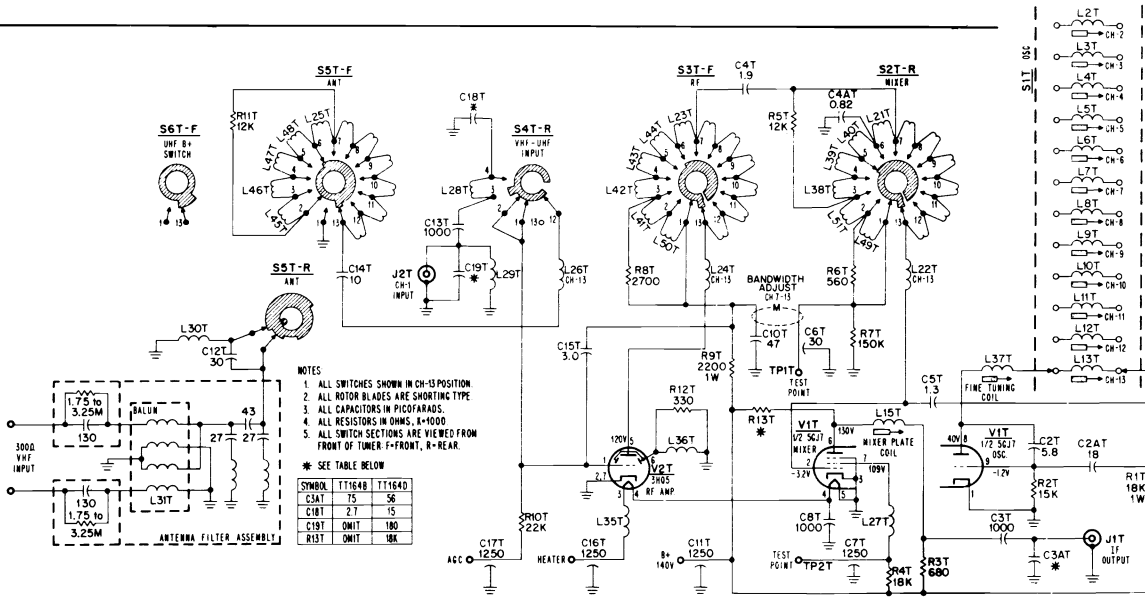

Schematic Diagram TT164B & TT164D Tuners

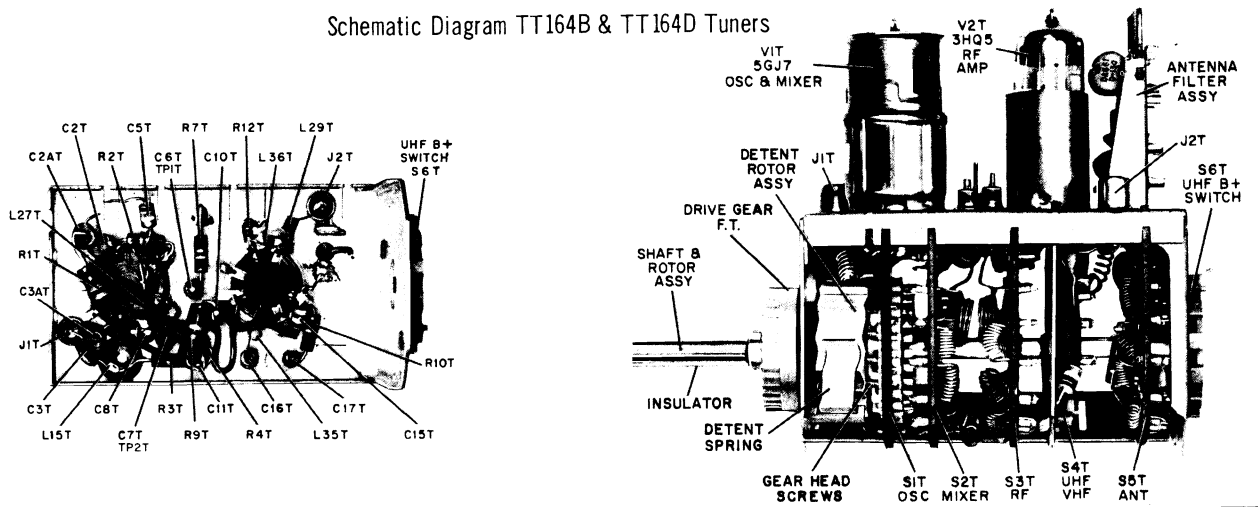

RCA VICTOR

Chassis KCS-160A, -B, -C, used in Models AH-066Y, AH-070BK, WK, AH-090MR, WR; Chassis KCS-156A used in Models AH-126B, E, W, are practically identical electrically. For alignment information see pages 119-120 and 123. Other data on pages 107-110.

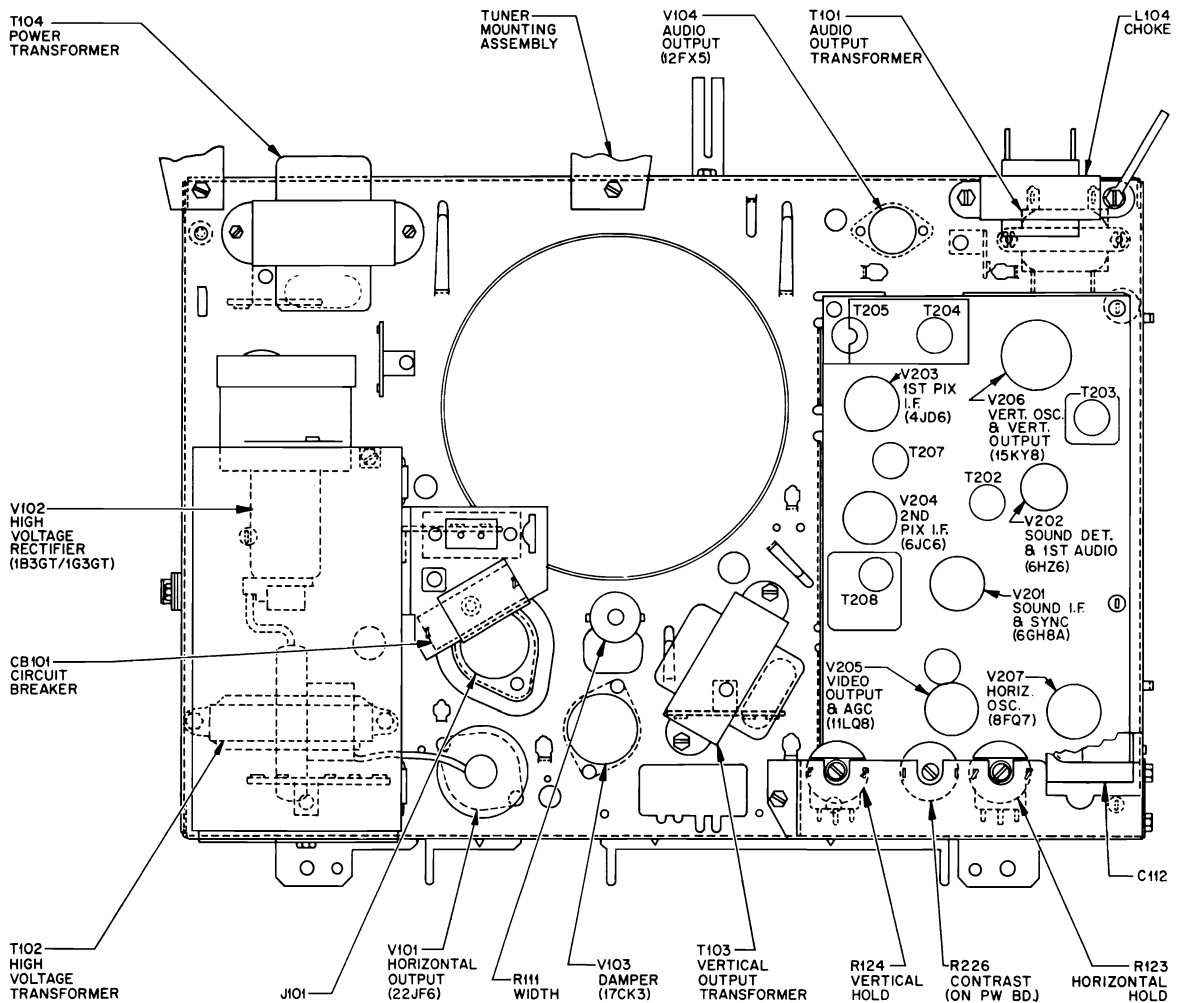

WIDTH AND LINEARITY ADJUSTMENTS

Set AC line voltage at 108 volts.

Adjust the height and vertical linearity controls for a symmetrical raster that just fills the screen from top to bottom.

Set the brightness and contrast controls to maximum and adjust the width control (R110) so that the raster just fills the screen horizontally. If necessary, turn the centering magnets to center the raster.

Turn the contrast control to minimum and center the raster vertically. If the height and linearity adjustments are correct the raster should fill the screen $+0, -1/4$ " at the top and bottom. When normal 120 volts line is restored, the vertical blanking bar should not change in width as the picture is rolled slowly downward and the picture should have the proper amount of horizontal scan.

HORIZONTAL SINE WAVE ADJUSTMENT

Remove sync by shorting Terminal "AE" (Zone A-6, PW200) to chassis ground. Short sine wave coil L207 by connecting a jumper wire between TP4 and Terminal "W" TP4 (Zone 5A, PW200) and Terminal "W" (Zone 4A, PW200).

Adjust horizontal hold control until picture sides are vertical. Remove short from sine wave coil (TP-4 and Terminal "W"), then adjust L207 sine wave coil so that the picture remains stationary with sides vertical. Remove short from sync (Terminal "AE").

From CCW direction of horizontal hold control, pull in from out of sync condition should be from 1 to 3 bars. From the CW direction from 1 to 8 bars. There should be no loss of raster on either extreme of control rotation.

RCA Victor Chassis KCS-160 Schematic Diagram

VOLTAGE WAVEFORMS

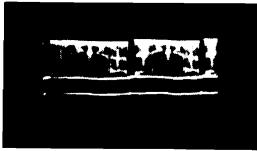

① TP-3
SECOND DETECTOR
VERTICAL RATE 2V P-P

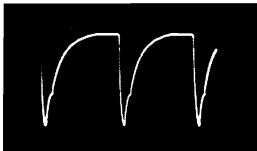

② V101 PINS 2 & 6
HORIZONTAL OUTPUT GRID
HORIZONTAL RATE 130V P-P



③ TP-5
SYNC PLATE
VERTICAL RATE 60V P-P

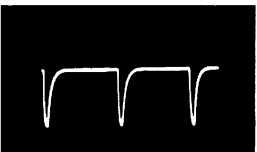

④ TP-5
SYNC PLATE
HORIZONTAL RATE 60V P-P



⑤ V206B PIN 9
VERTICAL OSCILLATOR GRID
VERTICAL RATE 180V P-P

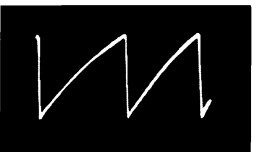

⑥ V206A PIN 2
VERTICAL OUTPUT GRID
VERTICAL RATE 28V P-P



⑦ V205B PIN 9
VIDEO AMPLIFIER PLATE
VERTICAL RATE 110V P-P

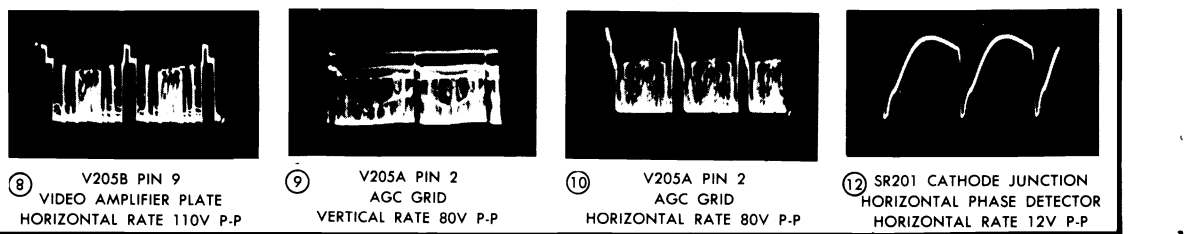
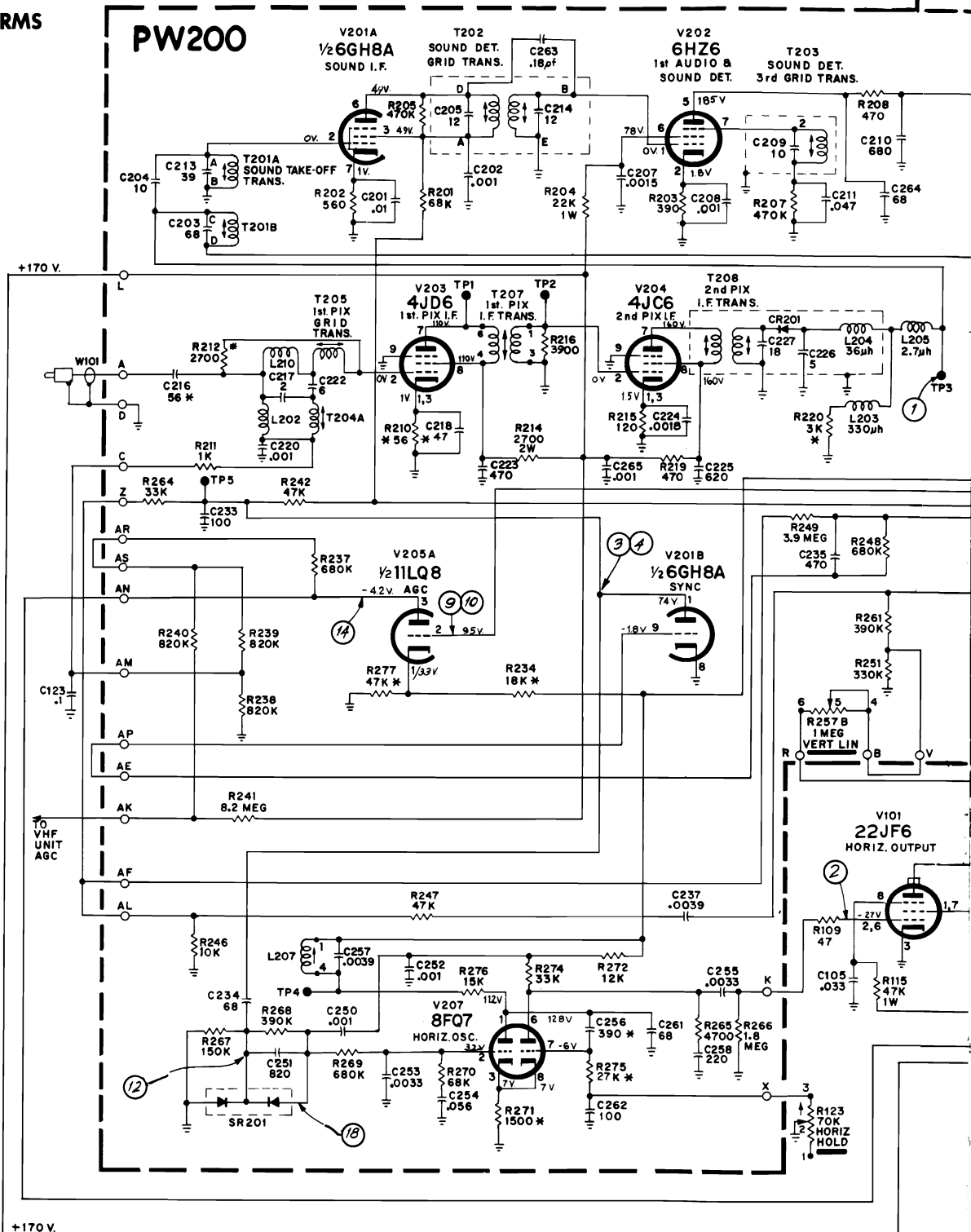

RCA Victor Chassis KCS-160 Schematic Diagram, Continued

ALL RESISTANCE VALUES ARE IN OHMS. K=1,000.
 ALL RESISTORS ARE 1/2 WATT, EXCEPT AS INDICATED.
 ALL CAPACITANCE VALUES LESS THAN 1.0 ARE IN μ F.
 1.0 AND ABOVE ARE IN μ F, EXCEPT AS INDICATED.
 DIRECTION OF ARROWS AT CONTROLS
 INDICATES CLOCKWISE ROTATION.
 VOLTAGES MEASURED WITH "VOLTOHMYST" & WITH NO SIGNAL
 INPUT AND SHOULD HOLD WITHIN $\pm 20\%$ WITH 120V. AC SUPPLY.
 * INDICATES 5% TOLERANCE.

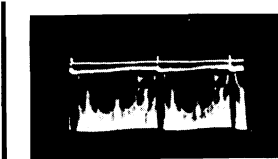
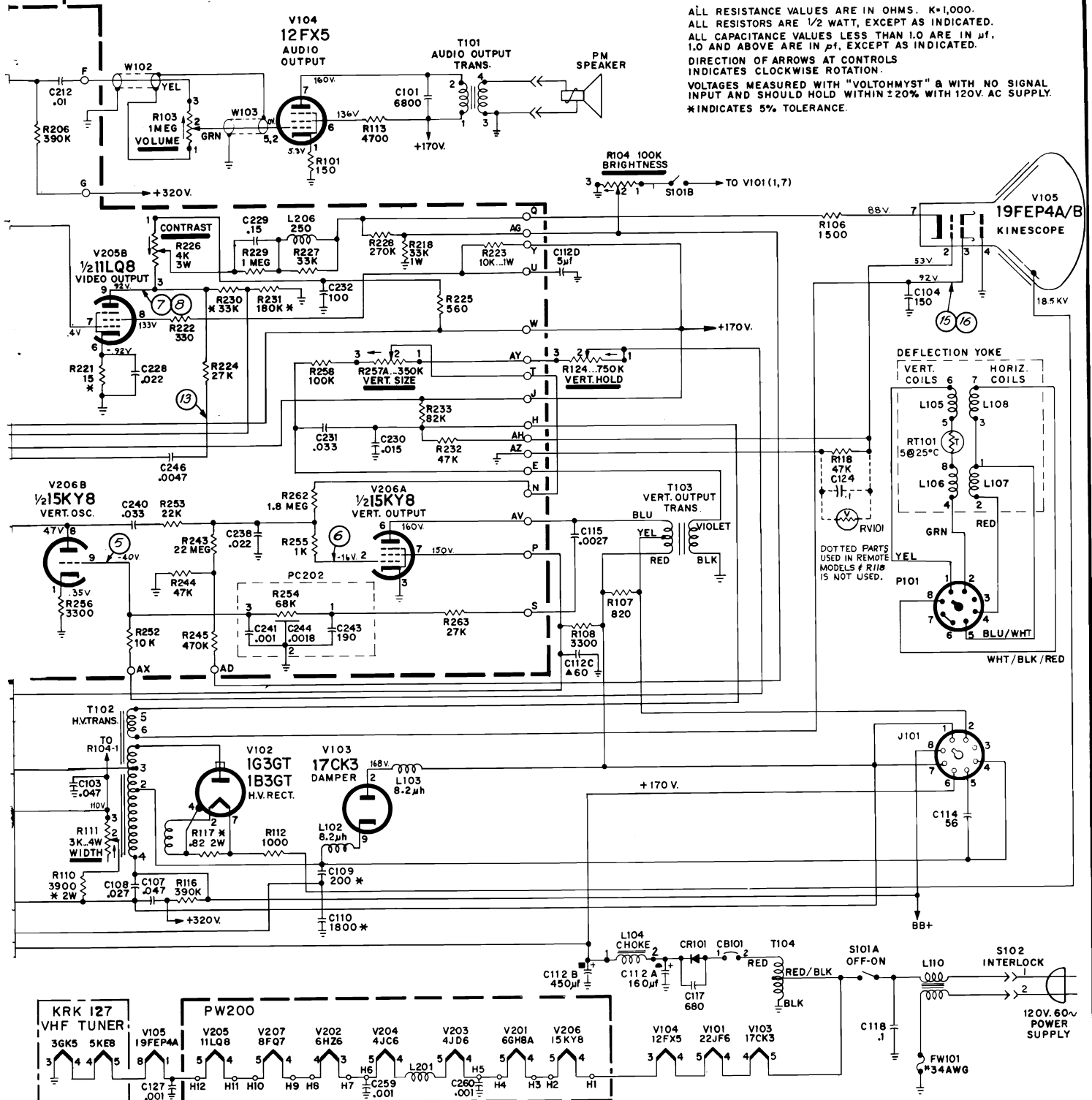

13 R224 & C246 JUNCTION (ZONE 1B PW200 BOARD) VERTICAL RATE 100V P-P

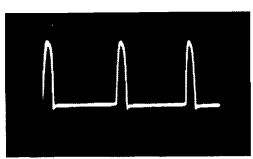

14 V205A PIN 3 AGC PLATE HORIZONTAL RATE 330V P-P

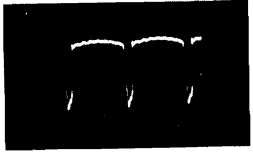

15 V105 PIN 3 KINESCOPE 1ST ANODE HORIZONTAL RATE 40V P-P



16 V105 PIN 3 KINESCOPE 1ST ANODE VERTICAL RATE 130V P-P



18 SR201 ANODE HORIZONTAL PHASE DETECTOR HORIZONTAL RATE 15V P-P

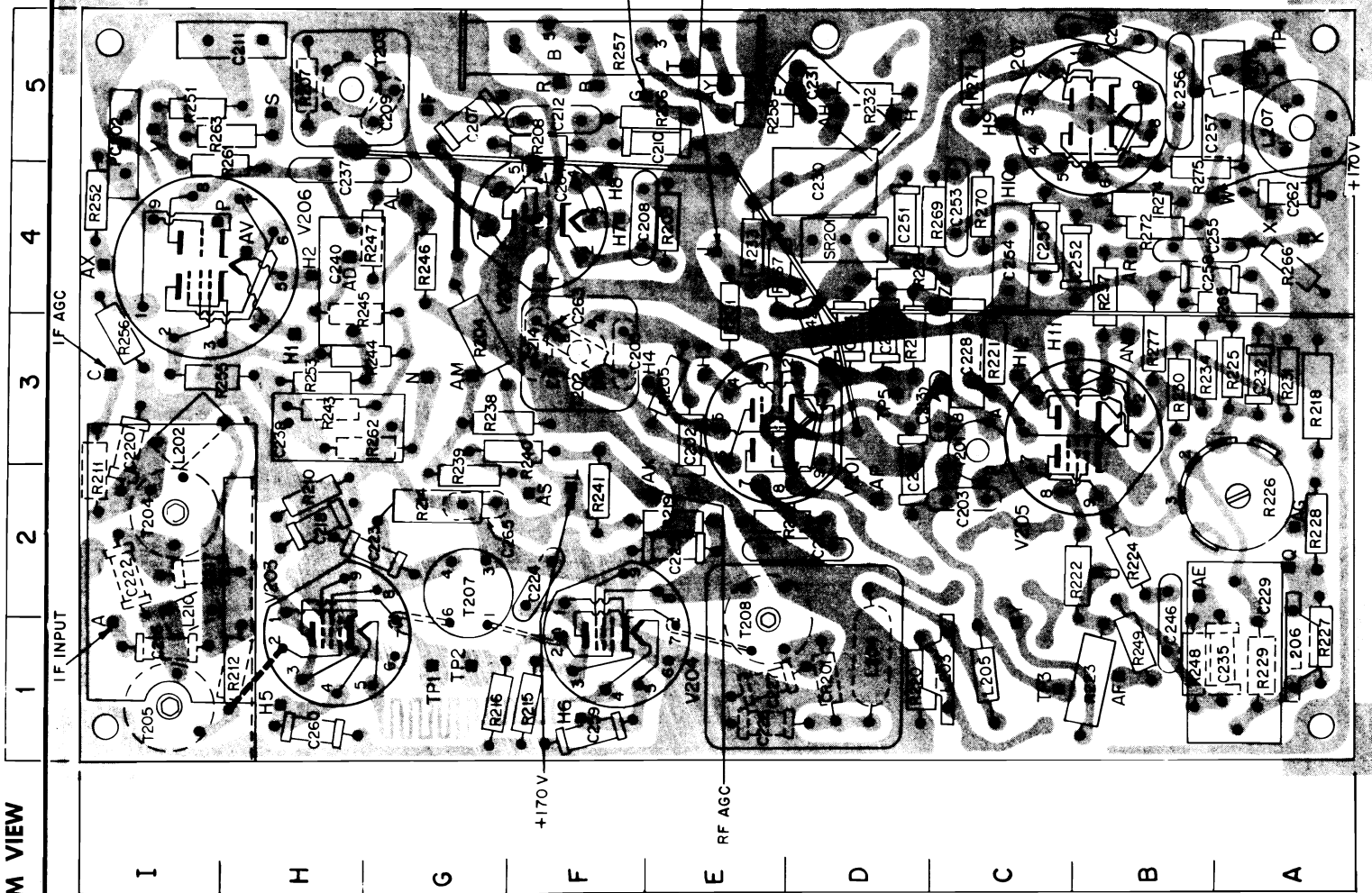

PW200 Board, Phantom View

PW200 KCS160 COMPONENT LOCATION GUIDE

C201 2D	C230 4D	C265 2G	R214 2G	R241 2F	R270 4C	A 3C
C202 2D	C231 5D	CR201 1D	R215 1F	R242 3D	R271 5C	A 3F
C203 2D	C232 3A	L202 3I	R216 1G	R243 3H	R272 4B	AD 4H
C204 2D	C233 3D	L203 1C	R218 3A	R244 3H	R274 4B	AE 2B
C205 3F	C234 3D	L204 1D	R219 2E	R245 3H	R275 4B	AF 1B
C207 5G	C235 1A	L205 1C	R220 1D	R246 4G	R276 5B	AG 2A
C208 4D	C237 4H	L206 1A	R221 3C	R247 4G	R277 3B	AH 5D
C209 5G	C238 3H	L207 2G	R222 2B	R248 1B	SR201 4D	AK 2E
C210 5E	C239 4H	L210 2I	R223 1B	R249 1B	T201 3C	AL 4G
C211 5H	C240 1B	PC202 5I	R224 2B	R251 5I	T202 3F	AM 3G
C212 5F	C241 4C	R201 3C	R225 3A	R252 4I	T203 5G	AN 3C
C213 3C	C242 4D	R202 2E	R226 2A	R253 3H	T204 2I	AP 2D
C214 3F	C243 4C	R203 4E	R227 1A	R255 3I	T205 1A	AR 4B
C216 1A	C244 4C	R204 3G	R228 2A	R256 3I	T207 2G	AS 2F
C217 2I	C245 4C	R205 3E	R229 1A	R257 5F	T208 1E	AV 4H
C218 2H	C246 4B	R206 5E	R230 3B	R258 5E	V201 2D	AX 4I
C220 2I	C247 5B	R207 5H	R231 3A	R261 5I	V202 4G	AY 5E
C222 2I	C248 4A	R208 5F	R232 5D	R262 3H	V203 2H	B 3C
C223 2G	C249 4B	R209 2H	R233 4E	R263 5I	C204 1E	
C224 2F	C250 1F	R210 2H	R234 1B	R264 3D	V205 2C	
C225 2E	C251 1H	R211 2I	R235 3B	R265 4A	V206 4H	
C226 1E	C252 5B	R212 1H	R236 4B	R266 4A	V207 5C	
C227 1E	C253 4A		R237 4B	R267 4E		
C228 3C	C254 3F		R238 2G	R268 4D		
C229 1A	C255 4F		R239 2G	R269 4C		
			R240 3F			

TEST POINT LOCATION GUIDE

B 3F	F 5G	H4 3F	H10 4C	N 3G	T 5E	W 3D
BC 5F	G 5F	H5 1I	H11 3C	P 4A	TP1 1G	X 4A
C 2C	H 5D	H6 1F	H12 3C	PC202 5L	TP2 1G	6 1C
CD 3I	H1 3H	H7 4F	J 4E	Q 2A	TP3 1C	
D 2C	H2 4H	H8 4F	K 4A	R 5F	TP4 5A	
E 3F	H3 3E	H9 5C	L 2F	S 5H	TP5 3D	

PW200 BOARD, PHANTOM VIEW

RCA VICTOR

Chassis KCS-161A, B, used in Models AH-184M, Y, AH-188WK, AH-196ER, WR; Chassis KCS-162A used in Models AH-192E, M, W, are practically identical electrically. For alignment information see pages 124-125 and 128. Other data on pages 111-114.

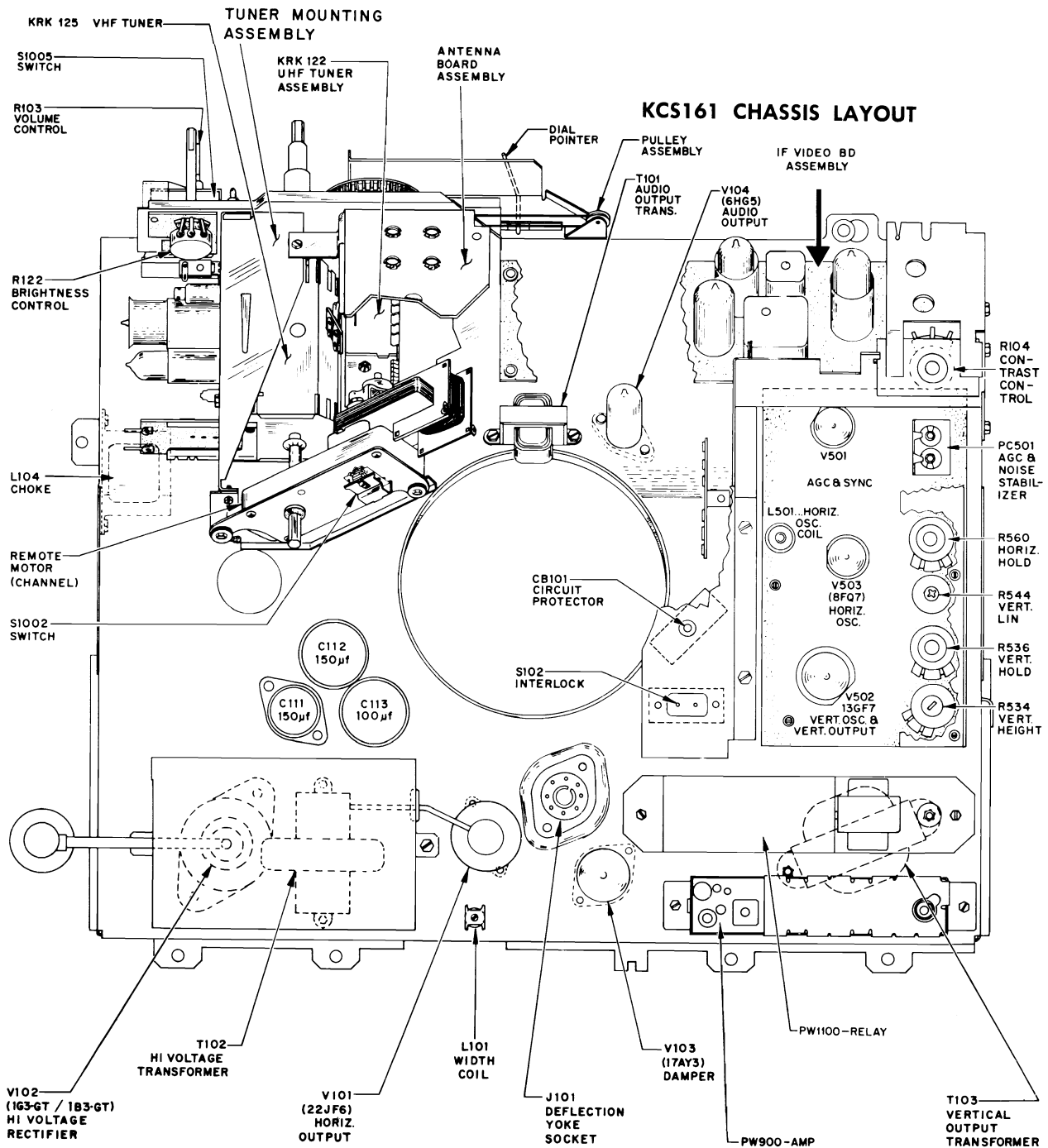

KCS161 Chassis Layout

RCA Victor Chassis KCS-161A,B, Schematic Diagram

RCA Victor Chassis KCS-161A,B, Schematic Diagram, Continued

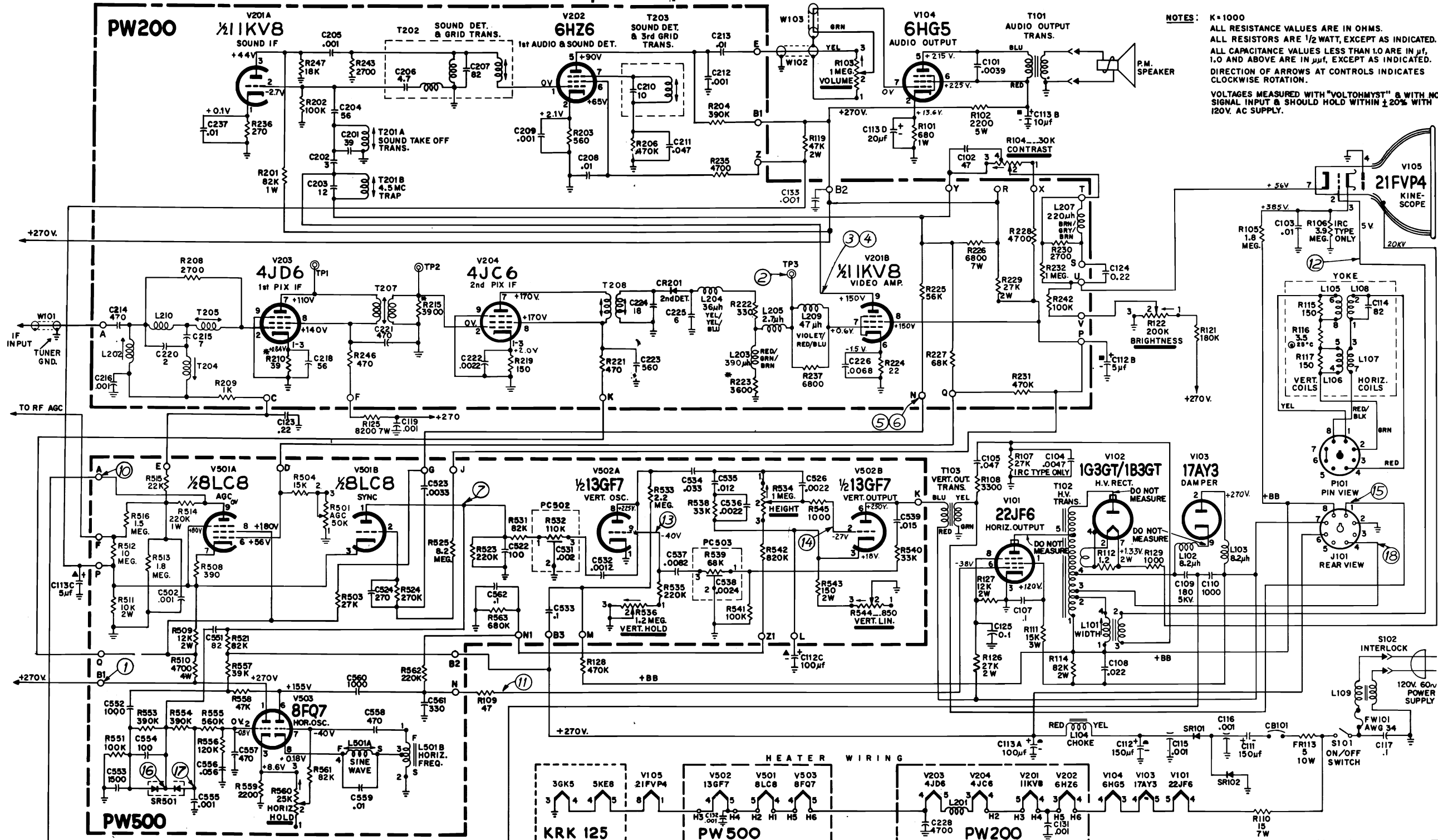

NOTES: K=1000
 ALL RESISTANCE VALUES ARE IN OHMS.
 ALL RESISTORS ARE 1/2 WATT, EXCEPT AS INDICATED.
 ALL CAPACITANCE VALUES LESS THAN 1.0 ARE IN μ F,
 1.0 AND ABOVE ARE IN μ M, EXCEPT AS INDICATED.
 DIRECTION OF ARROWS AT CONTROLS INDICATES
 CLOCKWISE ROTATION.
 VOLTAGES MEASURED WITH "VOLTOHMYST" & WITH NO
 SIGNAL INPUT & SHOULD HOLD WITHIN $\pm 20\%$ WITH
 120V. AC SUPPLY.

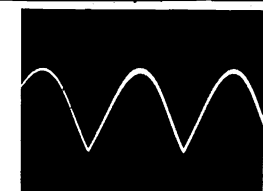

1 VERT. RATE 3.5 V P-P
 TERM. B1-PW500
 270V 8+ BUS



2 VERT. RATE 1.5 V P-P
 2ND DETECTOR
 TP3

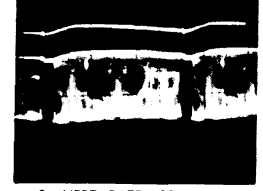

3 VERT. RATE 80 V P-P
 V201B PIN 9
 VIDEO AMPLIFIER PLATE

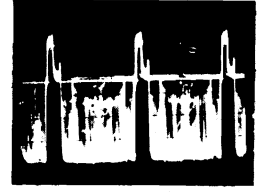

4 HORIZ. RATE 80 V P-P
 V201-B PIN 9
 VIDEO AMPLIFIER PLATE

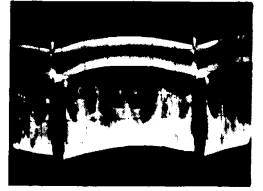

5 VERT. RATE 25 V P-P
 TERM. N PW200
 SYNC TAKE-OFF

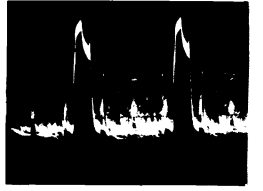

6 HORIZ. RATE 25 V P-P
 TERM. N PW200
 SYNC TAKE-OFF

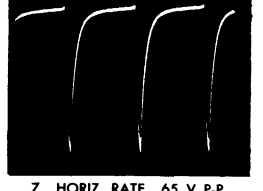

7 HORIZ. RATE 65 V P-P
 V501B PIN 1
 SYNC AMPLIFIER PLATE



10 HORIZ. RATE 650 V P-P
 TERM. A PW500
 AGC PLATE



11 HORIZ. RATE 165 V P-P
 V101 PIN 6
 HORIZONTAL OUTPUT GRID

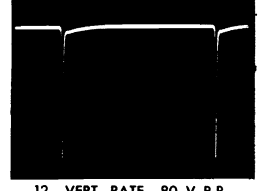

12 VERT. RATE 80 V P-P
 PIN 2 V105
 KINESCOPE GRID

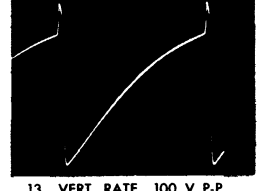

13 VERT. RATE 100 V P-P
 V502A PIN 9
 VERTICAL OSCILLATOR GRID



14 VERT. RATE 365 V P-P
 V502B PIN 2
 VERTICAL OUTPUT GRID

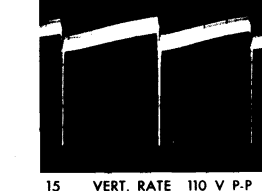

15 VERT. RATE 110 V P-P
 PIN 1 J101 (YOKE SOCKET)
 VERT. OUTPUT TRANS. SEC.

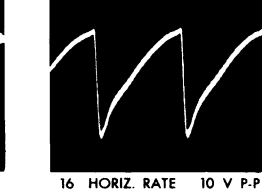

16 HORIZ. RATE 10 V P-P
 CATHODE JUNCTION SR501
 HORIZONTAL PHASE DETECTOR

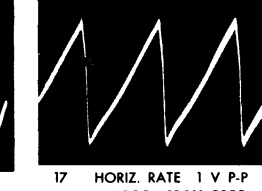

17 HORIZ. RATE 1 V P-P
 ANODE SR501-C555
 HORIZ. PHASE DETECTOR

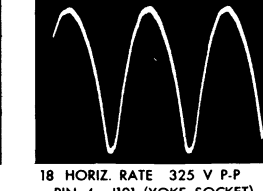

18 HORIZ. RATE 325 V P-P
 PIN 4 J101 (YOKE SOCKET)
 (B BOOST) HORIZ. YOKE WINDINGS

PW200 BOARD ASSEMBLY PHANTOM VIEW

VIDEO OUTPUT

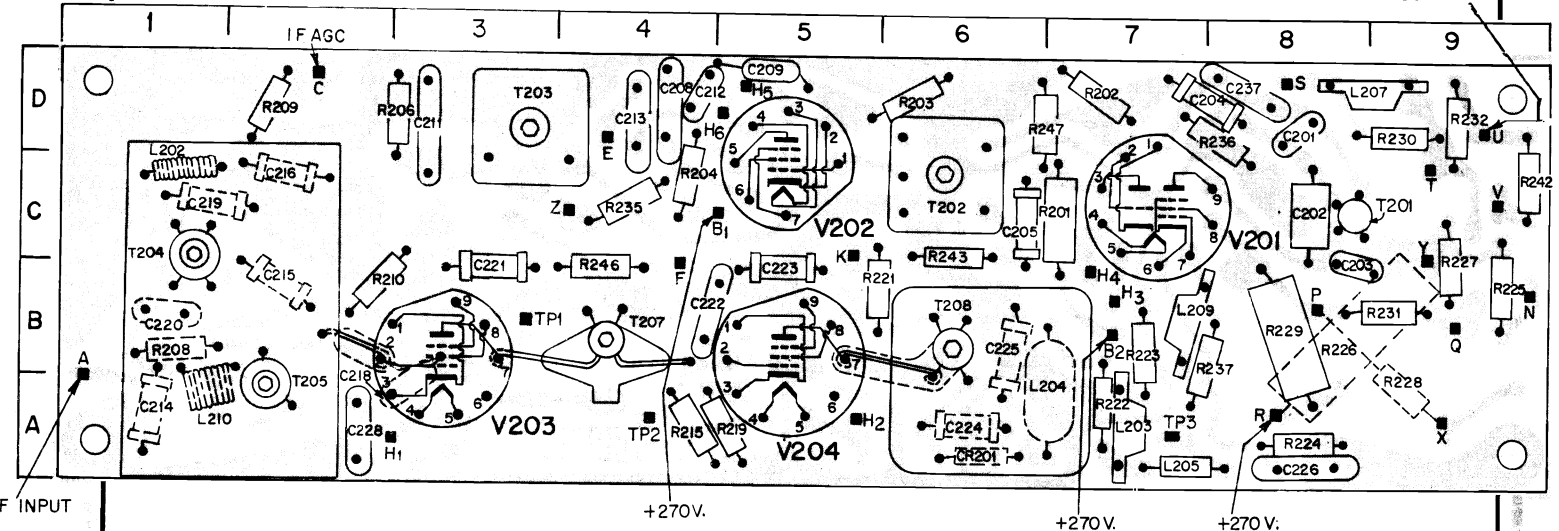

PW200 COMPONENT LOCATION GUIDE

C201	8D	L202	1D
C202	8C	L203	7A
C203	8C	L204	7A
C204	7D	L205	7A
C205	6C	L207	8D
C208	4D	L209	7B
C209	5D	L210	1A
C211	3D		
C212	4D	TP1	3B
C213	3D	TP2	4A
C214	1A	TP3	7A
C215	2B		
C216	2C	T201	9C
C218	3A	T202	6C
C219	1C	T203	3D
C220	1B	T204	1C
C221	3C	T205	2A
C222	4B	T207	4B
C223	5C	T208	6B
C224	6A		
C225	6B	V201	8C
C226	8A	V202	5C
C228	1A	V203	3A
C237	2A	V204	5A
CR201	6A	B1	5C
R201	7C	B2	7B
R202	7D	C	2D
R203	6D	E	4D
R204	4C	F	4C
R206	3D	H	4D
R208	1B	H1	3A
R209	2D	H2	5A
R210	2B	H3	7B
R215	4A	H4	7C
R219	5A	H5	5D
R221	5C	H6	4D
R222	7A	K	5C
R223	7B	N	9B
R224	8A	Q	9B
R224	8A	R	8A
R225	9C	T	9D
R226	8B	U	9C
R227	9C	V	9D
R229	8B	X	9A
R230	9D	Y	9C
R231	9B	Z	4C
R232	9D		
R235	4C		
R236	8D		
R237	8B		
R238	9B		
R242	9C		
R243	6C		
R246	7C		
R247	7D		

PW500 COMPONENT LOCATION GUIDE

C502	1H	R533	3B
C522	2F	R534	4B
C523	2G	R535	3A
C524	2G	R536	4C
C526	3A	R538	1C
C532	3C	R540	1A
C533	3B	R541	2A
C534	1B	R542	4B
C535	3B	R543	3C
C536	1C	R544	4D
C537	2A	R545	2B
C539	1A	R551	3C
C551	3D	R553	2C
C552	3D	R554	1C
C553	3C	R555	1D
C554	2C	R556	1D
C555	1D	R557	3E
C556	1C	R558	2E
C557	1D	R559	3C
C558	1E	R560	4E
C559	1E	R561	2D
C560	3E	R562	3F
C561	3F		
C562	2E	SR501	2D
L501	1E	A	1H
PC502	3C	B1	2E
PC503	2A	B2	3D
		B3	2B
		D	2H
R501	4H	E	1E
R503	2G	F	1G
R504	3H	G	2G
R508	2G	H1	2G
R509	2F	H2	2H
R510	2E	H3	1C
R511	1F	H4	1B
R512	1G	H5	3D
R513	1H	H6	3E
R514	1H	J	1G
R515	1H	K	1B
R516	1G	M	4B
R521	3E	N	3E
R523	3F	N1	2E
R524	2G	Q	2F
R525	1G	Z1	4B
R531	3F		

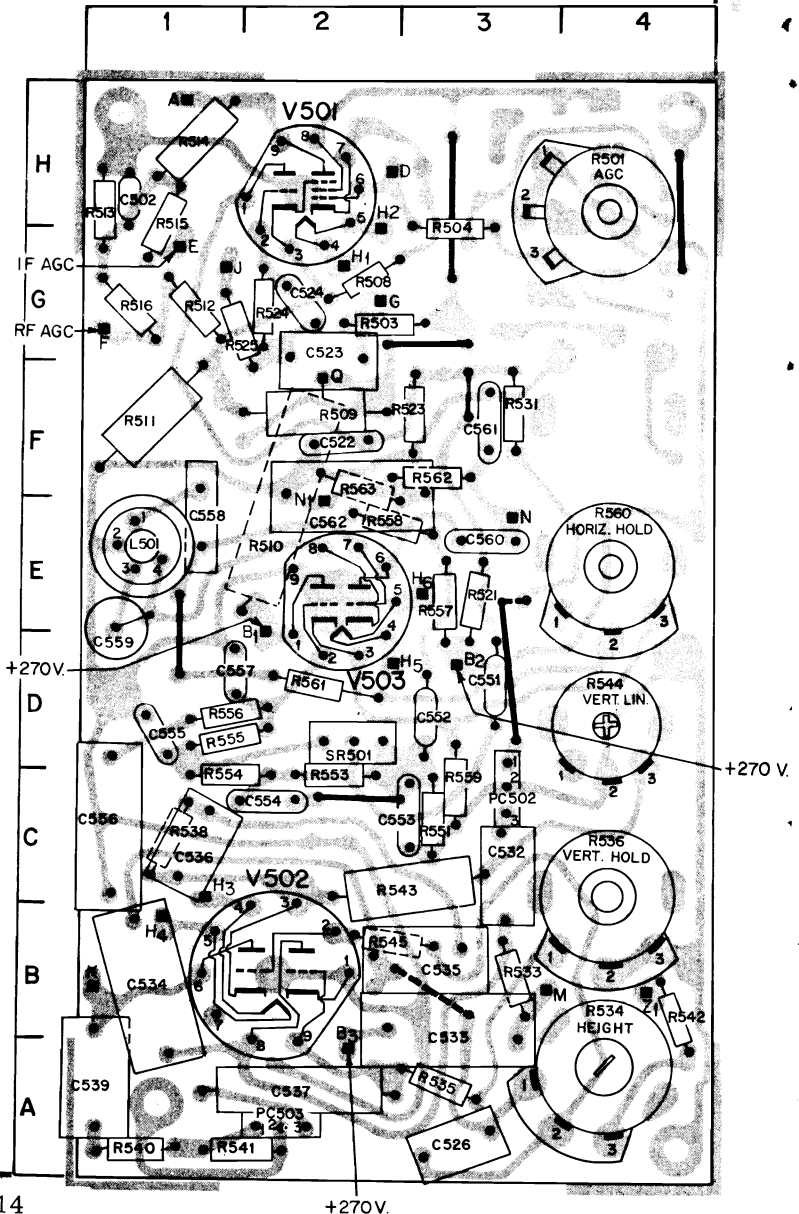

W500 BOARD ASSEMBLY PHANTOM VIEW

RCA VICTOR

Chassis KCS-163A, B, C, D, E, used in Models AH-130E, M, W, ER, WR, AH-138WRK, BH-208WK, CH-252WK, CH-276WK, CH-312WK, CH-320LK;
 Chassis KCS-164A, B, used in Models AH-074E, M, W, AH-078WK, YK, are identical in almost all respects to sets covered on these pages 115 through 118.
 For alignment information see pages 121 through 123.

HORIZONTAL SINE WAVE ADJUSTMENT

Remove sync by shorting Terminal "AE" (zone 2B, PW200) to chassis ground. Short sine wave coil L207 by connecting a jumper wire between TP4 (zone 5A) and Terminal "W" (zone 4A) on PW200.

Adjust the Horizontal Hold control, R123, until the picture sides are vertical. Remove shorting wire from across the sine wave coil. Adjust L207 Sine Wave Coil until the picture remains stationary and the sides vertical. Remove short from sync grid (Terminal "AE").

From counterclockwise direction of the Horizontal Hold Control, the pull in from out of sync condition should be from 1 to 3 bars, and from the clockwise direction, 1 to 8 bars. There should be no loss of raster on either extreme of control rotation.

WIDTH AND LINEARITY ADJUSTMENTS

Adjust the Vertical Height and Linearity controls for an approximately symmetrical raster.

Note: Width adjustments are most accurate when made with low line, 108 VAC, supply voltage.

Set both Brightness and Contrast controls at maximum. (Fully clockwise). Adjust width control, R111, until the raster just fills the screen horizontally $+0, -\frac{1}{8}$ ". Turn centering magnets together and individually to center the raster.

Turn contrast control to minimum, then center the raster vertically. After the Vertical Height and Linearity adjustments are completed at 108 VAC supply voltage, the raster should fill the screen $+0, -\frac{1}{4}$ " at the top and bottom.

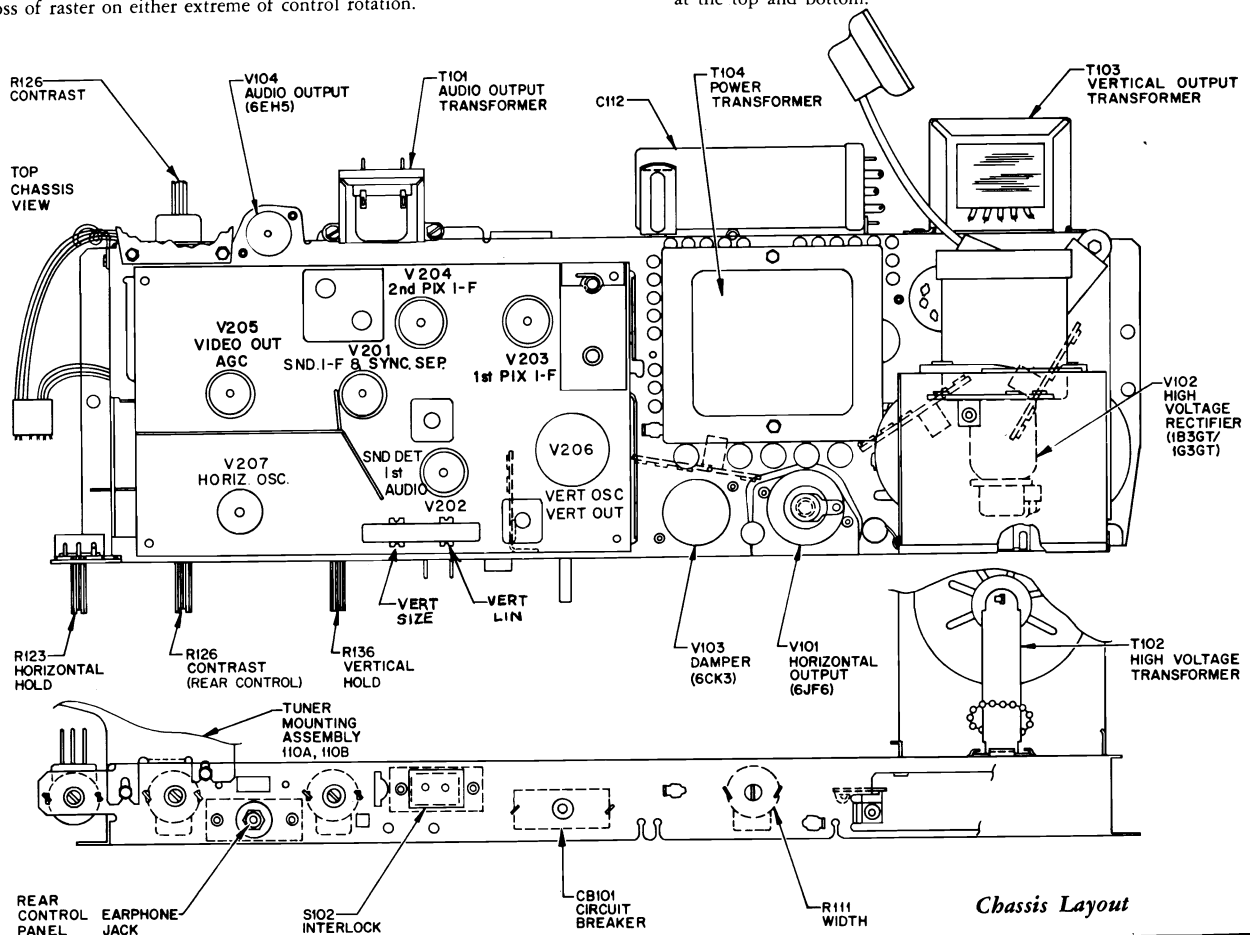

RCA Victor Chassis KCS-163 Series Schematic Diagram

CHASSIS WAVEFORMS

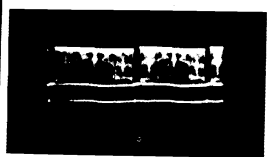

① TP-3
SECOND DETECTOR
VERTICAL RATE 2V P-P

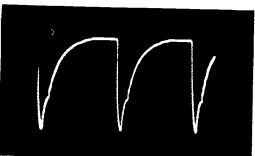

② V101 PINS 2 & 6
HORIZONTAL OUTPUT GRID
HORIZONTAL RATE 130V P-P



③ TP-5
SYNC PLATE
VERTICAL RATE 60V P-P



④ TP-5
SYNC PLATE
HORIZONTAL RATE 60V P-P

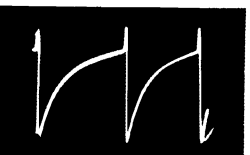

⑤ V206B PIN 9
VERTICAL OSCILLATOR GRID
VERTICAL RATE 180V P-P



⑥ V206A PIN 2
VERTICAL OUTPUT GRID
VERTICAL RATE 28V P-P

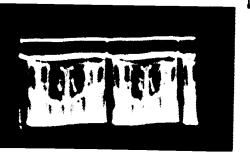

⑦ V205B PIN 9
VIDEO AMPLIFIER PLATE
VERTICAL RATE 110V P-P

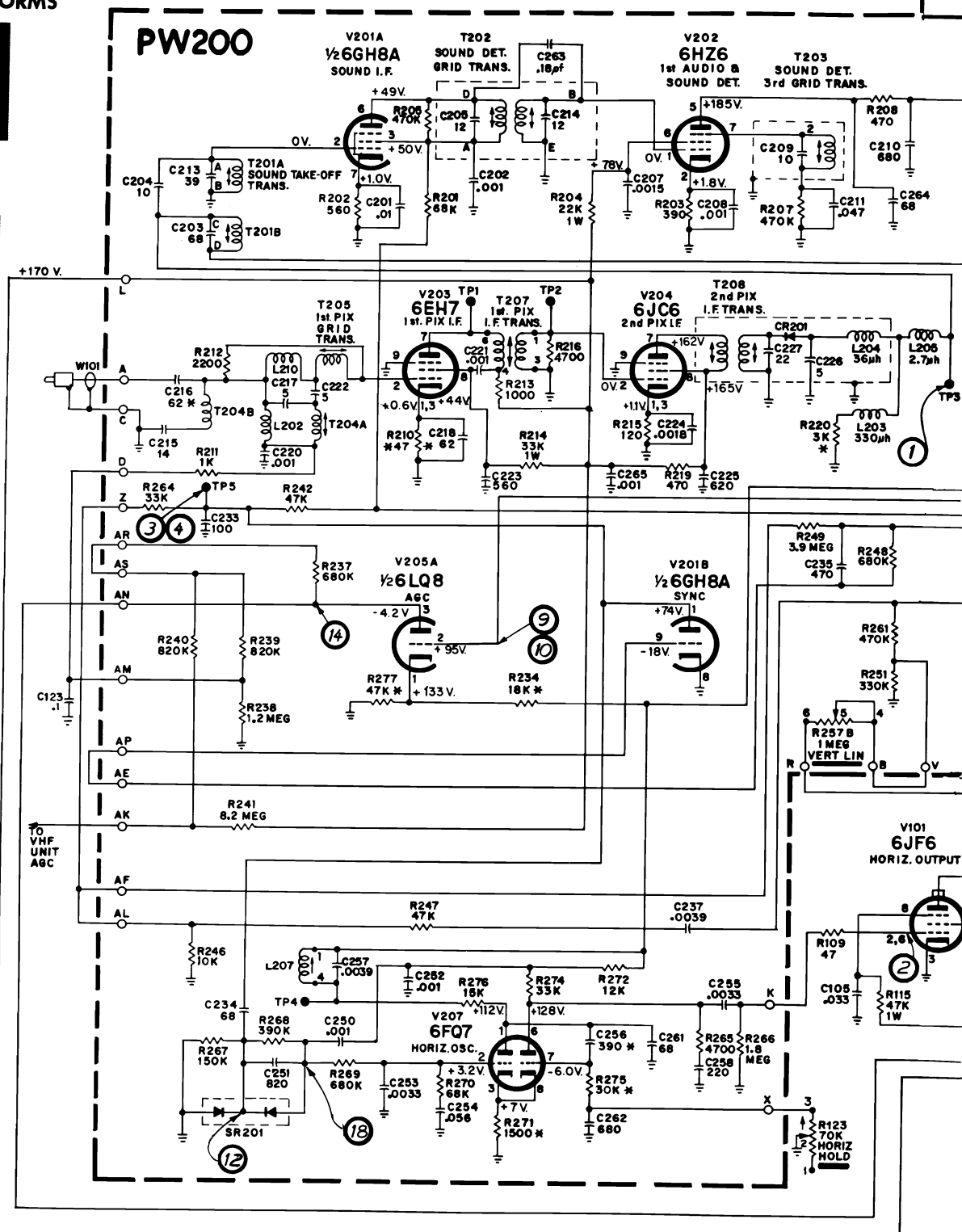

⑧ V205B PIN 9
VIDEO AMPLIFIER PLATE
HORIZONTAL RATE 110V P-P



⑨ V205A PIN 2
AGC GRID
VERTICAL RATE 80V P-P



⑩ V205A PIN 2
AGC GRID
HORIZONTAL RATE 80V P-P



⑫ SR201 CATHODE JUNCTION
HORIZONTAL PHASE DETECTOR
HORIZONTAL RATE 12V P-P

RCA Victor Chassis KCS-163 Series Schematic Diagram, Continued

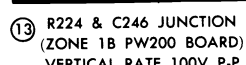
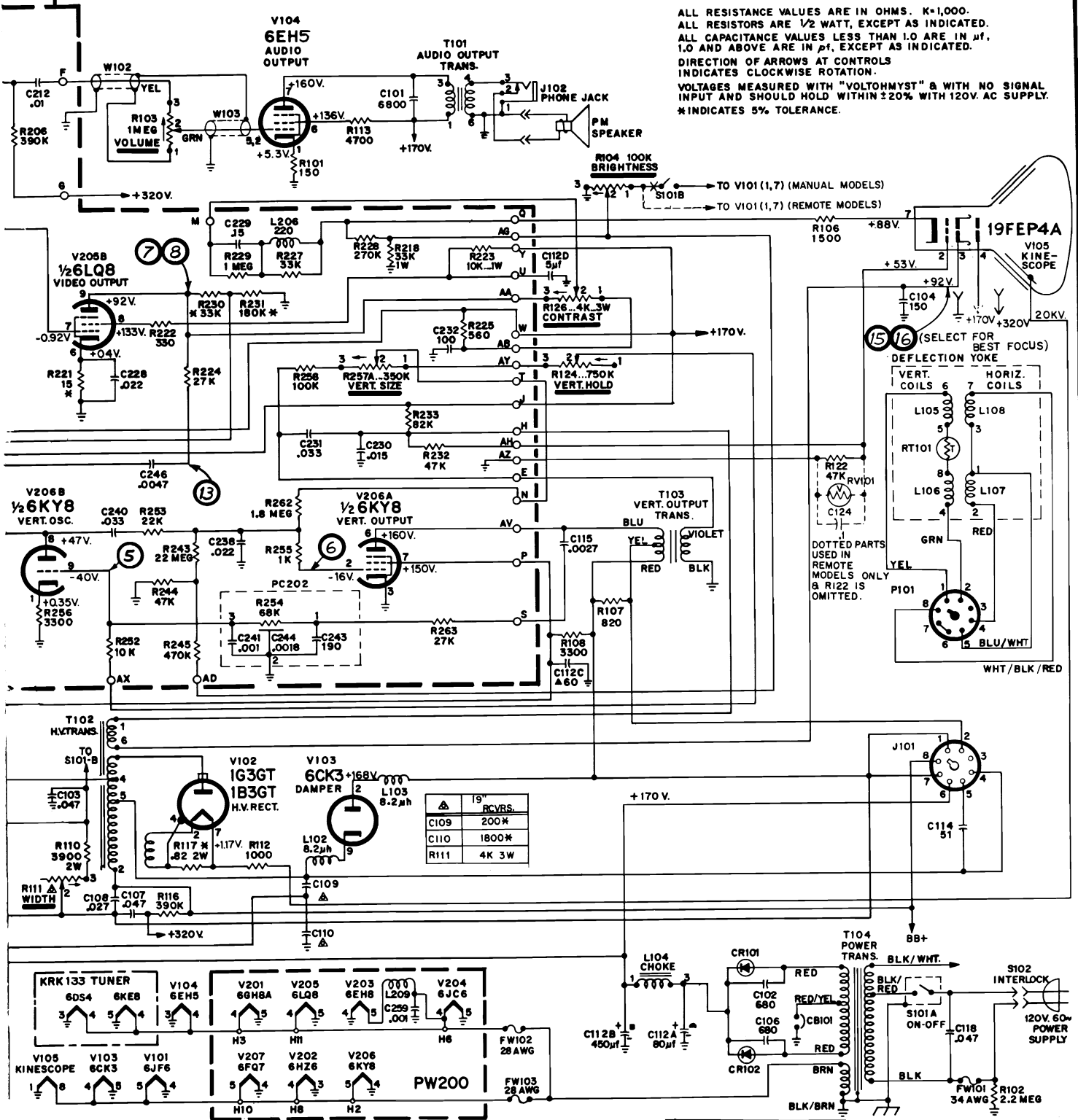

13 R224 & C246 JUNCTION (ZONE 1B PW200 BOARD) VERTICAL RATE 100V P-P

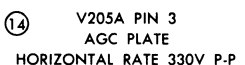

14 V205A PIN 3 AGC PLATE HORIZONTAL RATE 330V P-P

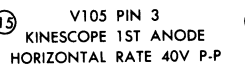

15 V105 PIN 3 KINESCOPE 1ST ANODE HORIZONTAL RATE 40V P-P

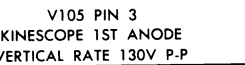

16 V105 PIN 3 KINESCOPE 1ST ANODE VERTICAL RATE 130V P-P

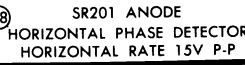

18 SR201 ANODE HORIZONTAL PHASE DETECTOR HORIZONTAL RATE 15V P-P

PW200 PHANTOM VIEW

LOCATION GUIDE

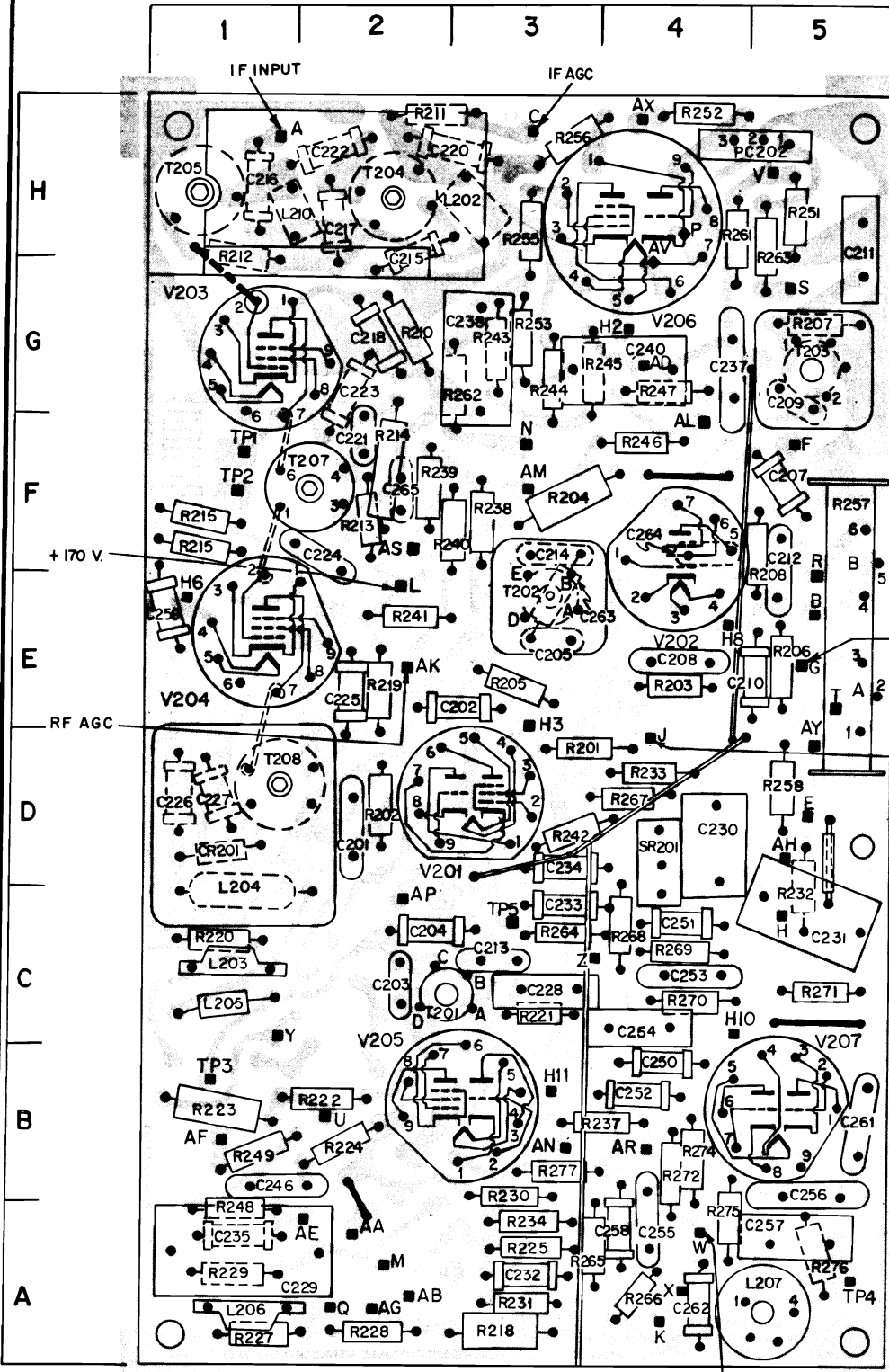

PW200 Phantom View

C201	2D	R237	4B
C202	3E	R238	3F
C203	1C	R239	2F
C204	1C	R240	3F
C205	3E	R241	2E
C207	5F	R242	3D
C208	4E	R243	3G
C209	5G	R244	3G
C210	5E	R245	3G
C211	5H	R246	4F
C212	5F	R247	4G
C213	3E	R248	1A
C214	3F	R249	1B
C215	2G	R251	5H
C216	1H	R252	4H
C217	2H	R253	3G
C218	2G	R255	3H
C220	2H	R256	3H
C221	2F	R257	5D
C222	2H	R258	5D
C223	2G	R261	4H
C224	2F	R262	3G
C225	2E	R263	5G
C226	1D	R264	3C
C227	1D	R265	4A
C228	3C	R266	4A
C229	1A	R267	4D
C230	4D	R268	4C
C231	5C	R269	4C
C232	3A	R270	4C
C233	3C	R271	5C
C234	3D	R272	4B
C235	1A	R274	4B
C237	4G	R275	4A
C238	3G	R276	5A
C240	4G	R277	3B
C246	1B	SR201	4D
C250	4B	T201	3C
C251	4C	T202	3E
C252	4B	T203	5G
C253	4C	T204	2H
C254	4C	T205	1H
C255	4A	T207	2F
C256	5B	T208	1D
C257	5A	TP1	1F
			TP2	1F
			TP3	1B
			TP4	5A
			TP5	3C
			V201	3D
			V202	4E
			V203	1G
			V204	1E
			V205	2C
			V206	4G
			V207	5C
C258	4A	A	1H
C259	1E	A	3E
C261	5B	A	3E
C262	5B	A	5E
C263	3E	A	5E
C264	4F	AA	2A
C265	2F	AA	2A
CR201	1D	AB	2A
L202	3H	AD	4G
L203	1C	AE	2A
L204	1D	AF	1B
L205	1C	AG	2A
L206	1A	AH	5D
L207	5A	AK	2F
L210	1H	AL	4F
			AM	3F
			AN	3C
			AP	1C
			AR	4B
			AS	2F
			AV	4H
			AX	4H
			AY	5E
			B	3C
			B	3E
			B	5E
			B	5F
			C	3H
			C	3C
			D	3E
			E	3E
			E	5D
			F	4G
			G	5E
			H	5C
			H2	4G
			H3	3E
			H8	4E
			H10	4C
			H11	3B
			HG	1E
			K	4A
			M	2A
			N	3F
			P	4H
			Q	3E
			Q	2A
			S	5G
			T	5E
			T	4A
			W	4A
			X	4A
R201	3D			
R202	2D			
R203	4E			
R204	3F			
R205	3E			
R206	5E			
R207	5G			
R208	5F			
R210	2G			
R211	2H			
R212	1G			
R213	2F			
R214	2F			
R215	1F			
R216	1F			
R218	2E			
R219	2E			
R220	1C			
R221	3E			
R222	2B			
R223	1B			
R224	2B			
R225	3A			
R227	1A			
R228	2A			
R229	1A			
R230	3B			
R231	3A			
R232	5D			
R233	4D			
R234	3A			

RCA Victor Alignment Information for Chassis KCS-156 and KCS-160

PICTURE I-F ALIGNMENT—KCS156 AND KCS160 CHASSIS

PICTURE I-F TRANSFORMER AND TRAP ADJUSTMENTS

TEST EQUIPMENT CONNECTIONS:

- BIAS SUPPLY**.....In step 1 ground I-F AGC terminal "C" of PW200. In step 2 use —5 volts bias to I-F AGC terminal "C" during trap adjustment and during sweep alignment except step 5.
- MARKER GENERATOR**.....Connect to Mixer Grid test point of KRK127 in series with pad shown in illustration.
- VTVM**.....Connect direct probe to TP3 (2nd Detector).
- MISCELLANEOUS**.....Connect a 300 ohm carbon resistor as a dummy load across the antenna terminals. Refer to illustration for all adjustment locations and responses.

PEAK ALIGNMENT

STEP	SWEEP GENERATOR	MARKER GENERATOR	ADJUST	REMARKS
1	Peak 1st Pix I-F Plate Trans.	NOT USED	44.25 mc. T207	Peak T207 and adjust Marker Generator output for approximately 3 volts at TP3 when finally peaked.
2	Adjust 47.25 mc. Trap		47.25 mc. T204	Adjust T204 for minimum.

PICTURE I-F SWEEP ALIGNMENT

TEST EQUIPMENT CONNECTIONS:

- BIAS SUPPLY**.....—5 volts to terminal "C" of PW200.
- OSCILLOSCOPE**.....Direct probe to TP3. Calibrate scope for 5 volts peak to peak.
- MARKER GENERATOR**.....Connect to Mixer Grid test point of VHF tuner in series with matching pad shown in illustration.
- SWEEP GENERATOR**.....Connect to TP2 (pin 2 of V204). Use short leads. Maintain sweep gain to produce full scale deviation of oscilloscope calibrated trace.

STEP	SWEEP GENERATOR	MARKER GENERATOR	ADJUST	REMARKS
3	Adjust 2nd Picture I-F plate Transformer	40-50 mc.	41.25 mc. 45.75 mc.	T208 (Top & Bottom Cores) Adjust for maximum gain and response curve "A". Set sweep gain to maintain 5 V. P-P.
Move the Oscilloscope to TP1 using a diode probe and 180 ohm pad. Calibrate the oscilloscope for 0.5 volts Peak to Peak. Sweep Generator to Mixer Grid TP. Lightly couple Marker to sweep cable. Channel selector to 3 (—5 V. AGC Bias).				
4	Adjust mixer plate coil and 1st I-F grid Transformer	40-50 mc.	41.25 mc. 45.75 mc.	L30 T205 Adjust for response "B". Use inner peak of L30 coil slug (bottom of winding).
Remove —5 V. bias from terminal "C" of PW200.				
5	Zero Bias Adjustment	40-50 mc.	41.25 mc. 45.75 mc.	L30 Mixer plate coil If necessary, readjust L30 slightly to bring the picture carrier (45.75 mc.) to one of the peaks on response "C".
Use direct probe and connect oscilloscope to TP3. Calibrate to 5 volts Peak to Peak. Remove 180 ohm pad. Reapply —5 V. bias to terminal "C" of PW200.				
6	Check I-F Overall	40-50 mc.	41.25 mc. 45.75 mc.	T207 Retouch T207 slightly to maintain response "D".
Remove dummy antenna load and substitute the sweep attenuator pad. Attach the sweep generator to the attenuator pad. The Marker Generator to tuner TP through pad shown. Adjust fine tuning for correct oscillator frequency.				
7	Check R-F/I-F Overall	40-50 mc.	41.25 mc. 42.5 mc. 45.0 mc. 45.75 mc.	T207 Make slight adjustments only. Observe response "E". If necessary, repeat complete alignment procedure.
Check UHF R-F I-F overall				

KCS156, 160 PICTURE I-F ALIGNMENT DRAWING

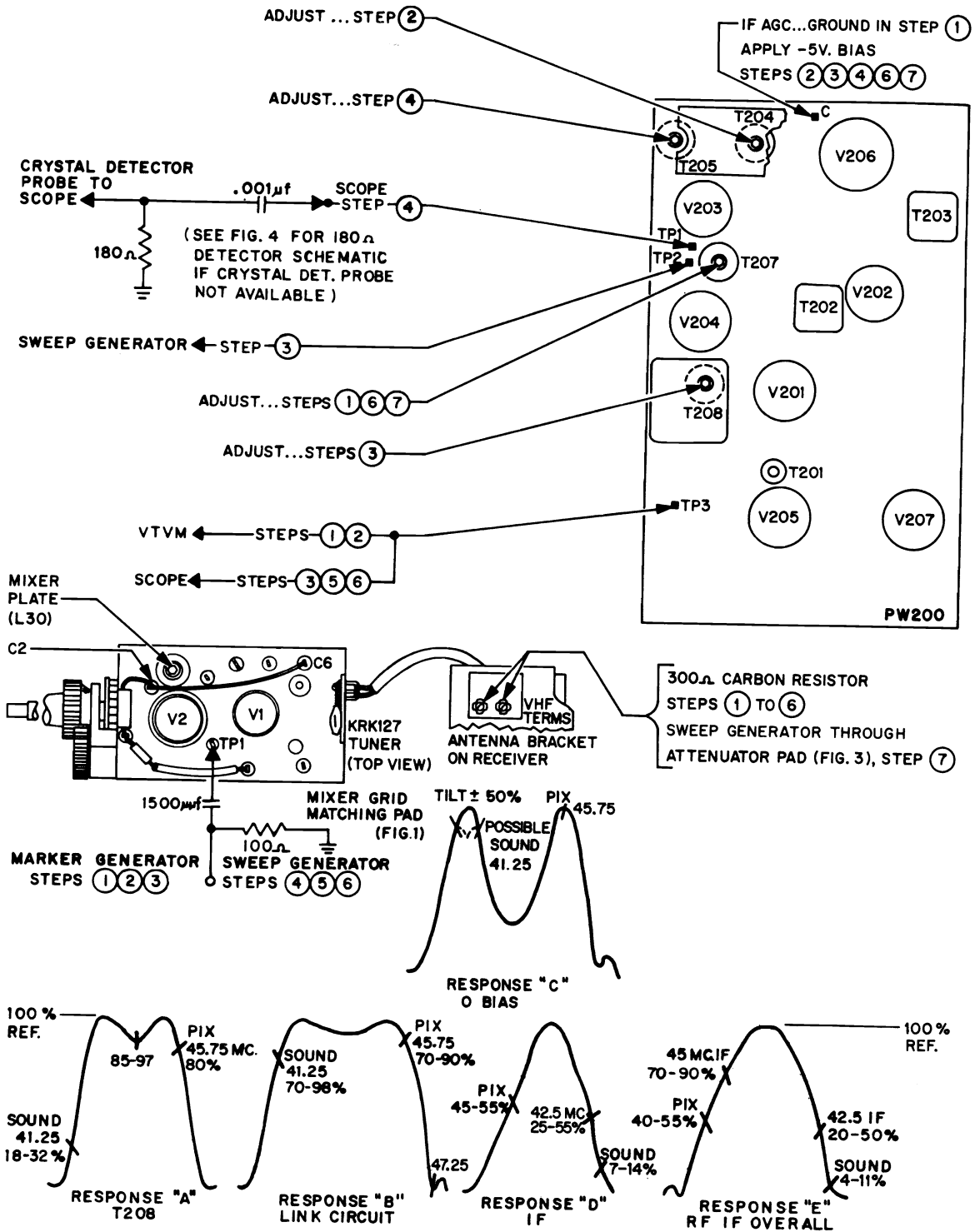

KCS156, 160 Picture I-F Alignment Drawing

RCA Victor Alignment Information for Chassis KCS-163 and KCS-164

PICTURE I-F ALIGNMENT—KCS163 AND KCS164 CHASSIS PICTURE I-F TRANSFORMER AND TRAP ADJUSTMENTS

TEST EQUIPMENT CONNECTIONS:

BIAS SUPPLY.....In step 1 ground I-F AGC terminal "C" of PW200. In step 2 use —8 volts bias to I-F AGC terminal "C" during trap adjustment and during sweep alignment except step 6.

MARKER GENERATOR.....Connect to Mixer Grid test point KRK133 in series with pad shown in illustration.

VTVM.....Connect direct probe to TP3 (2nd Detector).

MISCELLANEOUS.....Connect a 300 ohm carbon resistor as a dummy load across the antenna terminals. Refer to illustration for all adjustment locations and responses.

PEAK ALIGNMENT

STEP	SWEEP GENERATOR	MARKER GENERATOR	ADJUST	REMARKS
1	Peak 1st Pix I-F Plate Transformer	44.25 mc.	T207	Peak T207 and adjust Marker Generator output for approximately 3 volts at TP3 when finally peaked.
2	Adjust 47.25 mc. trap	47.25 mc.	T204B (Bottom Core)	Adjust for minimum. Readjust 47.25 mc. trap if necessary after step 4.
3	Adjust 39.75 mc. trap	39.75 mc.	T204A (Top Core)	

PICTURE I-F SWEEP ALIGNMENT

TEST EQUIPMENT CONNECTIONS:

BIAS SUPPLY.....—8 volts to terminal "C" of PW200.

OSCILLOSCOPE.....Direct probe to TP3. Calibrate scope for 5 volts peak to peak.

MARKER GENERATOR.....Connect to Mixer Grid test point of VHF tuner in series with matching pad shown in illustration.

SWEEP GENERATOR.....Connect to TP2 (pin 2 of V204). Use short leads.

STEP	SWEEP GENERATOR	MARKER GENERATOR	ADJUST	REMARKS
4	Adjust 2nd Picture I-F plate Transformer	40-50 mc.	41.25 mc. 45.75 mc.	T208 (Top & Bottom Cores) Adjust for maximum gain and response curve "A". Set sweep gain to maintain 5 V. P-P.
Move the Oscilloscope to TP1 using a diode probe and 180 ohm pad. Calibrate the oscilloscope for 0.3 volts Peak to Peak. Sweep Generator to Mixer Grid TP. Lightly couple Marker to sweep cable. Channel selector to 3 (—8 V. AGC Bias).				
5	Adjust Mixer Plate Coil and 1st I-F grid Transformer	40-50 mc.	41.25 mc. 45.75 mc.	L11 T205 Adjust for response "B". Use inner peak of L30 coil slug (bottom of winding).
Remove —8 V. bias from terminal "C" of PW200.				
6	Zero Bias Adjustment	40-50 mc.	41.25 mc. 45.75 mc.	L11 Mixer Plate Coil If necessary, readjust L11 slightly to bring the picture carrier (45.75 mc.) to one of the peaks on response "C".
Reapply —8 V. bias to terminal "C" of PW200. Change oscilloscope to direct probe and attach to TP3. Calibrate to 5 volts Peak to Peak. Remove 180 ohm pad.				
7	Check I-F Overall	40-50 mc.	41.25 mc. 45.75 mc.	T207 Retouch T207 slightly to maintain response "D".
Remove dummy antenna load and substitute the sweep attenuator pad. Attach the sweep generator to the attenuator pad. The Marker Generator to tuner TP through pad shown. Adjust fine tuning to correct oscillator frequency.				
8	Check R-F/I-F Overall	40-50 mc.	41.25 mc. 42.5 mc. 45.0 mc. 45.75 mc.	T207 Make slight adjustments only to maintain response "D". If necessary, repeat complete alignment procedures.
Check UHF R-F I-F overall				

KCS163, 164 PICTURE I-F ALIGNMENT DRAWING

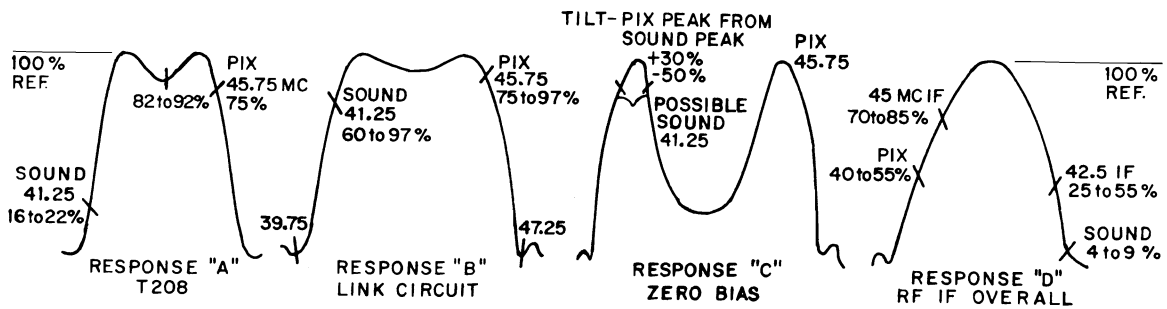
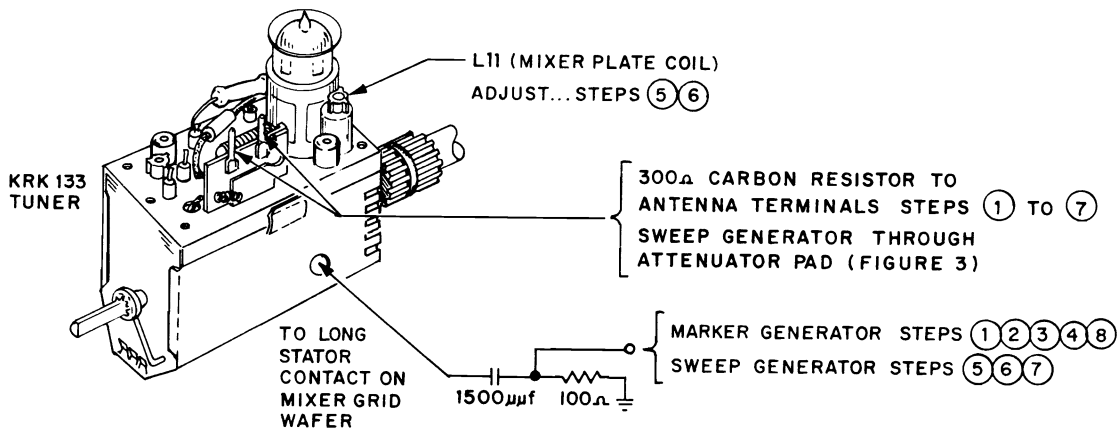
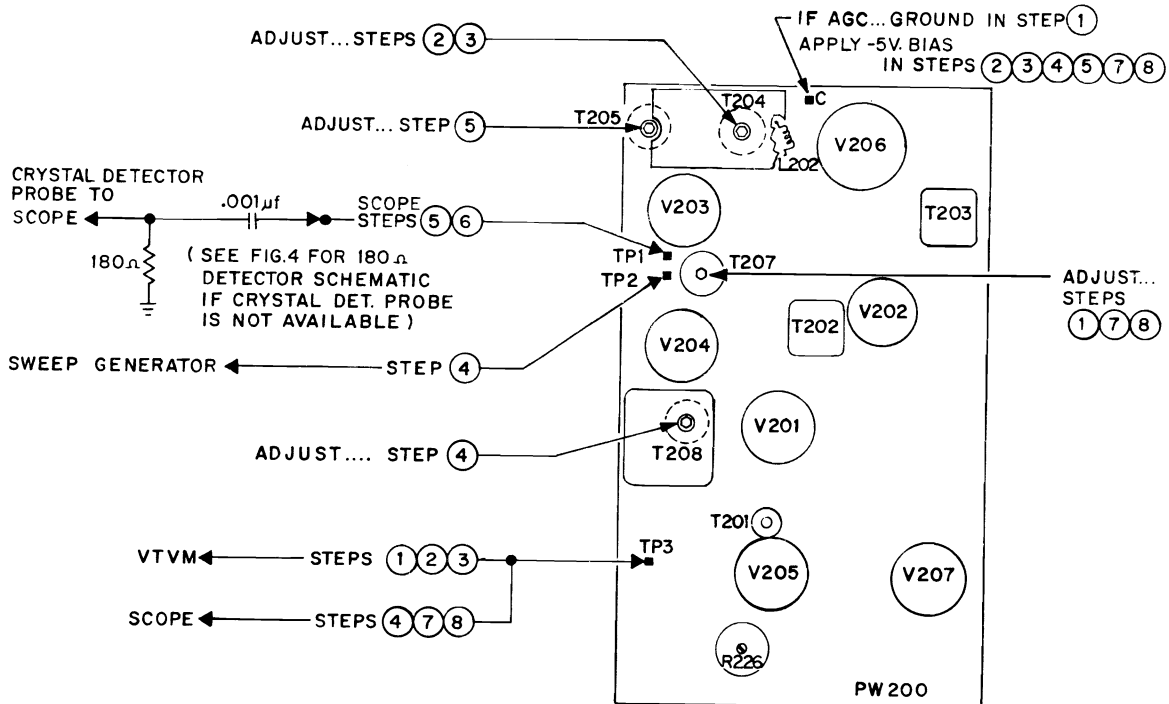

KCS163, 164 Picture I-F Alignment Drawing

SOUND ALIGNMENT OF KCS156, 160, 163, 164

SOUND I-F, SOUND DETECTOR AND 4.5 MC. TRAP ALIGNMENT

TEST EQUIPMENT CONNECTIONS:

- BIAS SUPPLY**.....Apply -10 volts to the I-F AGC bus at terminal "C" on PW200.
- OSCILLOSCOPE**.....Through test diode detector (figure 2) as shown to PW200 terminals "L" and "Q".
- SIGNAL GENERATOR**.....To TP3 on PW200.
- VTVM**.....Through test diode detector (figure 2) as shown to PW200 terminal "L" and V202 pin 7.
- GENERAL**.....Set contrast control fully clockwise.

STEP	SIGNAL GENERATOR	ADJUST	REMARKS
1	4.5 mc. 600 cycle. AM mod.	T201B (bottom)	Adjust for minimum 600 cps. indication on oscilloscope. The core should penetrate the coil from the board side when finally adjusted.
2	4.5 mc.	T202A & B	Adjust for maximum negative DC on meter. Set generator for 0.5 to 1.0 volts when peaked. T201A top core and T202A core should penetrate the coil from top of can and T202B should penetrate coil from board side when finally peaked.
3	4.5 mc.	T201A (top)	
NOTE: DO NOT READJUST T202B (BOTTOM) AFTER TRANSFORMER PEAKED IN STEPS 2 & 3.			
Disconnect bias and the diode test detector. Turn off signal generator and tune in strongest signal in area (use test pattern if available), adjusting volume control for normal volume (approx. 1/4 turn from C.C.W.). Turn core of T203 flush with top of coil form. Reapply bias and adjust until hiss can be heard in sound.			
4	Not Used	T203	Turn core clockwise to 2nd peak, adjusting for maximum volume and least hiss in sound. If necessary, retouch T201A & T202A (top cores) only.

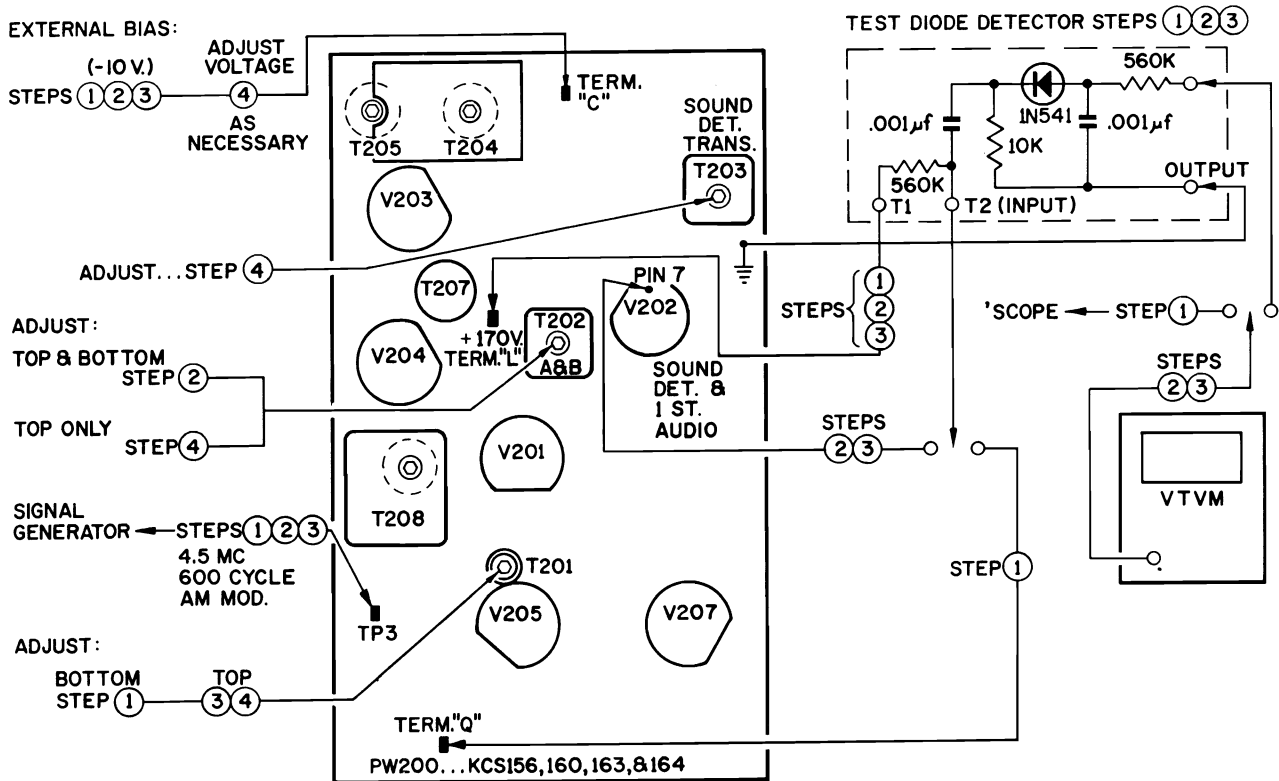

RCA Victor Alignment Information for Chassis KCS-161 Series

PICTURE I-F ALIGNMENT—KCS161 CHASSIS PICTURE I-F TRANSFORMER AND TRAP ADJUSTMENTS

TEST EQUIPMENT CONNECTIONS:

- BIAS SUPPLY**.....NONE IN STEP 1 (Ground I-F AGC terminal "C" of PW200). Bias I-F AGC terminal "C" at —6 volts when adjusting traps in step 2 and during sweep alignment except step 5.
- MARKER GENERATOR**.....Connect to Mixer Grid TP of KRK125 in series with mixer pad shown. (Figure 1.)
- VTVM**.....Attach through direct probe at TP3 (2nd Detector).
- MISCELLANEOUS**.....Attach a 300 ohm carbon resistor as a dummy load across the antenna terminals. Refer to illustration for all adjustment locations and responses.

PEAK ALIGNMENT

STEP	SWEEP GENERATOR	MARKER GENERATOR	ADJUST	REMARKS	
1	Peak 1st Pix I-F Plate Transformer (T207)	NOT USED	44.25 mc.	T207	Peak T207 and adjust generator output to maintain approx. 3 volts when finally peaked.
2	Adjust 47.25 mc. Trap		47.25 mc.	T204	Adjust for minimum. Readjust 47.25 mc. trap, if necessary, after step 3.

PICTURE I-F SWEEP ALIGNMENT

TEST EQUIPMENT CONNECTIONS:

- BIAS SUPPLY**.....Adjust to —6 volts. Same connection as above.
- OSCILLOSCOPE**.....Attach through direct probe to TP3. Calibrate to 5 volts peak to peak.
- MARKER GENERATOR**.....Connect to Mixer Grid TP of KRK125.
- SWEEP GENERATOR**.....Connect to TP2 (V204-2). Use short leads. Set gain to maintain full scale deviation of oscilloscope calibrated trace.

STEP	SWEEP GENERATOR	MARKER GENERATOR	ADJUST	REMARKS	
3	Adjust 2nd Pix I-F Plate Transformer	40-50 mc.	41.25 mc. 45.75 mc.	T208 (Top & Bottom Cores)	Adjust for max. gain and response curve "A". Set sweep gain to maintain 5 V. P. to P.
Move the Oscilloscope to the test point TP1 using the diode probe and 180 ohm pad. Calibrate the Oscilloscope for 0.3 volts Peak to Peak. Sweep Generator to Mixer TP. Lightly couple Marker to sweep cable. Channel selector to 4.					
4	Adjust Mixer Plate Coil (L30) and 1st I-F grid (T205)	40-50 mc.	41.25 mc. 45.75 mc.	L30 T205	Adjust for response "B". Use inner peak of L30 coil slug (bottom of winding). Set sweep for 0.3 V. P. to P.
Remove —6.0 V. bias from terminal "C" of PW200.					
5	Zero Bias Adjustment	40-50 mc.	41.25 mc. 45.75 mc.	L30 (Mixer Plate Coil)	If necessary, readjust L30 slightly to bring the picture carrier (45.75 mc.) to one of the peaks on response "C".
Change Oscilloscope probe to direct probe and attach to TP3. Calibrate to 5 volts Peak to Peak. Remove 180 ohm pad. Reapply —6.0 V. bias to terminal "C" of PW200.					
6	Check I-F Overall	40-50 mc.	41.25 mc. 42.5 mc. 45.75 mc.	T207	Retouch T207 slightly to maintain response "D".
Remove dummy antenna load and substitute the sweep attenuator pad (Fig. 3). Attach the sweep generator to the attenuator pad. The Marker Generator to tuner TP through pad shown. Adjust fine tuning to correct oscillator frequency.					
7	Check R-F I-F Overall	40-50 mc.	41.25 mc. 42.5 mc. 45.75 mc.	T207 & T208 Top Core only	Make slight adjustments only. Observe response "D". Do not disturb T208 bottom core.

KCS161 PICTURE I-F ALIGNMENT DRAWING

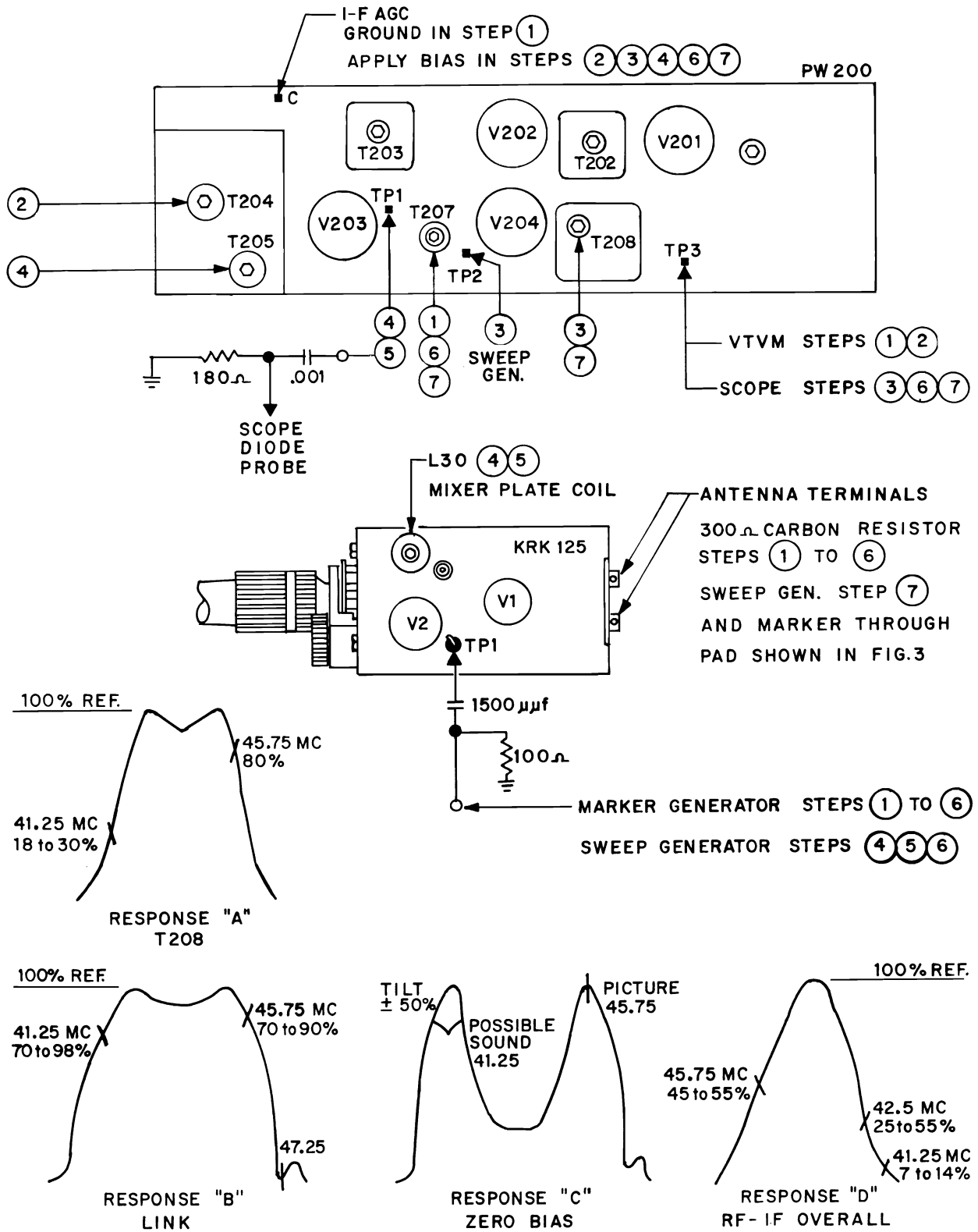

KCS161 Picture I-F Alignment Drawing

RCA Victor Alignment Information for Chassis KCS-162 Series

PICTURE I-F ALIGNMENT—KCS162 CHASSIS PICTURE I-F TRANSFORMER AND TRAP ADJUSTMENTS

TEST EQUIPMENT CONNECTIONS:

- BIAS SUPPLY**..... NONE IN STEP 1 (Ground I-F AGC terminal "C" of PW200). Bias I-F AGC terminal "C" at -6 volts when adjusting traps in steps 2 and 3 and during sweep alignment except step 6.
- MARKER GENERATOR**..... Connect to Mixer Grid TP of KRK125 in series with mixer pad shown.
- VTVM**..... Attach through direct probe at TP3 (2nd Detector).
- MISCELLANEOUS**..... Attach a 300 ohm carbon resistor as a dummy load across the antenna terminals. Refer to illustration for all adjustment locations and responses.

PEAK ALIGNMENT

STEP	SWEEP GENERATOR	MARKER GENERATOR	ADJUST	REMARKS	
1	Peak 1st Pix I-F Plate Transformer T207)		44.25 mc.	T207	Peak T207 and adjust generator output to maintain approx. 3 volts when finally peaked.
2	Adjust 47.25 mc. Trap	NOT USED	47.25 mc.	T204B (Bottom Core)	Adjust for minimum. Readjust 47.25 mc. trap, if necessary, after step 4.
3	Adjust 39.75 mc. Trap		39.75 mc.	T204A (Top Core)	

PICTURE I-F SWEEP ALIGNMENT

TEST EQUIPMENT CONNECTIONS:

- BIAS SUPPLY**..... Adjust to -6 volts. Same connection as above.
- OSCILLOSCOPE**..... Attach through direct probe to TP3. Calibrate to 5 volts peak to peak.
- MARKER GENERATOR**..... Connect to Mixer Grid TP of KRK128.
- SWEEP GENERATOR**..... Connect to TP2 (V204-2). Use short leads. Set gain to maintain full scale deviation of oscilloscope calibrated trace.

STEP	SWEEP GENERATOR	MARKER GENERATOR	ADJUST	REMARKS	
4	Adjust 2nd Pix I-F Plate Transformer	40-50 mc.	41.25 mc. 45.75 mc.	T208 (Top & Bottom Cores)	Adjust for max. gain and response curve "A". Set sweep gain to maintain 5 V. P. to P.
Move the Oscilloscope to the test point TP1 using the diode probe and 180 ohm pad. Calibrate the Oscilloscope for 0.3 volts Peak to Peak. Sweep Generator to Mixer TP. Lightly couple Marker to sweep cable. Channel selector to 4.					
5	Adjust Mixer Plate Coil (L11) and 1st I-F grid (T205)	40-50 mc.	41.25 mc. 45.75 mc.	L11 T205	Adjust for response "B". Use inner peak of L30 coil slug (bottom of winding). Set sweep for 0.3 V. P. to P. output or less.
Remove -6.0 V. bias from terminal "C" of PW200.					
6	Zero Bias Adjustment	40-50 mc.	41.25 mc. 45.75 mc.	L11 Mixer Plate Coil	If necessary, readjust L11 slightly to bring the picture carrier marker (45.75 mc.) to one of the peaks on response "C".
Change Oscilloscope probe to direct probe and attach to TP3. Calibrate to 5 volts Peak to Peak. Remove 180 ohm pad. Reapply -6.0 V. bias to terminal "C" of PW200.					
7	Check I-F Overall	40-50 mc.	42.5 mc. 45.0 mc. 45.75 mc.	T207	Retouch T207 slightly to maintain response "D".
Remove dummy antenna load and substitute the sweep attenuator pad (Fig. 3). Attach the sweep generator to the attenuator pad. The Marker Generator to tuner TP through pad shown. Adjust fine tuning to correct oscillator frequency.					
8	Check R-F I-F Overall	40-50 mc.	42.5 mc. 45.0 mc. 45.75 mc.	T207 & T208 Top Core only	Make slight adjustments only. Observe response "D". Do not disturb T208 bottom core.
Check UHF R-F I-F overall					

KCS162 PICTURE I-F ALIGNMENT DRAWING

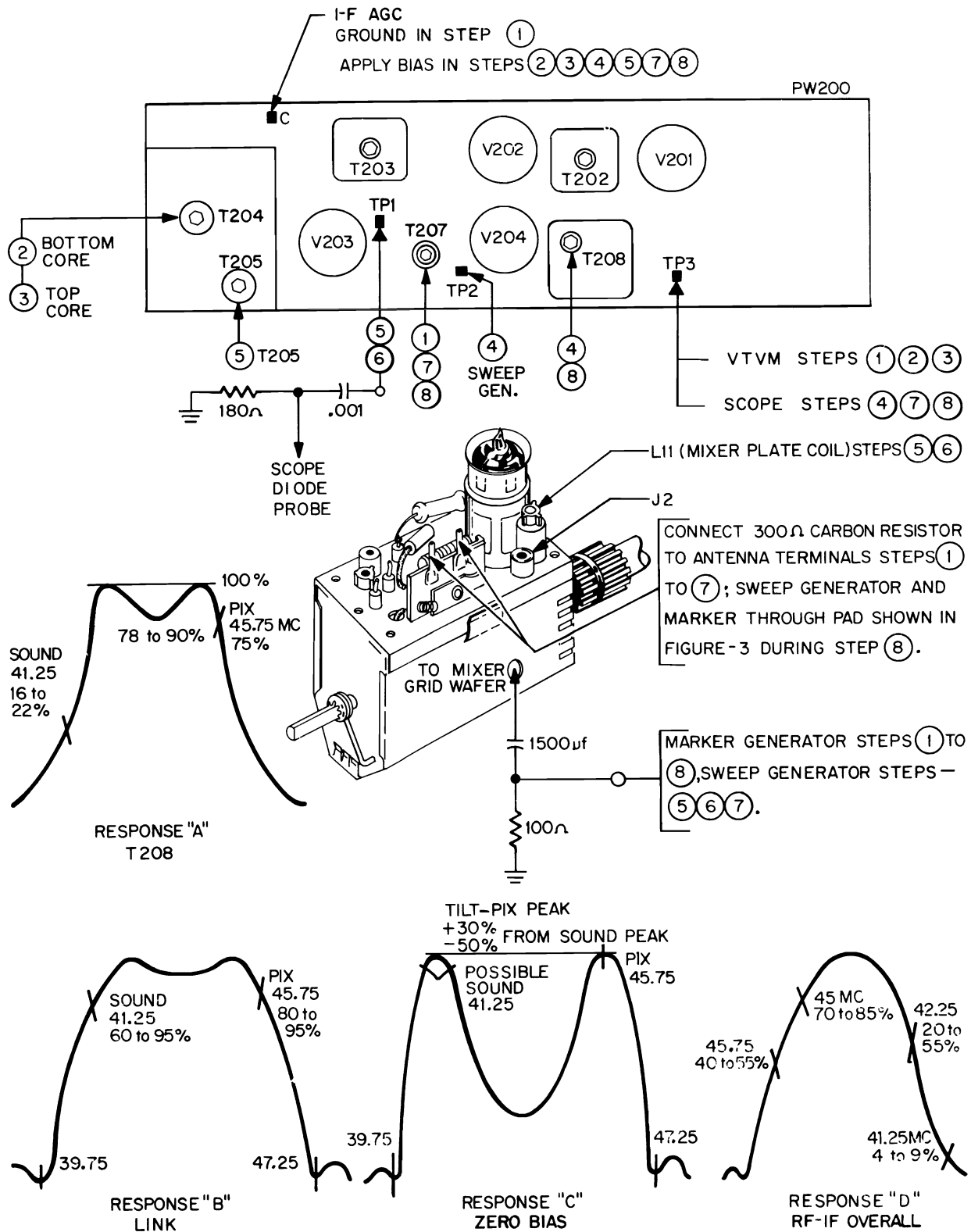

KCS162 Picture I-F Alignment Drawing

SOUND I-F ALIGNMENT OF KCS161, KCS162 CHASSIS
SOUND I-F, SOUND DETECTOR AND 4.5 MC. TRAP ALIGNMENT

TEST EQUIPMENT CONNECTIONS:

- BIAS SUPPLY**.....Apply -10 volts to the I-F GC bus at terminal "C" on PW200.
OSCILLOSCOPE.....Through test diode detector to PW200 terminal "U" and B+.
SIGNAL GENERATOR.....To test point TP3 on PW200.
VTVM.....Through test diode detector as shown to V202 pin 7 and B+.

STEP	SIGNAL GENERATOR	ADJUST	REMARKS	
1	Adjust detector grid transformer	4.5 mc.	T202	Adjust for maximum negative DC on meter. Set Generator for 1.0 to 1.5 volts when peaked. T201A top core and T202 core should penetrate the coil from top of can when finally peaked.
2	Adjust sound take-off transformer	4.5 mc.	T201A (Top)	
Disconnect the diode test detector. Turn off signal generator and tune in strongest signal in area, adjusting volume control for normal volume (approx. 1/4 turn from C.C.W.). Turn core of T203 flush with top of coil form. Remove bias.				
3	Adjust sound detector transformer	—	T203	Turn core clockwise to 2nd peak adjusting for maximum volume.
4	Adjust 4.5 mc. trap	4.5 mc., 600 cycle, AM mod.	T201 (Bottom)	Adjust for minimum 600 cps indication on oscilloscope. The core should penetrate the coil from the board end when finally adjusted.

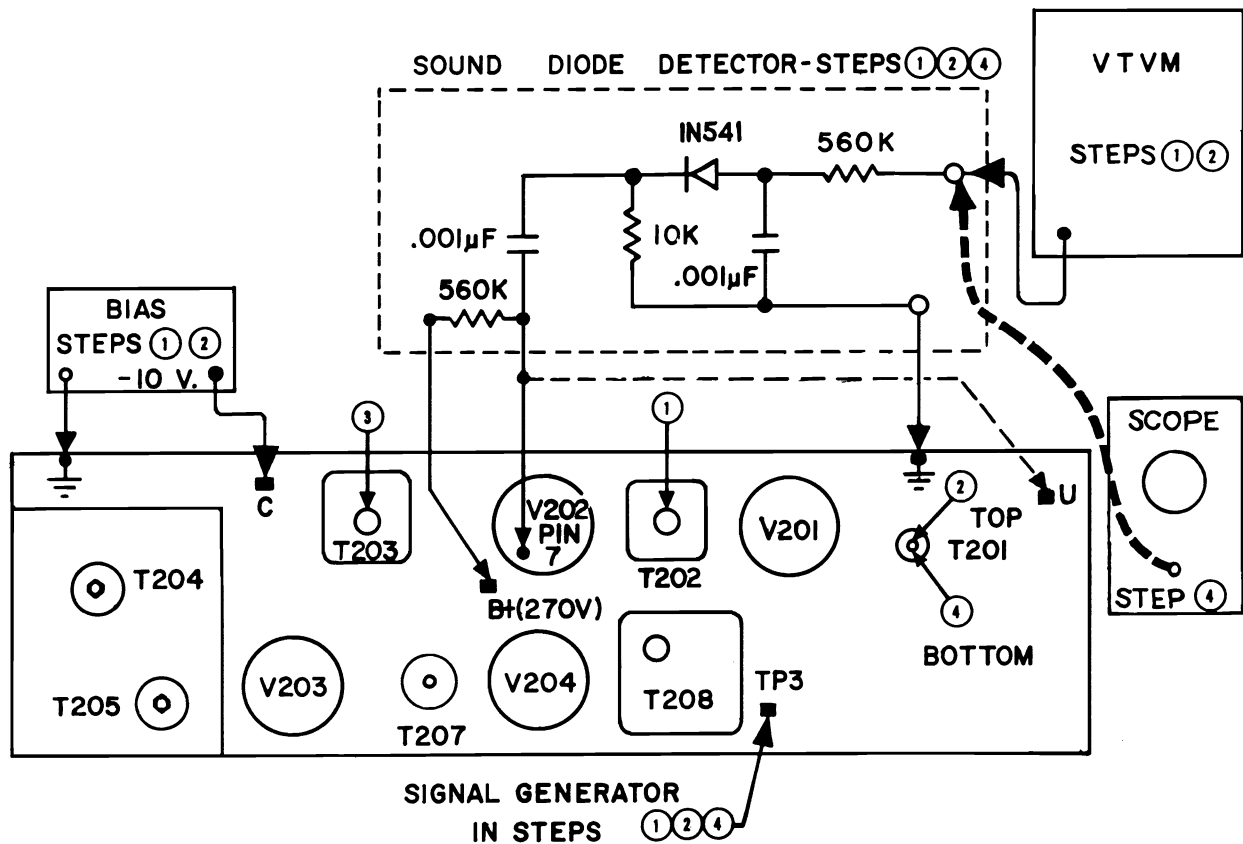

SEARS, ROEBUCK and CO.

Chassis 528.70480 used in Models 8127, 8132, 8140, 8141, 8142.
 Also Chassis 456.70286, 528.70286, 529.70286 used in additional
 Models 6127, 7131, 7132, 7133, 7140, 7141, 7142, 7143, are
 practically identical.

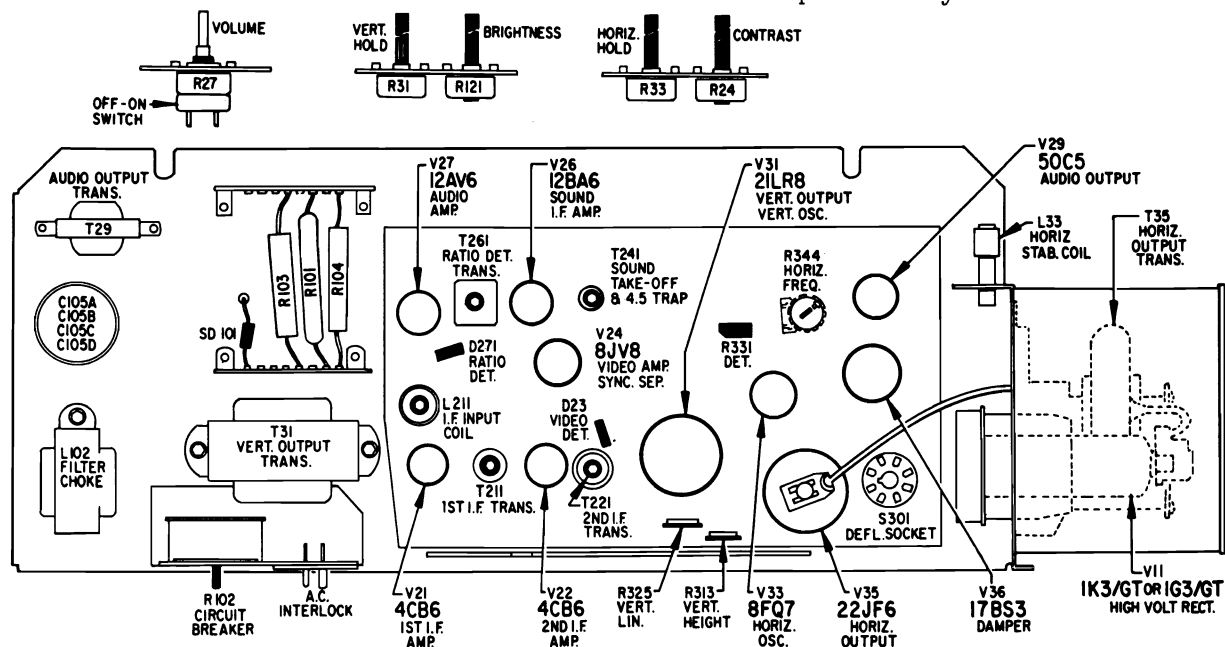

TUBE VIEW OF CHASSIS
 TELEVISION ADJUSTMENTS

FOCUS ADJUSTMENT

Connect pin No. 4 of CRT to either J282, J203 or J212 for well defined scanning lines.

DEFLECTION YOKE AND CENTERING RINGS ADJUSTMENTS

Follow this procedure to adjust the Deflection Yoke and Centering Rings.

1. Turn the receiver on and disconnect the antenna.
2. The deflection yoke is held on the neck of the picture tube by a clamp device. Loosen the clamp, by unscrewing the screw on the clamp, and carefully move the yoke as far forward as possible on the neck of the picture tube. Rotate the yoke until the top and bottom edges of the raster are squared with the chassis. Tighten the screw.

NOTE: A Width Device is located between the Deflection Yoke and the neck of the picture tube. This must be adjusted before the Yoke clamp is tightened.

3. Center the raster horizontally and vertically, and eliminate shaded corners by simultaneously, but independently, rotating the centering rings until the best effect is obtained.
4. Turn the brightness control to the point giving normal picture brilliance. Maintain brightness at this level during the following adjustments. Center the contrast control.

WIDTH DEVICE ADJUSTMENT

The Width Device is a piece of metallic foil attached to a sheet of plastic; it forms a half circle around the top half of the picture tube neck. (During all adjustments, the Width Device must remain centered on the top half of the picture tube neck.) Be sure that the Width Device is pulled as far toward the base of the picture tube as possible. The Width Device should be left in this position unless further adjustment is necessary. For further adjustment follow steps given below:

1. Loosen the screw on clamp which secures the Deflection Yoke to the picture tube.
2. During the following adjustment hold the Deflection Yoke in position and do not disturb the relative position between the Deflection Yoke and the picture tube. Slide the Width Device forward or backward until the picture has proper width. The plastic corners can be bent to ease moving.

NOTE: The Width Device may affect the vertical sweep, in which case, the Vertical Height and Vertical Linearity controls may have to be readjusted when the width adjustment has been completed.

HORIZONTAL FREQUENCY AND HORIZONTAL STABILIZER CONTROL ADJUSTMENT (Field)

1. Tune set to an active channel. Set horizontal hold control (R33) in the center of its range.
2. Short out L33 (Horizontal Stabilizer Coil) by connecting a jumper across J341 and J203.
3. Turn R344 (Horizontal Frequency Control) completely counterclockwise.
4. Advance R344 SLOWLY clockwise until picture just locks in.
5. Remove jumper from J341 and J203.
6. Leave the horizontal hold control in the center of its range and adjust the horizontal stabilizer coil to lock picture.

NOTE: Turn the horizontal hold control completely counterclockwise and momentarily switch off and on channel, observing to see if the horizontal remains locked or just breaks out of sync. Repeat with horizontal hold control completely clockwise. If the locking range does not appear to be centered, repeat Step 6.

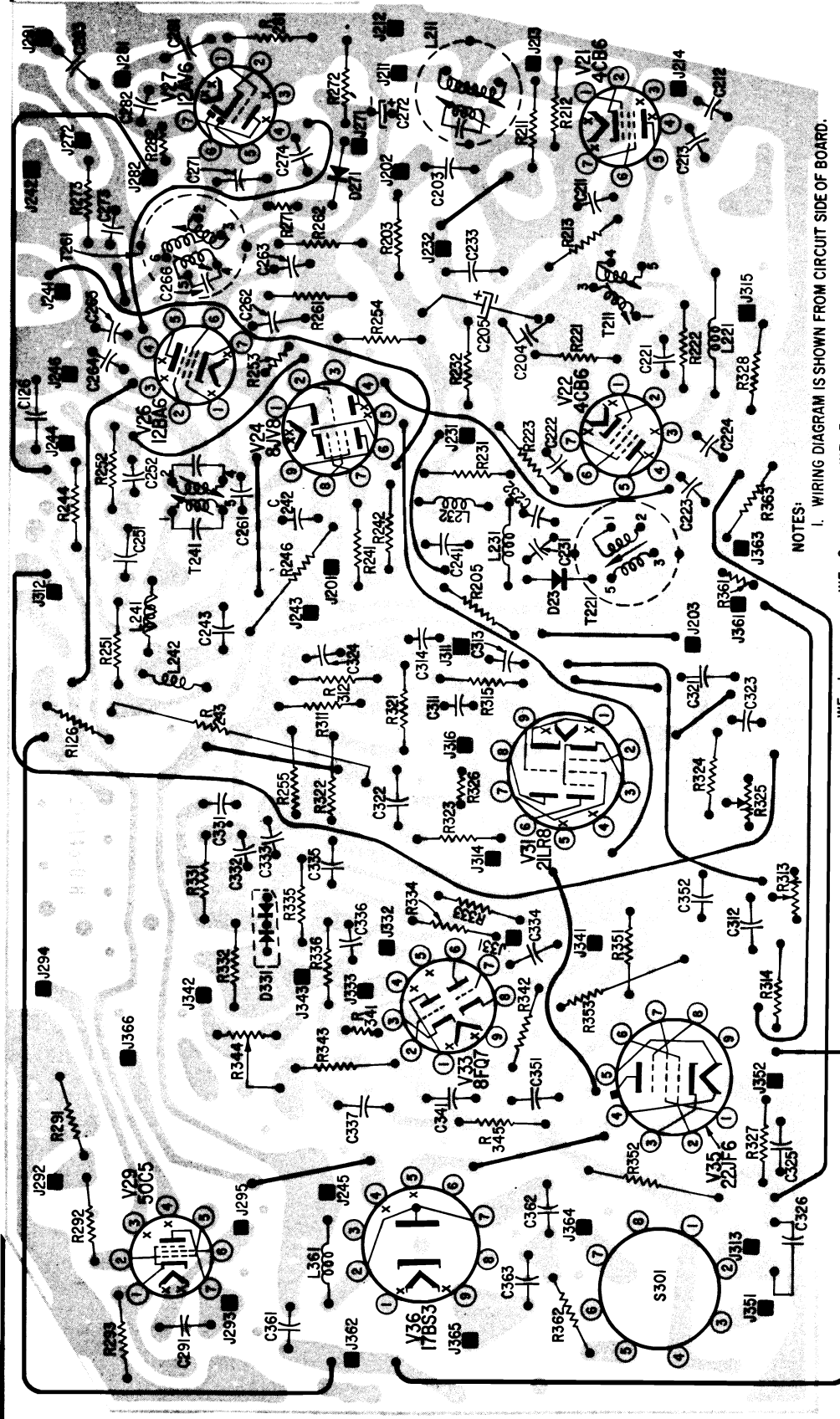

NOTES:
1. WIRING DIAGRAM IS SHOWN FROM CIRCUIT SIDE OF BOARD.

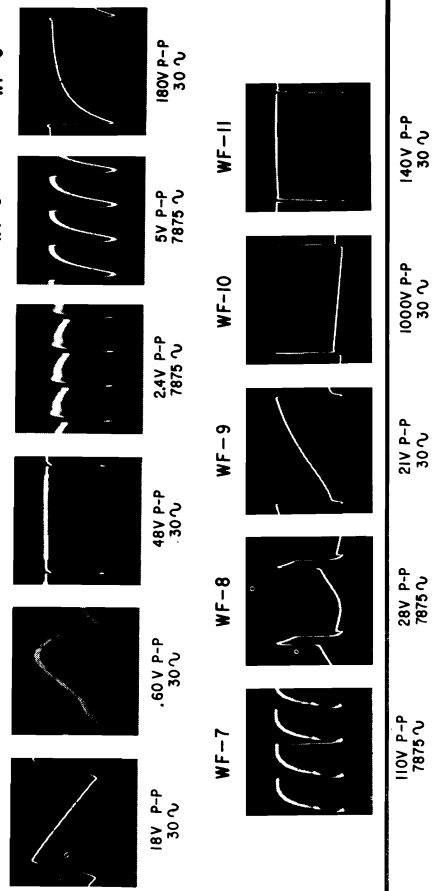

Wiring Diagram IF Sync Sound, Horizontal Vertical Board

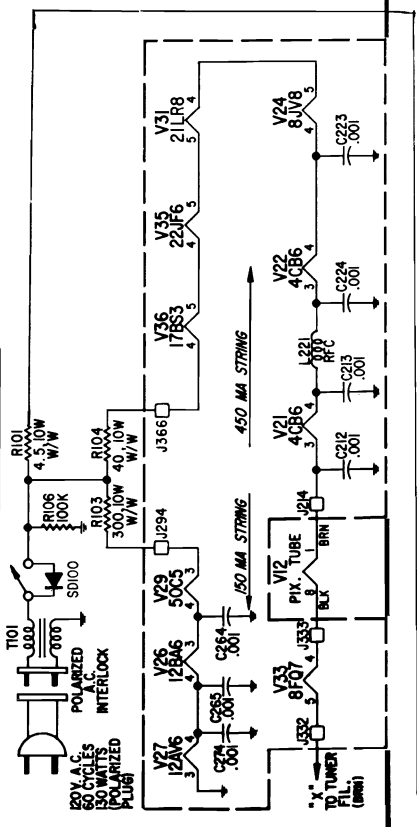

- SOLID LINES INDICATE WIRE JUMPERS.
- WIRE JUMPER UNDER V33 TUBE SOCKET BETWEEN PIN NO. 3 & PIN NO. 8, NOT SHOWN.

- RESISTANCE IS SHOWN IN OHMS K 1000 MEG 1000,000.
- ALL RESISTORS 1/2 WATT UNLESS OTHERWISE NOTED.
- CAPACITANCE VALUES ARE MFD UNLESS OTHERWISE NOTED.
- VOLTAGES READ WITH "VTVM" FROM POINT INDICATED TO CHASSIS GROUND.
- TUNER ON UNUSED CHANNEL CONTRAST & BRIGHTNESS AT MINIMUM -4.5 VOLTS BIAS ON A.G.C. LINE ON TEST POINT (C) OTHER CONTROLS AT NORMAL LINE VOLTAGES 120 VOLTS, ANTENNA TERMINALS SHORTED TOGETHER, BUT NOT TO GROUND.
- WAVEFORMS MEASURED WITH STRONG SIGNAL INPUT AND WITH CONTRAST. SET TO GIVE NORMAL PICTURE A.G.C. LINE OPERATING NORMALLY.
- 1, 2, 3, 4, 5, 6, 7, 8, 9, 10, 11, 12, 13, 14, 15, 16, 17, 18, 19, 20, 21, 22, 23, 24, 25, 26, 27, 28, 29, 30, 31, 32, 33, 34, 35, 36, 37, 38, 39, 40, 41, 42, 43, 44, 45, 46, 47, 48, 49, 50, 51, 52, 53, 54, 55, 56, 57, 58, 59, 60, 61, 62, 63, 64, 65, 66, 67, 68, 69, 70, 71, 72, 73, 74, 75, 76, 77, 78, 79, 80, 81, 82, 83, 84, 85, 86, 87, 88, 89, 90, 91, 92, 93, 94, 95, 96, 97, 98, 99, 100, 101, 102, 103, 104, 105, 106, 107, 108, 109, 110, 111, 112, 113, 114, 115, 116, 117, 118, 119, 120, 121, 122, 123, 124, 125, 126, 127, 128, 129, 130, 131, 132, 133, 134, 135, 136, 137, 138, 139, 140, 141, 142, 143, 144, 145, 146, 147, 148, 149, 150, 151, 152, 153, 154, 155, 156, 157, 158, 159, 160, 161, 162, 163, 164, 165, 166, 167, 168, 169, 170, 171, 172, 173, 174, 175, 176, 177, 178, 179, 180, 181, 182, 183, 184, 185, 186, 187, 188, 189, 190, 191, 192, 193, 194, 195, 196, 197, 198, 199, 200, 201, 202, 203, 204, 205, 206, 207, 208, 209, 210, 211, 212, 213, 214, 215, 216, 217, 218, 219, 220, 221, 222, 223, 224, 225, 226, 227, 228, 229, 230, 231, 232, 233, 234, 235, 236, 237, 238, 239, 240, 241, 242, 243, 244, 245, 246, 247, 248, 249, 250, 251, 252, 253, 254, 255, 256, 257, 258, 259, 260, 261, 262, 263, 264, 265, 266, 267, 268, 269, 270, 271, 272, 273, 274, 275, 276, 277, 278, 279, 280, 281, 282, 283, 284, 285, 286, 287, 288, 289, 290, 291, 292, 293, 294, 295, 296, 297, 298, 299, 300, 301, 302, 303, 304, 305, 306, 307, 308, 309, 310, 311, 312, 313, 314, 315, 316, 317, 318, 319, 320, 321, 322, 323, 324, 325, 326, 327, 328, 329, 330, 331, 332, 333, 334, 335, 336, 337, 338, 339, 340, 341, 342, 343, 344, 345, 346, 347, 348, 349, 350, 351, 352, 353, 354, 355, 356, 357, 358, 359, 360, 361, 362, 363, 364, 365, 366, 367, 368, 369, 370, 371, 372, 373, 374, 375, 376, 377, 378, 379, 380, 381, 382, 383, 384, 385, 386, 387, 388, 389, 390, 391, 392, 393, 394, 395, 396, 397, 398, 399, 400, 401, 402, 403, 404, 405, 406, 407, 408, 409, 410, 411, 412, 413, 414, 415, 416, 417, 418, 419, 420, 421, 422, 423, 424, 425, 426, 427, 428, 429, 430, 431, 432, 433, 434, 435, 436, 437, 438, 439, 440, 441, 442, 443, 444, 445, 446, 447, 448, 449, 450, 451, 452, 453, 454, 455, 456, 457, 458, 459, 460, 461, 462, 463, 464, 465, 466, 467, 468, 469, 470, 471, 472, 473, 474, 475, 476, 477, 478, 479, 480, 481, 482, 483, 484, 485, 486, 487, 488, 489, 490, 491, 492, 493, 494, 495, 496, 497, 498, 499, 500, 501, 502, 503, 504, 505, 506, 507, 508, 509, 510, 511, 512, 513, 514, 515, 516, 517, 518, 519, 520, 521, 522, 523, 524, 525, 526, 527, 528, 529, 530, 531, 532, 533, 534, 535, 536, 537, 538, 539, 540, 541, 542, 543, 544, 545, 546, 547, 548, 549, 550, 551, 552, 553, 554, 555, 556, 557, 558, 559, 560, 561, 562, 563, 564, 565, 566, 567, 568, 569, 570, 571, 572, 573, 574, 575, 576, 577, 578, 579, 580, 581, 582, 583, 584, 585, 586, 587, 588, 589, 590, 591, 592, 593, 594, 595, 596, 597, 598, 599, 600, 601, 602, 603, 604, 605, 606, 607, 608, 609, 610, 611, 612, 613, 614, 615, 616, 617, 618, 619, 620, 621, 622, 623, 624, 625, 626, 627, 628, 629, 630, 631, 632, 633, 634, 635, 636, 637, 638, 639, 640, 641, 642, 643, 644, 645, 646, 647, 648, 649, 650, 651, 652, 653, 654, 655, 656, 657, 658, 659, 660, 661, 662, 663, 664, 665, 666, 667, 668, 669, 670, 671, 672, 673, 674, 675, 676, 677, 678, 679, 680, 681, 682, 683, 684, 685, 686, 687, 688, 689, 690, 691, 692, 693, 694, 695, 696, 697, 698, 699, 700, 701, 702, 703, 704, 705, 706, 707, 708, 709, 710, 711, 712, 713, 714, 715, 716, 717, 718, 719, 720, 721, 722, 723, 724, 725, 726, 727, 728, 729, 730, 731, 732, 733, 734, 735, 736, 737, 738, 739, 740, 741, 742, 743, 744, 745, 746, 747, 748, 749, 750, 751, 752, 753, 754, 755, 756, 757, 758, 759, 760, 761, 762, 763, 764, 765, 766, 767, 768, 769, 770, 771, 772, 773, 774, 775, 776, 777, 778, 779, 780, 781, 782, 783, 784, 785, 786, 787, 788, 789, 790, 791, 792, 793, 794, 795, 796, 797, 798, 799, 800, 801, 802, 803, 804, 805, 806, 807, 808, 809, 810, 811, 812, 813, 814, 815, 816, 817, 818, 819, 820, 821, 822, 823, 824, 825, 826, 827, 828, 829, 830, 831, 832, 833, 834, 835, 836, 837, 838, 839, 840, 841, 842, 843, 844, 845, 846, 847, 848, 849, 850, 851, 852, 853, 854, 855, 856, 857, 858, 859, 860, 861, 862, 863, 864, 865, 866, 867, 868, 869, 870, 871, 872, 873, 874, 875, 876, 877, 878, 879, 880, 881, 882, 883, 884, 885, 886, 887, 888, 889, 890, 891, 892, 893, 894, 895, 896, 897, 898, 899, 900, 901, 902, 903, 904, 905, 906, 907, 908, 909, 910, 911, 912, 913, 914, 915, 916, 917, 918, 919, 920, 921, 922, 923, 924, 925, 926, 927, 928, 929, 930, 931, 932, 933, 934, 935, 936, 937, 938, 939, 940, 941, 942, 943, 944, 945, 946, 947, 948, 949, 950, 951, 952, 953, 954, 955, 956, 957, 958, 959, 960, 961, 962, 963, 964, 965, 966, 967, 968, 969, 970, 971, 972, 973, 974, 975, 976, 977, 978, 979, 980, 981, 982, 983, 984, 985, 986, 987, 988, 989, 990, 991, 992, 993, 994, 995, 996, 997, 998, 999, 1000.

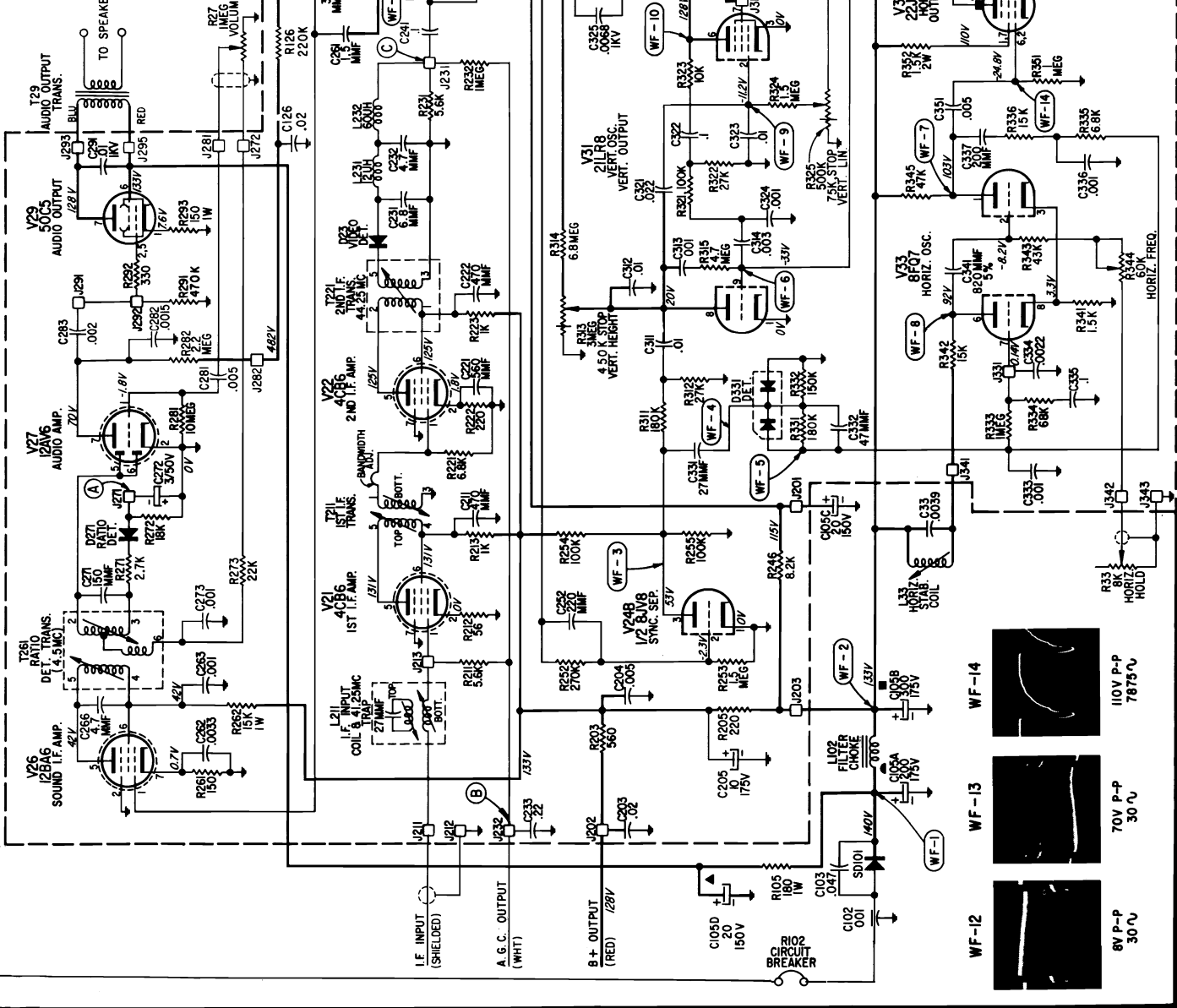

***Picture Tube 23HFP4 - 23 HFP4A

SEARS, ROEBUCK Chassis 528.70480 Diagram

SEARS, ROEBUCK Chassis 528.70480 Alignment Information, Continued

PRELIMINARY ALIGNMENT NOTES:

- It is recommended that the receiver be connected to an isolation transformer during alignment. Allow at least 5 minutes for set to warm up before any alignment is attempted.
 - Connect oscilloscope hot lead through 10K ohm isolation resistor to Point (C) Connect ground lead of oscilloscope directly to main chassis.
 - Adjust signal input to maintain 2V P-P at Point (C)
 - Apply -3 volts bias to AGC line, -side to Point (B) +side to chassis.
 - Connect to correct signal generator as shown in chart below.
 - Clip hot lead of marker generator to the insulation of RF sweep generator hot lead. Connect ground lead to chassis.
- NOTE: Before hooking up to Point "C" I.F. INJ., rotate Tuner to Channel 13.

VIDEO I.F. ALIGNMENT

Step	Sweep Generator (40-50Mc) Connect To	Marker Generator See Note Above	Output Waveform	Adjust	Remarks
1.	Pin 1 of 4CB6 (V21 thru .001 mfd. Cap	44.25Mc	Figure 1	T221	Adjust T221 for maximum response at 44.25Mc.
2.	Same	Same	Same	T211 (Bottom)	Turn top core of T211 to top of coil form before adjusting T211 bottom. Adjust T211 bottom for maximum response at 44.25Mc.
3.	Same	45.75Mc	Same	T211 (Top)	Adjust T211 top to position the 45.75Mc marker at the 3 db point of the response curve.
4.	Same	45.75Mc 42.75Mc	Same	T211 (Bottom)	Readjust T211 (Bottom) for symmetry of response shown in Figure 1.
5.	If necessary, repeat Steps 1 through 4 to obtain proper response. NOTE: If proper 3 db bandwidth is not obtained (3.0Mc ±.2Mc), refer to Bandwidth Loop Adjustment.				
6.	Point "C" (I.F. injection Point) See Figure 3.	41.25Mc	Figure 2	L211 (Top)	Adjust L211 top for minimum response at 41.25Mc.
7.	Same	45.75Mc.	Same	L905 Tuner I.F. Output Coil	Adjust L905 to position the 45.75Mc marker at the 6 db point of response curve.
8.	Same	42.75Mc 45.75Mc	Same	L211 (Bottom)	Adjust L211 (bottom for symmetry of response in Figure 2.
9.	If necessary, repeat Steps 6 through 8 to obtain response curve of Figure 2.				

BANDWIDTH LOOP ADJUSTMENT

The first I.F. transformer has a vertical hairpin loop in the secondary winding. This loop must not be touched unless the bandwidth specifications (3Mc ±.2Mc) are incorrect. Adjust as follows:

- To narrow the I.F. response curve, pull the loop away from the primary of T211 (top). Repeat Steps 2 through 5 of the Video I.F. Alignment. See Figure 4.
- To broaden the I.F. response curve, press the loop toward the primary of T211 (top). Repeat Steps 2 through 5 of the Video I.F. Alignment. See Figure 4.

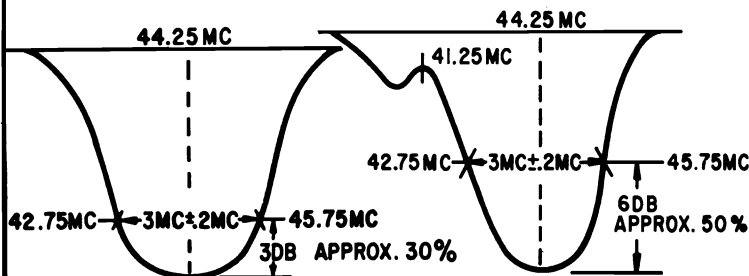
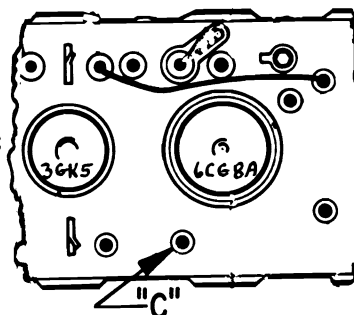

FIGURE 1

FIGURE 2



SOUND ALIGNMENT I.F. INJ. FIGURE 3

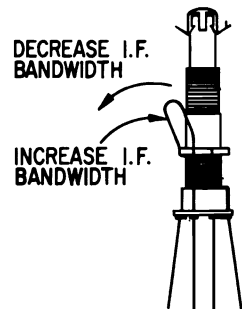

FIGURE 4

PRELIMINARY:

- Apply -9V bias to Point B
- Set channel selector to unused channel.

Step	Signal Generator Frequency	Connect to	Output Indicator	Connect to	Adjust	Remarks
1.	4.5Mc	J231 (Test Point (C))	VTVM	Junction of two 100K ohm resistors. See NOTE 1	T261 top for zero (mid-scale)	Sig. Gen. Output 1v.
2.	4.5Mc	Same	VTVM	Test Point (A)	T261 bottom for max.	Sig. Gen. output less than 10K uv (to avoid limiting)
3.	4.5Mc	Same	VTVM	Same	T241 bottom for max.	Same
4.	4.5Mc	Same	VTVM	Same	T241 top for max.	Same
5.	Remove meter, bias voltage, generator; tune set to station. Set fine tune for best picture and touch-up 4.5 Mc reject trap (T241) for minimum sound beat in picture.					

SEARS, ROEBUCK and CO.

TELEVISION CHASSIS NOS. 456. (70259
528. (70260
529. (70261

USED IN TELEVISION MODELS

7110	7112	7116
7111	7113	7117
		7118
		7119

(Material on pages 135 through 138)

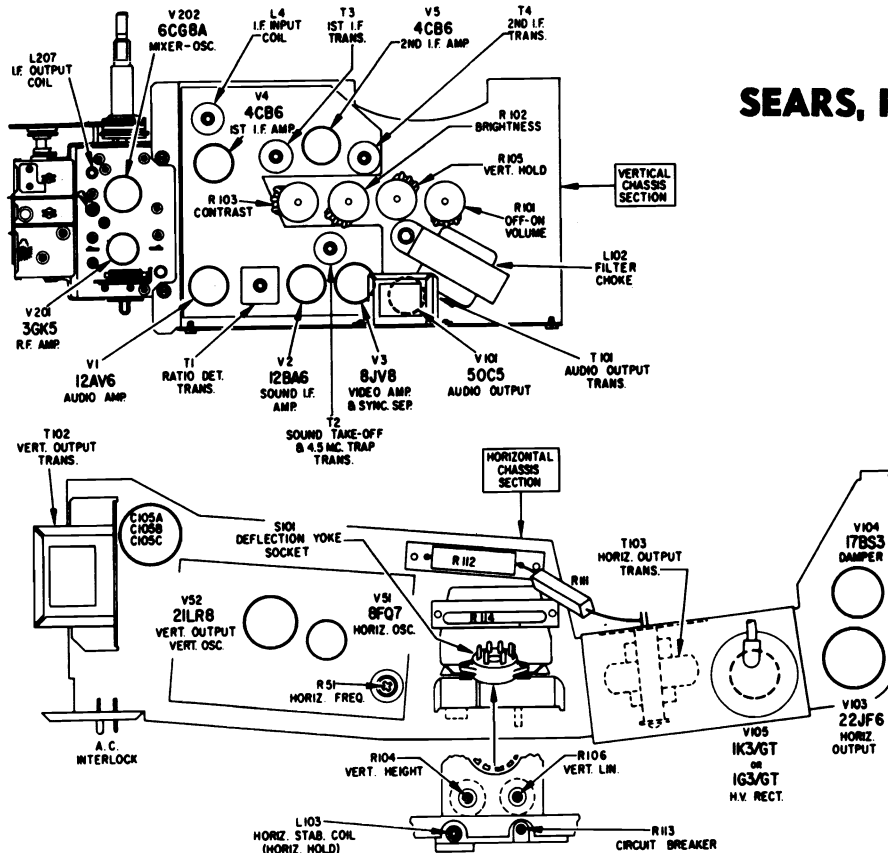

FOCUS ADJUSTMENT – The focus lead of the Picture Tube Socket (Blue with a connector) may be connected to any of the three Keller wrap posts (Ground J61, B+ 142 volts J70 and B Boost (filtered) 560 volts J72). See Vertical-Horizontal Diagram. Since each Picture Tube differs in characteristics, when replacing the tube, connect the focus lead (Blue) to each of the four Keller posts in turn. The lead should be permanently connected to the post which gives best focus at maximum Brightness.

DEFLECTION YOKE AND CENTERING RING ADJUSTMENT – Follow this procedure in adjusting the Deflection Yoke and Centering Rings.

1. Turn the receiver on and disconnect the antenna.
2. The deflection yoke is held on the neck of the picture tube by a clamp device. Loosen the clamp, by unscrewing the screw on the clamp, and carefully move the yoke as far forward as possible on the neck of the picture tube. Rotate the yoke until the top and bottom edges of the raster are squared with the chassis. Tighten the screw.

NOTE: A Width Device is located between the Deflection Yoke and the neck of the picture tube. This must be adjusted before the Yoke clamp is tightened.

3. Center the raster horizontally and vertically, and eliminate shaded corners by simultaneously, but independently, rotating the centering rings until the best effect is obtained.
4. Turn the brightness control to the point giving normal picture brilliance. Maintain brightness at this level during the following adjustments. Center the contrast control.

WIDTH DEVICE ADJUSTMENT – The Width Device is a piece of metallic foil attached to a sheet of plastic; it forms a half circle around the top half of the picture tube neck. (During all adjustments, the Width Device must remain centered on the top half of the picture tube neck.) Be sure that the Width Device is pulled as far toward the base of the picture as possible. The Width Device should be left in this position unless further adjustment is necessary. For further adjustment, follow steps given below:

1. Loosen the screw on clamp which secures the Deflection Yoke to the picture tube.
2. During the following adjustment hold the Deflection Yoke in position and do not disturb the relative position between the Deflection Yoke and the picture tube. Slide the Width Device forward or backward until the picture has proper width. The plastic corners can be bent to ease moving.

NOTE: The Width Device may affect the vertical sweep, in which case, the Vertical Height and Vertical Linearity controls may have to be readjusted when the width adjustment has been completed.

HORIZONTAL FREQUENCY AND HORIZONTAL STABILIZER CONTROL ADJUSTMENT (Field) Shop

1. Tune set to an active channel
2. Short L103 (Horizontal Stabilizer Coil) by connecting a jumper across J57 and J58, also short J52 to ground with a jumper lead.
3. Turn variable cathode resistor (R51) completely counter-clockwise.
4. Advance R51 SLOWLY clockwise until picture just locks in.
5. Remove jumper from horizontal stabilizer coil.
6. Lock in picture by adjusting the horizontal stabilizer coil, which in effect is the Horizontal Hold Control, finally, remove J52 ground jumper lead.

SEARS, ROEBUCK Chassis 456.70259/61 etc., Schematic Diagram

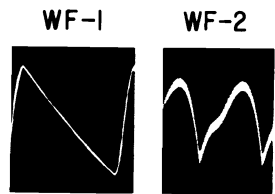

18V P-P
30 ~

64V P-P
30 ~

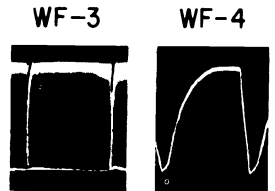

85V P-P
30 ~

4V P-P
7875 ~



10V P-P
7875 ~

290V P-P
30 ~

104V P-P
7875 ~

21V P-P
7875 ~

30V P-P
30 ~

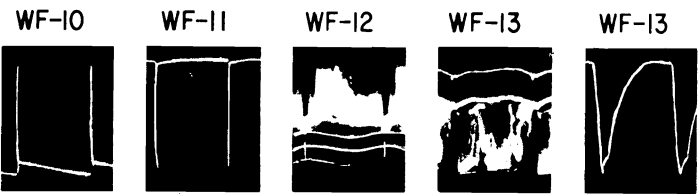

1360V P-P
30 ~

130V P-P
30 ~

6V P-P
30 ~

95V P-P
30 ~

102V P-P
7875 ~

70259 Chassis
Omit (T3) Part No. 10-56-3 First I.F. Transformer.
Add (T3) Part No. 10-82-3 First I.F. Transformer.
Omit (C64) .22 mfd. Capacitor Add (C64) .068 mfd Capacitor.
Add (C126) .02 mfd Capacitor.
Add (R126) 220K ohm Resistor.
Add (C103) .047 mfd Mylar Capacitor.
Reason: To Reduce Residual Audio Hum. at High Brightness Level.

70260 Chassis
Omit UHF Tuner Part No. 95-570-4.
Add UHF Tuner Part No. 95-585-3.
Reason: To evaluate Tuner for Production.

70261 Chassis
Add (R85) 220 ohm Resistor, connect from J70 to junction of J81.
Add (C85) 10 mfd Electrolytic, connect from J81 to Chassis Ground.
Reason: To eliminate intermittent Vertical Roll problem.

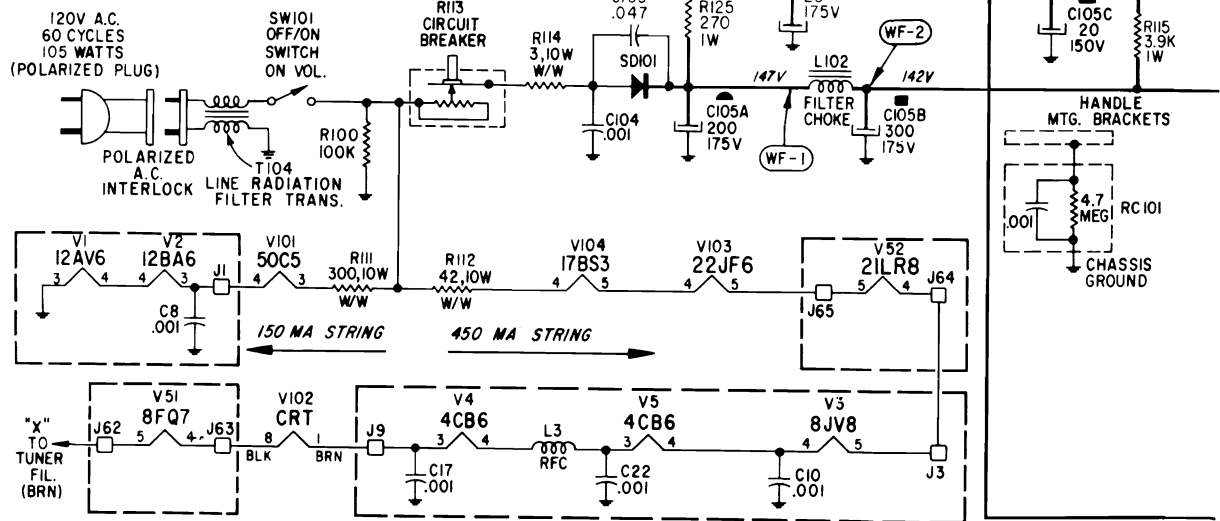

SEARS, ROEBUCK Chassis 456.70259/61 etc., Schematic Diagram, Continued

SCHMATIC DIAGRAM FOR CHASSIS
70259, 70260, 70261

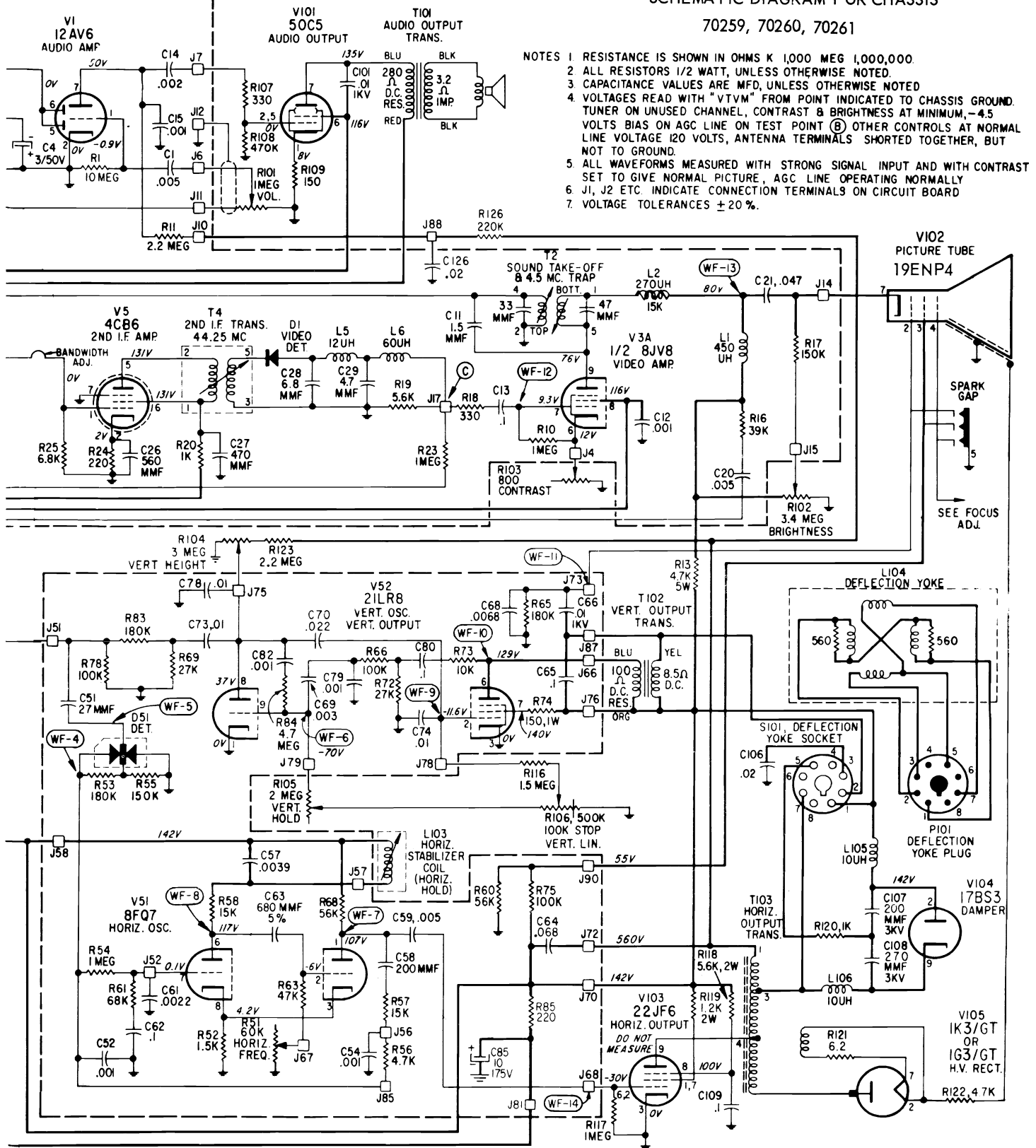

- NOTES
1. RESISTANCE IS SHOWN IN OHMS K 1,000 MEG 1,000,000.
 2. ALL RESISTORS 1/2 WATT, UNLESS OTHERWISE NOTED.
 3. CAPACITANCE VALUES ARE MFD, UNLESS OTHERWISE NOTED.
 4. VOLTAGES READ WITH "VTVM" FROM POINT INDICATED TO CHASSIS GROUND. TUNER ON UNUSED CHANNEL, CONTRAST & BRIGHTNESS AT MINIMUM, -4.5 VOLTS BIAS ON AGC LINE ON TEST POINT (B) OTHER CONTROLS AT NORMAL LINE VOLTAGE 120 VOLTS, ANTENNA TERMINALS SHORTED TOGETHER, BUT NOT TO GROUND.
 5. ALL WAVEFORMS MEASURED WITH STRONG SIGNAL INPUT AND WITH CONTRAST SET TO GIVE NORMAL PICTURE, AGC LINE OPERATING NORMALLY.
 6. J1, J2 ETC. INDICATE CONNECTION TERMINALS ON CIRCUIT BOARD.
 7. VOLTAGE TOLERANCES ± 20 %.

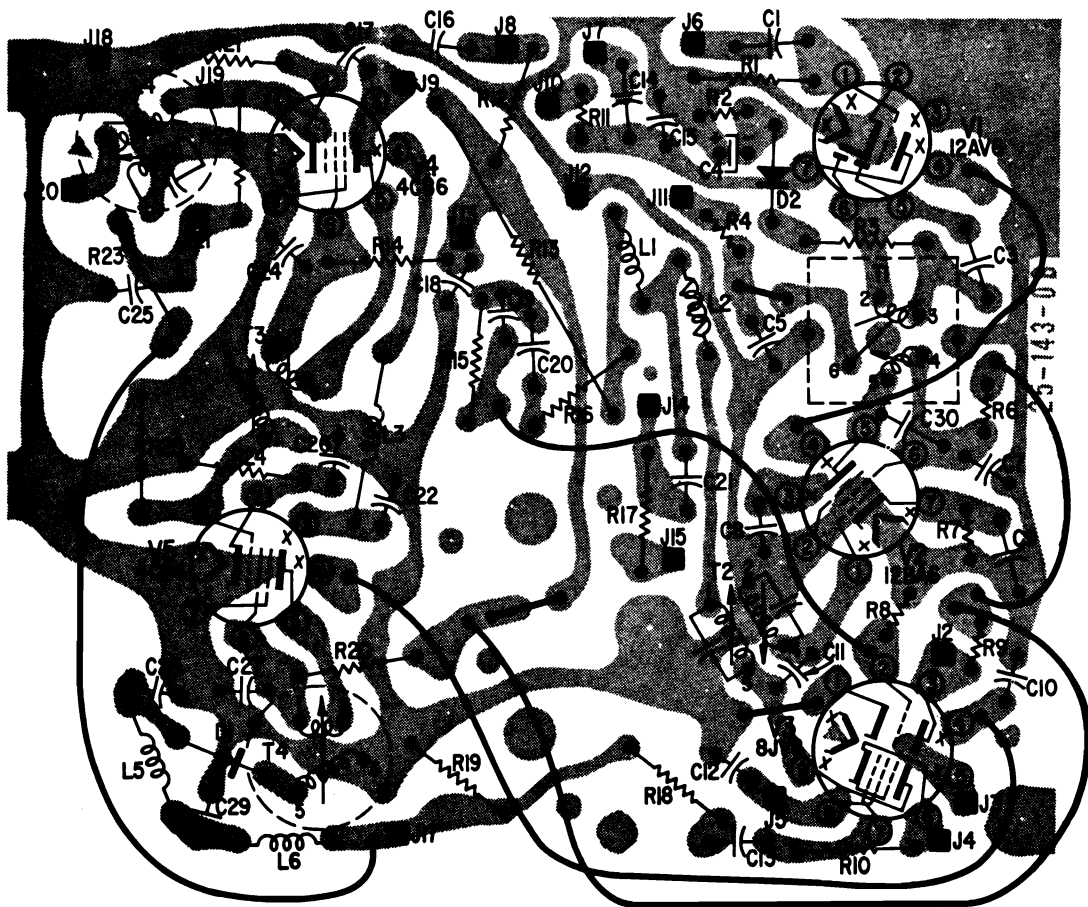

WIRING DIAGRAM I.F. AND SOUND BOARD

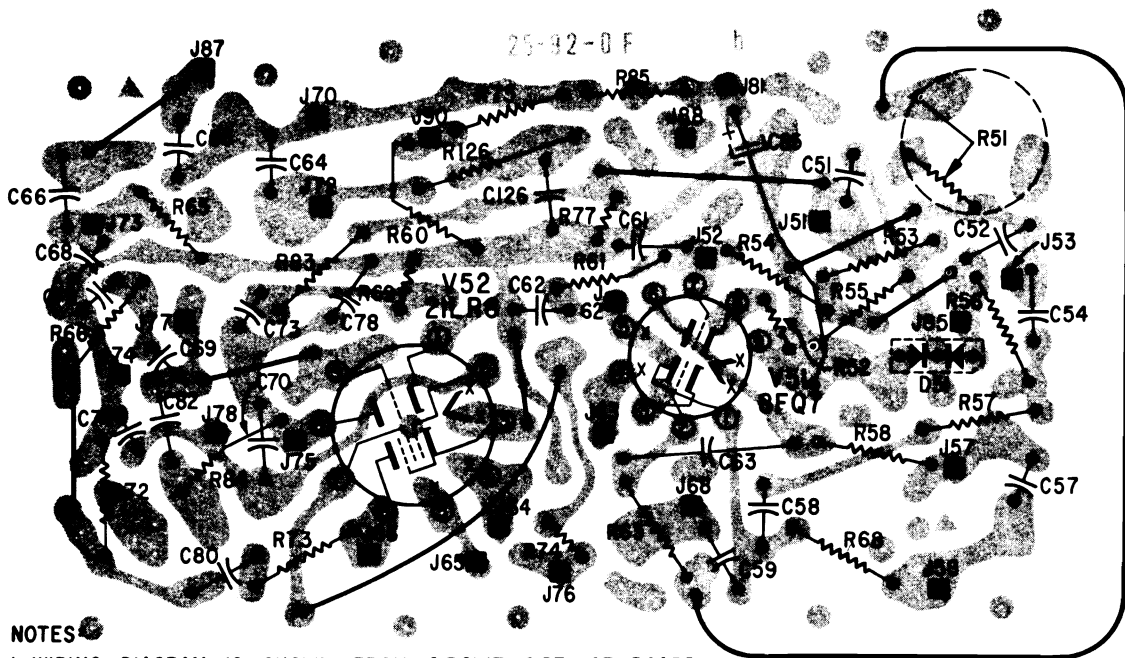

NOTES

1. WIRING DIAGRAM IS SHOWN FROM CIRCUIT SIDE OF BOARD.
2. SOLID LINES INDICATE WIRE JUMPERS.
3. WIRE JUMPER UNDER V51 TUBE SOCKET BETWEEN PIN NO. 3 & PIN NO. 8 NOT SHOWN.

WIRING DIAGRAM HORIZONTAL-VERTICAL DEFLECTION BOARD



MODEL 19P-11

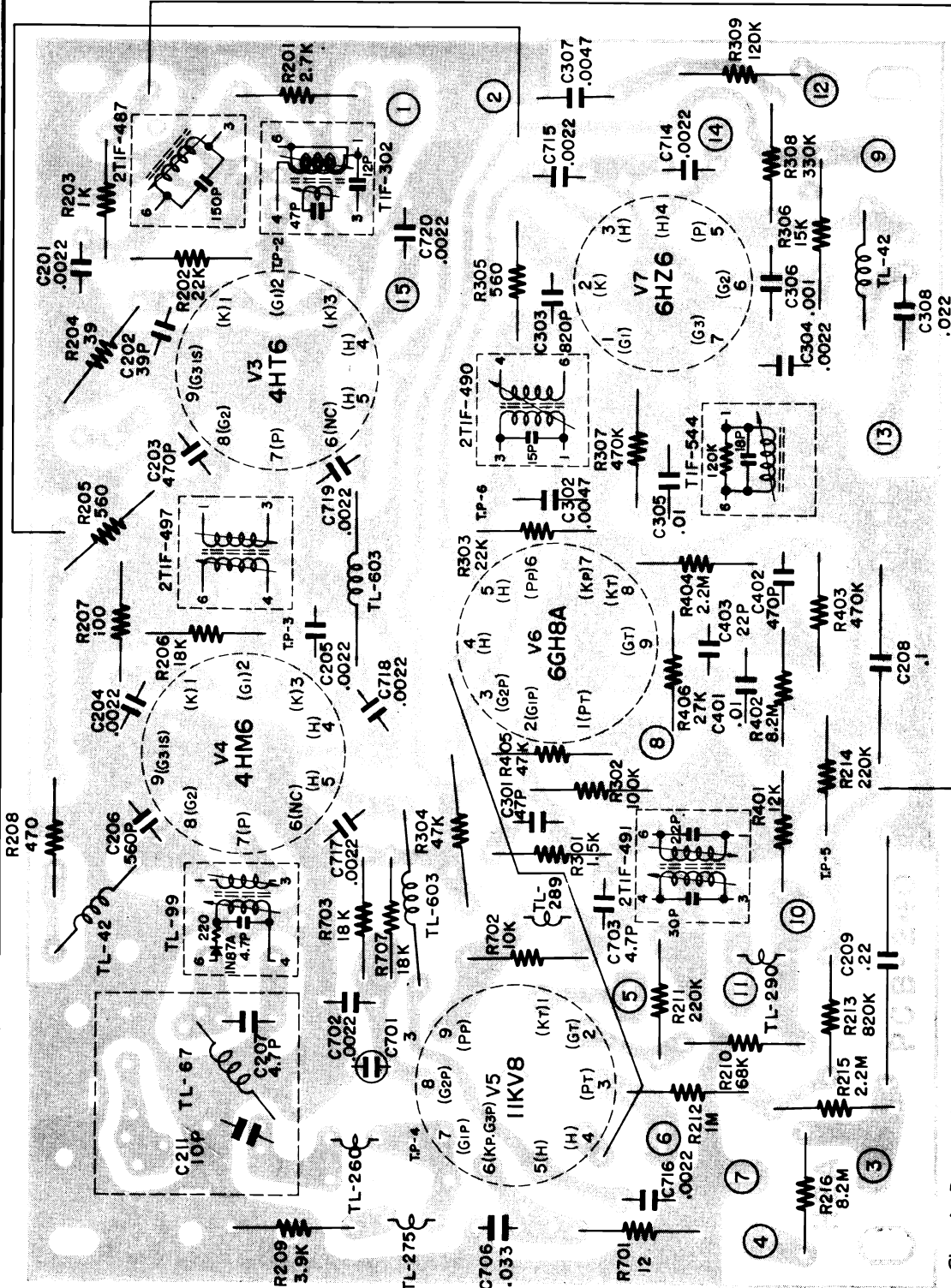

PRINTED CIRCUIT BOARD (Bottom View)

Chassis Removal

1. Remove the OFF-ON volume, Contrast, U.H.F. indicator, U.H.F. fine tuning, V.H.F. channel selector and V.H.F. fine tuning knobs from the front of the cabinet. Then lay the cabinet face down on soft pad.
2. Remove the eight cabinet back retaining screw, five of these screws are located on the top and both side of back cover and the remaining three on the bottom of the cover.
3. Remove the back cover and disconnect the antenna.
4. Remove deflection yoke plug, picture tube socket, anode lead, and speaker leads.
5. Remove 4 screws on the bottom of the cabinet and 2 screws on the chassis.
6. Remove 3 nuts retaining tuners bracket and a screw fining tuner bracket mounting insulator fiber to the cabinet.
7. Remove 3 screws retaining volume and contrast bracket.

SHARP Model 19P-11 Schematic Diagram, Continued

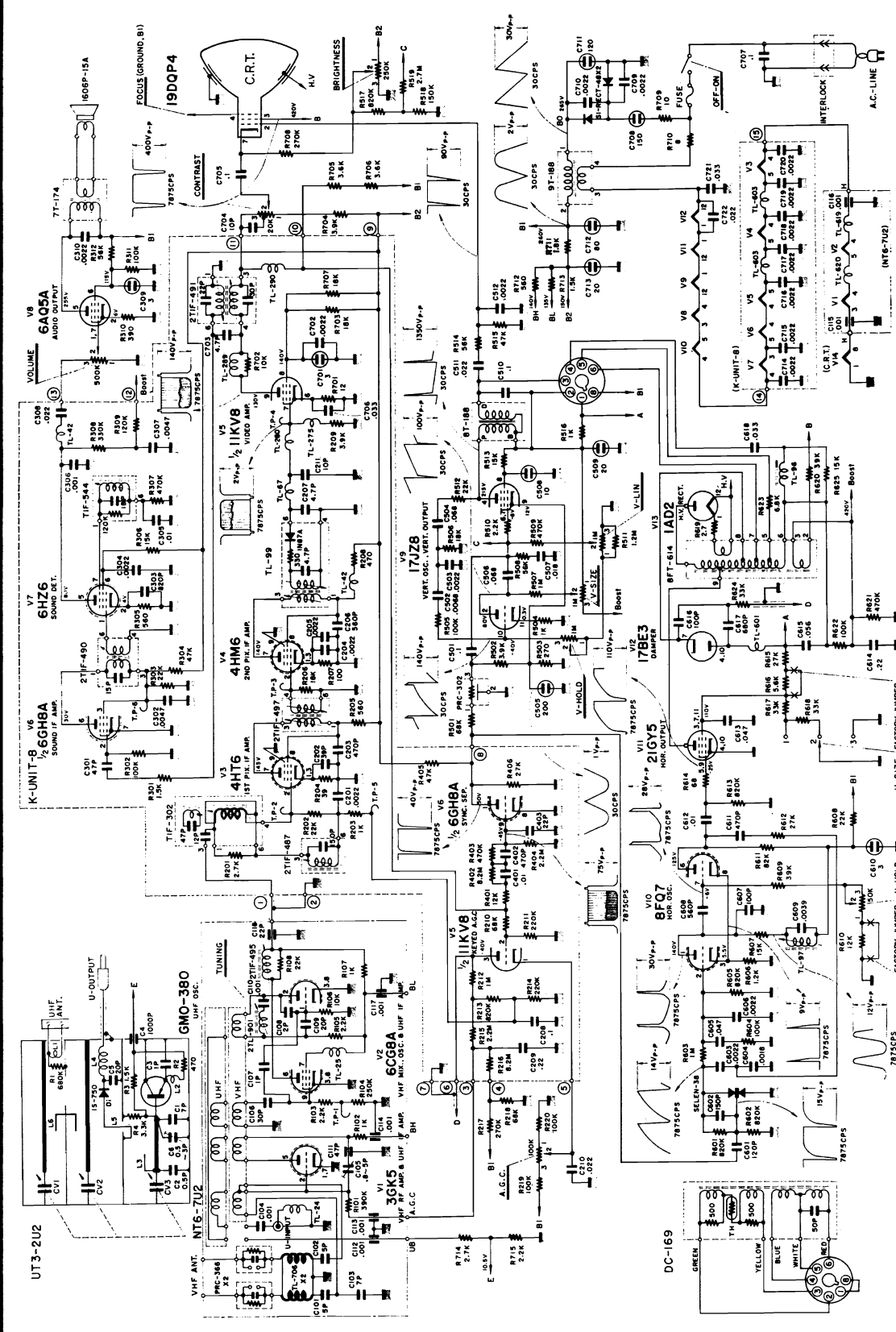

Horizontal AFC Alignment

1. Television receiver and test equipment should be turned on and allowed to warm up before starting alignment procedure.
2. Tune in a local station and adjust for normal picture.
3. Short-circuit both ends of horizontal ringing coil TL-97.
4. Connect 0.5 μ F capacitor between V6 pin 1 and the chassis to eliminate the synchronizing signal output.
5. Turn the Horizontal Hold volume to synchronize a picture horizontally.
6. Open the short of Horizontal Ringing Coil TL-97 and adjust its core to produce the same condition as in step 5.
7. Remove 0.5 μ F capacitor between V6 pin 1 and the chassis.
8. Repeat steps 5 and 6 until the Horizontal Hold control is set at the mechanical center of its range.

SYLVANIA

Chassis B04-3, B04-4, B04-5, B04-6, used in
Models 23T116, -1, 23T117, -1, 23L173, 23L174, 23L175

CENTERING ADJUSTMENT

1. Position deflection yoke as far forward as possible on the neck (against the flare) of the picture tube.
2. Rotate centering adjustment rings (located on yoke cover) individually or together, until picture is centered. Turn brightness control to a low level and check that no corner cutting exists in the picture.

FOCUS

With contrast and brightness at normal settings connect focus jumper to either tie point Y or Z whichever gives maximum sharpness and clarity of fine detail in center and edges of picture.

HORIZONTAL AFC ADJUSTMENT

Before performing the following procedure, check AGC adjustment as described under controls.

1. Set channel selector to strongest channel in area and adjust fine tuning control to correct tuning point.
2. Adjust vertical height, vertical linearity and width control for normal picture.

3. Adjust [L400] Horizontal Stabilizing coil for 10 volt AC with hot lead of probe at horizontal test point (D), ground lead to chassis, keeping picture locked in with [R414] Horizontal hold control as adjustment is being made.
4. Short pin 2 of V6 (6JT8) to ground and adjust [R414] until the picture becomes as stable as possible.
5. Remove short from V6, rotate channel selector to a position on which no signal is received; then return to the original station. The picture should immediately fall into sync. If not, repeat steps 3, 4 and 5.

HORIZONTAL LINEARITY

Before attempting to adjust Horizontal Linearity coil [L406], make certain all other controls are adjusted for normal picture viewing. Using a test pattern, preferably a circle, rotate core of [L406] until it is all the way out. Then slowly turn core inward until the right hand side of test pattern (as viewed from the front) is pulled out to its maximum. When maximum is reached, reverse rotation of the core very slightly until both sides of the circle are linear. Final adjustment of the Vertical Height, Vertical Linearity and width controls may become necessary after adjusting [L406]

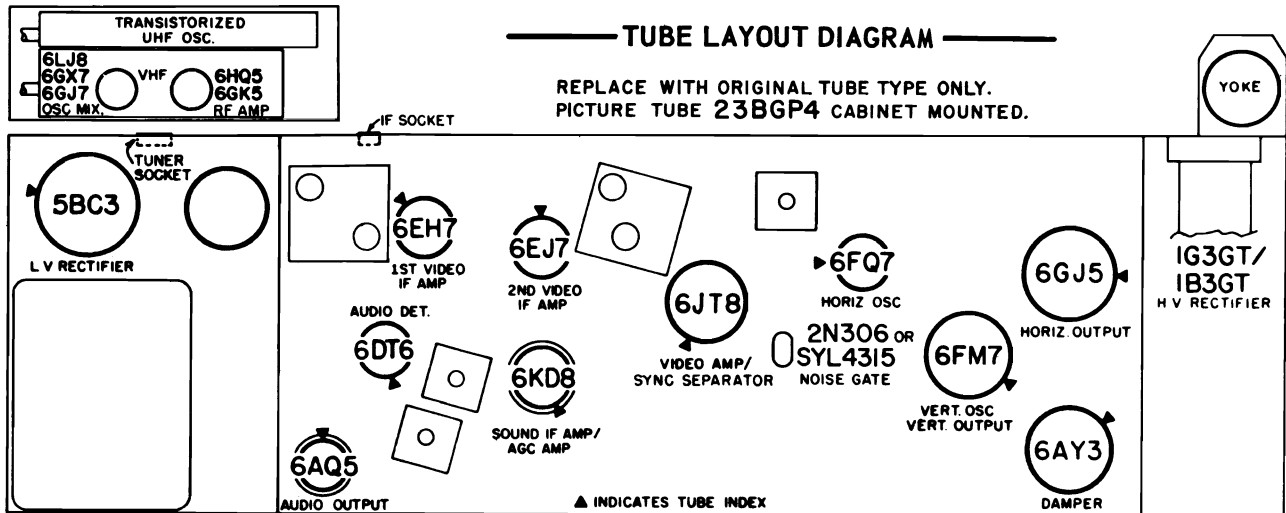

CHASSIS REMOVAL

1. Disconnect AC power cord and antenna connections. Remove interlock cover.
2. Disconnect the following plug and socket connections:
 - A. Yoke - at chassis.
 - B. Tuner cluster - at chassis.
 - C. Halo-Light (on some models) - at chassis.
 - D. Picture tube cable - at picture tube.
 - E. High voltage lead - at picture tube.
 - F. IF input - at chassis.
 - G. Speaker leads - at speaker.
3. Remove screw securing braided cable grounding tuner assembly to main chassis.
4. Remove chassis mounting screw.
5. Slide chassis to the left until clear of slots and then to the rear until clear of cabinet. NOTE: Lower front control

knobs will automatically disconnect while chassis is being removed.

- NOTE:** To remove yoke loosen screw on deflection yoke retaining ring. Slide yoke back on neck of picture tube until clear from tube.
6. Remove tuner cluster knobs by pulling straight outward.
 7. Remove screws securing antenna board to cabinet.
 8. Remove tuner mounting screws securing tuner to cabinet. (On some models remove screw securing tuner to mounting bracket.)
 9. Lift tuner cluster upward slightly and then back. Remove tuner cluster.
 10. To replace chassis, reverse the above procedure, engaging front controls by pressing ends of shaft assemblies over control shafts. Reconnect all plug and socket connections.

SYLVANIA Schematic Diagram Chassis B04-5, B04-6

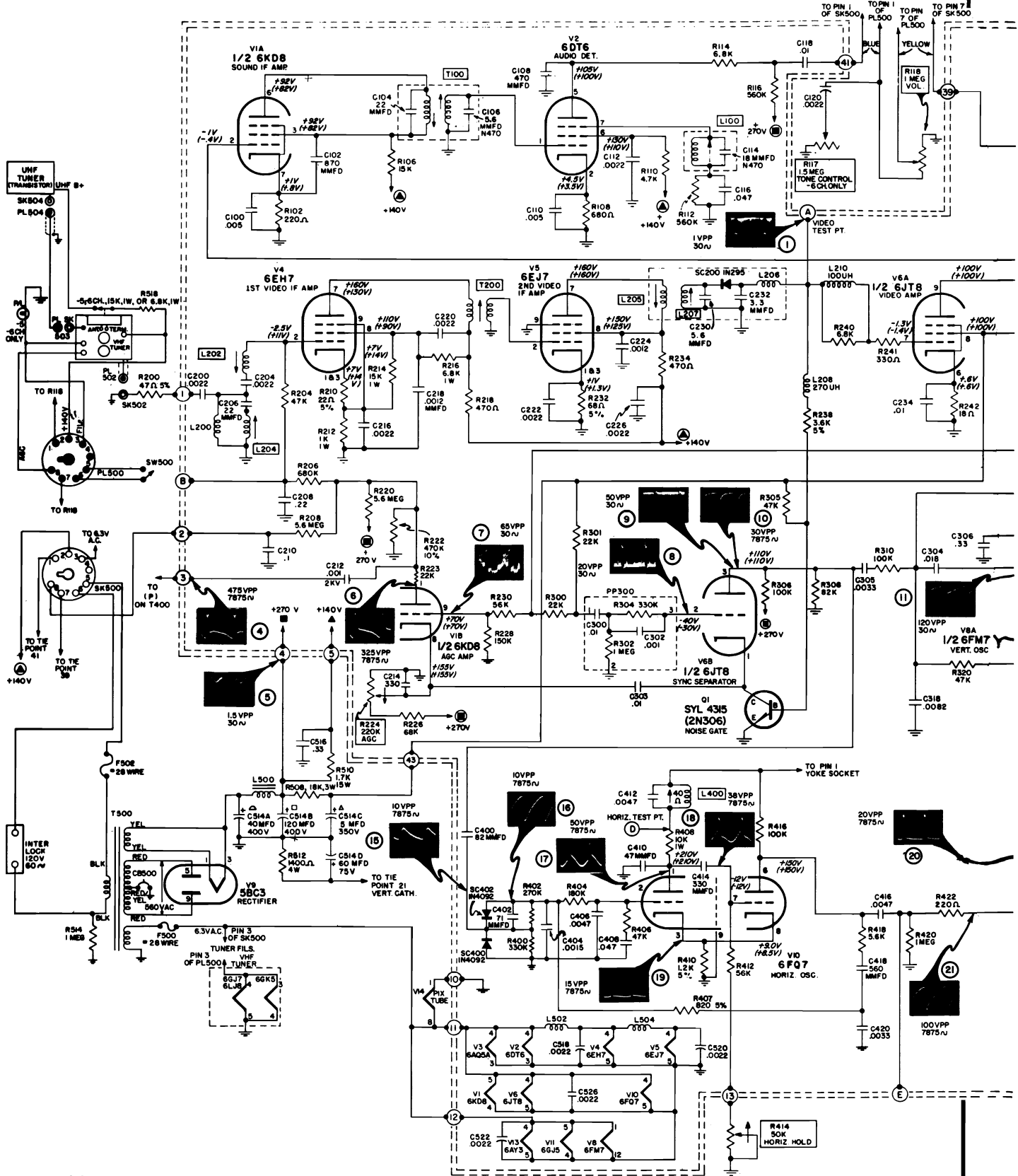

SCHEMATIC DIAGRAM (B04-5,-6)

SYLVANIA Schematic Diagram Chassis B04-5, B04-6, Continued

PICTURE TUBE HIGH VOLTAGE ANODE MAY HAVE A POTENTIAL OF 19,000 VOLTS. OBSERVE ALL HIGH VOLTAGE PRECAUTIONS WHEN SERVICING THE CHASSIS. DO NOT OPERATE THE RECEIVER WITH THE HIGH VOLTAGE COVER REMOVED USE SAFETY GOGGLES AND GLOVES WHEN HANDLING THE PICTURE TUBE.

SCHEMATIC NOTES

VOLTAGE MEASUREMENT CONDITIONS UNLESS OTHERWISE SPECIFIED.

1. Voltages measured to chassis using VTVM.
2. AC power source 120 volt 60 cycle line.
3. Voltage readings in brackets taken with no input; channel selector set to a free channel, antenna disconnected, antenna terminals shorted together and grounded to chassis.
4. Voltage readings not in brackets taken with a strong signal input; tuner set to a strong local station developing approximately -7 volt on AGC Buss. NOTE: AGC VOLTAGE AT TEST POINT (B) WILL VARY FROM -7 VOLT ON A VERY STRONG SIGNAL TO A +20 VOLT ON A VERY WEAK SIGNAL.
5. Contrast control set to maximum. Brightness control set to minimum.
6. Voltage values shown are average readings. Variations may be observed due to normal production tolerances.

SPECIAL VOLTAGE MEASUREMENT CONDITIONS

- (B) Picture tube anode voltage measured with VTVM high voltage probe at line voltage of 120 volts under conditions of normal signal, no brightness and correct scan size.
- ▲ High peak voltage of short duration may damage meter used for this measurement.

WAVEFORM MEASUREMENT CONDITIONS

1. Channel selector set to strong channel.
2. Contrast control set for signal of 70 volt peak to peak at yellow lead of picture tube.
3. Waveforms measured with respect to chassis using a wide band oscilloscope. (Other type oscilloscopes may alter waveform shapes or amplitudes.)
4. The terms 30V or 7875V refer to scope frequency used.

PARTS CODING

Sound Section	100-199
Video Section	200-299
Vert. and Sync Section	300-399
Horiz. and H.V. Section	400-499
L.V. Supply, Fil., Misc.	500-599

GENERAL SCHEMATIC NOTES

1. Voltage sources are indicated by encircled symbols, corresponding symbols without circles indicate voltage tie points.
2. Average resistances of coils and transformers are shown and are measured with component connected in circuit.
3. Encircled numbers on edge of printed circuit indicate tie points, corresponding with those shown on parts layout of printed board.
4. All capacitors are in microfarads unless otherwise specified.
5. Coils, transformers, plugs and sockets are shown as viewed from the bottom.
6. Arrows on controls indicate direction of clockwise rotation.

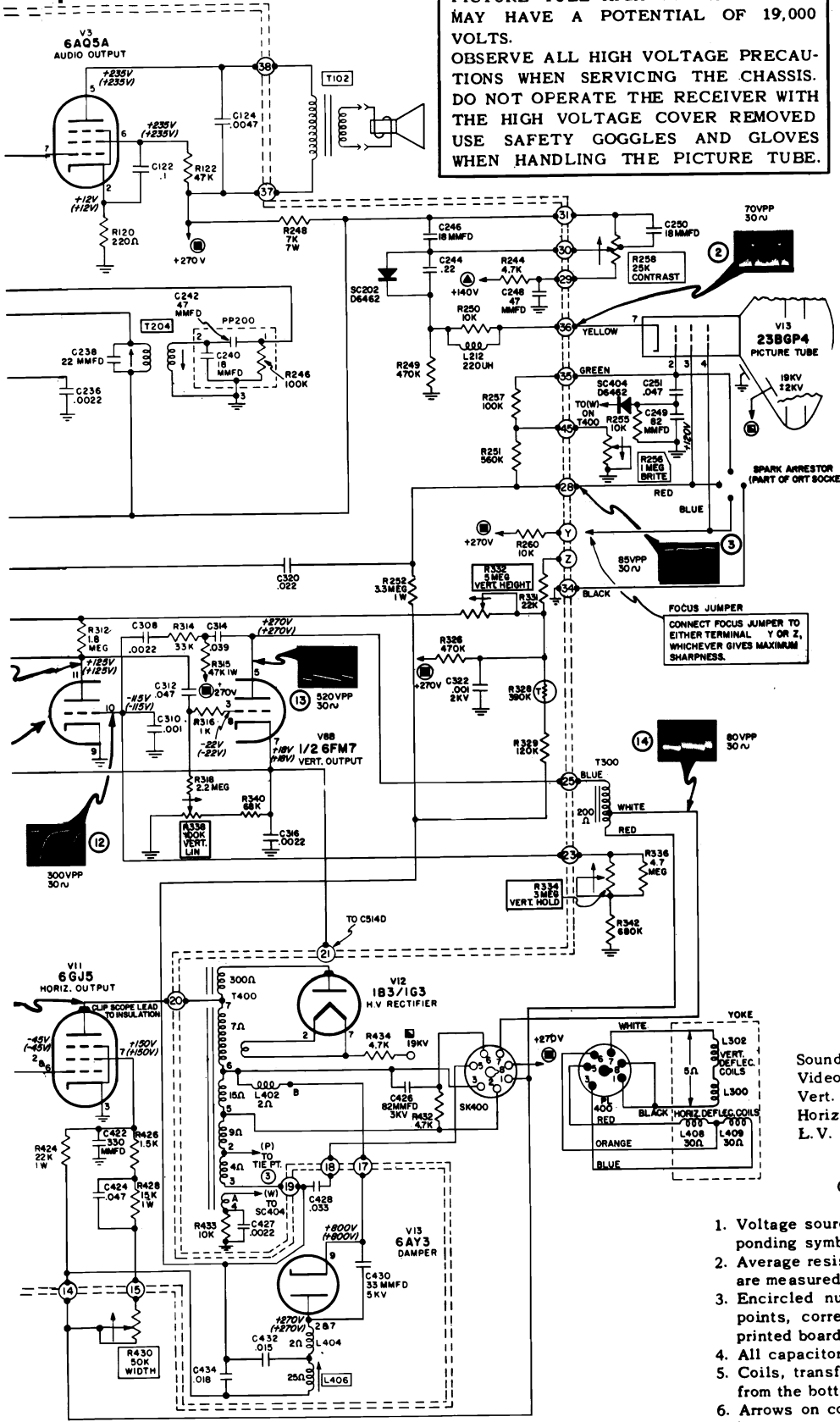

SYLVANIA Chassis B04-3, -4, -5, -6, Service Information, Continued

— VIDEO IF ALIGNMENT —

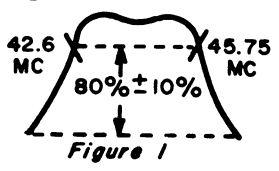
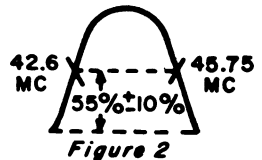
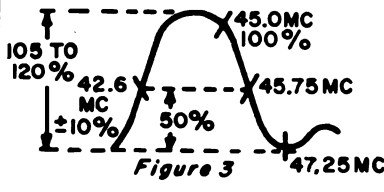
STEP	ALIGNMENT SET - UP NOTES	TEST EQUIPMENT HOOK - UP	ADJUST
1	<p>Set VHF tuner to a free channel that does not disturb the response curve.</p> <p>Short point (B) to ground and connect a -10V DC source to tie point (2).</p> <p>Connect - 30 volt DC source (-) terminal to pin 2 of V11 (+) terminal to chassis.</p>	<p>SWEEP GENERATOR - Through a .002 MFD capacitor to pin 2 of V5. Set generator to 43.5 MC with 10 MC sweep.</p> <p>SIGNAL GENERATOR - Loosely coupled as a marker to sweep generator lead.</p> <p>OSCILLOSCOPE - Through a 10K resistor connected to test point (A)</p>	<p>L205 and L207 so that the 42.6 MC marker and the 45.75 MC marker are of equal amplitude. See Figure 1.</p>  <p>L205 Positions marker amplitude. L207 Adjusts for tilt.</p>
2	<p>Same as Step 1.</p>  <p>Figure 2</p>	<p>SWEEP GENERATOR - Through a .002 MFD capacitor to IF test point on tuner. Set generator to 43.5 MC with 10 MC sweep.</p> <p>SIGNAL GENERATOR - Same as Step 1.</p> <p>OSCILLOSCOPE - Same as Step 1.</p>	<p>T200 so that both the 42.6 MC and 45.75 MC markers are of equal amplitude and at 55% of response curve. See Figure 2.</p>
3	<p>Same as Step 1.</p>  <p>Figure 3</p>	<p>SWEEP GENERATOR - Same as Step 2.</p> <p>SIGNAL GENERATOR - Same as Step 1.</p> <p>OSCILLOSCOPE - Same as Step 1.</p>	<p>L204 for maximum dip at 47.25 MC</p> <p>TUNER MIXER COIL - To position 45.75 MC marker at 50% of response curve while 45 MC marker is maintained at 100%.</p> <p>L202 To obtain response as shown in Figure 3. Top of response curve should be smooth and rounded and should rise from 105% to 120%.</p>

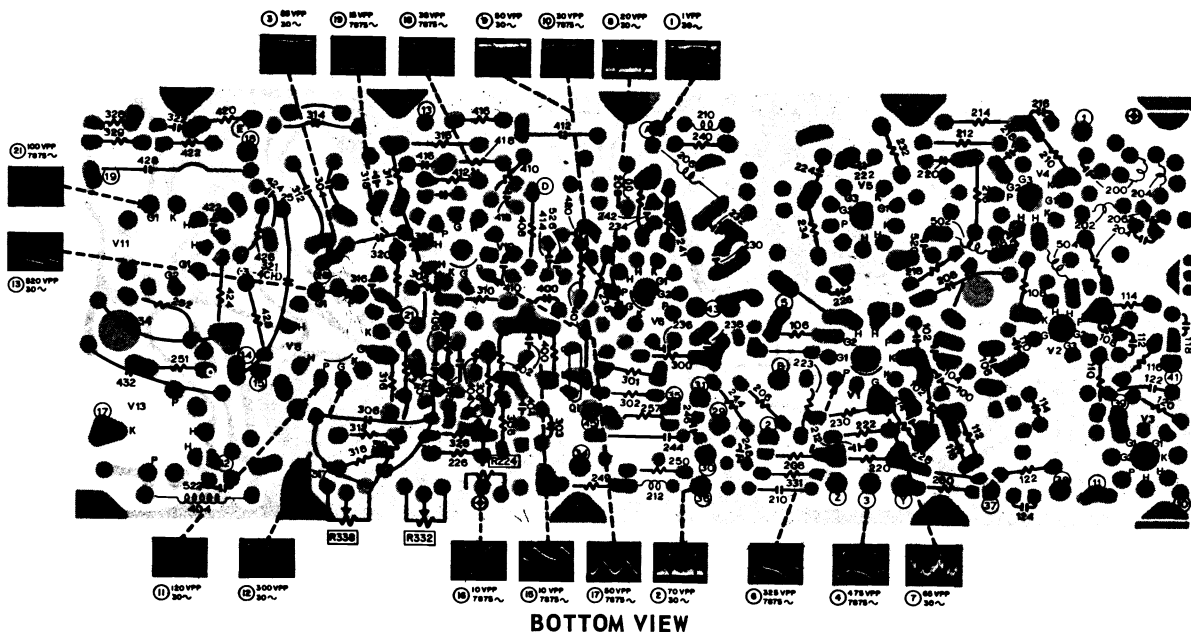

SYLVANIA

Chassis A04-1, -2, used in Models 12P15 and 12P16
(Material on pages 143 through 150)

CHASSIS REMOVAL

1. Disconnect power cord and antenna connections.
2. Remove the four (4) screws securing back of cabinet. Remove back of cabinet.
3. Remove knobs by pulling straight out.
4. Disconnect picture tube lead, H.V. Lead and yoke leads. (Identify yoke leads before disconnecting).
5. Lay front of cabinet on a soft material so as not to mar face of picture tube.
6. Remove four (4) screws securing chassis to front portion of cabinet and lift chassis away from cabinet and picture tube.
7. To replace chassis, reverse the above procedure.

PICTURE TUBE REMOVAL

1. Remove chassis as outlined under "Chassis Removal".
2. Loosen screw on yoke retaining Ring. Remove yoke.
3. Remove four (4) screws securing picture tube mounting frame to chassis.
4. USING GOGGLES AND GLOVES, remove picture tube and mounting frame from cabinet. **IMPORTANT: THE MOUNTING FRAME IS AN INTEGRAL PART OF THE PICTURE TUBE, DO NOT TRY TO SEPARATE.**
5. Reverse the above procedure for picture tube installation.

YOKE REMOVAL

1. Remove back of cabinet as outlined under "Chassis Removal".
2. Disconnect picture tube socket.
3. Loosen screw on yoke retaining ring.
4. Identify and disconnect yoke leads.
5. Slide yoke off carefully from neck of picture tube.
6. Reverse the above procedure for yoke installation. Make certain all leads disconnected are reconnected in their original positions.

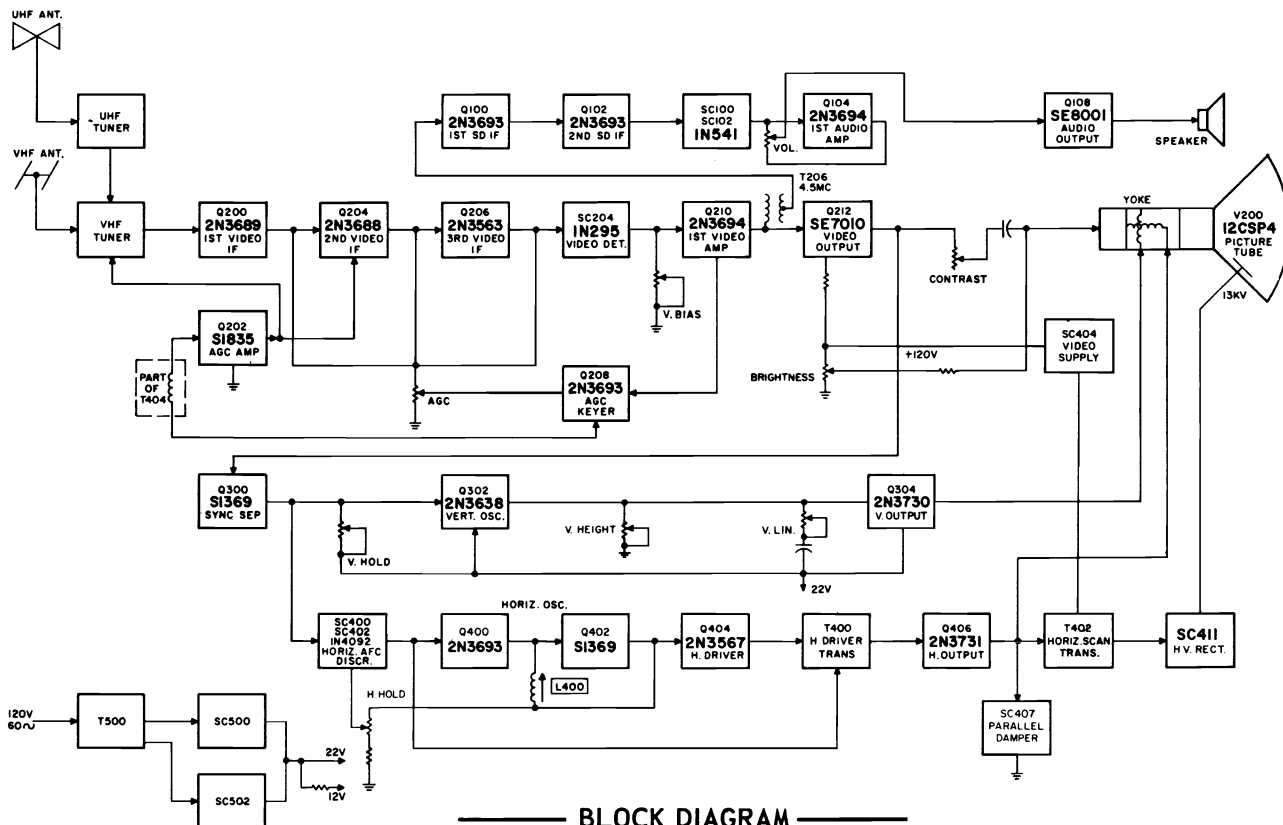

CONTROLS

UHF CHANNEL SELECTION - First rotate the VHF channel selector to the UHF position between channels 2 and 13. Then rotate the UHF channel selector knob until the desired channel (14 to 83) is obtained. Slight additional adjustment either side of the selected channel fine tunes for best picture and sound.

BRIGHTNESS-CONTRAST ADJUSTMENT - Rotate contrast (C) control fully counterclockwise (minimum contrast). Adjust brightness (B) control so that a known black object is a true black with little or no grey shading. Readjust contrast control for most pleasing picture.

NOTE: Once correct brightness setting has been established, it is not normally necessary to readjust the brightness control. Use the contrast control to adjust for variations in room lighting.

AGC - Use this control only if normal contrast cannot be obtained with CONTRAST Control, or if the picture is not steady. Tune in a strong channel and then rotate clockwise until the picture "jumps" or is unsteady, then back off until the picture becomes steady and normal.

HEIGHT-VERTICAL LINEARITY - These two controls are interdependent. If the picture is out of proportion vertically, or compressed at the top or bottom, adjust both controls until the picture assumes normal proportions. The Height Control should be adjusted first so that the picture fills the screen from top to bottom. Then adjust the Vertical Linearity Control for normal proportions at top and bottom of picture. Repeat procedure until normal picture proportions are obtained. Note: It may be necessary to readjust the Vertical Hold Control after making these adjustments.

VERTICAL HOLD - Use this control (V) to stop vertical movement, rolling up or down. To adjust, rotate knob until picture rolls slowly from top to bottom, then rotate in the opposite direction just beyond the point where the picture snaps in and is stable.

HORIZONTAL HOLD (Located at rear of receiver) - If the picture bends slightly, shifts horizontally, or if there are diagonal bars, adjust this control until the picture locks in and appears normal.

ADJUSTMENTS

CENTERING ADJUSTMENT

1. Position deflection yoke as far forward as possible on the neck (against the flare) of the picture tube.
2. Rotate centering adjustment rings (located on yoke cover) individually or together, until picture is centered. Turn brightness control to a low level and check that no corner cutting exists in the picture.

HORIZONTAL FREQUENCY ADJUSTMENT

Before making the following adjustments, check AGC adjustment as described under controls.

1. Set channel selector to strongest channel in area and adjust fine tuning control to correct tuning point.
2. Adjust Vertical Height, Vertical Linearity for normal picture.
3. Short across [L400] Horizontal Frequency coil.
4. Short to ground, base of Q300, Sync Separator.
5. Adjust [R420] Horizontal Hold until picture is as stable as possible.
6. Remove short across [L400] and adjust it and [R421] for best possible stable picture.
7. Remove short from base of Q300. Rotate channel selector to a position on which no signal is received; then return to the original station. The picture should immediately fall into sync, if not repeat procedure making certain finer adjustment is made when adjusting [L400] and [R420].

PRINTED BOARD ASSEMBLY

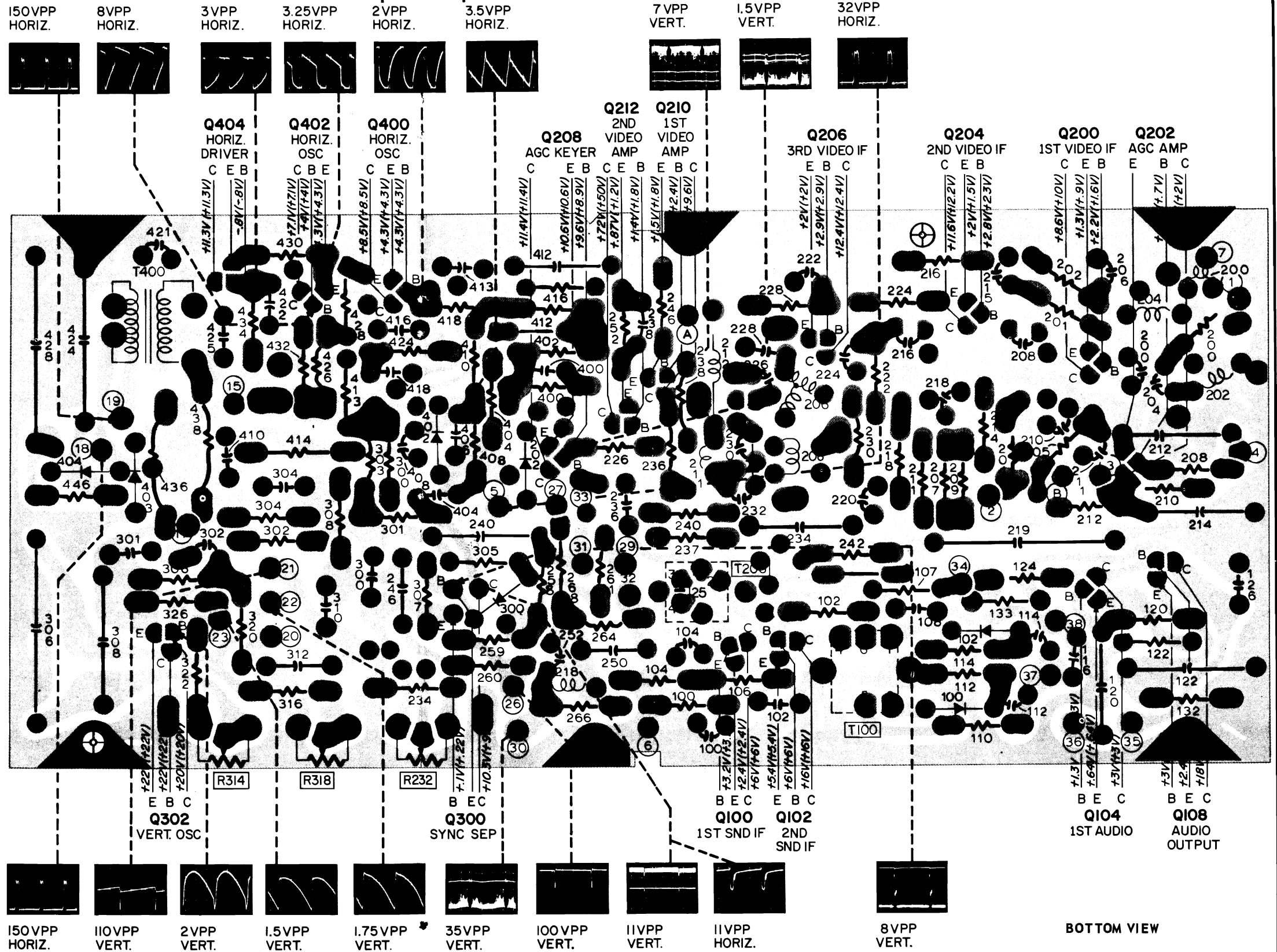

BOTTOM VIEW

SYLVANIA Chassis A04-1, -2, Schematic Diagram

SCHEMATIC NOTES

IMPORTANT

READ THESE INSTRUCTIONS CAREFULLY AND OBSERVE THE CONDITIONS NOTED WHEN TAKING VOLTAGE READINGS OR OBSERVING WAVEFORMS.

PICTURE TUBE HIGH VOLTAGE ANODE MAY HAVE A POTENTIAL OF 13,000 VOLTS. OBSERVE ALL HIGH VOLTAGE PRECAUTIONS WHEN SERVICING THE CHASSIS.

VOLTAGE MEASUREMENT CONDITIONS UNLESS OTHERWISE SPECIFIED.

1. Voltages measured to chassis using VTVM.
2. AC power source 120 volt 60 cycle line.
3. Voltage readings in brackets taken with a weak signal.
4. Voltage readings not in brackets taken with a strong signal.
5. Contrast and Brightness control set for normal viewing picture.
6. Voltage values shown are average readings. Variations may be observed due to normal production tolerances.

SPECIAL VOLTAGE MEASUREMENT CONDITIONS

1. Picture tube anode voltage measured with VTVM high voltage probe at line voltage of 120 volts under conditions of normal signal, no brightness and correct scan size.

WAVEFORM MEASUREMENT CONDITIONS

1. Channel selector set to strong channel.
2. Brightness control set for signal of 35 volt peak to peak at yellow lead of picture tube. AGC control set so that +2.9 volt is developed at test point (B).
3. Waveforms measured with respect to chassis using a wide band oscilloscope. (Other type oscilloscopes may alter waveform shapes or amplitudes.)
4. The terms VERT or HORIZ refer to scope frequency used.

GENERAL SCHEMATIC NOTES

1. Average resistances of coils and transformers are shown and are measured with component connected in circuit.
2. Encircled numbers indicate tie points.
3. All capacitors are in MFD unless otherwise specified.
4. Arrows on controls indicate direction of clockwise rotation.

PARTS CODING

Sound Section	_____	100-199
Video Section	_____	200-299
Vert. and Sync Section	_____	300-399
Horiz. and H.V. Section	_____	400-499
L.V. Supply, Misc.	_____	500-599

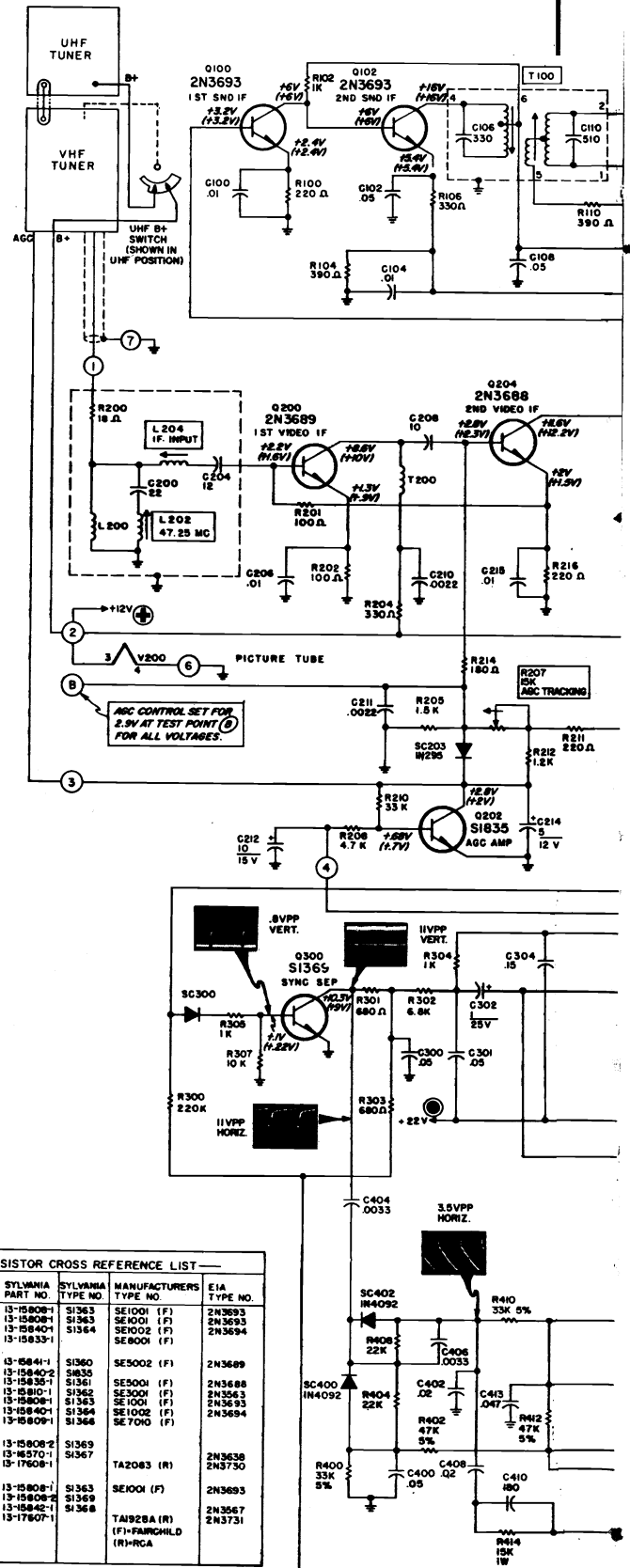
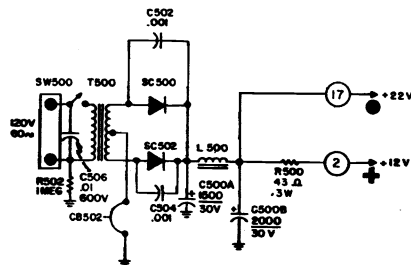

TRANSISTOR CROSS REFERENCE LIST

SCHEMATIC CODING	SYLVANIA PART NO.	SYLVANIA TYPE NO.	MANUFACTURERS TYPE NO.	EIA TYPE NO.
Q100	13-15808-1	S1363	SE1001 (F)	2N3693
Q102	13-15808-1	S1363	SE1001 (F)	2N3693
Q104	13-15840-1	S1364	SE1002 (F)	2N3694
Q108	13-15833-1	S1364	SE1000 (F)	2N3694
Q200	13-15841-1	S1360	SE5002 (F)	2N3689
Q202	13-15840-2	S1365	SE5001 (F)	2N3688
Q204	13-15835-1	S1361	SE5001 (F)	2N3688
Q206	13-15810-1	S1362	SE3001 (F)	2N3653
Q208	13-15808-1	S1363	SE1001 (F)	2N3693
Q210	13-15840-1	S1364	SE1002 (F)	2N3694
Q212	13-15809-1	S1366	SE7010 (F)	2N3694
Q300	13-15808-2	S1369	SE1001 (F)	2N3693
Q302	13-15701-1	S1367	TAZ083 (R)	2N3638
Q304	13-17608-1	S1367	TAZ083 (R)	2N3730
Q400	13-15808-1	S1363	SE1001 (F)	2N3693
Q402	13-15808-2	S1369	SE1001 (F)	2N3693
Q404	13-15842-1	S1368	TAI928A (R)	2N3567
Q406	13-17501-1	S1368	TAI928A (R) (R)-RCA	2N3731

SYLVANIA Chassis A04-1, -2, Schematic Diagram, Continued

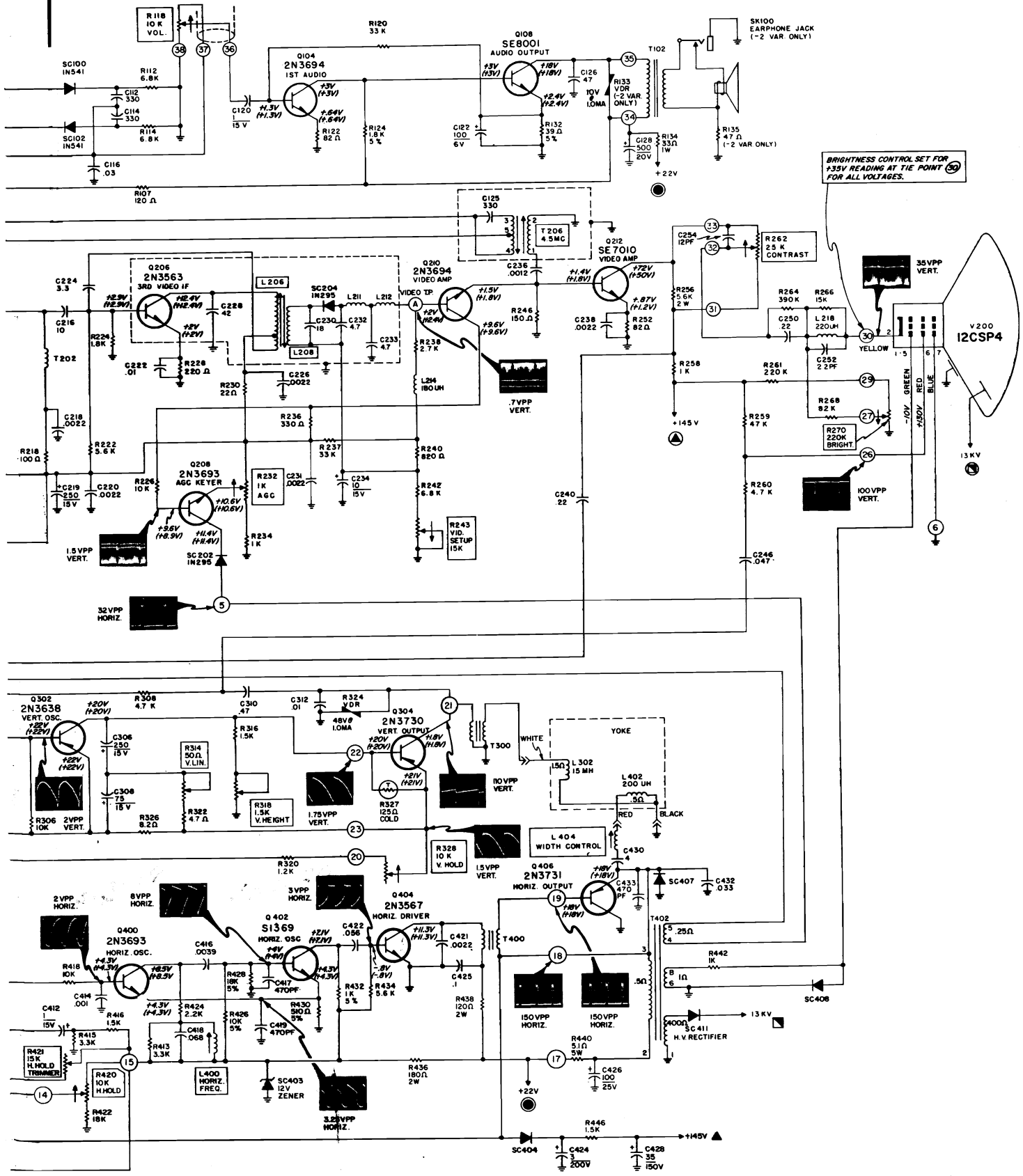

SYLVANIA Chassis A04-1, -2, Alignment Procedure

VIDEO IF, SOUND IF AND 4.5 MC TRAP ALIGNMENT PROCEDURES

PRELIMINARY INSTRUCTIONS

1. Line voltage should be maintained at 120 volts.
2. Keep marker generator coupling at a minimum to avoid distortion of the response curve.
3. Do not use tubular capacitors for coupling sweep into receiver. Disc ceramics are best.
4. For best results, solder the sweep generator ground to chassis, do not use clips.
5. Sweep generator "hot" lead must make good electrical contact at all points given under TEST EQUIPMENT HOOK-UP.
6. Adjust oscilloscope output for maximum peak-to-peak response curve.
7. Receiver and test equipment should warm up for approximately 15 minutes before alignment.

— VIDEO IF ALIGNMENT —

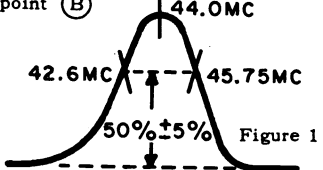
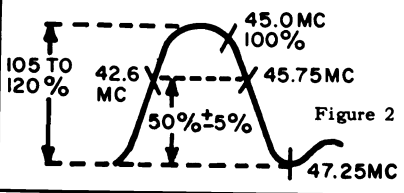
STEP	ALIGNMENT SET - UP NOTES	TEST EQUIPMENT HOOK - UP	ADJUST
1	<p>Set VHF tuner to a free channel that does not disturb the response curve. Apply a well filtered +4.5V bias to test point (B)</p> 	<p>SWEEP GENERATOR - Through a .002 MFD Capacitor to base of Q206. Set generator to 44.0 MC with 10 MC sweep..</p> <p>SIGNAL GENERATOR - Loosely coupled as a marker to sweep generator lead. (42.6 MC) (45.75 MC)</p> <p>OSCILLOSCOPE - Through a 10K resistor connected to test point (A)</p>	<p>[L208] for max. amplitude of response curve.</p> <p>[L206] so that the 42.6 MC marker and the 45.75 MC marker are of equal amplitude. See Figure 1.</p> <p>[L206] Positions marker.</p> <p>[L208] Adjust for tilt.</p>
2	<p>Same as Step 1.</p> 	<p>SWEEP GENERATOR - through a .002 MFD capacitor to IF test point on tuner. Set generator to 44.0 MC with 10MC sweep.</p> <p>SIGNAL GENERATOR - Same as Step 1. (47.25 MC) (45.75 MC) (45 MC) (42.6 MC)</p> <p>OSCILLOSCOPE - Same as Step 1.</p>	<p>[L202] for maximum dip at 47.25 MC.</p> <p>[L204] and tuner IF coil to obtain response as shown in Figure 2.</p> <p>Tuner IF coil positions the 45.75 MC marker at 50% while maintaining the 45.0 MC marker at 100% with Signal Generator output.</p> <p>[L204] adjust for smooth and rounded top.</p>
3	Remove Test Equipment and Test Receiver on an air signal.		

— 4.5 MC TRAP AND SOUND IF ALIGNMENT —

STEP	ALIGNMENT SET - UP NOTES	TEST EQUIPMENT HOOK - UP	ADJUST
1	Set contrast control to maximum.	<p>SIGNAL GENERATOR - Through a .0047 MFD capacitor to test point (A). Set signal generator to 4.5 MC, preferably crystal calibrated or controlled, with at least 100 millivolts output.</p> <p>VTVM - Through detector network shown in Figure 1, to cathode of picture tube - tie point 30.</p>	<p>Separate cores of [T206] then</p> <p>Adjust bottom core of [T206] for the first minimum reading on meter.</p>
2	Same as Step 1.	<p>SIGNAL GENERATOR - Same as Step 1.</p> <p>VTVM - To junction of R112 and C112.</p>	<p>[T100] Bottom core</p> <p>[T206] Top core</p> <p>For maximum meter reading using weakest possible signal.</p>
3	Same as Step 1.	<p>SIGNAL GENERATOR - Same as Step 1.</p> <p>VTVM - To junction of R110 and C116.</p>	<p>[T100] Top core for Zero reading on VTVM.</p> <p>Adjust [T100] top core so VTVM pointer swings freely plus thru 0 to minus and vice versa. Then adjust for zero reading. Adjustment must be accurate.</p>
4	Remove all test equipment leads etc. Connect antenna and check receiver on a strong local station.		

SYLVANIA Chassis A04-1, -2, Printed Board Assembly, Continued

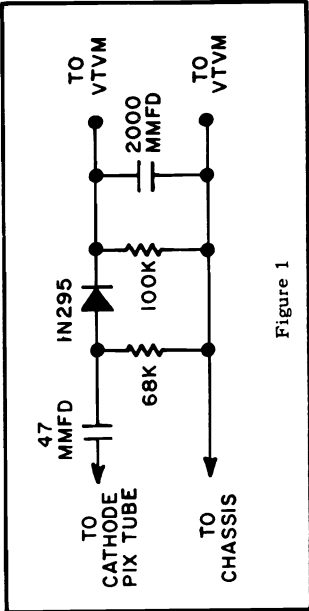
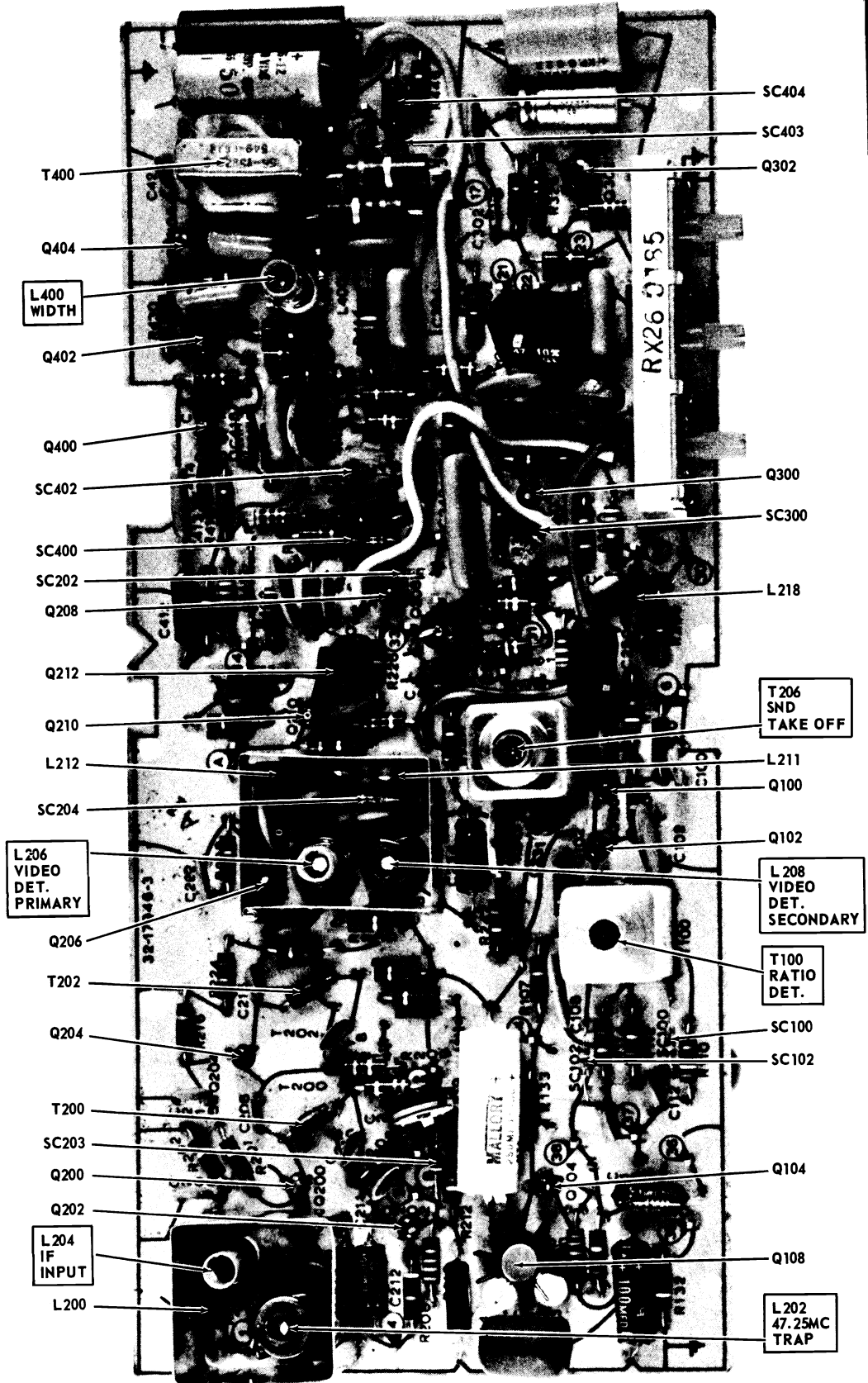

Figure 1

ALTERNATE SOUND ALIGNMENT USING TRANSMITTED SIGNAL

Turn AGC counterclockwise until sound gets weak and noisy. Adjust **T100** top and bottom core and **T206** bottom core for loudest and clearest sound and minimum hiss. Return AGC to normal setting.



MISCELLANEOUS

SYLVANIA Chassis A04-1, -2, Printed Board Assembly, Continued

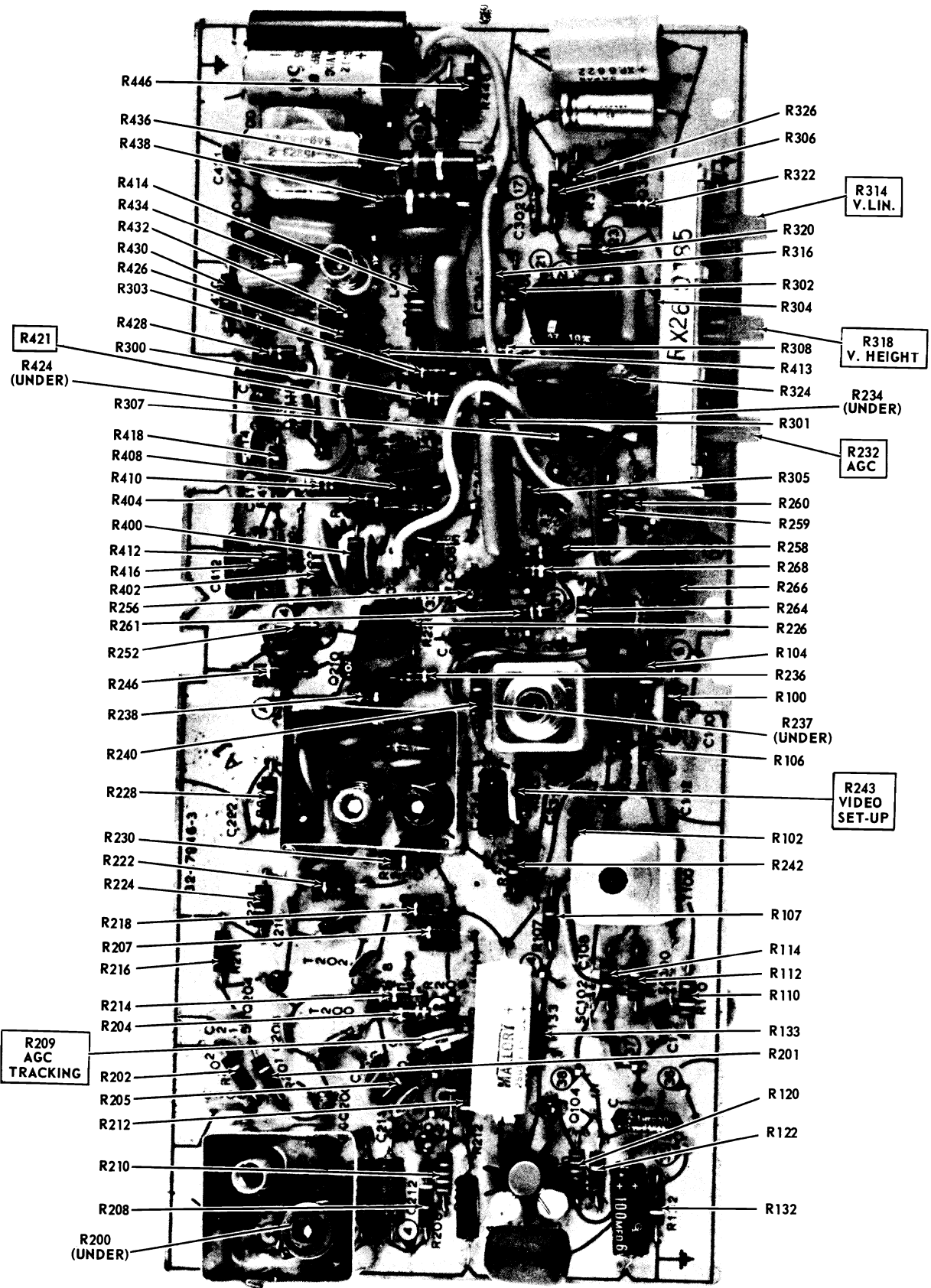

RESISTORS

Westinghouse

MODEL AND CHASSIS CHART

MODEL	CHASSIS	TUNERS	FEATURES	CRT
H-P3067	V2487-2	470V160D02 VHF 472V051D01 UHF	DOUBLE RECT. STEEL GUARD CRT INSTANT-ON	19FEP4A 114°
H-P3080 H-P3081	V2487-13	470V160D02 VHF 472V051D02 UHF	DOUBLE RECT. DIAL LIGHTS BLACK GLASS INSTANT-ON	19CMP4A 114°
BP19A770	V2487-14	470V160D02 VHF 472V051D02 UHF	DOUBLE RECT. BLACK GLASS INSTANT-ON	19CMP4A 114°
H-K4250A H-K4253A	V2487-11	470V162D03 VHF 472V053D01 UHF	DOUBLE RECT. DIAL LIGHT INSTANT-ON STEEL GUARD CRT	23HRP4 110°
HK4855	V2487-11	470V162D03 VHF 472V053D01 UHF	DOUBLE RECT. DIAL LIGHT INSTANT-ON BLACK GLASS	23HSP4 110°

Below are listed additional models using the basic V-2487 Chassis.

MODEL AND CHASSIS CHART

MODEL	CHASSIS	TUNERS	FEATURES	CRT
H-P3082	V2487-13	470V160D02 VHF 472V051D02 UHF	DOUBLE RECT. DIAL LIGHTS	19CMP4A 114°
		472V060D02 UHF ALTERNATE	BLACK GLASS INSTANT-ON	
H-K4251A H-K4252A	V2487-11	470V162D03 VHF 472V053D01 UHF	DOUBLE RECT DIAL LIGHT INSTANT ON STEEL GUARD CRT	23HRP4 110°
H-P9026 H-P9028 HOTEL-MOTEL	V2487-9	470V160D02 VHF 472V051D02 UHF	DOUBLE RECT BLACK GLASS	19CMP4A 114°
		472V060D02 UHF ALTERNATE	INSTANT ON DIAL LIGHT	
BP19B770	V2487-13	470V160D02 VHF 472V051D02 UHF	DOUBLE RECT BLACK GLASS	19CMP4A 114°
		472V060D02 UHF ALTERNATE	INSTANT ON DIAL LIGHT	

PC BOARD ACCESSIBILITY

To provide access to the underside of the PC board with the set operating:

1. Remove the chassis.
2. Turn the chassis around.
3. Connect the yoke CRT socket, and high-voltage lead (use a jumper). A test speaker may be connected to the audio output transformer.

CAUTION: To operate the set partially disassembled, connect a jumper from the aquadag CRT coating to chassis ground. Be careful that the high-voltage anode lead does not short or arc to the frame.

DIAL LAMP REPLACEMENT (V2487-1-13)

The dial lamps are located and mounted on the front of the tuner mounting bracket.

1. Remove the chassis (see chassis removal).
2. Cut-off the plastic sleeve over the dial lamp.
3. Cut out and replace the defective lamp.
4. Use tape to insulate lamp connections.

FUSE

The power supply fuse (F400) is located at the rear of the chassis near the AC input plug. The fuse is an "N" type 2-amp, 125-volt slo-blo.

WESTINGHOUSE Chassis V-2487-1, etc., Schematic Diagram

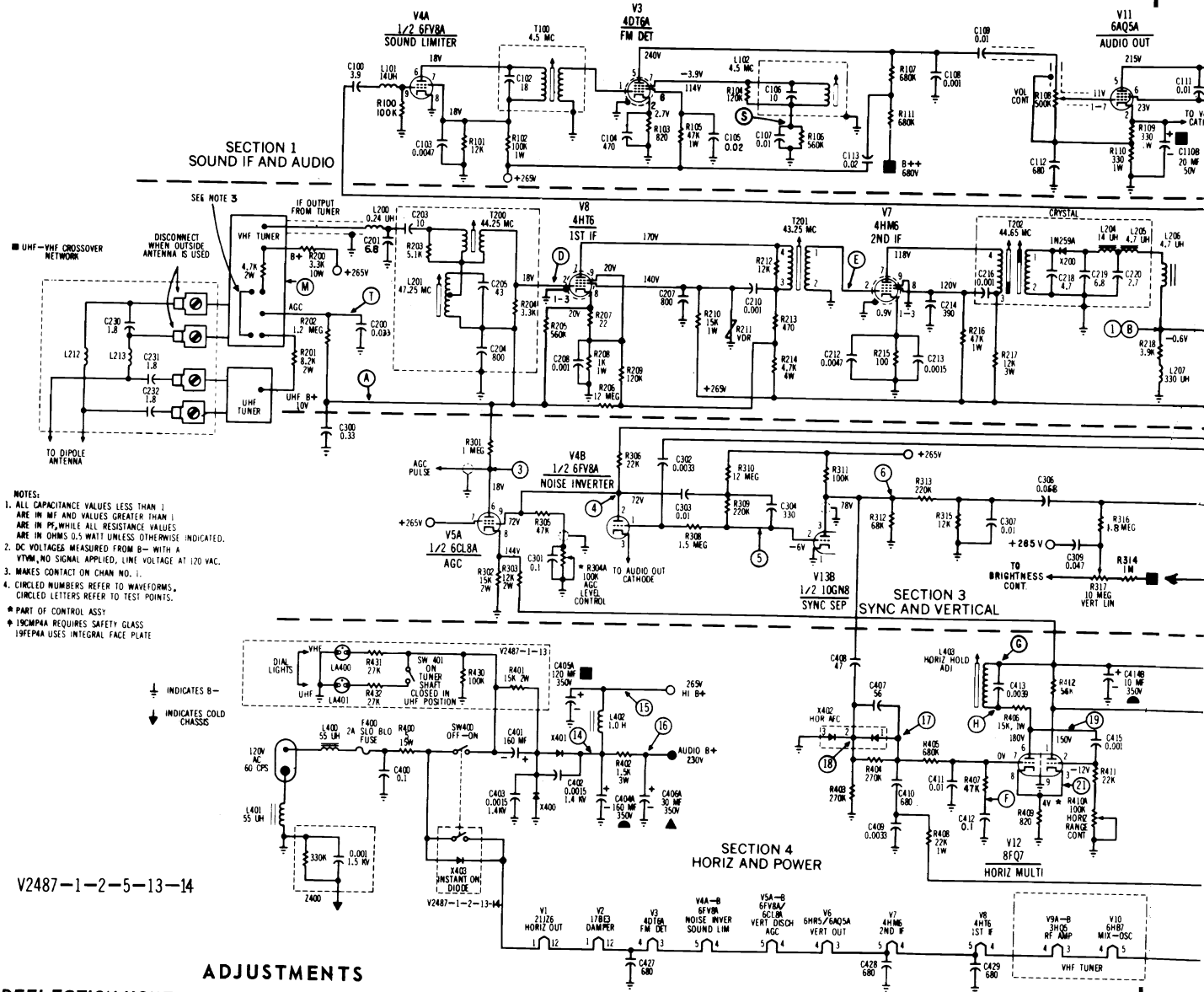

- NOTES:**
1. ALL CAPACITANCE VALUES LESS THAN 1 ARE IN MF AND VALUES GREATER THAN 1 ARE IN PF, WHILE ALL RESISTANCE VALUES ARE IN OHMS, 0.5 WATT UNLESS OTHERWISE INDICATED.
 2. DC VOLTAGES MEASURED FROM B- WITH A VTVM, NO SIGNAL APPLIED, LINE VOLTAGE AT 120 VAC.
 3. MAKES CONTACT ON CHAN. NO. 1.
 4. CIRCLED NUMBERS REFER TO WAVEFORMS. CIRCLED LETTERS REFER TO TEST POINTS.
- * PART OF CONTROL ASSY.
 † 19C5P4A REQUIRES SAFETY GLASS
 ‡ 19FEP4A USES INTEGRAL FACE PLATE

⊥ INDICATES B-
 ↓ INDICATES COLD CHASSIS

V2487-1-2-5-13-14

ADJUSTMENTS

DEFLECTION YOKE

The deflection yoke should be as far forward as possible (touching the bell of the CRT). Rotation of the deflection yoke is used to level the raster.

HORIZONTAL RANGE CONTROL AND HORIZONTAL HOLD ADJUSTMENT COIL, L403

1. Connect a jumper between TP (G) and TP (H) to short out coil L403.
2. Calibrate a VTVM to 0V center scale on the 1.5V range. Connect the meter to measure DC voltage between TP (F) and circuit ground.
3. Tune the receiver to a station of normal signal strength. Adjust the Horizontal Range Control, R410A (part of the Control Assembly, located at the top right of the chassis) to lock the picture into horizontal sync. Then adjust R410A for zero volts on the VTVM.
4. Remove the jumper across L403.
5. Tune L403 to lock the picture into horizontal sync. Adjust the core to the first position that will lock the picture into horizontal sync as the core is moved from the top of the coil form toward the PC board. Then adjust L403 for zero volts on the VTVM.

AGC LEVEL CONTROL, R304A

This control is part of the control assy located on the PC board.

Adjustment is factory set. Normally, no adjustment will be needed in the field.

Should adjustment be necessary, select the channel with the strongest signal. Turn the control clockwise until a slight bend appears at the top of the picture. Then turn the control slowly counterclockwise about 1/4 turn past the point at which the bend disappears.

HEIGHT AND VERTICAL LINEARITY CONTROLS

These controls are located at the lower left corner of the chassis. For adjustment, insert a thin bladed screw driver through the holes in the back cover, in a direct line with the controls. The back cover need not be removed.

On some models, the holes for the control adjustments are located in the lower left corner on the bottom of the cabinet.

WESTINGHOUSE Chassis V-2487-1, etc., Schematic Diagram, Continued

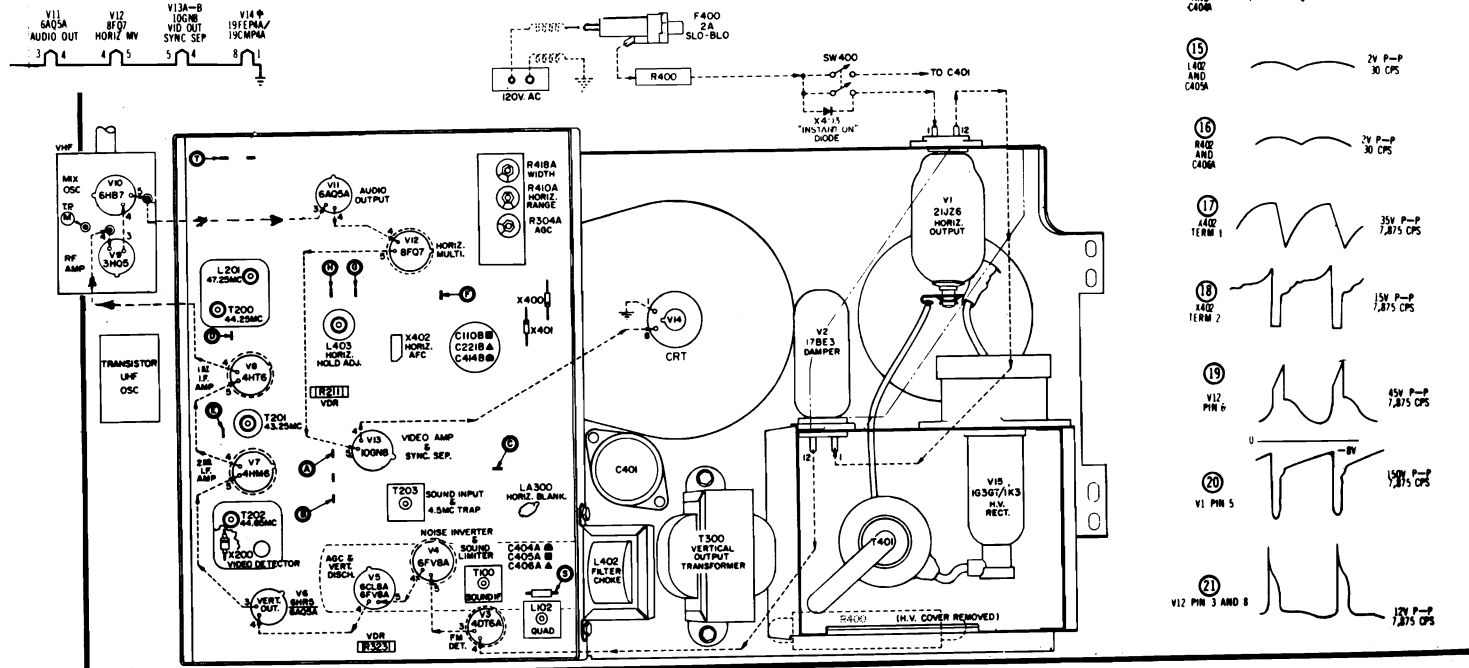
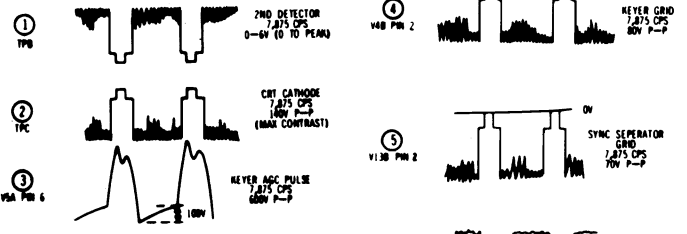
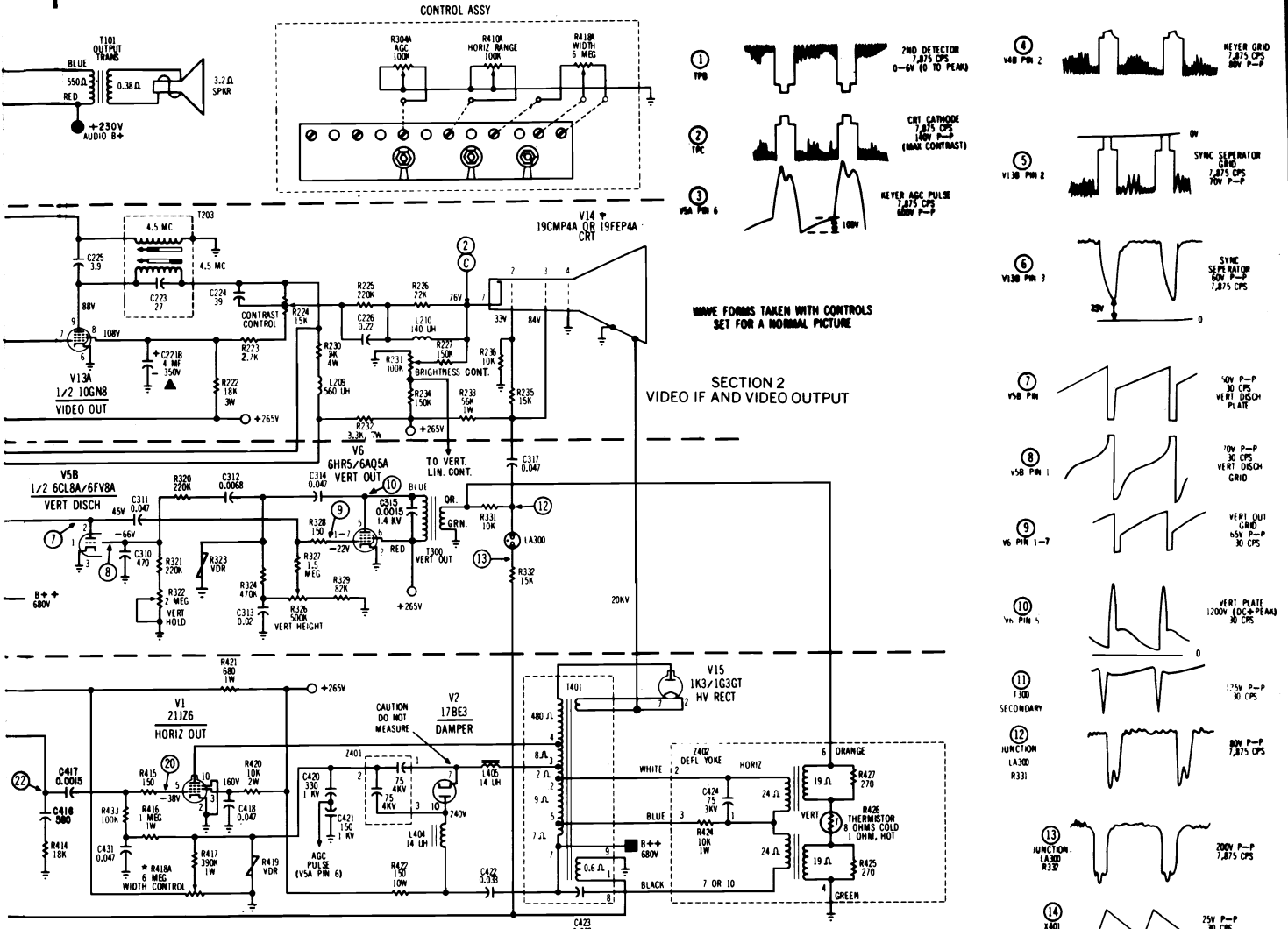

SOUND ALIGNMENT

4.5 MC TRAP ALIGNMENT

STEP	PROCEDURE	ADJUSTMENT
1.	Disconnect antenna.	Contrast control to maximum. (clockwise)
2.	Inject 4.5 MC CW signal through a .001 mf capacitor to TP ⑥.	_____
3.	Connect demodulator probe to VTVM. Connect .001 mf capacitor to other end of probe and connect it to TP ⑥.	_____
4.	Set VTVM to 1.5-2 volt DC range Turn on set and allow 10 minute warm-up.	T203 bottom slug for minimum on the VTVM.

**EQUIPMENT: VTVM
PROCEDURE:**

1. Select the strongest station available (preferably with test pattern and test tone) and adjust the FINE TUNING for best reception. Adjust the VOLUME control so that the station sound is audible.
2. Adjust the quad coil (L102) for maximum sound from the speaker.
3. Disconnect the antenna. Use a jumper wire to short TP ⑥ to B-.
4. Connect the VTVM to TP ⑤.
5. Adjust interstage transformer T100 for maximum negative

voltage on the VTVM.

6. Remove the jumper wire used to short TP ⑥ to B-.
7. Place the antenna input close to the antenna terminals so that the signal is loosely coupled to the receiver and the picture is barely visible. A pronounced nosiness (hiss) should accompany the sound.
8. Adjust the limiter input coil (T203 top slug) for maximum negative voltage on the VTVM. If the VTVM indicates a broad response while making this adjustment, the receiver input signal is too strong. When the signal coupling described in step 7 is at the necessary low point, no limiting takes place and the VTVM will indicate a sharp response to the limiter input coil adjustment.

IF ALIGNMENT

EQUIPMENT

1. Sweep Generator with a 10 MC wide sweep at center frequencies from 10 MC to 90 MC and 170 MC to 216 MC.
2. CW (Marker) Generator which accurately produces the IF and RF frequencies from 4.5 MC to 216 MC.
3. Oscilloscope with good low frequency response characteristics.
4. VTVM
5. Bias Supply of -2.5 volts.
6. Standard Alignment Tool with a 3/32" hexagonal tip. (long enough to reach bottom slugs)

Generators - Except where otherwise noted, all signal generating equipment should be terminated as shown in Figure 3. Connect the signal cable ground near the ground of the stage where the signal is injected. Adjust the CW generator output so that: (1) When the VTVM is being used its reading remains near the -1 volt point. (2) When the oscilloscope is being used the marker frequencies do not distort the response curve.

Oscilloscope and VTVM - Use a low-capacitance direct probe terminated with the decoupling network shown in Figure 4. Keep the oscilloscope calibrated for 2 volts peak to peak (P-P). Use a VTVM range suitable for measuring -1.5 volts.

TERMINATION AND ADJUSTMENT OF EQUIPMENT

These instructions on termination and adjustment of equipment will apply throughout the IF Alignment procedure.

All test equipment cables and leads should be as short and direct as possible.

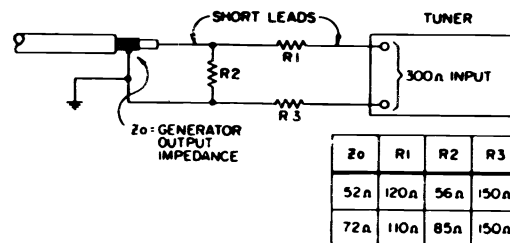

Figure 2. - Impedance Matching Network

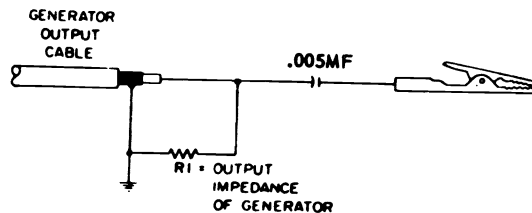

Figure 3. - Generator Cable Termination

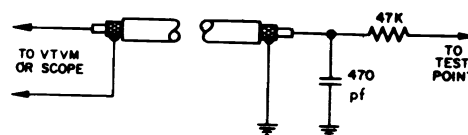

Figure 4. - Decoupling Network

WESTINGHOUSE Chassis V-2487-1, etc., Alignment, Continued

IF ALIGNMENT

Step	Test Equipment and Connection	Adjustment
1.	-2.5V bias to TP (T). Short antenna term. Channel selector to channel 10. Connect jumper front TP (A) to B-.	
2.	Oscilloscope and VTVM to TP (B). IF sweep generator with CW marker to TP (E). a. 44.65 MC. b. 45.75 MC.	a. T202 primary top slug: Maximum amplitude on VTVM. T202 secondary bottom slug: Rocking symmetrical response at 44.65 MC. b. Place 45.75 MC marker at 70% of peak response (see Figure 5 for waveshape and marker placement).
3.	CW generator to TP (D). a. 43.25 MC.	a. T201: Maximum amplitude on VTVM.
4.	CW generator to TP (M). a. 44.25 MC. b. 44.25 MC. c. 47.25 MC. It may be necessary to increase generator output and/or decrease bias.	a. Tuner mixer output coil: Maximum on VTVM. b. T200: Maximum on VTVM. c. L201: Minimum on VTVM.
5.	Connect sweep generator to TP (M) at 44.25 MC. Couple CW generator with marker at 44.25 MC to sweep generator cable. Keep marker amplitude low to avoid distorting response.	Mixer output coil for maximum amplitude. T200 for "rocking symmetrical response with waveshape and markers" as shown in Figure 7.
6.	CW generator to TP (M) at 47.25 MC.	Repeat step 4c.
7.	Remove short from antenna terminals. Sweep generator thru impedance matching network to antenna terminals (see Figure 2). Set pix marker at 211.25 MC, channel 13. Inject 45.75 MC marker into IF section by connecting CW output cable to outer insulated shield of IF link cable.	Fine tuning to center of range Channel selector to channel 13. Oscillator slug setting: Picture carrier should fall at 45.75 MC (± 300 KC) marker on scope. (See Figure 8)
8.	Repeat step 7 for all channels in descending order.	

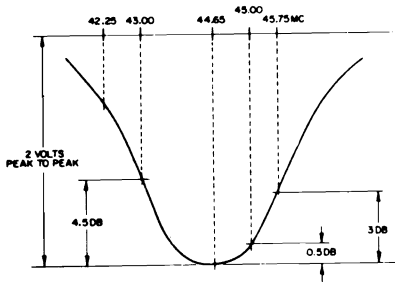

Figure 5 - Typical IF Reponse, 2nd IF Amp Grid to 2nd Det.

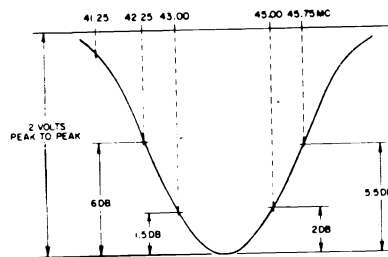

Figure 6 - Typical IF response, 1st IF Amp Grid to 2nd Det.

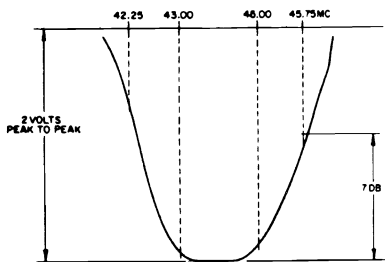

Figure 7 - Typical IF response, Mixer Amp grid to 2nd Det.

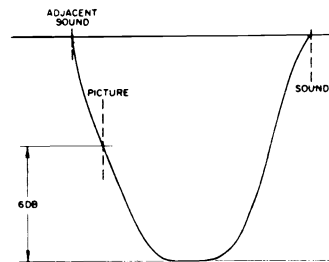

Figure 8 - Typical RF-IF response.

PC BOARD CALLOUTS

1. CRT socket: pin #8
2. Junction R415, R433 (V1)
3. C406A
4. T101 blue wire
5. T101 red wire
6. Volume control arm
7. Volume control low side
8. Tuner heater
9. Tuner B+
10. Tuner AGC
11. Tuner IF output
12. Tuner heater
13. Height control arm
14. Height control high side
15. Height control low side
16. Vert. hold control arm
17. T300 blue wire
18. Vert. hold control, high side
19. Junction C420, C421 (AGC)
20. Vertical linearity control arm
21. Junction R420, R422 (+265V)
22. Vertical linearity control
23. C405A
24. Jumper to (30)
25. T401 lug #7
26. V2 pin 12 (damper)
27. Volume control high side
28. Contrast control arm
29. CRT socket pin #3
30. Jumper to (24)
31. CRT socket pin #2
32. CRT socket pin #1
33. T300 secondary green wire
34. Yoke green wire, lug #4
35. T300 secondary orange wire
36. Yoke orange wire, lug #6
37. T401 lug #1
38. Brightness control arm
39. L402 black wire
40. T300 red wire
41. CRT socket pin #4
42. CRT socket pin #7
43. Brightness control high side
44. Contrast control high side
45. Contrast control low side
46. C401 (+ side)
47. C401 (- side)
48. AC switch
49. L402 yellow wire
50. C404A
51. to R417

TEST POINTS

- A. AGC for IF
- B. Video detector
- C. CRT cathode
- D. 1st IF grid
- E. 3rd IF grid
- F. Horiz MV
- G. Horiz Hold adjust coil
- H. Horiz Hold adjust coil
- M. Mixer grid on tuner.
- S. Quad coil
- T. AGC for tuner

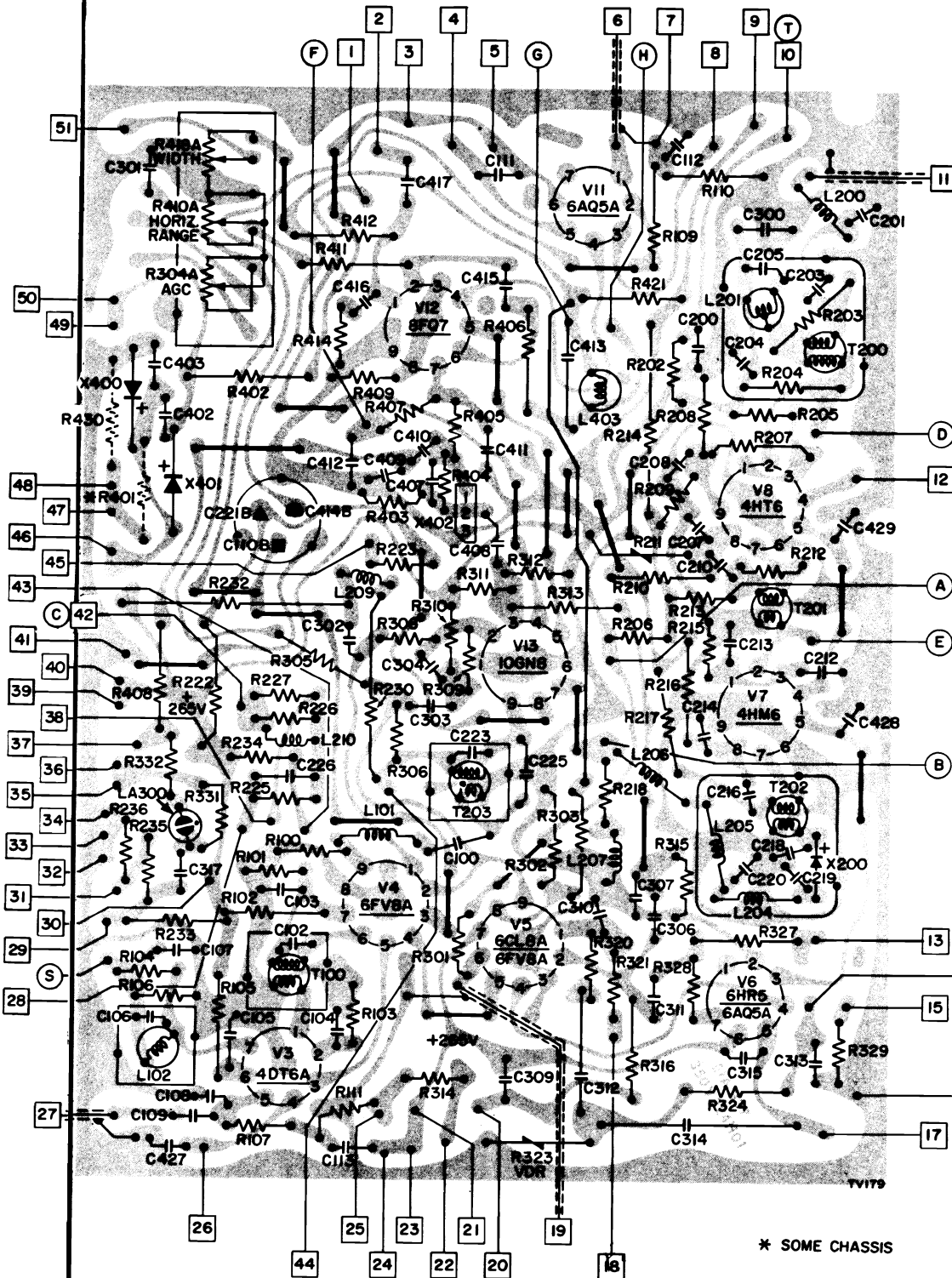

Bottom View of PC Board. Top Components are Shown in Solid Outline.
Tube Pin Numbering is for Bottom of Socket.

Westinghouse

MODEL AND CHASSIS CHART

MODEL	CHASSIS	TUNERS	FEATURES	CRT
H-P3051A H-P3052A	V-2486-1	VHF 470V059D02 UHF 472V051D01		19FEP4A 114"
H-P3061A H-P3062A	V-2486-2	VHF 470V160D02 UHF 472V051D01	Instant On	19FEP4A 114"
H-P3056A H-P3057A	V-2486-4	VHF 470V163D02 UHF 472V053D01	Instant On	19FEP4A 114"
H-P3075 H-P3076	V-2486-13	VHF 470V160D03 UHF 472V051D01	Instant On	19FEP4A 114"

CHASSIS REMOVAL - 19" PORTABLES

The speaker and CRT remain in the cabinet.

1. Remove the control knobs.
2. Remove the back cover. The horizontal hold knob remains on the back cover. The antenna terminal board stays with the chassis.
3. Unsolder the speaker leads at the output transformer.
4. Remove the CRT socket, loosen the yoke and remove the width insert. The yoke is removed with the chassis.
5. Discharge and disconnect the anode lead at the CRT.
6. Remove the screws holding the chassis and upper and lower control panel to the cabinet. Fig. 1.
7. Remove the chassis.
8. When replacing the back cover be sure the horizontal hold extension shaft engages the knob in the back cover.

PICTURE TUBE REMOVAL - 19" CRT

When replacing a Steel-Guard picture tube, use only an

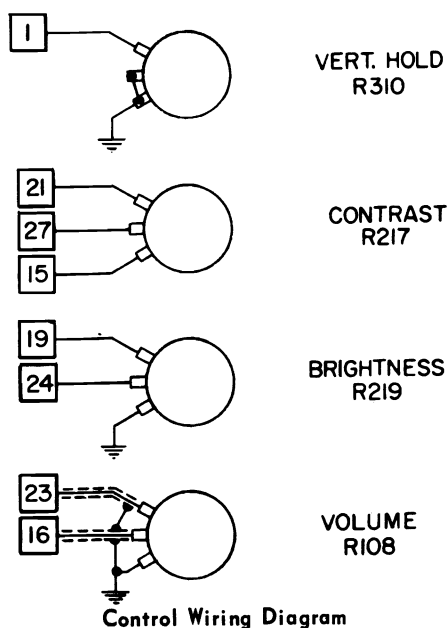

Exact Replacement tube.

1. Remove the chassis.
2. Place the cabinet face down on a soft cloth.
3. Loosen the screw which holds the wire retaining ring around the CRT.
4. Remove the four corner retainers from the cabinet.
5. Remove the retaining ring together with the four retainers.
6. Carefully remove the picture tube.

PC BOARD ACCESSIBILITY

To provide access to the underside of the PC board with the set operating:

1. Remove the chassis.
2. Turn the chassis around.
3. Connect the yoke and width insert, CRT socket, and high-voltage lead (use a jumper).

CAUTION: To operate the set partially disassembled, connect a jumper from the aquadag CRT coating and CRT band to chassis ground. Be careful that the high-voltage lead does not short or arc to the frame.

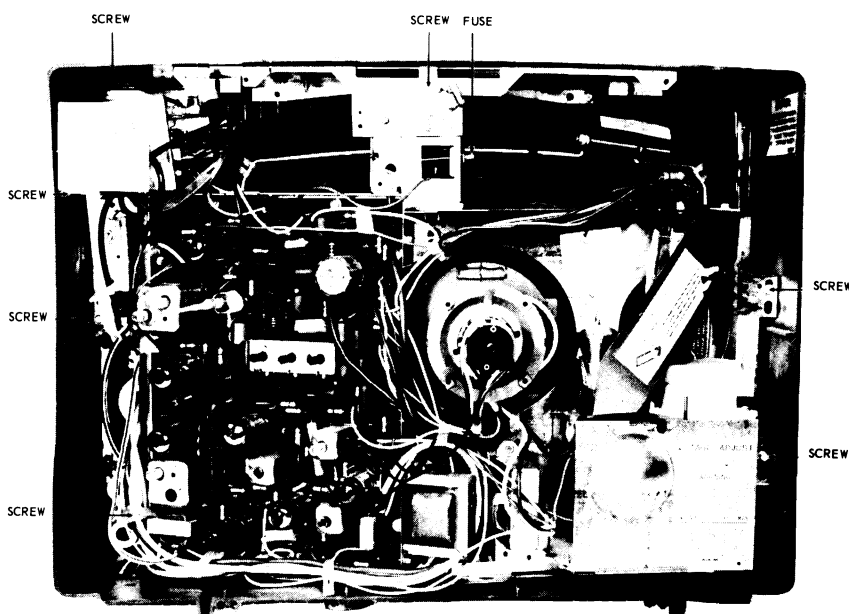
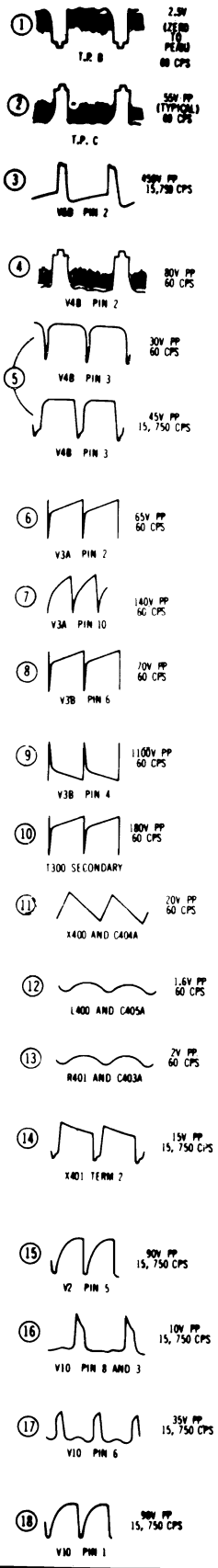
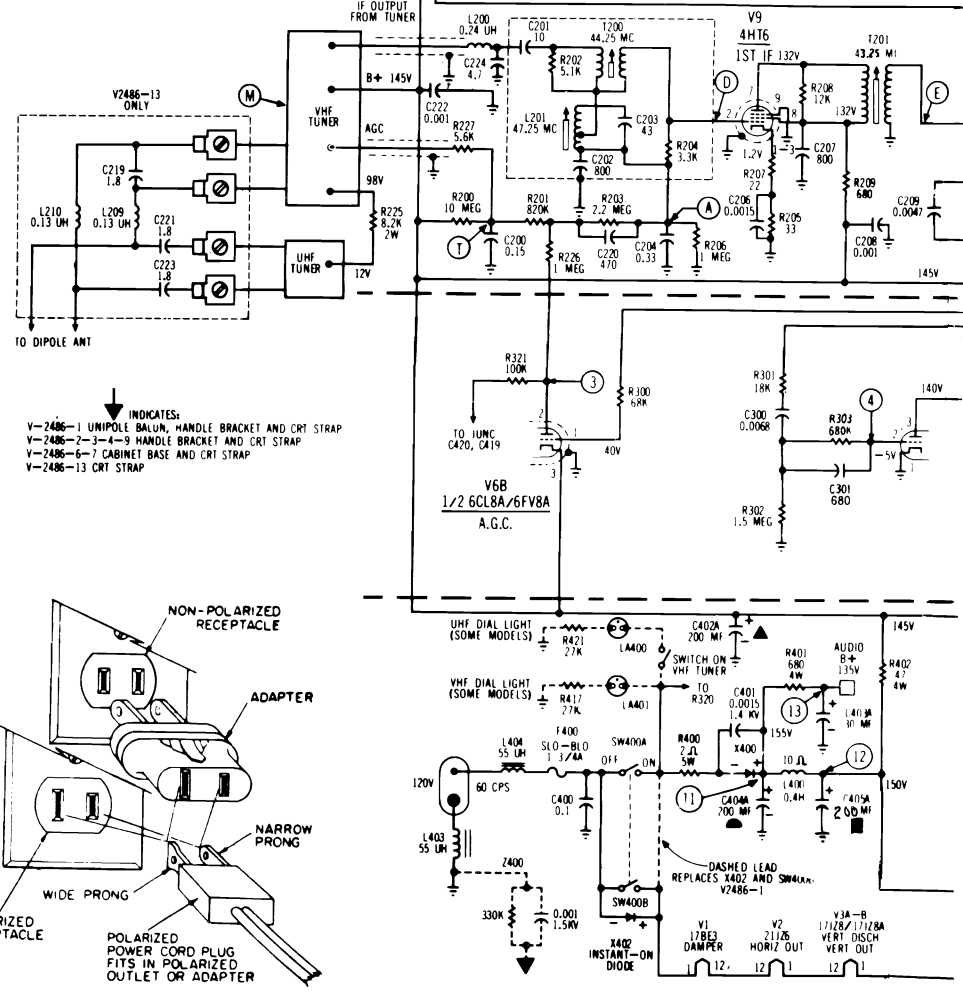

Figure 1. Chassis Removal

WESTINGHOUSE Chassis V-2486-1, etc., Schematic Diagram



- NOTE:
- ALL CAPACITOR VALUES LESS THAN 1 ARE IN MF, AND VALUES GREATER THAN 1 ARE IN PF (MICROMICROFARADS); ALL RESISTANCE VALUES ARE IN OHMS, 0.5 WATT UNLESS OTHERWISE INDICATED.
 - DC VOLTAGES ARE MEASURED FROM POINT INDICATED TO CIRCUIT GROUND WITH A VTVM. LINE VOLTAGE AT 120 V.A.C., NO SIGNAL APPLIED.
 - WAVEFORMS WERE TAKEN WITH CONTROLS SET FOR A NORMAL PICTURE.
 - * FOR VARIATION IN V2486-3 REMOTE CHASSIS SEE SUPPLEMENTAL SCHEMATIC.
 - IF T400 IS 493V020003 WHITE WIRE TO TERMINAL NO. 2 AS SHOWN AND R416, 3.3K, 2W. IF T400 IS 493V020002 WHITE WIRE TO TERMINAL NO. 3 AND R416, 2.2K, 2W.



Polarized Plug Adapter (754Y052H01).

INSTANT ON

"Instant On" provides immediate operation when the set is turned on, because no tube warm-up time is necessary. Silicon diode X402 is connected in series with the AC line and the tube filament string. With the line cord plugged into an AC receptacle and the OFF-ON switch in the OFF position, the AC line voltage is rectified by silicon diode X402. This permits a pulsating direct current to flow thru the tube filament string to keep the tubes warm. No B+ is present when the OFF-ON switch is in the OFF position. In "Instant On" chassis the OFF-ON and "Instant On" switch is a DPST switch. In the ON position, one section of this switch places a short across diode X402 and the other side completes the AC input to R400 and R320.

WESTINGHOUSE Chassis V-2486-1, etc., Schematic Diagram, Continued

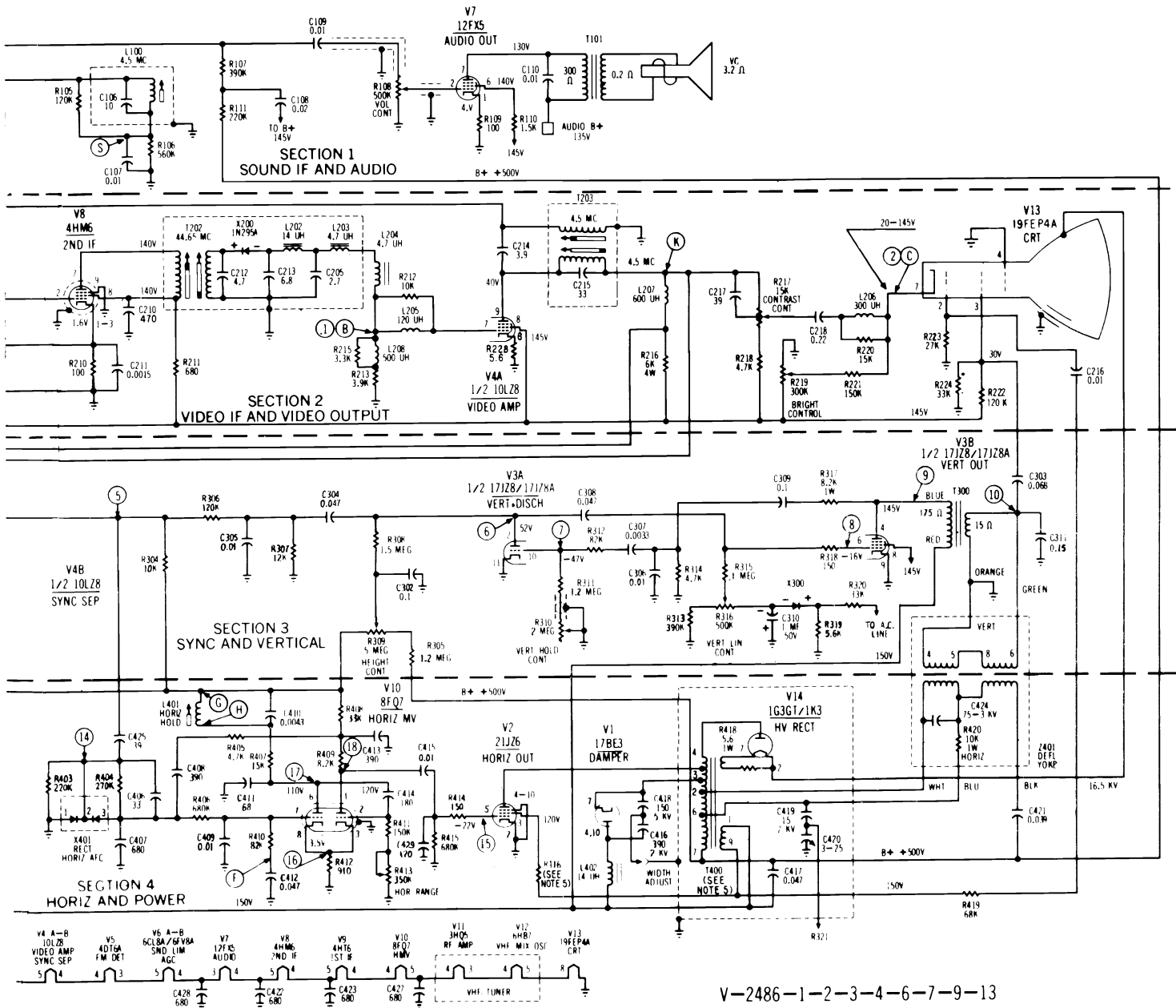

HORIZONTAL RANGE AND HOLD ADJUSTMENT

1. Short out Horizontal Hold coil L401 with a jumper connected across 'G' - 'H'.
2. With the meter zero set at center scale, connect a VTVM (1.5V range) across 'F' and B-.
3. Tune the receiver to a station of normal signal strength and adjust Horizontal Range control R413 to lock the picture into sync. Then adjust R413 for -0.5 volts on the VTVM.
4. Remove the jumper across 'G' & 'H', and adjust Horizontal Hold control L401 to lock the picture into sync.
5. Adjust L401 for -0.5 volts on the VTVM, and disconnect the VTVM.
6. Verify the horizontal sync adjustment by switching channels.

DEFLECTION YOKE

The deflection yoke should be as far forward as possible

(touching the bell of the CRT). Rotation of the deflection yoke is used to level the raster.

WIDTH AND LINEARITY

This insert is a plastic tab with a copper rectangle, bonded on one side. It protrudes out from between the yoke and the bottom of the neck of the picture tube. The shiny side of the copper rectangle should be positioned up against the picture tube. The rectangle must be centered at the bottom of the CRT neck. To increase width, ground the lead emerging from the left hand side of the high voltage enclosure to punch-out. To decrease width, unground the lead. Loosen the yoke clamp and slide the linearity insert in or out for best width and linearity. Re-tighten clamp.

CENTERING

The centering rings, located at the rear of the deflection yoke, should be rotated to center the raster.

WESTINGHOUSE Chassis V-2486-1, etc., Service Information, Continued

P. C. BOARD LEGEND

1. R310, vertical hold, high end
2. Pin 1 of 21JZ6 filament
3. T300, vertical transformer, blue
4. Tuner filament
5. Pin 8 or CRT, filament
6. Tuner B+, 145 volts
7. R414, horizontal drive
8. B+ from VHF tuner
9. B+ to UHF tuner
10. IF input from VHF
11. Tuner filament
12. AGC to tuner
13. C403A, audio B+, 135 volts
14. C419 and C420, AGC pulse
15. R217, contrast, low end
16. R108, arm of volume control
17. C404A, B+ filter
18. L400 filter choke
19. R219, brightness control, B+
20. C402A, B+ filter
21. R217, contrast control, high end
22. SW400, AC switch
23. R108, volume control, high end.
24. R219, brightness control, arm
25. Pin 4 of CRT (early prod. only)
26. Pin 7 of CRT
27. R217, contrast control arm
28. T400, lug 7, B++
29. T300, vertical transformer ground
30. Z401, yoke, black
31. Z401, ground
32. Z401 and T300, vertical blanking
33. Pin 3 or CRT
34. Pin 2 of CRT
35. T400, lug 9
36. L400, B+ filter choke
37. L402, damper choke
38. C405A, B+
39. T300, vertical transformer, red

TEST POINTS

- A AGC for IF
- B Video detector
- C CRT cathode
- D 1st IF input
- E 2nd IF grid
- F Horizontal MV
- G Horiz adj coil
- H Horiz adj coil
- M Mixer grid (Tuner)
- S Quad coil
- T AGC for tuner

*-EARLY PRODUCTION

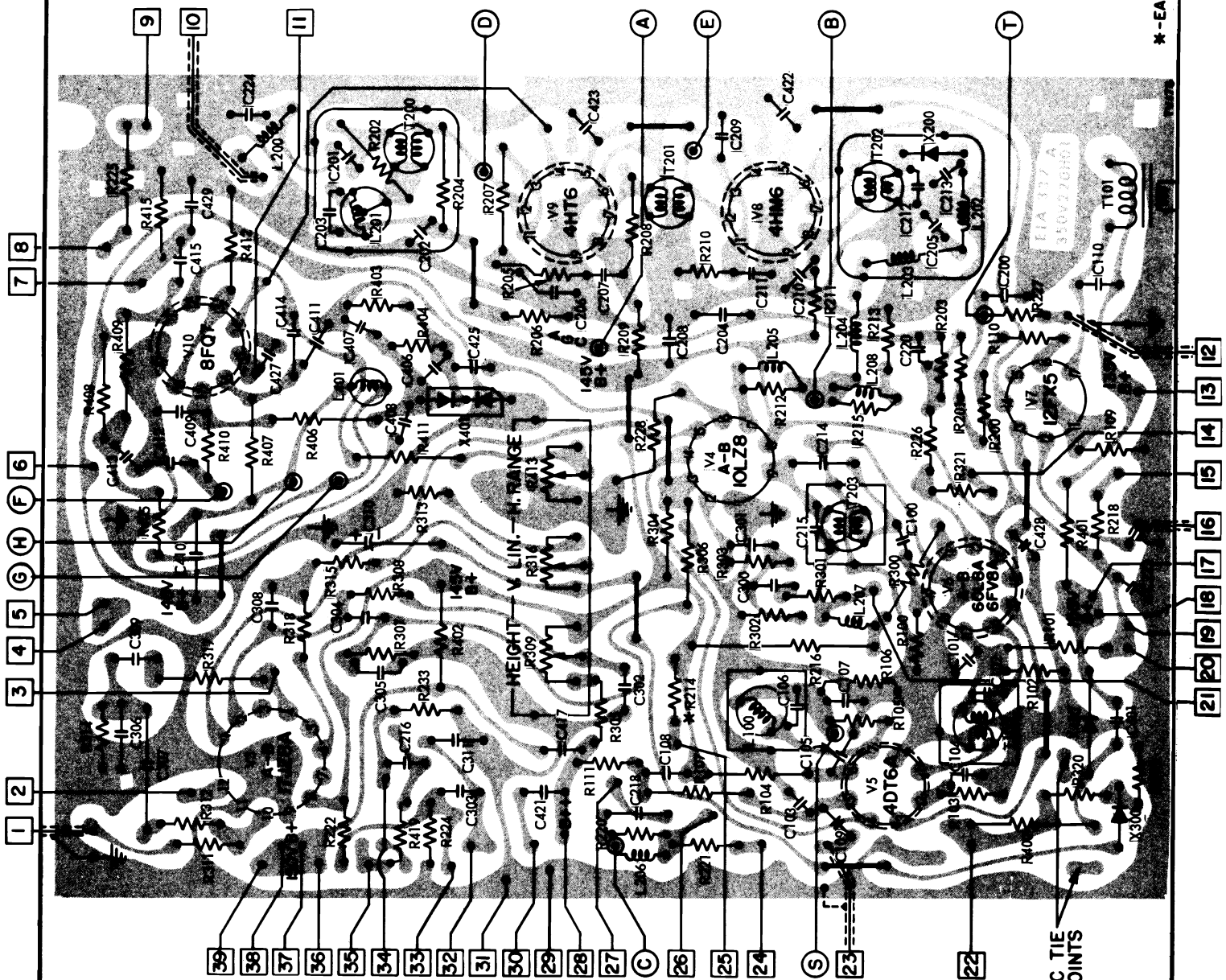

Bottom view of PC board. Top components are shown in solid outline. Tube pin numbering is for bottom of socket.

AC TIE POINTS

Westinghouse

MODEL AND CHASSIS CHART

MODEL	CHASSIS	TUNER	TUNER TUBES	FEATURES
H-P8030 H-P8031	V-2490-2	470V166D01/02VHF	RF AMP - 3HQ5 OSC-MIX - 6HB7	DIPOLE ANTENNA INSTANT ON EARPIECE JACK
		472V055D01 UHF	OSC-TRANSISTOR XTAL - 1N82AG	

The additional models listed below use different tuners and have other minor differences.

MODEL	CHASSIS	TUNERS	TUNER TUBES
H-P8030B H-P8031B	V-2490-8	VHF 470V158D01,D02,D03	RF AMP 3HQ5 OSC-Mixer 6KZ8
BP12A170 BP12B170	V-2490-7	UHF 472V056D01	UHF-OSC Transistor
BP12A67A	V-2490-8		Xtal - 1N82AG

CHASSIS REMOVAL & TUBE SERVICING

1. Disconnect the spade lugs from the antenna terminals.
 2. Remove the back cover screws.
- For further removal continue with the following:
3. Remove the ON-OFF-VOLUME knob and the VHF CHANNEL SELECTOR KNOB. Caution: the fine tuning knob and VHF-UHF dials are captivated to the tuner assembly.
 4. Unplug the CRT socket and anode connector from the CRT.
 5. Loosen the yoke clamp, and slide the yoke slightly to the rear.

6. Remove the three hex-head screws that hold the tuner and speaker assembly to the front of the cabinet.
7. Unsolder the spring clip from top of tuner bracket.
8. Remove two hex-head screws from chassis frame to cabinet front.

PICTURE TUBE REMOVAL

1. Remove the chassis.
2. Place the cabinet face down on a soft cloth.
3. Loosen the screw that holds the wire retaining ring around the CRT.
4. Remove the four corner retainers from the cabinet.
5. Remove the retaining ring together with the four retainers.
6. Carefully remove the picture tube.

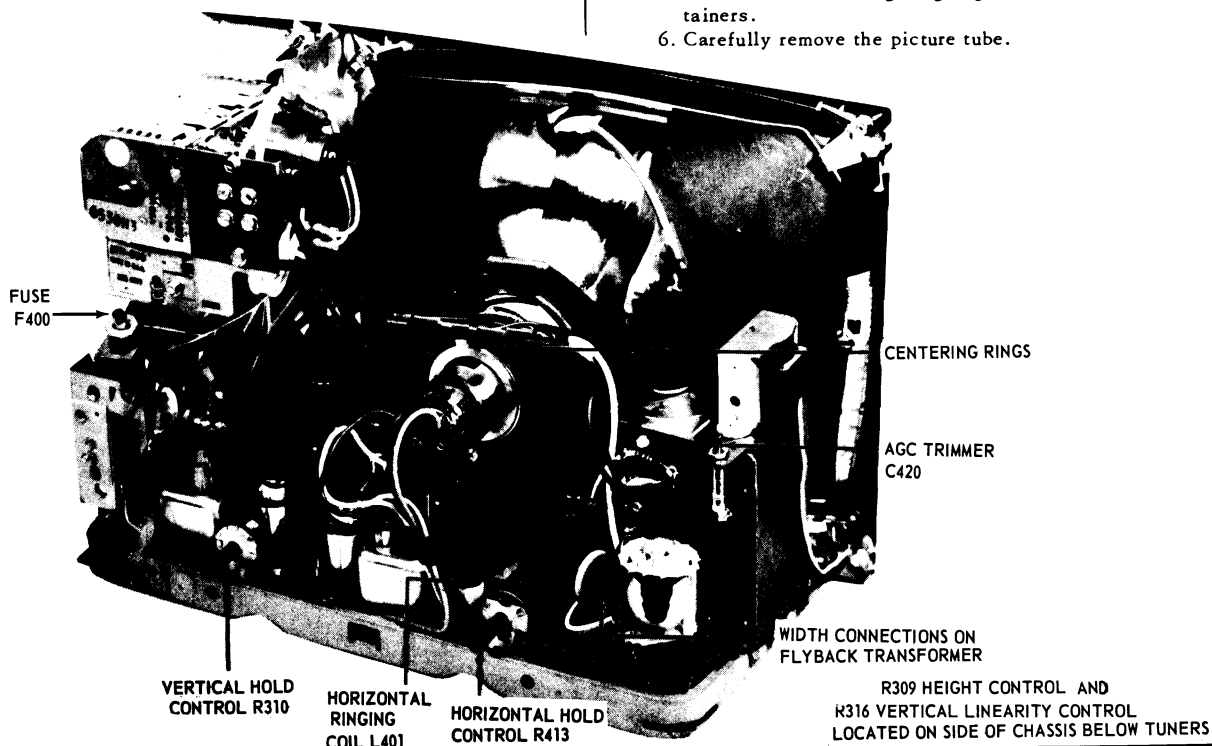

WESTINGHOUSE Chassis V-2490 Schematic Diagram

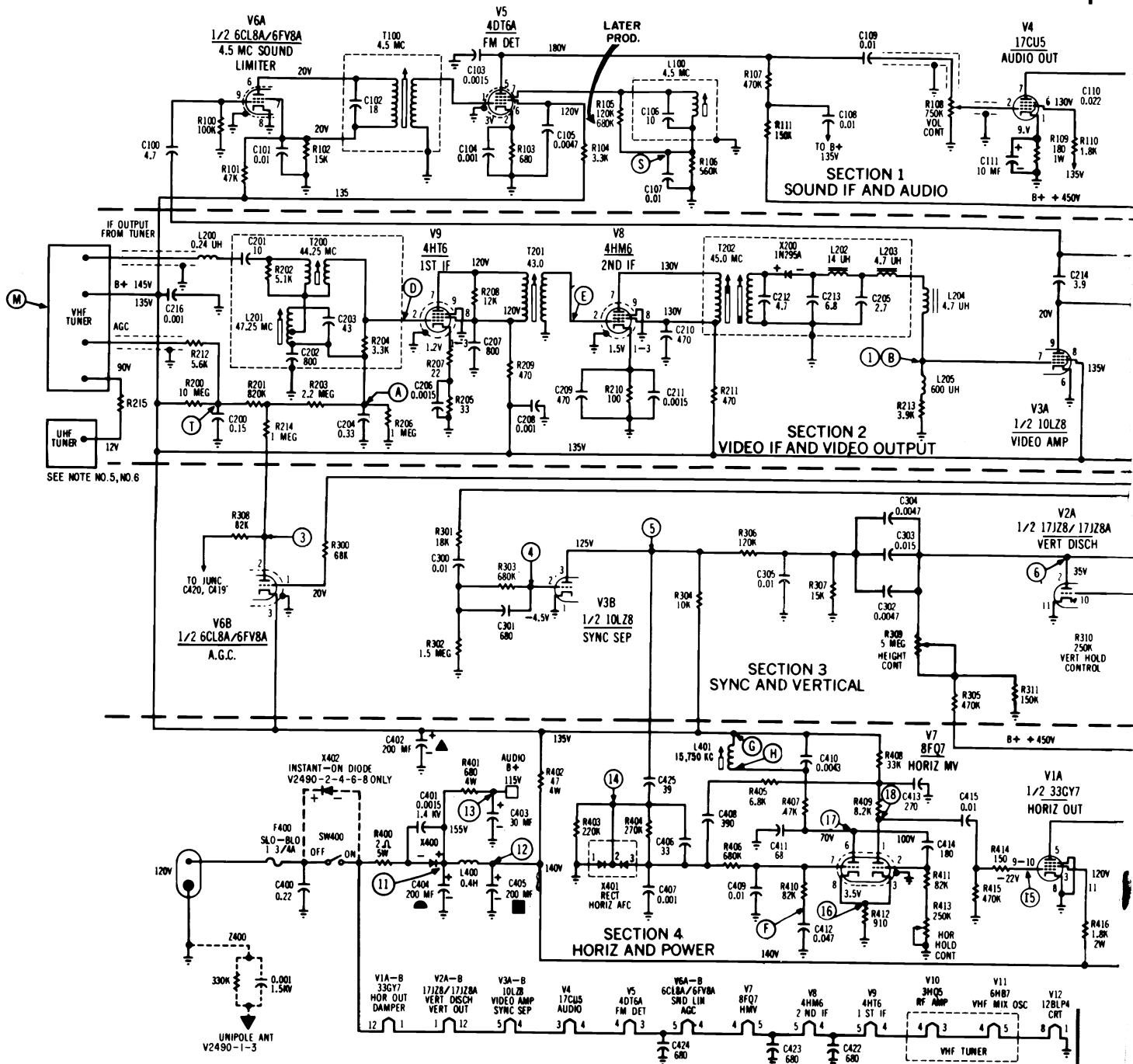

CENTERING

The centering rings, located at the rear of the deflection yoke, should be rotated to center the raster.

DEFLECTION YOKE

The deflection yoke should be as far forward as possible (touching the bell of the CRT). Rotate the deflection yoke to level the raster.

HEIGHT AND VERTICAL LINEARITY

The Height and Vertical Linearity controls, located on the side of the chassis, are adjusted alternately for correct picture height and linearity.

HORIZONTAL RINGING COIL

1. Tune the receiver to a station of normal signal strength.
2. Short out Horizontal Ringing coil L401 with a jumper connected across TP (G) and (H).
3. Connect a V.T.V.M., set to zero center scale (1.5V range), across TP (F) and circuit ground.
4. Adjust Horizontal Hold control, R413 for -0.25 volts on the V.T.V.M.
5. Remove the jumper from across the ringing coil L401 and adjust L401 for -0.25 volts on the V.T.V.M.
6. Verify the horizontal sync adjustment by switching channels.

WESTINGHOUSE Chassis V-2490 Schematic Diagram, Continued

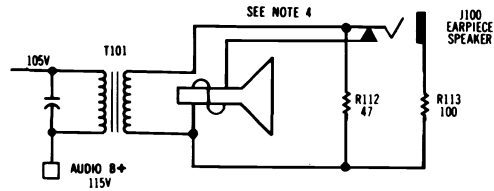

- NOTE:**
1. ALL CAPACITOR VALUES LESS THAN 1 ARE IN MF, AND VALUES GREATER THAN 1 ARE IN PF (MICROMICROFARADS). ALL RESISTANCE VALUES ARE IN OHMS, 0.5 WATT UNLESS OTHERWISE INDICATED.
 2. DC VOLTAGES ARE MEASURED FROM POINT INDICATED TO CIRCUIT GROUND WITH A VTVM, LINE VOLTAGE AT 120 V.A.C., NO SIGNAL APPLIED.
 3. WAVEFORMS WERE TAKEN WITH CONTROLS SET FOR A NORMAL PICTURE.
 4. EARPIECE SPEAKER AND R112, R113 PROVIDED ON V2490-2-4-
 5. UHF TUNER AND R215 NOT USED IN V2490-3-4 CHASSIS.
 6. R215 = 8200 OHM 2W V2490-1-2

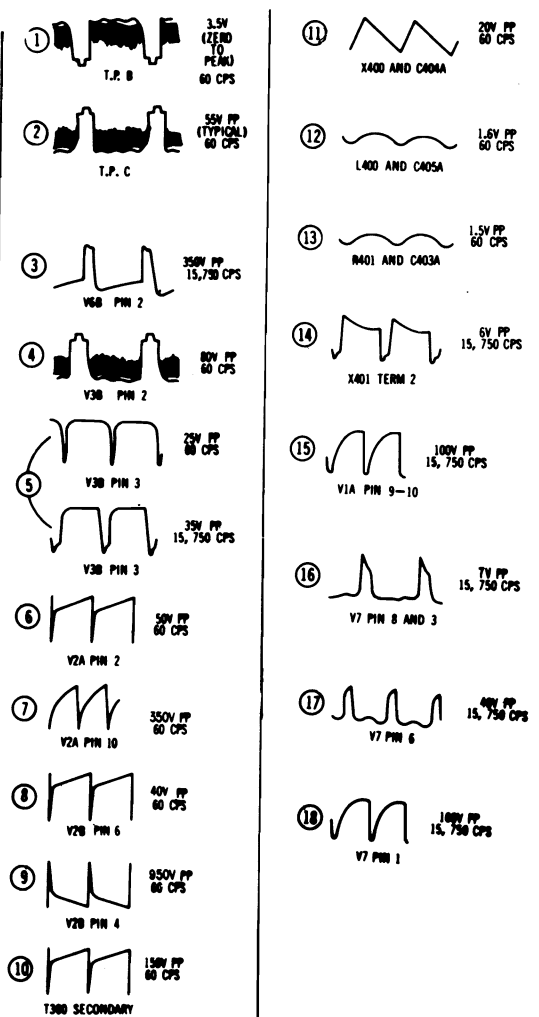
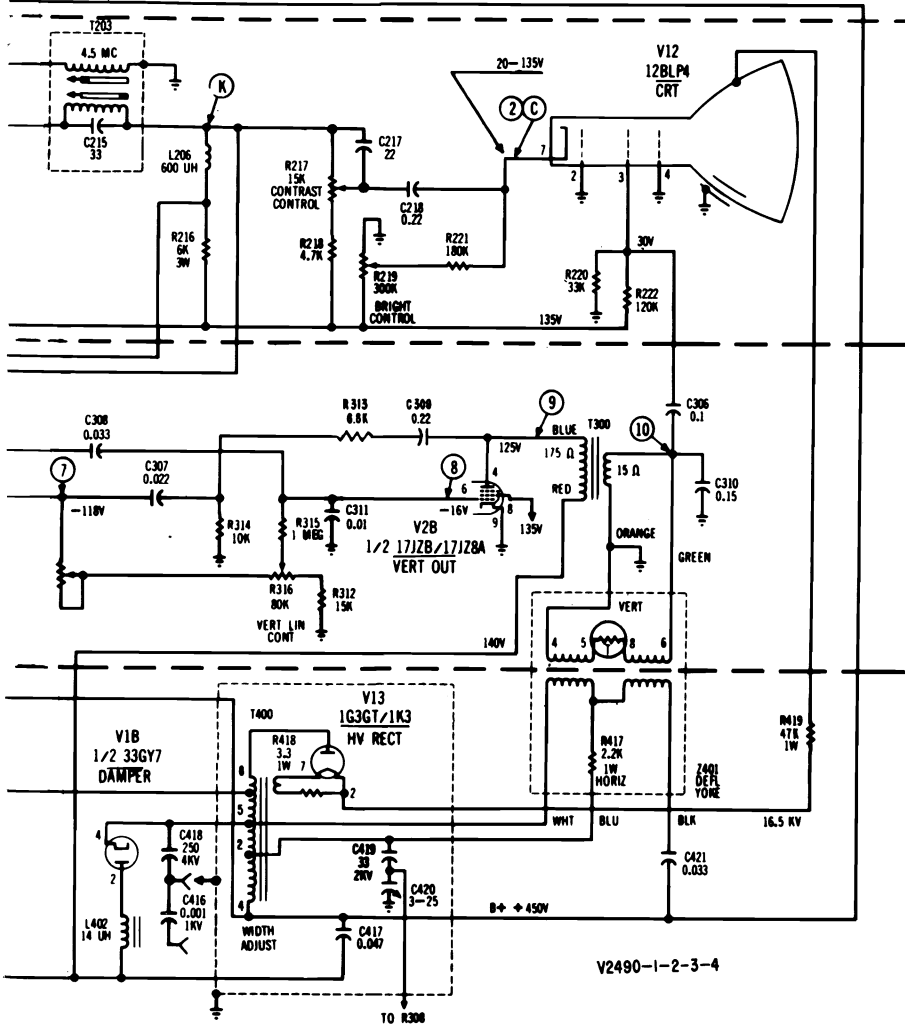

AGC ADJUSTMENT

Tune in the strongest station. Adjust C420 with screwdriver until the picture bends at the top. Then turn the screw back slightly until the bend disappears.

WIDTH ADJUSTMENT

1. To increase width, connect lead on lower left side of H.V. enclosure to terminal #6.
2. To decrease width, connect lead on lower left side of H.V. enclosure to terminal #7.

FUSE

The 1 1/4 amp, 125 volt slo-blo power supply fuse is located at the rear of the chassis, near the AC interlock.

INSTANT ON (V-2490-2)

The 'Instant On' chassis provides immediate operation when the set is turned on. When the set is off, partial heater voltage is applied to the series filament string through silicon diode X402. Turning on the set with off-on switch SW400 shorts out the diode X402, and full voltage is applied to the filament string. At the same time, line voltage is supplied to the B+ rectifier circuit.

EARPIECE JACK (V-2490-2)

The earpiece jack provides a means of listening to the sound without disturbing others in the viewing room. The switch contacts on earpiece jack J100 disconnect one side of the speaker from the audio output transformer when the earpiece plug is inserted in the jack.

WESTINGHOUSE Chassis V-2490 Service Information, Continued

PC BOARD LEGEND

- 1 200 mf \square , C405
- 1 Red lead - T300
- 3 200 mf Δ , C402
- 4 R308 at T400 (Flyback Transformer)
- 5 200 mf \circ , C404
- 6 To SW400 & X402
- 7 30 mf, C403
- 8 Red lead - T101
- 9 High end, Vol. Cont., R108
- 10 Blue lead - T101
- 11 Arm, Vol. Cont., R108
- 12 Low end, Brightness Cont., R219
- 13 AGC to tuner VHF
- 14 High end, Brightness Cont., R219
- 15 Low end, Contrast Cont., R217
- 16 Arm, Brightness Cont., R219
- 17 Pin #7, CRT
- 18 Arm, Contrast Cont., R217
- 19 To Flyback transformer
- 20 Blue lead - T300
- 21 Orange lead - T300
- 22 Blue lead - Pin #3 - CRT
- 23 Orange lead - Z401 - Yoke
- 24 IF input cable
- 25 Pin #1 - 33GY7
- 26 Filament, Tuner
- 27 Pin #8, - CRT
- 28 Filament, Tuner
- 29 Green lead - T300
- 30 Green lead - Z401 - Yoke
- 31 High end, Contrast Cont., R217
- 32 Pin #1 - CRT
- 33 Pin #2 - CRT
- 34 Pin #4 - CRT
- 35 Pin #4 - T400 (Flyback Transformer)
- 36 Pin #1 - 17JZ8

TEST POINTS

- A AGC for IF
- B Video detector
- C CRT cathode
- D 1st IF input
- E 2nd IF grid
- F Horizontal MV
- G Horiz adj coil
- H Horiz adj coil
- M Mixer grid (Tuner)
- S Quad coil
- T AGC for tuner

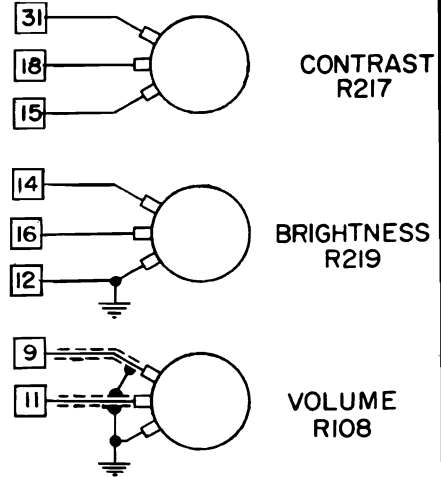
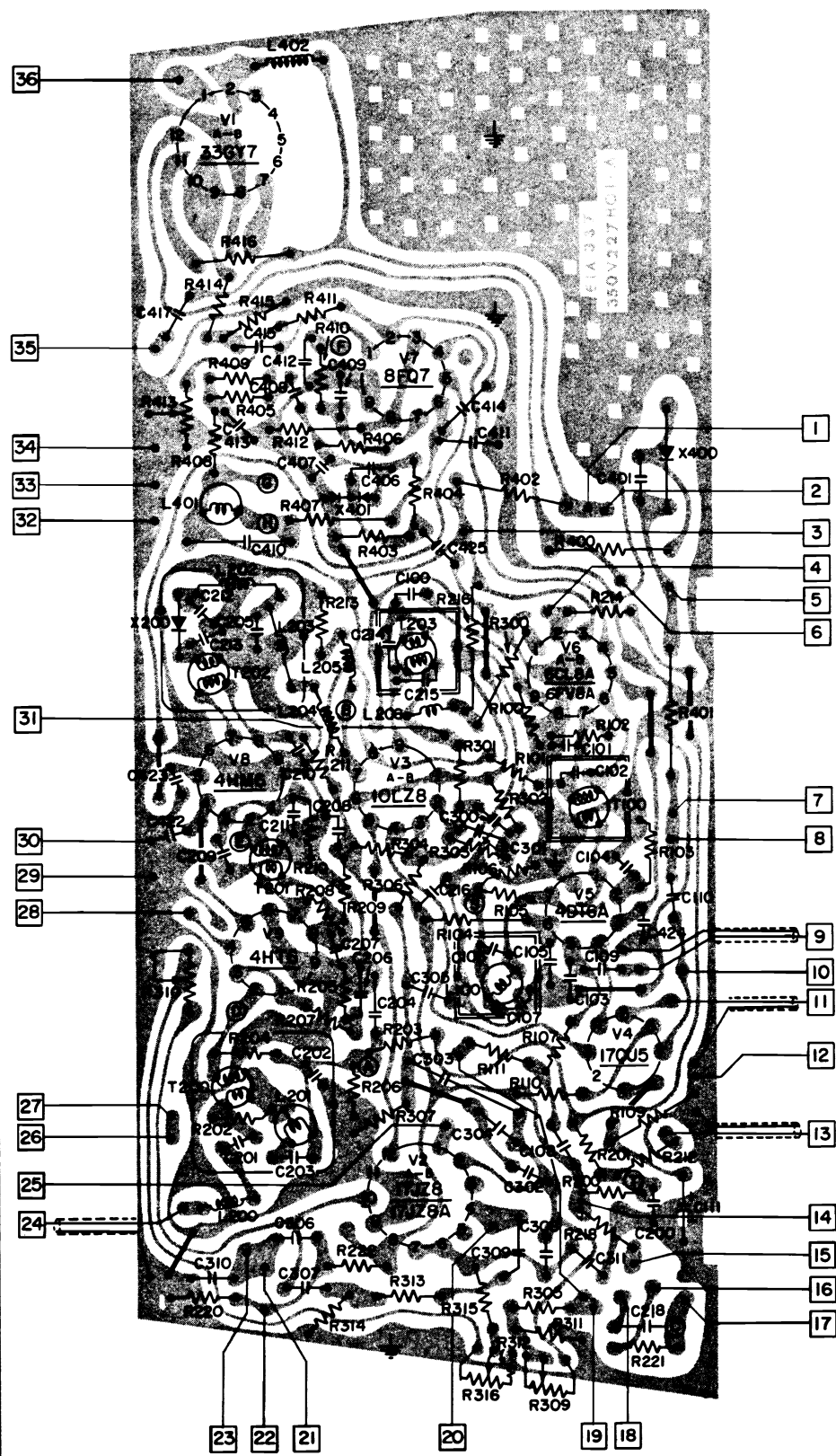

Bottom View P.C. Board

Control Wiring Diagram

SOUND ALIGNMENT

EQUIPMENT: VTVM

PROCEDURE:

1. Select the strongest station available (preferably with test pattern and test tone) and adjust the FINE TUNING for best reception. Adjust the VOLUME control so that the station sound is audible.
2. Adjust the quad coil (L100) for maximum sound from the speaker.
3. Disconnect the antenna. Use a jumper wire to short TP ⓑ to B-.
4. Connect the VTVM to TP Ⓢ.
5. Adjust interstage transformer T100 for maximum negative voltage on the VTVM.
6. Remove the jumper wire used to Short TP ⓑ to B-.
7. Place the antenna input close to the antenna terminals so that the signal is loosely coupled to the receiver and the picture is barely visible. A pronounced noisiness (hiss)

should accompany the sound.

8. Adjust the limiter input coil (T203 top slug) for maximum negative voltage on the VTVM. If the VTVM indicates a broad response while making this adjustment, the receiver input signal is too strong. When the signal coupling described in step 7 is at the necessary low point, no limiting takes place and the VTVM will indicate a sharp response to the limiter input coil adjustment.

4.5 MC TRAP ALIGNMENT

Disconnect the antenna and turn contrast control to maximum clockwise. Inject a 4.5 MC CW signal through a .001mf capacitor to TP ⓑ. Connect a .001mf capacitor to a demodulation probe tip. Connect the other end of the probe to a VTVM and the capacitor to TP Ⓢ. Set the VTVM to 1.5-2V DC range. Turn the set on and allow ten minutes for warmup. Then adjust T203 bottom slug for minimum on the VTVM.

IF ALIGNMENT

EQUIPMENT

1. Sweep Generator with a 10 MC wide sweep at center frequencies from 10 MC to 90 MC and 170 MC to 216 MC.
2. CW (Marker) Generator which accurately produces the IF and RF frequencies from 4.5 MC to 216 MC.
3. Oscilloscope with good low frequency response characteristics.
4. VTVM.
5. Bias Supply of -2.0 volts and -3 volts.
6. Standard Alignment Tool with a 3/32" hexagonal tip (long enough to reach bottom slugs).

All test equipment cables and leads should be as short and direct as possible.

Oscilloscope and VTVM - Use a low-capacitance direct probe terminated with the decoupling network shown in Figure 11. Keep the oscilloscope calibrated for 2 volts peak to peak (P-P). Use a VTVM range suitable for measuring -1.5 volts.

Generators - Except where otherwise noted, all signal generating equipment should be terminated as shown in Figure 10. Connect the signal cable ground near the ground of the stage where the signal is injected.

Adjust the CW generator output so that: (1) When the VTVM is being used its reading remains near the -1 volt point. (2) When the oscilloscope is being used, the marker frequencies do not distort the response curve.

TERMINATION AND ADJUSTMENT OF EQUIPMENT

These instructions on termination and adjustment of equipment will apply throughout the IF Alignment procedure.

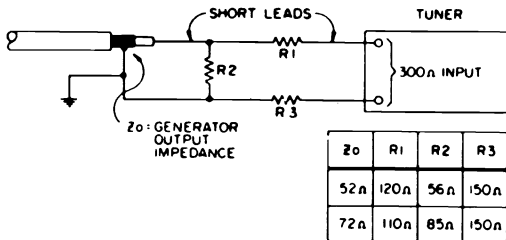

Figure 9 - Impedance Matching Network

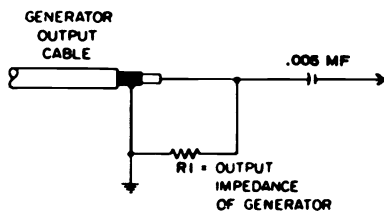

Figure 10 - Generator Cable Termination.

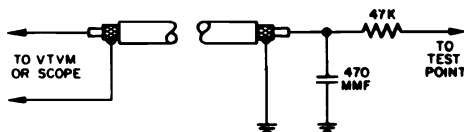
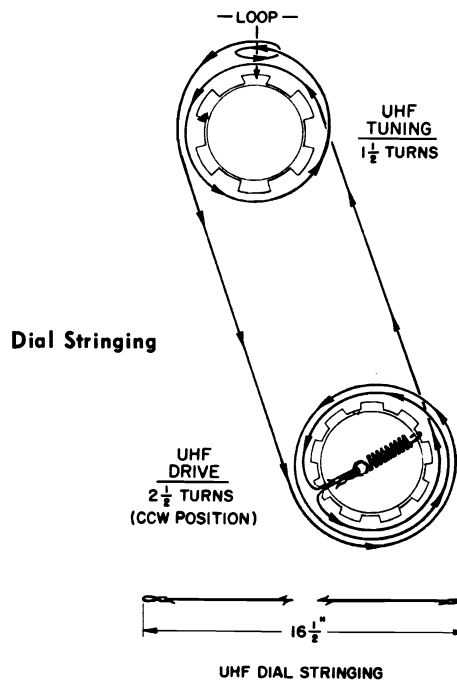

Figure 11 - VHF Decoupling Network.



WESTINGHOUSE Chassis V-2490 Alignment Information, Continued

IF ALIGNMENT

Step	Test Equipment and Connection	Adjustment
1.	-3 bias to TPⒶ and -2/0 bias to TPⓉ. Short antenna terminals. Channel selector to channel 10. Connect jumper from Pin 2 of V6B to B- to disable the AGC pulse.	
2.	Oscilloscope and VTVM to TPⓈ IF sweep generator with CW marker to TPⓈ. a. 45 MC. b. 45.75 MC.	a. T202 primary (top slug): Maximum amplitude on VTVM. T202 secondary (bottom slug): Rocking symmetrical response at 45 MC. b. Place 45.75 MC marker at 70% of peak response (see Figure 12 for waveshape and marker placement).
3.	CW generator to TPⓈ. a. 43 MC.	a. T201: Maximum amplitude on VTVM.
4.	CW generator to TPⓈ. a. 44.25 MC. b. 44.25 MC. c. 47.25 MC. It may be necessary to increase generator output and/or decrease bias.	a. Tuner mixer output coil: Maximum on VTVM. b. T200: Maximum on VTVM. c. L201: Minimum on VTVM.
5.	Connect sweep generator to TPⓈ at 44.25 MC. Couple CW generator with marker at 44.25 MC to sweep generator cable. Keep marker amplitude low to avoid distorting response. Adjust scope for 2V PP.	Mixer output coil for maximum amplitude. T200 for "rocking symmetrical response with waveshape and markers" as shown in Figure 14
6.	CW generator to TPⓈ at 47.25 MC.	Repeat step 4c.
7.	Oscilloscope, 2V PP. Sweep generator thru impedance matching network (see Figure 9) to antenna terminals. Set pix marker at 211.25 MC, channel 13. Inject 45.75 MC marker into IF section by connecting CW output cable to outer shield of IF link cable.	Fine tuning to center of range Channel selector to channel 13. Oscillator slug setting: Picture carrier should fall at 45.75 MC (\pm 300 KC) marker on scope. (See Figure 15).
8.	Repeat step 7 for all channels in descending order.	

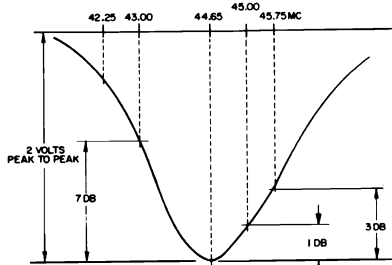

Figure 12 - Typical IF Response, 2nd IF Amp Grid to 2nd Det.

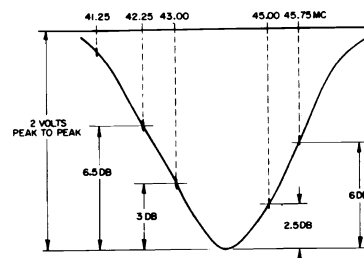

Figure 13 - Typical IF response, 1st IF Amp Grid to 2nd Det.

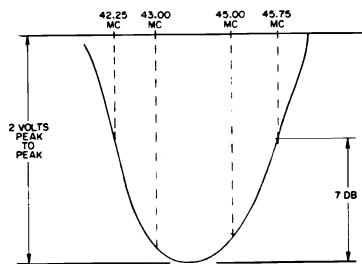

Figure 14 - Typical IF response, Mixer Amp Grip to 2nd Det.

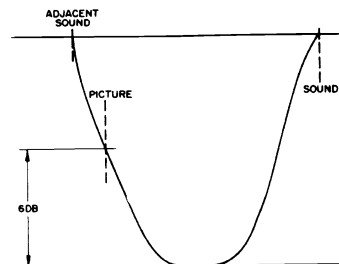
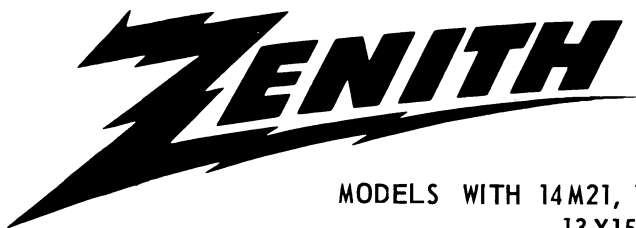

Figure 15 - Typical RF-IF response.

ZENITH RADIO CORPORATION



MODEL AND CHASSIS INFORMATION

MODELS WITH 14M21, 14N22, 14N26Z, 14N27, 14N28, 14N29 Z, 14N33, 13X15, 13X15 Z, 14X21 AND 14X21 Z CHASSIS

MODEL	TYPE	CHASSIS	MODEL	TYPE	CHASSIS
N1605J6, Y6	Portable	14M21	T2036H6, R6	Console	14N22
N1605JV6, YV6	Portable	14M21X	T2038M6	Console	14N22
N1610X6, Y6	Portable	14M21	T2044W6, WV6	Console	14N22
N2000C6, CV6	Portable	14N29Z	T2170W6	Portable	14N26Z
N2001L6, LV6, X6	Portable	14N29Z	T2610W	Portable	13X15
N2000C6A	Portable	14N33	T2610W1	Portable	13X15
N2000C6B,C6C,L6B	Portable	14N29Z	T2610W3	Portable	13X15Z
N2001L6A	Portable	14N33	T2620X	Portable	14X21
N2002W6A	Portable	14N33	T2620X1	Portable	14M21
N2002W6, WV6, H6	Portable	14N29Z	T2650C,X	Portable	14N33
N2004J6, JV6, X6	Portable	14N27	T2650C1,X1	Portable	14N29Z
N2005H6, W6, WV6	Portable	14N28	T2652L	Portable	14N28
N2109L6, LV6, X6	Portable	14N28	T2656L,P	Portable	14N28
N2110H6, W6, WV6	Portable	14N28	T2656L1,P1	Portable	14N28
N2180L6, LV6	Portable	14N26Z	T2668Y	Portable	14N28
N2185X6, XV6	Portable	14N26Z	T2668Y1	Portable	14N28
N2190H6, W6, WV6	Portable	14N26Z	T2675W	Portable	14N28
N2205L6, LV6	Portable	14N28	T2691W	Portable	14X26
N2210L6, LV6	Portable	14N28	T2655L,P	Portable	14N28
N2214W6	Portable	14N28	T2660L	Portable	14N27
N2270W6	Portable	14N26Z	T2665J,L,W	Portable	14N27
N2705W6, WV6, Y6	Table	14N22	T2672R,W	Portable	14N27
N2706F6, L6	Table	14N22	T2677W	Portable	14N28
N2717W6, WV6	Table	14N22	T2690W	Table	14N26Z
N2730R6, W6, WV6	Table	14N22	T2720W	Console	14N22
N2731W6, WV6	Console	14N22	T2720W1	Console	14N22
N2732H6, HV6, R6	Console	14N22	X1215C,L,P,X	Portable	13X15
N2733M6	Console	14N22	X1215C1,L1,P1,X1	Portable	13X15
N2735R6, W6, WV6	Console	14N22	X1215C2,L2,P2,X2	Portable	13X15Z
N2736E6, R6, W6	Console	14N22	X1215C3,L3,P3,X3	Portable	13X15Z
N2739M6	Console	14N22	X1225H,W	Portable	13X15
N2740H6, X6	Console	14N22	X1225H1,W1	Portable	13X15
N3311W6, WV6, Y6	Table	14N22	X1225H2,W2	Portable	13X15Z
N3331W6	Console	14N22	X1225H3,W3	Portable	13X15Z
N3332H6	Console	14N22	X1315C3,L3,P3,X3	Portable	13X15Z
N3333M6	Console	14N22	X1325W3	Portable	13X15Z
S2712R,W	Console	14N22	X1620J,Y	Portable	14X21
S2712R1,W1	Console	14N22	X1620J1,Y1	Portable	14X21Z
S2716W	Console	14N22	X1620J2,Y2	Portable	14M21
S2716W1	Console	14N22	X1625X,Y	Portable	14X21
SA2017R6,W6	Console	14N22	X1625X1,Y1	Portable	14X21Z
SA2017R6A,W6A	Console	14N22	X1625X2,Y2	Portable	14M21
SA2046W6	Console	14N22	X1720J,Y	Portable	14X21
SA2046W6A	Console	14N22	X1725X,Y	Portable	14X21
T1979C6A,X6A	Portable	14N33	X1910C	Portable	14N33
T1630J6, Y6	Portable	14M21	X1910C1	Portable	14N29Z
T1979C6, X6	Portable	14N29Z	X1910C2	Portable	14N33
T1983L6, P6	Portable	14N28	X1914L,X	Portable	14N33
T1984L6	Portable	14N27	X1914L1,X1	Portable	14N29Z
T1988J6, L6, W6	Portable	14N27	X1917H,W	Portable	14N33
T1991R6, W6	Portable	14N27	X1917H1,W1	Portable	14N29Z
T1995W6	Portable	14N28	X1919L,X	Portable	14N27
T2035W6	Console	14N22	X1921H,W	Portable	14N28

ZENITH Model and Chassis Information, Continued

X192IH1,W1	Portable	14N28	X2314W	Table	14N22
X1925J,L	Portable	14N28	X2317R,W	Console	14N22
X1930H,W	Portable	14N28	X2317R1,W1	Console	14N22
X1943L	Portable	14N28	X2320W	Console	14N22
X1946W	Portable	14N28	X2320W1	Console	14N22
X2010C	Portable	14N33	X2322H	Console	14N22
X2010C1	Portable	14N33	X2322H1	Console	14N22
X2014L,X	Portable	14N33	X2324M	Console	14N22
X2014L1,X1	Portable	14N33	X2324M1	Console	14N22
X2017H,W	Portable	14N33	X2326R,W	Console	14N22
X2017H1,W1	Portable	14N33	X2326R1,W1	Console	14N22
X2022H,W	Portable	14N28	X2328W	Console	14N22
X2022H1,W1	Portable	14N28	X2328W1	Console	14N22
X2027L,X	Portable	14N28	X2343W,Y	Table	14N22
X2027L1,X1	Portable	14N28	X2412L,W	Table	14N22
X2032M,W	Portable	14N28	X2412L1,W1	Table	14N22
X2043L,L1	Portable	14N28	X2414 W, W1	Table	14N22
X2046W,W1	Portable	14N28	X2417R,W	Console	14N22
X2112L	Table	14N26Z	X2417R1,W1	Console	14N22
X2112L1	Table	14N26Z	X2421W	Console	14N22
X2115P,X	Table	14N26Z	X2421W1	Console	14N22
X2120H,W	Table	14N26Z	X2422H	Console	14N22
X2145W	Table	14N26Z	X2422H1	Console	14N22
X2245W1	Table	14N26Z	X2424M	Console	14N22
X2310W2	Table	14N22	X2424M1	Console	14N22
X2314W1	Table	14N22	X2427R,W	Console	14N22
X2310W,Y	Table	14N22	X2443W	Console	14N22

ADJUSTMENTS

VHF TUNER CHANNEL OSCILLATOR ADJUSTMENT

In all VHF tuners, each channel can be adjusted individually with the receiver fine tuning knob without interaction with other channels. Several turns of the knob are permissible, in either direction, to obtain proper adjustment.

The 640 tuner and the 750 series tuners are equipped with an auxilliary oscillator trimmer to be used if adjustment cannot be made with the fine tuning knob.

FOCUS

14N22, 14N26Z and 14N28 Chassis: Focus control adjustment, rear of chassis.

ALL OTHER chassis:

Adjustment is by means of a three position tap.

WIDTH AND HORIZONTAL LINEARITY ADJUSTMENTS

13X15 and 14N22 Chassis: Width-Linearity sleeve on neck of picture tube.

Adjustment is made by sliding the metal width sleeve along the neck of the picture tube until both proper width and best linearity is obtained.

ALL OTHER chassis: Width Control and Linearity sleeve. A screwdriver adjustment at the rear of the chassis is used to adjust width and the sleeve on the neck of the picture tube is used to adjust linearity.

The sleeve is installed with the slot to the left when facing the rear of set. The initial width and linearity adjustment is made by turning the width control to its maximum counterclockwise position and sliding the sleeve to optimize linearity. The width control is then advanced to obtain correct width.

AGC ADJUSTMENT

Tune in a strong TV signal and slowly turn the AGC control until a point is reached where the picture distorts and buzz is heard in the sound. The control should then be backed down from this position and set at a point comfortably below the level of intercarrier buzz, picture distortion and improper sync. This setting corresponds

in general to 2.5 volts peak-to-peak at the Video Detector stage in the 13X15, 14N26Z and 14N27 chassis and 3.5 volts peak-to-peak at the Video Detector stage in the 14X21, 14N22 and 14N28 chassis.

CAUTION: Misadjustment of the AGC control can result in a washed-out picture, distorted picture, buzz in the sound or complete loss of picture and sound.

HORIZONTAL HOLD CONTROL

The horizontal hold control is equipped with a stop which limits knob rotation to approximately 270 degrees. To adjust the AFC, remove the knob and turn the shaft to a position where it is virtually impossible to disrupt horizontal synchronization when switching from channel to channel. After adjustment, install the knob with its pointer centered between the stops.

PEAK PIX CONTROL

14N22 AND 14N26Z CHASSIS ONLY:

This special customer control is part of the video detector load and has an effect on the video response. The picture can be changed from a slight smear at the extreme counterclockwise position to an exaggerated overshoot at the maximum clockwise position of the control.

The control is adjusted at the factory for best picture detail under normal signal conditions, however, it can be changed in the field to suit a particular signal or program condition.

ZENITH Adjustment Information, Continued

CENTERING ADJUSTMENT

The centering assembly is built into the yoke housing. This assembly is made of two magnetic rings which can be rotated by means of tabs. Centering is accomplished by gradually rotating each tab separately and/or rotating both tabs simultaneously until the picture is centered.

CORRECTOR MAGNET ADJUSTMENT

Two corrector magnets are used in all 23 inch models to prevent pincushioning of the sweep lines across the face of the picture tube. The magnets are mounted on the deflection coil support bracket. Adjustment is made by bending the flexible arms sideways and up and down. Correct adjustment has been made at the factory and readjustment should not be required unless the brackets have been accidentally bent out of position. If this occurs, proceed as follows:

1. With the vertical and horizontal size controls, reduce the size of the picture to a point where the four corners and sides are visible. (In some receivers it is not possible to reduce the picture sufficiently to see all sides and it may be necessary to shift the picture with the centering control to view one side at a time.)

2. Bend the corrector magnet arms until the corners become right angles and the top of the raster is parallel with the bottom and the left side is parallel with the right side. After adjustment, the picture should be restored to normal size.

NOTE: Misadjustment of the corrector magnets may cause pincushioning, barreling, keystoneing, poor linearity, etc.

ALIGNMENT

SOUND ALIGNMENT

Proper alignment of the 4.5 Mc intercarrier sound channel can only be made if the signal to the receiver antenna terminals is reduced to a level below the limiting point of the Gated Beam Sound Detector. This level can be easily identified by the "hiss" that accompanies the sound. Various methods may be used to reduce the signal level, however, a step attenuator is recommended for most satisfactory results. Alignment is made as follows:

1. Connect the step attenuator between the antenna and the receiver antenna terminals.
2. Tune in a TV signal. Adjust the step attenuator until the signal is attenuated to a level where a "hiss" is heard with the audio.
3. Adjust the sound take-off coil (top and bottom cores), intercarrier transformer, quadrature coil and buzz control for the best quality sound and minimum buzz.

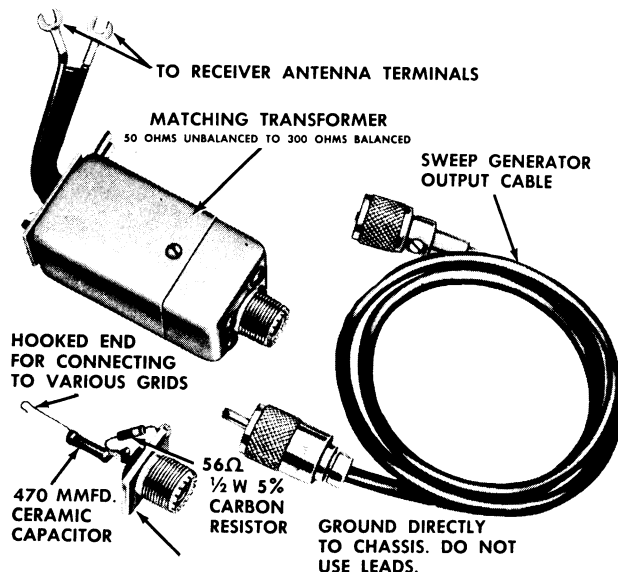

Fig. 1 Alignment Fixtures for RF-IF Alignment.

It must be remembered that any of these adjustments may cause the "hiss" to disappear and further reduction of the signal will be necessary to prevent the "hiss" from disappearing during alignment.

IF ALIGNMENT

A suitable VHF and UHF sweep generator in conjunction with an accurate marker must be used for IF and tuner alignment work. It is extremely important to terminate the output cable properly and to check for a reactive attenuator. If the attenuator is reactive or if the output cable is improperly terminated, correct alignment cannot be made since the degree of attenuation may change the shape as well as the amplitude of the response curve. The attenuator should only vary the amplitude and not the shape of the response curve.

IF ALIGNMENT

14N22, 14N26Z AND 14N28 CHASSIS:

Refer to the appropriate schematic diagram, tube and trimmer layout, and tuner drawings for reference test points.

1. (a) On the 700 series tuners; slowly turn the channel selector until it rests between channels 12 and 13. This will prevent an erroneous response.
(b) On the 640 and 750 series; turn the selector until it rests on channel 13.
(c) On the 500 series; turn the selector until it rests between any two channels.
2. Connect an oscilloscope through a 10,000 ohm isolation resistor to terminal "C" (detector). Connect the ground lead to chassis. In the 14N22 chassis, set the Peak Pix control fully to the left. In the 14N26Z chassis, set it at mid-range.

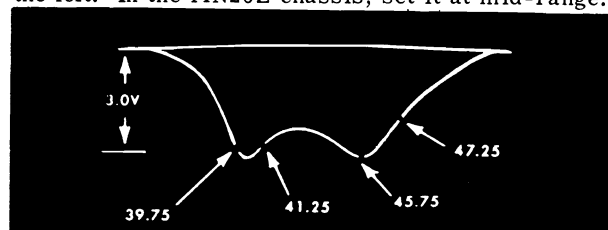

Fig. 2. 4th IF Response

ZENITH Alignment Information, Continued

3. Feed the sweep generator through a special terminating network as shown in Fig. 1. to Point "G" (Grid of the 3rd IF). Adjust generator to obtain a response similar to Fig. 2. with a detector output of 3 volts peak to peak. Do not exceed this level during any of the adjustments.

4. Set the marker generator to 45.75 Mc and alternately adjust the top and bottom cores of the 4th IF for maximum gain and symmetry with the 45.75 Mc marker positioned as shown in Fig. 2. The two peaks must be equal in height and the high frequency peak at 45.75 Mc. If the correct response cannot be obtained, check the position of the cores to see that they are not butted. The cores should be entering their respective windings from the opposite ends of the coils.

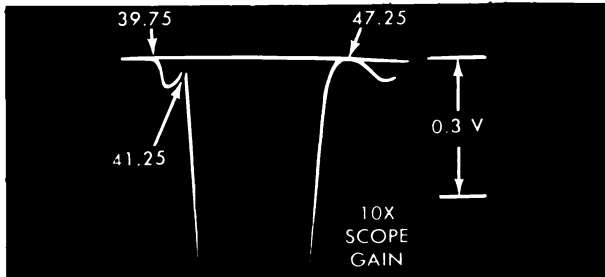

Fig. 3. Expanded View of Traps

5. Connect the sweep generator to terminal "A" (converter grid). Connect terminal "F" to chassis and connect a jumper between terminal "E" and chassis. Adjust the sweep to obtain a 3V. P.P. response similar to Fig. 5. Switch oscilloscope to 10X gain to "blow up" the traps (Fig 3).

6. Refer to Fig.3. and adjust the 39.75 Mc and the 41.25 Mc traps for minimum marker amplitude. Connect jumper between "E" and the junction of the 68 ohm and 1800 ohm resistors in the cathode circuit of the 1st I.F. This provides an additional "blow up" of the 47.25 Mc traps (Fig. 4). Adjust the 47.25 MC trap for minimum marker amplitude.

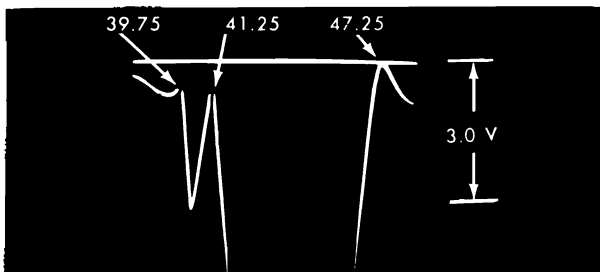

Fig. 4. Further Expansion of Fig. 3. for Detail View of the 39.75 and 47.35 Mc Traps.

7. Disconnect jumper between "E" and the 68 ohm and 1800 ohm cathode resistors. Connect this jumper between "E" and chassis. Adjust sweep generator for 3 volts peak to peak output at the second detector. Alternately, adjust the 2nd, 3rd, 1st IF and the converter plate coil until an overall response similar to Fig. 5. is obtained. It will be found that the 2nd IF affects the low side (42.75MC) and the 3rd IF, the high side of the response curve.

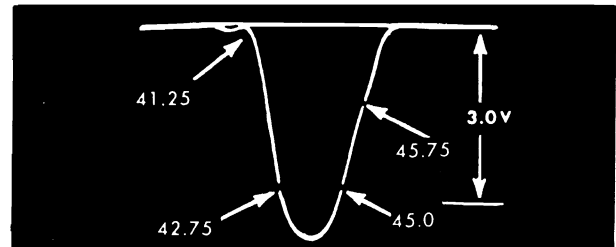

Fig.5 Overall IF Response Curve.

IF ALIGNMENT

14N27 AND 14N33 CHASSIS:

Refer to the appropriate schematic diagram, chassis tube and trimmer layout, and tuner drawings for reference test points.

1. Slowly turn the channel selector until the tuner rotor is made to rest between two channels. This will prevent an erroneous response.

2. Connect an oscilloscope through a 10,000 ohm isolation resistor to terminal "C" (detector). Connect the ground lead to chassis.

3. Feed the sweep generator through a special terminating network as shown in Fig. 1. to Point "G" (Pin 1 of the 3rd IF). Adjust generator to obtain a response similar to Fig. 6. Do not exceed the 3 volt peak to peak detector output during any of the following adjustments.

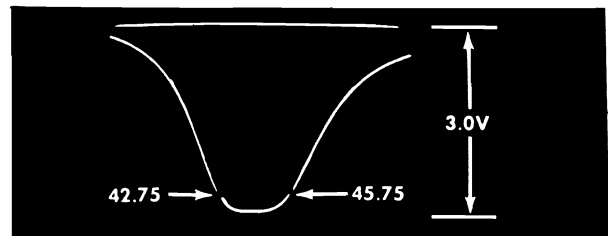

Fig. 6 4th IF Response Curve.

4. Set the marker generator to 45.75 Mc and alternately adjust the top and bottom cores of the 4th IF for maximum gain and symmetry with the 45.75 Mc and the 42.75 Mc markers positioned as shown in Fig. 6. If the correct response cannot be obtained, check the cores to see that they are not butted but are entering their respective windings from the opposite sides of the coil.

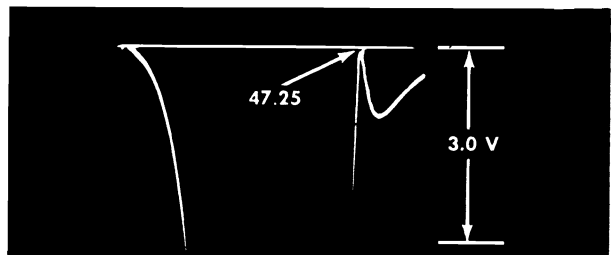
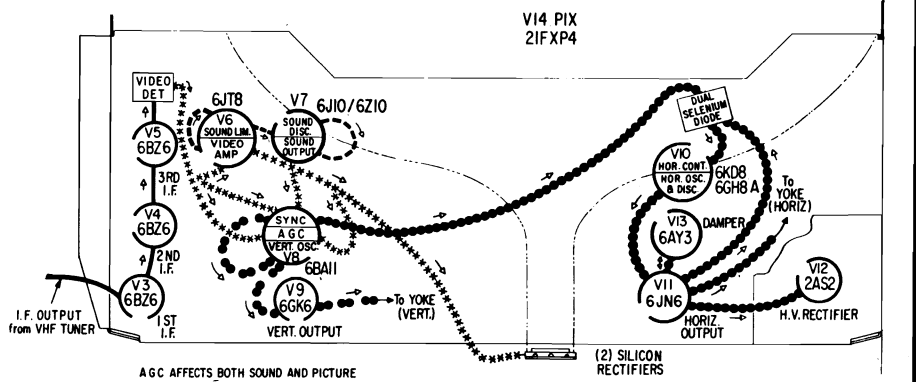
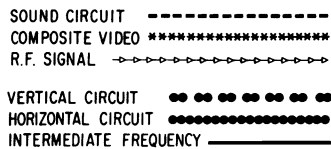
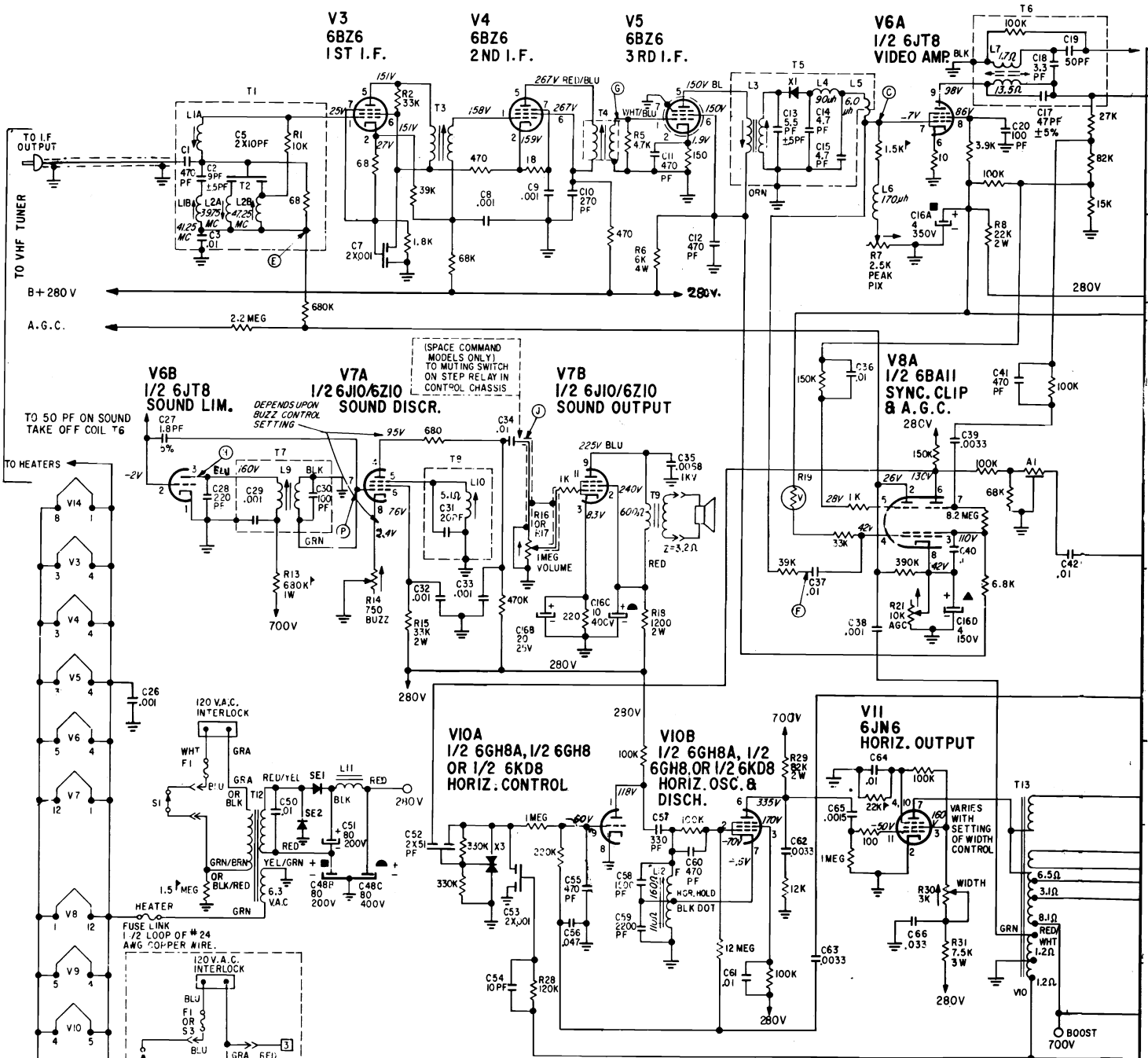

Fig.7 Expanded View of the 47.25 MC Trap Frequency.

5. Connect the sweep generator to terminal "A" converter grid (Refer to appropriate tuner tube and trimmer layout). Connect terminal "F" to chassis and connect a jumper between terminal "E" and the bottom end of the 68 ohm resistor in the cathode of the first IF. This provides a "blow up" of the 47.25 Mc trap (Fig. 7). Adjust the 47.25 Mc trap for minimum marker amplitude.

ZENITH Schematic Diagram of 14N26Z Chassis, Continued



ZENITH Service Information 14N26Z Chassis, Continued

Schematic Diagram of 14N26Z Chassis.

NOTES:

- ALL VOLTAGES MEASURED FROM CHASSIS TO POINTS INDICATED.
- ALL VOLTAGES ARE D.C. UNLESS OTHERWISE SPECIFIED.
- ALL D.C. VOLTAGES TO BE MEASURED WITH A VACUUM TUBE VOLTMETER HAVING 11 MEGOHM INPUT RESISTANCE.
- ALL VOLTAGE MEASUREMENTS TO BE MADE WITH NO SIGNAL PRESENT. NORMAL SETTING OF CONTROLS AND CHANNEL SELECTOR SET TO CHANNEL 2 UNLESS OTHERWISE SPECIFIED.
- ALL CAPACITOR VALUES IN MICROFARADS UNLESS OTHERWISE SPECIFIED.
- FOR CAPACITOR CAPACITY TOLERANCE SEE LEGEND.
- ALL RESISTORS ARE 10% TOLERANCE, CARBON, 1/2 WATT UNLESS OTHERWISE SPECIFIED.
- RESISTANCE MEASUREMENTS SHOWN WITH COIL DISCONNECTED FROM CIRCUIT.
- COIL RESISTANCES NOT GIVEN ARE UNDER ONE OHM.
- Ⓢ INDICATES 20% TOLERANCE.

- ARROWS ON POTENTIOMETERS INDICATE CLOCKWISE ROTATION.
- CHASSIS \perp INDICATES VOLTAGE SOURCE.
- PICTURE TUBE 2ND ANODE VOLTAGE TO BE MEASURED WITH ELECTROSTATIC MILDVOLT METER WITH BRIGHTNESS AND CONTRAST CONTROL: FULL COUNTER-CLOCKWISE.
- CX-CAPACITOR VALUE SELECTED FOR MINIMUM YOKE FINGERING. VARIES WITH A RANGE OF 47 PF TO 72 PF (3 K.V. ± 10%). WHEN NECESSARY, REPLACE WITH EXACT VALUE FOUND IN YOKE.
- CIRCLED LETTERS INDICATE ALIGNMENT AND TEST POINTS WHERE APPLICABLE.
- C - DETECTOR OUTPUT
- D - VIDEO OUTPUT
- E - I.F. A.G.C.
- F - GROUNDED FOR I.F. ALIGNMENT
- G - 3RD I.F. GRID
- H - SOUND LIMITER PLATE
- J - SOUND OUTPUT
- P - SOUND DISC GRID

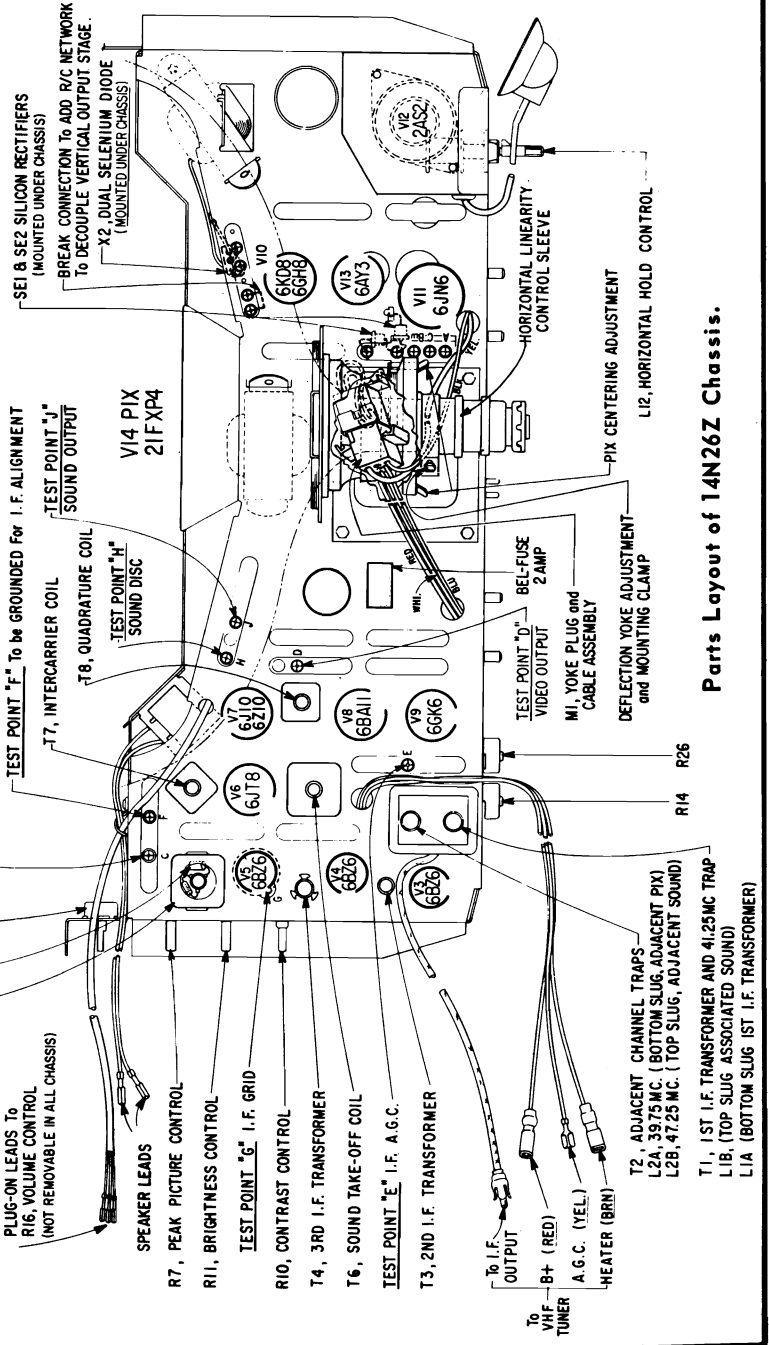
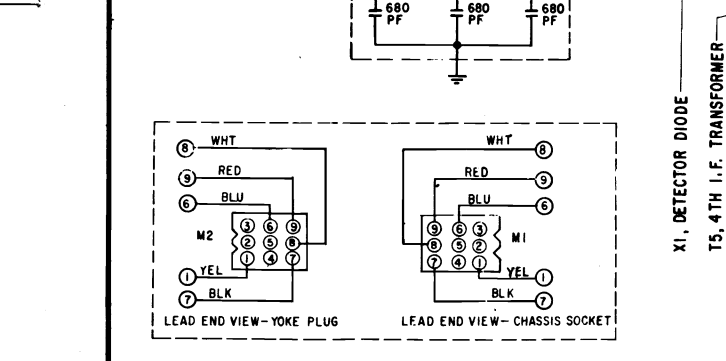
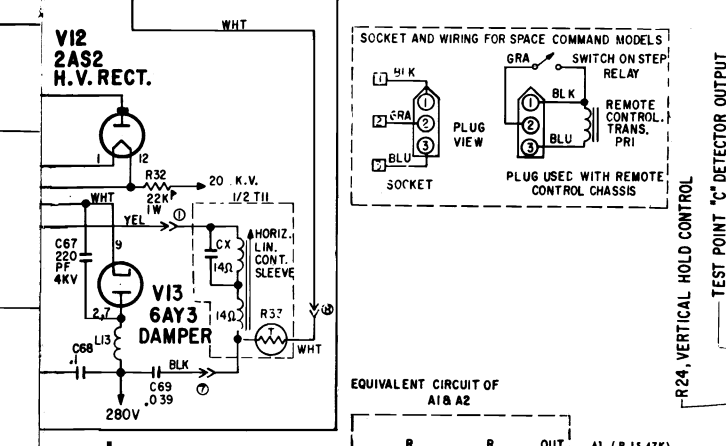
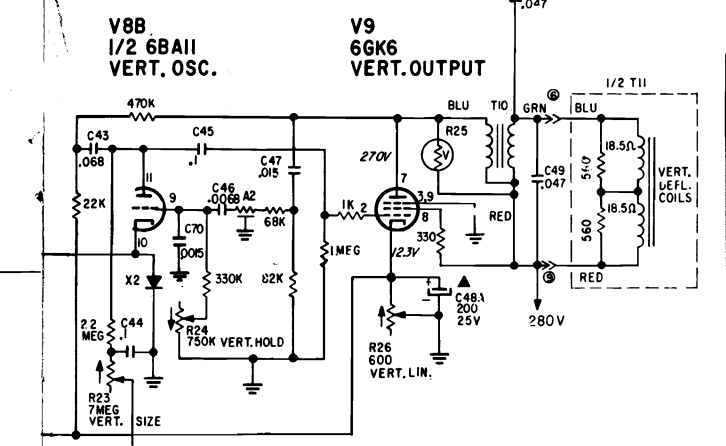
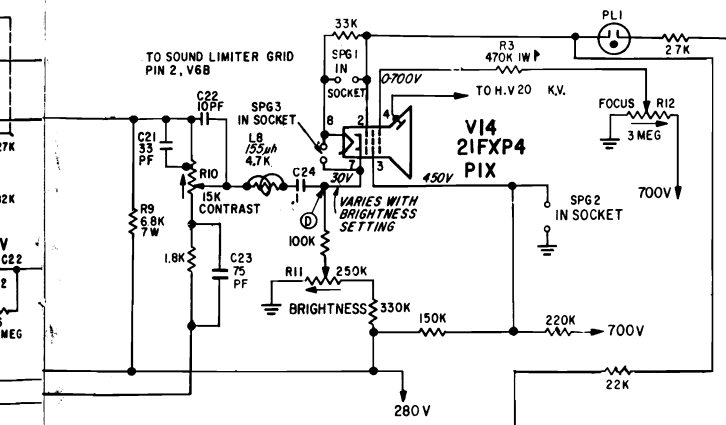

Parts Layout of 14N26Z Chassis.

ZENITH Schematic Diagram of 14N22 Chassis, Continued

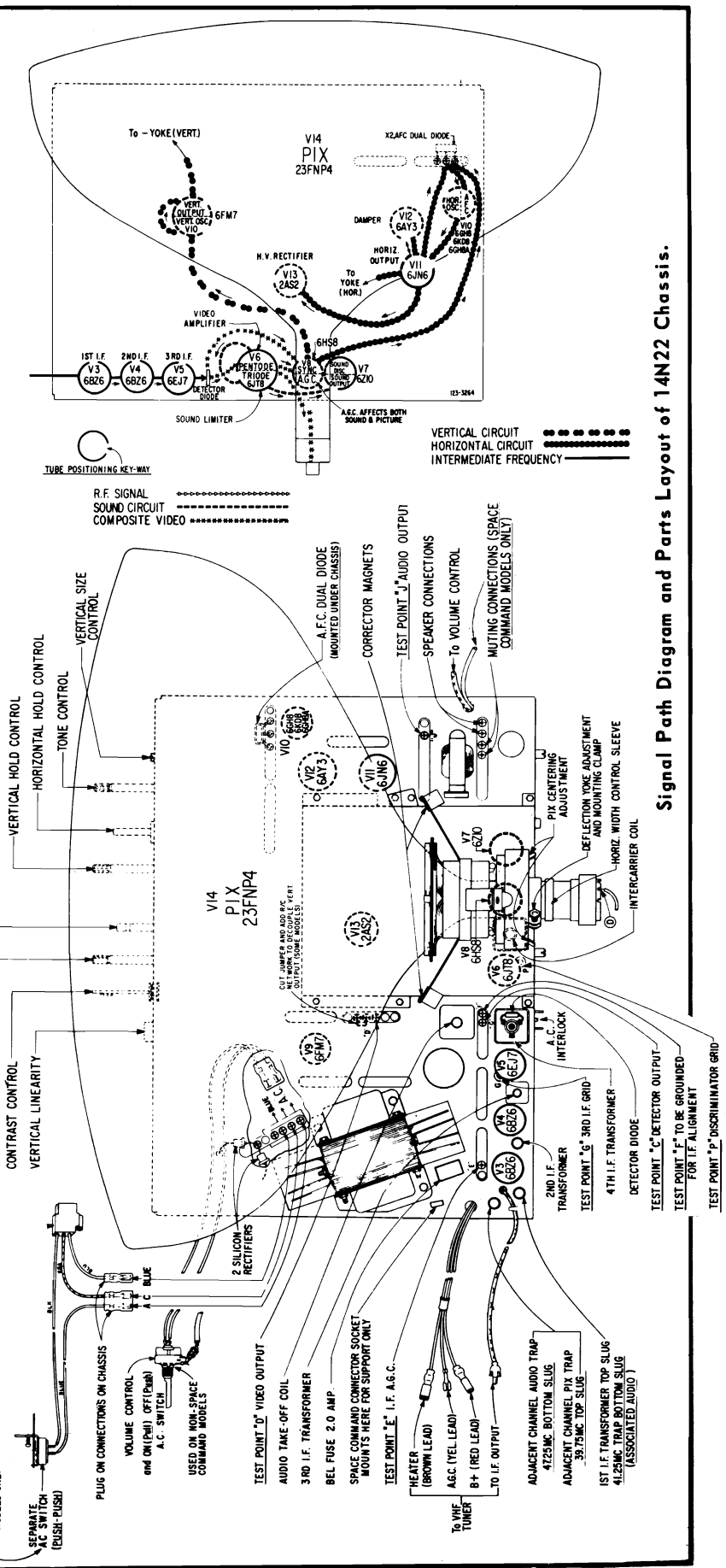
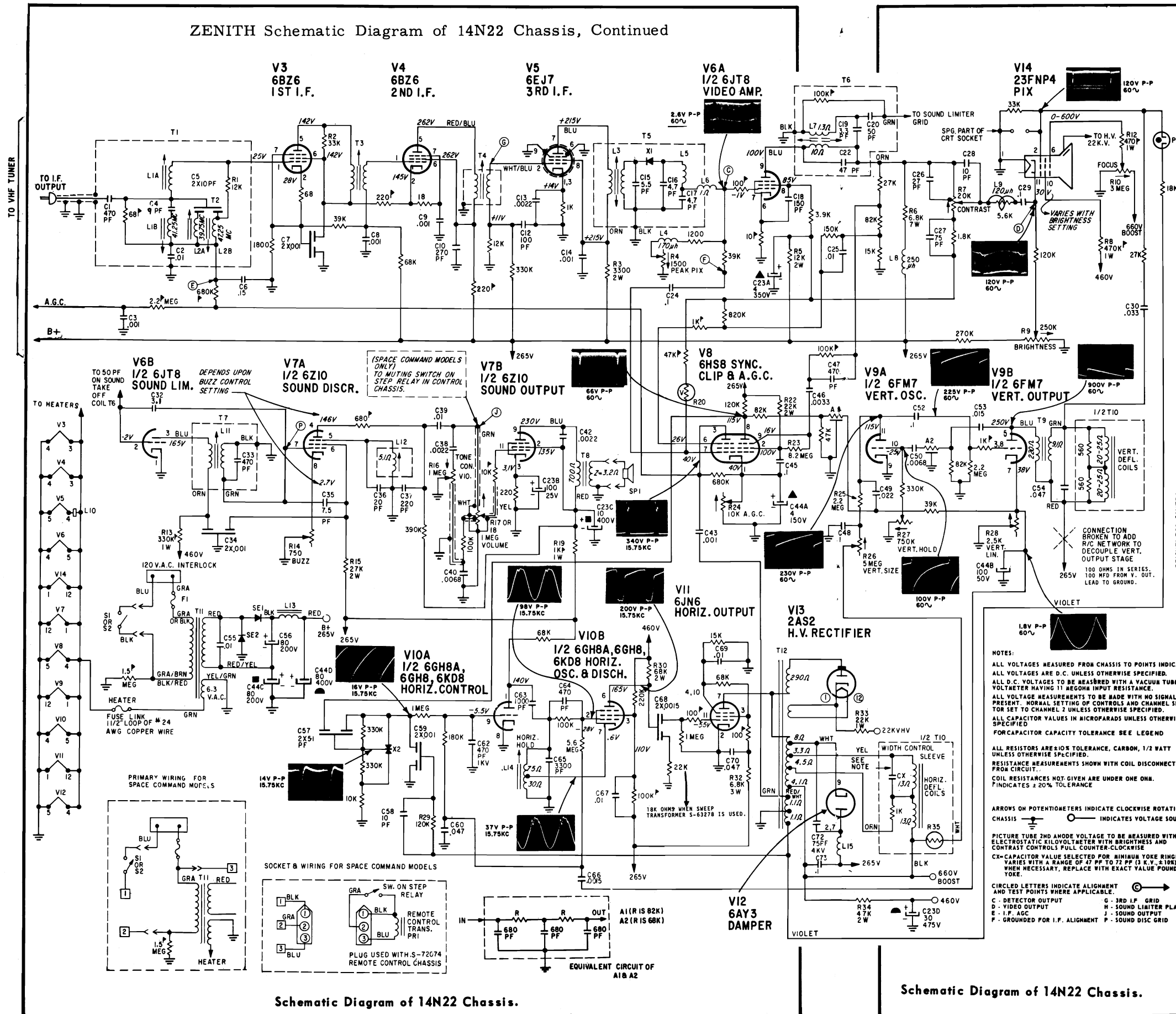

Signal Path Diagram and Parts Layout of 14N22 Chassis.

ZENITH Schematic Diagram of 14N27 Chassis, Continued

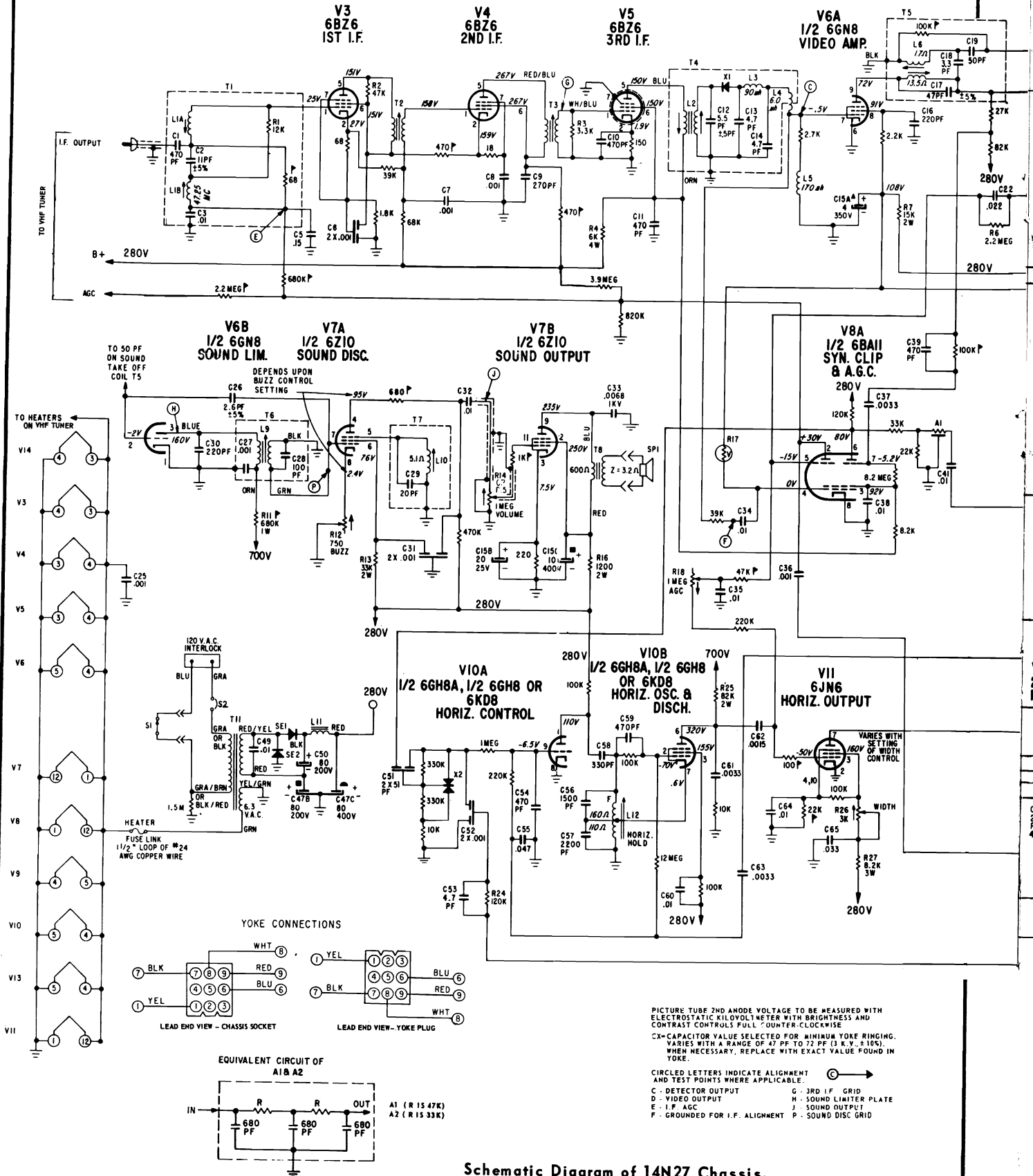

Schematic Diagram of 14N27 Chassis.

ZENITH Service Information 14N28 Chassis, Continued

Schematic Diagram of 14N28 Chassis.

NOTES:
 ALL VOLTAGES MEASURED FROM CHASSIS TO POINTS INDICATED.
 ALL D.C. VOLTAGES ARE D.C. UNLESS OTHERWISE SPECIFIED.
 ALL D.C. VOLTAGES TO BE MEASURED WITH A VACUUM TUBE
 VOLTMETER HAVING 11 MEGOHM INPUT RESISTANCE.
 ALL VOLTAGE MEASUREMENTS TO BE MADE WITH NO SIGNAL
 PRESENT. NORMAL SETTING OF CONTROLS AND CHANNEL SELFC-
 TOR SET TO CHANNEL 2 UNLESS OTHERWISE SPECIFIED.

FOR CAPACITOR CAPACITY TOLERANCES SEE LEGEND.

ALL RESISTORS ARE $\pm 10\%$ TOLERANCE, CARBON, 1/2 WATT
 UNLESS OTHERWISE SPECIFIED.

RESISTANCE MEASUREMENTS SHOWN WITH COIL DISCONNECTED
 FROM CIRCUIT.

COIL RESISTANCES NOT GIVEN ARE UNDER ONE OHM.

ARROWS ON POTENTIOMETERS INDICATE CLOCKWISE ROTATION.
 CHASSIS --- INDICATES VOLTAGE SOURCE.

PICTURE TUBE 2ND ANODE VOLTAGE TO BE MEASURED WITH
 ELECTROSTATIC K15 VOLTMETER WITH BRIGHTNESS AND
 CONTRAST CONTROLS FULL COUNTER-CLOCKWISE

CX-CAPACITOR VALUE SELECTED FOR MINIMUM YOKE RINGING.
 VARIES WITH A RANGE OF 47 PF TO 72 PF (3 K.V. $\pm 10\%$).
 WHEN NECESSARY, REPLACE WITH EXACT VALUE FOUND IN
 YOKE.

CIRCLED LETTERS INDICATE ALIGNMENT
 AND TEST POINTS WHERE APPLICABLE.

C - DETECTOR OUTPUT
 D - VIDEO OUTPUT
 E - I.F. AGC
 F - GROUNDED FOR I.F. ALIGNMENT
 G - 3RD I.F. GRID
 H - SOUND LIMITER PLATE
 J - SOUND OUTPUT
 K - SOUND OUTPUT
 P - SOUND DISC GRID
 P - INDICATES 20% MAY BE USED.

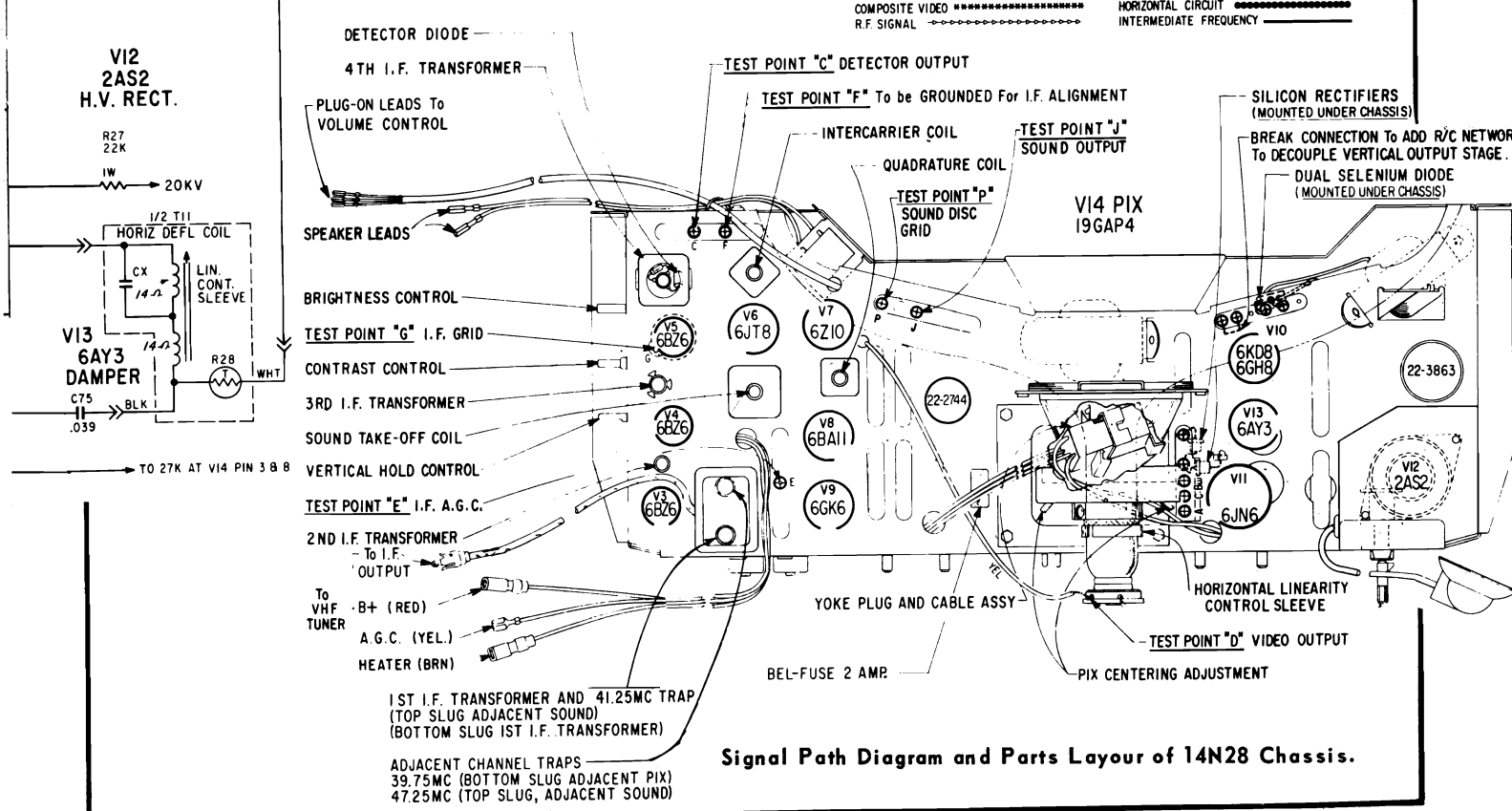
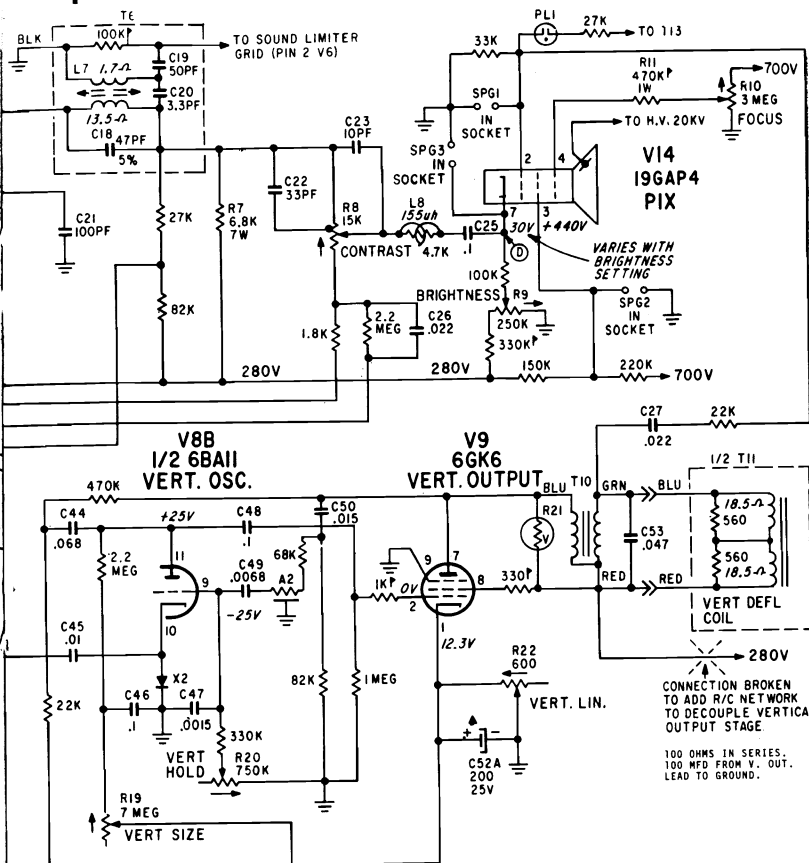
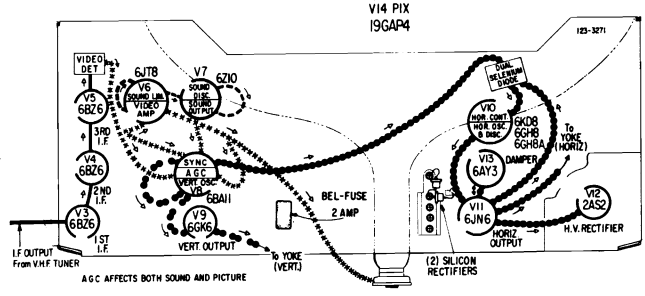

Signal Path Diagram and Parts Layout of 14N28 Chassis.

ZENITH Schematic Diagram of 14N33 Chassis, Continued

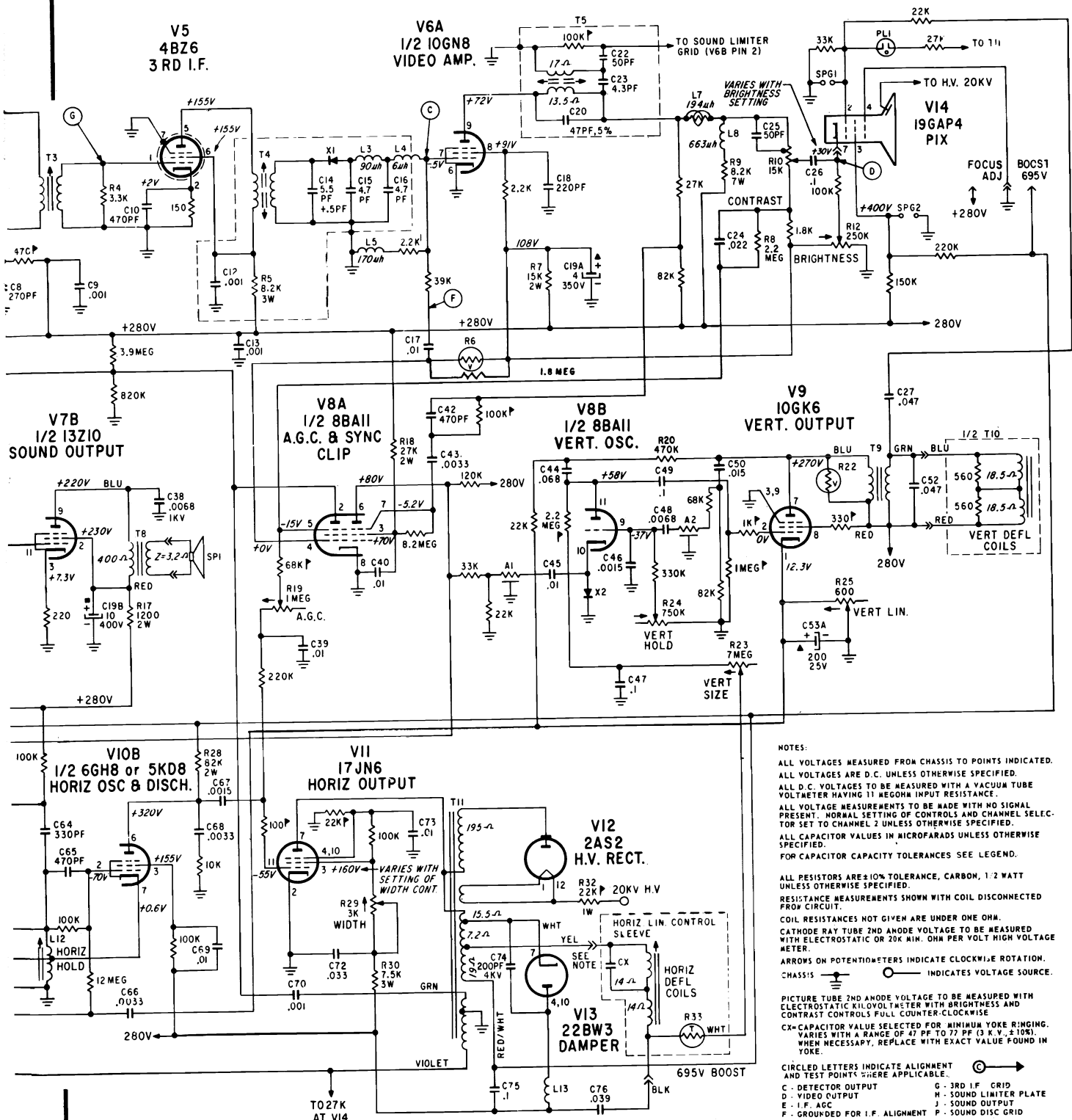

NOTES:

ALL VOLTAGES MEASURED FROM CHASSIS TO POINTS INDICATED. ALL D.C. VOLTAGES ARE D.C. UNLESS OTHERWISE SPECIFIED. ALL D.C. VOLTAGES TO BE MEASURED WITH A VACUUM TUBE VOLTMETER HAVING 11 MEGOHM INPUT RESISTANCE. ALL VOLTAGE MEASUREMENTS TO BE MADE WITH NO SIGNAL PRESENT. NORMAL SETTING OF CONTROLS AND CHANNEL SELECTOR SET TO CHANNEL 2 UNLESS OTHERWISE SPECIFIED. ALL CAPACITOR VALUES IN MICROFARADS UNLESS OTHERWISE SPECIFIED. FOR CAPACITOR CAPACITY TOLERANCES SEE LEGEND.

ALL RESISTORS ARE ±10% TOLERANCE, CARBON, 1/2 WATT UNLESS OTHERWISE SPECIFIED. RESISTANCE MEASUREMENTS SHOWN WITH COIL DISCONNECTED FROM CIRCUIT. COIL RESISTANCES NOT GIVEN ARE UNDER ONE OHM. CATHODE RAY TUBE 2ND ANODE VOLTAGE TO BE MEASURED WITH ELECTROSTATIC OR 20K OHM PER VOLT HIGH VOLTAGE METER. ARROWS ON POTENTIOMETERS INDICATE CLOCKWISE ROTATION. CHASSIS \perp INDICATES VOLTAGE SOURCE.

PICTURE TUBE 2ND ANODE VOLTAGE TO BE MEASURED WITH ELECTROSTATIC 1K OHM PER VOLT METER WITH BRIGHTNESS AND CONTRAST CONTROLS FULL COUNTER-CLOCKWISE. CX=CAPACITOR VALUE SELECTED FOR MINIMUM YOKE RINGING. VARIES WITH A RANGE OF 47 PF TO 77 PF (3 K.V. ±10%). WHEN NECESSARY, REPLACE WITH EXACT VALUE FOUND IN YOKE.

CIRCLED LETTERS INDICATE ALIGNMENT AND TEST POINTS WHERE APPLICABLE.

C - DETECTOR OUTPUT G - 3RD I.F. GRID
 D - VIDEO OUTPUT H - SOUND LIMITER PLATE
 E - I.F. AGC J - SOUND OUTPUT
 F - GROUNDED FOR I.F. ALIGNMENT P - SOUND DISC GRID

⤴ INDICATES ±20% TOLERANCE.

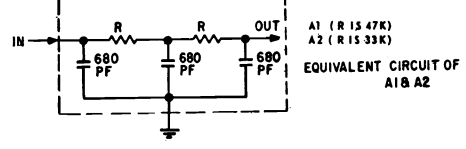

Schematic Diagram of 14N33 Chassis.

ZENITH Schematic Diagram of 13X15, 13X15Z Chassis, Continued

V5
4BZ6
3RD. IF

V6A
1/2 10JT8
VIDEO AMP.

V13 PIX
12BEP4 OR 12CBP4
(NOT INTERCHANGEABLE)

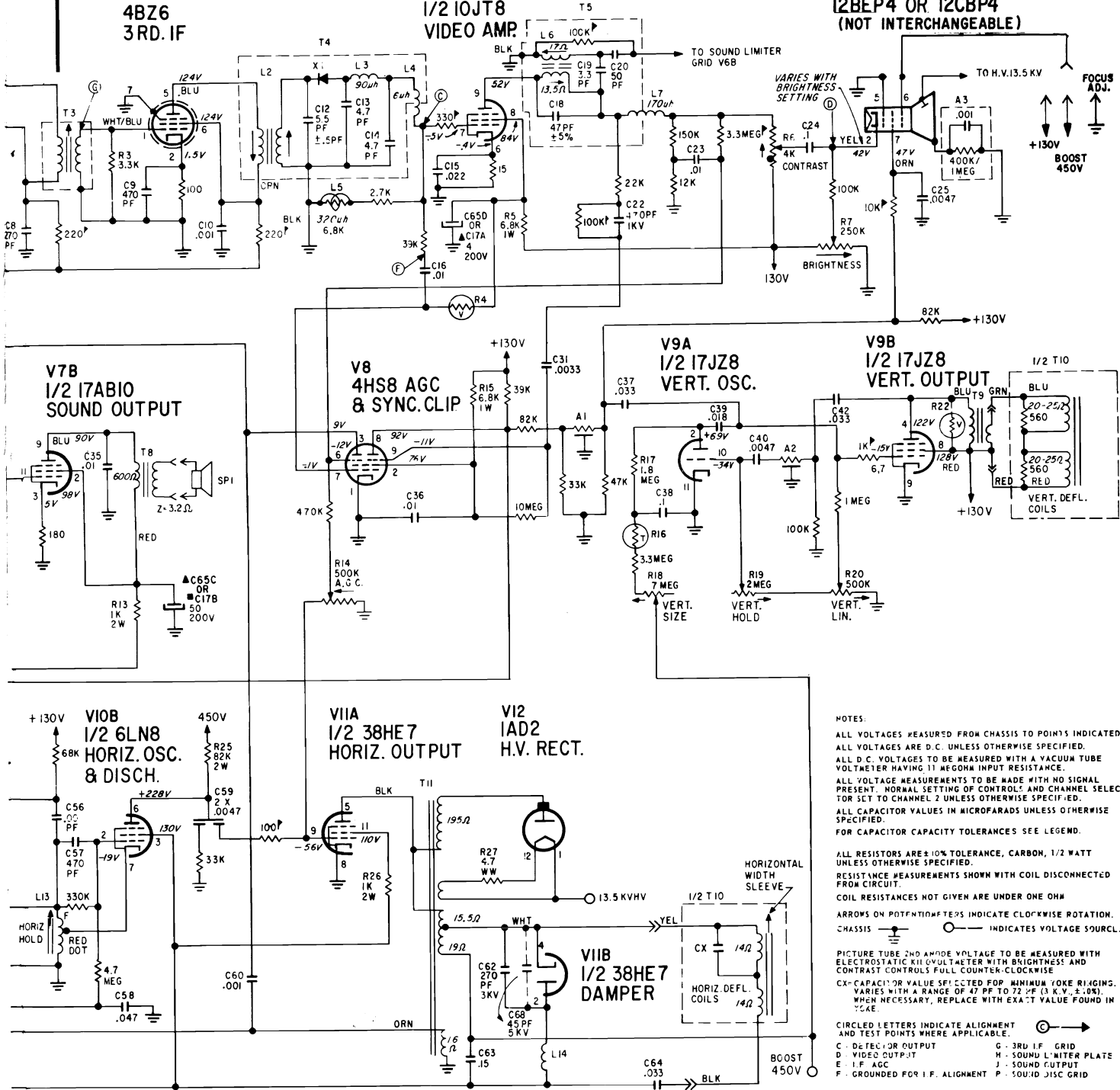

- NOTES:**
- ALL VOLTAGES MEASURED FROM CHASSIS TO POINTS INDICATED.
 - ALL VOLTAGES ARE D.C. UNLESS OTHERWISE SPECIFIED.
 - ALL D.C. VOLTAGES TO BE MEASURED WITH A VACUUM TUBE VOLTMETER HAVING 11 MEGOHM INPUT RESISTANCE.
 - ALL VOLTAGE MEASUREMENTS TO BE MADE WITH NO SIGNAL PRESENT. NORMAL SETTING OF CONTROLS AND CHANNEL SELECTOR SET TO CHANNEL 2 UNLESS OTHERWISE SPECIFIED.
 - ALL CAPACITOR VALUES IN MICROFARADS UNLESS OTHERWISE SPECIFIED.
 - FOR CAPACITOR CAPACITY TOLERANCES SEE LEGEND.
 - ALL RESISTORS ARE ±10% TOLERANCE, CARBON, 1/2 WATT UNLESS OTHERWISE SPECIFIED.
 - RESISTANCE MEASUREMENTS SHOWN WITH COIL DISCONNECTED FROM CIRCUIT.
 - COIL RESISTANCES NOT GIVEN ARE UNDER ONE OHM
 - ARROWS ON POTENTIOMETERS INDICATE CLOCKWISE ROTATION.
 - CHASSIS — INDICATES VOLTAGE SOURCE.
 - PICTURE TUBE 2ND ANODE VOLTAGE TO BE MEASURED WITH ELECTROSTATIC K110 VOLT METER WITH BRIGHTNESS AND CONTRAST CONTROLS FULL COUNTER-CLOCKWISE.
 - CX-CAPACITOR VALUE SPECIFIED FOR MINIMUM YONE RINGING. VARIES WITH A RANGE OF 17 PF TO 77 PF (3 K.V. ±10%). WHEN NECESSARY, REPLACE WITH EXACT VALUE FOUND IN TUBE.
 - CIRCLED LETTERS INDICATE ALIGNMENT AND TEST POINTS WHERE APPLICABLE.
 - C - DEFLECTOR OUTPUT G - 3RD I.F. GRID
 - D - VIDEO OUTPUT H - SOUND LIMITER PLATE
 - E - I.F. AGC J - SOUND OUTPUT
 - F - GROUNDED FOR I.F. ALIGNMENT P - SOUND DISC GRID
- † INDICATES 20% MAY BE USED.

EARPHONE JACK ASSEMBLY (SOME MODELS)

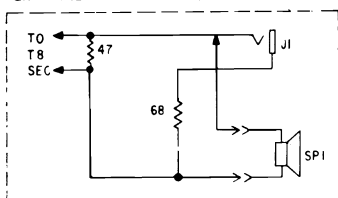

EQUIVALENT CIRCUIT OF INTEGNETS
A1, A2

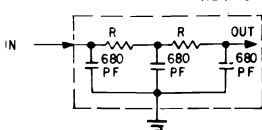

Schematic Diagram of 13X15 and 13X15Z Chassis.

ZENITH Chassis 14X21

PIX 168XP4

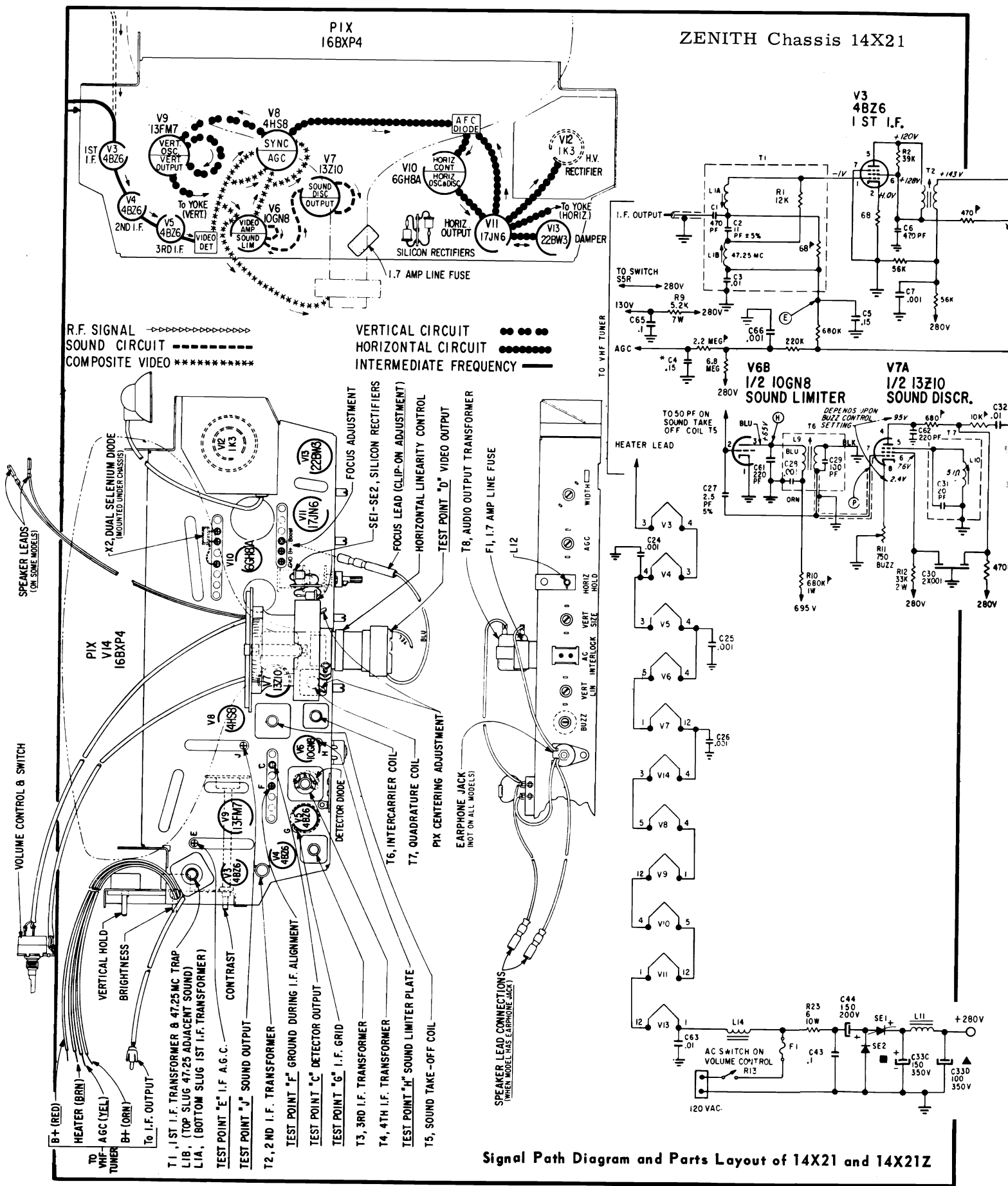

R.F. SIGNAL ———
 SOUND CIRCUIT - - - - -
 COMPOSITE VIDEO *****

VERTICAL CIRCUIT ●●●●●
 HORIZONTAL CIRCUIT ●●●●●
 INTERMEDIATE FREQUENCY ———

Signal Path Diagram and Parts Layout of 14X21 and 14X21Z

ZENITH Schematic Diagram of 14X21, 14X21Z Chassis, Continued

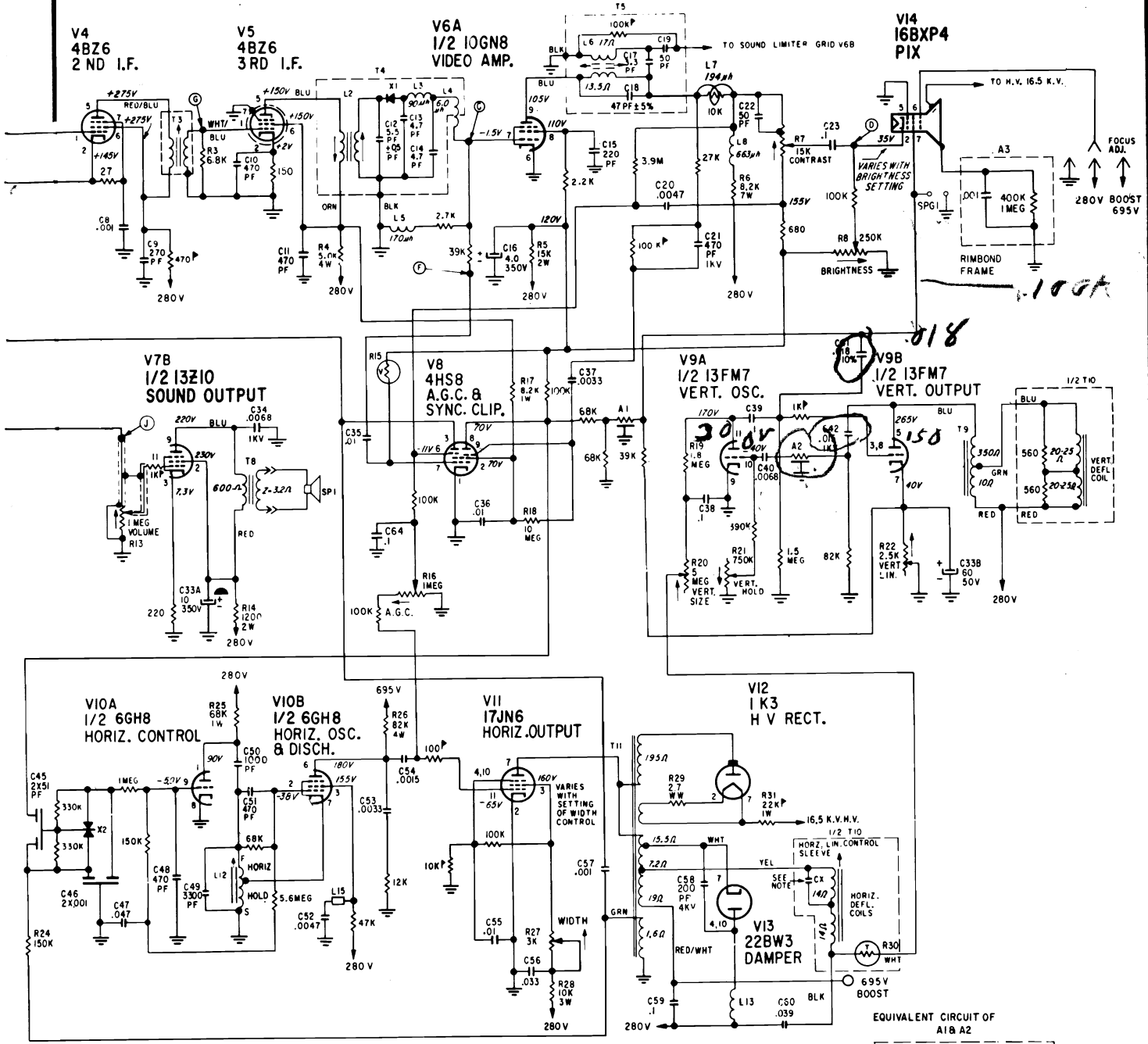

NOTES:

- ALL VOLTAGES MEASURED FROM POINTS INDICATED TO CHASSIS, ALL VOLTAGES ARE D.C. UNLESS OTHERWISE SPECIFIED.
- ALL D.C. VOLTAGES TO BE MEASURED WITH A VACUUM TUBE VOLTMETER HAVING 11 MEGOHM INPUT RESISTANCE.
- ALL VOLTAGE MEASUREMENTS TO BE MADE WITH NO SIGNAL PRESENT. NORMAL SETTING OF CONTROLS AND CHANNEL SELECTOR SET TO CHANNEL 2 UNLESS OTHERWISE SPECIFIED.
- ALL CAPACITOR VALUES IN MICROFARADS UNLESS OTHERWISE SPECIFIED.
- ALL CAPACITOR CAPACITY TOLERANCE ±10% UNLESS OTHERWISE SPECIFIED.
- ALL RESISTORS ARE ±10% TOLERANCE, CARBON, 1/2 WATT UNLESS OTHERWISE SPECIFIED. ▷ INDICATES 120% VALUE MAY BE USED.
- RESISTANCE MEASUREMENTS SHOWN WITH COIL DISCONNECTED FROM CIRCUIT.
- COIL RESISTANCES NOT GIVEN ARE UNDER ONE OHM.

ARROWS ON POTENTIOMETERS INDICATE CLOCKWISE ROTATION.
 CHASSIS \perp INDICATES VOLTAGE SOURCE.

PICTURE TUBE 2ND ANODE VOLTAGE TO BE MEASURED WITH ELECTROSTATIC KNOVOLT METER WITH BRIGHTNESS AND CONTRAST CONTROLS FULL COUNTER-CLOCKWISE.
 CX-CAPACITOR VALUE SELECTED FOR MINIMUM YOKE RINGING. VARIES WITH A RANGE OF 47 PF TO 72 PF (3 K.V., ±10%). WHEN NECESSARY, REPLACE WITH EXACT VALUE FOUND IN YOKE.

CIRCLED LETTERS INDICATE ALIGNMENT AND TEST POINTS WHERE APPLICABLE.

C - DETECTOR OUTPUT
 D - VIDEO OUTPUT
 E - I.F. AGC
 F - GROUNDED FOR I.F. ALIGNMENT

G - 3RD I.F. GRID
 H - SOUND LIMITER PLATE
 J - SOUND OUTPUT
 P - SOUND DISC GRID

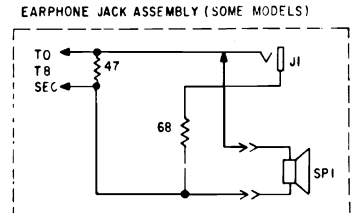
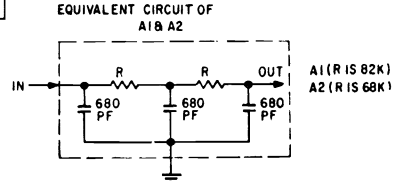

Schematic Diagram of 14X21 and 14X21Z Chassis.

ZENITH Tuner Service Information, Continued

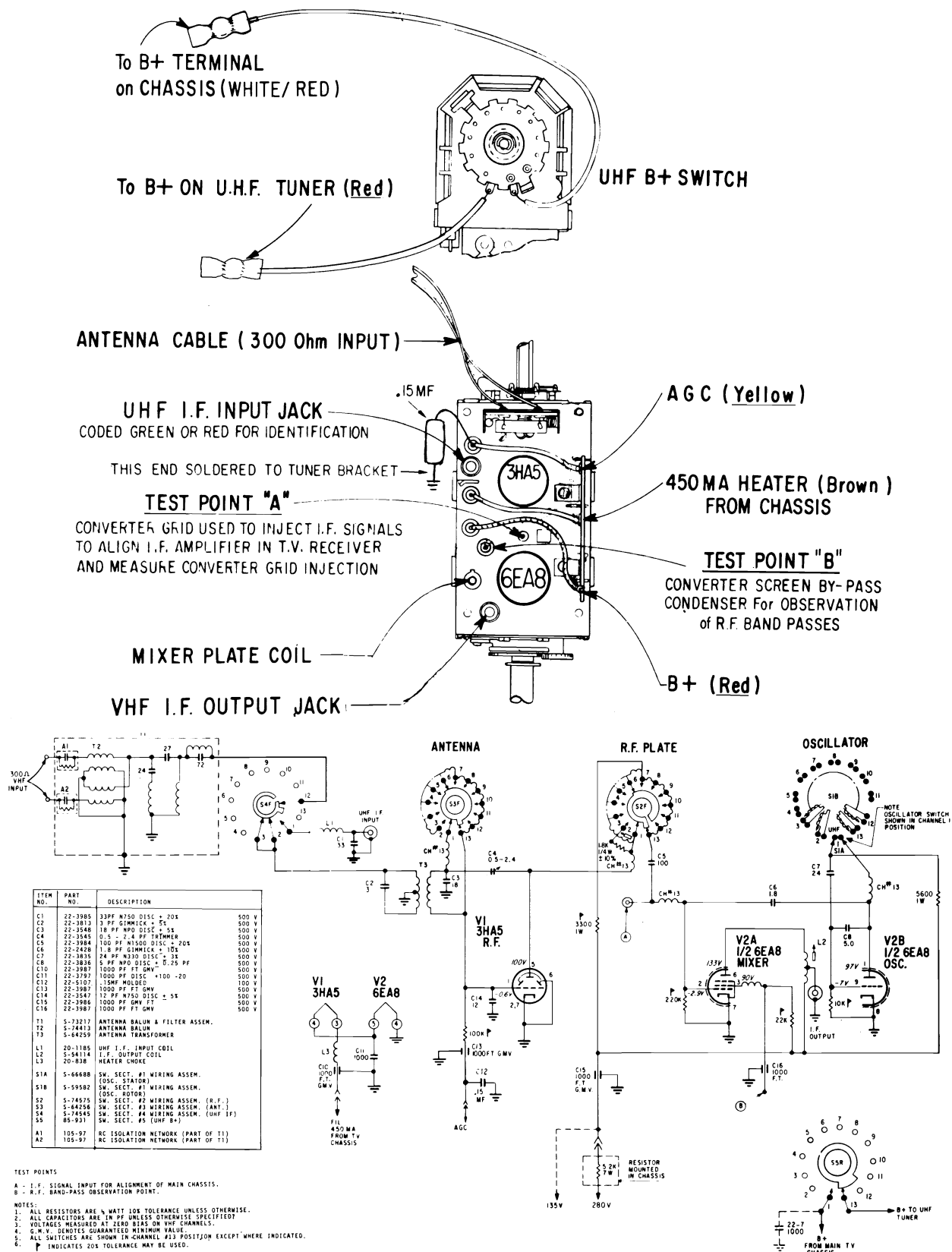

Schematic Diagram and Top View of De Luxe Video VHF Tuner (700 Series)
 Nos. 175-717 and 175-718.

INDEX

Under each manufacturer's name are listed that make chassis and models in numerical order, at left. The corresponding page number at right of each listing refers to the first page of each section dealing with such material.

Admiral Corp.	Admiral, Cont.	Emerson, Cont.	G.E. Cont.	Motorola, Cont.
H1-1A 7	TH3700 15	16P06 21	M401CSD 37	C18TS-597 69
2G521-1 15	PHS9340 15	16P07 21	M402CWD 37	D18TS-597 69
H2-1A 7	PHS9349 15	16P08 21	M403CWD 37	22TS-594 77
3G521-2 15	THA9349H,+ 15	16P09 21	M403C++ 37	C22TS-594 77
5G5 15	PH9511M 15	16P10 21	M405CWD 37	BP72BN 61
5H9N 15	PH9515 15	18P01 21	M407C++ 37	BP73BE,B+ 61
7G560-1 15	PH9516,M 15	18P16 21	M423CBG 37	BP301CN 61
9G557-1 15	AH9520 15	18P24 21	M425C++ 37	BP302CA,C+ 61
9G558-1,-2 15	PH9527 15	18P28 21	M452CEB 37	TS-461 61
G21D20-1 3	PH9650M,W 15	18P31 21	M454C++ 37	BP501CE 69
G21D22-1 3	PH9654,W 15	18P32 21	M503CSD 37	BP502CA 69
G21D23-1 3	PH9657M,W 15	18P33 21	M503CWH 41	BP503CB,C+ 69
G21D24-1 3	PH9660 15	19P14,A 27	M507CEB 41	JTS-594 77
H21B10-1 11	PH9666 15	19P15 27	M509C++ 41	TS-594 77
G556-1 15	AH9677 15	19P16 27	M718CWD 32	CTS-597 69
G557-1,-2 15		19P21 27	M720C++ 32	NCTS-597 69
G568-2 15	DuMont	19P22 27	M730CMD 32	TS-597 69
G569-1 15	43C07 27	19P24 21	M730CWD 32	BT601CE,CH 77
PG1330M 11	43C08 27	19P25 21	M732CMP 32	BT602CE,CN 77
PG1332M 11	43C09 27	19P26 21	M740CWD 32	BT603CH,C+ 77
PG1335M 11	43C10 27	19P27 21	M741CWD 32	BT702CW 77
PG1339M 11	43T02 27	19P28 21	M742CMP 32	BU704CW 77
PK1360 7	43T03 27	19P31 21	M743CCL 32	BU706CM 77
PK1369 7	43T04 21	19P32 21	M744C PN 32	BU707CF 77
PK1377 7	49P04 27	19P33 21	M760C+D 32	BU709CM,CW 77
PG1521 3	49P05 27	120804A 27	M762CMP 32	BS710CM,CW 77
PG1530 3	49P07 21	120805A,B 27	M770CWD 32	BS711CS 77
PG1535 3	49P08 21	120806A,B 27	M771CMP 32	BL712CM,CW 77
PG1539 3	120804A,B 27	120807A,B 27	TR810CTN 45	
PG1547 3	120805A,B 27	120823B 27	TR811TTN-1 45	Philco Corp.
PK1560 7	120806A,B 27	120837A 21	TR812CVY 45	17C21,A 85
PK1569 7	120807A,B 27	120839A 21	TR814CEB 45	17C21V,AV 85
PK1577 7	120837A 21	120840A,B 21	TR853C++ 45	17H22 91
PKC2100 15	120846B 21	120840C 21		17J25 91
PH2101 15	120847B 21	120841A,+ 21	Magnavox	17J27,A 91
PKC2101 15		120842A,+ 21	T910 53	17J28 91
PK2104 15	Emerson Radio	120843A 21		17JT41 99
PKC2107 15	13C12 27	120846B 21	Montgomery	17LT43 99
PH2110 15	13C14 27	120847B 21	Ward	17N35 91
PH2119 15	13C15 27	120848F,+ 21	GHJ-4017A 57	17NT45 99
PH2127 15	13C16 21		GHJ-4097A 57	TT164B,C,D 106
PH2140 15	13C17 21	General	GHJ-41147A 57	R1228GY 85
PH2146 15	13C18 21	Electric	GHJ-4157A 57	Q1230BR,+ 85
PH2157 15	13C18 21	AC Chassis 32	GHJ-4447A 57	Q1232BK,WH 85
LH3001 15	13K05 27	DC Chassis 37	GHJ-4457A 57	Q1233WA 85
LK3001 15	13T02 27	SC Chassis 41		Q1234WH 85
LH3002 15	13T04 27	TC Chassis 45	Motorola	Q2712WH 91
LH3005 15	13T05 21	T-1 45	12TS-461 61	Q2714WA 91
LK3005 15	13T06 21	M150CWH 41	C12TS-461 61	Q3330TN,+ 91
CK3011 15	15P01 21	M151C++ 41	D12TS-461 61	Q3332BR,+ 91
LH3011 15	15P08 21	M152C++ 41	E12TS-461 61	Q3334WA 91
CK3012 15	15P09 21	M156C++ 41	16BP76BN 69	Q3336GY 91
LK3021 15	15P10 21	M157CEB 41	16BP77BE,+ 69	R3346WA 91
LK3061 15	16P04 21	M400CGR 37	18TS-597 69	Q3392PE 91

INDEX Continued

Philco, Cont.	RCA, Cont.	Sylvania, Cont.	Zenith, Cont.	Zenith, Cont.
R3396WA 91	BH-208WK 115	23L173 139	14N33 167	N2185X+6 167
Q3562TN 91	CH-252WK 115	23L174 139	14X21,Z 167	N2190+6 167
R3563TN 91	CH-276WK 115	23L175 139	X1215++ 167	N2205L+6 167
Q3564WA 91	CH-312WK 115	23T116,-1 139	X1225++ 167	N2210L+6 167
R3567WA 91	CH-320LK 115	23T117,-1 139	X1325W3 167	N2214W6 167
Q3572BE 99			N1605+6 167	N2270W6 167
Q3574GY 99			N1610+6 167	X2310W,+ 168
Q3576WA 99	Sears, Roebuck	Westinghouse	X1620++ 167	X2314W,1 168
Q3730GY 99	6127 129	BP12A67A 161	X1625++ 167	X2317R1,W1 168
Q3734WA 99	7110 133	BP12A170 161	T1630+6 167	X2320W,W1 168
Q3910WA 91	7111 133	BP12B170 161	X1720J,Y 167	X2322H,H1 168
Q3912WA 91	7112 133	BP19A770 151	X1725X,Y 167	X2324M,M1 168
Q4330BK 91	7113 133	BP19B770 151	X1910C,+ 167	X2326R,+ 168
Q4332MB,WA 91	7116 133	V-2486-1 157	X1914++ 167	X2328W,W1 168
Q4334WA 91	7117 133	V-2486-2 157	X1917++ 167	X2343W,Y 168
Q4560MB,WA 91	7118 133	V-2486-4 157	X1919L,X 167	X2412L,+ 168
Q4562MB,WA 91	7119 133	V-2486-13 157	X1921H,W+ 167	X2414W,W1 168
Q4564MB,WA 91	7119 133	V-2487-2 151	X1925J,L 168	X2417R,+ 168
Q4565EA 91	7131 129	V-2487-9 151	X1930H,W 168	X2421W,W1 168
Q4566SWA 91	7132 129	V-2487-11 151	X1943L 168	X2422H,H1 168
Q4566SWA 91	7133 129	V-2487-13 151	X1946W 168	X2424M,M1 168
Q4568MC,+ 91	7140 129	V-2487-14 151	T1979+6 167	X2427R,W 168
Q4569WA 91	7141 129	V-2490-2 161	T1983+6 167	X2443 168
Q4570SWA 91	7142 129	V-2490-7 161	T1984L6 167	T2610W,+ 167
Q4574EA,MA 91	7143 129	V-2490-8 161	T1988+6 167	T2620X,1 167
Q4584WA 91	8127 129	H-P3051A 157	T1991+6 167	T2650C,X+ 167
Q4586WA 91	8132 129	H-P3052A 157	T1995W6 167	T2652L 167
Q4590WA 99	8140 129	H-P3056A 157	N2000C6+ 167	T2655L,P 167
Q4592MA 99	8141 129	H-P3057A 157	N2000L6+ 167	T2656L,P+ 167
Q4594PC 99	8142 129	H-P3061A 157	N2001L6+ 167	T2660L 167
Q4596CH 99	456.70259 133	H-P3062A 157	N2002+6 167	T2665J,+ 167
	456.70260 133	H-P3067 151	N2004+6 167	T2668Y,1 167
	456.70261 133	H-P3075 157	N2005+6 167	T2672R,W 167
RCA Victor	456.70286 129	H-P3076 157	X2010C,1 168	T2675W 167
AH-066Y 107	528.70259 133	H-P3080 151	X2014++ 168	T2677W 167
AH-070BK 107	528.70260 133	H-P3081 151	SA2017+6 167	T2690W 167
AH-071E,+ 115	528.70261 133	H-P3082 151	X2017++ 168	T2691W 167
AH-078WK 115	528.70286 129	H-K1250A 151	X2022++ 168	N2705+6 167
AH-078YK 115	528.70480 129	H-K1251A 151	X2027++ 168	N2706+6 167
AH-090MR,+ 107	529.70259 133	H-K1252A 151	X2032M,W 168	S2712R,W+ 167
AH-126B,+ 107	529.70260 133	H-K1253A 151	T2035W6 167	S2716W,W1 167
AH-130E,+ 115	529.70261 133	H-K1855 151	T2036+6 167	N2717W+6 167
AH-138WRK 115	529.70286 129	H-P8030,B 161	T2038M6 167	T2720W,1 167
KCS-156A 107		H-P8031,B 161	X2043L,1 168	N2730+6 167
KCS-160A,+107	Sharp	H-P9026 151	X2044W+6 167	N2731W+6 167
KCS-161A,B 111	19P-11 137	H-P9028 151	SA2046W6,A 167	N2732+6 167
KCS-162A 111			X2046W,W1 168	N2733M6 167
KCS-163A	Sylvania	Zenith Radio	N2109+6 167	N2735+6 167
through	A04-1,-2 143	13X15,Z 167	N2110+6 167	N2736+6 167
KCS-163E 115	B04-03 139	14M21 167	X2112L,1 168	N2739M6 167
KCS-164A,B 115	B04-04 139	14N22 167	X2115P,X 168	N2740+6 167
AH-184M,Y 111	B04-05 139	14N26Z 167	X2120H,W 168	N3331W6 167
AH-188WK 111	B04-06 139	14N27 167	X2145W,1 168	N3332H6 167
AH-192E,+ 111	12P15 143	14N28 167	N2180L6 167	N3333M6 167
AH-196ER,+ 111	12P16 143	14N29Z 167		

+ stands for various letters used.

Another

Supreme Publications

Service Manual