

# RADIO

OCTOBER, 1946

**MANUFACTURING  
AND  
BROADCASTING**

**The Journal for Radio & Electronic Engineers**

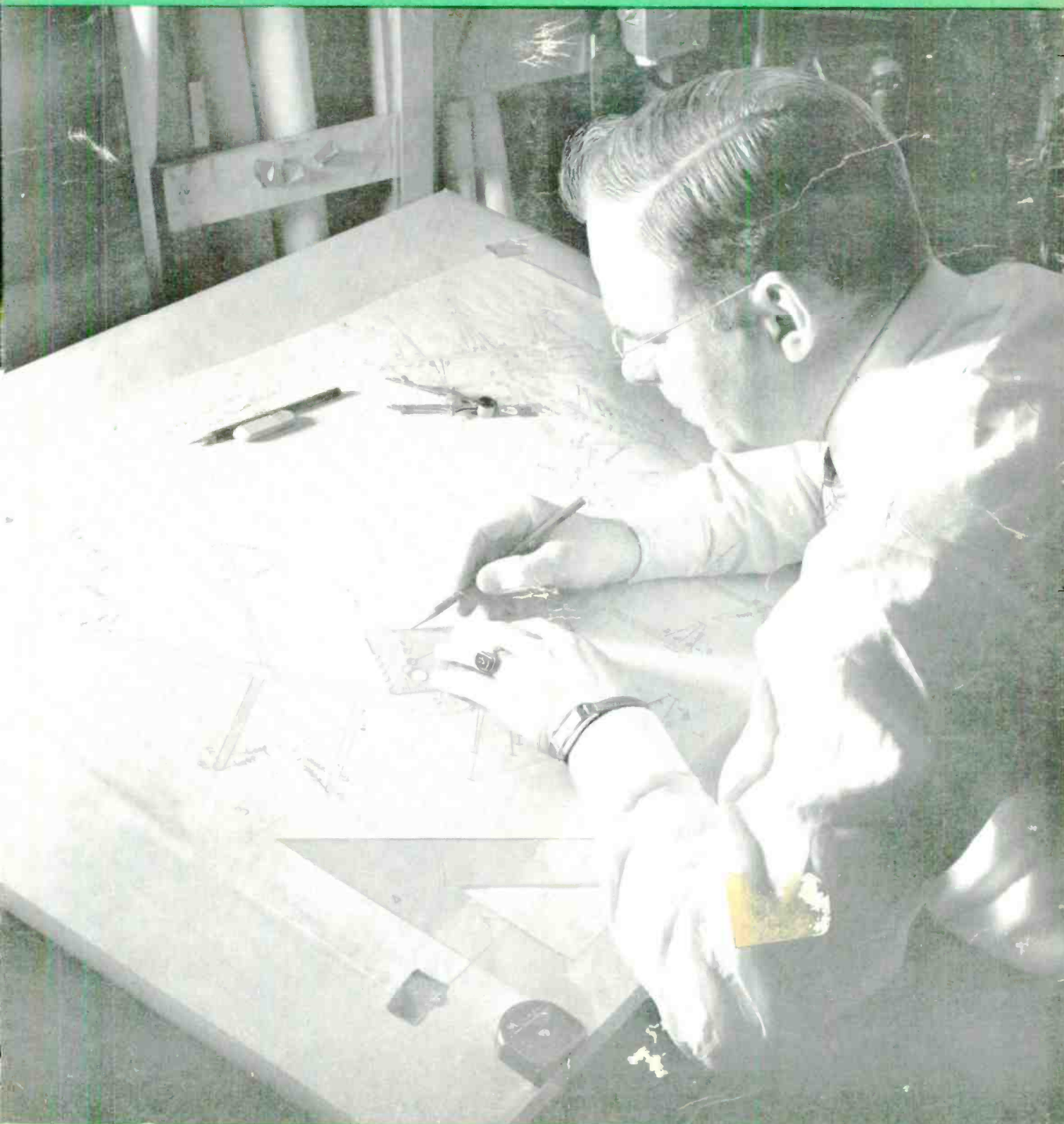

**Design • Production • Operation**

# New!

## Series 200

# A RELAY BY GUARDIAN with Interchangeable Coils

### BUILT IN TWO PARTS

★ Two basic parts—a coil assembly and a contact assembly — comprise this simple, yet versatile relay. The coil assembly consists of the coil and field piece. The contact assembly consists of switch blades, armature, return spring, and mounting bracket. The coil and contact assembly are easily aligned by two locator pins on the back end of the contact assembly which fit into two holes on the coil assembly. They are then rigidly held together with the two screws and lock washers. Assembly takes only a few seconds and requires no adjustment on factory built units.

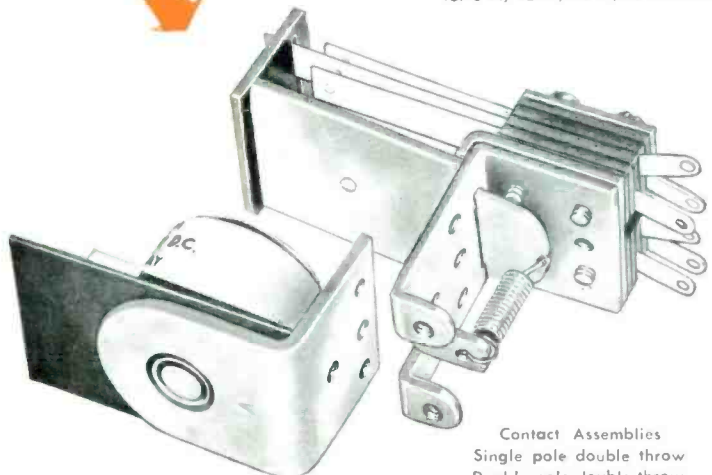

SERIES 200 RELAY

A. C. Coil Assemblies available for 6 v., 12 v., 24 v., 115 v.  
D. C. Coil Assemblies available for 6 v., 12 v., 24 v., 32 v., 110 v.

Contact Assemblies  
Single pole double throw  
Double pole double throw

## On Sale at Your nearest jobber NOW!

See it today! . . . this amazing new relay with interchangeable coils. See how you can operate it on any of nine different a-c or d-c voltages — simply by changing the coil. Ideal for experimenters, inventors, engineers.

### TWO CONTACT ASSEMBLIES

The Series 200 is available with a single pole double throw, or a double pole double throw contact assembly. In addition, a set of Series 200 Contact Switch Parts, which you can buy separately, enables you to build dozens of other combinations. Instructions in each box.

### NINE COIL ASSEMBLIES

Four a-c coils and five d-c coils are available. Interchangeability of coils enables you to operate the Series 200 relay on one voltage or current and change it over to operate on another type simply by changing coils.



Your jobber has this sensational new relay on sale now. Ask him about it. Or write for descriptive bulletin.

# GUARDIAN ELECTRIC

1605-L W. WALNUT STREET

CHICAGO 12, ILLINOIS

A COMPLETE LINE OF RELAYS SERVING AMERICAN INDUSTRY



# RADIO

Published by RADIO MAGAZINES, INC.

John H. Potts..... Editor  
Sanford R. Cowan..... Publisher

OCTOBER, 1946

Vol. 30, No. 10

## CONTENTS

### COVER

Preliminary paper work in designing a cable harness. It is worked up from a schematic, showing the lengths of the wires and the layout of the cable. Each line must be the exact length of the wire it represents.  
—*Courtesy Cambridge Thermionic Corp.*

### ARTICLES

- High Efficiency Modulating Method—*John Beckwith* ..... 9  
*Phase-modulated voltages developed in an R-C bridge arc combined with the unmodulated carrier to produce amplitude modulation*
- Notes on the Design of Squelch Circuits—*Frederick Delaney* .... 12  
*Particular attention is devoted to noise-suppression circuits for FM receivers*
- Improved Analysis of the R-C Amplifier—*J. Roorda, Jr.* ..... 15  
*A new and simple method of designing resistance-capacity coupled amplifier circuits for any frequency range is presented*
- Radio Design Worksheet No. 53—Graphics of Negative Feedback in Cascade ..... 17
- Chart—Decrease in Current and Energy Due to Improper Matching of an Ideal Transformer ..... 19

### MISCELLANEOUS

- Transients ..... 3
- TECHNICANA
  - Multi-Channel FM Transmitter ..... 4
  - Fun with Filters ..... 6
  - Series-Resonant Crystal Oscillators ..... 6
- This Month ..... 20
- New Products ..... 22
- Advertising Index ..... 32

John H. Potts.....*President-Editor*  
Sanford R. Cowan.....*Sec'y-Treas.—Adv. Mgr.*  
Robert G. Middleton.....*Associate Editor*  
Evelyn A. Eisenberg.....*Assistant Editor*  
Harry N. Reizes.....*Adv. Sales*  
David Saltman .....*Adv. Prod. Mgr.*  
Miriam Birnbaum.....*Circl. Manager*

#### MID-WEST OFFICE

H. S. Laufman, Manager  
82 West Washington St., Chicago 2, Ill.  
ANDover 1395

#### PACIFIC COAST REPRESENTATIVE

JAMES C. GALLOWAY  
816 W. 5th St., Los Angeles 13, Calif.

#### FOREIGN SUBSCRIPTION REPRESENTATIVES

Radio Society of Great Britain, New Ruskin House, Little Russell St., London, W.C. 1, England. Harris & Floyd, 297-299 Swanston St., Melbourne, C. I. Victoria, Australia

RADIO Magazine (title registered U. S. Pat. Off.) is published monthly at Boston Post Road, Orange, Connecticut, by Radio Magazines, Inc. Executive and Editorial Offices at 342 Madison Avenue, New York 17, N. Y. Subscription rates—United States, U. S. Possessions & Canada, \$3.00 for 1 year, \$5.00 for 2 years; elsewhere \$4.00 per year. Single copies 35c. Printed in U.S.A. All rights reserved, entire contents Copyright 1946 by Radio Magazines, Inc. Entered as Second Class Matter May 10, 1945 at the Post Office at Orange, Conn., under the Act of March 8, 1879.

# The Eye That Never Closes

You are looking at a thermistor — a speck of metallic oxide imbedded in a glass bead hardly larger than a pinhead and mounted in a vacuum. The thermistor was developed by Bell Telephone Laboratories to keep an eye on the amplification in long-distance telephone circuits.

When a thermistor is heated, its resistance to electric current changes rapidly. That is its secret. Connected in the output of repeater amplifiers, it heats up as power increases, cools as power decreases. This change in temperature alters the resistance, in turn alters the amplification, and so maintains the desired power level. Current through the wire at the left provides a little heat to compensate for local temperature changes.

Wartime need brought a new use for this device which can detect temperature changes of one-millionth of a degree. Bell Laboratories scientists produced a thermistor which could "see" the warmth of a man's body a quarter of a mile away.

Thermistors are made by Western Electric Company, manufacturing branch of the Bell System. Fundamental work on this tiny device still continues as part of the Laboratories program to keep giving America the finest telephone service in the world.

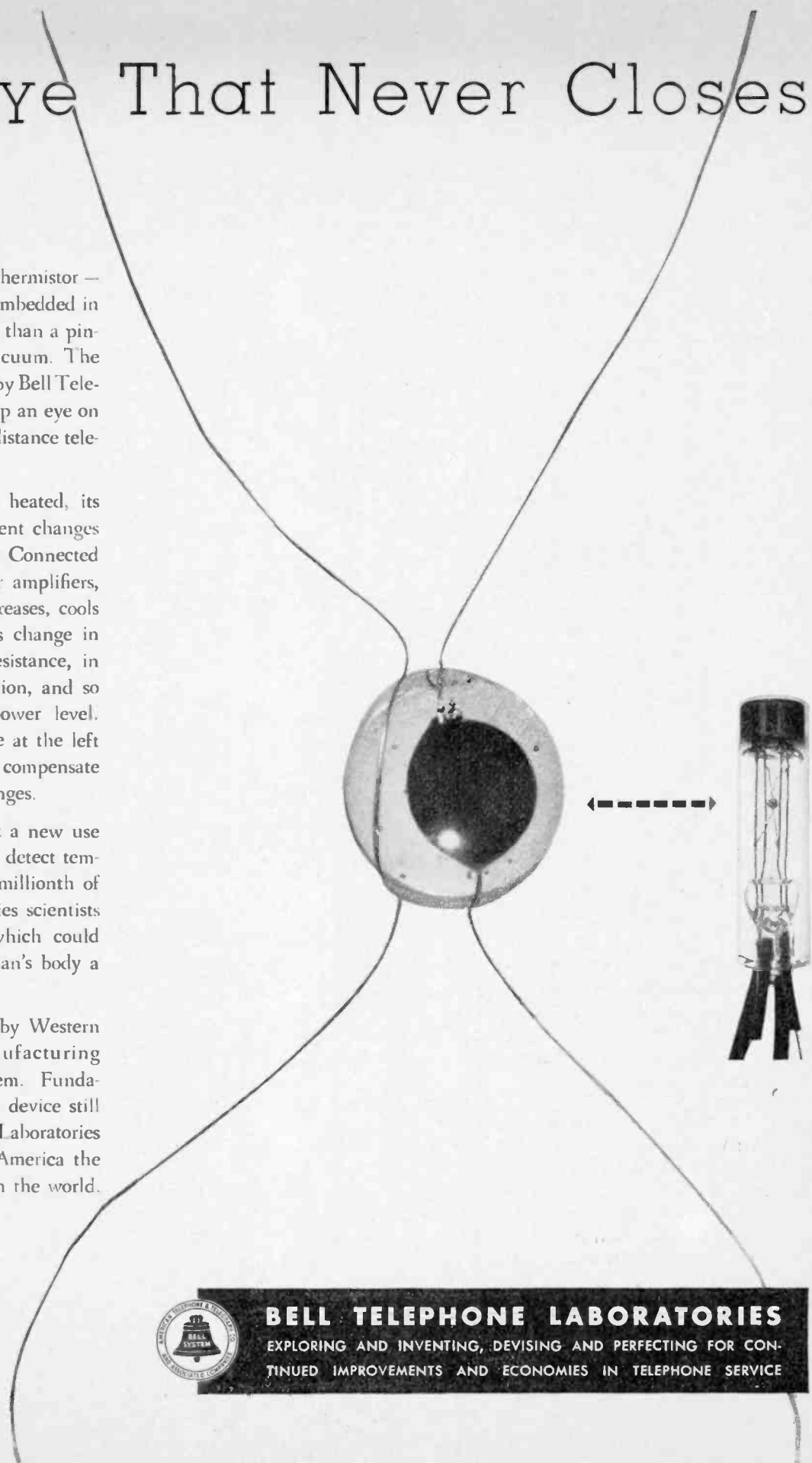

**BELL TELEPHONE LABORATORIES**

EXPLORING AND INVENTING, DEVISING AND PERFECTING FOR CONTINUED IMPROVEMENTS AND ECONOMIES IN TELEPHONE SERVICE

# Transients

## UNFINISHED BUSINESS

★ Despite soaring production figures, the quantity of radio receivers reaching the market is still far less than the potential capacity of the industry. Thousands of sets lie incomplete in manufacturers' warehouses, awaiting the time when one or more vital components become available before they can be finished. Unlike automobiles, radios cannot be shipped and sold when only partly assembled, and the accumulating stock of unfinished sets is now one of the major problems facing the industry.

In many instances some manufacturers have a surplus of some components needed by others to complete their receivers. It would be a great help all around if some sort of exchange basis could be worked out whereby a manufacturer who is long on one item and short of another could swap his surplus with someone else who needs it and who can supply items the other requires. A mounting pile of partly assembled receivers eats up capital and eventually constitutes a threat to the price structure for similar receivers. Should missing components suddenly become available to all, the resulting flood of sets would inevitably drive prices down.

For the good of the industry as a whole, manufacturers should work out some sort of co-operative plan to help each other through this period of shortages. Otherwise all will suffer. Should any manufacturers desire to list with us items they need to complete receivers, as well as those of which they have a surplus, we shall be glad to do what we can to help.

## CRYSTALS FOR PUSH-BUTTON TUNERS

★ The greatest problem confronting most manufacturers of quartz crystals has been to find new ways of utilizing their enormously increased production facilities developed during the war. Because improved techniques have lowered costs in quantity production, applications of crystal control are now being considered which were formerly limited to low-production, high-unit-cost apparatus.

One such application is in push-button tuning of broadcast receivers. While crystal tuning of receivers has been used for many years, it was formerly employed solely on special purpose equipment, such as aircraft, marine, and other apparatus in limited production. Now, however, at least two of the larger manufacturers of broadcast receivers are planning to go into mass production of sets employing crystal control of the frequencies used for push-button selection. Obviously, this method will have advantages over former systems, provided costs can be held to a reasonable figure. Less servicing will be required and more precise tuning will result.

To keep costs down, it would be well for all manufacturers contemplating using this system to get together and decide on a standard intermediate frequency so that the stock of crystals required to produce the

intermediate frequency will be kept to a minimum. Otherwise, the wide variety of crystals needed to cover all frequencies in the broadcast band may create inventory problems for the manufacturer and the radio serviceman. Experience has shown that new developments which are difficult or expensive for the serviceman to handle stand little chance of wide acceptance.

An article on this push-button tuning system is now in preparation and will be presented in an early issue.

## IMPROVING CIRCUIT ANALYSIS

★ The resistance-coupled amplifier is so well-known that it would seem that nothing new could be said on the subject. But the methods of calculating the performance of such amplifiers have been in use for such a long time that they are sadly in need of overhauling. Now that resistance-coupled amplifiers (or resistance-capacity coupled, if you prefer) are used in a great many applications other than as purely audio amplifiers, the need for a simpler method of attacking their design has arisen.

In his article in this issue, the Dutch writer, J. Roorda, Jr., presents an improved method of solving the design problems associated with such amplifiers. Because it is simpler, yet more rigorous, we believe this should supersede former ways of analyzing such circuits. Undoubtedly there are many other circuits in common use whose analysis might be simplified if given the same critical attention. So much stress has been laid on circuit applications that methods of analyzing performance seem to have been neglected. Although present methods are usable, we are going to need a lot of fresh designing in the radio industry in the next few years, and now is none too soon to look around for simpler and better ways of meeting these design problems.

## CUTTING ASSEMBLY COSTS

★ With every manufacturer faced with a labor shortage and mounting costs, it appears to be a good time to give consideration to improved methods of assembling and wiring receivers. Many schemes have been evolved during pre-war years, but for one reason or another, little has been done to get them into production. Except for the idea of printing the wiring on a photo-sensitive silver emulsion, which has very limited application, no radically new methods seem to have been given serious consideration.

One scheme which has always appealed to us is that of using an insulating material for the chassis, and flowing molten metal in grooves to make the necessary circuit connections. And there are many others. Next year, when costs merit even more careful study, undoubtedly some new production ideas will come into wide use. They should be tried experimentally now.

J. H. P.

# TECHNICANA

## MULTI-CHANNEL F-M TRANSMITTER

★ Interesting features of an experimental u-h-f f-m transmitter used for multi-channel telephony in Holland are described by A. van Weel in the *Philips (Eindhoven) Technical Review* for April 1946. The transmitter was developed for an experimental 90.5-cm link, working with a 99-cm link in the opposite direction.

Modulation is effected with initial carriers from 12 to 204 kc to accommodate 48 telephone channels, which in turn modulate a 36.9-mc oscillator, followed by three push-pull triplers. Frequency deviation is 67 kc maximum at the oscillator. The 48 frequency bands of approximately 3000 cps width are modulated on carriers lying 4000 cps apart, using single-sideband modulation. Thus the circuits must pass the total band ranging up to 200 kc.

The best signal-noise ratio would be obtained with a maximum deviation of ten times the highest modulating frequency, and a sideband at least 1.5 times greater must be transmitted to minimize distortion. Since this requires a 6-mc pass band for transmitter and receiver, the maximum deviation was reduced to three times the highest modulation frequency to make circuit design less difficult.

Modulating voltage is applied at *M*

in *Fig. 1* to conventional reactance tubes which frequency-modulate the 36.9-mc oscillator; *T*<sub>1</sub> and *T*<sub>2</sub> are push-pull triplers with unconventional coupling circuits described below. *V*<sub>1</sub>, *V*<sub>2</sub>, and *V*<sub>3</sub> are amplifier stages, with antenna output at *A*. The lower block sequence is concerned with the center-frequency stabilization system, discussed below.

Coupling between successive stages is

accomplished with the basic system shown in *Fig. 2*. *C*<sub>a</sub> and *C*<sub>g</sub> represent the inter-electrode capacitances, while *L*<sub>a</sub> and *L*<sub>g</sub> are the distributed inductance of the leads; a lumped inductance of suitable value is inserted at *L*. The resulting equivalent circuit is shown at *Fig. 2A*. In effect, the various impedances form a tapped tank circuit with a capacitance voltage-divider. Current

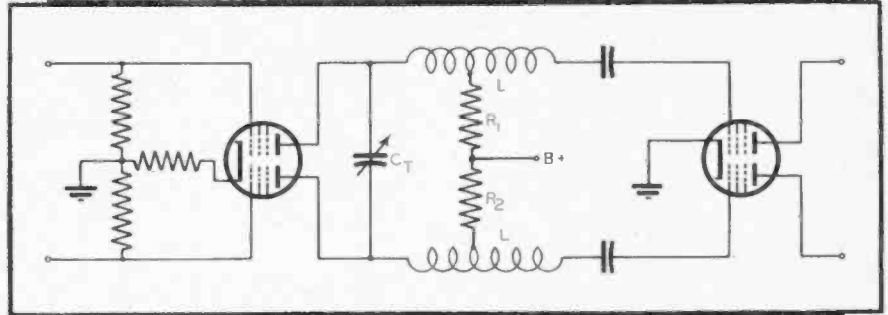

(Above) Figure 3, (below) Figure 4

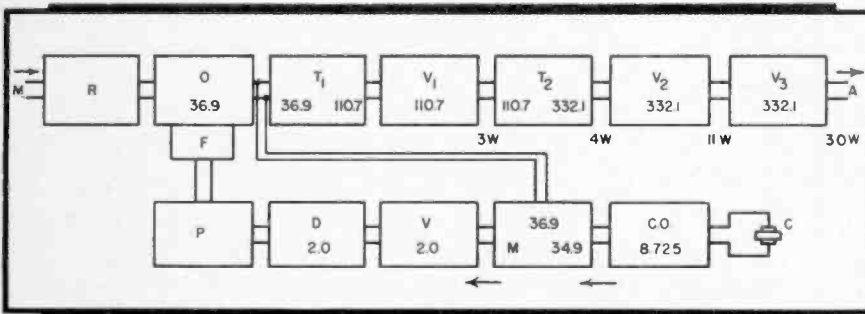
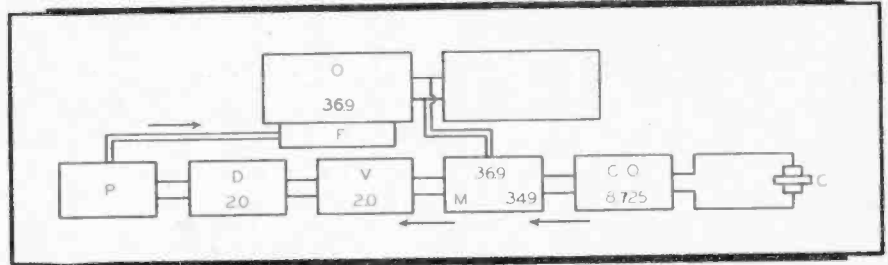

(Above) Figure 1, (below, left) Figure 2A, (below, right) Figure 2

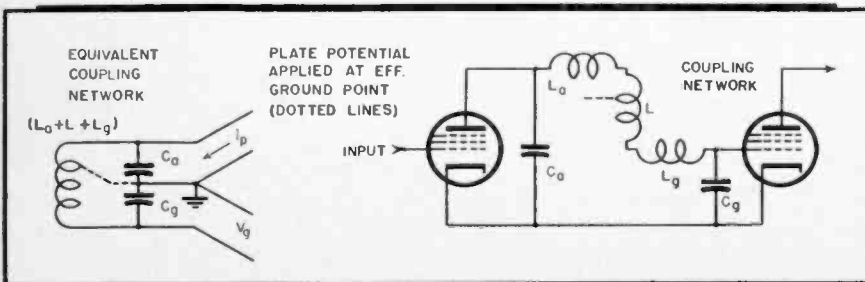

from the driver energizes the circuit at *C*<sub>a</sub>, as indicated by *i*<sub>p</sub>, while the grid voltage for the output stage is developed across *C*<sub>g</sub>, as indicated by *V*<sub>g</sub>. Since the common connection of *C*<sub>a</sub> and *C*<sub>g</sub> is at ground potential, an effective ground point may likewise be located on *L*, as shown by the dotted line. This is the point used to apply plate supply voltage.

Push-pull triplers were selected because common couplings throughout the circuits are minimized, as well as the filtering of the power supply. The resulting tripler circuit appears as shown in *Fig. 3*. *C*<sub>r</sub> is a small tuning capacitor, while *R*<sub>1</sub> and *R*<sub>2</sub> are small resistances used to reduce r-f flow in the power supply leads as a result of any small r-f unbalance at the feed-points on *L-L*.

The center-frequency stabilization system is shown in *Fig. 4*. *C* is an 8.725-mc quartz crystal; output of the crystal oscillator *CO* is applied to a mixer *M* in which the fourth harmonic of this frequency (34.9 mc) is mixed with the average center frequency of oscillator *O* (36.9 mc). The mixer is followed by a 2.0-mc amplifier which energizes a conventional discriminator. The unbalance voltage from the discriminator is amplified by a pentode at *P*, which delivers its output current to an inductor *F* with a ferro-magnetic core. The inductor is magnetically coupled to the oscillator circuit, and controls its frequency by

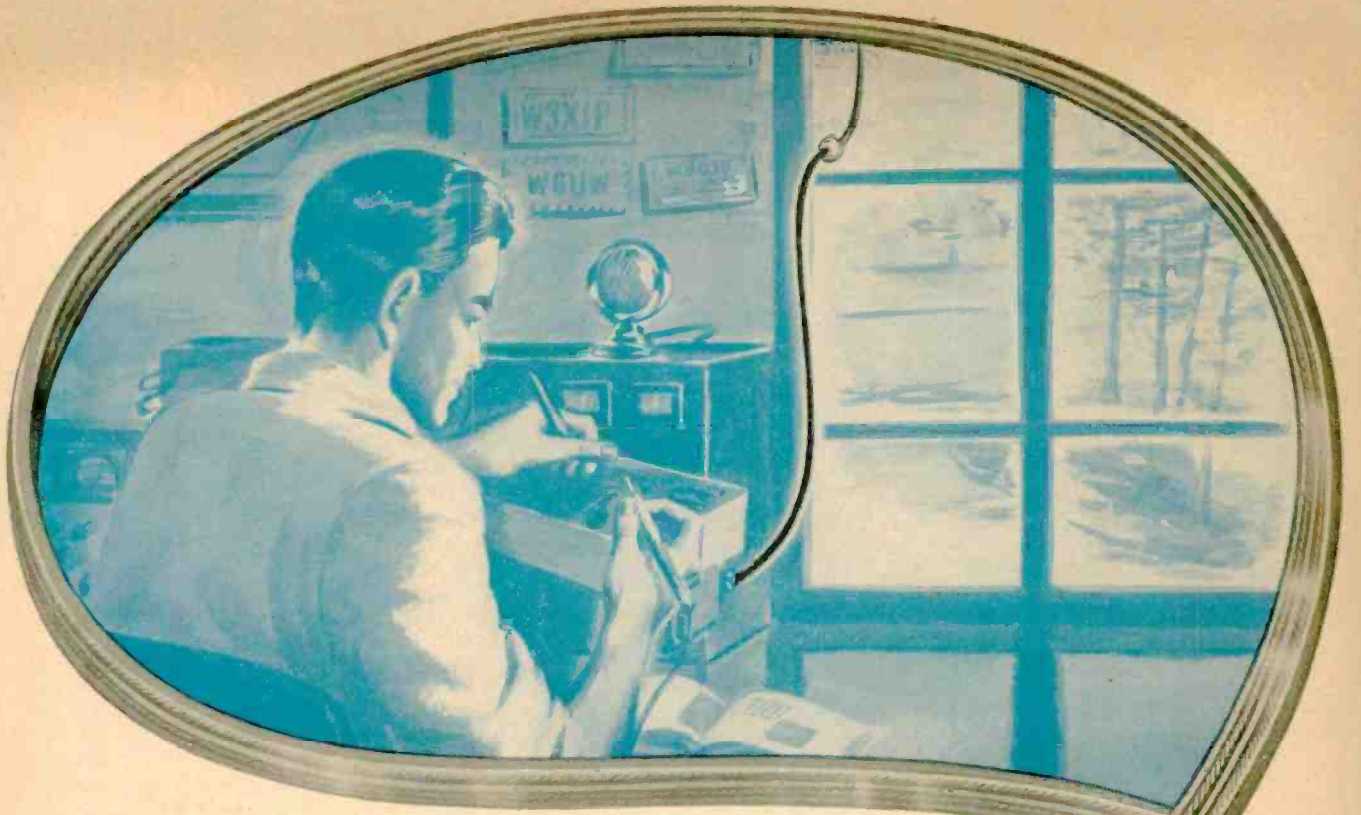

# Amphenol AND RADIO AMATEURS HAVE ALWAYS WORKED TOGETHER

Radio amateurs are the most versatile technical experimenters known—and so are Amphenol engineers. Amateurs have pioneered the greatest share of electronic developments since the dawn of radio—and Amphenol has pioneered in the development of components used by hams.

Amateurs have an appreciation of the electrical engineering problems in the production of components to give the best performance. They agree that Twin-Lead, pioneered by Amphenol, is one of the most important and useful new products in the field of electronics.



**AMERICAN PHENOLIC CORPORATION**  
CHICAGO 50, ILLINOIS  
In Canada • Amphenol Limited • Toronto, Ontario

COAXIAL CABLES AND CONNECTORS • INDUSTRIAL CONNECTORS, FITTINGS AND CONDUIT • ANTENNAS • RF COMPONENTS • PLASTICS FOR ELECTRONICS

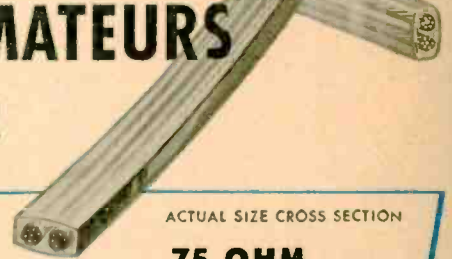

ACTUAL SIZE CROSS SECTION

## 75 OHM TRANSMITTING TWIN-LEAD

Amateurs asked for it — now here it is! It's the new heavy duty 75 ohm Amphenol Twin-Lead transmission line. Conservatively rated at 1000 watts for 30 mc or lower frequency. Available — now — at your distributor's.

Attenuation	Megacycles	75 ohm DB per 100 ft.
}	3.5	0.29
	7.0	0.49
	14.0	0.82
	28.0	1.40

Receiving Twin-Lead is available in 75 ohm, 150 ohm and 300 ohm impedances. Get a copy of Amphenol's new Twin-Lead bulletin from your dealer.

Other Amphenol products of interest to amateurs available at your dealer's:

Radio Tube Sockets. Industrial, standard, miniature and sub-miniature—plugs and accessories. Octal angle sockets for cathode ray applications.

Connectors. All types, with fittings — from 1 to 50 contacts.

Cables. Coax and Twinax (also connectors). Microphone cables (also connectors).

Plastics for Electronics. Plastic sheets, rods and tubes. Flexible tubing and spaghetti. Coil Dope. Molded coil forms, stand-off insulators, knobs and dial pieces.

Antennas. UHF dipoles and arrays.

[from page 4]

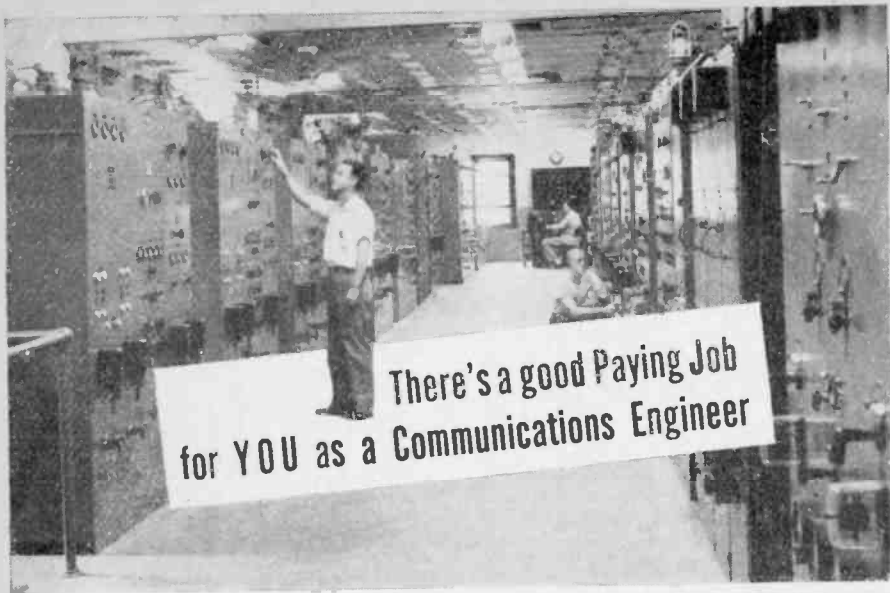

There's a good Paying Job  
for YOU as a Communications Engineer

PRESS WIRELESS PHOTO

## CREI Home Study Training Will Keep You Ahead of Competition—Keep Others from By-Passing You to Better Jobs—By Keeping You in Pace with the Industry

Never was there such an opportunity as exists today in Radio Communications. Thousands of highly trained expert technicians and engineers will be required.

You can pick your FUTURE. You can enjoy a permanent, profitable and lasting career.

CREI's home study training *now* will prepare you for these important career jobs. Easy-to-read-and-understand lessons are provided and each student has the benefit of individual guidance and careful supervision from a trained instructor. This is real-honest-to-goodness practical engineering training that will prepare you for a good job in many interesting fields of Communications.

Act now! See for yourself how easily you can fit yourself into one of these secure, good paying jobs in tomorrow's Communications. Mail your coupon today.

VETERANS! CREI IS APPROVED FOR "G. I." TRAINING!

# Capitol Radio Engineering Institute

E. H. RIETZKE, President

Dept. RA-10, 16th and Park Road, N.W., Washington 10, D. C.

Branch Offices: New York (7): 170 Broadway San Francisco (2): 760 Market St.

### FILTERING

The filtering process applies to men and equipment alike. There comes the day when men are re-shuffled and only the "fittest" survive. Today's and tomorrow's opportunities in radio-electronics are so great, that no man should ever allow himself to be caught in the "filtering out" process by being caught unprepared for his job.

*E. H. Rietzke*  
President of CREI

the reactance component of its reflected impedance.

Should the average center frequency of the 36.9-mc oscillator drift from its nominal value, the current through the non-linear inductor  $F$  varies, causing its reflected reactance in the oscillator circuit to vary correspondingly and bring the oscillator frequency back to its nominal value.

### FUN WITH FILTERS

★ A 'new filter theorem' is suggested by T. H. Turney, in *The Electrician* for April 26. The article, entitled "The Filter Theorem" is from a forthcoming book, "Electric Filters," published by Pitman.

"In order to construct a filter which will have all the above (classical properties), all that is necessary is to collect any number of any sizes of inductances and capacitances, and connect them up in any way and put four terminals anywhere, and one has produced a filter section. If one wants more than one section, others similar to the one made up can be constructed and connected end to end.

"What is the good of the theorem? (a) It is a contribution to one's knowledge of the subject. (b) It saves one thinking he may waste his time if he does research on fresh circuits. (c) Any teacher in college can make a filter for a pound or two without extensive knowledge of the subject, and demonstrate it with an oscillator and oscilloscope."

The writer promises a proof of the theorem in his book.

### SERIES RESONANT CRYSTAL OSCILLATORS

★ Circuits for oscillators which use the series-resonant frequency of a quartz crystal, rather than the parallel-resonant frequency, are discussed by F. Butler in *Wireless Engineer* for June 1946. The article concludes with suggested filters which make use of the series-resonant frequency.

The oscillator circuit frequency is found to be slightly influenced by the external series reactance of the circuit,



If you have had professional or amateur radio experience and want to make more money, let us prove to you we have the training you need to qualify for a better radio job. To help us intelligently answer your inquiry — PLEASE STATE BRIEFLY YOUR BACKGROUND OF EXPERIENCE, EDUCATION AND PRESENT POSITION.

RA-10

Capitol Radio Engineering Institute  
16th and Park Road, N. W., Washington 10, D. C.

GENTLEMEN: Please send me your free booklet, "Your Opportunity in the New World of Electronics", together with full details of your home study training. I am attaching a brief resume of my experience, education and present position.

Name .....

Street .....

City ..... Zone ..... State .....

CHECK  PRACTICAL RADIO ENGINEERING  
COURSE  PRACTICAL TELEVISION ENGINEERING  
 I am entitled to training under the G.I. Bill.

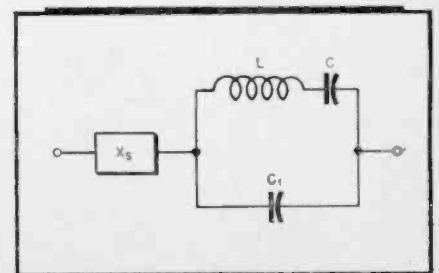

Figure 1



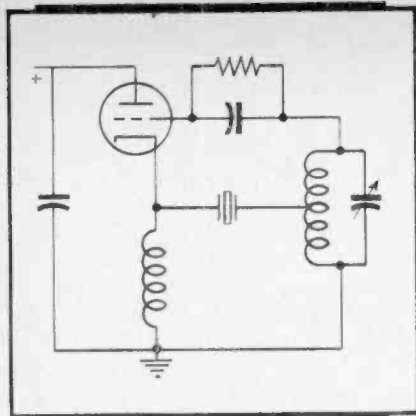

Figure 2

in contrast with oscillators using parallel crystal resonance in which case the frequency is affected by reactances in parallel with the crystal.

An equivalent circuit of a piezoelectric crystal is shown in Fig. 1, where  $L$  = effective inductance of the crystal,  $C$  = effective capacitance of crystal,  $C_1$  = holder capacitance, and  $X_s$  = series reactance (air-gap action, stray inductance, or inserted reactance). The parallel resonant frequency of this circuit is given by

$$\omega^2 = (1/C + 1/C_1)/L$$

and the condition of series resonance is that

$$(j\omega L + 1/j\omega C) = (-X_s/j\omega C_1) / (X_s + 1/j\omega C_1)$$

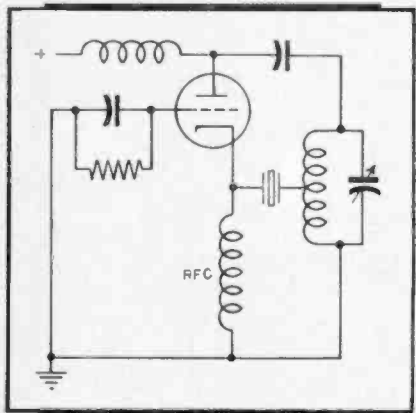

Figure 3

In the event that  $X_s$  is inductive,  $X_s = j\omega L_s$ , and the equation becomes  $(\omega L_s - 1/\omega C) = (L_s/C_1) / (\omega L_s - 1/\omega C_1)$  whence it appears that the true resonant frequency of the crystal is realized only when  $L_s = 0$ , or if the inductive reactance is resonated with suitable series capacitance.

In the case that  $X_s$  is a capacitive reactance,  $1/j\omega C_s$ , then

$$(\omega L_s - 1/\omega C) = 1/[\omega(C_1 + C_s)]$$

indicating that the crystal series resonant frequency is approached as the external capacitance is increased.

Practical series-resonant oscillator circuits are given by the author in Figs. 2, 3, and 4. At series resonance, the crystal appears as a low resistance, per-

mitting oscillation to take place. At other frequencies, a high reactance appears between the load and the low-impedance source, causing attenuation and phase shift with cessation of oscillation. The circuits are suitable for use with low-frequency crystals of poor quality, and will operate with crystals which refuse to oscillate in other circuits.

Figure 2 is a grounded-plate Hartley oscillator, while Fig. 3 illustrates the grounded-grid version. The circuit shown in Fig. 4 is a grounded-plate oscillator with feedback to the cathode circuit; this circuit is adapted for use with precision crystals designed to have one electrode grounded.

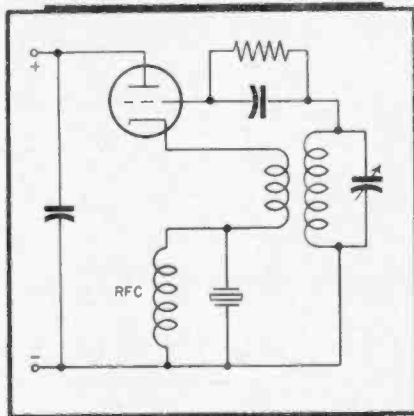

Figure 4

At higher frequencies,  $C_1$  (see Fig. 1) shunts the crystal reactance and allows oscillations to occur at other than crystal frequency. Neutralization is a convenient means of correcting the circuit, as shown in Fig. 5. A neutralizing capacitor is coupled to the main tuned circuit by a coil having the same number of turns as between the crystal tap and ground. When  $C_N = C_1$ , broad-band neutralization is effected.

A feature of all these circuits is that when using leak and capacitor bias, the optimum operating condition is at minimum plate current, in contrast with conventional crystal circuits which produce instability in this region.

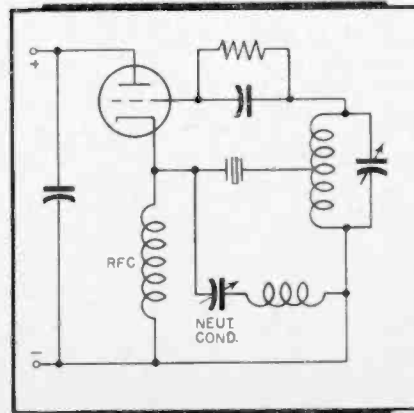
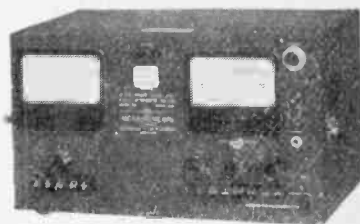

Figure 5

Laboratory Standards

By MEASUREMENTS CORPORATION



U. H. F. RADIO NOISE and FIELD STRENGTH METER

Model 58

FREQUENCY RANGE: 15 to 150 mc. Push-button switching for rapid, accurate measurement of noise levels or field strength.



SQUARE WAVE GENERATOR Model 71

FREQUENCY RANGE: 5 to 100,000 cycles. WAVE SHAPE: Rise time less than 0.2 microseconds. OUTPUT VOLTAGE: 75, 50, 25, 15, 10, 5 peak volts fixed; 0-2.5 volts continuously variable.

MANUFACTURERS OF  
Standard Signal Generators  
Pulse Generators  
FM Signal Generators  
Square Wave Generators  
Vacuum Tube Voltmeters  
UHF Radio Noise & Field Strength Meters  
Capacity Bridges  
Megohm Meters  
Phase Sequence Indicators  
Television and FM Test Equipment

Catalog on request

MEASUREMENTS CORPORATION  
BOONTON NEW JERSEY



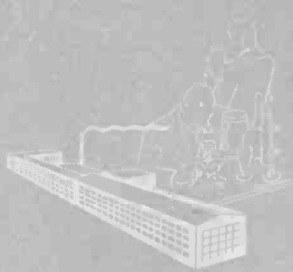

THE MAJOR CAPACITOR  
AND WIRE-WOUND RESISTOR  
DEVELOPMENTS OF THE PAST 5  
YEARS HAVE BEEN ENGINEERED

by

# SPRAGUE

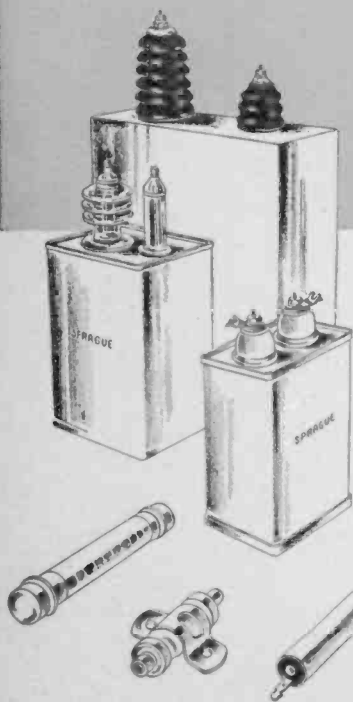

**THEY INCLUDE:**

• **\*VITAMIN Q** impregnated capacitors for higher voltages, higher temperatures and higher insulation resistance.

• **\*HYPASS 3-TERMINAL NETWORKS** that set new standards of performance in solving anti-resonant frequency problems at frequencies as high as 150 megacycles or more.

• **GLASS-TO-METAL** hermetically-sealed capacitors fully proofed against leakage, moisture, fungus, corrosion and shock.

• **ENERGY STORAGE** capacitors of greatly increased capacity in smaller physical sizes.

• **MEGOMAX** high-resistance, high-voltage resistors. Megohms of resistance operated at thousands of volts.

• **SPRAGUE \*KOOLOHM RESISTORS** with glazed ceramic coating and new type end seals in one standard type for use under any climatic condition.

• *Catalog of any type on request*

• *\*Trademarks Reg. U. S. Pat. Off.*

**SPRAGUE ELECTRIC CO., NORTH ADAMS, MASS.**

# High Efficiency Modulating Method

JOHN BECKWITH

Phase-modulated voltages developed in an R-C bridge are combined with the unmodulated carrier in the output stage for high-efficiency amplitude modulation

THERE ARE QUITE A NUMBER of ways of producing amplitude modulation of a radio-frequency carrier, but few which accomplish it at high efficiency. Chireix<sup>1</sup>, Dome<sup>2</sup>, Doherty<sup>3</sup>, and others have developed systems whereby an amplitude-modulated signal can be obtained without using relatively inefficient class B linear amplifiers. In most of these systems, modulation takes place between the oscillator and the last stage of r-f amplification, usually at the input to the last stage. This stage comprises at least two tubes (four for push-pull) and a number of reactances which are very critical in adjustment. There is also the problem of different bias voltages, and sometimes different plate supply voltages<sup>4</sup>. Some systems specify two antennas<sup>5</sup>. One method<sup>6</sup> requires five large tubes and several phase-shifting networks to produce a high-efficiency final stage. Some of these systems use low efficiency class B amplifiers, while others use class B together with class C.

The purpose of this article is to explain the functioning of a transmitter which approaches the ideal. Phase modulation of a portion of the carrier takes place immediately after the master oscillator. This is converted to amplitude modulation in the output circuit of the final class C amplifier.

Class C amplification, at full efficiency, is used throughout, without employing critical circuits. While the modulator is reactive, its design is simple and it cannot get out of adjustment. The overall system approaches the efficiency of a telegraph transmitter, making possible a high-power broadcast transmitter without a costly high-power modulator and associated power supply.

## The Modulator

The modulator is essentially an electronic phase shifter. Modulation is accomplished by shifting the phase of the carrier frequency at an audio-frequency rate and combining this phase-shifted component with the unmodulated carrier frequency to produce a resultant varying in amplitude as the phase is shifted.

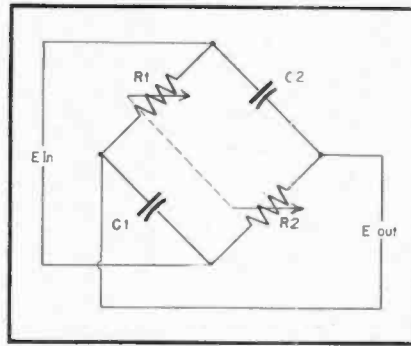

Fig. 1. Equivalent circuit of phase-shift bridge to obtain FM vector for combination with unmodulated vector voltage.

To obtain phase modulation, a bridge consisting of two resistances and two capacitors is used, as shown in Fig. 1. In this circuit,  $R_1$  and  $R_2$  are equal, as are  $C_1$  and  $C_2$ . The r-f carrier is applied at  $E_{in}$  and the phase-modulated voltage appears at  $E_{out}$ .  $R_1$  and  $R_2$  are high-transconductance triodes. When an audio signal is applied to their control grids, the plate resistance changes in accordance with the signal voltage. Over the positive half-cycle of the applied audio

signal, the resistances of  $R_1$  and  $R_2$  are low in comparison with the reactances of  $C_1$  and  $C_2$  at the carrier frequency. For all practical purposes,  $R_1$  and  $R_2$  will have zero r-f resistance. Thus the output voltage will be in phase with the input voltage.

During the negative half of the audio cycle, the resistances of  $R_1$  and  $R_2$  will become practically infinite in comparison with the reactances of  $C_1$  and  $C_2$  at the r-f carrier frequency, corresponding to a phase displacement of  $180^\circ$ . When  $R_1 = R_2 = X_{c1} = X_{c2}$ , there is a phase shift of  $90^\circ$  (refer to Fig. 2). When the vectors are in phase, the voltage is doubled at  $E_{out}$ , and when the vectors are  $180^\circ$  out of phase, the voltage is zero at  $E_{out}$ .

The locus of operation is a semi-circle as shown in Fig. 2, and the output voltage is seen always to equal the input voltage in magnitude, although shifted in phase. The result of these relations is to make it possible to obtain 100% amplitude modulation by combining the phase-shifted vector voltage with an equal unshifted vector voltage. This is done at a relatively high level,

This 335-foot steel tower located on the New Jersey banks of the Hudson River will soon carry Station WMGM's new Western Electric "Clover-leaf" FM broadcast antenna—the first in the N. Y. area.

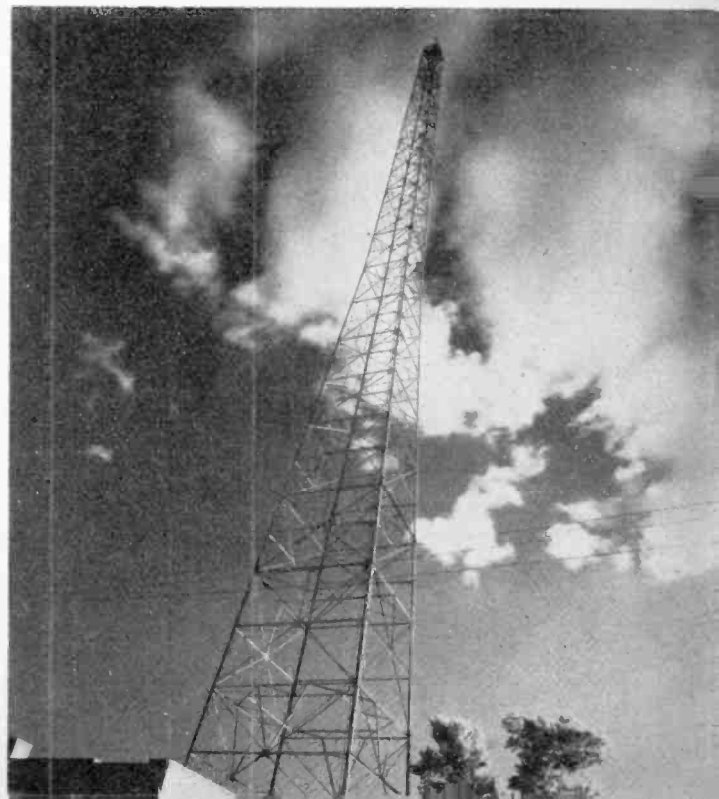

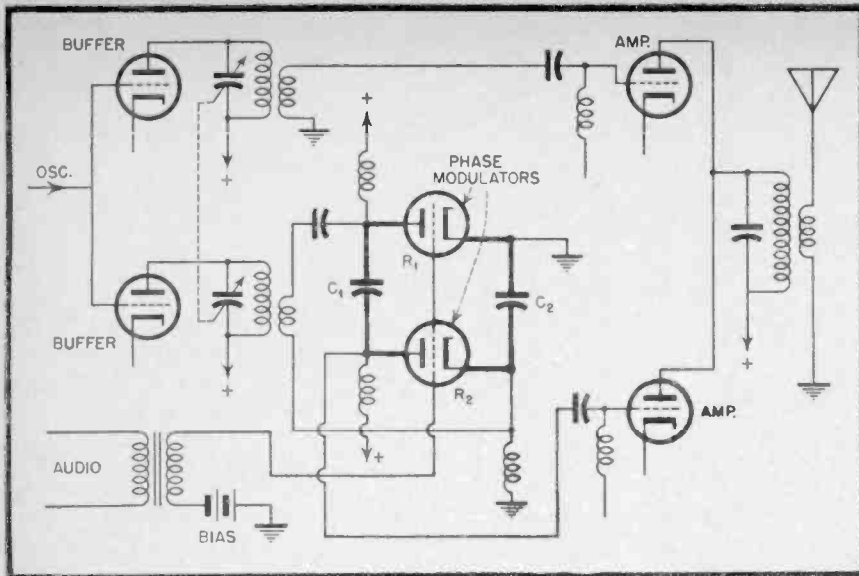

Fig. 3. Combination of vector voltages takes place at high level as shown in this basic schematic diagram.

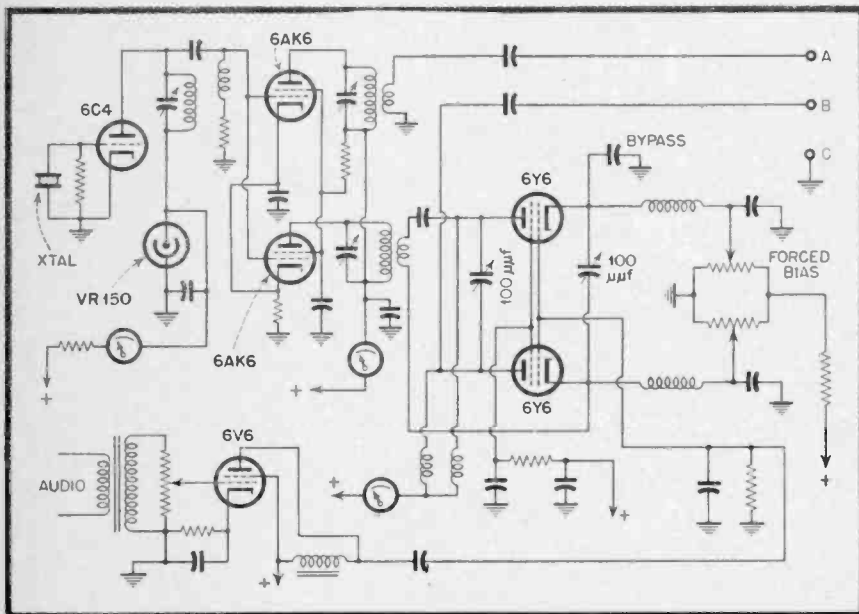

Fig. 7. Schematic diagram showing modulator section of 4.5-kw transmitter.

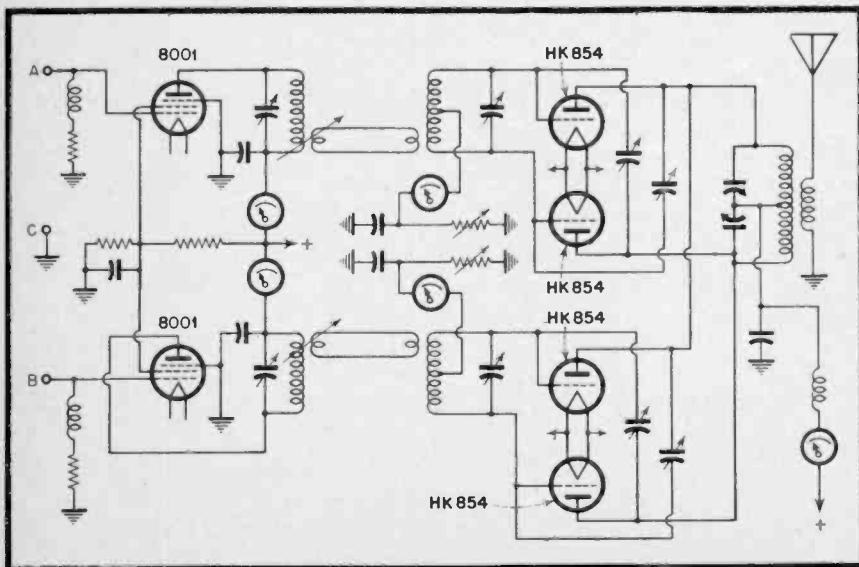

Fig. 8. Driver and final amplifier circuit for 4.5-kw transmitter.

as shown in Fig. 3. The results of phase shift shown in Fig. 2 are presented in developed form in Fig. 4 for shifts of  $0^\circ$ ,  $120^\circ$ , and  $180^\circ$ . The resultant magnitude of the two voltages is non-linear, being proportional not to the magnitude of the phase shift, but to the cosine of half the phase shift, as shown in Fig. 5.

Referring to Fig. 4, *A* represents the voltage at the plate of the class C amplifier of the unmodulated channel. Plate voltage of the phase-modulated channel is shown at *B*, for zero modulation and assuming an operating phase displacement of  $120^\circ$ . This is the value used in the experimental modulators which have been constructed. The phase-modulated voltage at maximum displacement, or  $180^\circ$ , is shown at *C*.

Maximum modulation, or a phase displacement of zero, is diagrammed at *D*. The waves shown at *B*, *C*, and *D* are voltages which are encountered in the modulation channel. At the junction point where combination takes place, the voltages from both channels will add vectorially, producing resultants shown at *E* for  $180^\circ$  phase shift, at *F* for  $120^\circ$  shift and at *G* for  $0^\circ$  shift.

$E_u$  is the unmodulated component, while  $E_m$  is the modulated component, and  $E_r$  is the resultant voltage. With reference to the diagram at *F*,  $E_r$  is the same amplitude as  $E_u$ , with the latter voltages having combined to form  $E_r$ . In diagram *E*,  $E_r$  is seen to be zero when  $E_u$  and  $E_m$  are opposite in phase. Diagram *G* shows the resultant voltage  $E_r$  as twice the amplitude of  $E_u$  or  $E_m$ , which is equivalent to four times power at the 100% modulation peak when  $E_u$  is in phase with  $E_m$ .

Comparison of these waveforms with the vector diagrams shown in Figs. 2 and 5 will make it clear that the output waveform represents an amplitude-modulated wave. A study of the circuit relationships shows that this amplitude modulation is not entirely linear for the simplified situations discussed above. Achievement of linearity is a separate consideration which receives attention at a later point in this paper.

Referring to Fig. 3, the output of one buffer feeds directly to one of the class C amplifiers. The second buffer applies the r-f signal to the modulators. The modulator output feeds the phase-modulated r-f signal to the other class C amplifier tube. The phase-modulated component is then combined with the unmodulated wave in the plate circuits of the class C amplifiers, as shown in Figs. 2 and 4. This addition is vectorial and has been previously developed by several persons, among them Plebanski<sup>6</sup> and Price<sup>7</sup>.

Because the modulation is not linear, the output might be expected to be equally non-linear. This is not actually

the case because the plate resistance of the tubes in the bridge is also non-linear, but in a direction which tends to straighten the modulation characteristic. When greater linearity, and hence greater fidelity is desired, the audio signal input to the modulator is kept below the limiting grid swing. If the modulator drive is reduced to one-half, the phase shift is reduced accordingly, but this phase shift can again be caused to vary between 0° and 180° if the frequency of each channel is doubled before recombination. That is, the phase shift is doubled when the frequency is doubled. Thus, the linearity of the system may be increased in general by diminishing the phase shift of the modulator and applying it to a sub-multiple of the carrier frequency. Fig. 2 shows the relations of Fig. 5 in graphical form.

**Class C Used**

If the phase-modulated r-f current is not recombined with the unmodulated r-f current following the r-f amplifiers shown in Fig. 3, but brought instead to individual tanks and further amplified before recombination, this amplification may be carried out in class C. This is because there is no change in amplitude of the r-f voltage (see Fig. 4) until after recombination, as shown in Fig. 6. Use of class C amplifiers following modulation results in a highly efficient and economical transmitter be-

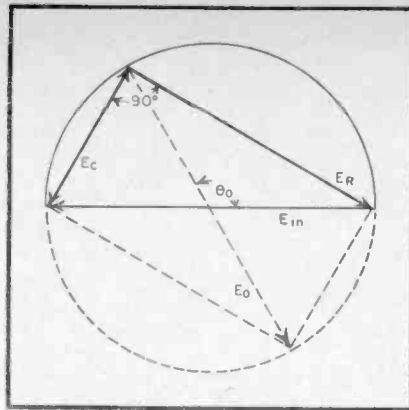

Fig. 2. (above) Circle diagram for modulator bridge. Fig. 6. (below) Resultant output voltage vs. modulation angle shown in Fig. 5

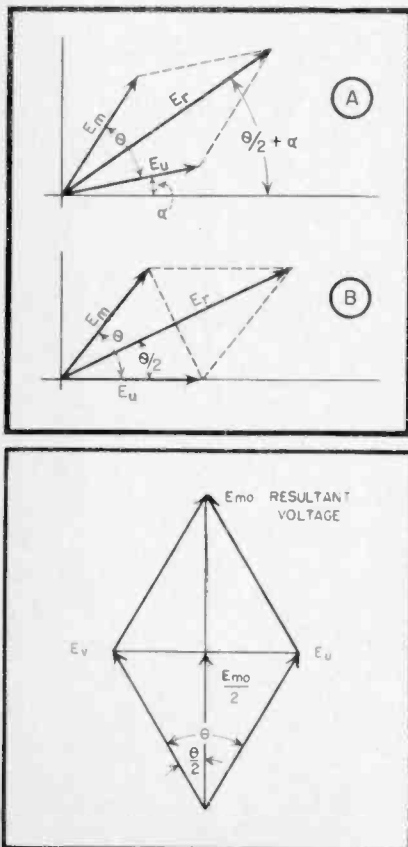
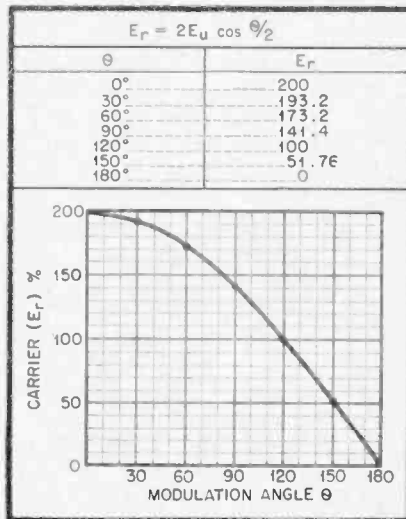

Fig. 5a. Resultant output voltage, with carrier at constant phase displacement; 5b, constant phase displacement of zero; 5c (bottom) vectors appearing in equation of text.

cause of the high plate efficiency obtainable.

Complete schematics for a 4.5-kw transmitter using small, inexpensive tubes, with only two stages of r-f amplification following the modulator, are shown in Figs. 7 and 8. It will be understood that the outputs of the last two tubes may be connected separately to higher-power tubes rated at 10 kw or more. These may be used to drive a 100-kw amplifier.

An experimental 4.5-kw transmitter built by the author consists of a crystal oscillator feeding two pentode buffer amplifiers, one for the modulated channel and one for the unmodulated channel; the modulator shown in Fig. 3 appears in the Fig. 7 schematic, plus the a-f tubes. Plate supply potentials for the various stages of Fig. 7 should be regulated.

Following the modulator are two medium-power pentode amplifiers shown in Fig. 8 which drive the final amplifier comprising a pair of tubes in push-pull for each channel. The push-pull amplifiers deliver their outputs to the utilization circuit in parallel. Coupling between stages is adjustable to compensate for unequal amplification in the two chan-

nels, and excitation to the stages should be equalized.

The cost of a phone transmitter using this system of modulation is comparable to the cost of a telegraph transmitter, on the basis of peak modulated output. This system of modulation can be easily adapted in most cases to existing transmitters using class B r-f amplifiers to provide twice the former output for a change-over price of less than 10%.

These figures compare favorably with the following: if it is desired to triple the output of a transmitter by class B r-f amplifiers, or by use of high-level modulation, the resulting cost of installation would rise at least 100%. Less massive equipment can be built for higher output with the new system of modulation, and will require fewer operating personnel.

For amateur radio, the circuit has great possibilities because of its reduced price and high output without use of complicated circuits.

**Phase-Modulation Sidebands**

Since phase modulation is used, these sidebands appear in the radiated wave as well as the a-m sidebands. However, these are not greater in magnitude and spread than specified by FCC regulations, and hence are not a matter of concern.

[Continued on page 32]

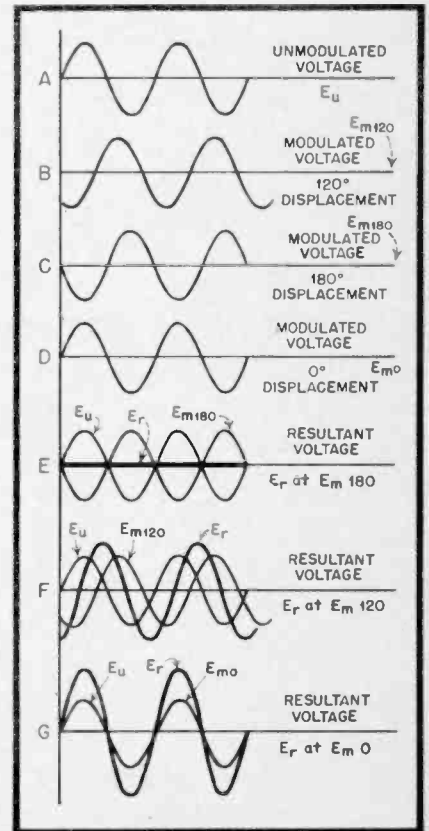

Fig. 4. Developed waveforms for three modulation conditions corresponding to phase shifts of 0°, 120°, and 180° obtained by combining unmodulated voltage with phase shifted voltage.

# Notes on the Design of SQUELCH CIRCUITS

FREDERICK DELANOY

This month the author devotes particular attention to noise suppression circuits for FM receivers

**W**IDE-BAND RESPONSE of f-m receivers, while contributing to high fidelity of reproduction, nevertheless increases the noise level encountered between channels. For this reason, squelch circuits are of particular interest to the f-m receiver engineer. These vary greatly in design, ranging from the electro-mechanical units described last month, to blocked-audio circuits of various designs, reflected-impedance squelch circuits, and squelch oscillators as described in this issue.

Numerous subdivisions of circuits include those suitable for a-c/d-c receivers, circuits requiring switching, and

those which make use of threshold controls. Some units require only one tube, others utilize several tubes to accomplish their purpose. At least one commercial method combines limiting and squelch action in one tube. This latter circuit, developed by the Admiral Corporation, is illustrated in *Fig. 1*.

## Squelch-Limiter Operation

Its operation has been explained by the inventor, Ernest R. Pfaff, as follows: Signals from the i-f tube are fed to the tuned transformer, and also to the grid of another amplifier shown as a triode section of a dual-purpose tube.

Limiting and squelch action takes place in the duo-diode section. Signals transferred inductively from the primary to the secondary are rectified by the full-wave rectifier circuit, causing a biasing voltage to be developed across the RC branch. This biasing voltage is applied to the plates of the duo-diode, reducing current flow through the diode sections.

During the time of current flow, the secondary is effectively short-circuited, and because of tight coupling between primary and secondary, the primary is likewise effectively short-circuited. Therefore, while the diodes are conducting, no signals are obtained at the triode output. This circuit provides both limiting and squelch action.

Amplitude-modulated peaks are limited or clipped to a level determined by the steady signal strength from the i-f strip, and by the value of the resistor *R*. When no signal is present, there is no drop across *R* (except for a small value due to contact potential), and any incoming signal voltage peak above this value will be rectified. Random noise impulses, being of very short duration, become completely rectified and do not appear at the output. The time constant *RC* is considerably greater than the duration of such impulses, so the impulse is over before the voltage drop across *R* has appreciably increased. Because noise is intermittent in character as compared with an incoming f-m carrier, the circuit serves as a squelching device.

When a carrier is present, the bias across *R* varies with the signal strength. To keep the signal input constant during fading, it is advisable to use AVC ahead of the limiter-squelch circuit.

If an adjustable positive bias is applied to the cathode of the limiter-squelch tube, limiting action may be adjusted manually for any desired pro-

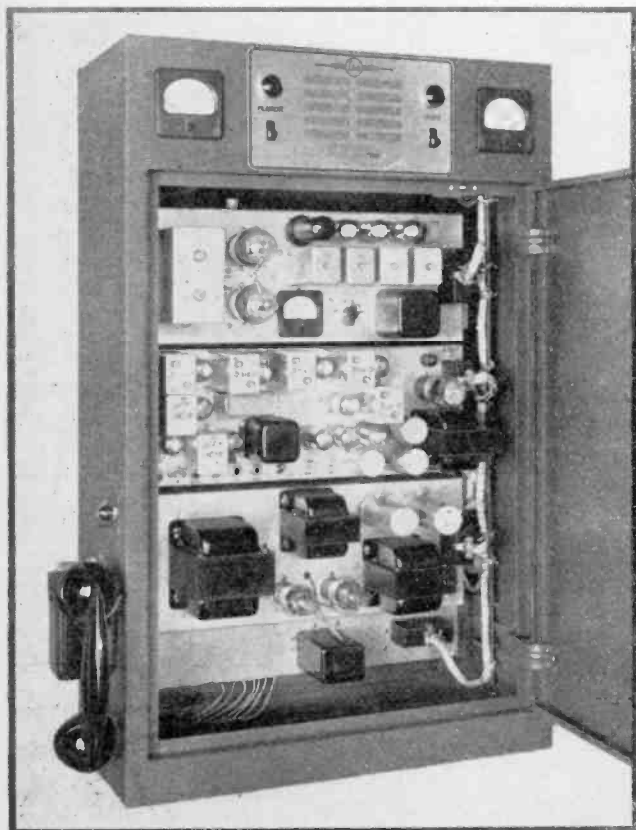

Typical f-m transmitter-receiver for specialized service, with squelch circuit in receivers.

—Courtesy Fred M. Link, Inc.

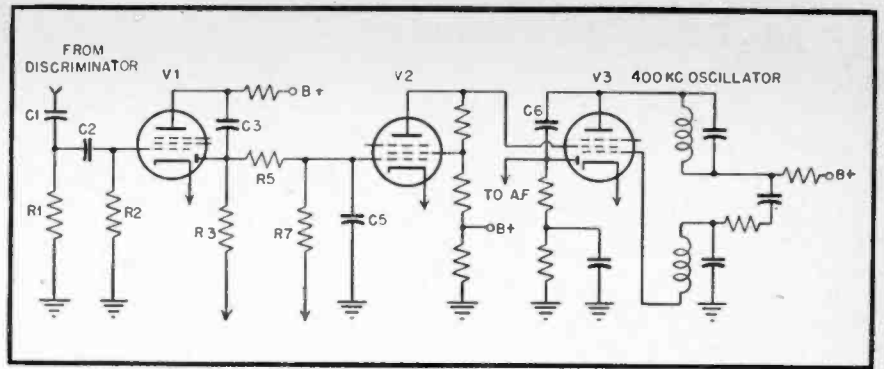
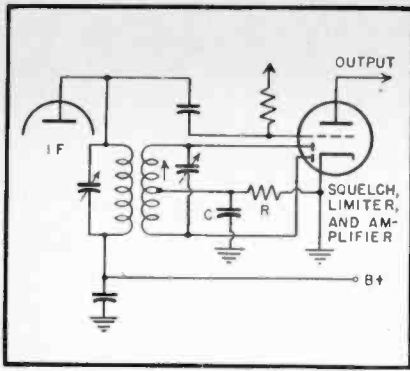

Fig. 1. (left) Combined limiter and squelch circuit for f-m receiver designed around principle of reflected impedance. Fig. 2. (right) Squelch oscillator V3 develops voltage controlled by discriminator output. Oscillator voltage is rectified and applied as squelch bias to the audio amplifier.

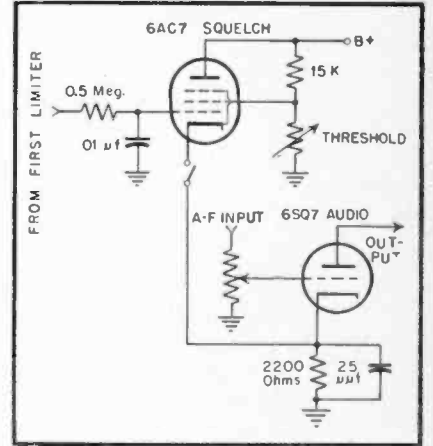
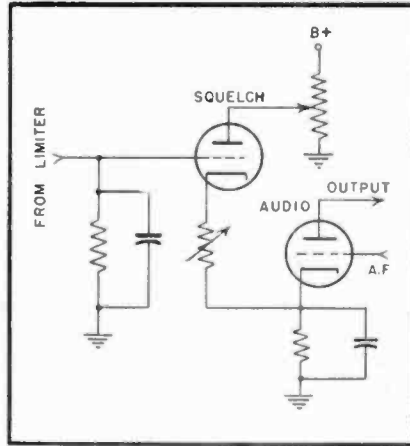
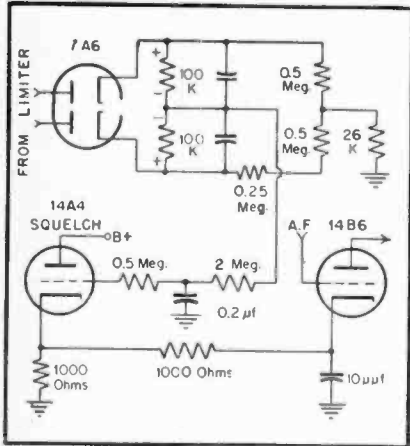

Fig. 3. (left) Schematic for typical a-c/d-c squelch circuit. Muting is incomplete, because of limited plate supply voltage. Fig. 4. (center) Two methods of controlling threshold in the cathode-coupled squelch circuit. Fig. 5. (right) Disabling switch is frequently provided in squelch circuits which do not cut off with sufficient rapidity to avoid threshold distortion.

portion of cut-off. However, the squelch action is destroyed by fixed bias. Without avc, the output will vary in the same manner as with self-bias. This is not entirely a disadvantage; limiting action is then obtained on weak, as well as strong, signals. With conventional limiters, weak signals may not be clipped, so amplitude modulation is mixed with the output. With this particular circuit, no amplitude modulation is passed, regardless of signal level.

### Oscillator Squelch

Another interesting f-m squelch circuit makes use of a local oscillator, the output of which is rectified and utilized as a squelch bias. The circuit is shown in Fig. 2.

This circuit uses two dual-purpose tubes.  $V_1$  is a combination noise-amplifier and rectifier.  $V_2$  is a d-c amplifier, and  $V_3$  is a combination squelch oscillator and rectifier. In reception of frequency-modulated signals, the limiter clips the peaks of the waves to effectively suppress noise impulses, because their a-m components are pronounced. The noise "rides on top of the signal."

However, when no carrier is present, conventional limiters fail to operate at the comparatively low noise-voltage level, and the output of the discriminator

contains noise impulses which are passed along to the a-f amplifier. This of course leads to objectionable inter-channel noise in the speaker output. With the circuit of Fig. 2, amplitude-modulated noise impulses are applied to the control grid of  $V_1$ . Capacitors  $C_1$  and  $C_2$ , in conjunction with resistors  $R_1$  and  $R_2$ , form a high-pass filter. The filter passes only high-frequency noise impulses, and blocks the lower audio frequencies.

These high-frequency noise impulses are amplified and coupled through  $C_3$  to the diode section of  $V_1$ , where they become rectified. The rectifier output polarity is negative, being taken from the plate side of the rectifier. In the presence of a carrier,  $V_2$  receives no negative bias.  $V_2$  is connected as a d-c amplifier, and has its grid driven directly through  $R_3$ .

Because the output of the rectifier consists of a succession of negative impulses,  $C_5$  is placed in shunt with the grid of  $V_2$  to smooth the negative bias supplied to  $V_2$ . Along with the negative voltage applied to the grid of  $V_2$ , a constant positive bias is supplied through  $R_7$ , which is adjusted to cause a high plate current in  $V_2$  with no noise signals coming through. Correspondingly, the plate voltage of  $V_2$  is low, which

makes the screen of  $V_3$  sufficiently low that the oscillatory circuit fails to function.

With noise signals present, the grid bias on  $V_2$  increases negatively, causing the plate voltage to rise as well as the screen of  $V_3$ , and the circuit breaks into oscillation.

The r-f output from the oscillator is coupled through  $C_6$  to the diode section of  $V_3$ , and diode current derived from oscillator voltage is utilized to develop a negative bias for cutting off the a-f amplifier.

### A-C/D-C Squelch Circuit

Because of the low plate potential available in an a-c/d-c receiver, squelch circuit problems are particularly severe. In general, it is not possible to suppress completely inter-channel noise with conventional circuits, but the noise level may be reduced to a point at which it is not objectionable. A commercial circuit which has proven effective is shown in Fig. 3.

Operation of the circuit involves biasing the cathode of the 14B6 tube as nearly to cut-off as possible. However, the squelch characteristic is of the "soft," or incomplete type, because of low plate-supply potential. In the presence of a carrier, the 14A4 becomes

biased to cut-off and does not draw current, reducing the drop across the cathode circuit of the 14B6 and bringing it out of cut-off. In the absence of a carrier, the bias on the squelch tube falls and causes a heavy flow of plate current, driving the 14B6 to the vicinity of cut-off and attenuating the noise in the a-f output to an acceptable level.

### Threshold and Switch Controls

Not all squelch circuits provide a rapid cut-off. Because of this characteristic, severe audio distortion will be encountered in the output with signal levels which partially actuate the squelch tube, but do not completely suppress reception. Two methods are available for meeting this situation: one design makes use of an adjustable threshold control, while another merely provides a switch for disabling the squelch tube. The unit shown in Fig. 6 has an auxiliary pilot lamp which is energized by the squelch circuit when the signal level is sufficiently high.

### Noise-Operated Squelch

The squelch circuit is (see Fig. 7) of the noise-operated electro-mechanical type. In the absence of a signal, the limiters are saturated by set noise and considerable a-f noise voltages are developed in the plate circuit of the 2nd limiter tube. This noise voltage is coupled through a high pass filter to the grid of the 1S5 squelch tube. This filter removes the low frequency audio components below 12,000 cycles, preventing the possibility of carrier modulation tripping the squelch. After amplification by the pentode section of the 1S5

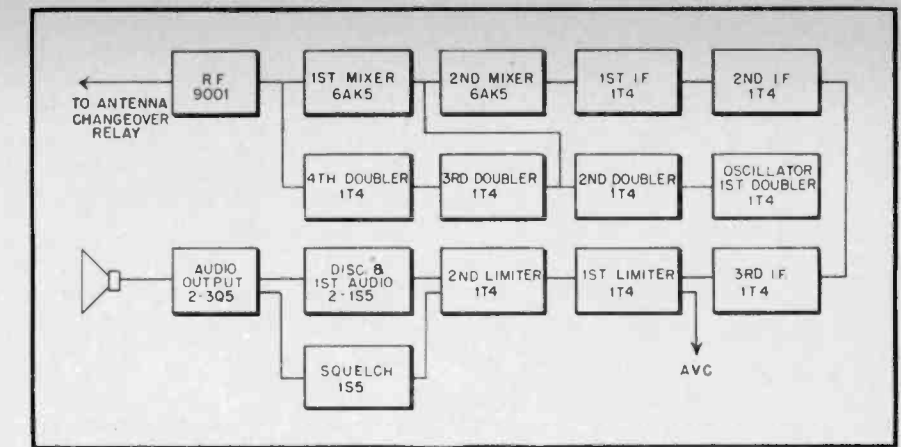

Fig. 7. Block diagram for Comco receiver unit of taxicab radio shown in Fig. 6.

squelch tube, the noise voltage is applied to the 1S5 diode. The negative voltage developed across the diode load resistor is used to bias the pushpull 3Q5 a-f tubes nearly to cut-off.

When a signal is received of sufficient strength to override the noise level, the noise voltage from the second limiter disappears. Thus the cut-off bias is removed and the 3Q5 tubes are restored to normal bias and operation. Positive squelch operation is further obtained by means of a relay in the plate and screen supply circuit of the 3Q5 tubes which operates when the bias is applied from the squelch circuit. In the squelched condition, the relay is open and the relay contacts short the speaker voice coil circuit to ground. Upon receiving a signal, the relay is closed, and in addition to removing the

ground from the voice coil circuit, it closes the circuit to the red indicator lamp on the control panel.

On single channel operation, the squelch circuit is so adjusted that a sharp whistle in the microphone causes the red lamp to flicker, thus giving the driver a means of checking both transmitter and receiver circuits for correct operating conditions.

In addition, the receiver is so designed that adjustment of the transmitter frequency may be made using the readings of the receiver discriminator circuit which has previously been checked against the headquarters transmitter. This eliminates the need for any frequency checking equipment except at headquarters, unless crossband operation is used.

Typical methods of controlling the threshold of a cathode-coupled squelch circuit are shown in Fig. 4. These are equally effective when suitable control ranges are provided. In application, either the plate or cathode control is employed, but not both. The threshold control enables the operator to increase the sensitivity of the receiver when necessary, without losing the advantages of squelch action entirely.

A squelch disabling switch for a commercial cathode-coupled squelch circuit is shown in Fig. 5, which also has an auxiliary threshold control. The voltage across the 2200-ohm cathode resistor is approximately eight times cut-off in the absence of a carrier. The 6SQ7 operates normally with -2 volts on the grid, and circuit relations are such that with -5 volts the 6AC7 will cut off and restore the -2 volts operating bias to the 6SQ7.

However, for intermediate values of carrier level, it is possible for the 6SQ7 to be biased between the operating and cut-off points, with resulting high distortion. Opening the squelch switch effectively cuts off the 6AC7 and the 6SQ7 operates normally, under all conditions of carrier level.

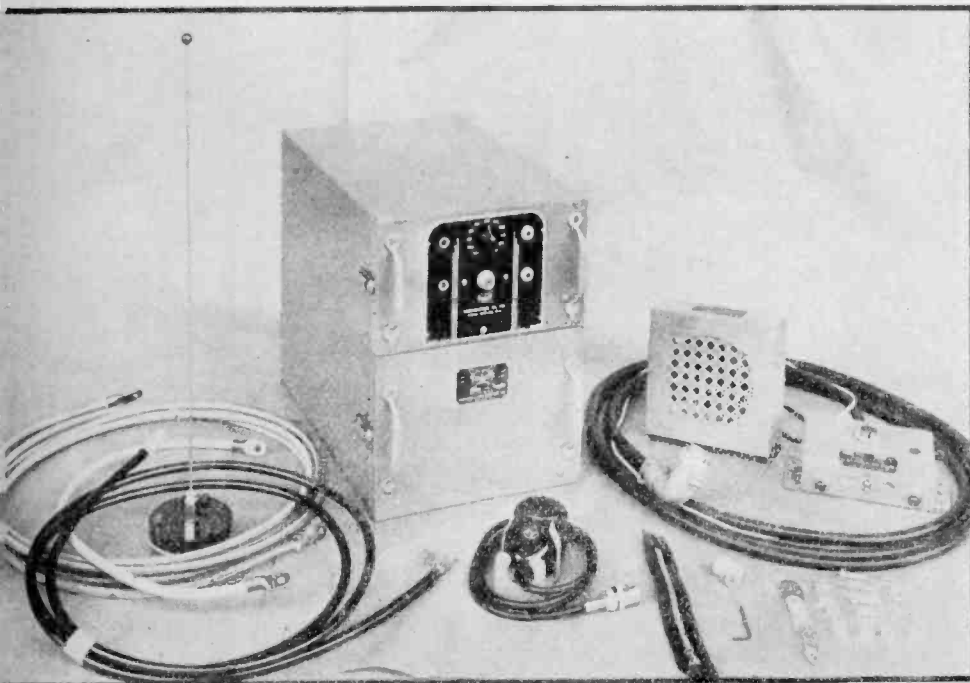

Fig. 6. Package VHF transmitter-receiver for taxicab installation, uses squelch-operated pilot lamp.



# Improved Analysis of the R-C Amplifier

J. ROORDA, Jr.

The author presents in this important article a new and simple method of designing resistance-coupled amplifier circuits for any frequency range

IT IS CUSTOMARY to design R-C amplifiers with the aid of three equivalent circuits, each of which involves certain approximations that may be justified over a portion of the frequency response range. This device, while workable, does not entirely satisfy the analytical mind. It would be preferable to evolve a rigorous solution without approximations, in addition to determining a simple equivalent circuit which holds true at all frequencies.

These considerations have led to new design formulas which are derived in this paper, and which afford a simplified method of computing R-C amplifier performance.

A schematic diagram of an R-C amplifier is shown in Fig. 1, drawn in conventional form. The plate load of  $T_1$  consists of  $R_1$  plus the coupling network  $R_2-C_e-R_2$ . It is required to choose  $R_1-C_e-R_2$  in such manner that  $E_{p2}$  shall be maximum over the required frequency-response range of the amplifier. Voltage amplification of the circuit is defined as the ratio  $E_{p2}/E_{p1}$ .

## Equivalent Circuit

Solution of the circuit requires at the outset that  $C_p$  and  $C_g$ , the plate-cathode capacitance and grid-cathode capacitance be taken into account. These capacitances will include the inevitable stray capacitances of wiring and circuit components. Thus the circuit of Fig. 2 is derived, which includes for convenience of analysis a constant-current source  $G_m E_{p1}$ . Resistance  $R_p$  is the resistive component of the input impedance presented by  $T_2$ , while  $C_p$  includes the capacitive component of this input impedance. These are to be evaluated in the conventional manner.

Circuit parameters to the left of  $C_e$  are lumped together and termed  $Z_p$  in the re-drawn circuit of Fig. 3, while the parameters to the right of  $C_e$  are termed  $Z_o$ . The elements of these lumped parameters are, by inspection:

$$1/Z_p = 1/R_p + 1/R_1 + j\omega C_p \quad (1)$$

$$1/Z_o = 1/R_o + 1/R_2 + j\omega C_o \quad (2)$$

where  $\omega$  is the angular velocity of the impressed a.c.

$E_{p1}$ , the a-c voltage developed across  $Z_p$ , is calculated:

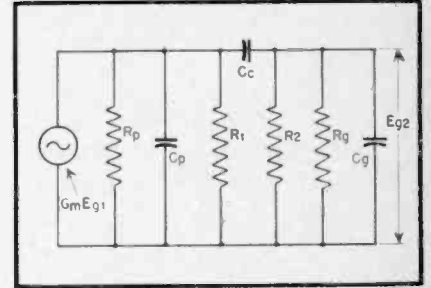
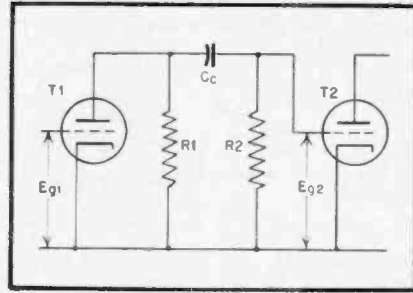

Fig. 1. (left) Conventional R-C amplifier circuit. Fig. 2. (right) Constant-current generator form of Fig. 1, with interelectrode and stray capacitances included.

$$E_p = G_m E_{p1} / [1/Z_p + 1/(Z_o + 1/j\omega C_o)] \quad (3)$$

and the ratio of  $E_{p2}$  to  $E_p$  is found:

$$E_{p2}/E_p = Z_o / (Z_o + 1/j\omega C_o) \quad (4)$$

## Gain

By eliminating  $E_p$  from (3) and (4), the amplification is derived:

$$\frac{A}{\omega} = \frac{E_{p2}/E_{p1}}{\omega} = G_m / [1/Z_p + 1/Z_o + 1/Z_p Z_o \times 1/j\omega C_o] \quad (5)$$

in which the underscored A signifies that this factor is vectorial.

Manipulation of (5) leads to separation of resistive and reactive components:

$$\frac{1}{\omega} = \frac{1/Z_p + 1/Z_o + 1/Z_p Z_o \times 1/j\omega C_o}{(1/R_p + 1/R_1)(1 + C_o/C_e) + (1/R_o + 1/R_2)(1 + C_p/C_o) + (1/j\omega C_o)(1/R_p + 1/R_1)} \quad (6)$$

where (5) assumes the form:

$$\frac{A}{\omega} = G_m / (1/R + 1/j\omega L + j\omega C) \quad (7)$$

in which  $R$ ,  $L$ , and  $C$  are evaluated from (6):

$$1/R = (1/R_p + 1/R_1)(1 + C_o/C_e) + (1/R_o + 1/R_2)(1 + C_p/C_o) \quad (8)$$

$$L = C_o / (1/R_p + 1/R_1)(1/R_o + 1/R_2) \quad (9)$$

$$C = C_p + C_o + C_p C_o / C_e \quad (10)$$

## Final Equivalent Circuit

It follows from (7) that the equivalent circuit of Fig. 2 can be redrawn as shown in Fig. 4, with values of  $R$ ,  $L$ , and  $C$  as specified by (8), (9), and (10). As no approximations are involved in equations (7) to (10), the equivalent circuit of Fig. 4 represents unrestrictedly the properties of the R-C amplifier, within the framework of linear analysis.

It is observed from Fig. 4 that there is only one frequency at which the amplifier network is purely resistive. This frequency  $f_o$  (angular velocity  $\omega_o = 2\pi f_o$ ) is defined as:

$$\omega_o^2 LC - 1 = 0 \quad (11)$$

The amplification of the circuit is maximum at  $f_o$ , and may be evaluated:

$$A_o = G_m R \quad (12)$$

by substituting (11) into (7).

## Analysis of Equivalent Circuit

It is found from inspection of (8) that, firstly, the largest value that  $R$  may attain is that of  $R_p$  and  $R_o$  connected in parallel (which occurs when  $R_1$ ,  $R_2$  and  $C_o$  may be considered infinite), and hence the maximum obtainable amplification is determined by the values of  $R_p$  and  $R_o$ .

Secondly, values of  $R_1$  and  $R_2$  should be made high with respect to  $R_p$  and  $R_o$  to obtain maximum amplification.

Thirdly, the capacitance of  $C_e$  should be as large as possible for maximum amplification. The phrase "as large as possible" is subject of course to practical limitations, and this point is considered later in greater detail.

Voltage amplification at an arbitrary angular velocity  $\omega$  may be evaluated from (7) in terms of the vector magnitude:

$$\frac{A}{\omega} = A_o / [1 + R^2(1/\omega L - \omega C)^2]^{1/2} \quad (13)$$

from which it is observed that the amplification off resonance is always less than maximum.

A further interesting observation may be made: terming  $\omega_1$  and  $\omega_2$  the angular velocities at the limits of the frequency range under consideration, ( $\omega_1$  being the lower limit) and assuming that the voltage amplification at the limiting frequencies is the same percentage of the maximum amplification, it follows from (13) that:

$(1/\omega_1 L - \omega_1 C)^2 = (1/\omega_2 L - \omega_2 C)^2$   
and since  $\omega_1 < \omega_0$  and  $\omega_2 > \omega_0$ , we may write:

$$1/\omega_1 L - \omega_1 C = -(1/\omega_2 L - \omega_2 C)$$

from which it follows that:

$$\omega_1 \times \omega_2 = 1/LC = \omega_0^2 \quad (14)$$

It is observed therefore that the resonant frequency of the circuit, at which point amplification occurs, is the geometric mean of the limiting frequencies. If the voltage amplification at the limiting frequencies may drop to a value  $pA_0$  where ( $p < 1$ ), it may be found from (13) that:

$$pR(1/\omega_1 L - \omega_1 C) = (1 - p^2)^{1/2}$$

and when (14) is introduced.

$$1 - \omega_1/\omega_2 = \omega_1 L(1 - p^2)^{1/2}/R \quad (15)$$

Equations (14) and (15) may be used in conjunction with (8), (9), and (10) to calculate exactly the performance of an R-C amplifier. The resonant frequency and maximum amplification are determined, and various pairs of  $\omega_1$  and  $\omega_2$  are next chosen in accordance with (14), computing values of  $p$  from (15).

### Design Procedure

With the aid of the foregoing equations, it is readily possible to design an R-C amplifier to meet a specified set of conditions. Given  $G_m$ ,  $R_p$ ,  $R_s$ ,  $C_p$ , and  $p$  at the limiting frequencies  $f_1$  and  $f_2$ , it is next desired to determine  $R_1$ ,  $R_2$  and  $C_c$ . Only two equations, (14) and (15), are available for calculating the three variables. We are therefore free to choose one of these variables, in order to determine the resulting values of the two remaining variables. This may be done in such manner as to considerably facilitate the computation.

It is possible, for example, to assume  $C_c$  sufficiently large that  $C_p/C_c$  and  $C_p/C_c$  can be neglected with respect to unity, and that  $C_p C_c/C_c$  is vanishingly small with respect to  $C_p + C_c$ . Thus  $C = C_p + C_c$  for practical purposes. Values of  $L$  and  $R$  are then computed from (14) and (15).

A suitable value of  $R_s$  is next chosen, and  $R_1$  calculated from (8). The value of  $C_c$  is found from (9). Finally, we examine the result to determine if the resulting value of  $C_c$  justifies the approximations made at the outset. To illustrate this process, the following example may be helpful.

### Example

Given a tube with a  $G_m$  of 5000  $\mu$ mhos, an a-c plate resistance of 1 megohm, and an output capacitance of 10  $\mu$ mf, given an input resistance to the next tube of 5 megohms, shunted by an input capacitance of 10  $\mu$ mf. Between these tubes we wish to design an R-C coupling network for a frequency range of 20-50,000 cps, with an amplification at the limiting frequencies of 90% of maximum, or a loss in gain of 1 db at these points. Likewise, the mid-band gain is to be determined.

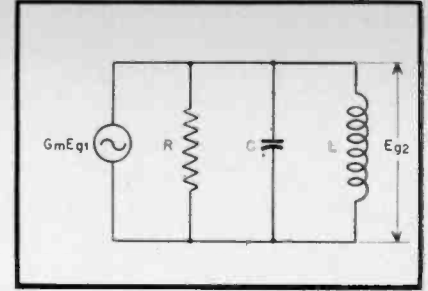
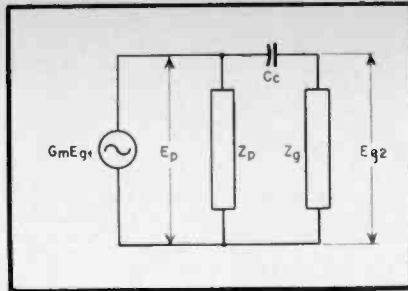

Fig. 3. (left) Redrawn circuit, in lumped impedance form. Fig. 4. (right) Final equivalent circuit consists of three shunt parameters driven by constant-current generator.

To solve the problem, we first determine the resonant frequency of the circuit. This can be computed from  $f_0^2 = f_1 f_2 = 20 \cdot 50,000 = 10^7$ , or  $f_0 = 3160$  cps and

$$\omega_0 = 2 \cdot 10^4$$

From (14) it is found that

$$1/LC = 4 \cdot 10^8$$

and  $p$  is given as 0.9, so that (15) can be written:

$$1 - \omega_1/\omega_2 = 1 - f_1/f_2 = 2\pi f_1 L(1 - 0.81)^{1/2}/0.9R$$

yielding

$$L/R = 1.65 \cdot 10^{-2}$$

For convenience we next assume that  $C_c$  is sufficiently large that we may choose  $C = C_p + C_c = 20 \mu\text{mf} = 2 \cdot 10^{-11} \text{f}$ , from which  $L$  may be determined according to  $1/LC = 4 \cdot 10^8$  as

$$L = \frac{1}{4} \cdot 10^8 \cdot 2 \cdot 10^{-11} = 125 \text{h}$$

and with this value,  $R$  may be determined from  $L/R = 1.65 \cdot 10^{-2}$ :

$$R = 125/1.65 \cdot 10^{-2} = 7600 \text{ ohms}$$

The maximum voltage amplification is accordingly,

$$A_0 = G_m R = 5000 \cdot 10^{-10} \cdot 7600 = 38$$

and hence the gain at mid-band is

$$G = 20 \log 38 = 21.6 \text{ db}$$

and at the limiting frequencies the gain drops to 20.6 db.

The next step is to determine the values of the coupling network. One value may be chosen from  $R_1$ ,  $R_2$ , or  $C_c$ . When choosing  $R_1$ , it should be kept in mind that excessively high values require excessively high power-supply voltages to obtain a satisfactory operating point on the characteristics.  $R_2$  is shunted across the input resistance of the second tube, and this latter resistance is not constant, varying continuously over the frequency range used. To minimize this influence, it is preferred to make the value of  $R_2$  a fraction of this input resistance.

$C_c$  should be chosen sufficiently large to justify the approximations of the computation. In theory, at least,  $C_c$  cannot be made too large, but in practice the leakage resistance is to be considered as well as the large stray capacitance to ground for the larger sizes. Increased stray capacitance of course diminishes both frequency range and mid-band gain.

To complete the design, a value may be chosen for  $C_c$ , such as 0.1  $\mu$ f. With this value of  $C_c$  the value of  $C$  deviates from  $C_p + C_c$  by only one part in a thousand, so that the approximation  $C = C_p + C_c$  is well justified. This is further

justified from the standpoint of the approximations  $1 + C_p/C_c = 1$  and  $1 + C_s/C_c = 1$  as the deviation is only one part in 10,000.

Therefore we may write

$$1/R = (1/R_s + 1/R_1) + (1/R_o + 1/R_2)$$

from

$$L = C_c / (1/R_s + 1/R_1) (1/R_o + 1/R_2)$$

we find, with  $L = 125 \text{h}$  and  $C_c = 10^{-11} \text{f}$ ,  $(1/R_s + 1/R_1) (1/R_o + 1/R_2) = 8 \cdot 10^{-10}$ . With  $R = 7600$  ohms, it is found that  $(1/R_s + 1/R_1) + (1/R_o + 1/R_2) = 1.32 \cdot 10^{-6}$ .

With the given values of  $R_s$  and  $R_o$ , these equations yield  $R_1 = 8000$  ohms and  $R_2 = 0.17$  megohms. As a matter of fact, two sets of values are found for  $R_1$  and  $R_2$ , but with practical consideration in mind, the values noted will be most suitable.

### Oscillatory Response

One more point remains to be investigated: According to Fig. 4, the system may respond in an oscillatory manner at its resonant frequency  $f_0$  when a suddenly changing voltage is impressed. Should transient oscillations occur, severe distortion would of course be encountered. Under usual conditions, however, the system is sufficiently damped by  $R$  that aperiodic response is obtained.

It can be shown that  $L$ ,  $C$ , and  $R$  are aperiodic if  $1/R^2 \leq 4C/L$ . It follows from (9) and (10) that  $4C/L$  is considerably less than  $4(1/R_s + 1/R_1) (1/R_o + 1/R_2)$ , and from (8) that  $1/R^2$  is considerably greater than  $[(1/R_s + 1/R_1) + (1/R_o + 1/R_2)]^2$ . Writing  $a = (1/R_s + 1/R_1)$  and  $b = (1/R_o + 1/R_2)$ , it is required for aperiodicity that  $(a+b)^2 \leq 4ab$ . Since  $(a+b)^2 = a^2 + 2ab + b^2 = 4ab + a^2 - 2ab + b^2 = 4ab + (a-b)^2$  it is seen that  $(a+b)^2 = 4ab$  when  $a = b$  and is evidently greater than  $4ab$  when  $a \neq b$ .

Under usual conditions the system is therefore aperiodic, and the amplifier will not develop transient oscillations. This situation may be altered, however, when  $R_o$  becomes negative (which is possible if suitable conditions exist with respect to the second tube and its circuits). The negative resistance may be equal to or greater than  $R_2$  under such conditions, but would not be frequently encountered in practice. In any event, the situation can be controlled by choosing  $R_2$  sufficiently small.

# RADIO DESIGN WORKSHEET

## NO. 53 – GRAPHICS OF NEGATIVE FEEDBACK IN CASCADE

**N**EGATIVE FEEDBACK from output to input of a single-stage amplifier may be followed graphically on the published plate characteristics\*†. In this manner the output may be plotted for a sinusoidal input of arbitrary magnitude, and a schedule analysis made of the output waveform to determine the harmonic amplitude distortion components. With a suitable complex input wave, the output waveform may likewise be analyzed for intermodulation components. While the analyses have nothing to say concerning stray capacitances or inductances or imperfections of coupling devices, and are limited to waveform modifications introduced by non-linear tube characteristics, much useful information is nevertheless supplied concerning mid-band performance.

In cascade amplifiers negative feedback is often applied over two stages, as shown in Fig. 1, wherein a combination

\*RADIO, March, 1946

†A more rapid analysis is scheduled for publication in the near future.—Ed.

feedback voltage is developed from both input-stage current feedback and two-stage voltage feedback. This combination voltage is 180° out of phase with the input voltage.

To analyze this circuit and follow its operation upon the plate characteristics, it is helpful to recognize at the outset that the tube does not know to what kind of circuit it is connected, and proceeds to respond to prevailing electrode voltages in the manner depicted by the characteristics. It does not become necessary or desirable to view the characteristics and feedback potentials as operating together to simulate a fictitious tube with new values of amplification factor and plate resistance.

Instead, the analysis starts with the grid-cathode voltage of the input stage, working back to the input voltage and total feedback voltage which this grid-cathode voltage implies. This is determinable algebraically in terms of the overall gain (which varies from point to point along the load line, and is there-

fore considered incrementally) and leads to recalibration of the input stage characteristics in terms of input voltage.

The voltage appearing from grid to cathode of the input stage is termed  $e_g$ , and is evidently the algebraic sum of the input voltage  $e_i$ , the current-feedback voltage  $e_k$  and the potential-feedback voltage  $e_f$ . The output stage operates without modification; its amplification is the same in the presence or absence of feedback to the preceding stage. The amplification  $A_1$  of the input stage, however, is diminished by both feedback voltages.

Current feedback develops a feedback voltage of a magnitude which is independent of the presence of the output stage. This voltage  $e_k$  is the drop across the un-bypassed cathode resistor  $R_k$ , which is directly proportional to the plate current  $i_1$  of the input tube. Since a fraction  $F e_{o1} = e_{o1} R_k / (R_k + R_L)$  of the plate swing  $e_{p1}$  is fed back to the grid of  $T_1$ , and  $e_{o1} = A_1 e_g$ ,  $e_k = e_i - F e_{o1} = e_i - F A_1 e_g$ . Solving for  $e_i$ ,

$$e_i = e_g (1 + F A_1)$$

Since  $e_g$  is the voltage between grid and cathode of  $T_1$ , it is also identified numerically with  $e_c$  upon the plate characteristics. Or,

$$e_i = e_c (1 + F A_1)$$

The parenthetical term, then is the factor by which each value of  $e_c$  upon the characteristics is to be multiplied in order to determine  $e_i$ . These values of  $e_i$  may then be noted beside the associated values of  $e_c$ . As pointed out before,  $A_1$  varies considerably from cut-off to the diode line (beyond which the analysis is not concerned). Therefore,

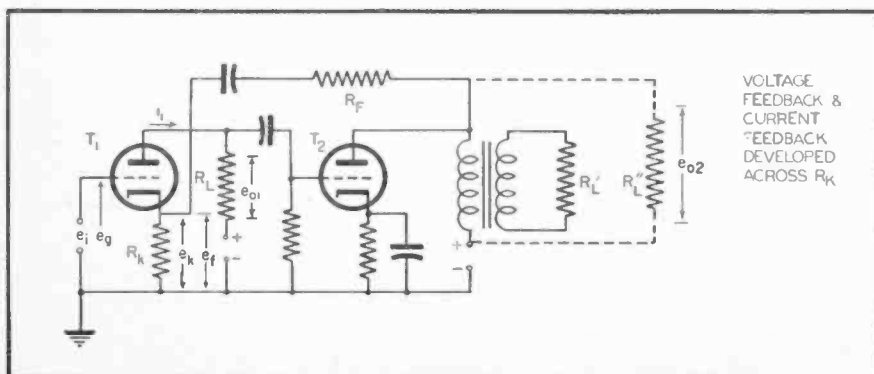

Figure 1

$A_1$  is determined incrementally for each successive value of  $e_1$ . In this manner, the variability of  $\mu$  is taken into account.

This recalibration shows the operation of the input stage from the standpoint of current feedback, as shown in Fig. 2. When the characteristics of the output tube are associated with those of the modified input stage, the output voltage may be determined as also shown in Fig. 2. The plate swing  $e_{o1}$  of the input stage drives the grid of the output stage, and the plate swing  $e_{o2}$  constitutes the output voltage swing across  $R_L$ , the reflected load  $R_L'$ .

The combined characteristics thus depict the operation of the two-stage circuit in the absence of voltage feed-

back, but with current feedback operative in the input stage. When the voltage feedback mesh is connected into the circuit, further modification of the input tube characteristics takes place. Let the fraction of  $e_{o2}$  fed back to the cathode of  $T_1$  be termed  $F'$ , whence the grid voltage of  $T_1$  is now diminished by the amount of  $F'Ge_1$ , where  $G$  is the gain of the amplifier with current feedback at the input stage.

$$F' = R_k / (R_F + R_k)$$

Like  $A_1$ ,  $G$  is non-linear, and is determined incrementally for successive values of  $e_1$  as shown in Fig. 2.

The voltage-feedback potential  $F'Ge_1$  opposes the input voltage  $e_1$ , and the quantitative relationship is given by

$$e_1 = e_1' - F'Ge_1$$

where  $e_1'$  is the input voltage required

under conditions of combined current- and voltage-feedback. The values of  $e_1'$  are desired for the complete circuit, and hence each value of  $e_1$  is to be multiplied by the factor  $(1 + F'G)$ .

The final operation consists in noting these values of  $e_1'$  beside their associated values of  $e_1$ , as shown in Fig. 2. The operation of the amplifier may now be followed by introducing a sinusoidal input, with successive instantaneous voltages of  $e_1'$ , following through the diagram to determine the corresponding output voltage swing  $e_{o2}$ , which affords the data required to plot the output waveform. A schedule analysis of this waveform yields the harmonics of the input which are generated in the circuit as a result of non-linear distortion.

In addition, the graphical analysis serves to show the desirable regions of operation for both input and output stages, with the result that the designer may avoid regions of high distortion by inspection, without actual plotting of output waveform. To find the value of any harmonic in the output, however, calculation may be carried out on the basis of the schedule analysis.

To interpolate for integral values of  $e_1'$ , a plot may be made on coordinate paper to show the relation of  $e_1'$  vs.  $e_1$ . Otherwise integral values may be located to a practical degree of precision with the aid of a pair of proportional dividers.

The gain of the circuit is of course the ratio of  $e_{o2}/e_1'$ , taken incrementally as shown in Fig. 2. From the grid of the first stage to the output, the overall voltage gain is approximately 31 for the parameters chosen, or expressed in terms of the input voltage, which is about 10 times greater for a given output because of feedback, the voltage gain becomes approximately 3.1 with the output-to-input feedback mesh connected. This increased amplitude of driving voltage is the price paid for the marked improvement in linearity of amplification.

An analysis of this type is particularly useful because the limits of operation may be established closely for a given circuit, without necessity of connecting up the components and making measurements. Likewise, if the driving tube is unsuited to the requirements of the output tube, this fact may likewise be determined without experimentation at the bench.

The two most time-consuming points in the analysis concern the determination of incremental amplification, and interpolation for integral voltage values which are desired. A method which reduces the time required, as well as the necessity of interpolation in this type of problem is in preparation, and will be presented in an early issue of RADIO.

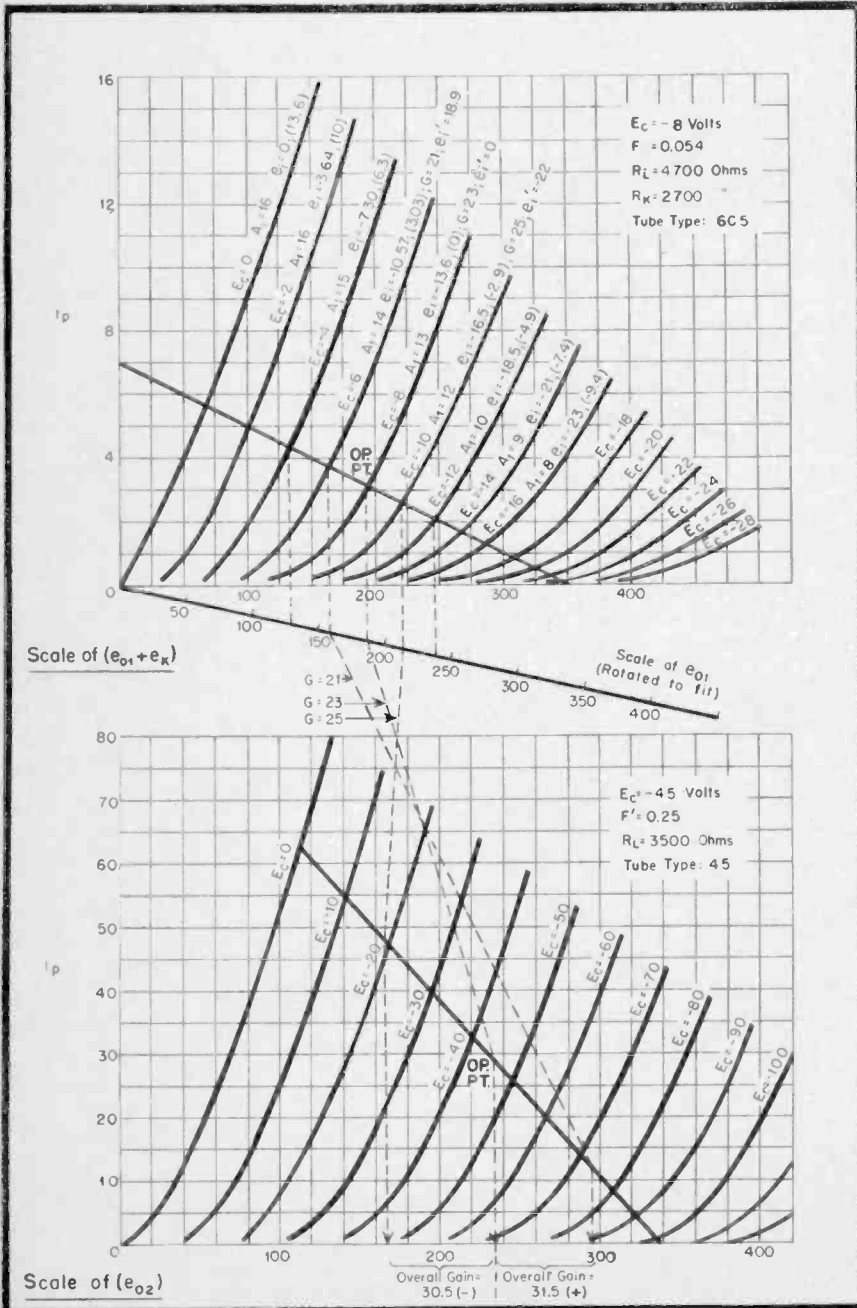

Figure 2

# DECREASE IN CURRENT AND ENERGY DUE TO AN IDEAL TRANSFORMER IMPROPERLY MATCHED

WHEN IDEAL TRANSFORMER IS PROPERLY TERMINATED

$$P_1 = \frac{E^2}{4R_2}$$

OTHERWISE

$$P_2 = \frac{E^2 R_2}{(R_1 + R_2)^2}$$

$$\frac{P_1}{P_2} = \frac{(R_1 + R_2)^2}{4R_2^2}$$

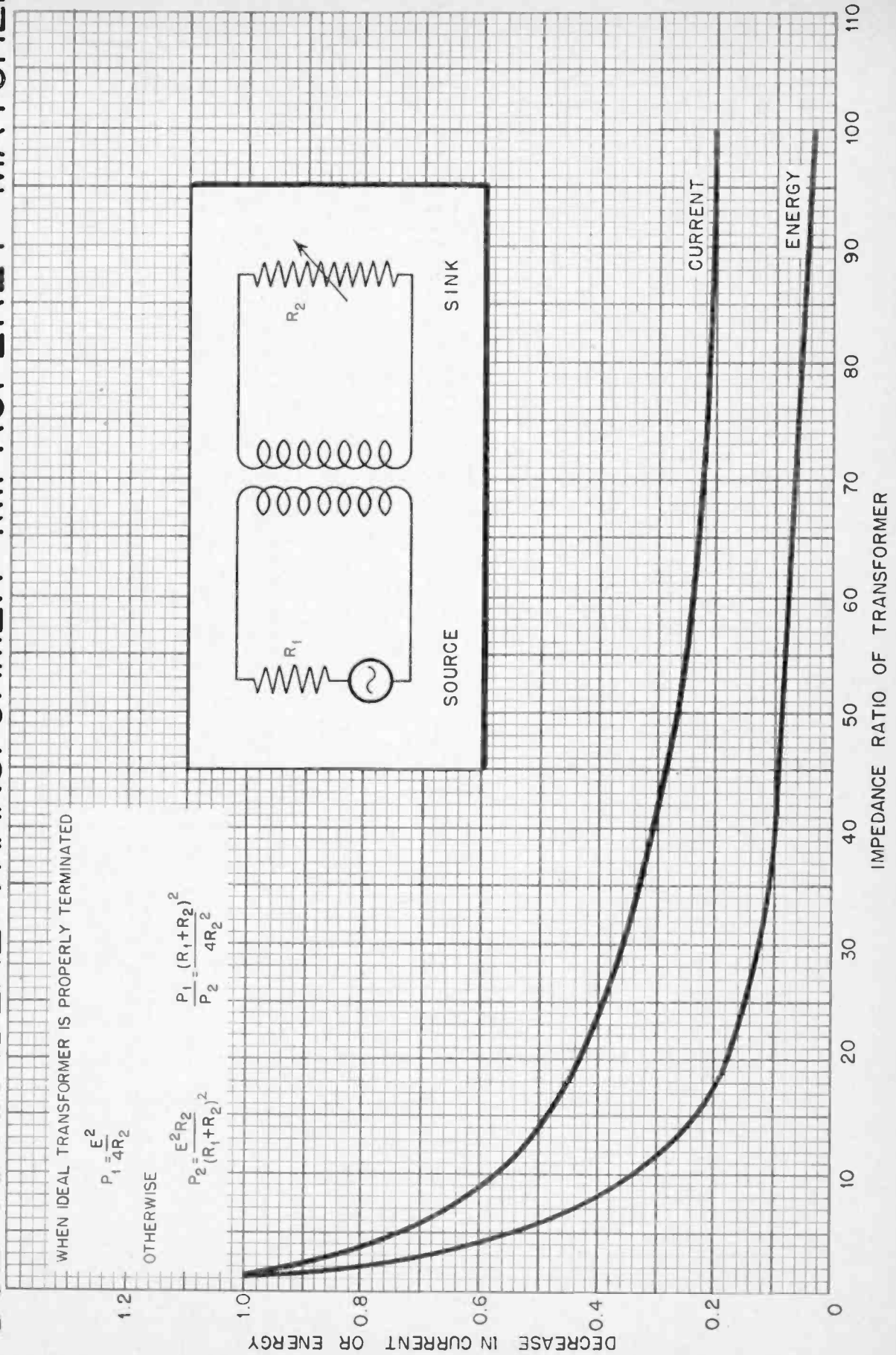
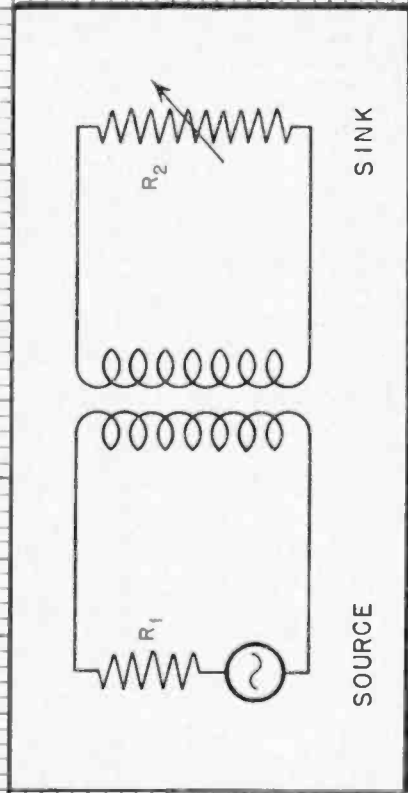

# This Month

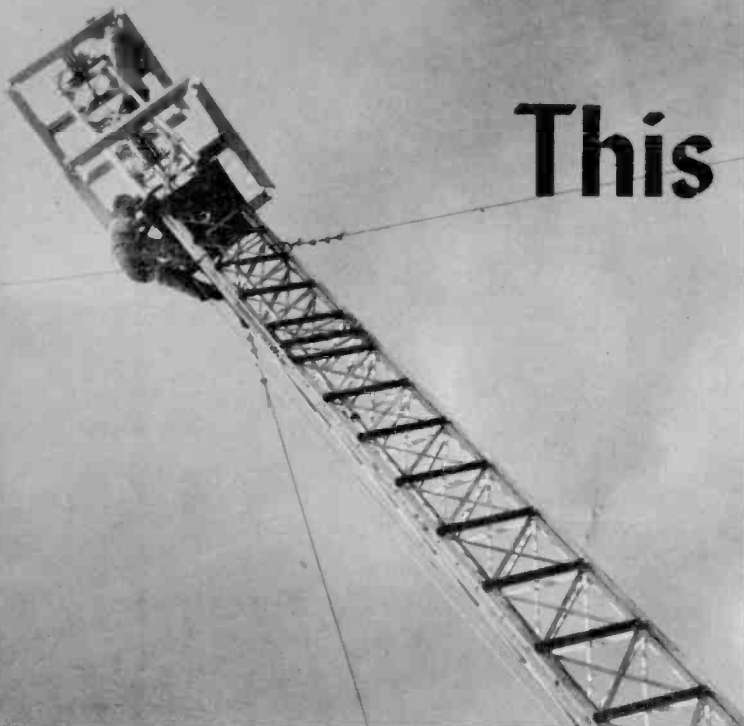

Final tuning adjustment on a two-element square-loop antenna developed by Federal Telephone & Radio Corp., Newark, N. J.

## ROCKET RADIO

A compact "rocket radio" weighing less than 100 pounds and with sufficient power to send its signal 240,000 miles from the moon to the earth is technically possible, according to Dr. J. A. Hutcheson, associate director of the Westinghouse Research Laboratories, in referring to recent rocket forecasts by the Army Air Force guided-missile branch. A 100-watt transmitter capable of beaming ultrashort waves from the moon to the earth would weigh less than 50 pounds and its power supply, consisting of several automobile storage batteries, would require only an additional 50 pounds.

Continuous operation during the trip to the moon, which Mr. Hutcheson estimated at 60 hours at a speed of 4000 miles per hour, would apply too heavy a drain on the batteries. He proposes an electric clock mechanism to turn on the radio for one minute each hour. Operated in this manner, the batteries would last for several days after landing on the moon's surface.

The proximity fuse developed during the war holds the key to providing a "soft" landing for moon-rockets. As explained by Dr. Hutcheson, a tiny radio set would detect the approach of the rockets to the moon's surface. This automatically would turn on reverse rockets and turn off forward rocket power. By starting reverse power at the right moment in this application, these proximity radio sets would make possible rocket landings without damaging delicate instruments.

Dr. Hutcheson heads research in microwaves and radar as well as nuclear physics at Westinghouse. He recent-

ly returned from the second atom bomb test at Bikini where he acted as special representative for the Manhattan Project.

## AUSTRALIAN TV

Introduction of monochrome television in Australia is advocated at an early date by R. C. Alsopp, consulting engineer, who cites U. S. techniques as yielding "better pictures than that provided by 16-mm home movies." He foresees stagnation and regression of u-h-f talent in that country, unless television is fostered by Parliament.

His views do not receive full acceptance, however. S. O. Jones, chief engineer of Philips Electrical Industries, has asserted that color television is essential in making a universal appeal. Mr. Jones likewise urges caution in the introduction of fm into Australia, citing a tendency in the U. S. to produce low-cost f-m receivers which "are little better than conventional a-m receivers."

## GERMAN PATENTS

James E. Markham, alien property custodian, announces that the recent accord on German-owned patents extends his office's policy of licensing former German-owned patents on a non-exclusive, royalty-free basis to citizens of other countries signing the accord.

He states that the patents will continue to be available to American citizens as before. He added that the patents which are being licensed to citizens of other countries under the accord are those in which there are no lawfully acquired proprietary interests, licenses or claims held by non-Germans prior

to August 1, 1946, which would conflict with the issuance of licenses.

## FEDERAL PUSHES T-V DEVELOPMENT

Federal Telephone and Radio Corp. will continue its development of television equipment, including transmitters for color and high-definition black and white, studio equipment, high-gain antennas, permitted by the use of higher carrier frequencies, and the application of Pulse-Time-Modulation, leading to a number of new features in television transmission and television receivers.

Federal Laboratories designed and manufactured the color television transmitter for the Columbia Broadcasting System and is licensed by CBS to manufacture color pick-up equipment. Federal has other color television transmitters under construction, and is also prepared to supply transmitting equipment for high-definition black and white, the design principles of which have considerably progressed due to the extensive research and development on the color transmitter.

## SOUTH AFRICAN BROADCASTS

The Union of South Africa expects to resume commercial broadcasting about June of 1947 after more than a decade during which it was banned. The South African radio is government-controlled like the British Broadcasting Company, which does not permit advertising on the air. But as a result of a recent study, the broadcasting board of the Union which sets radio policy for the country, has decided that by next June commercial programs can be resumed.

# Jensen *Speech Master* REPRODUCERS

...for clear, crisp, intelligible  
Speech\* *Reproduction*

Designed especially for speech reproduction in intercommunication and public address applications, this Speech Master family of JENSEN Reproducers, delivers clean, sharp, understandable announcements and orders. Like all JENSEN products, these Speech Masters were completely engineered to do their job efficiently and well.

#### MODEL NJ-300 SPEECH MASTER (Railroad Type).

PM design. Widely used in railroad intercommunication in locomotives, cabooses, signal towers and yards. Rugged case protects against shock and vibration; withstands dust, smoke and the elements. Voice coil impedance 12 ohms; power rating, 10 watts. Space provided inside case for 500-ohm impedance transformer. Overall height 11-3/4"; width 6-25/32"; depth 4-13/16". Holes provided in base for mounting in any position.

MODEL AR-10 SPEECH MASTER *ALNICO 5* design. Specially constructed reflex horn increases efficiency in mid-frequency range, giving added effectiveness and "punch" to speech quality; prevents direct access of rain and snow to speaker diaphragm. Voice coil impedance, 4 ohms and 45 ohms; power rating, 6 watts. Space provided inside for 1/2" x 1/2" transformer. Overall diameter 10"; depth 8". Complete with mounting bracket.

MODEL AP-11 SPEECH MASTER (Panel mounting). Similar to AP-10 but without base. Mounts in 4-27/64" cut-out; clearance eyelets for mounting screws. Depth 4 1/2" from front panel. Screws and drilling template included. Voice coil impedance 4 ohms or 45 ohms; power rating, 5 watts.

#### MODEL AP-10 SPEECH MASTER (Desk or Wall type).

PM design, desk or wall mounting. Complete with base and tilt adjustment. Double dustproofed. Rubber covered 36" cord. Internal mounting bracket for 1/2" x 1/2" transformer. Voice coil impedance 4 ohms or 45 ohms; power rating, 5 watts. Height 6-3/4"; depth 5 1/8"; diameter 5". Finish hammered gray with satin chrome trim.

MODEL NF-300 SPEECH MASTER (Navy Type). Developed for use as a loud speaker and microphone. Special case design over-rides wind and background noises for talk-back. Enclosed case and protective screen render this model proof against weather, dust and moisture *ALNICO 5*-PM design. Power rating, 10 watts; voice coil impedance 12 ohms. Mounts in 5 3/8" cut-out; six screw holes in rim. Overall diameter 6-7/16"; depth (from front of panel) 2-9/64". Finished in Munsel N4-5 gray enamel.

MODEL AP-20 SPEECH MASTER Heavy-duty unit for high-level paging and call systems in noisy industrial installations. PM design. Furnished with eyebolt for overhead suspension but available with stand for wall or table mounting. Voice coil impedance 8 ohms; power rating, 25 watts. Overall diameter 13 1/2"; depth 9"

\*For full discussion of Speech requirements, see Jensen Monograph No. 4.

#### JENSEN MANUFACTURING CO.

6615 S. LARAMIE AVENUE, CHICAGO 38, ILLINOIS, U. S. A.  
In Canada: J. R. Longstaffe, Ltd., 11 King Street, West, Toronto, Ont.

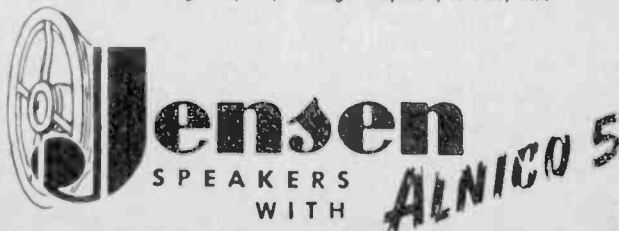

*Specialists in Design and Manufacture of Acoustic Equipment*

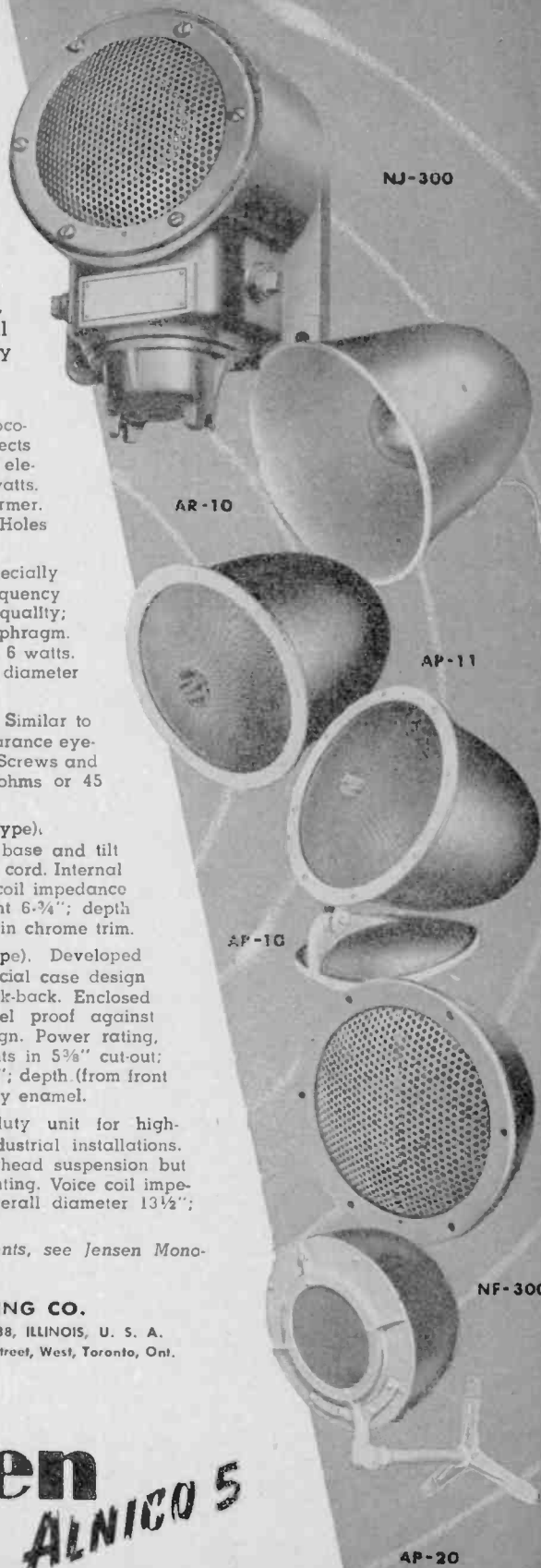

5

#### MONOGRAPHS AVAILABLE

If you haven't yet procured these five valuable technical booklets, order now—either from your dealer or direct—at 25c each.

1. Loud Speaker Frequency-Response Measurements
2. Impedance Matching and Power Distribution
3. Frequency Range in Music Reproduction
4. The Effective Reproduction of Speech
5. Horn Type Loud Speakers

25¢ each

# New Products

## FEED-THRU CAPACITORS

The new hermetically-sealed, metal-cased, feed-through capacitors are now in production at the Cornell-Dubilior Electric Corp.

Current feeds through a capacitor with exceptionally low inductance, impedance



and resistance. Designed specifically for attenuation of high frequency voltage components, these capacitors incorporate the better characteristics of larger, older, and more conventional types. These units also have an unusually low power-factor and remain unaffected by temperatures as high as 85° C.

Further details will be furnished upon request to Cornell-Dubilior Electric Corp., S. Plainfield, N. J.

## ELECTRONIC VOLT-OHMMETER

A new electronic volt-ohmmeter, Type PM-17, has been announced by the Specialty Division of General Electric Company's Electronics Department.

Developed and designed for general service and laboratory work, the new instrument is capable of measuring audio and r-f voltages from 60 cycles to over 100 megacycles.

Featuring extremely high input impedance and simple controls, measurements



may be made with the PM-17 without appreciably disturbing an existing circuit, according to division engineers.

The PM-17 weighs 15 pounds and operates from 105-120 volts, 60 cycles. An ohmmeter circuit is included for convenience in measuring high and low values of resistance.

Further information on the new electronic volt-ohmmeter is available on request to the Specialty Division of the G-E Electronics Department, Wolf Street Plant, Syracuse, N. Y.

## BLOWER MOTOR FILTER

The Air Filter Corp. of Milwaukee, Wis., announces the development of the Aircor Blower Motor Filter for radio transmitters.

Unique in design and structure, this can be used either as a dry filter or as a viscous filter by merely charging it with Filmcor filter adhesive oil. Its use as a viscous filter is recommended in locations where sand and extreme dust conditions prevail — such as airports.

## CuO RECTIFIERS

Copper-oxide rectifiers of new design, giving maximum output in minimum space, have been developed for battery chargers by Bradley Laboratories, Inc., 82 Meadow St., New Haven, Conn.

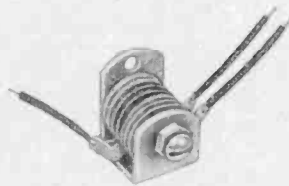

The new rectifiers are rated for 2, 3 and 4½ volts d-c output, with d-c current up to 1½ amperes.

Like all Bradley Coprox rectifiers, the new models have special features to combat aging. Lead wires are pre-soldered, and other types of terminals are specially designed, to prevent overheating during assembly.

## I-F TRANSFORMERS

A set of new transformers for high frequency FM and AM has been placed on the market by the National Company, Inc. of Malden, Mass. All operate at 10.7 mc and can be employed unchanged on the new FM band.

Iron core tuning, used in the transformer, does not affect the 100 kc bandwidth for the IFN or 150 kc for the IFM. The discriminator output is linear over the full 150 kc output and remains symmetrical regardless of the position of the tuning cores.

Insulation is polystyrene for low losses. The transformer is 1¾" square and stands 3½" above the chassis. It is available for delivery at the present time. Several variations of the above transformer have previously been manufactured by the National Company.

## SOUND AMPLIFIER

Greater flexibility in sound amplifier installations for any requirement is the feature of the new line of Multiamp Add-A-Unit amplifiers recently announced by Concord Radio Corp.

From a single compact basic amplifier unit, the power output can be increased from two to nine times by simply plugging

in additional, inexpensive power units. Additional output stages, to a total of six, can also be added — without additional cabinets or complicated connections. A phono-player, record changer, and output volume indicator may also be added in a matter of minutes.

## CHEMICAL WIRE STRIPPER

A new chemical wire stripper, known as Cold Wire Stripper #416, was developed to remove enamel, Formvar, Formex, impregnating varnish and many other types of coatings from wire.

The wire is dipped to the length desired stripped and kept immersed 15 to 45 seconds for enameled coatings and 1 to 2 minutes for plastics and varnishes. Loose insulation is removed by drawing cloth from top to bottom of the wire.

This non-inflammable stripper is manufactured by the Ellanar Chemical Co., 308 Randolph St., Chicago 6, Ill.

## NEW SPEED NUTS

A new low-priced line of heat-treated spring steel speed nuts has just been announced. This new line comprises all the sizes required to fit the ten most

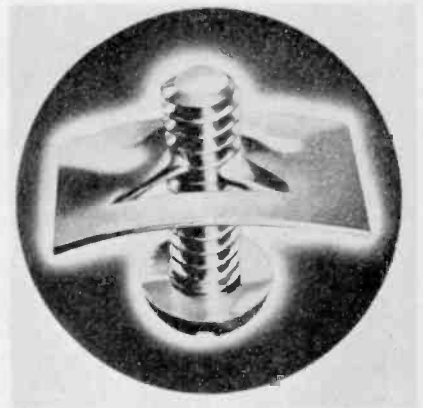

popular sizes of machine screws and sheet metal screws. Known as the C7000 Series, this new speed nut line has been engineered to a precision formula based upon the diameter and strength of the screw with which it is used. The new C7000 Series sells at a lower price than the threaded nut and lock washer.

Manufactured by Tinnerman Products, Inc., 2154 Fulton Road, Cleveland 13, Ohio.

## tone COMPENSATING ATTENUATOR

The Daven Company of 191 Central Ave., Newark, N. J., announces the development of a new tone compensating attenuator, Type LAC-720.

It is essentially a ladder network, designed so that the frequency characteristics follow the hearing response



# RACON IS THE BEST IN SOUND EQUIPMENT

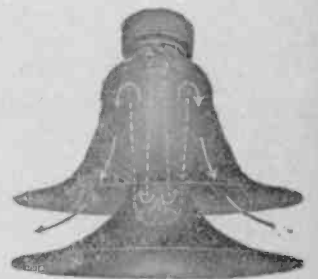

**RADIAL HORN SPEAKER;** a 3 1/2' re-entrant type horn. Projects sound over 360° area. Storm-proof. Made of RACON Acoustic Material to prevent resonant effects.

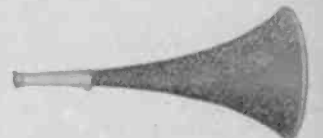

**PAGING HORN;** extremely efficient 2' trumpet speaker for use where highly concentrated sound is required to override high noise levels. Uses P.M. unit.



**RADIAL CONE SPEAKER;** projects sound over 360° area. Cone speaker driven. Will blend with ceiling architecture. RACON Acoustic Material prevents resonant effects.

Leading Soundmen everywhere specify RACON Horns, Speakers and Driving Units when quoting on potential sound installation sales or rental contracts because RACONS deliver maximum output and response for size of driving unit used. There's a RACON sound reproducer for every conceivable purpose. Each affords more dependable and efficient service and they are competitively priced.

SEND FOR CATALOG  
OF COMPLETE LINE

**RACON ELECTRIC CO., INC. 52 EAST 19th ST. NEW YORK, N. Y.**

curves of the human ear. The effect of such a response is that the bass frequencies have a smaller loss than the middle or upper registers, without rendering a false or "pumped" response.

By proper external connection to lugs on the terminal board, it is possible to obtain six different attenuation vs. frequency curves with the LAC-720, varying from the "human ear type of response" to a flat frequency response. When the unit is wired for a flat frequency response it functions as a straight ladder of 2.5 db per step.

The Daven Company will welcome inquiries and comments on this unit or variations of it. Complete engineering information, including a series of six

attenuation vs. frequency curves, are available on request.

### SYNCHROSCOPE

A synchroscope specially designed for the visual examination of the fine structure of periodic waveforms in television, pulse time modulation, sonic depth-finders, geophysical exploration and lo'an equipments has been announced by the Electronics Division, Sylvania Electric Products, Inc., 500 Fifth Avenue, New York 18, N. Y.

The instrument includes a five inch cathode ray oscilloscope; trigger generator for synchronization; space for the addition of a video amplifier and r-f envelope viewer; adjustable time delay



phasing circuits; and seven input connectors and selector switch for rapid viewing of separate external circuits.

Television applications include study of the shape, amplitude and duration of video pulses ranging from a fraction to several hundred microseconds. Used with a video amplifier and an r-f envelope viewer it provides a means of visual examination of r-f pulse envelopes or waveforms up to and including the microwave region.

### EIMAC CONNECTORS

Eitel-McCullough, Inc., of San Bruno, Calif., announces that their HR heat dissipating connectors are now available.

These connectors are used to make electrical connections to the plate and grid terminals of Eimac and other vacuum tubes, and, at the same time, pro-

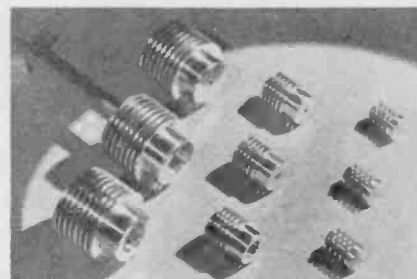

vide efficient heat transfer from the tube element and glass seal to the air. The HR connectors aid materially in keeping seal temperatures at safe value.

These connectors are machined from solid dural rod, and are supplied with the necessary machine screws. Complete specification and data sheets are available upon request to manufacturer.

### V-H-F RECEIVER

Featuring superior performance and mechanical design, the new RV-1-B crystal controlled, fixed frequency v-h-f receiver manufactured by the Radio Receptor Company, 251 W. 15th St., New York 11, N. Y., is specifically designed to meet the rigid requirements of the airlines. Using only 140 volts plate supply to assure high component reliability, and designed into a panel only 5/4" high, the RV-1-B produces an undistorted audio output of 1 watt over a frequency range of 100 to 162 mc, with

## Ingenious New Technical Methods

To Help You with Your Reconversion Problems



### New Thread Ring Gage Starts Round Stays Round With Every Adjustment!

Employing a new principle of design, the Woodworth Thread Ring Gage closes in round within .0002 maximum after .005 adjustment. It offers greater accuracy and stability since size adjustment is controlled along thread helix angle. Threads are held securely in alignment after adjustment, due to unique adjustment means. Wear is distributed over full circumference for all resettings, thus increasing life of gage.

Positive adjustment makes it almost impossible to change setting with ordinary knocks. Positive identification by a green "go" gage and red "not go" gage saves operator time. Aluminum alloy outer body cuts weight in half, to reduce operator fatigue and increase sensitivity.

To also reduce fatigue on precision jobs, many plant owners make chewing gum available for workers. Tests show that the act of chewing aids in relieving tension, which is often the cause of fatigue. These tests further reveal that chewing Wrigley's Spearmint Gum, for instance, helps workers stay alert, thus increases their efficiency to do more accurate work.

You can get complete information from  
N. A. Woodworth Company  
1300 East Nine Mile Road, Detroit 20, Michigan

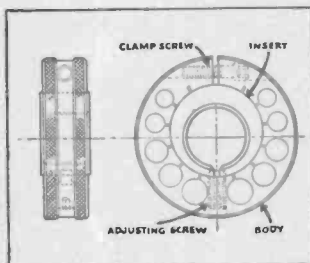

Woodworth Thread Ring Gage



AA-93

“Help me  
*walk*  
again...”



Join the  
**MARCH OF DIMES**

January 15-30

**THE NATIONAL FOUNDATION FOR INFANTILE PARALYSIS**  
FRANKLIN D. ROOSEVELT, Founder



*A New*  
**TRANSCONDUCTANCE  
READING  
Tube Tester**

**For the Man Who Takes Pride in His Work**

Micromho Dynamic mutual conductance readings and simplified testing—are two of the 20 exclusive features found in the new model 2425 tube tester. Transconductance readings are made possible through a simple measurement directly proportional to GM and a properly calibrated measuring instrument. No possibility of grid overloading. "Short" and "open" tests of every tube element. Gas test rounds out full check of all tubes. Switching flexibility allows full coverage of present and future tubes. New Easy-

Test Roll Chart. These and other exclusive features, amplified by Triplet Engineering, make Model 2425 the outstanding 1947 tube tester.

**Triplet**  
ELECTRICAL INSTRUMENT CO.  
BLUFFTON OHIO

a signal-to-noise ratio of better than 2:1 for a 2 microvolt signal modulated 30%. The selectivity curve of the receiver shows it to be more than 40 kc wide at 2 times down, less than 110 kc wide at 100 times down, and less than 200 kc at 10,000 times down. The am-

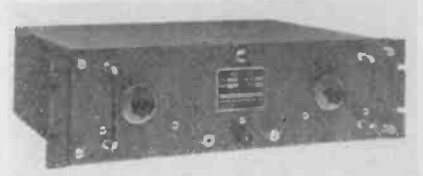

plified a-v-c audio output changes less than 4 db for signal inputs between 10 and 100,000 microvolts. A peak noise limiter which automatically clips impulse noise, and a special "snap-action" circuit which opens the audio channel when receiving carriers of 2 microvolts or more, are other exclusive features of the RV-1-B.

For more information, write the manufacturer for Bulletin 5007A.

**HEWLETT-PACKARD AMPLIFIER**

The -hp- 450A Amplifier is a wide-band amplifier ideal for general purpose or laboratory use. It provides unusual stability at 40 db or 20 db gain. Low phase shift is assured by a straightforward, resistance-coupled amplifier



design, together with inverse feedback. Frequency response is rated within 1/2 db between 10 and 1,000,000 cycles. Input impedance is 1 megohm shunted by 15 mfd. Internal impedance is less than 150 ohms over the entire range. Varying tube voltages or aging tubes have no appreciable effect on the gain or other characteristics.

**MIDGET CAPACITORS**

The Cornell-Dubilier Electric Corporation announces a complete line of flat midget capacitors, Type ZN, in addition to their extensive line of standard capacitors now available to manufacturers of ultra-compact electronic devices.

These new units are the smallest capacitors manufactured by C-D. Especially designed for hearing-aids and pocket-radios, they are flat and ideally adaptable for circuit applications where space is at a premium.

Type ZN midget capacitors are non-inductively wound with Kraft paper



**RADIO PARTS  
SETS • AMPLIFIERS  
Concord Catalog FREE!**

Revised! Up-to-the minute! Listing the newest, the latest and best in RADIO PARTS, RADIO SETS, AMPLIFIERS, AMATEUR GEAR, ELECTRONIC EQUIPMENT, SUPPLIES and ACCESSORIES! Hundreds of items for every Radio and Electronic need—Condensers, Resistors, Transformers, Tubes, Test Equipment, Tools and Repair, Replacement and Maintenance Parts of every kind. ●●● All standard top quality, nationally famous makes, are fully represented in the great new Concord Catalog. Complete lines including new and hard-to-get parts and equipment at latest O.P.A. prices or lower. Thousands of items—and complete stocks ready for immediate shipment from CHICAGO or ATLANTA. Your copy of the new Concord Catalog is ready now—FREE! Mail the Coupon below.

SEE... COMPLETE SHOWING of ham gear, equipment, supplies and accessories for AMATEURS, ENGINEERS, SERVICEMEN, SOUNDMEN, RETAILERS.

SEE... the first peacetime Concord line of modern Radio Sets and Radio Phonograph combinations—featuring a host of new, approved post-war developments... richer tone quality... super-selective tuning and reception... high fidelity... new modern design cabinets.

SEE... the thrilling new MULTIAMP Add-A-Unit Amplifiers, entirely new and revolutionary development in amplifier engineering. Sensational flexibility, power, fidelity, and economy, exclusive with Concord!

All in the new complete Concord Catalog. Mail the COUPON Now!

**10H 40 MA. CHOKE**  
Extremely compact highly efficient choke well suited for auto radio receivers and AC DC radios. Also excellent filter chokes for other receivers and amplifiers. 1 5/16" x 1 1/4" x 1 3/8" ins. Unshielded strap type mounting. **C1601** ..... **46¢**

**Midget Electrolytic**  
Midget dry electrolytic will handle any job requiring electrolytic capacitor. Polarity clearly indicated. Barely replaces larger wire leads. Cap. Mid 20-20. DC. WV 150. 7/8" x 2 inches **C3153** ..... **60¢**

**ROTARY SWITCH**  
Single gang, 6 pole, 3 position, shorting switch, 1 5/16" dia. with 1/4" shaft dia. Threaded bushing 3/8" long, 3/8" shaft. **5B3984** ..... **39¢**

**CONCORD**  
RADIO CORPORATION  
LAFAYETTE RADIO CORPORATION  
CHICAGO 7      ATLANTA 3  
901 W. Jackson Bldg.      265 Peachtree Street

CONCORD RADIO CORPORATION, Dept. F-106, 901 W. Jackson Blvd., Chicago 7, Illinois. Yes, rush FREE COPY of the comprehensive new Concord Radio Catalog.

NAME.....  
ADDRESS.....  
CITY..... STATE.....

and thoroughly impregnated with halowax. The leads are securely anchored to the capacitor body. Actually, it is impossible to pull leads loose from capacitor section, or to melt compound with a soldering iron.

Standard ZN types include units from 3/4" length, 1/4" width and 3/32" thickness to that of 1" length, 3/8" width

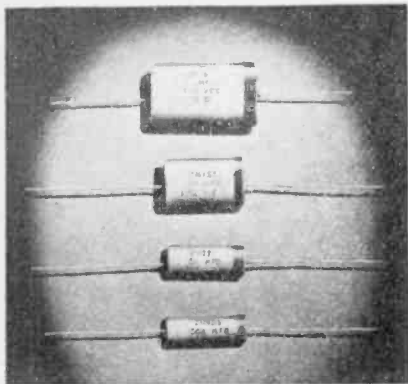

and 3/16" thickness. The values range from .0001 mfd. to 0.1 mfd.; D.C. rated voltages from 150 volts to 600 volts.

Complete details will be furnished upon request to Cornell-Dubilier Electric Corp., South Plainfield, N. J.

#### NEW DIA-CONE SPEAKER

Designed for the manufacturer whose objective is to meet the requirements of the discriminating customer who appreciates fine quality in his home radio, phonograph, music system, and FM reception. Altec Lansing announces the addition of Model 600 Dia-Cone speaker to the Altec Lansing speaker family. Others of this type are the 604 Duplex, and the popular 603 Multicell Dia-Cone, thus completing the line of speakers. This speaker, like the model 603, uses the exclusive Dia-Cone principle of reproducing low frequencies and high frequencies from separate diaphragms.

The Altec Lansing Model 600 Dia-

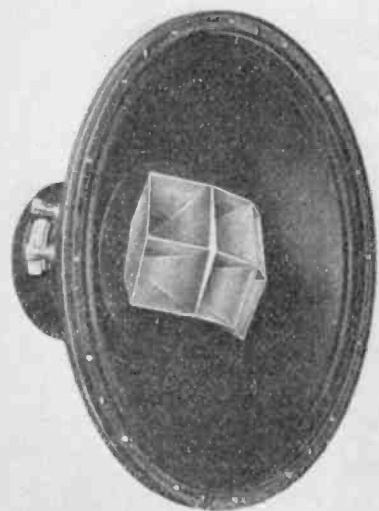

Cone speaker is mounted in a 12" frame. It uses an Alnico V permanent magnet and a 3" wound aluminum voice coil to which is mounted a domed aluminum alloy metal diaphragm and a seamless moulded cone. The seamless moulded cone vibrates as a piston with the voice coil to reproduce all lower frequencies up to approximately 2,000 cycles.

A moulded paper cone cannot faithfully reproduce frequencies above approximately 2,000 cycles since it begins to break up in that frequency range. As the cone begins to break up, the domed metal diaphragm, with its high mass stiffness and high transmission speed,

continues to operate as a piston with the voice coil resulting in a true reproduction of the higher frequencies. The shape of the metal diaphragm provides a means of radiating the high frequencies over a wide area with a smooth distribution pattern eliminating the high frequency beam. The light mass of the aluminum diaphragm and edge wound voice coil wire allows faithful reproduction of frequencies much higher than is produced by the ordinary loudspeaker unit.

The large Alnico V permanent magnet, the careful design of the magnetic circuit to close tolerances, and the use of an edge wound voice coil result in

## EVERYBODY IN RADIO NEEDS THIS NEW, LAFAYETTE CATALOG



it's  
**FREE!**

A STOREHOUSE OF  
RADIO INFORMATION

It's on the press!  
... 144 pages packed with the latest in radio parts, radio sets, ham gear and test equipment. This big, new Lafayette Catalog will offer you the most complete line of everything that's new in radio and electronics. Plus an

added extra... a special bargain section that lists hundreds of surplus, standard-make radio and electronic parts at money-saving prices. Mail the coupon below NOW - reserve your free copy - and cash in on these unheard-of radio values.

#### HUNDREDS OF HARD-TO-GET PARTS

Glimpse the host of post-war, critical radio and electronic items that Lafayette has dug up for you. All at typically low Lafayette prices. Our famous Super-Speed Service ships out your order the same day it is received.

#### THE NEWEST IN HAM GEAR

Here are nationally known communications receivers, Hallicrafters, Vomag, National, Meissner transmitters, tubes, anything and everything for the Ham. Choose a "Build-It-Yourself-Kit", designed for radio set fun at Lafayette economy.

#### STANDARD PARTS LEADING BRANDS

All Lafayette items are products of leading American manufacturers and of the highest quality. Also listed are the war-time developments and discoveries of the electronic field. Complete is the word for the Lafayette Catalog!

# LAFAYETTE Radio

RADIO WIRE TELEVISION, INC.

NEW YORK: 100 Sixth Avenue  
BOSTON: 110 Federal Street  
NEWARK: 24 Central Avenue

LAFAYETTE RADIO, Dept. BJ-6

100 Sixth Ave., New York 13, N.Y.

Reserve my FREE copy of the big Lafayette Catalog, and send as soon as ready.

NAME.....

ADDRESS.....

CITY.....ZONE.....STATE.....

PASTE ON PENNY POSTCARD. MAIL TODAY!

a very high efficiency that will deliver 89 db. (Ref.  $10^{-16}$  dynes per sq. cm.) at 5' with an input of .1 watt.

### NEW HOOK-UP WIRE

A thermoplastic insulated radio hook-up wire, tested to underwriters' standards, is now in volume manufacture by Federal

Tel. and Radio Corp., Newark, N. J. The extreme flexibility of Federal's Intelin hook-up wire, its small outside diameter, and permanent colors facilitate quick, accurate assembly and easy servicing.

It is stated that this wire is not affected by oxidation and changes in temperature, will not crack or become brittle, and will

remain operative under all conditions of humidity. The tough, abrasion resistant insulation reduces the possibility of accidental damage. Because the thermoplastic insulation is highly resistant to flame, equipment wired with Intelin is free from fire hazard.

The wire is high in dielectric and tensile strength. Short time tests show a dielectric strength of 800 volts per mil with a 0.020 inch wall thickness; thirty day tests at 90°C show a tensile strength of 2100-2250 pounds per square inch.

The free stripping feature is an aid to quick servicing, the conductor is left clean and bright for instant tightly soldered connections. Available in solid or stranded types, the wire ranges in size from 24 to 14 for high or low voltage needs in radio, electronics, appliances, and communications and comes in 14 brilliant colors.

### ELECTRONIC TESTER

A new portable, graphic type of instrument for servicing radio and other electronic equipment has been announced by The Sterling Manufacturing Co. of Cleveland.

This tester, according to the makers, simplifies selection of desired function and

## MANY FEATURES IN ONE INSTRUMENT

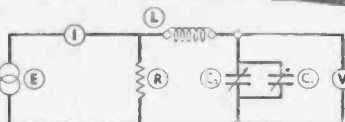
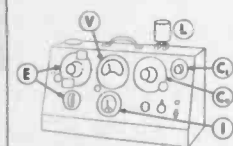

SIMPLIFIED LAYOUT AND SCHEMATIC OF THE 160-A Q-METER

**THE BASIC METHOD OF MEASUREMENT EMPLOYED IN THE 160-A Q-METER**  
An R.F. oscillator (E) supplies a heavy current (I) to a low resistance load (R), which is accurately known. The calibrated voltage across the load resistance (R) is coupled to a series circuit consisting of the inductance under test (L) and a calibrated variable air capacitor (C<sub>0</sub>) having a vernier section (C<sub>1</sub>). When this series circuit is tuned to resonance by means of capacitor (C<sub>0</sub>+C<sub>1</sub>), the "Q" of (L) is indicated directly by the V.T. Voltmeter (V). Variations of this method are used to measure inductance, capacitance and resistance.  
Oscillator Frequency Range: 50 kc. to 75 mc. in 8 ranges. Oscillator Frequency Accuracy: ±1%. 10 kc.—50 mc. Q Measurement Range: Directly calibrated in Q, 20-250. Multplier extends Q range to 625. Capacitance Range: Main section (C<sub>0</sub>) 30-450 mmf. Vernier section (C<sub>1</sub>) +3 mmf, zero, -3 mmf.

DESIGNERS AND  
MANUFACTURERS OF  
THE Q METER  
QX CHECKER  
FREQUENCY  
MODULATED  
SIGNAL GENERATOR  
BEAT FREQUENCY  
GENERATOR  
AND OTHER  
DIRECT READING  
TEST INSTRUMENTS

**BOONTON RADIO**  
BOONTON · N · J · U · S · A · Corporation

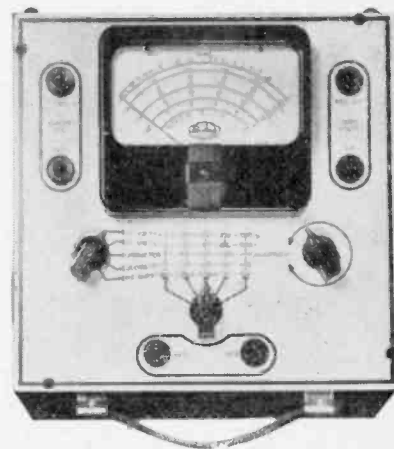

range. In operation, the graphic tester is read, as the term implies, quickly, easily and accurately, like a graph. Desired function and range are selected by means of two switches of the graphic selector system. The left, or function switch, is set for the type of measurement desired. The lower, or range switch, is set for the range of the type of measurement indicated by the function switch. The adjustment knob at the right is used to set the meter pointer to zero ohms for the three ohmmeter ranges . . . service men can then find the correct reading quickly and accurately on the large meter.

### MULTI-WIRE CONNECTORS

A new multi-wire connector announced by Alden Products Co., 117 North Main St., Brockton, Mass., features an unthreaded lock which engages by means of a slotted locking ring working against a rubber gasket. Numerous other new features are set forth in a bulletin which will be supplied on request.

### STATEMENT OF THE OWNERSHIP, MANAGEMENT, CIRCULATION, ETC., REQUIRED BY THE ACTS OF CONGRESS OF AUGUST 24, 1912, AND MARCH 3, 1933

of RADIO, published monthly at Orange, Connecticut, for October 1, 1945.  
State of New York } ss.:  
County of New York }

Before me, a Notary Public in and for the State and county aforesaid, personally appeared Sanford R. Cowan, who, having been duly sworn according to law, deposes and says that he is the Publisher of RADIO, and that the following is, to the best of his knowledge and belief, a true statement of the ownership, management, etc., of the aforesaid publication for the date shown in the above caption, required by the Act of August 24, 1912, as amended by the Act of March 3, 1933, embodied in section 537, Postal Laws and Regulations, to wit:

1. That the names and addresses of the publisher, editor, managing editor and business manager are: Publisher, Sanford R. Cowan, 1620 Ocean Ave., Brooklyn 30, N. Y.; Editor, John H. Potts, 154-18 35th Ave., Flushing, N. Y.; Managing Editor, None; Business Manager, S. R. Cowan, 1620 Ocean Ave., Brooklyn 30, N. Y.

2. That the owners are: Radio Magazines, Inc., 342 Madison Ave., New York 17, N. Y.; John H. Potts, 154-18 35th Ave., Flushing, N. Y.; and Sanford R. Cowan, 1620 Ocean Ave., Brooklyn 30, N. Y.

3. That the known bondholders, mortgagees, and other security holders owning or holding 1 per cent or more of total amount of bonds, mortgages, or other securities, are: None

4. That the two paragraphs next above, giving the names of the owners, stockholders and security holders, if any, contain not only the list of stockholders and security holders as they appear upon the books of the company, but also, in cases where the stockholder or security holder appears upon the books of the company as trustee or in any other fiduciary relation, the name of the person or corporation for whom such trustee is acting, is given; also that the said two paragraphs contain statements embracing affiant's full knowledge and belief as to the circumstances and conditions under which stockholders and security holders who do not appear upon the books of the company as trustees, hold stock, and securities in a capacity other than that of a bona fide owner; and this affiant has no reason to believe that any other person, association, or corporation has any interest direct or indirect in the said stock, bonds, or other securities than as so stated by him.

(Signed) SANFORD R. COWAN, Publisher.

Sworn to and subscribed before me, this 18th day of September, 1946.

(Seal.) SYLVESTER J. VITKANSAS, Notary Public.

Kings Co. Clk's No. 12, Reg. No. 64-Y-8; N. Y. Co. Clk's No. 48,  
Reg. No. 90-V-8; Bronx Co. Clk's No. 1, Reg. No. 28-V-8. Commission expires March 30, 1948.

# GROUP SUBSCRIBERS SAVE UP TO \$1.50 Each

**Form A Group Today!**

You and your co-workers can now save up to half the regular cost of a RADIO subscription by using the Group Plan. The more men in a Group the more each saves, up to 50%.

Present subscriptions may be RENEWED or EXTENDED as part of a group.

The combination of exclusive, fine and timely articles plus this low-rate subscription offer makes RADIO a must-have publication. So fellows, form a Group today and send it to—



## RADIO MAGAZINES, INC

342 MADISON AVENUE NEW YORK 17, N. Y.

—TEAR OUT—MAIL TODAY!

RADIO MAGAZINES, INC.  
342 Madison Ave., New York 17, N. Y.

Kindly enter the following subscription to RADIO Magazine. Remittance of \$..... is enclosed. (1 to 6 subscriptions may be ordered on this form).

- One 1-year subscription . . . . . \$3.00
- Two 1-year subscriptions . . . . . \$5.00
- Three 1-year subscriptions . . . . . \$6.00
- Four 1-year subscriptions . . . . . \$7.00
- Five 1-year subscriptions . . . . . \$8.00

Groups of 6 or more subscriptions in the U.S.A. and Canada will be accepted at the rate of \$1.50 each. For Foreign groups add \$.50 to each subscription ordered.

PLEASE PRINT

Name .....  
Address .....  
.....  
Position ..... Company .....

Name .....  
Address .....  
.....  
Position ..... Company .....

Name .....  
Address .....  
.....  
Position ..... Company .....

Name .....  
Address .....  
.....  
Position ..... Company .....

Name .....  
Address .....  
.....  
Position ..... Company .....

NOTE: If you do not wish to tear out this order blank, print or type a list giving each subscriber's name, address, employer's name and their respective positions. Mail it in today!



**Plug-In Sensitive Relays--  
More Compact  
Than Ever Before**

**SIGMA Type 41 RO (DC); 41 ROZ (AC)**

**NEW FEATURES OF THIS DESIGN:**

- Fits octal socket.
  - Outline dimensions: 1 1/4" x 1 1/4" x 2" above socket.
- Permits lining up contiguous relays as close together as the smallest octal sockets will permit.

**Features of All SIGMA Series 41 Relays:**

- DC sensitivity: — 0.020 watts (min. input.)
  - AC sensitivity: — 0.1 volt-ampere (min. input.)
- One standard 110 volt AC model draws about 1.5 milliamperes.
- Contact ratings up to 15 amperes on low voltage.
  - High quality construction — mechanically rugged.
  - Very low cost.

SIGMA sales and engineering departments are ready to give your relay problems prompt analysis and action.

**SIGMA**  
**Sigma Instruments, Inc.**  
*Sensitive* RELAYS  
66 Ceylon St., Boston 21, Mass.

**Personal Mention**

Roy Dally  
★ Roy Dally, contributor of numerous articles to RANTO on pickup design and



Roy Dally

related topics, has been appointed chief engineer in charge of phonograph and pickup design by Electrovox Co., Inc.

Lynn Brendel  
★ Lynn Brendel, systems engineer with Hallicrafters Co. since October 1945,



Lynn Brendel

has been promoted to the post of general service manager. Brendel assisted in development of the first auto radios.

Edward E. Schultz, Jr.  
★ Cook Electric Company, Chicago, announces the addition of Edward E. Schultz to the engineering staff of its new division, Cook Research Laboratories, devoted to studies of major physical problems involving industrial processing and instrumentation. Mr. Schultz will assist in directing research on transient motion, measuring instruments, flow controls, pressure switches, and aircraft controls involving electronic, hydraulic and mechanical systems.

A graduate of Northwestern University's School of Electrical Engineering, Mr. Schultz brings a broad background of experience to Cook Research Laboratories. He has been associated with Joseph T. Ryerson Steel Company, the National Broadcasting Company, and

**RUBYFLUID SOLDERING FLUX  
FOR BETTER SOLDERING**

Rubyfluid soldering flux in paste or liquid form is ideal for the intricate soldering necessary in radio work. It wets out freely, properly conditions the metal for a strong, neat union and produces strong joints. There are no objectionable or harmful fumes. See your jobber or write direct.



THE RUBY  
CHEMICAL CO.  
61 McDowell St.  
Columbus 8, Ohio

**Rubyfluid**



REX RHEOSTAT COMPANY, BALDWIN, L. I., N. Y.  
WRITE FOR NEW CATALOG NO. 3.  
RHEOSTATS & RESISTORS



**ADDRESS CHANGES—**

Subscribers to RADIO should notify our Circulation Dept. at least 3 weeks in advance regarding any change in address. The Post Office Dept. does not forward magazines sent to a wrong address unless you pay additional postage. We cannot duplicate copies of RADIO sent to your old address.

RADIO Circulation Dept.  
**Radio Magazines Inc.**  
342 Madison Ave., New York 17, N.Y.



# America finds a new, easy way to save

OUT of the war has come one blessing—a lesson in thrift for millions of those who never before had learned to save.

Enrolled under the Payroll Savings Plan in thousands of factories, offices, and stores, over 27 million American wage earners were purchasing "E" Bonds alone at the rate of about 6 billion dollars worth a year by the time V-J Day arrived.

With War Bond Savings automatically deducted from their wages every week, thrift was "painless" to these wage earners. At the end of the war, many who never before had bank accounts could scarcely believe the savings they held.

The moral was plain to most. Here was a new, easy way to save; one as well suited to the future as to the past. Result: Today, millions of Americans are continuing to buy, through their Payroll Savings Plan, not War Bonds, but their peacetime equivalent—U. S. Savings Bonds.

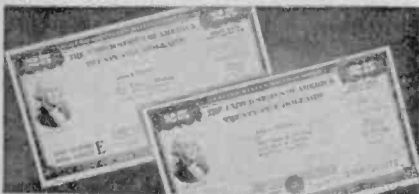

From war to peace! War Bonds are now known as U. S. Savings Bonds, bring the same high return—\$25 for every \$18.75 at maturity.



Out of pay—into nest eggs! A wage earner can choose his own figure, have it deducted regularly from earnings under Payroll Savings Plan.



New homes to own! Thousands of new homes, like this, will be partially paid for through Bonds wisely accumulated during the next five to ten years.



Keeping cost of living in check! Buying only needed plentiful goods and saving the money which would bid up prices of scarce goods keeps your cost of living from rising. Save automatically—regularly.

Weekly Savings	SAVINGS AND INTEREST ACCUMULATED	
	In 1 Year	In 10 Years
\$ 3.75	\$195.00	\$2,163.45
6.25	325.00	3,607.54
7.50	390.00	4,329.02
9.38	487.76	5,416.97
12.50	650.00	7,217.20
15.00	780.00	8,660.42
18.75	975.00	10,828.74

Savings chart. Plan above shows how even modest weekly savings can grow into big figures. Moral: Join your Payroll Savings Plan next payday.

**SAVE THE EASY WAY...**  
**BUY YOUR BONDS**  
**THROUGH PAYROLL SAVINGS**

*Contributed by this magazine in co-operation  
with the Magazine Publishers of America as a public service.*



# HOPP Plastic RADIO DIALS

DIAL WINDOWS, NAME PLATES, GAUGES, CALCULATORS, SCALES, CHARTS, ETC.

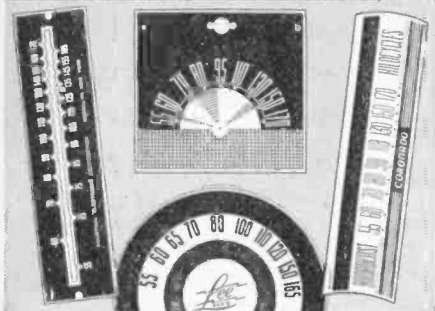

PLASTIC RADIO DIALS have endless possibilities in design, size, shape and color combination. Attractive and durable, our radio dials, windows and scales are preferred by many leading Radio manufacturers.

Not only for dials, but for numerous other electronic and electrical applications, Laminated Plastics are preferable.

Consult with our artists and engineers regarding applications for your particular purpose. Or send us your blue prints or samples for quotation.

**THE HOPP PRESS, INC.**  
460 W. 34th STREET, NEW YORK 1, N. Y.  
ESTABLISHED 1893

## 18 YEARS IN RADIO

Get This *New* Catalog  
By This *Old* Firm

Latest developments in radio and electronic parts and devices, newest ham gear, gadgets to delight the heart of the experimenter, bargains in war surplus supplies.



- Buy from B-A
- Save Time
- Save Money
- Get the Newest
- Deal with This Old House



### MAIL COUPON TODAY

Don't delay, get your copy of this book.

BURSTEIN-APPLEBEE CO.,  
1012 McGee, Kansas City 6, Mo.

Send me FREE new catalog. RADIO

AM \_\_\_\_\_  
STATE CONNECTION IN INDUSTRY

NAME \_\_\_\_\_

ADDRESS \_\_\_\_\_

TOWN \_\_\_\_\_ STATE \_\_\_\_\_

during the war was chief engineer of Press Wireless and Radio Craftsmen, Inc.

L. E. Bessemer

★ L. E. Bessemer, design engineer of Collins Radio Co., has been appointed



L. E. Bessemer

general manager of the manufacturing division. His initial job at Collins was wireman on a production line.

Cornish Representative

Cornish Wire Co., New York City, manufacturers of Industrial and Communication Wire, announces the appointment of Henry L. Mills to represent their complete line.

## MODULATING METHODS

[from page 11]

References

- 1. H. Chireix, "High Power Outphasing Modulation", *Proc. I.R.E.*, vol. 23, pages 1370-1392, November, 1935.
- 2. W. H. Doherty, "A New Power Amplifier for Modulated Waves", *Proc. I.R.E.*, vol. 24, pages 1163-1182, September, 1936.
- 3. R. B. Dome, "High Efficiency Modulation System", *Proc. I.R.E.*, vol. 26, pages 963-982, August, 1938.
- 4. Elwin J. O'Brien and Harvey Kess, University of North Dakota, "A High-Efficiency R-F Amplifier", *Communications*, pages 7-9, February, 1940.
- 5. Sydney N. Baruch, "Signal Transmission System", U. S. Pat. #1,957,419, May 1st, 1934.
- 6. Thomas H. Price, "Modulation System", U. S. Patent #2,294,800, September 1st, 1942.
- 7. Josef Plebanski, "Phase Control System", U. S. Patent #2,172,107, September 5, 1939.

In the Rocky Mountain Region it's  
**RADIO & TELEVISION SUPPLY CO.**

ELECTRONIC EQUIPMENT

252 HOBSON AVENUE, PUEBLO, COLO.  
P. O. Box #892

"If we don't have it, we'll get it—  
or it can't be had! Phone 5729"

## ADVERTISING INDEX

ADVERTISER	PAGE
American Phenolic Corp.	5
Bell Telephone Labs.	2
Boonton Radio Corp.	28
Burstein-Applebee	32
Capitol Radio Engineering Inst.	6
Concord Radio Corp.	26
Eitel-McCullough, Inc.	Cover 3
Guardian Electric Mfg. Co.	Cover 2
Hopp Press, The	32
Jensen Manufacturing Co.	21
Measurements Corp.	7
Racon Electric Co.	23
Radio and Television Supply Co.	30
Radio Wire Television	27
Rex Rheostat Co.	30
Rider, John F. Publisher, Inc.	32
Ruby Chemical Co.	30
Sigma Instruments, Inc.	30
Sprague Products Co.	8
Sylvania Electric Products, Inc.	Cover 4
Triplett Electrical Instr. Co.	26
Wrigley Jr., Co., Wm.	24

## BOOKS

FOR THE

## ENGINEER

### UNDERSTANDING MICROWAVES

(Chapter Heads)

The Ultra High Frequency Concept Stationary Charge and its Field • Magnetostatics • Alternating Current and Lumped Constants • Transmission Lines Poynting's Vector and Maxwell's Equations • Waveguides • Resonant Cavities • Antennas • Microwave Oscillators • Radar and Communication • Section Two is devoted to descriptions of Microwave Terms, Ideas and Theorems. Index.

400 PAGES

PRICE \$6.00

### A-C CALCULATION CHARTS

Student engineers will find this book invaluable. Simplifies and speeds work. Covers all AC calculations from 10 cycles to 1000 megacycles.

160 PAGES

PRICE \$7.50

### JOHN F. RIDER, Publisher, Inc.

404 FOURTH AVENUE, NEW YORK 16, N. Y.  
EXPORT DIV. ROCKE INTERNATIONAL ELEC. CORP.  
13 E. 40TH STREET, NEW YORK CITY CABLE: ARLAB

**Eimac**  
TUBES

THE COUNTERSIGN OF DEPENDABILITY IN ANY ELECTRONIC PRODUCT

# Eimac Tetrodes lead the way to simplified CRYSTAL FREQUENCY CONTROL FOR DIATHERMY and ELECTRONIC HEATING

Crystal control of frequency now becomes the practical answer to the new frequency stability requirements. Eimac tetrodes make crystal frequency control feasible and simple. *Crystal control through Eimac tetrodes means maximum frequency stability, end of objectionable radiation, and handy portability for electronic heating units of the future.*



Eimac 4-250A Tetrode

## Here's How an Eimac Tube Makes This Practical

The way just one Eimac 4-250A tetrode makes crystal frequency control practical is shown in this *operative*, experimental circuit assembled by Eimac engineers. The circuit is also applicable to other forms of electronic heating.

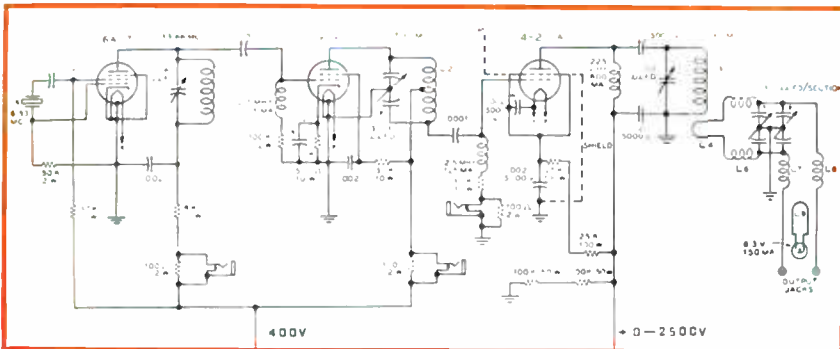

Eimac 4-125 Tetrode

## Here's Why Eimac Tubes Make Crystal Frequency Control Practical

Because of their unique characteristics, Eimac power tetrodes such as the 4-250A and 4-125A are ideal for use in circuits like the one above.

These tubes have an unusually high power-gain for efficient performance at medium, high, or the very high frequencies used in diathermy and heating. For example, the 4-250A (at frequencies up to 70 Mc.) develops power output of 750 watts with a driving power of less than 5 watts. The 4-125A tetrode delivers 375 watts output with less than 3 watts drive.

## Greater Stability... Longer Life

Both tetrodes have specially treated elements that insure longer life. Both have non-emitting grids which give great operating stability.

Because of their low grid-plate capacitance (0.12  $\mu\text{mf}$  in the 4-250A and 0.05  $\mu\text{mf}$  in the 4-125A), these tubes normally require no neutralization at diathermy or heating frequencies. (In fact, the 4-250A normally requires no neutralization up to 70 Mc; 4-125A ordinarily needs none even at 120 Mc.)

## Eimac Tetrodes for Power Amplification Throughout the Useful Frequencies

Dependable, durable Eimac tetrodes are admirably suited for diathermy or electronic heating work, or for almost any power amplification assignment at any frequency, including VHF. Write today to Eimac's local representatives or factory engineers for complete data on these tubes.

Follow the Leaders to

**Eimac**  
TUBES

**EITEL-McCULLOUGH, INC.**

1290G San Mateo Avenue • San Bruno, Calif.

Export Agents: Frazer and Hansen, 301 Clay St., San Francisco 11, California, U. S. A.

# SYLVANIA NEWS

CIRCUIT ENGINEERING EDITION

OCT.

Prepared by SYLVANIA ELECTRIC PRODUCTS INC., Emporium, Pa.

1946

## SYLVANIA COMMERCIAL ENGINEERING DIVISION AIDS IN PRODUCING EFFICIENT SET CIRCUITS



*Views of Sylvania Electric's renowned Commercial Engineering Department. Here, new discoveries from Sylvania's laboratories are built into the latest products.*

Helping to engineer the best possible radio circuits for many set manufacturers is one of the numerous achievements of Sylvania's famous Commercial Engineering Department.

Time and again circuits found to be unnecessarily complicated were simplified and made even *more efficient* through the work carried on here.



For nearly twenty years Sylvania's Commercial Engineering Department has contributed to the advancement of circuit design as well as to the development of a great variety of electronic and lighting products.

### SOME PRODUCTS OF SYLVANIA ENGINEERING RESEARCH

Radio receiving tubes, such as the famous Lock-In.

Miniature radio receiving tubes, including the tiny T-3.

1.4 volt battery tubes.

150 ma. line of 6.3 volt tubes.

Radio transmitting tubes.

Cathode ray tubes.

Pirani tubes.

Silicon Crystal Diodes.

1N34 and 1N35 Germanium Crystals.

Electroflash Tubes and Units.

Radio tube ports.

Fluorescent Jumps.

# SYLVANIA ELECTRIC

Emporium, Pa.

MAKERS OF RADIO TUBES; CATHODE RAY TUBES; ELECTRONIC DEVICES; FLUORESCENT LAMPS, FIXTURES, WIRING DEVICES; ELECTRIC LIGHT BULBS