

RADIO

DECEMBER, 1944

Design • Production • Operation

Including:
Audio
Loss Chart



The Journal for Radio & Electronic Engineers

**The Best
Show
On the Air
Saturday
Night!**

"MEET YOUR NAVY"
Now Carries the RAYTHEON Name
into 3,500,000 Radio Homes Each Week!

Free!

Ask your Raytheon distributor
for colorful, attention-getting
"Meet Your Navy" display to
tie in with this great program.
Easel-mounted, 17½ x 20½"



Every Saturday Night

ENTIRE BLUE NETWORK

Coast to Coast 181 Stations



RAYTHEON MANUFACTURING COMPANY

Waltham and Newton, Massachusetts



All Four Raytheon Divisions
Have Been Awarded Army-
Navy "E" with Three Stars

RAYTHEON

High Fidelity



ELECTRONIC AND RADIO TUBES

DEVOTED TO RESEARCH AND THE MANUFACTURE OF TUBES AND EQUIPMENT FOR THE NEW ERA OF ELECTRONICS



MYKROY

PERFECTED MICA CERAMIC INSULATION

DOESN'T LEAK

To engineers specializing in low-loss high frequency design, energy conservation throughout circuits is so important that a dielectric having the qualities of MYKROY with a *loss factor of 1* is extremely desirable. MYKROY—the perfected glass-bonded mica ceramic insulation, fills this vital need so dependably that it has opened the door to new and greater advances in high frequency research.

Circuits brilliantly conceived on the drafting board are successfully translated into practical application because of the many superior insulating properties of MYKROY.

In addition to possessing a *high dielectric constant* in combination with a *low power factor*, MYKROY is light—yet its mechanical strength is comparable to cast

iron—resists arc-heat carbonization and is impervious to gas, water and oil—keeps its shape (will not warp)—bonds easily with metals—molds readily to any specifications and machines perfectly to closest tolerances.

MYKROY is maintaining the efficiency of such a large variety of electronic equipment of advanced design that your most difficult insulation problems will find a speedy solution in its application.

If you are confronted with a high frequency insulating problem, our engineers will welcome the opportunity to acquaint you with the performance of MYKROY. It is available in ample quantities on rapid delivery schedules from our Chicago, Illinois and Clifton, New Jersey plants.

**IS THIS MYKROY
ENGINEERS MANUAL
IN YOUR FILE?**



In this comprehensive manual you will find full information regarding MYKROY . . . the perfected glass-bonded mica ceramic insulation. It tells you about: Machinability, Physical, Chemical and Electrical properties—Applications and uses—Sizes and shapes of stock forms—Design criteria, and includes samples of MYKROY. A request on your letterhead will bring your copy by return mail.

MYKROY IS SUPPLIED IN SHEETS AND RODS . . . MACHINED OR MOLDED TO SPECIFICATIONS

MADE EXCLUSIVELY BY **ELECTRONIC MECHANICS INC.** 70 CLIFTON BOULEVARD • CLIFTON, NEW JERSEY
Chicago 47: 1917 NO. SPRINGFIELD AVENUE . . . TEL. Albany 4310
Export Office: 89 Broad Street, New York 4, N. Y.

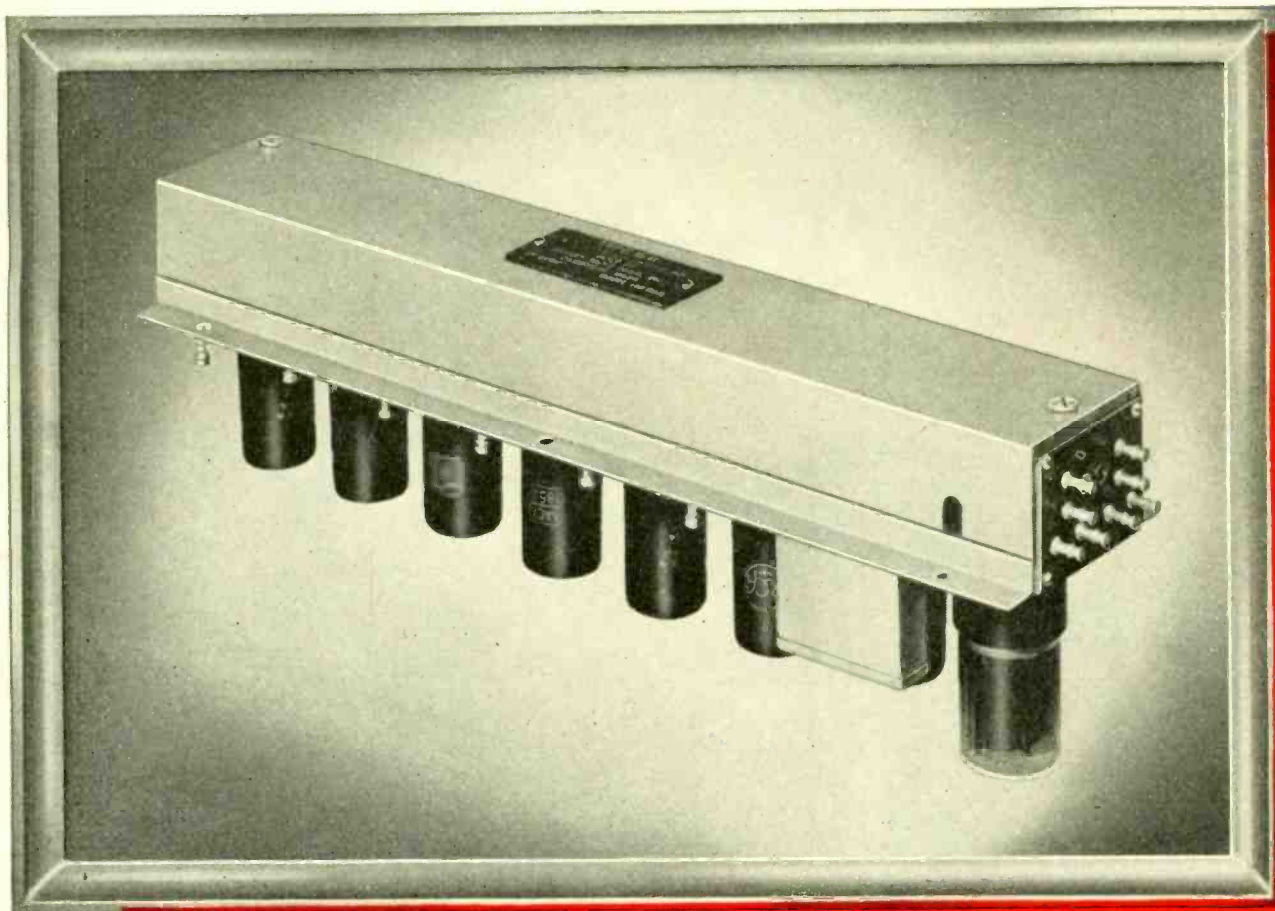

DOES THIS **HARVEY "AMPLI-STRIP"**
Fit Into Your Picture?

It does if you need thoroughly dependable I-F and AUDIO Amplification. The HARVEY "AMPLI-STRIP" was designed and developed to provide a compact, convenient and practical Audio and I-F Amplifier. Custom-made to meet *your* electrical characteristics. This tested and proved "AMPLI-STRIP" will meet your most exacting performance standards.

The "AMPLI-STRIP" provides an excel-

lent example of how the knowledge and experience gained by HARVEY through years of specialization in the radio-electronic field results in practical, efficient, reliable apparatus.

Why not let HARVEY of Cambridge help you to bring to a successful solution any of the present or projected radio-electronic problems that may be troubling you? Just get in touch with



HARVEY RADIO LABORATORIES, INC.
 454 CONCORD AVENUE • CAMBRIDGE 38, MASS.



**HARVEY
 UHX-25**

A 25-Watt
 General Purpose
 Radio Telephone
 Transmitter

Available for operation between 1.5 M.C. and 30 M.C.

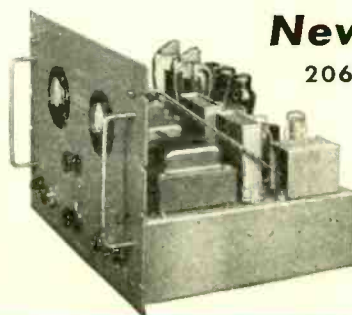

New HARVEY

**206 PA REGULATED
 POWER SUPPLY**

for Laboratory
 D. C. Source—
**RANGE 500
 to 1000 VOLTS**

500 to 700 at 1/4 ampere
 700 to 1000 at .2 ampere

RADIO

Published by RADIO MAGAZINES, INC.

John H. Potts Editor
Sanford R. Cowan Publisher

DECEMBER 1944

Vol. 28, No. 12

CONTENTS

COVER

Hidden by its metal container, a thermistor gets its protective cushion of sand. (*Western Electric photo*)

ARTICLES

- Pulse Time Modulation—*M. G. Bell* 21
A detailed analysis of a new system of modulation
- An Electronic Test Flash, *W. A. Hayes and J. E. Browder* 25
A new application for a multivibrator circuit
- Measurement of Receiver Characteristics, Part 2—*A. C. Matthews* 30
Describing the technique of making receiver tests
- Paper-Dielectric Capacitors—*J. M. Caller* 36
Design, construction, and applications of paper-dielectric capacitors
- Radio Bibliography: 17—Aircraft Radio, Part 4—*F. X. Rettenmeyer* 42
- The Terminology of Electromagnetic Theory, Part 6. 52
Definitions of terms commonly employed in microwave theory

MISCELLANEOUS

- Transients 5
- TECHNICANA
- Voltage Stabilization 8
- Grounded Grid Tube Circuits 10
- Inverted Triode Applications 16
- A-f Loss Chart 41
- This Month 43
- New Products 58
- Advertising Index 72

Executive & Editorial Offices
342 MADISON AVENUE
NEW YORK 17, N. Y.
Telephone MUrray Hill 2-1346

John H. Potts President
Sanford R. Cowan Sec'y-Treas.
Charles H. Farrell Adv. Manager
Ann Limberg Adv. Production
Miriam Birnbaum Circ. Manager

PACIFIC COAST REPRESENTATIVE
Loyd B. Chappell,
427 West 5th St., Los Angeles, Cal.

OHIO-PENNA. REPRESENTATIVE
A. Hawley & H. Stuart
Bulkley Bldg., Cleveland, Ohio

GREAT BRITAIN REPRESENTATIVE
Radio Society of Great Britain,
New Ruskin House, Little Russell St.,
London, W.C. 1, England

RADIO Magazine (title registered U. S. Pat. Off.) is published monthly at Boston Post Road, Orange, Connecticut, by Radio Magazines, Inc., Executive and Editorial Offices at 342 Madison Avenue, New York, N. Y. Subscription rates—United States and Possessions, \$5.00 for 1 year, \$9.00 for 2 years; elsewhere \$4.00 per year. Single copies 35c. Printed in U.S.A. All rights reserved, entire contents—Copyright 1945 by Radio Magazines, Inc. Entered as Second Class Matter October 31, 1942, at the Post Office at East Stroudsburg, Pa., under the Act of March 3, 1879. Permit for Second Class entry pending at Orange, Connecticut.

Federal Tubes...

come **CLOSER** to the

PERFECT VACUUM

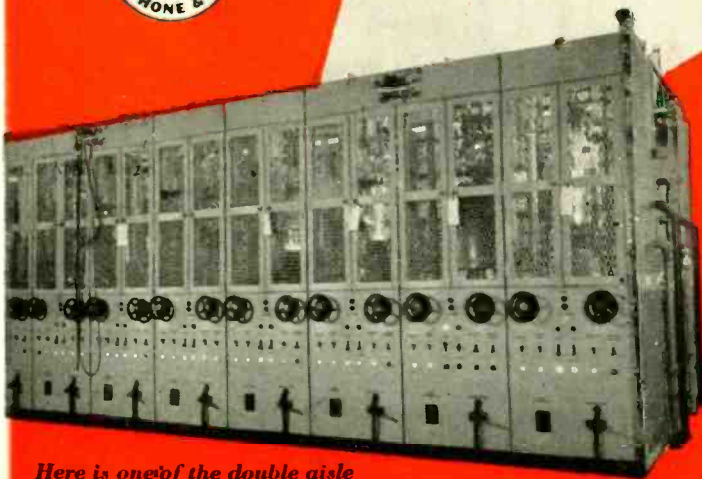

Here is one of the double aisle exhaust banks where 16 high power tubes can be exhausted at one time, each with individual control.

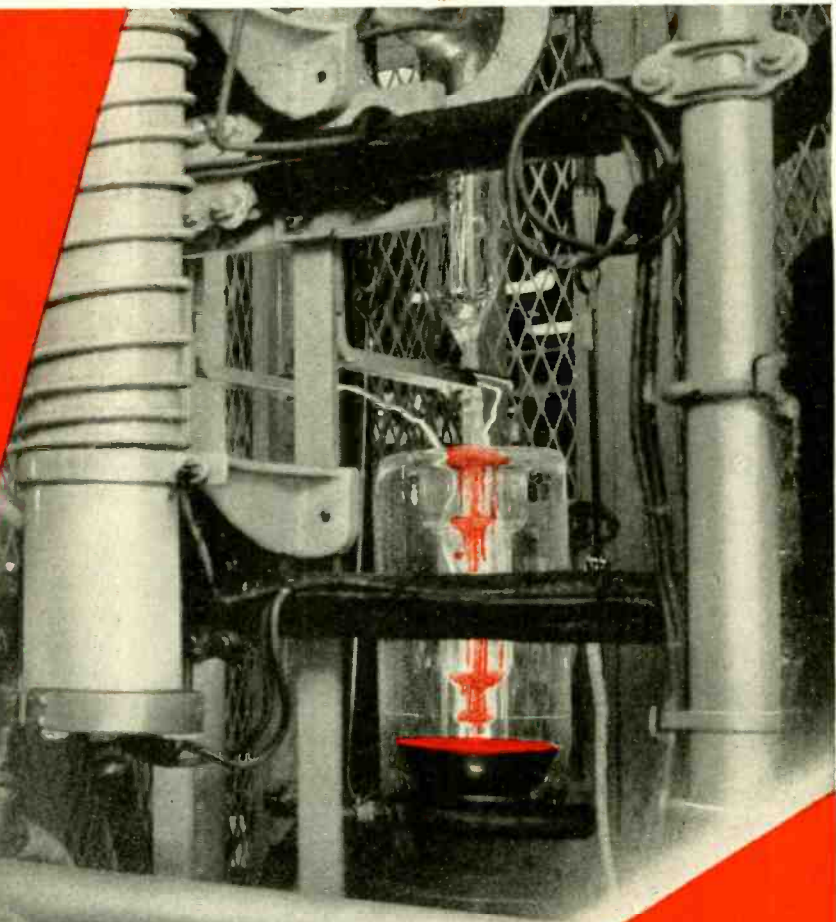

Always in the forefront of tube research and development, Federal makes another advance and now has added exhaust units of entirely new and original design to its production equipment.

This latest Federal achievement produces a tube that is substantially closer to the perfect vacuum—a tube with greater efficiency and longer life.

Arranged in banks of eight and operated with identical control equipment, these units exhaust uniformly every size of Federal tube—assuring a consistent and high standard of quality.

For any communication and industrial power tube need, turn to Federal now—test its reputation that “Federal always has made better tubes.”

Federal Telephone and Radio Corporation

Newark 1, N. J.



DECEMBER, 1944 *

RADIO

Transients

Navy Department,
Office of Navy Liaison Officer,
Harvard University, Divinity Ave.,
Cambridge 38, Mass.

Editor:

The following is submitted in accordance with your request for comments regarding Mr. O. B. Hanson's article, "Down to Earth on 'High Fidelity'," which appeared in the October, 1944, issue of RADIO. It does not necessarily constitute the views of the Radio Research Laboratory nor the Navy Liaison Office.

Mr. Hansen's article is indeed "Down to Earth" and treats the subject very practically and satisfactorily, but one important factor is treated only lightly. That factor concerns the rest of the definition of High Fidelity which is not only concerned with frequency spectrum, but includes volume range.

In the reproduction of sound more than just the fundamental frequencies are transmitted. Harmonics or overtones at relatively low levels are also developed, and these are not necessarily in the higher frequency spectrum. The harmonics appear usually in the entire spectrum, and because the power of the sound is concentrated in those frequencies below 1,000 cycles, the relative levels are higher there than in the region above 1,000 cycles. Because the amplitudes of the harmonics are relatively small, they determine "Presence," a term originated by the Bell Telephone Laboratories. A listener close to a source of sound will hear these small sounds or harmonics more readily than one who is more distant, thus obtaining the impression of nearness which is not established by loudness alone. True reproduction requires then, that the low level sounds should also be transmitted and this cannot be possible if noise levels of the intervening components are high.

Experiments and practice have shown that the usual -40 db noise level (below reference power) is not adequate to ensure the "Presence" of which we have been concerned so little. Various authorities have found that proper high fidelity response requires noise levels that do not exceed -55 db above 1 mw and even better results are obtained if the noise level is below -60 db.

Noise levels below -55 or -60 db impose a severe limitation upon all reproducing components which include not only receivers, but the transmitting

These letters are representative of many received regarding the article "Down to Earth on 'High Fidelity'", by O. B. Hanson, published in the October, 1944, issue of RADIO. We regret that space limitations preclude our publishing all the interesting comments we received

components as well. These include pickup devices, radio lines, amplifiers, mixers, etc. In receivers this limitation is to some degree a measure of the excellence of the device and quite unattainable in the low-price ranges. However, since it is possible to obtain such excellence in higher-priced equipment, it is paramount that broadcasters should concern themselves with producing a commodity answering the requirements of wide volume ranges in order to provide the element of "Presence." That is: transmitted noise levels at the antenna should not exceed -55 db.

John K. Mitchell,
Lieutenant, USNR.

The following communication gives, in part, Mr. McMurdo Silver's views on the subject.

Editor:

Not alone is frequency range important to fine reproduction. It is the important fundamental, but as Mr. Hanson so aptly points out, other items loom almost equally important. Without repetition of the points he so effectively makes, emphasis may be laid upon one feature inherent in FM, as contrasted to AM, broadcasting which seems to have been woefully neglected. It has struck the writer that the claimant extended high frequency range made for reproduction of music via FM amount to little of practical value indeed—yet emphasis heretofore has been placed upon them to the almost complete neglect of a vital improvement possible through FM. This much

needed improvement is in the matter of dynamic volume range. Practical requirements of AM broadcasting limit soft-to-loud volume range to about 50 db—in contrast to the roughly 80 db dynamic volume range required by much symphonic music to tell its emotional story.

Numerous tests having pretty conclusively demonstrated that 8,000 cycles as a top limit will satisfy the tone quality requirements of all but the almost "prissily" fussy pedants, why must proponents of double this audio frequency range still deny the results of tests made, of the basic validity of the points herein repeated and dwelt upon so effectively in referenced papers? A top limit of 8,000 cycles is possible to the standard AM broadcast band in almost any medium priced, honestly designed receiver. It is likewise possible to FM reception. Clean, adequately distortion-free reproduction within this limit is far, far better than only too easily deteriorated reproduction of higher frequencies, inconsequential as they are in any case. Were we of the industry to shift our emphasis from insisting upon reproduction of almost valueless extreme high frequencies over to advertising the perceptible, truly worthwhile, benefits of full dynamic volume range the industry and the public would be immeasurably benefited. Is that hoping for too much?

It is to be recognized that an 8,000 cycle top limit includes the second, generally considered predominant, harmonic or overtone of substantially the highest musical instrument fundamen-

tal tone. It includes the fourth harmonic of every tone above 2,000 cycles—and most of music lies here and below—certainly below 2666 cycles, the highest fundamental of which the third harmonic will fall within the 8,000 cycle range.

What of the low frequency limit? Mr. Hanson propounds the worthwhile theorem that the product, in a balanced reproducing system, of low and high-frequency limits should be about 500,000. This would suggest that a balanced system should cover from about 63 to 8,000 cycles. Issue is taken with this thought upon the basis of the well-known preference of the public for bass emphasis, together with the fact that broadcasting and recordings going down to about 50 cycles, no serious violation of Mr. Hanson's precept would result from a product-figure of 400,000—the result of a range of 50 through 8,000 cycles. Even a little compromise could be effected to extending the 8,000 cycle upper limit up to possibly 9,000 cycles. There it should stop, if adjacent channel carrier whistles are to be avoided by means of the low-cost "whistle-filters" which seem to be all that even the most costly broadcast receivers can provide.

But the writer is not satisfied with even this solution. Recent work has resulted in his ability to produce quite economically amplifiers flat (to a few db drop at 1,000 cycles actually desirable for reasons which will appear) from 20 through 25,000 cycles. This extreme upper limit is valueless, as expected, but the ability to go down to 20 cycles has appeared to contribute wonders to reproduced music, even coming from poorly baffled, low-cost commercial 12" speakers such as are found in the better receivers. Why this should be he is not sure of as yet, but true it has been pronounced by all who have heard the new system.

Because of the variation in sensitivity vs. frequency of the human ear with differing volume levels, good reproduction mandatorily demands the ability to accentuate bass and treble frequencies by substantially 20 db, preferably a bit more, if music reproduced at moderate volume in the home is to sound at all like the same music heard at high volume in a concert hall. Such compensation may be automatic, diminishing middle register tone amplitude as the volume control is manipulated. Though an old method, the writer recalls no commercial example which does this to the necessary degree—the best providing only a partial step in the right direction—a disappointing compromise at best. It is strongly felt that by providing such essential compensation in the form of separate bass and treble frequency controls the basic

requirement is satisfied, and satisfied exactly as the user may prefer, and as the invariably different and differing acoustics of his particular living room may require.

No impossible project requiring extensive investigation and research is needed to satisfy the desiderata set forth above. At a final selling cost of probably no more than five dollars higher than any good receiver commands today, the writer can satisfy fully the need for better than 20 db of controllable bass and treble frequency accentuation with but one more knob than usual, together with a frequency range flat from 20 cycles up to beyond the top limit of audibility. So, probably, could the design engineers of almost any broadcast receiver manufacturer—were the sales departments but to recognize the desirability of such features and instruct their engineering departments accordingly.

*McMurdo Silver,
Vice-President, Grenby Mfg. Co.*

Editor:

You have invited comment on Mr. O. B. Hanson's article, "Down To Earth On High Fidelity." I cannot qualify as one engaged in the design and manufacture of broadcast receivers but I do believe I am fairly placed in that other part of the trinity that rounds out the receiver business—the ultimate consumer. As such a one, I would like to offer a few observations.

Sound reproduction, by radio and records, has been a hobby with me. Attainment of TRUE fidelity has been my goal. As I must depend on the industry for the ways and means to reach this end, I do not believe that I am to blame for not reaching it. I read the advertisements; I hear the salesman's talk; I buy. Lest anyone think I am a little harsh, let him pick up any issue of National Geographic of the last five or six months and read the ads. Let him then console, if he can, the claims of said advertisers with what he actually hears from his loud speaker. And in the face of the valiant efforts to make Frequency Modulation "just more radio," too.

I believe Mr. Hanson has something worth while in the idea of better "balance" between low and high frequencies. I have missed clean bass as much as the naturalness of the higher notes but I discern in his article a setting of the stage to sell us on the idea that what we hear is the real McCoy.

Mr. Hanson claims that frequencies above 10,000 cycles are essential only in the "enjoyment" of sounds such as key jingles, footsteps, handclapping and resin squeaks and air rushes from musical instruments. This may be true but let us consider this information. I

have checked several charts giving the fundamental and harmonic range of various musical instruments and the human voice and find they are practically uniform.

Typical is a chart printed in a previous issue of RADIO showing the harmonic range of the piccolo as about 5,000 to 10,000 cycles; the flute, 2,000 to 15,000 cycles; oboe, 1,500 to 15,000 cycles; violin, 3,000 to 13,000 cycles; bassoon, 500 to 10,000 cycles. No hint is given that most of these harmonics are "air rushes, resin squeaks and the like."

As to Charlie McCarthy being as humorous on a 200 to 3,000 cycle range as on a wider range I have nothing to say but I'll wager that even Charlie would exclaim, "I'll mow you down, so help me," if he was to hear Richard Crooks or any other singer of fine voice on such a narrow range. The claim that even musically trained people prefer the "mellow tone" is not a valid reason for giving us such a fidelity when a better one is possible. I've heard some good musicians rave, "how natural that sounds," when at the same time they would have refused to play a concert on a piano with as relatively poor quality.

We are told that the great majority of radio sets sold are table models. Has anyone considered the idea that it might be this preference is based on the fact there is little to choose, tonally, between a table model and a console? Perhaps many have found the chief difference to be in the size of the cabinet and a "take" from their pocketbook of \$100 to \$200 and up. Certainly, the insides don't have what it takes to justify this difference in price.

Personally, I would like to see this radio business brought down to earth to a sane basis. Radios have been built in all shapes, sizes and forms one can imagine. They have been camouflaged as milady's powder box, as table lamps and what have you. Why? Did you ever see a piano so butchered? A hull fiddle or a bassoon conjured into a piece of living room furniture? Suppose someone tried selling radio and records for what they are—sound reproducing mediums. Then it might be possible to get nearer that acme of perfection, TRUE FIDELITY, and the folks might like it. I think it is high time we got the 120 mile range speedometers off autos that will barely do an honest 80 miles per hour and, for the radio business, I would repeat Miss Duffy in Duffy's Tavern, "likewise, I'm sure." This Pearl Harbor interlude would be a fine time to make the changeover.

*Noble D. Gilkeson,
Kansas City 3, Mo.*

**STRONG,
SMOOTH,
STABLE.**

*That's Formica
Pregwood!*

PREGWOOD is a relatively new material possessing many unusual qualities that have adapted it to many uses—such as switch gear in heavy duty switches, picker sticks on textile looms, ski bottoms on military skis.

The test figures shown below indicate the remarkable strength of the material—which has a lower specific gravity than aluminum.

Pregwood has a certain measure of efficiency as an electrical insulator. It is non-absorbent and does not take up moisture. It is chemically inert and can be used for apparatus parts that will be exposed to acids and alkalis.

Changes in humidity have relatively little effect on dimensions; and a low co-efficient of thermal expansion holds the material stable under marked changes in temperature.

It has the quality of wearing smoothly without slivering or cracking. This makes it especially desirable for parts of textile machinery where it will not snag threads of fabrics.

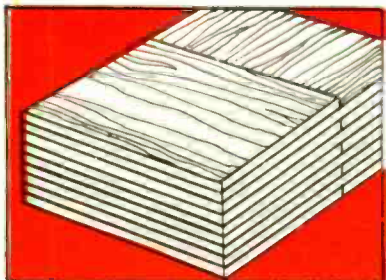

Pregwood is built up by impregnating wood lamina, tions with phenolic resins and pressing them together under heat and pressure. The laminations may be arranged with grain running one direction. This method produces high strength products such as Pregwood 1100.

THE FORMICA INSULATION COMPANY

4670 Spring Grove Avenue
CINCINNATI 32, OHIO



TENSILE STRENGTH

#/sq. in. 30,000

COMPRESSIVE

#/sq. in. 20,000

ZOD IMPACT

Ft. Lbs./In.

PREGWOOD 1100

FLEXURAL

#/sq. in. 48,000

Notch Width

Flatwise

7.0

Edgewise

6.0

Test samples are available on request—



Greetings

To the many friends of Stancor, our sincere thanks for your generous cooperation throughout the past year . . . It is a genuine pleasure to assure you that the future not only will bring greater fulfillment of your needs, but electronic refinements of which you and we both shall be proud . . . Won't you kindly accept our wishes for your good health and prosperity.

STANDARD TRANSFORMER CORPORATION, 1500 NORTH HALSTED ST., CHICAGO 22, ILLINOIS



TECHNICANA

VOLTAGE STABILIZATION

★ A circuit for power line voltage stabilization, called a "Stabilistor," is claimed to hold output voltage to within plus or minus 1.3% for input variations of plus or minus 15% and load variations from zero to full load.

This circuit is described in an article by A. H. B. Walker, entitled "The Stabilistor," appearing in the Nov. 1944 issue of *Wireless World*. The circuit is shown in Fig. 1.

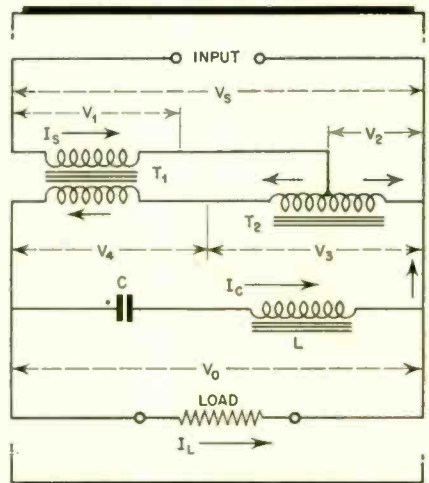

Figure 1

The input voltage V_s is the vector sum of V_1 and V_2 . The magnetizing current, I_m , in auto-transformer T_2 , adds vectorially with the current through C , and with the load current gives the total supply current I_s .

Inductance L is resonant with C at 150 cycles so as to short-circuit the third harmonic of the line frequency produced by T_2 . The line frequency employed was 50 cycles. At 50 cycles the LC combination acts like a condenser only, with current I_c leading the voltage.

Current I_s in the primary of T_1 results in voltage V_1 which leads I_s by approximately 90° .

When an increase in the supply voltage occurs, V_2 and V_3 increase slightly, but the I_m increase is greater, and I_m lags still further behind V_2 . To compensate for the increase in V_s , V_1 must increase and the phase angle between V_1 and V_2 must decrease.

In the output circuit V_4 has increased and lags further with respect to V_2 and V_3 , which are in phase. Since V_4 is small in magnitude and approximately 90° behind V_3 at all times, the resultant of V_3 and V_4 which

[Continued on page 10]

wherever a tube is used...



for example:

ELECTRONIC AIR CLEANING

Smoke, dust, and soot particles 100 times smaller than the eye can see are drawn out of the air electronically by an ingenious arrangement of positively and negatively charged plates. This device facilitates precision manufacturing of delicate instruments, guarantees purity and sanitation in food processing, promotes health and cleanliness in restaurants and hospitals.

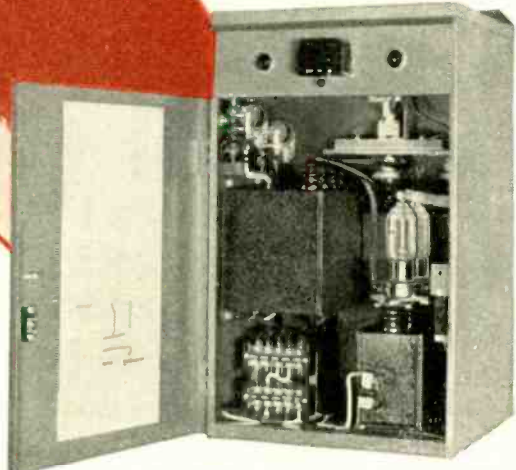

POWER PACK

THERE'S A JOB FOR *Relays* BY **GUARDIAN**

Electronic air cleaners ionize dust particles and collect these particles on a series of positive and negative plates called "Collector Cells" which are arranged in a venetian blind fashion. Rectifier tubes in a power pack change the a-c secondary voltage into pulsating d-c voltage. This d-c voltage is smoothed out by a capacitor and charges the Ionizer and Collector cells.

Relays are built into the power pack to protect it against short circuits or other irregularities in circuit operation. Typical of such relays is the Guardian Series 40 a-c relay which has a laminated armature and field piece.

The Series 40 is well fitted for use in power packs such as illustrated, because it is designed to handle a maximum of control in minimum space. It has a switch capacity of double pole, double throw with 12½ ampere contacts (rated at 110 volts, 60 cycles, non-inductive load). Coils are available for standard voltages up to 220 volts, 60 cycles. Normal power requirements are 9 V. A.

For details on this and other Relays by Guardian write for General Relay Bulletin.

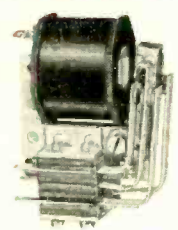

Series 40 A C Relay

Consult Guardian whenever a tube is used—however—Relays by Guardian are NOT limited to tube applications but are used wherever automatic control is desired for making, breaking, or changing the characteristics of electrical circuits.

GUARDIAN  **ELECTRIC**
 1605-P W. WALNUT STREET CHICAGO 12, ILLINOIS
A COMPLETE LINE OF RELAYS SERVING AMERICAN WAR INDUSTRY

Individually Designed

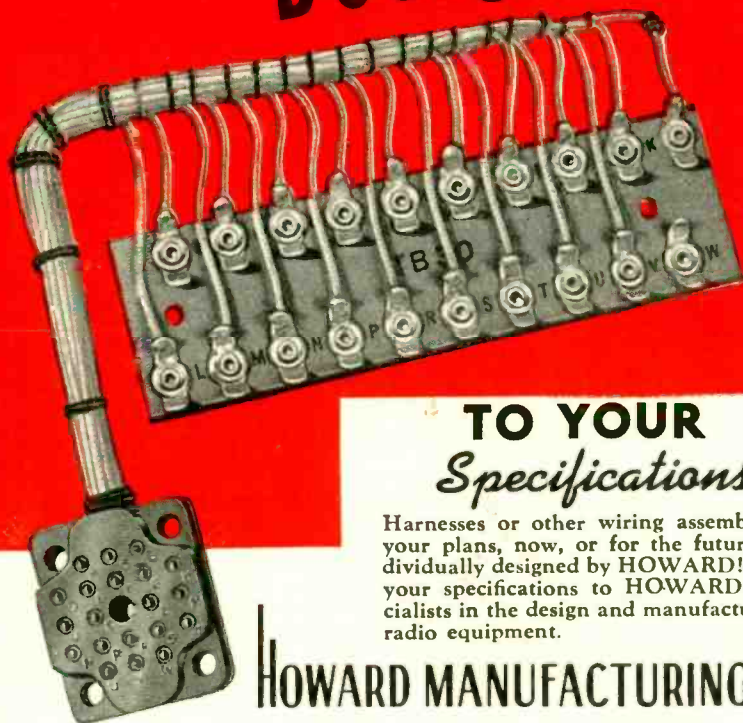

TO YOUR Specifications

Harnesses or other wiring assembly in your plans, now, or for the future, individually designed by HOWARD! Send your specifications to HOWARD, specialists in the design and manufacture of radio equipment.

HOWARD MANUFACTURING CORP.

COUNCIL BLUFFS, IOWA

★ BUY WAR BONDS ★

TECHNICANA

[Continued from page 8]

is V_0 , remains substantially constant in magnitude and phase.

When the load is reduced to no-load the voltages V_2 and V_3 tend to increase. I_m and I_s tend to lag further and V_1 moves nearer in phase to V_2 but must decrease since V_0 remains constant. V_4 lags somewhat more, but the output voltage remains as before.

Table I lists values of the output voltages for various values of input voltage and load, the line voltage being nominally 230 volts.

TABLE I

Load	Line Voltage		
	190	230	260
0	233	229	228.5
1/4	233	230	230.5
1/2	231.5	230.5	232
3/4	228.5	230	233
Full	227	229.5	233

It is noted that the load voltage increases for line voltage decrease. The output waveform shows low harmonic content due to saturation of iron by the magnetizing current. The author suggests that the waveform can be made almost perfect by the addition of an LC circuit which will resonate at the fifth harmonic of the line frequency.

GROUNDING-GRID TUBE CIRCUITS

The grounded-grid amplifier is a variation of more commonly used circuits and has the advantage of a low input impedance and an unusually high output impedance. It may be employed in high power short-wave transmitters or receivers.

The grounded-grid oscillator is useful when employed as the first oscillator in an FM transmitter.

When a grounded-grid amplifier, driven by a cathode follower stage, is converted to an oscillator the circuit is described as a "Cathode-coupled oscillator." Such a circuit is described by Mr. F. Butler in the November, 1944, issue of *Wireless Engineer*.

The "Cathode-coupled oscillator" is claimed to offer several advantages, including the elimination of tapped coils and reactive windings. When crystal controlled, high stability is obtained and a large amount of power can be obtained with weak crystal activity.

The author compares the basic types of amplifier-oscillator circuits. The conventional circuit, in which the cathode is grounded and the tube is

[Continued on page 12]



STEPPING UP PRODUCTION TEMPO

At its large, new, modernly equipped plant at Conneaut, Ohio. The Astatic Corporation is today supplying Microphones, Pickups, Cartridges and wartime unmentionables to the armed forces, essential industries and accredited government agencies. With all operations and departments now under one roof, Astatic looks optimistically forward into the new year with greatly increased production facilities and customer accommodations. These advantages will enable Astatic to make a quick transition to meet commercial demands when the reconversion time arrives.

THE
Astatic
CORPORATION
CONNEAUT, OHIO
IN CANADA: CANADIAN ASTATIC LTD., TORONTO, ONTARIO

NOTE: Please change Astatic address in your files to CONNEAUT, OHIO.

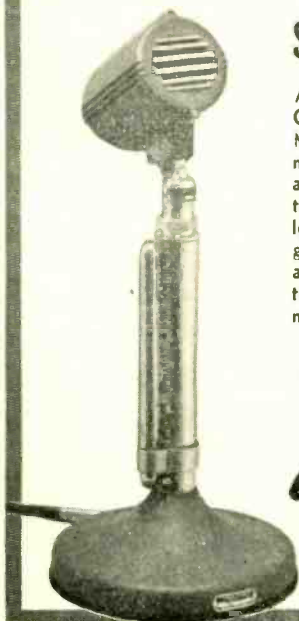

SYLVANIA NEWS

ELECTRONIC EQUIPMENT EDITION

DECEMBER

Published in the Interests of Better Sight and Sound

1944

Type EF-50 Pentode Found Useful at High Frequencies

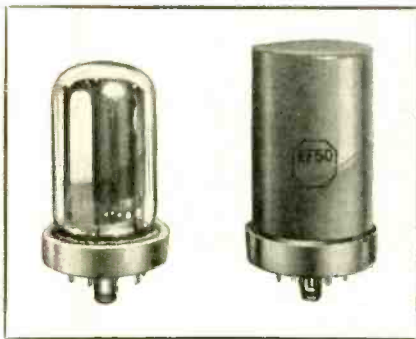

Sylvania's Type EF-50 Amplifier Pentode, originally produced primarily for military purposes, has a number of unusual features that suggest many applications in postwar design.

The outstanding characteristic of the EF-50 is that it is designed to operate at 250 volts on both screen and plate, permitting operation at higher frequencies because of the resulting reduction in input loading.

Tube is provided with its own external shield, grounded through center lug, as well as internal shielding brought out on two terminals. Since suppressor and cathode are brought out separately, 9 pins are needed.

Full technical data on the EF-50 can be obtained from Sylvania.



"Next time you go bailing out, for heaven's sake grab a set with Sylvania Tubes!"

Sylvania Equipment Helps B-29s Report "Mission Accomplished"

*Company's Tubes, Electronic Devices
Extensively Used on Superfortresses*

Radio communications equipment and electronic navigational aids have been developed to a new pitch of perfection aboard the giant Boeing Superfortresses, which have so convincingly demonstrated their ability to strike hard and effectively, deep within the enemy's territory, after flying from far-distant

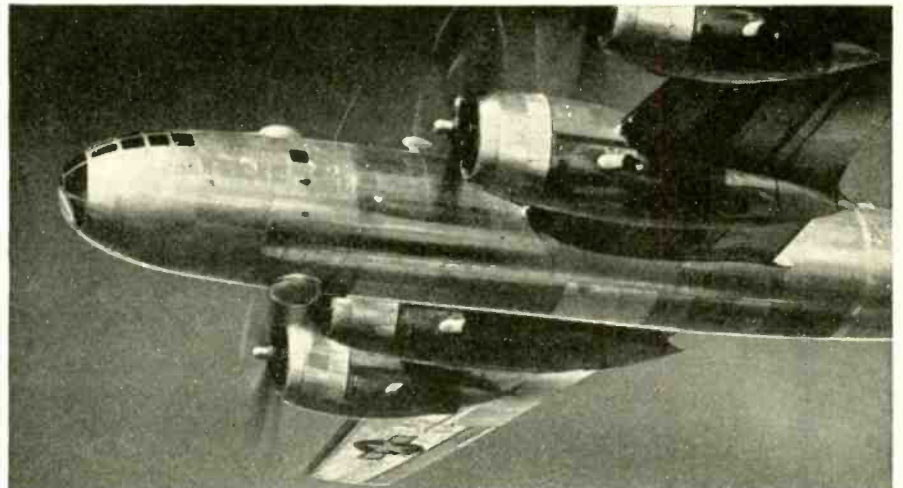

Exterior view shows the B-29 bristling with 50-calibre machine guns and 20 mm. cannon. The Superfortress is powered by four 2200-hp. engines, rolls on double-wheeled landing gear, carries electronic equipment such as is manufactured by Sylvania and others. (Boeing Photo)

bases. The long operating range of the Superfortresses necessitates a complex electronic nerve system to assure close contact in flight, accuracy in reaching target, and safe return to base. Radio and electronic equipment — estimated to total approximately one ton for each Superfortress — includes the most modern navigational devices, in addition, of course, to the transmitters, receivers and other apparatus necessary for communication between crew members, between aircraft in flight, and between planes and their distant bases.

Sylvania has made important contributions to the electronic equipment that helps make possible—and ultimately transmits—the terse, stirring message, "Mission Accomplished." Not only are many Sylvania tubes utilized in the various radio sets and control devices carried by the Superfortresses, but Sylvania is among the manufacturers supplying electronic equipment for the B-29s.

DID YOU KNOW...

That many industries use Sylvania Pirani tubes to measure pressures ranging from 1/10 to 1/10,000 mm?

★ ★ ★

That newly defined life ratings for Sylvania Fluorescent lamps show that, in many applications, life expectancy is greater than previously indicated, when lamps are burned on long time-on cycles?

SYLVANIA ELECTRIC

PRODUCTS INC.
Radio Division · Emporium, Pa.

MAKERS OF FLUORESCENT LAMPS, FIXTURES, ACCESSORIES, INCANDESCENT LAMPS, RADIO TUBES, CATHODE RAY TUBES, ELECTRONIC DEVICES

RADIO

★ DECEMBER, 1944

11

KEN-RAD Metal Tubes

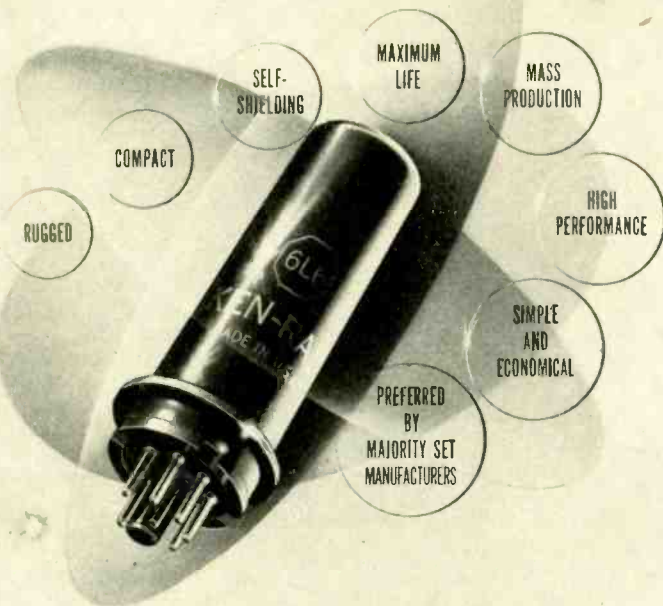

The weight and space saving advantages of Ken-Rad "self-shielding" metal tubes have long been recognized. Their sturdy ruggedness under severe service conditions in fighters and bombers is a matter of record.

Write for your copy of "Essential Characteristics" the most complete digest of tube information available

- TRANSMITTING TUBES
- CATHODE RAY TUBES
- SPECIAL PURPOSE TUBES
- RECEIVING TUBES
- INCANDESCENT LAMPS
- FLUORESCENT LAMPS

KEN-RAD
EXECUTIVE OFFICES
OWENSBORO · KENTUCKY
EXPORTS 113 MOORE STREET NEW YORK



OUTSTANDING QUALITY!

CETRON

*in Electronic Tubes
... Phototubes
Rectifiers and
Special Tubes*

CONTINENTAL ELECTRIC COMPANY
CHICAGO OFFICE 700 W. JACKSON ST. CHICAGO, ILL. NEW YORK OFFICE 360 W. 14th ST.

PROMPT DELIVERIES on most types
Send for Catalog

TECHNICANA

[Continued from page 10]

driven between grid and cathode produces a 180° phase shift in the output. The circuit illustrated in Fig. 2 has an infinite input impedance and a gain of $\mu R_p / (R_p + R_L)$, in which R_p is the plate resistance, R_L is the load resistance, and μ the amplification factor of the tube.

The cathode-loaded amplifier, or cathode follower, is driven between grid and plate, with the plate at

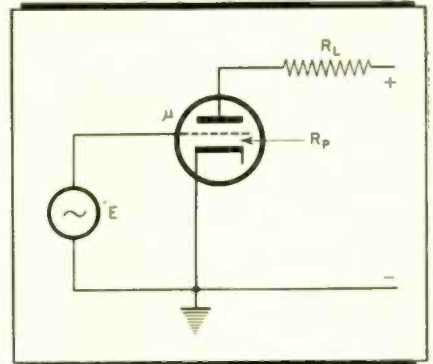

Figure 2

ground potential for r.f. The load resistance is in the cathode circuit, as per Fig. 3.

For the cathode follower the input impedance is very high and the output impedance is lower than for the conventional circuit. The stage gain is

$$\frac{\mu R_L}{R_p + (1 + \mu) R_L}$$

The grounded-grid amplifier is shown in Fig. 4, and its equivalent

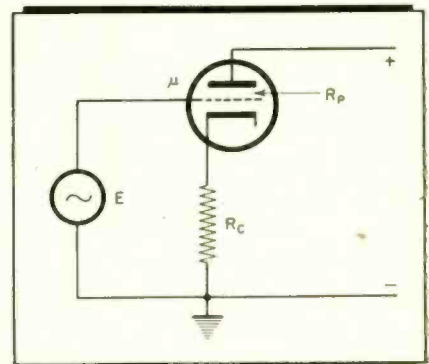
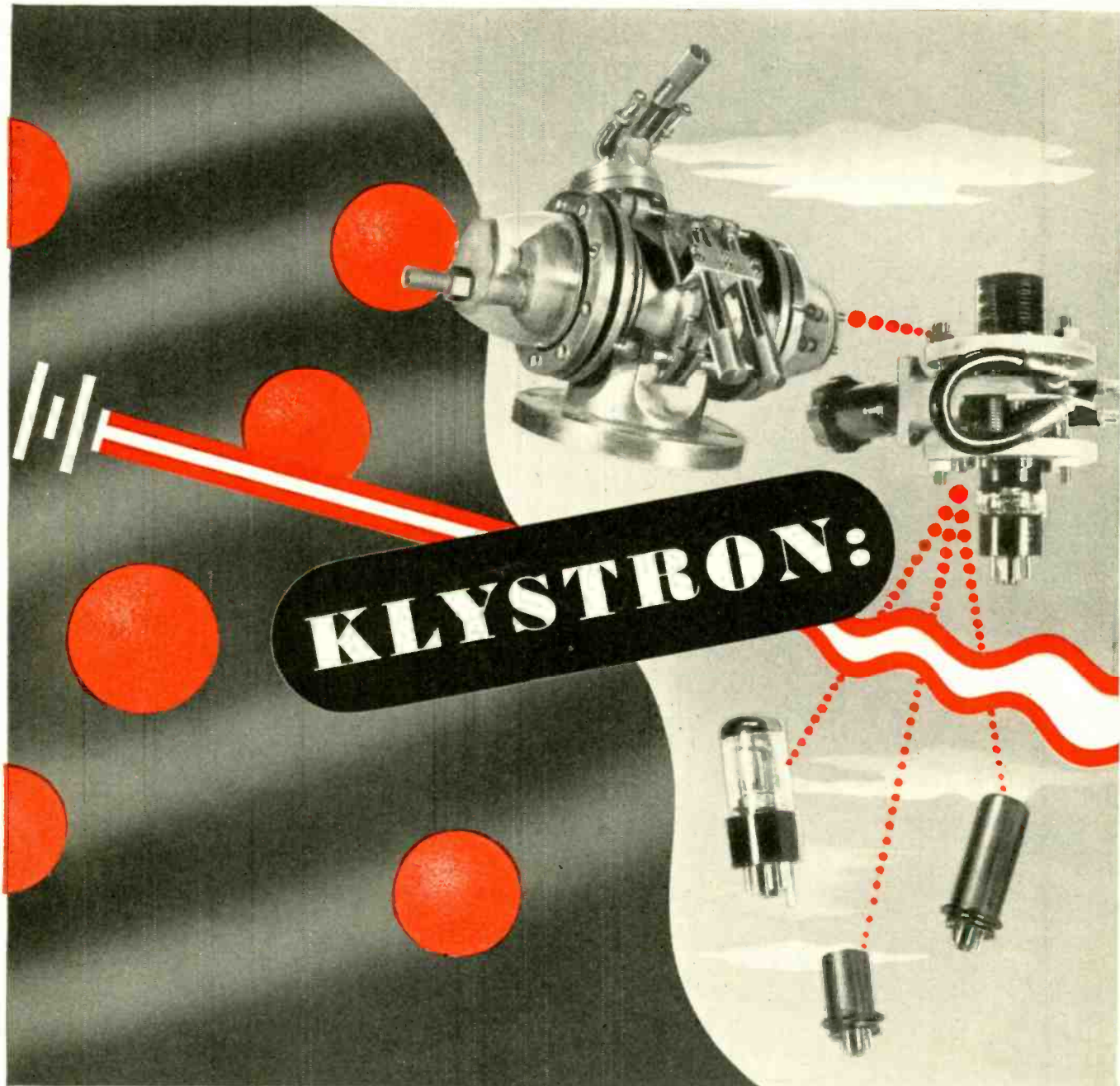

Figure 3

circuit in Fig. 5. Since any tube can be replaced by an equivalent generator delivering μ times the grid-to-cathode signal voltage, the circuit equations are

$$\begin{aligned} E + E_p &= i(R + R_p + R_L) \\ E + \mu(E - iR) &= i(R + R_p + R_L) \\ (1 + \mu)E &= i[(\mu + 1)R + R_p + R_L] \end{aligned}$$

[Continued on page 14]



How many Klystrons *are* there?

COMPARED with the early Klystrons which Sperry first developed some years ago, the more recent forms represent dramatic improvements in both size and performance.

And this is only the beginning!

Information on the newer types is presently restricted to those qualified under Military regulations.

But Sperry Klystrons are in use on many battle fronts, and in many applications . . .

There are small Klystrons, and large ones . . . low-powered ones and high-powered ones. There are Klystrons which generate, amplify, and multiply. Where required, frequency stability (better than that required for

broadcast purposes) is readily applied by conventional means.

Klystrons are easily modulated for new and all conventional purposes. And, by means of a single knob, they can be tuned continuously over a wide band, or the operator can snap-tune them to previously selected bands.

Write us for further information.

Sperry Gyroscope Company

GREAT NECK, N. Y. • DIVISION OF THE SPERRY CORPORATION

GYROSCOPICS • ELECTRONICS • RADAR • AUTOMATIC COMPUTATION • SERVO-MECHANISMS

RADIO ★ DECEMBER, 1944

13

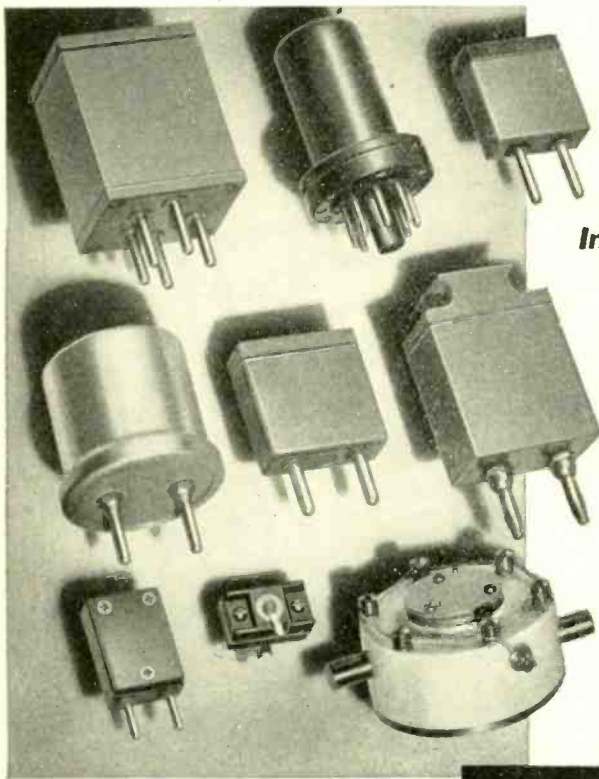

In **QUARTZ**
CRYSTALS
the most significant
advancements have
been introduced by
BLILEY

Do more than before . . .
buy extra War Bonds



BLILEY ELECTRIC COMPANY • UNION STATION BUILDING • ERIE, PENNSYLVANIA

Take a **TURRET TERMINAL LUG**
LIKE THIS . . .



Swage it to the Board
LIKE THIS . . .



And in a jiffy you have
a good, firm Turret Terminal

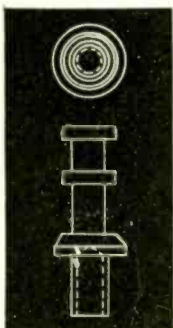

It's as simple as that with these heavily silver plated C. T. C. Turret Terminal Lugs. Quick soldering, too. Sufficient metal is used to give them strength but there's no surplus metal to draw heat and increase soldering time.

C. T. C. Turret Terminal Lugs are stocked to meet a wide range of board thicknesses. Order them from

CAMBRIDGE Thermionic CORPORATION

454 CONCORD AVENUE

CAMBRIDGE 38, MASSACHUSETTS

TECHNICANA

[Continued from page 12]

The output impedance is $R_p + (\mu + 1)R$ and is higher than for the two other circuits. The input impedance is

$$\frac{R_p + R_L}{\mu + 1}$$

which is fairly low. The stage gain is

$$\frac{R_p + R_L + (1 + \mu)R}{R_p + R_L + (1 + \mu)R}$$

In contrast to the conventional amplifier, both cathode follower and

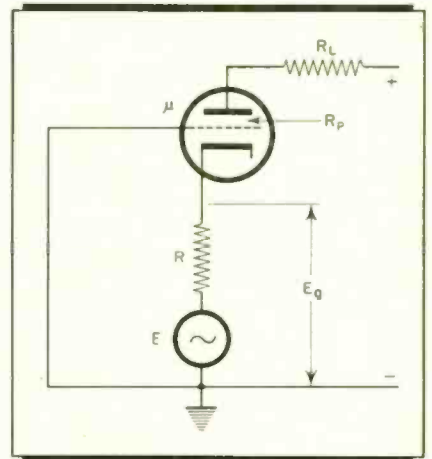

Figure 4

grounded-grid amplifiers produce output voltages in phase with the inputs.

Since any amplifier can be converted to an oscillator by feeding the output voltage back to the input in proper phase, and with sufficient amplitude to overcome the losses, the grounded-grid, or inverted amplifier, can be made to oscillate by coupling it to a tuned circuit so that the plate and cathode potentials are in phase. The load resistor of Fig. 4 is replaced with a tuned circuit, as in Fig. 6. R and C₂ provide grid bias.

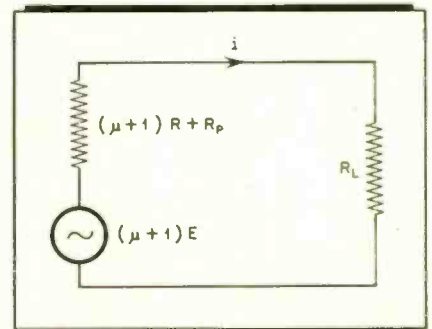

Figure 5

The grounded-grid oscillator can be driven by a cathode follower stage as a form of relaxation oscillator, as shown in Fig. 7. In this circuit V₂ serves as

[Continued on page 16]

Eimac "X" Grid

Solves grid emission problem!

Grid emission, with the resulting instability of operation, parasitic oscillations and prematurely burned out filaments, has become a thing of the past. The new Eimac "X" grid will not emit electrons even when operated at incandescent heat.

The solution to the problem of grid emission lifts a great barrier which has long stood in the path of electron vacuum tube development and the progress of electronics. Eimac Engineers in developing the "X" grid have made a real contribution . . . and a very important one . . . toward the development of new and more efficient vacuum tubes. It is such heads-up Engineering that has made Eimac first choice of leading electronic engineers throughout the world . . . and maintained them in that position year after year.



Follow the leaders to

Eimac REG. U. S. PAT. OFF.
TUBES

ELECTRONIC
TELESIS

The layman's handbook of Electronics will be sent you upon request without cost or obligation.

EITEL-McCULLOUGH, INC., 874 San Mateo Avenue, SAN BRUNO, CALIF.
Plants located at: San Bruno, California and Salt Lake City, Utah

Export Agents: FRAZAR & HANSEN, 301 Clay St., San Francisco 11, Calif., U.S.A.

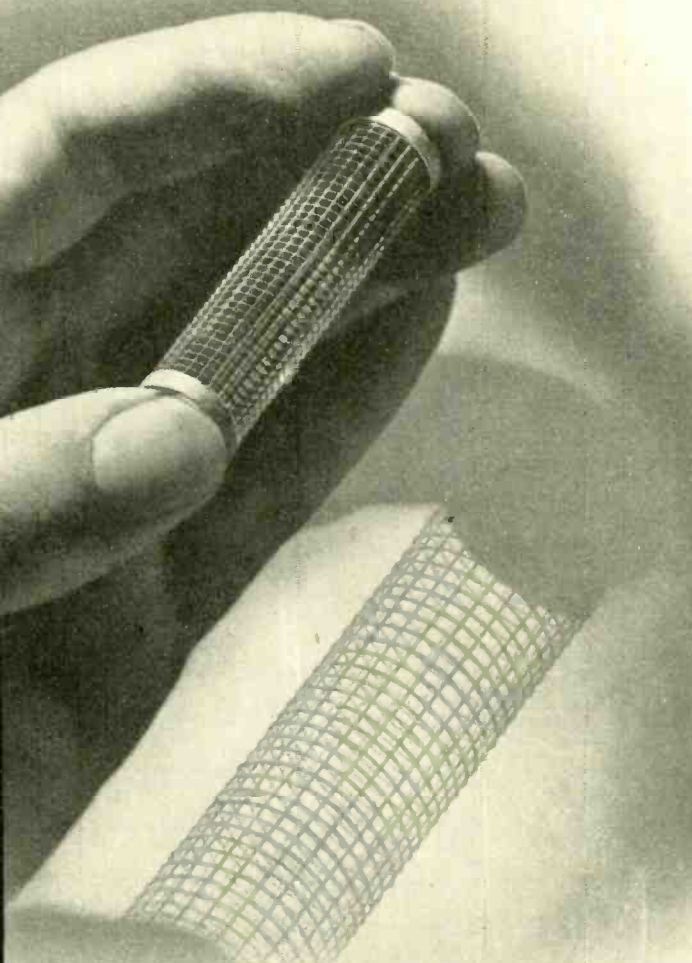

The Science Behind the Science of Electronics
is the focusing of all branches of science upon the development and improvement of electron vacuum tubes.



PHYSICS... Especially designed electron microscope enables operator actually to view electron emission.



OPTICS... Photomicrographic studies help achieve perfection in processing.



POWDER METALLURGY... Compounding special alloys.



CHEMISTRY... Experimentation with metallic components and preparation of chemical compounds.



THERMO-DYNAMICS... Vacuum furnaces heat materials to exceedingly high temperatures.

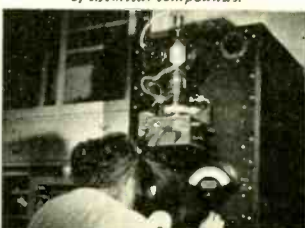

ELECTRONICS... Determining facts about and recording data on vacuum tube capabilities.

[Continued from page 14]

Talk About PRODUCTION Without DIES!

4,000 Parts Per Day with DI-ACRO Bender

Here is an example of "DIE-LESS DUPLICATING" typical of a great variety of formed parts readily made with DI-ACRO Precision Machines,—Benders, Brakes, Shears. Picture below shows an acute right angle bend and photograph above shows the finished part formed to die precision. Women



"Enclosed pictures in our plant prove the DI-ACRO Bender will do a real production job. We are making 4,000 completed parts per day which is competitive to most Power Presses." (Name on request)



DI-ACRO is pronounced "DIE-ACK-RO"

operating DI-ACRO units maintain a high out-put on production work.

Send for CATALOG

showing DI-ACRO Precision Machines and many examples of parts made with "DIE-LESS DUPLICATING."



O'NEIL-IRWIN MFG. CO.

346 EIGHTH AVENUE SOUTH • MINNEAPOLIS 15, MINNESOTA

HIGH "Q"s for MIDGETS Available in DX Isoso-Loops



During peacetime, as the World's largest loop aerial manufacturers, our job was to build the highest "Q" loop for every size and kind of radio receiver. If you make midgets you get the same DX Isoso-loop quality that goes into the large consoles. All of our present day efforts are devoted to making DX Xtals but we would like to discuss your post war receiver plans with you.

DX CRYSTAL CO.

GENERAL OFFICES: 1200 N. CLAREMONT AVE., CHICAGO 22, ILL., U.S.A.



"the heart of a good transmitter"

the cathode follower and V_1 the grounded-grid oscillator. Frequency can be altered by switching inductances.

For this oscillator

$$R[\mu_2(\mu_1 + 1)R_1 - (\mu_2 + 1)(R_{p1} + R_1) - (\mu_1 + 1)R_{p2}] = (R_{p1} + R_1)R_{p2}$$

in which R_1 is taken as the dynamic resistance of the LC combination.

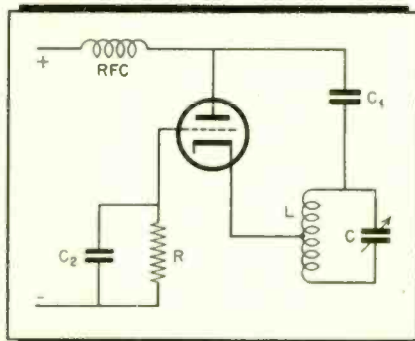

Figure 6

The circuit theory for a cathode follower driving an inverted amplifier is developed by the author and is used as the basis for the above oscillator equation.

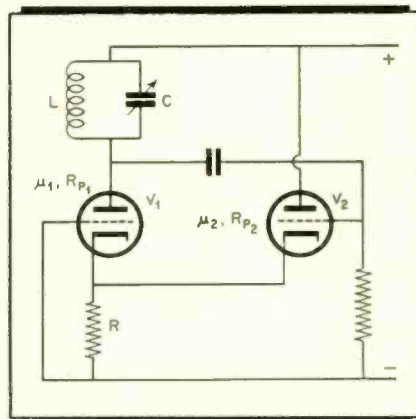

Figure 7

Resistance R can be divided into two parallel resistances separated by a crystal, for quartz crystal control. The crystal may be replaced by a tuned circuit for low harmonic output.

INVERTED TRIODE APPLICATIONS

★ Grid currents as minute as one-hundred thousandth of a billionth (10^{-11}) of an ampere can be measured with the inverted triode, according to W. A. Hayes, electronics engineer of Westinghouse. In this tube the outer electrode, which is normally the plate in an ordinary vacuum tube, is used as the control grid. This inversion minimizes the space charge effect thereby making it possible to select a valve of grid bias that will result in zero grid current. Such sensitivity of

[Continued on page 18]



EASTERN AIR LINES



MID-CONTINENT AIRLINES

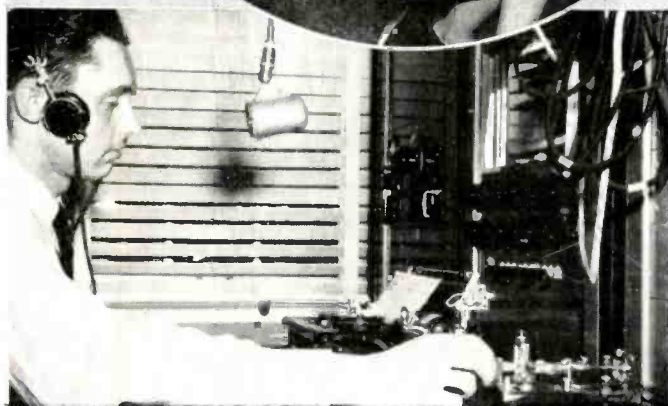

BRANIFF AIRWAYS



(ABOVE) PENNSYLVANIA-CENTRAL AIRLINES
(BELOW) AMERICAN AIRLINES

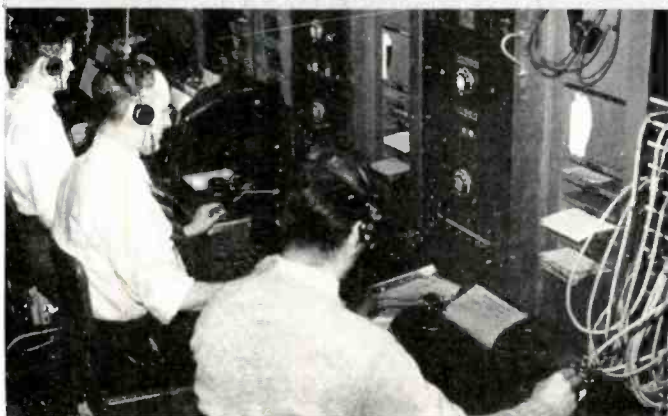

Wilcox Installations with the Airlines

*for Dependable
Radio Communications*

For many years the major commercial airlines of the United States have relied upon Wilcox dependability in their daily operations. In the postwar era of electronics and aviation, look to Wilcox for continued leadership in the development of radio communication.

**WILCOX
ELECTRIC
COMPANY**



Fourteenth and Chestnut Kansas City, Mo.
Manufacturers of Radio Equipment

**PRODUCTS
OF
MERIT
SHARE IN THIS
RECOGNITION—**



Merit Coil and Transformer Corporation is proud of this U.S. Navy Certificate of Achievement, awarded to us as part of Radar-Radio Industries of Chicago, Inc.

With highly skilled workers and the most modern equipment for manufacturing in accordance with the latest trends in radar-radio production and assembly, Merit has specialized in specific transformer applications for widely varying fields, climates and altitudes.

These same facilities and broad experience are available now for development of your post-war products.

Your inquiries will have prompt attention



MERIT COIL & TRANSFORMER CORP.
4427 North Clark St. CHICAGO 40, ILL.

TECHNICANA

[Continued from page 16]

measurement makes several operations practical that were previously considered very difficult or impossible. It is used to measure:

1. Hydrogen ion content of chemicals (pH).
2. Minute currents produced by photo tubes when subjected to starlight.
3. Ion current in mass spectrometer.
4. Alloying constituents of steel.
5. Minute quantities which previously required an electrometer or its equivalent.

This three electrode tube is designed to amplify currents and potentials which, when compared with valves used in common radio practice, are considered as infinitesimal quantities. With this tube, currents as low as 10^{-14} amperes can be measured and as low as 10^{-16} amperes can be indicated. Direct potentials can be measured to a sensitivity of 10^{-4} volts in circuits up to 10^{12} ohms in resistance.

The sensitivity of this tube is made possible by an extremely low grid current and a high grid to cathode resistance. Due to the small magnitude of the currents expected in the type of applications to which the tube is usually put, it is absolutely necessary that none of the minute quantities of current be absorbed in surface leakage. Therefore, every precaution has been taken to design the tube so that unusually high resistance exists between each electrode.

The use of so-called "glass pant leg" supports has provided a maximum surface leakage path between electrodes. The pant leg consists of a glass sleeve surrounding a wire which acts as support for mounting. This method of construction provides the insulation necessary between electrodes so that practically no energy is absorbed from the source being measured.

The tube may be termed an "Inverted Triode," as the outer electrode, which is normally the plate in an ordinary vacuum tube, is used as the control electrode or grid in this tube. This places the control electrode at a maximum distance from the space charge region surrounding the filament, thus minimizing the amount of electrons collected by the control electrode. In this manner the current to the control electrode is held at a minimum.

The mesh mounted between the filament and the control electrode is used as the anode. This particular construction provides more radiating surface to the grid, thereby decreasing its temperature and possible thermionic emission. The control element or grid, being farthest from the filament, thus decreasing emission from the grid. All references to the control electrode or anode of this tube refer to the function of those electrodes in the circuit and not to their physical construction or location.

The filament is operated at a low temperature to minimize the emission of photo electrons and primary electrons from the

[Continued on page 48]

CABINETS

PANELS

CHASSIS

RACKS



Serving the
Electronics
Field
Exclusively

Write for
Catalogue
No. 41-A

Though manufactured by modern high-speed methods, Par-Metal products have a definite quality of craftsmanship — that "hand-made" quality which is born of years of specialization.

PAR-METAL PRODUCTS CORPORATION

32-62—49th STREET . . . LONG ISLAND CITY, N. Y.
Export Dept. 100 Varick St., N. Y. C.

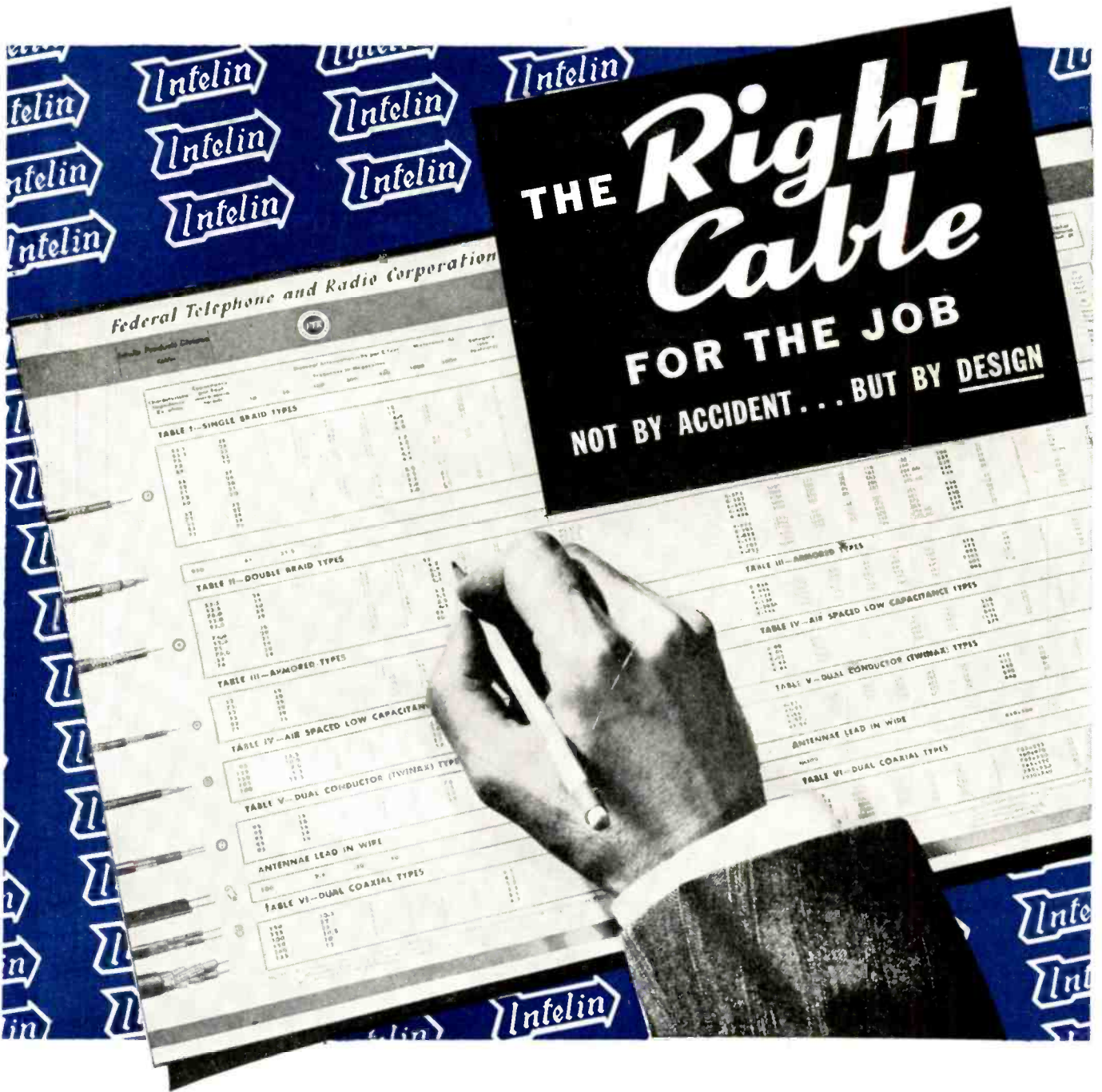

To assist the equipment designer Federal offers comprehensive data on high frequency cables.

This technical information sheet provides the design-engineer with pertinent electrical and physical characteristics...including impedance, capacitance, attenuation, diameter, materials, and weight... for Federal's wide variety of high-frequency cables.

Single and double braid, armored, dual con-

ductor and dual coaxial, air-spaced, low capacitance lines, and antenna lead-in wire... there's a right type for your job, backed by the built-in superiority that's a tradition with Federal.

Special developments in flexible low-loss cables by Federal have resulted in superior cables for all types of transmission. For a better job, see Federal first.

Write for your cable information sheet today.



Federal Telephone and Radio Corporation

Newark 1, N. J.

An Important Statement

BY **MYCALEX CORPORATION OF AMERICA**

*Issued in an Effort to Clear up and to
Avoid Continued Confusion in the Trade*

IT has come to our attention that in some quarters electronic engineers and purchasing executives are under the erroneous impression that the MYCALEX CORPORATION OF AMERICA is connected or affiliated with others manufacturing glass-bonded mica insulation, and that genuine "MYCALEX" and products bearing similar names are all "the same thing" . . . are "put out by the same people" . . . and "come from the same plant."

These are the FACTS:

- 1.** The MYCALEX CORPORATION OF AMERICA is not connected or affiliated with any other firm or corporation manufacturing glass-bonded mica insulating materials. It is 100% American in ownership and operation.
- 2.** The word "MYCALEX" is a registered trademark owned by MYCALEX CORPORATION OF AMERICA, and identifies glass-bonded mica insulating materials manufactured by MYCALEX CORPORATION OF AMERICA.
- 3.** The General Electric Company, by virtue of a non-exclusive license it had under a MYCALEX patent through the MYCALEX (PARENT) COMPANY, LTD., has been permitted use of the trade-mark "MYCALEX" on its glass-bonded mica insulating materials.
- 4.** The MYCALEX CORPORATION OF AMERICA has behind it over 20 years of research leadership, dating back to work done by the original MYCALEX (PARENT) COMPANY, LTD. of Great Britain, from which it obtained its American patents.
- 5.** The products of MYCALEX CORPORATION OF AMERICA are: (a) "MYCALEX 400"—the most highly perfected form of MYCALEX insulation, approved by the Army and Navy as Grade L-4 insulation. "MYCALEX 400" is sold in sheets, rods and fabricated form. (b) "MYCALEX K"—an advanced capacitor dielectric with a dielectric constant of 10 to 15, which can be fabricated to specifications. (c) MOLDED MYCALEX, available to specifications in irregular shapes and into which metal inserts may be incorporated.
- 6.** "MYCALEX" in the forms described above is made by exclusive formulae and exclusive patented processes. It is utterly impossible for any one other than the MYCALEX CORPORATION OF AMERICA to offer any product, similar in appearance, as "the very same thing."



Trade Mark Registered

**General Office
and Plant
CLIFTON, NEW JERSEY**

MYCALEX CORPORATION OF AMERICA
"OWNERS OF 'MYCALEX' PATENTS"

**Executive Offices:
30 ROCKEFELLER PLAZA
NEW YORK 20, N. Y.**

Pulse Time Modulation

M. G. BELL

A detailed analysis of a new method of modulation which may have wide applications in postwar radio and electronic apparatus

A new and interesting type of modulation has recently engaged the attention of a number of radio engineers and seems to hold out some promise of being useful for multiplex operation over a single radio channel and possibly for bettering signal-to-noise ratios.

Like many so-called new systems, the pulse type of modulation system is not really new and in one form was used at least as early as 1937, but more recent developments in the use of very short wave radio down to and including microwaves have again brought the system to the fore. This is because at extremely high frequencies it becomes

practical to break a radio wave up into pulses which are a very small fraction of a second in length. The reason is that if an ordinary radio frequency were to be turned on and off with exceedingly high rapidity, side bands with a great percentage spread would be created.

A pulse of radio-frequency energy at broadcast frequency which is only one microsecond long would contain only about one wavelength, and that is not enough to establish a frequency with any degree of precision. On the other hand, if frequencies of hundreds or even thousands of megacycles are used, then even though the transmitter is allowed to send out energy for only a microsecond at a time, each pulse will nevertheless contain many waves and will, in effect, allow the receiver to

distinguish the time interval between waves and thus the frequency with good percentage accuracy.

The basic idea of pulse-time modulation may be described quite simply by indicating how a system might be set up to meet requirements for a given number of channels with a given high-frequency response. Suppose, first, that it is desired to send audio signals faithfully which contain frequency components as high as 5,000 cycles. It then follows that whatever form of modulation is used, it must be possible for the receiver to adjust itself so as to feed a new output voltage to the loudspeaker or earphones, at least 5,000 times per second. Stating this another way, in order to transmit a frequency of 5,000 cycles, each channel of the radio transmission system must carry

¹This discussion is prompted by "Pulse Time Modulation" by E. M. Delorain and E. Labin in *Electrical Communications*, Vol. 22, No. 2 and in the main covers ideas suggested by them.

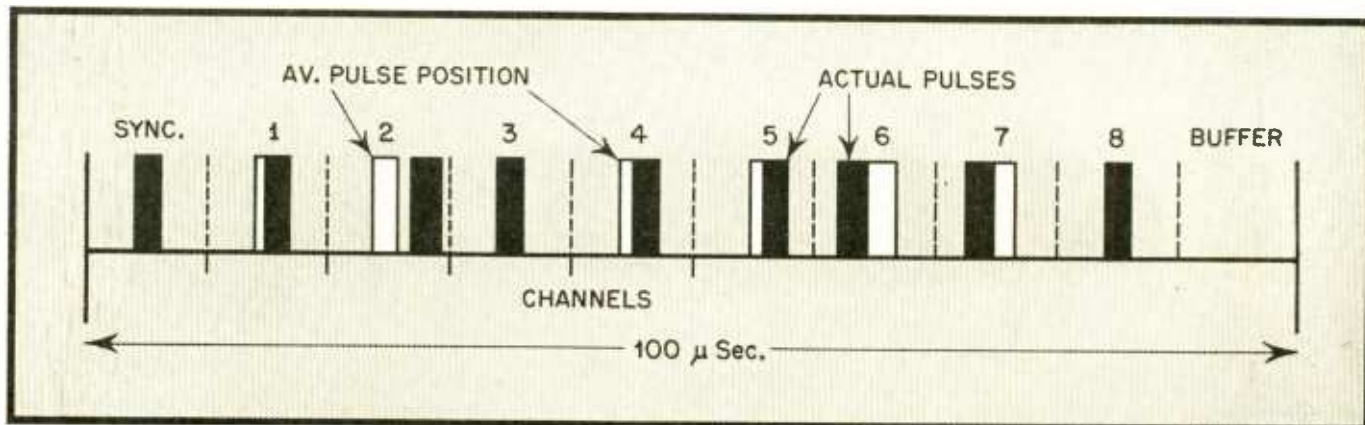

Fig. 1. An example of pulse time modulation arranged to provide eight channels

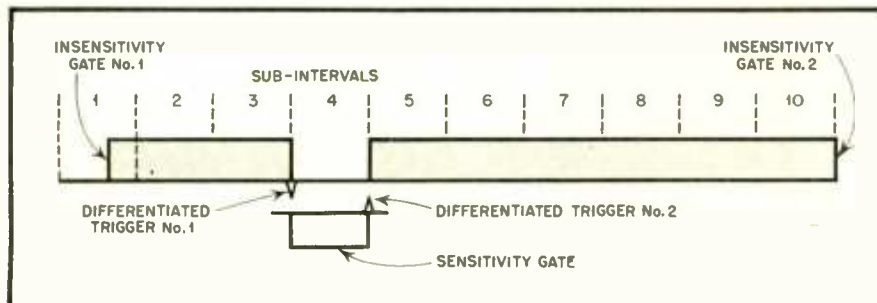

Fig. 2. Gating wave forms necessary in one form of a pulse time modulation receiver designed for channel 4

information from the transmitter to the receiver at least 5,000 times per second.

Actually, to maintain reasonable wave forms it is probably necessary to do somewhat better than this and it might well, for example, be decided in the case quoted that signals must be delivered through each transmission channel every ten-thousandth of a second. When this is decided the basic time interval of the pulse-time modulation system has been obtained. It is established that during each 100 microseconds (one ten-thousandth of a second) a signal must be sent through each channel to each corresponding receiver. It is because the whole 100 microseconds is by no means needed in order to send information concerning a voltage that pulse-time modulation channeling is possible. The channeling is a matter of dividing time up among the various receivers rather than frequency as is common with all other channeling systems.

If, for example, in the case we have been discussing it is necessary to have eight channels, the basic time interval of 100 microseconds might well be broken up into ten sub-intervals each 10 microseconds long. The first of these sub-intervals might then be reserved for synchronizing signals, the next eight used as channels, and the tenth be reserved as a buffer interval.

An example of how the system might be used for f-m pulse modulation can be understood by studying *Fig. 1*. Here the basic time intervals of 100 microseconds, which is constantly repeated, is shown graphically. Pulses are sent out during each sub-interval except the last. The synchronizing pulse is always centered in its interval and the channel pulses have mean positions which are also at the center of their intervals.

A considerable variety of circuits is then possible in the receivers to obtain the desired results. For definiteness it is perhaps best to describe a possible form for one of them. For example, a receiver suitable for channel 4 is arranged so as to be insensitive to all except the synchronizing pulse, and whatever is received during sub-inter-

val four. This may be accomplished by having the receiver normally cut off somewhere in its audio circuits and being operative only during the required time. If f-m principles are to be used, the receiver will then be fixed so that it delivers an output voltage proportional to the varying time interval (or the rate of change of that time interval) between the synchronizing pulse and the pulse of sub-interval 4. It ignores the presence of all the other pulses because it is gated off.

The actual circuit mechanism of the receiver which allows for discretion with time is rather more complicated to describe than it need be in actual practice. Thus a possibility for the gating mechanism for channel four may be illustrated by *Fig. 2*. It consists essentially of three biased multivibrators or other circuits accomplishing the same results. Pulses arriving every ten microseconds are, after limiting, arranged so that they just produce an ave voltage sufficient to keep the receiver cut off. This is necessary only to get the receiver in synchronism and is not the principle upon which the receiver depends for continued operation after synchronism is obtained. It therefore need not of necessity be a precision matter but can be one which is adjusted by the operator until a proper locking-in is achieved. The problem is one similar to that of framing a motion picture. In any event the idea is that the receiver does not respond, when it is first turned on, to any of the pulses of sub-intervals 1 through 8 because of the ave voltage of the preceding pulse. When the synchronizing pulse arrives, however, the situation is different because during the buffer interval the ave voltage has leaked away and the synchronizing pulse is able to operate a biased multivibrator which forms a single square gate, labeled insensitivity gate #1 in *Fig. 2*. Because the multivibrator is biased it does not continue to oscillate but lapses into quiescence after forming the gate and remains that way until the next synchronizing pulse comes along.

Insensitivity gate #1 turns the receiver off by biasing a grid of the i.f. amplifier to cut off and thus causes the receiver to ignore pulses in sub-intervals 1, 2 and 3. Because, however, this #1 gate is just 35 microseconds long the receiver is opened up again at the beginning of interval 4. Attached to the output of the multivibrator generating gate #1 is a differentiating circuit consisting of a resistor and a small condenser. During both the rise and fall of voltage in gate #1 this causes a differentiated trigger pulse to be formed. The one of polarity corresponding to the beginning of gate #1 is ignored but the differentiated pulse occurring at the end of that gate is able to trigger a second gate circuit, labeled as the sensitivity gate in *Fig. 2*. This gate is 10 microseconds long and not only is arranged to insure that the receiver is completely turned on but also is fixed to further bias off gate #1 so that the pulse of sub-interval 4 cannot restart gate #1. The following edge of the sensitivity gate is also differentiated and the resulting trigger used to set off a third gate of 60 microseconds duration. This third gate, which is labeled as insensitivity gate #2, in *Fig. 2*, again turns the receiver off so that the pulses of intervals 5 through 9 are ignored. At the end of interval 9, the receiver is again open and ready for the next synchronizing pulse which will restart the whole chain of events.

It is of course not necessary to use a frequency modulation type of pulse time modulation. Indeed, a simple system to describe in principle would be one completely analogous to amplitude modulation. The synchronizing pulse in that case might well be used for nothing at all except to time the various gates and the sensitivity gate of *Fig. 2* might be caused to allow the pulse of sub-interval 4 and only that pulse to change the output voltage 7, the receiver in accordance with its own strength. The arguments against such a system are essentially the same arguments that are used to describe the advantages of f.m. over a.m. plus the further argument that, since in pulse time modulation we are deliberately using non-linear circuits, it is probably less logical to ask for linear voltage response than to utilize circuits which need a limiting action.

In the broadest sense, pulse modulation system may be classified in terms of the possible variations which can be made in a train of pulses. In a series of pulses of radio energy we may control (1) the strength of the pulses, (2) the duration of the pulses, (3) the spacing between the pulses, and (4) the shape of the pulses. Any of these, or the rate of change of any

of them, may in principle be made the means of telling the receiver what voltage to send to the loudspeaker during the time interval which elapses before the next pulse arrives with a new directive. Only to the extent that a series of pulses can perform their duty for a given channel and leave free time for other uses of the frequency can the pulse system be considered superior to better known systems. The only exception to this may have to do with the signal-to-noise ratio. Since the receiver is turned off eight-tenths of the time, there is some reason to believe that the noise should be somewhat reduced.

It is pertinent to ask concerning the frequency bandwidth which is necessary in order to utilize a ten-channel pulse time system like the one described. The answer depends entirely upon the pulse widths that are used. Suppose, for example, that the pulses are essentially rectangular in shape and contain n wavelengths. Such a pulse is represented in Fig. 3 by a sinusoidal curve which may, for example, be a plot of voltage against time. In that representation time is taken as being zero at the center of the pulse and to have the values shown elsewhere. If it is assumed that the pulses are always far enough apart so there is no coherence between them, we need only to make a Fourier analysis of such a pulse to obtain the spectral distribution of frequency. In the particular system described this criterion is certainly justified. The pulse shown may be represented analytically by

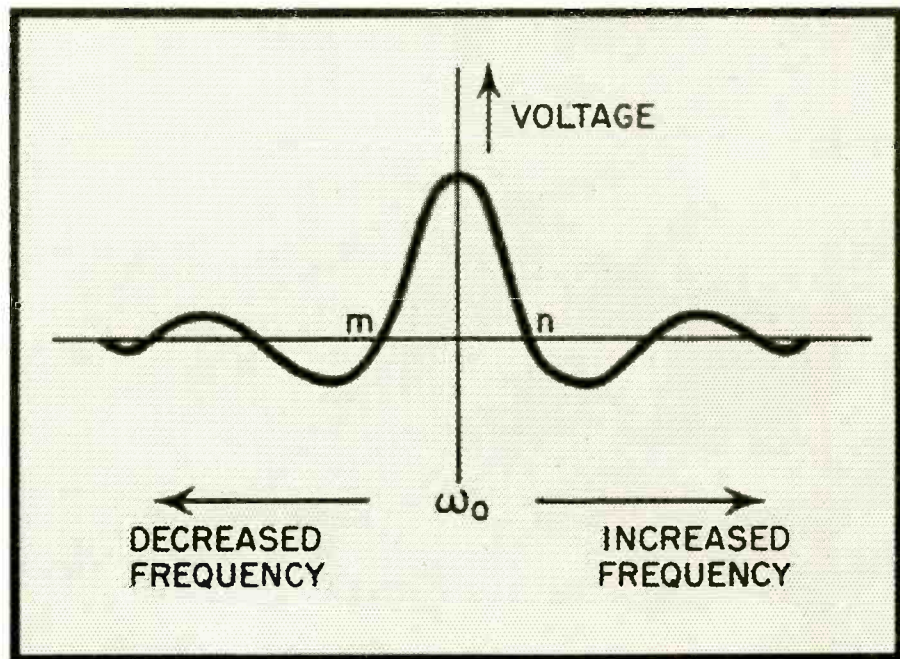

Fig. 3. Rectangular pulse of radio energy of such duration that it contains n complete waves

$$f(t) = 0 \text{ when } -\infty < t < -\pi n/\omega_0$$

$$f(t) = A \sin \omega_0 t \text{ when } -\pi n/\omega_0 < t < \pi n/\omega_0$$

$$f(t) = 0 \text{ when } \pi n/\omega_0 < t < \infty$$

In these equations as in Fig. 3, ω_0 is the angular frequency of the radio wave which is pulsed.

Now, as far as the radio receiver which is to pick up the signal of such a pulse is concerned, the frequency ω_0 has no particular significance. The receiver instead will find it necessary to respond to a whole group of fre-

quencies spread over a considerable band width if it is to reconstruct the pulse. At any frequency designated by ω , the Fourier integral tells us that the receiver must expect a voltage given by

$$V = \frac{A}{4\pi} \left[\frac{-2 \sin[(\omega_0 + \omega)\pi n/\omega_0]}{2 \sin[(\omega_0 - \omega)\pi n/\omega_0]} \right]$$

Where A depends upon the strength of the received signal. At high radio frequencies the first term is negligibly small because $\omega + \omega_0$ in the denominator is such a large quantity. Hence to a good approximation we may simply write

$$V = \frac{An}{\omega_0} \left[\frac{\sin[(\omega_0 - \omega)\pi n/\omega_0]}{(\omega_0 - \omega)\pi n/\omega_0} \right]$$

This is an expression of the form $(\sin x)/x$ which is well known and is plotted in Fig. 4.

If we are willing to assume that the band width required for the receiver is the frequency interval between the cross-over points m and n in Fig. 4, it is possible to obtain a very simple expression for the band width in terms of a percentage of the radio frequency ω_0 . Cross over point n of Fig. 4 is the first positive value of the argument of the sine function in the last expression for V which is able to make V take on a zero value. This occurs when that argument is equal to π . Hence

$$\frac{\omega_0 - \omega}{\omega_0} n = 1$$

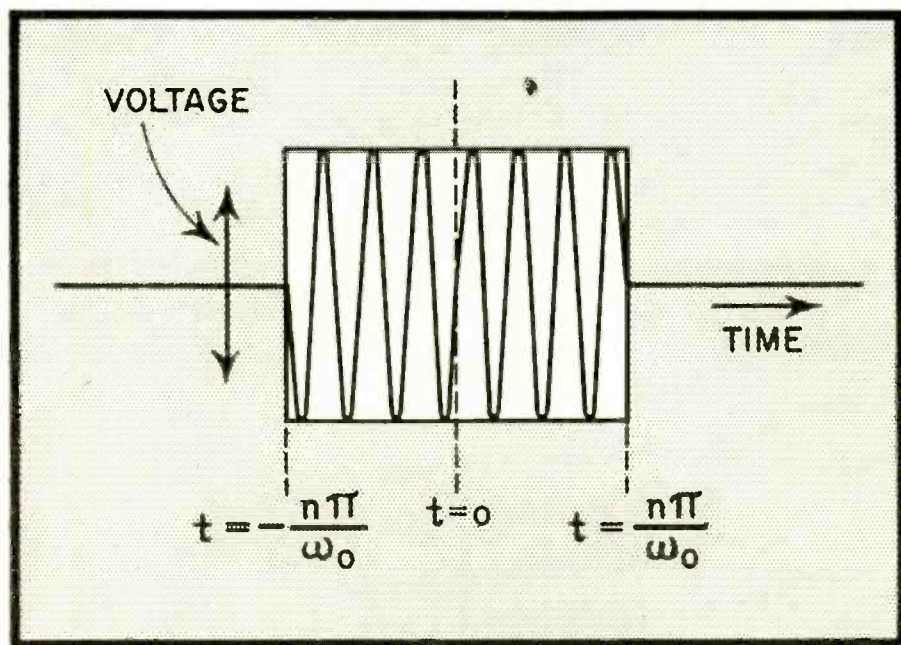

Fig. 4. An example of $(\sin x)/x$ curve which may be interpreted as a plot of amplitude vs. frequency which a radio receiver must detect to reproduce completely a rectangular pulse

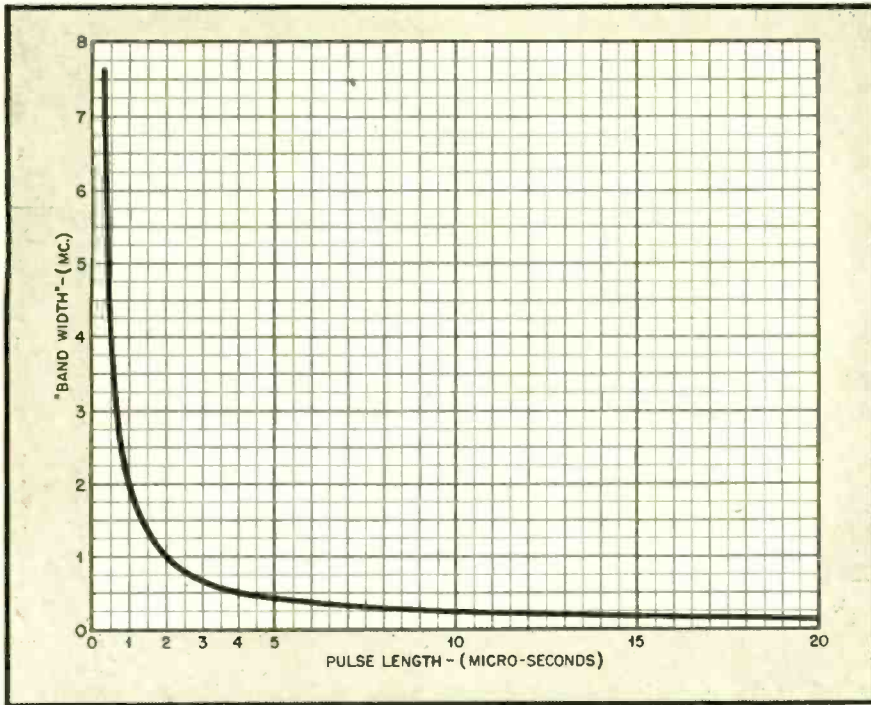

Fig. 5. The bandwidth necessary to transmit reasonable likenesses of rectangular pulse of radio frequency. This curve is reasonably accurate for any high-frequency radio wave. As will be noted, the band width depends only on the pulse duration

Now $(\omega_0 - \omega)$ is just one-half of the band width we require and $2(\omega_0 - \omega)/\omega_0$ is the percentage of the radio frequency which the band width will require. Since we are dealing with only a ratio of ω 's we may equally well

substitute actual frequencies, $f = \frac{\omega}{2\pi}$, for the angular frequencies and finally have

$$B.W. = 2(f_0/n)$$

It is somewhat more convenient to express this in terms of pulse length. If Δ is the length of the pulse in microseconds and f_0 is the transmitter frequency in megacycles it follows that

$$\Delta t \times f_0 = n$$

substituting, this gives

$$B.W. = \frac{2}{\Delta t}$$

This is plotted in Fig. 5.

One drawback to pulse time modulation which at least at present seems to be insurmountable has to do with the synchronization. It seems to be indicated that the system is not one of true multiple channel operation but only one that allows multiplexing. The various transmitters which send out messages over the various time channels must be located together. The receiver may be anywhere but the transmitters must all time their output from a single synchronizing signal. Even if two transmitters could be perfectly synchronized at a distance by means of an auxiliary radio channel or a coaxial

line, the system would still not work because that synchronism would be spoiled for radio receivers used anywhere except at fortuitous locations because of the difference in time of flight from the two transmitters in question.

Fig. 6 shows a possible form of the triggered gate type of circuit that is so important for pulse time modulation. It is designed to produce a gate voltage at the output terminal whenever a positive trigger voltage is applied to the input terminal and otherwise to do nothing at all. It is moreover designed to produce a gate of a given length quite independently of the exact form of the positive trigger voltage. In the absence of a trigger voltage vacuum tube T_1 is approximately at cutoff because of the self-bias introduced in R_4 by current flowing through T_2 . T_2 is not cut off in the undisturbed state because its bias is kept in the conducting region by the high impedance resistance network of R_1 , R_3 , and R_4 . However, when a positive trigger voltage is applied to the grid of T_1 , the situation changes for a while. T_1 begins to conduct and in doing so drops its plate voltage because of a drop in R_2 . This in turn increases the bias on T_2 which causes the plate voltage there to increase and the grid of T_1 to become even more positive because of the voltage carried through the condenser. Thus, as in any multivibrator, the trading of the conduction current from T_2 to T_1 occurs rapidly and completely when it is once started by the

positive trigger. This action raises the voltage on the plate of T_2 and forms the leading edge of the gate.

The gate is maintained as long as the charge on the condenser C is able to hold the grid of T_1 in the conducting region. Consequently, by adjusting C and the leakage resistor R_5 , as well as other circuit constants, the length of the gate may be established.

Once the charge on the condenser has leaked off enough to allow tube T_1 to begin to cut off, another chain of circumstances like the ones described for the leading edge to take control and the conduction current is quickly shifted back to T_2 . This causes the plate of T_2 to rise and hence form the following edge of the gate. Because a resistor has been used at R_1 instead of the condenser that would be there if an oscillating multivibrator were to be used, there is no tendency for the conduction current to trade tubes a third time until another trigger pulse arrives.

Pulse time modulation may prove to have a further advantage when it is necessary to use repeater stations, as will probably be the case with very short wave radio because of the limited range that can be obtained. With pulse modulation, there is no source of distortion due either to tubes or to circuit characteristics as long as the frequency band is large enough to reproduce the pulses with sufficient accuracy. With the f-m type of system it is not even necessary that the pulse shape be maintained in detail as it travels between repeater stations. Only the time position of the pulse is important, and as long as the distortion in pulse shape can be foreseen, it may prove feasible to cause each repeater to reshape the pulse so that cumulative decay in the accuracy of its position does not occur. For telephone circuits, the system appears to hold the most promise.

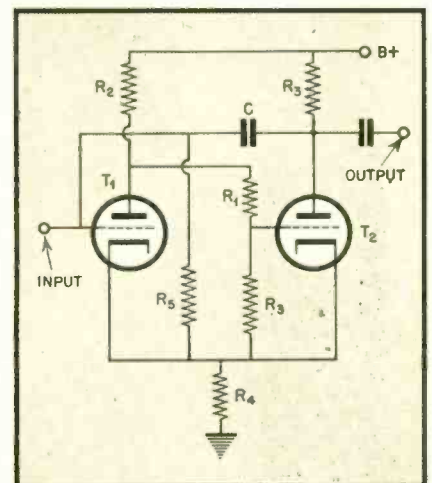

Fig. 6. Gate-forming multivibrator circuit

THE application of the device described in this paper lies definitely within the photographic field. The popularity of photography as an engineer's hobby is well known. This device employs interesting electrical circuits. It also provides an unusual tool for the test, adjustment, or investigation of various flash synchronizing mechanisms. For these reasons we believe that this article will be of timely interest to many readers of this publication.

In the early days of flash photography there may have been some doubt as to the cause of unsatisfactory flash synchronism. Flash bulbs of today are sufficiently uniform to place the onus of responsibility for synchronism faults almost entirely upon the synchronizing mechanism. This is in no way a reflection upon the design or construction of any of the several excellent flash synchronizers. Synchronism failures are almost entirely attributable to maladjustment of these units. This maladjustment may have resulted from abuse or from blind experimental readjustments in an attempt to improve performance. Aside from maladjustment, the only significant cause of synchronism failures is weak batteries. Since this fact is well-known, and the cure obvious, no further discussion lies within the scope of this paper.

The device described in this paper is the development of an idea originally conceived to replace futile, blind, "screw-twisting" with a sound and scientific approach. It is recognized that there are many possible attacks to this problem of attaining synchronism. A few will be mentioned in passing.

Other Methods

One experimental method consists of taking pictures, making adjustments, and repeating this cycle until the desired results are obtained. The chief objections to this method are the time and cost involved and the generally unsatisfactory results obtained.

Another experimental method consists of mounting a flash bulb in such a manner that it may be viewed through the shutter, connecting it to the synchronizer and tripping the synchronizer. This cycle is then repeated until the desired results are obtained. One significant difficulty in this method is in determining exactly when the flash and shutter opening coincide, since to do this precisely requires that the duration of "open shutter" equals the duration of the flash. Although this method may be reasonably satisfactory in view of the time consumed and results obtained, the cost completely eliminates its possibility as being a general practice.

An Electronic TEST FLASH

W. A. HAYES and J. E. BROWDER

This new application of a multivibrator to the photographic field shows how electronic engineers with creative imagination can expand the postwar radio and electronic field

Certain mechanical devices have enjoyed limited favor among a limited few. Since these are rather intricate, frequently cumbersome, and often include many variables difficult to evaluate, a detailed discussion of these will not be attempted.

The unit described in this article provides a flash of controllable duration following a controllable delay after the synchronizer contacts close. The first piece of equipment built to achieve this end was radically different in design. Basically, the timing scheme

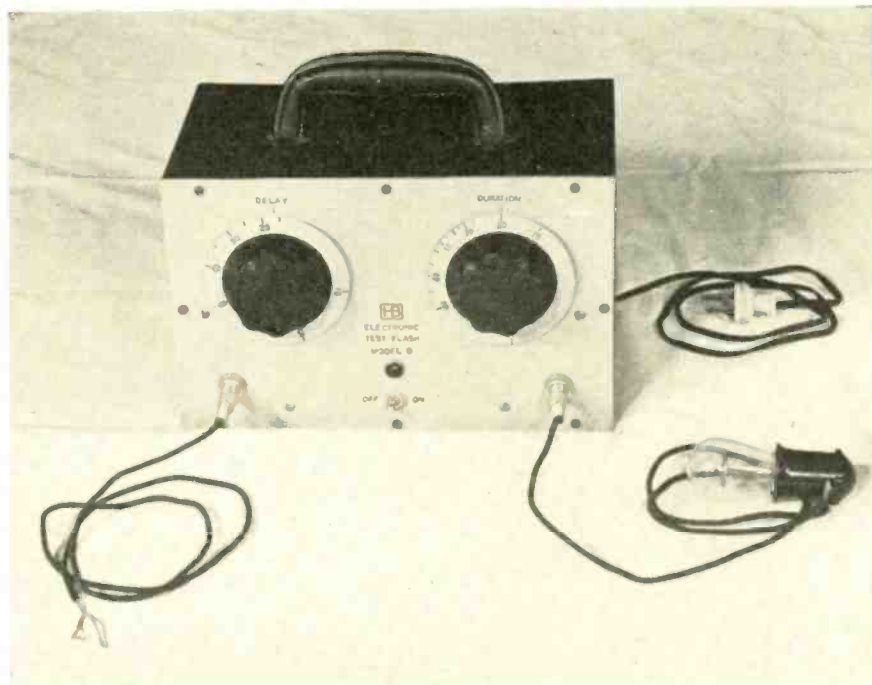

The complete test unit, ready for use

employed in the Model A unit consisted of sliding a reference potential up and down a saw-tooth wave with an abrupt leading edge and an exponential trailing edge. The design of the early model was based upon scientific possibilities and appeared to have an advantage in an exponential calibration curve on the dials. However, in use it was found to be decidedly unsatisfactory for several reasons. It was bulky and cumbersome, it employed a large number of tubes, the calibration was affected by line voltage variations and to quite an extent by temperature, and although it did a job, development of the current unit, Model B, has produced a far more satisfactory unit.

Flash Duration

The unit described and illustrated herein provides for a flash whose duration may be adjusted between the limits of 10 milliseconds and 100 milliseconds. This flash may be made to start immediately upon contact closure or it may be delayed as much as 40 milliseconds. Thus it may be seen that this unit may be made to duplicate the firing characteristics of any flash bulb now available and includes sufficient range in its adjustment to provide for simulating the characteristics of any likely to be developed in the immediate future. A point of significant interest is that the life of this unit is indefinite. It may be used over and over again at any repetition rate that may be required. This unit is not designed to illuminate a picture area but is purely a piece of test equipment for the test, adjustment or investigation of synchronizing mechanisms. The shape of the calibration curve on the DELAY and DURATION dials is controlled by the design of the variable resistors used.

A thumbnail sketch of the basic elements of this device includes the following:

1. Input Circuit
2. 1st Multivibrator (*Delay*)
3. Shaper Circuit
4. 2nd Multivibrator (*Duration*)
5. Oscillator
6. Power Supply

The discussion of these component circuits will be made in the above-mentioned order. Elements are identified by means of the legend used in the accompanying schematic.

In order to make this device as completely universal as possible a great deal of thought was given to the nature of the input circuit arrangement. Some synchronizer contacts close briefly during the operation of the unit, Other synchronizing mechanisms actuate contacts which stay closed during and after the ignition of the flash bulb. A third group of synchronizers incor-

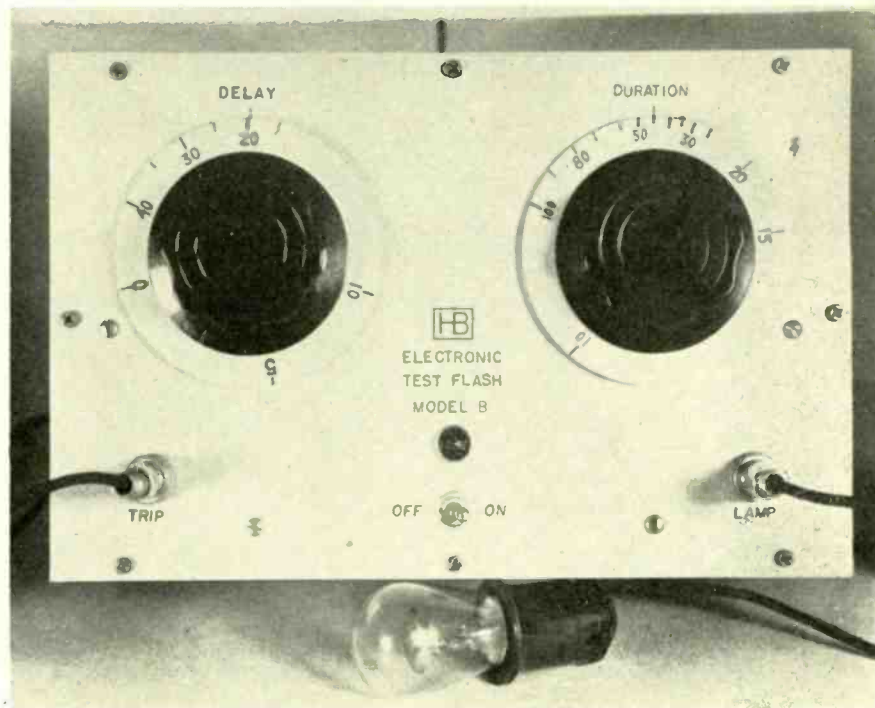

Front view of Model B Test Flash unit

porate magnetic trippers wherein a solenoid is connected across the flash bulb. In order to use this device effectively with all of the above-mentioned types of synchronizers, certain design conditions must be fulfilled.

Differentiating Circuit

The design requirements imposed by the first two above-mentioned groups may be quite conveniently met with the differentiating circuit indicated in the schematic diagram. A differentiating circuit is composed of a resistor and a condenser in series. Although not too generally known, the current in a purely capacitive circuit is the first derivative of the voltage impressed across that circuit. In the case of sinusoidal waves this phenomenon appears to be merely a phase shift because the first derivative of the sine is the cosine. In practice, the current in a capacitive circuit is seldom of significance. However, if this current is caused to flow through a resistance, a voltage is developed which may conveniently be used. If the value of the resistance is low compared to the reactance of the condenser used, a voltage drop across this resistance appears, which is a reasonably accurate derivative of the voltage applied across the series resistor-condenser combination. The fundamental requirement of a differentiating circuit is that the resistance be sufficiently small or the reactance be sufficiently great to cause the reactance, and not the resistance, to determine the current flow.

R_1 and R_2 form a voltage divider across the B supply. C_1 and R_3 form a conventional differentiating circuit. Under stand-by conditions C_1 charges through R_1 and R_3 to a potential determined by the ratio of R_2 and R_1 . Since R_1 is high compared to R_3 , the charging surge is of relatively long duration and relatively low amplitude and is not a differentiation of the applied wave, since R_1 and not C_1 , determines the current flow. By a cable and suitable adapters, synchronizer contacts are connected to J_1 . At the instant these contacts close, the path through C_1 - R_3 is completed through the synchronizer contacts discharging C_1 through R_3 . Since the inductance of the connecting leads and the resistance of R_3 are small compared with the reactance of C_1 , the current flow is determined largely by C_1 which has previously been charged positively with respect to its grounded terminal. As C_1 discharges through R_3 , the IR_3 drop is brief in duration and negative with respect to ground. Since the time constant of C_1 - R_3 is quite short (1/50 millisecond), C_1 completely discharges in less time than "fly-by" synchronizer contacts remain closed. Thus it will be seen that the IR_3 spike is of full amplitude even when tripped by "fly-by" contacts. This negative IR_3 spike trips the first multivibrator, which will be discussed in detail later. In the event that the synchronizer contacts remain closed after the instant of contact, the spike generated, in the manner above described, is the same. Un-

til the contacts open and allow C_1 to recharge, no further current flow occurs.

Mechanical Trippers

If this device were to be used only with mechanical trippers, the design of the C_1 - R_3 differentiating circuit could be much less critical. For example, a time constant of the order of several milliseconds might be employed. However, the application of this device to synchronizers employing magnetic trippers imposes more rigorous design requirements. In order to use this device with a magnetic tripper, it is necessary to use the solenoid to trip the shutter in the conventional manner since the delay in this type of unit is provided for in the design and adjustment of the solenoid tripper, and no other means of tripping the shutter may be readily considered an exact substitute for the solenoid tripper.

Thus it may be seen that the initiating stimulus in the case of the magnetic tripper is the voltage appearing across the tripper coil which is permanently connected across R_2 by means of the connecting cable, and is not the closure of normally-open contacts. The differentiating circuit employed in this device has been chosen to differentiate the rectangular wave of voltage appearing across the tripper coil when the actuating switch is closed, as well as to provide a similar standard initiating impulse when used with mechanical trippers having normally-open contacts.

Because of the extreme flexibility achieved through this input circuit, a very convenient means of connecting

this device to any flash equipment consists of connecting two tip jacks to a bayonet base such as is used in the miniature bulbs, and providing an adapter from bayonet base to Edison base. The cable from this device ends in phone tips which may be inserted in the tip jacks in the bayonet base adapter. The reason for using phone tips between the cord and the bayonet base adapter is that the input circuit is polarity discriminating, and to insure effectiveness on all makes of synchronizers, these tips may be reversed in the tip jacks to provide proper input polarity without regard for the polarity of the batteries used in the flash synchronizer. The polarity of the signal applied to J_1 should be negative with respect to ground.

In the case of mechanical trippers the input circuit may be connected directly to the synchronizer contacts or, quite as effectively and more conveniently, it may be connected in the flash bulb socket. This arrangement not only provides a significant measure of convenience, but it also eliminates the need for a large number of adapters to connect to the various tripping mechanisms employed in current flash guns. The battery polarity may be disregarded in this connection.

Summarizing the characteristics of the input circuit, we find that a negative IR_3 spike is generated by contact closure with any of the previously mentioned synchronizer arrangements.

This negative spike is capacitively coupled through C_2 to the trigger grid of the first multivibrator. V_1 and V_2 form the first multivibrator, commonly known as an Eccles-Jordan or flip-flop

trigger circuit. Under quiescent conditions V_1 conducts, producing a drop across R_5 which causes V_2 to remain cut off since its grid is connected to the midpoint of the voltage divider R_6 - R_8 , one end of which is connected to the plate of V_1 , the other end of which is returned to a point negative with respect to its cathode. If a negative impulse is applied to the grid of V_1 , this tube cuts off, eliminating the drop across R_5 and bringing the grid of V_2 to a potential where V_2 will conduct. This causes C_3 to charge to a new potential at a rate determined by its capacity and the value of R_4 . It may be seen that this appears as a negative signal on the grid of V_1 , accentuating the sharpness of cut-off and causing V_1 to remain cut off until C_3 has charge. At this time V_1 again starts conducting with an abruptness accentuated by the positive signal applied to the grid of V_1 through C_3 . As a result, this V_1 - V_2 multivibrator may be seen to generate a rectangular wave with very steep sides.

It is interesting to note that the duration of this rectangular wave is not in all cases accurately indicated by the time constant of C_3 - R_4 , since the time constant of an R - C circuit is defined as the length of time required for the charge to change from its initial value to $1/e$ (approximately 37%) of that value. The trigger range of the multivibrator circuit may be significantly different from the voltage range upon which time constant computations are based. In the trigger circuit described, the voltage excursion is appreciably greater than the time constant range, since the time constant of the circuit employed is of the order of 15 milliseconds, and the timing of the multi-vibrator is approximately three times that value.

Impulse Duration

Summarizing the characteristics of this multivibrator we find that a rectangular wave is generated by this multivibrator. The duration of this impulse is determined by the values of C_3 and R_4 , and the leading edge is coincident in time with the leading edge of the negative spike generated by the input circuit.

The output impulse from this multivibrator (negative in polarity) is capacitively coupled from the plate of V_2 to the grid of V_3 by means of C_4 . V_3 normally conducts, producing a large drop across R_{10} , therefore the condenser C_5 is quiescently charged to a relatively low potential. When the negative rectangular wave generated by the 1st multivibrator is applied to the grid of V_3 , this tube is cut off, allowing C_5 to charge through R_{10} and R_{11} . The rate of charge is determined



Test Flash unit with typical cameras and flash lamps

largely by the value of R_{10} . At the trailing edge of this rectangular wave, V_3 is again allowed to conduct, discharging C_5 through the plate resistance of V_3 and R_{11} in series. Since R_{11} and the plate resistance of V_3 are relatively small, the discharge of C_5 is quite abrupt. This discharge current flowing through R_{11} develops a voltage spike negative with respect to ground. The IR_{11} spike may thus be seen to approximate in shape the IR_3 spike previously mentioned, and serves to trip the second multivibrator. In order to insure positive tripping of the second multivibrator, the value of R_{10} must be large compared with the combined resistance of the tube (V_3) and R_{11} . Under conditions such as exist in this equipment, the resistance of the tube may be considered to be of the order of 10,000 ohms. The basic requirement of V_3 and its associated cir-

cuits is to produce a negative spike coincident in time with the trailing edge of the rectangular wave generated by the first multivibrator (V_1 - V_2).

Summarizing the operation of this shaper circuit, we find that the presence of a negative rectangular wave on the grid of V_3 allows C_5 to charge, and the termination of this wave allows C_5 to discharge through V_3 and R_{11} , generating a negative spike. Thus it may be seen that the IR_3 spike and the IR_{11} spike are separated in time by the duration of the rectangular wave generated by the 1st multivibrator. Since the IR_3 spike is coincident with contact closure and the IR_{11} spike trips the second multivibrator, the condition of controllable delay by adjustment of the first multivibrator has been achieved.

The function of the second multivibrator (V_4 - V_5) is to provide a pulse of adjustable length for the purpose of controlling the oscillator. The operation of this multivibrator is identical with that of the 1st multivibrator previously described in some detail. The only difference in these multivibrator circuits lies in the timing circuit C_7 - R_{12} which has been chosen for operation over a range of from 10 to 100 milliseconds.

The output impulse of the second multivibrator (negative in polarity) is capacitively coupled to the grid of V_6 . The time constant of this coupling network is of considerable significance. In order to insure proper operation of the succeeding circuits, it is necessary to use a relatively large RC product. In order to insure accurate timing it is necessary that the rectangular wave applied to the grid of V_6 maintain this tube at cut-off for the full duration of this wave. If the time constant of this coupling network is too small, its low frequency response will be limited and the tube may start to conduct before the termination of this impulse. It is also important that the storage capacity of this time constant be somewhat limited in order that the rectangular impulse applied to the grid of V_6 be sufficiently abrupt to insure accurate timing. An acceptable means of attaining these ends was found to be the use of a condenser of 0.2 μ fd capacity, and a total resistance of the order of 5 megohms. Since the voltage required to operate V_6 is small compared to the voltage output of the multivibrator, a voltage divider was employed. This arrangement provided for a long time constant with a moderate amount of resistance from grid to cathode, and removed the significant portion of the timing resistance from such effects as leakage across the socket, etc.

The function of V_6 is to key the os-

illator. Under quiescent conditions the absence of bias on V_6 allows it to draw plate current through R_{19} , causing a voltage drop which renders the oscillator inoperative. When the rectangular wave impulse from the second multivibrator is applied to the grid of V_6 , this tube stops conducting, thereby removing the drop across R_{19} and allowing the oscillator to function. At the end of this rectangular impulse the tube again becomes conducting, causing the voltage drop across R_{19} to bias the oscillator to cut-off.

Summarizing the operation of V_6 and its associated circuits, we find that this tube keys the oscillator for the duration of the rectangular impulse applied to it by the second multivibrator. Thus the condition of controllable duration by adjustment of the second multivibrator has been achieved.

Oscillator

The oscillator (V_7) is a conventional Hartley circuit with the bias arrangement just described chosen to insure good keying characteristics. In the model described the oscillator operates at approximately 8 kilocycles. This frequency is determined by the design of the transformer and the capacity of C_{10} . In order to insure good keying characteristics it is imperative that the time constant of the bias circuit be held to an absolute minimum consistent with stable performance. If the time constant of this bias circuit be made large, accuracy of calibration will be sacrificed because the charging time will be significant.

The output of the oscillator is capacitively coupled through C_{11} to the neon lamp connected at J_2 . In the event that slight leakage across C_{11} causes faint occasional flickers in the neon lamp, this condition may be remedied by shunting the lamp with some relatively high resistance, e.g., 1 megohm, which will act as a voltage divider in conjunction with the leakage resistance of C_{11} , and reduce the d-c potential across the lamp to a point well below the ignition potential without affecting the performance of the unit.

Summarizing the operation of the oscillator (V_7) and its keying tube (V_6), we find that the application of a negative rectangular impulse to the grid of V_6 cuts this tube off, returning the oscillator to normal bias. The oscillator then functions, generating audio frequency energy to light the neon lamp. When this negative rectangular impulse ends, the oscillator is biased to cut-off, extinguishing the lamp. The keying characteristics of this oscillator driving the neon lamp are excellent. The rise time and decay time of this keyed oscillator were found



The Electronic Test Flash unit is light and readily portable

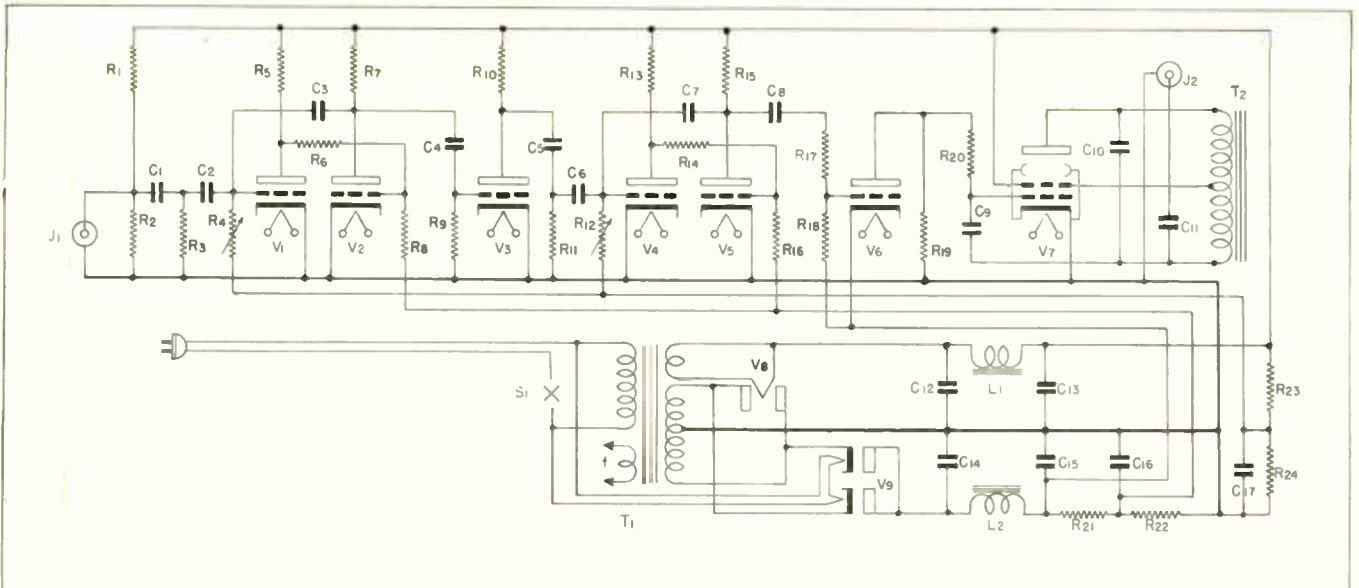

C1	0.004 μf MICA	J1	TRIP CIRCUIT JACK (M)	R14	500K 1/2W CARBON	V3	HALF 7N7 OR 6SN7
C2	250 μf MICA	J2	NEON LAMP JACK (F)	R15	30K 2W CARBON	V4	HALF 7N7 OR 6SN7
C3	0.01 μf MICA	L1	10MG 50MA CHOKE	R16	500K 1/2W CARBON	V5	HALF 7N7 OR 6SN7
C4	0.01 μf PAPER 400V	L2	20MG 20MA CHOKE	R17	5MEG 1/2W CARBON	V6	HALF 7N7 OR 6SN7
C5	1000 μf MICA	R1	250K 1/2W CARBON	R18	500K 1/2W CARBON	V7	705 OR 6V6
C6	250 μf MICA	R2	25K 1/2W CARBON	R19	10K 1W CARBON	V8	5W4 OR SIMILAR
C7	0.005 μf MICA	R3	5K 1/2W CARBON	R20	30K 1W CARBON	V9	117Z6GT
C8	0.2 μf PAPER 400V	R4	1.5 MEG AUDIO TAPER	R21	100K 1W CARBON		
C9	1000 μf MICA	R5	30K 2W CARBON	R22	500K 1W CARBON		
C10	1000 μf MICA	R6	500K 1/2W CARBON	R23	300K 1W CARBON		
C11	1000 μf MICA	R7	30K 2W CARBON	R24	1K 1W CARBON		
C12	10 μf ELECTROLYTIC 300W.V	R8	500K 1/2W CARBON	S1	LINE SWITCH		
C13	10 μf ELECTROLYTIC 300W.V	R9	500K 1/2W CARBON	T1	POWER TRANSFORMER		
C14	0.1 μf PAPER 400V	R10	200K 1W CARBON	T2	P-P OUTPUT TRANS		
C15	40 μf ELECTROLYTIC 300W.V	R11	5K 1/2W CARBON		TUBES		
C16	0.05 μf PAPER 400V	R12	2 MEG AUDIO TAPER	V1	HALF 7N7 OR 6SN7		
C17	0.05 μf PAPER 400	R13	30K 2W CARBON	V2	HALF 7N7 OR 6SN7		

SCHEMATIC
ELECTRONIC TEST FLASH
 DESIGNED BY
W.A.HAYES & J.E.BROWDER
MODEL "B" SINGLE RANGE
 DRAWN F.P.C. 10-10-44 CHECKED W.A.H. 10-12-44

Schematic diagram and parts list of the complete Model B Electronic Test Flash Unit

to be not greater than 1/2 cycle at 8000 cps.

Power Supply

The power supply incorporated in this device is essentially conventional. The 5W4 is used in a conventional full-wave rectifier circuit. The 117Z6 is used as an inverted rectifier to obtain negative potential from the same power supply. The choice of this tube was based upon its convenient filament voltage and the fact that it is two independent diodes in a single envelope having adequate current carrying capacity. The use of a 6H6 for this application was not practical.

The essential structural details may be seen from the accompanying photographs, and convenience, or available materials, will in most cases dictate the mechanical arrangement employed.

In order to calibrate this device, the use of an oscilloscope is indicated. A signal from the oscilloscope sweep may be used to trigger the 1st multivibrator by capacitatively coupling into J1. One precaution, however, must be observed in regard to repetition rate. The dynamic regulation of the power supply

is the most significant factor in determining the maximum tolerable repetition rate. On the model described, trigger rates not exceeding 10 per second were found to have no effect upon calibration. If the trigger rate is too rapid, the high duty cycle will alter by a significant amount the B+ potential, and consequently affect the calibration of the unit. Over reasonable voltage variation limits, the calibration is not significantly affected by the B+ potential.

The use of random tripping arrangements in calibrating this device are quite unsatisfactory. A very effective means of meeting the two apparently contradictory requirements is to use a very low frequency sweep (e.g., 5 to 10 cps) and relatively high gain on the horizontal sweep. This not only insures effective synchronism between the oscilloscope and this device and an acceptable duty cycle, but also makes use of only the early portion of the oscilloscope sweep wherein the linearity is, in general, best. If the oscilloscope is fitted for Z axis timing, this arrangement will be found most convenient. In the event that the oscilloscope is not

equipped for Z axis timing, a number of dodges are available. A signal of known frequency (e.g., 1 kilocycle) may be superimposed upon the vertical channel in any convenient means, or the frequency of the oscillator in this device may be determined and its frequency used as a time standard on the screen.

Relatively few precautions need be considered in the layout and wiring of this device except that all grid and plate leads should be as short, direct, and isolated, as is possible.

Applications

The uses of this device are almost self-evident. If one wished to determine the delay between the instant of contact closure and shutter operation, a convenient approach might be to set the shutter at 1/100 sec., the DURATION dial at 10 milliseconds, and trip the synchronizer at several settings of the DELAY dial. At one setting of the DELAY dial the total flash of 10 milliseconds' duration will be seen through the shutter which is open for

[Continued on page 68]

Measurement of Receiver Characteristics

A. C. MATTHEWS

A thorough analysis of methods and technique used in laboratory tests of broadcast receivers

SINGLE STAGE MEASUREMENTS

IN PART ONE the required equipment for making receiver measurements was discussed. Assuming the equipment to be in good order and calibrated, and assuming the component parts of the receiver to be as specified in the design, we are now ready to make single-stage measurements. In this article no attempt will be made to discuss design problems such as decoupling filters, chassis layout, by-passing and ground connections because of the limited space. It is assumed the receiver being measured has already had these refinements in design incorporated.

A logical beginning would be to start with the audio amplifier, work back through the second detector or discriminator, the i-f amplifier, converter-oscillator and the r-f stage. As each independent section is found satisfactory it is combined with the preceding section until the entire receiver is operating as a single unit.

Audio Amplifier

Fig. 10 shows a typical set-up for the measurement of audio amplifier characteristics. The output load resistor is connected across the primary of the output transformer through coupling capacitors having at least 10 μ fd capacity. These capacitors should have a minimum of capacitance to ground. With a single-ended amplifier as shown, only the capacitor in the high side (plate lead) would cause an erroneous reading; however, if a push-pull amplifier were being measured both capacitors would affect the results if there were any appreciable capacity to ground; this would attenuate the high audio frequencies as shown in Fig. 11.

PART 2

Some engineers prefer to measure the output voltage from output plate to ground; this method may be used but it is rather inconvenient for push-pull amplifiers unless the output of only one tube is measured. Incidentally, any ripple voltage appearing across the final filter condenser is also included in the measurement. This is of relatively little importance under ordinary circumstances unless distortion measurements are to be made at low power levels or when a-c/d-c powered receivers are being checked, in which case considerable trouble may be experienced.

At audio frequencies most ground connections are effective, nevertheless, it is good practice to ground the amplifier and the measuring equipment at one point, thus eliminating a possible source of error due to ground currents between the parts.

Having made the necessary connections we are ready to measure the characteristics of the amplifier. First, record voltages at all important points, i.e., grid bias, screen, plate and line supply, setting the latter at 117 volts as a nominal value. Record also the load resistance and a schematic of the amplifier giving all values of components.

This cannot be stressed too much as it eliminates beyond a doubt any question later as to just what the values of certain components were when the data was taken. It will also be par-

ticularly helpful if it is necessary to change the value of some part in order to obtain a more desirable result.

Usually the specifications require a certain undistorted output and most engineers measure this characteristic first. The procedure consists of applying an audio frequency of 400 cycles to the input of the amplifier and increasing it in small increments as the output voltage and distortion across the load resistor are measured. A high-pass filter should be connected between the amplifier load and the output meter during these measurements. A typical curve is shown in Fig. 12. If the input voltage is measured simultaneously with the output voltage the gain of the amplifier may be determined and an indication of when the peak input voltage equals or exceeds the normal amplifier bias is obtained.

If an oscilloscope has been used to monitor the output wave, experience will be obtained in correlating distortion and waveform. The internal sweep of the oscilloscope should be used for this check. Having determined the output capabilities of the amplifier and finding it to be satisfactory the next information of interest is the frequency response or fidelity. For home radio receivers we are mainly interested in the amplitude vs. frequency characteristic from 30 to 10,000 cycles. But it is possible to have a perfectly flat amplitude vs. frequency characteristic and yet, on a listening test, the fidelity may be objectionable, due to phase shift in the amplifier. As a simple means of checking this an oscilloscope may be employed as shown by the dotted connections in Fig. 10. Proper adjustment of the amplitudes of the input and output voltages should result in a straight

line or a narrow ellipse on the scope screen. The phase angle can be approximated by measuring the distances *AA* and *BB* on the screen as shown in Fig. 13 and calculating the ratio between them. Checks should be made at several points throughout the range.

The fidelity characteristic is obtained by maintaining a constant voltage input to the amplifier while varying the frequency in steps from 30 to 10,000 cycles and measuring the voltage across the output load. Data should be taken at the normal test output (see Table 1, Part 1). The amplitude at 400 cycles is taken as the reference point for audio measurements and the output at all other frequencies are compared to this reading. The fidelity curve is plotted in per cent of 400 cycle response vs. frequency, as shown in Fig. 11. Should the design include a tone control, curves should be repeated with the control or controls adjusted for both maximum and minimum response at high and low frequencies. Many receivers are so designed that the fidelity changes with different settings of the volume control; for example, circuits which include a tap on the control for bass compensation at low volume levels. Such receivers should be measured at the point where maximum compensation occurs. Receivers having excessive tone compensation may have a tendency to overload at certain audio frequencies. If this occurs obviously the curve should be repeated with less output.

Hum

Two methods of hum measurement are commonly used. The first method assumes no hum is present in the speaker when it is disconnected from the receiver. Should this be the case it is only necessary to connect a vacuum-tube voltmeter across the output load resistance with the volume control at minimum and measure the r-m-s volts output. Tone controls should be adjusted for maximum and minimum hum readings. A check should also be made with the power supply cord reversed and, if found to affect the magnitude of the hum reading, this should be noted. An attempt should also be made to measure the hum at maximum volume, although this does not always give a true picture unless the audio input is properly loaded. It may, however, indicate the need for "dressing" critical leads away from hum-carrying components or other leads.

The preceding method, while simple to perform, unfortunately is seldom applicable to most receivers since an appreciable amount of hum will usually exist with the speaker voice coil disconnected. This is caused by hum

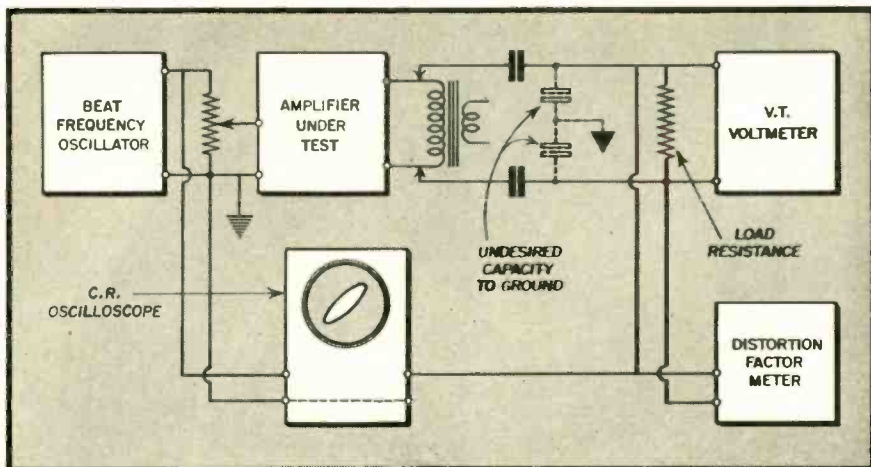

Fig. 10. Typical setup for measuring audio amplifier characteristics

current in the speaker field being induced into the voice coil. Such being the case, the hum should be measured in terms of current through the voice coil with the speaker connected. This procedure takes into account the hum originating in the receiver proper and also hum induced in the voice coil from the field. The hum-measuring equipment must not introduce an appreciable impedance in the voice coil circuit.

Measurements by either method should be converted into apparent power output.

Square Wave Testing

The testing of audio amplifiers with square waves instead of the usual sinusoidal wave forms offers exceptional possibilities for a quick checkup during development work. Because this is true and as this method will undoubtedly become more popular a brief summary of the technique will be given.

Square waves are composed of a large number of frequencies, depending upon the steepness of the wave front, the duration and repetition rate. For this reason the characteristic of an amplifier may be quickly determined by simply applying a square wave to the input and observing the resultant wave form on a cathode ray oscilloscope after it has passed through the amplifier. The fundamental frequency of a square wave is the lowest sinusoidal component included therein. Should the square wave output as observed on the oscilloscope appear different in shape than the original wave, the amplifier characteristic is deficient in some respect. Fig. 14 shows a few representative curves with deficiencies as noted.^{7, 8}

Second Detector

The measurement of second detector sensitivity is made with a modulated r-f signal generator. With the

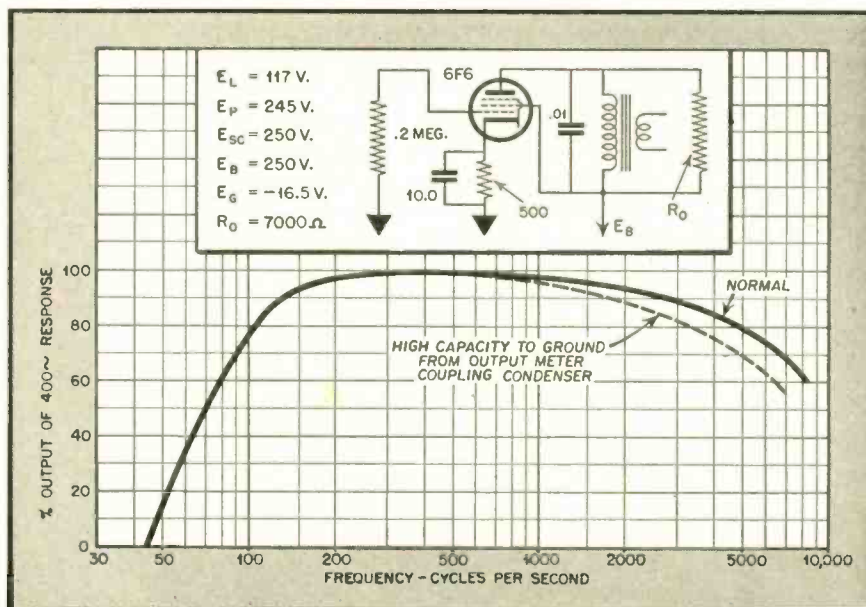

Fig. 11. Typical fidelity curve of audio amplifier. The output meter is connected across the output load resistor, R_0

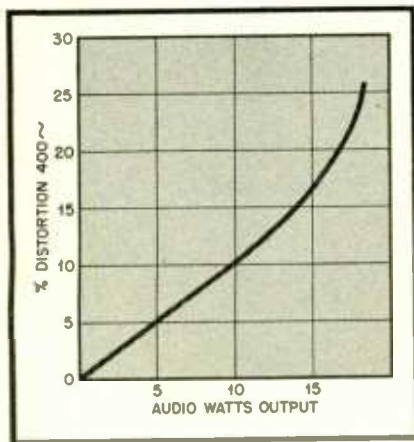

Fig. 12. Typical power output curve

volume control adjusted to maximum, the tone control set for normal operation, and the preceding i-f amplifier input circuit shorted, the r-f signal is applied through a 250 μmf condenser as shown in Fig. 15. Connection is made from the high side of the diode to ground; except for a-c/d-c powered receivers where $-B$ is used in place of the usual ground connection. An 0.05 μfd condenser should also be placed between the signal generator low-side and $-B$ to prevent accidental grounding of the power line should the polarity of the line be incorrect.

Having made these connections the signal generator output (tuned to the frequency of the i-f amplifier and modulated 30% with 400 cycles) is increased until normal test output is indicated on the receiver output meter. This measurement gives the total audio gain of the receiver for a 30% modulated signal. By increasing the amplitude of the signal the output of the receiver should increase up to the overload point of the output stage. If the maximum output previously measured on the audio amplifier is not reached, the overload characteristic of the second detector is obviously poor.

A test of the modulation capabilities of the detector should be made by maintaining normal test output from the receiver while the per cent modulation is increased from 30 to 100%. Distortion should be measured with modulating frequencies of 400, 2000 and 5000 cycles. By maintaining constant normal test output the distortion due to the audio amplifier is constant. Fig. 16 shows a typical curve of per cent distortion vs. modulation as measured correctly and incorrectly. By keeping constant output at the normal test level the per cent distortion curve remains essentially flat up to the point where the detector is incapable of handling signals of high percentage modulation. This point is determined by the design of the detector.⁵

When the output is not maintained at a constant level but allowed to increase with per cent modulation the audio power output will increase as a function of the modulation percentage and overloading will occur in the final amplifier stage with consequent increased distortion.

The accepted standard for second detector sensitivity is taken as the value of r-f input modulated 30% with 400 cycles which will produce normal test output across the dummy load resistor.

FM Discriminator and Limiter Stages

FM receivers require a different type of second detector than AM receivers and therefore the method of measurement described above does not apply. The second detector of an FM receiver is commonly known as a dis-

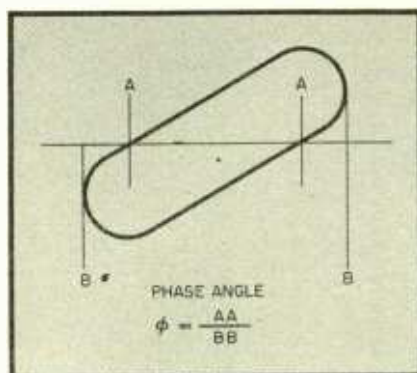

Fig. 13. Phase distortion calculation from oscilloscope pattern

criminator and usually operates in conjunction with a limiter stage (either single or cascade). The important characteristics of a discriminator include sensitivity, linearity and fidelity. Because of the difficulty in simulating actual working conditions, measurements are usually made with the limiter or preceding amplifier functioning in a normal manner.

The receiver may easily be aligned by using an FM signal generator and observing the discriminator curve on a cathode ray oscilloscope. As in AM measurements a modulating frequency of 400 cycles is used. By inserting a separate audio signal to amplitude modulate the generator, the discriminator curve will be filled-in as shown by the dotted lines in Fig. 17. Most generators are provided with such a connection. The 60-cycle power line fed through a Variac is ideal for this purpose and will assist materially in making the proper adjustments and obtaining a balanced output. The curve shown requires the scope be synchronized from the FM signal generator; if an internal sweep is used, instead of a

single curve two curves will appear, unless the sweep circuit is so designed that the return trace is eliminated.

Discriminator Curve

After having properly aligned the receiver the discriminator curve may be checked by the point-to-point method with an unmodulated signal. For this measurement an ordinary r-f signal generator may be employed by varying its frequency in steps over a range corresponding to the amount of normal deviation desired. Fig. 18 shows a representative set-up. The unmodulated r-f signal is first adjusted to the center frequency of the i-f amplifier which should correspond to the zero voltage point on the vacuum-tube voltmeter. Now, as the signal frequency is varied in steps of ten kc above and below the center frequency (depends upon the required deviation, 10 kc is representative for a deviation of plus and minus 75 kc) the d.c. developed by the discriminator is recorded at each point. The meter terminals must be reversed as the frequency crosses from one side of center to the other. Plotted, this data should take the form of an integral sign with its ends turned in. Sensitivity may be indicated as volts per kilocycle deviation over the linear portion of the curve, correcting, of course, for the gain due to the limiter stage.

The tube voltmeter is now disconnected from the discriminator and the audio amplifier is again connected. The FM signal generator is modulated 30% with 400 cycles (30% modulation is equal to 22.5 kc deviation, assuming full deviation to be 75 kc) and the volume control is adjusted to give normal test output on the output meter. The modulating frequency is then varied over the audio range and the output measured in per cent of the output at 400 cycles, thus giving the fidelity characteristic.

Another characteristic of importance is the distortion vs. per cent modulation curve. Here we maintain a constant audio output of normal test level and vary the per cent modulation (deviation) from 10 to 100% while simultaneously measuring the output distortion. This is equivalent to checking the amplitude modulation capabilities of an AM second detector as described

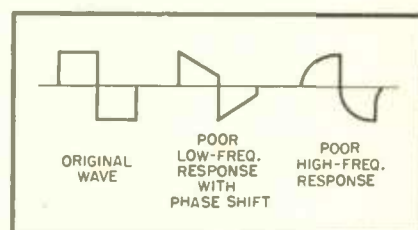

Fig. 14. Square wave response curves

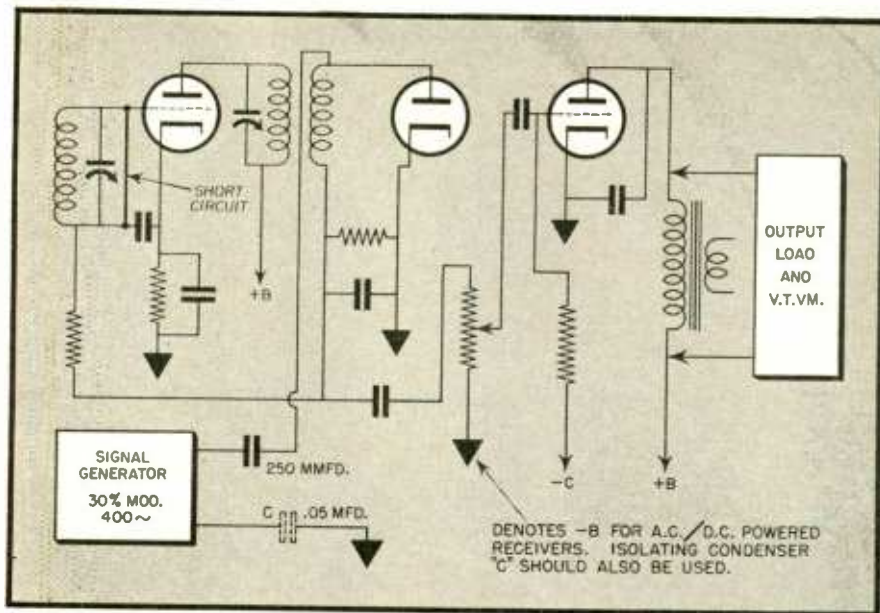

Fig. 15. Connections for second detector sensitivity measurement

previously. It should be possible to correlate the distortion vs. per cent modulation curve with the linearity of the discriminator curve.

The limiter, whether single or cascade, is measured as a unit. The i-f signal input is applied to the grid of the limiter tube (through the usual coupling network) and the output of the stage is measured with a vacuum-tube voltmeter. An input-output limiter curve should result as shown in Fig. 19. Selectivity is checked by selecting a value of input from the limiter characteristic sufficiently beyond the knee of the curve to assure good limiting action. With this input the generator frequency is varied in steps on each side of the center frequency and any change in limiter output recorded. This curve will be essentially flat over the i-f pass-band if adequate limiting is present.

I F Amplifier

The technique of i-f amplifier measurements is an important part in the series of checks made on a receiver. Due to the relatively high order of amplification and selectivity involved, the effects of regeneration and degeneration are very likely to cause considerable trouble in the proper evaluation of the amplifier characteristics. It is therefore imperative that these measurements be made with extreme care. This is particularly true when more than one stage is being measured in cascade.

The characteristics of an i-f amplifier stage are measured by applying an unmodulated signal of the proper frequency through the coupling network to the grid of the i-f tube. The secondary of the i-f transformer in the plate circuit of the stage under meas-

urement is then disconnected from the grid of the following tube and a tube voltmeter connected in its place. An exception to this procedure is where the i-f stage is feeding a diode second detector. Here the tube voltmeter would not simulate actual operating conditions so it is customary to have the diode connected and operating during the measurement. The avc, however, should be disconnected by returning the i-f grid through its decoupling resistor and capacitor to $-B$.

After having made the necessary connections it is then advisable to make sure that the stage being measured is thoroughly isolated from the effects of the other sections of the receiver. For instance, if due to extraneous pickup, a signal is introduced into the second detector circuit an avc voltage may be developed which might feed back to the grid of the i-f stage being measured. This obviously would not represent normal operation and must be prevented. A common method of rendering the second detector insensitive to such pickup is to shunt a bypass condenser (0.05 μ fd) across the diode. The input of the preceding stage should also be shorted in the same manner as before, when the second detector was being measured.

Stage Gain

Stage gain is determined by adjusting the amplitude of the input signal from the generator to obtain a convenient reading on the tube voltmeter. A value of 1 volt rms is ordinarily used for this purpose because this is not high enough to cause overloading of the stage being measured, yet is large enough to be easily read on the tube voltmeter. The gain is determined by dividing the value of the output

voltage by the input signal voltage and is expressed as a numerical value.

Assuming the stage gain to be satisfactory, the next measurement should be the selectivity, A.C.A. and coupling factor. These three parameters together with the stage gain gives us a complete story of the stage performance. Equipment connections remain the same as for gain measurements. With the frequency of the signal generator adjusted to the center of the i-f band, the input is set to give an output of 1 volt on the tube voltmeter. This input will be the reference point of the curve and all other input voltages will be referred to it in determining the curve. Detune the signal generator two, five, ten, twenty, etc., kc; first above and then below the resonant center frequency, adjusting the input each time to maintain a constant output of 1 volt, until the input has been increased at least 1000 times that of the initial value or the output of the signal generator exceeds one volt. The data thus obtained can be plotted on semi-log paper as shown in Fig. 20, where the frequency in kilocycles is plotted as abscissas on a uniform scale and the input ratios (resonant frequency equals one) plotted as ordinates on a logarithmic scale.

The A.C.A. (adjacent channel attenuation) may now be determined from the curve by reading the ratio of input required at 10 kc from resonance and recording it as a numerical value; for instance, in the curve Fig. 20, the A.C.A. is +5 and -4.5.

The coupling factor can likewise be determined from the selectivity curve. This is expressed as W_{10}/W_2 and is obtained by measuring the bandwidth of the selectivity curve where the attenuation is 10 times and 2 times down.

Converter Or First Detector

The measurement of converter characteristics is quite similar to those just described for the i-f amplifier. Instead of feeding an i-f signal to the grid, an unmodulated r-f signal is used, al-

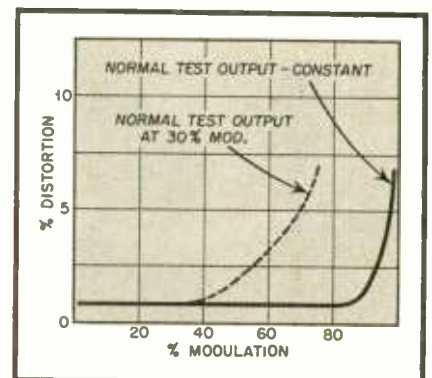

Fig. 16. Distortion vs. percent modulation curve showing effect of not maintaining constant normal output

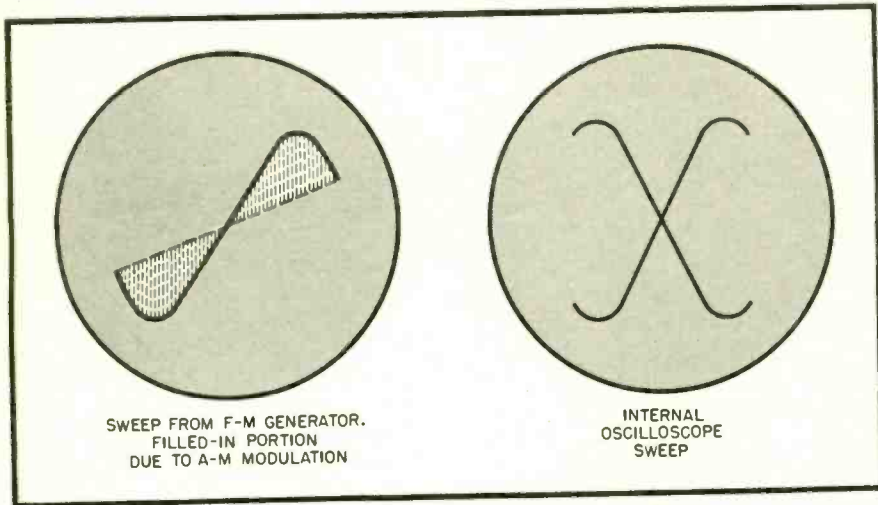

Fig. 17. FM discriminator curve as seen on oscilloscope

though, for record purposes the gain at i.f. should be initially measured. This will serve as a check on the operation of the stage at i.f. which will normally exceed the gain as a converter by approximately 25 to 35 per cent. The oscillator should be operating normally and the receiver tuned to the low frequency end of the band being measured. While the converter gain is being measured it is convenient to check the operation of the oscillator at the same time. As each frequency is measured for gain, the oscillator grid current is noted. This is usually converted to volts (current times resistance of the grid-leak) and indicates the oscillator strength over the band. Weak spots or an unusual change in oscillator voltage may affect the efficiency of the converter.

Having adjusted the equipment, and taken precautions to prevent signal pickup in the i-f amplifier from operating the avc system we are ready to proceed. It is assumed the frequency coverage of the oscillator has been properly adjusted to cover the required range. The receiver is then tuned to each of the test frequencies (at least three and preferably five points in each band) and the ratio of the r-f input from the signal generator to the i-f output as indicated in a tube voltmeter is determined. This is known as the converter gain.

It should be pointed out at this time that converter gain measured as described above does not always represent normal operation, particularly where coupling exists between the oscillator and r-f circuits. This is because the signal generator shorts the r-f circuit and therefore does not present the same impedance input to the stage being measured as would normally be present if the r-f or antenna stage were connected. This effect will be illustrated later when converter grid sensitivity is compared with over-all

sensitivity measurements. A check of selectivity will then indicate whether the discrepancy is due to regeneration, degeneration, or the fact that the signal generator has changed the circuit operation to such an extent that the converter gain is modified.

At this point it is in order to combine the converter, i-f amplifier, second detector (or discriminator) and audio amplifiers and measure them as a combination. This is known as the first detector sensitivity and is recorded in microvolts input to give normal test output. Should the sensitivity of the combination measure quite different from the calculated sensitivity as obtained by multiplying the individual stage gains together it would be well to investigate the reason. Usually a small amount of regeneration or degeneration will exist and is to be expected, however if it amounts to more than 10 or 15% it will likely prove serious under certain operating conditions which will be checked when the entire receiver is connected as a unit.

Particular care should be taken in connecting the equipment to avoid extraneous coupling between the signal generator input and the vacuum-tube voltmeter. Leads should be short and direct. Clip leads if used should be arranged in such a manner that circuit capacities remain constant during the measurements.

Oscillator Measurements

In addition to measuring the oscillator voltage appearing across the grid-leak, the frequency drift, pull-in effect, radiation and tracking or alignment should be checked.

Oscillator frequency stability⁶ can be measured by beating the oscillator against a secondary frequency standard or generator having known stability characteristics. Measurements are made near the high frequency and of each waveband using the following procedure. The receiver is tuned to the desired frequency and then turned on. As soon as the oscillator is operating the standard signal generator is tuned to obtain a zero beat in the heterodyne receiver used for this purpose. This should not take over one minute after having turned the receiver power on. For consistent results an effort should be made to complete this adjustment within a few seconds of the first minute. This is not difficult to do and will be well worth the effort. A measurement of frequency should be made every 15 minutes for two hours and the results recorded. Upon completion of all other measurements additional frequency checks should be made to determine the long-time stability characteristics. The procedure for starting these measurements is the same as described above for the two hour check, but in this case it is only necessary to check the oscillator frequency once every 24 hours. This

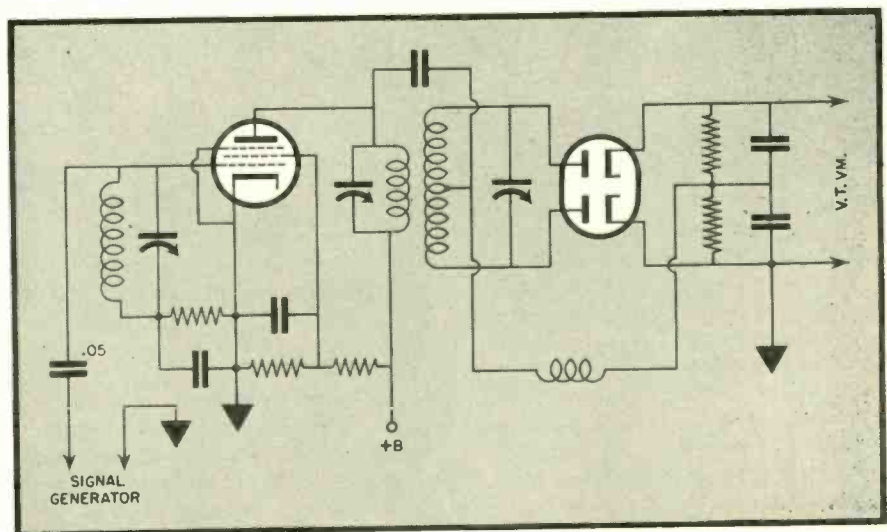

Fig. 18. Connections for checking discriminator performance

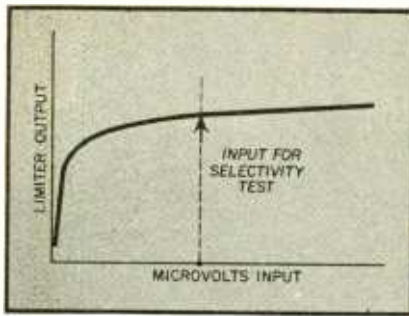

Fig. 19. Limiter operation curve

should be done after the first 20 hours of operation (the receiver should operate 20 hours and cool 4 hours per day) and each day thereafter for 5 consecutive days. The drift after five days operation indicates any tendency of the components to age.

Oscillator pull-in is usually not troublesome if the receiver has been properly designed. But if it exists, sensitivity measurements cannot be relied upon. A simple check consists of adjusting the converter padding condenser and noting whether the oscillator frequency changes. If the oscillator frequency shifts with tuning of the converter grid circuit, sensitivity measurements are likely to be poor unless both oscillator and converter circuits are tuned by simultaneously "rolling" the gang and adjusting the converter grid tuning. Obviously such a procedure is impractical for factory testing and should be corrected.

Radiation of the oscillator in a superheterodyne receiver unfortunately has had little attention in the design of ordinary home receivers, but it can cause considerable interference to other receivers in the neighborhood and should be minimized. No standards of measurement have as yet been adopted. A test may be made by operating the receiver in a normal manner, with the antenna connected, and measuring the field strength of the oscillator at some convenient distance. Power line operated receivers should be arranged with the power line cord extending away from the field strength meter. The receiver should be rotated up to 180° during the measurements if this affects the radiation properties. Measurements are made in microvolts per meter equivalent field strength at a specified distance.

Tracking

Several methods may be employed to check the oscillator/r-f tracking. One method consists of inserting an audio load of approximately 2000 ohms in the plate circuit of the converter tube, across which headphones are connected. A modulated test signal is applied using the receiver as a t-r-f unit

and a calibration made throughout each frequency band. After a satisfactory calibration curve has been obtained (frequency vs. dial setting) the modulation is removed from the test signal and its frequency adjusted to give a beat with the receiver local oscillator. By reading the frequency of the signal generator where zero beat occurs the oscillator frequency curve may be obtained. Since the accuracy of setting a signal generator is much higher than that obtainable by tuning the receiver, both r-f and oscillator frequencies should be checked with one adjustment of the receiver tuning, rather than completely checking the r-f curve before making any oscillator measurements.

Another method which is more practical, since it indicates the loss in sen-

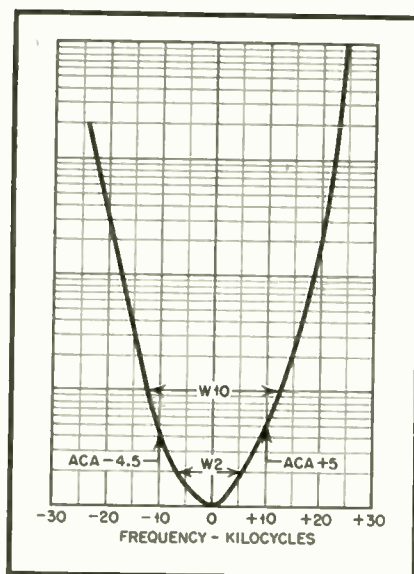

Fig. 20. I-f selectivity curve showing ASA and coupling factor, W_{10}/W_2

sitivity due to poor oscillator tracking, consists of measuring the receiver sensitivity with normal tracking, then carefully aligning the circuits at each test frequency and re-measure the sensitivity. The tracking error is expressed as a ratio of sensitivity with perfect alignment to that measured with normal alignment.

R-F and Antenna Stage

The characteristics of an r-f stage are measured in a similar manner to that described for the i-f amplifier. The ratio of input to output voltage is measured at three or five points throughout each frequency band. These measurements indicate the sensitivity or gain of the stage.

Selectivity is next measured as described previously for the i-f stage. Curves are taken at the mid-point of each band. From these curves the operating Q of the stage can be calculated, as shown in Fig. 21 where f_r is the

resonant frequency to which the stage is tuned and f_1, f_2 are frequencies either side of resonance where the response is equal to 0.707 that of maximum. The operating Q of a stage is its figure of merit and indicates the quality of performance.

When only one r-f stage is employed in a receiver its input is coupled to the antenna. Assuming this to be the case, the next measurement should be that of antenna stage characteristics. If the receiver is designed to use a regular outside antenna a standard dummy antenna can be substituted in its place for these measurements. The signal generator is then connected through the dummy antenna to the receiver input. The vacuum-tube voltmeter is connected to the antenna transformer secondary and measurements are repeated as above. Receivers which have a built-in loop antenna require different technique. In place of the standard dummy antenna the signal generator is connected to a radiating loop.^{2, 3} The loop which replaces the antenna stage can be measured with a sensitive vacuum-tube voltmeter or by combining it with the r-f stage. In the latter case the gain and selectivity of the r-f stage must be taken into account to determine the actual loop performance.

This completes the single stage measurements; next, we will consider the overall characteristics of the receiver

[To be continued]

References:

5. Factors Involved In Choosing Tube Types—Matthews—*RADIO*, June 1944.
6. Oscillator Frequency Stability—Matthews—*RADIO*, Dec. 1943.
7. Amplifier Testing by Means of Square Waves—Swift—*Communications*, Feb. 1939.
8. Network Testing With Square Waves—Arguimbau—*General Radio Experimenter*—Dec. 1939.

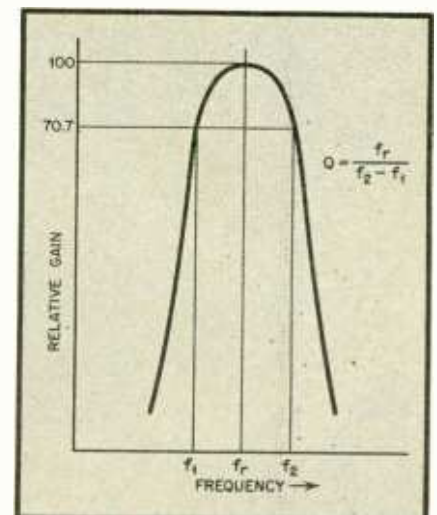

Fig. 21. Determination of operating Q from inverse selectivity curve

Paper-Dielectric CAPACITORS

J. M. CALLER

Sperry Gyroscope Co., Inc.

An analysis of the design, construction, and characteristics of paper-dielectric capacitors, with practical data regarding the selection of types to meet specific conditions

THE paper-dielectric capacitor today occupies an enviable position with respect to total quantities produced and its importance to the war effort cannot be over-emphasized. Several capacitors of this type are employed in every radio receiver and transmitter for purposes of bypassing, blocking, coupling, and filtering. They are likewise used in electronic control devices for industrial equipment, in certain types of single-phase motors, in automotive ignition systems, and in many other applications.

It would be extremely difficult, if not impossible, to enumerate the various physical sizes and shapes in which paper-dielectric capacitors have been built. The majority, however, do fall within three main classifications with respect to construction (see Fig. 1) as follows:

(a) *Molded*—Bakelite enclosure.

(b) *Potted*—Cardboard, bakelite, or metal case filled with wax or other suitable sealing compound.

(c) *Sealed*—Metal case filled with oil or wax and hermetically sealed.

In keeping with the physical variations encountered, electrical sizes and ratings also are legion. These range from about .001 to 100 microfarads at potentials from 100 to 100,000 volts and even higher. Molded types seldom exceed .05 μ fd or potentials of 1000 volts. Potted types are usually designed to operate on voltages up to approximately twice the latter value

and are available in larger capacitance values, as well, with an upper limit of perhaps 10 microfarads. Sealed types are substantially unlimited as to capacitance and voltage within the overall range given above and in addition offer important advantages with respect to moisture resistance, operation over an extremely wide temperature range, stability of electrical characteristics, fungus resistance, and life-expectancy.

CONSTRUCTION

All capacitors, paper-dielectric or otherwise, are essentially simple in construction. There is but one operative part, herein called the *capacitor element*, inside the case. In paper-dielectric capacitors, the capacitor element may consist of a single section or of several sections connected in parallel or series depending upon the desired electrical size in microfarads and the intended operating voltage. The capacitor element must furthermore be

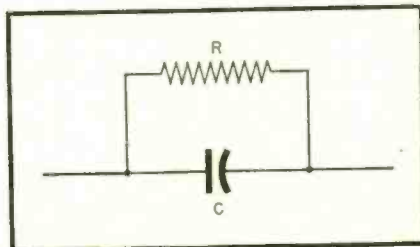

Fig. 1. Effect of insulation resistance

impregnated with an insulating oil or wax to obtain the desired operating characteristics and there are several types of impregnants employed commercially for economic as well as engineering reasons. It is fitting therefore to discuss only three basic considerations: (1) The capacitor element, (2) the impregnant, and (3) the assembly.

Capacitor Element

This operative portion of the capacitor consists of two conducting plates or electrodes insulated from each other by a paper dielectric. Aluminum or tin foils are commonly employed for the electrodes and linen or kraft paper tissue of high purity for the dielectric. The latter is specially processed to tissue thicknesses in the range of .0003 to .001 inch nominal with a minimum number of foreign (conducting) particles per unit area. Two or more sheets of such tissue are used between the foils depending upon the voltage rating desired.

A universal method of assembling the foils and tissues is to wind them together in continuous length to form a compact rolled section. Electrical connections to the foils are made either by inserting metal tabs at regularly spaced intervals throughout the winding or by offsetting the foils so that the edges protrude at each side of the wound section. The former is known as inductive winding and the latter as

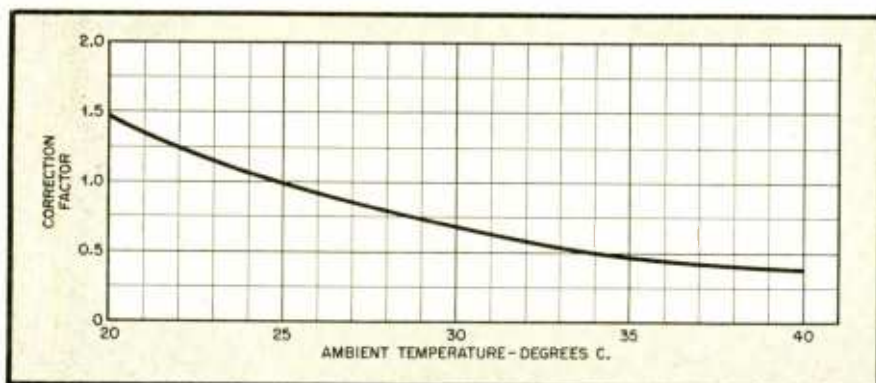

Fig. 2. Insulation resistance temperature correction factors

non-inductive which is unfortunate terminology since the inductance by measurement is largest in the "non-inductive" type. Most of the inductance is introduced by the leads, and these are longest in the non-inductive construction since they must extend from opposite sides or ends of the section. The so-called non-inductive types, however, do have considerably lower inductance which has been used prolifically in radio receivers. Other types are found in molded bakelite cases and metal containers of various shapes and sizes.

Sealed units are universally assembled in metal containers because of inherent advantages so obtained with respect to manufacture and operation. Hermetic sealing is accomplished most easily with metal cases since they can be soldered readily. Even more important, however, such construction permits the use of "liquid fill"; that is, the container may be filled with a liquid (oil) impregnant in which the capacitor element is immersed and sealed.* Liquid-filled capacitors cannot dry out series resistance and therefore lower power factor which is a very important consideration in many applications.

If the wound section is to be inserted in a tubular or cylindrical case, it is left in circular form; otherwise it is flattened to approximately rectangular shape. The leads or terminals are finally attached to the respective sets of tabs or foil edges, depending upon the type of winding employed. As noted previously, this finished section may be the entire capacitor element; or two or more of these sections may be combined in a single case, with or without electrical interconnection as required.

* Actually, there are two methods of assembly commonly employed for hermetically sealed units. These are known as: (1) the "wet" assembly just described, and (2) the "dry" assembly. In the latter method, the element is inserted in the case while dry and then impregnated, filled, and sealed. This sometimes necessitates slightly larger physical sizes but provides superior performance during life.

Impregnant

The capacitor element is impregnated with specially purified oil or molten wax, usually under vacuum, to remove all traces of occluded air and moisture and to fill all fibers of the paper dielectric. Such impregnation imparts higher dielectric strength to the paper and increases the capacitance in proportion to the dielectric constant (k) of the oil or wax employed. It will be appreciated at this point therefore that certain impregnants offer space-saving advantages. The highest dielectric constants are furnished by vegetable (castor) and synthetic (chlorinated diphenyl) oils. Mineral oil and wax are considerably poorer in this respect than the vegetable and synthetic oils and so are usually about 25 per cent larger and correspondingly heavier.

Several considerations other than physical size and weight, however, are involved in the choice of an impregnant. These concern the electrical characteristics of the finished capacitor and determine the behavior of the unit under adverse climatic conditions as well as the life expectancy. Here mineral oil is definitely superior to all of the other impregnants, particularly with respect to stability of capacitance value throughout a wide range of ambient temperatures. Such characteristics will be discussed in detail under the following section entitled "Performance."

Assembly

After impregnation, the capacitor element is measured to ascertain that the capacitance value is correct; that is, within the permissible tolerance of the nominal value. The element is then ready for assembly within the case.

Molded units are assembled in the same manner as the familiar "postage stamp," mica-dielectric capacitors. The capacitor element is simply hot-molded under pressure between two pre-

formed bakelite pellets which constitute the two sides of the case. In the curing process, the bakelite flows together from each side, leaving the capacitor element firmly embedded with the leads or terminals projecting through the case for external connection. Upon removal from the press, the finished capacitor is color-coded or stamped for identification and usually coated with wax to prevent the entrance of moisture.

Potted units are manufactured in a wide variety of case styles although the method of assembly is generally the same for all. In these types, the capacitor element is inserted in a pre-fabricated container and supported so as to assume an approximately central position. Molten potting compound is then introduced until the element is completely submerged and the unit is thereafter cooled to room temperature allowing the compound to solidify. The most common example of this construction is the cardboard tubular unit, sometimes called the "firecracker," during operation and so insure longer life expectancy. They also provide greater heat conductivity to the metal case which tends to restrict the rise of dangerous internal temperatures, particularly on a-c and pulsating d-c circuits. The most important advantage of the sealed construction, whether oil- or wax-filled, is that no moisture or contaminating materials can enter the case at any time, these being the two major sources of premature failure.

War Standard

It is worthy of note at this point that the American War Standard recently released for the procurement of paper-dielectric capacitors, C75.16-1944, covers only those which are hermetically sealed in metal cases and designed for operation on direct (d-c) voltages with relatively small a-c components. Capacitors of this type, however, satisfy practically all electronic-circuit applications, such as bypassing, blocking, etc., and a wide variety of the case styles and sizes commonly employed for such purposes are included as standard. There are small tubular cases with wire leads, large cylindrical cans with threaded mounting studs and terminals, bathtub styles, and several types of rectangular cases. This Stand-

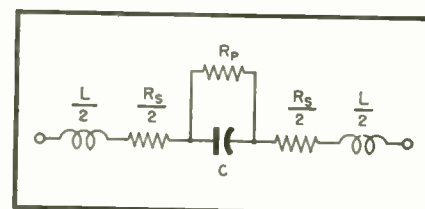

Fig. 3. Capacitor equivalent circuit

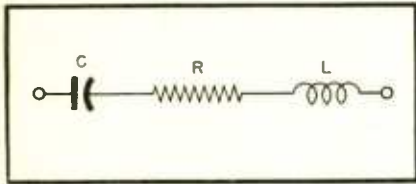

Fig. 4. Simplified schematic of capacitor

ard bears the official approval of the U. S. Army Signal Corps and the U. S. Navy, Bureau of Ships, Radio Division, and is now being processed for ultimate release as a Joint Army-Navy (JAN) specification of the War and Navy Departments. All capacitors to be used in equipments destined for sale to the Armed Forces therefore should be selected from within this War Standard in so far as possible.

Capacitors of the potted types, not being covered by a War Standard, should be avoided for reasons of procurement as well as performance. Molded capacitors of the small "postage stamp" series, however, are shown in a War Standard draft, C75/221, dated March 16, 1943. This draft-form specification has been approved by the Signal Corps to provide substitutes for molded mica capacitors of the same physical dimensions where used in non-critical circuits. It is also being converted to JAN status and augmented in the process by the inclusion of several larger (mica type) styles.

PERFORMANCE

In this section will be discussed the various electrical characteristics of the paper-dielectric capacitor which are of importance to the engineer or designer of electronic equipment. The variation in performance with respect to these characteristics through the use of different impregnants available commercially will be indicated where applicable so that a strategic selection may be made. Limitations established by the War Standard, C75.16-1944, also will be included.

Dielectric Test

Ability of the capacitor to withstand the intended operating voltage is determined by subjecting the dielectric to a direct-current test potential of

twice the nominal rated value. The same test potential is impressed between sections of multiple-unit capacitors to ascertain whether adequate isolation has been provided. Metal-clad types, except where the case is a terminal, are additionally subjected to a potential applied between terminals and case according to the following rule:

<i>Operating Voltage (E)</i>	<i>D-C Test Voltage</i>
600 volts or less	4 × E
Over 600 volts	(2 × E) + 1000 volts

These dielectric-test voltages are normally applied for a period of one to five seconds, through a series resistance sufficient to limit the charging current to a maximum of one ampere.

Insulation Resistance

A very important factor used to gauge the initial quality of a capacitor is the insulation resistance. In brief, this is the resistance offered by the dielectric to the flow of direct current and is therefore indicative of the amount of leakage present. For any given impregnant, the higher the insulation resistance, the lower the leakage and the better the capacitor.

It is convenient to represent the leakage effect in a capacitor as a shunt resistance as shown in R in Fig. 2. Although it is impossible to obtain infinite insulation resistance in practice, values adequately high to insure negligible leakage can be realized with good design and manufacture. The actual values obtained, above a reasonable minimum of perhaps 50 megohms, are of little consequence to circuit operation but do provide an excellent basis for quality control of the various impregnants employed.

For any given impregnant, the actual value will vary inversely with the capacitance because of the increased plate area exposed to the dielectric. It will be evident therefore that minimum permissible values of insulation resistance can be expressed as a constant product of megohms and microfarads for each different impregnant. This is done in the War Standard (C75.16)

TABLE I
Insulation Resistance

Impregnant	Minimum Product (Megohms x Microfarads)	Maximum Required Resistance (Megohms)
Note: Characteristic Letters are used in War Standard instead of names.		
Oil—		
Mineral	2000	6000
Synthetic	1500	4500
Vegetable	500	1500
Wax	2000	6000

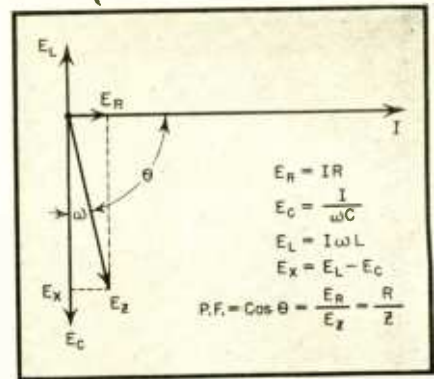

Fig. 5. Vector diagram of capacitor

which defines these minimum product values, at 25°C., for the various impregnants as shown in the left-hand column of Table I. The right-hand column defines practical limits of insulation resistance that need not be exceeded, regardless of the capacitance value.

Example: a 1/2-μfd, mineral-oil capacitor should have an insulation resistance of at least 4000 megohms whereas a 1/4-μfd unit need not exceed 6000 megohms even though the product would indicate 8000 megohms.

An additional requirement is imposed with respect to metal-encased capacitors. Except when the case is a terminal, such units are required to have an insulation resistance of at least 3000 megohms from each terminal to the case, irrespective of the impregnant employed. This is necessary, obviously, to insure against excessive leakage from terminals to ground.

In measuring insulation resistance, d-c potentials of 100 to 500 volts should be employed and the electrification period prior to reading should not exceed two minutes. Ambient temperature will greatly influence the results which should be corrected to 25°C. according to the conversion chart of Fig. 3.

Power Factor

For alternating-current operation,* another important criterion of performance in a capacitor is the power factor. As in the usual electrical sense, this factor expresses the cosine of the phase angle between the impressed voltage and the resulting current. In a pure capacitance, the current leads the voltage by 90 degrees and the power factor (cos 90°) is zero. Under such conditions, there is no power consumed since P = EI cos 90° = 0. Power can be consumed only when resistance is present, the latter introducing an in-phase voltage component which causes the current to be displaced from a perfect quadrature relationship with the applied voltage. The magnitude of this displacement is therefore indicative of the amount of

resistance present and of power dissipated in the form of heat.

Unfortunately, capacitors cannot be built without resistance although that parameter can be minimized with proper design so that the power factor at one kilocycle and at room temperature is well within one per cent. It has been shown in the preceding section that resistance is present in the dielectric medium. Resistance is also contained in the plates and leads (or terminals) of the capacitor, and these elements also contribute a certain amount of inductance which further influences the phase relationships. A schematic diagram of the actual physical capacitor is given by Fig. 4.

In this figure, the parallel resistance (R_p) denotes the insulation resistance and the series resistances ($R_s/2$) and inductances ($L/2$) are those of the plates and leads. Since it is difficult and unnecessary to determine separately the series and parallel resistances, it is customary to lump them into one called the "equivalent series resistance" which is simply equal to the real power divided by the square of the current. The two inductances also may be considered as one. Thus, the simplified diagram of Fig. 5 is fully representative of the capacitor circuit and the phase relationships existing in the capacitor are as shown by the vector diagram of Fig. 6.

In Fig. 6, the power factor ($\cos \theta$) is shown to be equal to R/Z . For phase angles larger than 80 degrees, which is true for all paper-dielectric capacitors, it will be recalled that the cosine and cotangent are substantially equal. The cotangent of the phase angle θ is equal to the tangent of the loss angle δ and this ratio (R/X) is called the "dissipation factor." Where this ratio becomes extremely small, as for very low capacitance values, it is usually convenient to use the reciprocal of the dissipation factor (X/R) which is known as the "Q" or the "figure of merit." Neglecting the inductance effect, the "Q" may be expressed as $1/R\omega C$, where $\omega = 2\pi f$ in which f is the frequency in cycles per second.

Effects of Ambient Temperature

The temperature to which paper-dielectric capacitors are subjected during operation is an extremely important consideration with respect to performance. Two major effects will be discussed: (1) life expectancy, and

*It has been noted previously that capacitors covered by the War Standard (C75.16) are designed and rated for d-c operation with relatively small superimposed a-c components. In such applications, power factor is of little or no importance but is specified as one per cent, maximum, at 25° C.

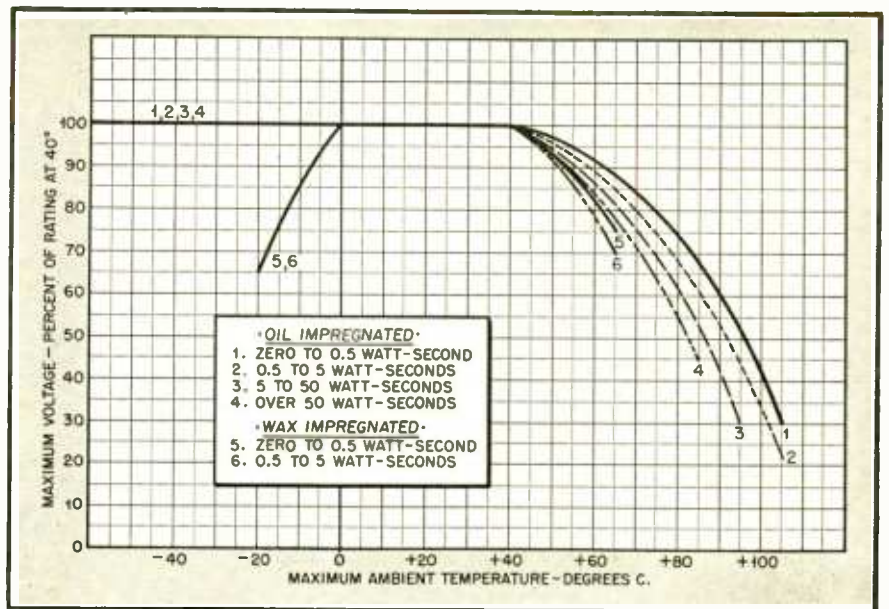

Fig. 6. Voltage derating for maximum ambient temperatures

(2) capacitance stability. Particular emphasis should be placed on the first of these factors to avoid premature failures in service; the second is less vital except where constancy of value is essential to circuit operation.

1. *Life Expectancy:* For a given operating voltage, the life expectancy decreases sharply with increasing temperature. The principal reason for this is the rapid decrease in the insulation resistance as the temperature is increased, which effect was shown previously in Fig. 3. Since the dielectric is not homogeneous, the current leakage may be concentrated in a limited number of paths through the material. These leakage currents, although small in magnitude, may be large compared to the area of the paths and thereby produce local heating. As the insulation resistance decreases, the leakage currents and local heating increase, leading to deterioration of the dielectric and ultimate breakdown.

On d-c circuits, the current through the capacitor is negligibly low under normal operation and the only source of heat is external through elevated ambient temperatures. Capacitors on a-c circuits may carry appreciable current and produce substantial internal heating due to the power losses incurred. The power factor also increases with temperature which further aggravates the latter condition. It matters little, however, whether the source of heating is internal or external since it is the ultimate operating temperature that is important.

The American War Standard (C75.16) rates all d-c capacitors thereon on the basis of a maximum operating voltage at 40° C. Derating factors are included to cover the permissible range of ambient temperatures for the various impregnants according to the curves of Fig. 7.

It will be observed that the amount of derating to be applied varies with

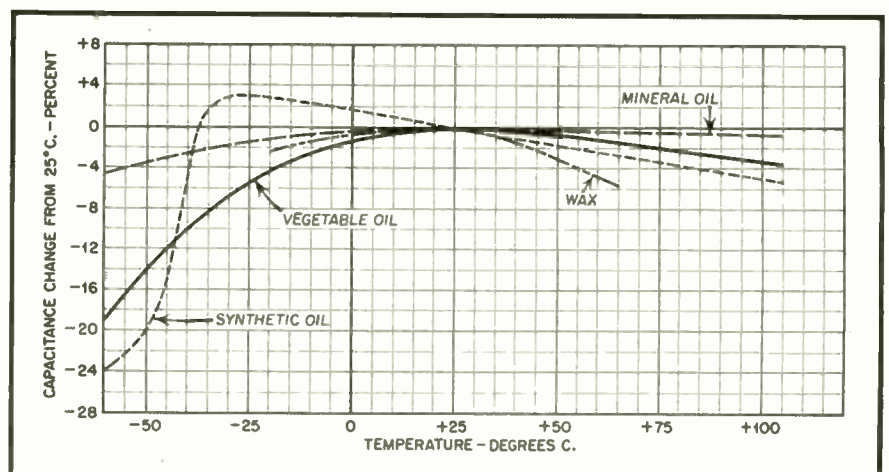

Fig. 7. Typical variations of capacitance with temperature for various impregnants

the energy content in watt-seconds ($P = \frac{1}{2} CE^2$), as well as with temperature. Also of interest is the fact that the oil-impregnated types may be operated over a range of from $-55^\circ\text{C}.$ to $+85, 95,$ or $105^\circ\text{C}.$ whereas the wax-impregnated units are restricted to from $-20^\circ\text{C}.$ to $+65^\circ\text{C}.$ The sub-zero derating in the latter case is necessary because wax suffers detrimental mechanical and electrical changes at lower temperatures.

The maximum operating voltages indicated above represent the consensus of opinion of about a dozen manufacturers and are intended to provide a life expectancy of one year of continuous operation at any maximum ambient temperature. Longer life can be expected by operation at still lower voltages; for example, a life ex-

terms, the variation of capacitance with temperature. All capacitors are substantially stable in value at room and elevated temperatures but tend to decrease in value with decreasing temperatures in the sub-zero (C.) range. The magnitude of this effect varies greatly for different impregnants and there is even an appreciable variation for each specific impregnant. Mineral oil and wax exhibit a much greater degree of stability than do the vegetable and synthetic oils and are much to be preferred where this characteristic is important to the application. Wax-impregnated capacitors are, of course, drastically limited in temperature range as compared to any of the oil-impregnated units. Typical curves for the various impregnants are illustrated in Fig. 8.

capitors shall be subjected to 125 per cent of the rated voltage for one minute at a barometric pressure of 3.4 inches of mercury. The voltage shall be applied between terminals, and between terminals and ground (container) except when the latter is a terminal. No flashover, breakdown, deformation of the container, or leakage of the impregnant is permitted.

Effect of Humidity

Great care is taken in the manufacture of capacitors to remove moisture from the capacitor element and prevent the re-entrance thereof during operation. Moisture, even in the minutest quantities, will ruin completely any capacitor however good originally. The only certain method of preventing the ingress of moisture under conditions of high humidity is the hermetically sealed construction.

To insure adequate "sealing," all capacitors covered by the War Standard are subject to a cycling test conducted at a relative humidity of 90 to 100 per cent with the temperature shifted every six hours between $55^\circ\text{C}.$ and $27^\circ\text{C}.$, for a total of ten complete cycles. They are further required to withstand five cycles of immersion in salt water, alternating every hour between hot ($65^\circ\text{C}.$) and cold ($0^\circ\text{C}.$) baths. At the end of either period, there shall be no harmful or extensive corrosion, the insulation resistance shall be at least 30 per cent of the values indicated in Table I, and there shall be no breakdown under the normal dielectric test.

CONCLUSION

The American War Standard, C75.16-1944, represents a major step forward in the field of paper-dielectric capacitors. Voltage ratings for each physical and electrical size are established on the common basis of operating temperature and adequate derating information is included to ensure satisfactory life under abnormal conditions of operation. As previously noted, this Standard is being converted to a Joint Army-Navy (JAN) Specification which will be a permanent procurement instrument for the Armed Forces, even during peacetime. Adherence to the Standard by designers of electronic equipment will insure good quality units available from several manufacturers.

Note: It may be observed that the tabulated data herein does not conform strictly to the War Standard as published. The reason for such discrepancies lies in the fact that the Standard is being currently revised prior to issuance of the aforementioned JAN Specification. All values shown in this article are those agreed upon by all concerned at the present time and which probably will be adopted in the near future.

TABLE II
Capacitance-Temperature Characteristics

Impregnant	Low Test Temperature	Permissible Capacitance Change from $25^\circ\text{C}.$ Value
Mineral Oil	$-55^\circ\text{C}.$	-15%
Vegetable or Synthetic Oil	$-55^\circ\text{C}.$	-30%
Wax	$-20^\circ\text{C}.$	-10%

pectancy of approximately five years may be obtained by further derating to 70 percent of the voltages shown. Also, a life longer than one year may be expected at the voltages listed if the maximum temperature prevails for only a portion of the whole operating time.

In general, mineral-oil impregnated capacitors will provide a longer life and a greater degree of permanence of electrical characteristics over the indicated temperature range than will the vegetable and synthetic-oil types. Mineral-oil units also may be used to advantage where extremely high operating temperatures in the order of $105^\circ\text{C}.$ or more are encountered for protracted periods.

To ensure adequate life expectancy, capacitors are subject to a life test for 250 hours on double rated voltage at $85^\circ\text{C}.$ for oil-impregnated types, or $55^\circ\text{C}.$ for wax-impregnated types. It should be noted that the rated voltage at these high test temperatures are derated from the respective nominal rated voltages at $40^\circ\text{C}.$ according to Fig. 7. As a result of this test, there shall be at $25^\circ\text{C}.$ no capacitance change in excess of 10 percent and the insulation resistance shall not decrease below 30 percent of the initial values given in Table I.

2. Capacitance Stability:

Another factor to be considered in using paper-dielectric capacitors is the temperature coefficient, or, in simpler

The American War Standard covers such variations with temperature by setting limits of permissible capacitance change between the measured values at $25^\circ\text{C}.$ and a low test temperature according to Table II.

It should be appreciated that these temperature coefficients are of little consequence in most electronic applications such as for bypassing, blocking, etc. There are some cases, however, where this characteristic is very important as in timing or rate circuits. Selection of a suitable impregnant therefore involves proper appreciation of the circuit function and the expected ambient conditions in service.

Effect of Atmospheric Pressure

Where capacitors are to be used in aircraft equipment, it is necessary to consider the effect of atmospheric pressure with respect to operating voltage. At an elevation of 50,000 feet, the pressure is reduced to about one-tenth of the value existing at sea level. Flashover distances are thereby reduced in effectiveness to about one-third of their respective voltage ratings, and corona may be encountered at relatively low voltages as compared to ground operation. The pressure differential also may produce leakage of the impregnant in oil-filled, hermetically sealed units.

To safeguard against this hazard, the War Standard requires that ca-

• AUDIO FREQUENCY LOSS IN CABLE AT 5 OHMS •

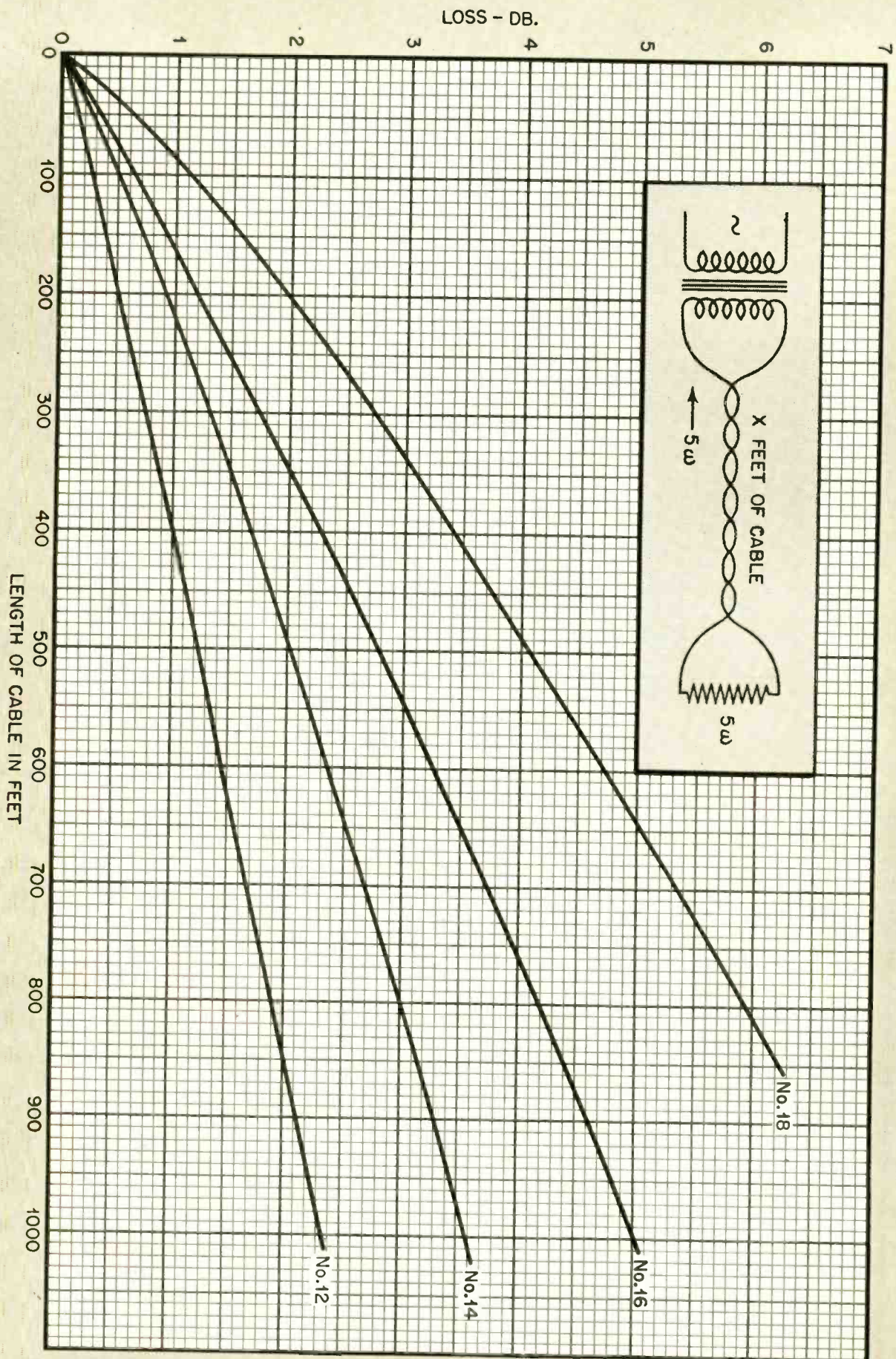
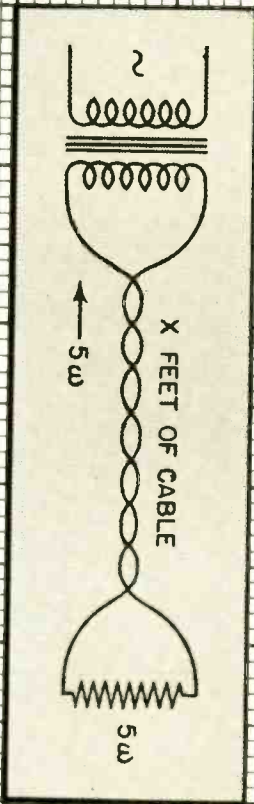

Copyright 1944 by RADIO MAGAZINES, INC., New York, N.Y.

RADIO BIBLIOGRAPHY

F. X. RETTENMEYER

RCA Victor Division, Radio Corporation of America

17—AIRCRAFT RADIO, PART 4

Principle and Theory of a New Design of the Automatic Radiocompass for Aircraft—A. B. Damyanovitch—*L'Onde Électrique*—Vol. 16, No. 181, Jan. 1937, Page 5.

Detrimental Effect of Horizontal Portions of Long Low Loop Aerial (for Aerial Navigation) Suppressed by One or More Impedances Symmetrically Introduced—Philips Co.—*Revue Générale de L'Électricité*—Vol. 39, Jan. 25, 1936, Page 30.

Flying by Radio; Test Flight in Canada Using Lear Radio Direction Finder—J. P. de Wet—*Canadian Mining Jnl.*—Vol. 57, January 1936, Page 26.

Radiogoniométrie Deviations on Board Airplane—Fromy—*L'Onde Électrique*—April 1936, Vol. 15, No. 72, Page 244.

Radio Compass: Description of Apparatus and Its Operation—J. P. Gary—*Aviation*—Vol. 35, May 1936, Page 24, June 1936, Page 15.

Western Electric Radio Compass—*Aviation*—Vol. 35, Feb. 1936, Page 50.

New Visual Radio Direction Finder—F. W. Dane—*Aero Digest*—Vol. 29, Nov. 1936, Page 48.

Direction Finder: Cathode-ray Beam Course Indicator—*Aviation*—Vol. 35, August 1936, Page 45.

Direct-Reading Direction Finder (with Rotating Frame Aerial . . .)—J. Marique: *S. A. Internationale de Teleg. Sana Fil.—Hochfrequenztechnik und Elektroakustik*—Vol. 48, No. 6, Dec. 1936, Page 216.

Automatic Radio Compass (Type RC-5) and Its Application to Aerial Navigation—H. Busignies—*Electrical Communication*—Vol. 15, No. 2, Oct. 1936, Page 157.

A Radio Compass for Aircraft (for Use in Conjunction with Type 17A Receiver)—C. B. Aiken—*Bell Laboratories Record*—Vol. 14, No. 5, Jan. 1936, Page 165.

Rotatable Adcock Direction Finder—A. Lieb and W. Kuhlewind: *Telefunken—Hochfrequenztechnik und Elektroakustik*—Vol. 46, No. 5, Nov. 1935, Page 177.

The Aircraft Radio Compass (and Some American Types of "Homing Devices")—*Electronics*—Vol. 8, Oct. 1935, Pages 7-10 and 29.

Kruesi Commercial Radio Compass—*Aviation*—Vol. 34, Feb. 1935, Page 72.

Kruesi Radio Compass for Commercial Use—F. W. Lutz—*Aero Digest*—Vol. 26, Feb. 1935, Page 50.

Lear Radio Compass—*Aviation*—Vol. 34, March 1935, Page 108.

Lear Radio Direction Finder—*Aero Digest*—Vol. 26, March 1935, Page 47.

Simon Radioguide for Aircraft—H. W. Roberts—*Aero Digest*—May 1935, Page 40; *Communication & Broadcast Engineering*—Aug. 1936, Page 5.

New Radio Compass to Aid Northern Fliers—*Canadian Mining Jnl.*—Vol. 56, Dec. 1935, Page 592.

U. S. Patent No. 1,992,019—L. A. Taylor—Radio Receiving Apparatus—Issued Feb. 19, 1935.

U. S. Patent No. 1,991,476—H. P. Thomas—Direction Finding System—Issued Feb. 19, 1935.

U. S. Patent No. 1,991,475—L. A. Taylor—Direction Finder—Issued Feb. 19, 1935.

U. S. Patent No. 1,991,473—L. A. Taylor—Direction Finder—Issued Feb. 19, 1935.

U. S. Patent No. 1,991,443—H. I. Becker—Direction Finder—Issued Feb. 19, 1935.

Radio Direction Finder of Simplified Type for Use on Airplanes—*Air Commerce Bulletin*—Vol. 5, No. 2, August 15, 1933, Page 31.

Errors in Direction-Finding Calibrations in Steel Ships Due to the Shape and Orientation of the Aerial of the Transmitting Station—*I.E.E. Jnl.* (London)—Vol. 73, Sept. 1933, Page 280.

An Airplane Radio Direction Finder—*Air Commerce Bulletin*—Vol. 3, No. 18, March 15, 1932, Page 433.

Un Nouveau Radio Compass—H. Busignies—*L'Onde Électrique*—Vol. 9, 1930, Page 397.

Unilaterals Peilwindelzeigergerat mit Rotierender Goniometer Ankopplungsspul—F. Berndorfer—*Z. Hochfrequenztechn.*—Vol. 35, 1930, Page 98.

Die Drahtlose Einrichtung an Board des A-28 (The Radio Direction Finder on Board the A-28)—R. Linsmayer—*Elektrotechnik und Maschinenbau (Die Radiotechnik)*—March 4, 1928, Page 23.

Appareils Indicateurs Donnant par Lecture la Direction d'une Onde—H. Busignies—*L'Onde Électrique*—Vol. 6, 1927, Page 277.

Direction Finders for Mail Planes—D. R. Lane—*Radio* (San Francisco)—Vol. 9, June 1927, Page 6.

Wireless Bearings Form the Air—*Wireless World and Radio Review*—Vol. 18, June 30, 1926, Page 866.

Mésures Radiogoniométriques en Avion—Comm. Franck—*L'Onde Électrique*—Vol. 3, Feb. 1924, Page 65.

The Radio Direction Finder and Its Application to Navigation—F. A. Kolster and F. W. Dimmore—*Bur. of Stds. Scientific Papers No. 428*—January 1922.

Aeroplanes and Radiogoniometers—A. Perry—*Radio News*—April 1922, Page 683.

Errors of Direction Finders—E. Bellini—*Scientific American Monthly*—Vol. 3, May 1921, Page 451.

A Remote Control Compass for Aeroplanes—A. Gradenwitz—*Aviation*—Jan. 3, 1921; *Tech. Rev.*—Vol. 8, March 8, 1921.

Aeroplane Radio Direction Finding—*Aerial Age Weekly*—Vol. 12, Jan. 12, 1921, Page 545.

Wireless Telegraphy for Position Finding in Aeroplanes—M. Dieckman—*Luftfahrt*—Vol. 26, April 1, 1920, Page 57; *Radio Review*—Vol. 2, Feb. 1921, Page 109.

[Continued on page 64]

This Month

BELL LABS APPOINTS COOK

Morris H. Cook has been appointed Director of Specialty Products Development of Bell Telephone Laboratories and will be responsible for the Laboratories' overall program in that field. He comes from the Hawthorne Works of the Western Electric Company, where he was Superintendent of Manufacturing Engineering.

An electrical engineering graduate of the University of Illinois, Mr. Cook had experience in several companies, and entered the Engineer of Manufacture organization of Western Electric in 1926. He became Development Engineer for telephone station apparatus in 1929, and progressed through various responsibilities to become Superintendent of Manufacturing Engineering, first in 1940 for station apparatus and then in 1941 for the Special Apparatus Shops at Hawthorne. In that post he had much to do with getting large scale production on radars, quartz crystals, and other special devices for the armed services. Thus he brings to Bell Laboratories valuable experience in putting into manufacture the developments of the engineers whom he will now direct.

Mr. Cook is a member of Eta Kappa Nu and of Sigma Tau. His new home will be in Summit, N. J.

ELECTRONIC LABS APPOINTS PEEK

Walter E. Peek's appointment as sales manager of Electronic Laboratories, Inc., Indianapolis, manufacturer of E-L Vibrators and Vibrator Power Supplies, was recently announced by Mr. Norman L. Kevers, President. Mr. Peek has been a member of the engineering staff of the company for the past four years, serving



Soldering connections on high-voltage Westinghouse transformers. Units of this type are widely used in war equipment and promise to have many peace-time applications



Walter E. Peek

in both a design and sales engineering capacity, with particular attention to the vibrator field.

In his new capacity, he will have complete charge of the sales of all E-L products to all fields, which include vibrators and vibrator power supplies for the operation, from non-standard voltages, of radio receivers, transmitters, sound equipment, standard AC appliances, fluorescent lights, neon signs, test equipment, and other electrical and electronic devices.

Besides his work at Electronic, Mr. Peek has had broad experience during the last fifteen years in the radio and electrical industry, especially in the auto and home-radio fields. He was chief radio engineer of Noblitt-Sparks Industries, Columbus, Indiana, for several years, as well as being active there for a number of years as a sales executive. Later, at the Colonial Radio Corporation, Buffalo, N. Y., Mr. Peek was associated with farm and portable radio design and sales.

THINNER HIPERSIL FOR HIGHER FREQUENCIES

Under tremendous war pressure, signaling systems, radar, and other very high frequency devices have required scores of unusual transformers that never before existed. To meet this demand transformer engineers have produced units that viewed by ordinary standards are freaks of the first order. For example, consider a transformer no bigger than your fist yet able to deliver 100 kw (for extremely brief intervals, of course). Another complete transformer weighs but one-half ounce. The production of the ultra-thin thicknesses of grain-oriented Hipersil by the engineers of the American Rolling Mill and Westinghouse has helped make possible these unusual designs.

The pressure on transformer designers for small size, light weight, and high capacity in these midget transformers comes from two directions. Much of this equipment is air-borne where the need for

weight and space saving is obvious. The other is that as the frequency increases the thickness of the core laminations should decrease. At frequencies of several thousand kilocycles the flux changes so rapidly it is not able to penetrate fully the magnetic material. A sort of magnetic skin effect comes into play. At these frequencies the flux would not penetrate more than five or ten per cent of the standard lamination. Thus to keep down eddy current losses which at these frequencies tend to eat up appreciable proportions of the meager power available, the laminations should be thin, very thin—i.e., have as much surface as possible.

Prewar standard Hipersil laminations were 29 gauge, or about 14 mils thick. Then came 7-mil Hipersil, used extensively

for 400-cycle aircraft transforming equipment, with an attendant saving in about 30 per cent in total.

Now engineers have produced on an experimental basis a Hipersil steel only half as thick as the two-mil steel. Four layers of this one-mil Hipersil would be required to equal the thickness of this paper. Such steel when it can be produced on a commercial basis will mean a 20 to 50 per cent further saving in weight, or, more important still, greater powers available for some war and post-war uses of frequencies now at the upper end of the frequency spectrum.

UNIVERSAL PICTURE SERIES

The series of full page illustrative advertisements published in RADIO the past

year by the Universal Microphone Co., Inglewood, Cal., has been reprinted in pictorial portfolio form with more than a dozen pictures depicting various stages in the advancement of communications through the ages.

The pictures, by Los Angeles artist Keith Thomas, start with the early days of the Phoenicians and Greek runners and end with a modern drawing from World War II.

The series has attracted wide and favorable attention and has been in demand by schools and colleges for classroom study. Several army posts have also requested permission to use them for research work, and at least one encampment has reproduced the Thomas creations in mural form for study hall decorations.

Interesting, instructional and educational, the series will be published in January. They are of suitable size and arrangement to frame for office, den or hobby room. Brief descriptions accompany each illustration to describe the successive steps in the advancement of communications methods.

The pictorial portfolio is being distributed without charge from the Inglewood plant of the company.

Ingenious New Technical Methods

Presented in the hope that they will prove interesting and useful to you.



New 9000° Arc Torch Can Be Used for Welding and Brazing All Ferrous and Non-Ferrous Metals and Alloys

Now an arc torch that makes it possible to do most jobs *electrically* that previously were thought possible only with gas. This attachment for arc welders provides an independent source of heat by means of two carbons. It is capable of producing intense heat, approximately 9000° F., over 2000° hotter than an oxyacetylene flame. Pure heat, no oxygen or gas to contaminate the weld. No pressure to force the molten metal away or blow holes in light sections.

Developed to capitalize to the fullest on the time-saving advantages of electric welding, the new Mid-States 9000° arc torch can be used with any AC or DC electric welder. It opens up new horizons of service in this field, never before possible with an electrically operated instrument.

New uses are being found every day for products that have been familiar to us for years. Wrigley's Spearmint Gum, always enjoyed for its chewing satisfaction, is now proving with the fighting men overseas many benefits which will be useful to you in peacetime. One of the big factors in mass production is the alertness and efficiency of the man on the job. The chewing of Wrigley's Spearmint will help keep you alert and wide-awake during those work periods that, while seemingly dull and monotonous, call for watchfulness in order to get perfection in the final assembly.

You can get complete information from Mid-States Equipment Co., 2429 S. Michigan Avenue, Chicago 16, Illinois

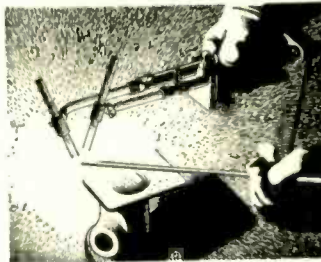

For BRAZING Steel, Cast Iron, Malleable Iron, Copper, Brass, Bronze, and other ferrous and non-ferrous metals.

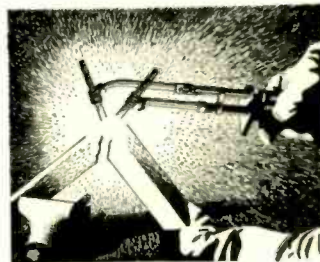

For HEATING to Straighten or Bend, etc.

Y-168

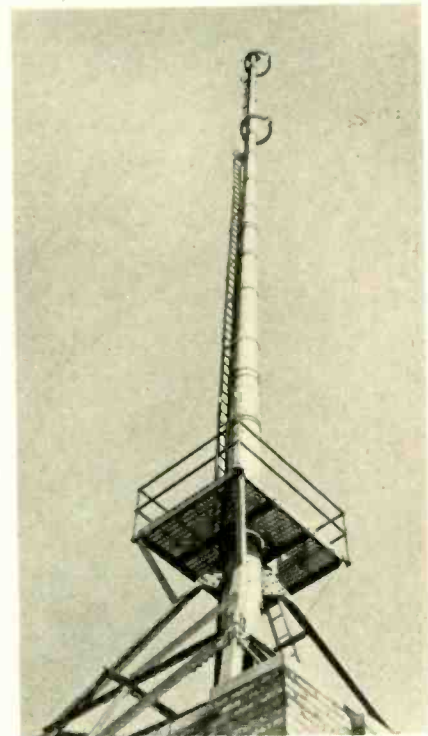

JENSEN MONOGRAPHS

To meet the need for dependable and useful information on the selection, installation and use of loud speakers and reproducers, Jensen Radio Manufacturing Co. has prepared a series of technical monographs to help the amateur and the professional in the field of acoustics.

Each monograph will deal with one important aspect of the science of sound as applied to loud speakers. The first of the series, *Loud Speaker Frequency Response Measurements*, is ready now. This mono-

new directions in radio . . .

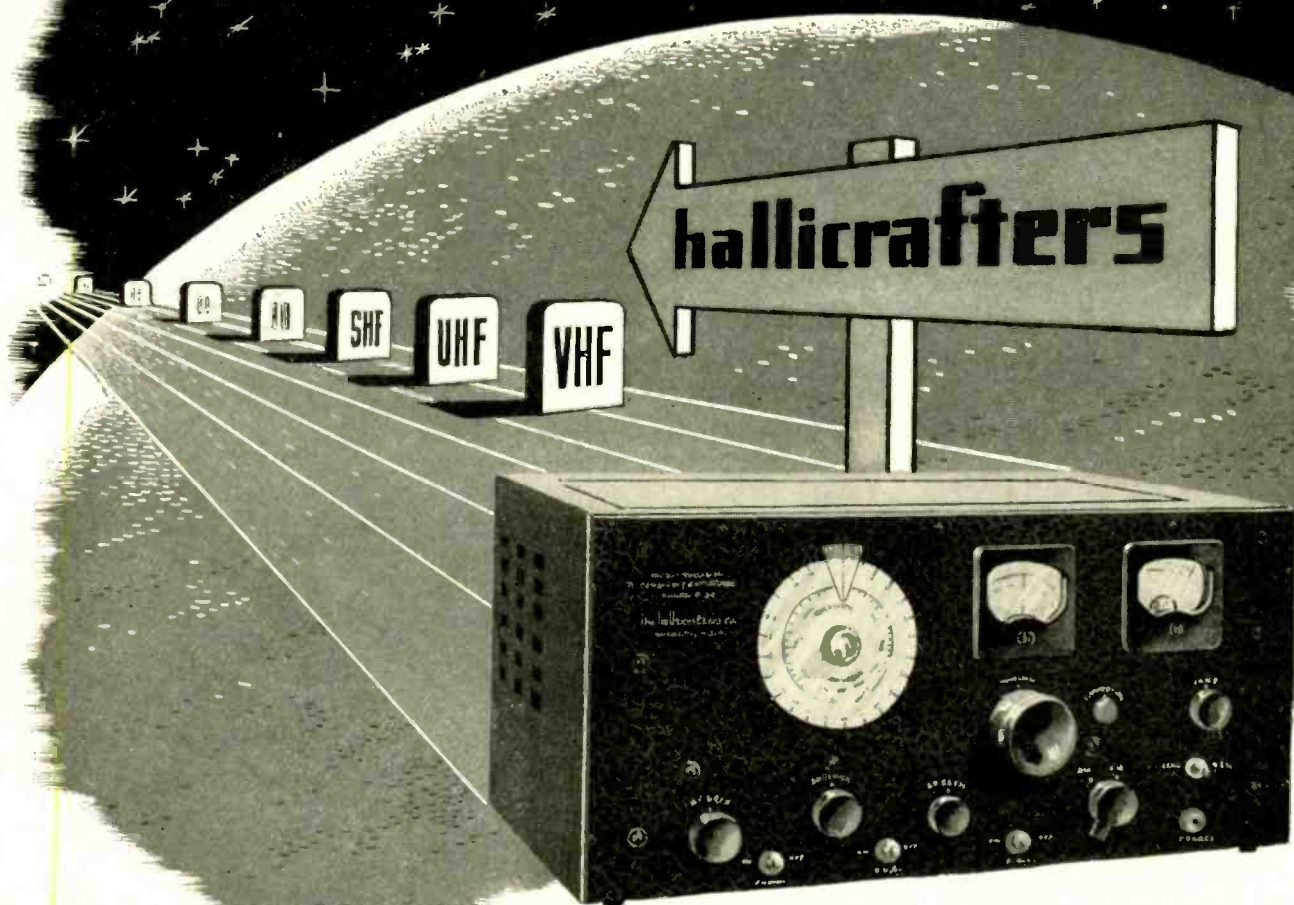

*New directions
in radio will
be charted by
Hallicrafters*

As radio development moves onward and upward, Hallicrafters engineers are setting the pace, pushing back the horizons in the exciting fields of very high frequency, ultra high frequency, and super high frequency development work. The range of the Model S-37 illustrated here covers higher frequencies than any other continuous tuning commercial type receiver. It is becoming a prime instrument of experiment and research in marking out the new directions that all radio will take,



hallicrafters RADIO

Buy a War Bond Today!



THE HALLICRAFTERS CO., MANUFACTURERS OF RADIO AND ELECTRONIC EQUIPMENT, CHICAGO 16, U. S. A.

RADIO

★ DECEMBER, 1944

graph, discussing one of the most interesting and controversial subjects in the field of acoustics, points out both the wisdom and the fallacy of using frequency response curves in judging the performance of loud speakers. It points out how the same loud speaker may quite correctly produce different results in the shape of a curve depending on the methods and the circumstances with which the measurements were made. *Loud Speaker Frequency Response Measurements* explains how laboratory technicians can use measured frequency response as essential data in their development and design work, and describes some of the equipment and methods that may be used.

Number two of this practical, instructive series of monographs is *Impedance Matching and Power Distribution in Loud*

Speaker Systems. The title suggests the scope and the treatment of a subject of vital interest to every one concerned with loud speakers and the reproduction of sound. The reading material is supported by twenty-eight drawings and tables. One of the many problems that is described, illustrated and solved is that of a comprehensive sound system for a military installation.

Future issues will treat generally the subject of proper selection, use and operation of loud speakers and loud speaker systems in the interest of improved sound reproduction.

Copies of all issues will be free on request to men of the Armed Services and to libraries and technical schools. Others who want these valuable and important treatises may obtain them from radio job-

bers and dealers, or by sending 25c for each copy to Jensen Radio Manufacturing Company, 6601 South Laramie Avenue, Chicago 38, Illinois.

UNIVERSAL RE-ISSUES MIKES

Universal Microphone Co., Inglewood, Cal., early in 1945 will re-issue its CU-1 and CU-2 microphones for mobile transmitter installation, including marine and aircraft installation. The precision instruments are also adaptable to many forms of transmission use in broadcast stations, amateur and other outlets.

The button impedance is 200 ohms and the output approximately 30 volts RMS across the microphone transformer secondary. A double pole, single throw, press-to-talk switch connects the microphone and relay circuits.

This standard microphone, made by Universal over a period of many years, is rugged and durable and withstands abrupt climatic changes. Voice reproduction is clear and crisp.

Motor noises, on mobile installations, are damped out by anti-noise design. Both models are single buttons with plastic case and special moisture proof cord reinforced at each end. Push-in mounting brackets are included.

The CU-1 has a three-way plug, while the CU-2 has the PL-68 telephone type of plug. Universal will also resume production soon with its KD and 15 mm's, both dynamics; the 200 series, handi-type; the 800 series, velocity; and the X-1 and XX, both carbons, as postwar microphone releases.

HIGH-TEMPERATURE INSULATION

Culminating seven years of continuous research, the Sprague Electric Company, North Adams, Mass., has evolved a process for depositing a thin ceramic (inorganic) coating on copper, nickel, and other types of wire.

This new insulation is known as Sprague CEROC 200. When applied to copper wire it maintains desirable electrical characteristics at a continuous operating temperature of 200° C. as compared to the present limit of 105° C. for conventional Class A insulations such as enamels, varnishes, and other organic materials. Thus, by designing motors, transformers, chokes, and similar equipment to utilize the full maximum operating temperature of CEROC 200, a very substantial increase in volt ampere rating can be obtained. Smaller-sized equipment can be designed to do larger-sized jobs.

Because of its inorganic ceramic composition, Sprague engineers believe that CEROC 200 meets all requisites of a Class C insulating material as classified under A.I.E.E. standards. Space factor is extremely good, in that CEROC 200 is thinly deposited on the wire. Typical space factor for CEROC 200 expressed in percentage of copper area to total cross-sectional area of finished wire is 98% for AWG #16 wire, and 95% for #24 wire by comparison with 80% and 64% respectively for other types of insulation that might be used for similar high temperature applications.

An important allied feature is the high degree of thermal conductivity of CEROC

NOW AVAILABLE —

NEW CATALOG, DESCRIBING THE COMPLETE LINE OF

Electro-Voice

COMMUNICATIONS MICROPHONES



Electro-Voice Differential Microphone, Lip-Type Model 245 for applications where background noise elimination, free use of hands and high articulation are required.

Electro-Voice Differential Carbon Microphone, Hand-Held Model 205-S, an ideal microphone for aircraft, industrial, railroad, police and emergency services.

Electro-Voice Carbon Microphone, Model 210-S, a single button microphone which embodies all of the latest developments required for military use.

Electro-Voice Dynamic Microphone, Hand-Held Model 600-D, designed for high fidelity speech pick-up in those locations where the ambient noise does not exceed 100 db.

ELECTRO-VOICE CORPORATION
1239 South Bend Ave., South Bend 24, Ind. A-12
Please send us your new "Electro-Voice Communications Microphones Catalog."
NAME OF COMPANY _____
ADDRESS _____
CITY _____ STATE _____
ATTENTION OF _____

Electro-Voice MICROPHONES

ELECTRO-VOICE CORPORATION • 1239 SOUTH BEND AVENUE • SOUTH BEND 24, INDIANA
Export Division: 13 East 40th Street, New York 16, N. Y., U. S. A. Cables: Arlob

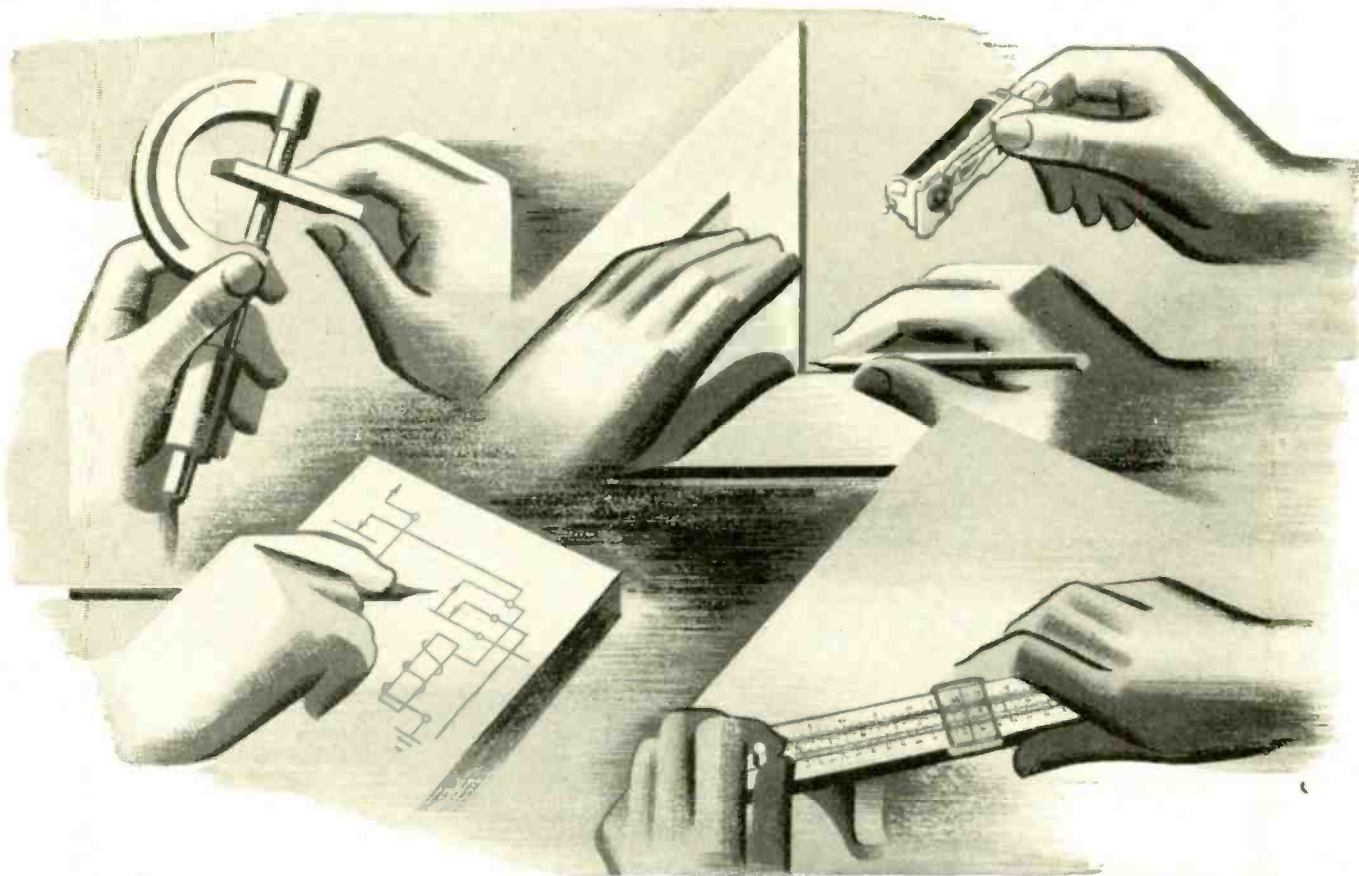

Your New Product may need the Magic of Electrical Control

TAKE another look at that new product your designers are planning. It may be that Automatic Electric control devices can make it function better—at lower cost. It's worth checking into.

To help designers perfect new developments—or improve old ones—Automatic Electric offers this unique three-point service:

1. Technical advice by experienced field engineers, who know the "how" and "why" of control technique.
2. A complete range of relays, stepping switches, and other control units—time-proved products readily adapted to your needs.
3. A design and manufacturing service for complete engineered assemblies.

Ask our field engineer for a copy of our catalog of control devices. He will be glad to show you how they can serve you.

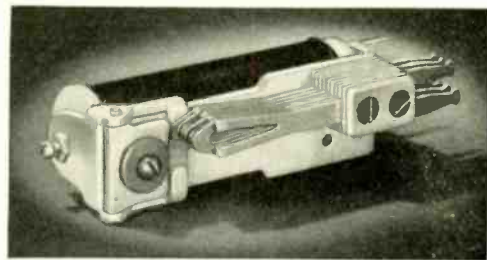

Here are jobs that can be done easier and better with Automatic Electric control devices:

Automatic Selection and Switching of Circuits • Time, Temperature and Sequence Control • Counting and Totalizing • Inspection and Sorting Operations • All Types of Electrical and Electronic Control.

Relays
AND OTHER CONTROL DEVICES
by **AUTOMATIC ELECTRIC**



AUTOMATIC ELECTRIC SALES CORPORATION
1033 West Van Buren Street • Chicago 7, Illinois

In Canada: Automatic Electric
(Canada) Limited, Toronto

PARTS AND ASSEMBLIES FOR EVERY ELECTRICAL CONTROL NEED

200. Both because of the highly favorable space factor and the ceramic composition of this insulation, coils wound with it dissipate heat rapidly. There is little or no tendency toward the development of hot spots which would nullify a large percentage of the high temperature gain that might otherwise be expected. Thus the high temperature advantages of CEROC 200 are real and not apparent.

The preferred thickness of CEROC 200 is 1/4 mil. Moreover, the coating is extremely uniform and makes for smooth, level winding in a minimum of space. Present preferred wire sizes for applying CEROC 200 are from 3 to 30 mils in copper wire (#40 to #21 AWG) and from 1 1/2 to 12 mils (#46 to #28) in nickel wire.

CEROC 200 is sufficiently flexible that round coils can generally be wound satisfactorily on existing equipment. In the case of rectangular coils or motor armatures, however, winding technique may require modification to assure that the wire is not stretched more than 10%.

Although now announced generally for the first time, CEROC 200 has been supplied in large quantities for some months past for important war equipment uses.

A new bulletin describing this important development will gladly be sent on request to the manufacturer, Sprague Electric Company, North Adams, Mass. Write for details.

The following characteristics are based on wire having a coating of the preferred 1/4 mil thickness:

Maximum stable temperature for continuous operation, 200° C.

Voltage breakdown between 2 wires of a twisted pair four inches long: Standard condition (25° C.), 300 volts A.C.; humid conditions (95% relative humidity), 300 volts A.C.; hot condition (200° C.), 300 volts A.C.

Leakage between two wires of a twisted pair 4" long at 95% relative humidity, greater than 100,000 megohms.

Flexibility by bending, 16% elongation.

Abrasion resistance. Average 16-18 scrapes at 200 g weight on G.E. abrasion test machine for #25 AWG wire. On wire sizes smaller than #25, this average is slightly less, and on larger than #25 wire, it is somewhat more.

Wire sizes. Although CEROC 200 is constantly being adapted to new uses, the present preferred ranges for Ceroc-coated wire are as follows: Copper wire—3 to 30 mils (#40 to #21 AWG). Nickel wire—1 1/2 to 12 mils (#46 to #28 AWG).

Winding characteristics. CEROC 200 is sufficiently flexible to present no winding difficulties that will not be far more than compensated for by its tremendous high temperature and space advantages. In general, round coils can be wound satisfactorily on existing equipment, although some modification in winding technique may prove necessary on rectangular coils or motor armatures, so that the wire is not stretched more than 10%.

Samples. On request to quantity users.
Manufacturer. Sprague Electric Co., North Adams, Mass.

TECHNICANA

[Continued from page 18]

grid. All of the electrodes are operated at rather low voltages to reduce the possibility of ionizing residual gas in the tube, which would cause positive ion current in the grid circuit.

It has been found in taking measurements of extremely minute currents that the electrostatic charges which build up on the inside surface of the glass bulb produce a sufficiently high electric field to seriously affect the overall sensitivity of the tube. This electric field also makes consistent results practically impossible. To eliminate this condition a small piece of spring wire resembling a "cat's whisker" is mounted with a slight pressure against the inner wall of the glass bulb. The so-called "cat's whisker" or shield is then brought out to the base pin labeled "shield." This shield terminal is connected to an electrical ground with respect to the other electrodes. If not thus

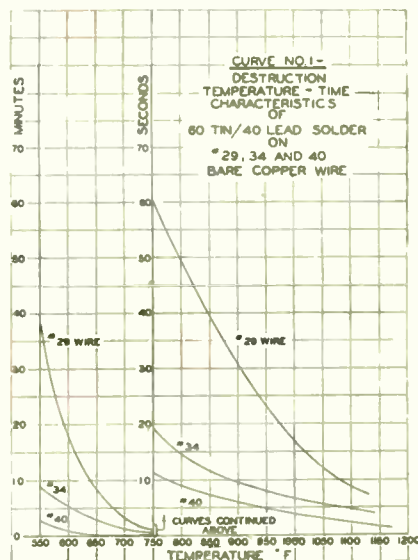
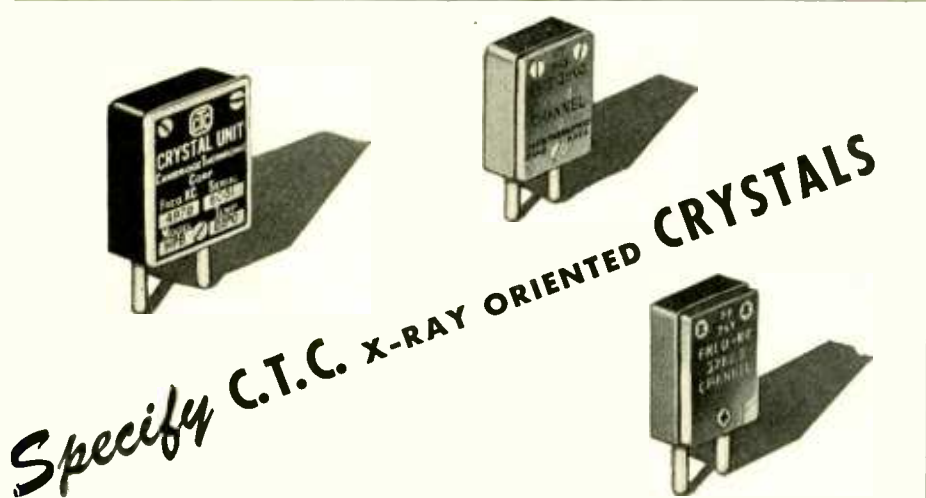

Figure 8

neutralized, electric fields created by the charge on the glass bulb can easily be of sufficient magnitude to exert a greater control over the electron flow than is obtained from the control electrode.

As low voltages are used on the electrodes, the anode current is low in comparison with ordinary triodes. Therefore, a microammeter or galvanometer must be used in the plate circuit to measure the small currents. The output may also be fed into a suitable voltage amplifier, in which case the RH-507 tube will serve as a coupling device between the source under measurement and the amplifier proper. Should the tube be used in this manner it is possible to use more rugged and cheaper instruments to obtain measurements previously requiring laboratory precision equipment. A typical electrometer circuit using a microammeter or galvanometer is shown in Fig. 8.

As low voltages are used on the electrodes to measure extremely minute currents, it is necessary to observe proper precautions in its operation. It should



You'll find that X-RAY ORIENTATION — predetermination of the crystallographic axes of the Crystals to permit accurate cutting — insures constant frequency over a wide temperature range in every C.T.C. Crystal.

Multiple mechanical lapping operations; dimensioning by edge lapping; finishing to final frequency by etching, are among the other important operations that guarantee high activity and constant frequency throughout the long life of C.T.C. Crystals.

For prices, delivery dates etc., get in touch with

CAMBRIDGE Thermionic CORPORATION

454 CONCORD AVENUE

CAMBRIDGE 38, MASSACHUSETTS

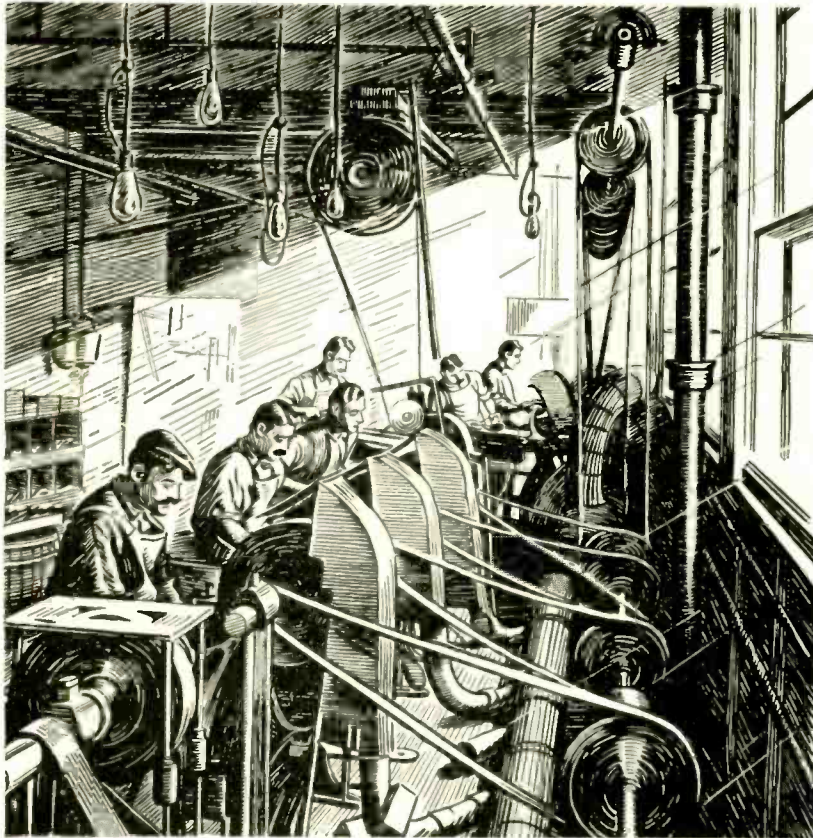

The telephone was still a novel device when *Connecticut Telephone & Electric* opened the doors of its first modest factory. Ever since, its people seem to have formed the habit of contributing to each revolutionary step ahead in communications.

For example, they helped to take the electronic tube out of the laboratory, and put it to work for everybody, by producing one of the first such tubes to be manufactured on a commercial scale.

For the past four years, every ounce of our engineering and production experience has been at work for Uncle Sam. Postwar American industry will naturally seek to draw on the know-how developed during the war. Ours applies not only to communications, but to the general field of electronics and precision electrical engineering and manufacturing. If you have a problem involving communications, product improvement, product control, ignition, or the manufacture of precision electrical devices, our particular know-how is at your disposal.

CONNECTICUT TELEPHONE & ELECTRIC DIVISION

GREAT AMERICAN INDUSTRIES, INC.
MERIDEN, CONNECTICUT

TELEPHONIC SYSTEMS • SIGNALLING EQUIPMENT • ELECTRONIC DEVICES • ELECTRICAL EQUIPMENT • HOSPITAL AND SCHOOL COMMUNICATIONS AND SIGNALLING SYSTEMS • IGNITION SYSTEMS



•
BACKGROUND
FOR
KNOW-HOW
•



RADIO

★ **DECEMBER, 1944**

49

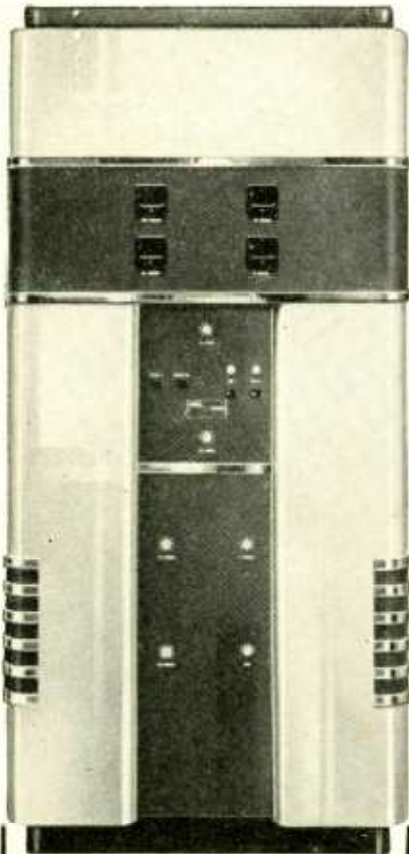

Broadcast Station Directional Equipment

Have you investigated the possibilities of increasing power by installing directional antenna equipment to "protect" other near-by stations on your frequency? If not, this should definitely be a part of your Post-War plans.

Johnson Engineers are pioneers in the directional antenna equipment field. They have completed and delivered 39 such units (probably more than any other manufacturer) and it is not too soon to place your order for Post-War delivery.

Johnson service includes working in cooperation with your consulting engineer in design of the equipment, building the phasing unit with cabinet to match your other equipment, furnishing tower coupling units, and furnishing concentric line, gas equipment and other accessories.

Write to Johnson today for further information and estimates.



E. F. Johnson Co. Waseca, Minn.

be considered as a very precise and sensitive piece of equipment instead of an ordinary vacuum tube.

The tube and all leads from the voltage supply should be shielded very carefully from any stray magnetic or electrostatic fields. It is also necessary to shield the tube from light as there may be some photoelectric effects while sensitive readings are being taken. It is advisable to mount the tube in a reasonably tight shielded can, containing a drying agent such as calcium chloride or phosphorous pentoxide to protect it from moisture in the air condensing on the bulb surface.

Even a microscopic film of moisture, if allowed to form on the bulb surface, provides a leakage path between the control electrode and the cathode. If a leakage of current occurs through this moisture film, the change in resistance in the control circuit causes the control electrode voltage to vary widely, thus destroying the accuracy of measurements. The minute currents being measured, are usually less than the leakage currents.

As added insurance against surface leakage, the outside surface of the bulb is sometimes treated with a solution such as Silicone Resin or some other suitable material. This coating, when applied, will help to break up the possible formation of moisture into tiny droplets which do not make contact with each other. Thus a continuous leakage path through the moisture is not possible.

If the tube is to be used continuously, the filament supply should be obtained from the Air Cell type of battery, otherwise No. 6 type dry cells may be used. Good "C" batteries may be used for the grid and plate supplies.

The filament current is very critical and must be held constant. If there is any drift due to battery or other changes the plate current will naturally shift, which will affect the constancy of the readings. It is therefore advisable to use only a battery which has been seasoned or has been stabilized so that its voltage has become practically constant.

The characteristic curves shown are taken from readings of several tubes. The plate current curves (Fig. 9) therefore represent average values, although individual tubes should not vary greatly from the average.

The grid current curves also represent average values taken on several tubes but the readings on individual tubes may vary considerably from the figures shown. The curve in Fig. 10 with 4.5 volts on the anode shows that the grid current passes through zero at minus 1.8 volts. The important feature to notice is that the grid current of every tube crosses zero at some bias voltage near this value. It is therefore possible to select a value of grid bias such that the grid current is zero; hence extremely minute currents can be measured accurately. By adjusting the grid bias so that the grid current is zero it has been found practical to measure grid currents as low as 10^{-14} amperes to obtain indications of grid currents as low as 10^{-16} amperes. By providing a bias adjustment on either side of the "floating potential," reversal of control current is effected to

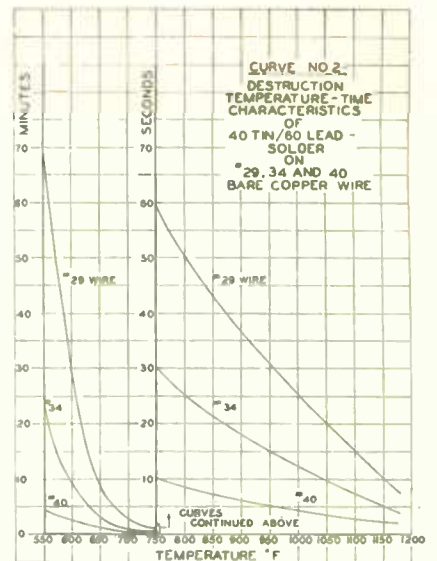

Figure 9

advantage in electrochemical polarization studies.

The construction of this tube has the following desirable features:

1. Low filament power.
2. Triode design.
3. Long life.
4. Low control electrode current.
5. Stable anode current.
6. Relatively low cost.
7. Low microphonic sensitivity.
8. Small size.

It should be noted that the measurement of currents of the magnitude mentioned requires that every precaution be taken to insure that no electrical leakage is present in the circuit wiring. Wherever possible, all leads from the electrodes should be air insulated. Where construction requires "feed through" insulators, the finest grade of insulating material should be used, such as quartz glass or a material which offers extremely high resistance to surface leakage.

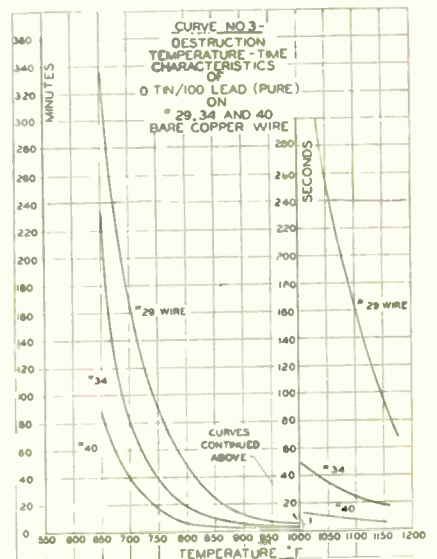
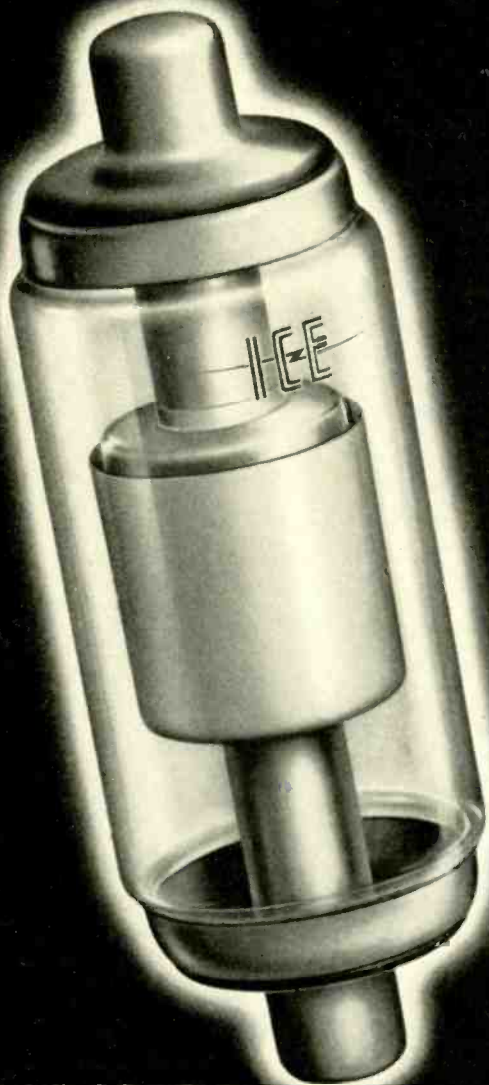
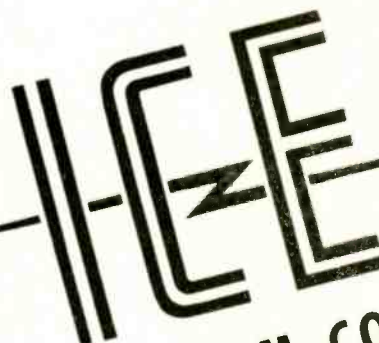

Figure 10

Announcing a new line of



This is the I. C. E. VC-100



VACUUM CONDENSERS

A brand new line of fine vacuum condensers . . . precision engineered and produced by I. C. E. . . . available now. New, improved designs in sizes VC-12 . . . VC-25 . . . VC-50 . . . VC-100 (illustrated) are ready for delivery.

These condensers have been tested and proved . . . now, they're ready to work for you. Remember, I. C. E. *precision engineering* is your assurance of quality-plus. Order now!

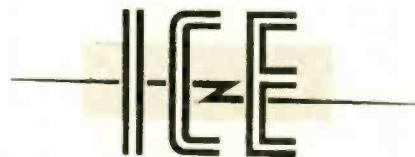

ELECTRONIC TUBES

INDUSTRIAL & COMMERCIAL ELECTRONICS
BELMONT, CALIFORNIA

RADIO

★ DECEMBER, 1944

The Terminology of ELECTROMAGNETIC THEORY

Because recent developments in the field of microwave radiation and generation have greatly widened the engineer's interest in electromagnetic theory, the following alphabetical list of terms, ideas, and theorems is presented. It is not so much intended that the discussions be rigorous definitions as that they shall give interesting ideas and serve as an introduction to the concepts.

Sheet Grids—A three dimensional grid may be placed in a hollow wave guide in such a fashion as to effectively remove all modes of propagation except the desired one. Such a grid or grating when viewed from the end is like any other grid structure but instead of being made of wires, the end view shows only the edges of metal sheets which extend along the guide for approximately a wave length.

The effectiveness of sheet grids depends upon the fact that thin conductors may be placed along an equal potential surface (i.e., perpendicular to the electric field) without disturbing the field in any way. The reason is simply that a metal sheet so placed finds every free charge that it contains to be at the same potential and hence under no compulsion to move. Since the charge of the metal sheet does not move it cannot affect the field.

On the other hand, if a metallic conductor is placed in a wave guide in such a fashion that a component of the electric field is tangent to the sheet, the free charges of the metal move in such a way as to cancel out the tangential field component. Thus if a circular wave guide is transmitting in both the *TE* and *TM* modes and it is desired to remove the *TM* energy, a radial sheet grid structure would be used. The *TE* electric field would find itself perpendicular only to the sheets, and hence be unaffected, but the longitudinal component of the electric field in the *TM* mode would be forced to lie tangent to the grid sheets and hence would be damped out. In actual practice sheet grids may easily be constructed to remove the unwanted component, but it is much harder to arrange them to have a minimum effect on the desired mode.

Shunt Admittance—Four terms must be distinguished and understood to discuss successfully the meaning of shunt admittance. These are shunt impedance, series impedance, shunt admittance, and series admittance. Either series impedance or shunt admittance is usually chosen to describe a given situation because they

are the ones which add directly while the others must be turned into reciprocals before an addition is made. *The shunt admittance of an element which is to be added to a transmission line is a quantity which may be properly added to the known admittance of that line so as to give the new admittance which will be found after the element has been installed.*

To make all this more clear it is helpful to consider an ordinary two-wire line. If somewhere along such a line a circuit is connected between the two wires, we conventionally speak of the addition as an impedance or admittance in shunt with the remainder of the line. We find it convenient to do so particularly if we talk of admittance because, with good judgment as to details, we can get the new admittances of the whole line by merely adding the admittance of the shunt to the original admittance of the line. Similarly, it is clear that if one conductor of a two wire line is broken and some element connected between the broken ends, we normally speak of the addition as a series impedance. In that case the new impedance is the old impedance plus that which is added. The word shunt is therefore looked upon as a signpost telling us to add admittances while the word series indicates that it is impedances which are to be added.

In certain wave guide cases, there is less immediate basis for deciding whether the properties of an additive element shall be described as a series or shunt arrangement. The decision as to which to compute is then based on convenience, along with some guidance which is available from the continuity of the electromagnetic fields. For example, a diaphragm may be installed in a rectangular wave guide and used as a matching impedance. An expression may be calculated for the approximate shunt impedance of such a diaphragm. It is not immediately clear that the diaphragm is in shunt rather than in series with the load and actually, since we have gotten away from wired circuits, it is not really a physical question anyhow. The name, shunt admittance, as applied to

the diaphragm nevertheless has a very definite meaning, inasmuch as it tells us how the expression is to be used.

Skin Depth— δ —When an electromagnetic wave reaches the surface of a conductor or a semi-conductor, it is in general subject to damping and its intensity falls off exponentially with penetration. For microwave frequencies the penetration is in general rather small and only the surface of the conductor has any effect on the microwave properties of the assembly. This is important in the construction of a hollow wave guide since it means that almost any material may be used as long as it is plated with a good conductor. Silver and copper are the most satisfactory conductors. *The skin depth is the distance into the material in centimeters or meters at which an incident electromagnetic wave is attenuated to the 1/eth its original strength.*

If a wave guide could be made of a material having a truly infinite conductivity, the skin depth would really be zero. The free charge of the conductor with its perfect mobility would shift even at the surface to cancel completely the incoming electric field. This shift of charge at the surface would constitute a current which, however, would be entirely lossless because of the absence of resistance. Thus the criterion for excellence in a material for microwave conductors is that of the smallness of the skin depth. In practical cases the skin depth of materials is greater than the minimum amount obtained for pure copper because of one or two reasons. In the first place if the conductivity is low penetration appears because the fields are not neutralized by the moving charge. Secondly, if an imperfectly conducting material is magnetic, the penetration is increased by internal magnetic coupling to the surface currents.

In Giorgi units, the skin depth in meters is given approximately by

$$\delta = \sqrt{\frac{\lambda_0}{\pi \sigma \mu_0}}$$

[Continued on page 54]



"In times like the present, men should utter nothing for which they would not willingly be responsible through time and in eternity."

Abraham Lincoln, 1861

*a Merry Christmas
and Happy New Year*

Jensen

Jensen Radio Manufacturing Company
6601 S. Laramie Ave., Chicago, Ill.

RADIO

* DECEMBER, 1944

53



Gas Filled Pressure Condensers

Johnson Engineers were among the first to design and build Gas Filled Pressure Condensers in fixed, variable, and combination fixed and variable types.

Gas Filled Condensers offer a decided advantage in size where large capacities or high voltage ratings are necessary. In some cases Gas Filled Condensers make possible an instrument that would be a mechanical impossibility in an air type.

Johnson Gas Filled Pressure Condensers are available in several sizes of housings depending on the rating specifications. Prices are low, efficiency is high, gas leakage is nil over long periods of time.

Write today for more information and prices.



E. F. Johnson Co. Waseca, Minn.

TERMINOLOGY

[Continued from page 52]

where λ_0 is the free space wave length, σ is the conductivity, and μ is the permeability. Even at frequencies corresponding to a one meter wavelength δ is only 3.8×10^{-4} cm for copper and at true microwave frequencies it is much smaller. For a poorly conducting medium such as sea water, the skin depth for one meter radiation is of the order of one centimeter.

Snell's Law—When a wave passes from one medium into another its direction of propagation is usually changed as it goes through the interface. Snell's law tells us about this change in direction. *If a wave approaches the interface at an angle i degrees to the normal and leaves at an angle r degrees from the normal, Snell's law is stated by $\sin i / \sin r = V_1 / V_2$ where V_1 and V_2 are respectively the velocities of propagation in the first and second medium.*

It can be seen that when the radiation moves from a fast to a slow medium so that the ratio of the V 's is greater than unity, any value of i may be chosen and r works out to be a smaller angle which may always be found. On the other hand, when motion from a slow to a fast medium is involved the situation is quite different. V_1 / V_2 is then a number less than one, and if i is chosen nearly equal to 90 degrees, Snell's law is found to require $\sin r$ to be more than one which is of course impossible. Physically, this sort of situation corresponds to the phenomenon of total reflection.

At angles where Snell's law would require impossible values of $\sin r$, there is no transmission through the interface at all. Total reflection occurs for incident angles greater than the critical angle which is specified by $\sin i = V_1 / V_2$.

It is not to be inferred from a discussion of the critical angle that an abrupt change to total reflection occurs when that angle is reached. Rather the ratio of the energy transmitted to the energy reflected decreases in an orderly manner throughout the whole range of increasing r and only becomes zero in actuality at the critical angle. At slightly smaller angles, transmission is possible but is very weak.

Stoke's Theorem—*If we construct any closed curve and integrate the tangential component of a vector around it, the result is equal to the surface integral of the normal component of the curl of that vector over an arbitrary surface bounded by the curve.* Mathematically this may be stated

$$\int F \cdot ds = \int \text{curl}_n F \cdot ds.$$

The proof of the theorem is simple enough although strictly mathematical in character and may be found in any book treating of vectors. To understand the physical uses of the relation, we must consider special cases.

If a vector specifies a field in which the curl is everywhere equal to zero, it is clear

that the integral of the curl will be zero no matter what closed curve or what surface is chosen. This in turn means, according to Stoke's theorem, that in such a curl free field the tangential integral taken about any curve will be zero. If the field is a gravitational one, for example, and F represents the force on a certain mass, that mass may be carried over any route and returned to its original position without a net loss of energy. Similarly, a charge may be carried around a closed path in a stationary electric field without a net loss or gain of energy. Such fields are called conservative fields and Stoke's law shows that the curl being identically equal to zero is a necessary and sufficient condition to insure that a given field is conservative.

If a magnetic pole is moved around a current carrying wire, a net amount of energy is involved even though the pole does return to its starting point. Magnetic fields are not conservative even in the stationary state case. In fact Maxwell's equations tell us that $\text{curl } H = 4\pi u/c$ even when the electric field is constant with time.

Stationary Fields—*Stationary electromagnetic fields are those which are independent of time.* They may be regarded as a special case of the general situation which is covered by Maxwell's equations. Specifically, in the stationary case, we may write Maxwell's equations without the partial time derivatives since they are identically equal to zero. Thus we have, in Gaussian units

$$\begin{aligned} \text{curl } H &= 4\pi u/c \\ \text{div } B &= 0 \\ B &= \mu H \end{aligned}$$

$$\begin{aligned} \text{curl } E &= 0 \\ \text{div } D &= 4\pi \rho \\ D &= \epsilon E \end{aligned}$$

In this case the electric field arises entirely from a charge density and may either be found by a vector integration over the charge or through the use of a scalar potential. The vector integration of Coulomb's law,

$$E = \int \frac{d\rho}{\epsilon r^2} \frac{\Delta}{r}$$

is clumsy at best and calculations are more frequently made by first setting up a potential. The curl E equation tells us that a scalar potential may be used and we define it as $E = -\text{grad } V$. Let us assume in general that we know how the charge density is distributed throughout the space in which we are interested. Furthermore, let us present this data in terms of a function, ρ , which has a particular value at each coordinate corresponding to the charge density at that point. The potential V is obtainable from Poisson's equation

$$\nabla^2 V = -4\pi \rho$$

and a solution of that equation yields an expression giving values of V at each point in space.

For the H field we cannot set up a scalar potential even for the stationary case because the curl of H is not zero. We therefore find it convenient to set up a vector potential defined by $\text{curl } A = H$ and div

[Continued on page 56]



**"I'LL BE BACK. I FORGOT TO TELL THE BOSS THAT
ALBION CAN SHIP ALL THE COILS HE NEEDS"**

SUPER-QUALITY COILS AT REASONABLE PRICES

More and more every day, the industry is turning to Albion for fast, quality and quantity production of coils, chokes, and transformers. That's because here you benefit from the unbeatable combination of management "know how," skilled workmanship, streamlined facilities, and central location. Your requirements will be given prompt and thoughtful attention.

**ALBION
COIL COMPANY**

ALBION, ILLINOIS

R. F. AND TRANSMITTING COILS AND CHOKES;
I. F. TRANSFORMERS

harvey

... Reliable
Supplier of
RADIO
and
ELECTRONIC
PARTS and EQUIPMENT

TUBES RESISTORS
RELAYS CAPACITORS
METERS TRANSFORMERS
TEST EQUIPMENT

The Goods:

We stock and sell items bearing the names of famous manufacturers... people who value their reputation as much as we value ours.

The Service:

We track down hard-to-find items, or suggest equivalent substitutions. We supply sound technical advice... help solve priority problems.

The Delivery:

Fast... within 24 hours, at times. And whether you order by mail, wire or phone, you'll receive immediate attention. Try HARVEY and see for yourself.

Telephone Orders to:
LONGACRE 3-1800

HARVEY

103 WEST 43rd ST., NEW YORK 18, N. Y.

TERMINOLOGY

[Continued from page 54]

$A = 0$. Here too we can find A by Poisson's equation,

$$\nabla^2 A = -4\pi u/c$$

involving the current density u which is presumed to be known in the space in which there is interest.

Thermal Noise— In an electrical circuit, noise is characterized by spurious voltages of a random character and may arise from any one of several causes including many that can be minimized or circumvented by good design. Thermal noise, however, is intimately tied up with the nature of things and establishes the upper limit to the sensitivity that can be built into a radio receiver. *Because the free charge in conductors and semi-conductors is subject to thermal agitation, random voltages are generated in strength given by*

square of effective value of voltage components lying between frequencies f_1 and f_2

$$= 4kT \int_{f_1}^{f_2} Rdf$$

where

$$k = \text{Boltzmann's constant} = 1.374 \times 10^{-23} \text{ joules per degree Kelvin}$$

$$T = \text{absolute temperature in degrees Kelvin}$$

$$R = \text{resistance component of impedance across which the noise voltage is developed}$$

$$f = \text{frequency}$$

When the element in which the noise originates is a pure resistance so that R is independent of frequency, the integration may be performed at once. The expression then becomes simply

$$E^2 = 4kTR(f_2 - f_1)$$

The free electrons in the conductor are in constant motion, moving hither and thither and constantly colliding with each other just as do the molecules of a gas. This motion is, in fact, heat. When a body of any sort is warmed the motion of the atomic particles in it is increased and we say the body is warm or hot and even find when we touch it that some of the rapidly moving molecules will so disturb the cellular structure of the flesh as to cause a burn. Likewise if any body is cooled the motion of its free electrons and molecules is reduced and in fact, if we could cool the body to absolute zero, would be stopped entirely. In a conductor these randomly moving electrons constitute an erratic current and generate the emf which we call noise.

It is particularly noteworthy that the energy of each electron is well known on the average. It is given by $(3/2)kT$ in which k is Boltzmann's constant. A statistical analysis of the effect of many electrons having this average energy can give rise to the formula we have quoted.

It will be noticed in the expression for the square of the effective noise voltage that the noise is independent of the frequency being amplified but does depend upon the band width of the amplifier.

Thus, if a one-megohm resistor is operated at room temperature (about 300 degrees K) in an amplifier which passes all frequencies between f_1 and f_2 which are 5000 cycles apart, that resistor must be considered, as far as the rest of the circuit is concerned, to be a source of noise voltage of $(4 \times 1.37 \times 10^{-23} \times 300 \times 10^6 \times 5000)^{1/2} = 0.9 \times 10^{-6} V$. This is true whether f_1 and f_2 are of the order of a few kc or have values equal to many megacycles. The peak value of the noise will be 3 to 4 times greater than this.

Townsend Discharge— *The description of what happens to charge in a gas when low current densities are present is referred to as a description of a Townsend discharge.* As a result of the Townsend model for gaseous discharge it may be shown that the current flowing through a gas that is contained between two parallel plate conductors is approximately given by

$$i = en_0 e^{ad}$$

where d is the distance between the conductors; a is a constant depending upon voltage and upon the pressure and nature of the gas; n_0 is the number of electrons emitted from the positive plate per second; and e is the charge of the electron.

This law, which is valid for voltages well below the breakdown, checks out well for a certain range of potential gradient. Its derivation depends upon a physical picture about as follows: With extremely low voltages the only current that can flow through the gas is that which is conveyed by electrons which are accidentally present because of heat or optical ionization or because of cosmic rays or some other such effect. In general, there will be a limited number of these electrons and as the voltage is increased in this region of very low gradient, a saturation effect will be found and the current will cease to increase because of the lack of electrons to carry the charge. But this plateau is usually very narrow and, with further increase in gradient, the current again starts to rise rather steeply in accordance with the relation we have stated. This portion of the current-versus-potential-gradient curve, which is still way below the breakdown point, is called the region of the Townsend discharge. What happens is that each electron accidentally present in the gas finds that, after it has traveled a certain distance toward the positive electrode, it has accumulated enough energy to ionize an atom with which it collides. Thus there become two electrons in place of each one, the original one and the one knocked off the atom with which the collision took place. This allows the current to be doubled and, if there is sufficient space between the two electrodes, the two electrons of the first collision will be accelerated and in due course collide again to make four electrons. This will continue indefinitely if there is enough space and is of course exactly the sort of phenomenon that gives rise to the exponential dependence that is quoted.

The geometrical progression by which one electron becomes two and then four, etc., is very aptly called a Townsend avalanche.

[To be continued]

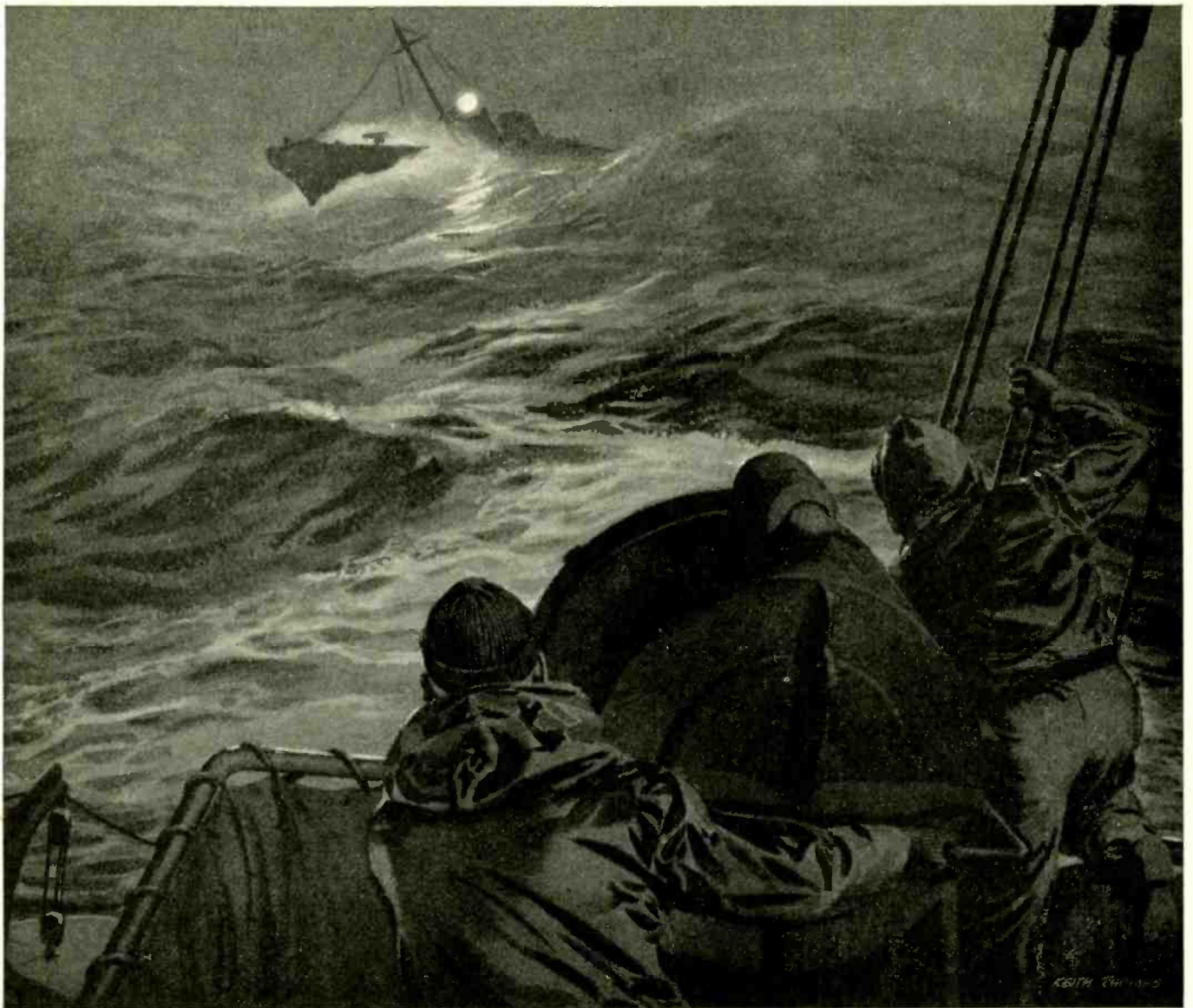

History of Communications. Number Twelve of a Series

COMMUNICATION BY THE BLINKER



The Blinker, an adaptation of the Heliograph with its own source of light, has been found invaluable for night and day Naval Communications. While limited by "line-of-sight" transmission and the elements of weather, it has been an aid to our cautious convoys during "radio silence."

When Victory is ours and the days of "radio silences" are gone forever, private citizens again will have electronic voice communication equipment for their yachts and other pleasure craft. With the release of civilian radio bands Universal will again offer the many electronic voice components for use in marine craft.

< *FREE—History of Communications Picture Portfolio. Contains over a dozen pictures suitable for office, den, or hobby room. Write for your "Portfolio" today.*



UNIVERSAL MICROPHONE COMPANY

INGLEWOOD, CALIFORNIA



FOREIGN DIVISION: 301 CLAY STREET, SAN FRANCISCO 11, CALIFORNIA · CANADIAN DIVISION: 560 KING STREET WEST, TORONTO 1, ONTARIO, CANADA

RADIO

★ DECEMBER, 1944

57

New Products

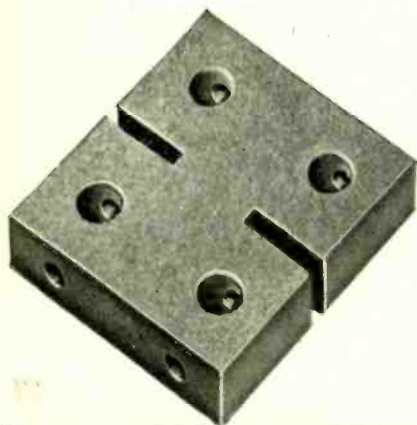

HAVE YOU INVESTIGATED MYCALEX?

Mycalex has many physical and electrical characteristics which make it outstandingly superior to any other electrical insulation for many purposes. It is particularly effective at ultra-high frequencies.

Mycalex can be sawed, drilled, tapped, ground, polished, turned or milled and dimensions can be held to very close tolerances. It is an ideal material where only a few pieces are required and die cost necessary for other materials would not be justified.

Mycalex is available in sheets, rods, bars, tubes and strips which can be fabricated into almost any shape or size required.

Mycalex is just one trade name for glass-bonded mica insulation also available under several other trade names. Johnson has used and is prepared to furnish any such material.

Johnson as a fabricator is approved and recommended by the manufacturers of this material. Johnson is one of the pioneer fabricators of Mycalex, probably has more complete equipment, and certainly has had more experience than other manufacturers.

Johnson's recommendations will be unbiased. Johnson regularly uses steatite, porcelain, bakelite, hard rubber and all makes of glass bonded mica. If you have an insulation problem, Johnson Engineers will be glad to make recommendations, submit samples or quote prices. Write Johnson today or contact the Johnson Representative in your territory.

AMPHENOL INSERT CHART

A unique, complete and practical Chart of Molded AN Insert Arrangements for Electrical Connectors has just been published by American Phenolic Corporation, Chicago 50, Illinois. It is an easily readable addition to any engineering department or drafting room dealing with this type of equipment.

The real advantage of the chart lies in its convenience and readability. Knowing the required number and sizes of wires, an engineer can make proper selection instantly. The inserts are plainly grouped by total number of contacts in vertical columns—in numerical order—reading from top to bottom and left to right.

All standard inserts from one contact to one hundred contacts are shown full size. All socket or pin arrangements are clearly indicated together with wire sizes—also included are coaxial cable connections and grounded or shorted inserts. Mechanical spacing of contacts and alterna-

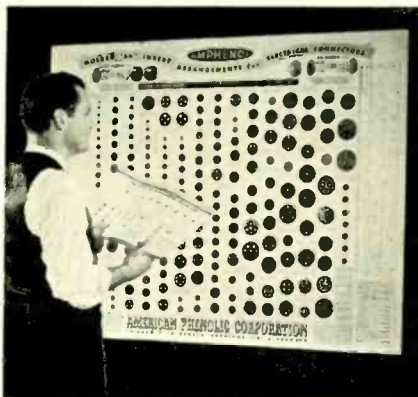

tive positioning of the inserts with new position numbers are given in each case. Exploded pictures of pin and socket inserts add considerably to the understandability of the chart. The chart is 50" x 38", printed in blue and black on heavy, durable yellow stock which aids in making the chart's information readable from desk chair position.

A complete chart of AN and Amphenol 97 shell types and styles is enclosed with each Insert Chart. This includes the special purpose shell types such as pressure-tight, moisture-seal, explosion-proof, light proof and other plugs and receptacles.

Believing that a complex matter becomes simple for handling as it is better understood, Amphenol also encloses a chart which diagrams the system, clarifying the long and complex numbers used in specifying connectors. Thus the significance of AN 3100-16-11-PY (101 S-8M) immediately becomes more intelligible to an average reader. This chart is also right up to the minute, including even the proper designation for connectors to be given the tropicalization treatment.

A copy will be sent promptly on receipt of a request on your company's letterhead.

NEW VACUUM GAUGE

An improved type vacuum gauge, known as the Tru-Vac (of the Pirani type) for accurate high vacuum measurement is now available for use in high-vacuum processes of all kinds. The Tru-Vac Gauge is already proving itself valuable to manufacturers in more than 50 types of industries, including the manufacture of radio tubes, fluorescent lamps, thermometers and other articles in great profusion.

The Tru-Vac Gauge gives instantaneous and continuous reading within a range of 0 to 3000 microns. It indicates the presence of water and other vapors, takes note of vacuum changes as they occur and is adaptable to any high vacuum pump or system. It is direct-reading and the state of the vacuum may be noted at any time.

These d-c operated gauges require only one or two #2 dry cells and may be installed in rubber, sealed to hard or soft glass systems, or coupled to one-half-inch standard pipe connections.

The Tru-Vac Gauge is manufactured by the Continental Electric Company of Geneva, Illinois, who will send literature free on request.

TAYLOR ANNOUNCES 803 TUBE

The first large pentode to be manufactured under RCA license has gone into mass production, it was announced by Rex L. Munger, Sales Manager of Taylor Tubes, 2312 Wabansia Ave., Chicago. The tube, the Taylor 803, is 9 3/8" max. overall length by 2 9/12" max. diameter and is fitted with the giant 5-pin mycalex base.

Electrical tube characteristics are: Filament voltage, 10 volts a-c or d-c; filament



current, 5 amps.; interelectrode capacitances, grid to plate (with external shield), 0.15 mmf; input, 17.5 mmf, output, 29 mmf.

Operation data for r-f Amplifier and Oscillator: D-C plate voltage, 2000 volts; suppressor voltage (grid #5), 500 volts; screen voltage (grid #2), 600 volts; grid

JOHNSON
a famous name in Radio



E. F. Johnson Co. Waseca, Minn.

"MICROMETER CONSCIOUS"



*in the quantity production
of minute precision parts*

Forty-five manufacturers of major prominence now are relying upon the micrometer-conscious Wadsworth Small Parts Division for scores of parts so minute and precise that their quantity production is difficult or expensive for the average plant.

At Wadsworth, such production is customary, and meets the highest critical standards.

Here, a unique machine setup and workers who *think* precision are intimately associated under one roof. They contribute special operations to many pieces and carry others through in their entirety, in great quantities.

We welcome conversations with all companies who intend to be postwar factors in their fields and will be glad to discuss the matter of applying Wadsworth skills to your special needs.

WADSWORTH FACILITIES

*Die Making
Jigs & Fixtures
Gage Making
Model Building
Milling
Drilling
Turning
Stamping
Screw Machining
Hard Soldering
Heat Treating
Line Assembly
Polishing
Lacquering
Photo-Etching
Silk Screening
Product Decorating
Metals Laboratory
Engineering Design
Product Design*

CURRENTLY SERVING THESE INDUSTRIES

*Aircraft
Automotive
Bearing
Electronics
Instruments
Machine Tool
Small Arms
Refrigeration*

SMALL PARTS DIVISION

THE *Wadsworth* WATCH CASE CO., Inc.
DAYTON, KENTUCKY, SUBURB OF CINCINNATI, OHIO
PHONE COLONIAL 8194 • (CINCINNATI EXCHANGE)



Wadsworth is heavily engaged in many-sided war work. But our steady production of Military Watch Cases and our constant designing of the precious metal cases for the future are preserving the art of fine watch case development.

The Publishers of RADIO
Announce the Launching of A New
Technical Monthly

CQ →

1st ISSUE

JANUARY 1945

Covering All Phases of
 Amateur Radio,
 Communications,
 Equipment & Techniques

SUBSCRIPTION PRICES:

12 issues \$2.50
 24 " 4.00
 36 " 5.00

In U.S.A. & Poss.
 \$3.50 per yr. elsewhere

**NOT FOR SALE
 ON NEWSSTANDS**

**ORDER YOUR SUBSCRIPTION
 DIRECT FROM**

**RADIO MAGAZINES, INC.
 342 MADISON AVE.
 NEW YORK 17, N. Y.**

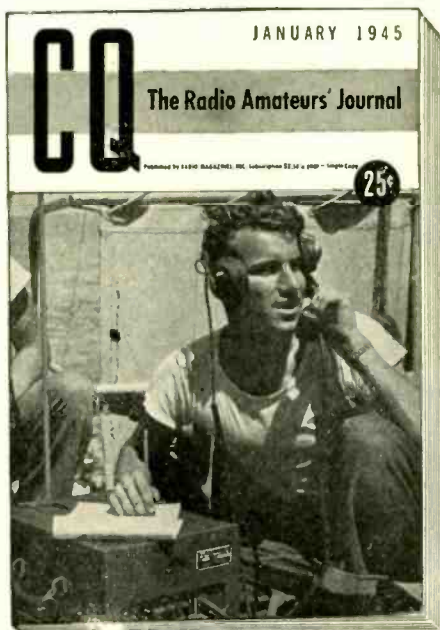

voltage (grid #1), —500 volts; d-c plate current, 175 ma; d-c grid current, 50 ma; plate input, 350 watts maximum; suppressor input, 10 watts maximum; screen input, 30 watts maximum; plate dissipation, 125 watts maximum; driving power, 2 watts approximately; power output, 210 watts approximately. Maximum frequency at full output, 20 megacycles. The tube may be mounted only in a vertical position with the base either up or down.

The Taylor 803 tube will be available solely for military and government orders on priority basis on War Contracts, it was stated.

3,000-VOLT DYNAMOTOR

Adding to the rapidly expanding Post-War line of dynamotors and hand generators, Robert W. Carter, Managing Director of Carter Motor Co., 1608 Milwaukee Ave., Chicago, announces that a new Super-Dynamotor providing 3,000 volts D.C. has been developed to be run from a 12-volt battery primary source.

The unit is 11½ inches long, 4½ inches diameter and 5 inches high and weighs less than 18 pounds without filter. It furnishes 3,000 volts D.C. at 0.05 amperes. The input to the motor portion of the

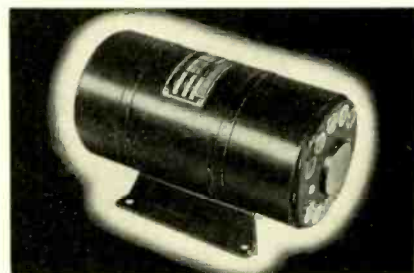

dynamotor can be had in voltages ranging from 12 volts to 115 volts D.C.

Some of the outstanding features found in this unit are: special laminations and special type insulation which is capable of withstanding the very high voltage without breakdown. Also, it is possible to furnish the unit with two 1,500-volt, 0.05 ampere outputs, instead of the 3,000-volt one. Because of the high voltage and the tendency towards sparks and corona effects, the ends of the unit, where the brushes are located, are enclosed in explosion-proof covers enabling the use of the unit in gaseous locations such as near airplane engine, in mines, and other similar positions.

It is expected that the units will be used in portable television equipment, portable high-voltage visual signaling devices and all portable and mobile equipment requiring that type of very high voltage.

GOODRICH BOOKLET

Produced especially for designers of industrial equipment as well as consumer products, The B. F. Goodrich Company, Akron, Ohio, has just issued a general booklet on its industrial rubber products, which can now be obtained upon request.

Included in the booklet are discussions of the company's line of Vibro-Insulators, devices of rubber and metal which reduce

OPPORTUNITY

FOR ABLE, PROGRESSIVE CHIEF ENGINEER

A growing company of many years standing, with a well established peacetime product sold all over the world, needs a topflight Chief Engineer. We have several outstanding postwar projects, one of which is a new product in the business machine field with a large American and international market. This company, employing between 500 and 700, has both mature know-how and energetic, forward-looking management. The man needed will be in charge of all engineering activities including design, processing and tooling for sound recording and communications equipment and diversified electrical products. He must be capable of vigorous and active leadership in development and manufacture.

He must be an engineer, though not necessarily with an M.E. or E.E. degree. He must have a broad manufacturing background with experience in design, engineering, processing and tooling for electrical assembly and manufacture. If you lack these qualifications, please don't apply for this Chief Engineer's job. However, we also need several other experienced electrical and mechanical engineers, preferably under 40, for other work in our company. These men need not have such broad experience.

Write a confidential letter to the President telling about your experience in detail, age, education, professional societies and recognition, and any other factors that will be helpful in giving us a better picture of your qualifications, and salary expected . . . bearing in mind that while we are now working on high priority contracts, these are permanent jobs with a well established company that has vigorous plans for the postwar period. Your photograph would be very helpful in enabling us to tell more about you, but it is not entirely necessary. No further investigation will be made without your express permission.

THE GRAY MANUFACTURING COMPANY
16 ARBOR STREET • HARTFORD, CONN.

"Checked up on Bridgeport?"

"You Bet! Bridgeport will be
our best postwar source for
coils and chokes...and just
look at their location!"



★ THIS IS BRIDGEPORT, ILL.

YES, LOOK AT IT. Right near the population center of America. Right for deliveries to all your plants with fast trunk-line service. Here in Bridgeport, in wartime, skilled technicians are building search coils and variometers to meet the most exacting requirements of the Armed Forces. They're doing a big war job well. After victory, Bridgeport will do your big postwar job equally well. You'll find them your most dependable source of supply for R. F. coils and chokes, I. F. transformers and transmitting coils and chokes. Write to Bridgeport today to insure early postwar delivery of the parts you need.

BRIDGEPORT

MANUFACTURING COMPANY

Bridgeport, Illinois

R. F. Coils • R. F. Chokes • I. F. Transformers
Transmitting Coils • Transmitting Chokes

Send Only 10c For This Handy TUBE AND CIRCUIT REFERENCE BOOK



OUR NEWEST
GET-ACQUAINTED
OFFER!

Here's a handy reference book that meets the demand for simple, easy-to-understand data on substitution of radio tubes. Contains a special section devoted to valuable technical information on tubes and circuits. It's a guide you'll refer to time and again. You can't afford to be without it. Send for your copy today! Only 10c postpaid.

TUBE-BASE
CALCULATOR
ONLY 25c



Here's just the calculator you've been looking for! Tells you quickly, tube characteristics that enable you to substitute available tubes for those hard to get. Send for one today. Only 25c. We pay the shipping expense.

FREE! Giant Radio Reference Map



Time zones, amateur zones, short wave stations and loads of other valuable information. Printed in colors; size 3½ x 4½ ft. It's yours free! Send 15c to help with packing and mailing.

WE'VE GOT THOSE
HARD-TO-GET
RADIO PARTS

You'll be surprised at the many hard-to-get parts we've been able to get for you fellows. Tubes, pickups, multi-testers, meters and many other items. They're yours as long as they last. Send today for our latest flyer. It's full of merchandise you've been trying to get! Stocks won't last long, so send today!



HALLICRAFTERS

For many years we have been one of the country's largest distributors of Hallicrafter equipment. We have Hallicrafters available for immediate delivery on priority. For full particulars, write.

WHOLESALE RADIO LABORATORIES

744 W. BROADWAY
COUNCIL BLUFFS, IOWA

—Mail Coupon Today—

Wholesale Radio Laboratories RM-11
744 West Broadway
Council Bluffs, Iowa.

- Send your reference book "Tubes and Circuits". Here's my 10c.
- You bet I want a Tube-Base Calculator. 25c is enclosed.
- Ship me your free radio map. 15c is enclosed for packing and mailing.
- Send your free flyer of hard-to-get radio parts.

Name _____

Address _____

Town _____ State _____

I am an amateur; experimenter;
 service man.

vibration, molded, extruded, lathe cut and sponge rubber products, rubber lined tanks and valves, products made with Koroseal, the company's flexible material created from plasticized polyvinyl chloride, V-belts and cements.

HALLICRAFTERS BROCHURE

The Hallicrafters Company is preparing its distributors and material suppliers for a distinctive postwar market.

Its latest move has been the publication of a brochure, featuring full color reproductions, in which the war service of company communications equipment is reviewed and the peacetime opportunities for Hallicrafters is emphasized.

The appeal of Hallicrafters advertising, the brochure discloses, is being directed to a quality market in publications of general interest and through technical publications to radio amateurs, aviation, marine and other fields.

The war picture of the Hallicrafters Company as related in the brochure revolves about the outstanding performance of the SCR-299, documented with messages from high ranking service officers and battle front news dispatches.

VACUUM IMPREGNATION

Vacuum impregnation of coils, armatures, transformers, etc., under pressure is demonstrating many advantages over ordinary dipping, and costs no more, according to Vacuum Impregnating Works, 638 Federal St., Chicago, Ill. This concern has developed a large and increasing business in this method.

Among the results shown, in addition to more efficient insulation are: Higher sustained voltages without overload; elimination of wear due to creeping of coils; prevention of insulation charring; protection of wire from vibration; permanent filling of spaces; maintenance of coil coolness; coils rendered positively moisture-proof; protection of windings from electrolysis.

Insulation material is suited to each individual type of work. Under the process employed, insulation is guaranteed to the very center of the unit impregnated. Details may be had by addressing Vacuum Impregnating Works.

H-F IRON CORE ENGINEERING DATA

Designers and builders of radio and electronic equipment will find the new Crolite Magicore Catalog a prolific source of practical data. Just issued, this catalog covers the uses and functions of powdered iron cores; the permeability and "Q" of various materials at different frequencies; the effects of the addition of adjusting screws; copper cores; mechanical considerations, standard pieces and sizes; and special cores especially of large dimensions.

A copy is available to any designer, engineer, purchasing agent or production man writing on his business stationery to Henry L. Crowley & Company, Inc., 1 Central Ave., West Orange, N. J.



• They were mighty tough before Pearl Harbor, and they are now still tougher, these Type "05" Aerovox oil-filled Xmitting capacitors, because of their service on many fighting fronts. You'll have these heavy-duty capacitors available for your bigger and better "ham" rigs or electronic assemblies just as soon as Uncle Sam releases them for your use. Remember Aerovox "05" Hyvols.

Convenient, moderate-priced oil-filled capacitors.

Reinforced round metal can. Hyvol impregnated and fill.

600 to 3000 volt D.C.W. ratings. Capacitance ratings from 1.0 to 4.0 depending on voltage.

Immersion-proof terminals with "double rubber bakelite," porcelain pillar insulator, lug and locking nuts.

Adjustable mounting ring for upright or inverted mounting.

• Ask your jobber about these Aerovox "05" Hyvols now available on suitable priorities, but generally available after V-day.

AEROVOX
Capacitors
INDIVIDUALLY TESTED

AEROVOX CORP., NEW BEDFORD, MASS., U. S. A.
In Canada: AEROVOX CANADA LTD., HAMILTON, ONT.
Export: 13 E. 40 St., New York 16, N. Y. Cable: 'ARLAB'

American OUT IN FRONT!

Whether it's the philharmonic, oratory, news, public address, sportscast or commercial, the quality of the program that goes through depends **first** on the microphone **OUT IN FRONT!**

D5



D5 DYNAMIC—An ideal microphone for general use, due to its versatility and dependability. Microphone contour and diaphragm protective grille designed to minimize wind noise and sound field distortion. Recommended for close talking as well as distant sound source pick-up.

There it stands, unattended, with the whole show going on. It just **has** to be dependable. It just **has** to have full range for the job.

D3

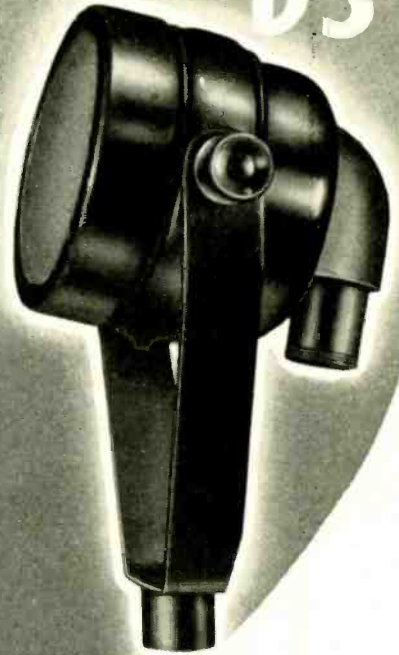

D3 DYNAMIC—Recommended for those microphone applications where high fidelity (uniform response from 50 to 10,000 cps) is of prime importance. Attention to detail in design and construction of each microphone insures stable operation and optimum performance for all types of audio pick-up.

D9A

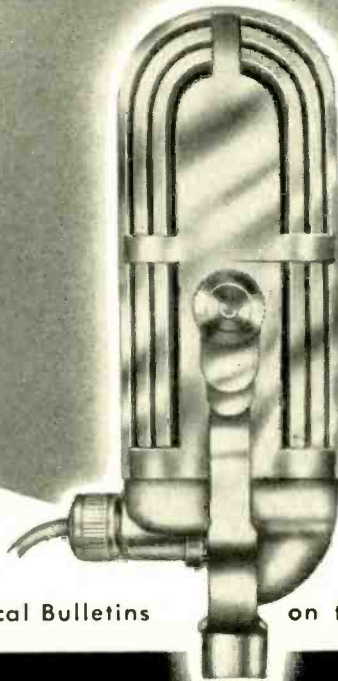

D9A UNIDIRECTIONAL DYNAMIC—A pressure-velocity combination microphone, will pick-up from front only, broad frequency response and high output, should fill the majority of requirements. Especially recommended for indoor use due to feed-back reduction and elimination of extraneous pick-up.

Write for Comprehensive Technical Bulletins

on these and other American Microphones.

American MICROPHONE CO.

1915 So. Western Avenue, Los Angeles 7, California

CONCORD Service!

NONE BETTER IN AMERICA FOR RADIO AND ELECTRONIC PARTS AND EQUIPMENT



Sure! Swift! Satisfactory! That's the story of Concord Radio Corporation's service. Twenty-two years of "delivering the goods" have made us a top supplier of radio and electronic merchandise to industry, government and the trade. Two strategically located "supply bases"—CHICAGO and ATLANTA—are as close to you as a letter, a telephone call, a telegram, or a message on the teletype. Here is what Concord can offer you:



Weston 2 1/2" Model 506 Milliammeter D.C. 0-100
Weston 2 1/2" Model 506 Milliammeter D.C. 0-200
Your Cost, either type \$4.95



IRC Dual Potentiometer 1 1/4" diameter—1 1/4" deep 1/4" shaft—1/4" long
Your Cost 89c



25 mfd. 25 volt condenser in aluminum can.
Your Cost 29c



Micro-Switch, Type Z, S.P.S.T. Normally closed. Acro. Switch, similar to above but normally open.
Your Cost, either type 79c

- The finest merchandise from the best manufacturers
- Large and complete stocks of components and equipment
- A seasoned selling staff of radio and electronic experts
- Consultant radio technicians and engineers
- Same-day shipment, wherever humanly possible
- Super-speed "special service" for military and industrial needs



FREE! Special Supplement! "Hard-to-Find Radio and Electronic Parts and Equipment". Sixteen pages, jammed to the margins with such items as condensers, wire, switches, volume controls, relays, resistors, test accessories, speakers, etc. There's not another listing like it anywhere in the country today.

CONCORD RADIO CORPORATION
901 W. Jackson Blvd., Chicago 7, Ill. Dept. No. F-124

Please rush me the new 16-page "Special Supplement" by Concord Radio Corp
NAME.....
ADDRESS.....
CITY..... STATE.....

CONCORD RADIO CORPORATION
Lafayette Radio Corporation

901 W. Jackson Blvd. CHICAGO 7, ILL. 245 Peachtree Street ATLANTA 3, GA.

BIBLIOGRAPHY

[Continued from page 42]

La Goniométrie Radioélectrique dans la Navigation Aérienne—*Industrie Électrique*—Jan. 10, 1920, Page 4.

Über Richtempfängerversuch im Flugzeug—E. Buchwald and R. Hase—*Jahrb. D. Drahtl. Telegraphie*—Vol. 15, Feb. 1920, Page 102; *Tech. Rev.*—Vol. 6, April 23, 1920, Page 384; *Radio Review*—Vol. 1, Aug. 1920, Page 562.

Versuche über Drahtlose Anpeilung von Flugzeugen—R. Baldus and E. Buchwald—*Jahrb. D. Drahtl. Telegraphie*—Vol. 15, Mar. 1920, Page 214; *Radio Review*—Vol. 1, Nov. 1920, Page 724.

Seaplane Flies by Radio Compass—*Aerial Age Weekly*—July 26, 1920, Page 683.

Radio Compass Successful—*Aircraft Jnl.*—Vol. 7, Aug. 30, 1920, Page 12.

Radio Compass for Directing Airplanes to Ships—*Scientific American*—Vol. 73, Nov. 6, 1920, Page 465.

Method of Direction Finding of Wireless Waves and Its Application to Aerial and Marine Navigation—J. Robinson—*Radio Review*—Vol. 1, 1920, Pages 213 and 265.

Airplane Direction Finder—A Development of the War—*Electrical World*—Vol. 73, Feb. 1, 1919, Page 222.

The Radio Compass and the NC Flights—*Wireless Age*—Vol. 6, Aug. 1919, Page 19.

Aircraft Direction Finding—*Communications*—Vol. 18, No. 10, Oct. 1938, Page 33.

Some Design Considerations in Adcock Direction Finders—H. W. Roberts—*Aero Digest*—Vol. 32, May 1938, Page 52.

Standard Adcock Direction Finding Equipment at Aerodromes Reduces Night Error (Abstract)—H. Busignies—*Electronics*—Vol. 11, March 1938, Page 60.

British Patent No. 363,617—1931—R. L. Smith-Rose and H. A. Thomas.

Variations of Bearings in Short Wave Direction Finding—M. Asukai and T. Hayasi—*Sci. Abs.*—Sec. B, Vol. 34, Dec. 1931, Page 682. Abstracted from *Radio Research—Japan*, Reports, V. 1, June 1931, Pages 89-93.

Analyse d'une Communication de M. Barfield à L'Institution of Electrical Engineers sur les progrès récents en radio-goniométrie—E. Bellini—*Soc. Fran. Electriciens*—Bull., Ser. 5, Vol. 1, Feb. 1931, Pages 140-144.

Polarization of High Frequency Waves and Their Direction Finding—S. Namba—Eiji Iso and S. Ueno—*I.R.E. Proc.*—Vol. 19, Nov. 1931, Pages 2000-2019.

Polarization of High-Frequency Waves and Their Direction Finding—S. Namba—E. Iso and S. Ueno—*Wireless Engr.*—Vol. 8, Sept. 1931, Page 491.

Polarization Phenomena of Low-Frequency Waves. Part I, Measurements on Polarization. Part II, A Note on Polarization Error in Direction Finding—*Wireless Engr.*—Vol. 8, Sept. 1931, Pages 490-491.

Radio Direction Finding at Post Office Coast Stations—G. H. Farnes and F. Hollinghurst—*P.O.E.E. Jl.*—Vol. 23, Oct. 1930, Pages 211-215.

Direction Finding Apparatus. Result of Tests at Slough—Superiority of Modified Adcock System—R. H. Barfield—*Electrician*—Vol. 104, April 11, 1930, Page 464.

Recent Development in Direction Finding Apparatus—R. H. Barfield—*Exp. Wireless*—Vol. 7, 1930, Page 262.

Recent Developments in Direction Finding Apparatus—R. H. Barfield—*Exp. Wireless*—Vol. 68—*Jnl. I.E.E.* (London), 1930, Page 1952.

Direction Finding for Planes—*Sci. and Inv.*—Vol. 16, Sept. 1928, Page 431.

New Systems of Radio Direction Finding—*Teleg. and Teleph. Age*—April 16, 1928, Page 176.

The Rotating Loop Wireless Beacon—R. L. Smith-Rose and S. R. Chapman—*Nature* (London)—Vol. 121, June 23, 1928, Page 1000.

Theoretical Discussion of Various Possible Aerial Arrangements for Rotating-Beacon Transmitters—R. L. Smith-Rose—*Jnl. I.E.E.* (London)—Vol. 66, 1928, Page 270.

Cause et Élimination des Erreurs de Nuit en Radiogoniométrie—P. Abadie—*Rev. Scientifique*—Vol. 65, April 9, 1927, Pages 210-211.

Kurzwellenpeilversuche mit Rahmen und Hilfsantenne auf grossere Entfernungen über See—F. A. Fischer—*Jahrb. Draht. Teleg. U. Teleph.*—Vol. 30, Dec. 1927, Pages 188-189.

Die Ermittlung wanrer Funkstralrichtungen auf Landpeilstationen—E. Nitzsche—*Exp. Wireless*—Vol. 4, Nov. 1927, Pages 587-588.

Radio Direction Finding—*Nature*—Vol. 120, Dec. 3, 1927, Pages 818-819.

The Radio Plane Locator. Stations Equipped with Radio Compass Can Find Exact Position of Airplane.—*Sci. and Inv.*—Vol. 15, August 1927, Page 344.

A Sensitive Long-wave Radio Direction Finder—R. L. Smith-Rose—*Jnl. Sci. Instruments*—Vol. 4, May 1927, Pages 252-262.

Further Measurements on Wireless Waves
[Continued on page 66]

NEW AUDIO OUTPUT TRANSFORMER

by FOSTER



* Also available in same case size and style are new microphone input transformer, and modulation transformer.

Only 1-inch in diameter by 1 $\frac{5}{8}$ inches long, this small, compact transformer* is Foster-designed for a longer life of steady, dependable service. Terminals are loop-shaped for easy hook-up and hermetically sealed against widely varying temperature and moisture conditions by VITROSEAL, the sensational new Foster development in hermetic sealing.

And this is only *one of more than a thousand* types of transformers designed and custom-built by Foster during the past year.

Wherever transformers of a specialized function or design are involved, it may well be worth your while to consult Foster Engineers or a Foster Representative, who are ready now to consult with you on either present work or post-war planning.

REPRESENTATIVES

BOB REID

810 EAST 57TH STREET,

INDIANAPOLIS 5, IND.

TELEPHONE: BROADWAY 2725

BAUMAN & BLUZAT

2753 WEST NORTH AVE.

CHICAGO 47, ILL.

TELEPHONE: HUMBOLT 6809-10-11-12

SPECIALISTS IN BUILDING TRANSFORMERS SINCE 1938

A. P. FOSTER COMPANY

TRANSFORMER ENGINEERS & MANUFACTURERS

719 WYOMING AVENUE, LOCKLAND 15, OHIO (SUBURB OF CINCINNATI)

RADIO

* DECEMBER, 1944

65

SLIDE RULE Or Screwdriver

... which will YOU be using
2 years from now?

Add CREI Technical Training to Your Present Experience—THEN Get That BETTER Radio Job You Want!

Thousands of new men have joined the ranks of the radio industry for the duration. But after the war, even more thousands will return from the armed forces. War production will settle down to supplying civilian needs.

Where will you fit into this picture? If you are wise, you will look ahead and prepare for the good-paying jobs in radio-electronics and industrial electronics.

It is up to you to decide if you will be a "screwdriver" mechanic or a real technician in a responsible engineering position.

CREI can help you prepare by providing you with a proved program of home study training that will increase your technical ability and equip you to advance to the better-paying radio-electronics jobs that offer security and opportunity.

Write for Details

About CREI Home Study Course

If you are a professional or amateur radioman and want to make more money—let us prove to you we have something you need to qualify for the BETTER career-job opportunities that can be yours. To help you intelligently answer your inquiry—PLEASE STATE BRIEFLY YOUR EDUCATION, RADIO EXPERIENCE AND PRESENT POSITION.

Free Booklet Sent



CAPITOL RADIO ENGINEERING INSTITUTE

Dept. RA-12, 3224-16th St., N.W., Washington 10, D.C.

CORWICO

WIRES

MADE BY

Engineers FOR
Engineers

VICTORY

concentrating upon

for the duration

cornish

WIRE COMPANY, INC.

15 Park Row, New York City, New York

CORWICO

BIBLIOGRAPHY

[Continued from page 64]

Received from the Upper Atmosphere—R. L. Smith-Rose and R. H. Barfield—*Proc. Royal Soc. (London)*, 116A, Nov. 1927, Page 682.—*Experimental Wireless (London)*—Vol. 5, Jan. 1928, Page 31.

The Cause and Elimination of Night Errors in Radio Direction Finding—R. L. Smith-Rose and R. H. Barfield—*Jrnl. I.E.E.*—Vol. 64, 1926, Page 831.—*Exp. Wireless*—Vol. 3, 1926, Page 367.

An Instantaneous Direct-Reading Goniometer—*Wireless World*—Vol. 18, March 10, 1926, Pages 367-369.

An Instantaneous Direct-Reading Radiogoniometer—R. A. Watt and J. F. Herd—*Exp. Wireless*—Vol. 3, April 1926, Pages 239-242.

Marine Direction Finding. Latest Developments Described. Details of the Radio Communication Company's Apparatus—L. Bainbridge-Bell—*Electrician*—Vol. 97, July 30, 1926, Pages 125-126.

A Direct-Reading Radiogoniometer; the Directional Indication of Wireless Signals by Cathode Rays—*Elec. Rev.*—Vol. 98, Mar. 26, 1926, Pages 515-516.

Nouveaux Radiogoniomètres—*Radio Electricité*—Vol. 6, April 10, 1926, Pages 129-130.

The Direction-Finding Equipment at Niton and Cullercoats—J. H. Rayner—*I.E.E. Jrnl.*—Vol. 27, Nov. 1925, Pages 1138-1140.

Coastal Errors in Direction Finding—R. L. Smith-Rose—*Nature*—Vol. 116, Sept. 19, 1925, Pages 426-427.

Installation of Antennas for Direction Finding—J. C. Franklin—*Air Commerce Bulletin*—Vol. 9, April 1938, Page 256.

The Extended Feeder Marconi-Adcock Direction Finder—*The Marconi Review*—May-August 1937, No. 66, Page 23.

Short Wave Adcock Direction Finder—R. H. Barfield and W. Ross—*I.E.E. Jrnl. (London)*—Vol. 81, Nov. 1937, Page 682.

Improved Medium Wave Adcock Direction Finder—R. H. Barfield and R. A. Fereday—*I.E.E. Jrnl.*—Vol. 81, Nov. 1937, Page 676.

Error-Free Bearings with the Pulse Direction Finding Apparatus—W. W. Dieffenbach: *Telefunken — Funktechnische Monatshefte*—No. 1, Jan. 1937, Page 25; and No. 2, Feb. 1937, Page 55 (Supplementary Note).

Direction Finding by Pulses—H. Plendl—*Hochfrequenztechnik und Elektroakustik*—Vol. 50, Aug. 1937, Page 37.

Improved Direction Finder (Marconi-Adcock aerial system at distance from receiver, or two receivers, operated simultaneously at center of common aerial system) (Marconi Company)—*Wireless Engineer*—Vol. 13, No. 158, Nov. 1936, Page 596.

Direct-Reading Direction-Finding Method Using a Rotating Directional System—M. Dieckmann and F. Berndorfer—*Hochfrequenztechnik und Elektroakustik*—Vol. 48, No. 6, Dec. 1936, Page 216.

Recent Development in Marconi-Adcock Direction Finder—S. B. Smith and G. F. Hatch—*The Marconi Review*—1 and 2, 1936, No. 58, Page 1.

Antennas for Air Navigation—D. G. Fink—*Electronics*—Vol. 9, Feb. 1936, Page 34.

Polarization Errors in Direction Finders—R. A. Watson Watt—*Wireless Engineer*—Vol. 13, No. 148, Jan. 1936, Page 3.

Scattering Polarization Errors and Accuracy of Short-Wave Direction Finding (results with spaced-frame direction finding system; comparison with Adcock System)—T. L. Eckersley—*Marconi Review*—Vol. 55, July-August 1935, Page 20.

Three Dimensional Direction Finder—W. Runge: *Telefunken—Hochfrequenztechnik und Elektroakustik*—Vol. 46, No. 6, Dec. 1935, Page 215.

German Patent 617,487, 1/24/34.

Experimental Investigations on Night Effect Producing Direction Finding Errors: Abstract—G. Brokowetz and A. Hagen—*Wireless Engineer*—Vol. 12, March 1935, Page 156.

Kolster Radio Direction Finder—*Marine Review*—Vol. 65, July 1935, Page 28.

Some Principles Underlying the Design of Spaced Aerial Direction Finding—R. H. Barfield—*Jrnl. I.E.E.*—Vol. 76, No. 460, April 1935, Page 423.

[To be continued]

WANTED DESIGNER

A Central New England manufacturer employing over 1000 people needs Draftsman-Designer on telephone and signaling (mechanical) apparatus. Knowledge of die-casting and plastic applications desirable.

WMC Regulations Prevail.

Reply to Box 223,

c/o RADIO Magazine

ELECTRONIC DESIGN SERVICE

- ELECTRONIC DEVICES
- TRANSMITTERS
- RECEIVERS

RADIO

BOX 111

A Safe Bet for Steady Sales

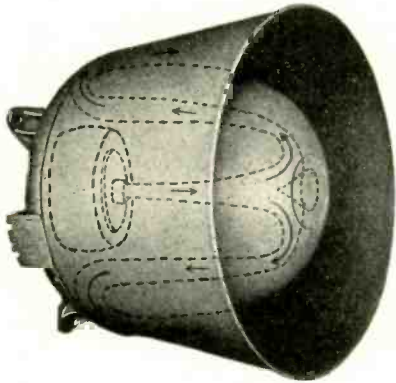

Left—MARINE SPEAKER; approved by the U. S. Coast Guard, for all emergency loudspeaker systems on ships. Re-entrant type horn. Models up to 100 watts. May be used as both speaker and microphone.



Right—RE-ENTRANT TRUMPET; available in 2½-3½-4½-6 ft. sizes. Compact. Delivers highly concentrated sound with great efficiency over long distances.

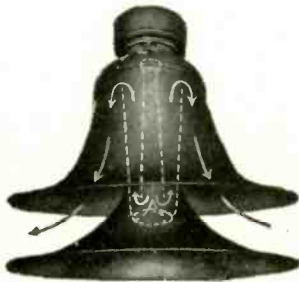

Left—RADIAL HORN SPEAKER; a 3½' re-entrant type horn. Projects sound over 360° area. Storm-proof. Made of RACON Acoustic Material to prevent resonant effects.



Right—AEROPLANE HORNS; super-powerful and efficient P.A. horns for extreme range projection. 9-4 and 2 unit Trumpets available.



Left—PAGING HORN; extremely efficient 2' trumpet speaker for use where highly concentrated sound is required to override high noise levels. Uses P.M. unit.

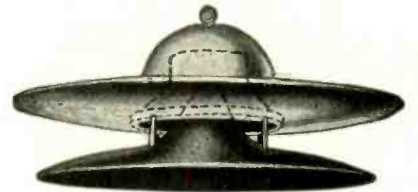

Right—RADIAL CONE SPEAKER; projects sound over 360° area. Cone speaker driven. Will blend with ceiling architecture. RACON Acoustic Material prevents resonant effects.

SEND FOR CATALOG

RACON, pioneer and world's largest manufacturer of loudspeakers, horns and driving units, is working at capacity filling diversified orders — speakers for Army, Navy, Maritime Commission, Signal Corps, etc. and industrial use. Now we are planning ahead.

Practically all industrial firms are users, or potential users of some type public-address, paging or sound distribution system. Statistics prove that a properly planned sound system installation is a good investment which in time generally pays for itself.

RACONS have always enjoyed a steady, high sales volume. We believe they always

will, for our products are the finest that money can buy, or engineering skill produce. Receiver units supplied with either metal or plastic diaphragms. RACON products generally cost less than competitive brands because a lower power-rated and lower-priced RACON will outperform higher power-rated units of other make. In other words, don't let catalog list-prices fool you. Basic costs and rated outputs are the prime factors worth considering. That's why leading soundmen prefer and specify RACONS, they are dependable—a safe bet for steady sales and satisfied users.



RACON ELECTRIC CO. 52 EAST 19th ST. NEW YORK, N. Y.



**YOURS
..FOR THE
ASKING**

Available from local dealers or by writing factory direct.

UNIVERSAL STROBOSCOPE

This handy phonograph turntable speed indicator, complete with instructive folder, is now available gratis to all phonograph and recorder owners through their local dealers and jobbers. As a recorder aid the Universal Stroboscope will assist in maintaining pre-war quality of recording and reproducing equipment in true pitch and tempo. Universal Microphone Co., pioneer manufacturers of microphones and home recording components as well as Professional Recording Studio Equipment, takes this means of rendering a service to the owners of phonograph and recording equipment. After victory is ours—dealer shelves will again stock the many new Universal recording components you have been waiting for.



Wanted ENGINEERS

Radio

* Electrical

Electronic

* Mechanical

Metallurgical

* Factory Planning

Materials Handling

Manufacturing Planning

Work in connection with the manufacture of a wide variety of new and advanced types of communications equipment and special electronic products.

Apply (or write), giving full qualifications, to:

R.L.D., EMPLOYMENT DEPT.

Western Electric Co.

100 CENTRAL AV., KEARNY, N. J.

*Also: C.A.L.

Locust St., Haverhill, Mass.

Applicants must comply with WMC regulations

TEST FLASH

[Continued from page 29]

1/100 sec. If the delay provided by this device is adjusted for a shorter period, the flash will be invisible or partly concealed by the opening shutter leaves. If the delay provided by this device is adjusted to a greater value, the flash will be invisible or partially obscured by the closing shutter leaves. By adjustment of the DELAY dial, the interval from contact closure to open shutter may thus be measured. If it is desired to use the device merely as a routine check on the operation of previously adjusted equipment, the DELAY and DURATION dials may be set to simulate the firing characteristics of the bulb to be used.

A word of caution might well be expressed at this point. When flash bulb manufacturers refer to ignition times, the interval which they express is from the instant of contact closure to the peak of a flash which is not rectangular in envelope. The flash envelope produced by this device is rectangular in form and the delay calibration is from instant of contact closure to the start of the flash. This design characteristic was established for the purpose of convenience. Although the details of application of this device lie within the photographic field and hence beyond the scope of this paper, a single illustration might serve to clear up some questions.

Suppose we select a given flash bulb and refer to the manufacturer's specifications. We find that the peak of the flash occurs 25 milliseconds after contact closure. We wish to adjust our synchronizer for optimum results from this bulb at 1/100 sec. exposure. Our exposure is, therefore, 10 milliseconds. The peak of the flash occurs 25 milliseconds after the contacts close. We wish to bracket this peak with our 10 millisecond shutter open. This means our shutter should open 20 milliseconds after contact closure and close 30 milliseconds after contact closure. We then set the DELAY dial to 20 milliseconds, the DURATION dial to 10 milliseconds and adjust the synchronizer mechanism until the brightest possible flash is seen when the neon lamp is viewed through the shutter. As a further check, we may, leaving the DURATION dial set at 10 milliseconds, set the DELAY dial at 10 milliseconds and make sure that the flash is almost invisible through the opening shutter leaves, and then set the DELAY dial at 30 milliseconds to make sure that the flash is nearly invisible through the closing shutter leaves. In

this manner small discrepancies can be noted which might be less obvious if this bracketing procedure were not employed.

N.U. APPOINTS SANDSTROM

Ejnar O. Sandstrom has been appointed Controller of National Union Corporation, cathode ray and electronic tube manufacturers, it was announced recently by S. W. Muldowny, president.

Mr. Sandstrom joined National Union Radio Corporation as an auditor in 1930. He was elected Assistant Secretary of the Corporation in 1935 and Assistant Treasurer in 1937. In addition to his new duties, he will continue to serve as Secretary, to which position he was elected in 1941.

Mr. Sandstrom is a member of the American Management Association and the National Association of Cost Accountants.

WINCHARGER EXPANDS

The use of wind-made electric power to increase farm production at a saving in man-power is being demonstrated by the Wincharger Corporation, Sioux City, Iowa, in a series of regional meetings. R. F. Weinig, vice-president and general manager of the company, points out that some Wincharger models completely electrify farms and ranches supplying 25% more power than the average used by farms on some Rural Electrification Administration lines.

BURSTEIN-APPLEBEE CO.
1012-1014 McGee St. • Kansas City 6, Missouri

WANTED DEVELOPMENT ENGINEERS

Mechanical and electrical. Graduate or equivalent training. Required for development work in the following branches:

1. Electro-mechanical devices, communication systems. Must be interested in development and familiar with magnetic circuits.
2. Measuring and control instruments. Background should be in electrical engineering, including electronics. Statement of Availability Required.

Box 222, c/o RADIO Magazine

Ted McElroy
World's Largest Manufacturer of Wireless Telegraphic Apparatus
COMPLETE CENTRAL OFFICE EQUIPMENT
McElroy Manufacturing Corp.
82 Brookline Avenue • Boston, Massachusetts

RADIO

**GROUP SUBSCRIBERS
SAVE UP TO 50%***

and Here's Why:



LOOK WHAT I SAVE--
A \$3 SUBSCRIPTION
FOR ONLY HALF!!!



MEBBE THEY'LL LEAVE
MY RADIO MAG FOR
ME FROM NOW ON



I NEVER GOT AROUND
TO SUBSCRIBING--THIS
IS QUICK AND EASY

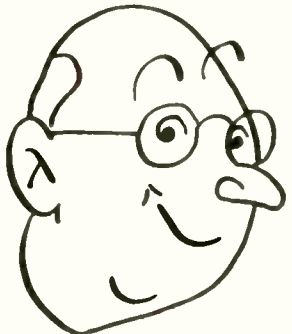

ME--I'M BUILDING A
REFERENCE LIBRARY
OUT OF EACH ISSUE

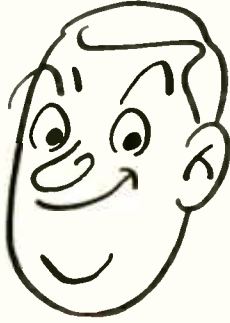

I'LL BE ABLE TO FOLLOW
PRESENT AND POST-WAR
DEVELOPMENTS



IF THEY'RE ALL GETTING
IT--I WANT TO KNOW
WHAT THEY'LL KNOW

FORM YOUR GROUP TODAY--

Every month, vital departments acquaint you with newest developments — editorial "ear-to-the-ground" releases keep you abreast of trends, in fact, ahead of most coming events.

For a limited time only—save up to half the regular cost of a RADIO subscription by using the Group Plan. The more in a Group the more each saves, up to 50%.*

*** THE GROUP PLAN**

Here's what Group Subscriptions cost:

One 1 yr. subscription\$3.00
Two 1 yr. subscriptions 2.50 each
Three 1 yr. subscriptions	... 2.00 "
Four 1 yr. subscriptions	... 1.75 "
Five 1 yr. subscriptions 1.60 "
Six or more 1 yr. subscriptions	1.50 "

Make a list giving each subscriber's name, address, employer's name and their respective positions.

RADIO MAGAZINES, INC.

342 MADISON AVENUE

NEW YORK 17, N. Y.



"I hear the war's practically over...back home!"

PROBABLY it's only natural for us here at home to feel that the war's almost won, the way the good news has been pouring in.

But the war's not over for *him*—not by a long sight! And he's just one of a few million or more that will stay over there until they finish the bloody mess. Or kill time for a few months—or years—in some hospital.

What about *you*?

This is no time to relax. No time to forget the unfinished business. It's *still* your war, and it *still* costs a lot.

So dig down deep this time. Dig down till it hurts, and get yourself a hundred-dollar

War Bond over and above any you now own—or are now purchasing. This 6th War Loan is every bit as important to our complete and final Victory as was the first.

Don't "let George do it"—get *yourself* that *added* bond and help finish a magnificent job *right*. The quicker you reach down deep, the better you do *your* job for war, the more you'll contribute to ending the fight. And the quicker they'll come back—the guys that can *still* be killed.

After all, you're safe and sound and *home*. That's worth another hundred-dollar bond to *you*, isn't it?



Buy at least one extra \$100 War Bond today!

RADIO

This is an official U. S. Treasury advertisement—prepared under auspices of Treasury Department and War Advertising Council.



*Radio's outstanding practical text...
...for war-training and regular purposes*

RADIO Handbook

NINTH EDITION

NINTH EDITION

Revisions in this edition adapt it even better than ever before for war-training and general use; contains added and simplified theory in the simplest possible language; added test equipment which can be home- or field-constructed; and a review of mathematics for solving simple radio problems.

More than 600 pages; durably clothbound; goldstamped. Get it from your favorite dealer, or direct from us, postpaid; please add any applicable taxes.

\$2.00 in continental U. S. A.

Elsewhere, \$2.25

Published by

Editors and Engineers, 1422 North Highland Avenue, Los Angeles 28, Calif.

VACUUM TUBE VOLTMETER RF - AC - DC

The result of 10 years of
Vacuum Tube Voltmeter
Engineering.

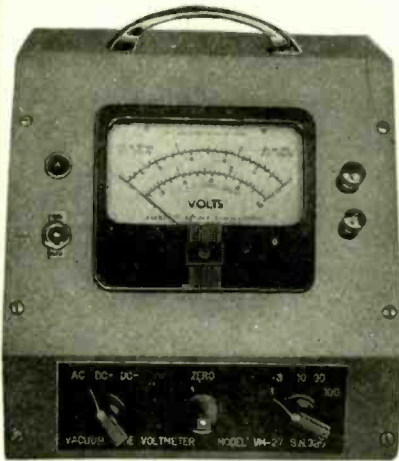

MODEL VM-27

1-3-10-30-100 volts full scale.
Peak response, r.m.s. calibration.
HIGH IMPEDANCE—4 megohms at 50
cycles, 60,000 ohms at 100 megacycles.
7 megohms for d-c.
ACCURATE—Better than 2 percent on
d-c and 60 cycles thru megacycles.
SELF-CONTAINED—115 or 230 volt
50-60 cycle line operation.



RF PROBE

Interchangeable probe included for
convenience and efficiency in making
AC and RF measurements. Input cap-
acity 5 micro farads. Ruggedly
mounted 6H6 tube in balanced circuit.
Complete \$150 net f.o.b. Flushing, N.Y.

ACCESSORIES

To increase VM-27 range to 1000 volts.



10X AC MULTIPLIER MODEL ACM-27

Input impedance even greater than
probe alone. Flat response from 20
cycles to 200 megacycles.

\$17.00 net f.o.b. Flushing, N. Y.



OX DC MULTIPLIER MODEL DCM-27

5 megohms input resistance.

\$8.00 net f.o.b. Flushing, N. Y.

IMMEDIATE DELIVERIES

ALFRED W. BARBER LABORATORIES
34-04 FRANCIS LEWIS BLVD.
FLUSHING, N. Y.

ADVERTISING INDEX

ADVERTISER	PRODUCT	PAGE
Aerovox Corporation	Capacitors	62
Albion Coil Company	Coils	55
American Microphone Co.	Microphones	63
Astatic Corp., The	Microphones	10
Automatic Elec. Sales Corp.	Relays	47
Barber Labs., Alfred W.	Test Equipment	72
Bliley Electric Co.	Quartz Crystals	14
Bridgeport Mfg. Co.	Coils	61
Burstein-Applebee Co.	Electronic Equip.	68
Cambridge Thermionic Corp.	Turret Lugs & Transformers	48, 14
Capitol Radio Eng. Inst.	Educational	66
Concord Radio Corporation	Electrical Equipment	64
Conn. Tel. & Elec. Div.	Electrical Equipment	49
Continental Elec. Co.	Electronic Tubes	12
Cornish Wire Company	Wire	66
D-X Crystal Co.	Crystals & Loop Antennas	16
Editors & Engineers, Ltd.	Books	71
Eitel-McCullough, Inc.	Tubes & Vacuum Pumps	15
Electronic Mechanics, Inc.	Insulating Materials	1
Electro-Voice Mfg. Co.	Microphones	46
Federal Tel. & Radio Corp.	Transmitters	19, 4
Formica Insulation Co., The	Laminated Plastics	7
Foster Co., A. P.	Transformers	65
Gray Mfg. Co., The	Help Wanted	60
Guardian Electric Mfg. Co.	Relays	9
Hallicrafters Co., The	Communication Equipment	45
Harvey Radio Co.	Radio & Electronic Equip.	56
Harvey Radio Labs., The	Electronic Instruments	2
Howard Mfg. Co.	Crystal Holders	10
Hytron Corporation	Tubes	Cover 3
Industrial & Comm'l Elec.	Vacuum Condensers	51
Jensen Radio Mfg. Co.	Acoustic Equipment	53
Johnson Co., E. F.	Transmitter Components	50, 54, 58
Ken-Rad Tube & Lamp Corp.	Electronic Tubes	12
McElroy Mfg. Corp.	Wireless Tel. Apparatus	68
Merit Coil & Trans. Corp.	Radio Parts	18
Mycalex Corp. of America	Insulating Materials	20
O'Neil-Irwin, Mfg. Co.	Duplicating Machines	16
Par Metal Products Corp.	Cabinets	18
Racon Electric Co.	Speakers	67
Raytheon Production Corp.	Tubes	Cover 2
Sperry Gyroscope Co., Inc.	Radio-Electronic Devices	13
Standard Transformer Corp.	Transformers	8
Sylvania Elec. Prod., Inc.	Tubes	11
Universal Microphone Co.	Microphones	57, 68
Wadsworth Watch Case Co., Inc., The	Precision Parts	59
Western Electric Co.	Help Wanted	68
Westinghouse Elec. & Mfg. Co.	Communications Equip.	Cover 4
Wholesale Radio Labs.	Tube Base Calculator	62
Wilcox Electric Co.	Communications Equip.	17
Wrigley Jr., Co., Wm.	Institutional	44

HYTRON has made them all!

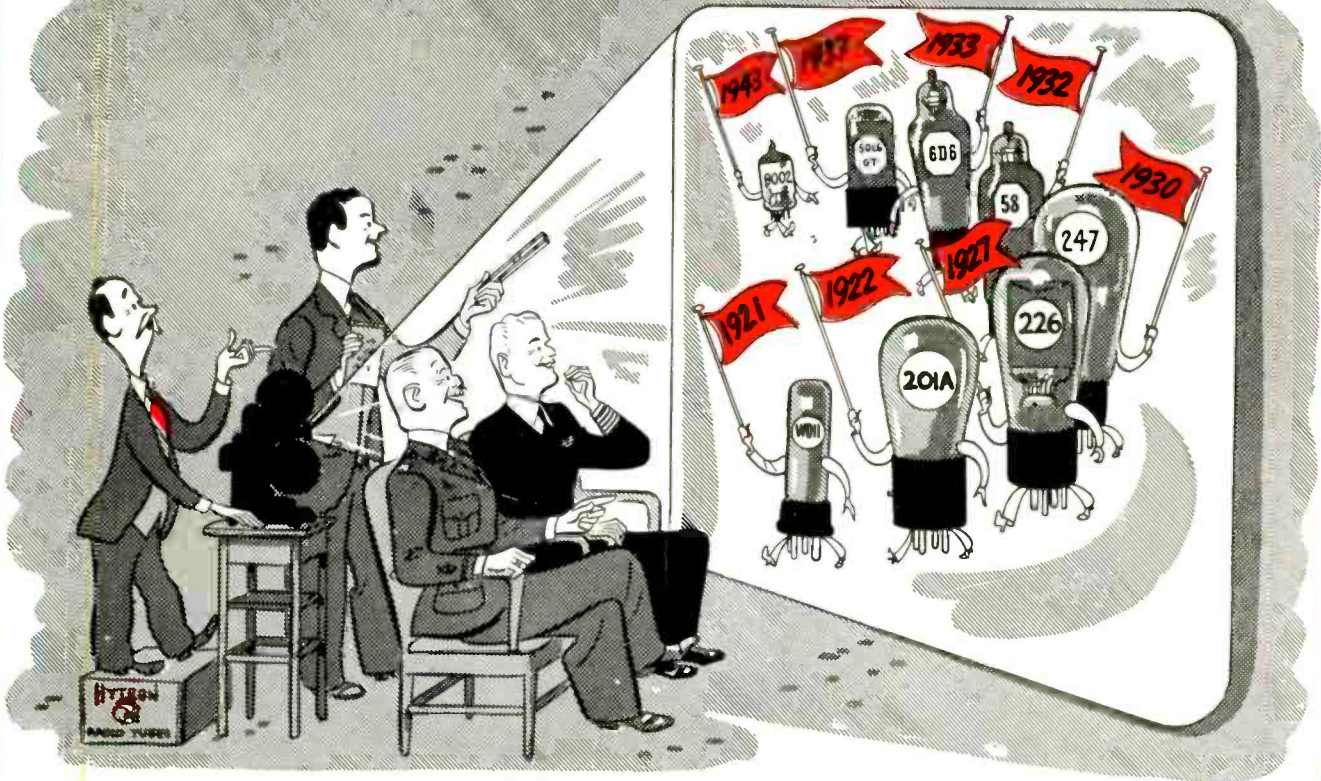

The march of Hytron receiving tube progress down through the years is fascinating. One looks back on tubes, tubes, and more tubes: battery, AC, AC/DC, diodes, triodes, pentodes, beam tetrodes, multiple purpose types, G's, MG's, BANTAM GT's—and now the miniatures. Price and size have been drastically cut; quality and performance, amazingly improved.

Hytron has made them all. Its long and varied experience is priceless in a complex industry where probably never will all the answers be known. In making radio tubes, painfully acquired practical

experience must supplement the formulae of science.

With an eye to present and future, Hytron is concentrating its production of receiving tubes on preferred BANTAM GT types needed for war—for today's civilian replacements—and ultimately for post-war. Its wartime activities are teaching Hytron new techniques of miniature production. Many potentially popular Hytron miniatures are in development. Typical American dissatisfaction with anything but perfection continues; the parade of Hytron receiving tubes marches on.

OLDEST EXCLUSIVE MANUFACTURER OF RADIO RECEIVING TUBES
HYTRON
 CORPORATION ELECTRONIC AND RADIO TUBES
 SALEM AND NEWBURYPORT, MASS.



BUY ANOTHER WAR BOND

"REASONS WHY"

FOR GREATER RELIABILITY OF WESTINGHOUSE D-C INERTEEN CAPACITORS

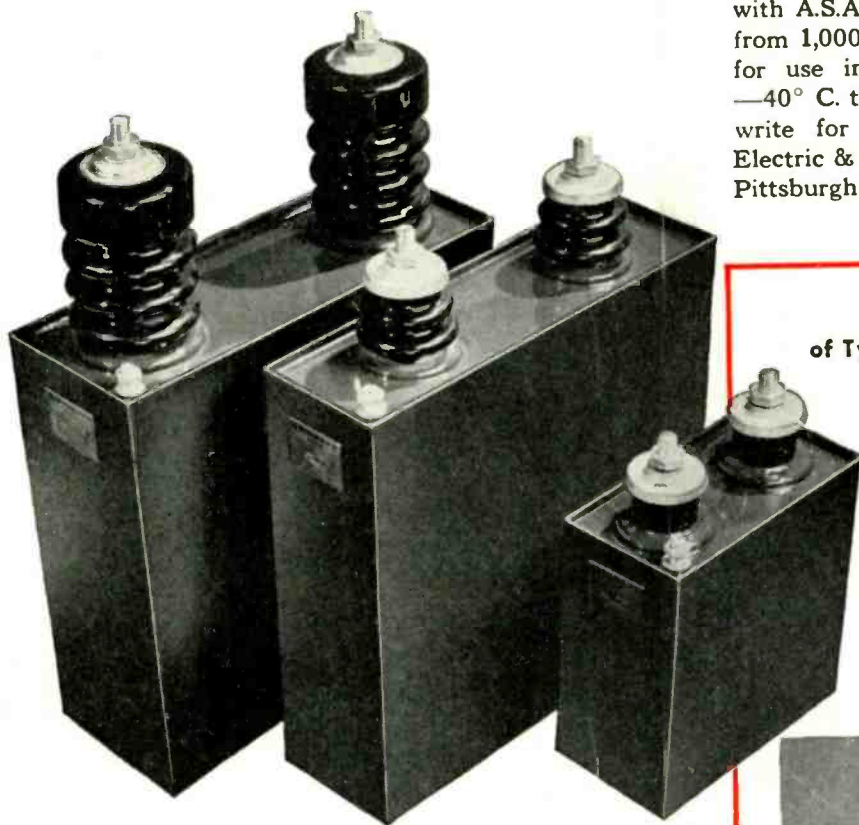

Westinghouse

INERTEEN CAPACITORS

For The Communications Industry

When a product scores an outstanding service record—there's always a sound "reason why".

In the case of Westinghouse D-C Capacitors, materials . . . processing . . . assembly techniques . . . are combined to produce units that will give maximum life under the most severe operating conditions on land, sea and air.

- 1 NONINFLAMMABLE, NONEXPLOSIVE "INERTEEN"**—the safe dielectric impregnating liquid. Its high dielectric constant provides greater capacitance per weight and volume than other insulating mediums. It gives maximum stability for high temperature service.
- 2 "SOLDER-SEALING"**—an exclusive Westinghouse development. It creates a hermetic seal between porcelain and metal, in all Type FP Capacitors. It gives positive protection against leaks, moisture entrance or any contamination that might result from breathing.
- 3 ELECTRONICALLY-CONTROLLED WINDING**—insures freedom from wrinkles and mechanical damage for the aluminum foil and Inertex dielectric paper which provide the capacitance.

Designers of communications equipment find that the complete Westinghouse line meets all requirements. Capacitors are made in accordance with A.S.A. standards CP-70 and CP-71. Range is from 1,000 to 250,000 volts d-c; 400 to .001 mfd; for use in ambient temperatures ranging from -40° C. to 75° C. For complete application data, write for your copy of B-3300. Westinghouse Electric & Manufacturing Company, P.O. Box 868, Pittsburgh 30, Pennsylvania.

J-60560

NOTE THESE FEATURES of Type FPC (Porcelain-clad) Capacitors for higher ratings

- End closures act as capacitor terminals.
- Metal case and bushings required by conventional capacitors are eliminated.
- Over-all dimensions and space are held to a minimum.
- For higher voltage ratings, units can be mounted in series.

