

# RADIO

OCTOBER, 1944

Design • Production • Operation

Including:  
Non-Linear  
Resistor Chart

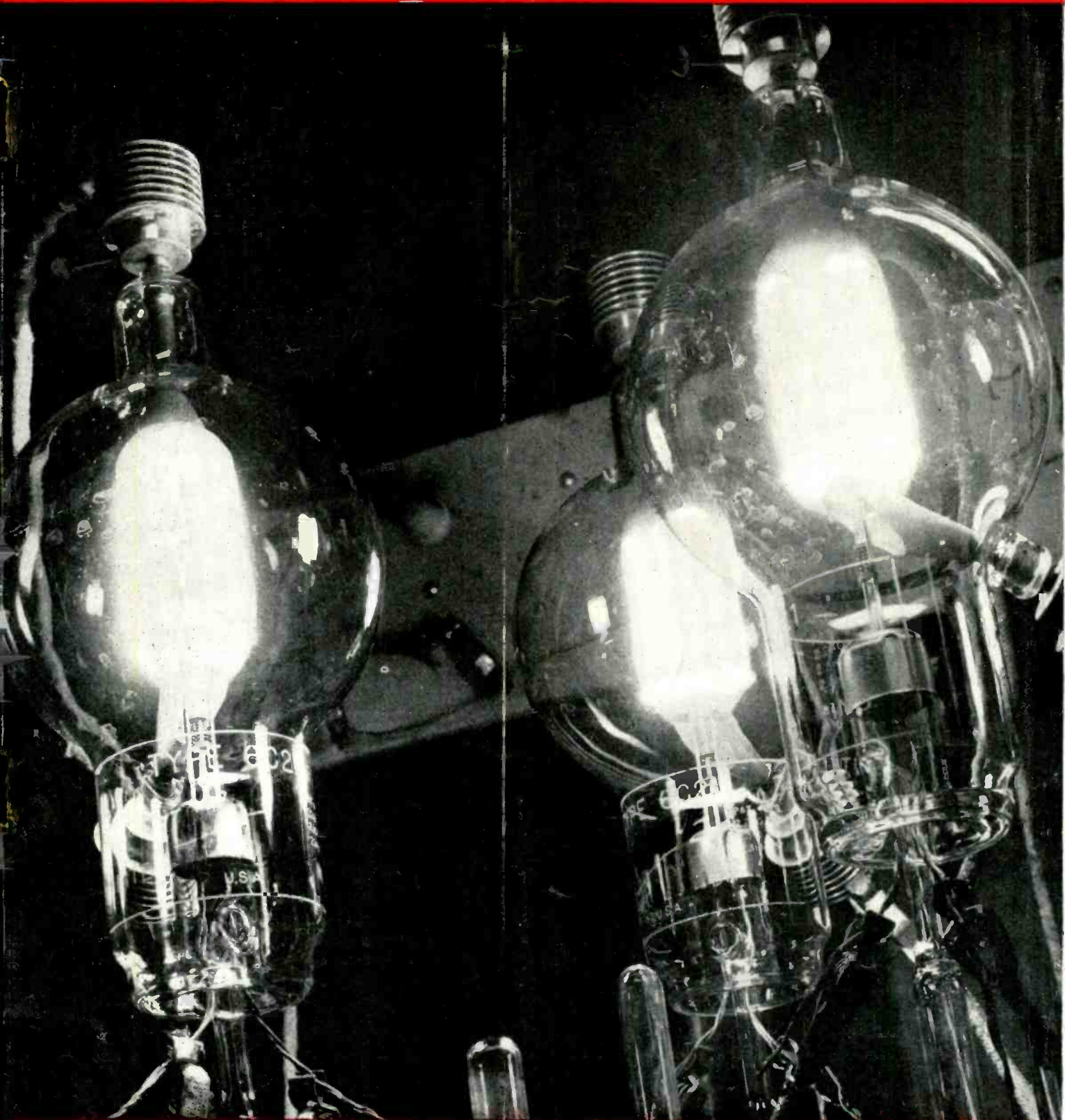

The Journal for Radio & Electronic Engineers



# NEW COMPLETE RADIO TUBE DATA BOOK BY RAYTHEON

**T**HE new complete data on tubes, including characteristics, outlined drawings and basing diagrams of all standard receiving tube types; simplified interchange information including over 1600 substitutions; hearing aid tube data and technical information regarding radio panel lamps. All this is included in the new Raytheon Tube Data and Substitution Chart prepared by the Technical Service Department of Raytheon Manufacturing Company.

The value of the technical information in this manual is inestimable and yet it may be obtained FREE from your Raytheon receiving tube distributor. Every-

one concerned in the repair and maintenance of radios must have this ready reference book.

This manual is the first step in a tremendous merchandising plan which will bring you better business. This program teamed up with the superior, "Plus-Extra" quality Raytheon Tubes, will assure you of better customer goodwill, faster turnover and greater profits.

*Raytheon Manufacturing Company*

RADIO RECEIVING TUBE DIVISION

Newton, Massachusetts • Los Angeles • New York • Chicago • Atlanta



All Four Divisions Have Been Awarded Army-Navy "E" With Stars

# RAYTHEON

*High Fidelity*

RADIO AND ELECTRONIC TUBES



DEVOTED TO RESEARCH AND MANUFACTURE OF TUBES FOR THE NEW ERA OF ELECTRONICS

# GUTHMAN *Discriminator* COILS

in **F.M.**  $\Rightarrow$  for  
Maximum Discrimination

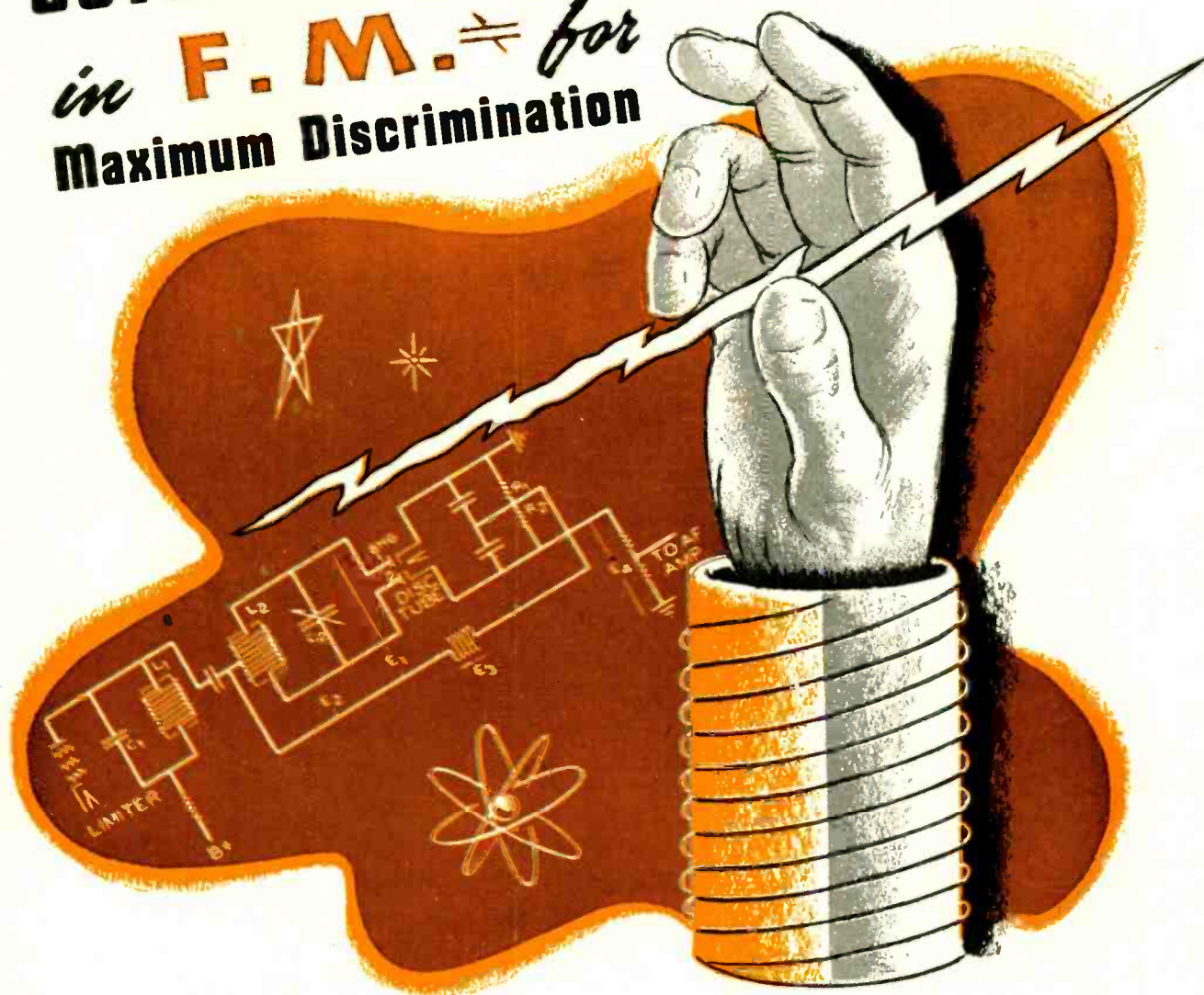

FREQUENCY MODULATION receivers require linear discrimination against undesirable signals. Guthman engineers have developed precise DISCRIMINATOR COILS to discriminate equally on both sides of the resonance curve, providing maximum discrimination.

**G**UTHMAN  
Leader in  
Inductronics

DO YOUR BEST . . .  
INVEST IN WAR BONDS!



**EDWIN I. GUTHMAN & CO.** INC.

15 SOUTH THROOP STREET CHICAGO

PRECISION MANUFACTURERS AND ENGINEERS OF RADIO AND ELECTRICAL EQUIPMENT

**RADIO**

★ OCTOBER, 1944

# wherever a tube is used...

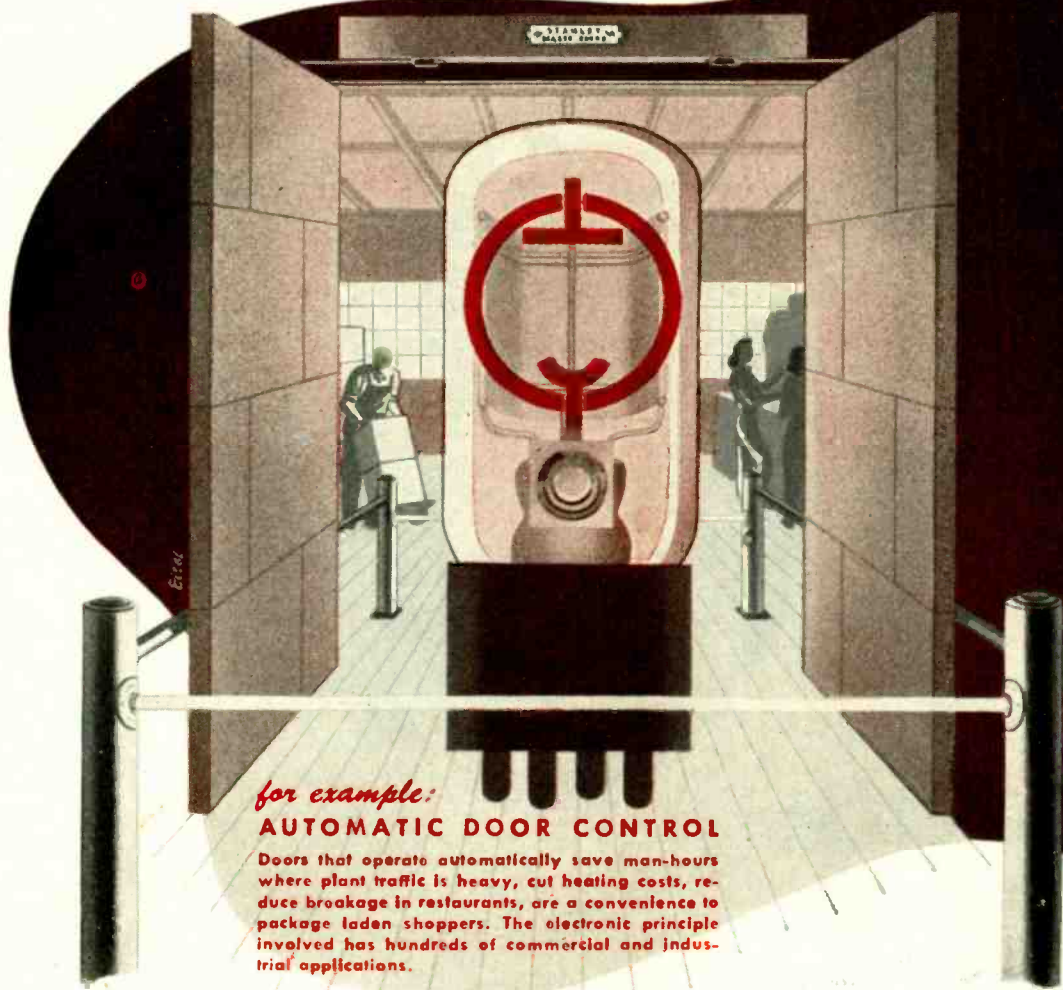

*for example:*  
**AUTOMATIC DOOR CONTROL**  
 Doors that operate automatically save man-hours where plant traffic is heavy, cut heating costs, reduce broakage in restaurants, are a convenience to package laden shoppers. The electronic principle involved has hundreds of commercial and industrial applications.

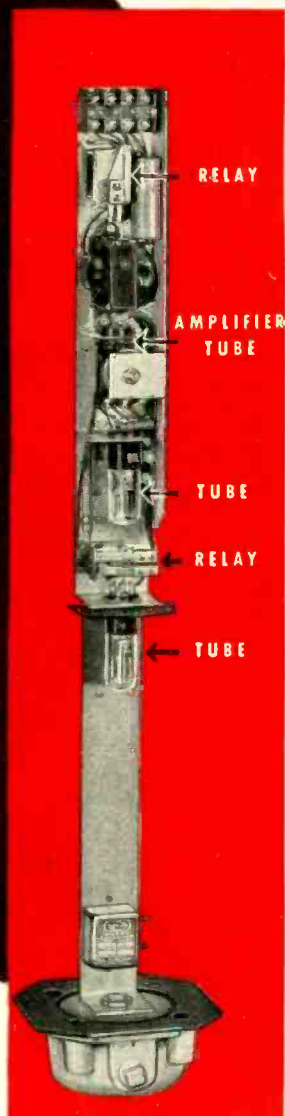

**PHOTO-ELECTRIC DOOR CONTROL**  
 Above unit manufactured by General Electric Co., is a part of STANLEY "MAG:C DOOR" CONTROLS.

THERE'S A JOB FOR

## *Relays* BY GUARDIAN

★ The "Magic Door" made by The Stanley Works of New Britain, Conn., uses a General Electric control unit which operates automatically at the approach of a pedestrian or vehicle. In this unit a beam of light focused on the cathode of a phototube causes a tiny current to flow. Enlarged through an amplifier tube this current operates a sensitive telephone type of relay such as the Guardian Series 405. Another phototube with an auxiliary relay, Guardian Series R-100, is employed to hold the doors open for anyone standing within the doorway.

The telephone type of relay is extremely sensitive and able to operate on the small current supplied through the electronic circuit. The auxiliary relay, Series R-100, is required to handle a greater current. It is a small, efficient relay having a contact capacity up to 1 KW at frequencies up to and including 28 megacycles. Contact combinations range up to double pole, double-throw. Standard coils operate on 110 volts, 60 cycles, and draw approximately 7 V. A. Coils for other voltages are available. For further information write for Bulletin R-6.

Consult Guardian whenever a tube is used—however—Relays by Guardian are NOT limited to tube applications but are used wherever automatic control is desired for making, breaking, or changing the characteristics of electrical circuits.

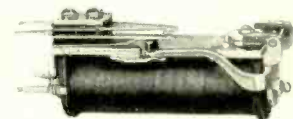

Series 405 Telephone Type Relay



Series R-100 H. F. Relay

# GUARDIAN ELECTRIC

1605-L W. WALNUT STREET

CHICAGO 12, ILLINOIS

A COMPLETE LINE OF RELAYS SERVING AMERICAN WAR INDUSTRY

# RADIO

Published by RADIO MAGAZINES, INC.

John H. Potts ..... Editor  
Sanford R. Cowan ..... Publisher

OCTOBER 1944

Vol. 28, No. 10

## CONTENTS

### COVER

Three Eimac 6C21's on a vacuum pump. (Courtesy Eitel-McCullough, Inc.)

### ARTICLES

Non-Linear Resistor Chart .....	13
The Terminology of Electromagnetic Theory, Part 4 .....	21
Incremental Permeability Tuning— <i>W. J. Polydoroff</i> .....	31
Characteristics of Variable Resistors— <i>A. P. Howard</i> .....	33
Down to Earth on "High Fidelity"— <i>O. B. Hanson</i> .....	37
Properties of Resonant Cavities— <i>V. J. Young</i> .....	41
Radio Design Worksheet: No. 30—Loudspeaker Motors .....	47
Revised List of Army-Navy Preferred Tubes .....	50
Radio Bibliography: 17—Aircraft Radio, Part 2— <i>F. N. Rettenmeyer</i> .....	58

### MISCELLANEOUS

Transients .....	5
TECHNICANA	
Noise Calculations .....	6
Cathode Ray Tubes .....	14
New FM Receiving System .....	16
Book Review .....	49
This Month .....	51
New Products .....	54
Advertising Index .....	76

### Executive & Editorial Offices

342 MADISON AVENUE  
NEW YORK 17, N. Y.

Telephone MUrray Hill 2-1346

John H. Potts ..... *President*  
Sanford R. Cowan ..... *Sec'y-Treas.*  
Charles H. Farrell ..... *Adv. Manager*  
Ann Limberg ..... *Adv. Production*  
Sylvia Bornkoff ..... *Circul. Manager*

#### PACIFIC COAST REPRESENTATIVE

Loyd B. Chappell,  
427 West 5th St., Los Angeles, Cal.

#### OHIO-PENNA. REPRESENTATIVE

A. Hawley & H. Stuart  
Bulkley Bldg., Cleveland, Ohio

#### GREAT BRITAIN REPRESENTATIVE

Radio Society of Great Britain,  
New Ruskin House, Little Russell St.,  
London, W.C. 1, England

RADIO Magazine (title registered U. S. Pat. Off.) is published monthly at 34 N. Crystal Street, East Stroudsburg, Pa., by Radio Magazines, Inc. Executive and Editorial Offices at 342 Madison Avenue, New York 17, N. Y. Subscription rates—United States and Possessions, \$3.00 for 1 year, \$5.00 for 2 years; elsewhere \$4.00 per year. Single copies 35c. Printed in U.S.A. All rights reserved. entire contents Copyright 1944 by Radio Magazines, Inc. Entered as Second Class Matter October 31, 1942, at the Post Office at East Stroudsburg, Pa., under the Act of March 3, 1879.

**RADIO**

★ OCTOBER, 1944

3

THIS BIG FAMILY OF

**Intelin**

# High Frequency Cables

MEASURES TO EVERY HIGH STANDARD

A big family — 29 types of high frequency cable — yet so high are their standards of construction and performance that every one of the following Intelin High Frequency Cables meets all the requirements of the most exacting specifications:

1. Coaxial, Solid-dielectric, Semi-flexible Lines: \*RG-5/U, 6/U, 8/U, 9/U, 10/U, 11/U, 12/U, 13/U, 14/U, 15/U, 17/U, 18/U, 19/U, 20/U, 29A/U, 54/U, 54A/U, 58/U, 59/U.
2. Coaxial, Air-spaced, Low Capacitance Lines: 7/U, 62/U, 63/U.
3. Coaxial, Attenuating Lines: RG-21/U, 42/U.
4. Coaxial, High Impedance, Spiral Delay Line: RG-65/U.
5. Dual (balanced) Lines: RG-22/U, 57/U.
6. Dual-coaxial. Highly Balanced Lines: RG-23/U, 24/U.

To date, for every new high frequency cable need, Intelin has developed and produced the answer. Whatever your requirements in high frequency cable, consult Federal first.

\*Type number designations are those of the Army-Navy R. F. Cable Coordinating Committee.



*Federal Telephone and Radio Corporation*



Newark 1, N. J.

# Transients

---

## NATIONAL ELECTRONICS CONFERENCE

★ The first National Electronics Conference has just been held in Chicago and will be remembered as one of the most efficiently organized and widely attended gatherings of its kind. Lectures were presented on schedule and where scheduled. Insofar as the mechanics of planning and handling an enterprise of this magnitude, the management is to be congratulated on having done a very excellent job.

Unfortunately, however, the material presented at some of the lectures left much to be desired. Some of the discussions were far too elementary and general in character to be of interest to those who came to the Conference to learn something. This was not due to any lack of competence upon the part of the lecturers, practically all of whom have done outstanding work in their respective fields, but rather that some were apparently asked to cover too much territory in too little time, to keep their discussions at a rather elementary level and, for security reasons, to steer clear of anything new. In fact, one speaker remarked that if there was anything in his lecture which was not generally known, it was due to some oversight on his part, or of the Governmental authorities, or, perhaps, of the audience.

There were exceptions, of course. The article on incremental permeability tuning which appears in this issue is an example, and there were others. While there are many interesting applications of this new development which could not be discussed for security reasons, these will undoubtedly suggest themselves to those working along similar lines.

In general, we feel the Conference officials would have been better advised if they had limited the papers to those which offered a direct contribution to the art, and allotted sufficient time to each presentation so that the author could have done a more thorough job. Better luck next time!

## TROPICALIZATION

★ One of the tragic things that communications equipment designers have learned as a result of the War is the poor service which such apparatus gives in the South Pacific and similar localities, unless the components are properly designed and treated to withstand such operating conditions. Units which give reasonably satisfactory service in ordinary broadcast receiver design in this country may fail within a few hours, or even less, in field service in certain war zones. We have had to learn how to guard against such failures, and some of the useful methods employed will be presented in a comprehensive article on this subject in a forthcoming issue of this magazine.

To those who are already familiar with these protective methods, and who are now working on postwar receiver design, it might be well to keep in mind that there are many thousands in our own country who would gladly pay more for apparatus which offers a reasonable assurance of trouble-free service over a long period of time.

This applies not only to components but also to tubes. One of the greatest drawbacks to the expansion of aircraft and industrial electronics is that we do not have a line of tubes which can be relied upon to give satisfactory service over a period of ten or twenty thousand hours, or more. It seems reasonable to believe, with all the skill in precision design and methods which have been developed during the War, that postwar products of far better performance will not be prohibitively costly to produce.

This was rather forcefully brought to mind at a recent television demonstration, to which press representatives were invited. Four receivers were set up for the demonstration. One was inoperative and not one of the remaining three gave consistently satisfactory performance.

—J. H. P.

# Crystal and Dynamic MICROPHONES

## PHONOGRAPH PICKUP ARMS CARTRIDGES and RECORDING HEADS

Known for efficiency, quality and durability. Available with proper priority ratings.



Manufacturing radio cable connectors, antennas, and special sound detection devices for wartime equipment.

**THE**  
*Astatic*  
**ASTATIC CORPORATION**  
CONNEAUT, OHIO  
IN CANADA: CANADIAN ASTATIC LTD., TORONTO, ONTARIO

## TECHNICANA

### NOISE CALCULATIONS

★ Calculation of the noise figures for an amplifier of two or more stages is subject to a basic error in the formula when using the definition for noise figure commonly employed by radio engineers.

The formula commonly used is

$$F = \frac{e_a^2}{e_s^2} \cdot \frac{R_{eq} + R_g}{R_o}$$

in which  $e_a$  is the open-circuit signal generator voltage,  $e_s$  is the signal voltage at the grid of the amplifier,  $R_o$  is the signal generator internal resistance,  $R_g$  is the effective thermal re-

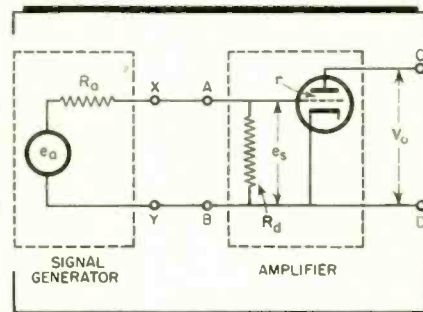

Figure 1

sistance in the first grid circuit of the amplifier, and  $R_{og}$  is the noise resistance in series with the grid circuit which accounts for all subsequent noise.

The correct "fundamental" definition which should be kept in mind for such calculations is that noise figure is the ratio of the input signal-to-noise ratio to the output signal-to-noise ratio:

$$F = \frac{S_i}{N_i} \cdot \frac{S_o}{N_o}$$

in which  $S_i$  is the available power from the signal generator when delivered to a matched load.  $S_o$  is the available signal power at the output.  $N_i$  is the available noise power from the signal generator, and  $N_o$  is the available noise power at the output. The generator delivers only thermal noise so that  $N_i = KTB$ , in which  $K$  = Boltzmann's constant,  $T$  = absolute temperature, and  $B$  = integrated noise band width.

The above discussion occurs in the June, 1944, issue of the *Philosophical Magazine*, in an article by D. K. C. MacDonald entitled "A Note on Two Definitions of Noise Figures in Radio Receivers."

[Continued on page 8]



# Insulators

BY ENGINEERS

ANTENNAS

CONDENSERS

TUBE  
SOCKETS

PLUGS  
& JACKS

INSULATORS

INDUCTORS

BROADCAST  
EQUIPMENT

CONCENTRIC  
LINE

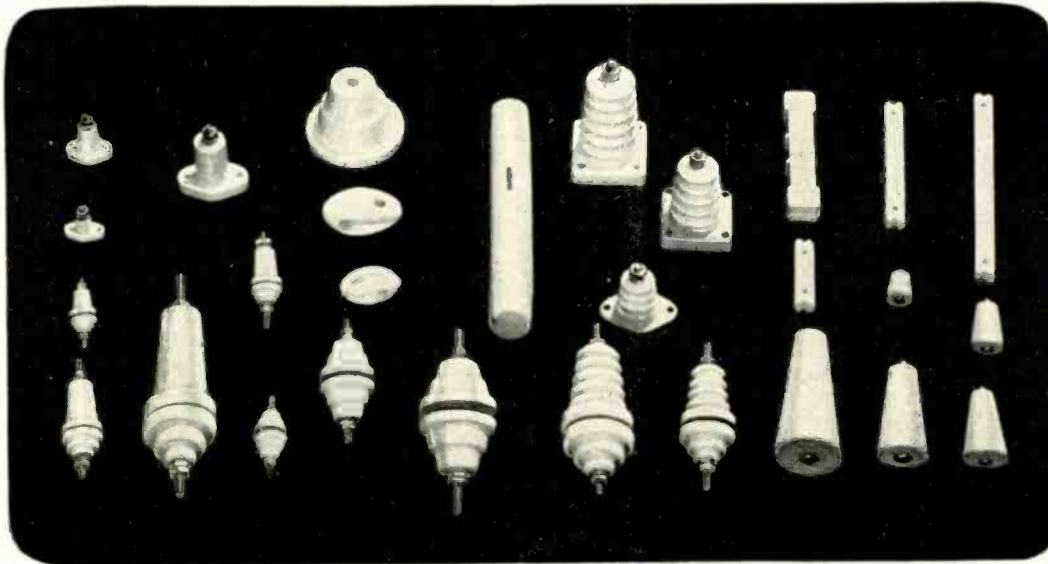

Johnson Radio Engineers have been specialists in insulator design for radio frequencies for almost a quarter of a century. Shapes to provide strength for strains and stresses—reinforced mounting holes and carefully designed mountings—high internal resistance to radio frequency voltage—long leakage path—careful treatment to present a surface that will not collect dirt and foreign matter—quality hardware, not punched nuts and poorly formed parts—materials selected for their radio frequency characteristics, not the "flower pot" variety of ceramics.

To Johnson Engineers an insulator is a piece of radio apparatus and given the same careful attention in design and production. As a result you can't buy a better insulator than Johnson. Send your next insulator problem to Johnson for recommendations and quotations. No obligation.

Ask for Catalog 968K.



# JOHNSON

*a famous name in Radio*

E. F. JOHNSON CO.  
Waseca, Minnesota

# WHY CONSULT SIGMA?

## TECHNICANA

[Continued from page 6]

### IF

any relay that works at all is good enough for your job . . . you are not interested in:

- Compactness
- Fast operation
- Precise timing
- Exceptional sensitivity
- Performance in difficult environment
- Maintenance of operate values within narrow limits



Then there is no reason to pick out Sigma from among the many competent relay manufacturers.

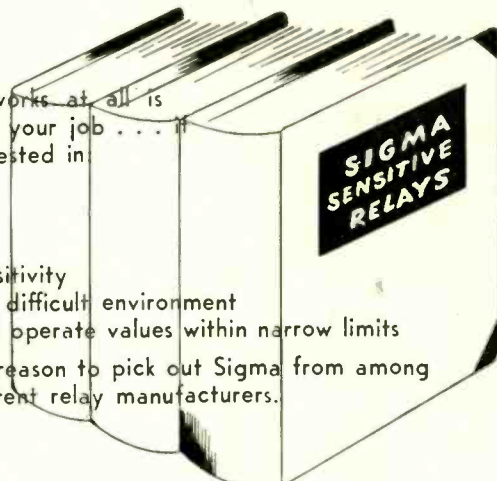

### IF

on the other hand, your requirements are stringent and must be fulfilled exactly, you will be interested in Sigma's method of operation.

We do not in general sell "stock" or "standard" items, even though our relays are all assembled from standard parts. Your problem is studied in detail by our engineering staff. Experimental work is done if necessary. Decisions are then made as to just what can be achieved. Then, when agreement with your engineering department

on what is to be expected from the use of our relays is complete . . . we accept your order.

Our guarantee does not stop with "faulty workmanship or defective materials," but includes performance up to the end result intended.

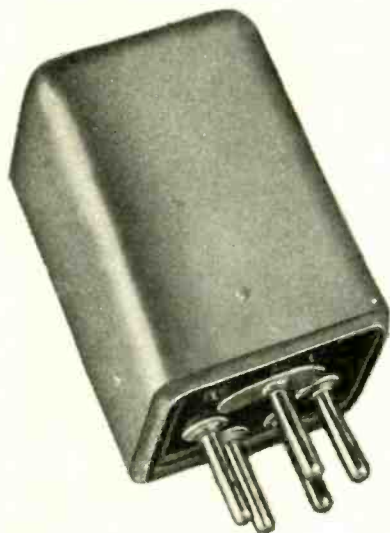

TYPE 5RH  
Hermetically Sealed  
(1 1/2" x 1 1/2" x 2 1/4")

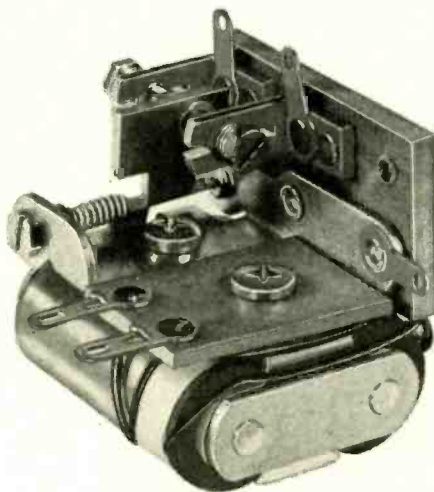

TYPE 5FMD  
Make Relay 0.2 Sec. Input  
.020 Watt For Aircraft Service

**SIGMA**  
**Sigma Instruments, Inc.**  
*Sensitive RELAYS*

**NEW ADDRESS**

66 CEYLON STREET  
BOSTON 21, MASS.

The equivalent resistance for two stages,  $R_{eq}$ , consists of the shot-effect noises of each tube plus the thermal noise in the input of the second tube. The latter component is the cause for error when attempting to short-circuit the fundamental definition.

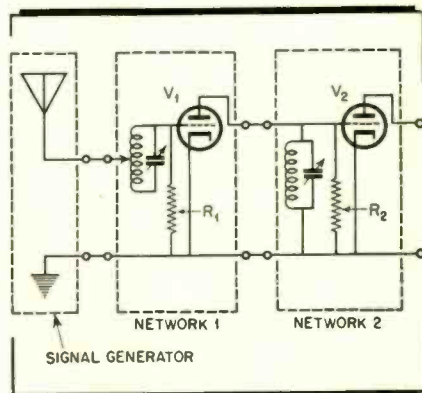

Figure 2

It is shown that the thermal noise to the input of the second tube,  $V_2$ , is represented by  $R_2/4$ , where  $R_2$  is the unloaded dynamic resistance of the coupling circuit to  $V_2$ , which is matched to the output impedance,  $r_1$ , of  $V_1$ .

The error of other authors has been in assuming that  $r$  acts as a shunt resistance to  $R_2$ , which would make the

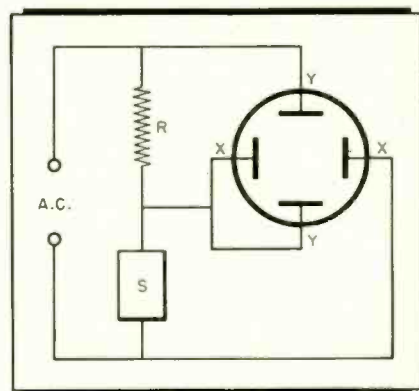

Figure 3

thermal noise resistance equal to  $R_2/2$ . Actually, since  $r$  is not a thermal noise source, it cannot be so considered.

The author derives the engineering formula from fundamental considerations for a single stage amplifier, shown in Fig. 1.

For a matched load,

$$R_d = R_a \text{ and } S_i = e_a^2/4R_a$$

$$\text{also } e_s = e_a/2$$

[Continued on page 10]

# WADSWORTH SKILLS

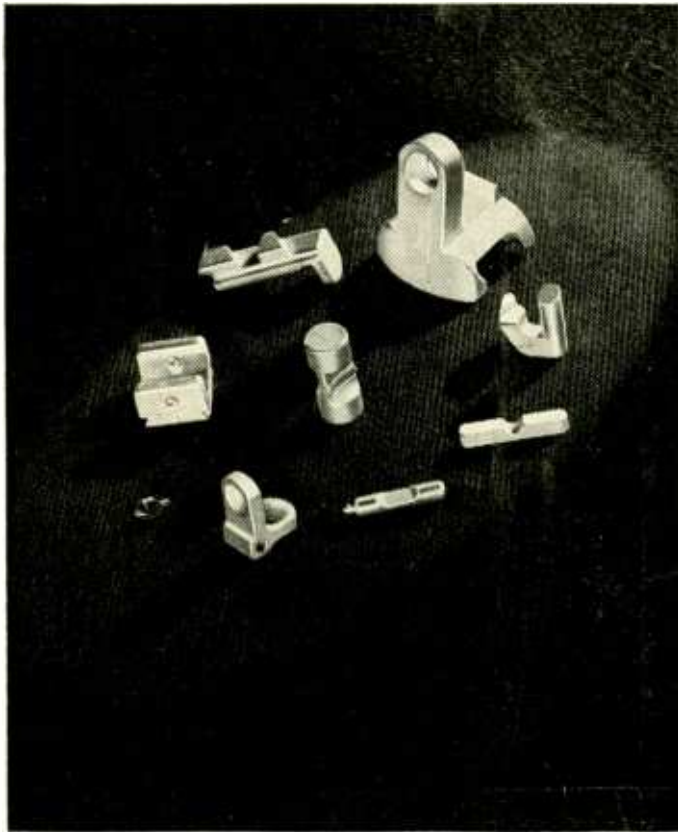

## WADSWORTH FACILITIES

Die Making  
Jigs & Fixtures  
Gage Making  
Model Building  
Milling  
Drilling  
Turning  
Stamping  
Screw Machining  
Hard Soldering  
Heat Treating  
Line Assembly  
Polishing  
Lacquering  
Photo Etching  
Silk Screening  
Product Decorating  
Metals Laboratory  
Engineering Design  
Product Design

## CURRENTLY SERVING THESE INDUSTRIES

Aircraft  
Automotive  
Bearing  
Electronics  
Instruments  
Machine Tool  
Small Arms  
Refrigeration

... built up through half a century of leadership in the exacting Watch Case Industry will be available soon to many manufacturers who will require large quantities of small precision parts for their postwar assemblies.

Work of this character is now being supplied to many leading companies which normally produce radio equipment, refrigerators, automotive parts, precision instruments.

Illustrated are nine small components of an Ordnance assembly which Wadsworth furnishes in great numbers. The production of these pieces, which are held to very close tolerances, brings a score of special Wadsworth facilities into play.

Wadsworth workers' feeling for precision and their ability to get work out on time will ease postwar headaches for many producers.



SMALL PARTS DIVISION

THE *Wadsworth* WATCH CASE CO., Inc.  
DAYTON, KENTUCKY, SUBURB OF CINCINNATI, OHIO  
PHONE COLONIAL 8194 • (CINCINNATI EXCHANGE)



# Moisture Proof OCTAL-TYPE BASE

Despite contraction and expansion caused by heat and cold, HOWARD'S Octal Type Base "seals out" all moisture and dirt by means of a gasket seated on a sealing ring. Designed for use in radio tubes, electrolytic condensers, and practically all types of plug-in equipment.

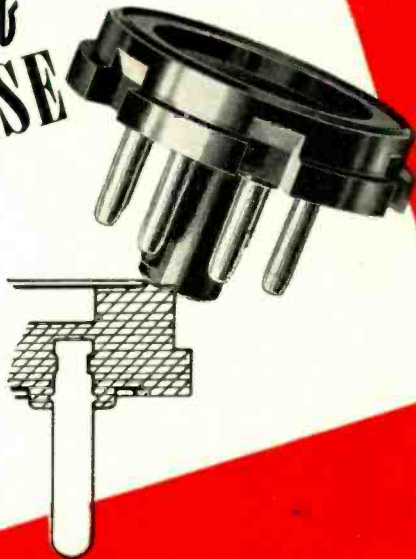

## MOLDED-IN PINS

Because HOWARD Molds-in the pins there is a complete seal around the pins preventing the entrance of any moisture or dirt. HOWARD Octal type base is made in black or natural Bakelite. Write HOWARD today for prices.

★ BUY WAR BONDS ★

# HOWARD MANUFACTURING CORP.

COUNCIL BLUFFS, IOWA

**HARVEY** is now a distributor of



the "Royal Family" of pickups, cutters, jewel points

AUDAX, now available through HARVEY, distributor of fine radio and electronic equipment, represents the ultimate in professional recording accessories. AUDAX Pickups are made with the unique "relayed-flux" principle so largely responsible for the sharp, clear-cut facsimile reproduction of Microdyne. Into the Pickups, as well as the Cutters and Jewel Points, has gone the delicate precision craftsmanship of masters of the trade. Long noted for its engineering and mechanical perfection, AUDAX

equipment is used in radio stations, recording studios and wherever the performance requirements are exacting.

Free! PICK-UP FACTS!

Write today for this valuable booklet which contains the answers to most questions in the field of sound reproduction, written by Maximilian Weil, leading authority on the subject.

**HARVEY**  
RADIO COMPANY  
**HARVEY**  
103 WEST 43rd ST., NEW YORK 18, N. Y.

Upon receipt of suitable priority, HARVEY can promise you reasonably prompt deliveries of all AUDAX products.

## TECHNICANA

[Continued from page 8]

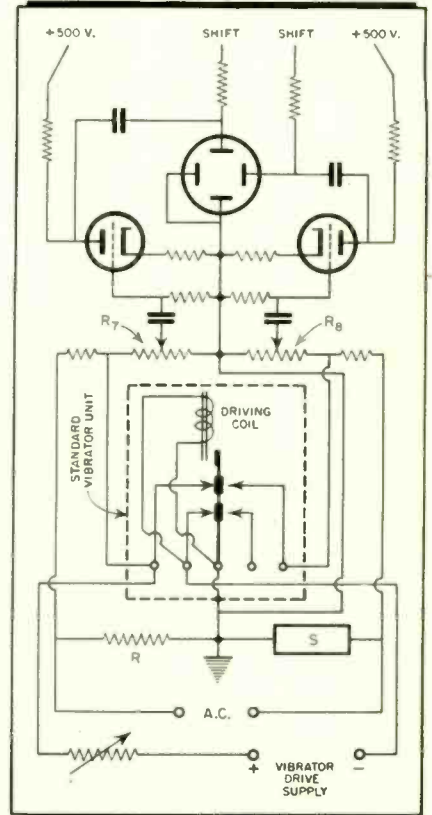

Figure 4

Similarly,

$$S_o = \frac{V_o^2}{4r} = \frac{\mu^2 e_i^2}{4r} = \frac{\mu^2 e_a^2}{16r}$$

$$G = \frac{S_o}{S_i} = \frac{\mu^2 R_o}{4r}$$

$N_o = N(t) + N(s)$ , where  $N(t)$  is thermal noise power amplified from the effective thermal grid circuit resistance,  $R_o$ , and  $N(s)$  is the shot noise in the tube.

$$\frac{N(t)}{N_i} = \frac{e_o i^2 / 4r}{e_i i^2 / 4R_o} = \frac{\mu^2 e_i^2 R_o}{e_i i^2 r} = \frac{\mu^2 R_o}{r}$$

$$N(t) = \frac{\mu^2 R_o}{r} KTB$$

$$N(s) = \frac{i_n^2 r}{4}$$

$$F = \frac{S_i}{N_i} \frac{S_o}{N_o} = \frac{4R_o}{R_a} + \frac{i_n^2 r^2}{2R_o KTB \mu^2}$$

In the above  $R_o = R_a/2$  since  $R_d = R_a$  and  $R_d$  is the resistance of the two in shunt. Also  $i_n$  is the r-m-s short-circuit shot noise current.

The equivalent resistance,  $R_{eq}$ , is the

[Continued on page 14]

# Federal Tubes...

come **CLOSER** to the  
**PERFECT  
VACUUM**

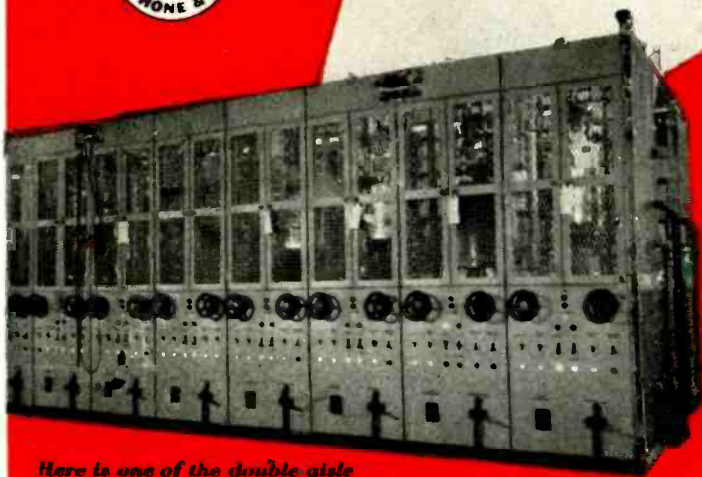

*Here is one of the double aisle exhaust banks where 16 high power tubes can be exhausted at one time, each with individual control.*

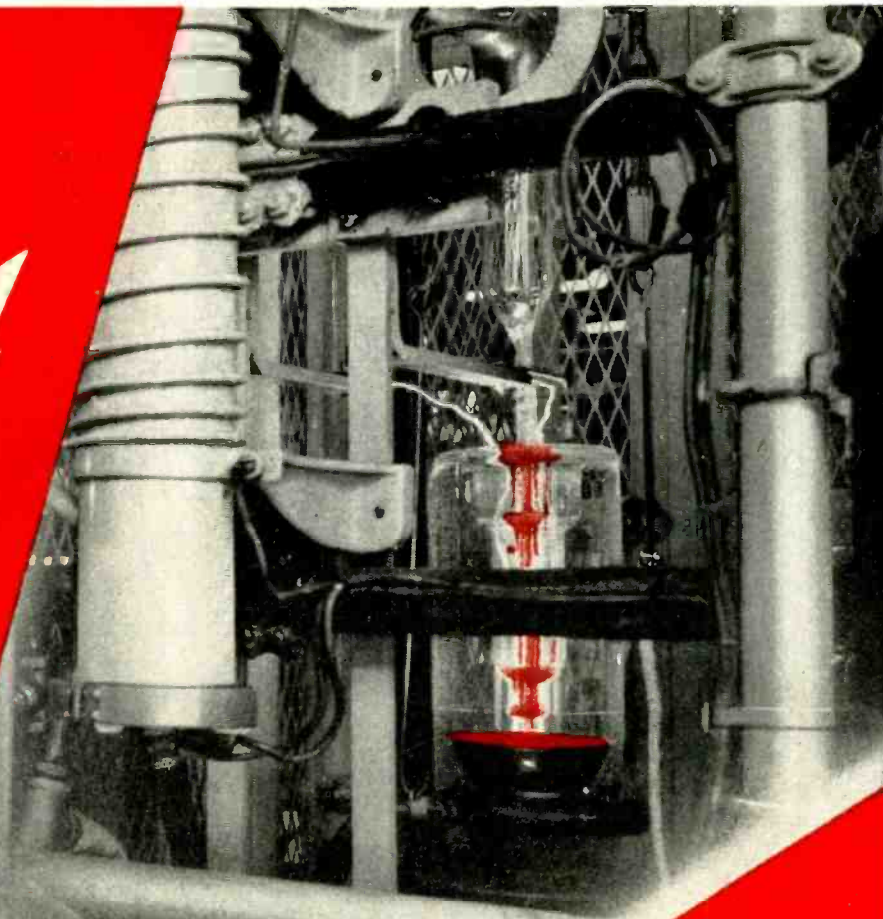

Always in the forefront of tube research and development, Federal makes another advance and now has added exhaust units of entirely new and original design to its production equipment.

This latest Federal achievement produces a tube that is substantially closer to the perfect vacuum—a tube with greater efficiency and longer life.

Arranged in banks of eight and operated with identical control equipment, these units exhaust uniformly every size of Federal tube—assuring a consistent and high standard of quality.

For any communication and industrial power tube need, turn to Federal now—test its reputation that “Federal always has made better tubes.”

## Federal Telephone and Radio Corporation

Newark 1, N. J.



*You'll Want this New*  
**JAMES KNIGHTS**  
 "Crystal Controlled"  
**Frequency Standard**

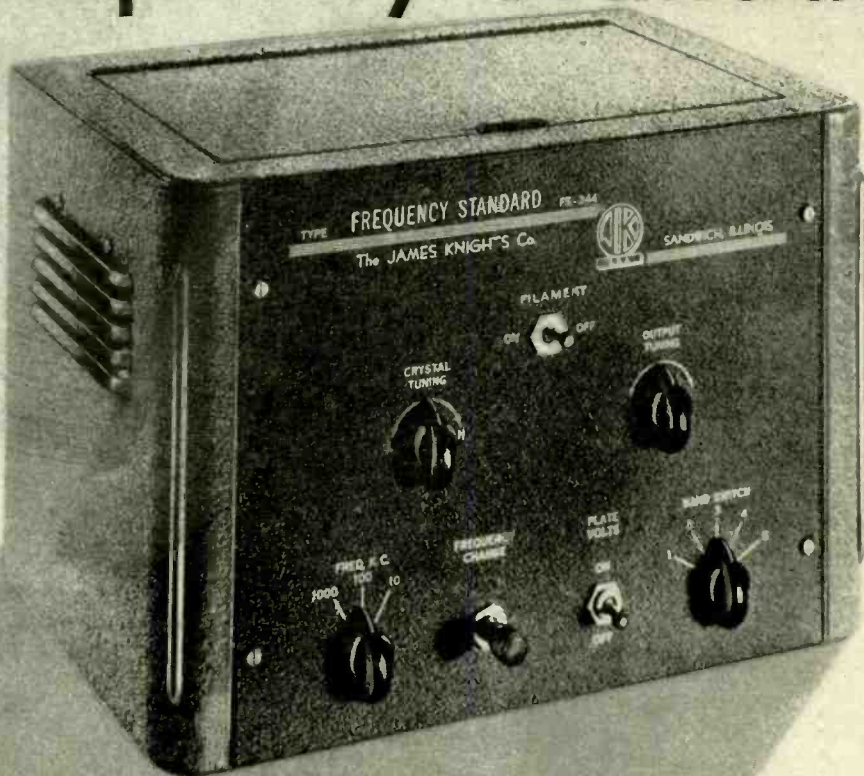

This is the ideal secondary frequency standard to check frequency of oscillators and transmitters, to calibrate and align receivers, etc. Can be used by the crystal manufacturer to check frequency standards for production. Useful many ways in the electronic laboratory or factory. Provides output up to 40 megacycles at 1,000, 100 and 10 kilocycle intervals. Complete cost only \$59.50. Descriptive catalog sheet on request.

**BUY WAR BONDS FOR VICTORY!**

**The JAMES KNIGHTS Co.**  
 SANDWICH, ILLINOIS

**CRYSTALS FOR THE CRITICAL**

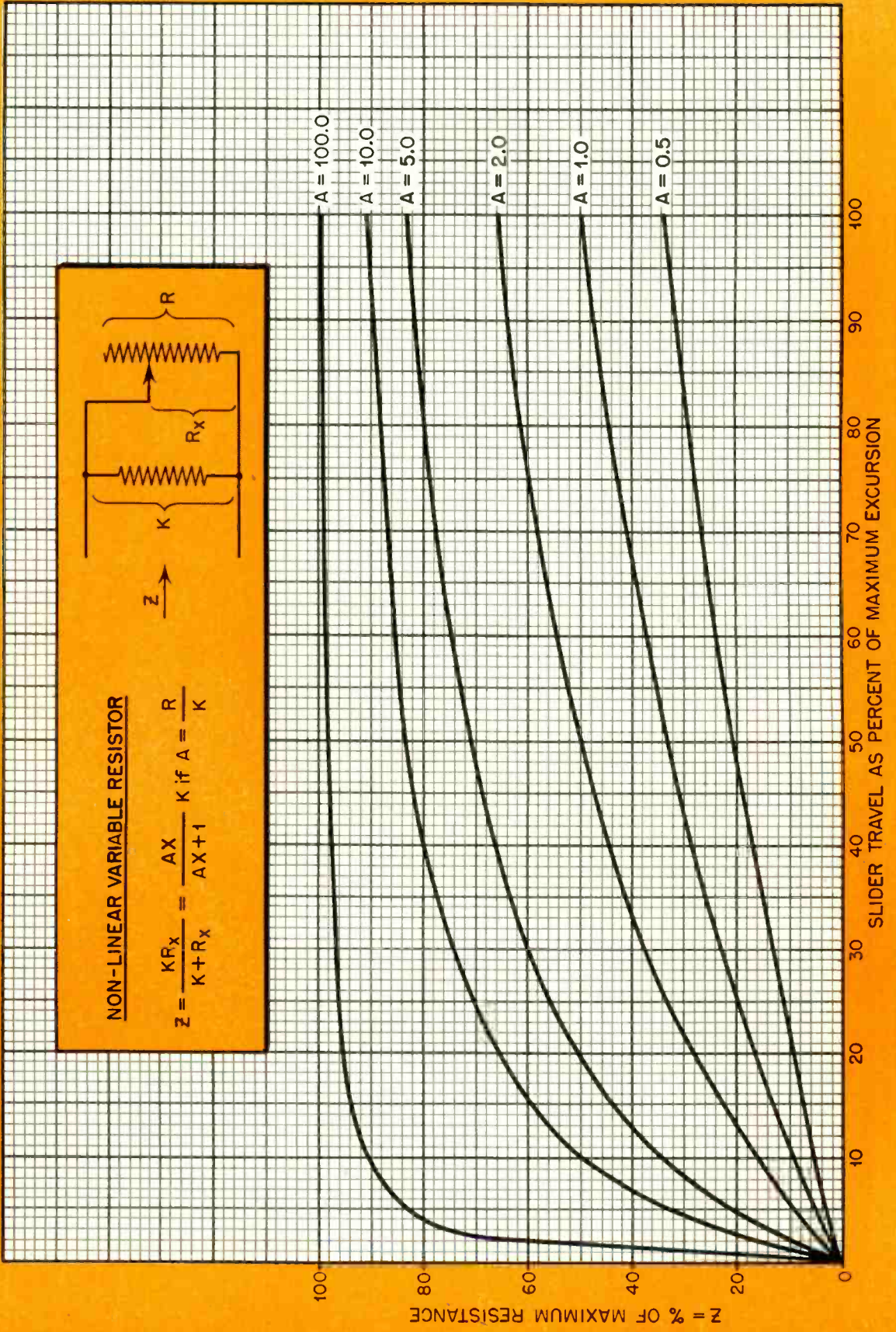
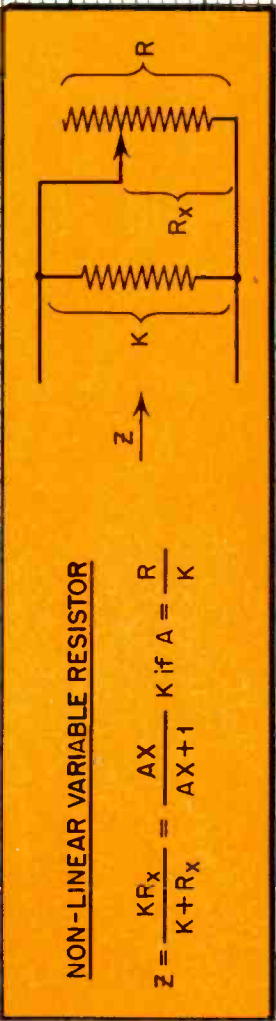

# WILEY BOOKS IN COMMUNICATIONS-ELECTRONICS



Post-war plans in your field are being made NOW. This is the time to step up your knowledge. Be ready for new duties. Look over the important titles listed below. Make your selection and order from the coupon today.

## FIELDS AND WAVES IN MODERN RADIO

By Simon Ramo and John R. Whinnery

503 Pages

\$5.00

Authoritative data on high-frequency circuits, skin effect, shielding problems, problems of wave transmission and reflection, transmission lines and wave guides, cavity resonators, and antennas and other radiating systems—with a rigorous account of the technique of applying field and wave theory to the solution of modern radio problems.

## HOW TO PASS RADIO LICENSE EXAMINATIONS—Second Edition

By Charles E. Drew

320 Pages

\$3.00

Newly revised and brought up to date, this well-known book, in question-and-answer form, offers much helpful material to amateur radio operators, radiotelephone and telegraph operators, whether interested in broadcasting, marine, aeronautical, or any other field of radio transmission and reception.

## RADIO RECEIVER DESIGN—Part I

By K. R. Sturley

435 Pages

\$4.50

Communications engineers will want to own this book, which covers radio frequency amplification and detection. A detailed study, stage by stage, beginning with the aerial and going as far as the detector.

## TIME BASES—(Scanning Generators)

By O. S. Puckle

204 Pages

\$2.75

Covers the subject from both the design and the development points of view; assembles more time bases circuits than have heretofore been available in one volume.

## PRINCIPLES OF RADIO—Fourth Edition

By Keith Henney

549 Pages

\$3.50

A complete and authoritative presentation of radio, in its fundamentals as well as its recent developments. Partial list of contents includes: Ohm's Law; Inductance; Capacitance; Circuits; Coils; the Vacuum Tube; Amplifiers; Rectifiers; Oscillators; Television; etc. Profusely illustrated.

## COMMUNICATION CIRCUITS—Second Edition

By L. A. Ware and H. R. Reed

330 Pages

\$3.50

An expansion of an eminently successful book to include new material on physical aspects of wave guide transmission, impedance matching, solution of circuits, and the theory of rectangular and cylindrical wave guides.

## HYPER AND ULTRA-HIGH FREQUENCY ENGINEERING

By Robert I. Sarbacher and William A. Edson

644 Pages

\$5.50

A practical treatment of an important new branch of communications engineering, requiring no special advanced knowledge. Of value to the beginner, as well as those having some familiarity with the subject.

## GUIDE TO CATHODE RAY PATTERNS

By Merwyn Bly

30 Pages

\$1.50

Important for technicians and laboratory workers. This book summarizes briefly by means of sketches and captions the cathode-ray pattern types encountered in the usual course of laboratory and test bench work.

## FUNDAMENTAL RADIO EXPERIMENTS

By Robert C. Higgy

96 Pages

\$1.50

Thirty-two basic experiments in electricity, electronics and radio, with a full explanation of the principles involved as well as laboratory procedure.

## BASIC ELECTRICITY FOR COMMUNICATIONS

By William H. Timble

603 Pages

\$3.50

A simple, clear presentation of the fundamentals of electricity and their application in the problems of communications and radio. The first twelve chapters illustrate the principles by simple application to communications appliances. The remainder of the book covers the appliances and their operation.

## SHORT-WAVE WIRELESS—4th Edition

By A. W. Ladner and C. R. Stoner

573 Pages

\$6.00

A book of inestimable value in this field as it contains the latest facts and theory (as far as they may be released now) on the many leading American, English and European developments taking place in short-wave and ultra-short-wave work. 180 new diagrams, plus illustrations and calculations supplement the text.

## TECHNICANA

[Continued from page 10]

equivalent grid noise resistance to account for all noise outside the effective thermal noise at the grid.

$$N_i = KTB = \frac{e_{eq}^2}{4R_{eq}}$$

$$e_{eq}^2 = \mu^2 e_{ra}^2 = i_n^2 r^2 = \mu^2 KTB \cdot 4R_{eq}$$

$$R_{eq} = \frac{i_n^2 r^2}{4\mu^2 KTB} = \frac{i_n^2}{4KT B g_m^2 \mu^2} \text{ Since } \mu = r y_m.$$

$$F = \frac{4R_g}{R_a} + \frac{4KT B R_{eq} g_m^2 r^2}{2R_g KTB \mu^2}$$

$$F = \frac{4}{R_a} (R_g + R_{eq}) \text{ since } R_g = \frac{R_a}{2}$$

This formula for  $F$ , derived from the fundamental definition, is equivalent to the engineering formula

$$F = \frac{e_n^2}{e_a^2} \cdot \frac{R_{eq} + R_g}{R_a}$$

since  $e_n = e_a/2$ .

The general result for two stages is given as

$$F_{1,2} = F_1 + \frac{F_2 - 1}{G_1}$$

in which  $F_{1+2}$  is the noise figure for both stages and  $G_1$  is the gain of the first stage.

When the gain of the first stage,  $G_1$ , is sufficiently large, the second term drops out, and the overall noise figure is the noise figure of the first stage.

For two stages the fundamental formula develops into

$$F_{1,2} = 2 + \frac{1}{R_1} \left\{ R_{eq1} + \left[ (R_2/4 + R_{eq2}) / \frac{\mu^2}{4} \right] \right\}$$

This is illustrated in Fig. 2.

## CATHODE RAY TUBES

★ The graph of a curve may be plotted directly on the screen of a cathode ray tube to show at a glance the dynamic characteristic of some non-linear variable, if a circuit is used as described by Mr. A. H. B. Walker in the Sept., 1944, issue of *Wireless World*. The article is entitled "Cathode-Ray Curve Tracer."

A cathode ray tube trace is produced by two voltages applied to the two pairs of deflecting plates. In a simple circuit the trace may be made to represent a voltage-current characteristic, as in Fig. 3. The current through  $S$  produces a proportional voltage drop across  $R$ , which is applied to the  $Y$  plates. The

[Continued on page 16]

## ON APPROVAL COUPON

JOHN WILEY & SONS, INC., 440 Fourth Avenue, New York 16, N. Y.

Please send me on ten days' approval the books I have checked in this advertisement (or I am attaching to this coupon a separate list of the books desired). At the end of that

time, if I decide to keep the books, I will remit indicated price plus postage; otherwise I will return the books postpaid.

Name.....

Address.....

City and State.....

Employed by..... R-9-14



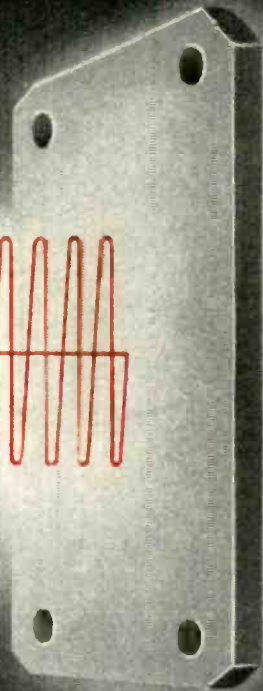

# MYKROY

PERFECTED MICA CERAMIC INSULATION

## DOESN'T LEAK

To engineers specializing in low-loss high frequency design, energy conservation throughout circuits is so important that a dielectric having the qualities of MYKROY with a *loss factor of 1* is extremely desirable. MYKROY—the perfected glass-bonded mica ceramic insulation, fills this vital need so dependably that it has opened the door to new and greater advances in high frequency research.

Circuits brilliantly conceived on the drafting board are successfully translated into practical application because of the many superior insulating properties of MYKROY.

In addition to possessing a *high dielectric constant* in combination with a *low power factor*, MYKROY is light—yet its mechanical strength is comparable to cast

iron—resists arc-heat carbonization and is impervious to gas, water and oil—keeps its shape (will not warp)—bonds easily with metals—molds readily to any specifications and machines perfectly to closest tolerances.

MYKROY is maintaining the efficiency of such a large variety of electronic equipment of advanced design that your most difficult insulation problems will find a speedy solution in its application.

If you are confronted with a high frequency insulating problem, our engineers will welcome the opportunity to acquaint you with the performance of MYKROY. It is available in ample quantities on rapid delivery schedules from our Chicago, Illinois and Clifton, New Jersey plants.

**IS THIS MYKROY  
ENGINEERS MANUAL  
IN YOUR FILE?**

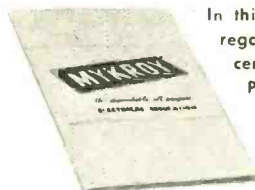

In this comprehensive manual you will find full information regarding MYKROY . . . the perfected glass-bonded mica ceramic insulation. It tells you about: Machinability, Physical, Chemical and Electrical properties—Applications and uses—Sizes and shapes of stock forms—Design criteria, and includes samples of MYKROY. A request on your letterhead will bring your copy by return mail.

MYKROY IS SUPPLIED IN SHEETS AND RODS . . . MACHINED OR MOLDED TO SPECIFICATIONS

MADE EXCLUSIVELY BY **ELECTRONIC MECHANICS** INC. 70 CLIFTON BOULEVARD • CLIFTON, NEW JERSEY  
Chicago 47. 1917 NO. SPRINGFIELD AVENUE . . TEL. Albany 4310

Expert Office: 89 Broad Street, New York 4, N. Y.

IT WON'T BE LONG NOW . . .

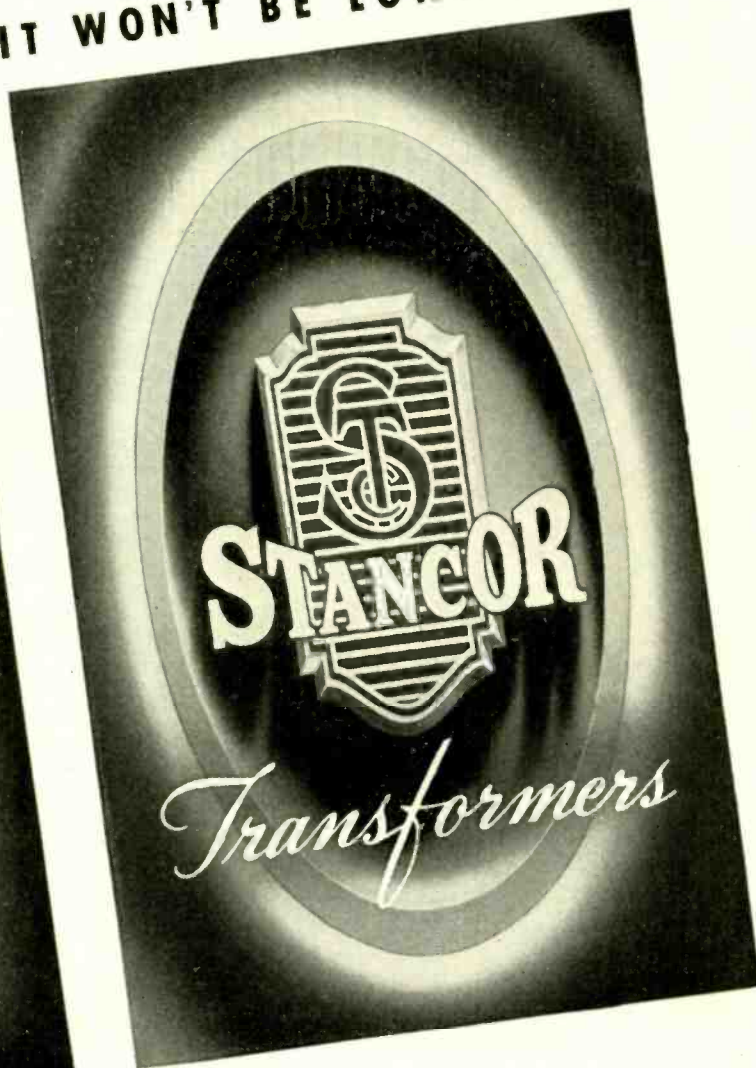

... and Stancor will "step ahead" with postwar plans that not only will include units for most every communication and electronic apparatus, but will have inherent in those transformers, design technique which our extraordinary war production has demanded . . . Yes, Stancor is worth waiting for. So, before you specify —consult "Stancor for Postwar."

**STANDARD TRANSFORMER CORPORATION**  
1500 NORTH HALSTED STREET, CHICAGO 22, ILLINOIS

## TECHNICANA

[Continued from page 14]

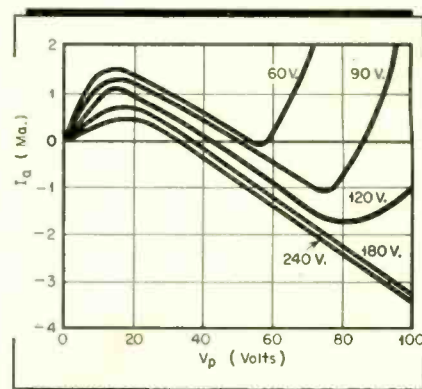

Figure 5

voltage across  $S$  is applied to the  $X$  plates. If  $S$  is a non-linear impedance, the tube trace will be a graph of the impedance characteristic.

In practice, provision should be made for adjusting the  $X$  and  $Y$  scales to produce a reasonable curve. Accordingly, amplifiers are used in each deflection plate circuit, as shown in Fig. 4. Potentiometers  $R7$  and  $R8$  are varied to produce a curve which fits the screen. The amplifiers must be of good design so as to avoid phase shift and consequent distortion in the tube trace.

In order to provide  $X$  and  $Y$  axes for the graph, the vibrator is introduced, as shown. At each swing of the vibrator reed, one of the resistances,  $R7$  or  $R8$ , is short-circuited, so that the tube trace returns instantaneously to either the  $X$  or the  $Y$  axis. Thus the electron beam produces three traces, in order—an  $X$ -axis, a  $Y$ -axis, and the graph of the characteristic of  $S$ . If the vibrator drive is adjusted according to the persistence characteristic of the screen, the curve and the axes can be made equally bright, for photography, if desired.

The author used the standard power line frequency for the deflection plates and a 120-cycle vibrator.

### NEW FM RECEIVING SYSTEM

A high degree of freedom from noise and from interference from undesired stations in the reception of FM (frequency modulation) radio programs is made possible by a new advance in the design of FM receivers, according to RCA.

The new development, designated as a "frequency-dividing locked-in oscillator FM receiving system," was described by its inventor, George L. Beers, of the Radio Corporation of America, at a technical session of the First National Electronics Conference in Chicago.

"Frequency modulation," Mr. Beers pointed out, "is still in its infancy in

[Continued on page 18]

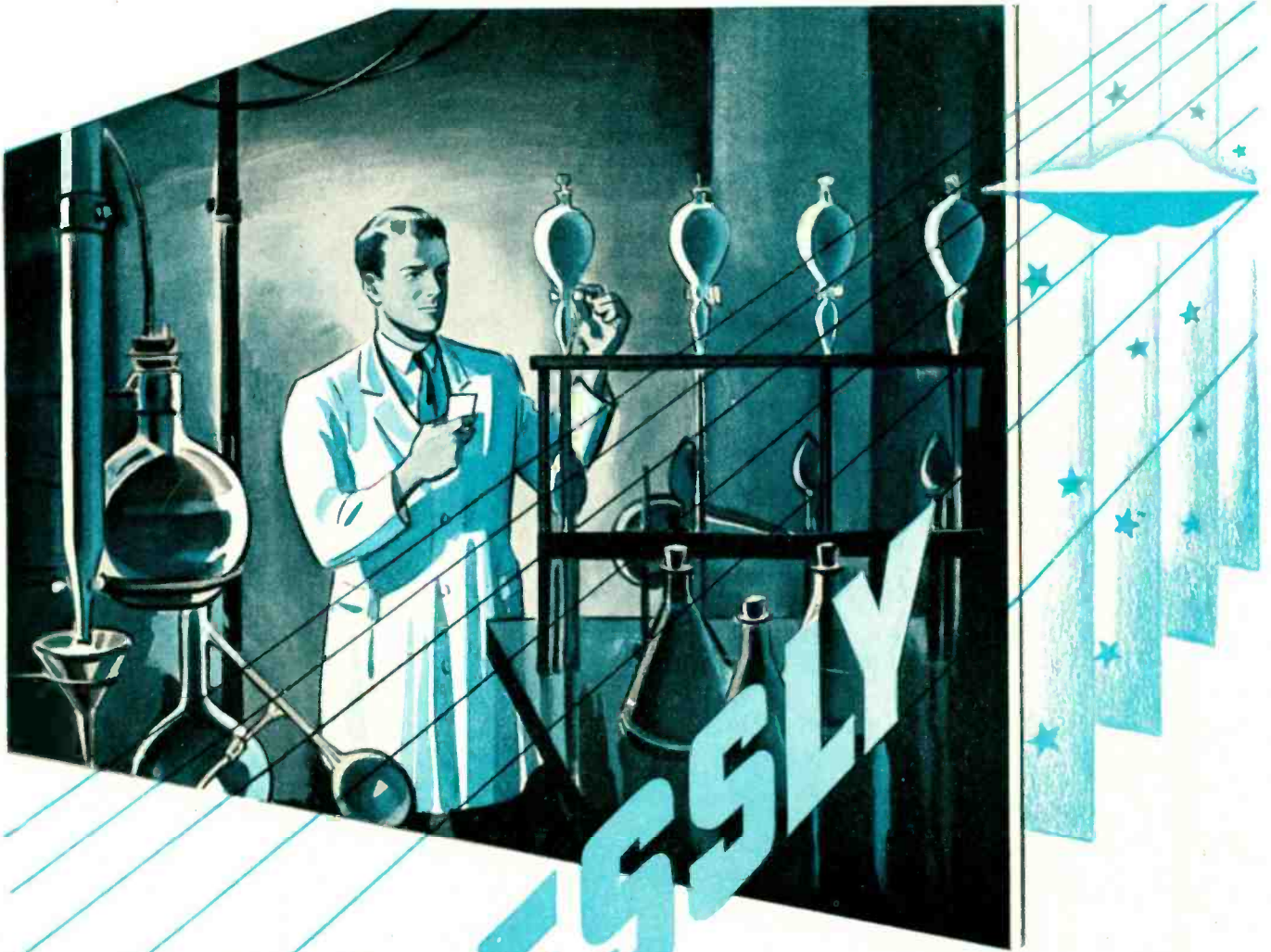

*the Improvement goes on...*

**ENDLESSLY**



**FORMICA**

• Since 1913, in the Formica Laboratories, a considerable force of competent research men has been busy every day seeking new ways to improve Formica and its usefulness to industry.

They have worked out a long line of improvements which have been additions to the art. During these war years they have been exceptionally busy, and productive.

Among the important recent developments have been glass cloth and glass mat grades for high mechanical strength, and improved insulation of high frequency currents; Pregwood for airplane propeller blades and other mechanical uses; alkali resistant grades for chemical processes, better laminated translucent sheet, sturdier and more decorative Formica finishes.

There are others which will soon be unveiled. All the knowledge of this laboratory is at your disposal when you have a problem in the use of laminated plastics to solve. Ask for it

"The Formica Story" is a moving picture in color showing the qualities of Formica, how it is made, how it is used. Available for meetings of business groups.

THE FORMICA INSULATION COMPANY, 4670 Spring Grove Avenue, Cincinnati 32, Ohio

**RADIO** ★ OCTOBER, 1944



## SIGNAL CORPS EQUIPMENT



Four basic controls  
by *Bliley*

All helping to "get the message through"...  
all precision proved in the tradition of

**BLILEY CRYSTALS**



*Bliley*  
CRYSTALS

Do more than before...  
buy extra War Bonds

BLILEY ELECTRIC COMPANY • UNION STATION BUILDING • ERIE, PENNSYLVANIA

If this tiny **ULTRA-HIGH FREQUENCY**  
**I-F TRANSFORMER** fits into YOUR plans...

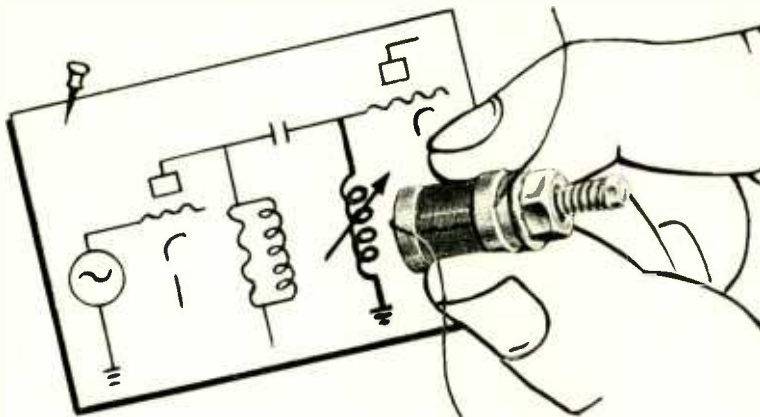

your transformer worries are over. It's the LS-1 Transformer, developed by C. T. C. for some high priority radio and electronic equipment and only recently released for more general applications. Tested and proved, this precision built, slug tuned transformer will meet your highest standards of quality and performance. And C. T. C. will do everything possible to meet your delivery requirements.

For complete information on the LS-1, write, phone or wire

**CAMBRIDGE** *Thermionic* **CORPORATION**  
454 CONCORD AVENUE • CAMBRIDGE 38, MASS.

## TECHNICANA

[Continued from page 16]

terms of a nation-wide entertainment service. Until a large number of high-powered FM broadcasting stations are operating on a commercial basis, the major technical problems which are involved in the design of FM receivers will not be fully appreciated.

"Probably the most difficult requirement to be met is that of obtaining adequate adjacent channel selectivity. This problem was emphasized by a report on 'Blanketing of High Frequency Broadcast Stations' issued in 1941 by the Federal Communications Commission.

"The new FM receiving system described in this paper, in which a continuously operating local oscillator is frequency-modulated by the received signal, represents a new approach to the problem. A substantial selectivity improvement has been obtained in the new system by designing the oscillator to lock-in only with frequency variations occurring within the desired channel."

Another important feature of the Beers system is a material improvement in the stability of the receiver from the standpoint of overall feedback. This results from the fact that the locked-in oscillator arrangement provides a substantial voltage gain at a different and lower frequency than the intermediate frequency employed in the receiver. High sensitivity is required in an FM receiver in order to obtain maximum performance. If this sensitivity is obtained at a single intermediate frequency, it is difficult to prevent over-all feedback and provide satisfactory receiver stability.

"Basically," Mr. Beers said, "the operation of the new system, on which a patent was recently granted, depends on producing, in the receiver, a local signal which is frequency-modulated by the received signal. The local signal is provided by a continuously operating oscillator. The received signal, after it has been amplified by conventional r-f and i-f amplifiers, is applied to the oscillator in such a way as to cause its frequency to change in accordance with the frequency variations of the received signal.

"In the particular applications of the system described in this paper, the oscillator is locked-in with the received signal at one-fifth of the intermediate frequency. With this 5 to 1 relationship between the intermediate frequency and the oscillator frequency, an equivalent reduction in the frequency variations of the local oscillator is obtained. Received signal frequency variations of plus or minus 75 kilocycles are reproduced as plus or minus 15 kilocycle variations in the oscillator frequency.

"It should be noted that the locked-in oscillator operating at one-fifth the intermediate frequency reduces the frequency deviation corresponding to any modulation frequency, but does not change the modulation frequency. The frequency-modulated signal derived from the oscillator is applied to a discriminator which is designed for this reduced range of frequencies.



**"THE BOARD OF DIRECTORS JUST LEARNED THAT ALBION  
COULD SHIP ALL THE COILS THEY NEEDED!"**

**SUPER-QUALITY COILS . . . WHEN YOU NEED THEM!**

More and more every day, the industry is turning to Albion for fast, quality and quantity production of coils, chokes, and transformers. That's because here you benefit from the unbeatable combination of management "know how," skilled workmanship, streamlined facilities, and central location. Your requirements will be given prompt and thoughtful attention.

**ALBION  
COIL COMPANY**

ALBION, ILLINOIS

R. F. AND TRANSMITTING COILS AND CHOKES;  
I. F. TRANSFORMERS

**RADIO**

\* OCTOBER, 1944

19

# World-Wide Radio Communications



## ...Provided by WILCOX Equipment

Today, Wilcox Aircraft Radio, Communication Receivers, Transmitters and other advanced radio equipment are in use in all parts of the world, helping make possible the sustained and mighty air attacks against the Axis. And for many years,

the major commercial airlines of the United States have relied upon Wilcox dependability in their daily operations. In the post-war period you can rely on Wilcox to retain its dominant position in the field of Radio Communications!

### WILCOX ELECTRIC COMPANY

*Manufacturers of Radio Equipment*

*Fourteenth & Chestnut, Kansas City, Mo.*

# The Terminology of ELECTROMAGNETIC THEORY

Because recent developments in the field of microwave radiation and generation have greatly widened the engineer's interest in electromagnetic theory, the following alphabetical list of terms, ideas, and theorems is presented. It is not so much intended that the discussions be rigorous definitions as that they shall give interesting ideas and serve as an introduction to the concepts.

**Hertz Vector- $\pi$**  — Generally, an electromagnetic field is given by specifying both  $E$  and  $H$  throughout the space in which we are interested.  $E$  and  $H$ , however, are interdependent in a way which is determined by the physical arrangement. Sometimes it is convenient to establish this interdependency by expressing  $E$  in terms of a scalar potential and  $H$  in terms of a vector potential and then writing down a relation between these potentials. Also, it is possible to write the interdependency of  $E$  and  $H$  by expressing both of them in terms of a single vector. That vector is called the Hertz vector and is often symbolized by  $\pi$ .

By the use of the Hertzian vector it is possible to describe the whole electromagnetic field with a single vector. For example, the Hertzian vector representing radiation into free space from an electric dipole has a magnitude given by

$$\pi = \frac{p(t-r/c)}{r}$$

and always points along a direction that is the same as the direction of motion of the oscillating charge. The dipole moment which is represented by  $p$  is here a function of time.

A charge may, for example, be imagined to be oscillating along the  $z$ -axis and about the origin of a Cartesian coordinate system. An equal stationary charge of opposite sign is at the origin. The dipole moment is by definition the product of the value of one of the charges and the separation between the two. The value of  $p$  is thus itself an oscillating function of time. The distance away from the dipole (always large compared to the dipole) at which a value of  $\pi$  is desired is  $r$ ;  $t$  represents time;  $c$  is the velocity of light. The electric field is given by

$$E = \text{grad div } \pi - (1/c^2) \delta^2 \pi / \delta t^2$$

and the magnetic field by

$$H = (1/c) \text{curl } \delta \pi / \delta t$$

where these equations are all written in Gaussian units. When we substitute for

$\pi$  its value for a dipole in free space and perform the indicated operations we get the usual directional radiation pattern that is well known for a dipole.

**Huygen's Principle**—*If the position of an electromagnetic wave front is known at some given time and if the transmission and reflection properties of the surrounding media and media interfaces are known, Huygen's principle furnishes us with a simple method of locating the position which the wave front will occupy at a later time.*

The method consists of assuming that several points on the known wave front are sources of spherical waves which emit new wave fronts at the instant at which the real wave's position is known. By measuring distances radially outward from each of the imaginary sources and by using the velocity of travel and the time elapsed to establish the proper distance, we can locate the wave fronts of these spherical waves at a later time. Huygen's principle then states that an envelope of these waves will give the anticipated position of the actual wave.

Several difficulties enter into the simple statement of Huygen's principle as just given. For one thing, it is clear that our statement would predict the formation of a backward wave as well as one in the forward direction. This may be overcome by introducing an obliquity factor into the intensity of the spherical waves. The spherical waves are then said to be imagined to have an intensity given by some constant times  $\cos^2(\theta/2)$  where  $\theta$  is the angle away from the direction of propagation of the original wave. This means that the intensity of each spherical wave is of cardioid form and no energy proceeds backward from the secondary sources.

The use of Huygen's principle in calculating microwave radiation patterns is also of somewhat limited value because it does not easily adapt itself to superposition with field components arising from currents in the neighborhood.

As an example of the use of Huygen's principle, the derivation of the rule for specular reflection from a plane mirror may be described. If the position of a plane wave front obliquely approaching a mirror is known, it is easy to first extrapolate the positions of various points on that wave and find the time at which each will reach the mirror. At those times we may, in accord with Huygen's principle, construct spherical waves at the mirror surface and if we draw them with a systematically varying radii so as to give a common time position, the envelope will give the position of the reflected wave. Only simple trigonometry is then required to establish the familiar rule that the angle of incidence is equal to the angle of reflection.

**Interference**—In much the same way that two batteries of equal voltage connection in series opposition can cancel each other so that no current flows, so two electromagnetic waves of precisely the same frequency may be so phased at certain points in space that no effect will be felt by a test charge or magnet imagined to exist at that point. *Interference between two waves is an effect due to phase which will in general cause the wave existing as the sum to be other than that which would be obtained by adding the energy present in the individual waves.*

In the study of optics it is frequently said that two light waves will only interfere if they come from coherent sources. A pair of sources is said to be coherent when their phases stay exactly in step. In the optical case this means in practice that the two interfering waves must arise from the same primary source, since the phase varies at random. This is because light is generated by the excitation of individual atoms.

With radio waves this is not true and interference between two transmitters is possible if they are very accurately held to the same frequency and phase. Directional antenna patterns formed by the use

[Continued on page 22]

# HIGH "Q" for MIDGETS

Available in DX  
Isoso-Loops



During peacetime, as the World's largest loop aerial manufacturers, our job was to build the highest "Q" loop for every size and kind of radio receiver. If you make midgets you get the same DX Isoso-loop quality that goes into the large consoles. All of our present day efforts are devoted to making DX Xtals but we would like to discuss your post war receiver plans with you.

## DX CRYSTAL CO.

GENERAL OFFICES: 1200 N. CLAREMONT AVE., CHICAGO 22, ILL., U.S.A.



the heart of a good transmitter

TRADE MARK

## TERMINOLOGY

[Continued from page 21]

of dipole arrays depend upon this fact for their operation.

### Klystron\* Bunching Parameter-x

—With simple bunching theory in which the velocity change in the beam is small compared to the average velocity of the electrons, the bunching parameter is a convenient quantity in terms of which the power available from a Klystron catcher can be discussed. The bunching parameter depends upon the beam voltage, the r-f voltage applied to the buncher, and upon the drift distance of the tube as well as upon the frequency for which the tube is designed.

A plot of power available from the catcher resonator versus the bunching parameter is a Bessel function of the first order and degree. Such a curve looks a little like a damped sine wave and thus indicates that there is more than one value of the bunching parameter which may possibly give satisfactory output but only one that gives maximum power.

This corresponds physically to the fact that those electrons which are speeded up by the buncher will catch up with the slower ones ahead of them in a more or less satisfactory manner, depending upon the time allowed for them to do so, the excess of their velocity over that of the slower electrons, and the average speed of all the electrons.

Specifically, moreover, the bunching parameter versus power plot takes account of so-called over-bunching in which the faster electrons overtake and pass the slower ones before reaching the catcher.

The bunching parameter is defined as

$$x = \pi N (V_1/V_0)$$

where  $N$  is the number of cycles of the output frequency which occur while an electron is traversing the drift space,  $V_1$  is the r-f voltage applied to the buncher, and  $V_0$  is the beam voltage.

For a given tube  $N$  is ordinarily fixed, since it depends only on the length of the drift space and the frequency of the tube. To keep a given value of  $x$  and thus maintain a given output it is therefore desirable to vary  $V_1$  and  $V_0$  together.

**Laplace Equation** — Probably the most used of all differential equations is the Laplace equation. In Cartesian coordinates it has the form

$$\frac{\partial^2 A}{\partial x^2} + \frac{\partial^2 A}{\partial y^2} + \frac{\partial^2 A}{\partial z^2} = 0$$

In other coordinate systems it has a somewhat different form but, of course, indicates the same physical situation. In terms of vector operators it may be written independent of the coordinate system as

$$\nabla^2 A = 0.$$

In the study of electromagnetic theory, Laplace's equation is used in at least three

\* Registered Trade Mark of Sperry Gyroscope Company, Inc.

[Continued on page 24]

Announcing a change of name!

Henceforth, the Lafayette  
Radio Corporation (Chicago and Atlanta)  
will be known as the

# CONCORD RADIO CORPORATION



The Lafayette Radio Corporation has, for 22 years, been one of the well-known names in radio and electronics. Our policies and our personnel, our reputation for integrity and outstanding service to our customers have enabled us to become one of the nation's great arsenals of radio and electronic equipment. In announcing the change of name to the Concord Radio Corporation, we emphasize that the name only is affected. To our thousands of customers, we promise a continuance and broadening of our organization and our policies. With the advent of new and greater horizons in electronics, the Concord Radio Corporation, will blaze new trails in engineering achievement and customer services. Watch for our future advertisements, and be sure that your name is on our list to receive postwar literature and catalogs.

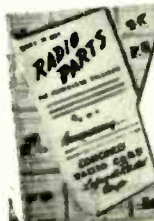

**CONCORD RADIO CORPORATION**  
901 W. Jackson Blvd. Dept. F-10  
Chicago 7, Ill.

Please rush me the new 16-page "Special Flyer" just published by the Concord Radio Corporation.

NAME .....

ADDRESS .....

CITY..... STATE.....

Just off the Press!

NEW, 16-PAGE "SPECIAL FLYER":  
... a last-minute compilation, by  
the CONCORD RADIO CORPORATION,  
of hard-to-find components and  
equipment for industry, service  
men, training schools, etc. MAIL  
COUPON TODAY.

# CONCORD RADIO CORPORATION

## Lafayette Radio Corporation

901 W. Jackson Blvd., CHICAGO 7, ILLINOIS ★ 265 Peachtree St., ATLANTA 3, GEORGIA





## Makes *vlf* waves behave

**T**HE KLYSTRON converts DC energy into radio frequency energy by modulating the velocity of an electron beam between spaced grids.

The ultra-high-frequency waves thus generated are so short that they approach heat and light waves in the electro-magnetic spectrum.

This makes it possible to project, by reflection, a shaped beam of *vlf* waves. Sperry engineers have put this principle to work in important wartime devices for our Armed Forces.

► **Klystrons are now in quantity production, and certain types are available. Write for information.**

The name "KLYSTRON" is a registered trade-mark of the Sperry Gyroscope Company, Inc.

Like other Sperry devices, Klystrons are also being made during the emergency by other companies.

**Sperry Gyroscope Company**  
INC.  
 GREAT NECK, N. Y. • DIVISION OF THE SPERRY CORPORATION

GYROSCOPICS • ELECTRONICS • AUTOMATIC COMPUTATION • SERVO-MECHANISMS

**RADIO**

★ OCTOBER, 1944

23

# KEN-RAD

## Metal Tubes

SIMPLE  
AND ECONOMICAL

RUGGED...  
THE BOY WHO  
RETURNS WILL  
TELL YOU

PREFERRED WITH  
AIRBORNE  
EQUIPMENT

SELF-SHIELDING  
...NO SEPARATE  
METAL ENCLOSURES  
NECESSARY

COMPACT...  
PERMITTING A  
FINER RADIO IN A  
SMALLER CABINET

PREFERRED  
BY A MAJORITY  
OF RADIO SET  
MANUFACTURERS

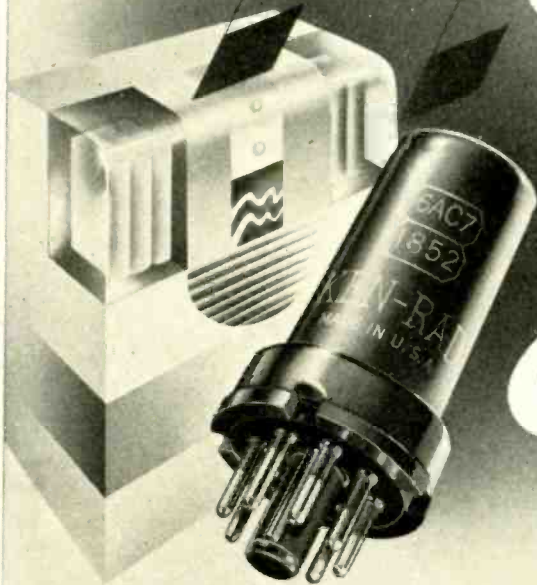

Write for your  
copy of "Essential  
Characteristics," the  
most complete digest  
of tube information  
available

1934 introduced the first metal receiving tubes  
In seven short years prior to Pearl Harbor  
over seven and one-half million new radio  
receivers were equipped with this finer  
Ken-Rad product

TRANSMITTING TUBES  
CATHODE RAY TUBES  
SPECIAL PURPOSE TUBES  
RECEIVING TUBES  
INCANDESCENT LAMPS  
FLUORESCENT LAMPS

# KEN-RAD

EXECUTIVE OFFICES

OWENSBORO · KENTUCKY

EXPORTS 15 MOORE STREET NEW YORK



## OUTSTANDING QUALITY!

# CETRON

in Electronic Tubes  
... Phototubes  
Rectifiers and  
Special Tubes

PROMPT  
DELIVERIES  
on most types  
Send for Catalog

CONTINENTAL ELECTRIC COMPANY

CHICAGO OFFICE  
600 N. MICHIGAN ST. CHICAGO, ILL.

GENEVA, ILL.

NEW YORK OFFICE  
303 W. 4th ST.

## TERMINOLOGY

[Continued from page 22]

distinct ways. First, the  $A$  in the equation above may represent vector magnetic potential; in that case Laplace's equation describes magnetic potential throughout free space. Second,  $A$  may represent and describe the electrostatic potential in a uniform dielectric. Third,  $A$  may show how the electric potential varies in the study of the steady flow of electric currents in solid conductors.

In all these cases the equation must be solved subject to the boundary conditions imposed by the particular physical arrangement but the mathematics may be the same in any event. It is this similarity of the mathematics involved in physically dissimilar problems that makes it possible for people skilled in such manipulations to often solve new problems quickly and from memory of other cases using the same mathematical equations.

**Laplace Transformation** — An important method of solving linear differential equations is that of the Laplace transformation. An equation of the form

$$\frac{d^2w}{dx^2} + p \frac{dw}{dx} + qw = 0$$

is transformed by the relation

$$w = \int u e^{st} dt$$

and the resulting differential equation in terms of the variable  $u$  is often simpler than the original equation expressed in terms of the variable  $w$ . The symbols  $p$  and  $q$  represent functions of  $x$  while  $u$  is a function of the variable  $t$ .

Suppose, for example, that at some time  $t = 0$ , a transmitter is turned on at the origin of a three-dimensional Cartesian coordinate system and allowed to generate a plane wave which travels out into free space along the positive  $z$ -axis. If the wave is polarized so that the  $E$  field is parallel to the  $x$ -axis and the  $H$  field is parallel to the  $y$ -axis, then by Maxwell's equations the field is determined by the following differential equations:

$$\frac{\delta H}{\delta z} + \epsilon_0 \frac{\delta E}{\delta t} = 0$$

$$\frac{\delta E}{\delta z} + \mu_0 \frac{\delta H}{\delta t} = 0$$

The fields  $E$  and  $H$  may be transformed by

$$\begin{aligned} E &= \int E' e^{t\alpha} d\alpha \\ H &= \int H' e^{t\alpha} d\alpha \end{aligned}$$

In these equations  $E'$  and  $H'$  are functions of  $t$ . The transformation is made with  $z$  considered as a parameter. That is,  $z$  is imagined to be a constant independent of  $t$  which we can vary at will. Since we can choose any value of  $z$  that we wish and make the transformation, it does not restrict the generality of the argument to hold  $z$  constant.

The transformed equations are obtained by performing the indicated differentiations,

[Continued on page 26]

# "The Heats On" To Verify Relay Material Composition

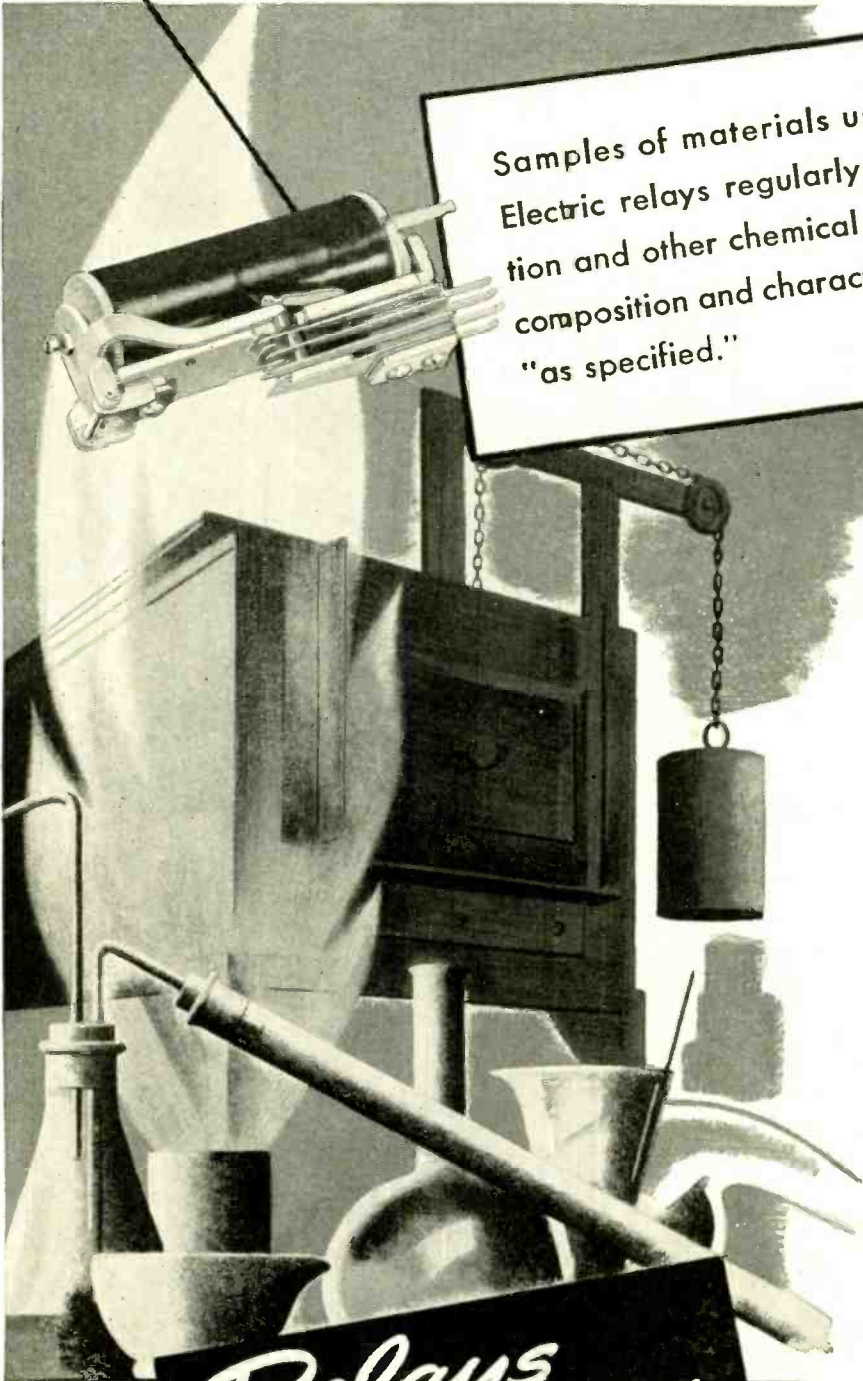

Samples of materials used in Automatic Electric relays regularly undergo combustion and other chemical tests to insure that composition and characteristics are exactly "as specified."

It may seem a simple matter—this job of selecting the right materials for making relays; but—

Automatic Electric designers know better. They know that correct design is only the beginning—that materials must also meet exacting standards, or performance will suffer. That is why they insist that quality control must begin in the laboratory.

When you need relays, call in the Automatic Electric field engineer. He can show you how quality pays, in longer life, better performance. In the meantime, for a preview of the Automatic Electric line, write for Catalog 4071.

*Relays*  
AND OTHER CONTROL DEVICES  
by **AUTOMATIC  
ELECTRIC**

★  
AUTOMATIC ELECTRIC SALES CORPORATION  
1033 WEST VAN BUREN STREET • CHICAGO 7, ILLINOIS  
In Canada: Automatic Electric (Canada) Limited, Toronto



PARTS AND ASSEMBLIES FOR EVERY ELECTRICAL CONTROL NEED

**RADIO**

★ OCTOBER, 1944

25

*Products of*  
**"MERIT"**

**MERIT COIL AND TRANSFORMER CORP.**  
ENGINEERS AND MANUFACTURERS OF TRANSFORMERS AND ELECTRICAL WINDINGS  
TELEPHONE LOUPOFF-6311  
4427 N. CLARK STREET  
Chicago 40, Illinois

*Announcing!*  
Our new plant is now in full production, greatly increasing our capacity. We believe it to be the most modern and efficient unit now engaged in the production of transformers, coils and allied electronic equipment.  
Please take note of our new address, where you will always receive a cordial welcome.  
Sincerely yours,  
*Paul*  
President.

**OUTPUT TRANSFORMER**  
Hermetic-Sealed  
Glass Terminals

**MERIT COIL & TRANSFORMER CORP.**  
4427 North Clark St. CHICAGO 40, ILL.

## TERMINOLOGY

[Continued from page 24]

which give as the transformed equations

$$\frac{\delta H'}{\delta z} + \epsilon_0 \alpha E' - \epsilon_0 E_0 = 0$$

$$\frac{\delta E'}{\delta z} + \mu_0 \alpha H' - \mu_0 H_0 = 0$$

where the terms involving  $E_0$  and  $H_0$  are of the nature of integration constants and represent the values of  $E$  and  $H$  at zero time. These equations involve the variable  $\alpha$  only as a multiplier and not as a variable in a differentiation. Thus the transformed equations can be solved simultaneously by separating  $E'$  and  $H'$ .

**Lecher Wires**—Two parallel ordinary wires which are long compared to a wavelength and spaced from each other by a distance equivalent to only a small fraction of a wave length, are called Lecher wires.

Such a pair of wires may be used to demonstrate standing electrical waves and some other phenomena encountered in the use of hollow rectangular wave guide and other types of microwave transmission lines.

Lecher wires like the ones shown are satisfactory for work with wavelengths

## ATTEN-SHUN!



**C. T. C. TURRET TERMINAL LUGS** are being ordered into action by more and more radio and electronics manufacturers. Here's why . . .



*First*—they're quick to apply. Just swage 'em to the boards and in a jiffy you have good, firm Turret Terminals.

*Second*—they save soldering time. Sufficient metal is used in their construction to provide strength, but not enough to draw heat and increase soldering time.

*Third*—quick delivery. Turret Terminal Lugs to meet a wide range of terminal board thicknesses are in stock.

Make C. T. C. **TURRET TERMINAL LUGS** your next order of the day. Write, phone or wire—

**CAMBRIDGE Thermionic CORPORATION**  
454 CONCORD AVENUE · CAMBRIDGE 38, MASS.

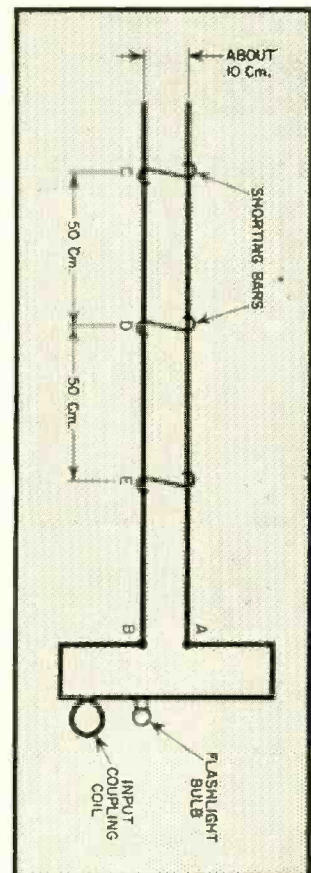

about one meter long. An oscillator producing the proper frequency feeds energy to the system by means of the input

[Continued on page 28]

## Right — for Fighting Wings

In a modern bomber there are some six dozen places where radio and electron tubes find vital use.

Many of these uses were made possible by Sylvania's development of special radio tubes. For example — there are Sylvania tubes small enough yet powerful enough to operate effectively on standard storage batteries without need of extra, weight-adding generators.

With much of our production now going into such all-important service, you can be sure of one thing about its quality.

Every unit produced is designed and built to just one standard—the highest anywhere known.



*For security reasons, radio equipment actually used in fighting planes is not shown here.*

## Right — for Future Fliers



No one is yet prepared to say how much the availability of rugged, lightweight radio and electron tubes will hasten the coming of the safe, light family plane.

But, obviously, wartime lessons in the possible uses of such tubes hold great promise for future developments.

Naturally, for such uses, only the highest and most dependable quality will do.

And they will represent a field in which you will have special reason to look for the Sylvania symbol as the mark of a single standard, and that the highest known. Sylvania Electric Products Inc., Executive Offices: 500 Fifth Avenue, New York 18, N. Y.

BUY WAR BONDS



# SYLVANIA

ONE STANDARD—THE HIGHEST ANYWHERE KNOWN



**RADIO TUBES** Sylvania was first to propose a standardized 6.3-volt radio tube for both home and automobile radio sets. Such standardization eliminated about half of the previous tube types and reduced cost.



**ELECTRONIC DEVICES** Heart of your postwar television set will be an electron tube. Such tubes are one of many types Sylvania is even now producing. Work in the field of electronics is a definite part of Sylvania's activities.



**LAMPS AND FIXTURES** Most of Sylvania's Incandescent Lamps and Fluorescent Lamps, Fixtures and Accessories are now going into Victory-effort use. But the day is coming when either type of lighting, made by Sylvania, will be readily available for your home.



# "DIE-LESS" DUPLICATING

SAVES  
MAN  
HOURS  
AND  
DELAYS

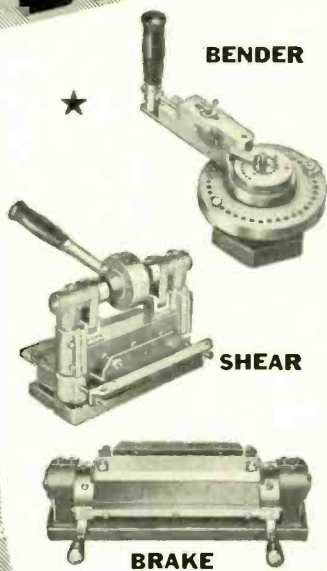

DIE  
ACCURACY  
WITHOUT  
DIES

Send for  
CATALOG



**O'NEIL-IRWIN MFG. CO.**

346 EIGHTH AVENUE SO. • MINNEAPOLIS 15, MINN.

## TERMINOLOGY

[Continued from page 26]

coupling loop. If a flashlight bulb is adjusted in position in the input circuit so as to be midway between the input terminals *A* and *B* (taking account of the length of wire in the coupling loop) then such a bulb will be at a current maximum and most sensitively indicate the positions of the shorting bars that cause resonance of the whole system.

If no shorting bars are used and if the wires are of arbitrary length, the indicating bulb will generally light only to partial brilliance. Waves even then are being reflected from the open ends of the wires but, except in special cases, they do not return to the indicating bulb in such phase as to completely cancel or reinforce the outgoing wave.

If, however, a shorting bar is moved along the wire, some position such as *C* will be found where the lamp glows most brightly. This position, which is also at a current maximum, is one where the wave reflected from the short circuit reinforces the outgoing wave a maximum amount at the indicating bulb. Other short-circuiting positions, such as *D* and *E*, can be found which have the same result. The distance between these points is just  $\frac{1}{2}$  wavelength and, because wave velocity over parallel lines is the same as that in free space, this is also just the wavelength of the generator's radiation. Such a scheme can be used to calibrate a wave meter.

If only shorting bar *C* is in place and a suitable thermal galvanometer is moved along the wires, its deflection will be observed to vary sinusoidally, indicating that standing waves are indeed present on the wires.

**Lenz's Law**—When it is desired to associate the proper direction of a changing magnetic field with the direction of an induced current, Lenz's law is a convenient rule to follow.

*The direction of the magnetic field generated by an induced current is such as to oppose the change of the field causing the induction.*

Thus if a horizontal loop is observed to have a current induced in it which is flowing in a clockwise direction as viewed from above, we know that the change of the field causing the induction must be opposed or compensated by a field directed downward. The right-hand rule in which the right hand is imagined to grasp the wire so that the thumb shows the direction of the current and the fingers show that the magnetic field passes downward through the loop is proof of this.

Since the current generates a downward magnetic field through the loop, it follows from Lenz's law that the field causing the induction is decreasing in a downward direction. This may be either an increasing upward field or a decreasing downward field.

**Line of Sight Range**—Microwaves, unlike longer radio waves, are limited to

[Continued on page 64]

## Send Only 25c for this Handy TUBE-BASE CALCULATOR

SPECIAL  
GET-ACQUAINTED  
OFFER

Thousands of service men, experimenters and amateurs have already taken advantage of this offer. Easy to use, this calculator tells you quickly tube characteristics that enable you to substitute available tubes for those hard to get. Send for yours today. Postpaid, only 25c.

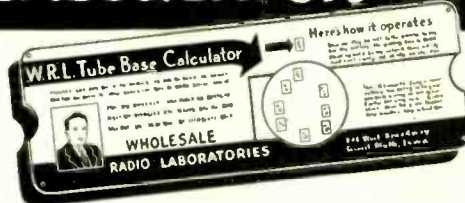

FOR HARD-TO-GET  
PARTS WRITE LEO

You'll be surprised at the many hard-to-get parts I've been able to get for you fellows. Mikes, pickups, multi-testers, meters and many other items. They're yours as long as they last. Send today for our latest flyer. It's full of merchandise you've been trying to get! Stocks won't last long so send today!

HALLICRAFTERS

For many years we have been one of the country's largest distributors of Hallcrafters equipment. We have Hallcrafters available for immediate delivery on priority. For full particulars, write.

FREE! Giant Radio Reference Map

Here's a gift from Leo—W9GFQ, that you'll want. Size  $3\frac{1}{2}$  by  $4\frac{1}{2}$  ft. Map has time charts, station list, amateur zones, networks, world short-wave, etc. Yours free. Send 15c to help with mailing and packing.

Leo—W9GFQ—Dept. RM10  
Wholesale Radio Laboratories  
744 W. Bdwy., Council Bluffs, Ia.

- You bet I want one of the tube base calculators. Here's my 25c.
- While you're at it, send your free radio map. 15c is enclosed for mailing and packing.

Name .....  
Address .....  
Town ..... State.....

I am a  service man;  experimenter;  amateur.

WHOLESALE  
RADIO  
LABORATORIES

744 W. BROADWAY  
COUNCIL BLUFFS, IOWA

# RE-DESIGNED "TO ORDER"

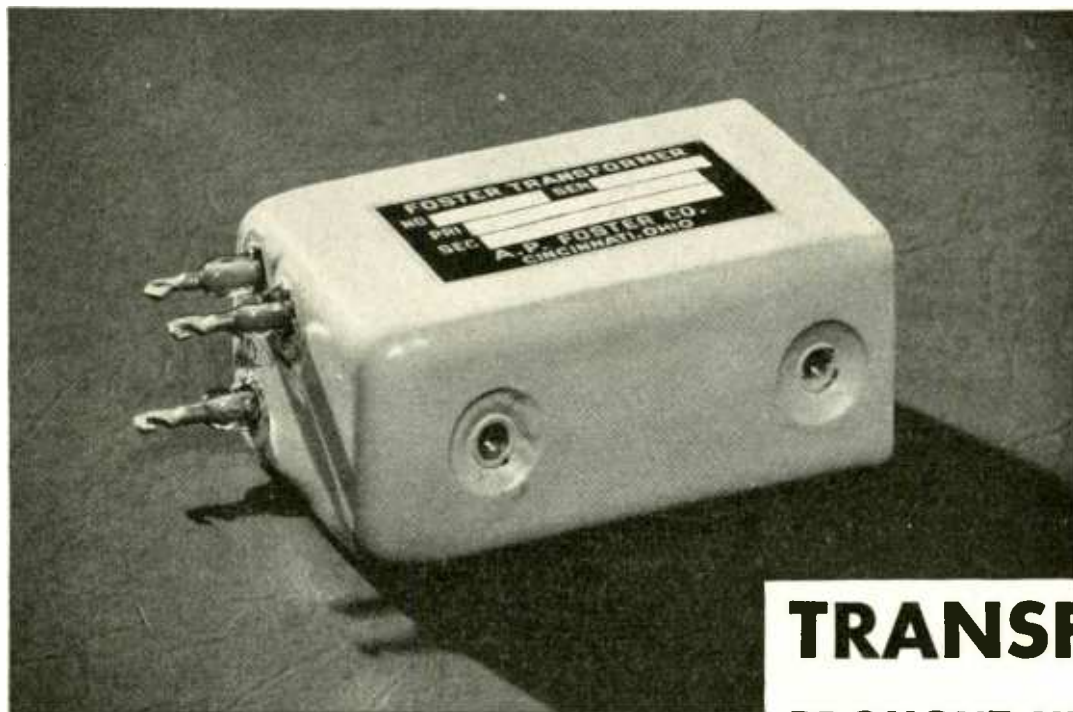

## TRANSFORMER BROUGHT UP TO PAR BY **FOSTER**

Some weeks ago a manufacturer brought this unit, as then being supplied to him, to Foster Engineers for examination. Performance of the original model of this transformer had failed to meet a certain high standard of minimum inductance and maximum resistance. Foster re-designed it, met the exacting specifications, somewhat reduced its over-all dimensions, yet kept the new Foster model interchangeable with the old—no costly changes were required in the product of which this transformer is a part.

It is another example of Foster skill and experience in designing and building transformers for specific requirements that will be of great value in the post-war world of electronic equipment. Our experience covers close tolerance vibrator transformers, output transformers, microphone transformers, saturable reactors, power transformers, audio filters and reactors . . . designed and custom-built to the most exacting individual requirements.

SPECIALISTS IN BUILDING TRANSFORMERS SINCE 1938

## A. P. FOSTER COMPANY

TRANSFORMER ENGINEERS & MANUFACTURERS  
719 WYOMING AVENUE, LOCKLAND 15, OHIO

NOW! IN-RES-CO

# TROPI-PRUF RESISTORS

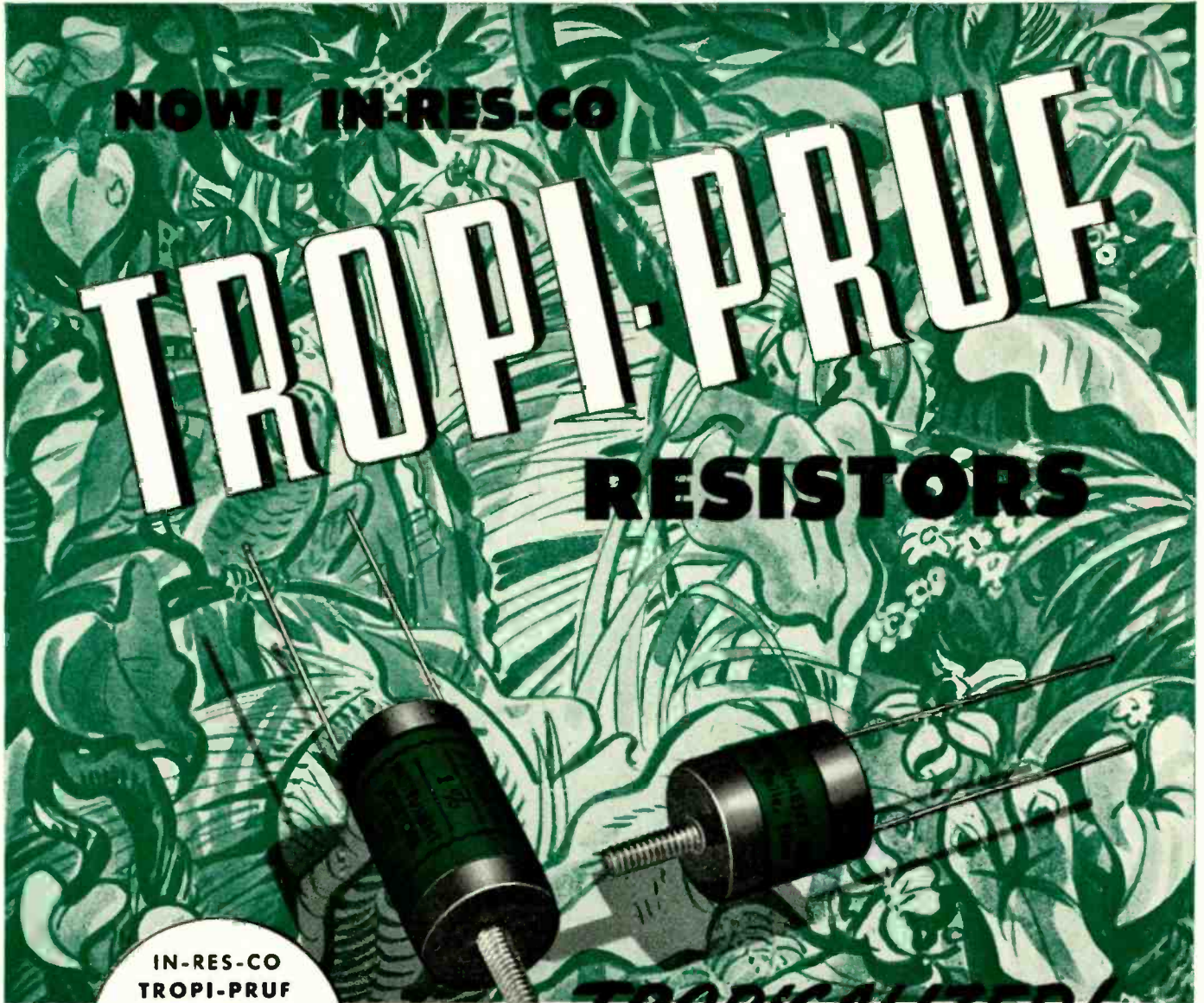

## TROPICALIZED!

IN-RES-CO  
TROPI-PRUF  
RESISTORS have  
all these features

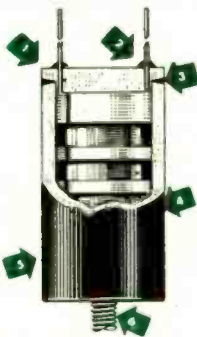

1. Specially engineered cap design for tight, penetration-proof fit.
2. Terminal leads bonded to cap for hermetic seal.
3. Special IN-RES-CO bonding material for lasting protection.
4. Special IN-RES-CO fungus-proof coating.
5. One-piece molded bakelite shell, with cap, assuring rugged durability and dependability.
6. #6-32 mounting screw, an integral permanent part of the shell.

## A new conception of resistor performance



Present day application of electrical equipment under drastic climatic variations, demands new considerations and requisites in engineering. In tropical climates, absorption and adsorption of humid spore-bearing atmosphere is not uncommon, and subsequent fungus growth plays havoc with delicate components and adjustments. Product failure—complete and irreparable in a matter of only two days—is the usual result. Thus, fungicidal protection becomes a foregone conclusion.

IN-RES-CO engineers—responsive to the new requirements, offer the complete TROPI-PRUF line of tropicalized resistors. New, proved and accepted, each wire-wound unit—itsself carefully protected against corrosion, moisture and deteriorating influences—is permanently sealed in a hermetically-tight bakelite case. Terminal leads are brought through close-tolerance openings,

and sealed to prevent creepage of moisture or fungus growth.

After dehydration, the complete piece receives several carefully controlled coatings of fungicidal finish. Signal Corps #71-2202-A approved, this protective film is non-toxic, resistant to thermal shock, mold and mildew, and possesses high dielectric strength. It is designed to withstand Navy Salt Spray tests, electrolytic action, condensation and corrosive influences.

All IN-RES-CO wire-wound resistor units are available in TROPI-PRUF. Included are a wide diversity of components for both general and high accuracy applications.

### WRITE FOR CATALOG.

The complete IN-RES-CO line of high-accuracy units, includes meter multipliers, shunts, choke coils, solenoids and special coils. Write for your copy of this 16-page data compilation; there is no obligation.



## INSTRUMENT RESISTORS CO.

23-25 AMITY STREET, LITTLE FALLS, NEW JERSEY



# Incremental Permeability Tuning

W. J. POLYDOROFF

Consulting Engineer

The inventor of permeability tuning describes a new system, utilizing incremental permeability, and some of its applications

RECENTLY a question was raised about the measurement of permeability of so-called iron dust cores, i.e., cores composed of finely divided insulated particles and embedded in a suitable matrix. In general, we have assumed in the past that these materials have constant permeability within the range of small magnetizing forces encountered in high frequency ranges. Telephone engineers already had indications that comminuted materials, especially of higher permeability of the order of 50-100, exhibit so-called "flutter effect." In these applications, the cores are sometimes subjected to considerable magnetizing forces which apparently caused change of permeability and of the inductance.

We have had at hand samples of high frequency iron of the carbonyl "L" variety which powder, because of its extreme softness and purity, may reach an initial permeability of the order of 50 and still be acceptable in high frequency applications, where it exhibits good Q. A toroid of such material

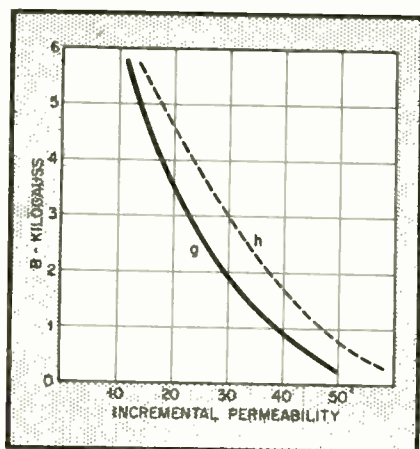

Fig. 2. Incremental permeability curves

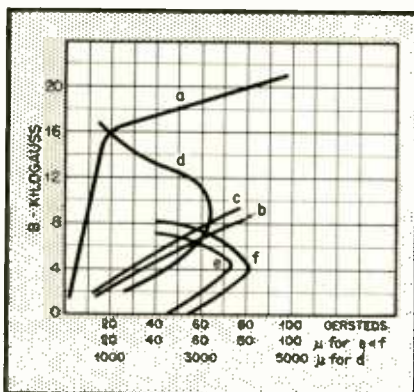

Fig. 1. B-H and permeability curves

shows an initial permeability of 50, measured by the a-c bridge method where current flowing through a coil is negligibly small and does not produce any appreciable degree of magnetic induction.

## Tests

In order to see the behavior of such material under strong magnetizing forces, a permeameter of the Fahy type was developed, capable of measuring magnetic properties of small bars of low permeability. The sensitivity of the permeameter was increased many fold by increasing the number of turns in the search coils, and rectangular bars, pressed of the same material and to the same density as the ring, were made.

The first measurements obtained from the permeameter readings indicated permeability of 75, thus causing quite a disagreement with the values obtained by a-c methods. By varying the magnetic induction and by plotting the B-H curve we finally arrived at the value of permeability of 50, the same as measured on the bridge, at extreme-

ly weak magnetizing forces. We are now able to compare the behavior of comminuted cores with the performance of solid magnetic material. Fig. 1 shows the results of this comparison. The curve *a* represents a typical B-H curve of Armco magnetic iron from which curve permeability is computed and shown on the curve *d*. The curves *c* and *b* are shown for two comminuted materials on the same B-H scale and their permeability versus

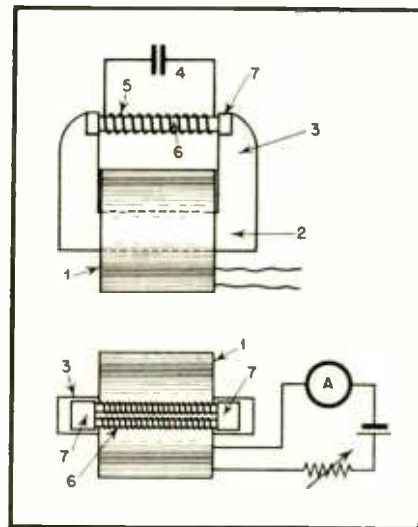

Fig. 3. Closed-type inductor design

magnetizing force is plotted on, a different scale. Although these permeabilities are of much smaller magnitude, the general shape of the curves is the same indicating that at a certain optimum magnetizing force the material passes through its maximum permeability. Here we may make one conclusion—that relatively high permeability comminuted magnetic material should be

used with caution if a stable inductance is desired.

The study of variation of permeability of comminuted cores led us to another application which is the subject of the present paper.

### Permeability Tuning

Over ten years ago I had the privilege of introducing "permeability tuning" which today is widely accepted and used for tuning radio circuits to a desired frequency. The term then accepted might suggest an idea of variable permeability which was not so in that case. Perhaps a more correct term would be variable reluctance tuning, for in that method the cores are moved in and out of the coil but the cores always retain the same permeability, it being the actual movement of the core which produces variation in the reluctance of a magnetic circuit surrounding the coil. This time a true permeability tuning is presented, for the magnetic material employed in a coil remaining stationary and the tuning is accomplished solely by the variation of permeability of the material per se.

In the method now proposed we have a compound action of a steady flux on which an a-c flux is superimposed. The permeability resulting from such a-c flux is usually termed "incremental permeability" which term is accepted when d-c flux is much greater than a-c flux.

In the same permeameter a rectangular bar, around which a high frequency winding (Litz) was closely wound, was inserted. This type of ferro inductor, when measured on a Q meter, exhibited a Q of 100 at a frequency of 400 kc, but when it was inserted into the yoke of the permeameter the losses of solid or laminated iron of the yoke and of the magnetizing coil pulled the Q down to 5. Nevertheless, it was pos-

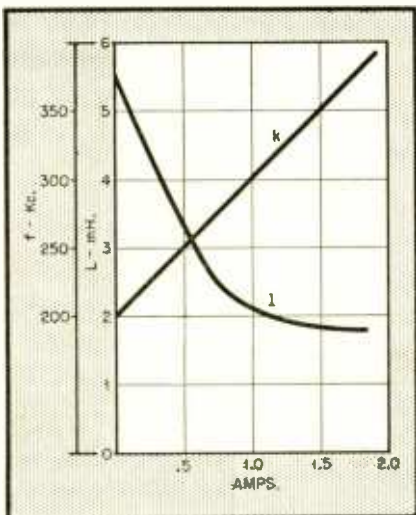

Fig. 4. Variation of inductance and frequency vs. d-c current

sible to obtain sufficient deflection on a Q meter to be able to observe the influence of steady flux on the inductance of this ferro inductor, which proved to change its value four fold for the range of magnetic densities from zero to 6 kilogauss.

### Closed Type Inductor

In order to obtain more accurate observations of inductance by resonance methods the Q of the circuit should be considerably raised. This has been accomplished by designing a closed type inductor in the form of an elongated binocular type in which the ends of the cores are connected by high frequency iron so that a greater portion of h-f flux would be closed within itself, while steady flux will pass through both branches of the magnetic circuit simultaneously. Such construction is schematically shown on Figs. 3 and 3a. In order to get a maximum density applied through the inductor its total cross section must be small compared with the cross section of magnetizing yoke and the ends of yoke should be gradually tapered to reduce the leakage field.

Another successful, although more

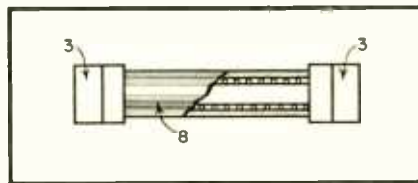

Fig. 5. Closed pot-type inductor

costly construction of ferro inductor is shown in Fig. 5. It takes the shape of an elongated, completely closed, pot-type inductor with the winding surrounded by high frequency iron in all directions. With the inductor of Fig. 3 the influence of yoke and magnetizing coil are eliminated to the extent that Q of the order of 50-100 is obtainable within the range of frequencies from 200-400 kc. The construction of Fig. 5 still further eliminates those losses, permitting higher Q.

It is interesting to note here that, contrary to a theory of reversible permeability, advanced by Germans, the losses decrease as the magnetization is increased. Were we to accept that theory in which elementary magnets are frozen by steady flux the magnetic friction and hysteresis should increase considerably when magnetizing flux is increased. The actual observations of Q and losses are in opposition to this theory.

With an inductor of the improved design we were able to measure the variation of inductance with variation of magnetic induction or magnetizing

force of direct current applied to the magnetizing winding. Knowing the initial permeability (at the zero magnetizing force) and assuming that the effective permeability is proportional to the full permeability, we are able to draw the curves of incremental permeability versus magnetic induction, which is shown on Fig. 2. Curve g of this figure shows a specimen of carbonyl iron which, as previously reported, has an initial permeability of 50. Curve h shows the same for a material of higher permeability in which permeability is increased by partial interfusion of the particles along their magnetic axis. It is now apparent that the higher the initial permeability, the more inductance variation is obtainable for the same change of magnetizing force.

### Frequency Control

Fig. 4 shows a variation of inductance and frequency plotted against d-c current applied to the magnetizing winding. To determine the frequency variation, the variable ferro inductor was bridged with a fixed value of capacity on a Q meter and the oscillator frequency of the Q meter was changed. It will be noted that in this particular type of construction we have arrived at a very desirable property of controlling the frequency by a direct current, the two quantities being proportional to each other. This would allow a circuit shown on Fig. 3a to have a frequency meter in the form of an ammeter whose dial is directly calibrated in frequencies. Should we substitute for d-c flux an a-c flux, we may arrive at a new linear system of frequency modulation if our magnetizing winding and yoke are made capable of receiving voice currents of

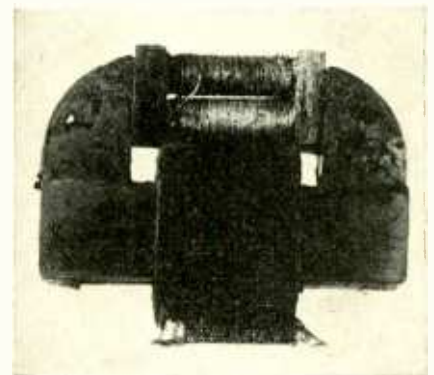

Fig. 6. Experimental inductor

sufficient magnitude so as to swing the frequency proportionally to the voice amplitude.

The present construction will operate either on 6 volt or 110 volt circuits, requiring approximately 25 watts

[Continued on page 72]

# Characteristics of VARIABLE RESISTORS

A. P. HOWARD

An analysis of the design, construction and applications of types of rheostats and potentiometers used in radio and electronic apparatus

THE VARIABLE RESISTOR is an extension of the principles and construction of fixed resistors. Many of the manufacturing techniques and end results are the same. These similarities stem from the fact that, as with fixed resistors, the industry is compelled to choose from two groups of materials in the building of variable resistors: carbon and resistance alloys.

Many words are in common use to describe the variable resistor: rheostat, potentiometer, volume control, tone control, etc. The use of the word "rheostat" is commonly reserved for high power handling devices; the use of the word "potentiometer" is applied generally to all variable resistors. "Tone control" and "volume control" are functionally used words, usually to describe a carbonaceous control.

The word "potentiometer" has been scrupulously avoided until recently because it can be confused easily with a voltage source which can be adjusted for a current null through a finely calibrated resistance network.

A more realistic approach, one shared by the trade, is the definition given in the Signal Corps Specification CESL-1008: "A rheostat is a variable

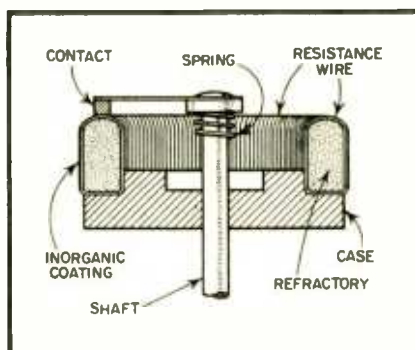

Fig. 1. Cross-section of power rheostat

resistor having two terminals only and an 'off' position. A potentiometer is a variable resistor having three terminals and no 'off' position."

For the purpose of this article, a rheostat will be defined as a high power

handling device and a potentiometer as a variable resistor.

## Construction

Essentially a potentiometer or a rheostat is a resistance material placed on an arc-shaped insulating strip so that a contact bears uniformly on the resistance element when adjusted by a control shaft. Each of the two common insulating materials, subject of *Table 1*, has its limitations. Resistance materials have been described in previous issues.<sup>1</sup>

The phenolic insulation used as a backing strip for the resistance material can be punched or machined easily and can be molded without expensive equipment. This material, however, possesses poor temperature characteristics. Thermosetting in nature, it

[Continued on page 34]

TABLE 1

COMMONLY USED INSULATING MATERIALS		
Characteristics	Phenolic	Refractory
Thermal Conductivity	.0006	.003
Safe High Temperature, °C.	110	1250
Linear Expansion, in/in/°C.	$20 \times 10^{-6}$	$1.5 \times 10^{-6}$
Softening Temperature, °C.	None	1400
Water Absorption, % in 24 hrs., weight	0.3 — 9.0%	1.0 — 5.0%
Machinability	Good	Poor

<sup>1</sup> RADIO, July and August, 1944.

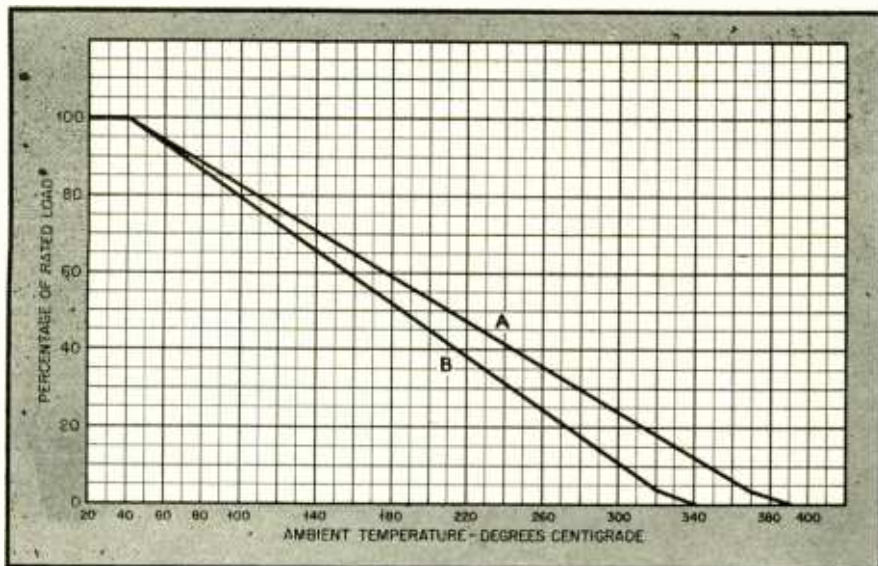

Fig. 2. Derating curve for power rheostats operated at elevated temperatures

does not remelt but rather disintegrates by charring at elevated temperatures. In addition, the thermal conductivity of the phenolic is not as high as that of ceramic.

Ceramic material, on the whole, cannot be worked with ease. These materials must be cast, extruded, or drawn to the desired shape under high temperature firing. Thermal conductivity and softening point are high.

It is the choice of these materials that distinguishes the power rheostat from the wire-wound potentiometer of lower operating temperature. As in the case of wire-wound fixed resistors, organic insulation limits the power handling ability of the component because of maximum safe operating temperature.

Considering first the power rheostat, illustrated in Fig. 1, it can be seen that the generous use of inorganic insulation such as the refractory winding form and the inorganic coating over the wire make this component capable

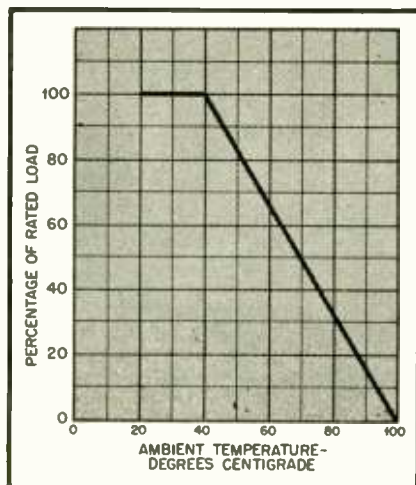

Fig. 3. Derating curve for low-temperature type, wire-wound potentiometer

of operation at higher ambient temperatures.

The selected resistance wire, of a size 2.5-mils or greater, is toroidally wound around the refractory ring and held in firmly by the application of inorganic coating, such as vitreous enamel, to the portion of the winding furthest from the contact. The contact is usually a heavy gauge metal one-piece assembly free to contact the resistance element at two adjoining points. The two arms of the one-piece assembly make for more even pressure distribution. Spring pressure is built into the shaft and adjusted for proper contact with low wear and low abrasion.

The limitation on wire size, alluded to above, is necessary for the same reason as in the case of the inorganic fixed resistor. During the firing operation, the bare wire tends to move and also to oxidize. The finer the wire, the greater the movement of the wire, the greater effect oxidation of the surface has, and the greater the breakage of the wire under the firing operation. Add to the problems encountered in inorganic resistor breakage the fact that a contact is moving over the resistance wire, introducing wear and abrasion. In commercial practice, however, the wire size limitation does not introduce any problems to the radio designer, for his primary concern is for motor starting, filament control, and the like, where low resistance values are employed.

#### Hot Spot Ratings

Rheostats of 100 watts and under have a hot spot temperature rating of 340°C. at 40°C. ambient and, over 100 watts, 390°C. hot spot temperature rating at 40°C. ambient. This rating, however, is based on the operation of a rheostat in still air and free space,

with all enclosures removed, and at full resistance value. Since this is a theoretical value and unrelated to practical problems, it has been conventional to employ rheostats at half their nominal rating.

Here it is necessary to consider how the power rating of a rheostat is derived. Since the ceramic is a relatively good thermal conductor, heat can be applied to one portion of the surface and the heat will be dissipated over the entire surface at a rapid rate. If the heat applied were the application of rated load, it would be expected that this heat would be uniformly dissipated over the entire surface at full resistance setting; if the rheostat were set at the half-resistance value, the heat would have to be dissipated over the half of the range where contact has been made and throughout such other portions of the refractory ring as can be heated by conduction. It is this thermal conductivity of the ceramic that makes it again more desirable than phenolic and it is this property which allows full load operation down to about the resistance midpoint, providing the current carrying capacity of the wire is not ignored.

As the rheostat is placed in a con-

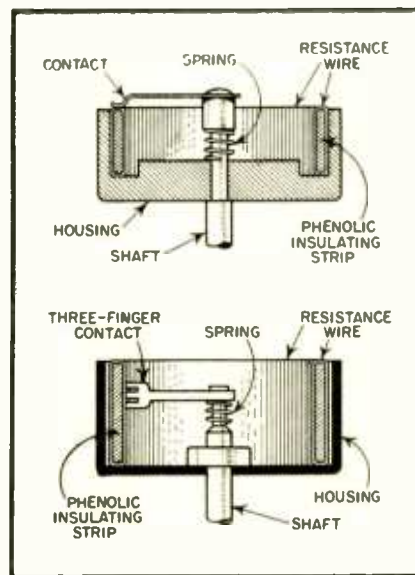

Fig. 4. Wire-wound potentiometer construction

finned space, its ability to dissipate heat decreases. As the confined space reduces itself to a metallic enclosure over the resistance element, approximately half of the dissipation ability is lost.

The two statements above would reduce proper use of a power rheostat to the following: when a metallic enclosure is present, the resistor shall operate up to 50% of rated load; full load or its proper equivalent depending on the enclosure may be safely applied to approximately the upper half of the resistance winding in any setting.

The application of these rules is ex-

pected to limit the maximum surface temperature at 25°C. to 275°C., the NEMA limit for inorganic insulation. Operation at elevated temperatures will necessitate further derating, shown on Fig. 2.

### Ruggedness

The power rheostat is built to be rugged. As presently supplied, the power rheostat is not expected to be used in a circuit where continual rotational life is necessary. Nevertheless, virtually all the commercially available rheostats will be satisfactory in all electrical and mechanical respects at the conclusion of 10,000 cycles of complete mechanical rotation. The total resistance change will be less than 5%.

Considerably less rugged are the wire-wound potentiometers of low operating temperature. Yet watt-for-watt, the wire-wound potentiometer is larger. Sizes listed in Tables 2 and 3, showing the expected standard sizes of power rheostats and of wire-wound potentiometers (low operating temperature), show the effect of inorganic insulation.

The use of organic insulation has two effects: a limit on the upper operating temperature of the potentiometer which in turn limits the power rating and an increase in resistance permitted because finer gauge wires can be used.

The latter effect, the use of finer gauge wire, can be traced to the firing operation mentioned above as contrasted with a simple glueing operation. Since little, if any, heat is required in a glueing operation, the possible damage to the wire through oxidizing, shifting, or breaking under high temperatures is eliminated. It has been customary to employ gauges to 1.75-mil diameter wire in low operating temperature wire-wound potentiometers, as opposed to 2.5-mil diameter wire in the power rheostats.

In theory, the power rating of a low temperature wire-wound potentiometer is based on a maximum surface temperature rise of 60°C. at 40°C. ambient. This temperature has been se-

**TABLE 2**

**SIZES OF POWER RHEOSTATS** (all enclosed)

Power Rating	DIMENSIONS (MAX. INCHES)		
	Diameter	Depth	Max. Resistance
25 watts	1 11/16	1 13/32	5000
50 watts	2 13/32	1 7/16	10000
75 watts	2 13/16	1 25/32	10000
100 watts	3 3/16	1 25/32	10000
150 watts	4 1/16	2 1/32	10000
225 watts	5 3/32	2 5/32	2500
300 watts	6 3/32	2 13/32	2500
500 watts	8 3/32	3 1/32	2500
750 watts	10 3/32	3 1/32	2500
1000 watts	12 3/16	3 1/32	2500

lected because it is felt that phenolic tends to disintegrate above that temperature. Therefore, any enclosures, operating at less than full resistance value, tapered sections, higher ambient temperatures—all will reduce the power rating.

Typical derating should be applied for temperature as indicated in Fig. 3,

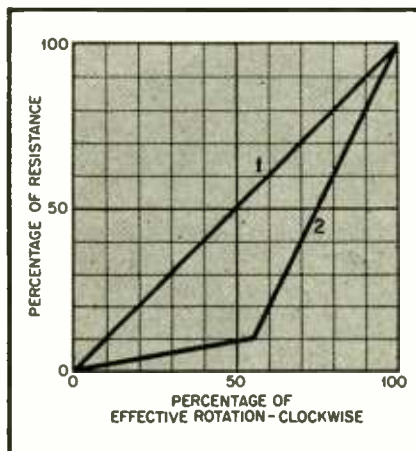

Fig. 5. Linear (1) and modified logarithmic (2) tapers for wire-wound potentiometers

Safe region for application of full power rating in free space and still air would be between 75% and 100% of full resistance. Further derating must be applied for insertion into confined spaces. This list of derating factors can be added to for great length, but all the rules can be reduced to: safe operating condition of a low tempera-

ture operating wire-wound potentiometer is a 100°C. maximum surface temperature, measured on the resistance wire surface.

### Wire-Wound Potentiometers

The construction of the wire-wound potentiometer differs in several other respects from the power rheostat. Conventional construction is illustrated in Fig. 4. Here the resistance wire is wound around the phenolic backing strip which is rolled into the case. Contact is made in several ways: either a three-finger one-piece contact arm on the side surface or a cup-shaped spring metal contact arm on the top surface. The entire assembly is often glued.

Conventional spacing of the wire around the insulating strip calls for the separation of each winding from the next winding by an equal distance. Viewing the change of resistance with the change in effective rotation, we have a linear taper or non-tapered winding.

(Taper is defined as the variation in the rate of change of resistance with angular rotation. Effective rotation is defined as the angular displacement which is effective in producing useful change of resistance.)

The difficulty in winding any resistance value other than one in which each succeeding winding is separated from the former and latter windings by an equal amount should be evident. Conceivably the potentiometer could be wire-wound by a motor which changes its rate of speed with respect to the rate of speed being controlled on the insulation strip. This, however, does not present itself as a ready answer for production. The answer usually suggested is that a carbon potentiometer is sufficiently taper controlled for this purpose.

The only concession to tapered windings usually made is the modified logarithmic winding, illustrated in Fig. 5. Both of the tapers illustrated are clockwise tapers, but their equivalents

**TABLE 3**

**SIZES OF WIRE-WOUND POTENTIOMETERS** (all enclosed)

Power Rating	DIMENSIONS (MAX. INCHES)		
	Diameter	Depth	Max. Resistance
2 watt	1 9/32	5/8	10,000
3 watt	1 41/64	27/32	15,000
4 watt	1 25/32	63/64	15,000
7 watt	2 5/16	15/16	50,000
8 watt	3	1 15/32	50,000
12 watt	3	2 5/8	200,000
25 watt	5 1/4	2 7/16	500,000

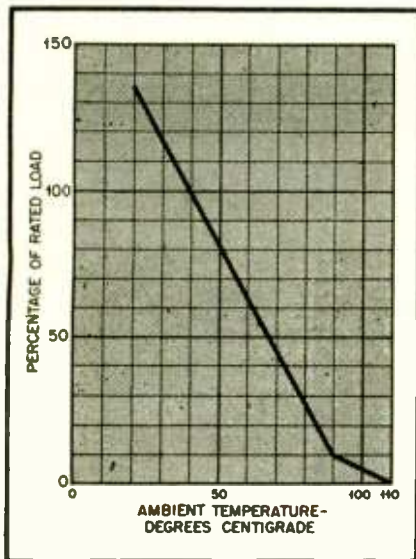

Fig. 6. Derating curve, composition potentiometers

can be produced in counterclockwise tapers.

It will be noted that the modified logarithmic taper is essentially a winding in which the wire is wound linearly over a fraction of the form and the separation is then changed to start another linear winding. This means only one adjustment in the winding operation and still commercially acceptable. Still other tapers can be reproduced such as a linear section over the winding middle section with sharp increases toward zero at either end.

Because the resistance winding is non-uniformly varied in Taper No. 2 of Fig. 5, the wattage dissipation is not linear, either. For this reason, tapers of this type must not be operated at more than 55% of rated load.

In contradistinction to power rheostats, these potentiometers are expected to operate under continual rotational life. It is this reason that compelled the construction of spring contact arms with proper lubrication. Each of the wire-wound potentiometers furnished in accordance with the latest government specifications must have a minimum rotational life of 25,000 cycles over the full mechanical range.

### Composition Types

The variable composition resistor is sufficiently different from the fixed composition resistor in construction and behaviour that some attention must be paid to the manufacturing processes.

In the construction of the fixed composition resistor, the composition resistance coating was either applied to a ceramic rod by dipping or spraying or was furnished as a solid carbon rod. This rod was placed in a phenolic molding powder and the combination of resistance element and phenolic were heated and pressed, forming a thermosetting compound. The molding

temperature and the pressure tends to "set" the resistor. The molded phenolic gave the element ample protection against adverse conditions of high humidity.

The same procedure is followed by some of the variable composition resistor manufacturers. Most, however, employ a laminated phenolic or pressed paper backing with a filamentous resistance coating.

In the molded composition construction, the entire assembly is formed under heat and pressure. This, of course, must be assembled to the shaft, contact arm, and housing of either metal or phenolic material.

### Construction Procedure

The filamentous coating is applied by spraying or dipping a laminated phenolic, pre-punched to shape, in a bath consisting of carbon particles suspended in a binder. The unit is dried and baked. Terminals, housing, shaft, and contact arm are assembled.

It should be noted that the statement, "pre-punched," should not be taken literally for all manufacturers. Conventional practice calls for the baking of the element and careful punching. The careful punching becomes ex-

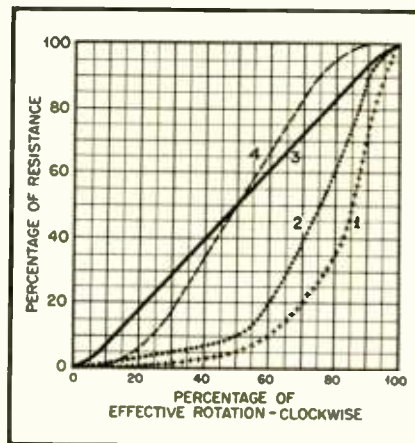

Fig. 7. Tapers for composition potentiometers

tremely necessary when problems of taper are introduced.

Under extreme atmospheric conditions, a paper backing is of doubtful use. This is, however, acceptable for home receivers where little variation in ambient temperature or conditions is encountered.

The molded composition control has different characteristics from the filamentous control, by virtue of its preparation. Its manufacturing difficulties are increased because the composition under molding is not as susceptible to analysis as the filamentous type. The molded composition can be expected to have long life under continual oscillation with a decrease of noise with life.

This action takes place inexplicably, according to the trade. Its initial low noise level arises from the fact that the terminals and the element are integral and, therefore, less exposed to thermal effects.

### Power Dissipation

The molded composition is capable of higher power dissipation per square inch. With the increase in the resistance value and consequent decrease of the width of composition film, the resistor must be derated about 25%. This is true of all composition potentiometers, but appears at slightly lower resistance values in this construction.

Since the filamentous coating is not formed under pressure, its coating is not as satisfactory under continual rotation or abrasion. This does not mean that the potentiometer will fail prematurely, but that the unit is not designed for such conditions. Its noise level, contrary to the other construction, will increase with age.

The designer of electronic and radio equipment should weigh these considerations and those to follow carefully. It can be stated, however, that in most applications the potentiometers of each type can be used interchangeably.

Both constructions, of course, are subject to the frailties of the composition resistor, previously described.

Care should be exercised in interpreting the nominal power rating. This is not a discreditory statement to the manufacturers, for the ratings are correct under proper conditions. The following rules can be safely applied: temperature derating should be made, following the curve indicated in Fig. 6. The full load can be applied, in accordance with this curve, to between 75% to 100% of the full resistance value. Below that point a maximum surface temperature of approximately 90°C. should be the governing factor. As the resistance value approaches 0.1 megohm, higher wattage potentiometers should be derated about 25%, lower wattage ones about 10%.

Taper is a more easily producible characteristic, since the composition can be applied in varying degrees of thickness. Some of the more commonly used types are shown in Fig. 7. Although these tapers are illustrated in a clockwise rotation, they can also be reproduced in counter-clockwise rotation. Power rating will be reduced 50%.

The conclusions on composition potentiometers presented herein are correct to the extent that they are presented, in the opinion of the writer. There is considerable testing being conducted at the present time by the Armed Forces and by the trade to determine what standardization can be accomplished.

# Down To Earth On "HIGH FIDELITY"

**O. B. HANSON**

Vice-President and Chief Engineer  
National Broadcasting Co.

**An analysis of factors which determine the degree of fidelity which may be attained in radio broadcast transmission and reception**

**T**HE term "high fidelity," as used at present in the general radio and sound reproduction field, has come to mean an extension of the audio range to the upper frequency limits of audibility of the human ear, as contrasted with a range limited to the usual 4000 or 5000 cycles. In reality, the term "high fidelity" is comparative, and it would be more correct to think of it as "higher fidelity."

Today there is available to the public a new system of program transmission, using frequency modulation of the very high frequency radio spectrum, where suitable channel spacing has been allocated by the FCC so that a wide audio band can be transmitted. In the interest of providing the public with a better radio broadcasting service, every advantage should be taken of frequency modulation toward establishing improved standards of transmission and reception. However, in determining these standards, it is quite important to take a practical view of what constitutes *realizable* high fidelity, bearing in mind that, in the overall result, various practical mechanical and electrical limitations, some physiological and psychological phenomena and, last but not least, the actual program content, are elements fully as important as a theoretically complete sound spectrum, or perhaps more so.

#### **True Fidelity**

Fidelity implies a faithful reproduc-

**This article deals with a topic which is of vital interest to all engaged in the design and manufacture of broadcast receivers.**

**Because this is a highly controversial subject, undoubtedly there are many who will disagree with the author's conclusions. Comments are invited.—Ed.**

tion of the original, a condition which in audio systems cannot actually be attained but, at best, only approached. True fidelity would require that:

1. The system not discriminate in any of its component parts against any frequency within the range under consideration.
2. No component part of the entire system introduce false harmonics.
3. There be no amplitude limitation of any portion of the spectrum in either transmission or reception.
4. The system be free from phase distortion.
5. The system be free from extraneous noise.
6. The loudspeaker and its driving amplifiers be capable of reproducing without distortion the full frequency range at loudness levels suitable for all listeners.
7. The acoustics of both the pick-up and listening spaces be suitable.
8. The spatial relationships of the sources of sound be transmitted and

reproduced. This last probably requires some form of binaural or stereophonic system, neither of which is economically feasible for general public service at this time.

A system as described above, with exception of binaural or stereophonic transmission, is not too difficult of realization from a transmitting standpoint. It might be closely approached in a receiver reproducing system, but the cost would probably be beyond the value which would be placed upon it by the purchasing public, particularly if the receiver were required to reproduce frequencies from 30 to 15,000 cycles.

It is curious that the emphasis in general discussions of high fidelity thus far has been on an extension of the upper portion of the sound spectrum, and little has been said about the required *balance* between said upper portion and the lower frequencies. Actually it has been discerned on the basis of much observation that a balanced frequency response is quite essential to program enjoyment, although this balance factor has not yet been reduced to a rigorous mathematical formula. One authority has said, and our experience has confirmed this general statement, that the product of the lower and upper frequency limits should equal a number in the vicinity of 500,000, and a simple example will show the approximate validity of this hypothesis as indicating the importance of balance. A system, the frequency re-

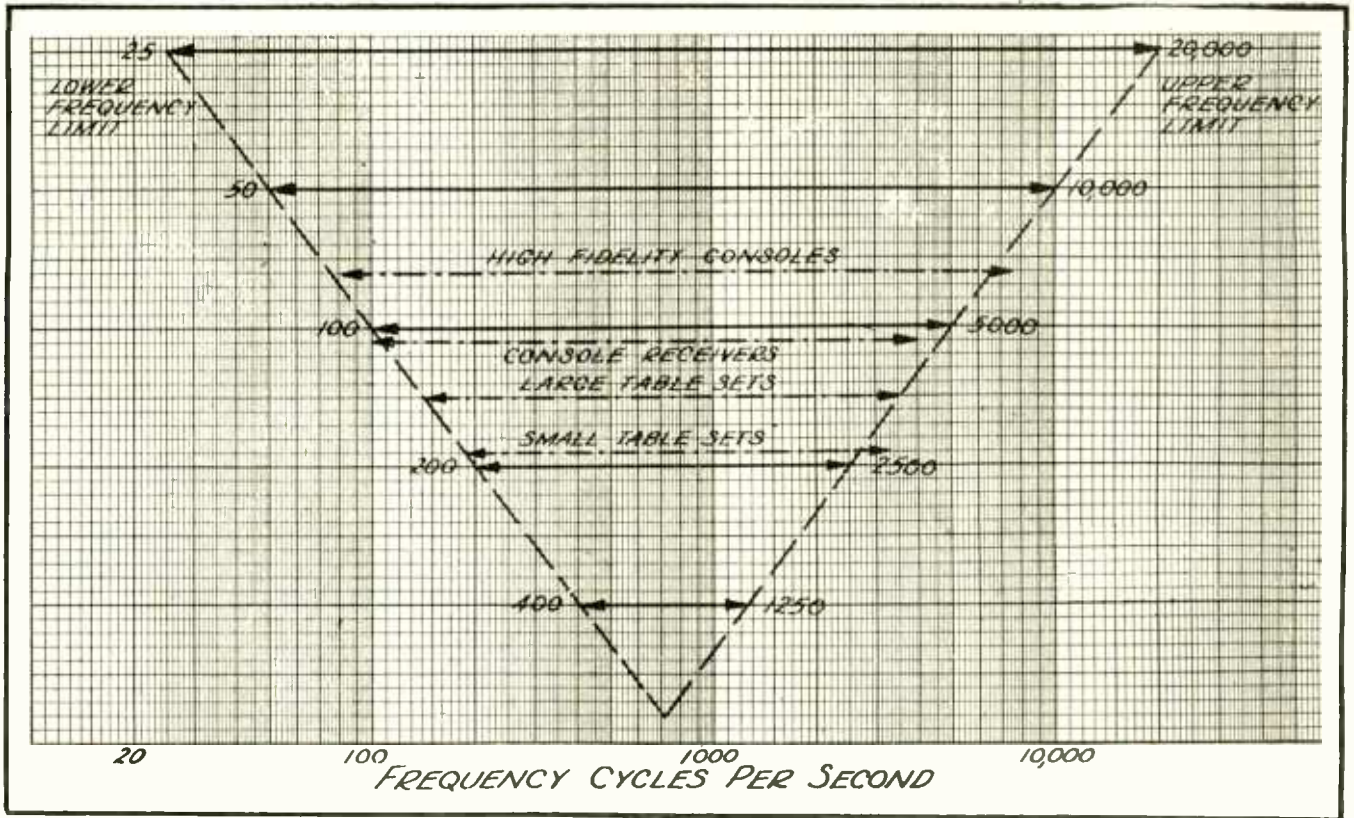

Fig. 1. Preferred lower and upper frequency limits. (Product equals 500,000)

sponse limits of which are 50 to 8,000 cycles, a total range of 7,950 cycles, is conceded as satisfactory by most authorities. If we retain this same range and compare it with a range of from 250 to 10,000 cycles, there is little question that the former is preferable for reasons of general "naturalness" but particularly because of the reproduction of a substantial range below 250 cycles. Note that, in the 50 to 8,000 cycles case the bulk of program energy is in the band centering about a point approximately at 700 cycles.

**Preferred Limits**

The attached curve in *Fig. 1* shows preferred lower and upper frequency limits in which the balance between the lower and upper portions is properly maintained. It will be noted that the product of the upper and lower frequency limits, as has been specified, is approximately 500,000. As an interesting fact in this connection many of the better home radio receivers of conventional type seem to fit surprisingly well within these frequency limits.

An extension of the frequency range to, perhaps, 17,000 cycles and down to 30 cycles would encompass the entire audible spectrum, but at only a small percentage of the total time would there be any appreciable energy in the region above 10,000 cycles. Reproduction of frequencies above 10,000 cycles adds only to the enjoyment, if that is the word, of such things as key

jingles, footsteps, handclapping and various extraneous noises (non-musical) from musical instruments, as resin squeaks, air rush from wind instruments, and the like. These "sound effects" can hardly be considered essential or worth high cost to attain!

Experience and various surveys have shown that, even when listeners have receivers capable of reproducing frequencies up to 5,000 cycles, they usually operate the tone control to restrict the audio range to an upper frequency cut-off of somewhere between 2,500 cycles and 4,000 cycles. Reasons given for this are that the "tone is mellow," "more pleasant," "less obtrusive," etc. Many listeners who are musically trained and who appreciate symphony and opera are, strangely enough, numbered in this class, indicating that this procedure does not stem from uncultivated tastes but has some other, more general, basis.

It has been claimed that, if distortion and noise were eliminated from the higher frequency band, the public would then prefer the extended upper range. Perhaps so, if the higher range is properly balanced by adequate bass reproduction. Distortion and noise are unpleasant at any portion of the sound spectrum.

Receivers, which at present provide millions of listeners with many hours of enjoyment, seem generally adequate for reproducing the intelligence and entertainment contained in

the program material. The witticisms of Charlie McCarthy, for example, are just as humorous on a receiver whose frequency range is 200 to 3,000 cycles, as on a higher fidelity system.

In this connection, it should not be overlooked that the entertainment and attention engaging factors in musical listening are not concerned with quality alone. Such matters as appreciation of technique, melody itself, rhythm and the like, are of great importance to the musical ear and all these of course can be reproduced satisfactorily within a reasonably restricted frequency range.

The average radio listener purchases the table model receiver rather than the console. The former type of receiver cannot adequately reproduce bass frequencies, the fundamental reason being lack of sufficient physical size. It is only in the console type that adequate reproduction in the low frequency range can be approached, but few even of this type have provided really good bass response free from noticeable cavity resonance. The higher frequencies, however, may be reproduced with the smaller receivers assuming proper design, but generally at the expense of an undesirable directional characteristic. This varies with frequency in the preponderant majority of loudspeakers, so that reproduction of these frequencies is accentuated in front of the speaker and decreases with the increase in angle from the



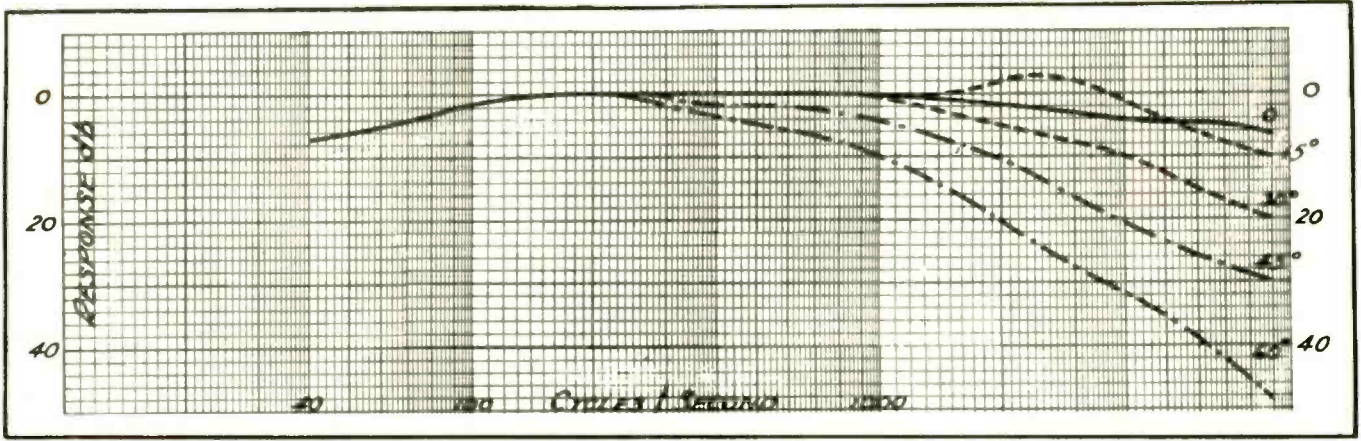

Fig. 2. Relative response with listener at various angles to loudspeaker

speaker axis. This is shown in Figure 2, and it can be seen that the response at 45° is substantially less than optimum, even at frequencies as low as 3,000 cycles. A true higher fidelity receiver must so distribute the higher frequencies that, within a specified solid angle, the response at all frequencies is substantially uniform.

#### Studio Conditions

The acoustical conditions of the studio and listening space can be controlled only over a frequency range approximately of 64 to 8,000 cycles, as design data and experience with materials and completed rooms is available only within those limits. At frequen-

cies of 4,000 cycles and higher, the absorption contributed by the air itself, at usual values of relative humidity, becomes of increasing importance. At 10,000 cycles and a relative humidity of 50%, the absorption of the air limits the reverberation time to about 1.5 seconds even though the walls, floor and ceiling are perfectly reflective; at 12,000 cycles the limit is approximately 1.2 seconds and at 15,000 cycles about 0.9 seconds. This factor should not be overlooked as it is one relatively fixed limit which certainly must affect consideration of higher fidelity, not only in the studio but also in the home.

The ear, the final criterion of judgment, is also to be taken into account,

as the higher frequencies can only be detected by relatively young listeners, since hearing loss at the higher frequencies increase with age. The curves in Fig. 5 show the results obtained by the U. S. Public Health Service in this field. Although few measurements have ever been made above 10,000 cycles, indications are that the curves do not trend upward!

Program fidelity is also determined by the loudness level at which the loudspeaker is operated. Curves in Fig. 3 show the frequency response of normal ears at four listening levels, "normal" ears being those of young people about 20 years of age. Note

[Continued on next page]

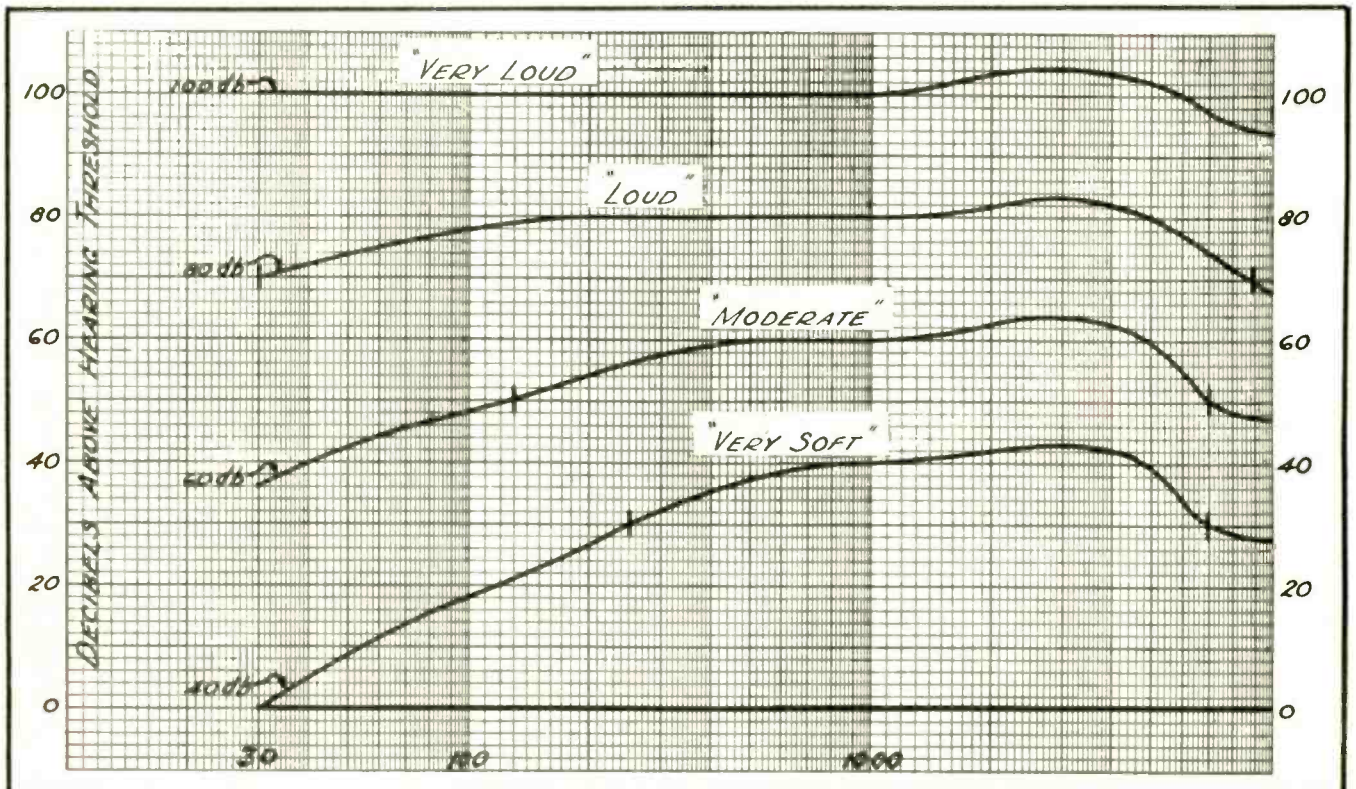

Fig. 3. Frequency response of normal ears at different loudness levels

Fig. 5. Hearing loss at various frequencies for different age groups

that only at the "very loud" and "loud" listening levels, 100 db and 80 db above the hearing threshold, respectively, is the low frequency response of the ear substantially flat. The decreased response of the ear at 50 cycles, 100 cycles and 200 cycles, as compared with 1,000 cycles, is tabulated below:

Condition (db above threshold)	Frequency (cycles per second)	50	100	200	1,000
Very Loud (100)		0	0	0	0
Loud (80)		-6	-2	0	0
Moderate (60)		-17	-11	-6	0
Very Soft (40)		-30	-22	-12	0

In the case of the "very soft" listening condition the response would further tend to be obscured at the low frequencies by local air-borne noises as this listening level compares with average residential noise. Any decrease of more than 10 db or so below this level will generally be obscured or masked by said noise. The response of a young listener seated at 45° from a radio receiver (with a reasonably uniform response up to about 10,000 cycles) operated at a loudness level of 60 db which is a "moderate" listening level, is shown in Fig. 4.

Thus it is apparent that the higher fidelity receiver should include compensation for listening level effects in the volume control used with the receiver to provide uniform loudness at low frequencies. This device could also be used to compensate, partially, for the directivity curve of the loud-speaker, where adequate distribution cannot be attained in the speaker design. Such a "tone" compensated volume control will then discriminate as the volume is lowered against the middle frequencies in favor of the low frequencies and, to a lesser degree, the higher frequencies, the effect to the

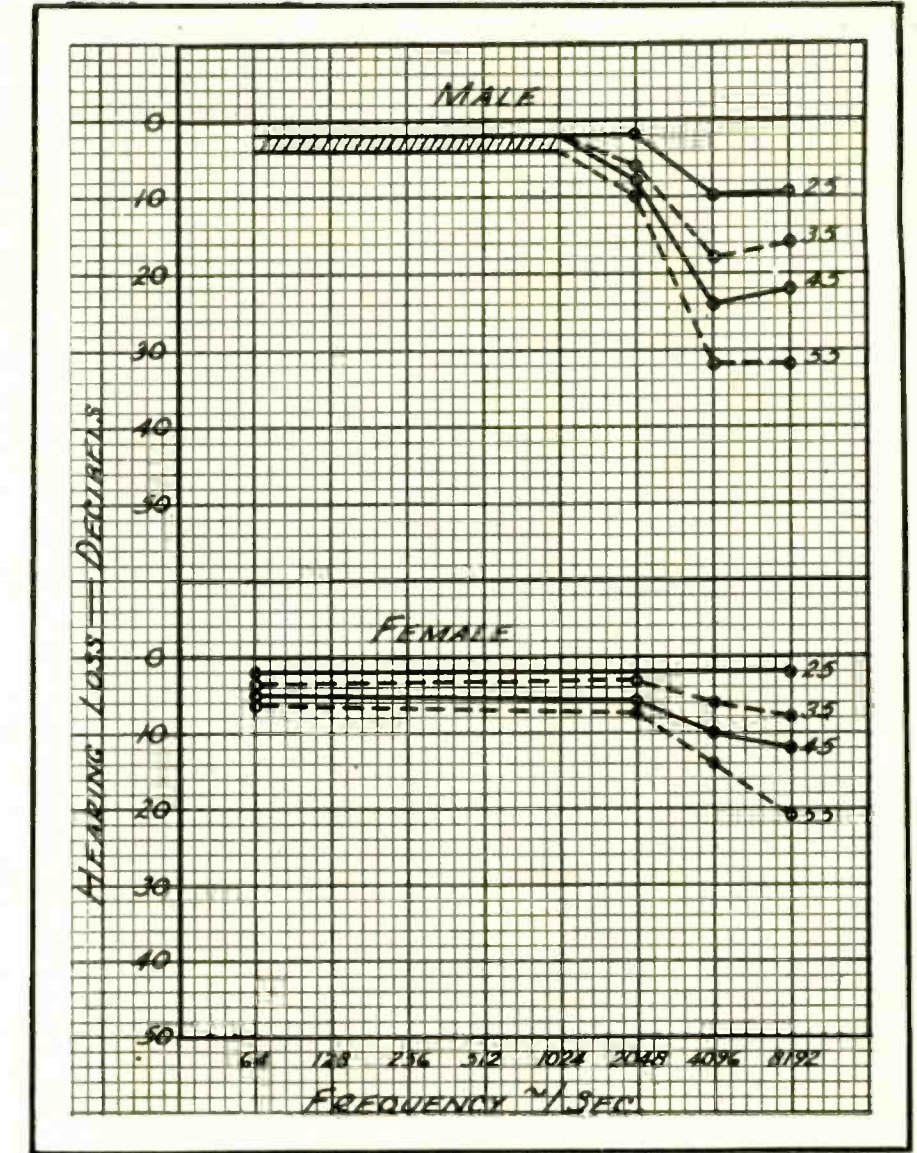

ear being more pleasing reproduction at the usual listening levels, which are commonly in the "moderate" classification.

The preponderant majority of sound systems are now, and will be for years

to come as far as can now be visualized, non-aural systems, whether they are utilized for recordings or for radio broadcasting. This fact alone indicates a fundamental departure

[Continued on page 70]

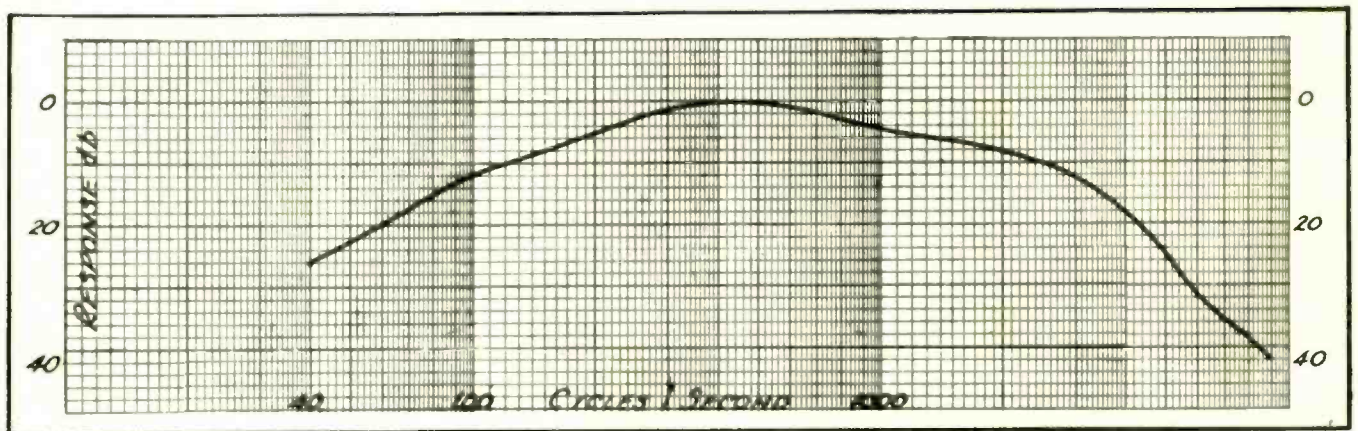

Fig. 4. Aural frequency response, young listener seated at 45° to loud-speaker, normal hearing, moderate loudness level

# Properties of RESONANT CAVITIES

V. J. YOUNG

Physicist, Sperry Gyroscope Co., Inc.

**A discussion of the various types of resonant cavities; how they function, and their applications with Klystron and similar tubes**

**R**ESONANT cavities and resonant circuits containing lumped values of inductance and capacitance serve the same function in oscillators which are designed to be used in greatly different frequency ranges. In an ordinary Hartley oscillator, the tank circuit containing inductance, capacitance, and resistance accomplishes at least three things. It fixes the frequency at which the oscillation is to take place: it provides a sort of storage place so that the oscillation may build up to great strength and, in conjunction with the rest of the oscillator circuit, it provides feedback to the grid in proper phase and with a proper impedance magnitude so that the oscillation will be maintained.

The resonant cavities which are used in a two-chamber Klystron<sup>1</sup> oscillator do the same things. The catcher and buncher cavities are tuned to determine the frequency of oscillation; the amount of power that can be obtained from such an oscillator depends upon the energy density in the catcher resonator, and the efficiency of the whole

oscillator depends upon the impedance match between the beam and the cavities, as well as between the cavities themselves and between the catcher and the output.

In *Fig. 1*, two types of oscillators employing these two kinds of resonators are shown. In each case the three properties we have mentioned are important. We may list them as the resonant frequency,  $f_r$ , the impedance of the resonator,  $Z$ , and the storage ability of the resonator, which is measured by  $Q$ . These operational constants of a resonant device are more or less common to the two sorts but they must be carefully distinguished from design characteristics, which are quite different. So likewise are the most fruitful descriptions of the methods of operation.

#### Construction of Tank Circuit

To construct a lumped constant tank circuit so that it will yield certain results in a Hartley oscillator, we need to translate  $f_r$ ,  $Z$ , and  $Q$  into  $L$ ,  $C$ , and  $R$ . To accomplish the analogous task for a cavity resonator, we are more apt to work directly with the operational parameters or, after having de-

ecided upon the general physical shape of the cavity, attempt to translate the requirements directly to physical dimensions and slots or loops for impedance matching. Before going into this sort of thing, however, we will discuss further *Fig. 1* and try to get clearly in mind the operational requirements of such resonant devices as they are used in oscillators.

The action of the Hartley oscillator is qualitatively easy to understand by talking about charge and current alone. Charge flows from plate  $m$  of the lumped capacity around through the inductance  $L$ . After piling up on plate  $n$  of the condenser, it is urged by the crowded condition there, and by the field around the inductance, to reverse itself and flow back through the inductance to the other plate. Because such a tank circuit has a definite period of charge flow, a certain time is necessary for the charge to make naturally a complete trip from one plate of the condenser through the inductance and back again. If this time is one-millionth of a second, then  $f_r$  is one megacycle, since the charge can make one million round trips in a second.

<sup>1</sup> Registered Trade Mark of Sperry Gyroscope Company.

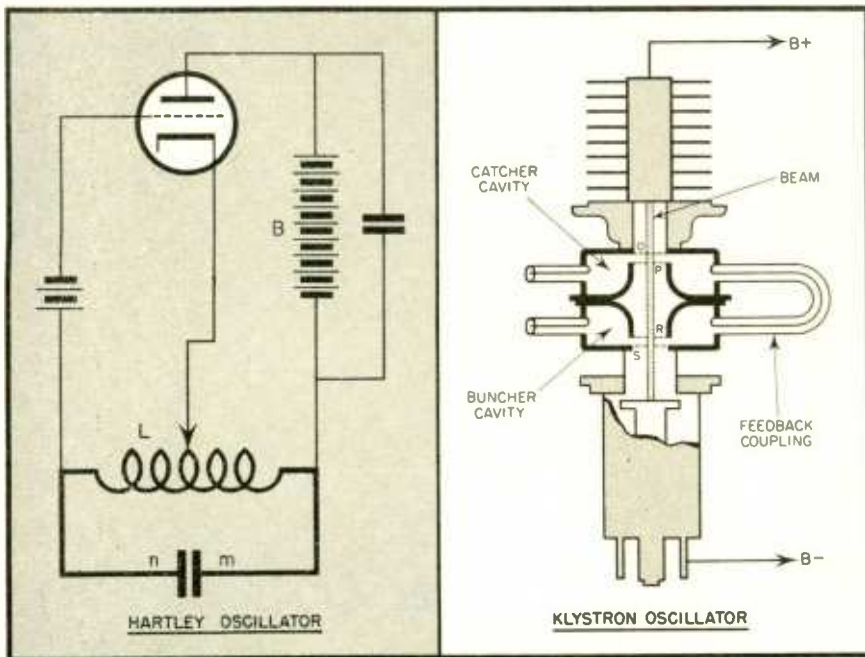

Fig. 1. Resonant cavities and resonant circuits in r-f oscillators. Cavities are more useful at higher frequencies than lumped-constant tank circuits, but are physically too large to be used at low radio frequencies

### Second Constant

The second operational constant of the Hartley oscillator has to do with supplying energy to start and to maintain this back-and-forth flow of charge. In order for the oscillation to be built up in the first place, energy must be fed into the tank circuit from the battery *B* at just the proper time in each cycle. This is accomplished by letting the oscillation itself affect the grid of the tube in such a way as to apply voltage across a portion of the inductance at just the right moment in each cycle.

This is equivalent to saying that the impedance which the grid sees must be of proper phase and magnitude. The resonant frequency of the tank circuit might, for example, be correct with an exceedingly small value of *L* and a correspondingly large value of *C*, but under such a condition the coupling between the plate and the grid turns of the coil would be inadequate to trigger the tube properly. In terms of impedance, the match between the plate or grid circuit would not be suitable in magnitude for the inductance and capacitance combination. Again, it may be that the cathode is attached to the wrong point on the inductance. In that case the impedance seen by the grid is wrong in phase and the grid voltage is not correctly timed to admit energy into the tank circuit in synchronism with the established oscillation. In brief it is not only necessary that the relation,  $f_r = \frac{1}{2} \pi \sqrt{LC}$ , be correct but also that the value of  $Z_o = (L/C)^{1/2}$  be such that energy is adequately

valued into the tank circuit by the tube.

Assuming these things to be correct in a Hartley oscillator, there is still another thing which will limit the intensity of the oscillation that can be built up and used as a source from which to extract a signal for useful purposes. This factor is expressed by *Q* and is a sort of a reciprocal measure of the friction of the oscillator circuit. When the Hartley oscillator is first turned on, only a small amount of charge travels back and forth from condenser plate to condenser plate. But as cycles elapse and additional energy is admitted to the tank circuit by the tube, the oscillating current grows and would continue to do so indefinitely if it were not for losses in the resonant circuit itself and from it into the load.

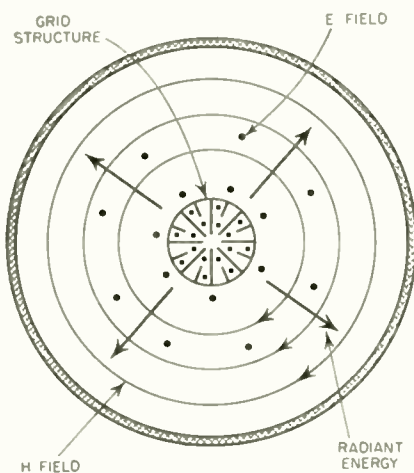

Fig. 2. Endwise cross-section view of a Klystron resonant cavity showing fields and radial direction of energy motion

The *Q* of the circuit is a measure of the degree of freedom from such losses. Thus, in an entirely loss-less circuit where the oscillations might indeed eventually become infinite in strength, the *Q* would be said to be infinite. In practical oscillators of the Hartley type, a *Q* of 50 or 100 is often encountered. With resonant cavities, unloaded *Q*'s running into the thousands may be obtained. In the Hartley circuit shown in Fig. 1 we may simulate all possible losses from the tank circuit by inserting a resistance *R* in series with the inductance and capacitance. If we do this we may write the *Q* of the circuit as  $Q = Z_o/R$ .

### Klystron Operation

The Klystron oscillator shown in Fig. 1 is also dependent for its operation upon the quantities which we have labeled as *f<sub>r</sub>*, *Z<sub>o</sub>*, and *Q*. When the tube is first energized, some irregularity in the intensity of the beam causes a momentary increase in the amount of charge present between the catcher grids *o* and *p*. This increase in charge density means an increase in the electric field between the grids. This electric field, which is parallel to the beam, is at right angles to a magnetic field, which is generated in the catcher resonator. The magnetic field takes the form of concentric circles around the beam just as such fields are formed around a wire carrying current. Now, Poynting's vector tells us that whenever mutually perpendicular electric and magnetic fields are formed by a changing current, radiation will flow in a direction mutually perpendicular to both fields. Fig. 2 shows an endwise view of the catcher resonator and indicates how this radiation energy travels to the circumference of the resonator and is reflected back. Just as with the case of the Hartley oscillator where we spoke of the motion of charge, so here we must consider the transit time of the electromagnetic energy. The reciprocal of the time of travel gives the resonant frequency of the cavity.

In the case of the Klystron oscillator there must likewise be a feedback of energy in order that the oscillator shall be built up and maintained. This is accomplished by means of a feedback coupling, such as the short length of coaxial line shown connecting the catcher and buncher cavities in Fig. 1. By means of this line some of the oscillating electromagnetic field generated in the catcher cavity is carried back to the buncher cavity and, if that cavity is tuned to the same resonant frequency, oscillations are also started there. But in the buncher, as the electromagnetic field travels from the beam out to the

periphery of the cylindrical resonator and back, work is actually done on the beam and the energy is supplied from the feed back coupling. Under proper conditions this work done on the beam in the buncher resonator may be just right to change the voltage at the buncher grids,  $r$  and  $s$ , so that the beam is accelerated at certain times and, later, is able to supply another density increase between the catcher grids. This may continue so that the oscillating electromagnetic field in the catcher builds up in strength to very high levels. Only a small part of that oscillating field in the catcher is needed for diversion back to the buncher in order to strengthen further the field of the catcher.

As can readily be seen from the above, timing and the adjustment of the proper quantity to be fed back is the essence of this type of oscillator. These are the very quantities that are taken care of when the impedances are properly adjusted.

### Cavity Q

The extent to which an oscillation will build up in a correctly connected and impedance-matched two-chamber Klystron oscillator, depends upon a property measured by  $Q$ . A low  $Q$  may result from anything that drains energy away from the cavity in question. As soon as this drain is equal to the energy carried into the catcher cavity by the beam, the tube has reached its limiting power. The  $Q$  of a cavity is, in practice, always less than infinity because the material of which it is made is less than a perfect conductor.

Actually, however, this is not usually the most important limiting factor. Rather, irregularities which are departures from the proper dimensions and symmetry plus losses that are necessary into the coupling loops or probes which extract energy from the cavity are more important. Because the load on the cavity often has a large effect, it is common to speak of loaded and unloaded  $Q$  for a resonant cavity, the same terminology that is used for wired resonant circuits.

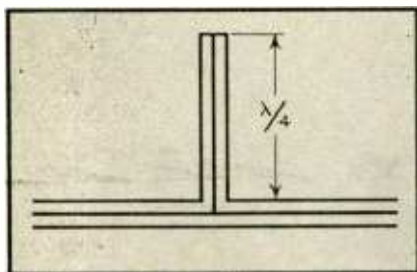

Fig. 4. A coaxial resonant cavity may be used as a stub support for a coaxial line.

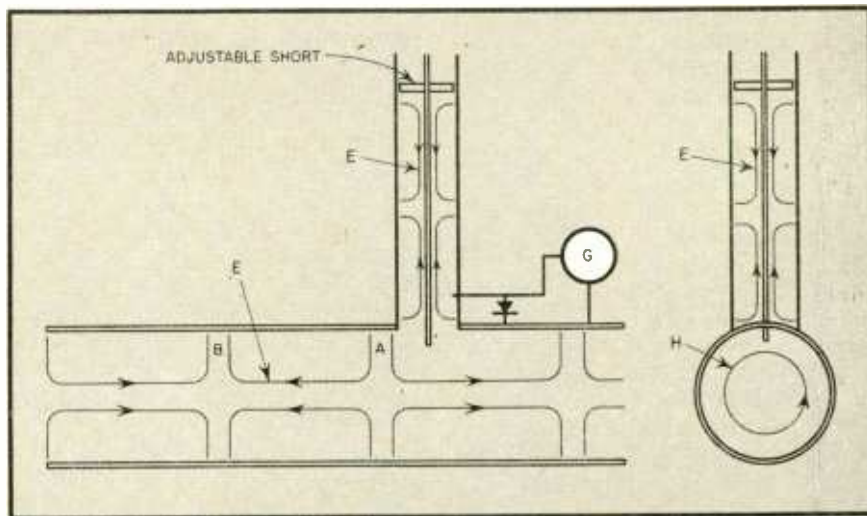

Fig. 3. Use of a coaxial resonant cavity to measure wavelength in free space of energy traveling along a cylindrical wave guide in the  $H_{01}$  mode

We have stressed so far the use of resonant cavities in connection with a Klystron oscillator and have compared this device with a Hartley circuit so as to demonstrate not only the similarities of the applications, but also the fundamental differences in construction and operation that exist between resonant circuits of inductance and capacitance and true resonant cavities. Actually, this is only one of several applications of resonant cavities. Just as the wired tank circuit has many other uses besides that encountered in a Hartley circuit, so resonant cavities are also rather versatile. In discussing various specific types of cavities, we shall make some mention of their use in conjunction with definite applications so that the complete operation may be clear.

### Coaxial Type Cavities

A coaxial type of resonant cavity is a good one to start the discussion with because it allows us most easily to parallel an explanation in terms of the electromagnetic field with one involving only current and voltage. Such cavities are used for support in coaxial lines and are referred to as stub supports. They also hold an advantage when used in conjunction with measuring apparatus inasmuch as the velocity of propagation in a coaxial line is over broad limits independent of frequency. This means that the phase velocity in a coaxial resonant cavity may be assumed to be just the velocity of light and measured wavelengths to be actual free space wavelengths.

In Fig. 3 is shown a tunable coaxial cavity arranged so as to be excited by energy tapped off a circular wave guide transmitting in the  $E_{01}$  mode. A galvanometer and crystal are arranged to measure the energy content of the res-

onator and thus indicate when resonance is obtained.

As the electric field configuration sketched in the wave guide of Fig. 3 moves along from left to right, the probe-like extension of the center wire of the coaxial line finds itself parallel to an electric field of varying strength and direction. For example, when point A of the field configuration in the wave guide is at the coaxial line, the coaxial probe finds itself charged positively at the tip.

This follows from the very definition of an electric field, which says that lines of electric force point in the direction that a free positive charge is urged. Since any metal always contains both free negative and free positive charges, the motion of a free positive charge to the end of the probe is equivalent to the flow of a negative charge into the coaxial line. At a later time, the traveling wave in the circular wave guide causes a point such as B to affect the coaxial line. The opposite situation is then in force and a positive surge of current is sent up the coaxial line. This procedure continues and varies sinusoidally so an alternating current is urged to flow in the coaxial line at a frequency equal to that of the energy in the wave guide.

Continuing to refer to Fig. 3, we can now see why an adjustment of the length of the coaxial line can cause it to act as a resonant cavity. The upward flow of charge of one sign in the center conductor is equivalent to the downward flow of charge of the other sign. As a matter of fact, we know that electricity in metals is actually almost entirely a matter of the motion of negative electrons. Positive ions have a much lower mobility and do not ordinarily contribute much to electric currents. The mention of

the flow of positive charge is only a convenient and harmless fiction based on long usage and has the same meaning as electrons going the other way. Uncharged bodies contain large but equal amounts of positive and negative charge; taking away negative charge is in every way the same as adding positive charge.

Thus, between the time the field configuration marked *A* is at the coaxial line and the later time when *B* arrives there, if the negative charge sent up into the line by the presence of field *A* can travel to the closed end and, finding things crowded there, be reflected back along the line so as to arrive at the probe end simultaneously with *B* of the guide field, then we have a very special situation in which the field lines *A* cooperate to generate the same alternating current as those of the lines marked as *B*. With this type of cooperation, large currents are built up in the coaxial line and the conditions of an abnormal energy distribution always characteristic of resonance are obtained.

A similar explanation of a coaxial resonator's operation may be given in terms of the electromagnetic field formed in the coaxial line. A study of Fig. 3 will illustrate how this can be done in terms of Poynting's vector.

#### Governing Factors

Having now talked of the way in which a coaxial resonant cavity works, we wish to find out what dictates the operational constants, *f*, *Z*, and *Q*, to which we have referred before. The resonant frequency *f* is dependent only upon the length of the coaxial line.

Since the negative charge, which we spoke of as traveling the length of the line and back, must do so while only a half wave-length of energy moves past the coaxial line entrance, it is clear that the coaxial piece should be of a length over which charge can travel one way in a time equal to 1/4 cycle. Since the velocity with which energy travels in a coaxial line is that of light, this is equivalent to saying that the resonant frequency of a coaxial resonator is  $c/4L$ , where *L* is the length of the line.

In the case we have discussed in Fig. 3, it is clear that the phase of the impedance is taken care of when the resonant frequency is arranged. The possible adjustments which can effect the amount of disturbance in the wave guide, caused by the coaxial stub, are the length of the coaxial probe and the sizes of the inner and outer coaxial conductors. Presumably, we here wish to make the coaxial line seem to be as high an impedance for the wave guide as possible. The shorter the distance the coaxial probe enters the wave guide, the less its presence will disturb the pattern there. How short the probe can be made in practice depends upon the sensitivity of the crystal and galvanometer or, more generally upon the *Q* of the resonator. The impedance which the coaxial stub presents to the wave guide also depends upon the dimensions of the coaxial line. An adjustment of the ratio of the diameters of the outer to inner conductor of the coaxial line to the value 9.2 gives the highest shunt resistance to the wave guide.

For a resonant cavity, the most fruit-

ful quantitative definition of *Q* is probably

$$Q = 2\pi \frac{\text{energy stored}}{\text{energy loss per cycle}}$$

In the coaxial resonator, losses may arise because the resistance of the material causes  $i^2r$  losses. This is usually very small except when *i* becomes large. Large currents may be encountered at certain points in the cavity if it is not well made and tuned.

The *Q* of the device of Fig. 3 is also limited by the energy drain to the crystal and galvanometer. The greatest unloaded *Q* of a coaxial resonator is obtained when the ratio of the dimensions of the outer and inner conductor is 3.6. This is not the ratio for optimum shunt resistance and, at times, a compromise is necessary.

It should be understood that the requirements of high shunt resistance and high *Q* are quite different although, in the case shown in Fig. 3, high values of either will aim to reduce the disturbance introduced into the wave guide by the attachment of a resonant coaxial stub. It must also be remembered in dimensioning a coaxial resonator that the diameter of the outer conductor must be small relative to a wavelength so as to avoid the possibility of exciting higher modes.

Fig. 4 illustrates the use of a coaxial cavity as a supporting stub for a coaxial line. Here, it is desired that, at resonance the stub lines should present a nearly infinite impedance to the main line and have such a high *Q* that no appreciable energy is needed to maintain the resonance.

#### Cavity Shapes

Three kinds of true hollow non-reentrant cavities are commonly calculated. They are the ones which have the shapes of spheres, cylinders, or rectangular prisms. All these are easily computed from Maxwell's equations in terms of well-known functions with only the assumption of perfect geometry, which can be approached by accurate machine work, and certain physical measurements of materials such as skin depth which are now fairly well known for good conductors. Of these shapes, the cylinder and the rectangular prism are the easiest to understand because, except for certain degenerative modes, they may be interpreted as simply pieces of cylindrical or rectangular wave guides closed off at both ends. Energy in such a piece of wave guide then travels back and forth, being successively reflected at each end, and if the time of travel is such as to synchronize itself with the energy fed into the cavity, resonance takes place.

As a practical matter, the cylindrical

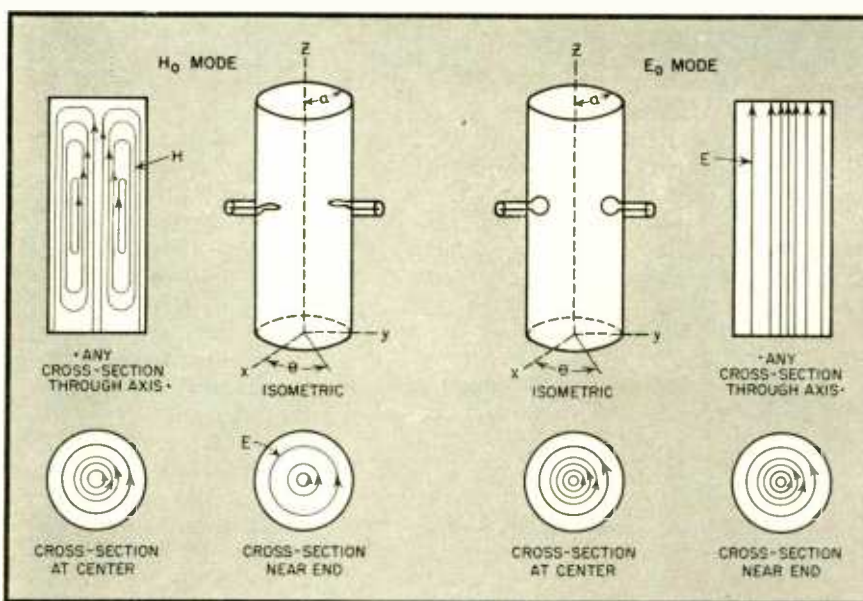

Fig. 5. Cylindrical resonant cavities operating in the  $H_0$  and  $E_0$  modes. The cross-section views show instantaneous standing wave orientations of the *E* and *H* vectors. Both cases have fields independent of the angle  $\theta$ . In the  $E_0$  resonator, the field is also independent of *Z*.

shape is most often used because radial dimensions can be accurately held by careful machining on a lathe. The spherical cavity is the most difficult of all to manufacture and, since it is not known to have any real superiority, it is seldom, if ever, used.

In Fig. 5, cylindrical cavities are shown with dimensions and coupling loops suitable for use in the  $E_0$  and  $H_0$  resonant modes. These two modes are the lowest of an infinite number of frequencies at which such cavities can be made to resonate.  $E$ -labeled modes are those modes in which the electric field has a component parallel to the axis. They are identical to the so-called  $TM$  modes, meaning those modes in which only transverse components of the magnetic field occur.

In the same way,  $H$  modes, which have magnetic fields with components running lengthwise of the cylinder, are also referred to as  $TE$  (transverse electric) modes. As we have said before, both the  $E$  and  $H$  modes possible in a cylindrical cavity are infinite in number. Subscripts are usually used to indicate a particular mode. Thus, the  $E_0$  and  $H_0$  modes are the lowest frequency modes in which the cavity will resonate in  $E$  or  $H$  modes respectively.

For example, as is indicated in Fig. 5, it will be noticed that the diameter of the cavity for  $E_0$  operation is equal to one-half wavelength. In traveling along the diameter of the cavity, we go from a zero electric field through a maximum and back to zero again, as in any travel over a half wavelength. The diameter might equally well be a whole wavelength or, for that matter, any integral number of half wavelengths. If it were two or more half wavelengths long, we would have a higher  $E$  mode of operation.

As a matter of fact, we may have higher  $E$  modes for other reasons too. We may have them because of a higher number of half wavelengths, which are required to fit into the length of the cavity or around the axis in an angular array in accord with the angle  $\theta^2$ .

### Mode Nomenclature

A complete nomenclature specifying all  $E$  and  $H$  resonant modes therefore needs three subscripts, such as  $E_{lmn}$ , or  $H_{lmn}$ . In each case one subscript gives the number of half wavelengths along a diameter, another the number along the axis, and the third describes the field as a function of  $\theta$ . Zero values of a subscript indicate that the field is constant in the dimension which the subscript describes. Thus, the  $E_0$  and  $H_0$  modes of Fig. 5 are more properly de-

<sup>2</sup> See, for example, "Hyper and Ultra High Frequency Engineering" by Sarbacher and Edson. John Wiley and Sons.

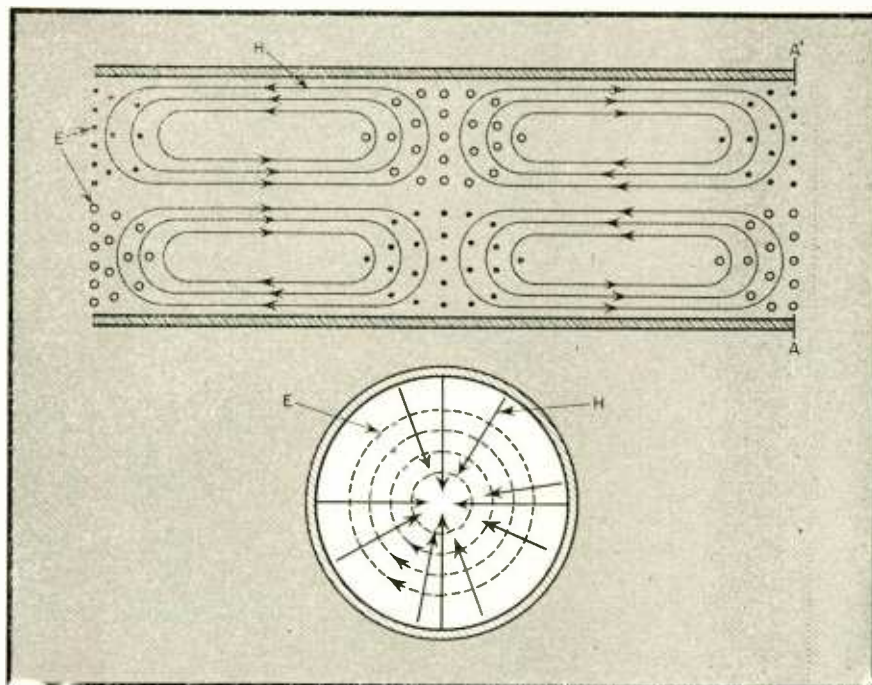

Fig. 6. The  $H_0$  mode of a cylindrical wave guide. The section shown is a wavelength long and indicates a wave traveling to the left.

scribed as  $E_{010}$  and  $H_{011}$  modes, since both have fields that are constant with angle, one-half wavelength wide along a diameter, and in the  $E_0$  case, constant along the axis but in the  $H_0$  case also one-half wavelength long in that dimension.

It is more difficult to sketch or describe in words the various modes of a cylindrical cavity than it is to understand once the general idea is grasped. Since designs are rarely, if ever, made for use in any but the very lowest modes, it is really only necessary to understand that higher frequency resonances are possible.

One other point of information, however, should be included for the sake of completeness. It has to do with the harmonic arrangement of the various resonant frequencies. It might be thought, for example, that since higher modes are always created by halving or otherwise dividing the wave length by integral numbers, it would follow that higher resonant frequencies would occur at multiples of the frequency which resonates the lowest mode. This is not true because unlike the coaxial line, the phase velocity of radiation in a hollow wave guide is dependent upon frequency. Thus when the wave length is halved the frequency is not doubled.<sup>3</sup> As a matter of fact, it turns out that the frequency progression for both  $E$  and  $H$  modes is given by expressions

<sup>3</sup> The relation between wave length, frequency, and velocity of a wave is  $v = f\lambda$ . If  $v$  changes with  $f$  then  $\lambda$  is not inversely proportional to  $f$ .

containing the roots of a Bessel function.

To see better how the  $H_0$  resonance of a cylindrical cavity may be interpreted as a piece of cylindrical wave guide in which energy travels back and forth along the length of the cylinder while suffering reflection each time it reaches an end, we now refer to Fig. 6, where the  $H_0$  mode for a traveling wave in cylindrical wave guide is shown. A look at that sketch shows that the wave is traveling to the left. Rotation of the  $E$  vector into the direction of the  $H$  vector, interpreted as the rotation of a right-hand screw, shows by the progression of the screw the direction of Poynting's vector and, hence, the direction of energy flow.

Now, if the end of such a wave guide is closed off, the wave is reflected, and a similar wave traveling in the opposite direction is also present in the wave guide. This reversal of flow might, in general, be accomplished by reversing the direction of either, but not both, the  $E$  or  $H$  lines, as shown in Fig. 6. In the case of the closed-off end the reflection must be due to the reversal of the  $E$  lines, since the net electric field tangent to the metal end of the cylinder must always be zero. If a section of cylindrical wave guide one-half wavelength long is sealed off at both ends, these waves traveling in opposite directions give a net field in the section which is a standing wave like the one shown in Fig. 5. It will be noticed that the sketch of Fig. 5 is called an instantaneous view of the field. As the two traveling waves combine, the

amplitude of the standing wave will change and even reverse direction at various time, although it will actually always retain to some scale the same general form as shown in Fig. 5.<sup>4</sup>

### Resonant Frequency

From all the above it is clear that the resonant frequency of an  $H_0$  cylindrical resonator depends upon the wavelength of the radiation in that wave guide. This wavelength in the guide is given by

$$\lambda_g = \frac{\lambda}{\sqrt{1 - (\lambda/\lambda_c)^2}}$$

where  $\lambda$  is the free space wavelength and  $\lambda_c$  is the longest wavelength that can be propagated in the wave guide. The free space wavelength may be calculated by  $\lambda = c/f$ , where  $c$  is the velocity of light. The cut-off wavelength,  $\lambda_c$ , for the  $H_0$  mode may be found by

$$\lambda_c = 1.64a$$

where  $a$  is the radius of the cylinder, chosen arbitrarily within the range where  $H_0$  propagation of the desired frequency is possible. With these calculations we can thus find  $\lambda_g$  and, having done so, we need only to dimension the length of the cylinder equal to  $\lambda_g/2$  in order to obtain an  $H_0$  resonant cavity at frequency  $f$ .

The calculation of  $Q$  for  $H_0$  resonant cavities is straight-forward, although it does involve a very complicated algebraic equation. It is really sufficient to say that the calculated  $Q$  is invariably very high (many thousands) and is not generally realized in practice because of loading and inaccurate construction. It is likewise possible to compute the impedance of coupling loops like the ones shown in Fig. 5. The only assumption is that the loop is entirely in the cavity. This, too, is not an entirely satisfactory calculation from the practical standpoint and more often impedance matching is obtained by experimental adjustment of the loop.

### The $E_0$ Mode

The  $E_0$  mode of a cylindrical resonator is of particular interest because its resonant frequency is dependent upon only one dimension, the radius. It is an example of a fully degenerative mode, as is indicated by the more elaborate nomenclature  $E_{010}$ . It resonates because of a periodic variation in the radial field which is always identical throughout the length of the cylinder. The  $E_0$  mode has a slightly lower  $Q$  than the  $H_0$  mode and demands a higher frequency, but has some design advantages. In the  $E_0$  mode, the resonant

<sup>4</sup>For a discussion of the way in which traveling waves combine to form standing waves, see RADIO, April, 1943, p. 19.

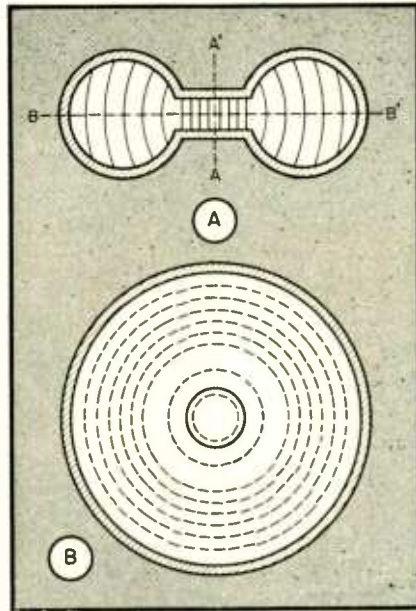

Fig. 7. Rhumbatron type of re-entrant cavity. (B) is a cross-section of the resonator cut along the line BB'

frequency and the radius of the cylinder are connected by

$$f_n = c/(2.61a).$$

The unloaded  $Q$  of such a resonator is given by

$$Q = \frac{ah}{\delta(a+h)}$$

where  $\delta$  is the skin depth penetration of the microwave frequency being used.

### Applications

Cylindrical cavities may be used as band pass filters either by feeding energy through them by means of the coupling loops shown, or by arranging wave guide coupling direct to the cavity so that the whole assembly is a rigid portion of the wave guide line. Also, because such resonant cavities have dimensions of only a few inches, when used at microwave frequencies, it seems likely that very carefully built cavities will some day play the roll in microwave radio that quartz crystals now do for more ordinary frequencies. Because of the very high  $Q$ 's available in resonant cavities, they can be built as very accurate frequency standards. A quartz crystal cannot be satisfactorily ground for use at frequencies above several megacycles because the necessary dimensions become too small.

A third class of resonant cavities which have re-entrant shapes are of importance mainly in the Klystron and allied tubes. In Fig. 7, a cavity of the so-called rhumbatron type is shown in a somewhat idealized form. As can be seen there, the shape is somewhat like that of a doughnut except that the hole of the doughnut is covered over with rather closely spaced webs. For at least

two reasons, this close spacing makes the practical operation of a Klystron a reality. For one thing, it turns out that the electric field is very high between closely spaced walls of the cavity. This means that if we introduce an electron beam into the cavity through grids installed in this re-entrant parts (i.e., the beam travels along line AA' of Fig. 7), the beam electrons are most efficient in establishing the proper electromagnetic field pattern or in being accelerated by an existing field.

Another way of speaking of the advantage of a rhumbatron cavity in a Klystron is to say that a re-entrant cavity of this sort allows us to obtain a better impedance match between the cavity and the electron beam. The essential idea is that the electric field to which the bunched beam is coupled has to be strong and uniform over the space through which the beam passes and also, has to fall off naturally in a radial direction, just as does the electric field about the charge. This may be described in terms of impedance because, in the case of electromagnetic fields, impedance means the magnitude and phase of  $E/H$ , while the vector product of  $E$  and  $H$  represents an energy flow which is known. Actually, we commonly speak of shunt impedance in this connection. The shunt impedance of a resonator may be compared to the resistance represented by a parallel LC circuit at resonance.

### Transit Time

The other reason that rhumbatron cavities are exclusively used in tubes like the Klystron is a purely practical one having to do with the transit time of the electron beam through the cavity. The electrons must traverse the electric field between the Klystron grids in less than one-half cycle. A much shorter transit time is desirable in order to make possible a greater variation of the beam current present in the resonator. For example, it is clear that in the extreme case in which the transit time is a whole cycle, the coupling fails altogether because the average current in the cavity remains constant. The re-entrant cavity makes it possible for the beam to traverse a short distance through the cavity. How close together the grids can be brought is ordinarily limited only by voltage breakdown and secondary emission troubles.

The unloaded  $Q$  of Klystron resonators is of the order of 10,000. When loaded under typical adjustment conditions, this is reduced to the order of 1000. The actual  $Q$  employed in various tubes depends upon such things as band width considerations.

\* Registered Trade Mark, Sperry Gyroscope Co., Inc.



# RADIO DESIGN WORKSHEET

NO. 30

## LOUDSPEAKER MOTORS

### LOUDSPEAKER MOTORS

Fig. 1 illustrates one of the simplest types of loudspeaker motors. It is generally known as the vibrating reed type of motor. It was one of the first motors used in loudspeakers and is still used occasionally in the smaller types of speakers. It consists of a magnet, either permanent or electromagnet, an armature hinged at one end and free to move at the other, and a voice coil coupled to the magnetic circuit which superposes an alternating signal on the

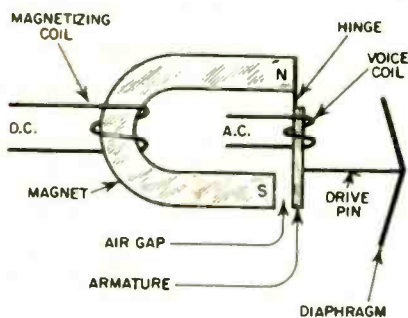

Figure 1

steady flux of the magnet. When an alternating current is passed through the voice coil, the free end of the armature is alternately attracted and repelled by the magnetic pole adjacent to it. The armature consequently vibrates in accordance with the pulsating current in the voice coil and drives a diaphragm through the medium of the drive pin.

Let

$\phi$  = steady flux across the air gap due to d.c. in magnetizing winding.

$A \sin \omega t$  = flux due to signal current in voice coil.

$F$  = magnetic force acting on free end of armature.

Whence

$$F = K(\phi + A \sin \omega t)^2 = 2K\phi A \sin \omega t + \frac{KA^2}{2} \sin^2 \omega t + K\phi^2$$

$$= 2K\phi A \sin \omega t + \frac{KA^2}{2} \cos 2\omega t + K \frac{(2\phi^2 + A^2)}{2}$$

The first term is the signal impulse, the second term the second harmonic of the signal (which represents distortion)

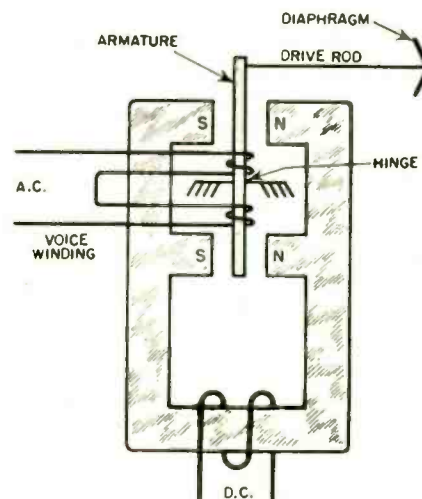

Figure 2

tion) and the third term represents a steady force.

Since the second term represents distortion, good design dictates that  $\phi/A$  should be as large as practicable consistent with efficiency and saturators of the pole pieces of the magnetic structure. The higher  $\phi$ , the stiffer must be

the hinge and the higher the resonance of the vibrating systems.

Fig. 2 represents the balanced armature type of structure. One purpose of the balanced armature is to reduce the second harmonic distortion

$$\text{Magnetic force due to one set of poles} = K(\phi + A \sin \omega t)^2$$

$$\text{Magnetic force due to other set of poles} = K(\phi - A \sin \omega t)^2$$

$$F = K(\phi + A \sin \omega t)^2 - K(\phi - A \sin \omega t)^2 = 4KA\phi \sin \omega t$$

In actual practice the balance of the windings is never perfect so that even harmonic distortion does result, but it is much reduced by the balanced armature motor of Fig. 2 compared to the reed type of Fig. 1. Sometimes the voice coils are connected directly to the plate circuit of the power amplifier so that the plate current flows through the voice coils, thus adding a steady pull to the magnet flux. This is likely to deflect the armature and pole pieces. Also, at maximum excursion of the

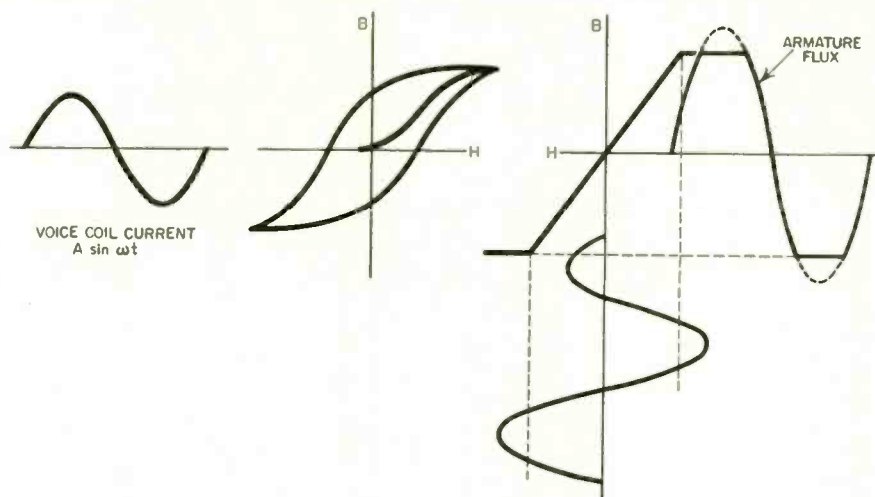

Figure 3

armature, the permanent magnetomotive force may produce sufficient momentary flux to cause saturation of the armature or pole pieces.

A simplified analysis will serve to show the effects of saturation. This analysis takes some liberties with facts and is not intended to do more than

illustrate as simply as possible the general effects of magnetic saturation and to enable the reader to visualize in a simple manner what takes place. Fig. 3 represents the magnetization curve of the magnetic system and the simplified magnetization curve assumed for the analysis.

The simplified diagram of Fig. 3 illustrates the flattening of the peaks of the resulting armature flux. Using the same nomenclature as before we have for the resulting armature flux.

$$B = b_1 \sin \omega t + b_3 \sin 3\omega t + b_5 \sin 5\omega t + \dots$$

In actual practice there would also be a series of even harmonics. Whence, for the motor of Fig. 1 we have

$$\begin{aligned} F &= K(\phi + b_1 \sin \omega t + b_3 \sin 3\omega t + b_5 \sin 5\omega t + \dots)^2 \\ &= K\phi^2 + Kb_1^2 \sin^2 \omega t + Kb_3^2 \sin^2 3\omega t + Kb_5^2 \sin^2 5\omega t + 2K\phi b_1 \sin \omega t \\ &\quad + 2K\phi b_3 \sin 3\omega t + 2K\phi b_5 \sin 5\omega t + 2Kb_1 b_3 \sin \omega t \sin 3\omega t \\ &\quad + 2Kb_1 b_5 \sin \omega t \sin 5\omega t + 2Kb_3 b_5 \sin 3\omega t \sin 5\omega t + \dots \\ &= \frac{K}{2} (2\phi^2 + b_1^2 + b_3^2 + b_5^2) + 2K\phi (b_1 \sin \omega t + b_3 \sin 3\omega t + b_5 \sin 5\omega t \\ &\quad + \dots) - \frac{K}{2} (b_1^2 \cos 2\omega t + b_3^2 \cos 6\omega t + b_5^2 \cos 10\omega t + \dots) \\ &\quad + Kb_1 b_3 \cos (\omega t - 3\omega t) - Kb_1 b_3 \cos (\omega t + 3\omega t) + Kb_1 b_5 \cos \\ &\quad (\omega t - 5\omega t) + Kb_1 b_5 \cos (3\omega t + 5\omega t + \dots) \\ &= 2K\phi b_1 \sin \omega t + 2K\phi b_3 \sin 3\omega t + \\ &\quad 2K\phi b_5 \sin 5\omega t + K(b_1 b_3 + b_3 b_5 - \frac{b_1^2}{2}) \cos 2\omega t \\ &\quad + K(b_1 b_5 - b_1 b_3) \cos 4\omega t - K(b_1 b_3 - \frac{b_3^2}{2}) \cos 6\omega t - Kb_3 b_5 \cos 8\omega t - \frac{Kb_5^2}{2} \\ &\quad \cos 10\omega t + \frac{K}{2} (2\phi^2 + b_1^2 + b_3^2 + b_5^2 + \dots) + \dots \end{aligned}$$

It is therefore apparent that saturation introduces a large number of harmonics into the force actuating the armature. It also appears that the amplitude of the harmonics increases with the degree of saturation.

Proceeding in like manner for the perfectly balanced motor of Fig. 2, we find that:

$$\begin{aligned} F &= K(\phi b_1 \sin \omega t + b_3 \sin 3\omega t + b_5 \sin 5\omega t + \dots)^2 \\ &\quad - K(\phi - b_1 \sin \omega t - b_3 \sin 3\omega t - b_5 \sin 5\omega t - \dots)^2 \\ &= 4K\phi b_1 \sin \omega t + 4K\phi b_3 \sin 3\omega t + 4K\phi b_5 \sin 5\omega t + \dots \end{aligned}$$

While the balanced armature motor will reduce greatly the even harmonics, the odd harmonics remain in their original relative magnitudes.

In a later Worksheet similar computations will be given for the dynamic and electrostatic loudspeaker.

# BOOK REVIEWS

**ELECTRICAL ESSENTIALS OF RADIO**, by Morris Sturzberg and William Osterheld. Published (1944) by McGraw-Hill Book Company, 330 West 42nd Street, New York 18, N. Y. 529 pages, Price \$4.00.

As the title indicates, this book treats the theory of electricity (and magnetism) needed for the understanding of radio. It deals with electrostatics, d-c circuits, a-c circuits, magnetism, meters, inductance, capacity, resistance, resonance, coupled circuits and filters. Therefore, all the linear circuit theory is covered. There is nothing on tubes, rectifiers, aeriels or radiation; this is to follow in a later volume.

The book is intended for the beginner; he may be a high-school student, a repairman, a worker in a plant. Little mathematics is needed to understand the text; in fact, it is stated in the preface that nothing but arithmetic is required of the reader. The simple algebra used in equations and problems is explained as the occasion arises.

Each chapter is followed by a bibliography, questions and problems. Answers to the problems are not given.

The introductory chapters give some sort of bird's eye view of communication and there are several appendices containing symbols, formulas, color codes, wire tables and mathematical tables.

It is a thorough-going book with much emphasis on the working out of problems both in the text and later by the student himself. The reader can here learn how to calculate many of the circuit constants required in radio sets, such as voltage dividers, ohmmeters, tuned and coupled circuits. In general, the text is clear but there are many instances of careless terminology. The most important of these is the use of the term "voltage" without making clear the distinction between e.m.f. and potential difference. Also, on page 32 the authors say: "An element is also called an *atom* by scientists and chemists."

There are many illustrations and diagrams which show tubes in circuits. The text discusses the circuits but not the tubes. We do not know how the average impatient youngster will take to this treatment. The whole thing must seem pointless to him since he does not reach his goal: a complete radio set.

The emphasis is on circuits while fields are rather neglected. Especially the subject of electrostatics gets little attention.

In the introductory chapters, which were no doubt included to lend some

interest, there are inaccuracies and signs of old age. So, on page 9, the Morse Code is shown but it is the code from before the Cairo Convention. It was changed then—remember? Also, on page 21 is a chart of the electromagnetic spectrum; among other things, it shows that frequencies from 108 mc to  $7.5 \times 10^9$  mc are "not used at present." The date of the book is 1944.

**RADIO DATA CHARTS**, A Series of Abacs Providing Most of The Essential Data Required in Receiver Design, by R. T. Beatty. Third Edition, revised by J. McC. Scwerby. Published (1943) by Wireless World, Iliffe & Sons Ltd., Dorset House, Stamford Street, London, S.E.1, England. 84 pages, price 7/6 net.

This book is a revision of the well-known collection of charts in nomogram form by the late R. T. Beatty. There are a total of 40 charts for the determination of circuit constants as in receiver design. Each chart occupies a full page and is accompanied by a page of explanatory text giving some of the theory, the equation used, and an example.

The new edition differs from the previous one in that many of the charts have been redrawn (so as to include larger ranges, for instance) and that 10 new charts have been added. The order has also been changed. The new charts deal with the influence of shields on the inductance and resistance of coils, with transmission lines and output transformers and loudspeaker dividing networks.

The complete collection now includes charts for finding  $L$  and  $C$  for a given frequency, design of single layer coils and multilayer coils, finding the best size wire for a coil of minimum resistance, influence of a shield on a coil, dynamic resistance and sideband transmission of tuned circuits, reactance of coils and condensers, design of transmission lines, design of power transformers and chokes, decibels, Ohm's Law, attenuation networks and wire tables.

Many of the charts were used and checked by your reviewer against data obtained in recent practice; these all agreed very closely. The  $L$ ,  $C$  and  $f$  charts are repeated, each time for different ranges so that one would not have to worry about the placing of the decimal point. The author did not take into account the different  $L/C$  ratios encountered, and so there are occasions where the required intersections fall beyond the limit of the chart and one has to juggle the decimal point anyway.

This was the only difficulty encountered.

**MARINE RADIO MANUAL**, edited by M. H. S. Richartz. Published (1944) by the Cornell Maritime Press, 241 West 23rd Street, New York 11, N. Y. 518 pages, price \$4.00.

A book for the sea-going radio operator in war time. This one differs from other books for the radio operator in many respects. It does not pretend to teach the technical side of radio, nor to cram the reader for the exam; it is a guide book for the man already on the job. Much of the contents is devoted to the laws and customs of the sea, what papers one needs for going on a voyage, the routine of message handling, keeping records, taking over the station from the previous operator, etc. This information was generally omitted in books for the radio operator.

There are also chapters on the operation, maintenance and repair of the equipment, transmitters, receivers, alarm systems and direction finders.

This volume will no doubt answer most of the questions which puzzle the new operator on his first trip.

**FOUNDATIONS OF WIRELESS**, by M. G. Scroggie, Fourth Edition, completely revised. Published (1943) by Wireless World, Iliffe & Sons Ltd., Dorset House, Stamford Street, London S.E.1, England. 358 pages, price 7/6 net.

A book for the man who knows little or nothing about radio and who has no mathematical background. Starting with elementary notions of electrons and charges, the reader is led through the theory of a-c and d-c circuits, tubes, amplifiers, oscillators, transmitters, receivers, aeriels, transmission lines—it covers the whole subject.

This book aims to teach the reader how radio circuits work. The emphasis is on trying to make him understand the function of the apparatus—not to build it, not to repair it.

The author manages to be remarkably clear and accurate. In too many texts explanations are inaccurate for the sake of simplicity. This text amply proves that no such compromises need be made. Such hard-to-understand subjects as the grid-leak detector and the mixer, are well treated.

There is something of the modern slant in the text. It starts with the three-dimensional illustration of the atom and winds up with such up-to-date subjects as the conception of the radiation field, aeriels, feeders, transmission lines, resonant lines and their uses. It is indeed a pity that frequency modulation receives but a passing mention.

# Revised List of ARMY-NAVY PREFERRED TUBES

EFFECTIVE SEPT. 15, 1944

1. The following Army-Navy Preferred list of Radio Electron Tubes sets up a group of unclassified general purpose tubes selected jointly by the Signal Corps and the Bureau of Ships. The purpose of this list is to effect an eventual reduction in the variety of tubes used in Service Equipment.

2. It is mandatory that all unclassified tubes to be used in all future designs of new equipments under the jurisdiction of the Signal Corps laboratories or the Navy Department be chosen from this list. Exceptions to this rule are hereinafter noted.

3. The term "new equipments," as mentioned in Paragraph 2 above is taken to include:

- a. Equipments basically new in electrical design, with similar prototypes.
- b. Equipments having a similar prototype but completely redesigned as to electrical characteristics.

c. New test equipment for operational field use.

4. The term "new equipments," as mentioned in Paragraph 2 above, *does not* include:

- a. Equipments either basically new or redesigned, that are likely to be manufactured in very small quantity, such as laboratory measuring instruments.
- b. Equipments that are solely mechanical redesigns of existing prototypes.
- c. Equipments that are reorders without change of existing models.
- d. Equipments in the design stage before the effective date of adoption of this Preferred List.

Note: The foregoing statements in Paragraphs 3 and 4 above are explanatory in nature and are not intended to be all-inclusive.

5. In the event that it is believed that a tube other than one of those included in this Preferred List should

be used in the design of new equipment for either the Signal Corps or Navy, specific approval of the Service concerned must be obtained. Such approval, when Signal Corps equipment is concerned, is to be requested from the Signal Corps Laboratory concerned with such equipment; the said Laboratory will then make known its recommendations in the matter to the Signal Corps Standards Agency where the final decision will be made and returned to the laboratory for transmittal to the party requesting the exception. When Navy equipment is concerned, the request for exception shall be addressed to the Radio Division, Bureau of Ships, Code 930-A, Navy Department.

6. The publication of this list is in no way intended to hamper or restrict development work in the field of radio electron tube or radio electron tube applications.

7. This list is to take effect immediately.

## RECEIVING

FILAMENT VOLTAGE	DIODES	DIODE TRIODES	TRIODES	TWIN TRIODES	PENTODES		CONVERTERS	POWER OUTPUT	INDICATORS	RECTIFIERS	MISCELLANEOUS
					REMOTE	SHARP					
1.4	1A3	1LW4	1LE3	3A5 387/1291	1T4	1L4 1LW5 1S5	1LC6 1R5	3A4 3D6/1299 3S4			CRYSTALS  1N21B 1N23 1N27
5.0										5U4G 5Y3GT	
6.3	6AL5 6H6* 559 9006	6A06 6SQ7* 6SR7*	2C22 2C26 6CA 6J4 6J5* 7E5/1201 9002	6J6 6SL7GT 6SN7GT	6SG7* 6SK7* 9003	6AC7* 6AG5 6AG7* 6AK5 6SH7* 6SJ7* 7W7 9001	6SA7*	6G6G 6L6GA 6N7GT/G 6V6GT/G 6Y6G	6E5	6X5GT/G 1005	PHOTOTUBES  91E 927
12.6	12H6*	12SQ7* 12SR7*	12J5GT	12SL7GT 12SN7GT	12SG7* 12SK7*	12SH7* 12SJ7*	12SA7*	12A6*	1629		VOLTAGE REGULATORS  0B3/VR-90 0C3/VR-105 0D3/VR-150
25 and above								25L6GT/G 28D7	991	25Z6GT/G	

## TRANSMITTING

TRIODES	TETRODES	TWIN TETRODES	PENTODES	RECTIFIERS			CLIPPER TUBES	GAS SWITCHING	CATHODE RAY
				VACUUM	GAS	GRID CONTROL			
2C26 2C44 6C21 15E VT127A 327B 434A 446A 527 530	801A 809 811 826 833A 838 1626 8005 8014A 8025	5D21 715B 807 813 814 1625	3E29 815 829B 832A	2E22 803 837	2X2 3824 5R4GY 371B 705A 836 1616 8016 8020	4B25 83 866A/866 872A/872	3C23 3C31/C1B C5B 8B4 2050	73 719A 1B32/532A 471A 532	2AP1 3BP1 3DP1 3FP7 5CP1 5CP7 5FP7 5JP1 7BP7 12DP7 12BP7

## MISCELLANEOUS

# This Month

## NTC ORGANIZED

Formation of the National Television Council, which will seek to keep the public informed of the latest developments in television and to exchange ideas and experiences in the field, was announced today by Richard H. Hooper, regional manager of advertising and promotion for the RCA Victor Division of Radio Corporation of America, and newly elected president of the NTC.

A planning group of representatives of all branches of thinking on television, the Council has set up permanent headquarters in the La Salle Hotel, where regular meetings will be held.

"As the end of the war draws nearer," Hooper said, "the need for such an organization, combining men who have pioneered in television in Chicago and other persons interested in the industry, has become increasingly evident."

Besides the regular sessions here, Hooper indicated that regional meetings would be held in cities throughout the South and Midwest, since many members of the group travel extensively in those territories. With requests for speakers on television mounting constantly, the Council also will function as a clearing house for these requests.

Members of the National Television Council include Commander William Eddy, on active duty with the Navy in Chicago, who has been responsible for several vital developments in television and is vice-president of the group; Ross Metzger, advertising executive, representing the thinking of advertising agencies, who is secretary-treasurer of the Council; Don McNeil, master of ceremonies of radio's Breakfast Club, and Burr Tillstrom, television puppeteer, representing the actors' viewpoint; Charles Lyons, representing television's counterpart of the commercial radio announcer, and F. K. Starbird, tire company official, bringing to the group the advertiser's point of view.

## FCC TO BUILD FM STATION

The Federal Communication Commission today announced it will construct and operate an experimental frequency modulation (FM) station, with the call letters W3XFC for the purpose of securing technical data on the operational characteristics of Frequency Modulation.



Dr. Hillier of RCA operating the console model of the RCA electron microscope. Dr. Zworykin (left) and Perry Smith of RCA look on

Operated by engineers in the Field Division in cooperation with the Technical Information and other Divisions of the Engineering Department of the FCC, station W3XFC will transmit only records, transcriptions and tone modulations. It will have a power output of approximately 50 watts and is authorized to operate on any frequency between 42,000 and 50,000 kilocycles with both wide and narrow band transmissions.

The station will be operated at several locations in the Washington area



Russel H. Lasche

on the same and channels adjacent to the local experimental FM station, W3XO, and other FM stations.

The project will not be completed for some time due to the shortage of personnel.

## FAIRCHILD APPOINTS LASCHE

Russell H. Lasche has been appointed director of engineering and research for the Fairchild Camera & Instrument Corp. of New York, one of the country's largest manufacturers of radio compasses, electrically operated gunfire control instruments, electrical aerial cameras, fractional horsepower motors, sound equipment, and other electronic instruments.

A graduate of the University of Wisconsin's engineering school, Mr. Lasche has been with the Fairchild Company 15 years, has recently directed all Fairchild sales to the war department. He was formerly in charge of the company's sound equipment division.

## RADIO BEST BEFORE FULL MOON

Radio reception has now been found to vary with the phases of the moon, it was disclosed here in a General Electric Science Forum address by Dr. Harlan True Stetson of Cambridge, Mass., director of the laboratory for

*(Continued on next page)*

# This Month

cosmic terrestrial research, Massachusetts Institute of Technology.

Citing the results obtained from data after more than 20,000 hours of observation over two periods of four years each, Dr. Stetson said:

"From the study of our data, made on those nights when the moon was overhead, we found radio reception definitely improved from the time of the moon's first quarter to shortly before full moon. After full moon, radio reception deteriorated, but began to improve again from about the last quarter until a few days before new moon. This, of course, is true for a certain particular frequency over a certain path we were measuring."

However, in observations made when "the moon was below the horizon"—observations made in the dark of the moon, "we found no such effect, where no radiation from the moon's surface could reach the radio waves over the path we were studying." Dr. Stetson pointed out.

"The same thing happened in both series of data, except that the lunar effect was more pronounced during the second four years of our data than during the first four years," he declared.

## WESTINGHOUSE TO BUILD HOME RADIO RECEIVERS AT SUNBURY, PA.

Selection of the Westinghouse Electric and Manufacturing Company plant at Sunbury, Pa., now devoted to the manufacture of war communications equipment, as the Company's manufacturing plant for production of home radio receivers was recently announced by Walter C. Evans, Vice President.

"After a careful survey of all Westinghouse facilities, we have determined that the Sunbury plant will offer the most efficient location for our Company's return to the manufacture of home radio receivers," he said. Westinghouse recently announced the formation of a new Radio Receiver Division, which will produce all basic types of home receiver equipment as soon as war conditions and the Company's war production commitments permit. The Company has not built home receivers since 1928.

## LAFAYETTE ENLARGES QUARTERS

Due to increased business, Lafayette Radio Corp., 901 W. Jackson Blvd., Chicago, has rented the entire 5th floor where additional warehousing facilities together with the kit and cable department will be located.

To expedite the many industrial orders being received daily from all over the country, Lafayette has recently installed a teletype connection with the call-letters "CG-320." By teletyping important orders there is no wasted time in delivery and delay incidental to the use of wires or letters.

## EDISON NAMES ODELL

Preparatory to increasing its activities in the aeronautical field, the Instrument Division of Thomas A. Edison, Inc., West Orange, N. J., has named Carl H. Odell as assistant man-



Carl H. Odell

ager. This was announced today by C. D. Geer, operating vice president of that division.

Mr. Odell was formerly with the Federal Telephone and Radio Corp. as an executive in its Direction Finder Division. Previous to that affiliation he was a manager of the electronics plant of the Sperry Gyroscope Corp. He came to Sperry from Jack and Heintz Corp. of Cleveland, with whom he was identified since the beginning of that organization. Mr. Odell lives in East Orange, N. J.

## LEAR APPOINTS MOUNTJOY

Garrard Mountjoy, winner of a National Association of Manufacturers "Modern Pioneer Award" and head of the Licensee Consulting Section of RCA Laboratories Industry Service Division, has been appointed head of the Lear, Incorporated Radio Laboratories.

Mr. Mountjoy will have complete supervision over all Radio Research and Development for Lear, and will make his headquarters in the company's New York Laboratories at 1860 Broadway.

## WCEMA ACTIVITIES

The West Coast Electronics Manufacturers' Association, which staged the coast's first Electronics Industry Show in August at Los Angeles, is actively engaged in discussion and furtherance of plans for present and postwar business.

The organization staged its trade show which was well attended and created considerable favorable comment everywhere. The Los Angeles Council, through Joe Spain, of Packard-Bell Co., has been actively engaged in advising the WPB Reconversion Board in Washington.

Members of the two councils continue to exchange ideas and business experience and advisory boards are constantly meeting.

The chief reconversion effort at this time is to help to establish a basic reconversion formula which may be helpful in determining the allocation of materials.

The Association has definitely gone on record as favoring the allotment of materials in proportion to all members based on their production of a half-year period preceding the return to civilian production.

## SURGE IN RECORD SALES FORESEEN BY RCA VICTOR

Estimating that only 15 percent of the potential market for records is equipped with phonograph turntables, RCA Victor Division of the Radio Corporation of America has predicted an enormous increase in record sales when production of phonograph instruments

[Continued on page 74]



Gerrard Mountjoy

**NOW HOGARTH IS ADMIRAL OF THE  
LOCAL FLEET. HE PROMISED THEM AN  
ECHOPHONE EC-1 AFTER THE WAR!**



### **ECHOPHONE MODEL EC-1**

(Illustrated) a compact communications receiver with every necessary feature for good reception. Covers from 550 kc. to 30 mc. on 3 bands. Electrical bandspread on all bands. Six tubes. Self-contained speaker. 115-125 volts AC or DC.



**ECHOPHONE RADIO CO., 540 NORTH MICHIGAN AVE., CHICAGO 11, ILLINOIS**

# New Products

## ANTENNA TUNING UNIT

The primary purpose of the new Andrew Type 48 antenna tuning unit is to couple efficiently a vertical tower antenna to a coaxial transmission line. It does this by means of an L network, the elements of which are variable to permit adjustment for optimum performance.

Features are:

1. Built-in isolation filter, to permit connecting a coaxial transmission line to an ultra high frequency antenna on top of tower. This permits operation of a high frequency "talk-back" antenna on top of a low frequency tower. A standard broadcast station would use this feature to connect a coaxial transmission line to a phase sampling loop, or to an FM antenna.
2. Substantial steel weatherproof cabinet.
3. Built-in tower lighting filter, to fa-

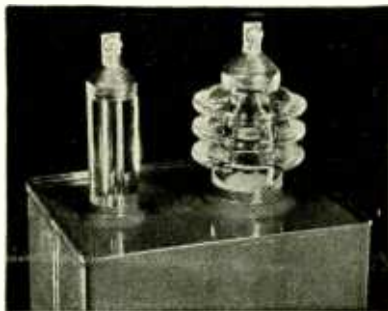

ilitate feeding aircraft warning lights on top of tower. The usual ceramic terminals are supplanted by those of glass. These glass bushings are then sealed by an exclusive Sprague process direct to the metal capacitor container, and do not require adjacent metal rings with "matched" temperature coefficients of expansion. On Koolohm Resistors, the resistance unit is encased in a special glass tube which is sealed directly to the metal ends. The resulting seals make glass and metal a solid, integral unit, and are leak-proof, shock-proof, and humidity-proof. In addition, they protect the component without the use of organic bushings or other materials which might be attacked by fungus.

## LITTELFUSE SWITCH BREAKER

A new circuit breaker relatively free from the effects of extreme high and low temperatures is announced by Littelfuse Incorporated, 200 Ong St., El Monte, California, and 4757 Ravenswood Ave., Chicago 40, Illinois.

The actual trip temperature of the new breaker without flow of current is 350° F., ambient temperature. This is accomplished by new bi-metal design. There is of course a clear distinction between operating and ambient temperatures. The high differential between operating and breaking temperatures is a distinguishing characteristic of this circuit breaker.

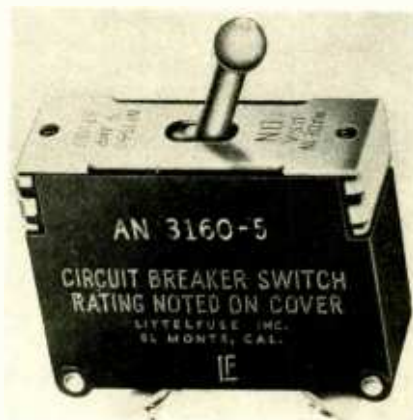

While primarily designed for military uses—aircraft, tanks, ships, landing craft, etc., its high time lag well adapts it to protection of motors and other equipment having high starting surge currents.

The importance of the achievement toward temperature compensation through design and function of the bi-metal, is indicated by the common experience of tripping at high temperatures—as for instance by aircraft parked in open desert with closed cockpits. Temperatures under these conditions reach 180° F.; 150° F. is not uncommon. At the other end of the scale, as low as -65° F. is met in high altitudes, and as low as -90° F. is of record. Between these extremes the Littelfuse breaker performs with small variations in ultimate trip values.

The Littelfuse switch breaker No. 1560 (AN 3160) is of switch type, non-trip free, performance specification AN-C-77.

The breaker is enclosed in moisture-proof black-bakelite case. It is panel-mounted by two 6/32 screws, 1/4" long, for 1/16" thickness of panels equipped with heavy copper terminal bus bars. Overall size 2 1/8" x 2" deep below panel x 3/4" wide.

Further details may be had by addressing the manufacturer.

## THERMISTORS

The Western Electric Company has added the thermistor to its long list of electronic and communications equipment now being manufactured for the Armed Forces.

The thermistor was designed by Bell Telephone Laboratories and is a small circuit element made of a mixture of metallic oxides which are pressed into discs, extruded into rods, or formed into tiny beads. These metallic oxides are members of a class of materials known as semi-conductors, which are characterized by high negative temperature coefficients of resistance. In other words the electrical resistance of the semi-conductor decreases rapidly as its temperature rises and conversely the resistance increases as its temperature falls. Temperature coefficients of resistance as great as 5% per degree centigrade are available.

Thermistors and their special characteristics may be used in electrical circuits wherever temperature changes can be produced. There are three basic

[Continued on page 56]

4. Steatite insulation throughout.

5. Plug in meter positions, to facilitate temporary metering in all branches of the circuit during adjustment.

6. Convenient outlet box, for soldering iron, extension light, etc.

Manufactured by Andrew Co., 363 E. 75th Street, Chicago 19, U. S. A.

## GLASS-TO-METAL SEALS

The old problem of guarding various capacitor and resistor types adequately against leaks and moisture is solved by a unique glass-to-metal seal pioneered and perfected by the Sprague Electric Company, North Adams, Mass., makers of Sprague Capacitors and Koolohm Resistors. In the case of Capac-



# THE EFFECTIVE REPRODUCTION OF SPEECH...

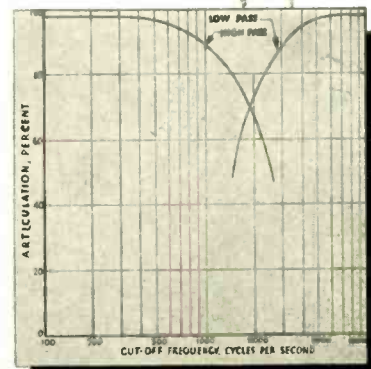
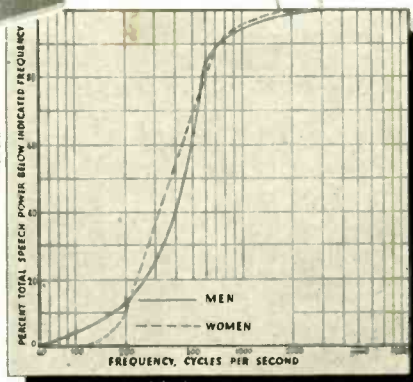
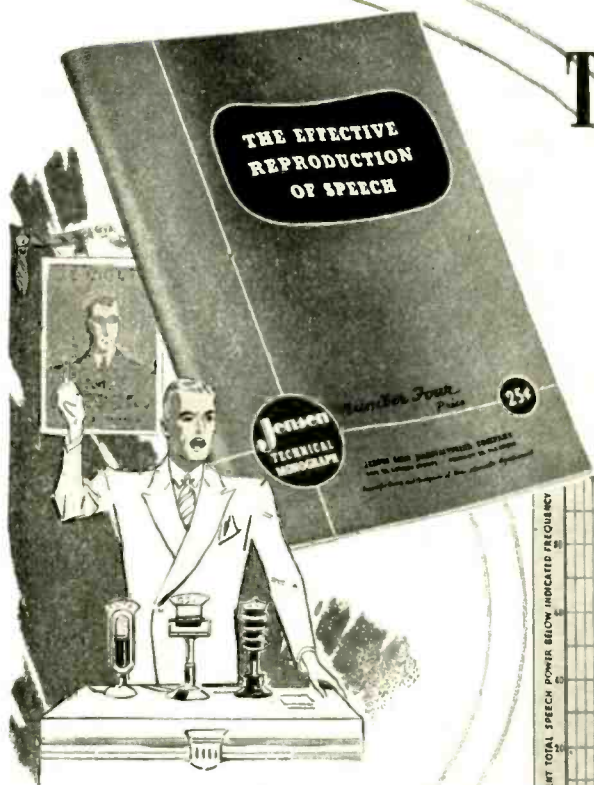

When casually considered, the reproduction of speech may appear to present less exacting requirements than the reproduction of music. Yet *faithful* speech reproduction requires a frequency band almost as wide as for music. Amplified speech for strictly communication purposes usually presents a different requirement. Here, such matters as articulation, loudness, masking, power requirements and the ability to deliver the message through noise, become the more important considerations.

"The Effective Reproduction of Speech"—Number 4 in the series of JENSEN Technical Monographs—presents much up-to-date data on this important subject in convenient form, together with useful conclusions and practical information for everyone interested in sound reproduction. Get your copy from your JENSEN jobber or dealer, or fill out the coupon and mail it with 25c for each copy ordered.

### The Series So Far Issued

- No. 1. Loud Speaker Frequency-Response Measurements.
- No. 2. Impedance Matching and Power Distribution.
- No. 3. Frequency Range in Music Reproduction.
- No. 4. The Effective Reproduction of Speech.

FREE to men in the Armed Services, and to Technical Schools, Colleges and Libraries.



**RADIO MANUFACTURING COMPANY**

6615 South Laramie Avenue

Chicago 38, Illinois

Send me  The Effective Reproduction of Speech.  
 Frequency Range in Music Reproduction.  
 Impedance Matching and Power Distribution.  
 Loud Speaker Frequency-Response Measurements.  
 (Check one or more. Send 25c for each book ordered.)

NAME \_\_\_\_\_

ADDRESS \_\_\_\_\_

CITY \_\_\_\_\_

ZONE \_\_\_\_\_

STATE \_\_\_\_\_



# New Products

[Continued from page 54]

ways of varying the temperature; externally, directly, and indirectly. If the ambient temperature rises, the resistance falls accordingly. If a current is passed through a thermistor, heat is produced internally, the temperature rises and the resistance lowers. If a small coil of wire is placed very close around the thermistor and a current is passed through it, heat is produced by the coil which in turn warms the thermistor and lowers its resistance. The unit is then said to be indirectly heated. Thus by suitable electrical connections, changes in the thermistor resistance may be used for measurement or for control of ambient or circuit conditions as desired.

One of the older types of thermistors, the IC, which may be known to some electronic engineers, will typify the operation of the 30 to 40 types now in manufacture. This is a directly-heated type of thermistor and consists of a minute bead of oxides suspended on fine wires and enclosed in a nitrogen-filled glass bulb with two wire terminals. This assembly is further encased in an insulating tube with metal contacts on the ends, much like a fuse housing. The overall length of the completed unit is approximately  $1 \frac{5}{16}$  inches, and the outside diameter is about  $\frac{1}{4}$  inch.

A IC thermistor, at room temperature, has a resistance of approximately 50,000 ohms. As current flows through the oxide bead, the unit is heated and its resistance decreases. To demonstrate the extent of the decrease brought about by the resistance versus power characteristics of the unit, let us raise the power input to 18 milliwatts. At this point the resistance of the unit will be approximately 18,000 ohms showing a decrease of approximately 32,000 ohms. When 100 milliwatts is applied, the resistance will be approximately 500 ohms.

The thermistor will trace and retrace the characteristics here indicated without appreciable deviation over an indefinitely long life.

## FREQUENCY STANDARD

The James Knights Company, of Sandwich, Illinois, announces a new Secondary Frequency Standard. Crystal controlled with a hermetically sealed James Knights MD cut dual frequency crystal, the instrument provides useful output up to 40 mc at 1,000, 100 and 10-kilocycle intervals. Operates from 60 cycle 115 volt line.

The unit is housed in a metal cabinet with gray crackle finish.

## CHASSIS CRADLE

A new device that is said to simplify and speed assembly and inspection of radio chassis and other electrical assemblies has recently been announced by Acro Tool and Die Works of Chicago. It is sold under the tradename Acro Chassis Cradle.

According to the manufacturer, the new Cradle holds the assembly in an easy-to-get-at position for quick inspection or repair. Allows workers to use both hands and permits them to position working area to their convenience. Assemblies can be rotated and locked in position by a "flick" of the finger.



It is further claimed that the new Cradle reduces the danger of damaging tubes, coils and other delicate parts as so frequently occurs by dropping and bumping during ordinary handling.

Manufactured by Acro Tool and Die Works, 4892 N. Clark Street, Chicago 40, Illinois.

## NEW UHF CABLES

New sizes and types of solid-dielectric coaxial cables, used in ultra-high-frequency radio and radar equipment for the armed services, have been added to the line of



cables manufactured by the Intelin Products Division of Federal Telephone and Radio Corporation, Newark, New Jersey, associate of International Telephone and Telegraph Corporation.

Federal cables are manufactured in five

basic types: Coaxial, dual-coaxial, twin-conductor, coaxial air-spaced and spiral delay. Designed, generally, for 50 to 70 ohms impedance, the cable selected is predicated upon power requirements or power loss limitations.

Coaxial lines include sizes from  $\frac{3}{16}$ " outside diameter up to and including cables over 1" in outside diameter. Standard designs include single and double-braided constructions with standard and armored covering.

Dual-coaxial lines have been developed to fill the need for parallel circuits having a high degree of electrical balance.

Twin-conductor lines, sometimes called "Twinax" are balanced shielded pairs, usually somewhat smaller than dual-coaxial lines, and provide nearly as good an electrical balance.

For low capacitance requirements, Federal has developed a line of coaxial air-spaced cables which can be made in any required length and which have capacitances as low as 8 micro-micro-farads per foot.

Spiral delay lines have been developed for special test sets requiring lines with an appreciable delay or very high impedances. Some of these lines have in a one foot length an electrical equivalent to that of 15 feet of coaxial cable.

Descriptive literature on these and other Federal products is available upon request.

Taylor type 208, glow discharge, fence controller tube



## FENCE CONTROLLER TUBES

Two fence controller tubes are announced by Rex L. Munger, Sales Manager of Taylor Tubes, Inc., 2312 Wabansia Avenue, Chicago, Illinois. One, the Taylor 208 is a glow discharge tube and the other, the Taylor 207, is a rectifier.

Both tubes have glass envelopes and a standard 4-pin base.

Electrical characteristics: Taylor 208 (shown)—Discharge at 875 to 950 volts D.C. at 8 milliamperes. Taylor 207—Filament volts, 2.5 a-c; filament current, 2.5 amperes; max. rms a-c volts, 1250; max. d-c, current, 125 milliamperes.

Connections are all brought out to the pins in the base.



**HARVEY 106 PA**  
200 to 300 VOLTS

# HARVEY

## OF CAMBRIDGE

*New*  
**HARVEY 206 PA**  
500 to 1000 VOLTS

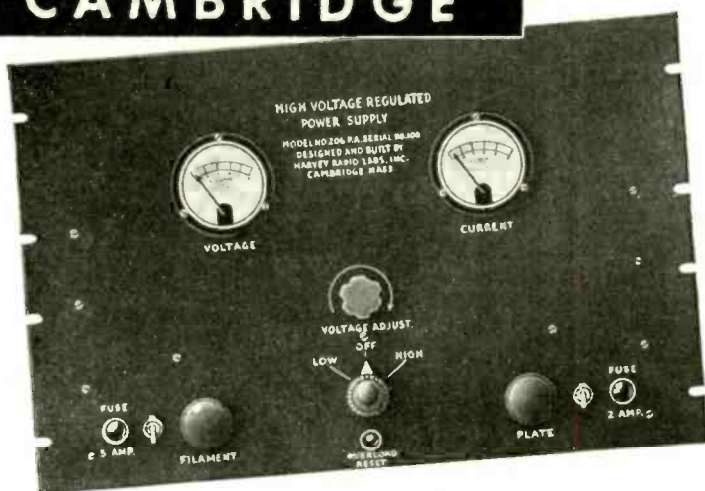

### for REGULATED POWER SUPPLY

If you're looking for a dependable, controllable source of laboratory D.C. power for operation with pulse generators, measurement equipment, constant frequency oscillators, amplifiers and other equipment requiring a constant flow of D.C. voltage, it will pay you to get in touch with Harvey of Cambridge.

The Harvey Regulated Power Supply 106 PA will meet your every requirement in the lower voltages. It has a D.C. output variable from between 200 to 300 volts that is regulated to within one per cent.

The new Harvey Regulated Power Supply 206 PA is for higher voltages. This latest Harvey development operates in two ranges 500-700 at  $\frac{1}{4}$  of an ampere and 700 to 1000 at  $\frac{1}{2}$  of an ampere. Both ranges have accurate regulation to one per cent or better.

Whatever your requirements, one of these Harvey Regulated Power Supply units will meet them with efficient, dependable performance.

We'd be happy to supply you with complete information on either or both of them.



**HARVEY RADIO LABORATORIES, INC.**

454 CONCORD AVENUE • CAMBRIDGE 38, MASSACHUSETTS

# RADIO BIBLIOGRAPHY

F. X. RETTENMEYER

RCA Victor Division, Radio Corporation of America

## 17—AIRCRAFT RADIO, PART 2

A Directive Type of Radio Beacon and Its Application to Navigation—F. H. Engel and F. W. Dunmore—*Bureau of Standards Scientific Papers*—No. 480, Jan. 1924.

Teletypewriter Weather Map Service now in Operation—*Air Commerce Bulletin*—Vol. 4, No. 12, December 15, 1932, page 290.

Aviation Radio Communications—A. E. Brundage—*Aero Digest*—Vol. 27, October 1935, page 34.

Aeronautic Radio—*Aeronautics Bulletin No. 27*—Published by Dept. of Commerce, Bureau of Air Commerce, July 1, 1937.

Geographical Separation of Radio Range Stations Operating on the Same or Adjacent Frequencies in the 200-400 Kc. Band—A. E. Harrison—Dept. of Commerce, Bureau of Air Commerce Safety and Planning Div. Report No. 4, Jan. 1938.

Note on the Aerials and Radiation Diagrams of Interlocked Signal Radio Beacons—Y. Rocard, Besson—*Bulletin de la S.F.R.*, No. 2, —Vol. 2, 2nd quarter 1937, page 33.

Monitor Stations for Radio Range Beacons—*Air Commerce Bulletin*—Vol. 7, No. 8, Feb. 15, 1936, page 189.

An Investigation of Medium Wave Radio Range Beacons (With Adcock Transmitting Aerials)—T. Amishima and M. Ikada—*Nippon Elect. Commun. Engineering*—Dec. 1936, page 467.

Crystal-Controlled Wireless Beacons—*Engineer*,—Vol. 160, July 5, 1935, page 19; *Electrician*—Vol. 115, July 12, 1935, page 52.

U. S. Patent #1,991,474—L. A. Taylor—Radio Beacon System—Issued Feb. 19, 1935.

A Method of Providing Course and Quadrant Identification with the Radio Range Beacon System—F. W. Dunmore—Research Paper #592 (part of *Bureau of Standards Journal of Research*—Vol. 11, Sept. 1933).

Phase Synchronization in Directive Antenna Arrays with Particular Application to the Radio Range Beacon—F. G. Kear—*National Bureau of Standards Journal of Research*—Vol. 11, July 1933, page 123.

Solution of the Problem of Night Effects with the Radio Range Beacon System—H. Diamond—*I.R.E. Proceedings*—Vol. 21, June 1933, page 208.

Remote Control Adopted for Airway Radio Station—*Air Commerce Bulletin*—Vol. 4, No. 17, March 1, 1933, page 424.

Simplification of Radio Range Beacon Position and Quadrant Identification—*Air Commerce Bulletin*—Vol. 5, No. 1, July 15, 1933, page 2.

Aeronautic Radio on Federal Airways System—*Air Commerce Bulletin*—Vol. 5, No. 5, Nov. 15, 1933, page 127.

New Type of Transmitting Antenna Developed for Radio Range Beacons—*Air Commerce Bulletin*—Vol. 4, July 15, 1932, page 33.

Phase Synchronization for the TL Antenna System—*Air Commerce Bulletin*—Vol. 4, No. 8, Dec. 1, 1932, page 259.

Applying the Visual Double Modulation Type Radio Range to the Airways—H. Diamond—Research Paper #148 (*Reprint from Bureau of Standards Journal of Research*—Vol. 4, Feb. 1930).

A Twelve-Course Radio Range for Guiding Aircraft with Tuned Reed Visual Indication—H. Diamond and F. G. Kear—Research Paper #154 (*Reprint from Bureau of Standards Journal of Research*—Vol. 4, March 1930).

Development of the Visual Type Airway Radio-Beacon System—J. H. Dellinger, H. Diamond and F. W. Dunmore—Research Paper #159 (*Reprint from Bureau of Standards Journal of Research*—Vol. 4, March 1930).

Radio Along the Airways. Invisible Beams Guide Birdmen in Flights between European Cities—Orrin E. Dunlap—*Sci. Am.*—Vol. 83, Jan. 1927, page 32.

Radio Phenomena at Salt Lake Radio Range Station Studied by Bureau—*Air Commerce Bulletin*—Vol. 8, No. 3, Sept. 15, 1936, page 65.

Radio Range Cone of Silence—C. W. Lample—*Air Commerce Bulletin*—Vol. 8, No. 5, Nov. 15, 1936, page 127.

Department of Commerce Seeking Perfection for Radio Range Beacons in Mountainous Country—*Air Commerce Bulletin*—Vol. 5, No. 9, March 15, 1938, page 211.

Multiple Courses of Radio Range Beacons Investigated—*Air Commerce Bulletin*—Vol. 6, No. 5, Sept. 15, 1934, page 55.

Report on Cone of Silence Tests at Knoxville, Tennessee—D. M. Stuart—Dept. of Commerce, Bureau of Air Commerce, Safety and Planning Div. Report No. 8, April 1938.

Unbending the Beams; Report of Progress on Modernizing the Airways, with Special Reference to Winger Operations—*Aviation*—Voy. 37, February 1938, page 78.

Simultaneous Transmission of Voice and Aural Radio Range Signals—*Air Commerce Bulletin*, Vol. 5, No. 11, May 15, 1934, page 268.

Simultaneous Transmission of Radio Beacon Signals and Voice in Trial Service at Pittsburgh—*Air Commerce Bulletin*—Vol. 7, No. 1, July 15, 1935, page 1.

A Radio Range Beacon Providing Both Aural and Visual Service Simultaneously—*Air Commerce Bulletin*—Vol. 4, No. 23, June 1, 1933, page 592.

Selected Circuits and Static Interference—J. R. Carson—*Bell Systems Technical Journal*—Vol. 5, No. 2, April 1925.

On the Design of Equisignal Radio Beacons with Overlapping Signals for Civil Air Routes—N. A. Miasoebov—*Electro Industry of Weak Currents Proceedings* (Russian) No. 10, 1936, page 12.

[Continued on page 60]



The United States Navy has awarded the men and women of Hallicrafters a special "Certificate of Achievement"... first award of its kind... for outstanding service with the radar-radio industries of Chicago in speeding vital war material to the Navy. Added to the four Army-Navy "E" awards, this makes five times Hallicrafters workers have been cited for distinguished service. They promise that this kind of service will be continued until total victory is ours.

★ BUY A WAR BOND TODAY

**hallicrafters RADIO**



THE HALLICRAFTERS CO., MANUFACTURERS OF RADIO AND ELECTRONIC EQUIPMENT, CHICAGO 16, U. S. A.

# RADIO BIBLIOGRAPHY

- On the Utilization of Power in Equi-signal Radio Beacons—N. A. Miasoebov—*Electro Industry of Weak Currents Proceedings* (Russian), No. 10, 1936, page 10.
- A Simultaneous Radiotelephone and Visual Radio Beacon for Airways—F. G. Kear and G. H. Wintermute—Research Paper #341 (Reprint from *Bureau of Standards Journal of Research*—Vol. 7, August 1931).
- Tests of the First Manufactured Fan Marker—W. E. Jackson, P. D. McKeel and H. I. Metz—Bureau of Air Commerce, Safety and Planning Div. Report #17, July 1938.
- The Development, Adjustment, and Application of the Z Marker—W. E. Jackson and H. I. Metz—Bureau of Air Commerce, Safety and Planning Div. Report #16, July 1938.
- Fan Markers to Have Characteristic Signals—*Air Commerce Bulletin*—Vol. 9, No. 12, June 15, 1938, page 304.
- Report on the Development of Fan Type Ultra-High Frequency Radio Markers as a Traffic Control and Let-Down Aid—H. I. Metz—Dept. of Commerce, Bureau of Air Commerce, Safety and Planning Div., Report #5, Jan. 1938.
- The Development of an Improved Ultra-High Frequency Radio Fan Marker—P. D. McKeel, J. M. Lee, and H. I. Metz—Bureau of Air Commerce Report #14, July 1938.
- Cone of Silence Markers Identify Exact Locations of Range Stations—H. I. Metz—*Air Commerce Bulletin*—Feb. 15, 1937, page 169.
- Some Problems of Aviation Radio (including "Z" markers to provide positive, instead of negative, indication of position directly over beacon, etc.)—F. X. Rettenmeyer—*Journal Institute Aeronautical Sciences*—Vol. 4, No. 7, May 1937, page 297.
- Method of Signal Emission for Guiding Aeroplanes Landing in Fog—A. Leib—*Hochfrequenztechnik und Elektroakustik*—Vol. 47, No. 5, May 1936, page 176. German Patent #622615 of 27.7.1933.
- Development of Airway Beacons—H. C. Ritchie—*Aero Digest*—Vol. 27, October 1935, page 38.
- Rose Type Airport and Airway Markers—*Aero Digest*—Vol. 27, Nov. 1935, page 42.
- Radio Marker Beacon Used to Indicate to Airmen Location of Radio Towers—*Air Commerce Bulletin*—Vol. 6, Nov. 1934, page 119.
- Radio Marker Beacons—*Air Commerce Bulletin*—Vol. 4, No. 19, April 1, 1933, page 467.
- Progress of Experiments on Elimination of Rain Static Reported by TWA—*Air Commerce Bulletin*—Vol. 8, No. 11, May 15, 1937, page 251.
- Snow Static Effects on Aircraft—H. M. Hucke—*Communication & Broadcast Engineering*—Vol. 4, No. 7, July 1937, page 7.
- Some Problems of Aviation Radio (including "Rain Static" and its elimination by electrostatically shielded loop aerials, etc.)—F. X. Rettenmeyer—*RCA Review*—Vol. 1, No. 4, April 1937, page 113.
- Fighting Snow Static—T. C. McClary—*Radio News*—Vol. 19, March 1938, page 519.
- Rain Static (Particularly Affecting Aircraft)—H. K. Morgan—*I.R.E. Proceedings*—Vol. 24, No. 7, July 1936, page 1375.
- Snow Static Detector—*Communications*—Vol. 18, No. 1, January 1938, page 28.
- Beacon Antenna Characteristics—H. K. Morgan—*Air Commerce Bulletin*—Vol. 9, No. 4, October 15, 1937, page 77.
- Receiving System for Radio Beacons (long summary of a patent)—P. H. Thomas—*Alta Frequenza*—Vol. 6, No. 6, June 1937, page 418.
- Radiobeacons—Bajenov and Miasoebov—(Text) (Russian) 1936.
- New Procedure to Facilitate Investigation of Radio Range Trouble—*Air Commerce Bulletin*—Vol. 6, No. 8, Feb. 15, 1935, page 187.
- T-Shaped Vertical Aircraft Radio Antenna Found to Be one of Most Suitable Types of Flying Radio Range Beacon—*Air Commerce Bulletin*—Vol. 6, No. 8, Feb. 15, 1935, page 187.
- Aural Radio Range Signals Shown Visually by New Device—*Air Commerce Bulletin*—Vol. 5, No. 11, May 15, 1934, page 265.
- On the Rotation of the Plane of Polarization of Long Waves—A. L. Green and G. Builder—*Proceedings of the Royal Society, Series A*,—Vol. 145, June 2, 1934, page 145.
- A Proposed Rotating Radio Beacon for Air Navigation—Lawrence J. Lish—*Popular Aviation*—November 1934, page 302.
- Connection of Several Receivers to One Aerial—M. Read—*Experimental Wireless and Wireless Engineer*—Aug. 1934, page 428.
- Electric Field Near the Antenna—K. Hashida—*Journal I.F.E. of Japan*—Vol. 54, No. 548, March 1934, page 20.
- The Cause and Elimination of Night Effects in Radio Range Beacon Reception—H. Diamond, Research Paper #513 (Reprint from *Bureau of Standards Journal of Research*—Vol. 10, January 1933).
- Antenna for Radio Range Reception—*Air Commerce Bulletin*—Vol. 4, No. 21, May 1, 1933, page 528.
- Action of Tuned Rectangular Frame Aerials for Short Waves—Palmer—*Proc. Royal Soc., Serial A*.—Vol. 136, May 2, 1932, page 193.
- Review of Recent Research on Airplane Radio Receiving Equipment—*Air Commerce Bulletin*—Vol. 3, No. 15, Feb. 1, 1932, page 357.
- The State of Polarization of Sky Waves—A. L. Green—*Radio Research Board of Australia Report #2*, 1932, page 11.
- Characteristics of Airplane Antenna Range-Beacon Reception—H. Diamond and C. L. Davies—Research Paper #313 (Reprint from *Bureau of Standards Journal of Research*—Vol. 6, May 1931). Bureau of Standards, Department of Commerce.
- The Absorption of Energy by Wireless Aerials—Ratcliffe—*Proc. Cambridge Phil. Soc.*, October 1931, page 578.
- A Course Indicator of Pointer Type for the Visual Radio Range Beacon System—F. W. Dunmore—Research Paper #336 (Reprint from *Bureau of Standards Journal of Research*—Vol. 7, July 1931).
- Theory of Design and Calibration of Vibrating Reed Indicators for Radio Range Beacons—G. L. Davies—Research Paper #338 (Reprint from *Bur. of Stds. Jnl. of Res.*—Vol. 7, July 1931).
- Automatic Volume Control for Aircraft Radio Receivers—W. S. Hinman—Research Paper #330 (Reprint from *Bur. of Stds. Jnl. of Res.*—Vol. 7, July 1931).
- A Tuned-Reed Course Indicator for the 4- and 12-Course Aircraft Radio Range—F. W. Dunmore—Research Paper #160 (Reprint from *Bur. of Stds. Jnl. of Res.*—Vol. 4, April 1930).
- A Course Shift Indicator for the Double Modulation Type Radio-Beacon—F. W. Dunmore and R. Diamond—Research Paper #27 (Reprint from *Bur. of Stds. Jnl. of Res.*—Vol. 3, July 1929).
- Aircraft Radio Receivers for Use with Rigid Antenna—R. H. Drake—*I.R.E. Proceedings*—February 1929.
- Design of Tuned Reed Course Indicators for Aircraft Radio Beacon—F. W. Dunmore—Research Paper #28 (Reprint from *Bureau of Standards Journal of Research*—November 1928).
- Receiving Sets for Aircraft Beacon and Telephony—Haraden Pratt and H. Diamond

[Continued on page 62]

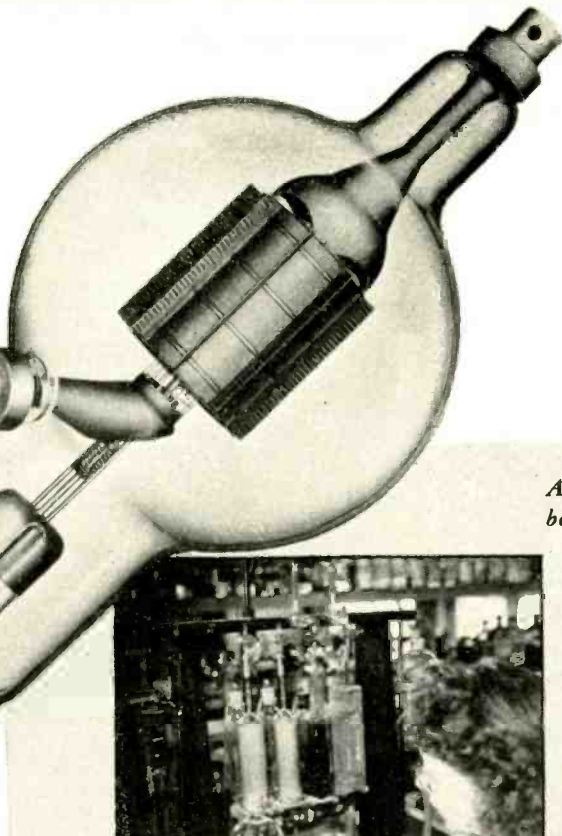
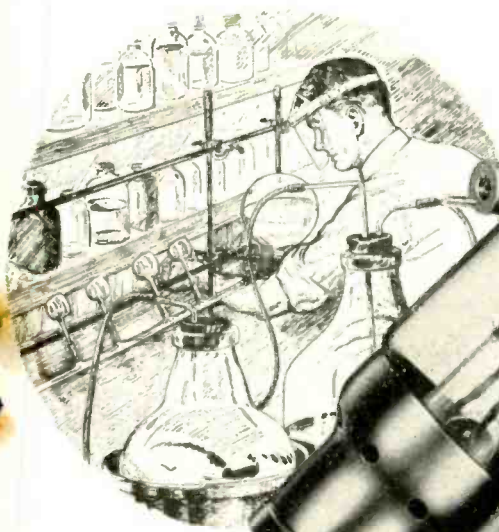

# the *Science* behind the science of electronics

The pattern of progress in the science of electronics is determined by the achievements in creating and developing new and more efficient electron vacuum tubes. Therefore, the whole complex task of vacuum tube development — involving the intelligent application of many sciences — comprises the real science behind the science of electronics.

To create and produce the modern vacuum tube requires experience and skill of the highest order in these many sciences in addition to complete facilities for their application. The list includes everything from chemistry and metallurgy — the technology of glass fabrication and vacuum pumping — to physics, optics, thermo-dynamics and most important of all — Electronics.

The resources and resourcefulness of Eimac laboratories have accounted for many outstanding contributions to the science of Electronics. A fact which is attested to by the leadership which Eimac tubes enjoy throughout the world. These comprehensive facilities are continuously being utilized to achieve better and better results for the users of Eimac tubes.

Eimac Engineering is devoted solely to the development and production of electron vacuum tubes. However, since the electron vacuum tube is the heart of all electronic devices it is advisable for users and prospective users of electronics to look first to the vacuum tubes required. A note outlining your problem will bring advice and assistance without cost or obligation.

Write for your copy of *Electronic Telesis* — a 64 page booklet fully illustrated — covering fundamentals of Electronics and many of its important applications. Written in layman's language.



*A few of the branches of the Science behind the Science of Electronics*

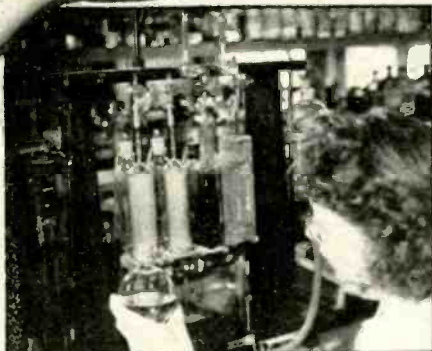

**CHEMISTRY**—Making Gas Analysis in the Eimac Laboratory

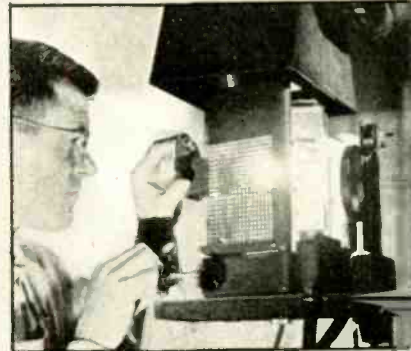

**METALLURGY**—Spectrographic Analysis of the Rare Metals Used in Vacuum Tubes

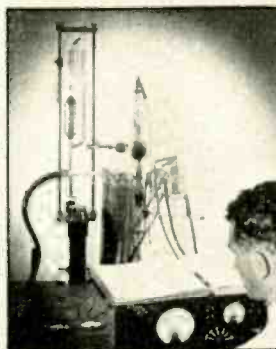

**VACUUM TECHNOLOGY**—Constant Research to Develop Better Vacuum Techniques



**PHYSICS**—Actually Viewing Emission of Electrons with Electron Microscope



**ELECTRONICS**—Determining Facts about and Recording Data on Vacuum Tube Capabilities



**OPTICS**—Studying the Effect Processing has on the Structure of Materials Through Photomicrography

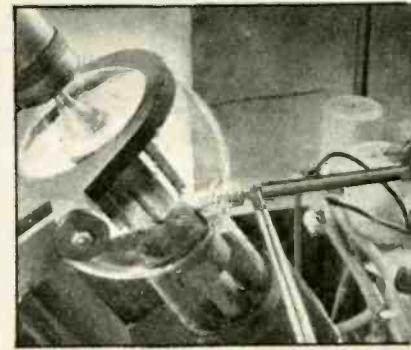

**GLASS TECHNOLOGY**—Special Equipment and Technique to Produce Complicated Glass Structures

Follow the leaders to

**Eimac**  
REG. U. S. PAT. OFF.  
**TUBES**

**EITEL-McCULLOUGH, INC., 869 San Mateo Ave., SAN BRUNO, CALIF.**

Plants located at: San Bruno, California

and Salt Lake City, Utah

Export Agents: FRAZAR & HANSEN, 301 Clay Street, San Francisco, California, U. S. A.

- mond—*Bureau of Stds. Jnl. of Research*—Vol. 1, No. 4, October 1928, page 543.
- Aircraft Radio Receiver Equipment with Rod Antenna for Reception of Beacon & Weather Service—F. H. Drake—*Aero Digest*—October 1928.
- The Theory of Receiving Aerials—F. M. Colebrook—*Experimental Wireless*—1927, Vol. 4, page 657.
- Screening of Receiving Aerials—Smith-Rose—*Wireless World*—1926, Vol. 18, page 61.
- Electric Oscillations in a Free Wire—M. Abraham—*Annalen Der Physik*—1900, Vol. 2, page 32.
- Preliminary Report on a Four-Course Ultra-High Frequency Radio Range—J. C. Hromanda—Dept. of Commerce, Bureau of Air Commerce, Safety and Planning Div., Report No. 3, Jan. 1938.
- Ultra-High Frequency Range Beacon—*Aero Digest*—Vol. 32, April 1938, page 70.
- Ultra-Short-Wave Guide-Ray Beacon and Its Application—E. Kramer and W. Hahnemann—*I.R.E. Proceedings*—Vol. 26, Jan. 1938, page 17.
- Rotary Radio Beacons—E. Kramer—*Aero Digest*—April 1938, page 38.
- U. S. Patent #2,112,824—Brown and Luck—Radio Transmitter for Direction Finding Device—Issued April 5, 1938.
- U. S. Patent #2,045,904—Furnival—Radio Beacon—Issued June 30, 1936.
- Application of Ultra-Short Waves to Radio Range Beacons (Equiwitnol m35hoe)—M. Okada and R. Kimura—*Nippon Elect. Communication Engineering*—Dec. 1936, page 465.
- Method of Exciting the Aerial System of a Rotating Radio Beacon—H. A. Thomas—*I.E.E. Journal* (London)—Vol. 77, August 1935, page 285.
- U. S. Patent #1,988,006—Greig—Direction Finding System—Issued January 15, 1935.
- U. S. Patent #2,014,732—Hansell—Radio Beacon System—Issued Sept. 19, 1935.
- U. S. Patent #1,933,248—Evans—Radio Direction Finder—Issued October 31, 1933.
- U. S. Patent #1,815,246—Englund—Radio Direction Finder—Issued July 21, 1931.
- Some Observations on the Orfordness Rotating Beacon—R. L. Smith-Rose—*Journal I.E.E.* (London)—Vol. 69, 1931, page 523.
- Some Experiments on the Application of the Rotating Beacon Transmitter to Marine Navigation—R. L. Smith-Rose and S. R. Chapman—*Journal I.E.E.* (London)—66, March 1928, page 256.
- Rotating Loop Radio Transmitters and their Application to Direction Finding and Navigation—T. H. Gill and E. S. Hecht—*Journal I.E.E.* (London)—Vol. 66, March 1928, page 241.
- A Theoretical Discussion of Various Possible Aerial Arrangements for Rotating Beacon Transmitters—R. L. Smith-Rose—*Journal I.E.E.* (London)—Vol. 66, March 1928, page 270.
- An Investigation of a Rotating Radio Beacon—R. L. Smith-Rose and S. R. Chapman—Radio Research Special Report #6, 1928.
- British Patent #19,878—(Sept. 6, 1906). U. S. Patent #259,301—(Dec. 14, 1911). German Patent #328,276—(Mar. 2, 1918). Northerly Turning Error of the Magnetic Compass for Aircraft—C. S. Draper, W. H. Cook and W. McKay—*Journal of Aeronautical Sciences*—Vol. 5, No. 9, July 1938, page 345.
- The Fairchild-Maxon Line of Position Computer—J. D. Peace—*Aero Digest*—Vol. 33, No. 2, August 1938, page 67.
- Hughes Flight Navigators and Navigation Procedure—*Aero Digest*—Vol. 33, No. 2, August 1938, page 63.
- Orientation and Landfall by Means of Pre-computed Curves—W. C. Bentley—*Aero Digest*—Vol. 38, No. 2, August 1938, page 92.
- Burgin Range Projector, Aid in Solving Problems of Radio Navigation Either in Flying the Radio Ranges or in Direction Finding—*Aero Digest*—Vol. 32, Jan. 1938, page 56.
- Developments in Aircraft Radio—*Electronics*—February 1938, page 20.
- Through the Overcast—A. Jordanoff—(Text), Funk & Wagnalls, 1938, page 241.
- Finding Your Way in the Air—P. V. H. Weems—*Aviation*—Sept. 1937, page 38.
- Sonic Marker Beacon for Fog Aviation and the Sonic Locator: An Aid to Fog Navigation—C. W. Rice—*Acoustical Society of America Jour.*—Vol. 8, No. 1, July 1936, page 26.
- Naval Direction Finding—*Wireless Engineer and Experimental Wireless*—Vol. X, No. 119, Aug. 1933, page 434.
- Wireless Direction Finding and Direct Reception—Keen (Text).
- Flying in Bad Weather—*Air Commerce Bulletin*—Vol. 4, No. 19, April 1, 1933, page 470.
- The Antenna Effect—A Simple Method for Its Elimination—S. R. Khastger and D. Chowdhivie—*Indian Jnl. of Physics*—Vol. 8, Dec. 15, 1933.
- Direction Finder for Storms Tested for Navy—*Popular Mechanics*—Vol. 87, Feb. 1932, page 207.
- Radio Direction Finding Experiments with Aurora—B. Dull—*Electronics*—Vol. 5, August 1932, page 268.
- Über die Ursachen der Nachtlichen Funkpeil—Schwankungen—B. Dull—*E.N.T.*—Vol. 9, Aug. 1932, pages 308-318.
- Radio-Compass Stroboscopi à Lecture directe—R. Hardy and Bertrand-Lepaute—*Comptes Rendus*—Vol. 195, Sept. 5, 1932, pages 517-521.
- Über die Peilbreite von Peilempfängern—P. Hermanspann—*Telefunken-Zeitung*—Vol. 13, March 1932, pages 35-36.
- Shipboard Observations with Cathode Ray Direction Finder between England and Australia—G. H. Munro and L. G. H. Huxley—*Jnl. I.E.E.* (London)—Vol. 71, No. 429, Sept. 1932, page 488.
- Sur la Determination du Pont par la Radiogonimétrie—Bertin, Ch.—*Comptes Rendus*—Vol. 193, Aug. 31, 1931, pages 394-395.
- Procèdes de Radioalignement—P. Besson—*L'Onde Électrique*—Vol. 10, Sept. 1931, pages 369-424.
- La Radiogonimétrie et la Navigation Serienne—G. Etienne—*Q.S.T. Français*—Vol. 12, March 1931, pages 47-51.
- Direction Finding for Aviation—Schwandt—*Electronics*—Vol. 3, Dec. 1931, page 243.
- La Radiogonimétrie appliquée aux Lignes Seriennes—Serre—*L'Onde Électrique*—Vol. 10, Oct. 1931, pages 425-457.
- A New Television Development—Shiels, C.—*Pop. Wireless*—c. 19, June 13, 1931, page 441.
- Unilaterales Peilwinkelzeigergerat mit rotierender Goniometer-Ankopplungspule—F. Berndorfter and M. Dieckmann—*Jahrb. Draht. Teleg. U. Teleph.*—Vol. 35, March 1930, pages 98-105.
- Le Guidage des Navires et des Avions—Bourgonnier, M.—*Soc. Fran. Électriciens, Bull.*—Vol. 10, June 1930, pages 660-666.
- Zur Frage der Standersbestimmungen aus drei Funkpeilungen—P. Duckert—*E.N.T.*—Vol. 7, Jan. 1930, pages 15-18.
- Un Nouveau Procède Cartographique que facilité le Trace des Radio-Routes—Jean Labadie—*Science et La Vie*—Vol. 38, July 1930, pages 50-52.

[To be continued]



**“They make  
everything  
in their line  
from the raw  
material to  
the finished  
product.”**

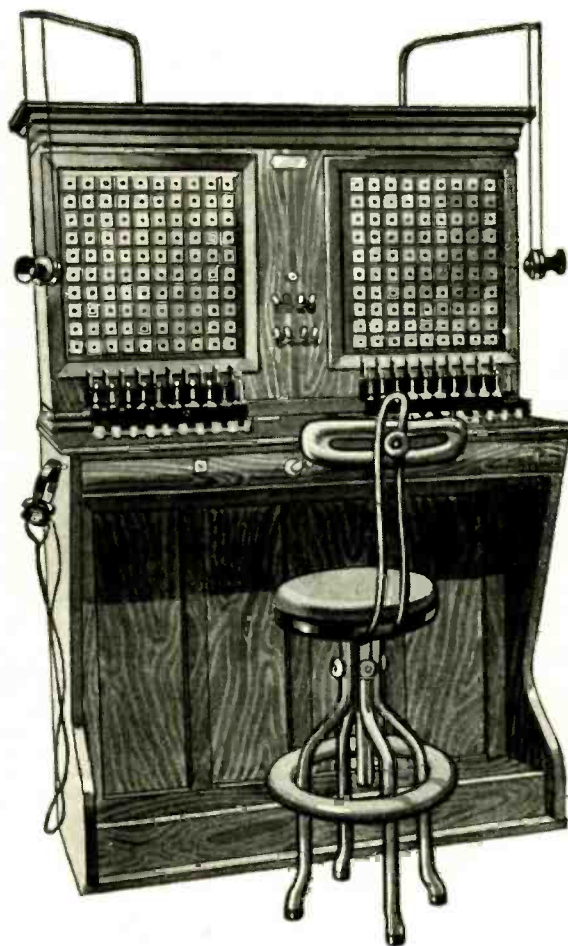
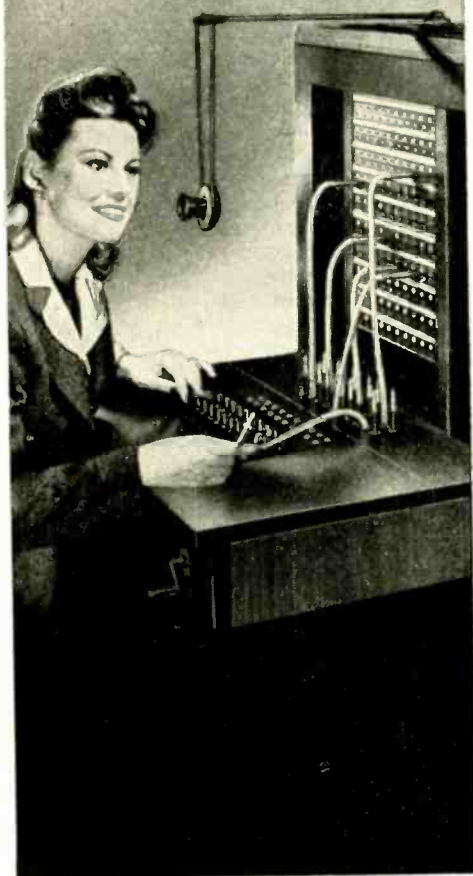

**T**his sentence was written about a news-worthy feature of Connecticut Telephone and Electric operations nearly forty years ago. It has been important ever since.

This Division's facilities for complete fabrication of electrical parts and devices within its own plants are unusual. Because of them, the production of vital communications equipment, aircraft ignition devices and other urgently needed war material is being speeded. It permits important manufacturing economies. It gives us better control of the equipment we make. These things are important in war and peace alike.

## **CONNECTICUT TELEPHONE & ELECTRIC DIVISION**

**GREAT AMERICAN INDUSTRIES, INC.**

MERIDEN, CONNECTICUT

TELEPHONIC SYSTEMS • SIGNALLING EQUIPMENT • ELECTRONIC DEVICES • ELECTRICAL EQUIPMENT • HOSPITAL AND SCHOOL COMMUNICATIONS AND SIGNALLING SYSTEMS • IGNITION SYSTEMS



# TERMINOLOGY

[Continued from page 28]

transmission over distances that are short enough so that the curvature of the earth does not obstruct their passage. In other words, microwave transmission is all accomplished by means of a ground wave.

No microwave skywave is ordinarily detected because the ionized layers of the stratosphere are not able to afford much reflection. Instead, the microwave energy continues out into interstellar space. For this reason it is frequently said that microwave communication is limited to line-of-sight range. This implies that a micro-

wave beam can travel from transmitter to receiver only if, except for fog and intensity requirements, it is equally possible to transmit a beam of light over the same distance.

All this is approximately equivalent to saying that the maximum range of microwave signals is limited to something like 200 miles and even then only if the receiver or transmitter can be well elevated.

Actually, it is not enough merely to take an average radius of curvature of the earth and proceed with simple geometry to find line of sight ranges for various elevations of the antennas because of refraction effects. In an actual case the intensity simply falls off with range in a regular manner and has been found by

K. A. Norton,\* who made measurements and calculations at 46 mc, to become nearly zero at 200 miles for well-elevated antennas. Only when power measurements as a function of altitude are made at several ranges and the maxima of each altitude set is plotted do we obtain a curve which we may interpret as the line-of-sight path.

It has been found that, for true microwave frequencies, this path allows ranges which are roughly equivalent to those which would be calculated geometrically if the average curvature of the earth were assumed to be 1.4 times larger than it actually is.

*Line of sight range for microwave transmission is the maximum distance over which microwaves can be transmitted. Refraction makes the distance somewhat greater than simple calculations of the earth's curvature would suggest but does not prevent that curvature from being the limiting factor.*

**Magnetic Dipole**—Antennas used to insert energy into or extract it from wave guides or resonant cavities may generally be divided into two classes. One is of the sort which, to a first approximation, acts like an electric dipole and the other is more like a magnetic dipole.

A small probe inserted in a wave guide so as to lie along the direction of the electric field is something like an electric dipole because charge oscillates back and forth along its length. A small loop inserted so that the magnetic lines of force pass through it may approximate a magnetic dipole since the current in the loop and the field passing through it act like variable magnetic poles of opposite sign on each side of the loop.

In terms of permanent magnets, the concept of a fixed magnetic dipole is easy to understand, because it is well known that no matter how many times a bar magnet is cut in two, both a south and north pole continue to exist on each piece. A very small piece of magnetized material is itself a fixed magnetic dipole. *A magnetic dipole is a pair of equal north and south magnetic poles spaced closely together.*

In the same way that an electric field may be observed to surround an electric dipole with a peculiar directional pattern so also may a magnetic field be observed in the neighborhood of a magnetic dipole even though the dipole contains both magnetic north and south poles in the same strength.

The equivalence of a current loop to a permanent magnet is well known because of the common use of electromagnets in relays, etc. The statement that a current flowing in a one-inch loop is equivalent to a whole array of magnetic dipoles arranged in the plane of the loop is due to Ampere and is explained in terms of the so-called Amperian currents. The idea is that if a current flows clockwise in a horizontal loop, that current may be replaced by a large number of equal currents flowing clockwise about each elemental area of the

\* K. A. Norton, *Proc. I.R.E.* 29, 623, 1941.

[Continued on page 66]

## Ingenious New Technical Methods

Presented in the hope that they will prove interesting and useful to you.



### Now—Air Operated Collet Chuck Relieves Second Operation Work on Screw Machines

Work formerly requiring automatic or hand screw machines can now be done at much less cost through the combination of this new air chuck and any drill press. The Redmer Air Chuck is a collet air chuck using standard Brown & Sharpe type screw machine collets. The collet remains stationary, the opening and closing controlled by a sleeve action.

By using a collet as the chucking means, slight variations in the diameter of the work as frequently experienced with automatic and hand screw machine products can be permitted without sacrificing accuracy or concentricity. Thus accomplishing an important saving in time and cost.

The air chuck is an ideal tool for holding parts for drilling, milling, slotting, burring, chamfering, boring, counterboring, tapping, threading, reaming and other work where the machine operation should be concentric with the chucking surface. It is adaptable to many different jobs merely by changing collet and stop. This results in saving of valuable production metals and materials. The chuck will take any type work whether round, hex, square or rectangular, and permits full efficiency of the operator, as it is operated by a foot operated valve thus leaving hands free to load and unload—reducing fatigue and cutting unproductive time to a minimum.

Wrigley's Spearmint Gum, too, is a help on the job. For chewing gum helps relieve dry throat, and helps ease fatigue brought on by the strain of work. And at the same time you are chewing and getting the benefits of swell tasting Wrigley's Spearmint, both hands are free and you need not take a "time out." The Army and Navy have recognized these benefits and are now shipping overseas *only*, all of the limited production of Wrigley's Spearmint. When Wrigley's Spearmint can again be produced in sufficient quantity for all, the valuable benefits of Wrigley's Spearmint Gum now being proven on the battlefield will apply to industry here at home.

You can get complete information from Redmer Air Devices Corp., 601 West Washington Blvd., Chicago 6, Ill.

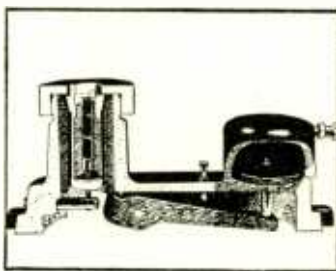

An air operated collet holding fixture for precision chucking or machine tools

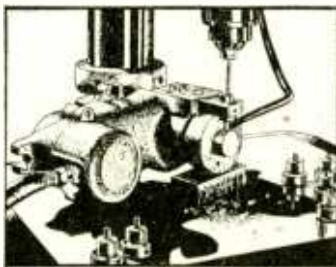

Chuck can be mounted on angle for angle milling job

Y-15\*

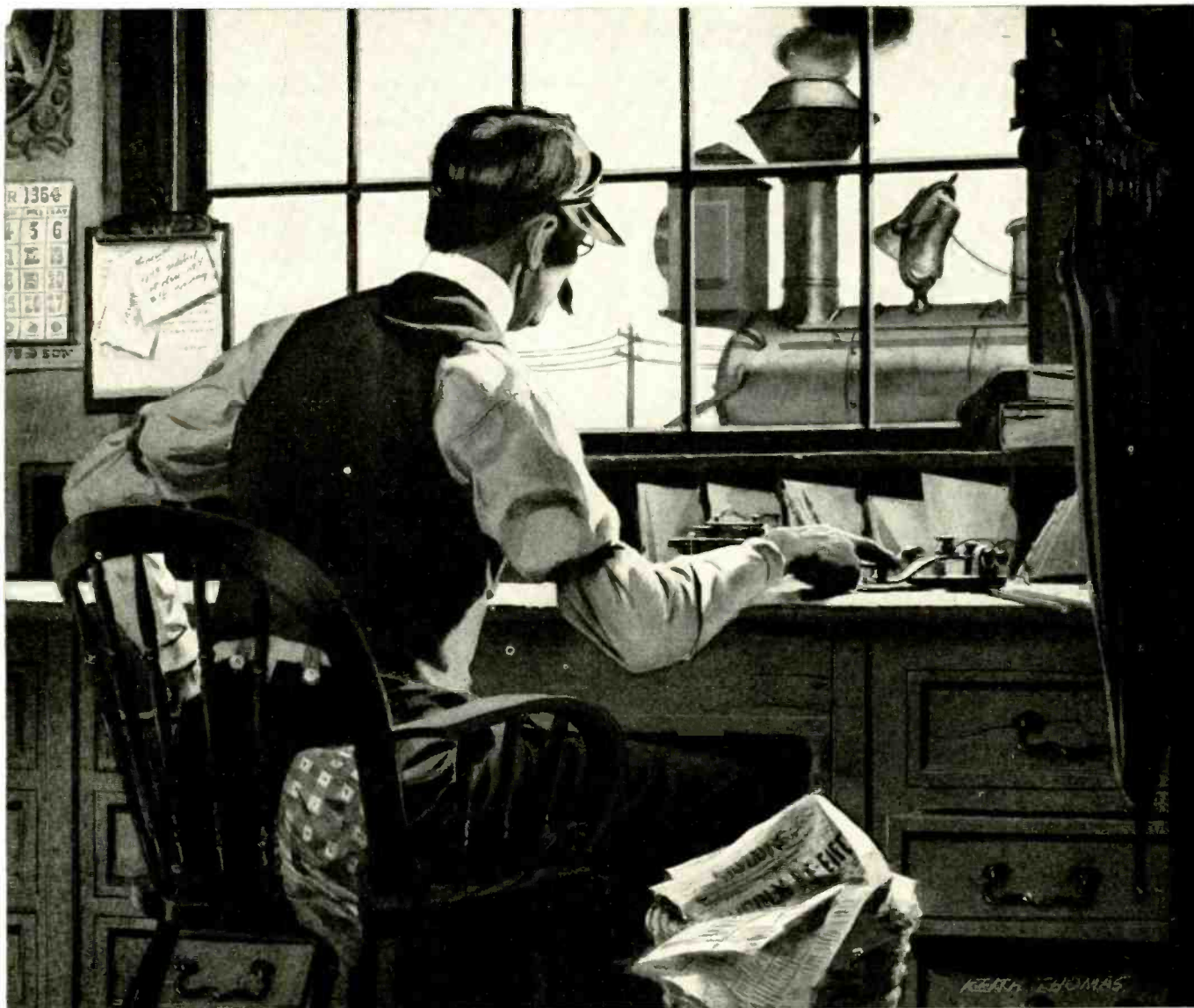

*History of Communications. Number Eight of a Series*

## EARLY RAILROAD COMMUNICATIONS BY TELEGRAPH



Communication by telegraph was probably one of the first of the electronic arts which met with commercial success in America. Of constant interest to every boy in a small town, the telegrapher down at the depot was a hero — a man of great science. With the advent of faster locomotives, telegraphy was a speedy method of traffic control.

Today, and for the postwar period, the picture will include electronic voice communications for the streamlined trains which travel one hundred miles per hour. There must be a more flexible control via electronics, plus the added possibility of passenger luxury in radio telephones. Universal stands ready as an electronic manufacturer to serve in the era of applied electronics.

< Model 1700-UB, illustrated at left, is but one of several military type microphones now available to priority users through local radio jobbers.



**UNIVERSAL MICROPHONE COMPANY**  
INGLEWOOD, CALIFORNIA



FOREIGN DIVISION: 301 CLAY STREET, SAN FRANCISCO 11, CALIFORNIA -- CANADIAN DIVISION: 560 KING STREET WEST, TORONTO 1, ONTARIO, CANADA

**RADIO**

\* OCTOBER, 1944

65

## TERMINOLOGY

[Continued from page 64]

plane enclosed by the loop. Except for the area elements adjacent to the wire the current around each element will just be canceled by that going around a neighboring element and only the current along element edges which are coincident with the wire will have a net value.

This consideration demonstrates that a current circulating in a wire loop will give rise to an array of magnetic dipoles or, as it is often called, a magnetic shell in the plane of the loop. Now if the current in the loop varies, the magnetic field of the

dipole will also vary. By Maxwell's equations we know that a changing magnetic field must be accompanied by an electric field and radiation from the loop be accomplished. Similarly, if the field changes, current of varying strength may appear in the loop.

Expressions for the distribution of the field from a sinusoidally varying dipole moment are readily found although they are of rather complicated form. In a spherical coordinate system,  $r \theta \psi$ , if the magnetic poles are arranged along the axis from which  $\psi$  is measured,  $H$  is found to have a component along  $r$  and another around the dipole with  $\psi$ . The electric field goes around the dipole with  $\theta$  as that symbol measures angles from some refer-

ence plane containing the dipole. Maximum radiation from an oscillating magnetic dipole occurs in a plane perpendicular to a line connecting the equal but opposite poles which form that dipole.

**Magnetic Field-H**—If it is desired to measure the magnetic field at a given point in a certain material, there are two general ways of going about it. The measurement called  $H$  is one obtained by considering the *cause* of the magnetism.

For example, if we wish to know the magnetic field at some point,  $A$ , in a certain medium which may be in the neighborhood of certain other magnetic and nonmagnetic materials, we can do so in five steps. First, a very tiny but pivoted permanent magnet is installed at  $A$  and allowed to point as it wishes; second, the torque necessary to deflect this magnet through some convenient angle is measured; third, the cause of the field at point  $A$  is removed by shutting off all currents in the neighborhood, by removing permanent magnetism from all nearby bodies except the tiny test magnet, and by bucking out the earth's field; fourth, the neighborhood is surrounded by a properly oriented and very long solenoid so that point  $A$  is at the center of the solenoid; and, fifth, a current is circulated in the solenoid so that the same torque as applied before will turn the tiny magnet at  $A$  by the same amount. The magnetic field  $H$  will then be given by  $H = (4\pi ni)/10$  oersteds, where  $n$  is the number of turns per cm on the solenoid and  $i$  is the current passing through them.

Briefly then,  $H$  is a measure of the magnetic field in terms of a current which can duplicate that field. Its measurement is independent of the medium and neighborhood in which point  $A$  is located, since any such effect is canceled out by leaving the physical arrangement undisturbed between the two torque measurements.

The Biot-Savart law is really a fundamental definition of  $H$  plus a statement that proper formulas may be written to give the same values of  $H$  for any current distribution causing the field strength in question. Thus, by using a different formula and a coil of another shape in place of the solenoid, the same value of  $H$  might have been obtained with the procedure described.

**Magnetic Induction-B**—A magnetic field can be measured in terms of an effect it has on a certain test instrument or in terms of its cause as discussed under the heading of *Magnetic Field-H*.

A field measurement in terms of effect is usually called magnetic induction and represented by  $B$ . Thus, if it is desired to measure the magnetic induction present at some point  $A$ , which may be in any medium and may have any sort of magnetic or nonmagnetic materials in its neighborhood, we may do so by placing a small loop in such a position at point  $A$  that none of the magnetic flux passes through it.

Now, if we turn this loop through  $90^\circ$  in a time  $t$  so that in its final position a maximum of flux is surrounded, we can compute the strength of the magnetic in-

[Continued on page 68]

This is the now-famous Electro-Voice "Lip Mike" which began a new era in transmission of voice and the cancellation of ambient noises.

... and this marks the second step in the development of a full line of Electro-Voice Differential (noise-cancelling) Microphones.

### Electro-Voice

## DIFFERENTIAL MICROPHONE

### NEW MODEL 205-S

Designed, developed and built by E-V engineers and technicians

- Provides extremely high intelligibility, even under intense surrounding noises
- A most efficient microphone for aircraft, factories, railroads, police and emergency services
- May be used in all temperatures from  $-40$  to  $+185$  degrees, and is interchangeable with conventional carbon microphones
- Close-talking, blast proof, waterproof and shock-resistant
- Operates satisfactorily in all positions
- Frequency response substantially flat from 100-5000 c.p.s.: high output level:  $-20$  DB (0 DB = 1 volt/dyne/cm<sup>2</sup>); internal noise level below .001 volt simultaneously, if desired
- High impact phenolic case, 4" x 2-5/16"; Fiberglas wind noise filter; weighs less than 8 ounces
- Cable length, 5 ft.; panel mounting on the back; available in two models: Model 205-S, and 205-SL with switch lock.

If your present limited quantity needs can be filled by any of our Standard Model Microphones, with or without minor modifications, please contact your nearest Electro-Voice distributor.

## Electro-Voice MICROPHONES

ELECTRO-VOICE CORPORATION • 1239 SOUTH BEND AVENUE • SOUTH BEND 24, INDIANA  
Expert Division: 13 East 40th Street, New York 16, N. Y., U. S. A. Cables: Arleb

# A Safe Bet for Steady Sales

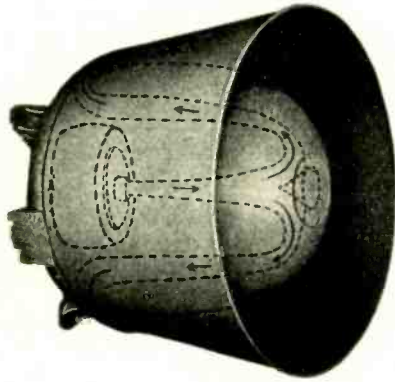

*Left*—MARINE SPEAKER; approved by the U. S. Coast Guard, for all emergency loudspeaker systems on ships. Re-entrant type horn. Models up to 100 watts. May be used as both speaker and microphone.



*Right*—RE-ENTRANT TRUMPET; available in 2½-3½-4½-6 ft. sizes. Compact. Delivers highly concentrated sound with great efficiency over long distances.



*Left*—RADIAL HORN SPEAKER; a 3½' re-entrant type horn. Projects sound over 360° area. Storm-proof. Made of RACON Acoustic Material to prevent resonant effects.



*Right*—AEROPLANE HORNS; super-powerful and efficient P.A. horns for extreme range projection. 9-4 and 2 unit Trumpets available.



*Left*—PAGING HORN; extremely efficient 2' trumpet speaker for use where highly concentrated sound is required to override high noise levels. Uses P.M. unit.

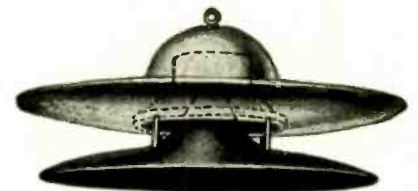

*Right*—RADIAL CONE SPEAKER; projects sound over 360° area. Cone speaker driven. Will blend with ceiling architecture. RACON Acoustic Material prevents resonant effects.

SEND FOR CATALOG

RACON, pioneer and world's largest manufacturer of loudspeakers, horns and driving units, is working at capacity filling diversified orders — speakers for Army, Navy, Maritime Commission, Signal Corps, etc. and industrial use. Now we are planning ahead.

Practically all industrial firms are users, or potential users of some type public-address, paging or sound distribution system. Statistics prove that a properly planned sound system installation is a good investment which in time generally pays for itself.

RACONS have always enjoyed a steady, high sales volume. We believe they always

will, for our products are the finest that money can buy, or engineering skill produce. Receiver units supplied with either metal or plastic diaphragms. RACON products generally cost less than competitive brands because a lower power-rated and lower-priced RACON will outperform higher power-rated units of other make. In other words, don't let catalog list-prices fool you. Basic costs and rated outputs are the prime factors worth considering. That's why leading soundmen prefer and specify RACONS, they are dependable—a safe bet for steady sales and satisfied users.



**RACON ELECTRIC CO. 52 EAST 19th ST. NEW YORK, N. Y.**

**RADIO**

★ OCTOBER, 1944

67

# DUMONT



## SUPERCAPS

Dumont Electrolytic tubulars for the duration have the following special features . . . and are guaranteed to give the same high quality performance for which all Dumont Electrolytic Tubulars have a reputation.

SELF HEALING  
LONG LIFE  
ECONOMICAL

VARNISHED  
TUBES

DOUBLE SEALED  
SMALL SIZE

FULLY  
GUARANTEED

**JOBBERS!**  
our products are distributed by exclusive Territory Arrangement only. Write for attractive proposition.

BUY  
MORE  
BONDS

Pats. Pend.

# DUMONT

## ELECTRIC CO.

MAF 2 OF  
CAPACITORS FOR EVERY REQUIREMENT  
34 HUBERT STREET NEW YORK, N. Y.

## TERMINOLOGY

[Continued from page 66]

duction at  $A$  in terms of the average voltage that is induced into the loop. The computation can be made from  $B = (V 10^8)/(A \Delta t)$ , where  $V$  is the observed voltage and  $A$  is the area of the loop.

Magnetic induction,  $B$ , is a measure of magnetic field made by observing a voltage generated when a conductor cuts through the field.

In the idealized method of measurement just described it is necessary that the loop be so small and turned so rapidly that the field strength over the area  $A$  is constant and unchanged during the time  $\Delta t$  to the extent of the accuracy to which the measurement is desired.

$B$  can also be measured in terms of the force on a charge,  $Q$ , moving through point  $A$  with a velocity  $v$  in a direction perpendicular to the magnetic field. In that case,  $B = (CF/Qv)$ , where  $F$  is the force on the charge and  $C$  is the velocity of light.

**Method of Images**—A great simplification in the plotting or calculation of electric and magnetic fields can sometimes be obtained by use of the method of images.

The method consists of replacing surfaces which may exist in the neighborhood of known charge and current by other charge and current which are so located and of such strength that we can show the field to be unaffected by the substitution.

When this can be done it is relatively easy to proceed by calculating the fields arising wholly from free charge even when it would be very difficult to make the calculation if we needed to take account of currents induced in conducting surfaces.

For example, consider a charge,  $q$ , placed a distance,  $d$ , in front of a very large and perfectly conducting plane. Certainly no electric field can exist along the conducting plane since if it did, currents would flow to equalize it. Now if the plane is removed and a second charge,  $q$ , of opposite sign is placed a distance,  $d$ , behind the position occupied by the conductor, it must be that we again have a situation in which there is no tangential field along the surface. This is sufficient to indicate that the electric field at every point in front of the position of the conducting surface is the same with the image charge as with the conducting plane.

It may be even easier to see that the image case is an equivalent situation by thinking in terms of potential. Along the surface occupied by the plane the potential must be zero with an image charge present because every point on that surface is equidistant from  $+q$  and from  $-q$ . It is likewise clear that the potential of a conductor must be zero or at least constant.

[To be continued]

### NEW TELEVISION TRANSMITTER

Engineers of the Federal Telephone and Radio Company have designed for the Columbia Broadcasting System a television transmitter which broadcasts both sight and sound on the same carrier frequency.

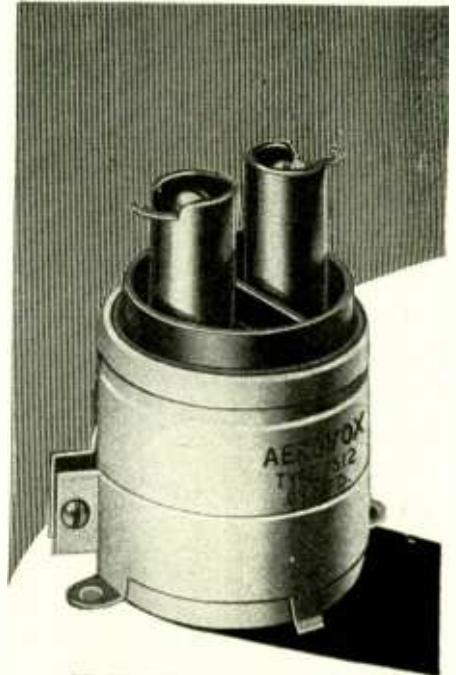

## HIGH-VOLTAGE requirements

● Aerovox Type 12 is an immersion-proof oil-filled paper capacitor designed to meet high-voltage, high-altitude operating requirements. Particularly suitable for high-voltage circuit applications such as in television, cathode-ray tube power supplies, high-voltage rectifier circuits, aircraft transmitters, or as a high-voltage by-pass capacitor. Note barrier in bakelite top. This further increases insulation and creepage path between terminals.

### AEROVOX TYPE 12 HVVOL

Supplied with adjustable mounting rim for vertical mounting. For certain less critical applications, ceramic insulators may be removed and unit used without them.

Voltage ratings from 2000 to 7500 volts d.c.w. Capacitances from .01 to 2.0 mfd., depending on voltage. For high-voltage, high-altitude operation, particularly aircraft, units can be had with special porcelain cover and single, taller insulator pillar terminal with corona shield.

● Write for Literature . . .

# AEROVOX

## Capacitors

INDIVIDUALLY TESTED

AEROVOX CORP., NEW BEDFORD, MASS., U. S. A.  
In Canada: AEROVOX CANADA LTD., HAMILTON, ONT.  
Export: 13 E. 40 St., New York 16, N. Y. Cable: 'ARLAB'

# RADIO

## GROUP SUBSCRIPTIONS SAVE YOU UP TO 50%!



----- TEAR OUT—MAIL TO RADIO -----

**RADIO MAGAZINES, INC.**  
342 Madison Ave., New York 17, N. Y.

Kindly enter the following subscriptions. Remittance is attached. (1 to 6 subscriptions may be ordered on this form).

<input type="checkbox"/> One 1-year subscription . . . . .	\$3.00
<input type="checkbox"/> Two 1-year subscriptions . . . . .	\$5.00
<input type="checkbox"/> Three 1-year subscriptions . . . . .	\$6.00
<input type="checkbox"/> Four 1-year subscriptions . . . . .	\$7.00
<input type="checkbox"/> Five 1-year subscriptions . . . . .	\$8.00

Groups of 6 or more subscriptions in the U.S.A. will be accepted at the rate of \$1.50 each. For Canadian groups add \$.50 to each subscription ordered.

**PLEASE PRINT**

Name . . . . .  
Address . . . . .  
Position . . . . . Company

Name . . . . .  
Address . . . . .  
Position . . . . . Company

Name . . . . .  
Address . . . . .  
Position . . . . . Company

Name . . . . .  
Address . . . . .  
Position . . . . . Company

Name . . . . .  
Address . . . . .  
Position . . . . . Company

**NOTE.** If you do not wish to tear out this order blank, print or type a list giving each subscriber's name, address, employer's name and their respective positions. Mail it in today!

You and your co-workers can now save up to half the regular cost of a RADIO subscription by using the Group Plan. The more men in a Group the more each saves, up to 50%. Present subscriptions may be **RENEWED** or **EXTENDED** as part of a group.

The combination of exclusive, fine and timely articles plus this low-rate subscription offer makes RADIO a must-have publication. So fellows, form a Group today and send it to—

**RADIO MAGAZINES, INC.**  
342 MADISON AVENUE NEW YORK 17, N. Y.

# HIGH FIDELITY

[Continued from page 10]

from perfection because of the absence of true space consciousness of the sound sources.

## Other Factors

Some other factors occurring in the general high fidelity problem, such as random noise and distortion, may also be mentioned. Since distortion components are multiples of fundamental frequencies, and since many audio devices, particularly recordings, have varying degrees of inherent distortion, difficult to eliminate, a wider band will increase the effect of same. This causes much of the upper frequency "fussiness" generally in evidence on most attempts at wide band reproduction. The phase distortion introduced by most sound systems is not believed to be a serious problem, as the ear is apparently not sensitive to moderate phase changes. The phase characteristics should, however, be uniform. Distortion must be kept to the lowest possible value and more attention should be directed to investigation and elimination of cross-modulation products as compared with present stress on the more simple harmonic distortion effects.

Multi-path effects resulting in distortion are observable in reception on both amplitude and frequency modulation systems. This form of distortion, when it occurs, can be more

noticeable with frequency modulation, and this effect has been observed in certain instances. It is possible that some listeners will be subject to this distortion, the effects of which increase with an extension of the audio range and deviation, however good limiting in a frequency modulation receiver should minimize this form of distortion.

Random noise is directly proportional to band width and any increase in latter will increase the amount of noise passed. This imposes stringent design conditions on all the units in the line-up and would be particularly difficult to get and to maintain, at a reasonable price, in the case of a practical home receiver.

Standard radio broadcasting is at present limited to an upper modulation frequency of 5,000 cycles as a result of the 10,000 cycles spacing of radio channels, but most studio equipment and transmitters are capable of transmitting up to 10,000 cycles or higher. However, satisfactory reception with this wide band is not generally possible in the evening, because of "monkey chatter" from adjacent channel stations so that a restriction in frequency response in the receiver is in such case actually desirable.

Whether or not we can make full use of a complete audio spectrum depends, in the final analysis, upon the ability of the manufacturers to provide receivers which will satisfactorily reproduce the lower frequencies. Only when this is possible in the average marketable receiver can we make full use of the higher portions of the frequency spectrum and can refer to the

system as one of higher fidelity. The average price of a broadcast receiver in 1940, of which many millions were sold, was about \$35, and at this price satisfactory reproduction of 50 to 15,000 cycles is not to be expected. The response of home receivers has been found to be substantially as follows:

Small table model 200 cycles to 3,000 cycles  
Large table model 150 cycles to 3,500 cycles  
Consoles\* 100 cycles to 4,000 cycles

It must be stressed that power handling facilities in all models were quite limited at the lower frequencies due to speaker design, so that the lower limit does not actually have the meaning it implies.

In an appeal to common sense and practicality in the matter of fixing an audio band width for receivers, it is suggested that the range from 60 to 8,000, or possibly 50 to 10,000 cycles be considered for all types of broadcasting, including frequency modulation. There is very little question in the opinion of those who have devoted their lives to the problems of sound reproduction, that good reproduction over a practical band will provide a better service to the listener than one of controversial and indefinite quality over a theoretically complete audio spectrum. Our efforts should therefore be directed rather towards the provision of a balanced system of reproduction as fine as we can possibly design and build it, than solely toward extending the upper frequency limits of audibility beyond 10,000 cycles with the possible neglect of other more important factors. It is especially stressed that reproduction at the lower frequencies be investigated and improved, because it is in this direction, the direction of balance as compared with present trends, that we can best provide what unbiased observation and listeners' preference demands.

How can publicizing and creating a demand for 15,000 cycle receivers or systems be possibly justified, when a good 10,000 cycle receiver than can be made available to the greater part of the public, has not yet been designed? For the sake of technical integrity and the future of the radio industry let's get down to earth in the matter of high fidelity. We are faced with the prospect of a post war era in which it is very likely that many claims for new materials, techniques and overall improvements, will face the spotlight of public test—and fail. Let us not, therefore, in our enthusiasm make claims that are too difficult, if not impossible, to realize.

\* (A few in this class were capable of fair reproduction to 8,000 cycles.)

### STATEMENT OF THE OWNERSHIP, MANAGEMENT, CIRCULATION, ETC., REQUIRED BY THE ACTS OF CONGRESS OF AUGUST 24, 1912, AND MARCH 3, 1933

of RADIO, published monthly at East Stroudsburg, Pa., for October 5th, 1944.

State of New York }  
County of New York } ss.:

Before me, a Notary Public in and for the State and county aforesaid, personally appeared Sanford R. Cowan, who, having been duly sworn according to law, deposes and says that he is the Business Manager of RADIO, and that the following is, to the best of his knowledge and belief, a true statement of the ownership, management, etc., of the aforesaid publication for the date shown in the above caption, required by the Act of August 24, 1912, as amended by the Act of March 3, 1933, embodied in section 537, Postal Laws and Regulations, to wit:

1. That the names and addresses of the publisher, editor, managing editor and business manager are: Publisher, Sanford R. Cowan, 1620 Ocean Ave., Brooklyn 30, N. Y.; Editor, John H. Potts, 98-50 67th Ave., Forest Hills, N. Y.; Managing Editor, None; Business Manager, S. R. Cowan, 1620 Ocean Ave., Brooklyn 30, N. Y.

2. That the owners are: Radio Magazines, Inc., 342 Madison Ave., New York 17, N. Y.; John H. Potts, 98-50 67th Ave., Forest Hills, N. Y.; and Sanford R. Cowan, 1620 Ocean Ave., Brooklyn 30, N. Y.

3. That the known bondholders, mortgagees, and other security holders owning or holding 1 per cent or more of total amount of bonds, mortgages, or other securities, are: None.

4. That the two paragraphs next above, giving the names of the owners, stockholders and security holders, if any, contain not only the list of stockholders and security holders as they appear upon the books of the company, but also, in cases where the stockholder or security holder appears upon the books of the company as trustee or in any other fiduciary relation, the name of the person or corporation for whom such trustee is acting, is given; also that the said two paragraphs contain statements embracing affiant's full knowledge and belief as to the circumstances and conditions under which stockholders and security holders who do not appear upon the books of the company as trustees, hold stock, and securities in a capacity other than that of a bona fide owner; and this affiant has no reason to believe that any other person, association, or corporation has any interest direct or indirect in the said stock, bonds, or other securities than as so stated by him.

(Signed) SANFORD R. COWAN, Business Manager.

Sworn to and subscribed before me, this 5th day of October, 1944.

(Seal.) JENE D. STERN, Notary Public.

Kings County, Kings Co. Clk's No. 246, Reg. No. 16756; N. Y. Co. Clk's No. 270. Commission expires March 30, 1946.



# Where Time Doesn't March On . . .



*. . . unless you step in now to help men in German prison camps fight that deadly "barbed wire" boredom*

**T**HE CLOCK has a hundred hours on its dial and each hour has 600 minutes when you're penned behind barbed wire.

Nothing to see but that wire, the bar-rack's wall, and a sentry's back. Nothing to hear but the tramp of his feet, the beefs of your comrades.

So you go slowly, grimly, and sometimes not-so-quietly, progressively towards the "barbed wire disease" unless...

Unless you're lucky enough to have the folks back home get behind the War Pri-

soners' Aid (one of the 22 participating agencies of the National War Fund) and provide the money to provide the things to feed the hunger of your heart and soul and mind.

Books and baseballs and tennis rackets. Textbooks and technical equipment so you can continue studies the war interrupted. Grease paint and playscripts for your own camp shows. Games of every sort. Anything and everything it's humanly possible to provide to start Time marching on again.

This is just one of the many vital jobs your contribution helps to take care of —when you support the National War Fund by giving to your New York War Fund. Your dollars go to work on six continents and in ninety-one countries—*including your own*, because this united campaign covers the big home-front needs too.

And don't just give a "token" contribution. The job is too big for that. *Give—really* give! Remember that no matter how much any of us gives in money it's still little compared to what the people you'll help have been giving in "blood, sweat, and tears."

GIVE GENEROUSLY TO YOUR

## New York War Fund

REPRESENTING THE National War Fund  
AND 9 LOCAL WAR SERVICE AGENCIES



**RADIO**

★ OCTOBER, 1944

71

COMMUNICATION  
EQUIPMENT  
AVIATION **RB** QUARTZ RADIO CRYSTALS

**ELECTRONIC EQUIPMENT  
QUARTZ CRYSTALS**

**MANUFACTURING  
ENGINEERING  
DESIGNING  
TO ORDER**

**REX BASSETT  
INCORPORATED**  
FORT LAUDERDALE  
FLORIDA

**YOURS  
..FOR THE  
ASKING**



Available from local dealers or by writing factory direct.

## UNIVERSAL STROBOSCOPE

This handy phonograph turntable speed indicator, complete with instructive folder, is now available gratis to all phonograph and recorder owners through their local dealers and jobbers. As a recorder aid the Universal Stroboscope will assist in maintaining pre-war quality of recording and reproducing equipment in true pitch and tempo. Universal Microphone Co., pioneer manufacturers of microphones and home recording components as well as Professional Recording Studio Equipment, takes this means of rendering a service to the owners of phonograph and recording equipment. After victory is ours—dealer shelves will again stock the many new Universal recording components you have been waiting for.

**UNIVERSAL MICROPHONE CO.**  
INGLEWOOD, CALIFORNIA

## PERMEABILITY TUNING

[Continued from page 32]

of direct current to produce a frequency swing of 1 octave (inductance change 4 to 1).

It is to be noted here that in all cases the incremental high frequency permeability decreases with the increase of magnetizing flux.

This new system of tuning has no moving parts whatsoever. The actual tuning is accomplished by the energizing of a winding by direct current for which a current circuit may be carried over any desired distance, thus providing an ideal remote control. At this initial stage of development it is difficult to predict whether the system will be accepted for practical applications since the cost of each tuner is many times greater than the other tuners now employed because, in addition to a ferro inductor, the tuner will include a laminated yoke structure with a heavy magnetizing winding. As frequency increases, the permeability of high frequency iron is decreased and therefore the incremental permeability will also decrease and range of coverage will diminish at higher frequencies. Nevertheless, there will be applications for automatic frequency control or variable fidelity over such ranges of tuning where but small variations in frequency are required. In that case, a very small variable inductor operating on this principle may be needed, such as devised for these applications and shown on Fig. 6.

Two miniature cores, each with binocular coils, are shown inserted between the ends of a laminated yoke structure which is surrounded with a small magnetizing coil. This coil may be energized by the anode current of the tube, the fluctuations of which will change frequency of the circuit associated with this inductor.

Several previous attempts to produce tuning by permeability have been published, mostly in the form of patents or theoretical discussions which employ a similar principle. To my knowledge no practical device capable of operating in high frequency oscillatory circuits, has been devised, mostly because of the damping introduced by magnetizing systems into the high frequency circuits of this kind. It is therefore hoped that the above system as described, which shows a practical application of the principle of incremental permeability tuning, will meet with interest in technical circles.

## ENGINEERS and DRAFTSMEN WANTED

Large Maryland manufacturer of radio and electronic equipment has immediate permanent openings for persons with the following experience:

Furniture design draftsmen for detailing radio cabinets.

Draftsmen and Detailers with experience working on sheet metal parts for radios.

Mechanical parts Detailers capable of working from both sketch and layout.

Radio receiver engineers, seniors and juniors.

Mechanical layout draftsmen  
Electrical draftsmen

Top salaries will be paid for well qualified personnel.

Box 123, RADIO MAGAZINE..  
342 Madison Ave., New York 17, N. Y.

## ... Here's How You Can Qualify for a BETTER RADIO JOB!

... CREI technical training is preparing others for good-paying radio jobs — WHY NOT YOU?

Are you finding yourself in a routine job—a job that any other man can handle just as well as you? Today, radio JOBS are many—but radio CAREERS are few! Now is the opportune time for you to equip yourself with the necessary technical training to qualify for an important engineering position with a sound future.

NOW when industry needs men, is the time for you to investigate radio career training. Your radio experience backed by modern CREI technical training will equip you to share in the good paying jobs that await trained men... and to make good in the important positions that lead to security and happiness!

### Write for Details

About CREI Home Study Course  
If you are a professional or amateur radioman and want to make more money—let us prove to you we have something you need to qualify for the BETTER career-job opportunities that can be yours. To help us intelligently answer your inquiry—PLEASE STATE BRIEFLY YOUR EDUCATION, RADIO EXPERIENCE AND PRESENT POSITION.



Free Booklet Sent

## CAPITOL RADIO ENGINEERING INSTITUTE

Dept. RA-10, 3224-16th St., N.W., Washington 10, D.C.

CHECK TRANSMITTER FREQUENCY IN LESS THAN A MINUTE



*THE BROWNING FREQUENCY METER, used by police and other emergency radio facilities for the past five years, is still the best meter for such services — because it was specifically designed for them. The design, which permits determination of any five frequencies from 1.5 to 120 Mc., makes for simplicity of operation which requires less than one minute to check one frequency. All Browning development work aims at specific, rather than broad, uses. Thus, all Browning equipment is best for its particular job. Furthermore, Browning Laboratory facilities are available for study and solution of your own, specific electronic engineering problems.*

*Write for data.*



**BROWNING**

**LABORATORIES, INCORPORATED  
WINCHESTER, MASSACHUSETTS**



**CORWICO**

# WIRES

MADE BY  
*Engineers FOR  
Engineers*

**VICTORY**  
concentrating upon  
for the duration . . . .

**cornish**  
WIRE COMPANY, INC.  
15 Park Row, New York City, New York

**CORWICO**

## THIS MONTH

[Continued from page 52]

for civilians is resumed.

Discussing so-called "revolutionary" new methods of recording such as strips of film, or tape, or a wire, RCA Victor reported that its research laboratories are investigating the possibilities of these recording techniques for the benefit of the various fields in which RCA operates, but concludes that the present type of recording for home records is regarded as the most practical.

"The disc method provides music of exceptionally high quality at low costs, in such simple form that a child can make full use of it," RCA Victor reports. "Moreover, it offers the advantage of pre-selection. We may hear any portion of a symphony at will, or all of it. The perfection of automatic record-changing mechanisms of low cost within recent years has made it possible to pre-select a symphony or musical program that can be played for more than an hour. In our opinion, nothing now contemplated in the laboratories or in use commercially at present shows any signs of offering such flexibility, tonal fidelity and simplicity, at low cost, as do the conventional disc and phonograph."

### RAULAND ADDS VISITRON

Announcement is made by the Rauland Corporation of Chicago of their recent purchase of the Phototube Division of GM Laboratories, Inc., Chicago.

The present acquisition of "Visitron," combined with that of the purchase, two years ago, of the American rights to all patents and processes of the British-Gaumont electronic tubes, indicates the strong position which has been developed by the Rauland Corporation in the important electronic tube field.

"Visitron" phototubes are now in production at Rauland.

### HALLICRAFTERS APPOINTS FOOT

The Hallicrafters Company, Chicago, producers of the SCR-299, mobile radio communications unit, and other short-wave radio war equipment, announced the appointment of Norman J. Foot as development engineer.

With many years of experience in ultra high frequency work, Foot will design new UHF and VHF equipment for the company, along the lines of the Hallicrafters S-27, the first commercially available high frequency FM-AM receiver.

## Wanted ENGINEERS

- Radio
- Chemical
- Electrical
- Electronic
- Mechanical
- Metallurgical
- Factory Planning
- Materials Handling
- Manufacturing Planning

Work in connection with the manufacture of a wide variety of new and advanced types of communications equipment and special electronic products.

Apply (or write), giving full qualifications, to:

R. L. D.

EMPLOYMENT DEPARTMENT

**Western Electric Co.**

100 CENTRAL AV., KEARNY, N. J.

Applicants must comply with WMC regulations

**Radio**  
AND  
**ELECTRONIC  
DEVICES**



**BURSTEIN-APPLEBEE CO.**  
1012-1014 McGee St. • Kansas City 6, Missouri

Prepare to get your "ticket"!

## HOW TO PASS RADIO LICENSE EXAMINATIONS

By Charles E. Drew  
I.R.E., A.I.E.D.



Here's the quickest, surest way to get the information you must have in order to win that important "ticket." Revised and brought right up to the minute, it covers every field of radio communication—

transmission or reception—whether in marine, aeronautical, police, or broadcasting.

In easy-to-follow question-and-answer form, it explains Basic Radio Laws; Basic Theory and Practice; Radiotelephone; Advanced Radiotelephone; Radiotelegraph; Advanced Radiotelegraphy.

**The "Bible" of the Radio Field!**  
Send for YOUR Copy Today  
Second Edition 320 Pages \$3.00

### On Approval Coupon

**JOHN WILEY & SONS, Inc.**

440 Fourth Avenue, New York 16, N. Y.  
Please send me on ten days' approval a copy of Drew's HOW TO PASS RADIO LICENSE EXAMINATIONS. At the end of that time, if I decide to keep the book, I will remit \$3.00 plus postage; otherwise I will return the book postpaid.

Name .....  
Address .....  
City and State .....  
Employed by .....

R-10-44

**RADIOTRON DESIGNER'S  
HANDBOOK**

*A Handbook of Practical  
Circuit Design*

Edited by the Amalgamated Wireless Valve Co. of Australia and reproduced in the U.S.A. by one of our largest radio manufacturers. Presents concrete design data and formulas of hundreds of circuits used in receivers, amplifiers and power supplies. Numerous schematic special circuits. 37 pages. 1 useful charts and tables. A valuable book for all radio engineers and technicians.

356 pages, 6x9, cloth bound—Only \$1.00 (plus 7c postage in U. S. A. and Canada.)

**THE ENGINEER'S BOOK COMPANY**  
P.O. BOX 575, ALEXANDRIA, VA.

**Ted McElroy**

World's Largest Manufacturer of  
Wireless Telegraphic Apparatus

COMPLETE CENTRAL OFFICE EQUIPMENT

**McElroy Manufacturing Corp.**  
82 Brookline Avenue • Boston, Massachusetts



*Radio's outstanding practical text...  
...for war-training and regular purposes*

**RADIO**  
*Handbook*  
NINTH EDITION

**NINTH EDITION**

Revisions in this edition adapt it even better than ever before for war-training and general use; contains added and simplified theory in the simplest possible language; added test equipment which can be home- or field-constructed; and a review of mathematics for solving simple radio problems.

More than 600 pages; durably clothbound; goldstamped. Get it from your favorite dealer, or direct from us, postpaid; please add any applicable taxes.

**\$2.00 in continental U. S. A.**

**Elsewhere, \$2.25**

Published by

*Editors and Engineers, 1422 North Highland Avenue, Los Angeles 28, Calif.*

# VACUUM TUBE VOLTMETER RF - AC - DC

The result of 10 years of  
Vacuum Tube Voltmeter  
Engineering.

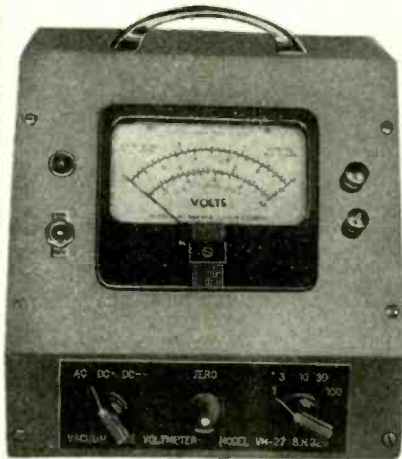

## MODEL VM-27

1-3-10-30-100 volts full scale.  
Peak response, r.m.s. calibration.  
HIGH IMPEDANCE—4 megohms at 50  
cycles, 60,000 ohms at 100 megacycles.  
7 megohms for d.c.  
ACCURATE—Better than 2 percent on  
d-c and 60 cycles thru megacycles.  
SELF-CONTAINED—115 or 230 volt  
50-60 cycle line operation.



## RF PROBE

Interchangeable probe included for  
convenience and efficiency in making  
AC and RF measurements. Input cap-  
acity 5 micro farads. Ruggedly  
mounted 6H3 tube in balanced circuit.  
Complete \$150 net f.o.b. Flushing, N.Y.

## ACCESSORIES

To increase VM-27 range to 1000 volts.



## 10X AC MULTIPLIER MODEL ACM-27

Input impedance even greater than  
probe alone. Flat response from 20  
cycles to 200 megacycles.

\$17.00 net f.o.b. Flushing, N. Y.



## 10X DC MULTIPLIER MODEL DCM-27

5 megohms input resistance.

\$8.00 net f.o.b. Flushing, N. Y.

## IMMEDIATE DELIVERIES

ALFRED W. BARBER LABORATORIES  
34-04 FRANCIS LEWIS BLVD.  
FLUSHING, N. Y.

# ADVERTISING INDEX

ADVERTISER	PRODUCT	PAGE
Aerovox Corporation	Capacitors	68
Albion Coil Company	Coils	19
Astatic Corporation, The	Microphones	6
Automatic Elec. Sales Corp.	Relays	25
Barber Labs., Alfred W.	Test Equipment	76
Bassett, Inc., Rex	Quartz Crystals	72
Bliley Electric Co.	Quartz Crystals	18
Browning Laboratories, Inc.	Test Equipment	73
Burstein-Appleebe Co., Inc.	Electronic Equipment	74
Cambridge Thermionic Corp.	Turret Lugs & Transformers	18, 26
Capitol Radio Engineering Inst.	Educational	72
Conn. Tel. & Elec. Div.	Electrical Equipment	63
Cont'l Electric Co.	Electronic Tubes	24
Cornish Wire Company	Wire	74
Dumont Electric Co.	Capacitors	68
D-X Crystal Co.	Crystals & Loop Antennas	22
Echophone Radio Company	Receivers	53
Editors & Engineers, Ltd.	Books	75
Eitel-McCullough, Inc.	Tubes and Vacuum Pumps	61
Electronic Mechanics, Inc.	Insulating Materials	15
Electro-Voice Mfg. Co., Inc.	Microphones	65
Engineer's Book Co., The	Books	74
Federal Tel. & Radio Corp.	Vacuum Tubes and Cables	4, 11
Formica Insulation Co., The	Laminated Plastics	17
Foster Co., A. P.	Transformers	29
Guardian Electric Mfg. Co.	Relays	2
Guthman & Co., E. I.	Tuning Units	1
Hallcrafters Co., The	Communication Equipment	59
Harvey Radio Co.	Radio & Electronic Equip.	10
Harvey Radio Labs., Inc.	Electronic Instruments	57
Howard Mfg. Co.	Crystal Holders	10
Hytron Corporation	Tubes	Cover 3
Instrument Resistors Co.	Resistors	30
Jensen Radio Mfg. Co.	Acoustic Equipment	55
Johnson Co., E. F.	Transmitter Components	7
Ken-Rad Tube & Lamp Corp.	Electronic Tubes	24
Knights Co., The James	Quartz Crystals	12
Lafayette Radio Corp.	Radio-Electronic Equip.	22
McElroy Mfg. Corp.	Wireless Tel. Apparatus	74
Merit Coil & Trans. Corp.	Radio Parts	26
O'Neill-Irwin Mfg. Co.	Duplicating Machines	28
Racon Electric Co., Inc.	Speakers	67
Raytheon Production Corp.	Tubes	Cover 2
Sigma Instruments, Inc.	Relays	8
Sperry Gyroscope Co., Inc.	Radio-Electronic Devices	23
Standard Transformer Corp.	Transformers	16
Sylvania Elec. Products, Inc.	Tubes	27
Universal Microphone Co.	Microphones	65, 72
Wadsworth Watch Case Co., Inc., The	Precision Parts	9
Western Electric Co.	Help Wanted	74
Westinghouse Elec. & Mfg. Co.	Communications Equip.	Cover 4
Wholesale Radio Labs.	Tube Base Calculators	28
Wilcox Electric Co.	Communications Equip.	23
Wiley & Sons, Inc., John	Books	14, 71
Wrigley Jr. Co., Wm.	Institutional	64

"Ham" Radio and

# HYTRON

PAST . . . .

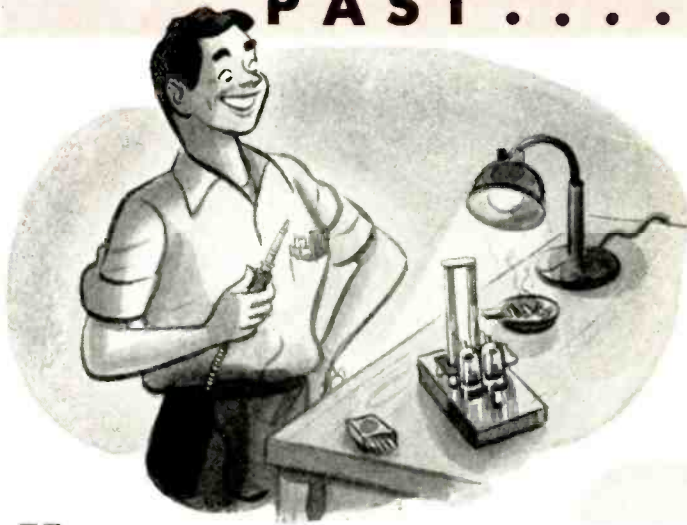

THE radio amateur trained himself during peace to be invaluable to the Nation during war. Specializing on tubes exclusively designed for ham radio, Hytron when war began was prepared for immediate and direct conversion to war production. Hytron transmitting and special purpose tubes proved by the ham were ideally suited—with little or no changes—to military applications. Years of practical experience made Army and Navy specialists of radio amateurs overnight. Peacetime tools of these same hams, Hytron tubes joined immediately this new fighting team.

. . . . PRESENT



HAMS with the Services in all parts of the world know the war job Hytron is doing. High-speed receiving tube techniques plus know-how derived from special purpose engineering of tubes for the amateur, make possible a flood of dependable Hytron radar and radio tubes to these fighting ex-hams and potential hams. Proud of winning the Army-Navy "E" for its performance on a huge production job, Hytron is also proud of its ham friends who are transforming innocent-appearing Hytron tubes into deadly weapons.

FUTURE . . . .

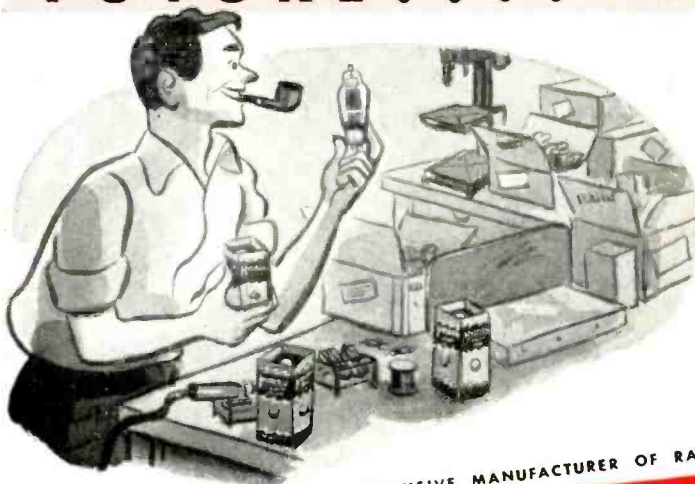

THERE should be no concern about adequate post-war amateur frequencies. Excellent wartime performance on far-flung battle fronts has made for ham radio many enthusiastic and influential friends. The ARRL reports that it looks forward with absolute confidence to the opening of new frontiers in expanded frequency ranges to be made available to the post-war amateur. Hosts of hams will return to their old friend, Hytron. For the more familiar lower frequency bands—the very high frequencies—or the new superhighs—their choice will be Hytron.

OLDEST EXCLUSIVE MANUFACTURER OF RADIO RECEIVING TUBES

**HYTRON**  
CORPORATION  
ELECTRONIC AND  
RADIO TUBES

SALEM AND NEWBURYPORT, MASS.



**BUY ANOTHER WAR BOND**

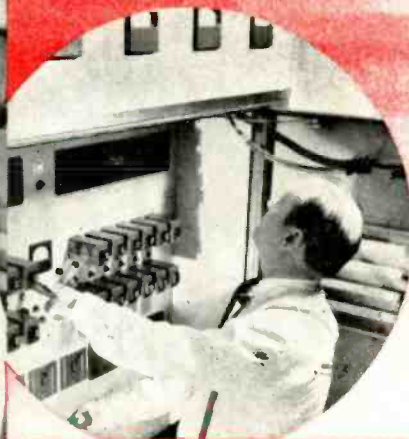

CONSIDER *Ease of Maintenance*  
WHEN YOU SELECT A NEW TRANSMITTER

Modern transmitters require little maintenance—but when they do, *ease of maintenance* is important.

In Westinghouse Transmitters all *units are easily accessible*, both for inspection and maintenance.

*Complete protection to operators* is assured by interlocks on doors to all compartments in which dangerous voltages are present. Controls are of the dead front type, instruments at ground potential for maximum safety.

*Indicator lights flash circuit conditions* to the operator in case of overload, making it easy to check up for the possible cause of the interruption.

We will gladly furnish complete information on these and other advantages of the HG-5-KW and HG-50-KW Transmitters, such as: *Low Operating Cost, High Fidelity Signals, Continuity of Operation, Simplicity of Control.*

**PLACE YOUR ORDER NOW  
FOR YOUR POSTWAR TRANSMITTER**

By placing your order today for a Westinghouse Transmitter, you assure yourself of the fastest possible delivery following the lifting of wartime manufacturing restrictions. We are scheduling deliveries in the sequence in which orders are received. For details, write Westinghouse Electric & Mfg. Company, Dept. 1NB, P. O. Box 868, Pittsburgh 30, Pa.

J-08078

**Westinghouse** RADIO DIVISION  
PLANTS IN 25 CITIES... OFFICES EVERYWHERE



**A M • E L E C T R O N I C S • F M**