

RADIO

ESTABLISHED 1917

#-247

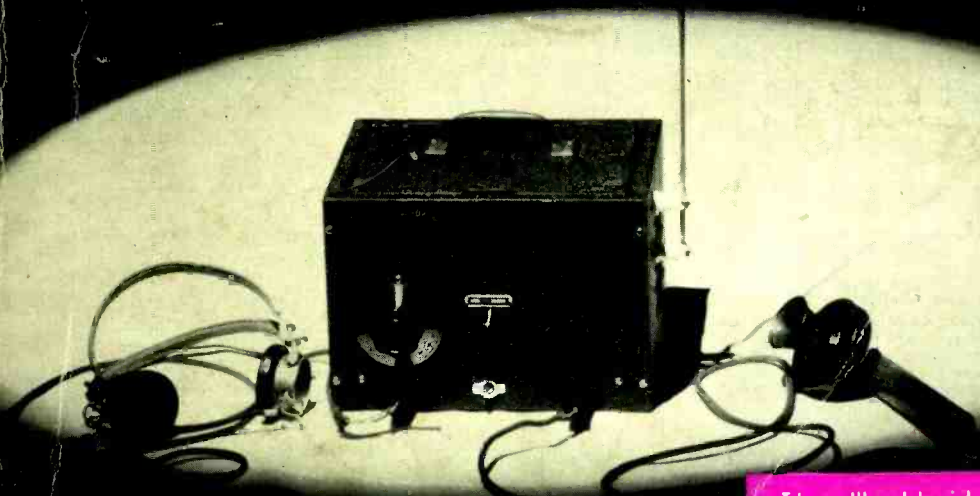

THIS MONTH

- COMPACT 2¼-METER BATTERY TRANSCEIVER
- A.M.C.—FOR ANY SYSTEM OF MODULATION

The Worldwide Authority of
Amateur and Shortwave Radio

★
★
March 1940

NUMBER 247

30c IN U.S.A.

STANCOR HAS THE VALUES!



TYPE "CD"



TYPE "CC"



TYPE "FF"



TYPE "DD"



TYPE "FS"



TYPE "NN"



TYPE "BB"

POLY-PEDANCE DRIVER TRANSFORMERS

POLY-PEDANCE MODULATION TRANSFORMERS

| Stancor No. | Capacity in Watts | Primary M.A. Per Side | RATIO | | Type Mounting | Net Price |
|-------------|-------------------|-----------------------|--|---------------|---------------|-----------|
| | | | Primary to 1/2 Secondary | 1/2 Secondary | | |
| A-4761 | 15 | 60 | 1.25:1, 1.4:1, 1.6:1, 1.8:1, 2:1, 2.2:1, 2.4:1 | | CD | \$3.45 |
| A-4762 | 15 | 60 | 2.6:1, 3:1, 3.2:1, 3.4:1, 4:1, 4.5:1, 5:1 | | CD | 3.30 |
| A-4763 | 30 | 120 | 1.25:1, 1.5:1, 1.75:1, 2:1, 2.25:1, 3.2:1 | | CD | 4.35 |
| A-4764* | 30 | 120 | 1.5:1, 2:1, 2.5:1, 3:1, 3.5:1 | | CD | 4.35 |

* P.P. 6L6's with 16% inverse feed back.

| Stancor No. | Watts Cap. | Pri. M.A. Per Side | Secondary M.A. | | Type Mtg. | Weight in Carton | Net Price |
|-------------|------------|--------------------|----------------|----------|-----------|------------------|-----------|
| | | | Series | Parallel | | | |
| A-3891 | 15 | 45 | 45 | 30 | D | 2.5 | \$3.00 |
| A-3892 | 30 | 80 | 80 | 160 | D | 6.0 | 3.90 |
| A-3893 | 60 | 125 | 125 | 250 | D | 7.3 | 4.80 |
| A-3894 | 125 | 150 | 150 | 300 | D | 12.0 | 6.30 |
| A-3895 | 300 | 260 | 260 | 520 | FS | 35.0 | 18.00 |
| A-3896 | 600 | 350 | 350 | 700 | FS | 75.0 | 37.50 |

PLATE TRANSFORMERS (TYPE P)

| Stancor Number | Primary 115v 50/60 Cycles | | D.C. Volts | D.C. M.A. | Net Cost |
|----------------|---------------------------|--|------------|-----------|----------|
| | Secondary A.C. Load Volts | | | | |
| P-6152 | 1550-0-1550 | | 1250 | 300 | \$9.60 |
| | 1350-0-1350 | | 1000 | | |
| P-5053 | 1660-0-1660 | | 1500 | 300 | 11.10 |
| | 1390-0-1390 | | 1250 | | |
| P-6156 | 2150-0-2150 | | 1750 | 300 | 12.00 |
| | 1850-0-1850 | | 1500 | | |
| P-6154 | 2430-0-2430 | | 2000 | 300 | 12.90 |
| | 2150-0-2150 | | 1750 | | |
| P-6155 | 2950-0-2950 | | 2500 | 300 | 17.70 |
| | 2400-0-2400 | | 2000 | | |
| P-3012 | 1250-0-1250 | | 1000 | 400 | 11.40 |
| | 950-0-950 | | 750 | | |
| P-6153 | 1570-0-1570 | | 1250 | 500 | 13.80 |
| | 1350-0-1350 | | 1000 | | |
| P-6159 | 2150-0-2150 | | 1750 | 500 | 22.50 |
| | 1830-0-1830 | | 1500 | | |

FILAMENT TRANSFORMERS

| Stancor Number | Primary Voltage | Secondary | | Type Mounting | Insulation in Volts | Net Price |
|----------------|-----------------|-------------|---------|---------------|---------------------|-----------|
| | | Volts | Ampetes | | | |
| P-6140 | 115 | 2.5 | 7.25 | N | 2,500 | .96 |
| P-3060 | 115 | 2.5 | 10 | B | 10,000 | 1.05 |
| P-4088 | 115 | 5 | 3 | B | 2,500 | 1.20 |
| P-6135 | 115 | 5 | 10 | N | 2,500 | 1.95 |
| P-6307 | 115 | 5 | 22 | N | 2,500 | 3.45 |
| P-5014 | 115 | 6.3 | 3 | B | 2,500 | .96 |
| P-6308 | 115 | 6.3 | 10 | N | 2,500 | 1.80 |
| P-5016 | 115 | 10 | 4 | B | 2,500 | 1.65 |
| P-6139 | 115 | 10 | 8 | N | 2,500 | 2.04 |
| P-6164 | 115 | 6.3, 5, 2.5 | 2.5 | B | 2,500 | 1.20 |

TWO BRAND NEW CATHODE MODULATION TRANSFORMERS

A-3888 - 250 M A

For modulating R.F. amplifier inputs up to 250 watts. Eight output impedances from 150 to 2500 ohms available.

YOUR NET COST **\$2.55**



A-3889 - 450 M A

For modulating R.F. amplifier inputs up to 600 watts. Eight output impedances from 150 to 2500 ohms available.

YOUR NET COST **\$3.60**

ASK YOUR NEAREST STANCOR DISTRIBUTOR OR WRITE FOR HIS NAME



STANDARD TRANSFORMER

• CORPORATION •

1500 NORTH HALSTED STREET . . . CHICAGO



NOW IT CAN BE TOLD!

HERE'S WHAT'S BACK OF THE

SUPER DEFIANT SX-25

This story began a long time ago. But not until now could it be told. For not until now did we have the overwhelming proof for the final chapter . . . proof that the new SUPER DEFIANT is one of the finest amateur receivers ever developed at the price.

After months in the hands of our engineers . . . designing, experimenting, testing, developing, perfecting . . . it was finally completed. But that was not enough. We wanted to KNOW what the SUPER DEFIANT would do in the hands of amateurs. No experimenting by customers. No selling it on faith alone. So a large number were placed with amateurs and key distributors for operation under almost every conceivable condition. Opinions were weighed, comparisons made, results checked.

These practical tests proved that it met every demand made of it. Distributors were notified . . . told about its performance . . . told that here is

a receiver amateurs were waiting for . . . told that at its low price the demand would hit a new high. They believed us. They ordered. They had SUPER DEFIANTS in stock, ready to make their announcements *at the same time* Hallicrafters did. And their confidence was justified.

"First one sold within five minutes," writes one. "The hottest receiver and biggest receiver value in my radio experience," writes another. "Showed it to a group of hams and they were so enthusiastic that they sent a telegram of congratulations to the factory," reports a third. "Sold five in one day." "Sold out first three days." "Rush two by express."

These are typical of the expressions in scores of wires and letters that have been pouring in from Distributors. If you haven't yet seen it, call upon your distributor at once. He'll give you the facts . . . why it is making such a hit with amateurs Everywhere . . . why it may be just the receiver for you.

the hallicrafters inc.
CHICAGO, U.S.A.

WORLD'S LARGEST BUILDERS OF AMATEUR COMMUNICATIONS EQUIPMENT

RADIO

1300 Kenwood Road, Santa Barbara
CALIFORNIA

Phone: 4242

Cables: RADIOLDT SANTABARBARACALIF
Teletype: S BAR 7390

Branch Advertising
Offices:

NEW YORK, 71 W. 35th St.,
Phone: CHickering 4-7399

CHICAGO, 3606 N. Bernard St.,

Production Office
for "RADIO"

Phone: JUNiper 5575
EAST STROUDSBURG, PA., 30 N. Crystal St.
Phone: Stroudsburg 1734 Teletype: SDBG 73

Advertising

Advertising inquiries may be directed to our nearest office. For fastest service prepare advertising copy in duplicate; send original copy and cuts (fully mounted and mortised) to East Stroudsburg, where "Radio" is printed; send duplicate copy, proofs of cuts, and space order to the advertising department at Santa Barbara. No advertisements will run until the home office telegraphs its approval.

Correspondence

Direct all manuscripts, subscription and book orders, payments, and general correspondence to the home office at Santa Barbara. Regarding advertising, see notice above. Unusable, unsolicited manuscripts will be destroyed unless accompanied by a stamped, addressed return envelope.

Rates

SUBSCRIPTION RATES: Two years, \$4.00, or \$2.50 yearly in U. S. A. (add 3% tax in California), Cuba*, and Mexico*. To Canada and Newfoundland, 25c per year additional. To Pan-American countries and Spain, \$0.50* per year additional. Elsewhere (except New Zealand), \$1.00* per year additional. New Zealand: order only from Te Aro Book Depot, Ltd., 61 Courtenay Place, Wellington. Special issues are included only with subscriptions of one-half year or longer. Refunds on cancelled subscriptions will be made at the difference between the rate paid and the rate earned.

THREE YEAR SUBSCRIPTIONS at the rate of \$5.00, net, in advance, are accepted from U. S. A. only. (Canada, \$5.75) Such subscriptions must be sent direct to our home office, not through agents.

SINGLE COPY PRICES: Prices are for regular issues; prices for special issues may vary but are usually those shown in parentheses. At newsdealers, book stores, and radio parts dealers, 30c (50c) per copy in U. S. A. by mail, postpaid, from home office, 30c (50c) in U. S. A., Canada*, Newfoundland*, Cuba*, and Mexico*; 35c (55c)* in other Pan-American countries and Spain. Elsewhere, 40c* (65c)*.

BACK ISSUES, when available, 5c extra net. Back issues will not be included in subscriptions.

***REMITTANCES** must be payable at par in continental U. S. A., except as follows: Add 10c plus exchange to Canadian checks, money orders and postal notes unless payable in U. S. dollars. From elsewhere, remit by bank draft (preferred) or international money order.

Miscellaneous Notices

IF YOU MOVE notify us in advance. We cannot replace copies sent to your old address. See "Changes of Address" notice elsewhere in this issue. **RADIO** is published ten times yearly (including enlarged special annual number) about the middle of the month preceding its date; August and September issues are omitted.

PUBLISHED BY RADIO, Ltd., Technical Publishers, 1300 Kenwood Road, Santa Barbara, California, U. S. A.

COPYRIGHT, 1940, by Radio, Ltd. All rights reserved. Reproduction without written permission is prohibited; permission usually granted amateur radio papers on request. Printed in U. S. A.

TITLE REGISTERED at United States Patent Office.

RESPONSIBILITY will not be accepted for subscriptions placed with unauthorized agents. Prospective subscribers are urged to inspect carefully the credentials of anyone soliciting their business. Agents are never authorized to vary the rates quoted on this page.

BRANCH OFFICES transact a cash business with customers who call in person; mail and open account orders should be sent only to Santa Barbara.

Principal Foreign Agents

Europe: (Subscription) N. E. Read, 24 Church St., Oswestry, Shropshire, England. Australia: "The Bulletin", Box 2521BH, Sydney; McGills, 183 Elizabeth St., Melbourne; Swain & Co., Pitt St., Sydney. New Zealand: Te Aro Book Depot, Ltd., 64 Courtenay Place, Wellington. South America: F. Stark, Caixa 2786, Sao Paulo; "Revista Telegrafica", Peru 165, Buenos Aires; Editorial Pan American, Peru 677, Buenos Aires. South Africa: South African Radio Publications, 40 Trust Buildings, Fox Street, Johannesburg.

PRINTED IN U. S. A.

The Editors of "Radio"

EDITOR

W. W. Smith, W6BCX

TECHNICAL EDITOR

Ray L. Dawley, W6DHG

ASSOCIATE EDITOR

Leigh Norton, W6CEM

K. V. R. Lansingh, W6QX

E. H. Conklin, W9BNX

CHICAGO

CONTRIBUTING EDITOR

Herbert Becker, W6QD

EDITORIAL AND TECHNICAL ASSISTANTS

Jack Rothman, W6KFQ

B. A. Ontiveros, W6FFF, Technical Draftsman

• • •

Business Staff

Santa Barbara

K. V. R. Lansingh, Publisher

A. McMullen, Managing Editor

Sales Department

John Snetsinger, Circulation and Advertising

Manager; **M. F. Zeis,** Chief Subscription Clerk;

R. Floberg, Chief Book Sales Clerk.

New York

V. R. Lansingh, Eastern General Manager

Chicago

C. W. Nelson, Asst. Advertising Manager

East Stroudsburg

W. E. McNatt, Jr., W8TLJ,

Production Manager

*The Worldwide Technical Authority of
Amateur, Shortwave, and Experimental Radio*

RADIO, March, 1940, #No. 247. Published monthly except August and September by Radio, Ltd., 1300 Kenwood Road, Santa Barbara, California. Entered as second-class matter September 26, 1939, at the Post Office at Santa Barbara, California, under the Act of March 3, 1879. Additional entry at East Stroudsburg, Pa. Registered for transmission by post as a newspaper at G.P.O., Wellington, New Zealand.

TAYLOR'S New

TW-75

Another THIN WALL Carbon Anode Tube

Following the immediate and sweeping success of the first Thin Wall Carbon Anode Tube, the outstanding TW-150, Taylor Tubes proudly presents the TW-75. Scientifically designed and built to achieve "top efficiency" on the Ultra High Frequencies, the TW-75 is surely destined to receive its full measure of deserving approval and popularity. It will be a leading favorite with that large group of exacting communication engineers who demand the best in operating results and long dependable tube life.

OUTSTANDING FEATURES!

- **VISIBLE OPERATING TEMPERATURE**
Operates at cherry red heat at rated plate dissipation.
- **COMPLETE ELECTRON CONTROL**
One-piece enclosed Anode, .015" thick, affords complete Electron Control assuring added efficiency—prevents glass failure due to electron bombardment.
- **PUNCTURE PROOF**
New scientific method of mounting the grid structure guarantees against punctures due to heating of glass.
- **PROCESSED GRID**
A new exclusive Taylor feature makes possible a more abuse-proof grid.
- **NONEX GLASS**
- **UX 4 PRONG BASE**
- **LOWER INTERELECTRODE CAPACITIES**
Can be operated in class C amplifiers at full rated input at frequencies up to 60 MC.



SAFETY FACTOR

Taylor Carbon Anode Transmitting Tubes are able to stand up to a 1000% temporary overload without injury to any of the elements.

The new TW-75 is factory tested at 600 watts plate dissipation. The conservative plate dissipation rating of 75 watts makes your SAFETY FACTOR 525 WATTS. This extremely high SAFETY FACTOR is due to the famous "Processed Carbon Anodes".

CHARACTERISTICS

| | | | |
|----------------------------|------|------------------------------------|-----------|
| Fil. Volts..... | 7.5 | As RF Power Amp..... | (Class C) |
| Fil. Amps..... | 4.15 | DC Plate Volts—max..... | 2000 |
| Amp. Factor..... | 20 | DC Plate Current—ma—max..... | 175 |
| Inter-electrode Capacities | | DC Grid Current—ma—max..... | 60 |
| Grid to Plate—mmf..... | 1.5 | RF Driving Power—watts approx..... | 15 |
| Grid to Filament—mmf..... | 3.35 | Plate Dissipation—watts—max..... | 75 |
| Plate to Filament—mmf..... | .7 | | |

\$8⁰⁰

ACTUAL
SIZE

"More Watts Per Dollar"

Manual Now Ready!
Taylor's 1940 Manual was delayed in order to include the TW-75. Your Distributor can furnish your copy NOW Free—or send .05c in stamps direct to us.

Taylor **HEAVY CUSTOM BUILT DUTY** Tubes

Past •
Present
and
• **Prophetic**

All Alone by the Radiophone

Now we know what it feels like to be alone in the wilderness. The 2½-meter transceiver shown in this issue works fine, but we have yet to work anything except the lab transmitter with it, and that's no fun because we hear those voices all day long anyhow. Of course that isn't the transceiver's fault—they just ain't anything else to work in or around Santa Barbara as yet. Several members of the local club have promised to build 2½-meter transceivers, however, and we may be well on our way to WASB (Worked all Santa Barbara) by the time this reaches print. Seriously, though, we are all rather pleased with the smooth operation of the little unit, and recommend it strongly to 2½-meter devotees.

Vertical or Horizontal?

The commercials, who seem a little less inclined than amateurs to jump at conclusions, have found little to choose in actual operating advantages between the time-honored vertical u.h.f. antenna and the horizontal type. The increasing amount of dx work being done with the horizontal type may indicate that it will eventually supersede the vertical for general u.h.f. usage, especially since the horizontal is usually easier to install and feed. On page 44 Conklin discusses the situation in light of some protracted commercial studies of the subject.

We're Stumped

Undoubtedly most readers will immediately notice the similarity of basic circuit between the photo timer shown on page 23 and the time-delay control system on page 42. This just happens to be coincidence, however; all time delay circuits are somewhat similar—or so we thought until the photographer who has been taking our equipment pictures brought his photo timer around and wanted to know if we could repair it. Well, we spent half a day *trying* to trace the circuit, and we haven't yet figured out how it works. Either

the circuit came to the designer in a nightmare or else he was trying to get around somebody's patents. In either case it is positively the weirdest circuit arrangement we have ever seen. It worked perfectly, however, after the contacts on the push-button were pried open; it seems someone had shorted the line voltage across them.

AMC for All

It was inevitable that Technical Editor Dawley, being, as he is, an ardent low-level-modulation fan, would eventually produce an AMC circuit applicable to his pet system, especially when the AMC allows effective use of extended positive peak modulation. Just for good measure he threw in provisions for checking carrier shift, audio monitoring and a terminal from which audio for degenerative feedback may be obtained. You can read all about beginning it on page 25.

Still Going Strong

The cathode-modulation "inventor's" battle still rages. Elsewhere in this issue will be found a letter from Charles Fiege, Jr., ex-2CZZ, who used the system in 1923. That's a long way back, and we have yet to hear from anyone with an earlier claim. In a recent letter VK3SG says that he described a cathode-modulation system in the April, 1939, issue of *Amateur Radio*, the official journal of the W.I.A. Do we hear any claims to the years prior to 1923?

Frequency Modulation

Those who wonder what we are doing toward applying frequency modulation to amateur transmission may be interested to know that several experimental frequency-modulation transmitters and receivers are in the process of construction or being tested. We are resting most of our hopes in a simple r/c super which can be used for either amplitude or frequency modulation. It is doubtful whether the more complicated types of receivers will be of interest to many amateurs, since those having the wherewithal to build such receivers will probably have ideas of their own as to how the set should be built. Our efforts in this direction will probably be confined to converters and developments in the signal-frequency stages unless, of course, our r/c idea doesn't work out as expected. In that case we will see if anything can be done to simplify things in the i.f. end.

There Goes Another One

Probably most readers are familiar with the old wheeze about the man and the "buzz" saw: the one where the man, when asked to show how he lost his finger in the saw, says,

[Continued on Page 85]

Twins at a glance



but

... actually, their resemblance is only "skin-deep." Down under — that's where you discover Cornell-Dubilier superiority. And this holds, not simply for the Type TQ (shown at right) but throughout the entire Cornell-Dubilier capacitor line. Type for type and feature for feature, C-Ds are better built capacitors. Thirty years of specialization does make a difference! A difference directly reflected in longer capacitor life . . . in greater capacitor dependability, and in the fact that there are more C-D capacitors in use today than any other make. Be specific—order capacitors by name. Ask your jobber for C-Ds—you can rely on 'em.

FEATURES LIKE THESE

in Type TQ make all the difference!

Lower R.F. resistance
Lower equivalent series resistance

Higher insulation resistance
Higher voltage breakdown

Hermetically sealed
Non-inflammable
Non-explosive
Non-corrosive
Triple tested

Safe for continuous operation at 10% above rated voltage
Universal mounting bracket
Compact

Suitable for panel or sub-panel mounting

Described in catalog No. 160T free on request.

MICA • DYKANOL • PAPER • WET & DRY ELECTROLYTICS



CORNELL-DUBILIER ELECTRIC CORPORATION

1017 Hamilton Boulevard, South Plainfield, New Jersey

Cable Address: "CORDU"

The publishers assume no responsibility for statements made herein by contributors and correspondents, nor does publication indicate approval thereof.

Table of Contents

ARTICLES

| | |
|--|----|
| A Self-Contained, Battery Powered 2½ Meter Transceiver— <i>W. W. Smith, W6BCX</i> - - - | 11 |
| A Combined V.F.O. and 100-Kc. Standard— <i>Robert M. Stephens, W1JLT</i> - - - | 17 |
| An Electronic Photo Timer— <i>Leigh Norton, W6CEM</i> - - - | 23 |
| A. M. C. for Any System of Modulation— <i>Ray L. Dawley, W6DHG</i> - - - | 25 |
| An Inexpensive High-Quality Mike— <i>George E. Sanders, VE3QC</i> - - - | 29 |
| Controlled Negative Peak Bias for A. M. C. - - - | 31 |
| Quick Phone-C.W. Changeover with Plate Modulation— <i>Eugene Black, Jr., W2ESO</i> - - - | 32 |
| U. H. F. Circuit Developments— <i>E. H. Conklin, W9BNX</i> - - - | 34 |
| A Highly Sensitive Field Strength Meter— <i>W. W. Smith, W6BCX</i> - - - | 37 |
| A Diode Peak Voltmeter— <i>P. M. Honnell</i> - - - | 40 |
| A Time Delay Control System— <i>R. K. Dixon, W8DYY</i> - - - | 42 |
| Antenna Polarization on the Ultra Highs— <i>E. H. Conklin, W9BNX</i> - - - | 44 |
| Keying Circuit Innovations - - - | 47 |
| Tubeless Noise Limiters - - - | 49 |

MISCELLANEOUS FEATURES

| | | | |
|--------------------------------------|----|--------------------------|----|
| Past, Present and Prophetic - - - | 6 | QRP—Reduce Power - - - | 91 |
| Feeding A Multi-Element Array - - - | 16 | Policing the Ether - - - | 92 |
| Helpful Hint for Handling Heavy Rack | | The Marketplace - - - | 97 |
| Units - - - | 30 | Advertising Index - - - | 98 |
| "SSSS" and "SOS" - - - | 89 | Buyer's Guide - - - | 98 |

DEPARTMENTS

| | | | |
|----------------------|----|-------------------------------------|----|
| DX - - - | 53 | Postscripts and Announcements - - - | 62 |
| The Open Forum - - - | 57 | Yarn of the Month - - - | 64 |
| U. H. F. - - - | 58 | What's New in Radio - - - | 66 |

**THE WORLDWIDE TECHNICAL AUTHORITY ON
AMATEUR, SHORTWAVE, AND EXPERIMENTAL RADIO**



SHEET-METAL PRODUCTS

DESIGNED FOR

Appearance - Utility - Versatility

BUD RADIO, INC.

CLEVELAND

OHIO



● The five-kilowatt stage in KNX's new transmitter. Notice the air-cooling fins and forced air feed for the tube; these eliminate the need for expensive and complicated water-cooling arrangements.

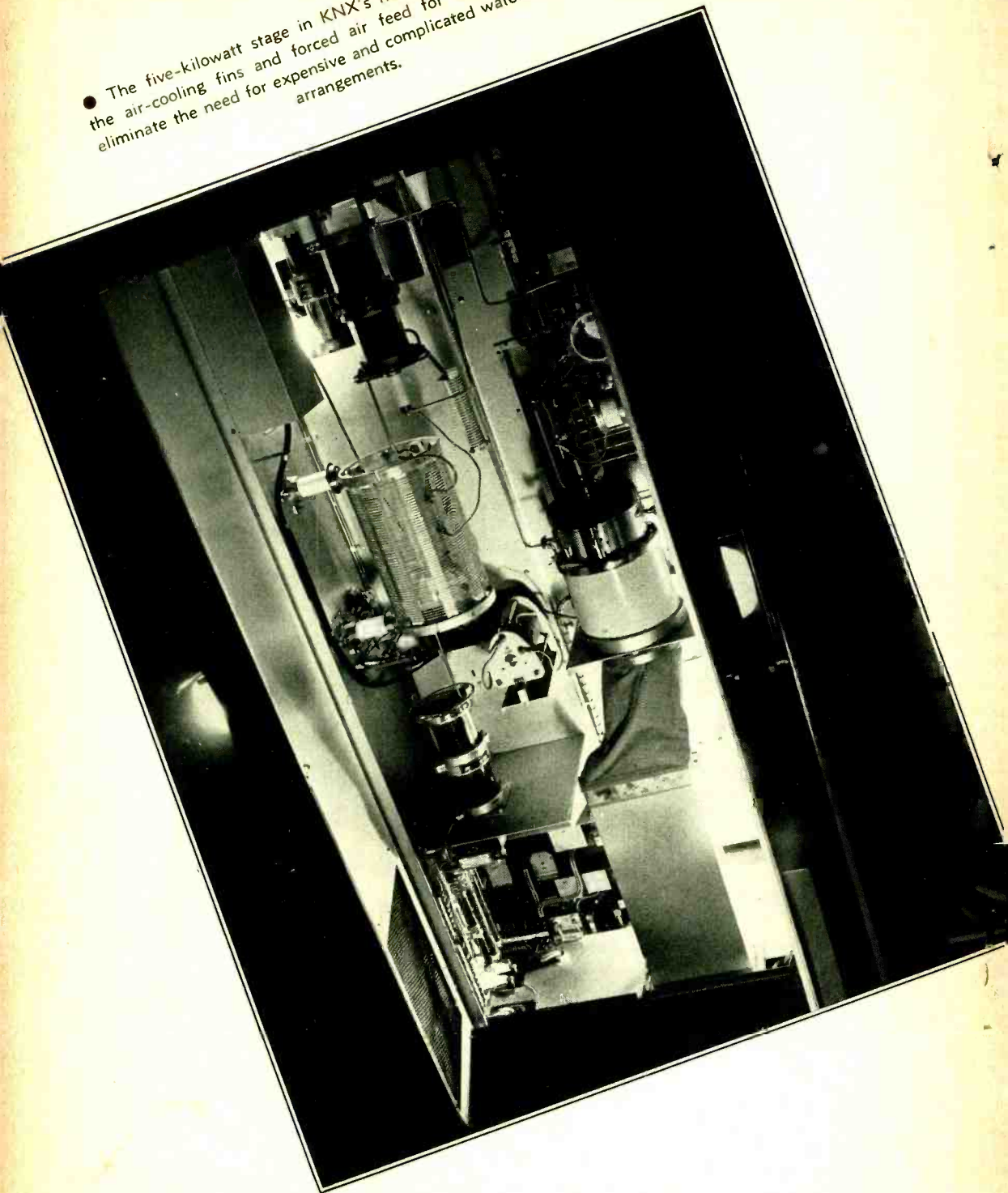

A Self-Contained, Battery-Powered 2.5 METER TRANSCEIVER

By W. W. SMITH,* W6BCX

Weighing but 13 pounds (not including microphone or phones) the little 2½ meter transceiver shown in the illustrations can be carried considerable distance without fatigue, and for this reason is suitable for many applications where a heavier transceiver or a transceiver requiring a 6-volt storage battery for power would not be practicable.

The 2½ meter transceiver of this article is generally similar to the 5-meter transceivers that were so popular a few years back, except that it uses the new 1.4-volt tubes in place of 2-volt tubes and a linear tank circuit instead of the conventional pee-wee tank coil. In fact, a 1G4-G (which is the 1.4-volt counterpart of the old type 30) doesn't work very well on 2½ meters when a regular coil-and-condenser tank circuit is used. But with the linear tank circuit, the output and efficiency are surprisingly good. Power is derived from a self contained A-B pack of the type commonly used in the new 1½-volt battery portable b.c. receivers. Cost of operation will be around ½ cent per hour, a single pack being good for over 500 hours of intermittent service with the transceiver.

A single button microphone is used to feed the grid of the 1Q5 modulator directly. When S₂ is thrown to "receive" the 1G4G acts as a superregenerative detector and the 1Q5-GT as an audio amplifier. The latter has sufficient output to drive a pair of phones to as much volume as is comfortable. A "sawed off" version of the 1G4G in the form of a 1G4-GT would undoubtedly make a better 2½-meter oscillator, but unfortunately no such tube is being manufactured at the time of this writing. The 1G4G does a good job, however; so there is no need to feel par-

ticularly unhappy about the fact that the tube manufacturers haven't seen fit to make a "GT" out of the 1G4G even though they are making GT versions of many of the other 1-4-volt tubes.

Construction

The transceiver is constructed in a standard manufactured cabinet measuring 7 x 10 x 8 inches deep, a 7½ x 9 inch sub-chassis measuring 1½ inches high being supported from the front panel. These items are made by a well known manufacturer and are commonly stocked throughout the country.

The 1G4G socket, which must be of steatite, polystyrene, or other low loss material, is mounted by means of two 1½-inch bushings and 1¾-inch bolts. The bolts are mounted in holes drilled exactly ¾ inch in from the edge of the chassis. The holes should be located so that the center of the socket is exactly 4 inches from the front panel. The socket should be oriented so that the ridge on the locating pin of the tube points towards the rear.

The socket for the 1Q5-GT is mounted with the center about 2¼ inches back from the front panel, and about 2¼ inches in from the right hand edge of the chassis. A ceramic socket is shown, but it could just as well be of the inexpensive fiber type.

As both sides of the tuning condenser C₁ are "hot," the condenser is mounted by

* Editor, RADIO.

means of an accessory bracket offered by the manufacturer of the condenser. This bracket bolts to the ceramic portion of the condenser, and does not touch either rotor or stator. The bracket is raised up off the chassis by means of two 1/2-inch collars and 3/4-inch 6-32 bolts. If this were not done, the tuning dial would sit too low on the front panel. Holes for mounting the condenser bracket should be so drilled that the condenser shaft is exactly 1 3/4 inch in from the edge of the chassis or 2 1/4 inches in from the edge of the front panel. A hole is drilled in the front panel bearing, 2 1/4 inches in from the edge of the panel and at the same height as the condenser shaft. A flexible, ceramic insulated coupling unit is used to drive the tuning condenser. A short piece of 1/4-inch steel, brass, lucite, or bakelite rod is used to connect the dial to the flexible coupling. The condenser should be mounted so that the ceramic front plate is exactly 3 inches back from the panel.

The send-receive switch S_2 is mounted so that the shaft is at the same height as the tuning condenser shaft, and midway between the right hand and left hand edges of the panel. The regeneration control R_2 is mounted exactly 2 1/4 inches in from the right hand edge of the front panel and at the same height as the other controls. As may be seen from the illustration of the front panel, the two jacks and the on-off switch are lined up directly underneath the three controls, 3/4 inch from the bottom edge of the panel.

The midjet transformer T and the choke CH are mounted on the rear drop of the chassis as shown in the illustration. The chassis is just barely high enough to accom-

modate these two items, but if the mounting holes are positioned correctly they will not prevent the back lip of the chassis from resting on the bottom of the cabinet.

The small 4 1/2-volt C battery is held in place by means of a bracket bent out of a small piece of galvanized iron, soldered to the edge of the chassis. The battery is slipped under this bracket and held firmly in place by means of a small angle bracket which is screwed to the positive battery terminal and bolted to the chassis. This not only holds the battery in place, but furnishes a connection from C plus to chassis (ground).

In order to permit mounting of the small u.h.f. filament chokes as close as possible to the 1G4G, two 1/2-inch holes are drilled near the socket. The chokes are mounted half above and half below the chassis, the leads to the socket pins being only a fraction of an inch long when the chokes are mounted in this manner. Each choke should have not over 1 ohm d.c. resistance or the filament will not receive rated voltage.

The linear tank consists of two lengths of no. 12 enamelled wire, spaced about 3/8 inch at the tube end and about 7/8 inch at the condenser end. Enamelled wire should be used; tinned wire will have higher losses and bare wire endangers the tube. When bare wire is used, the 1G4G can be permanently damaged with the switch on the "receive" position simply by touching both grid and plate wires with a hand moist with perspiration. This puts a positive bias on the grid, and the tube does not have a husky enough filament to stand such treatment without harm. With enamelled wire there is little

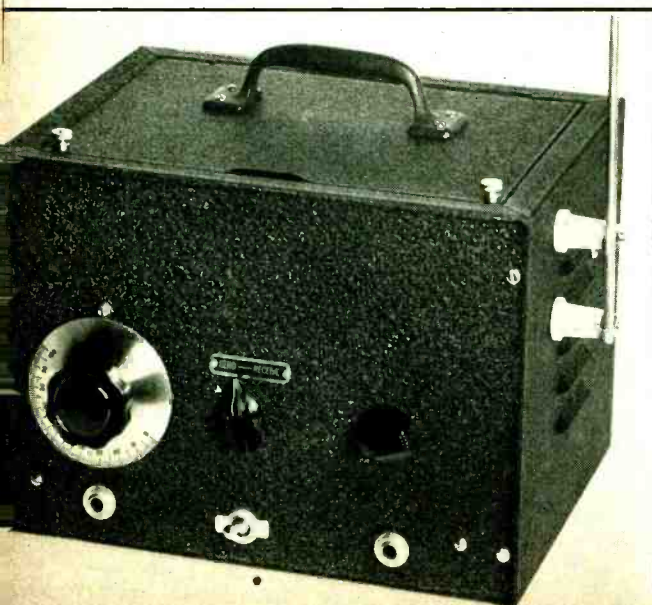

All ready to go for a walk. From a good vantage point, this little self-contained 112 Mc. transceiver has a range of several miles. The vertical rod radiator is supported as shown. Two bolts are soldered to the front lip supporting the hinged lid, and by removable thumb screws the lid either may be held down tightly for carrying by the handle or opened for access to the "works".

danger to the tube on this score, as one would be unlikely to touch both sides of the tuning condenser at once when reaching inside the cabinet to make antenna coupling adjustments.

Some alteration of the length of the tank elements may be necessary after the transceiver is fired up and the frequency checked by means of lecher wires, but to start off with the following dimensions should be used. Grid (front) wire: 9 inches. Plate (rear) wire: $9\frac{1}{2}$ inches.

The grid wire is deliberately made shorter than the plate wire, because the extra half inch is made up when the antenna coupling condenser is soldered to the grid prong of the 1G4G socket.

The grid wire solders directly to the rotor lug of the tuning condenser and the plate wire to the *farthest* stator lug. The wires are bent in the shape of a half moon, as shown in the illustration. The small grid resistor R, and the plate r.f. choke are soldered to the tuning condenser with the shortest possible leads. As previously mentioned, the antenna coupling condenser C is soldered directly to the grid prong of the 1G4G socket; be sure that the *stationary* plate is soldered to the grid prong.

The battery pack is mounted upside down as far to the rear as the cabinet will allow. This means that the battery overhangs the rear of the chassis about $\frac{1}{2}$ inch. A socket size hole is punched or drilled in the chassis to accommodate the leads from the battery. This is all clearly illustrated in the bottom view.

To keep the battery firmly against the rear of the cabinet, a piece of brass rod or tubing is cut the exact width of the cabinet and tapped at each end for a 6-32 bolt. Two holes are drilled in the sides of the cabinet so that when the tubing is bolted in place the battery pack is held firmly in position. Small blocks of wood between battery and cabinet or a couple of 1-inch 6-32 bolts protruding from the chassis can be used to keep the battery pack from slipping sidewise.

The antenna consists of a vertical half-wave rod, capacitively coupled to the grid of the tube. Better results, both receiving and transmitting, are obtained with the antenna coupled to the grid rather than the plate. The length of the antenna, *overall*, from the tip of the rod to the coupling condenser C, should be exactly 3 feet 6 inches. This is not quite as long as the usual 114-Mc. dipole, but it is an electrical half wavelength just the

Looking down on the transceiver with cabinet removed. The flexible lead terminated in a solder lug must be unfastened from the lower antenna feed through insulator before the unit can be slid out of the cabinet.

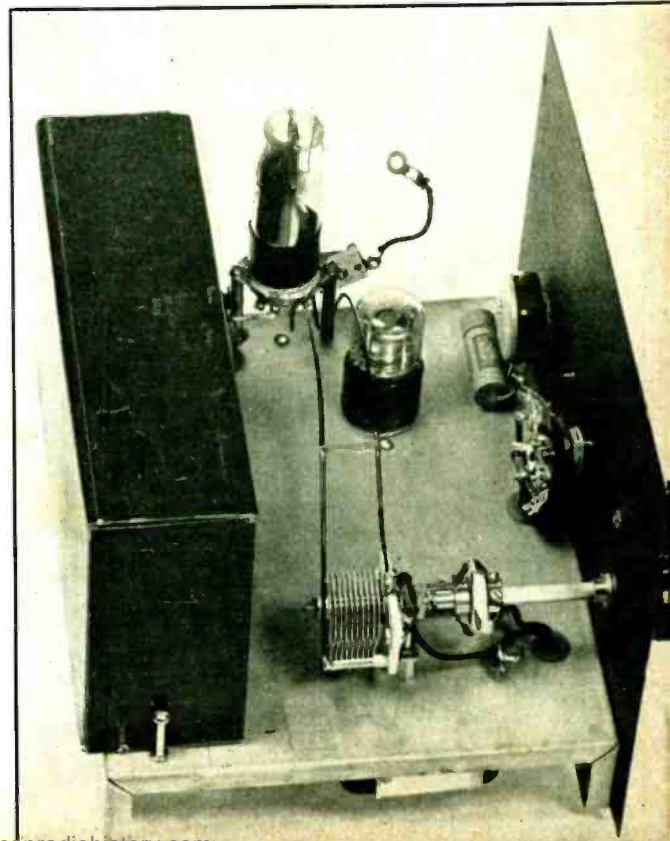

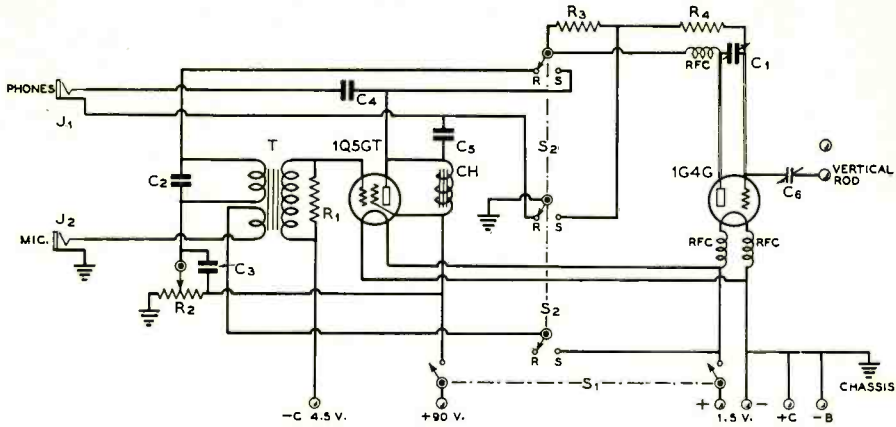

Figure 1. Wiring diagram of the 2½ meter transceiver.

C₁—100-µfd. midget condenser, ceramic insulation
 C₂—0.001-µfd. midget mica
 C₃—0.1-µfd. 200 or 400 volt tubular
 C₄—0.1-µfd. 200 or 400 volt tubular

C₅—0.01-µfd. 400 volt tubular
 C₆—3-30-µfd. mica trimmer, ceramic insulation, screw removed
 R₁—100,000 ohms, ½ watt
 R₂—100,000 ohm potentiometer

R₃—1 meg., ½ watt
 R₄—25,000 ohms, ½ watt

CH—Midget 7 to 10 hy. choke, 15 ma. or more

T—Transceiver type midget dual purpose a.f.t., plate and single button

mike to grid

S₁—D.p.s.f. toggle switch

S₂—4 pole 2 throw rotary "send-receive" switch

J₁, J₂—Open circuit jacks

RFC—U.h.f. type chokes, not over 1 ohm d.c. resistance

same because of the loading effect of the coupling condenser C_a.

The antenna rod proper is 3 feet 3 inches long. The rest of the length is made up by the feed-through insulator bolt and the 1½ inch flexible lead to the coupling condenser. The two medium-sized feed-through insulators are mounted one above the other, their centers 2¾ inches back from the front edge of the cabinet. They are spaced 1¾ inches and the top insulator is ⅞ inch below the top edge of the cabinet. The top insulator does not connect to anything; it merely serves to hold the antenna rod vertical. The two threaded rods for the feed-through insulators should be sawed off so that they are no longer than necessary, in order to reduce the stray capacity to ground (cabinet) as much as possible.

The antenna may be of aluminum, brass, dural, or even chrome- or cadmium-plated steel; may be either solid or hollow; and may be anything between 3/16 and 5/16 inch outside diameter. Aluminum or dural is the lightest, but a piece of small brass

tubing has the advantage of being capable of being fastened to the feed-through insulators by means of two husky solder lugs sweated to the tubing. If aluminum tubing is used, it should be of large enough diameter than when it is flattened with a hammer there is enough width that holes can be drilled without weakening it too much. The radiator shown in the illustration consists of a 3-foot length of 3/16-inch o.d. brass tubing to which two heavy lugs were soldered, and a piece of no. 10 copper wire stuck down inside the top end an inch and soldered. The wire is cut off so as to protrude just 3 inches, bringing the length up to the required 3 feet 3 inches. It just so happened that this particular tubing was available in standard 3-foot lengths.

Inspection of the wiring diagram will show that the filament switch S₁ also opens the B negative. This is necessary to prevent a continuous drain on the B battery by the potentiometer R₂.

After the wiring job is completed and carefully checked to make sure the B plus won't be inflicted on the filaments, the rig is ready for the initial firing up.

Under chassis view of the transceiver. Wires underneath the chassis need not be made short. Observe method of holding C battery by means of large stationary and small removable bracket, latter bolted to positive terminal and chassis.

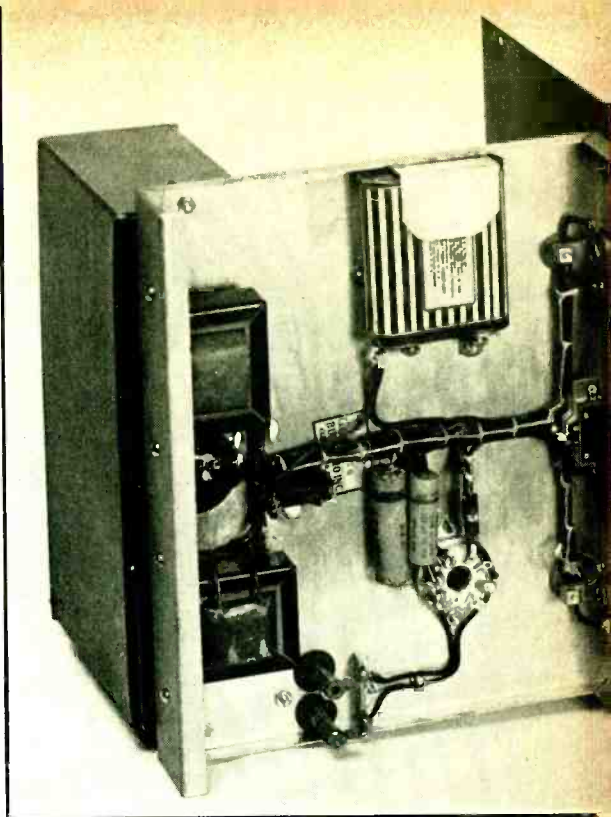

Initial Adjustment Procedure

Remove the adjusting screw from the antenna coupling condenser C6, and attach the antenna, making sure the flexible wire is connected from the coupling condenser to the terminal on the *bottom* insulator (this wire must be unhooked each time the set is removed from the cabinet). Insert the microphone and earphone plugs, making sure to get them in their correct respective jacks. It is possible to hear very weakly with the phones in the mike jack, but needless to say it is impossible to transmit with the microphone in the earphone jack. No damage will result if the two plugs are accidentally transposed.

With the switch on "receive," a loud hiss should be observed when the potentiometer is advanced full on and the tuning condenser is rotated. The circuit will not oscillate when the tuning condenser is tuned to less than 1/3 of maximum capacity. This means that only two-thirds of the scale is usable, but this is unimportant because the entire 2½ meter band covers less than half the dial. Using a smaller tuning condenser shunted with a 25 or 40 $\mu\text{mfd.}$ fixed condenser so as to permit oscillation over the entire dial range did not prove practicable, as the variable condenser has a rather unpredictable effect upon the frequency as it is rotated when shunted by a fixed condenser. The best answer appeared to be to use a 100 $\mu\text{mfd.}$ variable and not worry

about the fact that 1/3 of the dial range is "dead."

By means of another transceiver or Lecher wires the frequency should be checked. If necessary the two tank wires should be pruned an eighth of an inch at a time until the center of the band is found at about 2/3 maximum capacity. The nodes or dips on a pair of Lecher wires should measure 4 feet 3 inches apart for the approximate center of the band. The points can be observed quite readily by putting the potentiometer right on the edge of superregeneration. When the slider-jumper hits a node the receiver will be thrown out of superregeneration. A 0-10 or 0-25 d.c. milliammeter temporarily connected on the B plus lead also can be used as an indicator. In this case the switch S₂ should be thrown to "transmit." The tube will draw 5 or 6 ma. and dip slightly when a nodal point is reached. A hairpin link of *insulated wire* should be used to couple the Lecher wires to the condenser end of the transceiver tank, to avoid shorting the B voltage to the grid.

When the linear tank covers the band correctly (a small amount of leeway on either side), the circuit elements should be stiffened up to make them less susceptible to vibration. A small piece of celluloid or victron is cut to make a "spreader" by cutting it about 1/8 inch longer than the separation of the parallel wires at a point about one-third of the way

up from the tuning condenser. The ends of the spreader are notched with small "V" indentations with a pair of diagonals and the wires are pulled apart slightly to take the spreader. The wire is crimped a little either side of the spreader to provide a "bite" for duco cement, which is applied to hold the spreader firmly in place. The spreader should not be placed too far up the rods; if placed a third of the way up from "ground" the voltage across the spreader and consequently the losses will be small. Be sure the on-off switch is *off* when working on the tank wires.

If the 1G4G socket is of the ceramic type having a metal mounting flange crimped to the ceramic portion of the socket, duco cement should be applied copiously around that portion of the socket where the flange is crimped to the ceramic. After a few hours another coat should be applied both to the spreader and the socket, and then allowed to dry over night. Do not move either the tube or the tank wires while the cement is getting dry, and a rigid job will result, neither tube

nor tank wires vibrating excessively when the transceiver is jarred.

Next, the antenna coupling should be varied by adjusting the distance between the movable and the stationary plate. Closer spacing provides tighter coupling. The coupling should be increased to as much as will still permit superregeneration over the entire band, and then left alone. Ordinarily this adjustment will be about the same as the position assumed by the movable plate when the adjusting screw is removed.

It will be observed that on receiving some signals, better intelligibility is obtained when the transceiver is retuned very slightly from the transmit position. If this is done, be sure to return the dial to the original scale setting when the switch is turned to "transmit"; otherwise you and the station you are working will "chase each other across the band." In most cases the intelligibility will be sufficiently good with the dial left at one position for both receive and transmit.

See Buyer's Guide page 98 for parts list.

• • •

Feeding a Multi-Element Array

Cliff Alsop, W9EKD, has suggested the application of an old and seldom-used principle to simplify the feeding of a multi-element array. The resistance at the center of a three-element or four-element array is very low and requires special networks and matching arrangements to couple it into the conventional 600-ohm open-wire line. However, by making the driven element somewhat

longer than a half wave and then shortening it by means of a series capacity at the center, the two feeders may be connected to the two sides of the series condenser to provide a simple and effective match.

The simplicity of the arrangement is shown in the accompanying diagram. The following lengths and spacings have been determined by experiment as being proper for 29,000 kc.: reflector, 16 feet $6\frac{3}{4}$ inches; radiator, 20 feet 2 inches; directors, 14 feet $9\frac{1}{2}$ inches; reflector-to-radiator spacing, 78 inches; radiator-to-director and director-to-director spacing, 39 inches. These dimensions were found to be best for an array height of 54 feet above ground.

The parasitic elements are tuned in the conventional manner. This procedure has been discussed in previous articles on three-element and four-element rotary arrays. The length of the radiator is varied until resonance in this element comes at the same point as minimum standing waves on the feed line. The radiator length given will be satisfactory for operation on 29,000 kc. and would be increased or decreased proportionately for a higher or lower frequency.

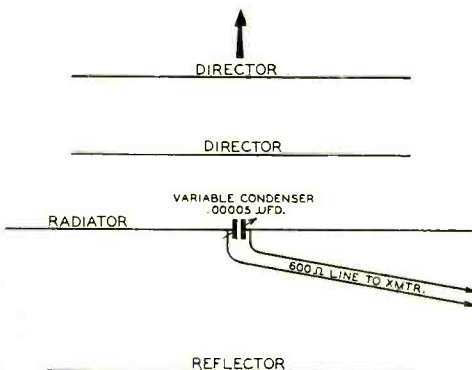

A Combined V. F. O. and 100-K C. STANDARD

By ROBERT M. STEPHENS,* WIJLT

A description of a stabilized variable-frequency-oscillator transmitter control combined with a 100-1000 kilocycle crystal frequency standard.

In recent months we have read many excellent articles on e.c.o.'s and other types of oscillators for the purpose of transmitter frequency control. There is much to be learned from a thorough study of these examples. However, when it comes time to decide upon the actual design of the unit to be built, it is best to set down the individual requirements and to employ ideas from the previous designs in making up the layout of the individual unit to be built. Very few would even think of copying or building exact duplicates of the pieces of equipment shown from time to time in these pages. Rather we try to observe the points which have merit and to attempt to avoid the troubles and headaches which others have experienced.

Our requirements can be set down as follows:

1. The variable-frequency oscillator must be capable of covering all bands from 3.5 through 28 Mc.
2. The v.f.o. must be built so as to be a quality frequency meter in order that the station conform to the FCC requirements.
3. Accurate frequency checking means must be built into the unit.
4. There must be no compromise with crystal control. The v.f.o. must be better than an X-cut crystal both from the standpoint of stability and note.
5. The v.f.o. must be located at the operating position and work into the existing push-button bandswitching exciter in the transmitter.

Although all-band coverage is required, it is best to utilize an arrangement that will not require coil changing or the resetting of condensers when the final amplifier is to be changed to a different frequency. Therefore, an oscillator having output from 3500 to 4000 kilocycles is essential. Then the output of the v.f.o. can be used in place of any of the 80-meter crystals in the existing exciter and the multiplying to frequency carried on in the exciter.

The only shortcoming of this arrangement is that the higher frequency bands will be somewhat crowded on the dial. However, a quality vernier dial which can be read to



Front view of the unit showing the precision vernier dial.

* 12 Marcella Avenue, Pittsfield, Mass.

V.F.O. TRANSMITTER CONTROL

STANDARD FREQUENCY CRYSTAL UNIT

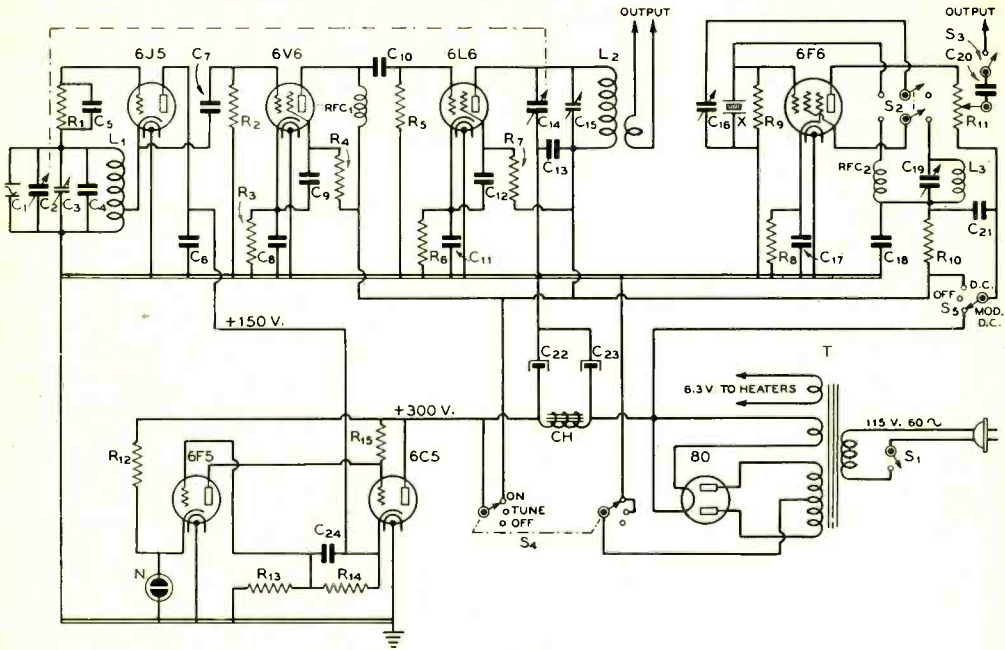

Wiring diagram of the variable-frequency oscillator standard-frequency unit.

| | | | |
|---|---|--|---|
| C ₁ —20- μ fd. negative coefficient | C ₁₅ , C ₁₈ —0.1- μ fd. 400-volt | R ₇ —10,000 ohms, 10 watts | L ₁ —40 t. no. 20 d.s.c. closewound on 1" form |
| C ₂ —100- μ fd. var. ganged to C ₁₅ | C ₁₆ —100- μ fd. mica trimmer | R ₈ —500 ohms, 1 watt | L ₂ —3.5-Mc. output coil and link, 1 1/2" form |
| C ₃ —25- μ fd. air trimmer | C ₂₀ —0.001- μ fd. mica | R ₉ —5 megohms, 1/2 watt | L ₃ —One pie of 2 1/2-mh. 125-ma. r.f. choke |
| C ₄ —200- μ fd. zero-coefficient | C ₂₁ —0.1- μ fd. 400-volt tubular | R ₁₀ —25,000 ohms, 3 watts | RFC ₁ —2 1/2-mh. 125-ma. r.f. choke |
| C ₅ —0.005- μ fd. mica | C ₂₂ , C ₂₃ —8- μ fd. 450-volt elect. | R ₁₁ —500,000-ohm potentiometer | RFC ₂ —8-mh. r.f. choke |
| C ₆ —0.005- μ fd. mica | C ₂₄ —0.05- μ fd. 400-volt tubular | R ₁₂ —5 megohms, 1/2 watt | X—100-1000 standard crystal |
| C ₇ —0.005- μ fd. mica | R ₁ —100,000 ohms, 1/2 watt | R ₁₃ —50,000 ohms, 1 watt | S ₁ —A.c. line switch |
| C ₈ —0.005- μ fd. mica | R ₂ —50,000 ohms, 1 watt | R ₁₄ —100,000 ohms, 1/2 watt | S ₂ —D. p. d. t. toggle switch |
| C ₉ —0.02- μ fd. mica | R ₃ —500 ohms, 3 watt | R ₁₅ —2 megohms, 1/2 watt | S ₃ —Rotary output on-off switch |
| C ₁₀ —0.06- μ fd. mica | R ₄ —50,000 ohms, 1 watt | CH—20-hy. 100-ma. choke | S ₄ —Two-pole three-position switch |
| C ₁₁ —0.005- μ fd. mica | R ₅ —100,000 ohms, 1 watt | T—750 c.f., 100 ma., 5 v. 2 a.; 6.3 v. 3a. | S ₅ —S.p.d.t. with center off position |
| C ₁₂ —0.002- μ fd. mica | R ₆ —200 ohms, 10 watts | | |
| C ₁₃ —0.006- μ fd. mica | | | |
| C ₁₄ —0.006- μ fd. 1000-volt mica | | | |
| C ₁₅ —100- μ fd. band-set variable | | | |
| C ₁₆ —25- μ fd. tracking variable | | | |
| C ₁₇ —25- μ fd. air trimmer | | | |

1 part in a thousand will overcome this disadvantage nicely. Even the 14-Mc. band will cover some 265 divisions on such a dial. Of course anyone not interested in the whole of the 3.5 to 4.0 Mc. band could increase the band spread to cover whatever of the higher frequency bands in which they might

be interested.

The requirements of (2) are simply that the job must be ruggedly made and be capable of calibration which can be maintained and checked at will.

A frequency checking means (3) which is reliable and always available can best be con-

structed by amateurs by the use of the 100-1000 kc. crystals recently brought out, (Bliley, etc.).

The number (4) requirement in our problem deals with what the other fellows hear and is the sole means of judging whether or not the job was worth doing. The v.f.o. must be stable in operation. It is well to repeat the main factors affecting stability of an oscillator. They are: plate-voltage changes, temperature changes, mechanical vibration, circuit loading and r.f. feedback. All must be taken into consideration when designing the v.f.o.

The number (5) requirement of our design problem is mainly circuit consideration and mechanical layout.

V.F.O. Features

In our case the following means were selected to eliminate or compensate for the five main factors affecting frequency stability in the oscillator.

- A. A voltage regulated power supply shall supply the power to the oscillator stage.
- B. All parts in the oscillator stage shall be mechanically rigid and free from vibration or movement with relation to other parts in this stage.
- C. Temperature compensation shall be employed to overcome changes in constants due to temperature variation.
- D. There shall be no change in loading on the v.f.o. This may be accomplished by following the v.f.o. stage with a class A amplifier.
- E. Last, but most important, the v.f.o. stage shall be isolated from outside r.f. disturbances. Complete shielding will in most cases accomplish the desired result.

6J5 V.F.O.

Reference to the complete diagram of the control unit will show that the v.f.o. circuit is one commonly used in receiver high frequency oscillators. A 6J5 is used in a grounded-plate oscillator circuit working on 1.75 Mc. followed by a class A isolating stage and an output stage which doubles to 3.5 Mc.

The grid tank of the 6J5 is made fairly high C, approximately 325 $\mu\mu\text{fd.}$ being necessary to get down to 1.75 Mc. Coupling is made to the cathode to reduce pulling effects.

Temperature Compensation

As long as we have temperature changes to contend with and to be compensated for, it was necessary from our viewpoint to shield

completely the v.f.o. oscillator stage, tube and all. All parts for the stage are rigidly mounted in a welded aluminum can $3\frac{1}{4} \times 4\frac{1}{4} \times 5$ inches.

Now the average frequency coefficient for the usual coil and condenser combination is approximately .006% per degree C. It just happens that the TiO_2 negative-coefficient capacitors are approximately negative .06% per degree C. Therefore a negative-coefficient capacitor approximately 1/10 of the circuit capacitance would be needed. Actually a 20 $\mu\mu\text{fd.}$ capacitor of .0007 $\mu\mu\text{fd.}$ per $\mu\mu\text{fd.}$ per degree C. negative temperature coefficient gives practically flat compensation after the first minute of heating. A curve could be run, showing the before-and-after compensation, but inasmuch as this would be different for each individual layout, and has been thoroughly covered in other articles, it will not be gone into here.

The shield can get quite warm, as was contemplated. Therefore changes in room temperature have little or no effect on oscillator stability. It is heartening to listen to the oscillator on 28 Mc. and hear it steady down in the one or two minutes time required for the tube to warm up.

Class A Buffer Stage

Variations in loading which must normally be expected, would most certainly affect the v.f.o. stability. Therefore no variations in loading can be allowed to get back to the v.f.o. stage. Circuit isolation is provided between the v.f.o. and the output stage, as well as the complete shielding of the v.f.o. stage as mentioned above.

The class A stage is an untuned 6V6 capacity coupled to the v.f.o. with a resistor across the grid circuit of the 6V6 and an r.f. choke in the plate circuit. To satisfy the conditions for class A operation there is no change in plate current when excitation to the 6V6 is removed.

Screen current for the 6V6 is obtained through a dropping resistor, although if desired it could be obtained from the voltage-regulated power supply.

The 6L6 Output Stage

There is little need for discussion of this stage as the circuit is quite conventional. Plate voltage is obtained from the high point of the power supply and the screen voltage is obtained through a dropping resistor. Series feed is used, with the main tuning condenser isolated from ground. However, the 25 $\mu\mu\text{fd.}$ condenser in parallel with the main tuning condenser has its rotor grounded. This small condenser is ganged with the

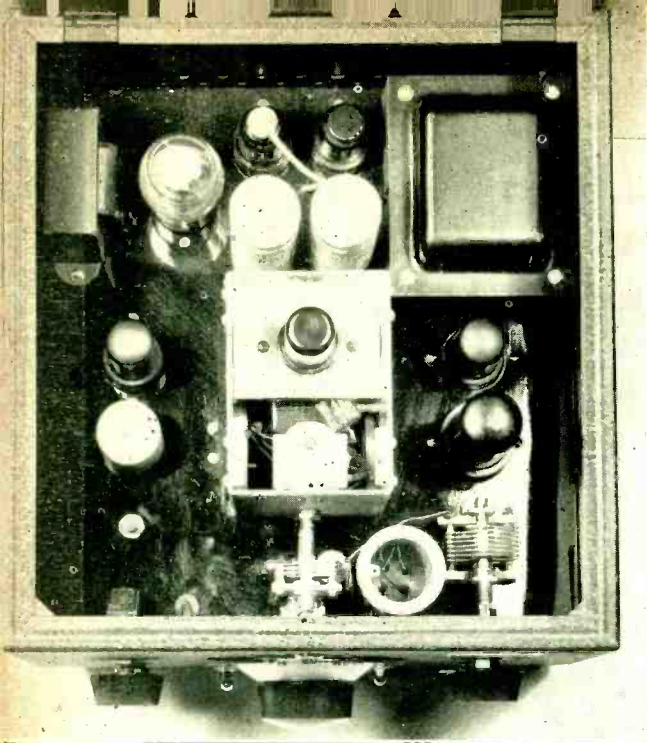

Looking down into the unit. The shield on the oscillator compartment has been loosened and turned back to show the components. The 6L6 output circuit can be seen along the front with the trimmer condenser on the tuning shaft, then the coil with integral link, and the output circuit bandset condenser on the right.

v.f.o. tuning condenser and allows output to be maintained at approximately peak value across the entire tuning range.

The output of the 6L6 is link coupled to a coupler unit located in the transmitter proper. This coupler unit can be switched or plugged into the circuit in place of 80-meter crystals without any circuit change. The coupler unit is tuned to a somewhat higher frequency than the 80-meter band in order to avoid any tendency toward self oscillation of the former crystal stage. Chokes should not be used in the grid or plate circuits of the former crystal stage as they are apt to cause low frequency oscillation.

Voltage Regulated Power Supply

The voltage regulator is conventional and uses a 6F5 and 6C5 with a neon tube as a means of obtaining a constant drop for the cathode of the control tube. Any neon tube of $\frac{1}{4}$ -watt size or larger with the resistance in the base removed will be satisfactory. The 5-megohm resistor from the cathode to plus high voltage is used to keep the neon tube ignited at low values of current drain through the tube. If the neon tube should tend to oscillate at low frequencies, a resistor and condenser in series across the neon tube should suppress the oscillation. The resistor may be from 50,000 to 100,000 ohms and the condenser from .006 to .02 μ fd. In our case no oscillation occurred so these parts were not required.

The voltage regulator part of the power supply is simple and its use may eliminate a

lot of trouble which otherwise might be encountered should the voltage stabilization of the oscillator be none too good. In this case the v.f.o. is extremely stable, even without the regulated supply, but the v.r. is just another point which adds to the overall performance of the v.f.o.

A switch S_1 is provided in the primary of the transformer, and a tap switch S_2 allows the plate supply to be (1) cut off completely, (2) supply v.r. power to the v.f.o. only for tuning, and (3) supply power to all tubes when ready to go on the air. Many other switching control arrangements will of course suggest themselves to fit the readers individual requirements.

Standard Frequency Crystal Unit 100-1000 Kc.

The circuit of the standard frequency crystal unit is shown on the main diagram. Details of such a unit were described in full in *QST* for January, 1939. The crystal is a Bliley Type SMC100 and a complete instruction sheet accompanies each crystal. There are no special requirements which need be followed from a constructional standpoint other than to build the oscillator ruggedly. In our case it was elected to mount the crystal beneath the sub-chassis as it would be cooler there with a resultant decrease in frequency drift of the crystal.

Construction

The really important points of construction are centered around the v.f.o. The photographs showing the different views of the unit clearly show the layout and arrangement of the com-

Underchassis view of the combined v.f.o. and frequency standard. The shielded cable carries the energy from the output circuit of the 6F6 standard crystal oscillator to a jack on the rear of the chassis.

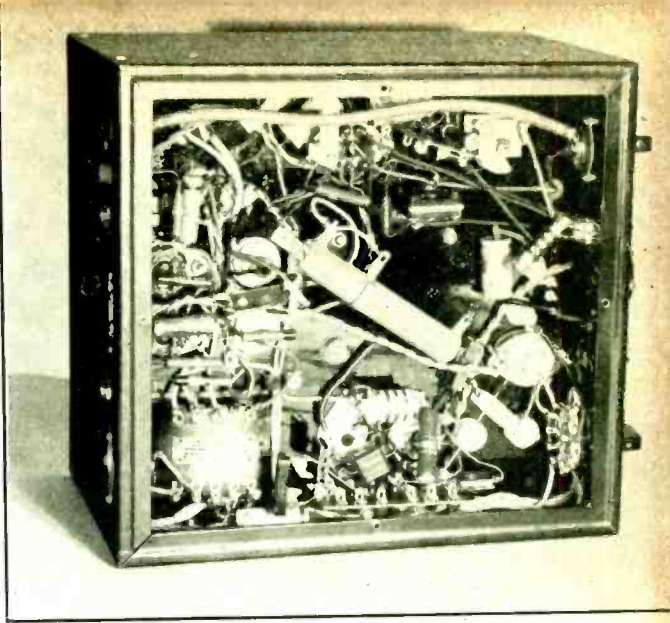

ponent parts. The entire unit is housed in an FB-7 receiver cabinet. This cabinet is not too large, and yet allows ample room for a neat layout of parts without crowding.

The v.f.o. unit is a complete, entirely shielded separate assembly which can be set up and operated, checked for band spread, stability, etc., before its final assembly in the cabinet. The shield can is made of 1/16" hard aluminum welded at the corners. One-quarter-inch square brass rods are securely fastened at 4 places both top and bottom for attachment to the chassis and for attachment of the cover. An aluminum shelf is mounted in a portion of the shield can to take the tube socket and mount the coil form which is a National XR-2. All parts are so attached to the shield can, that even with movement of the cabinet or sub-chassis, there can be no change in the relationship of the v.f.o. condensers, coils, etc. Small receiving type TMS Cardwells are used for the variable condensers. As these are not subject to vibration, even a sharp blow on the shield can does not affect the frequency of the v.f.o.

Looking at the top view of the v.f.o. section, the 6J5 tube is shown at the back on its sub-chassis. C_2 , the 25 $\mu\mu\text{fd}$. band setting condenser, is shown mounted to the front of the can, and below this but not shown is C_3 , the main tuning condenser. The grid leak and grid condenser as well as C_4 are also shown. The plate by-pass condenser and C_1 are securely fastened beneath the sub-chassis.

The main tuning condenser is driven through the ganged 25 $\mu\mu\text{fd}$. 6L6 output auxiliary condenser. No couplings are used at all. After the condenser shafts were assembled together and lined up, the threaded joints in the shafts were securely soldered

so that there would be no possible mechanical change which would affect the dial readings. With flexible couplings it has been found that the torque is not always transmitted straight through and some backlash results. Due to the rigid mounting of all these parts, no frequency change results even from pushing hard on the dial or any part of the cabinet.

The front panel of the cabinet is just about self explanatory. However the control knob to the left of the main dial is the attenuation control for the 100-1000 kc. crystal oscillator. The switch knob just below it is in the coupling lead from the oscillator. To the right is a d.p.d.t. toggle switch for selecting either 100 or 1000 kc., and to the right of that is the main on-off switch in the 115-volt line. The knob to the right of the main dial is the lining-up condenser knob for that condenser in the 6L6 tank circuit, and below it is S_1 controlling plate supply to the various tubes.

In assembling any parts to the cabinet or chassis, and in reassembling the cabinet, all points at which screws are used are scraped clean of paint and Shakeproof lock washers are used under the nut or screw head. A few extra screw holes were also placed in the cabinet to make its assembly more rigid.

The general layout is to have all the power supply components in the rear, the v.f.o. in the center, the class A and output stages to the right of the v.f.o. and the components for the 100-1000 kc. crystal oscillator to the left of the v.f.o. This pretty well keeps the wiring for the different sections segregated.

Since the photograph of the bottom view was taken, a better job of wiring has been done, and the output leads from the v.f.o. and the 6V6 tube socket have been completely

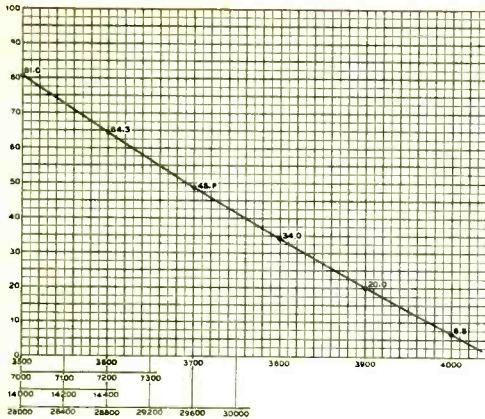

Sample calibration chart for the unit showing coverage of the various bands.

shielded. This was necessary due to the close proximity of the twisted pair output link line from the 6L6 stage.

Operation

As mentioned previously the v.f.o. unit was set up and adjusted for band spread before assembly in the cabinet. Calibration of the completed job was the first step in getting the transmitter control unit ready for operation.

After a complete warm-up, the 100-kc. crystal oscillator was first set to zero beat with WWV's 5000-kc. signals, and was allowed to run until such a time as the difference between the harmonic crystal frequency and WWV was not over a few cycles per minute. These beats could readily be found during the periods when WWV was not being modulated at the time of station announcements. When such slight differences in frequency could be held over a period of time, it was assumed that the 100-kc. crystal was at temperature. Of course during the initial heating up period the condenser in shunt with the crystal had to be adjusted slightly to compensate for drift until the crystal temperature was stable. It was then a simple matter to start from the 4000-kc. end of the phone band and pick up the 100-kc. harmonics down through the band on the receiver. At each point the signal from the v.f.o. was tuned to zero beat with the 100-kc. crystal harmonics, and from these points a curve such as shown was plotted. This curve is suitable for all the ham bands, even 160 insofar as the frequency meter part of the unit is concerned.

The 100-1000 kc. oscillator is of course highly helpful in setting home-made receivers to the different band edges, and if you are looking for a station on a certain frequency, just set the v.f.o. dial from the curve to the desired frequency, and there you have it on the receiver dial. The same is true for the transmitter, of course, although in practice one just roams the bands and sets the v.f.o. to whatever point desired by listening to the v.f.o. unit only. Then when ready to go on the air, turn the switch S₄ to the ON position and turn on the transmitter. This method allows the receiver to run at normal gain and still allows the v.f.o. to be heard comfortably when setting it to any desired position.

This v.f.o. transmitter frequency control unit has been in operation here at W1JLT since last May. It has been demonstrated at club meetings, moved around for photographs, and yet the calibration has been maintained. It is our practice to check the calibration against WWV approximately once a month. This practice has become nearly a routine gesture, as the calibration never has varied more than a few cycles per second from zero beat with WWV. Our favorite demonstration is to pick up the control unit and with a signal from the transmitter in the monitor, hammer the cabinet and finally drop it about 6 inches to the floor. There is absolutely no change in the beat note in the monitor when this is done, which, if nothing else, demonstrates the ruggedness of construction of the v.f.o. unit.

In closing, I wish to thank W2CVV for his assistance in originally suggesting certain pointers on the v.f.o. circuit, and for his excellent ideas on the construction of this type of oscillator. I also wish to thank W1LPP for his cooperation in the taking of the photographs which accompany this article.

• • •

"Signs of the Times"

In the interests of public service and radio station convenience, the FCC agreed recently that station announcements of the use of mechanical records can be made at 30-minute intervals instead of the 15-minute requirement as heretofore. This is to avoid interrupting the entertainment continuity of a recorded series of records, or of the long records now quite generally used, particularly of recorded programs relayed by wire facilities. The change was made effective from January 4, 1940.

An Electronic Photo Timer

By LEIGH NORTON, * W6CEM

After a couple of sessions as chief clock watcher and switchman with an amateur photographer who was making enlargements, the decision was made that the man might well be replaced by the machine in this sort of work with equal advantage to the "laborer" and the "employer," since neither was realizing any profit from the venture. Accordingly, after ascertaining that a time range of from 3 seconds to 1½ minutes would cover most enlargement and contact-printing work, a simple time-delay circuit was haywired together to test its possibilities for this type of work.

* Associate Editor, RADIO.

Time-Delay Operation

The result of the experimentation is shown in figure 1. The device effectively changes the amateur photographer from a clock watcher to a button pusher. Referring to the wiring diagram, figure 2, it will be seen that the circuit is that of a well-known time-delay arrangement with provision for a wide variation in the time element. When the push button, S₁, is in its normal, or up, position the 35Z4-GT half-wave rectifier delivers about 100 volts d.c. to the plate of the 35L6-GT control tube. The plate and screen of the latter tube pull about 40 milliamperes through the normally-closed relay, RY, thus holding its contacts open. When the push

Figure 1. The timer is enclosed in a small metal box. The focusing switch and the pilot light are at the top, time control in the center and the push button and range selector at the bottom. The scale for the time control was lettered on drawing paper and cemented to an ordinary 3-inch metal dial plate. A similar type of scale, to smaller dimensions, is used on the selector switch. Ventilation is provided by large holes in the rear of the box.



Occasionally the technically inclined amateur can pick up some spare change for himself by building electronic equipment which will fill a definite need in other fields. One such instance was in the construction of diathermy equipment. This field is now so well covered by various manufacturers that the possibility of realizing any profit from home-built diathermy equipment is practically nil. However, the unit described in this article is suitable to use by hobbyists and professionals and, for the time being at least, could well provide energetic amateurs with cigarette money.

pressed. This results in the grid condenser being charged with a rather high voltage of a polarity that places the grid negative in respect to ground.

While the charging process has been going on in the grid circuit, the plate and screen voltage have been removed from the tube and the plate relay has opened, thus placing the line voltage across the output terminals and turning on the light in the enlarger or contact printer. When the push button is released a half second or so after it was first touched plate and screen voltage is again applied through the relay but the bias has been raised considerably beyond the cut-off point so the plate current is zero and the relay remains de-energized (contacts closed).

Time Control

The time required for the grid condenser to discharge is controlled by the amount of resistor placed across it. As this condenser discharges down past the cut-off point of the 35L6, current begins to be drawn through the relay winding and, when the pull-down current of the relay is reached, (18 milliamperes in this case) the circuit to the output terminals is opened and the embryo print or bromide is ready for the developer.

A 3-megohm variable resistor is used across the grid condenser with the 3, 6, or 9 megohm multiplier added by the selector switch, S₁. Either the multiplier resistor arrangement shown in figure 2 or that of figure 3 may be used. The 3, 6, and 9 megohm resistors happened to be available when the original unit was built; the arrangement shown in figure 3 is somewhat simpler to wire, however, and the 3-megohm resistors are more universally available.

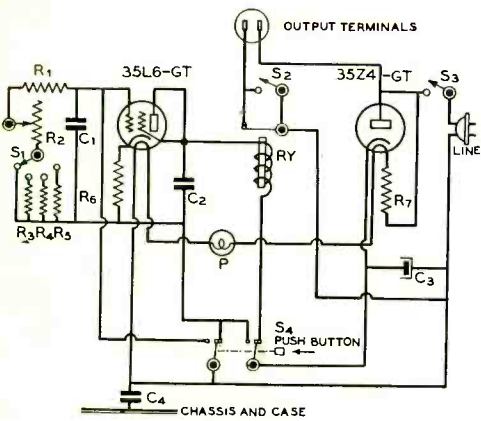

Figure 2. Wiring diagram of the printing timer.

- C₁—4- μ fd. 600-volt paper
- C₂—0.1- μ fd. 400 volt tubular
- C₃—8- μ fd. 150-volt electrolytic
- C₄—0.1- μ fd. 400-volt tubular
- R₁—250,000 ohms, 1/2 watt
- R₂—3-megohm potentiometer
- R₃—3-megohms, 1/2 watt
- R₄—6 megohms, 1/2 watt
- R₅—9 megohms, 1/2 watt
- R₆—200 ohms, 10 watts
- R₇—300 ohms, 10 watts (or 320-ohm line cord)
- S₁—4-position selector switch
- S₂—S. p. s. t. toggle (focusing switch)
- S₃—S.p.s.t. (on R₂)
- S₄—D. p. d. t. P. B. switch (non-locking)
- RY—Low-current normally-closed relay. Should operate on 10 to 20 ma.
- P—250-ma. 6.3-v. pilot light

button is pressed the voltage from the rectifier is removed from the plate circuit and applied across the grid condenser, C₁, the wiring to the push button is arranged so that the positive side of the supply goes to ground and the negative side to the grid when it is

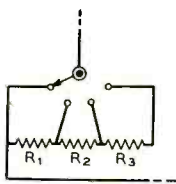

Figure 3. Alternative multiplier arrangement. R₁, R₂, and R₃ should be 3 megohms each.

The fixed resistor, R₁, is in the circuit to prevent the power supply from being shorted when the button is pressed with all the variable resistance element out of the circuit. This resistor also controls the minimum time which may be obtained—if times of less than 3 seconds are desired, 100,000 ohms may be used at R₁, instead of the 250,000 specified. The maximum time available with the 9-

[Continued on Page 73]

A. M. C.

for Any System of Modulation

By RAY L. DAWLEY,* W6DHC

Heretofore the use of automatic modulation control, with its many attendant advantages, has been limited to transmitters employing plate modulation. The simple, inexpensive, and foolproof unit described herein allows automatic modulation control to be used with any type of amplitude-modulated phone transmitter, whether it be cathode, control-grid, suppressor, or plate modulated, or whether the final stage be operating as a class B linear.

A system of automatically limiting the negative-peak modulation percentage to 100 per cent or slightly less was introduced about two years ago by L. C. Waller.¹ The system was called automatic modulation control and enjoyed fairly wide application among active phone operators. Its numerous advantages have been discussed a number of times previously but can be enumerated again to clarify the system to those unfamiliar with it and to those who did not give it serious thought because it could, previously, be used only with high-level plate modulation.

First, a.m.c. operates by virtue of a variable-gain stage operating at a low level in the speech amplifier. This stage is usually a 6L7 with its injection grid brought out through a suitable filter network to a source of a.m.c. bias. A 6K7 or other variable- μ pentode can be used with the a.m.c. voltage fed into the control grid, but approximately twice as much a.m.c. voltage is required for the same gain reduction in this tube as with the 6L7. The a.m.c. bias is obtained by rectifying the negative pulses of modulation voltage which exceed a certain predetermined percentage. The a.m.c. bias has previously been obtained from the plate return to the plate-modulated stage, hence limiting the application of the system to this type of

phone transmitter. The system to be described takes the negative modulation pulses directly from the carrier output of the transmitter and hence is universal in application; it can be used with any amplitude-modulated phone transmitter regardless of the system of modulation.

The advantages of the system are that negative-peak overmodulation is entirely eliminated—peaks that would be in excess of 90 to 95 per cent being attenuated. Since, within reasonable limits, it is impossible to overmodulate the transmitter, the audio gain may be run somewhat higher than without a.m.c. allowing a higher average modulation percentage to be maintained. Also, since the system operates only on the *negative* peaks of modulation, the positive peaks of modulation may go as high as the dissymmetry in the modulating waveform permits.² Naturally, to obtain all the advantages of extended positive peak voice modulation it will be necessary to attend to the proper phasing of the microphone or of the speech amplifier—but this with its attendant advantages has been thoroughly covered in the article referred to above.

Theory of the System

Figure 1 shows the simple circuit diagram of the universal a.m.c. unit. As can be seen

* Technical Editor, RADIO.

¹ "Automatic Modulation Control," Waller, RADIO, March, 1938, p. 21.

² "Comes the Revolution," Smith and Dawley, RADIO, December, 1939, p. 11.

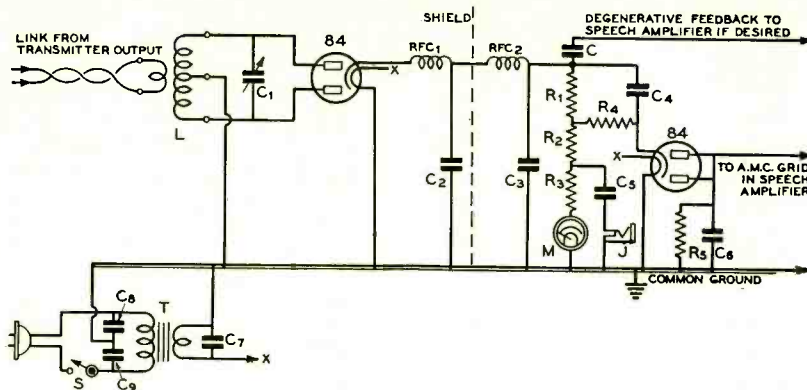

Figure 1. Wiring diagram of the universal a.m.c. control unit.

C—0.5- μ fd. 400-volt tubular if degenerative feedback is used

C₁—Single-section condenser to tune band of operation with L

C₂—0.02- μ fd. mica
C₃—0.04- μ fd. mica

C₄—0.5- μ fd. 400-volt tubular
C₅—0.1- μ fd. 400-volt tubular

C₆—0.001- μ fd. mica
C₇, C₈, C₉—0.01- μ fd. 400-volt tubular

R₁—4000 ohms, 2 watts
R₂—5000 ohms, 2 watts

L—Coil to tune to desired band of operation, accurately center-tapped with link wound around center

J—Monitoring jack
C₁, C₅, C₉—0.01- μ fd. milliammeter
T—Separate 6.3-volt trans.

R₃—1000 ohms, 2 watts

R₄—50,000 ohms, 1/2 watt

R₅—500,000 ohms, 1/2 watt

RFC₁—2 1/2 mh. 125-ma. r.f. choke

RFC₂—8-mh., 125-ma. r.f. choke

by inspection of the diagram there is nothing at all complicated about the unit, but it will be explained in detail so that the function of each component will be clearly understood. It will be noted that the unit also has provision made for a phone jack for monitoring transmissions, and for full audio output from the rectifier for use as degenerative feedback to the speech amplifier should it be desired to use it.

A link from the input of the a.m.c. unit is coupled to the final tank circuit of the transmitter, regardless of the type of modulation. C₁ is resonated and the coupling to the final amplifier varied until 20 milliamperes are flowing through the load resistor R₁-R₂-R₃. The first 84 is then acting as a full-wave rectifier of the carrier of the transmitter and, without modulation, is producing 200 volts of drop across the 10,000-ohm load made up of the three resistors in series. The shield and the r.f. filter (RFC_{1,2} and C₂, C₃) remove any trace of r.f. that might appear at the second 84 rectifier.

Now it will be noticed that the cathode of the second 84 is tapped at the junction of R₁ and R₂ as far as the d.c. voltage drop across the load resistor is concerned. This

means that (since R₁ is 4000 ohms and the sum of R₂ and R₃ is 6000 ohms) the cathode of the second 84 is 120 volts positive with respect to its plate although the total voltage drop across the load for the first 84 is 200 volts.

Under 100 per cent modulation the voltage at the top of R₁ will vary from 200 up to 400 and down to zero. (This variation would take place for sine-wave modulation of the transmitter. For the non-symmetrical waveforms encountered with speech modulation the extreme positive voltage might go as high as plus 600 but it could only go as far down as zero since that is the definition of 100 per cent modulation.) But since the cathode of the second 84 is coupled to the *high* end of the load resistor by C₄, the peak voltage appearing at the cathode of the second 84 will vary from plus 120 up to plus 320 or higher *and down to negative 40 volts*. As soon as the cathode of the second 84 begins to go negative with respect to its plate, current will flow through R₅ to produce a peak voltage at the plate end of the load resistor equal to the peak negative cathode voltage. It is this negative voltage, taken directly from the carrier output of the transmitter, that is

fed to the a.m.c. tube in the speech amplifier.

The positive excursions of voltage resulting from positive modulation peaks will have no effect on the a.m.c. load resistor R_3 since the 84 diode is non-conducting when its cathode is highly positive with respect to its plate. This, of course, is merely another way of saying that the plate is highly *negative* with respect to the cathode on positive modulation peaks.

Carrier Shift Indication

It will be noticed by reference to the circuit diagram that a milliammeter has been included as a part of the unit. This meter is not, of course, absolutely necessary. However, if the meter is not included it will be necessary to install a closed-circuit jack in the circuit so that a suitable milliammeter may be inserted to tune the a.m.c. unit properly.

It is recommended, however, that a 0-25 or 0-50 d.c. milliammeter be included as a part of the circuit as shown by the circuit diagram since the instrument can, if left in the circuit, also serve the purpose of a carrier shift indicator. The normal load current should be, as mentioned previously, 20 ma. If the transmitter is operating properly and without carrier shift there will be no movement of this meter with modulation. A very slight downward shift can be tolerated if the line voltage to the transmitter falls due to increasing load under modulation, but any greater amount than the percentage that the line voltage falls can be attributed to carrier shift and the cause should be corrected.

Another advantage of having the meter an integral portion of the unit is that it will assist in rapid retuning of the input circuit when changing bands. And therein lies the main disadvantage of this type of an a.m.c. control unit; it is necessary to change coils and retune when changing bands. However, since the device is entirely automatic in operation it is only necessary to plug in the appropriate coil for the desired band and retune to 20 ma. load current. The coupling to the final tank coil and the number of turns on the coil plugged into the unit should be determined beforehand for each band of operation.

It must also be remembered in using a device of this type that a definite amount of power is taken from the output of the transmitter in order to operate the unit. About five watts of r.f. power are required by the unit; four watts are dissipated by the load resistor on the first 84 and approximately another watt is lost within the tube and in the tuned input circuit. In a transmitter

having more than 75 to 100 watts output this power loss would be negligible; but in a transmitter having less than 50 watts output it would represent a definite loss.

Provision for Monitoring

The jack J in the circuit diagram is for monitoring the audio output of the transmitter. From the high end of the load resistor to ground there is approximately 140 r.m.s. audio volts (200 peak) at 100 per cent operation. Naturally this is too much to feed to a pair of phones, and anyway the placing of a pair of phones across this circuit would entirely upset its operation. Consequently a tap has been taken approximately one-tenth the way up from ground on the load resistor for the operation of the monitoring phones. This still gives a good strong monitoring signal in the phones which will be ample to override normal room noise. However, if a stronger or weaker signal is desired in the monitoring phones the value of R_3 may be increased or decreased taking care to make the sum of R_2 and R_3 remain 6000 ohms.

If the transmitter is remotely operated the output of this jack may be fed into the input of a monitoring amplifier to give a continuous check on the quality and text of the modulation. Or, alternatively, the output of this jack may be fed to the input of a cathode-ray oscilloscope for audio waveform checks or trapezoidal pattern adjustments.

Degenerative Feedback

As was mentioned earlier in the text, the audio output of the carrier rectifier may be fed back to one of the speech amplifier stages within the transmitter to include the r.f. portion of the transmitter within the feedback loop. The peak audio output through condenser C from this position will be 200 peak volts at 100 per cent modulation. This value of peak audio voltage may be used in determining the point at which it would be suitable to return the feedback and to determine the amount of feedback in decibels.

A number of amateurs have expressed a desire for a design for a feedback rectifier for use in their transmitter and the one shown herein can serve admirably for this purpose in addition to its normal function in supplying the a.m.c. peak rectifier. Of course it must be remembered that the audio loading imposed upon the rectifier load circuit must not be too great or the ratio of peak audio voltage to carrier voltage will be disturbed. This will cause the a.m.c. action to be sluggish and less active in operation. As long as the a.c. load imposed by the degenerative feedback external circuit is 50,000 ohms or

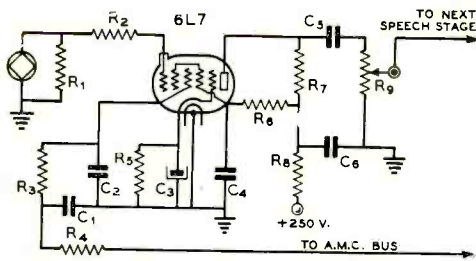

Figure 2. Wiring diagram of the recommended 6L7 a.m.c. speech stage.

| | |
|---|---|
| C ₁ —0.02- μ fd. mica | R ₃ —1.0 megohm, 1/2 watt |
| C ₂ —0.5- μ fd. 400-volt tubular | R ₄ —50,000 ohms, 1/2 watt |
| C ₃ —10- μ fd. 25-volt elect. | R ₅ —1000 ohms, 1/2 watt |
| C ₄ —0.5- μ fd. 400-volt tubular | R ₆ —250,000 ohms, 1/2 watt |
| C ₅ —.02- μ fd. 400-volt tubular | R ₇ —250,000 ohms, 1 watt |
| C ₆ —0.5- μ fd. 400-volt tubular | R ₈ —50,000 ohms, 1/2 watt |
| R ₁ —1.0 megohm, 1/2 watt | R ₉ —500,000-ohm potentiometer |
| R ₂ —50,000 ohms, 1/2 watt | |

• • •

more no trouble will be had with reaction upon the a.m.c. circuit.

If degenerative feedback from the carrier rectifier back to the speech amplifier is to be used it must be remembered that active precautions must be taken to minimize frequency discrimination and phase shift within the feedback loop. If this is not done properly the amount of feedback which it will be possible to use without singing will be so small that no usable advantage will be obtained.

Also, if feedback is to be used it will be almost imperative that the carrier-strength or carrier-shift milliammeter be a portion of the circuit. It will be necessary to see that the carrier strength is always pretty close to the proper value or the amount of degenerative feedback will vary. The stability requirements for a.m.c. operation only are very much less stringent.

Naturally, if r.f.-loop degenerative feedback is not contemplated the precautions and suggestions given under this head may be disregarded and the high-level audio output through condenser C eliminated from the unit.

The A.M.C. Speech Stage

Although the a.m.c. unit shown herein may be used with any speech amplifier in which a provision for a.m.c. has been made, most satisfactory operation will be had if the design of the a.m.c. stage follows that shown

in figure 2 fairly closely. The necessity for making this suggestion is due to a peculiarity inherent in the design of a device of this type. In a conventional a.m.c. rectifier operating on the audio output of the high-level modulator of a plate-modulated transmitter it is comparatively easy to obtain 150 to 300 peak volts of output for coupling to the control element of the a.m.c. tube. In the unit shown there is only a theoretical possibility of 80 volts output and practical operation has shown that only about 60 volts can be expected. This means that the time constant of the filter network that feeds the control element on the a.m.c. tube should, for best operation, be changed to provide a more rapid build-up of the a.m.c. bias commensurate with the lower peak driving voltage.

In determining the ratio between R₁ and the sum of R₂ and R₃ it is necessary to strike a compromise between maximum peak output voltage and the percentage of modulation at which the a.m.c. rectifier will begin to reduce the gain of the speech amplifier. The lower the percentage of modulation at which a.m.c. rectification begins, the greater will be the peak a.m.c. voltage output. In the design shown the compromise has been struck at 60 per cent modulation. This means that a.m.c. action begins to take place slightly after 60 per cent modulation has been reached (this earlier action should really be called volume compression since the real a.m.c. action can be considered as taking place between 90 and 100 per cent modulation.)

If it is desired to hold off the a.m.c. action until a greater modulation percentage has been reached the ratio of R₁ to R₂ plus R₃ may be changed proportionately. Decreasing the value of R₁ with respect to the other two will hold off the a.m.c. action until a greater modulation percentage is passed. But it must be remembered that changing the ratio in this direction will reduce the maximum peak a.m.c. voltage and hence the unit will not be so effective in clipping excessively strong modulation peaks as they come by. It is recommended that the values given be used unless experiment indicates that a change in the ratio would be desirable.

It will be noted that in the a.m.c. speech stage shown the cathode of the 6L7 is returned to ground through its cathode biasing network. This greatly simplifies the design of the speech amplifier. No complicated voltage divider networks are necessary to set the bias on the a.m.c. rectifier so that its operation will begin at a desired percentage of modulation; all this is taken care of in the a.m.c. control unit.

[Continued on Page 72]

An Inexpensive High Quality Mike

By GEORGE E. SANDERS,* (VE3QC)

I am sure that many amateurs of limited means have been faced with the problem of obtaining a good high-quality microphone for a small actual cash outlay. A solution to the problem which should be of interest to a goodly number of amateurs is given herein. It requires very little work and, of greater importance, no mechanical work that can't be done with a screwdriver on the kitchen table.

A few years ago when my first phone transmitter was put into operation a thoroughly used Western Electric 387 double-button carbon microphone was employed. After a long period of satisfactory operation the microphone developed a bad case of carbon hiss. In search of a more satisfactory mike a Brush crystal earphone was purchased and made into a microphone. It was mounted in a cowl-light case and the case attached to a desk-type telephone stand. The result was a fair mike but after the smooth quality of the 387 it sounded rather harsh due to the many peaks in the operating range.

Since the 387 was still available and its diaphragm was still intact, the idea of using the stretched diaphragm of the 387 as a driver unit for the crystal unit in the earphone suggested itself. The result of combining the two units was a very satisfactory microphone having a wide frequency response and no noticeable peaks and valleys in its response characteristic.

The Mechanical Alterations

The first step in making the change is to remove the front button and mounting bar from the double-button microphone. A circle of fine-mesh screen is then cut to fit inside the aluminum ring on the front of the mike. By slightly bending the rear edge of the ring it can be made to hold the screen without mounting screws. The screen is primarily for

protection of the diaphragm but also serves to improve the front appearance of the unit. Figure 1 shows a front view of the microphone.

The next step is to dismantle the crystal earphone. The cap is removed first; this is accomplished by prying it off with a screwdriver since it is only glued onto the case. The paper diaphragm inside the phone is then very carefully removed, being very careful not to injure the crystal element. A short piece of copper wire of about no. 22 gauge is then cemented to the same place on the crystal element as where the drive to the paper diaphragm came off. The wire should be attached with a good grade of duco cement and should be just long enough to reach the edge of a straight-edge laid across the top of the earphone.

Next the rear button of the 387 is removed and the diaphragm cleaned with carbon tetra-

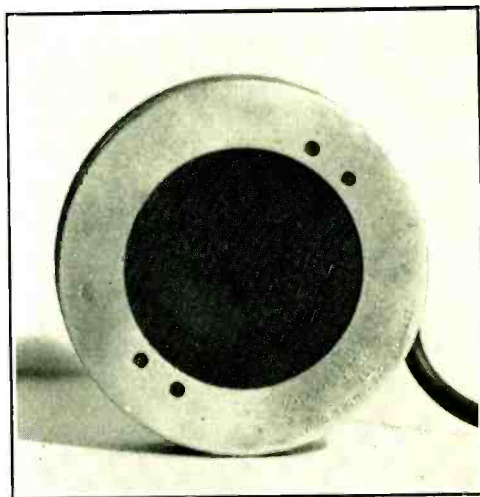

Figure 1. Front view of the mike with the button and button holding arbor removed and with the protective screen in place.

* 113 Waterloo Street, London, Ontario, Canada.

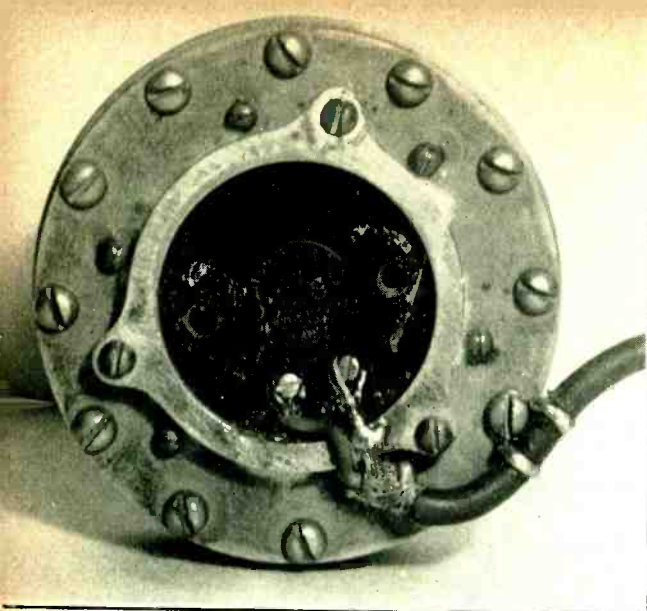

Figure 2. Showing how the retaining ring holds the phone in place making a rigid assembly. A piece of sheet aluminum to serve as a shield over the rear of the mike could be held in place by the three bolts that hold the retainer ring.

chloride to remove the carbon dust and grease. This cleaning must be done very carefully to avoid injuring the diaphragm.

It will now be found that the earphone will fit into the space made by the removal of the rear button. The mike is placed face down on the table and a blob of thick duco cement placed on the free end of the wire coming from the crystal element inside the earphone. The phone is then slid into place face down so that the wire and blob of cement will come in contact with the diaphragm of the 387. The assembly is then carefully laid away face down to dry for 24 hours or longer. It can now be seen why the wire attached to the crystal element can only be just long enough to come to the surface of the phone case; if it were longer it might either puncture the 387 diaphragm or put a tension on the crystal unit, either of which might be disastrous.

After ample time has been allowed for the unit to dry, cotton is packed into the space around the side of the phone to act as air damping. The retaining ring that formerly held the rear button in place is then used to clamp the phone firmly to the microphone to complete the mechanical assembly.

Electrical Connections

A piece of shielded crystal-mike cable is then connected to the rear of the phone portion of the mike. The center conductor is connected to one terminal and the shield on the cable is connected to the other terminal and to the body of the microphone. A rear view of the microphone with the shielded cable attached is shown in figure 2.

In this particular case no shielding was placed across the rear of the microphone but it would be advisable if the mike were to be

used in the vicinity of a high-powered transmitter. The shielding could easily be made of sheet aluminum and could be held in place by the bolts that hold the retaining ring in place.

If the completed microphone is now checked for quality it will be found to sound very clean and crisp without any tendency toward harshness or resonant peaks. During the short time that the mike was used on the air many quite favorable comments on the quality of transmission were received.

• • •

Helpful Hint for Handling Heavy Rack Units

Here's a stunt that obviates the necessity for a crew of assistants when putting a heavy power supply or amplifier into a rack or cabinet. In each hole on either rail where the top-most screw of the panel would go, place a regular 10-32 rack screw, putting it in from the *back*. It will then extend forward, and the panel can be rested or hung on this projecting screw, while the bottom is easily held back against the rails. While the panel is being held in this fashion, the bottom screws are put in place. Now the top screws can be removed one at a time and put in "right side out." Slotted studs can be used in place of the rack screws, making removal easier since they can be backed out from the front of the rack. —W8IOB.

Controlled Negative Peak Bias for A.M.C.

Figure 1 shows a circuit arrangement which has been in use by George Waster, W8TMX, to control the negative peak bias on the a.m.c. rectifier tube in his transmitter. The threshold at which the a.m.c. action begins to regulate the gain of the speech amplifier is easily adjusted by means of the control R_1 . The control system operates in the following manner:

The 6SK7 first speech stage operates under carrier conditions with about 12 volts of grid bias. Maximum gain of the stage is obtained with about 8 volts bias on this tube but the best control properties are obtained with the value specified above. V_1 , which can be either a triode with the grid and plate in parallel for low-voltage transmitters, a 1V for medium voltages, or an 879 for high voltages, acts to rectify the negative pulses of output from the modulators below a level determined by the setting of R_1 .

It can be seen that with R_1 at minimum resistance V_1 will not supply any additional negative bias to the grid of the 6SK7 until

after 100 per cent modulation has been reached. This is true because the cathode of this tube will not go negative until the actual voltage being impressed upon the plate of the final amplifier is negative with respect to ground.

However, as the resistance of R_1 is increased the audio voltage appearing at the top of R_2 will remain the same (due to the action of by-pass condenser C_1) but the d.c. voltage appearing at this point will decrease. Hence, the modulation percentage at which the cathode of V_1 will go negative with respect to its plate will be decreased as the resistance of R_1 is increased. Finally a.m.c. action will begin to take place at about 60 per cent modulation when all the resistance has been cut into the circuit. Thus by varying the setting of this resistor we have an easy way of controlling the point at which a.m.c. action begins to take place. Caution: This resistor is at a high potential both with respect to audio and d.c. and must be carefully insulated.

[Continued on Page 70]

Wiring diagram of the a.m.c. circuit and of the first speech stage.

C_1 —0.25- μ fd. 1000-volt tubular
 C_2 —0.2- μ fd. 400-volt tubular
 C_3 —0.1- μ fd. 400-volt tubular

C_4 —0.2- μ fd. 400-volt tubular
 C_5 —10- μ fd. 25-volt tubular
 C_6 —8- μ fd. 250-volt electrolytic

C_7 —0.0005- μ fd. mica
 C_8 —0.2- μ fd. 400-volt tubular
 R_1 —500,000-ohm potentiometer of best design

R_2 —150,000 ohms, 3 watts
 R_3 —200,000 ohms, 3 watts
 R_4 —200,000 ohms, 1/2 watt
 R_5 —500,000 ohms, 1/2 watt
 R_6 —1.0 megohms, 1/2 watt
 R_7 —3.0 megohms, 1/2 watt
 R_8 —750 ohms, 1/2 watt
 R_9, R_{10} —15,000 ohms, 3 watts
 R_{11} —100,000 ohms, 1/2 watt
 R_{12} —100,000 ohms, 1 watt
 RFC—2 1/2-mh. 125-ma. choke
 Mic—See text
 V_1 —See text

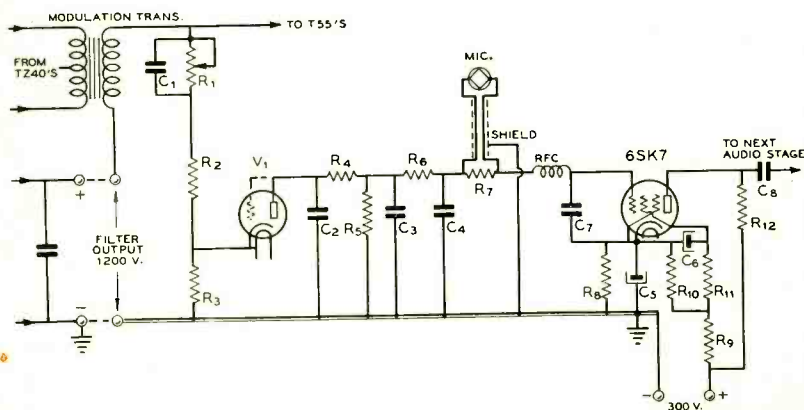

Quick Phone-C. W. Changeover with Plate Modulation

By EUGENE BLACK, JR., * W2ESO

Safety and convenience of operation dictate that the modern amateur transmitter be controlled from the front panel, in regard to all tuning, power controls and band switching. Of course, "pocketbook pressure" modifies this dictum to some extent, with most of us, but the following methods of phone-c.w. changeover with simple front-panel switching are so inexpensive and offer so much in the way of protection and time-saving that they should interest the man who divides his time between A1 and A3. Grid or cathode modulation offers no especial problem, but shorting out the modulation transformer secondary in a plate modulated rig most certainly does.

Figure 1 shows a simple system suitable for plate modulated transmitters up to 150 watts or so. The heart of the whole scheme is the underload relay, which is a rebuilt Ward-Leonard midget, Type 507-514. It is a very simple job to equip this model with a set of back-contacts, which are used to short out the secondary of the modulation transformer when the relay is not energized. The "make" contacts, which close only when the modulated amplifier is drawing plate current, (and is therefore loading the modulator, precluding the possibility of working the audio end unloaded and probably ruining the modulation transformer), may be used to close the primary circuit of the modulator plate power transformer or the center-tap of the high voltage secondary, if the same transformer is used to supply both plate and heaters.

If fixed bias is used on the r.f. amplifier stages, with oscillator keying for break-in c.w. operation, the key will also serve as push-to-talk control. In a certain number of cases, S₂ could be replaced by a rotary switch of the continuously shorting type, ganged to the

crystal selector switch, or to the tuning condenser of a r.f. oscillator, with the auxiliary rotary switch arranged to remove the short across the underload relay whenever the transmitter is put in a phone band. This could be easily worked out in cases where operation is on only one band, but obviously does not apply when 80-meter c.w. crystals are to be used for 80 and 40 c.w. besides 20-meter phone, or when 40- and 20-meter c.w. crystals are also used for 20- and 10-meter phone, etc.

With higher power, and consequent higher voltages, (1000 volts or more), it is no longer

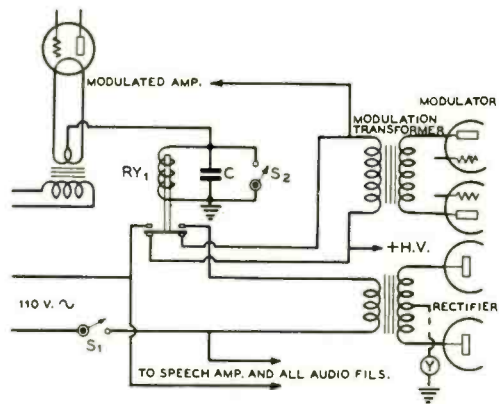

Figure 1. Switching system for medium powered transmitters.

RY.—Rebuilt underload relay with back contacts added. Make contacts can be used to complete high-voltage c.t. circuit at "Y" if modulator plate transformer also sup-

plies heaters or filaments
C—10- μ f. 50-volt electrolytic condenser
S₁—Main a.c. line switch
S₂—Changeover switch

* 170 West 73 Street, New York, N. Y.

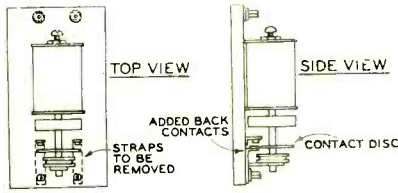

Figure 1A. Method of rebuilding the underload relay. The side view shows how the back contact is added. Remove the strap and add a new pair of binding posts close to the original shorting contacts. The back contacts were obtained with their mountings from an old trickle charger changeover relay.

safe to employ the back contacts for shorting. In one transmitter which had originally been equipped with the modified relay, an increase of plate voltage was met with the installation of a Guardian R-100 high voltage relay, piloted by the back contacts, and placed across the secondary of the class-B transformer as in figure 2A; the back contacts were also used to pilot a break-in relay in parallel with the R-100. If two relays are to be used, however, it is not necessary to make any changes in the manufactured underload relay. Figure 2B tells the story: relay 2 is a normally-closed Guardian R-100B. This method has the additional advantage over that of 2A in that the relay across the transformer secondary is energized only during the comparatively short transmission periods.

Illustrated in figure 3 is a less desirable way of doing the job, but one which turned out to be the easiest to install in a certain transmitter where it was not feasible to place the under-

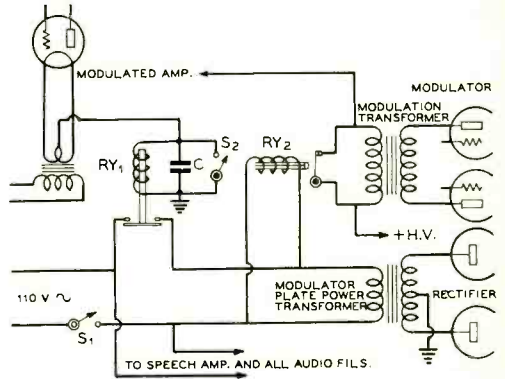

Figure 2B. An alternate circuit for high power use employing two relays and not requiring any changes in the manufactured underload relay.

RY1—Ward-Leonard 507-514 or 507-515 with no modification
 RY2—Guardian R-100B normally closed.

load relay winding in series with the filament center-tap of the modulated amplifier; this restriction will probably obtain in the majority of cases where the audio and r.f. systems are built as separate units. Advantages of this layout are that no changes need be made in the r.f. end, and no extra leads are required; disadvantages are that a slightly more expensive single pole double throw relay (Guardian R-100 C) is required as Relay 2, plus the necessity of insulating the underload relay from the metal panel with standoff insulators, since the coil is at plate potential. It is not advisable to put the relay in this

[Continued on Page 95]

Figure 2A. Higher powered switching circuit. Relay 1 is the same as before and relay 2 is a 110-volt a.c. normally open unit.

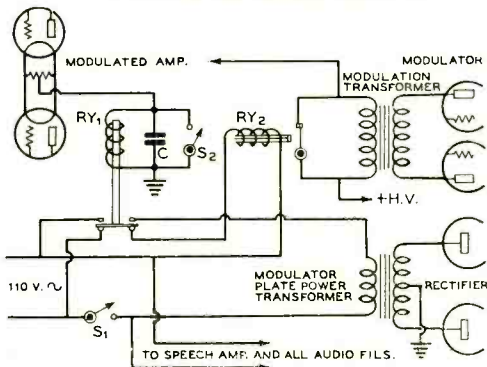
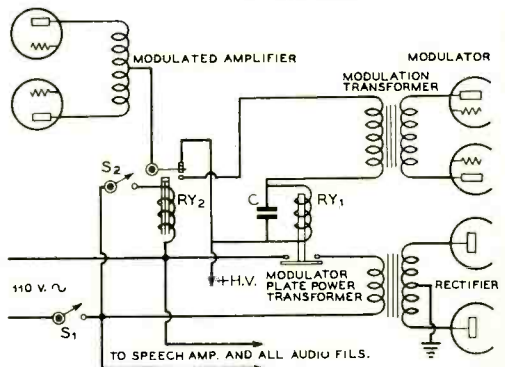

Figure 3. A simpler but less desirable change-over system for use when the overload relay cannot be placed in the filament c.t. of the modulated amplifier.



U. H. F. CIRCUIT DEVELOPMENTS

By E. H. CONKLIN,* W9BNX

In 1938, the Planning and Development Division of the Civil Aeronautics Authority undertook the task of designing a receiver to cover the range of 60 to 132 Mc., with adequate sensitivity and stability for aircraft service. The results have been published in a fifty page pamphlet¹ that contains much material of interest to amateurs working on ultra-high frequencies.

A study of radio frequency tuned circuits quickly brought a decision to use short sections of concentric lines² in order to obtain an adequate image ratio without a very high intermediate frequency. The inductive reactance of a line of fixed length is proportional to the frequency whereas the resistance is proportional to the square root of the frequency. For a given inductance, therefore, the Q (that is, X/R) increases with the square root of the frequency. Thus such a line has a decided advantage at high frequencies over a coil in which the Q decreases with frequency. The inductance of a line is a function of the ratio of conductor diameters and is not affected by the actual diameter; the resistance, however, is inversely proportional to the diameter, making Q proportional to the diameter for a constant ratio of diameters. When either space or cost is limited, therefore, it is well to note that the Q is better in a line half as long, and twice as large in diameter. There is another advantage in short fat lines over long thin ones which appears when they are loaded, even with acorn tubes.

* Ex W9FM, Associate Editor, RADIO, Wheaton, Illinois.

¹ P. D. McKeel, "An Ultra-High Frequency Aircraft Receiver," Report No. 2, Radio Development Section, Planning and Development Division, Civil Aeronautics Authority.

² Avery and Conklin, "An Ultrasensitive 56 Mc. Receiver," RADIO, June, 1939.

Resistance of Metals

Table I gives some of the characteristics of the more common metals available for construction of a coaxial line. It is seen that brass, bronze, and some forms of duralumin are not ideally suited to electrical applications whereas silver, copper, chromium and aluminum are good in that order. When a metal of low conductivity is used, such as brass with 30 per cent zinc, a thin plating of silver, copper, or even chromium will provide a high surface conductivity at ultra-high frequencies.

Inasmuch as the inner conductor contributes most of the resistance while the outer one provides mainly cost and weight, it is well to use copper or a silver plated metal for the inner conductor. The use of 17ST duralumin in place of copper for the outer conductor in the lines to be described later, results in a 20 per cent increase in calculated resistance and a proportional decrease in Q .

How Much Q ?

While high values of Q theoretically can be obtained with coaxial lines as resonant circuits, tube loading is severe and reduces it substantially. That is not to say, however, that an ordinary coil can approach such a line in effectiveness. With a 17ST duralumin

TABLE I
Resistivity of Metals

| Metal | Resistivity micro-ohms per cubic cm. |
|-------------------|--|
| Silver | 1.63 |
| Copper | 1.75 |
| Chromium | 2.6 |
| Aluminum (25-H) | 3.04 |
| Duralumin (515-T) | 3.85 |
| Duralumin (175-T) | 5.77 |
| Brass (30% zinc) | 8.2 |
| Iron (99.98%) | 10.0 |

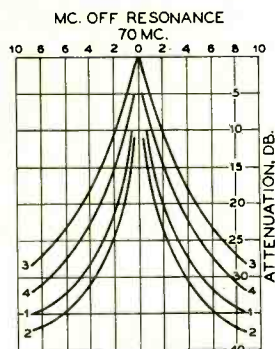

Figure 1. Selectivity curve of the resonant-line circuit with different amounts of loading at 70 megacycles. These curves are for the line in the mixer grid circuit with different grid coupling condenser values.

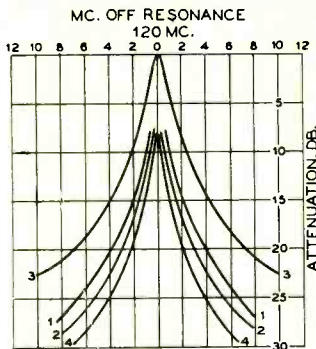

Figure 2. Selectivity curve of the same circuit with different amounts of loading at 120 megacycles. Line in mixer grid circuit with different grid coupling condenser values.

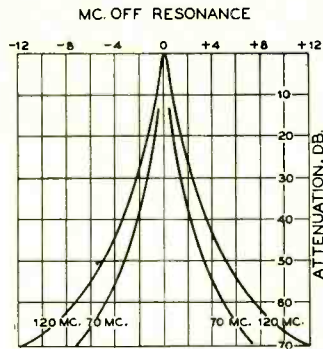

Figure 3. Overall selectivity curves for the receiver with one line in the r.f. stage, one in the mixer grid, and operating into a 5.5-Mc. i.f. channel.

outer conductor of $2\frac{1}{8}$ inch inside diameter and a half inch copper inner conductor only $8\frac{3}{8}$ inches long, providing an inductance of 0.06 microhenry, the calculated Q at 60 Mc. is about 3000, and at 120 Mc. (where the length is a larger part of the ideal $\frac{1}{4}$ wave) it is 4100. The lines are shunted by the input resistance of the tubes which, at ultra-high frequencies, can reach very low values³. Best performance is obtained with the 954 acorn pentode. At 60 Mc. this tube acts like a 55,000-ohm resistor connected across the entire tuned circuit, reducing the Q to about 1300 without an antenna, and to half that (650) if an antenna is connected in for maximum energy transfer. At 120 Mc., the Q of 4100 drops to 290 when the tube's 14,000-ohm input resistance is connected across the line, again to be halved for optimum antenna coupling.

The effect of this loading upon the selectivity of the tuned circuits is demonstrated by figures 1 and 2. Curves 1 and 2 are for the line in the mixer grid circuit with different grid coupling condenser values. Similarly the rest of the curves are for the r.f. stage. The over-all r.f. selectivity curves shown in figure 3 indicate that for a 5.5 Mc. intermediate frequency, the image response is down 75 db at 70 Mc., and 60 db at 120 Mc.

Stage gain is determined in part by tuned circuit impedance while selectivity is governed by Q . At ultra-high frequencies, amateurs

generally demand gain with its better signal-to-noise ratio if it can be increased without too much loss of selectivity. Short lines require less capacity to tune them if the ratio of conductor diameters is larger. A ratio of $3\frac{1}{2}$ or 4 should be selected in an oscillator where Q is important, but a ratio of between 6 and 10 would increase the tuned circuit impedance. This should be kept in mind when designing efficient tuned circuits for transmitters and receivers.

Another factor is worth mentioning. Inasmuch as high (non-regenerative) gain in the first stage is necessary to obtain a high signal-to-noise ratio at ultra-high frequencies, for a given antenna pick-up, and as high gain requires a high impedance output (plate) circuit in an r.f. stage as well as a good input (grid) circuit, it is desirable to link-couple an acorn r.f. stage to an ordinary mixer tube, or use an acorn mixer placed close to the r.f. tube's output tuned circuit. Connecting a standard tube across the output of an acorn r.f. stage will reduce the latter's effectiveness

Tubes

The characteristics of acorn tubes at ultra-high frequencies are so far superior to those of standard tubes that no serious worker on 56 Mc. or above is likely to consider using anything else. The cost is still above that of standard tubes but early reports of short life should now be discounted. A life of some 2000 hours is being attained at rated voltages. Satisfactory performance is reported by the C.A.A. in aircraft use, where vibration occurs.

³W. R. Ferris, "Input Resistance of Vacuum Tubes as U.H.F. Amplifiers," *Proceedings I.R.E.*, January, 1936.

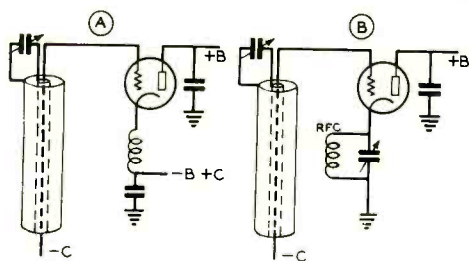

Figure 4. Single control oscillator with coil (A) or condenser (B) in the cathode circuit to provide coupling between plate and grid circuits.

Sockets and Regeneration

Condensers at ultra-high frequencies contain a noticeable amount of inductance which makes it difficult to obtain adequate by-passes. Screen, suppressor, and cathode (if cathode bias is used) must be by-passed to ground effectively. This is best done by building a large condenser into the tube socket clips⁴. A short piece of tubing should surround the tube as suggested by R.C.A. in their recommendations on installation of acorn tubes.

Unless these things are done, one may find that a really efficient tuned circuit will cause a stage to oscillate or at least to regenerate; the latter does not improve the signal-to-noise ratio so is deemed to be inadvisable. Effective by-passing can be tested when a receiver without an antenna is tuned to a local oscillator. Touch a screw driver to tube clips and other circuit points that should not be at high r.f. potentials above ground; if the local oscillator signal increases, the point is not at ground potential.

Oscillator Circuits

Although an ordinary Hartley oscillator with a coil can be used in a receiver, advantage can be taken of the stabilizing characteristics of coaxial tank circuits. The tuned-grid tuned-plate oscillator requires two tuned circuits; if the coaxial line is placed in the grid circuit with the grid tapped on near the shorted end of the line, the frequency is somewhat altered by tuning the plate tank.

It is often a constructional disadvantage, particularly when using long lines, to have the tube anywhere but at the open end of the line. To meet this situation and to eliminate the need for a plate tank, the circuit of figure

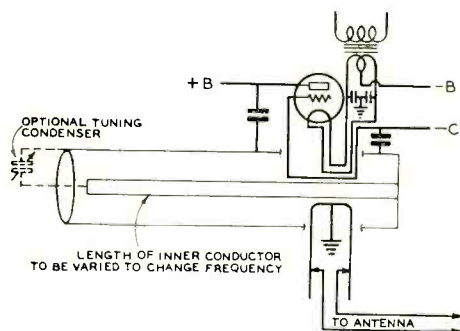

Figure 5. Single-tuned-circuit oscillator, cathode-above-ground type. The frequency can be varied either by the optional tuning condenser shown or by varying the length of the inner conductor of the concentric line.

4A was used by W9SQE at the writer's suggestion. No measurements on its stability have been made as yet, but it is apparent that tapping the grid down on the line (which means placing the tube perhaps midway along the line and yet close enough to the mixer tube to accomplish oscillator injection satisfactorily) should improve the stability. Another variation of this circuit, using a cathode series capacity shunted by a choke or resistor, is shown in figure 4B.

Both the cathode and plate coil arrangements have been improved upon by R.C.A. in a 1 k.w. oscillator⁵. In it the tube is best placed near the closed end of the line where the r.f. current is relatively high. The circuit is shown in figure 5. The plate is grounded to the outer conductor, through a by-pass condenser. Both the grid and the cathode (filament) are coupled to the line with $\frac{1}{2}$ -turn links insulated from the outer conductor through which they pass, extending close to the inner conductor to which they are parallel. In a power oscillator, the antenna coupling can be handled in the same manner. The grid loop must be longer and closer to the inner conductor than the cathode loop in order to accomplish the same condition that one finds in a cathode-above-ground ("electron coupled") oscillator. With this circuit, there are no long leads from the tube to the taps on the line. Interesting variations of this circuit are possible.

Our own experience with a coil-tuned Hartley oscillator using a 955 acorn triode, with

[Continued on Page 87]

⁴ Reber and Conklin, "An Improved U.H.F. Receiver," RADIO, January, 1939.

⁵ G. L. Usselman, "Wide-Band Variable-Frequency Testing Transmitter," R.C.A. Review, April, 1939.

A Highly Sensitive FIELD STRENGTH METER

By W. W. SMITH,* W6BCX

One of the handiest instruments around the amateur station is a sensitive field strength meter, especially when the operator realizes the importance of getting an antenna fired up "right on the nose." A field strength meter is not used very often, but when one is needed, it is worth its weight in gold. That is, if it is sensitive enough to do the job at hand.

Amateurs who have attempted to tune up a high frequency array (such as the 3-element close-spaced beam) by means of a thermogalvanometer or diode-type field strength meter have often discovered that a field strength meter with insufficient sensitivity is worse than no f.s. meter at all. To get an indication with this type of meter (diode or thermogalvanometer), it is usually necessary to use a resonant dipole to feed the meter and place it rather close to the array being adjusted.

Because the f.s. antenna has appreciable effect upon the array when resonant and in close proximity, some misleading results will be obtained. We know of one amateur who tuned up such an array by means of a thermogalvanometer in the center of a resonant dipole placed a short distance away, and he wound up with the director longer than the reflector. The thermogalvanometer showed excellent front-to-back ratio, but a check with other stations showed practically no discrimination whatsoever.

To avoid such an occurrence, it is necessary either to use a small, non-resonant pick up antenna, or else place the f.s. meter many wavelengths away from the array being adjusted. The latter is preferable, but either practice requires that the f.s. meter have high sensitivity, especially if the transmitter power is low.

One type of f.s. meter that is much more sensitive than a thermogalvanometer or diode-type f.s. meter and widely popular at the present time is the biased detector ("power detector") type. For most purposes this type of meter has sufficient sensitivity, but occasionally still greater sensitivity is required.

The grid leak detector still reigns supreme when weak-signal sensitivity is desired, and with this in mind an experimental f.s. meter utilizing a grid leak detector was lashed together. The results were so gratifying that construction was started post haste on the instrument shown in the accompanying illustrations.

A single 19 (or octal base equivalent 1J6) is used with the elements in parallel as a conventional grid leak detector. A useful range of 24 db is covered very nicely, and the device is so sensitive that a very short wire or rod can be used for pickup except at considerable distance.

It will be noticed that the coil table does not cover 80 and 160 meters. The reason for this is that field strength meters are seldom used on these frequencies, their use being confined primarily to the adjustment of directive arrays. There is no reason that the instrument cannot be used on 80 and 160 meters, however, provided suitable coils are wound for these bands.

The meter can be used with excellent results on 2½ meters if the mechanical construction is modified so as to be suitable for u.h.f. work. This requires a smaller tuning condenser and

* Editor, RADIO.



Front view of highly sensitive field strength meter, lid raised to show position of batteries and method of holding them in place by means of rod tapped at either end and bolted to cabinet after batteries are in place. Note inverted method of mounting the 0-1 milliammeter and hand calibrated db scale. Doublet feeder terminals are on side of cabinet, antenna terminal on rear of cabinet to reduce body capacity.

very short tank leads; in fact the coil must be mounted right on the tuning condenser for $2\frac{1}{2}$ -meter operation. Three turns one-half inch in diameter will hit $2\frac{1}{2}$ meters and will provide excellent sensitivity when a half-wave rod is coupled to the tank through the 3-30 $\mu\mu\text{fd}$. mica trimmer. The adjusting screw must be unscrewed until the movable plate is well out or the tank will not hit $2\frac{1}{2}$ meters.

If the meter is to be used only on $2\frac{1}{2}$, 5, and 10 meters, a 25 $\mu\mu\text{fd}$. condenser should

be substituted for C_1 . Suitable u.h.f. type manufactured plug-in coils are available and will permit operation on $2\frac{1}{2}$ meters as well as 5 and 10 meters. With standard $1\frac{1}{2}$ -inch plug-in coils in the layout shown, it is possible to hit 5 meters but not $2\frac{1}{2}$.

Construction

The instrument is constructed on a $7\frac{1}{2} \times 9 \times 1\frac{1}{2}$ inch sub-chassis to which is fastened a 7 x 10 inch front panel. A metal cabinet to fit provides shielding. This cabinet is large enough to contain a standard "Little 6" dry cell and a 45-volt portable B battery husky enough to have good shelf life. The smaller size 45-volt portable batteries cost just as much or more and have a comparatively short life even when the actual current drain is negligible.

Because an odd value of plate voltage is required (about 50 volts), a small $4\frac{1}{2}$ volt "C" battery is connected in series with the "B" battery to provide sufficient voltage. Even with more or less regular use, the batteries specified should last about 2 years.

The batteries are not strapped to the chassis, but just sit in the cabinet, held in place by a rod fastened from opposite walls of the cabinet about $2\frac{1}{2}$ inches above the chassis level. So long as the instrument isn't actually turned upside down, the batteries will stay in place. The batteries are installed by first placing them in the cabinet and then holding them up while the chassis is slid under them. Connections are made to the battery terminals by means of flexible leads which come up through a hole in the rear of the chassis. The 19 is nominally a 2-volt tube, but with a plate current of

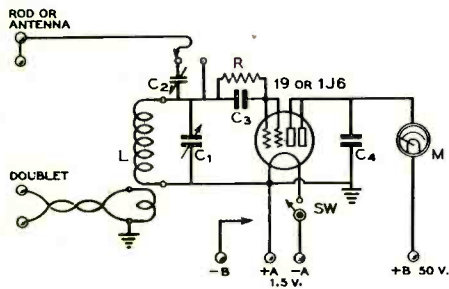

General wiring diagram of the f.s. meter. The B minus is connected to that side of the A battery which gives a plate current reading closest to 1 ma. with the plate meter inverted. Be sure A positive connects to chassis (ground).

- L—See coil table
- C_1 —50- $\mu\mu\text{fd}$. midget condenser for 5-40 meters (25- $\mu\mu\text{fd}$. for $2\frac{1}{2}$ -20 meters)
- C_2 —3-30- $\mu\mu\text{fd}$. mica trimmer
- C_3 —0.0005- $\mu\mu\text{fd}$. midget mica condenser

- C_1 —0.01- $\mu\mu\text{fd}$. midget mica condenser
- M—0-1 ma. 3 in. round (bakelite) case milliammeter
- R—Accurate 5-meg-ohm $\frac{1}{2}$ -watt resistor

Not much to the "works". The small trimmer condenser C_2 which is used as an adjustable coupling condenser may be seen soldered to the stator terminal of C_1 .

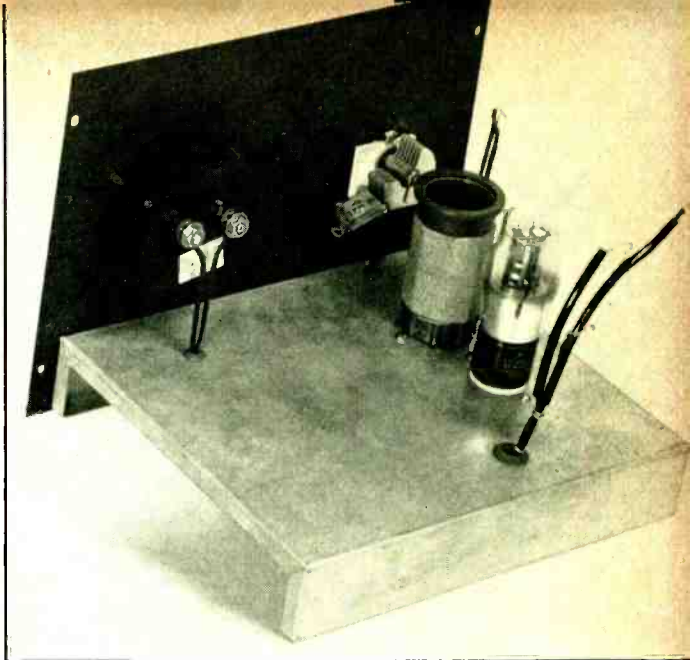

less than $\frac{1}{2}$ ma. per element, satisfactory results are obtained when the filament is run directly from a $1\frac{1}{2}$ -volt dry cell. A type 1G6G (1.4 volt version of the 19) should *not* be substituted for the 19 or 1J6G, as the characteristics are different.

Because the indicating meter will read "backwards" with respect to signal strength, it is mounted upside down. Care should be taken with the meter when installing it to make sure the negative meter terminal isn't accidentally shorted to ground (by the pliers or screwdriver touching the cabinet, or other means). The meter will be blown instantly by the B voltage if this happens. It is best to disconnect the B plus lead to the plate battery when connecting or disconnecting leads to the meter.

The small mica trimmer C_2 is soldered directly to the stator terminal of C_1 , and by means of a flexible lead terminated with a clip, it is possible to clip to either side of the adjustable trimmer, thus making its incorporation in the circuit optional.

This flexible lead is soldered to a feed through insulator on the rear of the cabinet, placed so as not to interfere with the batteries. Bringing the antenna lead out the rear of the chassis reduces "body capacity." A second feed through insulator is placed about an inch and a half above or below the first one to provide support for a short vertical rod when one is used for pick up. A 4 ft. or shorter length of $\frac{3}{8}$ inch aluminum tubing can be held quite rigidly by the two mounting insulators. For use with a single wire antenna, simply disconnect the rod and attach the antenna wire to one of the insulator terminals.

Two feed-through insulators out the side of the cabinet act as terminals for a twisted-pair doublet antenna when such an antenna is used. Because there is little body capacity effect to the twisted feeders, it is not necessary that they be placed as far as possible from the front panel, and therefore they are run out the side of the cabinet nearest the tank coil.

A three-inch 0-1 milliammeter is used, because the cost is but little more than for a two inch model, and the scale is considerably longer, permitting greater accuracy of reading. The standard round-case type meter permits hand lettering of the meter face as will be described later; the newer, square-case meters do not have sufficient blank space on the face for an additional calibration scale, and the db scale would have to be made on a substitute face and pasted over the old scale with rubber cement.

[Continued on Page 74]

COIL TABLE

| BAND | GRID TURNS | LINK TURNS |
|------|------------------------------------|------------|
| 5 | 2 t. spaced $\frac{1}{2}$ in. | 1 |
| 10 | 6 t. spaced to $\frac{3}{4}$ in. | 2 |
| 20 | 11 t. spaced to $1\frac{1}{4}$ in. | 2 |
| 40 | 15 t. close wound | 3 |

All coils are wound on standard $1\frac{1}{2}$ -inch forms. Link is wound at ground end (bottom) of coil, spaced $\frac{1}{2}$ inch from grid winding. Link turns are close wound. All coils are wound with no. 20 d.c.c. For $2\frac{1}{2}$ -meter operation physical layout of instrument must be changed as described in text.

A DIODE PEAK VOLTMETER

By P. M. HONNELL*

The measurement of radio-frequency voltages of magnitudes of one or two volts requires the use of multi-electrode tubes or amplification of some sort, in order to obtain useful deflections of the indicating device. On the other hand, accurate measurements of radio-frequency potentials in excess of ten volts are possible with the diode-type peak voltmeter—a simple device consisting of a diode, a high resistance voltage multiplier, a microammeter and by-pass condenser.

A schematic circuit of the voltmeter is shown in figure 1. The device consists of two parts: A measuring head, comprising a 6H6 diode with both plate leads brought out and a 0.01 microfarad by-pass condenser (preferably mica), connected by a three-wire shielded cable to the heater supply, microammeter, multiplying resistor and by-pass condenser. The 1.0 megohm resistance together with a 100 microampere meter will give a 10 to 100 volt range; addition of another 4 megohms, making a total of 5 megohms, will extend the range up to 500 volts, peak. The heater supply may be direct or alternating current, preferably a.c. from a separate filament transformer.

The shell of the 6H6 diode—to which is tied the cable shielding—forms the ground side of the voltmeter and must be connected to the grounded side of the radio-frequency

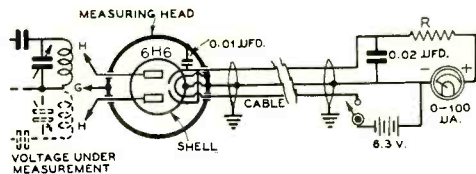

Figure 1. Schematic of the measuring head and of the microammeter end of the diode peak voltmeter. R should 1 megohm for 100 volts full scale on the instrument and 5 megohms for 500 volts full scale.

potential under measurement, thus completing the d.c. path which is necessary in order to obtain an indication with the instrument. Both anodes of the 6H6 diodes are brought out, making possible the equal loading of balanced-to-ground circuits, provided these circuits have their center-point available and provided it is connected to the terminal "G" of the voltmeter. The voltmeter reads the same whether one or both anodes are used with such circuits; namely, the peak voltage between one anode and ground is indicated.

Voltage measurements, in most instances, are made across a tuned circuit, the inductance furnishing the required d.c. path. Even if there are supply voltages fed through the tuned circuit, this method of connection is feasible; since the entire voltmeter circuit is then at the supply voltage above ground, due caution must be exercised. When a d.c. path is not present in the circuit under measurement a tuned circuit or choke and blocking condenser suitable to the particular frequency of measurement can be placed between the H and G terminals of the voltmeter to furnish the d.c. path.

Calibration

A 60 cycle per second calibration of the voltmeter will remain valid up to radio frequencies of the order of 30 megacycles per second. For this power-frequency calibration, the by-pass capacitance should temporarily be paralleled with a 10-microfarad paper

* ex-5KG; W2A1A, 615 South El Molino Ave., Pasadena, Calif.

Diode peak voltmeters are used extensively in commercial apparatus, yet have not come into common usage among the amateur fraternity. The writer feels that a specific design together with some consideration of the field of usefulness of this type of vacuum-tube voltmeter will undoubtedly make it more generally utilized than at present.

Figure 2. Closeup view of the measuring head of the diode peak voltmeter.

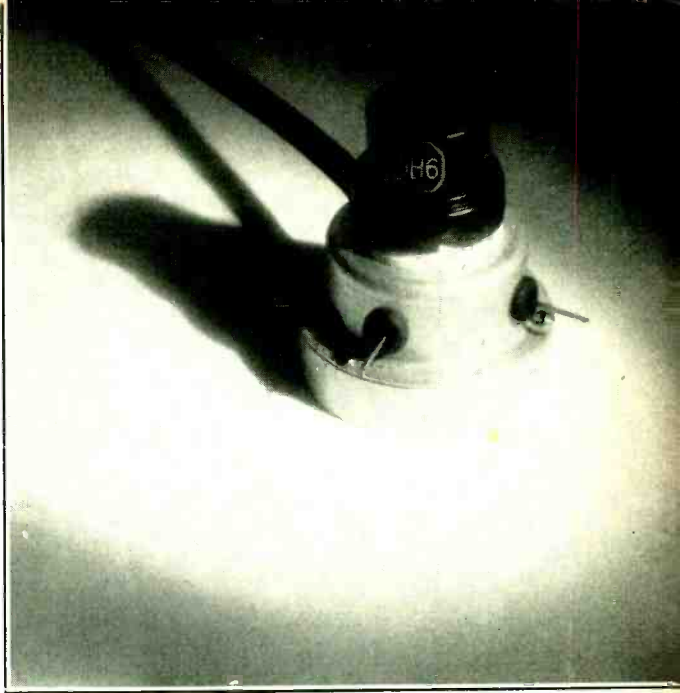

condenser. Experiment shows that the relation between the microammeter deflection and the applied peak voltage is strictly linear. Thus, a one-point calibration is often sufficient; but for greater precision it is desirable to apply calibrating voltages of variable amplitude, such as obtained from the secondary of a power-pack transformer, measuring the voltage with a suitable 60 c.p.s. meter. The r.m.s. voltage times 1.41 gives the peak value, and this should be used as abscissa of the plot, with the microammeter deflection as ordinate. The small space current which exists without applied voltage, due to the initial electron velocity, should be subtracted from all readings; this can be done conveniently by setting the microammeter needle to zero with the heater energized, but without applied voltage.

The product of the multiplier resistance and the microammeter reading will be found to be five to ten per cent lower than the applied peak voltage. Theory indicates that for a given value of resistance and with the 6H6 tube, the ratio of rectified voltage to applied peak voltage should be about 0.95. This ratio is so closely approximated that it is justifiable to take this product of multiplier resistance and microammeter reading as being sufficiently exact. It should be noted that some resistors have an appreciable voltage coefficient so that for the highest accuracy, wire-wound resistors are indicated—although of course, expensive.

The input impedance of the voltmeter is approximately that of a 1.5-micromicrofarad capacitance paralleled with an effective a.c. resistance equal to one half the multiplier

resistance. This can be seen as follows: The power input to the voltmeter is

$$\frac{E_{ac}^2}{2R_e}$$

where E_{ac} is the peak value of the applied radio-frequency voltage, and R_e is the effective resistance. The rectified power is

$$\frac{E_{dc}^2}{R}$$

where E_{dc} is the rectified voltage, and R is the multiplier resistance. Since $E_{dc} = E_{ac}$, approximately, for the constants given in figure 1 (which implies that the total power input is made available as power in the multiplier resistance), we obtain upon equating the two expressions that

$$R_e = \frac{1}{2} R$$

Thus the resistive component of the input impedance is of the order of 0.5 megohm for the 1.0 megohm range.

Uses of the Peak Voltmeter

The small dimensions of the measuring head make possible the measurement of voltages in confined places—such as receiver chassis—without upsetting circuit conditions by lengthy probe leads. Due to the extremely high input impedance of this voltmeter, it is very useful in many receiver tests. Thus the voltmeter can indicate resonance in i.f. stages, oscillation or non-oscillation of the beat oscillator, and all other tests requiring a vacuum-tube voltmeter.

The gain of radio-frequency amplifiers is easily measured by use of two identical peak

[Continued on Page 80]

A TIME DELAY CONTROL SYSTEM

By R. K. DIXON, * W8DYY

Numerous time-delay and control systems have been described from time to time in these pages and in the pages of other radio publications, but the one described herein has proven itself in over three years practical operation to be about the most flexible that has been seen. In addition to providing delayed plate voltage cutoff for c.w. use and push-to-talk for phone, the circuit provides time delay protection for the transmitting tubes and rectifiers making it impossible to apply plate voltage until they have reached proper operating temperature. The circuit is also quite suitable to remote control installations since only a three-wire line (of which one line may be grounded) is needed between the control position and the transmitter.

In its simplest form the circuit uses a tube, a relay designed to operate in the plate circuit of the tube, a few resistors, and a keying relay. The plate relay should be one having a coil resistance of 5000 to 10,000 ohms; the keying relay is standard and may be the one in use provided it closes two circuits when operated.

Relay RY₁ in figure 1 is the plate circuit relay and RY₂ is the keying relay. The control tube may be any heater triode depending upon the filament supply available. The filament and the grid and plate voltages for the control tube should be taken from a source that is turned on at the same time as the filament power is applied to the tubes in the transmitter. In most cases it should be possible to supply the necessary voltages from the bias pack in the transmitter since the drain of the control tube is very low. If necessary a

small separate supply may be made. The power transformer and the filter components may be quite small; good filtering in the pack is not necessary.

Operation

The operation of the control system is quite simple. When the keying relay is closed the cathode circuit of the crystal oscillator is completed and the grid of the control tube is grounded. This causes the control tube to draw plate current, closing the plate control relay and turning on the plate supply to the transmitter. During keying the control bias on the tube is maintained at a low value by the continued closing of the keying relay thus keeping the plate control relay closed and the plate voltage on the transmitter. After a predetermined delay in keying the bias will rise, cutting off plate current and allowing RY₂ to open. When this relay opens the plate voltage is, of course, removed from the transmitter.

The lag between the last keying pulse and the moment that the plate control relay opens is determined by the constants of the circuit and the supply voltages. With the values shown the lag may be varied from zero to approximately ten seconds as R₁ is varied. A two-second delay has been found most suitable for most keying speeds. The circuit responds almost instantaneously so that only a very small part of the starting character is cut.

With R₁ at zero relay RY₂ also follows keying making the circuit suitable for push-to-talk phone operation or primary keying of the plate supplies along with the crystal oscillator. Since relay RY₂ cannot be closed

* 536 Grove Ave., Johnstown, Pa.

A description of a simple control system which will automatically apply the plate voltage to the transmitter when the key is closed and then will maintain the plate voltage between characters until a specified period after keying is finished. The system will then remove the plate voltage instantly upon throwing another control switch. The system may thus be used to provide push-to-talk phone operation or to control automatically the plate supply to a c.w. transmitter.

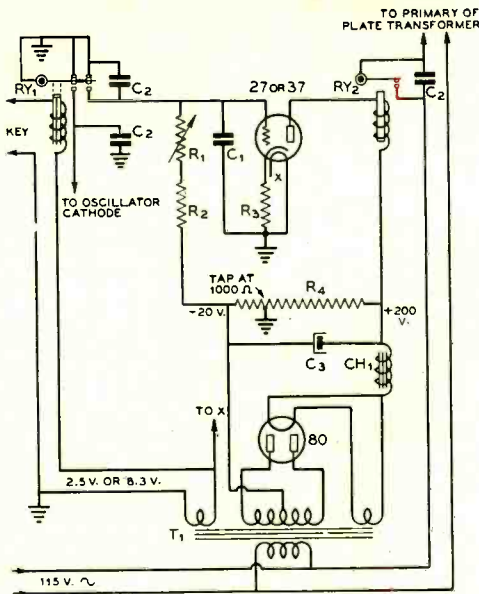

Figure 1.

Schematic diagram of the time-delay plate-control circuit.

- | | |
|---|---|
| C ₁ —1.0- μ fd. 400-volt paper | watt voltage divider, tapped at 1000 ohms |
| C ₂ —0.5- μ fd. 400-volt paper | T ₁ —600 v. c.t., 40 ma.; 2.5 or 6.3 v.; 5v., 2 a. |
| C ₃ —8- μ fd. 450-volt elect. | CH—20-hy. 40-ma. choke |
| R ₁ —2.0-megohm potentiometer | RY ₁ —D.p.s.t. or d.p. d.t. keying relay |
| R ₂ —10,000 ohms, 1 watt | RY ₂ —Plate current operated relay, see text |
| R ₃ —100 ohms, 1 watt | |
| R ₄ —10,000-ohm 20- | |



until the control tube has come up to operating temperature the circuit provides good time-delay protection for the transmitting tubes.

Components

The delay condenser C₁ should be a good grade paper condenser with high leakage resistance. Condensers C₂ are to reduce sparking at the relay contacts. The control relay RY₂ may either be purchased made to order, or a suitable one may be made from an old Philco eliminator relay by removing the coil and replacing it with the primary winding from an audio transformer. A homemade relay of this type has been in use in the original unit for over three years without giving trouble of any kind. However, any

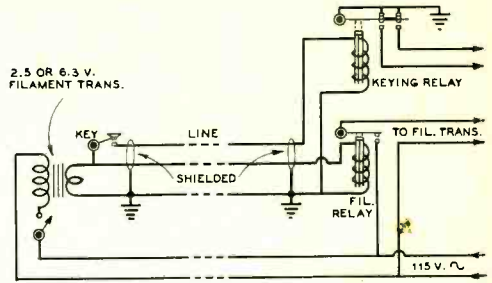

Figure 2.

The three-wire line remote-control circuit which is especially suited to use with the remote-control circuit. The interconnecting line may or may not be shielded depending upon the strength of the r.f. field through which it must be run. Also, the 110-volt lines at each end need not necessarily be common.



relay designed to close on 10 to 20 ma. will be suitable.

If the relay chosen has double contacts (as the rebuilt one did) they may be paralleled to carry heavier current or the other set may be used to throw an antenna relay. When using the system shown with high-power transmitters it will be necessary to use an auxiliary relay controlled by RY₂ to handle the heavy primary current. However, power up to 500 watts or so input to the final amplifier may be handled by the plate control relay directly.

Figure 2 shows a simple remote control system utilizing only three wires between the operating position and the transmitter. The 110-volt line between the two positions may or may not be common to the two; in most cases where the two positions were some distance apart the two lines would not be common.



Composite QTH

Recently W2APT addressed a QSL to: "Mr. Loren F. Spurr, W5DGB, 2805 Pine St., Plaquemine, La." A few days later he received a letter from W5KC as follows:

"... For your information W5ADB is Loren F. Spurr, W5AD is located at 2805 Pine St., and W5DGB is located at Plaquemine, La. As I work in the Post Office I fixed the card up with the correct address."

We have heard of a lot of QSL mixups but this appears to be some sort of record for a triple play.

ANTENNA POLARIZATION

on the Ultra Highs

By E. H. CONKLIN,* W9BNX

For a reason that may have been a good one, vertical antennas were the custom on five meters back in the days when five miles was good dx and antennas were relatively low. As time went on, the range was extended well beyond the horizon but, presumably due in part to the fact that a good signal is generally produced only by a receiving antenna in the same plane as the transmitting antenna, most tests resulted in confirmation of the superiority of verticals. Recently, a statement appeared in a well-known amateur journal to the effect that all tests show vertical to be better than horizontal polarization. At this date there is some reason to recheck old experiments and give some weight to experimental work done by RCA, the Bell Laboratories, and others.

Commercials Prefer Horizontals

The television transmissions in Europe have mostly used vertical antennas whereas those here have been on horizontals. Television involves problems not present in other types of work, such as the reduction of ghost images caused by reflected signals, and the possible need for separate sound and video antennas, both of which cannot be mounted at the very top of a building.

On the other hand, numerous frequency modulation transmitters are now using horizontal antennas, as are the several 100-Mc. circuits used by RCA to connect New York City offices with Rocky Point and, by two relays, with Philadelphia. Certainly there must be some reason for not using verticals for these purposes.

Making Tests

It is not enough to know that one polarization produces the best signal on the least fading. If the other polarization is not much inferior, it will be well to consider whether outside noise, such as ignition, can be reduced

even more, thus producing a better ratio of signal to outside noise.

An important consideration in making any tests of antenna polarization is the comparison of actual antenna power at the necessary low vertical angles. Putting up two antennas and testing them will show only which one is better when used with the antennas of the station being worked. If one of the antennas has a better low angle output, this should be given proper weight in the results, unless it is an inherent fault of that type of polarization that cannot be remedied by a rearrangement of the radiating system. Diagrams showing theoretical antenna patterns over "perfect ground" are not true for vertical polarization even over sea water¹. Another important factor is the nature of the terrain between the transmitting and receiving stations.

It appears that the effect of antenna polarization will show up in one of these forms:

- (a) A difference in the relative power radiated at useful low angles above the horizontal by the antenna.
- (b) Loss or cancellation due to ground reflection at either end of the circuit.
- (c) Direct diffraction effect around the earth's curvature and over the tops of intervening hills.
- (d) Amount of atmospheric refraction in the direct diffracted signal.
- (e) Effect upon the air mass boundary reflection ("bending") in the atmosphere.

Some Experimental Results

The results of careful studies should be of interest. One of these is summarized as follows:

"The superiority of vertical as compared with horizontal polarization over salt water with low antennas has been pointed out.

¹ E. H. Conklin, "Effect of Average Ground," RADIO, March, 1938, p. 36.

* Associate Editor, RADIO, Wheaton, Illinois.

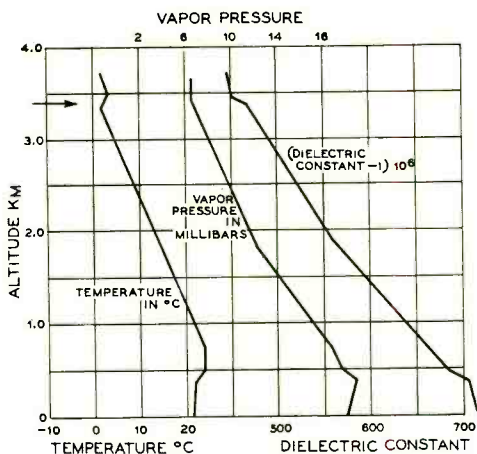

Figure 1. Air-mass boundary heights shown by U.S. Weather Bureau free air data, compared to measured heights from frequency-sweep patterns on ultra-high frequencies.

However, this should not be misconstrued to indicate that such a relation necessarily holds true for high antennas. Previous tests in the Hawaiian Islands have indicated no appreciable difference between vertical and horizontal polarization tests when using high antennas located several thousand feet above sea level.”²

A second comment is:

² Trevor and Carter, "Notes on Propagation of Waves Below 10 Meters," *Proc. I.R.E.*, March, 1933.

"The available data are based on over-land transmission, for which case there seems to be little difference between vertical and horizontal polarization. Over sea water, vertical polarization is superior to horizontal polarization, at least for moderate distances with relatively low antennas.”³

One of the best of the more recent studies, made by Bell Telephone Laboratories engineers, worthy of considerable note⁴, will be summarized here.

Over a period of two years, measurements were made on wavelengths between 1.6 and 5.0 meters. The transmitting site was in New Jersey near Sandy Hook at an altitude of 119 feet. A central 60-foot mast surrounded by four 30-foot poles supported a group of transmitting antennas. These included both a vertical and a horizontal rhombic, each terminated in its surge impedance with carbon lamps, an unterminated inverted "Vee," and a half-wave doublet. The receiving site with the same antenna equipment was nearly at sea level, 70 miles east, at East Moriches, Long Island.

Fading

It was found that fading was present almost all of the time. One type of fading was termed "roller" because of the long

³ H. H. Beverage, "U.H.F. Propagation," *RCA Review*, January, 1937, p. 86.

⁴ Englund, Crawford and Mumford, "Ultra-Short Wave Transmission and Atmospheric Irregularities," *Bell System Technical Journal*, October, 1938, p. 489.

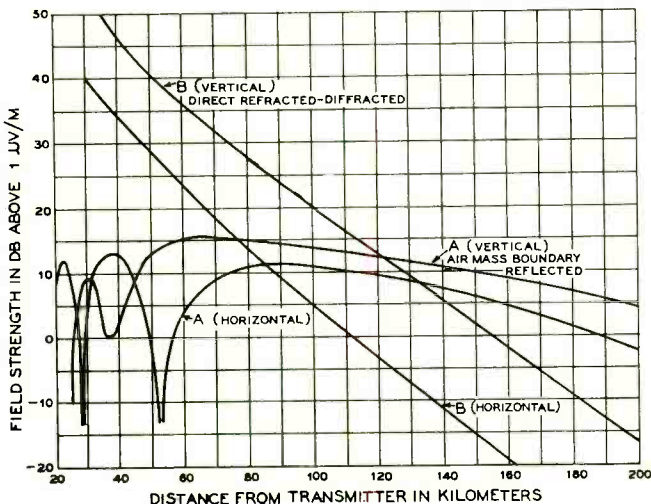

Figure 2. Calculated curves for air-boundary reflected and earth refracted-diffracted radiation components, in both vertical and horizontal polarization. Short doublet antennas, 1 kw. power radiated, wavelength 4.7 meters, ground conductivity 5×10^{-11} E.M.U., and dielectric constant 80 for sea water. Height of transmitting antenna 42 meters, of receiving antenna 5 meters, air boundary height 1500 meters, effective radius of earth 8500 kilometers.

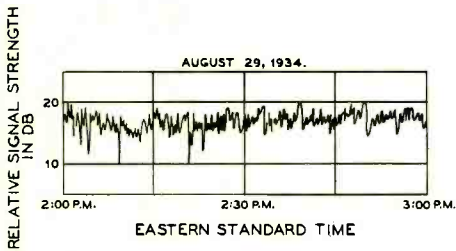

Figure 3. An oscillogram showing a good example of oscillating or "scintillating" fading as experienced on vertically polarized transmission, made on 4.7 meters.

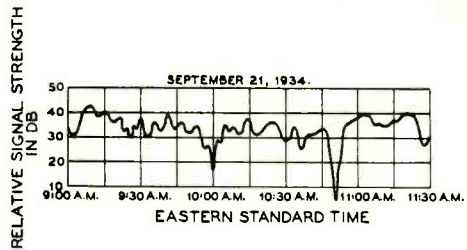

Figure 4. Oscillogram showing roller-type fade, also experienced on 4.7 meters with vertically polarized transmission and reception.

periods of high signal separated by short and sharp fades, particularly noticeable on signal-strength records. The other type was an oscillation that sometimes was as rapid as five times a second. The worst fading was 40 db. This condition made simultaneous recordings necessary when comparing two antennas or frequencies. In general, the horizontal component showed the worse fading, more per minute and of greater amplitude range, especially when that on vertical polarization was bad. Generally there was no coincidence between the fading on the two polarizations. Fading was usually worse on the lowest wavelengths. As the distance between transmitter and receiver was increased, fading increased as the signal fell. Using two horizontal doublets 14 and 52 feet high, a signal level difference of 12 db was observed in favor of the higher antenna, but fading was identical. On the only test made on two antennas 150 feet apart and substantially broadside to the radiation, identical fading was recorded.

If the study had stopped at that point, it would be just another observation of conditions with an attempt neither to analyze them for their causes, nor to find if the results are general. Happily, it went much farther, and only portions of it can be reviewed here.

How Signals Are Propagated

By wabbling the transmitters over a band of several megacycles and observing the received signal on an oscilloscope, the signal level at each frequency in a wide band could be seen instantly. Some of these patterns were simple enough to allow determining the difference in path lengths that caused wave interference, and calculating the height of the reflecting boundary in the atmosphere. It was found that some of these boundaries were as high as 5.5 kilometers, but most

reflections were characteristic of boundaries below an altitude of 2 kilometers. Airplane flights of the U. S. Weather Bureau provided temperature and water vapor data at various altitudes from which the dielectric constant of the air could be calculated. The measured heights of the reflections agreed quite well with the height of the discontinuity of the dielectric constant, inversions in temperature, and of water vapor pressure. These appear as jiggles in the curves as shown in figure 1. It will be noted that the temperature inversion below an altitude of 400 meters was not the cause of the reflection.

In arriving at the direct diffracted field strength, a correction for refraction was applied. Signals fall off with distance in part because the earth drops below the horizon of the transmitting antenna; this is less than the expected amount, the actual condition being very much as though the earth's diameter were about $1\frac{1}{3}$ times what it actually is. The amount of refraction of the direct signal depends on the season and the type of air mass, as given in the following table:

| Air Mass Type | Effective Earth Radius | |
|-------------------|------------------------|-----------------|
| Tropical Gulf | $1.53 \times R$ | $1.43 \times R$ |
| Polar Continental | $1.31 \times R$ | $1.25 \times R$ |
| Superior | $1.25 \times R$ | $1.25 \times R$ |

R = actual earth radius

Air Mass Boundary Reflections

The above types of air masses are also involved in the reflection (low atmosphere bending) that brings about most 200-mile dx on the ultra-high frequencies. The boundaries between air masses furnish discontinuities in the dielectric constant adequate for reflections at grazing angles and for very high frequencies. The greater the stability of the boundary, the more abrupt it is likely to be.

[Continued on Page 70]

Keying Circuit Innovations

The manager of the "Quick-and-Easy" department has recently received diagrams and descriptions of several circuit tricks which merit notice. Those shown here are concerned with keying and switching systems. Figure 1 shows a simple keying arrangement which is applicable to any transmitter in which a bias supply is used on all stages following the keyed stage or stages. Installing this sort of system is simplicity itself. All that is necessary is to break the positive (grounded) side of the bias supply bleeder and insert another resistor, R_2 , of the same resistance as the original bleeder between what was formerly the positive side of the bleeder and ground. The key is placed across the new section of bleeder resistor. R_2 can have a wattage rating half that of the original bleeder since the current flowing through it will be less than half that flowing through the original resistor.

The circuit operates by applying blocking bias, when the key is open, to the grids of whatever stages have their grid returns brought to point X. These stages should be designed to operate with either grid leak or cathode bias or a combination of both, under key-down conditions. The stages having the blocking bias applied to them should preferably be low-power ones or those which have a small amount of excitation applied to them. When it is impossible completely to cut off a single stage with this system, either the stage following or the one preceding the one on which the keying was originally tried should be connected to the circuit. When this is done the additional bias applied to the first of the keyed stages reduces the excitation to the following one to a point where the bias available will cut it off.

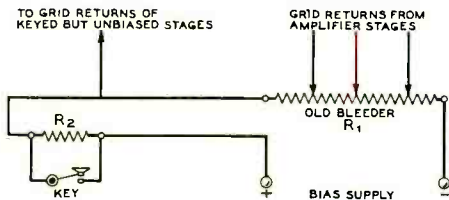

Figure 1. Simple blocked-grid keying system.

R_1 —Original bias-pack bleeder as R_1 , wattage rating may be half that of R_1
 R_2 —Same resistance

As with any excitation-keying system, the stages following the keyed ones must be absolutely stable if key clicks are to be eliminated. If these stages are not perfectly neutralized and stable in every respect, terrific key clicks can be generated by the stages going through an oscillating condition as the excitation is brought up and reduced during keying. No amount of key-click filter will be of much help in reducing this type of click. However, the ordinary type of click caused by the rapid make and break of keying may be eliminated in this system by the use of the ordinary simple key-click filter. The filter may consist of a condenser and resistor in series across the key. The values of these two components may vary with different transmitters but the condenser will usually be found to have a value between .05 and 0.5 μ f.d., while the resistor will be between 100 and 500 ohms.

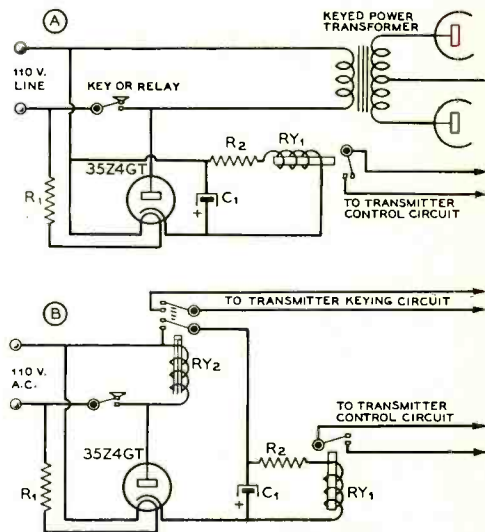

Figure 2. Simple key-control for the transmitter.

R_1 —600 ohms, 20 watt electrolytic (Paper condenser should be used if longer time delay is desired)
 R_2 —Depends upon relay resistance, sum of relay and R_2 resistances should be greater than 2000 ohms, 10 watts. See text.
 C_1 —8- or 16- μ f.d. 200-volt
 RY_1 —Low-current d.c. relay
 RY_2 —110-volt a.c. relay with s.p.d.t contacts

Semi-Break-In System

Another circuit which should be of interest to the c.w. operator who desires to minimize his switching operations is shown in figure 2. This circuit allows complete transmitter control (after the filaments have been lighted) by use of the key only. When primary keying is used the circuit takes the simple form shown at 2A. A 35Z4-GT is connected as a half-wave rectifier directly across the keyed power transformer. When the key is closed the rectifier supplies d.c. to the relay RY_1 , which takes the place of the usual transmit-receive switch, thus turning on the transmitter. When the key is opened the voltage stored in condenser C_1 holds relay RY_1 closed for a period of time depending upon the value of R_2 and the current drawn by the relay. In operation the time delay obtainable is sufficient for all practical purposes, the relay holding closed during the ordinary pauses experienced in communication. RY_1 should be a low-current unit drawing 50 milliamperes or less at 100 volts. Relays of lower voltage rating may be used by using a larger series resistor between C_1 and the relay winding. Maximum time delay on the shut-off will be obtained by adjusting the resistor to the highest value which gives positive relay operation.

The circuit shown at figure 2B should be used with transmitters using any form of keying other than primary. Relay RY_2 can replace the present keying relay, if one is used. This relay should have single-pole single-throw contacts. One set of contacts is used for keying the transmitter in the usual manner and the other to key the voltage to the 35Z4-GT control circuit. The circuit operation is identical with that described for the primary-keying application.

If the primary keying of a gridleak-biased final stage is used with the circuit of figure 2A, there will be an instant just as the key is pressed for the first time when full plate voltage will be applied to the tubes with no excitation and hence no bias. If they are not zero-bias tubes and are operating with high plate voltage the instantaneous plate dissipation may be quite high. If this instant of high plate dissipation is objectionable, the trouble may be alleviated in one of two ways. A small amount of fixed bias sufficient to reduce the unexcited plate current to a reasonable value may be inserted in series with the gridleak. Or another pair of contacts on RY_1 may be placed in series with the primary of the plate transformer for the final stage so that the plate voltage will not come on until the excitation has been applied.

Switching with 220-Volt Supply

Although it is admittedly poor practice, there are times when it is desired to use a s.p.s.t. switch or relay to control the transmitter during stand-by periods when 220-volt a.c. is used for one or more stages. This circuit usually takes the form shown at figure 3A and the results are usually quite surprising, it being impossible to turn the transmitter off completely. It is found that all stages in the transmitter continue to run with about one-fourth to one-half their original power.

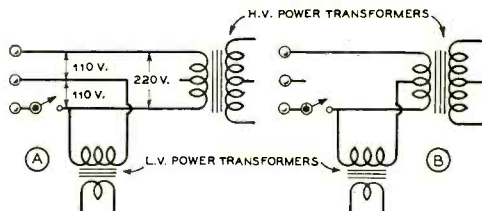

Figure 3. Single-circuit switching with 200-volt supply.

It may be seen from the diagram that the low and high voltage transformers are in series across the upper 110 volts when the switch is open, and nothing short of a double-pole switch will be of any assistance in turning off the transmitter. However, if the circuit is rearranged as shown at figure 3B the single-pole switch will do the job. Here the low voltage transformer has been connected across half the high voltage transformer primary, with the result that opening the switch kills both supplies. Placing the low voltage transformer primary across half the other primary does not result in any great unbalance or loss of voltage to the low voltage supply as long as its transformer does not have a rating greater than 15 or 20 per cent of the high voltage transformer rating, which is the usual condition in transmitters using this arrangement.

• • •

Descant

This radio biz has got me diz,
I wouldn't know what to do.
For every resistor I work out a twister,
For each little doubler the mu.
With a master stroke I always go broke,
For Henries and Millies I die,
But take it away and my evenings are grey,
So QRN, tear out on Hi!

—W6QVP

TUBELESS NOISE LIMITERS

It is possible to design the detector and a.f. system in a receiver so as to obtain noise limiting without the addition of either series or shunt noise limiting tubes. A particularly effective yet simple method for c.w. operation is described.

In one sense, the title to this article is misleading, because the tubes already in the receiver, the detector and audio stage, are made to do the limiting. However, there is no tube that functions solely as a noise limiter as in so many of the popular noise limiting circuits. So while there is no "noise limiter tube" in the customary sense, the noise limiting is still done by vacuum tubes.

A good detector, whether it be a diode, infinite impedance, or bias (power) detector, automatically provides noise limiting on one half the audio cycle, the maximum noise peak amplitude being limited on that half the cycle to the carrier amplitude. The reason for this is that a detector, by virtue of its very operation, can not have a modulation capability in excess of 100 per cent in a negative (downward) direction.

Coming out of the detector we have an audio envelope (replica of the modulated carrier) upon which is impressed the noise peak. On one half the cycle the noise peak never exceeds the peak modulation amplitude, but on the other half of the audio cycle the amplitude of the noise peak may be several times the amplitude reached by the audio envelope at 100 per cent modulation.

For phone work we lop off this peak right at the point corresponding to 100 per cent modulation of the carrier. We cannot chop any more off without chopping off part of the modulation on one half the cycle, thus introducing harmonic distortion.

But on c.w. work we need not worry about harmonic distortion; in fact some harmonic distortion makes a p.d.c. note less tiring to

listen to. So it is possible to eliminate the noise peak for c.w. work simply by designing the succeeding a.f. stage to work only on one half the audio cycle, the half on which the noise peak has already been limited by the action of the detector.

Such a circuit is shown at figure 1-A. The voltage generated by the carrier is negative with respect to ground; therefore modulation peaks (noise or otherwise) in a positive direction are limited to 100 per cent of the carrier amplitude. With the a.f. amplifier biased to cutoff, only the positive audio peaks will actuate the amplifier. A very effective limiting of noise peaks is the result. As a result of the harmonic distortion introduced by such an amplifier, overtones are present in the output, especially if the amplifier is biased to actual cutoff (zero plate current) rather than to theoretical cutoff (plate voltage divided by μ). The voltage required for actual cutoff is about $1\frac{1}{4}$ times the cutoff value as determined by the plate voltage and μ .

The audio component delivered by a bias (power) detector (figure 1B) is poled the same as for a diode connected as in 1A. In other words, a carrier develops voltage in a negative direction, and therefore the a.f. signal can be applied to the same type of a.f. amplifier to provide excellent noise limiting for c.w. work. In both cases it is desirable to operate the audio tube at a moderately high level (between 6 and 12 volts peak on the grid) in order to get best limiting action. For this reason the audio gain control would be better placed *after* this tube, but good limiting action will still be obtained with the volume control placed in the grid of the single ended class B audio amplifier as shown at

* Editor, RADIO.

Did you know that for c.w. operation all you have to do to get excellent noise limiting is to run the first audio stage either at zero bias or at cutoff bias, depending upon the type of detector used? The effectiveness of this simple system compares with that of the best limiters, and at the same time all d.c. notes are given a melodious modulation which makes for more pleasant copy. The limiting action is the same regardless of the strength of c.w. signals; therefore no "threshold" adjustment need be made for different signals, and the limiting action is not affected when the c.w. signal goes into a fade.

• • •

1A and 1B. The 6J5 in either case can be used to drive a pair of earphones instead of a larger audio stage if desired.

The output of the so-called infinite impedance detector produces modulation of opposite polarity. The noise peaks are in a *positive* direction, and therefore the detector must be followed by an audio amplifier that works only on the *negative* side of the audio envelope. Such an arrangement is shown at figure 1C. As the impedance of the driving source (the detector) is not sufficiently low to drive the grid positive, only a.f. swings in a *negative* direction will produce any effect upon the plate circuit. This system is about as effective as those shown at 1A and 1B for c.w. reception through short pulse noise of high amplitude (electric shavers, etc.). To prevent the generation of grid leak bias, the usual grid resistor has been replaced by a high impedance audio choke. It may be anything between 30 and 250 henries.

For best noise limiting action with 1C, the impedance of the driving source must be high at all times; hence the volume control must be placed in the plate circuit of the a.f. tube. This means that the circuit as shown is not suited for use with earphones, but must be used with another audio stage. Like the half-wave a.f. amplifiers of figure 1A and 1B the system of figure 1C will provide best limiting action when the signal voltage fed to the grid of the a.f. tubes is of the order of 4 to 10 volts.

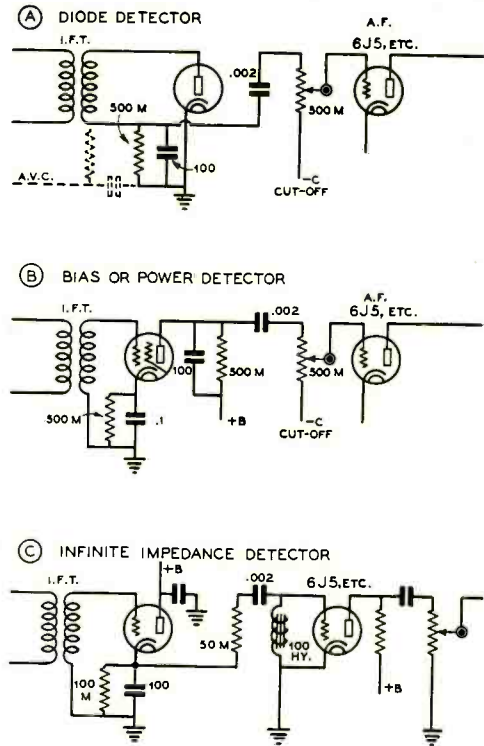

Figure 1.

Three simple methods of obtaining noise silencing for c.w. work. At the same time harmonious modulation is added to d.c. signals. The gain control should preferably be placed after the a.f. tube in A and B, though it can be placed in the grid as shown when the a.f. stage is used to drive a pair of phones instead of a power a.f. stage. The circuit at C, for use with infinite impedance detectors, requires that the gain control be placed after the first a.f. tube in all cases. The choke should have between 50 and 250 hy. inductance. In all three cases the first a.f. tube should be a small, medium μ triode for best results.

Phone-C.W. Limiter, Semi-Automatic

For intelligible reception of phone signals, at least a good portion of the other half of the audio cycle must be reproduced. The limiting action can be made adjustable simply by providing a variable source of bias for the limiting audio stage, adjustable from zero bias to about $1\frac{1}{2}$ times cutoff bias. This will provide any desired degree of limiting on phone signals, and complete elimination of one side of the a.f. envelope for maximum peak limiting with c.w. reception. Such a circuit is shown in detail in figure 2. For a diode detector connected as in figure 1A or a power

[Continued on Page 78]

● A really old one that is still operating — the 30-kc. wired-wireless transmitter used by a local public utility for interstation communication. It was installed about 1915 and still has the original UV204 oscillator UV204 modulator, and UV203 speech amplifier operating directly from a Kellogg mike. The receiver is the old Kennedy with a two-step amplifier.

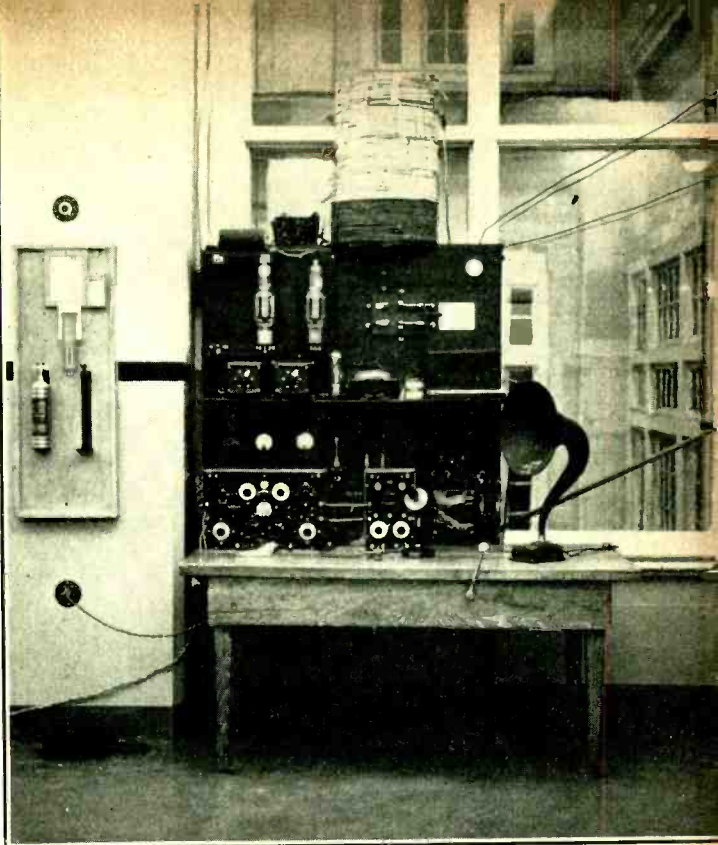

DEPARTMENTS

- **DX**
- **Open Forum**
- **U. H. F.**
- **Postscripts and Announcements**
- **Yarn of the Month**
- **What's New in Radio**

RADIO

"WAZ" HONOR ROLL

CW and PHONE

| | Z | C |
|-------|----|-----|
| ON4AU | 40 | 158 |
| G2ZQ | 40 | 147 |
| J5CC | 40 | 130 |
| W8CRA | 39 | 156 |
| W2BHW | 39 | 156 |
| W8BTI | 39 | 154 |
| W2HHF | 39 | 152 |
| G6WY | 39 | 151 |
| W6CXW | 39 | 150 |
| W6GRL | 39 | 150 |
| W9TJ | 39 | 149 |
| W2GTZ | 39 | 149 |
| W6CUH | 39 | 143 |
| W6KIP | 39 | 143 |
| W8OSL | 39 | 143 |
| W9KG | 39 | 141 |
| W6ADP | 39 | 140 |
| W6BAX | 39 | 140 |
| W80QF | 39 | 139 |
| W4CBY | 39 | 138 |
| W9TB | 39 | 134 |
| W2ZA | 39 | 134 |
| VK2EO | 39 | 133 |
| G5BD | 39 | 133 |
| W2GVZ | 39 | 132 |
| W6QD | 39 | 132 |
| W4CYU | 39 | 132 |
| W3EVT | 39 | 131 |
| W5KC | 39 | 130 |
| W2GWE | 39 | 129 |
| W6KRI | 39 | 129 |
| VE4RO | 39 | 126 |
| W7BB | 39 | 123 |
| W6HX | 39 | 123 |
| G5BJ | 39 | 120 |
| W2IYO | 39 | 119 |
| W8JSU | 39 | 118 |
| W2CYS | 39 | 117 |
| G2LB | 39 | 115 |
| W4IO | 39 | 115 |
| W7DL | 39 | 115 |
| W2GNQ | 39 | 113 |
| W6FZL | 39 | 112 |
| ON4HS | 39 | 111 |
| ON4FE | 39 | 110 |
| W1AQT | 39 | 110 |
| W6FZY | 39 | 109 |
| W9NRB | 39 | 98 |
| W6SN | 39 | 96 |
| W6GPB | 39 | 94 |
| XE1BT | 39 | 90 |
| K6AKP | 39 | 78 |
| W1BUX | 38 | 152 |
| W1CH | 38 | 150 |
| W2GT | 38 | 143 |
| W2GW | 38 | 143 |
| W5VV | 38 | 144 |
| W3HZH | 38 | 139 |
| W3EMM | 38 | 139 |
| W8BKP | 38 | 138 |
| W8LEC | 38 | 136 |
| W3EPV | 38 | 136 |
| W5BB | 38 | 135 |
| W9GDH | 38 | 134 |
| W3HXP | 38 | 133 |
| W4FVR | 38 | 130 |
| W9FS | 38 | 130 |
| W3EAV | 38 | 130 |
| W8JMP | 38 | 127 |
| W2GRG | 38 | 127 |
| ON4EY | 38 | 126 |
| W3EVB | 38 | 124 |
| W3GHD | 38 | 121 |
| W8AU | 38 | 120 |
| W8LYQ | 38 | 120 |
| W8DFH | 38 | 119 |
| W9PST | 38 | 119 |
| W8QXT | 38 | 119 |
| W8JIN | 38 | 119 |
| W3FQP | 38 | 119 |
| W8DWW | 38 | 118 |
| W1GDY | 38 | 118 |
| W2BMM | 38 | 118 |
| W1BGC | 38 | 117 |
| W6AM | 38 | 117 |
| W1ADM | 38 | 117 |
| L7AZ | 38 | 116 |
| W3DDM | 38 | 116 |
| W9UQT | 38 | 116 |
| W3GAU | 38 | 115 |

| | | |
|-------|----|-----|
| W8MTY | 38 | 114 |
| W9KA | 38 | 114 |
| W6VB | 38 | 113 |
| G6CL | 38 | 112 |
| W8HWE | 38 | 112 |
| G2QT | 38 | 112 |
| W8EUY | 38 | 112 |
| W9CWW | 38 | 112 |
| W2BXA | 38 | 111 |
| W6GRX | 38 | 111 |
| LY1J | 38 | 110 |
| W1AB | 38 | 110 |
| W6HZT | 38 | 110 |
| W9ELX | 38 | 110 |
| W8LFE | 38 | 110 |
| W4MR | 38 | 108 |
| W8KWI | 38 | 108 |
| W3BEN | 38 | 108 |
| W8BOX | 38 | 106 |
| W9ADN | 38 | 106 |
| W8OE | 38 | 106 |
| W9PK | 38 | 105 |
| W8GBF | 38 | 105 |
| ON4UU | 38 | 104 |
| G2IO | 38 | 103 |
| W8WBW | 38 | 98 |
| J2KG | 38 | 95 |
| G6XL | 38 | 95 |
| ON4FQ | 38 | 92 |
| W9VDQ | 38 | 79 |
| SU1WM | 37 | 138 |
| W2BJ | 37 | 134 |
| W6GAL | 37 | 131 |
| W8KKG | 37 | 127 |
| W7AMX | 37 | 125 |
| J2JJ | 37 | 123 |
| W2IOP | 37 | 122 |
| W1RY | 37 | 120 |
| G6NF | 37 | 115 |
| W8PQQ | 37 | 115 |
| W8ZY | 37 | 114 |
| W9RCR | 37 | 114 |
| W3TR | 37 | 113 |
| ON4FT | 37 | 112 |
| W9RBI | 37 | 112 |
| W6MEK | 37 | 112 |
| W6ADT | 37 | 111 |
| G2MI | 37 | 110 |
| VE2EE | 37 | 108 |
| W4DMB | 37 | 108 |
| W7AYO | 37 | 108 |
| W3KT | 37 | 105 |
| W9PTC | 37 | 103 |
| W6ITH | 37 | 103 |
| W3FJU | 37 | 103 |
| W9GBJ | 37 | 103 |
| G6GH | 37 | 102 |
| W3AYS | 37 | 102 |
| VK2DA | 37 | 101 |
| W6FKZ | 37 | 101 |
| W6JBO | 37 | 101 |
| W8KPB | 37 | 100 |
| W4DMB | 37 | 100 |
| W9AJA | 37 | 99 |
| W4EQK | 37 | 99 |
| ON4VU | 37 | 99 |
| W3EXB | 37 | 98 |
| ZL2CI | 37 | 97 |
| W6MHH | 37 | 95 |
| G2UX | 37 | 91 |
| W2BSR | 37 | 90 |
| W6MCG | 37 | 84 |
| W9UBB | 37 | 77 |
| W8AQT | 36 | 120 |
| W6MVK | 36 | 117 |
| K4FCV | 36 | 107 |
| W3GGE | 36 | 106 |
| W6BAM | 36 | 106 |
| W8DOD | 36 | 106 |
| W9AFN | 36 | 105 |
| W8QDU | 36 | 105 |
| W6NLZ | 36 | 104 |
| W5ASG | 36 | 104 |
| W5PJ | 36 | 105 |
| SP1AR | 36 | 103 |
| W6NNR | 36 | 100 |
| W6KWA | 36 | 99 |
| W8LZK | 36 | 99 |
| G6BJ | 36 | 99 |
| VE1DR | 36 | 98 |
| W9VES | 36 | 98 |
| W8LDR | 36 | 97 |

| | | |
|--------|----|-----|
| W8AAT | 36 | 96 |
| W6DLY | 36 | 96 |
| W9GKS | 36 | 95 |
| ZL1HY | 36 | 95 |
| G6YR | 36 | 94 |
| W2IZO | 36 | 94 |
| VE5AAD | 36 | 92 |
| W5ENE | 36 | 91 |
| W4ADA | 36 | 90 |
| W9LBB | 36 | 90 |
| W8JAH | 36 | 89 |
| W1APU | 36 | 89 |
| OK2HX | 36 | 86 |
| VK2NS | 36 | 84 |
| W6TI | 36 | 80 |
| W6GCX | 36 | 76 |
| W7DSZ | 36 | 73 |
| W2GXH | 36 | 71 |
| W1WV | 35 | 117 |
| W8OXD | 35 | 113 |
| W6GHU | 35 | 103 |
| W4QN | 35 | 103 |
| W9PGS | 35 | 103 |
| W8OUK | 35 | 99 |
| W8CJJ | 35 | 98 |
| W6HJT | 35 | 98 |
| W2WC | 35 | 98 |
| OK1AW | 35 | 96 |
| W8AAJ | 35 | 96 |
| W3RT | 35 | 95 |
| W9EF | 35 | 94 |
| G6QX | 35 | 94 |
| K6NYD | 35 | 94 |
| W3DRD | 35 | 93 |
| W6AQJ | 35 | 92 |
| VE5ZM | 35 | 92 |
| LU3DH | 35 | 89 |
| W9GNU | 35 | 88 |
| W9ERU | 35 | 88 |
| K6CGK | 35 | 88 |
| W9VDX | 35 | 86 |
| W6KQK | 35 | 85 |
| W6ONQ | 35 | 83 |
| ON4NC | 35 | 82 |
| G1TK | 35 | 80 |
| W4ELQ | 35 | 80 |
| W8QIZ | 35 | 78 |
| W6MUS | 35 | 76 |
| W6GK | 34 | 105 |
| W6HEW | 34 | 103 |
| K7FST | 34 | 102 |
| W8CED | 34 | 101 |
| W8BSF | 34 | 100 |
| W1APA | 34 | 98 |
| W2BZB | 34 | 99 |
| VK2AS | 34 | 94 |
| W8HGA | 34 | 93 |
| W3EYY | 34 | 91 |
| W8NV | 34 | 91 |
| W9MQQ | 34 | 89 |
| W2FLG | 34 | 89 |
| W6TE | 34 | 86 |
| G6WB | 34 | 88 |
| W6CVW | 34 | 88 |
| VK2OQ | 34 | 87 |
| G5VU | 34 | 85 |
| W9BCV | 34 | 83 |
| ZS1CN | 34 | 82 |
| W6PNO | 34 | 82 |
| VK2TF | 34 | 82 |
| W6MJR | 34 | 81 |
| ON4SS | 34 | 80 |
| W6HIP | 34 | 76 |
| VK2TI | 34 | 75 |
| W7AVL | 34 | 75 |
| W8JK | 34 | 75 |
| ZL2VM | 34 | 72 |
| W6LHN | 34 | 71 |
| VK2AGJ | 34 | 70 |
| VK2EG | 34 | 70 |
| VE5MZ | 34 | 69 |
| VK2VN | 34 | 63 |
| W9QOE | 34 | 56 |
| F8XT | 33 | 112 |
| W8ACY | 33 | 106 |
| W3DAJ | 33 | 97 |
| W6KEV | 33 | 96 |
| W8BWC | 33 | 93 |
| W9VKF | 33 | 93 |
| W6KUT | 33 | 90 |
| W6CEM | 33 | 88 |

PHONE

| | | |
|--------|----|-----|
| W3LE | 38 | 128 |
| F8UE | 38 | 103 |
| W6OCH | 36 | 107 |
| W6FJU | 36 | 97 |
| VE1CR | 36 | 87 |
| W3ICR | 36 | 81 |
| W9NLP | 35 | 95 |
| W9TIZ | 35 | 93 |
| K1ME | 35 | 79 |
| F8VC | 35 | 78 |
| W4CYU | 34 | 100 |
| ON4HS | 34 | 92 |
| W9EJC | 34 | 84 |
| W7BVO | 34 | 80 |
| W4DAA | 34 | 71 |
| W1ADM | 33 | 88 |
| W6NNR | 33 | 88 |
| GM2UU | 33 | 84 |
| F8XT | 33 | 70 |
| W3FAM | 33 | 68 |
| W6MLG | 32 | 92 |
| W8LFE | 32 | 91 |
| W8LKV | 32 | 90 |
| W9I | 32 | 86 |
| W1KKK | 32 | 85 |
| W8QXT | 32 | 85 |
| G5BY | 32 | 85 |
| W9EU | 32 | 85 |
| VK4JP | 32 | 85 |
| W4DSY | 32 | 84 |
| W6OI | 32 | 83 |
| W9TB | 32 | 82 |
| W6IKQ | 32 | 80 |
| VE1DR | 32 | 59 |
| W3EMM | 31 | 88 |
| W1AKY | 31 | 87 |
| W8LAC | 31 | 85 |
| G6BW | 31 | 83 |
| G3DO | 31 | 78 |
| W1KJT | 31 | 78 |
| W6FTJ | 31 | 77 |
| G8MX | 31 | 73 |
| W8RL | 31 | 71 |
| W9UYB | 31 | 71 |
| W6AM | 31 | 67 |
| F8KI | 31 | 58 |
| W9ZTO | 31 | 53 |
| W2GW | 30 | 86 |
| F4EE | 30 | 85 |
| W1JXC | 30 | 81 |
| W2IUV | 30 | 79 |
| W2AOG | 30 | 77 |
| W9BCV | 30 | 68 |
| W6MZD | 30 | 52 |
| W2IXY | 29 | 93 |
| W4BMR | 29 | 80 |
| CO2WM | 29 | 78 |
| K6NYD | 29 | 73 |
| W9RBI | 29 | 71 |
| W6NLS | 29 | 64 |
| W6NRW | 29 | 60 |
| K1CS | 29 | 59 |
| W2GRG | 28 | 74 |
| W8AAJ | 28 | 66 |
| W6PDB | 28 | 65 |
| W7EKA | 28 | 63 |
| VE2EE | 28 | 62 |
| W4DRZ | 28 | 62 |
| W1BLO | 28 | 62 |
| VK2AGU | 28 | 61 |
| W6GCT | 28 | 56 |
| W3EWN | 27 | 93 |
| W2DVR | 27 | 77 |
| W2HCE | 27 | 76 |
| G6DT | 27 | 59 |
| W5CXH | 27 | 52 |
| G5J | 26 | 77 |
| W5ASG | 26 | 62 |
| W8NV | 26 | 62 |
| W5VV | 26 | 61 |
| W4EQK | 26 | 61 |
| W8QDU | 26 | 61 |
| W9NMH | 26 | 61 |
| W5DNV | 26 | 60 |
| VK2OQ | 26 | 56 |
| W4TS | 26 | 54 |
| W6MPS | 26 | 51 |
| VE4SS | 26 | 50 |
| W6FKK | 26 | 47 |
| K6LKN | 26 | 46 |
| G6CL | 26 | 46 |
| W7AMQ | 26 | 48 |

DX AND OVERSEAS NEWS

by Herb. Becker, W6QD

Send all contributions to Radio, attention DX Editor, 1300 Kenwood Road, Santa Barbara, Calif.

Here we are again all ready to talk about dx, with no dx to talk about. Looks like a lean column ahead, fellows; so just relax in a nice easy chair—and even tune in a bc program 'cause it won't bother you. Looking at this thing from an analytical point of view, now that we aren't going to have much dx to talk about . . . what would be the next best thing? Well, the gang that has been working all of this stuff surely is doing something. They don't fold completely, or do they? Anyway it would seem to me they are either rebuilding, have the shutter-bug craze, golfing, hunting, skiing, playing poker, doing the family ironing, or writing chain letters again. They must be doing something and if I only had a good "super-snooper" we could look into some of their "goings on." Come to think of it my old "Operative 1492" hasn't been heard from for a long, long time. Good ol' "1492" has done us a lot of good and has reported things from time to time, that we wouldn't have gotten otherwise. Let's give "1492" a crack at it this time.

Touisset, Mass. "1492" dropped around to see what W1BUX was doing. He peeked in his shack window and saw Doug trying to get warm from a couple of kerosene "stink-pots." He was having a heck of a time and with about 6 inches of snow on the ground it was really cold. It seems that it takes so long to warm up his shack that Doug gradually freezes to such a point that he can't successfully punch the key. At least this *could* be his excuse for no new dx. W1BUX says, "Aw nuts, spring is coming and I'm still going to put up some rhombics."

Newton, Mass. Ol' "1492" sneaked up on W1AQT on the night of December 20th, just in time to catch him working AC4JS for one of those lifetime thrills. This really isn't fair 'cause we weren't going to talk about dx. This made Bob 39 zones and 110 countries. "1492" reports seeing Bob working on some peculiar gadgets, and upon nosing around a bit discovered they were filters to eliminate his bad ignition and commutator noises, which he gets every night. You see, W1AQT is confined to quite a small lot and has no room to expand.

Brookline, Mass. This time "1492" breezed in on the QTH of W1WV to find him with a puzzled look on his face and a huge question mark above his head. It seems that Miles had a bunch of calls, namely, U9AC, U9AZ, U9BC, U9ML, U9MF, and U9MI, written out in front of him. "Now lessee," says Miles, "U9AC is in Zone 17 . . . no it's in 18, and U9MF is in 17

. . . or are they both in 17?" Right here "1492" came to the rescue and gave forth: U9AC and U9AZ are in Zone 18 while U9MF and U9ML are in Zone 17. W1WV is a new one to our gang, and we welcome him with his 35 zones and 117 countries.

Still snooping around the W1's, "1492" found W1APA still quite busy as a traveling salesman. He discovered that Gil was giving away a wheelbarrow with every large order, trying to stimulate business. W1ADM is temporarily inactive, W1CH is going to rebuild his 852 rig, and W1JCX might still be honeymooning. "1492" looked in on W1JPE and of all things, he found pictures of aircraft and propellers all over the wall instead of QSL cards. Before leaving this neck of the woods Operative "1492" wanted it known that he is keeping an eye on W1AB, W1APU, W1HKK, W1AKY, W1GDY and W1BGC. Now let's find out what's going on in W2.

So "1492" trudges into Lakehurst, N. J., to find that W2DYR had just made up his final list for the Marathon, phone only, and it amounted to 25 zones and 63 countries. His Honor Roll totals are 27 and 77. Then to Long Island to discover W2IOP fooling around on 80. Larry says that he is on 3710 most every p.m. around 8:30 e.s.t. and would like to work some dx there. Says he has gotten as far as Denver and now wants W6's, K4's and K6's. Go get 'em fellows. Next, ol' Snooper "1492" stumbles into Red Bank, N. J., with W2AER swearing that his 1940 dx is going to be on 224 Mc. Anyway, W2AER, whose name by the way, is John Hollywood, winds up his 1939 Marathon phone total with 30 zones and 47 countries. His latest happened to be XU8RJ, XU8AM and EA7BB. (Of all things, poor "1492" thought he had discovered the founder of Hollywood, Calif.)

Back to Long Island we go to see what W2UK is doing. Tommy wasn't home but pretty soon he wandered in with a shotgun slung over each shoulder. Seems as if Tommy has been doing considerable duck hunting. "1492" said he looked up at 2UK's rotary beams and noticed a couple of the elements had a few feet chewed

1939 DX MARATHON

The official results of the 1939 DX Marathon will be published very shortly. Final revisions to the list which arrived within the time limit but too late for the February issue are now being made. These revisions will be included in the official totals.

off of them. Tommy's explanation went something like this, "Well, you see every once in a while a stray duck flew over and took a notion to perch on one of the elements. I thought the poor duck had a lot of nerve so I drew a bead on him and . . . wham . . . no more duck, to say nothing of the element."

Baltimore, Md. Here is where "1492" really had a surprise. He ran right into W3LE, and after a few minutes discovered they had something in common. It so happens that W3LE is connected with a detective bureau. It must have been quite a contest with one trying to "out-spy" the other. After it was all over "1492" came up with the fact that Lou now has 38 zones and 128 countries for the Honor Roll, while the Marathon ended at 38 and 115. These were all on a two-way phone. Recent cards received by W3LE were from HP1A, EK1AF, K4EMG, FO8AA, J8PG, J8CI and MX2A. This gives him 119 confirmations, which we'll have to admit is swell work. In a photo of his shack we notice cards on the wall that many an old-time c.w. man would give plenty to have. Lou gave out a little more to the effect that J8CI in Chosen is operating 28-Mc. phone, using an 849 with "20 watts" input.

Still snooping around Balto my operative "1492" reports that W3HZH and W3HXP have endless vee beams planned for when conditions get better. They may have to run them around the corner but they will be long without a doubt. Carl hasn't been heard from for a long time but we know he is just waiting for something to pop through. Another one in town is W3AYS who does some plain and fancy key pounding when he's in the mood. Right now I don't think Chas. is in the mood because he is reported as highly interested in phone. Tsk. Over in Hagerstown, Md., W3EPV is probably going to concentrate on 80, and while talking about 80 it might not be a bad idea for more of us to give it a whirl. With not much dx on the air, you won't feel as though you would be losing out, and in turn it would make an ideal time to see what you could do on 80. No, I haven't forgotten the roarin' forties either. The ol' 40-meter band is as open as we could hope for, and all we need is somebody to make use of its dx possibilities.

The other day I mentioned that with dx at a minimum now, it gives a break to the gal friend or xyl. Of course my very worthy operative pops up with, "Well, that's a matter of opinion". Now he's slipped down to Athens, Ga., and after locating W4EEE, he reports that 4EEE has 30 zones and 85 countries for the Honor Roll . . . phone only. George is a new one to our fold and we know he has been doing some fine work.

Greensboro, N. C. When "1492" arrived here he found W4MR in a terrible state of mind. He said one of his pet peeves was the inactivity on the 10-meter c.w. band. How about it fellows, are we letting the 10-meter c.w. band go to waste? 4MR has 38 zones and 108 countries.

Atlanta, Ga. "1492" thought he had seen everything until he tracked down ol' Fat Ben-

ning, ex-W4CBY, who now is W4BZ. He is reported as being the same as ever. That really means a lot, because most of you will remember when he and W4DHZ were plowing along together in Atlanta. But, alas, the story of a good ex-dx man is told in one short line: "Fat" is now operating 160-meter phone. No wonder the gang on 40 and 20 are asking where "Fat" is nowadays. Too bad Broughton, we sure miss your ol' 7-Mc. sig. While around this neck of the woods W4BMR should be mentioned as still upholding a phone man's rights on 20 and 10. Then too, W4CYU down around Miami way is doing all right with both the brass and the mike. While speaking about phone men W4DSY and W4DRZ cannot be overlooked just because they are working a lot of South Americans instead of the wide variety of dx "that usta was".

Austin, Texas. While our snooper was snooping around here for someone who looked like a ham, his wanderings took him across the golf course of the local country club. He spied a fellow going through some mighty peculiar antics. Upon approaching he discovered this fellow having great fun breaking up his whole set of clubs. Now, this procedure seemed very unusual because ol' "1492" had seen many a golfer break up clubs, but always with much disgust. Yet here was this guy having the time of his life.

Well, to satisfy his curiosity "1492" timidly asked what was going on. This golfing "maniac" replied . . . but not so timidly, "I've just broken the course record and I'm not supposed to be a golfer at all." And after a little coaxing he continued, "You see OM, par is 70 and I've just made 73 . . . er, that is, I mean 63." This would really make quite a hit with "1492", also, but there were two things that sounded mighty ham-like—that "OM" and the "73". So, with all his powers of deduction he went to work and about the time he was going to inquire as to his identity, the golfer pops out with, "Say, the handle here is Wilmer, W5VV." This was too much for "1492". It was a little too far west for mint juleps, but if it hadn't been he surely could have used one. After reviving him, Wilmer informed him that W5BB spent most of odd moments pitching woo, so he hasn't done much of anything on the air. Although further investigation showed where Tom had gone into the SS and worked 252 stations on phone. Next stop for W5VV, 5 meters, and for W5BB ?? (we know but won't tell).

San Leandro, Calif. Imagine finding W6OCH out in a huge bunch of acres with a truck load of antenna wire, huge spools of it, and stringing rhombics all over the place. Larry said one of his rhombics was so big that one pole was in Oakland and another was in San Jose. Of course, this is hard to believe, so until we locate those poles we just won't bet on it.

Something strange happened while stumbling around Larry's "farm". He actually mentioned something about dx . . . that he had worked OQ5AB and his Marathon ended at 31 zones and 84 countries. "1492" had a peek in at W6MEK and found out that MEK had a pleas-

ant surprise when he received a card from YM4AV. He had never expected to get it. W6ITH is now located in his new Moraga QTH, though he hasn't heard enough to really make use of this fine spot. Reg gives a few: PY2AK 28270, HH2PO 28300, KA1LZ 28255, XU8AM 28245, K7GTP 28520. W6NLZ ended his Marathon with 36 and 87, and said he thought the most outstanding sigs in South America for '39 were from CX2AJ and PY1AZ.

"1492" skidded to a stop in Ventura, Calif., and noticed W6GRL doing a little rebuilding, in order to be able to change bands in a fraction of a second. In Santa Barbara "1492" accidentally got into the office of RADIO and, as usual, ye Editor was yelling for the copy for the DX Dept. Up in San Bruno, it was revealed that W6BAX was busy listening to "Gang Busters" so couldn't talk about dx. In Los Angeles, W6NNR, this department's worthy assistant, is still so busy he can only get away to play golf three days a week now. W6JBO is yling a bit but no one hears much about it. W6ENV has his new final with 35T's all cranked up and as Andy says, "I don't know whether I should pipe it into an antenna or just a dummy load."

W6LYM, is doing yeoman's duty keeping K6 skeds for the benefit of some of the Orange County natives. W6SN is a "poppa" . . . should have said 'proud' . . . and yes, 'tis a jr. op.

W6DOB has retired to photography, as has W6KIP (temporarily). W6QAP is moving from Tucson, Arizona to Pasadena, Calif. There goes a good Arizona contact. W6CXW bought a couple of rotary antennas and put them in his storeroom. Claims he is going to get on as soon as he gets a little time off from business. In the 7th district "1492" found pretty slim pickings. W7-AMX is fooling around on phone, but can't find out what band. Could it be 224 Mc.? Still is with Portland bc station. W7AYO may be found every once in a while on 20 and 40, and just what Stan does in his spare time no one seems to know.

Here we go way over to the 8th district and he finds W8JSU of Franklin, Pa., very busy with his yl. Charlie says he and his yl have been breezing all over western Pa. in her car lately. One redeeming thing and that is he is on 40 meters once in a while. Even so Charlie has cards from 38 zones. W8PAK is now in Glendale, Calif., and expects to have a Calif. Kw. within a short time. The traveling of "1492" took him to Cannonsburg, Pa., and when around here his first thought was of W8CRA. So, he decided to surprise Frankie. He tip-toed up to his shack only to find 8CRA asleep, and from his bc receiver, the announcer was saying, ". . . and now you have just heard tonight's bedtime story. Happy dreams."

Chicago, Ill. This is the place where "1492" has been wanting to visit for a long time. For one thing he wanted to find out why every time W9VDX wrote in, he used a different hotel's stationery. He hasn't unraveled this as yet, but he did locate Chas. in one of them writing in to this dept. Well, 9VDX worked a guy signing AC4JS but doesn't believe even one letter of

the call was legitimate . . . so is not counting it.

He did work KF6ROV on Canton and KH6-RZQ, American Samoa—their frequencies being 7164 and 7000 ks. respectively. 9RCQ and 9GRV also landed the KH. 9VDX now has 35 zones and 86 countries. Out of W9TB's it was discovered he had worked AC4JS again and apparently this was the real one, as Wally had hooked him before. Wally said that he listened to him by the hour and never once did he work anyone west of W9HLF and himself. It seems that he comes through around 6:00 to 8:30 p.m. c.s.t. and quits right at 8:30. 9TB has been doing pretty good work on phone during the past year . . . thanks to W5BEN who does most of the phone operating. At 9TB, "BEN" has worked 32 zones and 82 countries, which is his Marathon total on phone.

W9GKS winds up his Marathon with 35 and 95, while in the Honor Roll he has 36 and 95. In South Bend, Ind., W9WCE seems to have increased his Marathon to 28 and 59 and wants to know if KE6QAC is ok. W9MQQ reported to "1492" that he had snagged AC4JS and this gives him 34 zones and 84 countries as his final Marathon score. "1492" gleaned a little dope from W9AKJ of Elkhart, Ind. Those of you who are wondering about HC1JB on 10- and 20-meter fone being ok—just rest with ease because 9AKJ says he is a friend of his, W9LZX, and may be reached as follows: Clarence Moore, c/o B.C. Station HCJB, Quito, Ecuador. He hopes to be on the air a bit more in the future. 9AKJ has worked HA1K, EA7BB, OQ5AB and a station signing OS5D. 9AKJ's xyl has a call W9FRR operating 20 c.w. but as yet hasn't worked the so called unusual dx. Before I forget, U9AW is ok. Just don't give up hope, they are pretty slow on their QSLing.

Leavenworth, Kansas. "1492" thought this town was rather familiar, and quite famous, mostly on the account of W9CWW. Charlie has been spending a lot of his time on 40 and 80 meter c.w. As a matter of fact for the fellows wanting another band for ragchewing, and to fill in during dead spots on other bands, why not give 80 a whirl? I expect this will get a rise out of the boys who live on 80, but I can take it. Anyway, W9CWW ended his Marathon at 36 and 99 which wasn't so bad for a year's work.

Our ever-on-the-jump Operative is back in Michigan again, this time grabbing W8OQF by his brasspounding arm, and pinning him down for a little news. Well, Ralph gave up after much coaxing and admitted he ended up with 38 zones and 106 countries in the Marathon, which is really rolling them up in the 12-month period. His Honor Roll is up to 39 and 139. Now to Taunton, Mass., to see W1RY, and here he is with a few new ones: EA9CM, KB6RWZ and PJ3CO. Roger's final Marathon score was 33 and 90.

While up in this neck of the woods ol' "1492" ran across W1BGC who has been having a heck of a time trying to get a card from Zone 17 . . . to be exact, U9ML. Rich ended last year with 36 zones and 82 countries, and the Honor Roll is up to 38 and 117. Rich also adds a bit of

shall we say subtle humor, when he remarks that if we have a Marathon in 1940, we should call it a "Walkathon". That'll be enough outa you, Mr. W1BGC. Carl Madsen, W3HZH, finished 1939 with 34 and 93 and adds that he worked some guy on Jefferson Island. Wherezat? W6ITH gives again: KF6JEG on Canton of the American Phoenix group, has 300 watts on 20 meter phone, 14202 kc. Reg also reports 10 meters with HP1A 28225, CE2BX 28312, LU5AE 28112, and K7FNV 28615.

"1492" wants to see what's going on outside of the U.S.A. so the first stop is K6 and K6ROJ comes into the picture. Most of the 28-Mc. phone ops have heard Ella during the past few months. She is the xyl of K6OQM, who has been a 10-meter standby for a long, long time. K6ROJ uses a single 807 with 40 watts input and has nabbed all States in a period of 29 days. 47 were worked in 20 days and it took her 9 days to land a station in Vermont. Antenna is a 3-element rotary, and the receiver is an RME-69 with a DB-20.

From K6DTR we have this: "I have received cards addressed to KH6DTR from hams in the eastern USA. I have never been there (Samoa), and as far as I know there is no one there using this call." December issue contained a line about KH6DTR which, of course, was sent in. But with the above explanation it looks as though it were all wet. On Guam, KB6RWZ related that J5CC is now operating portable near Hangkow signing XUGSS on 14267 kc. He is using 30 watts and is looking for USA contacts from 0900 to 1300 G.m.t. (I don't get the "G" in the XUGSS but that's what "1492" said—a "6" would be more like it). Another station on Guam, KB6ILT will be on phone, 14182 kc. after February 1st. He'll be using a lazy H. KB6RWZ says 20 c.w. was poor in Guam during December and January.

Here he is over in Porto Rico with K4FCV. Ramon tells "1492" that he now has 36 zones and 107 countries in the Honor Roll, and his Marathon ended at 34 and 99. K4DTH just about wore out his typewriter copying his Contest log; said it was sure some job. We are glad to hear from ex-ZL2VM who was very active until the thing broke out overseas. At that time his station was taken over, and is now being used as a relay broadcast station. Alan says his receiver hasn't been turned off for 14 weeks. He wishes like the very deuce he could get on and do a little brasspounding again, however he does listen to a lot of the W's during their ragchews.

Buenos Aires, Argentina. Many of you probably wondered how LU9AX was operating on three bands the second week-end of the WW Contest. A few months ago their government passed a law permitting them to the use of two frequencies only. LU9AX passes along the info, that he wasn't really prepared for the WW Contest so the first week-end he didn't spend much time on the air. However, during the week he visited the authorities, explaining about the DX Contest, with the consequence they made a special concession and allowed them unlimited time and

frequencies for the second week-end. I would call that cooperation "deluxe". We, also, heard that LU7AZ is stuck on 80 meters so did not get into the contest at all. Then, too, he hasn't been married very long.

It's a long way from Argentina to England but here we are with G2FT. Johnny sends in a belated but welcome report on his final Marathon score when he finished August 31, 1939. His last two QSO's were with LU7BV and VK3UM making 35 zones and 82 countries. And now look who's here . . . G2ZQ. John says he and G6WY (I should have said ex-) are Flying Officers in the RAF. Speaking of dx though, 2ZQ did a little purging on his own hook. His Honor Roll total is 40 zones and 147 countries, with 140 confirmed. The seven he needs are VS3AE, U8EC, H18X, H16Q, 5AOK or F3GOA, PX1A, HB1CE and TA1AA, TA1FF, TA1CC, TA2BS or TA3ZM. (See note from ON4HS in February column regarding getting QLS's from TA1AA.) Another bit from John was that the third card he sent OX7ZL was actually the first the OX had received from him. So it would seem, fellows, if you don't succeed on your first try, just try again. 2ZQ has been doing a certain amount of listening on 40 and contends that if the gang would occupy this band it would produce good results. Check, Mr. Hunter.

In Belgium ON4AU was found to be as active as ever in trying to collect cards from those who have not sent them. Those wanted most at this time are from PJ5EE, J8PG and KF6DHW. In Belgium they are suspended from operating but they do keep their licenses and calls. Ordinarily they must pay \$5.00 for a license calling for 50 watts input, and \$2.50 for 10 watts, but these payments are, also, suspended.

Again ON4HS was located by "1492", who incidentally seems to be covering a lot of territory. This time ON4HS tells about TA1AA moving on to Aleppo, Syria. He plans to be on each week-end from 2300 G.m.t. Saturday to 2400 G.m.t. Sunday, and will sign AR8AZ . . . probably using the same frequency he had at TA1AA which was 14280 kc. The QSL's will be handled through ON4HS. Those of you who have worked TA1AA on the above frequency, can get your QSL card by sending yours to TA1AA in care of ON4HS. Be sure to send along a reply coupon and an addressed envelope, and of course, the card must bear date of QSO, etc., for checking. The same procedure will be used for AR8AZ.

"WAZ" Honor Roll

To enter the Honor Roll it is necessary to submit a list of the Zones and Countries worked, showing the call of a station in each zone and country. It is not necessary to send confirmations but caution should be used in order not to include the so-called phony stations or bootleggers. The first three columns of the Honor Roll contain the total zones and countries worked on both c.w. and phone, or in other words the station's entire achievements in dx. The fourth column

[Continued on Page 86]

The Open Forum

Sirs:

Enclosed please find a photograph of the WAC store in Newark. I might say that this store sign isn't the only one of its kind on this street. There's a "WJZ Bar and Grill" and near it a "WOR Grill." The first bar has the initials of the owner in the name, but I don't know about the other.

Clement Van Velsor, W2HXX



Sirs:

I noticed the paragraph labeled "Inventors" in the January Past-Present-and-Prophetic section referring to this cathode modulation business.

Well here goes, and maybe some feller can make this one look like modern stuff by claiming to have modulated the negative return of an arc on 600 meters.

A way back in 1924-25 (W)6BGC got tired of burning up the carbon granules in telephone microphones in loop modulated 202 transmitters. The high cost and short life of Cunningham 202 tubes prevented using them too freely in modulating stages and c.w. was of prime interest on 200 meters.

By the still famous method of cut and try, an amplifier was built of 201 tubes and the output was found to work very well with

a plate-to-500-ohm line transformer connected in the center tap circuit of the filament transformer. The gain from a single button mike was found to be too great and rather than spoil a nice amplifier, I had to find some substitute for a mike that would have less output. A big goose neck Magnavox dynamic loud speaker was tried and she worked fine. I have several hundred cards accumulated from this (cathode-modulated) oscillator rig on 200 and later 80 meters. D.c. plate supply was obtained from a bridge-connected borax-lead-aluminum type rectifier. This same rig on c.w. was one of the first sixes to get across the Pacific on 80 and I believe the first to work Japan in 1925. I have a card from the J (J1KK) claiming that I was first USA amateur to work them, etc., etc.

I didn't mean to pester you with any more of this who-used-it-first stuff but 1924 is a few years ago at that.

Maurice E. Kennedy W6KQ, ex-W6BGC

Sirs:

Enclosed you will find a photo of the rear license plate of my car. The plate above the license was formerly of the type that one gets with a new car with the dealer's name on it. The plate was reversed and the call letters and QTH were printed upon it.

Bud Nastoff, W9TJH

[Continued on Page 84]





By E. H. CONKLIN, W9BNX*

It has been the policy of this column during the last five years not only to publish operating information, but also to mention unusual as well as usual conditions and to try to single out the cause wherever possible. Lately, with large numbers of amateurs using beams on five and ten meters, some peculiar conditions have been reported. One of these is the ability of many ten-meter stations to make contacts at distances which should be in the skip zone, by directing their beams southeast in the morning or southwest in the afternoon. It is with pleasure that the comments of the National Bureau of Standards on this odd condition are quoted here:

Your summary of high and ultra-high frequency transmission by scattered reflections is interesting. The directional effects of these transmissions have not been fully investigated but the results you report appear consistent with ionosphere observations.

Scattered reflections are returned to earth by clouds of electrons. Reflections may take place from the sides as well as from the bottom of the clouds, thus producing horizontal deviation of direction of propagation. During ionosphere storms, turbulence of the ionosphere is especially severe and unstable clouds prevail in and near the auroral zone. This condition of the ionosphere would reasonably account for unstable reflections from the north during ionosphere storms or aurora.

Somewhat similar transmissions, but not so severely erratic, are observed at frequencies above the maximum usable frequencies for F-layer transmission, especially at night. These transmissions are strongest at frequencies down near the F-layer maximum usable frequency. The electron density in the clouds decreases during the night until about an hour before sunrise and then increases

so that the clouds are more intense to the west and southwest in the evening and to the east and southeast during the morning. The more intense clouds are better reflectors than those of lower intensity. These conditions are consistent with the directional observations which you report. We believe that the radio waves in these experiments were reflected from clouds of electrons in the ionosphere. . . .

Those interested in this subject should read C. B. Feldman's article on "Deviations of short radio waves from the London-New York Great-Circle path," in *Proceedings IRE*, October, 1939.

The above comment also covers the reception of ten- and five-meter signals over distances of 100 to 400 miles during visible aurora displays. The Bureau feels that some systematic studies of this subject should prove interesting and valuable—but the proper method of attacking the problem is obscure.

28 MEGACYCLES

Percy Ferrell, Jr., of Pleasantville, New Jersey, is still hearing W8XNU in Cincinnati on 25.95 Mc. each morning, at a distance of 525 miles. We feel that this fits ten-meter conditions commented upon above. He might put up a beam and see if the signal comes direct or from the southeast. It comes in best on a horizontal at all times.

On numerous evenings in December, W9QDA in Chicago noticed sporadic-E layer short skip of the variety common in summer. On some nights, only W4EDD came through. Little directivity was noticed on these loud signals when swinging the horizontal beam, but the a.v.c. may have washed out some of the change. On quite a few evenings, long ground-wave signals were heard. A check of antenna polarization over a distance of 35 miles indicated that very little signal could be picked up unless the receiving antenna was in the same plane as the transmitting antenna. We may yet have two local bands on each of the u.h.f. bands—one for those with verticals and the other for horizontals.

W8OKC adds some comments on "one-way skip." Using 250 watts and a four-element beam, he gets out nicely on some days. On others, it seems that no one hears him regardless of how many calls he makes (that happened to yours truly once, and when the band opened up more, it was found that a lot of California kilowatts were parked on the same frequency). The band has been erratic at his location in Central Pennsylvania so his antenna tests have almost come to a halt, with a three-element beam turning out results apparently superior to those of the old four

* Associate Editor, RADIO, Wheaton, Illinois.

and six element jobs. Ten has opened for short skip quite often but he has not heard any five-meter dx recently.

Image Trouble

Jim Dickert, W9PEI, the silencer man, says that about the only thing he works nowadays is the sixth district. According to many W6's, he is usually one of the last stations to pass out, using one of those Brown vertical antennas with four quarter-wave fins for a ground plane. He installed a new W.E.-type concentric vertical with solid outer conductor concentric line, but got an increase in signal that was less than the measured loss in the old feed line. A voltage appeared along the outer conductor, which shouldn't be. He is mounting four quarter-wave horizontals at the top of the concentric outer conductor, making the W.E. type into a Brown ground plane vertical, hoping to find out if it will be still better. In order to match a 72-ohm concentric into a 36-ohm quarter wave vertical, he increases his feeder inner conductor size for the last quarter wavelength, using it as a Q-section.

Jim's major complaint is not with the band, but with images. Jim, you ought to try a concentric-line tuned circuit in the front end of your set. On an r.f. stage, this can be done by removing the grid clip from the tube, hooking the inner conductor to the grid, grounding the outer conductor, putting a tuning condenser across from grid to ground, and coupling the antenna into the line near the shorted end. During the test, the line can be supported on top of the set on some magazines. No damage is done to your receiver.

W9QDA is building up a 2½-5-10 converter using a 13-inch line, loaded with condenser. This should not be as good as a line much longer, especially on ten meters, but within a few months gain and selectivity information should be available on this rather simple job.

The ten-meter gang around Grand Rapids includes W8NOH BV QQE TCG LMP QQN RFW UGM RYF FJJ MTF. Some of these are in Holland and Kalamazoo so they will probably object to being called "around Grand Rapids." NOH on December 27 and January 10 worked W9IJX and heard W9CMC MAY, all too weak to register on an R-meter but all Q5. These are all in Illinois, apparently heard on air boundary reflections as are those mentioned by W9QDA. Almost every morning before the band opens for W6 and W7, NOH hears stations in Chicago, Detroit, Elkhart, Muskegon, Cleveland and Indianapolis coming in with a very fast 60-cycle fade. W8RLT in Detroit, 165

miles away, is the most consistent of these. This is probably the same type of lateral reflection explained by the National Bureau of Standards above.

G2YL advises that reception from the Americas and commercials in other continents indicate that conditions in November were inferior to those of a year ago. W's could be heard nearly every afternoon, and stations in Europe and South America came through, particularly on week-ends. Practically none of the stations logged used code. On the 24th, W6NLS and W7ACD were outstanding, and W6POZ put over the strongest W6 signal ever heard. Some calls heard from outside of the U. S. are UK3AH HA1K K6MVV (Not really outside!) KA1ME U9AW

| 56 Mc. DX HONOR ROLL | | | | | |
|-------------------------|----|----|--------|----|----|
| Call | D | S | Call | D | S |
| W9ZJB | 9 | 18 | W2LAH | 6 | |
| W3AIR | 8 | 24 | W4DRZ | 6* | |
| W3BZJ | 8 | | W6QLZ | 6 | |
| W3RL | 8 | 24 | W80JF | 6 | |
| W5AJG | 8* | 29 | W9AHZ | 6 | |
| W8CIR | 8* | 29 | W9NY | 6 | 13 |
| W8JLQ | 8 | | W1JMT | 5 | 9 |
| W8VO | 8 | | W1JRY | 5 | |
| W9ARN | 8 | 15 | W1LFI | 5 | |
| W1EYM | 8 | | W2GHV | 5 | 8 |
| W9CBJ | 8 | | W3GLV | 5 | |
| | | | W3HJT | 5 | |
| W9ZHB | 7 | | W6DNS | 5 | |
| W2AMJ | 7 | 22 | W6KTJ | 5 | |
| W2JCY | 7 | | W8EGQ | 5 | 10 |
| W2MO | 7 | 25 | W8NOR | 5* | 16 |
| W3BYF | 7 | | W8TGI | 5 | 9 |
| W3EZM | 7 | 24 | W8OPO | 5 | 8 |
| W3HJO | 7 | | W8PK | 5 | |
| W4EDD | 7 | | W8RVT | 5 | 7 |
| W4FBH | 7 | 20 | W9UOC | 5 | 8 |
| W5CSU | 7 | | | | |
| W5EHM | 7 | | VE3ADO | 4* | |
| W8CVQ | 7 | | W1JNX | 4 | |
| W8QDU | 7 | | W3FPL | 4 | 8 |
| W9USI | 8* | 21 | W6IOJ | 4* | |
| W9CLH | 7 | | W8AGU | 4 | |
| W9SQE | 7 | 22 | W8NOB | 4 | |
| W1HDQ | 7* | 18 | W8NYD | 4* | |
| W9ZUL | 7 | 16 | | | |
| W9VHC | 7* | | W1KHL | 3 | |
| W9WAL | 7 | | W6AVR | 3 | 4 |
| W9QCY | 7 | 10 | W60IN | 3 | 3 |
| W9GGH | 7 | | W7GBI | 3 | 4 |
| W1CLH | 6 | 12 | W8OEP | 3 | |
| W1DEI | 6 | 18 | W8OKC | 3 | 6 |
| W1VFF | 6 | 11 | | | |
| W1LLL | 6 | 17 | | | |
| W2KLZ | 6* | | | | |

* plus Canada. (reported in 1939)

Note: D—Districts; S—States

OQ5AB CE3AG CE3CZ HC1JB LU5AB
LU7BK LU9AX PY1DS PY2AC PY2AK
PY2MI PY5AQ YV1AQ HI7G TI2RC
TI3AV EA7BB LX1UU. The pirate stations
seem no longer to pretend to be "belligerents"
but have selected such calls as OS5D, TO7SH,
VL1A and ZZ1A.

56 MEGACYCLES

Perhaps December is trying to be classed as a spring or summer month even north of Florida. Or so it would seem from the numerous reports of short skip on ten meters and sporadic-E layer dx on five (it's all the same). The band has been reported open on November 27; December 8, 11, 13, 15, 16, 18, 21; and January 11.

W9USI of Brookings, So. Dakota, took time out in November for a football trip into Texas. He met W9ZJB in Kansas City and saw Vince's new rig. USI sends in his summer and fall list of contacts, giving information on several band openings. On November 27 at 7:05 p.m., he heard W3HOH. On December 8, W4FKN FBH AUU were all R9 plus while working Illinois stations. W3DBC was heard on c.w. December 11, after which a W8GH? was raised but he sounded "bootleg" and was anxious to sign without saying much. W6QLZ was heard calling W9QPK on December 18.

W6QLZ says that W1-2 signals on 42-45 Mc. came through very well on November 4, 5, 6 and 26 on what seems to be normal F₂ layer hops. Five meters was open on December 8 into Oklahoma, Mississippi and Missouri; on the 13th to northern California and Oregon; and on the 15th to Texas and Illinois. On the last date, W5AJG said that his signal was louder than at any time last summer.

On December 8, W9IZQ in Milwaukee heard W4AUU and called W9ANA on the phone who made a contact. IZQ also heard W5AJG on the 21st while 28 Mc. was spotty to W4 and W5. Pfister wants to know when the Chicago gang is going to put a signal up his way; well, when is the Milwaukee gang going to put one down here? W9VHG ZUL GGH are nicely located to start the ball rolling.

W5AJG began to hear harmonics of W4's at 4 p.m. on December 15 but not until 6:10 did W4AUU get on to put an R9 signal into Dallas. Then more harmonics until W6QLZ came in at 7:27, and almost an hour before W6OVK faded in with a strong signal. Short skip prevailed on ten meters, just like in the summer, both bands acting in the same way for the five hour stretch. While testing

on the 21st with a Ft. Worth station 40 miles away, AJG was heard by W9IZQ as reported above. Again the band opened at 7:45 p.m. January 11 when W5AJG worked W4AUU in Georgia—with no other signals heard. There was short skip to the east on ten at the same time.

At 4:30 p.m. Central time on December 16, W9SQE in Chicago heard an unidentified W2. Odd, how all the dx takes place on evenings and week-ends.

Honor Roll

The honor roll is slowly coming along, but many five-meter stations have not reported their totals to us. Do you want it to include states worked in 1940 along with the other information, to show who is doing good work this year? Send in the data during the coming months and it will be put in. This should give an advantage to the eastern gang until sporadic-E skip brings in a lot of new states for W4 and W9 stations.

The question has been raised about including the District of Columbia in Maryland. That is all right, just so someone doesn't try to annex Canada to something or other.

Miscellany

On this thing of horizontal antennas being selected by commercial and frequency modulated stations whereas amateurs generally prefer verticals for 100-200 mile dx, one station engineer points out the mechanical and electrical conveniences of horizontals especially when they are stacked to increase the local signal. A test showed that local field strength was better with vertical polarization by a factor of 8.9, but still the horizontal was chosen. At distances close to 100 miles, this factor may be much smaller or nonexistent.

The Merrimac Valley Club News states that W1LSN worked W8LKD during the second League u.h.f. contest, and that active stations now include W1EKT DJ HUV MJ AJW CGU CSU LPF DXK HDQ KLJ JQA HXP EHT MDN IUI HEP and many more. W1LCC has also returned to five meters.

Jumping to the other end of the country, W6AVR says that the band around Colton, Calif., is dead whereas 2½ is active to a limited extent. He used an extended-H array last summer, 10 feet wide by 20 feet high, hanging from a 50-foot pole guyed only from its center. This improved his local and air boundary reflected ("low atmosphere bending") signal over what he had before; his best contact was with mobile W6OIN in San Diego, better than 100 miles airline. He ran a hundred QSO's with W6CHY.

W9ZUL sends in an honor roll figure but says that it will be a little time before he gets the rig fired up from his new Morton Grove, Illinois, QRA.

Ferrell says that he was wondering if the band had gone dead in southern New Jersey until he started to hear the 55.75-Mc. sound from W3XE, the Philco television transmitter in Philadelphia, 53 miles away. During a test with vertical polarization, not even a peep on the carrier could be picked up on a horizontal.

On Mt. Wilbraham, Mass., W1HDQ may have to reduce five-meter activity unless the local gang helps out. *Et tu, Brutus?* He has a very nice rig, rack mounted, with 6J5-G crystal, 807 buffer, TZ40 and HK54's. The shack is near a 90 foot tower, permitting use of four half waves stacked vertically, a rhombic and a V. He wants to put up a "windmill" to change the polarization of a dipole for tests with other fellows similarly equipped, located within 200 miles or so. Who volunteers for this extra duty?

W9PEI complains of inactivity in the Chicago area. He isn't the only one. The gang promises to come back for the April or May opening of the dx season.

W8NOH says that there will be about 15 Grand Rapids stations on five by summer. He should be able to break through to Kalamazoo, Milwaukee and possibly Chicago.

In East Stroudsburg, Penna., W8TLJ seems to be in a mood to rebuild the California rig for u.h.f. purposes. He sent in a diagram of the concentric line tuned final that he is building.

W1HDQ wants to know why there is no continuous five-meter activity in places like Dallas and other reasonably large cities in the south and middle west, without relying on skip dx. With fellows working 100 miles daily from ordinary locations in the east, it would seem like there should be enough interest to keep the gang on the band. Some of the trouble, of course, has been this crystal-control rule before the fellows had even done enough with their modulated oscillators—and this Chicago-Milwaukee thing has yet to be worked, over fairly level territory!

W8OKC is getting ready with a sewer-pipe receiver (drat that term) and a rebuilt transmitter with 400 watts into a pair of HK54's.

W1DEI is still of the impression that it takes a metal shop to build a concentric-line-tuned receiver (not so, om). He claims that he can hear more than he can work using ¼ kilowatt input and a coil-and-condenser receiver. OK, Mel, perhaps you had better build the receiver for the other fellow!

An article by your conductor was translated into *English* and used in the *T & R Bulletin*. Such words as civilisation, aerial, motor car, connexion, favourable and centre are noted.

224 MEGACYCLES

A recent "hot" idea at W9BNX was to use a baby food can 6 inches in diameter and 8½ inches long as a concentric line outer conductor on five meters and below. It seemed at the time to be a good idea to copperplate the inside. However, when nice clear blue copper sulphate solution was poured in, it turned greenish. Other peculiarities during the process appeared. The end result was that the tin plate came off, replaced the copper in solution, and precipitated a messy layer of copper scum on the bottom. The next time, the can will probably go into the set without any copper plating!

W6AVR did some experimental work on center-stub-fed antennas at 2½ meters (see February column) with interesting results as to the length of the stub and of the antenna proper for the extended zepp. W8JK's comments on the data are quoted below:

"As far as resonance in the stub-and-antenna system is concerned, this is, of course, indicative of a condition of minimum impedance. For a given power input the current in the system is a maximum. The impedance may be considered to be lumped at the shorting bar. When resonance is obtained, the reactive component of the impedance is zero or nearly so, and the impedance is almost purely resistive. This is, as you know, the familiar condition for resonance in tuned circuits in general.

"As regards the lengths of the elements, or in W6AVR's case, the length of the stub plus radiator, this length which results in resonance is determined by what length gives minimum reactance. For different radiator lengths it is understandable that different amounts will be required and that the total wire lengths in each case will differ. The length of the system in this case is not at all connected with the velocity of the wave along it. (In a Lecher system the velocity can be determined, but only because the end effects are eliminated, by noting the distance between two successive minima or maxima of current along the line.) Accordingly, the observed variation in total length is not unexpected; when the system is inductively reactive some short-

[Continued on Page 80]

POSTSCRIPTS...

and Announcements

Corrections for Country List

Dxers who think they have gained or lost a few zones after a close examination of the zones shown in the January country list should note the following: Andorra is in zone 14, not in 36; Iran is in zone 21, not 22; Labrador belongs in zone 2 instead of zone 5; Sarawak is in zone 28, not 20; and Tunis is zone 33 instead of 35. All these are correctly shown on the map, of course. The mistake was made in transferring the numbers from the map to the country list.

Receiving Tubes Standardized

A plan to standardize the use of receiving tubes by the radio industry to a relatively small list of 36 standard types, which perform virtually all basic tube functions, as against the more than 450 overlapping tube types now extant has been advanced by the RCA Radio Tube Division.

A survey conducted under the supervision of L. W. Teegarden, RCA Tube & Parts Sales Manager, revealed that although 453 different types are produced by the industry, 90% of all sales are centered in only 90 tube types. And, for these 90 types, only 20 basic functions exist.

With these facts in mind, RCA tube engineers have selected a "preference list" of 36 tube types which fill the needs of design engineers for practically every type of radio receiver, including AC and AC-DC receivers, auto radios, battery instruments, and the majority of applications in which vacuum tubes are required.

Every tube on the "preference list" was selected because of its ability to perform one or more basic functions in a radio circuit to best advantage. Should technical progress result in the development of tubes which have superior performance to those now on the list, they will, of course, be substituted.

Taking the initial step in the direction of tube standardization, the RCA Manufacturing Company announced that all new RCA Victor radio receivers and Victrolas now contemplated for future production will be designed to include the radio tube types on the "preference list" of 36 basic types.

Standardization should lower the initial cost of tubes by permitting tube manufacturing operations to be carried on more efficiently. Better deliveries to radio manufacturers, to wholesalers and retailers will be possible, with concentration on fewer tube types. Tremendous simplification of ordering, shipping, handling, warehousing and stocking will also be accomplished. Dealers' and distributors' stock turnovers will be much faster, with lower stock investments and higher returns.

In addition, continuous manufacture of fewer tube types should result in improved quality, tending further to reduce initial costs to the industry and to the public. Moreover, standardization on fewer tube types will permit radio manufacturers to also standardize on component parts for radio receivers, such as resistors, condensers, transformers, coils, etc. These are but a few of the basic reasons for reducing the number of tube types used in the radio and electronic industry.

It is suggested that amateurs constructing new equipment such as receivers, test instruments, speech amplifiers, low power exciters, etc., use tubes on the preference list so far as practical, because undoubtedly when time comes for replacement the tubes will cost less than equivalent tubes not on the preference list.

RCA Preference List Receiving Tube Types

| Metal | | | |
|-----------|--------------|--------|-------|
| 6.3v | | 12.6v | |
| 6H6 | | 12SA7 | |
| 6J5 | | 12SC7 | |
| 6SA7 | | 12SJ7 | |
| 6SC7 | | 12SK7 | |
| 6SF5 | | 12SQ7 | |
| 6SJ7 | | 12C8 | |
| 6SK7 | | | |
| 6SQ7 | | | |
| Glass | | | |
| Non-octal | GT (6.3-50v) | CT & C | |
| 2A3 | 6J5-GT | 1A7-GT | 5U4-G |
| 6U5/6G5 | 6K6-GT | 1D8-GT | 5Y3-G |
| | 35L6-GT | 1G4-G | 6B8-G |
| | 35Z5-GT | 1G6-G | 6F6-G |
| | 50L6-GT | 1H5-GT | 6N7-G |
| | | 1N5-GT | 6R7-G |
| | | 3Q5-GT | 6V6-G |
| | | | 6X5-G |

San Diego Hamfest

The Helix Amateur Radio Club will again stage a Hamfest at the U. S. Grant Hotel, San Diego, Calif., March 16th, 1940, at 7:00

[Continued on Page 94]



A UNIQUE "Switch Board" TRANSFORMER DESIGNED ESPECIALLY for AMATEUR PURPOSES

The THORDARSON MULTI-MATCH is the only modulator transformer built with the plug-in-jack terminal board. It allows quick

and accurate matching of tube loads without soldering — simplifying experimental circuit changes. Check these types listed below.

| Type No. | Net Price | Cap. Watts | Pri. M.A. Per Side | Sec. M.A. | | | Dimensions | | | Wt. Lbs. |
|----------|-----------|------------|--------------------|-----------|------|-----------|------------|----|----|----------|
| | | | | Series | Par. | Mtg. Fig. | W. | D. | H. | |
| T-11M74 | \$ 5.40 | 40 | 100 | 80 | 160 | 3G | 4 | 4½ | 4⅝ | 7¾ |
| T-11M75 | 7.50 | 75 | 145 | 145 | 290 | 3G | 4 | 4½ | 4⅝ | 9 |
| T-11M76 | 11.70 | 125 | 210 | 160 | 320 | 3G | 5½ | 5½ | 6 | 18 |
| T-11M77 | 18.00 | 300 | 250 | 250 | 500 | 3G | 6 | 7½ | 7¼ | 30 |
| T-11M78 | 36.00 | 500 | 320 | 320 | 640 | 3G | 7 | 8½ | 7½ | 51 |

ASK YOUR PARTS DISTRIBUTOR FOR CATALOG NO. 400-D.

THORDARSON

Elec. Mfg. Co., Chicago

45th Anniversary

TRANSFORMER SPECIALISTS SINCE 1895

YARN *of the* MONTH

UNSUNG

The sun struck obliquely across the show window, setting into outline the graduated row of tubes, the expressionless meter faces, and the glistening miscellany of parts. Of the group that lingered, one stood apart looking abstractedly at a group of power transformers. The display seemed to fascinate him, yet his scrutiny was detached, as though he were toying with associations rather than with the realities of laminated cores and price tags.

Two years had passed since that summer. Two years during which the little room, once his haven of long evenings, had become an impersonal store room . . . an unfriendly place of congested emptiness. Once the magic chirps and whistles, the twinkling panel lights, and the humming transformers had carried him away each night. He could see the room now, and nostalgia swept him gently away from the window and along the crowded sidewalk. The train of thought once started could not so easily be dismissed, and he did not struggle against the memories that now possessed him.

Just two years ago there had been long evenings of forgetfulness and days that began only at dusk when the office buildings, emptied of their pettiness, stood silent and restive. Their togetherness had been sufficient and without effort he had foregone even thoughts of the hidden world so populous to him before his marriage. To one unfamiliar with the labyrinth unfolded by a short-wave receiver, and strange to the satisfying joy of tracking those pathways with a transmitter, the obsession finds little sympathy. To plan, to build, and to watch the growth of a creation is commonplace, but to know that through those veins and arteries

of wire life will flow, is something reserved for the amateur. The finished work does not stand awkwardly as a symbol. It awaits eagerly the pulse of current that transforms it into a live being carrying the mind of its builder across space.

The return had been gradual. At first a magazine casually purchased and as casually read, then the idle pencil sketching a design or a circuit.

Imperceptibly, equipment filtered into the room set aside for that purpose, and as gradually, misunderstanding crept into the relationship that had seemed so perfect.

Vacation time was approaching. For weeks the bench had been littered with parts, and the distinctive odor of melting rosin-core solder had permeated the atmosphere. The abandonment with which each project had formerly been launched was nevertheless lacking, and though neither admitted it, there was a tension that increased daily. Finally the ultimatum was delivered. There was to be no word, thought, or suggestion of radio throughout the two-week vacation or it might well be the last together. The demand was not wholly unexpected, nor did it at first seem unreasonable. The promise was made.

Alone in the shack he absently twirled the dials of the new five-meter portable on which many evening hours had been spent. Plans for the entire vacation had been built around this little rig. The spot in the mountains had been chosen with an eye to reception alone. The set was constructed rigidly and compactly, each unit planned carefully throughout tedious days in the office. Now the diminutive transmitter had been completed

[Continued on Page 68]

By ERIC LEDIN, W6MUF

W6GRL

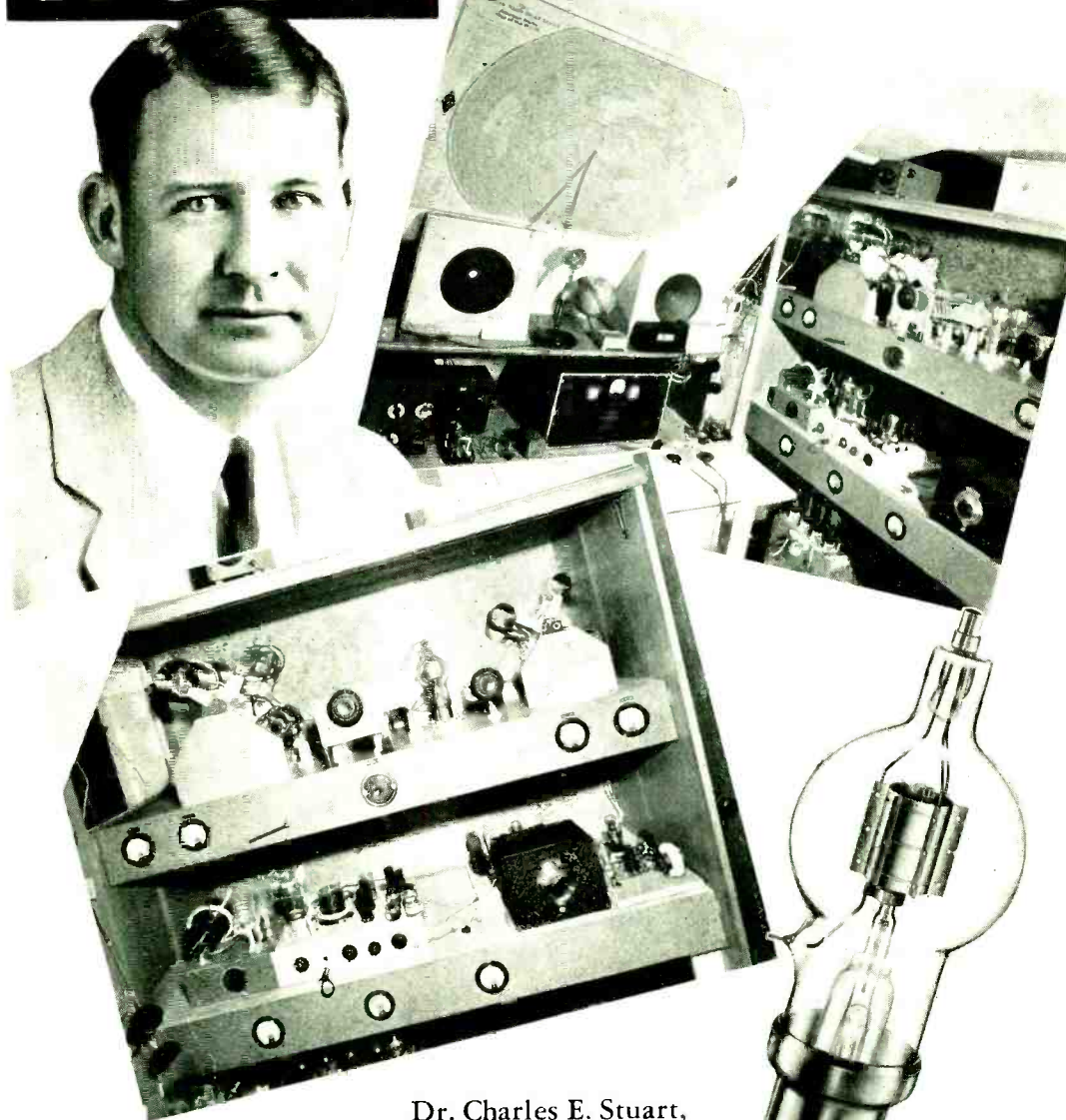

Dr. Charles E. Stuart, (affectionately known as "Doc") is perhaps the best known radio amateur in the world. His fine, clean-cut sigs and record breaking DX results can be traced directly to the pair of Eimac 250T tubes in the final of his transmitter. "Doc" is on the air regularly operating both phone and CW... a schedule with him and you'll understand why amateurs who use Eimac tubes stand the best chance of stepping out ahead of the crowd on the amateur band.

Eimac 250T tube
as used by
Dr. C. E. Stuart

Eimac
TUBES

EITEL-McCULLOUGH, Inc.
San Bruno, California

What's New

IN RADIO

HYTRON HY69 FILAMENT BEAM TETRODE

Hytronic Laboratories, 76 Lafayette Street, Salem, Mass., have announced a new filament-type transmitting beam tetrode which should find wide application in amateur transmitters, both fixed and mobile. The tube has a 6.3-volt, 1.5-ampere thoriated tungsten filament of the quick-heating type which makes the tube well suited to use in mobile transmitters where it is desired to apply the filament voltage at the same time as the voltage is applied to the primary of the motor-generator. By eliminating the need for burning the filament during standby periods the battery drain of the transmitter is cut off except during the time that the transmitter is actually on the air.

The HY69 employs efficient inter-electrode shielding and affords extremely high power sensitivity both as an audio amplifier and as an r.f. amplifier, oscillator, or frequency doubler. The increased plate dissipation rating of 40 watts as compared to the 25-watt rating of the heater-type beam tetrodes of the HY61 and 807 types allows more power output to be obtained, particularly as a plate-modulated r.f. amplifier. The tube is rated for 42 watts output as a class C amplifier at its maximum plate voltage rating of 600 volts. The internal structure of the tube permits operation at full ratings on frequencies up to 60 megacycles.

NEW TEST EQUIPMENT

The Aerovox Corporation, New Bedford, Mass., have published descriptive bulletins on their new capacity and resistance bridge, and also their new model 95 "L-C checker," for testing and aligning radio apparatus. This literature is available on request.

NEW TUBE MANUAL

The RC-14 RCA Receiving Tube Manual has been completely revised and brought up to date with information on the latest RCA receiving tubes. It now covers a total of 237 types arranged in numerical-alphabetical sequence for quick reference.

Readers can obtain a copy of the RC-14 from their RCA tube distributor, or by sending 25 cents to the Commercial Engineering Section, RCA Manufacturing Company, Inc., Harrison, N. J.

Two new tubes recently announced show some promise of successful application in amateur transmitters. One of these, the 6AG7, announced

by RCA, seems to be about in the same class as the 6V6, judging from the characteristics, but has a grid-to-plate capacitance of only .06 $\mu\text{fd.}$, which should allow it to be used as a buffer or amplifier without neutralization. The .06 $\mu\text{fd.}$ compares very favorably with the 0.2 $\mu\text{fd.}$ of the 807 and the x 0.3 to 0.5 $\mu\text{fd.}$ of the 6V6, 6F6 and 6L6 types.

Another new tube which should make a fine exciter stage or low-power amplifier is the 6AL6G, which seems to be a glass 6L6 with the plate lead brought out to a top cap. No data on the interelectrode capacitances or r.f. ratings are available at the present time.

FREE CAPACITOR REPLACEMENT MANUAL

Just off the presses and free to servicemen through jobbers is the new Cornell-Dubilier "Capacitor Manual for Radio Servicing," a speedy guide to the selection of standard Cornell-Dubilier capacitors for use as replacements in all existing types of receivers (including communications types).

Set manufacturers' names appear alphabetically, and under each are listed the manufacturer's models. For each model the data given includes capacitor values in each circuit, working voltages, C-D standard capacitor types recommended for replacement, references to basic filter and bypass circuits (over 165 of which are given in the rear section of the Manual), manufacturer's original parts numbers, and volume and page of the Rider Manual in which the complete schematic circuit can be found for checking complete circuit of the receiver.

A copy of the "C-D Capacitor Manual for Radio Servicing" can be obtained through any C-D authorized distributor, or from the main office of the Cornell-Dubilier Electric Corporation, South Plainfield, New Jersey.

NOVEL FLASHLIGHT

Quirk Battery Company, Highland Park, Illinois, has recently placed on the market a rechargeable flashlight battery which should be of considerable interest to the portable hounds. The case for the battery is made of lucite and the unit is the same size as a pair of the normal size flashlight cells. The output voltage of the storage cell (and it should be called a cell rather than a battery) is 1.93 volts and it is designed to operate with about a 500-ma. load. The unit should be just the thing

[Continued on Page 84]

BUY *the new Super Defiant* from **Bob Henry, W9ARA**

DURING the last ten years I have sold more than 10,000 amateur receivers. I have satisfied my customers and won thousands of new customers everywhere. And I have learned what receivers amateurs like. The SX-25 Super Defiant is such a receiver. Write to me for complete technical information on it or any other set.

Write me about your wishes and I will help you get the right receiver and will personally cooperate with you to see that you are 100% satisfied.

YOU get ten day free trial — you don't buy unless you are satisfied.

YOU get 6% terms financed by me with less cost — less red tape — quicker delivery.

You get big trade-in for your set — describe it and I will tell you its value.

You get prompt shipment in factory sealed carton from the world's most complete stock of receivers. Or shipment from factory if you prefer.

Write me about your wishes. I will send full information. Or send me your order and I guarantee you can't buy for less or on better terms elsewhere.



**Prompt shipment of the SX-25
and other sets on ten day trial**

| Model | Cash Price | Down Payment | 12 Monthly Payments |
|---------------------|------------|--------------|---------------------|
| SX-25 complete... | \$99.50 | \$19.90 | \$7.03 |
| S20R complete ... | 49.50 | 9.90 | 3.49 |
| SX-24 Defiant ... | 69.50 | 13.90 | 4.90 |
| SX-23 | 115.50 | 23.10 | 8.16 |
| SX-17 | 137.50 | 27.50 | 9.71 |
| Skyrider 5-10 | 69.50 | 13.90 | 4.90 |
| HT-6 | 99.00 | 19.80 | 6.99 |
| HT-9 | 199.50 | 39.90 | 14.09 |

SIMILAR TERMS ON ALL OTHER HALLICRAFTER EQUIPMENT

I have a complete stock of all amateur receivers, transmitters, kits, antennas, tubes, crystals, parts of all sorts. Send to me for amateur apparatus at the lowest net wholesale price in any catalog or ad. Your inquiries and orders invited.

Bob Henry

W9ARA

HENRY RADIO SHOP
BUTLER, MISSOURI

Yarn of the Month

[Continued from Page 64]

and tested, but it was to remain mutely at home.

As he stroked the glossy panel and touched each switch, his resentment grew. Not unreasonable, hardly that, because surely Ham Radio could be forgotten for a time. It was disappointment at the misunderstanding couched in the demand . . . an infringement

upon his rights, a request to foresake even temporarily a part of his own personality. Uneasily he came to a decision. There had never before been any deceit between them but neither had there been demands. The rig was going to the mountains.

From a high pinnacle he watched the sun erase the shadows from the landmarks below. The portable had easily been secreted in the trunk of the car and spirited up to this retreat. Each morning before darkness had completely receded, he would slip from the cabin, ostensibly for a solitary ramble, but instead to capture those two precious hours after sunrise when the audible world was at its lowest and radio reception at its peak. It had surpassed his expectations. He had worked seven districts on five-meter phone, and this in itself dwarfed his previous accomplishments with the big rig at home on forty. The days too had been serene with a gentleness and harmony misborn perhaps of his apparent sacrifice but only slightly marred by a sense of guilt.

The signals were commencing to emerge from weak carrier whistles into intelligible wisps of words. A ninth district station came in strongly for several minutes and then a W5 swung in to override him. The excitement of the opening band focused his attention again on the portable and he worked several stations in rapid succession. He had been toying with a weak carrier for several minutes and was about to leave it for others when a voice electrified him. That accent came from nowhere in the States. "Vee Kaay Two Kaay Zeddd standing by for any five-meter station."

It wasn't really an Australian that he heard, it couldn't be, yet the rapid fade and the unmistakable swing of dx . . . his heart pounded as he threw the switch to "send" and commenced calling. The contact was brief and unsatisfactory but the excitement in the tense voice of each operator supplied the words that would otherwise have been exchanged. No anti-climax of local contacts followed. In a daze, he picked up his equipment and went bounding down the steep path toward the cabin.

His first impulse was to dash in and proclaim his triumph but he checked himself in time. The blunderer who never before had achieved more than mediocrity was now the first amateur to span the Pacific on five meters. He had accomplished with his little portable the feat that high-powered stations had been attempting for years. Against this was a promise sincerely made and deliberately broken.

The Monday following the vacation somehow dragged to its weary end and as he opened the door, the aroma of his favorite

[Continued on Page 95]

UP-TO-THE-MINUTE!

Thanks to Radio Technical Digest, you can keep up-to-the-minute on everything that's happening in radio (except broadcast and entertainment), without spending a lot of time and money.



Between the covers of the bi-monthly Radio Technical Digest is the entire technical radio world at a glance! The outstanding articles from both foreign and domestic publications are reprinted or condensed; others reviewed in thumb nail sketches.

Subscribe today—or send twenty-five cents for sample copy.

\$1.50 Yearly. Two Years **\$2.50**

(In U.S.A., Canada, Newfoundland, Cuba and Mexico.)
For prices elsewhere, see page 4.

DIGEST BINDER

A sturdy and convenient binder that holds two years' copies of Radio Technical Digest. Imitation leather, gold embossed.

\$1.25 Continental U.S.A. Elsewhere **\$1.50**

THE EDITORS OF
RADIO 1300 Kenwood Road, Santa Barbara
CALIFORNIA

BIG AMATEUR NEWS FROM ALLIED

1 NEW BUDGET PLAN FOR PARTS PURCHASES

Here's "hot news"—the kind you've been waiting for. ALLIED comes through again with a new service for your convenience! Yessir, if you're a licensed Amateur—we'll sell you everything your "Ham Shack" needs—transformers, tubes, kits, anything in the way of receiving and transmitting gear—on the easiest and slickest Budget Plan you've ever seen! It's economical, too, for there aren't excessive charges; and best of all, there isn't any red tape! It's so simple you know in advance what you'll pay—just total up your order for parts, anything from \$20.00 to \$40.00—send only 20% for your down payment—add 6% charge to the unpaid balance—and then make three monthly payments on the unpaid total.

EASY TIME PAYMENT PLAN

There's more good news, too! If your parts order is more than \$40.00, you can use our regular convenient Time Payment Plan! We're offering this convenient new service because hundreds of Amateurs requested it! It's going to help you get the gear you want in a hurry and to pay for it on easy, convenient terms with the most economical carrying charges. Here are our terms: On orders from \$40.00 to \$70.00 the down payment is only 10%, 6% on the balance and a full 8 months to pay. Over \$70.00 on parts, you can have a full year to pay with the same low down payment and 6% charge! You'll find the Time Payment plan a convenient way to buy receivers or transmitters, too, because our new order blank for Amateurs is a contract. Once you send it in, there are no other papers to sign—no red tape—just FAST SERVICE!

2 A NEW EXCLUSIVELY AMATEUR CATALOG!

FOR YOU!

Yes—we've got a new kind of Amateur Catalog ready to send to you—an exclusive "Ham" catalog! Planned by Amateurs—laid out by Amateurs, written by Amateurs for Amateurs only! It's jam-packed with "months ahead" gear—with "Ham" equipment only—the kind of a catalog you'd plan yourself—the kind you've been waiting for. If you've got a license, you'll receive your copy soon. Watch for it!

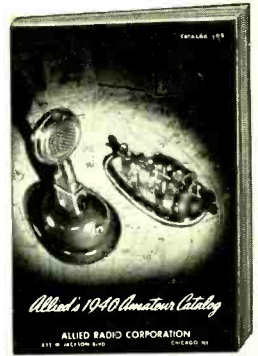

SOME TYPICAL PRE-VIEWS



THE NEW SX-25

A 12-tube communications receiver; tunes from 540 KC to 42,000 KC. Has six step selectivity with crystal filter; "S" meter calibrated in DB; Frequency Meter tuning; Two tuned R.F. stages; and automatic noise limiter. NET

CASH PRICE \$99.50

AVAILABLE ON TIME PAYMENTS

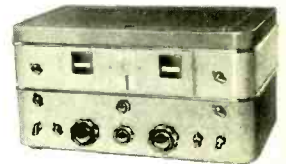

THE NEW AR-77

A 10-tube communications receiver, tuning from 540 KC to 31,000 KC. Has electrical bandspread on all amateur bands; drift compensated circuits; and a calibrated Carrier Level Meter; Automatic Noise Limiter; accurately calibrated dials for "reset" tuning.

NET CASH PRICE . . \$139.50

W9IBC Says...

Now that the pressure is over, we've a mighty proud bunch of Amateurs at ALLIED—proud of that new Ham Catalog we've just turned out for you. Boy—we've burned the midnight oil to do it, but we're sure worth it—and we think you'll agree it was worth it—being a real "Guide to that it's as close to being a real "Guide to Amateur Gear" as you've ever seen. You'll like it, we know—because it's easy to use and as complete and up-to-date as we could make it. Personally, I think it's swell—and if you do, too, I'd like to hear from you. If you like our new Budget Plan, and we're all quite sure you will, try it and see how easy it is to get what you need without putting a strain on the family wallet. You'll find it works as smoothly as a cash transaction—without red tape and delay—and that we really did plan it to help you. Just by way of reminder (if you need one) the coupon will bring you your copy of the ALLIED Amateur Catalog in a hurry—if you haven't already received one.

SEND THIS COUPON

73
D. L. WARNER.
W9IBC

GET YOUR ALLIED AMATEUR BOOK NOW!

ALLIED RADIO CORP.

833 West Jackson Blvd.
Dept. 14-C-O, Chicago, Ill.

Yes—I want your new 1940 Exclusive Amateur Catalog. Please Rush!

Name

Call Letter

Address

City State

[Continued from Page 31]

It should never be touched to make an adjustment except when the transmitter is off the air.

A disadvantage of the arrangement as shown is that a crystal microphone having both sides of the crystal element brought out separate from the grounded shield must be used. The actual microphone may either be one of the manufactured types in which this provision has been made or it may be one made from a crystal earphone. An alternative arrangement would be to run the control voltage from the a.m.c. rectifier into the suppressor of the first speech stage or into the injection grid of a succeeding speech stage which used a 6L7.

In the author's particular arrangement the 6SK7 feeds into the grids of parallel-connected 6N7 which in turn feeds a pair of 45 tubes. The gain control is between the 6SK7 and the grid of the 6N7. The 45's act as drivers for a pair of class B TZ-40 modulators. A test with an oscilloscope showed good syllabic response of the a.m.c. voltage under average modulation conditions—when the a.m.c. is acting properly to reduce the gain of the speech amplifier.

[Continued from Page 46]

Generally, it will be stable when a Superior air mass overlays one of the other two types above.

Formulae are now available with which to calculate field strength at increasing distances from a transmitter, resulting both from the direct refracted-diffracted signal transmitted along the earth's surface, and the "low atmosphere bending" signal reflected from an air mass boundary. A chart of these components for horizontal and vertical antennas, for a given set of conditions, appears in figure 2. The B curves indicate how sharply the "local" signal drops off beyond the horizon (the decline is sharper at higher frequencies), and also indicates that for this type of propagation, the vertical antenna produces about 15 to 18 db more signal than a horizontal, *over sea water*. The A curves, however, indicate that beyond fifty miles—and still over sea water—the advantage of the vertical antenna may be as small as 3 db, which will hardly be noticed, especially in the presence of some fading. Furthermore, if the horizontal array discriminates against outside noise, it may be preferred. Over earth that is less conductive than sea water, or in the case of a difference in power output at angles near the horizon, the advantage in signal strength may also be with the horizontal case.

Figure 2 will explain fading. When the direct refracted-diffracted field strength is about comparable with that of the air boundary reflected signal, wave interference may be expected to produce severe fading if there is any change in the reflected path length. At greater distances, fading in the boundary-reflected signal alone may arise from the fact that there will usually be several reflecting boundaries permitting wave interference between the several signal paths.

It is seen that technical literature gives an important advantage to vertical antennas at ultra-high frequencies only locally, and for low antennas over a sea-water path. It seems to be too early for amateurs to abandon horizontals—just when commercial u.h.f. transmitters are installing them almost universally.

"RADIO" Amateur Newcomer's Handbook

Just published, the "Radio" Amateur Newcomer's Handbook is really two complete books under one cover!



With easy-to-understand data on elementary radio theory (simplified), radio laws and regulations; how to learn the code; how to pass the amateur examination (including typical questions and answers); detailed construction data on simple receivers; a low-powered c.w. transmitter and a be-

ginner's phone transmitter—it contains everything needed to obtain a license and get on the air!

35c U.S.A. (including possessions). Elsewhere 40c

THE EDITORS OF **RADIO** 1300 Kenwood Road, Santa Barbara CALIFORNIA



UNIVERSAL CINEMA MODEL
for
Movie, Studio, Stage and Orchestra.
Crystal or dynamic in any impedance, high or low. New swivel yoke. Gun metal or pol. chrome. Incl. 25 ft. rubber covered cable. Amazing value. Embodies 1940 tech. advances and beauty of design. List only \$22.50. 1940 catalogues now ready.

UNIVERSAL MICROPHONE CO. LTD.
424 Warren Lane Inglewood, Calif.

640 PAGES — 640 PAGES — 640 PAGES — 640 PAGES — 640 PAGES —

BIGGER AND BETTER THAN EVER — BIGGER AND BETTER THAN EVER — BIGGER AND BETTER THAN EVER —

BIGGER AND BETTER THAN EVER — BIGGER AND BETTER THAN EVER — BIGGER AND BETTER THAN EVER —

TOPS!

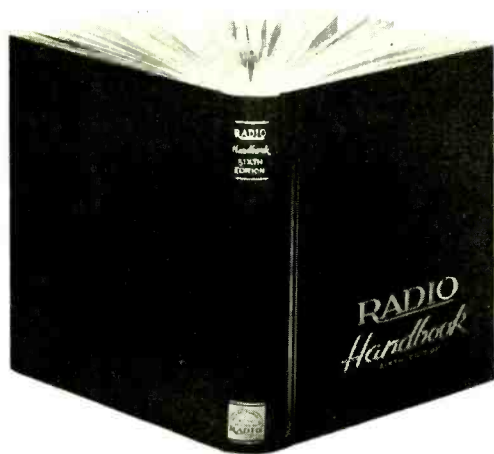

In two short months, the 640 page, 1940 Radio Handbook has been acclaimed the world over as the outstanding text of Amateur, Shortwave and Experimental radio.

Complete and easy-to-understand chapters on: Introduction to Amateur Radio; Introductory Electricity and Fundamental Radio Theory; Vacuum Tube Theory; Radio Receiver Theory; Receiver Tube Characteristics; Radio Receiver Construction; Transmitter Theory; Radiotelephony Theory; Transmitter Tubes; Transmitter Design; Exciters and Low-Powered Transmitters; Medium and High-Powered Amplifiers; Speech and Modulation Equipment; Power Supplies; Transmitter Construction; U. H. F. and Mobile Communication; Antennas; Test and Measurement Equipment; Workshop Practice; Radio Therapy; Radio Mathematics and Calculations; Radio Laws and Regulations; Etc.

STANDARD EDITION

Beautifully bound in strong, stiff card cover.

Continental U. S. A. **\$150** (Elsewhere \$1.65)

LIBRARY EDITION

Bound in handsome lifetime cover. Gold embossed in special library cloth.

Continental U. S. A. **\$300** (Elsewhere \$3.25)

(ALL SHIPMENTS PREPAID BY US—WHEN ORDERING, USE HANDY COUPON ON PAGE 95)

THE EDITORS OF
RADIO *technical publishers*

1300 Kenwood Road, Santa Barbara
CALIFORNIA

A.M.C. for Any System of Modulation

[Continued from Page 28]

A.M.C. Indicator

Under certain conditions it is desirable to have some type of an indicator to tell the approximate amount of a.m.c. action that is taking place. A magic eye tube connected in the conventional manner is excellently suited to this application. A 6E5 tube may be used and operated from the power supply for the speech amplifier. Its drain from the speech amp. power supply will be so small

as to be negligible. The control grid on the eye tube would be connected directly to the a.m.c. bus. It may be desirable under certain conditions to have an eye tube which will be able to indicate a greater swing in a.m.c. voltage than the 6E5; in this case a 6N5 may be used for somewhat greater swings, or a 6U5-6G5 for swings of even greater amplitude than the 6N5 will handle without overload.

Mechanical Construction

It is recommended that the a.m.c. control unit itself be built directly into the transmitter. It could, of course, be located on the operating table but it would be necessary to run a link line to carry the modulated r.f. output of the transmitter over to the input circuit of the a.m.c. control unit; this would be inconvenient and undesirable in most instances.

Several experimental models were built in the laboratory and it seems that only one main precaution need be taken: it is quite important that the second 84 rectifier be adequately shielded from r.f. fields. In one preliminary unit the second 84 was unshielded and considerable difficulty was experienced in determining beforehand the exact point at which the second 84 would begin to rectify the a.m.c. control voltage.

It has been found best to build the unit mechanically about as shown in the schematic diagram: the carrier rectifier, its associated tank circuit, and the first filter r.f. choke and condenser can be unshielded; the second section of r.f. filter, the load resistors and all the components associated with the second 84 rectifier should be thoroughly shielded inside a metal box set alongside the components of the carrier rectifier. Note that one side of the filament is grounded, that the other side is by-passed, and that both sides of the 110-volt line into the filament transformer are by-passed. This, coupled with the fact that it is necessary to use a separate filament transformer for the heaters of the 84's is made necessary because the cathodes of both 84's are hot—one with respect to r.f., the other with respect to a.m.c. peak voltage and audio. Any undesired coupling into these cathodes would entirely upset the operation of the unit. However, if the precautions shown are taken no trouble should be experienced with undesired r.f. coupling.

Crystal Cleaning Hint

In an emergency, when no carbon tetrachloride or alcohol is available, a dirty crystal may be successfully cleaned by soap and water, spirits of camphor or by alcoholic after-shave lotion.

Just out!



A complete guide to all the modern principles and practices.

Here is the television of 1940, in ten fact-packed chapters that cover fundamental principles, design, and equipment. The whole process is carefully investigated, from studio camera right through to the receiver screen image, with a thorough exposition of basic theory and today's practice.

Principles of Television Engineering

By DONALD G. FINK

Managing Editor, *Electronics*.

541 pages, 6x9, 313 illustrations, \$5.00

From design to maintenance, this book tells radio engineers and amateurs what they need to know about this important, rapidly growing field to become television engineers and cash in on the many good jobs becoming available.

Look at These Chapter Headings

In logical sequence the book presents the camera, amplifying and transmitting equipment, radiation through space, reception and amplification, detection, and image reproduction. The headings are: Television Methods and Equipment; Image Analysis; Fundamentals of Camera Action; Formation, Deflection, and Synchronization of Scanning Beams; The Video Signal; Video Amplification; Carrier Transmission of Video Signals; Image Reproduction; Television Broadcasting Practice, and Receiver Practice.

SEE IT 10 DAYS — SEND THIS COUPON
McGraw-Hill Book Co., 330 W. 42nd St., N. Y. C.

Send me Fink's Principles of Television Engineering for 10 days' examination on approval. In 10 days I will send \$5.00, plus few cents postage or return book postpaid. (We pay postage on orders accompanied by remittance.)

Name

Address

City and State

Position

Company R. 3-40
 (Books sent on approval in U. S. and Canada only.)

An Electronic Photo Timer

[Continued from Page 24]

megohm resistor cut into the circuit and with the 3-megohm potentiometer wide open is approximately 100 seconds.

The small shield box in which the unit is housed measures 4 x 4 x 6 inches. The potentiometer R_2 , the focusing switch S_2 , push button switch and the pilot light are mounted on one of the removable sides which becomes the top. The rest of the components, with the exception of the output socket, are fastened to the removable bottom. The output socket is a miniature Jones plug, which may be seen near the bottom of the left side in figure 1. No picture of the inside of the box is shown, since this type of construction does not lead to a very photogenic wiring job. The parts may be located wherever desired, however, with little fear that the unit will not operate satisfactorily.

Calibration

The calibration should be made after the box has had time to reach a stable operating temperature. Normally the time required to reach such a temperature will be about 15 minutes. If extremely high accuracy in the timing is desired it would probably be somewhat better to use a larger cabinet and separate the resistors in the grid circuit some distance from the rest of the unit. The interior of the box becomes quite warm during operation and causes a time variation of about 10 per cent on the lower scales and 15 per cent on the higher scales from "cold" to "hot." This amount of variation does not seem to affect the quality of the prints to any noticeable degree, however. Ventilation is provided by four $\frac{7}{8}$ inch holes in the back of the box—two directly behind each tube. The use of a line cord having a resistance element in place of R_1 would probably also help in reducing the temperature rise, although most of the heat seems to be generated by the tubes themselves.

Pilot Light

The pilot light is an ordinary 250 milliamperé one, and when operated in series with the 150 milliamperé heaters it burns rather feebly, which is what is desired in the dark-room. The jewel is an amber one, which, my photographically-inclined friends tell me, is close enough to the correct color for use with bromide enlargement papers. For contact papers a red jewel may be substituted, since the type of pilot light assembly used allows various colored jewels to be substituted without opening the cabinet.

P. R. MALLORY & CO. Inc.
MALLORY
Supplemental MYE
Monthly Technical Service

"THE FIRST ISSUE
IS WORTH THE COST
OF THE ENTIRE SERVICE"

"KEEPS GETTING BETTER
WITH EACH ISSUE"

"BEST LOW COST
TECHNICAL SERVICE
I EVER USED"

"INFORMATION
AVAILABLE
NOWHERE
ELSE"



The Supplemental MYE Technical Service is "going like a house on fire". Radio amateurs, eager to keep abreast of current developments, tell us that every issue helps them solve problems not covered by any other service regardless of cost.

The first issues, already published, contain: combined Tube Characteristics with complete tube charts... complete engineering data on Dry Electrolytic Capacitors... useful Servicing Information... new receiver listings covering all sets from June to December 1939. A few sets of these first 4 issues in attractive leatherette, 3-ring binders are still available. Eight equally valuable issues; one a month right through the year are still to come.

How to get it: Obtain the complete service by sending in your check or money order for \$1.50 direct to us. Or... you can save 50c by having your Mallory-Yaxley dealer order the service for you. You can't afford to be without this Mallory monthly technical service.

P. R. MALLORY & CO., Inc.
INDIANAPOLIS INDIANA
Cable Address—PELMALLO

Use
P. R. MALLORY & CO. Inc.
MALLORY
APPROVED RADIO
PRECISION PRODUCTS

Use
YAXLEY
APPROVED RADIO
PRECISION PRODUCTS

A Highly Sensitive Field Strength Meter

[Continued from Page 39]

Calibration

With the 0-1 ma. meter mounted upside down, it will take slightly more than 1 ma. to give a full scale deflection. Full scale deflection (a reading of exactly 1 ma.) with the meter in an inverted position will be obtained with very close to 50 volts on the plate of the tube. A slightly greater deflection will be obtained with the B negative connected to the A positive than to the A negative. After getting the needle to read as close to 1 ma. as possible by trying both connections for the B negative, bring the needle *exactly* to 1 ma. by adjustment of the "zero adjustment" screw. This will mean that when the instrument is turned off the meter needle will not sit exactly on zero, but this does no damage to the meter, even if the needle goes clear over against the needle stop below zero.

For highly accurate results, the instrument should be individually calibrated. This is done by using a small oscillator with variable input and an r.f. meter coupled to the tank by means of a pickup loop. If the r.f. meter is of the current squared type, the output power of the oscillator is proportional to the scale reading. Half scale would be 3 db loss over full scale, and quarter scale would be 6 db less than full scale. If the meter is not of the current squared type, a reading of 0.7 the full scale value represents a difference of 3 db, and 0.5 scale represents 6 db less than full scale.

Bearing in mind that with the meter upside down the meter will read towards the right with increased signal strength but backward with respect to the ma. calibration, take a point three scale divisions from the left as the zero reference point (assuming the meter has 50 scale divisions, or 5 divisions for each 0.1 ma.). This is the lowest point on the scale at which a 3 db increase in signal will result in a substantial increase in the reading, and represents the limit of usefulness of the meter. Accurate readings cannot be taken below this point; so this point is taken as 0 db and the scale is calibrated entirely in positive db.

To obtain plotting points proceed as follows: With the r.f. meter giving a scale reading corresponding to quarter power, adjust the *pick up* to the f.s. meter until the zero reference reading is obtained (3 scale points to the right of zero signal reading) at resonance. This pick up adjustment should *not* be made by detuning the f.s. tank condenser, for reasons which will be explained later. When the meter rests upon the point corresponding to 0 db, increase the oscillator input until the r.f. meter gives a reading corresponding to half the full-scale power. The f.s. meter reading should be logged as "3 db." Then increase the oscillator input until the r.f. meter reads full scale. The f.s. meter will give the plotting point for 6 db.

Now drop the input to the oscillator until the r.f. meter indicates quarter power again. Increase the coupling or pick up to the f.s. meter so that the needle rests exactly on the point corresponding to 6 db. Proceed as before, and calibration points for 9 db and for 12 db will be obtained. In four jumps of this kind (four coupling adjustments) it will be possible to obtain calibration points up to 24 db. Another point at 27 db may be made if desired, but no attempt should be made to extend the calibration beyond 27 db, as the operation of the grid leak detector becomes erratic beyond this point.

The readings should be made with care, because an error in plotting either the 6 db, 12 db, or 18 db point will affect the whole scale. Unfortunately it is impossible to cross check the calibration by a single jump of 18 or more db because it is impossible to read an r.f. meter accurately when it is more than 10 db "down" from full scale.

When the calibration log is finished, the 0-1 ma. meter should be removed (taking care not to short the plate voltage through it) and the "works" taken out of the case. With a medium-hard lead pencil or a pen and India ink the db scale can be marked directly on the face of the meter. Be sure to keep in mind that the meter will be installed upside down. The pencil marks can easily be removed with a rubber eraser if desired at a later date.

**THE CHAMPIONS
Tell You How To Learn or
Speed Up Your CODE!**

Would you like to have the personal coaching of the man who trained the world's fastest Radiotelegraph Operators?

WRITE TODAY! He will show you how to acquire Speed and Skill almost before you know it! If you want to read code as easily as you read print and copy several words behind with "mill" or pencil without strain or fear of "fading out", this internationally famous trainer of Radio Operators will coach you personally.

If you are **NEW** in Radio but want to start **RIGHT** in Code and Radio Fundamentals, this famous trainer will tell you how to do it the easiest, best and quickest way. His personal advice costs you nothing.

WALTER CANDLER has trained thousands of the leading Amateurs and Commercial Radio Operators, including the World's Champions. His individual Training and Personal Coaching eliminate all guess-work.

1940 BOOK of FACTS

sent to you without cost or obligation. Contains helpful information for Beginners, Amateurs and Commercial Operators. A postal will bring it.

**CANDLER SYSTEM
COMPANY**

Dept. D-3 Asheville, N. C., U. S. A.



RADIO

Approximate Calibration

Calibration points sufficiently accurate for most work can be taken from the following table, and marked directly on the meter scale. As the value of grid leak affects the calibration, the grid resistor (R) should be of good quality to make sure it is close to 5 megohms. Cheap resistors are often inaccurately marked.

With the meter works removed from the case and held in an inverted position, mark the db scale on the face to correspond to the table. Scale divisions are counted from the left end of the inverted scale, or position of the needle when the meter is turned on but no signal is being fed to it. It is assumed that the meter is of the type illustrated and has 50 scale divisions.

| Scale Divisions | Db Calibration |
|-----------------|----------------|
| 3 | 0 db |
| 5 | 3 db |
| 8 | 6 db |
| 12 | 9 db |
| 17 | 12 db |
| 22 | 15 db |
| 27 | 18 db |
| 31 | 21 db |
| 34 | 24 db |
| 36 | 27 db |

Using the Meter

As with any field strength meter, certain precautions must be observed when making measurements. In the first place, it is important that the needle rest exactly at 1 ma. when turned on but with no signal being picked up. If the needle is not exactly at 1 ma., the zero adjuster screw should be turned to bring the needle exactly to 1 ma. before any measurements are made.

The meter always should be used *at resonance*, because when the meter is detuned very far from resonance, the calibration is affected. If there is too much pickup, it should be reduced by moving the instrument farther away from the source of the signal or shortening or changing the orientation of the pick-up antenna, *not* by tuning the condenser to one side of resonance. When the condenser is detuned, a 3 db increase in signal strength will not give exactly a 3 db increase according to the meter. This throws the calibration off several db at the full scale reading of 27 db. For accurate readings it is only necessary to make sure that the meter is being used at or near exact resonance rather than way off to one side.

Another precaution that must be observed is to make sure that the signal is not so strong that it blocks the tube. The meter is cali-



where pennies count

- ★ You can get a lot of electrolytic capacity for very little money in these two popular AEROVOX types. Compact dimensions permit their being squeezed in anywhere, which makes them truly general-utility units. And their performance records are excellent.



- ★ Series PRS miniature-can electrolytics or DAN-DEES offer many AEROVOX refinements: Hermetic sealing; positive safety venting; spun-over jacket ends eliminating shorts; polarity-colored end disks, etc. In 25 to 450 v. DCW. 4 to 100 mfd. Also in dual sections, 8-8, 8-16, 16-16, 10-10 and 20-20 mfd. Additional line in 1000, 2000 and 3000 mfd., 6, 12 and 15 v.



- ★ Series PBS Cardboard-Case Electrolytics have long been popular. Heavily wax-impregnated cases. Adjustable metal-flange mounting, 5 polarity-colored leads. A quality job—at a bargain price.

★ Ask Your Jobber . . .

He'll gladly show you these two handy types. Always have a few on hand for emergencies. And be sure you have our new 1940 catalog—get your copy from your jobber or from us direct.

AEROVOX

CORPORATION
NEW BEDFORD, MASS.

IN CANADA: AEROVOX CANADA, Limited, Hamilton, Ont.

Quality above all
SOLAR
TRANSMITTING CAPACITORS



SOLAREX

Supervalue for filters, the ideal type for advanced amateurs, insuring utmost service and economy.

Write for catalog No. 10

SOLAR MFG. CORP.
 Bayonne, New Jersey

IS YOUR JOB PAYING YOUR WAY?

HOME \$ CAR \$ TRAVEL \$ FAMILY \$

- You can make more money by making yourself more valuable!

RADIO & TELEVISION ENGINEERING

Radio holds more than "just a job" for you. Ahead is success and opportunity, but you must have the ability that comes with modern technical training. Remember every man has the desire to succeed. Only a few really do. Why? Because they fail to plan ahead. Others, like CREI students, follow a tested plan that leads to more money and better radio jobs. Why don't you do the same thing? Then perhaps you'll be ready to step into a job in one of the 300 broadcasting stations and other branches of the industry now employing our men. The story of CREI spare-time training means a lot to you—it costs you nothing.

Send for Free Booklet:
 "The CREI Tested Plan"

48 interesting pages with scores of photographs and complete outline and description of CREI radio and television home-study courses (and Residence School).

Capitol Radio Engineering Institute
 Dept RO-3, 3224 16th Street, N.W., Washington, D. C.



brated only to 27 db, because beyond this point the operation becomes erratic; in fact a lesser reading with increased signal strength will result after a point approaching full scale is reached. When using the meter the tuning condenser first should be tuned completely through resonance before a reading is made, in order to ascertain if the signal is sufficient to block the tube. If the needle goes beyond 27 db as the condenser is tuned slowly through resonance, the signal input should be cut down as previously described.

The meter takes about as much signal for full usable deflection (27 db) as does a meter of the power detector type. The advantage of this instrument over a power detector f.s. meter is that it will give usable deflections on much weaker signals. It takes about 10 db more signal to give a usable deflection on the bias or power detector type, though the needle on a power detector f.s. meter will go up faster with increased signal strength *after it once begins to read.*

Because the scale on a power detector type meter is so spread out near full scale, such a meter is preferable for measuring small differences in signal strength (a fraction of 1 db for instance). The instrument described in this article is to be preferred when an extremely sensitive meter is required, or where the range to be covered exceeds 20 db.

The Pick-Up Antenna

On the lower frequencies a short rod can be used for pick up by clipping the antenna lead directly to the "hot" side of C_1 . The pick up rod can also be used on the higher frequencies by clipping the antenna lead to C_2 and adjusting C_2 for the desired degree of pick up.

To avoid body capacity and body absorption effects, which are annoying with any sensitive field strength meter using a single wire pick up antenna, a doublet antenna may be used in connection with a twisted pair line. Such an arrangement will give much more accurate results than a rod or single wire pick up antenna.

The doublet need not be a half-wave long unless the instrument is a great distance from the source of radiation or the radiated power is very low. For instance, a 10-ft. doublet can be used quite a distance from a radiating 20-meter antenna or array, but if greater sensitivity is required the doublet should be made exactly 33 feet over all (a half wavelength at 20 meters). Ordinary twisted lamp cord can be used for connecting the doublet to the f.s. meter.

If the radiating antenna or array is horizontally polarized, the pick up doublet should be placed parallel to the earth. The pickup can be varied by changing the position of the

doublet, keeping it horizontal but turning it towards a right angle with the transmitting antenna for decreased sensitivity.

If the antenna or array is vertically polarized, the pick up doublet should be placed in a vertical plane that includes the radiator. The pick up can be varied by tilting the top or bottom of the pick up doublet towards or away from the transmitting antenna.

Another simple method of varying the pick up when a doublet antenna is used on the f.s. meter is to use a common variable link instead of fixed individual links on the various coils. A 2 turn link 2 inches in diameter can be supported by its semi-flexible leads so that its position with respect to the grid coil can be changed. The link is fastened to tie points on the chassis and the coils are plugged in and out by inserting them down through the link.

When the filament switch is turned off there will be an upward kick of the meter needle. There is no danger of damage to the meter, however, even though the needle may bang the pin when it has been resting near 1 ma. So long as the filament has voltage applied, most of the emission is from the negative end of the filament, as that portion of the filament is at a greater negative potential with respect to the plate.

The upward kick of the meter is due to the fact that the filament does not lose its emission immediately when it is turned off, and until it does the whole filament emits, lowering the plate resistance and raising the plate current slightly for just an instant.

See Buyer's Guide, page 98, for parts list.

Shorts

Add to laughs at the expense of our engraver. The cut of the TA QSL card on page 52 (in last month's dx section) was identified on the invoice as follows: "120 Screen Copper Turkey." An amateur snapped in the act of tuning his receiver invariably is identified as "Man at Controls."

Transcontinental Broadcasting System will begin operation shortly after the first of the year as a new national chain. The system claims to have approximately one hundred participating stations. It is said to have enough commercial business to insure its profitable operation from the start.

PROVEN IN PRODUCTION

To assure full dependability

No chances are taken during the manufacture of Bliley Crystal Units—each crystal must prove itself by subjection to many checks and inspections during each processing operation. A final exacting inspection checks for:

POWER—All crystals are tested in a loaded oscillator and must meet definite power output standards.

ACTIVITY—The ability to follow keying under high oscillator loading is a specific requisite.

RUGGEDNESS—Excitation in excess of the normal maximum rating is applied to establish assurance of safe operation even under moderate overloads.

CALIBRATION—The frequency of oscillation is accurately determined by reference to a primary standard of frequency.

Only after Bliley Crystal Units have proven their right for existence are they O.K.'d for shipment to you or to your distributor. That's why they are in demand by discriminating amateurs everywhere.



BLILEY CRYSTAL UNITS

Tubeless Noise Limiters

[Continued from Page 50]

detector connected as in figure 1B, a 1/2-megohm grid resistor may be used. For use with an infinite impedance detector a high impedance choke (50 to 250 hy.) should be used in place of the grid resistor.

The 2000-ohm potentiometer used for a cathode resistor permits any desired degree of peak limiting on that half of the audio cycle not limited to 100 per cent modulation by the detector. Obviously greater peak limiting can be used on c.w. than on phone. Whether maximum peak limiting occurs at the cathode end or the ground end of the potentiometer depends upon which type of detector is used.

If the receiver has a good a.v.c. system, the amount of a.f. delivered by the detector will remain substantially the same for both weak and strong phone signals. As the gain control follows the peak limiting a.f. stage, the limiter control need not be adjusted for different phone signals or different positions of detector is used.

On c.w. the picture is somewhat different. As there is no a.v.c., the a.f. voltage impressed on the grid of the peak limiting audio stage will depend upon the strength of the received signal. Turning down the volume control on loud signals will not reduce the a.f. voltage impressed upon the first audio tube. The solution is simple, however; simply turn the limiting control to cutoff bias for c.w. and leave it alone. The limiting action will then be satisfactory regardless of signal strength.

Fully Automatic System

While the a.v.c. action in most receivers will tend to maintain a constant signal at the detector, a very loud phone signal is bound to impress slightly more a.f. voltage on the audio system than a very weak phone signal (assuming the same percentage modulation). This will require slight readjustment of the limiter control for maximum results, even

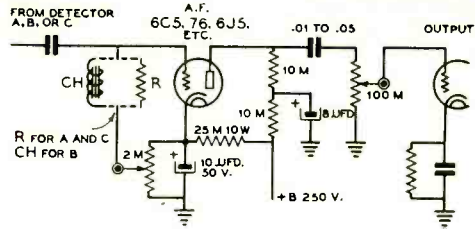

Figure 2.

By providing a potentiometer return for the bias on the first a.f. stage, the limiter can be used on both phone signals and c.w. signals, giving good noise limiting action on both. If an infinite impedance detector is used a high impedance choke should be substituted for the grid resistor. The grid winding of an inexpensive a.f. interstage transformer (not a driver transformer) can be used as the choke if you have such a transformer on hand but no suitable choke. Note that the plate load resistor for the first a.f. stage is lower in value than is customary. This permits operation of the grid at a relatively high a.f. swing without providing an excess of drive to the output a.f. stage. If push-pull output tubes are used, the primary of a push-pull input transformer can be shunted across the plate load resistor for transformer coupling. The 2000-ohm cathode potentiometer should preferably have linear taper.

• • •

though good action can be obtained by setting the control to a compromise position and leaving it alone.

The limiting system shown in figure 3 is fully automatic in this regard, automatically adjusting itself to the optimum value regardless of signal strength, once the limiter control has been adjusted. With this circuit the diode load resistance generates positive signal voltage and negative bias voltage (when the switch is on "phone"). Either single-ended or push-pull (full wave) detection may be used, depending upon whether the i.f.t. has a split secondary.

In actual practice this circuit will be found of little advantage over that of figure 2, and it is doubtful if the "fully automatic" feature is worth bothering with except where the receiver does not have particularly good a.v.c. action.

[Continued on Page 88]

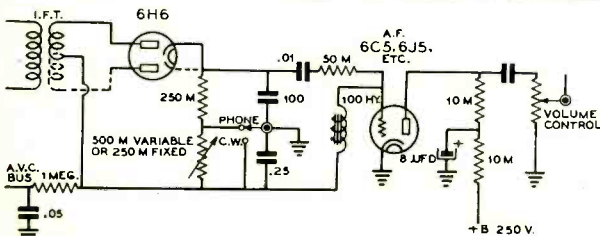

Figure 3.

Fully automatic circuit that provides same degree of limiting regardless of strength of phone signal. Either a single-ended or a push-pull (full wave) diode detector may be used. The grid winding of an interstage audio transformer may be substituted for the high impedance choke. In most receivers this circuit will be no more effective than that of figure 2.

Only ONE reason!

There is only one reason why radiomen the world over read and prefer RADIO

—superior editorial content!

Dozens of articles by such great technical writers as W. W. Smith, W6BCX; Ray L. Dawley, W6DHG; Leigh Norton, W6CEM; and many others. Outstanding features such as "U.H.F." by E. H. Conklin, W9BNX—and several departments including Herb Becker's famous "DX and Overseas News." As RADIO pays for accepted technical and constructional material, it publishes the "cream of the crop" from outside authors.

The acknowledged technical authority of amateur, shortwave and experimental endeavor, RADIO is profusely illustrated, easy-to-understand, unbiased, authoritative and packed from cover to cover with vital information that YOU will enjoy.

YOU and RADIO should get together. The low subscription rates below mean a real saving over newsstand prices. Use the handy coupon on page 95 of this issue and subscribe TODAY!



Don't Delay — Subscribe Today!

A SUBSCRIPTION SAVES YOU MONEY

| | |
|---------------------------|--------|
| THREE YEARS: | |
| at Newsstand prices | \$9.60 |
| by subscription | 5.00* |
| You Save | \$4.60 |
| TWO YEARS: | |
| at Newsstand prices | \$6.40 |
| by subscription | 4.00* |
| You Save | \$2.40 |
| ONE YEAR: | |
| at Newsstand prices | \$3.20 |
| by subscription | 2.50* |
| You Save | .70 |

NOTE: Three year subscriptions accepted at above rate from U.S.A. and contiguous countries only. *Above rates apply to U.S.A., Canada, Newfoundland, Cuba and Mexico. For prices elsewhere see page 4.

THE EDITORS OF
RADIO *technical publishers*

1300 Kenwood Road, Santa Barbara
CALIFORNIA

THE

Frank C. Jones

SYSTEM OF

CATHODE MODULATION

Now You Can Get Your Voice On The Air For A Fraction Of The Former Cost

■ The Frank C. Jones system of Cathode Modulation takes the high cost out of radiotelephony. This revolutionary system is explained from A to Z in a large, complete book—"CATHODE MODULATION"—by Frank C. Jones. It tells how to adapt cathode modulation to any tube lineup—contains more than 100 large circuits and photographs showing how to build many types of cathode-modulated transmitters for amateur or commercial service. No other book saves so much money for you. Order a copy today. Shipping weight 1 pound.

\$1.00 Per Copy—Postpaid

Pacific Radio Pub. Co., Inc.

Monadnock Bldg., San Francisco, U. S. A.

YOU'LL HAVE A FINER RIG WITH WARDS PARTS AND EQUIPMENT

You'll be amazed at the array of nationally advertised Amateur equipment—one of the most complete stocks in existence — now offered by WARDS. And remember, every part and accessory bears the unqualified approval of well-known Radio Engineers, who pronounce them the greatest value on the market today. Thus you can now build a finer outfit, or improve the performance of your present set.

New Amateur Catalog Saves You Money

Take Advantage of WARDS Convenient Time Payments 15-Day Trial Money-Back Guarantee

Use this new catalog for selecting receivers, transmitters, mikes, keys, parts—anything you need in radio or sound system work. Note how it makes it easy to compare testing instruments. And especially, note the money-saving prices on everything. It's FREE. Mail the coupon.

MONTGOMERY WARD

9 Great Mail Order Houses
More Than 600 Retail Stores



Montgomery Ward & Co.
Dept. AW-35, Chicago, Ill.

Please RUSH to me at once your new Amateur Radio Catalog.

Name
Address
City State

RADIO

A Diode Peak Voltmeter

[Continued from Page 41]

voltmeters (the indicating microammeter can be switched between the two for such measurements, it being necessary only to short the leads of the circuit in which the meter is not present). The ratio of the readings of the two voltmeters then gives the gain of the stage under test. At ultra-high frequencies, this provides one of the few dependable methods of measuring amplifier gain. It is not necessary to have an absolute calibration of the voltmeter as only ratios are desired, and the strict linearity of the peak voltmeter assures high accuracy in such measurements.

Radio frequency resistance or impedance measurements by reactance- or susceptance-variation methods require not only an indication of resonance but also exact voltage ratios; the diode peak voltmeter is ideal for such purposes due to its absolute linearity. It is also useful as a null-indicator in bridge circuits, especially in balanced-to-ground circuits.

In transmitter measurements, the practicability of the diode voltmeter cannot be over-emphasized. For instance, some typical tests with the peak voltmeter are: measuring the voltage across the crystal in a crystal oscillator, lining up a class B radio-frequency stage, indicating peak output voltages of a modulator, indicating neutralization of an amplifier, and finally the linearity of the voltmeter makes possible accurate determination of standing wave ratios on transmission lines, as required in impedance measurements or for adjustment of the line terminating impedance.

U. H. F.

[Continued from Page 61]

ening is needed from the free-space value of a half-wave, and when the system is capacitatively reactive some lengthening over the free-space value may be required."

New England data on 2½ this month is confined to WIDEI's threat to move down there, and items in the Merrimac Valley Club News. WILEA is on again, working W1ABD in Lawrence, W1IZE of Methuen, W1MCB of Nashua, New Hampshire, and W1BHL of Hopkington, Mass. (45 miles). He should be put down for at least two states worked. W1KXX of Newmarket, N. H., twice reported hearing W1JQA of Randolph, Mass. W1LBH sold out with the idea of building up equipment for 2½ only.

W6AVR can neutralize his 35T's fine on five meters but is having trouble on 2½. Possibly it is another case of inductance of leads and parts upsetting the balance.

W9PNV, near Chicago, has 150 watts on or about 112 megacycles. At least, W9TXU has a receiver and has not heard PNV. It is hard to tell just what that proves. Some other stations in the western suburbs are on the band, but activity still rates as "low."

W8NOH and several others around Grand Rapids expect to be on 2½ by April. NOH will use an HK24 and a delta-matched antenna.

W8PK says that several of the WHAM operators are planning 2½-meter rigs around Rochester, N. Y. PK is working on a low frequency FM rig which has a doubler in the receiver to widen the frequency band and operate a u.h.f. frequency modulation receiver.

W9ZGD listened to the Milwaukee gang on 112 and found W9YQM VZJ SYT HMO and others active. VDY may operate ZGD's new xtal rig which uses an HK24 driving a pair of the same, using a doubler circuit that permits a linear plate tank. He hangs the tube's plate on one conductor at the ungrounded end, and a condenser to ground on the other. Another way is to use a concentric line, which also prevents radiation.

New York Area

Fifty-one different 2½-meter stations have been worked by W2BZB since September, from his location at Palisade, N. J. Now, that sounds like activity. The majority of fellows are on Long Island, most of them using small beams. BZB uses five elements. Signals are generally better than on five meters, but this is hard to test in the absence of fellows up the Connecticut coast. W3CGU in No. Plainfield, New Jersey (30 miles), is a newcomer. W1AVV is still promising to get on. W2HNY in Riverhead, L. I., 100 miles from BZB, is expected on 2½ shortly (don't use one of those big RCA transmitters by mistake, om, or the boys will have heart failure when they hear you). Some of the fellows are constructing frequency modulation rigs and new receivers to use with them.

W2MLO of Rockville Center, N. Y., says that he has been appointed 112-Mc. reporter for the columns and sent dope for last month's issue. What with being delayed here and there, his letter arrived at Wheaton, Illinois, in plenty of time for the March number. A late air mail letter just arrived, the material from which will be sandwiched in. Remember the 13th—that's the day that the material must reach Wheaton to get in without special reason and an argument with the Editor.

Anyway, MLO says that Long Island activ-

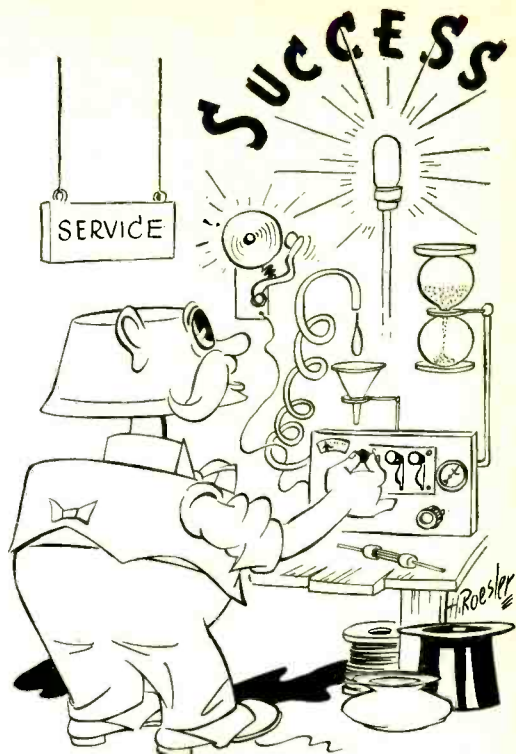

**--with the CENTRALLAB
LEVER ACTION SWITCH**

A flip of the Centrallab Switch tells all . . . whether to read the tell-tale meter . . . to test a reluctant tube, or to solve the inner mysteries of some intricate testing apparatus. Just a habit with Centrallab . . . to turn out a better mouse-trap so that a world of service men can make a beaten path to our jobbers.

Switches, controls, resistors, ceramic capacitors . . . in each field of endeavor . . . like Abou Ben Adam . . . "our name leads all the rest."

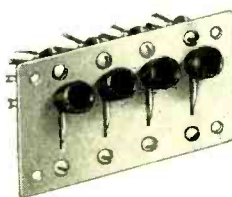

Contact clips of spring brass heavily plated (silver) treated for easy soldering. Switching combinations available use up to 12 clips per section.

Centrallab

Div. of GLOBE-UNION, INC.
Milwaukee, Wisconsin

ity has been very good since September and is now spreading around metropolitan New York and eastern New Jersey. New stations are springing up all over like wildfire, averaging four a week. Interference is heavy (!) every night, with most of the stations on from seven to eleven p.m. Dx is stretching out. He lists these as active: W2MLO EK1 MES MAL LEV MAH MRP AEE HGU BZB LPC LUN LJJ KTW JWH JNT EJA CPD MQJ MQS EA MIU MRA MHX GZ TY LVU FBI KYW KDB JND LAA DFB AZV HMT LFU HCL JNO ETL BFW MCG MBI JMK MLM FWX HDG DGJ HZV MME LKR LIW LUT LOS DJU HNY DFB LNP JCS IBW KZP DMM.

From Long Island, W2MLO worked W2HNY portable in West Orange, N. J., 40 miles airline, with R8 reports, using 25 watts into a 53 and a two-element beam. His best dx heard is W3CGU in North Plainfield, N. J., about 55 miles airline. W2KTW in the Bronx worked W3CKN (35 miles) and was heard in Devon, Connecticut, using 20 watts into a 45 and a two-wire matched-impedance antenna. W2BZB mentioned above used 100 watts on 35T's when working W2HMT in Ossining. The latter has a 6E6 with 20 watts input and a two wire

matched antenna. W2JND, Syosset, works W1's whenever they are on. Best dx is Bridgeport and Devon, Conn., 35 miles away, using 50 watts and a three-element rotary. W2MCG worked W2EKI and W3CKN, about 35 miles airline, with 55 watts into HK24's with a two wire matched antenna; he has been heard by several W1's.

W1LAS in Greenwich, Conn., pounds in all over Long Island, New York City and eastern New Jersey (he gets credit for two districts and three states!). He has worked W2MLO (30 miles), W2BZB (35 miles), W2KTW (30 miles) and W2MCG with no reports below R7. W3CGU in North Plainfield has worked W2BZB and is heard regularly by W2JND (65 miles). W2GZ of Hempstead, Long Island, worked W2HGU in Ridgefield, N. J., about 40 miles away. This work is all done in winter weather, and should be surpassed when summer brings more air-boundary reflections.

According to W2MLO, none of the fellows go for concentric lines as tuned circuits because they haven't enough ambition considering what you get out of it (oh yeah?). Several are experimenting with r.f. amplifiers; the 956 seems to work the best but even there they are not any too successful. They

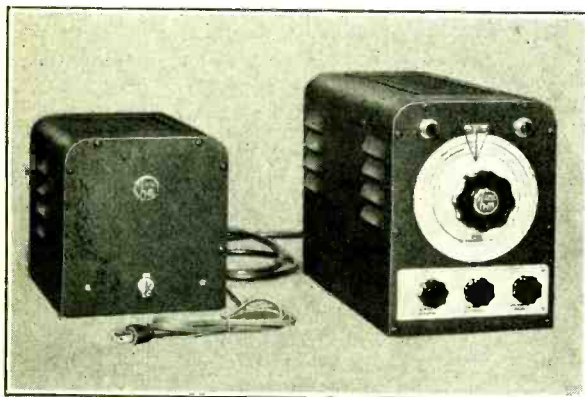

BRING YOUR STATION UP TO DATE

The "X-EC" will give you smooth, accurate variable frequency control. The smoothness found in the vernier calibrated dial will bring you a new tuning pleasure. The accuracy will astound you—both in stability and calibration.

No plug-in coils to bother with. The "X-EC" has RF output on 40 and 80 meters. The BREAK-IN keying is perfect—no bloops or yoops. The well regulated power supply is actually the pulse of the "X-EC", and being ISOLATED, eliminates heat, hum and vibration which would otherwise affect the stability.

Remember—the "X-EC" is NOT an ordinary electron coupled oscillator. It is a definite, absolute method of frequency control. ASK YOUR DISTRIBUTOR OR WRITE US FOR BULLETIN NO. 22

"X-EC"

**IMPROVED MODEL
HM-103A**

The Improved "X-EC" now covers the entire 80 meter band, 3.5 to 4.0 mc. BREAK-IN keying is, also, an added feature.

THE "X-EC" AT A GLANCE

1. POSITIVE "X-EC" STABILITY
2. ISOLATED POWER SUPPLY
3. "EC" OR "XTAL" OPTIONAL
4. RF ISOLATION
5. NO PLUG-IN COILS
6. VIBRATION-FREE MOUNTING
7. REGULATED BANDSPREAD
8. 40 OR 80 METER OUTPUT
9. CALIBRATED VERNIER DIAL

"X-EC" HM-103A

\$47.50 Net F.O.B. Los Angeles

Complete with ISOLATED power supply, set of Tubes, and Licensed by R. C. A.

RADIO-TELEVISION SUPPLY CO.

"Where Ham Spirit Prevails"

1701 So. Grand Ave.

Los Angeles, Calif.

want RADIO to publish an article or circuit for a really good one or two tube r.f. amplifier that really works. They seem to have overlooked the articles in January and June, 1939, RADIO. A stage gain of 15 without regeneration or instability is easy to obtain if the fellows will use a good socket, forego cathode bias, and use concentric lines (tin cans, aluminum stove pipe—70 cents for four feet—or copper tubing) as the tuned circuits. Nothing to it, Harvey; so much easier than struggling to get a coil-tuned job under control.

400 MEGACYCLES

Even the 3/4-meter band is now getting a play. Some of the fellows want to see what will happen when they use a 40-element beam! W2KDB in South Ozone Park puts 100 watts into a 304-A oscillator. Receiver is an 1851 (!) superregen detector and 42 audio, the antenna two half waves in phase. W2TY is also on 448 or thereabouts, but no details are given. Others abuilding are W2KTW EKC GZ.

It would be a shame not to use a lot of vertical stacking of antennas at these frequencies, getting a concentration of horizontal

radiation, whether or not broadsided elements are used to create a sharper beam. It would seem that the 1851 would act like a short circuit across a tuned circuit on 3/4 meters, and not at all comparable with a 955 or 956 which can still turn out a fair signal when associated with a good tuned circuit. Don't forget that tube shields and coffee cans make fine outer conductors of concentric-line tuned circuits at this frequency.

Photos

Let's take some nice clear pictures of apparatus and send them in so that the gang can see how the other fellow builds equipment, masts, antennas. What say?

RADIO at the Front

A card from F8VC at the Maginot Line says that it has been raining and snowing all the time but the sunshine comes in when RADIO arrives. He has met G8MQ and G3MP so he can engage in a little ragchew now and then.

F8VC's brother, CN8BA, is also at the front.

A real Combination

FOR A BAND SWITCHING TRANSMITTER



Here is a bang up combination for that new band switching transmitter you have been planning. Faultless, easy and low loss operation of the type 892 radio frequency switch combined with high efficiency ruggedness and low driving requirements of the 257 beam pentode make a perfect design. The 257 requires no neutralization on high frequencies because of its low interelectrode capacity and short dual screen and suppressor connections. It will stand up because the elements are all tantalum and there are no insulators.

WRITE FOR DATA



VERTICAL FIXED BEAMS

by **PREMAX**

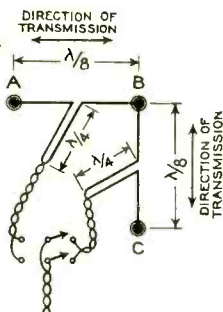

Fig. 24

The use of three vertical elements for the making of a fixed beam which covers four directions is shown in the accompanying diagram. The double-pole double-throw switch may be located near the transmitter.

Write or ask your jobber for Premax Technical Bulletin H-3 which illustrates 22 types of verticals, all of which are easy to erect with Premax standard units.

PREMAX PRODUCTS

Div. Chisholm-Ryder Co., Inc.

4032 Highland Ave. Niagara Falls, N. Y.

RADIO

What's New in Radio

[Continued from Page 66]

for operating the filaments of all portable equipment for an outing, since the depleted cell can be recharged as soon as a source of 110 a.c. is available to run the charger. Incidentally, the charger is very small and of a convenient size; the cell is merely clipped into it overnight to bring it back to full charge for another cycle of operation. A special recharging clip is also made for charging the cell from the automobile storage battery.

The midget storage cell is spill-proof due to an ingeniously arranged chamber and due to semi-fixation of the electrolyte. One discharging of the cell is about equal to the average life of a pair of normal size flashlight cells. For use of the storage cell in flashlights a special 1.93-volt 450-ma. lamp is made; it gives approximately an equivalent light output to a standard no. 14 bulb used with two dry cells. Stronger bulbs are available if even more light is desired.

The Open Forum

[Continued from Page 57]

Laurelton, N. J.

Sirs: I noticed in the January, 1940, RADIO your reference to the "Inventors" of cathode modulation and the item regarding the use of a telephone mike in the center tap circuit used by one of your staff in 1931. You ask if there are any prior claims, which is the reason for this letter.

Referring to an old log of my former station, 2CZZ, which was located in Elizabeth, I find that starting on April 3, 1923, and continuing until May 10, 1923, I used fone on the old 200-meter amateur band. The method used was an ordinary telephone mike in the center tap circuit of a Western Electric VT-2 in the 1DH sure fire circuit with very good results at the time.

I make no claim to having invented, discovered or stumbled upon this type of modulation. I tried it after seeing it in operation at 2ATS of Elizabeth, N. J., who had been using it quite some months before I tried it.

I notice some notes in the log refer to trouble experienced due to heating of the mike resulting in the carbon granules becoming welded into a solid mass. Operation was resumed by the process of shutting down and rapping the mike on the table until the carbon granules again became loosened. Those were the good old days.

Charles Fiege, Jr.

THE "RADIO" ANTENNA HANDBOOK

Everything worth telling about antennas can be found in the 100 page "Radio" Antenna Handbook. The foremost work on this subject, it is revised regularly.



Easy-to-understand, this book contains material found in no "general" handbook. Noise Reducing Receiving Antennas, Feeders of all types; Practical Arrays and Directive Antennas; Diagrams; Table of dimensions for all frequencies (no calculations necessary) etc. Profusely illustrated throughout.

75c

In Continental U.S.A. Elsewhere

85c

THE EDITORS OF
RADIO 1300 Kenwood Road, Santa Barbara
CALIFORNIA

Past, Present and Prophetic

[Continued from Page 6]

"Well, I just stuck my hand up close to the saw like this and—oops, there goes another one!" We didn't think it was very funny either until Editor Smith got started on the aforementioned transceiver. When he began ordering one 1G4G after another our suspicions were aroused. "Well," said Smith, "when you touch these grid and plate wires at the same time . . ." and, *blip*, there went another one.

We asked him why he didn't change the tank leads over to enamelled wire. "Well, it's simpler to plug in another 1G4G, and I figure next time I'll be more careful." A short time later another 1G4G was found in the trash box, and we saw Smith unrolling some enamelled wire.

Newcomer Department

This month instead of showing an additional unit under the Newcomer Department heading we are showing the 2½-meter transceiver in the regular text portion of the magazine. This affair should have universal appeal both to the beginner and to the old-timer who is interested in u.h.f. experimentation. Of course we could have put it into the department with the "Newcomer" heading, but many of the more advanced gang would simply pass it by as a matter of course since they ordinarily are not concerned with material in this department. By placing the article in the position it now has, both the beginners and the oldsters meet it face to face when they open their copy. We hope that many falling under both classifications will deem the unit interesting enough and close enough to their desires that they will be inclined to build one and give 2½ a try.

UNEQUALLED ON 5- UNSURPASSED ON 10



The "MC 28-56" 5 AND 10 METER CONVERTER *tops them all!*

No matter what kind of receiver you have—even if it provides 5 and 10 meter reception—you need this High-Gain Converter to be sure of maximum performance on these bands.

The "MC 28-56" incorporates two 1852's as RF amplifier and mixer, together with a 6F6 in a high-C oscillator circuit. The output frequency is 7.3 mc.—tuned in on the 40-meter band of any ham set.

The ultimate in frequency stability is designed into this superior converter by using a voltage-regulated "B" supply and ceramic insulation throughout. When you fasten onto a sig you're there to stay—no need to worry about frequency drift!

Design superiority does not end with the instrument itself—provisions are made for connection of separate, high-efficiency antenna systems for the 5 and 10 meter bands, together with the regular general-reception antenna, single-wire or doublet. The three-position band-selector switch selects the antenna along with the coils. Antenna Compensator and RF Gain controls are provided—average gain is 20 DB!

No feature has been omitted that would help in any way to improve high-frequency reception. See it at your Jobber's today—prove it on your own receiver!

WRITE FOR FREE CATALOG

Many other items of unusual interest to the radio Amateur are fully described in the big 48-page Meissner catalog. Send for your free copy at once. Just clip the lower part of this ad, write your name and address on the margin and mail on a penny postcard to the address below.

DEPT. A-3



New! TURNER Crystal 33X

Has 8 Ft. Cable Set

90° Tilting Head — \$21.00

Add \$1.50 for 25 Ft. Cable Set

Packed with Diagrams and
Chamoisette Mike Pouch

Engineering style, handsome satin chrome finish Crystal Microphone. Free from peaks, Rugged for amateur, P.A. or recording work. Low feedback. Crystal impregnated against moisture. Blast proof.

Write for Free Catalog
Licensed Under Patents of The
Brush Development Co.

The TURNER CO.

901 17th St., N.E., Cedar Rapids, Ia.



Range 30—
10,000 cycles.
Level—52DB

*I guarantee you
the fairest and
squarest deal . .*

It will pay you to write to me whenever you need any Amateur Equipment!

I will give you—

- the latest and best apparatus.
- the lowest prices obtainable—anywhere!
- the fastest service.
- the most liberal trade-in allowances.
- easy, time payment terms at only 6% cost.
- ten day trial of any receivers.
- my personal attention and full cooperation.

In short, I give you every possible reason for dealing with me—and continuing to deal with me.

For complete and lasting satisfaction—be sure to write me.

73,

Bill Harrison, W2AVA

HARRISON RADIO CO.
9 WEST BROADWAY, NEW YORK CITY

Authorized Factory Distributors of **ALL**
AMATEUR RECEIVERS, TRANSMITTERS,
KITS, TUBES, PARTS, AND EQUIPMENT
Since 1925 — "Harrison has it!"

RADIO

DX

(Continued from Page 56)

contains only those whose totals are for two-way phone contacts. The minimum number of zones for entry into the Honor Roll is determined by the lowest number at the end of the list. When reporting additions to your Honor Roll totals, please remember to list the calls of the new stations, also, stating your former totals, and then your revised totals. This will help considerably in compiling.

LX1SS Falls by the Wayside

K4FCV has received a letter from LX1RB (who is known to be ok) saying that LX1SS is not in Luxembourg. This apparently eliminates one of the LX's mentioned in this column in the February issue. LX1RB should know about this; he's active, and Luxembourg is small enough so that he knows what is going on.

World Wide DX Contest

Just as soon as it is possible to check the logs submitted by the participants in RADIO's first DX Contest, we will publish the official results. I would like to say that since the sketchy writeup in February regarding the scores, we have received a great many from out of the country. You're going to be surprised at some of the scores, too. The response has been very gratifying and about 99% of those who took it even in a semi-serious way were enthusiastic about the rules, and its general structure. While we're on the contest subject, we should all get in and pitch in the A.R.R.L. Contest in March. The changes in the rules will compensate in a measure for some of the dx that is absent now. We must keep active on the dx bands, and I know the fellows overseas who are snut down, are counting upon the W's to keep things open. We'll all have fun, so get everything tuned up, and let 'er go. Just a word about using your v.f.o. If you adhere to the practice of calling a dx station on his own frequency don't give him a long call. Take a few minutes to see if he is working them around his own frequency, and if he is, just give him a short call. Some of the beefing against v.f.o.'s is brought about by some guy calling a dx station on his own frequency, so long that if he comes back to someone else, the guy can't copy him because this first fellow is still calling. Let's use our v.f.'s with discretion—do not make QRM, avoid it.

Here's "1492" again, and he says he has done all the damage he can. The ol' Snooper did the best he could and where we realize there isn't much about dx, a few things were dug up that might prove of interest. Oh yes, for those who like the 28-Mc. phone band, W5EEZ was in town the other day, and said that he was on his way to the Orient. He is taking along his 10-meter portable mobile outfit and has a 10-meter rotary he is installing on the ship. This calls my attention to the fact that the Byrd Expedition is now on and a few of the fellows have heard KC4USC on c.w. . . . the low end of 40. By the time this gets to you, they should be rolling

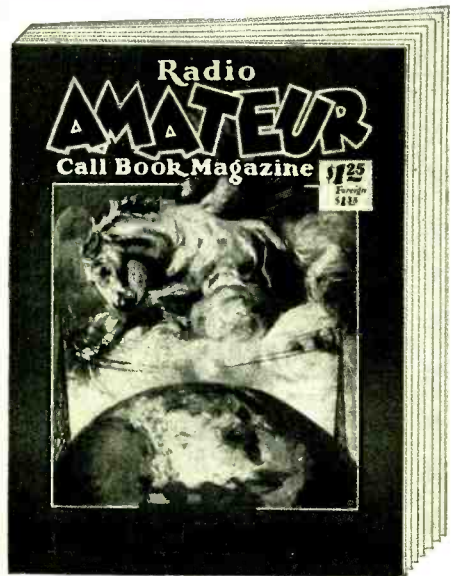

MARCH . . . JUNE . . . SEPTEMBER and DECEMBER

Annual subscription \$4.00

Single copies \$1.25

RADIO AMATEUR CALL BOOK, Inc.

608 S. Dearborn St.

Chicago, Ill., U. S. A.

RADIO

along in great style. "1492" was ambitious in his investigating around the shack of W6QD, but said there just wasn't a thing of interest to report—not even a W9. With that unkind remark I'm forced to call it quits for this time. See you next month.

U.H.F. Circuit Developments

[Continued from Page 36]

screen injection to the mixer, indicates that "pulling" of the oscillator is noticeable only on c.w. when the mixer and oscillator controls are not ganged. A pentode oscillator arranged for electron coupling at both tubes may completely overcome this effect. Cathode injections—not normally to be recommended because of the ill effects of a long cathode lead—was chosen by the C.A.A. in order to reduce oscillator power requirements for increased stability.

Band Changing

There is no reason to expect that a concentric-line-tuned receiver designed for 112 Mc. will not operate well on 56 and even 28 Mc. by putting a padding condenser across the open end of the line. Coils on 28 Mc. and above, particularly when shunted with ordinary receiving tubes, are not very effective; their performance will be outstripped by a relatively short—and practical—coaxial line if used with acorn tubes. The amount of capacity necessary to resonate short lines can be calculated or read from available charts.^{2, 3}

E. H. Conklin, "Transmission Lines as Circuit Elements," RADIO, April and May, 1939.

"RADIO" BINDER

Holds a year's copies of "Radio" and your copy of the big "Radio" Handbook.

Beautiful, red imitation leather, embossed in gold. Each book or magazine can be inserted or removed at will!

\$150 Continental U.S.A. Elsewhere **\$175**

THE EDITORS OF 1300 Kenwood Road,
RADIO Santa Barbara, Calif.



—that's what so many amateurs everywhere say —because they know that Ohmite Parts "stand the gaff" and do the job right day in and day out—no matter how severe the operating conditions! Insure your rig's performance too—take the same precaution specified by prominent manufacturers of amateur, commercial and broadcast transmitters and receivers—Use Ohmite Parts.

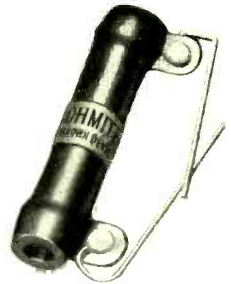

Brown Devils

Tough, dependable 10 and 20 watt vitreous enameled resistors for voltage dropping, bias units, bleeders, etc. Resistances from 1 to 100,000 ohms.

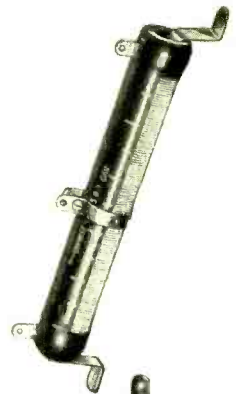

Adjustable Dividohms

Easily, accurately adjusted to resistance you want—or tapped where needed. Ideal voltage dividers. 10 to 200 watts. Resistances to 100,000 ohms.

Band Switch

A flick of the wrist on the knob of this popular Ohmite Band Switch gives quick, easy band change with really low loss efficiency. For rigs up to 1 K.W.

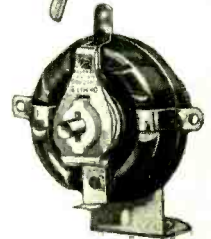

Get them at your Jobber or Send Today for Catalog 17
OHMITE MANUFACTURING COMPANY
4868 Flournoy Street Chicago, U.S.A.

OHMITE

RHEOSTATS RESISTORS TAP SWITCHES

UNBEATABLE SPRAGUE VALUES

The Dot
Changes Color



KOOLOHM RESISTORS . . . A development as revolutionary to resistors as the airplane was to transportation. Wires touch but do not short. Amazing non-inductive units sold at lowest prices ever. All values dissipate full wattage rating. Automatic overload indicator as illustrated above. Moisture-proof, heat-proof. Will not chip or break. Ask your jobber for Koolohms. Catalog free.

NOT A FAILURE IN A MILLION



The most famous condensers ever made—and still the fastest selling “by-pass” units on the market. Cost little, do a big job. Famous Sprague “inner seal” moisture protection and many other features. All ranges —at your jobber’s.

SPRAGUE “TC” TUBULARS

TOPS IN PERFORMANCE . . . TOPS IN SAFETY

Four outstanding features make Sprague Transmitting Condensers safest and best to use. (1) Lifeguard Insulation Caps protect you from shock at terminals; (2) Terminals are insulated from cans for twice the working voltage or more; (3) Metal cans may be grounded automatically through mounting clamps; (4) All condensers are oil-impregnated and oil-filled (not oil-impregnated and wax-filled) with SPRACOL the 500 degree flash protection oil.



(Unconditionally guaranteed.)
(Round or Rectangular types.)

SPRAGUE PRODUCTS CO., North Adams, Mass.

UNMATCHED SPRAGUE QUALITY

RADIO

Tubeless Noise Limiters

[Continued from Page 78]

It should be pointed out that no claim is made that any of these circuits will work more effectively on phone than the better noise limiter circuits now in use; the purpose is simply to show how the tubes already in the receiver—the detector and first a.f. stage—can be made to do the job. In the case of a c.w. receiver it is a different story, because the limiting action with this system is good regardless of signal strength. This is where many limiting circuits fall down on c.w.; the “threshold” control must be adjusted for c.w. signals of different strength, because a.v.c. cannot be used on c.w. and on a fading c.w. signal a compromise must be made. With the system shown here, 100% limiting action is obtained on c.w. signals regardless of fading or signal strength, and there are no adjustments to be made.

If it tires you to listen to “canary bird” p.d.c. notes, the “tubeless” system has another advantage; everybody sounds as though he were using a skimpy resonant filter, yet signals cover no more room on the dial than before. For c.w. operation exclusively, simply run the first a.f. tube at cutoff bias in the case of a diode or power detector, or at zero bias in the case of an infinite impedance detector.

Beat Oscillator Strength

It should be pointed out that for best operation of any noise limiter circuit on c.w., the beat oscillator carrier should be no stronger than necessary to give a satisfactory beat note. Best silencing will occur when the strength of the beat note is about the same as that of the received signal. This indicates the desirability of some provision for varying the strength of the b.f.o. A simple method is to employ a potentiometer or rheostat to vary the beat oscillator plate voltage. There will be negligible shift in the beat note as the oscillator voltage is varied, because the oscillator is so lightly loaded and because the frequency is so low.

If the receiver has separate r.f. gain (“sensitivity”) and a.f. gain (“volume”) controls, provision for adjusting the strength of the b.f.o. is not so important, because the relative strengths of the b.f.o. and signal can be varied by adjusting the r.f. gain control and the a.f. adjusted accordingly. In this case the a.f. control would be set at a suitable gain setting and left alone, the volume being adjusted by means of the r.f. gain control.

Background Noise Suppression

On c.w. signals which are overriding the steady “background noise” (such as beat

RADIO

oscillator hiss, etc.), the background noise can be eliminated simply by increasing the bias slightly beyond cutoff in the arrangement of figure 2. This does not apply to the type of high amplitude, short duration noise pulse which is acted upon by the limiting circuits, but to *steady* background noise. It will only work when the signal is definitely *stronger than the background noise*. The gain of the stage is reduced somewhat, but this can be compensated for by increasing the a.f. gain control.

"SSSS" and "SOS"

News dispatches from the war zone report that "SSSS" is rivaling "SOS" as the marine radio operators call of distress. If this is fact, the former is not internationally recognized as is the "SOS" signal in the International Morse Code.

In any event, the "SSSS" does not officially mean "Submarine Sighted" or any other particular words beginning with "S". The explanation is that the dot-dot-dot four times repeated (... ..), representing these letters, has a characteristic swing and through common understanding and usage identifies the nature of the distress case.

"SOS" does not mean literally "Save Our Souls" or "Save Our Ship" as is sometimes claimed, any more than the previous international distress call "CQD" meant "Come Quick Danger." All such calls are based on the speed and clarity with which they can be transmitted.

There was no special wireless call for sea emergency prior to the turn of the century, according to Federal Communication Commission records. About that time the Marconi International Marine Communication Com-

**Buy Quality, Yes—
BUT PAY LESS!**

Discover how much Lafayette can save you on nationally advertised "ham" equipment. Send for new radio catalog at once. It's **FREE!** And it's complete, saving you time as well as important money. Has everything you need—32 pages of HAM values and all guaranteed. Get the best for your rig—for less. Mail a postcard today.

LAFAYETTE RADIO

Dept. 6C—100 Sixth Ave., New York, N. Y.

Again it's **KENYON**

PRESENTING A BRAND NEW
FILAMENT TRANSFORMER
With Voltage Dropping Compensator

Designed
Especially for

THE NEW
RCA

811 and 812

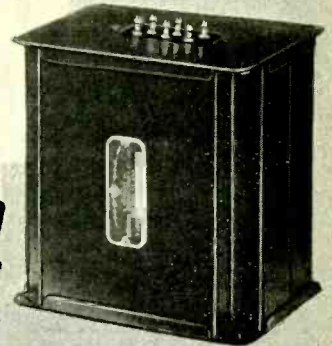

● Here is the latest from KENYON. A brand new transformer with an **EXCLUSIVE FEATURE** built right around the most popular tubes to ever hit the amateur market. Fully shielded, fully poured and vacuum impregnated. Constructed in our famous T-line 3-A case.

To compensate for the drop in voltage which usually takes place when the filament transformer is mounted away from the tube sockets, we have provided this unit with a tapped primary* to give the following secondary voltages: 6.3 volts, 6.45 volts and 6.6 volts at 8 amps.

KENYON Number T-387

Amateur Net Price \$2.40

* An exclusive feature.

HAVE YOU SEEN THE NEW KENYON AMPLIFIER KITS FEATURING CATH-O-DRIVE MODULATION?

Be sure you have our latest dope on the newest in **UNIVERSAL** amplifier kits! For Plate or Cathode Modulation or P.A. Work. Five to sixty watts. Save money by building them yourself! Your jobber can give you all the dope or write to us direct.

KENYON "50" 5 watts Class A Amateur Net \$18.75

Net

KENYON "150" 15 watts Class AB Amateur \$22.78

Net

KENYON "600" 60 watts Class AB2 Amateur \$35.13

Net

KENYON CATH-O-DRIVE TRANSFORMERS ARE AN ESTABLISHED SUCCESS!

Change that CAV Rig over and enjoy all the advantages of phone operation economically! Kenyon Cath-O-Drive Transformers will do it economically.

| Type | Sec. D. C. | Amateur Net |
|-------|------------|-------------|
| T-471 | 200 MA | \$2.40 |
| T-472 | 300 MA | 3.00 |
| T-473 | 450 MA | 3.60 |

See your jobber for **FREE** Literature or write us direct.

The **NEWEST** and the **OLDEST** . . .

Progress Radio Supply Co., Cleveland, Ohio.

Eugene G. Wile, Philadelphia, Pennsylvania.

Ask Them About **KENYON!**



KENYON TRANSFORMER CO. Inc.

840 Barry Street, New York, N. Y.

AMATEUR RECEIVER DE LUXE!



Sargent WAC - 44

Work
All
Continents
With
This
One

Look at These Features: "BAND SPREAD"

- 2 Stages of R.F. Pre-Selection
- Panel Line-up Adjustments
- Voltage Regulator
- Full-Vision, CALIBRATED, "Band Spread" Dial
- Crystal Re-Set Frequency Monitor
- Improved Noise Limiter
- Built-in 5-inch Jensen Speaker
- New Xtal Filter Circuit
- Audio Compensator

A whole, full-vision dial devoted exclusively to amateur bands and calibrations. And the calibrations MEAN SOMETHING—they are "right on the nose", — being checkable at any time against the Xtal frequency monitor. Dial markings for every 10 KC on 20 meter band, every 5 KC on 40, every 2 KC on 75! A real AMATEUR BAND TUNING DIAL.

Net Price, Complete \$139.00

Price includes a full set of R.C.A. tubes built-in speaker, power supply for 110 volts, 50/60 cycles A.C. Code Word "WACAA". Ready to operate.

Nothing else to buy.
Order NOW

Immediate Delivery -
Ask Your Distributor

E. M. SARGENT CO. 212 9th St., Oakland, Calif.

IMPROVED W. A. Z. MAP OF WORLD

The new, 28 x 50 inch, "DX" map consists of the W.A.Z. (worked all zones) map which shows in detail the forty DX zones of the world under the W.A.Z. plan.

An additional feature of this new, up-to-date edition is the inclusion of six great-circle maps which enable anyone, without calculations, to determine directly the great-circle direction and distance to any point in the world from the base city for the map in use!

35c

POSTPAID ANYWHERE

(SEVEN INTERNATIONAL REPLY COUPONS ACCEPTED AS 35c)

THE EDITORS OF **RADIO** 1300 Kenwood Road, Santa Barbara CALIFORNIA

RADIO

pany, Ltd., began equipping ships for radio-telegraph communication. In doing so it adopted "CQ", which had been in use in wire telegraph as a "general call" for many years, as a precedence signal for any ship desiring to communicate with another ship or shore station.

The need for a common distress call was recognized at the preliminary International Radio Conference held at Berlin in 1903. Here the Italian delegation suggested that in emergency a ship should send at intervals the signal "SSSDDD". No action was taken at this conference.

In 1904 the British Marconi Company instructed its ship radio stations to substitute "CD" for "CQ". Subsequently, the "D" was inserted in the old "CQ" call. At the 1906 International Radio Conference at Berlin, however, "SOS" was formally adopted. This combination was the outgrowth of "SOE" (.....) which had been used by German ships but which was somewhat unsatisfactory because the final dot was easily obliterated by interference.

Even so, "CQD" was so firmly established with some operators that its use was continued for some years thereafter. A notable example was its employment in summoning aid for the steamship *Republic* in 1909. "CQD" finally passed from the sea calls when the international radio conferences continued to approve "SOS".

U.H.F. Educational Broadcast Station

The University of Kentucky has made application to the FCC for a license to build and operate a broadcast station on one of the ultra-high frequencies set aside for the exclusive use of educational services. These frequencies already are being used by the public school systems of Cleveland, Ohio, and New York City.

BIG FREE CATALOG



ALL YOUR RADIO NEEDS

Here in this one big book you will find everything you need in radio... sets, parts and supplies... public address systems... amateur equipment... testers and kits... all of your nationally known favorites at lowest possible prices. Best of all, our service is better than ever... most orders are shipped same day they are received. Write now for your copy of this valuable book. Do it today.

PROMPT SERVICE ALWAYS

BURSTEIN-APPLEBEE COMPANY
1012-14 MCGEE STREET, KANSAS CITY, MO.

QRP

Reduce Power

By JERRY CROWLEY, W6HBT

There seems to be a prevailing thought that only those amateurs running an input of five hundred watts or more to the final amplifier should make provision to reduce power for local contacts. The result? Many short skip contacts on ten meters are missed because a couple of stations across town are tied up in a local rag chew, and putting in R9 plus signals at your QTH.

I grant that few transmitters with an input of less than five hundred watts are equipped with a means of reducing power. Yet, a ten-meter station with an input of a hundred watts feeding a beam antenna can lay down a terrific signal across town. If some means of reducing power were available, and the input could be cut to thirty or forty watts, would it help a great deal? I doubt it very much. Listening in on a few of the ten- or fifteen-watt portable-mobile rigs will soon prove that.

What then can we do to help out the situation? Here is one simple remedy. Since just a few watts input to a resonant antenna will put out such a strong signal, the answer lies not in trying to reduce power, but in doing something about the radiating system. Now what could be simpler than connecting a double-pole knife switch in the antenna feeders, and on local contacts switching over to a dummy antenna. The good old light bulb works fine.

Use a light bulb that will safely handle the output of the transmitter; don't forget that under full modulation it will have to dissipate somewhat more power than the r.f. carrier alone. You will have a nice signal for several miles without bothering the boys across town.

This system has worked out well for me. With an input of one hundred and thirty-five watts, and a hundred-watt light bulb for an antenna, I get R9 reports over a radius of five or six miles; but can't be heard across town. When I contact someone in that radius, I just throw over to the dummy antenna and my conscience is clear no matter how long the contact.



UNIVERSAL

Recording Chassis

With or without motors. For radio mics, and assemblies. Also cutting heads, arms, microphones, stands, accessories, etc. Attractive quantity prices.

UNIVERSAL MICROPHONE CO., LTD.
424 Warren Lane Inglewood, Calif.

FOR THOSE WHO WANT THE BEST

50% MORE R.F. OUTPUT* on 'PHONE!

at no extra cost by using the HY69 BEAM tetrode in your final amplifier.

Increased power output with the Hytron HY69 is possible for it has a 40-watt* plate dissipation compared with 25 watts for the equivalent cathode-type tubes (HY61, RK39, 807) which it replaces. When plate modulated it is not necessary to reduce the plate input power to the HY69 for the additional audio power input is safely dissipated by the 40-watt anode having special internal heat-radiating fins.



HY69 \$3.50 net

PHONE RATINGS*

- Plate and screen modulation
- Filament 6.3-volts @ 1.5 amperes
- Plate input (max.) .. 600 volts @ 100 ma.
- Screen input 225 volts @ 10 ma.
- D.C. grid current (approx.) 4 ma.
- R.F. driving power (approx.) 0.25 watt
- R.F. carrier power output 36 watts

* Above ratings are for continuous-service operation providing most watt-hours output per dollar. Full ratings up to 60 megacycles (5 meters). Fully shielded for R.F.—no neutralizing required.

The HY69 with its instant-heating thoriated-tungsten filament is ideally suited for all battery applications such as mobile and portable transmitters and high-power sound amplifiers. The HY69 conserves battery power since the filament can be off during stand-by periods.

Truly a universal tube, the HY69 is highly efficient as an oscillator, power doubler, buffer, final amplifier, class A and B audio amplifier-modulator. As a modulated doubler 27 watts R.F. carrier can be obtained—30 watts unmodulated.

Use the HY69 in your main transmitter—swap to your portable for summer—design the emergency rig for it.

Complete details from your jobber or factory.

On sale at all leading distributors.

HYTRON LABORATORIES



A DIVISION OF THE HYTRON CORP.

25 DERBY ST. SALEM, MASS.

MANUFACTURERS OF RADIO TUBES SINCE 1921

Policing the Ether

In administering and enforcing laws, regulations, and international treaties pertaining to radio, the Federal Communications Commission depends largely upon its field staff of 26 offices located strategically throughout the United States and its possessions, augmented by seven monitoring stations—at Atlanta, Baltimore, Boston, Grand Island, Nebr.; Great Lakes, Ill.; San Pedro, Cal., and Portland, Ore.

The monitoring stations, in general, do not participate in the investigation of "pirate" or other unlicensed stations other than to report and record their signals as proof of operation. This task is performed mainly by inspectors.

The 115 inspectors in the Field Division are radio engineers and, in addition, are capable radio operators, many having had previous experience in maritime, aviation, and other communications services. They are familiar with the procedure employed by authorized stations, including the military, and this assists them in uncovering illicit operations. In-

spectors are selected through Civil Service competitive examination.

Besides investigating unlicensed stations these experts inspect all classes of radio stations—broadcast, police, ship (domestic and foreign), amateur, aviation, and television; examine radio operators for various classes of licenses; monitor radio transmission for adherence to frequency, quality of emission and compliance with prescribed procedure; and investigate complaints of interference to radio reception.

A certain radio station was reprimanded recently for intercepting, decoding, and broadcasting secret radio communications of the British and German governments, in violation of the Federal Communications Act and treaty obligations. Also, there is definite provision in the Act requiring regulation by the Commission "for the purpose of the national defense."

As to apparatus and technique employed by inspectors, advantage is taken of certain fac-

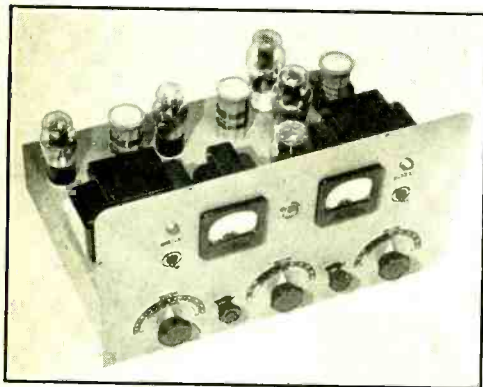

"10-20" FINAL

A "Hughes-Mitchell" Product

The "10-20" is primarily designed for 10 and 20 meter operation. Notice its extremely clean design and symmetrical layout. The "10-20" is designed for any triode specified, such as, 35T, 75T, 100T, HK-24, HK-54, RCA-808, RCA-812, T-20, T-40, T-55. The Panel model includes meters, panel, and brackets. Both models include grid and plate coil for either 10 or 20 meters, but less tubes. Extra set of coils \$3.00 per pair.

Panel Model
\$57.00 Net

Chassis Model
\$44.50 Net

"Hughes-Mitchell" products are Wired and Tested, and licensed by R.C.A. Prices are F.O.B. Los Angeles.

ASK YOUR DISTRIBUTOR for Bulletins No. 15 and 16.

**RADIO-TELEVISION
SUPPLY COMPANY, INC.**

1701 So. Grand Ave.

Los Angeles, Calif.

"BI-PUSH" De Luxe

A "Hughes-Mitchell" Product

EXCITER OR TRANSMITTER

40 Watts Output

3 Bands—1 Crystal

Hundreds of these "Bi-Push" Exciters are in use by Amateurs throughout the world. They, also, make ideal low power transmitters. The "Bi-Push" is now available in three models, Cabinet, Panel, and Chassis, the first two being supplied with 2 meters. All models are complete with RCA Tubes, set of Coils, and heavy duty Power Supply.

Cabinet Model
\$84.50 Net

Panel Model
\$79.50 Net

Chassis Model
\$70.50 Net

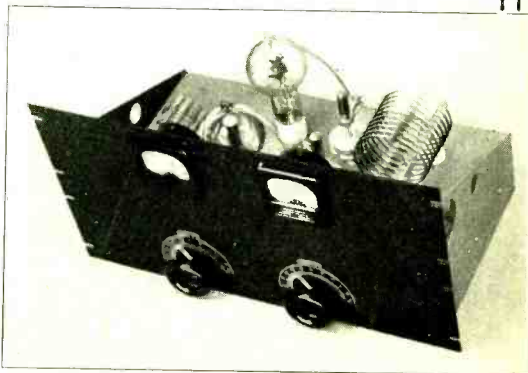

RADIO

tors such as the directive properties of antennas, attenuation of field intensity with increased distance from the transmitting antenna and skip distance phenomena. When taking radio direction finder bearing, allowance is made for reflections from standing waves on wires, coastline effect, fading and polarization of waves.

Frequently, an unlicensed station operating in the amateur bands first comes to the attention of an inspector when investigating a complaint of interference in the home of a broadcast listener by recognizing the interference as originating from key clicks in a telegraph transmitter even though the frequency of operation may be in a band many kilocycles removed from the broadcast band. Field offices also receive tips from the monitoring stations concerning the operation of illegal stations.

At each radio district headquarters, inspection cars are provided, one at least of which is equipped with an all-wave communication receiver which may be operated, if necessary, from the car's 6-volt battery while the car is in motion. Under certain conditions, it may be necessary to watch a station for a particular length of time. These receivers are constructed so that they may be removed from the car and operated from a 110-volt AC power supply available in a residence, tourist cabin or such other place that might be chosen by an inspector as a base of operation.

Mobile Units

The mobile units are equipped with special antennas to help run down unlicensed stations. The mobile equipment is also used to transport examination equipment to various points in the United States where applicants for operator licenses are examined. In addition, technical equipment necessary for inspection of radio stations is so transported.

Send Postage Stamp for
CATALOG

—OF NEW—

Radio Literature

**BOOKS, MAGAZINES,
MAPS, BINDERS**

THE EDITORS OF **RADIO** 1300 Kenwood Road, Santa Barbara
CALIFORNIA

Consider
CARDWELLS

WHEN YOU BUILD
Frequency Modulation Receivers

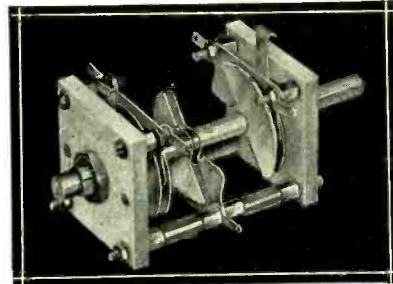

★
The New
TRIPLE
TRIM-AIR
TYPE
ER-10-AT

- 10 mmfds. per section
 - Capacity ratio better than 5 to 1
 - Isolantite insulation
 - Full double bearings
 - Rear shaft extended for ganging if desired
- Ham Net **\$1.80**

AND FOR THE PA-240
5 BAND R.F. AMPLIFIER

Have you your free drilling template and Instruction Bulletin? If not, see your jobber.

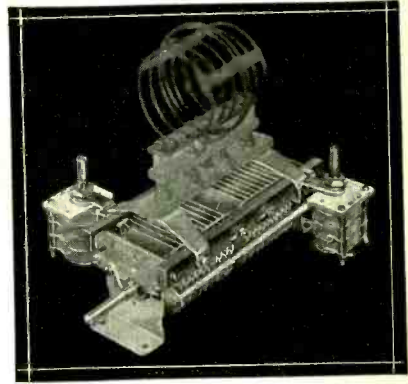

★
The
"AFU"
Plate Tank
Foundation

as used in Taylor Tube Manual, R.C.A. 240 watt phone output amplifier (described in November "Ham Tips"), and the CARDWELL PA-240 layout designed for application to any chassis by W-3DGP.
Type AFU Foundation — Ham Net **\$7.99**

CARDWELL #720 Feed-Thru Bushings
Finest glazed Alsimag #196

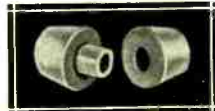

An insulating sleeve thru any panel up to 1/8" thick. For 1/4" panel-hole—takes 6-32 screw. As used in PA-240 R.F. amplifier.

Per set (1 male & 1 female) **15c**
Ham Net

THE ALLEN D. CARDWELL
MANUFACTURING CORPORATION
65 PROSPECT STREET, BROOKLYN, NEW YORK

DO YOU WANT TO LEARN WIRELESS and TELEGRAPHY?

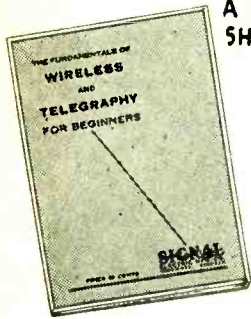

A BOOK EVERY AMATEUR
SHOULD HAVE —

Send Now!

15¢
POSTPAID
COIN, OR
STAMPS

Hundreds of amateurs have learned
from this book, so can you.

This book gives you the fundamentals of wireless and telegraphy. It contains the codes and how to learn them. Mail your order now to:

SIGNAL ELECTRIC MFG. CO., Menominee, Mich.

ESTABLISHED
1892



THE "RADIO" NOISE REDUCTION HANDBOOK

Tells in simple language how to eliminate or greatly reduce practically every form of radio noise with the exception of natural static.



Use of the noise-reducing systems described in this book often mean the difference between an unintelligible signal and one which can be read. Particular emphasis is laid on the elimination of the noise at its source. When this is impractical, a new, modification of the noise balancing method used in commercial work, which brings equally good results, is explained.

A complete description, theoretical and constructional, of the application of this method is included.

35c

U.S.A. (including possessions) Elsewhere

40c

THE EDITORS OF **RADIO** 1300 Kenwood Road, Santa Barbara
CALIFORNIA

RADIO

At certain field offices, mobile field strength measuring equipment is provided. This equipment is used primarily to determine the efficiency of broadcast station antennas. From the data accumulated, Commission engineers can ascertain whether a station is making legal use of its facilities. The actual coverage or service to the public from a technical standpoint is determined from these field intensity surveys.

Procedures

The first determinations made by an inspector on the track of an unlicensed station are the call letters employed by the station as well as the station or stations called, the type of emission, frequency or frequency band used for transmission, time and duration of operation, nature of the communication, and whether in plain text or code (if a telegraph station, characteristics of the operator's "fist") and any other peculiarities.

In cases of this kind a milliammeter requiring but a small current for full scale deflection is fitted with a crystal rectifier which in turn is connected to a wire concealed in the trouser leg of the inspector, or in a loop circuit made in the form of a vest worn by the inspector. A device of this kind is easily concealed and the meter can be easily held in the hand or pocket of the investigator as he proceeds from floor to floor, or door to door, observing at what point the highest deflection of the meter occurs.

Resourcefulness, keen power of observation, and patience on the part of investigators have been of invaluable aid in the locating of transmitters, as for example, observing that a certain light circuit on a back porch was nearly resonant and became incandescent each time the key of the transmitter was closed.

Postscripts and Announcements

[Continued from Page 62]

p.m. A snappy program of entertainment has been promised by the hamfest committee along with a reservation prize and door prizes for ladies and men, a good dinner, dancing, and a big raffle. Tickets are \$1.10 including tax. For reservations write W6ANU, 5060 Bancroft Drive, La Mesa, California.

New FCC Field Office

The establishment of a permanent FCC field office at Cleveland, Ohio, was ordered on December 12, to be effective January 1, 1940. It will be located in quarters used for the Commission's Great Lakes and Inland Waters Survey, now completed. This office will be a sub-office of the main district headquarters office at Detroit.

Yarn of the Month

[Continued from Page 68]

meal greeted him. She was beautiful coming down the hall to meet him, her face flushed and her eyes bright with excitement.

"There's a telegram from Hartford for you. It came about an hour ago and I could hardly wait until you came home." He tore at the envelope.

**CONGRATULATIONS STOP PLEASE
CONFIRM 56 MEGACYCLE QSO
REPORTED BY VK2KZ SEPTEMBER
TENTH STOP WHITECASTLE
TROPHY WILL BE AWARDED.**

He read it aloud, then watched the look of surprise and disbelief. Not trusting himself to speak, he reached for his pencil and scribbled a reply on the back of the telegram.

**SORRY MUST BE MISTAKE HAVE
BEEN INACTIVE FOR SOME TIME.**

Quick Phone - C. W. Changeover

[Continued from Page 33]

part of the circuit when very high voltage is used; however, in this particular installation, the relay winding is some 1600 volts or so above the potential of the contacts (in a half-kw. transmitter), and no sign of trouble has ever been noticed in nearly a year of operation.

Quite aside from the very apparent and very desirable standpoint of safety, the installation of such a changeover system is quickly justified by the increased ease and pleasure of operating. The "kick" of hooking up phone and c.w. stations, by virtue of the ability to shift to either type of transmission instantly, the solid satisfaction that comes when you jump from 20 c.w. to snag the first G of the morning to come over on 20-meter phone. down to the glow you get when you shift over, quickly and smoothly, to let some local hear what your voice sounds like, without having to waste ten minutes of the other fellow's time while you climb into the rig and change things. are all worthwhile. Perhaps if more of the brethren installed a similar set-up, they'd know more about how the other half was getting along—and then maybe we'd have less "phone vs. c.w." bickering, at a time when we can ill afford such dis-sension.

Title on unrevised *Radio Technical Digest* page-proof received from our printer: "Effect of Microphone Popularity on Percentage Modulation"!

Changes of Address

To become effective with
The Next Issue

**must be RECEIVED at SANTA BARBARA
by the 5th of this month**

Address labels are shipped to our mailers on that date. Remember: under U. S. postal laws, magazines sent to an old address are junked unless forwarding postage has been left in advance with the postmaster; unlike letters and cards, magazines are not forwarded either free or collect (except to addresses in the same city).

Circulation Department

THE EDITORS OF **RADIO** 1300 Kenwood Road, Santa Barbara
CALIFORNIA

Kindly send me the items listed below for which I enclose \$ _____ in payment.

- "Radio" (one year)
- "Radio" (two years)
- "Radio" (three years)
- "Radio" Handbook (standard edition)
- "Radio" Handbook (library edition)
- "Radio" Antenna Handbook
- "Radio" Telephony Handbook
- "Radio" Amateur Newcomer's Handbook
- "Radio" Noise Reduction Handbook
- Radio Technical Digest (one year)
- Radio Technical Digest (two years)
- Radio Binder
- Radio Technical Digest Binder
- New W. A. Z. Map

Name Call

Address

Note: All shipments are **prepaid** by us. Current editions are always supplied unless previous or future editions are requested in the original order.

LOVE AT FIRST SIGHT! BY W8EA

I WILL ALWAYS
DO MY BEST
TO PLEASE
THE RADIO
HAMS

WELL-YOU
SURE HAVE
GOT ME GOING
KID -

1940 RADIO HANDBOOK

RADIO
AMATEURS

The Marketplace

Classified Advertising

(a) Commercial rate 10c per word, cash with order; minimum, \$1.00. Capitals: 13c per word. For consecutive advertising, 15% discount for 3d, 4th, and 5th insertions; 25% thereafter. Break in continuity restores full rate. Copy may be changed as often as desired.

(b) Non-commercial rate: 5c per word, cash with order; minimum, 50c. Available only to licensed amateurs not trading for profit; our judgment as to character of advertisement must be accepted as final.

(c) Closing date (for classified forms only): 25th of month; e.g., forms for March issue, published in February, close January 25th.

(d) No display permitted except capitals.

(e) Used, reclaimed, defective, surplus, and like material must be so described.

(f) Ads not relating to radio or radiomen are acceptable but will be grouped separately.

(g) No commissions nor further discounts allowed. No proofs, free copies, nor reprints sent.

(h) Send all Marketplace ads direct to Santa Barbara accompanied by remittance in full payable to the order of Radio, Ltd.

TRANSMITTING TUBES REPAIRED—Save 60%. Guaranteed work. KNORR LABORATORIES, 5344 Mission St., San Francisco, Calif.

QSL's—Samples. Brownie, W3CJ1, 523 North Tenth Street, Allentown, Pennsylvania.

CRYSTALS—Police, marine, aircraft, amateur. Catalog on request. C-W Mfg. Co. 1170 Esperanza, Los Angeles, Calif.

AC Generators and plants—Have some good buys in used machines. Ideal for emergency. Katolight, Inc., Mankato, Minn.

CRYSTALS in plug-in heat dissipating holders—Guaranteed good oscillators. 160M-80M \$1.25. (No Y Cuts) 40X \$1.65. 80M Vari-frequency (5 Kilocycle variance) complete \$2.95. State frequency desired. C.O.D.'s accepted. Pacific Crystals, 1042 South Hicks, Los Angeles, Calif.

STEEL panels—Masonite. Chassis. Racks, Specials. R. H. Lynch. 970 Camulos, Los Angeles, Calif.

METERS, microphones, pickups, repaired—W9GIN, 2812 Indiana, Kansas City, Missouri.

QSL's—By W8N0S—"The QSL Craftsman"—13 Swan St., Buffalo, N. Y.

RECONDITIONED guaranteed receivers and transmitters all shipped on ten day free trial. Nearly all models cheap. For example: Late model SW3s \$9.00, Sky-Buddies \$15.00, FB7Xs \$15.00, Sky-Champions \$29.00, Breting 9s \$34.00, SX-24s \$49.00, NC80Xs \$59.00, NC81Xs \$59.00, SX-16s \$69.00, PR-15Ms \$79.00, RME-69s \$89.00, HRO Srs \$129.00. Terms. Send for free list. W9ARA, Butler, Missouri.

PRECISION TRANSFORMERS: Superior quality at lower prices. Full line—All types. Send for list. Custom winding and rebuilding. PRECISION TRANSFORMER COMPANY. Muskegon, Mich.

QSL's—That have eye appeal! Fritz, 455 Mason, Joliet, Illinois.

RADIO-KITS—\$3.95 up. Complete. Single band; all-wave; 5-10 tubes. Save 50%. Radio and parts catalog—FREE. McGee Radio, P-2015, Kansas City, Missouri.

CUSTOMBUILT speech amplifiers and modulators. Write for further information. Dick's Sound Service, 30—14th St., Jamestown, New York.

SPECIAL—custom ground 40M, x-cut crystals in ceramic holder within 5 k.c. \$2.50. KORADIO, Mendota, Illinois.

QSL's—Neater, new designs, faster service, samples. W4FVC, Gainesville, Georgia.

SWAP, used 160 phone rig for camera and supplies, typewriter or what. W9RJG South Range, Michigan.

HAVE RCA 813 with 50 hours use, Checked at Factory as Perfect. Want Riders Manuals, Signal Generator, Factory pre-selector, Taylor T-200, 100TH's, or what have you? W7F1V.

WILL finance any responsible amateur on any receiver or other equipment at cash prices with no interest charged. You pay ten monthly payments. Do you save? You figure. W2BDT.

NATIONAL AGSX. Want bandspread coils. Write details, condition, bands, price. W3AUB.

THE SYMBOL OF TECHNICAL AUTHORITY



ASSURES YOU OF
ACCURATE, COMPLETE
COVERAGE OF
AMATEUR,
SHORTWAVE and
EXPERIMENTAL
RADIO

Buyer's Guide

Where to Buy It

PARTS REQUIRED FOR BUILDING EQUIPMENT SHOWN IN THIS ISSUE

The parts listed are the components of the models built by the author or by "Radio's" Laboratory staff. Other parts of equal merit and equivalent electrical characteristics usually may be substituted without materially affecting the performance of the unit.

SMITH 2½ METER TRANSCEIVER

Page 11

- C₁—ZU-100-AS
- C₂—Cornell Dubilier type 1-W
- C₃, C₄—Cornell Dubilier DT-4P1
- C₅—Cornell Dubilier DT-4S1
- C₆—Meissner 22-5255
- R₁—Centralab Universal
- T—Thordarson 72-A-59
- CH—Thordarson T-14C61
- S₂—Centralab 1450
- Cabinet—Bud 999 with CB976 chassis
- Battery Pack—Burgess 4TA60
- Feed Through Insulators—Johnson type 42

NORTON PHOTO TIMER

Page 23

- C₁—Aerovox UC600
- C₂, C₃—Aerovox 484
- C₄—Aerovox PRS-150

- R₁, R₂, R₃, R₄—IRC BT-½
- R₅—IRC 13-140
- R₆, R₇—Ohmite Brown Devil
- S₁—Mallory-Yaxley 3215J
- S₂—Mallory-Yaxley 2006
- Tubes—RCA

SMITH SENSITIVE F.S. METER

Page 37

- C₁—Cardwell ZR-50-AS
- C₂—Sprague 45-35
- C₃—Sprague 1FM-35
- C₄—Sprague 1FM-21
- R—Centralab 516
- M—Triplet 321
- Cabinet—Bud 999 with chassis
- Feed-Through Insulators—Johnson 44
- 1½-Volt A bat.—Burgess "Little Six"
- 45-Volt B bat.—Burgess B-30
- 4½-Volt bat.—Burgess 5360

Advertising Index

| | | | |
|--|----|--|-----------|
| Aerovox Corporation | 75 | Premax Products | 84 |
| Allied Radio Corporation | 69 | Radio Amateur Call Book, Inc. | 86 |
| Bliley Electric Company | 77 | Radio Manufacturing Engineers, Inc. | Cover III |
| Bud Radio, Incorporated | 9 | RCA Manufacturing Co., Inc. | Cover IV |
| Burstein-Applebee Company | 90 | Radio Television Supply Company | 82, 92 |
| Candler System Company | 74 | RADIO | 79, 95 |
| Capitol Radio Engineering Institute | 76 | RADIO <i>Amateur Newcomer's Handbook</i> | 70 |
| Cardwell Manufacturing Co., The Allen D. | 93 | RADIO <i>Antenna Handbook</i> | 84 |
| Centralab | 81 | RADIO Binder | 87 |
| Cornell-Dubilier Electric Corp. | 7 | RADIO Catalog | 93 |
| Eitel-McCullough, Inc. | 65 | RADIO HANDBOOK | 71, 96 |
| Halicrafters, Inc., The | 3 | RADIO <i>Noise Reduction Handbook</i> | 94 |
| Harrison Radio Co. | 86 | Radio Technical Digest | 68 |
| Heintz and Kaufman, Ltd. | 83 | RADIO <i>WAZ Map</i> | 90 |
| Henry Radio Shop | 67 | Sargent Co., E. M. | 90 |
| Hytronic Laboratories | 91 | Signal Electric Company | 94 |
| Kenyon Transformer Co., Inc. | 89 | Solar Manufacturing Corporation | 76 |
| Lafayette Radio | 89 | Sprague Products Company | 88 |
| Mallory & Company, P. R. | 73 | Standard Transformer Corporation | Cover II |
| McGraw-Hill Book Company | 72 | Taylor Tubes, Incorporated | 5 |
| Meissner Manufacturing Company | 85 | Thordarson Electric Manufacturing Co. | 63 |
| Montgomery Ward | 80 | Turner Company, The | 85 |
| Ohmite Manufacturing Company | 87 | Universal Microphone Co., Ltd. | 70, 91 |
| Pacific Radio Publishing Company | 80 | | |

Did you know?

90KC.

60mc.

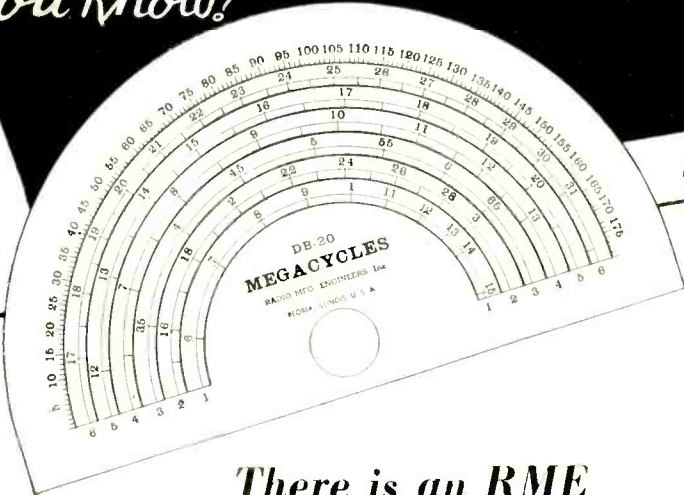

*There is an RME
for every frequency*

The scope of RME activity is broad and far reaching. The entire useful radio spectrum is serviced by means of some RME unit. No matter whether your receiving needs are situated in the long waves, or whether your interest lies in the ultra-high frequencies, you will find RME equipment available for precision reception. Our catalog will analyze your needs.

90-608Kc.
LF-90 INVERTER



Radio Mfg. Engineers
• —Inc.— •
111 Harrison Street
Peoria, Illinois

550-32000Kc.
RME 69-70

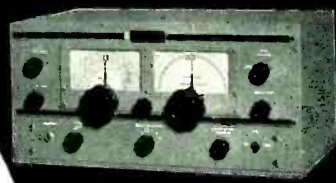

28-60mc.
DM-HF SERIES

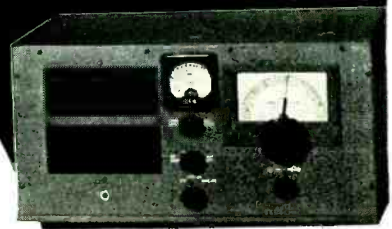

This ONE TUBE covers them all!

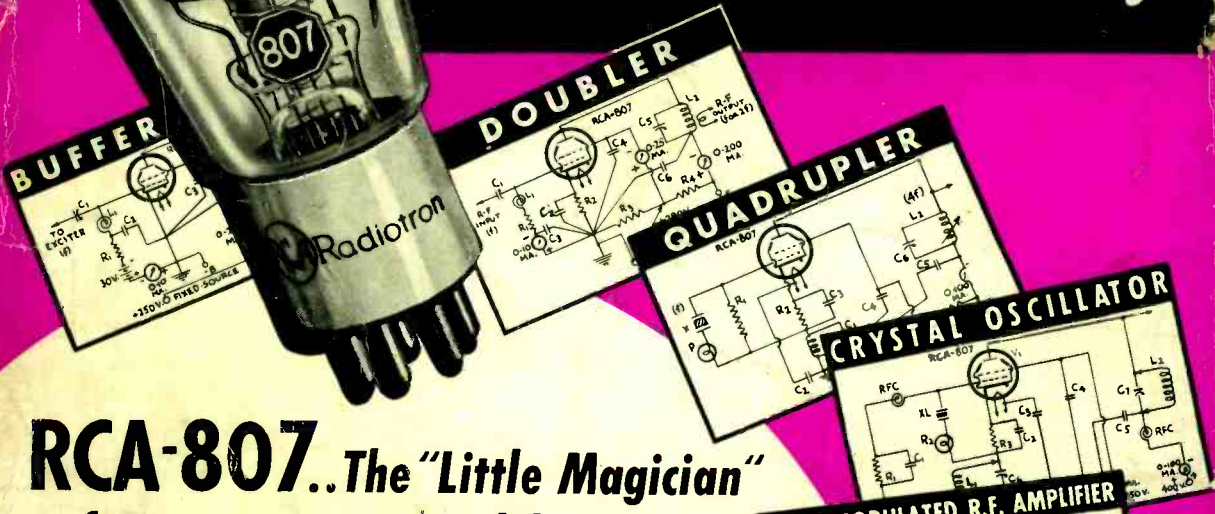

RCA-807..The "Little Magician" of Beam Power Amplifier Tubes

Most hams have used the RCA-807 Beam Power Amplifier, but not all are familiar with its ability to turn in a record-breaking performance on literally dozens of jobs. No matter how often you change your rig, there's nearly always a place for this versatile little tube. From crystal oscillator to doubler, quadrupler, buffer, Class C r-f amplifier, grid-modulated r-f amplifier, or modulator you can shift this little magician of beam power tubes and, each time, be assured of performance and durability not to be beaten at any price. It is especially useful for a low-power, portable, storage-battery-operated transmitter; a 6J5-G crystal oscillator will drive it very nicely. The RCA-807 is, without doubt, the handiest tube in any amateur shack. It will pay you to get acquainted with all of its countless possibilities.

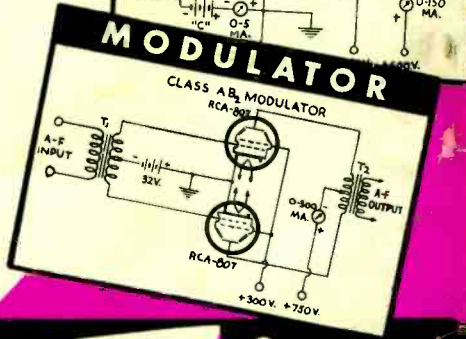
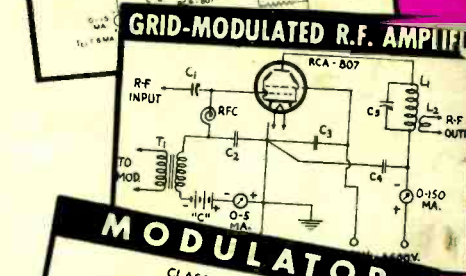
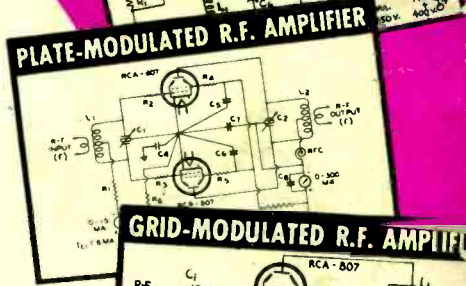

RCA-807—HALF A DOZEN TUBES IN ONE
 Plate voltage, 750 V. Plate Dissipation, 30 W.
 Plate input, 75 W. Amateur Net, \$3.50

The above ratings are maximum RCA ICAS Ratings (Intermittent Commercial and Amateur Service) for Class C Telegraphy.

All about Cathode Modulation! Ask your jobber for a copy of the Jan.-Feb. issue of RCA "Ham Tips".



RCA MANUFACTURING CO., INC.,
 CAMDEN, N. J.
 A Service of The Radio Corporation of America

Radio Tubes

FIRST IN METAL—FOREMOST IN GLASS—FINEST IN PERFORMANCE