

# RADIO

ESTABLISHED 1917



PROPERTY OF - F. E. J

RADIO AMATEUR STATION W6JWF  
1403 1/2 San Bruno Avenue  
San Francisco, California

February, 1936 — No. 206

30c in U.S.A. and Canada

1/3 in the United Kingdom  
2/- in Australasia

## THIS MONTH:

- New Multiband Antenna System
- 
- A New All-Band Transmitter
- 
- Instantaneous 75-160 Meter Excitation
- 
- "Modulation Movies"
- 
- Building Home-Made Air Condensers
- 
- Improving the Class B Amplifier
- 
- A DeLuxe U.H.F. Superheterodyne
- 
- Advice on Care of Transmitting Tubes

# EIMAC TRANSMITTING TUBES

Don't be

*Penny Wise . . . Pound Foolish*

when buying transmitting tubes

Remember—an EIMAC TUBE in that low power transmitter of today will give superlative performance, not only now, but in the future when you desire to increase power. The initial cost is only a little higher.

There is an EIMAC TUBE for every purse and service.

**EIMAC 50T—**

R.F. Output 90-250 watts  
Class "B" Audio 100-350 watts

Price \$13.50

**EIMAC 150T—**

R.F. Output 120-450 watts  
Class "B" Audio 200-750 watts

Price \$24.50

**EIMAC 300T—**

R.F. Output 200-800 watts  
Class "B" Audio 300-1250 watts

Price \$60.00

**EIMAC 500T—**

R.F. Output 400-1350 watts  
Class "B" Audio 500-2000 watts

Price \$175.00

All EIMAC TUBES use the rare metal TANTALUM for grids and plates permitting EIMAC to guarantee indefinitely against failure caused by gas released through accidental overload.

EIMAC TUBES are the unanimous choice of those amateurs who demand—  
Maximum Performance—Maximum Life—Maximum Value for each dollar invested.

EIMAC TUBES ARE AVAILABLE AT YOUR LEADING DEALER

**EITEL-McCULLOUGH, Inc.**

SAN BRUNO, CALIFORNIA

U. S. A.

CABLE "EIMAC"



The Ace of Professional Receivers . . .

# SILVER MASTERPIECE IV<sub>a</sub>

CUSTOM-BUILT • ALL-WAVE • WORLD-WIDE

The superlatively flexible receiver for professional and amateur use . . . also for high-fidelity broadcast reception. Now equipped with eight-pin sockets which take either the new Octal-based glass tubes or metal tubes. Many new and unduplicated features. Mail coupon for Free 32-page "Blue Book" giving complete technical description, also

**NEW LOW PRICES and  
NEW EASY TERMS!**

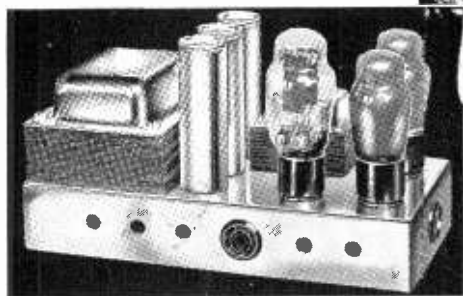
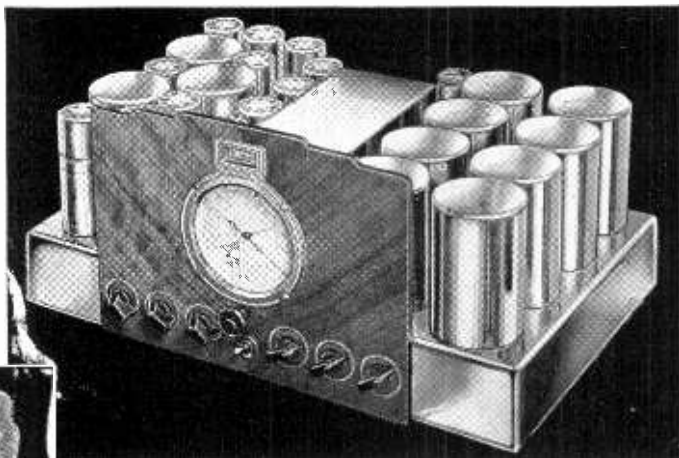

## 30 DAYS FREE TRIAL!

Try the MASTERPIECE IV<sub>a</sub> for 30 Days in your own home or laboratory. If it fails to PROVE to your ENTIRE SATISFACTION that it's the finest amateur receiver you've ever seen, return it undamaged and get your money back instantly.

## JONES-SILVER "SUPER GAINER"

**Three-Tube  
Superhet**

**The Ideal Set for  
Beginners**

The Super Gainer, with dual R.F. and I.F. regeneration, gives results almost equal to the most expensive factory built superhets. Its sensitivity is unlimited, exceeding even that of the highest priced receivers. Its selectivity is controllable—anything up to practically single signal.

Price fully assembled, wired and tested, with one pair of coils for 80 meter amateur and 49 meter broadcast, \$23.40 net. Add for four additional pairs of coils to cover 10, 20, 40 and 160 meter amateur and all s.w. broadcast bands, \$4.50 net. Add for complete A.C. and D.C. operation, all wired and ready to go, \$4.50 net.



## THE NEW SILVER "5D" SHORT WAVE SUPERHET

Amateurs all over the country are singing the praises of this 10-Tube High-Frequency Superhet. Has more valuable features than any other communication receiver at anywhere near its price. Covers all five amateur and all s.w. broadcast bands. Available direct from the laboratory or through your jobber, complete with 8-inch Jensen concert speaker, Bliley crystal, and 10 Raytheon tubes, for \$109.80 net to amateurs.

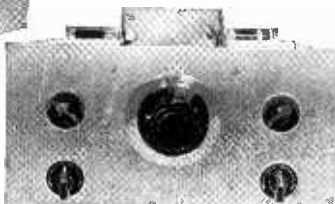

**McMURDO SILVER CORPORATION**  
3362 N. Paulina St., Chicago, Ill.

- Send Free 32-page "Blue Book", with low prices and easy terms on MASTERPIECE IV<sub>a</sub>.
- Send Free Circulars describing the 5D Superhet and the "Super Gainer".
- Enclosed 10c for Manual of Design, Construction and Operation of 5D Superhet.

Name .....

Address .....

City.....State.....

2RM

## McMurdo Silver Corp.

DIVISION OF G.P.H. INC.

3362 NORTH PAULINA STREET, CHICAGO, ILL.

RADIO, February, 1936, no. 206. Published monthly except August and September by Radio, Ltd., 7460 Beverly Blvd., Los Angeles, Calif. By subscription, \$2.50 yearly in U.S.A. Entered as second-class matter March 7th, 1934, at the postoffice at Los Angeles, Calif., under the Act of March 3, 1879.

# RME

# 69

9 TO 550 METERS

SINGLE SIGNAL SUPER

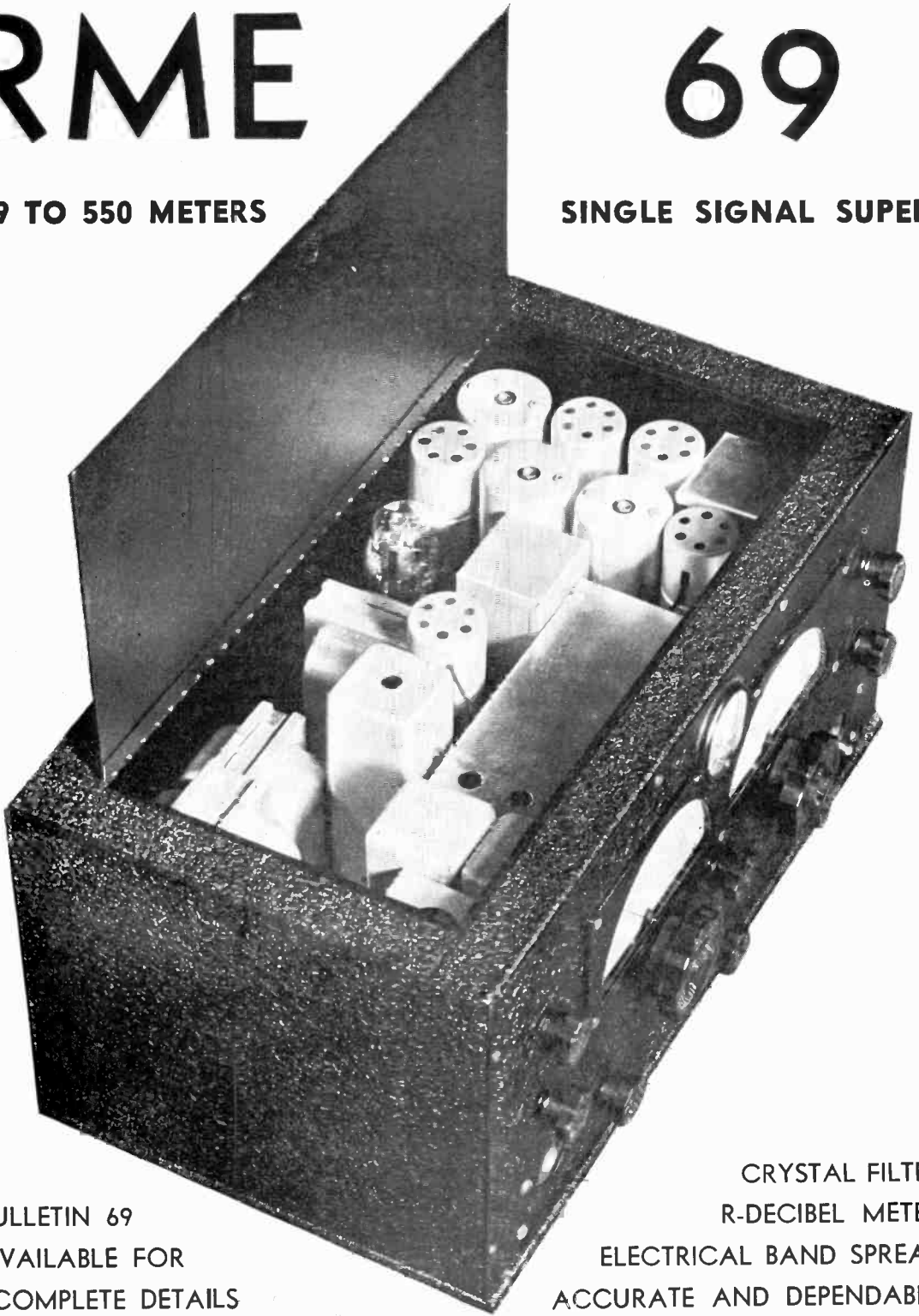

BULLETIN 69  
AVAILABLE FOR  
COMPLETE DETAILS

CRYSTAL FILTER  
R-DECIBEL METER  
ELECTRICAL BAND SPREAD  
ACCURATE AND DEPENDABLE

**RADIO MFG. ENGINEERS, INC., 306 FIRST AVE., PEORIA, ILL.**



*The publishers assume no responsibility for statements made herein by contributors and correspondents, nor does publication indicate approval thereof.*

CONTENTS

With the Editors	9
Modulating the All-Band Transmitter— <i>Ralph O. Gordon, W'6CLH</i>	10
"Modulation Movies"— <i>John L. Reinartz, W'1QP</i>	15
A Resonant Strip Oscillator— <i>Durward J. Tucker, W'5VU</i>	18
Grid Bias Detection— <i>Frank Offner, W'9FTO</i>	20
Building Fixed Air Condensers— <i>Robert S. Kruse</i>	22
A High-Fidelity U.H.F. Transmitter— <i>J. W. Smith</i>	25
The 300-T in Experimental Circuits— <i>Frank C. Jones</i>	28
Hams Across the Sea	32
A DX "Yardstick", W.A.Z.	34
An All-Band Transmitter— <i>Frank C. Jones</i>	40
A Multiband Antenna for High Frequencies— <i>Arthur A. Collins and L. M. Craft</i>	44
An Ultra-High Frequency Superheterodyne— <i>Walter H. Grosselfinger, W'2ATQ</i>	48
Instantaneous 75-160 Meter Excitation— <i>W. W. Smith, W'6BCX</i>	52
Calls Heard and DX Departments	54
28 and 56 Megacycle Activity	56
The Class C Amplifier— <i>J. N. A. Hawkins, W'6AAR</i>	58
The "5 Meter QRM Dodger"— <i>R. J. Haggerty, W'6JMI</i>	61
An Unusual Mobile Antenna Mounting— <i>H. Selvidge</i>	64
Notes on the Care of Transmitting Tubes— <i>J. N. A. Hawkins</i>	66
Getting the Most from the Pi-Type Antenna Coupler— <i>Robert B. Parmenter, W'9LPM</i>	69
Improving the Class B Amplifier— <i>D. E. Replogle</i>	72
The Marketplace	105

"RADIO" CONTRIBUTIONS

Contributions to our editorial pages are always welcome; though they will be handled with due care we assume no responsibility for those which are unsolicited; none will be returned unless accompanied by a stamped, addressed envelope. We do not suggest subjects on which to write; cover those you know best; upon request, we will comment on detailed outlines of proposed articles, but without committing ourselves to accept the finished manuscript.

Since we regard current "chiseling" policies as decidedly unfair, a small payment will be made, usually upon publication, for accepted material of a technical or constructional nature. Freehand, pencilled sketches will suffice. Good photographs add greatly to any article; they can easily be taken by the layman under proper instructions. For further details regarding the taking of photographs and the submission of contributions see "Radio" for January, 1936, or send stamp for a reprint.



# RADIO

7460 BEVERLY BOULEVARD  
LOS ANGELES

Phone: **Whitney 9615**  
Published by **Radio, Ltd.**  
**Eastern Business Office:**  
500 Fifth Avenue, New York  
Phone: **CHickering 4-6218**

Direct all correspondence to the home office at  
Los Angeles except as otherwise requested.

**San Francisco Office:**  
Pacific Building  
821 Market Street

**Cable address:**  
**Radiopubs, Los Angeles**  
**Eastern Editorial Office**  
and **Laboratory: Great Hill Road,**  
**Guilford, Connecticut**

## Rates and Notices

### Single Copy Rates

On newsstands:

30 in U.S.A. and Canada  
1/8 in the United Kingdom  
2/- in Australia and New Zealand

By mail, postpaid from home office:

30c in U.S.A., Canada, and all countries  
which take the \$2.50 subscription  
rate; back copies, 5c extra.  
40c elsewhere; no extra charge for back  
copies when available.

(These rates do not apply to annual or other  
special issues)

### Subscription Rates

U.S.A.\* (and possessions), Canada, An-  
dorra, Argentina, Bolivia, Brazil,  
Chile, Columbia, Costa Rica, Cuba,  
Dominican Republic, Ecuador, Guate-  
mala, Haiti, Honduras, Mexico, New-  
foundland, Nicaragua, Panama, Para-  
guay, Peru, Salvador, Spain (and 1 Year 2 Years  
possessions), Uruguay, and Venezuela;  
duties, if any, not included..... **\$2.50\* \$4.00\***  
Elsewhere, duties, if any, not included **3.25 5.50**

\*In California, add 3% sales tax.

### FREQUENCY

Published monthly under date as of the following  
month; ten issues yearly including special annual  
number; the August and September issues (which  
would normally appear in July and August) are omi-  
tted. Short-term subscriptions are accepted pro-rata,  
but no special numbers will be included.

### Terms and Remittances

Terms, strictly cash or equivalent with order. All  
foreign and territorial remittances must be payable  
*at par* in U.S.A. or Canadian funds or at current ex-  
change in British funds. Cash, stamps, "bearer in-  
struments", etc., are at sender's risk. Gummed, un-  
used U. S. postage stamps accepted in small amounts;  
3c denomination preferred.

### Back Copies

Subscriptions cannot be started with back issues.  
Back copies, if available, will be supplied from the  
home office at single copy rates above.

### Changes of Address

Notice of change of address must reach us by the first  
of month preceding nominal date of issue with which  
it is to become effective. We will not supply back  
issues nor pay forwarding postage because of failure  
to receive such advance notice.

### Advertising

Advertising is accepted only at terms stated on our  
current Advertising Rate Card which will be sent on  
request to the Los Angeles or New York offices. For  
classified advertising, see classified section of any  
issue.

### PRINCIPAL FOREIGN AGENTS

Canada: John A. Holmes, 2888 E. 1st Ave., Vancouver.  
Europe: N. E. Read, 37, Willow Street, Oswestry,  
Shropshire, England.  
Australasia: "The Bulletin," Box 2521BB, Sydney.

## The Staff

### Technical and Editorial Department

Technical Director and Associate Editor  
W. W. SMITH, W6BCX

Editor

K. V. R. LANSINGH, W6QX

Engineering Editors

FRANK C. JONES, W6AJF

ROBERT S. KRUSE,<sup>1</sup> W1FG

J. N. A. HAWKINS, W6AAR

Assistant Editors

HERBERT BECKER, W6QD

GEORGE D. WALKER,<sup>2</sup> W4CTO

E. H. CONKLIN,<sup>4</sup> W9FM

CHARLES A. HILL, W6BRO

RUFUS P. TURNER,<sup>3</sup> W1AY

Technical Consultants

RALPH O. GORDON, W6CLH

JAMES M. SHARP, JR., W6DMY

CHARLES D. FERRINE, JR., W6CUH

Laboratory Assistants

RAYMOND DAWLEY, W6DHG

MARTIN A. BROWN, W6ABF

FAUST GONSETT, W6VR

JACK HARWOOD, W6DIZ

LOUIS E. TOTH, W1BNR

Technical Draftsmen

M. S. DAVIS

WILLIAM ROBERTS, W3BOI

Photographer

ROBERT NELSON

Editorial Secretary

D. O. WORTHINGTON

### Business Department

Publisher

K. V. R. LANSINGH

Advertising Director

H. W. DICKOW<sup>5</sup>

Managing Editor

M. Q. HAURET

Circulation Manager

B. L. HOVER

Eastern Manager

V. R. LANSINGH

### Correspondence and Manuscripts

Address all correspondence and manuscripts to the  
home office at Los Angeles except as follows:

1. Technical and constructional manuscripts and  
relevant correspondence from east of the Missis-  
sippi River which may be sent to R. S. Kruse<sup>1</sup>.
2. *Radiodisties*, *Strays*, and the like may be sent to  
Rufus P. Turner<sup>3</sup>.
3. Calls Heard may be sent to George Walker<sup>2</sup>;  
also dx news and station descriptions from east-  
ern America and from transatlantic countries.

Unusable, unsolicited manuscripts will be destroyed  
unless accompanied by a stamped, addressed envelope.

Copyright, 1935. All rights reserved.

Reproduction without permission is forbidden; permission  
is usually granted amateur radio papers on request.

Printed in U.S.A. by

GLENDALE PRINTERS, GLENDALE, CALIFORNIA

<sup>1</sup>R/9 Laboratory, Great Hill Road, Guilford, Connecticut.

<sup>2</sup>Box 355, Winston-Salem, North Carolina.

<sup>3</sup>159 W. Springfield Street, Boston, Massachusetts.

<sup>4</sup>412 N. Main St., Wheaton, Illinois.

<sup>5</sup>Care San Francisco office.



★ ★ ★ ★ ★  
*Found Only in the New 1936 "Radio Handbook"*

*By Frank C. Jones and the editorial staff of "Radio"*

# Five Star Features . . .

- ★ **1 ONE-TUBE 2½ AND 5 METER TRANSCEIVER.**  
• A new Jones development . . . a transceiver using a single 76 tube, . . . high output on 2½ and 5 meters. Most practical one-tube transceiver ever shown. It's in the great, new 1936 Handbook by "RADIO".
- ★ **2 TWO-TUBE ULTRA-SELECTIVE "SUPERHET." A Sensation!**  
• Here's **SOMETHING!** A spectacular development. An amateur 2-tube superheterodyne that performs sensationally even on 10 meters. Unquestionably the finest development yet released by Jones. It's in the new 1936 Handbook by "RADIO" . . . and a full set of pictorial working plans is included.
- ★ **3 THREE-TUBE JONES EXCITER.**  
• Equal output on 10, 20, 40, and 80 meters, using a single crystal and an ingenious wave-switching arrangement. The answer to all-band operation from a single crystal. Output 10 watts. Every amateur will want this 1936 Exciter. More output and more efficiency than any other exciter yet developed. It's in the 1936 Handbook by "RADIO" . . . with complete working plans.
- ★ **4 FOUR-BAND SUPERHETERODYNE.**  
• A 2-kilocycle phone superheterodyne—uncanny in performance. The answer to the fone man's problem. Bust through the QRM with this advanced 1936 Jones development. Completely described, with all working plans, in the great, new 1936 Handbook by "RADIO".
- ★ **5 FIVE SURPRISE FEATURES — ALL NEW.**  
• This time "RADIO" will give you 5 red-hot surprises in its 1936 Handbook . . . not just ordinary improvements, nor trick circuits . . . but something **fundamentally** new. Expect great things . . . these secret features will be the talk of the entire amateur world. When the editors of "RADIO" speak . . . the radio world listens. In the new 1936 Handbook you find so many new things you won't know whether to build them all at one time, or one at a time. Literally, "RADIO's" new Handbook begins where other books leave off. It gives you **FACTS** . . . no poppycock horseplay.

— OUT IN FEBRUARY —

Late As Usual—Better Than Usual—\$1.00, as Usual  
(Foreign, \$1.15)

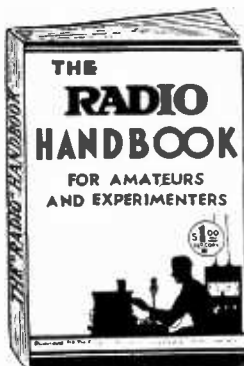

100,000 COPIES

RADIO, Ltd., publishers of "RADIO",  
7460 Beverly Blvd., Los Angeles, Calif.

Send me ..... copies of the greatest radio amateur Handbook ever produced . . . the 1936 Handbook by "RADIO".

[Dealers and jobbers: Attach this coupon to your letterhead and send to Pacific Radio Publishing Co., Pacific Bldg., San Francisco for quotations on trade prices.]

Name..... Call.....

Street and Number.....

City and State.....

FOR BETTER RADIO

*Use*

# Hammarlund TRANSMITTING CONDENSERS

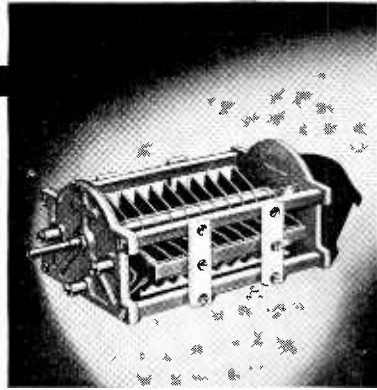

- 1 MAXIMUM RIGIDITY — LIGHT WEIGHT — ISOLANTITE INSULATION
- 2 CAST ALUMINUM END PLATES — TABLE OR SHELF MOUNTING
- 3 SPLIT FRONT BEARING — REAR BALL BEARING — NON INDUCTIVE WIPING CONTACT
- 4 HEAVY WIDE SPACED ALUMINUM PLATES — ROUND EDGES FOR HIGHER VOLTAGES
- 5 SINGLE AND SPLIT STATOR TYPES — 18 SIZES — 30 TO 1000 MMF. — VOLTAGES 1000 TO 13000
- 6 FULLY GUARANTEED

# HAMMARLUND *High-Frequency* SOCKETS



Canadian Office  
41 West Avenue North,  
Hamilton, Ontario

ONLY the highest grade, lowest loss, strongest Iso-lantite material is used in Hammarlund Sockets. Glazed on top and sides and treated underneath to minimize surface leakage under conditions of high humidity. With long leakage paths between new-type positive side-gripping contacts, Hammarlund Sockets are ideal for high-frequency work. The contacts *cannot twist, loosen or shift position* with changes in temperature or humidity.

A new circular guide-groove facilitates insertion of prongs. Made for 4, 5, 6 or 7 prongs, 60c each list.

Also a new, exceptionally efficient "Acorn" socket for .5 to 5-meter work. \$1.50 each list.



Write Dept. PR-2 for Catalog

Hammarlund Manufacturing Co.

424-438 W. 33rd St., New York





RADIO  
with the  
EDITORS

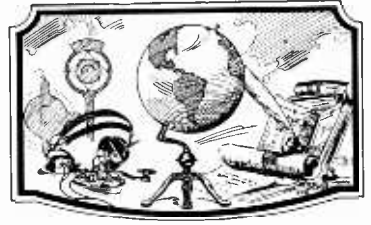

Maybe 20,000,000 Frenchmen can't be wrong, but every reader of RADIO seems to be.

December RADIO carried radiatorial comment anent the good, old days of commercial radio, days before we had "licenses", QRM, pure d.c. signals—days before we even had Warner. A



questionnaire was part of the radiatorial comment. The follow-question, asked as part of an oral examination given those who applied for a "Certificate of Skill" as Commercial Radio Operator was printed in the December issue. Readers were asked to provide the proper answer. Not a single reader that wrote in answered the question correctly. Here it is:

(1)—"You are applying for a Certificate of Skill as Wireless Operator. In order to qualify, you must first answer this question—Your station is in perfect shape. Absolutely *nothing is wrong*. I repeat—all of the equipment is in *perfect operating condition*. Yet you cannot hear a single station. Why?"

This question was asked of some who applied for the Certificate of Skill. Many failed to answer it *correctly*. Do you know why the operator didn't hear a single station, even though his equipment was in perfect operating condition? Write your answer to this damphool question on a post-card, send it to the editor, and a list of names of "successful applicants" will be printed in these columns next month.

And, believe it or not, the answer to the question is—*There was no station transmitting at the time.*

(Since the above was written and just as we go to press, four correct answers have been received. My, my, what bright students. Or maybe they took the examination way back in the "good, old days".)

#### That 30c Price

Perhaps comment of a "business" nature is out of place in an editorial section. Just the same this seems as good a place as any in which to answer a number of comments received on this matter.

It is perhaps superfluous to say that we believe that the new RADIO is worth thirty cents of any amateur's money. Not only has there occurred a notable (and expensive) improvement in the physical makeup of the magazine, but more important RADIO's increasing reputation as "The Worldwide Technical Authority of Amateur, Shortwave, and Experimental

Radio" has been earned by hiring some of the best brains in the field, for which 5c appears to us as a small and well worth while premium.

Nevertheless it is hoped that it will be possible in a few months to reduce the single copy price once again to 25c if RADIO's circulation continues to grow at a rate comparable to that of the last 60 days.

Have You Ever Looked at it in This Way?

Barnum continues to be right, even in this modern day and age. The unsuspecting radio amateur will swallow almost anything that is written, especially the high-power propaganda prepared by trained highly-paid specialists who profit from the amateur's achievements.

There is a statement which has been given world-wide publicity, one that calls for *loyalty* to an organization on the part of every licensed radio amateur. True, one can be loyal to an organization but it is likewise the duty of that organization to be *loyal* to its membership!

As we sit in our easy chairs and blow a ring or two of smoke from ancient pipes into the QRM-infested atmosphere of our radio shacks, we ponder for a moment and give thought to what this *loyalty* business is all about. We see someone writing out a check for \$2.50 for a subscription to an amateur radio magazine. He subscribes because he wants that magazine, not because he wishes to purchase \$2.50 worth of *loyalty* from anyone. When we subscribe to the *Saturday Night Stick*, *Snappy Stories*, or *Untrue Detective Tales*, we expect to get what we pay for, a year's supply of interesting, instructive, and entertaining literature. The publishers of those magazines do *not* expect us to be loyal to them . . . *not at all!* When they get our \$2.50 it is *up to them to be loyal to us* . . . and to give us what we paid for. That's the way to visualize this *loyalty* racket. If an organization, kind-hearted and true, sends us without cost a subscription to its magazine, then and only then may it perhaps expect us to owe some loyalty to it. But, when *we pay* for something with our hard-earned money, we fail to see how the recipient of our Roosevelt dollars can have the colossal nerve to then ask us to be loyal to them. It's their move . . . they have our money, and it's up to *them* to be loyal to *us!* Otherwise we'll want our money back to say the least!



# Modulating The All-Band Transmitter

By RALPH O. GORDON, W6CLH

The modulator unit is a complete speech system having sufficient gain to operate

from a diaphragm-type crystal microphone or any other type having about the same sensitivity such as most condenser, dynamic and ribbon types. If the unit is to be used with a carbon type mike the first tube can be omitted, as the additional gain is not needed. The first tube is a 57 pentode connected and produces very high gain. It is resistance coupled to a 53 with the elements connected in parallel, which produces an actual voltage gain of about 25. The gain control is in the grid circuit of the 53, so that it does not have to be disturbed regardless of what type mike is used. The 53 is resistance coupled to a 59 working class "A" (triode connected) which acts as the driver for the class "B" stage. A pair of 59's act as the modulator for the two 801's in the final class "C" r.f. stage, and furnish ample power to 100% modulate 80 watts of input with good speech quality.

The cuts show the modulator unit, which is mounted on an  $8\frac{3}{4}$ " x 19" 10 gauge steel panel, crackel finished to match the complete transmitter. The chassis is 8" x 17" x 2" deep. A shield can for the first two stages is mounted on the right end of the chassis and is 4" x  $7\frac{1}{2}$ " x 5" high with a removable lid. The bottom of the chassis has a shield partition that isolates the sockets and various other parts connected with the first two tubes. A bottom cover for the whole chassis completes the shielding of the unit. The jacks at the bottom of the panel are for reading the plate current of the individual tubes, except for the 57, which draws only about  $\frac{1}{2}$  ma.; for that reason no jack is provided for it. The jack on the extreme left is in the plus "B" lead to the class "B" tubes and with one of the meters plugged into it the meter becomes a good "VI" or volume indicator for setting the gain control and should be kept in that position while transmitting to provide a constant check on the modulation.

Two 150 ma. meters are mounted on the panel with rubber-covered cords and plugs attached to them so that any of the circuits in

*The exciter unit and the final amplifier shown in the illustrations were described in the January issue of "RADIO". This article gives the modulator details, and describes the completed transmitter in a rack-and-panel mounting. It has high output on all bands and the quality is excellent.*

the transmitter can be tested. The jack at the right top of the panel is for the microphone,

and the gain control is below it. The switch at the left top of the panel is the "communication switch."

As all of the tubes in the speech unit are  $2\frac{1}{2}$  volt filament and the total drain is 9 amps., the filament transformer is mounted on the chassis of the amplifier at the left rear to prevent a voltage drop that would occur if the heater current were brought up from the power supply chassis through a cable.

The circuit diagram of the modulator unit is shown in figure 1. The values of the resistors and condensers should be duplicated exactly if complete stability is to be had. An audio amplifier with such high gain will usually have a tendency to self-oscillate or "motor-boat" if certain precautions are not taken to prevent such instability. The amplifier described is absolutely stable with wide-open gain, and the hum is below audibility. Audio oscillation or motor-boating is usually caused by feedback through a common power supply and can be prevented by a separate resistance filter in the plus "B" lead to each tube. In this case the first three tubes work from a 300 volt pack, with a resistance filter isolating each of the first two tubes.

Many times it has been found that a certain speech amplifier—modulator combination that is absolutely stable when driving a transmitter operating on one band of frequencies will become very unstable when the transmitter frequency is changed to another band. Obviously the trouble is caused by r.f. getting into the speech channel, and these feed-back troubles and motor-boating conditions are sometimes very obstinate and their elimination often requires many hours of experimental changing of the values of resistors and condensers as well as the position of parts. The insertion of r.f. chokes and by-pass condensers in the speech circuits rarely provides a complete cure for the trouble and is liable to cause a loss of the high audio frequencies so necessary for the understandability of speech.



Front view of the speech unit, which is fully capable of 100% peak modulation on voice of over 100 watts input to the class C stage. The cords on the meter plugs are made long enough to reach up to the jacks on the r.f. panels, so that the meters may be used also to measure currents in the r.f. circuits. The knob at the lower right is the gain control.

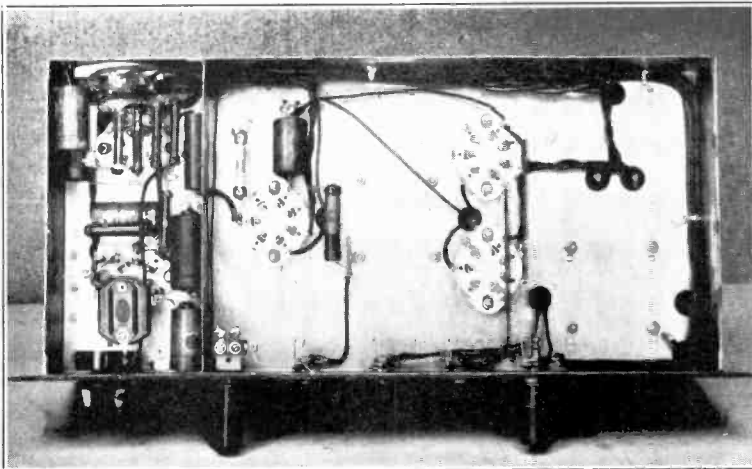
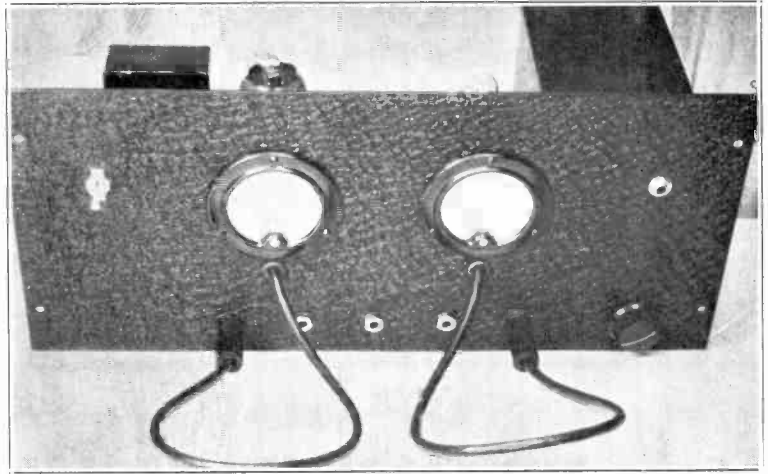

Showing underneath side of the speech system chassis. Note that the two "front end" stages are isolated below the sub-panel as well as above. The isolantite sockets are somewhat of a luxury for use in speech work, and were used mainly because they matched those in the r.f. system. All condensers and resistors should be amply rated.

Top view of the speech system, showing arrangement of parts. The shield-can on the left (top removed) houses the first two stages, those being the most susceptible to r.f. and a.c. pickup. Note that the filament transformer (lower right) is placed as far as possible from the input stage and with its core at right angles to those of the two a.f. transformers.

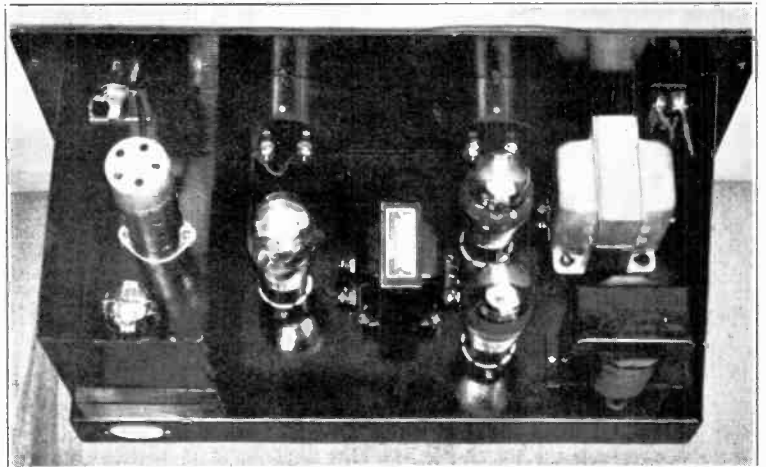

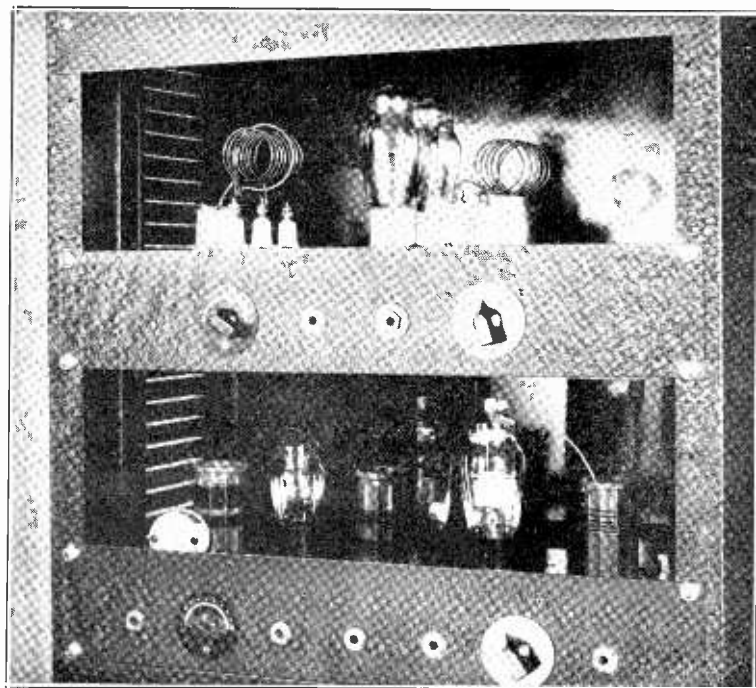

Two blank panels have spring "snap-on" fasteners to facilitate changing coils and making back-of-panel adjustments. The ready accessibility of everything when the panels are removed is apparent from this view. Some amateurs prefer screen panels (grille type), but these have the disadvantage of allowing dust to get inside the cabinet.

*Complete shielding* with heavy gauge steel for the speech input circuits is the surest way of preventing r.f. feed-back troubles in a speech amplifier. The unit described is absolutely stable with wide-open gain and with the transmitter operating on any of the amateur bands from 160 down to 5 meters. The microphone cable must be shielded, as should be the plug on the end of the cable.

Two power packs are used to operate the complete transmitter. One 300 volt pack capable of delivering about 100 ma. is used for the first three stages of speech and also for the 6A6 acting as crystal oscillator and multiplier. A 5Z3 is used for the rectifier in this pack, and the output is filtered with a double choke and three 8  $\mu$ fd. filter condensers. This power supply must be well filtered if hum in the carrier is to be kept low.

The other power pack delivers 500 volts at 350 ma., which means a heavy-duty transformer and filter chokes. An 83 is used for the rectifier. Choke input must be used to provide good regulation, because the current to the class "B" 59's will fluctuate from about 30 to around 150 ma. during modulation. This supply furnishes power for the 802 r.f. amplifier, the two 801's in the final r.f. stage, and the class "B" 59's in the modulator. The 802 will draw about 60 ma. and the 801's can be loaded up

to about 140 ma. The static current of the 59's will be about 30 ma., making a total of around 225 ma. continuous drain on the pack, but it must be capable of supplying the peak current drawn by the modulator in addition, which adds about 120 ma. A transformer rated for 350 ma. continuous duty is satisfactory for the maximum peak load, which occurs only on occasional voice peaks. The average load during normal speech is not more than 300 ma. Two 4  $\mu$ fd. condensers are used in conjunction with two chokes for the filter. The first choke is a swinging choke of 4 to 60 henrys and the second a 20 henry smoothing type. The voltage for the 59 modulators should be taken after the first choke.

In the rear view of the complete transmitter the power packs are on the bottom chassis, the speech amplifier and modulator next, then the crystal exciter and r.f. amp. with the final stage on the top. All of the units are integral with their panels so that by removing the panel screws any unit can be removed intact. A standard tube socket and socket plug on each chassis inter-connects all of the units except for the power pack chassis, which has a 10-contact plug and jack. The top chassis uses a 4 prong connector, the exciter a 5 prong, and the modulator a 7 prong, all of the terminals being used on each connector.

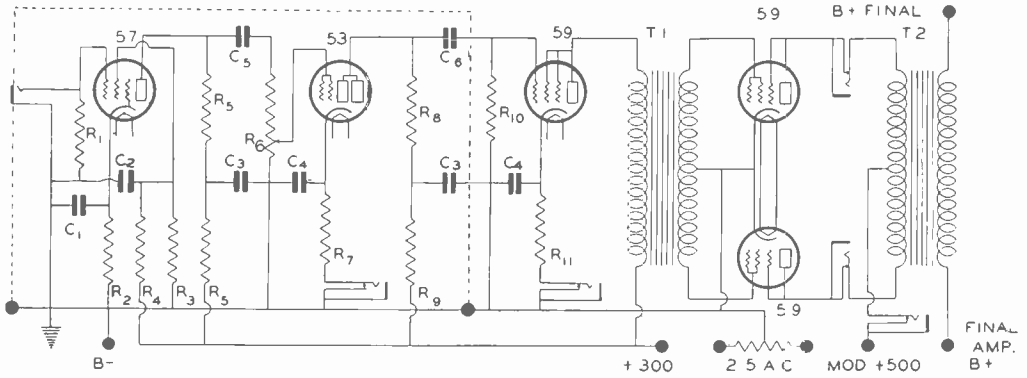

R<sub>1</sub>—5 megohms, 1 watt.  
 R<sub>2</sub>—2000 ohms, 1 watt.  
 R<sub>3</sub>—30,000 ohms, 1 watt.  
 R<sub>4</sub>—100,000 ohms, 1 watt.  
 R<sub>5</sub>—100,000 ohms, 1 watt.  
 R<sub>6</sub>—500,000 ohm tapered potentiometer.  
 R<sub>7</sub>—1000 ohms, 1 watt.  
 R<sub>8</sub>—50,000 ohms, 1 watt.  
 R<sub>9</sub>—10,000 ohms, 1 watt.

R<sub>10</sub>—250,000 ohms, 1 watt.  
 R<sub>11</sub>—1000 ohms, 2 watts.  
 C<sub>1</sub>—5 μfd. 25 volt electrolytic.  
 C<sub>2</sub>—0.25 μfd. 400 volt paper.  
 C<sub>3</sub>—0.5 μfd. 400 volt paper.  
 C<sub>4</sub>—25 μfd. 25 volt electrolytic.  
 C<sub>5</sub>—0.01 μfd. mica.  
 C<sub>6</sub>—0.05 μfd. 600 volt paper.  
 T<sub>1</sub>—Class B input for single

46 or 59 to Class B 46's or 59's.  
 T<sub>2</sub>—Class B output transformer for 46's or 59's, tapped secondary for load adjustment. Must be designed to carry steady d.c. through secondary. Filament transformer mounted on amplifier chassis.

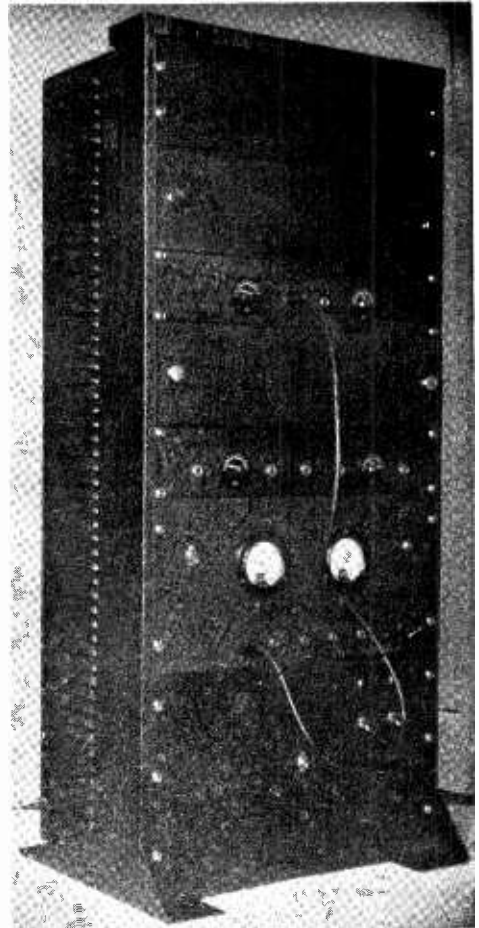
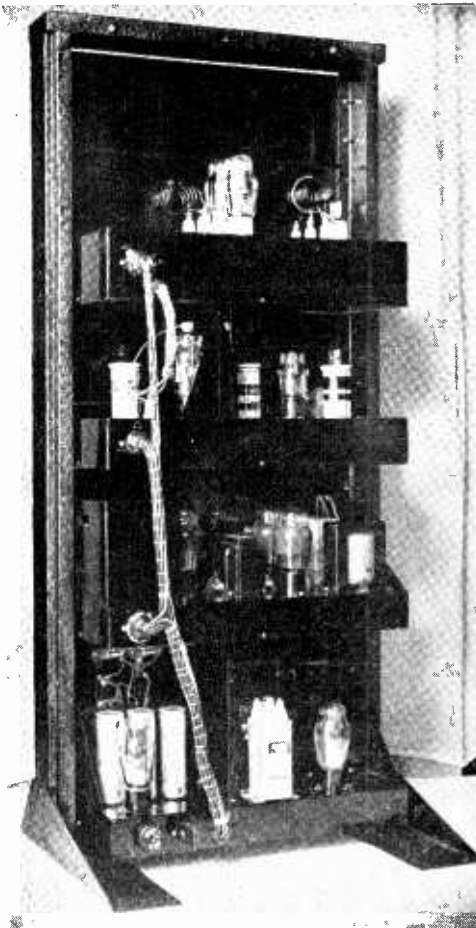



The front view of the complete transmitter shows the outfit ready for operation. The close-up view of the r.f. stages shows the snap-on panels removed for coil changing. These panels have a knob at either side and a spring clip at the back so that they can be quickly removed when it is desired to change bands.

This rig, which has been designed to use the minimum of tubes and parts consistent with high efficiency operation, should satisfy the most fastidious for appearance. As for the performance, the power output is adequate to work the world on 10 or 20 meters (perhaps 5; who can tell?). One week of operation on 10 meter phone with this transmitter resulted in dozens of stations being worked, many of the reports reaching R9 at the peak time of day.

One may economize on the tube layout by using standard type 10's instead of 801's. On the lower frequency bands no difference in operation will be noted, though the 801's operate with slightly higher efficiency than the 10's on 5 and 10 meters, probably due to less loss in the ceramic bases of the 801's than in the bases of the 10's at those frequencies. Sawing slots in the bases of the 10's will improve their operation at ultra high frequencies.

The output of the transmitter may be increased by using a separate power supply for the 801's, one delivering about 825 volts at 150 ma. This will put about 750 volts on the plates of the 801's, 75 volts being lost across the cathode bias resistor on the 801 stage. Do not forget to bypass this resistor with at least 10  $\mu$ fd. (correct polarity) of 200 volt electrolytic condenser when using the transmitter for phone. (See text January article.)

The input may safely be run up to 110 watts at this higher voltage on frequencies up to 14 mc. On 10 meters the plate voltage should be cut about 100 volts, and on 5 meters it is advisable to cut it a little more, 600 volts being about the maximum safe voltage on 5 meters if long tube life is expected (the cathode resistor will cut this to around 525 volts).

The 825 volt pack may be a 750-0-750 volt transformer using two type 80's in a full wave rectifier (each tube with its plates tied together) with 4  $\mu$ fd—20 henries—4  $\mu$ fd. for filter. Condenser input is permissible because extra-good regulation is not necessary for this power pack, the load on it being constant. The voltage may be cut for 10 and 5 meter operation by the use of series resistance in the primary of the power transformer. If the transformer

has a 600 or 650 volt tap, so much the better; the voltage may be cut that way.

If the separate 825 volt power pack is incorporated for the 801's, the 500 volt supply need not be as husky, 250 ma. components being sufficiently heavy to handle the modulators and the 802.

By "pushing" the 59's a bit, no trouble will be experienced in voice-modulating the 110 watt input 100%. The life of the 59's will not be shortened appreciably; if they don't last long, it is because you are overmodulating (which necessitates banging the 59's harder than is good for them). It is surprising how little audio power is necessary for 100% *peak* modulation of a transmitter on *voice*.

◆  
6A7?

Mr. R. Nine:  
Muy Señor mio:

Please, for favor, I am have much trouble again. I have move to new location where they have much different kind of peoples and they to speak much different kinds of languages—Japanese, Chinese, Portuguese and Magnesian, or do I should say *Polynesian*?

I read much time passed about "Translator Tube". Do Translator Tube translate all languages including Scandinavian? or is too difficult like Greek? Will one tube translate every language or will be necessary one language each tube?

Will you to please to publish circuit using tubes which translate languages mention in first part these letter. If take more than one tube, then to please show circuit which translate Greek because all sound like Greek to me. Gracias.

Su S. S.  
EL BORRACHO.

◆  
Comment from "The Mayor"

The boys out here in California gripe about the terrific QRM on 160 meters. But we wonder what it is like say in Ohio. They say nothing is so bad but what it can't be worse, but it is pretty hard for some of the west-coast 160 meter fellers to appreciate the fact, 'specially when their own sig is down about the fourth layer.—W6DDDS.

◆  
After listening in on the phone bands of an evening one is just about convinced of the fact that "that's the dope on that".



# "Modulation Movies"

By JOHN L. REINARTZ\*

Let us take a look at figure 1 in which we have drawn the lowest straight line (marked "0") to indicate the zero voltage of a power supply, and another line above that to indicate 500 volts. The second line is placed higher because it is supposed to be more positive than the first. Let us say the distance between the

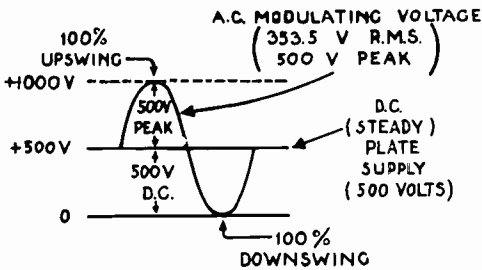

Figure 1  
How the plate-supply voltage must be modulated 100% to cause a tube to give a 100% modulated output.

lines represents 500 volts; in other words, the second line is 500 volts more positive than the first. You will see that the line is marked "+ 500 V". If we now assume that this 500 volts has been connected to the plate circuit of an r.f. amplifier that we wish to plate-modulate, we can see readily what the a.c. modulating voltage must be in order to produce 100% modulation and no more. If we add to the original positive voltage (+ 500 volts d.c.) an a.c. sine-wave voltage that has a peak of 500 volts it is clear that the positive a.c. peak will add to the d.c. voltage, giving a "positive modulation peak" of:

$$500 \text{ volts d.c.} + 500 \text{ peak a.c. volts} = 1000 \text{ volts mod. peak}$$

while the negative a.c. peak will subtract from the d.c. and give a "negative modulation peak" of:

$$500 \text{ volts d.c.} - 500 \text{ peak a.c. volts} = 0 \text{ volts neg. mod. peak.}$$

Because of the changes in the plate voltage supplied to it the tube's output goes from zero at the moment of the greatest downswing or negative modulation peak (no input, hence no output) to 4 times normal output at the moment of the positive modulation peak. (Double

voltage, therefore double current. Double current times double voltage gives quadrupled input and output.—EDITOR.)

Our problem is now to find means for determining when the conditions illustrated above have been obtained. As a simple first illustration let us consider a tube which is not being voice-modulated at all but is given 60 cycle (or 25 or 50 cycle in some towns) modulation by an a.c. supply used as a modulating voltage. If we can adjust this to produce 100% modulation we shall have learned something which will be useful later in voice-modulated systems.

(In figure 2 is a simple circuit which is an oscillator if left just as shown, or it may be cross-neutralized [Ballantine circuit] and used as an r.f. amplifier stage of the class C type. The amplifier requires r.f. grid input or "drive" from another tube acting as oscillator, but as a

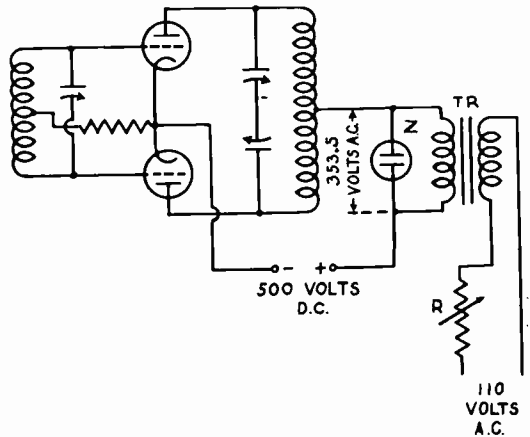

Figure 2  
A representative diagram for discussion.

compensation the amplifier is capable of accepting 100% modulation whereas the oscillator circuit, left as shown, produces severe distortion if fully modulated.—EDITOR)

If we have but an a.c.-d.c. voltmeter on hand we proceed as follows, referring to figure 2. We first measure the d.c. voltage, with the a.c. turned off. Let us say this is 500 volts as marked on the diagram. Then we apply the variable a.c. voltage obtained from the lighting line through the transformer TR, which has such a step-up ratio that when the rheostat R

\*W1QP, Manchester, Connecticut.



is varied we can adjust the secondary output voltage to 70.7% of the d.c. voltage. If the a.c. has a sine wave form this will give us a peak voltage just equal to the d.c. voltage. In our example we would adjust to get 70.7% of 500 = 353.5 volts as read on the meter, which gives 500 peak volts and therefore 100% modulation (see figure 1). (The neon tube Z, if it were chosen to "go off" at exactly 500 volts, would serve as an over-modulation indicator. As a practical modification use a 100,000 ohm resistor and tap the tube across part of it, adjusting the tap so the tube barely starts when the resistor is connected across the d.c. supply. Then transfer the resistor and tube to the position shown.—EDITOR)

With the use of the cathode-ray tube the problem is much more simple, though the fundamentals involved in the modulation set-up remain the same. Let us assume the simplest sort of cathode-ray equipment, depending on the 60 cycle house current for the horizontal sweep. (This is the same a.c. supply which is being used to modulate the tube in figure 2; therefore modulation and tube-sweep are automatically in step.) In this case the beam starts from the center of the screen of the cathode-ray tube, and swings to the right (and back to center) during one half-cycle of the a.c., then to left and back to center for the other half-cycle. Looking at figure 3 we have at upper left the appearance of the tube's screen before the sweep voltage is connected, and just to the right of it is the same tube with the a.c. sweep in operation. The line of the upper right-hand figure can be turned into a circle by the use of an electromagnet fed from the same a.c. line and applied while the a.c. sweep is on the tube, as shown in the 2d picture in the left column of figure 3. Stray fields from transformers or chokes at times produce defective forms of this figure and are to be suspected when an alleged line is broadened at its center.

Instead of using the electromagnet, let's see what happens when we connect the a.c. sweep-voltage to the vertical deflection plates of the tube as well as the horizontal deflection plates. We obtain a slanting straight line as shown in the third figure in the left column of figure 3. If the wires to the vertical deflection plate are reversed the line will lean to the right instead of the left. It may seem queer that the line is straight when we are dealing with a.c. which has a curved form (sine wave) as shown in figure 1, and shown once more in the sketch

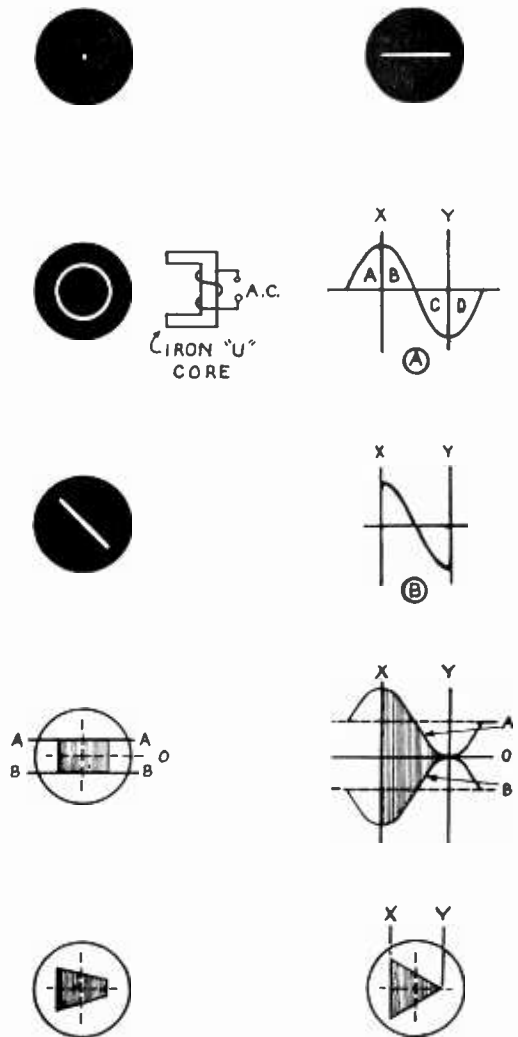

Figure 3  
How sine-wave effects produce linear pictures on the screen of a cathode-ray tube.

"A" of figure 3. If our horizontal "timing swing" were a linear or constant-speed one, the figure would be curved, and look like sketch "B" of figure 3. This figure is simply the sine wave of sketch "A" of figure 3 with the "D" part folded back onto the "C" part and the "A" part folded back onto the "B" part. But our timing wave or horizontal-sweep is *not* linear; because we use the same (curved) a.c. voltage on both sets of deflection plates we see a straight line as shown in the left column of figure 3. Whether the slope of this line is more or less than 45 degrees is determined by whether the voltage applied to the vertical deflection plates is greater (steeper line) or less (flatter



slope) than the voltage applied to the horizontal plates. That change of slope will be useful in a moment in showing us whether we have more or less than 100% modulation.

In the fourth sketch of the left-hand column of figure 3 we see a new sort of figure, a rectangle, with many vertical lines in it. This indicates that we have disconnected the vertical deflection plates from the 60 cycle a.c. supply and instead have connected to them a small pickup coil which has been placed near the r.f. stage of figure 2. The r.f. voltage picked up by the coil is swinging the cathode-ray spot up and down at a radio frequency while the a.c. timing voltage is swinging it sidewise. The r.f. is very much faster than the a.c.; therefore the many up-and-down lines. The picture is quite filled in, being a rectangle of greenish light.

Now comes the hardest part to understand. If modulation is applied, it affects the lines AA and BB of our rectangle by changing them into the sine curves of sketches A and B in the right-hand column. Accordingly we might expect to see a curved figure such as is shown to the right of the rectangle, but our timing wave remains a.c. (non-linear) and therefore we get the straightening-out effect previously explained; so our actual modulation figure is that shown in the last sketch of the right-hand column of figure 3. This is a 100% modulation figure.

If the modulating voltage is less the lines will slope less as was explained before and the triangle becomes a trapezoid as shown in the lower left corner of figure 3.

We now see how a sine-curve effect can appear on the screen as a straight-line picture, but it must be remembered that the triangle or trapezoid will only show when the *same* a.c. is used for the horizontal sweep and also for the modulating circuit.

(Unless this a.c. is considerably distorted a reasonably straight-line picture results. Thus it is possible to take the horizontal-sweep voltage from the audio amplifier of a transmitter, feeding a steady tone through the amplifier, and thereby at the same time producing modulation. It is usually satisfactory to connect a potentiometer of high resistance across an audio transformer, then running from one end of the potentiometer and the slider to the horizontal deflection plates of the c.r. tube. The other plates are of course connected to the pickup coil. The tone used should at least resemble a sine wave; for low pitches use the lighting

line, for higher pitches a makeshift tone may be manufactured by whistling softly.—EDITOR)

#### Home-made Crystal Holder

The plug-in crystal holder shown by the drawing is due to Jack Paddon, now Chief Engineer of Philips Ciné Sonor, London, and formerly of—oh, lots of places. We have note of some

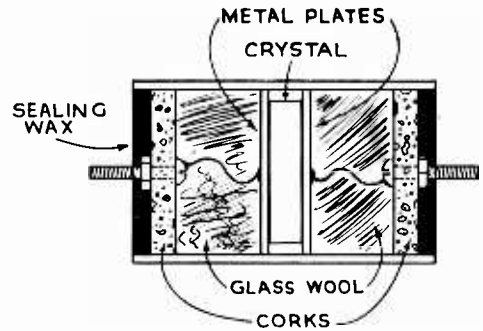

Home-made crystal holder

of his former calls: 1PW (spark), 8ACM, 6AGN, 1TM, 2FU, 1ARP and numerous others. The present one is G2IS.

The light pressure on the plates is provided by the spun glass "wool," which has the incidental merit of containing little moisture. The original sketch showed the metal plates and the crystal all of the same diameter as the inside of the glass tube. The notion of making the crystal smaller is original with our mistake-department and there is no charge for it. Wait—we might instead claim that we are showing a square crystal which is resting on its corners against the curve of the tube. That is really a better alibi.

If the corks fit fairly snugly, and not so tight as to keep on stretching after assembly, it is possible to adjust the pressure correctly by moving them in and out before adding the final wax seals.

#### Jinx Captured

Time after time the sound effects box has toppled from its table in Studio B, of WINS, New York, spoiling many a program. Even sound engineers were called in to investigate the mystery. Finally they found that a certain note played by a violinist in Louis Katzman's orchestra hit the fundamental frequency of the sound effects box and sent it down with a crash. The legs of the sound effects cabinet were shortened to take it out of the frequency of musical instruments.—*Broadcasting*.



# A Resonant Strip Oscillator

By DURWARD J. TUCKER\*

After operating resonant-rod five meter and two and one-half meter transmitters for

*A "resonant rod" ultra high frequency transmitter does not necessarily need to use resonant rods; it may use instead parallel strips. The use of copper strips offers several mechanical and electrical advantages, which are set forth in this article on the construction and use of such resonant strips.*

several months, the author began to wonder if some suitable substitute for the rods could be found. Because of the size and spacing of rods, it is difficult to find a suitable means of

lators. The lugs were soldered to the bottom edge of the copper strips.

Figure 1 gives the complete transmitter circuit layout. The 10,000 ohm grid resistor is made up of two 5,000 ohm resistances, as a 10,000 ohm resistor was not "in stock". The r.f. choke consists of 15 turns of no. 28 enamelled wire wound on a 1/4 inch vitron rod drilled and tapped on one end to mount on the top of the stand-off insulator supporting the "cold" end (farthest from the tube) of the resonant strips in the plate circuit. No difference in the operation of the transmitter can be noted with the r.f. choke in or out of the circuit.

As with resonant rod transmitters the length of the strips for two and one-half meters is affected by the tubes used, the strip separation,

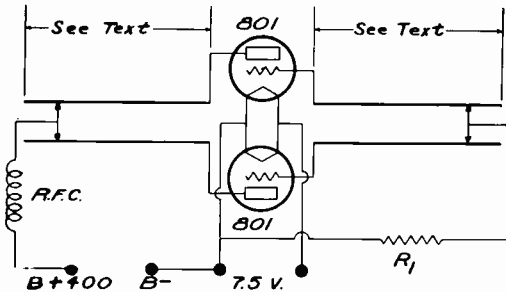

Figure 1

R<sub>1</sub>—10,000 ohms, 10 watts.  
R.F.C.—15 turns no. 28 wire wound on 1/4" Vitron rod.

NOTE: Grid and plate leads to strips should be as short as possible.

connecting the transmission line to the rods. Clips have been used to some extent, but a little tension causes them to slip on the round rods and short the rods, causing the plate current to go "sky-high". Small clamps are o.k. except when there are a lot of changes to be made.

It was decided that strips of copper should work just as well as the copper rods, as they would be a lot easier to clip on to and easier to mount.

## Construction Details

The idea was given a try on two and one-half meters, as it does not take up as much space as would have been required for a five meter transmitter. The thickness of the copper is immaterial just so long as it has plenty of rigidity. The width of the copper strip in this instance was one-half inch. Any other width, reasonably near this value, should work just as well except that the spacing of the strips might be different for most efficient operation.

The mounting of the strips was readily solved by the use of lugs and midget stand-off insu-



View of the 2 1/2 meter resonant strip transmitter showing relative layout of parts. The heavy cord is the filament cable.

and circuit elements within their field. The grid strips should be made approximately sixteen inches long and the plate strips approximately twenty-eight inches long. This provides ample length for varying the plate and grid shorting bars to obtain the frequency desired.

\*W5VU, 5712 1/2 Marquita Avenue, Dallas, Texas.

Once the desired length is obtained, the extra length may be cut off with only a slight effect on the frequency.

The photo illustrates constructional detail of the final transmitter and the arrangement of the different circuit parts. As can be seen from the picture, the whole transmitter is mounted on a long base-board.

### Tuning Up

After turning on the plate voltage two or three times and adjusting the shorting bars each time, it was found that the transmitter worked just as well as the two and one-half meter resonant rod transmitter. Further adjustments of the shorting bars showed that the minimum plate current could be reduced to 40 milliamperes, which was 25 milliamperes below the minimum plate current for the resonant rod transmitter using the same tubes, power supply and grid bias resistor. The minimum plate current may be further reduced by juggling the separation of the resonant strips. The change in plate current is so slight that a separation of one-half inch (same as strip width) was selected for simplicity and uniformity. It is surprising to note how far the strips can be separated before the unit finally quits oscillating. It is also interesting to note the effect on the oscillator when the resonant strips are placed in different positions with respect to each other. For example: without a load, the lowest plate current that could be obtained with any spacing was obtained with the plate resonant strips spaced  $\frac{3}{4}$ " at the "hot" or tube end and 3" at the "cold" end, and with the grid strips separated one inch at the grid end and  $\frac{1}{4}$  inch at the "cold" end.

As can be noted from the transmitter layout in the photograph, the grid strips are much shorter than the plate strips. A temporary layout with the strips extended for five meter operation showed that this effect is not as noticeable for five meters.

### Loading

A small-wattage ordinary 115 v. light bulb provides a means of obtaining a convenient purely resistive load for test purposes and in adjusting modulation. Flashlight bulbs do not have enough wattage and burn out readily. Clips with one inch leads made of stiff wire soldered to the base of the light bulb provide an excellent means of using conveniently the light bulb as a dummy antenna.

Loading this type of transmitter is quite simple. The antenna may be cut in the cen-

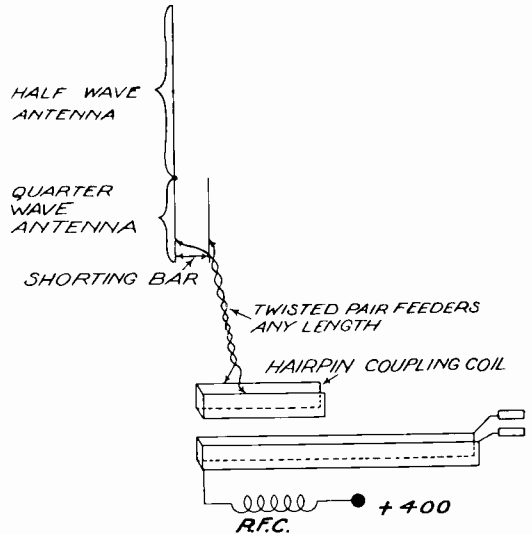

Figure 3

ter and the quarter-wave section clipped to the plate resonant strips near the cold end at a point approximating 72 ohms. It is seldom that one would want to operate the transmitter in this manner because of the greatly improved results that may be obtained by placing the antenna in the open and as high as possible and feeding the antenna with a transmission line.

By adjusting the coupling of the hairpin coupling coil and the feeder clips (figure 3) any desired antenna load may be obtained with inductive coupling. The transmission line, at the antenna end, must be clipped on to the quarter-wave resonant strips at a point which matches the impedance of the transmission line or trouble in the form of standing waves on the feeders will result.

If the line is terminated properly at the antenna end, the line may be clipped right on to the resonant strips of the transmitter without encountering trouble from standing waves. The oscillator load may be varied by changing the position of these clips.

### Sticking Meters

When the needle on a not-so-new-anymore meter starts sticking, take a typewriter screwdriver and tighten the bearing screw one-half turn. The needle sticks *not* because the screw is too tight in this case, but because the screw is too *loose*.

The window draperies at W1CBX's shack are embroidered with circuit diagrams, call letters, and the like—all in colors.



# Grid Bias Detection

By FRANKLIN OFFNER\*

With the appearance of diode detectors a few years ago, the older forms of detec-

*The widespread use of diode detectors in broadcast receivers does not indicate that such detectors are always desirable in an amateur receiver. On the contrary, in many amateur sets the old biased triode detector fits in the picture better than a diode, especially if one wishes to economize on parts.*

This brings us to the question of the design of a grid-bias detector, which was the

original purpose of this article. But each type of detector has its own particular advantages and disadvantages, and we believe there are many occasions where the now more familiar diode detector could well be replaced by some other type—especially the grid bias, or plate detector.

Although the theory is simple, we don't recall ever having seen it given explicitly in an amateur periodical. If it has been, we think it will bear re-

telling, as the bias detector is not enjoying the popularity it should.

The characteristics which have gained for the diode detector such wide popularity are: first, its simplicity, no grid bias supply being necessary; second, its ability to carry a wide range of signal level with little distortion; and third, the possibility of obtaining automatic volume control voltage directly from the detector. To be weighed against these advantages are the following points: the diode detector derives its power from the radio frequency output of the last r.f. or i.f. stage of the receiver. In consequence, it acts as a resistive load across the output of this stage. This has two effects: first, it considerably decreases the gain of the stage; and second, it greatly decreases its selectivity. Both these effects are so large that one may usually consider a super-het with one stage of i.f. amplification and grid bias second detection almost the equal (with regard to selectivity and sensitivity) of an otherwise similar set with two stages of i.f. and diode second detector. The usual practice of set designers is to make up for the loss in sensitivity by increased audio gain. But they seem to be forgetting about the loss in selectivity.

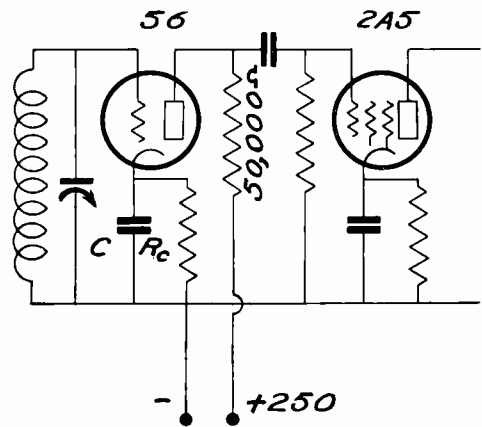

Figure 1  
C is 4  $\mu$ d. or more.

In broadcast receiver design, there is usually no difficulty in obtaining adequate selectivity and sensitivity, so the advantages gained by the use of diode detection usually far outweigh the disadvantages. But this can no longer be considered true when we come to short wave receivers—especially those designed for amateur use. Here, the substitution of a grid bias detector for a diode will usually be found to make the set perform much better. And what is more, if the detector is properly designed the audio quality won't suffer.

The most important point in the design of a grid bias detector is the source of grid bias. The most convenient source of grid bias is a cathode resistor (with suitable audio by-pass). But this immediately brings up the following difficulty:

It is well known that a grid bias detector is supposed to be biased to cut off, so that only the positive halves of the r.f. cycles on the grid result in plate current flow. But it will be asked, "If the tube is biased to cut off, so that no plate current flows, how can any bias be obtained from a cathode resistor?" The answer to this is simple: we aren't interested in the bias on the detector at any time except when there is a signal on the grid, and then there will be a flow of plate (and cathode) current. The procedure for the design of a cathode-resistor biased detector is then as follows: The operating plate current of the detector must first be determined. By "operating plate cur-

\*W9FTO, 1005 E. 60th St., Chicago, Ill.



rent", we mean the plate current the detector will draw with normal signal input. This may either be determined experimentally, or calculated approximately. We will consider only the experimental method here; it's usually the simplest.

The operating plate voltage must next be determined. This will be equal to the plate supply voltage, minus the IR drop in the coupling device. This latter will usually be negligible in choke or transformer coupled detectors, but must be considered with resistance coupling. We now must refer to the family of plate characteristic curves for the type tube we are using. These may be found in the R.C.A. tube manual. Picking the operating plate voltage, we find what value of grid bias corresponds to zero plate current flow. We then use Ohm's law to determine the proper value of cathode resistor:

$$\text{Cathode resistor} = \frac{\text{grid bias volts}}{\text{operating plate current (amperes)}}$$

It should be noticed that in the case of multi-grid tubes, the operating grid currents must be added to the plate current; therefore we should use the cathode current instead of plate current in the above formula.

An example may make the above calculation a little clearer. In figure 1 we have a type 56 detector, resistance coupled to a type 2A5 audio pentode. Let's assume  $R_p$ , the plate coupling resistor, is 50,000 ohms, and the plate supply voltage is 250. In our preliminary experiment we will try a 20,000 ohm resistor at  $R_c$ . We now tune in what appears to be a well-modulated carrier, and open up the r.f. gain on the receiver until the audio level of the signal is about what we want for normal operation. Now measure the plate or cathode current (they're the same, as we're considering a triode). Assume this normal operating plate current is one ma. Then the operating plate voltage is

$$250 - (0.001 \times 50,000) = 200$$

Referring to the characteristic curves on the 56, we find that at a plate voltage of 200, a grid bias of 16 volts is required for plate current cut-off. Therefore,

$$R_c = \frac{16}{0.001} = 16,000 \text{ ohms.}$$

This isn't critical, and anything from 15,000 to 17,500 ohms should be just as satisfactory. In the example above, the value cathode re-

sistor originally used was not much different from the correct value. If, however, the difference is very great, it will be well to recheck the operating current. If this differs very much from the value with the original cathode resistor, it may be necessary to redetermine the correct value, exactly as outlined above.

In operating a receiver having a grid bias detector, some attempt should be made to keep the plate current near the value used in the calculation of the cathode resistor. To this end, the author uses a milliammeter in the detector plate (or cathode) circuit; this also serves as an "R" meter. We have also developed a system of a.v.c. which accomplishes this same result, by virtue of its especially accurate control of volume. We hope to be able to describe this in a forthcoming issue of RADIO.

#### ◆ "Sure to Kill"

Ten sure ways of killing any organization were revealed by the Rev. R. C. Russell, speaking in St. Andrew's Church, Yass, New Zealand, recently. They were:

"(1) miss as many meetings as you can; (2) if you attend, come late; (3) wet weather is a fine excuse; (4) be sure to find fault with the work of the office-bearers and other members; (5) decline all offices, as it is easier to criticise than to work; (6) get sore if you are not put on a committee, or, if appointed, don't take any interest; (7) if asked your opinion, say you have none, but later tell others what ought to have been done; (8) do the least possible, and when others roll up their sleeves to help matters, howl because of the clique running things; (9) keep contributions long overdue, and delay answering all letters; (10) don't bother about getting new members; let the other fellow do it."

Just follow the above rules and your radio club will die a natural death.

—Radio Review (Australia).

#### ◆ Today's Lesson

If the gadget is used in a receiver it is a volume control, but if the same gadget is used in a transmitter or p.a. system it is a "gain control". Anyone who can give a logical reason why this should be so may go to the head of the class.

◆  
Blow the dust off your mill and load your camera. See page 80.

# Building Fixed Air Condensers

By ROBERT S. KRUSE

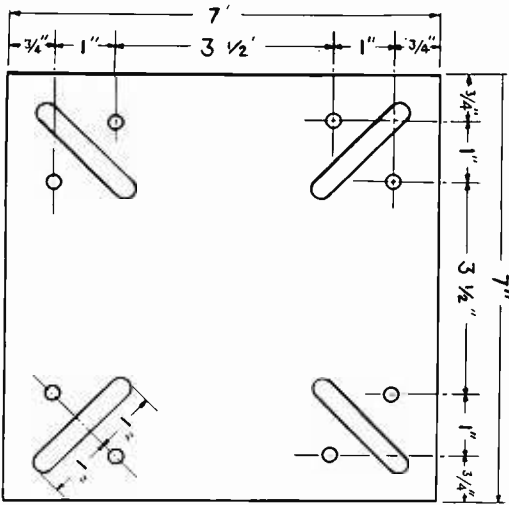

Figure 1  
Simple, though unorthodox, layout for insulating-end-plate to be cut from 7" panel stock.

At wavelengths of 20 meters or less the cost of variable condensers for tuning the plate circuit or "output tank" of the final amplifier of a transmitter is not too serious. At 80 meters it begins to be worth thinking about if voice work is to be done, for a voice-modulated tank must have a fairly decent capacity to produce good modulation linearity—though that is not the only requirement for such linearity. In the 160 meter and broadcast bands the cost of final-tank capacitors for any set using more than 2000 d.c. plate volts begins to be a real worry.

In commercial transmitters such final tanks commonly use fixed tuning condensers. Coarse tuning is done by moving a clip on the main coil; fine tuning is done by moving a slider on a small coil, or by a small heavy-conductor variometer, or by a 2-plate variable condenser shunted across the fixed air condenser. Still another scheme is to equip the main coil with a slider which runs around and around the coil, following the strip from end to end and therefore acting in itself as a fine-tuning device. Except for the last scheme, which is mechanically complicated, any of these arrangements are useful in amateur work, and represent a saving if a low-cost fixed condenser can be built with common hand tools, using ordinary materials. Such a condenser is described here.

## The Construction

Neither the drawings nor the design of this condenser are suited to manufacture. A machinist would laugh at the way the insulating end-plate is "laid out" in the drawing (figure 1) but it is a way any "ham" apparatus builder can understand and follow with nothing but a length of 7" insulating panel, a rule or square, and a "scriber"—or even a darning needle. If a pair of good firm dividers is at hand, that's better.

A number of these condensers were built from just such a "wrong" drawing by different folks. Each condenser went together solidly and squarely, and even the oldest one, built 5 years ago, is in A-1 shape.

The insulating end-plates are 7" x 7" panel stock and the aluminum plates (figure 2) are ordinary 1/16" stock, cut up by the local tin-shop's "square shears" and if necessary flattened by squeezing several at the same time between two 1" hardwood boards, using a vise large

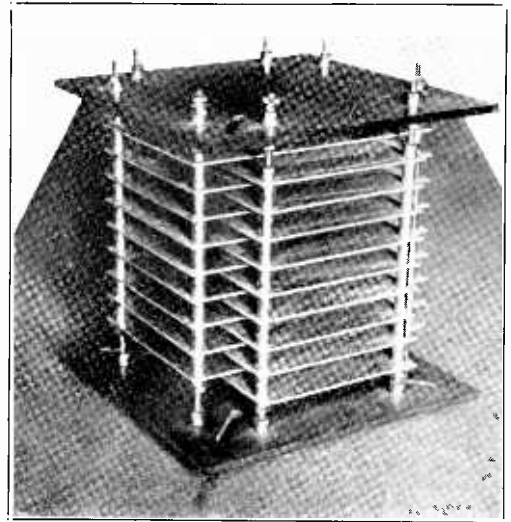

8000 volt home-made condenser with capacity of 0.000320  $\mu$ fd.

enough to press centrally. If no big vise is available, the job can be done with a 6 foot lever made of a 2" x 4" pressing on a roller or small block set on the upper one of your hardwood flats. This sounds very crude but it is far better than trying to true them by bend-





ing each separately and matching the kinks against a straightedge. Of course if someone around you has a press suited to doing a regular commercial flattening job, that's luck.

The drilled holes in the aluminum plates are of whatever size suits your particular rods and spacers; therefore no size is given. Copper washers or plated brass spacers which slide readily on an 8-32 screw are easily obtained, as is brass rod of size 8, and dime-store dies to cut the 8-32 thread. The 0.000320 microfarad condenser in the photograph is made with these slim rods and is quite solid after 4 years. However there can be no possible objection to using 10-32, 10-24, 12-24, 14-20 or 1/4"-20 rods if the spacers and rod are at hand; there is room enough in the design to guard against flashing to the rods. Flashing from the edge of the plates is made difficult, and the voltage rating of the condenser raised, by burnishing down the sharp edges of the aluminum plates in the manner shown in figure 3. The drilled plate is screwed down with its edge flush with that of the work-bench, which must be *very firm and flat* to prevent botching the job. Then a 3/8" or 1/2" round steel rod is used to "wipe" the edge down. The rod is held first as at A, until the raw edge has been rolled over, then raised as at B and finally as at C. The edge

made in one of several ways. One is to drill holes and connect them with a hacksaw, finishing with flat and rat-tail files, the thickness of the latter determining the necessary slot-width.

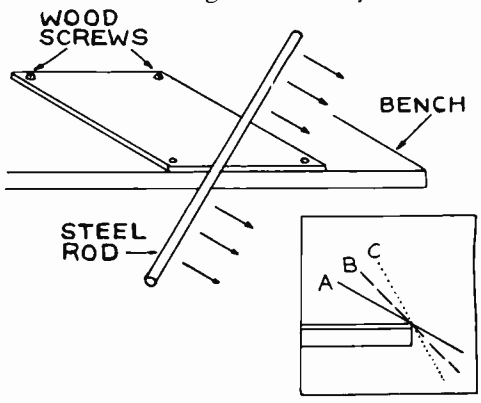

Figure 3  
 Method of burnishing down the edges of the plates.

Another scheme is to use a small circular saw, simply sinking it through the sheet. This wants to be done with care or the job lights in fragments over behind the furnace. An easier plan is to cut the slots in from the edge of the sheet. In this case the corners are then somewhat weaker mechanically. The condenser in the photo has end-plates of "radion" rubber 1/4" thick. Probably Victron would be better.

Note that the rods are threaded for some distance inside the insulating plates. This is to permit clamping the stack of metal plates and spacers solidly by a spacer and nut on either side of the stack (all rods). Then another nut is placed on each rod, the insulating plate dropped on and still another nut put on top. Thus the hard pressure of the plate-and-spacer clamping does not come on the insulating plates at all and these may be clamped lightly and true by adjusting the outer nuts and those just inside the insulating end plates. The description is much more formidable than the job.

Connections can be made either to the rods by lugs, or by Johnson helix clips pushed onto the narrow edges of the plates themselves. These particular clips are firm on such a plate without extending in far enough to induce flashing from the other set of the plates. Though shown on end the condensers are commonly used on their sides, the insulating end plates acting as a stand. Mounting schemes are too obvious to note.

In the condenser which is shown in the photograph the spacing washers were 0.163"

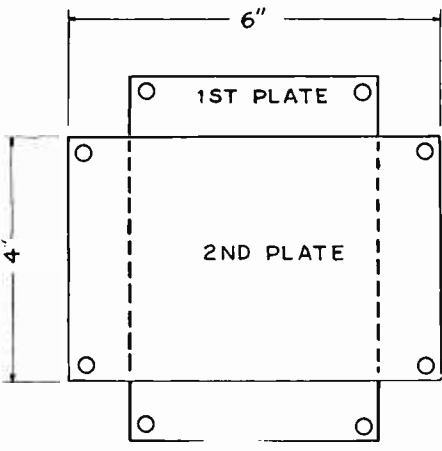

Figure 2  
 Shape and assembly of the metal plates.

can be finished faster than you can read these sentences, and if properly done is smooth and shiny.

Leakage and breakdown through the insulating end plate is guarded against by the slots, which approximately double the leakage distance and greatly reduce the leakage area. Their width is of little importance and they may be



thick and were used in sets of 3. Allowing for the thickness of a plate of the other set and dividing by 2 (two airgaps) this gives a clearance of about 0.213. The Morehouse 60 cycle peak flashover rating for a good variable condenser with such a clearance is about 7200 volts. On test the condenser flashes at 8000 peak volts quite consistently, which is quite safe for plate-modulated stages using d.c. plate voltages up to 2000 volts, and can be used for plate voltages up to 3000 volts if "bumps" due to switching or abrupt noises are not severe.

The calculated capacity for the 18-plate condenser shown is 0.000307  $\mu$ fd. and the measured capacity is 0.000320  $\mu$ fd., which is about the difference accounted for by edge-effect. As smaller capacities ordinarily suffice the following measured values for the same construction will be useful. 14 plates 0.000248, 9 plates 0.00015, 5 plates 0.000075, 2 plates 0.000020—all in microfarads.

#### Other Spacers

Usually the available spacers are of any thickness but that named, hence it is convenient to remember that the capacity changes nearly in *inverse* proportion to the airgap thickness—that is, the thickness of the air between plates of the opposite sets. Thus if we had spacers exactly 0.3" thick the airgap would be 0.3"—1/16" plate thickness, the result to be divided by two. This is (0.3"—0.0625")= 0.2375 which divided by 2 is 0.1187". For such a condenser with 9 plates the capacity would not be 0.00015  $\mu$ fd. as in the previous paragraph, but about 0.00027  $\mu$ fd. Other spacers can be figured up the same way.

The flashover voltage is not so simple but an approximate idea may be had from the following tabulation, which assumes plates 1/16" thick with edges well rounded.

Clear airgap	1/10"	2/10"	3/10"
60 cycle peak flashover volts	4750	6900	9100
10,000 kc. peak "	4200	5800	7500

### THE ELECTRON MULTIPLIER

The first known use of amplification of current by means of secondary emission was probably in 1916 when Hull of General Electric did his early development work on the Dynatron amplifier and oscillator.

Secondary emission amplification occurs because a single electron striking a suitably prepared surface can release ten or more secondary electrons from that surface. The ten secondary

electrons can then be focused on a second surface each releasing from the second surface ten more secondaries, making a total of 100 electrons available in two stages of amplification as a result of the initial impact of only one electron.

Farnsworth has made extensive use of this phenomenon in the low-level amplifiers of his television system, and Zworkin of R.C.A. has also done extensive development work on secondary emission amplifiers or electron multiplier tubes.

His latest development is a ten stage amplifier, built into one envelope, which gives a voltage gain of about one million times. As the amplifier tube requires no external coupling devices between stages and as the internal capacitances are quite low, the response of the amplifier can easily be made quite flat from 20 cycles or so up to several megacycles, which makes this type of amplifier quite useful for television and other broad-band applications.

Outside of the reduction in external coupling apparatus there is no great economy in the use of the electron multiplier; its main advantage lies in the reduction of inherent tube and circuit noise, which is very bothersome in the low-level stages of the typical low-level television amplifier. The photocell or scanner output is usually quite low and when ordinary vacuum tube amplifiers are used to amplify the output of the scanner it is found that tube noise and circuit noise often mask the very small impulses originating from the scanning of dark bodies. The use of the electron multiplier allows almost 20 db more amplifier gain to be used for a given signal-to-noise ratio. This means that considerably less light is needed for scanning a given television subject and indicates that we are one step closer to daylight scanning of distant subjects, such as a football game, etc.

There is relatively little possibility that the electron multipliers will replace hot cathode tubes except for use at very low levels, as at higher levels the usual types of vacuum tubes will do just as good a job and do it just about as economically.

#### "High Fidelity"

If high fidelity is high quality and visa versa, then why is a receiver with "high fidelity" supposed to be better than one with "high quality". After looking at the price on some of the 37-tube models we come to the conclusion that the fidelity is not the only thing that is high.

# A High-Fidelity U.H.F. Transmitter\*

By J. W. SMITH



Rigorous requirements covering frequency stability, percentage modulation, and total overall distortion have been placed on broadcast transmitters. Assignments of the ultra-high-frequencies in the United States have, up to the present time, been made only for experimental purposes and requirements as to the performance of radio transmitting equipment operating in this range have not become crystallized. If the fullest advantage is to be taken of the service possibilities of this portion of the radio spectrum, it is to be anticipated that high technical requirements will have to be met by the equipment which is employed. The new Western Electric No. 16 type radio transmitter and No. 88 type radio amplifier have been designed with this possibility in view and as a result have characteristics that will meet any requirements likely in the immediate future.

This new ultra-high-frequency apparatus consists of a 50-watt transmitter and a 500-watt

amplifier, so that outputs of either 50 or 500 watts are available. The two units, approximately equal in height and width, are shown together at the head of this article. The combination will operate at any frequency from 30 to 42 megacycles, in which range a number of frequencies have been designated for the operation of general experimental stations in the police, broadcast pickup, and other services. The transmitter alone has a wider range, extending up to 60 megacycles.

To obtain a high degree of frequency stability, the transmitter is crystal controlled, and maintains its frequency to better than twenty-five thousandths of one per cent. One of the new type crystals is employed which does not require temperature control, thereby eliminating heat-controlling relays, thermostats, and heat chambers.

A simplified schematic of the transmitter circuit is shown in figure 1. The crystal-controlled

oscillator employs a Western Electric 306A vacuum tube, and the second, third or fourth harmonic of the crystal frequency—generated in the plate circuit of this tube—drives another tube of the same type, which acts as an harmonic generator and produces either the second or third harmonic of its input frequency. Immediately following this harmonic generator is a radio-frequency amplifier, employing a 305A tube—and its operating frequency is thus either the 4th, 6th, 8th or 9th harmonic of the crystal frequency. The radio-frequency amplifier drives the modulating amplifier which employs two 305A tubes in a push-pull circuit. Modulation is accomplished by varying the supply voltage to the plates and screen grids with the output of the audio-frequency amplifier.

The audio-frequency amplifier employs three stages of transformer-coupled amplification. The first stage serves as a voltage amplifier and is coupled to a push-pull stage, which acts as a driver for the power amplifier—also a push-

\*Courtesy, Bell Telephone Laboratories.

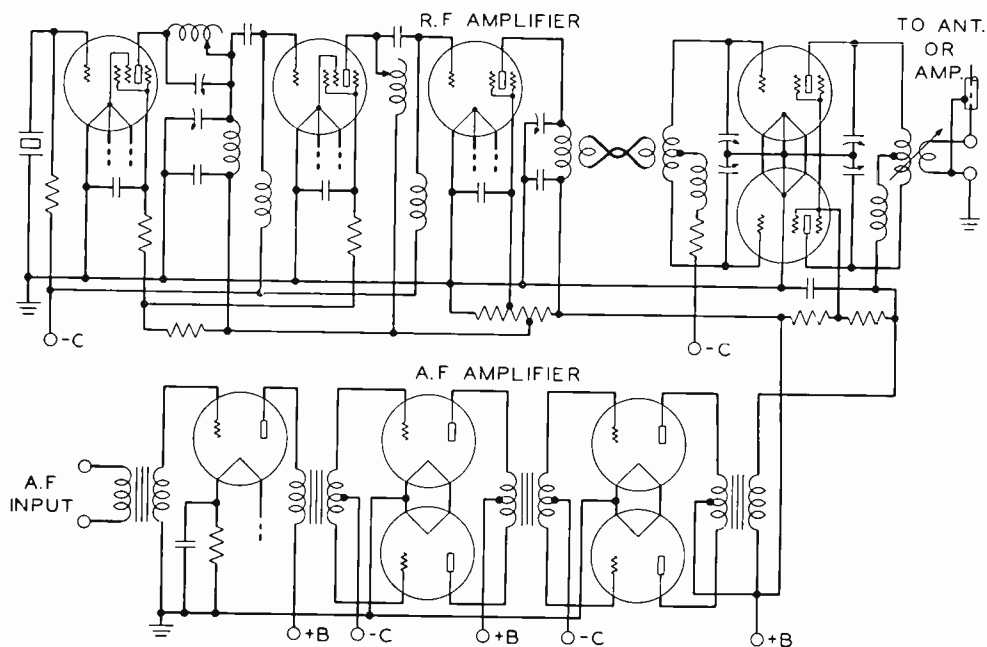

Figure 1  
Simplified schematic of the 16 type ultra-high-frequency radio transmitter.

pull circuit. Approximately 65 watts of audio-frequency power are necessary at 100 per cent modulation. This amount of power is obtained with 800 volts on the plate, which was taken as a desirable limit for the operating voltage. The grids of the audio power amplifier are driven only slightly positive, thus insuring a very low overall distortion. The input necessary for 100 per cent modulation is 20 db below six milliwatts, which is easily obtainable directly from a single-button carbon microphone.

The 88 type amplifier is a single-stage push-pull amplifier employing the 251A tubes already described in the *Record*.<sup>\*</sup> The tuned output circuits of both the transmitter and the amplifier are designed to couple to either an open-wire transmission line or a single concentric conductor to feed radio-frequency power to the antenna. To reduce possible harmonic radiation from the antenna, a  $\frac{1}{4}$  wavelength short-circuited section of concentric transmission line is shunted across the output terminals. At the fundamental frequency this shunt has a very high impedance and so has no effect, but at even harmonics it acts as a short-circuit and thus prevents the even harmonics from reaching the antenna. All of the harmonics above the second are satisfactorily reduced in amplitude

by the output circuits of the radio transmitter.

Both the transmitter and amplifier units have their own mercury-vapor rectifiers for plate supply. For the transmitter, a single-phase full-wave rectifier delivering 800 volts is provided, and for the amplifier a three-phase rectifier delivering 2500 volts. In the transmitter unit there is in addition a 265-volt single-phase rectifier, which supplies grid bias for both transmitter and amplifier. All these rectifiers employ Western Electric 249B mercury-vapor tubes.

Apparatus for the radio transmitter is mounted on six panels which form the front of a steel cabinet seven feet high, two feet wide, and a foot and a half deep. Access to the circuits is through a full height door covering the rear of the cabinet. An exhaust fan at the top of the door and a spun-glass air filter at the bottom provide an adequate supply of clean air to maintain the apparatus at satisfactory operating temperatures.

The 88 type amplifier is mounted in a cabinet divided into an upper and lower section, each with double doors on the front. The lower section includes the power supply equipment and the upper section, the two power tubes with their tuned input and output circuits. The doors of this upper section have glass panels, while those of the lower section are solid. A

<sup>\*</sup>Bell Laboratories Record, October, 1932, page 30

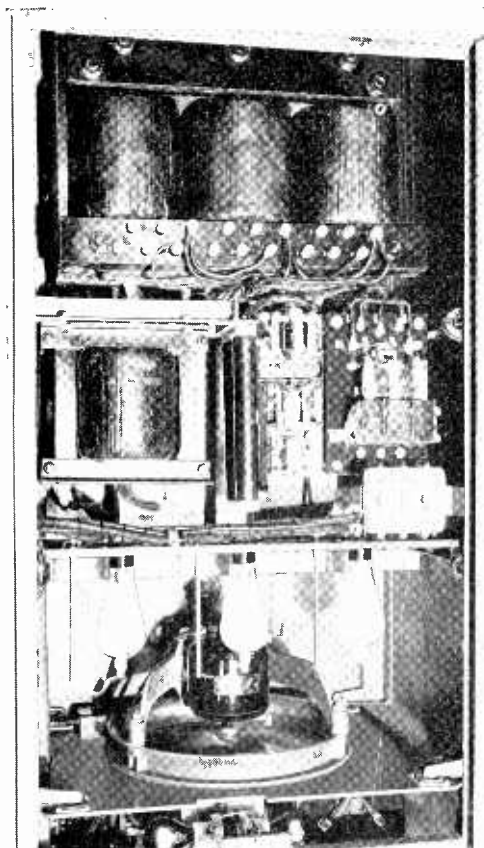

Figure 2

In the lower section of the amplifier is the mercury vapor rectifier providing the 2500-volt plate supply.

fan is installed in the partition between the two sections, which draws air from the lower part of the cabinet through an air filter, and exhausts it through the top. All doors on both cabinets are equipped with safety switches which disconnect the high voltage when the doors are opened.

The unit type of construction of the 16 type transmitter makes it possible to adapt the equipment to several types of communication. The first installation of the 16 type transmitter and 88 type amplifier was for one-way police broadcasts in the city of Newark;\* a photograph of this installation is shown at the head of this article. The first two-way installation of the 16 type transmitter was in Evansville, Indiana; and other installations have since been made.

The *cardiograf* is a new mechanical instrument employing radio principles and parts and is used for measuring human heart currents.

\*Bell Laboratories Record, June, 1935, page 290.

## SIGNALS FROM A DISTANT PLANET?

When the newspapers talk about strange phenomena in radio, the wise reader turns the page. But when the phenomenon is described by a reputable radio man the story takes on another color. Several months ago the eastern press reported "The Radio Shadow," a weird signal that had the sound of a "whirr", something that led one to believe that a crank operator was holding down his key at a distant point. This signal could be heard only in daylight, and on the short-wave bands. One of its mystifying actions was that it would change steadily in frequency, and that the receiving operator could follow the signal along the dial for several hundred kilocycles. Then the signal would disappear, only to return the following day. Later the "ghost signal" became inaudible on the east coast and it is now prevalent along the Pacific, being barely audible in Hawaii. It is believed that its intensity will increase westward towards the Orient in the weeks to come. No plausible explanation has been given. Some have stated there is a possibility that the signal is being radiated from a far-away planet, or from some rapidly moving body whose electrical discharges are reflected by the sun.

Fred Roebuck, operator in charge of the Globe Wireless station at Mussel Rock, California, reported the reception of the signal with such intensity that it has been impossible to communicate through it on certain wave-bands. Checking with the Honolulu station of Globe Wireless, the operators there report the signal barely audible, but increasing in intensity with the coming of the following day. The phenomenon is no longer audible on the east coast. It will probably remain one of the unsolved mysteries of radio.

### ◆ New QSL Manager for W6

Mr. D. Cason Mast, W6KHV, 423 E Street, Ontario, California has been newly appointed QSL Manager for the 6th district. Amateurs expecting dx cards should send Mr. Mast their envelopes. He says he has on hand a large stack of cards; perhaps some are yours.

### ◆ "The Nertz"

"100% plus" ordinarily means "very f.b.", "the berries", "the nertz", etc., but certainly *not* when referring to modulation.

◆

A Belgian ham complained in 1928 that making WAC was entirely too easy!



# The 300-T in Experimental Circuits

By FRANK C. JONES

The new Eimac 300T tube is rated at 300 watts plate dissipation, making an ideal one-kilowatt input

tube for amateur transmitters. Efficiencies of 80% are easily obtained without much grid drive on any band from 10 to 160 meters. An output of about 700 watts was obtained as a regenerative frequency doubler with a plate efficiency of 70%.

Experimental breadboard amplifier units were built up to test single and push-pull units using these tubes. A home-made tuning and neutralizing condenser assembly was built in order to try out an idea for this type of construction at high power. The single tube unit was converted to push-pull during certain tests. The oak baseboard is 24" x 11" x 3/4" and is mounted on 11" x 1 1/2" x 5" end blocks. The space beneath is for the 7 1/2 volt 22 ampere filament transformer and for the condenser adjusting rod and knob.

## The "Home Brew" Condenser

The tank condenser stator plates were each 9" long, 7 1/2" high, with a 3/4" mounting lip, and were bent from no. 10 gauge aluminum. These were mounted on four 5" stand-off insulators. The neutralizing condenser or condensers consisted of a rotating plate set near the opposite large stator plate. A large coil plug and jack allows setting of the neutralizing capacity to any desired value by swinging of the plate.

The "rotor" of the split stator condenser consists of a piece of no. 12 gauge aluminum bent in a U shape with a cross-member to make it rigid and to provide additional bearings for sliding of the assembly up and down on a pair of brass rods. The two sides of the rotor are the same size as the stator plates and are separated 1/2 inch from them. The 1/4 inch brass guide rods are threaded at the lower ends and bolted to the oak baseboard. The rotor slides up and down these rods, which stick up through the four holes in the center portion of the rotor assembly. A 1/4" threaded brass rod acts as a control drive through the baseboard. It threads through a brass nut which in turn is

*Even if you can never hope to have a pair of 300T tubes in your rig, these results of high power amplifier tests by Frank Jones will be of interest to you, for some of the conclusions apply to a pair of 210's just as well. The novel "home brew" condenser construction allows a substantial saving, and may be used in any high power rig using 852's, 150T's, etc.*

fastened to the baseboard by being sweated to a small copper or tin plate with a couple of screw

holes in it. The lower end of this threaded rod has a large knob on it and the upper end was turned down in a lathe to 1/8" diameter for a length of 1/4". A washer over this forms a collar and the rod turns in a 1/8" hole in the center of the rotor assembly.

The tuning of this condenser is rather a slow process as it takes about a minute to run the rotor up to the top position. The maximum capacity per section is only about 30  $\mu$ fd., making necessary coils with more turns than normal for operation of a low C tube such as the 300T.

This new tube has the following specifications:

Filament Voltage	7 1/2 volts
Filament Current	11.5 amperes
Plate Dissipation (continuous)	300 watts
Amplification Factor (approximate)	16
Plate Current (maximum)	.300 amperes
Grid Current (max. d.c.)	.075 amperes
Plate Voltage (maximum)	3500 volts
Plate-Grid Capacitance	4 $\mu$ fds.
Grid-Filament Capacitance	4 $\mu$ fds.
Plate-Filament Capacitance	.6 $\mu$ fds.
Envelope	GT 40 Nonex
Base	Standard 50 watt
Overall Height	12 1/2 inches

Numerous tests were made. As a regenerative amplifier a single 300T was crystal controlled on 20 meters from a 53 doubler to give a T-9 note with 600 watts output. As common with all inter-lock controlled amplifiers, careful monitoring at all times is necessary to be certain that the device is actually being controlled by the crystal oscillator or low powered doubler.

As a neutralized r.f. amplifier, outputs of 800 watts were obtained on 40 or 20 meters with one kilowatt plate input. The plate voltage was a little below the 3500 volt rating, and 50 ma. of grid current through a 10,000 ohm grid leak provided ample grid excitation. At 2800 volts, 40 ma. of grid current caused saturation, and at 1600, 25 to 30 ma. was ample. A pair of 10's at 600 volts drove over 40 ma. into the 300T with a single turn of link cou-

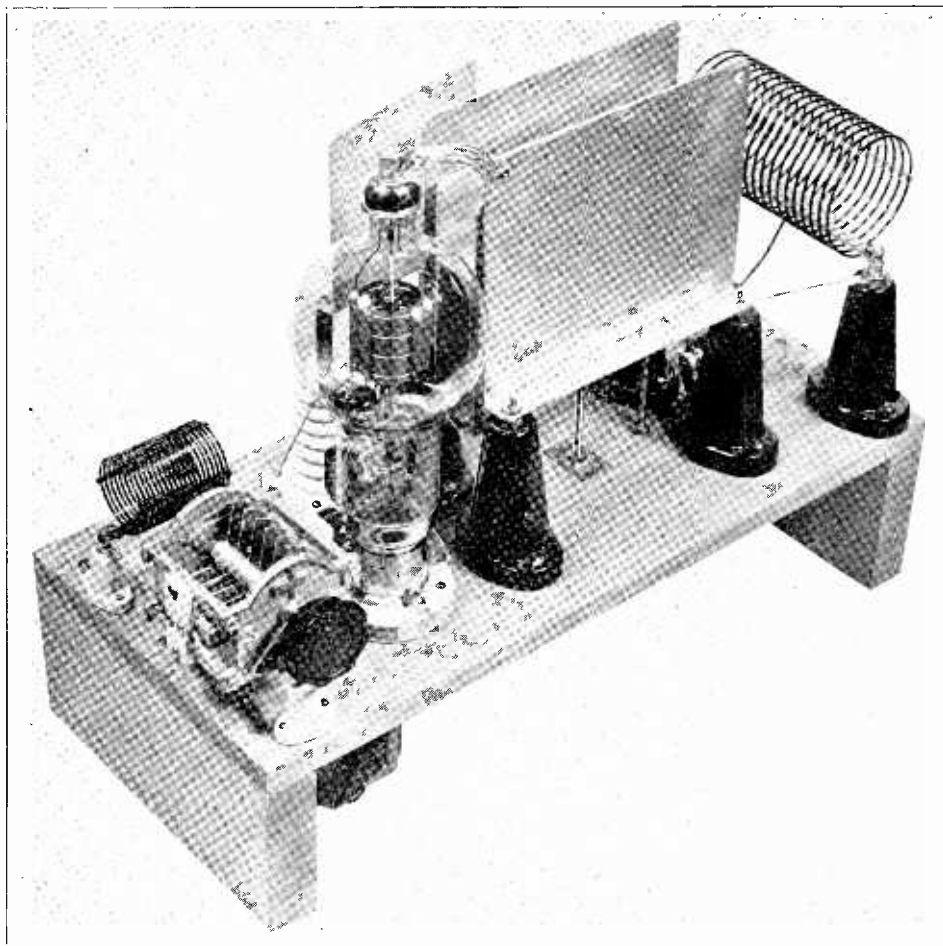

**The Single-ended 300T Amplifier Stage.**

pling. Operation of the buffer at 700 to 750 volts gave outputs more than ample to drive the 300T to 1 kw. input at 80% efficiency. Apparently not over 75 to 80 watts of grid driving power is necessary for saturation up to the amateur legal input rating of 1 kw.

When the coil center-tap was by-passed back to ground or tied to the rotor of the tuning condenser, excessive regeneration took place even on 40 meters. The required grid excitation dropped 50% but self-oscillation was too prevalent to advise this form of circuit for this particular tube. This form of regeneration can be used to advantage with most tubes to reduce the grid excitation requirements for c.w. operation. The mutual conductance of this tube is so high that excessive regeneration takes place, and since the tube doesn't require much grid drive, the standard circuit shown is advised.

#### Grid Modulation

Grid modulation was tried using a 1000 ohm cathode resistor for one tube and 500 ohms for two. The external fixed cut-off bias was 175 volts for a plate supply of 3000 volts. The carrier output was between 150 and 200 watts with a plate current of 200 ma. and from 0 to 2 ma. of grid current with a single tube. Push-pull tubes doubled these values. The audio output from a pair of 45 tubes was more than sufficient to obtain 100% modulation in either case. The 300T plates operated at a cherry red, indicating about 300 watts plate dissipation per tube. A pair of 872 rectifier tubes were used in a 2½ kw. power supply for these tests.

A single 300T gave excellent results as a regenerative doubler on 20 meter tests. Outputs of 700 watts could be obtained with one kw. input. 100 watt lamps in series parallel



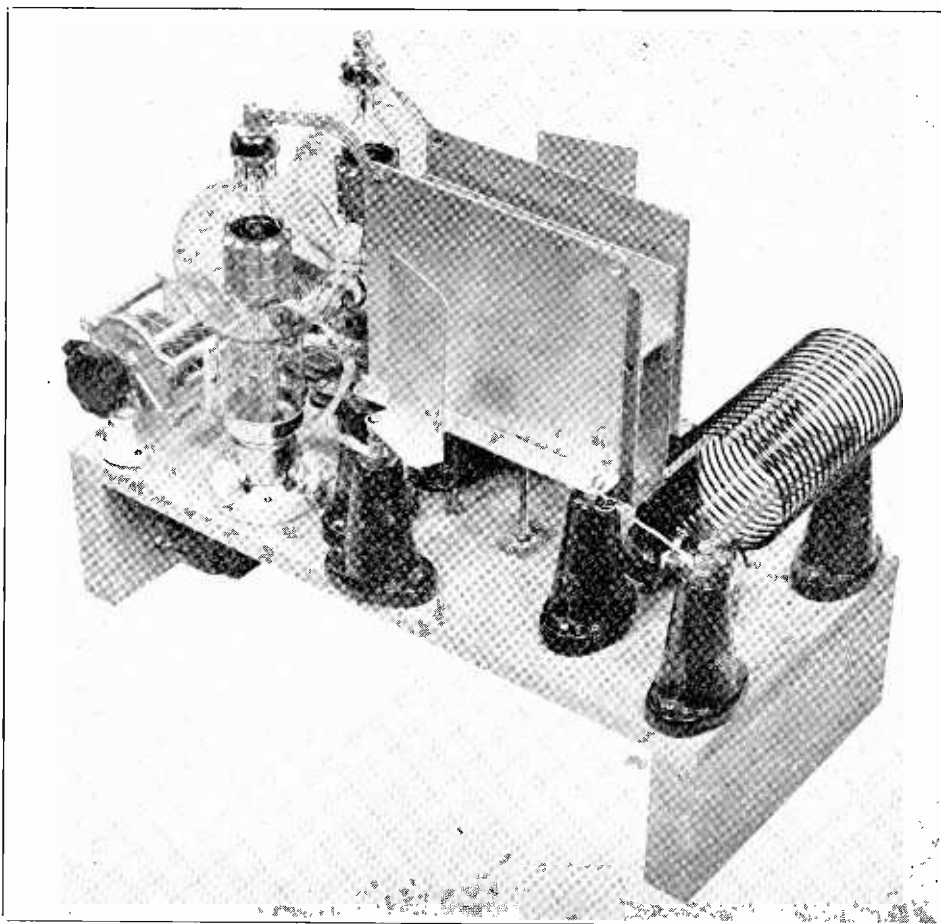

**The Same Transmitter Modified for Push-pull.**

acted as a dummy antenna while testing. All power output measurements were only approximate as normal brilliancy of each lamp in a bank was compared to another 100 watt lamp operating on the 115 volt circuit at the same time. As a doubler, the neutralizing condenser was set to give about twice as much capacity as for neutralizing an amplifier. The grid leak was increased to 25,000 ohms and the coil center tap had to be connected to the condenser rotor to get outputs of over 600 watts. 30 to 35 ma. of grid current give this high efficiency as a doubler.

For some unexplained reason, less output was obtained with two tubes in a push-push doubler than with the regenerative doubler described. This was probably due to lack of regeneration. Very high grid drive was needed for the push-push doubler.

An RK-28 with controllable output up to 200 watts was available as a buffer for driving the two 300T tubes in push-pull. Outputs of over 1 kw. were obtained with less than 2500 plate volts. Outputs of much over 1000 watts were not checked with the lamp bank as there were only ten 100 watt lamps available at the time of the tests. Four of those burned out due to overloads during the tests. The lamp bank looked at times like a bunch of photo-flood lamps used by photographers.

In the push-pull amplifier, very weak self-oscillation would take place when the coil center tap was connected to the rotor. At all times the rotor was never grounded, but was by-passed to filament. An r.f. arc would allow a d.c. short circuit path (which would collapse the r.f. choke in a hurry) if the rotor were grounded directly, possibly burning out power

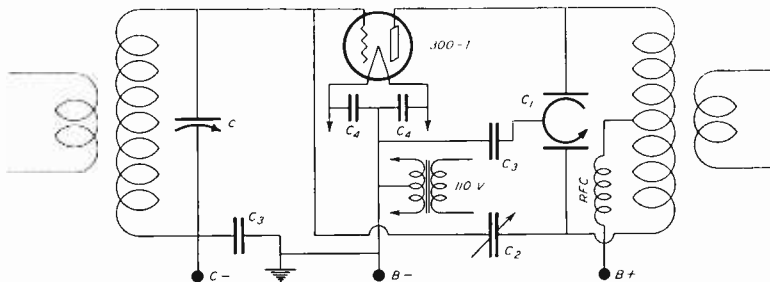

The "plate neutralized" single-ended 300-T stage.

- C—50  $\mu$ fd. 6000 volt spacing.  
 C<sub>1</sub>—Special tank condenser (see text).  
 C<sub>2</sub>—"Neutralizing flipper" attachment to C<sub>1</sub>, approximately 4  $\mu$ fd. (see text).  
 C<sub>3</sub>—.002  $\mu$ fd. mica, 5000 volts.  
 C<sub>4</sub>—.01  $\mu$ fd. 400 volt paper tubular.

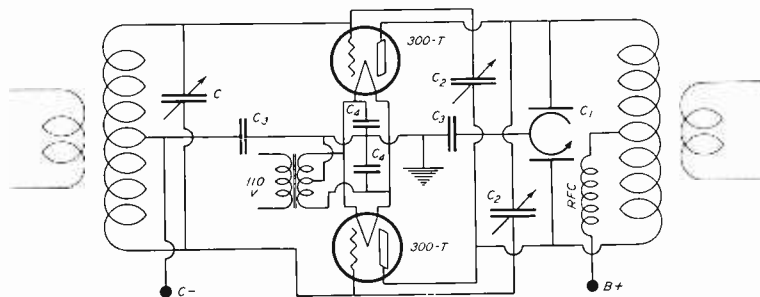

The "cross neutralized" push-pull 300-T stage. Constants same as for single-ended stage.

supply units.

Push-pull tests with a 5000 ohm grid leak indicated that grid currents of from 70 to 100 ma. were ample for full output of the two tubes.

The low value of plate tuning capacity meant that this amplifier would be unsatisfactory for phone operation except possibly at 10 or 20 meters. It is high enough for c.w. up to 40 meters and could be used on 80 meter c.w. fairly well if the antenna loading were not too great. Due to the remarkably low plate-to-filament capacity of this tube, a single-ended amplifier with split stator plate condenser will neutralize perfectly on 10 or 20 meters. There isn't enough capacity to unbalance the neutralizing circuit such as occurs with high capacity tubes.

#### Time Marches Back

Radio transmission of fourteen years ago was recreated by WOR to demonstrate the contrast between that and the station's present high fidelity transmission.

The engineering feat was achieved by the use of a filter which cut out certain frequencies and

eliminated high and low register notes which were lost in radio's younger days.

The filter was used to cut down the transmission to the embryonic state of 1922, when the telephone type microphone and old fashioned transmitter lost the low and high register notes. The next step was 1925, when the double button carbon "mike" was used, then 1929 with its condenser microphone, and in both steps improved and higher power transmitters.

The countless hundreds of hams now using 45's in transmitters will be amused to learn that this tube was once labelled, "not intended for use as an oscillator."

Though his ham licenses had been suspended for three months for a minor infraction of the law, C. B. Harrison, 9DOZ, went on the air and called aid to his town during a tornado some years ago.

There are slightly more b.c. stations west of the Mississippi than in the east.

Be sure to enter the contest. See page 80.

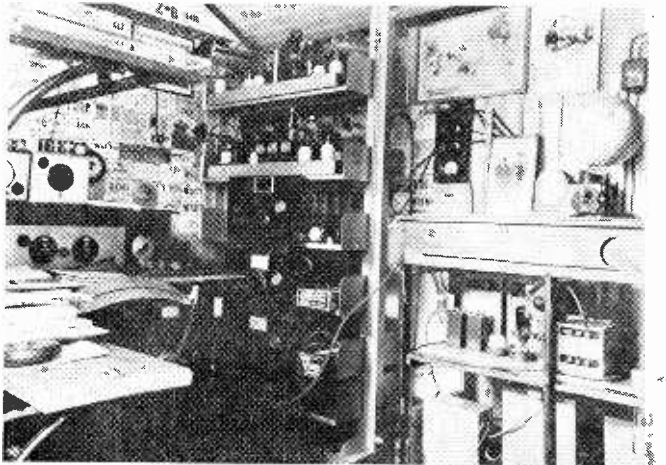

G6QX

### G6QX

There is hardly a ham who hasn't heard the rip-roaring sig of G6QX, Robert Jardine . . . if the said ham is DX minded. G6QX is a comparatively new station, first seeing the light of day in November, 1928, although his shortwave interest dates prior to BRS-142 days. 75 countries have been worked, and although this is not as many as others may have worked, it is due only to other responsibilities . . . such as all of us have. Jardine is married, has a son 16 years old, and during the War he served in France as pilot in fighter squadrons. G6QX has three receivers . . . a 4 tube peaked amplifier screen grid of the Ross Hull design, another is a Schnell O-V-1, and the third is a O-V-Pentode Reinartz. The latter is preferred and is used mostly on 14 mc. The transmitter consists of an LS5B for crystal oscillator; the next two stages are doublers and they, also, use the LS5B. The final amplifier on 14 mc. is a TY2-60 and usually runs at about 130 watts input. Another TY2-60 is used in the final for 7 mc. and runs 150 watts on this band. Each final stage is complete, and it takes Jardine only two minutes to change from 20 to 40. As the photo shows, the transmitter is built on several steel shelves which fit into slotted upright steel posts; the whole rack is sprayed with silver cellulose, making a very neat looking job. The antenna set-up at G6QX consists of two poles 40 feet high and about 140 feet apart. At present he is using a G2BI antenna to Windom's formula. For his frequency of 14,360 kc. it figures out to be exactly 66 feet 2-9/32 inches in length, and the

feeder taps on 8 feet 6-13/32 inches off center. These figures are, of course, for 79.5 mil wire. The flattop runs 5 degrees North of East, and from tests that have been carried on at QX it is very successful for his Western dx, such as W6, W7 and VE5. Eastward it works out fine for J and VK. All this is on 14 mc. because this is where he is most of the time. Jardine has not neglected the safety measures in building his station. All of the power supply equipment is exceptionally well insulated and very neatly arranged. Station G6QX is a well-balanced one, and from the sock of his signal on the West Coast he must know his dx.

### OZ2M

OZ2M owned by K. L. Ewald, uses a 4 stage c.c. rig on 14,110 kc. and runs about 100 watts input. His QSL card can be found on many walls throughout the world, and due to the scarcity of Danish stations OZ2M is responsible for a new country on many a DXer's list.

### J2KN

J2KN hardly needs an introduction, but at present he is one of the most active of the Japanese stations on the air. For his dx, nothing much need be said; the cards on the wall testify that he will keep up with the best of them.

### U3AG

This station has proved to be the first U worked by many W hams. Before other Russian stations were getting through, that chirpy signal of U3AG was on the job; probably most of us are acquainted with him by now. His out-





## A DX "Yardstick", W.A.Z.\*

RADIO herewith presents a new dx scheme believed to be much superior to any mere list of countries or continents worked. It not only provides an ultimate goal which is all the more desirable because few will probably achieve it, but more important for the average dx station it provides a means whereby the progress of different stations toward that goal may be easily compared, and concisely stated.

Nearly all of us are interested to a degree in working dx. Large numbers of QSL cards proudly bear the "W.A.C." (worked all continents) designation; many bear lists of the countries or prefixes worked. Even most old-time hams like to brag that some dx stations have reported them the "loudest W—station heard here, o.m.; R99 plus!"

Despite such well-nigh universal interest in dx, there seems to be no satisfactory "yardstick" by which to measure or compare the dx performance of different stations. "W.A.C.," once the goal of every ham who was either mildly or enthusiastically interested in dx, has been "made" by such a large number of hams that it is no longer a badge of special distinction except in a few localities.

"When Is a Country Not a Country?"

Realizing this, many such stations in the last few years have taken to listing the number of countries (or prefixes) worked and elaborate tables have been published of just what places are considered by the compilers as "countries." But such schemes lack the element of fairness to many stations. In several places on the earth's surface a considerable number of small countries are grouped together in one natural geographical area; dx stations that can work one easily can usually work all of them just as easily, unless some have very few hams. On the other hand, there are several large countries which lie in two or more natural geographical areas and it may be, and frequently is, a much more difficult feat to work stations in several parts of such a country; yet the station so doing takes credit for working but one country.

Accordingly the editors of RADIO have at-

tempted to evolve a zone scheme (*w.a.z.*—"worked all zones") which may be used as a fairer basis of comparison. As hinted above it may not only be used by those who have worked all zones but also by others who can readily compare their progress toward the ultimate goal with that of other stations having the same objective. The far-from-perfect result is shown in the accompanying map and the list of zones at the end of this article. Note that the map is not "official"; it is merely intended to give the general picture. Reference should be had to the list of places in each zone to settle questions which may arise.

Not a "Racket"

It is not our intention to make a minor "racket" out of the *w.a.z.* "degree". It is *not* necessary to join any association, to subscribe to any magazine, or to obtain any certificate to be entitled to call one's station a *w.a.z.* station. The designation is simply an indication of *performance*, and nothing else. However, for those who may want a certificate as a souvenir or evidence, RADIO plans to issue at cost a neat, engraved or embossed certificate (as unlike "oil stock" as possible), upon submission of satisfactory evidence as to the number of zones worked.† Please *do not* send in inquiries, applications, or QSL cards for this purpose until further announcement is made in these pages.

The *w.a.z.* degree should of course be used only by those who have reached the goal of working all forty zones. The scheme, however, is subject to much wider application as progress made toward that goal can be indicated by a designation such as *W35Z*, signifying that the station has "worked thirty-five zones."

In determining zone boundaries we readily admit that no two persons in the world would probably make up exactly similar lists. Careful attention has been given to topographical maps, calls heard lists, and similar factors in compiling the zone lists. For convenience in determining the zone in which a distant station may be located, zone lines have in most cases been made to coincide with political or call area boundaries even where *slight* departures from natural geographical boundaries were necessi-

†Such certificates will probably be available not only to *w.a.z.* stations, but also to those working a certain number of zones, such as 35 or more.

\*The entire contents of RADIO are fully protected by copyright with all rights reserved. Permission, however, is hereby granted to any publication appearing at regular intervals (except those published primarily to advertise the publisher's other products or services) and having a circulation among radio amateurs to reprint the text of this article in whole or in part. A credit line will be appreciated. The accompanying map may also be reproduced in such periodicals *not larger* than the size herein. Electrotypes are available at cost.



tated.\* Deliberately no consideration has been given to the number of amateur stations which may be located within a particular zone, as this is a factor of no permanence.

A number of stations in the eastern U.S.A. have objected that the scheme has been designed to favor the west coast station because more zones have been assigned to Asia than Europe. The plan has been laid out as carefully as pos-

\*Repeated objections to the division of the country even for such a purpose as the w.a.z. plan have been received from one of the more nationalistically inclined countries. No changes have been made on this account, however, as it is our contention that an advancing wavefront cannot recognize a political boundary even when it sees one.

sible without reference to any particular country or portion of a country. The number of zones on each continent is roughly proportional to its area.

Because of the difficulty of securing widespread publicity thereon and the cost of revising maps as well as the undesirability of making obsolete maps already in the hands of users, the question of promulgating changes in the plan will only be considered at infrequent intervals.

In the following list some overlapping units are included, that is, many places listed are subdivisions of other places also listed. This has been done purposely because sometimes one of the names is omitted in the postal addresses given on QSL cards.

## WAZ ZONE BOUNDARIES DEFINED

### Zone 1—Northwestern Zone of North America

Alaska (K7)  
Yukon (part of VE5)  
Canadian Northwest Territories (part of VE5)  
District of Mackenzie  
District of Franklin  
Islands west of 102° W., including Victoria, Banks, Melville, and Prince Patrick.

### Zone 2—Northwestern Zone of North America

Canada, that portion of Quebec (part of VE2) north of an east and west line drawn along and extended from the southern boundary of Labrador  
Canadian Northwest Territories (part of VE5)  
District of Keewatin  
District of Franklin east of Long, 102° W. including Islands of King William, Prince of Wales, Somerset, Bathurst, Devon, Ellsmere, Baffin, and the Melville and Boothia Peninsulas.

### Zone 3—Western Zone of North America

British Columbia (part of VE5)  
W7 except Wyoming and Montana  
All W6.

### Zone 4—Central Zone of North America

All VE3, VE4, W5, and W9.  
Wyoming and Montana (part of W7)  
Ohio and Michigan (part of W8)  
Tennessee and Alabama (part of W4)

### Zone 5—Eastern Zone of North America

All VE1, VO8, W1, W2, W3.  
VE2 (Quebec) south of line mentioned in Zone 2  
W4 except Tennessee and Alabama  
W8 except Ohio and Michigan.  
Bermuda.

### Zone 6—Southern Zone of North America

Mexico

### Zone 7—Zone of Central America

Honduras  
British Honduras

Guatemala  
Costa Rica  
Nicaragua  
Panama  
Canal Zone

### Zone 8—West Indies Zone

Cuba  
Puerto Rico  
Virgin Islands  
Jamaica  
Bahamas  
Barbados  
Haiti  
Dominican Republic  
All Greater and Lesser Antilles except Bermuda and those listed in Zone 9.

### Zone 9—Northern Zone of South America

Colombia  
Venezuela  
Dutch Guiana  
French Guiana  
British Guiana  
Trinidad  
Curacao  
Tobago  
Grenada

### Zone 10—West Central Zone of South America

Ecuador  
Peru  
Bolivia  
Colon or Galapagos Archipelago

### Zone 11—East Central Zone of South America

Brazil  
Paraguay

### Zone 12—Southwestern Zone of South America

Chile

### Zone 13—Southeastern Zone of South America

Argentina  
Uruguay  
Falkland Islands

### Zone 14—Western Zone of Europe

Portugal  
Spain  
Andorra  
France  
Switzerland

Belgium  
Luxembourg  
Saar  
Germany (except East Prussia)  
Denmark  
Sweden  
Norway  
Great Britain  
Irish Free State  
Netherlands (Holland)  
Azores Islands  
Faroes Islands  
Gibraltar  
Monaco

### Zone 15—Central Zone of Europe

Italy  
Albania  
Austria  
Liechtenstein  
Poland  
Finland  
Latvia  
Lithuania  
Estonia  
Czechoslovakia  
Yugoslavia  
Corsica  
Sardinia  
Hungary  
Malta  
Sicily  
San Marino  
Danzig  
Germany (East Prussia only [D calls ending in A])

### Zone 16—Eastern Zone of Europe

European portions of U.S.S.R., including European portion of Soviet Russia, White Russia or Belorussia, Ukraine, and Novaya Zemlya.

### Zone 17—Western Siberian Zone of Asia

Asiatic U.S.S.R.  
Ural  
Kirghiz  
Tadzhik  
Turkomen  
Uzbek  
Kara Kalpak  
Kazak

### Zone 18—Central Siberian Zone of Asia

Buryat Mongol  
Oymat

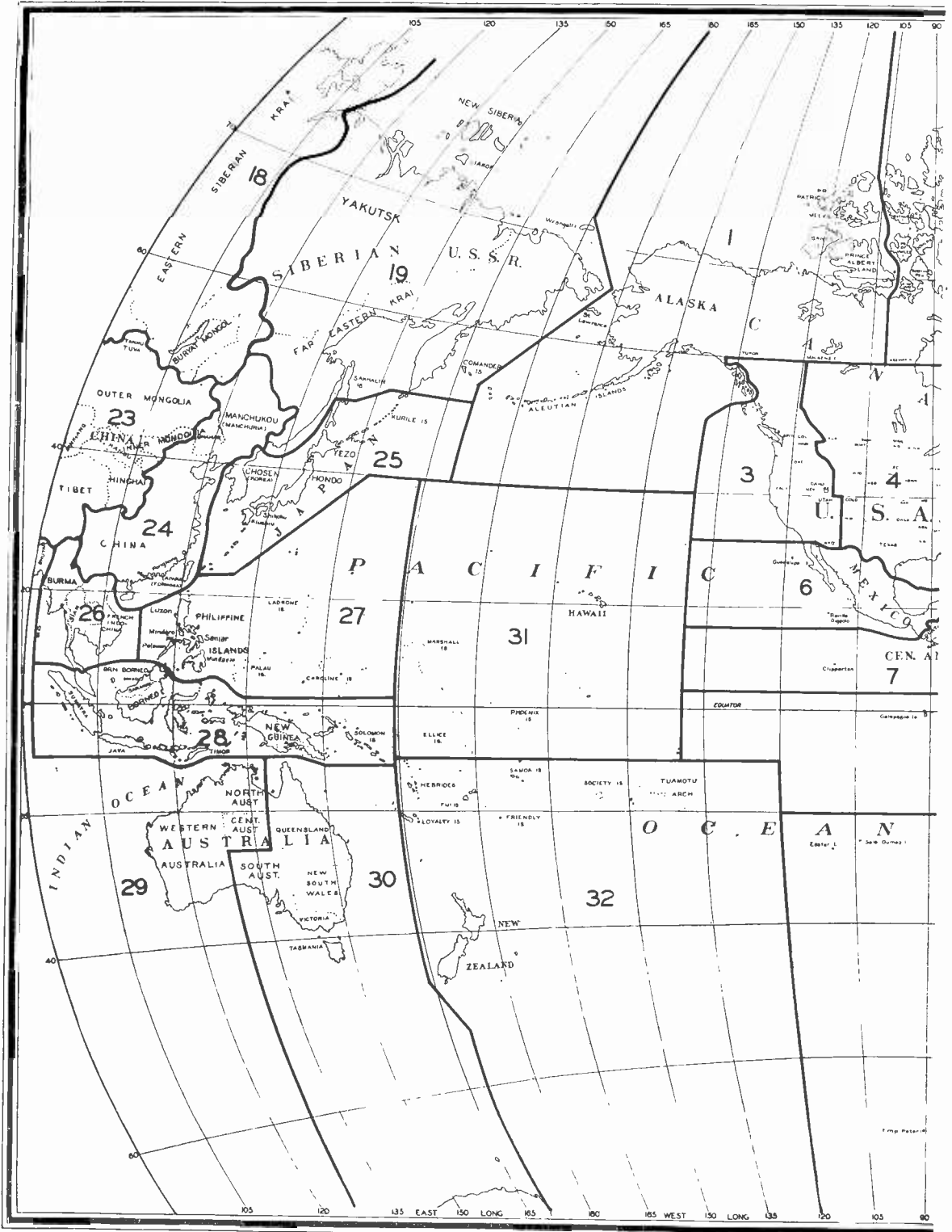

**DX ZONE MAP OF THE WORLD**

A large wall map with more detail and without advertising will be available later at a nominal cost.







## WAZ ZONE BOUNDARIES

(Continued)

- Siberian Krai (Eastern and Western)
- Zone 19—Eastern Siberian Zone of Asia**  
Yakutsk  
Far Eastern Area or Dalnevostchnyy
- Zone 20—Balkan-Asia Minor Zone**  
Rumania  
Bulgaria  
Greece  
Crete  
Aegean Islands  
Syria  
Palestine  
Transjordanian  
Cyprus
- Zone 21—Southwestern Zone of Asia**  
Saudi Arabia (Hedjaz, Nejd)  
Yemen  
Oman  
Aden  
Asir  
Iraq (Mesopotamia)  
Afghanistan  
Persia  
India (Baluchistan only)  
U.S.S.R. (Transcaucasia only, Georgia, Armenia, Azerbaijan)  
Kuweit
- Zone 22—Southern Zone of Asia**  
India (except Baluchistan and Burma)  
Assam  
Sikkim  
Ceylon  
Nepal  
Mahe  
Maldivé Islands  
Laccadive Islands  
Karakal  
Bhutan  
Pondichery  
Goa
- Zone 23—Central Zone of Asia**  
Chinese Republic, following portions only:  
Tibet  
Sinkiang (Chinese Turkestan)  
Tannu Tuwa (Tannou Touva)  
China Proper (Kansu province only)  
Outer Mongolia  
Inner Mongolia (except Chahar Province)
- Zone 24—Eastern Zone of Asia**  
China proper (except Kansu Province)  
Inner Mongolia (Chahar Province only)  
Manchukuo (Manchuria)  
Kwangchow  
Macao  
Hong Kong  
Darren  
Japan (Taiwan or Formosa only, 39)
- Zone 25—Japanese Zone of Asia**  
Japan (except Taiwan or Formosa)  
Chosen (Korea)
- Zone 26—Southeastern Zone of Asia**  
India (Upper and Lower Burma only)  
Siam  
French Indo-China  
Andaman Islands
- Zone 27—Philippine Zone**  
Philippine Archipelago  
Guam  
Yap  
Caroline Islands  
Mariana Islands  
Islands east of Philippines, west of Long. 163° E., north of Lat. 2° N., and south of a line from 153° E., 40° N. to 131° E., 23° N.
- Zone 28—Malayan Zone of Asia**  
Malay States (Federated and Non-Federated)  
Johore  
Straits Settlements  
Malay Archipelago, including Netherlands Indies (Dutch East Indies)  
Java  
Sumatra  
British North Borneo  
Sarawak  
Papua  
New Guinea (VK9)  
Borneo (PK6)  
Solomon Islands  
Timor Islands  
Portuguese East Indies  
Islands between Lat. 2° N. and 11° S., and west of Long. 163° E.
- Zone 29—Western Zone of Australia**  
Australia  
Western Australia  
North Australia  
Central Australia
- Zone 30—Eastern Zone of Australia**  
Australia  
Queensland  
New South Wales  
Victoria  
Tasmania  
South Australia  
Islands south of Lat. 11° S. and west of Long. 163° E.
- Zone 31—Central Pacific Zone**  
Hawaiian Islands  
Ellice Islands  
Gilbert Islands  
Islands between Lat. 11° S., and 40° N., and between Long. 163° E. and 140° W.
- Zone 32—New Zealand Zone**  
New Zealand  
Loyalty Islands  
Tahiti  
Fiji  
New Hebrides  
Samoa  
New Caledonia  
Chatham Islands  
Islands south of Lat. 11° S. and between Long. 163° E. and 120° W.
- Zone 33—Northwestern Zone of Africa**  
French Morocco  
Spanish Morocco
- Rio de Oro  
Tunisia  
Algeria (Northern and Southern)  
Ifni  
Madeira  
Canary Islands
- Zone 34—Northern Zone of Africa**  
Libya  
Egypt  
Anglo-Egyptian Sudan
- Zone 35—Western Zone of Africa**  
French West Africa  
Nigeria  
Ivory Coast  
Gambia  
Cape Verde Islands  
French Guinea  
Liberia  
Portuguese Guinea  
Dahomey  
Ashanti  
Sierra Leone  
Senegal  
Gold Coast  
French Sudan  
Togoland
- Zone 36—Equatorial Zone of Africa**  
Angola (Portuguese West Africa)  
Camerouns  
Spanish Guinea  
French Equatorial Africa  
Belgian Congo  
Northern Rhodesia  
Cabinda  
Rio Muni  
Gabon  
St. Helena Island  
Ascension Island
- Zone 37—Eastern Zone of Africa**  
Mozambique (Portuguese East Africa)  
British East Africa  
Kenya  
Uganda  
Tanganyika  
Nyassaland  
Ethiopia (Abyssinia)  
Italian Somaliland  
British Somaliland  
French Somaliland  
Eritrea  
Zanzibar Islands  
Socotra Islands  
Mafia Islands
- Zone 38—Southern Zone of Africa**  
Union of South Africa  
Southern Rhodesia  
Swaziland  
Basutoland  
British Southwest Africa  
Buchuanaland  
Tristan de Cunha Island  
Gough Island  
Bouvet Island
- Zone 39—Madagascar Zone**  
Madagascar  
Reunion Island  
Seychelles Island  
Admirante Island
- Zone 40—North Atlantic Zone**  
Greenland  
Iceland  
Svalbard (Spitsbergen)

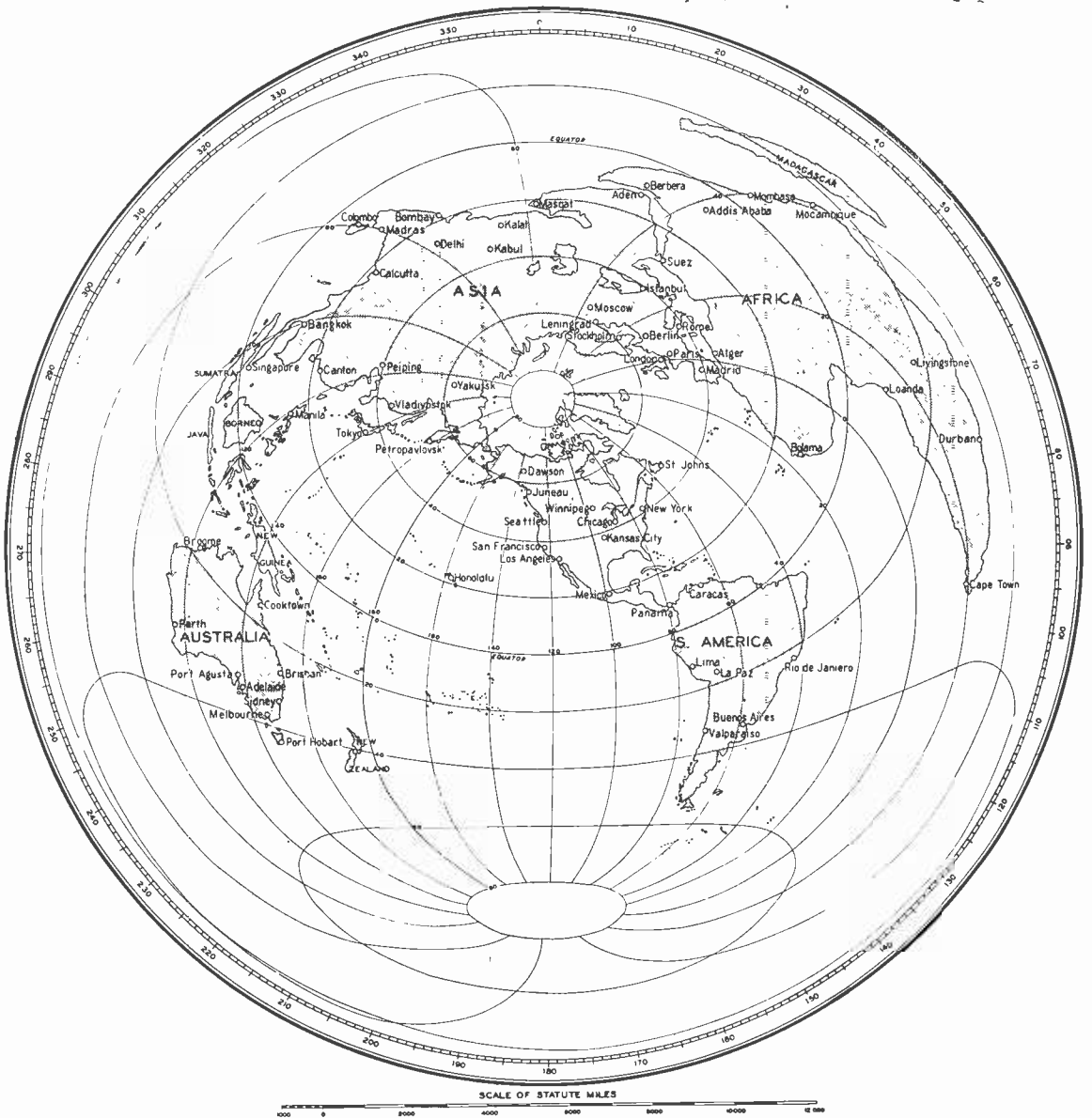

## GREAT CIRCLE MAP OF THE WORLD Centered on San Francisco

The great circle distance from San Francisco to any other point on the surface of the globe may be scaled off directly on this map using a straight-edge and the scale of miles shown directly below the map. Melbourne scales roughly 800 miles from San Francisco. Distances of distant points from other cities in the western United States can also be scaled off directly with sufficient accuracy for most amateur purposes. To determine distance in kilometers multiply miles by 1.6.

The great circle direction of any point from San Francisco may be determined by laying a straight-edge from San Francisco to the point whose direction it is desired to determine. The point at which the straight-edge crosses the numbered circle will give the direction. Thus Durban, South Africa, lies about  $13\frac{1}{2}$  degrees north of east from San Francisco ( $76\frac{1}{2}$  on the numbered circle). Verify this on a globe if you doubt it.



# An All-Band Transmitter

By FRANK C. JONES

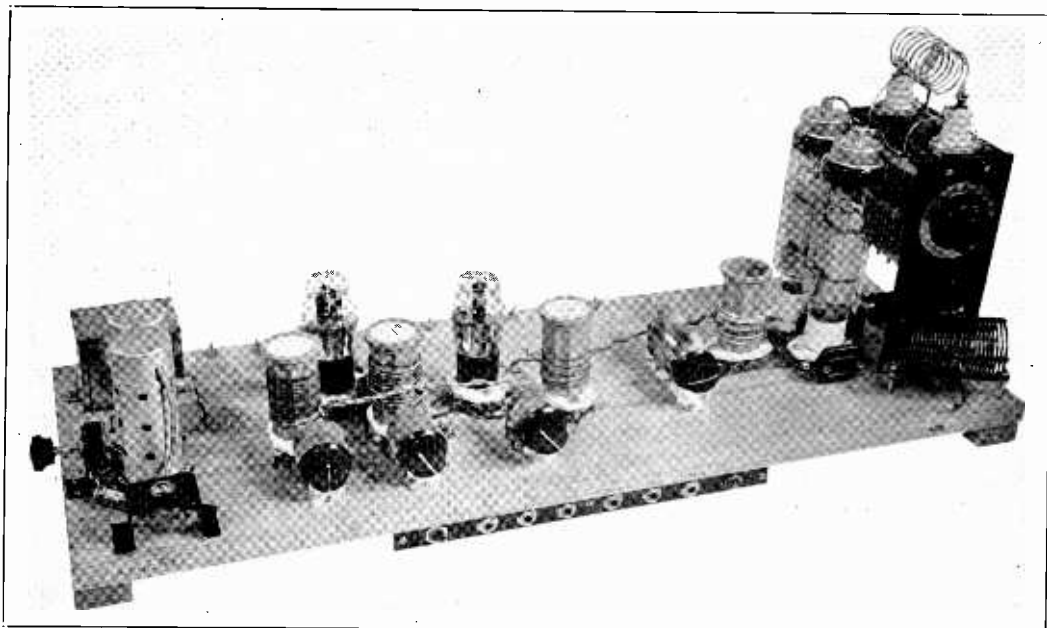

Economical Phone and C.W. on All Bands

This transmitter is suitable for operation on any band from 10 up to 160 meters as a phone or c.w. set. The output on c.w. ranges from 130 to 160 watts depending upon the power supplies available. On phone, the carrier is between 30 and 35 watts, with a capability of 100% modulation. Laboratory tests indicate full output on 10 meters with a minimum number of stages and very little modulator equipment.

RK-20 tubes are used in the final amplifier, and since these r.f. pentodes have excellent suppressor grid modulation characteristics, phone operation is economical and simple. The input and output capacities of an RK-20 are 11 and 10  $\mu\text{fd.}$  respectively; therefore the tubes are in push-pull rather than parallel for 10 meter operation. Push-pull connection puts these capacities in series, resulting in only about 5  $\mu\text{fd.}$  across the grid and plate tuned circuits. It would appear that this transmitter would work on 5 meters also if one of the new 20 meter power crystals were available.

For operation in any three bands only the final amplifier grid and plate coils need changing and there are no neutralizing adjustments.

Changing from c.w. to phone is accomplished by a single-pole double-throw switch which connects the suppressor grids either to + 45 volts or through the modulation transformer to - 45 volts. No other adjustments are necessary.

The exciter uses two 6A6 or 53 tubes. One acts as a crystal oscillator-doubler and the other as a push-push doubler. The oscillator tube circuit has been described in previous articles, the only difference being that the doubler coil is center-tapped in order to give a balanced circuit into the second 6A6 tube. Connecting the grid of the first doubler 6A6 triode to the free end of its plate coil through a small variable condenser would increase the harmonic output somewhat, but was not necessary with a 400 volt power supply. The new power cut type crystals should be used since the crystal r.f. current on 40 meters will run a little over 120 ma., causing frequency drift with ordinary X cut crystals.

The second 6A6 tube has its grids in push-pull and its plates in parallel for effective frequency doubling. Its 10 meter output is greater than the 20 meter output of the pre-

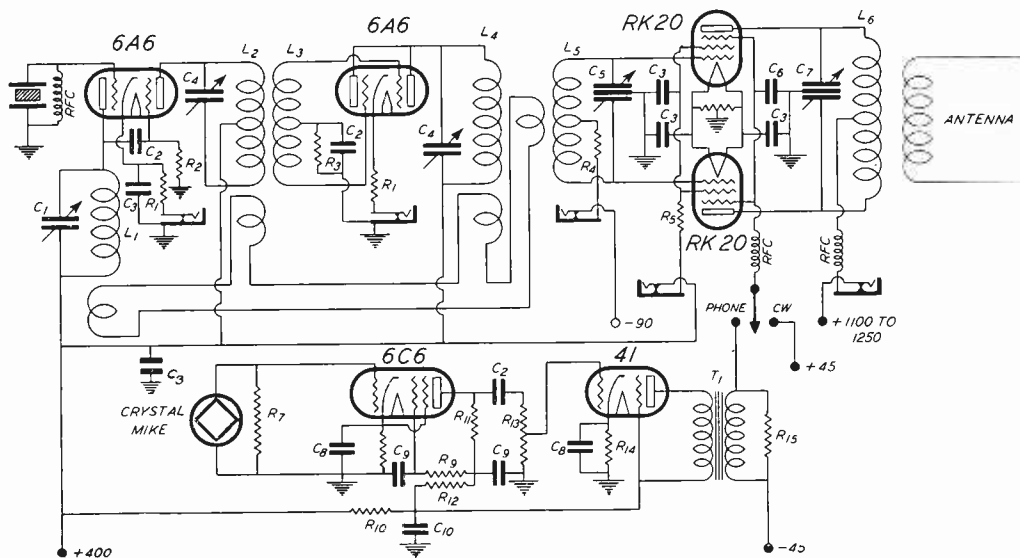

General Wiring Diagram of the RK-20 All Band Transmitter

- |   |  |  |
|---|--|--|
| C <sub>1</sub> —100 μfd. midget.                    | C <sub>10</sub> —0.1 μfd. 600 volt paper.      | R <sub>4</sub> —3500 ohms, 1 watt.               |
| C <sub>2</sub> —100 μfd. 1000 volt mica.            | C <sub>10</sub> —8 μfd. 600 volt electrolytic. | R <sub>5</sub> —2 megohms, 1 watt.               |
| C <sub>3</sub> —0.01 μfd. 1090 volt mica.           |  | R <sub>10</sub> —5000 ohms, 10 watts.            |
| C <sub>4</sub> —50 μfd. midget.                     | R <sub>1</sub> —400 ohms, 10 watts.            | R <sub>11</sub> —250,000 ohms, 1 watt.           |
| C <sub>5</sub> —140-140 μfd. split stator.          | R <sub>2</sub> —50,000 ohms, 2 watts.          | R <sub>12</sub> —50,000 ohms, 1 watt.            |
| C <sub>6</sub> —0.01 μfd. 1000 volt mica.           | R <sub>3</sub> —10,000 ohms, 10 watts.         | R <sub>13</sub> —1 megohm tapered potentiometer. |
| C <sub>7</sub> —90-90 μfd. split stator, 3000 volt. | R <sub>4</sub> —1000 ohms, 1 watt.             | R <sub>14</sub> —600 ohms, 2 watts.              |
| C <sub>8</sub> —10 μfd. 25 volt electrolytic.       | R <sub>5</sub> —100 ohms, center tapped.       | R <sub>15</sub> —10,000 ohms, 5 watts.           |
|   | R <sub>6</sub> —1500 ohms, 20 watts.           | T <sub>1</sub> —Class B input transformer.       |
|   | R <sub>7</sub> —3 megohms, 1 watt.             |  |

ceding tube when the exciter has a 40 meter crystal. The circuit constants shown give some regeneration, desirable because trouble was had on 10 meters due to lack of sufficient grid excitation for phone operation. According to tube data sheets, only 1.8 watts of r.f. are needed for the RK-20's. However, two or three times this value should be available from the exciter. About ten milliamperes of d.c. grid current should flow in the final stage, and none of the usual doubler circuits would supply this drive at 400 plate volts supply except the push-push doubler shown.

A 6A6 was connected as a triode doubler with and without regeneration, with and without the elements in parallel. Only about two-thirds of the necessary output could be obtained. Next, a 59 tube was tried both as a high  $\mu$  triode doubler and as a regenerative pentode doubler. The latter connection gave the most output but the grid excitation was still too low. The push-push doubler was finally tried and found satisfactory when in the form illustrated.

Link coupling provided a simple way of obtaining exciter output on any three bands without coil changes or any other complications. The system of connecting all the link coupling

coils in series proved satisfactory since each stage is double the frequency of the preceding tuned circuit. The loss even on 10 meters proved to be less than 10% by actual check in comparison to individual link coupling to the desired tuned circuit. This method should be credited to Mr. Lampkin, who first advocated this series connection. The desired frequency is selected by the tuned grid circuit of the final amplifier. If more than three consecutive bands, such as 40, 20, and 10 meters, are needed, then coils and crystals have to be changed in the exciter.

The modulator consists of a 6C6 high-gain pentode and a 41 tube. This combination gives a gain just sufficient for close talking into a crystal microphone. The tubes are shielded to prevent r.f. feedback and the whole modulator unit is mounted along one end of the baseboard. A one-to-one ratio modulation transformer is suitable for matching the suppressor grid load into the 41 modulator. The 400 volt power supply is reduced to about 250 volts for the plate circuits of these audio tubes and an eight  $\mu$ fd. electrolytic condenser, together with the voltage dropping resistor, form an additional hum filter section. The speech amplifier has an



additional resistance type filter so the hum level is negligible in the output of the modulator.

A single-button or *high level* double-button carbon mike would have sufficient output to work into the grid circuit of the 41 tube through a mike-to-grid transformer, eliminating the 6C6 stage.

No power supplies are shown as these have already been shown in RADIO. Testing in the laboratory was done with some power supplies and B batteries which were available. The 400 volt power supply should use a transformer rated at 500 volts each side of center at 175 to 200 ma. (r.m.s.). The total d.c. load is distributed as follows: 60 ma. to the first 6A6; 70 ma. to the second; 65 to 70 ma. to the RK-20 screens; and 30 ma. to the modulator. B batteries can be used to supply control-grid and suppressor-grid bias, three batteries being needed. The control grid bias should be  $-100$  volts, 90 from a C battery and 10 from the 1000 ohm grid leak. A  $-45$  tap gives suppressor-grid bias for phone and plus 45 from another 45 volt block gives positive bias for c.w. operation.

The high voltage supply for the RK-20 plate circuit can be taken from 866's in a full-wave rectifier with a 1400 or 1500 volt transformer each side of center-tap rated at 100 ma. r.m.s. On phone the total plate current runs about 80 to 90 ma. and on c.w. about 175 ma. Another form of power supply would be three 83 rectifier tubes in a bridge circuit using a 1200 volt, 150 ma. transformer. All of these power supplies should use choke input to the filter and a second-section filter choke and condenser. This will allow keying the crystal oscillator cathode circuit for break-in operation without excessive plate voltage rise.

Closed circuit jacks were used for convenience in metering all circuits. The only one which tends to flash over is the jack in the high voltage supply lead. This can be prevented by turning the high voltage power supply on and off when making measurements.

The tuning procedure consists of adjusting the link circuit on each coil and the tuning condensers for maximum grid current into the RK-20's. Without plate or screen voltage, this d.c. grid current should be between 15 and 25 ma. Under load it will drop to less than 10, generally speaking. The plate circuit of the final stage is tuned to resonance for minimum plate current with plate and screen voltages applied. Link coupling to a separate tuned

circuit allows any form of antenna feed without unbalancing the push-pull stage. From 1 to 3 turns around the center of the plate coil is enough for link coupling to the antenna coil. For phone operation, the antenna coupling should not be too tight, and sometimes the grid r.f. excitation has to be adjusted for best results.

A carrier shift diode indicator and monitor should be available for modulation tests. This may consist of any triode connected as a diode with a 0.1 or 0.1½ ma. meter in series with an r.f. pick-up coil. For monitoring, a headset may be connected in series with the meter. For linearity a 5000 or 10,000 ohm resistor, bypassed with a .002 µfd. condenser should be in series with the milliammeter. The use of some such device is required by Federal regulations. The meter should not flicker from some given reading of carrier while modulating; any movement at all, either way, indicates overmodulation.

The unit illustrated is mounted on an oak baseboard 30" x 11" x ¾" with end cleats. The space underneath is utilized for wiring, resistors, condensers, and current-measuring jacks. Not much shielding is necessary because most of the circuits operate at harmonic frequencies. The final plate tank circuit is mounted up in the air near the tube plate caps in order to have short r.f. leads. For the same reason the various r.f. bypasses in the final stage are all close to the tube sockets and go to a common ground point on this stage.

The only double-spaced plate tuning condenser is the one in the final stage. The r.f. voltages in the remainder of the set are low enough that ordinary midget tuning condensers are suitable. The final tank coils are small in diameter and have a relatively small external field. This, together with the low power of around 30 watts on phone, prevents r.f. feedback into the microphone circuit.

The same exciter circuit could be used to drive a single 10 or 801 at 500 plate supply on any of these bands. Plate modulation with a pair of 46's in Class B would give about 20 watts of carrier, which is less than that obtained with the pentodes suppressor-modulated. The RK-20 tubes could be plate-and-screen modulated by means of four 46 tubes in p.p. parallel Class B. The plate supply to the 46's should be about 500 volts and the d.c. plate voltage on the RK-20's about 900 volts. Under these conditions, from 65 to 75 watts of carrier could



### TRANSMITTER COIL DATA

Band	L <sub>1</sub> Osc.	L <sub>2</sub> Doubler	L <sub>3</sub> P.P.D. Grid	L <sub>4</sub> P.P.D. Plate	L <sub>5</sub> Final Grid	L <sub>6</sub> Final Plate
10 meters	None	None	None	4½ t. no. 18 e. 1½" d. ¾" l.	6 t. 1½" d. 1" l. c.t.	8 t. c t. no. 12 1½" d. 2½" l.
20	None	10 t. no. 18 e. 1½" d. 1½" l. c.t.	10 t. no. 26 d.c.c. c.t. Interwound with L <sub>2</sub>	9 t. no. 18 e. 1½" d. 1¼" l.	10 t. no. 18 d.s.c. 1½" d. 1" l. c.t.	11 t. c.t. 2⅛" d. ¾" l.
40	18 t. no. 20 d.s.c. 1½" d. 1½" l.	20 t. no. 20 d.s.c. 1½" d. 1¾" l. c.t.	20 t. no. 26 d.c.c. c.t. Interwound with L <sub>2</sub>	20 t. no. 18 e. 1½" d. 2" l.	33 t. no. 20 d.s.c. 1½" d. 1½" l. c.t.	21 t. c.t. no. 14 2⅛" d. ¾" l.
80	34 t. no. 20 d.s.c. 1½" d. 1½" l.	40 t. no. 22 d.s.c. 1½" d. 2¼" l. c.t.	40 t. no. 26 d.c.c. c.t. Interwound with L <sub>2</sub>	None	42 t. no. 20 d.s.c. 1½" d. 1¾" l. c.t.	36 t. c.t. no. 16 2⅛" d. ¾" l.
160	65 t. no. 22 d.s.c. 1½" d. 2" l.	None	None	None	70 t. no. 22 d.s.c. 1½" d. 2¼" l. c.t.	54 t. c.t. no. 16 d.c.c. 3" d. 3¼" l. Close wound

be realized. The audio frequency peak voltage would be 900 on the plates and 150 volts on the screens; therefore the Class B output transformer would need two secondaries, one having about one-sixth as many turns as the other. The impedance mismatch into the screen circuit would probably result in the proper turns ratio of the two secondary windings not being exactly 6 to 1.

The degree of regeneration in the push-push doubler can be controlled by the size of the grid condenser. Some regeneration greatly improves the efficiency of this doubler stage, but too much would result in uncontrollable oscillation at the doubling frequency.

In the illustration, a 40 meter final tank coil can be seen resting on the baseboard. A two-turn-link coupling coil is mounted over the center of the coil. The coil terminals are fitted with coil plugs for quick band changes.

Appropriately enough, WNRA is the call of the BC station at Muscle Shoals.

On Dec. 24th VK4AP and LU9AX hooked for the first WAC to be made from either continent on 10 meters.

On December 31st, W6JJU worked the west coast of Australia (VK6SA). That is considered a rare accomplishment on 40 meters, but Jerry says the VK6 was "duck soup" on 28 mc. JJU reports that the Asians have started coming through again, but at a somewhat later hour, some very rare ones coming through occasionally after the band has apparently gone dead about 4:30 p.m.

W1HMP's "kid sister" kept a sked on c.w. without any formal training in ham radio. HMP didn't know she could read code, and she says she learned principally by sitting in the shack during operating hours.

The ops of W2DEF, W2DEG, and W2DEH each have the first name *Robert*.

Only one ham station is listed for Ethiopia.

# A Multiband Antenna for High Frequencies\*

By ARTHUR A. COLLINS and L. M. CRAFT

A high frequency antenna and associated transmission line,

capable of efficient operation over a wide range of frequencies, has been urgently needed. Amateurs are rarely fortunate enough to have sufficient space for erecting more than one antenna, and commercial high-frequency stations are also

*With this new system you can use one antenna on all bands and realize high transmission line efficiency even at 20 meters. It is quite flexible and requires no complicated coupling circuits. A cut-to-length 300 ohm transmission line does the trick.*

the antenna and feeder system be kept electrically symmetrical as the

frequency is varied. Unfortunately, the impedance at the center of the antenna changes with the frequency, and any ordinary arrangement for matching the transmission impedance to the antenna impedance can be effective at only one frequency. Furthermore, the effective electrical height (which may be different from the physical height above ground) has a marked effect upon the antenna resistance, and an impedance matching system which is effective at only one value of antenna impedance cannot be counted on to give correct energy transfer to the antenna unless it is adjusted for each particular installation.

The problem, then, resolves itself into the designing of a transmission line which operates efficiently over a wide range of terminating or antenna impedances. The usual two-wire line, constructed of two no. 12 wires spaced about six inches and having a characteristic impedance of about 600 ohms, is not satisfactory for this purpose. For example, such a line one-quarter wave length long connected to the center of a one-half wave length doublet will not be terminated in its characteristic impedance of 600 ohms, but in the antenna resistance of about 75 ohms, and due to the properties of such a line the input impedance at the transmitter end will be about 5,000 ohms (mathematical study will be reserved, for it is not essential for a practical understanding of the system). An input impedance as high as 5,000 ohms is undesirable because it is difficult to transfer power to it, because a slight capacity unbalance will cause serious radiation from the line, and because line losses are high due to poor power factor, i.e., pronounced standing waves.

In practice the impedance at the center of a horizontal antenna varies between about 75 ohms and 1200 ohms as the frequency is varied. The lower values occur when the antenna length is one-half wave length, three one-half wave lengths, five one-half wave lengths, etc., and the impedance is highest for frequencies making the antenna length one or more full wave lengths long. If a transmission line with a

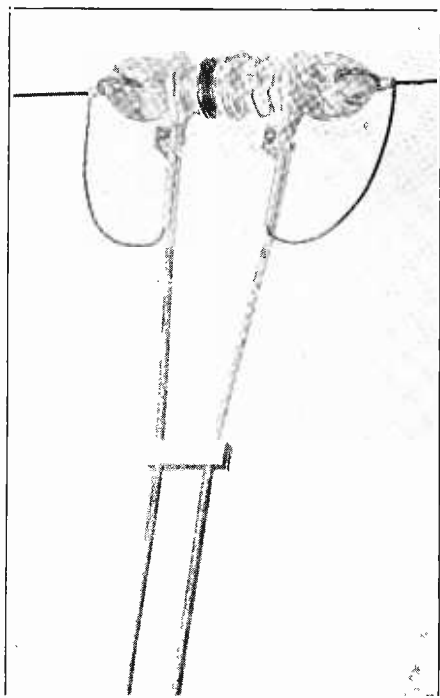

Showing how the "Multiband" line is connected to the antenna.

frequently located in restricted quarters where separate antennas for each channel cannot be used.

The ordinary high-frequency antenna consists of a doublet operated at its fundamental (the length equal to one-half wave length) or at a harmonic. Such antennas are popularly classified by the type of feeder system employed, such as "Center Fed," "End Fed or Zeppelin," "Single-wire Hertz," "Matched Impedance with Y connected feeders," etc. Only by connecting the feeders into the center of the doublet can

\*Courtesy, Collins Radio Co.





characteristic impedance of 300 ohms (the geometric mean between 75 and 1200) is used, the standing waves will be a minimum at all frequencies, and the input impedance will remain at all times a manageable value not exceeding 1200 ohms. A 300 ohm line can be constructed of two  $\frac{1}{4}$  inch tubes spaced  $1\frac{1}{2}$  inches by means of ceramic blocks at intervals of about 20 inches. The blocks can be located by crimping the tube slightly on either side of the block. A 50 foot copper line of this type weighs 10.9 pounds and is not difficult to support from the center of the antenna. If necessary, aluminum instead of copper tubing may be used to reduce the load on the antenna supports when the vertical part of the transmission line is greater than 50 feet. A line so constructed has surprisingly low loss. Figures 1 and 3 show the actual data, but the following excerpts indicate the minimum efficiency obtained for a line 100 feet long terminated in either 70 or 1200 ohms.

Frequency	Efficiency
3000 kc.	98.5%
7000 kc.	98%
14000 kc.	97%

By way of comparison it is interesting to note that a 100 foot twisted pair transmission line has the following efficiency when terminated in its characteristic impedance:

Frequency	Efficiency
3000 kc.	95%
7000 kc.	84%
14000 kc.	68%

Of course, an antenna with twisted pair feeders can only be used on one band.

A 600 ohm two-wire line 100 feet long terminated in 70 ohms has the following efficiency when *properly balanced*:

Frequency	Efficiency
3000 kc.	94%
7000 kc.	92%
14000 kc.	89%

In practice, slight unbalances in a 600 ohm line materially reduce the efficiency, whereas the 300 ohm line is not so susceptible to loss in efficiency.

In view of the above information it is seen that an antenna can be made to work very efficiently over a wide frequency range and with any antenna impedance between 75 and 1200 ohms by the simple expedient of using a specially constructed transmission line. Several different models of such an antenna system are possible and Table I shows representative combinations designed for use on amateur bands. In each of the arrangements shown in Table I the length of the multiband transmission line is so chosen that the reactance at the transmitter

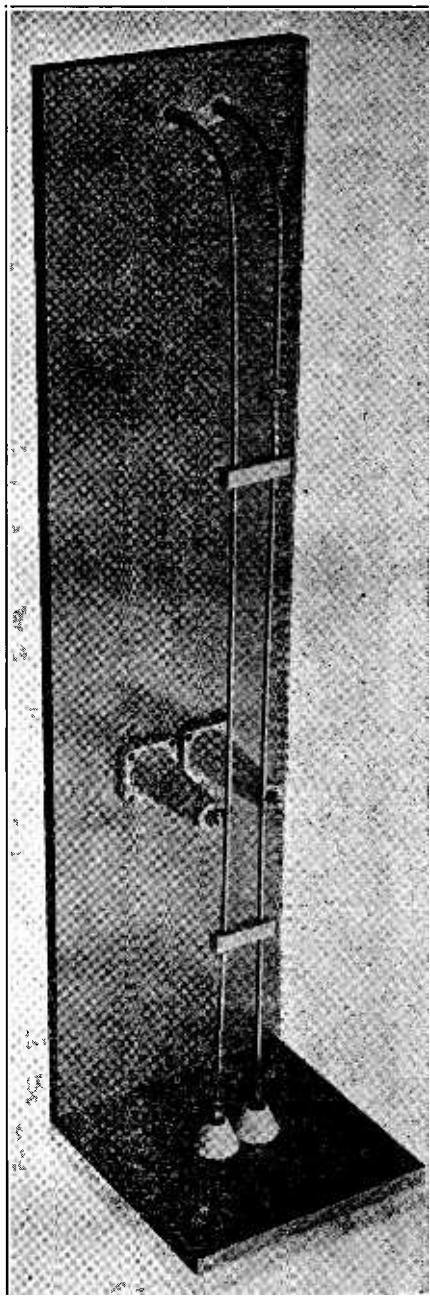

The constructional model illustrated above shows the manner of assembly. The spacers hold the  $\frac{1}{4}$  seamless copper tubing rigidly at  $1\frac{1}{2}$  inch spacing. The stand-off insulators and feed-through insulators facilitate installation.

end is negligible and the line can be coupled to the output tank circuit of the transmitter by a simple pickup coil. An impedance matching network need not be used provided the number

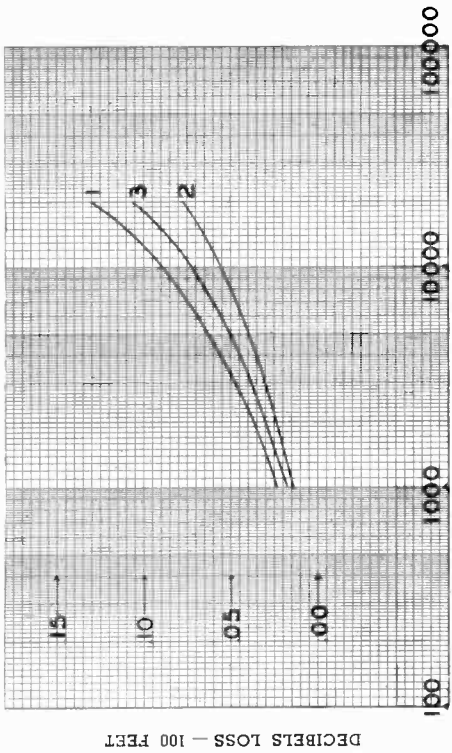

**LOSS VERSUS FREQUENCY (COMPUTED LOSS PLUS 50%)**  
 FREQUENCY — KILOCYCLES PER SECOND  
 1—No. 12 hard drawn copper spaced 6" (Z equals 500)  
 2— $\frac{1}{4}$ " copper tubing spaced  $\frac{1}{4}$ " (Z equals 300)  
 3— $\frac{1}{4}$ " aluminum tubing spaced  $1\frac{1}{2}$ " (Z equals 300)

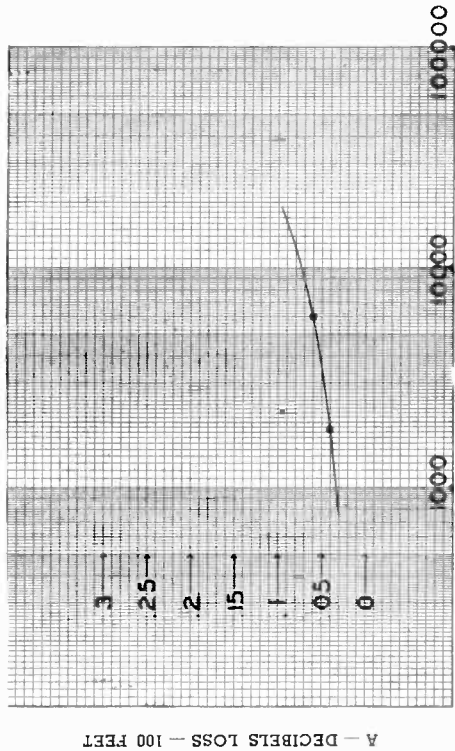

**LOSS VERSUS FREQUENCY (Measured Loss)**  
 FREQUENCY — KILOCYCLES PER SECOND  
 $\frac{1}{4}$ " COPPER TUBING SPACED  $\frac{1}{4}$ " (Z EQUALS 300 OHMS)  
 Velocity of Propagation Equals 95% of Free Space

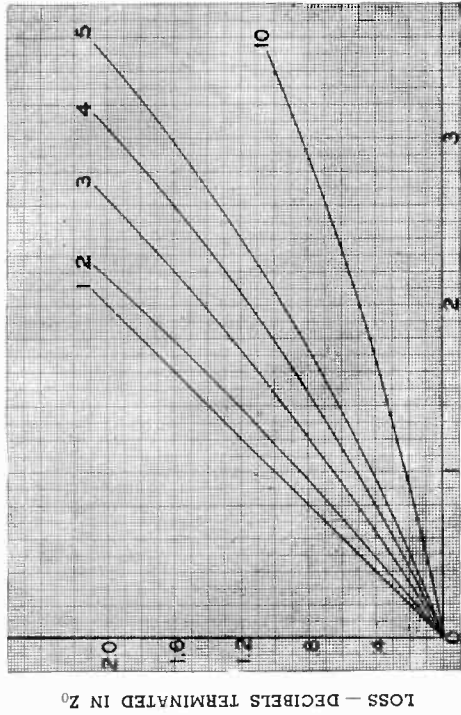

**LOSS - DECIBELS WITH MISMATCH a**  
**CHART FOR DETERMINING LOSS IN GIVEN TRANSMISSION**  
**LINE DUE TO AN IMPEDANCE MISMATCH**  
 (NUMBER ON EACH CURVE INDICATES IMPEDANCE RATIO)

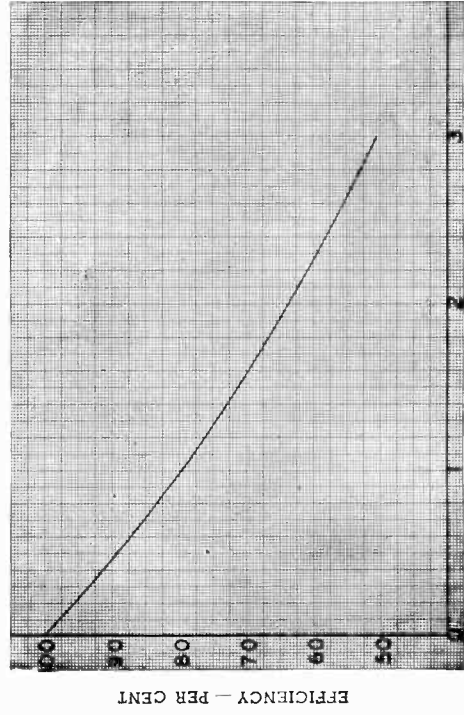

**LOSS - DECIBELS**  
**EFFICIENCY VERSUS LOSS**



TABLE I

Model	A	B	C	D	E	F	G
Antenna Length—Feet	136	136	275.5	250	67	67	103
Feeder Length—Feet	66	115	99	122	65	98	82.5
Frequency Range Mc.	3.7- 4.0 7.0- 7.3 14.0-14.4	3.7- 4.0 14.0-14.4	1.7- 2.0 3.7- 4.0 7.0- 7.3 14.0-14.4	1.7-2.0 3.7-4.0	7.0- 7.3 14.0-14.4 28.0-29.0	7.0- 7.3 14.0-14.4 28.0-29.0	3.7- 4.0 7.0- 7.3 14.0-14.4
Nominal Input Impedance	1200 ohms All Bands	75 ohms All Bands	1200 ohms 160-80-20 m. 75 ohms 40 m.	1200 ohms All Bands	75 ohms 40 m. 1200 ohms 20 m. 10 m.	1200 ohms All Bands	1200 ohms All Bands

of turns in the pickup coil is continuously adjustable.

In cases when it is not convenient to use a transmission line as long as is shown in Table I it is, of course, entirely practicable to reduce the length of the line to a convenient value and build out the equivalent electrical length by inserting an impedance matching network between the transmitter and the line. When such a network is used the line can be made any length, and then the only important dimension is the antenna itself. The only precaution which must be observed is that the transmission line should not be  $\frac{1}{8}$ ,  $\frac{3}{8}$ ,  $\frac{5}{8}$ , etc. wave length long at any of the operating frequencies. If the line happens to be cut to a length equivalent to an odd number of  $\frac{1}{8}$  wave lengths, trouble may be encountered due to the network transmitting not only the fundamental frequency but also harmonic frequencies. This difficulty can be overcome by proper adjustment of the impedance matching network, but a discussion of this subject will be reserved for a later article. In general it is better to avoid these specific lengths.

Table I can be used directly for designing multiband antennas for amateur use. It will be noticed that the antenna lengths shown are an even number of one-quarter wave lengths long at the lowest and highest frequencies. In the case of antennas for 14,000 kc. and 4,000 kc. operation the frequencies are not harmonically related, but the lengths are chosen for the highest frequency, and they are also approximately right for the lower frequency where small variations in length do not represent very large percentages of a wave length.

In designing similar systems for other groups

of frequencies, the antenna length should be  $(k - .05) 482,000/f$  ft. where  $f$  is the frequency in kilocycles and  $k$  is the number of half-wave lengths. Thus, for two or more frequencies integral values of  $k$  should be chosen to give approximately the same length and the exact length should be that for the highest frequency.

For example, consider model A antenna. At 14,300 kc. and  $k=4$  (a two wave length antenna) the length is 136 feet. This length is also correct for  $f=7,050$  and  $k=2$  or  $f=3440$  and  $k=1$ . The frequency range of the amateur bands may be tolerated by this length even though the transmission line be terminated in an antenna impedance not a pure resistance.

The feeder length should be determined by the relation  $234,000 m/f$  feet where  $f$  is the frequency in kilocycles and  $m$  is the number of quarter-wave lengths. That is, the 66 ft. feeder of model A antenna is one wave length at 14,200 kc., a half-wave length at 7,100 kc., and one-quarter wave length at 3,550 kc.

A slight variation from the above procedure is indicated in Model G. In this antenna the length of 103 feet is  $1\frac{1}{2}$  wave lengths at 14,100 kc. and approximately  $\frac{3}{4}$  and  $\frac{3}{8}$  wave lengths on the 40 and 80 meter bands. The feeder length of 82.5 feet is  $1\frac{1}{4}$  wave lengths at 14,200 kc. and approximately  $\frac{5}{8}$  and  $\frac{5}{16}$  wave lengths at the 40 and 80 meter bands. That is, on 40 and 80 meters the transmission line is terminated in an impedance largely reactive but is of such length that the impedance at the input to the transmission line is approximately a pure resistance. The loss in the transmission line is slightly larger under this condition, but this antenna may be used

{Continued on Page 84}



# An Ultra-High Frequency Superheterodyne

By WALTER H. GROSSEFINGER, W2ATQ\*

The performance of ultra-high frequency radio receivers in general use at the present time indicates that an improvement to minimize inherent noise is highly desirable. The

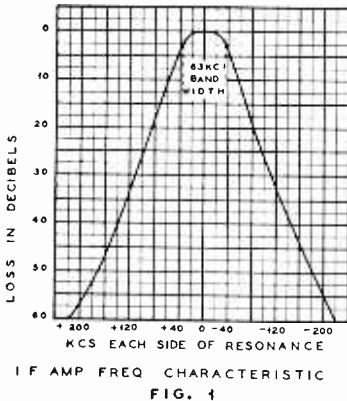

receiver described was constructed after an investigation of the signal to noise ratios of various u.h.f. receivers. Actual measurements disclose that the signal to noise ratio of this type is far superior to the super-regenerative and triple-detection receivers which use a series of oscillators. True, there is considerable difference between inherent noise and signal output in the latter two, but this depends upon the strength of the input signal. Thus in the two types mentioned, when a weak signal is received the noise level is high at a time when a low noise level is of prime importance. The ultimate is a receiver having a constant inherent noise level far below that of any received signal. The receiver described herein fulfills this requirement. It is also simple to understand that a receiver having but one oscillator is more stable than a receiver which depends upon three oscillators for its operation. Thus, a receiver having low internal noise characteristics accompanied by greater selectivity and stability is essential for efficient operation. This has been proven in commercial applications.

Originally the receiver was built for use on a fixed frequency to control a transmitter located at a remote point. As personal interest in the

\*Ex: W4BXR, W5EAZ, W10XAW. 2473 Elm Place, Bronx, N. Y. C.

56 mc. band developed, the receiver was redesigned to embody greater flexibility. It has also responded favorably on the 112 mc. and 28 mc. bands, although no measurements were made at these points. A glance at the schematic diagram discloses the conventional superheterodyne circuit, in which selectivity is primarily controlled by the intermediate amplifier. Although present amateur receivers have been used on 56 mc., results usually are unsatisfactory because the band width (in most cases) of the intermediate amplifier is only 3 kc. wide at minus 6 decibels. When it is considered that most 56 mc. amateur transmitters are both frequency and amplitude modulated, sometimes varying as much as 150 kc., it is evident that an amplifier having a broad frequency characteristic is required. Figure 1 is a graphical interpretation of the frequency response of the 4000 kc. amplifier used in this receiver. Note should be taken that the band width at minus 6 db is 97 kc., which is ample for satisfactory reception. The sensitivity of the 4000 kc. amplifier is 40 microvolts for an output of 30 milliwatts, the signal being modulated 30% at 400 cycles.

The entire unit is shielded and to prevent possible radiation a stage of tuned radio frequency is added. A gain in sensitivity of 24 db is realized by this addition and also an

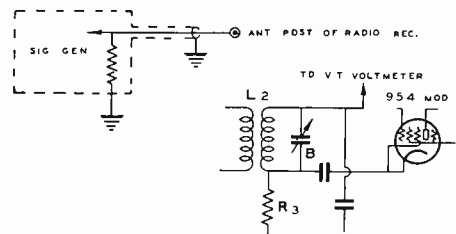

R F ALIGNMENT

increase in the image ratio is attained. The image ratio measured at 60 mc. is 6:1. A measurement was made on a manufactured amateur set (widely used) at 14 mc. less an r.f. stage and found to be only 3:1. Thus the performance of the r.f. stage may be considered as a valuable asset. The sensitivity of the receiver is of the order of 2-4 microvolts over the entire 56-60 mc. range for an output

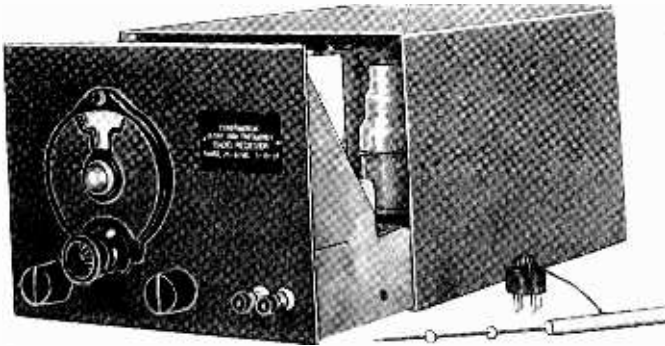

Front view with chassis partly removed to show how it fits into cover. One of the 112 mc. r.f. coils and a piece of the home-made concentric transmission line may be seen in the foreground. It is made by running a piece of wire, centered with glass beads, through a length of copper refrigerator tubing.

Top view of chassis with outside cover removed, showing mechanical layout of the different parts. The arrangement shown was arrived at after much study and consideration; therefore one will do well not to deviate from this design.

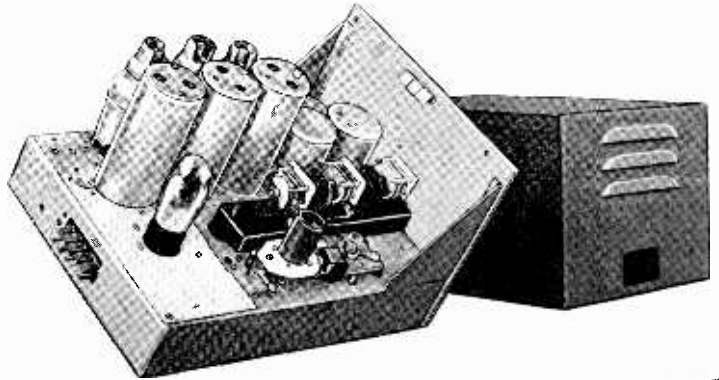

of 1.2 watts at 100% modulation. Noise was at such a low level that it was disregarded. With an additional stage of i.f. the sensitivity was found to be less than a microvolt at 2:1 signal to noise ratio for the same output (1.2 watts). In rating the sensitivity of a receiver it should be remembered that the output and noise level should also be stated, together with the modulation percentage, as these have a definite influence upon each other when determining receiver efficiency. The selectivity of the receiver is such that it was possible to use it for duplex operation, when located 10 feet from a 50 watt, 58 mc. transmitter with the receiver tuned to 58.2 mc. The audio characteristic is flat within 2 db over the entire 50-2000 cycle range, depending largely on the audio transformer used. In this case the transformer is not located in the receiver, being a component of the loudspeaker.

Antenna coupling is direct to the radio frequency tuned circuit, tapped at the proper point to match the transmission line impedance. Ignition noise being exceptionally high in the

locality where the receiver was to have been used, it was decided that a shielded transmission line would lower the noise level and prove an efficient conductor. Hence the 20 meter quarter-wave doublet was disconnected from the concentric tube transmission line in use at W2ATQ and a 56 mc. doublet was substituted.

Ample information for the construction and alignment of a receiver of this type may be realized from the experimental model described as follows:

The intermediate amplifier transformers consist of National Co. air tuned condenser assemblies, half of the plates having been removed, each originally having a capacity of about 75  $\mu$ fd. The 500 kc. transformer coils were replaced by three of the type shown in figure 2A. Each coil should be impregnated with paraffin before it is mounted in the shield with the condenser assembly. Care should be exercised to locate centrally the coils inside the shields, as the physical arrangement has a marked effect on the frequency characteristic. Alignment of the i.f. amplifier would be simplified if a small-

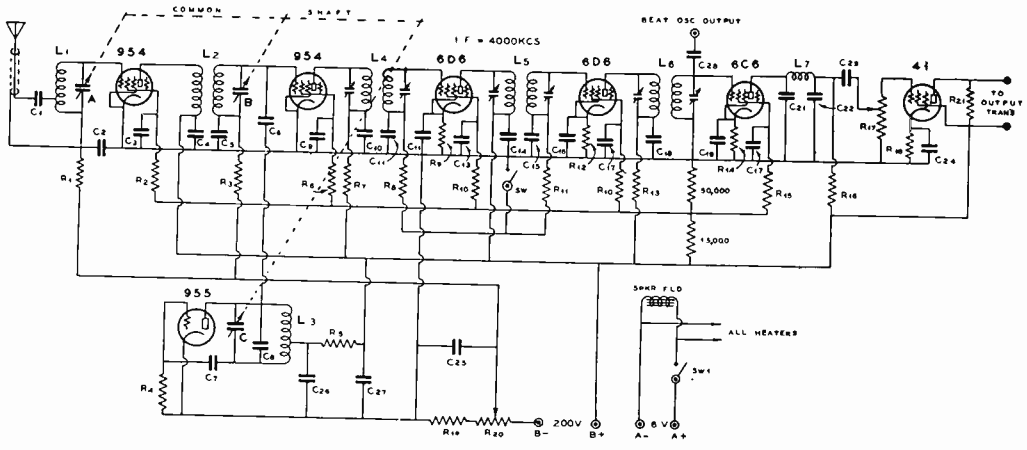

**CONDENSERS**

$\mu\text{fd.}$	$\mu\text{fd.}$	$\mu\text{fd.}$	$\mu\text{fd.}$
1-1.000	9-.1	16-.1	23-6.000
2-4.000	10-.1	17-.1	$\mu\text{fd.}$
3-4.000	11-.1	18-.1	24-.75
4-4.000	12-.1	19-.1	25-.1
5-4.000	13-.1	20-.1	$\mu\text{fd.}$
6-15 (x)	14-.1	$\mu\text{fd.}$	26-4.000
7-100	15-.1	21-500	27-4.000
8-14	16-.1	22-500	28-15

A & B—Cardwell Trim-Air, 5 Plates, Triple Spaced. Actual Capacity (Mounted) Min. 1.8  $\mu\text{fd.}$ , Max. 7  $\mu\text{fd.}$

C—Cardwell Trim-Air, 6 Plates, Triple Spaced. Actual Capacity (Mounted) Min. 2  $\mu\text{fd.}$ , Max. 9  $\mu\text{fd.}$

I.F. Trimmers—See text.

C<sub>11</sub>—No. 16 Bare Tinned Wire wrapped with no. 16 (push back insulated) for 1/2-in. If this capacity is too large, the mod. and osc. will inter-lock. This will be evidenced by inability to track the RF-Osc. See "Alignment".

**RESISTORS**

1-10,000 ohms	8-.1 meg.	15-.5 meg.
2-10,000 ohms	9-500 ohms	16-.5 meg.
3-10,000 ohms	10-10,000 ohms	17-.5 meg.*
4-25,000 ohms	11-.1 meg.	18-500 ohms
5-10,000 ohms	12-500 ohms	19-25 ohms
6-3,000 ohms	13-2,000 ohms	20-100 ohms†
7-2,000 ohms	14-1,500 ohms	21-.5 meg.

\* Level control.

† Sensitivity control.

SW—This circuit opened for external AVC system.

SW<sub>1</sub>—Filament switch incorporated in vol. control.

L<sub>1</sub>, 5, 6—See text.

L<sub>7</sub>—15 mh.

er capacity condenser were used, either by itself or in conjunction with a fixed capacity. As it is, adjustment is quite critical due to the great capacity change for a slight condenser rotation. The design of the transformer is such that a flat peak results (figure 1), and if this condition is to be attained the windings must be spaced as close to the dimensions shown as possible. Closer spacing will result in a deep

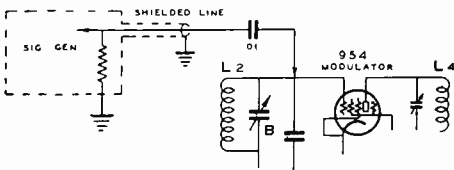

I F AMP ALIGNMENT

valley between two peaks and possible regeneration, whereas greater spacing results in a single peak, having a sharper frequency characteristic and lower gain. An efficient method of increasing the selectivity may be derived by resorting to a smaller coil shield.

Looking at the under side of the chassis, the plate leads of the i.f. amplifier may be seen

running through 3/16" copper tubing, which was used to aid stabilization of the amplifier. All by-pass condenser leads should be kept as short as practical and each as close to its own circuit as possible. If a frequency other than 4000 kc. is used for the i.f. amplifier a frequency outside the amateur bands should be selected.

A sufficient picture of the construction of the radio frequency portion of the receiver may be realized from the photos. It should be remembered that all leads should be kept as short as possible and that all capacitors and resistors of any one circuit should return to ground at a common point for each circuit. Cathode bias was found to be inferior in the r.f. portion of the receiver. In the original receiver 6D6 tubes were used in place of the 954's. Because of high tube losses and the necessity for long leads, etc., the acorn tube was selected with gratifying results. The efficiency of the modulator stage probably may be increased by the substitution of an R.C.A. 6L7 tube for the 954. (During the experiments no 6L7 tubes were available.) Care should be taken to maintain the rated voltages

on the acorn tubes, as they apparently are unable to withstand much overload.

$L_1$  and  $L_2$  are wound on R-39 rod threaded as shown in figures 2B and 2C.  $L_2$  consists of two windings, the primary being wound beneath the secondary. Before applying the secondary winding the primary coil is impregnated with paraffin and allowed to dry. This operation strengthens the insulation of the primary winding mechanically and electrically.  $L_3$ , the most critical coil, is wound on a smooth piece of R-39 rod so that adjustment of the coil is possible during tracking. Upon completion of the alignment of the receiver, cellulose acetate is used to fasten the winding into place. This is preferred to paraffin because heat will not affect the adjustment (the coil form is not threaded).

### The Tuning Gang

Originally a different type air condenser was used for tuning, which was replaced with the type shown because of noisy rotor contact surfaces. When selecting a tuning condenser for work on the ultra-high frequencies it is important to select a condenser with a good wiping contact. Pigtails are unsatisfactory. A split stator condenser would be excellent, as the rotor would establish electro-static coupling between the split stator sections, thereby eliminating friction contact, reducing objectionable noises. The minimum capacity of a condenser should also be taken into consideration in a receiver of this type. The condensers used present little distributed capacity and are very adaptable. Note that each condenser in the gang is coupled by an insulated coupling. This allows each condenser to return to the common ground in its own circuit.

### Alignment

The alignment of the receiver is accomplished with the aid of a signal generator (modulated r.f. oscillator) having a high ratio dial and capable of producing a signal at 4000 kc. and 56,000 kc., a rectifier type output meter and a vacuum tube voltmeter. The vacuum tube voltmeter may be used in place of the rectifier type if the latter is not available. Although r.f. measurements at the ultra-high frequency are not very accurate, those interested may find it practical to construct a Microvolter.\* Such an instrument was used for the 56-60 mc. measurements contained herein.

The filaments lighted and the plate supply on, the rectifier type output meter connected

[Continued on Page 99]

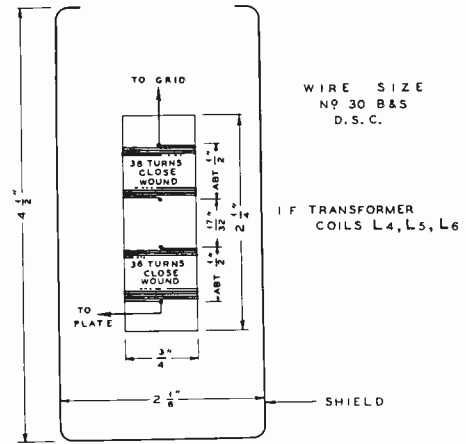

FIG. 2A

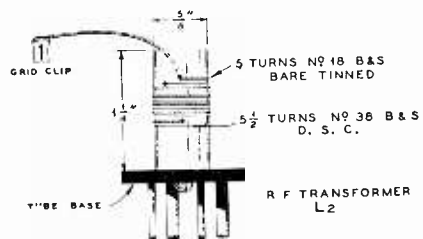

FIG. 2B

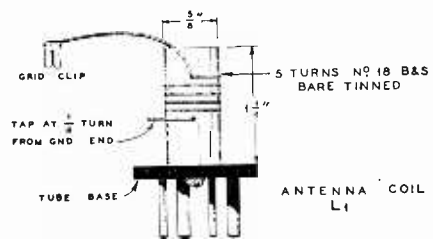

FIG. 2C

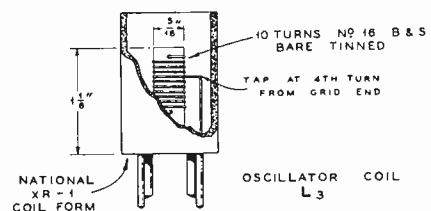

FIG. 2D

\*A Standard Microvolter—*Electronics*—July, 1932.

# Instantaneous 75-160 Meter Excitation

By W. W. SMITH, W6BCX

After listening to the bedlam on the 20 meter phone band, it is hard to believe that there actually are amateurs who, though they have a class A ticket, never venture from 75 and 160 meters. In spite of the fact that Sunday afternoons on 20 meters sound as though everyone in the U.S.A. with an unlimit-

*Those phone amateurs who work only on 75 and 160 meters, or have a separate transmitter for 20 meter work, will find this exciter quite handy for instantaneous change of 75-160 meter excitation. One changes bands by merely turning one condenser; no switching or changing of coils is necessary.*

only about 90% of the supply voltage. The tubes will have fair life at 500 or 550 volts

provided the plate current is kept down to 80 ma. or less for the three tubes. When measuring the current at  $J_2$ , it is necessary to subtract the screen current in order to get the exact plate current. However, the main purpose of the meter is for tuning, and if the total current (plate and screen) as read at  $J_2$  is kept below 100 ma., it may be assumed that the plate current is not excessive.

Because of the pentode oscillator tube, the crystal current is very low although the oscillator is running at 500 volts, and no drift will be noticeable even with an ordinary Y cut crystal. The crystal should have a frequency between 1950 and 2000 kilocycles, so that the second harmonic will fall in the 75 meter phone band. The condenser  $C_9$  is of sufficient capacity (260  $\mu\text{fd.}$ ) to hit 160 meters with a coil that hits 75 meters with the condenser plates almost "clear out". Thus either 75 or 160 meter output is available merely by tuning  $C_9$ . Because of the "low C" when tuned to 75, the output

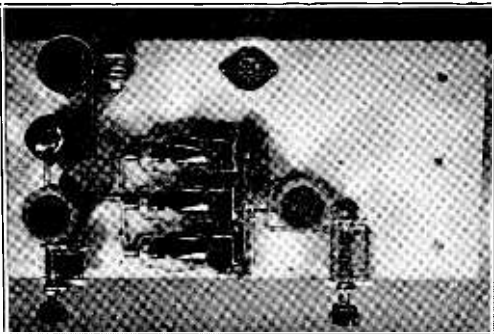

The "Quick Change" 75-160 Meter Exciter

ed license must be on the band, such is not entirely the case. Evidently a goodly number, after one listen to the 20 meter band when it is very active, decide that "it isn't worth the fight" and stay on the two lower frequency bands. Then of course there are always the boys who don't give two hoots about working anyone out of the state, and therefore have no interest in 20 meters. These "local rag chewers" usually spend afternoons on 75 and evenings on 160 meters. To the amateurs in these two categories the following exciter is dedicated.

The unit uses a 41 pentode oscillator, inductively coupled to three type 89 pentodes in parallel. The latter are very inexpensive (about 50c each at amateur prices) and because the grid lead comes out the top can be used without neutralization working "straight through" if proper precautions are taken. At low frequencies a pair of 89's will put out just as much r.f. as an 802 at the same voltage, and three in parallel will deliver 20 watts measured output in the exciter shown when fed from a 550 volt power supply. Part of the voltage is wasted across the cathode resistor (to provide "safety bias") and the voltage on the plates is actually

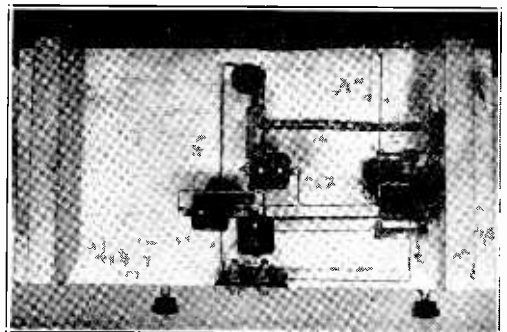

Bottom View

when doubling is approximately the same as on 160 working straight through with a high ratio of C/L. When link coupled to the grid of the following stage, the exciter has sufficient output fully to excite a modulated 203-A, 50-T, 211, or a pair of 801's. It also will excite a plate-modulated 150-T, HF200, HF300, or other low-C tube of high transconductance provided the input is not over about 250 watts.



# RADIO AMATEUR STATION W6JWF



34 San Bruno Avenue

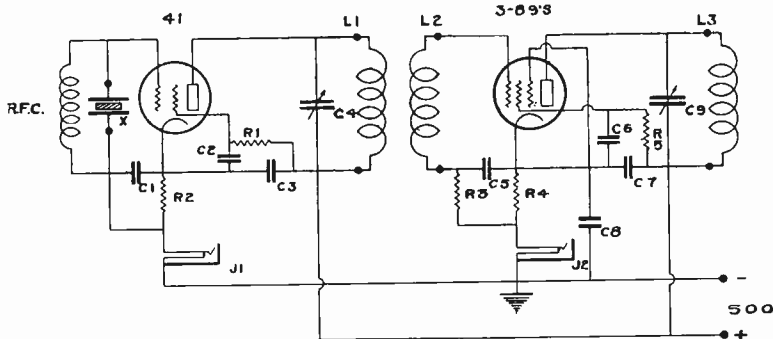

The General Wiring Diagram

- L<sub>1</sub>—50 turns of no. 24 enamelled on XP53 form.
- L<sub>2</sub>—12 turns of no. 20 hook-up wire (good insulation) wound directly over L<sub>1</sub>.
- L<sub>3</sub>—33 turns no. 20 d.c.c. on XP53 form.
- C<sub>1</sub>—100 μfd. midget.
- C<sub>2</sub>—260 μfd. midget.
- R<sub>1</sub>—50,000 ohms, 2 watts.
- R<sub>2</sub>—600 ohms, 2 watts.

- R<sub>3</sub>—5,000 ohms, 10 watts.
- R<sub>4</sub>—300 ohms, 10 watts.
- R<sub>5</sub>—15,000 ohms, 10 watts.
- R.F.C.—Radio frequency choke, at least 8 mh. (important).
- X—1952 to 1995 kilocycle crystal.
- All fixed condensers may be either .006 mica or .01 μfd. 600 working volt paper tubular, preferably mica.

The screening of the 89's is not all that could be desired, and they have a tendency to oscillate merrily without help from the crystal stage unless the type of coupling to be described is used between the plate of the 41 and the grids of the 89's. Laying the 89's on their sides as in the photograph helps some, as it allows much shorter grid leads.

The coil forms are standard Hammarlund XP53. Others may be used of course, but if of different diameter they will require a different number of turns than specified. The coil L<sub>2</sub> is wound directly over the L<sub>1</sub> winding. No. 20 hook-up wire with good insulation is used for L<sub>2</sub>, because of the difference in voltage carried by the two windings. This type of coupling gives better transfer of power in this case than capacitive coupling, introduces no more controls, and avoids self-oscillation of the 89 stage.

Capacitive coupling should not be used out of the 89 stage if it can possibly be avoided, as the efficiency of the 89 stage suffers noticeably when doubling unless link coupling is incorporated. A two or three turn link of hook-up wire around L<sub>3</sub> provides the best means of coupling to the following stage.

Originally the exciter used a pair of parallel 802's in place of the three 89's, and was an all-band affair, with any two adjacent bands instantly available by tuning C<sub>5</sub>. At 600 volts the output was quite good, falling off only slightly at the higher frequencies (due to the parallel connection). At low frequencies the two 802's gave approximately twice the output of a single

tube, and the use of a pair seemed justified on that account. The only catch was the cost of a pair of 802's, the cost being considerably greater than all the rest of the exciter.

To bring the cost down, the exciter was rebuilt with the three 89's substituting for the 802's. The plate voltage was dropped a little, the 75-160 meter coils were plugged in, and the unit was "fired up". Upon measuring the output, it was found to be nearly as great as with the parallel 802's. Hooray! The tubes gave 90% as much output, and cost but 20% as much. But at this point Frank Jones dampened our enthusiasm with a prophesy that the "tripallel" 89's would not do their stuff so well on the high frequency bands. Sure enough, though the output was satisfactory on 160, 75, and 40 meters, the exciter showed signs of anemia when called upon for 20 meter output, and would not work at all on 10 meters. This was partly due, no doubt, to the parallel connection and partly because the 89 does not seem to be nearly as good an ultra-high-frequency (12 megacycles and above) tube as the 802.

At 75 meters the exciter proved to be both efficient and economical. At 20 meters the best we could say for it was that it was economical. So we decided that for 20 meters the exciter was out—unless one wants to invest in a pair of 802's. A single 802 can be used if one is satisfied with less output. With the single 802 instead of a pair, the output is practically uniform from 10 to 160 meters, be-

[Continued on Page 85]

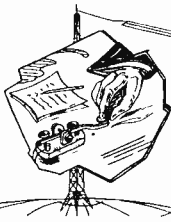

# CALLS HEARD AND DX DEPARTMENTS



William Trebilcock  
EDITOR

*Numerical suffix indicates "R" strength. Send Calls Heard to Calls Heard Editor\*, not to Los Angeles.*

**Eric W. Trebilcock, BERS-195, Telegraph Station,  
Tennant Creek, North Australia  
September 2 to October 5**

(7 mc. phone)

PK1GW-6.

(7 mc.)

CN8MI-4; CN8MM-5; CR7AQ-5; CR7MB-4; CTLKR-4; CT1LZ-5;  
CT1MS-4; CT1AJ-5; D4GRF-5; D4NXX-4; EA3EE-3; EA3EV-4;  
EA5CG-3; EA7AK-4; EA8AF-5; F8AT-4; F8EX-4; F8KJ-3;  
F8XH-5; F8BD-5; F8ST-4; FT4AG-5; G2IY-3; G5BD-5;  
G5CU-5; G5JM-4; G5JZ-3; G5IL-4; G5ML-4; G5KG-4;  
G6HW-3; G6PD-4; G6VP-6; J2MB-6; J8CD-5; K6CGK-6;  
K6LBH-7; K6LPW-6; K47LV-5; KA9JO-7; KA9WX-7; LY1J-3;  
OH6NN-4; OK1BC-4; ON4FC-5; ON4VM-5; PA0AL-4; PA0AZ-5;  
PA0JB-4; PA0LV-3; PA0PN-4; PA0PO-5; PA0QQ-4; PK2MP-5;  
SM6WL-3; SP1CC-3; SU1CH-6; SU5NK-3; U3DM-5; U9AY-3;  
VP4TC-5; VQ2WAV-4; VS6AQ-8; W2ABX-4; W5AFX-9; X2J-4;  
XU1B-6; XU8EC-6; YU1RV-5; ZS2X-5; ZS5H-4; ZSSZ-5;  
ZS6AF-4; ZS6AL-4; ZS6AM-4; ZT6AV-3; ZT6N-5; ZT6Y-4;  
ZU6A-5; ZU6B-6; ZU6M-5; ZU6Y-6.

(14 mc. phone)

H17G-8; J2HQ-5; J2KJ-5; K6CMC-5; KA1AN-6; PK1VH-7;  
TI2RC-4.6; VESHA-4; VU7FY-4; W5BAT-5.

(14 mc.)

W 1CCA-4; 1CMX-4; 1GSH-5; 1TS-4; 1ZB-4; 2AFU-6;  
2DTB-3; 2HW-6; 20A-4; 3AMP-4; 3BES-5; 3BPH-4; 3CHG-3;  
3FGO-5; 4CCN-5; 4CSZ-5; 4EF-5; 4FT-5; 40C-6; 4PL-4;  
4TR-6; 5AIW-5; 5AXI-4; 7BYF-4; 5CEW-5; 5CMY-6; 5COU-7;  
5EKK-6; 5EZA-6; 5FFL-5; 5LA-7; 5QL-8; 5OU-4; 6ACL-6;  
6AWT-6; 6AZP-5; 6BXL-6; 6CAM-5; 6CEM-8; 6CUH-4;  
6CUQ-6; 6JPW-7; 6JZL-5; 6KGD-6; 6LBW-6; 6LJA-6; 6LYM-8;  
6QD-5; 7EFO-5; 7LI-6; 8CNZ-4; 8CRA-7; 8CXC-5; 8DHC-7;  
8DYE-4; 8EUY-5; 8FSK-4; 8JBU-4; 8JRL-5; 8KO-5; 9AHX-5;  
9BWT-6; 9BVI-5; 9DIJ-5; 9FRU-3; 9MNU-6; 9NFA-4; 9PST-5;  
9SHE-4. — CM2DD-4; CR8AA-6; D4DML-4; D4GOF-3; E5TC-5;  
F8DR-5; F8BC-5. — G 2AS-4; 2NM-4; 2PL-4; 2SD-4; 2TM-4;  
2ZQ-5; 5GQ-3; 5WP-5; 6JB-5; 6WY-5; 6RB-4; 6YU-4. —  
HB9AT-5; HJ3AJH-5. — J 2CE-7; 2CN-5; 2HQ-8; 2KN-5;  
2KJ-8; 2LK-7; 2ME-7; 2MU-5; 3CR-4; 3DR-5; 3FI-6; 3FJ-6;  
3GC-6; 4CP-6; 5CE-6; 7GJ-7; 8CA-7; 9CD-6. — KA1AN-6;  
KA1CM-7; KA1ER-7; KA1LB-7; K6BUY-5; K6GNW-3; K6KEF-6;  
K6KKC-6; N2YAB-5; OA4J-5; OH3NP-4; OH7ND-5; OK3UA-4;  
ON4AU-5; ON4RX-3; OZ9Q-5; PA0JMN-4; PA0ZM-5; PH1VH-8;  
PH2KO-5; PH4RF-8; PH4RM-7; SM5SX-5; SU5NK-4; U2NE-5;  
U3DQ-4; U3DS-4; VE3WA-4; VE5BI-5; VESHA-5; VK9NW-5;  
VP2BX-5; VP5AB-6; VP5AC-6; VP5PZ-7; VS2AG-4; VS3AC-8;  
VS6AQ-6; VS6BD-7; VU2AU-6; VU2EV-5; VU2EP-4; VU2EQ-5;  
VU2JP-6; VU7FY-7; X1AY-5; XU1B-7; XU2JM-7; XU6LN-7;  
XU8MT-6. — ZL 1AK-6; 1DV-6; 1FE-5; 1QX-5; 2AC-6; 2CI-4;  
2GN-7; 2HR-5; 2KK-4; 2BB-4; 2LW-8; 2MO-5; 2OF-4;  
2QF-5; 3FP-4; 3CU-6; 3DJ-3; 3GN-4; 3HK-5; 3GH-6;  
3JA-7; 4BQ-5; 4GW-5. — ZT5V-5; ZT6AK-5; ZT6Y-3; ZE1JM-4.

(28 mc.)

CR7MB-5; CR8AA-6; CT1JU-3; CX1CG-5; D4ARR-4; EA4A0-5;  
E18B-3; E5TC-4; F3DN-5; F7CGV-8; FA8PW-4; F8BD-4;  
G6UF-4; HB9AT-5; HI7G-5; HK1Z-5; ILJKM-3; J2HJ-9;  
K4SA-5; K5AC-5; K6AUQ-5; KALCM-8; LA3I-5; LU1CH-5;  
LY1J-3; MX2B-6; OA4J-6; OE7JH-6; OH3NP-5; OK2OP-5;  
ON4RX-3; OZ9Q-3; PA0AZ-5; PK1MO-7; PK4RM-6; SM5SX-4;  
SU5NK-3; TI2EA-4; U2NE-4; VE5BI-5; VO1I-4; VP2AT-4;  
VP5PZ-7; VQ8AFX-4; VR2FF-6; VS2AG-7; VS6AX-4; VU7FY-8;  
VU1P-8; W6KRI-9; X1AY-5; XU1B-5; YL2BB-5; ZE1JY-4;  
ZS2X-6.

**Arthur Stevens, ZL2HR, Manawapou Road,  
Hawera, New Zealand  
November, 1935**

(3.5 mc. phone)

K6BIC-6; K6CMC-7. — VK 2BQ-8; 2HC-8; 2HU-7; 2IA-6;  
2JE-7; 2XO-6; 2YW-7; 3GM-5; 3KE-5; 3OF-6; 3PW-6; 3RG-6;  
3WE-6; 3XJ-7; 4GG-7; 5GL-6; 5IV-7. — W 1BES-7; 3HL-6;  
5DRY-5; 6GNR-4; 6HXP-5; 7A0B-6; 8BWH-5; 9PK-6.

\*George Walker, Assistant Editor of RADIO, Box 355,  
Winston-Salem, N. C., U. S. A.

(3.5 mc.)

W 1AMP-6; 1HNE-5; 3BFD-5; 3BBJ-6; 4PL-6; 6AHI-5;  
6CSC-5; 6FOM-3; 6IMS-5; 6LEW-4; 6LVQ-7; 6MBS-5; 6MBX-3;  
7BG-7; 7BVE-3; 7BVI-6; 8APT-5; 8ATT-4; 8BWH-3; 9ABB-6;  
9THQ-7.

(7 mc. phone)

VK4AP-7.

(7 mc.)

W 1IJL-6; 1MK-6; 1ZCZ-8; 2BEF-7; 3EEB-7; 2EVF-8;  
3FEA-7; 4CPZ-7; 4EPZ-7; 5BWJ-7; 5DND-8; 5EHM-7; 6AXE-7;  
6EGH-9; 6ENL-7; 6JPW-7; 6KSO-8; 6KWW-8; 6LFL-7; 6OPP-7;  
8FCL-8; 9RHT-8. — K5AC-7; K7ANQ-8.

(14 mc. phone)

W 2UG-7; 6FQY-7; 6LI-5; 9BY-7; 9DHP-4. — EA3AE-5;  
EA3AO-8; KASA-8; K6LJB-7; TI2RC-8; VK2QN-7; VK2QR-7;  
VK2UC-6; VK2XU-9; VK2YL-6; VK3KX-7; VK5GF-7.

(14 mc. c.w.)

W 1ARH-6; 1AYA-5; 1BUX-6; 1CLH-5; 1CUN-3; 1DBE-5;  
1DDE-7; 1DZM-5; 1ENE-5; 1IBL-5; 1SI-8; 1TS-6; 2AEW-6;  
2EPTJ-5; 2EWH-7; 2FUT-6; 2GDX-7; 2GRA-6; 20A-6; 2RS-5;  
3AJH-3; 3DAJ-5; 3DCG-4; 3DSY-5; 3EEC-7; 3LY-5; 4BBR-6;  
4BDU-3; 4COV-5; 4CSZ-5; 3DE-6; 4UP-6; 5ASY-4; 5DZU-6;  
5EUB-2; 6ABB-5; 6AH-8; 6BGJ-4; 7BRV-7; 6CUH-7; 6CVV-8;  
6CXW-8; 6DEC-5; 6EGJ-2; 6EPM-6; 6FXL-4; 6JJU-8;  
6KBT-4; 6KGD-6; 6KNH-5; 6KNS-3; 6KRI-7; 6KWA-6;  
6LYM-6; 6NFX-6; 6MR-5; 6TIW-5; 6TT-7; 7AFP-4;  
7BQX-6; 7BST-8; 7DXZ-5; 7EFG-4; 7JT-4; 8APB-5; 8ATP-3;  
8AWB-6; 8AZD-6; 8BRQ-5; 8CBI-5; 8CRA-8; 8CZU-4;  
8DHC-5; 8DWW-4; 8DYK-2; 8FTM-3; 8GTN-6; 8GYB-7; 8JDC-7;  
8JY-5; 8KKX-6; 8NXS-5; 8ONR-5; 8WK-6; 9AHX-5; 9BUL-8;  
9DHP-5; 9FOD-4; 9FWR-3; 9HD-7; 9HVJ-7; 9IWE-7; 9KG-6;  
9KHY-4; 9LQ-7; 9MNU-4; 9NUG-4; 9PTC-6; 9SRE-6.

**Alice R. Bourke, 2560 East Seventy-Second Place,  
Chicago, Illinois  
Station W9DXX  
November 10 to December 10, 1935**

(14 mc.)

CM2AF-6; CM2D0-5; CM2FD-6; CM2WD-7; CM6AA-6; CM6AD-6;  
CM8CK-6; G5UR-6; HPIA-8; K4BA-5; K5AC-7; K5AH-6;  
K6AUQ; LU7AZ-6; NY2AB-6; VE1AE-5; VE1IP-5; VE2AI-6;  
VE2CR-6; VE2EE-7; VE2JB-5; VE2LM-6; VE3AC-6; VE3BV-6;  
VE3HB-6; VE3QN-5; VE3SD-6; VE3UW-6; VE4AEI-6; VE4ADP-7;  
VE4FD-6; VE4PH-6; VE4PQ-6; VE4TR-8; VE4UN-6; VE5AEV-6;  
VE5GI-6; VE5HC-6; VE5HR-6; VP1IR-6; VP9R-5; YN1AA-6;  
Z56AL-5; ZT6Z-5.

(7 mc.)

CM2RM-5; VE4PG-5; VE4PQ-6; VE4VQ-6; VE4YL-6; VESHS-9;  
VP4BC-6.

**H. A. Robbins, W7BGG, care "M/S Standard  
Service" (KFSS) Richmond Beach, Washington  
(Heard between Seattle and Alaska)  
November 11 to November 17**

(28 mc. phone)

W3TP-4; W6FDM-7.

(28 mc.)

W 1BXC-4; 1DZE-4; 1FUR-4; 2AYJ-6; 2BCR-4; 4AGP-3;  
4AJY-5; 4EF-5; 5ELL-6; 5QL-7; 6EWC-6; 6GRX-6; 6HLH-7;  
6ITD-6; 6IXJ-3; 6JA-3; 6JN-8; 6KEV-8; 6KIN-5;  
6KJG-6; 6KPR-6; 6LGD-4; 6SC-5; 7EZC-9; 7FLU-8; 8CRA-5;  
8FQF-5; 8MOK-4; 9AGS-7; 9EF-6; 9FFQ-7; 9GHN-6; 9JIE-5;  
9KNN-8; 9LJN-6; 9NY-5; 9PED-7; 9PLH-6. — J2HJ-6; J2IS-7;  
J2LO-3; K6KSI-6; K7DVF-7; LU9AX-7; VE4QY-5; VK4AP-3;  
VK4E1-5.

**F. C. Whitmore, ZE1JJ, ZT6AZP, Box 591,  
Baluwayo, S. Rhodesia  
October 1 to October 31, 1935**

(14 mc.)

W 2MB-2; 6BYU-5; 6GAL-5; 6HX-5; 6INP-3; 6LFL-5;  
9MIN-6. — CR7GC-5; CR8AA-3; D4ARL-4; D4BTC-4; D4CSA-3;  
D4DIC-3; D4KMG-2; D4MNL-4; D4NWR-3; D4QET-3; F8EB-5;  
F8FC-4; F8ZC-4; FB8C-5; G2BQ-4; G2S0-3; G2ZQ-4; G5GQ-3;

G2M0-3; G1GYP-3; LULCR-4; LU2KH-2; LUSAZK-4; DELUH-4; OE3F1; OK1AA-3; OK1BC-4; OK1FZ-3; OK1SW-3; OK2OP-3; ON4MY-5; ON4PA-4; ON4RX-3; ON4TF-4; ON4UF-3; PAOJM-3; PAORN-4; PK4VF-3; PK4XM-3; VJ2AU-4; VK6FO-5; VK6LJ-4; VQ3CRO-5; VS2AG-4; VU2AE-3; VU2BY-5; VU2CQ-5; VU2EP-4; VU2NE-3; ZB1H-4; ZE1JB-5; ZE1JM-2; ZE1Js-4.

*J. V. McMinn, 12 Edge Hill,  
Wellington, New Zealand  
October, 1935*

(7 mc. phone)

LU4AI; TI1AF.

(7 mc.)

CR8AA; CT1FZ; CT1KG; D4B0V; D4B0Q; D4CEF; D4ZI1; D4LIM; D4M0L; EA1RA; EA1RU; EA3BP; EA3DP; EA5BD; EA5BM; EA6AM; EA7AK; EA7AO; F3BJ; F3LE; F8AQ; F8IF; G5TP; G6JQ; G6UF; G6US; G6NJ; HB9BD; HB9BG; HB9BK; ILKN; J8CD; LY1S; OK1WZ; OK2AE; OK2RB; ON4MD; ON4SS; ON4WR; PA0NC; PA0LR; PK4VR; SP1RB; U3LM; U3QT; UK5KP; UK9AZ; VU2EB; VU2EG; YM4AF; YR5CR.

(14 mc. phone)

W 1AJZ; 2BFE; 2OA; 2ZC; 3ZX; 4OC; 5ACF; 6HXP. — CX2AK; EA2BH; F8DR; HPLA; J2CB; K3SA; K6FKN; LU4BL; LU6KE; LU7AZ; TI2FG; TI2RC; VU2CQ; X1G.

(14 mc.)

CE1AU; CE3CR; CE4AD; CE7AA; CX1BG; CX1ZX; D4ARR; D4GRF; D4JXK; D4LYN; D4MNL; D4NXR; D4PBJ; EA1BC; EA1BU; EA3AN; EA2BV; EA3CY; EA4AO; EA4AV; EA5CK. — F 3DN; 8EB; 8EO; 8FC; 8FN; 8GR; 8GV; 8KJ; 8KV; 8NN; 8NV; 8NY; 8PU; 8TU; 8VK. — G 2NM; 2PL; 2TD; 2ZQ; 5BY; 5CW; 5GQ; 5IS; 5JU; 5MQ; 5RU; 5SY; 5XG; 6IF; 6LK; 6OT; 6QX; 6RB; 6WY; 6XL. — HAF3BZ; HAF8C; HB9AK; HB9AQ; HB9AT; HB9B; LU1CA; LU2AX; LU3EX; LU4FO; HC2MO; J3CT; J8CD; KA1AP; KA1CM; KA1HR; NY2AB; OA4J; OA4Q; OE1CM; OE1ER; OE1FH; OE1FP; OE3DK; OE3FL; OE3KH; OE3OK; OK1BC; OK1FZ; OK1RO; OK1RR; OK2OP; OK3VA; OK7JH; ON4FE; ON4FX; ON4GW; ON4PA; ON4RX; OZ7KG; OZ7KB. — PA 0AZ; OCE; OHT; OJM; OQF; OUV; OXD; OXM; OXR; OZP. — PK1DF; OK4RF; PK4XM. — PY 1AW; 2AE; 2BX; 2BY; 2CB; 2EA; 2QD; 5AA; 5AG. — SP1LG; SP1OX; SU1CH; SU1RO; SU1SG; SU2LJ; SU5NK; SU7F; SU9AK; SU9AQ; SU9AT; SU9B; SU9J; SU9YR; TI2EA; TI5MR; U2NE; UK3CS; VP1JR; VP5PZ; VR2FF; VS2AG; VS3AC; VS6AH; VS6AO; VS6AQ; VS6AX; VS6BD; VU2AU; X1AA; X1AY; X2C; XU1B; XU8HW; XZA1C; YM4DSG; YM4FS; YM4ZO; ZB1H; ZP2AC.

*John Medeiros, W1ME, 58 Jenny Lind Street,  
New Bedford, Mass.  
December 19-22, 1935*

(3.5 mc. worked)

D4ARR; F8QG; G2PL; G2ZQ; G6KI; G6PF; G6RB; HB9AQ; PA0QQ.

(3.5 mc. heard)

D4ARR-7; D4CSA-5; D4SMP-4; F3AM-6; F8QG-5; G2DQ-7; G2PL-7; G2ZQ-7; G5BD-6; G6KI-5; G6PF-7; G6RB-7; HB9AQ-7; ON4NC-7; PA0PB-4; PA0ASD-7; PA0QQ-6.

*J. R. Magee, W8CNC, 1057 Elm Road N. E.,  
Warren, Ohio  
November and December, 1935*

(3.5 mc. only)

D4ARR; F3AM; G2LQ; G5AF; G5FV; G5KG; G6PF; G6RB; HB9AQ; HB9Y; LA5T; OE5JB; ON4NC; ON4VO; ON4WR; PA0ASD; PA0PN; SM650; SM7YG; YM4AA; VK2KR; VK7XL; VK3HG; ZL2GN; ZL4FO.

*John Mediros, W1ME, 58 Jenny Lind Street,  
New Bedford, Mass.  
December 14 to 18, 1935*

(3.5 mc. only)

D4ARR-7; D4CSA-5; D4SNP-4; EI4J-4; F3AM-6; F8QG-5; G2DQ-7; G2PL-7; G5FV-5; G5GB-5; G5KG-6; G5RV-5; G6PF-7; G6RB-7; HB9AQ-7; PA0ASD-6; PA0UX-5.

*Ernest Chesbam, VE5DK, Rossland, B. C., Canada  
November 24 to December 8*

(28 mc. phone)

W5ACF; W5AXA-7; W5BDB-9; W5BFS-8; W5DXC-8; W5EBT-8; W5ECL-7; W5EME-9; W5ETL-7; W6FGV-8; W8MWM-9; W9ARN-9; W9BH0-8; W9BHT-9; W9CVN-9; W9CVI-6; W9DEF-9; W9EQB-8; W9FJ-7; W9FNR-7; W9GQY-6; W9GUJ-8; W9HAQ-9; W9HBB-8; W9HLG-9; W9JIE-7; W9KNH-6; W9LD-9; W9LLX-9; W9MCD-9; W9MML-9; W9JJC-7; W9OSD-9; W9QI-7; W9UUV-7; W9WC-8.

(28 mc. c.w.)

W2CWT-8; W3EVT-8; W4AJY-7; W4TZ-7; W5AIR-6; W5EKV-8; W5FV-7; W5QL-9; W5WG-8; W7GFM-5; W8ANN-7; W8BCT-8; [Continued on Page 90]

# DX



By HERB. BECKER, W6QD

Readers are invited to send monthly contributions for publication in these columns direct to Mr. Becker, 1117 West 45th Street, Los Angeles, California.

"That Deep, Deep Subject"

Now that everyone has recovered from his New Year's celebrating and we don't have to worry about Xmas shopping for about 340 more days, we can take up that deep, deep subject sometimes known as dx . . . or, as I've often heard it called, "who can tell the biggest lie."

In December RADIO the writer of this column made some sort of a crack about a six-band, six-continent WAC . . . in other words, a different continent worked on each of the bands: 5, 10, 20, 40, 80 and 160 meters. Well, this is it so far: Word from Charlie Myers, W3SI-W3CCF, brings the following information regarding his six-band WAC. He contacted North America on 56 mc., all continents on the 28 mc., 14 mc. and 7 mc. bands, 5 continents on 3.5 mc., and Europe on 1.75 mc. That surely covers the situation . . . plus. Then along comes W6AWT with his Oceania on the 150 meter band in 1922, South America on 80, Africa on 40, Europe on 20, Asia on 10, and North America on 5 meters. OM Bart got started way back in ancient times but he just about did it at that. The 150 meter band was almost 160 . . . and who am I to quibble over 10 meters.

QRPPP Dx?

W3CHG had an interesting experience a short time ago while QSO ZS6AM on 14 mc. When the QSO started ZS6AM was using 50 watts and he decreased his input in 4 jumps until he was using a mere 1/4 watt . . . and was still copied solid. That's what I call QRPPP. W3CHG would like to have some statistician figure up the number of kw. that have been wasted in calling VU2CQ.

A couple of new ones for the West Coasters to hop on are VQ2TT and VQ4CRH, both on 14325 kc. and T9X. ZZ2A has made many of the boys dive into the Alka-Seltzer (no adv.) wondering about his QRA, etc. Well, it seems that ZZ2A is a Greek ship which travels around the European coast. Frequency is about 14400 kc. and PDC. It's all Greek to me, too. VO48 is the portable call of VP90 and G5OT and he spends most of his time on high seas between Bermuda and England. ON4CSL is supposed to be on with a new high-power phone and c.w. rig, and has just invested in a new FB7A receiver.

OE1CM has been rounding up info. on the Eimac 150T, so you know what that means. Keep an eye open for him, you Owls, or mebbe I should have said "ear".

The VK's have started to come through quite regularly on the East Coast in the afternoons between [Continued on Page 96]



## 28 and 56 Megacycle Activity

[Reports and other material referring to the 28 and 56 mc. bands should be sent to E. H. Conklin, W9FM, Assistant Editor of RADIO, 512 No. Main St., Wheaton, Illinois, who will correlate and assemble the data for publication. Reports should reach him by the 22d of each month.]

### 28 Megacycle Conditions

In general, conditions from November 15 to December 15 continued similar to those since September, with many dx contacts reported, and the band open for a distance of 1500 miles and beyond, for most daylight hours.

John J. Michaels, W3FAR, outlines Pennsylvania conditions as follows: "During the first week in December, the band was wide open daily for U.S.A. work from 11 a.m. to 3 p.m. eastern time, when W5, W9 and X could be heard for hours pounding in R9, with W6 and W7 as well. The band is still holding up for European contacts, except the period has been shortened to just an hour daily and erratic at that, with the English and French stations fading. The band is open for them from 9 to 10 a.m. with strength R8 to R9 for about ten minutes in the middle of that period. I haven't heard a South American here since the last part of November. The only Aussie that broke through was VK3YP who one day came in as late as 7:45 p.m., R6 to R7 for about half an hour. I haven't heard an African for weeks either; old ZS1H and ZU6P are just gone. Dx heard from December 1 to December 8 is as follows, with those worked in brackets:"

ea4av; ei5f; ei8b; f8oz; f8wk; g2hx (g2pl)  
(g5by) g5dw (g5fv) g5ml (g5oj) g5wp  
(g6dh) (g6lk) (g6qb) (g6wy) g6yq; on4au;  
pa0az (pa0rn) vk3yp; x1aa; x2c.

A letter from a British station mentions that a 30 second QRZ is all that is needed to raise Europeans on this band, and complains about some of the five minute CQ's. He says, "W4—sends CQ for five or more minutes at R8/9 and when we G's go back (perhaps a dozen or more of us) it is disappointing to know that only one of us has been successful." Sounds like a complaint of a W station in a dx contest!

These W4's are often loud in England even on poor days for other W districts. The same situation holds for Illinois, where W4's are often the only W district audible.

While many U.S.A. stations use conventional power-amplifier transmitters on 28 mc., the

tendency in England is to use power frequency-doublers or locked oscillators. Our estimate of the situation is that those using the 852 type tube double in the final due to excitation difficulty, while those using more easily driven tubes run "straight through" the final amplifier after doubling in low-level stages.

Lots of the European signals we hear use less than fifty watts on the plate, and put a beautiful signal into this country. In a G QSO on November 9, W9NY was a good R8 using but a pair of 801's.

In a letter telling of many QSO's with stations on five continents, W9FUR says, "Believe it or not, I am using a 203A on 10 meters with a cool 350 watts input." We always hear said that the 203A is not a high-frequency tube.

Wayne Cooper, W6EWC, says that the J stations—all with T9 signals—are best heard on Saturday afternoons, and will last 1/2 to 1 1/2 hours, no fading, and generally about R5. Some of the frequencies: J2IS 28.2; J2JK 28.55; J2LK 28.6; J3FJ 28.45 mc.

With only a self-excited pair of 210's in the rig, W6EWC was among the first dozen 28 mc. WAC stations. Someone said, "Power will tell!"

Without schedules, W9TB raised VK3MR on 28, 14, and 7 mc. during one day of the recent VK-ZL contest. We have heard of one-day three-band trans-oceanic contacts before, but not without previous arrangements.

Bill Scofield of W2DTB returned to "10" November 13 after a year or more on other bands. All continents were worked in the first week. He says that the lack of active foreign stations is shown by the fact that in the 100 dx contacts in the first month, only about 50 different stations were represented, and only 65 dx stations have been logged. He worked 11IT for the first U.S.A.-Italy contact on the band, and was apparently the first W2 to work Japan for WAC. He has heard three J's who don't seem to realize that they are getting to the east coast, and have been heard calling VK4EI, W6JJU and VE5HC but seldomly call CQ. Bill reports hearing J2IS, J2LU, VK4EI and a half dozen Europeans in addition to the list worked, as reported in the calls heard section. The list includes three stations each in Africa, South America and Oceania.



W4AGP was overheard on December 13 saying that the Europeans were coming in well that morning, PA0AZ getting up to R8.

The Keefe boys operating W9HAQ in Davenport, Iowa, report working Japan for WAC at 4:30 p.m. central time November 21. W9NY reports one J, and LU, one North African, five VK's in addition to a long list of Europeans heard between November 21 and December 10, as listed in "Calls Heard". W9JGS finally started working the dx—Europeans and VP5PZ. W9WC mentions little dx but has a consistent noonday schedule daily with W7CHT. W9FM has heard Europeans on Sunday mornings from 7:30 a.m. central time, but has concentrated on searching for J's.

W6JJU provides west coast observations: "The ten meter band is still doing plenty of business here, in spite of the lull in European activity. The South Americans also have let down a little though LU9AX comes through quite regularly. ZU6P is getting through here quite often. Also, I learned from VK3YP that no South American has so far contacted a VK. The VK's and J's come through about the same as always. VK3YP is on every day from noon to 5:30 p.m. Pacific time. We will miss his loud daily signal when he leaves for a short visit to Tasmania. While there, he will operate at VK7JB—frequency near ZS1H (about 28,185 kc.). When it comes to raising Asians from the east coast, W8CRA can spot the average W6 a flock of db and then take the Asian away. J2IS was saying that Frank is consistently R8 to R9 there."

W7BPJ says that the J's tune from the low frequency end of the band, even though they may be located up at 28,800 kc. Yet lots of the boys scattered upwards from 28,200 kc. have been raising them—and we just recently heard W6BAM move out about 400 kc. more.

#### Short-range Conditions

At W9FM in Illinois, very few signals from W1, W2, W3, W5 and W8 have been heard since July, and then generally quite weak compared with the R7/9 signals from the west coast. In November, on the 3d, W2TP was heard; W8CRA came in on the 10th and the 16th but Frank's signals on this and other bands do not seem to follow the same rules; on the 10th W8MWL and some VE1's were heard; and on the 11th W1FJN was logged. At 7:30 a.m. central time December 1, several W3's came through along with EA4AV whom they were calling. On the 7th W9JGS heard

W1, W2, and W5; on the 12th W3FAR was heard for the first time. Throughout this period, ground waves up to 200 miles were heard consistently. W9NY lists a few eastern stations as well as nine W5's; W4's were probably heard though omitted from the list.

A theory of short-distance correlation with conditions on 7 and 14 mc. has been advanced. Most of us have noticed the time our bands go rather dead for U.S.A. work in December, although there seem to be no published records to work from. It has been noticed that when the 3.5 mc. band skips several hundred miles in the evening, the 7 mc. band goes dead around 6 p.m., and the 14 mc. band around 5 p.m., the year is a poor one for 28 mc. work within the U.S.A. This year, with the lower frequencies staying open in the evening during this and last winter, the 10 meter band continues very useful. This regards the long trend rather than day-to-day changes, of course. Comments and observations on this will be appreciated.

#### Antennas

Radiating systems, of great importance on the high frequencies, still receive attention. W9JGS has been making comparisons between a half-wave vertical and a 2-wave horizontal antenna with practically no conclusive results as yet, although on receiving weak signals from VK and VE5, the vertical antenna has appeared to have an advantage of several db.

W9HAQ has just erected a 75 foot wood mast with a 66 foot vertical wire down through the center—on which he raised his J using only an RK20 driven by two 53's. This antenna probably has a number of lobes at various angles including the horizontal, and may not be as ineffective as a full wave vertical we tested last summer with disappointing results.

Comparisons at the same time, with antennas having rather sharp vertical directivity, will probably be necessary before satisfactory conclusions can be drawn. Those interested in this phase of the work might read Hull's article in *QST* for January, 1929, and the papers by the following authors in the I.R.E. Proceedings indicated: A. H. Taylor, August 1926; Meissner and Rothe, January 1929; T. L. Eckersley, January 1930; Carter, Hansell and Lindenblad, October 1931. Also the papers by Friis.

Conrad, W9WC, is modulating his 211 doubler successfully on 28 mc.—although modulation power requirements are probably higher than for a straight-through modulatee. In order

*[Continued on Page 101]*



# The Class C Amplifier

## Part II\*

By J. N. A. HAWKINS, W6AAR

Practically all radio frequency amplifiers used in either the final amplifier or the last buffer of a phone or c.w. transmitter operate class C. Strictly speaking, a class C amplifier is any amplifier biased *beyond* cut-off. The plate modulated class C amplifier, capable of 100% modulation, is a special case and must be biased at least to twice cut-off bias.

There are four variable factors that must be balanced and compromised if optimum output and efficiency are to be obtained from a class C amplifier. These factors interact on each other and it is quite difficult to obtain the best set of operating conditions without a good working knowledge of the way that changes in these four factors affect the operation of the amplifier.

These four factors are: grid bias, grid excitation, plate voltage, and antenna loading.

### Grid Bias

The negative bias applied to the control grid is always, in a class C amplifier, greater than that negative voltage which is just sufficient to bring the plate current to zero. In other words, the bias is always greater than cut-off. Cut-off bias may either be determined experimentally or it may be calculated approximately by dividing the actual measured d.c. plate voltage applied to the tube by the amplification factor of the tube.

Thus when a class C amplifier has no r.f. excitation applied to its grid the plate current is zero. The r.f. grid excitation voltage consists of alternating current so that when it is superimposed on the constant negative grid bias, the *instantaneous* grid voltage swings alternately more and less negative about the axis determined by the negative bias voltage. See figure 1. When the instantaneous grid voltage is more negative than the d.c. bias the plate current remains at zero and plate current starts to flow only when the instantaneous grid voltage crosses over to the positive side of the point marked "Cut-off" in figure 1. As the grid swings more positive (or less negative, which is the same thing) the plate current gradually increases until the grid is at its most positive point. Then as the grid voltage swings back

on the next succeeding negative-half excitation cycle the plate current decreases to zero and remains there for some time, or until the grid again swings over to the positive side of the cut-off. Thus it will be noted that plate current follows for a relatively short pulse and that during most of the cycle the tube is not conducting at all. It is during this portion of the cycle that the tube cools off so that it will be seen that the *instantaneous* plate current and plate loss can be quite high as long as the *average* plate loss, measured over a whole cycle, is kept below the rated plate loss of the tube. It should also be noted that the higher the negative grid bias, the shorter the proportion of each cycle during which plate current flows. Thus for a given *instantaneous* plate voltage and plate current the plate efficiency raises as the negative bias is raised. However, remember that the power lost in the grid circuit of a vacuum tube is divided between the grid itself and the source of grid bias (bias voltage times the d.c. grid current) so that raising the negative bias voltage raises the amount of grid excitation power dissipated in the grid bias supply, so more r.f. power must be supplied from the preceding driver stage. Thus, in general, the *power gain* through a class C amplifier goes down as the grid bias is increased. It may also be said that the *power gain* goes down as the plate efficiency is raised, as long as raising the plate voltage is not the cause of the increase in efficiency. Raising the plate efficiency of a class C amplifier is desirable *up to a certain point*. The higher the plate efficiency, the more power output can be obtained from a given vacuum tube, as the output from most modern vacuum tubes is limited largely by the ability of the tube to dissipate heat. Thus the smaller the tube loss compared to the power output (which ratio defines plate efficiency) the more power output can be obtained from any given tube. However, since the grid driving power goes up as the plate efficiency is raised it is soon found that it is poor economy to raise the plate efficiency to the point where it takes more than about 10% of the power output to drive the grid. It is quite possible

\*Continued from Dec. 1935 issue of R/9.

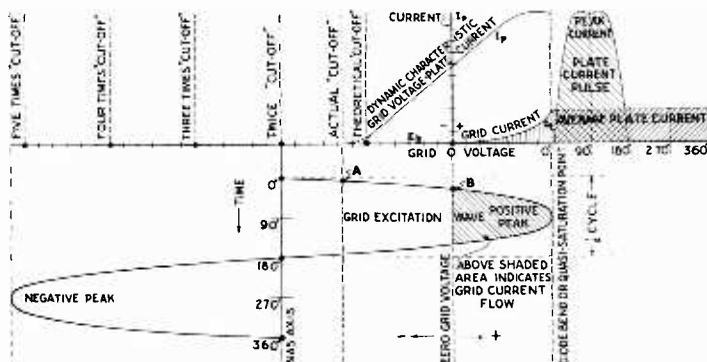

Figure 1

to get 90% plate efficiency from the newer tubes but in some cases it takes nearly 33% of the power output, applied in the form of r.f. grid excitation to the grid of the final amplifier, to obtain this high plate efficiency. In cases of this kind it is much more desirable to use a slightly bigger tube in the final amplifier in order to use a materially smaller tube as r.f. driver of the final amplifier. As a power gain of 10 usually represents a pretty good compromise for the average class C final amplifier, the bias voltage will be chosen so that the power dissipated in the grid circuit will be not more than about 10% of the r.f. power output of the amplifier.

If *power gain* is the principal objective (as it is in many buffer or r.f. driver stages) it is often better to bias the tube class B instead of class C. (Class B bias is that amount of bias that brings the plate current practically to cut-off.) Class B represents the best compromise where plate efficiencies of about 60 to 70% are satisfactory. It is possible with some of the newer high frequency triodes to get a power gain of between 40 and 60 through an r.f. amplifier biased to cut-off. This means that between a crystal oscillator and a 1 kw. final amplifier only about one buffer-driver stage is necessary, even for phone operation where an excess of grid excitation is desirable. Of course when trying to work on four or eight times the frequency of the crystal oscillator an additional doubler stage sometimes becomes necessary.

In the last few years there has grown up a regrettable tendency for amateurs generally to use too much bias and not enough grid excitation power to allow the operator to realize the advantage of high bias.

A fairly accurate rule of thumb for experimentally determining the proper amount of

negative grid bias is to start with more bias than necessary and then gradually reduce it until the stage draws the normal maximum d.c. grid current recommended by the tube manufacturer. It will be noted that for any given amount of grid excitation power the d.c. grid current rises as the bias is reduced. On page— is shown a table of d.c. grid current values for several common tube types. The grid current should not be much lower or higher than the value shown.

In using this table the amateur should utilize all the grid driving power he has available, as rarely does any amateur have *too much* r.f. excitation available. The point expressed here is that it is better to run at low bias and normal grid current rather than high bias and low grid current. Of course the operator using plate modulation must not go below about 2.2 times cut-off bias and the c.w. man must not let his negative bias go below cut-off.

Negative grid bias is best obtained from a combination bias source, except in the case of the extremely high  $\mu$  tubes, such as the 203A, 838, 46, etc., which can use grid leak bias alone. Fixed bias about equal to cut-off can be provided from batteries, a separate bias pack, or from a cathode bias resistor. The balance, if more than cut-off bias is used, can be provided from the voltage drop through a grid leak resistor. In varying the bias the resistance of the grid leak can be varied. The actual value of the resistance is unimportant. The idea is to use that amount of bias that will bring the grid current up to the optimum point.

The bias should be roughly adjusted with the plate voltage off, although it will probably be slightly high as the d.c. grid current *usually* drops when the plate voltage is applied (if the stage is perfectly neutralized). If the grid cur-



rent goes up when the plate voltage is applied the stage is regenerative. If the grid current goes way down when the plate voltage is applied the stage is suffering from *degeneration*, and in either case the neutralization is not perfect. After neutralizing and then applying plate voltage, the grid leak resistance can be reduced slightly to bring the d.c. grid current back up to the proper value. It will usually be found that changes in plate voltage or antenna coupling will affect the grid current so that when the antenna coupling is adjusted to the limiting point (when either the plate heats or the tube draws maximum rated current, whichever occurs first) some final slight re-adjustment of grid bias may be necessary.

#### Grid Excitation

Usually no adjustment of the r.f. grid excitation is necessary or desirable in a transmitter. It is usually left at the maximum obtainable from the preceding buffer stage and any adjustment of the effect of the excitation is left to the adjustment of the bias voltage mentioned above. However, if a large surplus of r.f. grid driving power is available it is a good idea to couple up the excitation while adjusting the negative bias to a point somewhere between 2.5 and 4 times cut-off so that normal grid current is drawn. Of course, by the rule of bias adjustment given in the paragraphs on grid bias, the amplifier would operate satisfactorily even though the excess of available grid excitation necessitated raising the bias even to ten times cut-off in order to get the d.c. grid current down to the normal operating value. However, the use of a grid bias in excess of 4 times cut-off adds but very little to the plate efficiency and is quite hard on the amplifier tube. It also materially increases the generation of r.f. harmonics in the output, which is undesirable. The adjustment of the r.f. excitation can be effected by adjusting the coupling link, if link coupling is used. If capacitive coupling is used between the driver and the driven stage the coupling can be adjusted either by tapping the grid down on the preceding plate tank or by varying the size of the blocking condenser between the driver plate and the grid of the driven stage.

If the driver stage does not draw normal plate current the coupling to the grid of the driven stage is probably too loose. In this event the coupling link should be moved up a ways toward the "hot" end of either the grid tank or the plate tank. If capacitive coupling is used

the size of the grid coupling condenser should be increased up to about 0.001  $\mu\text{mfd.}$  as a maximum. If the driver still does not draw normal plate current it will be necessary to tap the driver plate down on its plate tank, leaving the grid of the driven stage connected to the top of the tank.

If the driver stage draws too much plate current, or its plate runs too hot, it will be necessary to *reduce* coupling. This can be done by the opposite procedure, that is by moving the coupling links toward the "cold" end of the grid or plate tank, using fewer turns on the coupling link or, with capacitive coupling, reducing the coupling capacity or tapping the grid down on the driver tank coil. Tapping the grid down on the driver tank sometimes instigates undesirable parasitics, especially with those tubes such as the 841, 46, and 203A, which have secondary and primary emission troubles with the control grid. In general, link coupling is desirable, due to the fact that it is easier to get going. Capacitive coupling will give exactly as good results but it takes more work to get the grid impedance of the driven stage reflected back as the proper load impedance on the driver stage. For example, Collins, in their production transmitters, use capacitive coupling almost entirely. They have the laboratory facilities to get the excitation taps, plate voltages, etc., at exactly the right values to give optimum results. In the absence of such equipment it is much simpler to use the few extra parts required by link coupling to avoid all the troubles that *can* occur when amplifiers are capacitatively coupled by cut and try methods.

#### Plate Voltage

In a heavily driven class C amplifier the r.f. power output varies more or less as the *square* of the plate voltage, so that it is desirable to use fairly high values of plate voltage.

In most transmitting tubes the amount of plate voltage that can be used is limited by the internal insulation and gas content of the tube itself. For example, the average 203A and 211 type of tube can usually stand 1500 volts in a c.w. (unmodulated) transmitter operating on a frequency below 10 megacycles. Some makes of these tubes will stand 1750 volts on the plate. However, when operating these tubes at this high value of plate voltage care should be taken never to let the plate dissipation exceed rating, even momentarily. There are a few tubes available that have practically no insula-

[Continued on Page 80]



# The "5 Meter QRM Dodger"

By R. J. HAGGERTY\*

The following transmitter is the result of several months' experimental work, for, being like the average ham, I wanted to know which circuit worked best. A transmitter was desired that had fairly good output, good quality, stability, and last but not least,

*"RADIO" wishes to discourage the general use of modulated oscillators on 5 meters except for portable operation. But in this case it is somewhat justified because of the easy-QSY feature, a great aid in reducing QRM. Unfortunately, instantaneous QSY is complicated by the use of oscillator-amplifier transmitters. The ultra-audion circuit used here allows frequency control independent of excitation, and is ideal for rapid QSY. It is not unduly broad unless modulated excessively.*

often here the comeback was, "Sorry, o.m., I could work you duplex, but this transmitter won't QSY." So the only

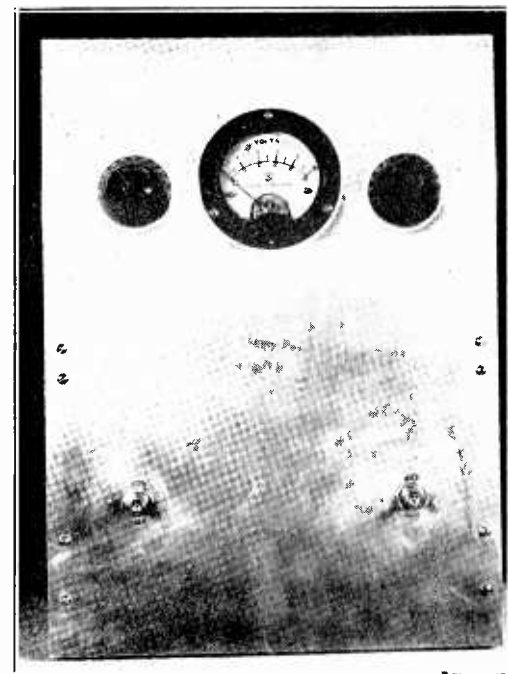

QSY faster than you can say it

the ability to QSY readily and easily, as QRM on 5 meters in the Los Angeles district made this feature a necessity.

So the old breadboard was brought out and a number of different rigs were built up with the following results:

The t.p.t.g. proved to be a very good oscillator but was ruled out because of its inability to QSY.

The "t.n.t." (or tuned plate semi-tuned grid) exhibited the same difficulty, as it proved efficient only over about  $1\frac{1}{2}$  megacycles. And too

thing left to do was to design a transmitter that could QSY to the other end of band if necessary.

The Split-Hartley overcame these objections but presented mechanical difficulties at 5 meters.

The Split-Colpitts was in the same category.

Unity-coupled rigs proved ready oscillators, but presented the same mechanical problems.

Push-pull was tried but presented a real problem when it came to capacity coupling the antenna. Capacitative coupling to a single wire feeder always showed an unbalance in the circuit with one tube doing most of the work.

So the old ultra-audion circuit was tried and it proved the answer to our prayer. It was simple, stable, efficient, and would work anywhere in the band. To QSY you only had to tell the other fellow to follow you and turn *one* knob. And it was simplicity itself—1 tube, 1 grid leak, 1 blocking condenser, 1 tank, and 1 r.f. choke.

And now the question as to the right tube for the oscillator: The 53 was too tricky. A 10 was found f.b. but due to the discrepancy between its normal plate voltage and the modulator plate voltage it would have necessitated two separate power supplies. The 71-A and 12 also proved efficient but would not stand up at a plate voltage of 300 for any length of time. The 47 and the 2A5 were found to put out only about one-half as much r.f. as a 45 at the same input; so a 45 was used. At a plate voltage of 300 and a current of 50 ma. the 45 put approximately 7 watts into a dummy antenna, which represents very good efficiency at these frequencies.

As to the right modulator tube—the 45 obviously did not have sufficient output and a 50 required a higher plate voltage. A 47 and a 2A5 were tried. The 2A5 proved to have better quality, greater output, and was easier to drive. At a plate voltage of 300, the 2A5 has about 5 watts audio output, which is sufficient to modulate the 15 watt r.f. input about 85%.

\*W6JMI, 1238 So. Cloverdale, Los Angeles

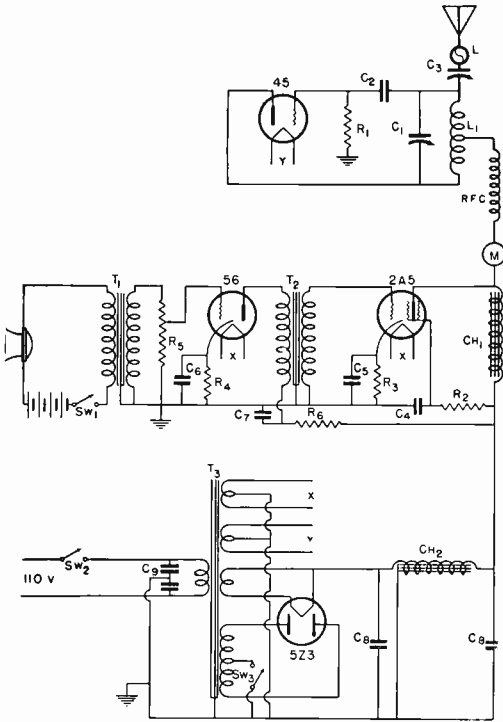

**ABOVE**

- T<sub>1</sub>—Microphone transformer.
- T<sub>2</sub>—Good 3:1 audio transformer.
- T<sub>3</sub>—Power trans., 300 volts @ 125 ma.,  
Two 2½ volt & one 5 volt winding.
- C<sub>1</sub>—15 μfd. variable.
- C<sub>2</sub>—.00025 μfd. fixed.
- C<sub>3</sub>—15 μfd. trimmer.
- C<sub>4</sub>—0.5 μfd. by-pass.
- C<sub>5</sub>—25 μfd. cathode by-pass.
- C<sub>6</sub>—25 μfd. cathode by-pass.
- C<sub>7</sub>—0.5 μfd. by-pass.
- C<sub>8</sub>—8 μfd. filter condensers.
- C<sub>9</sub>—.01 μfd. line by-pass.
- R<sub>1</sub>—50,000 ohms 5 watts.
- R<sub>2</sub>—10,000 ohms 1 watt.
- R<sub>3</sub>—600 ohms 5 watts.
- R<sub>4</sub>—2,000 ohms 1 watt.
- R<sub>5</sub>—500,000 ohm potentiometer.
- R<sub>6</sub>—25,000 ohms 2 watts.
- L—6 volt pilot lamp.
- L<sub>1</sub>—6 turns no. 14 enamelled, 5/8" d.,  
spaced 1/8", c.t.
- M—0-100 milliammeter.
- Ch<sub>1</sub>—30 henrys, 125 ma.
- Ch<sub>2</sub>—30 henrys, 125 ma.
- RFC—50 turns no. 30, 1/4" d.
- Sw<sub>1</sub>—Microphone Switch.
- Sw<sub>2</sub>—Line switch.
- Sw<sub>3</sub>—On and off switch.
- B—4½ volt mike battery.

**TO THE RIGHT**

Showing constructional detail and the method of mounting the tank coil to the tube socket and tank condenser.

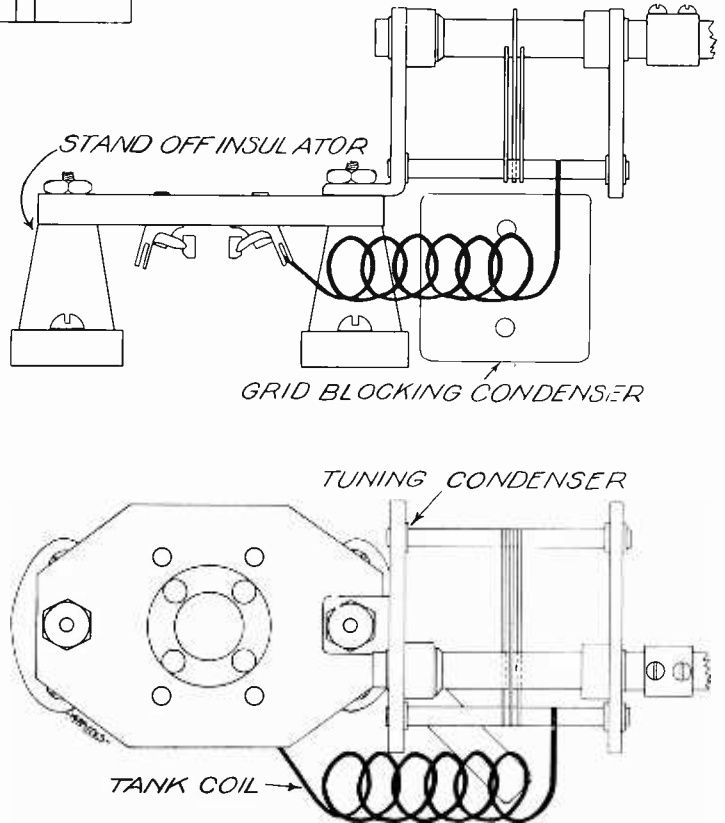

It is absurd to think of modulating a self-excited oscillator 100%. For those of a skeptical turn of mind all I ask is that they take a look at a self-excited oscillator modulated 85% on an oscilloscope and compare it with an s.e.o. modulated 100%.

The 2A5 can be driven directly by a single button microphone but greater gain was desired and a single stage of speech provided more than necessary. A 27 and a 56 were tried and showed negligible difference, but because of its higher amplification factor and lower filament current, the 56 was chosen. Resistance coupling gave very good quality but not quite enough gain. With a good quality audio transformer the voice quality leaves little to be desired. With the gain control about ¾ open one can talk about a foot away from the microphone.

As to the only other tube in the transmitter—the rectifier—the 80 had too much voltage drop; the 82 and the 85 introduced "mush". So the 5Z3 was the logical choice. An 83-v should also work out well.

The oscillator is straight-forward, except



that there are no lengthy leads. Notice from the photographs and drawings the simple and efficient method of mounting. The isolantite socket is mounted on two  $1\frac{1}{2}$ " stand-off insulators. A 1" brass bolt continues through the insulator, on through the socket hole, and thus makes the support for the tuning condenser. A soldering lug goes from this point to the plate prong of the socket and one end of the tank is soldered directly onto the plate prong. The other end of the tank fastens onto the grid blocking condenser and a very short wire is run from this to the tuning condenser. The other end of the blocking condenser fastens directly onto the grid prong of the socket. Be sure and use a non-inductive grid leak and fasten one end directly onto the grid prong. Due to the high resistance of this leak no grid choke is necessary.

It might be said that a 1 megohm grid leak gave a slightly greater output, but oscillation was not nearly as stable as with the lower value.

Various forms of antenna coupling were tried but the small compression-type trimmer condenser fastened onto the grid side of the tank proved the best. It is also a very handy way of adjusting the antenna for the proper load.

Possibly you have heard five meter phones where the voice was on one side of the carrier. An interesting observation was made on this point in this transmitter. When using shunt feed the voice was on the high frequency side of the carrier. But series feed put the voice right "smack in the center" of the carrier and at the same time put less work on the r.f. choke.

Too much cannot be said about the importance of the modulation choke. Get one with lots of iron and copper in its makeup and with as high inductance and low resistance as possible. If you have one that will carry the total current without saturating, you have gone a long way in getting good quality.

The resistor  $R_2$  was found necessary in order to drop the screen voltage on the 2A5 to the same value as that on the plate. Otherwise the screen ran red with consequent distortion.  $R_6$  dropped the voltage on the 56 to the recommended value of 250 volts. The use of high capacity across the cathode bias resistors of the speech-system preserves the low speech notes.

It is a wise idea to mount the different chokes and transformers so that their fields are at right angles to each other. This, together with grounding their frames, helps to lick feed-back.

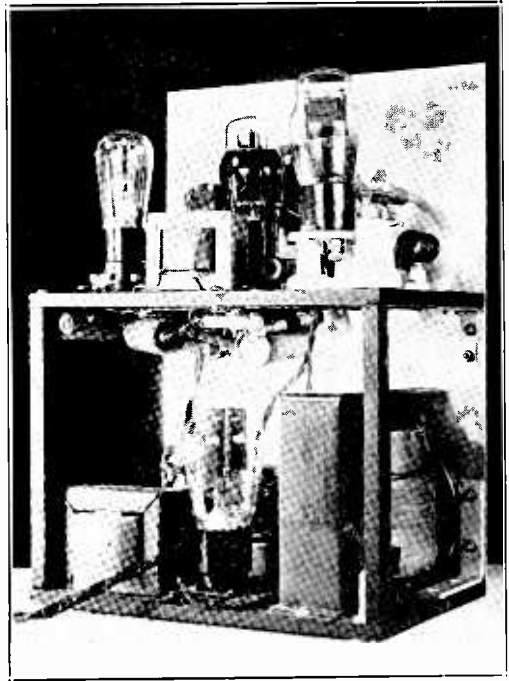

Back view showing mounting construction

The condensers  $C_9$  in the 110 volt line were the last step in licking our "Old Debil" and duplex operation is possible within about 500 kilocycles of our own frequency.

The photographs show how the different parts were mounted. The panel was made of  $3/32$ " dural, 10 x 14 inches. The two wood sub-panels measure 6 x 10 inches. The speech amplifier was mounted on one end of the top sub-panel; the modulator is in the center; and the oscillator is at the other end. The power supply was put on the bottom sub-panel. Incidentally, with the stated filter values no hum was present.

In reality,  $SW_2$  and  $SW_3$  amount to a double-pole single-throw switch. In this manner they will cut the microphone battery and high voltage at the same time during "stand-by" periods.

A six volt pilot lamp in series with the antenna serves a double purpose. Firstly: it indicates when you are getting the maximum power into your sky-wire. As you tune  $C_1$  across the band, when you come into resonance with your antenna the lamp will light up the brightest. Secondly: it serves as an excellent modulation indicator. When you speak into the microphone it should light up more brilliantly. The idea is to get as much variation in the lamp

[Continued on Page 85]

# An Unusual Mobile Antenna Mounting

By H. SELVIDGE\*

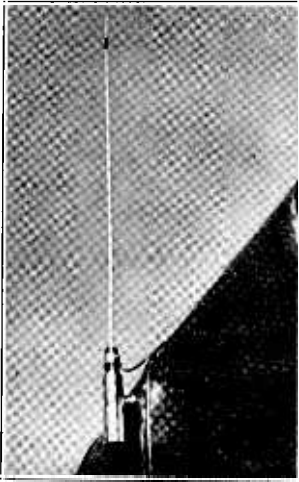

**Figure 1**  
The self-righting antenna on the copper-clad car.

In the October 1935 issue of *R/9* an antenna for 5 meter mobile use was described. It consisted of a metal rod mounted on an insulated fitting which could be screwed to the top door hinge of a car. The article advised one to have replacements handy in case the antenna struck an obstacle.

The following is a description of a mobile antenna which can "take it" as well as "dish it (r.f.) out." It solves the problem for those of us who can't remember to take down the antenna when we drive into the garage.

Figure 1 shows the antenna mounted on Cruft Laboratory's copper-sheather mobile unit. It consists of a quarter-wave aluminum rod, set in a cylinder of bakelite which is fitted into a cylindrical brass mounting. A better insulator, such as victron, might have been used, but since the r.f. voltage should be nearly zero at this end of the antenna, first class insulation is not necessary. The feeder connection is made by a flexible wire leading to the set-screw which holds the antenna in its mounting. The photograph shows, as does the drawing, how the antenna is pivoted so that it will rotate about the point of attachment to the car body. The solid brass cylinder acts as a counterweight. The pivot-rod extends through a bushing into the inside of the car body and there ends in a handle above the driver's seat, as shown by the second

photograph, figure 2. The handle is shown with the antenna in the raised position. It is held in this position by the brass counterweight outside and also by the spring catch inside which holds the handle in place. If the antenna strikes an obstacle while in the upright position, the shock pulls the handle out of the spring catch, the antenna swings down until clear, and then springs back up into the operating position! This action is caused by the combined efforts of the counterweight outside and the spiral clock spring inside the car. This spring is mounted on the shaft, behind the face plate, as shown by one photograph (figure 2) and the drawing. It has never failed to work, the only difficulty being that the spring and counterweight will not return the antenna to a completely vertical position while traveling faster than 50 miles per hour.

Our experience with this antenna leads us to believe that it is one of the best for mobile work. It has performed better than a half-wave antenna located on top of the car. It is fed by a concentric cable about a quarter wave long, part of which may be seen on the left in figure 2. This cable is made by stringing a copper wire through "fish spine" beads and

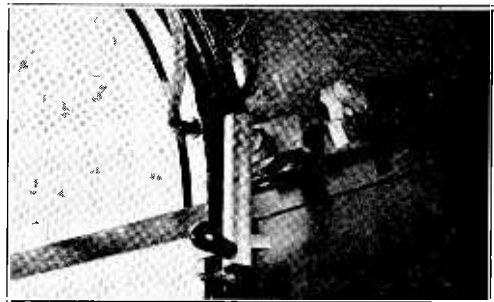

**Figure 2**  
Inside the car with the antenna up and the handle down. Note the concentric feeder along the top bow.

slipping this inside of copper braid. The braid is grounded to the frame of the car so insulation is no problem, and the feeder can be run anywhere. At the transmitter it terminates in a balanced pick-up with 3 turns coupled to each end of the plate coil.

With this antenna and the super-regenerative receiver described in the December issue of

\*Cruft Laboratory, Harvard University, Cambridge, Massachusetts.

## TWO HALF WAVES IN PHASE FED BY A TWISTED PAIR LINE

By JAYENAY

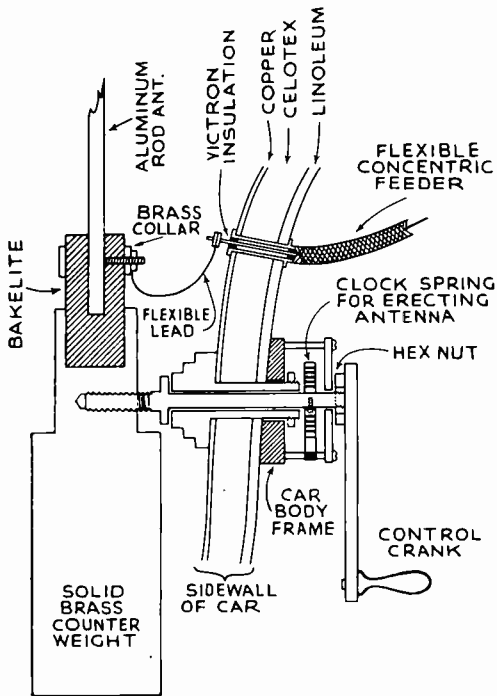

Figure 3

The construction is as shown, though the shaft is thicker and shorter for strength.

R/9, medium-power amateur signals on 5 meters have been heard 220 miles away. Many mobile QSO's under adverse conditions in cities such as Boston, New York and Washington, D. C., have convinced us of the superiority of this type of antenna with a quarter-wave concentric feeder.

Most owners will not wish to drill holes in their cars, though it could be done very nicely in the all-metal tops. However, it should be possible to mount a pivoted antenna of similar design in a board held between the door frame and the top of the window-glass.

The trick pivot-mounted antenna system was the brain-child of the author and J. A. Pierce, of W1JFO and of Cruft Laboratory. The latter was responsible for the modernistic chromium-plated construction work.

### Subscription Extensions

A few customers have suggested that refunds or extensions on subscriptions are in order because of the reduction of the yearly rate from \$3.00 to \$2.50. To these we point out that \$3.00 for twelve issues is exactly the same rate per copy as \$2.50 for ten issues. Starting December 1, 1935 for the former R/9 and January 1, 1936 for RADIO all subscriptions are accepted on a ten-issue-per-year basis as advertised.

The use of two half waves in phase, either horizontally or vertically, is a simple and cheap way to get some antenna directivity. The directivity of such an antenna is not great but usually is about as much as can be obtained from a half wave antenna and half wave reflector. Two half waves in phase can be fed in a number of ways but the use of the twisted pair line as shown in figure 1 is simple and effective.

Each half of the antenna proper should be one-half wavelength long, electrically, and the matching section should have each leg a quarter wavelength long. It should be noted that the impedance at the end of the quarter wave section is not 72 ohms but the mismatch at that point is too small to be bothersome. This antenna system is directional broadside and should be one-half wavelength above ground for the best concentration of the radiation in the vertical plane. The antenna can also be mounted vertically, in which case it concentrates the radiation at a low angle with regard to the horizon. Thus this type of vertical antenna is particularly useful for 5, 10, and 20 meter operation where high angle radiation is undesirable. The twisted pair line can be any rea-

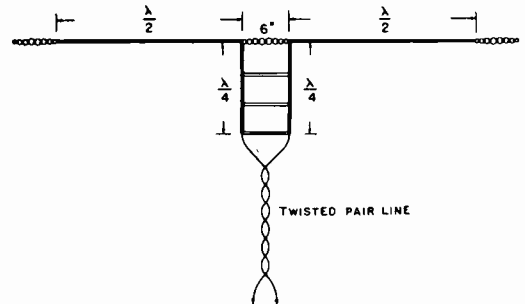

sonable length up to several hundred feet long. This antenna is also just as desirable for reception as transmission.

The 6Q7 is a metal duo-diode triode essentially similar to the 75 type of tube except that the  $\mu$  and plate resistance of the triode section are slightly lower than in the 75. The  $\mu$  of the 6Q7 is 70 and the plate resistance is 60,000 ohms. The two diode plates are separate except for the common cathode and can be used in all circuits suitable for the 75. The 6Q7 is similar to the 6H6 and 6F5 combined, although the triode sections differ slightly.



# Notes on the Care of Transmitting Tubes

By J. N. A. HAWKINS, W6AAR

In the last year or so there have been over twenty-five new transmitting tubes offered to the amateur.

Most of them represent a real contribution to the science of high frequency development. For years the only transmitting tubes available were Chinese copies of tubes designed as far back as 1919 in some cases, and even the 852 (considered to be one of the modern tubes) was designed back about 1926. Thus only recently did some of the independent manufacturers have enough initiative to get away from the "replacement market" fetish and really do some pioneering.

However, some of the ratings placed on some of the newer models look a little bit optimistic. Speaking as one who has burned up, softened, flattened out, and just plain worn out more than his share of tubes during the last sixteen years, this editor feels that he can speak with some authority on the subject of tube life.

The main factor in tube ratings that causes short life is the maximum average d.c. plate current in class C service. The other ratings are either correct or they are not. In any case it is rarely necessary to wait several hundred hours to find out. However, in the case of space current through the tube, the effect of excessive space current is only noticeable in shortened filament, or emission life. It is pretty well accepted that 1000 hours of service is about the shortest period for which a tube should be designed. Some tube manufacturers use 2500 hours as the minimum expected tube life. They may not guarantee their tubes for 2500 hours but they expect that when operated at rated values of space current and plate loss, the filament emission will not start to drop off materially until 2500 hours have gone by.

Many amateurs and others have the erroneous impression that the maximum rated plate current is just under the maximum that the *tube can be made to draw* with the closest possible antenna coupling and everything tuned to resonance. It happens to work out that way quite often but at other times the tube can be coupled

*It has been oft-repeated, both elsewhere and in these columns, that a certain amount of overloading may be applied judiciously in the case of vacuum tubes used in amateur transmitters. But it can be overdone, especially from the standpoint of plate current. Here are some good points on the practice of "dynamiting" tubes, and why sometimes it is poor economy.*

up until the space current is two to four times rating, particularly with the new high voltage tubes.

How many times have we heard the following: "Well, I coupled up until my 211 drew 300 ma. and everything ran stone cold. I have been running that way for six months and everything is still taking it, so why should I cut my plate current down to the 175 ma. that the manufacturer calls his rating? Everyone knows that the ratings are overly conservative."

Six months' operation of the average amateur station rarely involves 200 hours of *actual* operation, even if a phone station. If operating keyed the tube may not have even had 75 hours of actual key-down operation. Even the most active amateurs can hardly spare time enough on the air to make up 400 hours in six months. Thus it should be evident that a six months' test means nothing. If every amateur will sit down and figure with a pencil and paper just what his tube cost is, he will soon see that it is much better economy to use two 211's at 150 ma. each for 2500 hours (provided he uses a good make of 211) than one 211 at 300 ma. for about 300 to 500 hours, depending on whether he has enough sense to run the filament at 10.5 volts or not. Remember that thoriated filament tubes must never be run at less than the rated filament voltage when operating anywhere near rated maximum plate current. Running the filament from 5% to 10% high cuts the life down much less than running excessive plate current. In fact, some extensive tests on 211's showed that when operating at 225 ma. average d.c. plate current on a class C amplifier, that running the filament at 10.5 volts added 33% to the tube life. However, it should be noted that those running the tests finally decided to use more tubes and run them at 150 ma. for best economy. In other words, after a great deal of effort and expense in burning up fifteen tubes or so it was decided that Mr. R.C.A. knew what he was doing when he rated the 211 as he did. Of course this data also applies to the 203-A, 838 and 845 types, as they use the same filament.

**Table of Characteristics of Transmitting Tubes**

Tube	Fil Volts	Fil Amps	Max. Continuous Plate Loss	Max. Intermittent Plate Loss	Max. Continuous Plate Current (Average d.c.)	Max. Intermittent Plate Current (Average d.c.)	Max. Plate Voltage Modulated†	Max. Plate Voltage Unmodulated†	Inter-electrode Capacity Classification	Highest Frequency at which Max. Ratings apply	Amp. Factor $\mu$	Normal Class C Grid Current
<b>TRIODES</b>												
10	7.5 V.	1.25 A.	12 W.	15 W.	75 ma.	85 ma.	600 V.	750 V.	High-C	7500 KC	8	12 ma.
801	7.5	1.25	20	25	75	85	650	850	Med.-C	15,000	8	12
841	7.5	1.25	12	15	70	80	600	750	High-C	7500	30	16
830B	10	2.15	40	60	100	133	1000	1350	Med.-C	15,000	25	35
800	7.5	3.25	35	35*	90	110	1000	1350	Low-C	30,000	15	25
50T	5	6	50	100	125	175	3000	4000	Low-C	60,000	12	25
203A	10	3.25	100	125	175	200	1250	1650	High-C	5,000	25	50
211	10	3.25	100	125	175	200	1250	1650	High-C	5,000	12	35
852	10	3.25	90	110	125	175	3000	4000	Low-C	60,000	12	50
150T	5	10	150	300	225	275	3000	4000	Low-C	60,000	12	40
204A	11	3.85	200	250	250	300	2500	3500	High-C	5,000	25	75
<b>TETRODES AND PENTODES</b>												
802	6.3	.9	12	15*	35	50	600	700	High-C	7500	Varies with** Screen Voltage	
865	7.5	2.0	12	15	75	85	600	900	High-C	7500	"	12
RK20	7.5	3	35	45*	85	100	1000	1500	High-C	5000	"	10
860	10	3.25	90	110	125	160	3000	4000	High-C	7500	"	50
RK28	10	3.25	125	150	150	175	1500	2500	High-C	5000	"	25
803	10	3.25	125	150	150	175	1500	2500	High-C	5000	"	25

As manufacturers ratings vary so widely and it was necessary to establish a standard of maximum performance that could be applied to all makes of tubes, the following considerations were considered in determining the maximum plate current, gas pressure (degree of vacuum), "end effect", on the filament; space charge concentration; filament heating watts. Note that at high plate currents, it is absolutely essential to operate Thoriated filament transmitting tubes at *not less than rated filament voltage*. When in doubt it is better to run the filament as much as 5% high.

\*Due to the construction of these tubes special care must be taken never to let the plate, screen, or control grid structures overheat even momentarily.

\*\*The plate current of a tetrode or pentode is practically independent of plate voltage but is highly dependent on screen voltage. Cut-off bias can thus best be determined approximately by dividing the screen voltage by five. The amplification factors of the above tetrodes and pentodes are not available at this time.

Remember that the maximum values given above are, in many cases, in excess of the manufacturer's rating, and tubes will not be subject to replacement when operated at the values shown above.



Anyway, one conclusion was arrived at after these tests, which also included some research on the spiral filament types, such as the 852 and the 800, and the other cylindrical element type of double vee filament such as that used by Eimac and in the HK354.

Regardless of what the manufacturers call the maximum safe plate current for any tube, first multiply the filament voltage, in volts, by the filament current, in amperes, to get the filament heating watts. Then multiply the filament watts by 4 for spiral filament tubes such as the 800, 852, 831, 861, WE304A, and 860; multiply by 5 for the double vee filaments used in the other cylindrical element tubes such as the 50T, 150T, 300T, 500T, HK354, WE251A, WE279A, etc.; multiply by 6 in the case of the flat plate tubes using double vee filaments such as the 211, 203A, 845, 830B, 849, HF200, HF300, etc. This will give you the maximum average d.c. space current, in milliamperes, which is the sum of the plate current, control grid current, and screen current, if any. This value of space current is that allowable for use in a high efficiency class C plate modulated amplifier. For c.w. use where the tube is keyed and the filament gets a rest between characters this value can be exceeded by *not more than 20%*. Few tubes are any better than these figures and many tubes are somewhat worse. These figures of maximum economical space current apply only to good quality standard make tubes operated at *not less than rated filament voltage*. It should be pointed out that filament heating watts and the space charge configuration, as expressed by the fact that a given filament is in the spiral or one of the double vee groups, does not tell the whole story. However, it is accurate enough for most purposes. There are other things to consider, such as manufacturing uniformity in the wire and in carbonization schedules. Some manufacturers are much better than others in this respect. Then "end effects" on the filament must be considered. In other words, a short filament has a larger proportion of its total length cooled by the connecting leads than a long one. However, most of the long filaments usually have supports which cool the filament just as much as the connecting leads so that the five volt and the ten volt filaments are about equally good in this respect. Then a very important point to consider about filament life and maximum space current is the degree of vacuum in the tube. A thoriated filament re-

quires an exceptionally high vacuum in order to operate at all. That is why they can not use thoriated filaments in the imperfect vacuum found in most water cooled tubes. As there is no such thing as a perfect vacuum there is no such thing as the perfect thoriated filament.

However, the higher the vacuum the greater the *usable* filament emission from a given number of filament heating watts. Thus those tubes which require the least amount of getter to give the final clean up usually will have the highest vacuum. The maximum plate voltage rating is also an indication as to the vacuum. A tube with a 3000 or 4000 volt rating will almost always have a better vacuum than one with a 1500 volt rating. As a matter of fact, theoretically there should be no plate voltage limitation on transmitting tubes. Any tube with a thoriated filament should be able to stand that amount of plate voltage that would arc over the outside of the glass. Some 852's, HK354's, and 150T's have been tested with enough plate voltage to start an arc between the plate and grid leads *outside* of the glass envelope without any sign of internal arc over or turning blue due to ionization. In one case it took 35,000 volts of 60 cycle a.c. to start the arc. Of course the filament was not lighted during this test, as the insulation and gas pressure only were being tested. Now 35,000 volts of plate voltage would never be used on these tubes, but that is not the point. In order to get good results from a thoriated filament, the gas pressure should be low enough (vacuum high enough) to allow voltages of that order to be applied without ionization of the gases remaining in the tube. Of course, many types of tubes can not be made this hard due to their construction, but some day they all will be.

There is quite an argument between the proponents of tantalum, molybdenum, and carbon as a plate material. There is a lot to be said on this subject but most of it comes down to a matter of opinion. There are no patents on the use or fabrication of any of these three materials so any tube manufacturer is free to use any or all of them. The only point about the three materials that is not a matter of opinion is the cost. Tantalum is the most expensive of the three, "moly" is next, and carbon is the least expensive of the three. It seems that if they were all equally good all the tube manufacturers would use the least expensive material, which is carbon. Carbon is undoubtedly most

[Continued on Page 84]





# Getting the Most from the Pi-Type Antenna Coupler

By ROBERT B. PARMENTER\*

Since the appearance of Arthur Collins' original article early in 1934 on the impedance matching

network, this form of coupling has become universally popular. In general the results have been good; however a considerable number of amateurs have had varying success and report mediocre results on certain bands and unorthodox behaviour in general.

Reviewing the articles on this subject which have appeared in amateur publications we find only a very brief explanation of how the network actually functions, and no mention has been made of what occurs when the two capacities in the circuit are varied. It is true in most cases that the best results are obtained from any given piece of equipment when the operator is thoroughly familiar with the function of each part, for it is then possible to understand what may be the cause of any particular odd behavior. From actual contact with many hams it is believed that the average amateur has only a vague idea of the operation of the network and consequently runs into difficulties by merely "following the directions" for tuning. With this thought in mind we present the following:

As a starter we review the tuning procedure. Referring to figure 1-A, the network is disconnected from the amplifier plate tank coil.  $C_1$  is then tuned for resonance in the usual way until we have minimum plate current. After this initial adjustment of  $C_1$  it should not be disturbed. When the network is clipped on the plate tank coil and the plate circuit closed to the amplifier, the plate current is found to be extremely high and the general effect is as if  $C_1$ ,  $L_1$  were out of resonance with the amplifier driving frequency. Remembering that a parallel tuned circuit has a high impedance at resonance, and at any other frequency somewhat off resonance a comparatively low impedance, it becomes clear that the network by being out of resonance with  $C_1$ ,  $L_1$  has lowered the effective impedance in the plate circuit and the plate

*In spite of the widespread popularity of the "Collins" antenna coupler, a good many amateurs seem to have trouble in getting the system to function properly, usually due, no doubt, to insufficient understanding of the fundamentals upon which the network operates. A careful reading of this article will be of great help in getting your coupler to work properly.*

current is limited mainly by the plate resistance of the tube. Obviously  $C_2$  has become in effect the plate

tank condenser; so we now tune  $C_2$  until we have minimum amplifier plate current once more.

The output capacity  $C_3$  is now varied one way or the other until the amplifier plate current is normal for the tube used,  $C_2$  being reset for minimum plate current for each change of  $C_3$ . It might be well to mention that it is desirable to use less than normal plate voltage on the amplifier during the initial tuning of  $C_2$  as the high plate current encountered with the network out of resonance with the plate tank circuit is quite a strain on the filament and a few minutes of such an overload may ruin a perfectly good tube.

By rearranging the drawing slightly in figure 1-B we have exactly the same circuit but now it will probably be evident just what the network is and how it works. Looking at the network from the transmitter end, which is the way we are concerned with it, we have a parallel tuning control  $C_2$  which is across the split inductance  $L_2$  with the output capacity  $C_3$  inserted at the midpoint of  $L_2$ . That is,  $C_3$  is in series with the two halves of  $L_2$ . The input capacity serves but one function and that is to tune the network to resonance with the amplifier plate tank circuit; therefore  $C_2$  may be called the parallel tuning control of the network and acts in the same manner as any plate tank condenser.

It should now be clear that each time  $C_3$  is changed to obtain the proper load we are detuning our parallel tuned circuit  $C_2$ ,  $L_2$ ,  $C_3$ ,  $L_2$  so that the combination is no longer in resonance with the amplifier tank circuit  $C_1$ ,  $L_1$ . It becomes necessary to retune with  $C_2$ . As  $C_3$  is decreased in capacity  $C_2$  must be increased in order to maintain resonance with the amplifier. The reverse of this is also true.

Before taking up the action of the output capacity  $C_3$  in the network, it should be useful to examine the ordinary series and parallel tuning-methods for purposes of comparison later

\*W9LPM, 3939 Gilman Ave., Saint Matthew, Ky.

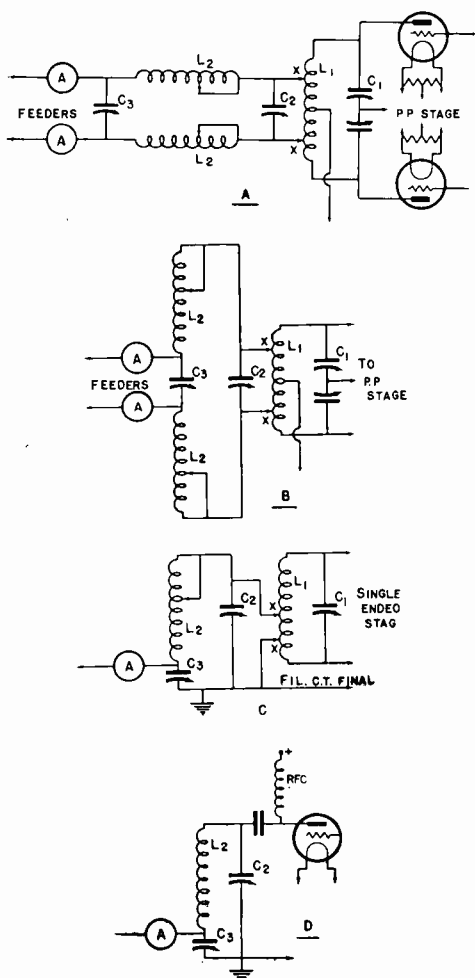

Figure 1

- (A) Impedance matching network for two-wire line.
- (B) The same circuit as "A", but rearranged better to show the operation.
- (C) Impedance matching network for single-wire line.
- (D) Simplified output circuit, eliminating one tank circuit. Shunt feed and grid neutralization should be used. Position of node on coil depends upon ratio of  $C_2$  to  $C_3$ , thus complicating attempts at plate neutralization or series feed.

on. Figure 2 shows such a tuning system in which the two-wire tuned line is 65 feet long. Such a line would be used to end-feed an antenna 135 feet in length for 3500 kc. operation. The current distribution is such that maximum current occurs at the transmitter end of the line which means that the impedance at this end of the line is low. Therefore we must use a low impedance coupling scheme in order to excite the system. This is done by using series tuning.

When this same length of line is used on 7 mc. we find it impossible to excite it by using series tuning because now the point of maximum current has moved up to approximately the center of the line leaving both ends of the line points of maximum r.f. voltage. This means that the ends of the line for operation on 7 mc. will represent a high impedance, and so we use a parallel tuned circuit which will present a high impedance to the line and supply voltage to the ends of the feeders in order to excite the system. The impedance matching network does exactly the same things in a slightly different way.

Now we come to the function of  $C_3$  in the network. As stated in Collins' original article both the input and output capacities should have a maximum capacity of 250 to 350  $\mu\text{fd}$ . If the output condenser  $C_3$  in figure 1-B has a minimum capacity of 10 and a maximum capacity of 350  $\mu\text{fd}$ s. the reactance at 3500 kc. figures out to be approximately 5000 ohms at minimum capacity and 130 ohms at maximum. So by a variation of  $C_3$  we can obtain any value in between these figures. This does not mean that these figures represent the true values of the impedance across  $C_3$  and at the transmitter end of the r.f. line. It does mean, however, that we use this means of varying the voltage across  $C_3$  since  $C_3$  is a part of the network, being in series with the two sections of  $L_2$ . One way of visualizing what takes place when  $C_3$  is adjusted in actual operation is to consider a variation of  $C_3$  as being the equivalent of clipping the feeders across the turns of  $L_2$  at different points until we obtain the proper load. When  $C_3$  is near its minimum capacity we have maximum voltage across it and applied to the ends of the feeders. This would represent a high impedance and would be obtained similarly by clipping the feeders across a considerable number of turns on  $L_2$ . This can also be compared with the parallel tuned circuit used on 7 mc. in figure 2, which has already been explained. When  $C_3$  is near its maximum capacity it is the equivalent of moving the feeders near the center of  $L_2$  and clipping them across only a few turns. This is the other extreme and represents a low impedance and may be compared with the series tuning of figure 2. The convenient part of the network is that it is possible to adjust it to intermediate values, making it possible to meet the requirements of odd lengths of line which ordinarily would be difficult to bring into resonance with either the

series or parallel tuning methods of figure 2.

All that has been said regarding the operation of the network as applied to a two-wire line applies as well to the single-line network shown in figure 1-C. Here the input capacity  $C_2$  is in parallel with  $L_2$  and  $C_3$ .  $L_2$  being in one coil requires approximately twice the inductance of either coil of the two-line network in order to tune the system to the same frequencies. In this case a variation of the output capacity  $C_3$  may be thought of as the equivalent of tapping the single wire line at various points on  $L_2$  until the proper match is obtained.

Some use has been made of the simplified network as shown in figure 1-D. The network is simply placed directly in the amplifier plate circuit. The only change necessary is parallel feed to the plate, since both ends of the inductance are above ground. Although no one seems to have used it the two-line network could be placed directly in the plate circuit of a push-pull stage to simplify this type as well. Parallel feed to each tube would of course be required. Neither of these simplified arrangements has been used by the author, but it appears that the impedance across  $C_2$  would vary with each adjustment of the output capacity  $C_3$  and under some conditions this might not be so desirable. Mention of these simplified types of the network has been made in order to cover their operation and to state that it is the same as that of figure 1-B and 1-C.

Now for some of the complaints which have been reported: In the first place too much importance has been placed on such things as stray coupling between the two halves of  $L_2$  in figure 1-B. Close coupling between these inductances would be the equivalent of increasing the minimum capacity of  $C_3$  and the net result would be a decrease in the useful range covered by  $C_3$ . Simply mount the coils at right angles to each other and as far apart as space permits. Coupling between the plate tank coil  $L_1$  and the network coils has even less effect; however, avoid mounting the network coils near the open ends of  $L_1$ . Coils having a diameter of not over  $2\frac{1}{2}$ " cause much less trouble in this respect.

The number of turns between the taps x-x in figure 1-B is not critical. Somewhere between one-third and one-half the total turns in the plate tank coil will be satisfactory. It would be desirable to clip across more turns of a high-C tank circuit than when a low-C tank circuit is used in order to give maximum output in

each case. When the number of turns between x-x is changed,  $C_2$  and  $C_3$  can be readjusted to give about the same output. Increasing the number of turns between x-x increases the load on the amplifier.

Blocking condensers are normally used in the two leads connecting the amplifier tank coil to

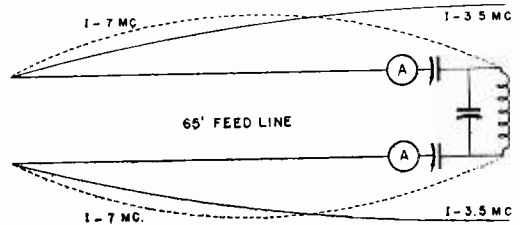

Figure 2  
Current distribution on a 65 foot tuned line at both 3.5 and 7 megacycles. Points of maximum voltage correspond with points of minimum current.

the input capacity  $C_2$  when series feed is used in the amplifier. They have been omitted from the diagrams shown here since they have no effect on the operation of the network and are used only as a safety measure to keep the d.c. plate voltage from appearing on the network, feeders, and antenna. These capacities, if they are used, should have a low impedance to the lowest frequency covered by the network. They should not be much less than .002  $\mu$ f. or some loss in power will result. If there is no danger of anyone coming in contact with the feeders or antenna they can be omitted.

The network should be tapped across an equal number of turns on each side of the center tap; otherwise a push-pull stage will be completely unbalanced, with one tube taking most of the load. This is a common complaint and may be due to any of the following: An unequal number of turns on each side of the center tap, unequal values of inductance in the two halves of  $L_2$  (figure 1-B.), or a zepp feed line which is not the correct length for the frequency used. This last condition can cause a bad unbalance and one tube may run hot because it is taking most of the total input. A particularly stubborn case of this kind was cured by using one less turn in one of the  $L_2$  inductances (in this case the side of  $L_2$  which was connected to the open-end feeder). After this was done a perfect balance was obtained, the plate current dividing equally between the two tubes, and the input could be increased to nearly double its former value without overloading

[Continued on Page 82]



# Improving the Class B Amplifier

By D. E. REPLOGLÉ

With all the new tubes that are coming out on the market, one very good bet the amateur has not had thrust in front of him is the 930B (830B) tube. While introduced two years ago, the possibilities of these tubes have never been properly presented to the engineer and experimenter.

A good Class B tube should have the following characteristics:

1. High amplification factor ( $\mu$ )
1. Ample filament emission
3. Moderate plate resistance to facilitate transformer construction
4. Good mechanical construction to withstand peak voltages
5. Good dissipation characteristics.

The high amplification factor makes necessary only a reasonable amount of driving power, and the construction, bringing the plate lead out the top, will permit the use of high peak voltages such as are encountered in Class B without the tendency of electrolysis across the bottom of the stem.

Here are the characteristics of the 930B tube:

1. Filament—25 watts,  $2\frac{1}{2}$  amperes at 10 volts
2. Plate resistance equals 8,000 ohms
3. Mutual conductance—3,000 micromhos
4. Amplification factor ( $\mu$ )—30
5. Plate voltage—1,000 normal
6. Maximum plate dissipation—50 watts
7. Maximum plate current—100 ma.
8. Plate material—graphite
9. Plate terminal—top cap
10. Base—standard four-pin
11. Audio watts per pair (maximum)—200 watts.

With these characteristics it seems that the 930B tubes possess to a great extent the characteristics needed for Class B operation. With its 200 watts of audio per pair it is possible to modulate a 2,000-volt Class C tube of the 204A type. Under these conditions the harmonic content will not exceed 12 per cent, which is amply satisfactory for good speech and fair music quality. Where high fidelity is required, these tubes are capable of delivering 150 watts of audio output with maximum harmonic content of 5 per cent. This would give excellent speech characteristics and good music quality.

## Plate Material

The traditional limit of vacuum tubes has been the heating of the plate, and conservative

users always loaded the tube just below the red point. With the coming of graphitized carbon plates it is no longer safe to use the plate color as a guide. As an example: a graphite plate will dissipate approximately twice as much power as a metal plate when loaded just to

show a barely visible red glow on the plate. The heating of the surrounding glass, however, is greater in a graphite plate tube and consequently must allow ample paths for leakage and ample bulb area. This has been done in the 930B. This means that if a graphite plate tube is run at the same load as a metal plate which would just start to glow, the graphite plate tube will run far below the red level and consequently there will be a lower heat radiant to the bulb and lower temperatures will be maintained on the stem supporting the wires to the elements—hence less danger from electrolytic causes.



Figure 1  
The new 930-B

In the 930B tube the external plate and grid leads have been made very heavy. This is particularly desirable if used at high frequencies as a self-excited oscillator or as a driven amplifier.

## Driving Power Required

For the grid power necessary to drive a Class B 930B stage, a Class A driving stage is recommended. It had best be the push-pull type to minimize feedback, and also it happens to work out very nicely with commercial sizes of driving tubes.

Power per tube required for full output is approximately  $4\frac{1}{2}$  watts. The types 59 or 2A5 are good choices for the push-pull driver stage. 2A3 tubes or type 10 tubes may also be used. It is assumed, of course, that the Class B input and output transformers are correctly designed.

Figure 1 shows a picture of the 930B tube. In overall dimensions it is a little larger than the well known 10 type tube—fits the same socket and is not excessive in cost.

The construction of this tube is very sturdy and, unlike some tubes that are recommended

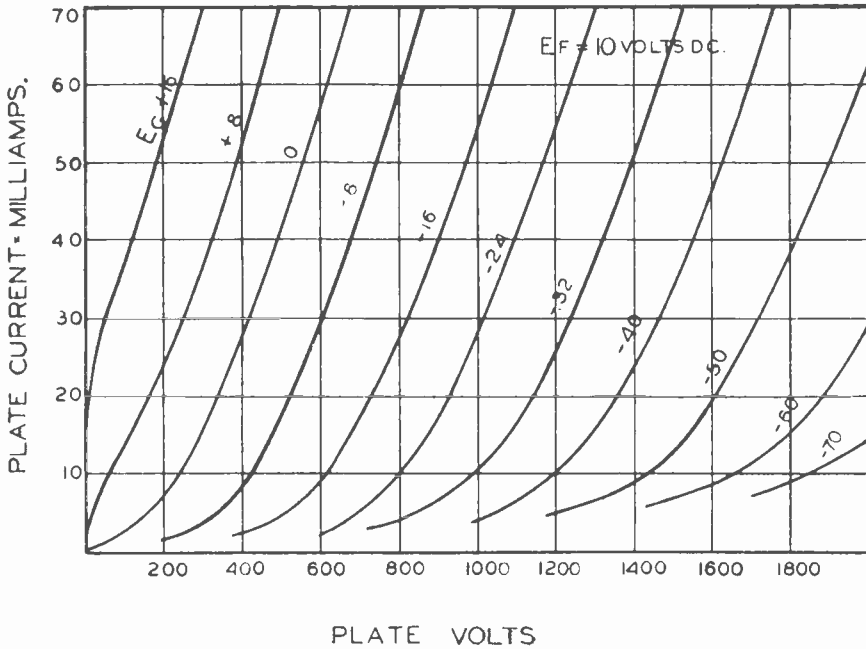

Figure 2  
Static characteristic curves of the tube.

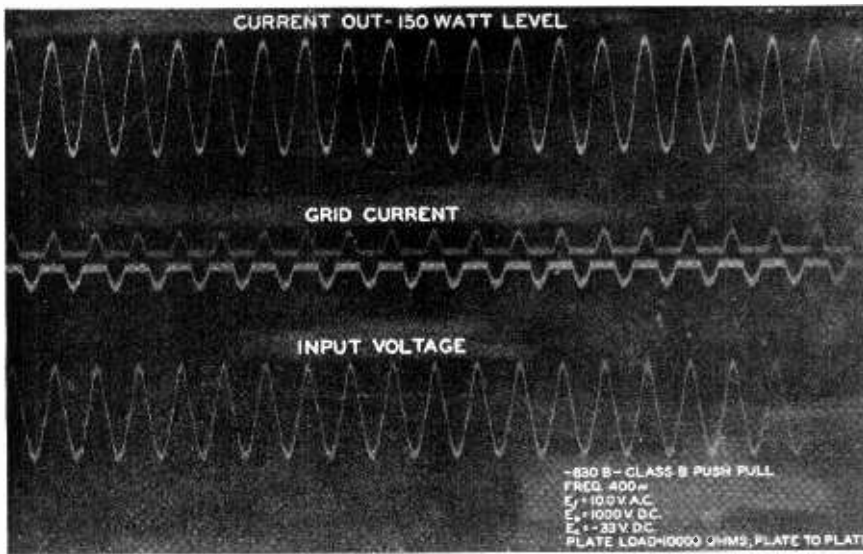

Figure 3  
Oscillographic record of the carrier output at 150-watt level.

for Class B service, it will maintain its characteristics through its life.

Incidentally, the 930B tube with the plate out the top makes an excellent r.f. oscillator or driven amplifier up to 30 megacycles, and with somewhat lowered efficiency up to 60 megacycles. It will be found that, in an oscillating

circuit, the frequency drift will be minimized due to the graphite plate, which will not change its form under heavy loads. This makes it particularly desirable for use in a modulated oscillator circuit.

Figure 5 shows the internal construction of the tube more closely, and the rigidity of the

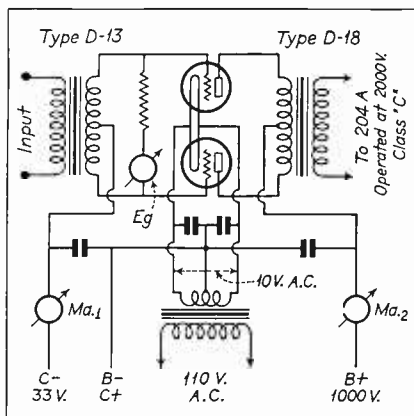

**Figure 4**  
Class B circuit referred to in text.

filament, grid and plate mountings will be noted. One other feature which is notable in this tube is the heavy plate and grid leads, making for tube efficiency at the higher frequencies.

The illustrations show oscillographic records of the carrier output at 200, 150 and 75 watt levels and also show the simultaneous grid current in each tube and the input voltage on the grid at a frequency of 400 cycles.

Note in examining these curves that this is continuous modulation. Actually 100 per cent speech modulation of the carrier will work the tubes only a little more than half the extent needed for 200 watts sustained tone audio output. Recently the author had occasion to drive a 150-watt motor with 60 cycles, and a Class B stage using two of the 930B tubes was utilized very satisfactorily for driving this motor full load for a sustained period of time. This is an excellent test of the durability of these tubes in audio service.

#### Proper Circuits

The circuit illustrated by figure 4 is indeed a simple one. The main considerations in this circuit are the plate and grid power supplies. Much has been said about the necessity of good regulation of plate power supplies. This is extremely important—an argument for this does not need to be repeated here.

To anyone designing or building a Class B audio stage this question of regulation in both plate and grid supplies cannot be emphasized too greatly—it is far better to err on the side of exceptionally good regulation than otherwise. Some of the most important features in a satisfactory power supply unit for Class B stages can be summarized briefly here:

If a rectifier filter system is used these precautions should be observed: The final filter condenser should not be less than 8  $\mu$ fds. in the grid unit, and the bleeder should be so low as to draw several hundred milliamperes. The transformer voltage can be low and it should have fairly good regulation to start with. The rectifier tube itself is very important.

Fortunately the type 866 rectifier is available and while it may seem a little large for the purposes required in this type of circuit, it is certainly best to use a tube of this type to take care of the peaks required. These tubes can be secured at a reasonable price and it is a wise designer who uses these tubes at the outset for his plate and grid voltage supply units.

The grid supply can be taken from batteries, of course, but here again the charging current

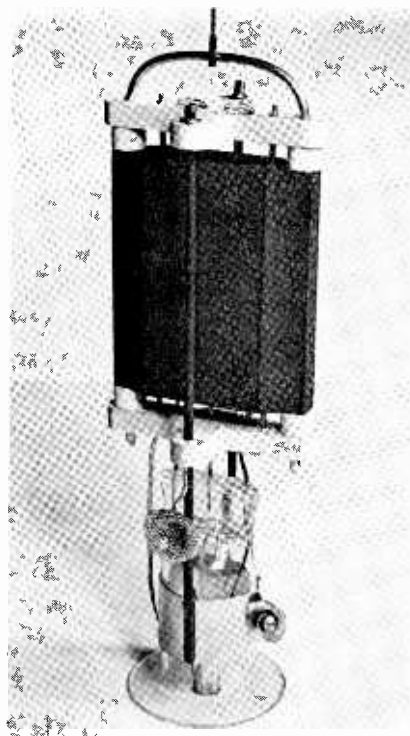

**Figure 5**  
Internal construction of 930-B tube.

through these batteries will vary the voltage and cause trouble. If they are to be used, provision should be made for cell-by-cell variation to maintain the bias constant at the proper setting.

Motor-generators are satisfactory if one can overlook their high cost and maintenance. They must, of course, be used with an adequate filter

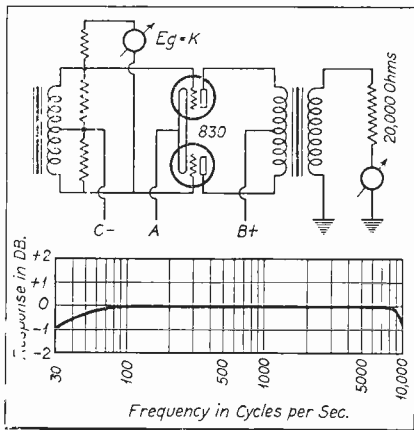

Figure 6  
Frequency-response curve—Class B modulation transformer. 930-B's push-pull into 20,000 ohm load; power, 100 watts.

which should be of a very similar design to that used with the conventional rectifier circuits.

### Correct Transformers

In a Class B audio transformer, the largest single source of distortion is usually the mismatching of impedance through an error of design or adjustment. Unfortunately we cannot see such an error in the technical data accompanying the transformer we buy, but if possible we should have the chance to check such transformers before actually putting them in service. Quite frequently transformers are sent out without individual calibration and the curves supplied are for the average of that type and may depart considerably from the curve of the individual transformer under consideration. Quite a number of other things may also enter into the situation. The transformer may be constructed of iron in which the characteristics are subject to change with sudden shock or jar such as dropping on a concrete floor, and even the transformers when individually calibrated may be supplied with the curves taken under conditions which do not correspond with those that are encountered in actual use. Many a good transformer under light loading will look good, but when actually loaded to the peak as it would be in the circuit where it is to be used, shows an entirely different characteristic. Too often the winding of transformers has been badly done and has spoiled an otherwise excellent Class B stage, and for this reason it is highly desirable to buy transformers put out by reputable manufacturers for use with tubes of given power outputs. The reputation of the manufacturer is your main reliance for correct performance of that trans-

former when used under conditions for which it was built.

### Input Transformers

The input transformer should be adequately large, and, while it is a push-pull transformer, precautions should be taken that it is loaded by resistors having values between 50,000 and 100,000 ohms. Care should be taken that the preceding amplifier has enough gain to swing the grids under normal conditions. Two type 59's are very satisfactory for the driving stage.

### Output Transformers

The output transformer is a more difficult task. It must combine the half-waves sent to its primary from each of the two Class B tubes and from them build a complete wave form (see the oscillograms). Usually it is called on to do this with direct current flowing through its windings to a load such as a modulated Class C tube. It must also transfer the load impedance to some other value, which would be correct for the Class B tubes when working

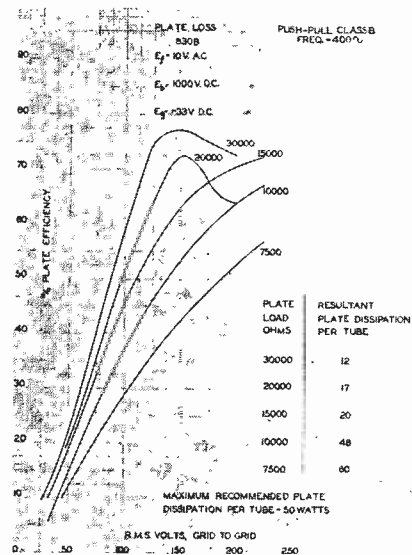

Curves showing plate loss and plate efficiency.

at a given level. It is readily appreciated that the iron of the core must go through many electrical gyrations not encountered in ordinary transformer design, so it is very necessary that the core be ample if flat response down to 30 cycles is wanted with an output of 200 watts.

### Tube Characteristics

The reasons why the 930B is an excellent Class B modulating tube are as follows:

1. It has high amplification factor.

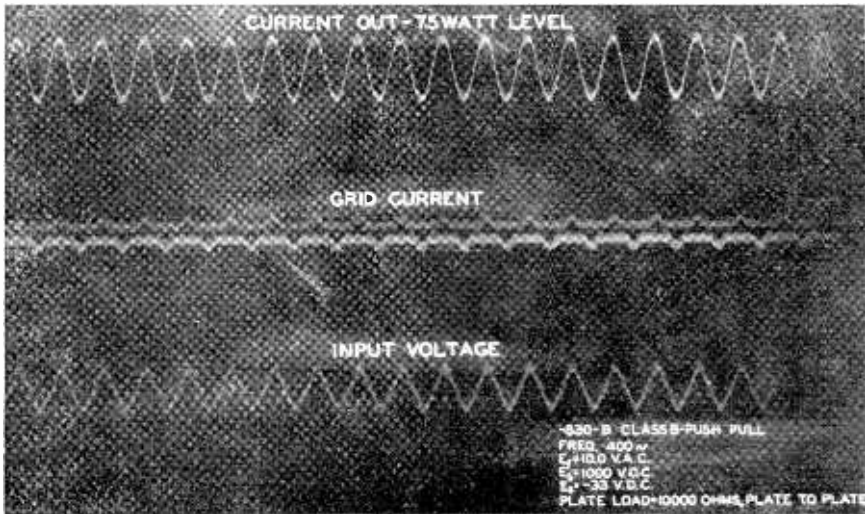

Oscilloscopic curves, 75 watt level, using circuit of Figure 4.

2. It has more than ample filament emission.
3. It has moderate plate resistance to facilitate transformer construction.
4. It is a three-element tube and has no screen or suppressor grid voltages to worry about.

can be obtained with these tubes at 100 watts power.

From these curves very complete information can be had on the use of this tube in any Class B circuit.

#### Adjustment of the Class B Stage

The meters of a Class B audio stage are not present for decorative purposes. They are essential in both adjustment and operation.

The use of the meters can best be shown by example. Let us therefore assume a 930B pair working at 1,000 volts plate and —33 volts grid bias, with a steady sinusoidal a.c. input to the grid sufficient to produce a 150-watt output from the pair. This requires 200 volts r.m.s. on the grids—measured grid-to-grid between the two 930B tubes.

At this point the first meter enters in. We *must* be able to measure the a.c. voltage applied to the Class B grids; otherwise, we are pawing around in the dark. Unlike class A grid circuits, we are here dealing with moderate impedances; hence there is no harm in connecting a rectifier-type voltmeter across the circuit. It had best have a range of 0-300 volts. The meter may be calibrated as a volume indicator or as a modulation meter, the procedure being fairly obvious. In any case, make a red mark on the scale to show where the fidelity becomes unsatisfactory, as shown by listening tests made by a close observer.

From the conditions given, the two class B tubes should be "looking into" a 10,000-ohm load. More precisely, they should be working into a transformer which is not only capable

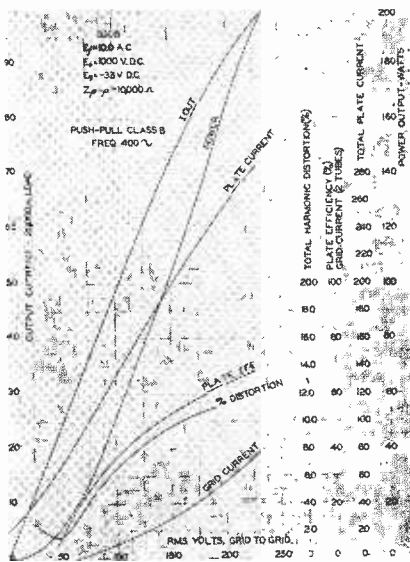

Curves showing input and output power, plate and grid current, percentage distortion and plate efficiency.

Figure 6 shows an actual frequency response curve run under full load conditions using 930B tubes in the circuit shown. It will be noted that this curve will do credit to most high quality broadcast stations of today, and shows the type of high fidelity output which



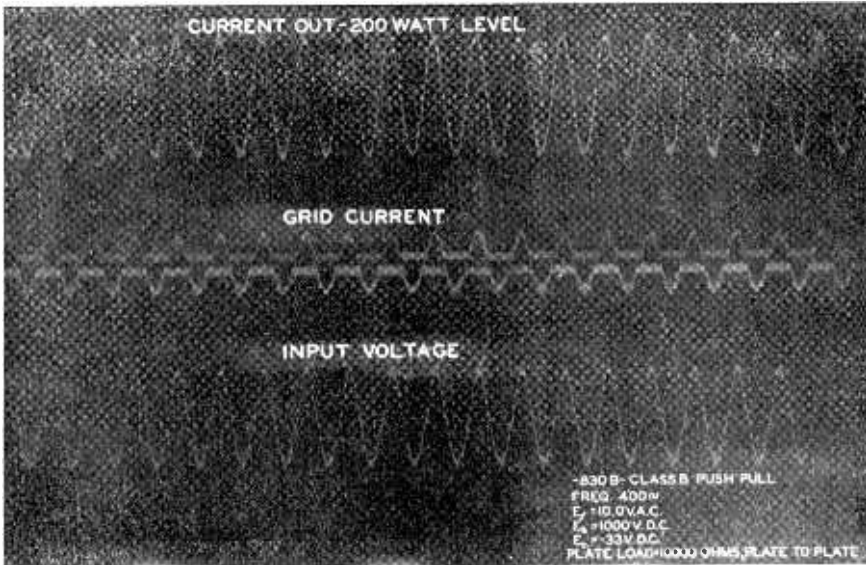

Oscilloscopic curves, 200 watt level, using circuit of Figure 4.

of combining their half-wave contributions into a whole-wave output, but which also has the proper ratio of secondary to primary turns so that the actual secondary *looks* like 10,000 ohms when seen from the primary side. Under these conditions (with the 200 volts of steady a.c. still applied to the grids) the meter  $Ma_1$  should read 30 ma. for the two grids together, and the meter  $Ma_2$  should read 260 ma. for the two plates together.

Suppose that instead we have the tubes looking into an excessive impedance, for example, 20,000 ohms. With the same driving voltage the grid current will now be 50 ma. and the plate current 165 ma. *Whenever the impedance of the load is too high, through error in either the transformer or the load, the plate currents will be too low, the grid currents too high.* Without such curves it is difficult to know how proper adjustment is to be made.

On the other hand, suppose that the tubes "see" only 7,500 ohms, because either the load or the transformer is wrong. We now find that the grid meter  $Ma_1$  reads but 25 ma. while the plate supply meter  $Ma_2$  reads 270 ma. This gives us rule no. 2: *Whenever the load seen by the tubes has too low an impedance through error in either load or output transformer, the plate supply current will be higher and the rectified grid current lower than normal.*

#### Output Power and Overload

Unfortunately there is no such positive and simple indication of overload as is found in

Class A work. Furthermore, we are not assured of any particular output power just because we

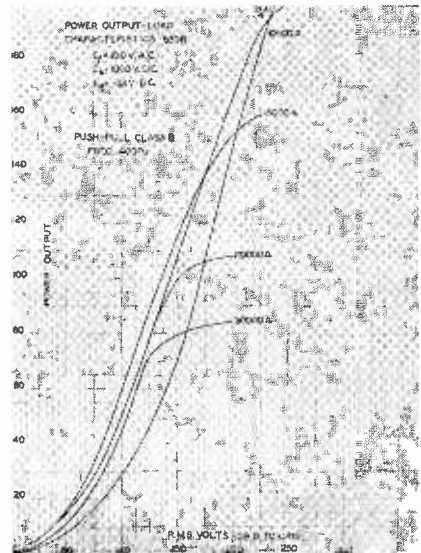

Curves showing output with varying plate impedances.

know the grid swing, as shown by the grid voltmeter.

#### Speech Overload Indications

The tests given above enable us to make proper impedance adjustments with a steady input tone, but no longer apply directly when we are using an unsteady sound like speech or music.



Violent leaps of the grid-current meter are overload indication. Speaking at an even level, advance the gain control slowly. The grid and plate meters obediently start upward and for a time continue to rise fairly evenly. Quite suddenly the plate meter hesitates, and at the same moment the grid meter becomes excited, and advances rapidly or jumps, depending somewhat on the speech used. This is definitely an overload condition; back down until it disappears.

If the load impedance is too high the effect just mentioned appears early in this rough test, exactly as one would judge from the charts.

### The "Ghost Signal"

With the monitoring station at Grand Island, Nebraska, constantly on watch for information which may lead to the eventual discovery of the whereabouts of the "ghost signal", with commercial ship and shore operators in all parts of the world reporting the peculiar phenomenon, and with practically no solution in sight, the radio world is confronted with a very unusual mystery.

The ghost signal has been analyzed on an oscilloscope by one of the large eastern radio laboratories. The modulation frequency of the emission is 1/10th cycle lower than 60 cycles (59.9 cycles). Grand Island believes the signal emanates from the west, because it has the same peculiar characteristics as other western signals. Furthermore, it acts in the same manner as a signal 1000 miles to the west of Grand Island, going through the same cycles of fading, etc. Reports coming from Japan indicate that the signal is being received from an easterly direction. The intensity of the signal is R9, and it will completely drown out the loudest of commercial signals, often making it necessary for stations to shut down for considerable intervals until the frequency of the ghost signal changes.

The *S. S. President Harrison*, cruising in the Mediterranean, reports loud reception of the ghost signal, thus disproving the former theory that the signal may be emanating from an Italian or an Ethiopian station, for purposes of disrupting war-time traffic in the belligerent zone.

The signal comes in, and goes out, from daylight until dark. Many radio engineers insist it is man-made, in that its frequency is slightly less than 60 cycles, and because the signal "jumps" at very short intervals, a few kilo-

cycles at a time, going up the band, then down again, just as if one were tuning a high-power transmitter. Yet the unusual reports received, where the signal at one time is R9 in Japan, then powerful in the east, then powerful in Africa, leads one to believe that the radio fraternity has at last found a hard nut to crack.

The ghost signal usually starts on 24 and 25 meters, creeps up to 30 meters, stays there for a while, then goes down again. Strange is the fact that its harmonics are so loud that it is causing serious interference with 10 meter reception, making it impossible at times to work even a powerful local station through the QRM of the ghost.

The signal fades out at times, but comes back with marked audibility, increasing in intensity, then holding its own for long periods of time. It is *definitely* an a.c. signal, of tremendous power. It sounds like the final amplifier of a transmitter which is emitting parasitics or spurious oscillations. The signal is what could be termed "Type A-2, plus".

It is understood that an airplane is being fitted with excellent measuring equipment, and the plane will soon start on a world-wide cruise in order to make field strength and direction finding tests of the ghost signal in an endeavor to locate its origin.

Some state it is malicious interference created by a crank, or a genius. Others contend it is a powerful raw a.c. transmitter on a foreign warship, which is secretly cruising the globe in an endeavor to find out which frequencies are most suitable for daylight communication from any part of the world at any time of the day. Others still insist that it is the work of a belligerent nation to cause willful QRM with enemy traffic.

Another explanation for the phenomena that is gaining supporters is that several medical laboratories are experimenting with ultra-high powered diathermy equipment. One such laboratory is currently developing over 100 kw. of r.f. power in the neighborhood of 16 meters. It may be that a similar diathermy oscillator may, by some freak, be coupling an excessive amount of power into adjacent power or telephone lines which in turn happen to radiate effectively enough of this power to cause the observed signal.

There is absolutely no doubt but that, if the signal originates on this planet, its location can be determined to within a very few miles. Simultaneous observations taken by amateurs

all over the world should enable accurate data to be taken as to the time of day that the signal fades in or fades out. From these data, it should not be difficult to establish the direction and distance from any given point. Also, as the signal is R9 so much of the time, observations made with carefully-shielded loop antennas should provide an accurate check on the direction from which the signal arrives at any point.

Amateurs are requested to send in data giving time, in Greenwich mean time, when the signals fade in and out at their particular location. The important factor is to make daily observation for some time as it is the *shift* in the skip distance as the season changes that is most important. It would also help for those amateurs engaged in observing this signal to check the strong commercial stations in the range of 19 to 32 meters in an attempt to find a known commercial signal whose fade in and fade out characteristics match the unknown signal at the point of observation.

The reason why the signal radiates such powerful harmonics, most of them with the intensity of the original frequency, is somewhat difficult to understand. The signal seems to have four separate and distinct "humps", all R8 and R9 in intensity.

As one tunes the receiver and hears the ghost signal, a loud raw a.c. note is first heard in the early morning hours, right after sunrise. Then the signal takes a short, quick jump, a few kilocycles higher, stays there, then jumps again.

Unquestionably, this problem offers one of radio's great unsolved mysteries and the progress which is being made in the detection of the signal and its origin will be reported in more detail in next month's RADIO.

(Just as we go to press we hear that the interference has been traced by the Navy Department to experimental high-power diathermy machines, radiating from the power supply lines.—EDITOR.)

## RADIODDITIES

Germany made the first move toward radio legislation . . . Fees for ham licenses were recommended in the U. S. Congress as early as 1922 . . . The Czechoslovakian government imprisoned a radio fan for six weeks for building a receiving set without the necessary license. . . .

### Meet the Gang

Joe Kisser is W9FAT. . . . W5DTC's name is *Work*; W5JP's, *Pretty*; W2GKW's *Paradise*. . . . David Sarnoff, radio executive, who as a commercial op, wrote in 1913, "I am not very different from the average wireless man who follows the sea". . . . Don C. Anthony, W9DFE, says that since he is single he can appreciate that less QRM is experienced with *single* signal systems! . . .

# A Daily HAMFEST

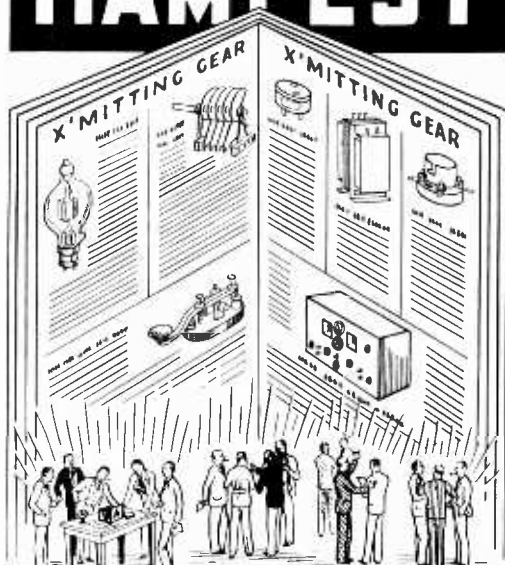

## in your ALLIED CATALOG

**E**VERY live Amateur likes a Hamfest—a bright chance to chew the fat—to swap tall stories—to X-mit burning ideas and discoveries—and to rcv new and exciting Short Wave dope. Hamfests are the highlights of the Amateur year, leaving behind them, remembrances of good-fellowship, of new things learned, and of renewed pride in the Brotherhood.

**W**E, at ALLIED, invite you, through the pages of our current catalog, to take part in our continuous Hamfest—a 24 hour per day, 365 day per year Amateur Show. Go places with the new equipment we show—stay up-to-the minute on both X-mitting and Receiving—swap tales and tribulations with our 21 cracker-jack Amateur Operators—save time—save money—get the ALLIED Hamfest Habit—it pays!

**ALLIED RADIO  
CORPORATION  
833 W. JACKSON BLVD.  
CHICAGO, ILL.** 

# The Granddaddy of them All!



## GAMMATRON TYPE 254

(Manufactured by Heintz and Kaufman, Ltd.)

11 KW Actual Output Per Pair  
5000 Volts Plate Supply  
1500 Watts Normal Plate Dissipation

**LARGEST RADIATION  
COOLED GLASS TUBE  
COMMERCIALLY  
MANUFACTURED**

• • •

The Same Quality Features, General  
Construction and Excellent Performance  
are secured with

## TYPE 354 GAMMATRONS

At Only

**\$24.50 Net**

f.o.b.

South San Francisco



**850**

Watts Output  
1 KW Plate Input  
3500 Volts Plate  
Supply  
150 Watts Plate  
Dissipation

PREFERRED BY LEADING AMATEURS  
STOCKED BY LEADING DEALERS

Write for Bulletin 354-A

**HEINTZ AND KAUFMAN**  
LTD  
South California  
San Francisco U. S. A.

## Contest

"Radio" is convinced that there are dozens of capable authors in the amateur ranks who have insisted upon "hiding their light under a bushel basket" and, as potential authors, need particular coaxing or incentive to rouse them to the extent of "taking pen in hand". We are therefore sponsoring a contest for the express benefit of these shy, retiring amateurs.

The rules of this article contest are as follows:

- 1) The contest is open to anyone who has had no feature-length article published in R/9 or Radio since July 1, 1934.
- 2) The article must be technical in scope to qualify; constructional articles will be given more "points" than non-constructional articles of the same merit. Photos count 25%.
- 3) Manuscript must be postmarked by March 30th.
- 4) All articles accepted for publication will be paid for at regular rates without regard to the contest.
- 5) The author of the article that is chosen as best of all entries submitted will receive, in addition to payment for the article at regular rates, a bonus of \$50.00.
- 6) No rejected manuscripts returned unless accompanied by a stamped, addressed envelope.
- 7) The members of the Radio technical staff will act as judges. Their decision will be final.
- 8) The story must be original and must not have appeared in other periodicals.
- 9) We reserve the right to declare "no contest" should not more than two entries suitable for publication be received and accepted at regular rates.

## The Class C Amplifier

(Continued from Page 66)

tion or gas limitation, such as the 852, 831, 50T, 150T, and 354. However, it has been determined that there is little advantage in using more than about 3000 volts on the 50T, 150T or the 354, and more than 4500 volts on the 852 and the 831. At higher plate voltages there is little gain in efficiency or ease of driving and the tank and filter condensers become quite expensive.

Here are some fundamental relationships that should be kept in mind.

In the January issue appeared a notice that the special \$2.00 offer of "Radio" for one year and a copy of the "RADIO HANDBOOK" had been advanced in price to \$2.50 and that orders postmarked after December 15th would not be honored.

All orders postmarked before readers had adequate time to receive the January issue have been honored, as that issue was late in being published and was still later in reaching readers due to delays in the Christmas mails.

The Circulation Department has been "snowed under", but is sending acknowledgments as rapidly as possible.

The higher the plate voltage, the easier a tube is to excite to a given output and plate efficiency.

The higher the plate voltage, the higher the plate efficiency will be for a given output and grid drive.

The higher the plate voltage the looser the antenna coupling will be for a given power output.

The higher the plate voltage, the looser the the antenna coupling, the higher will be the circulating current in the tank circuit; it follows that resistance losses in the tank are more bothersome at high plate voltage.

The higher the plate voltage, the less tank capacity is necessary for a given amount of circuit merit, or "Q", for a given tube and power output.

#### Antenna Coupling

The last step in setting a transmitter in operation, after the bias, excitation and plate voltage are fixed, is to adjust the antenna coupling.

The fundamental rule in adjusting the antenna coupling is to start with very loose coupling and then couple tighter in small steps until one of three things happens: either the plate starts to show color, the plate current reaches the maximum allowable for the particular tube used, or the antenna current stops increasing with an increase in antenna coupling.

If high plate voltage is used it is probable that plate color will be the first limit reached. If low plate voltage is used it is quite possible that the plate current will reach the maximum allowable value before the plate begins to show undue color.

If the antenna current stops increasing with increases in antenna coupling before either the plate shows undue color or the plate current reaches maximum, it indicates that there is not sufficient capacity in the plate tank circuit. In other words, less L and more C should be used to strike resonance.

The question of L to C ratio should be checked even if plate color or maximum plate

[Continued on Next Page]



**if...**

you want to be up-to-date in your "Ham" activities, get a copy of this book. You will be using the cathode-ray oscillograph soon. Now is the time to learn its theory and applications.

336 pages over 450 illustrations \$2.50 Postpaid

John F. Rider, Publisher 1440 Broadway New York City

# Get This New Catalog of ...AMATEUR EQUIPMENT FREE!



68 Pages  
Thousands  
of Items.

Here's the book you've been waiting for! Written by amateurs for amateurs. Within its 68 pages are crammed the greatest array of short wave equipment and ham stuff ever assembled by one organization—possible only because we are the largest organization of its kind in the entire world! You'll find x'mitters up to 140 watts C.W.—35 watts phone; receivers from 2 to 15 tubes; transceivers, 2½ and 5 m. equipment; tubes, racks, kits, monitors, preselectors, power units, parts and accessories. Practically every leading manufacturer is represented!

Besides you'll find practical data on ham receiving and x'mitting problems, diagrams, coil winding data, etc.

And always remember—because we are the largest organization of its kind in the world we can always supply parts for any receiver or transmitter that you want to build.

Our Chicago Mail Order Distributing Point insures faster, more economical delivery to all points in the West and Far West.

Wholesale Radio Service Co.,  
901 W. Jackson Blvd., Dept. R-26,  
Chicago, Ill.

Please send me your Free 68 page Catalog of Amateur Equipment.

Name.....

Address.....

City.....State.....

**WHOLESALE RADIO SERVICE CO.**  
CHICAGO, ILL. NEW YORK, N.Y. ATLANTA, GA.  
901 W. JACKSON BLVD. • 110 G. SIXTH AVE. • 409 W. Peachtree St. N.W.  
BRONX, N.Y. NEWARK, N.J.  
242 E. 270TH ST. 819 CENTRAL AVE.

current is the first limit reached.

The L to C ratio can be checked by the following test. Tune the plate tuning condenser through resonance. If maximum anten-

na current occurs at exactly the same point as minimum plate current, there is enough C in the circuit. *If maximum antenna current and minimum plate current do not synchronize, then more C and less L is necessary in the plate tank circuit.*

In other words, it will be seen that the tank tuning is quite sharp when the antenna is uncoupled, and the tuning becomes broader as the antenna coupling is increased. If there is not enough Q (circuit merit) in the tank circuit it is possible to overcouple the antenna, which tremendously reduces plate efficiency and power output.

There can be too much C in the plate tank circuit, and too much C can be identified by measuring the minimum plate current with the antenna uncoupled. If the minimum unloaded plate current does not go *below* 10% of the plate current when properly loaded there is too much loss in the plate tank circuit. If the tank coil is properly designed and built to have low losses, and if there are no high resistance joints in the tank circuit connections, the chances are that the C is too high, and more L and less C should be used to strike resonance at the operating frequency. The following rules show the relationship between antenna coupling and the other circuit parameters:

The tighter the antenna coupling, everything else remaining constant, the higher the plate current, the greater the power output, the greater the plate loss, and the lower the plate efficiency.

The tighter the antenna coupling, the more harmonics are radiated. The tighter the antenna coupling, the lower are the losses in the plate tank itself, due to the lower circulating current.

The tighter the antenna coupling, the more C is necessary in the plate tank circuit for a given value of circuit Q.

### The Pi-Type Coupler

[Continued from Page 71]

either tube. The r.f. line was 45 feet long and the frequency 3500 kc. The network coils were made of 3/16" copper tubing and were made to plug in, one pair of coils for each band thus doing away with the usual shorted turns.

An ideal arrangement which permits absolute balance of the load in a push-pull amplifier is to add one more condenser of the same capacity in series with  $C_3$  in figure 1-B. Both rotors are connected together and grounded. One stator section is then connected to each half of  $L_2$ . If this arrangement is drawn out on paper it will be seen to be the same as two single-line

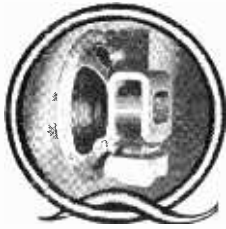

The only Speaker  
with Armored  
Field Coils.  
"licensed under  
Quam patents"

**QUAM  
SPEAKERS**

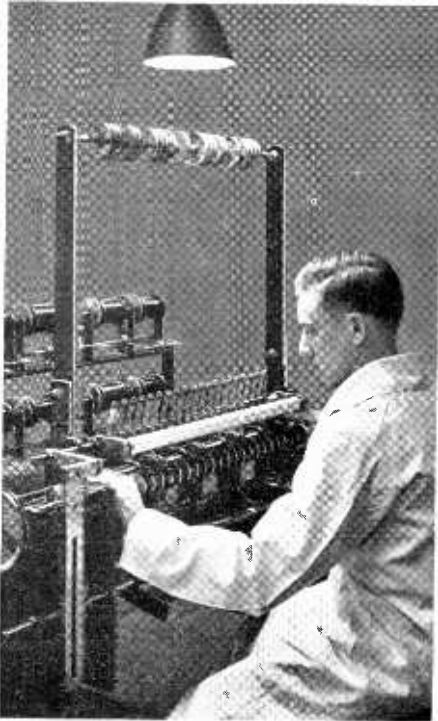

**T**HE coils used in Quam Speakers are wound in our own plant to our exact specifications and under our direct supervision, to provide positive control and maintenance of Quam's high standards of quality.

**QUAM-NICHOLS CO.**  
1624 Broadway, New York    1022 W. 74th Street, Chicago    309 E. Pike Street, Seattle  
309 W. 17th Street, Los Angeles    3037 Knox Avenue, S. Minneapolis

**"AMERICA'S LARGEST SPEAKER MANUFACTURERS"**

networks which have been placed together. A variation of one of these output condensers varies the load on the tube connected to that side of the network. It is desirable to balance the plate currents in push-pull amplifier or it will not be possible to obtain maximum output. The line currents may or may not balance.

Complaint number one seems to be that the use of the impedance matching network throws the amplifier out of neutralization. The trouble is not in the network, but is ordinarily due to imperfect operation of the amplifier. It is an easy matter to unbalance an amplifier that is not working properly. Of course in case of poor design in which one of the  $L_2$  inductances has been jammed up near the grid side of the amplifier, trouble will develop as soon as the network is connected to the tank coil. This is purely a case of feedback and is no fault of the network. It must be admitted that it is possible to maintain a fair degree of neutralization with an amplifier which is not perfectly neutralized when using the ordinary variable coupling coil by a careful adjustment of the neutralizing condenser after the proper degree of coupling and load have been obtained. In this respect the variable coupling coil is superior due to its low capacity to the plate tank coil.

Another complaint is inability to get the feeders to take a normal load, and the reverse of this (plate current too high). In the first case decreasing the inductance at  $L_2$  and operating  $C_3$  near minimum capacity should produce the desired load. Often  $C_2$  is of too small maximum capacity to permit resonance with  $C_3$  near its minimum capacity. This is the reason for specifying a maximum capacity of at least 250  $\mu\text{fd}$ . for  $C_2$ .

The second case, in which the plate current is consistently too high and it is impossible to lower it, can be remedied by increasing the inductance of  $L_2$  and increasing the capacity of  $C_3$ . Of course it is understood that  $C_2$  is reset for minimum plate current for all changes that are made.

Finally, don't expect the network to completely overcome inefficiency caused by the use of very long tuned feeders, etc. Tuned feeders are most efficient when they are one quarter wave in length, and probably the best compromise length for tuned feeders which must operate on several bands is 45 feet. And of course the network should not be expected to make up for deficiencies in the antenna itself (radiating portion).

The recent commercial prize contest created much interest. The "CQ swap" call of a W6 was answered by a VK, but the W6 said that there was a local contest on and cut the QSO short.

It may mean \$75 to you. See page 80.



*-it's a Landslide  
for CENTRALAB*

Every serviceman from coast to coast knows Centralab . . . everybody's his friend and the worst his enemies can say is that he's a mighty smooth article.

Yes . . . he's smooth all-right . . . and its that famous non-rubbing contact that makes him "that way."

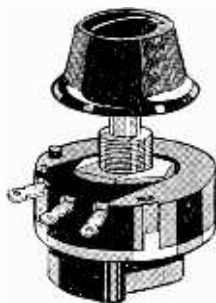

*... a tip from campaign headquarters: a mere handful will service practically any set ever made . . . "better than ever before."*

Every Radio Set . . . should be a member of the Institute of Radio Service Men

# Centralab

Milwaukee, Wisconsin

RADIOHMS

SUPPRESSORS

FIXED RESISTORS

## The Multiband Antenna

[Continued from Page 47]

successfully where space is a factor.

Many amateurs are using so-called "zeppelin" antennas rather than antennas fed at the center because their transmitters happen to be located nearer the end than the center of the antenna and the transmission line is shorter if it is connected to the end of the doublet. The zeppelin antenna is an inherently unbalanced system (zeppelin feeders balanced for equal currents are not balanced for equal phase and vice-versa) and a considerable portion of the energy is unavoidably radiated from the feeders, which radiation may or may not be useful for transmission. The multiband system just described should receive preference over the zeppelin arrangement even if the transmitter is close to one end of the antenna, because the additional loss introduced by running the transmission line horizontally to a point under the center of the antenna, then vertically to the antenna itself will be entirely negligible, and probably will be considerably less than the loss in zeppelin feeders. The multiband antenna is readily supported from suitable stand-off insulators and can be carried around corners by making bends having a minimum radius of about 10 inches. It is entirely feasible to double back the line in trombone fashion, if desired, to obtain a length which will obviate the use of an impedance matching network.

The directional properties of the multiband antenna vary as the frequency is changed. The directivity is not ordinarily considered in amateur installations where transmission is carried on in random directions, though there are a large number of possible combinations giving different degrees of directivity. (We hope to present a review of this subject with special reference to multiband operation in a future article.—EDITOR)

## Care of Transmitting Tubes

[Continued from Page 68]

desirable for quantity production. It is very uniform and a large batch of tubes can be pumped together (so many minutes on low plate voltage, then so many minutes on the next higher plate voltage, etc.). In other words, the operator handling the pumps merely follows a fixed time schedule and does not have to use judgment in pumping. With both moly and tantalum the exhausting operator has to know exactly what he is doing in order to do a good job.

### Plate Loss Ratings

Plate loss represents the difference between plate input and power output and must be dissipated from the plate of the tube in the form of heat. The hotter the plate, the higher is the gas pressure in the tube and the less filament emission there is. This is due to the fact that pressure of a gas is merely a measure of the speed of the movement of the gas molecules, and this speed increases with temperature. Also most tube plates when heated give off gas molecules, which is undesirable. Tubes with plates made of nickel give off a great deal of gas whenever heated to show any color at all. This is true no matter how long the nickel has been pumped, so nickel is a good metal to avoid anywhere in a vacuum tube. Carbon also almost always gives off gas when heated to any perceptible color but color on a carbon plate normally involves a 250% overload, as they are usually quite large for what they have to do. Some color may be allowable on a moly plate tube providing it has been pumped for a long time. The Western Electric tubes are particularly good in this respect. The 852 also is usually quite well pumped and some color is allowable. However, no moly plate tube should be operated more than a very dark cherry red, and spots of color are dangerous. Tantalum is unusual in that it actually absorbs gas up to a bright cherry red, and thus tubes with this plate material may be operated intermittently at about twice normal rated plate loss. In these tubes the continuous plate loss is usually limited by the temperature of the glass, so forced air draft should be used if the plate loss ratings are to be exceeded.

Last but not least, remember that only about one tube in ten used in amateur service ends its life through normal wearing out of the filament; give your pocketbook a break by going easy on your tubes.



Be sure to enter the contest. See page 80.

## Hi-Power for Sound Equipment



The Carter Genemotor supplies the most Reliable and Economical "B" power for Class A or B Amplifiers from a 6 or 12 volt battery. Output up to 500 volts. Sturdy—Compact — Quiet in operation—Requires no oiling—Guaranteed. Write

Write for Bulletin showing complete line of Genemotors for every purpose or specify your requirements.

**CARTER MOTOR CO.**

365 W. SUPERIOR ST.

CHICAGO





### The "QRM Dodger"

[Continued from Page 63]

as possible without causing the oscillator current to change appreciably. In our own case this does not vary more than 3 mils. It is true that the lamp represents a variable resistance in the antenna circuit but no difference in reports was received when it was shunted.

In conclusion, this rig was first built up bread-board style in order to get all the "bugs" out of it and then it was put in the set-up shown. It has been in daily operation for over a month and it has proved to be extremely satisfactory and a joy to own and operate. It has never failed to "perk" when turned on and neither has it ever popped out of oscillation. In fact, you can hold your hand on the tank and it will not pop out. It doesn't drift; the voice is in the center of the carrier; and it is a pleasure to QSY. No exceptional dx has been worked because none is heard at this particular QRA. But reports have always been "very good quality," and it has worked everything I have heard with an average report of R8 plus. What more could you ask?

### The "75-160" Exciter

[Continued from Page 53]

ing about 16 watts when working straight through or 12 watts when doubling. 50 volts plus on the suppressor helps the output of an 802 considerably.

The final conclusion was that the 89-89-89 arrangement made a nifty 75-160 meter quick-change exciter, and had much to commend it; that it was absolutely "n.g." for 10 and 20 meters.

In a future issue we will show the exciter adapted for a pair of 802's, for those who want all-band operation and are willing to spend a few extra dollars on the tube lineup.



First Southwest Division quarterly banquet, 2 p.m., Saturday, February 8th. Prizes, turkey, technical talks; \$1.00. Auspices Pasadena Short Wave Club, sponsored by the Federation. Place: Masonic Temple, Pasadena. For more details see last issue of 73. Nuf sed.



Incidentally, "XE" is not a new country. The Mexican amateurs started using this official Mexican prefix the first of January.

# YOUR ANSWER TO THE QUESTION — "Do CARDWELLS Cost More?"

MAXIMUM CAPACITY	PEAK VOLTAGE	PLATE EDGES	CARDWELL'S PRICE	COMPETITOR "A"	COMPETITOR "B"
100 mmf.	3000	Buffed	\$2.64	\$2.40	\$3.30
150 mmf.	3000	Buffed	3.30	2.95	3.90
100 mmf.	6000	Buffed	5.40	5.40	5.70
—DOUBLE—					
(per sec.)					
50 mmf.	6000	Buffed	6.00	6.00	7.20
100 mmf.	3000	Plain	4.80	8.10	6.60
500 mmf.	1500	Plain	3.60	not in line	5.40
—MIDGET—					
50 mmf.	.....	Plain	.96	.96	.96
100 mmf.	.....	Plain	1.05	1.15	1.35

Both the "M" and "T" Series listed in the New Cardwell Catalogue (which will be sent on request) are exclusively CARDWELL! ALL CARDWELL Condensers are manufactured under U.S. Patent No. 1,672,367 and No. 1,626,391, protecting the exclusive CARDWELL Low-loss design.

THE ALLEN D. CARDWELL MFG. CORP., 81 Prospect St., Brooklyn, N.Y.

# CARDWELL CONDENSERS

Your choice of

**Six  
popular  
routes**



**Round  
the World**

**"ALL  
EXPENSE"  
TOURS  
ALSO  
AVAILABLE**

◆ **CRUISE** around the world on a tour of your own planning—a cruise personally conducted by no one but yourself. Go where you please, stay in any land that suits your fancy. And your ticket is good for two years. Roam the seven seas—on either

side of the equator. New thrills await you . . . the mysteries of Asia . . . enchanting Bali . . . the spell of India . . . the drums of Africa . . . the Holy Land . . . Europe, New Zealand, Australia. Where do you want to go? Come in and discuss your plans with us. Over 200 itineraries from which to choose. Special round the world service.

**Send for Descriptive Booklet**

Information regarding the various routes, fares and sailings are included in our new booklet, "Independent Round the World Tours". Ask your local agent or the Canadian Pacific: New York, Chicago, Los Angeles, San Francisco, Montreal and 32 other cities in the U.S. and Canada.



**5 Meter Dx Revived**

The recent attempts to duplicate the 1927 long-distance 5 meter work seem to be at last bearing fruit. The reception of W6DOB at W3SI on 5 meters as mentioned last month has been verified. W3SI was sure of the transmission actually being on 5 meters because W6DOB indicated so in one of his transmissions. But just to satisfy the skeptical, a detailed report was sent to W6DOB to be checked against the W6DOB log, which agreed perfectly with the report from W3SI.

W6DOB was heard November 24th at 12:33 p.m. (e.s.t.) and again at 1:03 p.m. coming through QSA4, R6-8. W3SI hurriedly tried to put his rig on 5 meters, but at 2:15 when he finally got things fired up, W6DOB was no longer coming through.

Two weeks later W6DOB was heard again, but weaker.

It is quite probable that many 5 meter long distance contacts would be made if only more stations would get on 5 meters with high power c.w. Harmonics of 10 meter stations are being heard regularly across the continent, and reasons to believe that these are actually "traveling" on 5 and not just being "mixed" in the receiver are given as follows:

- 1) The harmonics come through for from 5 to 30 minutes, while the fundamentals of the same stations come through for a much longer period.
- 2) The signals are oftentimes several "R's" louder on 5 meters than on 10, sometimes coming in on 5 when the fundamentals cannot be heard.
- 3) The harmonics are louder on a 5 meter antenna than when received on a 10 meter antenna. W3SI has a 5 meter vertical "J" with a transmission line and another one for 10 meters. The transmission lines are coupled to the receiver inductively through an electrostatic shield. The harmonics are received much louder on the 5 meter "J", and the fundamentals are louder on the 10 meter "J".

These same effects have been noticed by Ralph Gordon (W6CLH), who has been hearing transcontinental harmonics of 10 meter signals for the last several months. Though it is quite possible to hear "5 meter harmonics" of 10 meter signals on certain receivers and with certain types of antennas and coupling when actually the harmonics are not really coming through, it looks as though in these two cases there is no reason to doubt that true harmonics are being heard.

W6DOB uses an RK20 into a 242-A into a 354 Gammatron with 200 watts of d.c. input to the final stage (crystal controlled). His log shows him to have been on 5 meters each time W3SI heard him, and in each case W3SI listened for him unsuccessfully on 10 meters although other 6th district stations were coming through on 10 meters at the time.

It has been reported that W6DOB has been heard on 5 meters at X1AY, though this has not as yet been confirmed. X1AY (XE1AY) has left 10 meters and is now exclusively on 5 meters.

W6DOB has regular "listening schedules" on 5 meters with X1AY, W3SI, W1FG, W9NY, W9GHN, and W4TZ. It is expected that 2-way work with one of these stations will soon take place.

### My Goodness!

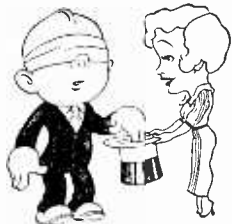

At the annual hamfest of the San Joaquin Valley Radio Club, December 14th, there were fifty-four people present. It so happened that the prize committee had provided fifty-four prizes to be drawn during the evening. A special prize, or joker, had been wrapped up for Mr. Chas. Busby, W6GCF, and this was prize number 54. His name was on the box and he was to receive it as the last prize of the evening. It so happened that his number, which by the way was no. 1 (he having bought the first ticket) was the last number drawn from the box. So GCF came by his prize legitimately.

At this moment a special prize, an Eimac 50T, was donated by W6AVV to be given on a new drawing. All 54 numbers were put back in the box and the lucky ticket was drawn out. Believe it or not, it was no. 1, GCF again! By this time he was convinced the whole thing was a frame-up of some sort. A careful check all around convinced everyone present that it was just luck. Busby says this was the first time he had ever won *anything* at *any* hamfest. Some one present remarked that if only the affair had been held on the 13th instead of the 14th of the month, it would indeed have been a story for Ripley!

F.C.C. rule no. 411 has been amended to read as follows:

"411. *Eligibility for reexamination:* An applicant who fails examination for amateur privileges may not take another examination for such privileges within 90 days, except that this Rule shall not apply to successive examinations at a point named in Rule 30-a."



## These Splendid Books...FREE!

Think of it! 2 books full of invaluable information, to be had for just the mailing costs! One with 20 *complete transmitter designs* including 12 tested transmitter RF section designs and 8 modulator and speech amplifier designs. Circuits, complete parts specifications, inductances, etc., all included. Outputs ranging from a little fellow all the way up to the big ones comparable to the best broadcasters.

*Ten complete designs for public address amplifiers* in the other book. It includes one for every purpose, from 3 Watts to 30 Watts output, tried and tested designs that you can build, with complete parts list for each.

These books should be in every amateur's technical library. They are invaluable for reference purposes. Just 22 cents in stamps, to cover postage, brings them both to you, or get them from any Standard Distributor. Send for your copies today.

## STANDARD TRANSFORMER CORPORATION

850 BLACKHAWK ST., CHICAGO, ILL.

**MAIL THIS COUPON!**

STANDARD TRANSFORMER CORP.,  
Dept. B. 850 Blackhawk St., Chicago

- I am enclosing 12c for Transmitter Manual.  
 I am enclosing 10c for Amplifier Manual.

Name.....

Address.....

City.....State.....

## We're Sorry!

Despite our having printed several thousand extra copies of the January issue, our supply was quickly exhausted. We apologize to those new subscribers whose orders for that issue we have been unable to fulfill. Some copies of the January issue may be found remaining at certain dealers, and may be purchased from them at the regular single-copy price so long as any remain.

## RADIOODDITIES

W5HH is the longest all-dot call assigned . . . There is really a Podunk Hollow Radio Shack . . . In 1927, SJ5BX was located at the bottom of a 6,000-foot canyon (really the crater of an extinct volcano) in a bandit-infested region . . . A message from a W8 to a Brazilian station traversed 22,000 miles before reaching its destination. First given to an American boat in Chinese waters, it was passed to Honolulu, then to London, and from there to South Africa. A second South African finally hands it to Brazil . . . Ham radio brought an applause radiogram from Australia to Schenectady three minutes after WGY started a program . . . In an amateur daylight relay test in 1923, one message arrived at its destination ahead of the sun, so that it wasn't a daylight message at all and could not be counted in the contest . . . W9EFK had a schedule with NL4LX, a leper on an isolated island . . . Amateur radio beat the Associated Press line by twelve hours in bringing news of the landing of Australia's lost flyer, Anderson, in 1927.

## Scratchi's Control Room

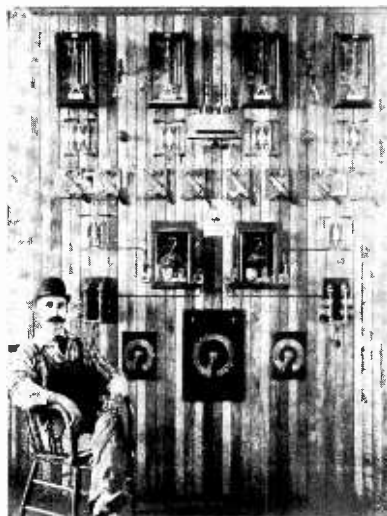

Control Room of Scratchi's Ham Station

Pictured above is the fourth assistant to the second assistant's assistant to the assistant to the secretary's assistant of the assistant editor of RADIO, showing none other than the lowly editorial scribe in person, posed in front of the new control panels of Scratchi's radio transmitter in Osockme, Japan. Ye editorial scribe was fortunate in having Scratchi himself take the photograph, and it is here submitted for the pleasure of the reader.

From left to right, bottom row, going from the ground floor up, is the group of rheostat controls which deliver the varying currents to the crystal oscillator of Scratchi's transmitter. The one in the center is the control which regulates the heat of the crystal oven; the two on either side regulate the inductance of the r.f. chokes in the grid of the oscillator circuit and the Jones Cathode Bias resistor in the cathode of the 53 tube.

Directly above these controls are the band switching relays which, when brute force is applied, make for a rapid change in the coils used to tune either band. These delicate brute-force controls are housed behind glass, so that the setting of the relays will not vary with temperature changes, thereby affecting the L/C ratio of the tuning circuits. Still farther above are the circuit breakers which go off with a bang (but sound like a flat tire) when the crystal current exceeds 500 ma. At the very top are the glass-encased CQ timing controls, which automatically shut the transmitter off when the operator has sent CQ more than 74 times before signing his call letters. The remaining control, not shown in the photograph, is a main-line circuit breaker to disconnect the entire apparatus from the 11,000 volt line in the event of storms, Madrid Treaties, or other catastrophes. The thing which the operator is wearing on his head is called a hat.

**NOW**

**A SPECIAL HEADSET  
for  
MONITORING**

*Designed and built by*

**TRIMM**

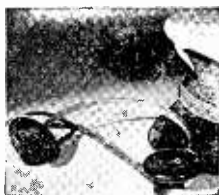

Combines at one time the lightness and comfort of the Adapted to the particular needs of monitoring service, famous TRIMM FEATHERWEIGHT—with a phone of exceptionally uniform response characteristic.

Write for complete data—Dept. B-11

**TRIMM RADIO MANUFACTURING CO.**  
1770 W. Berteau Ave. Chicago, Ill.

**The Worldwide Authority  
Take "Radio"**

## DRILLING GLASS

By JOHN D. KRAUS, W8JK

From time to time, many amateurs are confronted with the problem of drilling a hole through glass. It may be in a window pane for a lead-in wire or in a strip of glass to be used for mounting purposes. Most persons regard the process as a very laborious and time-consuming one. It may not be out of place, therefore, to describe a technique which is simple, sure, and fast; but which does not seem to be familiar to a large number of amateurs.

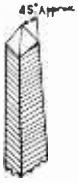

A small three-cornered file is required. One breaks this off to a convenient length, say about 3 inches. One end should be about the diameter of the hole which one wishes to drill. Three small faces or facets are ground on this end of the file by holding it against a grinding wheel. These facets may make a fairly blunt point to the file. An angle of about 45°, as shown in the figure, works very well. Some glass drillers prefer a sharper point, but this is harder to make.

The file is placed in a hand-drill chuck in the usual manner of a small twist drill. The drill is pressed against the glass with a "gentle firmness" and turned very slowly until a light crunching sound is heard. This indicates that a nick has been made in the surface and that the drilling can proceed more rapidly. As one turns the drill, the top of the drill brace should be made to describe slowly a circle about 6 inches in diameter. This prevents the drill from binding in the hole. Only a moderate pressure should be used. If the drill is a good one, it goes through the glass like the proverbial "Swiss cheese." The drill chews the glass out in the form of a white powder at a rapid rate. An occasional drop or two of turpentine is helpful. As one approaches the opposite side of the plate, considerable caution should be used. At the time that the drill breaks through the opposite side, a click will be heard. The drilling may then be completed from the opposite side. Windows may be drilled right in place, but this must be done very carefully. The safest way is to place the work flat on a mat of newspapers.

[Continued on Next Page]

## THE DECKER COIL AND LINK

A LOW-LOSS WIRE COIL THAT TAKES  
A KILOWATT AND LIKES IT!

Band	Coil	Series "A"	Series "B"
160	Final	\$4.15	\$6.25
80	Final	3.30	5.00
40	Final	2.90	4.40
20	Final	2.50	3.75
10	Final	2.10	3.00
All Bands	Link	1.50	2.50

Above prices are list  
40% discount extended licensed amateurs

When ordering be sure to state capacity with which you intend to tune. Also if possible diagram circuit in which used.

**DECKER MFG. CO.**  
SOUTH PASADENA, CALIF.

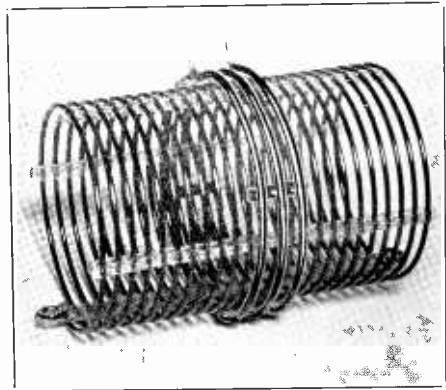

The final important improvement in air wound wire coils has been achieved. The unavoidable mechanical weakness of copper wire has been overcome.

The new series "B" Decker Coil is made of a special high carbon steel-core wire. The Series "B" not only "Takes a kilowatt and likes it", but also smiles at mechanical abuse.

The electrical efficiency remains the same and the strength is increased enormously by the steel core.

We continue to supply the Series "A", coil as before. The net price remains the same.

If your dealer cannot supply you order direct.



[Continued from Last Page]

A number of trials may be necessary on the grinding wheel before one obtains a drill point which is especially effective. A good drill will bite into the glass. One can easily drill an eight-inch diameter hole through an eighth-inch plate of glass in less than two minutes.

One should remember to treat glass with some respect, for although it can take a surprising amount of punishment, it has an elastic limit which, if exceeded, causes a sudden rise of the "cuss quotient." It takes such a short time to drill holes by this method that it is wise to make a few practice holes before drilling a choice plate of glass. In fact, this method gives such sheer delight that there are cases on record of persons who have spent pleasant evenings drilling all the glassware within reach—windows, tumblers, fruit jars, and even beer bottles.

Dr. J. D. Tear has proven that harmonics of extremely short radio waves are identical with heat rays.

The first and last of ham radio—W1AA in Auburndale, Massachusetts, and W9ZZ in Kansas City, Mo.

W9TQW is located on Minnehaha Ave. in Minneapolis, Minnesota. W6HXL is in Echo, Wash. Irving Vermilya, W1ZE, lives on Vermilya Ave. W4CYP's QRA is a cemetery.

COMING NEXT MONTH

Your SW-3 into a Superhet for only \$11



the... MIXER MONITOR

is designed for phone stations—it incorporates a linear detector—will indicate carrier shift and/or overmodulation—allows aural monitoring which may be audio-mixed in the receiver output—will function as a tone source

for modulation testing—uses 6A6 or 53 tube and requires external filament-plate voltage supply. Price, \$9.90 net, less milliammeter, post-paid in U.S.A. for cash. Write for further information on this versatile unit.

LAMPKIN LABORATORIES BRADENTON, FLA.

Calls Heard

[Continued from Page 53]

W8BIQ-9; W8CPR-8; W8CRA-7; W8DYK-8; W8HC-8; W8HGW-9; W8HIL-8; W8IMS-6; W8IXS-7; W8JLQ-7; W8LEA-7; W8MJK-7; W8MWL-8; W9AEH-9; W9AGM-7; W9AXL-7; W9AMM-8; W93MM-9; W93QM-8; W9CCT-7; W9DNB-7; W9EF-9; W9GFD-9; W9GHN-8; W9HAQ-9; W9INB-7; W9KPD-7; W9KTW-7; W9LBB-8; W9LQT-9; W9MCD-9; W9MDF-9; W9MIN-7; W9NY-8; W9JFL-7; W9Jf-7; W9P9D-8; W9USL-6; W9XAN-7; VE3WA-9.

Alois Weirauch, OK1AW, Mestec Kralove 9 October 6 to November 14 28 mc.

LUL1EP; CX1CG; VK4EJ; VK4BB; SU15G; SU1R0; CT101; U9MJ; OK2AK; OK1AA; ON4AU; OJ4RR; D4GWF; W5QL; W5WG; FA 81H 8CR; 8CT; EA 4A0; 3CG; W1 CSR; DF, AEP, FJN, ZB, ZI, DZE, LZ, AYX, GSH, SZ, A.V.V. IQ2; W2 BCR; CFW, GJB, GUM; W3 FAR, AIR, DLB, ZF, A.F. FED; W4 AGP, AUU, AJY, TZ, MR, BBP; W8 JAX, CRA, KIW, PK, MWL; W9 1CJ, KPD, CIU, ABE, LF, RKP, DSC, GHN.

H. F. Wareing, W9NY, 4547 N. 21 Street, Milwaukee, Wisconsin Nov. 21 to Dec. 10, 1935 (28 mc. only)

D4ARR; D4GWF; EA4AV; E15F; F8CT; F8KJ; F8OZ; F8RJ; F8WK; F81H; G2AU; G2HG; G2UX; G2YL; G5BY; G5FY; G5ML; G5WP; G6DH; G6GJ; G6GS; G6LK; G6NF; G6VJ; G6YQ; G6ZV; J2HJ; LU9AX; OK1AW; PA0FX; VE1DR; VEFW; VE4LK; 1B.N.M; 1BUX; 2AER; 2B0K; 2FHI; 2FWK; 2iP; 3EVT; 5A.A; VE5HC; VESHR; VESFN; VK2LZ; VK3YP; VK4EI; VK4GK; VK5WJ; V04I; VP5AC; VP5PL; XIAM; X1AY; X2C. — w 5BBR; 5CNV; 5DDP; 5DNV; 5EHR; 5ELL; 5JV; 5QL; 6AET; 6AFA; 6AHZ; 6A0A; 6BAM; 6BAY; 6BIP; 6BXU; 6BXV; 6CIS; 6CNX; 6DGG; 6DGY; 6D10; 6D0B; 6DVI; 6DWW; 6DYM; 6EAR; 6EBJ; 6ETX; 6EWC; 6EZB; 6FMY; 6FQY; 6FVJ; 6GDJ; 6GEI; 61IF; 61UX; 61RX; 61TD; 6JJU; 6JN; 6JNR; 6J0; 6KB; 6KBD; 6KEV; 6KGD; 6KPR; 6KRI; 6KRM; 6KU1; 6LBW; 6LDF; 6LRH; 6QD; 6RH; 6SZ; 6ZH; 7AMX; 7AVV; 7AWU; 7AYQ; 7BCI; 7BLK; 7BP; 7CHT; 7CMB; 7COR; 7DNK; 7DNP; 7DCC; 7DTG; 7DUV; 7EF; 7TS; 8B1Q; 8CRA; 8MOK; 8PK; 9AEH; 9ARM; 9BHT; 9BPU; 9BQM; 9CCT; 9CVN; 9DBC; 9FM; 9FUR; 9GBJ; 9HAQ; 9IC0; 9JGS; 9LF; 9LQ; 9MCD; 9MIN; 9R0; 9SPB; 9VSO.

W. B. Scofield, W2DTB, 88 Smith Avenue, White Plains, N. Y.

November 13 to December 8, 1935 (28 mc. worked only)

D4ARR; EA4AV; F8CT; F8KJ; F8OZ; F8PU; F8VS; F8WK; F81H; G2AU; G2HG; G2MV; G2NH; G2PL; G2rL; G.LB; G5FY; G5LA; G5ML; G50J; G5SY; G5WP; G5CJ; G6DH; G6GS; G6LK; G6NF; G6QB; G6WY; G6XN; HB9J; ILIT; J2HJ; LUL1EP; LU9AX; LU9BV; OK1AW; ON4NC; PA0AZ; PA0FX; PA0RN; PA0UN; PA0AM; VK3BD; VK3YP; YM4AA; ZL3AJ; ZSLH; ZU6P.

R. J. Painter, W4BBP, 736 Lillian Avenue, Atlanta, Georgia (28 mc. stations worked)

CX1CG; E18B; F8KJ; F8OZ; F8WK; G2HG; G2MV; G2PL; G5BY; G5ML; G6DH; G6LK; G5NF; G6WY; LUL1EP; LU3DH; OA4J; OK1AW; ON4SD; PA0AZ; PA0RN; VELEA; VK3YP; X1AA; X1AY; ZL2KK.

STAMP COLLECTORS



Our reputation as the largest approval house in the world demands that we supply customers with stamps from every country including stamps not easily obtainable. To the advanced collector and also to the beginner we offer a service without equal anywhere. Send for fine choice as assortment: 100 stamps or if you prefer 15 old 19th Century stamps with our valuable booklet 'Building Successful Collections'. Only 10c, including attractive approval selections. Order today.

GLOBUS STAMP COMPANY 268-4th Avenue, Dept. 157, New York, N. Y.

## Behavior of Dx Signals

Long distance contacts on 20 and 40 meters have become so common in the last few years, even with low power, that few operators call anything under about 8000 miles true dx on these bands. 4000 miles is still pretty good dx on 80 and 10 meters and 2500 miles is good dx on 160 meters.

There are some characteristics of 20 and 40 meter signals that are worth keeping in mind. They do not always apply but they are fairly accurate over long periods. The following points resulted from a Bureau of Standards survey of the frequencies below 15,000 kc. over paths ranging from 6000 miles to 10,000 miles in length, all of which crossed the equator.

1) In general, a signal minimum occurs over a wholly light path.

2) A rise in signal intensity generally occurs as the path becomes partially dark, 20 meter signals rising and reaching a maximum before 40 meters.

3) A steady fall in signal intensity occurs after the maximum has been reached, starting with 20 meters and then following on 40 meters and becoming most pronounced after the path has become wholly dark. Transmission conditions do not appear to become fixed or steady either during daylight or darkness. A secondary rise and maximum is frequently observed as daylight approaches the transmitter end of the path.

4) An apparent diminution in signal intensity takes place generally for a given daylight-darkness path, when the darkness portion is prolonged.

5) A decrease in signal intensity appears to take place when the darkness wall is advancing so slowly as apparently to allow the attenuation along the prolonged daylight portion of the path to increase more rapidly than the diminution in attenuation at the advancing darkness wall.

To use these general rules of wave behavior properly it will be necessary to procure a special map of the world called the Azimuthal projection, which shows the earth as a circle with the receiving or transmitting station at the center of the map. The U.S. Printing Office has two such maps available, one showing Washington, D.C. at the center and the other showing San Francisco, California at the center. Great circle paths to any point on the surface of the world from either of these two points appear as straight lines on the maps. Private map companies have made these maps for hundreds of

points on the earth's surface, mainly for the large communications companies, who need them for directive antenna design.

It then is also necessary to draw in on this type of map the seasonal variations in the daylight and darkness areas so that the darkness area may be estimated at any time of day and at any season of the year. An almanac usually

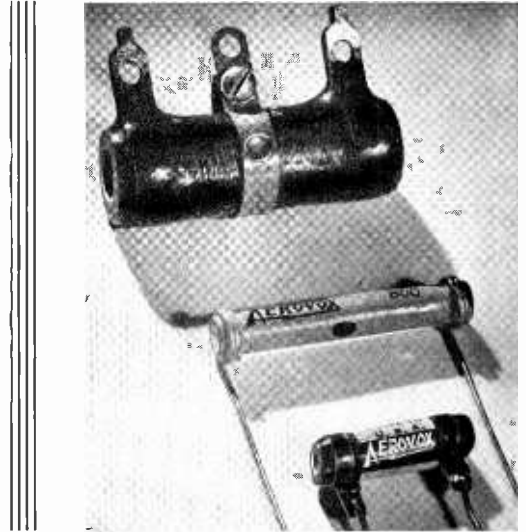

## RESISTORS

... for Three Functions



Aside from the largest line of condensers available today, AEROVOX offers you a complementary line of resistors. For instance:

- ★ *Slideohms* . . . vitreous enameled wire-wound resistors with sliding contact band . . . for arriving at exact, fixed resistance value by the cut-and-try method.
- ★ *Carbon Resistors* . . . improved, stay-put, positively uniform and accurate resistors . . . in 1/3, 1/2 and 1 watt ratings, for circuits handling limited current. RMA color coded and stamped.
- ★ *Pyrohm Jr.* . . . genuine wire-wound vitreous-enameled resistors of startling compactness. Note 5-watt Pyrohm alongside 1-watt carbon unit in illustration. Ideal for the handling of tough loads in tight places.

**DATA** Send for new 1936 Catalog covering largest line of condensers and resistors. Also sample copy of monthly *Research Worker*.

**AEROVOX**  
CORPORATION

72 Washington St.

Brooklyn, N.Y.

gives the time of sunrise at many points on the earth for four or more dates during the year. A curve joining these points at any instant will show the edge of the daylight wall. Likewise the time of local sunset at these same points can be obtained defining the edge of the darkness wall. Thus the area enclosed by the two lines will define the darkness area at any instant and the seasonal shift in the darkness area can also be indicated by establishing darkness areas for the center of the four seasons.

With these four maps, the amount of daylight and dark between any point and your own location can easily be estimated and by this means some degree of forecasting signal peaks in intensity can be established. Considerable data on the correlation of radio signal intensity and the index of magnetic storm activity have been made, and some remarkable forecasts have resulted.

Some of the less familiar radio services granted station licenses include geophysical (ore-locating) and motion picture services.

### Free Handbooks!

Each month we will pick at random from the latest callbook several amateur calls and list them somewhere on the "Marketplace" page among the classified ads. If the holders of the calls listed will drop a postcard to RADIO to the effect that they have noticed their call, they will be mailed free a copy of the 1936 "Radio" Handbook. The card must be postmarked before the 15th of the month on the cover of the issue in which the call appears.

### WHAT'S NEW

The Bliley Electric Company has recently issued a 16 page catalog describing its complete line of quartz crystals, holders and ovens for transmitters, single signal filters and standard frequency bars. Both general communication and amateur frequency crystals are included. In addition several pages are devoted to technical information on crystals and crystal circuits. Copies of this bulletin may be secured by writing to the Bliley Electric Company, 203 Union Station Bldg., Erie, Pa.

### Instrument Booklet

To those readers who are interested in test instruments design or who are making their livelihood from the repair of radio receivers, the Supreme Instruments Corporation of Greenwood, Mississippi, manufacturers of radio test instruments, offers a 16 page booklet "The Evolution of Tube Testing."

This very interesting and instructive booklet is crammed full of technical data on various types of tube testing circuits and is supplemented by numerous diagrams.

You can obtain a free copy by writing Supreme Instruments Corporation, Greenwood, Mississippi, using your business letterhead or enclosing your business card and mentioning this publication.

### New Centralab Switches

Centralab, Milwaukee, Wis., manufacturers of volume controls, sound projection controls and fixed resistors, have purchased the *Perfex Controls Co.*, of Milwaukee, Wis., line of wave change switches and other radio products.

*Perfex* switches have enjoyed considerable acceptance and are used by leading radio manufacturers. These switches under the Centralab banner will be included in the line and will be advertised along with Centralab's other products.

### Poly-Iron Information

The iron-core r.f. transformers for intermediate amplifiers and some higher-frequency applications are described in a new bulletin called "Data Sheet 1135" and available on request. Write Aladdin Radio Industries, 466 West Superior Street, Chicago. That's a new address.

### Very Audible Indeed

The "Radio Institute of the Audible Arts" is not as awesome as its name. It appears to be a branch of the Philco Radio and Television Corporation, located at 80 Broadway, New York, N.Y., and engaged in sending out information as to the when and where

[Continued on Page 94]

## 25 TIME-TESTED TRANSMITTING TUBES



TYPE		PRICE
303A	130 Watts	\$ 15.00
304A	350 "	97.50
310	25 "	5.75
311	130 "	17.50
311C	130 "	17.50
312D	250 "	75.00
361A	130 "	17.50
376A	130 "	17.50
930	40 "	8.75
937B	60 "	10.00
938	130 "	18.00
941	25 "	5.75
942	Audio	5.75
943	Audio	17.50
949	500 Watts	160.00
951	1250 "	350.00
952	165 "	16.40
911CH	150 "	19.50
317C	Vacuum Rectifier	20.00
966	Mercury Rectifier	2.25
966A	" "	5.00
972	" "	15.00
972A	" "	16.50
967	" "	14.00
973	" "	25.00

\*Nominal RF Power Output.

Consult your Dealer or write direct to—

**UNITED ELECTRONICS CO.**

42 SPRING ST., NEWARK, N.J.



# REMARKABLE PRICE REDUCTIONS

On LEEDS Constructional Accessories due to greatly increased demand

## RELAY RACKS



Our Relay Racks are built to stand up under the heavy loads of modern transmitter construction. Uprights are made of 3/16" stock, 1 3/4" wide. Welded angle supports, cross braces and sturdy cross bars insure extreme rigidity. LEEDS Racks unlike some units on the market, are drilled for panel mounting according to Bureau of Standards specifications.

**Table Rack type RAD** 3 3/4" panel space high, 20 1/2" wide, 12" deep, with a complete set of drilled and tapped panel mounting holes **\$5.75**  
Shipping weight 30 lbs.

**Type RBD rack** 6 6/8" panel space high, 20 1/2" wide, 12" deep, with a complete set of panel mounting holes **\$7.45**  
Shipping weight 30 lbs.

**Brackets**—4" high, 5 3/4" deep, 1/2" bend for mounting; pair 25c; 7 1/2" high, 9 1/2" deep, 1/2" bend for mounting, pair 35c

## GENERAL RADIO VARIACS



Are the ideal answer to the QRP problem. Type 200 CU delivers 0-135 volts continuously variable at 900 watts from 115-volt line. Price..... **\$14.50**  
Type 200-B—0-115 volts at 170 watts. Price **\$10.00**

**100-K**—0-115 v at 2000 w. Price **\$40.00**  
LEEDS Leads as the only distributor in the country, handling G. R. Amateur accessories and laboratory apparatus. Bulletin No. 936 mailed on request.

**GENERAL RADIO** coil forms type 677-U price 50c; type 677-Y price 75c. G. R. amateur accessories always in stock.

G. R. dials, with fluted knobs 4" — **\$1.50**; 3 1/4" — **\$1.25**; 2 3/4" — **\$1.00**.

**MAGNAVOX** 8" permanent magnet dynamic with single pentode matching transformer ..... **\$5.95**

## A THIN DIME

Now that the 1936 bulletins are available, we are renewing our offer of last year. A thin dime brings to you post paid the latest bulletins of 25 manufacturers of short wave equipment, together with our own B-73 bulletin. Far more information on the latest and best short wave equipment is contained in this assortment than can be found in any mail order catalog. Write for yours today.

## Rack Panels



By LEEDS are furnished with black shrivel finish in the standard 19" length, 1/2" thick. Mounting slots are spaced according to Bureau of Standards specifications, insuring freedom from all trouble in mounting or interchanging panels.

Steel	Price	Width	Aluminum	Price
PS-1.....	\$.52	1 3/4"	PA-1.....	\$.74
PS-2.....	.57	3 1/2"	PA-2.....	1.03
PS-3.....	.68	5 1/4"	PA-3.....	1.30
PS-4.....	.71	7"	PA-4.....	1.55
PS-5.....	.95	8 3/4"	PA-5.....	1.90
PS-6.....	1.15	10 1/2"	PA-6.....	2.45
PS-7.....	1.30	12 1/4"	PA-7.....	2.90
PS-8.....	1.50	14"	PA-8.....	3.35
PS-9.....	1.70	15 3/4"	PA-9.....	3.70
PS-10.....	1.90	17 1/2"	PA-10.....	3.95
PS-11.....	2.05	19 1/4"	PA-11.....	4.45
PS-12.....	2.30	21"	PA-12.....	5.20

Brass panel mounting screws 1/2" long 10/24 thread, 15c per dozen.

## No 'Random Frequencies' at LEEDS

Our crystals provide the greatest accuracy at the lowest cost. All LEEDS crystals are 7/8" square with a guaranteed accuracy of plus, minus 1 kc. on 1.7 mc. and 3.5 mc. plus, minus 2 kc. on 7.0 mc. Two days delivery on any desired frequency.

X cut 1.7 mc. and 3.5 mc.....	<b>\$2.25</b>
X cut 7.0 mc.....	<b>\$3.25</b>
AT cut 1.7 and 3.5 mc.....	<b>\$5.00</b>
Leeds crystal holder for UY socket mounting.....	<b>\$1.00</b>
Hill all metal adjustable holder	<b>\$1.65</b>

## Leeds Transmitting Tubes

provide the greatest power output at the lowest cost. Backed by our usual 90 day guarantee against all defects except filament and envelope breakage.

*203-A.....	<b>\$8.45</b>	†830-B.....	<b>\$7.25</b>
†210-HF.....	<b>1.75</b>	*838.....	<b>11.75</b>
866.....	<b>1.50</b>	†841.....	<b>2.95</b>
*211.....	<b>8.45</b>	845.....	<b>11.50</b>
†800.....	<b>7.25</b>	*852.....	<b>11.50</b>
†801.....	<b>2.95</b>	866-A.....	<b>1.95</b>

\*Graphite Anode Tubes  
†Isolantite Base

Tubes Shipped by Express Only



**LEADS THE FIELD**

World Wide Service to Amateurs

43 Vesey Street

New York City

Telephone Cortlandt 7-2612

Cable Address: "RADLEEDS"

## BASES and DEMI-BASES

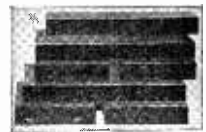

By LEEDS for use with rack panels are now available in a greatly increased variety at lowest prices. Crystalline finished units of 20 gauge steel; each base is finished with a bottom cover plate, so that apparatus underneath the chassis may be kept free from dust and at the same time electro statically and electro magnetically shielded.

8 1/2 x 8 x 2....	.65	10 x 17 x 2.....	<b>1.10</b>
8 1/2 x 20 x 2....	.70	10 x 17 x 3.....	<b>1.30</b>
8 x 17 x 2....	.95	12 x 17 x 2.....	<b>1.30</b>
8 x 17 x 3....	<b>1.15</b>	12 x 17 x 3.....	<b>1.40</b>
4 x 17 x 2.....	.70		

## NEW !!

Alladin iron core air tuned **\$3.23**  
L.F. transformers; each, priced

PIEZO Astatic crystal phonograph pick up 8" arm; List \$15.00. **\$6.75**  
Special.....

We carry a complete stock of Thordarson power and audio components.

**NATIONAL** steatite wafer sockets, 4-5-6-7 and 8 prong; each..... **36c**

**LEEDS SHORT WAVE COIL KITS** for regenerative detectors and TRF receivers; four coils covering 15 meters to 200 meters with 140 mmf tuning condenser.

Type A 2 winding UX base coil kit.....	<b>57c</b>
Type B 3 winding 6 prong coil kit.....	<b>75c</b>

## HAMMARLUND Star Midget Condensers

140 mmf.....	<b>73c</b>	50 mmf.....	<b>53c</b>
100 mmf.....	<b>59c</b>	25 mmf.....	<b>50c</b>
15 mmf.....	<b>50c</b>		

**Communications Products** glazed vitrolex coil forms in stock. 2 1/2" diameter 30 turns winding space; price..... **60c**

**VITROLEX** Universal form; 3 coils in one; pictures last month..... **\$1.50**

**MAC** Keys in stock. The finest bug on the market; only..... **\$7.95**

## PHONES

Trim 2000 ohm. All bakelite case. List \$3.00. Special..... **\$1.75**  
Trim 1000 ohm. List \$3.75. Special..... **\$2.25**  
Trim featherweight, high impedance. Special..... **\$5.88**  
Western Electric, P-11. Special **\$3.95**

## Navy Type Telegraph Key

List \$3.60 Navy knob—1/8" Tungsten contacts. Only a few left at..... **\$1.15**  
With regular knob..... **.95**



[Continued from Page 92]

of nearly any sort of radio programs you, Uncle Henry, Kid Sister or Granpaw may care about. The R.I.A.A. frequently includes comments that are genuinely useful and informative. A letter to 80 Broadway may be well sent.

### Short Wave News and Technical Review

A 10c monthly in semi-newspaper form appears under the above name, starting with January. It is issued from 1107 Broadway, New York City, and edited by Frank A. Petrie with George Bunster and Herman B. Levy. The first issue has 16 pages of about newspaper tabloid size.

### "Tiny Mike"

An ultra-compact 450 volt dry electrolytic condenser is offered by the Sprague Products Co., under the name of "Tiny Mike", or type TM. These condensers are stated to occupy roughly one-half the space of the usual condensers of similar rating. The 1936 catalogue, sent on request, gives the story.

### Vented Wet Electrolytics

An ingenious vent is featured in wet electrolytic condensers recently made available by Aerovox to the general trade. The same units had previously been available only to manufacturers.

Instead of a bit of gauze for venting purposes, which arrangement sometimes fails to prevent seepage of liquid electrolyte and subsequent corrosion of condenser and chassis components, these "wets" are

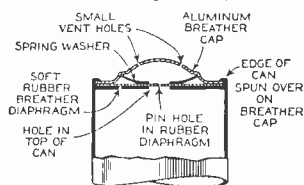

CROSS-SECTIONAL ILLUSTRATION OF THE VENT CONSTRUCTION IN AEROVOX WET ELECTROLYTIC CONDENSERS

provided with a double-seated vent. Any gas pressure built up within the can escapes through a pin-hole in a soft rubber diaphragm and through offset holes in the dome cap. However, if electrolyte presses against the diaphragm, the latter instantly presses against the offset holes in the dome, sealing same securely. There can be no seepage or corrosion.

Usual advantages such as high capacity for minimum bulk, ability to take severe punishment, self-heating and low cost, are retained in these new units.

# More Harrison Values!!

## JEFFERSON AMATEUR APPARATUS

Acknowledged as the largest manufacturer of transformers in the world, the Jefferson Electric Company has put its years of experience into the design of a complete, high quality, popular-priced Amateur line. Power transformers, chokes, input, driver, modulation, and filament transformers—your entire rig can employ Jefferson to good advantage. More efficiency—better regulation—much greater value—and just look at the prices!

We are proud to present the new line of Jefferson Transmitter components! We carry a complete stock, a catalog of which will be sent upon request.

A few of the outstanding items of this superior make follow:

866 filament transformer, 2½ volt, 12 amp, center tapped. **7500 volt insulation!** Open frame mounting with heavily insulated flexible leads. **Your cost...\$1.18**  
 10 volt, 7 amp. CT. 5000 volt insulation. Open frame mount.....**\$2.35**  
 Same in neat metal case with porcelain standoff insulators.....**\$3.52**

Plate Xformer. Two separate 3000 volt center-tapped windings. May be connected in parallel for DC output of 1250 volts at 500 MA out of filter (Choke input). In series will deliver 2500 volts at 250 Ma DC. Both full wave rectification! Has primary tap for reducing voltage 25%. In massive case with huge porcelain terminals.

Net weight 60 pounds! **Your cost \$25.57**

Plate Xformer. Two separate 1150 volt windings for series or parallel connection and bridge rectification. DC output 1000 volts at 400 Ma. or 2000 volts at 200 Ma. Cased as above. 28 lbs.

**Amateur price—\$14.70**

(Large items shipped from New York or Chicago)

## FILTER CONDENSERS

With filter condensers being offered everywhere at all kinds of prices we had to be dead sure that our condensers lived up to the Harrison reputation of "the best for the least".

They are made by one of the most reputable manufacturers—they are oil impregnated (Don't be fooled! You can't get oil filled tank condensers for less than double these prices.)—they have neat enameled metal cases with mounting feet and porcelain insulators—they are full capacity and conservatively rated—and they are unconditionally guaranteed by both the maker and ourselves.

We honestly believe that it is impossible to buy as good a condenser anywhere else for less than these prices.

Capacity Mfd.	Continuous D.C. Working Voltage		
	1000	1500	2000
1	\$1.10	\$1.45	\$1.75
2	1.50	2.00	2.45

"Save with Safety at Harrison's"

## "GENERAL"

Manufacturers of clean, amply proportioned power and audio units, reasonably priced. Sponsors of the well known "Progressive" Transmitter.

We illustrate a few of their more popular items:

Filament Xformer with three 5 volt center-tapped, 3 amp. windings for bridge rectifier. 3000 volt insulation. Open frame mounting with flexible leads. **Your cost.....\$1.47**

In neat metal case.....**\$2.05**

Three 2½ volt center-tapped windings for 66's in bridge. 5000 volt insulation. Priced at.....**\$2.35**

Shielded type in metal case.....**\$2.94**

Plate Xformer. 1500-2000 each side of center. 500 Ma. 1 KW output. 40 lbs. ....**\$17.64**

1250-1500 each side of center. 500 Ma. 35 lbs. ....**\$16.17**

(Above transformers in heavy cast iron casing with porcelain insulators. **\$3.53** additional).

### CASED FILTER CHOKES

Porcelain terminals. 5000 volt insulation.

12 Henry inductance at full rated load.

200 MA. 125 ohms.....**\$2.94**

300 MA. 100 ohms.....**4.10**

500 MA. 100 ohms.....**6.46**

Swinging Chokes. 18 to 6 Henry. Same type—same prices.

(Heavier units shipped from New York or Chicago)

Complete literature upon request.

**Harrison Radio Co.** 12 West Broadway  
 Dept. 91, New York City

Telephone WOrth 2-6180 • • • Visit Our New Store When In Town!

Shoot Your Order In Now, OM! You'll Like Dealing With Us!

# More Miles per Watt ...

The yardstick of efficiency!

# More Watts per Dollars

The ultimate measure of economical buying!!

Harrison customers ACTUALLY DO realize more useful value for every dollar spent! Try us and see for yourself!—NO RISK! We honestly will return every cent of your money if you are not entirely satisfied!

## XTALS

Xcellent Xtals that Xude an Xtravagance of Xceedingly Xact Xcitation!

These frequency control units (xtals to you) are ground from the finest quartz and are carefully calibrated to better than .03% accuracy. Good, strong oscillators! Guaranteed to give complete satisfaction or your money back!

- 1.7 or 3.5 Mc. X cut.....\$1.55
- 7.0 Mc. X cut..... 2.25
- 1.7 or 3.5 Mc. AT cut..... 2.75

(From stock within 10 Kc.)

- Bakelite holder. Finely machined, with accurately lapped brass plates.....\$1.25
- New HILL all brass adjustable holder.....\$1.65
- RCA pressure contact holder.....\$2.50
- Bakelite Holder. Spring pressure. Special..... 84c

## Esico Soldering Irons

Best known—well made—low priced. Used by thousands of hams and servicemen. Sold with regular Esico warranty—backed by "Harrison's regular guarantee of complete satisfaction."

- "Nick-Nack" 55 Watts.....\$ .66
  - "Midget" 65 Watts..... 1.05
  - "Junior" 85 Watts..... 1.65
  - "Trophy" 150 Watts..... 2.54
- (All for 100-120 volts AC-DC. Special irons to order)

## OUR NEW STORE

We have just opened what we consider to be the largest and finest store devoted exclusively to Amateur Equipment! Everything from Xtals to Xmitters. All standard lines at lowest wholesale prices. "Ye Trading Post" department, "Specials", etc. Just a REAL Ham store!

And our new location (between Barclay and Vesey streets) is most convenient to all transit facilities. Don't fail to drop in and meet the gang here at our new place!

73  
de Bill Harrison W2AVA

## New! Harrison Dome Bulb Fifty Watters!

An improved 203-A with standard characteristics. New dome shaped bulb provides support for mica cushions attached to the carbon plate producing a very rugged tube with a minimum of insulating material and metal supports. Both the plate and the grid leads are brought through the side of the stem instead of through the press, thus eliminating the "weak spot" of the ordinary tube.

A standard 03-A that will take over 2000 volts and stand up!! Backed by the Harrison guarantee for 1000 hours' service. Special Price.....\$9.45

## READ EVERY WORD, PLEASE!

We try to make our ads interesting and instructive. Read to learn how to "Save with Safety"!

## BUD PRODUCTS

A well designed, comprehensive line of components that are exceptionally reasonable in price. Harrison carries a complete stock and will gladly send the Bud catalog upon request. Here are a few interesting items:

- 50 WATT SOCKET. Four heavy split bushings mounted on a glazed Isotex base securely grip the tube prongs. Eliminates metal shell, weak spring contacts, and high price. Costs you only 58c
- Giant Bakelite coil forms. Ribbed. 2 1/4" diameter. 3 1/4" winding space. 4 prong—36c. 5 prong—39c. 6 prong.....42c
- Ribs grooved for winding 12 turns to the inch—15c extra.

### Xmitting Variable Condensers

Midget size. Brass plates, securely soldered. Isolantite insulation. Double, positive contact, bearings.

Cap.	Gap.	Price
4 mmf.	.200"	\$.83
8 mmf.	.130"	.88
15 mmf.	.080"	.88
35 mmf.	.095"	1.18
35 mmf.	.060"	.96
50 mmf.	.060"	1.18
75 mmf.	.060"	1.47

### REALLY REMARKABLE VALUE!

Xmitting coil form. Well glazed Isotex. Grooved and drilled for No. 10 wire or smaller. 20 or 40 meter form. Grooved 21 turns in 4" winding space. 2 1/2" O.D. x 5" long.....88c

80 meter form. 32 turns in 5" space. 3" O.D. x 6" long.....\$1.18

160 meter form. 48 turns in 6" space. 4" O.D. x 7 1/4" long.....\$1.33

(Add 50c to above if plug-in arrangement is desired. Consists of two giant plugs and jacks mounted on 1 1/2" stand-offs). Many more good ham items in the Bud Catalog.

## BUY BY MAIL!

It's fast - it's safe - it's economical - and IT'S EASY!!

Just list the items you need (from this ad or any other ad or catalog), enclose a 20% deposit, and mail to us. A few hours after it reaches us your order is on its way to you—carefully packed and insured for safe delivery. Even counting the small transportation cost—Harrison prices are so very much lower than local prices that each purchase means a real saving to you.

In addition, our enormous stock enables us to send you the exact thing you specify without delay.

ORDER TODAY and—"SAVE WITH SAFETY AT HARRISON'S"

## WIRE

New, clean, perfect wire. Cut to your order. Full measure. Full size.

SOLID WIRE: Enameled—Soft Tinned (for hook-up or coils)—or Hard Tinned (for sagless antennas).

- Size (B & S) No. 10 No. 12 No. 14
- Per 100 feet..... 85c 55c 40c
- E01 Transmission Cable.....7c per foot
- Over 50 ft......6c

Twisted pair for doublet leads.....\$1.25 per 100 feet

Rubber covered shielded flexible mike cable

- 1 wire (for Xtal mikes, per ft..... 4c
- 2 wire—6c. 6 wire—10c

Complete stock of assorted cables, wires, shielding, hookup wire, magnet wire, spaghetti, etc.

## DUNCO RELAYS

An inexpensive AC relay made by one of the foremost relay manufacturers—the Struthers-Dunn Company. Midget type RA-1. Heavy contacts close two separate circuits. For keying, remote control, etc. Wound for 2 1/2 volts AC or 6 volts AC. (6 volt model will operate perfectly on a 1 1/2 volt cell).

Either model .....\$2.00

## WHOLESALE PRICES

ON ALL STANDARD LINES

40% and 2% Discount on: Cardwell

— Hammarlund — Johnson — Bud —

General Electric Capacitors — Shure

— RCA — Patterson — General —

Thordarson — Hoyt — Esico — Hal-

licrafters — Ward Leonard — RME —

Signal — Beede — Leichner — Syl-

vania — Birnbach — Jefferson — Ohmite

— Astatic — American — MacKey —

Alladin — Etc., Etc.

LOWEST AMATEUR PRICES ON:

Raytheon — RCA-DeForest — Weston

— Burgess — all publications, tools,

hardware, small parts, etc., etc.

LARGE STOCK - PROMPT SHIP-

MENT - SATISFACTION GUAR-

ANTEED - ORDER whatever you

need - HARRISON HAS IT!!

## — HOYT HOT WIRE — R.F. AMMETERS

New models in black polished bakelite cases. Mount in 2 1/2" hole. Flush panel flange 3/4" dia. Most inexpensive, accurate antenna meter available!

1 1/2, 3, or 5 Ampere range.

Your Cost .....\$3.24

## New Heavy Duty Dome Bulb 10

Extra large plate—mica insulation—wide spaced press. FB for high voltage! (Each one tested at 1500 volts in an oscillator). SPECIAL.....89c

# Harrison Radio Co.

12 West Broadway  
Dept. 91, New York City

Telephone WOrth 2-6180

• • • Visit Our New Store When In Town!

Shoot Your Order In Now, OM! You'll Like Dealing With Us!



## DX NOTES

[Continued from Page 55]

3:00 and 5:00 p.m. e.s.t., giving the boys a lot of fine ragchews.

W9OLC, Bill Hanks, works a few nice ones in snagging VU2CQ, J8CA, and LA4K . . . all three on 14 mc. Says his antenna is a 660 ft. wire. Sounds to me more like a private line to the above stations. W9ARL also hooked VU2CQ and had a pretty nice chat; so I guess there are some fellows who get this elusive VU. W9KG did a QSY to 14 mc., was on that band for only 25 minutes but grabbed off VQ8AF, which is nice going any way you look at it. W9LBB kicked in with the above paragraph and also says that VU7FY is coming through nearly every morning around 1530 g.m.t. Tnx, Harris.

In 45 minutes W3AYS heard PA0MZ, VU2CQ, FB8AB, ZL2BZ, X1AM and LU6FV. He asks for comparisons from other W3's.

CT2AC is coming through quite well with his r.a.c. on 14.350 kc.

W6KRI works a new one in VS4CS. This fellow is located in Sarawak, of the East Indies group, and claims he is the first official station licensed there. This on 7 mc. KRI says CL3AC ex CR10C in Timor is on 14.370 kc. once in a while. The QRA of VQ8AC and VQ8AF is Mauritius.

VQ8A's call has been changed to ZD8A, Ascension Island, and comes through on the Pacific Coast around 4 p.m. p.s.t.

W9NTW-OHK hooked up with PZ1AB in Surinam . . . a new country for him, also on 40. W9NTW has a vertical and a horizontal antenna. Claims it is a swell idea as when he cannot raise 'em on one he invariably will get 'em on the other antenna. Some stations heard by him which I think are quite unusual, and should be mentioned, are as follows . . . all on the 40 meter band: TS2UU, J2LN, XOHIT, (Finnish School Ship), HH2R, FA8IH, FA8JO, EA8AL, EA8AC, EA3EV, EA5BM, EA7AO, ON4GU, ON4MD, OM2RX, OM2BC, ZX1A, FA8PR, FA8BO, VO1P, D4NXX, YV5AM, CN8IB, CT1LC.

### Birthday Present?

Here's one for the book: R. A. Ohle, W8AAT, celebrated his birthday on November 24th, by getting down on 28 mc. for the first time in his life. After coaxing his 242A along a bit it finally got going and he worked 'em in this order: G5BY, W6GEI, VP5AC, ZU6P and X1AY . . . 3 continents and 5 countries for his first crack at ten. Nice going; better try it again on your next birthday.

Here's a few that are being QSO'd by the gang all over U.S.A.: SM5VJ 7030 kc., U3QE 7130 kc. T8, SP1DE 7012 kc. T9, SP1IA 7050 kc. T9, SP1FI 7100 kc. T8, SP1IT 7100 kc. T8, F8AT 7055 kc. T9.

G5YH has gotten over the flu and is back on the air with that 852 rig . . . and wotta sig . . . about R10 on the East Coast.

Does anyone know the QRA of SV1B? We know it is in Athens, Greece . . . but where in Athens? Come on, somebody; break down, and make a lot of DXers happy.

W3SI is building a new rig using Gammatrons in the final. This is to be used on 5 and 10 meters, and running at a full kw. I'll bet he plans to clean up on all bands during the next International Contest. Chas. reports that ON4AU has been visiting EA4AO and now that he is back home is going to combine with ON4AC and build a bigger and better superstation on the outskirts of Antwerp.

W8DOD worked ZL2GN . . . on 80 meters . . . at 3:26 a.m. e.s.t.

I wonder if W8CRA is still taking J's away from W1SZ. Frank worked V8AC for country no. 114 and is chasing VS7JW but won't give his frequency until he hooks him. Wotta pal. Anyway, Frank, someone told me that the VS wasn't official, so watch your step.

This country stuff sometimes is a laugh. If you have 50 countries nobody pays any attention to you. If you have 70 they say "Uh-huh"; if you have 90 it's, "Is zat so"; then when you get 100 their eyes open and they say, "Jeez, I wish I could get that many"; but when you get 110 or 120 they say nothing but look at you with one eye squinted; and then when you say you have 130 or 140 countries,

## Let's Get Together

Your inquiry about any apparatus will prove to you that it is to your advantage to buy from me. I give you specialized personal service of genuine value that is not available from other jobbers. I take in trade apparatus you do not need and I sell on time.

I stock at lowest prices all amateur apparatus.

**GOOD NEWS:** Positively plenty of PR-16s in stock for prompt delivery \$95.70 shipped prepaid and HRO Jrs. \$99.00. All receivers shipped on ten-day trial. You need send but \$5.00 with order.

### In Stock—Immediate Delivery

PR-16s complete prepaid.....	\$ 95.70
National HRO Jrs.....	99.00
National HROs.....	167.70
RME-69s complete.....	134.90
Bretting 12s complete prepaid.....	93.00
Silver 5Ds complete prepaid.....	109.80
Super Skyriders complete.....	79.50
Super-Sevens complete.....	49.50
ACR-136s complete.....	69.50

ALL COLLINS, RME, RCA TRANSMITTERS.

### Trade In Your Receiver or Transmitter

Every inquiry and order is personally attended to by Robert Henry, W9ARA; an active amateur for eleven years; graduate E.E. from M.I.T.; and owner of Henry Radio Shop selling amateur apparatus for seven years. You can reach me by letter, telegram, or phone call 24 hours a day, 365 days a year. When in a hurry order from W9ARA. Write for any information.

## HENRY RADIO SHOP

211-215 North Main St.

Butler, Missouri

## 7000 Kc XTALS

Thick C&S cut—Highly Active—  
Low Drift—Single Freq.—Cleaner  
Note—Close to Freq. Guaranteed

**\$2.25**  
p.p.

80M-160M—C & S cut as above.....\$2.00 pp.  
80-160M—Thinner Cut Low Drift.....\$1.35 pp.

## C&S XTALS

836 E. WEBER AVE.

STOCKTON, CALIF.

they blow up and say, "Yeah, well I've heard some big ones, but I can't stretch it *that* far."

W8MRR hooked up with another one of those rare ones in getting VL4U. Comes in at 7130 kc. with an n.d.c. sig and gives his QRA as Delphis Island off the coast of Sierra Leone, West Africa.

W8BTI, one of those really consistent dx brass-pounders, does himself proud in working PK1WK on 7 mc. for his 93d country. Congrats, Carl, as that is great work.

W8KPB says he went chasing this YS1FM after W6GRL and CXW got through with him . . . and all he got out of it was a darn good hangover. Never heard of that kind but guess it's possible. Ned also reports that 8CRA worked U8VO in Turk-istan. What next. Maybe we should start squinting one eye????

Speaking of this battle-axe Lucas, W8CRA . . . a bunch of the boys would like to know what the deuce he does with a full grown telescope in his shack. Some funny rumors are floating around but judging from a picture that I saw of him, (think it was in a magazine) I can't say that these said rumors would fit him.

From W6HXU's dx column in "73", the following interesting piece of news is snatched: "W6AUX and W6CNX have combined and have a beautiful layout on top of the Del Rey hills. In the past week they have been averaging about 15 European QSO's every morning on 20 meters. They attribute their success to a brand new, beam antenna. It is a diamond affair, three and one-fourth waves long on each leg and one wave high. Besides the Europeans they have been contacting plenty of South Africans with this set-up. A couple of unusual stations they have hooked recently are SX3A, in Greece, and FR8CX on Reunion Island."

I am sorry that the Atlanta bunch didn't kick through with some DX information but I suppose there is a reason . . . the most logical being that W4CBY did his holiday shopping too early and still has some left. As for W4DHZ . . . well, your guess is as good as mine, but word comes from up north that Dave has met the "only one".

Thanks

To the fellows who contributed bits of news for this month's dx section, I want you to know that it is really appreciated. Keep up the good work; it's your column. And while I think of it, let's hear from the other districts in the U.S.A. as well as from every point on the Globe. Information on all types of antennas is especially welcome, and when it is sent in don't forget to include all details, such as length, height, method of feed, slant, direction, and any other points that every dx ham likes to hear about. Squibs about dx are always interesting whether humorous or otherwise; also are the rare dx contacts that are not made every day in the week. When listing stations such as these, please give time, frequency and tone.

No, we don't know the QRA of EU3H. If anyone has information as to the location of this station, we would appreciate getting the data. There is always the possibility that he is located in the same country as I8AB, K9P, and B4UP. *Maybe*, we say.

Oh yes . . . activity at W6QD has been just swell. I thought I remembered making one or two dx contacts during the past month, but when I went to look in my log book for 'em, they were both lost in a whole flock of W's.

**Be Thrifty — Save a Dollar**  
"Radio", 1 yr., \$2.50 "Radio", 2 yrs. \$4.00  
U.S.A., Canada, Spain, Newfoundland, and all  
independent American countries.

# INCA Transformers

FOR THE HI-POWER  
FAN



Hams using HK 354's or 150-T's and wishing to get a kilowatt input without mortgaging the old homestead will be interested in the INCA numbers listed below. These husky, well-insulated transformers and chokes are designed for exceptional hi-power service.

**INCA B-37**—will supply 2000 or 3000 volts D.C. at 500 M.A. through a choke input filter, primary for 115 or 230 volts—heavy case—exceptional impregnation—porcelain terminals.

List Price - - - - \$49.75

**INCA I-33**—Filament transformer for two HK 354's or 150-T's—Skeleton Mounting—3500 volts insulation—deliver 5 volts at 20 amperes—Primary 105-110-115-120 volts.

List Price - - - - \$5.40

**INCA D-45**— and D-32 — Respectively — 60/12 henries and 20 henries—Swinging and smoothing choke for 500 M.A. circuits. Heavy cast case—Porcelain terminals—10,000 volts insulation.

List Price — D-45 \$14.00

List Price — D-32 \$15.00

All the above, and many more quality transformers, are described in INCA BULLETIN No. L-11, obtainable from your jobber or from:

**PHELPS DODGE COPPER  
PRODUCTS CORPORATION**  
INCA MANUFACTURING DIVISION  
2375 East 27th St., Los Angeles, Calif.

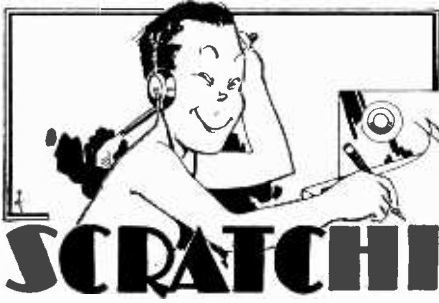

Osockme, Japan.  
September 23, 1935.

Hon. Friend Editor of  
RADIO, dear pal Ed.:—

Scratchi sit down for square meal at round table and make questions with self and answers for such that it seem appropop to open retale radio parts store here in Japan for purpose of making quick fortune from radio amateur trade.

All other radio dealer friends seem to ride in alleged automobiles, whereas Scratchi still find himself on foot travel basis. Prosperity are a state of the mind and into such I herewith make formal entry. It seem evident to Scratchi that if radio dealers can give discount of 40% off to amateurs, dealer need only pay next to nothing or less for such merchandise which he sell. I make inquiry from friend who represent large manufacturers and he tell me that it are always best to first make impression on radio manufacturing people that Scratchi are going to do tremendous large business.

I find sootable locatinn for radio store and I buy many large baskets of flowers to congratulate my own opening. I send telegrams to myself from distant places wishing me success and posterity, and I fill store window full of empty radio parts boxes which I find in ash can of competitor dealer who have store across street from where I open up and close at ten. I hang help wanted sign in window which say, "Growing Boy Wanted for Growing Concern."

I pick up telephone and call manufacturer representative and I ask for quotation on ten thousand transmitting condensers. He snap back and say such condensers cost eight cents per each in ten thousand lots so I tell him to please send up two at that price. I make promise to pick up balance of 9,998 condensers when business pick up.

I take such condensers and put in window with sign which read "Transmitting condensers, \$12.50 retail, 21 cents whllesale your price, minus 40% discounts".

Business are slacks on opening day in Scratchi store. My wife come in to see how business make go and she say "Scratchi, I see business are rushing" and I say to my wife, "yes it are rushing past the door". She then say I should put on great special sail and reduce all merchandise halfpence to bring in more customers. Next hour policeman come into store and inquire how cold are the weather and what are good to heat it up with. I tell him snappily that I are not a drinking man.

Next hour, magazine salesman come in who say he are working his parents through college and wish for me to take subscription tn seventeen uncensored magazines which I can lay on chairs in store for customers to read when clerks are busy. I tell him to come back at such time.

I stay open until clock strike me pink at 11 PM., so I go home without profit or cash but with much experience gained on opening day of store.

I make resolution to start following day with determination to do business. I put on first great sail. I hang sign in window. It say, "High Freakency Transmitting Tubes, regular price \$55.00, our sail price only \$3.19". My competitor across street see such sign and he become frosty at mouth. He hang up sign in his own window which say, "Same tubes as gyp across street have can be purchase here for \$2.19". That are sad blow to Scratchi, so I make new sign which read, "Beware of the trust, buy your tubes here for only \$1.19 each". So my competitor across street become insensed and put up another new sign which say, "Buy your High Freakancy tubes from us, our tubes are used by all of great doctors in Japanese hospitals for curing sickness with diathermy treatment, our special price for such tubes today are only 19c each. Take one home and cure all of your own ills".

Scratchi then hang up sign which say, "Business have been brisk with the undertaker".

Next moments my competitor from across street make wild plunge for my throat and threaten me with bodily harm if I continue make such disastrous price cut sales for bringing business into store.

I make reason and propostion with him. I tell him we merge. We figure out great scheme. He buy my business and pay me cash spots for it. I accept. He give me job in my store. Customer walk into his store and want to buy tube. He ask for price. He are told that such tube will cost \$9.12. He say that are too much, he can go right across street to Scratchi store and buy same tube for three dollar less. He then get insulting remark from man behind counter and he say he go straight across street to Scratchi store to buy tube. So he come into my store and tell me he will never again buy from gyp who owns store on other side of street. I sell him same tube for three dollars less than store across street charge. He pay me. I laugh very loudly. My wife come back into store. She say what you make such silly laugh for Scratchi? I tell her that customer do not know that my friend across street also own my store. If you do not think such are funny joke, Hon. Editor, please write and I will draw diagram of explanation for you, with proper legend and symbols.

Your pre-prosperous subscriber,  
HASHAFISTI SCRATCHI.

**60 to 10,000 Cycles**

Wide response is one feature of Brush Type A headphones. There are six others:

1. High impedance and great sensitivity that permits operation from any normal source.
2. Brush phones handle excessive volume without overloading.
3. Light weight—6 ounces complete.
4. Cases especially designed to minimize breakage.
5. Rugged construction. No magnets to cause diaphragm chatter.
6. A quality product . . . now available at the new low price . . . only \$9.00 list.

Data Sheet No. 10 gives full details and circuit diagrams. Free on request. Send for your copy today.

**The BRUSH DEVELOPMENT COMPANY**  
1886 E. 40th St. CLEVELAND, O.  
MICROPHONES • MIKE STANDS • TWEETERS • HEAD PHONES • LOUD SPEAKERS

## U.H.F. Superhet

*(Continued from Page 51)*

between the plate of the output tube and ground through a condenser (1 mfd.), a 4,000 KC modulated signal should be impressed on the 954 modulator tube through a .01 mfd. or other suitable condenser. The grid lead

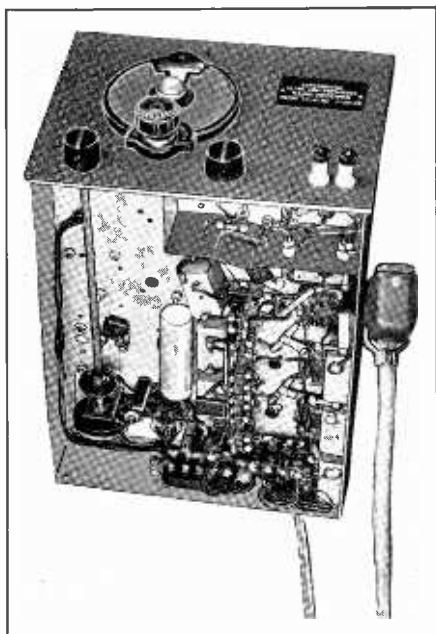

Sub-chassis View

should be connected to the 954 grid. Otherwise the tube will be operating without bias. A headset placed in parallel with the output meter may prove of use in locating the signal. Trim the I.F. transformers for maximum signal output, decreasing the input as necessary to prevent blocking of the I.F. amplifier. When this has been accomplished adjust the output to some optimum value or 12 volts output. Now, vary the signal generator minus kilocycles to one side of maximum until the output has dropped 10 (4 volts) decibels. Then, vary the signal generator through the peak to the high frequency side of 4,000 KC until the output meter falls to 4 volts as before. If the I.F. amplifier curve is symmetrical the signal generator dial calibration will show an equal number of divisions either side of 4,000 KC. If this is not the case, symmetry may be attained by re-alignment. Should the curve still remain irregular, this condition may be corrected by slightly adjusting one of the trimmers until the frequency at minus 10 db is equally distant either side of 4,000 KC. A slight loss will result by the latter method. However, more than sufficient gain is obtained to offset the misalignment. When this condition has been attained the curve will be symmetrical for all practical purposes from 0 to minus 10 db and may be considered satisfactory

for use. Further checks may be made at minus 20, minus 30, and minus 40 db. The band width may be extended by staggering the transformers, i.e., tuning the grid circuits a trifle higher than 4,000 KC and the plate circuits a trifle lower in frequency.

The same procedure is followed to equalize the peak as previously. The adjustments outlined above are essential to the efficiency of this receiver, although it is not claimed that operation will be impossible by a rough adjustment as is made in the alignment of many ham-built receivers.

**R.F. Circuit**—The signal generator is connected to the antenna post of the receiver through a condenser. The grid clip of the 954 modulator tube is removed and connected to the vacuum tube voltmeter, the other side of which is connected to ground. Both leads should be as short and direct as possible. Make certain that grid lead capacities to ground simulate actual conditions. In this case, a General Radio Co. vacuum tube voltmeter was used and proved very satisfactory. Although it is a calibrated instrument, these calibrations are of little value at 56 MC, and any readings obtained are for comparative purposes during alignment. A vacuum tube voltmeter, using a 954 tube, would probably be more efficient. As the modulator tube is not being used during these adjustments it would prove of value in the vt voltmeter. The three condensers comprising



## The Most Complete Callbook Ever Published

*Your QRA is listed in the latest edition*

The only radio callbook published that lists all radio amateur stations throughout the entire World.

Also a complete list of high frequency commercial stations, International abbreviations and amateur prefixes, "Q, R, & T," systems for reporting signals, new US inspection districts and high frequency time, press and weather schedules.

Each copy contains a double post card addressed to the CALLBOOK for use in reporting your new QRA. We are extremely anxious to publish a callbook that will be 100% correct and want you to help us by checking your QRA at once in the latest edition and advise us of any errors.

**PUBLISHED QUARTERLY MARCH, JUNE, SEPTEMBER AND DECEMBER**

Single Copies \$1.25 Annual Subscription USA, \$4.00

*Order your copy today from your local radio jobber or direct from:*

**RADIO AMATEUR CALL BOOK, Inc.**  
606 South Dearborn Street, Chicago, Illinois



the variable gang should not be coupled, so that either may be turned at will. Impress a strong signal on the antenna post of the receiver, adjust the antenna and modulator tuning condensers for maximum deflection of the voltmeter, and note the position of each. Both condensers should be meshed approximately 15%. Therefore the coils may be trimmed until both condensers fall at that position. Now, change the frequency of the signal generator in 1,000 KC steps until the condensers are fully meshed. At each 1,000 KC each of the tuning condensers should be varied to check for any possible increase in output at that point. If an appreciable increase in output is possible, the tuning coils or the condenser plates should be bent until a fairly uniform maximum output is realized throughout the tuning range. Adjust the signal generator to 60 MC as before, and tune both condensers for maximum signal output. Lock the coupling between the condensers. As before they should be meshed about 15%. If the correct capacities have been used in the construction of the receiver, the antenna and modulator will tune from 55 to 61 MC. A chart recording signal generator calibration in 1,000 KC steps against radio receiver dial divisions should be made up as it will be required in the tracking of the oscillator circuit. A sample chart is shown herewith:

Sig. Gen Freq.	RF Dial Div.	RF-Osc. Dial Div.
61 MC	100	97
60 MC	85	85 ALIGNMENT
etc.	etc.	etc. AT THIS POINT

By using this method it is impossible to align either the R.F. or modulator tuned circuit to an image frequency. Remove the vacuum tube voltmeter from the circuit, replace the 954 modulator tube, and connect the grid and plate leads. Reference to the chart indicates that the signal generator and the receiver should be tuned to 60 MC and 90 divisions, respectively. Apply modulation to the signal generator, which is still connected to the antenna post on the receiver, vary the oscillator condenser, and at the same time listen for the signal with the headset connected to the output. As the oscillator is rather critical, it may be necessary to add or remove a turn or two in order to locate the signal. When this has been accomplished,

adjust the oscillator coil, spreading the turns until the oscillator tuning condenser aligns with the R.F. and modulator gang. Always reduce the input to the receiver, using as little signal input as required for normal output. Lock the oscillator tuning condenser to the modulator condenser. The three condensers will now move as one, completing the gang. Tune the signal generator to 60 MC and the receiver dial to 85 divisions as indicated on the chart data, previously recorded. The signal should be heard at maximum at this point. Tune the signal generator every 1,000 KC and the receiver to the corresponding dial recordings. If the signal is not at max. at the same point as recorded for the R.F. dial divisions, it will be necessary to change the turns on the oscillator coil and/or bend the oscillator tuning condenser plates until this has been accomplished. The closer the tracking, the greater will be the efficiency of the receiver. This procedure should be followed through a few times to insure a good adjustment, as movement of the plates at one end of the range will change the alignment at the other end. After this has been completed the receiver may be considered ready for operation.

The unit is also very efficient for 28 MC work. Coil data is not available due to the fact that a complete complement of "finished" coils was not constructed.

As an afterthought a 4,000 KC beat oscillator was coupled to the 6C6 detector tube. By using this arrangement it was possible to receive stations never heard before. It should prove a valuable asset in increased range for CW work and is being incorporated in the present receiver. It also serves in detecting a weak unmodulated carrier during a duplex transmission.

As a final test the outfit was carried to the 56 MC "proving grounds" atop Eagle Rock in West Orange, N. J. At 8:00 PM 28 stations were logged during one dial rotation, some were heard "splashing" into the band beyond the range of the receiver. Each was well separated and only one case of bad QRM was experienced.

Anyone building a receiver of this type will be more than satisfied with the performance derived therefrom, for surely it is far superior to the super-regenerative and the resistance coupled superheterodyne. Certainly it may be called the forerunner of amateur ultra-high frequency radio receivers.

Note: Power output measurements are based upon an 8,000 ohm effective load.

Output meter—1,000 ohms per volt.

Antenna System: The concentric tube transmission line referred to earlier consists of 3/8-in. copper tubing, a No. 14 hard drawn

## Special Radio Services by Robert S. Kruse, E.E.

- For the Professional:  
Apparatus and station designs and improvements.  
Construction of special apparatus.  
Problems involving cathode ray equipment.
- For the Amateur:  
High-grade discontinued commercial transmitting equipment.  
"The Answer Factory," a low-cost information service on operating and constructional problems.  
Quotations on request.

**ROBERT S. KRUSE**  
GUILFORD, CONNECTICUT  
(Near New Haven)

## LITTELFUSES

Radio men can use Littelfuse Products profitably in their work. New test instrument—pocket size—TATTELITE—cost only \$1.00. Also Littelfuses for instruments; Hi-Volt Fuses for transmitters, etc. Neon Voltage Fuses and Indicators. Aircraft, auto, radio Littelfuses—mountings. Write for catalog.

### LITTELFUSE LABORATORIES

4236 Lincoln Avenue

Chicago, Ill.



copper wire and small glass beads. The copper tubing is of the refrigerator variety, the interior of which is free of contamination. The glass beads are spaced every two inches and fastened into place by depositing a drop of solder on either side, or crimping the wire. In this case crimping was a very simple matter, due to the fact that the beads presented a snug fit.

The surge impedance of the concentric line is 75 ohms, and proved itself superior to other forms, such as: twisted pairs which are subject to leakage caused by varying weather, poor insulation at high frequencies, etc.\* A small piece of the concentric line may be seen in the photograph with one of the 112 MC R.F. transformers and the complete receiver.

### Radioddities

An early radio editor suggested that all hams lay off radio during Lent as a means of self-denial. . . . Selling tubes in sealed cartons is a new innovation hereabouts, but they were doing it in England in 1925. One British manufacturer provided contacts by means of which a tube might be tested without removing it from its container. . . . An old-timer announced a big find when claiming increased sensitivity when a strong magnet is placed near a tube. . . . In the beginning, all broadcast stations were assigned the same wavelength—360 meters. . . . The first collegiate ham radio club was formed at Harvard in 1902. Calling themselves the *Weld Phonepterograph Company* (after Harvard's Weld Hall which housed them) their interest prompted Prof. G. W. Pierce to inaugurate a radio course in the physics dept. . . . In 1913 radio was called a great boon to communication in Central Africa. It seems that the telegraph people there had experienced no end of grief when native belles tore down their wires and fashioned the pretty copper into bracelets and the like. . . . A 1914 news article states that the Secretary of Commerce approved a fine of twenty-five dollars imposed upon a ham whose wavelength had exceeded the legal figure by 370 meters.

\* Antenna Terminations—"ELECTRONICS", August, 1935.

28 and 56 Mc.

[Continued from Page 57]

to kill radiation of the 14 mc. driver output, he uses a 20 meter filter.

56 Mc.

W9NY and W9GHN are now building crystal controlled 56 mc. rigs and are going after the five meter international dx cup to be awarded by the Milwaukee Radio Amateurs Club. W9JGS says that W6DOB has heard *all districts on 56 mc.* and is ready with his Gammatron to work a few now. X1AY, W1DZE, W2TP and W6JJU have already started their high power five meter rigs. W6JJU says the big outfit runs cold at 400 watts input, getting T9 xtal reports. That sounds like plenty of improvement over the old five meter sets. Between April and August, 1936, we expect to hear reports of many 1000-2000 mile 56 mc. contacts. Get your rigs all set, particularly for use of tone-modulated c.w. When 28 mc. signals are coming in at distances of 250 to 600 miles, drop down to "five".

If you haven't seen page 80, turn to it right now.

*The Tower of Hospitality*

**MORRISON HOTEL**

CHICAGO

In the Heart of the Loop

SINGLE ROOM \$2.50 UP

\$4.00 Double

Each, with Bath, Servidor and Circulating Ice-Water

LEONARD HICKS  
Managing Director

### TRADE IN YOUR RECEIVER.

- HAMMARLUNDS-NATIONALS-RME 69
- MCMURDO-SILVER-PATTERSON, ETC.,  
RECEIVERS SHIPPED PREPAID-NO EXTRA CHARGE TO WEST COAST.

### SCHWARZ RADIO SERVICE

15 LAWRENCE AVE., DUMONT, N. J.



# BUYER'S GUIDE

Where to Buy It

## CHICAGO, ILLINOIS

Chicago Radio Apparatus Company, Inc.

415 South Dearborn Street - Harrison 2276  
Dependable Radio Equipment - Estab. 1921  
Bulletins on request. Everything for the amateur.  
Get our very low prices.

## HAWAII, HONOLULU

Honolulu Furniture Co., Ltd.

Cor. Beretania & Emma Sts.

## SAN FRANCISCO, CALIFORNIA



1452 Market Street

"The House of a Million Radio Parts"

Hammarlund and National sets and parts  
RCA and EIMAC Tubes.  
Arcturus Receiving Tubes.  
Trimm Phones, all types.  
Johnson Antenna Feeders, Insulators,  
Transposition Blocks.

## FRESNO, CALIFORNIA

Ports Manufacturing Co.

3265 E. Belmont Ave. Radio W6AVV  
National FB7-SW3 and Parts: Hammarlund,  
Cardwell, Bliley Crystals; Johnson Insulators  
Distributors RCA-DeForest Transmitting Tubes  
Established 1914 Send for Wholesale Catalog

## OAKLAND, CALIFORNIA

Radio Supply Company  
2085 BROADWAY

Hammarlund, Yaxley, Carter, National, Johnson, IRC, Cardwell, Miller, Morrill, Flechtheim, Triplett, Haigis Transceivers.  
W6GPF

## NEW YORK, N. Y. 227 FULTON ST.



Complete Stock of Amateur Radio Supplies  
at Wholesale Discounts

## CINCINNATI, OHIO

Steinberg's, Inc.

633 Walnut

## PARTS REQUIRED FOR BUILDING EQUIPMENT SHOWN IN THIS ISSUE

The parts listed are the components of the models built by the author or by "Radio's" Laboratory staff. Other parts of equal merit and equivalent electrical characteristics may usually be substituted without materially affecting the performance of the unit.

### RK-20 All Band Transmitter

- C1—Hammarlund Star SM-100
- C2—Sangamo 1000 volt
- C3—Same
- C4—Hammarlund Star SM-50
- C5—Hammarlund TC1D-140-MC
- C6—Sangamo 1000 volt
- C7—Cardwell XP-90-KD
- C8—Sprague tubular electrolytic
- C9—Sprague tubular paper
- C10—Sprague cardboard electrolytic
- R1, R3, R5, R10—Ohmite
- R2, R4, R7, R8, R9, R11, R12, R13, R14—C.R.L. resistors
- R15—Aerovox
- T1—U.T.C. no. NS-30
- Sockets—Hammarlund isolantite
- Microphone—Astatic D-104
- Coil forms—Hammarlund SP-53 standard

## CHICAGO, ILLINOIS

Chicago Radio Apparatus Company, Inc.

415 South Dearborn Street - Harrison 2276  
Dependable Radio Equipment - Estab. 1921  
Bulletins on request. Everything for the amateur.  
Get our very low prices.

## LOS ANGELES, CALIFORNIA

Radio Supply Company

912 So. Broadway

THE AMATEURS' HEADQUARTERS OF THE WEST

All Nationally Advertised Parts for Receiving and Transmitting Carried in Stock at All Times 9 Licensed Amateurs on Our Staff.

## TORONTO, CANADA

Radio Trade Supply Co.

587 Yonge Street

## BOSTON, MASSACHUSETTS

The Radio Shack

46 Brattle Street

The amateur supply house of New England.  
Distributors of all better radio parts lines.

## ST. LOUIS, MISSOURI

Walter Ashe Radio Co.

11th and Pine Sts.

## DENVER, COLORADO

Inter-State Radio & Supply Company

1639 Tremont Place

Amateur Radio Headquarters in the Rocky Mountain Region

## SEATTLE, WASHINGTON

SEATTLE RADIO SUPPLY, INC.

2319 SECOND AVENUE

Four Hams, W7WE, BRS, CR, AVC,  
ready to serve you with technical data  
and highest quality parts.

# These Reputable Merchants stock the parts needed to build equipment shown in "Radio"

They solicit the patronage of our readers.  
Established dealers of known reliability are invited to write for rates.

## DAYTON, OHIO

Standard Radio Parts Co.  
25 North Jefferson Street

## BOSTON, MASSACHUSETTS

"Ben's"-Tremont Electric  
Supply Co.  
10 BOYLSON STREET  
Up-to-date and complete line of short and long wave receiving and transmitting equipment.

## ATLANTA, GEORGIA

Garvin Electric Co.  
75 Forsyth St., N. W.

## CHICAGO, ILLINOIS

Mid-West Radio Mart  
520 South State Street

## DENVER, COLORADO

Inter-State Radio & Supply  
Company  
1639 Tremont Street  
Denver's Pioneer Radio Distributors

## CHICAGO, ILLINOIS

NEWARK ELECTRIC CO.  
226 WEST MADISON STREET

The Best at Lowest Prices—Write for  
Complete Catalog

## HOUSTON, TEXAS

Straus-Frank Co.  
1209 Milam Street

## Gordon 59 Modulator

R1—S. S. White  
R10—Lynch metalized  
R11—Girard Hopkins  
Other resistors—Centralab  
T1—Thordarson T-5289  
T2—Inca N-16  
Condensers—Cornell-Dubilier  
Meters—Triplet type 321  
Sockets—Eby Isolantite  
Chassis and rack—Radio Engineering Products  
Filament transformer—Thordarson T-5455

## 300-T R.F. Amplifier

C—Hammarlund TC-50-A  
C3—Sangamo 5000 volt  
C4—Aerovox paper tubular  
Coils—Decker  
Sockets—Johnson

## 75-160 Meter Exciter

C1—Hammarlund MC-100-M  
C3—MC-250-M same  
RFC—Hammarlund CH-8

## Test Sets

The Supreme Instruments Corporation announces four new laboratory models which are applicable to purchase by Government loan through the Federal Housing Act. The new line includes the popular 85 Automatic Analyzer-Tube Tester, the 339 Deluxe Analyzer, the 89 Deluxe Tube Tester and the 189 Signal Generator, all housed in hard oak cases with sloping panels and designed for laboratory and shop use.

## New Catalog

A new sixty-eight page catalogue devoted exclusively to amateur receiving and transmitting equipment has been issued by Wholesale Radio Service Company, Inc., of New York, Chicago, Atlanta, and Newark. It measures 7" x 10" and is printed throughout on high quality coated paper. Copies of this catalogue are available free of charge to amateurs and experimenters.

## DETROIT, MICHIGAN

## RADIO SPECIALTIES COMPANY

171 E. JEFFERSON AVENUE  
Ham Supplies  
National and Hammarlund Sets and Parts

## PITTSBURGH, PENNSYLVANIA

CAMERADIO COMPANY  
603 GRANT STREET

## SEATTLE, WASHINGTON

Wedel Company, Inc.  
520 Second Avenue  
Largest assortment of parts and tubes on the Pacific Coast. Wholesale distributors. "The Ham's Paradise".

## PHILADELPHIA, PENNSYLVANIA

M & H Sporting Goods  
Company  
512 Market Street

## DALLAS, TEXAS

Southwest Radio Supply  
107 So. St. Paul Street

## SPOKANE, WASHINGTON

Spokane Radio Co., Inc.  
611 First Avenue

## MILWAUKEE, WISCONSIN

Radio Parts Company  
332 West State Street

A NATURAL...

# ALL-WAVE RADIO

The New Monthly Magazine  
covering

**ULTRA SHORT WAVE**

**SHORT WAVE**

**BROADCAST**

**LONGWAVE**

A COMPREHENSIVE AND TECHNICALLY AUTHORITATIVE  
PUBLICATION.

SCORED AN INSTANT SUCCESS ON ITS  
FIRST ISSUE.

WE WANT YOUR REACTION!



**Take advantage of this SPECIAL OFFER to readers  
of "RADIO"**

**8 issues - - - - - for \$1.00**

**Regular subscription - 1 year \$1.50**

USE THIS COUPON

ALL WAVE RADIO, 200 Fifth Ave., New York City  
Enclosed please find \$1.00 for special 8 issue offer.

Name.....

Street & No.....

City..... State.....

## The Marketplace

(a) Commercial rate: 10c per word, cash with order; minimum, \$1.00. Capitals: 13c per word. For consecutive advertising, 15% discount for 3rd, 4th, and 5th insertions; 25% thereafter. Break in continuity restores full rate. Copy may be changed often as desired.

(b) Non-commercial rate: 5c per word, cash with order; minimum, 50c. Available only to licensed amateurs not trading for profit; our judgment as to character of advertisement must be accepted as final.

(c) Closing date (for classified forms only): 25th of month; e.g., forms for March issue, published in February, close January 25th.

(d) No display permitted except capitals.

(e) Used, reclaimed, defective, surplus, and like material must be so described.

(f) Ads not relating to radio or radiomen are acceptable but will be grouped separately.

(g) No commissions nor further discounts allowed. No proofs, free copies, nor reprints sent.

(h) Send all Marketplace ads direct to Los Angeles accompanied by remittance in full payable to the order of Radio, Ltd.

(i) We reserve the right to reject part or all of any ad without assigning reasons therefore. Rates and conditions are subject to change without notice.

LARGE STOCK new and used equipment for sale by Southern Ohio's only amateur owned amateur business—Jos. N. Davies, Box 602, R.R. 9, North Bend Rd., Mt. Airy, Cincinnati, Ohio.

A free handbook to W1BML.

SARGENT RECEIVERS \$59.50—W8ANT.

VIBROPLEXES, rebuilt \$5-\$7, guaranteed. New large base bugs \$9. Lydeard, 28 circuit, Roxbury, Mass.

BREITING RECEIVERS—in stock—W8ANT.

ONE copy of the Handbook to W4AKW.

NEON TUBES, four inches, for RF testing, Oscilloscopes, special lengths made to order. Postpaid (U. S., Canada) \$3.00. W8AXB, GLOMU SPECIALTIES, 3411 Harrison Avenue, Cheviot, Ohio, Dept. B.

QSL's, SWL's-Cards. Finest quality stock. Very attractive. Photo type. Different. Very reasonable. Samples? (Stamps). RADIO-PRESS-W8ESN, 1827 Cone St., Toledo, Ohio.

USED TUBES—852's, 860's, 800's, 42A's—W8ANT.

TRANSFORMERS: Power and modulation, filter chokes, etc., to order. Guaranteed 12 months. Reasonable. California Radio Laboratories, W6CYQ, 2523 So. Hill St., Los Angeles, Calif.

MODULATED Watts in a Nutshell; 500 Watt Amplifier in Sunday Clothes, and other equipment described in "R/9" and "Radio", were built in R. H. Lynch racks or cabinets. Send for circulars. R. H. Lynch, 970 Camulos, Los Angeles, Calif.

RELAY RACKS—cheap—W8ANT.

TRANSFORMERS REWOUND and built to specifications. Very best quality materials and workmanship. Ecoff Transformer Co., 1929 Forest Ave., St. Louis.

A free handbook to W9MUF.

FOR SALE—newest and most modern high-power amateur transmitter ever designed. Constructed in the laboratories of Frank C. Jones. This transmitter, phone and c-w, uses new Eimac 300-T in final, driven by RK20. Output on c-w 800 watts; phone output 150 to 200 watts, grid modulated. Has oversize, specially-built power supply in separate cabinet. R.F. and speech units mounted on standard 4-foot relay rack. Coils for all bands, including 10 meters. Price \$350.00, which actually is less than net cost of parts. Price includes tubes and coils, but does not include crystal mike and crystals. Frank C. Jones, 237 Durant Ave., Berkeley, California.

PYREX 3" stand-offs—35c—W8ANT.

W8TA may write for a free handbook.

"SUPER-PHONE-SUPER" described in Jan. "RADIO" for sale. This is the laboratory model built for editorial purposes. Price including 10 to 80 m. coils, but less tubes and power supply, \$50 f.o.b. Frank C. Jones, 2037 Durant Ave., Berkeley, Calif.

WANTED—One copy each of Southern Edition "QST" for March, April, September, 1935, and of Western Edition, March, 1935. S. B. Young, "Maplewoods", Wayzata, Minn.

DANGER! High voltage card (red and blue), 10c; CALL-BOOKS, \$1.25. Bliley 14 mc. crystal, \$7.50. W8DED, Holland, Mich.

CRYSTALS: SATISFACTION OR MONEY BACK. 160-80 meters within 10 kilocycles Y-cut \$1. X-cut \$1.35. Wright Laboratory, 5859 Glenwood, Chicago, Ill.

SELL: Emerson 500 v. m.g. set. Skyrider r.f. a.c. five, other equipment. List for stamp. Hosea Decker, Delaware, Ohio.

QSL SWL Cards, neat, attractive, reasonable. Samples free. Miller, Printer, Ambler, Pa.

METERS: New and used Weston, Jewell meters at bargain prices. All types, perfect condition, individually checked. Free bulletin. W2EDW, Far Rockaway, New York.

WHEN you don't know what to build it in, see R. H. Lynch, 970 Camulos, Los Angeles. Steel cabinets and racks, aluminum cans, panels. Special sizes to order. Send for circulars.

SELL 500 watt Dawley Amplifier described last month. Complete with 40 meter coils but less two 50-T tubes, \$46.00 (plus tax in California). Shipped by Express. "RADIO", 7460 Beverly, Los Angeles.

WANTED: Edison storage "A" batteries, UX852s. Grote Reber, Wheaton, Illinois.

NEW EIMAC 300T—\$60.00—W8ANT.

FINE QSL's! SWL's! Samples. W9UII Press, 2009 Fremont Street, Chicago.

100 Watt Phone, 300 Watt c.w. Transmitter (minimum power rating), complete with coils for 3 bands. Uses 2 Eimac 50T's, 210, 53 in r-f circuit. Grid Modulated. Mounted in 3-foot relay rack. Power supply included. Operates on 10 meters as well as on other bands. Controlled Carrier can be cut in or out. This transmitter designed and built by Frank C. Jones for his own use. Will sell for \$135.00, less tubes, microphone, and crystal. For sale by Frank C. Jones, 2037 Durant Ave., Berkeley, California.

TWO unused Sylvania 845 graphite plate tubes. Excellent for audio. Perfect condition, guaranteed. One unused RCA-211, perfect condition. 1 Hickok Type SG test set, cost \$68.00 net. Best cash offer takes. C. Robbins, 2356 Cecelia Ave., San Francisco, Calif.

COMPLETE 1935 volume "RADIO", January to December. Several on hand. \$3.00, postpaid, Pacific Radio Pub. Co., 422 Pacific Bldg., San Francisco, Calif.

A copy of the handbook free to W6CAV.

AIR-WOUND coils—W8ANT.

# RALPH O. GORDON CONSULTING ENGINEER

## High Frequency Radio and Sound Equipment

●

5708 Keniston Ave.  
Los Angeles, Calif.  
Phone University 7570

PROPERTY OF -F.E.J

THIS SPACE IS RESERVED FOR:

**RADIO ENGINEERING  
PRODUCTS**

LOS ANGELES, CALIF.

RIGHT ON TOP OF YOU . . .  
*the* **TEMPERATOR** *Season*



Ideal for chilly bathrooms. Set the Temperator at the temperature wanted and this will be maintained automatically and economically, because the Temperator operates only a part of the time.



The Temperator is a great comfort for invalids and old folks.



Extra heat for baby's bath time—quickly, economically.



Chilly offices become cheery offices with the Temperator.

Everyone needs auxiliary warmth  
 —in home or office... **\$7.95**

And everyone can afford to pay  
 for a thermostatically controlled warm air  
 circulator that gives instant heat where it's  
 wanted, when it's wanted, how it's wanted

**H**ERE is the quickest, handiest, most easily portable, most efficient  
 and economical electric auxiliary heater ever offered to the public.  
 An everyday source of comfort from earliest Fall to latest Spring.

A convenient package item  
 —sell it over the counter.  
 Just a glance and a few  
 words of explanation and  
 your customer knows in  
 how many ways it can  
 serve the home or office.  
 Easiest thing in the world  
 to demonstrate. Plug it in;  
 turn a switch—that's all.  
 The Crosley Temperator  
 has so many uses that it  
 appeals to everyone. And  
 when you mention the sen-  
 sational price of only \$7.95  
 —then the sale is practi-  
 cally made.

From now on until the last  
 trace of chill is out of the  
 air—and that will be well  
 into the summer—resolve  
 to go to town with this fast-  
 selling, over-the-counter,  
 package item.

*(Western Price Slightly Higher)*

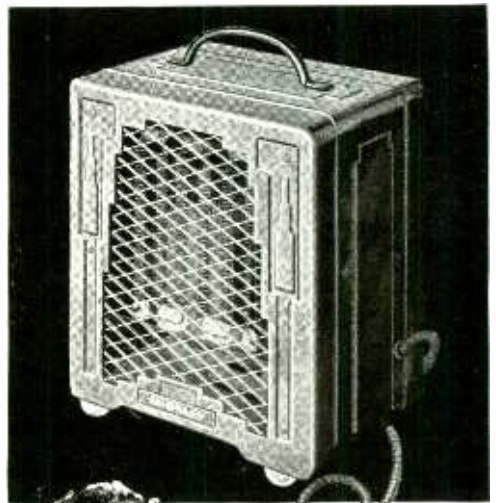

An electric heater plus a fan plus thermostatic control equals—CIRCULATING HEAT.

The circulating heat of the Temperator is splendid for drying hair.

**THE CROSLY RADIO CORPORATION, CINCINNATI**

POWEL CROSLY, Jr., President  
 Pioneer Manufacturers of Radio Receiving Sets  
 Home of "the Nation's Station"—WLW—500,000 watts—most powerful in the world—  
 70 on your dial

**CROSLY TEMPERATOR**

**THERMOSTATICALLY CONTROLLED**





*Most Complete Transformer  
Line in the World*

**QUALITY · RELIABILITY**

**A Universal Modulation Output Choke for Every Purpose**

*The Answer to Your Audio Modulation Problem*

Broadcast and phone men who want an output audio unit that will match all possible tube impedance combinations to the R F Stage cannot afford to be without the new UTC Universal Modulation Output Chokes.

TYPE OUTPUT CHOKE	INPUT		OUTPUT	LIST PRICE	NET PRICE
	CLASS B	A PRIME	R F TUBES		
HUC - 20 will handle 30 watts audio peak	46-59-53-6A6 etc...	45's-42's 2A3's	46's-210's-801's 211-50T-etc...254A's- etc...	\$ 7.00	\$ 4.20
HUC - 50 will handle 60 watts audio peak	210's-801's-830's 841's, etc...	P.P. Parallel 250's-45's 2A3's	RK 20-203A-838-860 211-50T-etc...254A's- 210's-801's-830's	\$12.50	\$ 7.50
HUC - 100 will handle 125 watts audio peak	800's-211 E's 50 T's	845's-284's etc...	852-203A-242A-211 50T-RK 18's-RK 20's 860's-282A's-etc...	\$20.00	\$12.00
HUC - 200 will handle 250 watts audio peak	203 A's-838's 50 T's-etc...	P.P. Parallel 845's-284 A's 800's-etc...	203 A's-838's-50 T's 860's-803-etc... HF 200's	\$32.50	\$19.50
HUC - 500 will handle 650 watts audio peak	204 A's-150 T's HK 354's-HF 200's	849's-150 T's 212 D's	150 T's-204 A's-849's HF 200's-HF 300's	\$80.00	\$48.00

**WHAT THIS UNIVERSAL MODULATION CHOKE WILL DO:**



The choke may be used to match the output audio stage to an R F Pentode stage for screen plate modulation.

It is tapped so that it can be used as an autotransformer coupler from Class B to Class C stages, various impedance taps are available, so that each choke will readily accommodate push pull Class A — Prime or Class B Modulators, single ended Class A Modulator with the DC adding, or single ended Class A Modulator with the DC bucking.

The chokes are huskily constructed and air gaps are arranged to take care of the maximum currents.

Included with each choke is our data sheet 112 which indicates the application of each unit for different tubes and circuits.

**BALANCE COILS**

The new UTC development which permits paralleling mercury vapor rectifier tubes with equal current distribution.

List Net

**PA 10B**

Center tapped choke to equalize the load between two 80's, 81's, 82's, 5Z3's, 83's, etc.

\$ 5.00 \$3.00

**PA 11B**

Center tapped choke to equalize the load between two 866's, 866A's

10.00 6.00

**PA 12B**

Center tapped choke to equalize the load between two 872's, 872 A's

25.00 15.00

**UNITED TRANSFORMER CORP.**

72 SPRING STREET

NEW YORK, N. Y.

EXPORT DIVISION - 15 LAIGHT STREET, NEW YORK, N. Y.