

$$E = I \times R$$

$$R = \frac{E}{I}$$

$$I = \frac{E}{R}$$

CONDENSERS IN SERIES

$$C_{TOTAL} = \frac{C_1 \times C_2}{C_1 + C_2}$$

RESISTANCES IN PARALLEL

$$R_{TOTAL} = \frac{R_1 \times R_2}{R_1 + R_2}$$

RADIO

ESTABLISHED 1917

SHORT-WAVE AND EXPERIMENTAL

BOTTOM VIEWS OF SOCKETS

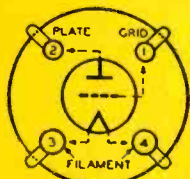

4-PRONG SOCKET
50-201-A, 45, 210, 30, 31, ETC.

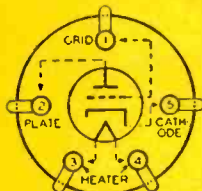

5-PRONG SOCKET
56-46-47-76-27-37

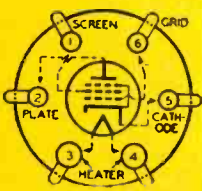

6-PRONG SOCKET
2A5-41-42-43

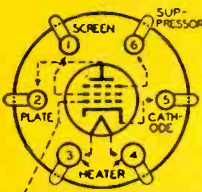

GRID-METAL TOP CAP
6-PRONG SOCKET
57-58-606-606-77-78

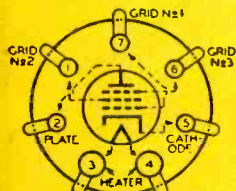

7-PRONG SOCKET 59

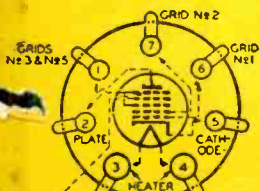

GRID No 4 - METAL TOP CAP
7-PRONG SOCKET
2A7-6A7

-IN THIS ISSUE-

The New Communications "Gainer"
 Parallel vs. Push-Pull Operation
 A Powerful Five-Meter Receiver
 Complete Data on Crystal Microphones
 The New AT-Cut Quartz Crystal
 400 Watts From A 5-Meter Rig
 A Simple Tunalite Oscillograph

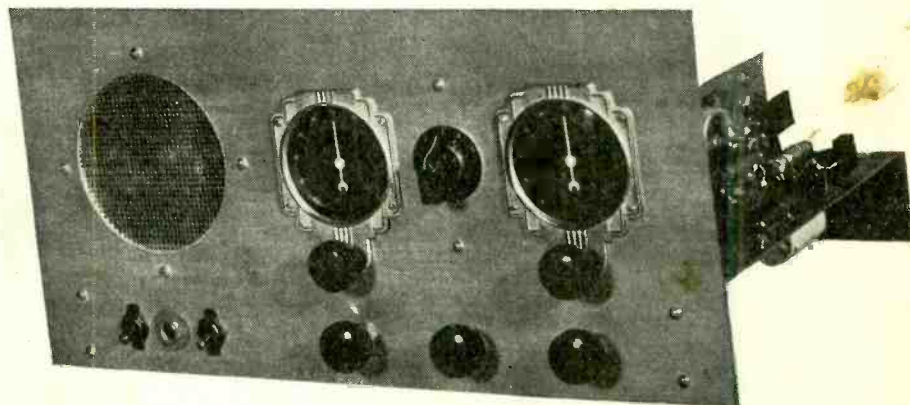

THE NEW COMMUNICATIONS GAINER
A 5-Tube A.C. Operated Regenerative Receiver With R.F. Amplification

See Page 6

FEATURE ARTICLES By . . .

- Clayton F. Bane - - D. B. McGown - - John L. Reinartz - - J. N. A. Hawkins
 Frank C. Jones - - - - I. A. Mitchell - - - - G. F. Lampkin

Sylvania

Reg. U. S. Pat. Off.

FIRST TO SUCCESSFULLY MANUFACTURE GRAPHITE ANODE TRANSMITTING TUBES

The specialized transmitting tube engineers of Hygrade Sylvania Corporation's Electronics Department originated and developed the only complete line of standard air cooled transmitting tubes embodying GRAPHITE ANODES.

Sylvania has started a procession. Broadcasters and amateurs are clamoring vociferously for GRAPHITE ANODE tubes for use in their transmitters. All are hungry for this truly modern tube design. Fall in line with the many followers of Sylvania and enjoy the long service life and lower operating costs that Sylvania GRAPHITE ANODES can deliver.

Remember, over a year ago our electronics engineers mastered this graphite process. Others have been unsuccessful in approaching the standards set by Sylvania with its complete line from 210 to 851 in graphite.

Sylvania sustained leadership in GRAPHITE ANODE tubes is unchallengeable proof of an extraordinary engineering personnel.

That Sylvania can give you better transmitting tubes than anyone else, is the safest kind of a bet.



GRAPHITE ANODES

HAVE SET NEW
STANDARDS
IN TUBE
DESIGN

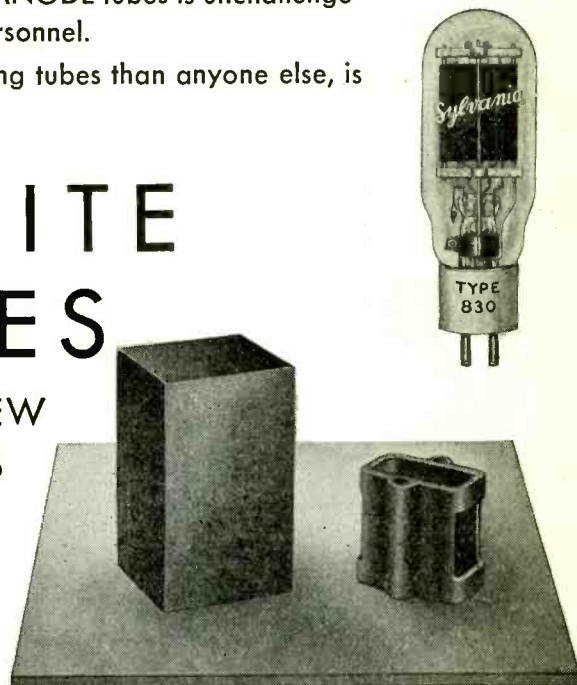

HYGRADE SYLVANIA CORPORATION

ELECTRONICS DEPARTMENT
AMATEUR RADIO DIVISION

CLIFTON, N. J.

FACTORIES: EMPORIUM, PA.

ST. MARYS, PA.

SALEM, MASS.

CLIFTON, N. J.

HAMMARLUND'S

First Low-Priced

COIL FORMS

New XP-53 Low-Loss Dielectric Assures High Efficiency!

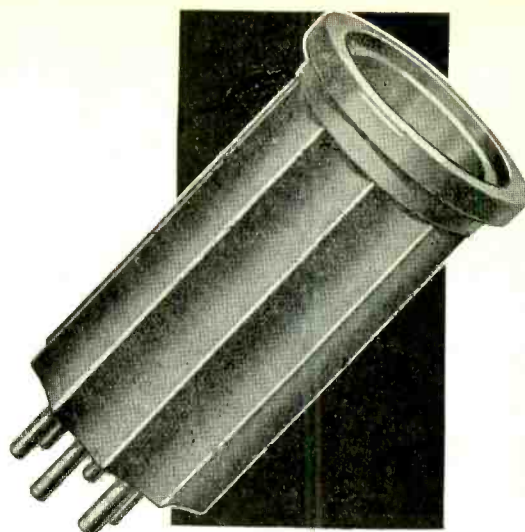

HAMMARLUND has never before made low-priced coil forms or coils, because, until now, only high-priced dielectric compound has measured up to Hammarlund's low-loss standards.

But the recent perfection of "XP-53," the remarkable new Hammarlund insulating material, presents a real opportunity.

Rugged, durable, good-looking and most important—the XP-53 dielectric losses are extremely low. Its amber color is natural—no artificial coloring to cause losses. The proportions of these new Hammarlund coil forms provide the most practical form factor. The forms are ribbed for air-spacing and have easy flange-grips with neat "meter-index" inserts for wavelength marking. A molded shelf inside each coil provides for mounting a Hammarlund "IBT" or "APC" trimming or padding condenser for tuning the coil to a fixed frequency, or for bandspread arrangement.

Supplied with 4, 5 or 6 prongs at 35c each list. Individually packed for protection.



"IBT" Mica-Dielectric Trimming or Padding Condenser



"APC" Air-Dielectric Trimming or Padding Condenser



New S-W COIL SETS

Wound on the new XP-53 forms described above.

Set of 4 coils (4 prongs, 2 windings) for 15-220 meters, \$3.00 list.

Set of 4 coils (6 prongs, 3 windings) for 15-220 meters, \$3.75 list.

Other coils (4 or 6 prongs) available for extending bands down to 10 or up to 550 meters.

Secondaries of the higher-frequency coils (10 to 75 meters) are wound with special low-loss silver-plated wire.



HAMMARLUND MANUFACTURING CO.,
424-432 W. 33rd St., New York

.....Check here and attach 10c for 16-page Hammarlund 1935 Short-Wave Manual, illustrating and describing most popular S-W circuits of past year, with schematic and picture diagrams and parts lists.

.....Check here for FREE information on XP-53 Coil Forms and Coils.

.....Check here for FREE General Catalog.

Name.....

Address.....

PR-9

FOR REAL THRILLS - BE SURE TO SEE

THE WONDER SHOW OF THE YEAR!



You owe it to yourself to see the year's biggest thrill treat—1934's great, new

RADIO AND ELECTRICAL EXPOSITION

In a few short, amazing hours, you'll SEE the latest scientific wonders—have them demonstrated before your eyes—improvements and inventions that will be talked about for months to come. Photography by radio . . . the latest in Short Wave Radio Receivers . . . Electric Eye (Photo Electric Cell) . . . Crystal Broadcasting Studios where you will see Famous Radio and "Talkie" Stars in Action . . . Army and Navy

Exposition open every day from 11:00 to 11:00

Radio Research . . . New York Police Department—"Radio Catches the Crook!" . . . the last word in Electrical Kitchens . . . Auditions for Coming Radio Stars . . . Electro Chemical Exhibits . . . New Electronic Devices.

These and hundreds of other fascinating exhibits show the incredible progress of the Electrical Age.

Come! See! Hear! In no other way can you become so well posted on the latest developments in the radio and electrical fields. Be sure to bring the family too—the 1934 Exposition is a treat for all!

Admission only 25 cents; after 6 P. M., 35 cents

MADISON SQUARE GARDEN

SPONSORED BY THE ELECTRICAL ASSOCIATION OF NEW YORK
EIGHTH AVENUE AND FIFTIETH STREET, NEW YORK CITY

BRANCH OFFICES:
New York City,
253 W. 128th St.
Tel. MOnument 2-2812
Boston,
J. H. Condon,
6 Marlboro St.
Chicago,
C. W. Nelson,
3618 North Bernard St.
Los Angeles, Calif.
1455 Glenville Drive.
Tel. CRestview 4017

RADIO

ESTABLISHED 1917

Reg. U. S. Pat. Off.

A NATIONAL MAGAZINE - PUBLISHED MONTHLY

Publication Offices—Pacific Building, San Francisco, California

Clayton F. Bane, Editor

H. W. Dickow, Business Manager.

Norris Hawkins, Associate Editor.

D. B. McGown, Technical Editor.

Frank C. Jones, Ultra-Short-Wave-Engineering Editor.

Clair Foster, Amateur Activity Editor.

George B. Hart, Contributing Editor.

25c per copy, \$3.00 per year by subscription in the U.S. \$4.00 elsewhere. Send subscriptions to the San Francisco office. Entered as second class matter at the Post Office at San Francisco, California, under the Act of March 3rd, 1879.

Vol. 16

SEPTEMBER, 1934

No. 9

RADIO'S PLATFORM

DURING the past year any discriminating reader of RADIO should have had no difficulty in recognizing that its primary purpose is to present the best available information about new and better methods for transmission and reception. As efficient operation is being hampered by the overcrowded condition of the channels which have been allocated for amateur use, any suggestions for improving these conditions also naturally becomes a part of RADIO'S mission.

THIS, unfortunately, has injected a political angle into the situation, due to the fact that the old-time leaders of amateur radio have been content to accept passively the various restrictions which have been imposed upon them. They frown upon any aggressive policy or plan to regain or extend the privileges they once enjoyed. They regard those who are trying to regain what they have lost as their enemies. As a result, they spend more time and effort in fighting critics of their dilatoriness than in fighting for the amateur. RADIO is fighting for the amateur. All the members of its staff are licensed amateurs, some dating back to 1907. Its statements of fact as to how and why the amateur has lost what he once possessed are intended to awaken him. Its statements regarding unused channels which might be beneficially employed by amateurs are intended to provide an incentive for action. Its exposures of those who have taken the amateur's former rights from him, and who are not adequately using

what they filched, point the direction in which the campaign should be waged.

TOO few amateurs realize that they have been the victims of a systematic campaign of despoilment ever since the commercial value of their achievement was first recognized. Not until they had proved the value of what was once thought valueless were they dispossessed by the claim-jumpers.

THE amateur, both by right of discovery and by right of first occupancy, is better entitled to the short-wave channels than are those who have seized them for profit. Might does not make right, nor should profit take precedence over the general welfare. But what can you expect when your leaders lay down and almost beg to be kicked?

THE lost channels cannot be regained by a policy of passive acquiescence or timid protest. What is needed is a bold stand backed by firm conviction that you are justified in your every demand. The amateurs want more and wider channels. Because their leaders are afraid to try to get them, this magazine has taken up the fight, working in co-operation with such organizations as the Amateur Radio Protective Association. The purpose is constructive—to build up amateur radio instead of letting it fall to pieces from dry rot.

DOES this frank declaration in favor of a more aggressive policy in getting for the amateur what he requires—our political platform—merit your approval?

Front View of the Receiver
 Left to Right: Loud Speaker Grille, Tank Tuning Dial, Coil-Changing Switch, Band-Spread Dial. The small knobs under the dials are, from left to right: Regeneration, Volume and Tone Control. One of the Toggle Switches under the Speaker grille disconnects the Negative "B", the other is the phone-or-speaker Switch.

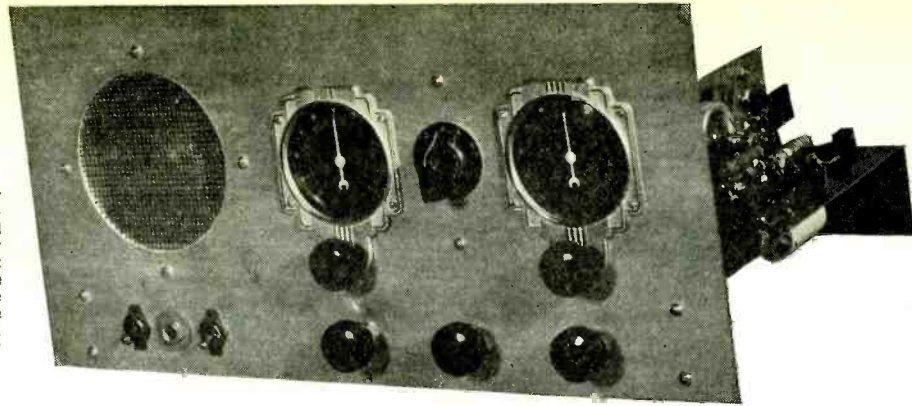

The Communications "Gainer"

It Employs Coil-Switching, Untuned R.F. Amplification, and a Dynamic Speaker

By CLAYTON F. BANE

THERE is no doubt that the smaller types of receivers are still very much in demand. Several months ago we presented the "GAINER" and the popularity which this receiver has achieved is rather astounding. Hundreds of letters have given us an extremely good cross-section of opinion around which to design still another "GAINER" receiver.

Progress in the radio receiver field is so rapid that it is difficult to keep in step with the latest developments. We do not subscribe to the policy of bringing out a new

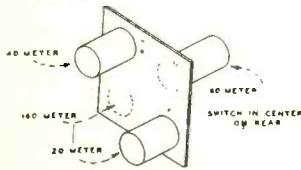

Metal Support for holding the Four Coils and the Yaxley 2-Gang, 5-point, No. 1625 Coil-Changing Switch. The 20 and 40 meter coils are mounted on the front of the support, the 80 and 160 meter coils on the rear. The metal support and the wide spacing between coils makes for effective shielding and elimination of interaction. The Coil Changing Switch is mounted on the metal coil support piece and an extension shaft is brought to the front of the panel, as one of the photographs show.

receiver in each issue of the magazine. Unfortunately, many receivers with fancy titles are nothing more than some basic receiver with a different external appearance.

A great many of the present-day super-heterodynes use coil switching instead of plug-in coils. Plug-in coils are undesirable from the standpoint of rapid band switching. Aside from the fact that a great many coils are necessary to cover several bands, the inconvenience of the changing operation is also to be considered. Argument has waxed furiously as to the efficiency of the switching arrangement vs. the plug-in coil. The physical dimensions of the good plug-in coil are such as to assure a good form factor, while the insulating materials (notably Isolantite and celluloid), have particularly low losses. It would seem that the prime objection to the use of a switch to change coils lies in the fact that losses are higher because of tiny forms used for the various coils in order to fit several coils into a limited space. High-resistance switches were to blame for most of

the difficulties formerly experienced when coil-switching systems were used.

A number of new switches are now available. They have good, positive contacts and unusually low resistance.

In the Communications Receiver herein described such a switching arrangement is used to cover a practically continuous range of from approximately 18 to 200 meters. It is an undisputed fact that the receiver could have been fitted into half the space used . . . and suffered from all the evils that are to be avoided. The coils used in this receiver are only slightly smaller in diameter than the usual plug-in size and the windings are so arranged that the inductances have a reasonably high Q; highly desirable if good gain is to be obtained, particularly on the higher frequencies where "Q" drops rapidly.

The untuned RF coupling stage was incorporated for but one reason, to provide a means for coupling any type or length of antenna to the receiver without introducing the sometimes prevalent dead spots and hand capacity effects. When an antenna is coupled directly into the detector, the length of the antenna will sometimes be such that the receiver will have a "hot" panel, and trouble from hand capacity is experienced. Obviously, a change of antenna length then becomes necessary. The RF coupling stage permits the use of any length of antenna and the only precaution to observe is to change the coupling capacity for radically different antenna lengths.

If gain is supplied to the RF stage, the length of the coupling leads into the detector must be very short. Because the plate lead of the RF stage comes from the base, and because the grid of the detector tube is on top, the problem is not a simple one. It was solved by mounting both tubes in a horizontal position, with the grid-cap end of the detector tube at the same end as the socket base connections of the RF tube. Thus the leads are made extremely short. The RF stage uses shunt plate feed in order to avoid the complexities of inductive coupling and, on the other hand, the undesirable features of plate voltage through the grid coil of the oscillator. When good RF chokes are used, it is safe to say that very little loss is incurred due to the parallel plate feed, and the simplicity of the system more than justifies its use. It may be found that the size of the coupling condenser from plate to grid coil may vary with different receivers in order to avoid possible dead spots.

With the exception of the coil system, the detector circuit is similar to that used in our "GAINERS". A screen grid detector is used because of its great sensitivity and large audio output, and the original Dow electron coupling is used to provide stability of oscillation. This system of coupling is absolutely essential if creeping is to be avoided. It has the additional advantage that it is not easily "pulled-in" when tuned close to zero beat.

When using screen grid detectors, particularly with two stages of audio, it is very important that proper filtering is used in the output in order to avoid feedback, which will most certainly be present without suitable advance precaution. Particular attention is called to the split resistor in the plate circuit of the 57 detector. Instead of being bypassed at the B side, the plate coupling resistor actually consists of two resistances, 250,000 ohms toward the plate end and 50,000

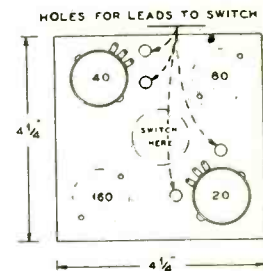

Showing how to run the leads from coils to switch.

ohms toward the plus B. A half mike condenser to ground is connected to the junction of the two resistors and, presto, most of those well-known squawks are gone.

The builder of this receiver is advised to use all of the by-passes shown. While it may seem that some of the condensers are unnecessary, you are assured that such is not the case, and every by-pass has been added for specific purpose.

THE series band spread system has been abandoned for but one reason . . . it was very desirable to have one of the large condensers on the front of the panel (with a vernier dial) to tune the lower frequencies. Ordinarily, this large condenser is set to the center of the band on which it is desired to work and all the tuning is accomplished with the smaller condenser, which has such a small capacity that it allows ample band-spread on

all bands. Of course, this system lacks the variable band-spread feature of the series system, but this is offset by the ability to cover almost a continuous range and thus avoid the use of additional coils.

A built-in power supply is used, although we have long advocated the use of a separate power supply in order to avoid hum pick-up. However, it was determined by experiment that the power supply can be successfully incorporated on the same chassis if care is taken to keep the power components out of the field of the RF end of the circuit. This means, of course, that the chassis on which the units are mounted must be of larger-than-usual proportions. A glance at the photograph of the top view shows that the power supply is well isolated directly at the rear of the chassis, with the speaker in front. Some of the better quality midget dynamic speakers are very suitable for use in this receiver. The one shown in the illustration is the new Magnovox 5-inch midget dynamic with 2A5 matching transformer.

Built-in speakers can well be a part of every amateur receiver. By a flip of a switch, the speaker is cut in or out at will.

CONTRARY to belief, the tone quality and freedom from excessive vibration leave little to be desired. A double-pole, double-throw switch on the front panel gives the operator instant choice of either

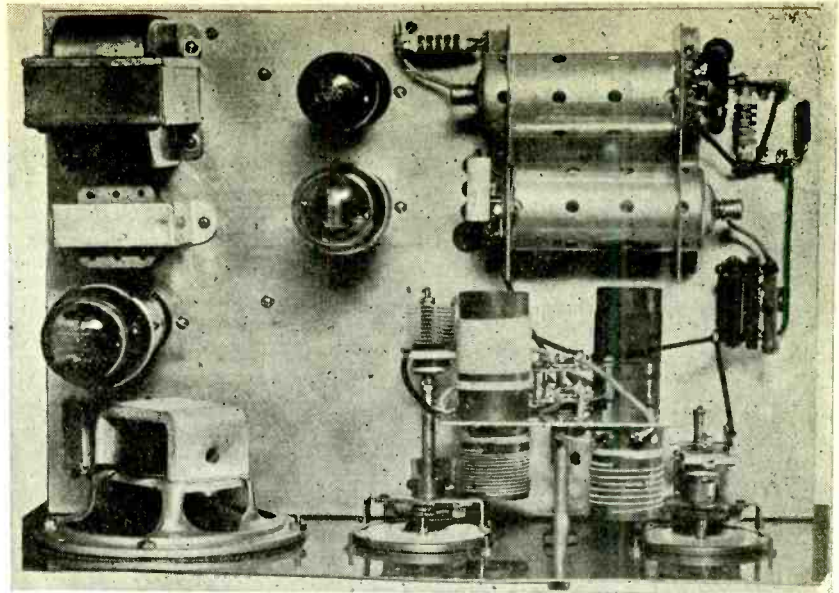

LOOKING DOWN ON THE CHASSIS

The Dynamic Speaker is at the extreme left, front. The Power Transformer is at the rear, left. The 2A5 Audio Tube and the 5Z3 Rectifier are between the Speaker and Power Transformer. The method of mounting the coil assembly is clearly shown at the right. Behind the coil assembly is the support which holds the horizontally-mounted RF and Detector Tube Shields in place.

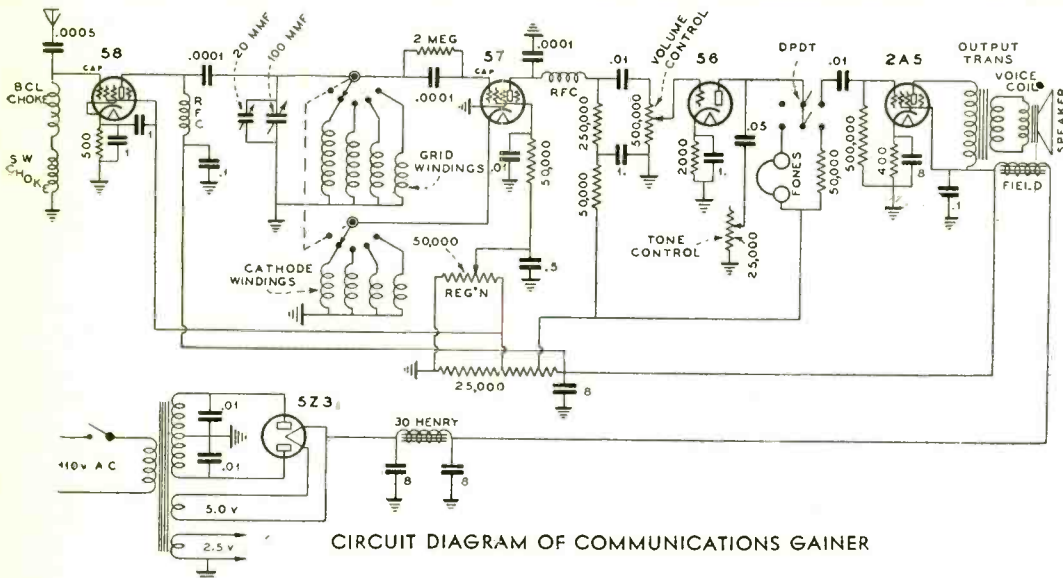

CIRCUIT DIAGRAM OF COMMUNICATIONS GAINER

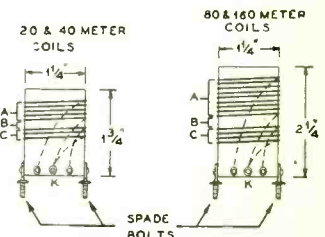

Coil Winding Data for Communications Gainer.

20 METER COIL

"A"—8 turns, No. 22 DCC wire, space wound to occupy $\frac{7}{8}$ -inch.

"B"— $\frac{1}{8}$ -inch spacing between secondary and tickler.

"C"—4 turns, No. 22 DCC wire, close wound.

40 METER COIL

"A"—13 turns, No. 22 DCC wire, space wound to occupy $\frac{7}{8}$ -inch.

"B"— $\frac{1}{8}$ -inch spacing.

"C"—4 turns, No. 22 DCC wire, close wound.

80 METER COIL

"A"—30 turns, No. 22 DCC wire, close wound.

"B"— $\frac{1}{8}$ -inch spacing.

"C"—4 turns, No. 22 DCC wire, close wound.

160 METER COIL

"A"—58 turns, No. 28 DSC wire, close wound.

"B"— $\frac{3}{8}$ -inch spacing.

"C"—5 turns, No. 28 DSC wire, close wound.

NOTE:—"A" is the Secondary winding. "B" is the spacing between Secondary and Tickler. "C" is the Tickler winding.

speaker or phones. When phones are used, the 2A5 second audio amplifier is cut out; the plate resistor of the 56 is also cut out and the phones are automatically substituted.

Tone control, far from being a needless refinement, is actually a necessary adjunct to the communication receiver. By judicious use of this control, many external noises can be either completely eliminated or greatly reduced. Certain kinds of power leaks submerge themselves completely in the background when Mr. Tone Control is advanced to the proper position.

The regular audio volume control is also brought to the front panel, also the tone control. In this manner both tone and volume are under control when using only the first audio amplifier for headphone operation.

A close inspection of the plan view of the receiver will show many details that require no further discussion. Particular attention is directed to the placement of the coil switching unit and the band-spread condenser, the RF and detector tubes and the radio frequency chokes. The RF tube is the one nearest the rear end of the chassis; the detector tube is mounted immediately adjacent.

NEW type Crowe airplane dials are used, and they are mounted on the chassis by merely bending the dial support

piece into a right angle, instead of slotting the chassis to allow the projecting metal piece of the dial to pass through. The tuning condensers are mounted on small metal brackets at a level to correspond with the shaft collar on the dial. Since the rotors of both condensers are at ground potential, they need not be insulated from panel or chassis.

The drawings serve to illustrate various mechanical details of the coil switching arrangement. It is strongly advocated that this arrangement be followed carefully as to size of coils. Coil turns and spacing data are found in the chart.

The power supply is a conventional one, using a 5Z3 rectifier tube, full wave connection. The field of the dynamic speaker acts as the second choke and derives its field voltage automatically.

A very careful attention to all details, particularly the by-pass condensers, is essential for best results. Everything in the set was included for a specific purpose . . . stable, reliable performance. This receiver, within its limitations, is only a step below the superheterodyne. We express our thanks and appreciation to Mr. Frank C. Jones, whose advice and counsel on coil-switching devices and receiver stabilization were most helpful.

A Rack-and-Panel Phone Transmitter

By CHAS. L. WATSON

THIS radiophone transmitter is a completely AC operated unit which has a carrier output of not less than 50 watts and which may be modulated 100%. It is mounted in a steel frame 27 inches wide, 50 inches high, and 19 inches deep. The frame is divided into six separate compartments as follows: lower right, transformers; lower left, filters and relays; center left, speech amplifier; center right, modulator; top left, crystal and buffer; top right, the final amplifier.

Considering the sections individually, the transformer deck contains the high voltage plate transformer, filament transformer, low voltage plate transformer, the 866 rectifier tubes, and the 5Z3 rectifier. Mounted beneath the rectifier tube shelf are the fuse blocks and terminal strip for the 110 volt AC line. The filter deck contains two chokes, and their associated condensers for the high voltage supply, two chokes and their associated condensers for the low voltage supply as well as the low voltage and change over relays. Also mounted in this compartment is a 10-point terminal strip which provides all of the necessary external connections with the exception of the 110 volt AC. Mounted in the door jam in both lower sections are safety switches which automatically disconnect the power when the door is open. Mounted directly above the two high voltage filter condensers is a bleeder strip which provides the necessary plate voltage for the buffer stage.

The center left hand deck contains the complete speech amplifier consisting of three Type 56 tubes, 3 No. 6 dry cells for microphone battery and in the rear corner a change over switch to transfer the control from microphones to 500 ohm line. The center right hand shelf contains two Type 845 tubes in parallel as Class A modulators with their associated coupling transformer. The rear

half of the top left hand deck contains the crystal oscillator stage which consists of a Type 59 tube with its associated condenser and inductance and Duplex Crystal Oven, in which are mounted two crystals. Change over from one crystal to the other is affected

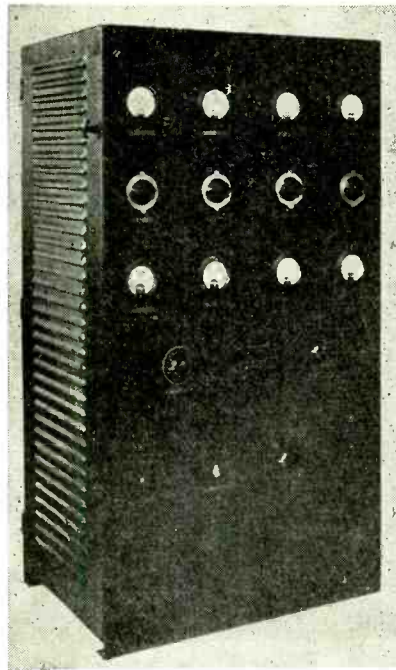

A Westinghouse steel cabinet houses the transmitter.

by means of a flexible lead and grid clip. The buffer amplifier occupies the front half of this shelf and consists of a Type 865 tube with its associated condenser and inductance. The final amplifier which is on the upper right hand deck consists of a Type 211 tube with its associated tuning equipment as well as the neutralizing condenser for this stage. Mounted directly above this equipment is a small bakelite sub-panel upon which is mounted the two antenna series condensers with their associated inductances which form a low pass filter network.

Putting the Transmitter into Operation

1.—The 866A, mercury vapor tubes used to rectify the high voltage, should be allowed to burn for at least a half hour before any plate voltage is applied. This is to vaporize any mercury that may be clinging to the filaments. This precaution must also be taken if, for any reason, tubes are allowed to remain idle for several days.

2.—Since the quartz crystals for this transmitter are made to operate under temperature control, the transmitter should never be used until the crystal oven has been on for at least 20 minutes and preferably a half hour. Failure to observe this precaution will result in the transmitter working off-frequency.

3.—An auto transformer is provided to compensate for variations in line voltage. For safety reasons, the switching device controlling the voltage has dead points in between each step. The voltage will go to zero if the switch is set on one of these dead points.

4.—The switch which cuts the plate voltage off the final amplifier is a rotary affair

and is to be turned in a clock-wise direction for both "on" and "off". This type of switch is necessary to cleanly break high voltage.

5.—The fuses for the 110 AC input are 15 amperes and are of the screw-plug type.

a.—The fuses for the modulator, and final amplifier milliammeters should be one-half ampere, small, glass-cartridge type.

b.—The fuses for the 866A rectifier circuits are one ampere rating and are of the small, glass-cartridge type.

6.—Both of the side doors of the transmitter have safety switches on them, making for maximum safety to the operator. The transmitter will not operate, if either, or both of these doors are open.

7.—The 110 volt AC input should come through the porcelain inlet bushing on the bottom of the set. This bushing is located on the left-hand, rear of the set and is located under the metal deck which supports the small transformers and the three rectifier tubes.

8.—The microphone and/or 500 ohm line is connected to a small terminal strip on the right-hand rear of the bottom deck. Both the microphone and the line are connected permanently to this terminal strip and either may be used by changing the double-pole, double throw snap switch located on the bottom of the speech amplifier deck.

Tuning up of the Transmitter

1.—Throw the Main Power line switch.

2.—Throw Crystal Oven switch.

3.—Throw "Start relay" switch which turns on all filaments.

4.—Make certain that the Amp. plate switch which disconnects the high voltage from the final amplifier stage is "OFF".

5.—At approximately a one minute interval after the filaments have been turned on throw the external switch on the microphone which turns on all plate voltage.

6.—Rotate the oscillator dial on the crystal stage until the plate current as shown on the oscillator milliammeter shows a sudden dip. It will be found that on one side of this dip the plate current will rise very rapidly, and on the other side comparatively slowly. Determine this latter side and lock the oscil-

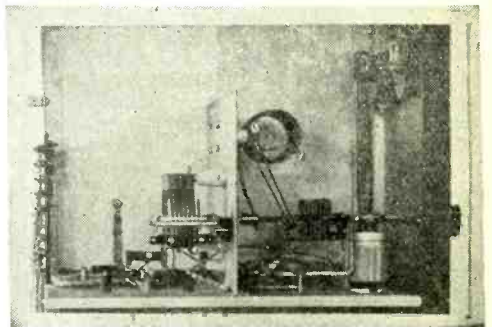

The '59 and 865 stages

lator dial to a point that is 5 milliamperes higher than the minimum setting. This is the position for maximum stability of the crystal oscillator.

7.—Determine the milliamperes reading on the amplifier grid milliammeter in the grid current of the 50 watt stage. Rotate the buffer tuning condenser on the buffer stage until this reading is at its highest value. This setting indicates resonance in the buffer stage.

8.—Make certain that the two flexible leads

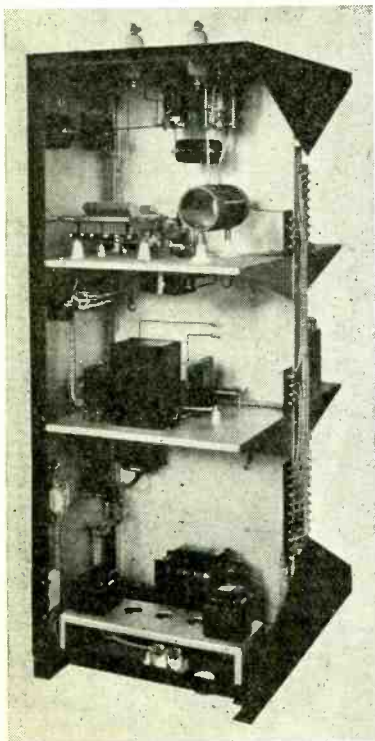

Side view showing high-voltage power supplies, 211 final and Collins Antenna Network.

that connect the Plate Circuit Inductance (50 watt stage) to the Antenna Tuner are disconnected. Note: See "Putting the Transmitter into Operation", Section E.

9.—Set the Neutralizing condenser on the final amplifier to approximately 90 divisions.

10.—Rotate the final amplifier tuning condenser through an arc until the milliammeter in the grid circuit shows a pronounced dip. At the bottom of the dip, or at the point of minimum reading on the grid meter the final amplifier will be in resonance.

11.—Change the setting of the neutralizing condenser, meanwhile rotating the final amplifier tuning condenser through a narrow arc. As the stage comes closer to neutralization the dip on the grid meter will be less and less evident, until at exact neutralization, the final tuning condenser can be rotated through its complete arc without the slightest change in reading on the grid meter.

12.—A slight retuning of the buffer tuning condenser will usually result in a slightly higher reading on the grid meter since neutralizing may detune the buffer stage by a small amount.

13.—Turn the high voltage on the final amplifier by turning the snap switch on the panel in a clock-wise direction.

14.—Tune the final amplifier tuning condenser to a point of minimum reading on the plate circuit milliammeter.

15.—Turn off all plate voltage by means of the switch in the crystal cathode lead (on microphone) and then replace the flexible antenna leads on the plate coil of the 50 watt stage.

16.—If not already connected, connect the two antenna feeder wires to the two lead-in insulators on the top of the cabinet.

17.—With all plate voltage on, determine the value of current indicated on the final amplifier milliammeter. When the antenna system is properly tuned, the current on this meter should read, approximately 90 milliamperes.

18.—CAUTION!

Do not, under any circumstances, disturb the setting of the final amplifier, plate or neutralizing condensers once this stage has been properly adjusted and the antenna tuning apparatus leads connected. Changing the setting of either of these condensers will mean that all tuning operations from No. 7 to No. 14 will have to be repeated.

Tuning the Antenna to the Transmitter

The two antenna tuning condensers are placed near the top of the frame and their shafts are accessible through openings on the top shield. An insulated screwdriver (Bakelite) should be used to turn these condensers.

1.—With all the adjustments completed in tuning the transmitter, and the final ampli-

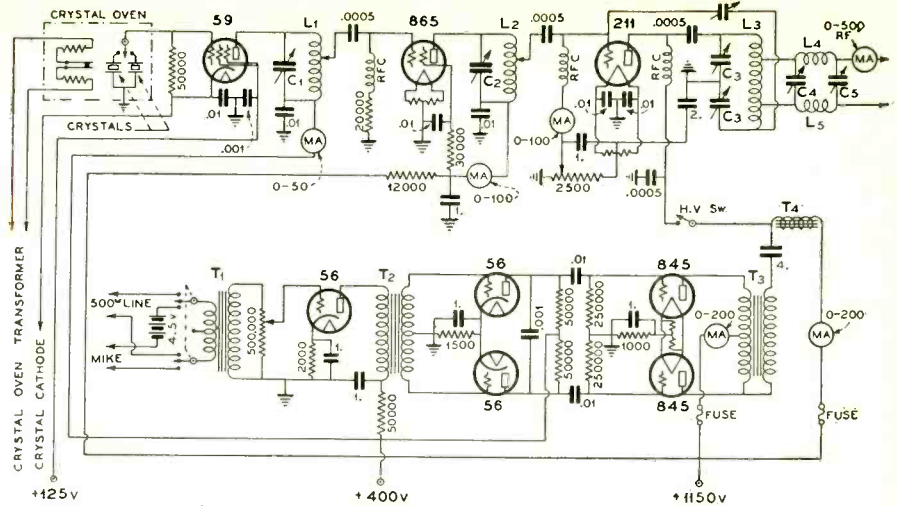

Circuit Diagram for 50-Watt Class A Radio Telephone.

C1—75 mmf. C2—75 mmf.

C3—220 mmf., each section, Split-Stator.

C4-C5—350 mmf. each.

Coil Winding Data for 75-80 Meter Operation:

L1—35 turns, No. 20 DCC wire on 1/2-inch dia. form, close wound.

L2—22 turns, No. 16 Enameled, 14 turns per inch, on 2 1/2-inch dia. form.

L3—22 turns, No. 10 Enameled, 6 turns per inch, on 3 1/2-inch dia. form, with antenna coil taps 1/4 down from each end.

L4-L5—Each 15 turns, No. 12 Enameled, 12 turns per inch, on 2-inch dia. forms.

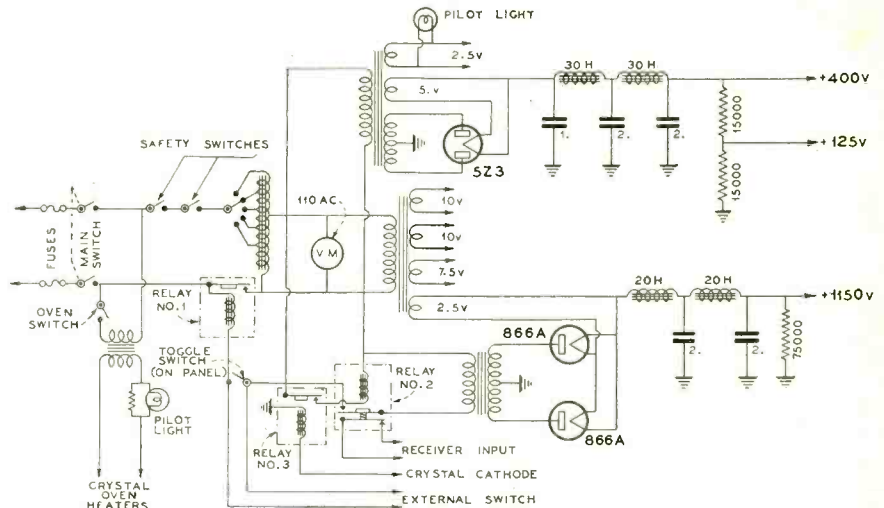

fier showing some steady value of plate current, the antenna condensers must be adjusted to establish the final amplifier plate current at the correct point.

2.—If the plate current should read high (150 to 200) the antenna condenser nearest the front panel should be rotated until this value drops to some lower reading. Bring this reading to a slightly lower one by adjusting the second antenna tuning condenser.

3.—Generally speaking the first antenna condenser establishes the value of load (high on low reading on the 50 watt plate milliammeter) and the second condenser merely brings the antenna into exact resonance (as indicated by a slightly lower milliammeter reading).

4.—The correct reading with the antenna connected should be 90 milliamperes plus or minus 3 mills.

Adjusting the Speech Amplifier and Modulator

1.—Connect the microphone terminals to the proper posts on the terminal strip in the bottom power supply section.

2.—With the radio-frequency portion of the transmitter properly adjusted and working, determine the reading on the milliammeter in the plate circuit of the modulator stage. If the line voltage is up to its normal value,

this meter should read approximately 140 milliamperes.

3.—With either voice or tone of constant amplitude applied to the microphone, adjust the audio gain control (on the panel) until the antenna current, as read by the radio-frequency meter in the antenna circuit, increases 22% above its normal, steady value. If, for instance, the steady value of antenna current was 300 milliamperes, it should rise to 360 milliamperes for 100% modulation. Since speech is never of constant amplitude, and since certain vowels and consonants have greater amplitude than others, the gain control should never be set at this maximum point as a working value. The meter used in the antenna circuit has a certain inertia so that it will not move rapidly enough to follow all voice peaks.

4.—In operation, set the gain control always below the point where the meter in the plate circuit of the final amplifier flickers when speech is applied. A decided movement of this meter is an indication of distortion, (usually over-modulation).

5.—Excessive movement of the milliammeter in the plate circuit of the modulator is also an indication of distortion, although moderate movement of this plate current, (plus or minus 10 milliamperes is allowable).

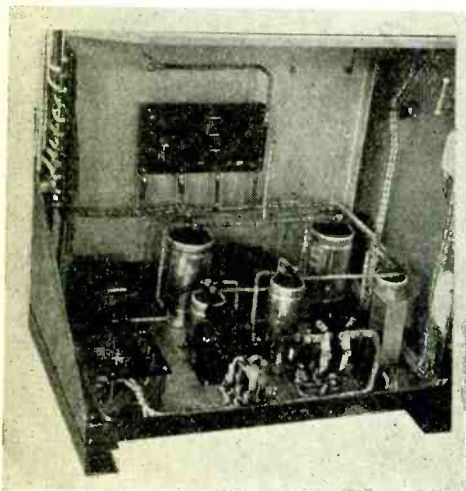

Low Voltage Power Supply

Push-Pull vs. Parallel Operation

By JOHN L. REINARTZ, WIQP*

CONFRONTED with the question, "If you have two tubes to be used in the final amplifier would you connect them in push-pull or in parallel?" I unhesitatingly answered, "In push-pull." The question, however, made me think, so just to make sure that my answer was correct I decided to experiment, first with the push-pull and then with the parallel type of final amplifier. The purpose of the experiment was to bolster up my original answer or to make me take it back.

It was not hard to make a choice of the type tube to use in the experiment, since a great many amateurs use the type 46 for intermediate amplifiers as well as for the final stages. Accordingly, 46's were used.

AS I saw the problem, the entire question was to find out if there was any difference in the power loss when exciting a pair of tubes in push-pull or in parallel, this power loss being what it would take to properly excite the grids of the tubes to the point where a determined-upon grid current flow would result. Since grid current was to be a constant for either type of operation, some form of variable was desirable. The grid resistor was, therefore, made variable from 1 to 5 thousand ohms in steps of 1 thousand ohms.

The next step in the problem was to find means for determining the values of the RF voltage applied to the grids for one set-up and that of the other set-up. The tuned circuit supplying the RF voltage was to derive its exciting power from a driving circuit of good regulation. For measurements, the cathode-ray tube came in very handy. A type 906 with a sweep-circuit voltage supplied by the 110-volt lighting system was used in order that there might be no heating of the glass at the screen when no RF voltage was applied to the other set of deflecting plates. Provision was made to measure any RF voltage by means of a pair of dividers made from wood; also, by means of the lighting voltage, a series of calibration points were made on the tube face with a crayon. The calibration voltages applied were carefully checked with the aid of a dynamometer type meter; the voltmeter readings were then multiplied by the square root of two to obtain the peak voltage values shown by the cathode-ray tube.

THE driving circuit which was to supply the power to excite the grids of the tubes under test was a crystal controlled outfit of ample capacity and a tank circuit of good regulation. The tank circuit could be moved toward or away from the tuned circuit connected to the tubes under test; the amount of such movement could be accurately measured. That the coupling distances would vary was anticipated only to the extent that it was felt necessary to have some means for varying the coupling.

After some cogitation, during which time the pipe went out, it was decided that for this experiment at least, no voltage or circuit connection would be made to the plates of the tubes under test in order that there might be no variable to worry about from that source. Therefore, only the filaments and the grids were connected, the filament being properly excited from an AC source with a center-tap connection. This center-tap connection was shunted to each side of the filament with by-pass condensers. The grid resistor was also shunted with a by-pass condenser.

*RCA Radiotron Company, Inc.

ALL being in readiness for the experiment, the push-pull arrangement was first set up, as shown in Fig. 1. A represents the driver; B the driving circuit tank; C the tuned driven circuit which excited the grids of the 46's under test; and D the cathode-ray tube which measured the RF voltage across the tuned, driven coil circuit. A milliammeter was inserted in the grid-resistor circuit to measure the grid current. The only part that was moved after once being placed was the driving circuit tank coil with its attached tuning condenser; all other parts were kept fixed with respect to other parts of the set-up.

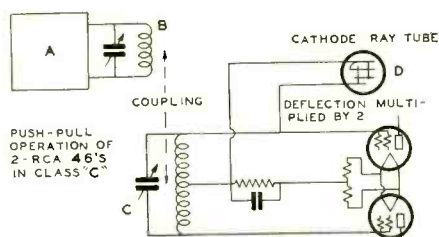

FIG. 1

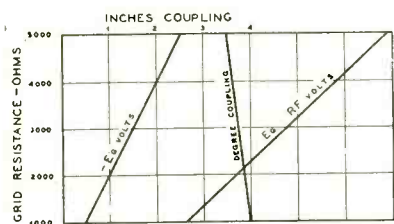

FIG. 1A

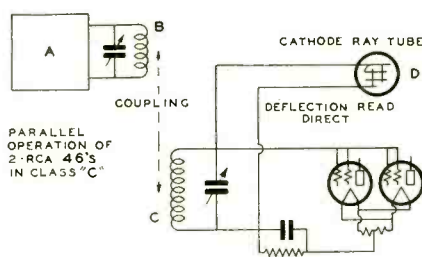

FIG. 2

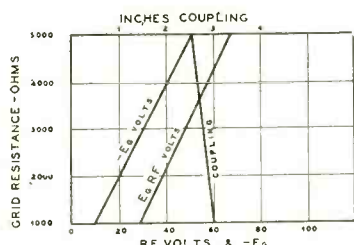

FIG. 2A

Then, with one thousand ohms in the grid resistor circuit and the driven circuit tuned to resonance, the coupling was adjusted until exactly ten milliamperes grid current was indicated by the milliammeter. The RF voltage across the driven circuit indicated by the cathode-ray tube was measured as was the degree of coupling expressed in inches. This procedure was repeated for 2, 3, 4, and 5

thousand ohms of grid resistance. The results are plotted and shown on Graph 1A. This Graph shows some interesting things, one being that the amount of coupling is a linear function of the watts lost in exciting the grids of the tubes under test. When such loss is a function of the grid resistance value used, the coupling distance decreases as the grid resistance value is increased. Also the RF across the tuned, driven circuit increases linearly as the grid resistance value is increased; for example, 53 volts peak at 1,000 and 137 volts peak at 5,000 ohms grid resistance. The negative voltage at the grids of the 46's, a function of the resistance used and the grid current expressed as $R_1 I$, went from 10 volts to 50 volts while the watts in the same circuit, expressed by $I^2 R$, went from .1 to .5 watts.

THE second phase of the experiment was now carried out and the tubes were connected in parallel. The circuit arrangement is shown in Fig. 2. Again, the 1000 ohm grid resistor was placed in the circuit and the coupling adjusted until the grid current indication was exactly 10 mills. This was followed by the 2, 3, 4, and 5 thousand ohm grid resistors and like adjustments in coupling; the grid current was always kept at 10 mills. The results are shown in Graph 2A. As in Graph 1A, there are some very interesting likenesses. Again, the degree of coupling is linear, but reduced in value, also the RF is linear but reduced in value. Let's see how the fact, heard expressed in the past, that the RF voltage needed across a push-pull circuit must be twice that needed across a parallel circuit, checks up. In the case of the push-pull circuit and at 1000 ohms grid resistance, the RF is 53 volts while for the parallel circuit it is 29 volts. If allowance is made for observational errors, the statement is correct. Again, at 5000 ohms grid resistance the RF voltage for the push-pull circuit is 137 volts, while for the parallel circuit it is 64 volts. The same observational errors can account for the slight difference. In each circuit the grid bias voltages were of the same value as were the watts lost in the grid resistor circuit. Since the RF voltage is approximately double for the push-pull circuit there is but one difference left and that is in the degree of coupling necessary for the same amount of grid excitation. Closer coupling is necessary for parallel operation of tubes in Class C circuits and, with all other factors alike, is about 75% of the spacing for push-pull.

WE are now back to the original question: "Shall we operate tubes in parallel or in push-pull?" I still says push-pull, for aside from the fact that there is little difference when it comes to excitation, there is some difference when you consider the output wave form and the possible harmonic content. The second harmonic fades out of the picture when push-pull is used. However, the second harmonic may be an asset when the tubes are used as intermediate amplifiers.

And now I hear someone ask, "What happens in push-pull or in parallel if you have a plate load on the tubes?" Well, if the editor agrees* it will be the second installment to this treatise on Push-Pull vs. Parallel Operation of Class C Amplifiers.

*The Editor quickly agrees!

400 Watts of Carrier On 5 Meters

By JAYENAY

HERETOFORE it has been difficult to obtain stable operation on five meters with the higher-power tubes due to various reasons. Among them are: (1) High inter-electrode capacity in certain types of tubes, (2) The necessity for long leads from grid to plate, (3) The refusal of practically all of the common tubes to amplify at a reasonably low plate voltage on 5 meters. A tube that will not amplify properly will not oscillate without excessive grid losses, (4) A rugged grid and grid lead is essential because of the high radio-frequency grid current that flows at 60 MC, even in the low capacity tubes.

THE tantalum grid used in the 354 led us to believe that it could be the answer to the high-power 5-meter problem. Experiments confirmed this belief and exceeded our fondest expectations, especially on the score of plate efficiency, which is usually so hard to obtain at 5 meters. Efficiencies of 35% in oscillators or class C amplifiers have been as high as one could realize in the "pre-354 era". Imagine our surprise, therefore, when we realized a plate efficiency of over 55% when using the conventional TNT oscillator circuit shown in Fig. 1. By substituting about 5 feet of No. 14 wire, as in Fig. 2, for about \$10 worth of tank coil and condenser, the efficiency promptly jumped to over 66% and we obtained 400 watts of (measured) output with only 600 watts input, instead of 700 watts necessary when the conventional plate tank circuit was used.

The tank circuit in Fig. 2 is nothing but a pair of Lecher wires suspended vertically from the plate caps of the tubes, and held in position by the aid of a fine grade of Woolworth wrapping string. The transmission line to the Johnson "Q" antenna was clipped on the Lecher wires at a point approximately 2 inches each side from the RF choke through which plate voltage is supplied.

As an example of how theory can be confounded by practice, the first Lecher wires consisted of 1/4 inch copper tubing; the tubing became warm under operation and the efficiency was a little better than when the conventional tank circuit was used.

The good book says—"If a conductor heats up, use a larger conductor". So half-inch copper tubing was tried. This became distinctly hot and the efficiency dropped materially. Becoming slightly puzzled, but still game, we borrowed some 1 1/2-inch copper tubing and dared the efficiency to stay down. This large tubing not only became hot, but it got darned hot! The plates of the 354s began to approach that peculiar white-hot color which characterizes Mr. William Eitel's far-famed tube evacuating process. At this point we realized that we were headed in the wrong direction, so we tried 1/8-inch copper tubing. Everything cooled-off at once and the efficiency jumped 'way up, which proved we were on the right track. No. 16 enameled wire proved ideal and did not even become

warm with 600 watts input. It was finally decided that the excess metal in the field of the "tank" caused these excessive losses.

The exceptionally high "Q" of this "tank" improved the frequency stability of the oscillator to a marked degree, always welcomed at 5 meters. We intend to try this "tank"

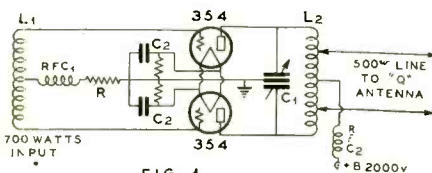

FIG. 1

Circuit Diagram of High-Power 5-Meter Transmitter.

- L1—5 turns, No. 10 wire, 3/4-in. diameter.
- L2—4 turns, 1/8-in. tubing, 1 1/2-in. diameter.
- C1—40 mmf. per section, 3000 volt condenser.
- C2—.001 mfd., low voltage condenser.
- R—10,000 ohms, 100 watt.
- RFC1, RFC2—50 turns, No. 28 DSC on 3/16-in. Bakelite Rod.

on 10 and 20 meters at an early date. Who knows but that our Zepp feeders may yet prove to be the perfect tank coil? Comments from readers who are inclined to conduct such experiments are solicited.

The breadboard is covered with a thin sheet of aluminum, tacked at the edges of the board to hold it in place. Try this on your own breadboard transmitters, on any band, because it often straightens-out that stage which refuses to neutralize, due to improved grounding and shielding. Sheet copper is just as good as aluminum and has the further advantage that solder will stick to it. This shield also reduces dielectric losses

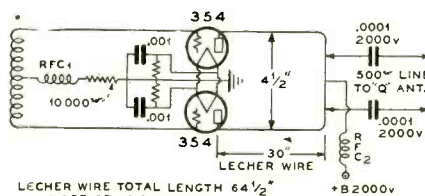
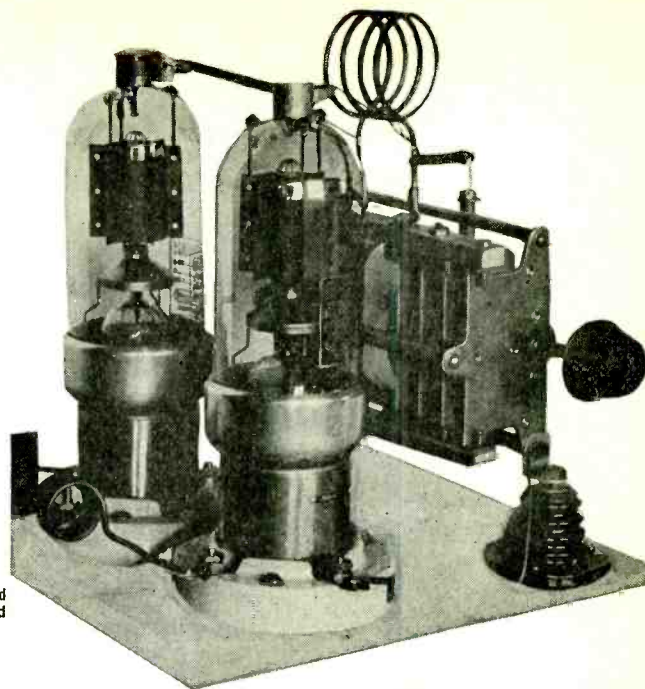

FIG. 2

Antenna tap at 3/8 turn each side of center.



Usual Tank Coil and Condenser Method used previous to Lecher wire experiment

in a breadboard, often quite high, unless the wood is very dry. It may interest the reader to know that some breadboards can become distinctly warm when subjected to a strong electrostatic field, as in the final amplifier of a high-power transmitter, because of the poor dielectric nature of soft woods.

The remainder of the circuit is conventional

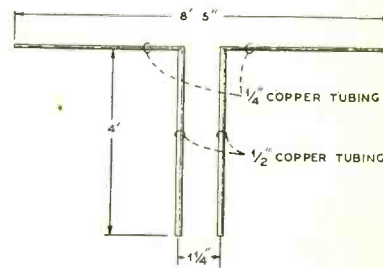

TRANSMISSION LINE NO. 14 WIRE SPACED 2" WITH JOHNSON BLOCKS

FIG. 3

TNT practice and the frequency is determined by the length of the tank which, as is shown in Fig. 3, is a single loop of wire. A similar tank was used in the grid circuit but proved unsatisfactory. The 300 watts of audio power necessary to modulate this oscillator was obtained from another pair of 354s in class B, running at 1000 volts.

What Was It the Senator Said?

Charles H. Stewart, W3ZS, St. David's, Pennsylvania, vice-president of ARRL, would have the amateurs believe* that RADIO's report of what actually transpired at a Senate Committee confab on the Madrid Treaty Ratification matter was erroneously reported in our columns. But read Stewart's copy on page 66, the last 16 lines of the column. If those 16 lines do not repeat the essence of our June Radiatorial Comment, read them again! The point that RADIO drove home in its Radiatorial is the fact that amateurs DID protest the ratification of the Treaty to the Senate, that the League officials saw no reason why the Treaty should not be ratified. Quotations from "Congressional Record" merely adds more weight to our accusation. Thanks to Mr. Stewart, we now learn that "those on the committee who were looking after their (amateur's) interests and caused the hearing to be, had advised them that they thought the treaty afforded to them more protection than they ever had". Well . . . who else is supposed to protect the amateur's interests but the ARRL? RADIO believes it is time to bury this Madrid fiasco, no matter how hard some may try to further deviate from the main point at issue. The commercials won . . . the amateurs LOST! That's how our "amateur interests" were safeguarded. Better luck next time.

* QST, September, 1934.

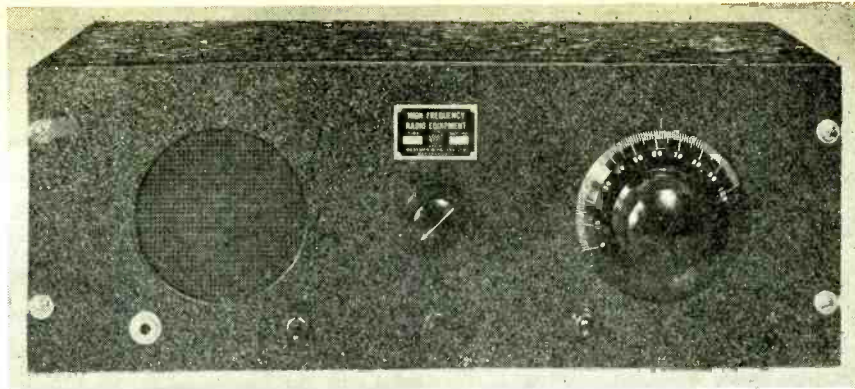

FRONT VIEW OF 5-METER POLICE RECEIVER
It is ideal for amateur communication. A companion transmitter will be described in October "RADIO"

An A. C. Operated 5-Meter Receiver

By FRANK C. JONES

Ultra-Short Wave Editor

THE need for a receiver for standby and two-way ultra-short wave communication for police and fire departments made it necessary to develop receivers of the type shown in the illustration. The new police and fire department channels are assigned between 7 and 9 meters, calling for special types of circuits.

Ultra-short wave superheterodyne receivers can be made quite sensitive by the use of extreme regeneration, and can even be made broad enough in tuning to serve for standby operation. However, these sets are apparently much more sensitive to neon sign and auto ignition interference than super-regenerative sets. The fact remains that a good "stiff" super-regenerative receiver gives a better signal-to-noise ratio for average,

through the internal capacities of the detector tube, and external circuit to ground capacities. Either an RF choke input can be used with a resonant receiving antenna, or a small semi-fixed tuned input circuit can be used.

Since an RF stage is used, any super-regenerative detector circuit could be utilized. The writer prefers a blocking grid-leak detector system in which the grid leak return is to a high positive potential. When the detector is coupled directly to an antenna, this particular type of circuit radiates about three times as much as the more usual form using a separate IF oscillator.

The sensitivity of the usual form of blocking grid-leak with ground or cathode return is about the same as in this circuit in which

ode are such as to cause a blocking action, producing super-regeneration and the familiar loud hissing sound when no signals are being received.

THIS circuit seems to function as an ordinary oscillator in which the grid leak is too high in value to allow the electrons on the grid to leak off at a rate which would give a constant value of grid voltage. This causes a change of average bias and stops oscillation because the plate current is decreased and the mutual conductance of the tube drops. The grid leak and condenser values and circuit decrement determine the rate and discharge, or number of cycles-per-second that this occurs; in this case an inaudible rate. Apparently the plate circuit must maintain a fairly low impedance path

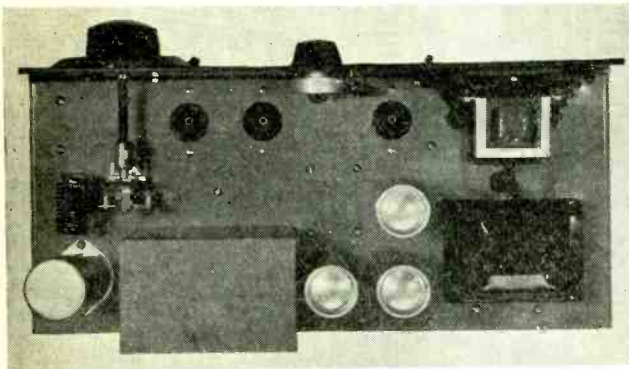

The R.F. Stage is in the small shield can at left.

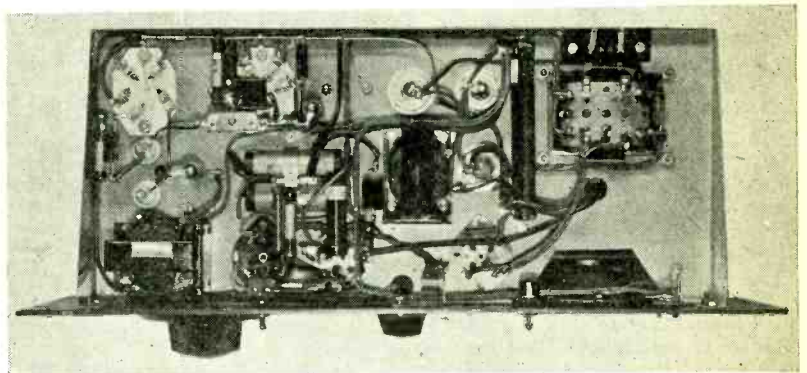

Neat workmanship characterizes the under-chassis assembly and wiring.

moderate-strength signals. By a "stiff" super is meant one in which the detector is super-regenerating quite strongly.

This latter condition makes for bad receiver radiation unless a radio-frequency stage is used to couple the antenna to the detector. The actual gain in the RF stage is relatively small, being from 1 to 8, as against several thousand in the detector circuit. Its main use is in preventing radiation, which is terrific when the detector is even coupled loosely to an antenna.

The RF tube can be coupled to the detector in several ways; one is shown in this receiver circuit. This scheme permits an adjustable amount of coupling and consequently does not load the detector input circuit too much. The RF signal completes its path

the grid leak return is to +B voltage. However, the detector overloading effect is greatly reduced when receiving strong signals and, in general, the tone quality is much better. The action is similar in effect to a receiver with automatic volume control, so that nearly all signals are received at the same volume and only an audio volume control is necessary.

The detector consists of a regular Colpitts oscillator circuit in which the internal capacities of the tube act as the voltage dividing elements and hence produce oscillation. The grid leak is of such a high value that even with a positive return it still builds up a negative voltage, due to grid current. The circuit decrement and values of grid leak and condenser, and plate return by-pass to cath-

to cathode at this inaudible frequency because the plate by-pass should be at least .002 mfd., whereas .006 mfd. seems none too large. With either resistive or transformer coupling to the audio amplifier, no super-regeneration will take place without a fairly large plate-to-cathode return by-pass condenser. In the circuit shown, this by-pass condenser has no effect on the RF portion, since it is on the low RF potential side of the RF choke.

TWO stages of audio amplification are used in order to insure more than ample volume under all conditions of reception. In some locations local noise is high, and a loud signal is required in order to make it intelligible. Many ultra-high frequency transmitters are of the modulated oscillator type which have a strong carrier signal with

moderate or weak values of modulation. A strong carrier will eliminate the super-regenerative hiss or roar, but the actual voice signal will be weak unless plenty of audio amplification is used. Since a high value of audio amplification is available, it was necessary to use a well-filtered power supply, as shown in the circuit diagram. The pentode power tube, used as an output amplifier, provides ample power for the small dynamic loudspeaker. Head-set operation is possible by means of the switch which cuts-in either the headset and the first audio amplifier, or both stages and loudspeaker.

A super-regenerative detector tunes very broadly, normally covering a band of at least 100 KC. It is thus satisfactory for standby operation when receiving modulated oscillator transmitters or mopa transmitters in which there is a carrier frequency drift due to temperature changes. This broad tuning effect is readily explained when it is realized that the detector circuit is oscillating periodically over a wide band of frequencies, usually from 60 to 200 KC in width. An ordinary 6 or 7 meter oscillator will vary its frequency 30 to 100 KC when its DC plate voltage is varied 50%. A super-regenerative detector is an oscillator which has its plate voltage, or grid voltage, varied over much wider limits. As it goes in and out of oscillation (super-regeneration effect) a great many thousand times per second, it also varies its high frequency oscillation period, which gives the broad tuning effect. This is a decided asset in some cases, such as the purpose for which this receiver was designed.

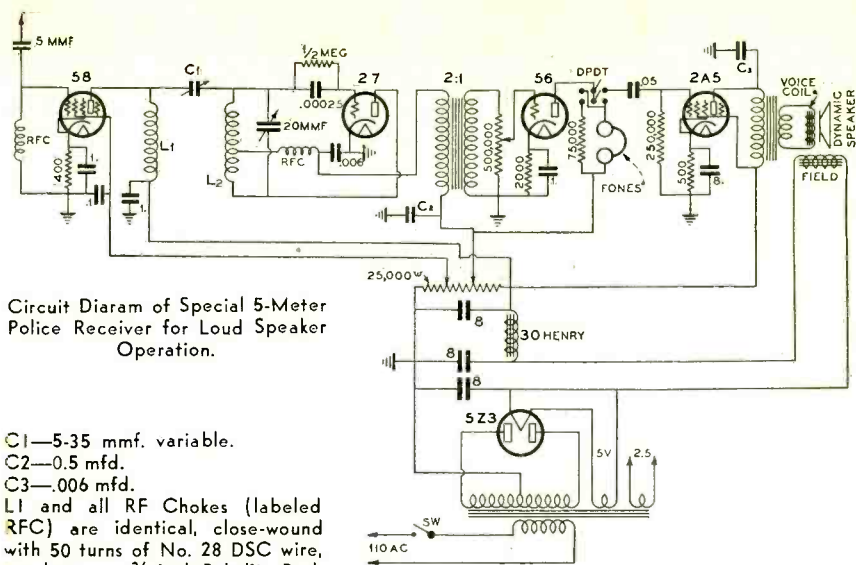

Circuit Diagram of Special 5-Meter Police Receiver for Loud Speaker Operation.

C1—5-35 mmf. variable.
 C2—0.5 mfd.
 C3—.006 mfd.
 L1 and all RF Chokes (labeled RFC) are identical, close-wound with 50 turns of No. 28 DSC wire, one layer, on 3/8-inch Bakelite rod.
 L2—6 turns No. 14 Enameled wire, 1/8-inch dia., spaced one diameter, and self-supporting. A tap is taken on L2 at 2 turns from the bottom (plate side of L2 which connects to the '27 Tube).

The Transformer between the plate of the 2A5 and the Voice Coil of the Dynamic Speaker is an 8000-10 step-down.

The Field Coil of the Speaker (which acts as one filter choke) can be made the output choke, instead of input choke as shown, if hum develops.
 Plate Voltages should be adjusted as follows: To L1 and to Step-down Output Transformer, 250 volts. To Interstage Transformer (between '27 and '56 tube) and to Fones, 120 volts. To Screen of '57 RF Tube, 90 volts.

The New AT-Cut Quartz Crystal

By JAYENAY

PRACTICALLY all forms of oscillators whose frequency is stabilized by means of the Piezo-electric effect inherent in the quartz crystal use either the X-cut or the Y-cut crystal. The Y-cut crystal is usually more active, and thus requires less excitation and dissipates less power in itself, allowing somewhat more power to be realized from its associated oscillator tube. However, the Y-cut crystal has two bad habits and its disadvantages have resulted in the wider use of the X-cut type.

Messrs. Lack, Willard and Fair of the Bell Telephone Laboratories have recently developed a variation of the Y-cut crystal which seems to overcome the two major disadvantages of this type.

Fig. 1 is a phantom view of the mother crystal with the three main axes shown, and the ordinary Y-cut crystal in the center. On the right in the same illustration is shown the finished crystal. The AC output voltage appears at the points marked E_y .

The frequency-thickness constant of the Y crystal is close to 192 KC per CM thickness, and the frequency coefficient is approximately plus 85 parts in a million per degree centigrade. It will be seen that the Y-cut crystal is quite sensitive to changes in temperature and a well-regulated oven is necessary to avoid drift.

Aside from the high temperature coefficient, the oven is necessary for another reason. In Fig. 2 is shown a curve of frequency against temperature for an average 1000 KC Y-cut crystal. It will be seen that the Y-curve is not continuous, but is broken at many points. As the temperature of the crystal crosses these points, either one of two things happens . . . the crystal stops oscillating or it jumps several KC in frequency. The Y-cut has been known to jump as much as 75 KC because harmonics of the resonances caused by the other dimensions take control when two or

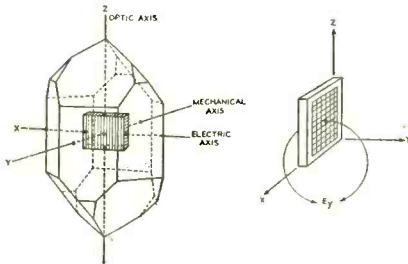

FIG. 1—Showing Relation of Y-cut quartz Crystal to the Crystallographic Axes.

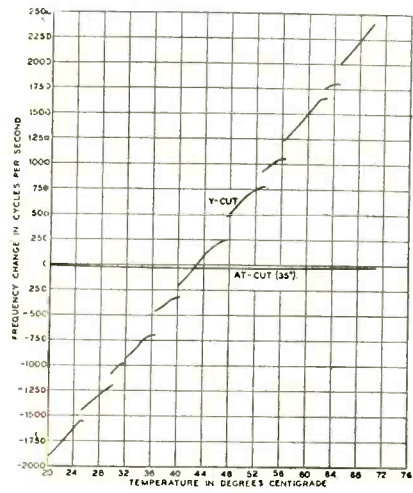

FIG. 2—Frequency Temperature Characteristics of AT-cut and Y-cut Plates of same frequency and area.

more of the resonances interact. This occurs quite often in the normal operating range of temperatures. The interaction between the low frequency resonance points and the Y axis resonant point also makes the grinding process rather difficult because the frequency of the crystal, as a whole, changes in spurts or jumps, as it is ground, instead of gradually and evenly increasing as the grinding proceeds. If the grinding process ends at a point where one of the discontinuities occurs in the normal range of operating temperatures, the crystal can be quite unstable. For this reason most good Y-cut crystals are ground until a point is reached where the curve of frequency against temperature is continuous over the normal range of temperatures. It is therefore difficult to grind a stable operating Y-cut crystal to a predetermined frequency.

The effect of the secondary spectrum, which includes all of the unwanted low-frequency resonances and their harmonics, can be minimized by rotating the cut about the X axis (See Fig. 1). This rotation affects the coupling between the unwanted vibrations and the desired vibration. It was determined that a positive rotation of 31 degrees practically eliminates all of the discontinuities in the temperature-frequency curve and removes the tendency for the crystal to jump in frequency while being ground.

Not content with this improvement, the Bell Laboratories engineers decided to do something about the high temperature coefficient. It was found that rotation about the X axis also had a great effect on the temperature coefficient and that a positive rotation of 35 degrees brought the temperature coefficient to practically zero, yet kept the secondary spectrum of vibrations to a minimum (see curve AT, Fig. 2). It was also found that the Piezo-electric activity of the crystal

(continued on page 22)

A Simple Two-Tube Transmitter For Newcomers

By HENRY WILLIAMS

THE REDUCTION in list price of the receiving type 210 tube to 50 per cent of its former price, and a reduction in the price of many other tubes which are useful in amateur practice, behooves the amateur to make his debut by means of a modern, crystal-controlled 2-tube transmitter, using a 47 as oscillator and a 210 in the amplifier stage. Such a transmitter is here described. The type 210 receiving tube is ideal for this transmitter.

THE increasing number of amateurs who are replacing old-time self-excited transmitters with modern crystal control has brought repeated requests for detailed information on the exact number of turns of wire to wind on standard plug-in coil forms for use in the oscillator stage, for the grid tuning coil and for the plate coil of the amplifier. The low-priced midget condensers are also suit-

The results secured from a simple 2-tube transmitter, using standard 1½-inch Isolantite coil forms and small midget tuning condensers, were so gratifying that the constructional details are here presented for those who wish to duplicate the transmitter.

From San Francisco it has been possible to work amateurs in Australia and New Zealand five nights consecutively, on the 80-meter band, using the transmitter here described. Amateurs in New Jersey, Pennsylvania, Ohio and elsewhere have been worked with ease. The construction of the transmitter is such that additional stages can be added at any future time.

All coil-turns data is shown in the table. The table is handy for future reference. A turn or two of wire can be added to, or removed from each coil, depending on the particular conditions under which the trans-

tor stage are mounted beneath the baseboard and the board is raised from the operating table by four standoff insulators. Isolantite sockets are used throughout.

To the right of the oscillator stage is the grid coil, mounted horizontally, and spaced 6 inches between centers from the oscillator coil. Wide spacing is necessary, and the grid coil should be mounted horizontally so as to prevent interaction between the oscillator coil and the grid coil. The horizontal mounting for the grid coil is made simple by merely mounting an Isolantite socket on a supporting block, 2½ by 2½ by ½ inches. A hole, 1⅝ inch diameter, is cut out of the center of the support so that the grid coil can pass through the support and plug into the socket. The support is screwed to the baseboard. The grid coil tuning condenser is directly in front of the grid coil support

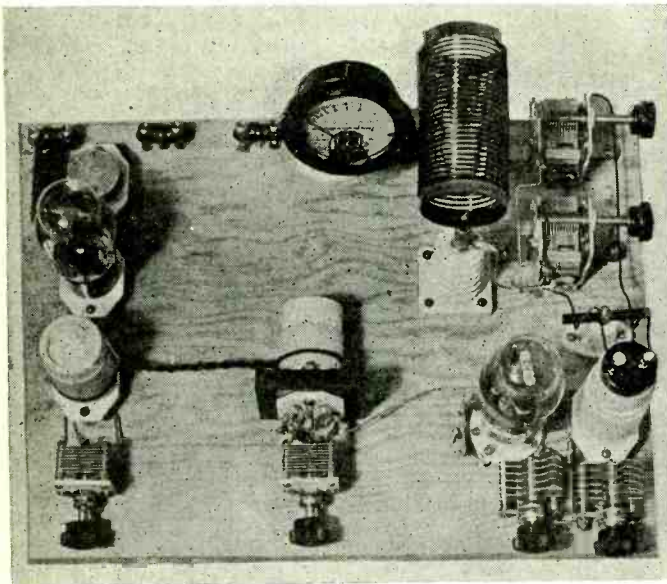

Left—The 47-210 Oscillator-Amplifier Breadboard Transmitter. Note the simple link coupling method between the oscillator plate coil and the grid coil. A small antenna

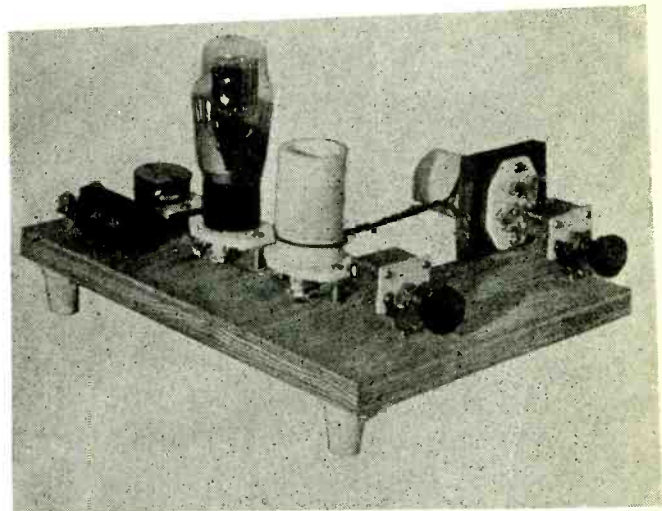

coil is coupled to the 210 plate coil, as shown. The antenna coil is tuned with the two .00035 mfd. variable condensers, right rear. A Collins Matching Network can be used, if desired, and the large coil alongside the antenna meter is then used. Thus the transmitter can use either type of antenna coupling. The illustration to the right is a closeup of the crystal oscillator, showing the utter simplicity of the link-coupling from the plate coil of the 47 to the grid coil of the 210 stage. The coupling loops are at the extreme bottoms of the windings of both coils, as the picture shows.

able for plate and grid tuning in low-power stages. Standard sizes of these small condensers are 35 mm. and 100 mmf. The 35 mmf. size, double spaced, is suitable for tuning the plate coil in an amplifier stage using a type 210 or even larger tube. It is also ideal for neutralizing such a stage. For the crystal oscillator plate tuning circuit a 100 mmf. variable condenser can be used; it is equally suitable for tuning the grid coil of the first buffer, doubler or amplifier stage.

It has been found from experience that the low-loss Isolantite 1½-inch coil forms give perfect satisfaction in low-power stages, using up to about a 210 or 830 tube. These Isolantite coil forms, when used with Isolantite sockets, make a highly efficient and practical coil assembly. For 24, 40 and 80 meter work it hardly behooves the amateur to use coil forms larger than the 1½-inch standard Isolantite types. For 160 meter work, these same small forms can be used in the oscillator and grid tuning stages, but a larger form should be used for the amplifier plate coil.

denser, plate coil, 47 tube, quartz crystal. The resistors and condensers for the oscillator will be called upon to operate. However, the winding data is useful because it was computed from coils tuned with small midget condensers.

The illustration shows the breadboard transmitter. The 47 oscillator stage is at the extreme left. The 47 tube has given the best results, by far, of any tube used in the crystal circuit. The oscillator stage, from front to rear, consists of a 100 mmf. tuning con-

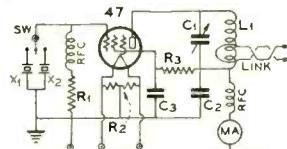

THE CRYSTAL OSCILLATOR

Two crystals can be used, if desired; one for 40 meters, another for 80. A switch "SW" throws in either crystal at will. R1—5,000 to 50,000 ohms. R2—100 ohms. CT. R3—50,000 ohms. C1—100 mmf. C2—C3—.006 mfd. L1—See Coils Turns Table on page 15.

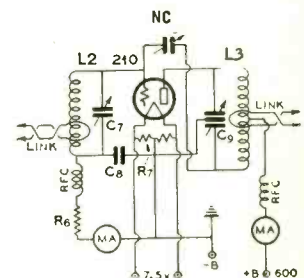

THE 210 AMPLIFIER

Although a split-stator condenser is shown at C9, a single-section condenser was used in the photographs above. When a single-section condenser is used, a .006 mfd. condenser is connected between the Positive 600-volt tap and ground, and the ground connection now shown as going to the rotor of the condenser C9 is eliminated. C7—100 mmf. C8—.006 mfd. C9—35 mmf. midget variable, double spaced. R6—10,000 ohms. R7—100 ohms. CT. L2—Grid Coil. L3—Plate coil for 210 stage. The key is connected in series with the center tap of R7 and the negative "B". To use this 210 stage as a driver for another stage, merely link-couple, as the circuit shows. If the 210 stage is to feed the antenna, place the antenna coil on top of L3, coupled about 1 inch away from it. See Table on Page 15 for Antenna Coil, plate coil and grid coil data for single section condensers.

block. This condenser is a standard 100 mmf. midget variable.

Link coupling is used between the oscillator plate coil and the grid coil. The advantages of this system of coupling have been told previously and are too numerous to mention here. The coupling link is simply a piece of No. 20 (or larger) insulated wire, made into a twisted pair, with a loop at each end. The open ends are soldered together to form a continuous loop. The loops at either end of the coupling link are 1 5/8 inches inside diameter, so that they will slip snugly over the oscillator plate coil and grid coil windings. Variable coupling is not required for the coupling loop. Simply slip the loop over the coils and place them at a point about 1/4 inch (or less) from the LOWER end of each coil. It makes little difference where the loops are placed, as long as they are near the bottom (cold end) of each coil. Place the loops at the very bottom of the coils when first tuning up. Make sure that the "hot" (plate) lead of the oscillator connects to the top turn of the plate coil and also to the stator of the tuning condenser. Likewise, the top connection of the grid coil connects to the grid of the tube in the 210 stage, also to the stator of the grid coil tuning condenser.

The center-tap resistors across the filaments of the 47 and 210 tubes are shown as 100 ohm size. Any size from 50 to 100 ohms is suitable. The resistor across the crystal can be anything from 10,000 to 50,000 ohms, although many crystals will not "start" unless 20,000 ohms or more is used. Play safe by using 25,000 ohms.

The 47 tube screen dropping resistor is shown to have a value of 50,000 ohms, although anything from 30,000 to 60,000 ohms will suffice. This resistor should be of 5 or (Continued on page 19)

TRANSMITTER COIL WINDING DATA For '47 Oscillator and 210 Amplifier Using Single Section Condensers

NOTE: L1—Oscillator Plate Coil. L2—Grid Coil. L3—210 Amp. Plate Coil.

160 METERS		TUNING CONDENSER
Note: Coils L1 and L2 wound on 1 1/2" Isolantite Forms.	L1—70 Turns, No. 22 DSC, close wound.	100 mmf.
	L2—70 Turns, No. 22 DSC, close wound.	100 mmf.
	L3—85 Turns, No. 20 DCC, close wound on 2" dia. form, 4" winding space.	35 mmf.
80 METERS		
All 3 Coils Wound on 1 1/2" diameter Isolantite Forms.	L1—35 Turns, No. 22 DCC, close wound.	100 mmf.
	L2—32 Turns, No. 22 DCC, close wound.	100 mmf.
	L3—45 Turns, No. 22 DCC, close wound.	35 mmf.
40 METERS		
All 3 Coils wound on 1 1/2" dia. Isolantite Forms.	L1—19 Turns, No. 20 DSC, space wound, one diameter spacing between turns.	100 mmf.
	L2—Same as L1.	100 mmf.
	L3—24 Turns, No. 16 Enameled, 12 turns to inch.	35 mmf.
ANTENNA COILS		
160 METERS		
For 160 meters a Marconi antenna is well suited. Use the Collins Impedance Matching System. Wind antenna coil with 30 turns No. 12 enameled, on 2 1/2" dia. form, 5 turns to inch.		350 mmf.
80 METERS		
For Zepp Antenna, use coupling coil with 13 turns No. 16 DCC on 1 1/4" dia. form. If Collins System is used, 80 meter coil is same as 160 meter coil.		350 mmf.
40 METERS		
For Zepp Antenna use antenna coupling coil same as for 80 meters. If Collins System is used, wind only 7 turns on antenna coil. This coil is also satisfactory for 20 meters.		350 mmf.

The Multi-Arc as a Rectifier for Amateur Transmitters

By GEORGE BECKER

THE Multi-Arc Rectifier Tube was developed for the purpose of providing the transmitting amateur with a sturdy, reliable and fool proof source of rectified alternating current. The tubes have been in the laboratory and in the field for the past year and a half and they have shown that "they can take it." With the advent of this rectifier the amateur now has available a composite rectifier tube THAT HE CANNOT OVERLOAD, either with high voltage or high current.

Considering its capacity, the tube is small in size, being about 10-in. high and about 7-in. wide, measured across two opposite anode arms. It is constructed of Pyrex glass and will operate continuously at normal temperature without resorting to oil or other cooling mediums. The tubes are highly evacuated to assure a breakdown voltage far in excess of amateur requirements; the current carrying capacity depends only on the heat dissipation and the size of the sealing wires leading into the tube. Nominal rating is given as 10 amps. total current leaving the mercury pool (or positive terminal), regardless of the impressed voltage across the tube, so that it can be used to charge storage batteries during spare moments, thereby creating some revenue for the station. Hi!

Mercury Arcs last so long that nobody ever ran a life test on one; if they did, they would probably outlast the tester. After one year of overloading and beating, no Multi Arc Tube has shown signs of weakening.

The writer has been questioned repeatedly in regard to "mush" from the Arc ruining standby reception or breaking operation. It must be admitted that without shielding the tube and by-passing the keep alive trans-

former to ground, considerable mush is present. The shielding is not difficult. It can be metal screening or other well ventilated material. The automatic starter operates so rapidly and so surely that the tube can be cut off after transmission without the re-start delaying come-back.

Many amateurs are using CC with the necessary doublers and buffer stages, and a big bottle in the final. What could be better

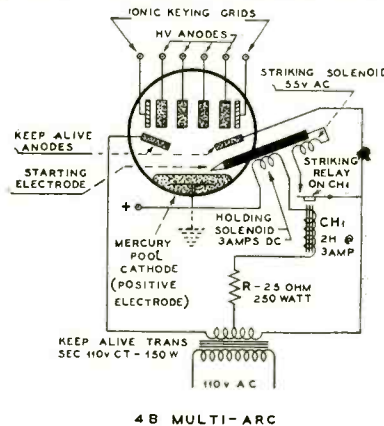

4B MULTI-ARC

than a rectifier which would produce two or more separate power supplies for the entire transmitter? One of comparatively low voltage for the first stages, and a big sock for the final—one rectifier—two filters and a Multi-Arc will solve the problem. Either pair of

HV anodes will rectify from 50 V DC to 5000 DC and do it easily, quietly and without the slightest strain.

THE auxiliary apparatus consists of keep alive transformer and a keep alive choke, upon which is mounted the starting relay. The keep alive transformer should be a one-to-one ratio with the secondary winding center-tapped. If used in a circuit where the positive is grounded, it need not be highly insulated. However, if the positive is above ground, the secondary must be insulated for full high voltage. If the positive is ground, the filament transformers in the transmitter are hot to ground. The transformer should be built with a very poor voltage regulation in order that the power in the keep alive circuit can be kept as low as possible. It need not be over 150 watt rating.

The keep alive choke can be almost anything; its purpose is merely to prevent the keep alive current from ever reaching zero. Anything in the neighborhood of about 2H at 3 amps gives a smooth, steady arc. The starting relay is mounted at the air gap of the choke so as to isolate the starting electrode as soon as the arc is in operation. It is a simple, single contact relay with a hold-back spring strong enough to hold the contacts closed with AC in the choke, but allowing them to separate from the DC flow when the arc starts with normal current in the keep alive circuit. The resistance R may be necessary to hold the keep alive current down to 3 amps. but if the choke has enough DC resistance and if the voltage regulation of the transformer is poor enough, it may be dispensed with. The entire starting mechanism of the Multi-Arc is built into the tube, except (Continued on page 22)

The Crystal Microphone

By D. B. McGOWN, Technical Editor

OVER A CENTURY ago, A. C. Becquerel discovered that certain crystalline substances exhibited an electric charge when they were subjected to pressure. This charge is called "piezo" or pressure electricity. In 1881 the Curies and Lippman carried this work still further, experimentally and mathematically, and from this research came the oscillating piezo electric quartz and tourmaline system of crystal control. Hund, Cady, and others also contributed to its development. In any piezo electric system we have a crystalline substance, a means of exerting pressure on the crystal, and usually two electrodes which serve as conductors for the charge. The crystalline substances are carefully cut slabs or sections, and the electrode arrangements are many and varied. If we can set up an electric current by pressure, this action is reversible, and thus we can also produce a pressure, or mechanical distortion in a suitably shaped and mounted crystal, fitted with electrodes, if the crystal is supplied with electric current of the proper frequency and voltage to "match" the natural or fundamental vibration period of the crystal. During the World War, attempts were made to use this principle as a source of "supersonic" or super-audio sound waves for submarine signaling and underwater telegraphy, but due to various difficulties the idea was never brought to a practical conclusion.

AMONG THE substances known to be piezo electric is the very active Rochelle Salts (Potassium Sodium Tartrate), which is a crystalline solid. Crystals of Rochelle salts can be quite easily prepared from saturated aqueous solutions, and such crystals show very active piezo electric properties. Crystals prepared in this manner, however, are very unsatisfactory because they absorb water from the air and disintegrate in a very short time into a white powder. It remained for the Brush Laboratories Co., under the direction of the late Charles F. Brush Jr., to produce and develop Rochelle Salts crystals that are free from these troubles. By so doing, it has been possible to manufacture commercially successful piezo electric devices, such as loudspeakers, microphones, pick-ups and similar sound producing and reproducing instruments.

Rochelle Salts crystals as produced for piezo electric use are manufactured by the Brush Laboratories Co., and sold through their various patent licensees. The crystals are clear and colorless, cut to the size and shape desired for the purpose they are to be used. The details of growing the crystals, the cutting and the method of sealing to keep out moisture are trade secrets of the Brush Company. Raw or unmounted crystals are not supplied to the public. Unmounted or unfinished crystals are supplied only, as far as is known, to the exclusive patent licensees, and are not available to others, or for amateur assembly. Fortunately, the completed units are available on the commercial market.

ROCHELLE SALTS crystals are composed of crystalline plates cut perpendicular to the length of the crystal. Two or more such plates, when cemented together, make a composite arrangement in which one element contracts, the other expands, and thus a maximum piezo electric effect is obtained. Such an assembly might be compared to a bi-metallic thermostat, and is called a "bi-morph" crystal assembly. The optimum results obtainable from any par-

ticular crystal arrangement are produced from this assembly. These bi-morph crystal units are the basis of microphones and pick-up devices. Obviously, if these plates are provided with the proper electrodes, the charges produced due to bending of the crystal can be used to operate an amplifier, or a source of sound energy can be used to drive a loud speaker or other unit.

The bimorph crystals usually are arranged so that they are of equal size, cut square. The bimorph arrangement results in two crystals being set with their axes at like angles. When the bimorph unit is finished it resembles a small square affair, similar to two small squares of window glass cemented together. This unit is the fundamental part of all Brush Crystal devices. Various sizes, types and thicknesses are provided for various classes of service. The smallest units are the single cells which are used for pick-up. The entire unit is but $\frac{1}{4}$ inch square, others varying up to about $2\frac{1}{2}$ inches square for larger units used to drive loud speakers.

TWO DISTINCT types of crystal microphones are available commercially. One type uses the sound cells mentioned above, and the piezo electric output provided is due to the very slight displacement of the tiny quarter-inch-square bimorph crystals which are placed in the sound field. The other type uses a diaphragm which drives the crystal through a small lever attached to a corner of a bimorph crystal. The other three corners are held securely between rubber clamping members. The diaphragmless type is capable of exceptionally high quality reproduction, and may, indeed, be flat over a far wider range than is possible to use at the present time. Due to the small size, the audio power output of these units is very low and considerable pre-amplification is required. These units are intended for high-quality broadcasting, public address, sound recording and similar fields; they are supplied in single cell, 4 cell and 20 cell units, and are mounted in small monel metal protective screen housings which are strong and rigid. These microphones are practically non-directional, and are capable of higher quality performance than the associated apparatus commonly used with audio frequency systems. The other, or diaphragm type of crystal microphone has a much higher audio output and hence requires less amplification to obtain a satisfactory level. They are much cheaper in price than the high-quality units and are to be preferred for use in amateur stations. The audio response of the micro-

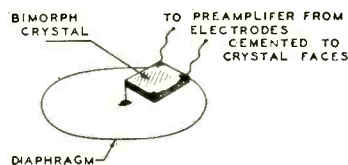

FIG. 1

phone is approximately as follows: High-quality units, single cell, minus 90 d.b.; 4-cell units, minus 75 d.b.; 20-cell units, minus 70 d.b. Diaphragm type units, minus 60 d.b. These values are approximate, but will be found suitable for general use. It will be seen that the response of any of these types is much below that of the double button microphone which is usu-

ally about minus 30 to 40 d.b., all figures to a zero reference level of 6 milliwatts.

Figure 1 shows a skeleton arrangement of a diaphragm-type crystal microphone. This is actually the view from the rear, and just the diaphragm and crystal are shown. The sound strikes the opposite side of the diaphragm than that which is shown. Suitable mountings are provided to hold the diaphragm securely at the edges, and the bimorph crystal is held at the three corners through soft rubber mounts, by the frame of the unit, as shown. Electrodes are provided in the form of thin foil on the sides and between the crystals, which absorb the charge caused by the motion in the crystals, communicated to it by the diaphragm.

THE PIEZO-CRYSTAL microphone has numerous advantages which recommend it for general use. It generates the low-level audio current directly from sound, and the only problem is to provide an amplifier system to amplify these currents without distortion to the required level. No polarizing currents, magnetizing winding, button current or other auxiliaries are needed. Because the unit is strongly and ruggedly constructed, it is immune from ordinary damage from shock, jars and handling. The crystal is sealed with a specially developed sealing material which renders the unit free from the action of moisture; normal temperature variations have but little effect on it. Care should be taken to keep the operating temperature reasonably low because the response and sensitivity drop off at temperatures above 100 degrees, Fahrenheit, although normal performance is again obtained as soon as the temperature is lowered.

The piezo-electric microphone is a high impedance device, and acts very much like a rather high-capacity, slightly leaky condenser. The approximate impedance is from 100,000 to 150,000 ohms, and hence it is possible and satisfactory to connect the microphone directly in the grid circuit of a vacuum tube, very similar to the usual connection of the quartz crystal in oscillator circuits. The leads between the microphone and the grid of the first tube of the pre-amplifier can be quite long, without introducing serious distortion. The maximum length recommended is not more than twenty or thirty feet, although in some cases direct leads as long as 150 feet have been used. The leads should be run in shielded twisted pair cable, the shielding grounded.

THE PIEZO-ELECTRIC microphone can be mounted in any conventional manner, preferably in a conventional microphone stand which is grounded. Springs or rubber bands may be used to absorb shock, in the usual manner, and to prevent vibration and extraneous noise from reaching the instrument. With the high quality types it is not necessary to arrange the microphones with reference to any front, back or side positions. The pick-up is equal in a horizontal direction and above and below, except in a direct line from the stand or support. When the high-quality instruments are used, pick-up can be secured from almost uncanny distances, with perfect fidelity and performance, and without the introduction of the familiar cavity resonances or other objectionable features so common with other microphones. When the diaphragm type instruments are used they have the usual directional characteristics of diaphragms. For best results the speaker should stand directly in front

of the microphone, although he can be several feet away from it or quite a distance off to one side, without serious impairment of quality. For public address work with the

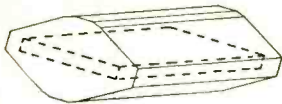

Twelve-sided crystal of Rochelle Salts. The dotted section shows how the crystal is cut for production of a crystal microphone slab. Two of these sections, placed at right angles, form a "bimorph" crystal.

high quality types, the low feedback or howling point allows considerable more amplification than is required for other types. Due to the very small inertia of the crystals themselves, the feedback can be reduced by simply reducing the volume control; a very advantageous feature.

THE CIRCUITS for use with the piezoelectric microphone differ slightly in the input end from the conventional arrangements. It is absolutely essential that some form of preliminary amplifier be used (commonly abbreviated "pre-amplifier"). Such an amplifier must be capable of rather large gains and may commonly be considered as a voltage amplifier. In most cases a two-stage amplifier will give very satisfactory gain, if used ahead of the mixer or volume control. It is much better practice to raise the level in the pre-amplifier, then feed the output to another final or speech amplifier and place the volume control potentiometer between these two amplifiers, rather than to try to control volume in the pre-amplifier itself.

Figure 2 shows a method of connecting the crystal microphone to the grid of a fila-

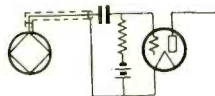

FIG. 2

ment-type tube. The C battery, or bias battery, is connected between the grid resistor of about 5 megohms, with a condenser of about 0.01 or 0.02 mfd., between the microphone and the grid. Figure 3 shows the

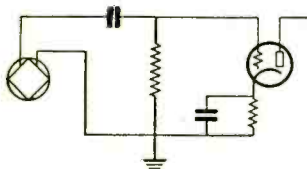

FIG. 3

conventional circuit to a heater-type tube, with a self-biasing resistor in the cathode return. The values of grid condenser and resistor are the same as previously and the

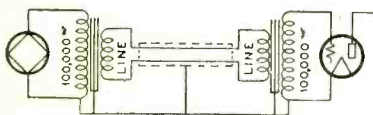
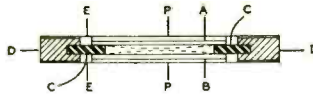

FIG. 4

values of cathode resistor and condenser depend on the type of tube used. Figure 4 shows the use of a line transformer between the microphone and the first tube, a very desirable arrangement if the input line is

long. Two transformers of identical characteristics can be used, with ratios of 100,000 with either 200 or 500 ohms output, as de- to 500 or 200 ohms. The crystal im-



Section of a single cell crystal microphone. A and B are composite Rochelle Salts plates (Bimorph Crystals). D is the Mounting. E is the Sealing Membrane or Varnish.

pedance is about 100,000 ohms and it is fed directly into a transformer of this value, sired. Then the input to the pre-amplifier can be a similar transformer, with the 200 or 500 ohm side connected to the line, and the 100,000 side connected to the grid of the first tube. In Figure 4 no bias is shown for the first tube, for the sake of simplicity; obviously, proper bias should be provided. In Figure 4, the cores of the transformers and all shielding are shown connected together; sometimes hum or interference will be eliminated by grounding these to a separate

CONSTANTS FOR FIG. 5

- R1—5 meg. R2—50,000 ohms. R3—5,000 ohms. R4—20,000 ohms. R5—1/2 meg. R6—50,000 ohms. R7—2000 ohms. R8—15,000 ohms. C1—0.02 mfd. C2—1 mfd. C3—1 mfd. C4—1/4 mfd. C5—1 mfd. C6—1 mfd. C7—1/4 mfd. C8—1 mfd. CH1-CH2—250 Henry, 15 Mil Chokes. T1—Plate-to-Line Transformer.

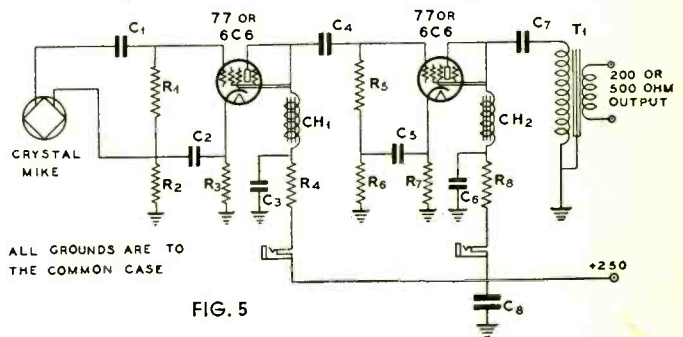

FIG. 5

ground which has no other device connected to it.

Figure 5 shows the circuit diagram of a complete pre-amplifier suitable for use with either the high quality or diaphragm type crystal microphones. It differs in no way from any other similar pre-amplifier, except for the input arrangement, as shown. The resistor R1 should be an unusually good one, about 5 megohms. Cheap resistors will introduce objectionable noise into the circuit. It may be necessary to check a few resistors before a quiet one is found, and even this resistor may get noisy while it is in service. A power supply suitable for the complete operation of the unit on AC is shown in Fig. 6. Type 77 or 6C6 tubes connected as triodes with the screens and shields connected directly to the plates of the tubes are used in the pre-amplifier. This connection provides a very satisfactory high-gain, non-microphonic tri-

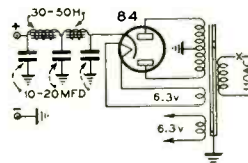
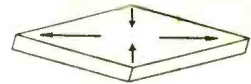

FIG. 6—Power Supply for Pre-Amplifier

ode tube. The case for the pre-amplifier should be of strong metal, preferably iron or steel, and should be of generous size. The hum will be reduced by using a heavy gauge magnetic metal case. It is advisable to keep the parts at least an inch away from the sides of the case. A separate case for the power unit should also be provided, of heavy sheet iron or steel. It should be kept several feet away from the pre-amplifier. It may be desirable to ground the metal cases to a good ground, preferably one that is not used for other purposes. Of course, battery

supply can be used, if desired, for plate or filament power.

It may sometimes be desirable to reduce the actual frequency response of the micro-



phone. This can be accomplished in several ways. Figure 7 shows one method, but with considerable reduction in performance. It also introduces two variable resistor units into the grid of the pre-amplifier. These resistor units often introduce noise and hum. All noise caused by the variable contact, or from the sliding arms, will be amplified in the entire system, and will produce objectionable results. A better method would be to reduce the low frequencies by reducing the capacity of the grid input resistor (C1, in

phone. This can be accomplished in several ways. Figure 7 shows one method, but with considerable reduction in performance. It also introduces two variable resistor units into the grid of the pre-amplifier. These resistor units often introduce noise and hum. All noise caused by the variable contact, or from the sliding arms, will be amplified in the entire system, and will produce objectionable results. A better method would be to reduce the low frequencies by reducing the capacity of the grid input resistor (C1, in

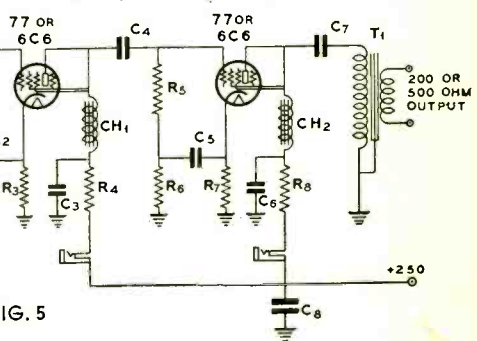
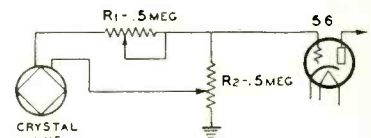

FIG. 7

Figure 5), to about .005 mfd., or even smaller. To reduce the high frequencies a 50,000-ohm resistor in series with a 0.01 condenser can be connected across the primary terminals of the output transformer, T1, in Figure 5. This latter arrangement is the same as that commonly used in broadcast receivers to make the tone (?) more mellow (?). The condenser-resistor can also be connected across the output of the final amplifier to accomplish the same result, if desired.

Great care should be taken to keep the crystal microphone well away from all AC, especially when high-quality type micro-



R1 - CONTROLS THE HIGH FREQUENCIES
R2 - CONTROLS THE LOW FREQUENCIES

FIG. 7

phones are used. A great deal of pick-up and hum will be introduced if the grid leads are long. Use a transformer and shielded-line arrangement, as shown in Figure 4, which is also advantageous if the microphone is to be used near a radio transmitter where there is danger from radio frequency pick-up, unless proper shielding is used. To eliminate all hum and pick-up it may sometimes be necessary to cover all leads and connections with complete and continuous shielding.

ONE OF THE best recommendations for this type of microphone is its use by the Byrd Expedition in Little America. Any microphone that can stand up under such punishment must be good.

Speech Input Equipment and Mixers

By I. A. MITCHELL*

SPEECH input equipment while generally associated with radio broadcasting is now finding application in many other fields, such as amateur radio, recording, public address, etc. While the equipment for large broadcasting systems is generally elaborate and complex, the fundamental design factors for all speech input service can be readily enumerated:

- (1) Uniform frequency response
- (2) Low harmonic distortion
- (3) Low hum and noise level
- (4) Flexibility of use
- (5) Simplicity of construction and operation

For portable equipment, two other factors enter:

- (6) Weight
- (7) Size

If we further analyze this type of equipment, we find that it can be broken up into three major components: Voltage amplifier; power supply-mixer; volume indicator.

Voltage Amplifier

IN THE March 1934 issue of "RADIO", the writer discussed the general factors governing voltage amplifier design. Fig. 1 illustrates the schematic circuit of an AC operated preamplifier described in this issue having excellent characteristics. The new 6C6 tube lends itself admirably to use in the audio action of this amplifier, and due to a change in the internal shielding of the tube, about 5DB reduction in the tube hum has been made possible. This amplifier follows perfectly the requirements enumerated above. The frequency response which is substantially flat from 30 to 15,000 cycles. The harmonic distortion is less than 2 per cent at plus 2DB

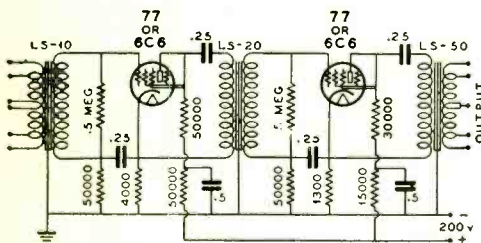

RIBBON OR CRYSTAL MIKE PRE-AMPLIFIER

FIG. 1
Circuit of Amplifier Unit

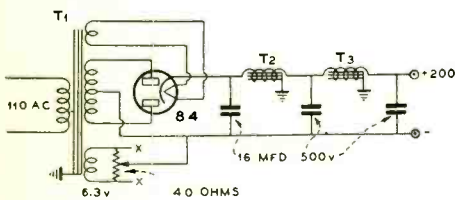

PLATE SUPPLY FOR RIBBON OR CRYSTAL MIKE

FIG. 2

output (normal level for transmission on telephone circuits). In accordance with the desire for flexibility, the input and output transformers have provision for matching to 50, 125, 200, 250, 333 or 500 ohms. This allows the use of a number of lines individually or simultaneously.

*Chief Engineer, United Transformer Corp.

While the power supply and amplifier will each fit on a 3 by 19-inch rack panel, the excellent shielding of the power and audio components makes possible the use of both power supply and amplifier in one portable case for remote pickup broadcasting. One broadcasting system, using this amplifier for remote work, houses the amplifier, power supply, mixer and copper oxide type volume indicator in a portable wood case only 14x14x5 inches. This makes a truly portable

Mixers

A MIXER system is used where a number of input sources, such as microphones and pickups, must be coupled either simultaneously or individually to audio equipment. For proper operation, it should be possible to set the output level of each source independently of the others, and at the same time to increase or decrease the level of their entire combined outputs. Each microphone or pickup is operated into the primary

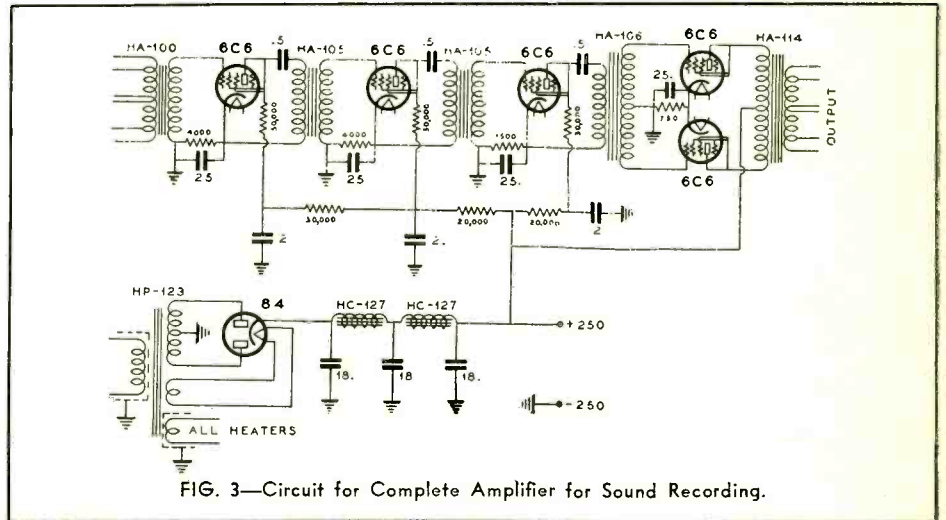

FIG. 3—Circuit for Complete Amplifier for Sound Recording.

speech input unit, not comparable with the many units of a few years back which took two men to carry.

Recording Equipment

FOR sound on film, acetate, wax and aluminum recording, a complete amplifier is generally desirable having sufficient gain to operate from a dynamic, velocity, or crystal microphone, and having approximately 1 watt undistorted output.

Fig. 3 illustrates in schematic form the circuit for a complete amplifier of this type, suitable for battery or AC operation. This recording amplifier consists of four transformer coupled stages, the last one being push-pull. The overall gain is extremely high, 140DB, which is ideal for recording work, where in many cases the microphone has to be placed at a distance from the sound source. Due to the high gain involved, battery operation is more commonly used with this type of amplifier. The construction is such that battery connection is very simple, 6V being required for the filament and 250 for the plate. The transformers are of a very compact type using a new type of nickel iron core material and magnetically shielded in cases made of the same material. This entire unit takes up a space of only 5x4 1/2 x 9 inches and weighs only 9 pounds. When used for portable service, the entire amplifier can be housed in a steel case 6x7x9 1/2 inches, including a copper oxide volume indicator and single channel pad. With the proper output transformer, this amplifier will operate directly into a lamp for glow lamp recording or into a monitor speaker. Where recording is done at higher level than 1 watt, this unit can be used to drive a pair of 2A3's. The frequency response of this 4-stage system is uniform from 60 to 10,000 cycles as per Fig. 4.

of a mixer transformer. The secondary output is controlled with a T or H pad, and then the output of these pads is fed into a master control. Up to a few years ago parallel mixers were used extensively. In the parallel mixer, the outputs of the individual gain controls are connected in parallel to the main control. Unfortunately, with this method, the action of the individual controls is not independent and mismatch sometimes occurs. The series type mixer is more customarily used at the present time. Fig. 5 illustrates a 4-position series mixer which is being used extensively in modern equipment. Each mike or pickup is fed to a matching transformer whose secondary is normally loaded with a 50-ohm T pad and the combined output is in turn controlled by a 200-ohm pad. When the primary side of the transformers are not loaded, the 50-ohm dummy resistance should be switched into the circuit as shown, to effect proper impedance relationship. This same circuit can be used where 2, 3 or 5 positions are used. The mixer gain controls work perfectly in a circuit of this type. Any one of the channels can be raised or lowered in level from maximum to minimum without affecting the level or quality of any other channel. For smoothness of control, the gain control should be in steps of not over 2DB.

Fixed Attenuators

IN many cases, it is found necessary to mix two or more input sources which are widely variant in level. This occurs, for example, when mixing a low level microphone and a tuner output into a PA system. The same effect occurs in the broadcast station where a carbon mike is used by the announcer and a ribbon or dynamic mike is used for music. If identical gain controls are used for both these inputs, the high level control

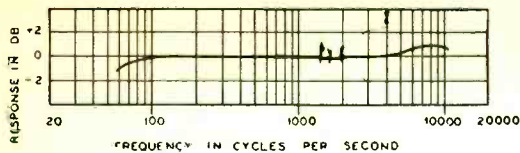

FIG. 4

would have to be turned to almost the off-point to operate properly. At this point control is poor, and frequency discrimination often becomes appreciable. To compensate for this effect, a fixed attenuator can be inserted between the high level source and the corresponding variable gain control. This attenuator can be chosen so that the final level of both sources is practically identical, and good control is possible.

Pad Data

An ideal attenuator must maintain proper impedance on both input and output and must show no frequency discrimination throughout this audio range. The customary pads used for such service are the "T", "H", or double pi. Fig. 6 illustrates a chart designed to simplify the design of such networks for any attenuation from .1 to 100 DB. The data shown has been computed very accurately and is suitable for making atten-

tuators for all laboratories or professional applications. Obviously, a number of fixed attenuators can be grouped to form a custom built variable pad. To examine the use of this chart, let us assume that it is desired to mix the carbon and velocity mike as shown in Fig. 5. The difference in level between these units is about 60 DB. If they were operated directly into this mixer, the lower pad would be set at minimum loss and the upper pad at maximum loss, and we still would not have proper operation. Instead of this, a 60-DB attenuator could be inserted in the carbon mike circuit making both inputs readily controllable. Referring to Fig. 6, we see that for 60 DB attenuation, a 500-ohm T pad can be constructed with the use of two 500-ohm resistances and a 1-ohm resistance. Inasmuch as the circuit of Fig. 4 would require a 50-ohm pad, these values are multiplied by 50/500, or the final resistors are 50, 50, and 11 ohms.

There are many cases in public address work where it is found desirable to couple a number of microphones, pickups, or tuner into an amplifier without too complicated an intervening mixing circuit. Through the use of simple fixed attenuation as described above, all inputs can be brought down to an equal level and then a single volume control will govern the group.

Volume Indicator

The most important accessory in speech input equipment is the level meter or volume indicator, generally indicated by the term VI. This instrument is used to indicate the level at which output is held, whether for recording, P.A., or broadcast use. The copper oxide type of VI is rapidly gaining favor due to its simplicity and accuracy and is now being adopted even by Western Electric. This meter is generally calibrated from -10 to +6 DB and is connected directly across the 500-ohm output from the amplifier. The output transformers indicated in the amplifier schematics previously described have terminations so arranged that that even when matching to a 200-ohm line, 500-ohm terminals are still provided for the VI.

In view of the fact that speech input equipment is normally operating at low level, it is important that all components be well shielded. In the amplifiers shown, the transformers, which are most susceptible to magnetic and electrostatic pickup are fully

ATTENUATION NETWORK DATA

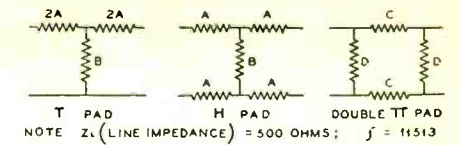

$$\text{ATTENUATION} \quad A = \frac{Z_L}{2} \times \tanh\left(\frac{N}{2}\right) \quad B = \frac{Z_L}{\sinh(N)} \quad C = \frac{Z_L}{2} \times \sinh(N) \quad D = \frac{Z_L}{\tanh\left(\frac{N}{2}\right)}$$

NO. DB	A	B	C	D
.1	1.440	43420	2.879	86850
.2	2.878	21720	5.755	43440
.3	4.318	14480	8.635	28950
.4	5.758	10850	11.52	21710
.5	7.193	8685.	14.40	17380
.6	8.635	7232.	17.29	14480
.7	10.07	6198	20.17	12420
.8	11.51	5421.	23.06	10870
.9	12.95	4818.	25.95	9656.
1.0	14.38	4333.	28.85	8690.
2.0	28.65	2152.	58.08	4364.
3.0	42.75	1420.	88.08	2925.
4.0	56.58	1049.	119.3	2209.
5.0	70.03	822.4	152.0	1785.
6.0	83.08	669.4	186.8	1505.
7.0	95.65	558.0	224.0	1308.
8.0	107.7	473.1	264.3	1162.
9.0	119.1	405.9	308.0	1050.
10.0	129.9	351.3	355.8	962.5
15	174.5	183.6	680.8	756.3
20	204.5	101.0	1238.	611.2
25	223.5	56.40	2216.	559.5
30	234.7	31.65	3949	532.7
35	241.3	17.79	7027.	518.0
40	245.1	10.00	12500	510.1
45	247.2	5.624	22230	505.7
50	248.5	3.163	39530	503.2
55	249.2	1.775	70300	501.8
60	249.5	1.0	125000	501.0
65	249.8	.5623	222300	500.5
70	249.8	.3163	395400	500.4
75	249.9	.1779	703000	500.2
80	249.9	10	1250000	500.1
85	250.0	.05620	2223000	500.1
90	250.0	.03161	3954000	500.0
95	250.0	.01879	7027000	500.0
100	250.0	.010	12500000	500.0

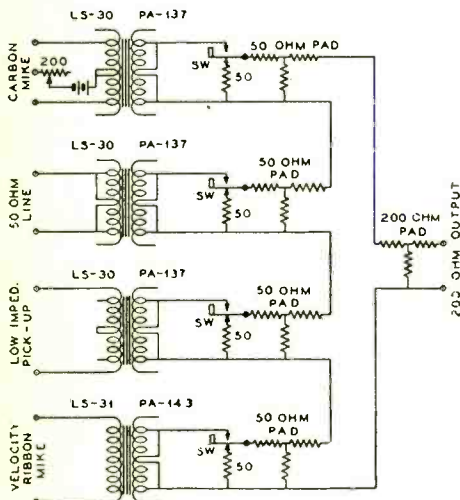

FIG. 5

Newcomer's Transmitter

(Continued from page 15)

10 watt size. The screen by-pass condenser and the blocking condenser are shown as .006 mfd. The condenser should be of the mica type. The choke (RFC) should be of good manufacture; a small receiving type Hammarlund or National choke is satisfactory.

In the 210 amplifier stage, the bias resistor has a value of 10,000 ohms, 2 watt rating. As in the oscillator stage, the by-pass condensers should be of the mica type. The negative B lead from the oscillator stage is connected to the negative B lead of the amplifier stage. The neutralizing condenser and the plate condenser in the 210 stage are both 35 mmf. double-spaced midgets. These condensers are very low in price and are entirely satisfactory for use in this circuit. The key, for CW transmission, is in series with the center-tap of the filament resistor and the negative B terminal.

If a Zepp antenna is used, a simple coup-

ling coil consisting of 13 turns of No. 16 DCC on a 1 1/4-inch bakelite coil form, can be placed directly on top of the plate coil. This antenna coil is tuned with a .00035 mfd. receiving type variable condenser in parallel with the Zepp feeders, or series tuning can be used by placing a .00035 mfd. receiving type condenser in series with each feeder and the respective ends of the antenna coil. Coupling can be varied by placing a hinge on the antenna coil, or it can remain fixed by merely holding the plate and antenna coils in place by means of a cardboard sleeve, slipped into both coil forms.

Another alternative is to use the Collins Impedance Network, as shown in the diagram. This system permits use of an antenna of any length. The antenna coil, L4, and the two .00035 mfd. receiving condensers are both illustrated.

The oscillator is supplied with 300 volts, the 210 stage with 600 volts. Two separate power supplies can be used, although many amateurs prefer a single transformer and a bridge rectifier. The plate current is turned on after the tube filaments are lighted. A DPDT switch can be inserted in the high voltage leads to the rectifier tubes.

shielded. In addition, it is advisable to mount power supply and audio sections at an appreciable distance from each other. In commercial practice, it is customary to place the mixer controls between these sections.

With proper care, any broadcast station, amateur, or public address engineer can construct speech input equipment from standard components which is comparable to commercially produced equipment in quality and dependability—better suited to the individual user's requirements—and far less expensive than equipment purchased in complete form.

Modesto Club to Award Trophy

THE Modesto Amateur Radio Club will again award its Wouff Houg Trophy to the best station in the 6th district. The old Modesto Radio Club originated the trophy and it is a perfect copy of the original. It is made from the plates of hundreds of old transmitting tubes from all over the world. Engraved on it are the calls and dates of award of the previous winners of the trophy. The award will be made on the following points: (1) DX miles per watt, 35 per cent; (2) Traffic handled, 25 per cent; (3) Operating ability, 20 per cent; (4) Percentage of home-made apparatus, 20 per cent. Write to C. E. Marsh, W6FFU, for further details, and send him your DX list with QSL cards, Station Log from October 1, 1933 to October 1, 1934.

More Calls Heard Wanted

FROM present indications it sounds like the coming fall and winter months will be unusually good for DX reception. The large number of newer and better receivers now in use by many amateurs should help make the DX hunt more fascinating than ever. GOOD DX lists are wanted for publication in each issue.



RCA CUNNINGHAM

TYPE	NAME	BASE	SOCKET CONNECTIONS	DIMENSIONS MAXIMUM OVERALL LENGTH x DIAMETER	CATHODE TYPE #	RATING			USE Values to right give operating conditions and characteristics for indicated typical use	PLATE SUPPLY VOLTS	GRID VOLTS #	SCREEN VOLTS	SCREEN MILLI-AMP.	PLATE MILLI-AMP.	A-C PLATE RESISTANCE OHMS	MUTUAL CONDUCTANCE MICRO-MHOS	VOLTAGE AMPLIFICATION FACTOR	LOAD FOR STATED POWER OUTPUT OHMS	POWER OUTPUT WATTS	TYPE
						FILAMENT OR HEATER	PLATE	SCREEN												
1A6	PENTAGRID CONVERTER	SMALL 6-PIN	FIG. 28	4 1/2" x 1 1/8"	D-C FILAMENT	2.0	0.06	180	67.5	180	-3.0; min.	67.5	2.4	1.3	500000	—	—	—	—	1A6
1C6	PENTAGRID CONVERTER	SMALL 6-PIN	FIG. 28	4 1/2" x 1 1/8"	D-C FILAMENT	2.0	0.12	180	67.5	180	-3.0; min.	67.5	2.4	1.5	750000	—	—	—	—	1C6
2A3	POWER AMPLIFIER TRIODE	MEDIUM 4-PIN	FIG. 1	5 3/8" x 2 1/8"	FILAMENT	2.5	2.5	250	—	300	-45	—	—	—	—	—	—	—	—	2A3
2A5	POWER AMPLIFIER PENTODE	MEDIUM 6-PIN	FIG. 15A	4 1/2" x 1 1/2"	HEATER	2.5	1.75	250	250	300	-62	—	—	—	—	—	—	—	—	2A5
2A6	DIODE-TRIODE HIGH-MU TRIODE	SMALL 6-PIN	FIG. 13	4 1/2" x 1 1/8"	HEATER	2.5	0.8	250	—	300	-62	—	—	—	—	—	—	—	—	2A6
2A7	PENTAGRID CONVERTER	SMALL 7-PIN	FIG. 20	4 1/2" x 1 1/8"	HEATER	2.5	0.8	250	100	250	-3.0; min.	100	2.2	3.5	360000	—	—	—	—	2A7
2B7	DUPLEX-DIODE PENTODE	SMALL 7-PIN	FIG. 21	4 1/2" x 1 1/8"	HEATER	2.5	0.8	250	125	250	-3.0; min.	100	1.7	5.8	300000	950	285	—	—	2B7
6A4	POWER AMPLIFIER PENTODE	MEDIUM 6-PIN	FIG. 6	4 1/2" x 1 1/2"	FILAMENT	6.3	0.3	180	180	180	-6.5; min.	100	1.6	9.0	83250	1200	100	11000	0.31	6A4
6A7	PENTAGRID CONVERTER	SMALL 7-PIN	FIG. 20	4 1/2" x 1 1/8"	HEATER	6.3	0.3	250	100	250	-3.0; min.	100	2.2	3.5	360000	950	285	—	—	6A7
6B7	DUPLEX-DIODE PENTODE	SMALL 7-PIN	FIG. 21	4 1/2" x 1 1/8"	HEATER	6.3	0.3	250	125	250	-3.0; min.	100	1.7	5.8	300000	950	285	—	—	6B7
6C6	TRIPLE-GRID DETECTOR AMPLIFIER	SMALL 6-PIN	FIG. 11	4 1/2" x 1 1/8"	HEATER	6.3	0.3	250	100	250	-3.0; min.	100	0.5	2.0	800000	1600	1280	—	—	6C6
6D6	TRIPLE-GRID SUPER-CONTROL AMPLIFIER	SMALL 6-PIN	FIG. 11	4 1/2" x 1 1/8"	HEATER	6.3	0.3	250	100	250	-3.0; min.	100	2.0	8.2	800000	1600	1280	—	—	6D6

o Grids #3 and #5 are screen. Grid #4 is signal-input control-grid.

† Applied through plate coupling resistor of 200000 ohms.

** For grid of following tube.

‡ Applied through plate coupling resistor of 250000 ohms.

6F7	TRIODE-PENTODE	SMALL 7-PIN	FIG. 27	4 1/2" x 1 1/8"	HEATER	6.3	0.3	100	—	250	-3.0; min.	100	1.5	6.5	850000	1100	900	—	—	6F7
100-A	DETECTOR TRIODE	MEDIUM 4-PIN	FIG. 1	4 1/2" x 1 1/8"	D-C FILAMENT	5.0	0.25	45	—	—	-3.0; min.	—	—	—	—	—	—	—	—	100-A
01-A	DETECTOR & AMPLIFIER	MEDIUM 4-PIN	FIG. 1	4 1/2" x 1 1/8"	D-C FILAMENT	5.0	0.25	135	—	—	-4.5; min.	—	—	—	—	—	—	—	—	01-A
10	POWER AMPLIFIER TRIODE	MEDIUM 4-PIN	FIG. 1	5 3/8" x 2 1/8"	FILAMENT	7.5	1.25	425	—	—	-31.0; min.	—	—	—	—	—	—	—	—	10
11	DETECTOR & AMPLIFIER TRIODE	WD 4-PIN	FIG. 12	4 1/2" x 1 1/8"	D-C FILAMENT	1.1	0.25	135	—	—	-4.5; min.	—	—	—	—	—	—	—	—	11
12	DETECTOR & AMPLIFIER TRIODE	MEDIUM 4-PIN	FIG. 1	4 1/2" x 1 1/8"	D-C FILAMENT	1.1	0.25	135	—	—	-10.5; min.	—	—	—	—	—	—	—	—	12
19	TWIN-TRIODE AMPLIFIER	SMALL 6-PIN	FIG. 25	4 1/2" x 1 1/8"	D-C FILAMENT	2.0	0.26	135	—	—	-3.0; min.	—	—	—	—	—	—	—	—	19
20	POWER AMPLIFIER TRIODE	SMALL 4-PIN	FIG. 1	4 1/2" x 1 1/8"	D-C FILAMENT	3.3	B.132	135	—	—	-16.5; min.	—	—	—	—	—	—	—	—	20
22	R-F AMPLIFIER TETRODE	MEDIUM 4-PIN	FIG. 4	5 3/8" x 1 1/8"	D-C FILAMENT	3.3	0.132	135	67.5	180	-1.5; min.	45	0.6*	1.7	725000	375	270	—	—	22
24-A	R-F AMPLIFIER TETRODE	MEDIUM 6-PIN	FIG. 9	5 3/8" x 1 1/8"	HEATER	2.5	1.75	275	90	250	-3.0; min.	90	1.7*	4.0	400000	1000	400	—	—	24-A
26	AMPLIFIER TRIODE	MEDIUM 4-PIN	FIG. 1	4 1/2" x 1 1/8"	FILAMENT	1.5	1.05	180	—	—	-7.0; min.	—	—	—	—	—	—	—	—	26
27	DETECTOR & AMPLIFIER TRIODE	MEDIUM 6-PIN	FIG. 8	4 1/2" x 1 1/8"	HEATER	2.5	1.75	275	—	—	-21.0; min.	—	—	—	—	—	—	—	—	27
30	DETECTOR & AMPLIFIER TRIODE	SMALL 4-PIN	FIG. 1	4 1/2" x 1 1/8"	D-C FILAMENT	2.0	0.06	180	—	—	-4.5; min.	—	—	—	—	—	—	—	—	30

* For Grid-leak Detection—plate volts 45; grid return to + filament or to cathode.

• Applied through plate coupling resistor of 250000 ohms or 500-henry choke shunted by 0.25 megohm resistor. *Maximum.

31	POWER AMPLIFIER TRIODE	SMALL 4-PIN	FIG. 1	4 1/2" x 1 1/8"	D-C FILAMENT	2.0	0.13	180	—	—	-22.5; min.	—	—	—	—	—	—	—	—	31
32	R-F AMPLIFIER TETRODE	MEDIUM 4-PIN	FIG. 4	5 3/8" x 1 1/8"	D-C FILAMENT	2.0	0.06	180	67.5	180	-3.0; min.	67.5	0.4*	1.7	1200000	640	610	—	—	32
33	POWER AMPLIFIER PENTODE	MEDIUM 5-PIN	FIG. 6	4 1/2" x 1 1/2"	D-C FILAMENT	2.0	0.26	180	180	180	-18.0; min.	180	5.0	22.0	55000	1700	90	6000	1.4	33
34	SUPER-CONTROL R-F AMPLIFIER PENTODE	MEDIUM 4-PIN	FIG. 9A	4 1/2" x 1 1/8"	D-C FILAMENT	2.0	0.06	180	67.5	180	-3.0; min.	67.5	1.0	2.8	600000	600	360	620	—	34
35	SUPER-CONTROL R-F AMPLIFIER TETRODE	MEDIUM 5-PIN	FIG. 9	5 3/8" x 1 1/8"	HEATER	2.5	1.75	275	90	250	-3.0; min.	90	2.5*	6.3	300000	1020	305	420	—	35
36	R-F AMPLIFIER TETRODE	SMALL 5-PIN	FIG. 9	4 1/2" x 1 1/8"	HEATER	6.3	0.3	250	90	250	-3.0; min.	90	1.7*	3.2	550000	850	470	525	—	36
37	DETECTOR & AMPLIFIER TRIODE	SMALL 6-PIN	FIG. 8	4 1/2" x 1 1/8"	HEATER	6.3	0.3	250	—	—	-6.0; min.	—	—	—	—	—	—	—	—	37
38	POWER AMPLIFIER PENTODE	SMALL 6-PIN	FIG. 9A	4 1/2" x 1 1/8"	HEATER	6.3	0.3	250	250	250	-18.0; min.	—	—	—	—	—	—	—	—	38
39-44	SUPER-CONTROL R-F AMPLIFIER PENTODE	SMALL 6-PIN	FIG. 9A	4 1/2" x 1 1/8"	HEATER	6.3	0.3	250	90	250	-3.0; min.	90	1.4	5.8	750000	1000	750	1050	—	39-44

* For Grid-leak Detection—plate volts 45; grid return to + filament or to cathode. † Either A, C, or D, C, may be used on filament or heater. ‡ Except as specifically noted. For use of D, C, on A-C filament types, decrease stated grid volts by 1/2 (approx.) of filament voltage.

• Applied through plate coupling resistor of 250000 ohms or 500-henry choke shunted by 0.25 megohm resistor. † Applied through plate coupling resistor of 100000 ohms. *Maximum.

TUBE SYMBOLS AND BOTTOM VI

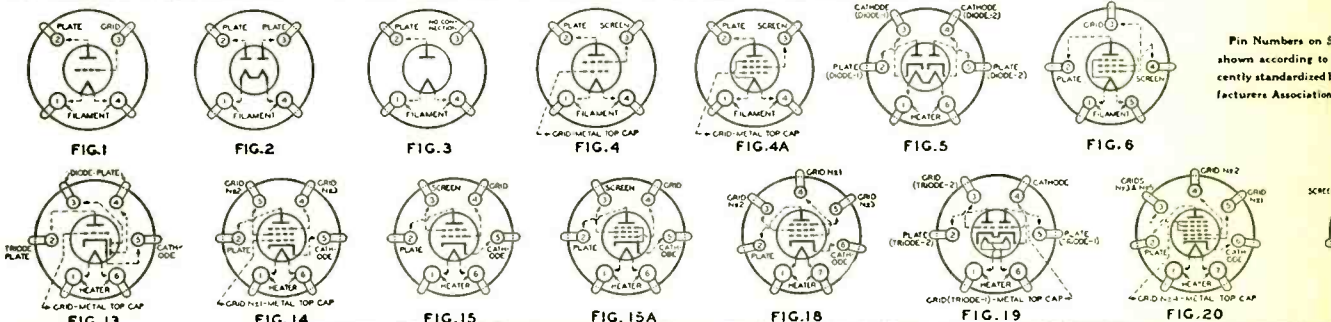

Pin Numbers on 8 shown according to centy standardized h facturers Association

INDEX OF TYPES BY USE AND BY CATHODE VOLTAGE

CATHODE VOLTS	POWER AMPLIFIERS	VOLTAGE AMPLIFIERS Including Duplex-Diode Types	CONVERTERS IN SUPERHETERODYNES	DETECTORS	MIXER TUBES IN SUPERHETERODYNES	RECTIFIERS	CATHODE VOLTS
1.1	—	11, 12	—	11, 12	—	—	1.1
1.5	—	26	—	—	—	—	1.5
2.0	19, 31, 33, 49	30, 32, 34	1A6, 1C6	30, 32	1A6, 1C6, 34	—	2.0
2.5	2A3, 2A5, 45, 46, 47, 53, 59	2A6, 2B7, 2A, 27, 35, 55, 56, 57, 58	2A7	2A6, 2B7, 2A, 27, 55, 56, 57	2A7, 2A, 35, 57, 58	82	2.5
3.3	20	22, '99	—	—	—	—	3.3

Technical Bulletins on these types

RADIOTRON CHART



TYPE	NAME	BASE	SOCKET CONNECTIONS	DIMENSIONS MAXIMUM OVERALL LENGTH x DIAMETER	CATHODE TYPE	RATING			USE Values in right column operating conditions and characteristics for indicated typical use	PLATE SUPPLY VOLTS	GRID VOLTS	SCREEN VOLTS	SCREEN MILLI-AMP.	PLATE MILLI-AMP.	A-C PLATE RESISTANCE OHMS	MUTUAL CONDUCTANCE MICRO-MHMS	VOLTAGE AMPLIFICATION FACTOR	LOAD FOR STATED POWER OUTPUT OHMS	POWER OUTPUT WATTS	TYPE
						FILAMENT OR HEATER	PLATE	SCREEN												
40	VOLTAGE AMPLIFIER TRIODE	MEDIUM 4-PIN	FIG. 1	4 1/8" x 1 1/8"	D-C FILAMENT	5.0	0.25	180	—	135	-1.5	—	—	0.2	150000	200	30	—	—	40
41	POWER AMPLIFIER PENTODE	SMALL 6-PIN	FIG. 15A	4 1/8" x 1 1/8"	HEATER	6.3	0.4	250	250	100	-7.0	100	1.6	9.0	103500	1450	150	12000	0.33	41
42	POWER AMPLIFIER PENTODE	MEDIUM 6-PIN	FIG. 15A	4 1/8" x 1 1/8"	HEATER	6.3	0.7	250	250	180	-13.5	180	3.0	18.5	81000	1850	150	9000	1.50	42
43	POWER AMPLIFIER PENTODE	MEDIUM 6-PIN	FIG. 15A	4 1/8" x 1 1/8"	HEATER	25.0	0.3	135	135	250	-18.0	250	5.5	32.0	68000	2200	150	7500	3.40	43
45	POWER AMPLIFIER TRIODE	MEDIUM 4-PIN	FIG. 1	4 1/8" x 1 1/8"	FILAMENT	2.5	1.5	275	—	180	-31.5	180	—	31.0	1650	2125	3.5	2700	0.82	45
46	DUAL-GRID POWER AMPLIFIER	MEDIUM 5-PIN	FIG. 7	5 1/8" x 2 1/8"	FILAMENT	2.5	1.75	400	—	250	-50.0	250	—	34.0	1610	2175	3.5	3900	1.60	46
47	POWER AMPLIFIER PENTODE	MEDIUM 5-PIN	FIG. 8	5 1/8" x 2 1/8"	FILAMENT	2.5	1.75	250	250	300	0	—	—	22.0	2380	2350	5.6	6400	1.25	47
48	POWER AMPLIFIER TETRODE	MEDIUM 6-PIN	FIG. 15	5 1/8" x 2 1/8"	D-C HEATER	30.0	0.4	135	100	125	-19.0	96	9.0	52.0	—	3800	—	1500	2.0	48
49	DUAL-GRID POWER AMPLIFIER	MEDIUM 5-PIN	FIG. 7	4 1/8" x 1 1/8"	D-C FILAMENT	2.0	0.12	180	—	135	-20.0	100	9.5	56.0	—	3900	—	1500	2.5	49
50	POWER AMPLIFIER TRIODE	MEDIUM 4-PIN	FIG. 1	6 1/8" x 2 1/8"	FILAMENT	7.5	1.25	450	—	300	0	—	—	6.0	4135	1125	4.7	11000	0.17	50
53	TWIN-TRIODE AMPLIFIER	MEDIUM 7-PIN	FIG. 24	4 1/8" x 1 1/8"	HEATER	2.5	2.0	300	—	250	0	—	—	35.0	2000	1900	3.8	4600	1.6	53
55	DUPLEX-DIODE TRIODE	SMALL 6-PIN	FIG. 13	4 1/8" x 1 1/8"	HEATER	2.5	1.0	250	—	135	-10.5	—	—	3.7	11000	975	8.3	25000	0.075	55
56	SUPER-TRIODE AMPLIFIER DETECTOR	SMALL 5-PIN	FIG. 8	4 1/8" x 1 1/8"	HEATER	2.5	1.0	250	—	250	-13.5	—	—	6.0	8500	975	8.3	20000	0.160	56
57	TRIPLE-GRID DETECTOR AMPLIFIER	SMALL 6-PIN	FIG. 11	4 1/8" x 1 1/8"	HEATER	2.5	1.0	250	100	250	-3.0	100	0.5	2.0	—	—	—	—	—	57

* For Grid-leak Detection—plate volts 45, grid return to + filament or to cathode. ** Requires different socket from small 7-pin. † Grid next to plate tied to plate. ‡ Two grids tied together. ** For grid of following tube. †† Applied through plate coupling resistor of 250000 ohms.

58	TRIPLE-GRID SUPER-CONTROL AMPLIFIER	SMALL 6-PIN	FIG. 11	4 1/8" x 1 1/8"	HEATER	2.5	1.0	250	100	250	-3.0 min.	100	2.0	8.2	800000	1600	1280	—	—	58
59	TRIPLE-GRID POWER AMPLIFIER	MEDIUM 7-PIN	FIG. 18	5 1/8" x 2 1/8"	HEATER	2.5	2.0	250	250	250	-10.0	100	—	—	—	—	—	—	—	59
71-A	POWER AMPLIFIER TRIODE	MEDIUM 4-PIN	FIG. 1	4 1/8" x 1 1/8"	FILAMENT	5.0	0.25	180	—	180	-43.0	—	—	10.7	2170	1700	3.0	3000	0.185	71-A
75	DUPLEX-DIODE HIGH-MU TRIODE	SMALL 6-PIN	FIG. 13	4 1/8" x 1 1/8"	HEATER	6.3	0.3	250	—	250	-1.35	—	—	5.0	9500	1450	13.8	—	—	75
76	SUPER-TRIODE AMPLIFIER DETECTOR	SMALL 5-PIN	FIG. 8	4 1/8" x 1 1/8"	HEATER	6.3	0.3	250	—	250	-20.0	—	—	—	—	—	—	—	—	76
77	TRIPLE-GRID DETECTOR AMPLIFIER	SMALL 6-PIN	FIG. 11	4 1/8" x 1 1/8"	HEATER	6.3	0.3	250	100	250	-1.5	60	0.4	1.7	650000	1100	715	—	—	77
78	TRIPLE-GRID SUPER-CONTROL AMPLIFIER	SMALL 6-PIN	FIG. 11	4 1/8" x 1 1/8"	HEATER	6.3	0.3	250	125	250	-3.0 min.	100	1.7	7.0	800000	1450	1160	—	—	78
79	TWIN-TRIODE AMPLIFIER	SMALL 6-PIN	FIG. 19	4 1/8" x 1 1/8"	HEATER	6.3	0.6	250	—	180	0	—	—	—	—	—	—	—	—	79
85	DUPLEX-DIODE TRIODE	SMALL 6-PIN	FIG. 13	4 1/8" x 1 1/8"	HEATER	6.3	0.3	250	—	160	-10.5	—	—	3.7	11000	975	8.3	25000	0.075	85
88	TRIPLE-GRID POWER AMPLIFIER	SMALL 6-PIN	FIG. 14	4 1/8" x 1 1/8"	HEATER	6.3	0.4	250	250	250	-10.0	100	1.6	9.5	104000	1200	125	10700	0.33	88
V-99 X-99	DETECTOR AMPLIFIER TRIODE	SMALL 4-PIN	FIG. 10	3 1/8" x 1 1/8"	D-C FILAMENT	3.0	0.063	90	—	90	-4.5	—	—	2.5	15500	425	6.6	—	—	V-99 X-99
112-A	DETECTOR AMPLIFIER TRIODE	MEDIUM 4-PIN	FIG. 1	4 1/8" x 1 1/8"	D-C FILAMENT	5.0	0.25	180	—	180	-13.5	—	—	7.7	4700	1800	8.5	—	—	112-A

* For Grid-leak Detection—plate volts 45, grid return to + filament or to cathode. ** Grid #1 is control grid. Grid #2 is screen. Grid #3 tied to cathode. † Grid #1 is control grid. Grids #2 and #3 tied to plate. ‡ Applied through plate coupling resistor of 250000 ohms. †† Grids #1 and #2 connected together. Grid #3 tied to plate. ** For grid of following tube. ††† Requires different socket from small 7-pin.

RECTIFIERS

523	FULL-WAVE RECTIFIER	MEDIUM 4-PIN	FIG. 2	5 1/8" x 2 1/8"	FILAMENT	5.0	3.0	—	—	—	—	—	—	—	—	—	—	—	—	523
1223	HALF-WAVE RECTIFIER	SMALL 4-PIN	FIG. 22	4 1/8" x 1 1/8"	HEATER	17.6	0.3	—	—	—	—	—	—	—	—	—	—	—	—	1223
2525	RECTIFIER-DOUBLER	SMALL 6-PIN	FIG. 5	4 1/8" x 1 1/8"	HEATER	25.0	0.3	—	—	—	—	—	—	—	—	—	—	—	—	2525
1-V ²	HALF-WAVE RECTIFIER	SMALL 4-PIN	FIG. 22	4 1/8" x 1 1/8"	HEATER	6.3	0.3	—	—	—	—	—	—	—	—	—	—	—	—	1-V ²
80	FULL-WAVE RECTIFIER	MEDIUM 4-PIN	FIG. 2	4 1/8" x 1 1/8"	FILAMENT	5.0	2.0	—	—	—	—	—	—	—	—	—	—	—	—	80
81	HALF-WAVE RECTIFIER	MEDIUM 4-PIN	FIG. 2	4 1/8" x 1 1/8"	FILAMENT	2.5	1.25	—	—	—	—	—	—	—	—	—	—	—	—	81
82	FULL-WAVE RECTIFIER	MEDIUM 4-PIN	FIG. 2	4 1/8" x 1 1/8"	FILAMENT	2.5	3.0	—	—	—	—	—	—	—	—	—	—	—	—	82
83	FULL-WAVE RECTIFIER	MEDIUM 4-PIN	FIG. 2	5 1/8" x 2 1/8"	FILAMENT	5.0	3.0	—	—	—	—	—	—	—	—	—	—	—	—	83
84 also 62z	FULL-WAVE RECTIFIER	SMALL 5-PIN	FIG. 23	4 1/8" x 1 1/8"	HEATER	6.3	0.5	—	—	—	—	—	—	—	—	—	—	—	—	84

Mercury Vapor Type. * Interchangeable with Type 1.

TYPES OF SOCKET CONNECTIONS

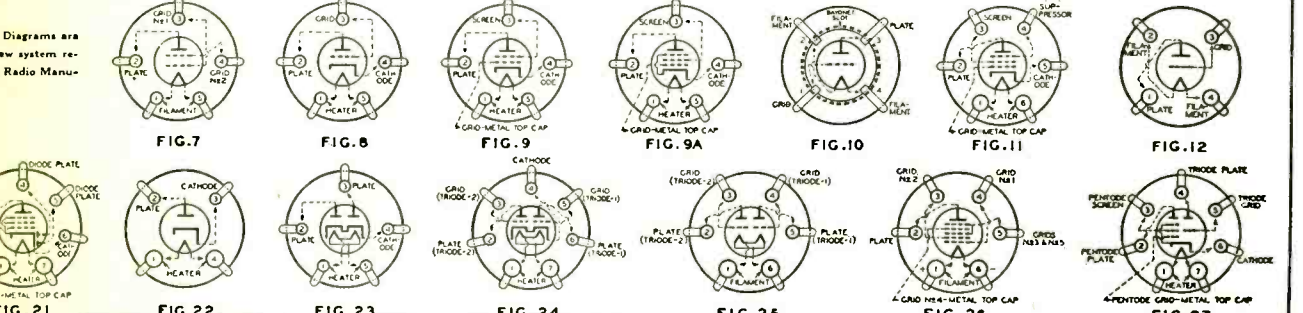

CATHODE VOLTS	POWER AMPLIFIERS	VOLTAGE AMPLIFIERS Including Duplex-Diode Types	CONVERTERS IN SUPERHETERODYNES	DETECTORS	MIXER TUBES IN SUPERHETERODYNES	RECTIFIERS	CATHODE VOLTS
5.0	112-A, 71-A	01-A, 40, 112-A		00-A, 01-A, 40, 112-A		523, 80, 83	5.0
6.3	6A4, 38, 41, 42, 79, 89	6B7, 6C6, 6D6, 6F7, 36, 37, 39-44, 75, 76, 77, 78, 85	6A7, 6F7	6B7, 6C6, 6F7, 36, 37, 75, 76, 77, 85	6A7, 6C6, 6D6, 6F7, 36, 39-44, 77, 78	1-V ² , 84	6.3
7.5	10, 50					81	7.5
12.6						1223	12.6
25.0	41					2525	25.0
30.0	48						30.0

may be obtained by writing to: **TRON COMPANY, INC., HARRISON, NEW JERSEY**

A 49-Cent Oscillograph

By G. F. LAMPKIN, W8ALK*

PROBABLY the best of all modulation indicators for amateur phone stations is the cathode-ray oscilloscope. Much has been done lately to popularize and make available to all this type of indicator. Fifteen or twenty dollars for even the smallest tube, however, bulks pretty large in many a radio-telephone budget, and forty-nine cents can be included with far greater ease. The latter sum will cover the cost of an indicator that has several things in common with the cathode ray.

The Tunalite tube was originally developed for use in a.v.c. broadcast receivers. It is

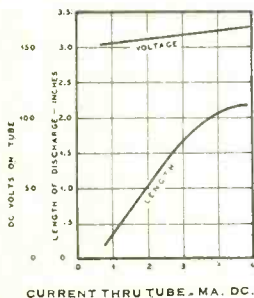

FIG. 1

Characteristics of Typical Tunalite Tube.

used in place of a meter to give an approximate indication of plate current for accurate tuning. It is a gaseous-discharge neon tube, having for one electrode a central rod, or wire, extending about 2¾ inches down the length of the tube; and a short ½-inch wire for the other electrode. The base is the single-contact bayonet type as used on automobile bulbs. When current is passed through the tube, the characteristic pink neon glow appears on the central wire, and the height of the glow depends on the value of the current.

The Tunalite tube works on radio frequency, just as the G-10 and other neon bulbs that have been used since 'way back for tuning-up ham transmitters. The height of discharge is a function also of the RF voltage values—so that to use the tube for a modulation indicator, all that is necessary is a rig similar to that of the diagram. The Tunalite is connected across a midget condenser and a coil, and the combination is tuned to the phone transmitter, to which it is coupled by the link circuit and line. The coupling is adjusted to give about a half-inch discharge on the central rod. When modulating, the discharge will flicker up and down the rod, reaching about the full length on 100% modulation.

* G. F. Lampkin Laboratories, Cincinnati.

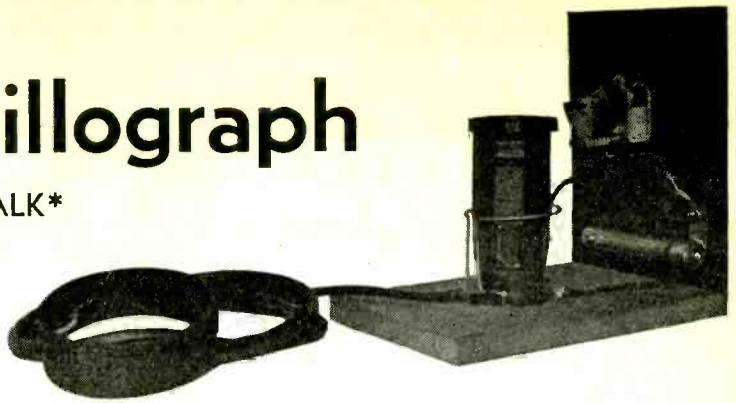

The appeal of the method lies in its utter simplicity. Unlike the cathode ray tube, the Tunalite requires no auxiliary apparatus or power supply. In fact, if the transmitter is in good view of the operating position, the midget condenser and coil are not even necessary. The Tunalite can be connected across the correct portion of the tank coil, or coupled directly with a few turns to the tank.

Like the cathode ray tube, the Tunalite is an electron-operated device, and its lag as a modulation indicator is nil. It will follow the fastest modulation, and will show the degree of modulation on sharp peaks where audio voltmeters or RF ammeters haven't a chance. For showing overmodulation, however, the trigger-alarm indicator in which a DC meter indicates average carrier value, is

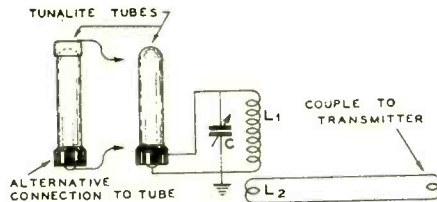

FIG. 2

Tunalite Hookup for Modulator Tube.

- C—Midget Variable Condenser.
- L1—Plug-in-Coil.
- L2—Coupling Link.

just as good as the Tunalite. The former will always kick even when the eye cannot accurately follow the neon column.

Here are a few practical observations: some of the Tunalite tubes do not have a linear variation of discharge with current. This can be checked by tuning the pickup tank smoothly through resonance. The discharge in some tubes will jump rapidly at a point along the rod, rather than climb and drop smoothly. If any choice is had in tubes, check this characteristic for a good specimen.

The circuit layout or placement of the tube can affect the character of the discharge. As a rule the column is more uniform with soldered connections to the base, rather than with a socket. The tube should be out in the clear from any fields which will distort the discharge or give hot spots. A variation

worth trying is to solder one wire to the central pin in the Tunalite base, and connect the other to a tinfoil or conducting-paint cap at the top of the tube. A high L/C ratio in the pickup tank gives more voltage on the tube with less reaction on the transmitter.

The column can more easily be followed if it has a dark background, and mounting behind a slot in a closed box will automatically fulfill the condition. Placing a white, or bright line at the height of column for full 100% modulation, will give a mark to shoot at, but never cross.

In Fig. 3 is given the basis for figuring height of discharge vs. percentage modulation. It was obtained by varying plate voltage on the modulated stage, and reading RF tank current and length of column. It is obvious that, with carrier resting, the coupling to the Tunalite circuit should be made to give discharge to about 'O'. Then on modulation the top of the discharge will follow the instantaneous peaks, and at 100% modulation will reach 'X', at which point the instantaneous current is twice that at 'O'. It

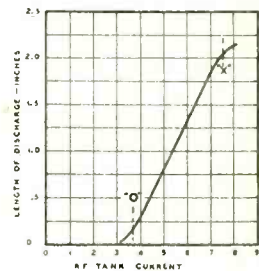

FIG. 3

Tunalite Tube as Indicator of Instantaneous RF Current Peaks.

is a good idea to check, if possible, the modulation performance by other well known means, and then a direct-reading percentage-modulation scale can be made for the Tunalite.

If the Tunalite is viewed in a mirror held four or five inches away, and if the mirror is rocked on an axis parallel to the tube, a fair representation of the positive halves of the actual modulation waves will be seen.

The AT-Cut Crystal

(Continued from page 13)

varied with the rotation, but the 35 degree location reduced the activity only a trifle.

Further research proved that crystal fracture and failure are largely due to the inter-coupling between the secondary spectrum of vibrations and the primary resonant point, and that in eliminating the secondary spectrum the ruggedness of the crystal was tremendously increased. No trouble was experienced in obtaining outputs of about 50 watts without sacrificing normal safety factors, and 200 watts output was obtained with care. Our

information indicates that triodes were used as the oscillator tubes and that no special circuit treatment was required. These crystals give good output up to 20 megacycles and they are quite rugged at these high frequencies. It looks like the 20 meter crystal is here at last.

The Multi-Arc

(Continued from page 15)

in those of the tilting type, in which it is replaced by a small side electrode.

Many amateurs have inquired about transformers and chokes for the Multi-Arc and in some cases have desired to secure them in

conjunction with the tube. Both transformer and choke have been designed to fit the Multi-Arc and full constructional details for the amateur who likes to build his own will be in the next issue of "RADIO". The amateur will be enabled to obtain a complete set-up, ready to wire into the 110 AC and HV and his present filter.

A recent experiment in the laboratory shows promise of developing an ideal system for keying the final or HV for the transmitter. This device has been called Ionic Keying, and a hint is given in the illustration. While still in the experimental stage some interesting developments are expected. Information will soon be forthcoming.

Globe Giraffes

Conducted by W6WB

W8DED -- Holland, Michigan

ONE of Michigan's pioneer DX stations and traffic enthusiasts is W8DED of Holland, Michigan. The station is owned and operated by Russ and Bill Sakkers. Many records have been made by W8DED during the ten years of operation. The station started in 1924 on the old 200 meter band with a Rolls Royce five watter which was used until this year when a modern four-stage crystal control station was installed.

Among the records of W8DED is working all continents, four times each. Any ham who has tried to work DX from Michigan will assure you that is no easy task. Michigan is located in a spot that seems to be poor for DX; ask any Michigander. W8DED has also placed in every DX contest, winning it on two occasions and placing second or third in all the rest. From 1926 to 1929 W8DED led Michigan in traffic totals. A total of 60 countries has been worked. W8DED was also the first station to work Australia and New Zealand from Michigan.

The new 75 watt transmitter is built for efficiency as well as for looks. All amateurs visiting W8DED admire the beauty of the transmitter and agree that it is one of the best they have ever seen. One room is entirely devoted to radio. The transmitter uses a 47 xtal osc., 210 buffer and doubler, and a 210 buffer feeding into the 852 final amplifier using 200 watts input. The transmitter has separate power supplies for each stage in addition to a separate filament supply for each filament of each tube. The receiver is a tuned RF job using one '32 and two '33s. The antenna is a Zepp with 66-foot flat top and 33-foot feeders.

W8DED is interested in all departments of amateur radio, traffic, DX, experimenting,

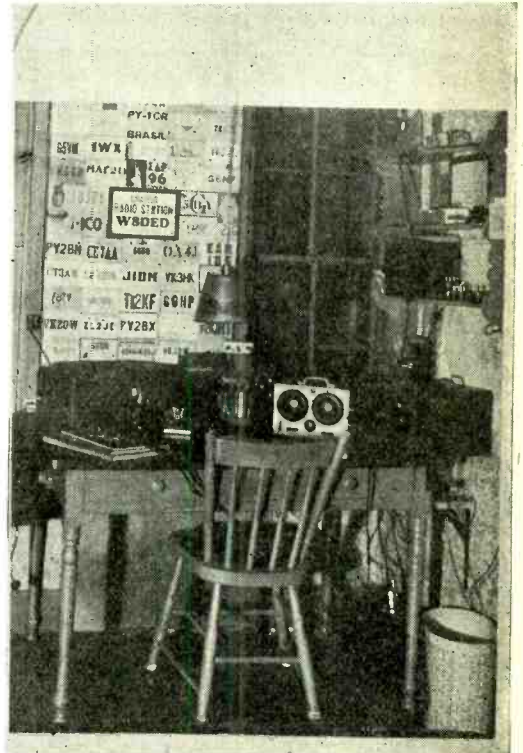
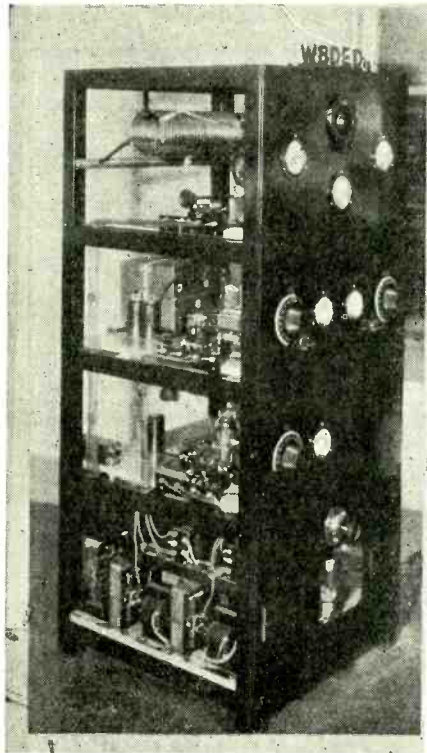

W8DED Has an Impressive Layout. The Picture Tells the Story

etc. Rag chewing is a great hobby. W8DED is a member of ARRL, ORS, WAC, OBS, IRF, AARS, exRM, RCC, and is known throughout the United States as one of the best QSL print-

ers. Millions of cards have been printed by "Rus" who does most of the operating at W8DED. Look for W8DED on 3800, 3640, 3550, 7280, 14100 and 14300 KC.

DX NEWS

5-Meter Activity Grows

MEMBERS of the Cleveland Heights Amateur Radio Club have banded together for some real 5-meter activity. Mr. Paul M. Cornell, W8EFW, tells us that the little one-tube Frank Jones 5-meter job shown in July "RADIO" has been built by quite a few of the club members and that it is really a little knockout. Says Paul: "That 5-meter job using the single '19 tube seems to make a better transceiver than the more elaborate setups using '30s and '33s. All are very enthusiastic over the fine performance. We are doing a lot of experimenting, because we finally managed to get a number of amateurs interested in 5 meters. So far the best DX with the Frank Jones Transceiver is about 10 miles from an airplane to ground. On shorter distances the rig works very well. We have done quite satisfactory work along mobile lines, communicating between moving autos while driving through city streets for distances up to 2½ miles."

Such information is encouraging. In the Los Angeles district 42 5-meter phones were in operation on a single afternoon and that old-timer of ham radio, John L. Reinartz, got a real thrill out of some 5-meter work at W6AM a few weeks ago. W6AM has worked 40 cities on 5 meters from his location. The secret—he can see all 40 cities from the top of his 5-meter "Q" antenna stick, which, by the way, is being hoisted to 125 feet, plus 6 feet 6 inches more when W6AM stands on top of the stick.

Believe it or not, the original Scratchi, who writes for these pages, sailed into port the other day and hot-footed it to the first radio store to buy two sets of parts for 5-meter jobs. Scratchi is still holding down his job as a commercial operator on one of the Grace liners on the N. Y.-S. F. run, and he is going to take a whirl at 5 meters on the briny deep, to see just how far the signals will carry over water. He will have an authentic report for us real soon.

Country Classification

MUCH INTEREST was aroused by the publication in August "RADIO" of a new DX-country list. Obviously, this list was subject to addition, correction and revision and the great number of letters received during the past few weeks is proof that there is an immediate need for a reclassification of DX countries. Our thanks to the host of amateurs who have so kindly commented on the idea, and to those who have sent us lists containing names of additional countries which are to be added to the originally published list.

In October "RADIO" we will print another list, perhaps the most complete of its kind yet presented. In this list will be included all of the names of all of the countries sent in by our contributors. The DX-Country Committee will receive advance proofs of this list so that comments can be secured from them before the next issue of the magazine goes to press.

Coil Winding Charts for Copper Tubing Tank Coils

Compiled for "RADIO" By CHAS. PERRINE, JR., W6CUH*

HOW TO USE THE COIL-WINDING CHART

THE values given are a close approximation to your particular requirements in each case, but exact accuracy depends on the circuit arrangement and the length of the leads in the plate circuit of the tube to be used. The two factors mentioned become more important as the frequency increases. Long leads necessitate fewer turns on the coil, but the leads should be long enough to keep the tank condenser separated from the coil by at least the coil diameter.

All the values in the table are for the tubes specified when used as single-ended amplifiers with the neutralization tap near the center of the coil. If placed in the center of the coil, this tap will automatically give fixed neutralization on all bands. For push-pull amplifiers, decrease the number of turns by 25% for any given tube. The reason for this decrease will be apparent upon close comparison of single-ended and push-pull circuits. Just twice as much tube capacity is shunted across the tank in push-pull circuits as when single-ended circuits are used.

In low-C tanks, such as these, the voltage rating of the condenser should be equal to four times the plate voltage on the tube for single-section types, and twice the plate voltage (each section) for split-stator models.

CHART NO. 1. For Coils Tuned With Split-Stator Condenser and Used in Circuits Employing Low-C Tubes, Such as 354, 852, 800, 825, RK18.

BAND	2" Dia. Coil	3" Dia. Coil	4" Dia. Coil	5" Dia. Coil	6" Dia. Coil	Size of Tuning Condenser
160	N.S.	N.S.	N.S.	N.S.	80 Turns 36" Long 3/4" Tubing	250 Mmf. Each Section for Full Band Coverage.
80	N.S.	N.S.	60 Turns 20" Long 1/4" Tubing	50 Turns 18" Long 1/4" Tubing	40 Turns 18" Long 3/8" Tubing	100 Mmf. Each Section for Full Band Coverage.
40	N.S.	46 Turns 16" Long 1/4" Tubing	34 Turns 12" Long 1/4" Tubing	28 Turns 12" Long 1/4" Tubing	22 Turns 12" Long 1/4" Tubing	35 Mmf. Each Section.
20	32 Turns 15" Long 1/4" Tubing	20 Turns 12" Long 1/4" Tubing	16 Turns 12" Long 1/4" Tubing	14 Turns 12" Long 1/4" Tubing	10 Turns 12" Long 1/4" Tubing	35 Mmf. Each Section.
10	8 Turns 4" Long 1/4" Tubing	6 Turns 4" Long 1/4" Tubing	4 Turns 4" Long 1/4" Tubing	4 Turns 4" Long 1/4" Tubing	3 Turns 4" Long 1/4" Tubing	35 Mmf. Each Section. N.S. Indicates: NOT SATISFACTORY.

CHART NO. 2. For Coils Tuned With Single-Section Condenser and Used in Circuits Employing Low-C Tubes Such as 354, 852, 800, 825, RK18.

BAND	2" Dia. Coil	3" Dia. Coil	4" Dia. Coil	5" Dia. Coil	6" Dia. Coil	Size of Tuning Condenser
160	N.S.	N.S.	N.S.	N.S.	60 Turns 36" Long 3/4" Tubing	100 Mmf.
80	N.S.	N.S.	50 Turns 20" Long 1/4" Tubing	40 Turns 18" Long 1/4" Tubing	30 Turns 18" Long 3/8" Tubing	100 Mmf. For Full Band Coverage.
40	N.S.	36 Turns 14" Long 1/4" Tubing	24 Turns 12" Long 1/4" Tubing	20 Turns 12" Long 1/4" Tubing	16 Turns 12" Long 1/4" Tubing	35 Mmf.
20	22 Turns 12" Long 1/4" Tubing	16 Turns 12" Long 1/4" Tubing	12 Turns 12" Long 1/4" Tubing	10 Turns 12" Long 1/4" Tubing	8 Turns 12" Long 1/4" Tubing	35 Mmf.
10	6 Turns 5" Long 1/4" Tubing	4 Turns 5" Long 1/4" Tubing	4 Turns 5" Long 1/4" Tubing	4 Turns 5" Long 1/4" Tubing	2 Turns 5" Long 1/4" Tubing	35 Mmf.

CHART NO. 3. For Coils Tuned With Split-Stator Condenser and Used in Circuits Employing High-C Tubes, Such as 50 Watters, 210, 204A, 849, 212D, 830, 46, RK20.

BAND	2" Dia. Coil	3" Dia. Coil	4" Dia. Coil	5" Dia. Coil	6" Dia. Coil	Size of Tuning Condenser
160	N.S.	N.S.	N.S.	N.S.	72 Turns 36" Long 3/4" Tubing	250 Mmf. Each Section for Full Band Coverage.
80	N.S.	N.S.	54 Turns 16" Long 1/4" Tubing	46 Turns 18" Long 1/4" Tubing	36 Turns 18" Long 3/8" Tubing	100 Mmf. Each Section for Full Band Coverage.
40	N.S.	36 Turns 14" Long 1/4" Tubing	24 Turns 10" Long 1/4" Tubing	20 Turns 10" Long 1/4" Tubing	16 Turns 10" Long 1/4" Tubing	35 Mmf. Each Section.
20	24 Turns 10" Long 1/4" Tubing	16 Turns 10" Long 1/4" Tubing	12 Turns 10" Long 1/4" Tubing	10 Turns 10" Long 1/4" Tubing	8 Turns 10" Long 1/4" Tubing	35 Mmf. Each Section.
10	8 Turns 5" Long 1/4" Tubing	6 Turns 5" Long 1/4" Tubing	4 Turns 5" Long 1/4" Tubing	4 Turns 5" Long 1/4" Tubing	3 Turns 5" Long 1/4" Tubing	35 Mmf. Each Section.

CHART NO. 4. For Coils Tuned With Single-Section Condenser and Used in Circuits Employing High-C Tubes, Such as 50 Watters, 210, 204A, 849, 212D, 830, 46, RK20.

BAND	2" Dia. Coil	3" Dia. Coil	4" Dia. Coil	5" Dia. Coil	6" Dia. Coil	Size of Tuning Condenser
160	N.S.	N.S.	N.S.	N.S.	60 Turns 36" Long 3/4" Tubing	100 Mmf.
80	N.S.	N.S.	50 Turns 20" Long 1/4" Tubing	40 Turns 18" Long 1/4" Tubing	30 Turns 18" Long 3/8" Tubing	100 Mmf. For Full Band Coverage.
40	N.S.	32 Turns 14" Long 1/4" Tubing	22 Turns 12" Long 1/4" Tubing	18 Turns 12" Long 1/4" Tubing	14 Turns 12" Long 1/4" Tubing	35 Mmf.
20	18 Turns 10" Long 1/4" Tubing	14 Turns 10" Long 1/4" Tubing	10 Turns 10" Long 1/4" Tubing	8 Turns 10" Long 1/4" Tubing	6 Turns 10" Long 1/4" Tubing	35 Mmf.
10	4 Turns 5" Long 1/4" Tubing	4 Turns 5" Long 1/4" Tubing	4 Turns 5" Long 1/4" Tubing	4 Turns 5" Long 1/4" Tubing	2 Turns 5" Long 1/4" Tubing	35 Mmf.

* Chief Engineer, Radio Division, Audio Products Co., Los Angeles.

How to Couple the Collins System From a Push-Pull Final Amplifier to a Single-Wire Antenna

MANY readers have asked how to utilize the Collins pi network between a push-pull final and a single wire fed antenna. Some simply tie the pi net to one side of center and let it go at that, but they usually find that the load on the tubes becomes unbalanced when this is done, causing one tube to heat more than the other, and also causing neutralizing troubles as well as generating even harmonics.

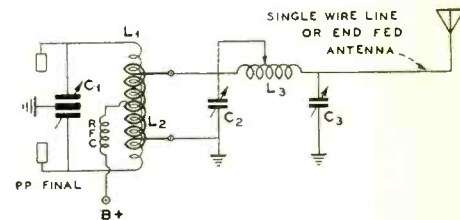

- L1—Usual Tank Coil.
- L2—1/3 Tank Turns, interwound or otherwise very-closely coupled.
- L3—Standard Collins pi Network.
- C1—Plate Tank Condenser.
- C2-C3—Regular Collins pi Network Condenser Sizes.

The circuit shown in Fig. 1 evenly loads each side of the push-pull stage and only causes a very slight capacity unbalance, which is too minor to affect the neutralization of the stage. C1 is the conventional plate tank condenser of the push-pull stage and is shown as a split-stator, although its use is not essential to the antenna coupling system. L1 is the regular tank coil. L2 has about one-third as many turns as L1 and is exceptionally closely coupled to it. It may be wound inside or outside of the plate tank although the inter-wound coil shown is to be preferred. It is impossible to obtain close enough coupling by placing L1 and L2 end to end, as is done with most Zepp and other inductive antenna coupling systems.

C, C3 and L3 are the conventional single-ended components of the Collins pi network and their constants are unaffected by the presence of the coupling coil L2.

Uncles Dave Off For Europe

DAVE L. MARKS, known to amateurs as "Uncle Dave", is on his way to Europe on a combined business and pleasure trip. He's a full-fledged ham and has taken a portable transmitter with him so that he can contact our fellow hams in England, France, Belgium and other Central and Western European countries. He will represent a number of prominent manufacturers of amateur equipment and he hopes to establish a number of European agencies for our American-made ham goods. Uncle Dave will make the rounds of the radio clubs "over there" and he is anxious to hear from those who want to get in touch with him while abroad. His address will be: David L. Marks, 3 Kensington Gardens, Northshields, England.

Alan Radio Opens Los Angeles Branch

Mr. Phillip Kessler, member of the firm of Alan Radio Corporation of 83 Cortlandt St., New York City, has been placed in charge of the new Los Angeles branch which will be located at 1028 Olive St. Alan Radio Corporation is the manufacturer of a large line of short-wave equipment. The entry of the New York firm into the Los Angeles market is the beginning of a new expansion program which has created much interest in radio circles.

Tobe All-Wave Filterizer Kit

TWO models of All-Wave Aerial Filterizer Systems have recently been developed by the Tobe Deutschmann Corporation of Canton, Massachusetts.

Features of the Tobe Filterizer systems are: Practical and inexpensive installation requirements, true all-wave band efficiency, and great reduction in radio noise and interference pick-up.

These All-Wave Aerial Kits are readily adapted to one-quarter wave Marconi or one-half wave Hertz Aerials.

The Brightest Stars of Radio are presented at SHORT WAVE HEADQUARTERS

NATIONAL "FB-7A"

- ★ High Selectivity and Sensitivity
- ★ Uniform Gain over Entire Frequency range
- ★ Two I. F. High Gain Stages
- ★ Seven Tubes not including Rectifier
- ★ Band Spread and Full Range Coils
- ★ Full Range 34 MC to 1500 KC

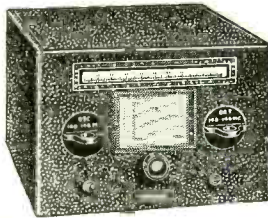

This seven-tube (plus rectifier) superhet S. W. receiver has been designed for the experienced amateur and is known the world over for its wonderful performance. It incorporates every latest feature including full vision dial, front panel plug-in coils, send and receive switch, heat oscillator switch, calibration chart, etc.

rates every latest feature including full vision dial, front panel plug-in coils, send and receive switch, heat oscillator switch, calibration chart, etc.

N13867—FB-7A Receiver, with air Dielectric Condensers in I. F. Amplifier, completely wired, less coils and tubes. List price \$57.00—your cost **\$34.20**

N13874—Complete kit of tubes, 1-56, 1-57, 2-58's, 1-59, 2-24's—your cost **\$5.95**

World-Wide Distributors

For all nationally known Radio Equipment at lowest wholesale prices. If you want S. W. Transmitting apparatus see us first. Here are a few of the lines we carry in stock at all times:

CARDWELL,
HAMMARLUND,
NATIONAL,
UNITED TRANSFORMER
ALLEN-BRADLEY,
WESTON,
TRIPLET,
LEICHNER,
CORNELL-DUBILIER,
SANGAMO,
PYREX,
SIGNAL, ETC., ETC.

When in need of S.W. apparatus the logical place to buy is from Wholesale Radio Service Company at **LOWEST WHOLESALE PRICES!**

*All products
manufactured by
The NATIONAL Co
can be supplied by us
at discounts of 40%*

NATIONAL

Cathode Ray Oscilloscope

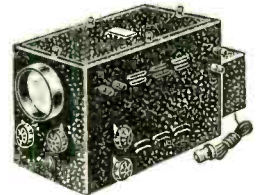

Offers a means of checking both phone and C.W. transmitters by providing an instantaneous graphic picture of actual operating conditions in transmitter circuits... unobtainable by other means. Indicates Percentage Modulation, Signal Distortion and Peak Voltages. Unit entirely self contained.

List price less tubes, \$29.50—your cost... **\$17.70**

RCA type 906 Cathode Ray tube with 3-inch screen. \$18.00
Net price **\$18.00**

The Band Spread Portable

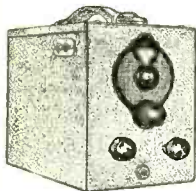

COMPACT AS A CAMERA

You'll be amazed that such a trim, small set can give such performance! This 2-tube Band Spread Portable has brought in London, Berlin, Madrid. Take it any place for it weighs but 9 pounds complete with its self-contained batteries! Station finding is easy due to a simple arrangement whereby the main tuning condenser is connected across only a portion of the secondary winding while a small adjustable variable condenser is connected across the entire grid winding. The main tuning condenser, therefore, has a very slight tuning effect so that the entire dial movement represents but a limited frequency range—hence the "band spreading action."

Kit of parts **\$7.95**
Kit of 2 tubes, add **\$1.44** Kit of batteries, add **\$1.18**
Coils covering following bands, 19, 20, 25, 31, 40, 49, 80 & 160 meters **.55 each**

New PEAK Preselector & Amplifier

Besides tremendous signal gain, PEAK gives increased selectivity; absolute rejection of image or repeat spots; reduction of background noise and increased sensitivity. Employs 2 tuned stages of high gain 58 type tubes.

Hundreds of tests have proven that signals of R3 audibility can be consistently boosted to R9 and R9+. Operates with any S.W. or All-Wave receiver. PEAK is used by the N. Y. Times as well as many commercial companies and amateurs everywhere.

Comes complete with 3 sets of built-in coils covering all frequencies with overlap from 14-200 M. Other features include airplane type dial, smooth regeneration, automatic changeover switch, self contained filament supply. **\$19.80**
etc. List price, less tubes, \$33.00. YOUR COST

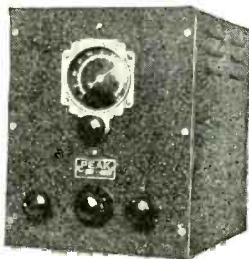

FREE 1935 CATALOG ready Sept. 15th

This new 1935 Radio Catalog No. 56 is the greatest we or any company has ever published. More pages, more items, more lines, more specialized departments. Over 50,000 items have been assembled in this 192 page market place.

There is a special department on the latest broadcast and All-wave receivers from 2 to 10 tubes—a model for every requirement. And you'll find an entirely new money making department on REFRIGERATION parts and accessories while an entire section is devoted to every type of PUBLIC ADDRESS EQUIPMENT. Here, too, is listed the greatest mobilization of REPLACEMENT PARTS and ACCESSORIES ever assembled.

Then there is our matchless SPECIALIZED SHORT WAVE department which in itself is a complete catalog; listing everything for the Ham, Brasspounder and Experimenter. Sets, Kits, Transceivers, Preselectors, Converters, as well as every S.W. part and accessory you will ever need.

Everything is listed; every leading manufacturer is represented... always at **LOWEST WHOLESALE PRICES.**

WHOLESALE RADIO SERVICE CO. INC.
100 SIXTH AVE. 430 W. PEACHTREE ST. N.W.
NEW YORK, N.Y. ATLANTA, GA.

LOCAL BRANCH—219 CENTRAL AVE., NEWARK, NEW JERSEY

WHOLESALE RADIO SERVICE CO.
100 Sixth Ave., Dept. P-94
New York, N. Y.

- Send me 16 page Catalog listing complete line of NATIONAL receivers and accessories.
- Send me your new 1935 Catalog No. 56 of 192 pages.
- Send me the items I have listed in attached letter.

Name
Address
City State

The Band-Spread Portable

By FRANK LESTER*, W2AMJ

IT IS a peculiar but undeniable fact that many "hams" who spend weeks on the construction of a new receiver or transmitter do not have enough patience to take a couple of evenings off and assemble that most vital accessory in every amateur station—a monitor. Although the importance of this little unit has been stressed time and time again in various magazine articles and books, it is usually the last gadget the "ham"

THE big problem in a set of this kind is filament supply; even the smaller size B battery will last a number of months and, therefore, is no worry. The two type 30 tubes are connected in series with each other and also with an 8 ohm fixed resistor, R2, the combination being connected directly to a large size 4½-volt C battery which measures only 4-in. x 3-in. x 1⅜-in. Since the total filament drain is only 60 milliamperes, the battery lasts a surprisingly long time. The battery used in several experimental models has given five full weeks of service and still seems to have plenty of life left in it. For intermittent use the A battery will last for months. Plate supply is furnished by a single medium sized 45-volt B battery. The two batteries together occupy exactly one-half the space inside the carrying case, as shown in an accompanying illustration.

The rest of the mechanical construction is simple. The socket for the plug-in coil is elevated about 3½-in. above the bottom of the case by means of a couple of long brass studs, so that the top of the coils come just above level with the top of the cabinet. The tubes are mounted on either side of the coil socket, the audio transformer and various fixed condensers and resistors in the space to the left, and the tuning condenser, C1, the antenna

140 mmf. midget variable condenser C1 and regeneration is controlled by the 100,000 ohm resistor in series with the detector plate. The transformer coupled audio stage gives considerable amplification.

Band spreading action on either the short-wave broadcast or amateur bands (depending on the particular coils used) is obtained by the use of special tapped plug-in coils. These differ from ordinary coils in that only a portion of the winding—about one-quarter of it—is tuned by the regular variable condenser, in this case C1. Each individual coil is fitted with a postage stamp type condenser, marked C5, which is connected directly across the entire grid or secondary winding. This condenser is set by an adjusting screw at the top; the idea merely is to set this "padding" condenser to the bottom of a particular wavelength band and to do the main tuning with the variable condenser C1. Since condenser C1 connects across only a fraction of the secondary winding, its overall tuning effect is comparatively slight and it gives the effect of very wide band spreading.

THE effective shielding provided by the right metal case of this little monitor prevents excessive pickup from a close-by transmitter. In actual service it has been found that a straightened out paper clip, fastened under the aerial binding post, provides enough pickup from a 7½ watt transmitter five feet away to give a walloping signal in a pair of phones. The actual length of aerial wire required for satisfactory monitoring pickup will depend, of course, on the arrangement of each particular "ham" station.

When carried in a car as a portable set, the Band Spread Portable will provide a great deal of entertainment for the "ham" who likes to listen in, at least, while he is away from home. A twenty-foot length of flexible insulated wire thrown over the roof of a car or into the branches of a tree will bring in

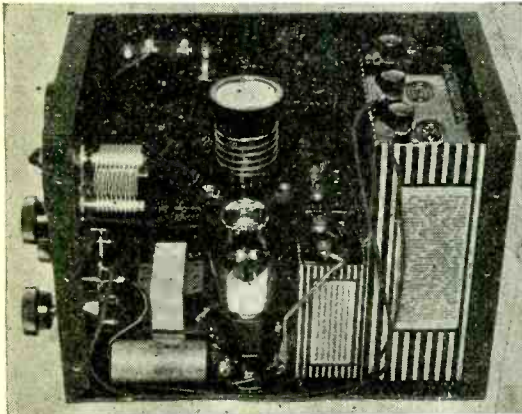

Interior view, showing compact arrangement

makes or buys for himself, if he does so at all.

To overcome this natural inertia on the part of "hams", an eastern radio firm has designed a kit of parts for a simple but effective monitor that also makes a very swell little portable receiver for field use. It has been named the "Band Spread Portable", because this title is so completely descriptive.

The Band Spread Portable uses two type 30 tubes in a sensitive and highly efficient circuit. The receiver proper and the necessary A and B batteries are all contained in a compact metal box measuring only 8¾ in. x 6¾ in. x 5¼ in. This is finished in black crystalline enamel, which is very durable and which also acts, to some extent, as an insulator against the summer sun when the set is used outdoors. Weighing only nine pounds complete with batteries, and fitted with a comfortable handle, the set resembles a small Graflex camera and can be carried around just as easily as one. It underwent its final tests at the hands of three different people during the recent heat wave and no one of these people ever had the impulse to drop it quietly into the nearest ash can.

The carrying case, of indestructible spot welded construction, is made in two pieces. The first comprises the bottom, ends and one long side and the other the top and the remaining side. The two sections are fastened together by means of small machine screws. Access to the coil socket, for the purpose of changing plug-in coils, is had through a hole in the top of the case just under the carrying handle. This opening is protected against dust and dirt by a tight fitting cover plate. The tuning controls are mounted on one end of the box and in spite of the fact that they are fully exposed, have never suffered the slightest damage in several hundred miles of automobile, subway and foot travel. It is necessary to unscrew the two sections of the cabinet only when putting the set into service initially or when replacing tubes or batteries.

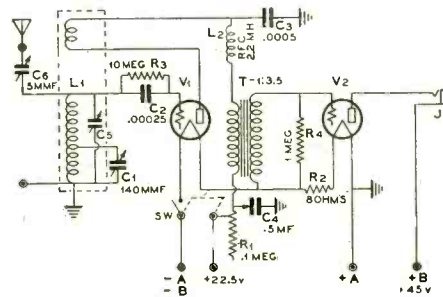

LIST OF PARTS

- L1—Two-winding five-prong band spread coils, to cover the 25, 31 or 49 meter broadcast bands or the 20, 40, 80 and 160 meter amateur bands as desired.
 - L2—2.2 mh. RF choke coil
 - C1—140 mmf. Midget Variable
 - C2—.00025 mf. Mica Grid Condenser
 - C3—.0005 mf. Mica By-pass Condenser
 - C4—.5 mf. Paper by-pass Condenser
 - C5—Trimmer Condensers built into coils
 - C6—Two-plate 5 mmf. Antenna Trimmer
 - R1—100,000 ohm Potentiometer
 - R2—8 ohm wire wound resistor
 - R3—10 megohm Grid Leak
 - R4—1 Megohm Grid Leak
 - V1-V2—Type '30 Tubes
 - J—Single open circuit phone Jack with insulating washers
 - T1—3½-to-1 ratio uncased Audio Transformer
- Three-inch vernier dial for condenser C1, knobs for R1 and C6 double binding post strip, five-prong socket for plug in coil L1, two four-prong sockets for the tubes, and incidental hardware and mounting screws.
- 1—Steel cabinet as specified
 - 1—4½-volt C battery Burgess No. 2370
 - 1—45-volt B battery Burgess No. 5308
- All parts used in this set are "Tru-test".

trimmer, C6, and the regeneration control, R1, and the earphone jack, J, on the end that forms the control panel.

Reliability being a prime requisite of a station monitor or portable set, the Band Spread Portable has been constructed to use a straight regenerative detector one stage audio hookup, which is absolutely sure fire in action. Tuning is accomplished by the

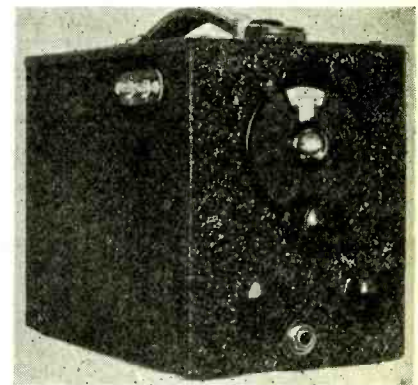

The receiver in its portable case

more CW and phone stations than the operator cares to log.

The Band Spread Portable is available in both kit and completely assembled form. Home assembly is rather easy, as the carrying case is supplied completely formed and drilled. The entire set can be put together in a couple of evenings of easy effort.

* Engineer, Wholesale Radio Service Co.

I. R. F. NEWS

(Formerly I.T.K.)

The Amateur's Legion of Honor

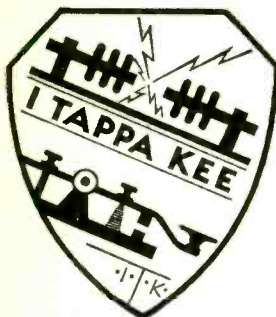

This department is edited by the President of the International Radio Fraternity, J. Richard Meloan (Jo) radio W6CGM-W6ZZGB, KERN. All communications concerning the International Radio Fraternity, as well as inquiries from any amateur as to the Requirements for Membership, should be addressed to I.R.F.

Headquarters, either to the Secretary-Treasurer, Kenneth M. Isbell, W6AMR-W6BOQ, 5143 So. 6th Ave., Los Angeles, or to the President, J. R. Meloan, W6CGM-W6ZZGM, 1411-9th St., Bakersfield, California.

IRF Announces New Deal!

WHAT is IRF doing? What are its plans? Will it meet the demand for a New Deal for the amateur? Is it conscious of present conditions?

The IRK-ITK plan was conceived seven years ago. Various theories have been tried. While others talked, IRF has been in action. Today it consists of over 400 very carefully chosen amateur leaders whose numbers will continue to be restricted to only the finest. These men are the old timers of amateur radio, averaging ten years of experience with outstanding records of achievements. They have written radio history. They are influential both in their own communities and in the world that knows their signals so well. They are out of their knee pants—95% are over 25 years of age. They know what it is all about and they are men in all walks of life. From this cross section of the finest that amateur radio has to offer has come a new deal. IRF has at all times diligently abided by the wishes of its members. Every issue has been voted upon—questionnaires have been sent.

Many of you have "tuned in late." You haven't had the opportunity to follow IRF's activities in this department. You lack much necessary information. What follows is NEWS! It is a significant movement in amateur radio history. On August 10th by vote of the general membership, a Junior Membership was created making possible the following plan which we respectfully submit to the amateur world as IRF's answer to the present situation—the New Deal in Action!

The International Radio Fraternity

ORIGIN AND TRADITIONS: Organized in 1926 to fill a definite need in amateur radio, it was chartered by Iota Tau Kappa of the Oregon Institute of Technology, as an exclusive fraternity for skilled and experienced amateur radio operators, technicians and engineers. ITK men now cover the world, everywhere performing outstanding service in the field of radio communications. By recent vote a Junior Membership has been created providing for admittance to IRF of all desirable licensed amateurs, but maintaining the high standards of IRF in its order of ITK.

PURPOSE: By fraternal organization to accomplish these manifold aims: To foster a spirit of closer comradeship; to preserve and carry on the noble traditions of radio's personnel; to mobilize the courageous honorable thinking men of amateur radio in the cause of better amateur conditions; to provide a forum for the discussion of common interest and the dissemination of knowledge pertaining to the art of radio communication.

FUNDAMENTALS: IRF is a personal amateur organization with honest and fair administration of amateur affairs, courageous representation of amateur opinion. It recognizes amateur legislative rights and believes in militant aggressive organization to insure protection of those rights. In the spirit of democracy IRF gives each member direct and equal vote on all questions, thus making each member a definite part of the whole organization. By close comradeship and fraternal structure it recognizes the fine fellowship existent among radio operators and sponsors friendship by definite methods. It is amateur radio's only international fraternity. It substantiates the amateur's claim to public service by an advanced type of traffic network and by military cooperation. It is opposed to commercialism in amateur radio. IRF has an unblemished, unchallenged record of accomplishment. It believes in ACTION!

(Continued on page 30)

PFANSTIEHL SINGLE SIDE BAND SUPER

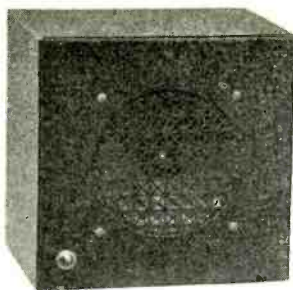

MODEL 70AP PACK



MODEL 70A RECEIVER

Complete with Coils for 20-40-80-160 Meter Bands

Amateur Net Price.....	\$34.95
Model 70AX—with Bliley Equipped Crystal Filter Add.....	11.76
Model 70AP—Pack-Speaker Combination, Net.....	13.50

AN AMATEUR BAND RECEIVER

With all the desirable features . . . automatic as well as manual volume control, airplane dial, full AC operation, receive-transmit switch, the ability to log accurately, good image suppression, crystal IF filter, special treatment of metal parts for tropical and salt air service, 3 watts audio output, unusual stability and gain especially on the 20 and 10-meter bands, hum-free at all frequencies, all components operated at half of their rating, earphone jack, coils thoroughly moisture-proofed. Each set individually calibrated, 8 tubes including rectifier.

Write for Circular—Dealer Inquiries Solicited

McCULLA MFG. CO. 112 S. Washington St. WAUKEGAN, ILL.

DWYER TRANSMITTING CONDENSERS

Designed with the requirements of the progressive amateur as the deciding factors, these condensers offer radical departures from the previously accepted standards. Chief among the features embodied in this line are the elimination of staked or swaged plates, allowing for an assembly that may be readily altered to meet the ever-changing requirements of present day high-frequency transmission.

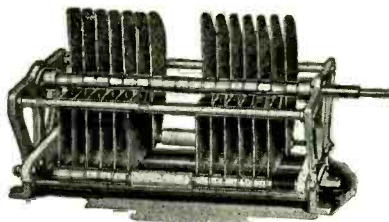

5-10-11,000 VOLT BREAKDOWN

Dwyer Split-Stator Transmitting Condensers are available in sizes from 72 mmf. maximum capacity to 235 mmf.; from 7 to 29 plates, at prices ranging from \$6.47 to \$11.22, net to Amateurs.

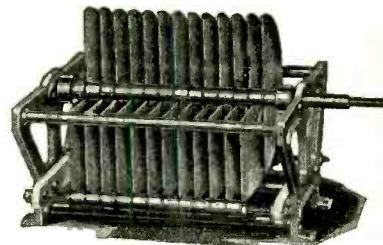

Dwyer Single-Section Transmitting Condensers are built to withstand voltages of from 5,000 to 11,000 volts. There is a size for every purpose, from 72 mmf. to 385 mmf., and ranging in price from \$3.53 to \$9.11, net to Amateurs.

GENERAL SPECIFICATIONS

Aluminum plates .040" thick. Rotor plates 2 3/8 inch radius. Overall width 6". Cast Aluminum End Plates. Plated spring brass contact material. Split spring bearing at each end of contact shaft. 3/8" "Diamond X" Shaft, with 1/4" extension for knobs. Cadmium plated brass spacer collars.

WRITE FOR DESCRIPTIVE CIRCULARS

DWYER ELECTRIC PRODUCTS CO. Factory and General Offices: WAUKEGAN, ILL.

SMITH-PRECISION CRYSTALS

Full-sized, specially ground X cut crystals; powerful, accurately calibrated, single-frequency oscillators. Unconditionally guaranteed.

3500-4000 kc /s—Close to Frequency,	\$2.35
7000-7500 kc /s—Close to Frequency,	\$3.95
3500-4000 kc /s—To Exact Frequency,	\$2.90
465-525 kc /s—S.S. Filters X Cut...	\$2.60

Postpaid by airmail.

Commercial Frequencies at Attractive Prices.

W. W. SMITH W6BCX

Pioneer Manufacturer of Fine-Quality Piezo Plates

215 West Cook Santa Maria, Calif.

CONNECT phones and key into the Mixer Monitor, and you have a first-rate code-practice oscillator. Strong, steady tone, volume control.

It's an excellent listening monitor.

For CW, or phone—It's always useful—

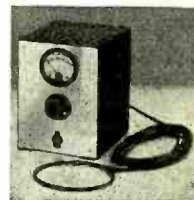

Your dealer can get them

G. F. Lampkin Laboratories

146 West McMillan St. Cincinnati, Ohio

The NEW 5C PROFESSIONAL SINGLE SIGNAL SUPERHETERODYNE

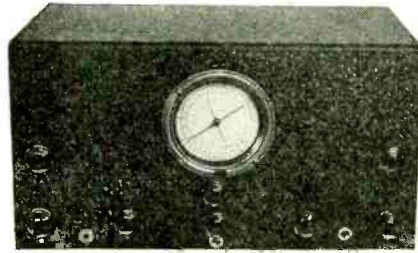

The 5C is the 1935 improved model of the now famous 5B—choice of W9USA of the World's Fair and amateurs the world over in preference to all available competition.

The first outstanding feature of the new 5C is the accurately calibrated large airplane "watch" dial, having one pointer for the three-gang main tuning condenser, and a second pointer on a 0-100 division scale for the three-gang band spread condenser—available by simply pulling out the tuning knob!

The 5C has a new high-gain tuned r.f. stage on all bands for image selectivity and excellent signal to noise ratio, a crystal filter circuit sacrificing absolutely no signal volume for its extreme selectivity, and manual or automatic volume control at the turn of a switch, plus all the features that have made the 5B famous, including air tuned i.f. amplifier.

That it is far in advance of all other competitive receivers is proven conclusively by the roster of its users—from W9USA to Col. Foster, W6HM.

TECHNICAL FEATURES

SENSITIVITY: Every 5C receiver shipped from the laboratory is guaranteed to have a sensitivity of 1 microvolt absolute or better.

SELECTIVITY: Each 5C will have selectivity curve 28 kc. wide 10,000 times down without crystal, or 50 cycles wide with crystal.

FIDELITY: The overall antenna to speaker fidelity of the 5C without crystal is uniform to 6 decibels from 30 to 4000 cycles—or absolutely uniform over the entire fundamental musical range at the loud speaker output. Yet by means of the crystal control knob, 50 cycle selectivity can be had at will.

POWER OUTPUT: The undistorted power output of the 5C is three watts.

VOLUME CONTROL: The 5C is equipped with audio volume control for use when the A.V.C. is switched in, and with manual i.f. sensitivity control for use when A.V.C. is switched out for high speed telegraph reception. By the turn of a knob the sensitivity can be raised to the maximum and very weak distant stations may be brought in easily—or lowered for locals.

CIRCUIT: All wave superheterodyne employing a '58 r.f. amplifier, 2A7 high efficiency first detector and electron coupled oscillator, two '58 i.f. amplifier stages, '55 diode second detector, diode A.V.C. and triode first audio stage, '58 audio beat oscillator for C.W. code reception, 2A5 in Class A power output stage, and one '80 rectifier.

WAVE LENGTH RANGE: 13 to 200 meters, or 1500 to 23,000 kc. in three low C bands.

DIAL: One illuminated dial accurately calibrated (error not over 1%) in megacycles (thousands of kilocycles) for the three short wave bands. Tuning ratio is nine to one.

BAND SPREAD TUNING: All stations can be tuned on the main dial, or will be found well spread out and easy to tune on the band spread dial, which, located on the main large airplane "watch" dial, is brought into use by simply pulling out the tuning knob, which then operates the band spread pointer and three-gang band spread condenser. Band spread 200 degrees

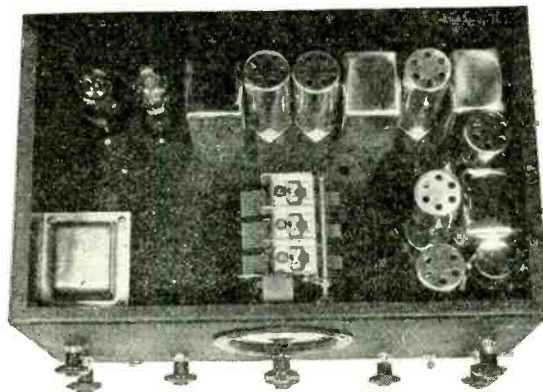

for 80 and 160 meter, 100 degrees for 20 and 40 meter amateur bands approximately, and available anywhere in range of receiver by pulling out tuning knob.

WAVE LENGTH CHANGE: One knob, with colored indicators matching dial scale colors. Knob actuates positive three position, six-gang selector switch having positive non-wearing, silver plated contacts.

I.F. AMPLIFICATION: Two stages of dual air tuned 465 kc. amplification using a total of five "Litz" wound tuned circuits and two '58 super control tubes.

SHIELDING: All r.f. and i.f. circuits completely shielded from external pickup. Two antenna binding posts only "hot" points exposed. Heavy cabinet provided with hinged top for easy access.

LOUD SPEAKER: Specially designed and matched Jensen dynamic unit in cabinet 7" square and 3½" deep.

TROPICAL CLIMATE PROVISION: All transformers, coils and condensers specially sealed against moisture, particularly for tropical climates. All filter condensers, power transformers, chokes and resistors greatly oversize to avoid possibility of breakdown in places remote from replacement part sources.

FINISH: Crystalline black on all parts except tube and r.f. shields, which are polished aluminum.

DIMENSIONS AND WEIGHT: 17" long over all, 10¾" deep and 8¾" high.

ANTENNA: Separate r.f. primaries for each band allow use of doublets or Marconi antennas at will.

CRYSTAL: When ordered, the 5C can be supplied with special Bliley quartz crystal resonator in Bliley holder, and with i.f. amplifier properly aligned to exact crystal frequency.

Type 5C communication receiver, as above, complete with eight tested Raytheon tubes, Jensen speaker and cabinets, ready to operate, list price \$124.50. Net price to amateurs \$74.20. Order it direct or from your dealer. Add to above for Bliley 465 kc. crystal in Bliley holder and specific receiver alignment for individual crystal supplied, list price \$15.00. Net price to licensed amateurs \$9.00.

McMURDO

3362 NORTH PAULINA STREET

TYPE 10D 100 WATT PROFESSIONAL PHONE-C. W. TRANSMITTER

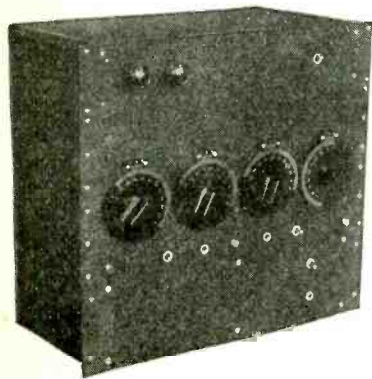

The type 10D transmitter is the amateur's dream come true. It provides 100 to 120 watts of crystal controlled r.f. power on the 10, 20, 40, 80 and 160 meter amateur bands modulated 100% with high fidelity broadcast station modulation, all at a cost below what you can build it for!

It employs one RK20 screen grid r.f. pentode as a crystal controlled Tritet (electron coupled) oscillator. Modulation is effected by suppressor grid voltage variation, which is obtained from a simple three stage audio modulator.

But read its specifications, look at its price, and get on the air with 100 watts of broadcast station voice quality, cheaper than you can build a 100 watt telegraph transmitter!

Order it from your dealer or direct and join the P.W.A.C. Club (Phone Worked All Countries.)

SPECIFICATIONS

R.F. OUTPUT: 100 to 120 watts on fundamental crystal frequency. 60 watts on crystal second harmonic.

FREQUENCY RANGE: 10, 20, 40, 80 or 160 meter amateur bands. One pair of two plug-in coils covers each band.

TUBES NEEDED: 1—RK20 Oscillator
1—RK19 Rectifier
1—2A5 Power Amplifier
1—53 Voltage Amplifier (2 stages)
1—80 Rectifier

MODULATION: Linear suppressor grid modulation variable from zero to over 100% at will. Harmonic distortion less than 5% at 100% modulation.

AUDIO FREQUENCY RANGE: Modulation curve flat to 4 db. from 40 to 8000 cycles. Variable tone control provided for high audio frequency attenuation as desired.

A.C. MODULATION HUM: Negligible.

PHONE-TELEGRAPH SECTION: Two position toggle switch and r.f. unit selects phone or C.W. telegraph operation at will.

ANTENNA TUNING: Two 365 mmf. condensers provided for series antenna tuning, or parallel antenna tuning by shift of two connecting links.

METERS: None provided except on special order (mounted on r.f. unit panel). One 0-150 ma. milliammeter and, if desired, one 0-2 antenna thermoammeter are all required to check operation.

CONTROLS: Oscillator plate, r.f. plate and two antenna tuning dials. Phone-Telegraph, send-receive, modulator on-off and power on-off switches. Screen and plate current measuring jacks. Key jack.

SIZE: Total height of all three 19" x 3/16 aluminum relay rack panels, 19 1/4". Supplied complete in dust cover shielding cabinet of perforated steel with hinged rear door. May be operated on table, or mounted in relay rack.

POWER REQUIRED: 350 watts at 105 to 125 volts, 50 to 60 cycle A.C.

ACCESSORIES NEEDED: One Bliley crystal and holder (specify frequency), one crystal microphone, and tubes as listed above.

Price net to Amateurs, \$119.70.

Five Raytheon tubes \$25.23 net.

Coils, per set of two (one set included, specify if for 20, 40, 80 or 160 meter band) \$3.60.

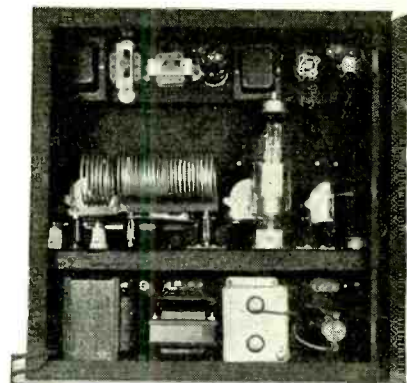

SEND 3c

stamp for new complete catalog describing above items, E.C. Frequency Meters, New Airplane Dials, Relay Racks, R.F. Chokes, Audio, Power and Filter Transformers, and a host of new and interesting amateur and commercial apparatus.

SILVER, Inc.

CHICAGO, U. S. A.

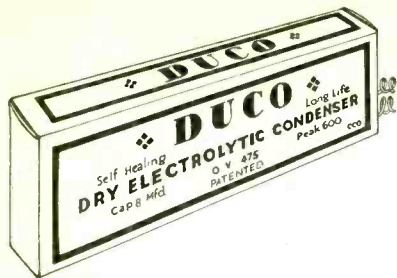

DUCO

"Best by Test"

All DUCO Condensers fully guaranteed for one year.

IN NO OTHER CONDENSERS DO YOU FIND THESE FEATURES:

1. Duco condensers are positively self-healing, even up to 3000 volts.
2. Better and longer life than the wet electrolytic condensers.
3. Smaller in size than any other make on the market.
4. For economy in costs it has no equal.
5. DUCO condensers in use over six years showing long shelf and use life.
6. All condensers are rated very conservatively.
7. Growing faster than any other make.
8. Used by best service men in the world.
9. Adopted by finest engineers of set manufacturers.
10. Guaranteed for one year.

DUCO CONDENSERS are fully protected by patents and patent applications all over the world. The response since we introduced our new condenser has been remarkable.

You, too, will be surprised at its performance.

Send for Free Catalog

Sales and Jobber Territory Open

Mfgd. by

DUMONT ELECTRIC CO.

453R Broome Street

New York City, N. Y., U. S. A.

Big News for Amateurs

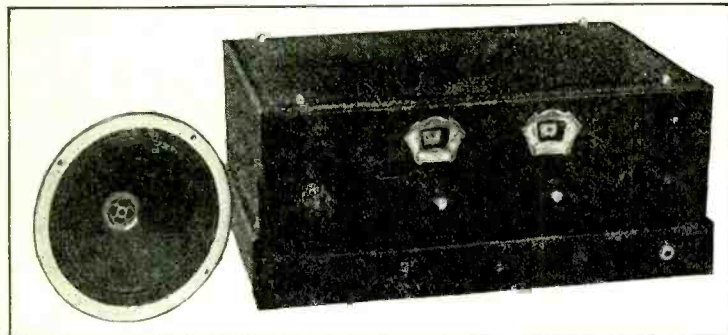

PRICE \$49.50
Complete with tubes and Dynamic Speaker

SARGENT 8-34 Amateur Super-Het

LOOK AT THESE FEATURES

Completely Shielded and Isolated—Separate C.W. Beat Oscillator Tuning Range 15-550 Meters—Power Supply Self-Contained Continuous Band Spread—Built Like a Battleship Large Tuning Knobs

The most sensational value ever offered in an Amateur Super-het. Not a "cheap super" but a ruggedly built instrument that will out-demonstrate sets selling at twice the price. Hairline selectivity, fractional microvolt sensitivity, easy adjustment, a good band spread. A knockout on 20 meters. Knows no superior on 40 and 75.

Don't take our word for it. You can buy it on 5 day, MONEY-BACK TRIAL. Send us \$49.50 and we will ship immediately. You have five days to test it in your own location. If it is not exactly what you have been looking for, return it and your money will be immediately refunded.

ORDER YOURS TODAY

Your Jobber Should Have It in Stock. If He Cannot Supply You, Send Your Order Direct to Us.

E. M. SARGENT CO. 2085 BROADWAY OAKLAND, CALIF.

RADIO ENGINEERING



RCA Institutes offers a combined course of high standard embracing all phases of Radio. Practical training with modern equipment at New York and Chicago schools. Also specialized courses and Home Study Courses under new "No obligation" plan. Illustrated catalog on request.

RCA INSTITUTES, INC., Dept. RA-34
75 Varick St., New York 1154 Merchandise Mart, Chicago
Recognized Standard in Radio Instruction Since 1909

\$1 Brings You the Next 4 Issues of "RADIO"—Subscribe Now



Write today for instructive bulletin.
4503 Ravenswood Ave. Chicago, Ill.

Low Range FUSES

INSTRUMENT LITTELFUSES
1/100, 1/2, 1/4, 1/8, 1/4, 3/8, 1/2, 3/4, 1, and 2 amps, positively protect meters, radios, amplifiers, etc. Also made in 1000, 5000, and 10,000 volt ranges for broadcast equipment, etc. \$100 Protection Guarantee. There is a distributor near you.
LITTELFUSE LABORATORIES

I. R. F. News

(Continued from page 27)

ORGANIZATION STRUCTURE:
ORDER OF ITK—DEGREE SECTION
(Selected skilled amateurs)
IRF JUNIOR MEMBERSHIP
(Any desirable licensed amateur)

MEMBERSHIP REQUIREMENTS: (Briefly)
Junior Member: Any desirable licensed amateur whose application is approved. Application same as (C) below but without three-year requirement.

Order of ITK "The Amateur's Legion of Honor":
(A) Licensed amateur with first class license having an active station open to any traffic that he may handle expeditiously.

(B) Recommendation of three ITK Brothers for good conduct and operation.

(C) Candidate must submit detailed record of experience, station equipment and activities and personal details. He must have at least three years' operating experience.

(D) Candidate is subject to investigation and approval of the Membership Committee.

(E) Candidate's code speed must be 20 wpm or better.

HOW TO BECOME A JUNIOR MEMBER: Secure an application blank. Fill in all requested details and submit with dues to headquarters.

HOW TO BECOME AN ITK FRATERNITY MAN: If you are properly pledged you will be sent a formal invitation and application blank. Submit your application to headquarters with dues. If you have not been pledged but believe you have the necessary qualifications you may secure and submit an application to headquarters who will inquire as to whether an ITK Brother will pledge you. If so, then your application follows the usual channels.

NOTE: Any applications refused will have the dues returned to the applicant. It is not unusual for some application to be refused, especially in the Degree Section, the Order of ITK.

DUES: For either Junior Members or ITK the dues are \$1.00 per year with no initiation fees. Dues \$1.50 per year for foreign countries.

PROGRESSION: An eligible amateur can become an ITK directly but an amateur not eligible to ITK may make application as a Junior Member and when eligible apply for admittance to ITK. If his record as a Junior Member has been satisfactory he will be favorable considered for ITK.

BENEFITS: Full privileges of membership and participation in IRF affairs. Every member both Junior and ITK has equal vote. Each receive the monthly news bulletin, "The Lightning Jerker", the handsome "gold" membership certificate; eligibility to various offices such as State Chief, Division Chief, Official Dispatching Station, Trunk Line Station on Primary and Secondary Nets, etc., depending on grade of membership. IRF has no financial connection with any publishers but several of these make IRF Members special rates; such as "RADIO" which members may receive at half price (\$1.50 a year) and in which appears "IRF News and Activities". Also other similar offers all of which are entirely optional to the member and entirely to his own benefit.

MEETINGS: ITK men meet in ITK Chapters. Both ITK and IRF Junior Members meet in official IRF Clubs. Isolated members are kept in touch with all activities by means of radio and news bulletins.

DIVISIONS: There are eleven Divisions in the United States and its Possessions. Divisions in Canada and foreign countries are according to their geographical boundaries and names. Each Division and State has its Chief.

WEST COAST DIVISION: California, Arizona, Nevada, Hawaii and Philippine Islands.

GREAT LAKES DIVISION: Illinois, Minnesota, Wisconsin, Michigan, Indiana and Ohio.

CENTRAL DIVISION: Kansas, Nebraska, No. Dakota, So. Dakota, Missouri, Iowa.

BORDER DIVISION: New Mexico, Texas and Oklahoma.

CONTINENTAL DIVISION: Montana, Wyoming, Utah, Colorado and Idaho.

OLYMPIA DIVISION: Oregon, Washington and Alaska.

ATLANTIC DIVISION: New York, New Jersey and Rhode Island.

EAST COAST DIVISION: Connecticut, Massachusetts, Vermont, New Hampshire and Maine.

CAPITOL DIVISION: Pennsylvania, W. Virginia, Virginia, District of Columbia, Maryland, Delaware.

EVERGLADES DIVISION: Florida, Georgia, North Carolina and South Carolina.

SOUTHERN DIVISION: Arkansas, Mississippi, Alabama, Tennessee, Kentucky, Louisiana.

IOTA RHO SIGMA: The Sorority unit of IRF for expert women amateurs. Requirements the same as for the Order of ITK with Degrees.

IRF SILVER TROPHY: Each year this fraternity offers a large silver cup to the "Best Amateur Station in North America" in a unique annual contest judged by the leading short wave engineers of North America. The contest is open to all amateurs regardless of fraternal affiliations.

COMMUNICATIONS: Supervised by the Chief of Communications and his Assistant Chief and aided by the various State Chiefs, the IRF-ITK traffic network sets new standards in this field. Its slogan is "Every message must reach its destination."

(Continued on page 31)

A-C CURRENT-ANYWHERE!

WITH Kato LIGHT PLANTS

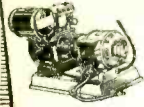

A Little Gas & a Kato AC plant enables you to operate transmitters, AC radios, amplifiers, refrigerators and all other standard household appliances. Sizes 300 watts and up. Write for interesting descriptive literature.

KATO ENGINEERING CO., Mankato, Minn., U. S. A.
Mfg's of AC Generators and Converters for operating AC Radios on 32 and 110 volts DC.

Engraved Terminal Plates

WRITE for complete bulletins just printed showing several types of terminals and other useful items for every short wave transmitter. Select type of terminal and send us sketch of panel with dimensions. Show location of terminals with lettering and numbering. Quotation will be sent by return mail.

Our products have been used by manufacturers for over ten years

HOWARD B. JONES
2300 WABANSIA AVE. CHICAGO, ILLINOIS

"WHO'S WHO IN AMATEUR RADIO"

An absolutely indispensable book for the active ham. Contains 170 pages of photos, personal and station writeups of over 3000 amateurs. Your shack is incomplete without a copy. Sent for one dollar, postpaid.

RADIO AMATEUR PUBLISHERS, 1107 Bway., New York

RADIO CLUBS

Special Group
Subscription Rates

are offered if 5 or more members subscribe at one time. Write for rates.

"RADIO," Pacific Bldg., San Francisco, Cal.

FONE AMATEURS!

You will be interested in
THE MICROPHONE

The only publication in America devoted exclusively to

RADIOPHONE

Published monthly—50c per year

Send stamps for free sample copy

THE MICROPHONE

E. L. Rockwood, W6BBJ, Publisher
738 SAN PABLO AVE. EL CERRITO, CALIF.

For better and longer service, better filtration with no current leakage,

Use G-H PAPER WOUND
ELECTROLYTIC REPLACEMENT CONDENSERS

GIRARD-HOPKINS, Oakland, Calif.

I. R. F. News

(Continued from page 30)

nation station within 48 hours regardless of the destination." Number of messages is subordinated to importance, speed and reliability. Official traffic frequencies are 3645-7290 KC supplemented by other special frequency channels. IRF also sponsors many useful contests and almost invariably awards some good material prize.

FINANCIALLY: Dues are set as low as possible. It costs IRF the amount of your dues to have you as a member. No profit is derived from a publishing business or other commercial institution. Financial statements are printed regularly that the member may know how his money is spent. Officers receive no salaries. If and when IRF becomes so large as to demand their entire attention then reasonable salaries will be affixed by vote of the general membership. IRF is entirely free of commercialism.

SOCIALLY: IRF asks that you as a member conduct yourself as a gentleman and a regular fellow that you may reflect credit on the fraternity of which you are a necessary and representative part.

ANY OTHER INFORMATION, application forms, etc., may be secured by addressing the IRF Headquarters.

THE INTERNATIONAL RADIO FRATERNITY

HEADQUARTERS

Secretary-Treasurer's Office:

5148 Sixth Avenue Los Angeles, Calif.

President's Office:

1411 Ninth Street Bakersfield, Calif.

OFFICERS IRF-ITK

President..... J. R. Meloan, W6CGM

Secretary-Treasurer..... Kenneth M. Isbell, W6BOQ

Chief of Communications..... F. Cuevas, W6AOA

Asst. Chief of Com'ns..... Ellsworth McNeely, W6CII

Each Division and State has its Chief.

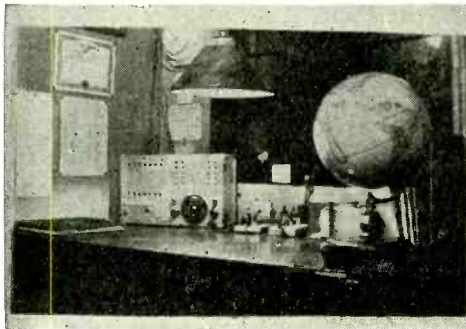

"ITK Station W9EGE"

James E. Shaw, Connerville, Ind.

W9EGE is one of the first six 1926 Charter Members of ITK-IRF.

Transmitter is as follows: 860 PA with Collins pi section. Works all bands including ten meters. Exciter unit with a '47 Osc. Doubler and two '47s in parallel as a doubler amplifier.

Input to final stage is 750 watts.

CALLS HEARD

W6ENV-W6FKC, Los Angeles—Calls Heard On 14 and 7 MC This Season

14 MC

D4BAR, D4BBN, D4BBU, D4BCK, D4BDR, D4BMJ, D4BTM, D4BUF, D4BVK, D4CAF, EA5EG, EA4AV, EA5BE, F3AN, F8EO, F8EX, F8FC, F8GG, F8JQ, F8PZ, F8RJ, F8TQ, F8VJ, F8WB, F8XL, G2BG, G2BO, G2BQ, G2BM, G2BS, G2DC, G2DI, G2DV, G2GF, G2MA, G2MR, G2OI, G2ZJ, G2ZQ, G5BJ, G5BY, G5EV, G5MA, G5MR, G5ML, G5NF, G5NI, G5NJ, G5QA, G5RX, G5WY, G5XT, G5YH, G5YV, G5YX, G6CJ, G6DL, G6HP, G6LK, G6LM, G6ML, G6MY, G6PY, G6QB, G6QX, G6RB, G6US, G6VK, G6XS, HAF3D, IITKM, LA1X, LY1J, OE1CM, OE1ER, OE3FL, OH3NA, OH3NP, OK1BC, OK2DD, OK2HM, OK2MA, OK2MS, OK2OP, ON4AU, ON4BZ, ON4DX, ON4EN, ON4JB, ON4MY, PA6AF, PA6CE, PA6LL, PA6QL, PA6XF, SM7WS, SP1DE, SU1EC, SU1EG, SU1SG, SU6HL, U2PZ, YR5AA, ZD2A, ZS1H.

7 MC

EA3AN, F8JI, G2AA, G2JF, PA6SP, CR7AD, ZE1JF, ZE1JJ, ZS1B, ZS1CP, ZS1H, ZS1Z, ZS2A, ZS2D, ZS2F, ZS2H, ZS2X, ZS2Z, ZS4M, ZS4T, ZS5A, ZS5E, ZS5Q, ZS5U, ZS5X, ZS6AA, ZS6AF, ZS6B, ZS6C, ZT1H, ZT1R, ZT1Z, ZT2A, ZT2E, ZT2F, ZT2H, ZT2L, ZT5F, ZT5R, ZT5V, ZT5W, ZT5Z, ZT6D, ZT6N, ZT6X, ZU1E, ZU1N, ZU1P, ZU5G, ZU5Y, ZU6E, ZU6M, ZU6P.

QST Oscillating Crystals

"Superior by Comparison"

All "Scientific Radio Service Crystals" are accurately ground to an accuracy better than .03% on equipment tested regularly by the U. S. Bureau of Standards standard frequency signals

BROADCAST and COMMERCIAL BANDS Mounted in our Standard Holder and ground to our usual high degree of accuracy \$35.00 each. Mounted in our NEW Insulative Monel Metal Crystal Holder \$45.00 (adjustable air gap). Prices for other Frequency Bands quoted upon application.

AMATEUR BAND

Ground to within FIVE Kilo-cycles of your specified frequency in either 80 or 160 meter bands \$15.00 each. Accurate calibration with each crystal.

Free! Send for New Illustrated Folder—Free!

Scientific Radio Service

"The Crystal Specialists" Since 1925



124 Jackson Ave., University Park, Hyattsville, Maryland

Twice as Big as Before
IS

THE SECOND EDITION of KRUSE'S RADIOPHONE GUIDE

● and is just as full of operating and constructional information that isn't found elsewhere.

● And furthermore . . . there's a complete set of

Batcher's 'Radiographs'

the simplest problem-solvers we ever saw.

● At your dealers or Postpaid for 50c (Canada 75c)

ROBERT S. KRUSE, Guilford, Connecticut

QSL's

We make every effort not to see how cheaply QSLs can be made, but to make the finest available funds for the work permit. At your request, you will receive a few samples—ideas of others—and prices. See what improvements you can make upon them, and let us create your ideal!

CHAS. E. SPITZ

BOX 1804

(W6FZQ)

PHOENIX, ARIZ.



New Book—
Just Out!

"5-METER RADIO-TELEPHONY"

By FRANK C. JONES
25 cents per copy. Sold by "RADIO", Pacific Building, San Francisco.

Best and Most Complete 5-Meter Book Ever Published



The boys on the service benches all over the land are "eatin' 'em up."

No wonder . . . for CENTRALAB



Replacement Controls are doing a keen job . . . and (ahem) in many cases making the original old fashioned control look like six cents in comparison. For these replacement units represent the last word in Volume Control efficiency.

The CENTRALAB patented non-rubbing contact eliminates wear and insures both mechanical and electrical smoothness of operation.



CENTRAL RADIO LABORATORIES
Milwaukee, Wis.

Centralab RADIOHM

56-60 MC. TRANSCIEVERS



Rugged, compact units—the inevitable choice of those who demand the best in Quality and Performance.

No excessive current drain or confusing controls
2-volt model . . . \$18.75 6-volt model . . . \$17.95
Tested tubes . . . 3.01 Tested tubes . . . 1.68
Type MT-5 Pickard coil for 5 meter operation . . . \$1.50

NEW APPARATUS

56-MC. TRANSMITTERS—Type MO-71 with 2-3 watts output and Type MO-45 with 8-10 watts output. Both types are class B modulated and mounted on 17" black lacquer chassis. Ideal for mobile or fixed use. Either unit wired and tested with tubes. . . . \$29.50
5-10 METER RECEIVER—Type HF-3, a 3 tube non-radiating receiver employing a stage of tuned radio frequency with plug-in coils to cover frequencies up to 10 meters. Type HF-3 receiver with one set of coils less tubes, \$23.50
RK-20 POWER AMPLIFIER as described in QST for August, complete with two tested tubes and coils for one band \$69.50

Write for our new High Frequency Bulletin describing the above equipment in detail

Harvey Radio Laboratories

12a Boylston St. Brookline, Mass.

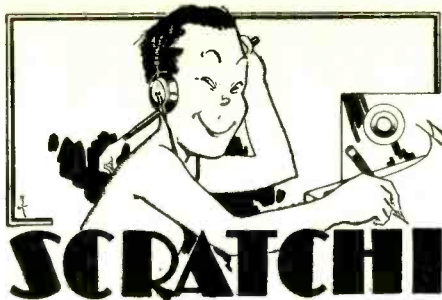

Osockme, Japan.
July 25, 1934.

Hon. Editor of "RADIO" which print multiplicity of misinformation.

Dear Ed:—

Banzai! Scratchi have got it! Scratchi will become famous! You will make interest, Hon. Ed., in knowing that from within your columns Scratchi have chiseled information which lead to most important discovery of years and ages. Reference are made to new multi-purpose tubes, with notice announcement in recent pages that manufacturer now have ready available for market vacuum tube which perform many kinds and varied purposes, such as amplification, detection, rectification, oscillation, back-feeding, stupid-regeneration and so forth and fifth, all from one tube.

Your correspondence school graduate chief radio engineer, Igiolo Scratchi, have invented new tube which are far more stupendous in scope and application. Tube which Scratchi invent will make all previous inventions of Hurts, Macaroni, Mike Farad, Edisome, and Gernspeck look like childish achievements. Because to Scratchi come new theory and new idea which shall bring revolution to radio tube manufacturers.

You shall soon come face to face with large newspaper front pagings of picture of Scratchi holding such new tube between forefinger and aft-finger. Patent applied for name of tube are THE SCRATCHI TUBE. It have but one glass bulb. Inside of such bulb are situated at most convenient places, not only plate, grids, filaments, suppressors and cathodes, but in addition there are also two loudspeakers of low and high frequency, one special coil of transposition-blocked antenna lead-in which pull out from special cap on tube, one quarter wavelength collapsible antenna pole, two shovels full of moist dirt for good ground connection and one self contained six volt storage battery which supply everlasting power for lighting up filaments.

Scratchi have been given honor pledge from great patent attorney that such tube will find enormous market, and patent attorney only take seventy-five yen away from Scratchi for deposit which are make necessary for patent filings.

While I wait for patent OK to come with me, I make perusal of mail bag letters from fan readers which have writ me. First one come from See You Aich. He are big H.P. (that mean high power) amachewer from Los Angeles, near U.S.A. I writ him protest. He make advertising in magazine which say that if make purchase of tanked condenser which Audium Products piddle make, such users of condensers can draw ten-inch sparks from tanked coil. I ask him how he make such lengthy pyrotechnic display and be forthwith send me long instruction sheet, which read like thus: (1) Go to cigar store which have wooden Indian in front. (2) Make purchase one long pipe cleaner. (3) Dip such pipe cleaner into can of gasoline. (4) Tie pipe cleaner to long-handled screwdriver. (5) Be sure you have make plenty capacity from your body to ground. (6) Stand on metal plate. (7) Light pipe cleaner, which are soaked with gasoline, and tie one end of pipe cleaner to tank coil. (8) When pipe cleaner have much bright flame coming from it, press key. (9) Pull hard on pipe cleaner and it will stretch 10 inches, and spark from tanked coil will run all along ten-inch surface of pipe cleaner. (10) Such spark can be made even much longer, he say, if two pipe cleaners are connected in serious. I quickly try such contraption on small exmitter in shack, and find that long flames come from pipe cleaner even when no current go into rig, because when once pipe cleaner are lighted with match, and when pipe cleaner are soaked in gasoline, it become uselessly unnecessary to apply RF to pipe cleaner to make spark.

I next read from currents issue of "RADIO" that new DX country classification shall become made. It are evident that preparer of such new list have forgotten several important countries which must be added so as to make list more complete and usable. He have forget to include such places as Hoboken, San Pedro, Oakland, and Hartford. Such places are all considered foreign countries to amateurs who live more than five miles away from them. I make request that such be added to new DX country list.

I have also express interest in Cathode Ray Osillyscope which are shown in last recent issue. I make such device and turn on juice. Awful weird hieroglyphicks make presence on fluorescent
(Continued on page 33)

ACTUAL TROUBLES

In Commercial Radio Receivers

By BERTRAM M. FREED

If you are a serviceman this book can be as valuable to you as your set analyzer. It points out those faults that the analyzer cannot detect. Over 500 model sets treated, includes 46 diagrams. A compilation from thousands of actual records on which the author with the cooperation of several service organizations throughout the country, spent many months of work.

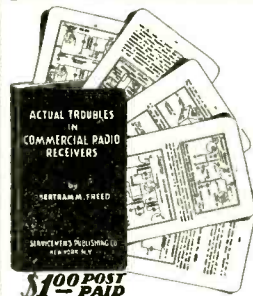

Free Trial

Sold on money-back 10 day trial. Send \$1.00. This includes free supplement.

SERVICEMEN'S PUB. CO.
136F LIBERTY ST., NEW YORK CITY

RADIO CLUBS

Special Group Subscription Rates are offered if 5 or more members subscribe at one time. Write for rates. "RADIO," Pacific Bldg., San Francisco, Calif.



NEW EDITION Now Ready

The only Radio Call Book published that lists all of the radio amateurs throughout the entire world.

Also a complete list of high frequency commercial stations, International abbreviations and amateur prefixes, "Q, R, & T," systems for reporting signals, New US radio inspection districts, high frequency press, time and weather schedules, and high frequency commercial stations listed by frequencies.

Every ham should have one. Always up-to-date. Single copies \$1.10. Annual subscription \$3.65.
RADIO AMATEUR CALL BOOK, INC.,
600 SOUTH DEARBORN ST. CHICAGO, ILL

Complete Assortment

STEEL CHASSIS

ALL SIZES . . . FOR ANY PURPOSE

Heavy lead-coated steel chassis for power supplies, receivers, pre-amplifiers, public address, etc.

WILL NOT RUST

Supplied either in blank form or with holes drilled to your specifications. Send plan drawings for drilling holes. Holes drilled for 10c each hole; wafer socket size.

STOCK SIZES OF CHASSIS	8x12x2 1/2 in. . . \$1.10 net
6x8x2 inches . . . 60c net	10x12x3 in. . . \$1.25 net
6x10x2 inches . . . 75c net	10x18x3 in. . . \$1.65 net
8x10x2 inches . . . 90c net	24x12x2 inches \$2.15 net

NEW NATIONAL REFILLED TRANSMITTING TUBES

211 RCA Type Refills \$7.00 NET

GUARANTEED TO BE IN PERFECT CONDITION

NEW SARGENT SUPERS & R.F. SETS & KITS

8-34 Super, with speaker \$49.50

Amateur 3-tube receiver with stage of r. f. (KIT) . . . \$15.75

Wired \$19.75

Write for Amateur List

We stock almost everything in new and used equipment

San Francisco Radio Exchange

"The Amateur's Paradise"

1284 Market St. San Francisco, Calif.

SCRATCHI

(Continued from page 32)

face of tube. When I press key of exmitter, front of cathode ray tube show picture of large camel with knots on knees and next door amateur friend tell me such are proof that filter condensers are dry, and filter choke have two humps, which can be seen most plainly by looking at camel's back. I iron out such humps from filter with large flat iron, and make more experiments. Next picture on cathode ray tube show two green snakes having fist fight. Amateur friend tell me that such are proof that antenna lead are full of kinks and must be straightened out. Come next experiment which then show picture on cathode ray tube of Spanish dancer with casketnets in hand, and loud, slapping noises come from tube.

Ah, say my friend, that are now proof that your rig are full with key clicks. Such cathode ray tube are really marvelous thing to have in shack. It show everything and more. Scratchi try one more experiment. Cathode ray tube begin to get foggy and large drops of moisture drip from face of tube. My friend then tell me that such are proof of power leak.

Scratchi then decide to give public performance of television demonstration with new cathode ray tube and invitations are sent to performing artists who are being request to come to stewdio and become televised. Very pretty young girl come to stewdio and beg that try out television performance be given her. Scratchi ask her what she can do. She say, "I are from Hon. family of Scotch People. I can do fancy dancing." This sound interesting to Scratchi and I speak to her—"Cmn' up and bring a pair of tights with you." So she come up next night and bring her Scotch father and mother.

I am sure, Hon. Ed., that such television performance will bring profits to Scratchi and I make invitation to you come up some nite also and bring false face with you so can make television picture from you and show radio audience my appreciation for teachings I have receive from your magazine.

If you do not come, Hon. Ed., I must make resort to bringing large jackass to stewdio and hang sign on him which read with your name on it.

Hoping you will recognize your friends when you see them from television picture, I am,

Your plutocratic friend,

Scratchi.

•••

The Oahu Radio Club Puts On A Hamfest By W6MV

UPON returning to Honolulu after an absence of fourteen years, the writer immediately looked up some of the hams in the locality and found that the radio club was sponsoring a hamfest. It seemed that some of the boys had made arrangements through some friend of some friend to use the beach home of another friend for the occasion. Those who could get away planned to leave on a Friday afternoon, go over to Kawelo Bay on the other side of the Island from Honolulu, find the house (through the use of a very elaborate map) and get things all set-up and installed. They were supplied with a key to the house, which, as luck would have it, was of a brand not often seen around these parts. Huge boxes of food and a complete transmitter (kindly loaned to them by Mr. Cameron, the local RI) two receivers, a Comet Pro and a Lincoln all-wave job were taken along. Some had brought fishing equipment, including the large and very black kerosene torch commonly used for night fishing in these waters. Honolulu is a very cosmopolitan place, various and sundry nationalities were represented; Hawaiians, Japanese, Chinese, Portuguese, Americans and whatnot. Even so, a more friendly and congenial crowd would be hard to find.

About five P.M. on said Friday the caravan arrived at Kawelo Bay, supplemented by a large truck carrying cots, mattresses, blankets, a stove and those of the gang who couldn't find seats in the cars. There ensued an intensive treasure hunt for the house in whose lock the key would both fit and turn. After about a two hours' search, a house was found in whose lock the key would fit but would NOT turn. Lengthy pow-wows ensued—yes it was—no it wasn't—well, we better not take a chance. We'll sleep in the yard (it's warm in Hawaii) and look further tomorrow when it gets light again. Ah! a decision reached. All disembark, the cars and truck pour forth their loads and the truck departs for Honolulu some forty odd miles distant. Every one is busy, cots set up and made, boxes unpacked and the stove set up and dinner started. The Comet Pro is turned on. A piece of wire hung over a tree serves as an antenna and signals pour in from three continents. W's, VK's J's, and others all about equal in volume. However, no transmitter is available, so finally everyone gets sleepy and the camp goes to sleep. About midnight it rained and everyone had to gallop madly for shelter under houses, trees, in cars. After about ten minutes the rain stopped and everyone went back

(Continued on page 36)

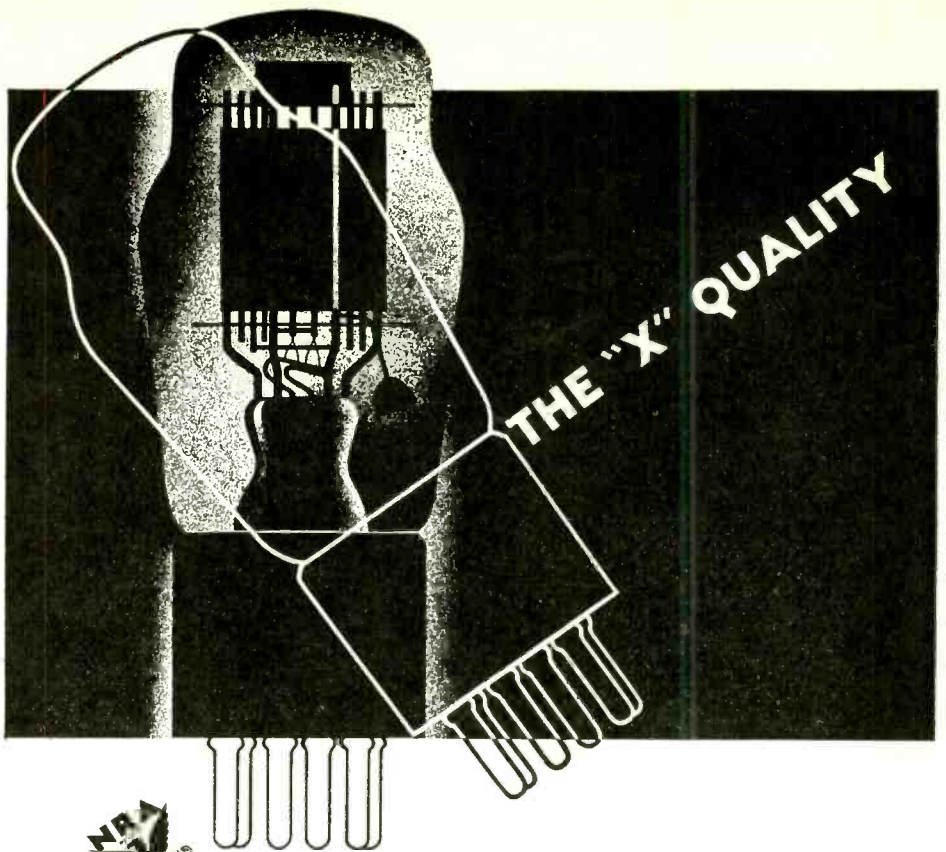

"X" stands for the *unknown* . . . for something that is present, but unseen. You can compare it to

the hidden character that makes one paint last longer than another, one suit of clothes give better service than another, one kind of marble stand up better than another which *looks the same*.

It is the "X" quality in Raytheon 4-pillar Tubes that makes them the chosen tube for polar expeditions, for the nation's largest air transportation companies, for police departments throughout the land, automobile radios and millions of private set-owners.

You can attribute the longer and better service of Raytheons, of course, to the 4-pillar principle. But it goes even deeper than that. It goes down to the "X" quality. And the nearest you can come to explaining that is by calling it *the integrity of their manufacture*.

For Raytheons are manufactured by craftsmen steeped in the watchmaker's tradition. That's why all their elements are precisely aligned . . . and *kept* precisely aligned by the patented 4-pillar support-principle.

You can recommend Raytheon 4-pillar Tubes with utmost confidence — knowing their performance will back up all you claim for them. Their "X" quality, in short, protects your word.

RAYTHEON PRODUCTION CORPORATION

30 E. 42nd St., New York City

445 Lake Shore Drive
Chicago, Illinois

55 Chapel St., Newton, Mass.

555 Howard St.
San Francisco

RAYTHEON

TRADE-MARK

4-PILLAR RADIO TUBES

ASTATIC

dependability

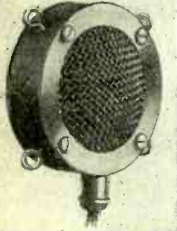

CRYSTAL MICROPHONE

An instrument of remarkable performance and rugged construction permitting complete freedom of handling WHILE IN USE. No delicate adjustments to be made; nothing to get out of order. No carbon granules to pack; no background noise. Now in extensive use in studios, amateur stations and public address systems. "And it's Clear as a Crystal."

D-104 list \$21.00
Net to hams \$12.60

THE ASTATIC CRYSTAL PICKUP

See your nearest
jobber

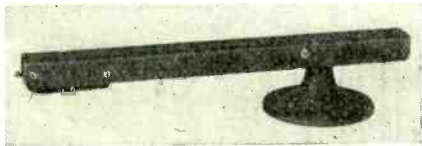

S-8 list \$15.00
Net to Hams . . . \$ 9.00

An exceptionally light weight transcription unit, the performance and fidelity of which is startling in its reality. Rising low frequency response makes practical for the first time the correct reproduction of constant amplitude recordings.

Licensed under Brush Development Co. patents

ASTATIC MICROPHONE LABORATORY Inc.

YOUNGSTOWN, OHIO

Greater Power with GRAPHITE ANODES

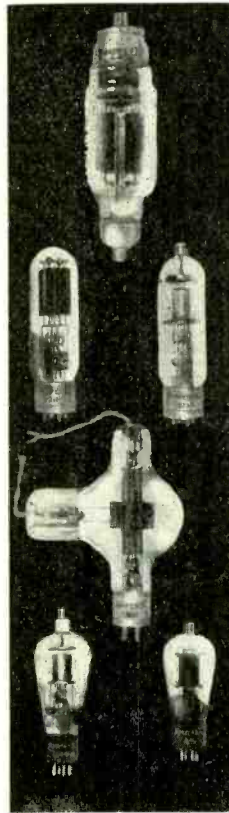

The Cooler Operation of Amperex Power Tubes—because of the greater surface and black body radiation of the Graphite Anodes results in longer life and greater power output.

800	—	\$ 10.00	List Price
203A	—	15.00	List Price
211	—	12.50	List Price
210	—	3.00	List Price
830	—	8.75	List Price
845	—	17.50	List Price
852	—	22.50	List Price
860	—	35.00	List Price
866A	—	5.00	List Price
872	—	15.00	List Price
872A	—	17.50	List Price
204A	—	95.00	List Price
849	—	160.00	List Price

Dealers write for complete catalog and discounts

AMPEREX ELECTRONIC PRODUCTS, INC.

79 Washington St., Brooklyn, N. Y.

AMPEREX
Power Tubes •

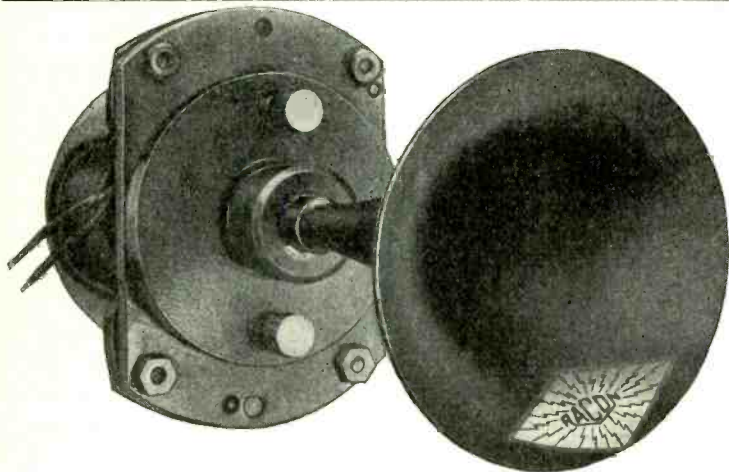

High-Frequency Loudspeaker

High-quality low-frequency units are available for a wide range of power inputs. The complete line is described in a new catalog just issued. A copy will be sent upon request.

Racon electrodynamic horns and units are manufactured under 14 exclusive Racon patents

RACON ELECTRIC CO. INC.

59 EAST 19th STREET, NEW YORK, N. Y.
Sales Offices in Principal Cities

for WIDE-RANGE HIGH-FIDELITY REPRODUCTION

RACON can now supply a complete line of electrodynamic units for both low and high-frequency reproduction. The high-frequency loudspeaker illustrated operates in the band from 3000 cycles to 10,000 cycles. Special types for higher-frequency reproduction can be supplied.



Super-Giant Electrodynamic Horn Unit



Ham Hints

By JAYENAY

Man-Made Noise

NEW refrigerators, dishwashers, oil furnaces and air conditioners are being sold as fast as the finance companies can draw-up the papers. This is all very fine, but where does the poor ham get off? New sources of R9 noise are constantly being invented and perpetrated on the poor unsuspecting public, and when the BCL set gets noisy the ham down the block gets the blame. When are we going to wake up and play some practical politics and get some laws passed which will make it illegal to own, operate or sell any device which causes, or is capable of causing, interference to any form of radio communication? Several communities have already passed such laws. Our biggest aid should be the dealer in BCL sets because he is the man who will actually profit in dollars and cents from a reduction in noise. The more stations the BCL can hear, the more sets he will buy.

Two New Tubes Needed!

WHILE the tube manufacturers are in the mood to design new low-powered transmitting tubes, how about two more? A low mu pentode with a plate dissipation of about 25 to 33 watts, stand 2,000 volts on the plate and give as good output on 500 to 1000 volts as present tubes. We also need the same tube with the screen and suppressor grid left out, for use as a fairly low power final amplifier, or as an oscillator on ten or five meters. This triode should be able to stand 3000 volts without turning gassy. The pentode would be ideal for a crystal oscillator and frequency multiplier. There is absolutely no reason why such a small tube should be limited to 500 or 1000 volts plate voltage if the tube is "hard" enough and the plate and grid leads are well insulated from each other and from the filament.

These tubes should have a thoriated tungsten filament with either 2.5V, 5V or 6V heating voltage, preferably as low as possible.

And PLEASE Mr. Manufacturer, make the tube really "Hard". We are beginning to think that any tube that turns "gassy" in service is either improperly designed or built, or both.

The newest high frequency phone and CW transmitters built in Holland use a 20 watt pentode buffer-doubler, using 500 volts as a crystal oscillator and 5000 volts as a buffer-doubler. The seven stage 10 KW transmitter uses one power supply for everything but the crystal oscillator and the microphone amplifier, and the big power supply gives 5000 volts. There is no reason why we should not operate our buffers and doublers at the same plate voltage we use on our final amplifiers, except that our low power tubes are too soft and gassy to stand the high voltage. Naturally, we would have to use more care in tuning-up our gear, but a small tube should fail no quicker than a big one if it is properly designed, because it would draw less plate current when operated improperly. Anyway, no tube manufacturer should lose sleep over the tubes which fail in service due to the fault of the operator to keep the plate current and dissipation within the tube's rating. All hams worthy of the name have learned to first tune the rig with low voltage, the others are learning fast.

POWER CRYSTALS

MAXIMUM OUTPUT
SATISFACTION GUARANTEED
40-, 80-, 160-METER CRYSTALS (ground to approximate frequency)

\$3.75 each, NET.

Crystals ground to exact frequency, at special prices.

S.S. SUPER CRYSTALS.....\$4.00, NET.

These crystals can be supplied for 450, 465 or 520 KC.

Crystals For Commercial Transmitters and Receivers. Prices on application.

We specialize in Commercial Crystals. All crystals guaranteed to give complete satisfaction.

ALBERT F. HOEFLICH

626 Sixteenth Ave., San Francisco, Calif.

RME-9D SINGLE SIGNAL SUPER

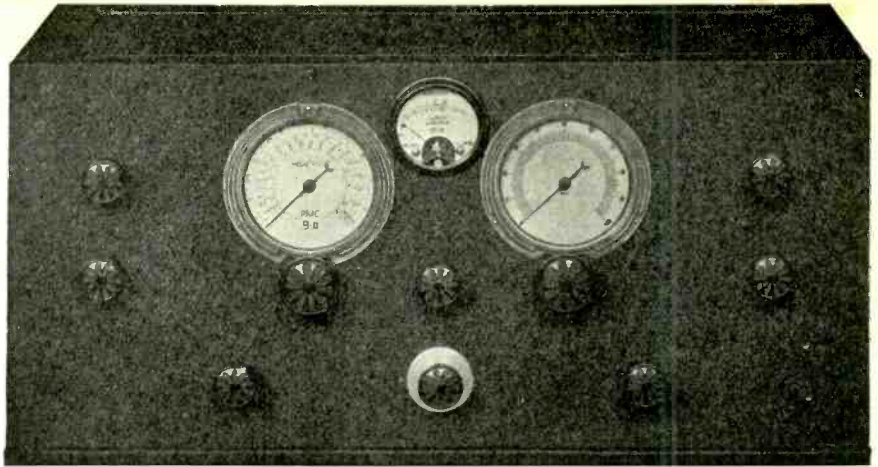

CONTINUOUS BAND SPREAD FROM 13 TO 540 METERS

No plug-in coils used. All controls located on the front of panel. A precision instrument built with the idea in mind that the best is never too good for particular amateurs. Mention a desir-

able feature and you will find it incorporated in the RME-9D. It does the job better than you have ever heard it done before. (For details see July issue of "RADIO," page 27). 10c in stamps will bring a complete descriptive folder.

RADIO MFG. ENGINEERS

313-315 BRADLEY AVENUE

PEORIA, ILLINOIS

ALAN STILL LEADS!

WITH THE INTERNATIONAL AND THE PRIZEWINNER!

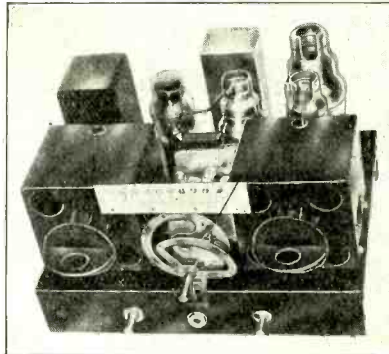

ALAN INTERNATIONALE
T.R.F. Circuit AC - DC Power Supply
Front Panel Plug-in Coils

Available for 110 v. A.C.—D.C. S. W. 15—200 meters, also 220 v. A.C.—D.C. 2 and 6 v battery operation, four tubes 1-6F7, 1-78, 143, 1 25Z5. Completely shielded in black crackle, hinged cover, metal cabinet.
Complete including 4 pairs of coils, 15-200m \$24.95
Set Arcturus tubes..... 4.95
Complete Kit with Blueprints..... 21.25

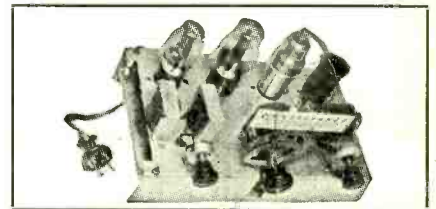

PRIZEWINNER
A.C.-D.C. S.W. (15 to 200 meters)

Completely self powered, latest type 77-43 and 25Z5 Tubes. Provision for Head Phones and Speaker. Complete, less tubes, in rich crackle-finish cabinet. Assembled, wired, tested, ready to plug in, including four coils..... \$12.95
Kit of RCA or Arcturus Tubes to match..... 3.75
Complete Kit of parts, including 4 coils..... 10.55

Write for Free Catalog and Short Wave List

ALAN RADIO CORP.

83 CORTLANDT ST. Dept. 10M N. Y. CITY
Save time on western shipments by buying from our Pacific Coast Branch
1028 SOUTH OLIVE ST. LOS ANGELES, CALIF.

QUALITY

at a Price You Can Afford to Pay!

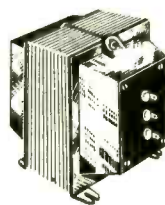

FRANKLIN Transformers

Very conservative ratings on Transformer and Chokes for every Amateur Station.

"MOST SOCK PER DOLLAR"

Write for Catalogs

FRANKLIN TRANSFORMER MFG. CO.
607-609 22 Ave. N.E., Minneapolis, Minn.

Latest In "B" Power

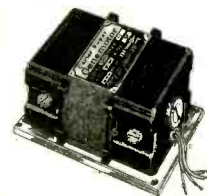

Smallest unit on the market. 2 3/4" wide. 4" high by 5" long. This complete Genemotor furnishes up to 200 volts D.C. Operates from 6 volt storage battery. Ideal for Auto, Airplane or Battery Radios, and Portable Amplifiers.

Write for details and prices on this and other types.

CARTER MOTOR CO.

365 W. Superior St. Chicago, Ill.

IN STOCK NATIONAL

at Allied Radio
Hammarlund

at Allied Radio
BLILEY

at Allied Radio
THORDARSON

at Allied Radio
de Forest

at Allied Radio
JOHNSON

and all other standard Amateur lines. Whatever your wants, we can supply them quicker and better at ALLIED, at consistently lower prices. The thing to do O. M. is to write to-day for the new 1935 ALLIED Catalog which is yours for the asking.

Allied Radio

833 W. Jackson Blvd., Chicago, Dept. J. **YOUR CATALOG**

Please send me your Free 1935 Catalog with the Radio Amateur Listing.

Name

Address

City



? ? ? ? ? ? ? ?

DUAL REACTION

What Is It?

Important Announcement in October Issue

STOP

Did You Get Your Copy?

A catalog completely illustrated, containing valuable and descriptive information as to the correct Lenz Radio Wire Products to serve your particular needs, including several new items.

Push-Back DOUBLE BRAID Hook-Up Wire with non-fraying insulation, thoroughly saturated in MOISTURE-PROOF compound is effective in reducing leakage so as to minimize "hums." Furnished in SOLID or STRANDED, WAXED or LACQUERED. Sold by leading distributors everywhere.



RADIO PRODUCTS
PUSH BACK WIRE

West Coast Representative:
FRANK A. EMMET
 741 S. Burnside Ave., Los Angeles, Calif.

LENZ ELECTRIC MFG. CO.
 1753 N. Western Avenue, Chicago
 Please send me copy of your Catalog No. 20

Name

Address

City State

FORMS CLOSE ON THE 10th OF MONTH



RATES 10¢ PER WORD PAYABLE IN ADVANCE

CLASSIFIED RADIOADS

"R9 SIGS!" Book on transmitting antennas. Post-paid 60c net. Get louder reports and more DX! W6BY, Box 31, Redlands, Calif.

CATHODE RAY OSCILLOSCOPES completely built and tested to your order. Special designs. Send us your specifications. Prices on request. Prompt, reliable engineering service. Frederick Kahn, 1366 21st Ave., San Francisco, Calif.

CRYSTALS: 80 or 160 meter bands, Y cut, 1" square, accuracy .002%, \$1.50. W8CHJ, 9255 Herkimer St., Detroit, Mich.

BACK COPIES OF "RADIO", 25c each, some issues, can be secured from the New York office. Address your orders to Edw. J. Byrne, 253 West 128th St., New York City, New York.

FOR SALE—DeForest 571 Tube, 500 watts plate dissipation. Will stand 350 mils at 4000 volts. Used only 20 hours. Guaranteed to be in perfect condition. Replaces the type 831 tube. Cost \$200. Will sell for \$39. Ronnie Martin, W6ARD, 125 Southwood Drive, San Francisco, Calif.

SURPLUS MATERIAL. Send for our list of bargains, surplus and used material covering motors, generators, vacuum tubes, receivers and parts. Heintz & Kaufman, Ltd., Tanforan Ave., South San Francisco, California.

CRYSTALS: 80 or 160 meter bands, Y-cut, 1-inch square. Accuracy .002%, \$1.50. Arthur Schuelke, 9255 Herkimer St., Detroit, Michigan.

UP TO \$50.00 paid for Indian Head Cents, Half Cents, \$250.00; Large Cents, \$2,000.00, etc. Send Dime for list. ROMANOCOINSHOP, DEPT. 302, Springfield, Massachusetts.

Oahu Hamfest

(Continued from page 33)

to bed. That happened five times during the night, and needless to say very little sleep was had by anyone.

After breakfast it was decided that the house which we occupied must be the right one, so it was opened up!! and found very, very dirty from disuse. All turned to with mop and dust-rag and scrubbed the entire place. Next, all the baggage and equipment was carried in and placed. The transmitter was set up and a permanent camp made. The rest of the day was spent in swimming, rag chewing, fishing, card playing and general lolling around. In the afternoon the rest of the gang arrived on the scene and another argument took place as to whether it was the right house or not, but finally it was decided, rather dubiously, to stay anyway. Another big dinner was prepared and eaten, the dishes washed and put away and the transmitter started up. Quite a few stations were contacted and everything was going nicely when suddenly an apparition in the guise of an angry xyl appeared in the doorway, followed immediately by the O.M. himself. What tha—why tha—how cum—etc., for several minutes. The situation got no better, fast. If only a talkie could have been made of those few minutes. MIM! Anyway, as you probably have surmised by this time, we were in the wrong house and the rightful owners were there on the scene with their two small children outside in the car. I heard more plausible explanations and more diplomatic evasions in those few minutes than I've ever heard in all the past put together. Well the boys made the grade. It turned out that some one knew the O.M. and patched things up in great shape. However, there we were in the house at about ten P.M. and the owners wanted to move right in. All of the aforementioned equipment was picked up bodily and stowed in the cars outside. Three of the gang, including the writer, started out on another search for the right house. Well we found it and the key both fitted and turned, and everything was transferred to the new QRA. In fact the new location proved much better, larger and cleaner. (I bet that O.M. was glad to get his place cleaned at that). The transmitter was set-up again and was on the air almost all night. Some of the gang went fishing, after the tide was low enough, and came home with some nice fish. Next day was filled with contests for the prizes of which there were quite a few. Mr. Cameron appeared on the scene in the morning (as a visitor, not on business) and spent the day with the fellows. The party broke up about two P.M. and one by one the cars pulled out with their respective loads. A good time was had by all and to the two visitors from the coast, W6DTR and W6MV, it was a most interesting and humorous affair.

NEW MRL Lowest Loss Coils

Try a Celluloid Coil Form . . . and HEAR the difference! The ever-increasing popularity of the new M.R.L. Celluloid Forms is proof of their superiority. Set of coil forms for the 3-tube R.F. Sargent Receiver, \$2.00 per set.

Ultra-Efficient Transmitting Inductances. Wound on 2 inch Celluloid Forms, with 5-prong bases to plug-into standard sockets, 160, 80, 40 or 20 meter bands, \$1.50 list, each.

Dealers and Jobbers Are Invited to Write for Territory

Send 3c stamp for latest MRL OSCILLATOR. Contains many timely circuits and much s.w. data.

Modern Radio Laboratories
 151-F LIBERTY ST., SAN FRANCISCO, CALIF.

CONCOURSE CONDENSERS

Used by Radio Men Who Know Superior Products

DRY ELECTROLYTICS

HIGH AND LOW VOLTAGES

Made in Every Type and Size with the Reputation for "Standing Up"

"Peewee" Paper Tubulars

New and Improved Construction in the Smallest Dimensions Ever Made

WAX PAPER UNITS

ALL VOLTAGES, ALL CAPACITIES

Write for Our New Free Catalog

Concourse Condenser Co.

387-411 WALES AVE., NEW YORK
 Pioneers of Wax Paper and Dry Electrolytic Condensers

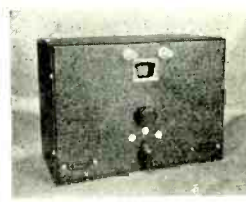

Power and Portability

19 TYPE CLASS B MODULATED
8 WATT OUTPUT

56 M. C. TRANSCEIVER

Ten times the output of 30 type units. Strong voice when Flea Power Signals fade out. Completely dry battery operated. 2 volts filament, 135 volts plate. Fil. voltage control compensates for battery deterioration. Rugged crackle finish metal case—10x7x5 inches. Weight 9 1/4 pounds. Vernier dial. Cardwell tuning condenser. Equivalent of 5 tubes—1-30 and 2-19's. 6 volt and AC models available.

All Orders Receive the Personal Attention of the Original Designer

NET PRICE \$22.50—TUBES \$2.58
 20% with order—balance C. O. D.

RADIO TRANSCEIVER LABORATORIES
 8427 - 105 Street Richmond Hill, N. Y.

The Best Product

is only as good as its weakest link.



If it is a TRIMM headphone your customer will have no complaint. Over 100 standard styles. A special phone to meet any requirement.

TRIMM RADIO MFG. CO.

The Pacemakers in Headphone Development

1528 ARMITAGE AVE. CHICAGO, U. S. A.

Behind the **POLYMET**
Trade Mark



This midget size mica condenser is extremely popular where space limitation is a factor—Polymet fabricates seven different types of mica condensers from .000005 mfd to .03 mfd capacities.



Hi-Frequency Condensers

These condensers are designed to eliminate the common faults of ordinary condensers such as poor power factor and inductance. Because of their low loss characteristics Polymet's new Hi-frequency line is particularly recommended for use in short wave receivers.

POLYMET PRODUCTS

Are recognized by many of the leading manufacturers in both the radio and electrical industries for that HIGH QUALITY so essential to dependability. THEIR ENGINEERS DO NOT GUESS—THEY KNOW. The successful service man, experimenter, or amateur does not guess, he knows that the use of POLYMET products in his work is his GUARANTEE OF SATISFACTION.



POLYMET STANDARD WET ELECTROLYTIC

This type wet electrolytic condenser type is most popularly used throughout the entire world because of its established reputation for quality and durability.

Polymet Condensers

- ELECTROLYTIC—Wet and Dry Types
- PAPER—Tubular and all can types
- MICA—All Types, Midget Sides with lugs & leads
- TRANSMITTING OIL CONDENSERS
- CONDENSER for all PURPOSES



PETITE CONDENSER

A new POLYMET Tubular paper condenser in greatly increasing demand by radio manufacturers. Its compactness and low cost effect many economies in radio.



POLYMET DRY ELECTROLYTIC CONDENSERS

Exceptionally popular in the leading AC-DC receiving sets. Furnished in many combination dual and triple units. Supplied in either cardboard or metal containers.

We Also Manufacture TRANSFORMERS and WIRE WOUND RESISTORS

Polymet Manufacturing Corporation

831 E. 134th ST.

NEW YORK, N. Y., U. S. A.

Write for New 1934 Catalog

A Ham Receiver Lacking These Features is Antiquated!

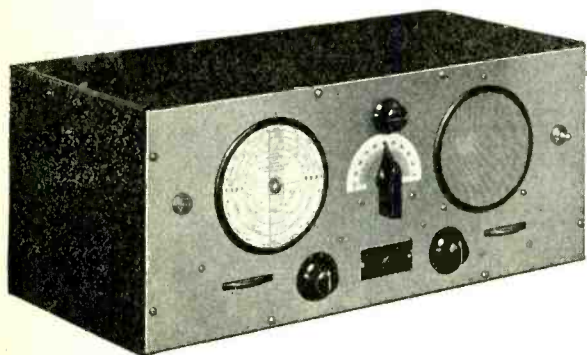

The SKYRIDER The MODERN Ham Receiver

Pioneer W9RA Enthusiastic

George E. Joyce, President Chicago Radio Apparatus Co., a distinguished ham of pioneer days, W9RA established in 1909, says: "If a signal is on the air, the SKYRIDER gets it. Cuts through static—actually seems to thrive on this nuisance! I get a new thrill everyday from my SKYRIDER—more thrill than from any set I've ever owned, due to the extreme ease of locating stations and its extraordinary sensitivity. It's the best buy on the market. Congratulations!"

- Actual Fractional Microvolt Sensitivity
- Built-In Monitor Calibrated Dial
- Co-Axial Coils with Non-Failing Switch
- Continuous Band Spread
- Built-In Power Pack and Speaker
- you get them all in the SKYRIDER

The old spark coil, the loose coupler and the "three piece" receiver with an arm load of plug-in coils have a warm spot in my heart. I used them—in the early days. But, like 2-cylinder cars and corsets they belong buried in the past!

Yet, because the manufacturer long neglected the ham, thousands of amateurs have had to lumber along with antiquated equipment. So, we built the SKYRIDER — a thoroughly MODERN Amateur Receiver, with everything to fit today's requirements, including a fair price.

SEND for BOOK: I can't cover half the features of the SKYRIDER here — ask your Jobber for the SKYRIDER Book or request it of me. It's free.

the hallicrafters, inc.

W. J. Halligan, President

417 North State Street

Chicago, U. S. A.

Radio Dealers and Jobbers who desire to advertise in these columns are invited to write for rates.

RADIO BUYERS' GUIDE

A Monthly Listing of Reliable Radio Dealers and Jobbers who solicit the patronage of our readers. Buy from your nearest Dealer or Distributor. He is dependable and reliable.

CHICAGO, ILLINOIS

Chicago Radio Apparatus Company, Inc.

415 South Dearborn Street
Harrison 2276

Dependable Radio Equipment
Established 1921

Bulletins on request—we specialize in short wave transmitting and receiving apparatus.
Catalog Ten cents.

CHICAGO, ILLINOIS

MID-WEST RADIO MART

520 South State Street
CHICAGO

Write for Special Catalog—Free

CHICAGO, ILLINOIS

Newark Electric Company

226 W. Madison St.
Chicago

All Kinds of Equipment for
Service Men - Amateurs - Experimenters
Write for free catalog

OAKLAND, CALIFORNIA

RADIO SUPPLY CO.

2085 BROADWAY.

New 2-Tube Sargent DX-Ranger Kit, \$12.50 complete
New Sargent 9-33 Superheterodyne, \$69.50, net,
less tubes

Sargent Short-Wave Sets and Kits.
Write for Circulars.

ST. PAUL, MINNESOTA

LEW BONN COMPANY

2484 University Avenue

Rex L. Munger, W9LIP, Sales Engineer

Radio Wholesaler

Complete Stock

ST. LOUIS, MO.

HAMS' TRADING POST

Want to buy? We have it to sell. Want to sell? We will buy for cash. Want to trade? We will trade.
References—any midwest ham.

WALTER ASHE RADIO CO.

121 North Eleventh

CHICAGO, ILL.

Allied Radio CORPORATION

833 W. Jackson Blvd.

5 meter Headquarters. Complete Stocks of all standard lines of Transmitting equipment, replacement parts, tubes, etc.

Write for our 100-page free catalog

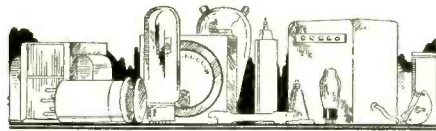

NEW PRODUCTS

New Govt. Short-Wave Call Book

THE Department of Commerce's official list of world short-wave radiophone transmitters is the first of a series of quarterly publications of that nature, and contains information concerning approximately 2,400 stations arranged by frequencies. All short-wave broadcasters and the higher-powered stations in other services are cross indexed in a geographical list.

Distances from the United States to foreign stations may be readily ascertained by means of a novel chart and tables, and the difficulties attendant upon identifying stations by call letters pronounced in foreign languages is simplified by a pronunciation table. Special identification of some of the better-known world stations is provided in a brief tabulation.

Included among these authorities were the British Broadcasting Corporation's publications, the Federal Communications Commission, 32 commercial and 400 consular offices of the American government abroad, as well as numerous amateurs, radio publishers, and organizations which cooperate with the Electrical Equipment Division of the Department of Commerce in checking on its foreign broadcasting service information.

The list contains 112 pages, including two maps. One of the maps aids in finding the distance from any point in the United States to foreign stations; the second map is a reproduction of the Navy Department's official chart of world time zones.

The new list sells for 25 cents a copy and may be obtained from the Bureau of Foreign and Domestic Commerce in Washington or the Bureau's district offices located in many principal cities of the United States.

Smallest "B" Unit Is Made by Carter

THE smallest Rotary type "B" Eliminator ever designed with full power output is now being placed on the market by the CARTER MOTOR COMPANY. It is only 2 3/4 inches wide, 4 inches high, and 5 inches long, and weighs only 7 pounds. Being so compact and light in weight, it can be easily placed in either the Radio or Speaker case. The unit is completely enclosed and shielded and requires no adjustments whatever.

The new type Thrust Ball-Bearings used, do not require oiling and permit the unit to operate at highest efficiency in any position. The unit consists of a newly designed motor generator with a reflex filter circuit and operates from a 6 volt storage battery delivering voltages up to 350. When used as an auto "B" Battery Eliminator separate filters and chokes are not required as the Reflex Filter system uses the motor field coil for part of the filter.

This "Pocket" Edition is ideal for auto radios, airplane transmitters, and receivers, farm battery sets, portable sound equipment and many other uses, due to its small size and light weight.

The new CARTER GENEMOTORS can be supplied for both AC and DC output up to 500 volts, and also are made to operate from 32 volt Home Lighting Plants.

The Chicago Police Department, after a year and a half of constant service tests are now equipping 250 squad cars with CARTER GENEMOTORS.

Precision Wire Wound Resistors

THE Electrad precision wire wound resistors are wound on a grooved ceramic core with adjacent sections wound in opposite directions. They have extremely low distributed capacity. They are wound to an accuracy of plus or minus one per cent. The standard type 6P is furnished with wire terminals. This type can be converted to the ferrule type resistor by adding ferrule terminals which are sold separately.

Made in values from one ohm to one megohm, these units find ready application among experimenters and laboratory workers.

Maker—Electrad, Inc., 175 Varick Street, New York City.

CHICAGO, ILLINOIS

Chicago Radio Apparatus Company, Inc.

415 South Dearborn Street
Harrison 2276

Dependable Radio Equipment
Established 1921

Bulletins on request—we specialize in short wave transmitting and receiving apparatus.
Catalog Ten cents.

PITTSBURGH, PENNSYLVANIA

CAMERADIO COMPANY

603 Grant Street

Tri-State "Ham" Headquarters

Standard Apparatus Standard Discounts

FRESNO, CALIFORNIA

PORTS MANUFACTURING CO.

3265 E. Belmont Ave. Radio W6AVV

National FB7-SW3 and Parts; Hammarlund, Cardwell, Biley Crystals; Johnson Insulators.

Complete Stock --- Write for the Dope
Established 1914 Leading Ham Supply Store

SAN FRANCISCO, CALIFORNIA



1452 Market Street.

"The House of a Million Radio Parts"

Hammarlund and National sets and parts.
RCA-DeForest Amateur Transmitting Tubes.

Collins Transmitters.

Arcturus Receiving Tubes.

Trimm Phones, all types.

Johnson Antenna Feeders, Insulators,
Transposition Blocks.

SEATTLE, WASHINGTON



LARGEST PARTS SUPPLY DEPOT IN THE NORTHWEST

Four of Our Employees Are Licensed

W7BRS Amateurs W7CR
W7AVC W7WE

CORNELL DUBILIER, BILEY, PATTERSON
SETS, COLLINS, WARD, LEONARD,
UNITED TRANS.

VANCOUVER, B. C.

Palmer Radio Supply Company

524 WEST PENDER STREET

B. C.'s Original "Ham" Supply House
Everything for the Amateur and Service Man
Write for Catalogue

AMAZING POPULAR APPROVAL

GREETSS THE NEW CROSLEY CHEST SHELVADOR



THE enthusiastic reception accorded the new Crosley Chest Shelvador proves that Crosley has again struck the keynote of what people want. Housewives—homeowners—everywhere see instantly that here is value beyond anything ever offered in electric refrigeration; they see the convenience, where space is limited, of a complete Shelvador electric refrigerator that is only 36" high, 23 $\frac{3}{8}$ " wide, 20 $\frac{1}{2}$ " deep; they appreciate the porcelain table top. To those who hitherto could not afford electric refrigeration, the Crosley Chest Shelvador is the boon of boons. Now they need wait no longer for the food hygiene, economy, and convenience that only electric refrigeration provides. Others find it a marvelous convenience as an auxiliary electric refrigerator—both for food storage and beverage cooling.



Homes



Apartments



Second Refrigerator



Beverage Cooler



Summer Camps



Roadside Stands



Hospitals

For the many who need a second electric refrigerator to place, for example, in the entertainment room or pantry, the Crosley Chest Shelvador is ideal. It is compact, remarkably economical in operation, low in price, easily moved. It also makes an excellent beverage cooler.

In summer camps and cottages where electricity is available, the Crosley Chest Shelvador will be welcomed, with its ample supply of ice cubes—not less than two pounds—and its surprising roominess.

Small delicatessens, roadside stands, sandwich shops and other places with moderate electric refrigeration requirements will find the Crosley Chest Shelvador ideal.

In hospitals or other institutions where individual refrigeration is desirable this model, with its table top, will be found useful.

Remember that the Crosley Chest Shelvador has every essential Crosley Shelvador feature—the same quiet economical, long-life, trouble-free cooling unit that has made Crosley electric refrigerators famous—the same Shelvador convenience that adds greatly to the "usable" capacity. See your Crosley distributor at once—learn all about this new Crosley Chest Shelvador and how it opens up to you an entirely new and practically untouched market for electric refrigerators. No dealer can afford not to handle Crosley!

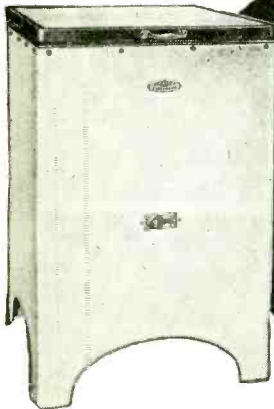

\$72.50

DELIVERED — INSTALLED
ONE YEAR FREE SERVICE

● This refrigerator is amply large for the preservation of the actual amount of food necessary in the average home, and is one for which many have been waiting and practically everyone can afford. Here—as in the most expensive Crosley model—is found the amazing Shelvador feature which provides space for small articles that in ordinary refrigerators are difficult to find and take up much room.

Montana, Wyoming, Colorado, New Mexico and west, prices slightly higher.

THE CROSLEY RADIO CORPORATION

(Pioneer Manufacturers of Radio Receiving Sets)

Home of "the Nation's Station"—WLW—500,000 watts—most powerful in the world—70 on your dial

POWEL CROSLEY, Jr., President

CINCINNATI

ALL PRICES INCLUDE DELIVERY INSTALLATION ONE YEAR FREE SERVICE

Crosley Shelvador and Tri-Shelvador models represent the greatest value in the history of electric refrigeration. Incorporating the famous Crosley Shelvador and other features, they are the outstanding successes of the 1934 season. Illustrated below are household electric refrigerators for every purse and purpose.



3.5 cu. ft. NET capacity, 7.5 sq. ft. shelf area, 2 ice trays—42 cubes. Dimensions: 48 $\frac{1}{2}$ " high, 23 $\frac{3}{8}$ " wide, 24 $\frac{1}{2}$ " deep.

Model EA-35.....\$99.50

4.3 cu. ft. NET capacity, 9.15 sq. ft. shelf area, 2 ice trays—42 cubes—one double depth tray.

Dimensions: 54 $\frac{1}{2}$ " high, 23 $\frac{3}{8}$ " wide, 24 $\frac{1}{2}$ " deep.

Model EA-43.....\$117.00



5.5 cu. ft. NET capacity, 11.6 sq. ft. shelf area, 3 ice trays—63 cubes—one double depth tray. Dimensions: 55 $\frac{1}{2}$ " high, 29" wide, 25 $\frac{1}{2}$ " deep.

Model EA-55.....\$145.00

4.3 cu. ft. NET capacity, 9.15 sq. ft. shelf area, 2 ice trays—42 cubes—one double depth tray.

Dimensions: 56 $\frac{1}{2}$ " high, 23 $\frac{3}{8}$ " wide, 24 $\frac{1}{2}$ " deep.

Model E-43.....\$135.00



5.5 cu. ft. NET capacity, 11.6 sq. ft. shelf area, 3 ice trays—63 cubes—one double depth tray. Dimensions: 57 $\frac{1}{2}$ " high, 29" wide, 25 $\frac{1}{2}$ " deep.

Model E-55.....\$157.50

7 cu. ft. NET capacity, 14.9 sq. ft. shelf area, 4 ice trays—84 cubes—one double depth tray.

Dimensions: 58 $\frac{1}{2}$ " high, 32 $\frac{1}{2}$ " wide, 26 $\frac{1}{2}$ " deep.

Model E-70.....\$185.00

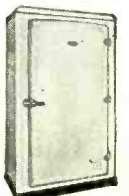



High Fidelity Hiperm Alloy Audio Components for Portable Pre-Amplifier and Remote Pickup Applications

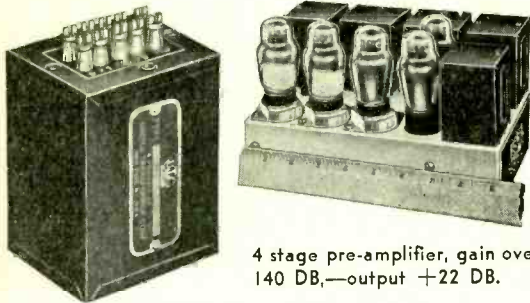

4 stage pre-amplifier, gain over 140 DB,—output +22 DB.

Specifically designed for portable use. Extremely compact and light in weight. Smallest high fidelity transformers available. Made possible through development of HIPERM ALLOY, a nickel iron alloy having extremely high initial permeability.

HIPERM ALLOY COMPONENTS USED IN HIGH GAIN 4 STAGE PRE-AMPLIFIER

	List Price	Net to Dealers Hams
HA-100 Variable impedance line to single 6C6 grid	\$12.50	\$7.50
HA-105 Cascade, single 6C6 plate to single 6C6 grid	9.00	5.40
HA-106 Input, single 6C6 plate to push pull 6C6 grids	11.00	6.60
HA-114 Push pull 6C6 plates to variable impedance line	12.50	7.50
HC-127 Hum bucking tapped filter and audio choke, alloy core	15.00	9.00
HP-123 Shielded plate and filament transformer for a portable pre-amplifier using 6 volt tubes	15.00	9.00

UTC Niklshield Audio Filter and Power Components FOR THE SERVICEMAN, PUBLIC ADDRESS ENGINEER AND EXPERIMENTER

At Prices All Can Afford

UTC Niklshield compact audio and filter units are designed for the discriminating radio manufacturer, experimenter, and professional public address engineer. Weight has been kept to a minimum and quality at a maximum for this grade of equipment. Only the finest of materials and the highest grade of workmanship is incorporated in the construction of all units.

A wide variety of input coupling, mixing, matching and output transformers are shown.

Write for NS-R Bulletin Describing These Units

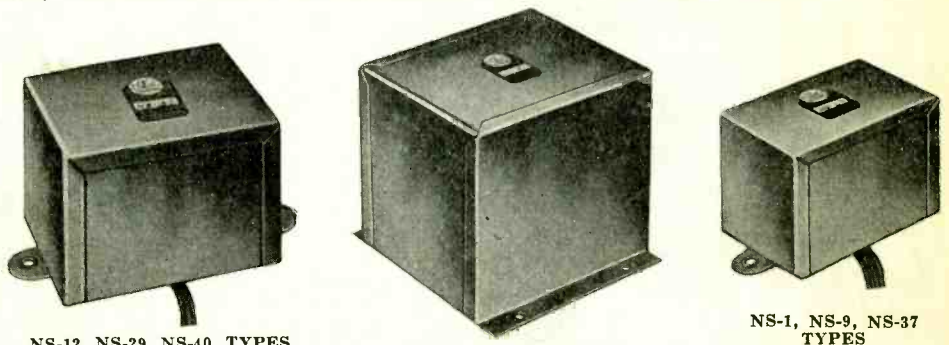

NS-12, NS-29, NS-40, TYPES

NS-50, NS-51 TYPES

NS-1, NS-9, NS-37 TYPES

CLASS A INPUT TRANSFORMERS

	List Price	Net to Dealers Hams
NS-1 1 plate to 1 grid. 3½:1 ratio	\$ 2.35	\$ 1.41
NS-2 1 plate to 2 grids, split secondary. 2:1 ratio	2.50	1.50
NS-3 Push pull plates to push pull grids. 1.8:1 ratio	2.75	1.65
NS-5 Single or double button mike to 1 grid	2.50	1.50
NS-6 Single or double button mike to 2 grids	3.00	1.80
NS-8 Ribbon velocity mike to 500 or 200 ohms	3.50	2.10
NS-9 Mixing carbon mike, 500 or 200 ohm line to 500 or 200 ohm line	3.50	2.10
NS-10 Single plate and carbon mike to one or two grids	3.50	2.10

CLASS A OUTPUTS

NS-13 Push pull 250, 245, 59 triode or 71A plates to 8, 4, or 2 ohm voice coil	3.00	1.80
NS-15 Push pull 2A3 plates to 8, 4, or 2 ohm voice coil	3.00	1.80
NS-17 Single 250, 245, 59 triode, 71A to 500, 8, 4 or 2 ohms	3.00	1.80
NS-19 Push pull 250, 245, 59 triode or 71A plates to 500, 8, 4 or 2 ohms	3.50	2.10
NS-20 Push pull 18, 20, 33, 41, 42, 2A5, 59 pentode, 89 triode plates to 500, 8, 4 or 2 ohms	3.50	2.10
NS-21 Push pull 2A3 plates to 500, 8, 4 or 2 ohms	3.50	2.10
NS-24 Push pull 250, 245, 59 triode, 71A to 4000 or 2000 ohms	3.25	1.95
NS-25 Push pull 18, 20, 33, 41, 42, 47, 2A5, 59 pentode or 89 triode plates to 4000 or 2000 ohms	3.25	1.95
NS-26 Single 26, 56, 27, 55, 77 triode or 864 plate to 500 or 200 ohms	3.00	1.80

CLASS B INPUT TRANSFORMERS

NS-29 Driver plate to 49, 53, 79 or 89 grids	2.75	1.65
NS-30 Driver 46 or 59 plate to 46 or 59 grids	2.75	1.65

CLASS B OUTPUT TRANSFORMERS

NS-32 Push push 46 or 59 plates to 8, 4, or 2 ohms	3.25	1.95
NS-33 Push push 49, 53, 79 or 89 plates to 5000 or 3500 ohms	3.50	2.10
NS-34 Push push 46 or 59 plates to 5000 or 3500 ohms	3.50	2.10
NS-36 Push push 46 or 59 plates to 500, 8, 4, or 2 ohms	3.75	2.25

FILTER AND AUDIO CHOKES, FILAMENT TRANSFORMERS

NS-38 Filter choke. 15 henrys 60 MA; resistance 240 ohms	2.00	1.20
NS-39 Filter choke. 20 henrys 90 MA; resistance 400 ohms	2.50	1.50
NS-41 Filter choke. 10 henrys 150 MA; 95 ohms	3.00	1.80
NS-42 Class B input choke Max. D.C. 175 MA	3.00	1.80
NS-44 Detector plate shunt choke. Max. D.C. 3 MA	2.25	1.35
NS-45 Pri. 115 A.C. Sec. 2½ V.C.T. 6A	1.75	1.05
NS-46 Pri. 115 A.C. Sec. 6.3 V.C.T. 3A	2.25	1.35
NS-47 Pri. 115 A.C. Sec. 2½ V.C.T. 12A	2.25	1.35
NS-48 Pri. 115 A.C. Sec. 5V 4A	2.25	1.35
NS-49 Pri. 115 A.C. Sec. 7½ V.C.T. 3A	2.25	1.35
NS-50 Plate Transformer for small power tubes, Class A and B. Pri. 115 V.A.C. 60 cycles. Secondaries: 300-0-300 at 75 MA; 5 V.C.T. 3 A., 6.3 V.C.T. 2½ A., 2½ V.C.T. 6 A	7.00	4.20
NS-51 Plate transformer for push pull power tubes Class A and B. Pri. 115 V.A.C. 60 cycles. Secondaries: 400-0-400 at 125 MA; 2½ V.C.T. 5 A., 2½ V.C.T. 10 A., 5 V.C.T. 3 A	9.00	5.40

The UTC HIPERM ALLOY audio transformers are described in the new U-1000C bulletin. Send for your copy today.

UNITED TRANSFORMER CORP.

264-266 CANAL STREET

Export Division, 15 Laight St., New York, N. Y.

NEW YORK, N. Y.

Exclusive UTC distributors carrying a complete stock of UTC products.

Wholesale Radio Service Co., Inc.	100 Sixth Ave., New York, N. Y.
Wholesale Radio Service Co., Inc.	219 Central Ave., Newark, N. J.
Sun Radio	227 Fulton Street, New York, N. Y.
William Gram	1444 Sheridan St., Lansing, Mich.
Mohawk Electric Co.	1335 State St., Schenectady, N. Y.
Walter Ashe	1100 Pine St., St. Louis, Mo.
H. Jappe	46 Cornhill, Boston, Mass.
Nutter & Cross	990 Milk St., Boston, Mass.
Radio Service Lab. of N. H.	1008 Elm St., Manchester, New Hampshire

Hatry & Young	203 Ann St., Hartford, Conn.
W. H. Edwards & Co.	32 Bway, Providence, R. I.
SEATTLE, WASH.—Seattle Radio Supply Inc.	2319 Second Ave.
Portland Radio Supply Co.	1300 W. Burnside, Portland, Ore.
LOWER CALIFORNIA	
Pacific Radio Exchange Inc.	729 S. Main St., Los Angeles
Radio Supply Co.	912-14 S. Broadway, Los Angeles
Coast Electric Co.	744 G. St., San Diego
Prest & Dean Radio Co.	400 American Avenue, Long Beach

JANUARY, 1929

25 CENTS

RADIO



IN - HIS ISSUE

RADIO IN THE ANTARCTIC
THE DYNAMIC LOUD SPEAKER
HOW TO SHOOT TROUBLE IN A.C. SETS
ALL ABOUT PHOTOELECTRIC CELLS
INDUCTANCE COIL DESIGN
BUILDING A CRYSTAL CONTROL TRANSMITTER

76
75
80
85
90
88