

JANUARY, 1929

25 CENTS

RADIO



IN THIS ISSUE

RADIO IN THE ANTARCTIC
THE DYNAMIC LOUD SPEAKER
HOW TO SHOOT TROUBLE IN A.C. SETS
ALL ABOUT PHOTOELECTRIC CELLS
INDUCTANCE COIL DESIGN
BUILDING A CRYSTAL CONTROL TRANSMITTER



MAGNAVOX *"Dynamic"* SPEAKERS



*"And ev'ry voice is heard repeating
The merry burthen of glad song." — CARMEN.*

The Aristocrat

Beautiful burr burl walnut cabinet finished in two tones.
For A-Battery Operation . . . \$60
For AC Operation \$70



The Beverly

Gracefully proportioned cabinet finished in light mahogany.
For A-Battery Operation \$50
For AC Operation \$60



A Startling illusion studio realism in the home. Only a dynamic speaker can so faithfully reproduce the full, rich beauty of the original . . . in volume . . . undistorted. Magnavox created the dynamic, makes only dynamics, supplies leading set makers.

Other floor and table models up to \$175
Units only; DC \$30; AC \$40.



THE MAGNAVOX COMPANY

Oakland, California

Chicago, Illinois

The phantoms of music now become REALITY!



INSTRUMENTS—golden notes—for-
merly lost to radio now come through
broadcast receivers in full tonal beauty.
No longer does the bass viol come in
thinly on overtones alone—no more do
the shrill notes of the piccolo at top
register die away in a shrill, reedy ab-
surdity. The modern radio has TONE!

Better broadcasting—better tubes—
better speakers—but it has remained for
Sangamo to build transformers to match
these improvements. And particular at-
tention is called to Sangamo Push-pull
Input Transformer has an extremely high
primary inductance to secure faithful

amplification of low notes and an accu-
rately divided secondary insures practi-
cally identical frequency characteristics.
There are Sangamo Push-pull Output
Transformers to match the impedance of
the various type power tubes and special
Output Transformers for dynamic speakers.

In the Sangamo line there are trans-
formers which permit set builders and
manufacturers to produce the real tone
fidelity. Are you ready for us
to send you the data?

Sangamo Condensers

Molded in Bakelite—unchang-
ing value under all conditions
of service.



Tone!

"X" Line Transformers
Type AX straight audio ampli-
fication, list price.....\$6.00
Type BX Push-pull Input unit,
list price.....\$6.50
Type CX-171 Push-pull Out-
put transformer, for 171 or
250 power output tubes for
cone speaker, list price...\$6.50
Type DX, same as CX except
for 210 and 112 power tubes,
list price.....\$6.50
Type HX Push-pull Output for
171 or 250 Power output tubes
to match the impedance of mov-
ing coil of Dynamic loud speak-
ers, list price.....\$6.50
Type GX, same as HX except
for 210 and 112 power tubes,
list price.....\$6.50
Type E output choke to match
impedance of the various type
power tubes, list.....\$5.00

"A" Line Transformers
(Similar to "X" line but with
special core metal to give
slightly better curve)
Type A straight audio ampli-
fication, list price.....\$10.00
Type B Push-pull Input trans-
former for all tubes, list price
.....\$12.00
Type C-171 Push-pull Output,
for 171 or 250 type power tubes
with cone speaker.....\$12.00
Type D-210, same as C except
for 210 and 112 power tubes
.....\$12.00
Type H-171, Push-pull Output
for 171 or 250 power tubes for
Dynamic speaker.....\$12.00
Type G-210, same as type H
except for 210 and 112 tubes,
list price.....\$12.00
Type F Plate Impedance for use
as a choke to prevent oscilla-
tion and for impedance coupled
amplifiers, list.....\$5.00

SANGAMO

ELECTRIC COMPANY

Springfield, Illinois

For 29 years preeminent manufacturers of electrical precision instruments

Pacific Coast Offices:

1061 Howard Street, San Francisco

750 Subway Terminal Building, Los Angeles

Tell them you saw it in RADIO

RADIO

Established 1917

Published Monthly by the Pacific Radio Publishing Co.

ARTHUR H. HALLORAN, Editor
H. W. DICKOW, Business Manager

P. S. LUCAS, Associate Editor
A. I. RIVETT, Draughtsman

FRANK C. JONES, Technical Adviser

Entered as second-class matter at Post Office at San Francisco, Calif.

Subscription Price, \$2.50 per year in U. S. and Canada \$3.00 in Foreign Countries

Copyright 1929 by the Pacific Radio Publishing Co.

Address all communications to

PACIFIC RADIO PUBLISHING COMPANY
Pacific Building, San Francisco, California

VOL. XI JANUARY, 1929 No. 1

CONTENTS

RADIOTORIAL COMMENT	9
RADIO IN THE ANTARCTIC.....	11
THE DYNAMIC LOUDSPEAKER....	13
<i>By Frank C. Jones</i>	
DESIGN OF LOW LOSS INDUC-	
TANCE COILS	14
<i>By D. L. Bedingfield</i>	
LIGHT-SENSITIVE CELLS IN	
VISUAL COMMUNICATION	16
<i>By John P. Arnold</i>	
A NEON LAMP STROBOSCOPE.....	18
FOTO-CELLS AND THEIR	
APPLICATION	18
<i>By D. E. Replogle</i>	
THE RAYFOTO SYSTEM OF STILL-	
PICTURE RECEPTION	19
HELP FOR THE RADIO TROUBLE-	
SHOOTER	20
<i>By J. Garrick Eisenberg</i>	
CONSTRUCTION OF A CRYSTAL-	
CONTROLLED TRANSMITTER....	22
<i>By G. F. Lampkin</i>	
TECHNICAL BRIEFS	25
THE COMMERCIAL BRASS-	
POUNDER	27
<i>By P. S. Lucas</i>	
THE "WOOLWORTH" UTILITY	
OSCILLATOR	27
<i>By Jack Bront</i>	
GOODWILL CRUISE TO SOUTH	
AMERICA	27
INTER-CITY RADIO TELEGRAPH	
COMPANY SYSTEM	27
<i>By Fred V. Trueblood</i>	
LECHER WIRES AND STANDING	
WAVES	28
<i>By Glenn E. West</i>	
INSIDE STORIES OF FACTORY-	
BUILT RECEIVERS—THE ACME	
A. C.-7	29
RADIO KIT REVIEWS.....	30

FORECAST OF FEBRUARY ISSUE

The leading article is an interesting account of how radio is used to aid the farmer in the marketing of his products. Keith La Bar discusses the effect of room design upon loudspeaker performance. Thomas A. Marshall describes an unusually effective antenna coupling unit. Frank C. Jones has a constructional article on an experimental five tube a.c. screen-grid receiver with a "power" detector. J. R. Nelson analyzes the gain and selectivity of an r.f. amplifier using a screen grid tube. John P. Arnold follows up his article on photoelectric cells with one on the amplification of photoelectric currents. He also continues his description of the Cooley system and presents other interesting material on radio pictures. A. Binneweg, Jr., presents practical information on the construction of parabolic reflectors. R. Wm. Tanner tells how to make a 30 k.c. intermediate frequency transformer. T. F. McDonough explains how a pick-up unit should be used so as to give the best results. C. A. Kuhlmann has a chart for determining the constants for band-pass filters.

"You Can Forget the Condensers—If They Are DUBILIER'S"

Specially designed for Thordarson Power Packs Type 574 for use with the Ratheon BH tubes or the Elkon Metallic EBH rectifier.

Type 575 for use with 210 type tubes and 281 rectifier tubes.

Type 1152 for use with 210 and 250 type tubes and 281 rectifier tubes.

Type 1120 for use with 280 type rectifier tubes or the Elkon E-80 metallic rectifier.



There
is

No Substitute for Quality!

No amount of lurid claims by nimble-penned advertising writers will take the place of quality in the final analysis—the operation in your power supply.

Ever since the advent of Radio, Dubilier has been the manufacturers' standard—and the set builders' stand-by. Built in every Dubilier Condenser is a factor of safety which is your safeguard for years of service without failure.

DUBILIER LIGHT
SOCKET AERIAL
—“A Moulded Bakelite Product”

Bring in programs with a minimum of interference. Do away with the unsightly and trouble causing outside aerial and lightning arrestor. Simply attach to the set and plug into the nearest light socket. Uses no current. Sold by all good dealers. Price \$1.50.

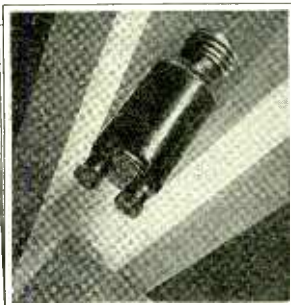

Dubilier
CONDENSER CORPORATION

10 East 43rd Street, New York City

Address
Dept. 22



for free
catalog

Start the New Year Right
By Subscribing to "RADIO"

WHY pay \$3.00 per year for your copies of RADIO which you buy from a newsdealer when you can get the next 12 issues for \$2.50? Let us send "RADIO" to your address for the coming year. A subscription insures you against missing much valuable information which "RADIO" will publish during 1929. Subscribe now. Send the coupon and \$2.50 today.

"RADIO,"
Pacific Building, San Francisco, Calif.
Here is \$2.50. Send the next 12 issues of "RADIO" to

Name.....
Address.....

RADIO AMATEURS..

This short cut lifts you into the real MONEY CLASS



Radio Operator, \$90 to \$200 per month with all expenses paid



Radio Inspector, \$2,000 to \$4,500 a year

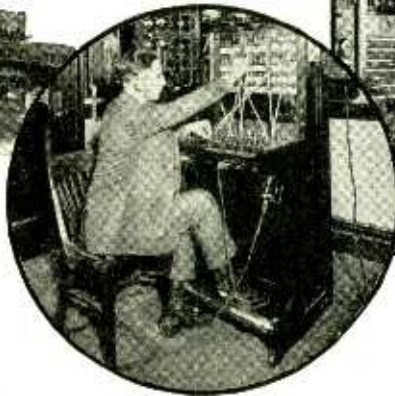

Broadcast Operator, \$1,800 to \$4,800 a year

DON'T look upon Radio as a mere plaything. Thousands of men are making big money at it—and so can you!

Just a little commercial training is all you need to give you that professional confidence and ability. You can secure this training in your spare time . . . through a marvelous home-laboratory course sponsored by RCA, General Electric and Westinghouse. Our big FREE Radio book tells all about it.

Round out your knowledge with this home-laboratory training

Put the finishing touch to your Radio experience. Get the "How" as well as the "Why" of Radio with this commercial training. Only an hour or so a day—in spare time—is all you need. As part of your course, you receive absolutely free of extra charge—a magnificent outlay of fine apparatus. With this outfit you learn to build fine sets and solve the radio problems that bring big pay. You acquire not only the ability but the confidence to succeed in a big commercial way.

*Training backed by
RCA . . . General Electric . . . Westinghouse*

Our graduates are in big demand everywhere. They enjoy greater success because they're posted right up-

to-the-minute in everything in Radio. Radio's progress each year is measured by the accomplishment of the great engineers at work in the research laboratories of

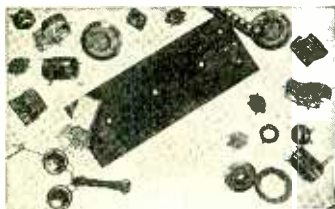

RCA, General Electric and Westinghouse. These three Radio organizations set the standards for the industry.

Money back if not satisfied

The lessons prepare you for success in all phases of Radio—manufacturing, servicing, selling, ship and shore broadcasting, Television, Photodiagrams and radio equipment. A signed agreement backed by RCA assures you of complete satisfaction upon completion of the training—or your money will be promptly refunded.

Read this thrilling free book

It may mean the turning point in your life. It gives you the real "dope" about Radio and it describes in detail the famous training that has enabled us to place thousands of our students in fine positions, usually from 3 to 10 days after graduation! It tells in 50 fascinating pages and photos all about Radio's brilliant opportunities for adventure and success. Mail the coupon now—the book is absolutely free! Radio Institute of America, Dept. R. A. 1, 326 Broadway, New York, N. Y.

Radio Institute of America
Dept. R. A. 1
326 Broadway, New York, N. Y.

Gentlemen: Please send me your big FREE 50-page book which tells about the great opportunities in Radio and about your famous laboratory-method of radio instruction at home.

Name.....

Address.....



The national success of the CROSLLEY AC Electric GEMBOX at \$65 is recommendation enough



OPERATES POWER SPEAKER

CROSLLEY DYNACONE \$25.

VIRGINIA
Crosley GEMBOX the most talked of radio in South Atlantic States. Sold by...
DELAWARE
Crosley GEMBOX meeting...
WEST VIRGINIA
Crosley the...
OHIO
Our...
KENTUCKY
Crosley...
INDIANA
Indiana...
MISSOURI
Crosley GEMBOX...
MISSISSIPPI
Crosley...
LOUISIANA
This...
SOUTH CAROLINA
Crosley...
TENNESSEE
Crosley...
ALABAMA
Crosley...
ARKANSAS
Crosley...
TEXAS
Here...
NORTH CAROLINA
Crosley...
GEORGIA
This...
MONTANA
Maintain...
KANSAS
Crosley...
UTAH
In...
DISTRICT OF COLUMBIA
We...
FLORIDA
We...
ARIZONA
Crosley...
NEW MEXICO
Crosley...
PENNSYLVANIA
Crosley...
MAINE
Political...
MASSACHUSETTS
Greatest...
NEW YORK
Crosley...
VERMONT
Crosley...
RHODE ISLAND
There...
CONNECTICUT
Customers...
NEW HAMPSHIRE
We...
ILLINOIS
Popular...
MICHIGAN
Without...
IOWA
Business...
WYOMING
We...
IDAHO
GEMBOX...
WISCONSIN
Never...
OREGON
Business...
NEBRASKA
Unmatched...
NORTH DAKOTA
GEMBOX...
SOUTH DAKOTA
GEMBOX...
MINNESOTA
GEMBOX...
OKLAHOMA
Demand...

Crosley radio is modern. Important late radio developments and refinements are found in all models.

1. Crosley radios are highly sensitive — thanks to superior radio amplification of neutrodyne circuit.
2. They are selective — thanks to efficient shielding of elements.
3. They have volume — thanks to Mershon Condenser in AC sets which permits use of full power.
4. They have volume control that cuts reception to a whisper.
5. They have illuminated dials.
6. They fit all types of furniture.

Extract every bit of enjoyment from the air with this amazing radio which only Crosley dealers sell!

Sales records shattered this season report Crosley dealers from coast to coast. Why? What is the reason? Ask the Crosley dealer near you to hook a Crosley radio to your antenna and then that question answers itself. You will be thrilled for you will hear radio reception so realistic, so beautifully rich and mellow and so full toned that you will say— "This is radio I never thought could be possible." And when you contemplate the price— \$65, and note the latest radio features . . . shielding . . . power speaker operation . . . illuminated dial and neutrodyne circuit, you will understand fully why Crosley Radio is such a tremendous success!

THE CROSLLEY RADIO CORPORATION
Powel Crosley, Jr., Pres. Cincinnati, Ohio
Montana, Wyoming, Colorado, New Mexico and West prices slightly higher

..You're there with a Crosley!..

Prices quoted are without tubes.

Tell them you saw it in RADIO

Other Crosley Radios are the SHOWBOX, an 8 tube AC electric receiver with push-pull audio and two 171 power tubes in the last audio stage \$80

The BANDBOX, a battery type receiver with new features as in the AC sets — operates a dynamic tube speaker \$55

The BANDBOX, Jr., is a dry cell set of modern design for use where storage battery recharging is inconvenient — \$35 and operates the MUSICONE — Crosley's great development in magnetic type speakers . . . sweet toned. Volume and natural reproduction . . . \$15

The Crosley Radio Corporation,
Department 19,
Cincinnati, Ohio.
Please send me literature regarding the
Crosley Radio I have checked:
AC Gembox at \$65 . . . AC Showbox at
\$80 . . . Dynacone at \$25 . . . Battery type
Bandbox at \$35 . . . Dry cell Bandbox
Jr. at \$35 . . . Musicone at \$15
Name
Address



THE AMAZING NEW 5000 HOUR ELKON RECTIFIER FOR "B"

ELIMINATORS

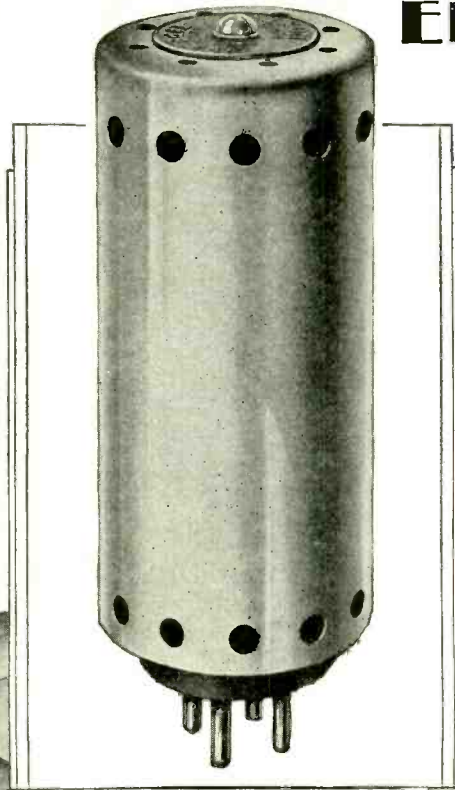

ONLY 200,000 AVAILABLE THIS SEASON

JUST as the Elkon dry, low-voltage rectifier revolutionized the design of chargers and "A" Eliminators, the new Elkon "B" type Rectifier will revolutionize the design of "B" Eliminators.

The Elkon EBH Rectifier plugs into any Eliminator using the former standard "B" rectifier tube. Simply take out the fragile 1,000 hour tube—plug in the husky Elkon EBH and the change is made. No changes in wiring—no adjustments.

It is sturdy, solid, dry—has none of the frailties of a tube—not affected by accidental overloads or line surges. It is self healing. The power is smoother, quieter.

From the orders already received from dealers and jobbers in all parts of the country, we know that we will be tremendously oversold this season—only 200,000 of these revolutionary rectifiers will be available.

The elaborate manufacturing, testing and aging equipment necessary to produce the Elkon EBH Rectifier precludes any greater production the first year

Look for the Red and Yellow display carton on your dealer's shelves. The new EBH is packed in a metal can.

Buy one from your dealer today! Plug it into your "B" Eliminator—Trouble free for at least 5,000 hours!

ELKON, INC.

Division of
P. R. Mallory & Co., Inc.

350 MADISON AVENUE
New York City

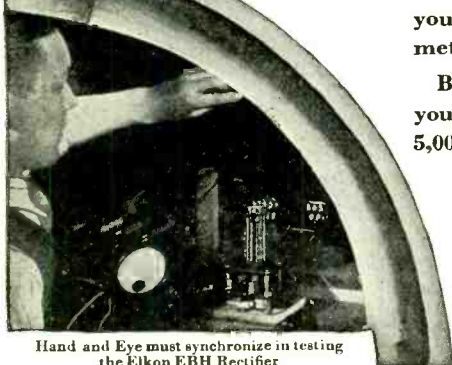

Hand and Eye must synchronize in testing the Elkon EBH Rectifier

ELKON, INC., DEPT. E-36
350 Madison Avenue, New York City

Gentlemen:
Please send me complete information on Elkon
Quality Radio Products.

Name.....
Address.....

Tell them you saw it in RADIO

*The Jensen
Model 7 Cabinet*

This beautifully designed cabinet harmoniously fits into artistically furnished music and drawing rooms.

Jensen Dynamic Speakers are made in types to operate with 110 volt A. C. house current, 6 volt storage battery, "A" eliminator or trickle charger, 110 volt D. C. house current and 90 to 180 volt D. C. current as provided by many of the late model radio sets. The sensitivity of the instruments is the same in any case.

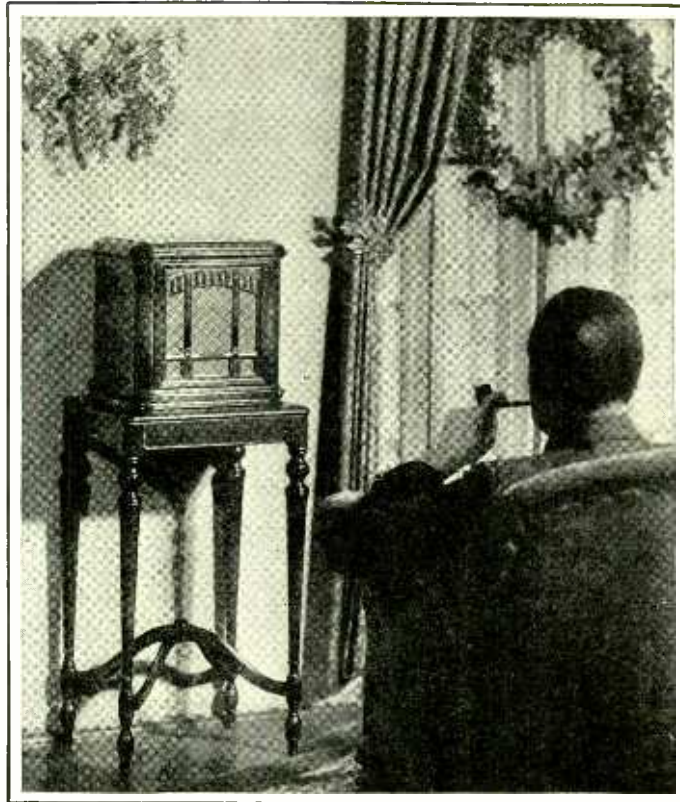

At the end of this year of Jensen achievement

AS 1928 draws to a close, the Jensen Radio Manufacturing Company extend heartiest season's greetings to all who have taken part in placing Jensen in its respected position throughout the industry. 1928 has been a year of great achievement. Jensen has gained acceptance as the leader in the field of dynamic speakers. No small part of this widespread approval can be traced to the enthusiasm of the trade. Jensen thanks the trade and assures them that for 1929 Jensen will continue to keep far in advance of the industry.

Jensen Radio Manufacturing Company
212 9th St., OAKLAND, CALIF. 338 N. Kedzie Ave., CHICAGO, ILL.

Jensen
DYNAMIC SPEAKER

JENSEN PATENTS ALLOWED AND PENDING
Licensed under Lektophone and Magnavox Patents

Read what BIG money these fellows have made in the RADIO BUSINESS

\$375 One Month Spare Time



"Recently I made \$375 in one month in my spare time installing, servicing, selling Radio sets. And, not so long ago, I earned enough in one week to pay for my course."
EARLE CUMMINGS,
 18 Webster St., Haverhill, Mass.

\$1597 In Five Months



"The N. R. I. is the best Radio school in the U. S. A. I have made \$1597 in five months. I shall always tell my friends that I owe my success to you."
HENRY J. NICKS, Jr.,
 302 Safford Ave.,
 Tarpon Springs, Fla.

\$1164 Spare Time Profits



"Look at what I have made since I enrolled, \$1,164—money I would not have had otherwise. I am certainly glad I took up Radio with N. R. I. I am more than satisfied."
HENRY R. HEIKKINEN,
 123 W. Erie St., Chicago, Ill.

Over \$1000 In Four Months



"My opinion of the N. R. I. course is that it is the best to be had at any price. When I enrolled I didn't know a condenser from a transformer, but from December to April I made well over \$1000 and I only worked in the mornings."
AL JOHNSON,
 1409 Shelby St., Sandusky, Ohio.

I will show you too how to start a spare time or full time Radio Business of Your Own without capital



Radio's amazing growth is making many big jobs. The worldwide use of receiving sets and the lack of trained men to sell, install and service them has opened many splendid chances for spare time and full time businesses.

Ever so often a new business is started in this country. We have seen how the growth of the automobile industry, electricity and others made men rich. Now Radio is doing the same thing. Its growth has already made many men rich and will make more wealthy in the future. Surely you are not going to pass up this wonderful chance for success.

More Trained Radio Men Needed

A famous Radio expert says there are four good jobs for every man trained to hold them. Radio has grown so fast that it simply has not got the number of trained men it needs. Every year there are hundreds of fine jobs among its many branches such as broadcasting stations, Radio factories, jobbers, dealers, on board ship, commercial land stations, and many others. Many of the six to ten million receiving sets now in use are only 25% to 40% efficient. This has made your big chance for a spare time or full time business of your own selling, installing, repairing sets.

So Many Opportunities You Can Make Extra Money While Learning

Many of our students make \$10, \$20, \$30 a week extra while learning. I'll show you the plans and ideas that have proved successful for them—show you

how to begin making extra money shortly after you enroll. G. W. Page, 1807-21st Ave., S., Nashville, Tenn., made \$935 in his spare time while taking my course.

I Give You Practical Radio Experience With My Course

My course is not just theory. My method gives you practical Radio experience—you learn the "how" and "why" of practically every type of Radio set made. This gives you confidence to tackle any Radio problems and shows up in your pay envelope too.

You can build 100 circuits with the Six Big Outfits of Radio parts I give you. The pictures here show only three of them. My book explains my method of giving practical training at home. Get your copy!

I Will Train You At Home In Your Spare Time

I bring my training to you. Hold your job. Give me only part of your spare time. You don't have to be a college or high school graduate. Many of my graduates now making big money in Radio didn't even finish the grades. Boys 14, 15 years old and men up to 60 have finished my course successfully.

You Must Be Satisfied

I will give you a written agreement the day you enroll to refund your money if you are not satisfied with the lessons and instruction service when you complete the course. You are the only judge. The resources of the N. R. I. Pioneer and Largest Home-Study Radio school in the world stand back of this agreement.

Get My Book

Find out what Radio offers you. My 64-page book, "Rich Rewards in Radio" points out the money making opportunities the growth of Radio has made for you. Clip the coupon. Send it to me. You won't be obligated in the least.

Address

J. E. Smith, Pres.
Dept. 9M75

National Radio Institute
Washington, D. C.

This Book points out what Radio offers you Get a copy!



This coupon is good for a FREE copy of my Valuable Book, Mail it NOW!

J. E. Smith,
 President,
 Dept. 9M75
 National Radio Institute, Washington, D. C.

Dear Mr. Smith: Send me your book. I want to know more about the opportunities in Radio and your practical method of teaching at home in spare time. This request does not obligate me to enroll and I understand no agent will call on me.

Name.....Age.....
 Address.....
 City.....State.....

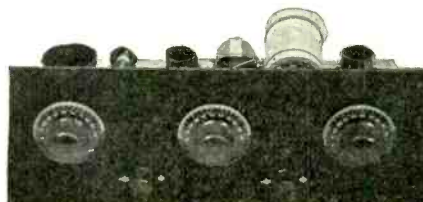
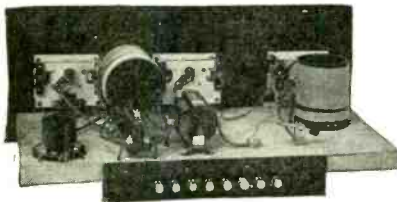
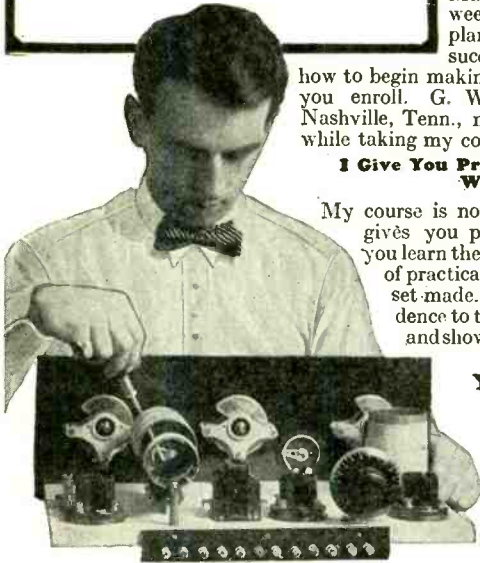

Tell them you saw it in RADIO

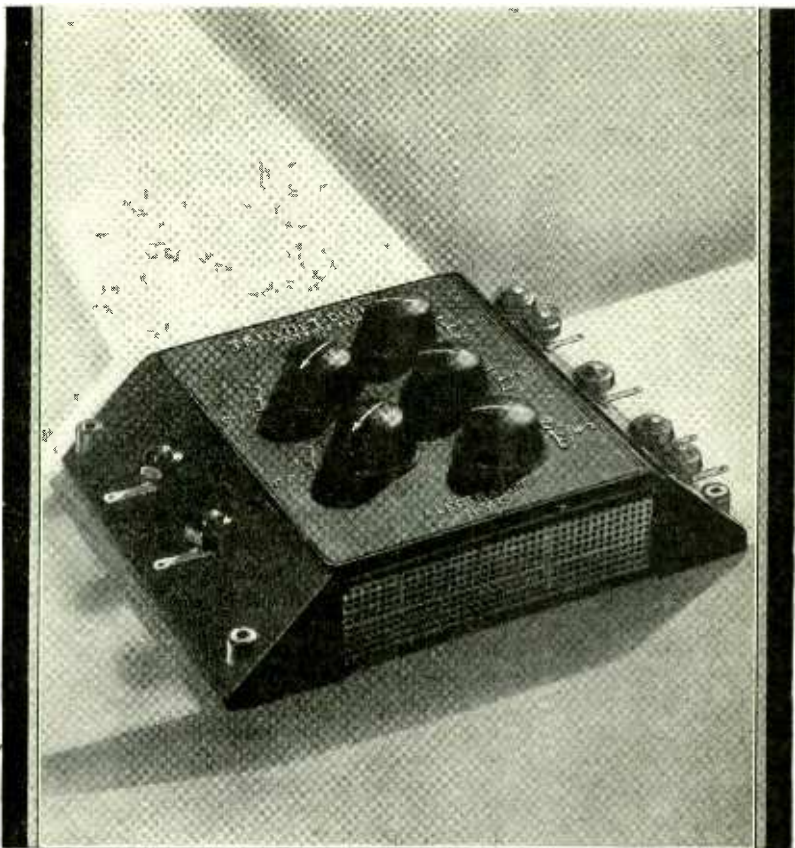

TRUVOLT

DIVIDER *Correct Voltage*

A NOTABLE advance in the control of filtered voltage — the new Electrad TRUVOLT Divider combines in one compact unit, variable, wire-wound resistances with handy knobs that regulate desired voltage for any receiver using up to twelve tubes.

Think of the trouble it saves! No guessing—no complicated mathematical calculations—no voltage-regulating tubes—no fixed resistances of uncertain value—no superfluous wiring.

The knob settings have been calibrated in the Electrad laboratories to give *exact* voltage wanted from *any* type battery eliminator — plus a smooth, *graduated* control for any *in-between* value.

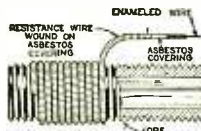

Electrad Wire-wound Resistances are superior in principle and workmanship. They last longer, give more accurate voltages and smoother operation.

WHERE you want it
WHEN you want it
HOW you want it!

A handsome molded Bakelight, ventilated case that can be mounted on the base or sub-panel, or used as the front panel of your eliminator. Easily accessible input and output terminals. Three "B"

voltage regulator-knobs and two for "C" bias. Price \$12.50 at your Dealers.

Mail the coupon for TRUVOLT DIVIDER Manual and other Power-Pack information.

ELECTRAD

ELECTRAD, Inc., Dept. H 1 175 Varick Street, New York

Send me free copy of TRUVOLT DIVIDER MANUAL and other Electrad Voltage-Control Data

Name _____
 Street _____
 City _____ State _____

RADIO

VOLUME XI

JANUARY, 1929

No. 1

Radiatorial Comment

RADIATIONS from oscillating receivers have been such an unmitigated nuisance that news of their possible application to a useful purpose comes as a pleasant surprise. Dr. E. F. W. Alexanderson of the General Electric Company is the genius who has discovered how an everyday radio nuisance may become a valuable aid to aviation. He has found that when one of these much-maligned devices is carried on an airplane which changes its distance from a reflecting surface by an amount equal to one-half the wavelength to which the receiver is tuned, its whistling note is varied in pitch by the reflected wave. By recording the cycles of variation, he suggests that an aviator can determine his altitude, much as a bat is believed to avoid obstacles by the use of echoes.

* * *

SHOULD the Federal Radio Commission be continued as an administrative body? The law provides that its administrative duties be restored to the Radio Division of the Department of Commerce on March 15, and that thereafter it function merely as a judicial body or court of appeal. But Congress has the power to again prolong the life of this hybrid child of its creation.

Answer to this question will undoubtedly appear in President Hoover's first message to Congress. While nobody else is in an authoritative position to predict his recommendations, and much less to prophesy Congressional reaction thereto, it is generally believed that the Commission has outlived its life of uselessness and that, like the old Missouri mule without pride of ancestry nor hope of posterity, it should now be sent to the fertilizer factory.

The Commission is a child of the same kind of political expediency that has dictated the appointment of several of its members. Its ostensible purpose of doing away with the chaos in the use of the radio channels by the broadcasters, could have been done just as well, if not

better, by the Radio Division of the Department of Commerce. But the politicians wanted to hamstring the then Secretary of Commerce. So they provided an independent Commission, another body of tax-eaters, without regard to their technical qualifications for administering the most technical of all businesses subject to governmental regulation.

These are plain words and hard facts which can be verified by anyone familiar with the political situation at Washington two years ago. They would not be written now were it not for the danger of the continuance of these unnecessary political jobs.

* * *

OPINIONS regarding operation with the new broadcast frequency allocations are divided. Reception on the cleared channels is reported as being generally good, except in the case of distant stations whose channels are close to those of powerful locals. Many have complained of heterodyne interference on the partially cleared channels and on those channels which are used by a large number of stations.

One cause of frequent protest is the interference between local stations which operate on nearby channels. While a fifty kilocycle separation is theoretically sufficient to obviate such interference, it does not always prove so in practice. Although the fault is usually due to the non-selectivity of the receiver, it can readily be corrected by giving a greater frequency separation to the stations. This should and possibly will be done wherever it can be accomplished without upsetting the set-up.

After such adjustments have been made, nothing more can be done, except to reduce the number of hours that a station may use a channel, or to reduce the number of stations. Such action naturally raises a storm of protest from the stations. A similar situation has arisen in the overcrowded colleges. They merely raised the entrance requirements and periodically "flunked"

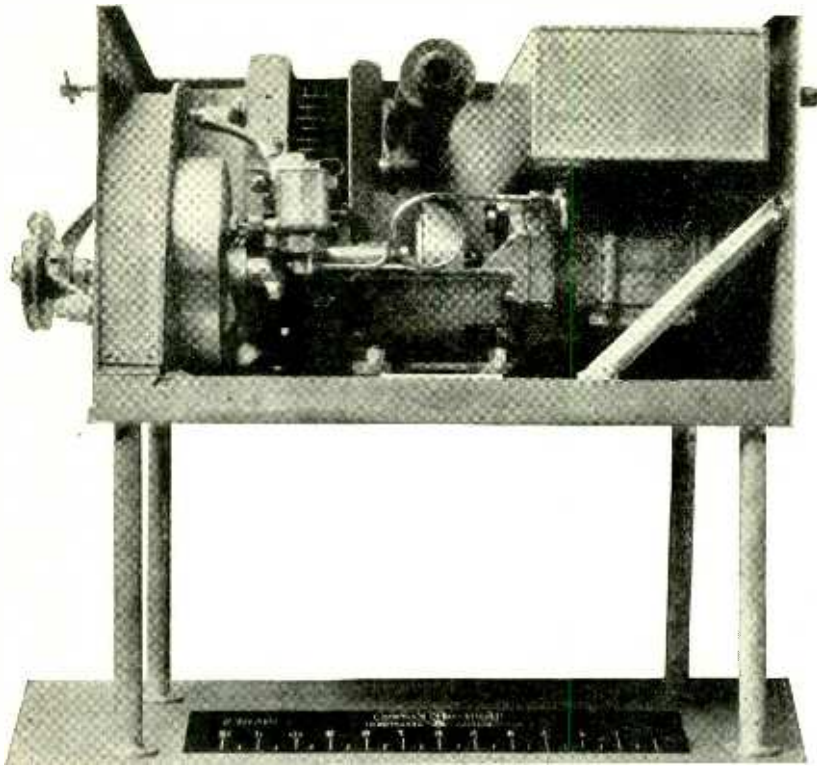

1-h.p. Gas Engine—Generator Unit for the Base Stations

the history-making apparatus for the ill-fated Dallas Spirit and the world-renowned Southern Cross. The commander's expectations were high; he wanted a great deal of equipment packed into a very small space. He required a transmitter that would operate on short waves as well as those in the ship bands by changing not more than two controls. It must not weigh more than 50 pounds or occupy more than 1000 cu. in. of space.

This was a big order, for there is a lot of equipment necessary in a 50 watt, short and long-wave transmitter; but Mr. Heintz evolved a transmitter weighing 25 pounds, occupying 700 cu. in., and operating on any wave within a band of from 20 to 75 meters and one of from 400 to 667 meters.

Two single pole, foolproof switches, S_1 and S_2 in the circuit diagram, are used to short out the long-wave inductances when it is desired to transmit on short waves, and worm-gear condensers C_1 and C_2 do all of the tuning within the limits of the two bands employed. A in the diagram is a 0-3 ampere thermo-couple ammeter, and RFC is an interchangeable radio frequency choke, the winding of which is on the inside of a $\frac{3}{4}$ -in. quartz tube. It is shown in the upper left-hand corner of the transmitter, just in front of the



Wavemeter employed on both expeditions

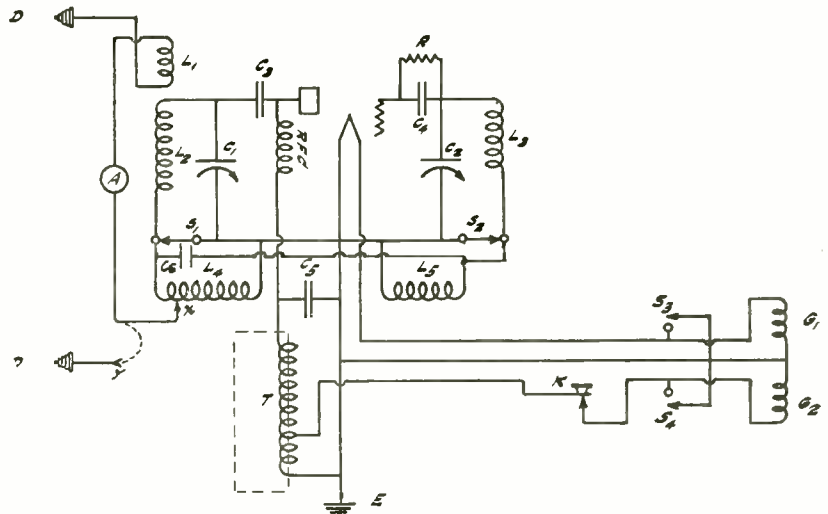
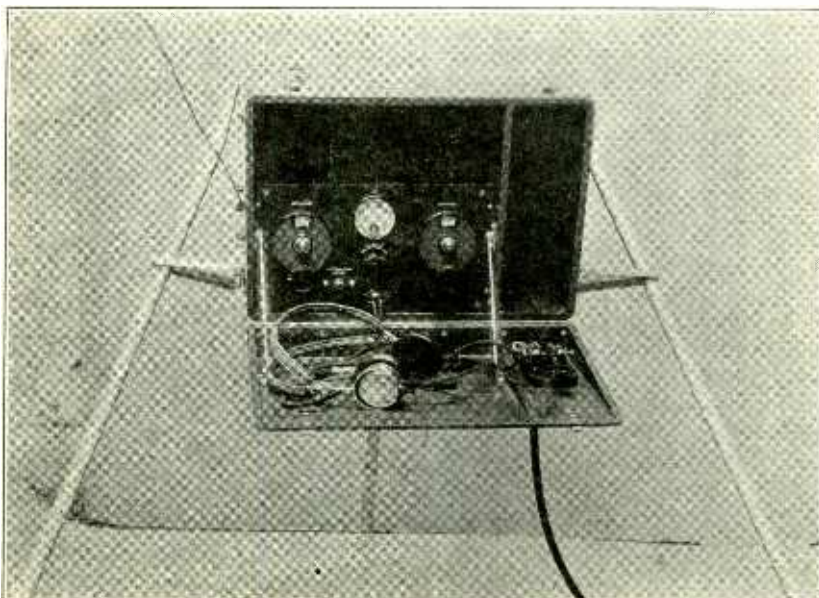

Fig. 1. Circuit Diagram of Byrd's 50-watt, 20-75; 400-667 Meter Portable Transmitter



Type of Receiver Used by Wilkins

power transformer and grid condenser. The case is built of heavy aluminum, as are the tuning inductances, and the former is hinged on all four sides so that if it should ever be necessary to open the cabinet when aboard a plane or in other cramped quarters the operator may choose the side from which he wishes to work by removing any three of the pins and leaving the fourth. For packing, the transmitter may be put in its sack and hoisted over the shoulders.

While in the air the generator may be coupled to the plane's motor or may be attached to the fuselage and driven by the usual impeller; but when the transmitter is set up on land some other means must be used to drive it. So Mr. Heintz designed and built a 1 h.p. gas engine; built an aluminum frame around it and equipped it with detachable legs so that in extremely cold weather a stove

(Continued on Page 36)

The Dynamic Loudspeaker

A Discussion of Its Design and the Manner in Which It Functions

By FRANK C. JONES

THE general explanation of the operation of a dynamic speaker as the production of sound by a plunger type of diaphragm is true only for the very low frequencies. For high frequency response the present models depend on a wave action.

By plunger action is meant the movement of the entire mass of the diaphragm or cone as a unit, like a piston of an engine. This plunger action is true for low frequencies, where the amplitude of motion must be relatively great to produce sound. The larger the diaphragm or cone, the less the necessary amplitude of motion for a given sound output. So a dynamic speaker with a cone considerably larger than those now in use should present less mechanical difficulties. With present speakers, the amplitude of motion is so great that rattling is liable to take place and the spider support may break.

With one or two type '50 power tubes and an audio amplifier that will give good response down to 30 or 40 cycles per second, the average dynamic speaker will last from one to four months before breaking. Practically all of the present day models have either a bakelite or

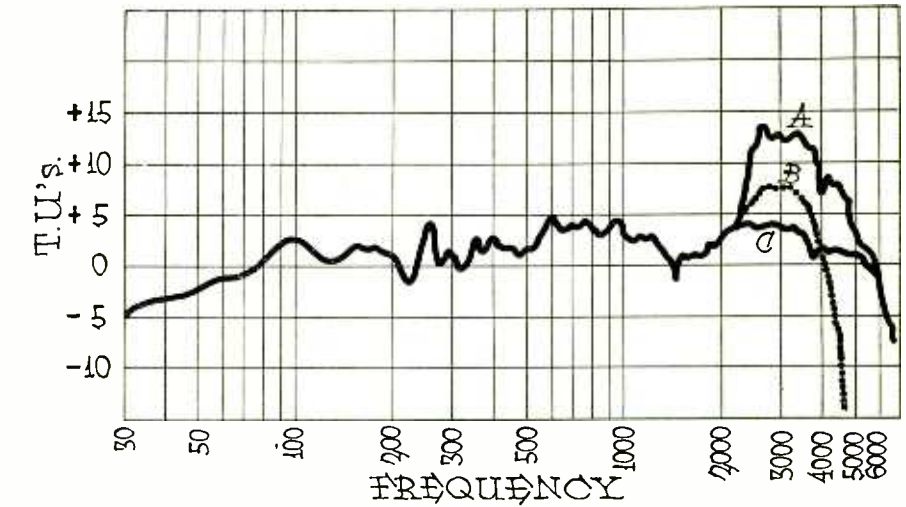

Fig. 1. Response Curve of Dynamic Speaker

aluminum spider to support the moving coil between the poles of electromagnets. This spider consists of two or three curved springs which allow the coil and cone to move back and forth in the magnetic field. If the amplitude of motion is great enough and is continued long enough, some form of crystallization will take place in the springs and they

will break. The author has seen dynamic speakers with both bakelite and metal spiders break after a few days of intermittent use on frequencies below 75 cycles.

Fortunately most present day amplifiers, and broadcast station transmitters too, do not respond to very low frequencies. However, each year sees a great improvement in audio quality and this may be a real problem for next year.

By wave action, for high frequency response, is meant that the force is applied at the vertex of the cone so that flexural waves are transmitted through the diaphragm. A certain amount of reflection takes place from the outer edges of the cone so as to produce standing waves. These cause resonant peaks and depressions in the response curves, as shown in Fig. 1. But these little peaks and depressions are so close together that their resulting effects on music or speech are inaudible. The wave action, I believe, gives nearly constant sound output if the amplitude of motion varies inversely as the first power of the frequency.

The inertia controlled, or plunger type diaphragm, on the other hand, gives constant sound output if the amplitude of motion varies inversely as the square of the frequency. This means that when there is a combination of these two actions, the result may be difficult to calculate. It can be measured, however, as shown by the curve A of Fig. 1. Evidently the combination of the two actions causes a broad peak at about 3000 cycles per second in which the sound output is greater than it should be. Curve C of

(Continued on Page 40)

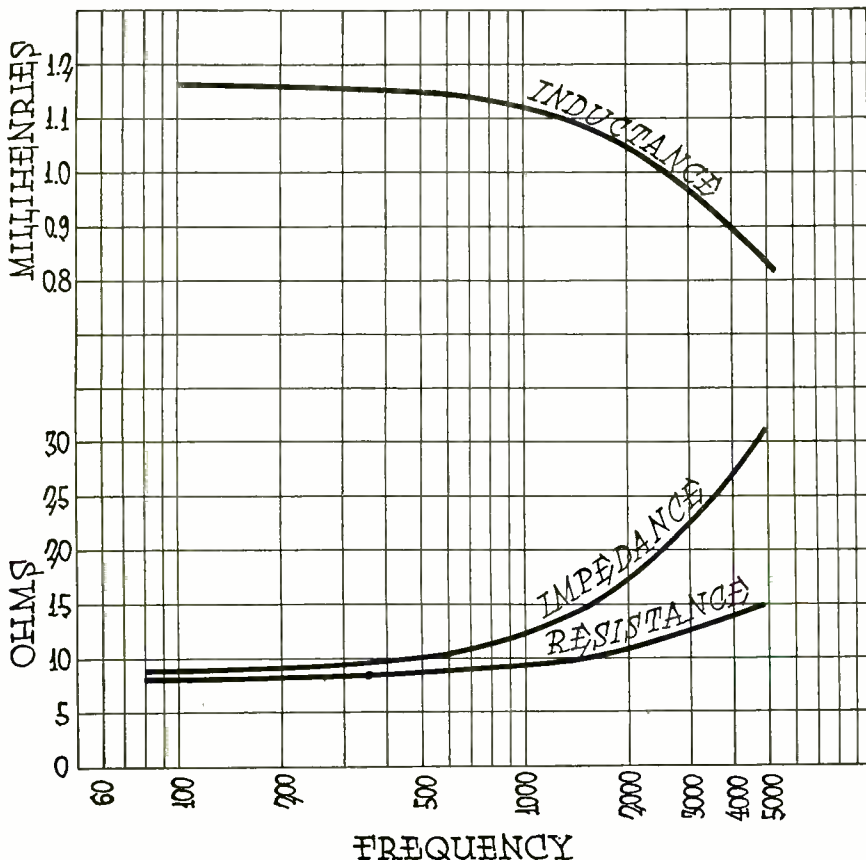

Fig. 2. Moving Coil Measurements

Design of Low Loss Inductance Coils

By D. L. BEDINGFIELD

WITH the advent of the screen-grid tube comes the need for a simple means of designing low loss inductance coils for use as the secondaries of r.f. transformers. This can be readily done in the case of a solenoid which is wound with a single layer of solid wire. Such a high efficiency coil can be designed to give a splendid amplification per stage in a well-neutralized receiver using screen-grid tubes. But in receivers which are not neutralized and which depend on circuit losses for stabilization, the substitution of a coil having losses as low as here described would cause oscillation which could be eliminated only by reducing the amplification.

As the amplification obtainable from an r.f. stage depends primarily upon the magnitude of the factor L/CR , it is evident that maximum amplification at resonance requires a circuit of maximum inductance and minimum capacity and resistance. In this factor, L is the tuned inductance, C the total capacity in parallel with it, and R the effective resistance in series with it.

As L is necessarily limited by the maximum capacity of the condenser with which it is tuned to the longest wavelength to be received, any increase in

loose coupling to reduce the effect of aerial capacity.

Were it not that R is the r.f. and not the d.c. resistance, it could be readily reduced by merely increasing the size of the wire. But Fig. 1 shows that

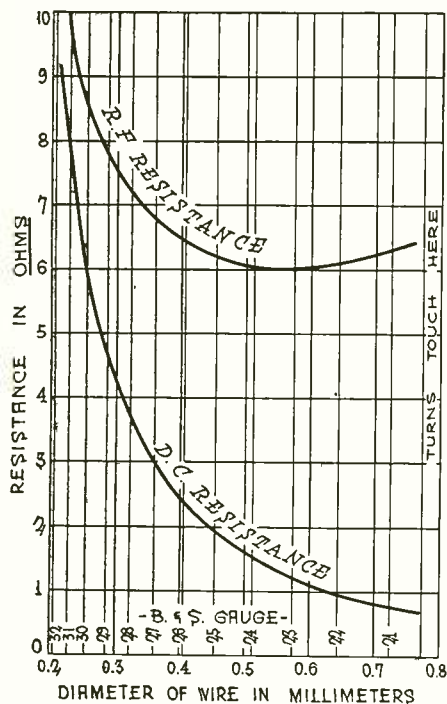

Fig. 1. Comparison of D.C. and R.F. Resistance

amplification must obviously come from a reduction in R . Thus 340 m.h. is the maximum inductance permissible with .00025 mfd. in covering the broadcast band, and even then to tune below 250 meters requires a series condenser or

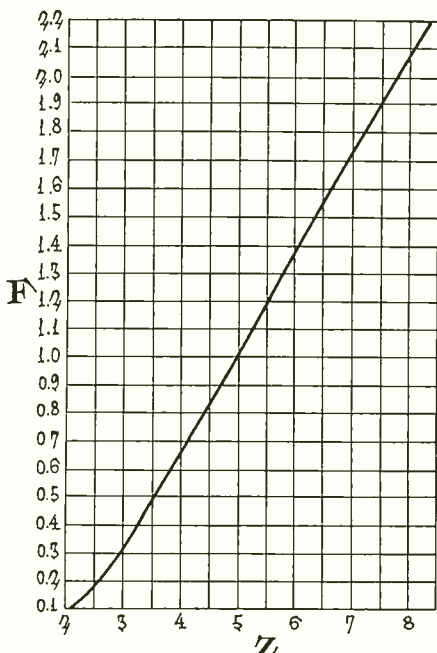

Fig. 2. Values of "F" Corresponding to "Z."

there is a point beyond which any increase in wire diameter represents an increase in r.f. resistance.

These curves were taken for a 74-turn solenoid 3 in. in diameter and 2 1/4 in. long, the r.f. resistance being calculated for a 300-meter wavelength from Butterworth's formula:

$$R_1 = R \left\{ 1 + F + G \left(\frac{K n d}{2D} \right)^2 \right\}$$

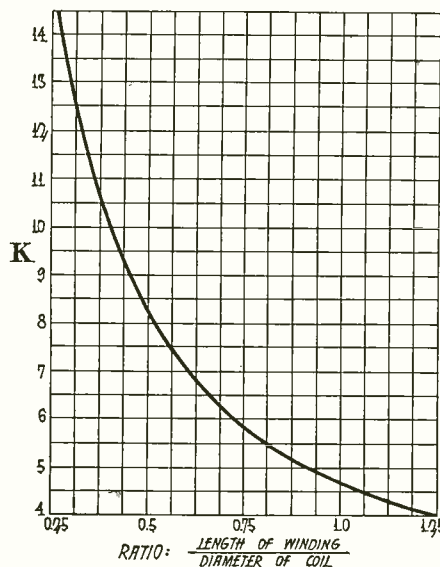

Fig. 4. Values of "K" for Various Coil Ratios

where R_1 is the r.f. resistance of the coil in ohms, R is the d.c. resistance of the winding in ohms, n is the total number of turns, d is the diameter of the wire in the same units as D the diameter of the coil, F and G are factors proportional to $Z = d\sqrt{f}/92.8$ (where f is frequency in cycles per second and d diameter of wire in millimeters), and K is a shape factor depending upon the ratio between the length and diameter of the winding. The values of F , G and K may be taken from Figs. 2, 3 and 4 respectively.

As an example, compute the r.f. resistance of 0.565 m.m. wire in the coil specified in the preceding paragraph at 300 meters, 1,000,000 cycles. The d.c. resistance of 0.565 m. m. wire is .02145 ohms per ft.; 74 turns 3 in. in diameter $= .25 \times 3.1416 \times 74 = 58.1$ ft., and the d.c. resistance $R = 58.1 \times .02145 = 1.24$ ohms. $Z = 0.565 \times \sqrt{1,000,000} \div 92.8 = 6.09$. Then from Fig. 2, $F = 1.43$ and from Fig. 3, $G = .948$. The ratio of coil length to diameter is $2.25:3 = .75$, and from Fig. 4, $K = 5.9$, $n = 74$, $d = .565$, $D = 3$ in. $= 76.2$ m. m. Consequently $K n d / 2D = 5.9 \times 74 \times .565 \div 152.4 = 1.62$; this squared is 2.62. So

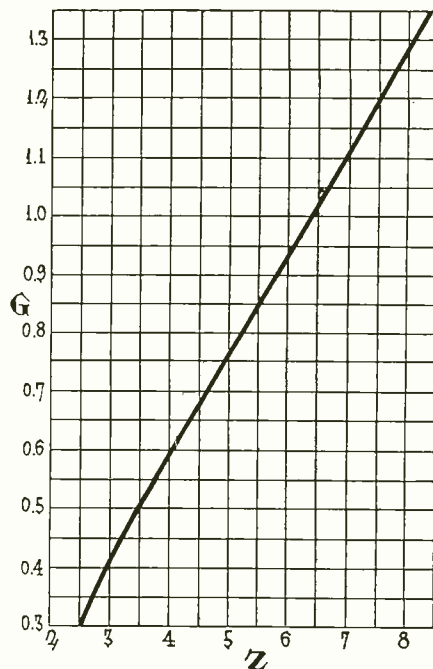

Fig. 3. Values of "G" Corresponding to "Z"

$$R_1 = 1.24 (1 + 1.43 + .948 \times 2.62) = 6.09 \text{ ohms.}$$

Returning to the actual design of a coil, after this digression on calculating its r.f. resistance, we find that the required inductance can be determined from the formula $L = \lambda^2 \div 3,553,225 C$, where L is the inductance in millihen-

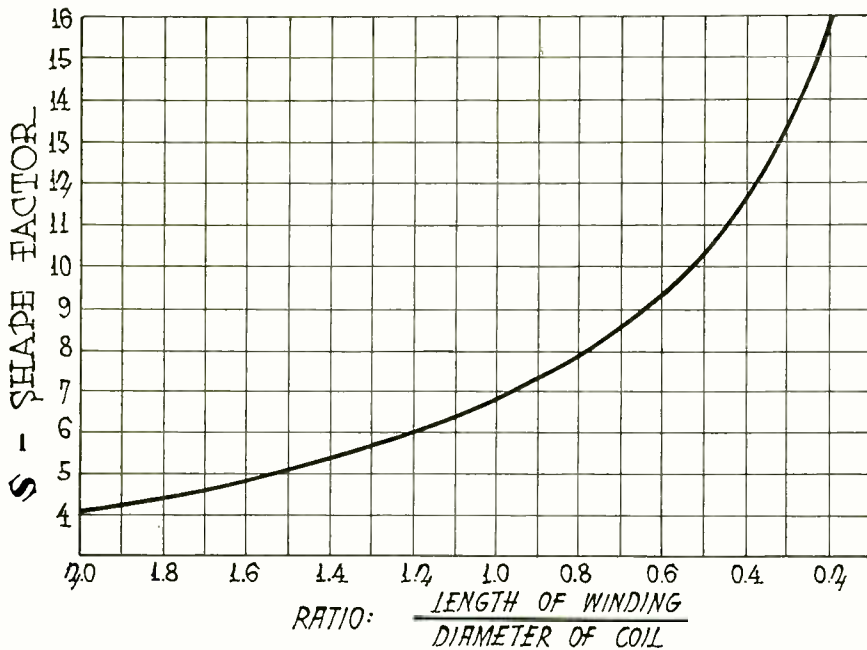

Fig. 5. Shape Factor

ries, λ the wavelength in meters, and C the capacity in microfarads, which is in parallel with the coil, including the antenna, tube, and stray capacities, as well as that of the tuning condenser. This inductance must be figured for both the longest and shortest wavelength to be received, using the maximum and the minimum capacity in parallel with the coil. The minimum usually ranges from .00005 to .0001 mfd.

If the two calculations give the same value for L , it may be accepted as correct. If the inductance for the longest wave is smaller than that for the shortest wave, split the difference. But if the

long-wave inductance is larger, the tuning condenser is too small, a larger size condenser must be used, and the calculations repeated.

For a given inductance L the required number of turns is $\sqrt{1000L \div SD}$, when S is the shape factor taken from Fig. 5 and D the diameter of the coil in centimeters.

The most suitable diameter of wire for any length of winding along 2, 2½ and 3 in. coils may be determined from Figs. 6, 7 or 8, depending upon the inductance of the solenoid.

These graphs show, in general, that

the lowest r.f. resistance is obtained when the largest coil diameter is used. But an increase in diameter is accompanied by an increase in magnetic field, with corresponding instability which can be remedied only by using a screening box of impractical dimensions. On the other hand, the resistance of the coil rapidly increases if its diameter is less than 2¼ in.

For broadcast frequencies, the resistance curves show that an optimum is reached when the winding length is 1⅓ to 1¼ times the diameter. This is contrary to a widely published statement that the lowest coil resistance can be obtained when the diameter is 2.46 times the length.

The writer's compromise standard is a 2¼ to 2½ in. winding length on a 2½ in. diameter coil. The screening compartments are 8 in. high; the coils are mounted vertically so as to be equidistant from the top and bottom of the screening compartment, and at least 1¼ in. from the sides.

The optimum diameters of wire, as shown in the charts, are for bare wire. If it is insulated, the insulation can be used as a spacer to distribute the required number of turns over the allotted length of winding. Enameled wire wound on a grooved form gives a total coil resistance about 20 per cent greater than that of the bare wire, as shown on the charts. With silk insulation for wire spacing, the coil resistance is about 30 per cent greater than shown on the chart, while untreated cotton insulation adds 40 per cent or more. This latter may be somewhat reduced by baking the

(Continued on Page 34)

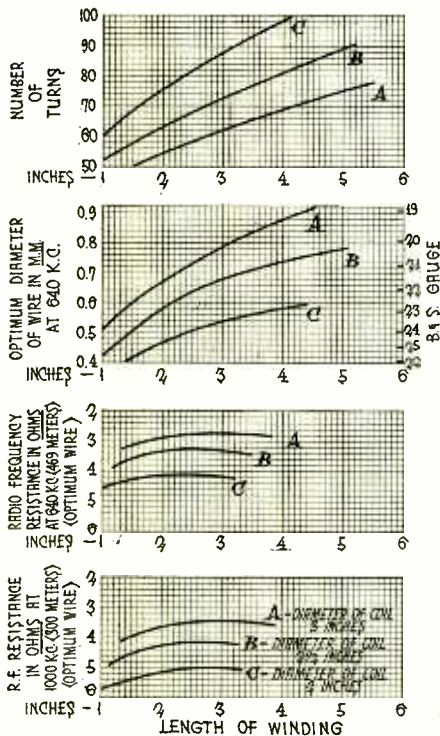

Fig. 6. Wire Data for 200 m.h. Coil to be tuned from 200 to 600 Meters with .0005 mfd. Condenser

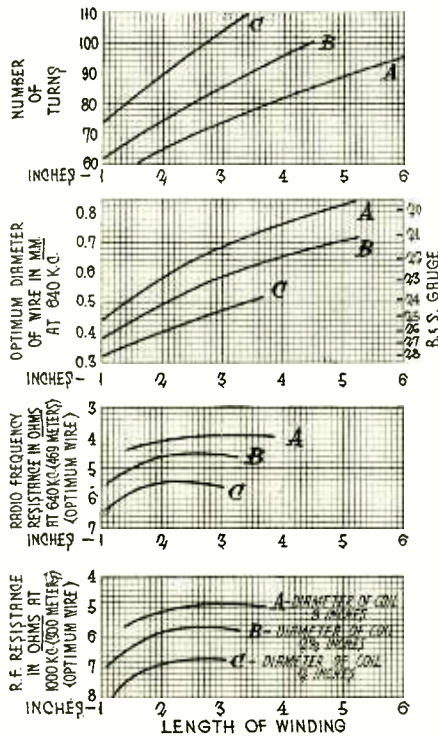

Fig. 7. Wire Data for 280 m.h. Coil to be tuned from 230 to 580 Meters with .00035 mfd. Condenser

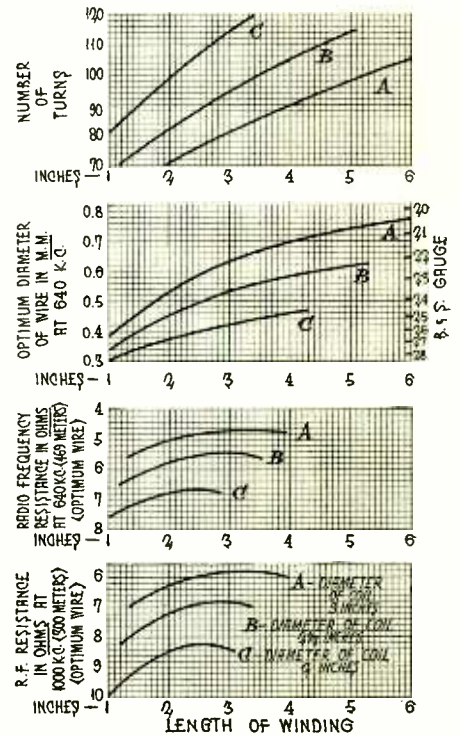

Fig. 8. Wire Data for 340 m.h. Coil to be tuned from 250 to 550 Meters with .00025 mfd. Condenser

Radio Picture Transmission and Reception

Photoelectric Equipment and Methods for Visual Communication

By JOHN P. ARNOLD, *Departmental Editor*

LIGHT-SENSITIVE CELLS IN VISUAL COMMUNICATION

THE transmission of information over great distances in short intervals of time is effected solely by electrical means. When we communicate directly with another person, we ordinarily do so by an appeal to the senses of sight or hearing; that is, we either show or tell our *vis-a-vis* something. But when we are beyond the physical range of these senses, we must employ electrical communication channels.

Since the information to be conveyed exists primarily as sound or light, some means of transferring these forms of energy into electricity are required. Suitable instruments have been devised for this purpose. In aural communication, the microphone or speech transmitter is used at the sending station to impress the sound waves, which strike its diaphragm, upon a steady electric current. This may readily be transmitted to a distant receiving station where it is again reconverted to sound.

In practical, modern systems of visual communication, where the problem is to convert the "spacial distribution of brightness," which represents the subject of the information, into some characteristic of an electric current, the light-sensitive cell has been found to be the most satisfactory instrument yet available. In view of its vital importance in this form of communication, it is desirable to have a full knowledge of its construction and operation.

The types of light-sensitive devices which are or have been used for this purpose may be classified as (1) photo-conductive, (2) photo-voltaic and (3) photo-electric cells. Grouped in this manner, each class represents different, although related, aspects of light-sensitive phenomena. The selenium, copper oxide, and alkali metal cells are, respectively, typical of each class, (See Fig. 1).

Selenium cells as ordinarily constructed, consist of a film of gray crystalline metallic selenium deposited between two metallic electrodes. When the latter are connected in series with a battery and a current-measuring instrument, an increase in current through the circuit is indicated when light falls upon the selenium.

Thus, such cells, which increase their electrical conductivity (lower their resistance) when illuminated, may be used as energy-transferring devices in a manner quite similar to the employment of the carbon-button microphone in sound transmission. Although the current which can be passed through these cells is of the order of several milliamperes, making them highly satisfactory in this respect, they are not reliable for applications where a high frequency of response to changing values of illumination is required. Due to their property of inertia, the change in conductance lags behind the instantaneous values of illumination.

The early experimenters in still picture transmission were able to minimize this defect, as well as the fatigue characteristic to which these cells are also

subject, by improved technique in the design and construction of the cells themselves and also by devising compensating systems in order that the cells might be used where the time of transmission could be prolonged. At present, cells of this type are considered to be obsolete for communication work.

Copper oxide cells are constructed by placing two metallic electrodes of considerable area close together in an electrolyte. When the electrodes are connected to a sensitive voltmeter and one of them is illuminated, a difference of potential will be noted. Such cells, which generate their own electromotive force, might be termed "light batteries." The frequency response characteristic is much more rapid than that of the photo-conductive cells and, although the current output is not as great, they may be used in still picture transmission.

Turning to the photo-electric group, the practical alkali metal cell may be generally defined as a light-operated and light-controlled electrical device, consisting essentially of an evacuated, transparent inclosure into which have been inserted two electrodes—a cathode composed of an insulated, sensitive material which emits electrons from its surface when illuminated and an anode, whereby accelerating potentials may be applied in order that a convection current will flow between the electrodes.

In appearance the alkali metal cell resembles both the thermionic vacuum tube and the even more familiar incandescent lamp. But in the manner of its electrical operation, it is more readily comparable to the Fleming valve or diode. Both of these devices employ an electron-emitting cathode and an adjacently disposed anode which is maintained at positive potential with respect to the former, drawing the electrons over to it. The difference to be noted is, of course, that in the one, the emission is due to the incandescence of a suitable filament; in the other, to the action of light on an alkali metal.

The alkali metals as a group are the most active chemically, this activity increasing with the rising atomic weight; that is, in the order of lithium, sodium, potassium, rubidium and caesium. The pure metals, their compounds (especially the hydrides), and amalgams are also very active photoelectrically, their sensitivity to light lying in the ultra-violet and visible regions of the spectrum. In regard to the pure metal surfaces, the sensitivity to light of longer wavelength (toward the red) increases as the metal selected is more electro-positive. The cor-

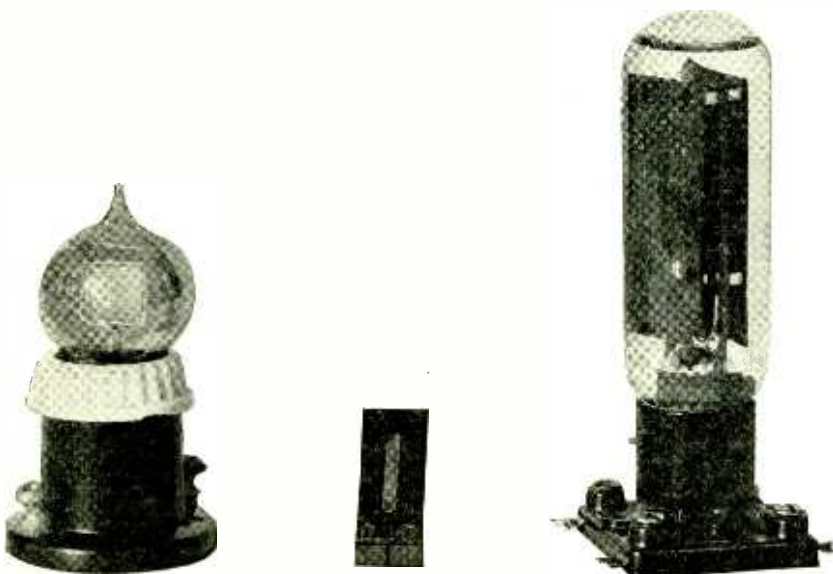

Fig. 1. Types of Light Sensitive Devices; on left, Potassium-Hydride Cell; in center, Selenium Cell; on right, Copper-Oxide Cell

responding hydrides are sensitive to slightly longer wavelengths than the pure metals. Although any of these elements may be used for light-sensitive cells, practically all of the commercial type, either for visual communication or for industrial applications, employ potassium hydride which is easier to manipulate.

But the alkali metal cells that are most suitable for visual communication should also be, as Dr. Ives of the Bell Laboratories states, of the "central anode, gas-filled, colored" type, which may be taken to mean that the anode or positive terminal is centrally disposed (Fig. 2) in relation to the cathode or light-sensitive surface which is usually deposited on the inner walls of the glass bulb; that the cell is filled with an inert gas to increase its sensitivity due to ionization by collision, and that the pure metal is "colored" or converted to a hydride which also greatly increases its sensitivity. Dr. Ives constructs cells of this type in the following manner:

"The alkali metal ordinarily used is potassium. This is introduced by distillation on the pump. The cell is first baked to a temperature of 400° C. for several hours while on the pump in order to drive out all traces of water vapor. The potassium for use in making up the photo-electric cells is first distilled in a vacuum into long glass tubes. In this preliminary distillation, the greater part of the absorbed gaseous impurities are removed. After the cell has been baked out on the pump, a piece of the glass tube containing potassium is broken off and introduced into the pump system. Between the point of introduction and the cell are a series of bulbs. The potassium after melting in vacuo is distilled successively through these bulbs and into the photo-electric cell, where it is condensed on the walls of the bulb. A window is then made in the cell by applying a small flame on the appropriate part.

"The next step is to introduce a small amount of pure hydrogen gas, which is permitted to enter from a reservoir on the system. This hydrogen gas goes through the system of bulbs through which the potassium has been distilled, which still contain a large amount of potassium, and is thereby cleaned of all traces of gases or vapors which might react on the potassium in the cell. A glow discharge is then passed from a high voltage source, until, by illuminating the alkali metal surface and reading the current on a sensitive galvanometer, it is found that a maximum of sensitiveness has been attained. The hydrogen is then completely removed by long continued pumping.

"The final step in the preparation of the cell consists in the introduction of a small quantity of carefully purified argon. The argon for this purpose is held in a reservoir in which there is a pool of sodium-potassium alloy. By passing

an electric discharge from this pool to an electrode through the gas, the argon is purified of all active impurities. It is introduced into the cell through the same series of potassium coated bulbs already mentioned, the potassium in the meantime having been vigorously heated to drive off all occluded hydrogen, so that the gas when it finally reaches the photo-electric cell is entirely inert. The gas pressure is carefully adjusted while the cell is still on the pump so as to give an optimum effect, after which the cell is sealed off." (See reference 1.)

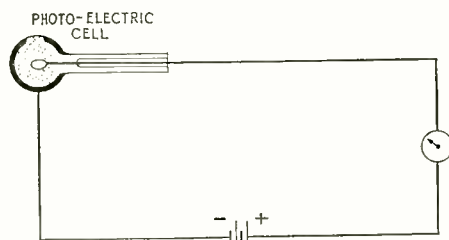

Fig. 2. Photo-Electric Cell with Battery and Current-Measuring Instrument

An inert gas, such as argon, helium, neon, etc., is introduced into the cell in order that it will not react with the alkali metal, but will still serve the purpose of amplifying the photo-electric current due to ionization caused by the collision of electrons with the gas particles between the electrodes. The nature of the gas chosen is of little material importance, but the adjustment of the pressure to the critical point of maximum sensitivity is an essential condition. Koller has pointed out that this pressure ranges from .02 mm. of mercury in large cells to 1 mm. in small cells.

The electrical characteristics of these cells have been reviewed (RADIO, p. 25; Feb. 1928) and will not be treated extensively here. For communication work, the specific requirements are that the cell is so designed that the photo-electric current is directly proportional to the intensity of the illumination and that its electrical output is of sufficient magnitude that thermionic vacuum tube amplifiers may be employed for transmission of these currents. To meet this latter condition, so necessary in television, the cells are made with a very large cathode surface and a wide aperture to permit the reflected light from the subject to be transmitted to fall upon its surface.

The current-voltage characteristic is probably of the most importance in practical work and this information regarding the voltages to be used with a particular cell is usually given by the manufacturer in the form of a graph. If this is not supplied, the curve may be found by placing the cell in the circuit shown in Fig. 2 and by plotting the photo-electric current for various voltages under the maximum illumination for which the cell is to be used. In an

alkali metal cell of the gas-filled type, the current increases with the voltage, slowly at first, but with great rapidity as the point of critical voltage is approached, where a glow discharge occurs in the cell. This critical point should never be exceeded, as the cell may be ruined. The most satisfactory rule is to apply the lowest possible voltage which will give the desired results. For instance, an additional stage of amplification may be added. Another advantage in working well below the glow point is that small variations in the potential source will have only a negligible effect on the output of the cell.

The problems that arise in connection with the use of cells in television systems may be better understood from the following quotation:

"Like the eye, an artificial television system must have some light-sensitive element or elements by means of which the light from the object shall produce signals of the sort which can be transmitted by the transmission system to be used. For a television system to operate over electrical transmission lines this means some photoelectric device. It is obvious that this photoelectric device must be extremely rapid in its response, since the number of elements of an image to be transmitted must be some large multiple of the fundamental image repetition frequency, that is 16 per second. The response should, of course, be proportional to the intensity of the light, and finally, the device must be sufficiently sensitive so that it will give an electrical signal of manageable size with the amount of light available through the scanning system.

"This latter requirement, that of sensitiveness, is one which, it was realized, from studies made with our earlier apparatus for the transmission of still pictures over the wires, would be extremely difficult to meet. In the picture transmission system a very intense beam of light from a small aperture is projected through a transparent film and on to a photoelectric cell. In practical television, the system must be arranged to handle light reflected from a natural object, under an illumination which would not be harmful or uncomfortable to a human being. Actual experiment showed that the greatest amount of light which could be collected from an image, formed by a large aperture photographic lens on the small scanning aperture of the picture transmission apparatus, was less by a factor of several thousand times than the light projected through it for still picture transmission purposes. Assuming the same kind of photoelectric cell to be used, the additional amplification required over that used in the picture transmission system, taking into account also the higher speed of response demanded, would bring us at once into a region where amplifier tube noise and other sources of inter-

(Continued on Page 32)

Help for the Radio Trouble-Shooter

The Second of a Series of Articles Concerned with the Detail of Servicing A.C. and D.C. Receivers, Using Test Unit Described in December Issue

By J. GARRICK EISENBERG

THE first thing to do when tackling a job is to get the owner's story of what happened and why; not that it will do much good, but then it is the polite thing. Sometimes, surprisingly, it does help in making a speedy analysis (or call it guess if you will) of the trouble.

Assuming this and the other usual formalities of snapping on the filament switch, jiggling the tubes about, etc., to be over with, plugging into the various stages of the receiver with the test set should show definite voltages at filament, grid, and plate terminals. Filament failures will show up in obvious manner; grid voltages, it should be kept in mind, will indicate negative bias at the r.f. stages as well as at the a.f. stages, whereas the detector should indicate a positive bias. This may not always hold true for a.c. receivers; in such cases the cathode terminal may be touched to the filament connection, upon which a hum will be developed in the receiver if the grid return is complete through the tuning coil. The same test may be made, from grid terminal to either side of the filament, so as to short out the *A* supply of a d.c. set where the tuning coil is suspected to be open. The short must be removed at once, of course. This method is only to be used where it is not possible to observe grid potential, and there is doubt as to the grid coil continuity. In some receivers the grid is actually held at the same potential as the filament, though this is not good practice.

Failure to secure plate voltage readings at the tube socket calls for a check of the *B* supply. If this shows normal output, the failure may be checked back through the receiver by using a pair of external leads to the voltmeter connections of the test set; this trouble almost invariably is due to burnt-out audio transformer primary, though in some cases may be due to broken connections.

Should the *B* supply show no output it should be disconnected from the receiver and then checked again. If now it shows some appreciable voltage, it is probable that a by-pass condenser in the receiver is shorted, which accounts for the lack of reading when the device was connected to the set. A *B* supply unit will indicate practically normal voltage under open circuit when a high resistance voltmeter is used, even though the rectifier unit has been seriously damaged due to the short-circuiting drain; therefore this check should be made under load conditions.

The defective by-pass condenser in the receiver may be localized by checking through with a small battery in series with the load resistor terminals. Care should be taken to cut in at least half of the resistance, and the 100 m.a. scale should be used for this test, since when the defective condenser is found, it may pass current as readily as a direct connection. A badly leaking condenser may only show spurts; a battery of at least 22½ volts would be preferable for this test since the condenser may show up perfect on lower voltages. The *B* source may be used for checking purposes, of course, if no battery is at hand. Some slight amount of leakage current will be observed even with a good condenser; this will never show a voltage reading in excess of 5 per cent of the applied voltage, however, for a good condenser. If there is any doubt whatsoever, unsolder the condenser from the circuit and connect the receiver up to the *B* source for checking again.

In checking for emission of the rectifier tube, a pair of leads are connected from the high voltage and negative terminals of the eliminator to the terminals on the test unit marked "load." Make sure that most of the load resistance is cut in. Incidentally this load resistor must be of large current-carrying capacity; the author has found the T50 Tru-volt having a maximum value of 5000 ohms, and rated at 25 watts, to be quite satisfactory for this purpose. With all the resistance in, with an applied voltage of 200, the current drain will be 40 mils. The load resistor may be varied now, so that actual circuit conditions may be approximated; even a cheap eliminator unit should be capable of putting out a +40-mil load without any difficulty.

Now, leaving the leads from the eliminator connected to the test unit, short the terminals on the lower left corner of the d.c. panel marked "M.A." It will be seen from the schematic that this shorts out the meter, but it will leave the eliminator on the load as previously measured. Using the voltmeter connections, measure the output of the *B* device. A good unit will not show more than a 30-50 volt drop between no load and full load, and many will show considerably less.

I would like to emphasize again that a simple no-load measurement of *B* output is practically useless especially when using a high resistance voltmeter. The same remark holds true for *B* batteries, and these also should be made to deliver

load current while they are under test. Otherwise a device that is actually run down may be passed over as being perfectly normal, if it has had an opportunity to recuperate to its normal "static" voltage.

Should the voltage checks at the various tube sockets show normal, and all circuits show perfect continuity, the next test is for defective tubes. The plug-in cord may be inserted in any convenient socket and each tube in turn inserted in the emission test socket on the d.c. panel. If no chart is at hand showing the normal plate current under the test plate and grid voltage conditions, the average showing of plate current may be taken as the correct one; deviations of more than 2 mils from this average may be considered as indicative of a bad tube, assuming of course that all tubes being tested are of the same type.

If this check shows normal conditions, and the previous checks do not show up any defections, then the trouble may now be looked for outside the receiver proper. It will probably be found in either the antenna circuit or in the loud speaker. The latter may be checked through for continuity in the usual manner with battery and meter.

One other possibility offers—a shorted tuning condenser. This may be found quickly, if it is in any of the r.f. stages, by taking the antenna lead to the grid of the detector tube directly, then working backwards to the first r.f. stage until the signals disappear. Sometimes a single tuning condenser shorting out at some particular point is not indicated by total loss of signals. This can be checked with the oscillator, however, in a manner to be described later.

After checking the eliminator and ascertaining that it is not delivering its output to the receiver, the various steps for isolating the possible trouble may be carried out. Previously, of course, it will have been discovered whether any particular tap of the device is open. If this prove the case, an external resistor may be connected in series with the high voltage terminal, so as to drop the voltage to the desired amount for the intermediate circuits to be supplied. Should a test across the high voltage terminal and negative show no reading, it may be assumed that the trouble is not in the voltage divider circuit.

A check should first be made of the supply source, and then, working backwards from the output terminals of the *B* device to the a.c. transformer, the

various units should be tested. An open filter choke will not be difficult to discover, but a shorted filter condenser will give no indications of its presence by a meter test. If no d.c. voltage is obtained directly at the rectifier tube terminals, probably the simplest procedure is to plug in a new tube at once. If it glows bright red it is a certain indication of a shorted filter condenser. If it does not, check for d.c. output again. The only other source of trouble would be an open a.c. transformer. This will have to be checked for continuity with the battery method again, since the a.c. meter will not handle the high secondary voltages. Some time may be saved over this check, if you are certain everything else is O. K., by checking the line fuses again.

Other Possible Troubles

Bad hum suddenly developed. Possible causes: (1) Low emission amplifier tube, if '26's are in use, causing a shift from straight-line characteristic. (2) Low emission rectifier tube in supply unit. (3) Voltage loop set up between a.c. supply and radio circuits. The latter may be due to imperfect grounding of cores and cases of a.c. units, or the breaking of the ground connection entirely.

Poor quality reproduction. Possible causes: Run-down batteries or low emission rectifier unit in *B* supply. (2) Low emission tubes causing a shift in operating point away from straight-line characteristic. It should be understood that poor filament emission produces the same effect as too low a *B* potential on the amplifiers, and it will be noted that the same causes which govern the development of abnormal hum in an a.c. receiver also operate to produce serious distortion in the d.c. type. (3) Ruptured cone or diaphragm of loud speaker. (4) Defective blocking condenser in the case of resistance or impedance coupled a.f. amplifiers, permitting part of the plate voltage to be applied to the grid of the next stage as a positive potential, or too high a value of leak resistor, permitting the tube to block just enough to ruin the quality on strong signals.

It is understood of course in connection with the above considerations that we are analyzing only such troubles as crop out suddenly. It is assumed also that the receiver is not working under such conditions as produce serious overloading of any of the tubes, thus contributing to audio distortion.

Failure to receive any signals above or below a certain tuning point on the dial. Probable cause: Shorted tuning condenser in some stage which effectively shorts out everything beyond this particular point, but permits normal tuning at other points.

High-pitched squeal suddenly developed. Probable cause: Run-down *B* batteries, causing interstage reaction.

This sketchy outline of the everyday

variety of troubles encountered, together with the check tests previously outlined, should in practically every instance indicate the source of trouble in a minimum of time. There will no doubt be many other sorts of trouble not mentioned here, but once familiar with the use of the test equipment, these may all be expected to respond to a logical checking scheme.

Use of Oscillator

The oscillator equipment has been found invaluable for proper balancing of tuning circuits where a gang condenser is operated from a single control, and in the localization of shorted tuning condensers in any particular stage. It uses the conventional oscillator circuit, having in addition two pick-up coils, one of which is taken off to a neon lamp for resonance indication, the other

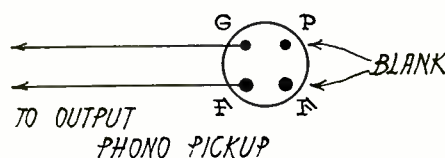

Fig. 3. Phonograph Pick-Up Socket for Use with Comparison Amplifier

being used as a coupling coil to the circuit under test.

The numerals alongside each coil indicate the number of turns, the wire size used being No. 22 D. C. C. The tuning coil and coupling coil are wound on a piece of bakelite $2\frac{1}{2}$ in. in diameter, the coils being separated about a $\frac{1}{2}$ in. from one another. The tickler coil may be wound on a 2-in. form and slipped inside the tuning coil form. The lamp winding may be wound on this 2-in. form also. The lamp indicator is actually a refinement not absolutely essential, since the milliammeter in series with the plate circuit gives a much sharper indication of resonance.

The method used is the dip method of resonance. The circuit is set into oscillation at any convenient point, the meter indicating this point by a maximum of plate current when the tuning condenser is revolved. It will be seen that the oscillator circuits derive their energy from the plug-in cord, and the plug may most conveniently be inserted in an audio socket for power supply. A 171 tube is considered the most desirable for this use; in some cases it is necessary to cut down the negative bias at the tube socket before the circuit will oscillate.

When a fairly high plate current is indicated for the oscillator, two leads are connected from the oscillator output terminals across the tuning coil terminals in any particular stage, and the tuning condenser rotated. Resonance with the oscillator circuit is indicated by a very sharp deflection of oscillator plate current (since the receiver circuit is absorbing a maximum of energy from the oscillator at resonance). This point is

easy to observe and no difficulty should be had in tuning sharply to maximum dip; the oscillator circuits must not be touched again, of course. The same connections are made to the next stage, and if the dip is less pronounced here, the rotor adjustment should be slipped, and the condenser varied independently of the dial control until resonance is achieved. The same procedure is then carried out for each stage.

A remarkable difference in selectivity and signal strength is caused by a tiny readjustment for resonance in a receiver which has never been properly lined up. A shorted condenser is indicated by a lack of response in plate current variation when the condenser is rotated: If it touches at only one point, this point will be indicated by an upward deflection of plate current when it is passed, and then a drop again toward the peak dip (if the resonant point has not already been passed through).

The oscillator is also invaluable for checking inherent receiver oscillation which is just beyond the point of audibility and which will contribute to poor quality of reproduction. For this purpose a separate supply socket must be provided. The receiver will not show any response unless oscillations are being produced in the receiver itself so as to beat with the external oscillator and thus produce an audible note.

The same set-up may be used to check r.f. continuity if desired, when all other methods fail, and when the antenna circuit is suspected of being at fault. The oscillator will of course have many uses in the lab, which cannot be covered in this article. Its dial may be calibrated directly in wavelength by using the dip method and beating with a known standard wavemeter.

Use of Comparison Amplifier

This unit should have high quality transformers. With a station tuned in the receiver, the detector tube is slipped out of its socket and the plug of the test set inserted in its place, the loud speaker being connected up to the terminals so marked. A slight readjustment in tuning is made necessary due to the extra length of plug-in lead now in the detector circuit.

This comparison arrangement is invaluable for showing up (1) distortion due to r.f. spilling over, (2) distortion due to transformer saturation, poor quality audio transformers or bad overloading of tubes, (3) poor quality loud speaker. While not strictly a troubleshooting device, it will aid in making sales of replacement equipment where it is obviously necessary. Quite often, too, a set owner desires to add an expensive high quality speaker to his installation without making any other changes. We all know how this is apt to show up the inferior quality of the audio components,

(Continued on Page 36)

Construction of Crystal-Controlled Transmitter

By G. F. LAMPKIN

CRYSTAL control has peculiar advantages in a radiotelephone transmitter, over and above those accruing from frequency stabilization. Ordinary crystal-control oscillators seldom run higher than 5 or 10 watts in power, and amplification is used to bring the r.f. energy up to the desired level. It is possible, then, to modulate at low power, with a minimum of equipment, on one of the initial r.f. stages. This is contrasted with the usual transmitter system employing Heising modulation, where the number of tubes required for modulation is at least equal to, and for best results greater than, the number of oscillator tubes. Such a requirement very nearly doubles the cost of a transmitter, where power tubes are the major item of expense.

The essential requirement in low-

power modulation with subsequent amplification is that the amplifiers operate without self-oscillation, or extraneous feedback, so neutralization and shielding must be complete. Furthermore the transmitter must have accessibility, good appearance, durability, and low cost.

A transmitter meeting these requirements was built at the University of Cincinnati and used under the call 8YX. Because special modulating systems were to be tried, and the work could be best done at very low power, the

crystal oscillator unit used a 201A tube with 120 volts on the plate. The subsequent r.f. units used a 201A, a 210, and

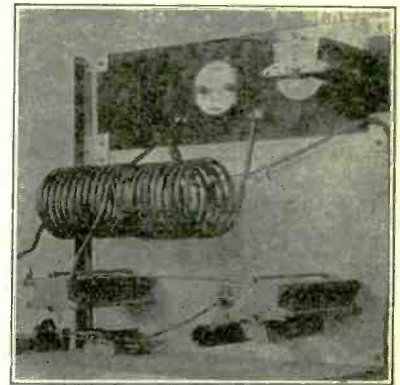

Rear View of Power Amplifier and Antenna Panels

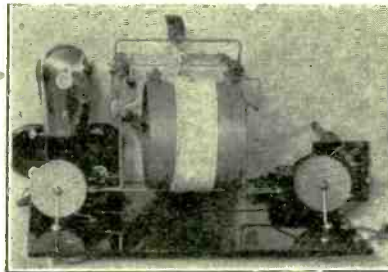

Unit 3. 201-A R. F. Amplifier

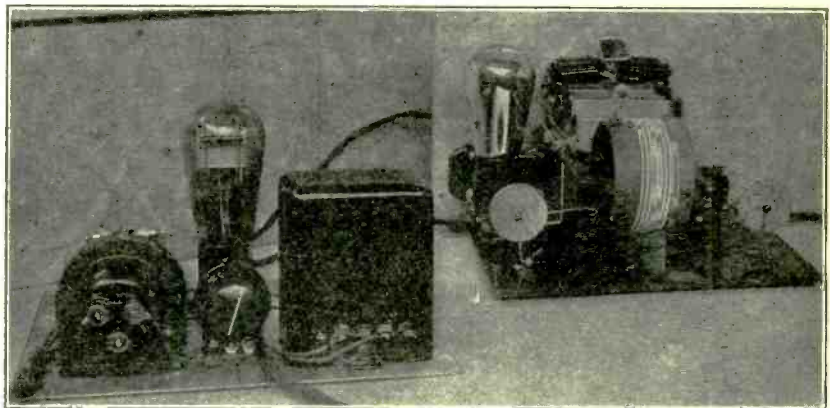

Unit 4. Modulator and R. F. Amplifier

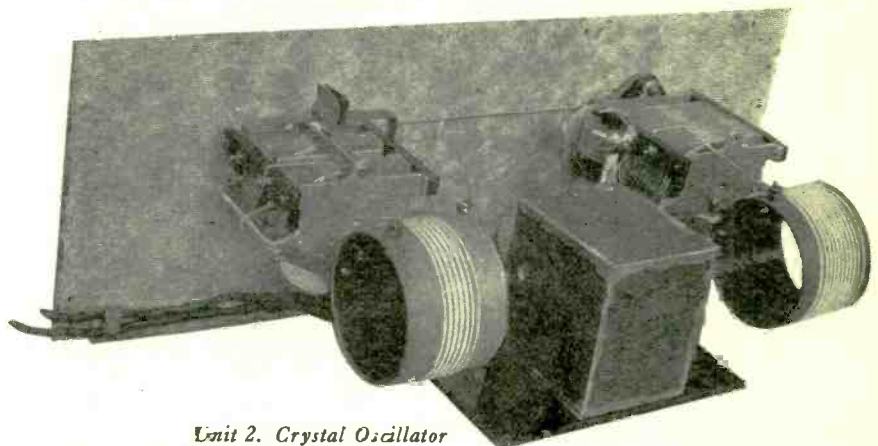

Unit 2. Crystal Oscillator

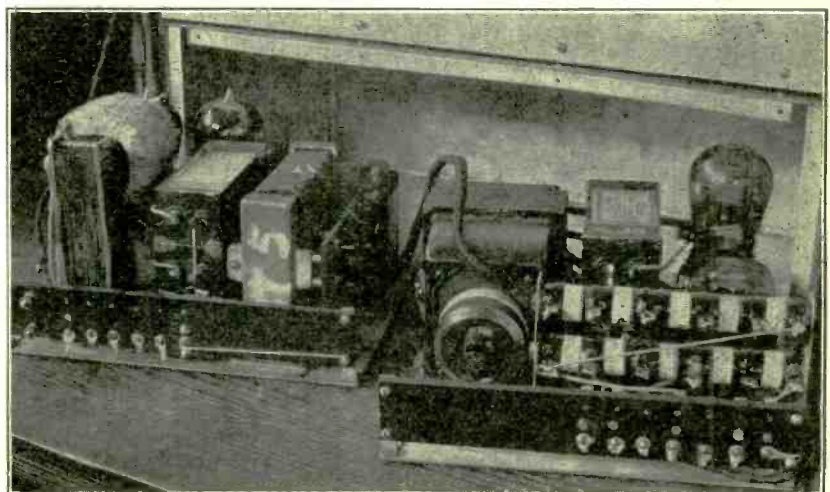

Unit 1. Power Packs

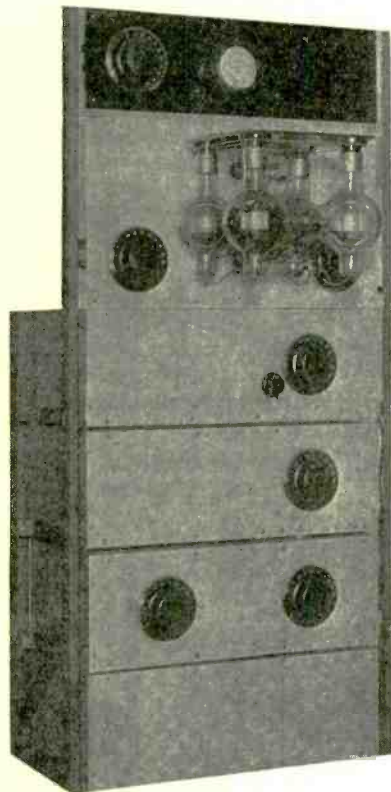

Complete Crystal-Controlled Transmitter

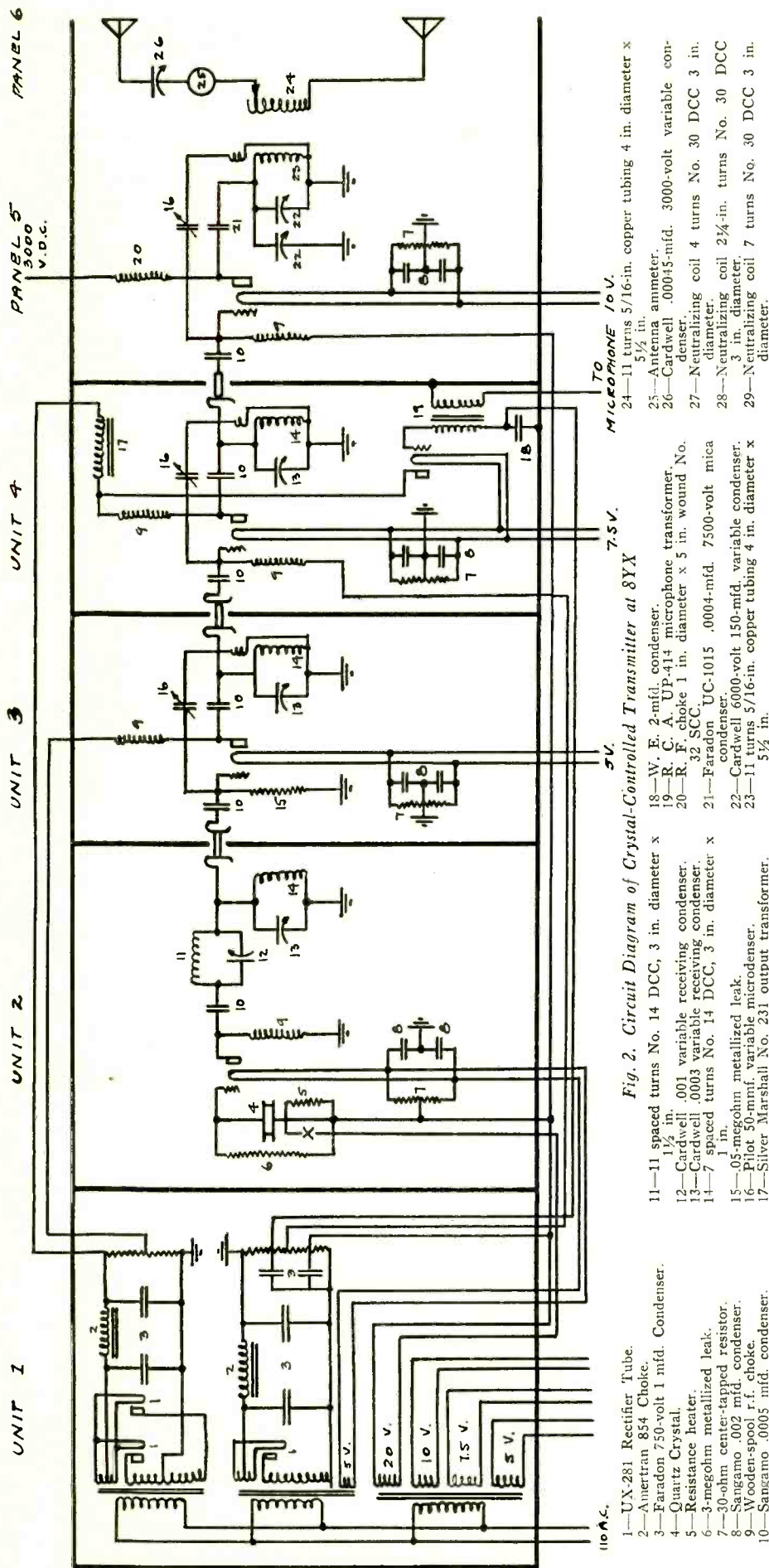

Fig. 2. Circuit Diagram of Crystal-Controlled Transmitter at 8YX

- 1—UX-281 Rectifier Tube.
- 2—Ametran 854 Choke.
- 3—Faradon 750-volt 1 mfd. Condenser.
- 4—Quartz Crystal.
- 5—Resistance heater.
- 6—3-megohm metallized leak.
- 7—30-ohm center-tapped resistor.
- 8—Sangamo .002 mfd. condenser.
- 9—Wooden-spool r.f. choke.
- 10—Sangamo .0005 mfd. condenser.
- 11—11 spaced turns No. 14 DCC, 3 in. diameter x 1 1/2 in.
- 12—Cardwell .001 variable receiving condenser.
- 13—Cardwell .0003 variable receiving condenser.
- 14—7 spaced turns No. 14 DCC, 3 in. diameter x 1 in.
- 15—.05-megohm metallized leak.
- 16—Pilot 50-mmf. variable microcondenser.
- 17—Silver Marshall No. 231 output transformer.
- 18—W. E. 2-mfd. condenser.
- 19—R. C. A. UP-414 microphone transformer.
- 20—R. F. choke 1 in. diameter x 5 in. wound No. 32 SCC.
- 21—Faradon UC-1015 .0004-mfd. 7500-volt mica condenser.
- 22—Cardwell 6000-volt 150-mfd. variable condenser.
- 23—11 turns 5/16-in. copper tubing 4 in. diameter x 5 1/2 in.
- 24—11 turns 5/16-in. copper tubing 4 in. diameter x 5 1/2 in.
- 25—Antenna ammeter.
- 26—Cardwell .00045-mfd. 3000-volt variable condenser.
- 27—Neutralizing coil 4 turns No. 30 DCC 3 in. diameter.
- 28—Neutralizing coil 2 1/4-in. turns No. 30 DCC 3 in. diameter.
- 29—Neutralizing coil 7 turns No. 30 DCC 3 in. diameter.

four 852 tubes, as shown in the block schematic.

Ordinarily a 210 tube with 300 plate volts could feed the 210 r.f. amplifier directly, and so do away with one unit of the transmitter. However, the layout will be described as it was constructed, and with modulation on the 210 stage. The extra stage can be used to advantage, for with modulation accomplished on the 210 amplifier, the crystal oscillator is isolated by the stage and greater frequency stability results.

The transmitter was designed to cover the band from 50 to 100 meters, using

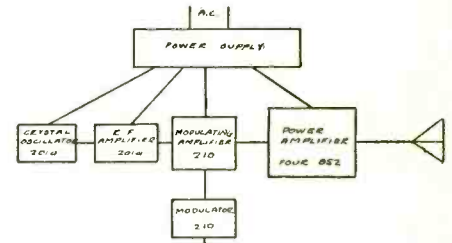

Fig. 1. Block Schematic Diagram of Transmitter

the second harmonic of a crystal operating in the 100 to 200-meter range. For this reason two tuned circuits were provided in the output of the crystal oscillator: one, to resonate to the fundamental of the crystal, in order to sustain oscillations; the other, to pick out the second harmonic of the crystal for impression on the first amplifier stage. This gave a second harmonic voltage of about 70 per cent of the fundamental voltage generated under the same conditions.

The d.c. return to the oscillator tube filament was made through a 30-ohm center-tapped resistor, as for all succeeding tubes. Both sides of all filaments were by-passed for radio frequency directly to ground with .002 mfd. mica condensers. The plate and filament voltages for the crystal oscillator tube were obtained from a power pack. From the same B eliminator were taken grid bias voltages for the 210 and 852 stages.

This latter connection made it necessary to ground the positive side of the eliminator, making it impossible to ground the crystal-oscillator filament. In other words, the plate of the crystal oscillator was at ground potential, and the filament above ground, for d.c.; while the filament was at ground, and the plate above ground, for radio frequency. The schematic circuit in Fig. 2 brings this out.

It was also necessary to insulate from ground both the stator and rotor of the variable condenser in the fundamental tank circuit of the oscillator. This was done by using a false formica front on the variable condenser.

The temperature control consists of a bi-metallic thermostat of riveted iron and zinc strip; a heater of 30 turns of

No. 30 Calido resistance wire on a $1/16 \times 3/8 \times 2$ in. form, supplied with 0.4 amperes at 20 volts a.c. through the thermostat contacts; and a plywood and asbestos-paper insulated container. The assembly held temperature constant to plus or minus 1.3° C. over long periods of time. The transmitter was used only in the amateur band. Much higher accuracy of control could be had by greater care in the design and construction of the container and elements.

Enough of an idea of the layout of the parts can be gained from the pictures of each of the six units. The caption of Fig. 2 gives dimensions.

The first and the modulating amplifiers are straightforward r.f. amplifiers with direct coupling between stages. Both obtain their plate voltage supply from a full-wave power unit delivering 550 volts d.c. to the 210 tube, the 201A supply being tapped in at 115 volts. A small coil coupled to each amplifier tank

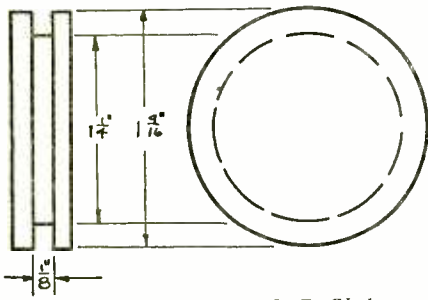

Fig. 3. Wooden Spool R. F. Choke

circuit and fed back to the respective grid through a variable microdenser is the means of neutralization. The neutralizing shaft has an insulating coupling between it and the grounded metal panel. All r.f. chokes, with one exception, were of the wooden spool type shown in Fig. 3. With 130 turns of No. 30 S. C. C. they are effective over the 50 to 200 meter band. The plate choke on the power amplifier stage is a single-layer solenoid type, necessary to withstand the high r.f. voltage.

The power amplifier was built around four UX-852, 75-watt tubes. They worked into a tank circuit of two Cardwell 6,000-volt, 150 mmf. condensers in parallel across a copper-tubing helix. The last stage assembly was mounted on a 12×20 in. panel of 16-gauge galvanized iron. The "hot" r.f. lead from the 210 unit was thoroughly shielded right up to the grids of the 852 tubes. A detail of the tube mounting and the shielding is shown in Fig. 4. With this precaution total enclosure of the stage in a shield was unnecessary. The grid leads were inverted so as to make the hot lead as short as possible. The plate supply for the last stage was taken from a 1.5 k.w., 3,000-volt generator.

The antenna condenser, inductance, and meter were supported from a 6×20 in. panel of formica. The antenna in-

ductance, also of $5/16$ in. copper tubing, was so supported by its terminals from studs on the panel that it could be swung up and down to vary the coupling.

Space in the UX-210 unit was made available for the modulator assembly. Another 210 modulated the r.f. amplifier in the Heising system. An old R. C. A. UP-414 functioned excellently in its role of microphone transformer. More than enough speech voltage was obtained from the secondary, when using a 6-volt battery and W. E. 284W desk stand microphone, to swing the grid of the 210 modulator. In fact, a 0.1-megohm resistor had to be bridged across the transformer output to prevent overloading the modulator. A Silver-Marshall 231 output transformer was used as the Heising constant-current choke. For this latter purpose any 10-henry or larger choke that would carry 50 m.a. would serve as well. If frequency constancy is not of extreme importance, the 201A could be modulated exactly as was, and instead of, the 210. The audio system would then have to be carried no higher than a 112 or a 171 tube.

The quality obtained was above the usual telephone standard, though of course not approaching that attained in the better broadcast transmissions. To attain broadcast quality the usual stretched diaphragm, push-pull microphone and associated apparatus would be necessary. The modulator should consist of two 210 tubes, to insure that they are not worked beyond their distortion limits on 100 per cent modulation. The same methods and care should be taken

with the modulators as with any high-quality power amplifier for audio frequency, for that is essentially what the modulator is.

The shielded unit type of construction is apparent from the pictures. The box units were $9\frac{1}{2} \times 7\frac{1}{2} \times 20$ in., soldered together of 16-gauge galvanized iron. Flanges were extended $\frac{1}{2}$ in. into the box, flush from the edges at the sides and top. The front panel carried a similar flange at its bottom.

On the front panel, and a formica subpanel bracketed to it, was carried the entire unit assembly of coil, condensers, tube, etc. Thus all parts were accessible at once by unscrewing and bringing out the panel.

The leads for power supply to a unit came out the lower front corner of the box in shielded braid conductor. They were tucked in the corner between the angle iron frame and the boxes and run down to the power unit. Threaded brass studs were run between, and projected into each unit approximately $\frac{1}{2}$ in., directly above the normal position of the variable condenser. These studs were the "hot" r.f. leads between units. They were insulated by means of formica bushings. Spring brass angles made a wiping contact with the studs when the front panel was put in place.

An angle-iron framework supports the boxes and the two top panels; $1\frac{1}{2} \times 1\frac{1}{2} \times \frac{1}{8}$ in. angle, 27 in. long, constitutes the two rear uprights. The front columns are $\frac{5}{8} \times 1 \times \frac{1}{8}$ in. angle-iron, 47 in. long. Between the uprights, at the sides, pieces of bar iron $1 \times \frac{1}{8} \times 10$ in. are fastened, offset so as to bring the

(Continued on Page 41)

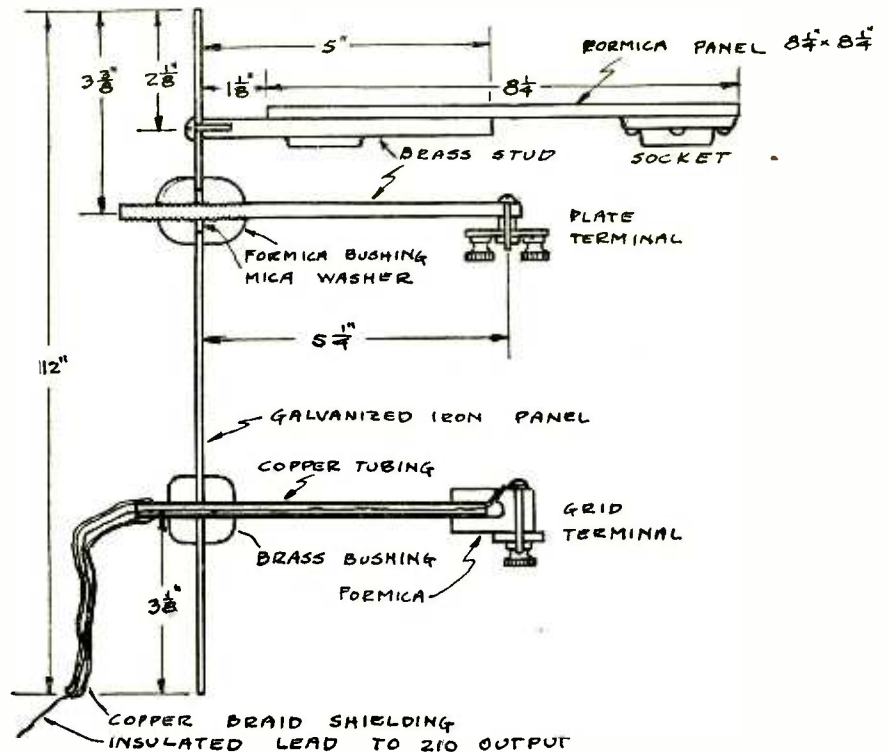
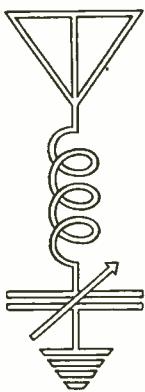
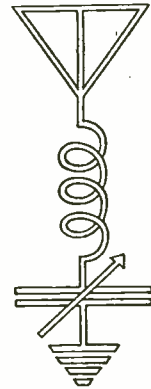

Fig. 4. Mounting for Four 852 Tubes



TECHNICAL BRIEFS



THE reason that only the same volume of sound is obtained from some of the new 250 type power amplifiers and dynamic loud speakers as was formerly had from a 112 power tube and ordinary horn or cone type loud speaker is because of the much wider band of frequencies which are reproduced in the latest amplifiers and speakers. With the older amplifiers the audio response was generally peaked from 500 to 2000 cycles per second with practically no response below or above that range. Higher notes were entirely lost and lower notes either lost or else re-

produced in the form of the higher harmonics, thus distorting the original speech or music.

the strains emitted from an old-time phonograph?

For this reason a type 250 power tube or two 210 tubes in push-pull, when used in a very good amplifier and dynamic speaker in a very large baffleboard, will not give much more volume than is needed for an average living-room. The difference in cost of the two systems discussed is well worth while. Would you rather listen to Paul Whiteman's orchestra or perhaps a great symphony orchestra, or would you prefer

THE average new vacuum tube has a vacuum of 2 or 3 microns, a micron being one-millionth of the usual atmospheric pressure of 15 pounds per sq. in. An incandescent lamp has a vacuum of 150 microns. Special long-life tubes are being made with a vacuum of less than 1 micron.

A "soft" or low-vacuum tube cannot withstand the high voltages necessary for amplification, although it may be used at low voltages as a detector. The life of a tube is largely dependent upon the degree of vacuum which it holds, varying from 100 hours for a poor vacuum to several thousand hours for a good vacuum.

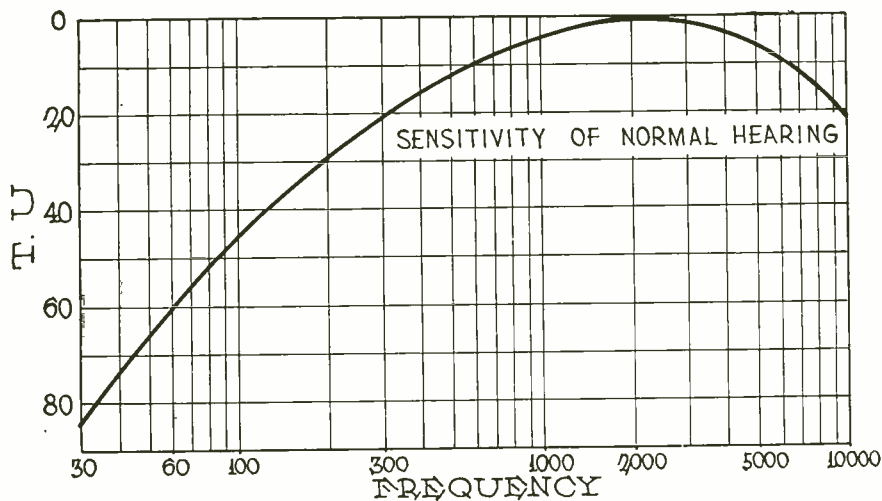

Curve Showing Sensitivity of Hearing at Various Audio Frequencies

SEVERAL of the new factory-built receivers employ as a volume control, a 500,000-ohm potentiometer shunted across the secondary of the first audio transformer, or across the secondary of the second audio, at the input to the power tube. While this method has the advantage in an a.c. operated set, of tending to reduce the a.c. hum, it may become a serious producer of distortion, especially when the set is operated in a region of many local stations. A properly designed radio set always overloads the power tube first. One which overloads the preliminary audio stages, or the detector, before the power tube, will lack power output, and in nine cases out of ten, will badly distort long before the maximum power output of the power tube is attained.

produced in the form of the higher harmonics, thus distorting the original speech or music.

The range from 500 to 2000 or even 3000 cycles per second is most easily heard by people with normal hearing, as shown by the accompanying curve. Frequencies above or below, especially those below 500, must be of relatively great intensity to be audible. Since the middle range of frequencies are most easily heard, an amplifier and loud speaker reproducing only these tones may, with small power output, fill an ordinary room with sound.

With a given size of power tube, the wider the band of frequencies to be passed, the less the apparent volume of sound. This means that the middle frequencies, to which the ear is most sensi-

the strains emitted from an old-time phonograph?

TUBES for automatically controlling volume in radio receivers are of value in districts where there is bad fading. With ordinary tubes the r.f. amplifier must have considerable gain for an automatic volume control to operate satisfactorily. The usual arrangement is to connect the grid of the control tube across the detector tube so that changes in its plate current cause a change in grid bias of the r.f. amplifier tubes. This controls the volume by changing the amplification of the r.f. amplifier, decreasing it for strong signals. This volume control tube functions like a high bias or plate detection tube detector. This necessitates an additional '27 type tube.

The reason for this is as follows: A local station is tuned in, and when the tuned circuits are in resonance, the volume is too great, or the power tube is overloaded, and the operator cuts down the volume by adjusting the potentiometer across the first audio amplifier tube input. This reduces the volume until the power tube is no longer overloaded, at which point the volume is probably just right for the particular conditions where the set is located. But all this time the detector tube is being overloaded by too much energy from the r.f. amplifier circuit, and the first audio tube is thus receiving distorted signals which will be distorted in the loud speaker in greatly amplified degree.

The best test for this sort of trouble

is to insert a milliammeter in the plate circuit of the power tube, and note whether there is any fluctuation of the meter needle when loud signals are being produced. If it requires a very low setting of the volume potentiometer to stop the swinging of the needle, then it is a safe bet that tubes ahead of the power tube are being badly overloaded. It is not practicable to check the detector tube for overload with an ordinary milliammeter, due to the small amount of plate current, but the above test will quickly indicate whether the power tube or the system of volume control is at fault.

To determine whether a set has such a system, trace out the leads from the volume control to its associated apparatus. If these leads go to one of the audio transformers, find out which one. If it is across the primary of the first audio, then be careful how local stations are tuned in, and use the tuning control as an auxiliary volume control rather than depend entirely on the main volume knob. Most sets use control of the r.f. amplifier as the main volume control, but even though this system has its faults in an a.c. set, it is infinitely preferable to one which depends entirely on audio-frequency gain.

To meet the demand for a 1000 to 1500 volt amplifier system capable of supplying 170 milliamperes for amateur transmitters and power amplifiers the General Radio Co. recommends the arrangement and equipment shown in Fig. 1. It uses four 281 type half-wave rectifier tubes to give a full wave

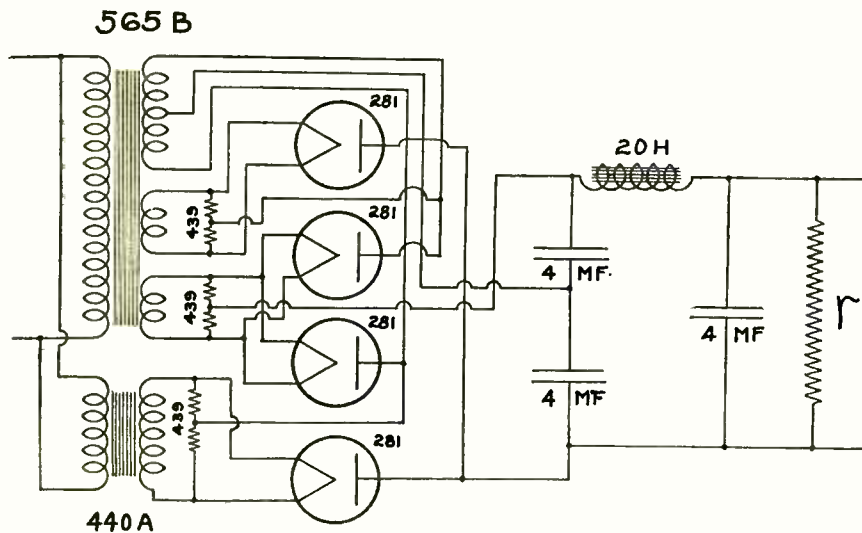

Fig. 1. Full Wave Voltage Doubling Rectifier Filter Circuit

voltage doubling circuit, one of these tubes being rated to deliver 85 m.a. at 700 volts.

Three separate filament windings or transformers insulated for the full output voltage are required. The filaments should be operated slightly below their rating of $7\frac{1}{2}$ volts.

The first filter condensers must be

able to withstand one-half the load voltage. A condenser larger than 4 mfd. should not be used unless it is possible to close the filament circuit of the rectifier tubes before the high voltage is applied. The initial charging surge may overload the tubes and cause an arc if the filament is allowed to come up to temperature with the high plate voltage turned on.

The fixed resistance r should be 100,000 ohms, capable of carrying 20 milliamperes. If a milliammeter is connected in series with r it will give an approximate indication of the output voltage. The scale reading with a 100,000 resistor becomes 100 volts per milliampere.

All connections should be in the form of heavily insulated wire and all exposed terminals should be protected by some sort of a guard or covering. Under all circumstances the current should be turned off before any adjustment is made.

A SATISFACTORY volume control for most a.c. receivers consists of a 50,000 or 100,000 ohm variable resistor in series with the cathodes of the '27 type tubes. This scheme will apply only to receivers using '27 tubes as r.f. amplifiers, since in these receivers a.c. modulation of the carrier and side band frequencies is minimized. The variable resistance must be capable of carrying the total plate current of r.f. tubes without being noisy. Generally shunting it with a 1 mfd. condenser will keep the operation quiet. The method in which this

affects the voltages on the remainder of the set. If the voltage divider in the power pack is of fairly low resistance so there is good voltage regulation, this change of voltage on the other tubes may not be great enough to seriously affect their operation.

A SIMPLE inductance bridge for measuring the constants of r.f. transformers may readily be constructed from discarded parts. In the circuit diagram of Fig. 2 almost any old-style variometer will cover the range of most r.f. transformer secondaries from 150 to 280 microhenries. Any two units having exactly the same resistance may be used for R_1 and R_2 , though preferably they should be non-inductive and of about 100 ohms each. R_3 is a 10-ohm filament rheostat used to balance the resistive components of the variometer and the unknown inductance L .

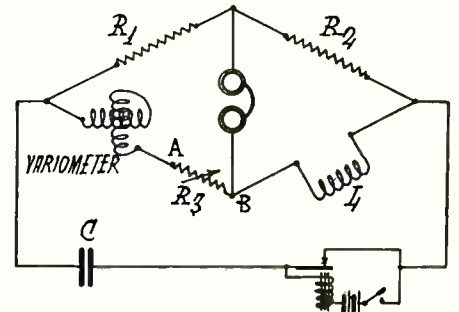

Fig. 2. Inductance Bridge.

A carbon compression type rheostat is best for this purpose as it is non-inductive. The buzzer may be of any type giving a tone of from 500 to 1000 cycles per second. The 1 mfd. condenser C is used to prevent the local battery circuit from short-circuiting the interrupter through the inductive arms of the bridge. An old pair of telephone receivers completes the job.

One lead of these receivers should connect to either point A or B , depending upon whether the variometer or L has the greatest resistance at 1000 cycles.

The bridge may be calibrated by winding some solenoids of various numbers of turns, say on a 3-in. diameter. Coils of from 20 up to 100 or 150 turns may be made and from the diameter of the coil, the number of turns of wire per inch and the length of winding, the inductance may be calculated from the charts given in January, 1927, RADIO. These data have been published elsewhere, so this should present no great difficulty. With a set of 5 or 6 coils the bridge can be calibrated and a curve of inductance in microhenries drawn against dial reading. These 5 or 6 coils are used of course only for the original calibration.

control functions is in changing the C —bias on the r.f. tubes, raising it from its usual value of 9 volts or so to 20 or 30 volts as the resistance is increased from 0 to full value. This of course controls the amplification or gain since it changes the mutual conductance of these tubes. Since this changes the plate impedance and so decreases the plate current, it also



The COMMERCIAL BRASSPOUNDER

A Department for the Operator at Sea and Ashore



Edited by P. S. LUCAS
R. O. COOK, Assistant

WE HAVE talked a lot about operating conditions, low pay, lack of respect, and the other lamentable features of the brasspounding profession, partly to ease our minds and partly because we have hoped that certain parties would read and repent of their wrongdoings. We have blamed the ham, the school, the steamship company, the government, and ourselves. We have eased our minds and arrived at many conclusions, but we have not solved the problem.

After reading one of Mr. Halloran's "Radiotorials" in the November issue a faint gleam of light seems to appear on our horizon. And if we are not impatient we may yet live to see our dreams fulfilled. He calls attention to the fact that radio operators are no longer merely code men, but that they are being confronted with more and more elaborate apparatus; more difficult problems. He says, further, that eventually the great bulk of radio traffic will be sent by photoradio; that "the world is rapidly approaching the point where it will be difficult to find men to cope with the modern machines which are being created."

He is right. "Still" pictures are being transmitted today with great success. Tomorrow it will be a commonplace affair for the radio operator at sea to be sending an illustrated message from his captain, or "12 sq. in. of type" from the chief engineer or a homesick passenger. Such is the trend of the times.

When this time arrives it is going to be hard for the steamship companies to get good men. No rapid-fire school course or question and answer book is going to teach a man how to handle photoradio transmission and reception. A man is going to keep his job and get his second berth from what he knows and how well he can do his work rather than from the fact that he holds the necessary license. Briefly and colloquially, a man will have to know his onions to be a radio operator in those times; and when that can be said of all men in a profession, that profession will be esteemed by all other men who are themselves efficient. If men must be good, and if good men are hard to get, salaries, living conditions, respect, are all at the command of those who qualify.

This change in affairs will be accompanied by hard work and much concentration. Some of the romance, thrill and fun will be lost, and the man or boy who answers the "Easy work, big pay" ad will not make the grade. Again our light comes into view on the horizon.

It looks like a solution of our problem is almost at hand, but a lot of our good men are going to be caught napping.

ERRATUM NOTICE.—In the November issue a typographical error in Paul Otto's Spanish-English weather vocabulary should be corrected to make "Este" East, "Oeste" West, and "Occidental" or "Occ." Western.

THE "WOOLWORTH" UTILITY OSCILLATOR

By JACK BRONT

MANY interesting experiments and helpful tests may be made on shipboard with an r.f. oscillator, the most important of which is the calibration of long and short wave receivers and wave meters. A few points from various constant wave-length stations will give harmonics all the way down the line, so that whether it be 3000 meters or 30, the same oscillator will do the trick.

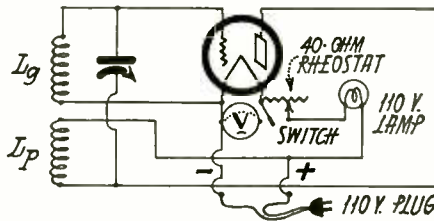

Fig. 1. Hookup of the "Woolworth" Utility Oscillator

The usual 110-volt d.c. supply is very convenient for the brasspounder to construct his oscillator. The 110 volts are used to supply the filament through a lamp and rheostat combination, and the plate direct. Coils and condensers depend only upon the wavelength desired. Honeycombs and other plug-in coils may be used very nicely. A power tube similar to the UX-112, or any that will oscillate with 110 volts on the plate will be o. k.

KOZC ON "GOODWILL" CRUISE TO SOUTH AMERICA

By WM. A. BRENNAN

On October 6, the S. S. *City of Los Angeles*, flagship of the Los Angeles Steamship Co., left San Pedro for a "goodwill" cruise around South America, the trip being sponsored by the Los Angeles Times. The vessel will touch Callao, Valparaiso, Straits of Magellan, Buenos Aires, Montevideo, Santos, Rio de Janeiro, Port of Spain, Carcassas Panama, and several Central American ports when homeward bound.

This is the first goodwill cruise that has ever been inaugurated from a Pacific Coast port. All reservations were taken over a month before sailing time.

M. G. Somers (GS), Bill Brennan (BR) and Vern M. Taschner (VT) are retaining their berths for the voyage. A short-wave receiver has been installed so that good press may be copied all the way around the Horn.

The *City of Los Angeles* is ideal for this

trip as she is well fitted for tropical cruising. She originally ran to Buenos Aires out of New York, for the Munson Line, under the name "Aeolus." She is the largest American vessel on the Pacific, being 580 feet long and having a displacement of 22,500 tons. She has a speed of about 17 knots.

THE POINT TO POINT RADIO COMMUNICATION SYSTEM OF THE INTERCITY RADIO TELEGRAPH COMPANY

By FRED V. TRUEBLOOD

FOR the benefit of the seafaring brasspounders who have at some time or other expressed their desire for a shore job in the radio telegraph game, I am relating the dope on the point to point radio communication system of the Intercity Radio Telegraph Company, an organization which operates one of the fastest radio networks in the country. The cities accommodated by this service are Detroit, Cleveland, Buffalo, Columbus, Duluth, Rogers City, (Mich.), Chicago and Sheboygan, (Wis.). The Intercity is in direct competition with the wire communications companies and surely gives them a merry run for their money. The Intercity handles traffic on a basis of at least ten cents saving on every message as compared to the wire rates.

To hold down a trick on this circuit a man must be a Morse operator as well as Continental. He must be competent to copy above thirty words a minute, Continental, all day long; and faster when the traffic piles up.

The business consists largely of automotive supply and automotive factory inter-office communications. The Intercity has no messenger service and all of its traffic is received and delivered via telephone. The factory or office executive need not bother to tell his secretary to take a telegram but simply call the Intercity on the phone and reel it off. As soon as the girl pulls the blank from the mill it is in the air, and within three minutes it is telephoned to the executive in the other city. This rapid service means a big bulk of traffic, which is just what the Intercity gets.

The transmitter at WDI, Detroit, Mich., consists of a pair of 250-watt tubes connected in a self-rectified circuit. It is located on the twenty-ninth floor of the Bok Cadillac Hotel in the center of the down-town district. The antenna is swung between two high steel towers on the roof of the hotel. The receivers are Navy Standard tuners with RCA detectors and two-stage amplifiers. The equipment at the other stations is similar to that at WDI.

The following are the calls of the vari-

(Continued on Page 38)

With the Amateur Operators

LECHER WIRES AND STANDING WAVES

Complete Instructions for Calibrating a Wave Meter from 5 Meters to 90 Meters

By GLENN E. WEST, 7ZU

UNDER the new radio regulations of the Washington Convention it is important that every amateur transmitter be tuned accurately within the assigned wave bands. This means that the amateur must buy or build and calibrate an accurate instrument for the purpose. The ideal method would be to build a separate wave meter for each of the different amateur bands. The cost of having four or five separate meters calibrated is quite beyond the means of the average amateur. The Lecher

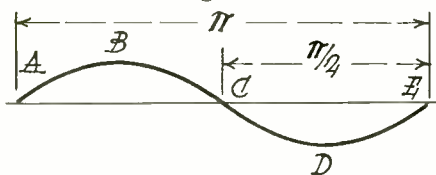

Fig. 1. Crest, "B," Trough, "D," and Nodes "A," "C" and "E," of a Water Wave Whose Wavelength is "AE"

wire method of calibrating wave meters without the use of a standard is offered as a solution to the problem. An accuracy of 1/5 of 1% is not difficult to attain with it.

A brief discussion of the theory of standing waves may be of some help. When a water surface is disturbed, waves pass outward from the point of disturbance. These waves appear somewhat as shown in Fig. 1. Point B is called the crest and point D is called the trough of the wave.

If one end of a rope is fastened solidly to a wall and the other end, while being held in the hand, is given a sharp upward motion, a wave will travel along the upper side of the rope to the wall. At the wall the wave will be reflected and will travel back along the underside of the rope as a trough. This is shown in Fig. 2. If now the rope be given a periodic motion by the hand, the reflected waves will cause interference with the incident waves and there will appear to be standing waves on the rope.

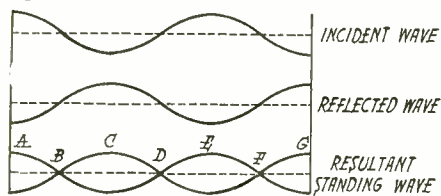

Fig. 2. Standing Wave Caused by Interference Between Incident and Reflected Wave, "B," "D" and "F" Being Nodes and "A," "C," "E" and "G" Anti-nodes

In much the same way standing waves are caused to appear on the Lecher wires. The oscillator sends out the periodic impulses which travel along the wires and are reflected from the open end. Thus stationary waves of potential and current are maintained.

A series of experiments were conducted at 7ZU to find a practical method of using the Lecher wires to calibrate a wave meter. For waves from 90 meters down to 25

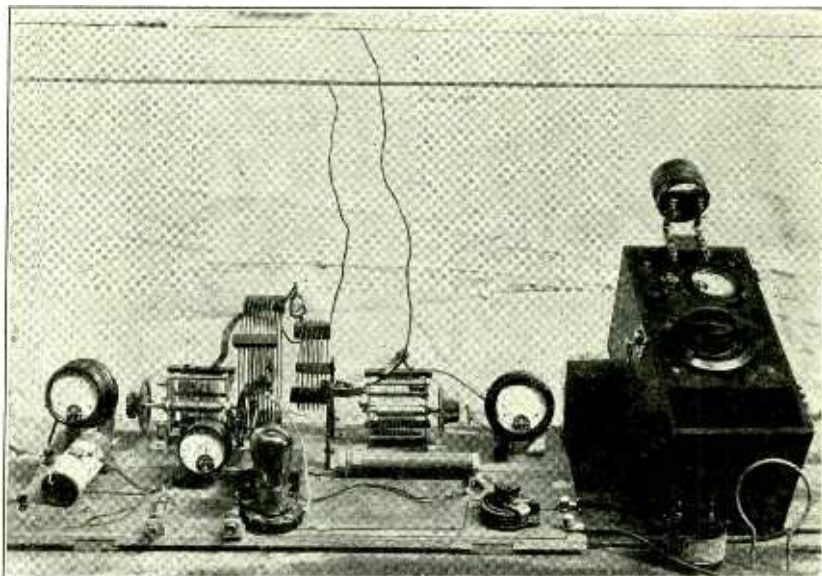

Fig. 4. Lecher Wires, Hartley Oscillator and Wavemeter

meters two wires 140 ft. long and spaced 5 in. apart were used. For waves from 25 meters down to 5 meters two wires 40 ft. long and spaced 2 1/2 in. were used. The spacing was not critical but a correction had to be made for the length of the "feeling" rod between the wires. This is explained in detail later.

One of the wires used in each case was of No. 14 bare copper while the other wire

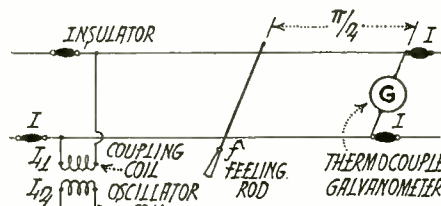

Fig. 3. Lecher Wires and Auxiliary Apparatus

was a surveyor's steel tape calibrated in feet, tenths of feet and hundredths of feet. Thus it was easy to read accurately the exact length of wire being used.

The indicating instrument was a Weston thermo galvanometer placed at the very end of the Lecher wires.

The ring in the end of the steel tape was passed over a 3/4-in. bakelite rod supported from the wall. The No. 14 wire was dead ended by winding once around the rod. The galvanometer leads were made as short as possible and placed between this bakelite rod and the back side of the loops, thus connecting it at the very ends of the Lecher wires. A flash lamp and a neon tube were also tried as indicating devices but neither proved satisfactory.

The "feeling" rod used to find the half-wave point on the wires consists of a brass rod with balls at either end and a long hard rubber handle. A piece of heavy copper wire fitted with a wooden handle would have served as well.

The oscillator shown in Fig. 4-5 is an ordinary Hartley transmitter. It worked nicely from 90 down to 25 meters. For waves from 25 meters down to 5 meters and below, a special simplified Hartley oscillator was borrowed from 7FL. The circuit diagram is shown in Fig. 5. Using the 2-

turn coil in the tank circuit this oscillator tuned down to 6.09 meters. With the 1-turn coil it tuned down to 2.75 meters and gave plenty of energy to excite the Lecher wires.

The tube was a UX-210 in an ordinary socket. Somewhat shorter waves might have been reached by soldering the leads directly to the tube base. The plate was supplied with 350-500 volts d.c. from a motor generator set.

The Lecher wires were inductively coupled to the oscillator through a coupling coil and flexible leads. The degree of coupling was varied to suit conditions but in general was very loose—just close enough to give a reading of from 5 to 20 scale divisions on the galvanometer. When the coupling was made tight the frequency of the oscillator was affected and in some cases oscillation stopped entirely. A coupling coil of 4 turns placed about 3 in. from the tank coil proved to be about right for most frequencies.

The method is simple. Start the oscillator in the usual manner, allowing the tube plenty of time to warm up so that the

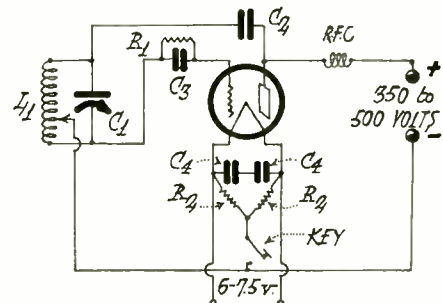

Fig. 5. The 7FL Simplified Hartley Oscillator

oscillations may become steady. Tune the oscillator to approximately the longest wave to which it is desired to calibrate the wave meter. Couple the oscillator loosely to the Lecher wires and watch the galvanometer at the end of the wires. Change the coupling until the galvanometer shows a reading of from 5 to 20 scale divisions.

Now bring the wave meter up toward the oscillator coil and tune to resonance,

(Continued on Page 43)

Inside Stories of Factory Built Receivers

THE ACME AC-7

THE new Acme receivers consist of a three-tube set for reception of local programs, and a six-tube outfit for all-around use. The six-tube set has three stages of tuned r.f. amplification, using 226 a.c. tubes, a heater tube detector, a type '26 first audio stage, and a power stage employing a type 71-A tube.

The six-tube circuit is shown in Fig. 1, which includes the power plant. The latter can be seen in the picture, Fig. 2, at the extreme right of the chassis. The power equipment is completely enclosed in metal, and the rectifier tube is mounted on the main chassis of the set, near the front panel, so as to have ample cooling space. The power plant consists of a type '80 full-wave rectifier tube, with power transformer having a split 440-volt secondary, making the effective voltage at the output of the filter approximately 200 volts. Filament windings for the a.c. receiving tubes are also included in the power transformer, and the electrical center of the filament circuit for both the r.f. and first audio tubes is obtained by means of a slide-wire resistor.

The antenna circuit is aperiodic and un-

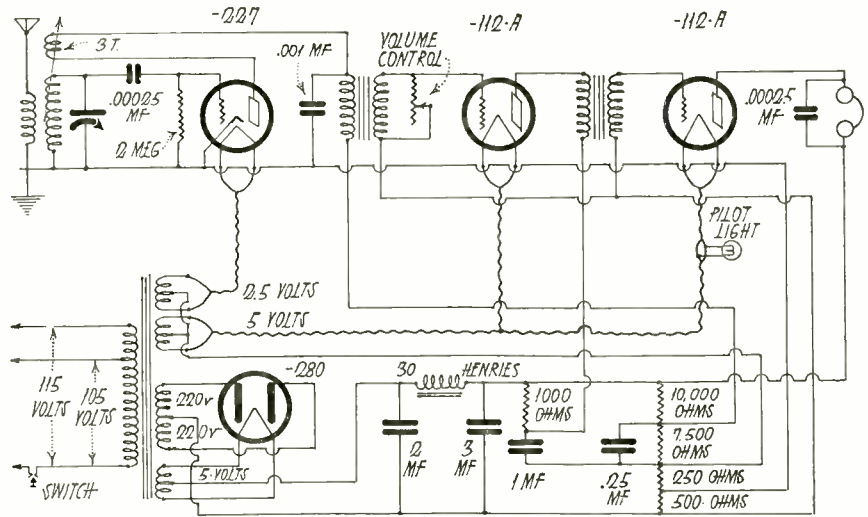

Fig. 3. Circuit of Three-Tube Local Program Receiver

tuned, the first tube acting as a low gain insulating tube, between the antenna and the r.f. amplifier, which is controlled by

means of a three-gang condenser. Volume control is obtained by means of a potentiometer shunted across the secondary of the first audio transformer.

The B voltage supply taps are taken off a tapped resistor of a 33,250-ohm resistor, which also supplies the necessary C voltages for the various tubes in the set.

The three-tube set circuit is shown in Fig. 3, this receiver being primarily designed for the reception of local programs, and hence is less expensive than the six-tube model. It consists of a three-circuit tuner, with regenerative detector, and two stages of transformer coupled audio, with 112-A power tube, and a type 80 full-wave rectifier in the power plant. The latter is practically the same as for the six-tube model, except in the arrangement of the B voltage supply taps in the resistance group. The chassis has the same appearance as the six-tube model, and the front panel is identical with that of the larger set.

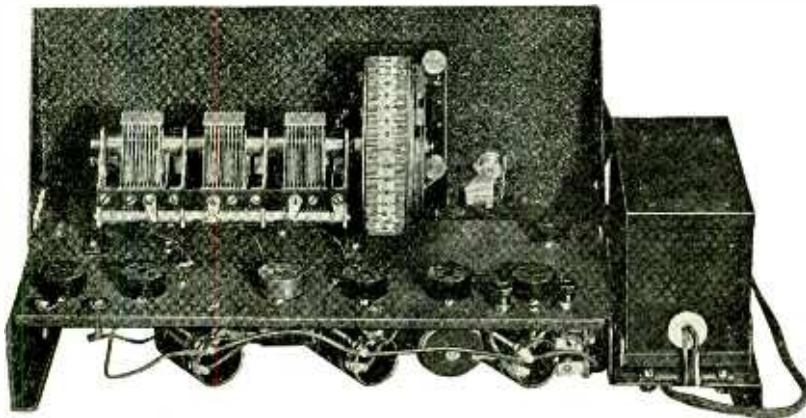

Fig. 2. Rear View of Chassis of Six-Tube Set

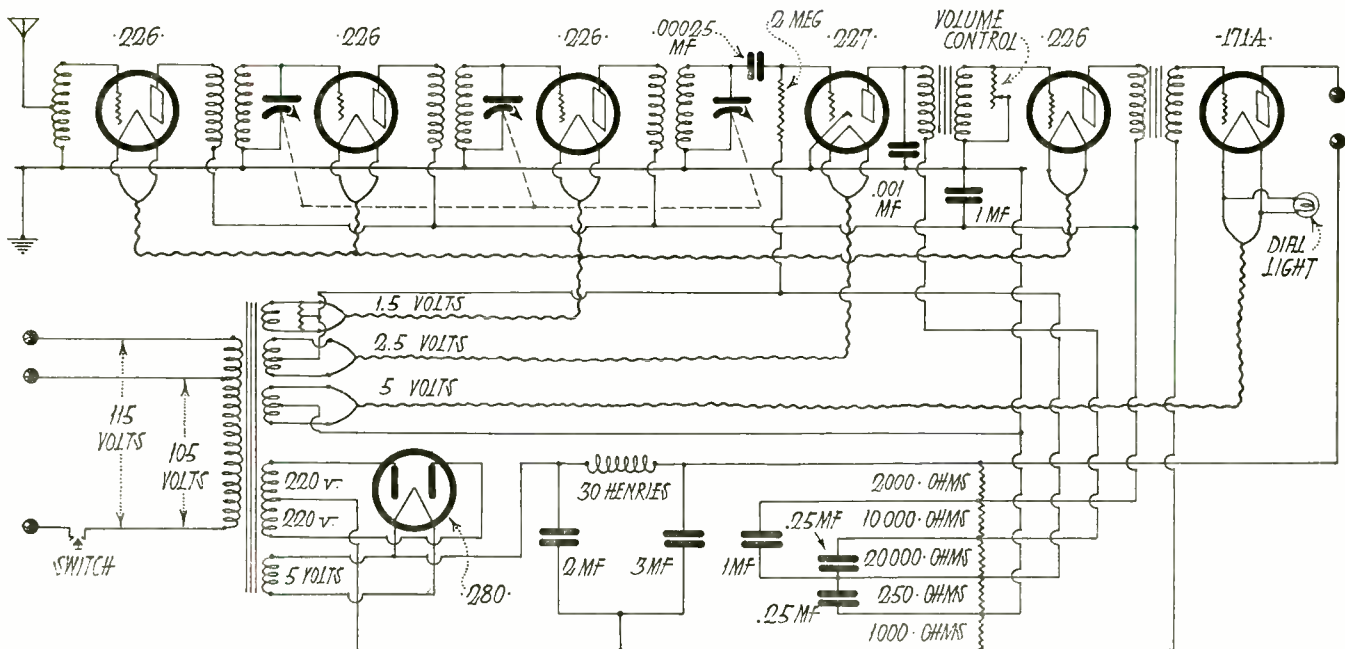

Fig. 1. Circuit of Six-Tube Acme Receiver

Radio Kit Reviews

AERO RADIOPHONE TRANSMITTER

THE 1929 Aero transmitter, Model 55, uses the "tuned grid tuned plate" circuit and is designed to operate on the 20, 40 and 80-meter bands with a UX210 tube as the oscillator and on the 80-meter and longer wavelengths with UX250 tubes. Thus it may be rated at from 15 to 50 watts output. It will transmit either code or speech, using two stages of speech amplification with 210 tubes as modulators for the latter purpose.

The construction is arranged for two deck assembly, the upper deck containing the oscillator circuit and the lower deck, all the circuits associated with the power and voice currents. On the upper panel are mounted the meters and controls for tuning condensers. On the lower panel is the modulator volume control, change-over switch, plate-meter switch, and the binding posts.

Reference to the circuit diagram shows that the complete transmitter consists of three units: the oscillator, the speech amplifier, and the power supply. Oscillation is produced by tuning the tube's grid and plate circuits to the same frequency, when the feed-back through the tube's inter-electrode capacity causes oscillation. The antenna circuit is inductively coupled to the plate circuit. A wavelength range between 16½ and 192 meters is covered without gaps by three sets of plug-in coils. The tuning condensers are Cardwell type 123-B, the grid choke an Aero type C-60 and the plate choke type C-248.

In the speech amplifier the input transformer impedance from the microphone is designed to match the single carbon button type of hand microphone. An adjustable attenuator between the transformer second-

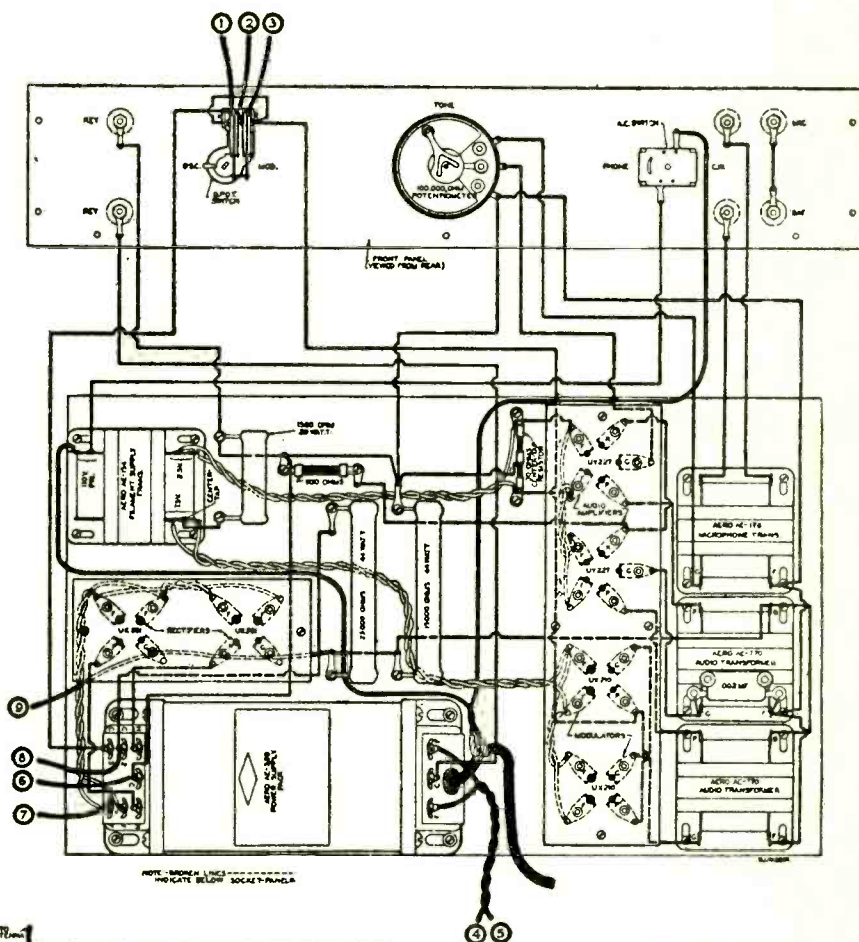

Bottom Deck of Radiophone Transmitter No. 55

ary and the grid of the first speech amplifier tube prevents over-modulation, as may be observed by watching the modulation milliammeter. These tubes are of the '27 type, their filaments as well as those of the two modulator tubes being supplied from an independent transformer which is readily cut out of the circuit when only CW transmission is wanted. The Type AE 770 transformers are high grade.

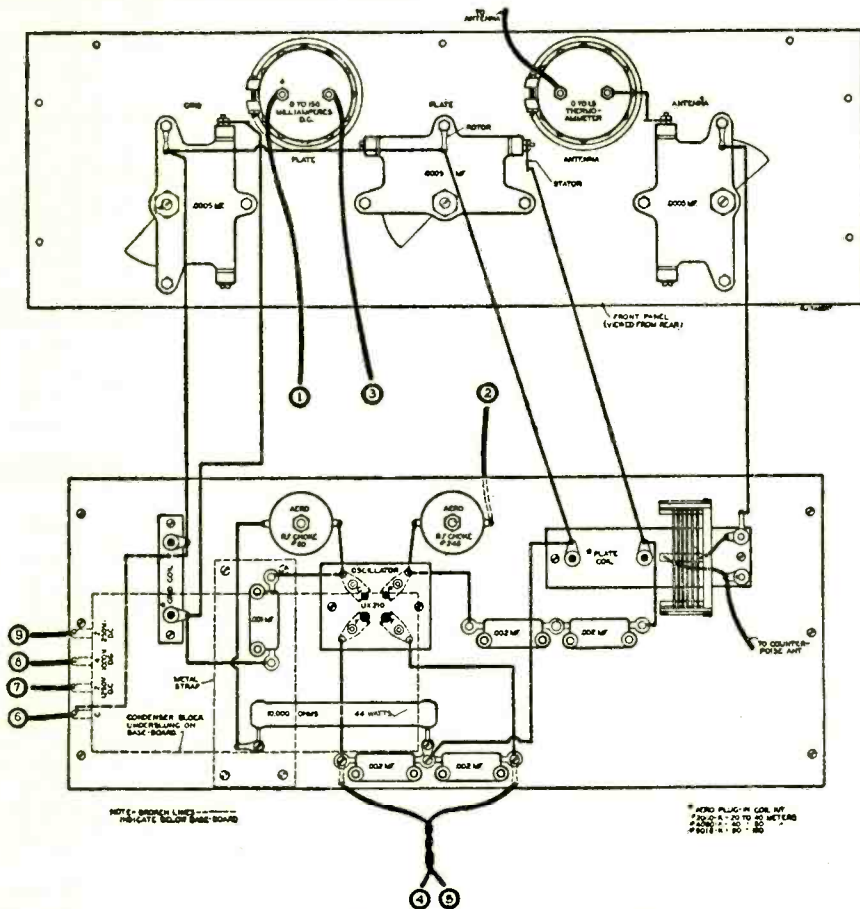

Top Deck of Radiophone Transmitter No. 55

LIST OF PARTS FOR AERO RADIOPHONE TRANSMITTER

- *1—Aero Foundation Unit No. 55.
- *3—Cardwell Type 123-B Condensers. .0005 Mfd.
- *1—Weston No. 507 Thermo Ammeter. 0/1.5.
- *1—Weston No. 506 Milliammeter, 0/150.
- 2—Aero AE770 Audio Frequency Transformers.
 - 1—Aero AE-176 Microphone Transformer.
 - 1—Aero AE-154 Filament Transformer.
 - 1—Aero AE-320 Power Pack.
- *1—Aero K-2040, K-4080 or K-9018 Coil Kit.
 - 1—Potter AE-242 Filter Block.
- *1—Ward Leonard 10,000 Ohm Resistor.
- 1—Ward Leonard 15,000 Ohm Resistor.
- 1—Ward Leonard 25,000 Ohm Resistor.
- 1—Yaxley 132,000 Resistor.
- 1—Centralab 100,000 Ohm Potentiometer.
- *1—Carter No. 110 A.C. Switch.
- 1—Yaxley 8900 Resistance.
- 1—Yaxley 830 C Resistance.
- *5—Aerovox .002 Mfd. Mica Condensers.
- *3—No. 567 Kurz Kasch Dials.
- 1—Kurz-Kasch Knob.
- *1—Single Socket Shelf.
- 1—4 Gang Socket Shelf.
- 1—2 Gang Socket Shelf.
- *6—Eby "Jr." Binding Posts.
- *50—Ft. Braidite Hook-up Wire.
- *1—Screw Assortment.
- 1—No. 760 Yaxley Switch.

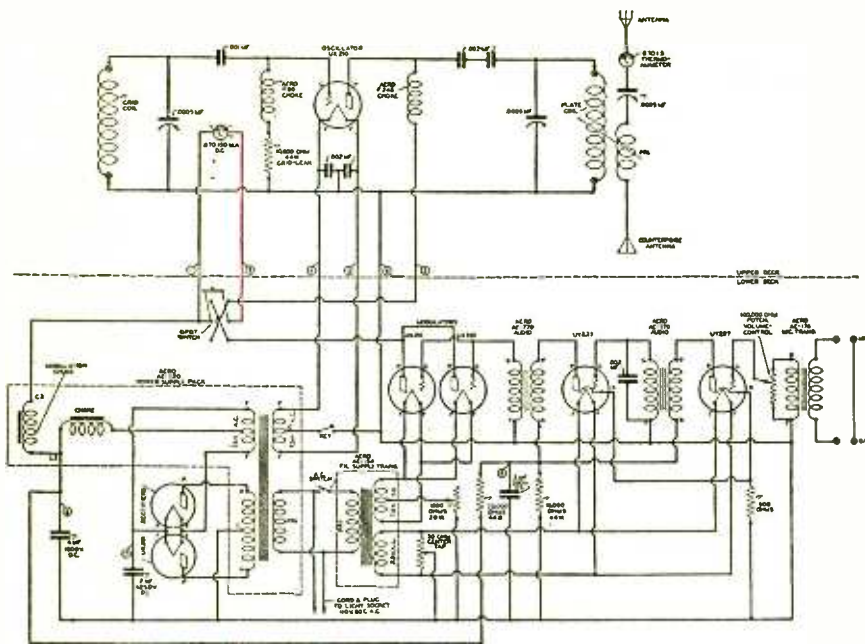

Circuit Diagram of Radiophone Transmitter No. 55

The power supply transformer has three secondaries which supply filament current for the two '81 rectifiers and the two oscillator tubes as well as plate voltage for the rectifier tubes. The filter and modulator chokes are in the same case. The condenser block has a 2 mfd. and 4 mfd. high voltage condenser and a 2 mfd. condenser of lower break-down rating for the speech amplifier plate.

The parts listed herewith are supplied in the kit No. 55 for the radiophone and CW transmitter. Those marked with an asterisk are supplied in kit No. 56 for a code transmitter with battery operation. Complete constructional details and suggestions for operation are supplied with each kit.

The Ray-227 Raytheon is a new heater type a.c. tube which employs a novel construction to give long life, reduced "heating" time, and minimum of hum. This construction consists of a metal cylinder which encloses a centered helical heating wire supported at top and bottom by insulating corks. This eliminates frictional wear, chemical action and unequal heating between the heater wire and the usual insulator tubing. Only 8 to 15 seconds heating time is necessary and the wire is heated

uniformly. This construction is claimed to eliminate any variation in signal strength due to tube characteristics, and to minimize the a.c. hum. The tube also employs an especially strong and rigid form of glass support to hold the elements permanently in position and thus give uniform characteristics.

The Insuline Resistovolt is a device for automatically controlling the voltage supplied to a.c. filament tubes, thus avoiding burn-outs due to line surges. It is thoroughly



air-cooled so that it can be handled any time while in use. One model also combines
(Continued on Page 38)

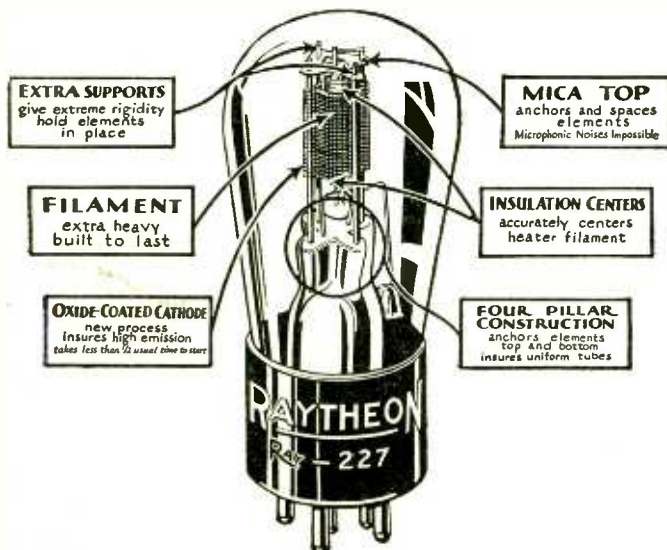

Tell them you saw it in RADIO



You, Too, Can Have Full-Toned Reception



\$13.50

No. 7568

Two years ago few, except the experimental engineers, even dreamed of radio reception as it is today. No wonder Radio has come into its own—that politics and sports now reach millions of people heretofore but little interested. The life-like reality of reproduction would indeed be startling had we not grown accustomed to it gradually.

You, too, can possess that kind of radio reception — at comparatively slight cost. Power amplification is the biggest reason for the marvelous quality of radio today. One of the greatest single successes of the 1928 season is the Dongan Power Amplifier Transformer, No. 7568, used with 2 UX 281 Tubes to supply B and C power to receiver and power for 2 UX 250 Tubes. With this Transformer use Dongan No. 6551 Double Choke.

You can secure information on Approved Parts—Transformers, Condenser Blocks and Units—for various hook-ups by writing the Dongan Laboratories.

Orders filled immediately on No. 7568 Transformer. Send check or money order\$13.50

CUSTOM SET BUILDERS

can secure any of these items direct from factory at trade discounts.

SET MANUFACTURERS

are offered the full cooperation of Dongan engineering department for their individual requirements.

DONGAN ELECTRIC MFG. CO.

2981-3001 Franklin St., Detroit, Mich.

TRANSFORMERS of MERIT for FIFTEEN YEARS

TELEVISION

although still in an experimental stage, has now advanced sufficiently to enable amateurs to build outfits that will give edifying results.

Write today for our price list of television apparatus.

Photo Electric Devices, Inc.
594 Fifth Ave. Brooklyn, N. Y.



You'll Like This HAMMARLUND DRUM DIAL

It's beauty will add richness to your radio panel and its perfect mechanism will delight you. More than fifty years of hard service is built into it.

Illuminated drum. Knob control can be placed anywhere on panel.

*If Your Dealer Can't Supply You,
Write Direct to Us*

HAMMARLUND MFG. CO.
424-438 W. 33rd St. New York

For Better Radio
Hammarlund
PRECISION
PRODUCTS

RADIO'S HALLMARK
OF QUALITY
DeJUR-AMSCO
WORLD'S LARGEST
MANUFACTURER OF
HIGH GRADE RADIO PARTS

The DeJur-Amsco line of quality radio parts is the most complete and diversified in the industry. Whenever you need anything from the smallest part to the largest unit in a receiver, go to your dealer and ask him to show you the DeJur-Amsco line.

We are the world's largest and oldest manufacturers of high grade radio parts. Our long experience assures the highest quality and our larger output and most modern manufacturing facilities assure the lowest prices consistent with quality.

WRITE FOR CATALOG

Write today for DeJur Catalog No. 28 illustrating, describing and pricing every item in the DeJur-Amsco line.

DeJUR-AMSCO CORPORATION
Broome and LaFayette Streets
NEW YORK CITY



"Bathtub" Condenser

LIGHT-SENSITIVE CELLS

(Continued from Page 17)

ference would seriously affect the result. This indicated clearly that some more efficient method of gathering light from the object than the commonly assumed one of image formation by a lens was required, unless some much more sensitive type of photoelectric cell should be found." (See reference 2.)

A few investigators have been attracted by this possibility of securing a more satisfactory type of light-sensitive cell. A discovery of this nature may be found among those substances that exhibit the photo-conductive effect. In this class, molybdenite appeared to be promising. Compounds of antimony, bismuth, copper, lead, silver, thallium and various others have also been tried. As yet, however, nothing of importance has been found which seems likely to displace the alkali metal hydride cells for practical communication work. In view of these facts, engineers must be content with the perfection of cells of this latter type.

SELECTED BIBLIOGRAPHY

1. Ives, "The Alkali Metal Photoelectric Cell." Bell Sys. Tech. Jour., Vol. 5, pp. 320-335; April, 1926.
2. Ives, "Television." Bell Sys. Tech. Jour., Vol. 6, pp. 551-559; Oct. 1927.
3. Allen, "Photoelectricity." London, 1925. Chap. 17.
4. Baker, "Wireless Pictures and Television." New York, 1925. Chap. 2.
5. Coblenz, "Instruments and Methods Used in Radiometry, III," Bur. Stand. Sci. Paper No. 319, pp. 512-530; June, 1918.
6. Korn, "Bildtelegraphie." Berlin, 1923. Chap. 4.

FOTO CELLS

(Continued from Page 18)

High voltage is essential for best operation of the vacuum type foto-cells. Voltages up to 600 volts d.c. are recommended. The gas-filled foto-cells, on the other hand, should be operated as close to their ionization voltage as possible. The best way to obtain this condition is to expose the foto-cell to the maximum light to be used, and gradually increase the applied voltage until ionization occurs. This voltage is noted, and a voltage 10 volts lower is then selected as the best voltage to be applied. Ionization occurs when a pinkish glow can be seen in the foto-cell.

Before Buying any "A" Eliminator

Get my authorized Discount Card and complete description of the finest "A" Power Kit ever offered.

DAVID W. KNAPP, Pres.
Knapp Electric, Inc.
Division of P. R. Mallory & Co., Inc.
Room 416-A, 350 Madison Ave., N. Y. C.

Tell them you saw it in RADIO

GET THIS BIG GREEN BOOK NOW!

New!

AERO
KITS
1929

The Big Green Book gives the very latest details on Aero Coils and Kits, Short Wave Radio, newest broadcast radio receivers, short waveconverters, telephone transmitters, coil kits, adapters and a host of new wrinkles for 1929.

24 Different New Kits Shown for 1929

The kits everyone is talking about are fully described in the new 1929 Aero Green Book—Aero 7-29, Aerodyne 6-29, Chronophase, Metropolitan, Trio, International, Standard, Radiophone—in Shield Grid, A. C. and D. C. models. Be sure to send for your copy of this 25c Big Green Book—worth \$25.00 to anyone who wants to keep up with the latest radio wrinkles.

Mail coupon for your copy today—NOW!

AERO PRODUCTS

INCORPORATED

4611 E. Ravenswood Ave., Dept. 511
CHICAGO, ILL.

MAIL THIS COUPON NOW

AERO PRODUCTS, INC. Dept. 511
4611 E. Ravenswood Ave., Chicago, Ill.

Send me your Big Aero Green Book, 25c, giving the latest information on What's New in radio, short wave, etc.

Name _____

St. and No. _____

City _____ State _____

Send for New Radio Book—It's Free!

New hook-ups. This book shows how to make short-wave receivers and short-wave adapters. How to use the new screen grid tube in D. C. and A. C. circuits. How to build power amplifiers, ABC eliminators. Up-to-the-minute information on all new radio developments. It's free. Send for copy today.

KARAS ELECTRIC COMPANY
4031M North Rockwell Street, Chicago, Ill.
Portland, Oregon, 53 4th St.
San Francisco, 585 Mission St.
Los Angeles, 324 N. San Pedro

Name.....
St. and No.....
City and State..... 4031L2



OMNIGRAPH

Today—as for 20 years
The Surest, Easiest, Quickest
Code Training Marvel

Right in your own HOME the Omnigraph AUTOMATIC TRANSMITTER will teach you the code in preparing to become a Broadcaster, Operator, Railroad Official, Manager, etc. The U. S. Govt. tests you for a license with it. Radio and Telegraph Schools, Universities and Scientific Institutions throughout the world use the Omnigraph.

Ask your dealer about it. Catalog FREE.
Omnigraph Mfg. Co., 15 R. Hudson St., N. Y. C.



O'NEIL Dynamics

The
Speaker
Hit of
the Season

Two types—one for A.C. operation, the other for D.C. Equipped with our dynamic units. Beautiful two-tone walnut finish to match the popular sets. Write for literature.

O'NEIL MFG. CORP.
West New York New Jersey



THORDARSON
EQUIPPED

Do You Realize the Importance of this Endorsement?

Each successive year that we use Thordarson transformers strengthens our faith in your organization. Both our laboratory tests and our experience have proven conclusively that Thordarson transformers are in perfect accord with the high standards maintained throughout in Zenith Receivers.

President
Zenith Radio Corporation



ZENITH RADIO
—LONG DISTANCE—
AUTOMATIC

IN the last analysis, there is no test for the merits of any product that is more conclusive than an investigation of the customer clientel of its manufacturer. Among the users of Thordarson Radio Transformers you will find the aristocracy of radio . . . leading radio set manufacturers whose receivers are universally hailed as musical instruments of undisputed superiority.

Such an endorsement of performance means much to any purchaser of radio apparatus. It means that Thordarson radio transformers have passed successfully the most exacting tests under the eagle eye of the laboratory.

It means, also, that any receiver equipped with Thordarson power supply and audio transformers can be relied upon for a dependability of service and a fidelity of reproduction that represents the acme of engineering development.

Whether you are buying a complete receiver or building your own instrument . . . if you are seeking the ultimate in radio performance insist on Thordarson Transformers.

Thordarson Electric Manufacturing Co.
Transformer Specialists Since 1895
Huron, Kingsbury and Larrabee Sts., Chicago

THORDARSON RADIO TRANSFORMERS

S U P R E M E I N M U S I C A L P E R F O R M A N C E

Tell them you saw it in RADIO



Cunningham
RADIO TUBES

carry you safely
to all "Front-
page" events

With a new, wide-
awake Cunningham
Radio Tube in every
socket of your set you
are "among those
present" whenever
and wherever things
happen. With these
faithful sentinels on
duty, you are reli-
ably radio-informed.

Look for the mono-
gram  on the top
of each tube and in-
sist on them by name.

E. T. Cunningham, Inc.
NEW YORK CHICAGO
SAN FRANCISCO

INDUCTANCE COILS

(Continued from Page 15)

coil, to drive out the moisture, and painting the winding with amyl acetate.

Where only one or two coils are to be figured, the optimum diameter of wire may be obtained by drawing the r.f. resistance curve similar to that in Fig. 1. Where the formula has been worked out for one diameter of wire and the wire diameter is the only variable quantity, it is unnecessary to work out all the factors of the formula again for each new diameter of wire. Thus, the d.c. resistance of wire varies inversely as the square of its diameter; if the diameter is halved, the resistance is quadrupled; if the diameter is doubled, the resistance is reduced to a quarter of its former value; it will be seen that the new value of R following a change in the diameter of the wire can readily be determined.

The factor Z , used for determining F and G , varies directly as the diameter of the wire, and would thus be halved if the wire diameter were reduced by half; the new values of F and G can then be read off.

The factor $(\frac{Knd^2}{2D})^2$, taken as a whole, varies directly as the square of the wire diameter; if the wire diameter were doubled, this factor would be quadrupled. The consideration of four or five different diameters, say, two on each side of a guess at the optimum diameter, would be sufficient to plot a curve, and, if this were drawn as in Fig. 1, the lowest point in the curve would obviously point to the optimum diameter of wire.

The writer wishes to stress the importance of using a wire as little larger as possible than the optimum, not only because the resistance increases slightly, but also because of the considerable increase in self-capacity which will be caused. One ill effect of this self-capacity is a considerable increase in the total losses of the coil. The other is that it increases the total minimum capacity of the circuit so that a slightly smaller inductance is called for than would otherwise be the case; but the increase in losses is the most important consideration.

A sufficient number of measurements (made by means of a reflex tube voltmeter and a number of coils of known inductance and resistance) have been

made on coils similar to those dealt with in Figs. 2, 3 and 4, to check the work as a whole, and subject to the limitations already dealt with, the accuracy of these charts can be relied upon.

It is hoped in the not too distant future to deal with the primary of radio-frequency transformers, as well as the secondary, since, while for the time being the screen-grid tube has to some extent put transformer coupling out of court, it is by no means improbable that the introduction of yet another electrode will render this new tube suitable for use with a step-up radio-frequency transformer. In dealing with the primary, it will be possible to point the way to calculate the amplification obtainable from a given stage of r.f. "step-up."

A Real Log Book JUST OUT

HERE is what you have long waited for. An INDEXED LOG BOOK with all of the very latest November 11 listings, corrected to December 15—right down to the very minute.

Each index sheet shows the wave and kilocycle listings on each page. Makes logging and dial checking speedy—reliable and absolutely accurate. Each channel arranged for dial logging. This log is the only one of its kind published and has met with great success. Printed on stiff card paper—will last a year. Then at the end of the year you merely return the worn out copy to us and a new Log Book will be sent to you for a dime. Here's a real buy. The price asked for the new Log Book is just about what it cost to compile it.

Only 50c Postpaid

IMMEDIATE DELIVERIES

Send the Coupon and
50c in stamps or coin

COUPON

"RADIO,"

Pacific Bldg., San Francisco, Calif.

Here is 50 cents for which you will immediately send, postpaid, one of the very latest LOG BOOKS.

Name

Street and No.

City

State

SET BUILDERS

write for

Discount Card

Enabling you to purchase the new and Improved Knapp "A" Power Kit at big discount—Write for full particulars.

DAVID W. KNAPP, Pres.

Knapp Electric, Inc.

Division of P. R. Mallory & Co. Inc.

Room 416-A, 350 Madison Ave., N. Y. C.

Tell them you saw it in RADIO

There Is a **REMLER KIT** for Every Purpose

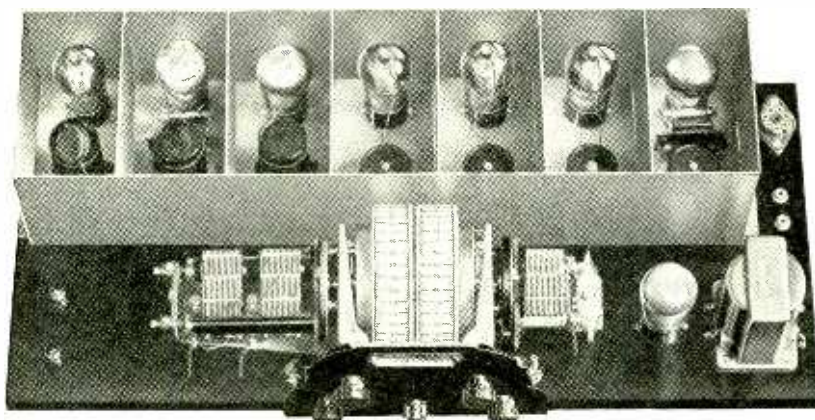

The **REMLER 29**

incorporates a stage of shield-grid radio frequency amplification, oscillator, first and second detectors in the first of which regeneration is used, three stages of transformer-coupled shield-grid intermediate amplification functioning at 115 Kc., and an audio amplifier. It is to be built up on a pressed steel chassis which is drilled for Remler Audio Transformers. Remler Audio Transformers provide reproduction far superior to that which can be had from any other units. Either one or two stages of audio amplification can be built into the receiver proper. It is particularly recommended for use in cities where the usual broadcast congestion exists.



The 1928 **INFRADYNE**

incorporates one feature which commends it to everyone. While it is a ten-tube set, a switch is provided so that a five-tube, single-dial tuned radio frequency set is immediately available for local reception. This single-dial feature makes it the ideal set for all members of the family. The complete Infradyne is immediately available whenever the extra selectivity and sensitiveness necessary for distant reception are necessary. The Infradyne is intended for antenna operation and may be operated from a "B" eliminator if desired. A storage battery is recommended as a filament supply.

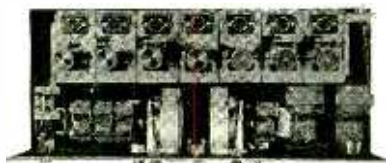

The **BEST 115 SUPER**

The Best 115 Kilocycle Super-heterodyne differs from the Remler 29 in that it incorporates two stages of shield-grid radio frequency amplification instead of one and two stages of impedance-coupled shield-grid intermediate amplification functioning at 115 Kc. as against three stages of transformer-coupled intermediate in the "29." The sensitivity of the "29" and the "115" are approximately the same although the selectivity of the "115" is slightly greater due to the use of two stages of radio frequency amplification. The Best 115 Kilocycle Super-heterodyne is not quite so compact and so easily constructed as the "29" but full-size blueprints with both schematic and pictorial diagrams and an instruction book make it simple for the man with average radio experience to build and operate. The "115" cannot be surpassed for selectivity and is highly recommended for use in cities where broadcast congestion is very bad. It will bring in distant stations under conditions which make the successful use of any other set impossible.



REMLER COMPENSATING TRANSFORMER

Any radio set can be improved from 25 to 100% in tone range. That is a flat, simple, direct statement from Remler—a firm famous for ten years of radio reliability.

The new Compensating Transformer, No. 905, replaces the first audio transformer in your receiver. This easy change is quickly made—and results are amazing. Especially when used with a dynamic speaker, the new Compensating Transformer proves its worth by delivering energy over the complete range of the speaker. Use it to get the most out of your Dynamic Cone. Not an experiment—proved and tested in every popular set and circuit.

Complete information on any of these popular circuits or audio transformers will be mailed upon request

REMLER

Division of

GRAY & DANIELSON MFG. COMPANY

CHICAGO

260 FIRST STREET, SAN FRANCISCO

NEW YORK

Thousands ~
call CeCo the
clearest toned
longest life -
tube on the
market



...and it ought to
be—here's why

THE finest materials skillfully employed by able craftsmen and the foremost laboratory experts give CeCo marked advantages over other tubes. Not only a purer, clearer, more pleasing tone, but a longer, more serviceable life.

CeCo Mfg Co., Inc. Providence, R. I.

**CECO Radio
Tubes**

On the Air Every Monday Evening, 8:30 Eastern Time; 7:30 Central Time; entire Columbia Broadcast Chain of 20 Cities, CeCo Couriers Sparkling Musical Program.

RADIO IN THE ANTARCTIC

(Continued from Page 12)

could be put under it to thaw it out. Oil and grease solidify at low temperatures which makes starting a gas engine well nigh impossible. The complete engine and generator weigh but 65 pounds.

Due to the fact that the men who will handle Wilkins' apparatus have had practically no operating experience, an entirely different type of transmitter was designed for him. Only one wave was desired (33.5 meters) as communication

RADIO TROUBLE SHOOTER

(Continued from Page 21)

to the detriment of the really good speaker. With a high quality amplifier at hand it may be demonstrated that it is necessary to replace the audio equipment as well to secure the best results from the new speakers.

Still another use for the amplifier is in the demonstration of phonograph pick-up devices. The average old audio installation does not do these justice. If the phonograph output be brought to a

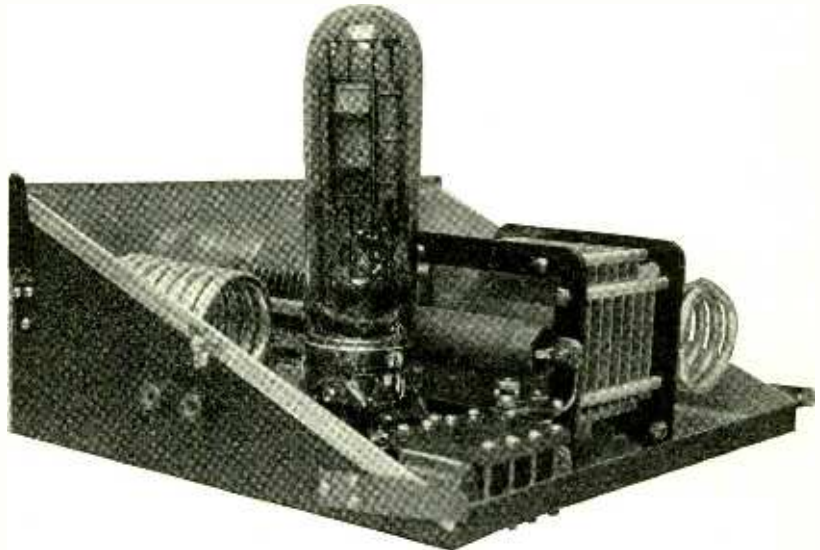

One of Wilkins' 33.5 Meter Transmitters

will be established only when absolutely necessary. So a fixed inductance and capacitance were used in the plate circuit, the antenna length being the only adjustment necessary to obtain resonance. Not a switch nor a meter was employed; the antenna leads and jacks for the key and generator cord being all that the operator need worry about. A little "vest pocket" wavemeter is supplied for the receiver and for a final check on the transmitter. This meter has a range of from 10 to 150 meters and is being used on both expeditions.

In the small cases which hold Wilkins' receivers are two drawers in which he carries spare transmitting and receiving tubes, extra coils, headphones, key and stethoscope, the latter to be used instead of phones in rainy weather. Three widely spread legs so brace the receiver that keying and copying may be accomplished without vibration.

The Byrd expedition maintains a daily schedule with Fred Roebuck at the San Francisco Examiner station, KUP, formerly 6ARD, and communicates with amateur stations all over the world. 34.05 meters is usually used for this long distance communication and amateurs are much enthused over the prospects of being chosen to relay official traffic.

socket, the comparison amplifier may be plugged directly into this for pick-up.

When the comparison amplifier shows the same distortion as does the receiver amplifier, which distortion is not recognized as inherent in the loud speaker, it may be assumed that the cause is either due to r.f. circuit conditions or to insufficient *B* or *A* supply. These should be checked of course, as should the amplifier tubes (for emission) before an attempt is made to demonstrate the superiority of this equipment. This unit is wired for d.c. tubes, as will be seen; this may be changed to suit individual convenience of course, the only necessary addition being the filament transformer and two a.c. sockets. The last stage is wired for a '71 power tube.

There are of course many other uses for the equipment involved here which do not properly come within the scope of service work. There are also probably other and more consistent methods of trouble-checking than those outlined, but it is felt that if these schemes be followed as a general guide by the service man, a larger measure of success may be expected than is at present the rule. With the elaboration which experience will dictate, the level of radio servicing should be raised to the status which permits its enjoying the public esteem its importance merits.

Tell them you saw it in RADIO



Safeguard

Your A. C. Installation

Satisfactory and economical operation of A. C. receivers is contingent upon maintaining close regulation of operating voltages, by means of suitable A. C. measuring instruments. This is necessary because of the wide fluctuation in the potential or secondary lines furnishing current to house lighting circuits.

Set manufacturers, dealers and electric light and power companies everywhere are cooperating to the end that voltage regulation, both on supply lines and in connection with voltage control equipment of the receivers themselves, may be effected for the better operating service of all set owners. For this reason, as well as for other testing requirements outlined in the following, all purchasers of A. C. receivers are urged to provide themselves with an instrument such as is shown in the illustration—known as the Weston Model 528 A. C. Voltmeter, range 150/8/4 volts.

When you find that there is an excessive in-pu voltage, it follows that there is too high a voltage on the filament which shortens the operating life of the rectifying tubes. The Model 528 Voltmeter therefore checks the line supply voltage at all times and indicates when adjustment should be made to manually operated line voltage regulators between the power supply and the power transformer. This voltmeter also indicates when the line voltage is over-rated, thus enabling the operator to make an adjustment in the set for the higher line voltage so that normal life can be obtained from his tubes.

The Model 528 is also made as Ammeters which are especially useful in checking the total load of the A. C. Set—in conformity with set manufacturers' instructions. The determination of A. C. filament flow in A. C. tube filament circuits is easily obtained by means of this instrument.

Write for your copy of Circular J fully describing the Weston Radio Line.

**WESTON ELECTRICAL
INSTRUMENT CORPORATION**

600 Frelinghuysen Ave.
NEWARK, N. J.

Pacific Coast Representatives

Graybar Electric
Company, Inc.
84 Marion St.
Seattle, Wash.
J. H. Southard
San Francisco,
Calif.

A. A. Barbera
Los Angeles, Calif.
Repair Service
Laboratory
682 Mission St.
San Francisco,
Calif.

**WESTON
RADIO
INSTRUMENTS**

Now...4 or 6 Volts
with the
Improved

**Knapp
"A" POWER**



Operates on 105 to
120 volts, 50 to 60
cycles.



**The only "A" Power
Suitable for all Sets**

— Irrespective of number of tubes — including
SuperHets, Short Wave and Television receivers

THE new Knapp "A" Power is designed for the most exacting service — super-hets, short wave and television receivers included. I knew that if it would perform satisfactorily with these receivers that there could be no question as to its efficiency on ordinary broadcast signals. The three Elkon dry condensers, the improved choke coils and the special Elkon dry rectifier make the difference between ordinary and Knapp performance.

No Change in Price

Even with these wonderful and costly improvements, there has been no advance in price—due to the tremendous volume going thru my plant. Remember that the Knapp is the fastest selling "A" Power on the market.

KNAPP ELECTRIC, Inc.
—Division of P. R. Mallory & Co., Inc.—
350 Madison Ave., New York City

See your dealer today

Go to your dealer today. Most of the good ones carry the Knapp in stock. Do not accept a substitute—because only in the Knapp will you get full satisfaction as typified by the famous Knapp "A" Power. If your dealer cannot supply you send the coupon.



David W. Knapp, Pres.

Mr. David W. Knapp, Pres.,
Knapp Electric, Inc., Dept. K-12
350 Madison Ave., N. Y. C.
Send me complete information on the Knapp
"A" Power.

MASTER the CODE

Phonograph Motor
Good pay. Travel. Excitement. Adventure. This wonderful instrument will teach you to read the code like an expert. Reproduces actual sending of expert operators. Sends messages, radiograms, etc.—regular code traffic anywhere, anytime and at any speed. Easy and fascinating. Waxed tape-records carry complete instructions. Just what you need for home practice. Why delay?

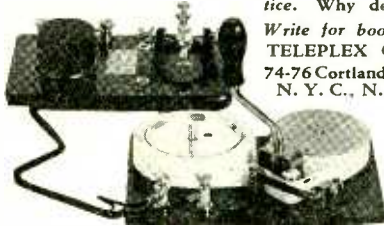

Write for booklet.
TELEPLEX CO.,
74-76 Cortlandt St.,
N. Y. C., N. Y.

CUSTOM SET BUILDERS

Browning-Drake has an interesting and unusual proposition. Take advantage of the fact that more Browning-Drakes are built than any other. Write today.

BROWNING-DRAKE CORP.
CAMBRIDGE, MASS.

RADIO FREE CATALOG

AT WHOLESALE PRICES

A fascinating pastime that puts real money in your pocket. Everything in radio at actual wholesale prices. Send for catalog and particulars now.

ALLIED RADIO CORPORATION
711 W. Lake St. Dept. E 4 Chicago

\$1.00 Brings you the next 6 issues of "RADIO"

SET BUILDERS

Get this Book



Barawik, the first and oldest radio specialty house, offers you unusual service this year. Bigger stocks, quicker shipments, lower prices. Deal with an old established, reliable house. Get honest goods, honest service, honest prices. Barawik service makes you more money. Send now for big new Catalog showing lowest wholesale prices.

BARAWIK CO. 181 Canal St., CHICAGO, U. S. A.

Mail This Coupon Now for Free Radio Guide

Name _____
Address _____

Write for this Discount Card NOW!



It will enable you to purchase the New and Improved

KNAPP "A" POWER KIT at a liberal discount

The new Knapp "A" is the finest and most complete kit ever offered. It is the only "A" Power adaptable to Short Wave—Super Heterodyne and Television reception.

Take advantage of the wonderful offer today—write

David W. Knapp, Pres.

Knapp Electric, Inc.

Division of P. R. Mallory & Co., Inc.
Room 416-A, 350 Madison Ave., N. Y. C.

COMMERCIAL BRASSPOUNDER

(Continued from Page 27)

ous stations: Chicago, WCFL; Detroit, WDI; Columbus, WCL; Cleveland, WTL and WTK; Buffalo, WAM; Rogers City, WLC; Sheboygan, WSK; and Duluth, WME. The wavelengths are 1960 and 1764 meters, Rogers City and Sheboygan collect traffic from vessels and relay by radio to the Intercity stations for delivery. All stations of the Intercity with the exception of Columbus have ship to shore service on 715 meters also.

All the installations are remotely controlled; the transmitters being located in the center of the city. The executive offices of the Intercity are located in Room 1006 Rockefeller Bldg., Cleveland, Ohio. Mr. Clarence Gielow is chief operator and has all the operators, both ship and shore, under his supervision. The president of the corporation, Mr. Emil J. Simon is an able radio engineer. The slogan of the organization is: "The fastest radio service in the world." The executives as well as the employees of the company are all very enthusiastic about their work, as their conversation always tells.

KIT REVIEWS

(Continued from Page 31)

a light socket aerial, thus utilizing one socket for both aerial and current supply.

Arcturus heater type tubes are especially designed to give a long life and a minimum of microphonic noises. These characteristics make them ideal for use in either a.c. or d.c. circuits, especially as they minimize the hum in a.c. circuits. These characteristics are due to the rugged structure of the tubes and the rigid mounting of the heater element. Tests show a life of over 5000 hours and one-fifth the amount of microphonic noise from a filament type. The negative temperature co-efficient of the carbon heating element limits the initial current surge experienced with the metallic filament type. These tubes are made as a '27 type for use in 2½-volt circuits, and as amplifier, detector, hi mu power, and shield grid tubes for use in 15-volt a.c. circuits.

The Thermatrol voltage control is designed to protect a.c. tubes from burn-out or paralysis due to excessive voltage. The device is equipped with heavy contact pins which are plugged into a baseboard recep-



tle. On its 2-in. diameter face are a set of voltage outlets corresponding to the nominal voltage to be automatically maintained by the device, whether 110-115, 115-120, 120-125, or 125 and over.

The Chicago-Jefferson Fuse and Electric Co., Chicago, has published catalog No. 33R-1, which illustrates and describes their entire line of radio transformers, accessories and fuses for the coming season.

Tell them you saw it in RADIO

Potter Condensers

Quality

Long Life

Uniformity

Economy



Potter T-2900 Condenser Block for single 250 type tube amplifier—\$20.00.

Potter T-2950 Condenser Block for the push-pull 250 type tube amplifier—\$22.50.

Potter T-2098 Condenser Block for the single 210 type tube amplifier—\$20.00.

Potter T-280-171 Condenser Block for a power pack with 280 type tube rectifier for a 171 type tube power tube—\$18.00.

Potter by-pass and filter condensers are available in all capacities and working voltages.

The Potter Co.

North Chicago, Illinois

A National Organization at Your Service

USE THE CLASSIFIED ADS IN "RADIO"

They Bring Results

CORWICO Braidite
HOOK-UP WIRE
THE BRAID SLIDES BACK

Cuts Wiring Time in Half

Shove back the insulation, solder the connection and the braid slides back into place, leaving no exposed sections of bare wire. Braidite is the quickest and easiest working hook-up wire made.

Safe as insulated wire and as convenient as bare wire. You cannot scorch or burn Braidite with a soldering iron. Use Braidite in the next set you build.

At All Dealers

25 Feet Stranded..... 35c
25 Feet Solid..... 30c
Red, Green, Yellow, Blue, Black

FREE Send us the name and address of your dealer and we will send you a sample package of Braidite FREE. Include 10c for Postage.

CORNISH WIRE CO.

26 Church Street New York City

New Air-Cooled DeLuxe
RESISTOVOLT
Automatic Voltage Controller



Checks all line voltage in excess of 110 Volts, protecting tubes and set wiring. Embodies new efficient principles of construction, all metal, air-cooled regardless of overload.

\$1.75

At All Dealers

ANTENNAVOLT

COMBINATION OF THE AIR-COOLED RESISTOVOLT AND A PERFECT LIGHT SOCKET AERIAL.

It is the talk of Radio Engineers!

\$2.25

At All Dealers

If dealer cannot supply write:

INSULINE CORP. of AMERICA
RADIO TELEVISION
Standard Products Since 1921
70-80 Cortlandt St., N. Y. C.



"A

whispering campaign will ruin the popularity of any set owner — if the set has adenoids"

THE RADIObUSTER

By

VOLNEY G. MATHISON

THE adventures of a deep sea radio operator, told in humorous style. 112 pages of short, snappy tales from life.

"RADIO"

Pacific Building San Francisco

LET YOUR EAR BE THE JUDGE



Using the BBL Loud Speaker Motor licensed under patent No. 1,1667,331.

This powerful SEE JAY SPEAKER reproduces the broadcasting voice and music faithfully and naturally throughout the entire frequency range. The BBL Loud Speaker Motor used in this speaker is a new and original development licensed under Patent No. 1,1667,331. It embraces a uniform sensitivity to pitch and the ability to handle a large sound volume output without blasting. A special moisture proof diaphragm is used and the entire speaker unit housed in a beautiful cabinet finished in dark or two-tone walnut. Sold direct from factory on a 10-day money-back guarantee. Price \$19.95.

Address—SEE JAY CO.
911 Brook Ave., N. Y. C.



AmerTran Push-Pull Power Stage (illustrated above)—completely wired with input transformer and a choice of 4 output transformers depending on speaker and power tubes. Adaptable to 171 or 210 tubes, cones or dynamic type speakers. Price, east of Rockies — less tubes—\$36.00.

Remember it isn't what they say to your face about your set—it's what they say behind your back. And how those hammers do get busy when they get a set with "adenoids" to talk about.

Preserve the good opinion of your friends—and get the enjoyment you deserve—perform that adenoid operation today—take out the inferior transformers and in their place put AmerTran tone-true radio products.

You can use AmerTran DeLuxe audio transformers—or push-pull for 171 tubes—or better yet the completely built Power Amplifier for two 210 type tubes and the AmerTran Hi-Power Box.

No matter what the change—if you switch to AmerTran you will improve the quality of your set.

Perform that adenoid operation today—turn the sneers to cheers! AmerTran Radio Products will do the job for you.

AMERTRAN

AMERICAN TRANSFORMER COMPANY
60 Emmet St. Newark, N. J.
Transformer Manufacturers for more than 29 Years

FERRANTI

Radio Products

Highest quality audio and output transformers for power and general purpose amplifiers.

Don't lose sight of the fact that the best audio amplifier can be rendered ineffective through the use of a poor output transformer or other amplifying device which falsifies or fails to transmit all frequencies.

Ferranti Output Transformers get the best out of your amplifier and speaker.

Type	Ratio	Speaker	Amplifier	Tube
OP-1	1-1	Magnetic	Standard	171-210
OP-2	25-1	Dynamic	Standard	171-210
OP-3 C	1.9-1	Magnetic	Push-Pull	171-250
OP-4 C	25-1	Dynamic	Push-Pull	171-250
OP-4 CC	25/50/1	Dynamic	Push-Pull	171-250

Technical data and prices sent on request

FERRANTI, Inc.
130 West 42nd St. New York, N. Y.
Ferranti, Ltd. Ferranti Electric
Hollinwood Limited
England Toronto, Canada



TRUE TONAL VALUES

de Forest AUDIONS

FOR those who appreciate better radio reception, the new perfected De Forest Audions—the latest achievement of Dr. Lee De Forest—assure the true tonal values of reproduction which add so much to radio enjoyment.

Sold by leading dealers everywhere

DE FOREST RADIO CO.
Jersey City, New Jersey

DE FOREST
AUDIONS



KROBLAK

WIRE WOUND RESISTANCES

For all Eliminators, Power Amplifiers, Electric Sets and Television. For Service Stations we carry a complete line of Resistances for all standard make Receivers. Use Mountford Plunger Type Variable Grid Leaks. Write for circular.

C. E. Mountford, 30 Sullivan St., N. Y.

DYNAMIC LOUDSPEAKER

(Continued from Page 13)

Fig. 1 shows the same speaker with a shunt equalizer which is normally built into the loudspeaker unit of one model. Other models use a low-pass filter which gives the curve *B* of Fig. 1.

The impedance measurements on a dynamic speaker in Fig. 2 show why plunger action is not sufficient at the high frequencies. It will be noted that the moving coil has a small amount of inductance which causes the reactance to increase with an increase of frequency. Assuming a perfect audio amplifier, the moving coil would have a constant voltage impressed across it at all frequencies. As the current varies with the impedance, the output will vary and will be less for the higher frequencies where the impedance increases.

As the reactive component is of little use in driving the cone, the moving coil would theoretically consist only of a resistance. The useful part of this resistance would be the motional resistance due to the work done in the form of sound output. Unfortunately, the usual dynamic speaker moving coil has an appreciable inductance and the load on the moving diaphragm is not sufficient to make this coil look like a pure resistance to the amplifier. Possibly a long exponential horn would load the diaphragm sufficiently to do this, but not so with any of the dynamic cone speakers measured.

It seems to be a problem to properly design the shape and weight of the diaphragm and coil so as to have the wave action properly boost the plunger action and give constant sound output for all frequencies. The use of a larger diaphragm may mean that a different texture of paper, a different angle between sides of the cone, and a different stiffness of support on the outer edge, will be necessary to obtain a proper balance between wave and plunger action. Using a shallower cone would cause the wave action to become effective at a lower frequency because the cone would not be as stiff. Heavier paper causes an energy loss due to the added weight and may affect the higher frequencies by giving a stiffer cone.

The curves of Fig. 1 were taken with calibrated amplifiers, vacuum tube voltmeters, and a microphone. The loudspeakers were placed in a large flat baffleboard and the microphone suspended about 15 cm. in front of the diaphragms. By having the microphone so close to the loudspeaker, the effects of room resonance, standing waves of sound, and interference are small. The curves are useful in comparing different loudspeakers but are quite different from those obtained when the microphone is placed several feet away and a cabinet used instead of a large flat baffleboard.

New Birnbach Cord



"IT'S MOISTURE-PROOF"

Birnbach Extension Cord enables you to move the Radio Speaker on one side of the room and the Set on the other, or to any room in the house. Attaches instantly to the cord of your Speaker.

It will pay you to replace your old cord with the New Birnbach Moisture-Proof Extension Cord and put an end to distortions often caused by poorly insulated cords. Your neighborhood dealer has these sizes in stock: 10-20-30-40-50 and 100 foot lengths. Get one today.

BIRNBACH RADIO CO.
254 WEST 31ST STREET, NEW YORK CITY

Send For WESTERN RADIO New 1929 Catalog

Dealers and Set Builders

THE NEW 1929 Catalog is crammed full of the FINEST, NEWEST, Nationally known A.C. sets, consoles, cabinets, dynamic speakers, kits, eliminators and accessories at LOWEST PRICES. Largest stock of radio parts. Prompt delivery. Write for our FREE catalog Western Radio Mfg. Co. 128 W. Lake St., Dept. R-11 CHICAGO

FREE



The Big
Friendly
Radio House

USE THE CLASSIFIED ADS
IN "RADIO"

They Bring Results

Mail Your "Ad" Now

GET MY
DISCOUNT CARD!

Before buying a
KNAPP "A" POWER KIT
Absolutely dry—Magically
silent—the finest "A" Power
adaptable to Short Wave,
Super-Heterodyne and Tele-
vision reception.

WITH THE
10 NEW IMPROVEMENTS
Write me today for details of this
money saving plan and get your dis-
count card. Address

DAVID W. KNAPP, Pres.
Knapp Electric, Inc.
Division of P. R. Mallory & Co., Inc.
Room 416-A, 350 Madison Ave., N. Y. C.

CRYSTAL-CONTROLLED TRANSMITTER

(Continued from Page 24)

boxes $1\frac{1}{4}$ in. inside the line of the up-rights. Each box is supported by such an offset bar at each end. A cross brace of the same $1\frac{1}{8}$ in. bar iron is put at the base of the frame, at the sides, and across the back. The whole is a rigid, rugged assembly, with excellent shielding and easy accessibility.

To accomplish neutralization of any one stage full radio frequency was placed on the grid of the stage and the d.c. plate voltage made zero. Any radio frequency voltage which then appeared across the output of the stage was due to stray couplings. This voltage was indicated by a vacuum-tube voltmeter using plate detection. The neu-

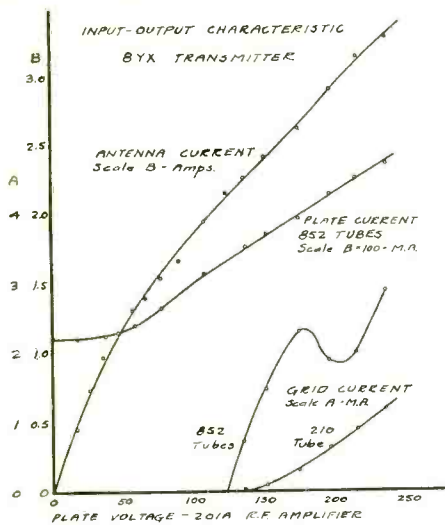

Fig. 5. Transmitter Input-Output Characteristics

tralizing condenser was adjusted till the leakage voltage was cut to practically zero, readjusting the tank circuit condenser if necessary. The neutralization should be such that at no setting of the output circuit does appreciable voltage appear across it. Then plate voltage is applied to the stage and the neutralization process repeated for the next stage.

An input-output characteristic should be taken to check the transmitter adjustments. This is done by varying the plate voltage on the amplifier stage in which modulation takes place, and reading the resulting antenna current. A plot between the two quantities should approach a straight line. In Fig. 5 is shown the characteristic for the 8YX transmitter for modulation on the 201a stage. Also are plotted curves of plate current on the power amplifier stage and of grid currents on this and the 210 stage.

Up to about 50 volts plate on the 201a the last stage does not have its radio frequency plate current swing much outside the straight-line portion of its dynamic characteristic. Past this point the plate current swings beyond

"First Aids"

NO MATTER what your interest in radio may be, whether just an average listener-in or a dyed-in-the-wool experimenter, you must obtain better results if you use Clarostat "First Aids."

For greater signal control—try a Clarostat Antenna Plug, the different and improved device which makes an excellent antenna out of any socket or outlet.

For your regular broadcast set—don't fail to use a Grid Leak Clarostat for maximum sensitivity, as well as a Volume Control Clarostat for regulating plate voltage, oscillation and loud-speaker volume and tone.

For loud-speaker control—use the Table Type Clarostat, which can be connected in series or in shunt, nearby or at a distance, for regulating radio volume and tone to fit any occasion. No tools required.

For your radio power unit—apply a Duplex Clarostat for better voltage regulation, for obtaining extra taps, for increasing or decreasing existing taps, and for obtaining C or grid bias voltages.

For television—use the standard scanning disk control—the Speed Control Clarostat, now employed by leading television broadcasters and experimenters.

WRITE for the Clarostat literature, which tells the story at length on how you can improve your radio results. Better still, send 25 cents in stamps or coin for "The Gateway to Better Radio"—88 diagrams, over 20,000 words, and a wealth of ideas. The best investment you ever made in radio!

CLAROSTAT MFG. CO., Inc.

Specialists in Variable Resistors

287 North Sixth St. Brooklyn, N. Y.
SAN FRANCISCO, PORTLAND

Mem. R. M. A.



CLAROSTAT

SILVER THE KING

Gosilco Super Aerial Wire

Gold over Silver on Copper

Greatly Increased DX Range. 50% More Volume—Clearer Tone—35% Sharper Tuning—Non-Corrosive. Endorsed by Naval Research Laboratory. Gerald M. Best, Major Mott, Ormiston, Van Buren, World's DX Champion. A permanent investment. No. 14, 100 ft., \$4.00; 75, \$3.25; 50, \$2.50. Pat. applied for. If dealer cannot supply you, write or phone us. Over 50,000 GOSILCO Aerials in use—There's a Reason.

GOSILCO RADIO PRODUCTS CO.

6420 Marbrisa Ave. DE. 3940 Huntington Park, Calif.

Northern California Customers Order Your GOSILCO SUPER AERIAL WIRE from

Radio Dealers Supply Service

Wholesale Division of



1452 Market Street

San Francisco, California

Tell them you saw it in RADIO

LIFE BEGINS *in* **ARCTURUS TUBES**

WHEN IT ENDS IN OTHERS

800 hours sounds the death knell for usual tube efficiency. But this is only the starting point for Arcturus Tubes—their efficiency plus, just begins, resulting in clearer, better reception.

They live so long, you forget they are in your receiver. And your set responds with 7-second action, humless reception and more volume—
—the ideal combination for tubes—
procurable only with Arcturus.

Re-tube with Arcturus—put one in each receiver receptacle—you'll marvel at the vastly superior reception. Get a set from your dealer.

Arcturus Radio Co., Newark, N. J.

WEST COAST DISTRIBUTORS

UNIVERSAL AGENCIES
905 Mission Street
San Francisco, Cal.

ARCTURUS
A-C LONG LIFE TUBES

cutoff on the negative half cycle and apparent rectification takes place, as shown by the increase in the average plate current. At about this same point the antenna-current curve changes slope slightly, bending down toward the horizontal. When the amplifiers take grid current the slope of the output-current curve again changes slightly. For telephony, for which the transmitter was built, the characteristic is easily enough linear. It could be straightened out by increasing the bias on the 852 stage, if thought necessary. The antenna current approaches saturation at about 3.5 amperes. The saturation occurs in the 210 stage, which is rather small to feed four 852 tubes. From the curve the correct operating point for the 201a tube may be taken at about 120 volts d.c.—midway between zero antenna current and saturation. Modulation swings then have equal territory above and below this point.

Using the transmitter for telegraphy is simple. A key need only be inserted in the plate lead to the 201a. In this case the plate voltage should be run up around 250, to work the transmitter at maximum output when the key is down. At the adjustments used to get the input-output characteristic the no-load plate current on the 852 tubes was 110 m.a. This may be cut to zero by increasing the grid bias, so that the tubes are loaded only when transmitting. It is interesting to note that when running the four 852 tubes as a tuned-grid oscillator the maximum antenna current obtainable on the same wave was 2.26 amperes. When running as power amplifiers the current output was 3.5 amperes—very nearly twice the power output.

NEW RADIO CATALOGS

"The Electro-Dynamic Principle" is the subject of an interesting booklet from the Magnavox Company, Oakland, California. In it is traced the evolution of telephone reproducers and the methods of their operation.

The United States Civil Service Commission announces an open competitive examination for Assistant Radio Inspector. Applications must be in Washington by December 31. Entrance salary: \$2400 a year. Education, training and experience will count. It's not out of reach of the man who shunned his "watch below."

Newest Information TO SET BUILDERS

LATEST RADIO GUIDE **FREE**

Elections, football games, big National events will boost radio business this year. Set builders will reap a rich harvest. Barawik service will make you money. Everything in A-C sets, parts, supplies. World's largest radio stocks on hand. Orders shipped same day. Lowest rock-bottom wholesale prices.

Mail coupon for free Radio Catalog now

BARAWIK CO. 181 Canal Sta., CHICAGO, U. S. A.

Mail this coupon for Free Radio Guide

Name _____

Address _____

BUILD IT RIGHT

This New Catalog of **YAXLEY**

parts and accessories will help you. Yaxley products are used in vital places in many of the most prominent and successful sets on the market today. Send for the new catalog.

YAXLEY MFG. CO.
Dept. A—9 So. Clinton St., Chicago, Ill.

More "A" Power For Less Money!

With the Set Builders discount card you can purchase a **KNAPP "A" POWER KIT** at a liberal discount.

Write me today for full details telling about this new money-saving plan for set builders.

DAVID W. KNAPP, Pres.
Knapp Electric, Inc.
Division of P. R. Mallory & Co., Inc.
Room 416-A, 350 Madison Ave., N. Y. C.

LECHER WIRES AND STANDING WAVES

(Continued from Page 28)

using as loose coupling as possible. Leave the wave meter in this position and tune to resonance. Record the wave meter setting in degrees.

Next place the "feeling" rod across the Lecher wires at any point. The galvanometer reading should drop nearly to zero. Move the "feeling" rod slowly along the wires, keeping watch of the galvanometer. At a certain point the galvanometer needle will go up suddenly. Move the rod back and forth very slowly in order to find the exact point where the galvanometer reading is maximum. Usually this amount will be about twice the amount which the galvanometer read before the "feeling" rod was placed on the wires.

Read off the exact distance from the galvanometer to the "feeling" rod in feet and hundredths of feet. Add to this one-half the length of the "feeling" rod between wires or rather one-half of the spacing between the wires expressed in hundredths of a foot. Be careful to use only one-half of the spacing, not the whole distance between the wires. This corrected length is exactly half of the wave length of the standing wave on the Lecher wires and is also one-half of the length of the oscillator wave.

To convert this reading to meters multiply by 2 and then by 12 in. and divide by 39.372. The result will be the exact wave length of the oscillator and should be recorded opposite the wave meter setting.

(Continued on Page 44)

Be Warned

You can use second rate condensers in your SHORT WAVE RECEIVER —BUT, remember the fellow blowing the trombone who complained, "I blow it in so nize and it comes out so rotten."

HIGH FREQUENCY WAVES will go into your circuit readily enough, but the results may not be so good.

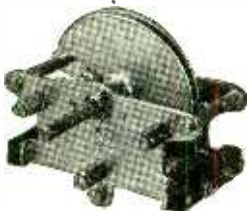

CARDWELL TAPER PLATE Condensers have heavy, die cast plates, hold their calibration, don't vibrate, and will give the stability so necessary in the SHORT WAVE RECEIVING CIRCUIT.

YOU'RE NOT GAMBLING WHEN YOU CHOOSE A CARDWELL.

CARDWELL CONDENSERS
VARIABLE - FIXED
TRANSMITTING - RECEIVING

"The Standard of Comparison"

[Literature upon request]

The Allen D. Cardwell Mfg. Corp.
81 Prospect Street Brooklyn, N. Y.

EVERY SET MUST HAVE A Radio Control Box for Safety

THIS is one accessory that is in demand by the owners of all socket operated radio sets. Widespread competition by the radio press has acquainted the individual with the necessity of a line voltage control or regulator to compensate for high line voltages found in every locality.

You can supply this demand with a unit that is excep-

tionally efficient, neat in appearance, and at a price that your customers are willing to pay. Centralab fully guarantees the Radio Control Box and advises it as a real money making item for any retail store. Send for booklet describing Centralab Resistances and Volume Controls. Many live items that will stimulate business are described therein.

Centralab Radio Control Box



List Price \$3.00

26 Keefe Avenue

Centralab
CENTRAL RADIO LABORATORIES

Milwaukee, Wisconsin

POWER TRANSFORMERS for the UX 250 Power Tube



TYPE 565-A TRANSFORMER (200 watts)

PRICE \$13.50

The General Radio Type 565 Power Transformers consist of two models for both half and full-wave rectification utilizing the 281 type of rectifier tube. The Type 565-A Half-Wave Transformer illustrated consists of one 600-volt secondary, two secondaries of 7.5 volts and one of 2.5 volts. It is designed for 105 to 125-volt, 50 to 60-cycle lines.

Bulletin No. 931 will be sent on request.

General Radio Co.

30 State Street, Cambridge, Mass.
274 Brannan Street San Francisco, Calif.

LAST MINUTE SPECIALS

R. C. A. Uni-Rectron Power Amplifiers. List \$88.50.....	Our Price \$19.75 ea.
Genuine Black Bakelite Panels 38" x 43" 3/16" thick. Reg. Price \$29.....	" 8.75 "
E210 Bradleystats. list \$4.00, fine A. D. Line Voltage Control.....	" 1.60 "
G. E. Kenotron Rectifying Tubes (Type T.B.1).....	" 1.25 "
Gould Kathanode Unipower, Automatic Radio "A" Power (6 volts), list \$39.....	" 13.75 "
2 Henry—250 Mill Choke Coils, D.C. Resistance 20 ohms. List \$25.....	" 7.50 "

AMERICAN SALES CO., 19-21 WARREN ST., NEW YORK CITY

PROFESSOR HERMANN SCHNITZEL

Of the Ooniversity of Cincinnapolis, O-ho-ho

has written a booklet containing 21 short radio lectures which have been broadcast from many stations. 50 cents per copy, postpaid. You will enjoy this book.

For sale by "RADIO," Pacific Building, San Francisco

Tell them you saw it in RADIO

FROST



FROST VOLUME CONTROL

Gives complete, stepless and wonderfully smooth control of volume and oscillation. Wearproof roller contact arm, Bakelite case and dust cover. \$2.00 and \$2.25.

FROST VOLUME CONTROL WITH A.C. SWITCH

We equip our famous Volume Control with approved A.C. Snap Switch tested to carry 250 volts at 3 amperes, so that both switch and volume control may be handled by single knob. \$2.75 and \$3.00.



FROST VOLUME CONTROL WITH D.C. SWITCH



Equipped with sturdy German silver switch mounted on Bakelite panel, and with switch points fitted with sterling silver contacts, this Volume Control gives quick operation, positive-locking off position and saves space. For battery operated sets. \$2.55.

FROST GEM VOLUME CONTROL

Identical with our standard size Volume Control units except in size. Gem units are only 1 1/2 in. in diameter, and only 1/2 in. thick. Great space savers. \$2.25 and \$2.50.



FROST GEM RHEOSTATS



Made to deliver a service that is not usually expected from little rheostats like these. Mighty good little rheostats, taking up little space and supplied either plain or with D.C. switch. Easy to solder to. Plain, 75c. With switch, \$1.00.

FROST BAKELITE RHEOSTATS

Long the standard air-cooled Bakelite Rheostat, as well as the original of this type. Resistance wire is wound on die cut Bakelite strip over moulded Bakelite frame. Wide choice of resistances. \$1.00 and \$2.50.



FROST MOULDED MICA CONDENSERS

Cannot be affected by moisture or climate. Moulded Bakelite with finest mica dielectric. Easy to attach. 45c. to 90c.

HERBERT H. FROST, INC.

Main Office and Factory

ELKHART, IND.

Chicago

San Francisco

RADIO

(Continued from Page 43)

Example:

$$\lambda = \frac{L \times 2 \times 12}{39.372}$$

Suppose that $L = 130.4$ feet.

$$\text{Then } \lambda = \frac{130.4 \times 2 \times 12}{39.372} = 79.58 \text{ meters}$$

Now reduce the wavelength of the oscillator circuit by decreasing the capacity in the tank circuit. Tune the wave meter to this new wave and proceed as before to measure the wave on the Lecher wires. Record all results. Continue in this manner decreasing the wavelength for each reading until the lower limit of the oscillator has been reached.

In order to reach still lower waves an oscillator which will oscillate at the higher frequencies must be used. Difficulties multiply rapidly when one tries to build a driver which will oscillate below 2 meters. The Lecher wires will, however, measure the shortest waves which can be produced.

If one wishes to locate certain wavelengths on the wave meter the method is just the reverse of the one described above. For example it is desired to locate the upper and lower limits of the amateur 10-meter band, i. e., 10.71 meters (28,400 kc.) and 9.99 meters (30,000 kc.). In order to do this it is necessary first to calculate the exact length of Lecher wire corresponding to 9.99 meters.

Example:

$$L = \frac{39.372 \lambda}{24}$$

Where L is the length of the Lecher wire to be used and λ is the wavelength to be located on the wave meter:

$$L = \frac{39.372 \times 9.99}{24} = 16.4 \text{ ft.}$$

Fasten the "feeling" rod solidly across the wires 16.4 ft. from the galvanometer. Start the oscillator and change its wavelength gradually while watching the galvanometer closely. Continue to tune the oscillator carefully until the galvanometer reading is a maximum. The driver will then be oscillating at exactly 9.99 meters. Tune the wave meter to resonance and record both wave meter setting and wavelength.

10.71 meters can be located in the same manner. The intermediate points can be located with almost any desired degree of accuracy.

The readings in meters may be converted to kilocycles, thus making the wave meter a modern frequency meter.

Example: What is the frequency in kilocycles when the measured wavelength is 39.98 meters?

$$f = \frac{299,820}{\lambda} = \frac{299,820}{39.98} = 7495.5 \text{ kc.}$$

In this way all of the readings may be converted to kilocycles and a frequency curve plotted. It is even possible to calibrate the meter by locating points which represent frequencies in even kilocycles.

In using the Lecher wires observe the following precautions. Use an oscillator which has a low resistance tank circuit. Keep the plate and filament supply voltages steady. Always allow the tube to heat up before starting to take readings. In running the "feeling" rod be sure to find the point which gives the maximum galvanometer reading. There will be other points where the galvanometer needle will rise but at only one point will it rise to the maximum. If the galvanometer reading is too high before the "feeling" rod is placed across the wires loosen the coupling. Remember that a galvanometer will burn out very quickly if overloaded. Be careful to read the tape correctly. If a tape which is calibrated in feet and inches is used then the readings should be converted to feet and decimals of a foot before substituting in formulas given above.

Tell them you saw it in RADIO

END RADIO BOTHERS

DO YOU KNOW what's wrong when your radio set isn't working right? Ten to one, you don't. Twenty to one, you would if you had a copy of

Hoff's Radio Trouble Finder

Ever hear of M. M. Hoff, radiotrician, of Philadelphia? He was one of the very first "radio bugs" and has been building and studying sets ever since. And now, out of his broad experience, this man has written a book to tell radio owners how to keep their sets working right.

He tells in plain words and illustrations how a set is made, what the parts are called, what are the few usual troubles and how to fix them. Then he lists 103 troubles that sometimes happen and tells how to detect and fix each one.

The book is a regular cyclopedia of radio information—only it's in a language anyone can understand. Read it five minutes and you'll know more about radio than you ever dreamed of.

It will save you many a repair man. It will save you hours of guessing and fussing and fuming. It will help you to keep the tone of your set always sweet and strong. It will keep you from losing many programs. And, best of all—

IT WILL MAKE YOU STOP SWEARING—MUCH TO THE SURPRISE OF YOUR FAMILY—because radio repairs are expensive. Why hire them done when you can easily learn how to keep your set from needing them?

All It Costs Is \$1

Send cash with your order and you get also a Dictionary of Radio Terms and the latest list of Radio Broadcasting Stations with call letters and the new Federal Radio Commission wave lengths. Send your dollar today while the copies last. Six copies for \$4.00.

CHICAGO BARGAIN STORES

426 Quincy Building, Desk 5 Chicago, Ill.



Your Tubes STEADY AS THE STARS When AMPERITE-Controlled

Don't let "A" battery current fluctuations spoil your radio reception or ruin your tubes. Install Amperites and automatically keep the filament temperature constant according to tube rating. Entirely unlike fixed resistors. With AMPERITE control tubes last longer and your set sounds better. Panel arrangement improved and wiring simplified. Tuning is easier and volume is increased. A type for every tube—battery or A. C.

\$1.10, with mounting (in U. S. A.) at all dealers.

Radiall Company
30 FRANKLIN ST., NEW YORK



FREE "Amperite Blue Book" of latest circuits and construction data. Write Dept. R. 11.

AMPERITE
The "SELF-ADJUSTING" Rheostat

\$1.00

Brings the Next Six Issues of "RADIO" to your address

Before Buying

Any "A" Eliminators

Write me about the discount card which enables you to purchase the new and improved

Knapp "A" Power Kit

at a liberal discount.

The most complete "A" Power Kit ever offered—Address for details of plan—

David W. Knapp, Pres.
Knapp Electric, Inc.

Room 416-A, 350 Madison Ave., N. Y. C.

X-L LINK

Is Your Set ENTIRELY A. C.?

X-L
LINK
List
Price
\$5.75



The most favorable feature of the A.C. set is convenience; the fact that it requires no external batteries, power units, etc., deriving power straight from the light socket. It still has the disadvantage, though, of requiring an antenna and ground with the accompanying inconveniences of a wire on the roof, lead-in and ground connection.

This also can now be eliminated! The X-L LINK furnishes antenna and ground to any set from the light socket, using the shielded light wires for antenna and ground. In addition, it provides line voltage regulation, double socket outlet and switch for Dynamic Speaker, complete fusing as a protection to all parts in the set and can be attached in a moment's time without wiring or complicated connections of any kind. Simply plug the LINK into the socket and the set into the LINK.

Manufactured and unqualifiedly guaranteed by the makers of the X-L Vario-Denser. If your dealer cannot supply you, it will be sent postpaid on receipt of price.

X-L RADIO LABORATORIES

DEPT. J 1224 BELMONT AVENUE, CHICAGO

AEROVOX BUILT BETTER CONDENSERS AND RESISTORS

HOW DO YOU BUY CONDENSERS?

MOST filter condenser blocks are bought merely on the basis of price and their voltage ratings.

In view of the many overrated condensers now on the market, the only dependable indicator to use in buying condensers is their insulation specifications and the care with which they are tested.

The Aerovox Wireless Corporation makes no secret of the



insulation specifications of their filter condensers and their condenser blocks. This information is contained in detail in the 1928-1929 catalog.

The next time you buy filter condensers or blocks make your comparison on the basis of insulation specifications, voltage rating and price. On that basis Aerovox Filter Condensers and Blocks will undoubtedly be your choice.

A Complete Catalog with illustrations and detailed descriptions may be obtained free of charge on request.

The Research Worker is a free monthly publication that will keep you abreast of the latest developments in radio. Your name will be put on the mailing list free of charge on request.

AEROVOX WIRELESS CORP. 70 WASHINGTON ST. BROOKLYN, N.Y.

Three Hot Numbers from Our New Catalogue!

Buy In
The West

Send at once for our new catalogue of leading numbers for 1929. In addition to the items listed we carry an extensive stock of parts and sets by the leading manufacturers at Eastern prices. Investigate these remarkable values. Supplementary catalogues and lists on request.

1. Sargent-Rayment "7"—the champion distance-getter in kit and wired form de luxe and standard models—10 kilocycle selectivity and the enormous amplification of 4-SCREEN GRID tubes.

2. Knapp "A" POWER UNIT—the "A" eliminator with 10 recent improvements that make it a leader—far ahead of its time.

3. Utah Dynamic Speaker—a model for every purpose—handle any volume with life-like tone. Beautiful cabinet work.

ELECTRIC SUPPLY CO.

(EDD N. WATKINS)

370 ELEVENTH ST.

OAKLAND, CALIF.

Private Label Radio the Answer!

RADIO retailing is fast approaching standardization. Let us compare. On the one hand we have "restricted" dealers handling "national brand" sets—at narrow, factory-controlled prices and profits with competition everywhere, with a big radio stock to carry on their inventories.

On the other hand are the independent dealers selling Premier sets with their own private label—at unlimited profits and no competition because of exclusive rights. They have no territory restrictions—no fixed price—no problem of unturned stock.

The wise radio dealers today—the ones who are making most money—select Premier for their private brand. This is the answer to the present radio sales question and it spells P-R-O-F-I-T-S. Every set you sell advertises for you—and you only.



CONSOLE
MODEL

Beautiful walnut finished cabinet equipped with Magnetic or Dynamic Speaker. Size 26" x 40" x 16" deep. Furnished in 6-tube standard Code No. PC-2829-RAC-6 and 7-tube Push Pull Code No. PC-2829-RAC-7.

CHASSIS SPECIFICATIONS

All-metal chassis; rigid, strong, stays put. Unconditionally guaranteed. Apparatus 100% shielded. Licensed under U. S. Navy Patents and Hogan Patent No. 1,041,002.

Premier Private Label Radio Receivers are equal in tone, power, looks, distance and selectivity to any sets offered today. No other receivers outperform them, regardless of price, because high price and costly advertising do not make radio quality. That is determined by engineering skill, materials and careful manufacturing. Premier comes in both Table and Console Models—furnished standard in 6-tube and 7-tube "Push Pull" Also combination phonograph with electric pick-up.

Write for price and full details. No obligation.

PREMIER ELECTRIC COMPANY

Established 1905—Manufacturers Ever Since
3826 RAVENSWOOD AVENUE

CHICAGO, ILLINOIS

Free Radio Apparatus

"RADIO" will present you with one of the following premiums, free of all cost, if you subscribe now to the magazine for only one year. The full price is \$2.50. Take your choice of one of the following premiums, which we will send to you postpaid, in return for your subscription.

Set of Spintite Wrenches
or Continental Control Switch
or Latest November 11th Log Book
or General Radio SLW condenser, Type 334
or Na-Ald Midget Cone Speaker
or Three G. R. Rheostats, 6, 12 and 25 ohms.

OR—

1 year subscription to MOTION PICTURE MAGAZINE
or

1 year subscription to SUNSET MAGAZINE
or

1 year subscription to PICTORIAL REVIEW.

Subscribe for 2 years (\$5.00) and get either the new heater type Arcturus detector or amplifier tube, type 126H or 127.

Or—Subscribe for 5 years (\$12.50) and get an AIR KING SHORT WAVE FIT FREE. This great offer will be withdrawn shortly. ACT NOW. Get your subscription in the mails. We ship your premium on the same day that we receive your subscription.

"RADIO"

428 Pacific Building
SAN FRANCISCO, CALIFORNIA



New York's Newest Hotel The Piccadilly

227 West 45th Street at Broadway
NEW YORK

Adjacent to Every Activity. 600 Bright, Sunlit Rooms. Each with Bath, Electric Fan, Ice Water. Single Room & Bath, \$3.00 Double Room & Bath, \$4.50 Exceptional Restaurant and Luncheonette. Wire at our Expense for Reservations. F. D. SOFIELD, Mgr. Dir.

RADIOADS

A CLASSIFIED ADVERTISING SECTION READ BY BETTER BUYERS

The rate per word is eight cents net. Remittance must accompany all advertisements. Include name and address when counting words.

Ads for the February Issue Must Reach Us by January Fifth

IMAGINE AN ORGANIZATION with over 4,000 clients scattered throughout the world, all radiowise dealers, builders, experimenters, hams. Over \$50,000.00 stock of high grade receiving and transmitting parts only, no sets. Spend \$5,000.00 yearly on our own experimenting. Carry nothing until it passes our tests. 50c brings prepaid over four pounds catalog, circuits, data, etc. Weekly data (more than all radio magazines together)—20 weeks, \$1.00; 52 weeks, \$2.50. Sample "Over The Soldering Iron," 32-page experimenter's magazine, 25c. Full trade discounts to licensed hams and radiowise builders. We carry approved items advertised in RADIO. Kladgo Radio Laboratories, Established 1920, Kent, Ohio.

NAVY SURPLUS 800 brand new ball bearing generators, General Electric 24/1500 volt, .233 ampere, \$37.50; extension shaft, \$3.00; 24/750 volt, .2 ampere, \$27.50. Crocker-Wheeler 24/1500 volt, 450 watts, \$45. Holtzer-Cabot 12/500 volt, 35 watts, \$20. 500 watt, 500 cycle with exciters, \$15. 900 cycle complete with transmitter, \$30. Others in stock. Fotos and literature. Henry Kienzle, 501 East 84th Street, New York.

ALFALFA SEEDS, hardy common varieties, \$8.40, \$10.20, \$12.60 bushel; Grimm variety Alfalfa seed \$18. Scarified sweet clover \$3.90, \$5.20; Alsike or red clover \$15. Bags Free. Send for samples and catalogue. Kansas Seed Co., Salina, Kan. (3T)

FREE TO THE FIRST HUNDRED CUSTOMERS ONLY, pound Kester Solder with purchase of the highest grade Electrical Iron made at the bargain price, \$2.00 postpaid. Additional solder \$.50 pound. Oravec, 1240 North Keeler, Chicago.

FOR SALE.—Scott's Shield-Grid Super. Very selective and a wonderful set that upholds the claims of its designer. Completely wired and ready to go for the wholesale price of the parts only. \$85. J. W. Howlett, Santa Paula, Calif.

"B" ELIMINATORS REPAIRED. New Condensers installed; Chokes, Transformers, etc., repaired; \$2.00 to \$4.00. Fast Service. Clark Brothers Radio Co., Albia, Iowa.

REJUVENATE OLD BATTERIES. Rebuild for \$2.98. Get our cut prices on battery molds, groups, boxes, etc. Wonderful money making plan. Lightning Battery Co., St. Paul, Minn.

SPEAKERS REPAIRED. Rewound, Magnetized, Guaranteed, \$1.50 to \$2.50. Fast Service. Clark Brothers Radio Co., Albia, Iowa.

FOR SALE.—No. 2 Omnigraph, 15 Dials. Used eight months, and is yours for \$22.50. Raymond Dennis, 303 Campus Ave., Pullman, Wash.

WANTED—Men to work with National Radio Service organization. No selling scheme. Radio Doctors, Inc., Dept. R, Essex St., Salem, Mass.

MAKE MONEY WITH PATENTS! We offer patents with money-making possibilities; circular free. Floyd Clymer, Denver, Colo. (2T)

RADIO STATION stamps bought, sold and exchanged. Chas. A. Phildius, 510 East 120th St., New York, N. Y. (2T)

FOR SALE.—Latest model Best's Shielded Grid Super without cabinet. Perfect condition. \$100. Address Owner, 1129 Mandana Blvd., Oakland, Cal.

BIG PAY.—South American work. American firms pay fare, expenses. South American Service Bureau, 14,600 Alma, Detroit, Mich.

NEW LOG BOOK

Corrected to Nov. 11. With all new allocations. 25 CENTS POSTPAID

"RADIO," Pacific Bldg., San Francisco

SHERMAN SQUARE HOTEL

70TH ST. & B'WAY NY

CONVENIENT

HOMELIKE

QUIET

COMFORTABLE

EXCELLENT FOOD AT MODERATE PRICES

COURTEOUS SERVICE

SINGLE ROOM AND BATH

\$2.50

FOR TWO

\$4.00

REASONABLE RATES
WIRE AT OUR EXPENSE

in
Philadelphia
Your Choice Should Be
The

HOTEL MAJESTIC
BROAD ST. AND GIRARD AVE.

400 LARGE ROOMS

Only Hotel in Philadelphia with a subway entrance from main lobby.

MOST MODERATE RATES!

Single room, running water	\$2.00
For two	\$3.50
Single room, private bath	\$3.00
For two	\$5.00-\$6.00

↓
Garage Connected with Hotel

↓
Wire at our expense for Reservations
JNO. C. GOSSLER, Mgr. Dir.



Free

A Continental Control Switch will be given free with a one year subscription to RADIO (\$2.50) if you act immediately. Only a few on hand.

"RADIO"

Pacific Building San Francisco

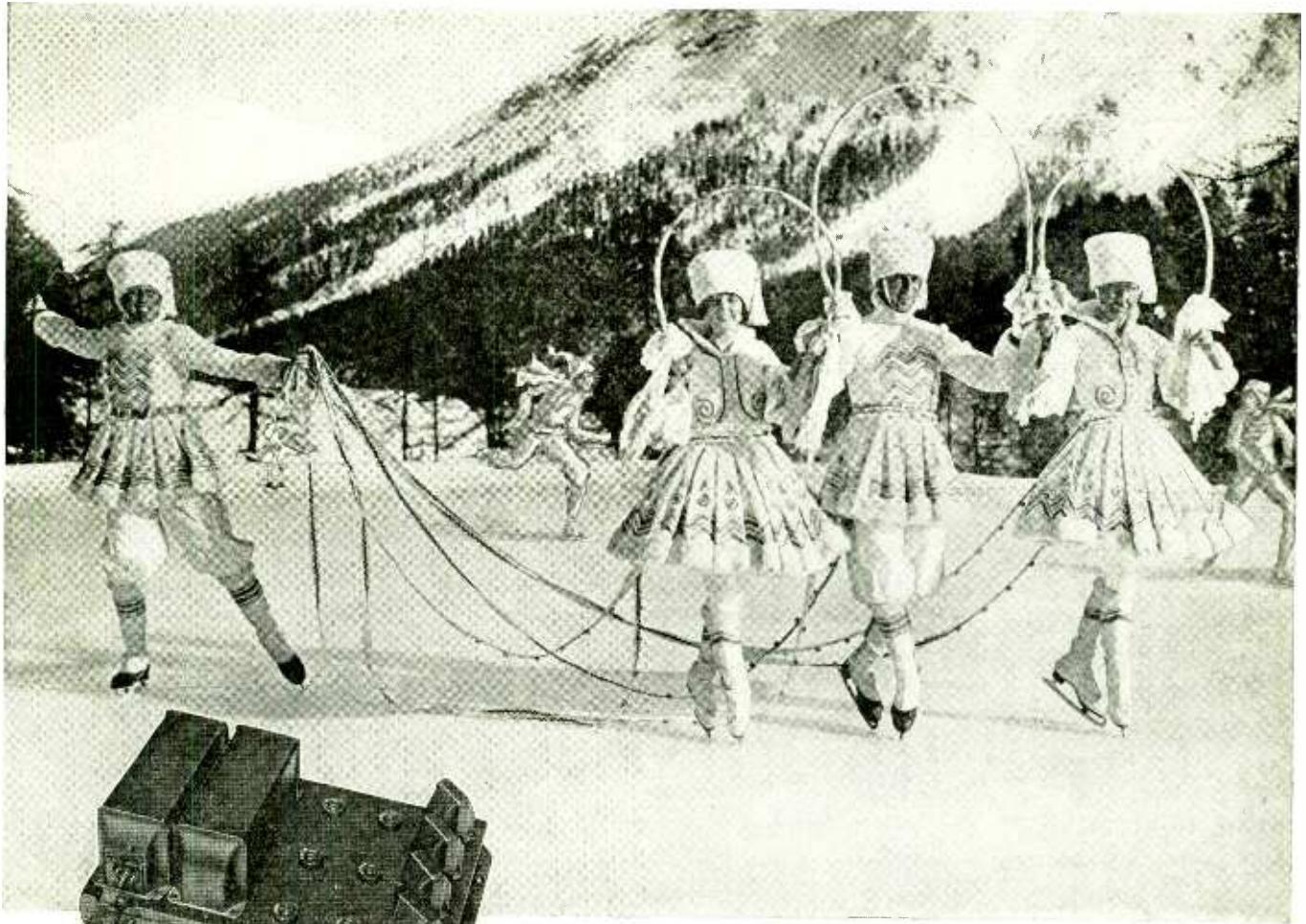

PAM 19 or 20
Price without tubes
\$175.00

Successful Carnivals Must Have PAM Music

Carnival Music must be heard over large areas—above the shouts and laughter of the skaters, and the ring of skates upon ice.

Make your carnivals, at the club or public rink—indoors or out—a great success this winter with crystal clear music and plenty of it. For clear-cut announcements, use a MIK 1 two stage microphone input amplifier which is designed for use with any of our PAM amplifiers.

The PAM-20 is identical with the PAM-19,

except that it furnishes in addition field current for a dynamic speaker designed to have its field energized by 90 to 165 volts direct current. For all other types of speakers, including dynamics, having their field energized from storage battery or AC 110 volt 60 cycle, use the PAM-20. Both amplifiers are designed to operate from 105 to 120 volts 50 or 60 cycles AC.

Send for handsome folder R3, describing the above and other Samson PAM Amplifiers which are also a "Sound Investment"

Main Office: Canton, Mass.
Manufacturers Since 1882

Samson Electric Co.
Member R. M. A.

Factories at Canton
and Watertown, Mass.

New Admiralty Model NORDEN-HAUCK **SHIELDED SUPER-10**

FEATURES

10 tubes used. Five 222 screen grid R.F. amplifiers, 200A detector, two 240 Hi-Mu's and two 210 tubes in the power audio amplifier.
Extremely sensitive—long range.
Totally shielded.
Super-selective—10 Kc. separation.
Perfect quality of reproduction.
Indicating Meters on Panel.
Removable R.F. Transformers for all wavelengths up to 25,000 meters.
Electric or Battery operated.
Simple to operate—only two major tuning controls.
A laboratory precision Instrument built according to U. S. Navy Standards.

Complete attractive illustrated literature sent upon request. Full size genuine Blue Prints and constructional data \$2.00 Postpaid.

Write, telegraph or cable today

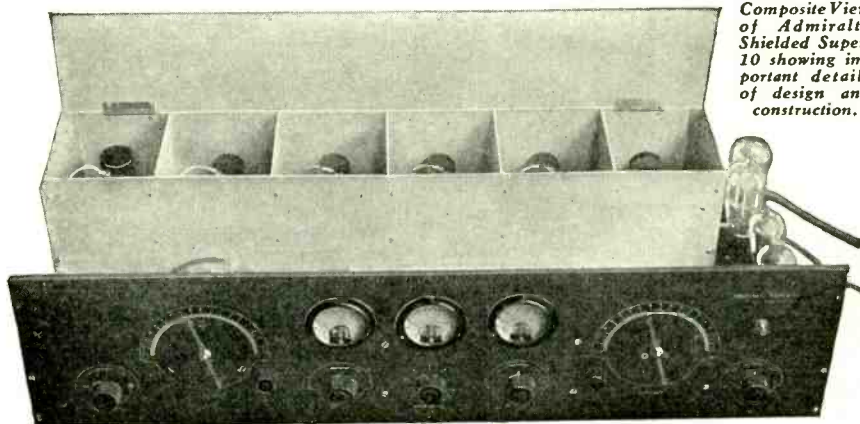

Composite View of Admiralty Shielded Super-10 showing important details of design and construction.

This great new Receiver is far in advance of competition. It is a powerful 10-tube model incorporating the most complete and up-to-date principles. Using the new screen grid tubes in the R.F. amplifier and push-pull audio system, make this new model the outstanding development in Receiver designs for years.

NORDEN-HAUCK, Inc., Engineers

Dept. R, Marine Bldg., Philadelphia, Pa.

CABLE—NORHAUCK

BUILDERS OF THE HIGHEST CLASS RADIO APPARATUS IN THE WORLD

POWERIZER

REG. U. S. PAT. OFF.

SALES AND SERVICE STATIONS HAVE NO COMPETITION THIS YEAR!



Complete A-B-C Supply for A.C. tubes 226, 227, 171

While the ordinary dealer is trying his darnedest to sell A.C. Electric Sets, **POWERIZER SALES AND SERVICE STATIONS** are allowing 100% trade-in value on the battery set on which the owner is already sold.

If you have the equipment and the ability, write in for the Powerizer Sales and Service Station proposition.

There are nearly six million battery sets from Maine to California—Conversion of battery sets and Power Amplifier installations will be *the* thing this year. Write for Bulletin P. R. 1022.

Radio Receptor Co., Inc.
106 Seventh Avenue, New York

Licensed by Radio Corporation of America and Associated Companies

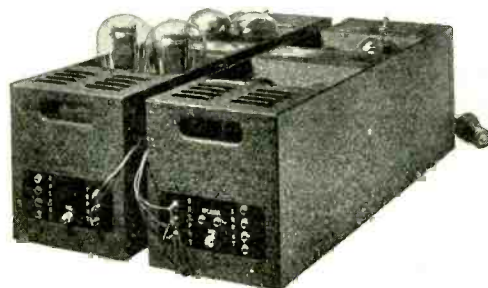

The Most Powerful 3-Stage Push-Pull Audio-Amplifier

No More "Call Backs"

when you service
with a

SUPREME

A Real Money Maker for Dealers
and Service Men



Model 400A

The Only Instrument on the Market That Will Make All These Tests

The SUPREME is the only service instrument that makes oscillation tests on all radio tubes—the true measure of the value of a tube.

The exact working conditions of any tube from 1½ to 15 volts, including screen grid, heater type, and rectifier tubes are shown by meter readings; the only instrument that shows output of rectifier tubes on meter.

The oscillation tests from alternating current are made possible by the exclusive self-contained SUPREME Power Plant. Every radio engineer and service man will appreciate this feature.

The SUPREME radiator sends out a modulated wave. Simply plug into A. C. line. No more wasting valuable time on broadcast stations; always at your service and finer adjustment assured. Condensers can be balanced or synchronized—not by the former tedious methods—but with both meter reading and audible click. Easy and much more accurate.

All continuity tests can be made from socket on either A.C. or D.C. sets, with independent cathode readings.

The SUPREME heavy duty rejuvenator provides scientific method of rejuvenation of any thoriated filament tube. Will reactivate up to 12 tubes at one time without removal from set. Push a plug—the SUPREME does the rest.

The SUPREME will give direct reading of amplifying power of tubes and will show actual working condition of all tubes. The SUPREME will play radios with open transformers and will give condenser, choke coil output and capacity output on radios not wired for that purpose.

Access is provided to all apparatus through pin-jacks. Will test condensers for breakdown. Contains various fixed condensers from .001 to 2 mfd., a 30 ohm rheostat, a 500,000 ohm variable resistance, and an audio transformer, for instant use and various combinations.

It will give plate and filament voltage readings with or without load; will test voltage and current of all radios, including those using tubes such as 210 and 250. It will give grid circuit readings up to 100 volts; will test output of trickle charges, or any output up to 2½ amps.

IN FACT, THE SUPREME WILL GIVE YOU EVERYTHING THAT CAN BE OBTAINED WITH ALL OTHER SET TESTERS AND ANALYZERS COMBINED. AND IN ADDITION WILL PROVIDE MANY OTHER REALLY IMPORTANT TESTS THAT CANNOT BE OBTAINED BY ANY OTHER MEANS.

The Sign of Efficient Radio Service



Radio Owners: Look for this emblem in your radio shop or on the button worn or card carried by your service man. *IT IS YOUR GUARANTEE OF DEPENDABLE SERVICE.*

The Model 400A Supreme is not only the most thorough and complete testing apparatus available, but the instrument comes in a handsome brass bound traveling case especially designed for use by the practical service man. This case is most complete and convenient in its appointments, providing adequate and easily accessible compartments for all tools, accessories and supplies. It also contains a special swinging tube shelf providing absolute protection and instant accessibility to tubes. Complete set of tools and materials, from electric soldering iron to screw-driver, is furnished, each located in its proper place in the case. All of this is accomplished by ingenious design without making the case bulky or cumbersome; the exterior measurements of the case being only 18 in. x 10½ in. x 7 in., and the weight approximately 23 lbs. complete.

Instrument lifts out of traveling case for store or laboratory use.

Three Weston Meters

Mounted in Bakelite cases.

1 Voltmeter, three scales of 0/10/100/600, 1000 ohms per volt.

1 Millammeter, of 125 mils and 2½ amps.

1 A.C. Voltmeter, three large scales of 0/3/15/150.

USE THE SUPREME IN MAKING INSTALLATIONS AND REPAIRS. BALANCE THE RADIO FREQUENCY TUBES. TEST ALL TUBES AT TIME OF SALE. ASSURES YOUR CUSTOMER MAXIMUM RESULTS, SAVES TIME AND INCREASES PROFITS FOR YOU AND CREATES GOOD WILL THAT BUILDS BUSINESS. WITH THE SUPREME, ONE MAN DOES THE WORK OF THREE AND DOES IT MORE ACCURATELY AND EASILY. BECAUSE IT SUBSTITUTES SCIENTIFIC ANALYSIS FOR GUESS WORK.

Prices and Terms

Under our time payment plan the Model 400A SUPREME can be bought for \$38.50 cash and 10 trade acceptances (installment notes) for \$10.00 each, due monthly. Cash price, if preferred, is \$124.65. All prices are net and do not carry dealers' discounts.

SEND NO MONEY

The SUPREME must sell itself to you on sheer merit and performance. We are willing to place it in your hands for actual use in your service work, and allow you to be the sole judge of its value. Fill out and sign the following request for six-day trial:

REQUEST FOR 6 DAY TRIAL

Date.....
Supreme Instruments Corporation,
309 Supreme Building,
Greenwood, Mississippi.
Please ship me one Model 400A Supreme.
Upon delivery of the instrument I will deposit with the express agent either the cash price of \$124.65 or \$38.50 cash and 10 trade acceptances (installment notes) for \$10.00 each, due monthly, at my option, subject to the following conditions:
It is agreed that the deposit made with the express agent shall be retained by him for six days. If, within that time, after testing the instrument I am not entirely satisfied, I have the privilege of returning the instrument to the express agent in good condition, with the seal unbroken (see note below) and all tools and parts intact. Upon such return and upon the prepayment of return express charges, the deposit I have made with the express agent will be promptly returned to me.

Signed.....

Firm Name.....

Address.....

City..... State.....

Please send three or more trade references, including at least one bank, with this coupon.

NOTE: The seal on the panel of the instrument covers the master screw in the assembly. It is never necessary to disturb this, and it does not in any way prevent or restrict the use of the instrument. Factory guarantee ceases with disturbance of seal.

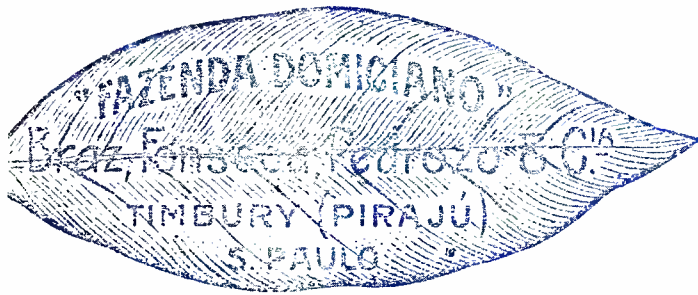

END. TELEGRAPHICO:

BRAZ, PIRAJÚ

CODIGOS USADOS:

A. B. C. 5 TH EDITION

BRASIL

PRIVADO

Fazenda Domiciano,

October 28, 1928

DECTADA POR: 5000

ESCRITA POR:

RESPONDENDO A SUA DE:

ASUMPTO: *Congratulations.*

*Browning-Drake Corporation
Cambridge, Mass., U.S.A.,*

Gentlemen

I live here in this my coffee farm, 500 miles from São Paulo, 950 from Rio de Janeiro and 1,800 from Buenos Ayres.,

I have noney enough to buy all the Sets I want and, by Jove, I have done it., I have had all the Victus, Radiolas, Selects, Zeniths, Magestics, Fids, Strombergs, SuperHartleys made by myself and "magna caterus",,, but I have found no other than your little Model 6-A. in connection with a 560 A. V. Western Electric Loud Speaker.,

For that reason I want to shake hands with you.,

I tell always to my friends:—Who that do not want but noise, may buy any other radio set, but who that want real music cannot buy a better set than theBrowning-Drake.,

Yours truly

E. de Moura Fonseca.

Please excuse my bad english., In 1911, when I was 18, I used to be a brasilian student in that dear old Chicago town, but since that time I have no more written in e nglish