

# RADIO

WITH WHICH IS INCORPORATED "RADIO JOURNAL"

VOLUME IX

APRIL, 1927

No. 4

## *Radiatorial Comment*

Now that radio transmission is to be governed by law under the new radio commission, public interest centers on what this commission may do to clear up the chaos that ensued while there was no adequate law. This chaos is evident in the mutual interference which listeners suffer between various services. This interference is a symptom of a fundamental fault in the system, or rather lack of system, under which radio has recently developed.

### **The Problem of Radio Regulation**

Diagnosis shows that this fault is due to the attempt of more stations to occupy a given space simultaneously than that space can accommodate. The overcrowded conditions in the worst city tenements are mild in comparison. The nearest parallel case is the congestion in automobile and street railway to traffic during rush hours.

Three obvious remedies are available: either reduce the number of stations, or increase the space occupied, or divide the time used. Which of these three remedies would best relieve the trouble and work the least hardship is difficult to determine.

To reduce the number of broadcast stations, of which there are now over seven hundred, would aggrieve those who might be excluded. They may object to what amounts to a virtual confiscation of their property when they are refused a license to use their equipment. The courts may sustain them in their objection. Judging from the litigation that has arisen over the somewhat similar contentions regarding the right to use water, we may expect a long list of court decisions regarding the privilege of using radio channels, even though the law expressly provides that a station has no proprietary right in the use of a wavelength.

The two guiding principles in the settlement of disputes over water have been that of the most beneficial use and that of priority of use. These principles may likewise be applied to radio when the most beneficial use is that which most benefits the listening public and the prior use is that of the pioneer. The former principle is implied in the new law when it gives the commission authority to grant a license, if public interest, convenience, or necessity is served thereby. The latter is recognized as simple equity.

While the commission has the power to disbar any station, its decision is subject to court appeal. So as to obviate the possibility of a reversal of its decisions and also allow more room, the commission may enlarge the band of wavelengths devoted to broadcasting.

### **Extension of Waveband**

By opening up the band between 150 and 200 meters (2000 to 1500 kilocycles) 50 more 10 kilocycle channels would become available. This would give a total of 159

channels as compared with the 89 now in use. While this would not accommodate seven hundred stations without interference, it would greatly reduce the heterodyning that now occurs.

The 150 to 200 meter band is now mainly devoted to amateur transmission. Part of it is also reserved for governmental service, which could find space elsewhere, and for point-to-point communication in the Hawaiian Islands, which does not interfere with continental transmission. The amateurs make but little use of it as they are getting better results on 40 and 80 meters. They would undoubtedly acquiesce in its relinquishment to broadcasting.

If this band were opened up, the pioneer stations could use the longer wavelengths and the newcomers be assigned to the shorter. Any present receiver can be cheaply adapted to receive 150 to 200 meters, which eliminates a fundamental objection to their use. Furthermore they will probably be found to be much better in distance covering ability than the longer waves so that the stations that secure them will be the gainers.

One objection that has been raised to this proposal is the necessity of conserving this space for some possible future need. Much of such conversation about conservation avoids the truism that conservation is wise utilization. Whereas a demand may now exist for utilizing this space for broadcasting, there is nothing in the law to prohibit its use for some other radio service yet to be developed. The space is not destroyed by use, as would be coal or oil. So posterity would suffer no deprivation by such present action.

The third alternative, that of time division between stations, is already partly accomplished by the three-hour difference in time between the Atlantic and the Pacific Coasts. It has also been locally employed successfully in cases where some stations desired only certain hours or days which dovetail between those wanted by another. But it has usually been accompanied by the objection that it confiscates part of the station's opportunity to give return on its capital investment, and to serve its public.

The choice between these several plans will be difficult, especially as applied to individual stations. Undoubtedly the doors will be at least temporarily closed to any new stations until provision can be made to take care of those already on the air.

The entire matter is now in the hands of the commission. The results of their deliberation will be announced in due time. And when they are, the public should give a fair trial to the new plan, whatever it may be. Public tolerance and co-operation will be essential to any scheme designed to improve service to the public.

# The Passing of A Pioneer

Some Recollections of Wireless Before It Was Radio

By George E. Baxter

THE dismantlement of KFS, the Beach Station at San Francisco, marks the passing of a pioneer at the advanced radio age of seventeen years. The mighty towers which stood near the Golden Gate as guards of the Pacific, were felled late in January of this year and every vestige of the sta-

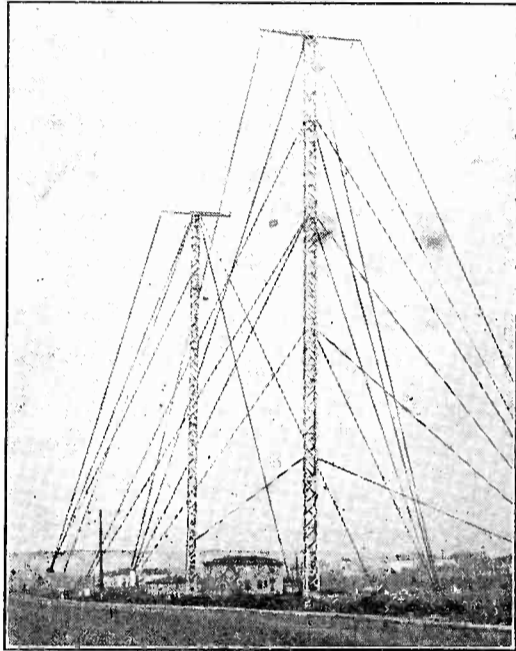

Old Lattice-Work Tower at KFS, Now a Thing of the Past.

tion is gone from the site. Thus progress and the demands for residential expansion take their toll.

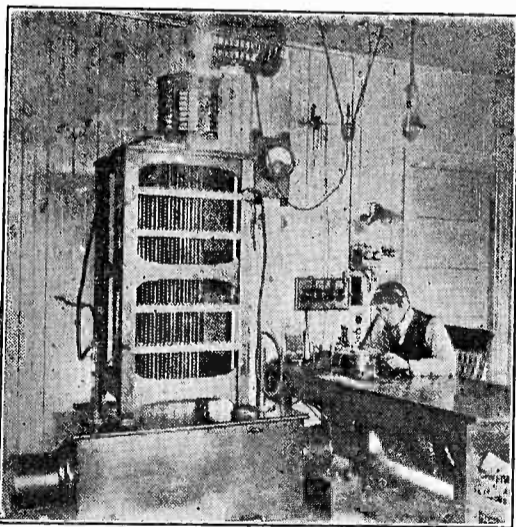

7½ K. W. Transmitter and Receiving Equipment at the Massie Wireless Station, San Francisco, 1907-1909.

The Beach Station was the first sea-level station to be built on the Pacific Coast. The radio engineers had previously contended that efficient operation depended more upon altitude of location than closeness to water. The first California station was erected on top of Mt. Tamalpais. The next in 1907 was on Russian Hill in the heart of the North Beach district of San Francisco. But as the residents strenuously objected to the staccato crashes of the open spark gap it was removed

to the top of the Chronicle Building and there operated until the "Hillcrest" station was completed in 1910.

In the meantime the Massie Wireless Company erected a 7½ k.w. station in the Richmond. Its apparatus was then the last word in radio accomplishment, although, as may be noted in the picture, it would hardly attract more than passing interest outside of a museum today.

By July, 1910, the engineers of the Federal Telegraph Company decided that the elevation of a station above sea-level was not as important as was the benefits to be derived from a good

points was the determining factor in the radiating qualities of the transmitting unit. This was a veritable bombshell in the ranks of the theorists and marked a new step in the advancement of the art. A site was selected on the Beach, and construction was started in the face of much opposition. All eyes were turned toward the new venture to see whether or not the new theory would hold water. And so it was that the Beach Station was erected on the rolling waste of sand dunes and salt grass which is now the beginning of a new residential district.

Apart from the radical change in the antenna and ground systems, these engineers were interested in a new method of signalling known as the Poulsen Arc for the propagation of continuous waves (CW) and the first wireless transmitter to be silent in operation. When the station was completed in September, 1910, it was the first time that the Poulsen system was given a tryout in the United States.

Although the original arc was extremely crude, the success of the station was apparent from the start and it was but a short time before improvements were made which permitted the use of much greater power than was at first believed possible. From the original transmitter of 10 kilowatts—a powerful transmitter at that time—the Federal engineers developed an arc of 30 kilowatt capacity. Then, in rapid succession, arcs of 50, 100 and 250 kilowatts were developed and operated successfully until at the beginning of the world war these engineers were engaged in

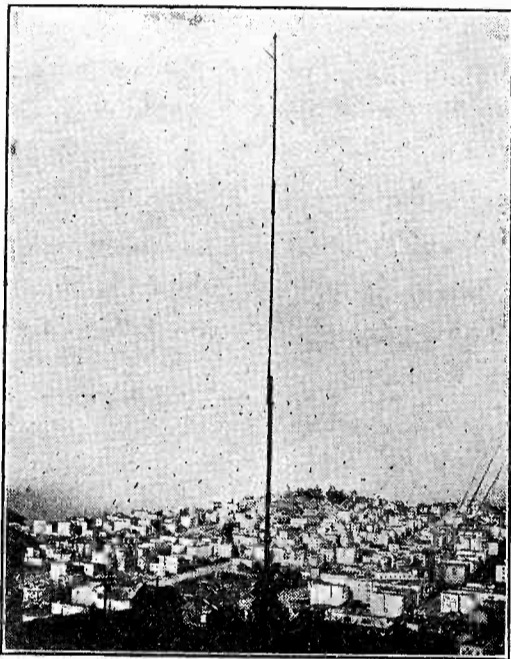

Russian Hill "PH" Station of the United Wireless Co.

ground connection. They figured that the antenna and ground connections were, in effect, a condenser and therefore that distance between these two

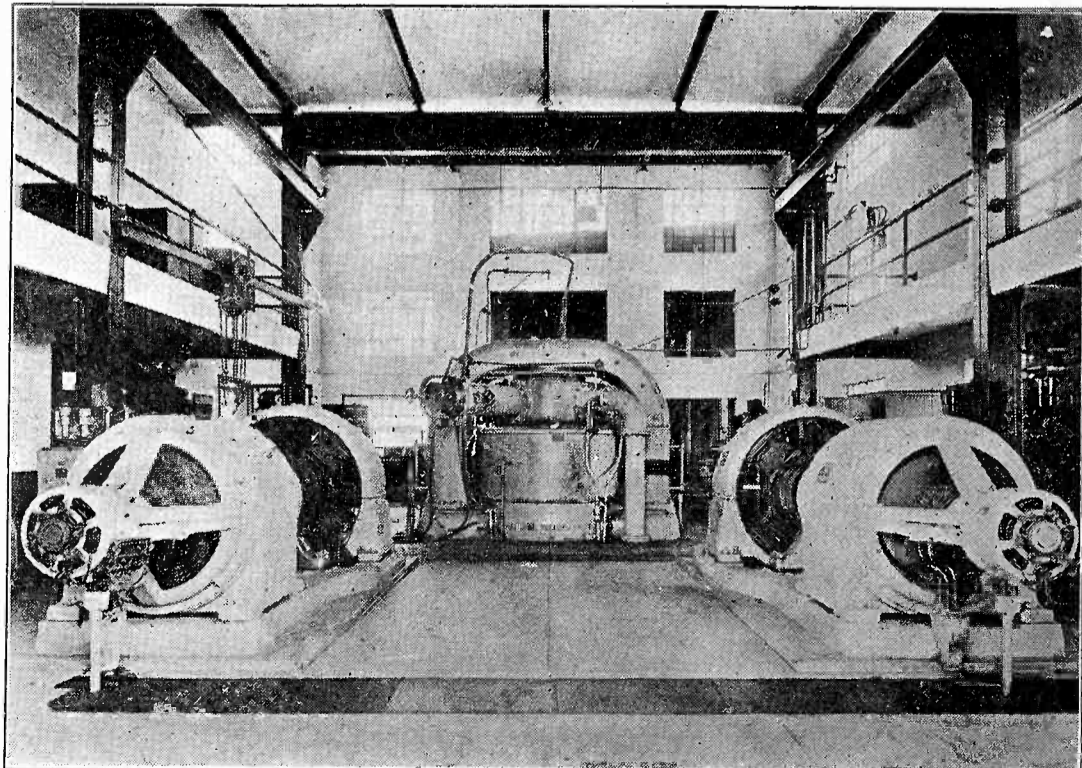

500 Watt Arc Transmitter at Pearl Harbor, T. H.

installing a 500 kilowatt arc transmitter for the United States Navy Department at Annapolis, Md. The successful operation of this installation proved conclusively that the use of high power in radio transmitters was not only possible but was highly practicable and great distances were easily spanned by the new equipment.

As a final test, a 1000 kilowatt transmitter was built at the Palo Alto factory and shipped to Bordeaux, France, soon after the United States entered the war. Its installation and successful operation at the "Lafayette" Station marked the height of development of this type of transmitter and shortly after the station was officially turned over to the Navy, they, in turn, presented it to the French Government. It is now serving in the trans-Atlantic service.

Thus it will be seen that the Beach Station was the original arc and CW commercial installation in this country and its early performance was responsible for much of the development of continuous wave transmission throughout the world.

During the world war, the Beach Station was taken over and operated by the Navy Department as a war necessity and many improvements were made in the building for the accommodation of the large force of operators and engineers quartered there. It was not until 1921 that control was resumed by the Federal Telegraph Company. In the following year the station played an important part in the rescue work connected with the burning of the *SS City of Honolulu* which, after being ravaged by fire, finally sank in mid-ocean.

Due to the exceptionally long distance obtainable with the arc transmitters during the daylight hours, the Beach Station was able to effect direct communication with the Steamer *West Faralon* which was approximately 1200 miles west of San Francisco at the time the *City of Honolulu* foundered and the former vessel was ordered to proceed to

the scene of the disaster and render all assistance possible to the passengers and crew of the ill-fated vessel who were then adrift in the lifeboats. Had this not been possible, the work of rescue would have been delayed several hours, adding to the discomfort of the occupants of the open boats, who were at the mercy of the seas.

Since that time, the station has participated in several equally thrilling rescues—the details of which read more like magazine fiction than coldblooded facts. And many an injured seaman owes his life to the KFS operators who, through their prompt handling of medical messages to the U. S. Marine Hospital in San Francisco, have rendered invaluable service to the ships that carry no doctors. Medical assistance in such cases is but one of the many free services rendered by radio in the cause of humanity.

The consistency with which the station has carried on long distance communication with vessels in all parts of the Pacific has meant much to the shipping interests of the Pacific Coast. In

considered exceptional for communication to be established with vessels from four to five thousand miles distant. Ships that sail majestically through the Golden Gate are soon forgotten by those on shore, but not so with the operator at KFS. His work starts when the ship

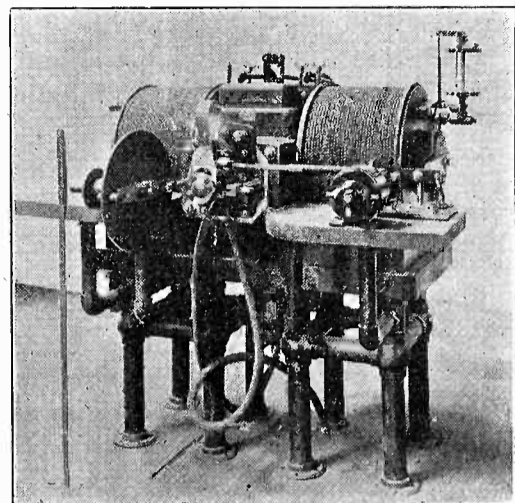

*Original Arc Transmitter.*

has cleared the harbor and it does not stop until it has reached its destination whether it be New York, Sydney, Manila or Nome.

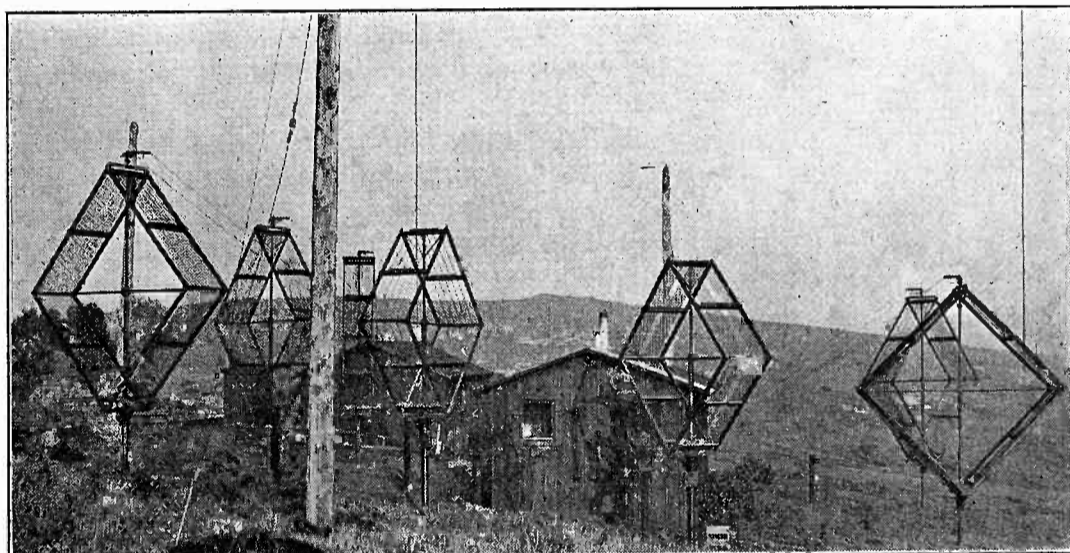

*Federal Telegraph Receiving Station at Daly City, San Francisco, 1927.*

every day routine, the operators work with vessels in Australian, Chinese, Japanese, Alaskan, Panama, Carribean and West Atlantic waters and it is no longer

The new "Daly City Station" is one of the most modern stations in existence in any country. The receiving apparatus and the operators are located at Daly City while the transmitters and the engineers are located on the Marsh land near Palo Alto. By using this method, it is possible to work with two ships simultaneously. The very latest type receivers have been installed and work in conjunction with a loop and antenna system known as a "barrage," or, directive reception. Telegraph wires connect the station with the main office of the Federal in the heart of San Francisco while a city telephone connection insures personal contact between the operator on watch and the various steamship officials who will be able to secure firsthand information regarding the movement of their vessels with just as much ease as if the telephone connection were extended to the vessel itself.

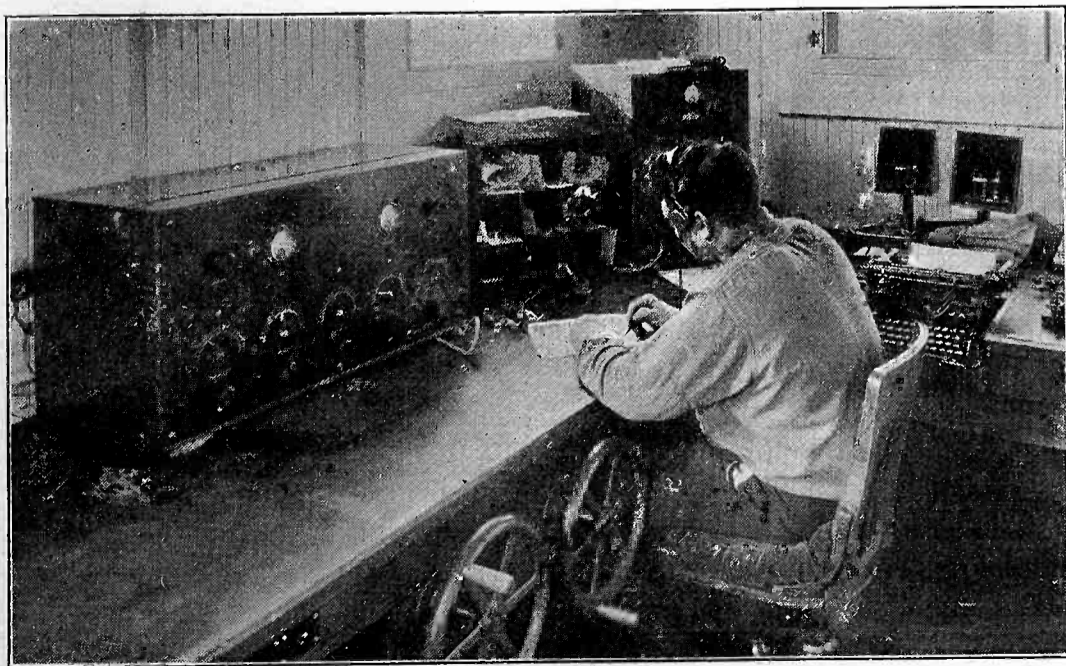

*The New KFS Operating Room at Daly City.*

# The Dweller on the Threshold

A Compilation of Observations on the Relationship Between Static and the Weather

By Earle Ennis

IN a world of scientific achievement, where radio represents but a harness by which the new horse of civilization is driven, there remains a mystery which defies the best-trained of the modern investigative brains—Static! In its elfin way it flits in and out. It cajoles. It allures. It threatens and intrigues. And when the scientist reaches for his salt-shaker, it flirts its independent tail and is gone into infinity.

The name of this elfin exasperation is legion. America calls it static. England prefers "atmospherics" as more indicative of its home. France and Germany, with greater scientific accuracy call it "X"—the unknown. The ship operator hears it rattle in his "cans" and dubs it "QRN" in the designation of the international code, and the broadcast listener hears it in his loud speaker and calls it noise. But in the laboratory it is the omnipresent "Dweller on the Threshold" who never reveals its purpose or its destiny.

The expressions of static are as myriad as the sands of the sea. Sometimes it drums like the hoofbeats of the Four Horsemen. Sometimes it taps like spirit fingers on the windows of human consciousness. Sometimes it crashes with the thunder of the gods. And sometimes it swings with the rhythm of a vast ocean, as though waves from some far planet were beating upon the shores of Mother Earth, or whispers through the stilly watches of the night like a distant Lorelei, conscious of her hidden power.

Of all the agencies that have undertaken to unveil this mystery of the electrical world, Uncle Sam has been, perhaps the most indefatigable, utilizing every resource of at least five departments of the government continually over a period of years to arrive at some answer to the queer phenomenon which hinders but never helps radio transmission and reception. In England the Royal Meteorological Society has cooperated, not especially with our government, but in the compilation of data so that in the final additions of the two agencies, much that is interesting has been learned.

Perhaps the outstanding observation of the government was made by the *U. S. S. Kittery* whose itinerary took in Cuba, Haiti, Porto Rico, and the Virgin Islands, during which she made a close observation of weather, static and communication conditions. The ship made an astonishing discovery, viz., that a certain relationship was apparent be-

tween the state of the atmosphere as plotted on the weather map from the Arlington station broadcast, and static. This was shown by the manner in which static affected the reception of code signals from which the weather map was fabricated.

As a result of the *Kittery's* observations, it soon became apparent that the radio operator was a good barometer. Each time he complained of heavy static, there was an area of changing atmosphere between the ship and Arlington, or the ship was close to one of the islands where local static was registered as intense. In every case where static was intense there was a storm area noted in the atmospheric record. When the Nassau and Miami hurricanes swept between the *Kittery* and Arlington, all signals were completely blotted out.

The operator also noted that invariably the intensity of the static disturbance was roughly proportional to the intensity of the atmospheric pressure or the rate of change in pressure, and that when a high pressure area interposed between ship and station there was improved reception. If the high area was a large one, static was unusually mild, which led to the conclusion that static was either directly or indirectly due to the consequences of steep pressure gradients. Summed up, the *Kittery* trips showed beyond question the following "static axiom" — "Atmospheric high pressure is static free and low pressure areas are attended by heavy static discharges."

Researches into static and atmospheric conditions by the cable steamer *John W. Mackay*, off Nova Scotia, recorded by the Royal Meteorological Society of London, disclose that static discharges may be copied 2,000 miles from their course, and that there is every reason to believe that some of the discharges encompass the earth, or a distance of 25,000 miles. But, as the society aptly puts it: "The Beaufort of atmospherics is not yet!" Its says further:

"The evidence that the atmospheric was well, if rashly named is accumulating rapidly, and the summaries of the most recent work show that the location of 'cold fronts' by radiotelegraphic observations on atmospherics is an established possibility."

H. B. Jackson, London scientist of the Royal Society, remarks that "X's" are more frequent in summer and autumn than in winter and spring, near high

mountains than in open sea, in south than in north winds (in the Mediterranean), in the front of a cyclonic disturbance than in the rear, with falling barometer than with a rising one.

C. G. Crawley, also a London engineer, observes that "X's in Mediterranean are worst when pressure is low, temperature high, and the humidity low. The sirrocco forms an exception, always bringing high atmospherics."

A. Esau, Leipsic physicist, in observations conducted at Halls with a crystal detector on a plain antenna, found static to increase with increase in atmospheric transparency, wind velocity, and cumulus clouds, dust content and fog, and variable during precipitation.

Mosler, who has done a lot of research work in Berlin, discovered that static signals did not materially increase in strength or value when storms were raging over Bohmen and Saxon Switzerland and concludes therefrom that lightning static does not propagate much beyond 200 kilometers. Yet Flajolet in Paris of the Royal Academy of Sciences describes the recording of thunderstorms up to 500 kilometers by crystal detector and galvanometer.

H. J. Round, a London Marconi engineer, brings out the interesting information that the minimum of static disturbance is within one minute of sunset and considers this due to minimum air turbulence.

Observations by Franck - Duroquier for a year at Anche' (Indre and Loire) indicate that a slight "sifflement" is caused by a hailstorm passing near a receiver; violent "craquements" indicate a thunderstorm; weak "craquements" generally preceded a fall of temperature or a spring frost, while regular, strong impulses foretell gales. This investigation also showed the interesting fact that if the wind is about to turn, the static discharges were of short wave lengths and seemed to come in strings. It also showed that the approach of rain, snow or fog by increasing the conductivity of the atmosphere and ground facilitate radio communication while dryness and cold impede it.

Perret Maisonneuve mentions observations at Mount St. Aubert, Tournai which showed that an absence of static predicated fine weather; little precipitate cracklings, hail or heavy rain; distant crackling, fine weather; numerous and prolonged cracklings, stormy weather; prolonged sound like water from a gutter, change of weather; pro-

(Continued on Page 62)

# The Quadrphase

A New Single Control Tuned R. F. Receiver with Phasatrol Balancing for All Wavelengths

By G. M. Best

WHILE the construction of a single-control tuned r.f. receiver has been successfully accomplished in the factories for a long time, the difficulty in procuring accurately matched inductance coils and ganged condensers properly adjusted has somewhat handicapped the home constructor of this type of set. But such assembly becomes an easy task by using some newly developed parts now generally available. Consequently the details for building the Quadrphase, a selective five-tube set easily operated with one drum-dial, should be interesting.

The name comes from the use of Quadraformer shielded transformers and Phasatrol regulation of oscillation, combined with a Remler three-gang condenser having a single drum dial, and a high grade audio amplifier. The circuit, as shown in Fig. 1, is similar to several previously described in these columns, the antenna being conductively coupled to the secondary of the first r.f. transformer. Different adjustments of antenna coupling may be obtained by means of a three-tap switch and a small antenna series condenser.

The set was originally constructed with two Phasatrols, as shown in the picture, but experience has shown that the one in the first r.f. stage can be omitted. This unit consists of a fixed condenser shunted by a 50,000 ohm ad-

justable resistance. By placing it in the plate circuit of the second r.f. tube its reactance shifts the phase of the r.f. current so that the tube's tendency to oscillate through the capacity of its elements is obviated.

The three secondary windings of the shielded r.f. transformers are tuned with .00035 mfd. condensers with a common connection to each condenser from the filament end of each transformer. Due to the fact that the grid return of the detector may be to the positive end of its filament, for certain types of detector tubes, the grid leak is placed in a separate mounting, and not shunted across the grid condenser, as is usually done.

The audio frequency amplifier consists of two stages of transformer cou-

pled amplification, using high quality transformers. A power tube of the 112 type is recommended for average use, but the type 171 may be used without the requirement of an output transformer if the plate voltage is kept at 135 and the C voltage at 22½.

The rear view of the set shows the arrangement of the shielded r.f. coils, the three gang condenser, drum dial, and the audio amplifier. The drum dial and condenser are in one unit, and are held to the panel by the mounting nut of the dial knob and a flat head machine screw.

The subpanel, on which are mounted the coils, sockets, fixed condensers and miscellaneous apparatus, is of bakelite, and is fastened to the panel by two metal brackets, so that a clearance of slightly more than 1½ in. is available

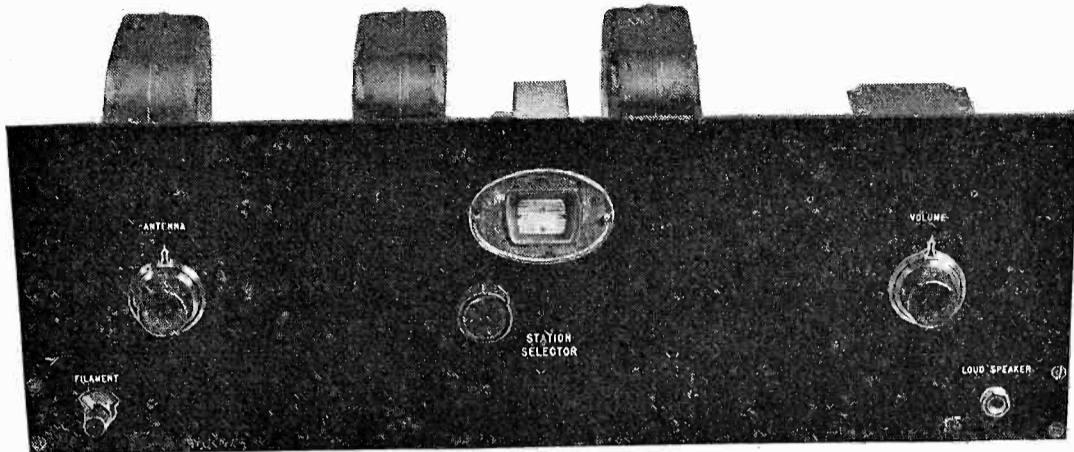

Panel View of Quadrphase.

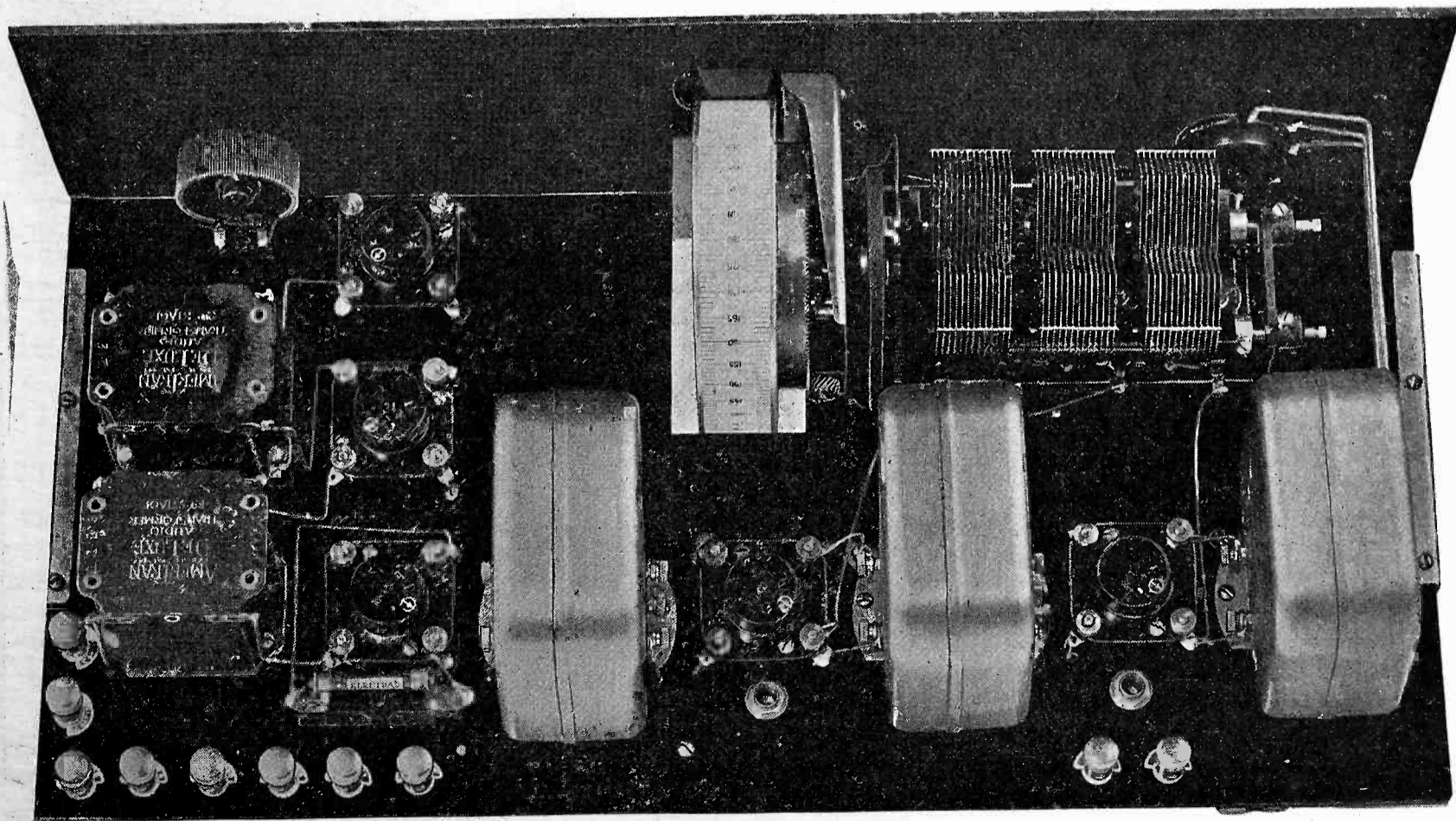

Rear View of Quadrphase.

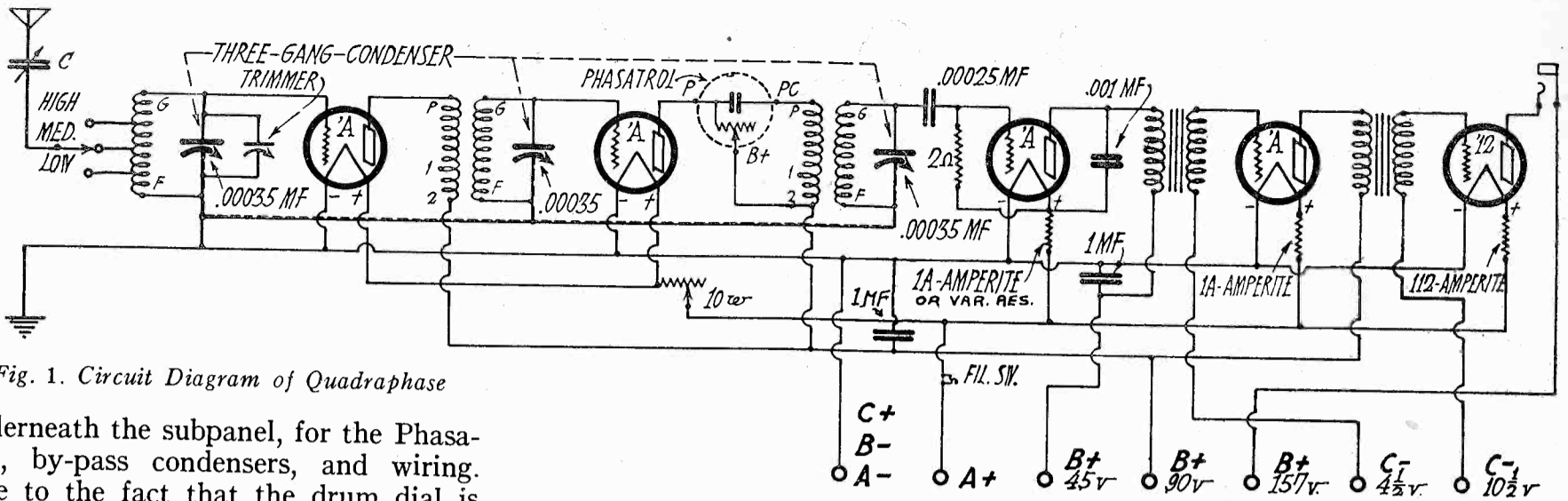

Fig. 1. Circuit Diagram of Quadrphase

underneath the subpanel, for the Phasatrol, by-pass condensers, and wiring. Due to the fact that the drum dial is rather large in diameter, the subpanel is slotted as shown in Fig. 4, so that the dial will not rub at any point. The picture of the under-part of the subpanel shows the relation of this slot to the dial, and the necessity for providing it will be more easily understood. If the panel were to be made 1 in. higher, the subpanel could be lowered  $\frac{1}{2}$  in. and the slot avoided, but this would make the panel non-standard, and the purchase of a ready-made cabinet for the set would be out of the question.

The list of parts gives the specifications for the panel and subpanel size, the brackets, and itemizes the material needed to duplicate the laboratory model. Substitutions may be made where it is deemed advisable, keeping in mind the amount of space available for each part. Since the subpanel top is 2 in. from the bottom of the main panel, no part more than 5 in. high will clear the top of the cabinet, so that this detail must be kept in mind when purchasing the material.

A drilling specification for the panel is shown in Fig. 2, the condenser mounting holes being for the unit specified in the list of parts. A  $1\frac{1}{2}$  in. hole should be cut in the panel for the drum dial port-hole, the window being mounted over this hole so that the scale of the dial is centered properly.

In the laboratory model, the antenna switch was placed on the panel at the

left of the dial, but in order to provide space for one trimmer condenser, which was found advisable in several locations where the set was tried out, the antenna switch was moved to the subpanel, and a trimmer installed in its place. This change is not shown in the picture, but is indicated on the pictorial wiring diagram of Fig. 3. As there is not much room between the panel and the end of the three gang condenser, a shallow trimmer such as the Silver Marshall No. 34 should be used. For all practical purposes this trimmer, when once adjusted, can be let alone. But it was thought best to place it on the panel so that if the antenna switch must be varied to avoid local interference, the

first r.f. coil can be lined up with the rest of the circuit without difficulty.

Assembly of the receiver should start with the panel parts. The drum dial should be fastened to the three gang condenser, and then mounted on the panel. When in place, the gang condenser should be exactly parallel with the plane of the panel. The filament switch goes at the lower left, the output jack at the lower right, the volume control rheostat at the upper right, and the trimmer condenser at the upper left. Now fasten the two brackets to the back of the panel, so that the flange is on top, and the bottom of each bracket is exactly even with the bottom edge of the panel. The subpanel fits underneath the flanges of the brackets;

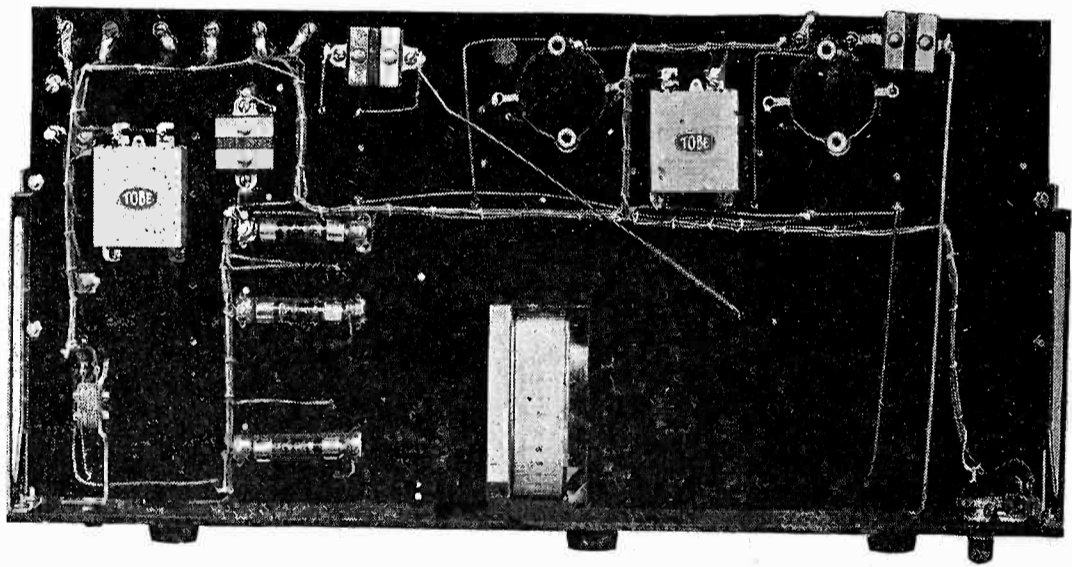

Lower Side of Sub-Panel.

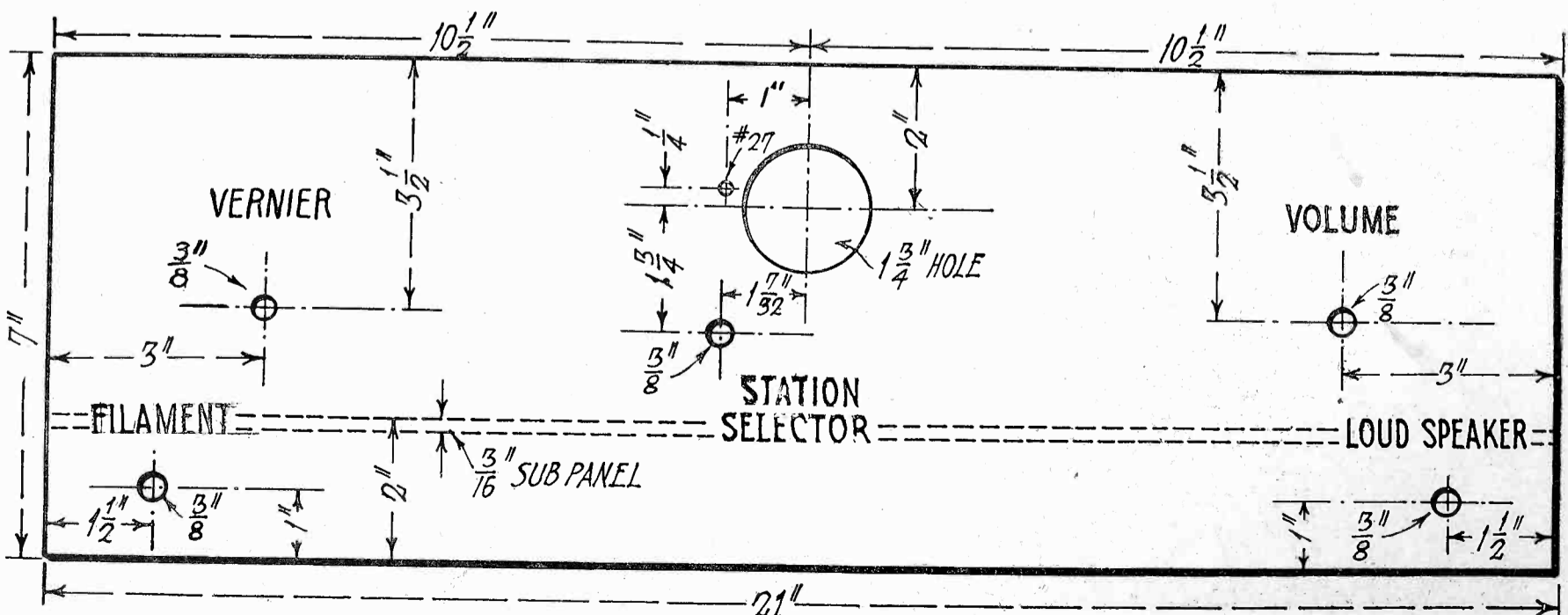

Fig. 2. Panel Layout.

if it were placed above the flanges, the slot cut in the center would not be large enough to clear the drum dial, and would have to be enlarged to such an extent that it would weaken the sub-panel.

Place the three shielded transformers in the positions shown in the picture, with the two r.f. tube sockets in between. The rear edges of the coils should be approximately 1 in. from the back edge of the sub-panel, with about 3 1/2 in. between coils. The detector and two audio tube sockets are mounted in a uniform row, with the audio transformers at the left hand end of the sub-panel, as viewed from the front. At the rear edge of the panel the binding posts are arranged, as shown in the pictorial wiring diagram.

The Phasatrol is mounted underneath the sub-panel, with the adjusting screw hole projecting through, and directly in back of the 2nd r.f. tube socket. The two 1 mfd. bypass condensers are placed underneath the sub-panel, as shown in the pictures, and the three Amperites are mounted adjacent to their associated tube sockets.

In the experimental model, a fixed antenna series condenser was employed, as the characteristics of the antenna were known, but for the average installation, it is better to provide a variable mica condenser, such as is specified in the list of parts, so that the best adjustment for the particular antenna with which the set is to be used, can be obtained.

The grid condenser is mounted underneath the sub-panel, below the detector socket, and the grid leak is placed above, in back of the socket. The bypass con-

denser in the plate of the detector is also under the subpanel. The antenna and ground binding posts are placed in back of the first r.f. tube socket.

- LIST OF PARTS FOR QUADRAPHASE**
- 1—Set Quadraformer coils, including switch equipment.
  - 5—Benjamin cushion sockets.
  - 2—Amertran DeLuxe Audio Transformers.
    - 1—Remler No. 333 Capacity Unit.
    - 1—Remler No. 110 Drum Dial.
  - 1—Frost No. 700—10 ohm rheostat.
  - 1—Frost No. 233 Pantab Jack.
  - 1—Yaxley filament switch.
  - 1—Silver Marshall No. 340 midget condenser.
  - 1—Pair Benjamin No. 8629 brackets—2 in. high.
  - 1—Electrad Phasatrol.
  - 1—XL Model G-5, Antenna Series Condenser.
  - 1—Electrad .00025 mfd. fixed mica condenser.
  - 1—Electrad .001 mfd. fixed mica condenser.
  - 2—Tobe 1 mfd. bypass condensers.
  - 2—1-A Amperites.
  - 1—112 Amperite.
  - 1—Electrad Grid Leak Mounting.
  - 1—Electrad 5 megohm fixed metallic leak.
  - 11—Eby binding posts —A, +A, —B, +B Det., +B 90, +B 135, —C, +C, Ant., Gd.
  - 1—Bakelite or Formica panel, 7x21x3/16 in.
  - 1—Bakelite, Formica or wooden subpanel, 10x20 3/4 x 3/16 in.

All apparatus is fastened to the sub-panel with 6-32 round head machine screws, drilling the holes with a No. 33 drill and threading them with a 6-32 tap. One of the screws holding each audio transformer in place should be at least 1/2 in. long, so as to enable the placing of a soldering lug, and lock nut under the sub-panel.

Wiring the set is a matter of individual preference, insofar as the style of wire used, and the method of making the connections. The writer prefers to run all filament, ground, negative and positive B and C battery wires in insulated flexible or solid wire, following

a path as is shown in the picture and wiring diagram, cabling all wires together after they are in place, and the terminals soldered. Drill holes through the subpanel directly underneath each tube socket soldering lug, and at the corners of the audio transformers, for the B and C battery wires.

The gang condenser comes with the rotor terminals of the center condenser reversed, so that no two grids will have condenser connections adjacent. If all three grid connections were to rotors placed in line, shielding would be necessary. The filament connection to the condenser is made to the three lugs next to the panel, and the grid connections are made to the three lugs on the opposite side. The grid wires for the two r.f. tubes are made directly to the grid terminals of the sockets, but the grid connection for the detector is made underneath the subpanel. Connect the trimmer condenser in parallel with the first unit of the gang condenser, at the left hand end of the front panel. Solder a wire to the lug connected to the top of the tension spring on the gang condenser shaft, and connect this wire to ground, so as to ground the drum dial

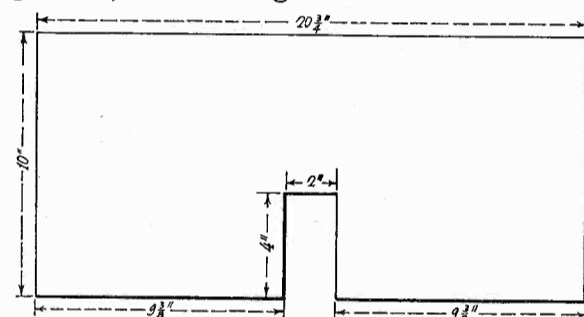

Fig. 4. Subpanel Dimensions.

metal parts thoroughly. Also ground the metal cases of the two audio transformers by running a wire from the two

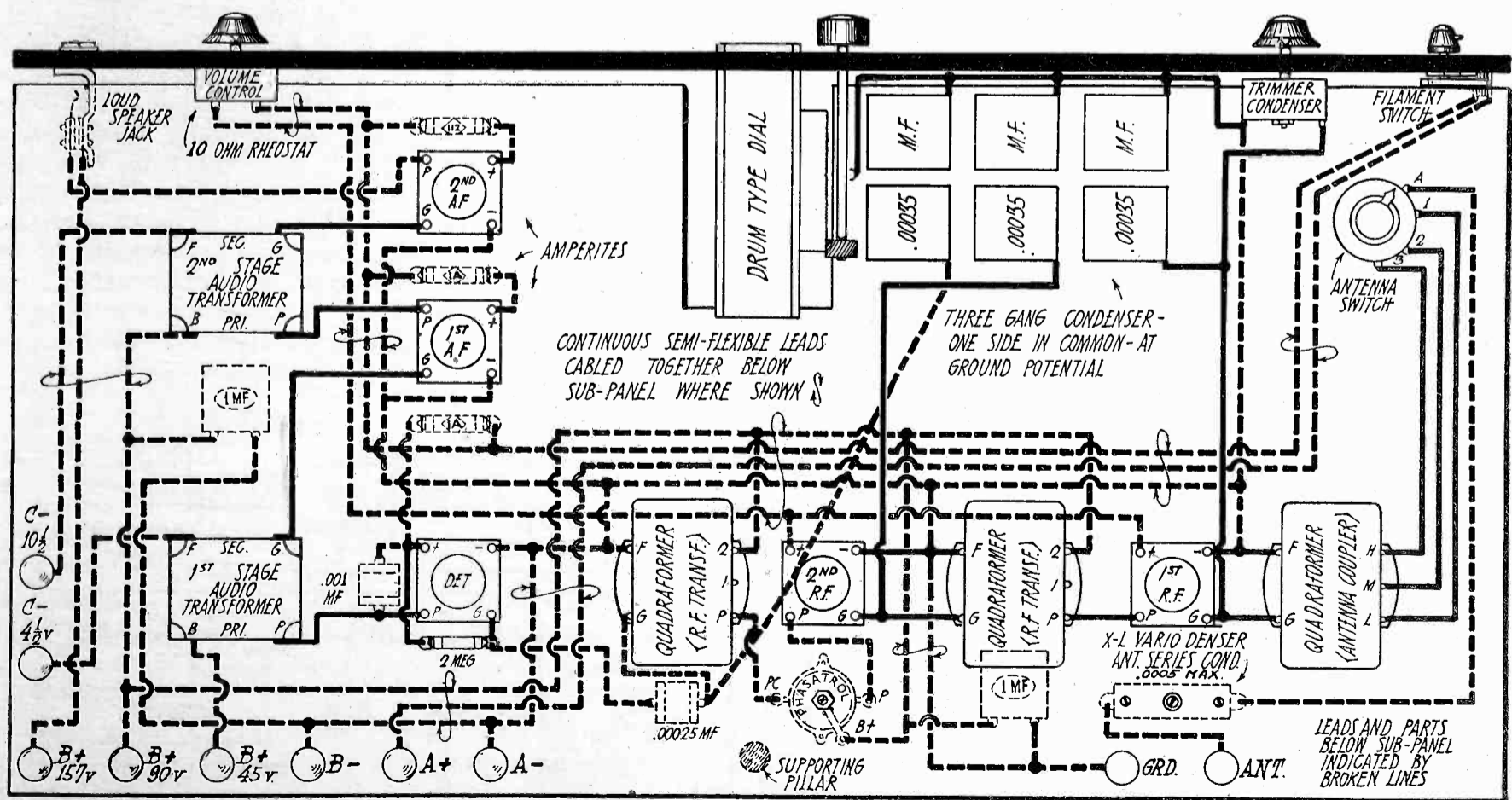

Fig. 3. Pictorial Wiring Diagram.

soldering lugs underneath the panel, to the negative *A* battery binding post. Do not ground the r.f. coil shields.

In wiring the Phasatrol, the terminal marked *P* goes to the plate of the 2nd r.f. tube, the *PC* terminal to the *P* terminal of the 2nd r.f. transformer, and the *B* terminal to the positive *B* battery. The middle tap of each r.f. transformer primary is not used. If a CX-300-A detector is to be used, a 10 ohm Carter adjustable resistance should be installed on the subpanel near the detector socket in place of the amperite and adjusted so that the detector is operated at its maximum sensitivity.

Precautions against short circuits and mistakes in wiring are next in order, the customary procedure being first to connect the negative and positive *A* bat-

tery leads to their respective binding posts, and insert an "A" tube in each socket in turn, with the volume rheostat on full. Then connect the positive *A* lead to each positive *B* lead in turn, making sure that the tube does not light in any of the sockets. Now connect the *B* and *C* batteries, with a 25 watt mazda lamp placed in the negative *B* lead. If this lamp lights ever so dimly, there is a short circuit somewhere in the set. Should everything be O.K., and a loud ringing sound is heard in the phones or loud speaker when the detector tube is tapped, the set is ready for lining up and the lamp can be cut out of the circuit or bypassed with a 2 mfd. condenser.

After the antenna and ground are in place, adjust the variable antenna series condenser until the set-screw is practically all the way in. Turn the Phasatrol setscrew clockwise as far as it will go. Now turn the dial back and forth until a station is located, and adjust the volume until it is slightly below the normal setting for regular use.

Between each condenser unit in the condenser bank will be found a mica trimmer condenser, which can be varied

by a small screwdriver, having a shaft long enough so that the handle will not touch the condenser plates. With the station coming in on the loud speaker, turn the setscrew down slowly, and note if the signal becomes louder or softer. If louder, keep on turning until the maximum is reached, and the signal begins to fall away. Back off the screw until the maximum is again reached, and the adjustment is complete for that particular unit. If the signal should become weaker as soon as the setscrew is turned down, adjust the drum dial a very small amount so that there is slightly less capacity in the condenser unit, and then turn down the trimmer until the maximum is reached. Adjust each condenser in turn in the manner described above, and if in doing so, the

volume becomes too loud, back off on the volume control until the volume is below normal again. The antenna trimmer is the final adjustment, and the most critical. Set the variable trimmer to about half capacity, and then adjust the mica trimmer located on the gang condenser, until maximum is reached. Now cut out capacity in the antenna series condenser by unscrewing the adjusting screw, until a noticeable lessening of signal occurs. Tune in another station at a wavelength 100 meters or more away from the first station tuned in, and repeat the adjustment of the trimmers to see if it is neces-

sary to change them very much. If it is found that the antenna trimmer has to be changed a considerable amount, there is still too much capacity in the antenna series condenser and this should be reduced until the trimmer setting for the 250 and 500 meter waves is approximately the same.

The adjustment of the Phasatrol is next in order. Tune in a station at 250 meters or lower, and turn up the volume until the r.f. amplifier breaks into oscillation. Now turn the adjusting screw of the Phasatrol in a counter clockwise direction until the oscillation ceases. In the laboratory model this point occurred after the screw had been rotated through 180 degrees. No further adjustment should be required after the first one, unless changes in tubes or other apparatus is made.

The antenna switch mounted on the subpanel is most useful in congested localities, where a number of high powered local stations are operating. When using the set for local, and moderate distance reception, the switch should be left on the middle tap. If hunting for extreme distance on the waveband below 400 meters, and the local interference is noticeable, the low tap should be used, and for distance reception above 500 meters, the high tap should be employed. Never use the high tap below 450 meters under any circumstances, as the tuning will be broad, and the antenna trimmer will be hopelessly out of adjustment.

The fact that this type of set can be made single control for all practical purposes, and non-oscillating, makes it a very desirable one to have for the use of the family, and a little time and care spent in lining up the trimmer condensers, adjusting the antenna condenser, and the Phasatrol will be amply repaid by the results obtained.

**T**O MAKE the receiver as simple to operate as possible, with the main filament switch on the panel controlling all auxiliary apparatus, a power plant equipped with automatic relay was assembled, and is shown in Fig. 5. This group of accessories consists of a compact *B* eliminator of the Raytheon type, a trickle charger, and a relay, all mounted on one base, so that the only additional accessory to the

(Continued on Page 61)

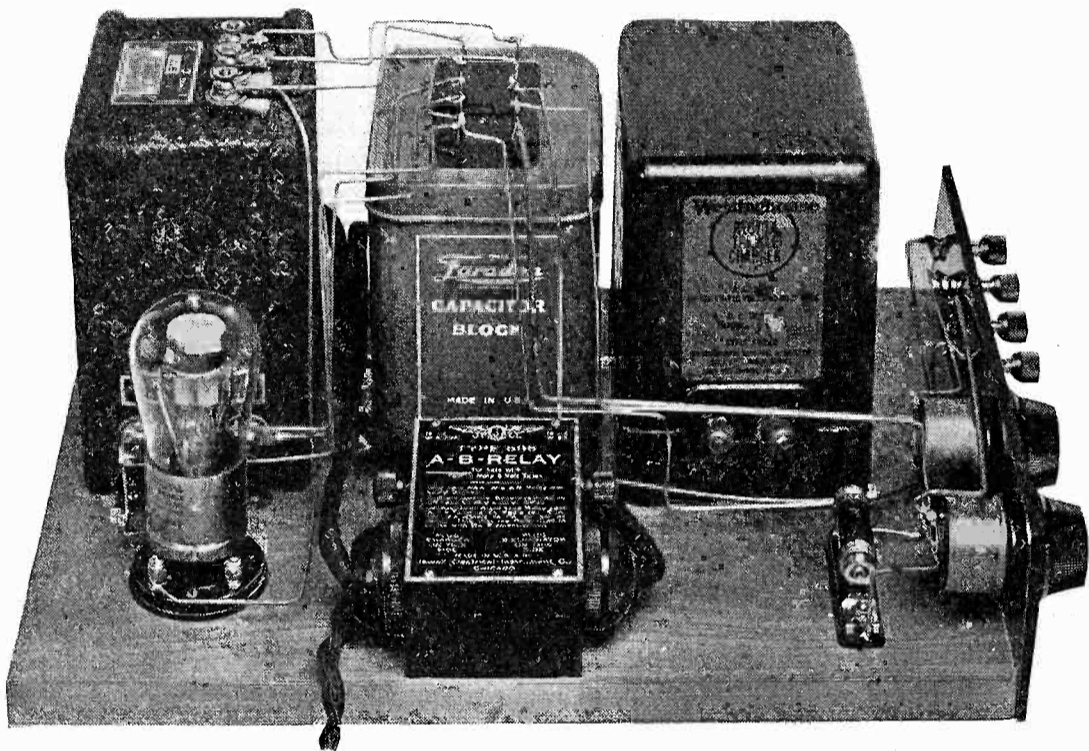

Fig. 5. Compact Power Plant for Quadrphase Receiver.

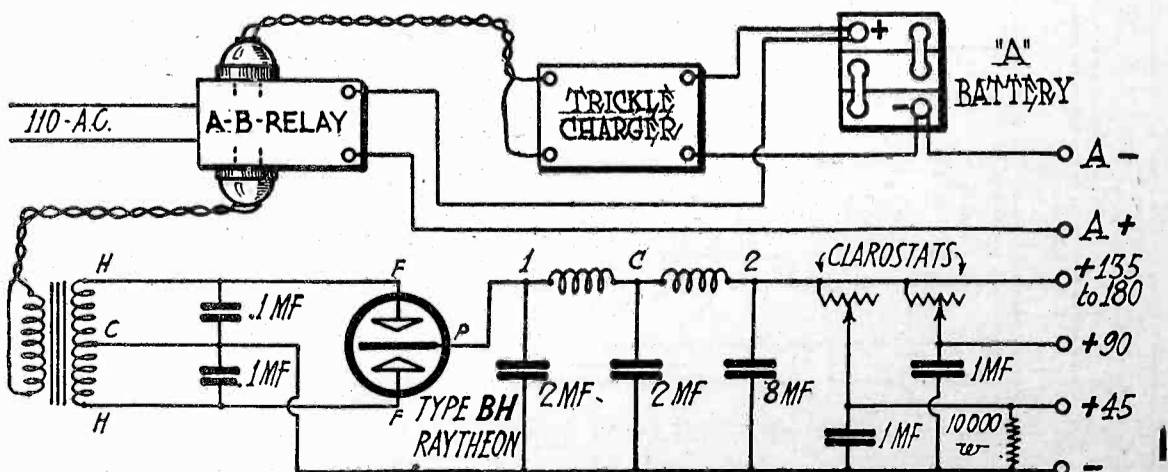

Fig. 6. Circuit Diagram of Power Plant.



# Radio Frequency Transformers

Various Simple Considerations Affecting Their Design and Operation in Vacuum Tube Amplifiers

By F. F. Redfern

THE design of transformers for use with vacuum tubes is a more complicated problem than for use with the ordinary electric power circuits. Consideration must be given not only to the internal circuit of the vacuum tube but also to two external circuits, the output, (or plate) and the input (or grid).

The plate resistance of the ordinary receiver tube may vary from 12,000 to 30,000 ohms or higher, depending upon the type of tube. In series with this plate may be the primary winding of the radio frequency transformer. If this has an impedance lower than the plate resistance, the voltage impressed across its terminals will be low. If its impedance is higher than the plate resistance the primary, and therefore the secondary, voltage will be greater. A low ratio transformer frequently gives a better signal transfer than a high ratio transformer, as will be explained later.

As the ordinary detector tube, without regeneration, functions better with strong signals than with weak, it is necessary that voice frequency signals have a high voltage at the secondary terminals of the transformer. This can be best secured by winding the primary of the r.f. transformer so that its impedance matches the plate resistance of the tube with which it is to be used. In many self-constructed sets the builder uses a tube which is not correct for use with the "coils" he has bought or made. Thus the set does not function at its greatest efficiency.

The effect of plate resistance on the primary winding is illustrated in Fig. 1. With low plate resistance  $R_p$ , as compared with the impedance of the primary winding, a greater voltage is im-

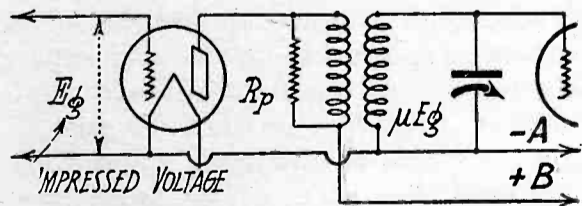

Fig. 1. Effect of Plate Resistance.

pressed across the primary winding than with high plate resistance. With low impedance in the primary winding, as compared with the plate resistance, a smaller voltage is impressed across the primary terminals.

Thus, assuming no losses, with 10 volts in the plate circuit of a tube having 20,000 ohms plate resistance and a transformer having 20,000 ohms pri-

mary impedance,  $20,000/40,000 \times 10 = 5$  volts across the primary and 15 volts across the secondary of a 3:1 transformer. With the same tube but with a 2:1 ratio transformer having a 60,000 ohm primary impedance  $60,000/80,000 \times 10 = 7.5$  volts across the primary and likewise 15 volts across the secondary terminals.

These factors are modified by coupling, resistance values, and distributed capacity which may by-pass part of the r.f. voltage. Consequently a low ratio transformer may give even a higher secondary voltage than a high-ratio transformer. Efficiency at high frequencies is especially dependent upon a low distributed capacity in the primary and secondary windings. Single-layer solenoids, space wound, and flat spiral, pancake or spider-web coils are therefore best for high frequencies. The effect of distributed capacity is to increase the equivalent inductance of a coil, increasing the wavelength or decreasing the frequency point of resonance. In low frequency work the design of the coil is more influenced by the necessity for low resistance with a specified inductance.

The effect of distributed capacity is shown by the dotted lines in Fig. 2.

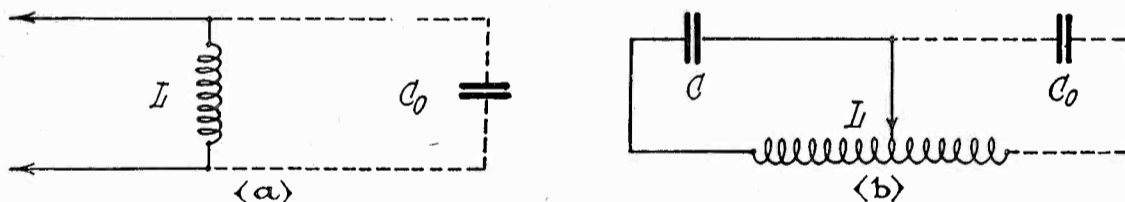

Fig. 2. Effect of Distributed Capacity.

The primary winding in Fig. 2a is equivalent to a closed oscillatory circuit and may couple with a grid circuit so as to cause oscillation.

Fig 2b shows the effect of distributed capacity in dead-ends. That portion of the circuit shunted by  $C_0$  is directly coupled to the functioning circuit  $LC$  and if their resonant frequencies are nearly identical, the apparent impedance and resonant frequency of  $LC$  will be changed and considerable current wasted. Furthermore the circuit may respond to two frequencies and be non-selective. The unused portion, if large, should be short-circuited so as to increase its impedance and minimize the current absorbed or wasted. If the unused turns are few in number, they should be left open as they will then have greater impedance.

As a receiving set should cover a definite range of frequency, these several considerations show that the pri-

mary winding should approximately match the type of tube used, being neither too small nor too large as compared with the tube's plate resistance. If it is too small, the voltage is low. If too large, the capacity effects waste current.

If the primary is of fixed value and a fixed steady frequency is available in the plate circuit, an increase in the number of secondary turns causes an increase in voltage at the secondary terminals until it reaches a maximum peak and then drops off. This is a resonant effect brought about by the transformer and the tube capacities. This phenomenon is frequently observed by changing coupling between the primary and the secondary of the transformer. So the coupling must also be of a specific nature with this transformer. This shows that the primary will have a higher impedance near resonance, and will generally show a rapid decrease at places above and below this resonant point, that is, the transformer has a point of high amplification. (The peak of the band-pass.) At other points, there is a slight drop of voltage impressed across the primary terminals by the preceding tube, and a corresponding de-

crease in radio-frequency gain at the secondary terminals.

For telegraph reception this has a decided advantage, in that it is selective to a marked degree. Too much selectivity is worthless in broadcast reception as it produces side band distortion. That is, besides the carrier-wave, the side bands must be let through faithfully and clearly for amplification. At the resonant point the tubes show a marked tendency to oscillate quite vigorously, distorting reception.

With a set that is functioning properly, we may replace the radio-frequency tubes with another type, thus forcibly demonstrating that the transformer must be designed for a specific type of tube. If the change was made from low amplification to much higher amplification factor tubes, it is quite apparent that the latter do not give as good results as the former. The high amplification factor tubes will always

have a higher plate resistance  $R_p$  than the lower rated tubes. It is obvious then, that, the tube characteristics do not conform to the specifications of the transformer design.

Figs. 3 and 4 illustrate the effect of change in the plate load or output impedance of the tube. Fig. 3 shows a

## DO WAVES INTERFERE?

By KIRK B. MORCROSS

Of more than passing interest, particularly since broadcasting stations have been privileged to select the frequencies upon which they wish to broadcast, is the subject of heterodyne whistles between carrier waves.

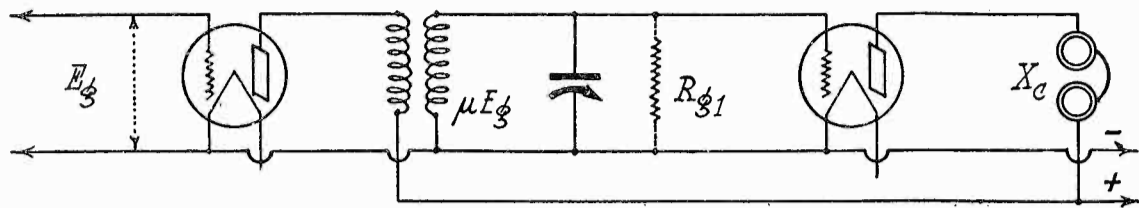

Fig. 3. Effect of Change in Load Resistance.

capacitive or resistance load such as a pair of headphones in the r.f. plate circuit. This effectively decreases the input impedance  $RG$ , and absorbs considerable power from the input circuit. Any amplification gain from the r.f. transformer would be lost due to this effective short across the external grid circuit.

An inductive plate load, such as an r.f. transformer primary, increases the

When two stations are broadcasting simultaneously on frequencies differing by ten kilocycles, a whistle of a frequency of 10,000 cycles will be produced in the head phones of a receiving set. This frequency is of too high a pitch to be annoying and at times it can not be heard. The reasons for this variability depend upon a variety of factors involving the power of the received carrier frequencies, the characteristics of

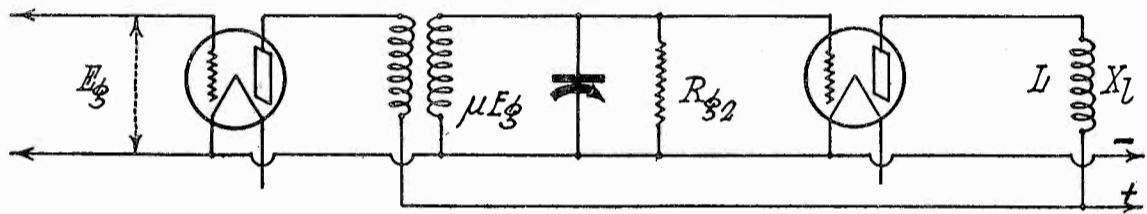

Fig. 4. Effect of Change in Plate Impedance.

input impedance  $RG_2$  in Fig. 4 and gives a negative resistance so that any coupling through the tube or with the grid circuit may start oscillation. This is corrected by any of the usual neutralizing or stabilizing methods. This explains why the old type of transformer whose high resistance secondary completely neutralized the negative resistance of the input impedance frequently gives less trouble from oscillation than a "low loss" transformer used with a tube for which it is not designed.

Most of the requirements entailed by these various limitations are met by a 3 in. solenoid with a .00035 mfd. condenser across the secondary to improve the tone quality. Higher voltages on the plates of the amplifier tubes also improve quality and add volume. But above all else, the best tube should be adopted for the transformer used or the transformer should be designed for the tube to be used.

A receiving set will work fairly well without an aerial, in a location close to large broadcasting stations, if the ground wire is disconnected from the ground binding post and connected to the grid side of the secondary, or to the aerial binding post. A nail driven into the trunk of a tree, about a foot from the base, will make a good ground-antenna for trying this stunt with a portable set.

the receiving equipment and the ear of the observer.

It is sometimes contended that this whistle is produced in space and not in the receiving circuit. It is not difficult, however, to show the incorrectness of this assertion. There is, for instance, the general argument based on common sense. If stations with frequency separation of 10 kilocycles produced that frequency in space so also would two other stations with a frequency separation of say, 600 kilocycles produce that resulting frequency. To be more specific, suppose that one station had a frequency of 1250 kilocycles and the other, 650 kilocycles. Assuming that the interference between these frequencies caused a frequency of 600 kilocycles in space, this frequency would in turn combine with another producing an endless conglomeration.

Again, in the realm of light waves, it is known that a beam of light may be passed through another beam without interference. Light waves are in the same family with radio waves so why should there be any difference in their behavior in this respect?

Could not the 600-kilocycle frequency (using the illustration above) be produced in the receiving equipment in the same manner that an audible beat is produced? It can, but only in case the set receives the initial frequencies of 1250 and 650 kilocycles simulta-

neously. That result may be achieved by utilizing two receiving sets in conjunction with an untuned antenna, or again, if one of the transmitting stations is sufficiently close it may affect the receiving set while the set is tuned to the distant station.

Thus when interference between stations is manifested in the receiving set we may correctly maintain that such interference is not produced in space. In the case of two frequencies of small separation the resulting beat is produced because the set is receiving some energy from each station.

To obtain an idea of the highest frequency which could be noted in the head phones of a receiving set some simple tests were made by the writer. A receiving set employing one audio frequency stage of amplification was tuned to the local broadcasting station and an oscillator was tuned to zero beat with the carrier frequency. The frequency of the oscillator was then carefully measured with an accurately calibrated wavemeter and this was of course the frequency of the broadcasting station. The frequency of the oscillator was now gradually increased (or it could have been decreased) until an observer wearing the head phones connected to the receiving set was unable to hear the whistle. At this point the frequency of the oscillator was again measured. The difference between this frequency and the frequency of the broadcasting station gave the highest audible to the observer.

The test was repeated a number of times, a different observer being used in each case. The results gave frequencies ranging for the most part from 15,000 to 17,000 cycles.

It is not claimed that these experiments were of any value as far as estimating the upper limit of audibility of the human ear is concerned. The type of head phone employed, the kind of amplification used in the receiving set and other factors would undoubtedly give different results even with the same observers. Also it should be mentioned that the local oscillator supplied a sufficient amount of power to be the equivalent of a powerful carrier frequency. The results of the experiments did show, however, that the ten-kilocycle separation is capable of producing a noticeable beat note.

To throw further light upon this conclusion other tests were made by adjusting the oscillator so that beat frequencies in the neighborhood of 10,000 cycles were produced and again, so that frequencies of 5,000 or 6,000 cycles were heard. At the lower frequency values the beats were very much stronger than in the region of 10,000 cycles. This emphasizes the importance of maintaining accurate spacings between carrier frequencies.

# Experimental Shop Practice

Minor Tools, Materials, Calculations and Methods, Including Soldering and Brazing

By Samuel G. McMeen

THE three essentials to successful shop practice are tools, materials, and methods. Let us consider some of each, as applied to the shop equipment heretofore described in February and March RADIO.

Of the minor tools one of the most useful is a tubing-saw which is distinguished from the usual kind of hacksaw by having fine teeth set in pairs—two teeth pointing one way and two teeth the other. It is a rapid cutter, does not bind nor jam, and is recommended especially for cutting thin-walled tubing.

The drill press may well be provided with an auxiliary vise with its sides parallel and at right angles, with an extra bevel-jaw permitting it to grasp odd shaped pieces. Precision of work is possible by the use of such a tool, and we cannot overstress the gratification of accurate performance. Kipling says of two war correspondents that they did some work "that almost satisfied themselves." There is no more severe criterion.

For the regular run of shop measurements there is nothing so good as a steel scale. The homely foot rule should have no place in a good equipment. The principal objection to this time-honored tool is the width of the division marks. Being printed into the wood they can not possibly equal the exactness of the marks in a steel scale.

It is well also to choose scales equipped with three types of heads to fit them. These are a head of right angles and 45 degrees, one of the movable protractor type, and a third having a complete right angle so set as to be bisected by one edge of the steel scale blade. This latter is for use in finding the center of the end of a round piece of any size. It depends on the fact that the line bisecting the two tangents must pass through the center of the circle. Therefore two lines scribed along the edge of the scale-blade at different angles will intersect at the desired center. The protractor head is settable at any angle.

For long dimensions, and to fully avoid the temptation to use a traditional two-foot rule, there should be a three-foot scale of steel. This, too, is graduated to 64ths, a thing impossible with precision in any wooden rule. This three-foot scale has the further usefulness that its edge, while not rigidly and absolutely straight, is very nearly so, and will serve all usual straight-edge purposes.

It is an excellent plan to take dimensions, wherever possible, from the actual object rather than from a measurement of that object. For example, it is better to take the actual piece to be matched in sawing and set the guides of the saw to that piece rather than to get the di-

mensions from the piece in inches and set the saw guide from them.

The same principle applies in the use of calipers. They are valuable because they get direct setting from the piece under measurement and apply that same setting, without change or possible error, to the work being made. When, however, it is desired to know in inches the diameter of a turned piece or rod, sliding calipers are better than the type with two radial arms. The sliding calipers are graduated on a blade, have one fixed and one sliding head. Rather exact readings can be had, and they are to be recommended. They usually read to 64ths of an inch.

So far as exactness and general precision are concerned, the premier of shop measuring devices is the screw micrometer. Some minds shy from it, because of a fancy that its use is abstruse and its readings difficult. It is not so. It is as easy to set as the simple sliding caliper, and the matter of reading it, while it must be understood once for all, is not complicated.

This is the whole procedure of setting and reading a micrometer: To set; unscrew the sleeve and spindle (which are integral), then screw them back against the piece under measurement. The pressure against the object should be firm but not forced. There are two sets of graduations on the micrometer; one is arranged lengthwise on the barrel, and the other around the sleeve that surrounds the barrel. The barrel graduations are .025 in. apart. That is, each division represents .025 in. On the sleeve there are 25 circumferential ("around-the-sleeve") graduations. A little thought will show that each sleeve graduation corresponds to .001 in. To read: note the number of full (not partial) barrel divisions; multiply by 25; note the number of sleeve divisions and add them to the product of multiplying. The result is the diameter of the piece in thousandths of an inch.

For example: There show three full barrel divisions, and part of another. Multiplying the three full divisions by 25 gives 75. There are also visible twelve sleeve divisions. Add these to the 75. The result, 87, is the diameter, which is .087 in.

There is no shop whose operations are immune from calculations of one kind or another. It is a good thing to simplify all calculations, because the simpler the operation the less the chance

## TAP DRILL SIZES

Society of Automotive Engineers			United States Standard			Machine Screw			
Diameter of Tap	Tap Drill	Clearance Drill	Diameter of Tap	Tap Drill	Clearance Drill	Number of Tap	Threads	Tap Drill	Clearance Drill
1/4	No. 1	9/32	1/4	13/64	9/32	2	56	49	43
5/16	9/32	11/32	5/16	17/64	11/32	3	48	45	40
3/8	11/32	13/32	3/8	5/16	13/32	4	36	42	33
7/16	25/64	31/64	7/16	23/64	31/64	6	32	35	28
1/2	29/64	35/64	1/2	13/32	35/64	8	32	28	19
9/16	1/2	5/8	9/16	31/64	5/8	10	24	24	10
5/8	9/16	11/16	5/8	17/32	11/16	10	32	19	10
11/16	5/8	3/4	11/16	19/32	3/4	12	24	14	7/32
3/4	11/16	13/16	3/4	21/32	13/16	14	20	7	1/4
7/8	13/16	15/16	7/8	23/32	7/8	14	24	9	1/4
1	15/16	1 5/64	7/8	49/64	15/16	16	18	3	9/32
1 1/8	1 3/64	1 13/64	15/16	63/64	1	18	18	1/4	19/64
1 1/4	1 11/64	1 21/64	1	27/32	1 5/64	20	16	17/64	21/64
1 1/2	1 27/64	1 37/64	1 1/8	63/64	1 13/64	20	18	17/64	21/64
1 3/4	1 43/64	1 27/32	1 1/4	17/64	1 21/64	24	16	5/16	3/8
2	1 59/64	2 5/64	1 1/2	1 11/32	1 27/64	30	14	3/8	29/64

of error. One great aid to such calculations is a slide rule. It owes its remarkable powers to its ability to add, subtract, multiply and divide logarithms. But the good feature is that one does not realize when using the rule that it is engaged upon the manipulation of logarithms at all. One simply slides the movable piece to position and reads divisions.

To multiply, set the left end of the lower scale (marked 1) directly over one of the numbers to be multiplied. Find the other number on the sliding scale and read the number directly below it as the product.

To divide: Pick out the divisor on the sliding scale and set it above the dividend on the lower scale. You will find the quotient directly under the left end of the slide graduations.

To square a number: Read the square on the top scale directly above the number to be squared on the bottom scale.

To extract square root: Reverse the process of squaring, observing however, that there are two square roots for any given set of figures where the decimal point is ignored, as is the case in all slide rule operations *per se*. Both roots are in plain sight for any number, and the right one can usually be told by a moment's inspection.

The rule will also cube numbers, extract cube roots, give the logarithm of a number, as well as the sine and tangent of any angle. And all this bound up in a little stick ten inches long!

Of almost equal value, and equal in convenience, are the little known and too much neglected mathematical tables of Bottomley. These tables are unique. So far as is known to us, they are the only ones that disclose on one pair of open pages all the logarithms of all the numbers there are. That is, one opens the book at "logarithms," and without turning another page, finds what he is seeking. Similarly, when he has a logarithm and wants to know its number, he turns to another pair of pages and finds it. The plan holds throughout the book. Compressed in its sixty pages are tables of logarithms, anti-logarithms, squares, square roots, natural sines, co-sines, tangents, co-tangents, secants, co-secants, likewise logarithmic ditto in each case, reciprocals and radian measure. The book is altogether so valuable to the shop worker that we recommend it even to those who have no great amount of calculating to do, on account of the pleasant adventure into the mathematical realm. Frankly, it is called "Four-Figure Mathematical Tables," by John T. Bottomley, and is published by Macmillan and Company, Limited, St. Martin's Street, London.

Even at the risk of seeming to indulge in a *reductio ad absurdum* we can not forbear to mention a convenient mathematical wrinkle which is useful in a variety of cases. Principal among these

cases is the need of learning the watts in direct current and the volt-amperes in alternating current when the volts are 110. In both there is the case of multiplying by 11. In the considerable majority of two-figure amperes this can be done at sight and the answer written forthwith. This is how: Add together the two digits of the amperes and put the sum between the two digits. For example: To multiply 27 by 11. Add the two and seven, getting nine; put the nine between the two and seven; that gives the answer, 297.

The reason for thus including mathematical conveniences in a discussion of minor tools is the close relation between measurement and mathematics. And the slide rule and tables really are tools. So, in a degree, is the following graphic method.

A problem arising once in a while is to learn the joint resistance of two conductors, and this is usually calculated by the rather simple rule that the joint resistance is equal to the product of the two resistances divided by their sum. But even the limited labor of doing that multiplication and division can be sidestepped by setting up the simple draw-

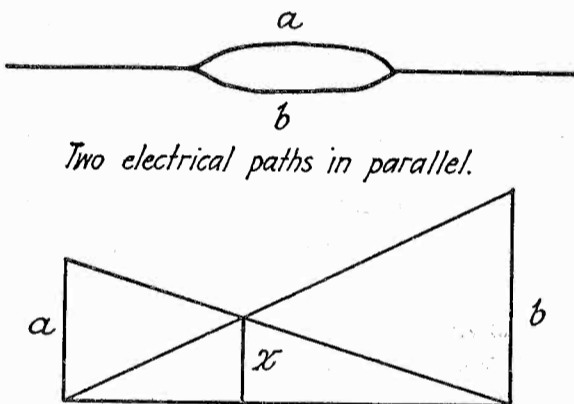

Fig. 1. Joint Resistance of Two Conductors.

ing shown in Fig. 1. The requirements are merely these: On a base line erect two perpendiculars, as high, respectively, as the resistances. Join the top of each with the bottom of the other. Drop a perpendicular from the point of intersection of these diagonal lines. The latter perpendicular is, in length in the same units, the joint resistance sought. For example, if the resistances are respectively 2 and 3 ohms, the resulting joint resistance will be 1.2 ohms, by either method of determination.

This plan is somewhat elaborated in the accompanying large chart for the calculation of the parallel resistances and inductances and of series capacities. For instance, to find the joint capacity of a .0005 mfd. condenser in series with a .00035 mfd. condenser find the intersection of the oblique line from 5 at the right with the oblique line from 3.5 at the left and read 2.05 at the left, which is .000205 mfd. One limitation to its use is that the given values must be in equivalent multiples of the same unit.

Reverting to the minor tools, an occasional necessity is a step chuck for holding flat disks in the lathe. These

chucks are to be had with the collet-type draw-in portion, and with solid faces which the worker may turn out to suit his fancy, and re-turn from time to time if the steps need adjustment. The chuck is made of cast iron, and is of great value. Fig. 2 shows such a device.

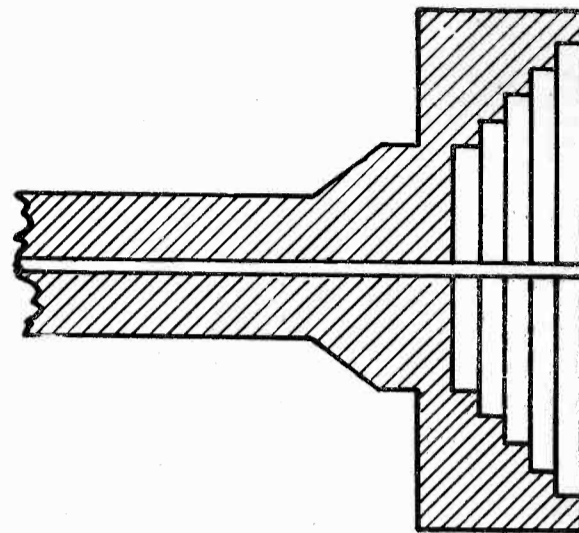

Fig. 2. Step Chuck.

The side guide of the circular saw table offers little difficulty, as it is always parallel with the right and left edges of the table, or at any rate of the saw itself. But it is not so of the cross guide. It is most essential to accurate work that the angle between the plane of the saw and the blade of the cross guide be really the angle needed. The most common angle for that setting is a right angle. The next most common is 45 degrees. The first can be insured by the simple expedient of setting a steel try-square against the side guide and adjusting the blade of the cross guide to the other limb of the square. For the 45 degree angle the procedure is

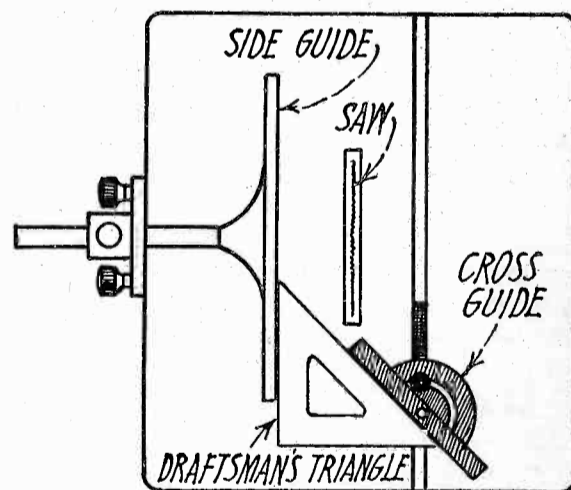

Fig. 3. Setting Saw-Table Cross-Guide.

shown in Fig. 3, in which a draftsman's 45-45-90 degree triangle is set against the side guide and the blade of the cross guide, and the latter adjusted to it.

Frequently there arises the task of piercing the edge of a sheet of metal with a plurality of holes. Drilling sheet metal in the lesser thicknesses is most unsatisfactory, and can only be done at all with extreme care. It is much more workmanlike to punch such holes. Fortunately, punches of any of the smaller sizes, from say  $\frac{1}{16}$  up to  $\frac{1}{2}$  in., can be readily made in any shop. Fig. 4 shows the details of one such device.

(Continued on Page 48)

# GRAPHIC CALCULATOR

FOR

JOINT RESISTANCE OF TWO CONDUCTORS IN PARALLEL

JOINT INDUCTANCE OF TWO COILS IN PARALLEL

JOINT CAPACITY OF TWO CONDENSERS IN SERIES

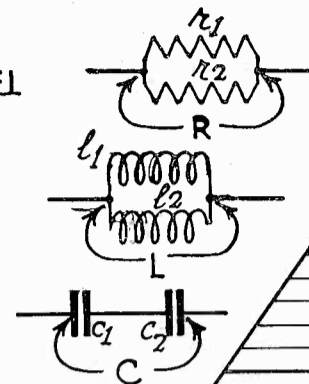

METHOD:- FIND INTERSECTION OF OBLIQUE LINES FROM TWO KNOWN VALUES. READ UNKNOWN JOINT VALUE ALONG HORIZONTAL LINE THRU POINT OF INTERSECTION..

— II —  
**RADIO**

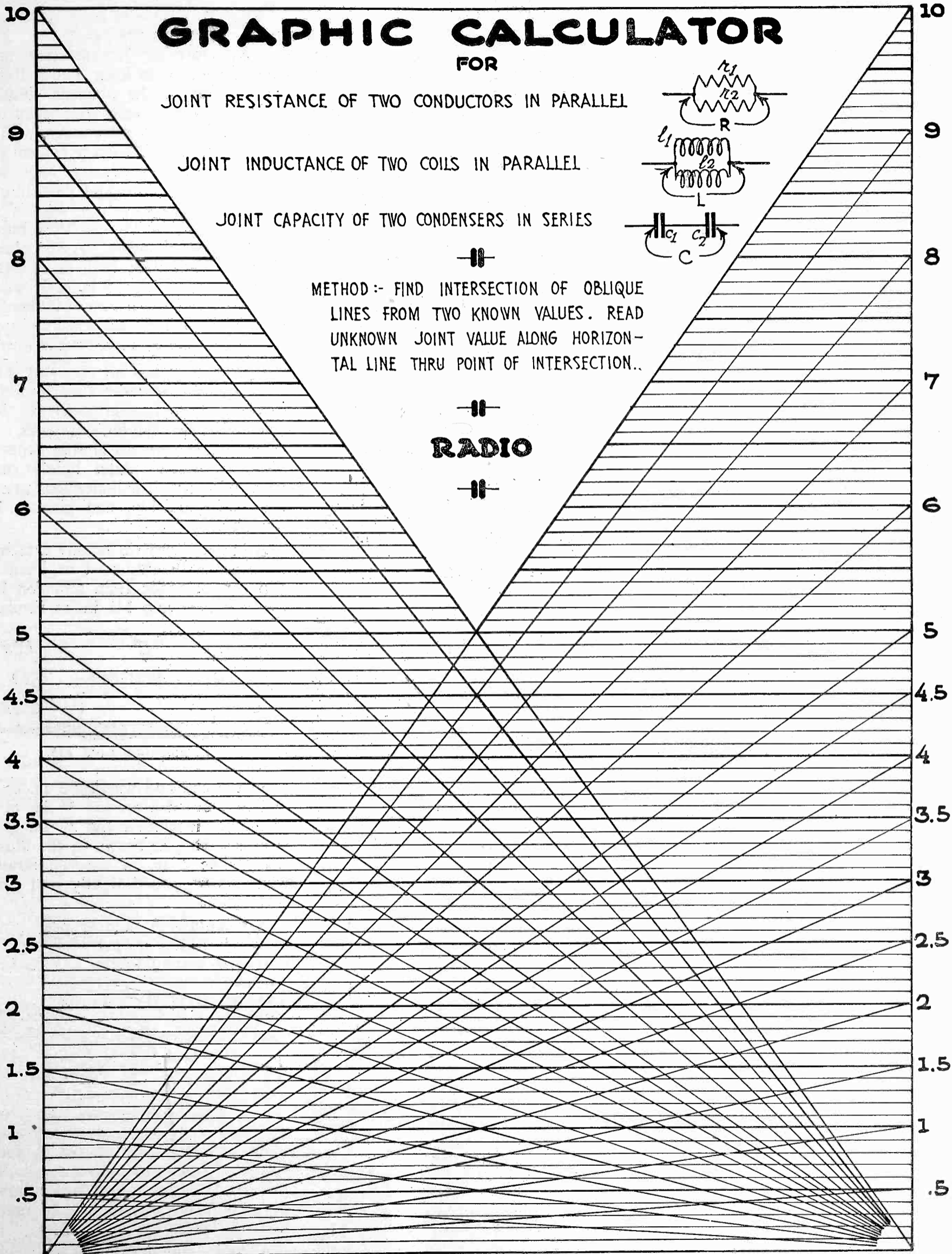

Handy Chart for Figuring Parallel Resistances and Inductances and Series Capacities.

# Radio Construction Pointers

By Paul Oard

AS variable condensers have gradually replaced variable inductances for tuning radio sets, many improvements have been made in their electrical and mechanical construction. One of the most convenient changes is that whereby, through specially shaped plates or verniers, the wavelength spacings are equal over the entire scale of the dial. Yet a well-constructed old type condenser is much to be preferred to a cheap job in the newer types, even if the short wave stations are banded at one end of the dial.

The first point to be examined in determining the merit of a condenser is the bearing, especially if constant dial settings are necessary as in gang condensers in single control r.f. sets. A loose or over-sized bushing may cause a variation of several points on the dial, due to uneven pressure from the operator's hand. Furthermore there is danger of a short if the stator and rotor plates come close together.

The end plates should be of non-warping material so as not to throw the plates out of alignment. All insulating strips, used with metal end plates to support the stator, should be short so as to obviate warping coils.

The contact at the rotor bearing should be good, as a poor contact causes more racket than a brisk lightning storm. If a spring strip instead of a pig tail is used to make contact it should be heavy enough to take tension from a set-screw and should be located on the outside of the end plate where it can be removed when corrosion must be cleaned.

The rotor and stator plates should be smooth, as rough plates gather dust, which can be taken off with a pipe-cleaner. But a plate which has been polished on a buffing machine requires but little dusting.

Although straight line bus-bar wiring with square bends improves the appearance of exposed wiring in a radio receiver, it should be used only on low tension leads and on such high tension return leads as are not subject to capacity effects. Direct point-to-point wiring is better for grid and plate connections which are sensitive to capacity effects. Stranded lamp cord can well be used for the latter as the solder takes good hold on the five strands and as the rubber insulation is more than sufficient for the usual voltages. When a tight contact is desired in bus-bar wiring it is well to wind about the joint a short length of No. 24 to 28 wire, soldering

over this. A convenient supply for this is to unstrand ordinary antenna cable, which is usually tinned, and which assists in a neat job of soldering, and insures a joint which can not let go from crystallization of the solder.

In a past issue of RADIO, the writer called attention to a unique method of fixed condenser construction, in which a metal rod is used as one plate, while a coil of insulated magnet wire, wound around the rod, forms the other plate. This method of construction may be used in the construction of a grid condenser with the leak mounted directly upon it, as shown in the illustration.

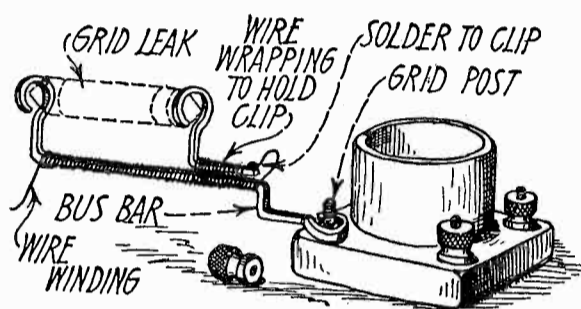

Combined Grid Condenser and Leak.

Ordinary bus-bar is bent as shown, to form one plate. Enameled wire, No. 30 or thereabouts, is wound the length of the straight part of the wire, the end farthest from the eyelet being left about an inch long. Paint the winding with collodion to insure its remaining fixed and holding constant capacity. Fasten the remaining short length of bus-wire, which has been bent as shown, to the completed winding by wrapping back the wire a short way, soldering the end to this short length of bus wire, having first made sure that the two mounting eyelets are the right distance apart to hold the leak cartridge intended to be used.

This form of leak and condenser is easily mounted and adapts itself readily to a limited space. The coil and the wire plate should be about two inches long for average work. Capacity of this type of condenser is dependent upon the size of the wire, the length of the coil and the diameter of the wire or rod that forms one plate. The insulation is ample for all ordinary use to which a grid condenser is subjected.

A "crackle" finish for loud speaker horns, which has been claimed to overcome the tendency to vibrate at certain frequencies, can be given by shellacking the interior of the horn and covering the damp surface with oatmeal or cornmeal. It should be given a final binding of clear varnish.

Some sort of a protective device should be used to keep high voltage *B* current out of the filament circuit in any set using radio frequency coils whose primary is interwoven with the secondary. The *B* battery current passing through the primary may break down the insulation and pass into the secondary, whose return end is connected to the *A* circuit, thus burning out the tube filaments. A 500 ohm resistance, flash light bulb or *B* battery fuse should be placed in each positive tap. If a resistance is used it should be shunted by a fixed condenser to by-pass the r.f. energy. This is no idle warning.

Collodion makes an excellent dielectric for fixed condensers in circuits not carrying high tension current. Mica should be used for high voltages. The condenser is built up of thin copper or phosphor bronze plates lightly coated with collodion. It is impervious to moisture, dries quickly, and gives a high capacity.

A battery cord tip readily attachable to either a binding post or Faenstock clip can be made from stranded lamp cord by removing 1½ in. of insulation



Combination Cord Tip.

from the end and winding 3 in. of tinned No. 22 wire around ½ in. of the remaining insulation and ½ in. of the stranded wire, as shown in the illustration. The 1 in. of exposed stranded wire is then rolled tightly and tinned with solder.

A combination binding post can be made by drilling a Faenstock clip from an old *B* battery for an 8/32 machine

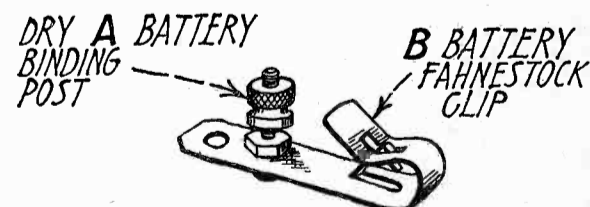

Combination Binding Post.

screw and mounting therein a binding post head from a discarded *A* cell. This will handle either a standard telephone tip or ordinary wire or may be used to join two leads.

A loose coil winding can be held firmly in place by means of a piece of friction tape or by means of collodion applied for ½ in. along its length.

# Science vs. Common Sense

By Philip N. Emigh

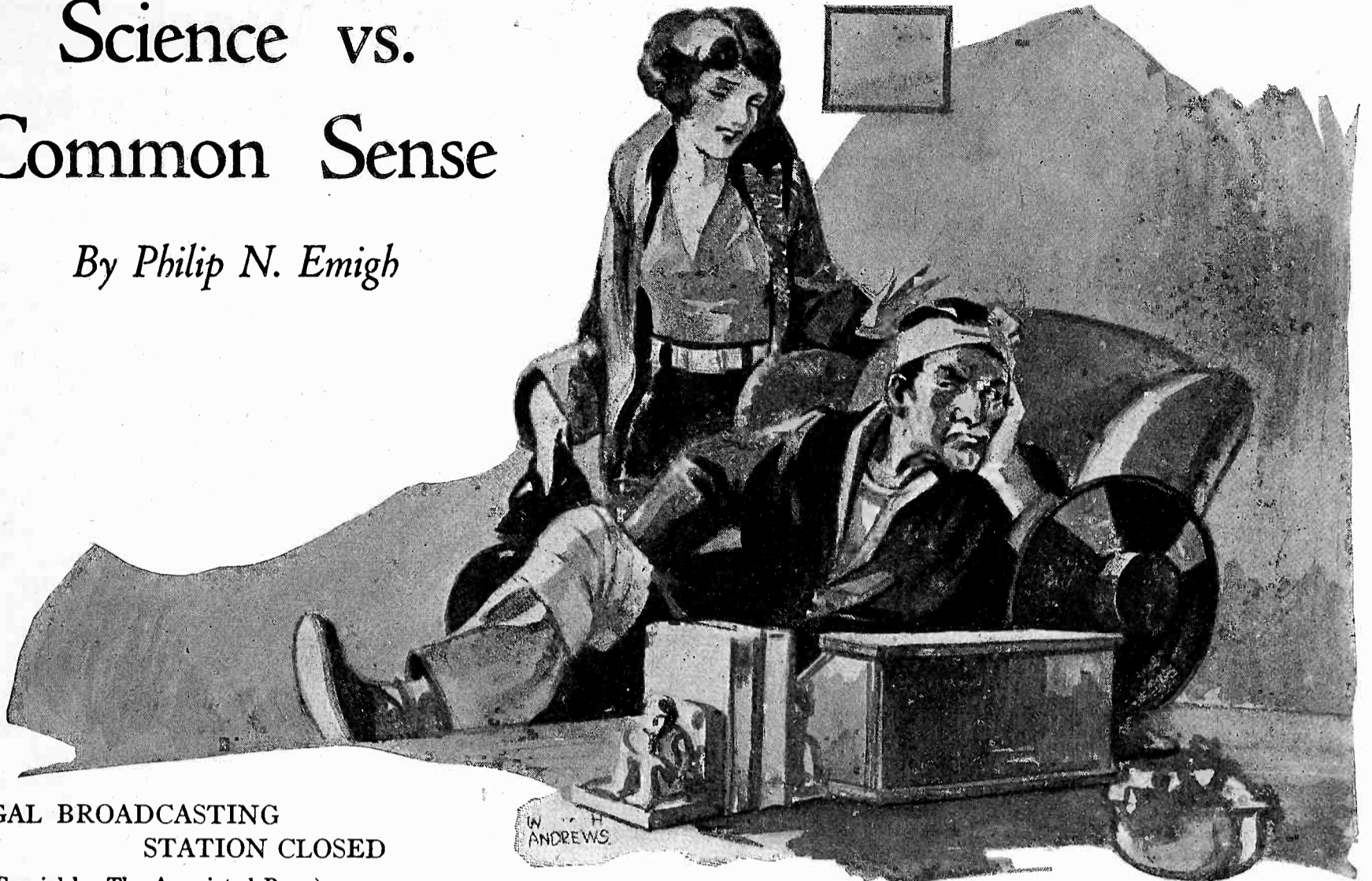

## ILLEGAL BROADCASTING STATION CLOSED

(Special by The Associated Press)

AUG. 15, 1923—William H. Green and Donald R. Sampson of Indian Run were arrested late yesterday, charged with the illegal operation of an unlicensed broadcasting station. It is said that secret service agents have been on the case for months, or ever since complaints of interference had been lodged with the District Radio Inspector. The station operated under the call letters, "I. C. U. The Unknown Broadcaster." The Department is to be congratulated on rounding up the first radio pirate.

**T**HE above item, which appeared in the newspapers some years ago, was perused by numerous readers over their morning coffee, and, by the majority, not given a second thought. To those of us living at Indian Run, the case will always be remembered with unholy glee as we think of the parts Professor Ernest and his daughter, Marie, played in locating this station.

Those residing within a radius of 200 miles of Connersville, may remember how, in the earlier days of broadcasting, a sudden voice would break into the midst of their favorite selection and remark, "This is I. C. U., the Unknown Broadcaster. The opening number on our evening's program will be," etc., etc.

The selections following would be of good quality, carefully chosen, and the music was usually loud and clear. It was noticed that it was always "canned music."

At first, the interference was accepted as a necessary evil, due to the development of broadcasting, but as I. C. U. became bolder and was on the air more, several complaints were lodged with the Radio Inspector. Suspicion centered on

Connersville, as the majority of the complaints originated at that place, also several amateur transmitting stations were located in the city.

The amateurs themselves attempted to locate the station, but failed, as compass bearings were hard to take at that time. In the course of time, a quiet, unobtrusive man, the Radio Inspector, arrived on the scene and closely scrutinized each and every amateur and his station.

The music stores were next visited, but it was found impossible to check up on the sale of records. Also, the people buying records were obviously not radio fans and the owners of transmitting stations were not buying records. Of course not. Records cost money. Finally the receiving sets were all examined, and the owners quizzed as to the possibility of their receivers being used as transmitters.

Results were nil, and nothing resembling a microphone was found. As the power of I. C. U. was variously estimated to be from 250 to 2500 watts, the co-operation of the power company was enlisted, and, accompanied by one of their meter readers, the Inspector visited all establishments using one or more kilowatts. Still nothing.

One evening, I. C. U. electrified his audience by saying that while stocking up on new records, he had talked with the Radio Inspector and would likely do so again. This was followed by the declaration that, "he, I. C. U., was so well hidden that he would never be

caught." The program followed as usual.

In the natural course of events, the Inspector's report reached headquarters. It was terse and merely stated that with the limited equipment at his command, he was unable to locate the unlicensed broadcasting station operating under the call, "I. C. U." and recommending that steps be taken to run it down as soon as possible.

Shortly after this episode, a large closed car accompanied by two square-jawed men arrived in Connersville. A glance into the interior of this car (were it possible) would have roused the envy of any fan. At the right side, was a fine multitube receiving set. A loop aerial was swung from the car top. At the other side reposed a smaller set of the same general plan, but constructed so as to be readily portable. Several batteries and tubes of assorted kinds and sizes completed the equipment.

A run around the streets of Connersville that evening was followed by the unofficial report to the superintendent of the local power company that a grounded arc line was causing interference at a certain point.

The next day, the car with its two occupants, drifted out of town in a general south-easterly direction. They seemed in no hurry and often stopped to admire the scenery and listen in on the big set, slowly rotating the loop at the same time. About three o'clock, they seemed to hear that for which they

(Continued on Page 52)

# A High Mu Tube At Work

## A Study of the Effect of Grid Bias for Various Plate Voltages Showing The Necessity for A Negative Grid

By J. E. Anderson

MUCH information has been published about general utility tubes, and their characteristics are generally well known. But practically nothing has been published about tubes having a high amplification factor. Yet these tubes are continually assuming a greater importance in circuit design, in view of the increasing popularity of resistance and choke coil coupled amplifiers. It is well known that these circuits do not always perform according to expectation, which in part may be due to improper operation of the tubes. To determine this question and to add a bit to the knowledge of the characteristics of high mu tubes the writer has made a few curves.

Characteristics of the tubes themselves have little practical significance. Tubes are always used under dynamic conditions, and therefore dynamic characteristics must be considered. Curves must be taken of the tube and the circuit in which the tube is to operate, for only these curves will be of much use in designing amplifiers.

The tube used in taking the curves had a rated amplification factor of 20, but it actually measured 24; and it was designed to operate directly off a 6 volt storage battery without any resistor in the filament circuit. Such a tube has a high output resistance and therefore the load resistance or impedance must also be high. The most common resistance used is 100,000 ohms, and hence a resistor having this rating was used throughout.

The first set of curves was taken with negligible resistance in the grid circuit, that is, in such a way that the grid potential was determined by the voltage of the grid battery. The circuit arrange-

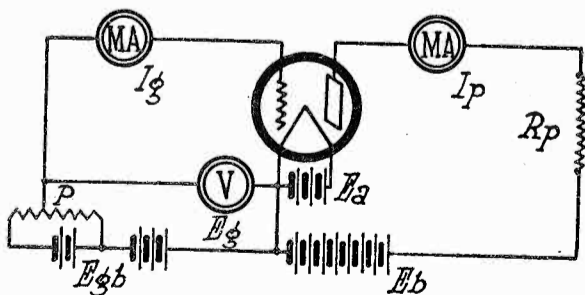

Fig. 1. Circuit Arrangement for Securing Curves in Fig. 2.

ment is shown in Fig. 1.  $E_a$  is the filament terminal voltage, which was kept constant at 6.2 volts for the first set of curves.  $E_b$  is the applied plate voltage, kept constant for any one curve. The applied grid voltage  $E_g$  was measured

with a voltmeter  $V$ , permanently connected. The potentiometer  $P$ , used for adjusting  $E_g$  to convenient values had a resistance of 2200 ohms, but it was always set near one end so that its effect on the grid current was negligible. The plate current  $I_p$  and the grid current  $I_g$  were measured with sensitive milliammeters located where shown in the figure.  $R_p$  is the 100,000 ohm resistor.

With this arrangement the five plate-current grid voltage characteristics shown in Fig. 2 were taken, corresponding to five different values of  $E_b$ . It will be observed that each curve has a portion which is very nearly a straight line, the length of which increases as the plate battery voltage increases. Apparently, then, the tube is capable of distortionless amplification when operated under conditions assumed in Fig.

1. The curve for  $E_b=63$  volts, shows that the amplitude of the input voltage may be as great as 2 volts before harmonics would become appreciable, while the curve for  $E_b=180$  shows that the amplitude may be as great as 4.5 volts. It will also be observed that the two lower curves are more nearly straight than the two upper, which would indicate that the distortion would be less for the lower curves. The highest curve in particular has a rising characteristic up to within a couple of volts of the saturation level. This would show that for the higher plate voltages a higher plate output resistance should be employed to maintain the curve straight, or at least the output resistance should remain constant for the higher values of current and not decrease as the one employed did.

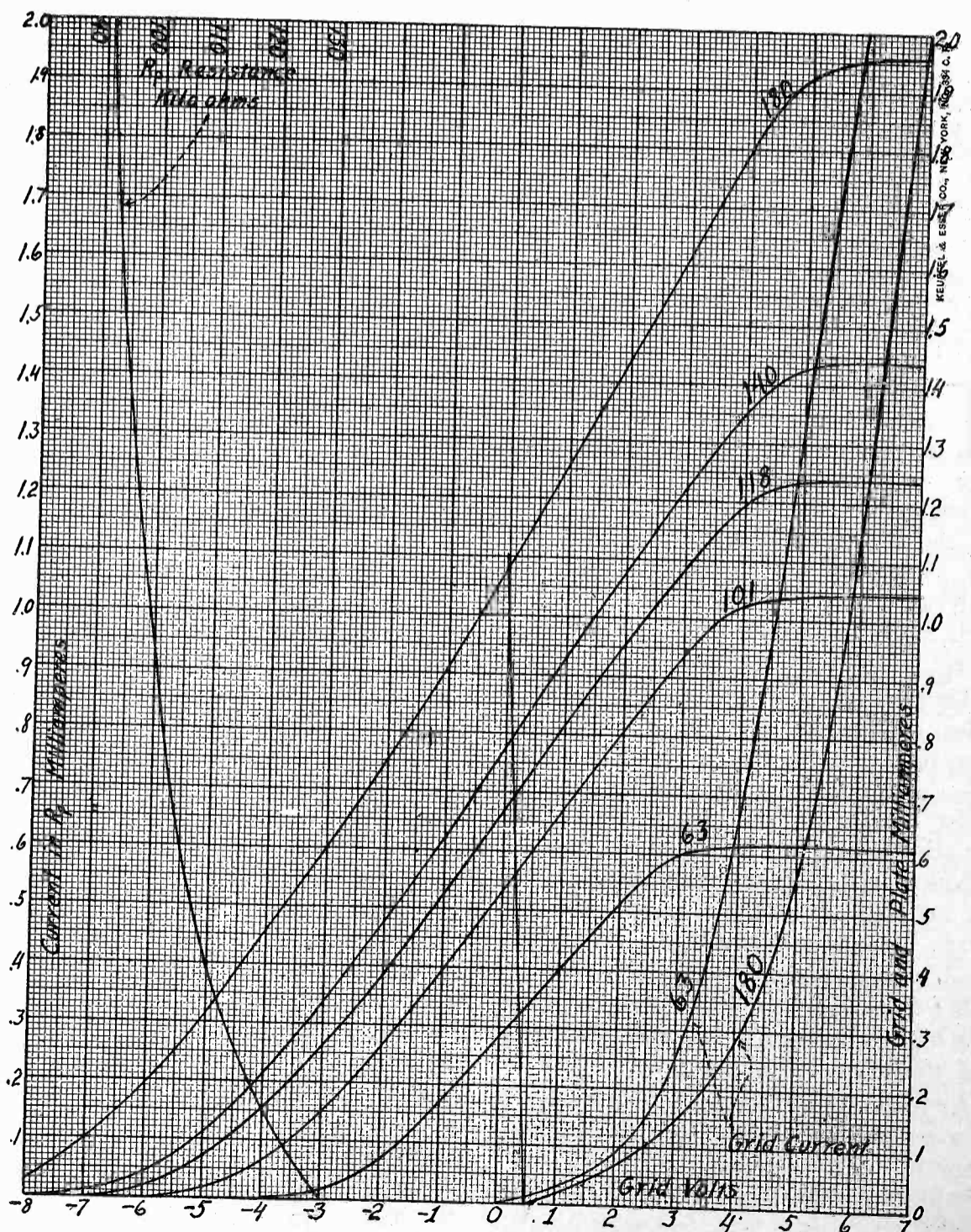

Fig. 2 Characteristics of High Mu Tube in Circuit of Fig. 1.



Apparently the same grid bias may be used for all the values of the applied plate voltage, and it may be either positive or negative. The middle of the straight portion on each curve is not far from zero grid bias, and it tends to stay on the positive side.

The curves are somewhat deceptive and the term "apparently" was used advisedly. As soon as the grid goes positive the input resistance of the tube becomes very low and soon amounts to a short circuit of the device delivering the voltage. This would reduce the positive half of the input voltage more than the negative half, and consequently amplification would be one-sided. A parallel tuned circuit would have an impedance thousands of times greater than the input impedance of the grid on the positive side, and under such conditions there would be no appreciable amplification. But on the negative side the input impedance of the grid is practically infinite and there the amplification would be what the curves indicate. Also when the input device has a very small impedance the plate current would follow the curves on the positive side as well as on the negative.

The rapid decrease in the grid input resistance is shown by the rapid increase in the grid current as the grid voltage is increased. The grid current has been plotted in Fig. 2 for two values of the plate battery voltage. It will be seen that the grid current very quickly becomes several times greater than the plate current, which follows from the necessary construction of a high mu tube. For a plate battery voltage of 63 volts and a grid bias of plus 4 volts the grid current is .667 milliamperes, and therefore the grid resistance at that point is only 6,000 ohms. When  $E_b=180$  the grid current at the same grid bias is .285 milliamperes and the grid resistance is 14,000 ohms.

It is obvious that the tube cannot be operated with zero or positive grid bias, at least not in any practical radio receiver. If some amplification is obtained it would still cut down the selectivity of any parallel tuned circuit connected across the grid to a point where the tuner would be rendered useless.

In view of the fact that the curvature of these curves at the upper bend is very great one would expect the tube to be a good detector if operated at this point. For example on the  $E_b=63$  curve at 3 volts positive bias it looks very favorable for detection. But that is not the case. The tube is dead at that point as far as detection is concerned. The low impedance of the grid circuit is the reason, as was explained above. The tuner is short-circuited, because the grid resistance is only 5,000 ohms. At minus 3 volts, on the other hand, the tube is an excellent detector, although the curvature at that point is not nearly so

favorable. The grid resistance at that point is infinite. No doubt the tube is a good rectifier at the upper bend provided the impedance of the voltage source is very small.

The amplification obtainable with the tube when proper grid bias is used may be obtained very easily from the curves. It is proportional to the slope of any curve at the point of operation, and is obtained by multiplying the slope of the curve by the plate resistance  $R_p$ . The slope is the mutual conductance of the tube and circuit under dynamic conditions.

Before proceeding with examples of amplification calculation it is well to call attention to the fact that the load resistance  $R_p$  does not remain constant. It decreases with an increase in the current. The variation of the resistance is shown in the curve at the left of Fig. 2. At 2 milliamperes its value is only 91,000 ohms and it increases gradually up to a value of 130,000 ohms for extremely minute currents. The resistor used was of the carbon type, but the resistance of other types varies in somewhat the same way.

Now then let us calculate the amplification at a number of points on the different curves. On the  $E_b=63$  curve at  $-0.5$  volts the current is .223 milliamperes, and the corresponding value of  $R_p$  is 116,500 ohms. The current at zero grid is .28 ma., and at  $-1.0$  grid it is .17 ma. The difference is .11 ma. Therefore the slope of the curve is 110 microhms, which makes the amplification at  $-0.5$  equal to  $116,500 \times 110 \times 10^{-6} = 12.82$  times. Similarly the amplification may be obtained at any other point. Thus on the  $E_b=101$  curve at  $-1.0$  grid bias the amplification is 14.3, on  $E_b=118$  at  $-1.0$  grid bias it is 15.1, on  $E_b=140$  at  $-1.5$  it is 15.4, and finally on  $E_b=180$  at  $-2.0$  it is 15.85. The voltage amplification thus increases with increased plate voltage.

An interesting fact may be observed about the saturation level of the plate current for the different curves. If the saturation current be multiplied by the load resistance the result is equal to the applied plate battery voltage. For example, on the lowest curve the saturation current is .615 ma. and the value of  $R_p$  for that current is 104,500 ohms. The product is 64.4 volts. On the highest curve the saturation current is 1.96 ma., and the corresponding value of  $R_p$  is 91,600 ohms. The product is 179.8 volts. Similarly for the other curves, beginning with  $E_b=101$ , the products are 102.8, 118, and 136 volts. In each case the product is, within experimental error, equal to the applied battery voltage. This means that all the applied voltage is used up in the external resistance and none is left for the internal resistance. The latter then must either be zero or else the grid voltage drives

the plate current through that resistance. This relationship also holds for other tubes.

The curves shown in Fig. 2 are not of wide application, even when the grid is maintained negative for all input voltages, because there are very few practical circuits in which the external grid resistance may be neglected. As soon as the resistance is appreciable, say over 500 ohms, the grid current makes the curves take a different shape.

To investigate how a high mu tube behaves in a typical resistance coupled amplifier the circuit shown in Fig. 3

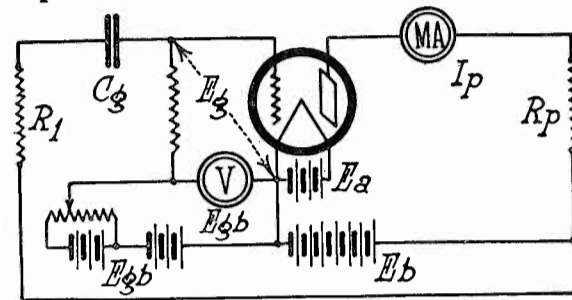

Fig. 3. Circuit of Typical Resistance Coupled Amplifier.

was arranged. A grid leak  $R_g$ , a grid stopping condenser  $C_g$  and a plate coupling resistor  $R_1$  have been added to the circuit arrangement in Fig. 1. The rated values of these additions were  $R_g=1,000,000$  ohms,  $R_1=100,000$  ohms, and  $C_g=0.5$  mfd. The grid milliammeter was omitted because the grid current was no longer measurable with it.

The object of including  $R_1$  and  $C_g$  was to simulate actual conditions as nearly as possible and to note the effect of any leakage through the condenser and the resistor mounting insulation. One condenser of good reputation was found to leak more than the grid leak, and it was impossible to maintain the grid negative with any reasonable value of grid battery, and the action was very erratic. Also a mounting of uncertain composition was found to leak very badly. But when a bakelite resistor mounting and a good condenser were used it made no appreciable difference whether  $C_g$  was connected or not, or whether the high plate battery voltage was connected to  $R_1$ .

In the arrangement shown in Fig. 3 the grid potential is no longer the same as the applied grid voltage, as measured with the voltmeter  $V$ . It is less by the voltage drop in the grid leak, and this depends on the grid current.

The curves obtained with the arrangement in Fig. 3 are shown in Fig. 4. In these curves essentially the same plate battery potentials were used as in the previous set of curves.

Comparing the two sets of curves it will be seen that they are practically identical on the negative side of the ordinate corresponding to a grid battery voltage of  $-1.0$  volt. As the applied grid voltage increases from this point the curves in the second family fall be-

low those in the first and gradually reach a low saturation value. This rapid approach to the saturation value is due to the grid current which flows as soon as the grid is positive.

Again by comparing the two families of curves it is possible to tell, approximately, what the grid current is for any value of applied grid voltage. The plate current depends only on the grid potential, other conditions remaining constant. Hence if the plate current is known, the grid potential is also known. And if the grid potential and the resistance of the leak are known, then the grid current may be found. For example, on the  $E_b=63$  curve in Fig. 4, at plus 3 volts grid, the plate current is 0.28 milliamperes. On the corresponding curve in Fig. 2 the plate current is 0.28 milliamperes at zero grid. Hence in Fig. 4 the actual grid potential is zero and not plus 3 volts. Therefore there must be a drop of 3 volts in the grid leak, and this drop is equal and opposite to the applied grid bias. Since the grid leak had a resistance of one megohm, the grid current must be 3 microamperes.

Apparently, there is some grid current flowing when the grid potential is zero, which may also be inferred from the fact that the two sets of curves begin to deviate while the grid is negative. There must be an e.m.f. in series with the grid circuit other than that of the grid battery.

The straight line drawn diagonally across the family of curves in Fig. 4 is

the locus of correct grid bias when the tube is to operate as an amplifier. This line, however, is empirical and is a matter of judgment. It satisfies the equation  $-E_{gb}=0.0174E_b+0.3$ , which for convenience has been drawn in the upper left corner of Fig. 4.

By comparing the two families of curves it is seen that one effect of the grid leak is to limit the allowable grid voltage that may be impressed before distortion occurs. Thus in the lower curve the amplitude of the impressed voltage may not exceed about 0.5 volt, while the amplitude allowable on the highest curve may be about 2.5 volts. The voltage amplification has not been greatly affected by the grid leak. Thus at  $-3.5$  on the  $E_b=184$  curve the amplification is 15.1 times. A voltage having an amplitude of 2.5 volts would then cause a voltage amplitude of 37.8 volts across the coupling resistor, which is not far from the maximum allowable input to a 171 type power tube. One favorable change caused by the grid leak is a marked straightening of the curves for the higher plate voltages.

It has been stated repeatedly that high mu tubes operating in resistance coupled amplifiers do not need any negative grid bias, and that the grid return may be connected directly to the negative end of the filament. The curves in Fig. 4 emphatically deny the truth of this. They show that to connect the grid return to the negative end of the filament, that is, to make the grid bias zero, is about the worst way of oper-

ating the tubes. At zero grid the curvature is quite great, and the tube at that point is not an amplifier but a distorter.

Both sets of curves discussed above show that it is necessary under practical conditions to use a negative bias on the grids of high mu tubes, and especially so when there is a considerable resistance in the grid circuit.

#### RELATIVE SELECTIVITY OF RECEIVERS

A graphical illustration of the relative selectivity of four general types of radio circuits is shown herewith as given by Dr. Alfred N. Goldsmith. The vertical lines in the sketch indicate frequency in kilocycles. The horizontal lines may be taken to represent the strength of signal which will give a normal sound volume in a loud speaker.

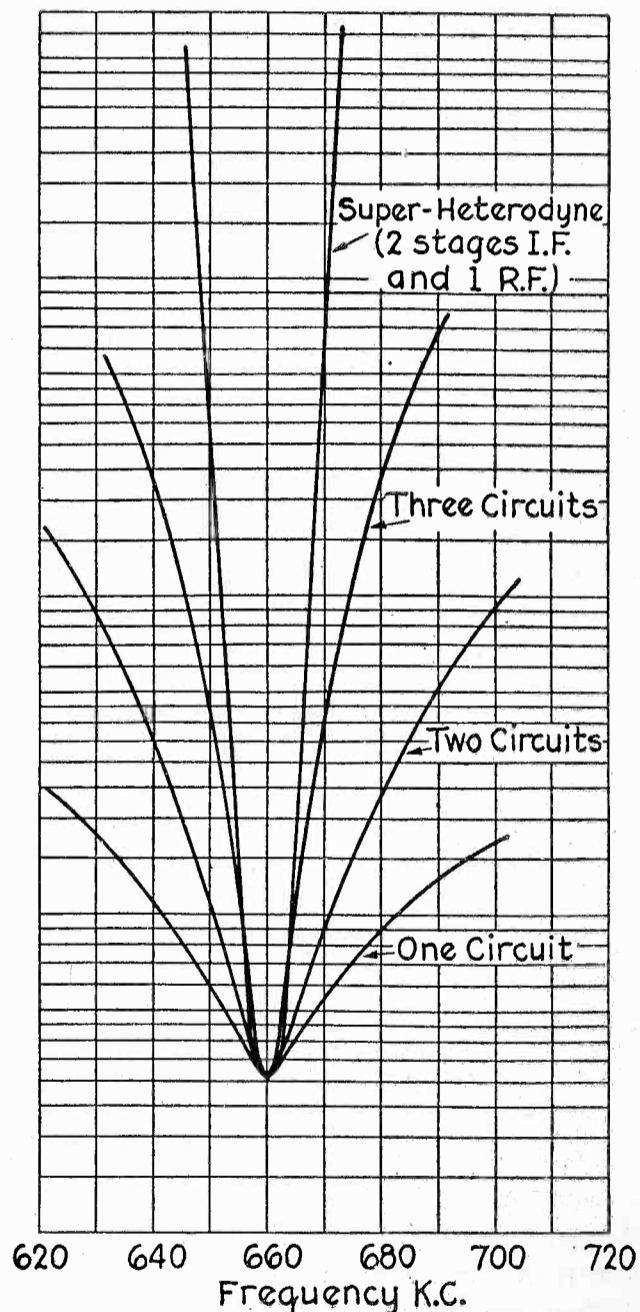

Relative Selectivity of Receivers.

Assuming that each of the four receivers remains tuned to a 455 meter (660 k.c.) station, curves are plotted to show the corresponding increase in signal strength required to produce the same standard of audibility from stations transmitting on frequency channels 10 k.c. removed from 660 k.c.

Thus for a single circuit receiver, a relatively small increase in the strength of an undesired signal 10, 20, 30, 40

(Continued on Page 50)

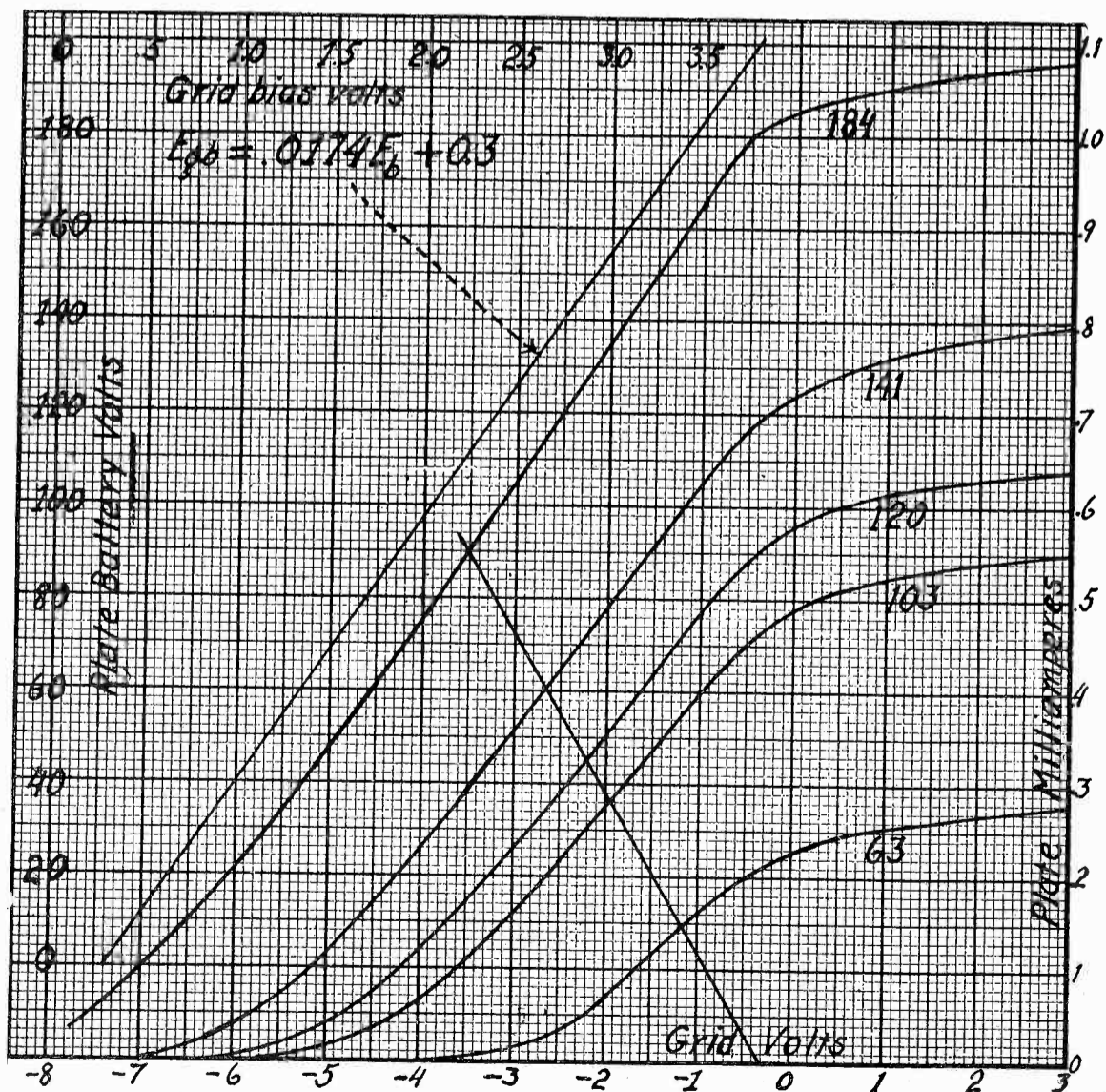

Fig. 4. Characteristics of High Mu Tube in Circuit of Fig. 3.

# How To Calibrate A Wavemeter

## Methods Employed for Quartz Crystal Primary Standard, Secondary Standards, and Standard Frequency Transmissions

By C. T. Burke

A WAVEMETER is essential in every transmitting station and radio laboratory. To be of use, it must be calibrated or compared with a standard. Its value depends upon how closely it can be checked against the standard and how long it will maintain its calibration. Ordinarily another wavemeter is used as a standard, but back of this must be some fundamental primary standard.

The most reliable primary standard is a thin plate cut from crystallized quartz and connected in a vacuum tube circuit so as to control the system's frequency of oscillation. This frequency depends entirely upon the size of the quartz disk. Such a quartz crystal normally has two fundamental frequencies, one depending on its thickness and the other on its diameter. The tuning of the plate circuit of the vacuum tube determines upon which fundamental the crystal and the system will oscillate. Then by using the harmonics of this fundamental, a whole series of frequencies is made available for calibration points.

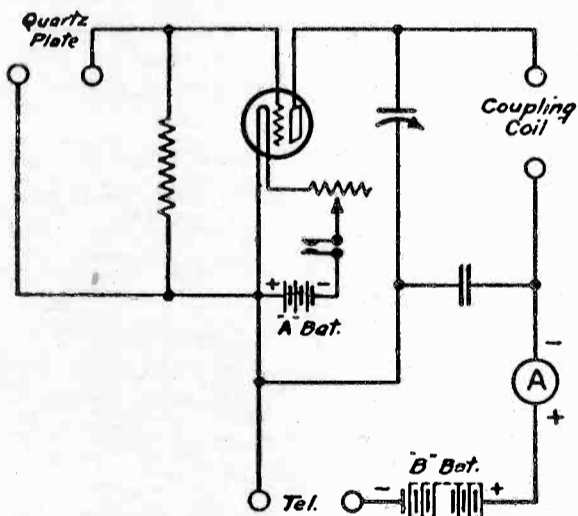

Fig. 1. Piezo Oscillator Circuit.

The circuit diagram of such an oscillator is shown in Fig. 1 and a quartz crystal and its mounting in Fig. 2. A piezo-electric oscillator using this circuit is shown in Fig. 3, this primary standard being in compact form with

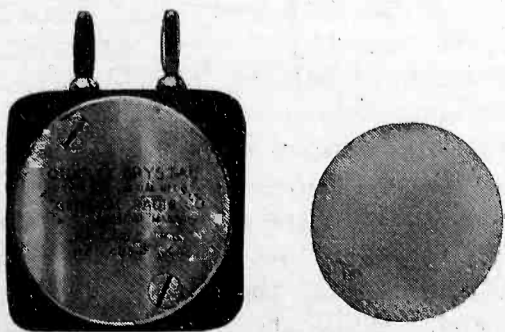

Fig. 2. Quartz Plate and Mounting.

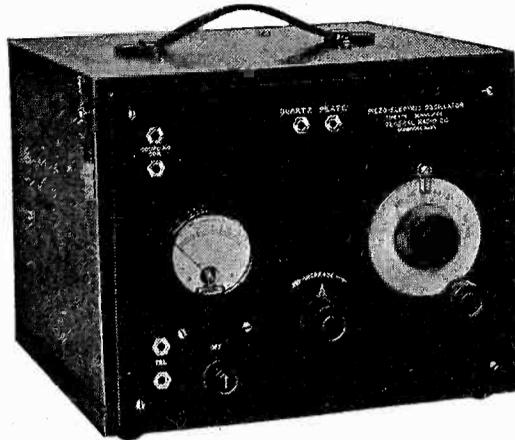

Fig. 3. A Commercial Wavemeter Working on the Piezo Principle.

all necessary batteries. Plug connection is provided for the crystal holder of Fig. 2 and for a coupler coil. A complete range of frequencies may be obtained by using several crystals.

While there is an approximate relation between the crystal's thickness and its frequency, the latter cannot be foretold accurately enough for calibration work. So the crystals are ground to frequency and not to thickness, this being checked as described after explaining the method whereby one manufacturer of wavemeters prepared a master standard.

The original basis was a crystal having a fundamental of 56 kilocycles, as approximately determined with a tuning-fork.

This was used in the circuit of Fig. 4 to control the frequency of a 56 k.c. vacuum tube oscillator. A 14 k.c. oscillator was operated with its fourth harmonic in synchronism with the piezo oscillator to which it was closely coupled, the piezo oscillator controlling the frequency of the 14 k.c. oscillator over narrow limits and maintaining constant frequency. The 14 k.c. was then slipped down to 1 k.c. by means of another tube oscillator—the piezo oscillator still controlling frequency.

Finally a variable frequency oscillator whose output drove a synchronous motor with a clock mechanism was coupled to the 1 k.c. oscillator. The frequency of this fourth oscillator was not controlled by the quartz crystal, but was adjusted so that the desired harmonic beat with the 1 k.c. oscillator. The clock mech-

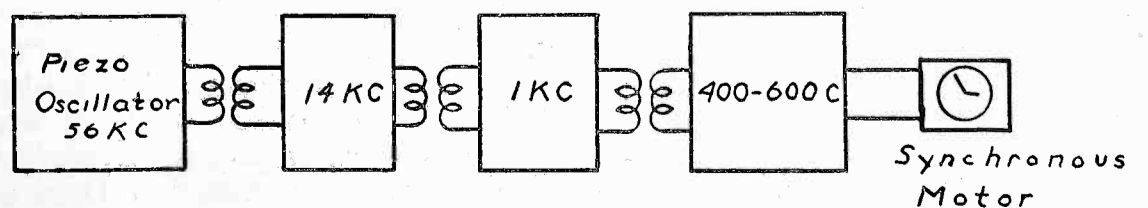

Fig. 4. Method Used in Calibrating Quartz Crystal.

anism provided an accurate count of the lowest frequency oscillator, which was timed over an interval great enough to reduce errors to the vanishing point. Knowing the frequency conversion factor in each oscillator, it was an easy matter to calculate the exact frequency of the original plate.

Several plates of higher frequency were calibrated in the same manner, providing not only additional fundamental frequencies, but cross checks on the standard. The measurement of the low frequency is accurate to about one part in 10,000. By the proper use of harmonics this series of plates covers the entire radio frequency range up to 20,000 k.c. Crystals which have been calibrated in this manner may be used for calibration of other crystals or of wavemeters.

The instrument shown in Fig. 3 may be used as a station standard, as well as for calibration purposes. As the crystal is good only for a few fixed frequencies, the principal use for this form of wavemeter is in stations operating on a single frequency, for example, broadcast stations. It is of course possible to control the frequency of the transmitter directly by means of quartz plates.

A disadvantage of the quartz standard for routine laboratory measurements is its discontinuity, providing fixed points only. It is like an accurate clock without hands, striking the hours only. For this reason, a secondary standard, the type of continuously variable wavemeter shown in Fig. 5, is employed for daily use. Frequent checks

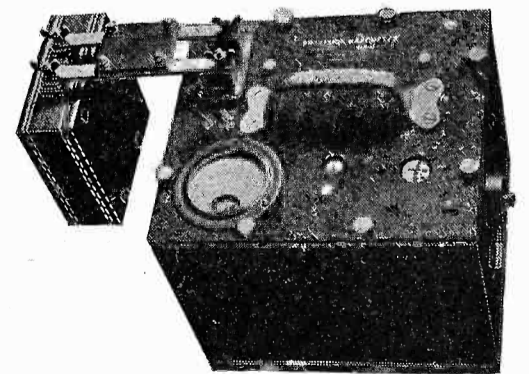

Fig. 5. Wavemeter Used as Secondary Standard.

against the standard crystals insure the accuracy of this meter.

When the quartz crystals are used for the calibration of the secondary standard, an auxiliary oscillator is required. This is an ordinary Hartley type of oscillator and should be equipped with plug-in coils for an extended wavelength range. For a check at the frequency of the quartz crystal, the auxiliary oscillator is adjusted for zero beat with the piezo oscillator, phones being inserted in either oscillator circuit for this purpose.

The wavemeter is coupled to the oscillator during this operation, but is short-circuited. When the two oscillators are adjusted to zero beat, the short-circuit on the wavemeter is removed. As the wavemeter condenser is rotated, the beat will reappear due to the reaction of the wavemeter on the auxiliary oscillator. The wavemeter is adjusted in turn for zero beat, which indicates resonance between it and the auxiliary oscillator. The coupling between the wavemeter and the auxiliary oscillator should be so loose as to provide a fairly narrow band of zero beat. It will be noted that the resonance indicator on the wavemeter is not used in the calibration.

The method of checking crystals in preparation of standards for other laboratories or broadcast stations is simply a reversal of the above operation. The auxiliary oscillator is set to the required frequency, using the standard wavemeter. The plate is then adjusted by grinding to bring the piezo oscillator to zero beat with the auxiliary oscillator.

For calibration at frequencies above the fundamental of the piezo oscillator, the auxiliary is adjusted for zero beat with the successive harmonics of the piezo oscillator, and the wavemeter adjusted to resonance with the auxiliary oscillator. For frequencies below the fundamental of the quartz plates, the auxiliary oscillator is adjusted for zero beat between its successive harmonics and the fundamental, the wavemeter again being adjusted to resonance with the auxiliary oscillator. Additional points, almost without number, on either side of the standard plate may be obtained by beating harmonics of the piezo oscillator with harmonics of the auxiliary oscillator. Since harmonics as high as the seventy-fifth are measurable, the number of such combinations is very large. In making these adjustments, the phones should be plugged into the circuit oscillating at the higher frequency.

In calibrating a meter for the amateur bands, for example, a crystal of about 1500 k.c. fundamental would be used. This is about as high a frequency as advisable for which to grind crystals, owing to practical considerations. The auxiliary oscillator would be adjusted

to zero beat with the piezo oscillator and the wavemeter to resonance with the auxiliary oscillator. The data for this point are recorded and the frequency of the auxiliary oscillator is raised until another beat note is heard. This should be the beat between the fundamental of the oscillator and the second harmonic of the piezo oscillator at 3000 k.c., although it may be a "fractional" harmonic, as a beat between the second harmonic of the auxiliary and the third harmonic of the piezo oscillator which would be at 2250 k.c.

An additional wavemeter, which is approximately calibrated, is desirable in order to avoid confusion of this kind. If no wavemeter is available, the position of the harmonic on the calibration curve will usually reveal its order, as will its intensity. Close coupling between the piezo and auxiliary oscillators is necessary for the observation of fractional harmonics. The integral harmonics have considerably greater strength than the fractional. The frequency of the auxiliary oscillator is again reduced (changing coils if necessary). The next beat note should be the third harmonic at 4500 k.c.

Similar data are obtained at the fourth, fifth, sixth, and seventh harmonics, giving frequencies of 6000, 7500, 9000, and 11,500 k.c. By working carefully, the gaps may be filled by beating the various harmonics of the auxiliary and the successive harmonics of the piezo oscillator. Thus the second of the auxiliary and the third of the piezo beat at 2250 k.c., the third of the auxiliary and the fourth of piezo at 2000 k.c., and so forth.

Calibration against a quartz plate involves more trouble than is necessary for the average user of wavemeters. The use of this method is mainly confined to laboratories whose work requires a particularly accurate standard. For ordinary purposes, calibration against a secondary standard is quite acceptable. This operation is comparatively simple, requiring a secondary standard, calibrated to the necessary accuracy, and some sort of oscillator. The secondary standard used in this work must be a high grid meter, and should be frequently checked against the quartz plates.

The oscillator is set in action and the frequency checked by means of the secondary standard. An indicator is generally included in the wavemeter. The standard is removed and the meter undergoing calibration is substituted for it and adjusted to resonance and the reading recorded. For accurate work, it is essential that a very fine adjustment of the wavemeter be possible. Meters for the highest grade of work have a slow motion gear with accurately divided scale and subscale. Data are obtained in this way for a number of

points over the wavemeter range, and plotted on cross section paper. It is important that the scale of the plot be large enough so that the calibration chart can be read as closely as the wavemeter, otherwise, the advantage of the close reading meter is lost.

Where a wavemeter is to be used over a limited range, and extreme accuracy is not required, it is possible to dispense with the calibration chart and build a wavemeter which is direct reading. The process of calibration is identical with that of the one just described except that the auxiliary oscillator is adjusted to a definite frequency for each calibration point. The data may be inserted directly on the dial. It is desirable to subdivide the scale, obtaining finer divisions than can be obtained by direct calibration without a great deal of labor.

If semi-circular plates are used on the condenser this cannot be done conveniently, since on this type of plate equal angles do not represent equal wavelength changes over the scale. If the space between two calibration points was divided up into say ten equal divisions, each of these divisions would not represent one-tenth of the difference in wavelength between the two points. If a plate shaped according to the law  $C = K^2$  (straight line wavelength) is used, equal angles subtend equal wavelengths, and the angle between two calibration points may be divided into approximately equal parts. In commercial practice, the calibration points are marked on a temporary dial and are transferred to another dial and the subdivisions made with the assistance of a dividing engine.

The wavemeters whose calibration have been described up to this point are of types somewhat more elaborate than those used by the average amateur. They are of the types used in laboratories and high power transmitters. The meters of a majority of amateurs probably resemble the familiar type of Fig. 5 more than the elaborate meters which we have been discussing.

Some meters designed for use on the amateur bands use a lamp as a resonance indicator. Others have no resonance indicator, resonance being indicated by the reaction of the meters in the oscillator circuit.

In wavemeters having the lamp type of indicator, it is advisable both in calibration and in use to operate the lamp at low brilliancy. The resistance of the lamp is lower at the lower temperature, and small differences in brilliancy are more noticeable at low brilliancy.

The calibrations so far discussed require two accessories, an oscillator and a standard wavemeter which must possess at least as accurate a calibration as is desired on the wavemeter being checked. While the oscillator is easily

*(Continued on Page 60)*

# The Pomegranate and the Gourd

## A Parable

By C. Sterling Gleason

IN the beginning there was chaos. And over all the world of radio hung a mist, so that no man might know his neighbor, nor see the peaks and valleys of his neighbor's lands. And the strong oppressed the weak, and justice was not; the mighty spark of the commercial beat down his weaker brother, and the thunderings of the 5-kw. ham blotted out his less fortunate fellow. He of the tiny spark coil took a fiendish delight in the goadings of his obliterating buzz, nor was "jamming" beneath the dignity of any, for mercy dwelt not in the heart of the radio man.

Now in the days of the fathers of radio some went before the great council, even the Senate of the land, saying, "O, wise and mighty fathers, have mercy upon us, for strife and turmoil filleth the air, and we are sore oppressed." And they beseeched them that they divide among them the ether, so that each might know his own domain, where others might not trespass.

And the wise ones hearkened unto their plea, and deliberated long and sagely among themselves, and at length caused to be written upon parchments a decree, of surpassing wisdom and complexity. And they divided the whole realm of radiocommunication among the people, even as they had been beseeched.

They decreed that whosoever would radiate into the ether of the land, be he humble citizen or rich potentate, must make petition thereof unto the great council of rulers. And when his petition was granted, would there be given unto him a mystic name or symbol whereby all might know him; and this sign would be written upon the pages of a great book of record, and none else might call himself by this name. And whosoever would tap a key must bear a license in token of his wisdom and knowledge; nor might one radiate into the ether one dot save under the permission of his license. That the knowledge and accomplishment of all aspiring operators might be determined, they set forth a test, which all must answer.

And the whole land they divided into nine countries, called districts, and in each established an office; and these offices they caused to be filled with wise men of exceeding skill and knowledge, so that each might perform the work of ten; they invested each with the title, "Radio Inspector," or, in the later day, "Supervisor of Radio," to inspire with awe all common folk. And each was to examine all who would become oper-

ators, in his district, and when he found one worthy of the name, should bestow upon him a parchment, or "ticket," of a hue pleasing to the eye and indicative of the degree of excellence thereof.

And the whole ether known to mankind they divided among the people; to the ship upon the waters was given a goodly supply of wavelengths, and likewise the station upon the shore; the mighty leviathans of radio, the arc and the alternator, might choose the more choice waves of their requirements; and unto the forces of the nation itself, the army and the navy, was given a supply of bands meet for their uses.

Yet there remained a goodly number unassigned; and one saith, "Lest the youth of our nation be neglected, let us set aside for them a small space, that he who experimenteth for the love of the art may not be overlooked." So unto the amateur (him called "ham") were given waste lands of little value, which he might call his own, and from the boundaries of which he might not stray; even thus did a certain nation give unto its aboriginal citizens rocky and desolate lands which in later days became priceless because of the oils and minerals found thereupon, and even so in a later day did the scorned land of the ham become of great worth, and the envy of every broadcaster. And they set forth sundry other commandments, and placed administration in the hands of those ordained as "Inspectors," and over all of them set a sage and busy man of business, called by men, "Secretary of Commerce."

Now when all was finished and these commandments were set before the people, a great rejoicing was heard on every hand, and peace was restored indeed. Now might the harassed operator upon the shore carry on his work unhampered by the irrepressible ham or the unholy spark coil. The amateur might frolic undisturbed in his own territory, and chin with his neighbor in the next block with all two kilowatts of energy heating the atmosphere, and yet cause not an outburst of dreadful profanity from the suffering commercial.

Truly did these rulings rejoice the hearts of all those of radio and bring order out of chaos. Now that each had unto himself an appointed place, no longer was the night hideous with bickerings, but instead did all traffic together in glorious concord. And none bore malice toward his brother, but instead did all become united in the bonds

of common interest and goodwill. Nor even did any rebel and cry out against the commandments of the wise; but if one of the younger generation strayed from the fold into the forbidden land above 200 meters, or with illicit spark coil made merry, then would his elder brethren admonish him and guide him in the paths of rectitude; and for the unruly one was devised the mystic wouff-hong and the damask rettysnitch. And all dwelt together in brotherly righteousness and amity; the commandments were kept, and revered and respected was the Inspector of Radio.

Now as the years passed by and came the time known as "After-the-war," a seer wrought miracles with the voice of man, causing it to shape the tremblings of a strange device of glass and metal called the "audion," and to be cast forth upon the ether, whence all might pluck it at will. And there came to him a vision; and in his vision he saw tens of thousands of his tribe gathering the sounds thus flung abroad, and sitting rapt at the tidings brought to their ears by no human messenger; he even saw some enchanted by the sound of harp and cymbal making merry the night, or a lute brought into the tents of his people by this marvelous instrument.

And he made known his dream unto certain great barons of trade, and they marveled greatly thereat, and caused him to work with some of their own servants, to the realization of the dream. And it came to pass that when they labored, they did indeed cause the sound of music to be cast upon the air, and transmitted straightway to the ears of all who would listen, and many of the tribe of radio did hear with their own ears sounds never before thrilling their diaphragms. And now this new art became a marvel and sensation of the age, and all the common people knew of it, and talked of it, and hungered that they might into their own dwellings bring music from afar.

And as they hungered, certain cunning merchants did build simple instruments that a novice might operate, and sell them at exceeding profit; and when the tribe of radio perceived this, at once all hastened to do likewise, that their coffers might be filled with jingling shekels. And as they did thus, more and more did the great public yearn for sets, and the mania spread as the fire of the prairie, and a great industry sprang up as the mushroom, so that every plumber and every plumber's son

became an expert, building sets for the eager public.

**T**HE pomegranate ripeneth slowly, storing up sweetness day by day, but when it attaineth full growth, is a joy and a blessing to mankind. The gourd springeth up overnight, and being fullgrown, is filled with water and delighteth not the heart of man.

Even as the pomegranate, the brass-pounding fraternity, growing slowly from a humble beginning, ripening in the wind of adversity as well as the sun of prosperity, and nurtured by love of the art, did dwell in fear and respect for the law and goodwill for the guardians thereof. But the new industry, fostered by the lust for gain and blossoming in the heat of public desire, grew into contempt for the commandments of the fathers, and loved not the keepers of the waves. And now those who nightly filled the air with diverse forms of entertainment had so increased in number that their allotted domain was crowded to overflowing, and some, perforce, must divide with their neighbor the precious hours upon the air. And there was weeping and wailing and gnashing of teeth, and those who had the poorer wavelengths often gnawed their fingernails at their brethren of the choicer assignments. And discontent sat heavy upon the heads of all, and there was much growling and snapping, each at his neighbor. And they began saying among themselves, "Who is this, called Inspector of Radio, who ruleth all radio with an iron hand, and favoreth his own chosen, oppressing the righteous who labor for the entertainment of the public?"

And now some of the discontent searched out certain wise men skilled in the law, and bade them delve into the mysteries of the great book of commandment, that they might know what should befall him who broke the sacred

precepts of the fathers. And these wise ones returned unto their employers, and pointed out certain sections of the law, saying, "There is a loophole, and here may one trespass without fear, and here is no penalty for transgression." And the malcontents rejoiced exceedingly at these tidings, that the lordly overseers of radio might not, under the law, bring retribution upon the breakers of the commandments.

And a certain one, dissatisfied with his lot, went out from his own post assigned by the fathers, and encamped upon the wavelength of a neighboring tribe. And when the fathers of the neighboring tribe did plead with him, he made mock of them, saying, "Why should I fear, for it is not written that he who wandereth from his own domain may be punished." Neither did he look into the future, seeing that one day the great fathers of the Senate, perceiving the transgressions of the people, would cause to be written another commandment, so that those who honored not the laws of the land would be fittingly dealt with.

**Y**ET as the days passed into years it came to pass that once more the great fathers met in holy conclave. And one of them rose up, saying, "Behold, how the wicked ones stray from the fold of the righteous, making merry upon the pastures of others." So they deliberated sagely among themselves, and in their wisdom brought forth a decree: that whosoever should wander in the allotted domain of another should be visited upon in the full vengeance of the law. And they made known throughout the land this new commandment, and the people all rejoiced exceedingly, save only those who held not the law in respect.

Yet, lest those who had formerly forsaken the paths of righteousness go unscathed, the fathers resolved to devise

for them some fitting punishment. So they called all those who had made free with the assignments of others, haling them before a tribunal of the highest magistrates of the land, and there formally accused them of their wrongs. And despite all the impassioned pleas of their attorneys, and sympathizers of the sob sisters of the land, they were found guilty, in a deep degree. And when a great multitude of people gathered round, and would at once take justice into their own hands, hanging the culprits to the limb of an elder tree, the judges said unto them, "Nay, let the law punish its own and retribution right its wrongs;" they dispersed the multitude, and the tribunal counselled among themselves.

And at length they returned a verdict, full of righteousness. They decreed that he who first had wilfully forsaken his allotted post upon the air should die by the sword; and that those others who had followed in his erring ways should be consigned to torment all the days of their lives; and after much weighty deliberation among themselves, the judges agreed that this torment should be in this wise: that the guilty ones should be confined in a dark and dank dungeon, and that at all times should be heard a loudspeaker, sounding forth the outpourings of all who broadcast upon the air.

Thus, as always, did the wicked receive just reward, and the trespasser upon the rights of others was squelched. And regarding those who were cast into the dungeon, some say that they still live in sorrow at being forbidden the ether, and others that they died a speedy death from listening unto the torrent of nondescript sound broadcast by their kind. However it may be, in our days, when would fain one migrate from his own wave into the territory of another, he recalleth the fate of the foolish broadcasters, and piously rejoiceth that he himself hath not strayed from the paths of rectitude.

Audio howling in a receiving set is often caused by the sounds from the loud speaker setting up a vibration in the tubes in the receiving set. This causes a ringing sound that is amplified by the audio amplifier, and converted into sound by the loud speaker; only to act on the tubes again with greater force and cause the vibration to increase. The louder the howling of the loud speaker, the greater the vibration of the tubes — this cycle continues until the audio amplifier is working at its full output. The howl thus generated is the same as that caused by putting the receiver against the mouthpiece of a telephone. It can usually be stopped by moving the loud speaker farther from the receiving set; and mounting the tubes in cushion sockets.

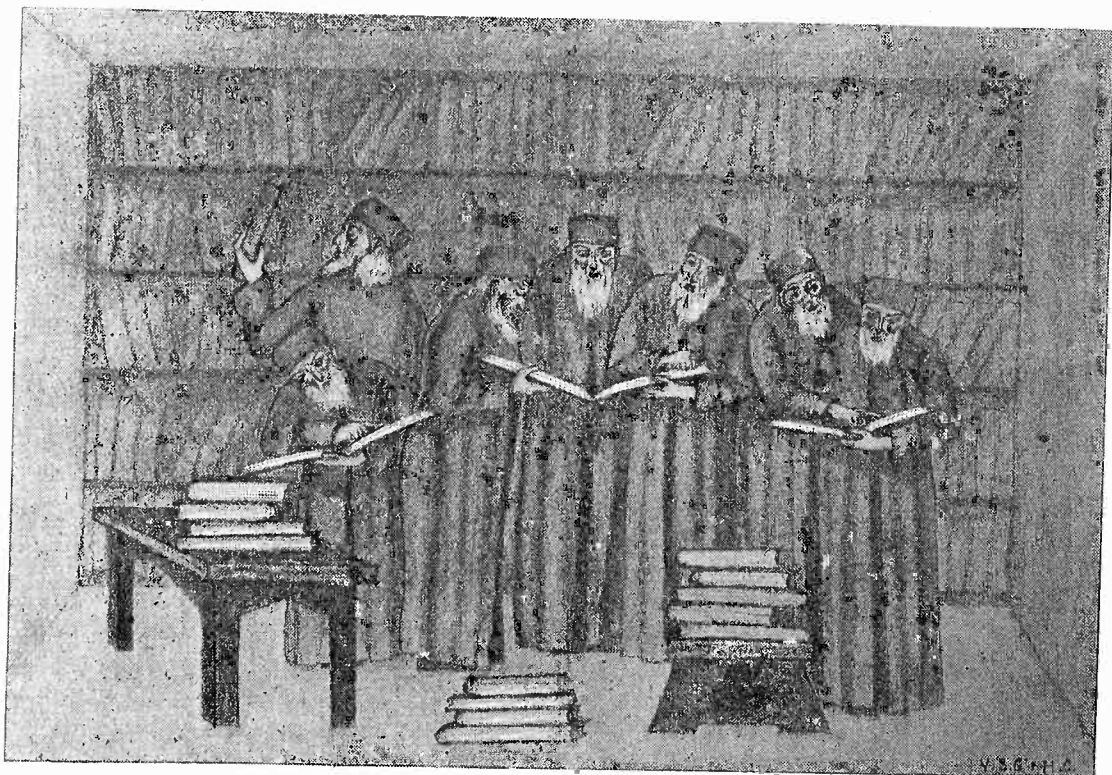

"And they delved into the law, saying 'Here is a loophole'."

# Letters From Larry

By Jack Bront

Nr. 267 Check 732½, Radio SS. Lake Discomfort Filed Date. George Hassenpeffer, 218 River Street, Hoboken.

Dear old horse (stop) Well this trip was sure KO OM except the third was sea sick (stop) He didnt even know I relieved him (stop) Sure I took your watch at two ax I says—just about the time the moon come up (stop) Oh he says was that the moon (stop) I was so sick he says OM that he didnt notice what come up (stop)

Well old horse Miss Cruikshank asked us how was the candy she made down in the pantry last trip (stop) And was it KO (stop) Yes Miss I says why Honk says the radio recipe candy was KO except he could taste the static bad (stop) Well OM I guess I blooped Honk off Miss Cruikshanks wavelength and now he wont hardly speak to either of us (stop)

Say OM the mate dropped in yesterday and he says is McReady in the game today (stop) Why he just kicked off I says (stop) Migosh he says did he suffer much (stop)

Tuesday the third told Mr Gillis his msg was delayed account of QRN raging all along the coast (stop) Migosh Mr Gillis says is any of the boys down sick with it (stop) Mr Gillis asked me to be sure and call him if an answer come while he was at lunch (stop) Dont worry Mr Gillis I says this WX report says you aint even going to be hungry at lunch time (stop) Oh he says you mean I may contract mal de mare (stop) Well I says most people get it without a contract Mr Gillis (stop) And I says Mr Gillis you might call it mal de mare or just plain horse but I says if you and your friend both get sick why itll be horse and horse—a horse apiece as they say in them cigar store dice games OM (stop)

Well OM a Scotsman come up to the radio shack this trip and he says hoot mon hoot hoot (stop) Come ahead I says there aint no traffic cops around here (stop) But he says OM I canna pay the heavy charges for cable on that message mon—hae ye not a bit of an auld used one ye might send mon (stop) And dinna put on the date mon—come next all Saints Day I can send the carbon copy by mail for next year mon (stop)

Well OM the third went to the city storeroom for a new quartz crystal for the wave checker (stop) Well says the storekeeper we havent any quartz in stock (stop) Well says the third maybe you can give us the same thing in pints he says OM (stop) What do you think youre getting says the storekeeper—distilled water (stop)

Well on Monday Honk busted our distilled water bottle and I says Honk this company has a staff of research and experiment engineers ashore and I think the board of directors is well satisfied with their work—and they dont need the benefit of your vast experience and any products of your own personal research (stop) Ah whats the squawk Honk says (stop) Well I says Honk we dont want any more demonstrations of the piece-o effect on the water bottles Honk (stop) They cost money Honk (stop) Ah get off the air and observe the silent period Honk says OM (stop)

Say OM I see the coast guard is using compasses to trace the rum runners (stop) I wonder do they smell it or is it just plain radio (stop) Well OM the time we went down to the South Georgia whaling grounds on the old Mendoza we used the compass to locate the whales after they had been fired on (stop) We just put a portable set on their backs OM and picked them up when wanted (stop) Well all was KO until one big fish started circling around the ship so fast he set up ac in the antenna and we had to build an ac eliminator so we could hear the other stations (stop) That was sure some whaler (stop) I mean the whaler ship (stop)

I never told you OM about the excursion down to Brazil for the Sao Paulo revolution OM (stop) Well we had portable transmitters for the rebels stashed in Santos and in Sao Paulo OM (stop) These were fed from lead cells (stop) I mean the transmitters (stop) Well when De Silva come down from Asuncion we trekked the stuff over to San Joao and to make sure the yellows didnt spill our electrolyte (stop) We soaked it up in green coffee beans and

packed it in rubber sacks (stop) Well the Federals captured San Joao and as they were short of coffee General Febreiro had the beans served at his table (stop) I always was glad those royal mail ships make fast time coming up from down under the southern cross (stop) I didnt leave no forwarding address but I guess General Febreiro would like me to visit his country as I sure think he would like to interview me on the coffee situation OM (stop)

The skip transmitter seems KO only it appears to skip every place we have tried to work yet (stop) Well be careful of horse cars there in the city OM—there sure has been a lot of street accidents lately OM (stop) More next trip old scout (stop) 73

(sig) Larry

Nr. 291, Check \$7.44 Radio, SS Lake Discomfort, 6.66 Pm, Date. George Hassenpeffer, 218 River Street, Hoboken.

Dear OM (stop) Well It Wont Be Long Now (stop) We just put in the short wave set and she perks KO (stop) The third came out of his bunk long enough to inquire if the watches was going to be shorter now that we had the short wave set (stop) Honk says Dunk where was you born (stop) I was born and drugged up in the state of Nevada says Dunk (stop) Well says Honk your folks must have moved away early (stop) Why says Dunk (stop) Well Honk says you been in your bunk in a state of coma ever since you been on this packet (stop) Zat so says Dunk (stop)

Who gets all the press says Honk (stop) Who gets all the weather says Honk (stop) Yeah and who gets all the bawling out says Dunk (stop) I cant give them any press or weather says

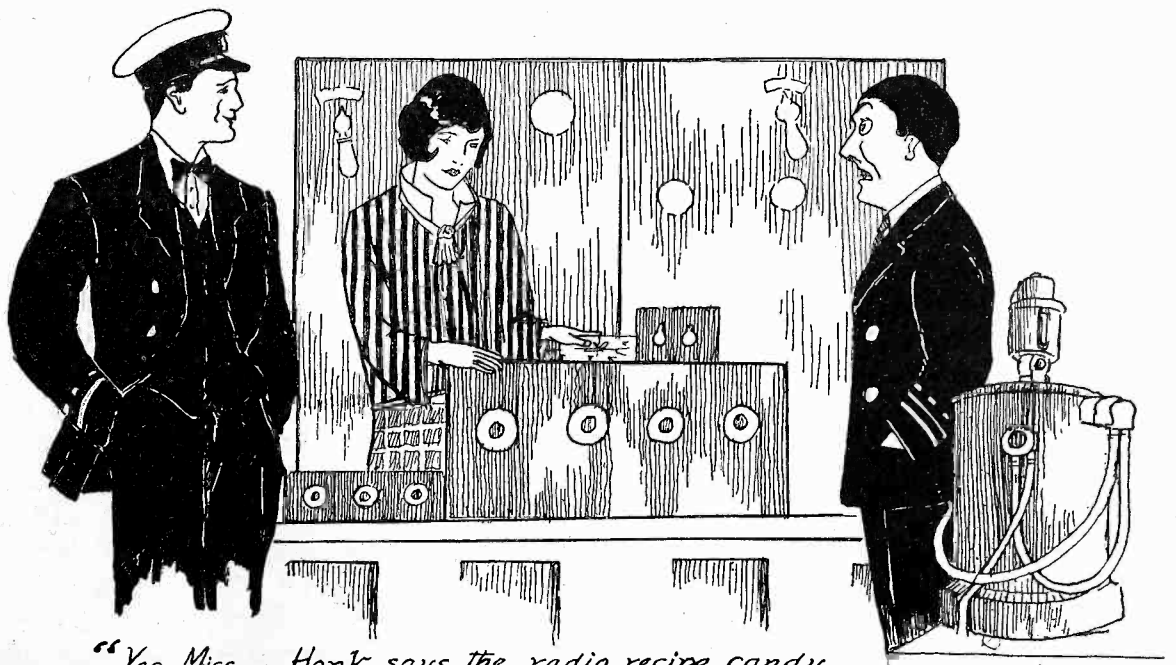

*"Yes Miss — Honk says the radio recipe candy was KO — except he could taste the static bad"*

Dunk (stop) I told the bed room steward not to throw them old newspapers overboard (stop) Migosh a man cant do everything Dunk says (stop) Yeah and some of them cant do anything Honk says (stop) Gents if you will both look directly into the lens I will try and do you both justice I says (stop) I will guarantee that your names go sounding down the aisles of the press and arrange for personal appearances in all the large cities and publicity will —Aw quit sounding off says Honk I aint arguing with him Im just telling him (stop)

Well OM Im using a infradyne amplifier and its sure KO (stop) I sure been laying out one sum after another sum at great frequency lately OM (stop) The purser came up and he says says he do you own any property real or personal (stop) Well Hw cum I says thats a real personal question (stop) Well he says the steamship company says you drew so much money that they are getting kind of short and would you mind letting them have two bit piece back some time this week as they got expenses to meet (stop)

Honk bust into the shack the other day when he was off the bar (stop) I says Honk did you change the ground on this here Knavy Knob set (stop) No he says but see the ground swell thats running inshore maybe that makes a swell ground haw haw (stop) Honk I says you was in the Signal Corps during the war now did they have mules in the Radio Company (stop) No he says why (stop) Oh nothing I says haw haw (stop)

Say OM last Wednesday Blonde Preferred was up in the radio shack and just then the skipper come along (stop) He looks in right stern like and he says Miss Harper have you any legitimate business in the radio cabin (stop) Well er yes sir says Preferred I er was looking for a well for a monkey wrench she says sort of all flustricated (stop) Well well a monkey wrench he says Miss Harper Ive been going to sea for eighty-six years and thats a new one on me (stop) Will you kindly permit the radio men he says to resume their duties and you please repair to your own duties below (stop) Yes sir she says but they aint nothing busted down there (stop) Cap Beaker threw his hands in the air caught them again and walked off snorting in disgust OM (stop) And skippers thought they had it tough in the North Sea during the war he says (stop)

Say OM poor old Cap Beaker is so afraid of women that he wont go down to the main saloon for his meals (stop) 'E heats is' chow in ther chartroom the Limie second steward says (stop)

C U next trip OM (stop) Look out for the horse cars (stop) 73

(sig) Larry

## AN INEXPENSIVE VOLTMETER MULTIPLIER

By HARRY R. LUBCKE

Often it is necessary to measure an electromotive force of larger value than the range of the voltmeter on hand. In the regular D'Arsonval voltmeter the pointer deflection for a given voltage is due to the current that is flowing through the movable coil. A large resistance is put in series with this coil so that the current will be as near zero as possible. To increase the range of the instrument we place more resistance in series with the meter. If we double the resistance of the circuit, by adding a resistance equal in value to that of the meter, we will decrease the deflection to one-half, and consequently double the range of the instrument.

It is possible to use some of the inexpensive resistors now on the market for this series resistance. Two units that have proved suitable for this purpose by actual test are the "Bradley-unit" and the "Vitreohm." A heavy duty resistor is necessary since it must carry a current of 20 milliamperes, which means a dissipation of 2.0 watts for a 5000 ohm unit. It must carry this current without any sign of heating or variation of resistance, otherwise the recalibration will not hold and the readings will be in error.

The Bradleyunits can be mounted directly on the instrument by soldering a No. 14 B. & S. gauge wire in the hole provided in the cap, and shaping it into a closed loop that will fit around the binding post. The Vitreohm can be clamped to the instrument posts by means of the connection lugs supplied.

The instrument is then recalibrated. That is, the actual voltage applied, and the corresponding scale readings obtained are determined for a number of points distributed throughout the scale; and these values used later to construct a graph. By means of this graph the voltage actually applied can be determined for any value of the scale reading.

Assume that an instrument of 0 to 15 volts range is to be increased to a 0 to 150 volt range for measuring *B* battery voltages. In general it will not be possible to make the new range some simple multiple of the old, due to the fact that the resistance required will be some odd value not agreeing with the standard values that are manufactured. The Weston model 301 voltmeter is wound to a resistance of 62 ohms per volt. Consequently the resistance of a 0 to 15 volt size is  $15 \times 62 = 930$  ohms. We wish to increase the scale reading 10 times. Hence the total resistance in the circuit must be 10 times as great as before, or 9300 ohms. But 930 ohms resistance is in the meter so we will need  $9300 - 930 = 8370$  ohms, external resistance. Unfortunately we cannot buy

a unit of that exact resistance on the market so the nearest standard value of 7500 ohms is chosen.

The recalibration can best be done with a second voltmeter that covers the desired new range. Both meters are connected across a source of electromotive force that can be varied in convenient steps. The readings of the two instruments are taken for each voltage. The second voltmeter should preferably be a precision instrument, for the recalibration accuracy is dependent upon its accuracy. A *B* battery forms a readily available source of e.m.f., although it must have a sufficient number of taps to give several points throughout the scale range.

In the absence of a second voltmeter use a fully charged storage *B* battery which can have its e.m.f. measured in small parts within the range of the voltmeter without the external resistor connected. Thus with our 0 to 15 volt meter, the taps on the battery must be 15 volts or less apart. In this case the first step of, say, 14 volts is measured with the meter and found to be 13.5 volts. The series resistor is then connected in series with the meter and the reading noted again. It might be 1.2 now. Then we know that when the actual applied voltage is 13.5 the scale reading is 1.2, this pair of values being one point on the graph. Next the resistor is disconnected and the next step measured, which may be 13.3 volts. Now the resistor is reconnected and the *two* steps measured in series. This gives us the sum of their voltages:  $13.5 + 13.3 = 26.8$  volts; while the scale reading will come out about 2.4. The voltage of the third step is then ascertained, added to the other two to give the applied voltage, and the corresponding scale reading secured by reconnecting the resistor and measuring the three steps together.

This process is continued until the maximum scale reading is reached, care being taken that the meter is not accidentally placed across several steps without the external resistor in series, for this may burn it out. Much time will be saved if the resistor is left connected to the meter and connections between it and the battery made with clip leads; then if the resistor is to be in the circuit the clip is fastened to it; while if not, it is fastened to the meter terminal.

Lastly, the graph is drawn by plotting each pair of values on cross section paper. The result should be a series of dots lying in a straight line. If such is secured, draw a line through these points and the recalibration is completed. If not, repeat the voltage measuring process entirely since it is possible that the battery voltage may have varied, or other errors introduced; taking special care this time to eliminate all errors possible.

(Continued on Page 58)





# QUERIES *and* REPLIES



Questions of general interest are published in this department. Questions should be brief, typewritten, or in ink, written on one side of the paper, and should state whether the answer is to be published or personally acknowledged. Where personal answer is desired, a fee of 25c per question, including diagrams, should be sent. If questions require special work, or diagrams, particularly those of factory-built receivers, an extra charge will be made, and correspondents will be notified of the amount of this charge before answer is made.

Have added a stage of tuned r.f. to my three circuit regenerative receiver. The set works fine on wavelengths from 200 to 320 meters, but above that point, it is poorer with the amplifier than without it. Can you tell me what is the trouble and how to remedy it?—G. L., Sebastopol, Calif.

If you are using the antenna coil of your old three circuit tuner for the r.f. transformer primary, there are probably insufficient turns to make the coil suitable above 350 meters. Try adding a few turns to this coil, and note whether the set has a tendency to oscillate at the shorter waves, and has greater sensitivity on the longer waves. A 1 mfd. bypass condenser connected from the positive B terminal of the primary coil, and the negative filament of the r.f. tube will also be advisable.

Is it possible to stop the noise caused by violet ray apparatus so that no interference will be caused in radio receivers?—T. B. J., Ventura, Calif.

So far as we know, such interference as is radiated by the vibrator and associated equipment which acts as the input to the violet ray tube, can be eliminated only by operating the apparatus in a shielded room, which is not practical. Where the interference travels back through the 110 volt lighting circuit, and into radio receivers using the same power service, a pair of heavy duty r.f. chokes placed in the 110 volt line at the service meter, with a bypass condenser across the line on the house side of the chokes, will help in eliminating this sort of interference.

I have broken the adjustment knob on the regeneration control of my infradyne amplifier. Where can a replacing knob be obtained, or should the whole unit be returned to the factory?—K. Y., Venice, Calif.

A new knob can be obtained from Gray & Danielson, 260 First St., San Francisco, Calif., by writing to them, and stating the circumstances.

Can one or more stages of tuned r.f. amplification be placed ahead of the Best Superheterodyne?—L. I. McM., Trenton, Mo.

See the February 1927 issue of RADIO, in which a new Best Superheterodyne with a stage of tuned r.f. amplification is employed. An extra stage could be added if the proper shielding, and care in design of the amplifier was employed.

Have read with interest several published articles on the Loftin and White circuit, but have been unable to obtain accurate information as to the circuit, and its constants. Please publish this data.—A. H., Berkeley, Calif.

The circuit shown in Fig. 1 is taken from a paper by Loftin & White before the I. R. E. It is designed to overcome the difficulty which is had with most receivers using tuned r.f. amplification, where the amplification is not uniform over the entire broadcast band. By combining the electro-magnetic coupling ordinarily employed in such circuits, with electrostatic coupling, through condensers, an even transfer of energy from the primary to the secondary circuits is obtained over a wide frequency band. In the circuit herewith presented, the r.f. transformer and antenna coil are the same as used in the average tuned r.f. set, so that any good make of tuned r.f. transformer can be used. The tuning condensers are .00035 mfd., and are placed in series with fixed mica condensers of .004 mfd. or more, with the ground side of the primary coil connected to the mid-point of the two condensers. The plate voltage for the r.f. tube is supplied through an r.f. choke, and the high frequency component in the plate circuit passes through a small adjustable condenser having a maximum of .001 mfd., through the primary, and back to the filament circuit through the .004 mfd. fixed condenser. The small variable condenser in the plate circuit shifts the phase of the high frequencies being fed into the primary coil so that no feedback of energy can take place through the capacity of the tube elements. For a technical description of this circuit, see the proceedings of the Institute of Radio Engineers for October, 1926.

Have an Atwater Kent five tube set which is not equipped with a "C" battery. How can this battery be installed?—H. S., Ione, Ore.

The audio amplifier in your particular model is contained in a circular metal case, so that the screws on the top of the case should be removed, and the top, on which are mounted the sockets and rheostat, swung back so that the wiring to the audio transformers is accessible. From the negative filament spring of each amplifier tube socket, you will find a flexible wire connected to its associated audio transformer, and this wire should

be disconnected from the socket spring. Connect the wires thus removed together, and solder to the common connection, a flexible piece of wire which should be passed through a hole drilled in the top of the amplifier case. Carefully insulate this joint with friction tape, and the top of the case can now be screwed back in place. This wire is the negative "C" battery wire, and for 90 volts plate on the two amplifier tubes, the "C" battery should be 4½ volts. The positive "C" battery terminal should be connected to the negative "A" battery binding post located on the top of the amplifier case.

Kindly inform me as to where I can obtain constructional data on the Best 45,000 cycle superheterodyne using dry cell tubes throughout.—W. F. H., Toledo, Ohio.

The particular model you mention was described in the May, 1924 issue of RADIO and copies of this issue, as well as reprints of the article, are no longer to be had. A revised circuit diagram, containing improvements necessary to bring the circuit up-to-date, can be sent upon receipt of the usual question and answer fee.

In the article on the "A" battery eliminator, published in January RADIO, data for the winding of the power transformer includes No. 8 wire for the filament lighting secondary, but in another place in the article, No. 12 wire is mentioned. Which is correct?—R. McC., Seattle, Wash.

No. 8 wire should be used throughout, both for the filament winding, and the connecting leads.

Can you give me data and blueprints of the latest Marine Radio Equipment suitable for study in connection with examination for commercial operator's license?—G. K., Hill City, Minn.

The circuit shown in Fig. 2 is a schematic diagram of a typical tube transmitter used in marine radio installations, together with the necessary batteries and auxiliary apparatus. The battery should be large enough to operate the set for at least 4 hours, so that a battery of 150 ampere hour capacity will be required. A set of 60 lead cells, or 90 cells of

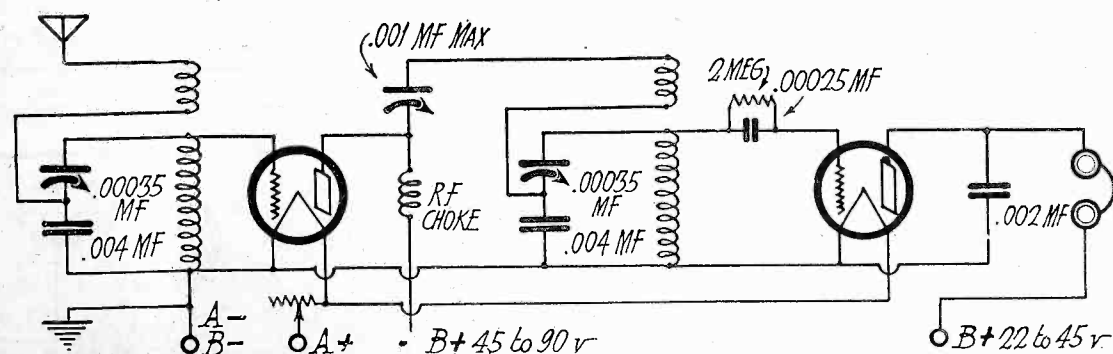

Fig. 1. Loftin and White Circuit.

Edison battery will do. These cells must be arranged in two sets so that they may be charged in parallel and discharged in series. This battery not only operates the main set, but serves as an auxiliary power supply for any emergency service.

In the diagram, a simple send-receive switch is shown, with three points, one "send," one "receive" and the other grounded. The receiver shown is the simplest form of one tube regenerative circuit, without audio frequency amplification. Amplifiers are customarily used on skipboard, and may be added to the diagram if wanted. A keying system is not shown in the diagram, for the sake of clearness, but the keying may be most satisfactorily accomplished by biasing the grids sufficiently negative so that the tubes will not oscillate.

## LETTERS TO THE EDITOR

Sir: I notice on page 68 of the February issue of RADIO a short note stating that I am building a commercial station at Alpena, Mich. In this connection the following information may be of interest to the readers of your Commercial Section:

The station will be for PG Great Lakes service and is to be housed in a small cement building which was put up for this purpose on the former NSM Navy Station site. A lease has been obtained on the old Navy towers, which will carry two antennae, one for ships and long wave point-to-point relay work and one for short wave work, which may be used in the future for some of the point-to-point relay work during the worst part of the summer static season.

The transmitters for long and short waves will both have two 250 watt tubes, the plates of which will be fed by a 500 cycle alternator, which, however, will run somewhat below normal speed in order to give our station a note which we hope will be distinctly different from the ordinary run of 500 cycle a.c. CW sets. Break-in relays will be used on both transmitters.

The station will be open through the season of navigation from March 15 until January 1, during which time continuous watch will be kept. Because of the fact that our local Western Union office closes at 9 p. m. and does not open again until 8 a. m., which would leave us without landline connection during the night, a special Western Union loop has been put in to enable us to give Western Union service direct from the radio station at all hours. This loop will also enable us to relay time signals at noon and 10 p. m., E.S.T. A schedule of weather forecasts and information concerning lake level fluctuations and lake currents will be published in the near future.

Please note that although I am building the equipment alone, Mr. L. W. Wright, who sailed on the Coast and the Great Lakes, and formerly of WDR Detroit, will also be on the job as my partner and operator; and watches will be split up between us in two 12 hour shifts.

Coast tax and relay charges have not definitely been decided upon, nor have call letters been assigned by the Department of Commerce, but these are minor details compared to the snappy service we intend to give.

Any additional information will be gladly given if you think it to be of interest to your readers. Yours very truly,

C. H. WESSER.

Alpena, Mich., Feb. 3, 1927.

## OAKLAND RADIO CLUB

The Oakland (Calif.) Radio Club has been formed to bring together transmitting amateurs who have a serious interest in the radio art from a technical standpoint. The officers are: P. W. Dann, 6ZX, president; James H. MacLafferty, Jr., 6RJ, vice-president; Philip Tait of Alameda, 6AEA, secretary; Burton Dare, 6OC, treasurer, and J. Walter Frates, 6CZR, publicity. MacLafferty, Howard McCauley, 6JS, and William Fisher of San Leandro, 6ANE, were appointed a committee to draft the by-laws and constitution of the new organization. MacLafferty, Thomas Babcock, 6APA; Walt Smith, 6CCT, and A. R. Tag-

gart, 6AMO, will serve on the new advisory board of the club.

Elaborate plans are being made for the activities of the club during the coming year, which will include a number of novel features of special interest to amateurs. Experts who have specialized on the problems of high frequency transmission met by amateurs will address the members at their meetings.

Broadcast listeners may become associate members of the club, if they possess a bona fide interest in radio telegraphy and make a formal application to the officers. Under the constitution the membership of the club is restricted to three classes: full member, honorary and associate. The full members will comprise radio operators and transmitting amateurs who hold government licenses, while the associate members will include those broadcast listeners who are interested in radio telegraphy and express a desire to join the club. The honorary members will be outstanding figures in radio activities and amateurs of other cities who do not come under the other two classes. The first two honorary members inducted into the club were Bernard H. Linden, radio inspector, and J. E. Lewis of Santa Barbara, 6CBJ.

Application has been made to the American Radio Relay League, to which all members of the club belong, for affiliation with that organization, and through it with the International Amateur Radio Union.

## ERRATA NOTICE

In the article on "Infradyne Tips" in March, 1927 RADIO, the circuit diagram should show a grid return from the common rotor of the triple condenser to some point between the 112 Amperite and the filament switch on the negative filament supply wire. A 1 mfd. condenser should also be connected between No. 6 on the oscillator and the negative side of the oscillator filament. The second sentence in next to the last paragraph should start "This combination" instead of "This elimination" and should end "resistance on the two r.f. tubes" instead of "infradyne unit."

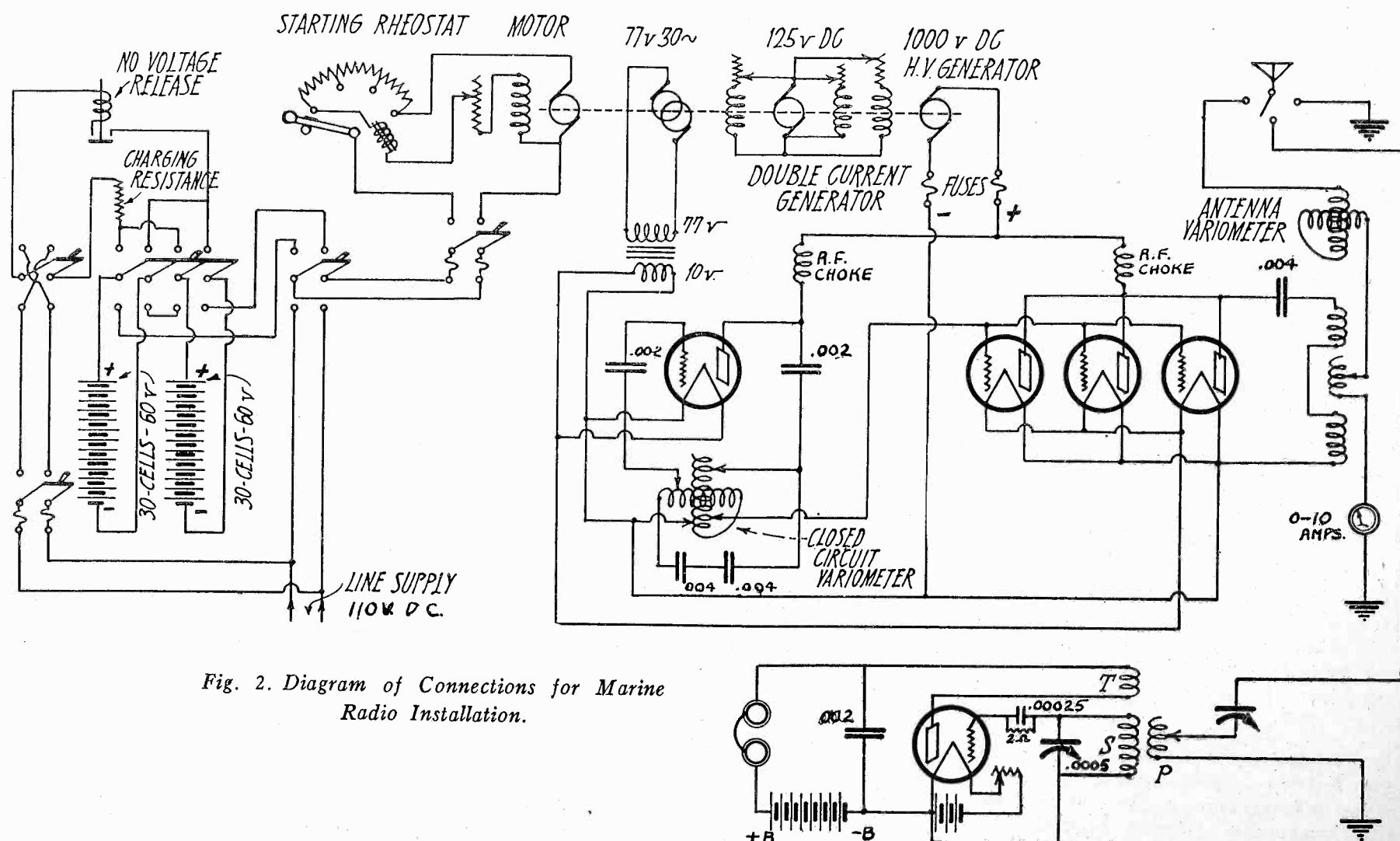

Fig. 2. Diagram of Connections for Marine Radio Installation.

# A Receiver "A La Brasspounder"

By Forest R. Ritz, K. D. Q. Z.

What should be the most efficient equipment in the modern ship's radioshack is no doubt open to argument, but here is one hombre who talks with his hands who believes the receiving equipment should be right up to the minute. And judging by the number of brasspounders who make their own, there are others who realize just how important it is to have a good receiver to stand a good watch. And there is certainly no better way to learn the interesting things about radio reception than to get a bunch of parts and build your own.

The receiver herein described, and now in use on KDQZ, has grown from a "plug-in" three coil regenerative (Weagant X circuit), and one step of transformer coupled audio amplification, to the present one stage of tuned radio-frequency, regenerative detector (Weagant X), one step of transformer coupled audio, and two steps of resistance coupled audio-frequency amplification. The resistance coupled A.F. is used only on music, and time ticks to the bridge when loud speaker volume is desired.

The three coil regenerative lashup alone, although sensitive, was found to be broad in tuning to quite a degree, unless the primary coupling was varied, or tuned with a variable condenser, which naturally decreased the signal strength. So the stage of tuned radio-frequency was hooked up, and along with the desired sharper tuning, an increase in signal strength was obtained, which was especially noticeable on distant signals. As the two tuning controls read almost alike, it is as easy, if not easier, to keep the receiver in resonance on the desired wave-length, as with the conventional three circuit honeycomb coil receiver. In this receiver honeycomb coil mountings are not used, nor are they recommended, on account of the greater number of coils to be handled, and the intercapacity between contacts in the mud mountings. The coil mountings used are made of strips of scrap bakelite, and the jacks and plugs are a General Radio product. This arrangement for the coils is very satisfactory, the coils being easily plugged in or pulled out, and the contacts sure-fire.

Referring to the diagram it is evident that the Federal 4.P.D.T. panel mounting switch was installed for a reason, and not for an ornament. On the higher arc wave-lengths

the stage of tuned radio-frequency was not considered essential, mainly because of the extra coils necessary, and thereby a greater outlay of dinero. By means of this switch the tuned radio-frequency is cut out, and the primary of the detector circuit connected to the antenna and ground instead of to the plate of the R.F. tube and R.F. B battery connection.

By soldering a piece of busbar on one of the two contacts so that it forms a make and break contact switch, and by insulating the pressure contacts with adhesive tape, a filament switch was provided to turn off the R.F. tube when the switch is thrown to the detector position. Besides being used to cut out the R.F. when not wanted, this arrangement was found to be handy as a "standby" when thrown to the detector position and tuned broadly.

Also comparison can be made of results obtained with and without the tuned radio-frequency. When it is desired to listen on both 706 and 600 while using the R.F. the detector dial is set near 700 and the R.F. dial at the 600 meter setting, and a very handy "standby" is the result. Although this circuit is much more selective than detector alone, it is not too sharp. In fact, the many advantages of this type of receiver can only be fully appreciated after operating one for a time.

It is not considered necessary that a detailed panel layout be given, and the average person will use the parts he has on hand. But for the information of those who might desire it, here is a list of the parts used in the KDQZ receiver, and approximate retail prices, exclusive of the coils and tubes:

1 Panel, 7"x18"x3/16" .....	\$ 2.00
1 Baseboard, 11"x17 1/2"x1/2" .....	.....
2 Remler .0005 mfd. var., without dial...	9.00
1 Remler .0005 mfd. var.....	5.00
2 National 200' dials, vernier.....	5.00
3 Remler UX type sockets.....	2.25
Grid cond. grid leak.....	1.00
1 10 ohm Carter rheostat.....	1.00
1 Carter filament switch.....	.50
3 Carter phone jacks .....	2.70
1 Federal 4.P.D.T. switch.....	3.25
10 GR plug tip jacks.....	1.00
40 GR plug tips.....	4.00
2 1 mfd. Sangamo fixed conds.....	3.00
1 .5 mfd. Sangamo fixed cond.....	1.00
7 Binding posts .....	.70
1 GR 6 to 1 a.f. transformer.....	6.00
Strips scrap bakelite (approx.).....	3.00
15 lengths round busbar No. 14.....	.75

Total, without res. amplifier.....	\$49.65
Resistance 2 step amplifier .....	.....
4 Sangamo res. clips.....	.40

2 .1 mfd. Sangamo condensers.....	1.70
2 .1 Meg. Daven resistances.....	1.50
1 .5 Meg. Daven resistance.....	.60
1 1. Meg. Daven resistance.....	.50
2 Remler UX type sockets.....	1.50

Total .....\$ 6.20  
\$49.65

Total of entire receiver.....\$55.85

The panel is shielded with thin copper sheeting in back of the two tuning controls. This was necessary to eliminate body capacity effects which were prevalent, probably because of the metal content of the National vernier dials. These dials are worth the trouble of shielding, however, if you are interested in fine tuning. No body capacity is noticeable when adjusting the regenerative feedback control.

One 10 ohm rheostat controls all the tubes, and a filament switch turns 'em off and on, thereby saving wear and tear on said rheo.

Three phone jacks are used. The first connects phones to detector, second to 1st step audio, and third to 3rd step audio. The third jack is a filament control jack to the two resistance amplifier tubes.

The tuned radio-frequency and detector circuit variable condensers are Remler .0005 straight-line-frequency. The regeneration feedback variable condenser is a Bremer-Tully .00025 mfd., but is going to be replaced by a Remler .0005 mfd plain, as the maximum capacity is not sufficient. When selecting variable condensers, coils, etc., beware of high loss junk, as any circuit of high resistance will not tune sharply. But nowadays there is plenty of good low-loss material to choose from. The General-Radio 6 to 1 ratio audio transformer is surely OK, and gives fine reproduction of music when that is desired. The two step resistance coupled amplifier is made up of standard parts, as listed, and is just the thing when volume and quality both are wanted.

Fig. 1 shows the circuit diagram. No neutralization system has been used, as no interstage coupling was noticeable, even on BCL waves. The coil mountings must be placed at right angles to each other, however. The bakelite mountings for the coil jacks were made of strips 7 by 1 in. Spacing between primary and tickler jacks is 5/8 in. and between secondary jacks 2 1/2 in. A radio frequency choke coil is used in the plate lead of the detector as shown, and consists of a secondary of a Remler super-het intermediate transformer with about half of the outer turns stripped off.

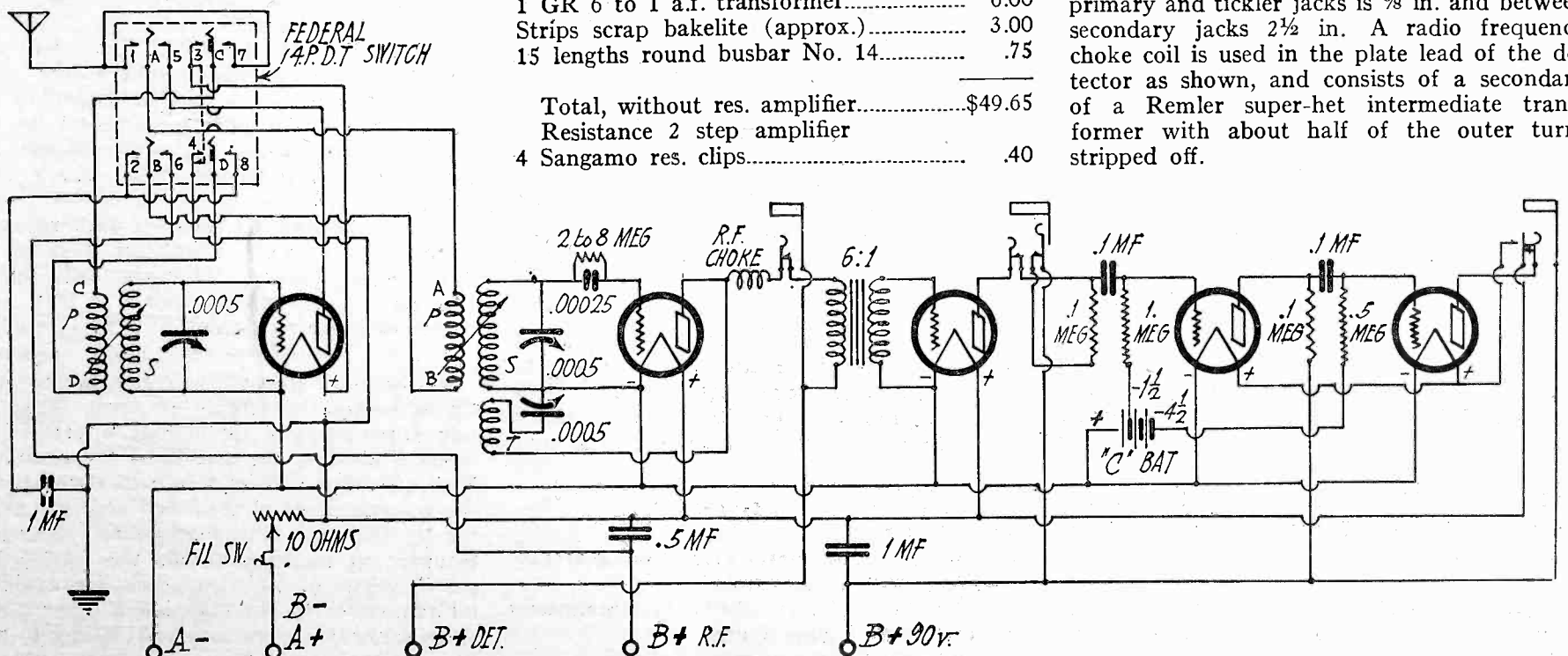

Circuit Diagram for Receiver "A La Brasspounder."

A "Mickey Doran" short wave adapter is used for the amateur wave-lengths, as the tuning of this receiver on the shorter wave-lengths such as the 40 meter band, was found to be too critical, on account of the .0005 mfd. variables used. This short wave adapter as described in November, 1926, RADIO is excellent. Here's how to Doran for passing on a real idea, and his many other fine articles!

On all wave-lengths up to 1000 meters or thereabouts, honeycomb coils will not give the signal strength nor selectivity that other types of inductances will. Although when mounted on the type of mounting suggested, without their mud bases, honeycombs could be used satisfactorily on the 600 meter wave band. On waves higher than that they are the best that could be used, on account of the saving in space and ease of handling. It is surprising the difference in signal strength that is obtained when honeycomb mountings are dispensed with, and well spaced plug and jack mountings are used. In selecting scrap bakelite strips to make these mountings, be careful to get a good grade of bakelite, and not mud.

The coils used on KDQZ on the 600 meter band are rather makeshift and haphazard looking affairs, but upon using them they were found to be very satisfactory. The radio-frequency coil has 150 turns in the secondary and 75 turns primary. The secondary was wound on a 3 in. cardboard tube. The tube was first cut lengthwise in three places, the cuts beginning and ending about 1/2 in. from either end. Then strips of celluloid were placed about 2 in. apart lengthwise on this form, the wire wound over them, and a thin coating of collodion applied to the celluloid strips. The cuts in the form were then completed and the cardboard removed, thereby leaving the coil practically air supported. The wire used was No. 22 enameled copper, although cotton covered or D.S.C. would have been used if obtainable at the time. The primary was wound on 7 pegs set in a 3 in. circle, like the Lorenz coil form, but without as many pegs.

The detector coil for the 600 meter band is rather unusual, consisting of three Remler super-het oscillator couplers set in a row and spaced about 5/16 in. apart. The secondaries are connected in series to get the required inductance value. Two of the primaries are in series, and are used as the primary, while the third primary was made into the tickler by winding about 40 extra turns over the original wire, and applying some collodion to hold the turns in place.

In place of this arrangement it is suggested that Hammarlund coils be used. These are 3 in. coils wound with No. 24 S.C.C. In this coil the tickler consists of 40 turns placed inside of the filament end of the secondary. A set of these coils is going to be tried on KDQZ using the ticklers which are already wound and in place as the primaries, and the tickler for the detector coil will be about 50 turns of No. 30 D.S.C. wound bunch fashion and placed inside of the primary, in the filament end of the secondary.

For the BCL waves Benjamin Lekeless transformers are used. Regeneration in the detector coil was obtained by winding 25 turns of No. 30 D.S.C. on a form smaller than the inside of the coil, bunch fashion and securing with thread, and then it was placed in the filament end of the secondary and secured with more thread. Rather haywire, but nevertheless efficient. These coils being designed to use with .00035 mfd variables, a wider

range is obtained on account of .0005 mfd variable condensers being used. When condensers are tuned to maximum capacity the resultant wave-length is 706 meters; 600 meters comes in about ten degrees lower, on the dial. The coils described for use on the 600 meter band give a range from about 300 to 1200 meters, so some of the major broadcasting stations can be heard on them.

If the switch arrangement as described is used the coils for the detector combination would be necessary on the higher waves only. But on the 1200 to 4000 meter band it is suggested that the stage of tuned radio frequency be used, as the extra wallop on the press broadcasts in this band, and on 2400 meter reception, would be a great advantage.

This receiver was designed to use type UX-201-A or CX-301-A tubes in all sockets, and gives fine results on all waves. But desiring greater signal strength on the 600 meter band and BCL waves, a CX-300-A detector tube has been in use. On the higher arc wave-lengths, a type 201-A tube cannot be beat as an oscillator for detection of CW.

The B battery voltages are 90 volts on the radio-frequency and audio-frequency amplifier tubes, and 45 volts on the detector. The plate of the radio-frequency tube is connected to a separate lead to the B battery as some tubes work as well or better with 45 volts B when used in radio-frequency.

No doubt a word about some of the results obtained with this lashup might prove of interest. On the BCL waves, although nothing phenomenal has been done considering that KDQZ, like any other large steel ship, has the advantage of a large antenna and ground; the best DX so far has been KDKA, Pittsburgh, several Chicago stations, and other midwesterners, on the loud speaker. Around 3 a. m. P.S.T. three Japanese broadcasters, and as many in Australia, have been heard on the phones. For fear of arousing the mate, etc., the loud speaker was not tried. Japanese broadcasters do a great deal of talking, evidently speeches, and for an idea of how the music sounds, step into the galley when the cooks are banging the pots and pans around, and yowling at each other.

Any night on the coast, and while bound from there to Honolulu, such eastern coast stations as WCC, WSC, WGV, WPA, WAX and WSH roll in, and are readable through considerable interference at times on 600-625 ICW. In the early morning JOC, 600 meter ICW in Japan, with audibility of R-68, is not uncommon. Of course, all the Pacific Coast stations are carried across to Honolulu, with an audibility of R-88 or R-99 at night, and as far out as 1200 miles in daylight (noon or thereabouts) with an audibility of from 2 to 6. It is surprising how far out ships with power of from 1 to 2 K.W. clearing traffic on the coast can be heard in daylight. Many times on different trips to Honolulu in the last ten months different lumberbuckets with their 1 K.W. transmitters have been heard as far as 1000 miles in daylight, to say nothing of the larger steel ships with their 2 K.W.s. It has been found that the stage of tuned radio-frequency has made the daylight reception range much greater than without it.

On the 2400 meter wave band very satisfactory results are obtained with detector and one step audio only, many eastern coast stations and ships being heard regularly with good audibility. With the stage of tuned radio-frequency greater signal strength and

selectivity is obtained. Of course on the wave-lengths from 4000 meters up most anything will pull 'em in, so detector and amplifier only are used.

In conclusion, there is nothing more to be said, except that since building my first "Gibbons" in 1922, different circuits have been built and rebuilt, and at last such satisfactory results are being obtained that for a time at least there will be no more striving for something better in the line of a receiver "A La Commercial Brasspounder," unless it be to jerk out a tube that has gone flooey, bounce it off the bulkhead and insert a good one in its place. So here's 73 Qru Qsu . . . .

Addendum: Here is some later dope on this receiver, which makes it complete. If anyone tries it, let us know how it comes out.—Dept. Editor.

As I mentioned in the text, I had planned to get a set of Hammarlund coils, but being unable to do so, I got some No. 30 D.C.C. wire, some celluloid and collodion, and now have a set of coils constructed that sure are fine for 400 to 1400 meters. In both coils I am using 25 turns in the primaries and 150 turns in the secondaries. The tickler of the detector coil is 45 turns. I decided to use No. 30 wire, because of the saving in space, and by comparing with the coils I had these are much better. I used 3 in. diameter cardboard forms, cut lengthwise, so they could be removed after the wire was wound. Over these I placed celluloid overlapping it about a quarter of an inch. While winding collodion was applied where the celluloid overlapped and after the coils were completed a coat of collodion was applied over the entire coil. In this way a very solid and good looking job is the result, and as far as I have been able to learn celluloid as a low loss coil form is not to be sneezed at.

## THE FEDERAL RADIO COMMISSION

The newly created Federal Radio Commission, appointed by President Coolidge, is made up of the following men:

Wm. H. G. Bullard, Media, Pa., six year term and chairman of the commission. He is a retired rear-admiral of the U. S. Navy and is recognized as an authority upon radio matters.

O. H. Caldwell, New York City, five year term. He has served as editor of "Radio Retailing" since its inception and previously as editor of electrical trade publications.

E. O. Sykes, Jackson, Miss., four year term. He was formerly justice of the Supreme Court of Mississippi.

Henry A. Bellowes, Minneapolis, Min., three year term. He was director of radio station WCCO at Minneapolis.

J. F. Dillon, San Francisco, Calif., two year term. He is a lieutenant colonel in the Signal Corps Reserve and a retired major of the U. S. Army. Until his appointment he was Radio Supervisor for the sixth district and has been in the federal radio service since 1912.

The commission has complete authority over radio for one year. Thereafter it is to act as an advisory board and appeal body for the Secretary of Commerce who will then have charge of radio regulation.

As Admiral Bullard will not return from China before the middle of April, the other four commissioners are holding informal conferences pending the arrival of the chairman. Thereafter but a short time will elapse before the announcement of their first orders in clearing up the chaos in broadcasting. Secretary Hoover has announced that the facilities of the Department of Commerce are available for the use of the Commission if other means are not found, due to Congress' failure to pass the appropriation bill.

R.F. Pri. Turns	R.F. Sec. Turns	Det. Pri. Turns	Det. Sec. Turns	Det. Tickler Turns	Range Meters Approximate	Type of Coil
15- 25	60	15-25	60	25	200- 550	Benjamin or Browning-Drake
25- 50	150	25	150	50	400- 1,200	Honeycombs
150-200	400	150	400	200	1,200- 4,000	Constructed or Hammarlund
600-750	1000	600	1000	400	4,000-14,000	Honeycombs
750	1500	750	1500	750	6,000-18,000	Honeycombs

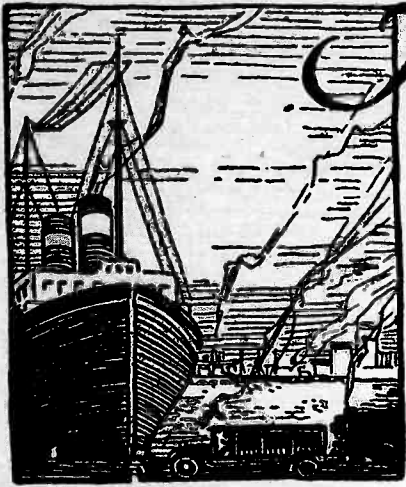

R. O. KOCH, *Great Lakes Correspondent*

# The COMMERCIAL BRASSPOUNDER

## A Department for the Operator at Sea and Ashore



Edited by P. S. LUCAS



C. W. RADOS, *Boston Correspondent*

Not much room for editorials this month. There's too much real DOPE; first class, concrete, up-to-the-minute information to print. We certainly appreciate the way you fellows have taken hold of this C. B. Department and put it over. We are getting quite a few letters from different operators who want to tell us that they like to read the department, and that they get some worth-while dope from it. Thanx, fellows; such letters stimulate the desire to keep poking. And thanx, also, to you who have helped with material.

Now, don't let this encouraged discourse leave the impression that we are so swamped with literary manuscripts that we can't keep our feet on the floor. No such luck! While we are managing to keep a little ahead of the game, we are not flooded, by any means. Right at the present we couldn't scrape together enough dope for next month's issue, although we are trusting to the mails as usual. No, don't forget us.

May we ask just one more favor before signing off? Has any one of you taken advantage of any of the constructional articles we have been running? If so, won't you tell us about your results? In the past twelve months have appeared several radio frequency ideas for ship receivers; the Superdyne circuit for ships, by W. L. Jepson; a splendid article on the McCaa band eliminator by Carta McCormick; a Short Wave Adapter by Mickey Doran and many others equally as good. If you have put some of these ideas to the test and have benefited thereby, the various authors would certainly be glad to know it. And so should we.

Again, many thanx for your support.

The 13th of December seemed to be an unlucky day for WDD, S.S. PM No. 18. She ran aground near Milwaukee, Wis., in thick weather and knocked a hole in her bottom. Last winter she ran on near Manitowoc. Her motto seems to be, "A new bottom every year." She will be taken to Manitowoc for drydocking and repairs as soon as released.

The QRA of that new station signing WDM is Menominee, Mich. It is owned by the Ann Arbor Railway and is open only during the day time. The operator is Ferris McKesson, who was formerly at WFK. The new op at WFK is George Honold, ex WDP.

C. M. Bennett, operator on SS. *Mosella*, has been laying up at Jacksonville, Fla., en route from WGV to Rotterdam, while the engines and boilers are being repaired. He advises that WNU has resumed his 11:30 a. m. E. S.T. sked. and WAX is back in his early a. m. sked. GBR, Oxford, sends press at noon, 8:45 p. m. and midnight GMT on 18,430 meters, which can be copied on this side in daylight.

KFT of Everett, Wash., has installed a 500 watt 500 cycle CW set, using both 600 and 40 meter bands.

### AUTOMATIC DEVICES

By GEORGE IMLACH, *Chief Operator, San Bruno*

Ever since the loss of the *Titanic* in the spring of 1912, efforts have been made to invent a device that would respond to SOS calls, but so far, in spite of the great advancement of radio, no satisfactory device has been contrived. The general trend has been to devise an instrument that would ring a bell whenever a distress signal was received, but which would not respond to other signals, excepting in some cases to a call for the particular ship.

The difficulties to be overcome are chiefly interference, atmospheric disturbances and the difficulty of maintaining the device sensitive over a considerable period of time under varying climatic and physical conditions. As every year sees more ship and shore stations opened, interference is constantly on the increase.

The elimination of atmospheric disturbances is drawing the attention of many experimenters and, with the amplifying apparatus necessitated by the employment of an automatic device, static becomes a very serious problem indeed.

Small ships, on which only one operator is carried and on which such a device would be installed, are susceptible to vibration when light. In heavy weather they certainly know how to throw themselves about, so that the difficulty of keeping an automatic device sensitive under such conditions becomes apparent.

As in the words of Professor G. W. O. Howe in "The Electrician" for July, 1922, "it is one thing to make an apparatus which can be adjusted until it will respond with certainty in the laboratory to a signal of the required type and of known wavelength and signal strength; it is quite another thing to insure that, when installed on board ship and removed from the tender care of the laboratory staff, it will respond to a signal of unknown strength sent out from the emergency transmitter of a sinking vessel by an operator in a state of nervous excitement. It is equally important to insure that it will not respond to any other signal, since it is not difficult to imagine what will happen to it if it gives a number of false alarms."

Experienced operators know that it will take a considerable number of years before these inherent difficulties can be overcome. No doubt such a device will be perfected in time, but it is important that operators on ships carrying more than one operator should not be replaced by such devices until the latter can be designed to perform with absolute efficiency.

Considering the prime reason for radio on board ship, namely, safety of life at sea, this cannot be too strongly emphasized.

CS at WFK says that he is going to have his sine copyrighted if the boys don't stop using it when asking for "TRS."

### EXPOSURE No. 3

C. O. SLYFIELD

C. O. Slyfield, who signs "CS" at WFK, was born at Frankfort, Michigan, May 11, 1898. He has lived at Frankfort practically all of his life, and he will tell you that the old home town is plenty good enough for him.

His radio career started 'way back in 1913, when he rigged up a spark coil transmitter by borrowing (?) a spark coil out of his dad's gas boat. For some time this station was transmitting only, and the results were checked by transmitting for a half-hour, and then running down to the home of a friend to see how much of it had been copied. Somehow or other, CS could never develop enough speed to get down there in time to hear how his own sending was coming through, so he made up his mind to have a receiving set.

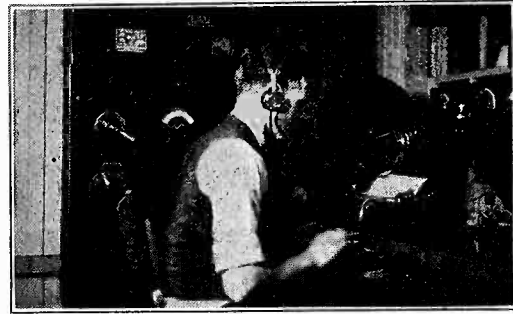

C. O. Slyfield

After getting a "rock" and catching the family cat, he was able to do receiving! The tuning coil was wound on a rolling pin (yes, the signals did swing) and the "headset" was a single telephone receiver without a head band. In 1914 the call 8PH was assigned to this station. Results? Signals were heard from the stations on the west shore of Lake Michigan, as well as the numerous carferries plying the lake.

WFK was then in charge of Tom Joynes, one of the best operators that ever jerked lightning. Being a kind, fatherly sort of a fellow, he took considerable interest in CS, and coached him with untiring effort until he felt that CS was capable of passing the commercial examination. The only RI in this part of the country at that time was Mr. J. F. Dillon at Chicago. Out of the forty applicants who sat around the buzzer on May 15, 1915, six were able to pass the code test—CS was one of them. Living in a port like WFK, he was able to do considerable relief work on the carferries during spare time. He finished high school in 1916 and then wired O. R. Redfern (chief operator of Lake Superior) for a job. He was assigned night trick at WCM, Calumet, Michigan, which position he held until the close of navigation. He returned to WFK just in time for the rough weather and got a job on the *Str. A. A. No. 3*. For the next two weeks the fish got three square meals per day. The Ann Arbor Company purchased the *Str. A. A. No. 6* a little later, and CS was transferred to her.

He held this position until April 17, 1917,



## NOTES ON COMMUNICATION FACILITIES ON THE WEST AFRICAN COAST

By P. A. GIRARD, IWTCO.

Funchal Maderia Island, CTQ, but mail steamers in port stand continuous watch and ships may sometimes have their messages delivered ashore by calling ships anchored in Funchal.

Rabat and Casa Blanca, Morocco, CNP, French radio stations with a normal daylight range of 150 miles. Station keeps good watch, but has much interference from the station at Gibraltar. Has good cable and inter-station telegraph facilities.

Teneriffe, Canary Isles, EAT, with a normal daylight range of 3/400 miles. Keeps good watch, except from noon to 3 p.m. Good cable facilities. Coast .09 LL.01.

Las Palmas, Canary Isles, EAL, with a normal daylight range of 800 miles; night range 1500 miles. Keeps good watch, except from noon to 3 p.m.

St. Vincent, Cape Verde Isle, CRF. Normal range 500 miles. Keeps good watch from 6-14, 16-19, 22-2 GMT. Coast .09. No LL to St. Vincent.

Dakar, Senegal, HWB. Range 250 miles daylight, 1000 miles night. Spark, 120 cycles rotary also 240 cycles rotary. Waves, 300, 450, 600. Hours, continuous, except closes down when static is bad; 240 cycles spark carries about 1000 miles clear. All traffic worked at about 15 words per minute. Is good for long distances. Keeps good watch, except when static is bad, but is willing to work through considerable interference. Ships bound for St. Vincent can work Dakar easily when north of Cape Bogador, but this causes interference to Las Palmas and Teneriffe. Usually it is better to wait until south of Cape Blanco. Gibraltar BYW comes in very strong and causes interference with ships working. Dakar will frequently QRT ships when their signals are jamming traffic. Dakar covers French CW stations at 1700 GMT, especially Bordeaux (LY). Dakar carries very well southward and eastward after local stations have closed down. In spite of heavy static, this station will be good for traffic up to approximately Cape Three Points, after which he is not heard again except on exceptionally good nights. Coast .04 LL .03 cable facilities.

Bathurst, British Gambia, VSH. Range, 75 miles daylight; 150 miles night. Waves, 300, 600. Hours, 0700 to 2100 GMT. Charges, Coast .12, No LL to Bathurst, but .03 to river ports service is supposed to be continuous from 7 a. m. to 9 p. m., but station is usually hard to raise, and it takes a long time to answer. Service is very poor, operators are native and cannot handle traffic very fast. Spend a lot of time calling VSW (McCarthy Isles), but never get any answer. On making Bathurst in the distance, coming up Gambia river, three large masts are seen about eight miles below the town. This is BZK, Cape St. Mary Radio, closed down since the war. Static is usually very strong in afternoons. Best working time is between 7 a.m. and noon. This time also applies to any part of the West African coast.

Conakry, French Guinea, HWD. Range, 400 miles; spark, 600 cycle telefunken; waves, 600, 3000; hours, continuous, except when working Rufisque on 3500; charges, Coast .09, LL .30 for first ten words, .04 each additional word. Good operators and good watch. Can be depended upon for traffic a short way south of Dakar to Grand Bassam. Usually takes TR'S from ships bound down the gold coast when they are first heard working Bathurst or Bissao, and this information is phoned to ship's agent, and messages filed for transmission shortly thereafter. It is necessary therefore to listen for Conakry a day or two before ship is due in port, as the station usually has

traffic. Covers French CW stations. Cable facilities.

Freetown, Sierra Leone, VPU. Range, 150 miles; spark, 600 telefunken; waves, 300, 450, 600; hours, 7 a. m. to 10 p. m. GMT; Sundays, 8 to 10 a. m., 4 to 6 p. m. Does not carry well, and does not keep good watch. Is very inaccurate and careless and makes no attempt to work distant ships. Operators are native and equipment not changed since 1911. Coast .12. No LL.

Monrovia, Liberia, HWE. Range, 150 miles; waves, 300, 600; hours, 7 a. m. to 10 p. m. GMT; charges, Coast .09. No LL. Cable facilities.

Bissao, Portuguese Guinea, CRA, CRB and CRC. Range, 300 miles; waves, 300, 450, 600; spark, 60 cycle rotary; hours, 500 to 1230, 1500 to 1700 GMT; charges, Coast .09, LL .01. CRA— Poor range in daylight, hard to read over 100 miles. Operators, however, are very good, and speak very good English. CRB— Bolama, capital of Bissagos Isles, 60 cycle note. Very poor. CRC—Bubaque Isles; 240 cycle note. Hours, 0800 to 1100 GMT, 1500 to 1700. Portuguese military station on the Bolola river. Does not ordinarily handle traffic with ships, but will relay in case of necessity without charges. Radio service very poor on account of strong static.

Grand Bassam, Ivory Coast, HWG. Range, 100 miles; spark, 500 cycles; waves, 600; hours, 0800 to 1100 GMT, 1400 to 1700, 2100 to 2200; Sunday, 8 to 10 a. m. Charges, Coast .05 LL .01, min. 2.50 frs. Station does not carry well, and operators do not try to work distant ships. Useless to call more than three or four times, even when the operators are on watch within 250 miles. Usually Tabou HWF will answer if Grand Bassam does not hear. Station cannot be relied on for traffic up to any great distances, and does not give all ships equal chance to clear traffic.

Accra, VPG. Range, 150 to 200 miles; hours, 8 a. m. to noon, 2 to 5 p. m., Sundays, 8 to 10 a. m.; waves, 600; charges, Coast .08 LL .02. Cable facilities.

Secondee, Elmina, Cape Coast Castle, Saltpond, Appam, Winnebah. Steamers lying at these ports can work Accra and Lagos radio, but work steamers north of AXIM. Steamers lying at any port on West African coast where there is no radio station, may act as radio station and accept radio messages as PDH to captain of port vessel, asking him to inform agents, etc. Watch is first ten minutes of hour.

Lome, Anecho, Grand Popo, Guiddah. Cable and French government landline. Cable messages are considerably delayed because of relays. Also radio service through ships anchored in harbors.

Cotonou, Togoland, HWH. Range, 100 miles; hours, 0800 to 1100, 1400 to 1700, 2100 to 2200 GMT; waves, 600; charges, Coast .09. No LL. Does not carry well, poor range. Does not keep very good watch, and does not try to work distant ships. Operators are native.

Lagos, Nigeria, VPY. Range, 300 miles; hours, continuous from 7 a. m. to 9 p. m.; wave, 600; charges, Coast .12. No LL. Cable and radio with a normal range of 300 miles, which does not increase at night on account of atmospherics. Keeps very good watch and willing to work through static for distant stations. Is one of the most important stations on West Coast, as most agencies have headquarters at Lagos. Ships are not allowed to work in harbor until after 9:30 p. m.

Fernando Po Bight of Baffia, Gulf of Guinea (Spanish), EAY. Range, 200 miles; spark, 600 telefunken; waves, 300, 600, 800; hours, 6 to 9 a. m., 10 to noon, 2 to 10 p. m. local time; charges, Coast .11. No LL. Note: Traffic radiograms addressed to Duala and

forwarded via Fernando Po carry OL charges only of .07 with no minimum. Cable out of commission since 1923. This station can be heard working ships in his vicinity when in the Niger Delta, north of Bonny, at Port Harcourt, Abonema, Degama, etc., and may be worked at times, but usually fails to answer calls due to atmospherics. Operators at Fernando Po are very careless in sending code and cipher messages. It was noted that messages were incorrectly repeated when traffic was forwarded to Duala. Code combinations were frequently mutilated, and no effort was made to correct this. As a precaution in receiving code messages, operators should be made to give special repetition of text for check and verification of code groups. It will be noted on copying traffic between Fernando Po and Duala that 25 per cent consists of service messages from such points as Hamburg, London, Barcelona, etc., requesting repetitions of doubtful or mutilated words in messages handled through this station.

Duala, French Camerons, HWZ. Range, 100 to 150 miles; hours, 6:30 to 11 a. m., 2:30 to 5 p. m.; waves, 300, 600; spark, 500 cycles; charges, Duala works continually with Fernando Po (neither station being any good), and neither keeps exactly to his schedule with ships. Duala wave for transmission is really about 700 meters, and takes a long time to answer a ship's call, usually from three to five minutes. Inaccurate in transmission, makes frequent errors, poor service and hard to have acknowledge a message. Operators are natives. Will not work through static.

Kribi, Bonny, Port Harcourt. Cable facilities and radio service only through ships anchored in harbors. Cable from Lagos to these ports very poor. Took four days for message from Lagos to Kribi (80 miles) on one occasion.

Libreville, LIB (outlaw station). Range, 75 miles. Does not keep specific hours watch, and handles messages as PDH (i.e. Please advise, etc., etc.).

Cabinda, Angola, CRQ. Range, 150 miles; hours, 7 to 11 a.m., 4 to 7 p.m., Sundays, 7 to 11 a.m.; charges, Coast .08, LL .01. Cable facilities. Does not stand good radio watch.

Sao Thome and Prince's Isle, CRD. Range, 750 miles daylight, 1000 night; hours, 5 to 12 a.m., 4 to 7 p.m. GMT; waves, 300, 600, 900, 1000, 1500; spark, 500 cycle; charges, Coast .08, LL .01. Keeps very good watch and operators efficient. Will work through static for distant ships. Spark very broad and when working on 1000 meters it is heard clearly on 600 meters.

Banana, Belgium Congo, ONA. Range, 150 miles; hours, 8 to 11 a. m., 2:30 to 5 p. m. GMT; wave, 600; charges, Coast .10. No LL to Banana, but LL .10 to Matadi. Cable facilities. Connected with the interior Belgium Congo by government land lines. Watches are continued till 11 p. m. when mail boats are expected to arrive. Steamers going up to Matadi should advise the Congo river pilots well in advance of arrival. It is advisable to notify the Congo pilots as soon as possible beforehand, as it is impossible to copy the banana station before sighting her masts, due to fierce static.

Matadi-Boma, Belgium Congo. Cable facilities through banana radio, and also radio service through ships at anchor in harbors.

Loanda, Angola, CRL. Range, 150 miles; hours, 7 to 11 a. m., 4 to 7 p. m.; waves, 600, 900, 1200, 1600, 2000; charges, Coast .08, LL .01. Cable facilities. Does not stand good radio watch. Most usually handles traffic with CRD, and very little ship traffic. Traffic to Lobito Bay, Benguela and Mossamedes may be handled through this station. It is usually best to do so, as the cable is very slow.

(Continued on Page 44)

# With the Amateur Operators

## RADIO STATION 3AIY

Radio station Nu3AIY started in April, 1924, with the usual UV-201 and then in steps grew up to the present 50 watter. The station is owned by Charles Hackenyos, Jr., and is operated almost every evening after the usual quiet hours, as the transmitter creates quite a lot of QRM around the neighborhood. The only wave length used is 81 meters.

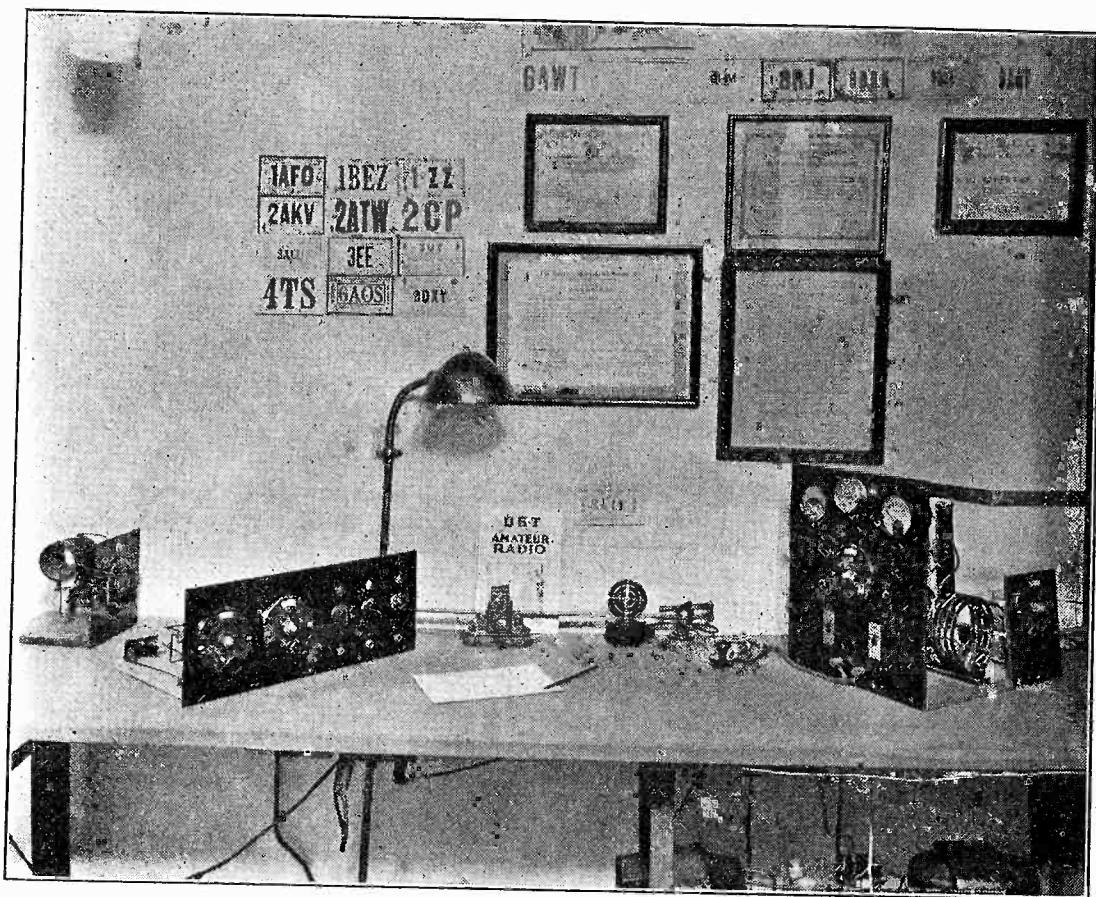

Radio Station 3AIY

The conventional inductively coupled Hartley is used on the transmitter working on or above the fundamental of the antenna; 850 volts are put on the plate of a WE-211, giving a good to excellent RAC note at all times. The high voltage is rectified by "S" tubes and is filtered with a 35 henry and two 5 henry chokes with 1 mfd. across the output. All leads are of No. 14 gauge wire or larger.

The receiver consists of Bremer-Tully coils in the Schnell circuit and uses a UX-200-A as detector and a UX-112 in the second step. Enormous volume can be obtained, assuring good signals at all times. A small indoor antenna is used and break-in is worked with anyone that uses that method.

The main antenna is a four wire cage of 4 in. diameter and is tapped in the center to work on the fundamental. The counterpoise is also a four wire cage, but is fanned out from the center. The counterpoise is between two houses and is about 45 ft. away from the antenna.

On the wall is the station and operator's license with the April certificate and an ORS to the left. Since the picture was taken an Army amateur radio station certificate has been added. The little frame on the extreme right explains itself. The station does not boast of any DX outside of the U. S., but does of the many long chats with fellows that seem to be right next to the key and that EVERY card received is QSLed whether a three or a six.

The QRA is Charles Hackenyos, Jr., 1131 W. Indiana Ave., Philadelphia, Pennsylvania.

## RECEPTION ON 20 METERS

By MAJOR R. RAVEN-HART

As published results on this wave-length seem scanty, the following may of use to other experimenters.

Location—Los Andes, Chile.

1. Comparison (by ear) of reception on a horizontal Hertz antenna 40 meters long by 4 meters high, with that of an inclined 45

slightly better vertical than horizontal during this period.

After about 1730 (sunset here) the ratio tends to reverse again, as noted on WIZ, 6-OI and various U. S. amateurs between 1730 and 1800. From 1800 to midnight a very large number of observations on 6-OI (all hours) and on many U. S. amateurs, chiefly before 2000, show a distinct advantage horizontal over vertical reception. It is to be noted, however, that the signals from FW do not show this change, being at any given moment of about the same strength on horizontal or on vertical antenna, until about 2130, when they disappear. These results are very consistent, checked on over 300 observations of FW: they would seem to suggest that there is a difference in polarisation effect on waves going from "dark" to "darker" compared with those going from "darker" to "dark."

It was not expected that directional effects would be noted, as no proper precautions were taken (shielding, etc.), but considering that the exigencies of space compelled an E-W antenna, such superiority in reception of U. S. (northward) signals over vertical antenna reception was not hoped for.

It is, of course, realized that when using the horizontal antenna the vertical one is contributing largely to the signals, but the fact that no appreciable difference can be noted whether this latter is disconnected or earthed suggests that its contribution is not important. This is confirmed by the fact that bringing the lead-in of the vertical antenna into close inductive relationship with either of the leads-in of the horizontal one increases signals, but not to the extent as to indicate that such inductive (or the inseparable capacity) coupling is the dominant factor.

From a practical point of view, it is of interest to note that the horizontal antenna was very roughly installed, without strain insulators (merely tied to post and building with string), and entering by the woodwork of the window, without insulators. On the other hand, the normal antenna-earth system was installed with great care.

The most surprising result occurred on two occasions when a railway track two meters from the nearest end of the horizontal antenna was occupied by a train of empties, chiefly cattle wagons about 3.50 meters high, with corrugated iron roofs and appearing to shield the two horizontal wires completely. Nevertheless, signals were stronger at 1800 to 2300 on these wires than on the normal (vertical) antenna.

On 40 meters signals are at all times distinctly better on the vertical antenna, though the difference is often slight, and on nights of bad atmospherics, signals may be more readable on the horizontal one.

2. Light and Darkness. 6-OI is audible from 1730 to 0200, and again (but much weaker) from 0700 to 1000. Stations farther east become audible earlier in the evening—Cuba at 1615, 5VA at 1645, 5XH at 1710, 2NZ at 1722, are some of the earliest heard. New Zealand (2AC) has been heard as early as 1900.

FW is particularly useful, as it is heard from 1600 till about 2130, thus giving ample opportunities for observations. One striking point is the rapidity with which signals build up—e.g., R 2 at 1600, R 4 at 1610, R 5 at 1630. After that signals continue to increase, but slowly. At about 1900 they begin to fall off from a maximum of R 7, and are R 4 by 2100, R 3 by 2130 and then lost.

As far as these and similar observations go, they seem to indicate that there are two "belts" adverse to 20 meter signals, one of

degree antenna, 50 meters long by 40 meters high at free end, with excellent earth system.

In both cases with untuned antenna circuit, inductively coupled to secondary, using the same coupling with both antennas. Tests made chiefly with NU6-OI, Palo Alto, Calif.; PKE (Dutch), FW (France), WIZ (on 20 meters, Rocky Point), also with U. S. amateur and experimental stations 1CMX, 2NZ, 4SA (Porto Rico), 4TV, 4VQ, 5AFB, 5AIN, 5FC, 5VA, 5XH, 6XG, 8AXA, 8CQV, 8DON, 9BAF, 9BSK, 9DAG, 9DRJ, 9DVF, New Zealand 2AC, and others.

Taking E.S.T. for convenience (Chilean local time is E.S.T. plus 17 minutes): at midnight, 0100, 0200 the reception on the horizontal antenna is strikingly better than on the vertical, somewhat of the order of R-5 vertical to R-6 or 7 horizontal. These are observations on 6-OI only, no other stations having been heard during these hours, in over 20 nights' work.

From 0300 to 0700 no observations could be made, no stations being audible (although 6-OI transmitted for test). At 0700 6-OI was just audible on one occasion, but too weak for comparison test to be made.

From 0800 to 1000 and from 1600 to about 1730, observations on all stations heard (5XH, 6-OI in the morning and FW, PKE, WIZ and many U. S. amateurs in the afternoon) gave approximately equal reception on either antenna, with perhaps slightly stronger on the vertical. Between 1000 and 1600 the only station heard was AGB (Europe), and although this is on a considerably longer wave, it may be mentioned that here also the signals were



**TRANSMITTING**

## KITS-SETS -PARTS

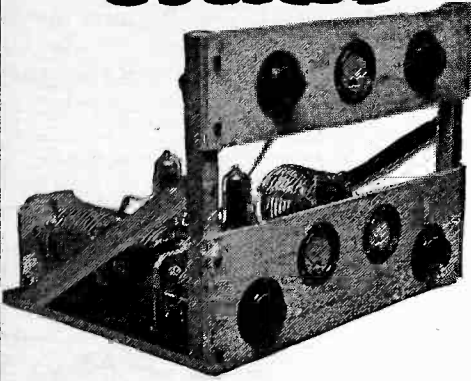

**Complete Transmitter Installations 5 to 1000 Watts**  
Full Line of Transmitting Parts at Reduced Prices  
JEWELL, THORDARSON, ACME, WESTON, HAMMARLUND, CARDWELL, NATIONAL, RCA, FARADON, GENERAL RADIO, ALLEN-BRADLEY, WARD-LEONARD, LYNCH, R. E. L., AERO PRODUCTS, TOBE-DEUTSCHMANN, PYREX, FLERON, SIGNAL, BUNNELL, VIBROPLEX, WESTERN ELECTRIC, G. E., ETC.

## Unsurpassed DX with the ARSCO RS-100

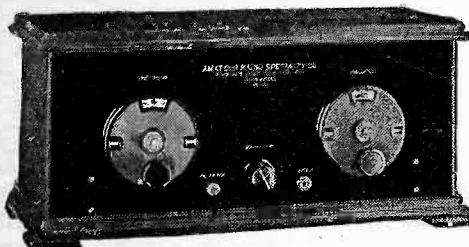

10-110 Meters  
1 Stage A. F.

A precision instrument designed and built for maximum efficiency on the short waves.

Price Including mahogany cabinet and full set of plug in coils . . . \$38.00

SEND for CATALOG  
**ARSCO**  
77 CORTLANDT ST.  
New York  
AMATEUR RADIO SPECIALTY CO.

maximum daylight, centering about noon at any point, and one of maximum darkness, centering about 3 a. m. at any point. Bad reception may be expected when either of these belts is between the stations: i.e., when it is anywhere about noon or about 3 a.m. at either the sending or the receiving station. In terms of these "belts" the effect on the polarisation could be expressed in the form that, when the transmission travels towards the dark "belt," more horizontal polarisation may be expected than when the transmission travels away from it. This is, of course, nothing more than a tentative suggestion.

7EK of Everett, Wash., is down on 20 meters. DX is plentiful on 20, sez 7EK.  
7BM of Aberdeen, Wash., has just returned from a trip to Frisco on a freight ship.

## New Model

ADVANCE

"SYNC"

## Rectifier

With 1/4 H. P. Motor

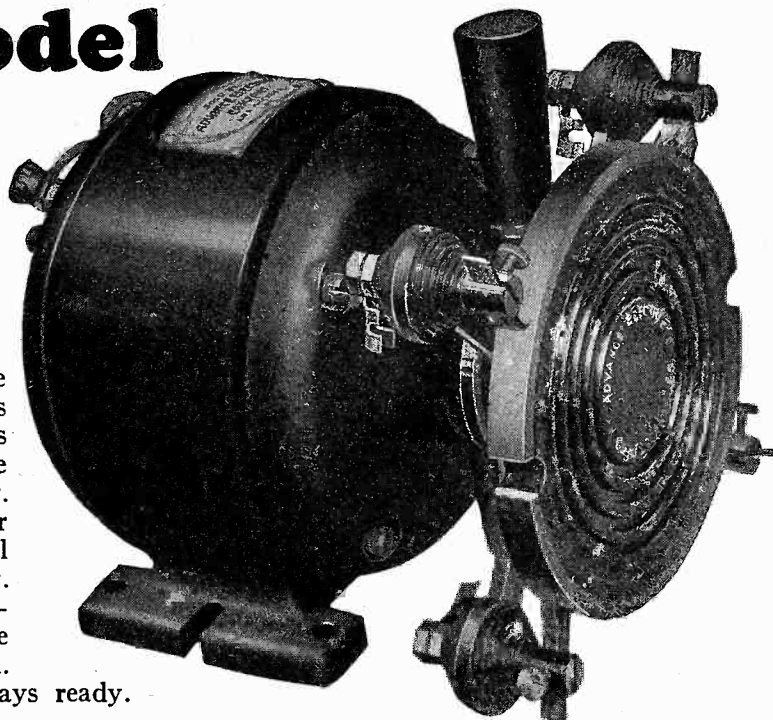

Although lower in price, the ADVANCE Sync Rectifier is far superior in quality—as proven by its prevailing use in international transmitting. It actually does what other rectifiers claim to do. Meets all requirements for heaviest duty. Can be easily and quickly filtered. Speedy starting because of Advance Bakelite wheel. Requires no attention—always ready.

Revolving disk is moulded bakelite six inches in diameter. Nickel plated brush holders with adjustable gauze copper brushes. Convenient control handle. Disk, aluminum brush arm support and brush holders perfectly insulated.

Price complete with Westinghouse 1/4 H.P. Synchronous Motor.....\$55.00  
Rectifying wheel with complete brush assembly and mounting ring to fit your own motor.....\$21.50

**ADVANCE ELECTRIC COMPANY**  
1262 W. Second Street, Los Angeles, Calif.

WE PAY ALL TRANSPORTATION CHARGES IN U. S. A.

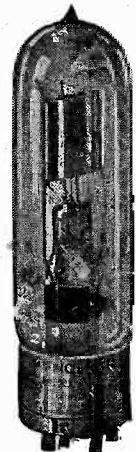

Never Before At This Sacrifice Price  
HIGH VOLTAGE

## RCA KENOTRON RECTIFYING TUBES RCA MODEL U. V. 217

A. C. Plate Voltage 1500 volts. Filament Voltage 10 volts.  
Used with U. P. 1016 Power Transformer or similar Transformer.

These GENUINE R.C.A. U. V. 217 Tubes are very efficient Rectifiers and they will pass plenty of current and voltage for 50 watters and H. Tubes and also can be used for 250 watters.

EVERY TUBE IS BRAND NEW AND PACKED IN ORIGINAL CARTON  
List Price \$26.50 ea. EXTRA SPECIAL \$12.50 EA.

**AMERICAN SALES COMPANY**  
21 WARREN STREET NEW YORK CITY

## Portable Short Wave Transmitter



Complete with all accessories including power supply \$90.00

We specialize in Xtal control transmission and are ready to quote prices on complete amateur or commercial installations, including power supply. Write today for prices.

**TRANSMITTING EQUIPMENT LABORATORIES**  
3982 WOODLAWN AVE., LOS ANGELES, CALIF.

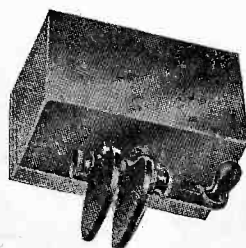

\$12.50

DIRECT  
TO YOU

Semi-automatic transmitter; platinum points, adjustable speed, nickel plated case with lock and key. Order today. K. N. FORD, 1411 1/2 Alta Vista Blvd., Los Angeles, Calif.

## Your Library Not Complete Unless it contains third edition of "RADIO THEORY AND OPERATING"

By MARY TEXANNA LOOMIS

Lecturer on radio, Loomis Radio College.  
Member Institute of Radio Engineers.  
886 Pages—700 Illustrations—Price \$3.50.  
Postage paid to all points.

Buy of your dealer, or send check or money order to

**LOOMIS PUBLISHING CO.**  
Dept. X, 405 9th St., Washington, D. C.

## COMMUNICATION ON THE WEST AFRICAN COAST

(Continued from Page 41)

**Compass Stations**—Absolutely none on west coast. Many of the mail boats carry direction-finding equipment, but whether they would give compass bearings is doubtful.

**Press**—No press is sent from coast. European high-power stations, such as Bordeaux LY, Nauen POZ and Rugby GBR, can be copied, although to as far as Dakar, Annapolis NNS, and New Orleans WNU may be copied.

**Time Tick**—Tick is copied from the above stations. Bordeaux LY may be copied as far down as the Belgium Congo, on good nights.

**Weather**—No station transmits weather on the west coast. Walvis Bay sends out weather on schedule, but it doesn't cover the west coast.

## WHO'S WHO AND WHERE

"Bill" Mockler, NRH during the war, is now on the *SS. Tampa*, running from New Orleans to Miami. Bill left the game last year.

William Hocke and John Egar are holding down the *Mary Weems* on the Baltimore-Miami run. Pay rotten but good eats, they say.

Charlie Brey, who counts 32 ships to his credit during the last 7 years, is now chief on the Clyde liner *Cherokee*. He's been there six weeks and was planning on making another trip, which is something of a record for Charlie. Maybe the combination of arc and spark has something to do with it.

John McIntyre was found on the Berkshire, Phila-Miami run, where we last saw him a year ago. He was sitting in the same place as last time, so we don't know whether he has moved or not. Stanley Lowe, also an old-time Atlantic man, is Junior.

George C. Ahrens is on the *Munrio*.

L. J. Hornster climbed off the *S. C. T. Dodd* to take the *India Arrow*. He likes the Arrow boats.

Charles Carter, once of the Edison Company, is now holding down a berth on the *Halo*, relieving Sidney J. Peters.

The shack on the *Emidio* is now in command of Allen R. Matz.

The BCL's at Manitowoc had a chance to "kurs" when KURS, the *Wisconsin*, grounded in the Manitowoc harbor. WMW says that he would liked to have switched all the phone calls over to KURS. They were hot! And now we wonder if that has anything to do with the new telephone installation at WMW?

One thing is certain. The ICW from WLD will never block our tubes. The CW is OK though.

Somehow it seems that the call WCY doesn't match a V.T. transmitter. Will you ever forget the wail of that old rotary at Cape May? We wish that someone had made a phonographic record of it.

## FROM THE RADIO MANUFACTURERS

The Hoyt A-B-C Tester is a switch-board type of meter with a 5 in. scale which can be easily read at a distance of 8 ft. It is specifically intended for testing dry batteries when a customer purchases them. It may be mounted on the wall or set on a counter. Contact springs are arranged testing 1½ volt dry cells as to current capacity in am-

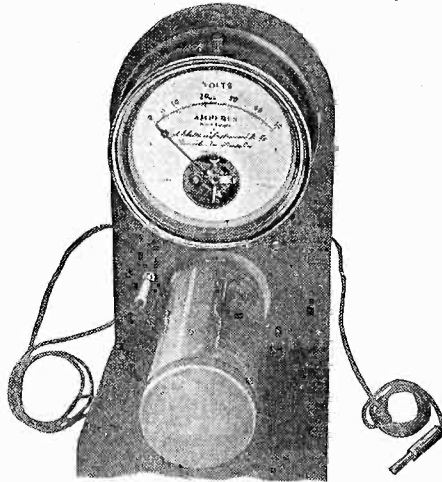

peres. The voltage of a 22½ or 45 volt battery is tested by pressing two prods on their terminals, these prods being filtered to the ends of long rubber-covered cables. Due to the high resistance in the coil movement the current drain is negligible. The voltage scale reads from 0 to 50 and the current scale from 0 to 50 amperes.

The Powertone Wave Trap is circular in shape, housing a solenoid coil and variable condenser, which is tuned by a knob at the top.

While convenient to place this at the



side or back of the set, it can easily be mounted inside the set if space is available. It is intended to overcome conditions where there is station interference due to the non-selectivity of the set.

The Pausin Octacone is a new cone type loud speaker, with the cone placed

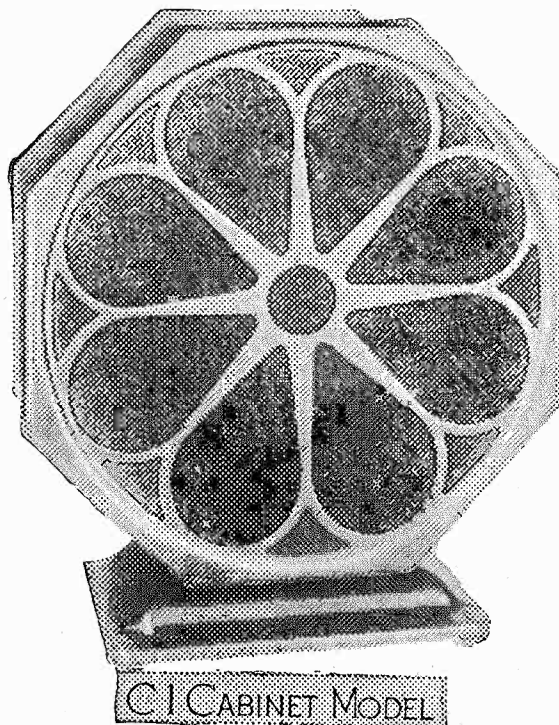

inside a heavily reinforced steel casing, finished in attractive enamel. It is claimed to give faithful reproduction of speech or music, and to have the right impedance to match the present types of power tubes. Due to the steel casing, the speaker is not easily damaged.

The Klosner Type A Rheostat has an improved one-hole mounting with a steel shaft turning inside of a brass bushing. This gives a smooth-running, long-life bearing with positive and noiseless con-

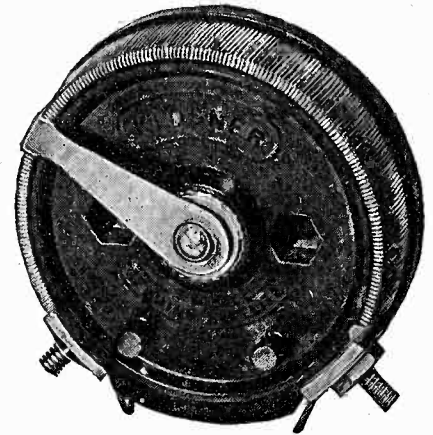

trol. The contact arm is of spring phosphor bronze. The base and dial are of glossy black bakelite. The winding is uniform and constant in resistance. This type is made in 6, 10, 20 and 30 ohm sizes and also as a 350 ohm potentiometer.

The Mershon Condenser is a high capacity condenser of the electrolytic type, designed for use in filter circuits of "B" eliminators, or in amateur transmission



where the source of direct current is to be filtered. It is arranged in a convenient glass case, with clips provided so that the capacity can be cut in half in case the total amount available is not wanted. The condenser is self healing in case of breakdown.

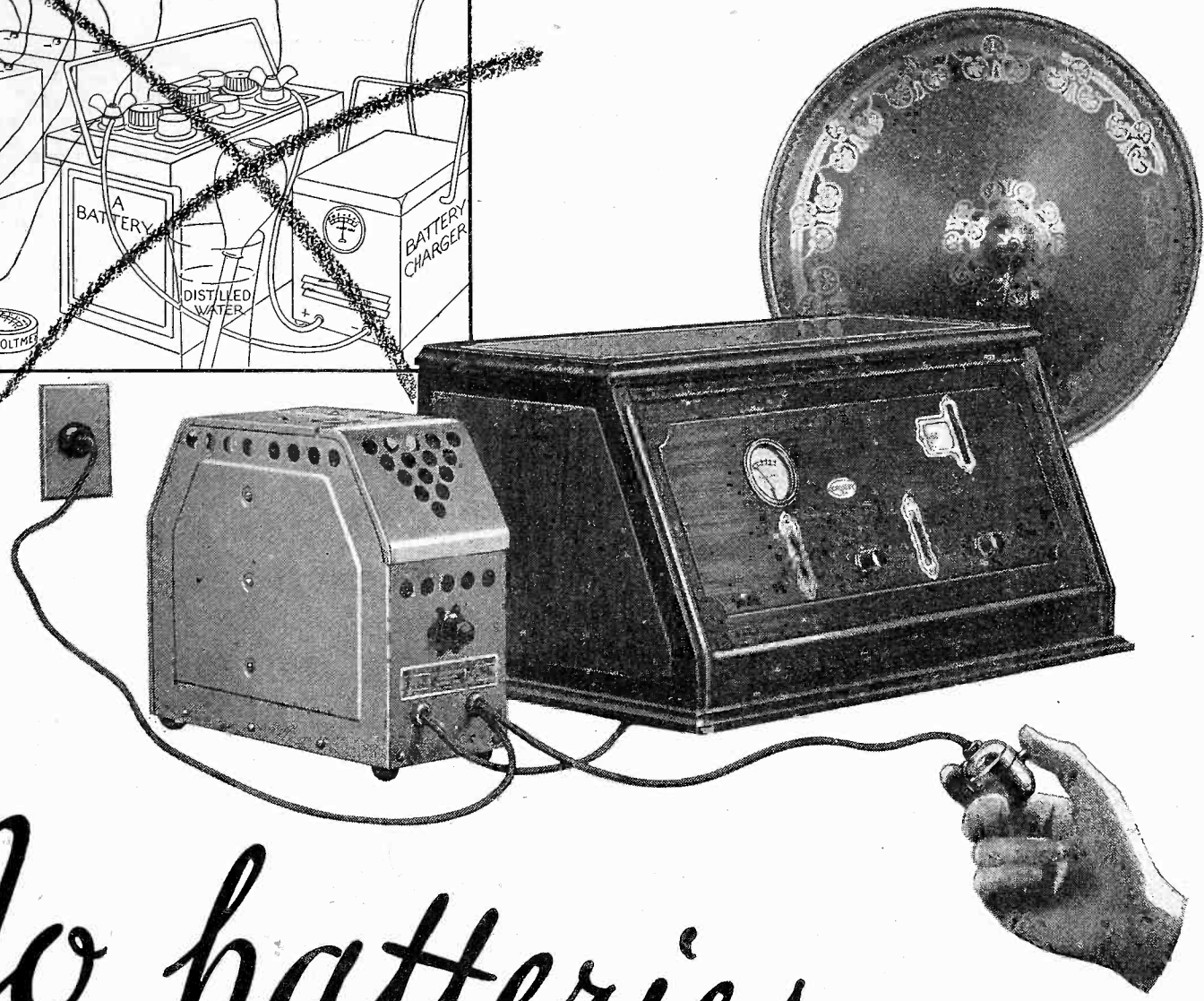
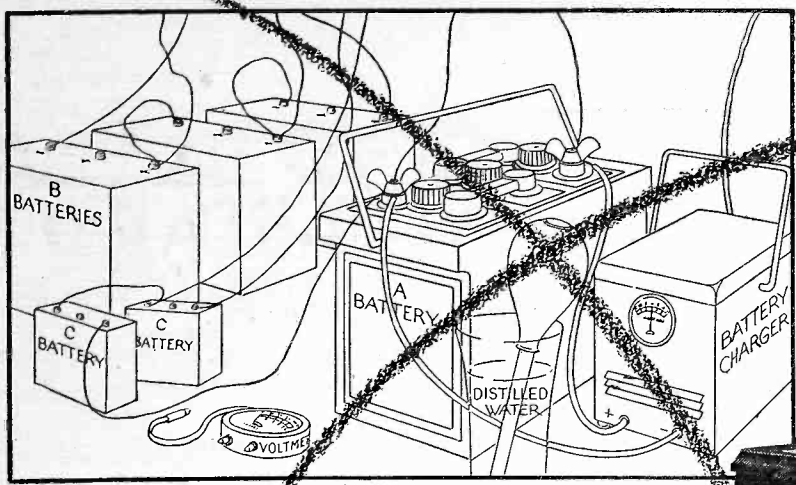

# No batteries—

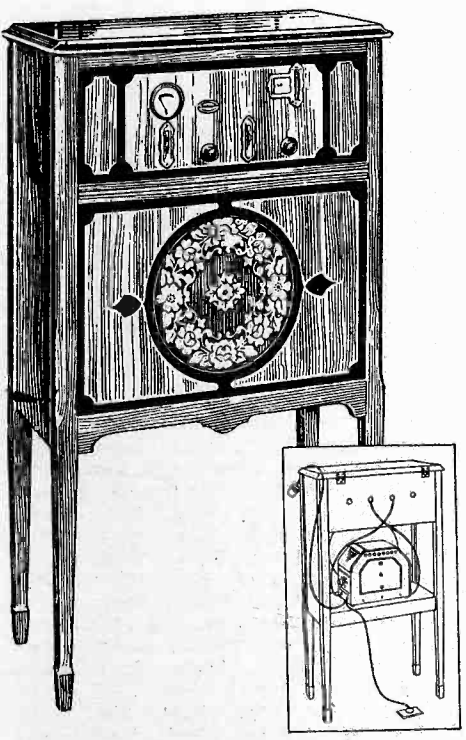

Radio's most revolutionary development! Run this radio direct from house current outlet. Ordinary 110 volt 60 cycle domestic electricity transformed mechanically into smooth, quiet radio A, B and C power as you use it. Radio power supply annoyances ended for all time. A snap of the switch is the only demand radio will make upon you from NOW ON.

- No more batteries to fuss with.
- No more trickle chargers to watch.
- No more keeping something filled with water.
- No batteries to renew or recharge.
- No upsetting the home to have the radio serviced.

See these wonderful sets at any Crosley dealers, or write Dept. 19 for descriptive literature.

**The Crosley Radio Corporation**

Powel Crosley, Jr., Pres. Cincinnati, Ohio

## Radio Energy Unit

Crosley Radio Energy Unit weighs only 13 lbs., is only half the size of an ordinary "A" storage battery—operates without interfering hum and with the certainty of an electric motor.

**\$50**

## 6-tube AC Receivers

*for use with Crosley Radio Energy Unit*

Crosley radios designed for use with this marvelous power supply are the AC-7, a 6-tube table model at \$70, and the AC-7-C, a 6-tube console at \$95.

Crosley sets are licensed under Armstrong U.S. Patent No. 1,113,149, or under patent applications of Radio Frequency Laboratories, Inc., and other patents issued and pending.

*Prices slightly higher west of the Rocky Mts.*

# CROSLLEY

# RADIO

**CROSLLEY  
ULTRA  
MUSICONE  
\$9.75**

Tell them that you saw it in RADIO

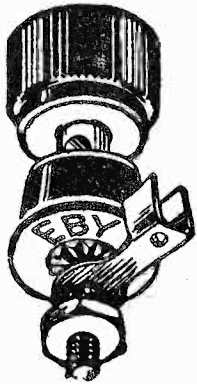

## Radio Has Learned To Rely Upon EBY BINDING POSTS

—because they have proven to be the one sure, safe and fool-proof way of insuring a positive contact.

That's why eight out of ten radio manufacturers and the majority of the great circuit designers use and specify EBY exclusively.

Your dealer has all of the different markings. Insist on and get genuine EBY binding Posts—15c each.

**THE H. H. EBY MFG. CO., Inc.**

4710 STENTON AVE.,



PHILA., PA.

# EBY

## BINDING POSTS

Specified in these and other Circuits

Madison-Moore  
Browning-Drake  
Hammarlund-  
Roberts  
Infradyne  
Kenneth Harkness KH 27  
Victoreen  
General Radio 400  
All American  
R.F. Set  
Loftin White  
S. C. 2  
Cockaday LC 27

## CALLS HEARD



By 8DED, William Sackers and Russell Sackers, 53 East 7th Street, Holland, Michigan

1aao, 1adl, lary, laeq, lasf, lamd, lavl, lbbm, laxx, latz, lbgw, lblf, lbhs, lbad, lbez, lci, lcti, ldi, lej, lfh, lgw, lmo, lnc, ldl, lrd, lqb, lty, luo, lyb lzd, lxam, laan, 2adt, 2aet, 2agb, 2ayi, 2akz, 2adh, 2bad, 2bb, 2bc, 2bo, 2bkr, 2ce, 2cep, 2ctn, 1cjd, 2cxl, 2gc, 2sf, 2sm 2hc, 2uo, 2qu, 2wh, 3au, 3ahl, 3any, 3auv, 3bkt, 3btr, 3buv, 3bwt, 3cht, 3cch, 3ckj, 3cx, 3db, 3ee, 3fi, 3gp, 3hu, 3jj, 3jo, 3kr, 3oq, 3pf, 3rt, 3uo, 3vi, 3zm, 3zo, 3zw, 4ag, 4ajr, 4aah, 4by, 4cv, 4db, 4eq, 4ft, 4gd, 4iz, 4ks, 4lt, 4oc, 4pz, 4mi, 4pt, 4rr, 4rn, 4sp, 4te, 4vl, 5adz, 5aeg, 5agl, 5aao, 5ahd, 5ain, 5aik, 5ajj, 5ajs, 5ajr, 5ak, 5akl, 5akn, 5amf, 5api, 5apo, 5arf, 5asc, 5asv, 5ck, 5dt, 5hy, 5fj, 5jf, 5jy, 5kc, 5ql, 5rg, 5sw, 5tt, 5ww, 5zav, 5zai, 6adp, 6adu, 6agr, 6ahn, 6ahe, 6ain, 6akm, 6akw, 6am, 6amo, 6aon, 6asv, 6auk, 6axd, 6bba, 6bch, 6bek, 6bhv, 6bhz, 6bia, 6biy, 6bjl, 6bjv, 6bjg, 6bpm, 6bq, 6bqd, 6bqt, 6brm, 6bux, 6bvb, 6bxi, 6bzy, 6bxr, 6bzd, 6cak, 6cau, 6eel, 6eco, 6ecf, 6ecg, 6ehe, 6chl, 6cht, 6cik, 6clp, 6cmt, 6csd, 6csj, 6csx, 6cuc, 6cyh, 6dcq, 6dau, 6en, 6ew, 6gg, 6ha, 6he, 6hh, 6ob, 6qui, 6ta, 6mb, 6vr, 6xl, 6xv 6zat, 7aek, 7aat, 7al, 7alk, 7ef, 7fh, 7hi, 7aib, 7iz, 7jf, 7kz, 7ls, 7nc, 7ob, 7bb, 7pv, 7rx, 7vq, 7vv, 7or, 7oo, 7fe, 7wu, 7zn, Ef-8yor, Ef-8qrt, EI-1co, FO-a3b, FO-a5o, FO-A4z, NA-7de, NC-1ar, NC-3cs, NC-2fo, NC-3wab, NS-4dy, 4dq, NC-4ck, NC-1wr, NC-5ef, NC-5go, NC-8azs, NJ-2pz, NM-1n, NM-1aa, NM-aj, NM-cyi, NM-9a, NN-nem, NP-4sa, NQ-8kp, NC-4al, OA-4ac, OA-7dx, OA-7cw, OA-2mh, OH-6axw, OH-6cfq, OZ-2xa, OZ-2ac, SA-BA-1, SA-cbs, SA-des, SB-1ac, SB-1ap, SB-1aw, SB-1ib, SB-2af, SB-2as, SB-2ag, SB-1ak, SB-2ig, SB-2am, SB-5aa, SB-sqlx, SC-2as, SC-2bl, SU-1bu, SU-1cg, SC-2ab, NI-acd, NP-nau, WIK, LPZ, TMU, HJG, SM-1p, NAR, NISN, AWI, FW, XG, KGKL, NAA, NKF, OCDJ, WWDO.

QSL hr ok. Pse report my sigs. QRH hr 38 meters.

By J. A. Kerr, 6BFS, ex-9EAF, 3056 West Eighth St., Los Angeles, Calif.

1abo, 1aau, 1axa, 1azr, 1avf, 1bnw, 1byx, 1cay, 1ga, 1lp, 1pr, 1vc, 1vy, 2aes, 2ahm, 2ak, 2anm, 2bbx, 2bur, 2cin, 2coa, 2cuz, 2dy, 2gy, 2kr, 2md, 2om, 2or, 2sq, 2uo, 2wc, 3ajc, 3auv, 3bhv, 3bwt, 3cl, 3ep, 3fu, 3kr, 4bl, 4aq, 4dk, 4fz, 4fl, 4io, 4km, 4pk, 4pr, 4qb, 4rm, 4rw, 4si, 4sl, 4tn, 5aaq, 5abk, 5abv, 5acf, 5acl, 5adz, 5afs, 5afw, 5agl, 5agu, 5ai, 5ajj, 5ajs, 5akf, 5akg, 5akn, 5ako, 5aky, 5alg, 5alq, 5amf, 5amo, 5apy, 5aq, 5aque, 5arn, 5atf, 5atn, 5att, 5au, 5aur, 5auz, 5avb, 5bk, 5bx, 5ca, 5ck, 5dl, 5dv, 5em, 5ft, 5gf, 5he, 5hr, 5hs, 5hz, 5ik, 5in, 5iq, 5iu, 5iy, 5jd, 5jf, 5kc, 5kk, 5km, 5kn, 5lh, 5mx, 5pk, 5ob, 5ql, 5rg, 5rh, 5sk, 5tt, 5uk, 5uw, 5vm, 5zai, 5zav, 7aa, 7abb, 7abf, 7ag, 7aib, 7ec, 7ef, 7ek, 7gj, 7hf, 7iz, 7jf, 7jp, 7ju, 7ll, 7mh, 7mp, 7nf, 7ou, 7oy, 7rj, 7tk, 7tt, 7uj, 7vh, 7vm, 7wb, 7wp, 7wu, 7ya, 8ahd, 8ajn, 8alo, 8aly, 8amu, 8asb, 8asd, 8aul, 8ayo, 8bau, 8bcv, 8bfk, 8bja 8bpl, 8bre, 8cau, 8ccq, 8ccs, 8cfq, 8ci, 8civ, 7ded, 8drs, 8ft, 8gz, 8it, 8sx, 8wk 8zu, 8zw, 9abr, 9aca, 9adn, 9adr, 9aek, 9aao, 9aep, 9agk, 9ahq, 9ahu, 9akt, 9alb, 9aon, 9aqz, 9asd, 9asx, 9arn, 9atq, 9auk, 9avu, 9awo, 9axh, 9axq, 9ban, 9bbr, 9beq, 9bgm, 9bhi, 9bht, 9bh, 9bir, 9biy, 9bjn, 9bkq, 9bkr, 9blu, 9bnw, 9bce, 9bnw, 9bye, 9bzg, 9bzi, 9caj, 9caw, 9cbe, 9cei, 9cet, 9cei, 9cfk, 9chq, 9ckf, 9cku, 9cls, 9cnt, 9cor, 9cpm, 9ctg, 9cv, 9cvn, 9cuv, 9cuy, 9cwn, 9cxq, 9cxz, 9cya, 9cz, 9dac, 9dbh, 9ddz, 9dga, 9dij, 9dkc, 9dki, 9dkm, 9dlu, 9dny, 9dol, 9dpd, 9dr, 9dra, 9drw, 9drz, 9dsy, 9dta, 9dud, 9dyl, 9eab, 9ebj, 9ebp, 9eea, 9eev, 9eez, 9efk, 9ekf, 9iz, 9jh, 9kb, 9kg, 9kv, 9nk, 9sb, 9sd, 9sk, 9xi, 9za, 9ck. Miscellaneous: NA-7bh, SB-5pw, NC-2co, 4eb, 4fz, 5ef, 5fk, 5go, NM-9a-xc6i, EM-5ab-5gl, HU-6acg, 6axw, 6def, KDGL, KDZQ, WIK, WIZ, WGY, NAW, NPN, NPM, NPU, NPG, FX-I, NKF, NPC, Naa. KSL es 73's.

By 9APY, 3337 Oak Park Ave., Berwyn, Illinois  
1ask, (1bdc), 1beb, 1caw, (1ex), 2adh, 2afx, 2ali, 2amq, 2cbg, (2cc), 2cpd, 2csx, 2cyq, 2et, 2fs, 2oq, 2xaf, 3aea, (3aly), 3avm, 3bz, 4dh, 3ku, (mv), (3om), 3vf, 4ak, 4cf, 4dk, 4fe, 4gp, 5afs, 5aio, 5ajs, 5ak, 5akk, 5ala, 5anc, (5anl), 5aqe, 5arn, 5bd, 5gc, 5jd, (5lh), 5ml, (5rg), 6bhv, 6bhz, 6bkr, 6bsv, 6bv, 6co, 6ct, 6cyx, 6dcq, 6jm, 7aat, 7aab, 7ag, (7iz), 7jf. Brazil: Sbzlak, Sbzlar. Canada: Nc3nj, Nc4ck, Nc4dw, Nc4hs, Nc5ef. Chile: Sch2as, Sch3ba. Jamaica: Njm2pz. Mexico: Nmln, Nm9a. Miscellaneous: aax, EAD, lp1, NAA, NAM, XYR. Card for card, gang.

## SAVE 50%

Build Your Own With Our High Quality Kits —matched and tested in our own laboratory, and save half the cost of a factory-built receiver.

### BEST'S Quadrphase KITS

As listed on page 17 of this issue of RADIO. All parts — exactly as specified by Best. Build this wonder receiver NOW!!!

**\$88.40**

PROMPT SHIPMENT GUARANTEED

INFRADYNE KITS . . . . .	\$118.00
Hammarlund Roberts HI-Q . . . . .	63.05
Browning-Drake 4-Tube Kit . . . . .	64.00
Browning-Drake 5-Tube Kit with National Impedaformers . . . . .	65.00

### NEW REMLER Drum Dials and Condenser

JUST OUT. The brand new Remler No. 333, capacity unit described on page 3 of this issue of RADIO. Complete with 3 trimmer condensers, new Remler Drum Control and Remler Window Panel. The finest merchandise you have ever seen.

**\$19.50**

Sets wired, re-wired, serviced and tested.

Write today for prices.

Complete blue-prints and instructions for building your own receivers

WE SELL INDIVIDUAL PARTS FOR ALL POPULAR CIRCUITS

**TERMS** CASH WITH ORDER AND WE PAY THE EXPRESS TO ANY POINT IN THE U. S. OR 50% CASH WITH ORDER AND BALANCE C.O.D.

**426 Pacific Bldg. N. E. BORCH & CO. San Francisco, California**  
Successors to International Radio Sales Co.

Eveready Layerbilt  
"B" Battery No.  
486, the Heavy-  
Duty battery that  
should be specified  
for all loud-speaker  
sets. Price \$5.00.

The Layerbilt patented  
construction revealed.  
Each layer is an elec-  
trical cell, making au-  
tomatic contact with its  
neighbors.



## Radio is better with *battery* power

RADIO receivers designed for quality reproduction operate best on well-made dry cell "B" batteries. What your ear tells you about the performance of battery-run sets is confirmed by laboratory tests that reveal that batteries alone provide steady, noiseless "B" current, taking nothing from and adding nothing to radio reception. Batteries, and batteries alone, provide pure DC (pure Direct Current). Only such current can give you the best results of which your set is capable.

Battery Power is dependable, convenient, and reliable, under your sole control, ever ready to serve you when you turn on your set. As your "B"

batteries approach the end of their usefulness, a slight drop in volume warns you in ample time. You need never miss a single concert if your set is battery-equipped.

Not only in results, convenience and reliability are "B" batteries unequalled, but they are also unapproached in economy, provided, of course, the correct size batteries are used. That means the Heavy-Duty type for all receivers operating loud speakers, as most do nowadays. Smaller batteries are not as economical, though they give you the quality advantages of Battery Power.

For best economy, choose the Eveready Layerbilt "B"

Battery No. 486. In every test and trial this has proved conclusively to be the longest-lasting "B" battery ever built. Its unique, patented internal construction is responsible for its astonishingly long life. It is, we believe, the most economical, as well as the most satisfactory, convenient and reliable source of "B" current available. Just remember this: Radio is better with *Battery* Power, and the extraordinary Eveready Layerbilt "B" Battery No. 486 offers you that power most economically.

NATIONAL CARBON CO., INC.  
New York San Francisco

Unit of Union Carbide and Carbon Corporation

Tell them that you saw it in RADIO

# CeCo Type "G" High MU

For Impedance or Coupled Receivers

When used in all audio sockets, except last or output, of such receivers will surprise and delight the user with their clearer reproduction and increased volume.

"CeCo" Type "G" tube will carry more power without overloading than any other available High Mu.

Average voltage amplification 20 — Average Output Impedance 25,000.

Price \$2.50

Write for Complete Data Sheet  
C. E. Mfg. Co., Inc., Providence, R. I.

# CECO

A Type for Every Radio Need

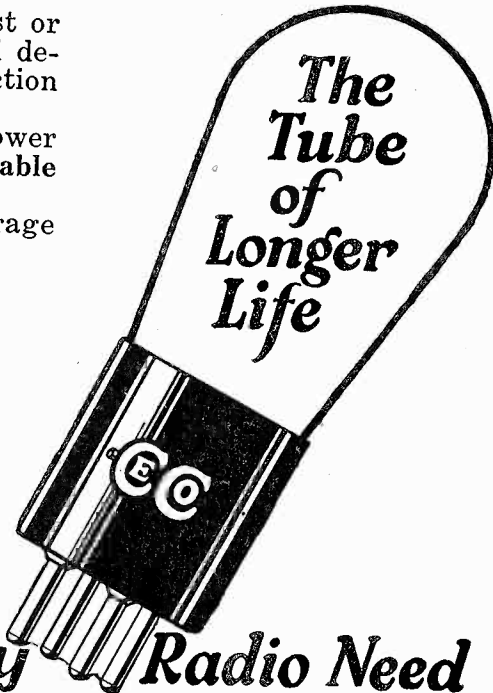

## EXPERIMENTAL SHOP PRACTICE (Continued from Page 22)

In it, a bar is cut with the hack saw as deeply as one thinks he will need to punch from the edge of the sheet. Then the sized hole needed is drilled across the bar at right angles to the plane of the slot. A rod of tool steel (Stubs' drill rod is good material) is then provided as a punch and the tool is complete. It is always well to err on the side of finish in such matters, and so it

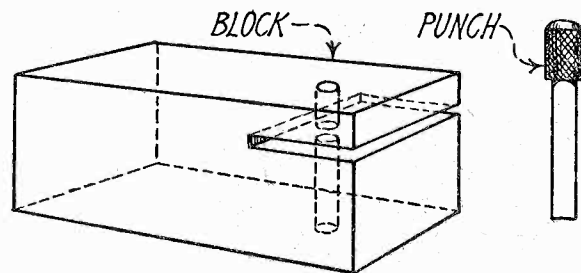

Fig. 4. Punch for Sheet Metal.

is not amiss to leave the upper portion of the punch somewhat large and to knurl that part. To cut the hole, slip in the sheet, drop in the punch and hit it with a hammer.

Most work on a precision lathe is done with the compound slide rest, as it requires cuts at right angles to each other in the main, with an occasional straight cut at a definite angle from one of these. For irregularly formed pieces, such as those involving curves, turning may often be done with advantage by means of a hand tool, worked over a hand rest. One of the most useful all-round tools of this type is the graver,

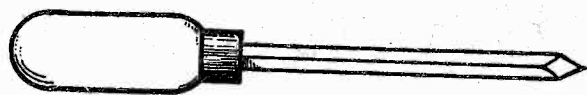
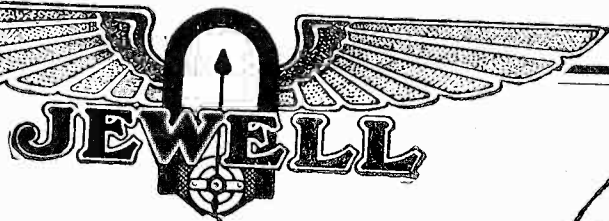

Fig. 5. Graver.

which is shown in Fig. 5. This tool is simply a bar of rectangular steel, ground off at an angle of 45 degrees at the point. The cutting edges are therefore two, both formed at an angle of 60 degrees with the flat side of the tool.

Belts form a part of shop equipment in almost all cases. A countershaft is essential in the cases of the lathe and the drill press, for the purpose of getting the necessary changes in speed. Where there must be a countershaft there must be a belt from the motor to the countershaft, and one from the countershaft to the lathe or drill press. The saw, as it always runs at top speed, needs no countershaft.

There are four principal ways of joining the ends of belts to make them endless as required for their task. To cement, to lace with rawhide, with wire, and to attach the ends by means of special fasteners. Lacing with rawhide is probably the most common method, and it is good. The wire lacing is quicker to apply, and also is good. If the wire be annealed iron the lacing will wear a long time and there is only the one drawback, that the ends of the lacing



# Lightning

Lightning has no respect for people or for their radio sets. Your unprotected antenna leaves but one path for a lightning charge to travel, and that, through your set.

The Jewell lightning arrester is good protection for your radio set. It is small and easily connected. Waterproof construction enables either indoor or outdoor installation. The enclosing case is of attractive glazed porcelain and the arrester is listed as Standard by Underwriters Laboratories.

Write for descriptive circular No. 1019

**Jewell Electrical Instrument Co.**  
1650 Walnut Street

"27 Years Making Good Instruments"

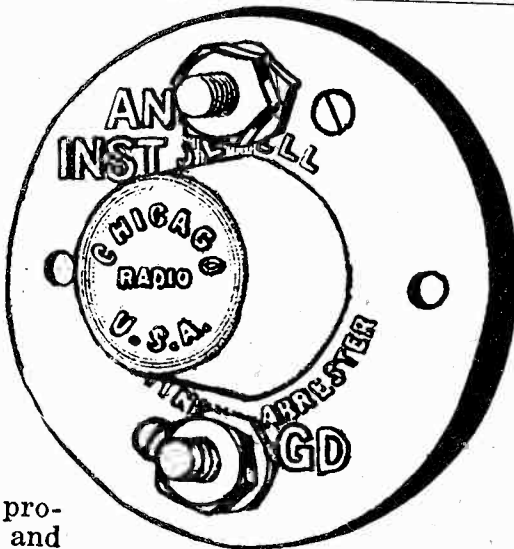

Jewell Lightning  
Arrester



# Amateurs-ATTENTION

THE new Amateur Call Book will be out right before March first. It will give listings of "HAMS." The World's Amateur Transmitters. All new and corrected calls. The only international Amateur Call Book published. Get one at your favorite "HAM" store or send 75 cents direct to—

**CITIZENS' RADIO AMATEUR CALL BOOK**  
508 SOUTH DEARBORN ST., CHICAGO, ILL.

Tell them that you saw it in RADIO

offer a little hazard as to striking some part of one's person when in motion. This can be minimized by proper care in stowing the ends of wire. Fig. 6 shows one of several ways of lacing a belt with rawhide or wire. The numbers near the holes in the drawing give the order of lacing.

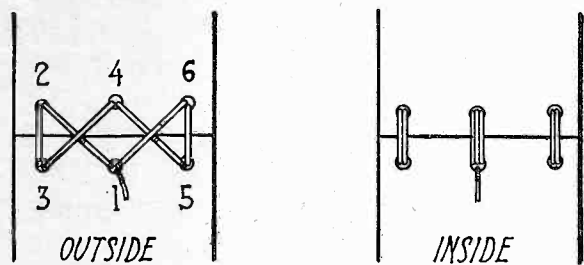

Fig. 6. Lacing Belt with Rawhide or Wire.

For cementing belts the Russian isinglass cement described in the February issue of this magazine is excellent. Skive off the two ends of the belt at an angle, the same inclination on each end, heat the cement and apply it, closing the joint while the cement is still hot. Clamp the joint between flat surfaces till dry. Lubrication with neatsfoot oil will keep many belts soft and pliable and extend their life.

Soldering may be accomplished either by melting the solder with an "iron" or by heating the pieces to be joined with the solder in a bunsen flame. The iron should first be well heated, filed till its end is thoroughly bright and free from whitish spots, and then tinned by soldering it in a mixture of rosin and solder or sal ammoniac and solder. It is then in condition for use.

A flux is usually necessary to de-oxidize the surfaces to be joined. For ease of soldering, a zinc chloride base is the best. But as it is ruinous to insulation it should not be used in radio work. Consequently rosin is used on account of its non-corrosive and non-conducting properties as well as because it is a good flux.

Zinc chloride may be used in either liquid or paste form when the joint is merely a mechanical problem and insulation is not involved. The joint should be washed after soldering so as to remove the remaining corrosive material. It may be made in liquid form by dissolving strips of zinc in a fifty-fifty solution of muriatic acid and water. When no more zinc can be taken up by the acid, filter or strain the solution till it is clear, and add an equal volume of alcohol and 1/20 of the total volume of glycerine, the latter to help the liquid flux so made to cling where it is placed. This will serve as well as the manufactured pastes, though not as handy to use.

Rosin can be applied to the joint as a powder, followed by the soldering copper or the Bunsen flame. But the most convenient and direct form is as a core to the solder itself. At the first application of heat, the rosin flows and thereafter the solder, just the condition

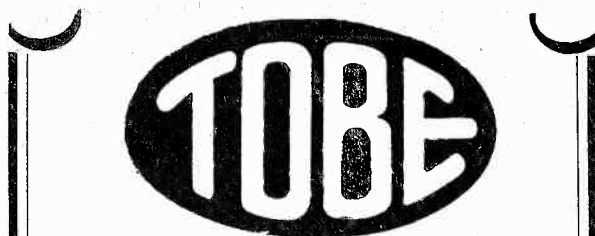

Trade Mark Reg'd U. S. Pat. Off.

## CONDENSERS and B-BLOCKS

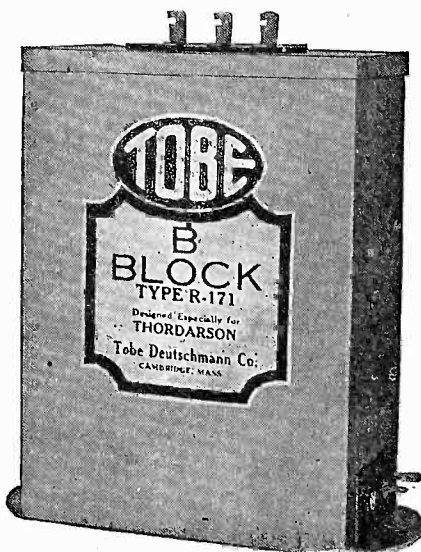

The first condenser B BLOCK, specifically designed for use with the Thordarson Power Compact Type R-171, is the TOBE B BLOCK Type R-171. The terminals are arranged so that they come close to those on the Thordarson Power Compact, for minimum time and length of wiring, short-path, non-inductive condensers are used for increased efficiency. The price is \$12. Thordarson makes a 210 unit, also, and there is the TOBE B BLOCK Type R-210 to go with it. Price \$13.

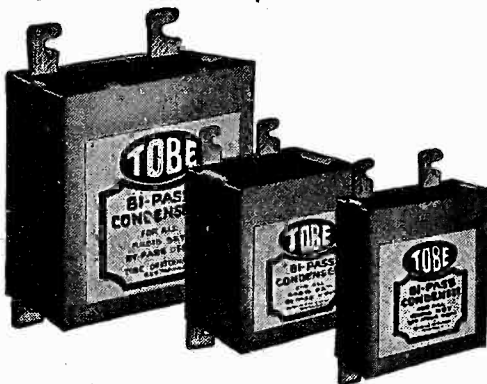

A 1-Mfd. TOBE By-Pass Condenser is specified for use with the

### Official Browning-Drake Kit-Set

This embodies the latest and most advanced thought of Glenn H. Browning in the design and construction of the famous BROWNING-DRAKE Circuit. TOBE Condensers are used throughout. This is another substantial recognition of TOBE quality. Write for price list P-4

**Tobe Deutschmann Co.**

Engineers and Manufacturers of  
Technical Apparatus  
Cambridge Mass.

required by the problem. No after-washing is necessary in the making of such a joint.

With all its virtues, soldering with lead and tin has its limitations and its disadvantages. The solder itself is one of the weakest of combinations of metals. Where great strength is needed, as is often the case in mechanical work, silver soldering and brazing are great boons. These processes are identical as far as the technique of doing them is concerned, the only difference being that in the first case silver is the solder and in the second it is spelter, which is about the same as brass. The flux is

Tell them that you saw it in RADIO

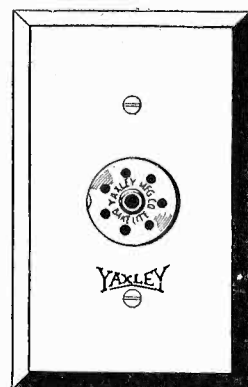

## Radio Convenience Outlets

The Spring is the time to install Radio Convenience Outlets. They enable you to get greater joy from your radio by eliminating all un-

sightly wires from the room. The Radio Convenience Outlet shown above is for battery connections — batteries can be placed in basement, closet or any out of the way place and wires led to set in a neat, attractive way. Take your loud speaker to the porch this summer by using the No. 135 Radio Convenience Outlet. You can also have radio in as many rooms as you wish without removing the set from original location.

No. 137 for Battery Connections \$2.50  
No. 135 for Loud Speaker..... 1.00  
No. 136 for Aerial and Ground.. 1.00

You'll like the Yaxley 444 Automatic Power Control for switching your B eliminator and trickle charger on or off when set is used. Sells for \$5.00.

At your dealer's. If he cannot supply you send his name with your order to

Direct Representative

**HENGER-SELTZER CO.**  
1111 Wall Street, Los Angeles  
377 Brannan Street, San Francisco

**DON H. BURCHAM**  
1553 E. Everett Street, Portland

**YAXLEY MFG. CO.**  
Dept. A, 9 So. Clinton St., Chicago



FROST-RADIO FROST-RADIO FROST-RADIO FROST-RADIO

## FROST-RADIO

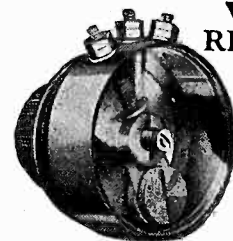

### VARIABLE HIGH RESISTANCE UNITS

For fine control of tone and volume you should install FROST-RADIO Super-Variable High Resistance Units as indicated in our free booklet. Far superior to wire wound types. Operation is smooth and noiseless because of the exclusive roller contact arm. Nickered brass case. Single hole mounting. Supplied in resistances from 50,000 to 500,000 ohms. List \$1.25.

### BAKELITE and METAL FRAME RHEOSTATS

The neatest, most compact and most serviceable rheostats made. Have smooth-working contact, bakelite pointer knob, single hole mounting. Finest nichrome or chromel A wire; wide resistance strip keeps rheostat cool under heaviest load. A type to suit every requirement from 25 to 75 ohms. Bakelite type, list 75c. Metal Frame Type, list 50c. Your dealer has them.

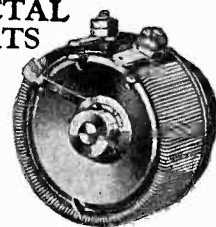

**HERBERT H. FROST, Inc.**

160 N. La Salle St.  
CHICAGO



New York  
Los Angeles

FROST-RADIO FROST-RADIO FROST-RADIO FROST-RADIO

borax, in both cases. American coin silver is excellent silver solder.

To braze, as to solder, have the surfaces of the work clean. Whether the task is to braze or to silver solder, paint the surfaces with a limpid paste or thick solution of borax ground up on some slightly rough surface. A piece of ground glass is good. Apply the borax paste with a soft brush, just where the spelter or solder is to "take." Clamp or hold the parts together in just the position desired in the finished work, and apply



**Oh boy**  
**KESTER**  
*Rosin Core*  
**Radio SOLDER**  
*Sure is Safe and Simple*

Approved by  
**Radio Engineers**  
*A Genuine Solder*  
 CHICAGO SOLDER COMPANY  
 4254 Wrightwood Ave., Chicago, U.S.A.

*Originators and  
 World's Largest Manufacturers of  
 Soft Fluxing Solder  
 and Rosin Core Solder  
 YOUR DEALER  
 CAN SUPPLY YOU*

**ACME**

**FLEXIBLE  
 CELATSITE**

Flexible, stranded wire for point-to-point and sub-panel wiring. Non-inflammable "spaghetti" covering. In black, yellow, green, red and brown; a color for each circuit. Put up in 25-foot coils.



**The Original Celatsite**

—a tinned, copper bus bar wire with non-inflammable "spaghetti" covering, for hook-ups. 5 colors; 30-inch lengths.

**Celatsite Battery Cable**

—a silk-covered cable of vari-colored Flexible Celatsite wires, for connecting batteries to set.

Prevents "blowing" of tubes; gives your set an orderly appearance.



We also offer the highest grade of "spaghetti" tubing for Nos. 10 to 18 wires. 5 colors; 30-inch lengths.

**Stranded Enameled Antenna**

Best outdoor antenna you can buy. 7 strands of enameled copper wire; maximum surface for reception. Prevents corrosion and consequent weak signals.

Send for folder

THE ACME WIRE CO., DEPT. R  
 NEW HAVEN, CONN.

**ACME WIRE**

**MAKES BETTER RADIO**

**Raytheon**  
 LONG LIFE RECTIFYING TUBE

**ACCEPT  
 This With Our  
 Compliments**

To the many thousands of radio fans who buy their copy of RADIO every month from a news stand, we offer to send, without any cost, one of the latest style Brach Electric Soldering Irons with a subscription to RADIO for one year at \$2.50. The regular price of a subscription for one year is \$2.50 and you get the Brach Electric Iron FREE. We will even pay the forwarding charges to your address.

Almost every radio fan needs one or more electric soldering irons. The Brach Iron is ideal for the radio constructor. It is liberally guaranteed by one of the most prominent manufacturers in the radio field.

When you buy RADIO by the month, you pay \$3.00 a year for your copies. Why not save 50 cents by subscribing and get the Brach Electric Soldering Iron in the bargain?

There are only a limited number of these Irons available and we urge you to act promptly if you want to get in on this special subscription offer.

Clip the coupon at the foot of this advertisement—attach your check, money order or currency to it and mail now. We promise to make shipment of the Brach Soldering Iron on the same day your subscription reaches us.

Local radio fans can call at our office in San Francisco for the premium.

**Use the  
 Quick Action  
 Coupon Now**

**COUPON**

RADIO  
 Pacific Building,  
 San Francisco, California.

Here is \$2.50. Send RADIO for one year and mail me, at once, the Brach Electric Soldering Iron. It is fully understood that \$2.50 covers the entire cost of this special offer.

Name.....

Address.....

City and State.....

high heat. This heat is the usual stumbling block to good brazing. It is to be had in two ways. One is to provide a glass worker's foot bellows and a double barreled blowpipe, one barrel carrying air and the other illuminating or fuel gas. With this equipment there results a fine, hot, blue flame as the bellows is worked, adjustable from a pointed to a brushlike form. It will heat all moderately sized pieces to the brazing temperature in quick order.

The alternative heating method is that of acetylene gas, used with air in a blowpipe made by the gas manufacturers, and not with oxygen. It is most excellent for brazing and silver soldering as well as for tool hardening and tempering. The tank can be hired and the gas bought. With the joint painted with flux and the heat ready, lay bits of silver solder or spelter about the edges of the joint, in contact with the fluxed portion, and apply the heat. The solder or the spelter will presently turn red, liquefy and draw into the joint. Let the liquefaction be complete, err if at all on the side of too-long heating, then let the work cool.

**RELATIVE SELECTIVITY OF  
 RECEIVERS**

(Continued from Page 28)

or even 50 kilocycles removed from the 660 k.c. to which the set is tuned will be just as loud as the 660 k.c. signal. A considerable field strength of an interfering station is necessary to produce an equal disturbance if a two circuit receiver is used. With a three-circuit receiver signals 50 kilocycles from the desired frequency will be excluded unless their intensity is extremely high. This is true in even greater measure for a superheterodyne with one stage of tuned r.f. and two stages of intermediate frequency amplification.

Of course none of these curves indicate the presence of any background of sound less than that of the desired signal. But they do give a relative idea of the comparative selectivity of these four types and of their ability to meet the present congestion in wavelengths.

**Sawing Off Machine Screws**

There are two simple means for preventing burrs on the end of machine screws which have been cut off with a hacksaw. One is to screw down a nut on the machine screw until it is near the head. After the screw is cut off, removing the nut will turn off most of the burrs. The other is to hold the machine screw in a vise by the end that is to be cut off. It will be found that a fine hacksaw will make little burrs and the jaws of the vise will not touch the part of the screw that is wanted for use.

Tell them that you saw it in RADIO



# It will never "Run Down!"

## Majestic "B" Current Supply

delivers pure direct current from your light socket

**"B" Power at full strength  
any time and all the time**

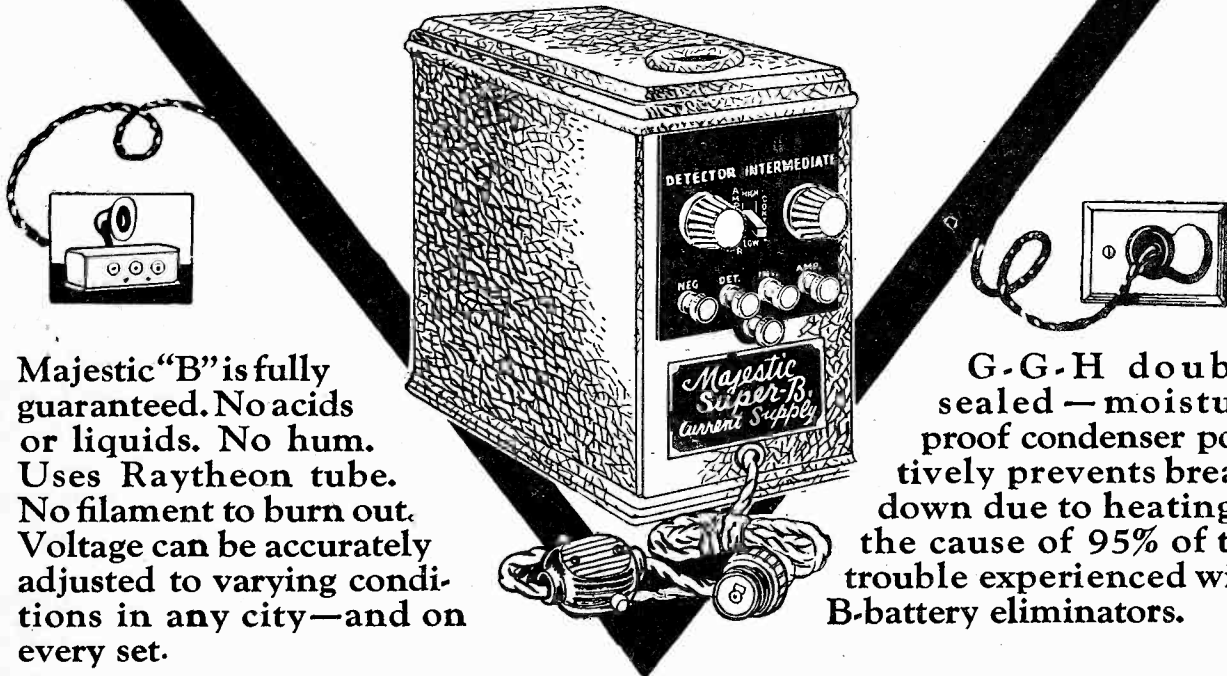

Majestic "B" is fully guaranteed. No acids or liquids. No hum. Uses Raytheon tube. No filament to burn out. Voltage can be accurately adjusted to varying conditions in any city—and on every set.

G-G-H double sealed—moisture proof condenser positively prevents breakdown due to heating—the cause of 95% of the trouble experienced with B-battery eliminators.

## When you buy a Majestic "B" you say "Good-bye" to trouble

caused by poor "B" power. Majestic gives you an even, continuous flow of "B" current today, tomorrow—whenever you turn on your set. It's economical, too. When you put a "Majestic" to work it stays put. You'll never have to "replace" it as you did "B" batteries. Majestic's first cost is low, and the upkeep only a fraction of a cent per hour.

To know how good, really good radio reception can be, try a "Majestic" on your radio set. Your dealer will arrange a trial without obligation to buy. Phone him today.

**Majestic Standard-B**  
Capacity, nine 201-A tubes or equivalent. 45 miliamperes at 135 volts.

**\$26.50**

West of Rocky Mts., \$29.00  
Raytheon Tube \$6.00 extra

### Majestic Super B

Capacity one to twelve tubes, including the use of power tubes. 45 mils. **\$29.00**  
at 150 volts..

(AS ILLUSTRATED)

West of Rocky Mts. \$31.50  
Raytheon Tube \$6.00 extra

**Majestic Master-B**  
Positive control of all output voltage taps. For sets having high current draw or heavy biasing batteries. 60 mils. at 150 volts.

**\$31.50**

West of Rocky Mts. \$34.00  
Raytheon Tube \$6.00 extra

**Can Be Purchased on Deferred Payments**

**GRIGSBY - GRUNOW - HINDS CO., 4580 ARMITAGE AVE., CHICAGO, ILL.**

W. J. SEROY, Pacific Coast Sales Manager  
122 Broadway, Oakland, California

Tell them that you saw it in RADIO

DIRECT FROM FACTORY TO YOU

# Western "B" Power Unit

- Ample power for 171 tube.
- Two voltage controls.
- No hum.
- No distortion.
- Full wave rectification.

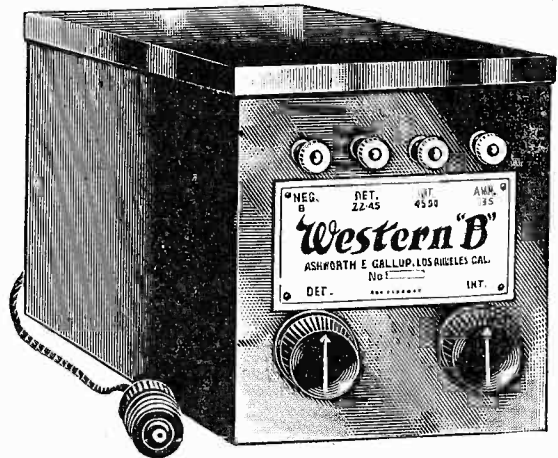

180  
VOLTS

**\$18.50**

Why be troubled with batteries when you can now buy a guaranteed Western "B" Power Unit for less than half the price of others. The Western "B" Power Unit is a quality product throughout, made of the finest materials, absolutely guaranteed to give complete satisfaction or money refunded.

OPERATES ANY SET FROM THE LIGHT SOCKET.  
LIKE HAVING NEW BATTERIES EVERY NIGHT.

**Mail the Coupon Today**

Shipped same day order received.

Endorsed by the Calibration Laboratory of RADIO Magazine for use with sets from one to ten tubes.

ASHWORTH & GALLOP,  
5845 S. Broadway, Los Angeles.

Gentlemen:—Please send me at once one Western "B" Power Unit. If after seven days' trial it is not satisfactory, I will return it and you will refund my money.

- Payment Enclosed, \$18.50.
- Send C. O. D.

Name.....  
Address.....  
City..... State.....

## SCIENCE VS. COMMON SENSE

(Continued from Page 25)

were listening, for one man immediately gathered up the small set and disappeared in the tangle of sumac and laurel that covered the hills. It seemed to settle down to a routine affair, for with I. C. U. caught in two directions, it would have to be at the junction of these lines. The driver idly wondered why he and his companion had been called for so simple a proposition as this seemed to be.

About five o'clock, the first man returned, saying he had followed the signals about two miles, or until they had ceased; caching the set he had gone in the same direction, and had come out on top of a hill, overlooking a small town, Indian Run, he believed.

Indian Run at this time was a small village of about twenty houses. Lying at the junction of a creek of the same name with Rough River, it had many natural advantages, which made it ideal as a summer camp site. The houses were scattered, except for a small cluster near a large compressor station. The entire town was built on a farm, abandoned some twenty years before, and which had been allowed to grow up to blackberry vines and poison-ivy. The compressor station was the excuse for a power line in this vicinity, and most of the houses were connected for lights. A large inn had been erected just across the river from the town, and the usual summer crowd was there.

The radio car was driven down near the inn and parked. As the men ate a lunch, one kept on the phones listening for the first sound of the mysterious I. C. U. Suddenly swinging the loop, he announced "Got him right off the reel and say, get that carrier wave—must be right handy. Swing the car around so I can sight through the windshield." This was done.

"Where do you make it?" the driver asked.

"Directly across the river," was the response.

Leaving his companion, he made his way to the river bank, where he found a boat. Rowing across, he looked back and blinked his flashlight for a bearing. "To the right," was the answering flash from the car. Soon he was in line and proceeded rapidly over rough ditches, small streams, ledges of limestone, and the like. As he looked back, he got a flash to "wait." After waiting several minutes, he got another signal to "return to car."

"What is the matter," he asked immediately upon his arrival.

"Funniest thing I ever ran across," was the answer. "You were right in line when suddenly the music faded out. I waited a minute, then swung the loop and look at it now, just 85 degrees off the first bearing, and just as strong as ever." And so it was.

**demand**  
**AEROVOX**

**FILTER CONDENSER BLOCKS**

For Working Voltages of 200, 300, 400, 600 and 1000 Volts D. C.

Flexible leads for connections eliminate all possibilities of leakage from soldering.

AEROVOX WIRELESS CORPORATION  
60-72 Washington Street  
Brooklyn, N. Y.

# LYNCH METALLIZED

WARRANTED FIXED RESISTORS

THE vital importance of a silent, accurate resistor cannot be overestimated. Comprising a concentrated metallized deposit one-thousandth of an inch thick, upon a glass core and sealed forever within the tube, each Lynch Resistor is warranted absolutely noiseless, permanently accurate, dependable! Guaranteed accuracy—10%; in production they average 5%. .25; .5; 1; 2; 3; 4; 5; 6; 7; 8; 9; 10 Meg., 50c. .025; .09; .1 Meg., 75c. Single mounting 35c; Double, 50c. If your dealer cannot supply you, send stamps, check or money order. We ship postpaid same day order is received.

Dealers—Get on our mailing list; we keep you posted on new developments. Write us today! 426 RP

ARTHUR H. LYNCH, INC. **RMA** MEMBER 250 W. 57th St. New York, N. Y.

## Powertone Wave Trap



(Station Separator)

Price \$2.00

At all good dealers or direct by mail on receipt of price.

Dealers and Jobbers Write

Manufactured by

**POWERTONE ELEC. CO.**  
221 FULTON ST., NEW YORK CITY

Real Sensation of the Year  
**CHELSEA**  
TRUPHONIC SIX—\$60.00

Write us.  
**Chelsea Radio Co.**  
Chelsea, Mass.

Even as they listened, the music faded ever so slightly, paused, then died down. Hastily swinging the loop, the music was again found and followed as it apparently wandered up the river a mile or so.

The evening was spent in this pleasant (?) manner, trying to get a bearing on a station that would not stand still, as any respectable station should. As I. C. U. signed off, it made the usual statement, "We will never be caught."

Introducing themselves at the inn as students from "Tech," they made arrangements for lodgings. Making friends easily, they were soon acquainted and, as they turned out to be interested in radio, they had no difficulty in examining the receiving sets, seven in all, at Indian Run. Nothing remotely resembling a transmitter was found. Guarded inquiries as to the activities of I. C. U. elicited the information that it was an unusually powerful station, that at times it was hard to tune out, at other times it was very sharp and did not bother much. They apparently had not paid much attention to it one way or the other.

That evening, the Secret Service Agents got a real shock, for at the beginning of the program, it was announced that "I. C. U., the Unknown Broadcaster, would render a special program for our two friends, the Secret Service agents, sitting in their range-finding car, on the north bank of the Rough River. The first selection will be 'Somewhere a Voice is Calling.' This will be followed by 'Shall We Gather at the River.' During the intermission, that old-fashioned game, 'Station, Station, Who's got the Station' will be played."

With their identity exposed, it was necessary to work in the open, so the next day by using their credentials, each and every dwelling at Indian Run was searched. As a further precaution, all aeri-als were temporarily grounded. The compressor station came in for its share of attention. As a further check, the electricity was turned off at the power house for a few hours.

All to no purpose. "I. C. U., the Unknown Broadcaster," came in better and stronger than ever. With the small receiver carried between them, they tried to run down the outlaw station, but would soon discover they had over-run it, apparently. Upon going back, they would find it was off in another direction.

When I. C. U. signed off that night, the agents were badly demoralized, and the receiving set was a total loss, as they had fallen over a ledge of rock into a trout stream, and had to swim across. For two weeks, they hung on, hoping against hope that I. C. U. would drop a clue that would not, figuratively

## NATIONAL TUNING UNITS

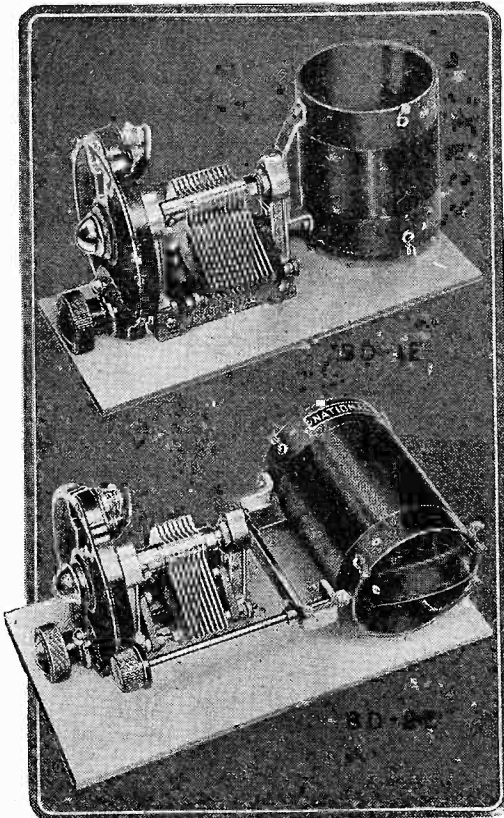

Comprise the famous BROWNING-DRAKE Coils and R.F. Transformers with Slot-wound primary, and Space-wound secondary. These coils and R.F. Transformers were mathematically developed by Glenn H. Browning and F. H. Drake, at the Cruft Laboratory, Harvard University.

DESIGNED and OFFICIALLY APPROVED BY GLENN H. BROWNING

The coils are mounted on the new NATIONAL EQUITUNE Condensers, the plates of which are designed to space out stations evenly over 1/2 revolution. The rigid, structurally designed Girder Frame of the EQUITUNE Condensers occupy a minimum space and are extremely light in spite of their rigidity.

Price—BD-1E—\$10.75 (with illuminated dial)  
—BD-2E— 14.25 (with illuminated dial)

NATIONAL Tuning Units are standard for good Radio sets. So are NATIONAL Impedafomers, for quality audio, NATIONAL Tone-Filters, for power tube output connection.



NATIONAL ILLUMINATED Velvet-Vernier Dials are fitted to these tuning units. Each tuning unit is packed completely set up and may be used without change for experimental work or may readily be mounted on any kind of a panel.

NATIONAL Co. makes heavy-duty B-Supply Units and 3-stage Power Amplifiers. Write National Company, Inc. W. A. Ready, Pres., Cambridge, Mass., for Bulletin 116-P-4.

### LOG YOUR STATIONS

10c For a Copy of the Radio Log Book. 16 Pages.

"RADIO," San Francisco

### 25c NEWS to Set Builders



Set builders, radio fans and those interested in the best radio receiver ever developed, send for this new book explaining the wonders of Camfield's Super-Selective Nine. Exceptional selectivity, sensitivity and tone quality. Changes from 5 to 9 tubes instantly. Send 25c for your copy today—now. CAMFIELD RADIO MFG. CO., 357-362 E. Ohio St., Chicago, Ills.

## Modernize Your Set for \$2.50

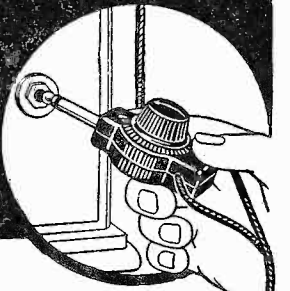

TONE improvement is this year's only real radio advance. Just one change will modernize your present set. Replace your loud speaker plug with the Centralab Modu-Plug and your set will equal the tone performance of the latest high-priced receivers. Gives any degree of tone volume. No other control but the small knob on the plug. Interfering noises are reduced.

\$2.50 at your dealer's, or mailed direct on receipt of price.

Central Radio Laboratories  
14 Keefe Ave., Milwaukee, Wis.

Centralab variable resistances are used by 69 makers of leading standard sets.

## Centralab

### famous "Perfect" ONLY BELMINATOR 4.75 Complete

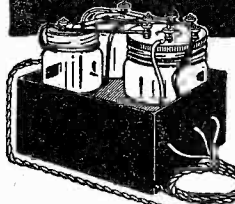

FOR ANY SET  
Makes "B" Batteries obsolete. Costs much less than a set of cells. Ends plate current troubles forever. Hook it up just as your old batteries were connected. No "frying" noises caused by old cells. Sharper tuning — more power because of steady flow of current through tubes.

No Extras to Buy

Completely equipped and assembled. Our amazingly low price of \$4.75 covers everything. Just plug in on any light circuit, direct or alternating. Gives power up to 90 volts, using full wave of power supply. Operates any set up to 7 tubes. Thousands of enthusiastic users in all parts of the country.

10 DAYS TRIAL

Money Back If Not Delighted

Just send \$1.00 now. Pay postman balance of \$3.75 (plus few cents postage) when he delivers your Eliminator. Use it 10 days. If not delighted, return in good condition and we will refund your money. Our guarantee protects you absolutely. Reference—Pearl Market Bank, Cincinnati, Ohio.

PERFECT ELIMINATOR CO.

3 U National Theatre Bldg., Cincinnati, Ohio

### Tubes Matched for Ten Cents Each

Send us your vacuum tubes. Let us select the best detector, oscillator, r.f. or audio amplifier and see how much better your set will work. Price only ten cents per tube. Each tube will be plainly marked. We also sell selected tubes at regular retail prices.

Laboratory of "Radio," 435 Pacific Bldg., San Francisco

### SOUND EXPERT ADVICE

On Radio and Scientific Patents

Specializing in Radio Patents and Trade Marks and Investigations Relating Thereto

John Flam, Patent Attorney

821 Merchants National Bank Building  
Los Angeles California

# Gerald Best's Choice

THIS SPECIALLY DESIGNED

## Filter Transformer

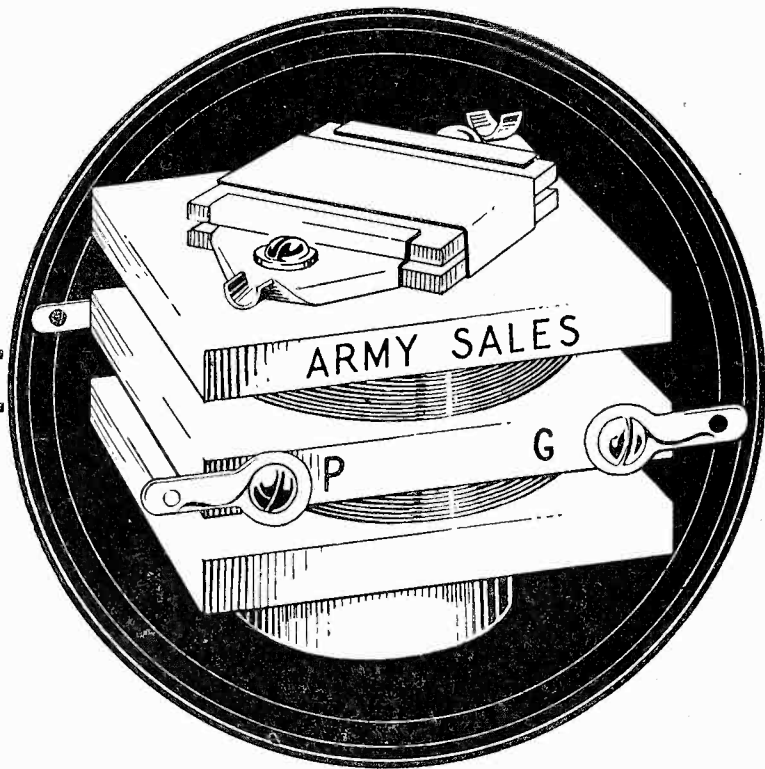

For Your Superheterodyne

**\$5.00**

The price is reasonable. The illustration shows the completed transformer with its matched condenser on top. Built of finest insulating material and wound by hand. Convenient soldering lugs are attached. The product is unconditionally guaranteed to give positive results. Your money cheerfully refunded if you are not entirely satisfied.

### How to Order

When ordering please state the type and frequency range of your intermediate transformer in order that the proper filter can be selected to meet your local conditions. For extremely congested districts where an unusual degree of selectivity is needed a pair of these Filter Transformers, matched to exactly the same frequency, will enable you to cut out undesired local stations and receive the distant ones having a wavelength separation of only a few meters from the locals.

A sharply tuned filter transformer furnished with specially selected tuning condenser. A genuine custom-built laboratory product, designed by engineers and subjected to the closest inspection before delivery to you. Guesswork in selecting a separate tuning condenser of unknown capacity is eliminated. This Filter Transformer can be used in any superheterodyne with intermediate frequency between 25 and 80 kilocycles. Simply tell us the make or frequency range of your intermediate transformers and we will furnish a filter transformer with an accuracy of 1%. A new arrangement of the windings permits of unusual selectivity and yet the sidebands of the modulated radio wave are not cut down appreciably, resulting in retaining the full tone quality. What an improvement this transformer makes. Order direct from manufacturer if your dealer cannot supply you. Orders filled same day we receive them. We pay the forwarding charges. Dealers are invited to write for trade proposition.

**ARMY SALES COMPANY**  
1650 Jackson Street San Francisco, Calif.

and literally speaking, lead to a stone wall.

For a mile in every direction, the country was examined at close range. From the hills, powerful field glasses were used, and every suspicious hump or hollow was looked into, but still nothing. By this time, their batteries were about exhausted, and after an exchange of code telegrams with headquarters, they headed their car up the hill and Indian Run saw them no more.

PROFESSOR ERNEST usually spent his summers at Indian Run. Several reasons governed this. First, it was quiet, and the fishing, boating and swimming were excellent. Second, some rare specimens of the snail-eating beetles had been found in the narrow confines of Indian Run Valley. For it must be known that the professor was an amateur entomologist at the top of his chosen branch. For ten months of the year, he had occupied the chair of mathematics at one of the universities, and beetles (and lately, radio) was his relaxation.

His daughter, Marie, was interested in neither beetles nor figures, unless the latter were clad in duck trousers and collegiate sweaters. She and the professor were as near opposites as it were possible to be. "Mathematics rule the Universe" he would say, in his most approved lecture voice. "Worlds, Comets, all, are governed by one thing and one only, Mathematics."

"Nonsense" would be Marie's answer. "Good common sense will win every time."

A hostile look would be the only answer to this.

The professor was exceedingly busy. He had found one very, very rare specimen, and needed the other two to complete the series. The season was waning and so far he had been unsuccessful. Also, he had discovered that a good loop aerial in conjunction with his super-sensitive crystal set and a pair of 20,000 ohm phones, would pick up an amazing lot of music.

Shortly after the departure of the Secret Service men, the talk again turned to them, and the professor sided against them, saying that two experts with their equipment could locate the station if they wanted to do so. "I'll wager they were here on other business altogether," he testily exclaimed.

"Could you locate it?" he was asked.

"Easiest thing in the world" was the prompt reply. "Those men made too much fuss about it. Problems of this sort are worked out by mathematics first; then, by a process of elimination, the actual location is ascertained."

"Sounds easy" said someone. "I would eliminate a lot of locations for \$500.00." "Five Hundred Dollars?" asked another.

"That is the latest on I. C. U." was the reply. "Turn him in and collect."

That night, one of the less reputable citizens of Indian Run got a scare that kept him sober for nearly a week. Returning home just after dark, he was horrified to see what looked like a huge spider-web floating around a few feet above the ground. At the center, a big spider sat, but even while he watched, it seemed to turn to a human head with large unwinking eyes that coldly stared. It could not be a human head, for where the ears should be were two large black objects, horns, no doubt.

As he stood looking, the spider began to mutter, and suddenly swung in his direction. This was too much, and falling over the fence, he headed for the compressor station and light. Of course, this was only the professor, and it will not be necessary to follow his adventures except to say that he failed as badly as the rest.

The following morning, the professor was in a bad humor. His knee, where he had fallen over the log, hurt. He wondered if immersion in water left any permanent results in 20,000 ohm phones. He felt the back of his hands and neck where sundry welts remained. He knew that hornet stings, even in large numbers, left no serious after-effects. As he gingerly felt his nose, he wondered why women *would* leave a clothes line hanging down in that manner. Above all else, he wondered why *he* had gone out on that fool's errand, or so it looked now.

At this moment, Marie, passing, rapped on his door. "Come in," he growled. Fresh from her morning dip in the river, in her trim bathing suit, she looked like the Goddess of Dawn.

"Why, Daddy, what happened?" she asked. "Did science fail to locate I. C. U.?"

"D—n I. C. U. and everything connected with it," shrilled the professor. "Look at me, look at those phones, and then ask me if science failed in a country where they hang out lassos at night and park wheelbarrows with no red lights? Yes, science failed, and now let me see you use some of that common sense for which you are so strong. If you find I. C. U. I will add \$500 to the federal authorities' offer, and you can get that platinum wrist watch you wanted."

Marie had turned color slightly at this tirade, but her gaze was steady as she replied, "Very well, Daddy," and passed on to her room.

At lunch, she was still quiet, and shortly afterwards, a storm coming up, she excused herself to take a nap. That evening she was unable to sleep, and her father's words came back to her. No doubt he felt bad, but even at that—still on the other hand—well, he was just tired out, likely his head ached.

# BRACH Storm King LIGHTNING ARRESTER



Over 2,000,000 Radios  
are Now Protected  
by Brach Arresters

Price  
Only **\$1**

Like all Brach Arresters  
the Storm King is backed  
by our

**\$100 INSURANCE  
GUARANTY**

Electrify your Radio  
with the Wonderful  
**BRACH**

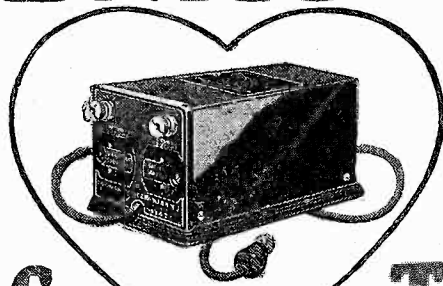

**CONTROLIT**  
THE HEART OF THE POWER PLANT

Over 75,000  
used within  
First Four Months

**L.S. BRACH MFG. CO.**

MEMBER  
**RMA**  
NEWARK, N. J. TORONTO, CAN.

## HERE IT IS!

Marvelous Townsend  
**"B" ELIMINATOR**  
(Complete)

only  
**4.95**  
\$1.00 down  
Balance C.O.D.

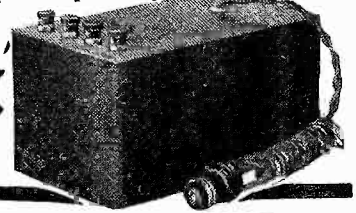

Direct From Factory  
at Lowest Price on Record

Great news! For half the price of a set of "B" batteries you can now enjoy greatly improved reception and be done with unreliable "B" batteries. We make the Townsend "B" Eliminator complete in our own factory. That's the reason we can give you at such a remarkably low price a high quality instrument backed by a real guarantee. Users report splendid results. A fine "B" Eliminator at the lowest price on record. Our 10 days Free Trial proves it.

**10 Days  
FREE  
TRIAL**  
You are the  
Judge!

**MONEY BACK If Not Amazed and Delighted**  
You alone are the judge. We could not afford to make this guarantee if we were not sure of the Townsend "B" Eliminator's splendid performance. Delivers up to 100 volts on any set up to six tubes, on direct or alternating current—any cycle. Gives full wave rectification. Full tone, clarity and volume.

**Rush Order Today** Simply put your name and address on a piece of paper, pin a \$1 bill to it and get it into the mail at once. Your "B" Eliminator will be sent you promptly. Deposit \$3.95 only with the postman. Try out for ten days—then if not thrilled by improvement in operation, return Eliminator to us and purchase price will be refunded in full. You don't need to put up with battery nuisance another day when it is possible to own a "B" Eliminator at this startlingly low price. Send for it today.

Townsend Laboratories, 713 Townsend St., Dept. 18, Chicago, Ill.



NO set is better than its tubes, no tubes than their filament control. Amperite alone controls filament current automatically, perfectly. Order by name. Accept nothing else. Simplifies wiring. Eliminates hand rheostats. **FREE—Send for Radial Book.** Explains Amperite operation. Gives season's popular Hook-Ups and Construction Data. Address Dept. R4

**Radial Co., 50 Franklin St., New York**

Price \$1.10  
mounted (U.S.A.)  
Sold Everywhere

**AMPERITE**  
REG. U.S. PAT. OFF.  
The "SELF-ADJUSTING" Rheostat

## Potter Condensers

Potter condensers, American made of highest quality materials to full capacity, build the best Socket Power Devices, Power Amplifiers, Impedance Amplifiers. And they are best for Filter Uses, Rectifiers, By Pass, and Blocking D.C. All types and sizes.

**POTTER MANUFACTURING CO.**  
North Chicago, Illinois

**LOG THOSE STATIONS**  
**10c** For A Handy Pamphlet  
"RADIO"  
433 Pacific Building San Francisco

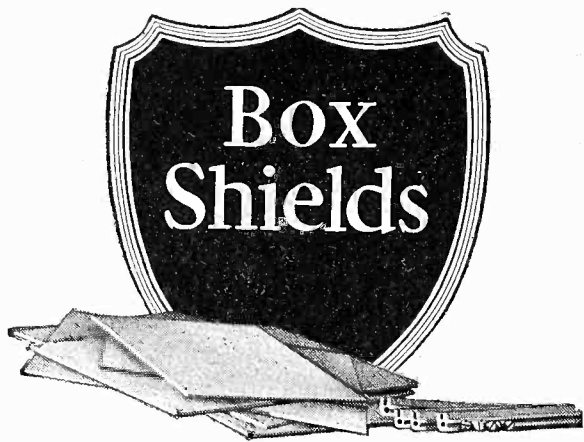

## Made of "ALCOA ALUMINUM"

MEETING the highest radio standards—shipped to you in the most convenient knocked-down form for easy assembly. These Box Shields are made of heavy Aluminum (.080"—No. 12 B. & S.) and are supplied 5"x9"x6", which will cover most requirements. If the size does not meet your exact needs, change it—Aluminum is easy to work.

Manufacturers can obtain these shields made to their exact specifications or they can secure the necessary corner-post moulding and sheet to manufacture under their own supervision.

Those who use Aluminum have ample proof of its advantages. Insist on "Alcoa Aluminum." Ask your dealer or write us.

### "Alcoa Aluminum" Box Shields

Consist of: Top, Bottom, Sides  
4 Extruded Corner Posts  
8 Aluminum Screws

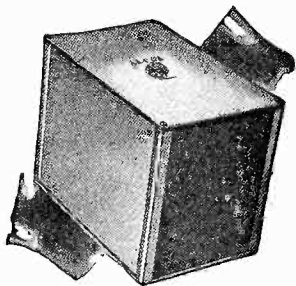

"ALCOA ALUMINUM"  
is furnished to manufacturers  
in the following forms:

Sheet: for shields, chassis, variable condensers, cabinets.  
Panels finished in walnut and mahogany.  
Die and Sand Castings.  
Screw Machine Products.  
Foil for fixed condensers.  
High Purity Rods for rectifiers.  
Stamping, rod, wire, rivets.

ALUMINUM IN EVERY  
COMMERCIAL FORM

ALUMINUM COMPANY of AMERICA  
2323 Oliver Building, Pittsburgh, Pa.



# FRESHMAN AUTOMATIC CHARGER

## Connects Right to Your Light Socket

\$15



# NO MORE "A" BATTERY TROUBLES

Sold by Authorized Freshman  
Dealers Only

Write for new literature

CHAS. FRESHMAN CO., INC.  
Freshman Bldg., New York

### Send For This QUOTATION NOW!

Let us mail you, free of cost, a copy of the rate schedule for testing, matching and calibrating radio apparatus. Our new Matching and Testing Laboratory is now ready for you. Gerald Best and D. B. McGown will match and test your radio parts. The rate schedule is yours for the asking. Use the coupon.

RADIO, Pacific Building,  
San Francisco, Calif.

Send me your rates for testing  
and matching apparatus.

Name.....

Address.....

She could not repress a giggle at the recollection of the unlighted wheelbarrow. After all, he was ageing, and she must look out for him better.

Still, she could not sleep, and she tried the old expedient of counting sheep. No good. Gazing out the open window, she tried counting the lights across the river, and visualizing the houses. Suddenly, she was fully awake, staring as if her life depended on it. Stepping softly to the floor, she busied herself a few minutes and then with a satisfied smile, lay down and was asleep in no time.

The next morning, she appeared dressed for a hike, in smart knickers, heavy shoes and leather leggings. A revolver of small caliber was belted at her waist.

Refusing all offers of company, she set out, rowing across and down the river, landing near the abandoned farmhouse. This had collapsed years before and nothing remained but the cellar walls and a few rafters and pieces of roofing paper, the whole overgrown with poison-ivy and black-berry bushes. It was reputed to be haunted, and was generally shunned, but not on account of ghosts—no, indeed. Papa and Mama Copperhead had investigated the stone walls years before, and finding it to their liking, had settled down and raised several large families. They could be seen almost any warm day, lying on the stones with their ugly triangular heads drawn back over their thick bodies.

Marie did not pause, but kept on. In half an hour, she came to the Western Virginia Railroad, and followed it up the river a few miles until she was able to cross at a place called "The Narrows."

Following the C. & A. back, she reached the inn just in time for lunch.

"Daddy," she asked, "if I were to locate I. C. U., whom should I notify?"

"Did you find that pirate?" he exclaimed.

"No-o," was the slow response, "but I have a clue and I believe I can run him down."

"Well, if you find that pest, call Pine 7325, and they will do the rest."

Quietly, Marie faded into a phone booth.

Meeting the 4:30 accommodation from Pittsville, she was accosted by one of two quietly dressed men. After a brief conversation, these were introduced as friends from the university.

Immediately after dinner, the trio taking different directions, met at the river and took a boat, landing somewhat above the haunted house. Marie remained in the boat while her companions proceeded.

The first Secret Service agent took a position near the house, while the second made for a small stream possibly two hundred yards away. Arriving, he got his bearings from a large white rock and pulling aside some bushes, uncovered an opening in the bank. Slipping his automatic from its holster to his coat pocket, he entered.

After traveling some distance underground, he could hear voices, faintly at first, then louder, as he noiselessly approached. Suddenly turning a corner, he was able to see his goal.

A large broadcasting station was in full blast. Four huge transmitting tubes glowed in the semi-darkness. Dimly, row after row of storage batteries was seen, extending back into the darkness. A talking machine of the latest type, with a tremendous stack of records, occupied the foreground. Two young men were busily engaged in the multitude of duties attendant upon a station of this size.

As the Secret Service agent watched, the record came to an end, and he stepped forward with drawn revolver, saying as he did so, "Well, boys, the jig is up."

Showing no excitement whatever, the station operator cut in his hand microphone and made his final announcement: "This is I. C. U., the Unknown Broadcaster. We regret to announce at this time that this was our concluding number, as we are signing off forever. Adios."

Switching off the power, he said to the Secret Service agent, "At your service, Sir!" His companion had stepped forward, and they were both placed under arrest.

Motioning his captives ahead, the operative made his way out of the underground passage-way, arriving at the cellar of the old house, where they were joined by the other operative. Leaving him to guard the equipment, the second agent and his two captives crossed the river, where the evening flier was flagged to pick them up.

The next morning, conversation at breakfast was general until someone spoke of I. C. U.

"Wasn't it queer, his signing off in that manner, saying he was signing off forever. Wonder if he meant it?"

This was Marie's opportunity. "I. C. U. will never be heard again," she softly said, "for the station was raided last evening and the two operators were taken to Pittsville on Dukane at 7:30."

A pin could have been heard drop. Then—"Who were they?" "Where was the station?" "Did they put a fight?" "Can we see where it was?" "Who found it?"

In a few terse sentences, Marie explained. This was followed by a rush for boats to visit the scene. Entrance was refused until the radio equipment



## You'll Be Surprised

at the big difference a little thing can make. X-L Products tone up your circuit to the pitch of exactness demanded by experts. That's why they are specified in all popular hook-ups.

**MODEL "N"**—A slight turn obtains correct tube oscillation on all tuned radio frequency circuits. Neutrodyne, Roberts two tube, Browning-Drake, McMurdo Silver's Knock-out, etc., capacity range 1.8 to 20 micro-micro farads. Price.....\$1.00

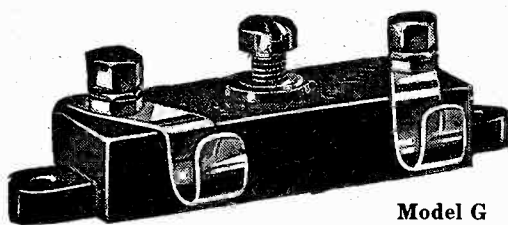

Model G

**MODEL "G"**—With grid clips obtains the proper grid capacity on Cockaday circuits, filter and intermediate frequency tuning in heterodyne and positive grid bias in all sets.

Model G is made in three variable capacities:

- G- 1- .00002 to .0001 MF.
- G- 5- .0001 to .0005 MF.
- G- 10- .0003 to .001 MF.

Price Each With Grid Leak Clips, \$1.50

**X-L PUSH POST**—Push it down with your thumb, insert wire, remove pressure and wire is firmly held. Release instantly. Price 15c.

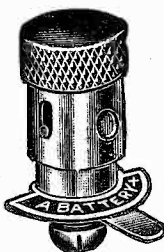

X-L Push Post

**PUSH POST PANEL** permanently marked in white on black insulating panel. In box including soldering lugs, raising bushings and screws for mounting, etc. Price \$1.50.



X-L Push Post Panel

FREE Wiring Diagrams showing use in the most popular circuits sent on request. Write today.

**X-L RADIO LABORATORIES**  
2428 LINCOLN AVENUE, CHICAGO, ILL.

### KARAS EQUAMATIC MANUAL

Price 10c.

Build the Karas Equamatic 5-Tube Radio Sensation—the most selective receiver ever designed. Mail 10c today for 16-page Manual of wiring diagrams and complete instructions for building this remarkable receiver. Address:

**KARAS ELECTRIC COMPANY**  
1049 Association Building Chicago, Ill.

### COILS MATCHED

Radio frequency coils accurately matched for Infradynes and other sets. What a difference this makes. Only 35 cents per coil. Send them to LABORATORY of "RADIO," Pacific Bldg., San Francisco. We also are in a position to purchase these coils for you.



## Engineering and Mass Production

Those two features are important to you, the manufacturers of sets and eliminators. Dongan's reputation for being a step ahead in transformer design and a large factory devoted entirely to the production of parts has placed Dongan transformers and chokes as standard equipment in many leading sets and battery-eliminators.

As a source of supply you will find the utmost in cooperation in the Dongan organization.

### This is NEW!

Dongan Transformers & Chokes

for use with

Raytheon BA 350 MA and Q.R.S. 300 MA Rectifying Tubes

Write for complete details

**Dongan Electric Manufacturing Company**  
2981-3001 Franklin St. Detroit

TRANSFORMERS of MERIT for FIFTEEN YEARS

## A New Booklet

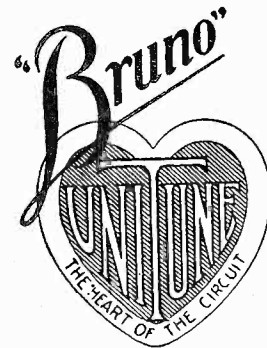

36

Pages of the latest radio diagrams, parts, circuits and blueprints.

General description and constructional data written in simple style by a Master of radio technique. Truly instructive.

4 Wiring Diagrams,  
4 Circuits, 4 Blueprints,  
47 Illustrations,  
3 complete pages of parts,  
36 pages of radio knowledge.

Send 25 cents for your copy

**BRUNO RADIO CORPORATION**  
Long Island City New York

# Hoyt Radio Rotary Meter

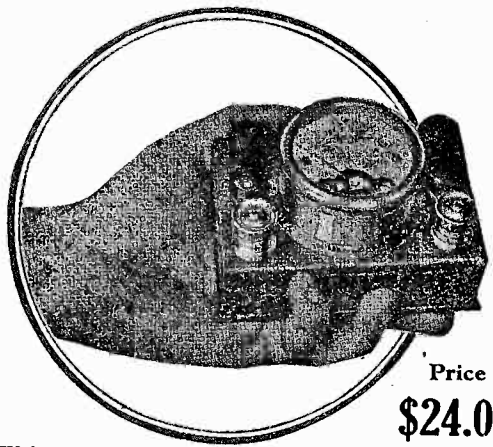

Price  
**\$24.00**

This is a unique 5-range precision moving coil voltmeter, made specially for the Radio Service Man, Dealer and Owner. It will make all tests necessary on Radio Receiving Sets, tubes, batteries. It is rugged and will last a lifetime, yet will retain its extreme accuracy. Operation is simple and accident-proof.

## BURTON-ROGERS CO.

857 BOYLSTON ST., BOSTON, MASS.  
Sales Dept. for HOYT Electrical Instrument Works  
HOYT makes a complete line of Radio Meters.  
Send for book et, "HOYT Meters for Radio"

## Make Your Own Three-Foot Cone Speaker in Less Than an Hour

**WORLD'S FINEST LOUD SPEAKER**  
GENUINE  
"ENSCO" 3" CONE KIT

ONLY \$10  
Can be assembled  
in Less Than an  
- HOUR -  
The Original Three-Foot  
Cone Speaker  
- KIT -

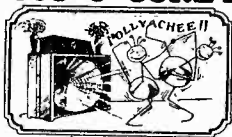

NO DISTORTION  
THE SOLUTION OF THE  
LOUD-SPEAKER PROBLEM  
The Office of Leading Engineers  
PERFECT FIDELITY

Complete parts furnished in kit form. We guarantee this speaker the equal of any manufactured cone speaker at any price.

With this THREE FOOT CONE SPEAKER you hear all the tones. It brings out the true depth and beauty of orchestral and instrumental music. Can be operated softly for Living Room Music or full volume for dancing, and without trace of distortion.

Kit includes famous "ENSCO" cone unit, the only direct-drive, distortionless unit for large cones; Alhambra Fonotex for big cone, with brass apex, two Sepia Prints showing cabinet or simple stand construction. All necessary instructions.

Buy this wonderful speaker under our absolute guarantee. Your money back if you are not convinced that it is the finest reproducing medium obtainable at any price. It works on any Set, with ordinary Tubes or with Power Output.

Engineers' Service Company  
25 Church St. (Desk Y)  
New York City

### Send No Money!

Write your name plainly, as indicated below, then mail and complete kit will be forwarded to you. Just pay postman \$10.00 upon delivery.

Engineers' Service Company  
25 Church St. (Desk Y)  
New York City

## Valley Chargers

Manufactured by  
VALLEY ELECTRIC CO.  
ST. LOUIS, MO.

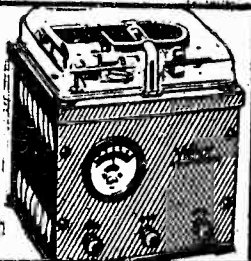

was all removed and crated for shipment to headquarters for examination.

However, no antenna could be found, unless a small coil of peculiar construction could be so called. In view of the tremendous power and range of I. C. U., this did not look reasonable. Also, it did not explain how the apparent location of the station could be shifted at will. It remained for Marie to discover, and the professor to explain this seeming paradox.

Noticing a large stone that seemed loose, she pried it out of the wall, uncovering a section of large tile pipe. Supported in the center of this was a duplicate of the coil mounted on the transmitter. Connected to the coil was a peculiarly constructed cable stretching back into darkness. It seemed to have a Litz center of perhaps 100 strands of No. 30 gauge wire. This was wrapped with No. 18 gauge enameled wire. A layer of heavy insulation followed, and finally another wrapping, in the opposite direction, of No. 18 wire. Investigation showed several of these buried aerials, stretching out in different directions.

Professor Ernest expressed his belief that by coupling the transmitter coil to any particular antenna coil, the operator could, at will, energize any particular antenna. He also expressed his belief that the peculiar construction of the wire allowed it to act as an attenuated resonance coil, and that by means of a cunningly built system of relays, the operator could select the first, second or third resonant point from which to propagate the carrier wave. As these points were roughly 1200 feet apart, it will be seen why I. C. U. escaped detection so long.

These details were brought out at the trial. As the authorities realized that these young men had invented something worth while, they were told that if they made a clean breast of the whole proceedings, the authorities would take a very lenient view of the case. This was done and the boys were placed on parole at one of the Navy training stations, where their inventive genius was used to better advantage.

All was over except "Marie, how on earth did you locate that station?" With a very demure look on her face, Marie said, "Daddy, I cannot tell a lie, I saw it with my little eyes."

"But how could you when the country was crosshatched with a fine comb?"

"Well, Daddy, I may as well 'fess up. Do you remember last Tuesday when it rained and I twitted you about finding I. C. U. and then I took a sleep in the afternoon? Of course I could not get to sleep that night, and I began to count the lights across the river as a person counts sheep jumping over the fence. Finally, I began to visualize the houses and I noticed a peculiar thing.

There were thirteen lights and only twelve houses."

"I could see, too, that the extra light was away from the rest and of a different color, more reddish like.

"I got the wood strip from my window shade and stuck in two pins like gun sights. Then I blocked this so the light was directly in range, and in the morning found it pointed to the haunted house. That day I hiked past and saw two cigarette stubs in the old cellar-way, and besides, I could detect a very faint odor of gas from storage batteries on charge, so I knew the station must be there.

"I remembered last year when you and I visited the old spring where the still was raided years ago, and I saw a rabbit run in a hole in the bank. I remembered, too, what that Mr. Watkins told us, that the old house was built in Indian days, and the people were supposed to have dug a passage-way from their cellar to the spring, so that in case they were besieged by Indians, they could always get water.

"I just knew that the station was in that passage-way, and that was what I told the Secret Service department when I phoned them. They came out and—well, I guess you know the rest. I get the thousand dollars, do I not?"

"Well! Well! Well!" said the professor. "Well! Well! Brains and a woman's intuition. Science failed; Radio failed, but Common Sense won. Yes, Marie, you get the thousand dollars."

"Thank you, Daddy."

## VOLTMETER-MULTIPLIER

(Continued from Page 34)

It is to be understood that the addition of the resistor to the voltmeter in no wise impairs the original accuracy or character of the instrument. By disconnecting it the meter can be used as before, while with it the range of usefulness of the meter has been greatly increased, since several resistors of varying values can be calibrated to give several ranges. For a Weston 0 to 15 volt model 301 instrument the following resistor values will give the ranges shown. Other makes will have approximately the same values.

1,000 ohm,	0 to 30 volts (approx.)
2,500 ohm,	0 to 30 volts
5,000 ohm,	0 to 100 volts
7,500 ohm,	0 to 160 volts
10,000 ohm,	0 to 200 volts

Rumor tells us that the great white fleet, known as the banana navy and United Fruit Company, will soon junk the spark transmitters and add tube sets. For many months the radio department of the company has been experimenting in order to discover the best possible apparatus for marine use. Once they make up their minds we know that, as in the past, their ships will be the equals of any and superior to many other services.



---

# Where can you duplicate this unusual service?

**T**wo months ago the publishers of "RADIO" announced that Gerald M. Best and D. B. McGown were ready to test, match and calibrate your radio apparatus. The announcement has met with the most gratifying response. We have served the needs of hundreds of our readers and every day our laboratory business increases. "RADIO" renders a distinct and unusual laboratory service. Best and McGown have at their disposal a completely equipped modern testing and calibration laboratory. In this laboratory we can match coils and condensers—select tubes of various characteristics best suited for the different parts of the circuit. We can match and peak intermediate frequency transformers and filters for any desired frequency. Audio transformers can be matched in pairs. Capacity measurements of small fixed condensers can be accurately made. Receiving sets can

be calibrated to read in wavelengths. Grid leaks can be measured. An investment of several thousand dollars in precision instruments enables us to render a service second to none. We invite all readers of "RADIO" to send their apparatus to us for testing, matching and calibrating. The rates are unusually reasonable for this work. For example—tubes can be "picked" or matched for ten cents each. Wavemeters calibrated for as low as \$2.50. Inductance coils for radio frequency circuits matched for 35 cents each. Gang condenser banks matched with coils for Infradynes and other circuits for 70 cents per coil and condenser bank. A complete schedule of rates for other work is now ready for mailing. A post card will bring you this information. Write for it now.

We will also purchase radio parts for you and sell them to you at the regular retail price. When

parts are bought from us they are inspected, tested and matched at no extra cost. Any or all of the parts needed for building the various sets described in "RADIO" can be secured from our laboratory. Your mail orders will receive prompt attention. You can wire us for a set of parts—if you are in a hurry. Parts for Best's new Quadrphase Receiver can be secured from us for \$88.40. Parts for the Infradyne, \$118.00. Loftin White, \$85.10. Dealers and professional set builders who specialize in custom built radio sets can profitably avail themselves of our laboratory service. Readers of "RADIO" living in the vicinity of San Francisco are invited to inspect the laboratory. When shipping parts to us for matching or calibrating kindly address your shipment to LABORATORY, Pacific Radio Publishing Co., 435 PACIFIC BUILDING, San Francisco, Calif. Insure your shipments and pack in wooden boxes to avoid breakage.

## CALIBRATION LABORATORY

Pacific Radio Publishing Company

PACIFIC BUILDING



SAN FRANCISCO-CAL.

## AERIAL WIRE

ENAMELED  
TINNED COPPER  
BARE COPPER  
SOLID  
STRANDED  
BRAIDED

## COILS

MAGNET WINDINGS  
FOR LOUD SPEAKERS  
TRANSFORMER AND  
CHOKE WINDINGS  
FOR BATTERY  
CHARGERS  
AND ELIMINATORS  
COILS FOR AUDIO  
TRANSFORMERS

## MAGNET WIRE

ENAMELED  
COTTON COVERED  
SILK COVERED  
SINGLE OR DOUBLE  
WHITE OR COLORED



## Dudlo Manufacturing Corporation

FORT WAYNE, IND.

**A. S. LINDSTROM CO.—Western Representative**

274 Brannan Street  
San Francisco

324 N. San Pedro Street  
Los Angeles

95 Connecticut Street  
Seattle

146½ N. 10th Street  
Portland

221 South West Temple  
Salt Lake City

## WAVEMETER CALIBRATION

(Continued from Page 30)

assembled, the wavemeter is not ordinarily available. Because of this, the Bureau of Standards, co-operating with other agencies, has arranged for the transmission of various standard frequencies, which are widely used for the calibration of home built wavemeters.

The method of calibration using the standard frequencies as transmitted does not differ materially from the laboratory procedure which has been described. The principal difference is that the standard and the oscillator are separated from the meter under calibration by miles instead of by inches. The standard is in the hands of the operator of the transmitting station, his transmitter the oscillator, adjusted to resonance with his wavemeter.

Because of the distance separating the meter under calibration from the oscillator, the indicator of the wavemeter will not of course be actuated, nor will it be possible to observe a reaction of the meter in the oscillator to indicate resonance. This fact required the addition of another element to the system used for the laboratory calibration, namely, an auxiliary oscillator, which generally takes the form of an oscillating receiving set. If the standard transmitter happens to be quartz controlled, the layout is practically identical with that used for calibration against the quartz plate, the transmitter being the piezo oscillator and the receiving set the auxiliary generator.

The auxiliary generator (receiving set) is adjusted to zero beat with the transmitter, exactly as was done in the laboratory calibration. The wavemeter under calibration is coupled to the coils of the receiving set and adjusted to resonance. While there is usually no meter in the plate circuit of the oscillating tube, it will be necessary to provide one if an accurate calibration is desired. If no millimeter is available, a voltmeter may be used, connected in series as an ammeter.

The phone click method of observing resonance between the two circuits is very inaccurate, and cannot be relied upon for better than a two or three per cent calibration. The distance between the two oscillators will prevent the obtaining of additional points by the method of harmonics employed with the piezo oscillator. In order to get more calibration points, it is necessary to obtain checks against several transmitters, one for each point. Standard frequencies at amateur wavelengths are transmitted at intervals from Washington.

## Going for a Song!

300 \$7.50 Holtzer-Cabot Loud Speaker Units with Condenser enclosed in heavy metal case, finished in black satin enamel. One of the finest radio units made. Tone arm of most phonographs can be made to accommodate this unit by means of rubber tube. This is the standard No. 20 Holtzer-Cabot adaptor. These units must be sold at once. Will sell all 300 in one lot or break up into smaller lots. Best price takes them. Your offer by letter or wire solicited. Act quickly. They won't last long. Each unit guaranteed to be absolutely new—perfect and in original condition.

## WESTERN TRANSFORMER COMPANY

618 EAST ELEVENTH STREET,

OAKLAND, CALIFORNIA

## USE "RADIO'S" NEW LABORATORY SERVICE

Write today for rate schedule for matching and testing your radio parts. We are equipped to give you prompt service.

"RADIO"—Pacific Building, San Francisco, Cal.

## Gerald Best's Superheterodyne Blue Prints in half size. Sent postpaid for One Dollar.

"RADIO"—PACIFIC BUILDING, SAN FRANCISCO

HEAR the wonderful  
New Acme Speaker at  
your dealer's

**ACME**  
for amplification



**INFRADYNE  
MANUALS**  
25c  
PACIFIC RADIO  
PUB. COMPANY  
SAN FRANCISCO.

## THE QUADRAPHASE

(Continued from Page 18)

set, besides the loud speaker, would be the storage *A* battery, and the necessary *C* batteries. The relay is similar to several described in past issues of RADIO, and is of the series type, so that when the receiver filament switch is closed, the filaments are turned on and the relay operates to turn on the *B* eliminator. When the switch is open, the relay is restored to its original position, turns off the *B* eliminator, and turns on the trickle charger.

### PARTS REQUIRED FOR POWER PLANT

- 1—Thordarson Type 171 Power Compact.
- 1—Faradon Condenser Block, No. 3750  
8, 2, 2, 1, 1, .1, .1 mfd.
- 2—Clarostats.
- 4—Eby Binding Posts.
- 1—Na-Ald tube socket.
- 1—Aerovox 10,000 ohm lavite resistance with mounting.
- 1—Baseboard 10x13x½ in.
- 1—Bakelite strip 3x10x3/16 in.
- 1—Westinghouse Rectox Trickle Charger.
- 1—Jewell A-B Relay for 5 volt tubes.
- 1—Raytheon Type BH tube.

Fig. 6 shows the circuit arrangement of the complete outfit. The *B* eliminator consists of one of the new combined power transformer-choke coil units, mounted in one case, a condenser block containing all condensers needed in the circuit, a set of fixed and variable resistances, tube socket, and binding post strip. The diagram shows the connections required between the various pieces of apparatus. It is not necessary that the exact arrangement of parts shown in the picture be followed, as they can be mounted in any convenient manner to suit the individual needs of the user. The trickle charger is placed in the space between the condenser block and the terminal strip, with the attachment plug on the end of the lamp cord associated with the charger plugged into the side of the relay. The attachment plug for the *B* eliminator transformer is plugged into the other side of the relay, and the attachment plug connected to the relay is in turn plugged into the 110 volt a.c. circuit. The relay is equipped with two binding posts, one being connected to the positive *A* battery, and the other to the positive *A* terminal on the radio receiver. The d.c. resistance of the series winding of the relay is about 0.2 ohm, so that even with 1.5 amperes flowing through the relay, no series voltage drop due to the relay resistance will occur.

The adjustment of the trickle charger is permanent, so that it is connected to the *A* battery terminals, and needs no further attention. The *B* eliminator is provided with variable voltage taps for the 45 and 90 volt supply to the receiver, so that when connecting the power plant, the variable resistances should have their adjusting knobs unscrewed as far as they will go before the receiver is turned on. If a milliam-

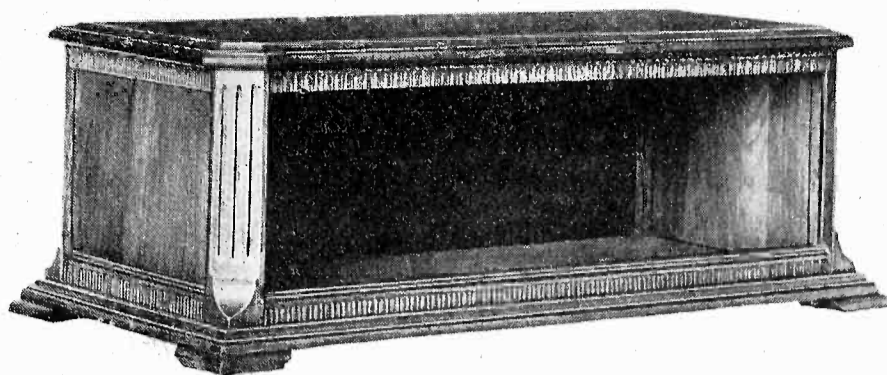

### A BEAUTIFUL CHEST CABINET

*Designed Especially To Take The —*

## Gerald Best's Quadrphase

*Constructed of Walnut with Embossed Mouldings around Top and Bottom. Finished in Hand-Rubber Lacquer.*

*Panel Size 7x21 inches. 10 inches deep inside.*

**PRICE \$21.50 NET**

F. O. B. LOS ANGELES

## A-1 WOODWORKING COMPANY

1332-1342 San Julian St., Los Angeles, Calif.

## LET US BRING YOUR



## UP-TO-DATE!

**W**E specialize on the DeLuxe Model of the Sargent-Rayment Infradyne. This receiver is acknowledged to be the outstanding set of the 1927 season. Our own experience with the set convinces us that it is destined to lead the radio field for many years to come. In our test laboratory we have received two Japanese Stations—JOAK and JOBK; 2BL in Sydney, Australia, as well as PWX, CZE, WBZ, WEAN, WNYC, WRNY, WGY and WJZ. Selectivity is razor-edged.

We guarantee to rebuild or service any Infradyne and make it the equal of our laboratory model. We have installed special laboratory test instruments to do this. Charges are reasonable. Send in your set and when you get it back all parts will be matched. It will be tested on DISTANCE and DIALS LOGGED for direct reading in wavelength.

**[NOTE]** When shipping the set, remove it from the cabinet and put in heavy carton or wooden box. If shipped in a box, screw the baseboard to the inside of the box. Ship by prepaid express.

**INFRADYNE  
KITS**

Containing only specified parts, each part laboratory-tested and matched to the others. Full instructions accompany each Kit. SARGENT-RAYMENT KIT, Complete

**\$118.00**

INFRADYNE BLUE PRINTS—\$1.00 per set, postpaid

## RADIO SERVICE COMPANY

357 TWELFTH STREET, OAKLAND, CALIFORNIA

## LEADING PUBLICATIONS

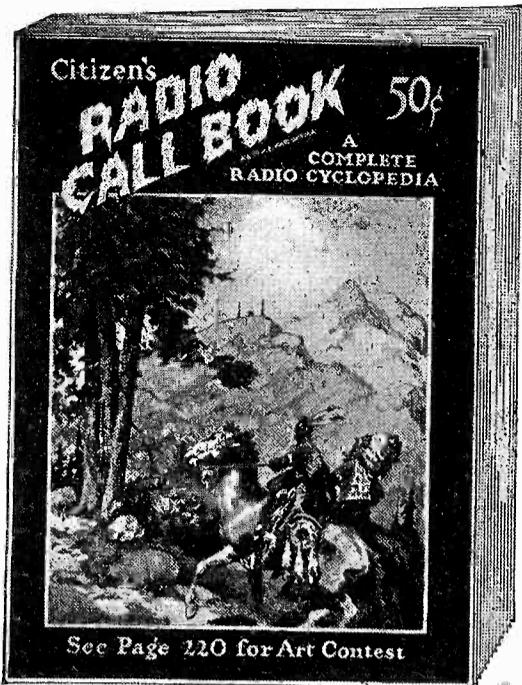

The CITIZENS RADIO CALL BOOK is Radio's Greatest Publication. Contains all the latest information of construction so simply told anyone can build superheterodynes as easily as laboratory men. Large section contains beautiful photos of leading station announcers and entertainers. Also contains the most complete list of the World's broadcasting stations—every one—their transmitting schedules, wavelengths, slogan and plenty of space under each to log that station for future reference. Really Radio's Greatest Publication. You'll be delighted.

Price only 50 cents postpaid

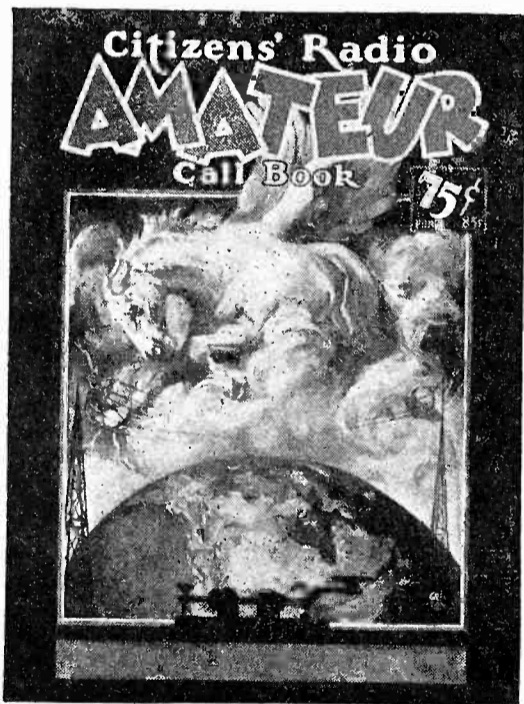

The CITIZENS RADIO AMATEUR CALL BOOK is an international list of call letters, names and addresses of the World's amateur transmitters. Compiled from official sources and the most authentic list obtainable anywhere. Remember, the whole World, U. S., Canada, Australia, France, Germany, etc. The whole international list. Also commercial ship and land stations.

Price only 75 cents postpaid

If you are unable to obtain either of the above mentioned publications from your news dealer or radio store, they will be sent postpaid upon receipt of the amount in U. S. stamps, coin, check, or P. O. money order.

**Citizen's Radio Call Book**  
500 S. Dearborn St. Chicago, Ill.

meter is available, place it in the 45 volt positive lead to the set, and screw in the 45 volt adjusting knob until the plate current is about 1.5 milliamperes. Now place the meter in the 90 volt positive lead, and with the volume control rheostat on full, the plate current should be about 10 to 12 milliamperes. With a type 112 power tube, and the full voltage of the B eliminator applied to its plate, from 10½ to 12 volts C battery will be required. The plate current should not exceed 10 or 12 milliamperes, or the life of the power tube will be shortened.

### DWELLER ON THE THRESHOLD (Continued from Page 14)

longed and singing sound, seemingly distant at first and approaching little by little until quite strong—violent thunder storm or tempest.

Lutze of Leipsic opened up a new field of observation when he used a balloon, and discovered that static decreased with height, but that it was more intense inside of a cloud than out.

The radiotelegraphic investigations of the Committee of the British Association revealed that static storms coincide with convective weather, rapid fluctuation of pressure and rapid movements of depressions. In Australia daytime rain is preceded by static in 80 per cent

of all cases; in Ireland static is bad with a northwest wind on the Atlantic Coast; while in Sierra Leone the periodic dry wind suppresses static.

C. J. DeGroot of the Institute of Radio Engineers of New York observed "clicks from near or distant lightning but of a range less than 900 kilometers; hiss, an intermittent direct current from the aerial, when low charged clouds are over the station; a continuous rattle, always present in the East Indies but unfamiliar in Europe." He ascribes the latter to a bombardment of the upper atmosphere by cosmic particles.

Culver of Philadelphia went into his observations more in detail, using a 14,000-meter wave length, with bent aeriols 100 ft. long and 15 ft. high directive to France, at several American stations. He found the following: pressure—no agreement, but static bad with an anticyclone off Newfoundland; wind—no agreement with direction but tendency for variation inverse to velocity; soil temperature—no conclusion; air temperature—audibility of static low when temperature at or above normal value; cloud—no relation save in thunderstorm; absolute humidity—no relation; relative humidity—audibility of static and relative humidity *directly related*; potential gradient—audibility

# RADIO ADS

A Classified Advertising Section Read by Better Buyers

8 cents per word, net. Remittance must accompany all advertisements. Include name and address when counting words.

Ads for May Issue must reach us by April 3rd

SHIP OP'S—Mignon 2500-24,000 meter receiver, \$18.50; Navy CN-113A, 300 to 2500 meters, \$14.50. Olson, 593 East 40th, N., Portland, Oregon.

THROW AWAY YOUR "A" BATTERY CLIPS. My terminals practically indestructible. Absolutely non-corroding. Seventy-five cents per pair, postpaid. Frank C. Jones, 3716 68th St., Southeast Portland, Oregon.

HAMS: QSL CARDS—Fast service. Two colors, postpaid. We send COD. Stock form: 100, \$1.10; 250, \$2.50; 500, \$4.25. To order: 100, \$1.50; 250, \$3.25; 500, \$5.00. KEY KLICKS PRESS, W. 1319 3rd Ave., Spokane, Wash.

FREE—Selective Crystal Set Hook-up. Enclose two cent postage stamp with request to California Radio Minerals, 904 Oak Grove Avenue, Burlingame, Calif.

A-1 CRYSTAL; guaranteed best crystal obtainable. Postpaid fifty cents each. Harry Grant, Jr., 904 Oak Grove Ave., Burlingame, Calif.

RADIO SCHOOL—Extension courses in practical radio offered for the radio repair man and the enthusiast. McKAY INSTRUMENT CO., 424r Morgan Bldg., Portland, Ore.

SEAGOING OPERATORS — Blueprint of two kilowatt spark converted to ICW and commercial radio traffic manual—only book of its kind in world. Both for one dollar. Howard S. Pyle, 1922 Transportation Building, Chicago. (TC)

DO YOU GET TIRED of buying "B" batteries? A lifetime Edison will solve your troubles. Good, live, large size elements connected with pure nickel wire, electrically welded, 7c pair. All parts for sale. Sample cell and dope sheet, 10c. Paul Mills, Woodburn, Oregon.

MAKE \$100 weekly in spare time. Sell what the public wants—long distance radio receiving sets. Two sales weekly pays \$100 profit. No big investment, no canvassing. Sharpe of Colorado made \$955 in one month. Representatives wanted at once. This plan is sweeping the country—write today before your county is gone. OZARKA, Inc., 431 N. LaSalle Ave. B, Chicago.

SET BUILDERS—We furnish jobs for you. (No fee) Competent men needed today in every community to build LC-27, Hammarlund-Roberts, Ultradyne, Loftin-White and Browning-Drake sets. Big money for you if you can qualify. Register NOW, giving particulars, experience, references. Allen-Rogers, Inc., 118 E. 28th, New York City.

SHORT AND LONG WAVE RECEIVERS Calibrated in WAVELENGTHS. Gerald M. Best and D. B. McGown will do this for you in the new laboratory of "RADIO" magazine. Ship your set to us and we will log the dials in wavelengths. The price for this work is only \$2.50 for a complete calibration. "RADIO," Pacific Bldg., San Francisco, Calif.

VIBROPLEX and Albright semi-automatic transmitters. Will sell used machines in good condition that have been taken in from railroad and telegraph companies for \$9.00 each postpaid in United States. Send remittance with order. K. N. Ford, 1411½ Alta Vista Blvd., Hollywood, Calif.

HOW IS YOUR RADIO SET WORKING? Send us your set parcel post prepaid and we will test it FREE. We furnish you a written report describing felt faults found and the cost of remedying them. Your set is held until you pass on our report. McKAY INSTRUMENT CO., 424r Morgan Building, Portland, Ore.

low with high positive potential gradient; no conclusion in the new negative gradients examined. Static bad when recorded potential gradient is fluctuating rapidly. Terrestrial magnetism—static found to be directly related to H. and V. Solar constant—inverse relation.

Esau of Berlin has discovered that one type of static impulse begins at sunrise, reaches a peak in the afternoon, and dies away at sunset, to be replaced with another type of static which begins shortly after sundown, reaches a peak at midnight or later, and in turn dies at sunrise.

Perhaps the most elaborate classification of static has been made by K. Stoye of Berlin in the plains of the upper Rhineland, using wave lengths of from 600 to 2000 meters, or as we would designate it here, from spark to arc transmission bands. He classifies static into ten groups, all of them meteorological in nature. They are: (1) Prevailing weather type—a whistling sound; (2) Mist type—a weak hissing sound; (3) Cloud break-up type—repeated groups in the form of explosive crashes; (4) Cirrus type—"t-r-r-r-ta-s-s-s;" (5) Lightning type—"r-r-r-r-r-ssss;" (6) Front type—squally wind; creaks like a revolving clapper; (7) Cumulus development type—short, single sharp cracks; (8) Thunderstorm cumulus type—sharp cracks of different lengths coming in groups; (9) Sunrise type—violent rattling and scratching of longer duration but not in group form; (10) Sunset type—super position of (3), (9) and other types, partly due to surface cooling and condensation and partly to cloud break-up.

When Michael Pupin retired as president of the American Society for the Advancement of Science last year, he reviewed fifty years of progress in electrical communication between human beings. In his consideration of static he found it to be not merely a disturbance which annoys the clumsy methods of human operators, but, in all probability, messages transmitted to us by cosmic activities.

This then, a rough compilation of some of the most important researches that have been carried on in various parts of the world in regard to Kid Static, the clown of the electrical world, an elf of a thousand faces and many forms, a playfellow gamboling down the wind, darting behind the rolling mists, and hurtling through the storm, its voice mocking those who would learn its identity.

Wherefore, with a certain grim authority, Uncle Sam has named at least the winter home of the "Dweller on the Threshold" providing an emphatic clue to some of its vagaries that may lead to the revelation of its true identity in the days to come.

## GET \$1 DISTANCE

**Amazing Discovery For Any Radio**

Why confine your radio programs to a few local stations when the expensive concerts, dance music and lectures of hundreds of big cities are ready for you? With every order for our treatise, "The Distance Getter," we include FREE our wonderful new Distance Transformer. Tune your set according to our special instructions and presto—the distant stations roll in!

**SATISFACTION GUARANTEED**

Your money instantly refunded if you are not satisfied. The attachment furnished FREE with the "Distance Getter" alone is worth the price. Galloway of Chicago writes: "Results beyond all expectations. Cut through locals like a knife." Homes of Palos, Ill., says: "Send three more for my friends. I get Denver and California easily."



**MAIL COUPON TODAY**

**Hazleton Laboratories,**  
4554 Maiden St., Dept 15, 101  
Chicago, Ill.

Send me "The Distance Getter" postpaid. Inclosed find \$1 (M. O., stamps or check).

Send C. O. D., plus small postage added.

Name.....

Address.....

City..... State.....

### Intermediate Transformers MATCHED

Let Gerald Best and D. B. McGown match and "peak" the intermediate transformers for your super. Proper fixed condensers will be attached. This entire service for \$2.50.

Laboratory of "RADIO," San Francisco

## Lowest Wholesale Prices!

### ULTIMAX KITS NOW READY FOR DELIVERY

Madison Multi-Chokes, Cockaday LC-27, R. B. Lab., Hammarlund-Roberts, Alden Tru-phonic, Amer-Tran Power Packs, LR-4, In-fradyne, Benjamin Controlladyne Kits in stock.

**JOBBER-DEALERS  
PROFESSIONAL SET BUILDERS**

Before buying, get our quotations on our Guaranteed Kits. 3-Hour Shipping Service.

**1927 BUYING GUIDE**

A few copies left for Dealers and Professional Set Builders. Send for yours today. It's free! Address Dept. R.

We are the exclusive direct representatives of the Committee of 21 Manufacturers.

## Allen-Rogers

Incorporated

"Kit Headquarters"

118 East 28th St., New York, N.Y.

## WAVE METERS CALIBRATED

Send your wavemeters to us for accurate calibration. Our equipment for this work is second to none. Price for calibration is \$2.50. Ship your meters to Laboratory of "RADIO," 435 Pacific Bldg., San Francisco.

## HAMMARLUND Precision CONDENSERS For Every Purpose

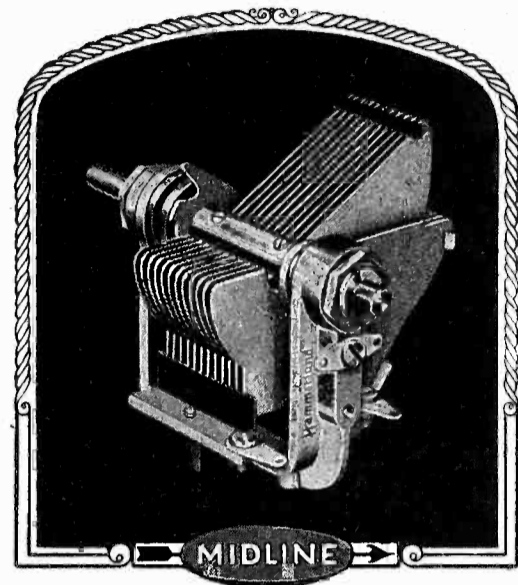

ASK any radio engineer his opinion of Hammarlund Condensers. He knows and will tell you that their quality of workmanship and efficiency of performance are unexcelled.

The Hammarlund "Midline" Condenser is designed to adequately separate stations on all broadcast wave-lengths. It is very compact, measuring only four inches with plates fully open.

It has a full-floating rotor with removable shaft. By substituting a longer shaft, two or more condensers can be coupled in tandem, or any other scheme of single-control, multiple-condenser operation can be successfully arranged.

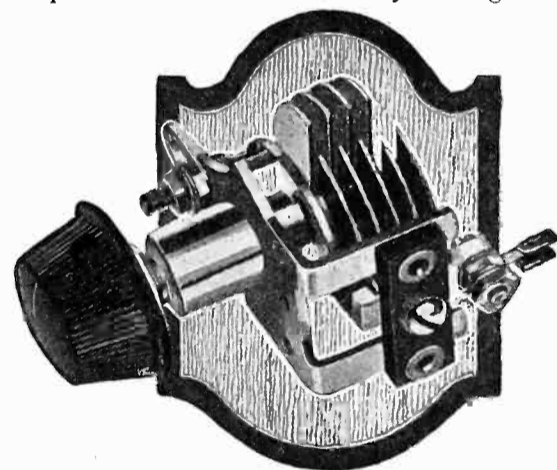

"Hammarlund, Jr." is a high-ratio, shielded midget condenser for neutralizing purposes, balancing multi-tuned circuits, or as a vernier. It has every quality characteristic of the larger Hammarlund models and is designed for either baseboard or one-hole panel mounting. Bakelite Knob is supplied, but any other dial may be substituted, as the shaft is standard size.

Twenty-eight leading radio designers officially specify Hammarlund Products for their newest circuits. If your dealer cannot supply you, write to us.

**HAMMARLUND MFG. CO.**  
424-438 W. 33rd Street, New York City



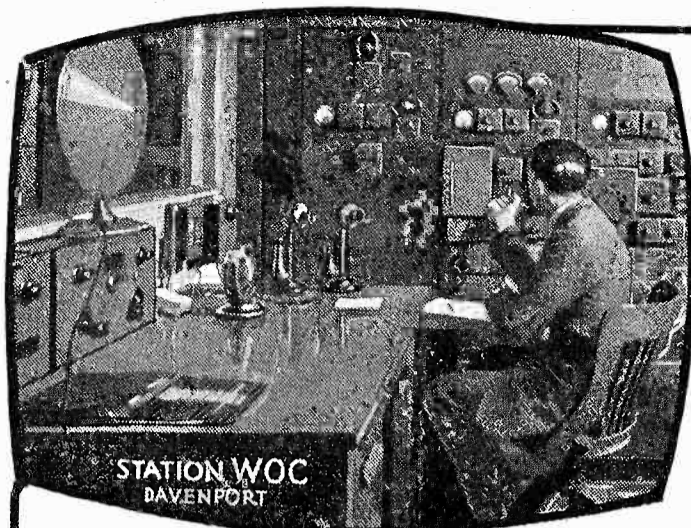

**HERE'S WORK THAT IS ALMOST ROMANCE!**

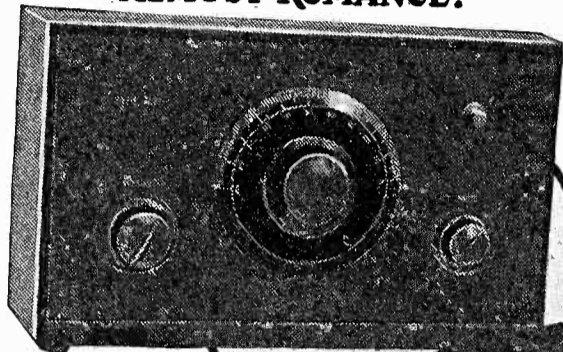

**These Instruments Given FREE of Extra Cost**

All instruments shown here and others sent to all my students free of extra cost under special offer. Clip coupon now—find out all about this big unequalled offer while you still have time to take advantage of it. This training is intensely practical—these instruments help you do the practical work.

**My Radio Training is the "Famous Course That Pays for Itself"**

● Make more money quick when you take up this practical course.



**\$70 in one Day for T. M. Wilcox**

"I am in business for myself and recently made \$70 in one day. I was an electrician of rich experience and was occupying a splendid position as telephone superintendent when I enrolled with your course believing it would open up greater opportunities—have not been disappointed. Estimate that Radio will be worth tens of thousands of dollars to me in the next few years." T. M. Wilcox, Belle Island, Newfoundland.

I show you how to increase your earnings almost from the start of your course through practical pointers I give you.

**Howard B. Luce of Friedens, Pa., made \$320 in 7 weeks during his spare time.** D. H. Suitt of Newport, Ark., writes "While taking the course I earned in spare time work approximately \$900." Earl Wright of Omaha reports making \$400 in a short time while taking his course—working at Radio in his spare time only! Sylvester Senso, 207 Elm St., Kaukana, Wis., made \$500. These records not unusual—these men are a few of hundreds.

And when you graduate, my big Free Employment Department helps you get the job. You get just the same preparation and assistance toward success we gave C. C. Gielow, Chief Operator of the Great Lakes Radio Telegraph Co., E. W. Novy, Chief Operator of Station WRNY, Erle Chambers, Radio Engineer for Stewart-Warner, J. E. Fetzer, Chief Engineer of Station WEMC. The National Radio Institute, established 1914, today offers you the same opportunity these men had under a contract that pledges you full satisfaction or money refunded on completing our training. It's your big chance to get into the great Radio field—Mail coupon TO-DAY for my big Free Book and proof

**Originators of Radio Home-Study Training**



**Kimball With WMAQ Chicago**

"Accepted a position with the Chicago Daily News Station WMAQ. My income practically doubled, thanks to your fine course. I handle all consultation also do operating." Keith Kimball, Station WMAQ, Chicago, Ill.

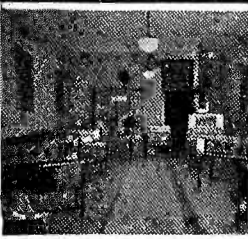

**Promoted to Big Job**

"Just been made Sales Manager of this Radio firm—received a very good increase in pay. Up to present have been getting salary which in 3 months enabled me to purchase a new car." R. Jones, Bay City Mich.

**Now Owns a Radio Store**

"The Radio business is rushing just now. Building many Super Heterodynes, also doing installation and repairing. To your course I owe all my success in the Radio profession." A. J. Ommodt, Bowman, N. Dak.



**Controls First Car by Radio**

"I operate the portable broadcasting station in rear car, driving front car by Radio control. Will operate this car from New York to Frisco—13 months trip. Then we take the car around the world—a three years' tour. I owe it all to you." Leo Paul, New York City.

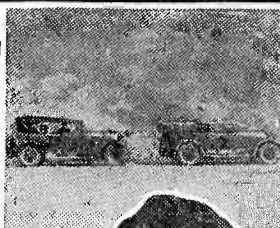

# You Can Do What These Men Did!

## I Will Train You at Home to Fill a Big-Pay Radio Job

Get into the great new Big-pay Industry—Radio. If you're earning a penny less than \$50 a week, clip coupon now. Send for AMAZING FREE BOOK, "Rich Rewards in Radio." Why go along at \$25 or \$35 or \$45 a week when many are now earning \$50 to \$250 in the same six days as a Radio Expert? Hundreds of N. R. I. trained men are doing it—why can't you? I'll train you just as I trained them—just as I trained the men whose letters you see on this page. I'll teach you quickly at home in your spare time to be an expert in Radio, the Easy, Fascinating Big Money field.

### Big Jobs Go to the Trained Expert

It's the thoroughly trained man who gets the big jobs of this profession—paying \$75, \$100, \$200 a week and up. Free book gives all the facts. Hundreds of N. R. I. men are to-day holding down good, big jobs in the Radio field. Men like you—men like those whose stories I show you here. You can prepare just as they did by new practical methods, learn right at home in your spare time. Lack of experience no drawback—common schooling all you need. Our tested clear methods make it easy for you. Our years of experience in the big field of Radio means that we can train you as we have done thousands of others.

**Clip Coupon Now for FREE BOOK**

Most amazing book on Radio ever written—full of facts and pictures—tells all about the great Radio field, how we prepare you and help you start. You can do what others have done—GET THIS BOOK. Send coupon today—no obligation.

J. E. Smith, Pres.  
NATIONAL RADIO INSTITUTE  
Dept. CB-5  
Washington, D. C.

Read the true stories printed in this border of men who got out of the rut



**Chief Engineer Station WEMC**

"Please communicate with my two junior operators here who want to increase their knowledge of Radio. Being a graduate of your course I know they could do nothing better for themselves than study it for it is the way to success in this profession." John E. Fetzer, Chief Engineer, Station WEMC, Berrien Springs, Michigan.



Photo shows Graduate E. F. Spadoni in his own Radio store at Chicago, Ill. "Your course gets the credit," says Spadoni.

**RADIO NEEDS TRAINED MEN!**



**J. E. Smith, President NATIONAL RADIO INSTITUTE**  
Dept. D 5, Washington, D. C.

Dear Mr. Smith: Without obligating me in anyway, send me your free book "Rich Rewards in Radio" and all information about your practical, home-study Radio course.

Name..... Age.....

Street Address.....

Town..... State.....

Tell them that you saw it in RADIO