

RADIO

VOLUME VII

NOVEMBER, 1925

No. 11

Radiatorial Comment

THE "hands off" policy of the government has been largely responsible for the rapid development of radio in the United States. This is in marked contrast to the restrictions imposed in other countries. Consequently there are almost as many amateurs and radiocast stations in the United States alone as in the rest of the world.

Results to date have more than justified Secretary Hoover's policy of a self-regulating industry. The annual advisory conferences of radio representatives have given his department the benefit of the views of all branches of the industry. What adjustments as have been necessary to settle disputes have been agreed upon in open meeting and have been accepted as the basis for the department's rulings.

The chief point of discussion has been the allocation of wavelength bands for the various classes of service. During the past three years this has become increasingly difficult because of the expanding needs of radiocast stations. They have already encroached upon the space previously assigned for ship and amateur purposes. But notwithstanding that within four years their allocation has been increased from a single 360 meter wavelength to the great band extending from 200 to 545 meters, there is not enough room to take care of those who have been licensed, to say nothing of new stations desiring space.

Meanwhile the department has been functioning under laws passed in 1912, long before radiocasting and other modern inventions had been developed. The existing laws do not provide for the suppression of man-made static nor can motor-driven ships be compelled to carry radio equipment, simply because the law designates steamships. It has frequently been necessary to make rulings whose strict legality may have been questioned. But be it to the credit of the radio industry that the justice, if not the legality, of the decisions has always been recognized and conformed to.

While it has been possible to thus "get by" with voluntary self-regulation during radio's infancy, it has now grown to be such a sturdy youth that some stronger method of control seems necessary to protect the public interest. Since radio has reached the dignity of public service, the interest of the public becomes paramount to the private interests of those engaged in the art.

The private interests will naturally object to stricter regulation, just as other public utilities originally objected to the establishment of public service commissions. But now there is hardly a gas, electric power or railway company that

would prefer to go back to the old days of free-for-all competition. Likewise it is to be hoped that all radio interests will realize the compensating advantages of regulation.

History shows that whenever established law and order has not been strong enough to handle a bad situation, some sort of a vigilante committee has adopted drastic measures to accomplish what it deems right. This always establishes a dangerous precedent and too often is subversive to the public interest. Surely no one wants a vigilante committee in radio!

Consequently the outstanding discussions at the next radio conference will undoubtedly revolve around the question of what kind of regulation will be most effective and practical. Will it be sufficient, for instance, to rely upon a station's recognition of the fact that its success is dependent upon the maintenance of public good will? Should a radio service commission be established? Or should greater regulatory power be vested in the Department of Commerce?

In view of the evident and commendatory hesitancy of Secretary Hoover to ask for arbitrary power so as to handle the situation, it may be well for the radio industry to follow the lead of the baseball and movie man when they feared the loss of public good will. Judge Landis and Will Hayes have done much to inspire public confidence. Certainly Secretary Hoover or Judge Davis could do likewise for radio, if either could be induced to relinquish his present broader duties.

Such men, with suitable assistants in various parts of the country, could determine whether a station is giving sufficient service to the public to justify the continued use of the wavelength assigned to it. This implies the setting of standards as to power, location, broadness of wave, and particularly as to character of program, which might even limit religious and other forms of publicity. It would involve a censorship which is inconsistent with and abhorrent to governmental supervision, but which could be tolerated if the standards were determined in accordance with a good sense of the stations themselves.

It is neither our intent nor our province to say which one of these or other suggested methods is the best. Any one of them is better than the present functioning under obsolete laws. But some means should be speedily adopted to protect the interests of the public and thereby increase public interest in radio. This is a real task for the radio conference.

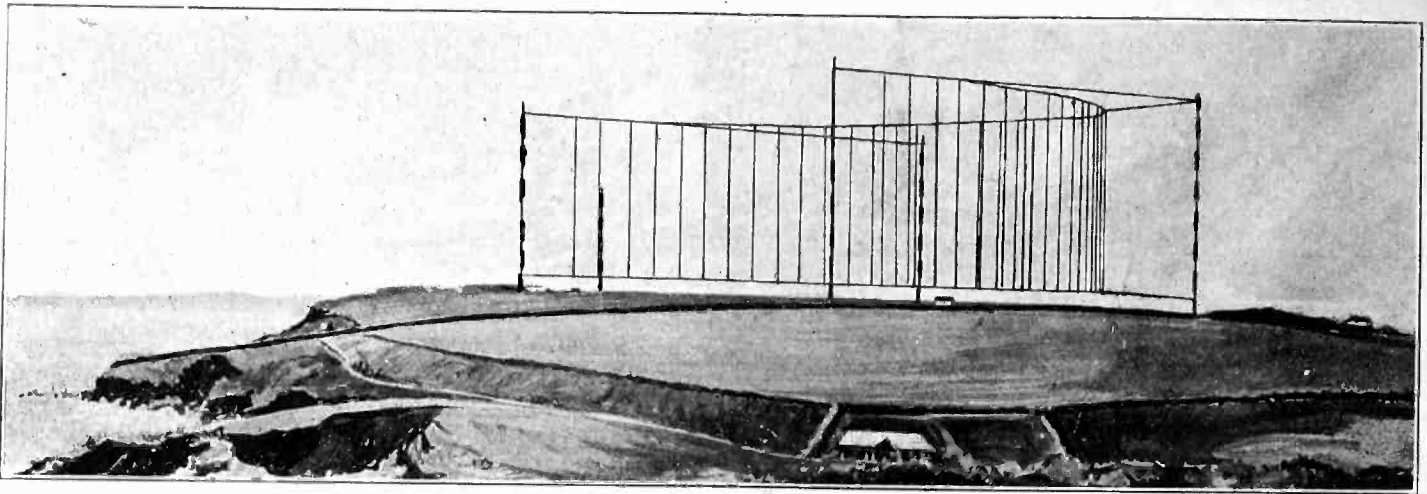

Fig. 4. Marconi Beam Station, Poldhu, England.

Marconi Radio Beams

An Authoritative Description of This New Means Which May Revolutionize Transmitting Methods

By H. de A. Donisthorpe

BEFORE describing the essential features of the Radio Beam it is perhaps advisable to briefly review the more important factors governing the propagation of electrical waves as connected with the existing methods of radio telegraphic and telephonic transmission. These waves are radiated from an aerial so as to spread out simultaneously in every direction, their energy being dispersed more and more widely as they travel further from their source. Consequently only a very small proportion of the energy transmitted from the antenna is intercepted by the intended radio receiving station.

Going still further, it will easily be seen that the waves from such a transmitter can be picked up by any number of receiving stations for which they are not intended, in fact by an unlimited number of receiving stations providing they lie within the range of that transmitter. It follows naturally that a much greater amount of energy must be radiated from the transmitter than is really required in order to operate any one receiver. All the existing radio telegraphic stations are rapidly producing a congested ether and it is only a matter of time before a saturation point is reached when no further stations can be erected as the interference will be too great to allow of useful working.

Luckily the advent of radio beams will go a long way towards eliminating unnecessary interference and a regular system has already been worked out whereby the outlying dominions of the British Empire will soon be linked up with the mother country by means of these beams. It therefore seems very

likely that these beams will cause the existing high power long distance range stations to become obsolete within the next ten years.

The radio beam is nothing more than a concentration of electrical waves in one direction, this being accomplished by means of special reflectors. In this manner the whole energy from a transmitting station can be directed into a beam of not more than 15 degrees convergency and can be intercepted only by receiving stations lying within the arc of

that beam. Compare for a moment this new method of radio transmission with that of the old, by referring to Fig. 1.

The outstanding advantages of the beam can be immediately appreciated; for example, there is a minimum amount of interference caused, together with an enormous saving in radiated energy, because with the beam there is no waste due to waves being radiated out in directions other than that towards the intended receiver. In the case of the existing transmitting systems as has been pointed

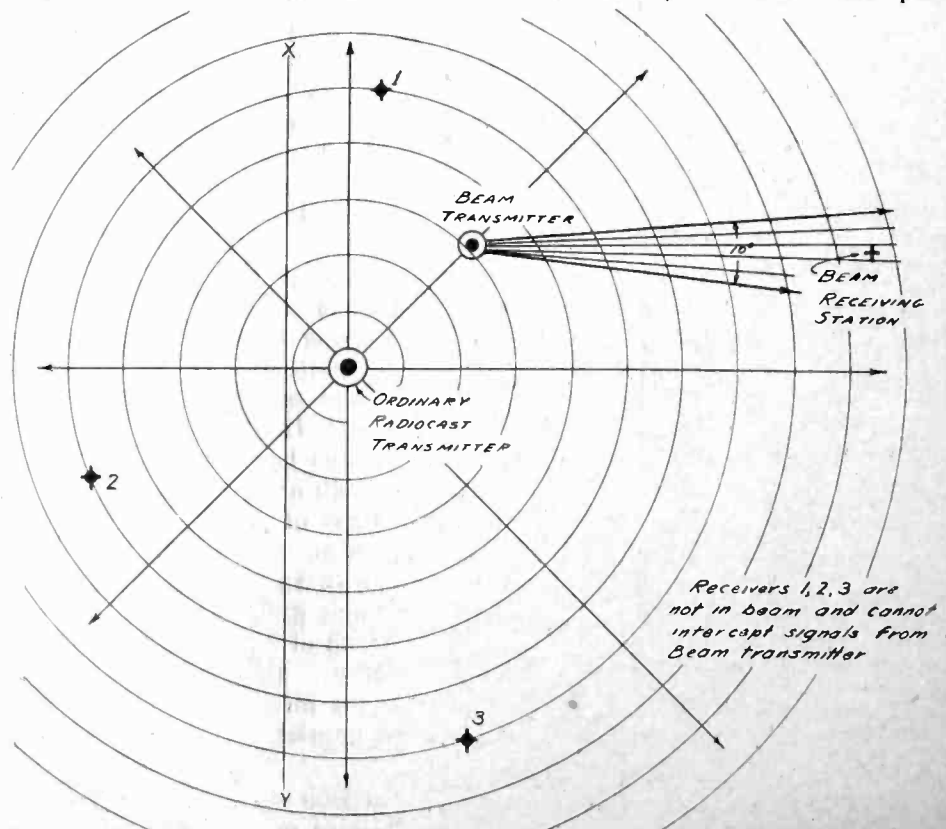

Fig. 1. Selectivity Comparison of Ordinary and of Beam Transmitter.

out before, the waves are thrown out in every direction like those surface waves produced by a stone striking the surface of a pond.

The immediate result of this saving of electrical energy is reflected in the initial outlay and maintenance costs of a transmitting station. Later on in this article, by reference to figures, it will be shown arithmetically how the beam station compares in efficiency with a station broadcasting its waves.

It must not be thought that these beams are something quite new, as Marconi, in the very early days of his radio experiments, discovered that electromagnetic waves like those of light could be reflected. It will perhaps be of interest to study these early experiments, firstly, because of their historic interest and secondly, because they are closely allied with the modern methods.

The apparatus and circuits employed by Marconi in his original beam work are shown in Fig. 2. Here the waves were reflected by means of metal reflectors of the shape shown, the waves being produced by a spark coil through the aid of the electrical oscillator, the spark gap of which was placed in the line of the focus of the reflector.

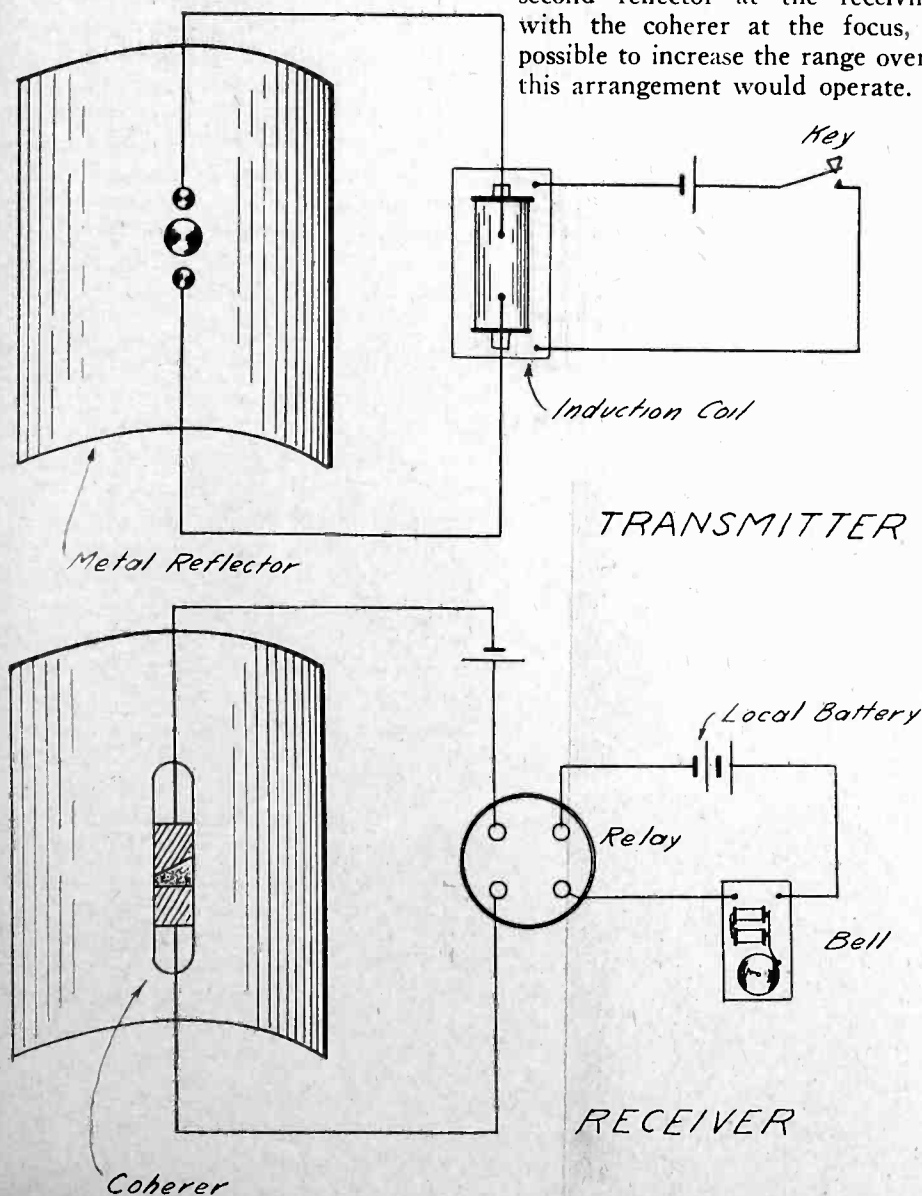

Fig. 2. Marconi's Early Beam Apparatus.

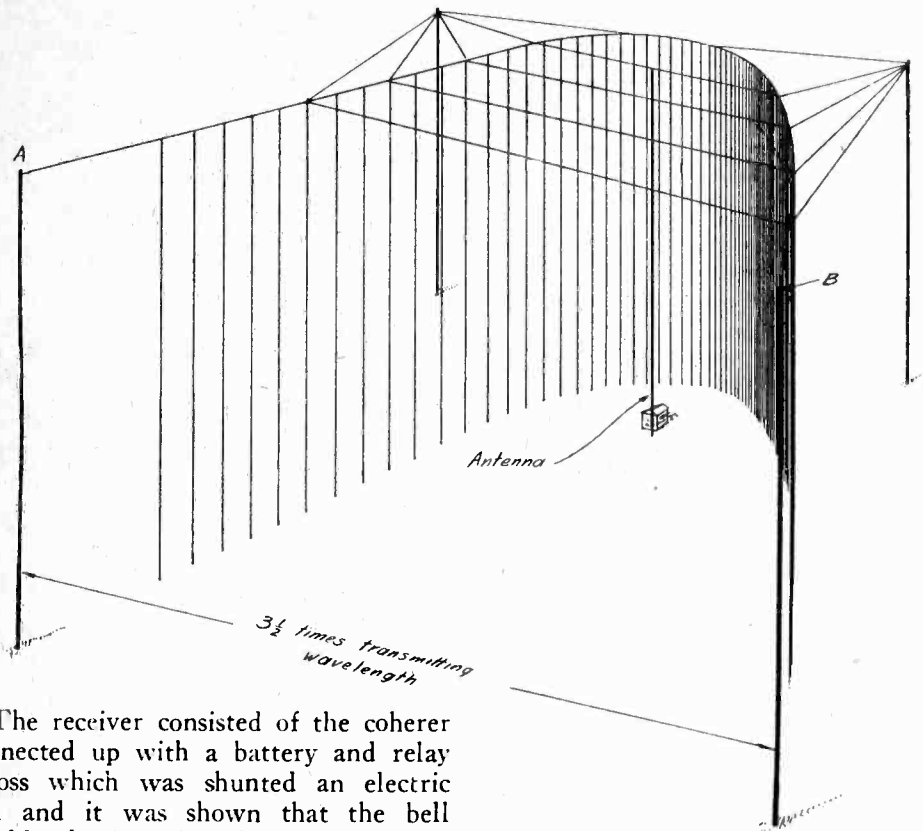

Fig. 3. Parabolic Reflector.

The receiver consisted of the coherer connected up with a battery and relay across which was shunted an electric bell and it was shown that the bell would only ring when the aperture of the transmitter's reflector was directed towards the receiver. By establishing a second reflector at the receiving end with the coherer at the focus, it was possible to increase the range over which this arrangement would operate.

These experiments however, proved that only electro-magnetic waves of a very small wavelength could be used if the reflectors were to be anything like a practical size and in those early days of radio, short waves were very hard to produce owing to the type of apparatus then available.

The advent of the thermionic tube and its use for the production of electro-magnetic waves solved this last named difficulty and consequently, during 1916 Marconi once again turned his thoughts toward his old experiments, having in mind an idea for using these beams for certain war purposes. The inventor was impressed with the possibilities such a system of radio telegraphy would afford in arresting the tapping of messages by the enemy. This idea will become apparent by referring to Fig. 1, once again, assuming that the enemy receiving stations lie on the left of the line XY. From that year until now, continual experimental work has been carried on, and not without avail, for some astounding results have been obtained.

It is not the intention of the author to discuss the methods of producing electric waves of short wavelengths as these follow those of ordinary radio transmitters and are doubtless known to all, so the remainder of this article will be devoted to the description of the present day methods of reflecting electro-magnetic waves, and to the results of their work.

The first type of reflector used in recent work is shown in Fig. 3. It will be seen that the reflector in this instance consists of a number of vertical wires

placed parallel to the antenna, and spaced around it on a parabolic curve of which the antenna constitutes the focal line.

The wires which comprise the reflector are all tuned to the electrical wavelength of the wave which is to be transmitted. The size of the aperture of the reflector is also an important factor and to give the best directional effects it has been found that the distance between the two ends of the reflectors *A* and *B* must be equal to $3\frac{1}{2}$ wavelengths of the wave transmitted. With regard to the first named condition it is not necessary for the reflector wires to be tuned to the transmitted wave if their length is an undesirable or unpracticable one as a suitably proportioned length will also produce good directional results.

Fig. 4 shows a picture of an actual parabolic beam reflector as has been erected at Poldhu in Cornwall, England. This station has been used in all the recent experiments with radio beams and worked in conjunction with Marconi's yacht the *S. Y. Electra*, on which was installed the receiver.

With the results given by this reflector the great value of the beam became apparent, as it was found by measurements that the value of the energy received on the yacht was two hundred times greater than that which could be received from that transmitted without the aid of the parabolic reflector.

Translating this fact into practical figures shows that results can be obtained from a beam transmitter with a power of 0.1 kw. which will be equal

in strength to those produced by the waves emanating from an ordinary non-directional 20 kw. transmitter.

These experiments were carried out with a 97 meter undamped or continuous wave. The actual transmitter utilized eight transmitting tubes all connected in parallel so as to dissipate some 12 kw. The antenna radiation from this arrangement was approximately 9 kw. If an ordinary station has been erected to give the same results at an equal distance away from it, the transmitter would have had to be designed to accommodate 120 kw.; a startling difference in power but nevertheless true.

The receiving antenna on the yacht throughout these experiments consisted of a vertical wire 20 meters in length above sea level. This antenna was connected to the usual type of inductively coupled receiver with two stages of tuned radio frequency and auto-heterodyning detector tube circuit; an optional two stage amplifier was also included.

Before passing on to the very latest form of reflector it will perhaps be of

interest to dwell a moment on the results of the experiments carried out between the Poldhu station and the *Electra*. Throughout the cruise of the yacht wonderful signals were received during the night for long distances with only 12 kw. from the transmitter, although at times the receiving was carried out under adverse conditions. The signals during the day, however, were found to weaken and disappear at definite times according to the distance from the transmitter and depending on the altitude of the sun at the site of transmission and reception. But it was found that a reliable commercial radio-telegraphic service could be efficiently carried out for a large portion of the twenty-four hours covering distances up to 2300 miles using only 1 kw. of energy in the transmitting antenna.

Since this early form of reflector a further type has been evolved which is undoubtedly more practical from a constructional point of view and this is known as the flat type of reflector. This new reflector, together with the anten-

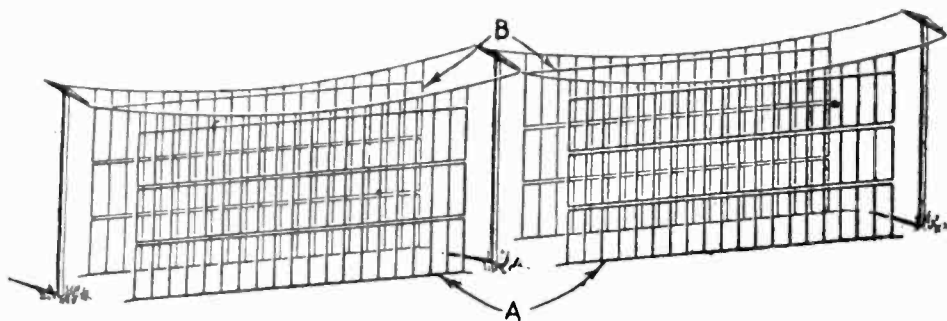

Fig. 5. Latest Form of Antenna and Reflector.

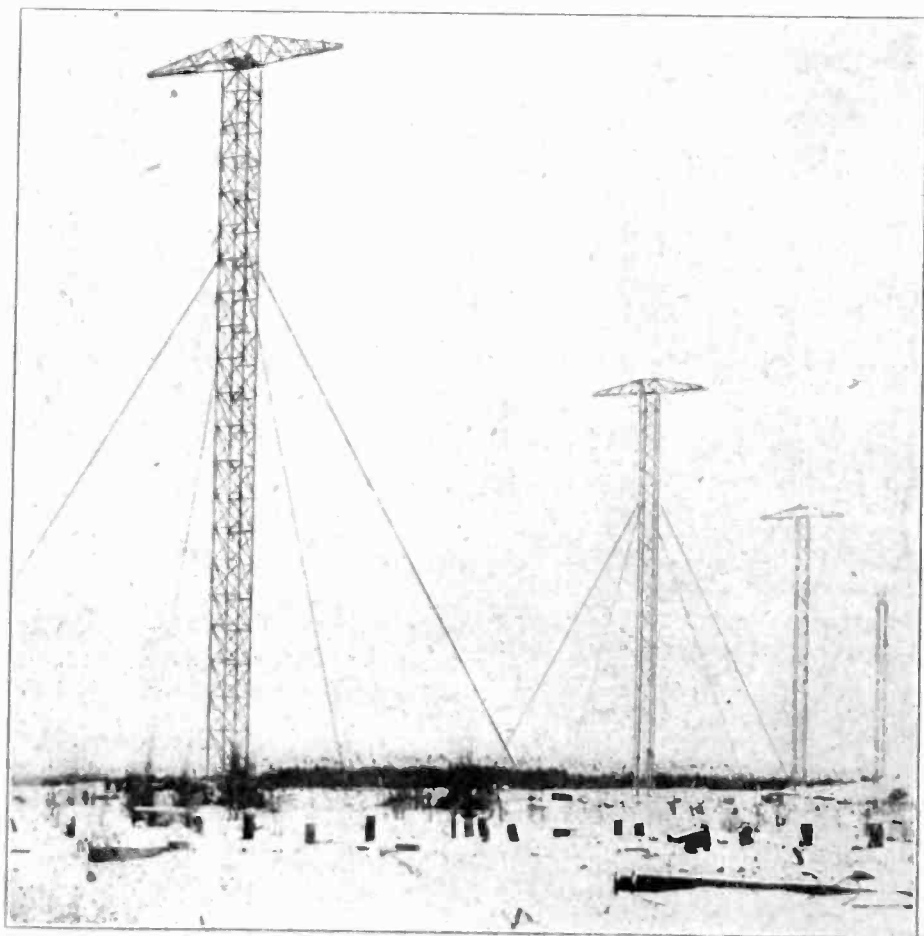

Fig. 6. Beam Station Masts Erected in Canada for a Flat Reflector.

na, is illustrated in Fig. 5. Here *A* represents the actual antenna whilst *B* represents the reflector. The former consists of a series of vertical wires which may or may not be connected together by horizontal wires and constitutes an antenna of most marked bi-directional properties at right angles to its plane. This type of antenna approximates as near as possible to a uniform current short circuit in which the current is everywhere maintained at the same relative value, by feeding it simultaneously at a number of points by means of a special feeding system from the actual transmitter. The directional property of the energy radiated from such an antenna is a function of its dimensions relative to the wavelength, which necessitates careful calculation in its design.

By placing a similar arrangement behind this antenna of wires the directional property of the same is made unidirectional and becomes the reflector. In order that this effect may become apparent it has been found essential for the distance between the antenna and the reflector to be equal to one quarter of the wavelength transmitted.

(Continued on Page 62)

Short Wave Reflectors

Detailed Directions for Constructing a Parabolic Reflector for Increasing the Range of Amateur Transmission

By Roy C. Hunter

SINCE the opening of the extremely short wavelengths for amateur use, directed waves, or beam transmission by the use of reflectors, has come into important notice. The fact that radio waves could be reflected has been known for a long time, but until Marconi performed his experiments with the use of parabolic reflectors nothing very definite was known.

Due to the large size of reflectors designed to be used on wavelengths over 10 meters it is not practical for the amateur to construct a revolving reflector for use with wavelengths greater than these. The 5 meter band makes it possible to construct a moderate sized reflector but it is still too large to be placed in the amateur's lab. The recent opening of the $\frac{3}{4}$ meter band makes it possible to construct a reflector that can be placed in the laboratory without taking up much space.

This band is practically unexplored. It is a great deal harder to get a tube to oscillate on this extremely low wavelength than it is on the higher wavelengths. If the knowledge that has been found on the 5 meter band and below is applied it should be possible to get one or two five watt tubes to oscillate on this wavelength without much trouble. With the use of a properly designed reflector for both transmitting and receiving the efficiency of these low powered short wavelengths may be multiplied many times. The reflector to be described here is designed to operate on $\frac{3}{4}$ meter. However, instructions are given whereby almost any sized reflector may be built.

The so-called $\frac{3}{4}$ meter band extends from 400,000 kilocycles (equaling .7496 meters) to 401,000 kilocycles (equaling .7477 meters). This band is large enough for one hundred radiocasting stations to operate without interference and yet the difference between the wavelengths of two adjacent stations would be only .00077 in. and the difference between the wavelengths of the highest and the lowest would be only .077 in. or less than $\frac{1}{12}$ in. So you can get an idea of the difficulty of designing instruments for use of these wavelengths. We have a great deal more to learn before we will have the same efficiency on these wavelengths as we have on the radiocast wavelengths.

The reflector to be described is shown

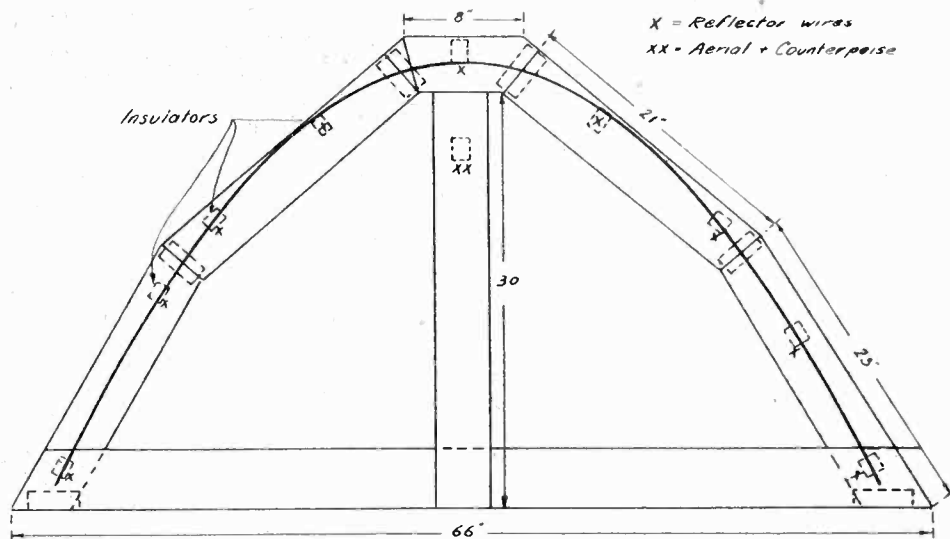

Fig. 1. Plan of Parabolic Reflector.

in Fig. 1. It is formed by a number of vertical wires fixed in the shape of a parabola. Each wire is supported at its ends by insulators. The length of the wires may be $1, \frac{1}{2}$ or $\frac{1}{4}$ the length of the wave to be transmitted. For practical use the wires are made slightly shorter to compensate for the capacity effect between wires, which causes a higher wavelength. The aerial and counterpoise is one length of wire the same length as the reflector wires. A small loop is made in the center for coupling to the transmitter. The aerial and counterpoise are mounted vertically in the focus of the parabola.

Probably the best length for the vertical wires is slightly less than one-half

wavelength, at least it is more handy and economical. The closer the wires the sharper the beam of energy transmitted, which is to be desired, but at the same time allows part of the energy to escape out of the back, called back leakage. The longer the sides of the parabola the sharper the beam. The best reflector then is one with moderate spacing of the wires and with the sides extended. This would give practically no back leakage and a very narrow beam. With these instructions reflectors for most any wavelength can be designed.

How to lay out the parabola is shown in Fig. 2. Say the parabola is to be used as a reflector for wavelengths of $\frac{3}{4}$ meters. The English equivalent of

(Continued on Page 94)

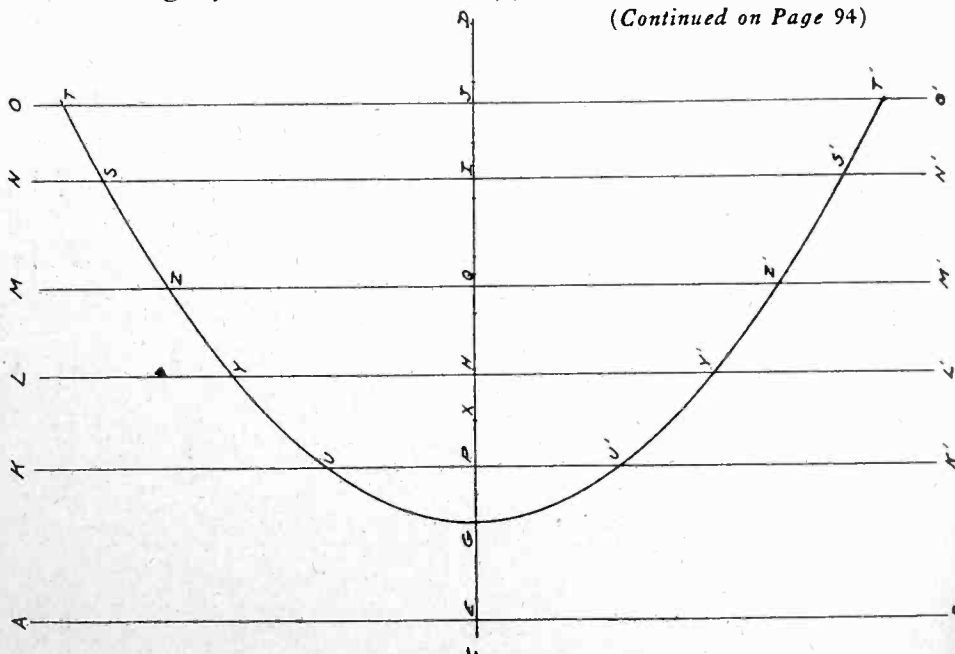

Fig. 2. Construction of Parabola.

A Universal Radio Frequency Amplifier

Adapted for Use With Any Standard Receiver and Employing a New Method for Preventing Oscillations

By A. J. Haynes

THERE is always a demand for an easily constructed and efficient radio frequency amplifier unit which may be connected ahead of any standard receiving set. Many have attempted the construction of such unit, but few have succeeded due to carelessness in design and lack of attention to details.

Tuned r. f. amplification at comparatively low wavelengths requires careful work in assembly and selection of apparatus. Among the rules which must necessarily be followed is to maintain a high ratio of inductance to capacity, in the tuning controls, and to employ a low capacity tuning condenser having a high minimum to maximum capacity ratio. The amplifier must have a method of coupling to the receiving set tuner whereby the amplifier is independent of the type of circuit used in the receiver, and can be used with any set.

Such an amplifier is shown in the pictures, and the schematic diagram shown in Fig. 1 will give the reader an idea of the arrangement of apparatus. In the output of the r. f. tube circuit the r. f. and d. c. currents are divided, the B battery being fed directly to the plate through a choke coil, while the r. f. component in this circuit, being blocked by the choke coil, passes through the .002 coupling condenser to the primary winding of the detector circuit.

This is not the only function, however, which the choke coil fulfills. The circuit makes use of a principle which, as far as I know, is new in r. f. amplification. Without going into technical explanations it can be seen that the small r. f. choke through which the B battery is fed to the plate of the radio frequency tube is tuned to some natural resonant frequency, in this case approximately 550 meters. This choke is purposely designed to have a broad tuning characteristic.

By properly proportioning the capacity of the coupling or blocking condenser between the r. f. and detector tubes together with the inductive coupling between the primary and secondary of the r. f. transformer the following condition can be attained: On the high wavelengths, where the r. f. choke is effective, practically all of the r. f. current passes through the primary of the r. f. transformer which results in a maximum coupling between the two tubes.

As the received wavelength decreases, instead of this inter-tube coupling increasing with the frequency, which is the case in the usual tuned r. f. circuits, more and more of the r. f. energy is shunted through the r. f. choke which becomes less effective as the wavelength decreases. Thus an automatic safety valve is provided which when properly set maintains the first r. f. tube in its

most sensitive adjustment without allowing it to go into oscillation.

This principle is applicable to two or three stages of tuned r. f. and in such a case it is necessary that the values of the coupling circuits be carefully adjusted. When only one stage is used ahead of a regenerative detector it is not necessary to bother about attaining this condition precisely, as the regeneration in the detector tube acts as a compensating device. Due to the fact, however, that the r. f. tube is working near its point of maximum efficiency over the entire wave band, even with no regeneration in the detector tube, it is not necessary to use the regenerative control except on very weak or distant stations.

The fact that both the r. f. and detector tubes can be worked at their highest gain over the entire wavelength band accounts for the unusual sensitivity and volume attained with this circuit.

In most receivers the ground end of the primary or antenna circuit is connected to either the plus or minus battery lines. If this is not the case, it can be easily done by connecting the ground post on the receiver to one of the battery lines.

In Fig. 1, the r. f. unit is shown connected ahead of the three circuit DX regenerative receiver, the general design of which, since its appearance four years ago, has been followed more or

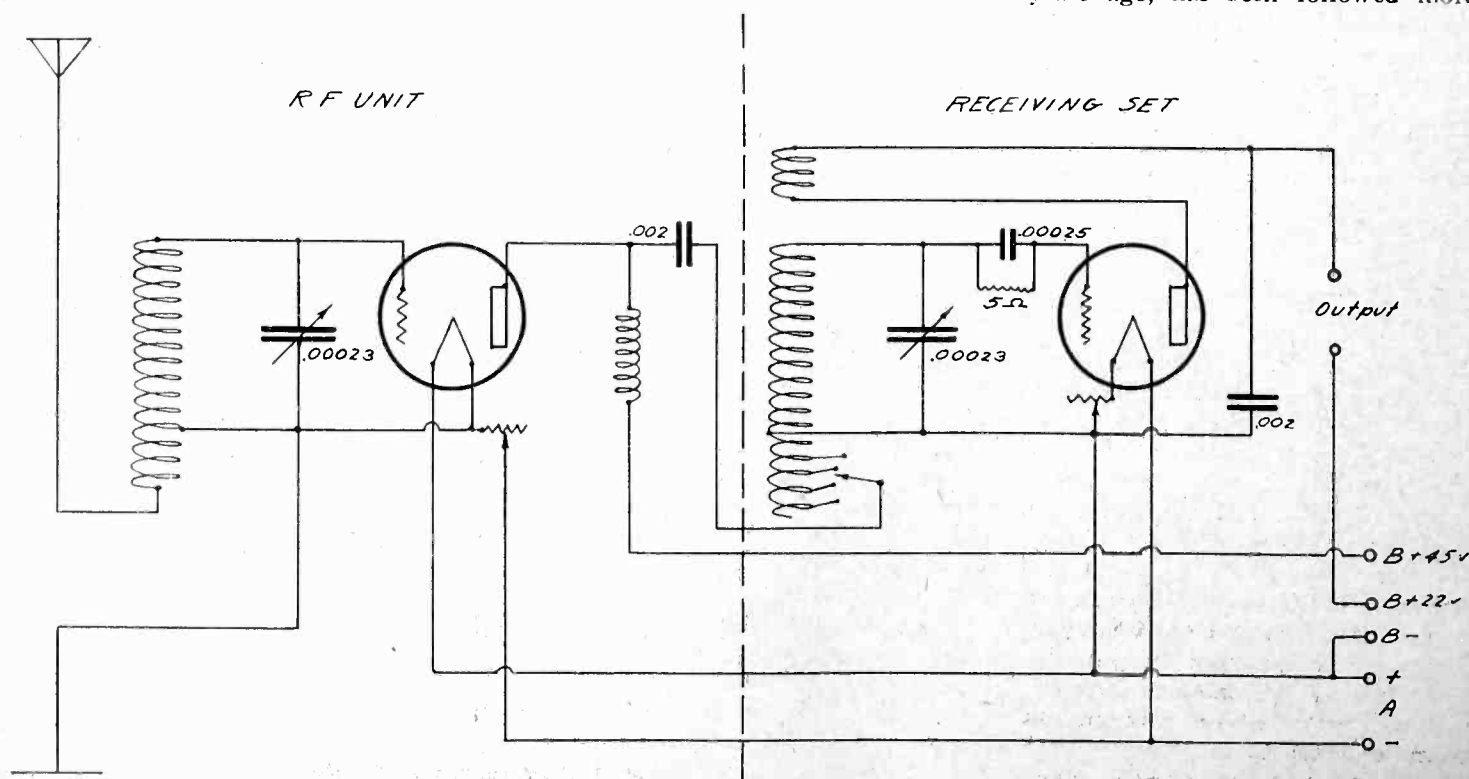
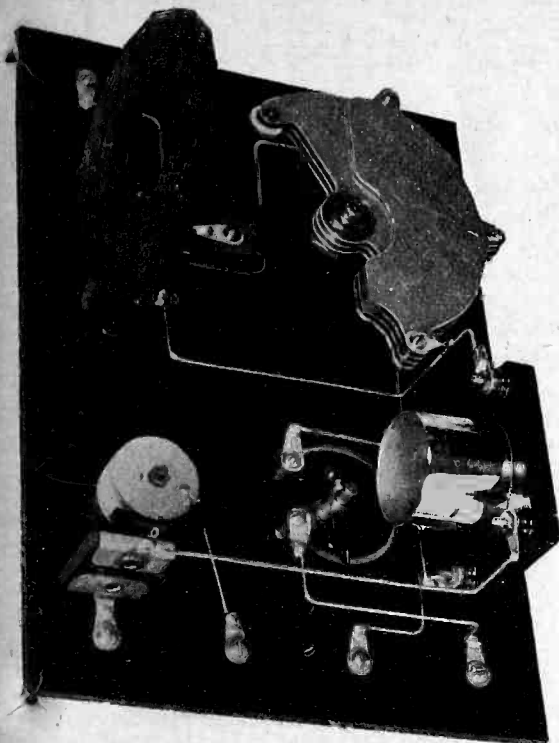

Fig. 1, R. F. Unit Connected to Receiving Set.



Rear Panel View of Amplifier.

less closely by so many regenerative circuit designers that it will serve as a good example for our purpose.

The tuning inductance, or antenna coupler as it is commonly called, in this r. f. unit may be made in the form of a diamond weave spider web. It should have an inside diameter of $1\frac{1}{2}$ in., the winding being made on 15 pins by the usual over two and under two method, 87 turns of No. 24 SCSS wire being used, the exact number depending somewhat on the condenser. The coil is tapped at the 15th turn from the inside for the ground connection, the inside of the coil being connected to the antenna binding post, while the outer end is connected to the grid of the r. f. tube and the stator plates of the tuning condenser. The choke coil may be wound on an ordinary small spool such as comes with sewing silk. Its construction is not critical, but should consist of approximately 400 turns of small insulated wire, anything from No. 30 to No. 40 being satisfactory.

Fig. 2 is a diagrammatic view of the back of panel, showing in detail the wiring for the r. f. unit, while those who prefer to work from a schematic diagram should use Fig. 1. The actual layout of the apparatus on this $7 \times 4 \times 3/16$ in. panel is indicated in the picture, the view showing clearly the simplicity of the instrument, the condenser dial being the only tuning control.

The most valuable use for the r. f. unit is in connection with a standard regenerative receiver having an adjustable or tapped primary. When the r. f. unit is used with single circuit receivers, the antenna and ground posts on the receiver should be connected to a small fixed condenser of .00025 mfd. capacity.

The condenser is placed directly across the antenna and ground binding posts of the single circuit tuner and a few turns of insulated wire are wound around the filament end of the receiver's tuning inductance. One end of this wire is connected to the ground post on the receiver, while the other end goes to the post marked *P* on the r. f. unit. Five or six turns are usually sufficient.

In general, however, on all other types of receivers, binding post *P* on the r. f. unit is connected to the antenna post on the receiving set and the plus *B* post of the r. f. unit is connected to the 45 volt tap of the *B* battery, which is already being used on the receiver. The minus and plus *A* posts of the r. f. unit connect to the *A* battery on its respective terminals. The antenna and ground proper are no longer connected to the receiver itself, but to the antenna and ground posts on the r. f. unit.

control will have no effect on the r. f. tuning, and it will be found that its adjustment, when the r. f. is added, is very simple and not at all critical.

If the circuit should go into oscillation with a sharp thump when the regeneration is advanced too far, it means that a higher value of grid-leak should be used, which applies to any regenerative receiver whether used with the r. f. unit or not. With the proper grid-leak the circuit should slide smoothly into oscillation as the tickler is advanced.

In using the r. f. ahead of the *DX* receiver, the tickler coil or rotor should be reduced to 10 turns, and the entire 10-turn primary of the coupler should be used. The primary switch may be retarded if greater selectivity is desired although this is seldom necessary. If extreme sharp tuning is desired, the primary switch may be retarded fully, so that only the one turn is included in the primary winding, which will result in

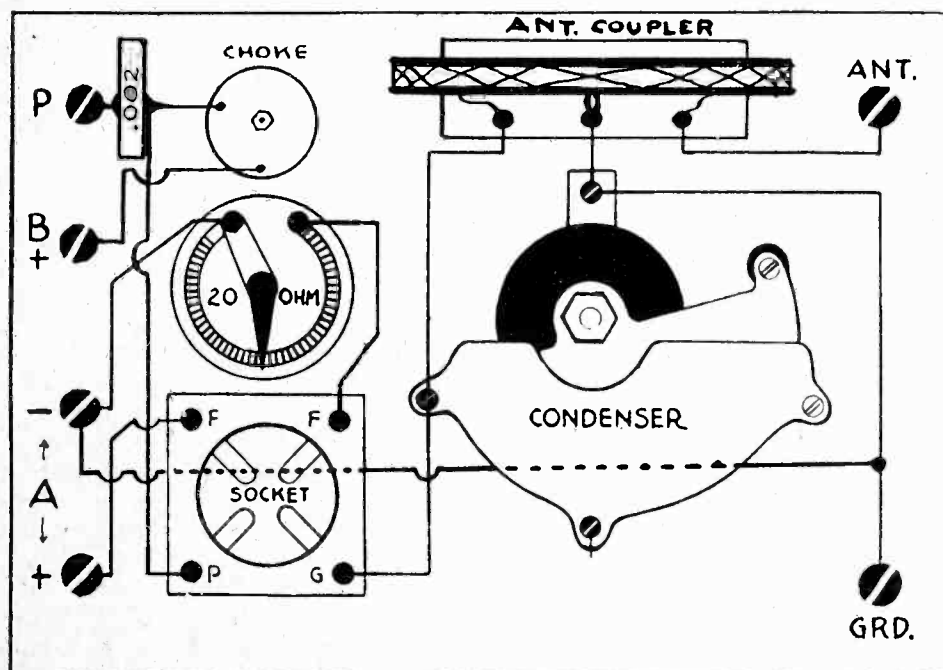

Fig. 2. Pictorial Wiring Diagram of R. F. Unit.

The following procedure should be used in operation. The regenerative or tickler adjustment on the receiver is turned to zero and the rheostats on both the r. f. unit and the receiver are then adjusted to their proper points. The tuning controls on the r. f. unit and receiver are then adjusted until some station is received. The primary coupling on the receiver should then be adjusted either by means of its taps or by rotating it, as desired, until the set does not oscillate when tuned to a low wave station with both tuning controls in resonance. When this adjustment is obtained, the primary of the receiver may be left alone and the set operated exactly as it was before the r. f. was added, the only difference being that two condensers must now be tuned to the signal rather than one. The regenerative con-

remarkable selectivity. Due to the fact that the tuning controls do not affect each other, stations may be accurately logged on the dials.

When connecting a set up for the first time, it is best to connect the filament battery, only, at the start, and see that all the tubes light properly. Then disconnect this battery entirely, and after removing the tubes, apply the plate supply, with a small 110 volt lamp (about 15 watts) in series, and if it lights up, or shows any glow at all, look for trouble. If all is ok, then re-connect the filament battery, and go ahead. This small trick may seem unnecessary, but as it may save a tube, or even a set of tubes, it will be well worth while.

An Ideal Audio Frequency Amplifier

Directions for Making a Three Stage Impedance Coupled Amplifier of Unusual Quality, Adaptable to any Radio Set

By Ernest W. Pfaff

RECENT improvements in the quality of radiocast transmission and in loudspeakers have caused a demand for correspondingly high grade audio frequency amplifiers, in order that maximum enjoyment of music or speech may be attained. In the construction of such an amplifier, the key to high quality lies in the selection of inter-tube coupling units which will pass all desired frequencies faithfully without introducing distortion.

The three common methods of coupling are by the use of transformers, resistances or impedances, transformer coupling being the most popular because of the high amplification possible per stage, and the ease of assembly. A fair degree of tone quality has been realized with the use of well designed transformers, and until the appearance of cone type loud speakers, transformer coupling was adequate for general use. Resistance coupling produces practically perfect reproduction over the entire musical range, but has the fault of low amplification per stage, and excessive B battery consumption, due to energy loss in the plate resistances. It is evident that an ideal amplifier must incorporate the high amplification per stage and battery economy of the transformer with the practically perfect amplification characteristics of resistance coupling, and the amplifier herein described has these desirable qualities through the use of a modified form of impedance coupling with autotransformers.

The impedance coupled amplifier operates upon principles very similar to re-

sistance coupling but due to the low ohmic resistance of the choke coils, practically the entire B battery potential is effective on the plate of the tube. No greater amplification per stage, however, is obtainable with the conventional type of impedance coupling, than is possible with resistance coupling, so that an explanation of the theory of the autotransformer will enable the reader to obtain a better understanding of why this type of amplifier is superior to others.

Referring to Fig. 1, the current, which is represented by the single headed arrows, flowing through the circuit *a-f-e-b* will set up lines of magnetic force, as represented by the dotted lines. As the current from the alternating current

source changes direction, all of the arrows in the diagram will change likewise, including the lines representing the magnetic flux. As these lines of force collapse and build up again in the opposite direction, they cut across all the turns of wire in the coil *g-e-f*, inducing a potential opposite in direction to the supply voltage. The induced voltage in the winding *e-f* will serve to limit the current in that coil to a very small amount, while the induced voltage in the coil *g-e* will act as an auxiliary voltage in series with the source. The total voltage will cause a current to flow through the circuit *a-f-d-c-g-e-b*, this current being represented in the diagram by double headed arrows. Since the step-

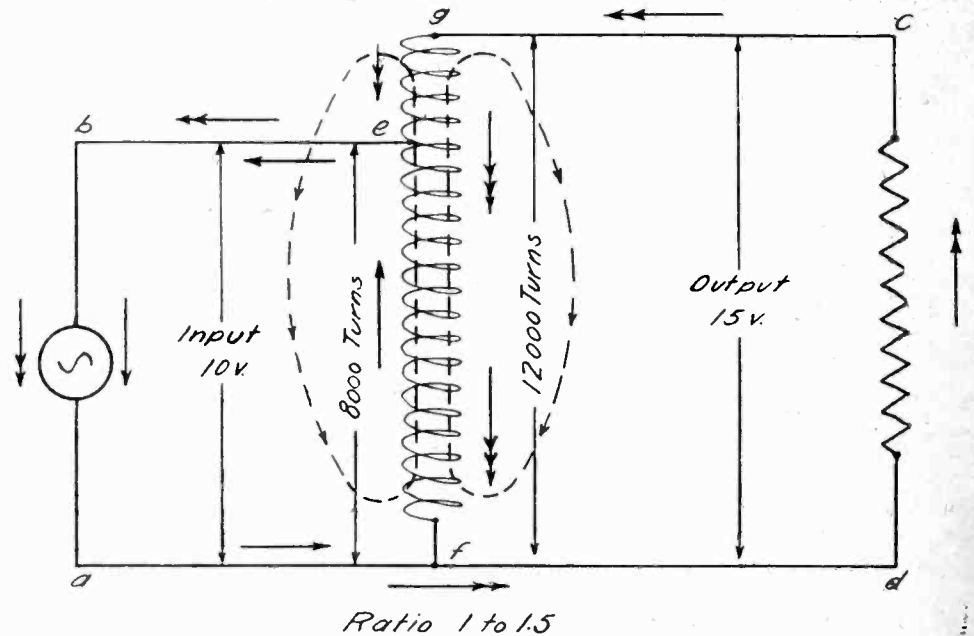

Fig. 1. Current Relations in Auto-Transformer.

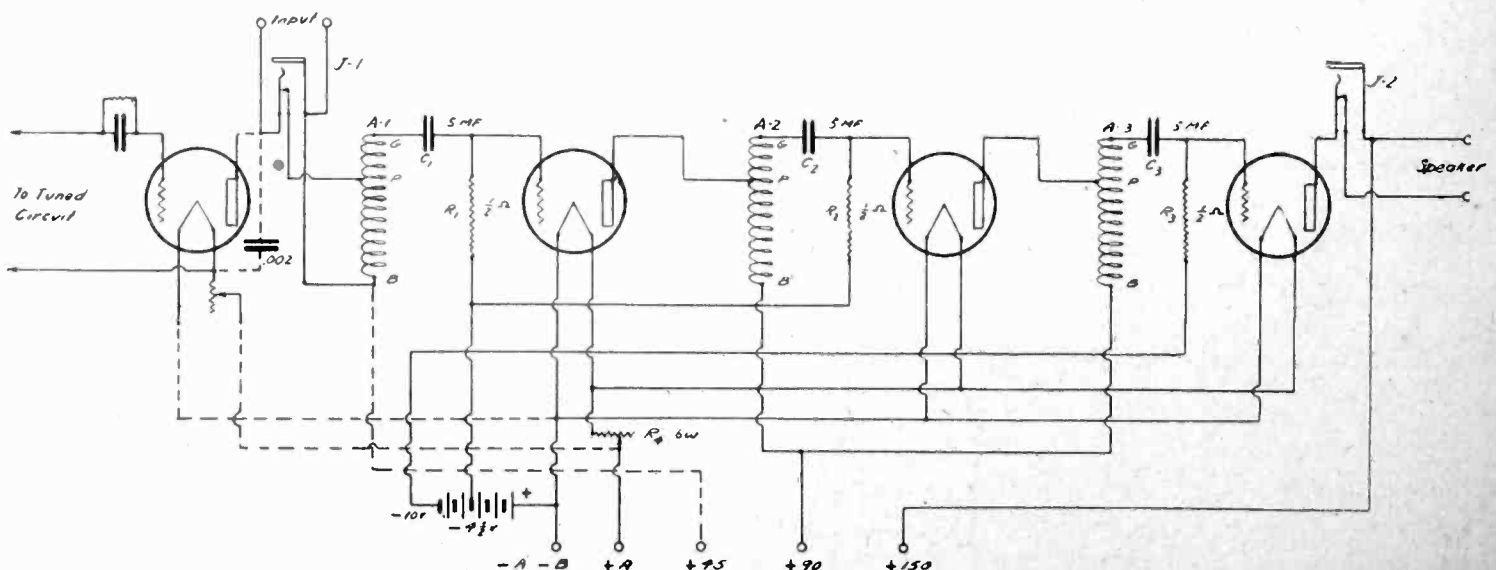

Fig. 2. Circuit Diagram of 3-Stage Impedance Coupled Amplifier.

up ratio of input to output turns is 1 to 1.5, it is obvious that the total output voltage will be greater than the supply voltage and the resultant voltage available on the grid of the following vacuum tube to which the coil is connected will be greater than if a single winding choke coil were used.

It is not as difficult to design a good auto-transformer as it is to work out a transformer of the conventional type, for the magnetic leakage is reduced and the coefficient of coupling increased to such a degree that with the use of a large iron core of high grade, a winding of very high inductance is obtained with low ohmic resistance. Hence, by winding the coil in a manner such that the distributed capacity is low, we have a practically ideal tube coupling device.

Fig. 2 shows the schematic circuit diagram of the amplifier which is shown in the pictures, the first two tubes acting as voltage amplifiers, and the last tube as a power amplifier. As explained in the theory of the autotransformer, voltage from the detector tube is applied to the primary winding of the coil, and the induced voltage in the combined primary and secondary windings is applied to the grid of the first amplifier tube through the blocking condenser C_1 . Were it not for the step-up properties of the autotransformer, the voltage applied to the grid of each amplifier tube could not exceed the output voltage of the preceding tube, but in this case a voltage amplification is obtained in each coupling unit, with increased overall gain in the amplifier.

The blocking condenser is used to prevent the B battery voltage from being impressed upon the grid of the following tube, the capacity being large in comparison to the grid-filament capacity of the tube, and sufficient to pass the lowest frequencies of the musical scale. A value of .5 mfd. was selected as the proper size, a larger capacity requiring too long a period of time to be discharged, with consequent paralyzing of the tube grid. The discharging circuit of the condenser is the grid leak (R_1 , R_2 or R_3

PARTS REQUIRED FOR 3-STAGE IMPEDANCE COUPLED AMPLIFIER		
No. Required	Circuit Designation	Description
3	A-1, A-2, A-3	Thordarson Autoformers.
3	C-1, C-2, C-3	.5 mfd. fixed condensers.
2	R-1, R-2	.5 megohm grid leaks.
1	R-3	500,000 ohm variable grid leak Centralab Modulator.
1	J-1	Three contact jack.
1	J-2	Two contact jack.
1	R-4	6 ohm rheostat.
2		Grid leak mountings.
8		Insulated top binding posts.
3		Cushioned vacuum tube sockets.
1 pair		Shelf mounting brackets.
1		Panel, 7 x 10 x 3/16 in.
1		Sub-panel, 6 x 7 x 3/16 in.
Miscellaneous screws, nuts, bus-bar wire and lugs.		

in the diagram), which must be high enough so that it will not cause a loss in voltage impressed on the grid of the tube. In the second stage, the grid leak is made variable, so that an effective volume control is obtained.

The vacuum tubes used in the first two stages may be any of the A type tubes, with amplification constant of 7 or more, but the tube in the last stage should be a power tube, such as the new UX-CX-112 or the Western Electric 216-A. The value of C battery given in the diagram is for the CX-112, but will serve equally well for the 216-A. The C battery is very important in this circuit, each grid receiving its negative potential with respect to the filament through the grid leak, and preventing the grid from becoming positive when a strong signal is being received.

In building the amplifier, the accompanying list of parts will aid in selecting appropriate apparatus.

The panel may be laid out in accord-

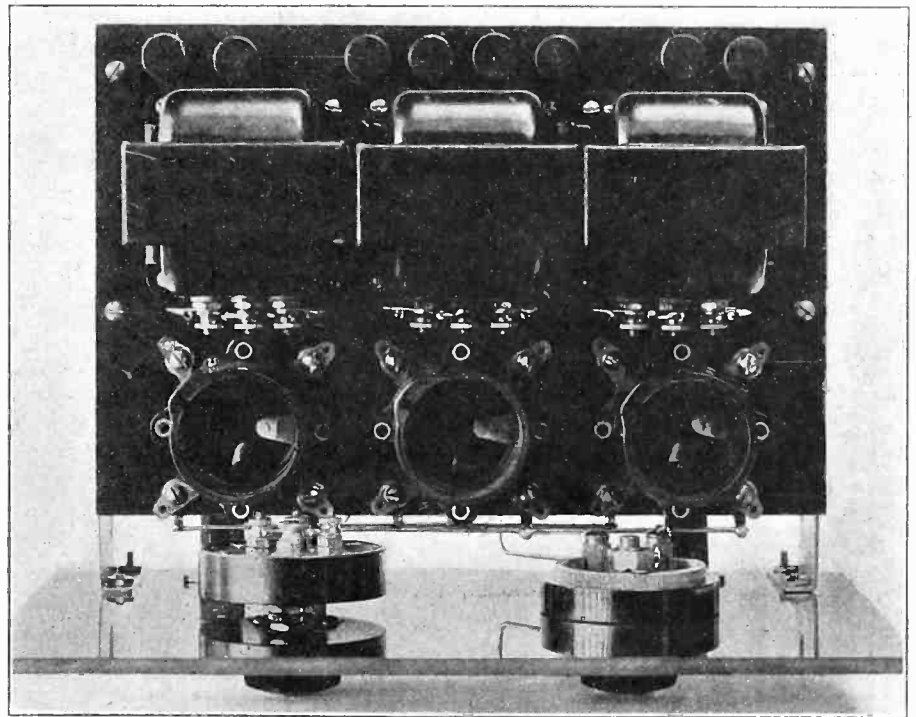

Upper Side of Sub-Panel.

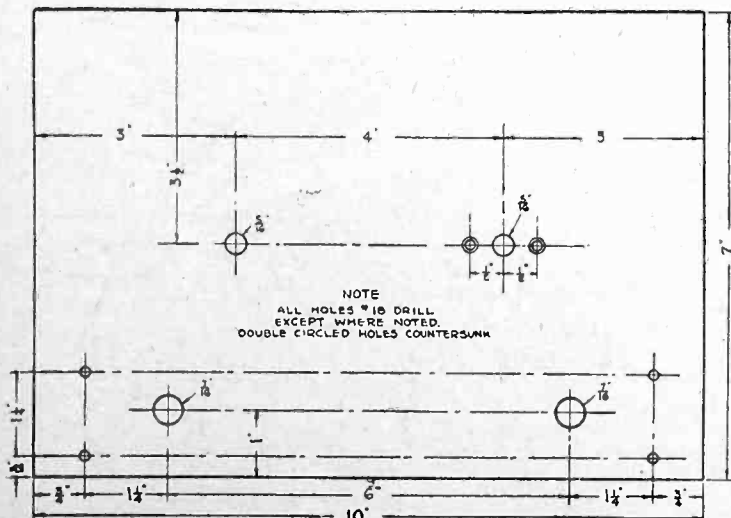

Fig. 3. Front Panel Layout.

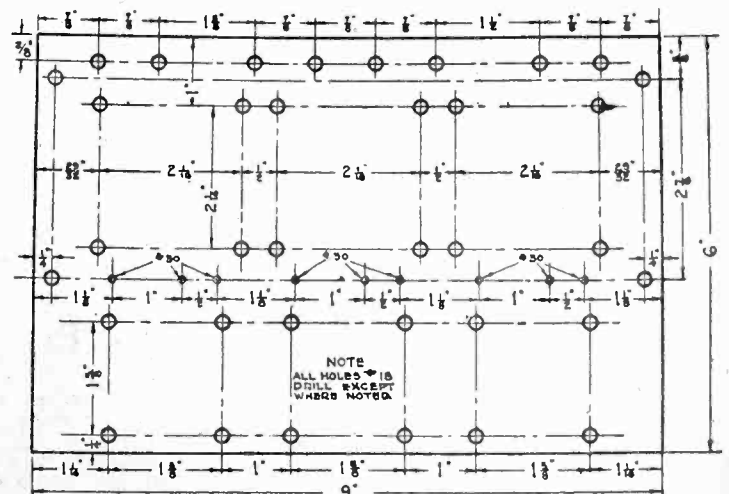

Fig. 4. Sub-Panel Template.

ance with Fig. 3, and the driving directions for the subpanel are given in Fig. 4. If it is desired to use other apparatus than that listed, the mounting holes can be changed accordingly. It is good practice to mount all the apparatus on the sub-panel first, and completely wire it before attaching to the front panel. Only a few parts are mounted on the front panel and these may be easily wired to the sub-panel apparatus after the brackets are installed. From the pictures, it can be seen that bus bar wire was used for all wiring, each wire being carefully bent, cut and fitted in position before attempting to solder it. The use of flat soldering lugs will greatly facilitate wiring, since they eliminate many bends and result in neat appearing work. Use rosin core solder in preference to any other, and remove all excess solder

The amplifier should be connected to the detector of the receiving set, and for the sake of convenience, the wiring of the detector tube is shown in Fig. 2 in dotted lines, so that the same *A* and *B* batteries may be used to operate the receiver and the amplifier. No other audio stages should be used, as three stages is ample for all requirements. In case the radio receiver is not equipped with a bypass condenser in the detector plate circuit, it is advisable to connect a .002 mfd. fixed condenser in the position shown with dotted lines. Otherwise, high frequency will get into the amplifier circuit and may overload some of the tubes, resulting in distortion of the audio frequencies being amplified.

When testing the set, care should be taken to see that the springs of the jacks are making good contact, and the tube

STATIC MITIGATION

By HENRY W. HALL

While static can not yet be eliminated, the experimenter can greatly reduce the severity of the intermittent or "click" variety by using two identical receivers and two antennas or loops. This is accomplished by means of the bridge balancing principle illustrated in Fig. 1.

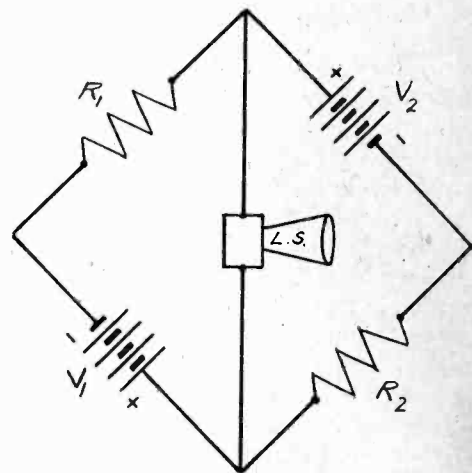
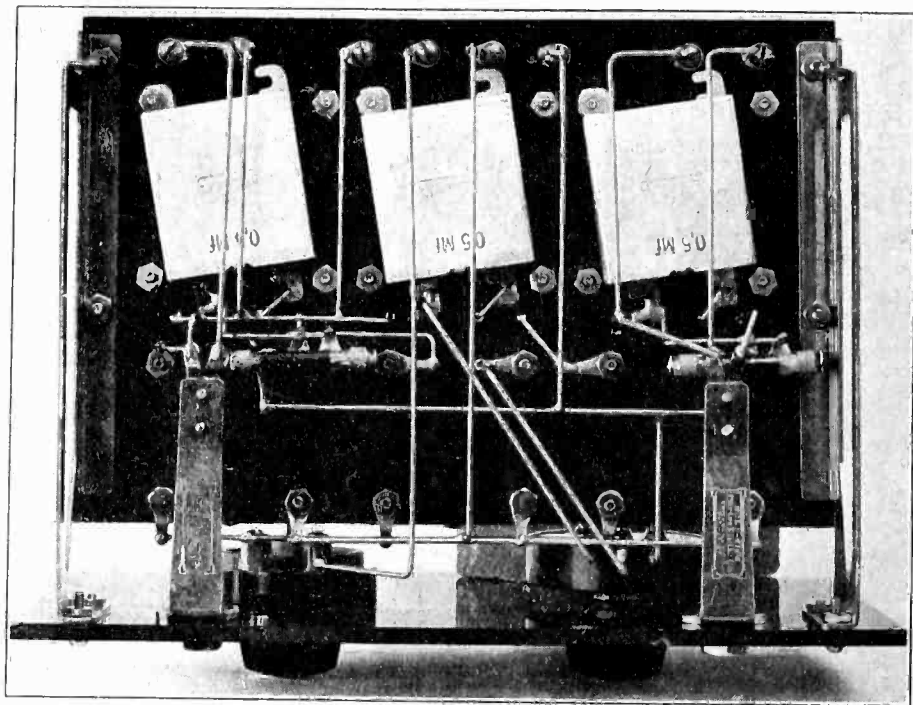

Fig. 1. Balancing Bridge Principle.

According to the familiar principles of the Wheatstone Bridge no current will flow through the loudspeaker *LS* if R^1 and R^2 are equal and if the potentials at V^1 and V^2 are the same. Let the two resistances be the plate resistances of the output tubes of the two receivers, and let the potentials be the voltages of the two *B* batteries. Then if we connect the outputs of the two receivers as shown in Fig. 2, we will have the same arrangement. If one receiver is arranged to receive only static while the other is receiving both signal and static, the static impulses coming at identical instants will not affect the loud speaker, if adjusted to equal intensity, while the signal coming in on only one receiver (and changing the resistance of its output tube only) will unbalance the bridge and cause current to flow through the loud speaker.

This sounds quite logical and easy, but the author wishes to warn those who try the circuit that considerable care in adjustment is necessary to obtain the desired result. The reason for the use of identical receivers is in order that the wave shape of the static impulses in the two output tubes will be the same. This would probably not be the case if different receivers employ-

(Continued on Page 90)



Lower Side of Sub-Panel.

from each joint so that there will be no danger of short circuits due to drops of solder in close proximity with each other.

When the amplifier is completed, a few simple tests will safeguard the tubes and batteries. Connect the *A* battery to the binding posts provided for it, insert the tubes in their sockets and turn on the filament rheostat. If the tubes light and show proper control from the rheostat, disconnect the positive *A* lead and connect it to the positive *B* binding post. If any of the tubes should light, there is a short circuit and it should be located before the *B* battery is connected. If no trouble is found, all the batteries may be connected and the amplifier is ready for operation. If UV-201-A or C-301-A tubes are used in the first two stages, and a UX-CX-112 is used in the last stage, the *B* and *C* battery voltages given on the diagram are the proper ones to use. If other tubes are used, the *C* voltages specified by the tube manufacturer should be employed.

socket springs should be polished with fine sandpaper so that a perfect contact can be assured. The volume control rheostat enables perfect control of the volume from zero to maximum, and for best quality, this should be set somewhere near the halfway mark, as the first audio tube may become overloaded with a very low volume setting. If blocking occurs in spite of the adjustment of the volume control, the grid leaks may be defective, and new ones should be substituted.

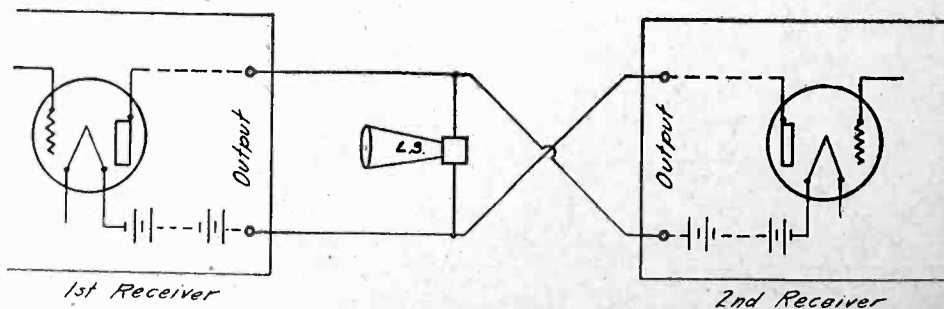
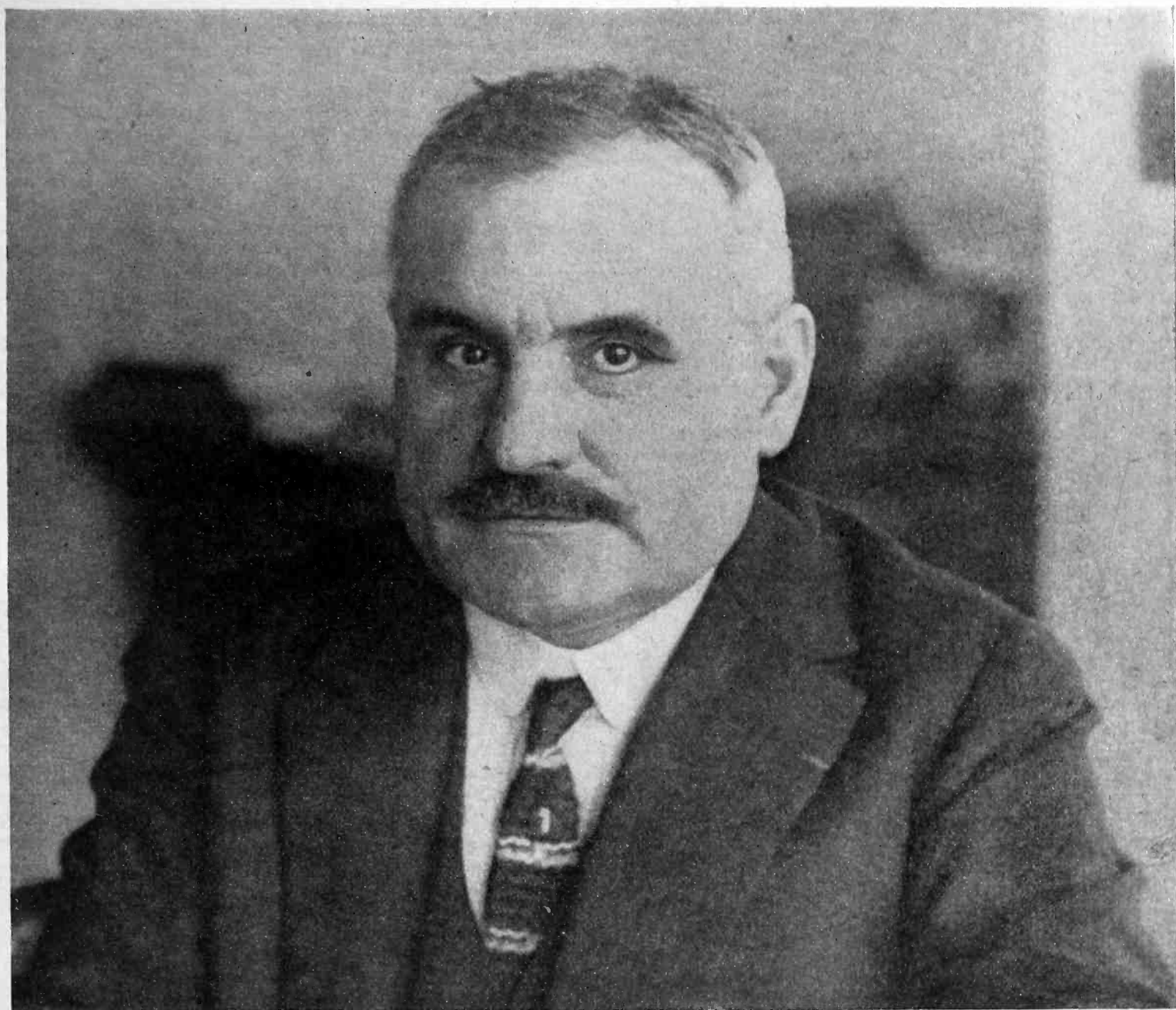

Fig. 2. Connections for Mitigating Static.



Marius Latour

An Interesting Pen Picture of this French Inventor and of the Far-reaching Effect of His Patents

By Walter Emmett

THE backwash from the excitement created by the visit of Dr. Marius C. A. Latour to the United States in the spring of 1925 has died down sufficiently to allow a rational perspective of his position in the radio situation to be obtained. His work in 1915 and later for the French War Radio Service and the result of his researches have been extraordinarily effective commercially.

There was in 1916 no general appreciation of the possible extension of the American use of radio receivers in the future, and so, while Europe, and France especially, were generally fa-

miliar with the fact that he had successfully employed iron in radio frequency transformers, and had made and stabilized reflex circuits, his later amazement at the public demand for the cascade and reflex amplifier embodying his ideas was genuine.

When he came to us, various engineers denied the priority of his claims, although in some cases they had developed their own ideas with the French Army. Every American manufacturer who used either radio or audio frequency coupling transformers, single *B* batteries, grounded filaments, or transformers, reflexed tubes in multi-stages, or iron radio

frequency transformers, was potentially, at least—an infringer.

By his late entry into the field of basic claims for patent control of the American industry, this brilliant inventor stood ready to wield a financial wand compared to that in the hands of the victors in the regenerative or superheterodyne system of receivers.

No one except Schloemilch and Von Bronk, who antedate him for a single tube reflex circuit and radio frequency amplifiers, could apparently escape the charge of infringement. Not even the "balanced" or "neutralized" systems of

avoiding oscillations in a receiver were immune.

Who, and what is this type of inventor, who knows first what to invent and second how to sit back until the developing radio art carries his work forward to commercial importance?

He is not fundamentally a radio engineer at all, paradoxical as this may seem. Long before the radiocast era dawned, Prof. Latour was a teacher and consulting electrical engineer in France, with a very firm position as a leader among the designers of various types of alternating current motors. He developed a famous type of compensated repulsion motor known by his name, where armature reactions were balanced out and very desirable speed-torque characteristics were obtained with the successful use of a commutator. A very instructive and brilliant controversy with an engineer in England on this subject followed and goes to show his many-sidedness.

He is a philosopher and a student of psychology, as well as a brilliant practical technician. Like many brilliant European engineers and mathematicians, Marius Latour is a man of very broad training in the "humanities." His interest in sociological questions and the general progress of mankind is much on a par with that type of mind which has made H. G. Wells a leader of thought in England. Robert Thurston, probably the greatest authority on the thermodynamics of the steam-engine which America has yet produced, was of a similar type of mind: his interests ranged over the whole field of human activity and was by no means confined to the exact sciences. The practical success of men of broad scientific training, whose interest in the general cultural progress of the world does not prevent intense application to technical problems, is also shown in the heights reached by men like Alexanderson and Steinmetz, who are illustrations of the fact that to understand any one science or art thoroughly, a broad foundation of interrelations with allied branches of cultural knowledge must be kept up all through life.

Marius Latour is a typical inventor insofar as a problem when solved is to him simply an indication of a still more interesting field to be conquered. He has stated that his greatest hope for fame rests not on his technical work but on his highly original and significant book on "The Mathematics of the Emotions" and is merely reflecting the real tendency of all inventors to whom the struggle is more interesting than the result.

He is not of an over-sanguine temperament; as his own opinion of his work shows that this book which he considers his masterpiece is not expected to bring him true recognition for generations. He does not fear that his favorite work will share the fate of some of the great

but now obscure products of the Middle Ages. Real work often has been sidetracked in the minds of the public by more superficial successes.

For those who wish to know what his actual position in the modern world signifies, it may be said that officially he is a professor at the Ecole Supérieure d'Electricité in Paris. He is a natural research engineer and has made this his hobby when he is not writing books on poetry and philosophy. Hiram Maxim was a similarly endowed inventor and his work on the science of poetry will repay comparison with that of Latour.

Latour is a linguist and his English is just as perfect as that of Clemenceau, who was a school teacher in America for some time. Being a consultant and research engineer for the General Electric Company at Schenectady, N. Y., from 1904 to 1911, a great many patents were granted him along the lines of X-ray tubes, high frequency oscillator circuits, high frequency alternators and repeater circuits.

It should not be forgotten that from the date of the advent of the mercury arc and its use as a rectifier, which was finally awarded to Peter Cooper Hewitt, after a struggle with the General Electric Company, the ease of producing oscillations from such a device was readily seen by several inventors, among whom was Vreeland. It did not require very long consideration by a powerful mind to devise a negative resistance. Some of these patents are the basis today of the licenses that have been granted to the Radio Corporation of America and others. The number of patents granted to date is 14 and there are about 68 applications pending.

Just before the War, Professor Latour licensed a French company on a royalty basis to make and use his inventions, and it was largely due to his efforts as Chief of Staff of the Radio Research Division of the French Army that the reflex circuit was brought to its state of efficiency during the War.

American engineers who worked in collaboration with this section of the French Army seemed to have thought along the same lines, and some of them are challenging his priority in the matter of coupled radio frequency transformers so interrelated as to reduce the oscillations which usually produce howling and distortion in reception. It is not generally realized that Professor Latour's patents on high frequency alternators have been developed by other French engineers, such as Bouthillon, to a very high degree of refinement. In fact, the alternators in the Eiffel Tower station are run with their rotors working in vacuo to reduce the power lost in windage.

Furthermore, his patents on the low antenna sectionalized cover the practice of efficient long-range transmission. These two patents, taken in conjunction

would, if rigidly enforced, have placed the American radio telegraphic industry in a very dependent position, but the field has now been fortunately cleared by mutually amicable settlements.

Latour alternators are highly efficient, and their only rival is the high power tube, such as those now being operated in Carnarvon, Wales, and in other places on competitive tests. The advantage of the tube is its great flexibility in regard to range of adjustable wavelengths. The alternator, however, has the natural advantage of giving a purer wave than the tube, unless special means are taken in the latter to eliminate the families of upper frequencies or harmonics which are given off.

The scope of the inventions made by Professor Latour covers so many inventions that, unlike the late Oliver Heaviside, he is already very comfortable, financially, from the proceeds of royalties. His first electrical patent goes back to 19 years ago, and strangely enough, is for a negative resistance produced in a mercury vapor tube. The importance of this device in certain applications of voltage and current amplification, such as are illustrated in the "dynatron," will not be fully appreciated by the public until their application in the radio art is further developed than it is today.

It is interesting to realize that the necessity of distortionless amplification in radio frequency transformers was clearly foreseen by Latour; as he distinctly specifies that radio frequency amplification, in order to be distortionless, must be "aperiodic." To secure this particular result, he introduced resistances, and it is on these points that some workers in the French Service from America now dispute his priority, with what results remains to be seen.

Even in the question of "line-radio," he has been able to dispose of patent rights to the Postal Telegraph Company. These will not interfere with the situation as covered by the patents of G. O. Squier, which patents are broadly indicated in the work of Hutin and Leblanc, Dr. John Stone and Professor Michael Pupin, dating back more than twenty years and now lapsed.

One of the first things that Latour did was to use finely laminated iron core transformers to secure radio frequency amplification. By using this type of transformer there was enough hysteresis loss introduced to act as an automatic dampener of oscillations. Of course, the amplification voltage ratio was reduced but the net performance was improved as regards freedom from oscillations.

The question of the use of a common B battery for multi-stage sets is an interesting one and is possibly capable of being decided in favor of early American inventors; as there is a great deal of early actual experimentation recorded

(Continued on Page 60)

RADIO'S New Calibration Laboratory

A Description of Its Equipment and a Statement of Its Purpose in Reader Service

PLEASURE is taken in announcing a new service to readers of RADIO, in the form of a calibration laboratory, whose primary purpose is to furnish a means by which readers may have their apparatus, such as fixed or variable condensers, inductance coils, wavemeters, etc., accurately calibrated so that their equipment will contain no unknown quantities or apparatus of doubtful accuracy.

Heretofore radio publications have generally confined the service of their laboratory, where such existed, to testing new apparatus as it appeared on the market, and issuing certificates of excellence or other recommendation where the apparatus was found to be of good quality. Such certificates, when published in the columns of the magazine, are seldom of sufficient benefit to the readers to warrant the space, and hence our laboratory service is confined to such purposes as will give the most benefit to the experimenter, home set constructor, and the amateur.

The illustration shows a portion of the equipment. In the upper picture, along the back of the table, is a vacuum

tube oscillator having a range from 50 to 100,000 cycles, and having an output free from harmonics and steady in value. Connected to the oscillator is a gain set, which permits measurement of vacuum tube amplification, frequency characteristic curves of audio or intermediate frequency transformers, resistance or impedance coupled amplifiers, in terms of either voltage amplification or in telephone transmission units.

With the gain set it is possible to measure the peak frequency of superheterodyne transformers, and tune the filter transformer to match the intermediate frequency transformers. This will be particularly useful for those who have made their own transformers and desire to know at what frequency they will operate best.

Adjacent to the gain set are the crystal oscillator and its associated beating oscillator, as described by D. B. McGown in October RADIO. This oscillator has crystals calibrated by the Bureau of Standards, and will be used in checking the wavelength accuracy of Pacific Coast radiocasting stations. The range of these oscillators is from 100,000 cycles

up to 10,000,000 or more. They give reasonably accurate calibration of any vacuum tube or buzzer type wavemeters.

Besides the high frequency equipment, there are two capacity bridges, one for testing fixed condensers at audio frequencies and the other for calibrating variable condensers at radio frequencies. An impedance bridge, which is at the right of the picture, enables measurement of the impedance of any inductance coil, audio or intermediate frequency transformer or loud speaker, either with the vacuum tube connected to the apparatus, or without, as preferred. A laboratory standard high resistance voltmeter and high voltage storage battery is used to test the insulation of radio apparatus and the resistance of grid leaks or variable high resistances of any sort. A Leeds & Northrup inductance bridge permits the measurement of inductance coils, together with their low frequency resistance.

In the lower picture is shown the General Radio Oscillograph, for analyzing any frequency up to 5000 cycles. It permits the measurement of noise in A

(Continued on Page 64)

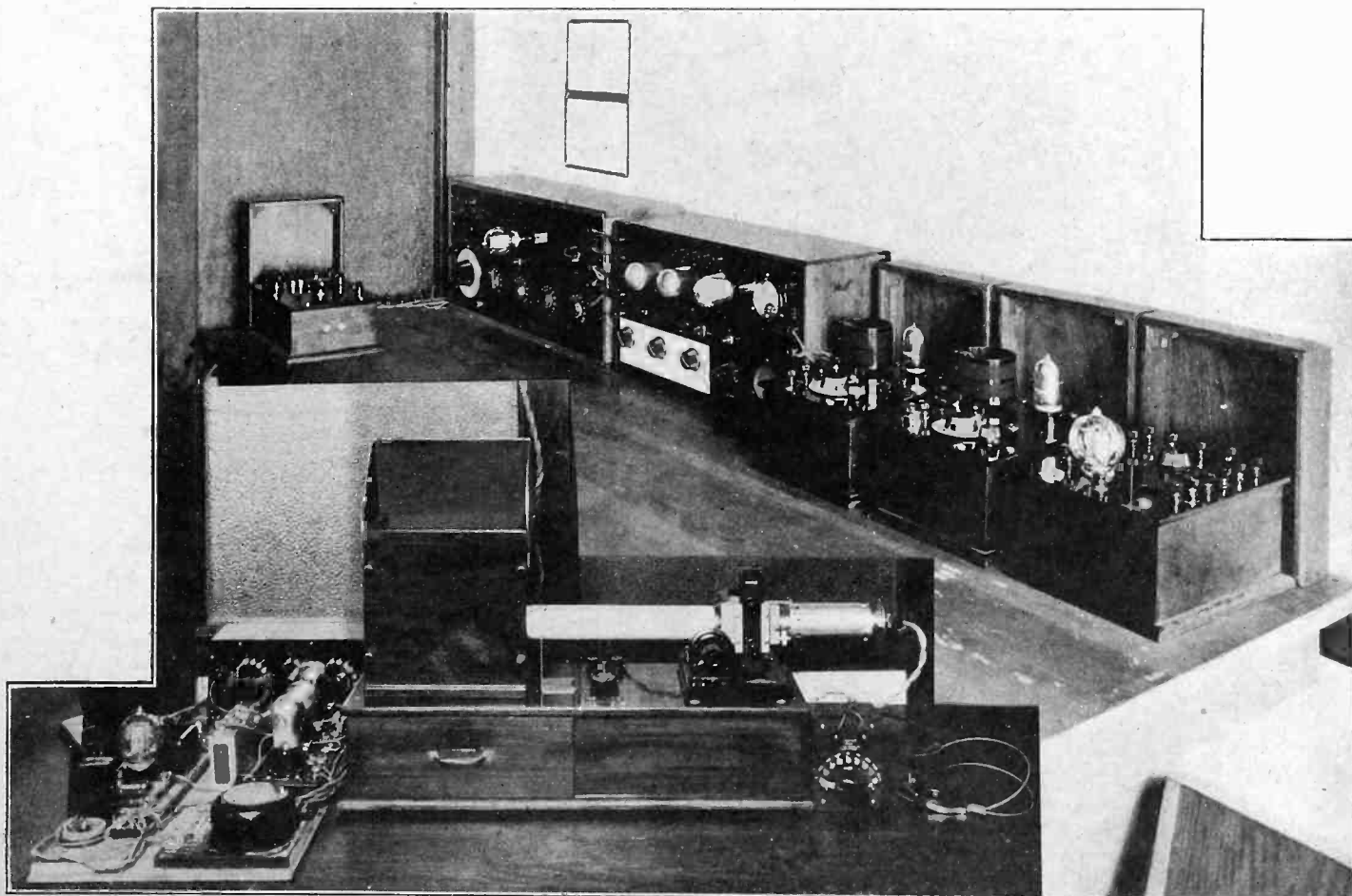

A Corner in RADIO'S Calibration Laboratory

After the License--- What?

Helpful Hints for the Aspirant to the Position of Commercial Operator on Ship or Shore

By James W. Harte, WHE.

HAVING decided that we are going to sea as a radio operator, how do we go about getting a job? We don't pick out a nice looking craft and decide that she suits us and then approach the captain, or go the rounds of the various steamship offices. If we do we are doomed to disappointment.

There are three large operating companies which render radio service to steamship companies. It is to one of these companies that the new operator should look for assignment. True, there are several steamship companies which have their own radio systems, but unless sorely pressed for a man such companies demand an experienced operator.

The man who has little or no practical experience with radio transmitters will do better at the beginning to seek a berth as junior operator. However, hundreds of tyros have found themselves outside the breakwater with no one to advise them.

In order to get any kind of a berth it is necessary to present ourselves at the local office of one of the large operating companies, two of which have their headquarters on the Atlantic Coast, the other on the Pacific Coast. We cannot expect to be placed immediately upon making application. Nor can we expect always to be notified to report far in advance of sailing. If a ship is sailing sooner than expected, if an operator quits without notice, if for any reason an operator is required at short notice the man who is on the spot, or can be easily reached, has the best chances for assignment.

Those steamship companies not maintaining their own radio departments have a service contract with one of the large operating companies whereby the latter maintains the apparatus, controls the traffic and supplies the operators. However, since the operators sign the ship's articles, they are paid by the steamship company. This enables the operator to draw on his salary during the trip, a decided advantage over the old days when the service company paid the operator, who, unless the recipient of an income, contracted many a debt if the trip was a long one.

Having been selected to stand a watch in the radio shack of some vessel, the operator is given an assignment slip. This he presents either to the captain of the vessel or the marine superintendent of the steamship company, whichever the case may be.

Arriving on board the operator will in all probability find the door of the radio room locked. This is as it should be. Inquiries will soon tell him who has the key. It is usually left with the chief officer or the chief steward. Upon going ashore in any port the operator should leave the key with some responsible authority, so that the government radio inspector or other proper officials may inspect the apparatus.

After hanging our license in a conspicuous place we should, whenever possible, check over everything with our predecessor. After doing this we should make out a requisition for the necessary supplies. Each operating company has its own ruling on this, but all of them hold the present operator responsible for equipment and supplies. A junior operator will, of course, not be held responsible except while he is on watch.

A very important thing to remember is to be on hand when the ship's articles are signed. These articles are an agreement between the master and crew. They are usually drawn up for a definite period, six months or a year, new articles being drawn up every voyage in the case of deep-water vessels. If the voyage is completed before the stated time, the articles automatically expire. If the vessel is still away on a voyage, that is, if she is not returning to a point mentioned in the articles where the crew can be signed off, then the crew can demand

to be paid off, and transportation must be furnished them to the point of signing on.

These articles are signed before a United States Shipping Commissioner, who reads them aloud to the assembled crew.

Vessels making short, regular coast-wise voyages usually sign new articles every three months, unless the whole personnel should change before that time.

On passenger vessels sailing on scheduled time the rules demand that the radio men be on board at least three hours before sailing. If the sailing time of a vessel is uncertain it is advisable not to venture ashore before determining the sailing hour from a responsible officer of the ship or the steamship company on the dock. On vessels compelled to carry radio, since the ship is subject to a fine if it sails without the operators required, they make sure that the radio men are aboard. A cargo vessel, voluntarily equipped, may sneak off without the operator.

On merchant vessels the radio operators rank as junior officers. That is they rank with the second officer, this despite the fact that many hardboiled mariners refuse to recognize them as such. The great war did nothing to change many of these opinions, for the radio operators during that hectic period were mostly enlisted men, while the

(Continued on Page 66)



The Beat Note

By H. A. Highstone

HARD citizens every one, these men grouped about the council fire in the center of the rude village, lithe, muscular men, bearded, and clothed in rough garments made of a coarse brownish cloth. Their implements of war and defense were for the moment laid aside, held by the women and children grouped outside the circle, spears, clubs, and bows made from the wood of the red yew tree. Every eye focused on the head man of the tribe, a tremendous bull of a fellow dressed in the skins of the mountain lion and topping head and shoulders above the wizened figure of the ancient at his side. The chief had moved into the clear space by the fire and was speaking to the men of the council in a deep measured voice, turning from time to time to face every portion of the circle, that none might feel slighted.

"There is a legend come down to us," he rumbled, "through four generations, of a time when this land of ours was not the place we know now. But a few of you are familiar with it, I know, for it is fast fading from the minds of all save the scribes. Exaggerations have, of course, crept into the substance of this story, for it is very old and it has been told and retold many many times, but even so, there is little doubt that at one time there were one hundred thousand people living between the sea and the high range of mountains rising to the eastward of this valley." He paused for a moment as a little ripple of incredulity passed over the crowd, and continued.

"Aye, it sounds fantastic, but on a journey I and my father once made far to the northward I viewed a great waste of ruins of an ancient city in which our village might be lost a thousand times over. But it is not now a time to argue the matter and I see that many of you are curious to know from whence came this ancient man beside me, and for what purpose. A sentry picked him up last night by the river and brought him at once to me. I have talked with him for many hours and he has told me many a strange tale of the powerful people who were once the inhabitants of this land and of the miracles which they wrought and of one which at last destroyed them. We are come down from this tribe and it is well that we should have the history of these mighty ancestors of ours. One of them stands before you. Speak, old man," he concluded and withdrew to his council seat.

HE WAS old, very old, this ancient man, and as he stood there in the flickering light of the fire, blinking his dim eyes and inhaling a last few puffs from a cigar of dried willow root, he looked as though the sun and wind and rain of a thousand years might well have worked their will upon him. A tangled mass of white whiskers dropped almost to his waist from the bald dome of his head. Deliberately he sucked at his cigar until the last permissible amount of smoke had been drawn from it and then, after first warming his hands and then his back before the blaze, he began speaking in a mumbling monotone, half to the crowd and half to himself.

"Lessee," he began hesitantly, cocking one eye up at the moon and vigorously scratching himself, "This here's 2015 or maybe 2017; I've kinda lost track of things lately; anyway, this all happened about ninety years ago, a good many years before any of you ginks were born.

"Things was different then; airplanes, railroad trains that whizzed you along sixty miles an hour, automobiles, big cities and millions of people living right here in this state, to say nothing of all those who were still back in Kansas or Ioway. Heh! heh!; Great times—those days. But it was radio as how

done for everything; smashed up the whole works and left the country populated with a bunch of damn cave men. Radio! It made me and then it busted me, like it did everything else. I was running a gyp radio store up in a place called Oakland away up north of here, selling total-loss condensers and molded mud sockets and bum bootleg tubes and the like and what with the 'super-long-distance' coils what I made for two bits and sold to the suckers for eight dollars I got along fine. I——" Athos, chief of scribes, interrupted.

"What was this radio of which you speak?"

"Radio," answered the old man, "was something that let you talk to people a hundred miles away, or ten thousand miles away if you was a mind to without wires or anything else except something to send with and another jigger to receive with. You put together what they called a transmitting station and when a man made a speech into it everybody in the world could hear him if they had strong enough receivers. There were radiocast stations scattered all over the country and night times they sent out music and speeches and songs and everybody as had a receiver could listen

(Continued on Page 48)

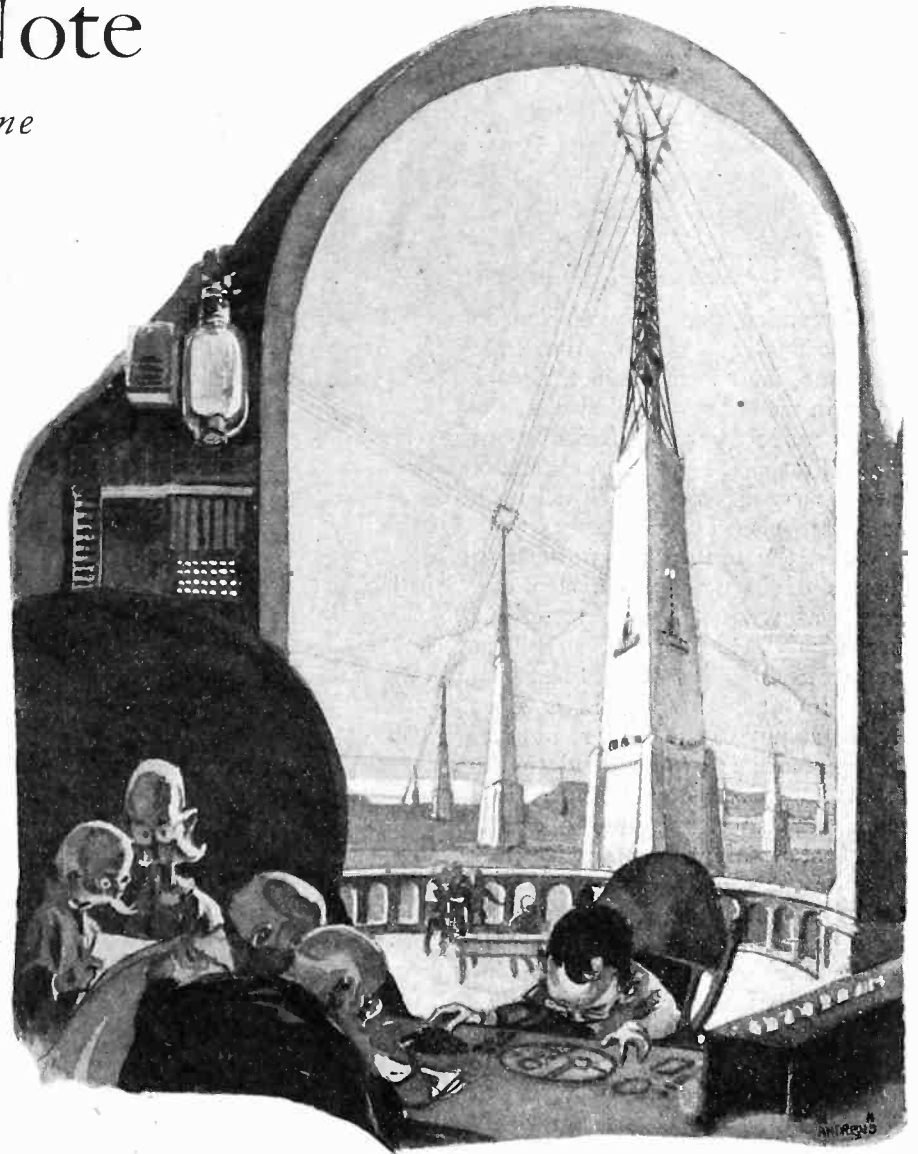

Comparative Efficiencies of Coils

A Statement Based Upon Numerical Calculations of the Ratio of Inductance to Length

By J. E. Anderson

TO determine the relative efficiencies of various coils which, from time to time, have been given the place of honor in radio store windows, the author has made a series of calculations of their L/l ratio, L being the inductance of the coil in centimeters and l the length of the wire, also in centimeters. In other words, the ratio is the number of centimeters of inductance per centimeter length of wire. This is strictly a measure of the efficiency of a coil at low frequencies, but it may also be taken as a measure at high frequencies since it may be assumed that the radio frequency resistance is proportional to the length of the wire as well as the low frequency resistance. Assuming equality, the constant of proportionality may not be quite the same for all the different types of coils, but it will not be greatly different from the mean.

For the sake of definiteness an inductance of 165,000 centimeters was used as the basis of calculation for each coil. This is an average value of the inductance in a radiocast receiver in which a .0005 mfd. condenser is used for tuning. Also the same size of wire was used in every instance, the hypothetical size which winds exactly 10 turns per centimeter, i. e. 25.4 turns per in., which is an average size of wire as used for tuning coils. The shape of a given coil was made such, wherever it was possible, that the inductance for a given length of wire was maximum. It was assumed that the diameter or other winding form was made to fit these conditions exactly, and also that the number of turns, to a fraction of a turn, was put on the form. Only the form was assumed, and not any solid matter in the form to support the wire. In other words, each coil is strictly an air core inductance.

The method of calculating the L/l ratio was as follows. First an expression was obtained for the inductance in terms of the dimensions. The best formula available for the inductance of a coil of given form was used for this purpose. Then an expression was obtained for the length of the wire, and one was divided by the other. The result gave the L/l ratio in terms of a constant and the radius of the coil or other dimension, or in terms of some constant and the number of turns on the coil. The unknown quantity, whether it be a dimension or the number of turns, was then determined by making use of

the known value of the inductance; that is, 165,000 centimeters, and the known shape ratio. When this unknown had been determined it was multiplied by the constant and the numerical value of the L/l ratio was obtained.

As an illustration of how L/l was calculated, consider the single layer solenoid. The formulas in the case are

- (1) $L = (2\pi a)^2 N n K$ (Nagaoka's formula for inductance of solenoid).
- (2) $l = 2\pi a N$ (Length of the wire).
- (3) $2a n / N = 2.46$ (Condition for least resistance).

in which L is the inductance of the coil in centimeters, l the length of the wire in centimeters, a the radius of the coil in centimeters N the number of turns on the coil, n the number of turns per centimeter and K is the shape factor. When condition (3) holds the shape factor is equal to .476, so this value may be substituted in the formulas in place of K . Also the size of wire assumed makes the value of n equal to 10.

Now if (1) is divided by (2) there results $L/l = 2\pi n K a = 29.9a$. The value of a may be obtained by putting 165,000 for L in formula (1) and by eliminating N between this changed (1) and formula (3). This gives $a = 4.77$, and this multiplied by 29.9 gives $L/l = 142.5$, the ratio sought. The ratios for the other forms of coil were obtained in a similar manner.

The value of the L/l ratio is not a constant for all values of inductance, and for that reason the same inductance has been used in each case, the ratio being greater, the greater the inductance. If a wire size other than that assumed be used, the ratio may be different; but for a given number of turns, the L/l ratio will be the same for all sizes of wire as long as the product of n and a remains constant. That is, the diameter of the wire must be proportional to the diameter of the coil.

The various coils investigated will now be taken up in detail, and some of the advantages and disadvantages of the coils will be pointed out.

The Three-Banked Wound Coil

The inductance of this coil was obtained on the assumption that three turns occupied the space of one of the wire used, or that the number of turns per centimeter was 30 instead of 10, but that each turn of this wire had the same conductivity as the heavier wire. It was also assumed that the diameter of the coil was that of the mean of the

three banked turns. This idealized single layer solenoid was given the shape ratio which gives the highest inductance for a given length of wire.

The value obtained for the L/l ratio was 206.0, the required number of turns was 55.8, and the radius of the coil was 2.29 centimeters. The value obtained for the L/l ratio for this coil is the highest of any of those considered. The value is slightly high, however, due to the fact that the turns in the actual coil are not placed quite so closely together as they were assumed to be. But the difference is small.

The main advantages of this coil are that the inductance to resistance ratio is high and that a given inductance may be put in a very small space. Where compactness is the main consideration this coil is most desirable. The main disadvantage of the coil is that it has a high distributed capacity and hence a high natural wavelength, which limits its tuning range with a given condenser. It is efficient provided it is not operated near its natural wavelength.

The Two-Banked Wound Coil

The two-banked wound coil is similar to the previous coil in the method of winding except that only two turns are banked instead of three. That is, two turns occupy the same space along the axial length as one turn of the same size wire would in the single layer solenoid. Hence for the purpose of calculating the inductance it may be assumed that the wire is such that it winds 20 turns per centimeter instead of 10 without any change in the conductivity of each turn. The diameter used in the calculation is the mean between the diameters of the inside and outside turns.

The value obtained on these assumptions for the L/l ratio was 178.0. The calculated radius was 2.97 cm. and the number of turns was 48.3. On account of the fact that the turns are separated by finite distances the L/l ratio obtained is slightly too large, but it does not deviate as much from the true value as did the three-banked coil.

The advantages of this coil are the same as those of the three-banked coil, namely, a high inductance to resistance ratio and compactness for a given inductance. Neither is as great, however, as the corresponding advantages of the three-banked coil. The disadvantages are also the same in quality but not in

(Continued on Page 76)

An Improved Loop Receiver

By R. Lewis Rockett

RECEIVING sets employing radio frequency amplification have proved very effective in long distance reception. Used with a loop antenna added selectivity is obtainable and the set can easily be moved from place to place.

A workable combination involving three stages of radio frequency amplification, detector and two stages of audio amplification is shown in the illustrations, there being only five tubes used. A study of the circuit diagram, which is shown in Fig. 1, indicates the simplicity of the wiring, and the manner in which the third radio frequency serves also as the first audio amplifier, by the use of the reflex principle. Two stages of untuned r. f. amplification, with a third stage of tuned r. f. provide the set with sufficient sensitivity for operation with the loop antenna, the two tuning controls being the loop condenser and the variable capacity across the secondary of the tuned r. f. transformer.

The panel layout is shown in Fig. 2, the center holes of each piece of apparatus being shown, as equipment different in dimensions from that used in the experimental model may be used, and the holes for the mounting screws would not always be the same. The layout of apparatus on the baseboard is shown in Fig. 3, the most essential dimensions being shown for convenience in mounting the various parts. The list of parts shows the amount of material required, the tuned r. f. transformer being home-made.

A shield should be placed between the untuned transformers, the shield being

LIST OF PARTS	
1	1st stage r. f. transformer.
1	2nd stage r. f. transformer.
2	Audio transformers.
1	200 ohm potentiometer.
2	.0003 grounded rotor condensers.
1	Vernier condenser.
2	6 ohm rheostats.
5	Sockets.
3	.00025 mica fixed condensers.
1	.005 mica fixed condenser.
1	.001 mica fixed condenser.
1	4½ V. C battery.
1	Single circuit jack.
1	Double circuit jack.
1	Filament switch.
1	Panel, 7x24x3/16 in.
1	3 in. length 3 in. composition tubing.
1	Shield 2½x2½ in.
1	Baseboard 9½x24x½ in.
	Binding posts, wire and spaghetti.

connected to the ground binding post. In wiring the set, avoid parallel leads as much as possible, particularly in the grid and plate wires of the r. f. stages. This makes the set somewhat irregular as regards wiring, but is the best method in the long run. The construction of the tuned transformer is as follows:

On a 3 in. bakelite or fiber tube 3 in. long wind 64 turns of No. 24 D. S. C. wire for the secondary, and over this winding place 20 turns of the same size wire for part of the primary and wind

the remainder of the primary with 8 turns in the opposite direction on a piece of paper tubing which will just fit inside the 3 in. tubing. Place the 8 turn part of the primary directly underneath the 20 turn section, which is wound at one end of the tubing. The secondary is tuned with a 13 plate condenser having a capacity of .0003 mfd.

In series with the *B* battery is placed a 1½ volt flashlight bulb, which will blow out in case a short circuit develops in the set, in the *B* battery leads. One of the new G. E. protective tubes will also serve the same purpose. If more volume is desired in the last audio stage, than is possible with *A* tubes, one of the new UX-CX-112 tubes will be the best to use, with the additional *B* and *C* battery voltages specified by the manufacturer. For 135 volts plate, the *C* battery should be 9 volts.

The loop antenna, which is shown in the picture, has an untuned primary. Fig. 1 indicates the manner in which the loop windings are connected. The loop may be constructed from two pieces of 1 x 1 in. wood 29 in. long fastened together

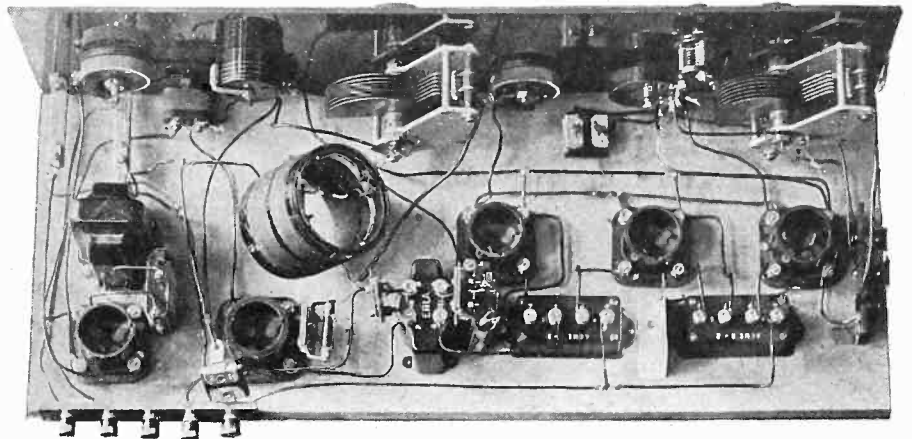

View of Completed Set.

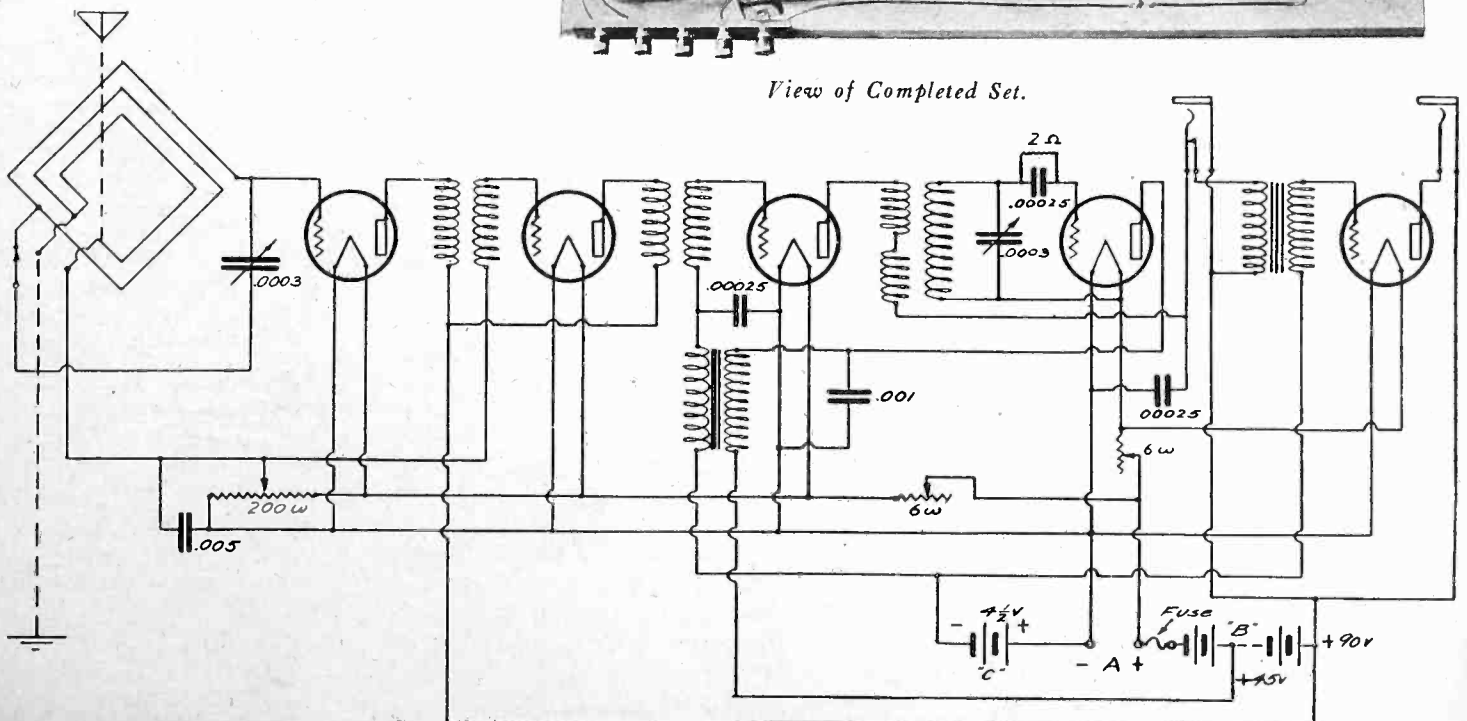

Fig. 1. Schematic Wiring Diagram.

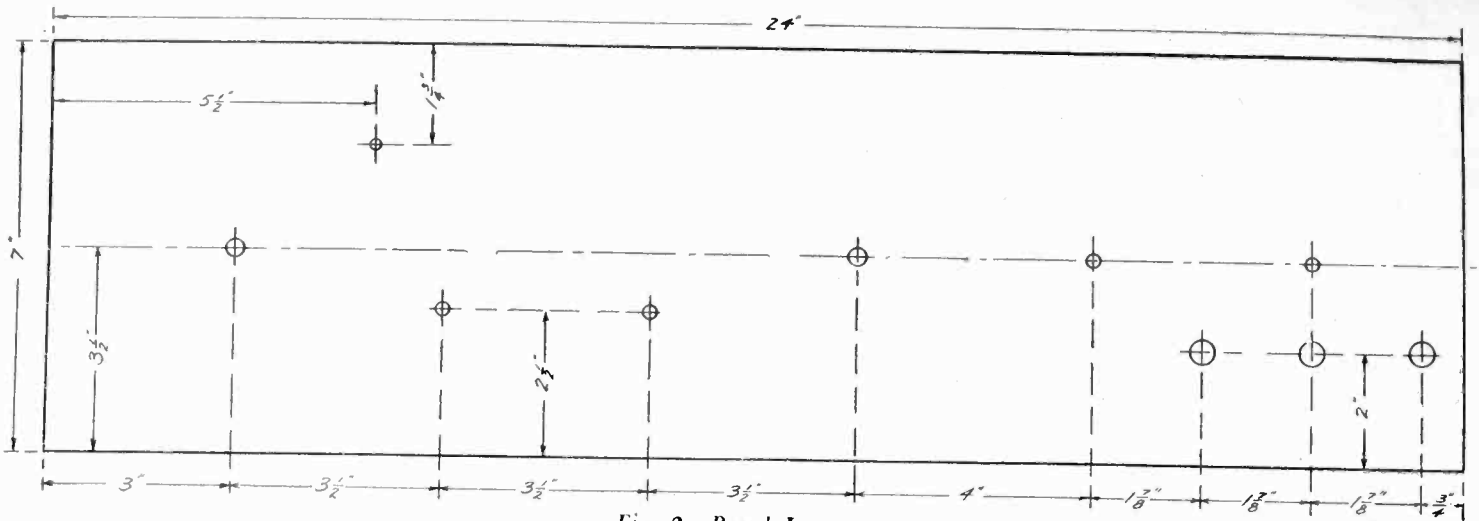
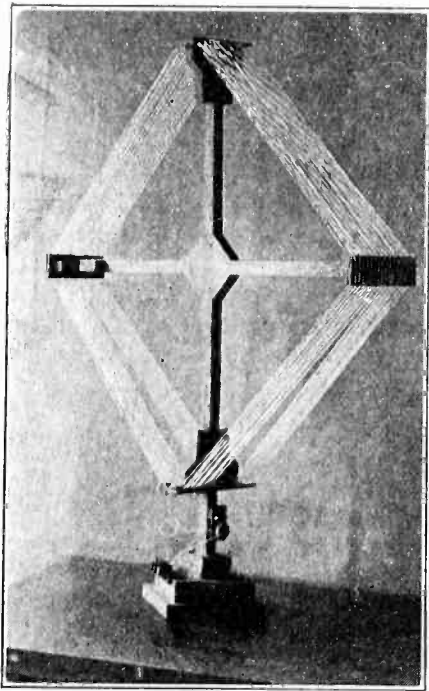

Fig. 2. Panel Layout.

in the form of a cross as shown in the illustration. To each end of the cross



Appearance of Two Winding Loop.

glue a piece of bakelite 5 1/2 in. long and 1 1/2 in. wide, grooved at top and bot-

tom to support 20 turns of wire spaced 1/4 in. apart. A swivel base of conventional design enables swinging the loop to the desired angle, and the terminals are mounted on the base, with pigtail leads to the loop. The untuned primary consists of 4 turns of No. 18 d. c. c. wire wound in the opposite direction to the secondary, which consists of 16 turns of No. 18 wire, tapped at the second turn. The tap is at the end of the secondary nearest the primary winding, and is brought out to a small two point switch which is mounted on the side of the loop. With the untuned primary, the antenna may be connected if extreme distance is desired, and if the loop without the antenna is satisfactory, the primary winding may be disregarded. When using both the antenna and ground, the dotted lines in Fig. 1 show the proper connections. The grid return lead should go to the end of the loop opposite to the antenna connection, although this is not necessary if a small indoor antenna should be used.

In operating the set, the usual precautions and tests should be made to locate any possible short circuits in the wiring, before connecting the batteries

and placing the tubes. The best plan is to connect the *A* battery and light the filaments of the tubes, after which the positive *A* connection should be successively made to the 45 and 90 volt positive *B* terminals. If the filaments light, or a spark is seen when the connection is made, there is a short which should be located before the *B* battery is connected. These tests should be made with the suggested fuse out of the circuit. The volume control is obtained by means of the 200 ohm potentiometer, the slider of which is connected to the grids of the first two r. f. tubes. The potentiometer may work satisfactorily with only the grid of the first r. f. tube connected, in which case the second r. f. tube grid may be connected to the negative 4 1/2 volt *C* battery terminal. For convenience in tuning, a vernier condenser of .00005 mfd. capacity may be shunted across the first tuning condenser, although a vernier dial for this condenser will obviate the necessity of the extra control. In the experimental set, two *C* batteries are shown, but one battery can be made to do the work of two, as is shown in the wiring diagram.

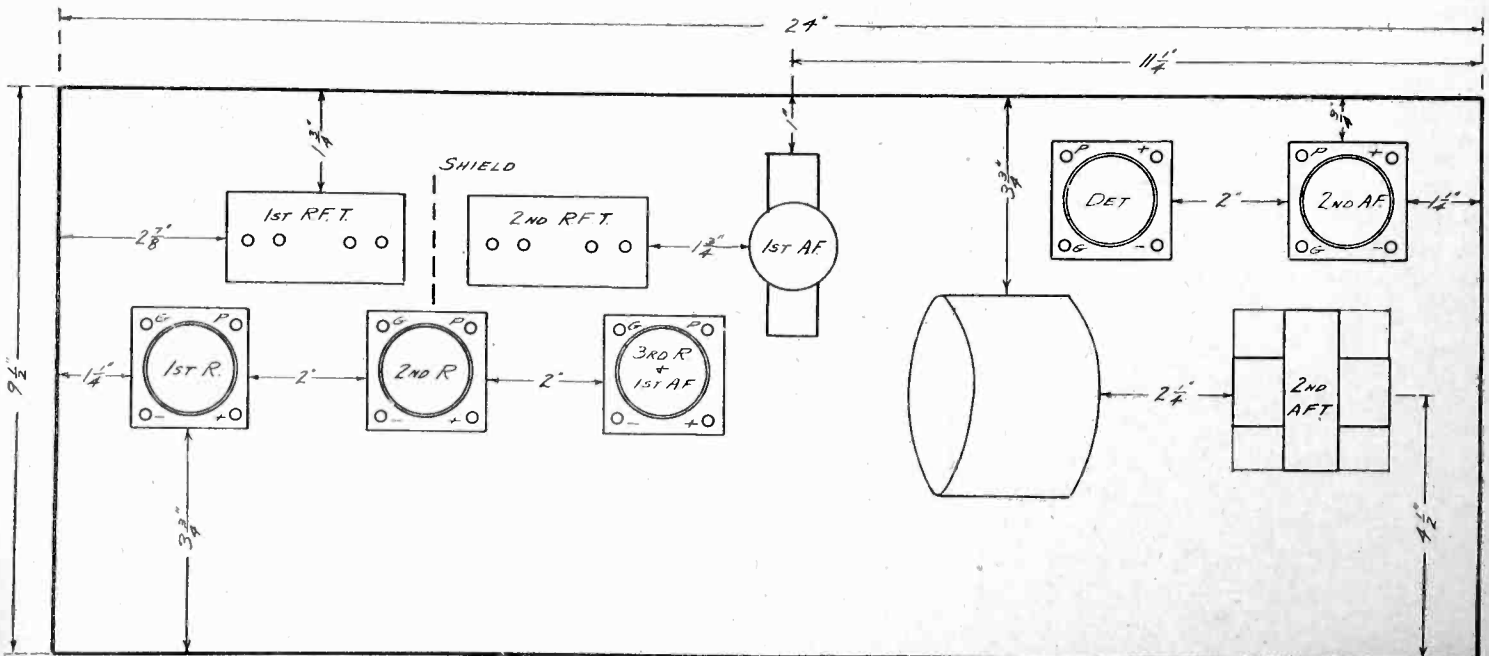

Fig. 3. Arrangement of Baseboard Apparatus.

Building for the Future

Complete Directions for Building a Simple Radiocast Receiver for Hearing the Very Short Wavelength Transmissions

By Harry A. Nickerson

THE AMATEUR, who is primarily interested in telegraphy knows a great deal about the very short waves, having tried the various single and double circuits with a few improvements of his own. It is unnecessary to tell him what he should be able to hear below 100 meters, but the radiocast listener has much to learn about that wave band.

First, what can one hear on a low-wave set? The amateur would say "Code, and lots of it," which is true. "Ah," says Mr. B. C. L. "Not for me. I hear more commercial code than I want on my 200 to 550 meter playground, so why bother with code below it?" As a matter of fact, on these low waves, there are stations radiocasting the same programs that are heard on the 200-550 band of waves, although the listener-in on short waves is quite likely at times to feel that he is entering into a great field of silence out of which comes pure music, unmarred by the squeals of regenerative receivers, the heterodyning whistle of overlapping radiocast transmissions, and the subdued background accompaniment of the persistent local radiocaster, who will never quite "tune out."

What stations are using the low wavelengths? In the eastern part of the country, KDKA operates between 60 and 70 meters and WGY usually at 100 meters, along with a host of other stations. To be sure, the "host of others" is not listed in the call books and many of them would much rather they were not heard on low waves at all. The explanation is that many of the stations have audible so-called "harmonics" on, say one-half of their normal or fundamental wavelength. Some stations have louder harmonics than others and many stations which have harmonics audible locally would not send out these harmonics with sufficient volume to be audible at a distance.

It often takes considerable skill to tune in these harmonics, because they are so weak in volume, and the "space" occupied on the tuning dial is but a small fraction of a degree.

In order to get comfortably loud signals on distant stations it is suggested that one stage of audio amplification be used with any short wave set. The writer has heard WGY and KDKA down stairs on a speaker, with short wave set located in Boston, Mass., us-

ing one stage of audio. Of course a great deal depends on location of the receiving set and unless one heard WGY or KDKA well on the normal broadcast wavelength, it should not be expected that WGY and KDKA would come in well on their special experimental low waves.

A high ratio audio transformer theoretically should give greater amplification than the lower ratios and for one stage of audio, distortion should not be noticeable. The writer uses one of the General Radio 5.95 to 1 ratios, not because of the high ratio, but because in practice it seems to give high and equal amplification. A second stage of audio may be added to the "hook-up" shown in Fig. 1 in the usual manner. At least

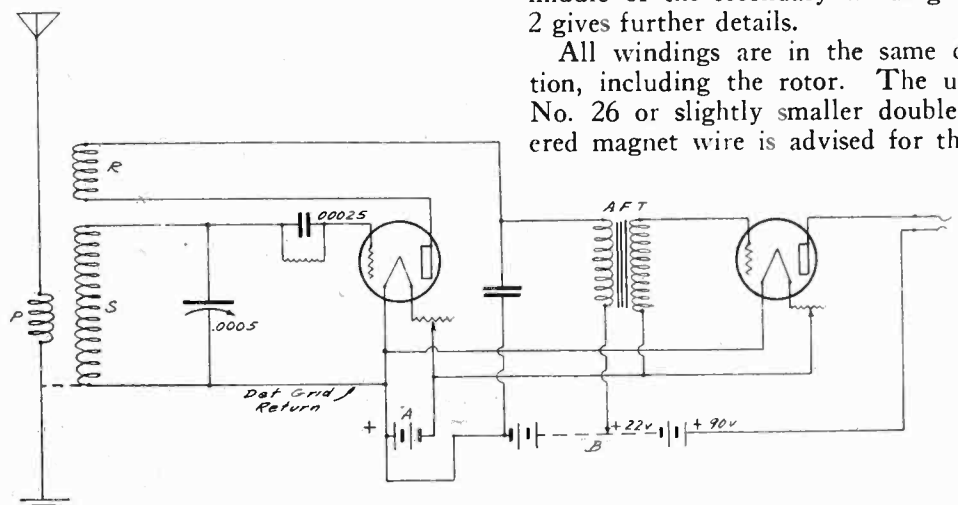

Fig. 1. Circuit Diagram for Short Wave Radiocast Receiver.

67 volts should be used on the plates of the audio stages in order to get good volume. The detector tube alone does not give satisfactory volume even for headphones, except possibly for nearby stations.

The easiest way to "make" a 100 meter set is to buy one of the manufactured tuners specially designed for the purpose and assemble it in a set. An ordinary coupler, preferably of the 180 degree type may be rewound with the proper wire and number of turns, for low wave work.

It seems like going back into the "dark ages" to describe the making of an ordinary variocoupler, when this has been so long a time used in radio, but since the one to be described is simple and of rather low "losses," the description is given. If a coupler is made according to directions, the difficulty some-

times experienced in "getting the set to work" is not likely to be experienced.

A pasteboard tube dipped in boiling paraffin is used for the stator; a paraffined wooden rotor is mounted on a hollow brass shaft, which turns in bushings set into the walls of the stator. Double cotton covered No. 16 or No. 18 magnet wire is used for the winding, principally because it is cheaper and easier to procure than silk covered. The stator may be 3 to 4 in. outside diameter, with the equivalent of about 12 turns on a 3½ in. tube as the secondary and 5 turns on the same tube as the "untuned primary." The rotor or "tickler" should have the equivalent of about 14 turns on a 2½ in. ball rotor. The shaft bushings are placed at the middle of the secondary winding. Fig. 2 gives further details.

All windings are in the same direction, including the rotor. The use of No. 26 or slightly smaller double covered magnet wire is advised for the ro-

tor,—the idea being to give a large inductance in the rotor with only a small amount of metal in the wire to act as one plate of a condenser with the stator winding as the other. The added resistance of the smaller wire in this particular part of the circuit is of trifling importance.

By cutting an opening in the hollow shaft of the rotor, inside the wooden ball, pigtail connections may be brought out to the rear. By running these pig-tails direct to the binding post "P" on tube socket and B Plus on audio transformer, losses incident to most commercial couplers may be saved.

The rotor may be kept properly centered between the bushings by using a piece of metal tubing slipped over the rotor shaft between the rotor and wall of stator at the front, while at the other end of the shaft, a coil spring, with

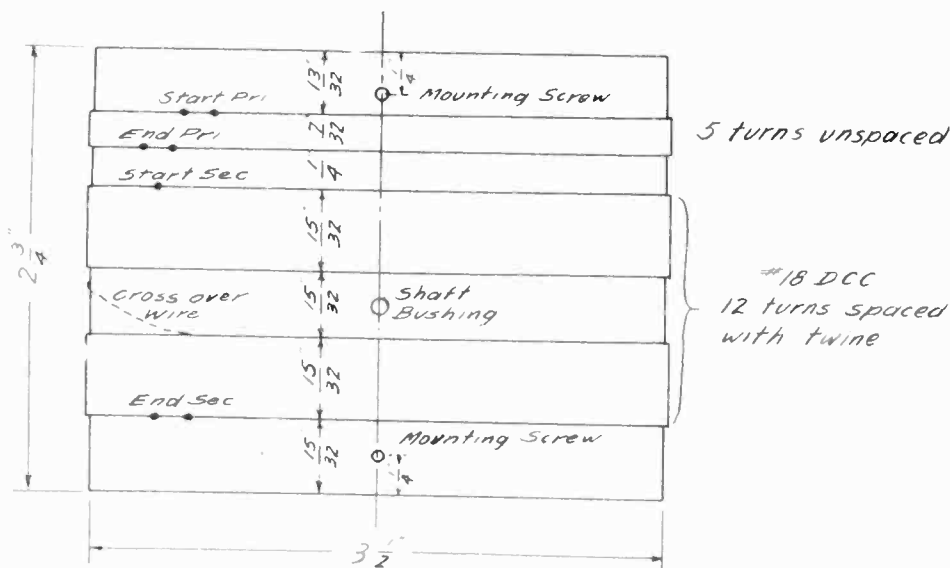

Fig. 2. Stator of Short Wave Coupler.

washers to protect the wall of the stator and rotor, may be slipped over the shaft to keep it from turning too freely. A piece of busbar swaged into an opening in the shaft wall so that rotation of the shaft will cause the busbar to strike a small machine screw in the panel is a simple form of stop. Sometimes the ridge inside a dial may be used as a stop, striking against the projecting head of a machine screw driven into the panel front.

The coupler may be mounted on the panel of the set with a machine screw inserted near top and bottom of the stator tube, keeping the coupler well away from the panel by use of spacers cut from a piece of hollow brass tubing.

Builders of "untuned primary" sets of the double circuit type shown in Fig. 1 often are troubled with a "dead spot" at some low wavelength setting of the tuning dial. If such a spot appears, one method of eliminating it is to insert a small value of fixed condenser in series

with the antenna lead.—a value even smaller than .0001 mfd. may be necessary. This smaller value of fixed condenser may be obtained by connecting two or more .0001 mfd. in series.

Fig. 3 shows a method of connection whereby with switch arm and switch points, either the full 5 turn untuned primary, a tapped (3 turn) untuned primary, or the 5 turns in series with a fixed .0001 mfd. condenser, may be used. The aerial should not be longer than 50 ft. The insertion of the small fixed condenser, however, will permit the use of a somewhat longer antenna with good results. It is suggested that trial be made with and without the fixed condenser in series, and that the switch arm and points be not incorporated permanently into the set unless necessary. The addition of such points and the switch lever, with extra wiring, means so much more in the way of "losses."

A long antenna of say 125 ft. will

probably cause a strong local station, operating on a fairly low wavelength, to "come in all over the set," although the set may pick up low wave stations rather well, even with a long antenna.

With all respect to the more conventional method of "lining up" detector and amplifier tubes, whereby the detector tube is placed at the right hand side of both coupler and tuning condenser, it is demonstrable that shorter, more direct leads may be had by placing the detector tube socket between coupler and condenser, preferably with the coupler at the right hand side. This not only

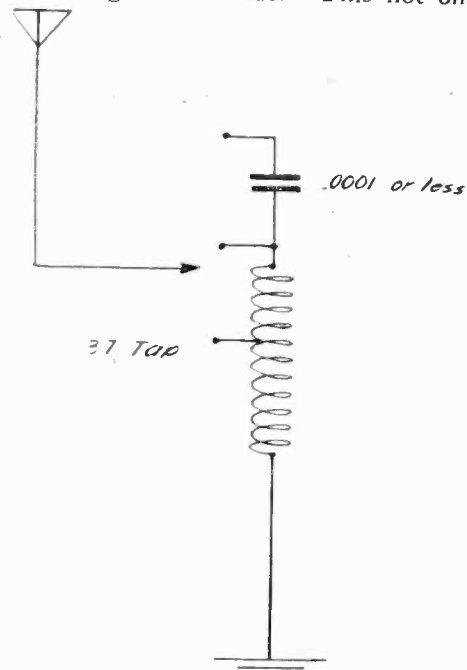

Fig. 3. Method of Connecting Coupler.

keeps the grid leads short but permits the plate lead from the rotor to be kept short.

At least a 7 x 12 in. panel should be used to mount detector and one stage of audio. The coupler and variable con-

(Continued on Page 82)

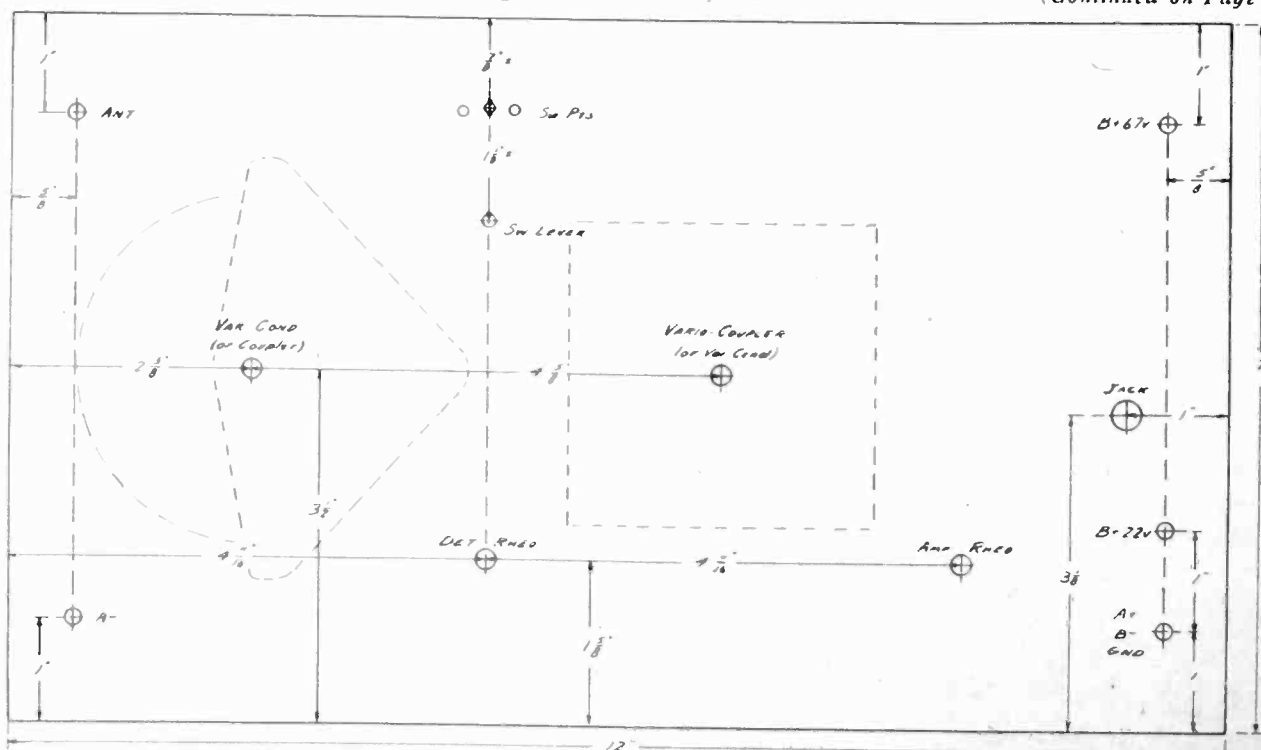

Fig. 4. Panel Layout for Detector and One Stage of Audio.

The Vacuum Tube as a Generator

The Simple Theoretical Basis for an Understanding of the Design,
Construction and Operation of Amateur Transmitters

By Lieut. Jennings B. Dow, U. S. N.

BY CONFINING attention to those properties and characteristics of a vacuum tube which enable it to function as a generator of electrical oscillations it is possible to get a better understanding of the action of a radio transmitter than may be obtained when the text is confused by a discussion of its action as a detector or amplifier. Fig. 1 shows the plate and filament portions of a vacuum tube circuit, without present consideration of the grid circuit. It includes an *A* battery for heating the filament and a *B* battery for maintaining the plate at a positive potential.

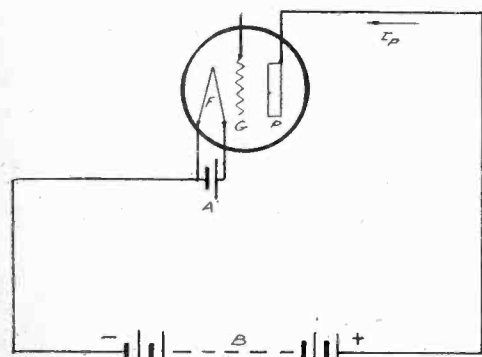

Fig. 1. Plate and Filament Portion of Vacuum Tube Circuit.

If the filament is heated by the battery *A*, it will emit electrons into the evacuated space surrounding it, the number depending upon the temperature of the filament, its composition, diameter, and length. For a given filament, the number of electrons emitted per unit time will be constant if the filament temperature is constant.

If the plate is made positive with respect to the filament by connecting a *B* battery into the circuit, a flow of electrons will be established between the filament and plate, the negative electrons being attracted by the positive plate. This movement of electrons constitutes an electric current flowing in the plate circuit. Because of the convention adopted before the electron theory was understood, an electric current being assumed to flow from the positive to the negative terminal whereas the electrons actually move from the negative to the positive, this current is conventionally indicated as flowing from the plate to the filament inside of the tube and from filament to plate in the external circuit. The number of electrons attracted to the plate, and conse-

quently the strength of the current, will be dependent upon the plate potential. As shown by A_1 of Fig. 2, the plate current increases from zero with zero plate potential to a certain limiting value.

When all of the electrons emitted by the filament are attracted to the plate, no further increase in plate potential will

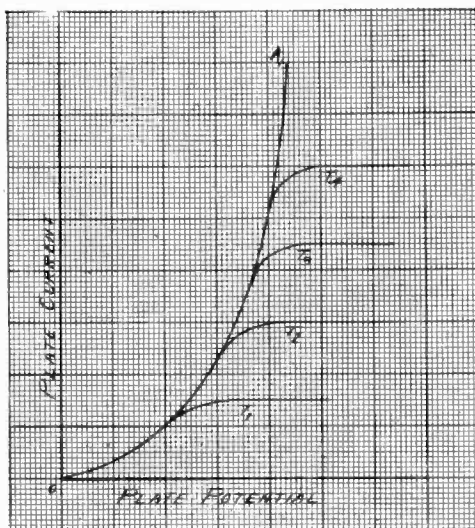

Fig. 2. Relation of Plate Current to Plate Potential at Different Filament Temperatures.

cause an increase of plate current. This is indicated by the curve T_1 of Fig. 2. At this point the tube is said to have reached the saturation point for a given filament temperature. If the filament temperature is increased to a value of T_2 , the plate current can rise until a new saturation point is established as indicated by the flat portion of this curve. The plate current may therefore be increased by increasing the filament temperature until the condition of equilibrium is reached wherein all of the electrons emitted by the filament are attracted to the plate at the same rate as they are emitted.

Next, consider that a fixed positive potential is applied to the plate as the filament is gradually heated. Before the filament reaches a temperature where electron emission begins, no plate current will flow. As the filament is heated, more and more emission occurs. Due to this fact and to the fact that the electrons move with a finite velocity, there is always present in the space between plate and filament a cloud of electrons which has been designated, by common usage, a *space charge*.

As the filament is further heated a

new condition of stability ensues wherein no increase in plate current will result with increasing filament temperature. At this point, the quantity of electrons, or the negative *space charge*, is in excess of the amount which the plate, at the given potential, is able to attract. When this condition is reached, it is necessary to increase the plate potential to obtain an increase in plate current. The family of curves shown in Fig. 3 is typical of this condition.

Effect of Gas in Tube. What has already been stated applies only in the case of a perfectly evacuated tube. As

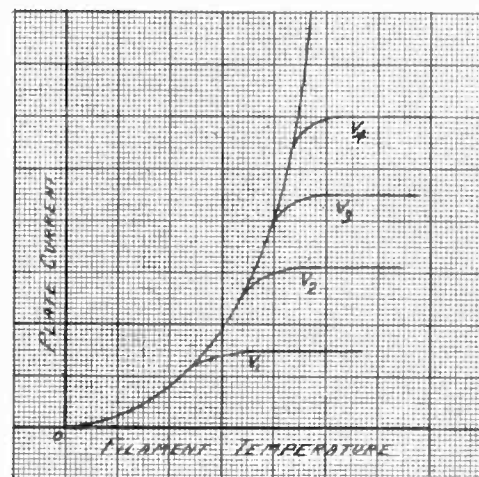
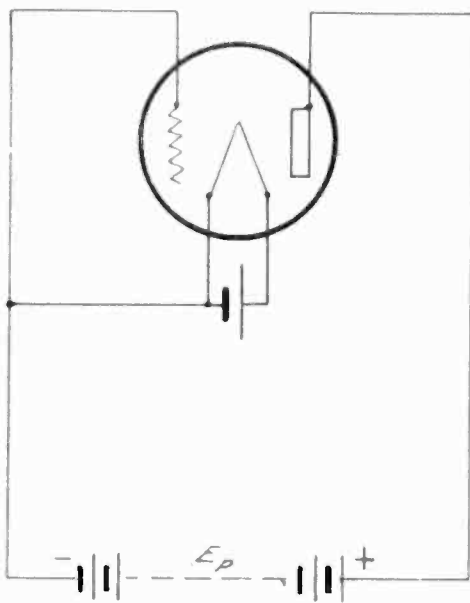

Fig. 3. Relation of Plate Current to Filament Temperature at Different Plate Potentials.

this is only approximated in practice, it will be well to consider the effects of gas within the tube. Since the velocity of the electrons attracted by the plate is dependent upon the plate potential, and since this velocity often reaches a value of many miles per second, their kinetic energy is sufficient to break down the gas into free electrons and ions. The ions move to the filament, and the electrons to the plate, resulting in an increase of plate current just as though more electron emission took place as a result of increasing the filament temperature. The well known blue glow is indicative of the presence of gas within the tube, and it will be observed that this blue glow usually begins around the plate where the electrons have reached the maximum velocity.

The Grid. Let us now consider the effect of the grid or control element between the filament and plate as shown in Fig. 4(a) where the *B* battery potential E_p causes an electric field between



(a)

Fig. 4(a). Unbiased Grid.

the plate and the filament. The grid is at the same potential as the filament because of the connection indicated. The effect of the plate is to attract the electrons through the openings in the grid. If the grid is nearer to the filament than is the plate it is obvious that we can nullify the effect of the plate by putting a negative potential, as in Fig. 4(b), on the grid, this being less than the plate potential. But if the grid were very close to the plate, as compared to its

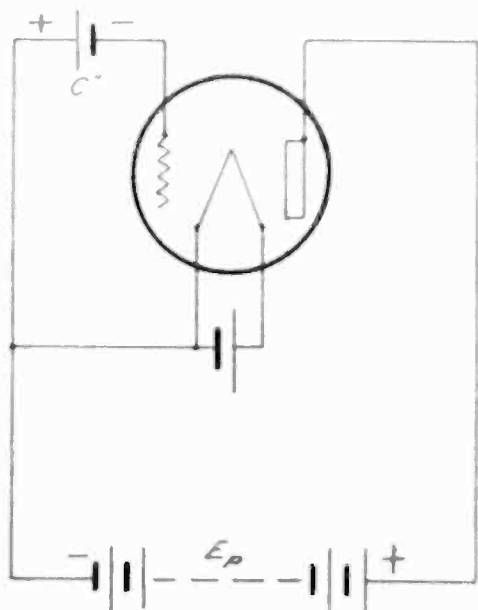

(b)

Fig. 4(b). Biased Grid.

proximity to the filament, this negative potential would have to be almost equal to the plate potential in order to nullify it.

Consequently, it is evident that the negative potential required on the grid to nullify the effect of the plate in attracting electrons, and thereby establish a plate current, varies directly as the positive plate potential, and inversely as a factor depending upon the construction of the grid and the distance be-

tween grid and plate. This factor is called the amplification factor of the tube and is conventionally represented by μ .

The grid may therefore be considered as a valve, which, by its potential, regulates the flow of current in the plate circuit. The greater the amplification factor of the tube, the less will be the change in grid potential required to produce a given percentage change in the plate current.

The internal plate resistance is so-called because, like the energy loss due to the ohmic resistance of a conductor, an energy loss as heat is caused by the impingement of the electrons on the plate. As the plate potential is increased sufficiently the resulting increased velocity of the electrons develops enough kinetic energy to make the plate white hot.

If, with constant grid voltage, the plate current is plotted against plate potential for present types of low power transmitting tubes, a curve will be obtained resembling the solid line in Fig. 5. Assuming that the resistance of the

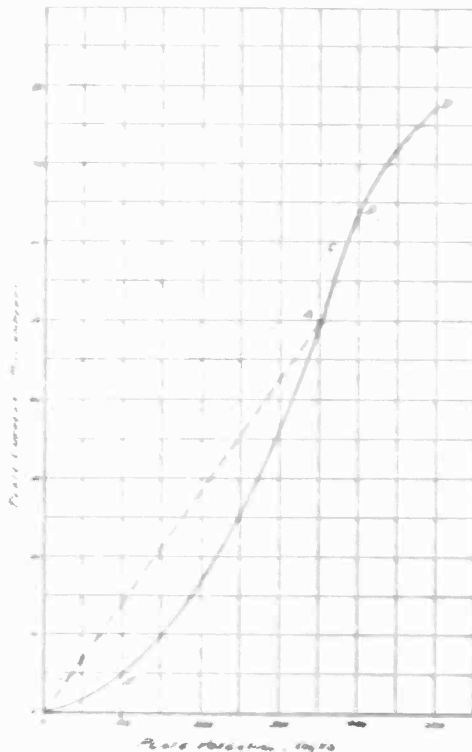

Fig. 5. Curves of Internal Plate Resistance.

external plate circuit, including the B battery, is negligible, the internal direct current resistance of the tube at any point A, when the plate potential is 350 volts and the plate current 50 milliamperes (.05 ampere) is equal to $350/.05$ or 7000 ohms. (Ohm's Law).

If the slope of the dotted line OA represents the ratio of plate current to plate potential, the inverse slope is the ratio of plate potential to plate current, which has just been shown to be equal to the internal direct current resistance of the tube. Likewise, the inverse slope of the solid line at any point A is defined as the internal a. c. plate resistance at that point, this being the quan-

tity we are generally interested in when studying tube behavior.

Because the slope of the solid curve is not constant, the internal a. c. resistance is not constant. At some point C, where the slope of the curve is a maximum, the internal resistance is a minimum. At any other point it is greater, becoming almost infinite for zero plate current. Between two points such as E and C of Fig. 5, it can be shown mathematically that the a. c. internal plate resistance is one-half of the d. c. value, as is also evident by inspection of the dotted and solid lines.

Internal Plate Impedance. When a tube is used as an oscillator, the plate current, instead of being steady, is pulsating, behaving very much as would an alternating current with respect to capacities and inductances. So at very high frequencies, the capacity of the plate with respect to the other elements of the tube becomes an important factor in its behavior. When consideration is given to the effect of this plate capacity, the term "internal plate impedance" is often used in contrast with the internal a. c. plate resistance. For practical purposes at ordinary frequencies no harm results from using the terms interchangeably.

The amplification factor of a tube is dependent upon the size of the grid wires, the distance between the wires and the distance between grid and plate. It may be computed approximately from these constants or may be experimentally determined, as can likewise the internal plate resistance or impedance. By definition, the amplification factor of a tube is the ratio of plate and grid potential variations which will produce identical plate current variations.

Dynamic Characteristics. The static characteristics of any tube are those resulting from a study of the tube in its cycle of operation with various constant plate potentials and variable grid potentials. In order to understand the phenomena attending the operation of the tube in a circuit wherein the constants of the plate circuit influences its behavior, recourse must be made to the dynamic characteristics.

(The author here makes a quantitative analysis of the static and dynamic characteristics of a typical oscillating circuit. This is omitted because it is of little interest to most readers who are concerned with the qualitative deductions. In general, it is shown that the impedance of the external plate circuit, which may be very great and is in the nature of a resistance, greatly reduces the plate current, whereas, with an oscillating current in the grid, the plate potential may be much greater than the constant potential source.—Editor.)

Mutual Conductance. This important quantity is a measure of the effect of grid potential upon the plate

current. It is numerically equal to the quotient of the amplification factor and the internal plate resistance measured under dynamic conditions. Its value is a direct measure of the value of a power tube.

Since the internal plate resistance is not constant, so the mutual conductance is not constant. Consequently, its average value must be used. It is decreased by the resistance in the external plate circuit.

Oscillation Generator. Now that consideration has been given to all the factors which affect the behavior of an oscillating tube and the action of the grid in controlling the current in the plate circuit, let us connect a tube as a generator E in a simple circuit consisting of inductance, capacity and resistance in series, as shown in Fig. 6.

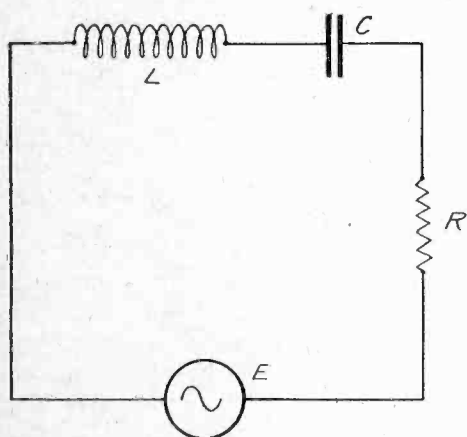

Fig. 6. Simple Oscillating Circuit.

If this circuit is put in resonance, either by changing the frequency or by changing the value of L and C , the effective current I is equal to E/R . In the construction of an oscillating circuit, R is made as small as possible by the use of large wire or tubing in L and by using a condenser C with low internal losses. Thus the current, at resonance, may rise to a high value.

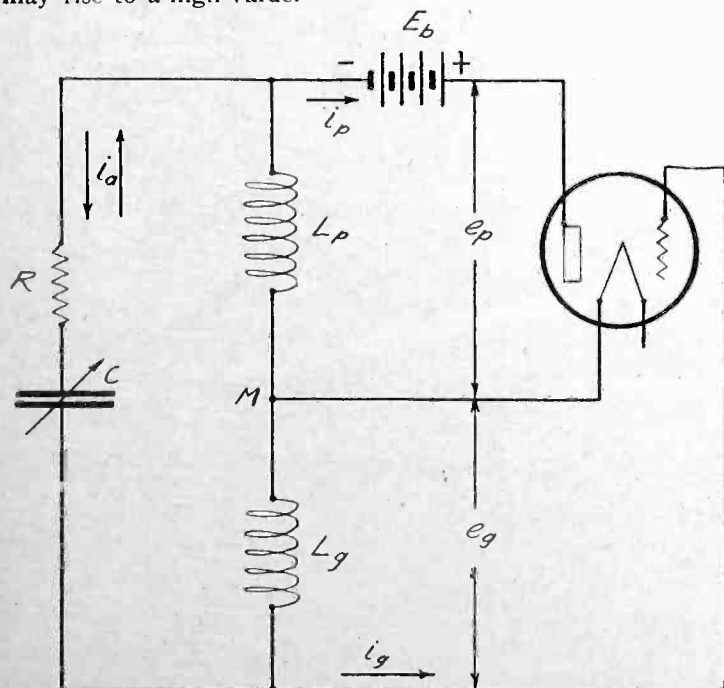

Fig. 7. Direct Coupled Generating Circuit.

The oscillating circuit of a simple tube transmitter may be thought of as a capacity C in the form of an antenna and the inductance L , which includes the coil in the antenna circuit as well as the inductance of the antenna and ground leads. The resistance R depends upon a number of things, the more important of which are:

1. The radiation resistance and other constituents of antenna resistance.
2. The plate-filament resistance of the tube.
3. The grid-filament resistance of the tube. This is of negligible moment when the grid is negative.

The current which flows in the oscillating circuit of a tube transmitter is therefore governed by a number of resistances. Notwithstanding this fact, the effect of such resistances may be made small enough to make the oscillating current in the output circuit of Fig. 7 very great for the value of plate potential impressed across L_p .

Fig. 7 represents the so-called Hartley circuit, which is typical of the circuits used for generating oscillations. The grid and filament of the tube are connected to the branched circuit containing inductance and capacity, constituting the oscillatory circuit, in such a manner as to include a portion of the inductance of that circuit, that is the coil L_g . Likewise between the plate and filament of the tube is included the coil L_p . In this particular circuit no mutual inductance exists between L_p and L_g .

Suppose, first, that the tube is not generating oscillations. Under the action of the plate battery a steady current will flow from the plate to the filament inside of the tube and from filament to plate through the coil L_p in the external circuit. The magnitude of

this current will vary with the voltage of the grid; it can become zero when the grid is highly negative but can not reverse in direction. Also there can be a flow from grid to filament inside the tube, the current returning from filament to grid through the coil L_g in the external circuit. This latter current is appreciable only when the grid is positive with respect to the filament. Except for effects which are extraneous to this treatment, this current is also unidirectional.

When the tube is in the oscillating condition, these currents will not be steady, but will become pulsating. The pulsating currents generated by the tube enter the circuit from the filament and leave it through the plate and grid connections; they are pulsating, and not alternating, on account of the unidirectional conductivity between filament and plate and filament and grid. The circuit $L_g L_p C$ is resonant to the fundamental constituents of these pulsating currents, and an oscillatory current is generated so as to circulate around this branched circuit, flowing in series through the condenser C and the coils L_p and L_g . This current, which will be called the output current, can be many times greater in amplitude than either of the pulsating currents.

The pulsations in the steady current, which flows during the static condition from the filament to the plate, are caused by periodic variations in the potential of the grid with respect to the filament; these variations in grid potential are induced in the grid coil L_g by the output current. There is a similar voltage induced by the output current across the plate coil L_p .

It is true of this circuit, and typical

(Continued on Page 84)

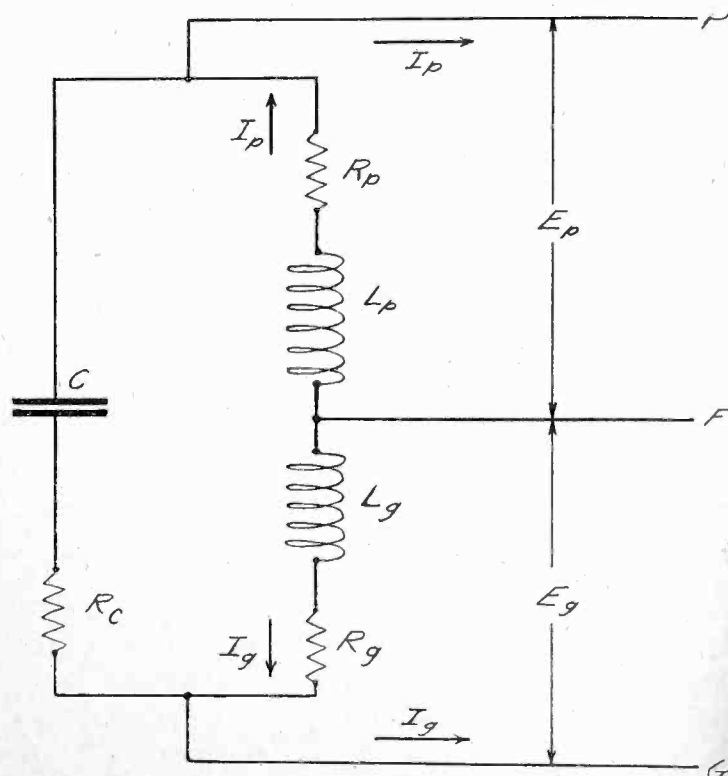

Fig. 8. Output Circuit of Fig. 7.

The Life of a "B" Battery

An Analysis of the Factors Whereby it May Be Lengthened

By Arthur Hobart

THE probable life of a *B* battery of the dry cell type can be predicted from the conditions under which it is to be used in a radio receiving set. Several of the manufacturers have conducted tests, from the published reports of which it is possible to determine when the battery will reach the end of its useful life.

The first factor in such a determination is the personal judgment of the user as to when a battery is dead. The sound intensity from a loud speaker decreases as the battery gets older. So the smaller the volume that satisfies the user the longer the battery is alive. One widely accepted standard sets the "cut off" voltage of a 22½ volt battery at 17 volts. This will be adopted as our basis of comparison.

The larger batteries, being made up of large cells, live proportionately very much longer than the small batteries. The products of different manufacturers vary somewhat in weight but the average small 22½ volt battery weighs about one pound, the medium size about two pounds, and the large size about five pounds. The corresponding sizes of 45 volt batteries are almost twice as heavy, the extra large 45 volt type weighing about fourteen pounds.

Tests show that 5 milliamperes will be delivered for 100 hours by a small battery, for 300 hours by a medium one, and for 1000 hours by a large one of the 22½ volt type. Thus an increase of 5 times in weight gives 10 times the number of hours of service for the same rate of current supply.

The greatest single factor in reducing the current drain on a *B* battery and therefore in prolonging its life, is the use of a *C* battery in all amplifier circuits. When properly installed, this also improves the quality of sound delivered by a loud speaker. The *C* battery supplies a negative voltage to the grid of the vacuum tube. The greater the negative voltage, within reasonable limits, the less the *B* battery consumption. A 4½ volt *C* battery will give three times the life to a 90 volt *B* battery supplying 201-A or 301-A tubes. Approved practice calls for the use of 1½ volts *C* battery with 45 volts *B*, 4½ *C* with 90 *B*, and 9 volts *C* with 112½ to 135 volts *B* battery.

Then again, the greater the current drain (the more tubes used), the shorter the life. Thus a large battery may give 5 milliamperes for 1000 hours and 25 milliamperes for only 100 hours.

Another important factor in the life

of a battery is the manner of its use. If a 22½ volt battery is used two hours a day until it finally drops to 17 volts it will give nearly twice the number of hours of service as if it were used continuously. Practical tests are based on intermittent use.

The final general factor is the age of the battery when put into service. A battery deteriorates somewhat when standing idle. The small batteries have an idle life of about one year. The large batteries are usually good for 18 months.

Therefore it is evident that the small batteries should be used only when the available space or the desirable weight is limited. The greatest life and consequently the greatest economy is secured by using the large sizes. For multi-tube sets having a heavy current drain the extra large size should be used. And always should it be remembered that the highest efficiency in the use of batteries for amplifiers is secured only by adding a *C* battery.

These general facts are specifically illustrated in the accompanying curves taken from the report of one manufacturer. These curves are plotted from the results of many tests and represent an average that may be used as a basis for calculation.

Fig. 1 graphically illustrates the decrease of the service hours with increase

of current drain on 1, 2 and 5 lb. batteries. It shows, for instance, that 10 milliamperes will not be supplied by a 1 lb. battery, that a 2 lb. battery will have a life of only 100 hours in such service while a 5 lb. battery is good for 400 hours, or say six months under such conditions.

Fig. 2 shows the average *B* battery current drain for an *A* type 5 volt tube at various plate voltages and with various grid bias or *C* battery voltages. Similar information for a small 3 volt tube is shown in Fig. 3. By the use of these curves it is possible to determine how much current is drawn by a tube and from this to determine the required *B* battery capacity as shown in Fig. 1.

Consider, as an example, a five tube neutrodyne with two stages of radio frequency, detector, and two stages of audio, using "A" tubes. Comparatively few of these sets have a *C* battery when sold, as only one neutrodyne manufacturer has secured a license for its use. It is common practice to employ four 22½ volt *B* batteries to supply 90 volts to the amplifier tubes, two of them also being used to supply 45 volts to the detector.

It will be noted from Fig. 2 that for 90 volts *B* battery and zero grid potential (no *C* battery) each amplifier will draw down 5¾ milamps, or 23 milamps

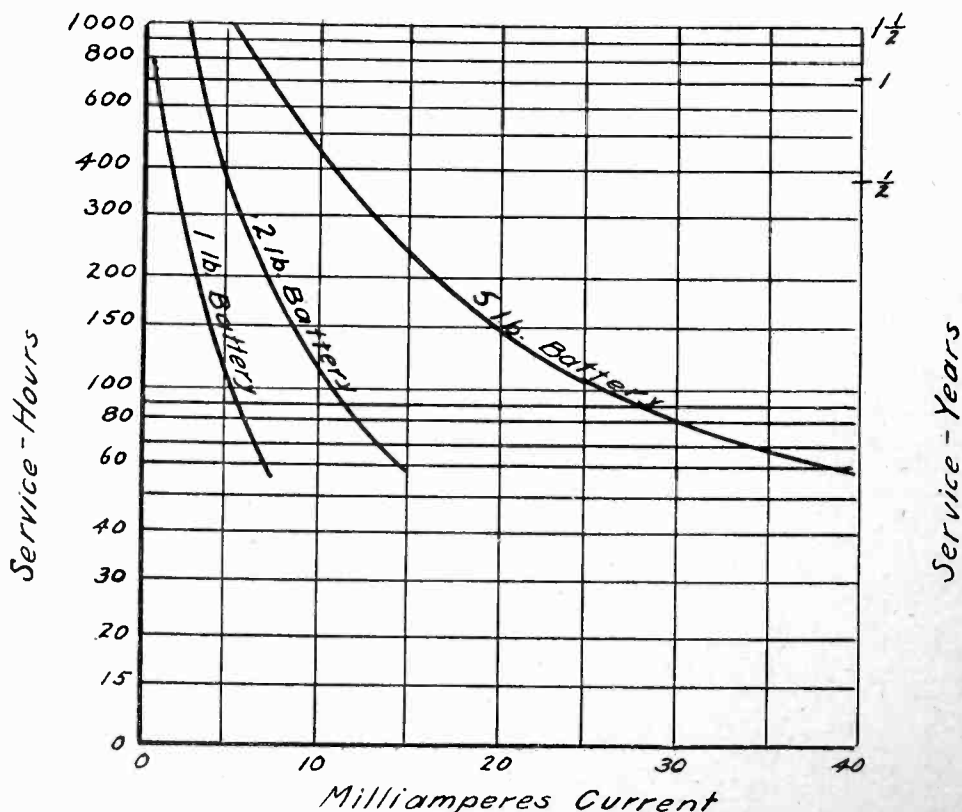

Fig. 1. Relation of Service-Hours to Current Drain.

for the four, and that the detector will draw down $1\frac{1}{4}$ milamps, a total of $24\frac{1}{4}$ milamps. From Fig. 1 it will be noted that a 5 lb. battery will give 25 milamps for 100 hours, which places a probable battery life of less than one month for average use.

On the other hand, the addition of a $4\frac{1}{2}$ volt C battery, as may be noted in Fig. 2, will reduce the current drain to $2\frac{1}{2}$ milamps for each amplifier, or 10 milamps for the four. By reference to Fig. 1 it may be seen that this drain should give a B battery life of over 300 hours. Thus one C battery costing 60 cents will more than treble the life of four B batteries costing \$8.00. Obviously the pair of batteries supplying only the amplifiers will have a slightly longer life than the two supplying both the detector and the amplifier.

In the same way it is easy to calculate the advantage of using a large battery, particularly in multi-tube sets. Consider, for instance, an 8 tube superheterodyne using dry cell tubes with 45 volts on all but the two audio tubes, which have 90 volts. Good design in such a super calls for $1\frac{1}{2}$ volts C battery on the oscillator and the three intermediate frequency amplifier tubes, and $4\frac{1}{2}$ volts on the first detector and two audio tubes, there being no grid bias on the second detector.

Consequently the B battery consumption may be estimated from Fig. 3. The

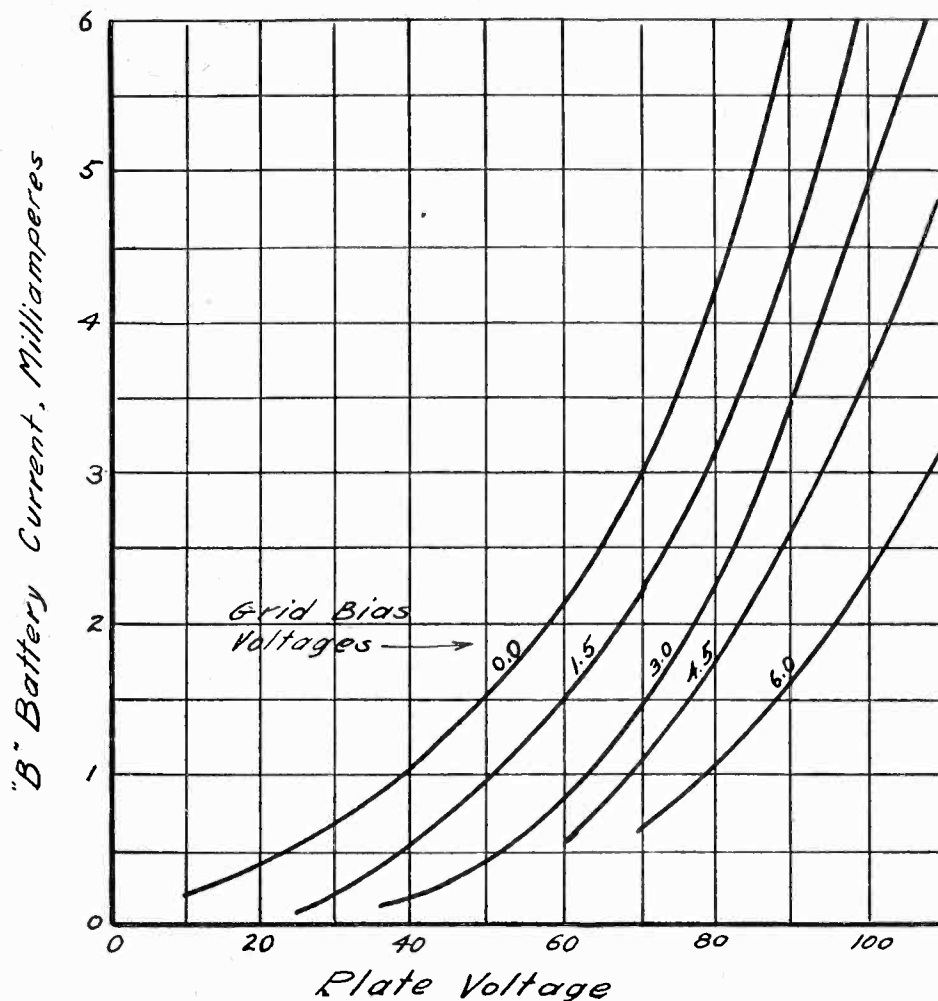

Fig. 2. "B" Battery Drain Caused by "A" Tubes.

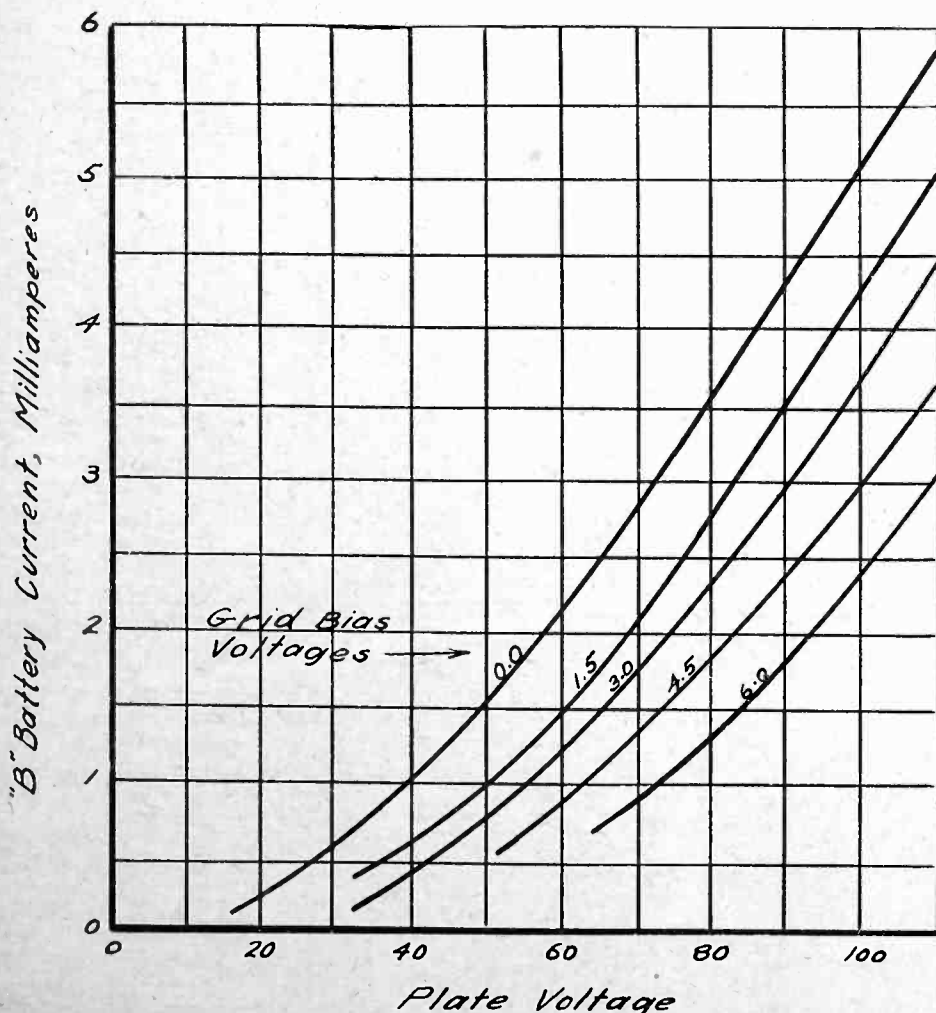

Fig. 3. "B" Battery Drain Caused by "99" Tubes.

second detector requires 1.3 milamps; the oscillator and three intermediate frequency amplifiers 0.75 milamps each, or 3 milamps for the four; the first detector needs 0.6 milamps; and each audio 2.4 milamps; a total of 9.7 milamps. Thus less B battery is required for this 8 tube super than for the 5 tube neutrodyne with C battery, due largely to the use of the smaller tubes.

While on the subject of dry cell batteries, it is of interest to consider them as a source of filament supply. A single dry cell, whatever its size, supplies $1\frac{1}{2}$ volts. Thus the $22\frac{1}{2}$ volt B battery is made up of 15 cells connected in series. Two in series gives 3 volts, the requirements for the filament supply of a "99" type tube. But as the voltage drops with use it is customary to connect three in series and cut down the excess voltage with a rheostat.

The standard A battery cell is 6 in. in height and $2\frac{1}{2}$ in. in diameter, weighing about 2 lbs. Its normal and most efficient rate of discharge is from $\frac{1}{8}$ to $\frac{1}{4}$ ampere to an end voltage of 1 volt. The average ampere hour capacity is about 25, giving a theoretical life of 100 hours for a $\frac{1}{4}$ ampere rate and 200 hours for a $\frac{1}{8}$ ampere rate of discharge.

The UV-199 or C-299 tube requires .06 ampere filament supply. Four of these tubes draw down about $\frac{1}{4}$ ampere.

(Continued on Page 74)

The Neon Tube as a Rectifier

By William H. Fortington, English 6 AG.

OF THE three general methods of rectifying an alternating current for use in an *A* or *B* battery eliminator—the hot cathode or electronic emitter, the chemical or electrolytic, and the gaseous conduction tube—the last seems to offer the greatest possibilities. This is especially so in the case of the neon tube, which the writer finds will pass a heavy current and has long life when used in the *B* battery eliminator to be described.

The rectifying action of this tube, like that of any other gaseous conductor, depends upon a great difference in size between the electrodes. The polarity of the electrodes changes with each half cycle, so that if one has a much greater area than the other, the larger will throw off many more electrons and establish a uni-directional current by ionizing the gas in the tube. Other determinants are the pressure and purity of the gas, the quality of the material of which the electrodes are made, the frequency of the current, and the voltage with reference to the distance between the electrodes.

The essential parts for a *B* battery eliminator using a neon gas tube are the tube, a 110-240 volt transformer, a choke coil, two condensers that will withstand 500 volts; one 6 mfd., the other 4 mfd. and a fixed or variable resistance of sufficient ohmage to supply the required voltages.

A neon tube may now be bought from most radio or automobile supply dealers. The general arrangement of the parts is shown in the circuit diagram of Fig. 1.

The transformer may be bought or may be made up by the experimenter. The core is built up of laminated strips of silicon steel $\frac{3}{4}$ in. thick, having overall dimensions of $2\frac{3}{4}$ x 3 in., the laminations being staggered or overlapping. The primary winding consists of 1100 turns of No. 27 enamel on double silk covered wire. The secondary has 2400 turns of No. 32 or 33 wire. Where enamel wire is used the winding must be layer wound.

A suitable choke for use in the filter

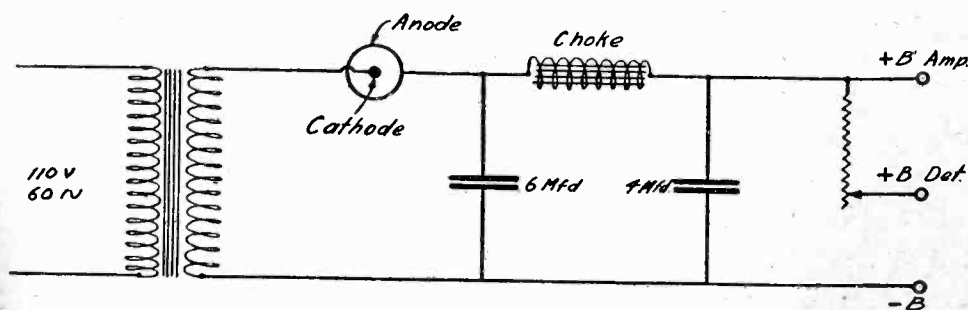

Fig. 1. Circuit Diagram for Neon Tube "B" Eliminator.

circuit may be composed of 15,000 turns of No. 33 double silk wire, scramble wound on a suitable former. The lamination for the iron core should be L shaped, not staggered but having an air space at their point of contact. This tends to keep the saturation point of the core down. Only good condensers should be used, as the writer has experienced considerable trouble due to

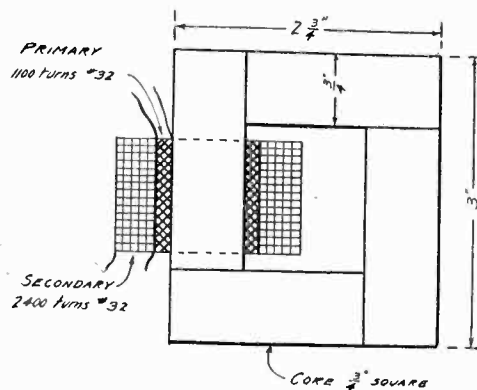

Fig. 2. Transformer Cross Section.

breakdown. Some means of varying the detector circuit output is desirable, and a variable resistance capable of carrying at least 10 milliamperes should be used.

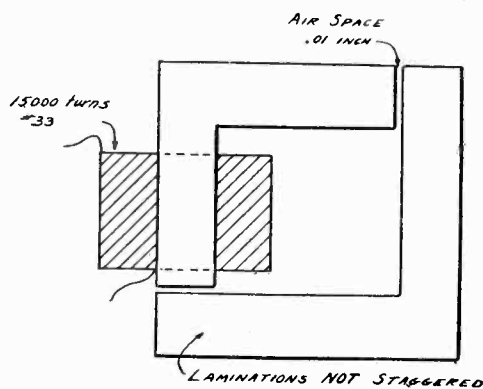

Fig. 3. Choke Coil Cross Section.

The carbon compression type of resistance is suitable for this purpose.

There is infinite scope for experiment along these lines, utilizing gaseous conduction tubes as rectifiers. Perhaps the most successful gaseous tube on the market is the commercial tungar, as used in

battery chargers. This is the hot cathode or filament type rectifier employing argon gas as a conducting medium in the tube. It has of course the disadvantages of having a filament to burn out, although its life is perhaps more pronounced than other types of rectifier tubes. It is capable of passing severe currents.

While on the subject of filamentless gaseous tubes, it might be mentioned that the writer has at present a tube capable of passing $\frac{1}{4}$ of an ampere, and simultaneously rectifying both sides of the wave. By employing one tube to accomplish full wave rectification the differences in the characteristics of two separate tubes is overcome. At present this tube is in an experimental stage, and it is hoped that details will be available later.

KINK FOR MOUNTING A VARIABLE CONDENSER

By CHARLES F. FELSTEAD, 6CU

To make a neat job of mounting a variable condenser without the aid of a template is a very difficult feat unless some stunt is employed to locate properly the holes for the shaft and mounting screws of the condenser. When a dial is to be used on the condenser, such extreme care in locating the holes for the mounting screws is not so necessary because the holes are hidden; but when a knob and pointer are used, neatness is necessary for the sake of appearance.

A simple way to do this is first to find the exact place where the condenser is to be mounted on the panel, and then to drill a hole there that will fit the condenser shaft snugly. The screws are taken out of the mounting pillars on the condenser, and the pillars smeared on the ends with red lead or paint. The shaft is then put through the hole in the panel from the back, and, taking care that it is held level, the condenser is pressed firmly against the panel. The exact center of the rings of red lead or paint left on the panel by the mounting pillars can then be center-punched and drilled.

When mounted, the condenser should be found to fit perfectly if care has been taken in the drilling. The hole for the condenser shaft can now be enlarged to $\frac{1}{2}$ or $\frac{3}{4}$ in.; so there will be no chance of the condenser shaft binding, and so the dial or pointer and knob can run perfectly true without hindrance. This enlarged hole also helps to better insulate the condenser, for air is a superior insulator to bakelite or hard rubber.

The Helium Tube Rectifier

An Account of the Theory and Practical Construction of
A New "B" Battery Eliminator

By Edwin E. Turner

A RECTIFIER for use in B battery eliminators should possess certain qualifications, in order that the device as a whole will prove equal to the exacting task which it is called upon to perform. These are: complete rectification, long life, good regulation, high voltage output, high current output and stable characteristics. A new helium tube, which closely approximates the ideal, has been placed

PARTS REQUIRED

- 1 Raytheon Type B rectifier tube.
- 1 Power transformer, General Radio Type 365, Dongan Type 509.
- 2 Choke coils, Dongan Type 514, General Radio Type 366 (1 required).
- 5 2 mfd. Tobe Deutschmann, Dubilier-Filter.
- 1 1 mfd. Tobe Deutschmann, Dubilier-Filter.
- 1 .5 mfd. Tobe Deutschmann, Dubilier-Filter.
- 2 .1 mfd. Tobe Deutschmann, Dubilier-By-Pass.
- 1 Variable resistance, 10,000 to 100,000 Bradleyohm, Centralab Potentiometer.
- 1 Fixed resistance, 10,000 ohms, Daven.

trode the smaller is the back current and hence the more complete is the rectification.

Heretofore the difficulty of insulating the positive electrode in the presence of a gaseous discharge gave a practical limitation to the reduction of its size. But

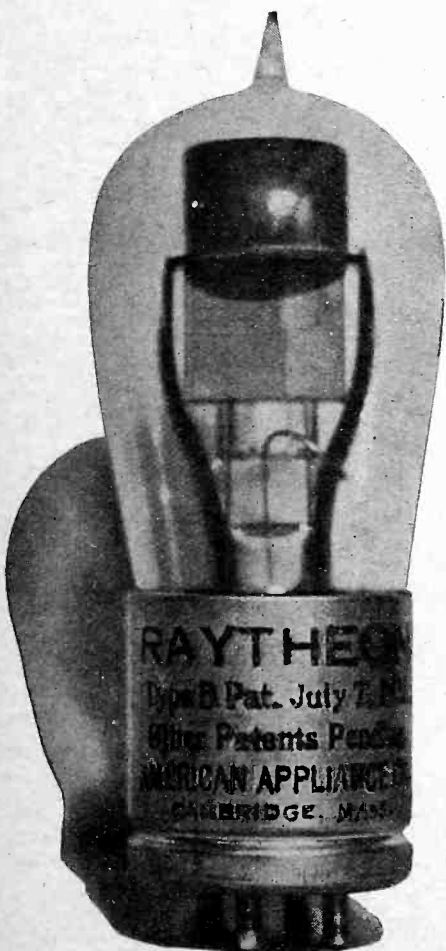

Fig. 1. General Appearance of Helium Tube.

on the market under the trade name of "Raytheon." The tube is an outgrowth of the same fundamental electrical laws which gave rise to the "S" tube, but it is a new development in itself. Full wave rectification is performed in the single tube, rectification is unusually complete, the regulation is good and the life of the tube, when subjected to the conditions of ordinary reception, is unusually long.

This gaseous rectifier operates upon "the short path principle," whereby a rarified gas acts as an insulator between points which are in close proximity. This is an apparent contradiction of the ob-

served phenomenon that the smaller the distance between two points the more readily a spark will jump between them due to the ionization of the gas. But if the distance is small enough and a suitable gas is used at sufficiently low pressure an electron may encounter no gas molecules in its path between the points and there will be no ionization by collision. Consequently the inert gas helium may be made to act as a perfect insulator at low pressures.

Furthermore it has been found that when the larger electrode of a gas conduction tube is negative there is a greater current flow than when the smaller electrode is negative and that the smaller the positive relation to the negative elec-

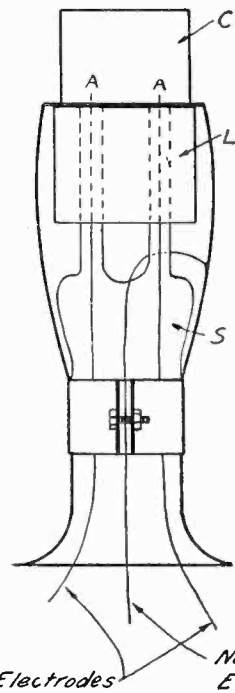

Fig. 2. Constructional Details of Helium Tube.

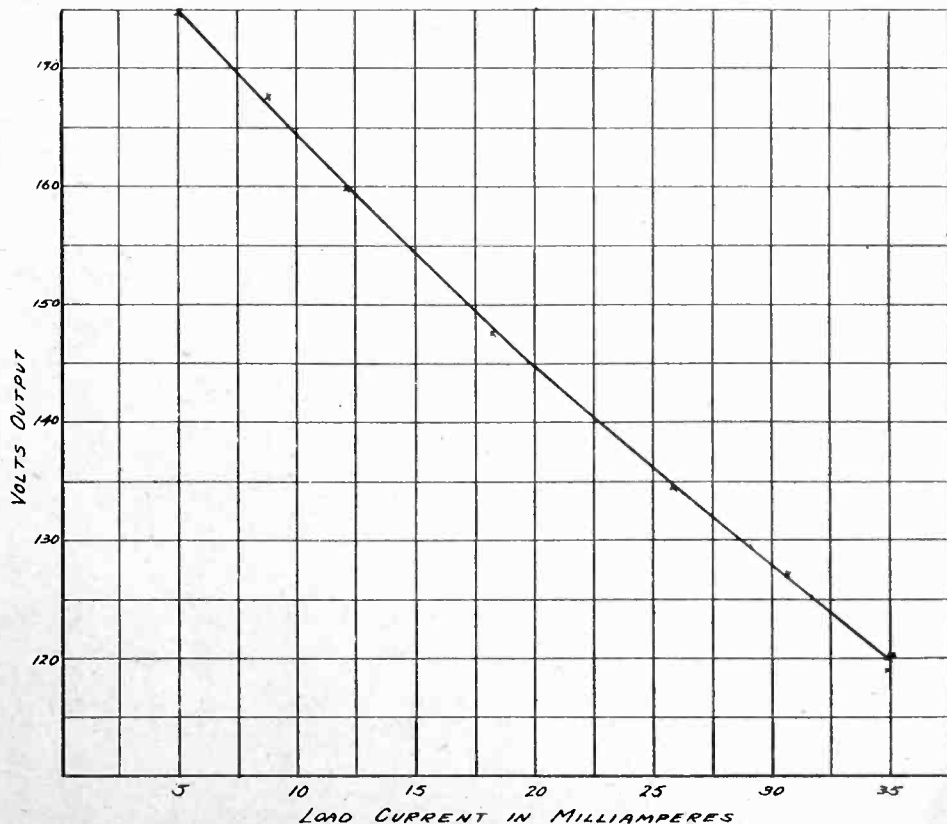

Fig. 3. Regulation Secured in "B" Battery Eliminator.

in the tube the "short path principle" eliminates the difficulty.

Fig. 1 indicates the appearance of the tube and Fig. 2 shows its construction. The two small positive electrodes *AA* are carried through two small glass tubes imbedded in a lava insulating block *L* so as to project very slightly into a relatively large cup *C* whose walls constitute the negative electrode, being connected to the negative terminal through the base. The diameters of the small wires and the diameters and position of the holes whereby they enter the cup are so proportioned as to give the necessary short path to the negative electrode. The cup *C* contains helium gas at such low pressure as to prevent gaseous conduction.

This gives an insulation of great reliability and long life. It makes possible extremely small anode surfaces which reduce the back current to a negligible quantity. The urgent necessity for the reduction of back current in a rectifier to be used in battery eliminators is not generally recognized. Beside shortening the life of the insulation as above described, back current increases the load on the filter circuit, making the elimination of the hum almost impossible. It lowers the current and voltage output of the device and makes for poor regulation. The regulation of the model built by the author is shown by the curve of Fig. 3. This regulation is partly a function of the filter circuit used.

A *B* battery eliminator, using the new rectifier is shown in Fig. 4. The schematic diagram of the eliminator is given in Fig. 5, the constants being shown for all apparatus.

The input voltage of 110 volts 60 cycles is passed through a transformer, shown at the right of Fig. 4, which delivers a secondary voltage of 250 on each side of the center tap. The rectifier, operating during both halves of the cycle delivers a pulsating direct current to the filter system *L*₁, *L*₂, *C*₃, *C*₄ and *C*₅ in Fig. 5 which smooths out the variations, delivering a pure direct current to the resistances *R*₁, *R*₂ and to the external load. The terminal voltage of the de-

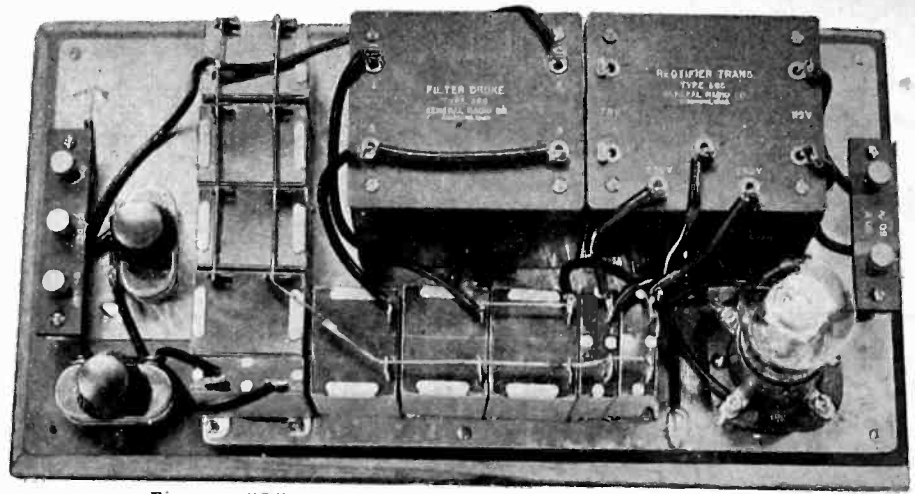

Fig. 4. "B" Battery Eliminator Using Helium Tube.

vice is lowered by means of the voltage divider *R*₁, *R*₂, so that a suitable low value may be obtained for the detector. Condenser *C*₆ is used in shunt to the fixed carbon resistance *R*₂ to prevent carbon noises.

For those who want to construct their own power transformer, the following data will be useful: Core is 3/4 in. square and is built in the form of a square window having inside dimensions of 1 3/4 in. on each side. The primary is wound with 1220 turns of No. 28 enameled wire, over which is wound the secondary, which consists of 5440 turns of No. 33 enameled wire, with a tap at the center turn. A layer of thin paper should be placed between each layer of wire, and a piece of empire cloth should be used between the primary and secondary windings.

The choke coil may be made by winding 6000 turns of No. 31 enameled wire on a core having a square window 2 in. on a side, and having a cross section 1/2 x 3/4 in. A 0.003 in. air gap should be provided at one joint of the core pieces.

In constructing the eliminator it should be noted that the cases of the transformer, the chokes and the condensers, together with one side of each condenser, the center tap of the transformer and one side of the fixed resistance *R*₂ are connected together and to the *B* minus terminal. In order to sim-

plify the construction and wiring, the experimental model was mounted on a brass plate secured to a wooden baseboard, the apparatus being grounded directly to the plate. In this way a major part of the connections are made through the plate, and with this method of construction the wiring is a simple matter.

The rectifier tube is designed to fit the standard 201-A socket. The two anodes, marked *FF* in Fig. 5 correspond to the filament terminals of the socket and the cathode *P* to the plate terminal of the socket. The grid terminal is not used and may be left without connection. The model shown in the photograph uses a second variable resistance of 10,000 to 100,000 ohms set at minimum in place of the fixed resistance of 10,000 ohms called for, since a fixed resistance of this value was not available at the time. The fixed resistance may be used here more economically.

In connecting the choke coils, if both windings are on a single core, care should be taken to have the polarity correct in order that the inductances are series aiding. Particular care should be taken in the selection of condensers for this device. It is important that the condensers have high internal resistance, high dielectric strength and that they agree within 10 per cent of their rated capacity. The choke coils may be had from a number of manufacturers who have built them to very rigid specifications. The filter circuit in this eliminator was designed by Prof. F. S. Dellenbaugh of the Massachusetts Institute of Technology, one of the foremost authorities on filter design. The performance on this particular type of plate supply is extremely gratifying, for it acts as theory dictates it should. On a ten tube superheterodyne receiver, using *A* tubes with a total current consumption of 37 milliamperes the hum was entirely negligible with the loudspeaker in operation. The quality was equal to that delivered by a storage *B* battery supply, which was alternated with the eliminator. On sets using less tubes the performance was slightly better, the hum being indistinguishable with the receiver unmodulated.

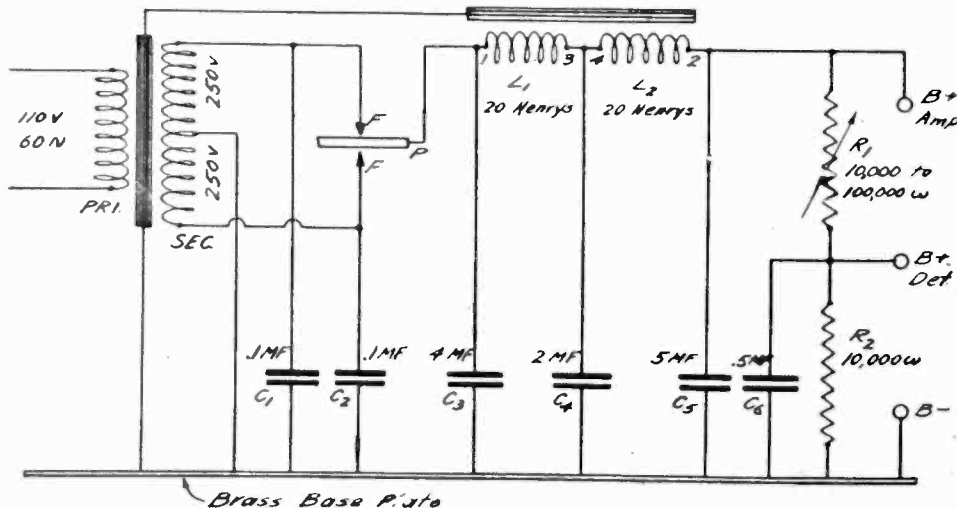

Fig. 5. Schematic Diagram of "B" Battery Eliminator.



QUERIES *and* REPLIES



Questions submitted for answer in this department should be typewritten or in ink, written on one side of the paper. All answers of general interest will be published. Readers are invited to use this service without charge, except that 25c per question should be forwarded when personal answer by mail is wanted.

Have a 5-tube Fada Neutrodyne and would like to know if it would be of any advantage for me to buy a Western Electric 25-A amplifier and cone type speaker. Will the speaker function properly with my set if I do not buy the amplifier, and if I use the amplifier, will it interfere in any way with the use of a Valley B battery eliminator?—H. A. C., San Francisco, Calif.

If your neutrodyne has an audio frequency amplifier equipped with C batteries, you can employ one of the new UX or CX-112 tubes in the last audio stage and operate the Western Electric speaker satisfactorily. Otherwise, you will require the 25-A amplifier in order to obtain real volume from the cone speaker. The use of the amplifier will not interfere in any way with the B battery eliminator.

Please show me how to add a stage of untuned radio frequency amplification to my Harkness two-tube reflex receiver. Will this extra stage complicate tuning?—J. H. L., Cicero, Ill.

In Fig. 1 is shown the circuit rearrangement, with an untuned radio frequency transformer for coupling between the 1st and 2nd r. f. tubes. If you are careful with your wiring and arrange the coils so that coupling is at a minimum, you may not need a potentiometer in the grid circuit, but if oscillation troubles result, the grid of the 1st r. f. tube should be connected to the slider of a 200 ohm potentiometer which is bridged across the A battery, instead of to the C battery as is shown in the diagram. One of the new balloon type inductances would be very satisfactory in the antenna

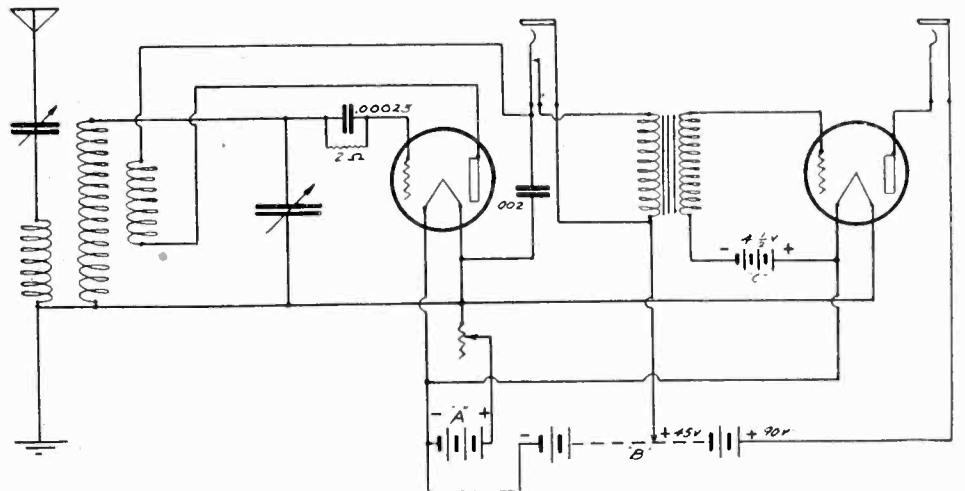

Fig. 2. Modifications of the "DX Bringer-In"

circuit, as it has no appreciable external field, and coupling from other parts of the circuit, to this coil, would be at a minimum.

Have built the "DX Bringer-In" set described in September 1923 RADIO and have had fine results with it. Wish to add another tube, and would also like to be able to tune in stations around 200 meters, which I cannot do at present.—J. C. H., St. Joseph, Mo.

A single stage of audio frequency amplification, using a high quality transformer, will increase your range somewhat, and will not necessitate great changes in the set. If you will use a condenser having a capacity of .0005 mfd. instead of the .001 mfd. condenser now used, your minimum wave-

length will be considerably lower than at present, and you should be able to tune to 550 meters, if you have 53 turns on a 4 in. tube, as specified in the article. Fig. 2 shows how to add the audio frequency stage, and shows improvements to the circuit as suggested.

I would like to know the input to my transmitting set, which uses a standard C-302 tube. The plate voltage is unknown, the plate current is 18 milliamperes, and the filament voltage 7½.—A. W. K., San Francisco, Calif.

If the plate voltage is not known, it is difficult to even hazard an estimate for the plate input. Assuming that the curves furnished by the E. T. Cunningham Co., in

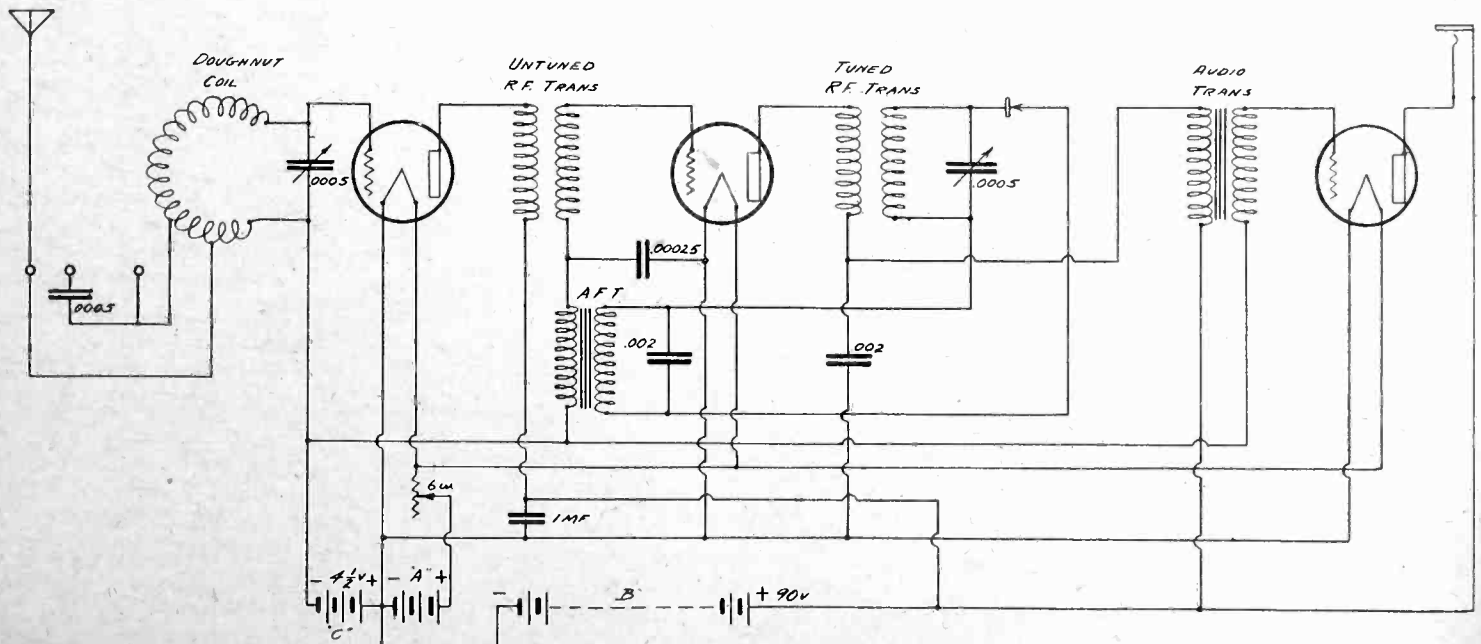

Fig. 1. Harkness Reflex With Radio Stage Added.

their tube data book, are correct for your particular tube, your plate voltage is 350, and in that case, your power input into the plate circuit is 6.3 watts.

Please tell me how the minimum receiving range of the 300 to 30,000 meter receiver described in February RADIO can be reduced to 30 meters. Would the addition of 2 stages of radio frequency amplification help, together with the use of straight line frequency condensers?—W. J. B., San Francisco, Calif.

The simplest method would be to construct special plug-in coils to fit the honey-comb coil mountings, for it would not be advisable to take taps from the coils provided for the 300 to 700 meter range. For a range from 30 to 100 meters, the primary should be 8 turns, the secondary 12 turns and the tickler 10 turns, all on 3 in. tubing. For 100 to 300 meters, the primary should be 20 turns, the secondary 25 and the tickler 20 turns. Radio frequency amplification with this type of receiver is out of the question, especially at the waves below 100 meters. Straight line frequency condensers will separate the stations at the lower end of the wavelength range better than the condensers shown in the article, but will not lower the range of the set.

Have built the Best Superheterodyne described in January, 1925 RADIO, and want to know if there would be any advantage in rebuilding this set according to the directions in the September issue? I wish to use all UV-199 tubes.—J. S. Riley, Kansas.

If you do not wish to receive on the very short waves, or at wavelengths above the present radiocast band, there is no particular advantage in rebuilding the set, especially since you want to use all dry cell tubes.

Could a neutrodyne coil be used in place of the coupler shown for use in the antenna tuner, in the Superheterodyne described in August RADIO? Could one stage of radio frequency amplification be added ahead of the frequency changer?—J. T. M., Wapato, Wash.

You can use the neutrodyne antenna coil if you wish, but the selectivity will be very poor compared with the circuit recommended. If you are at some distance from a high power radiocasting station, you will not need super-selectivity, and the untuned antenna primary circuit can be adopted. A radio frequency stage can be added, but this results in complications and is not recommended unless special directions for winding the coils are available. Read the article by A. J. Haynes in July RADIO, and you will see how the radio stage can be added. Mr. Haynes gives directions which can be applied to the Best superheterodynes without difficulty.

In building the Haynes De Luxe Superheterodyne described in February and July issues of RADIO, what ratio audio transformer may be used? Can a panel type battery switch be used instead of the knife switch? Will Baldwin Pacific, Remler or Branston intermediate transformers work in this circuit? I cannot locate any No. 24 S. C. S. S. wire recommended for the radio frequency transformer. What may be used in its place? H. P., Brooklyn, N. Y.

A transformer having a ratio not over 3:1 is recommended. It is better to use the knife switch, as the panel switch has too much capacity between the blades and will act as a small fixed condenser in a very undesirable place. Any of the intermediate transformers mentioned will work in the circuit. No. 24 double cotton covered wire can be substituted for the single cotton single silk wire.

Please publish a circuit for a good 5-watt transmitter, using rectified a. c. for the plate supply, to operate on 40 meters.—J. F., Porterville, Calif.

The circuit shown in Fig. 3 is for a 5-watt transmitter, using a reversed feedback cir-

and 45 volts to the tubes in the radio frequency end of the circuit, the ratio of the 120 volt line to the 45 volt supply is 2.7 to 1. Probably the wiring from the power mains to the house is not large enough to properly carry the load of the range as well as the

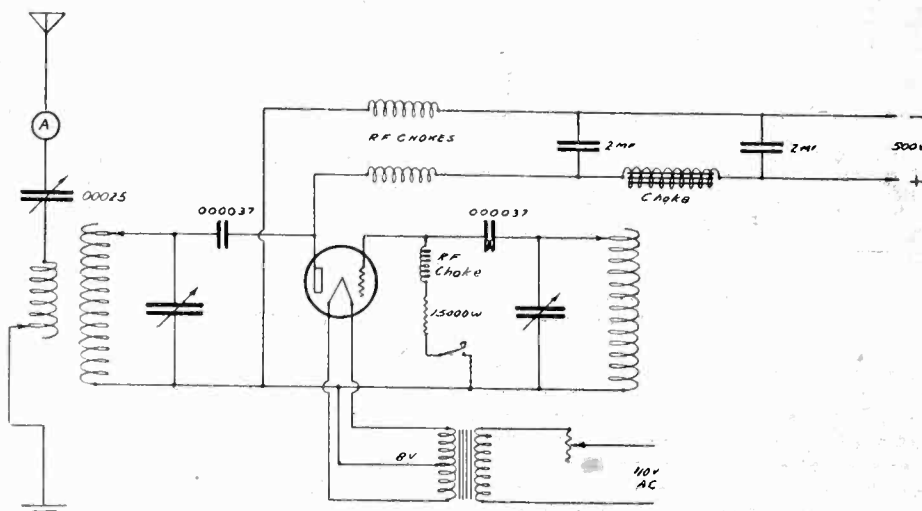

Fig. 3. Circuit for 5-Watt 40-Meter Transmitter.

cuit. See the article on this type of transmitter, on Page 39 of September RADIO. The circuit is almost identical with that used on the Yacht *Eloise*, and a description of the transmitter was given on Page 11 of the same issue. The key may be placed in the negative high voltage lead between the filter and the rectifier, or at any other conventional position that will produce no key click interference.

In the article by William Hawk on the construction of a cone type loud speaker, which appeared in August RADIO, no directions were given as to the best method of mounting the loud speaker element to the bracket. How can this be done?—C. L. P., Redding, Pa.

The receiver element should be fastened to a strip of wood which is placed across the bracket shown in Fig. 3e, in the article, so that the element is in the exact center of the circle. If no convenient holes are provided in the receiver element, the heavy magnet on the base of the receiver can be drilled and tapped for a 6-32 machine screw, and a hole drilled through the wooden strip to pass the screw, so that the receiver is firmly fastened in place.

The B eliminator which was described in June 1924 RADIO does not seem to give the proper voltage to the detector tube in my 7-tube superheterodyne receiver. What value of resistances should be used, and what changes in the set should be made to overcome the squealing which I get when using the eliminator.—R. M. B., Syracuse, N. Y.

A Bradleyohm, or other variable high resistance should be used to control the voltage of the detector tube, and a 2 mfd. condenser should be connected between the receiving set side of the resistance, and the negative B connection, to prevent oscillation due to coupling through the resistance. Without the condenser, the set will oscillate continuously.

I have a "B" battery eliminator, using UV-201-A tubes as rectifiers, for supplying plate voltage to an 8 tube superheterodyne. When the electric range in the kitchen is turned on, the signals from distant stations fade away, and it is necessary to adjust the battery eliminator before the station again becomes audible. What is the cause of this fading and how can it be eliminated?—E. E., Berkeley, Calif.

Assuming that your B eliminator is furnishing 90 volts to the audio frequency tubes,

house lights and a considerable drop in voltage results. This will affect the battery eliminator in proportion, and for a drop of 15 volts in the line, the 45 volt supply will be reduced to 38 volts, thus reducing the overall amplification in the superheterodyne receiver noticeably. It is then necessary to cut out some of the resistance in the eliminator, in order to bring the voltage back to normal. The only remedy possible will be the replacement of the existing conductors from the pole terminal to the meter with wires of larger size, which should be done by the power company.

The hinges on a radio cabinet can often be used to bring the leads from a loop to the inside of the set. This allows the loop to be mounted in the lid, and a suitable socket placed therein, without the usual trouble of either a socket inside the set, or binding posts on the front.

BOOK REVIEWS

"Vision by Radio. Radio Photographs" by C. Francis Jenkins, 140 pp. 6x9. Published by Jenkins Laboratory, Inc., Washington, D. C.

In its suggestions of future possibilities and in its record of past accomplishments this book demonstrates that the eye as well as the ear is soon to be served by radio. Each of the various systems now employed are briefly and clearly described, especial emphasis being placed upon that developed by the author. Many pictures of the equipment used and of the results attained are shown. The book should interest every radio experimenter.

"Radio in the Philippines" by Fred J. Elsen, 140 pp. 5x8. Published by the author at Manila, P. I.

The title of this interesting volume is a misnomer as it is really an elementary treatise on the principles of radio communication. It is written primarily to interest the neophyte BCL and amateur resident in the islands. Its chapters are concerned with radio reception, principles of radio propagation, antenna construction, simple transmitters, the radio telephone, formulas and regulations. The treatment indicates that the author is thoroughly familiar with his subject and has the ability to impart his knowledge to others.

With the Amateur Operators

AN UP-TO-DATE TRANSMITTING ANTENNA MAST

By A. BINNEWEG, JR., 6BX

When working on short waves below 80 meters it is possible to use a vertical antenna without the usual expense of erecting a very high mast. The antenna system described herein has proved so successful as regards efficiency and weather resisting properties that a short description of its construction will interest transmitting amateurs.

The pole which is shown in the picture, consists of three sections securely bolted together and well guyed. The lower section is a piece of 4 x 4, 24 ft. long, either sunk into the earth or bolted to the side of the shack. The next section consists of two 2 x 4's spaced 4 in. at the bottom and 2 1/2 in. at the top, the space between them being bridged with short lengths of 2 x 4 spaced 2 ft. apart at the bottom and 2 1/2 ft. at the top. This section fits over the 4 x 4, overlapping it 4 ft. and is bolted to it with three 9 in. bolts. The last section fits into the second for 5 ft. It may be either a 2 1/2 x 2 1/2 in., 26 ft. long, or, if one can be secured, a straight pole 3 to 3 1/2 in. at the butt and 2 1/2 to 3 in. at the tip. This is bolted into the preceding section, a clear view of the construction being shown in Fig. 1.

The material for a 65 ft. pole is as follows:

- 1 pc. 4 x 4 in. x 24 ft.
- 2 pcs. 2 x 4 in. x 24 ft.
- 1 pc. 2 1/2 x 2 1/2 in. x 26 ft. or 1 straight pole as described.
- 3 3/8 in. bolts (for bolting to shack).
- 3 3/8 x 9 in. bolts.
- 3 1/2 x 5 in. bolts.
- 1 3/8 x 30 in. galv. iron rod.
- 25 lbs. galv. No. 12 guy wire.
- 20 No. 0 screw eyes.
- 20 porcelain strain insulators.
- 140 ft. of rope.
- 1 galv. iron pulley.
- Paint as desired.

All wood should be free from knots and if the pole cannot be placed against a building, sink it 4 to 5 ft. in the earth and guy the first section securely with several heavy guys just below the first joint. Otherwise it will be exactly the same.

It will be well to give the lumb a coat of paint not only for preservation but for appearances also, light lead being preferable. When dry, drill three holes in the 4 x 4, as shown in Fig. 2 and set it against the shack in the desired position. If the shack is of the usual home brew variety, it may be well to sink the pole a few feet in the earth so as to prevent it from over-turn-

ing the building when a high wind comes along. Next drill three holes evenly spaced along the building and bolt through.

For the second section lay the two 2 x 4's side by side with 2 in. edges up and select the strongest end of the poles to serve as the bottom. Lay off 4 ft. 1 in. from the bottom and put in a 4 in. piece of 2 x 4, securely nailing from both sides of the poles. Now 5 ft. from the other end put in a similar piece 2 1/2 in. long and starting at the bottom, nail in a piece every 2 ft. for about 8

ft., and then every 2 1/2 ft., spacing the last few feet so as to come out even. Now drill the three 1/2 in. holes so as to exactly correspond with those drilled in the preceding section and drill 3 holes at the top, measuring them out and drilling from both sides. Be very accurate with these holes, as they are extremely important. If a pole has been secured for the last section, it must be cut down slightly to fit the preceding piece. About 5 ft. from the butt place a saw cut on opposite sides deep enough so the remaining

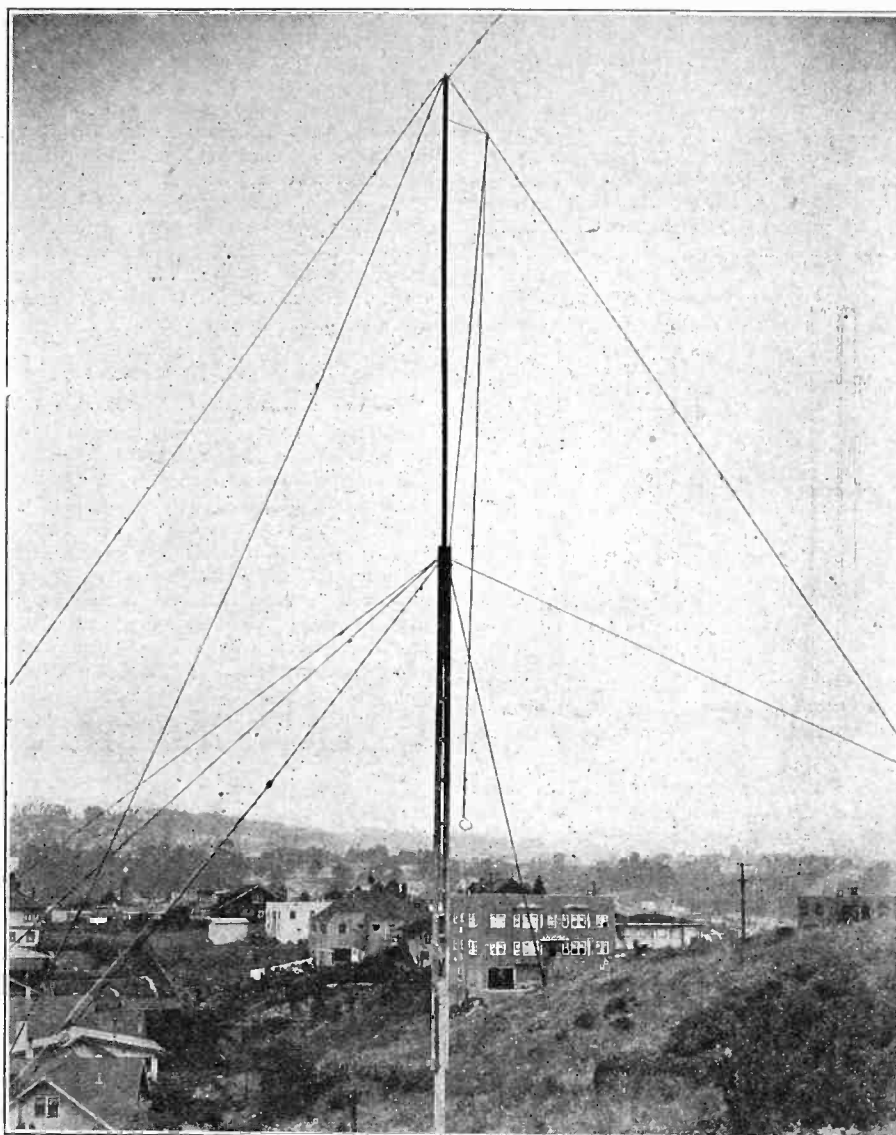

View of Completed Antenna System.

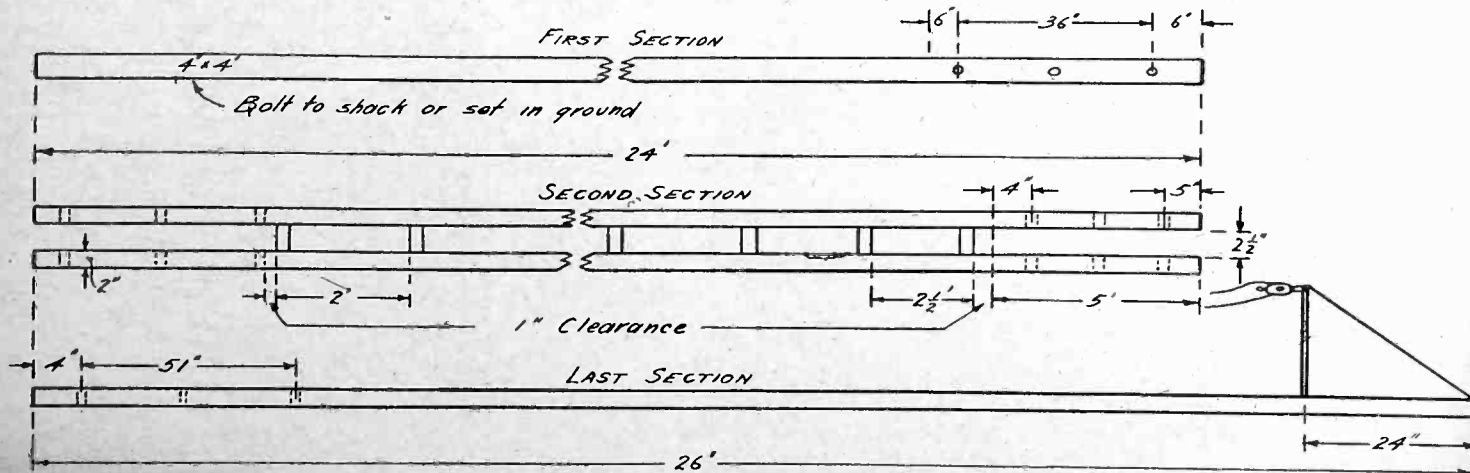

Fig. 1. Dimensions of Three-Section Mast.

wood is $2\frac{1}{2}$ in. through, chisel back the wood to make two parallel plane surfaces, plane them smooth so that the thickness at the butt is also $2\frac{1}{2}$ in. Bore two $\frac{1}{8}$ in. holes $\frac{1}{2}$ in. apart and $\frac{1}{2}$ in. from one end of the $\frac{3}{8}$ in. iron rod, which is to support the antenna. Determine which way the rod must be set into the pole so that the antenna will be vertical and then drill a $\frac{5}{16}$ in. hole 2 ft. from the top of the pole, driving the rod in until its end is flush with the side. Through one of the holes in the rod pass a piece of guy wire and securely fasten at the top. Through the other hole fasten the galvanized pulley by means of a piece of wire, and drill three holes in the butt of the pole to correspond with the holes at the top of the last section.

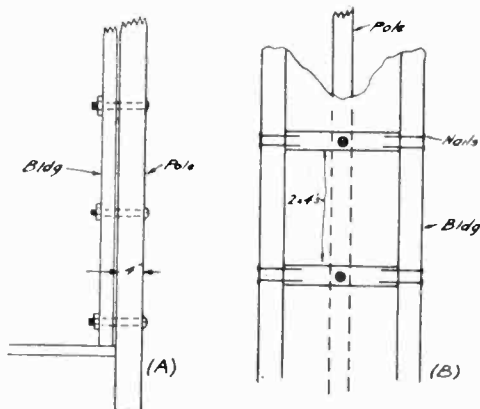

Fig. 2. Two Methods of Securing Mast.

Determine the direction of the prevailing winds and run one of the guy wires from each section in this direction. At least two guys should be run to compensate for the strain due to the antenna rope pulling downward, and the remaining guys should be spaced at equal intervals. Having determined the approximate positions for the guy wires, set in the screw eyes which are to be used for securing the guys to the pole. In determining the length of the guys before cutting the wire, obtain the square root of the distance in feet from the bottom of the pole to the guy junction plus the distance from the center of the pole to the guy anchor and you will have the proper size. Run the guys out in the yard and insulate them about every 15 ft., having one of the insulators about 5 ft. from the end. Select the proper anchoring points, which should be capable of withstanding a pull of 50 lbs., and drive in one of the large screw eyes into each.

In raising the completed sections, prepare a pole 30 or 40 ft. long of old lumber, and determine which is the easiest side to raise from, placing the section so as to raise from that side. Nail a small piece on the opposite side of the first section to prevent this one from falling though and place the bottom hole in the second section over the corresponding one in the first and bolt though. Do not screw down the nut too tightly or you will have difficulty in raising. Secure the prepared pole to the top by means of a nail, and secure the assistance of two helpers to support the job while you are raising it. Two temporary screw eyes should be conveniently placed and assistants instructed whether to haul in or pay out at a given signal. Raise the section clear and hoist up while they pay out on the guys, keeping the pole straight. When it is vertical, have one of them hold it while you run in the bolts, securely fasten all guys and take up the slack with turnbuckles. If well tightened, this section may be climbed with impunity.

To raise the last section secure a block and tackle with a mechanical advantage of at least two. Fasten a screw eye about 3 ft. from the top and put one end of the tackle through the eye, attaching the other

end to the bottom of the last pole. Pass this up through the crotch at the top and place a clamp around the two. The clamp may be made from two 1 x 7 in. pieces of $\frac{1}{4}$ in. strap iron, bolted together with $\frac{1}{4}$ x 5 in. bolts. With assistants at all guys, hoist into position, and while it is held in place, pass the bolts through, tightening up and securely fastening the last guys.

Having now completed the mast, the screw eye which you used for the block and tackle may be used to pass the antenna guy rope through, thus keeping it free from the antenna. The lead-in insulators for the antenna system shown in the picture were pyrex bowls, with holes drilled in the center of each bowl so as to pass a No. 10 wire. The strain insulator at the top was made from a piece of thick walled $\frac{3}{4}$ in. glass tubing, looped at each end to receive the antenna wire or guy rope.

SHORT WAVE RECORDS OF NEW ZEALAND AMATEURS

During the past few months, amateurs in New Zealand and England have been accomplishing wonderful work in low-powered communication, especially the performance of Z3AL in working English station 2LZ with a power of $2\frac{1}{2}$ watts. By pre-arranged agreement, these two stations established communication with their usual power, the New Zealand station being equipped with one 5-watt American made tube, and the English amateur having one 250-watt British tube. After exchanging test messages on full power, the power of the New Zealand station was gradually de-

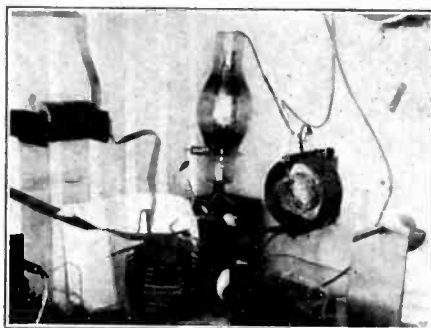

Arrangement of transmitter at Z4AG Dunedin, N. Z.

creased until finally only 160 volts was applied to the tube, with a plate current of 16 milliamperes, making a total of 2.5-watts input into the tube. With this extremely low power, the New Zealand sta-

tion could still be heard in England, and most of the message text read correctly.

Station Z4AG is another New Zealander with a fine set of distance records, having established daylight communication with English station 20D with an input of 150 watts at each station. The picture shows the transmitter used at Z4AG, the four coil Meissner circuit being used, as is shown in the circuit diagram. The tube obtains power from the city mains, through an electrolytic rectifier, and is coupled to the antenna through the set of coils shown in the picture. The grid coil consists of 16 turns of No. 14 wire wound low-loss fashion to a $2\frac{3}{4}$ in. diameter. This coil is loosely coupled to the lower aerial coil by being suspended from an ebonite rod resting across the supports of the coil. Across this coil, for 80 meters only, is a .00025 mfd. variable condenser. The plate coil is similar to the grid coil and is coupled to the upper aerial coil. Using a single wire inverted L antenna, 90 ft. long, and 50 ft. average height, the radiation is 1.3 amperes on 20.5 meters, using the third harmonic of the antenna, which has a fundamental of 60 meters. The receiver used at Z4AG is a single tube Reinartz, no audio stages being used for any of the distance records attained.

6ZD, Pacific Coast A. R. R. L. director, has received a letter of thanks from the Secretary of the Navy for his work in expediting the transmission of the news of the finding of the PN9-1 to the Pacific Fleet at Tahiti. This he did by communicating on 40 meters with Schnell, NRRL, on the Seattle. His performance is an excellent indication of what can be done through static with a 100-watt short wave transmitter,—4000 miles.

6BAA, Amos Kanaga, 4228 26th St., San Francisco, Calif., has put in a 50-watt and will appreciate reports of his experimental work on 40 meters.

2 AHU, Benjamin L. Berger, 166 Montgomery Avenue, Irvington, N. Y., has 5 watts on 40 meters.

A. Kalachnikoff of Tomsk, Siberia, Russia, Krasnoarmeiskaja St. 66 is a Russian amateur wishing to correspond with Americans who enclose a 30 to 60-cent International Reply Coupon with their letters.

The QRA of 6ALR is Harry Billings, North Avenue, Fresno, Calif., operating 5 watts c.w. and phone. All Q.S.L.'s answered.

5AUQ at 712 East Mississippi Avenue, Ruston, La., is on the air with 20 watts phone and c.w.; 150-200 meters; operated by Gaston Johnson. Q.S.L.'s answered.

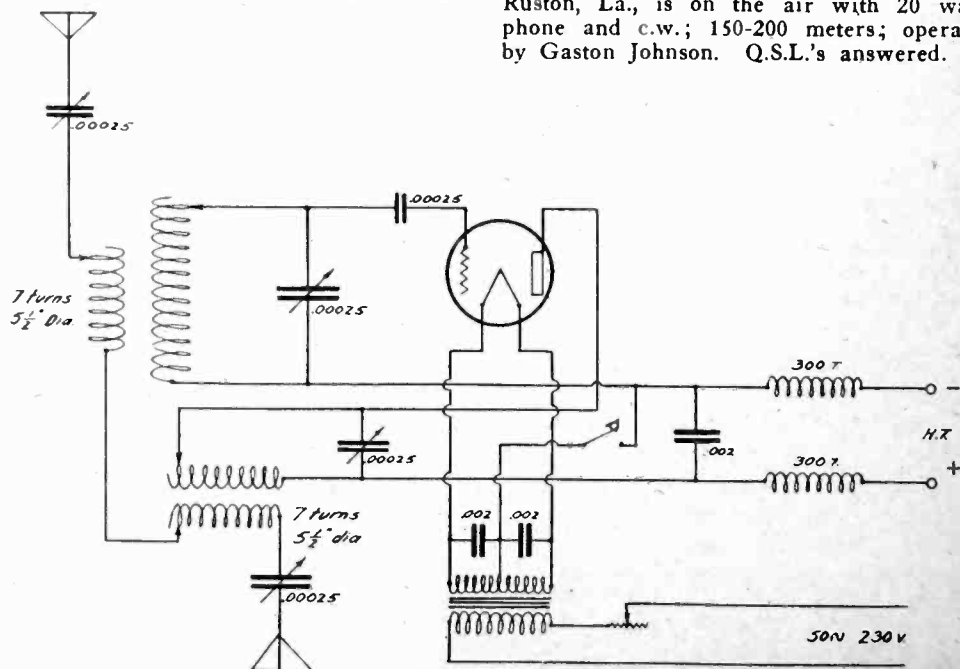

Circuit used by Z4AG.

NAVY BROADCAST TO AMATEURS

On October 27th various stations of the U. S. Navy will transmit a message of vital interest to all amateurs, who are invited to tune in to any one of the stations operating under the following schedule:

7:15 and 9:15 p. m. NPG at San Francisco on 43 and 45 meters.

7:30 and 9:30 p. m. U. S. S. California at Bremerton Navy Yard, Washington, on 120 meters.

7:45 and 9:45 p. m. U. S. S. West Virginia at San Pedro, Calif., on 40 meters.

8:00 and 10:00 p. m. U. S. S. Litchfield at San Diego, Calif., on 40 meters.

STANDARD RADIO FREQUENCY TRANSMISSION, NOVEMBER TO JANUARY

The Bureau of Standards transmits, twice a month, radio signals of definitely announced frequencies, for use by the public in standardizing frequency meters (wave-meters) and transmitting and receiving apparatus. The signals are transmitted from the Bureau station WWV, Washington, D. C., and from station 6XBM, Stanford University, California.

The transmissions are by unmodulated continuous-wave radio telegraphy. A complete frequency transmission includes a "general call," a "standard frequency signal," and "announcements." The "general call" is given at the beginning of the 8-minute period and continues for about 2 minutes. This includes a statement of the frequency. The "standard frequency signal" is a series of very long dashes with the call letters (WWV or 6XBM) intervening. This signal continues for about 4 minutes. The "announcements" are on the same frequency as the "standard frequency signal" just transmitted and contain a statement of the frequency. An announcement of the next frequency to be transmitted is then given. There is then a 4-minute interval while the transmitting set is adjusted for the next frequency.

The signals can be heard and utilized by stations equipped for continuous-wave reception at distances within about 500 to 1000 miles from the transmitting stations. Information on how to receive and utilize the signals is given in Bureau of Standards Letter Circular No. 171, which may be obtained on application from the Bureau of Standards, Washington, D. C. Even though only a few points are received, persons can obtain as complete a wavemeter calibration as desired by the method of generator harmonics, information on which is given in the Letter Circular.

The schedule of standard frequency signals from both the Bureau of Standards and Stanford University is as follows:

SCHEDULE OF FREQUENCIES IN KILOCYCLES						
(Approximate wavelengths in meters in parentheses)						
*Time	Nov. 5	Nov. 20	Dec. 5	Dec. 19	Jan. 5	Jan. 20
7:00 to	3000	125	300	550	1500	3000
10:08 p.m.	(100)	(2400)	(1000)	(545)	(200)	(100)
10:12 to	3300	133	315	630	1650	3300
10:20 p.m.	(91)	(2254)	(952)	(476)	(182)	(91)
10:24 to	3600	143	345	730	1800	3600
10:32 p.m.	(83)	(2097)	(869)	(411)	(167)	(83)
10:36 to	4000	155	375	850	2000	4000
10:44 p.m.	(75)	(1934)	(800)	(353)	(150)	(75)
10:48 to	4400	166.5	425	980	2200	4400
10:56 p.m.	(68)	(1800)	(705)	(306)	(136)	(68)
11:00 to	4900	205	500	1130	2450	4900
11:08 p.m.	(61)	(1463)	(600)	(265)	(122)	(61)
11:12 to	5400	260	600	1300	2700	5400
11:20 p.m.	(55)	(1153)	(500)	(231)	(111)	(55)
11:24 to	6000	315	666	1500	3000	6000
11:32 p.m.	(50)	(952)	(450)	(200)	(100)	(50)

*Eastern standard time for WWV, Washington, D. C.
Pacific standard time for 6XBM, California.

CALLS HEARD



By F. L. Ulrich, aboard U. S. S. Langley, Enroute to Hawaii.

April 2st, 1020 miles SW of San Francisco. 1aa, 1w1, 1abf, 1-awx, 1aja, 1pa, 6cke, 1af, 1ga, 2ud, 2rk, 2bgm, 2fz, 2adk, 3zo, 3bcm, 3ot, 3ajd, 4ll, 4gw, 4eq, 4xx, 4ku, 5ajj, 5za, 5oi, 5aiu, 5uk, 5ov, 5ald, 5alh, 5mg, 5qh, 5bf; 6's and 7's too numerous; 8aa1, 8xg, 8alg, 8ba, 8epi, 8gt, 8cdf, 8bu, 8ana, 8bcp, 8bde, 8ob, 8doo, 8abs, 8chy, 8ro, 8bi, 8ccq, 8xb, 8dgv, 8jz, 9cjt, 9auy, 9zt, 9mm, 9mw, 9ada, 9ehy, 9efo, 9ala, 9it, 9cpm. At Honolulu, April 29: 1awx, 1aja, 1pa, 1bdt, 1cke, 2rb, 2aey, 2bgm, 2kf, 2rk, 2ud, 2wb, 3zo, 3ly, 3ape, 3bco, 3cmf, 3oq, 3ot, 3wb, 4ll, 4gw, 4lo, 4io, 4ke, 4eq, 4xe, 4xx, 5za, 5ajj, 4aiu, 5cn, 5vo, 5sd, 5lh, 5vo, 5hn, 5se, 5uk, 6abh, 6ask, 6agk, 6bm, 6ss, 6cgc, 6chx, 6chr, 6chr, 6chz, 6zh, 6cdn, 6bas, 6bur, 6cto, 6egw, 6xad, 6eb, 6ew, 6awt, 6emu, 6pl, 7uk, 7sg, 7um, 7uk, 7hs, 7hi, 7df, 7pz, 7us, 7ku, 7gj, 7kw, 7ao, 7uq, 7sb, 7dd, 7dm, 7yb, 8aa1, 8abn, 8gs, 8xb, 8aad, 8gz, 8ccq, 8bem, 8cko, 9ada, 9cmp, 9cc, 9ehy, 9bdt, 9vc. New Zealand: 2ac, 4aa. Canadian: 3ap, 3xi, 9bm, 5go. Porto Rico: 4sa. Mexican: 1x, bx.

At 6cpg-6bhr, Earl Wiseman, 1001 Spaulding Avenue, Hollywood, Calif.

1ow, 1pl, 1te, 1xu, 1xz, 1yb, 1aa0, 1abf, 1ami, 1are, 1cmx, 2bw, 2cv, 2gk, 2kr, 2qh, 2aey, 2agw, 2cee, 1cyx, 2hg, 3ym, 4rm, 4rt, 5bf, 5ce, 5ew, 5hi, 5io, 5nj, 5nw, 5ov, 5ox, 5ph, 5uk, 5vf, 5vl, 5wi, 5zm, 5aa1, 5aav, 5acl, 5aec, 5ahr, 5aij, 5aks, 5amw, 5asv, 5asr, 5ath, 5atv, 7ay, 7cw, 7dc, 7ec, 7en, 7fr, 7gb, 7gj, 7gy, 7iy, 7ku, 7lq, 7ls, 7mf, 7nh, 7nt, 7nx, 7ny, 7pz, 7rl, 7ws, 7wu, 7ya, 7zz, 7adm, 7aek, 7aij, 7akk, 8er, 8gz, 8jj, 8nx, 8ry, 8to, 8abm, 8ajn, 8apw, 8avi, 8ayy, 8brc, 8bsv, 8chk, 8dme, 9ee, 9el, 9oo, 9rz, 9sr, 9sv, 9wo, 9xi, 9zw, 9aac, 9adg, 9aey, 9afe, 9aio, 9aot, 9ays, 9ayg, 9baa, 9bdu, 9bdw, 9bfp, 9bjp, 9bmx, 9bnf, 9brf, 9brk, 9brx, 9bvo, 9caa, 9ccs, 9cd, 9cul, 9cxw, 9cxx, 9dat, 9dbz, 9ded, 9dex, 9dfh, 9kl, 9dum, 9dun, 9eak, 9ejy, 9elb. Naval: nkf, nrll. Canada: 3qs, 5gf, 5ba. Mexico: 1b, 1k, 2t. Porto Rico: 4sa. Hawaii: 6buc, 6cst, npm. Japan: 1aa. Australia: 2bk, 2cm, 2ds, 2yl. New Zealand: 1ao, 2ae, 2xa, 4aa.

At Sbrb, Apollo, Pennsylvania

1afn, 1ajg, 1are, 1arh, 1asa, 1aum, 1awv, 1axa, 1blp, 1bs, 1bvl, 1ckp, 1cw, 1ql, 1qm, 1ut, 1vd, 4bs, 4cu, 4cv, 4du, 4kb, 4pu, 4sc, 4tm, 5adh, 5agz, 5aih, 5ail, 5ais, 5ajh, 5amw, 5asv, 5atv, 5co, 5gm, 5pv, 5uk, 6aad, 6agk, 6awt, 6bfm, 6bgz, 6bhx, 6bnp, 6bni, 6cc, 6clp, 6clr, 6cpf, 6cse, 6ctr, 6cto, 6dgc, 6fm, 6im, 6jp, 6km, 6nd, 6ts, 6ut, 6vc, 6vw, 6xap, (6zb or 6zde), 7abf, 7ay, 7gb, 7gj, 7mf, 7nt, 7nx, 7rl, 7ya, 7zu, 9xi, 9xn, 9zt, nrll. Canada: 2es, 4tk. Mexico: 1k. France: 8ss. B. 3ad. A. 1oj.

WAVELENGTH OF ARGENTINE AMATEUR STATIONS

Mr. Federico Nosiglia, of Buenos Aires, Argentina, informs us that he is operating station AH-2 on a wavelength of 30 meters, and together with several other Argentine amateurs, has a calling schedule from 9:30 to 12:00 o'clock midnight, E. K., in an effort to reach American amateur stations. These amateurs are greatly interested in intensifying inter-American radio relations, and will greatly appreciate reports from those hearing their stations.

By Ed Craven, 4JJ, 408 Edith Place, Memphis, Tenn

6fg, 6uo, 6ajl, 6bgi, 6bhm, 6bjv, 6bni, 6bse, 6btu, 6cgv, 6cmq, 6cuc, 6cub, 6dab, 6zbn, 7ec, 7it, 7uz, 7aek. Canadian: 3aa, 1ar. Cuba: 2mk. Mexico: 1b, (1k), 1x, 1af, 9a. Argentine: cb8. British: 2lz, 2nm. Australia: 2ft, 2tm, 2yl, 3bd, 3bm 3bq, 3ef. New Zealand: 2ac, 2xa, 4ag. Miscellaneous: (nerk 1), (br7), xda, wap, nrll, (nve), npg. Unknown: 2re (qra?). Will qsl to any of above on request. 5 watts here.

By 6CLZ-6COW, 1238 Peralta Avenue, Berkeley, California

1aao, 1aci, 1aep, 1ahg, 1ahl, 1ana, 1anq, 1apc, 1are, 1arf, 1axa, 1bqt, 1cak, 1cex, 1ckp, 1cmx, 1ka, 1kp, 1mp, 1pm, 1ts, 1xg, 1xu, 1za, 1zw, 2aes, 2afn, 2agb, 2aim, 2bqa, 2bum, 2bur, 2byw, (2cgj), 2ctb, 2cty, 2cvj, 2cxw, 2eyu, 2bw, 2ds, 2ha, 2lu, 2mu, 2nf, 2wc, 2xaf, 2xi, 2zv, 3bva, 3ckg, 3hg, 3jw, 3ll, 3ot, 3vx, 3wo, 4bf, 4ou, 4er, 4fl, 4fu, 4gy, 4hh, 4iv, 4js, 4rm, 4sl, 4tv, 4kda, 4el, 4kfx, 4kfh, 4kfm, 4kwh, 4aj, 4cc, 4ndj, 4nisv, 4nkf, 4npg, 4nrll, 4numm, 4nve, 4wap, 4wgy, 4wir, 4wiz, 4wql, 4wqn, 4wwdo, 4wyh, 4cxl. Alaska: 7ahb, (7do). Australia: 2bb, 2bc, 2cm, 2cs, 2ds, 2ij, 2im, 2yl, 3bd, 3bq, 3ef, 3ju, 3yx. Canada: 3aa, 4aa, 4aj, 4bf, 4bv, 4gt, (6ba), 5bf, 5bm, 5ct, (5ef), 5fk, 5go, 5gt, 5hp, (9ck), vdm, Ceylon: 4db. Chile: 9tc. Great Britain: 2nm. Guam: npn. Hawaii: 6aff, 6buc, 6tq, 6xl, npm. Mexico: 1aa, 1af, 1b, 1k, 1x, 9a, xda. New Zealand: 1ax, 2ac, 2ae, 2xa, 4aa, 4ag, 4ak, 4al, 4ar, 4as. Philippines: npo. Samoa: 6zac, npu, qra7, f8z, qrk, 6clz, 6cow? All cards gladly answered.

By 6ALV, Alameda, Calif.

1bql, 2ahm, 3bta, 4j17, 4sa, 5wi, 6cst, (7ay), 8zf, (9bmx). Foreign: c3aa, (c9ck), c4bl, miaa, m9a, a3zm, (a3yx), (a3bd), (a2yl), (P.I. 1hr), j3aa, (nrll), nrir, nrx, nrm, npr, npo, nisv, f8z, (nedj), numm, nwud, wap.

By NUMM, U. S. S. Litchfield (330), care Postmaster, San Francisco, Calif.

Stations heard at Christchurch and Wellington, New Zealand, August 11 to 23, inclusive: 1baj, 1cap, 1cgb, 1cmk, 1kt, 1pl, 1ua, 1zs, 2aiv, 2bee, 2cbg, 2cgv, 2cvj, 2gy, 2lu, 2mu, 3bct, 3btq, 3chg, 3lp, 4ael, 4am, 4jr, 4sa, 4rl, 5acl, 5agn, 5adz, 5ew, 5hp, 5kc, 5oq, 5ox, 5uk, 3xc, 5zal, 5zl, 6add, 6ajj, 6akz, 6aol, 6apq, 6awt, 6bgo, 6bgv, 6bhx, 6bil, 6bjj, 6bjx, 6bmw, 6btm, 6bup, 6bvy, 6cah, 6cai, 6cfe, 6cgv, 6chi, 6chs, 6cmq, 6ct, 6ctm, 6dah, 6dal, 6def, 6fa, 6ih, (6jp), 6km, 6ll, 6rv, 6sb, 6z, 6vc, 6vr, 6zac, 6zbn, 6zd, 6zh, 7ay, 8ay, 8axn, 8bgn, 8pl, 8sf, 9aed, 9akf, 9bht, 9ctu, 9ded, 9dkv, 9dpx, 9eht, 9ek, 9ff, 9hp, 9uq, 9xn. Hawaii: 6aff. English: 2cc, 2kf, (2lz), (2od), (2xy), (2nm), 5lf, 6rm, 6tm. French: 8bf, 8bp, 8fq, (8tok), 8ufv, 8wg. Brazil: (1ab). Argentina: a3, bal. Canada: 4gt. Mexican: 1af, 1b, 1x. Italy: (1rt). Chile: 1eg, 9tc. Philippines: 1hr. Holland: osv. Switzerland: 9ad. Aust.: 2bb, 2bg, 2cm, 2nj, 2tm, (2yi), (3bd), 3bm, 3bq, (3ef), 3ju, 3ot, 3tm, (3yx), (4an), 5bg. Naval: naj, nas, nirx, nkf, npg, nrm, npr, npo, npu, nrll, nve. Commercial: (kfh), vis, wap, wiz. Miscellaneous: fx1, ab (qra?). PSE QSL IF U HR NUMM. Ops: J. R. Mohler, R. B. Brightman, D. W. Imel.

By E. Stine, 122 Kingman Ave., Battle Creek, Mich.

6agk, 6ae, 6aff, 6afg, 6afz, 6ahq, 6ajj, 6ajm, 6ap, 6aop, 6arw, 6aum, 6bbv, 6bgv, 6bgb, 6bil, 6bid, 6bjv, 6bvy, 6bwa, 6bww, 6cbj, 6cej, 6cfi, 6cgv, 6cgc, 6chx, 6chs, 6cix, 6cmx, 6cpf, 6crr, 6csw, 6ct, 6cto, 6das, 6dat, 6dck, 6ew, 6hw, 6ih, 6jc, 6jp, 6js, 6li, 6tz, 6vr, 6zh, 7aek, 7ay, 7it. Can.: 5hp, 5gt. Mexican: 1b, 9a. Chilean: 2ld. Argentine: cb8, bai. New Zealand: 2ac, 2ae, 2xa, 2ij, 4ak, 4al, 4ag. Australia: 2bb, 2cm, 2yl, 3bd, 3bq. Miscellaneous: nrll, npg, nerkl, nedj, kfh. All cards QSL'd.

3BVA, 40 S. Beaver St., York, Pa.

(5aaq), (5ac), (5adz), (5afd), (5aj), (5as), (5atp), (5atv), (5ax), (5ce), (5ed), (5ew), (5hi), 5jd, 5jf, 5kc, (5in), 5ms, (5nj), (5nq), (5oq), (5ox), (5ph), 5rg, 5uk, (5va), (5vl), 5zai, 6aak, 6agk, 6akz, 6ajm, (6aiv), 6aqp, 6avj, 6awt, 6ban, 6bel, 6bil, 6bjv, (6bix), 6bq, 6bur, (6cai), (6cah), (6ccv), 6cev, (6cgv), 6cgc, (6chs), 6che, 6cix, 6cnc, 6css, (6csw, (6cto), (6dab), (6dah), 6dao, 6dar, 6dh, 6fh, 6fa, (6li), 6pb, 6nx, 6sk, 6ur, (6vc), (6xad), 6xg, 7aek, 7df, (7ij), (7it), (7nx), (7uz), 9bm, 9caa, (9efy), 9dfh. Special: naj, nas, nerkl, nkf, nkf-1, nivr, npg, npr, nrll, numm, (nve), kfh, cgr, sgc, wap, (wnp). Porto Rico: (4kt), (4oi), (4rl), (4sa). Canada: (1ac), 1aa, (1am), 1ar, 1dd, 4cr, 4gt, 5ef. Bermuda: (Ber). Chile: 1eg. Hawaii: 6buc, 6zac, fx-1. Brazil: (1ab), 1af, 2sp. Argentina: afl, af2, cb8. England: 2cc, (2kf), 2kz, (2lz), (2nm), 2od, 2wj, 2sz, 5dh, (5lf), 5nn, 5qv, (6lj), 6tm. France: 8bf, 8bv, (8ct), 8eu, 8fg, 8gn, 8qq, 8rdi, (8yor), 8wag, (8uiui). Italy: (1er), (1mt), lrg. Switzerland: (9ad). Holland: (2pz), pccm, (o-sv). Belgium: 4yz. Australia: 2ay, 2bc, (2bb), 2bk, 2cm, (2ds), 2ij, 2lu, 2me, 2yg, (2yi), 2ym, 3bd, 3bq, (3ef), 3ju, (5bg). New Zealand: 1ao, (2ac), 2ae, 2ap, (2xa), 4aa, 4ag, (4ak), 4al, 4ar, 4as. Mexico: (1aa, 1af, 1ax (1b), 1j, (1k), 1g, 1n, 1x, 2ei, (9a). Denmark: 7ec. Sweden: smyy, smzs. Cuba: 2by.

(Continued on Page 44)

FROM THE RADIO MANUFACTURERS

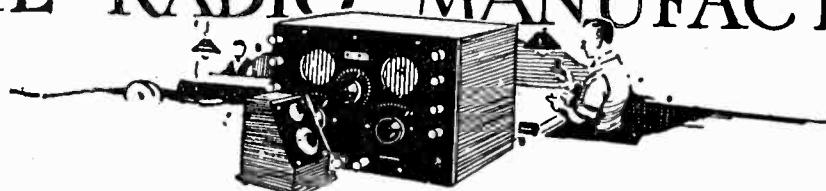

The Elkey super-selector is a five-tube receiver consisting of one stage of tuned r.f. detector, one transformer audio and two resistance coupled audio. It uses



any style of tube and is claimed to have unusually good tone quality, selectivity and sensitivity. The operator has full control of selectivity and oscillation in a patented clarifier adjustment.

The Lombardi straight line condenser is made in two types, one giving straight line wavelength tuning, the other straight line frequency, thus enabling separation of short wave stations. It is designed for minimum loss or variation from rated capacities of .00025, .00035 or .0005

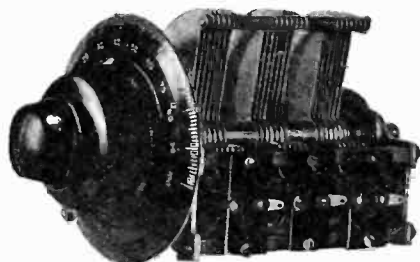

mf. It is made up as a single, double or triple unit, the last being illustrated herewith. Its geared vernier shaft runs through the rotor shaft so that one panel hole suffices for both.

The Zinke dual charger is a new device for charging A and B batteries of all makes. It uses two Tungar 2½ ampere



tubes wired in parallel so that should one burn out the other may be used for charging at the 2½ ampere rate instead of 5, as when both are used.

The Hemco tube vitalizer is a compact device for giving a brief over-voltage to the filament of a vacuum tube so as to bring a fresh supply of thorium from the inside of the filament to the surface. Here it becomes active as the source of electrons necessary for the operation

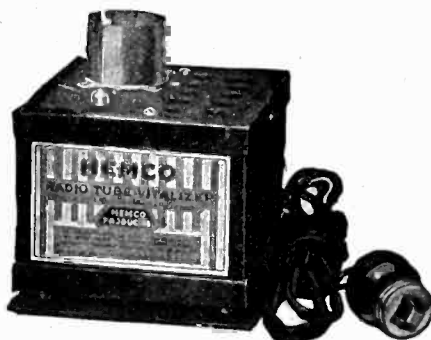

of the tube. The results from any thoriated filament tube can be greatly improved by an occasional treatment in this device. It operates from either an a.c. or d.c. 110 volt circuit.

The Clarostat is a new rheostat giving a remarkably gradual change in resistance as the knob is changed. The de-



vice is built like a watch so as to insure uniformity in movement. It is designed to accurately control filament current.

The Thorola Iso-dyne is a five-tube tuned radio frequency receiver employing doughnut coupling coils and radio frequency transformers with straight line frequency condensers. It is designed to



give equal amplification on all wavelengths and to be extremely selective. It has three dials, which may be logged, and a separate volume control.

The Pacent Universal base is a new form of tube socket made of Isolantite. It permits interchangeability, lowers the total capacity of a circuit, and gives bet-

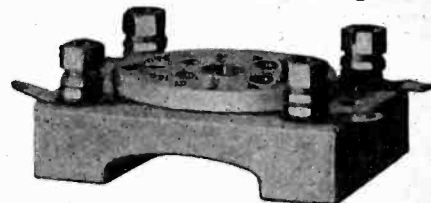

ter contact with the tube prongs, which are given a firm side grip by concealed contacts. It is especially adapted to radio frequency circuits.

The Comparaphon is an instrument for making a comparative test of loudspeakers in a dealer's stores by means of a phonograph when radio music is not

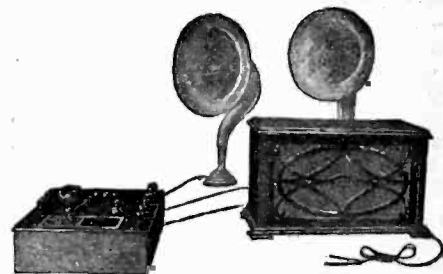

available. It gives the prospective purchaser the privilege of judging tone quality without the need for a home demonstration.

The Thompson "Minuet" is a complete dry battery tube receiver built into a cylindrical cabinet 18½ in. wide, 21½ in. high and 10½ in. deep. The front part contains a cone type speaker

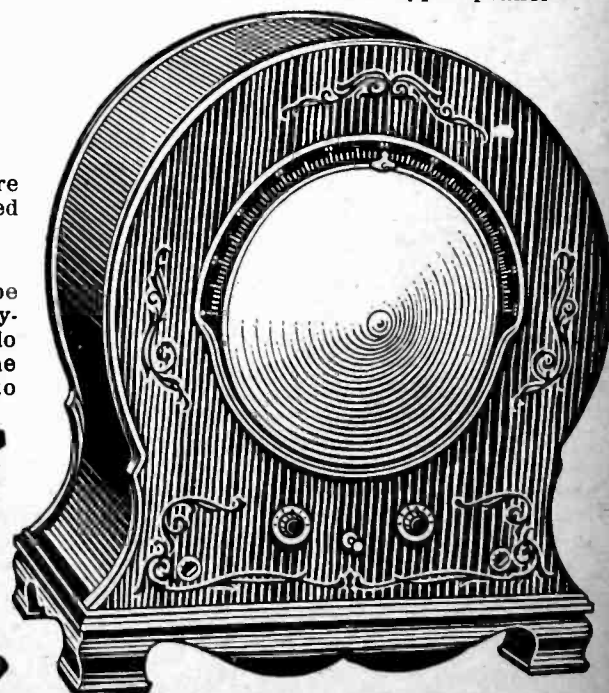

around the periphery of which a tuning handle may be moved to a desired scale setting. Two small compensation knobs are used for fine adjustment in tuning. Of the five tubes, two are r. f. amplifiers, one detector and two audio.

THE ONE-DIAL
MU-RAD
 TRANSCONTINENTAL RECEIVER



MODEL A—\$175

Sockets Fit All New Type Tubes

Radio's Remarkable Innovation

YOU made this radio receiver. To answer a tremendous demand for simplicity without sacrificing efficiency, Mu-Rad Engineers developed this New One Dial Receiver for you. This innovation in radio reception marks the most distinctive advance since the conception of radio. In addition to the one dial control, Mu-Rad Receivers embody every principle necessary to good radio reception.

Just a slight turn of the one dial brings in any local or distant station. A station once logged always comes in at the same dial setting. It is so simple a child can operate it.

Write Dept. G3 for Literature

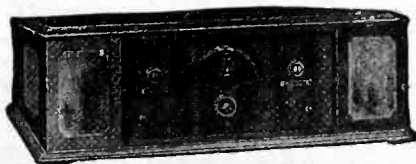

*Ask Nearest Dealer
 for Demonstration.*

Tune It Yourself.

MODEL B—\$125

Sockets Fit All New
 Type Tubes

MU-RAD RADIO CORPORATION

Factory:
 Asbury Park,
 New Jersey

General Sales Offices:
 972 Broad Street,
 Newark, N. J.

NOW! for Tuned Radio Frequency Matched AERO COILS!

95%
Air Dielectric
Dopeless
Air-Spaced
Windings



NOW you can build a set and have all three tuning dials tune exactly the same—or, you can build a one control set using a gang condenser and know that it's going to work right. AERO Coils are matched!

But—the matched feature of Aero Coils is not their only exclusive feature.

Aero Coils are, by electrical measurement and by use tests, the most powerful, most selective and most sensitive inductances ever designed. They will enable your set to sharply cut through powerful locals and will bring in, with tremendous loud speaker volume, signals you have always had to listen to on head phones.

Build with Aero Coils. You are sure of their superiority because that which makes them so is patent-protected. The Tuned Radio Frequency Kit is \$12.00 complete with circuit diagrams and instructions. At your dealers—or direct, if your dealer hasn't them.

Free booklet giving valuable information on radio frequency amplification sent on request. Write now for the "Aero Booklet".

AERO PRODUCTS, Inc.

1772 Wilson Ave., Chicago

AERO COIL

All Aero Coils embrace a patent-protected method of construction which makes possible a far more efficient induction performance than is possible with any other type of coil.

The only Tuned Radio Frequency Kit comprising 3 units whose secondaries are identically matched.

Use AERO COILS

In Any Circuit

[The only Air Dielectric Coils]
Having Variable Primaries
In Antennae Circuits
3 Circuit Tuner

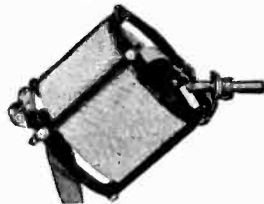

Another adaptation of the pat. protected Aero Coil construction. \$8.00

Radio Frequency Regenerative Kit

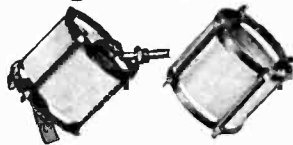

Makes the most powerful, most selective 4-tube, non-radiating set possible to build, Matched - \$11.00



Wave Trap Unit

Also for Crystal Sets
Makes an exceptionally efficient wave trap for crystal set - \$4.00

Oscillator

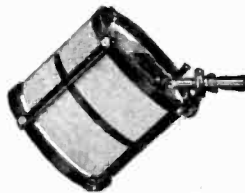

Tremendously increases the efficiency of the oscillator circuit in any Super Heterodyne receiver \$5.50

CALLS HEARD

(Continued from Page 41)

EX 7NQ Now 7TK, 612 4th St., Hoquiam, Washington

1af, 1ed, 1tr, 2by, 2gz, 2kj, 3bau, 3ccy, 3gq, 3oe, 3ws, 4dy, 4hh, 4ll, 4ss, 4tj, 5afb, 5alz, (5amh), 5apq, (5asd), 5bz, (5cg), 5fr, (5ql), 5rg, (6abg), 6aoz, (6atn), 6aum, 6bcn, (6bgb), 6bgc, 6bis, 6bnh, 6btn, 6bsf, 6bsj, 6brn, (6cah), (6ceck), 6ccv, 6cku, (6chx), 6cel, 6cm1, 6cro, 6crz, 6cux, (6cvk), (6dbs), (6fg), 6fm, 6je, (6jj), (6ml), 6sl, (6sz?), (6tj), 6uci, (6uo), 6wd, 6xg, 6zbt, npg, (nqg), 86a, Alaskan (7kn)—others numerous, 8bm, 8cye, (8jq), 8xas, 9ace, 9act, (9adr), 9az, 9baz, 9caa, 9ca, (9ckh), 9cko, 9coo, 9cuo, 9cuv, 9cv, 9cvn, 9cvo, 9dbg, 9ded, 9dgo, (9dla), (9dmj), 9drz, (9dvl), 9ejl, 9ek, 9eky, 9fp, 9ql, 9qs, 9xl, Canadian: 3xl, 4dy, (4fv), (4io), (5af), (5as), 5br, 5bh, 5co, (5cu), 5dd, (5ds), (5fk), (5hk), (5hp), 5hs.

By IALP, Frank L. Baker, Jr., 30 Minot Street, Neponset, Mass.

4aae, 4ask, 4au, 4er, 4js, 4kw, 4me, 4mf, 4mg, 4ml, 4nj, 4oa, 4oy, 4pi, 4rz, 4sa, 4sb, 4tv, 4xe, 5amh, 5kc, 5ox, 5rg, 5sy, 5uk, 5va, 6bhz, 9adk, 9aeg, 9aot, 9ape, 9bdw, 9bht, 9bmx, 9cap, 9dcq, 9dpx, 9ecc, (9es), 9ff, (9og), 9sn, c-lac, (c-2be), c-3vh. Will confirm any of these reports by asking. All on 40 meters for the month of August.

By 7MF, Harold De Voe, 1310 West Main Street, Medford, Oregon

1ahg, 1ka, 1pl, 2fb, 2mu, 2xaf, 3ab, 3ckg, 4ll, 4oa, 4sl, 5aj, 5arn, 5kc, 5zal, 6cod, (Hawaii), 8ayy, 8bpl, 8chk, 8cnl, 8eq, 8jq, 8ks, 8qf, 8xx, 8zv, 9adr, 9akf, 9aod, 9amm, 9apn, 9azp, 9bek, 9bht, 9bpb, 9brs, 9bvh, 9bwx, 9bxq, 9cdf, 9edv, 9cxx, 9dex, 9df, 9dlt, 9efy, 9egn, 9ek, 9eq, 9jc, 9lt, 9oq, 9pz, 9qr, 9uq, 9xn, Australia: (2bc), (2yl), Canada: c4aa, 4gt, 9ck, Chile: leg, England: 2yt, Mexican: 1aa, 1ax, 1b, 1x, New Zealand: 2ac, 2xa, Naval: naj, nje, nkf, npg, npu, nqg, nrri, nve, Miscellaneous: gbe, kfuh, wap, wbz, wir, wiz. Cards will be sent to any of the above on request. All QSL's appreciated and answered. 50 watt cw. on 40 meters at present.

By GAE, Geo. W. Carter, 4400 So. Harvard Blvd., Los Angeles, Calif.

U. S.: 2aci, 1bqt, 2bur, 2lu, 3bq?, 3ckg, 3ot, 4do, 4fl, 4oa, 4rm, 4si, 5aid, 5amd, 5ako, 5akz, (5alj), 5arn, 5asv, 5atv, (5aqw), (5agn), 5ew, 5he, 5kc, 5nj, (5se), 5tg, 5uk, 5qs, (7ay), 7dc, 7df, 7it, 7lj, 7ly, 7uz, (8ac), 8aly, 8hsc, 8byn, 8er, (8gi), 8drs, (8jq), 8pl, 9aey, 9bht, 9bng, 9bst, 9cdv, (9edo), 9czz, 9cia, 9dfh, (9dkv), (9dpx), 9dvt, 9dfj, (9ek), 9efy, 9oo, 9wo, (9uq), 9xa, 9xn, Hawaiian: 6aff, 6asr, Canada: 4go, 5ef, 5gf, 9ck, Mexico: 1aa, 1k, 1x, 9a, Porto Rico: 4rl, Australia: 2yl, Naval: (nve), npg, nkf, nisv, npm. All reports appreciated and promptly QSLed at this station.

By 7MF, Harold De Voe, Medford, Oregon.

U. S.—1aao, 1ahg, 1anq, 1bvl, 1byx, 1pl, 2ds, 2nf, 3ab, 3aha, 3bta, 3ckg, 4fg, 4ll, 4oa, 4si, 4tv, 5ado, 5adz, 5akn, 5atv, 5ew, 5kc, 5zal, 6aff (Hawaii), 6cod (Hawaii), 6zac (Samoa), 6zbe, 8avl, 8ayy, 8bf, 8bgn, 8bpl, 8brc, 8chk, 8cyl, 8dcb, 8dke, 8eq, 8jq, 8ks, 8pl, 8qf, 8ry, 8xk, 9ado, 9adr, 9aey, 9agl, 9ald, 9aod, 9ape, 9apn, 9atq, 9bbh, 9bek, 9bfg, 9bht, 9bmx, 9bpb, 9bpy, 9brs, 9bvh, 9bwx, 9caa, 9cdf, 9edo, 9cdv, 9cju, 9clo, 9cxx, 9ded, 9dex, 9dkv, 9dpr, 9dpx, 9dvl, 9ecc, 9efs, 9efy, 9egn, 9ek, 9ff, 9jc, 9oo, 9pz, 9se, 9wo, 9xn, Australia: 2bb, 2bc, 2cm, 2yl, 3bq, Canadian: 4aa, 4al, 4cr, 9ck, Chile: leg, Mexican: 1aa, 1ax, 1b, 1x, N. Z. 2ac, 2xa, 4ak, Naval: naj, nkf, npe, npg, npm, nqg, npu, nrri, nve, Misc.: kfuh, kie, wap, wbz, wir, wiz.

7MF is on 40 meters with a fifty watt. All reports appreciated and crds all answered. Will QSL to any of the above at request.

Albert E. Scarlett, Jr., 23 Cooley Place, Mount Vernon, N. Y.

40 meters. U. S. A.—6ahg, 6alf, 6aqp, 6bbv, 6bil, 6cfe, 6cgw, 6clx, 6csw, 6dal, 6fa, 6js, 6xad, Greenland: wap, wnp, Bermuda: ber, Chile: leg, 2ld, Germany: aga, pof, Holland: pcuu, Denmark: 7ec, Brazil: 1ab, 2sp, Belgium: ke, w7, Cuba: 2mk, England: 2cc, 2es, 2dx, 2kf, 2nm, 2sz, 5bv, 5dh, 5lf, 5si, 6lj, 6rm, 6tm, France: 8cb, 8gm, 8tk, ftj, Porto Rico: 4ja, 4jv, 4oi, 4rl, 4sa, Samoa: 6zac, Fanning Island: kfuh, New Zealand: 2ac, 2xa, 4ag, 4ak, 4al, nedj, Australia: 2cm, 2ds, 2lj, 2tm, 2yl, 3do, 3bq, 3ef, 3ju, nrri, Indo China: hvd, Off Panama: nve, Atlantic Ocean: 1n, Unknown: sgc. All hrld during August on 1 audio and 80 ft. indoor antenna.

(Continued on Page 92)

ARE YOU A SUBSCRIBER?
SEND FOR TRIAL SUBSCRIPTION
\$1.00 FOR SIX MONTHS

FAMOUS 'COAST TO COAST' MIRACO GUARANTEED
RADIO'S-FACTORY PRICES GET SPECIAL OFFER
SAVE 1/3 TO 1/2

Users everywhere report Miraco Radios get programs coast to coast on loud speaker; outperform sets three times as costly. Many hear foreign countries. Radio's most amazing values in guaranteed factory-built, factory-tested long distance sets—let testimony of users convince you.

Powerful New Multi-tube Miraco gets long distance on loud speaker. Set, ONLY \$27.35 retail

FREE! Literature on latest improved 1 to 6 tube models, new low prices, testimony of users and SPECIAL OFFER. Write, AGENTS DEALERS Write!

MIRACO RADIO GETS 'EM COAST TO COAST

MIDWEST RADIO CORP'N
Pioneer Builders of Sets
414-C E. 8th St., Cincinnati, Ohio

BIG CATALOG FREE DISCOUNTS TO RADIO DEALERS

A lifetime opportunity is open for you as a radio dealer. Radio promises its biggest record-breaking season. Make the most of it by getting our new big catalog before you buy. Huge stocks of standard radio parts, sets, kits ready for quick shipment at lowest rock-bottom wholesale prices. Wonderful special offers on finest sets, tubes, batteries. Write for free copy NOW

W. C. BRAUN COMPANY 34-48 S. Clinton St., Chicago, U. S. A.

Tell them that you saw it in RADIO

The New WAVE MASTER-a Radio Set Worthy to Bear the KELLOGG Name



The Wave Master Console Model
A handsome genuine mahogany design with battery compartments and inbuilt horn. Price, **\$275.00**
Without battery table, price **\$225.00**
Also made in the beautiful Console model, genuine mahogany, price, **\$235.00**

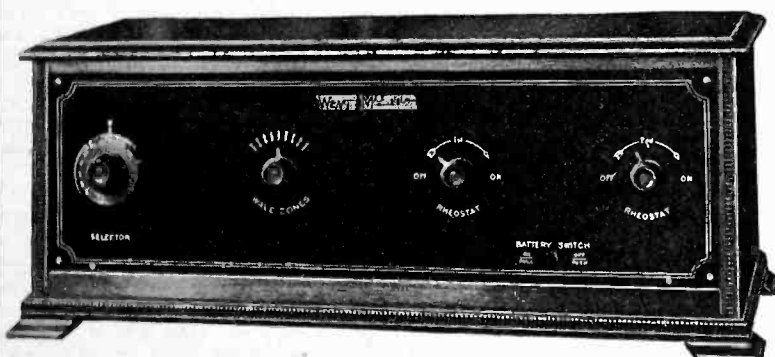

A Year Ahead! The WAVE MASTER, 5-Tube Standard Model
Cabinet of solid, Genuine Mahogany, beautifully finished, 28 inches long, 11 inches high. Price **\$125.00**

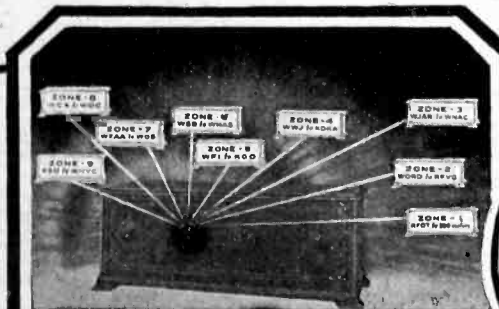

A Separate Circuit for Each 40 Meter Wavelength Band
One-Dial Control, Yet Greater Selectivity.



Kellogg Symphony Reproducer
\$25.00

"I never dreamed it was such fun"

"I used to be content to enjoy radio merely as a listener, never realizing how much greater pleasure I was missing. I had no idea of the fascinations of radio tuning—the fun of going after any station and getting it."

WHEN you make a telephone call, the operator connects you first with the "exchange" and then with the desired number of that group or division.

To "connect" the WAVE MASTER instantly with any desired broadcasting station, you first set the pointer for the "Exchange" or wave zone group to which the station belongs and then merely turn the Station Selector dial. "Expert" tuning becomes child's play. To separate stations very close together in their wavelengths, is astonishingly easy. When buying any radio set, protect yourself by learning something about the firm that produced it—their reliability and experience. For 28 years Kellogg has produced the finest of telephone apparatus. Since radio began Kellogg has built the highest quality parts.

If you do not know where you can see, try and hear the WAVE MASTER in your neighborhood, write us. We'll give you the name of your nearest dealer, and, if you wish it, a full technical explanation of the Wave Master Circuit. Ask for Folder No. 2 X.

Radio Dealers and Jobbers

The WAVE MASTER franchise backed by Kellogg resources and our powerful advertising campaign, is most valuable. Open territories are being rapidly taken up. If interested, wire or call on us promptly for our money-making proposition.

Kellogg Switchboard & Supply Company
1066 West Adams Street, Chicago, Illinois

KELLOGG WAVE MASTER SWITCHBOARD & SUPPLY CO.

Tell them that you saw it in RADIO



ALL-AMERICAN
TRADE MARK

Beauty and Permanence

Radio Built for the Years to Come



Model R Receiver
Complete without tubes **\$90**

The radio receiver here pictured is offered to the public by the ALL-AMERICAN RADIO CORPORATION, a pioneer in the manufacture of reliable radio apparatus, as an ideal example of the *solid value* which a thoroughly equipped and experienced organization can build into a product.

Forget for a moment the entire question of price. Think of any radio set you have ever admired or wished to own. Compare, first, its *construction*, with this brief outline (on opposite page) of the value which is built into the ALL-AMERICAN Model R.

Then, apply the final test—*compare the performance* with that of your former ideal of a radio receiver. After that—and not until then—remember the price at which it is offered, and simply ask yourself—“What can I get by paying more?”



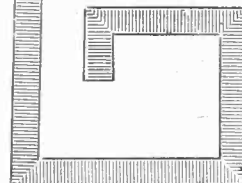
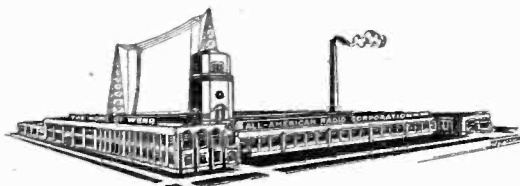
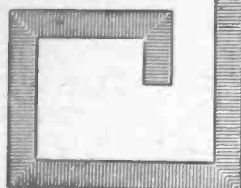

Built and wired complete in the new ALL-AMERICAN factory, the Model R embodies many notable improvements developed in the ALL-AMERICAN Laboratories. It is offered at a *moderate price*, but with the emphasis upon its superlative *quality*, deliberately inviting your frank investigation of this question—

What Can You Get by Paying More?

ALL-AMERICAN challenges comparison on the basis of the Six Vital Principles of Solid Value in Radio Receivers

1. Quality of tone

In the belief that tonal perfection is all-important, the ALL-AMERICAN Model R is equipped complete at the factory with *Rauland-Lyric* tone amplification. These laboratory-grade transformers, designed especially for lovers of artistic music, are recognized by highest authorities as the very finest on the American market.

2. Ease in Tuning

Two dials (360° type) control the ALL-AMERICAN Straight-Line-Frequency TUNING, reaching easily all wave channels, new and old, and eliminating all crowding of the low-wave stations. Touching the fingers to the dials does not affect the tuning.

3. Quietness

Practically all the various noises picked up directly from the air by ordinary coils have been eliminated in the ALL-AMERICAN Toroids. The unequaled quality of the *Rauland-Lyric* tone amplifier results in a remarkable quietness.

4. Selectivity

A test of the ALL-AMERICAN Model R will be a revelation to the experienced listener, in the sharpness of tuning which has been achieved solely through improved condenser and inductance design, without impairing tone quality in the slightest degree.

5. Sensitiveness to distant signals

The ALL-AMERICAN Tuned-Radio-Frequency system embodies the most advanced refinements of the present year. The result is a sensitiveness which challenges comparison with any other set made, irrespective of the number of tubes employed.

6. Appearance and serviceability

The ALL-AMERICAN Model R comes in a beautiful two-tone mahogany cabinet, with inlaid designs, which accords with the decorative scheme of the most fastidious home. Ample space is provided within it for all batteries, or for a "B" socket-power if preferred. The ALL-AMERICAN "steel chassis" construction rounds out a set that will be a source of uninterrupted enjoyment for years to come.

Have your dealer demonstrate the Model R for you

The leading wholesaler of radio apparatus in your community has probably been, for years, an ALL-AMERICAN Authorized Distributor. ALL-AMERICAN Guaranteed Radio Products are sold everywhere by responsible and reliable dealers.

ALL-AMERICAN RADIO CORPORATION, 4209 Belmont Avenue, Chicago, Illinois
E. N. Rauland, President



OWNING AND OPERATING STATION WENR—266 METERS

ALL-AMERICAN

Pioneers in the Radio Industry

MEETING POPULAR DEMAND



**5 ampere
Tungar
in a new
model!**

The new five ampere Tungar—at the same price as the old—means a quick charge of all kinds of storage batteries.

- It is more silent than ever.
- It cannot burn out Radiotrons.
- It cannot create radio interference.
- It is ideal for auto batteries—and charges 2 to 6 volt radio “A” batteries, or 24 to 96 volt “B” batteries, in series—all without attachments.



The Tungar is a G-E product developed in the great Research Laboratories of General Electric.

Two ampere Tungar (East of the Rockies). \$18.00

Five ampere Tungar (East of the Rockies). \$28.00

60 cycles—110 volts

Tungar
REG. U.S. PAT. OFF.
BATTERY CHARGER

TUNGAR—a registered trademark—is found only on the genuine. Look for it on the name plate.

Merchandise Division
General Electric Company, Bridgeport, Conn.

GENERAL ELECTRIC

The “Windham” Variable Condenser

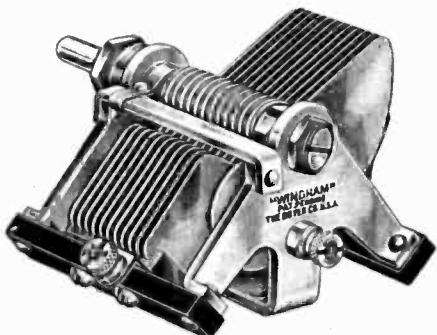

A durable, rigid instrument with correct electrical characteristics and made by skilled mechanics. It is provided with adjustable bronze cone bearings, the brake is independent of the bearings and adjustable. The plates are straight line.

It occupies small space, single hole mounting.
The price is right.
Desirable territory open.

The Goyer Company, Willimantic, Conn., U. S. A.

THE BEAT NOTE

(Continued from Page 23)

to them; that is, until along about 1927, or somewheres around there.”

“Applesauce!” growled Athos, reaching for another piece of parchment.

“It was in 1925 that the trouble really started. Up until then anyone who had a receiver anyways selective could pick and choose pretty near any station in the United States except maybe in the middle of summer, when you had to be satisfied with locals unless you had an extry good location. Even up in Oakland with two or three locals going every night we managed to get DX pretty good until everyone began to get this ‘super-power’ idea in their heads. It was a station called KFY down in Los Angeles that started it when they got leave from the government to increase their power to 5,000 watts so that they could reach out farther and brag a lot more about themselves. A bunch of windbags for fair, them; I mind how they used to sign off ‘KFY, Los Angeles—First in Everything—Where April showers come in March.’

“Well, now up in Oakland there was another station—KDO, operated by the Major-General Electric Company and no sooner had KFY started in with their 5,000 watts than they had to get a license for the same amount of power, although they had been running on pretty near ten kilowatts before that anyway, and just about paralyzing everything for more’n half a mile around. They raised their power, so they claimed, so that they could bat through the summer static, but the main idea they had in mind was the same as that of the KFY outfit—they wanted to be the biggest toad in the puddle.

“This super-power stuff made business pretty good, seeing as how lots of people had to junk their sets and get new ones which would let them listen to something else besides KDO when they took a notion to. Of course the superhets and the neutrodynes and some of the tuned radio frequency sets weren’t bothered much but the rest of them had mighty hard sledding, wave-traps or no wave-traps. The winter of 1925 come around and the static stopped but KDO and KFY kept right on with their dynamiting and what with their blanking everything within twenty degrees of them on the dials there was serious talk of lynching amongst some of the wilder minds of the BCL’s.

“Just about the time that the twenty-ninth petition to revoke KFY’s license was being started the gang who owned the station opened up a new subdivision only forty-one minutes by airplane from the Pacific Electric Terminal and collected enough money to add another 5,000 watts to their outfit. And the ink on their license was still wet when

(Continued on Page 50)



RADIO 'RITHMETIC

"A" batteries + "B" batteries + RECTIGON = clear radio reception



HARK back to your old arithmetic and those busy boys "A" and "B". They were forever doing "a certain piece of work". They're still inseparable. Nowadays "A" and "B" storage batteries are busy with clear radio reception.

"A" still depends upon "B" and vice versa. Both need to be kept fully alive to do their best work. Both can be kept alive easily and dependably through the use of *one* [did you know that?] compact, little device—

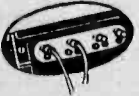

The Westinghouse Rectigon Battery Charger

© 1925. W. E. & M. Co.

 <p>To recharge 1- or 2-cell radio "A" batteries merely adjust "snap" terminals as shown here. Takes but a moment.</p>	 <p>To recharge 3- or 6-cell radio "A" or automobile batteries merely adjust "snap" terminals as shown here. Simple as can be.</p>	 <p>To recharge 11- to 48-cell "B" batteries merely adjust "snap" terminals as shown here. (An instruction sheet packed with every Rectigon).</p>	<p>Superiorities</p> <p>THERE'S no muss or fuss when you use the Rectigon. No acids or chemicals. No moving parts and no noise!</p> <p>It has high quality insulation throughout. Even the case is protected with Rectigon maroon, acid-resisting enamel. Guaranteed to completely satisfy.</p>	<p>No storage battery radio is complete without a RECTIGON</p>
---	---	--	--	--

Tell them that you saw it in RADIO

www.americanradiohistory.com

for Spectacular Performance and Super-Selectivity

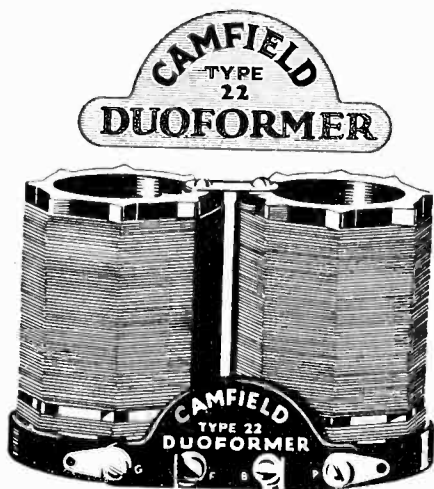

The closed magnetic field, and special winding of the new Type 22 Camfield Duoformer is the secret of the selectivity and sensitivity of the Duodyne Circuit.

Camfield Duoformers are boxed and sold in kits of three. Price \$10.00 complete.

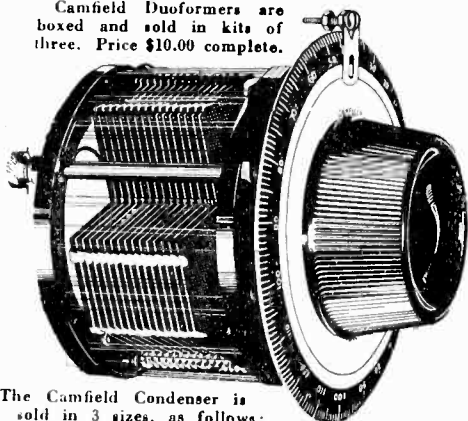

The Camfield Condenser is sold in 3 sizes, as follows:
Type 886 .00025 mfd. \$6.00
Type 887 .00035 mfd. 6.00
Type 888 .0005 mfd. 6.50

build the new Duodyne with the Camfield Type 22 Duoformer, and the Camfield Type 886 .00025 mfd. Straight Line Condenser.

This circuit—using either dry or storage batteries—is designed for the new power tubes, CX220, or UX120, and CX112 or UX112, and gives a combination of

**Selectivity
Sensitivity
Volume
Tone Quality**

never before obtained in a five tube set. The wavelength range is 150 to 550 meters.

Send 25c for "The Duodyne Circuit," a complete descriptive booklet with instructions and drawings for building.

DEALERS:

If your jobber can not supply you with a complete line of Camfield parts, send us his name and your order direct.



This condenser embodies a new principle of construction, combining every essential and desirable feature in a single unit. Its straight-line action together with the 360° dial, absolutely eliminates the necessity of a vernier.

The Camfield Condenser is enclosed in a transparent Dust-Proof Case which prevents the accumulation of dust between the plates, thus making it PERMANENTLY LOW-LOSS.

CAMFIELD RADIO MANUFACTURING COMPANY

807 HARRISON STREET
OAKLAND, CALIF.

1268 WEST 115TH STREET
CLEVELAND, OHIO

Factory Representatives:

Baker-Smith Co., Inc., 1270 Broadway, New York City; 30 N. Dearborn St., Chicago
A. S. Lindstrom Co., San Francisco, Los Angeles, Portland, Seattle, Salt Lake City

ARE YOU A SUBSCRIBER?

SEND \$1.00 FOR A TRIAL SUBSCRIPTION TO "RADIO" FOR 6 MONTHS

YOU NEED THE NEW CARTER "Dialite"



Gives you light right where you need it over the dials. Makes logging simpler and surer. You can put your set in any part of the room and always be able to read the dial marking.

Can be used in addition as a battery switch—shows you when your tubes are burning. A quarter turn snap switch, positive in action, operates on either 6 or 4½ volts. Current consumption negligible. See one at your dealer's today. Simple to install. Single hole mounting.

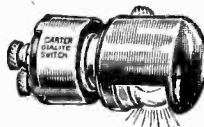

\$1.75 Complete
With Lamp

Branch Offices at
Los Angeles
Portland
Seattle
Salt Lake City

In Canada:
Carter Radio Co., Limited, Toronto.



Coast
Distributors:
A. S. LINDSTROM & CO.
274 Brannan St.
San Francisco, Calif.

THE BEAT NOTE

(Continued from Page 48)

KDO called their bet and raised it, coming on the air with 12,500 watts and running occasional tests four or five nights a week on 25,000.

"Them was desperate times. Everything but the superhets went out of business entire and with them bringing in KDO in forty fifty places on the dials nobody got much of anything. Any little two-for-a-nickel crystal set would bring him in on a loud-speaker for fifty miles around and with nothing but a steady stream of soprano solos regular every night and jazz bands playing up to 3:30 in the morning radio took a big slump. Every other station in both Los Angeles and the San Francisco Bay region went out of business early in 1927, being unable to stand this cut-throat business of raising the pot and until old Hartz brought out his Fourth Dimension Circuit things were pretty much at a standstill all over the Pacific Coast.

"The Fourth Dimension outfit went big. Nobody understood much about it except that it had only one control and four funny looking steel tubes without any filaments. It worked off the electric light system and cut out KDO or KFY like the superhets had done before and brought in the distant stations fairly well although seeing as how in July 1927 there was only one station using less than 5,000 watts in the whole United States it didn't take so much of a much to bring them in. At that time there were only twenty-two stations left, out of the six hundred odd which had been working the year before. The rest had quit because it wasn't stylish for people to listen to the low power outfits anymore.

"Then began the big fight amongst the survivors. KDO fired the first shot by putting in a bank of twelve 10-kilowatt tubes and every Hartz receiver on the Pacific Coast went out of business while he began causing serious interference with those as far back as Salt Lake City and Denver. They had to move the station forty miles out of Oakland on the Farallone Islands on account of their burning up nearby houses by melting the wiring, and electrocuting people who got too close to the station. I remember the night when they overloaded their tubes up to two hundred thousand watts and before their towers melted down they had stopped every street car in Oakland and San Francisco to say nothing of wrecking the P. G. & E. power lines for two miles around and setting fire to the Allendale sub-station. But they were picked up on crystal sets as far away as Johannesburg in South Africa and an unconfirmed report from the Samoan Islands stated that they had wrecked three receiving outfits in Tu-tuila.

"Within a month radio was at a stand-
(Continued on Page 52)

Zenith was created for the home

ALL one needs to get the finest radio results from Super-Zenith is good musical taste and a feeling for exquisite tonal values.

So far as *technical ability* is concerned, the Super-Zenith is so easily controlled that a child can bring in just as many stations—just as quickly—*each with the same clear quality of tone*—as a radio engineer.

Only a demonstration can make completely evident the remarkably selective character of the Super-Zenith—its clear, sweet tone—its thorough dependability.

Such a demonstration is yours for the asking—in your own home, if you so desire. Simply telephone your nearest dealer.



Again Commander Donald B. MacMillan chooses Zenith for his Arctic Expedition. When human life may depend upon the reliability of radio performance, only one reason can explain his choice: Zenith has proved to be the best obtainable at any price.



Super-Zeniths are priced at from \$240 to \$2,000. Each instrument is sold under a quality guarantee. Above is shown the De Luxe Spanish model.

- Super-Zenith VII . . \$240
- Super-Zenith VIII . . 260
- Super-Zenith IX . . . 355

Also Zenith regenerative sets (non-radiating) licensed under Armstrong U. S. Patent No. 1,113,149

- Zenith 4R \$100
- Zenith 3R 175

Zenith Radio Corporation, *Straw Building, Chicago, Ill.*



(Continued from Page 50)



Give Your Tuner a Man-sized Voice

NOW—you can enjoy loud speaker reproduction with your favorite tuner.

Using the "Electrad" 3-Step Resistance Coupled Amplifier Kit it's easy and economical to build an amplifier kit. And you will get a clarity and fidelity of tone unequalled by any other amplifying method.

"Electrad" 3-Step Resistance Coupled Amplifier Kit No. 1-C—A big \$6.75 value. Contains the necessary Resistor Couplers, Certified Mica Condensers, Condenser mounting, Certified Grid Leaks, and Resistors. Nothing else needed except sockets, rheostat and bus-bar.

At all Good Radio Shops or Sent Direct—Ask Your Dealer, or Write, for Folder on Resistance Coupling Amplification.

ELECTRAD, Inc.

428 Broadway, New York City

Also makers of other handy radio essentials—Certified Grid Leaks, Audiohms, Lightning Arresters, Lamp Socket Antenna and many others.

"ELECTRAD" VARIOHM

Price \$1.25—Gives that much desired last hair's breadth tuning, clears up DX reception. Gives any resistance from $\frac{1}{4}$ to 30 megohms. Mounted \$1.50.

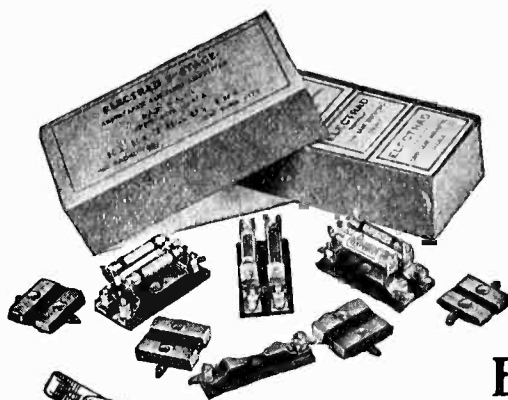
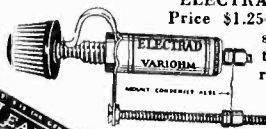

"ELECTRAD" LEAD-IN

Price 40c

Fits under locked windows or doors. No holes to bore. Quickly installed. 3000 volt insulation. Extra water-proofing. Meets the quality standard set by "Electrad"—there is a difference.

ELECTRAD

INC.

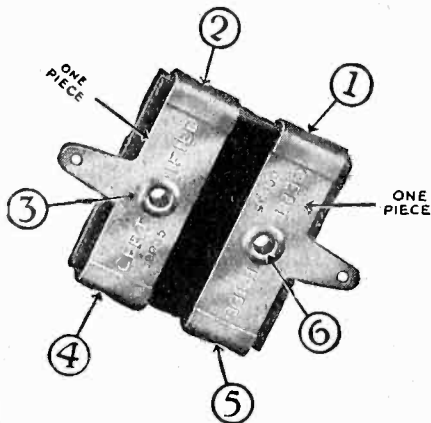

"The Six Point Pressure Condenser"

THE "Electrad" Certified Fixed Mica Condenser is a revelation in accuracy and design. Ingenious, rigid binding and firm riveting fastens parts securely at Six different points insuring positive electrical contact. Impervious to temperature and climatic variations. Exerts even pressure upon the largest possible surface—can't work loose. Binding strap and soldering lug in one piece. Accuracy and quietness assured always. Value guaranteed to remain within 10% of calibration. Standard capacities, 3 types. Licensed under Pat. No. 1,181,623, May 2, 1916 and applications pending. Price 30c to 75c in sealed dust and moisture proof packages.

still all over the United States, and for that matter, all over North America. Nobody closer than five thousand miles to KDO could listen to anyone except him or use anything more sensitive than a crystal set with safety. The sheriff locked me up soon after that and within a few months everyone had nearly forgotten about radio; aerials had been torn down everywhere on account of the fire hazard, while radio sets were selling for a dollar apiece with no takers. When KFY at length secured a license early in March 1928 to work on 150,000 watts there were only ten stations left in North America with nobody closer than Europe or Asia to listen to them. KFY was forced to move to the middle of the Mojave Desert to keep from going broke paying judgments which people won against them for burning down houses or electrocuting their relatives.

"KFY was hardly settled in its new location when the Major-General Electric Company sold ten of their eastern factories and with the capital thus obtained raised their power to a new unheard of height—300,000 watts, twice the power of their only competitor, for by that time the remaining eight stations had surrendered.

"KDO opened up with his 300,000 watts the morning of January 1st, 1929 and telegrams and cable messages which came pouring in soon confirmed their boast of a crystal set range of 12,500 miles—girdling the globe! There was a delay in the opening, which had been scheduled for Christmas Day, 1928, due to a lien for unpaid wages which had been obtained by a number of workmen employed in the construction of the station. The company was fast going to pieces with the terrific expense of their continual additions in power and the appalling cost of replacing tubes and electrical equipment which was constantly being ruined by high-frequency surges. The stock of the company dropped to less than 38 when the sale of the eastern factories was announced and within a week it had fallen off ten points to rise again to an unsteady 32½ for a long period.

"Despite the best efforts of their frenzied engineers KFY succeeded in being heard on a crystal set in but one isolated case at a maximum distance of 10,552 miles from Los Angeles and the citizens of that city, forgetting their past grievances against the station rose as one man and overnight subscribed a fund of \$4,429,621.07 for a super-super-station of 500,000 watts to be later increased to 750,000 watts if necessary.

"The new station rose apace; gigantic towers reached toward the clouds in an immense antenna system forty miles square, equipped with 750 Johnson energy couplers to allow the radiation

(Continued on Page 54)

*This Catalogue
represents the
world's greatest
radio store*

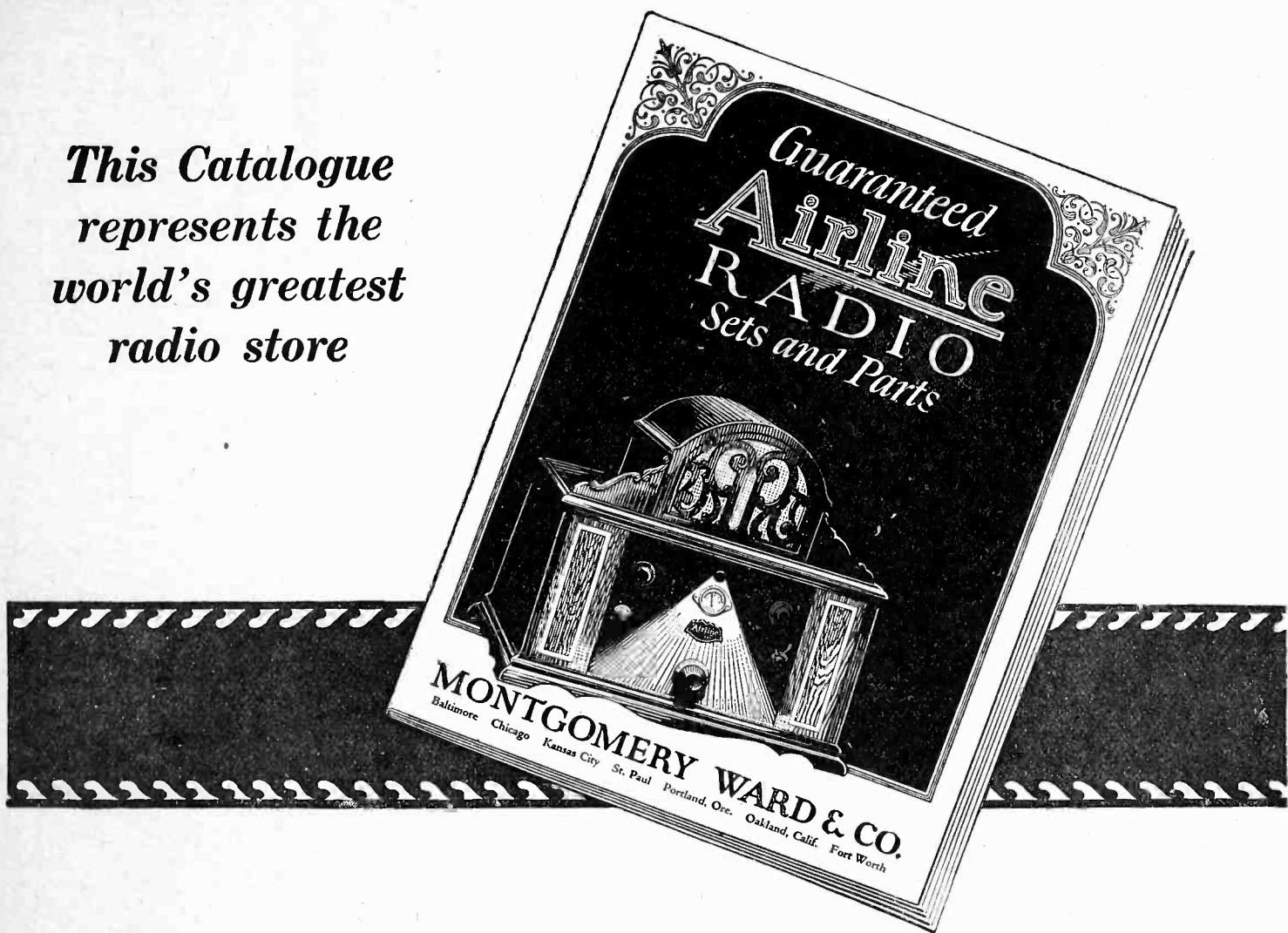

Ward's New Radio Catalogue Is Yours Free

Where you buy Radio is equally as important as the set you buy.

Send to Radio Headquarters for the most complete Catalogue of the season. See for yourself what is new in Radio and what has been actually tested and approved.

See for yourself what low prices can be made on Radio when it is sold without the usual "Radio profits."

A Complete Radio Manual

This new 52 page Radio Catalogue shows everything in parts, batteries, cabinets, contains a list of stations, a radio log for recording stations. It shows the best of the new sets. One tube sets that give amazing results. Five tube sets with a single dial to turn. Think of tuning in

one station after another by turning a single dial!

Every price quoted means a big saving to you. Everything offered is tested by our own Radio Experts; in fact, the best experts compiled this Catalogue for you.

Write for this free 52 Page Book. It is yours Free.

Our 53 Year Old Policy

For 53 years we have sold only quality merchandise under a Golden Rule Policy. You can rely absolutely upon the quality of everything shown in this Radio Catalogue.

To Montgomery Ward & Co. Dept. 39-R
Baltimore Chicago Kansas City St. Paul
Portland, Ore. Oakland, Calif. Fort Worth
(Mail this coupon to our house nearest you.)
Please mail my free copy of Montgomery
Ward's New Radio Catalogue.

Name.....

Local address.....

Post Office.....

State.....

ESTABLISHED 1872
Montgomery Ward & Co.

The Oldest Mail Order House is Today the Most Progressive

Baltimore Chicago Kansas City St. Paul Portland, Ore. Oakland, Calif. Ft. Worth



Distortion



Perfection

Where is the difference in radio transformers?

THE audio frequency transformers in your radio perform a most important duty. They aid in increasing the volume of sound . . . in building it up to the desired strength. BUT—

When sound is increased, the tendency is toward distortion. That's where the difference comes in transformers. Inefficient transformers will give distorted reception, just as a defective mirror will show a distorted image.

Whether you are building a set, or buying one, be sure about the transformers. No radio, remember, can be better than its transformers. A safe guide to follow is the Jefferson trade mark. You can depend on quality in performance when the name "Jefferson" is on the product.

Jefferson Transformers are made by transformer specialists—the world's largest manufacturers of small transformers. There is a very definite reason why leading radio engineers specify "Jefferson." You'll find it in the clear, sweet, life-like amplification which Jefferson Transformers give. Sold by the better dealers used by leading set manufacturers.

JEFFERSON ELECTRIC MANUFACTURING CO.

501 So. Green St., Chicago, Ill.

Makers of Jefferson Radio, Bell Ringing and Toy Transformers; Jefferson Spark Coils for Automobile, Stationary and Marine Engines; Jefferson Oil Burner Ignition Transformers.

JEFFERSON

RADIO TRANSFORMERS



JEFFERSON
Tube Rejuvenator

Keep your radio tubes like new! Rejuvenate them regularly. AT HOME, just as you recharge your storage battery. Jefferson Home Rejuvenator doubles and trebles tube life, quickly pays for itself. Raises your set's efficiency to 100%, and keeps it there! Completely restores paralyzed or exhausted tubes. Takes large or small tubes—types 201-A, 301-A, UV-199, C-299, 5-VA. Don't be without this long-awaited radio necessity. \$7.50 at leading dealers.



(Continued from Page 52)

of this tremendous power on a wavelength of 112.7 meters, the exact wavelength of their rival, KDO. It was in this manner that they hoped to drown out the signals of their only remaining enemy and drive him from the air lanes, for it was common knowledge that the Major-General Electric Company was on the verge of bankruptcy and incapable of raising sufficient money to meet this last and greatest increase of power. By March 1929 the new station was well toward completion and on July 4th of that year it was finished and scheduled to open at eight o'clock, p. m.

"The attention of the entire world was focused upon the thrilling climax of this epic battle and dark hints of a counterplot by KDO raised the odds against the Oakland station from 2 to 1 to almost even money. Feeling ran high in both cities and several men who looked like Oaklanders were hanged to lamp posts in Los Angeles by bloodthirsty mobs of local patriots.

"Seven-fifty p. m. that fateful day. Slowly the tremendous banks of motor generators at KFY started, one after another; engineers hurried about supervising the warming-up of the gigantic tubes, the announcer stood at his post, chronometer in hand; daring citizens of Los Angeles dragged out their ancient crystal receivers, eager to hear the opening words of the announcer regardless of almost certain death by electrocution.

"Seven fifty-five! In the operating room of KDO the engineers labored frantically with their apparatus, one group busy with a set of wavemeters, another making certain dangerous changes in the wiring. In mad haste they labored toward the culmination of the horrid scheme which they had evolved, sweating and straining every muscle and sinew, they ran their temporary connections about the vast building that their desperate plot might succeed. Not that there was a lack of time; there were whole days, weeks left in which they might perfect it to a successful conclusion, but the honor of KDO was at stake. KFY must never, even for the space of a minute drown out their signals. Almost certain death awaited them, but death was a lesser calamity than defeat.

"At 7.58¾ p. m., Pacific Time, KDO's signals were heard as the giant station commenced its last stand, as usual slipping in a few minutes on the silent period which was even then still observed as a matter of custom. Far back in the Gobi Desert of China the observers of KFY adjusted their crystal sets; another group in a steamship far to the southward of Cape Horn were at their instruments, chronometers in hand, eager to hear the voice of their beloved new station crashing through that of their competitor.

(Continued on Page 56)

FADA Radio



Why wait for *to-morrow* listen in to-day!

WAITING for someone to invent a better radio than Fada Radio is like saying—"I won't buy a car yet—we'll all be driving planes one of these days!"

Waiting Time is Wasted Time When Joy is on the Air!

"Fada Radio—the Standard of Reception" promises these things and proves them!

Splendid clarity and tonal values—Absolute control of volume—Ability to get remarkable distances—Certainty and ease in tuning in and tuning out—A demonstration of these qualities in your home or at the store, and without obligation—A Fada Service that guarantees satisfaction.

If You Waited Fifty Years You Couldn't Improve on That

Call up the local Authorized Fada Dealer and ask him to demonstrate Fada Radio in your home to-night. Try it before you buy it—let your "listening-in" decide!

Most Fada dealers will be glad to arrange convenient terms of payment. Send for the book D, "Fada Radio—The Standard of Reception."

F. A. D. ANDREA, INC.
CHICAGO NEW YORK SAN FRANCISCO
FADA RADIO, LTD.—TORONTO FADA RADIO, LTD.—LONDON
*Manufacturers of TUNED RADIO FREQUENCY
receivers using the highly efficient NEUTRODYNE principle*

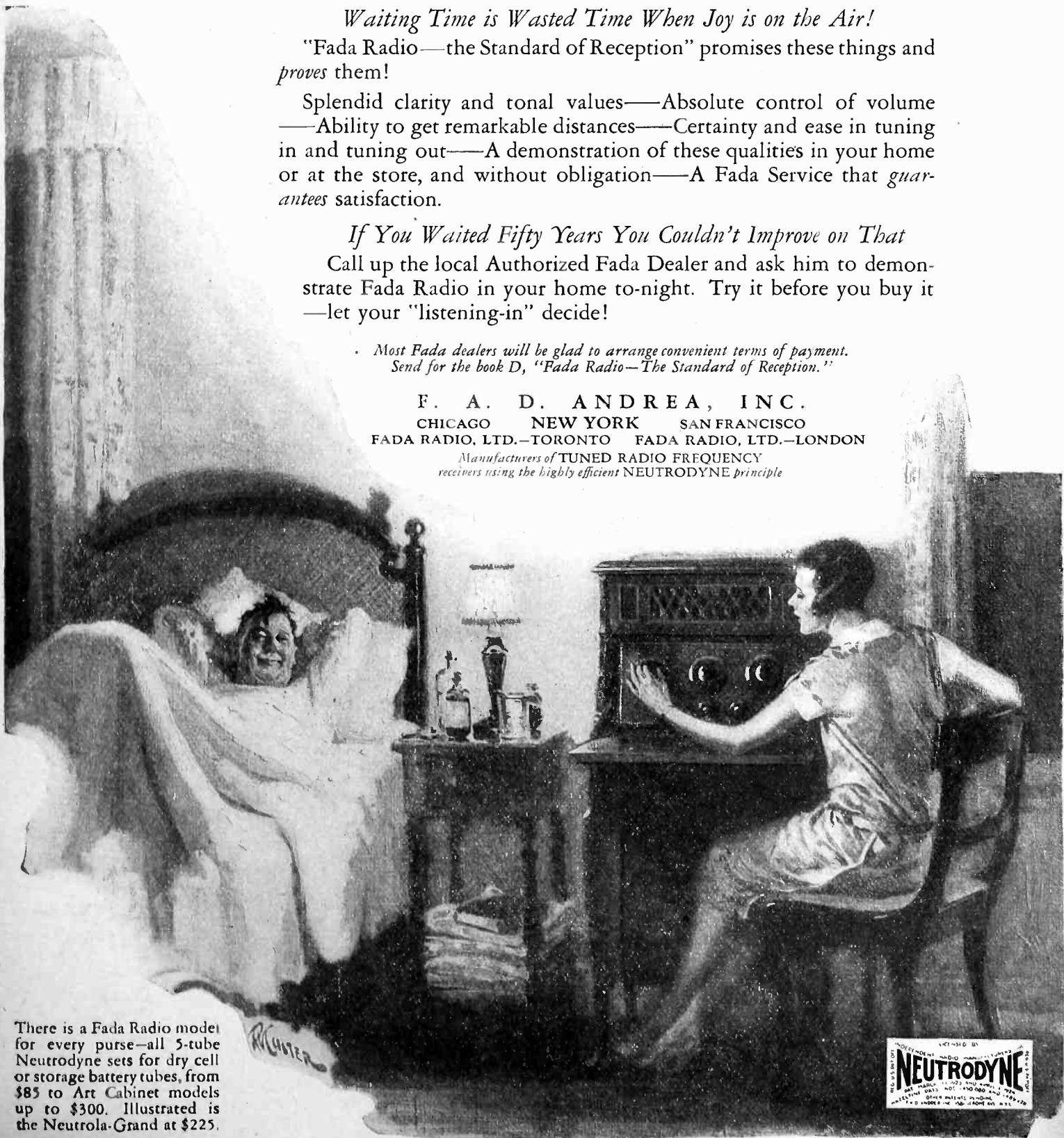

There is a Fada Radio model for every purse—all 5-tube Neutrodyne sets for dry cell or storage battery tubes, from \$85 to Art Cabinet models up to \$300. Illustrated is the Neutrola-Grand at \$225.

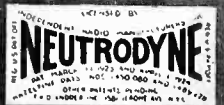

Tell them that you saw it in RADIO

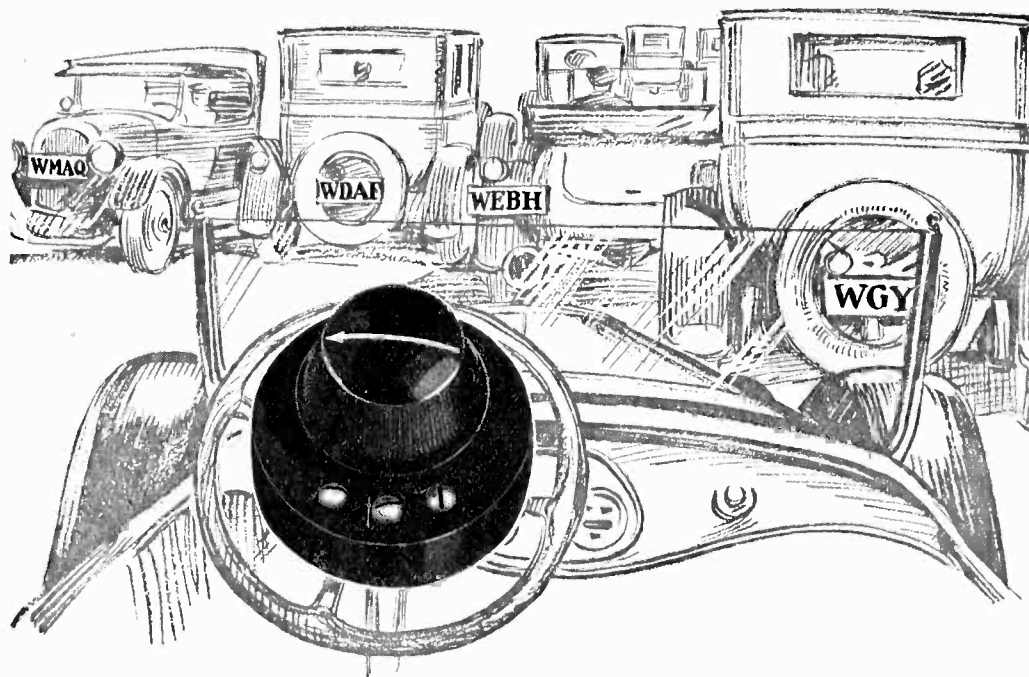

Through the "Radio Traffic"

WHEN you run into a flock of high-powered broadcasting stations, all riding the ether at the same time, can you pick your way through to your desired destination without getting tangled up in the jam?

The *Centralab Radiohm* will enable you to "ride" through the "radio traffic" with ease — slip past unwanted "locals" and bring in selected "DX" loud and clear. Smooth variation from zero to 200,000 ohms. Especially adapted to plate circuit control of oscillation. Now used as a standard unit by more than a score of leading radio manufacturers.

*\$2.00 at your radio dealer's—or mailed direct.
Write for literature and circuits describing
this and other Centralab patented controls.*

CENTRAL RADIO LABORATORIES
14 Keefe Avenue Milwaukee, Wisconsin

Centralab

BAKELITE PANEL ENGRAVING

VOLNEY G. MATHISON & CO.

660 Twelfth Street, Oakland, California

Wholesalers of BAKELITE PANELS, SHEETS and TUBING. BAKELITE CUTTING, DRILLING, and SUPER-FINE ENGRAVING

Special machine service to the trade; lathe-work, drilling, forming brackets, shields, etc. Mfgs. of all kinds of radio inductance coils, doughnut, super-machine weave, or on bakelite tubing.

WRITE FOR PRICE LISTS

(Continued from Page 54)

"The operating room of KDO was an inferno of laboring apparatus. The giant tubes glowed with a red heat, the generators smoked and growled and spat fire from their commutators under the terrific overload imposed upon them; up went the needle of the wattmeter—400,000—415,000. It wavered and dropped slightly and the tense group of engineers before it cursed with one voice. Then upward it staggered again as the operators recklessly sped up the generators and cut out coil after coil of controlling resistances and reactances 425,000 watts! The steel of the tubes had reached all but welding heat and exactly at 8:00 p. m. when the triumphant voice of the announcer at KFY spoke the opening words of his address the wattmeter at KDO had reached the terrific figure of 461,322!

"Far back in the desert of Gobi the observers of the Los Angeles station exchanged wondering glances; aboard the steamship far below the southern tip of South America the watchers shook their crystal sets and feverishly prodded their galena for new points. In that fatal moment thousands of people in far off Africa, in Europe, in the frozen wastes of Siberia frowned in perplexity and hunted for new points on their detectors. It was not music which bellowed from their loud speakers, only an insane medley of whining sound in which mingled the signals of KDO and KFY. Something was wrong! But in the laboratories of KDO the engineers watched their fusing tubes and smoking apparatus and laughed in triumph even in their knowledge of the catastrophe so swiftly approaching.

"A minute passed and one of the operators of KFY detected a subtle movement of the earth beneath his feet and mentioned it to his companions. Likewise the engineers of KDO felt this vague quaking, and trembled, for they knew the awful meaning of this as yet insignificant vibration. With whitened faces they silently gripped the hands of their fellows. Death before dishonor!

"In the far-off reaches of the Gobi Desert the observers of KFY felt this motion of the ground and the steamship hove to in the far southern reaches of the Antarctic shuddered with a vibration foreign to its movement as the unheeding citizens of Los Angeles aboard her prodded their crystals and even risked destruction by listening on a one-tube reflex receiver.

"It was then that the chief engineer of KFY received the first intimation of the disaster in a rush cablegram from China. For a full minute he glared at the fatal message and then with a wild cry of horror he leaped to the switchboard as his active brain grasped the fiendish plot. One quick pull at the master switch and the giant tubes were

(Continued on Page 58)

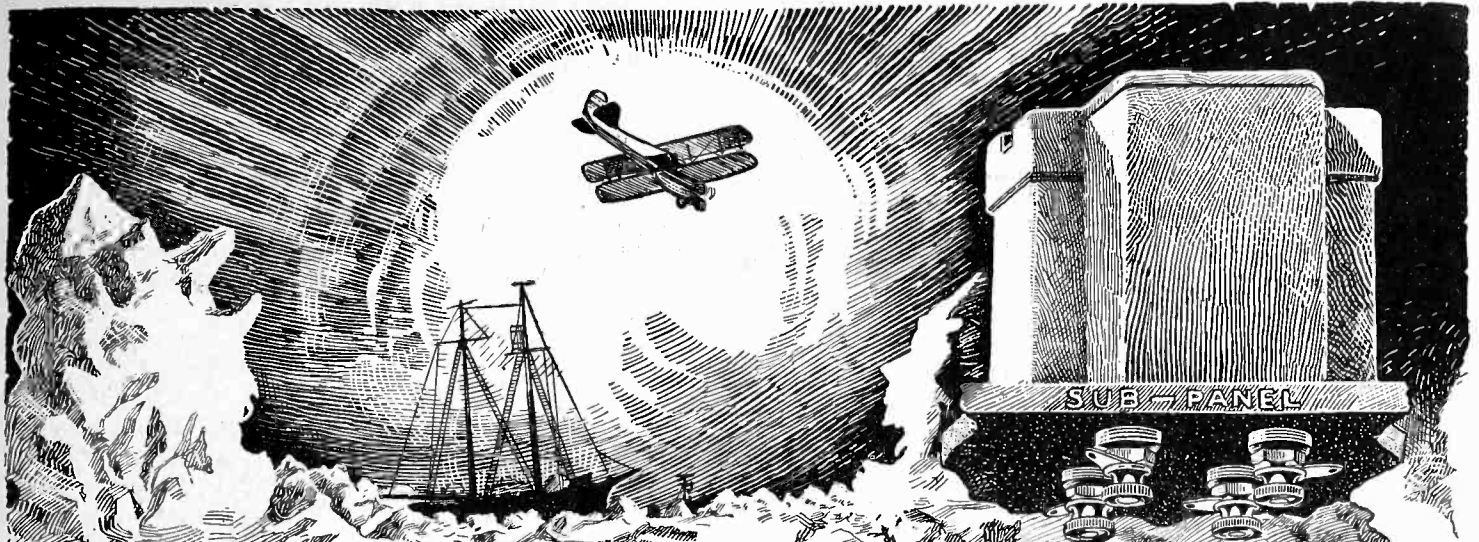

MacMillan received and sent with Thordarson Transformers

If you were commissioned to explore the polar regions, you too would be very particular to select the best equipment — especially in radio, your sole means of communication.

ZENITH
KENNEDY
Radiodyne
Planstiehl
Howard
Thermiodyne
GLOBE
Deresnadyne
ADLER-ROYAL
MURDOCK
MU-RAD
Valley
Silver-Marshall
OZARKA
ULTRADYNE
Newport
LEICH
NUNN-LANDON
KUSTOMBILT and
many others
use

THORDARSON Super Amplifying Transformers — the identical transformers sold by dealers everywhere and used in a majority of quality sets—have been the exclusive choice of MacMillan on his Arctic expeditions.

Surely no greater tribute can be paid to the actual supremacy of Thordarson Transformers, product of the world's oldest and largest exclusive transformer specialists. Faultlessly they amplified programs and messages from great distances on the 1923-1924 expedition — and came back "as good as new." Equally successful was their performance on the last expedition.

The wisdom of MacMillan's choice is further confirmed by the fact

The Thordarson "Autoformer" All Frequency Amplifiers are our latest development. They amplify clearly the lowest as well as the highest notes of any instrument. An adaption of impedances, resistances and capacities. Write for the Autoformer Hook-up Bulletin—it's free.

that year after year, leading builders of fine sets—makers of fine instruments especially noted for distance and superb tone qualities—use more Thordarsons than all competitive transformers combined.

In addition to Thordarson audio frequency and power amplifying transformers in his receiving sets, Mac Millan chose Thordarson Transformers for exclusive use in his broadcasting station, WAP, on board the Peary. WAP successfully broadcast the weird voices and instruments of Eskimo entertainers back to civilization.

Thordarsons cost more to build — but no more to buy. Dealers everywhere. Interesting bulletins on amplification mailed free.



Autoformers are \$5 each. Other Thordarson Radio Transformers: Audio Frequency (subpanel or top mounting types), 2-1, \$5; 3½-1, \$4; 6-1, \$4.50. Power Amplifying, \$13 the pair. Interstage Power Amplifying, each \$8. If dealer cannot supply, order from us.

THORDARSON ELECTRIC MANUFACTURING CO.
Transformer specialists since 1895
WORLD'S OLDEST AND LARGEST EXCLUSIVE TRANSFORMER MAKERS
Chicago, U.S.A.

THORDARSON Super

AMPLIFYING TRANSFORMERS
Standard on the majority of quality sets

Vital Parts of Leading Radio Sets

Nowhere is the axiom "an article is no better than the parts it contains" more true than in the radio world. So it is not surprising that leading manufacturers of radio sets choose the accessories for their hookups only after gaining a full technical knowledge of their make-up and the results they give.

In full consideration of this, the choice of Benjamin Radio Products, above all others, by the manufacturers of many of the finest modern radio sets, bespeaks eloquently of their worth as practical radio parts made by one of the oldest manufacturers of electrical goods.

Each has been made a super radio part—to secure for the owner of the set the purest, loudest and clearest radio signals possible. Used together, their total efficiency spells the acme of selectivity, tuning range, the elimination of disturbance and distortion, and the reduction of radio losses. And, the logical total of these many worthy features is "Better Radio."

**Benjamin
Electric
Mfg. Co.**

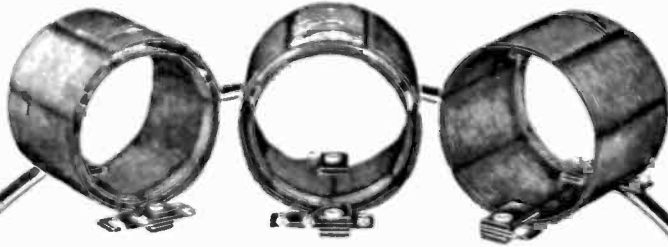

120-128 S. Sangamon
St., Chicago
247 W. 17th Street
New York
445 Bryant Street
San Francisco
Manufactured in Canada by
the Benjamin Electric Mfg.
Co. of Toronto, Ltd.,
Toronto, Ontario

BENJAMIN Tuned Radio Frequency Transformers

Low Resistance—Low Distributed Capacity

Wires are space wound, adjacent coils are parallel, air insulated and so separated that while capacity is reduced to a minimum, inductance is maintained at a high point of efficiency.

Greater Tuning Range—Greater Selectivity

These coils are very uniform, both in inductance and distributed capacity, so that if desired they may be geared for stage control of the three tuned stages. A minimum amount of material is used in the field of the coil and an anti-capacity circuit is used only where the wires cross. Coils are coupled so as to reduce capacity coupling to a minimum. Green double silk covering provides high insulation and gives a fine appearance to the coil.

Benjamin Cle-Ra-Tone Sockets

Benjamin Cle-Ra-Tone Sockets prevent the transmission of outside vibrations into microphonic diaphragms. Four delicately adjusted double springs support the socket—"float" it above the base—and absorb all jar and shocks. An absolute necessity in portable sets. Used by leading manufacturers and recommended by radio engineers in their most popular hookups. There are no other parts so delicate. Bakelite is used wherever possible to insure resistance, long life and high insulation. Heavy legs make soldering easy. Small base is of die-cast metal and does not affect the frequency of the Cle-Ra-Tone sockets. It is mounted on a gasket of Bakelite which gives the socket set anchorage in other material. Benjamin Products have a plenty of spare stock.

Benjamin Low-Loss, Long-Range Condensers

Straight line type. Definite and positive control of inductance changes in condenser capacity. Spreads the broadcast range on the higher frequencies, and eliminates bunching of stations on the lower side of the dial. Aids sharp tuning and increases selectivity. Many other features to meet and exceed what you expect. Long life, made of strongest steel. Unmatched when you finish. Small size of condenser makes it adaptable to any set. In regard to covering of adjustment, it is superior to any other type. It is made of Bakelite and is of the most durable type. It is made of the finest material and is of the most durable type. It is made of the finest material and is of the most durable type. It is made of the finest material and is of the most durable type.

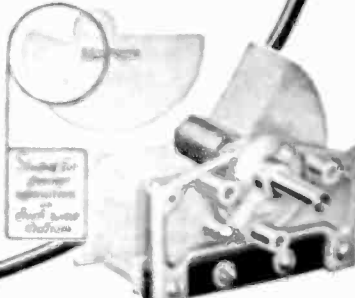
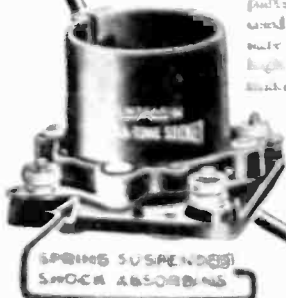

DON'T WAIT!
Pep Up That Set Now With
X-LV ARIO DENSERS

Install them in your receiver and hear them speak for themselves.
Designed by
GERALD M. BEST
Endorsed and Used By the Foremost
Radio Engineers

Model N—Capacity range 1.8 to 20 micro-microfarads for balance in Roberts two tube, Brownrigg, Drake, Richards, Sinton's, Kenwood, Neutrodyne and other radio frequency circuits. Price \$1.00
Model G—Two capacity ranges, 200 to 2000 and 200 to 2000 microfarads, for the Colson circuit, filter and intermediate frequency tuning in superheterodyne and positive grid sets. Price \$1.00

X-L ARIO LABORATORIES
1222 Lincoln Avenue CHICAGO

How to pass
US Govt
Radio
Examination

310
Actual questions
and answers
by I.A. Smith

For a short
time only **60c**
RADIO INSTITUTE OF AMERICA
323 Broadway, New York City

ARE YOU A SUBSCRIBER?
SEND FOR TRIAL SUBSCRIPTION
\$1.00 FOR SIX MONTHS

(Continued from Page 56)
extinguished. Rapidly he worked the controls of the switchboard and with a soft slurring of brushes the tempo of the giant dynamos dropped lower and lower while ever more pronounced grew the vibrations. Too late had the message been received! Chimneys began to fall, the frail shack of the Gobi observers collapsed like matchwood. A tower fell at KFY, another and another, the ceiling of the gigantic auditorium cracked and falling plaster rained upon the panic stricken mob which fled for the open. And through all these warnings of the approaching holocaust the strains of a soprano solo from KDO shrieked over the entire globe. The last broadcasting station on earth!

"A still more violent tremor of the earth and suddenly the voice of the singer grew blurred and strange. Then with a flash of incandescent metal the giant tubes of KDO collapsed into ruin and the faithful generators gradually slowed to eternal rest.

"Still more tremendous grew the vibrations; the entire globe rocked to its core at its fundamental vibration, seven cycles per second. For the engineers of KDO had changed their wavelength on that fateful evening, changed it a fraction of one meter to heterodyne with the carrier wave of KFY and produced a beat note of seven cycles per second! And as they had hoped and prayed the tremendous force behind this slow vibration had rocked the earth, gradually at first, but with ever increasing amplitude until houses fell like matchwood, cities were collapsed like feeble things of pasteboard and mountains toppled to ruin. The earth opened in huge chasms, it rose and fell like the waves of the sea and new mountains were formed in a minute. Sea bottoms were laid bare while vast areas of land were forever sunk beneath the surface of the intruding waters, huge fires started and burned for months afterward under the impetus of the terrific storms which sprang up at the moment of the cataclysm. For the two hours the vibrations continued, gradually diminishing in intensity and when they at length ceased the civilization of two thousand years had vanished. Only a few half-insane survivors wandered in a daze about the new earth to shortly relapse into barbarism."

The voice of Athos interrupted. "Say," he plaintively inquired, "Is this old windbag gonna carry on all night? If he is, somebody's got to get me some more parchment."

"Applesauce!" he growled to his assistant as they carted their notes toward the scribe's home. "The old boy's batty—been wandering around with the sun shining on that bald dome of his too long!"

Absolute Accuracy!

For the man who demands absolute accuracy in radio apparatus, there is no substitute for "General Instrument."

Their products have become recognized by the competent radio technician as a nucleus around which can be built a radio receiver that will perform unflinchingly. Radio engineers use them as standards for comparison.

If you are a seasoned amateur, you know the meaning of "General Instrument." If you are a beginner just learning the mysteries of Radio and have the ability to become an expert, you will soon discover the open door to radio perfection is "General Instrument."

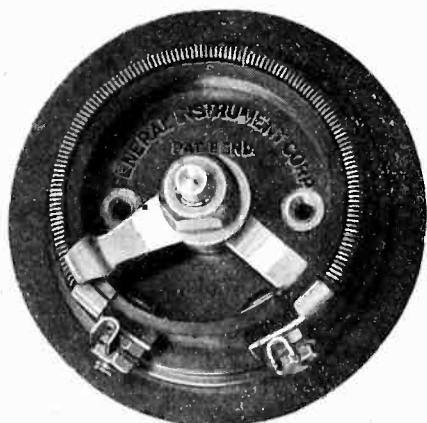

TYPE 40

The inimitable Rheostat

Without the organization of General Instrument back of it this rheostat could not be built. Therefore it cannot be imitated. Once you get it you have the real thing—but you must say "General Instrument."

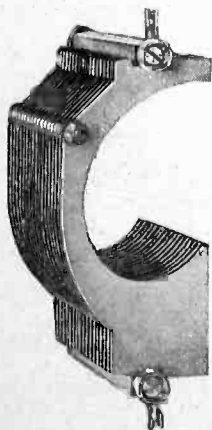

STATOR

Concentric Straight Line Frequency Condenser

(Pyrex Insulated)

Not a trade name but an accurate description of General Instrument Type 80.

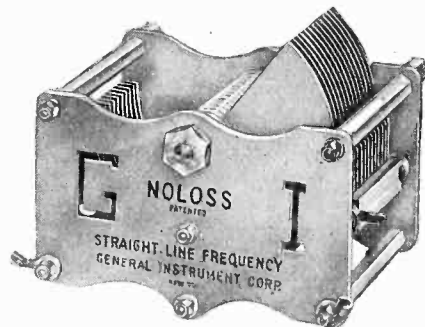

PATENTED

OBTAINABLE AT BETTER CLASS RADIO DEPARTMENTS

General Instrument Corporation
Manufacturers of Laboratory Equipment

423 Broome Street New York City

Tell them that you saw it in RADIO

www.americanradiohistory.com

8 TUBE KITS!

BASEBOARD MODEL, \$84.75

3 Jefferson No. 150 radio frequency transformers, \$15, or Remler No. 600, \$18.00; 1 Jefferson No. 155 filter transformer or Remler No. 610, \$5; 1 each General Radio Oscillator Coils: No. 277A, \$1.25; No. 277B, \$1.25; No. 277C, \$1.25. One coil mounting, No. 274B, \$1. Twelve Coil Mounting Plugs, each 15c. One Bradleystat, \$1.85. Two No. 631 Remler condensers, each, \$5; two, \$10.00. Three Federal Jacks, \$2.10. Three small Benjamin Sockets, 5 large Benjamin sockets, each, \$1. One Weston voltmeter, \$8. One 2 mfd. Dubilier cond., \$1.75. One 1 mfd. Dubilier cond., \$1.25. Two .00025 Dub. fixed cond., each, 35c. One .002, 60c. Two .006, each, 75c. Two .0005, each, 35c. Two 3 meg. Leaks, each, 20c. One .1 meg. Leak, 20c. One 2000-ohm Federal potentiometer, \$2.20. Seven Eby binding posts, each, 15c. Four No. 1-A Amperites, each, \$1.10. One No. 112 Amperite, \$1.10. Bakelite panel, drilled, engraved, polished, 7x20 inches, \$5.75. Baseboard, 35c. Bus wire, 50c. Screws, 35c. Two Audio Transformers, Thordarson, each, \$5.00. Or two Karas Harmonic Audios, each, \$7.00, or Lyrics, each, \$9.00, or All-American, each, \$4.50.

Complete kit as above, \$84.75.

Karas audio transformers extra, each, \$2.00, or Lyric Audio Transformers extra, each, \$3.50.

Shielded Model Kit, complete with panel, ready-cut shielding, etc., ready to assemble, \$89.50.

All Parts Sold Separately at Above Quoted Prices

RADIO TUBE MATCHING SERVICE

We scientifically match up sets of tubes especially for use in superheterodynes and tuned-frequency receivers. Price per tube, Cunningham or Radiotron, each, \$2.50, postpaid. Furnished in matched groups of 3, 5, 6, 7, 8 and 9.

RADIO OWNERS SERVICE COMPANY

660 Twelfth Street

Oakland, California

AEROVOX

CONDENSERS

AEROVOX
for Accuracy

AEROVOX
for Quality

Made in all capacities.
Write for particulars of
our complete line, includ-
ing Resistoforms, Rheo-
stats and Grid Leaks.

AEROVOX
for Results

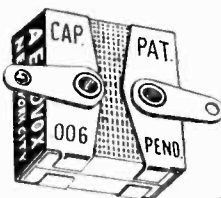
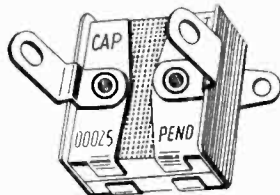

AEROVOX WIRELESS CORP. 489 Broome Street, New York City

Chicago Office: 53 W. Jackson Boulevard

Western Representatives: RICE-HITT CO., SAN FRANCISCO-LOS ANGELES

de Forest

The Greatest Name in Radio

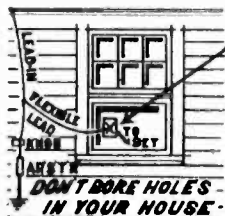

The Window-pane Lead-in Connector

Sticks to glass without holes. On or off instantly \$2.00 at your dealer or post paid D. S. DU BOIS 1065 Tibbitts St. Portland, Oregon



Diameter 4" Over All

B. M. S. VERNI-JUSTER

The new B. M. S. Verni-Juster gives razor-edge selectivity. Not just a dial with makeshift vernier attachment, but an accurate, well-made mechanism. Positive action — 15:1 gearing. Insulated friction clutch eliminates body capacity—no tools whatever are required to attach it. **\$1.50**

Brooklyn Metal Stamping Corp.

718-728 Atlantic Ave., Brooklyn, N. Y.

Western Representative:

F. L. Tomlinson & Co.

443 So. San Pedro St., Los Angeles, Calif.
152 Security Bldg., Portland, Oregon

MARIUS LATOUR

(Continued from Page 20)

in connection with work along these lines in this country.

In regard to the question of reflexing, the Schloemilch-von Bronk patent, now held by the Alien Property Custodian, has raised an issue which is not yet decided. As a matter of fact, scarcely any of these patents have been litigated thoroughly, and it is remarkable that a foreign inventor could come to America and in view of the powerful interests involved, amounting to the possible assessment of royalties of the order of \$110,000,000,—secure an adjustment of claims in view of the above facts.

The time is rapidly approaching when the tendency of the radio art, as controlled by patents of leading inventors, will be to form "gentlemen's agreements" to avoid expensive litigation rather than to tie up business through the uncertainty of the results following indiscriminate merchandising under these conditions. This has been the history of the lighting and power divisions of the electrical industry and the tendency is to bring the same situation about in the realm of communication.

The half-million odd dollars received by the inventor for waiving his rights as a plaintiff in patent litigation for up-to-date and future royalties, will do much to clear the industry of the spirit of restraint in regard to future development. Latour was astounded both at the extent of the radio industry in this country and the vast improvements which have been made on his own disclosures, by American inventors. There is no exaggeration in stating that our audio frequency transformers are being perfected to an extent undreamt by him.

Latour seems to have neglected no possible detail in regard to patenting slight improvements, such as a tap coil, which is generally used in the radio art, and coaxial transformers for radio and audio frequency circuits. He realized the deleterious effects of cross capacitance in these transformers, and also how to turn the same to advantage in securing stability.

All in all, the workings of his mind show a tremendous constructive imagination and also a very businesslike opportunism, qualities which are necessary for any inventor to possess in order to keep on his feet in the midst of the rush in negotiations which any vast improvement will bring upon him. Latour promptly capitalized his work in his own country, but, like many Frenchmen, even though at one time visitors to America, he had very little conception of the American temperament in regard to nation-wide response to new ideas.

It is somewhat amusing to realize the similarity of invention which crops out at different parts of the world when

(Continued on Page 62)

Your set at its best *always* with a **Super-Ducon**

-the "B" Battery Substitute

When guests come in, your set is ready. No run-down "B" batteries—no batteries being recharged. There's the Super-Ducon plugged into the light socket—ready to deliver a steady, silent flow of current.

It's the perfect substitute of "B" batteries—equipped with a specially designed RCA tube (Rectron UV-196) that has an average life of more than 1000 hours. It's a thoroughly efficient device—made and backed by Dubilier. And it *keeps* your set at its best!

Tested and listed by the National Board of Fire Underwriters.

Dubilier

CONDENSER AND RADIO CORPORATION

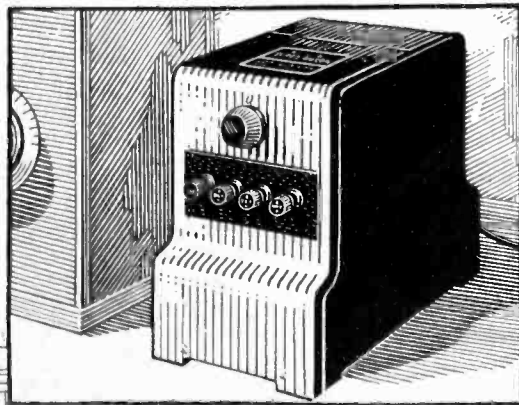

Price \$47.50

Write for descriptive
booklet No. L-3

*"The Super-Ducon—
and how to install it."*

4377 Bronx Boulevard
New York City

Superadio Receiver

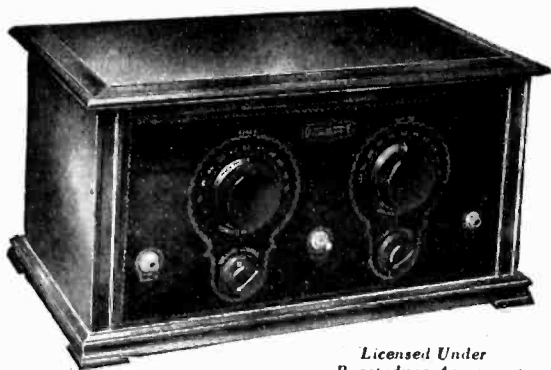

Licensed Under
Reactodyne Agreement

At last—true beauty is combined with scientific design so that results never before expected are now easily achieved. Loose, extravagant claims are not made for this set, which must be seen and heard to be appreciated.

Results Undreamed of Now Secured

Operates on radically new principle—inductive reaction. Housed in a handsome, compact, solid walnut cabinet with black bakelite panel engraved in deep gold. Produces full rounded tones with all their color and shading. Oscillations automatically controlled. Use of low loss S. L. F. Condensers and highly developed Solenoid R. F. Transformers results in tremendous power without disturbing squeals, while simple controls, only two, regulate the thunderous volume to fairylike whispers, if desired.

Send for circular giving engineering details why the Superadio is so far ahead of present day conceptions.

Tested Tubes Now Possible

Remember—you can now buy TESTED tubes—where the Superadio Dynamometer is on the job. This meter is direct reading. Measures the amplification factor, plate impedance and mutual conductance of any radio tube. Extremely easy to operate. Tests three tubes per minute.



Superadio Dynamometer equipped with phones and plug. Price \$120. (Patents Pending)

Jobbers and Dealers

Write for details on the Dynamometer and our liberal selling proposition. Be the first in your town to sell TESTED tubes.

De WITT-La FRANCE Co., Inc.

54 Washburn Ave., Cambridge, Massachusetts

Boston Representative:

Martin, Hartley & De Witt Sales Co., 99 Bedford St.

Chicago Representative:

William A. Welty & Co., 36 So. State St.

Burns LOUD SPEAKER

With Concert Unit

The large size of this Unit gives great range with tone of most pleasing quality, which, combined with the special amplifying properties of the Burns horn, produces remarkable results. A speaker that will add to the enjoyment of any receiving set. Pleases the eye as well as the ear.

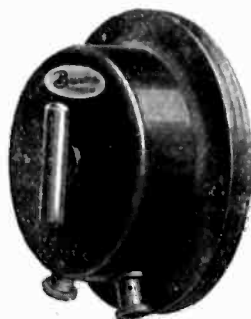

Horn is of a distinctive design with pyralin flare in several handsome finishes.

No. 205B—With Black Flare.....	\$22.50
No. 205D—Mahogany Tinted Flare.....	25.00
No. 205P—Mother-of-Pearl Flare.....	30.00
No. 100 —Medium Phonograph Unit.....	10.00
No. 120 —Concert Phonograph Unit.....	12.00

At your dealers, or write direct to manufacturers.

American Electric Company

State and Sixty-fourth Streets

CHICAGO, U. S. A.

(Continued from Page 60)

ideas are "in the air," so to speak. The loading down of an antenna by periodically distributed inductances, condensers, or other combinations, seems to be a kind of "electrified mood" through which most radio inventors pass at some time or other, and Latour has been no exception to this desire for improvement of the characteristics of antennas with "shortened" fundamentals.

There has been formed the American Latour Corporation which has sold 80 per cent of its stock to the Hazeltine Corporation for \$250,000.00 and his interests are no longer directly involved in the domestic radio situation except through the possible future development of present patent applications. His good fortune in cashing in on his early work is a splendid illustration of the fact that "make haste slowly" is a safe method of watching the development of a field in which pioneer claims have been allowed. Selden illustrated this attitude in the automotive industry and Latour has done so even more brilliantly.

MARCONI BEAMS

(Continued from Page 12)

It is not the intention of this article to delve deeply into the theoretical explanation of this phenomenon brought about by the presence of the reflector but it will suffice to say that the energy set up in *A* produces oscillations in *B*; this reflector then in turn re-radiates the electro-magnetic waves from *A*. These re-radiated waves interfere with those produced by the antenna in a definite and constant manner so that the strength of radiation is increased to a very marked extent in one direction whilst in the other direction the waves cancel each other.

With this arrangement it is possible to concentrate all the energy into a beam of 10 degrees convergency so that any receiving station lying in the arc of that beam will be able to receive 36 times more energy than it would if the same power was radiated uniformly throughout the 360 degrees, as is practically the case with existing transmitting stations.

Putting this in another way a 10 kw. station projecting its waves within a 10 degree beam becomes, so far as the distant receiver is concerned, equivalent to a broadcasting radio transmitter having a power of 300 kw.

NEW RADIO CATALOGUES

"Radio Vacuum Tube" from the C. E. Manufacturing Co. of Providence, R. I., gives a detailed description of the methods of manufacture employed and of the characteristics of "Celeo" tubes.

American Battery Co. of Chicago, has published a folder describing the construction and performance of the Big American B battery charger. This is a chemical rectifier which may also be used as a trickle charger for *A* batteries.

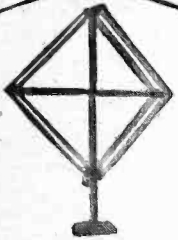
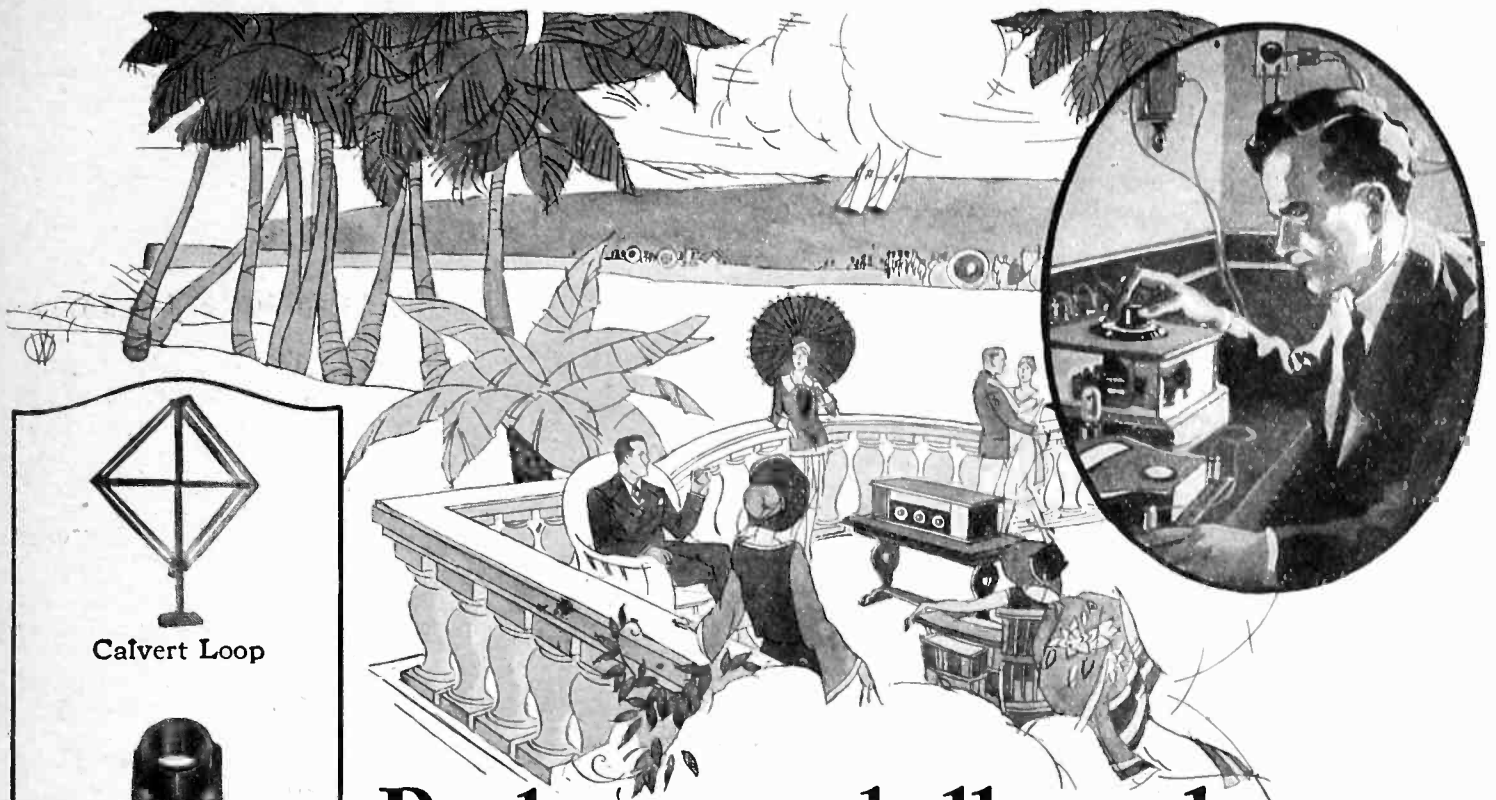

Calvert Loop



Bennington
Tube Socket



Mason Z & T Jr.
Detector



Saal
Soft Speaker



Pacent Knob



Pathe Dial

Radio tested all insulations- and adopted Bakelite

In the laboratories of radio manufacturers, in actual use in all climates and under adverse conditions, Bakelite has proven its superiority for radio insulation.

The reason for this dominance of Bakelite in radio is easily understood. Its high insulation value, so essential to tonal quality, is unimpaired by time, temperature variations or by service.

Bakelite is generally used for exposed radio parts, dials, knobs, panels and accessories, because its color and high finish are permanent, undimmed by exposure or handling.

The use of Bakelite in the set you buy or build will insure you against inferior reception through defective insulation. It will pay you to make sure that Bakelite is used in the radio set or parts that you buy.

Write for Booklet No. 30

BAKELITE CORPORATION

247 Park Avenue New York, N. Y.
Chicago Office: 636 West 22nd Street

Western Representative:

ELECTRICAL SPECIALTY CO.

443 S. San Pedro St. 75 Fremont Street 1041 Sixth Ave., So.,
Los Angeles San Francisco Seattle

Bakelite is an exclusive trade mark and can be used only on products made from materials manufactured by the Bakelite Corporation. It is the only material which may bear this famous mark of excellence.

BAKELITE



BAKELITE

is the registered trade mark for the phenol resin product manufactured under patents owned by the Bakelite Corporation.

REG. U.S. PAT. OFF.

THE MATERIAL OF A THOUSAND USES

MOZART GRAND

Manufacturers of

Fine Instruments

235-49 Elizabeth Ave.

Newark, N.J., U.S.A.

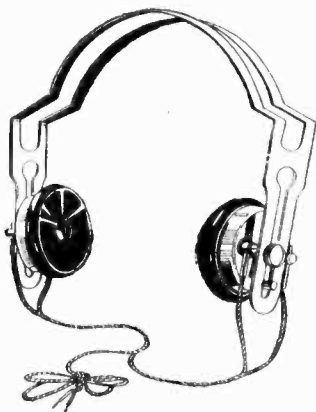

MOZART-RADIOCIEVE
SUPER HEADSET,
\$5.00

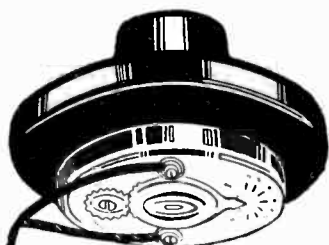

PHONOGRAPH UNIT
TYPE A, \$4.00
TYPE B, \$6.00



BABY GRAND
COMPLETE
WITH
TYPE A UNIT, \$9.00
TYPE B, \$12.00



MOZART UPRIGHT SPEAKERS

THE STANDARD - -	\$ 8.00
THE BLACK BEAUTY	10.00
THE 12-IN-B - - -	12.00
THE 14-IN-B - - -	14.00

NOW it is neither necessary to buy an indifferent "loud speaker" or to use headphones unsuitable for amplifying service.

These speakers—true reproducers—provide highly satisfactory entertainment—and the low cost makes them available to all. They will give results far superior in tone and volume to other instruments at, or, near their price.

These speakers are correct, and, only a demonstration is needed to prove their unquestionable quality.

CALIBRATION LABORATORY

(Continued from Page 21)

and B battery eliminators, as well as the proper design of filters for B eliminator circuits.

A precision capacity bridge giving accurate readings for any capacity desired is included in the equipment. This enables the measurement of condenser resistance at any frequency desired.

The scale of fees required for Calibration work represents less than cost of labor, particularly in the plotting of curves of the results, and no part of the charge includes anything for the cost of apparatus. The following list gives the type of work which we are prepared to do at once. Other services will be added as rapidly as new apparatus can be secured.

CALIBRATION FEES

Wavemeters: \$1.00 for first two coils, \$.35 for each additional coil; \$.50 extra for each curve. For buzzer type the calibration covers 100-3000 meters; for vacuum tube type 25-25,000 meters; tube type to be accompanied by actual tube and statement of filament, plate and grid voltage to be used and anticipated range of each coil.

Variable Condensers: \$1.00 for capacity curve drawn from 10 tested points, including maximum and minimum.

Fixed Condensers: \$.25 each for calibration at either radio or audio frequency as specified.

Grid Leaks: \$.25 each for d.c. resistance.

Inductances: Fixed or variable; \$.50 each up to 100 millihenries; \$.75 from 100 millihenries to 1 henry; \$1.00 above 1 henry.

I. F. Transformers: \$2.00 for matching with specified tuned transformer; \$1.00 for frequency characteristic curve.

A. F. Transformers: \$1.00 for curve of frequency characteristic from 60 to 5000 cycles; \$.50 for impedance or inductance measurement at any desired frequency.

Vacuum Tubes: \$.50 for measurement of amplification constant at any one audio frequency.

All equipment should be securely packed in wooden box with screwed lid so as to be usable for return shipment. Fees do not include return express or insured parcel post charges, which should be added. Stamps not accepted in payment. No responsibility is assumed for breakage during shipment.

In addition to this calibration service, facilities have been provided for testing all kinds of transmitting equipment. These include phantom and real aerials for tests from 5 to 1500 meters, direct current power from 12 to 2000 volts, a. c. at 110-220 volt 60 cycle single phase, 2 kw. 220 volt 500 cycle single phase and 220 volt 60 cycle three phase. Transformers are installed to give 1100, 2200, 3300, 4400 and 6600 volts, which may be rectified by a high tension mercury arc. Proper meters are available with all this apparatus.

Owing to the special nature of these tests no quotations can be made until full details have been arranged by correspondence.

More important than the equipment available is the fact that the men on RADIO's technical staff are competent and experienced in making the tests. Their reports may be relied upon.

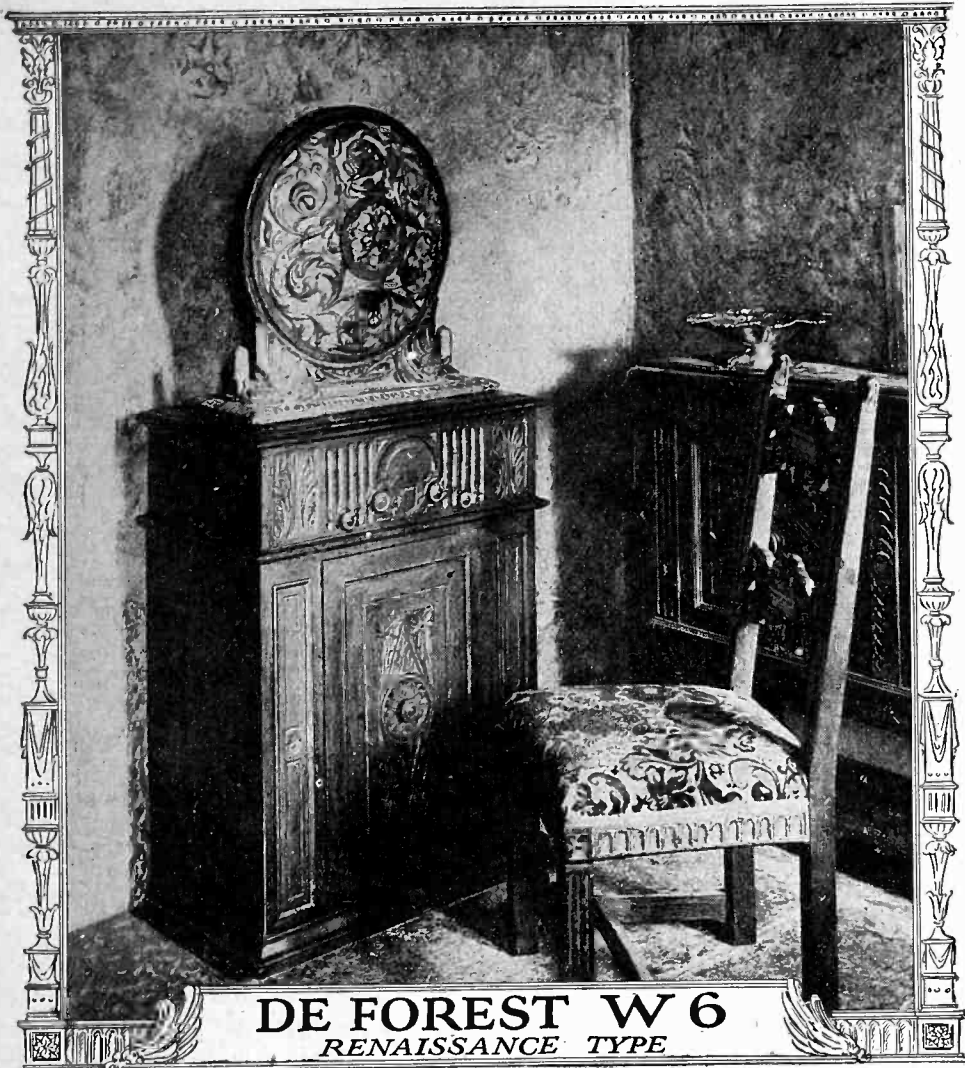

DE FOREST W 6
RENAISSANCE TYPE



DE FOREST AUDION
is the world standard in tubes. De Forest created the first successful radio tube, and his invention made broadcasting possible. The De Forest policy of a specific type tube for each socket insures finer reception and greater distance. Price, \$3.

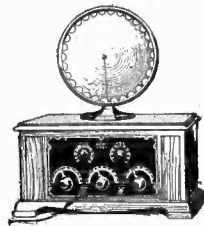

DE FOREST F-5 AW
A compact, powerful set in polished walnut that will bring joy to many a household. Gives rich volume, and has the capacity to separate stations positively so that you can pick the broadcast gems without interference. Extremely easy to operate. Price (minus tubes, loud speaker and batteries) \$90.

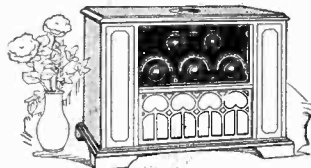

DE FOREST F-5 M
A superfine 5-tube set in two color mahogany cabinet with built-in loud speaker and concealed compartments for "A" and "B" batteries. A great distance-getter, with uncanny power to tune in and out stations at will, and gifted with splendid tonal qualities. Extremely simple to operate. No howling or hissing in tuning in. An unsurpassed value at \$110.

De Forest Radio Sets can be bought at prices ranging from \$85 to \$450.

De Forest Genius now Humanizes Radio!

MARVELOUS new circuit, just perfected, reproduces flawlessly the mellow, soft modulations of the human voice and captures the hitherto elusive overtones of the musical register . . . tuning simplified . . . a new ease in operation . . . all embodied in the new and beautiful De Forest W₅ or W₆ Radiophones.

The voice of radio is no longer flinty and metallic, but mellow, human and musical—thanks to the development by Roy A. Weagant, Vice-President and Chief Engineer of the De Forest Radio Company, of a new and marvelous circuit.

This ingenious circuit, and all the joy it means to radio lovers, makes its first public appearance in the De Forest W₅ and W₆ Radiophones, masterpieces of cabinet art worthy only of a scientific development so outstanding.

So wonderful is the reproduction of tone in the De Forest W₅ or W₆ that only the presence of the lovely instrument dispels the illusion that the living artist is in the rooms.

Piano chords come to you with their full rich resonance—true piano tone. High notes

dance, ripple and sparkle . . . clearly, distinctly . . . *musically!* Those brooding low notes, never caught in average reception, are heard distinctly—as though from the next room.

In the reproduction of orchestral music the full importance of the De Forest achievement stands out. For the first time you get the overtones as well as the middle tones . . . the majestic roll of the kettle drums, the crooning of the bass viols, the strident crash of the brasses and the piping heraldry of the cornets and trombones. A symphony orchestra heard over the De Forest W₅ or W₆ stirs the soul. No incoherence, no oscillating jumble of noise—every instrument, every octave, in its true value. *A magic achievement!*

To the lover of dance music the De Forest W₅ or W₆ brings more sprightliness, more beauties of syncopation . . . you should hear Vincent Lopez, Joseph Knecht, The Night Hawks, or any others over either of *these* instruments!

All the tenderness of song, every shading of the soprano's voice, all the pathos of the folk song—exquisite but elusive elements so much desired but lost in practically all present-day reception, are captured by these De Forest masterpieces.

To everything that is broadcast, the De Forest Radiophone gives animation, life and humanness.

But Tonal Supremacy is Not All—

Elbert McGran Jackson, renowned sculptor, architect and painter, put into this hand-wrought, hand-carved cabinet the spirit of radio, in design, in motif—it is not an adaptation of a phonograph. An image of charming individuality, it harmonizes with the setting of any home.

One unit, everything self-contained—not a wire in sight, nothing to connect . . . and *portable*; move it any place! Only charm and beauty for the eye.

The artistic conical reproducer is an inseparable part of the cabinet and its tonal mechanism peerlessly attuned to that of the Weagant circuit. There are just two controls for tuning, and these operate on one dial, which makes the normally perplexing task of "tuning in" extremely simple. There are special power tubes in the fifth and sixth sockets which can give you volume to flood an auditorium, if you desire it. And, at your fingers' tips, the means to tune in a far-distant station you want no matter how powerful nearby stations may be.

See the incomparable De Forest W₅ and W₆ at your De Forest dealer's or write for an interesting booklet describing these masterpieces in detail.

DE FOREST RADIO CO., Jersey City, N. J.

DE FOREST

The Greatest Name in Radio

DEALERS IN ALL CITIES AND RADIO COMMUNITIES

THE EPOCH-MAKING ACHIEVEMENT WHICH MAKES ORDINARY RADIO RECEPTION A THING OF YESTERDAY

Tell them that you saw it in RADIO

Build Quality Into Your Receiver If You Would Get Quality Out of It!

HAMMARLUND
Precision Products
Have Never
Been Excelled

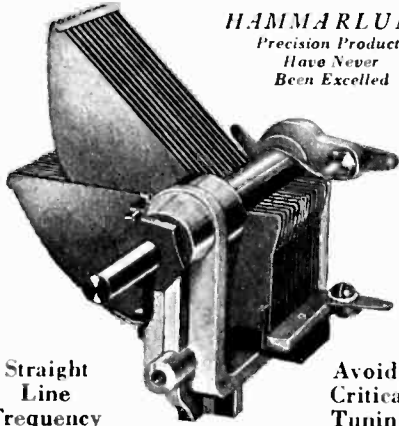

Straight Line Frequency

Avoids Critical Tuning

The New Hammarlund Straight-line Frequency Condenser distributes stations equally over the dials. It has all the familiar Hammarlund low-loss features, plus many new ones—the perfections of advanced engineering. Made in all standard capacities.

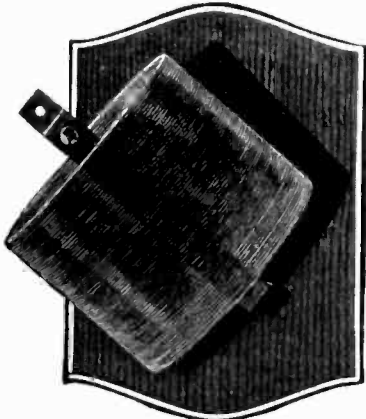

The Hammarlund Space-wound Coil is supported by a mere film of transparent dielectric. Its inductance is high and its losses are extremely small. Made for the "Roberts," Tuned Radio Frequency, and other standard circuits. "Hammarlund, Jr.," is a

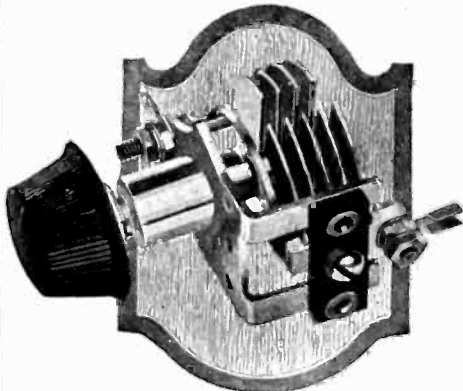

distinctive precision midget condenser of many uses. It is similar in construction to the larger Hammarlund models, and requires only one hole for mounting. Circuit diagrams of uses sent on request.

Write for Descriptive Folder

Hammarlund Mfg. Co.

424-438 W. 33rd St., New York

Pacific Coast Representatives:

ATLANTIC AND PACIFIC AGENCIES CORP.

383 Brannan St., San Francisco

For Better Radio
Hammarlund
PRECISION
PRODUCTS



Alfred J. Koenig, the "boy wonder" of radio as he appears today.

A Radio Operator —at Fifteen!

ALFRED J. KOENIG worked as an office boy by day and studied radio at the Radio Institute of America by night. At the age of fifteen he received his First Class U. S. Government Commercial Radio Operator's License. Today he is engaged in the transmission and receipt of photoradiograms at the Radio Corporation of America's station in Hawaii.

Thousands of our graduates are now holding successful positions in radio. *And YOU can attain success in radio, too.*

Study radio in spare time

Even though you may be employed at present, the Radio Institute of America's Home Study Course in Radio can give you all the knowledge you need to be able to pass your radio license examination—to be ready for your first radio job. This is the world's oldest radio school—conducted by the Radio Corporation of America. For further information, address the

RADIO INSTITUTE OF AMERICA

Formerly Marconi Institute

Established in 1909

322 Broadway New York City

—CUT HERE—

Radio Institute of America
322 Broadway, New York City

Please send me full information about your Home Study Course of radio instruction.

I am interested in the complete course, including code instruction, which qualifies for the U.S. Gov't Commercial or Amateur Radio License.

Name.....

Address.....

AFTER THE LICENSE

(Continued from Page 22)

merchant marine officers were given commissions. The civilian operator who succeeded a "gob" after the war had no easy job regaining lost prestige.

Perhaps a great many operators have themselves to blame. It may be what we were taught, but more than one of us has gone aboard ship fully convinced that if ill befell the skipper the rest of the crew would immediately pay homage to the wireless man.

More than one radio man who has felt at peace with the world has boarded a ship to find himself the heir to a gang of enemies. Why? Just because his predecessor refused to acknowledge any authority other than the master's, and in many cases not even the captain's. Then, again, it nettled many ship's officers to see a landlubber step right into their class, or to read how heroic they were—the operators—when the rest of the crew deserved as much, perhaps more, praise.

In our own case we have found that life aboard ship is just what we make it. We once had conferred upon us what was considered—at that time—a compliment. A mariner, with more than the usual amount of intelligence, condescended to confide to us that we were the "most rational" wireless man he had sailed with.

Just what comparison our friend was drawing we don't know. He may have known the radio man who nailed the skipper's shoes to the bridge—and got away with it,—or the other who invited animosity by going to the engine room skylight and yelling at the chief who stood on the top grating, "Hey! Let's have the juice, will ya?"

All these digressions may seem to have nothing in common with commercial radio operating. On the contrary they are essentially worth knowing, are seldom taught, and learned only through experience.

One thing a radio man soon learns is that the practice of keeping secret the contents of messages will hold him in good stead, for very often he is made the confidant of all classes on board; and if he relayed some of the stuff given him, it would be the stirring up of a hornet's nest for fair. When the sea is rough or men are out of sorts they say and do things they would not do ordinarily. Talk about old women! There is no seafarer who cannot find a thousand and one things to grumble about if he wants to.

The radio man should be a diplomat like the skipper, who, confronted by an irate crew, reprimanded the steward before them. "Steward," says he, "didn't I tell you to give these men all the potatoes they want? Give them all they want!" Meanwhile, the exact amount

(Continued on Page 68)

Fine Radio



Apparatus

FILTER CONDENSERS

Specified for the Helium Tube Rectifier
("B" battery eliminator)

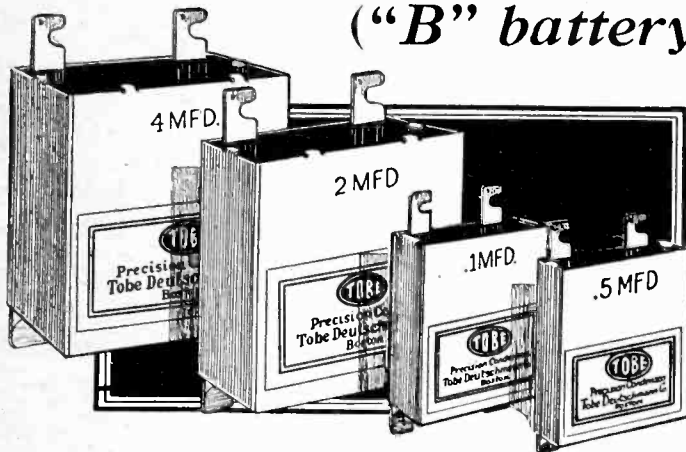

Mr. Edwin E. Turner, in his interesting article "The Helium Tube Rectifier" in this issue, specifies the following TOBE condensers;—3 type 711, 4 MFD.; 1 type 709, 2 MFD.; 1 type 707, 5 MFD.; 2 type 705, 1 MFD.

Any "B" battery eliminator circuit depends very largely for its operating efficiency upon the filter condensers used. TOBE condensers alone possess all the following favorable characteristics:

.5 MFD. Type 707	\$.90
.1 MFD. Type 705	.70
2. MFD. Type 709	1.75
4. MFD. Type 711	3.75

Will operate at voltages up to 700 D. C. without breakdown or overheating.

High megohm resistance—indicating perfect insulation.

Capacities guaranteed to be within 5% of accuracy.

Extreme heat or cold has no effect on TOBE condensers.

Compact and handsome in appearance.

Current consumption practically nil.

TOBE condensers are distinguishable by their silvered finish case—"A better condenser." Ask your dealer for them by name "TOBE."

Manufacturers, dealers, and jobbers write for informative circular.

The Leading Collapsible Loop!

for Super Het. or any circuit

ELECTRICALLY SUPREME; large size—27 inch sides—gives great pick-up. Genuine Litz with spacing permanently assured. Very low R. F. resistance. Unique system of taps with jumpers to divide loop without dead ends, adapts it to center tap and loop regenerative sets and allows tuning at low wavelengths without change of condenser. Graduated circular plate at base gives compass settings.

MECHANICALLY SUPREME; constructed of beautifully finished hardwood, structurally rigid with minimum weight. Folds instantly for storage or transportation. When open all looseness in wires is immediately taken up—appearance always perfect.

MADE TO LABORATORY STANDARDS FOR A LIFETIME OF EFFICIENT USE

820 Market Street, San Francisco, California

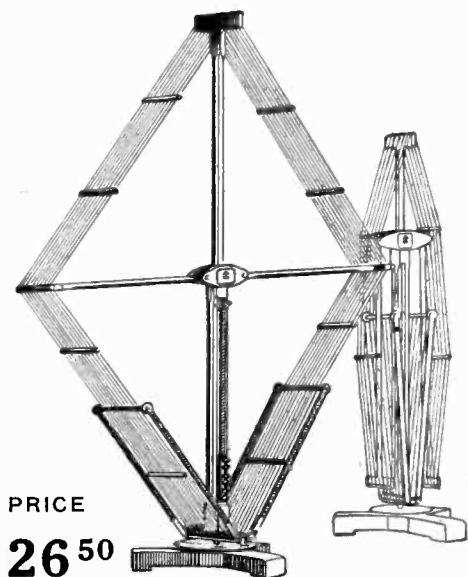

PRICE

26⁵⁰

Tobe Deutschmann Co.

CORNHILL BOSTON MASS.



The Season's Sensation

\$15⁰⁰

THE KODEL MICROPHONE LOUD SPEAKER is an exact replica of the transmitting microphone used in broadcasting.

The efficient Kodel reproducing unit, with an ingenious new snail-shell horn, mounted inside the microphone case, produces a remarkably clear, full-toned volume. Non-vibrating tone chamber eliminates distortion.

The \$15 model incorporates the new Kodel, Jr. unit, with the large Kodel unit, \$20.

Radio dealers everywhere have them
THE KODEL RADIO CORP.
 507 E. Pearl St., Cincinnati, O.

KODEL
 MICROPHONE
 SPEAKER

Design
 Patented

The **KODEL**
MICROPHONE
LOUD SPEAKER

The **Andrews**
Deresnadyne
 RADIO RECEIVING SET

Combines Tone Quality and Selectivity With Distance
 Price \$165 Without Accessories

ANDREWS RADIO CO., Tribune Tower, Chicago
F. L. TOMLINSON CO., Los Angeles and San Francisco
ROBINSON SALES CO., Seattle

A Laboratory Product

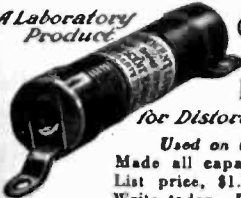

CRESCENT
LAVITE
RESISTANCES

For Distortionless Amplification
 Used on the U. S. N. Dirigibles
 Made all capacities, 12,000 ohms and up.
 List price, \$1.50. Special sizes to order.
 Write today. Discounts to dealers.
CRESCENT RADIO SUPPLY COMPANY
 3 Liberty St., Jamaica, N. Y.

ARE YOU A SUBSCRIBER?

Send for Trial Subscription
\$1.00 for Six Months

(Continued from Page 66)

was indicated by the skipper's wagging index finger.

Once away from the dock we begin to feel that we are somebody. As we watch the receding coastline we begin to realize that "pounding brass" at sea is far different than in our cosy home surroundings. No quitting if we want to; no hanging the message on the hook until the next night. We are responsible for maintaining communication with land, the sole connecting link with the rest of the world. So, when you hear your station called and try to pick your message through what seems to be an impenetrable barrier of signals, you begin to feel that you were not fully justified in criticising from your favorite corner at home.

Commercial traffic, like any other traffic, depends upon the class of station and the power of the equipment. The larger passenger vessels with their 500 and 1000-watt continuous wave transmitters have, of course, a great volume of traffic. They maintain constant communication with shore. They have from three to seven or eight operators. An operator for such a craft does not necessarily have to be a speed artist. He must be able to transmit and receive consistently at an average speed of 25 words per minute. There must be no lost motion, for the number of ship stations is far in excess of the number of shore stations, and there is always some one waiting to work the fellow you are in communication with.

The practice of calling up the nearest coastal station and notifying him of leaving the dock, also of giving him a QRU? or QTC? has not been encouraged since radiocasting became so popular. A minimum of harbor traffic seems to be the order of the day. Many coastal stations send out QST's every two hours or so with a list of ships for whom it has traffic. Such schedules will be furnished the operator by the company assigning him. On cargo vessels having but one operator it is not compulsory to stand a continuous watch while along the coast, if these schedules are adhered to.

Once away from the coast, the cargo vessel operator's time is practically his own. The only watch he must observe almost religiously is for the time signals, weather forecasts and press dispatches. The volume of traffic is small on a cargo vessel, much of the work having to do with bearings while along the coast.

In the handling of any kind of traffic an operator will save himself a lot of time and trouble at the end of the voyage if he abstracts, as soon as possible, what traffic he handles. These abstracts are handed into the radio operating company at the completion of each voyage. Each company has its own forms and

(Continued on Page 70)

SM

SILVER

SIX

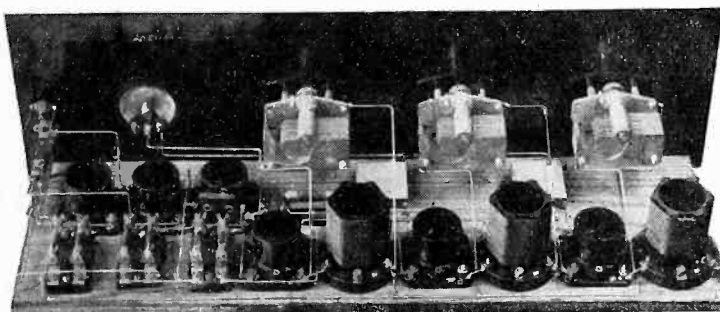

FACTS THE "WHY OF THE SIX"

*As Described in Radio Broadcast of November
and December.*

SELECTIVITY is such that out of town stations may be brought to Chicago through twelve powerful local stations. Selectivity can be regulated at will, from a degree satisfactory for ordinary reception, up to the surprising limit where side-bands are cut. **SENSITIVITY** is so great that nothing will surpass the "Six" except special laboratory-built super-heterodynes. Either coast may be brought in to Chicago during the summer months on a small antenna—in many cases on a loop.

FLEXIBILITY permits the use of antenna or loop with either detector, one or both stages of radio frequency amplification. Interchangeable R. F. Transformers, with adjustable antenna coupler, permit operation on all waves from 50 to 550—or higher if desired.

VOLUME is so great as to paralyze any but the best loud-speakers. Yet it may be adjusted to any degree by a single knob.

QUALITY cannot be excelled due to resistance coupled amplification. It is the only receiver that will bring real appreciation of "cone" speakers.

CIRCUIT consists of two stages of R. F. amplification with special oscillation control uniformly effective at all wavelengths, grid-biased detector and three stage resistance coupled audio amplifier.

EASE OF CONTROL allows use of one, two or three dials at will.

TUBES may be either dry cell or storage battery, with UV201-A's recommended. "B" Battery Consumption at 135 volts is below 10 milliamperes—less than one-third that of other six-tube receivers.

ASSEMBLY requires but a few hours, using only parts supplied in kit.

BOOMERANG CRITICISM

The Silver Six is at once the most satisfactory and the most unusual broadcast receiver ever devised. It is the first practical receiver with Sensitivity, Selectivity and Tonal Quality which cannot be surpassed. This can only be understood by a careful study of the receiver's characteristics as analyzed under "FACTS."

The Silver Six was put through its paces for a prominent Editor, an Engineer and an Executive just after it was perfected. How did they react? The Editor asked to have the tuning broadened . . . The Engineer was astonished at the uncanny ability to bring in DX Stations in daylight . . . The Executive objected to the intensity with which notes low on the musical scale were reproduced. Why did these men react this way? Simply because the Silver Six was not "just another receiver" of merit easily recognized in comparison with existing standards . . . But because it was an accomplishment so far in advance of the commonplace that these three authorities had to revise their standards in order to appreciate ideal performance—not merely in theory—but when the "Six" actually demonstrated it to their amazed senses.

These men were unable to demand and the "Six" fail to produce. Selectivity was at their command—ease of control theirs for the asking—one, two or three dials as preferred—volume adjustable by a single knob from a whisper to a roar without a discordant note—rather, with a perfect harmony that enthralled the listeners.

**WHAT WAS THEIR VERDICT? UNQUALIFIED APPROVAL!
WHY? BECAUSE SEEING IS BELIEVING!**

TYPE 600 KIT, including all parts necessary to build the complete "SIX" **\$53.00**

TYPE 610 KIT, essentials only, including 3 condensers, 3 inductances and 3 inductance sockets..... **\$27.75**

See These and Other SM Products at Your Dealer's

Silver-Marshall

INC.

106 South Wabash Avenue
CHICAGO

Mail this Coupon

Silver-Marshall, Inc., Chicago, Ill.

Gentlemen: Please send me:

A—Complete building data on the Silver "Six," for which I am enclosing 50c.

B—Descriptive circulars on S-M Products.

Name.....

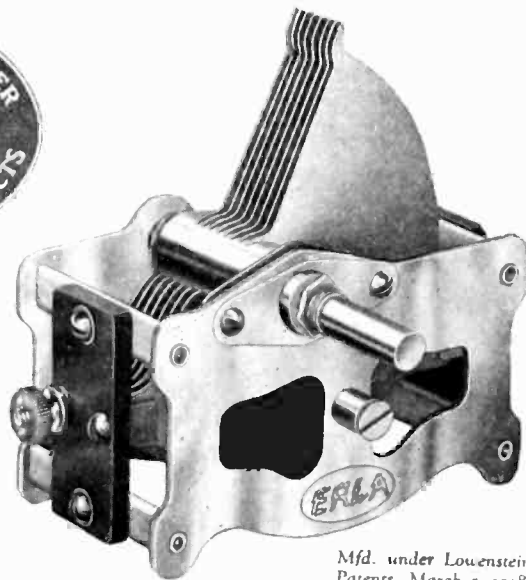

Mfd. under Lowenstein Patents, March 5, 1918.

Equi Space Gives Ideal Tuning at all Wave Lengths

Spreads low wavelength stations without crowding those from 50° to 100°. Lightweight and compact in style.

HERE is a new condenser that surpasses all present-day types. The conventional straight line frequency condenser spreads stations on the low wavelength proportions on the dial but it also brings stations between 50 and 100 too close together. On the higher wavelengths are many high-powered stations that are extremely difficult to separate.

The Erla *Equi Space makes allowance for this. It gives maximum spreads between stations over the entire range of the dial. Specially designed plates make this possible.

Now all stations, low frequency as well as high frequency, are spaced on the dial to insure the best results. Tuning is made far sharper. Sensitivity is greatly increased, reducing losses to an unprecedented minimum. Plates of special spring brass are scientifically spaced and give maximum conductivity. Scientific tests show a resistance far lower even than costly laboratory types.

Special Erla Features

- Minimum capacity only 10 m. m. f.
- Ratio of maximum to minimum capacity 35 to 1.
- Total resistance of only 3 ohms at 1000 cycles.
- Four riveted cross members supporting stator plates provide rigidity unapproached.
- Single-hole mounting makes it easy and quick to attach.
- Light weight plates of special spring brass appreciably reduce bulk and weight, and tremendously reduce tendency toward misalignment from rough usage.

Equi Space is small and compact, requiring little space. Very light but having extreme rigidity because of four riveted cross members.

Go to any radio store and see this amazing condenser today. It will make a striking difference in any set.

Send your name and address today and we will mail free, news of the latest radio discoveries and inventions.

*Trade Mark Registered
Electrical Research Laboratories
 CHICAGO, U. S. A.

Electrical Research Laboratories, 2500 Cottage Grove Ave., Chicago, Ill. Tell me what's new in radio.

Name

Address

City

County State

(Continued from Page 68)

methods and instructs the operators in the use of them.

There are three important classes of messages handled by commercial stations. Private paid messages using the prefix "P" if sent direct, the prefix "X" if to be relayed; Captain's service messages, i. e., messages pertaining to ship's business, using the prefix "MSG"; Dead-head or franked messages using the prefix "PDH". These latter are usually enjoyed by the captain, officials of the steamship company and of the radio company, and by the operator. These frank privileges entitle the above to a certain number of free words within the lines of the radio company operating the station.

The wavelengths in common use for commercial work are 600 meters for calling and 705 and 875 for traffic, and also the band 1800 to 2400 for C.W. traffic. Bearings are handled on 800 meters. Some ships are tuned to 450 meters for bearings in foreign ports only.

Modern ship installations leave little to be desired. Not so a decade ago. Then most of the radio rooms were converted staterooms. What had been the upper bunk supported the apparatus except the motor generator, which was stuck in the remotest corner beneath the lower bunk upon which the operator slept.

In our own experience we have more than once awakened to find the 1 K. W. "coffin" on our chest. When occasion demanded that a new brush be put in the m.g. we either incurred the enmity of the steward by ruining the bunk, or jeopardized some vaudeville performer's job by enacting the role of a contortionist.

Modern equipment and the rooms into which it is placed seem to have been designed by men of vision. What repairs that are necessary to make can be done without wrecking the place. In this respect it is wise to keep in with the engineers. Not all ships carry spare armatures for the generator. If you should be so unfortunate as to burn out an armature coil, if it is at all possible to repair it, the engine room is the logical place to do it. Other necessary repairs can usually be taken care of by the operator. These can be kept at a minimum by the proper care and inspection of the apparatus. Most companies require an apparatus report at the end of each voyage, and send inspectors aboard to check up.

Should an operator experience serious trouble at a time when being able to transmit is a matter of life and death, and he is literally up against it, he must resort to his own ingenuity. A couple of years ago two operators found themselves in such a predicament. With their generator "shot" beyond repair

(Continued on Page 72)

KEY TO THE AIR

Pyradolin Panel, Key to the Air Low Loss Coll., Clever and Sharp Tuner, Westinghouse Type Binding Posts, Key to the Air Permanent Detector. (No cat-whiskers).
 The lowest priced Receiver in the world equipped with this standard Detector. A real little wonder.

Usual Key to the Air Guarantee.

STAFFORD RADIO COMPANY
 2R, Medford Hillside, Mass.
 Jobbers and Dealers, Send for Sample Receiver.
 Western Representative: A. S. Lindstrom Co., 274 Brannan St., San Francisco, Cal.

SCORES AGAIN!

A complete Radio Receiver

\$2.00, List



A new era in radio delight

BEAUTIFUL to look at—thrilling to operate—superb in tone—the Super-Thompson Duo-Tone Console inspires pride of ownership.

The Thompson laboratories have built into it the wide knowledge acquired during 16 years' experience. Over 116 different Thompson-built types of radio apparatus stand back of it, sponsors of its performance, its trueness of reproduction, its power, and its ability to secure distant stations.

This instrument gives its owners a new understanding of the charm and fascination of present-day broadcasting. The Super-Thompson Duo-Tone is built especially for those whose home equipment is of the best. Other Thompson Receivers from \$125. Thompson and Thompson-Fuller Speakers, \$28 and \$35. All prices slightly higher west of the Rocky Mountains and in Canada. Sold by the better dealers everywhere. R. E. Thompson Manufacturing Company, 30 Church Street, New York City.

SUPER-THOMPSON DUO-TONE CONSOLE

Model C-61 List Price \$360

Stations come in sharply one after the other by simply moving the single master control. Equipped with newly developed Thompson Duo-Tone reproducing system—two separate built-in speakers reproducing bass and treble tones distinctly. Creates a sound perspective and a range of tonal reproduction never heretofore attained. Has improved volume control, graduating from loud to soft without change of tone or pitch. Beautiful mahogany Queen Anne Console Cabinet provides space for all batteries or battery eliminators. An improved Neutrodyne operating on three UV-201A and two UX-112 power tubes. In tonal reproduction, ease of operation, volume and distance-getting ability, the Super-Thompson is the finest receiver to come from the famous Thompson laboratories to date.

THOMPSON

*Built by makers of army and navy apparatus
used by leading nations*

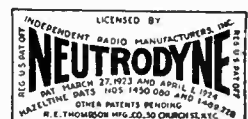

RADIO

Tell them that you saw it in RADIO

www.americanradiohistory.com

WE SOLD 4000 SETS

Had 4000 Favorable Reports

Before We Felt Justified to Say



Quality Radio Apparatus

Now we invite you to go to your APEX Dealer who will be glad to make a personal demonstration for you in your home or in his store. A demonstration will prove to you that APEX Radio Receivers will give you everything you can possibly wish for in a radio receiver from the standpoint of selectivity, clarity, volume, distance and attractiveness of design.

The APEX Super Five \$95 Without Accessories	The APEX Utility Radio Table \$75
The APEX De Luxe \$135 Without Accessories	The APEX Entertainer (Loud Speaker) \$22.50
The APEX Baby Grand Console \$225 Without Accessories	The APEX Console Enter- tainer \$27.50

Upon Request We Will Gladly Mail You Descriptive Folder

APEX ELECTRIC MFG. CO. 1410 West 59th St. **Chicago**
Dept. 1110

Prices West of Rockies Slightly Higher. Canadian Prices Approximately 40% Higher

Western Representative: A. S. LINDSTROM CO., San Francisco, California

Branch Offices: Seattle, Portland, Los Angeles and Salt Lake City

Northern California Distributor: UNITED RADIO SUPPLIES CO., San Francisco

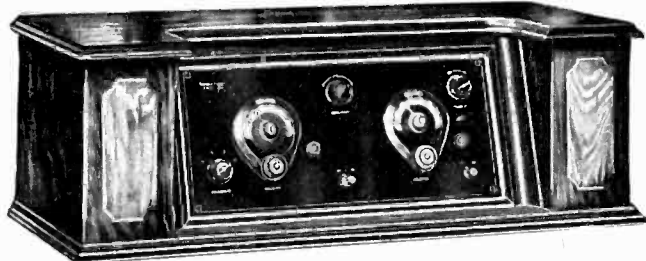

The Climax of Our Achievements

Since the beginning of broadcasting B-T apparatus and circuits have set new standards of efficiency. The first 3 circuit tuner, the first vernier Condenser, the "Nameless"—all B-T triumphs.

The B-T "Counterphase-Six." Three stages of radio frequency,—only two tuning dials,—sharp, selective, sensitive,—requires only a short indoor aerial for distance reception,—the "Counterphase-Six" is truly the climax of our achievements.

Complete set and kits for the home builder are both available. See your dealer. Send for Illustrated Circulars.

Flewelling Indorses B-T Sockets

This noted radio authority says: "The standard tube sockets of your manufacture have so met the approval of my laboratory staff that we have decided to use them practically exclusively."

The only socket made that takes all Navy base and both large or small UX tubes without an adapter. Price, 75c. Send for Circulars.

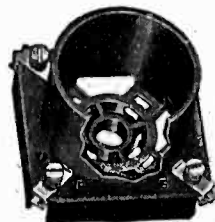

BREMER-TULLY MFG. CO.

532 S. Canal Street

Chicago, Illinois

ARE YOU A SUBSCRIBER?

SEND \$1.00 FOR A TRIAL SUBSCRIPTION TO "RADIO" FOR 6 MONTHS

(Continued from Page 70)

they contrived an apparatus for interrupting the direct current by taking an ordinary electric fan and providing brushes for the same. These were placed in the direct current circuit. In this way they were able, by making the fan blades act as a motor and make contact with the improvised brushes, to give a pulsating current through the transformer. This improvised emergency set made it possible for them to communicate up to 1400 miles, and earned for them commendation from the Department of Commerce.

The fellow who gives everybody the impression that he can get along without them had best be careful. Some night, when the wind is high and the moon and stars are as visible as the announcer at a distant station, although they may never have heard of Joseph Conrad or Captain Dingle, the boatswain and his gang will give the haughty person every opportunity to impersonate one of these author's characters while he tries to fix the aerial.

But what does it all lead to? A sea-going operator has as much, if not more, opportunity for sightseeing as any person on board ship. If he is wise he will make this a profitable pastime. A camera is an invaluable aide. A prolific writer can always find a market for travel articles. Operators have had all sorts of "side lines." We know of two, both of whom are at present editing two very prominent radio magazines, who had very diversified lines. One wrote newspaper articles and stories, the other sold beef-tea tablets.

Very often an operator becomes enamoured of the fickle sea and decides to make it his lifework. Shifting over to the deck or engine departments is the next step. Or, if the shipping business appeals to him, the job of freight clerk and so on up to purser are steps to a position ashore. Again, he might get interested in the huge profits made by shipchandlers and break into that game via the steward's department.

But, if it is the operator's intention to stick at radio, and he tires of ship work, in order to land a trick at a shore station we suggest here and now that he get himself assigned to a vessel that gets him back to headquarters very often. Big companies have a way of forgetting seniority and giving the man close at hand a crack at the job.

With the daily increasing volume of traffic a coast station operator must not only be able to copy an infinite variety of fists, but must also be capable of exerting his imagination. A knowledge of Morse telegraphy while not imperative is very often a valuable asset.

The high-powered trans-oceanic stations require operators who have special training and are usually recruited from

(Continued on Page 74)



6-VOLT "A" BATTERY
Here is the rugged, good-looking Exide 6-volt "A" Battery. One-piece case.



2-VOLT "A" BATTERY
Compact Exide for low-voltage tubes. Also made in 4-volt size.



24-VOLT "B" BATTERY
In glass cells, 6000 milli-ampere capacity. Also in 48-volt size.



RECTIFIER
Exide Rectifier for economical recharging of "B" Battery from your own house current.

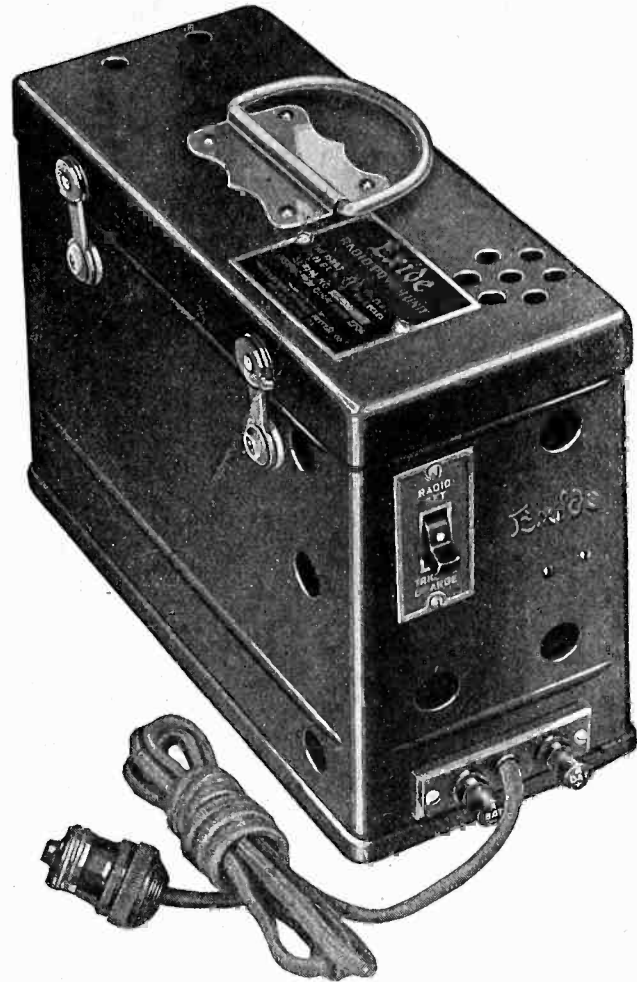

THE EXIDE RADIO POWER UNIT
(Combination "A" battery and charger)

This unit is kept connected to your electric light socket as well as to the radio set. Raise the small switch on the end and the receiving set is ready for use; lower it and the battery is automatically placed on charge. Finished in rich mahogany color, the Exide Radio Power Unit is furnished in two sizes — one, for sets using 4-volt tubes; the other for sets using 6-volt tubes; retailing at \$28 and \$38 respectively — slightly higher west of the Rockies.

Range far and near with your radio set

BRINGING in the distant stations, selecting the choice numbers from local programs—in short, getting the most enjoyment from your radio set—is largely a matter of proper current supply.

All the distance, volume, and clearness that an ample, uniform supply of current gives to radio reception are yours when current is supplied by Exide Radio Batteries. There are Exide "A" and "B" storage batteries for every requirement, and a rectifier for recharging "B" storage batteries.

See the complete line at any Exide Dealer's or at your favorite radio store.

Exide

**RADIO
BATTERIES**

THE ELECTRIC STORAGE BATTERY COMPANY, Philadelphia
Exide Batteries of Canada, Limited, 153 Dufferin Street, Toronto

FOR BETTER RADIO RECEPTION, USE STORAGE BATTERIES

Tell them that you saw it in RADIO

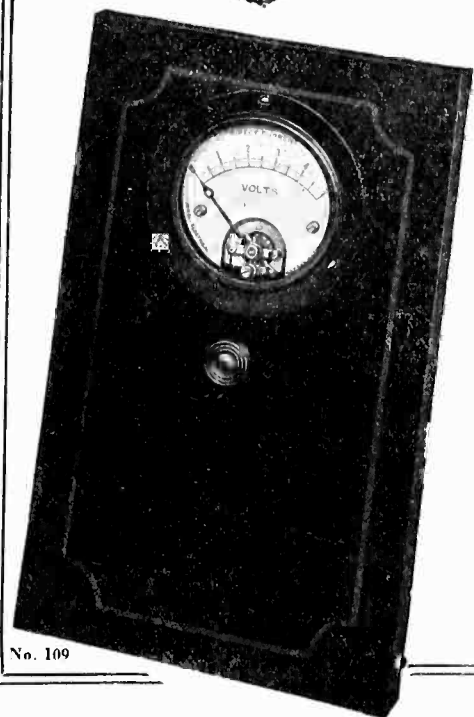

No. 109

Radiola Portable Super-Heterodyne

OWNERS:

—send for special No. 109 circular and get our suggestion for protecting your tubes and watching your batteries. Good reception is what you want.

The Jewell No. 109 High Resistance Volt Meter Panel was designed for Radiola Super-Het owners. We make other instruments that can be easily mounted on other sets. *Order from Dealer*

Send for 15-B Radio Instrument Catalog

Jewell Electrical Instrument Co.

1650 Walnut Street - Chicago

(Continued from Page 72)

ship and shore stations. Limited commercial stations, such as employed by large industrial concerns in communicating between offices in different cities, usually require an experienced operator. They handle a certain type of traffic, and a knowledge of typewriting is essential. This is a valuable asset in any case and is often demanded of operators.

Commercial operating has its opportunities. Ship operators are broadened by travel, and have ample time for self-improvement—or for losing money playing poker if they disagree with Dr. Eliot's fifteen minute a day theory.

Many prominent radio men started in as "brass pounders," not the least known being the youthful vice-president and general manager of the Radio Corporation, David Sarnoff. Broadcasting has opened up a new field for the commercial operator, but we regret the decline in operators and the increase in engineers when this step is taken.

All in all it's a great game. Salaries have never been princely for several reasons. Who can blame a student—even if he doesn't need the money—for spending his holidays in this profitable manner? It has often been referred to as a woman's job. Some intrepid females have taken a fling at it, but they were few and far between.

If you want to make radio your life work, don't for a minute think that the commercial end of the game is not worth a trial. It affords a splendid take-off in soaring the heights of this intriguing art.

THE LIFE OF A "B" BATTERY

(Continued from Page 33)

Consequently it is safe to assume a life of 100 hours for three cells in series. Much greater life, proportionately, is actually secured at the $\frac{1}{8}$ ampere rate, so that it is true economy to connect two cells in parallel for each $1\frac{1}{2}$ volt duty, giving a battery of six cells in series—parallel connection for sets using four or more such tubes.

Except for portable sets, a storage battery will be found more satisfactory as a source of filament supply for the larger tubes. This is also true, in the long run, in the case of B batteries.

In cutting off the power from a set, a "two pole" snap switch is advantageous, as it can be used to break one side each of the filament and plate battery, respectively, thus rendering the entire set "dead," if any work is to be done on it, and as a good safety precaution, as well, when not in use.

Worn out, or weak dry cells can be easily revived for short service by punching full of holes, and soaking in strong salt water for a couple of hours.

Just Published
Our New
96 Page
RADIO GUIDE

"Chockful" of data and valuable information for RADIO ENTHUSIASTS. Trouble shooting chart. Latest released list of BROADCASTING STATIONS, and hundreds of

RADIO VALUES

WRS Prices Are Lower!

WRS Service Is

PROMPT, EFFICIENT,

COMPLETE!

EVERYTHING IN RADIO!

GET OUR PRICES

FIRST!

You'll Save Money!

Be sure to write for

Catalog CR10



Note that word "service" in our name. It is your SATISFACTION INSURANCE! Everything you buy here—from bus bar to the finest multi tube set is guaranteed with "money-back!" You receive one hundred cents' worth of value for EVERY dollar you invest at WRS.

SHOULD BE IN EVERY
FAN'S LIBRARY
SEND FOR
FREE YOUR BOOK NOW

Complete parts for latest model BEST SUPERHETERODYNE, new 8-tube loop model, covering the range from 50 to 600 meters. WRS prices for this circuit, including ALL standard, exactly as specified by the inventors. Be sure to get our prices FIRST—you'll save money, get better value and better service.

\$71.50

WRS is headquarters for All Standard Parts, Kits and Sets. Every Approved Circuit!

Everything Fully Guaranteed. Money-back Basis!

WHOLESALE
RADIO SERVICE CO.

6 CHURCH ST
NEW YORK, N.Y.

Notice to our Readers

We have a few copies of the August, 1925 issue of "RADIO" on hand. This issue contains Best's Super-Heterodyne feature.

Send 25c for a Copy

Pacific Building "RADIO" San Francisco

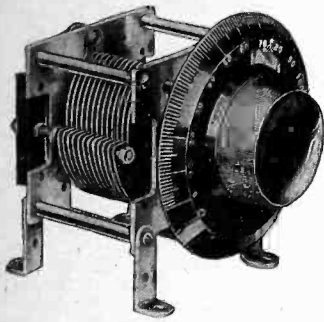

National Condenser
Type DX
Straight Line Wave Length

NATIONAL Velvet Vernier Dial

Type B

(Patents Pending)

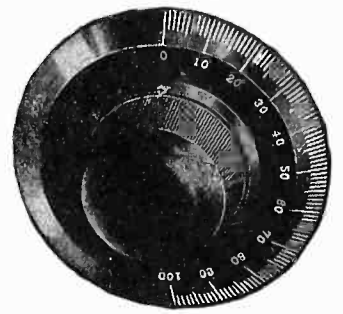

National
Velvet Vernier Dial
Type A

Recognizing the demand for a Velvet Vernier Dial which can be readily mounted on *any* variable condenser, our engineers have developed this new design embodying the same mechanical drive as the conventional Type A Velvet Vernier Dial (Patents pending), and retaining its velvety smoothness of operation and freedom from backlash.

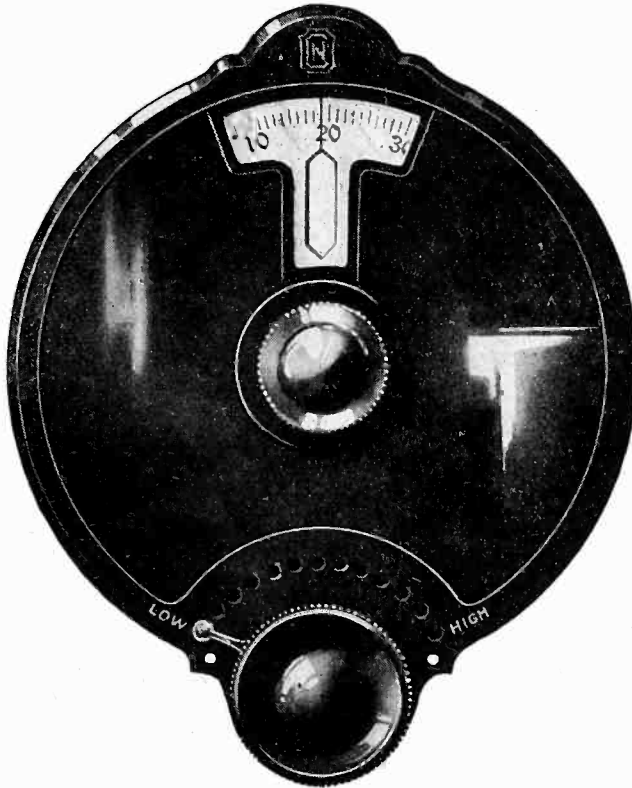

In addition, a new and exclusive feature has been included. A variable ratio having a minimum reduction of 6 to 1 and a maximum of 22 to 1 may be obtained instantly by simply shifting a small lever. Thus the user may select the particular speed best suited to local conditions.



National Velvet Vernier enthusiasts now have the option of the more conventional type *A* dial or the new Type *B*.

List price of either *A* or *B*, **\$2.50**

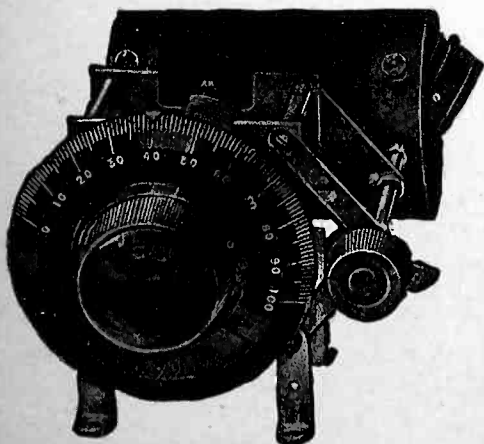

National Tuning Unit
Type BD-2

Use genuine NATIONAL
Dials, Condensers and
Tuning Units for they
give supreme
satisfaction

Write for Bulletin 107R

NATIONAL CO., Inc.

W. E. READY, President
110 Brookline St., Cambridge, Mass.

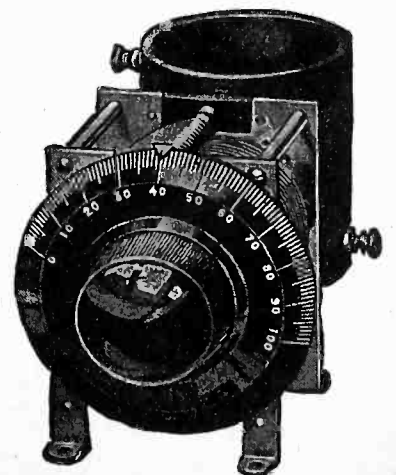

National Tuning Unit
Type BD-1

WASHINGTON JEWELRY CO., BOSTON, MASS.

AMPLIFIES! BEAUTIFIES! CLARIFIES!

Burns "MEL-O-TONE" Loud Speaker

10 Days Trial
Absolutely **FREE!**

Great Acoustic
Achievement

Super-
Sensitive
Unit

Send
NO **75c**
Plug FREE
Money



MARVELOUS Super-sensitive Unit. Famous electro-magneto coil construction with **PRECISION** adjuster to regulate reception from faintest whisper to thunderous **VOLUME** that will fill an auditorium. Stands 22 inches high. Bell is 14 inches and made of lustrous jet black Pyralin, in graceful flower petal design. What a beauty it is! Worthy of the finest homes! The sound conduit is polished aluminum, non-vibrating, non-resonating—eliminates harsh, raspy sounds. Mounted on swivel—swings smoothly in all directions. A \$50 Speaker in construction and appearance. **\$22.50**
OUR PRICE

Send NO money! Pay NOTHING to postman! 10-day trial FREE!



Two Generations
of Honorable Dealings

**WASHINGTON
JEWELRY Co.**

Importers and National Mail Order House
365 Washington St., Boston, Mass.
Largest Distributors of "MEL-O-TONE"
Loud Speakers

For prompt attention address Radio Dept. 110
Gentlemen: Please send me \$22.50 Burns
"MEL-O-TONE" Loud Speaker with 75c
plug included FREE. I enclose NO money,
and pay NOTHING to Postman. If I am
satisfied after ten DAYS' TRIAL, I have
the privilege of paying cash or at the rate
of \$4.00 monthly. Otherwise, I shall re-
turn it.
NAME _____

ADDRESS _____

Please write **PLAINLY!** Tear this coupon
out **NOW!** If you wish to tell us something
about yourself, it will be appreciated.
Radio 11-25

We want you to **SEE!** to **HEAR!** to **ENJOY!** it!—before pay-
ing a cent. If satisfied after 10 days' trial, you may pay
cash, or on our Nationally Famous Charge **\$4** A
Account Payment Plan—\$1 WEEKLY or—

TO OWN the Burns "MEL-O-TONE" Loud Speaker is to
give friends and family real **ENJOYMENT** when listen-
ing to broadcasts. It amplifies **CLEARLY, FAITHFULLY,**
SWEETLY, the beautiful strains of the violin; stirring airs
of bands; snap and pep of jazz music; thrilling notes of
opera singer; natural inflections of the orator; delightful
richness of concert music. We have sold hundreds to "fus-
siest" Radio Fans—and they are delighted with the Burns
"MEL-O-TONE" Speaker!

NOTE Eminent Radio Scientists endorse the Horn
Type Loud Speaker. The curved throat and
wide mouth produce **concentrated volume, di-
rectional volume, greater volume,** than the
Non-horn type which diffuses volume. Try the Burns and
test the truth of this **FACT** yourself.

ORDER Yours Today! Send
NO Money! This
Amazingly Liberal Offer
for Limited Time Only!
Send Coupon Now!

COIL EFFICIENCY

(Continued from Page 24)

degree. The coil has a comparatively high distributed capacity and a high natural wavelength, and hence it is not suitable for circuits in which a wide tuning range is required with a given condenser. This coil is a mean in all respects between the single layer solenoid and the three-banked wound coil.

The Single Layer Solenoid

This case has already been considered in the illustration above. The L/l ratio found was 142.5, the radius of the coil was 4.77 cm., and the number of turns required was 38.8. The diameter of this coil is very nearly equal to 3.75 inches. The advantages of this type of coil are that it is easy to design and to wind, that it has a fairly high inductance to resistance ratio, and that it has a comparatively low value of distributed capacity. The disadvantages are that it requires a large space and that its external magnetic field is large.

The Lorentz Coil (Basket weave)

This is the particular type which has been given the name of "low loss." The L/l ratio of it will show to what extent it is entitled to the appellation. There are different modes of winding this coil, and all look very much alike unless the windings are examined very closely. For the purpose of obtaining the L/l ratio certain assumptions as to the mode of winding were made, the coil was reduced to the equivalent single layer solenoid, and this was given the best shape.

The first assumption made was that the coil was so wound that three turns occupied the axial space that two turns would have occupied in a single layer solenoid; that is, that the turns per centimeter was 15 instead of 10 and that there was no change in the conductivity per turn. It was also assumed that the meshes were such that the angles were 150° and 30° . The kinking of the wire increases its length and hence decreases the L/l ratio, and the amount of variation in the length of the wire depends on the angles of the meshes.

The value obtained for the L/l ratio was 155.8. This, however, neglected the decrease in inductance caused by the separation of the turns in the meshes. This decrease is considerable, but is too difficult to calculate: The ratio is therefore larger than it should be and it is probable that if account were taken of this decrease in the inductance that the L/l ratio would be reduced to equality with that of the single layer solenoid. The number of turns required was 4.43 and the radius of the equivalent solenoid was 3.64 centimeters, or the diameter required was 2.75 inches.

The advantages of the Lorentz type of coil, if any, are low distributed capacity and the absence of solid dielectric in the field. The disadvantages are dif-

CARDWELL TORO-TRAN

The ideal inductance

Allen D. Cardwell Mfg. Corp.

81 Prospect Street
Brooklyn, N. Y.

FREE RADIO GUIDE

FREE Radio Catalog & Guide
full of newest ideas, over 100 latest hook-
ups. Saves you as much as half on a set.
Shows standard radio parts, kits, sets at
big savings. Be sure to get this thrifty
book before you buy. Also please in-
clude name of radio fan.



BARAWIK CO. 103-124 So. Canal St.,
CHICAGO, U. S. A.

RADIO from Factory to YOU

Get our list price on Parts also
Knocked Down 1 and 3 Tube Sets
Compare List Price with others then
Deduct 20 to 50 per Cent Your Price
A. C. HAYDEN CO., Brockton, Mass.

You Can Get
Greater Reflex or Crystal
Set Reception if you use
the
BROWNLIE
Vernier Detector

\$2.00 at Your Dealer or Direct
ROLAND BROWNLIE & CO.
22 Saunders St. Medford, Mass.



faculty of winding, lack of mechanical strength, and inconstancy of inductance.

The Spider-Web "Low Loss" Coil

This coil is about the same as the previous "low loss" coil except that it is wound in pancake instead of cylindrical fashion. The meshes are assumed to have the same angles, the number of turns per centimeter is the same, 15, and the shape factor is the one which gives greatest inductance for a given length of wire. In this case this is given by the relation $c = .75a$, in which c is the radial depth of the winding and a is the mean radius of the coil. The L/l ratio is 156.7, the number of turns required is 42.7, and the mean radius is 3.8 cm, or nearly 1.5 in.

The properties of this coil are about the same as those of the Lorentz coil. The L/l ratio seems to be slightly larger but in view of the fact that some of the assumptions are only approximate it may be regarded to be the same. As in the Lorentz coil, the ratio is a little too high for the same reason. This coil has the additional advantage of greater compactness, and it is also possibly more rugged.

The Flat Pancake Coil

In this case each turn is a perfect circle and all the turns lie in the same plane. The turns are wound 10 to the centimeter in the radial direction. The L/l ratio is 141.8, the mean radius is 3.32 cm, and the number of turns 37.3. There is practically no difference between this coil and the single layer solenoid, except that it occupies less space.

The Standard Coil

This is the single layer coil wound on a regular twelve sided form such as is used for the standard coils at the Bureau of Standards. The turns are not spaced, however, like these turns on the standard coils, but are close wound. The inductance has been calculated on the assumption that the inductance of the polygonal coil is equal to the inductance of the circular coil which has a radius equal to the mean of the inscribed and circumscribed circles of the polygon, the turns remaining constant. It is this mean circular coil which has been given the shape ratio of 2.46 to give greatest inductance for a given length of wire. The length of the wire is the perimeter of the twelve sided figure multiplied by the number of turns. The calculation gave a value of 141.7 for the L/l ratio, which is only slightly less than the ratio for the single layer circular solenoid. The radius of the circumscribed circle is 4.85 cm and the number of turns is 38.8.

Single Layer Coil of Square Section

In this case also the mean cylinder between the inscribed and the circumscribed was given the best shape. The inductance was calculated by two dif-

Increased Sensitivity, Selectivity and Distance Range

HAYNES R. F. UNIT

Now you can add radio frequency amplification to any set with positive assurance of a marked gain in sensitivity, selectivity, and distance.

COMPLETE PARTS FOR THE R. F. UNIT \$10

1 Haynes-Griffin DX Condenser .00023	\$ 3.50
1 Haynes-Griffin Socket	1.00
6 Hard Rubber binding Posts	.30
1 20 Ohm Rheostat	.75
1 .002 Fixed Condenser	.40
1 Special R. F. Choke Coil	1.20
1 Special Antenna Coupler	3.15
1 3-inch Dial	.50
1 7 x 10-inch Hard Rubber Panel (Drilled)	.95
Bus Wire, Solder, Lugs, Etc.	.20
Total	\$11.95

Special combination price **\$10**

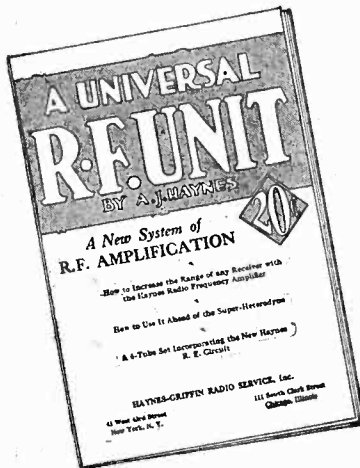

Price Per Copy **20c**

HAYNES-GRIFFIN RADIO SERVICE

Incorporated

41 West 43rd St., New York, N. Y.

111 S. Clark St., Chicago, Ill.

A New System of R. F. Amplification

Simple, practical and highly efficient. The new Haynes R. F. Unit is easy and inexpensive to build. No changes in the original wiring of your set required.

Regarding the results obtained with the R. F. Unit, Mr. Haynes says:

"Stations which are absolutely inaudible on the ordinary set alone, come in clearly and distinctly when the R. F. Unit is used ahead of the receiver."

Mr. Haynes' New Booklet on the R. F. Unit

Discusses the R. F. Unit and radio frequency amplification thoroughly in simple, non-technical language. How to build and operate the R. F. Unit ahead of the superheterodyne, Browning Drake, Roberts, and other popular sets. An ideal method of coupling the "Super" to an antenna, giving a distinct increase in amplification and selectivity.

Complete with schematic and pictorial wiring diagrams and photographs. Send for your copy now. Use the handy coupon.

R-11

HAYNES-GRIFFIN RADIO SERVICE, Inc.

41 West 43rd Street New York, N. Y.

111 S. Clark St., Chicago

I enclose 20c. Send me a copy of Mr. Haynes' new booklet on the R. F. Unit.

Name.....

Address.....

THE Antennaphone
REPLACES THE AERIAL
IMPROVES RECEPTION
Gives wonderful results with any radio set. Not attached to, but merely placed under the telephone. Price One Dollar. Complete with insulated wire and simple instructions. At Your Dealer or Mailed C.O.D. on 3 days approval.
ANTENNAPHONE CO.
90 West St. New York City

ULTRA-LOWLOSS CONDENSER
SPECIAL CUTLASS PLATES DISTRIBUTE THE STATIONS EVENLY OVER THE DIAL - SIMPLIFIES TUNING. CAPACITY .0005 MFD.
\$5.00
PHENIX RADIO CORP., 116-F East 25 St., N.Y.C.

AUGUST & SEPTEMBER

BACK COPIES OF "RADIO" With Best's Super-Het. Articles. Both for 50c. "RADIO" : SAN FRANCISCO

DAVEN

Why Resistance Coupled Amplification?

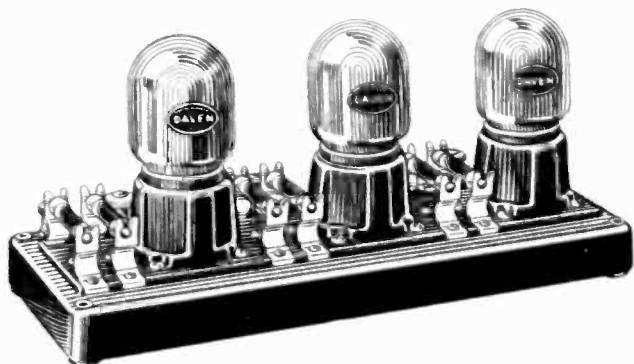

BECAUSE this method of amplification is the only way to procure quality of tone without the slightest distortion. The Daven Super-Amplifier can be conveniently put into any existing set. Use it also in the new set you are going to build.

To increase volume 50% and have no distortion use Daven High Mu Tubes in resistance Coupled Amplifiers. Prices—High Mu-20, \$4.00. Mu-6 (for last or output stage), \$5.00.

Mail the coupon for complete information

The Sine of Merit

DAVEN RADIO CORPORATION

Resistor Specialists

Newark

Reg. U. S. Pat. Off.

New Jersey

DAVEN RADIO CORPORATION
158 Summit Street, Newark, N. J.

A-11-25

Please send me the following:

- Resistor Manual, 30c is enclosed.
 Complete Catalogue (free).

Name _____

Address _____

For Dealers: Send your letterhead and we will have our nearest distributor communicate with you.



Get the Hand-
book of Resist-
ance Coupled
Amplification.
At Dealers, 25c.
By mail, 30c.

THE BIG LITTLE THINGS OF RADIO

Premier 5 TUBE Ensemble

Before you decide on a radio of any kind at any price, see the new Premier 5 Tube Ensemble. A complete Ensemble of genuine Premier parts (not a kit) already attached to panels of genuine black walnut grained Bakelite. Selectivity! Distance! Superb reception! Does anything any set at three or four times its price can do. It is today's unmatched radio value. See your dealer at once. Find out why a hundred thousand Ensembles will be sold in the next few months. See your dealer. Ask him. There is a genuine surprise waiting you.

\$35

PREMIER ELECTRIC CO.

Dept. M-29, 3813 Ravenswood Avenue, Chicago, Illinois

Get a Phonograph Unit FREE

With only one subscription to "RADIO" for one year—\$2.50. Unit is made by The Union Fabric Company.

SUBSCRIBE NOW
"RADIO"
Pacific Building, San Francisco

ferent methods, both of which gave substantially the same results. The first was by considering the mean cylinder and the second by employing the formula for a square coil. The L/l ratio was 125.0, the length of the side of the square was 6.9 cm, and the number of turns was 50.5.

The D Coil

Much praise has been given this coil from time to time. It is usually stated that its inductance is 50 per cent greater than the inductance of the single layer solenoid of the same number of turns and diameter of tubing. The inference is that the coil is 50 per cent more efficient than the simple coil. This is not true, for the D coil is about 25 per cent less efficient than the single layer solenoid. This is due to the fact that the increase in the required amount of wire is greater than the increase in the inductance. In the single layer solenoid the length of one turn is equal to 3.1416 times the diameter. In the D coil the length of one turn is two diameters greater, since the wire crosses over from side to side twice for each complete turn. Therefore the length of each turn in the D coil is 5.1416 times the diameter of the winding form. This makes the total length of the wire in the D coil about 64 per cent greater than the length of the wire in the simple solenoid. But the inductance of the D coil is never more than 55 per cent greater than the inductance of the simple coil, and therefore the percentage is against the former. The 55 per cent increase is for very short D coils; for coils of approximately the same length as is required for the best shape ratio in the single layer solenoid, the percentage increase in the inductance is only about 33 per cent. A practical D coil would fall somewhere between these two values.

In the coil calculated the shape ratio was 3.33, giving an inductance increase of 46.5 per cent. This gave an L/l ratio of 111.7. The required number of turns was 29.4 and the required radius was 4.9 cm, or a diameter of 3.86 in. The main advantage of this coil is that it has a very small external magnetic field. The main disadvantage is the difficulty of winding it.

The Astatic Pair of Solenoids

An astatic pair of solenoids are two single layer coils of equal inductance placed side by side with their axes parallel and connected in series aiding, or so that their fields in space are in opposite directions; that is, so that the external field of the one is in the same direction as the internal field of the other. No exact inductance formula is available for this case and therefore the results obtained are in doubt. However, the writer derived an expression by making certain assumptions which showed that the

mutual inductance between the two when placed about 1/8 in. apart was equal to one twelfth of the inductance of one of the coils. Measurement of the mutual checked this result very closely, more closely, accidentally, than the accuracy of the measurement or the assumptions warranted. Nevertheless it gave two legs to proceed on. The results will, of course, be somewhat different when different shape ratios and separations between the two coils are used. Two cases will be given, one which more nearly represents the theoretical result and the other which more nearly represents the measured coils.

In the first case each of the two solenoids was given the best shape ratio, and the inductance of each was taken as 76,200 centimeters. This gives an inductance of 165,000 centimeters when the two are properly connected in series. The L/l ratio obtained was 119.1, the required number of turns on each half was 30.0, and the radius of each was 3.68 cm, or the diameter was 2.9 in. This coil is more efficient than the next one, but it requires too much space and is not convenient. It requires a baseboard space of 2.9 in. x 6 in.

The second case was a pair of coils each of which had a shape ratio of unity, that is, the length of the winding was equal to the diameter. The same separation between the two coils was used, and also the same mutual inductance was assumed for lack of something more definite. The L/l ratio obtained was 112.7, the number of turns on each half was 48.3, and the required radius of each half was 2.42 cm, or a diameter of 1.9 in. Although this is not quite so efficient as the previous coil, it is much more convenient and requires less baseboard space. The shape of this coil was very nearly equal to the shape of the measured coil.

An astatic pair is much easier to make than a D coil, and it appears to be somewhat more efficient. Like the D coil it has a small external magnetic field.

The Toroidal Coil of Circular Section

This is the doughnut coil. It is the most efficient of the toroidal coils for the reason that each turn is a circle. There is an accurate formula for the inductance of this type of coil, namely, $L=4\pi N^2 (R-\sqrt{R^2-r^2})$ in which L is the inductance in centimeters, N is the number of turns, R the mean radius of the ring, and r is the radius of the cross section, or of each turn. The length of the wire is given by $l=2\pi rN$.

This coil has a best shape, that is, a shape which gives the greatest inductance for a given length of wire. The condition is that $r=.5205R$. When this condition is put into the formula for inductance this becomes $L=3.53rN^2=165,000$ cm.

Every Precise Instrument is a Laboratory Product

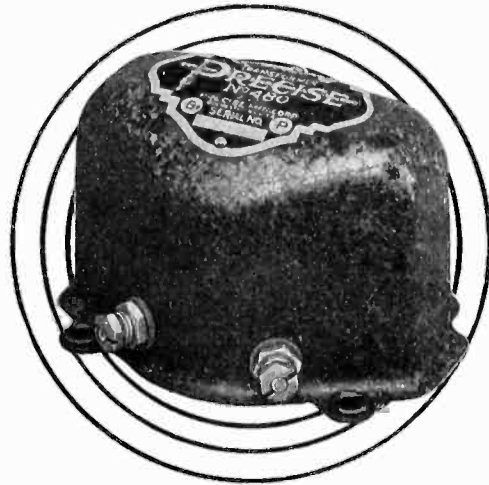

PRECISE
Supersize No. 480
Audio Transformer

A PRECISE Transformer for every ratio

THE Precise Line includes the most complete line of transformers in the world. There is a Precise transformer for every ratio and purse.

The new No. 480 Supersize Audio Transformer is the latest addition to the Precise Line. It is designed to bring forth with magnificent volume and perfect shading of tones, the deep toned bass or the high, clear soprano. Mr. James L. McLaughlin, R. E., the noted superheterodyne authority, specifies the Precise No. 480 for his new One-Control Receiver. Ask your dealer to show you the complete Precise line.

COMET
Ratio 3½ to 1
Price, \$3.25



No. 285
The Original
Type 285
Transformer
Ratio 4½ to 1
Price, \$5.00

Rochester, New York

Branch Offices:

126 Liberty St., New York City
53 W. Jackson Blvd., Chicago, Illinois
821 Market St., San Francisco, California
454 Builders' Exchange, Minneapolis, Minn.
1127 Pine Street, St. Louis, Mo.
701 A. O. U. W. Bldg., Little Rock, Arkansas

Canadian Distributors: PERKINS ELECTRIC, Ltd.,
Toronto—Montreal—Winnipeg

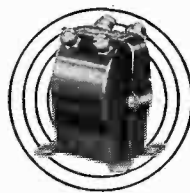

ARE YOU A SUBSCRIBER?

SEND \$1.00 FOR A TRIAL SUBSCRIPTION TO "RADIO" FOR 6 MONTHS



**RASLA
FIXED
DETECTOR**

"every one
a Good one"

FOR louder, clearer reception with your reflex set, go to your nearest dealer and ask for the RASLA Fixed Detector. Lists at only \$1.25.

Write to the Davidson Radio Corporation, 222 Fulton Street New York City, N. Y., for the FREE Rasla Book of Hook-ups



FROST-RADIO

FROST-RADIO PAN-TAB JACKS ARE BEST for YOUR RADIO SET

The finest radio jacks made, for either paneling assembly or usual installation. At your dealer's 65c to 90c list.

HERBERT H. FROST, Inc.
314-324 West Superior Street Chicago

Tell them that you saw it in RADIO

Bare Necessities

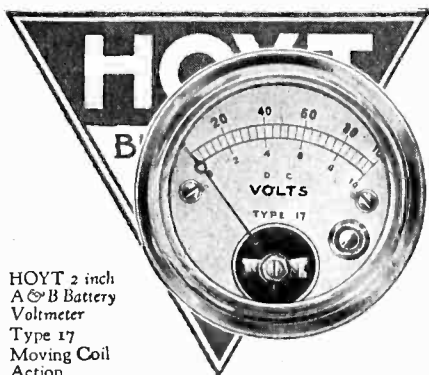

HOYT 2 inch
A & B Battery
Voltmeter
Type 17
Moving Coil
Action

Your car will run without an ammeter, oil gauge or speedometer. But would you care to run it in that way? At any moment electric current might fail, bearings burn out, gasolene give out, all without warning.

When you run a radio set without the positive knowledge of its condition and operation, that can be given only by the use of meters, you are taking just the same kind of a chance. You may damage your set and its accessories irreparably without a moment's warning.

The first automobiles were sold without full equipment — because the public had not been educated to demand it.

Radio sets have been similarly sold. But as the public becomes more educated it is demanding meters.

**KEEP AHEAD OF THE TIMES
AND TROUBLE IN YOUR
RADIO WITH HOYT METERS.**

Our book "HOYT METERS FOR RADIO" shows the complete HOYT line of Radio Meters. Send for it.

Burton-Rogers Company
26 Brighton Ave. - Boston, Mass.

National Distributors

M & M Low Loss INSULATORS

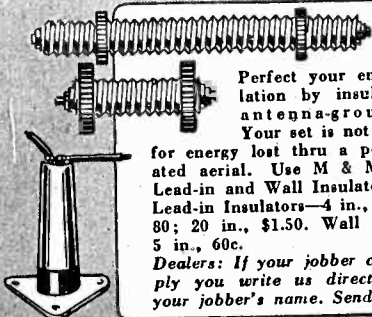

Perfect your entire installation by insulating your antenna-ground system. Your set is not responsible for energy lost thru a poorly insulated aerial. Use M & M Low-Loss Lead-in and Wall Insulators. Lead-in Insulators—4 in., 50c; 10 in., 80; 20 in., \$1.50. Wall Insulators—5 in., 60c.

Dealers: If your jobber can not supply you write us direct, giving us your jobber's name. Send for catalog.

The M & M Co.
CLEVELAND, OHIO.

There's Economy and Satisfaction in these Valley units

You will find both economy and satisfaction in the use of the Valley B-Eliminator and the Valley Battery Charger.

Economy in the B-Eliminator because it stops forever the expense of buying new B batteries. . .

Economy in the charger because it recharges your own storage battery at home overnight at one-tenth the cost of service station charging. . .

And satisfaction in both because, by using them, you need never miss a program on account of low or worn-out batteries.

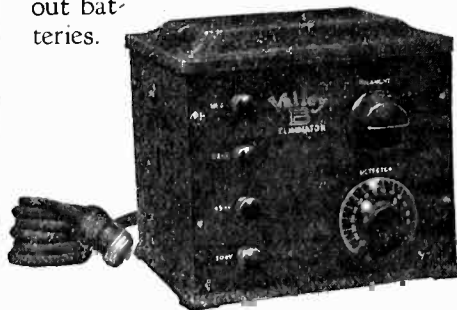

THE VALLEY B-ELIMINATOR operates from ordinary light socket; provides a steady, noiseless flow of B current at a constant voltage all the time.

With it, there can never be any decrease of signals or frying noises due to low B batteries. Volume is maintained. Reception is uniformly good.

For receiving sets of from one to eight tubes. Costs less at the start than wet B batteries. Costs less in the long run than dry cells. Much more satisfactory than both.

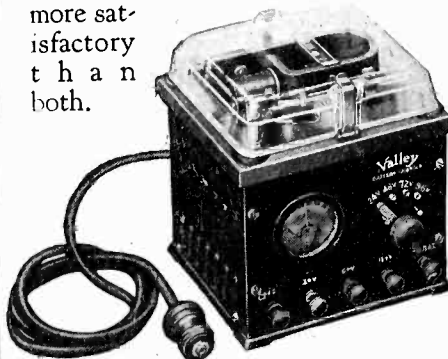

THE VALLEY BATTERY CHARGER is the only charger needed for all radio storage batteries. Its correct 6-ampere charging rate makes overnight charging a possibility.

The Valley Charger also functions on any lamp socket. It takes about a dime's worth of current for an average charge. Quiet in operation.

Most radio dealers handle the Valley B-Eliminator and Valley Charger. Any one of them will be glad to show you these units and explain their advantages.

Radio Division
VALLEY ELECTRIC CO. ST. LOUIS, U. S. A.
Branches in Principal Cities

Valley Electric

Tell them that you saw it in RADIO

The number of turns on the coil is given by $N=2\pi n(R-r)=57.8r$, since $n=10$, being the number of turns per centimeter. Solving these equations, the L/l ratio turns out to be 78.3, the number of turns required 139.3, the radius of the cross section 2.41 cm, and the radius of the ring 4.63 cm. This coil is not very convenient since the overall diameter is more than 5.5 inches. The Toroidal Coil of Square Cross Section

This coil is similar to the doughnut coil, but is not quite so efficient. The formula for the inductance of a toroidal coil of rectangular cross section is $L=2hN^2\log R/r$, in which h is the axial length of the coil, N the number of turns, R the outside radius, and r the inside radius. Of all the toroidal coils having a rectangular cross section the one having a square section is the most efficient. In order that the section be a square the value of h must be equal to $(R-r)$. As in the case of the doughnut coil, the rectangular sectioned coil has a best shape. The condition is that the ratio of the outside radius to the inside be equal to the square root of the base of natural logarithms, or very nearly that $R=1.649r$. When this condition is put into the formula for inductance it becomes simply $L=hN^2$, or if the section is square, $L=(R-r)N^2=.649rN^2$.

The length of the wire in the coil is given by $l=4hN=4(R-r)N$. Hence the L/l ratio is simply equal to $N/4$. The number of turns that can be put on the form is given by $N=20\pi r$. Solving the equations for the unknowns gives $L/l=63.0$, $N=252$, $R=6.61$ cm, and $r=4.01$ cm. This coil has an overall diameter of approximately 5.25 in., and is therefore about as inconvenient as the doughnut coil.

The external characteristics of these two coils are alike. They have no external magnetic field, and that fact is their only advantage. This makes it possible to use these coils in crowded places without any danger of undesirable coupling between the several coils, or between the coils and other parts of the circuit. Taken by themselves these coils are only about half as efficient as the single layer solenoid, but when it is considered that losses from eddy currents in adjacent metal parts are practically eliminated by the absence of an external field, their efficiency in a crowded set is more favorable. Eddy current losses may be considerable in an open coil like the single layer solenoid when this is placed in a wrong position with respect to shields or condenser plates. No special arrangement of angles or positions is necessary with the toroidal coils.

The D coil and the astatic pair come about half way between the toroidal and the open type of coils, both with respect to efficiency by themselves and with respect to the intensity of the external field.

In the accompanying table the inductance to length of wire ratios of the several coils have been arranged in the order of their values. The first column gives the name or type of the coil, the second the *L/l* ratio, the third the percentage of efficiency based on the the *L/l* ratio for the single layer solenoid, and the fourth the percentage of efficiency based on the *L/l* ratio of the three banked wound coil.

	<i>L/l</i>	Comparison % of S. L. Solenoid	Efficiency of Coils % of Three-Bank Coil
Three Bank Wound.....	206.0	144.7	100.0
Two Bank Wound.....	178.0	125.0	86.5
Spider Web Low Loss.....	156.7	110.0	76.0
Lorentz Low Loss.....	155.8	109.3	75.6
Single Layer Solenoid.....	142.5	100.0	69.2
Pancake Circular.....	141.8	99.5	68.8
Standard coil 12 sided.....	141.7	99.4	68.7
Square Single layer.....	125.0	87.7	60.6
Astatic Pair Short.....	119.1	83.6	57.8
Astatic Pair Long.....	112.7	79.0	54.7
D Coil Medium length.....	111.7	78.4	54.2
Torus or Doughnut.....	78.3	55.0	37.0
Toroid of Sq. Section.....	63.0	44.2	30.6

A concealed loop can often be mounted on the back of the frame of a picture, hung on a wall. This can't be swung around, but sometimes will help when for fitness and concealment is a factor.



Weston Model 506 Two-inch Radio Panel Voltmeter

WESTON FOR RADIO

The Famous Instant Change Radio Plug, 60c.

This 2-inch voltmeter for accurate control of tube and battery voltages assures most effective operation and longest life from the equipment. Because of its high internal resistance, 125 ohms per volt, the drain on the "A" battery is insignificant. This is a specially important feature when dry cell tubes are used. The Instant Change Plug gives rapid and sure shift from headset to loudspeaker.

Send for a complimentary copy of "Weston Radio Instruments" describing the Weston Radio line.

WESTON ELECTRICAL INSTRUMENT CORPORATION

156 Weston Avenue, Newark, N. J.
Pacific Coast Office: 682 MISSION ST., SAN FRANCISCO

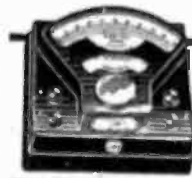
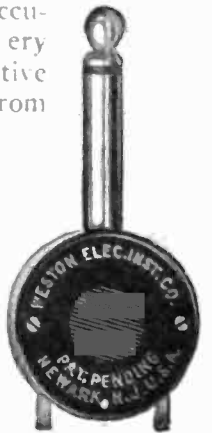

STANDARD THE WORLD OVER

WESTON

Pioneers since 1888



Splits a Single Degree Into Hair's Breadth Divisions!

You'll never know how much difference a dial can make until you get this new MARCO dial in your set. Without the least suggestion of backlash, it responds instantly to your slightest touch. Smooth-working, handsome, supremely accurate, it's typical of MARCO. And you keep a record of dial settings in the two slots—right on the dial itself!

Nickel Plated, \$2.50. Gold Plated, \$3.00

Martin-Copeland Company
Providence, Rhode Island

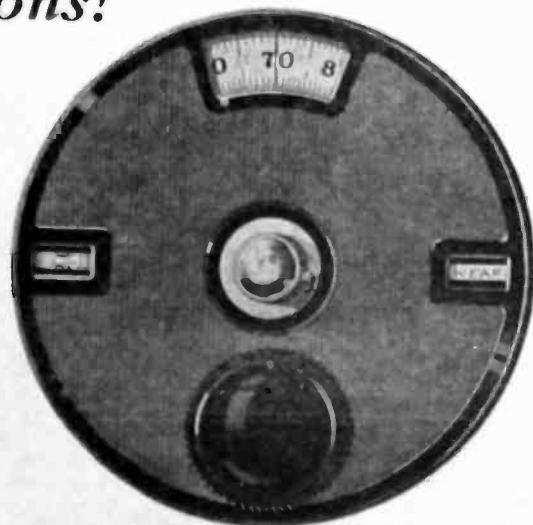

This is the dial specified in the McLaughlin single-control superheterodyne described in this issue.

MARCO RADIO PRODUCTS Vernier Dial



Trumpets

Timbre of brass and thunder of trombone! Out over mountain and prairie, through storm and sunshine, it is carried on the waves of the air from the steel towers of the broadcast station. And in your home it rings out clear and strong — held fast to all the purity of the original by the marvelous power of Rauland-Lyric.

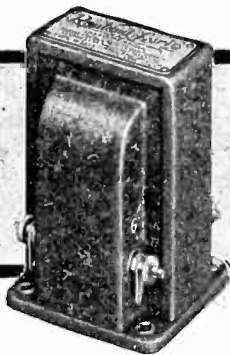

Rauland-Lyric is a laboratory-grade audio transformer designed especially for music lovers. The price is nine dollars. Descriptive circular with amplification curve will be mailed on request. All-American Radio Corporation, 4201 Belmont Ave., Chicago.

Rauland-Lyric
AN
ALL-AMERICAN
TRADE MARK
TRANSFORMER

The Choice of Noted Music Critics

New!

The biggest
little thing in Radio

this
season

DURHAM Variables

Panel Mount
\$1.00
Standard
75c

Bring control of
high resistance
to the panel

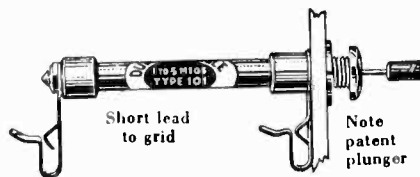

Both types in
three sizes:
#100—1000
to 100,000
ohms.
#101—.01
megs. to 5
megs.
#201A—2
megs. to 10
megs.

Always a one-finger control and now at your finger ends — that's the new DURHAM Variable. The familiar ease and accuracy of these standard high resistance units in their latest form may be placed anywhere on your panel, preferably near the tube they control. Only a ¼" hole required. For most hook-ups, you'll need two DURHAMS — detector and audio.

Look for the plunger

The patented DURHAM combination of sliding plunger and non-wear compound is your protection and guarantee for accurate high resistance control.

Dealers: Get This

Order from jobber now
specifying type, panel
mount and standard.

DURHAM & CO., Inc.
1936 Market St., Philadelphia

Radio Dealers WANTED!

If you are the type of dealer who hustles after business, who isn't content to wait for trade to come in but who takes sets out to demonstrate, can talk and sell quality merchandise, and knows Radio values, we have a big proposition for you. Are you that dealer?

50% Discount to Dealers

We manufacture a complete line of high-grade receivers and sell to dealers at 50% discount. We are distributors for more than 225 Nationally advertised lines.

Write today for amazing offers, new 112-page catalog and regular monthly catalogs quoting below - the - market prices on latest merchandise — all free. Everything in Radio for less.

American Radio Mfg. Co.
1422 McGee Street Kansas City, Mo.



BUILDING FOR THE FUTURE

(Continued from Page 28)

denser should be kept as far apart as possible and away from the audio transformer.

Since this is a regenerative set, a sensitive detector tube must be used. The grid return of the detector in Fig. 1 is shown to *A Plus* as is usual with "hard tubes" of the 201-A and WD-12 type. With the grid return to *A-*, a loss of sensitivity may be felt, but a much smoother regeneration control may be had in many cases. With a soft tube, and the Sodian D 21, used for detector, the grid return should be to *A-*. Some writers stress the necessity for removing the bases of tubes used for detector but the necessity does not seem apparent in a set of the construction in this article. A fixed grid leak, usually 5 to 10 megohms, with the hard tube for a detector, should be chosen in preference to lower values, as a rule.

A first-class ground connection is essential for the set, otherwise "hand capacity effects" will be abominable. One test of a "good" ground is to tune in a faint signal on a regenerative set, then touch the ground post with a moistened finger; if a perceptible change in tuning occurs, the ground needs improvement. A good ground is even more essential with the short wave set than with a 200-550 meter set, since the tuning at the low wave set is very much shaken. With a poor ground, if hand capacity effects are present, one must sit "just" or a signal once tuned in will be "dial" when the hand is taken from a dial.

Either a "grounded rotor" type variable condenser should be used, or the variable condenser should be shielded in the usual manner, by sticking foil to the inside of panel and connecting this foil to the ground post. The foil must be cut out generously around the mounting screws and shafts of the various instruments.

Note that rotor of the variable condenser is connected to filament. Connecting this filament to ground as indicated by the dotted line in Fig. 1, thus making "conductive coupling" is generally better than "inductive coupling" as made by omitting the dotted line connection.

A "straight line wavelength" or "straight line frequency" variable condenser has many advantages over the more usual straight line capacity type, in that the tuning range is more spread out on lower dial settings.

Since this is modernized version of the "standard regenerative set," the tuning is the same. The variable condenser is varied throughout its arc, while the rotor is simultaneously turned with the other hand so that a rough hissing sound just short of a more violent "grunting," "clicking," or "squawking" sound is heard in the phones. It is regrettable

that this method of tuning is bound to cause some interference to others receiving on the same wavelength, but with so few using low wave sets as compared to those using 200-500 meter sets, the interference is almost nothing. When distorted music is heard, turn back tickler and make small adjustments of dials until music is clear.

If a coupler which does not permit full rotation of the rotor, or a so-called 180 degree coupler be used, care should be taken that the connections be made of rotor leads as shown in Fig. 1; with all windings in same direction, maximum regeneration is then had when the rotor windings are turned to parallel those of the stator. An infrequent source of trouble in "home made couplers," is the winding of the two halves of the rotor winding in opposite directions. If the windings are all properly made, a raising or lowering of *A* and *B* voltages, increase of turns on the rotor, a different detector, or a different grid leak may produce the desired regeneration.

EXAMINATION FOR JUNIOR RADIO ENGINEER

The U. S. Civil Service Commission announces that applications for an examination for the position of junior radio engineer will be received at Washington until November 14th. The entrance salary is \$1860 a year with advancement to \$2400 without change of assignment. The examination is to fill vacancies in various branches of the Government service throughout the United States. Appointments to positions formerly known as "radio inspector" in the Bureau of Navigation of the Department of Commerce, will be made from this examination.

The duties of this position consist of such work as routine testing, performing field work, assisting in conduct of experimental research tests, compiling reports, handling technical correspondence, and other related work. Competitors will be rated on general physics; pure mathematics; practical questions on radio engineering, including applied mechanics; and education, training, and experience.

Full information and application blanks may be obtained from the United States Civil Service Commission, Washington, D. C., or the secretary of the board of U. S. civil service examiners at the postoffice or customhouse in any city.

The 1926 Model Radio World's DIAMOND of the AIR

Brand New Audio Hookup, by Herman Bernard. See it in

RADIO WORLD

The First National Radio Weekly

15c a copy All Stands

See Current Issue:

Seven Days' Programs—Complete List of Stations—Radio University: A Great Question and Answer Department—Newspaper Trade Department—Service Articles, With Diagrams, by Eminent Authorities—Everything for Novice and Expert. Profusely illustrated. Current Prices for Standard Sets and Parts. \$6 per year (52 numbers); \$3 six months; \$1.50 three months. SPECIAL: Send \$1 for 8 issues.

RADIO WORLD

1493 Broadway

New York City

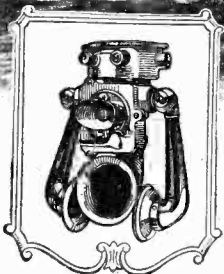
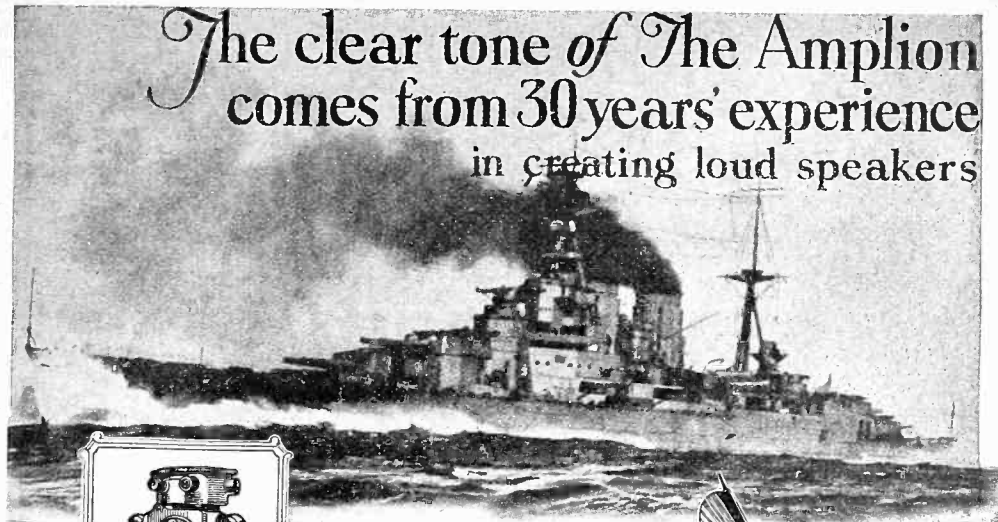

Distinct voicing of commands at sea is vital! At left, one of the naval loud speakers produced by the Amplion organization and installed on over 12,000 ships of leading navies and shipping companies throughout the world.

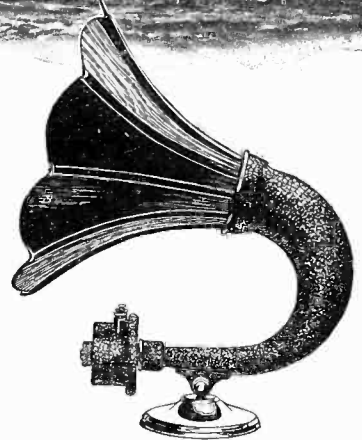

Clarity is also essential to full enjoyment of radio. Thirty years' experience in creating loud speakers, unrivaled for clearness of tone, evolved The Amplion. Ask to hear the improved new Amplion Dragon, AR-19, illustrated above

ALL who hear the Amplion are won by its wonderful clearness and deep, full, life-like tone-qualities which have made it the world's largest-selling loud speaker.

The explanation is that The Amplion was evolved by the actual originators and oldest producers of loud speakers.* Long before radio attained general popularity, Graham loud speakers had been adopted—because of outstanding excellence—by the exacting British Admiralty and naval experts of other nations. The Amplion, introduced in 1920, was based on thirty years of successful experience.

Hear The Amplion in comparison with any or all other radio reproducers. Let your ears tell you why it is so widely known as "The world's finest loud speaker." Amplion Loud Speakers, \$12 up. Phonograph units in two sizes. Interesting literature and dealer's address on request.

THE AMPLION CORPORATION OF AMERICA

Executive Offices: Suite O, 280 Madison Ave., New York City

Canadian Distributors: Burndep of Canada, Ltd., Toronto

*Alfred Graham & Co., London, England, Patentees

AMPLION

The World's Standard Loud Speaker

- The supremacy of The Amplion has won world-wide recognition and leadership in sales. Partial list of nations in which Amplions are ruling favorites among music-lovers:
- UNITED STATES
 - DOMINION OF CANADA
 - ENGLAND
 - SCOTLAND WALES
 - IRELAND
 - NORWAY SWEDEN
 - DENMARK
 - HOLLAND BELGIUM
 - FRANCE SPAIN
 - SWITZERLAND
 - ITALY JAPAN
 - SOUTH AFRICA
 - NEW ZEALAND
 - AUSTRALIA

The "Windham" Wire Former

A Handy Tool for

Electricians, Radio Fans and Mechanics

This rugged little tool not only makes accurate loops or eyes for No. 4, 6, 8 and 10 screws but will make either sharp or easy radius right angle bends and the sharp cutter will cut the toughest wire as well.

It is drop forged of the very best steel and carefully tempered in oil.

Retails for \$1.25

Dealers and Jobbers send for full information. Desirable territory still open.

THE GOYER COMPANY

Willimantic, Conn., U. S. A.

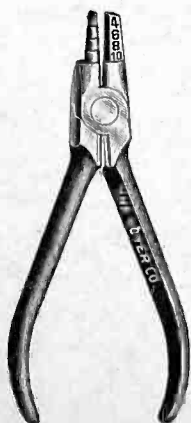

CHELSEA

Makes Home Sweet Home

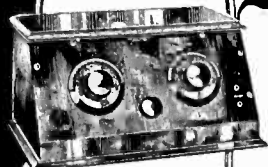

Three Tube RECEIVER \$26.00

Licensed Under Armstrong Patent No. 1113149

The only genuine Armstrong circuit 3-Tube Set, at this low price, with a dust-proof, fool-proof inside panel. Cord connections to batteries, no binding posts and many other refinements. Operates on all standard tubes. For distance and real tone quality, the equal of many \$100 sets.

Added Features

Both of these New Chelseas possess performing features and refinements of design only found in the most expensive models. Each Chelsea is a manufactured product—not an assembled job—and is fully guaranteed.

Chelsea Branches

New York, Philadelphia, Cleveland, Detroit, Chicago, Los Angeles

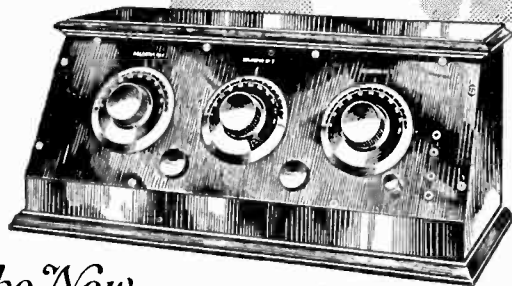
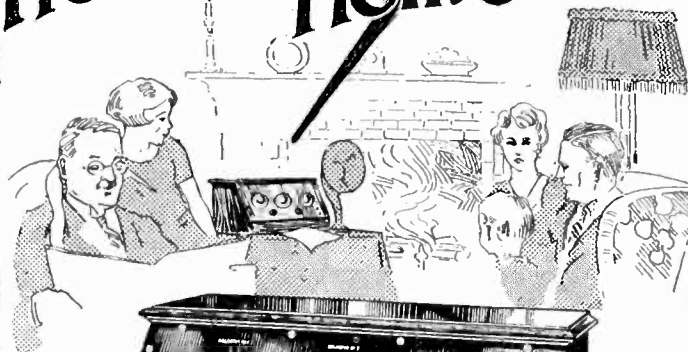

The New Super-Five \$50.00

There's no place like home with a Chelsea. After supper, dishes done, the family gathers round the living room to enjoy the radio wonders of the air—never more delightful and satisfying than with the New Super-Five. Here, power and perfect living tone quality are combined with easy operation. Dependable, enjoyable results are always assured.



Send for Folders Describing All Latest Chelseas

CHELSEA RADIO COMPANY
179 SPRUCE STREET, CHELSEA, MASS.

VACUUM TUBE

(Continued from Page 31)

of any circuit for generating oscillations, that during that portion of the cycle of the output current when the grid is positive with respect to the filament as a result of the voltage induced in the coil L_g , the voltage drop between the plate and filament connections (across the coil L_p) is such as to oppose the voltage of the plate battery and hence to reduce the voltage acting between filament and plate in the tube. During the other part of the cycle when the grid is negative with respect to the filament, the voltage acting between plate and filament is increased above that of the steady voltage of the plate battery. During the portion of the cycle when the grid is positive with respect to the filament, current flows within the tube between the grid and filament, and this current increases as the grid becomes more positive. The direction of the current flow is in the direction of the emf, that is, from grid to filament inside the tube and from filament to grid outside of the tube.

Further, as the grid becomes positive with respect to the filament, there is a resultant increase in the current flow between the plate and filament of the tube, even though the plate voltage on the tube is being reduced. This increase is limited when the stable oscillating condition has been reached, by the saturation effect, which may occur at lower values of plate current than that corresponding to the total filament emission, owing to the loss of electrons to the grid.

The plate current wave is distorted at the other extreme of the cycle—that is, when the grid is negative—by rectification effects; moreover, the grid current is always pulsating, and may be zero for a considerable part of the cycle while the grid is negative. Consequently, the waves of current supplied to the circuit between F and P , and I' and G , Fig. 8, are each composed of a direct or average constituent, a fundamental constituent corresponding in frequency to that of the output current, and a number of higher frequency or harmonic constituents.

Speaking only in terms of the useful current constituents, a sinusoidal alternating current flows in the grid circuit in phase with the alternating voltage across the coil L_g , and therefore represents a withdrawal of power from the output circuit, which power is expended within the tube. On the other hand, a sinusoidal alternating constituent of plate current flows in opposition to the voltage across the coil L_p ; this means that power is being supplied to the output circuit from the plate circuit of the tube. The impedance of the output circuit to all frequencies that are harmonic multiples of the fundamental is

(Continued on Page 86)

RADIO AGENTS WANTED 5 Tube Demonstrator FREE!

Earn \$25 to \$100 a week, part or full time. Everyone a prospect. Complete line standard sets and accessories, \$5 to \$90. Write today for illustrated catalog and exclusive selling plan for live dealers and community agents. 20TH CENTURY RADIO CO., 1011 Coca Cola Bldg., Kansas City, Mo.

ARE YOU A SUBSCRIBER?

Send for Trial Subscription
\$1.00 for Six Months

Potter

BY-PASS

CONDENSERS

- Prevent "B" voltage fluctuation
- Allow undistorted amplification
- Make possible full bass tones
- Improve reception with "B" Supply Units.

Made in $\frac{1}{10}, \frac{1}{5}, \frac{1}{2}, 1, 2, 3$ and 4 Microfarad sizes

At Your Dealer's

POTTER MANUFACTURING COMPANY
North Chicago, Illinois



**LOW REL LOSS
LOW WAVE COILS**

In the Lead Again!—"REL" Basket Weave Coils now equipped with Plug-in Mountings—Quick, efficient coil changing—Five interchangeable units in each outfit—Triple cotton covered paraffined wire—Chocolate color, won't soil—For any low-loss, low wave circuit—Covers 10 to 110 meters efficiently—Inexpensive—Rugged—No increase in Price!

Price \$4.50, including mounting.

At your dealer's, or order direct
**RADIO ENGINEERING
LABORATORIES**

27 Thames Street New York, N. Y.
"THE LOW LOSS COIL PIONEERS"

**You Can Make \$100
Weekly Selling Radio**

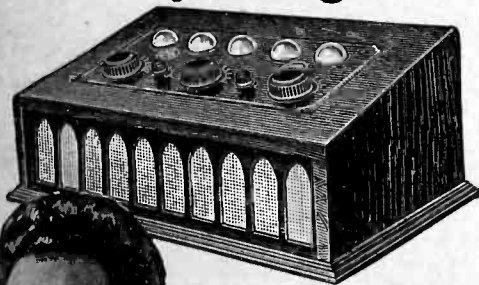

J. Matheson Bell, Pres.

Demonstrate once—results mean sure sales! Sell what everybody wants—radio at low prices. Coast to coast reception—4, 5 and 7-tube instruments.

**12 Selling FREE!
Lessons**

Establish a business of your own. Start in spare time—evenings. Sales course in 12 lessons and 10 radio service lessons teach you everything.

3100 Men Are Now Doing It!

Success with over 3,100 men proves merit of our proposition. \$100 weekly not unusual—many Ozarka men make more in spare time!

Free Book! Write me personally—tell me about yourself. I'll see that my 64-page book, Ozarka plan No. 100, is sent you without cost. Please mention the name of your county. Mail the coupon!

OZARKA
120 Austin Avenue E.,



INCORPORATED
Chicago, Illinois

Gentlemen: 10-25

I am greatly interested in the FREE BOOK "The Ozarka Plan" whereby I can sell your radio instruments.

Name.....

Address..... City.....

County..... State.....

Radio Never Had a Tube
Equal to
EMPIRE-TRONS



Type '99 also supplied with '01 base (all Bakelite).

Every tube is a model of perfection; finest mechanical construction, unequalled for clarity, sensitivity and perfect reception. Has been tested for 1200 hours' continuous operation.

Satisfactory Performance Guaranteed

Comparative tests invited—ask your dealer for an EMPIRE-TRON and hear the difference.

Superior Quality Priced Right

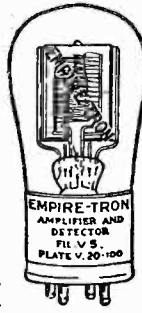

Made in U.S.A.

Tested in Our Factory

Distributors and Dealers Wanted
Some Choice Territory Still Open
Write for Circular and Particulars



MODEL A
Bell 10 in.
Height 22 in.



MODEL C
Bell 14 in.
Height 22 in.

**EMPIRE
SPEAKERS
and
UNITS**

A beautiful line of Speakers made of unbreakable composition handsomely finished in rich dark brown, crystalline effect. Very graceful and an ornament to any home. Brings out tone perfectly.

Model "A": Bell 10 in., height 22 in., fitted with EMPIRE Adjustable Unit—retails at \$13.50.

Model "C": Bell 14 in., height 22 in., fitted with EMPIRE Adjustable Unit—retails at \$16.50.

EMPIRE Adjustable Unit; constructed with greatest scientific care. Guaranteed to bring out the full volume of any set—true and clear-toned. Retails at \$6.50.

"The Home of Empire Products"

They speak for themselves.

Write for circulars and prices.

American International Trading Co.

59-61 Pearl Street, New York

Cable Address: "Stanmarks, N. Y."

**RADIOCAST
WEEKLY**

Forty-eight Pages of Programs, Photos, Humor, Musical Reviews, Schedules, Tables, Editorials, Etc.

5c Per Copy Radiocast Weekly
433 Pacific Bldg.,

SAN FRANCISCO

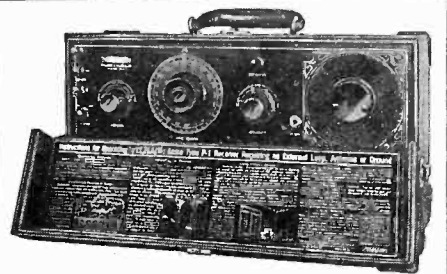

The Famous Truly Portable
TELMACO P-1 Receiver
Four Tubes Do the Work of Seven

The peer of portables in size, weight, ease of tuning, selectivity, distance, volume, workmanship and price. Aerial, loud speaker and batteries self contained. Complete with tubes and batteries. **\$125.00**
\$141.50 Receiver only

P-1 Kit Saves You Money!

Our offer of the Telmaco P-1 Receiver in kit form has met with enthusiastic reception. This contains all parts, as built by us, including case, drilled and engraved panel, and illustrated instructions. **\$80.00** Complete kit
Ask your dealer or write us. Descriptive folder free.

Radio Division:

Telephone Maintenance Co.
20 So. Wells St. Dept. A Chicago, Ill.



Quality Radio Exclusively Established 1918

CLARITY



RATIOS 3 1/2 TO 1—5 TO 1

No set is better than its parts and no one part is more important than the Audio Transformer. That's why you should insist upon Supertrans in your set—they are by test, the best transformers on the market.

Distributed by

L. W. Cleveland Co., Portland, Me.
E. P. Denham, Seattle, Washington
Waite Auto Supply Co., Providence, R. I.
Gray Sales Co., Philadelphia, Pa.
Rice-Hitt Co., San Francisco, Calif.
B. Darmslader, Chicago, Ill.
Whiting Radio Co., Bridgeport, Conn.
Paterson Radio Co., Paterson, N. J.
Buffalo Radiophone Co. Inc., Buffalo, N. Y.
The Jack L. Hursch Co., Denver, Colo.

FORD RADIO & MICA CORP.
111-113 Bleeker St., N. Y.



REGISTERED U.S. PATENT OFFICE

AUDIO TRANSFORMER

ARE YOU A SUBSCRIBER?

SEND FOR TRIAL SUBSCRIPTION

\$1.00 FOR SIX MONTHS

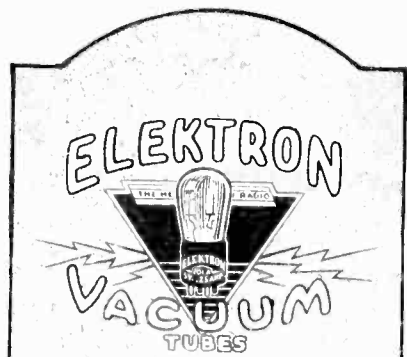

Elektron Tubes have proved to be the finest receiving amplifiers and detectors that money can buy. Reliable and highly efficient. Satisfaction guaranteed.

There's an Elektron (201-A, 199, or 199-A) for every type of circuit and battery equipment. DEALERS! Some excellent territory is open. Write for our proposition.



Lectrodio Corp.
LYNN MASS

SAVE MONEY

RADIO GUIDE FREE
Hot off the press—latest Radio Catalog & Guide brimful of new ideas, over 100 special hook-ups with information—all free. Shows savings as high as 50% on sets and supplies. Be sure to get this thrifty illustrated book before you buy. It means money in your pocket. Standard guaranteed goods.
Write letter or postal note. Also please include name of radio friend.

B. RAWIK CO., 103-124 S. Canal St., Chicago, U.S.A.

BIG MONEY FOR RADIO

Demand for high pay radio men is so great that a big Kansas City wholesale concern is now fitting men free to get into the radio business for themselves and make \$60 to \$200 a week without any capital invested. Select territory open. Send today for free catalog and amazing offer. Write direct to Mr. H. J. Sazow, Standard Radio Co., 1422 Walnut St., Kansas City, Mo.



To-day
-in every
good set!

**Tone Clarity
Beyond Expectation**

Just pull the switch and note the clarity and richness of tone any Amperite-equipped set gives you. Amperite is the automatic rheostat which does away with hand rheostats and filament meters. No guessing. No uncertainty as to correct tube current. Tubes last longer. Makes any novice a master operator. Insist upon Amperite when you buy or build. Price \$1.10.

Write for free hook-ups

RADIALL COMPANY

Dept. R-16, 50 Franklin St., N.Y. City

AMPERITE
REG. U.S. PAT. OFF.

The "SELF-ADJUSTING" Rheostat

RADIO MAPS

POSTPAID
ANYWHERE

10c

PACIFIC RADIO PUB. CO.
Pacific Bldg., San Francisco

**Takes the mystery
out of Radio**

JUST OUT—514 PAGES

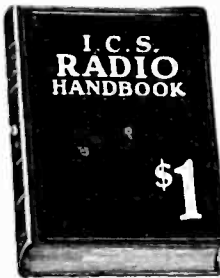

Compiled by
HARRY F. DART, E.E.
Formerly with the Western Electric Co., and U. S. Army Instructor of Radio.

Technically edited by
F. H. Doane

NO MORE need you turn from book to book, hoping to find what you want. It is all here, in 514 pages crammed full of every possible radio detail. Written in plain language, by engineers for laymen. 100,000 sold.

IT EXPLAINS: Electrical terms and circuits, antennas, batteries, generators and motors, electron (vacuum) tubes, many receiving hook-ups, radio and audio frequency amplification, broadcast and commercial transmitters and receivers, super-regeneration, codes, etc.

Send \$1 today and get this 514-page I. C. S. Radio Handbook—the biggest value in radio today.

International Correspondence Schools
Box 8262-D, Scranton, Penna.

I enclose One Dollar. Please send me—post-paid—the 514-page I. C. S. Radio Handbook. It is understood that if I am not entirely satisfied I may return this book within five days and you will refund my money.

Name.....

Address.....

Check here and enclose \$1.50 if you wish the edition bound in Leatheroid.

(Continued from Page 84)

very great, hence there are no appreciable multiple frequency constituents of the current circulating in the output circuit, and the alternating voltages across the coils L_p and L_g are in all cases practically sinusoidal.

Consequently the useful power supplied by the tube can be determined in terms of the alternating voltage across L_p and the fundamental constituent of plate current. If we could neglect the grid current, this would be the power available for dissipation in the resistances. As the output current increases, the amplitudes of the alternating voltages across the plate and grid coils increase proportionately. The alternating grid current increases more and more rapidly, as the amplitude of the plate voltage becomes larger. On this account the power loss to the grid increases. The power supplied by the plate increases with increasing plate voltage, but as the grid voltage increases, the effective saturation current is reached when the grid is positive, and the plate current becomes zero for an appreciable part of the cycle when the grid is negative; consequently a continued increase in the amplitude of the output current results chiefly in an increase in the harmonic constituents of plate current without greatly increasing the fundamental. Obviously, then, a condition of stability ensues when the power supplied by the fundamental of plate current minus the power dissipated by the fundamental of grid current is just equal to the power dissipated by the output current in R_g , R_p , and R_c .

GRID POTENTIAL AND COUPLING. In the Hartley circuit of Fig. 7 the instantaneous grid potential is determined by the potential across L_g . This potential is a function of L_g and the current flowing in this coil. Here, L_g and L_p are not mutually coupled. Referring to the circuit of Fig. 9, it will be seen that

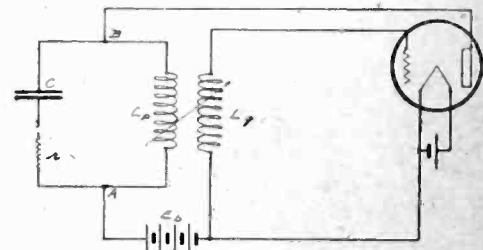

Fig. 9. Generating Circuit With Coupled Grid and Plate Inductances.

the operating grid potential is obtained by coupling L_g to L_p . Here, L_g is not a part of the oscillatory circuit.

By definition, the mutual inductance of two coils such as L_g and L_p of Fig. 9 is the number of interlinkages of magnetic flux from coil L_p with L_g per ab-

(Continued on Page 88)

THE TUBE WITH A SENSIBLE GUARANTEE

REG. U.S. PAT. OFF.
SUPERTRON
A GOOD TUBE



Made with
Precision!

Right from the start at our factory each SUPERTRON is produced with PRECISION as the dominating factor.

The material, each process, the triple test, and the final inspection, are all guided by the most exacting PRECISION. The unit of PRECISION called SUPERTRON is serial numbered and wrapped in a certificate bearing a corresponding number.

Thus giving you a means of identification to assure full satisfaction.

Pacific Coast Offices:

LOS ANGELES—Pacific States Commercial Co., 3208 Glendale Blvd.
SAN FRANCISCO—American Commercial Co., Rialto Bldg.

Branch Offices Thruout the United States

SUPERTRON MFG. CO., Inc.
HOBOKEN, NEW JERSEY

Export Department, 220 Broadway, New York

All
Types
\$2.00

Canada
\$2.75

SUPERTRON
A SERIAL NUMBER GUARANTEE



\$39.50

MARWOL

The Line of

MONEY MAKERS

FROM the MARWOL BABY GRAND at \$36.50 to the MARWOL CONSOLE GRAND at \$130, the MARWOL line holds the greatest sales and profit-making opportunities this year.

MARWOL is the outstanding line of the season, from every standpoint—quality, performance, appearance and range of models and price.

MARWOL Dealers know from past experience that MARWOL will not cut prices—that there is no Summer dumping of MARWOL—that MARWOL stands firmly behind its guarantee.

Our new Factory of twenty-five thousand square feet is in full production. This means that every MARWOL order will be shipped promptly—no delays or disappointments for dealers standardizing on MARWOL.

Write or wire today direct to us or to the Sales Branch nearest you for catalog of the complete line, discounts and full information.

MARWOL RADIO CORP.

546-548 BROADWAY

FACTORY No. 2

85 MERCER STREET, NEW YORK CITY

Pacific Coast Representatives:

In California:
MARSHANK SALES COMPANY
926 Insurance Exchange Bldg.,
Los Angeles, California

In Oregon and Washington:
C. E. GAY
166 Lowndale Street,
Portland, Oregon

In Idaho:
R. T. CARR
906 Sprague Street,
Spokane, Washington

The Sensation of the Season

MODEL 5-F-S

New and Improved FRESHMAN MASTERPIECE



A five-tube tuned radio frequency receiver, encased in as fine a heavy 5-ply solid genuine mahogany cabinet as ever graced any radio set.

Every part embodied is newly constructed resulting in greater efficiency and finer tone quality. The illustration shows our new straight line wave length, low loss condenser and vernier device, permitting the reception of stations over a wave length from 190 to 550 meters.

For Sale By Authorized Freshman Dealers Only

Chas. Freshman Co. Inc.
Radio Receivers and Parts
FRESHMAN BUILDING
240-248 WEST 40TH ST.-NEW YORK, N.Y.
CHICAGO OFFICE — 327 S. LA SALLE ST.

\$60.

Slightly Higher
Denver and
West

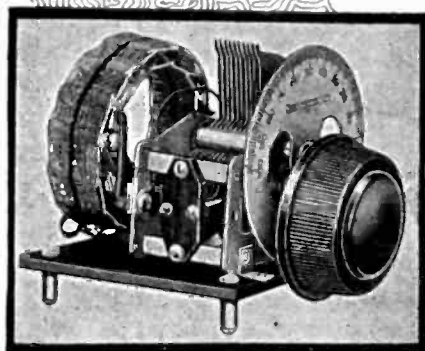

Vernier feature assures greater selectivity and sharper tuning.

ARE YOU A SUBSCRIBER?

SEND \$1.00 FOR A TRIAL SUBSCRIPTION TO "RADIO" FOR 6 MONTHS



"The Elixir of SET Life"

Just as the Heart is the most vital organ of the human body—the tube is the most vital part of the radio set. The SIMPLEX SUPER POWER TUBE performs its function in the radio set with the same sensitivity, accuracy and regularity as a healthy heart in the human body.



REJUVENATE YOUR SET WITH THE SIMPLEX SUPER POWER TUBE, IT MEANS LONGER LIFE AND BETTER RECEPTION.

GUARANTEE: Your dealer is authorized to exchange or return money for any defective S. S. P. Tube, within ten days.

PRICE: Silvered Tube \$2.00
Blue Tube \$2.50

ASK YOUR DEALER FOR THE SIMPLEX SUPER POWER TUBE

Types: S. S. P.
201A, 199, S. S. P.
12, Silvered and
Blue.

TITANIA MANUFACTURING COMPANY, 105 West 40th St., New York

(Continued from Page 86)

solute ampere change of current in coil L_p . The voltage set up in coil L_g is dependent directly upon this mutual inductance and the rate of change of current in coil L_p .

Suppose the circuit of Fig. 9 is generating oscillations of maximum strength. If the mutual inductance between L_p and L_g is decreased by separating the two coils the alternating potential induced in L_g is decreased. By virtue of the controlling action of the grid, this decrease in coupling results directly in a decrease in the amplitude of the plate current wave and a decrease in the variation of plate potential across L_p . This results further in a decrease in the strength of oscillations until a condition of stability ensues for the particular value of coupling between L_p and L_g . As the coupling is further decreased the oscillations will become weaker and weaker and finally stop at a particular value of coupling which is determined by the condition that for oscillations to exist, the mutual conductance of the tube must be at least equal in numerical value to a factor depending upon the constants of the external plate circuit and the particular value of mutual inductance between L_p and L_g . Once oscillations are stopped by decreasing the coupling, they will not again start until the coupling is increased appreciably beyond the previous stopping point.

The condition for strongest oscillations exists when the quantity involving the constants of the external plate circuit and coupling between L_p and L_g is such as to operate the tube over the portion of its characteristic corresponding to minimum mutual conductance for the tube itself. If the coupling is increased beyond this point, the oscillations will again decrease in strength. There is, therefore, an optimum value of coupling between L_p and L_g for most desirable operation.

CONDITION FOR MAXIMUM OUTPUT.
The output of a tube and its circuit can be increased by increasing either the plate current or plate potential. We can increase the plate current by increasing the filament temperature. The detrimental effects of excessive filament temperature do not often make this a desirable method of increasing the output. We may, however, increase the plate potential providing at the same time we make the grid more negative by an amount equal to the quotient of the increase in plate potential and the amplification factor. Safety hinges upon adequate insulation and the maintenance of the necessary negative grid potential.

If output is plotted against external plate circuit resistance, other conditions remaining constant, it will be found that maximum output is obtained when the external plate resistance is equal to the internal plate resistance.



Precision
Inducto
Coupler
Price, \$1.85

McLaughlin Recommends It

James L. McLaughlin, the authority on superheterodyne design, recognizes the superiority of Precision Coils. He says: "The Precision Inducto Coupler is the only coil I recommend for use in my new One Control Superheterodyne.

The Inducto Coupler has been designed for use where a split winding coil is desired. Made of the best moulded hard rubber, which insures lowest losses.

The Cockaday 4-Circuit Coil is the only coil ever specified by Laurence M. Cockaday, inventor of the famous Cockaday Four-Circuit Tuner, for use in his set. Double silk covered copper wire results in increased volume and greater selectivity.

Cockaday
4-Circuit
Coil

Price, \$5.50

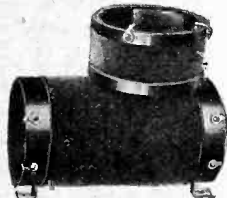

PRECISION COIL CO., Inc.
209 Centre Street, New York, N. Y.

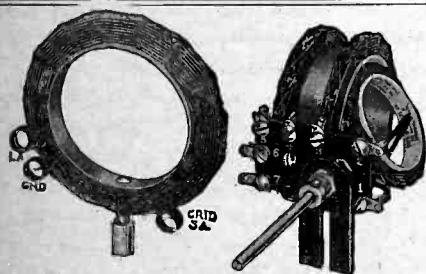

Coil Set No. 24 for Browning-Drake Circuit

SICKLES DIAMOND WEAVE COILS

(Trade Mark Registered Aug. 4, 1925)

**For Browning-Drake
Roberts, Craig and
Hoyt Circuits**
(Patented Aug. 21, 1923)

Sickles Coils for the famous Browning-Drake Circuit are the latest Sickles achievement in efficient design for a particular use. They are priced at \$7.50 a set.

The New No. 18A Coils for any Roberts Circuit are absolutely standard equipment. They are priced at \$8.00 per set.

Coil Set No. 20, at \$4.50, is for use specifically with the new Reflex Receiver designed by Albert C. Craig using the Sodion detector.

Coils for the Hoyt Circuit at \$10.00 a set for the Knockout Reflex Circuit at \$4.00 a pair, and the Tuned Radio Frequency coils at \$2.00 each are other standard Sickles Coils. We manufacture also for manufacturers' special requirements.

Send for descriptive catalog

The F. W. Sickles Co.
138 Union St. Springfield, Mass.

This Chart Tells the Success Story of the Signal Spiral Cam Condenser

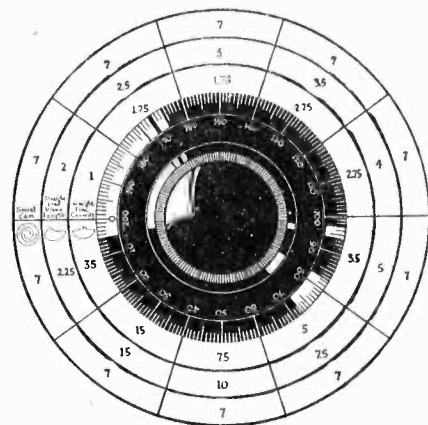

The Signal Spiral Cam Condenser is the only condenser on the market equipped with this unique and highly efficient control. The distinct advantage of its construction is best illustrated by the chart reproduced above. Note the even distribution of stations over the complete 360° of the dial as compared to typical condensers of other types. It's all in the cam!

Other Important Features

The Signal Spiral Cam Condenser operates with velvety smoothness and with a complete elimination of backlash, permitting easy and accurate tuning. The electrostatic field is concentrated within a small area and the dead dial shaft is not connected to either set of plates. It is compact, being no larger than the old semi-circular type. It is die cast throughout, insuring absolute uniformity. It is designed for either single or three-hole mounting, and air core transformers can in turn be mounted directly on the condenser. Signal Spiral Cam Condensers are built in three sizes with unusually low minimum capacities in all sizes, giving a high tuning ratio. One price for any capacity—.00035, .00025, .0005—\$4.00. See one at your dealer's.

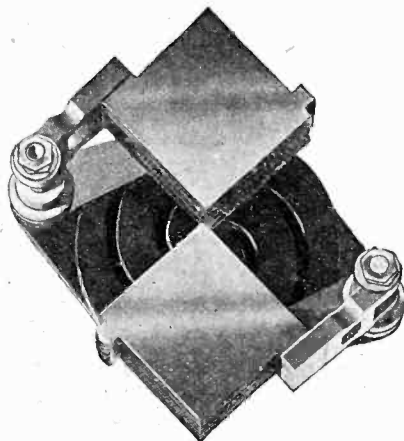

NOW—A BRACKET TYPE LOOP AERIAL

Cut out that extra piece of apparatus by attaching a Signal Bracket Type Loop Aerial right onto the end of your radio cabinet. This aerial will turn a complete 360° in a space no greater than the width of the average cabinet. This new aerial has all the advantages of the famous Signal Table Type Loop. Constructed of solid walnut with third tap for sets requiring them. See both types at your dealer's.

SIGNAL ELECTRIC MANUFACTURING CO.

Dept. 3-K, Menominee, Michigan

Western Representatives:

DON E. CAMPBELL
1216-17 Hearst Bldg., San Francisco, Calif.

RADIO DISTRIBUTING CO.
408 San Fernando Bldg., Los Angeles, Calif.

Branches in all principal cities

Get a Phonograph Unit FREE

With only one subscription to
"RADIO" for one year—\$2.50.
Unit is made by The Union
Fabric Company.

SUBSCRIBE NOW

"RADIO"
Pacific Building, San Francisco

HEATH

RADIANT CONDENSERS
For Real Radio Reception
HEATH RADIO AND ELECTRIC MFG. CO.,
208 First Street, Newark, N. J.



Na-ald DeLux sockets are the only ones with these 3 exclusive features—lowest loss, lowest capacity and positive side-scraping contact. Send for booklet and laboratory test. Alden Mfg. Co., Dept. G9, Springfield, Mass.



Vigilance

Constant vigilance is the price of uniformity and constant vigilance is maintained over Magnatrons. That is why Magnatrons are uniform, and uniformly good.

The Magnatron DC-201A, DC-199, and DC-199 (large base) now list for only \$2.50 each

Connewey Electric Laboratories
Magnatron Building, - Hoboken, N. J.

Pacific Coast Representative:
Pacific Radio Laboratory
256 So. Los Angeles St., Los Angeles, Calif.

MAGNATRON
REX
the new
tube for
B battery
eliminators



MAGNATRONS

Good Company

MAKE YOUR TUBES KEEP GOOD COMPANY

Bad tubes in your set spoil the good ones

REFORM your backsliding tubes with the

\$7.50

**BURTON & ROGERS
TUBE
FLASHER**

BRINGS BACK
BAD TUBES

One model for
D.C. or A.C.,
all cycles.

Utmost simplic-
ity of opera-
tion.

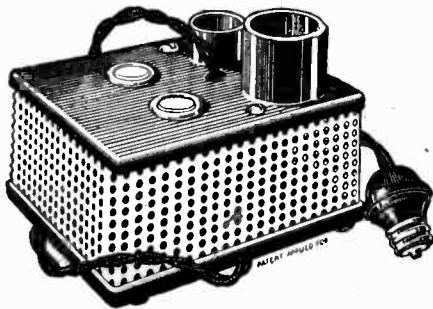

For tubes with
thoriated fila-
ments.

Results will
exceed your ex-
pectations.

Send for our booklet "Save a Life"

BURTON & ROGERS MANUFACTURING CO.

755 BOYLSTON STREET, BOSTON, MASS.

STATIC MITIGATION

(Continued from Page 18)

ing different makes of a.f. transformers were used, and then a balance between the impulses would be difficult.

The antenna-ground circuit of each receiver must be coupled to the first tube circuit as in a neutrodyne receiver, and the connection which joins the A battery to ground must be removed to avoid the possibility of short circuiting any of the batteries through the common ground connection. Of course, separate A and B batteries must be used on each receiver. In case loop receivers are used, the two loops should be pointed in the same direction, since static from different directions is different in character.

The method of operating the two receivers is as follows: The outputs of the two are connected as shown: Fig. 2, using only a single loud speaker. They are then both adjusted to a station, the filaments of one being turned off while adjusting the other. Then both sets of filaments are turned on at once, and the intensity of static and signal adjusted by filament control until both are reduced to practically zero in the loud speaker. This is a test for the identity of characteristic of the two receivers. One receiver is then tuned sufficiently off of the station wavelength so that the signal is lost on it and only the static remains. The filaments of the other receiver should be turned off during this procedure. The detuned receiver should not be tuned so far off that it picks up some other station. It should have merely static on it and should be as close to the original signal wave as possible, without containing any of the signal energy. For this reason sharply tuned receivers such as the neutrodyne or super-heterodyne are desirable for this test.

After the condition of static on one receiver and static and signal on the second is obtained, it will probably be necessary to increase the static intensity on the first slightly, since it will not be quite as strong as on the second, in which the signal tends to accentuate the static impulses. By careful adjustment of the filament currents of the two receivers, the intensity of the static on the two can be equalized. Due to the fact that the two receivers are tuned to slightly different waves, only that type of static will be balanced which is substantially the same on all waves. The sudden sharp click variety is most nearly equal on all wavelengths, and it is this type on which this system is most effective.

It should be remembered that this is not a static "eliminator." If it did anything as final and definite as that, the author would be getting out a patent and selling stock. However, if sufficient care is taken in the adjustment of the receiver, a definite improvement in the ratio of the static to the station signal can be obtained.

**Introducing
"SUPERUNIT
JUNIOR"**

A little brother to the standard Type A and Type B "Superunits."

He measures 5x10" and he consists of a stage of tuned R.F., the detector and two stages of Thordarson audio.

He has plug-in coils and the standard set of coils which he uses will tune from 170 to 570 meters when used with the S-C Capacity Element to make a one dial set. Other coils for other wave lengths.

He makes the most efficient set for use with an aerial and there are just 11 connections to complete him.

YOU SHOULD MAKE HIS ACQUAINTANCE!

Price, complete with instructions \$37.50

MATERIALS NEEDED FOR A COMPLETE SET

- 1 "Superunit, Jr."
- 1 S-C Capacity Element or 2 .0005 condensers.
- 1 Front panel, size 7x10 or larger.
- 2 Bradleystats.
- 1 Double circuit jack.
- 1 Single circuit jack.

Note: No baseboard is required.

Hanscom Radio Devices

Mfgs. of the S-C Capacity Element, the one dial control for two control sets.

Woonsocket, R. I., U. S. A.

Pacific Coast Representative:

S. A. WINSOR

1221 Venice Blvd., Los Angeles, Cal.

RADIOCAST WEEKLY

Forty-eight Pages of Programs, Photos, Humor, Musical Reviews, Schedules, Tables, Editorials, Etc.

5c Per Copy Radiocast Weekly
433 Pacific Bldg.,

SAN FRANCISCO



**FYNUR
VERNIER
CONTROL**

NO BACKLASH Is Possible In This New Dial!

In the new Fynur dial there are no gears to mesh, so there can be no lost motion; no backlash. Forward or backward, the movement is always smooth, free and without the slightest break or interruption.

Traction (beveled wheels) makes this new Vernier Control the most accurate tuning dial on the market. It is simple in construction and beautiful in appearance, and owing to a special automatic compensation adjustment for wear, it will outlast the set on which it is placed. If you want the utmost accuracy in reception, use Fynur Dials.

Ask your dealer or write to us

August Goertz & Co., Inc., 270-286 Morris Ave., Newark, N. J.

\$3.50

ARE YOU A SUBSCRIBER?

SEND \$1.00 FOR A TRIAL SUBSCRIPTION TO "RADIO" FOR 6 MONTHS

POWERPEP!!!!

A brand new device for eliminating the antenna. Simply place POWERPEP under your telephone and listen-in. The results are amazing. Order one of these novel devices today. They are selling fast.

ONLY 35 Cents--Postpaid

Dealers and Jobbers' Prices on Request

ATLANTUS MFG. CO.

74 Front Street

Port Jervis, N. Y.

Morrison

now offers the

Mocking Bird Unit

Patented

\$7.50 List

All fans remember the pioneer of adjustment units—Morrison Model C. For 3 years this unit was a standard of comparison. In trend with radio's great growth, Morrison now offers the Mocking Bird Unit, the peer of all units.

You cannot equal the tone reproduction of the Mocking Bird Unit attached to the phonograph. Radio assumes new delights—purity of tone and the remarkable volume (adjustable) are marvelous.

The Handsome Mocking Bird Cabinet at \$30 list is a real musical masterpiece. Morrison Mocking Bird Cabinets and Units at most good dealers or send your order to factory. Absolute money-back guarantee if not satisfied.

Set Manufacturers:

Attractive quantity prices on Units to build into your Sets.

Dealers:

Morrison has always been a merchandising leader. New schedule of discounts ready—write or write.

Morrison Laboratories Inc.

325 E. Jefferson Ave., Detroit, Mich.

Pacific Coast Distributors:

D. S. Spector Co.
Rialto Building, San Francisco

Morrison



Loud Speaker

B ELIMINATORS

Assured Success with
New Type Tubes

and



Transformers

Chokes

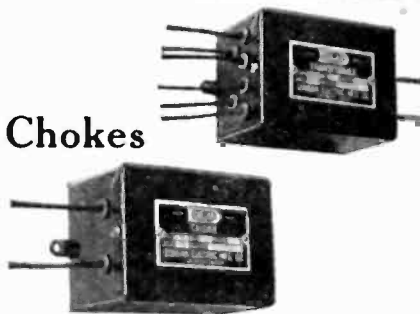

Designed especially for operation with the new Filament and Non-Filament Tubes, Dongan Transformers and Chokes are most essential parts of the remarkable new B-Eliminators. These new Eliminators are thoroughly endorsed by Cockaday and other authorities.

Names famous in the industry are found on these new type tubes. Likewise Dongan—long a leader in the production of quality transformers—shares in this achievement.

Order by Number

PRICES AND SPECIFICATIONS:

No. 509 Full Wave	For Raytheon Tubes	List
No. 537 Full Wave UX213	For R. C. A. Tubes	\$7.00
No. 537 Full Wave CX313	For Cunningham Tubes	
No. 538 Half Wave UX216-B	For R. C. A. Tubes	\$5.00
No. 538 Half Wave CX316-B	For Cunningham Tubes	

CHOKES

No. 514	20 henry	\$5.00
No. 506	30 henry	
No. 539	50 henry	

Other Special Transformers and Chokes for Both A and B Eliminator Requirements

Build your B-Eliminator with Dongan Transformers and Chokes. See your dealer or send check or money order Now. Shipments made same day order received.

Dealers!

Get your share of this business. Full details upon request.

Manufacturers!

We can serve you on any quantity. Prices on request.

DONGAN ELECTRIC MANUFACTURING CO.

2981 Franklin St. Detroit, Mich.

Transformers of Merit for Fifteen Years

Pacific Coast Representatives:

San Francisco—
Industrial Sales Co., 171 Second Street
Los Angeles—
W. A. Breuniman, 443 So. San Pedro Street
Portland, Ore.—
C. E. Gay, 166 Lowndale Street
Seattle, Wash.—
E. P. Deuhau, 2726 45th Avenue S. W.

CALLS HEARD

(Continued from Page 44)

By GCSW, 2330 Hillhurst Ave., Hollywood, Calif.

1aao, 1aai, 1aep, 1ahg, 1alw, 1anq, 1bqi, 1bqt, 1ekp, 1cmx, 1ka, 1pl, 1uw, 1xu, 2afp, 2agw, 2bbx, 2buy, 2by, 2cty, 2dx, 2gu, 2gy, 2lu, 2nf, 2mk, 2qw, 2xaf, 3awh, 3bta, 3bva, 3cfn, 3jw, 3kg, 3ot, 3vx, 4ac, 4av, 4fg, 4fl, 4jd, 4jr, 4oa, 4oi, 4rl, 4rm, 4sa, 4sl, 5aaq, 5adt, 5afd, 5ahw, 5aid, 5aki, 5amh, 5aph, 5asv, 5pu, 5qs, 5sd, 5uj, 5va, 5va, 6aff, 6buc, 6aji, 6cst, 6dof, 6xi, 6bgn, 6biq, 6bkq, 6bqi, 6brc, 6byv, 6bzi, 6ced, 6ckm, 6cyl, 6dea, 6dme, 6eb, 6eq, 6jj, 6jq, 6sf, 6ul, 6zm, 6adr, 6aed, 6aef, 6afx, 6all, 6aon, 6aot, 6atq, 6aud, 6bex, 6bdw, 6bck, 6bmv, 6brk, 6brq, 6ccb, 6ccs, 6cfy, 6cdo, 6cuo, 6daw, 6dbq, 6dkv, 6duc, 6dum, 6dwz, 6hp, 6pn, 6pz, 6se, 6zd, 6zk, 6zt. Canada: 3aa, 4aa, 4cr, 4gt, 4hz, 5ba, 5bf, 5ef, 5go, 5hp, 5ct, 9ck. Mexico: 1aa, 1af, 1ax, 1b, 1g, 1x, 9a. Australia: 2bb, 2bc, 2cm, 2ds, 2lj, 2xl, 3bd, 3bq, 3ef, 3ju. N. Z.: 1ao, 1ax, 2ac, 2ae, 2xa, 4ag, 4ak, 4al, 4ar, 8pl. Chile: 1eg, 2ld, 9tc. Argentina: bal, afy. P. I.: 1hr. Misc.: nas, nedj, nkf, npu, nrri, numm, nuqg, wap, kfuh, jbc, 266? QRK? All cards answered.

By H. C. C. McCabe, 71 Holloway Road, New Zealand

U. S.—1xu, 1aep, 1aoo, 1cx, 1bgc, 1my, 1anq, 1aa, 1are, 2xaf, 2aiu, 3bva, 3hg, 4rr, 5oa, 5aatv, 5atv, 6ea, 6eb, 6asv, 6rw, 6bse, 6xad, 6cso, 6css, 6jp, 6no, 6ts, 6aol, 6avj, 6awt, 6aff, 6bhx, 6cdy, 6oo, 6bcl, 6cub, 6js, 6ajm, 6bge, 6bih, 6cnd, 6chs, 6bur, 6dah, 6bqb, 6bmw, 6chz, 6agk, 6aij, 6awo, 6fa, 6aji, 6ctn, 6qd, 6csw, 6bgo, 6cgv, 6cgo, 6bde, 7ay, 7aek, 7nt, 7gj, 7uz, 8chc, 8apw, 8ced, 8adm, 8tx, 8bgn, 8gz, 9akf, 9bht, 9ug, 9ek, 9bn, 9wo, 9ado, 9xn, 9pl, 9ft. Miscellaneous: wiz, nkf, npg, nrm, nrri, gbe, wap, nve, numm, cxl.

By GASD, 2347 Lucerne Ave., Los Angeles, California.

(40 meter band)

1anq, 1any, 1are, 1fx, 1nq6 (qra?), 1te, 1zm, 2act, 2bxl, 2afp, 2ahm, 2aim, 2bbx, 2bur, 2cgj, 2dx, 2gy, 2kr, 2ia, 2np, 3bv, 3bce, 3btv, 3bva, 3chg, 3eu, 3ot, 3xb, 4ave, 4bv, 4eg, 4fg, 4gt, 4js, 4km*, 4rm, 4sl, 4tn, 5aaq, 5ade, 5ado, 5agn, 5aid, 5all, 5akn, 5akz, 5al, 5ame, 5apa, 5apm, 5aqa, 5arn, 5ary, 5ask, 5asv, 5ba, 5ce, 5co, 5ms, 5ox, 5pa, 5se, 5uk, 5ux, 5va, 5wa, 5xbh, 5zal, 7aek, 7ald, 7df, 7gj, 7it, 7kg, 7nx, 7uz, 7ya, 8alf, 8aly, 8by, 8ben, 8bhm, 8bpl, 8ced, 8cyl, 8dal, 8dkk, 8dno, 8eq, 8gi, 8gz, 8pl, 8rk, 8tk, 8tx, 8uk, 8zz, 9ado, 9aef, 9adr, 9aek, 9aep, 9aey, 9apn, 9atq, 9bex, 9brg, 9bpb, 9bvh, 9bwo, 9cea, 9ccs, 9cju, 9cld, 9cvm, 9czz, 9dac, 9dbb, 9dce, 9dkv, 9dpx, 9ouc, 9dvr, 9dwn, 9dwz, 9dzn, 9ecc, 9efa, 9eht, 9ek, 9ft, 9hp, 9oo, 9pn, 9tj, 9um, 9wo, 9xn, 9yav, 9zk. New Zealand: 4ak. Canada: 2aa, 4aa, 4gt. Hawaii: 6aff. Mexico: 1b, 1k, 9a. Naval: nkf, npg, nrri. Com.: wir, wiz. Unknown: hjd, xa2, ya2.

By J. G. Tinney, 74 Kaimai Rd., Hataitai, New Zealand

(For July and August (20 to 45 meters) Detector only.)

1ag, 1my, 1sf, 1te, 1za, 1anq, 1are, 1bgo, 1blu, 2gy, 2ha, 2lu, 2nf, 2xg, 2xl, 2yt, 2zv, 2afn, 2afp, 2bbx, 2bee, 2brb, 2bur, 2buy, 2cty, 2xaf, 3bz, 3hg, 3auv, 3bva, 3ckg, 4cu, 4fu, 4oa, 4oi, 4rl, 4rm, 4sa, 4vl, 4afu, 4ask, 5ef, 5ew, 5fh, 5kc, 5jd, 5nj, 5nq, 5oo, 5ox, 5uk, 5acl, 5akz, 5al, 5atv, 5zas, 6ct, 6dh, 6dn, 6dq, 6ea, 6fa, 6jp, 6ll, 6nx, 6ql, 6rm, 6rw, 6sb, 6tz, 6xg, 6zd, 6zh, 6agk, 6aj, 6alv, 6aji, 6ajm, 6akz, 6alf, 6apk, 6apw, 6asv, 6avj, 6awt, 6bap, 6bbw, 6bcl, 6bhg, 6bih, 6bmw, 6bse, 6bur, 6bve, 6cby, 6cgy, 6cgo, 6cgv, 6che, 6chs, 6cmu, 6cmq, 6cno, 6csa, 6css, 6ost, 6cto, 6cvj, 6dab, 6dah, 6dcf, 6ets, 6mgk, 6xad, 7ay, 7nt, 7uf, 7uz, 7aek, 7xaf, 8eq, 8er, 8es, 8gz, 8jj, 8ka, 8nk, 8pl, 8ry, 8sf, 8xn, 8adm, 8amb, 8apw, 8ayy, 8bgn, 8cak, 8cau, 8ces, 8chk, 8xyz, 9bn, 9dx, 9ed, 9ek, 9hp, 9nf, 9og, 9ug, 9xh, 9xn, 9ado, 9all, 9akf, 9aod, 9apm, 9bac, 9bek, 9bht, 9bpb, 9ccb, 9ded, 9dac, 9dpx, 9dqu, 9duc, 9dvw, 9dwj, 9eht, 9yav, 9xq. Alaska: 7de. Algeria: 8alg. Australia: 2bb, 2bc, 2bd, 2bq, 2cm, 2dj, 2ds, 2gq, 2lj, 2rg, 2so, 2ss, 2tm, 2ws, 2yl, 2zn, 3ad, 3ef, 3bq, 3lm, 3lr, 3pm, 3ry, 3ul, 3yx, 4an, 4rb, 6am, 7gh, 7pf. Argentina: cb8. Brazil: 1ab, 2af, 2sp. Canada: 4gt. Chile: 1eg, 9tc. Cocos: 99x, (qra?). England: 2cc, 2kf, 2lz, 2nm, 2od, 2sz, 5if, 5nn, 6rm, 6tm; phone 2nm. France: 8co, 8ct, 8eg, 8fq, 8qq, 8tok, 8wag, 8yor. Hawaii: 6aff, 6xi. Holland: o-ba, no-sv, pcuu. Italy: 1er, 1mt, 1no, 1rg, 1rt. Mexico: 1aa, 1b, 1x, 9a. Miscellaneous: aga, bbvp, cxl, f8z, kfuh, kfym, m52, naj, nrj, nve, npg, nph, nrm, npn, npo, npu, napp, nasn, nedj, nrx, nrri, numm, pof, wlr, wqn. North Polar Region: wap, wnp. Samoa: 6zac. Sweden: smyy.

(Continued on Page 96)

The Wilson "B" Radiopower Unit

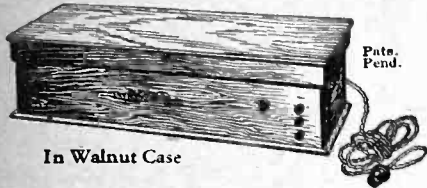

In Walnut Case

This new unit makes it possible to use a light socket for "B" voltage, *without any troublesome hum from alternating current.*

Supplies the constant voltage necessary for perfect reception. No acid to spill. No moving parts. Requires no attention. Semi-automatic in operation. The least expensive type of unit because of low first cost, minimum current consumption and long life. *In handsome walnut case. Price \$35.*

The Andrews Paddlewheel-Coil



Price \$3.00

For best results in home-built sets it is safer to use equipment employed in the best commercial receivers. Here is a superior coil used in such high grade receivers as the *Deresnadyne* and *Buckingham*. It can be used in any hook-up requiring a high type inductance.

Has exceptionally high ratio of inductance to resistance with minimum distributed capacity. Improves tone. Increases range, volume and selectivity. Blue prints of tested hook-ups employing this coil are available.

Our Technical Dept. will answer inquiries.

Duo-Spiral Folding Loop

Handsomely finished in silver and mahogany to harmonize with the finest home furnishings.

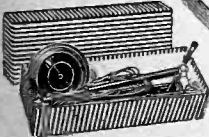

Price \$8.50

Easily portable. Has insulated handle and graduated dial. Reduces static and other interference. A special model for every circuit.

See these standard units at your dealers or write for complete information.

Radio Units Inc.

1303 First Avenue Maywood, Illinois
Perkins Elect. Ltd., Montreal, Toronto, Winnipeg

**Electric
Soldering
IRON---
FREE**

Subscribe to "RADIO" for one year—\$2.50—and get a 110-volt MARVEL Soldering Iron FREE.

"RADIO," San Francisco

Smallest Uniform Frequency Condensers made easily fit into present sets

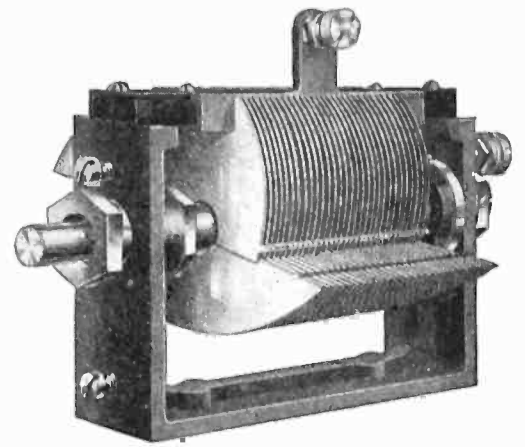

They are half to a third the size of others, are only 2¼" in diameter with plates fully extended, so will easily go into your set.

Do away with crowding of station readings—85 out of 100 come below 50 on dial with ordinary condensers—by using

Samson Uniform Frequency Condensers

These condensers are built to 1/10,000 inch, silver plated all over and—in addition—have gold plated plates to prevent oxidization. Grounded rotor type—minimum capacity 12 mmf. losses lower than most laboratory standards. 500 mmf., \$7.00; 250 mmf., \$6.75; 250 mmf., \$6.50.

**SAMSON
ELECTRIC COMPANY**
CANTON, MASS.

Member RMA

Lombard J. Smith, 24 N. San Pedro St., Los Angeles, Calif.; A. S. Lindstrom, 274 Brannan St., San Francisco, Calif.; Mr. H. A. Killam, 146½ N. Tenth St., Portland, Oregon; Mr. G. H. Maire, 95 Connecticut St., Seattle, Washington; Jennings & McCollom Co., 407 Dooly Bldg., Salt Lake City, Utah; Jack L. Hursch Co., 1641 Stout St., Denver, Colo.

Manufacturers of Quality Electrical Products Since 1882. Sales Representatives in Thirty Leading American Cities. Western Representative: A. S. Lindstrom Co., San Francisco, Los Angeles, Portland, Seattle, Salt Lake City.

Practically uniform high amplification over entire audible range with minimum distortion is obtained by using Samson Helical Wound Transformers. Ratios—6:1, 3:1. \$5.00.

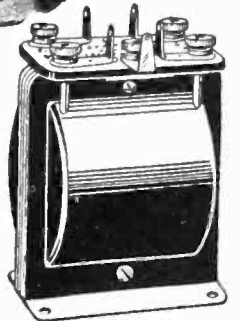

RADIOCAST WEEKLY

Forty-eight Pages of Programs, Photos, Humor, Musical Reviews, Schedules, Tables, Editorials, Etc.

5¢ Per Radiocast Weekly
Copy 433 Pacific Bldg.,

SAN FRANCISCO

MARVOL
Tuned
Radio Frequency

SEND FOR TRIAL SUBSCRIPTION
\$1.00 FOR SIX MONTHS

LOOK!

Radio Mileage Chart, 10x16 inches. Not a map. No scale necessary to get your mileage. Mailed on receipt of 50 cents. Address:

Graph & Chart Service

P. O. Box 945

Waterbury, Conn.

LABORATORY SERVICE

By G. M. BEST

THE complete laboratory of the Pacific Radio Publishing Company is at your service. We make tests---calculations---give you expert advice on your radio problems. Gerald M. Best is in charge of our own laboratory. We have an assortment of the finest testing equipment available.

Use this service. Let us answer your radio questions for you. We give you expert advice on your radio problems. Our service is most accurate---entirely dependable and PROMPT.

We will answer ten of your radio questions if you subscribe to "RADIO" for only one year. With your subscription to "RADIO" you will receive ten coupons, entitling you to answers to ten radio questions.

The regular cost for answering ten questions is \$2.50. Save this money! Subscribe to "RADIO" and get your answers without cost.

Use the coupon. Attach your remittance of \$2.50 to it and mail now. Your investment of \$2.50 will pay big dividends. The coming issues of "RADIO" will surprise you.

COUPON

"RADIO," Pacific Building,
San Francisco, Calif.

Here is \$2.50. Send me "RADIO" for one year and 10 free coupons entitling me to answers to ten radio questions.

Name.....

Address.....

City and State.....

SHORT WAVE REFLECTORS

(Continued from Page 13)

$\frac{3}{4}$ meter is 29.51 in., $\frac{1}{4}$ of which is 7.38 in. This will be used later as the focal length. On a large sheet of paper draw line AB near one side. Line CD is drawn perpendicular to AB at its center E . On the line CD 7.38 in. from E a point is located at G . This point is the vertex of the parabola. Another point 7.38 in. from G on line CD is located at X . This is the focus of the parabola. A number of lines, KK' , LL' , MM' , NN' , OO' are drawn perpendicular to CD as shown. They cross CD at points P , H , Q , I and J . Take a compass and with distance EP as a radius strike an arc from X on KK' making points UU' . Then with the distance EH as a radius, from X strike arcs on LL' making points YY' , then taking the distance EQ do the same on CC' . Continue until the parabola is finished or in other words until the opening in the parabola is the right size, or in this case until the opening is 59 in. The distance from the vertex to the center and perpendicular to the line joining the sides of the opening or line GD is 30 inches.

The construction of the reflector needs little explanation. It is made of finished white pine. The top and bottom frame is made from 1 x 4 in. material. They are separated by posts 2 x 4 x 16 $\frac{3}{4}$ in. long. The whole frame is nailed together securely. A full sized drawing of the parabola is made on some wrapping paper. Nine equidistant points are located on the curve of the parabola on the drawing. By laying the drawing on the frame these points are transferred to it. These points are where the reflector wires are to be located.

The insulators shown in Fig. 3a consist of $\frac{1}{8}$ in. bakelite, 1 x 1 $\frac{1}{2}$ in., with $\frac{1}{8}$ in. hole $\frac{1}{8}$ in. from one end, which is screwed to a wooden block 1 x 1 x 2 in., which in turn is screwed to the

frame so the center of the bakelite insulator will be over the point for the reflector wires. The insulators for the aerial-counterpoise are the same except that they are 1 x 4 $\frac{1}{2}$ in. This allows for the coupling coil in the center. The reflector wires are cut from No. 14 bare copper wire. They are exactly 16 $\frac{1}{4}$ in. long and should be as straight as possible. The ends of the wires are slipped through holes in the insulators and twisted back around itself.

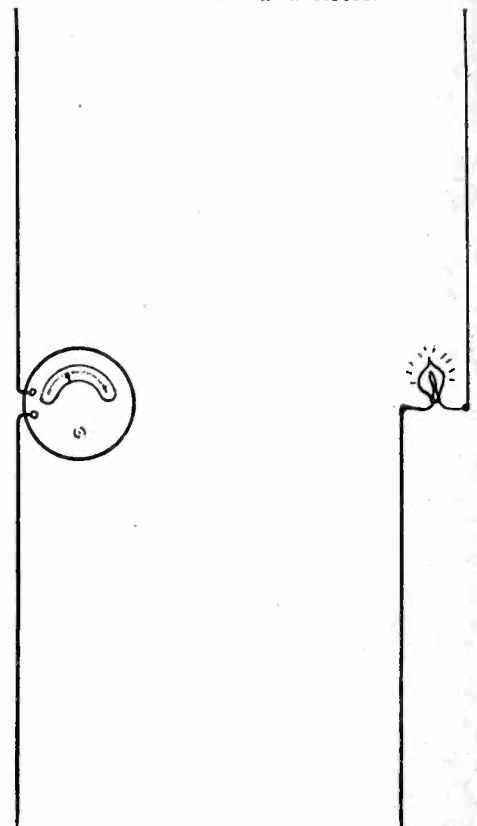

Fig. 4. Tuning Mechanism.

The transmitter is placed directly behind the reflector and is coupled to it by a link coil. The end coupled to the coil in the reflector is separated about $\frac{1}{8}$ in. and held by two small insulators made like porcelain cleats, as shown in Fig. 3b.

(Continued on Page 96)

The MOLLIFORMER "B" UNIT REPLACES "B" BATTERIES

SEND FOR complete description of this powerful "B" Unit that you can build in an hour at most reasonable cost. Uses the current from the light socket—Excellent for Supers and all TRF Sets—Assures greater Clarity—DX and Volume—Noiseless—No Tubes nor Acids—Utilizes full wave rectification.

Guaranteed to Give Complete Satisfaction or Your Money Refunded

Complete Kit— 60 Cycle Unit..... \$22.50
Complete Kit— 25 Cycle Unit..... 24.50

Kits include Rectifiers.

Parts sold separately if desired.

DEALERS—Write for our proposition.

C. E. JACOBS, Sole Mnfr.
2808 N. Kedzie Avenue CHICAGO

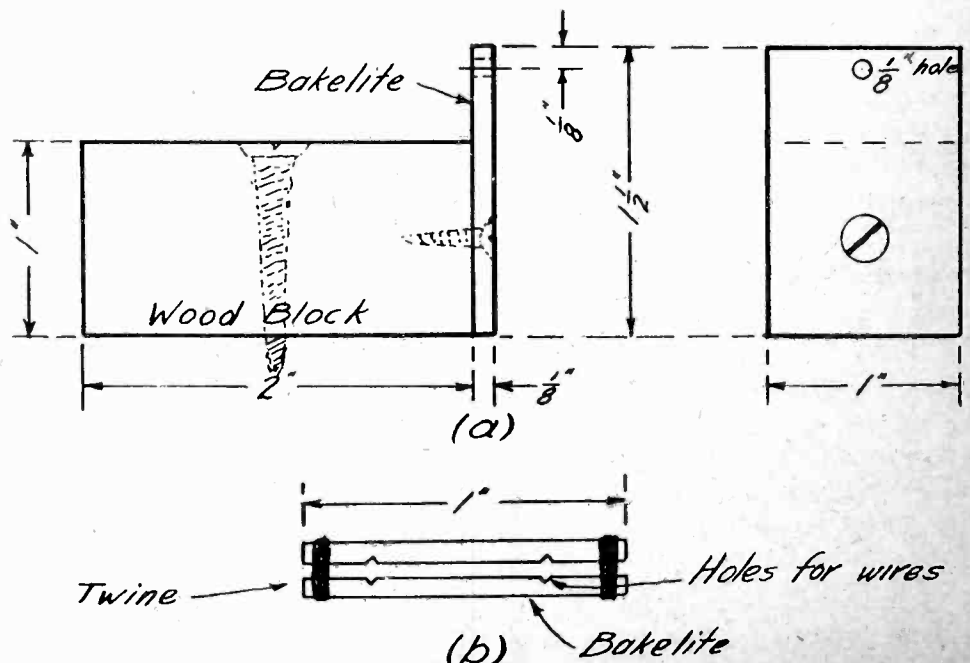

Fig. 3. Insulators.