

RADIO

Established 1917

Volume VII

APRIL, 1925

No. 4

Radiatorial Comment

THE greatest menace to the popularity of radio is its improper use in advertising. Once hailed as the broadcasters' salvation, because it promised to provide funds to meet the rising costs of station maintenance, radiotising now threatens to destroy this wonderful new medium of public entertainment and instruction. "Whom the gods would destroy they first make mad." Surely some of the station owners are going mad.

So insidious has been this progress of undermining general interest in radiocast programs that few yet seem to realize the danger which may come from its abuse. The toll broadcaster is becoming increasingly bold in the direct sale of commodities, notwithstanding the implied governmental request that advertising by radio be indirect in its appeal.

From the standpoint of the good of radio we are not concerned with the ethics of the case. We are not interested in its competition with other advertising mediums. But we are disturbed by its disastrous effect in lessening the desire to listen to radio programs. People first endure, then resent, and finally shut off the offending station.

Toll broadcasting usually consists of a ten minute advertising talk interspersed between musical numbers which are announced as being given under the auspices of the advertiser. For this publicity the advertiser pays from \$100 to \$1,500, depending upon the location of the station, the time of day and the power of the transmitting equipment.

A censor is supposed to pass upon the talk so as to tone down the intensity of its selling argument, but too often he seems to be blinded by commercialism. Consequently we are all too familiar with the merits of Dr. Bluffum's magic cure for sciatica, how to use it, how quickly it gives relief, and where it may be bought. Everything is told except the price, which, as in trade association discussions, still seems to be taboo.

This evil is not yet here in sufficient force to do immediate harm. There is yet time to prevent its spread before it kills interest in radio. So far, comparatively few stations have employed it to any great extent and some of the best stations refuse remuneration for putting on a program. Our stricture is intended merely as a warning to such stations as are overstepping the bounds.

Rightly conducted, radiotising may prove an effective means for financing a station. Wrongly conducted, it will kill the station's popularity. When good-will is changed to resentment a station loses its audience and consequently its value to the advertiser.

One reason for the decrease in the number of spontaneous applause cards is that many people already sense the fact that their interest in radio is being capitalized by some of the radiocast stations. While everyone realizes that some means must be found for supporting stations it is obvious that flagrant advertising will fail to accomplish this purpose.

From present indications all the stations, like Gaul, may soon be divided into three classifications according as they are conducted by radio manufacturers, by religious or educational institutions, or by toll broadcasters. The order of listing is probably representative of relative public favor. Unless extreme care is exercised the toll broadcaster will degenerate into the same class as the advertising movie in which advertisements are sandwiched between parts of a picture shown in public waiting rooms.

Radio is too fine a thing, it has too great possibilities in the advancement of human welfare, to be prostituted to such base ends. If this practice continues to increase, if the warnings are not heeded, the public will realize that it is being imposed upon and turn to other forms of entertainment.

The Army Radio Station at Fort Leavenworth

Interesting Details Concerning a 10K.W. Master Oscillator Transmitter

By Paul B. Findley

SOME three or four years ago the War Department undertook to provide a radio net which would be capable of maintaining communication between Washington and the headquarters of all the Corps Areas, nine in number, for emergency use. The Naval radio station at Arlington, near Washington, was incorporated in this plan by installing there a transmitter and antenna system controlled from the War Department independently of those controlled by the Navy Department. Use was also made of several other Naval radio stations already installed along the seacoast, in order to reduce the investment necessary. On account of the large number of Corps Area headquarters and their comparatively short distance apart, it was not deemed necessary at the outset to install high power transmitters. In order to reach the headquarters of the Western areas it was necessary therefore, to repeat the messages through several stations. Although this plant was provided for emergency use it was soon realized that it could not be available in an emergency unless some personnel were trained in its operation and the equipment constantly maintained in operating condition. The best way to achieve these results seemed to be to actually operate the station.

The War Department official traffic has been utilized to furnish the experience and maintenance required in these stations for the past two years and the operations have fully justified expectations. The number of relays required and the unfavorable conditions existing in the Southwest during the summer months made it very desirable to install a few high power stations to insure communication at all times and to reduce the relays. One such station already existed at Headquarters, 8th Corps Area, Fort Sam Houston, Texas, having been installed during the Mexican disturbances of 1916. That station was provided with a 30-kilowatt arc transmitter. After examination of many sites in the West it was finally determined to erect another station of comparatively high power at Fort Leavenworth, Kansas, which would be able to communicate with Washington under al-

most any conditions and also with Fort Sam Houston, Texas. The chain was extended one step further by installing a similar transmitter at Fort Douglas near Salt Lake City. This station occupies a strategic position in the plan for military operations on the Pacific Coast, because it is at the junction point of three railways leading to the Coast and is capable of communication with any point on the Coast. With this chain in operation it has been found to be perfectly feasible to carry on communication between Washington and the headquarters of the Pacific Coast and the Texas Area, with two relay points, namely Fort Leavenworth and Fort Douglas.

The 10,000 watt radio transmitter installed at Fort Leavenworth was designed and built by the engineering department of the Western Electric Company, under the direct supervision of E. L. Nelson, F. M. Ryan and J. O. Gargan. Five water-cooled vacuum tubes are used—three to rectify alternating current for power supply, and two as radio frequency amplifiers. The set has an output of 10,000 watts for telegraphy and an output of 5000 watts for telephony. A switching system provides a quick change to any of several

Continued on page 62

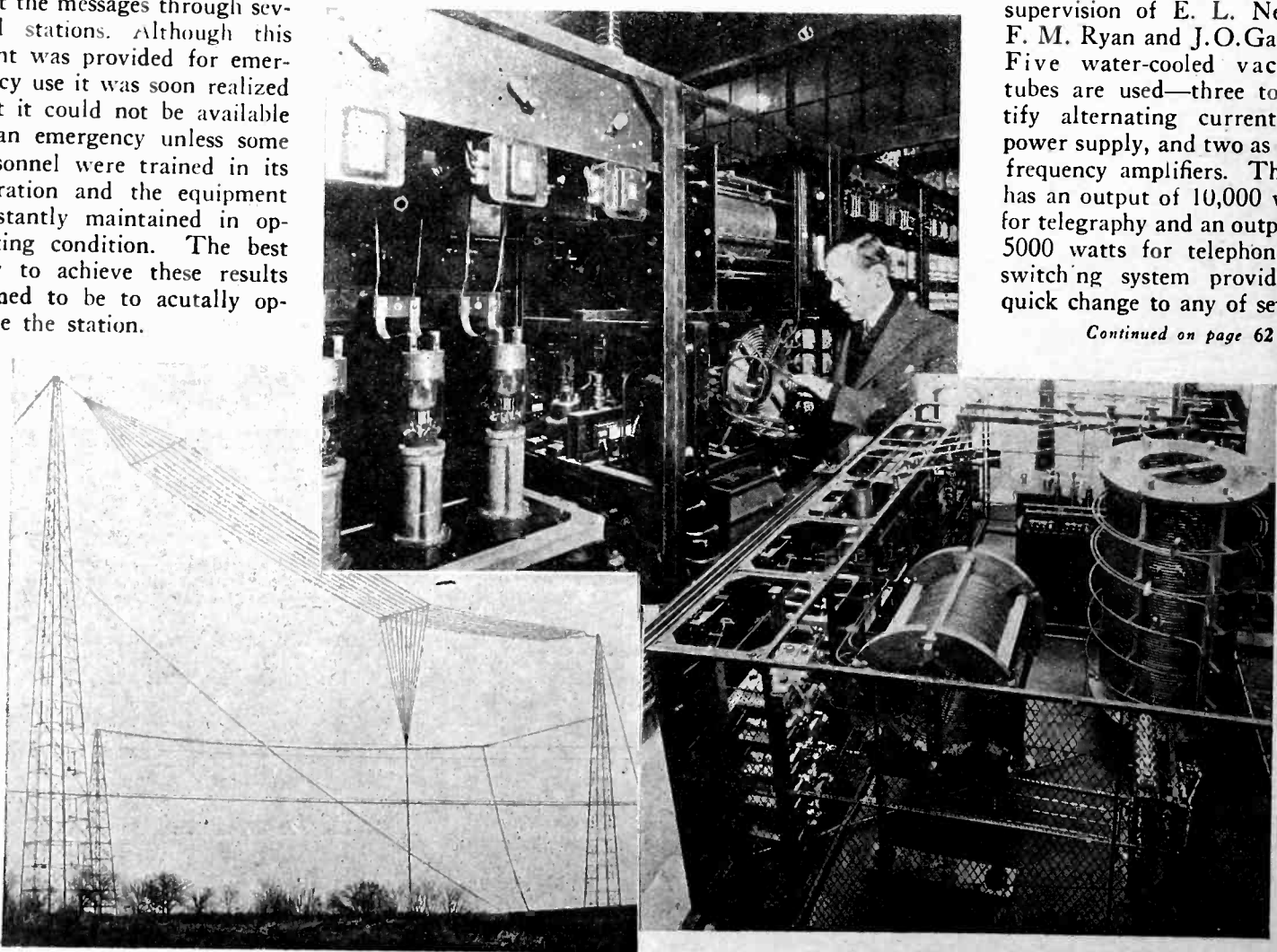

Fort Leavenworth Radio Station, showing antenna system and views of transmitting equipment.

The New Army Transmitter at Annapolis

Some Interesting Facts About a New 20K.W. Transmitter Now to be Found on 5950 Meters

By S. R. Winters

POWERFUL enough to be heard 6,000 miles and yet operating with such freedom from harmonics or objectionable interference as to permit of radio reception from distant transmitting stations under the very shadow of its antenna system, is the 20 k.w. vacuum-tube transmitter, designed and built by the Radio Test Shop of the Washington Navy Yard, and placed in operation in a newly constructed building at Annapolis, Maryland, for the radio-telegraph traffic of the War Department. From the Munitions Building, Washington, D. C., messages are dispatched by remote control on a frequency of 100 kilocycles. A 24-hour service will be maintained between War Department headquarters and three of its network of radio-telegraph stations, namely, those located at Leavenworth, San Antonio, and Fort Douglas. Formerly, the War Department routed this traffic by remote con-

trol of a telegraph key in NAA, the naval station at Arlington, Virginia.

Before releasing this 20-kilowatt transmitter for use of the War Department, the Radio Test Shop of the Washington Navy Yard conducted comparative tests with this electron-tube sending device and the 350-kilowatt arc-converter at Annapolis. Despite the difference of power input of 30 against 300 kilowatts, the signals emanating from the vacuum tube were heard on the coast of the Pacific Ocean and in the Canal Zone with equal if not greater strength than those radiated from the 350-kilowatt arc transmitter. These comparative tests were negotiated under like conditions—that is, the telegraph keys at each transmitter were functioning on the same night and at the same moment. Thus, atmospheric conditions, which may vary from night to night, do not enter an influencing factor when such a direct comparison is made.

Reports to Washington from vessels then cruising in the Mediterranean Sea, and from land stations in Alaska, and at Pearl Harbor, Hawaiian Islands, indicated good signal strength in copying messages experimentally broadcast by this powerful vacuum-tube transmitter. Pearl Harbor, for instance, is approximately 6,000 miles distant from Annapolis or Greenberry Point. For a brief period, the naval traffic ordinarily routed through the Sayville, Long Island, New York, radio-telegraph station was handled by this newly installed electron-tube transmitter. That is to say, the 200-kilowatt arc transmitter and the 100-kilowatt alternator at Sayville were temporarily relieved of service as an experiment in determining the possibility of dispensing with these devices in the future. Ultimately, the station at Sayville may be abandoned. In fact, this is contemplated when a 20-kilowatt vacuum-tube transmitter is installed at NAA, the naval radio sta-

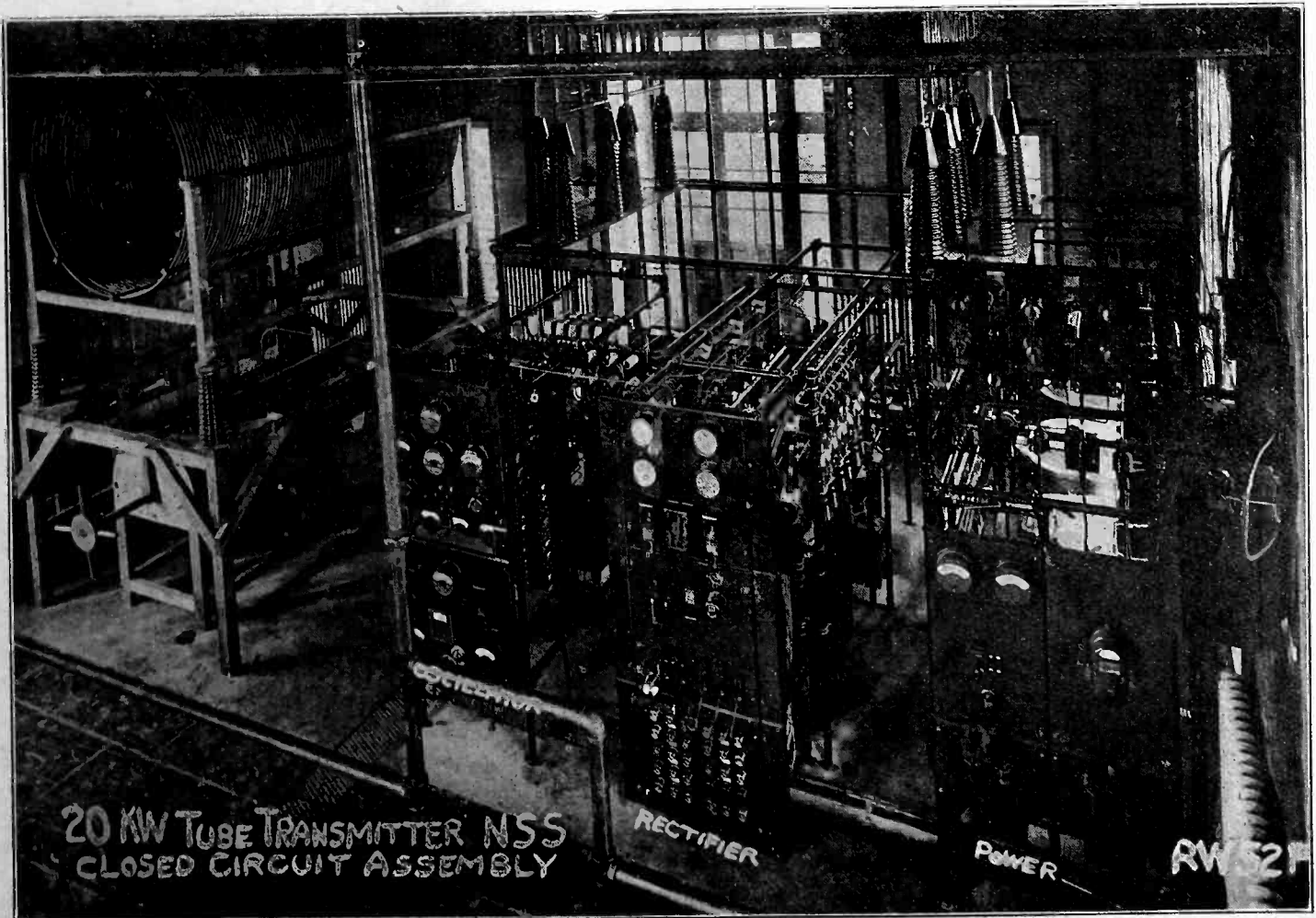

General View of 20 K. W. Tube Transmitting Equipment at Annapolis

The Army Radio Station at Fort Leavenworth

Interesting Details Concerning a 10K.W. Master Oscillator Transmitter

By Paul B. Findley

SOME three or four years ago the War Department undertook to provide a radio net which would be capable of maintaining communication between Washington and the headquarters of all the Corps Areas, nine in number, for emergency use. The Naval radio station at Arlington, near Washington, was incorporated in this plan by installing there a transmitter and antenna system controlled from the War Department independently of those controlled by the Navy Department. Use was also made of several other Naval radio stations already installed along the seacoast, in order to reduce the investment necessary. On account of the large number of Corps Area headquarters and their comparatively short distance apart, it was not deemed necessary at the outset to install high power transmitters. In order to reach the headquarters of the Western areas it was necessary therefore, to repeat the messages through several stations. Although this plant was provided for emergency use it was soon realized that it could not be available in an emergency unless some personnel were trained in its operation and the equipment constantly maintained in operating condition. The best way to achieve these results seemed to be to actually operate the station.

The War Department official traffic has been utilized to furnish the experience and maintenance required in these stations for the past two years and the operations have fully justified expectations. The number of relays required and the unfavorable conditions existing in the Southwest during the summer months made it very desirable to install a few high power stations to insure communication at all times and to reduce the relays. One such station already existed at Headquarters, 8th Corps Area, Fort Sam Houston, Texas, having been installed during the Mexican disturbances of 1916. That station was provided with a 30-kilowatt arc transmitter. After examination of many sites in the West it was finally determined to erect another station of comparatively high power at Fort Leavenworth, Kansas, which would be able to communicate with Washington under al-

most any conditions and also with Fort Sam Houston, Texas. The chain was extended one step further by installing a similar transmitter at Fort Douglas near Salt Lake City. This station occupies a strategic position in the plan for military operations on the Pacific Coast, because it is at the junction point of three railways leading to the Coast and is capable of communication with any point on the Coast. With this chain in operation it has been found to be perfectly feasible to carry on communication between Washington and the headquarters of the Pacific Coast and the Texas Area, with two relay points, namely Fort Leavenworth and Fort Douglas.

The 10,000 watt radio transmitter installed at Fort Leavenworth was designed and built by the engineering department of the Western Electric Company, under the direct supervision of E. L. Nelson, F. M. Ryan and J. O. Gargan. Five water-cooled vacuum tubes are used—three to rectify alternating current for power supply, and two as radio frequency amplifiers. The set has an output of 10,000 watts for telegraphy and an output of 5000 watts for telephony. A switching system provides a quick change to any of several

Continued on page 62

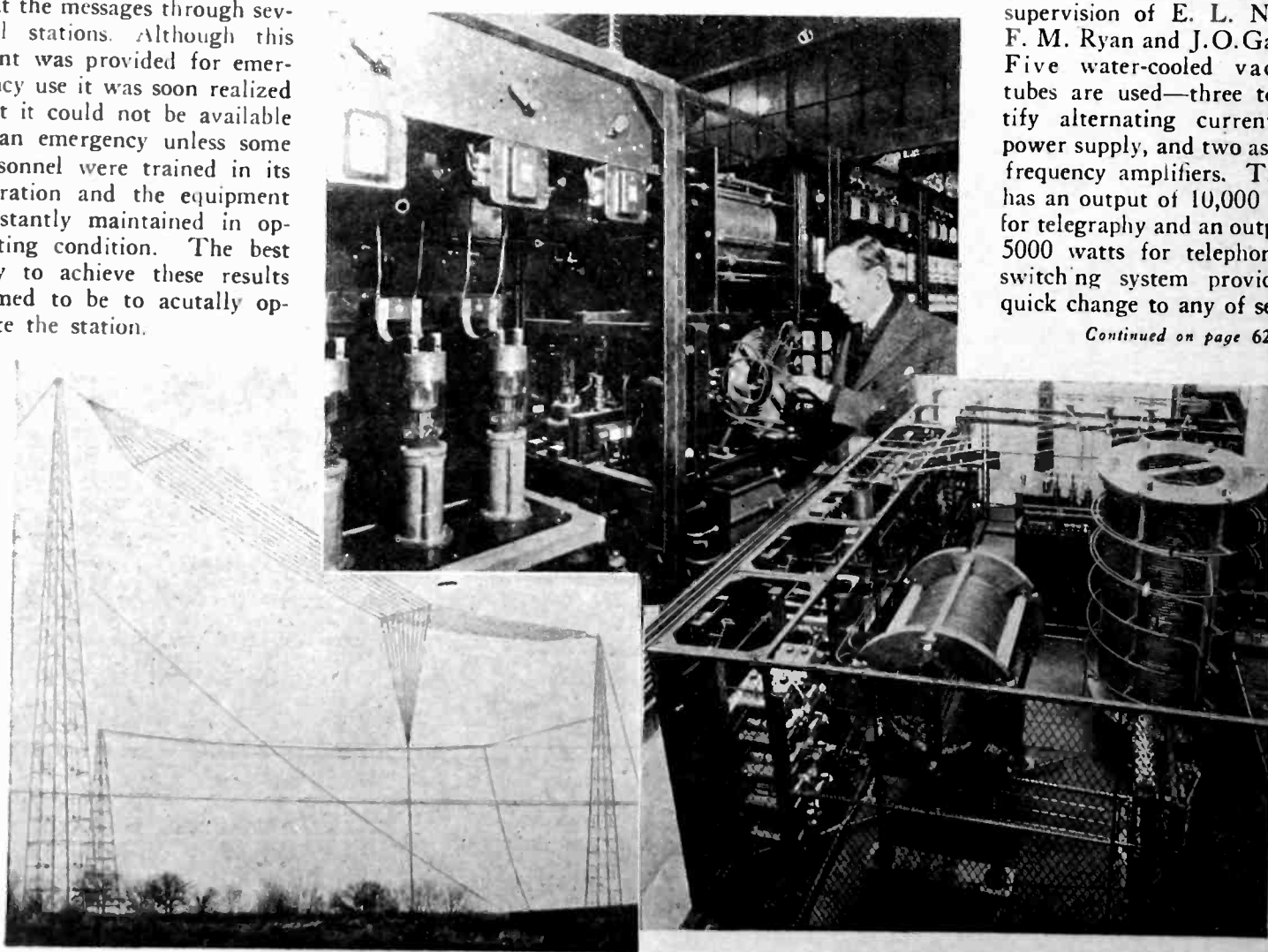

Fort Leavenworth Radio Station, showing antenna system and views of transmitting equipment.

The New Army Transmitter at Annapolis

Some Interesting Facts About a New 20K.W. Transmitter Now to be Found on 5950 Meters

By S. R. Winters

POWERFUL enough to be heard 6,000 miles and yet operating with such freedom from harmonics or objectionable interference as to permit of radio reception from distant transmitting stations under the very shadow of its antenna system, is the 20 k.w. vacuum-tube transmitter, designed and built by the Radio Test Shop of the Washington Navy Yard, and placed in operation in a newly constructed building at Annapolis, Maryland, for the radio-telegraph traffic of the War Department. From the Munitions Building, Washington, D. C., messages are dispatched by remote control on a frequency of 100 kilocycles. A 24-hour service will be maintained between War Department headquarters and three of its network of radio-telegraph stations, namely, those located at Leavenworth, San Antonio, and Fort Douglas. Formerly, the War Department routed this traffic by remote con-

rol of a telegraph key in NAA, the naval station at Arlington, Virginia.

Before releasing this 20-kilowatt transmitter for use of the War Department, the Radio Test Shop of the Washington Navy Yard conducted comparative tests with this electron-tube sending device and the 350-kilowatt arc converter at Annapolis. Despite the difference of power input of 30 against 300 kilowatts, the signals emanating from the vacuum tube were heard on the coast of the Pacific Ocean and in the Canal Zone with equal if not greater strength than those radiated from the 350-kilowatt arc transmitter. These comparative tests were negotiated under like conditions—that is, the telegraph keys at each transmitter were functioning on the same night and at the same moment. Thus, atmospheric conditions, which may vary from night to night, do not enter an influencing factor when such a direct comparison is made.

Reports to Washington from vessels then cruising in the Mediterranean Sea, and from land stations in Alaska, and at Pearl Harbor, Hawaiian Islands, indicated good signal strength in copying messages experimentally broadcast by this powerful vacuum-tube transmitter. Pearl Harbor, for instance, is approximately 6,000 miles distant from Annapolis or Greenberry Point. For a brief period, the naval traffic ordinarily routed through the Sayville, Long Island, New York, radio-telegraph station was handled by this newly installed electron-tube transmitter. That is to say, the 200-kilowatt arc transmitter and the 100-kilowatt alternator at Sayville were temporarily relieved of service as an experiment in determining the possibility of dispensing with these devices in the future. Ultimately, the station at Sayville may be abandoned. In fact, this is contemplated when a 20-kilowatt vacuum-tube transmitter is installed at NAA, the naval radio sta-

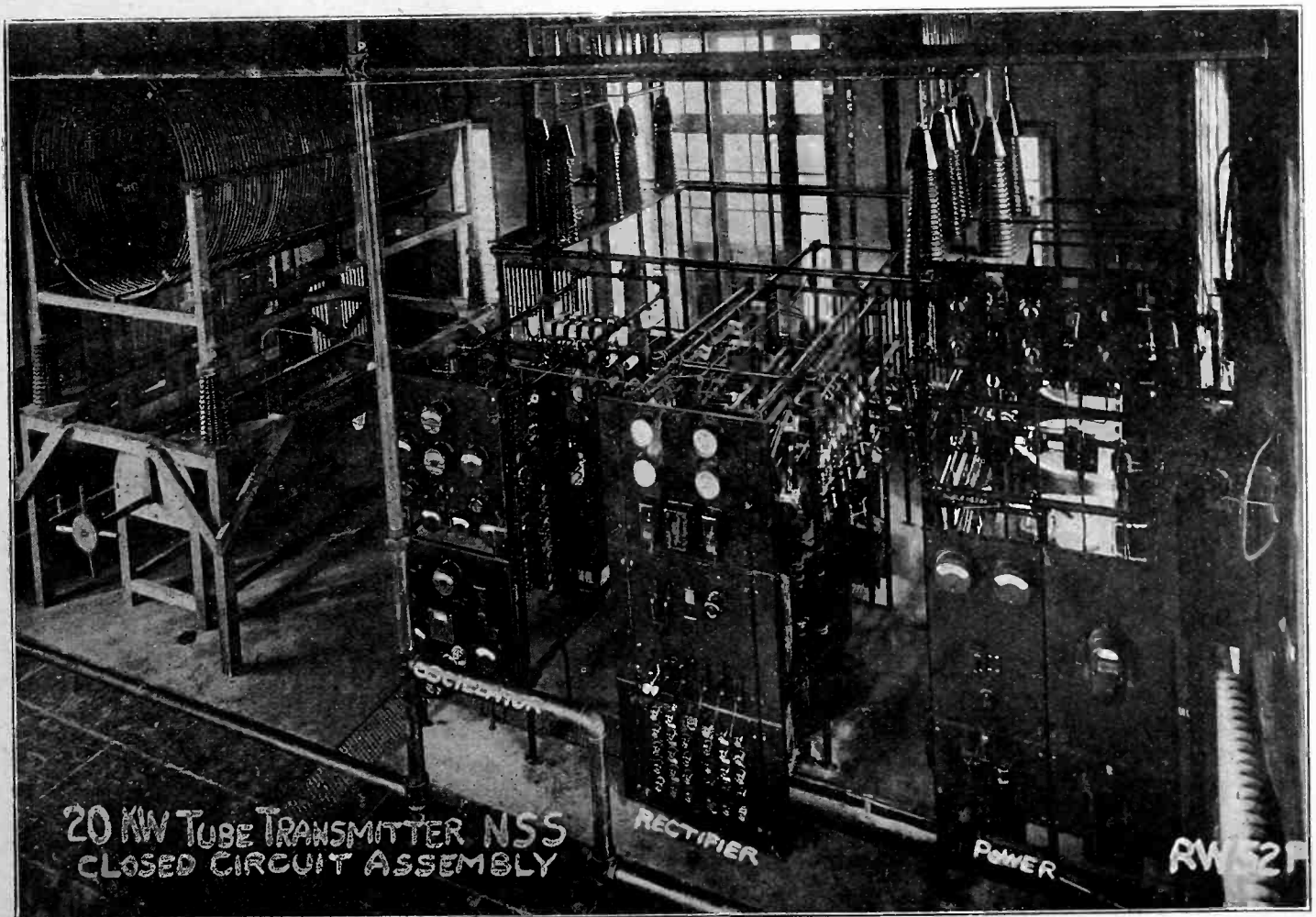

General View of 20 K. W. Tube Transmitting Equipment at Annapolis

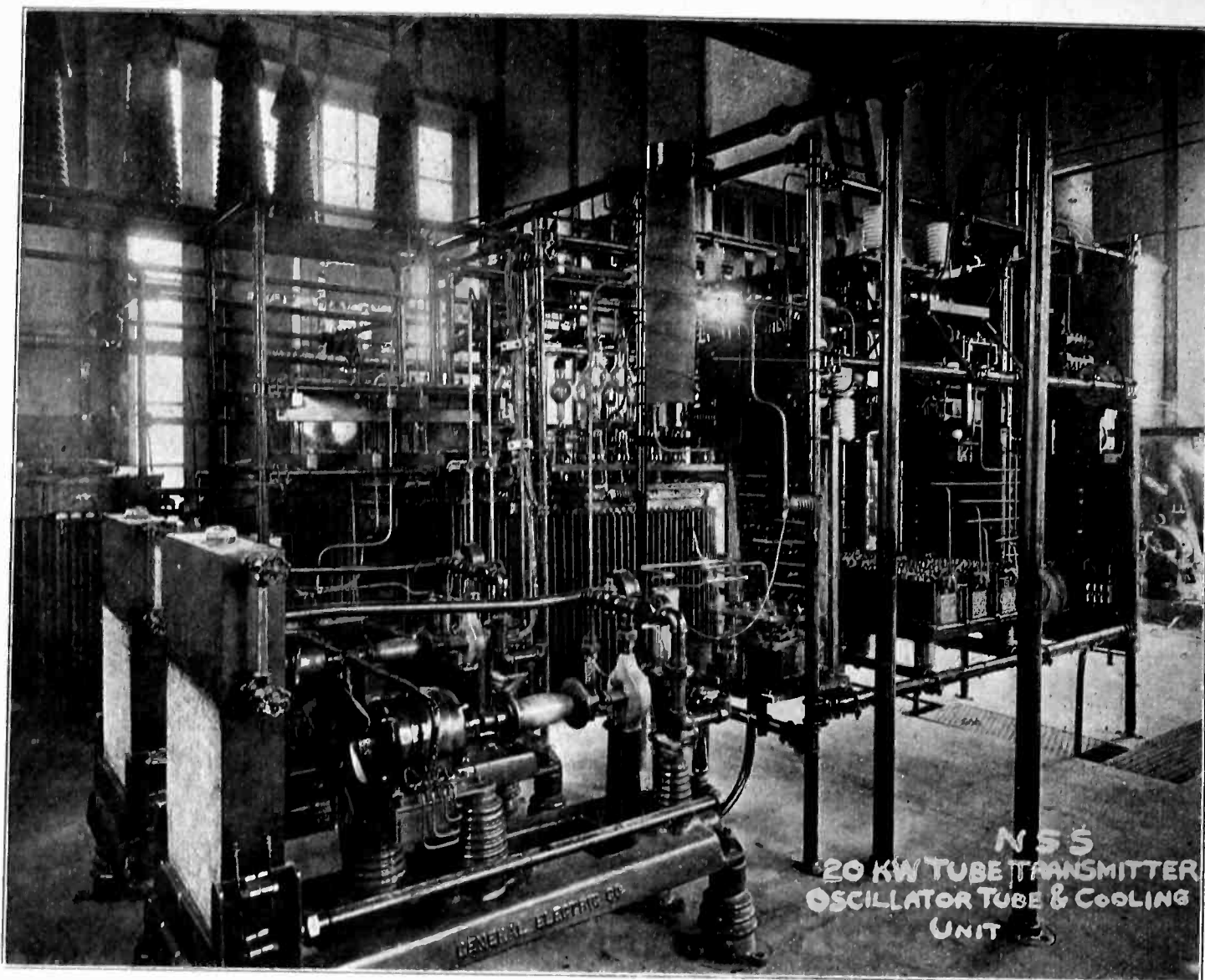

Oscillator Tube and Cooling Unit

tion at Arlington. This may be accomplished during 1925.

The installation is housed in a new brick building and consists of: power panel, rectifier, oscillator unit, control tube unit, primary or closed radio-frequency circuit, antenna radio-frequency circuit, and the antenna system.

The power unit comprises two panels for the control and metering of the lighting and power supply from the lines of the Washington, Baltimore & Annapolis Railway. This supply is 25 cycles at 6,600 volts, which is reduced through a bank of three 25-kilovolt-ampere delta connected transformers to 220 volts for operation of the various units.

The 220-volt supply is stepped up by a transformer; it is rectified by twelve 2.5-k.w. kenotrons; it is filtered by a combination of a capacity element and reactors, and the supply is then delivered to the oscillator unit at from 7,000 to 15,000 volts, direct current. A plug board and a plug on the low side of the transformer enable the operator to vary the direct-current voltage in steps of 1,000 volts. Meters indicate the input and output.

The oscillator tube unit provides for

the control of one 20-kilowatt water-cooled vacuum tube, and a switching arrangement to a duplicate tube in the event of an emergency. The cooling units are self-contained, consisting of a motor-pump and radiator, which is piped through a flow indicator to the water jacket for the vacuum tube. A thermometer shows the temperature of the water. An interlocking switch system prevents operation of the tubes without cooling.

The control vacuum-tube unit is mounted directly above the oscillator. This control element consists of two 250-watt electron tubes, with adequate meters and controls for operating either tube. There are also controls accessible for the manipulation of two 150-volt Edison storage batteries. The keying of the transmitter is effected by a control of the biasing voltage on the 250-watt vacuum tube, which is connected in the grid circuit of the 20-kilowatt electron tube. The telegraph key is in duplicate, thus lessening a chance of delay of traffic due to impairment of one of the vacuum tubes or relay troubles. Each necessary manipulation, even the lighting of the filaments, is remotely controlled.

The transmitter employs the Hartley circuit. The .002 mfd 75,000-volt air condensers are made up of 2-inch brass tubing. A frequency changer enables the operator to select any one of five frequencies, between a range of 113 and 50.4 kilocycles.

The antenna system is of the fan type and consists of eight wires 600 ft. long, supported by a triatic between two 600-ft. masts. The 8-wire fan design is arranged in two groups of an equal number of wires, which allows the bringing in of two separate leads. By use of a switch these lead-ins are tied together for connection to the transmitter; or, in another position, they may be associated with the armature of a direct-current generator as a means for melting an accumulation of ice on the antenna system. The antenna circuit includes a coupling section, mounted in a screened compartment with the primary coupling coil; a variometer for precise control of the frequency; and a loading inductance coil.

The entire equipment, with the exception of the antenna loading coil and variometer, is screened as a measure of

Continued on page 65

A Remarkable Tuned R.F. Transformer Development

An Account of the Browning-Drake Transformer and Its Application to a Four-Tube Set

By Volney D. Hurd

THE developments in radio during the past five years show but few fundamentally great changes. A receiving set is merely a series of tubes and coupling devices, the number depending upon the amplification desired.

A regenerative detector can only do so much, depending upon the amount of energy transferred into its grid circuits. All sorts of coupling and feed-back devices have been employed but it is only so sensitive and no more. It goes up to just this side of the oscillating point. Beyond that its only too apparent use is in heterodyning incoming waves so that distant stations may be found easily.

Tubes have not changed much as far as amplification is concerned. Filament consumption has been considerably reduced but a good tube today will give an amplification around 6 or 7, seldom more. Audio transformers still give a certain step-up, depending to a large extent on the turns ratio of the primary with respect to the secondary. Improvements have been made in materials so as to improve the quality but the amplification is essentially the same.

This leaves the radio frequency end as the field for greatest improvement. The popularization of the neutralizing methods of Hazeltine and others has reduced the tendency to oscillate. Tuned R.F. transformers have made for selectivity and higher amplification per stage.

Yet when we think that with a tube amplification of 7 we seldom get an amplification of over 3 or 4 per stage with a tuned air core transformer we must realize that the real weakness in radio to date has been in the radio frequency transformers used. We get the best tubes possible and plan and work so that their circuits will give the highest amplification possible and then, after building up this energy we lose from 33 to 50 per cent of our energy in transferring it to the next stage.

It is as though one were loading a ship and for every two packages swung aboard by the crane one or two were allowed to fall in the sea and stay there. No shipper would stand for that long. The loss would be tremendous. And yet that is exactly what we have been doing in radio frequency amplification.

The introduction of the superhetero-

dyne is proof of this statement. Practically every advocate of this type of receiver as well as its inventor, Mr. Armstrong, will tell you that it was due to the inefficient amplification at short waves that the superheterodyne was brought into being. The first detector and oscillator are used to change the incoming wave so that it can be amplified at a frequency where efficient transformers are possible. But here again we have a loss.

With three intermediate stages we are getting three stages of tuned radio frequency. But if one must use two extra tubes in the form of an oscillator and detector to get this we are still losing a lot of our cargo overboard. Of course a regenerative first detector helps a lot. But still this seems a sort of a makeshift proposition since we still have an oscillator merrily burning up energy.

It was the realization of the inherent transformer inefficiency at radiocast wavelengths that caused Glenn H. Browning and Frederick H. Drake, both research fellows at Harvard University, to start their work on a tuned air core transformer in 1923.

The first step was to work out a mathematical formula for the design of a tuned radio frequency transformer. A deep search into technical literature showed little of much use so that these two young men had to develop it by themselves. Once having achieved this, the next point was to construct a transformer that would even approach the theoretical amplification outlined.

This was a long, tedious job. Transformer after transformer was made, calculations worked out and readings taken, only to show them that they were still far below their goal. The best transformers found were those used in the neutrodyne sets of the time. These give about half the desired amplification. With a tube amplification of 7 or 8 they give from 4 to 5.

It was found that a high number of turns were necessary to get a good transfer of energy, but that when this was done a great loss still existed. This was finally traced to "capacity coupling" between the primary and secondary. This technical sounding phrase is really a simple thing. The metal in the primary forms one side of a small fixed condenser and the metal in the second-

ary the other side. We thus have a condenser or capacity effect which is disastrous to efficiency at radiocast and shorter wavelengths.

The final solution was unlooked for and yet simple. The primary was wound with fine wire placed in a small slot in a disc of wood which fitted snugly inside of the secondary, as shown in Fig. 1. In this way a large number of turns

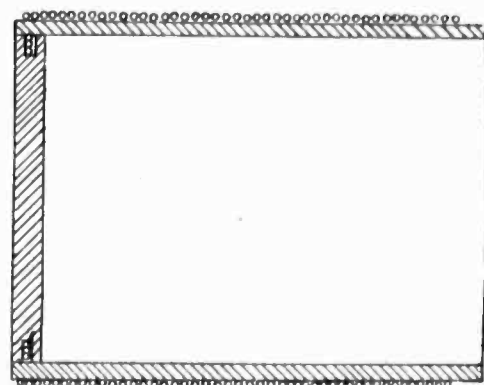

Fig. 1. Cross-section of Regenaformer

could be used and yet the capacity or condenser effect between windings kept extremely small.

An effort to reach the same point has been made by winding the primary on the same tubing as the secondary so that only one wire of it comes near the secondary but this method reduces the coupling. In the Browning-Drake transformer the inductance is bunched. To those who would hold up their hands in horror at the use of fine wire, since so much "low loss" using big wire has been taught to them, it may be stated that there is such a very large amount of resistance in the plate circuit anyway, that the small amount caused by the fine wire is negligible.

Actual measurements show that this type of transformer and associated type has an amplification factor of 9 or better between 300 and 600 meters.

This development seems to have solved the one really weak point in radio, the inefficiency of tuned radio frequency transformers. It lessens the need for changing over to the superheterodyne. In the writer's humble opinion, it ranks, therefore, as one of the great developments in radio of the past five years, and there are those who consider it the greatest, even surpassing the superheterodyne and neutrodyne in importance.

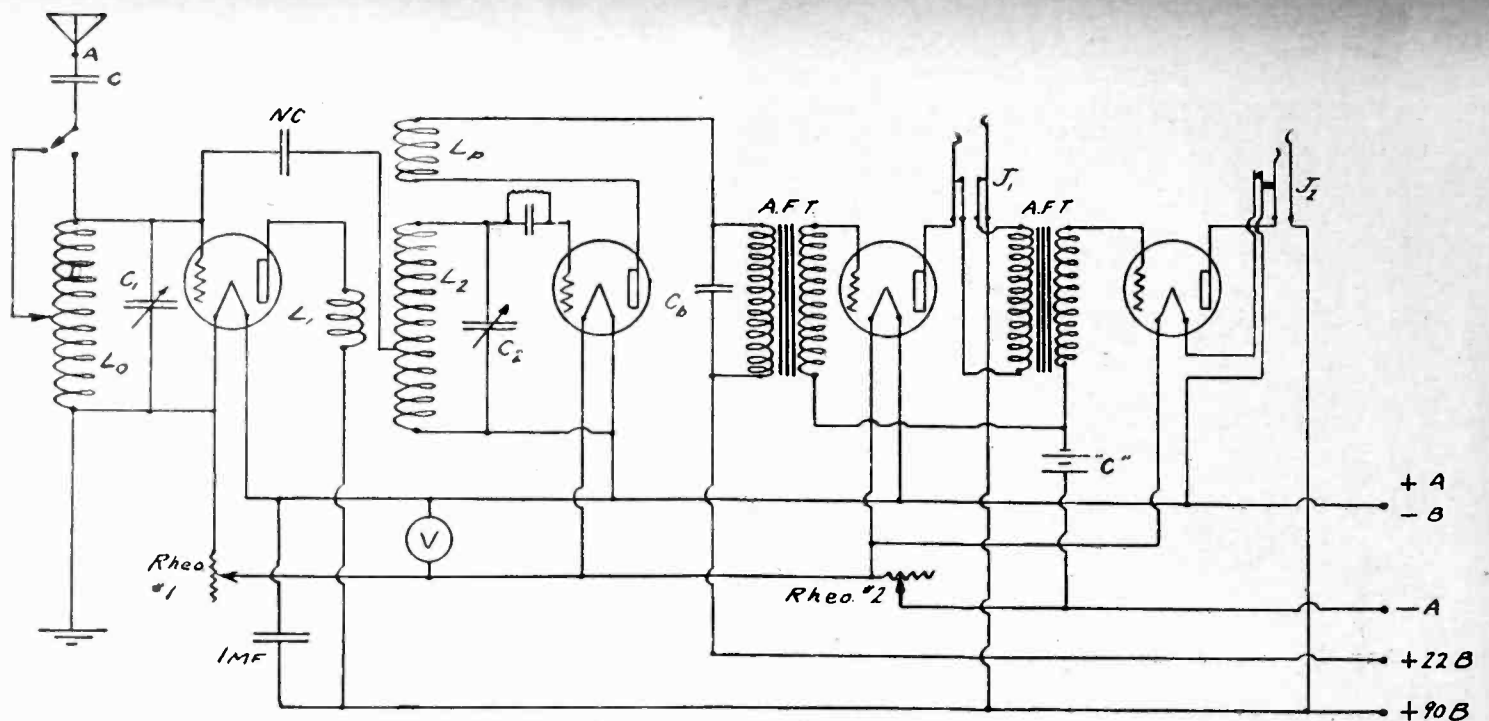

Fig. 2. Circuit Diagram for One Stage R. F., Detector and Two Stages A. F.

Another essential point not to be overlooked in this case is the sharp tuning obtained. With the high amplification possible, this transformer tunes extremely sharp.

This type of transformer may be used in any tuned radio frequency receiver, or combination thereof. It demands careful placement of coils in order to neutralize it properly and for general use the small 199 tube works best, particularly as the radio frequency tube. Its amplification is practically as great as the larger tubes. And it neutralizes easily.

A splendid set in which to try this transformer is shown in the accompanying circuit diagram. In this set a stage of tuned radio frequency is used ahead of a regenerative detector with two stages of audio added for loudspeaker reception. When used with regeneration a slight change is necessary in the number of turns on the primary of the transformer, since this changes the characteristics of the transformer somewhat. Where a primary of 35 turns is used in a non-regenerative circuit this is reduced to 24 for the transformer with regenera-

tion. The writer dubbed this combination of transformer and tickler "Regenaformer" the first day he saw it and the name has stuck. It makes an easy way to differentiate between the two types of transformers.

The plan of layout may be seen in the accompanying illustrations. While the receiver shown is a sub-panel wiring job this is not recommended to the average builder as he may get into difficulties.

The antenna coil consists of 50 turns of No. 20 D. S. C. wire wound on a piece of 3 in. hard rubber or bakelite tubing. This is tapped in the center so that those using a long antenna may compensate for its length in attaching it to their set. More energy is fed into the receiver from the tap on the grid side of the coil but a long antenna will not permit the set to cover all the wavelengths when attached at this point.

The regenaformer is made by winding 77 turns of No. 20 D. S. C. wire on a piece of 3 in. tubing which should be about 5 in. long in order to allow for mounting the tickler. This is the secondary and is tapped at the 14th turn for neutralization. The primary is made

by winding, in a jumble fashion, 24 turns of No. 30 D. C. C. wire in a slot $\frac{1}{4}$ in. deep and $\frac{1}{8}$ in. wide on the tread or outside curve of a small wooden disc which will fit snugly into the long piece of tubing on which the secondary is wound. This primary should be mounted under the first turn of wire on the low potential end of the secondary; that is, the end whose lead goes to the A battery.

The tickler consists of 30 turns of wire wound on a piece of tubing 2 in. in diameter, mounted on a rod that is fastened to end pieces secured to the variable condenser and which finally extends through the panel to a small knob for operating purposes.

Going over the parts indicated in the diagram C is a .0001 mfd. fixed condenser. L_0 , the antenna coil, has been described. C_1 is a .0005 low loss type condenser with a vernier dial. NC is a very small vernier condenser for neutralization purposes. L_1 , L_2 and L_p have been described, the three coils constituting the regenaformer. C_2 is a .00035 variable condenser of the same type as the one first mentioned. The vernier dial is im-

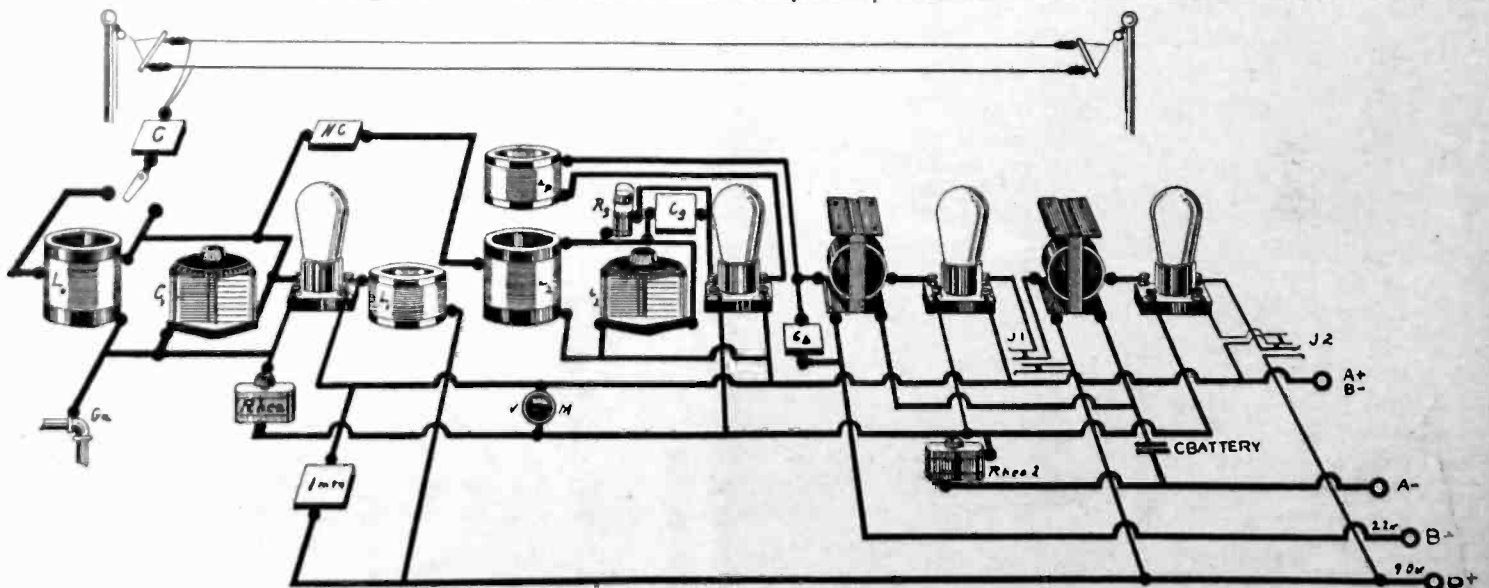

Fig. 3. Pictorial Layout of Parts. (L_1 , L_2 and L_p should be combined in one regenaformer)

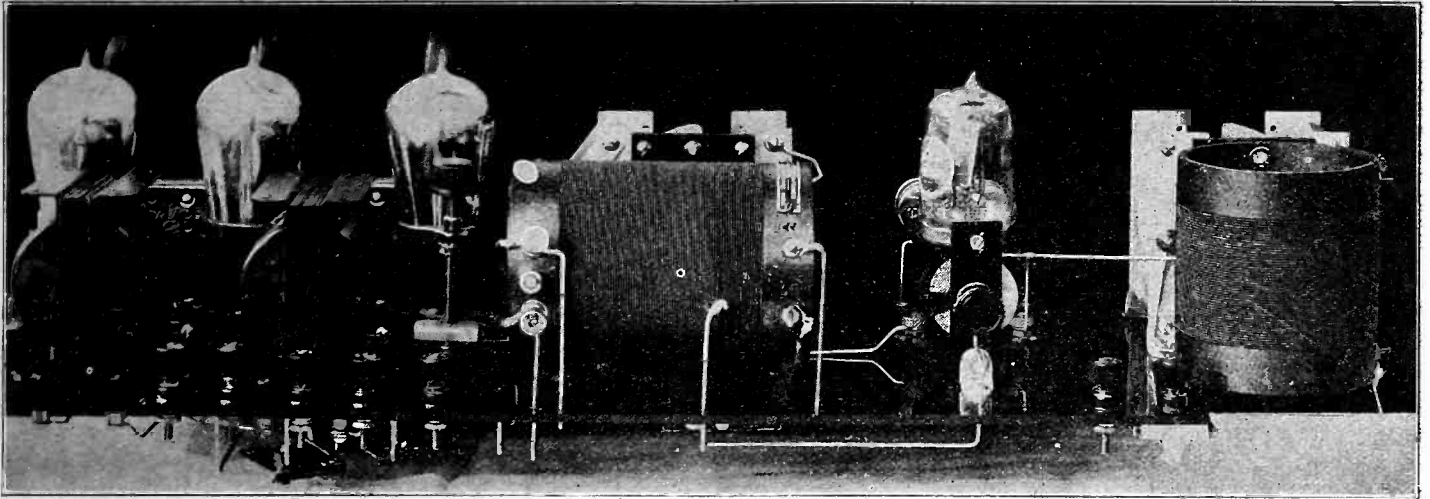

Fig. 5. Rear View of Browning-Drake Four-tube Set

portant for this condenser. C_g is a .00025 grid condenser while R_g is a variable gridleak. While ordinarily not specifying any one apparatus as peculiarly fitted for a circuit, experience has shown the Electrad Variohm works well at this point. Any other leak that will run up to 15 or 20 megohms will do as well.

C_b is a .002 fixed mica condenser. This is most essential. Without it the set will not work properly since regeneration is practically impossible. J_1 is a double circuit jack while J_2 is a single circuit, filament control jack lighting the last tube only when that stage is being used.

The other parts are apparent. The system of rheostats should be particularly noticed. The one on the right acts as a master rheostat controlling all the tubes. The one on the left acts on the first tube only and makes a splendid volume control. By using this method the master rheostat prevents more than the necessary voltage from going to the filaments of the tubes. The first rheostat should be turned on full ordinarily. A voltmeter is essential if dry cell tubes are to be used since they will not last very long under excess voltage. One

point in favor of this set is that it works well on four 199 or 299 tubes. The small tubes are so very easy to neutralize that it is a great point in their favor. Many people using large tubes in the rest of the set use a small tube in the first place so that neutralization is more stable. In this case a fixed resistance should be inserted in one of the filament

night to the Pacific coast. One person in Tacoma, Washington, gets KDKA night after night on the first two tubes since he has not added his audio amplifiers as yet. The one striking feature of the whole thing is the question of comparison. Practically every person that builds this set and operates it compares it with a superheterodyne, nothing less.

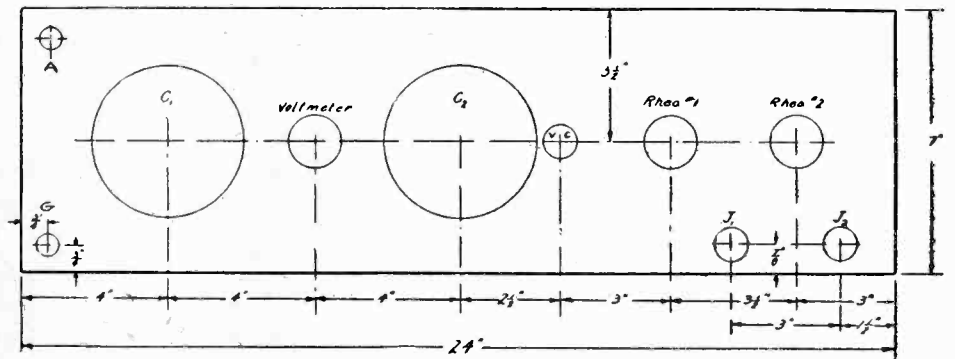

Fig. 4. Panel Layout

leads to this first tube in order that it will not get more than 3 volts. This resistance should have a value of some 50 ohms.

As to results, that is where we scarcely dare to speak. The set on the Atlantic coast has ranged its way night after

The set needs only a short antenna. We have heard Chicago night after night at Boston on from 10 to 20 ft. of wire strung across the room. But best of all in the writer's opinion is not the great DX work but the consistent

Continued on page 70

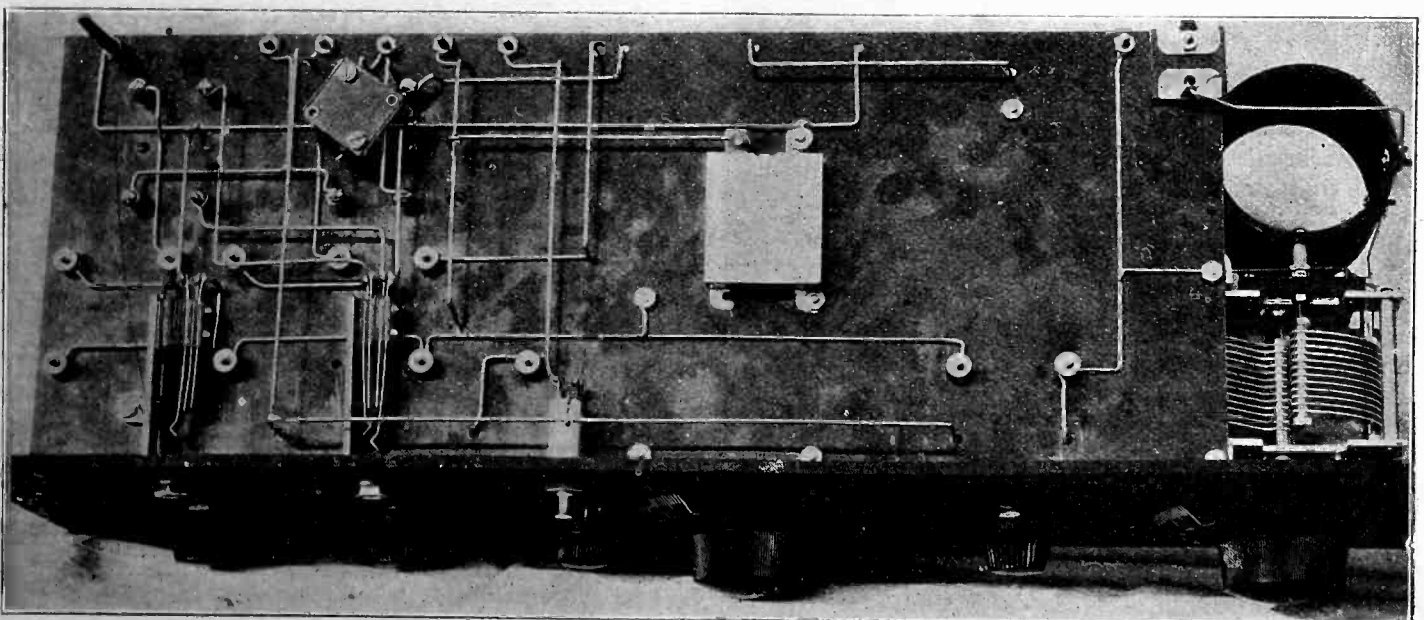

Fig. 6. View of Sub-Panel Wiring

Reflex Circuits

Ranging From a Single Tube Reflex With One Control to a Three-Stage Set With Three Controls

By E. C. Nichols

THE general trend toward simplification of controls in the commercial receivers should arouse in those who build their own the desire to take advantage of any condition in a circuit which will permit the elimination of a control without sacrificing efficiency. This should apply particularly to one of the most popular and perhaps the most satisfactory receivers of the less pretentious type, namely, the single tube reflex. It is the object of this article to describe three circuits based on experiments with the single tube reflex in the endeavor to simplify controls and apply the latest developments in tuned radio frequency amplification, with suggestions for the proper type of antenna coupling.

In the future, the use of the crystal detector should prevail to a much greater extent because of its many advantages. It means good quality which should be pre-eminent in any radiocast receiver. It has quiet operation due to its conductive isolation from the rest of the circuit. This latter advantage makes it preferable when *A* and *B* battery eliminators are used.

The tendency to jump to new circuits sometimes results in overlooking desirable features in a receiver about to be discarded. This happened in the case of the untuned radio frequency amplifying transformer, a satisfactory piece of apparatus when used under the proper conditions. This condition exists in the single tube reflex and the untuned R. F. transformer can be used to advantage in this circuit.

Usually those who purchase or build a receiver purely for entertainment from local sources prefer the simplest sort of station selector. When considering the single tube reflex it will be noted that the second control is not very effective for greater selectivity because of the effect which the crystal and audio transformer have on it. This suggests the idea of discarding it altogether and substituting in its place an untuned R. F. transformer having a range from 200 to 600 meters. This substitution results in a single control receiver comparing favorably with the two control circuit in volume and selectivity. The use of the untuned R. F. transformer is not a new idea and its application at this point is extremely practical. This transformer should be carefully selected by actual test in the circuit as the different makes vary considerably. An Acme type R4

was used in these experiments. Fig. 1 shows the single control circuit with an additional step of audio amplification with interstage jacks.

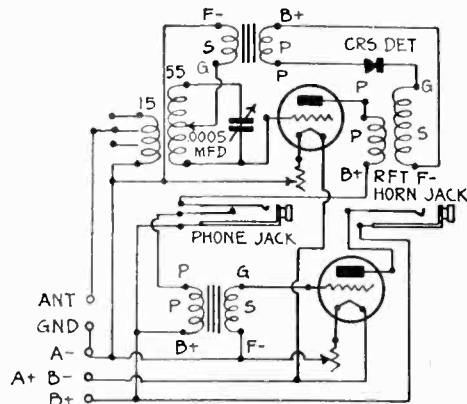

Fig. 1. Single Control Reflex with One Stage of R. F.

The two circuit tuner can be constructed in various ways but the most desirable incorporates adjustable coupling. The secondary has 55 turns of No. 24 d. c. c. wound on a 3 in. tube and is tuned by a .0005 mfd. variable condenser. The primary has 15 to 20 turns wound on a rotor and is mounted in the end of the secondary tube. An easy way is to wind a 15 turn primary with taps at 8 and 12 turns directly over the secondary winding with paper or cloth insulation between. The specially wound coils can be used if desired. Winding an ordinary cotton string between each

turn will reduce the internal capacity of the coil and, if used, the number of turns should be increased about 25 percent. When testing the circuit any tendency to self oscillation can be avoided by reversing the leads to the primary of the untuned R. F. transformer.

In Figs. 2 and 3 are shown circuits with an additional stage of tuned R. F. amplification which will be found to be the most satisfactory when greater selectivity combined with stronger signal strength are required, making a two control receiver with two stages of R. F. amplification. The stability of the first tube is obtained by the adaptation of the Rice method of counterbalance to prevent oscillation, permitting the tube to be worked to its maximum efficiency. A small neutralizing condenser is used for this adjustment. A small amount of regeneration is desirable in any receiving circuit providing it is controllable and care should be taken when adjusting the counterbalancing condenser to take advantage of this fact as too much capacity will impair the distance capabilities of the receiver.

In case of any circuit the type of tuning coil or antenna coupling should be determined after considering the location of the receiver relative to the nearest radiocasting source and possible interference. The receiver close in demands selectivity and a two circuit tuner, while those in the remote districts require greater signal strength and should take

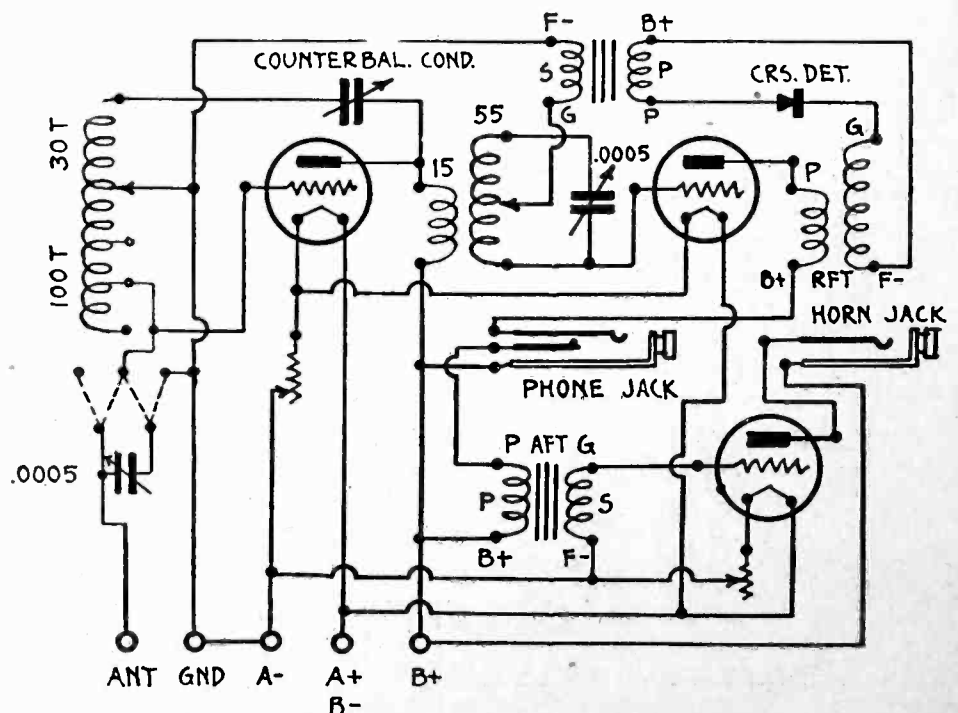

Fig. 2. Single Circuit Tuner with Two Stages of R. F.

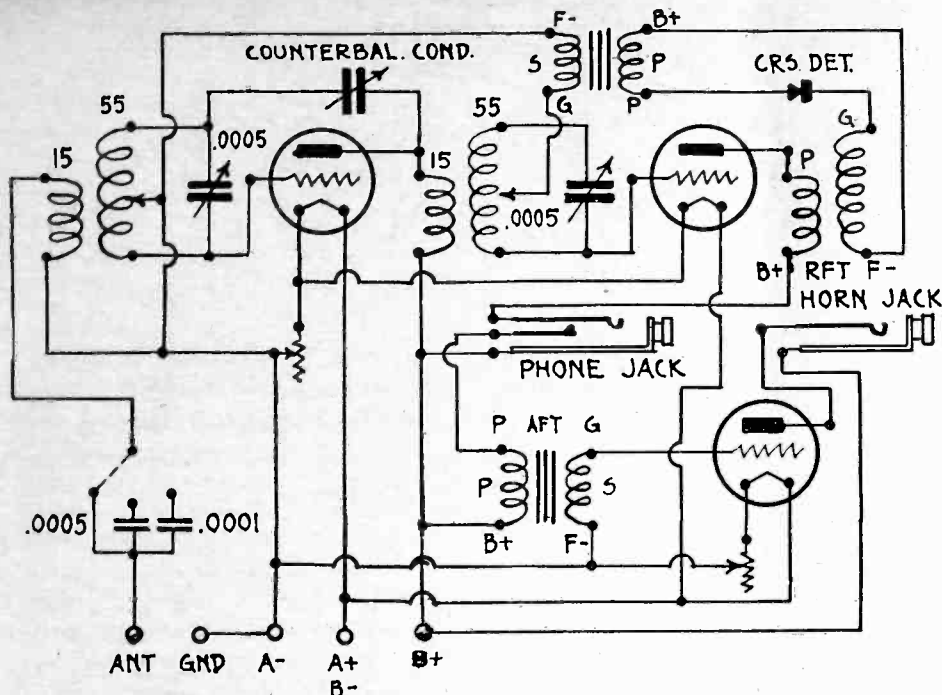

Fig. 3. Two Circuit Tuner with Two Stages of R. F.

advantage of the single circuit tuner when ever possible.

The two circuit tuner in Fig. 3 is the same as that in Fig. 2 except for the addition of a middle tap on the secondary coil which leads to the negative filament. One end of the secondary coil goes to the grid as usual, the other end goes to the counterbalancing condenser which is connected to the plate of the first tube. The use of the condenser bank in the antenna circuit will increase efficiency on the lower wavelengths and improve selectivity.

The single circuit tuner in Fig. 2 should be 100 turns on a 3 in. tube with one or two taps and a .0005 variable condenser. To aid in counterbalancing there is an additional 30 turns continuing from the ground tap and connecting to the counterbalancing condenser. A switching arrangement is shown for con-

necting the variable condenser in series or multiple with the tuning coil.

There will always be those who are reluctant to discard the superior sensitiveness of the tube detector for the crystal and Fig. 4 shows a switch combination whereby a crystal or tube detector can be used, the change being instantaneous, affording an ideal means of comparing these two methods of rectification.

Although the use of three stages of R. F. amplification is usually associated with laboratory apparatus and considered too complex for radiocast reception, it is possible by taking advantage of certain inherent factors existing in a circuit and combining with them an efficient method of tube counterbalance to construct a thoroughly satisfactory and efficient receiver of this type for D X and local reception. Fig. 5 shows a circuit of this type using three stages of R. F. amplification with three controls combining

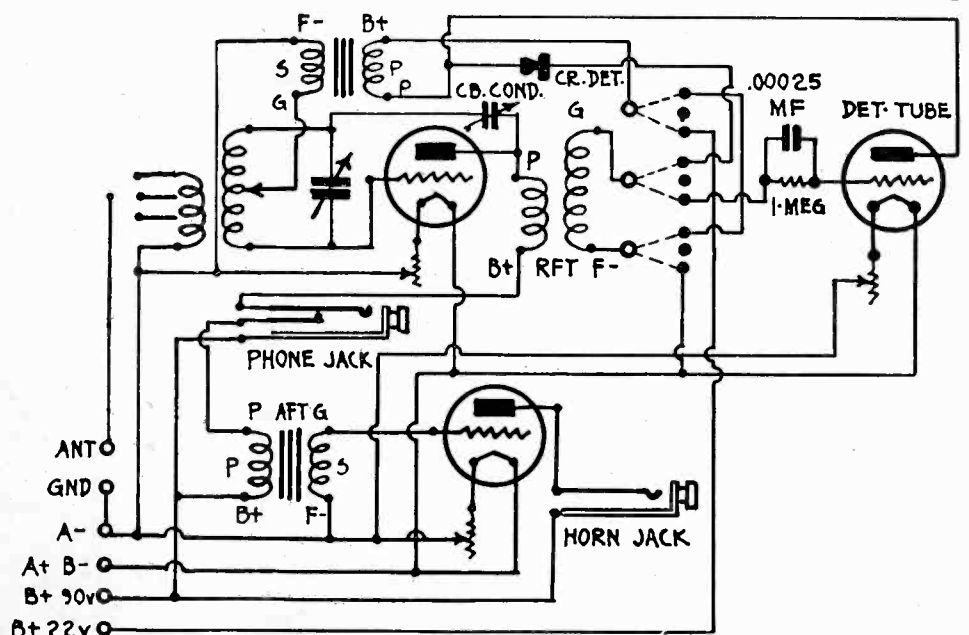

Fig. 4. Circuit Using Either Crystal or Tube Detector

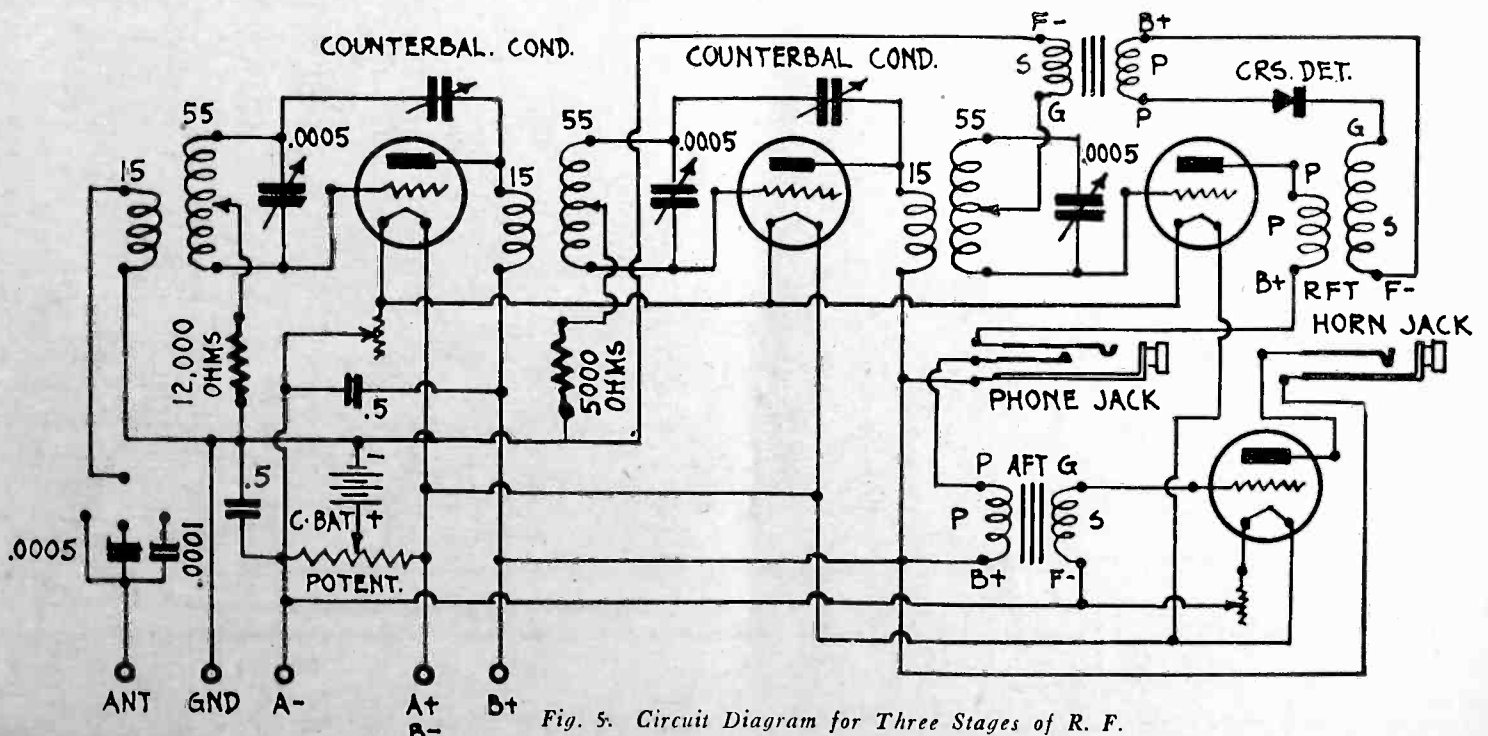

Fig. 5. Circuit Diagram for Three Stages of R. F.

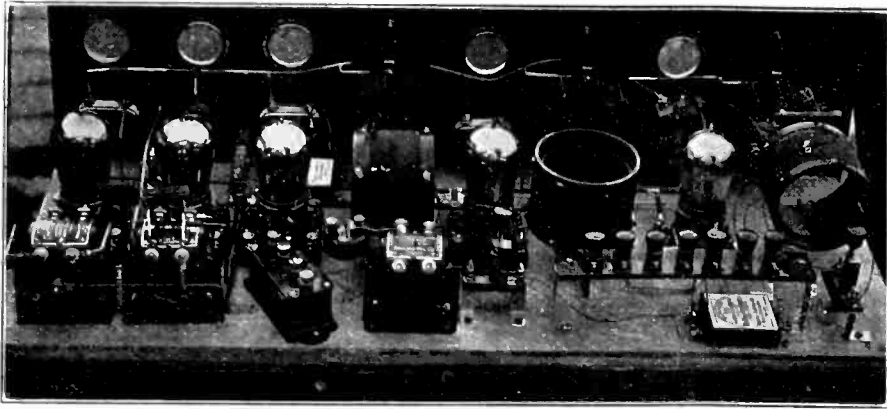

Fig. 6. Rear View of Three Control Receiver

good tone quality with sensitivity and the required selectivity.

Here again the Rice method of tube counterbalance is used on the first and second stages of R. F. The crystal detector and the untuned R. F. transformer assist in stabilizing the third R. F. tube. It has been necessary in most cases of multi-stage R. F. amplification to take advantage of every possible condition which will assist in greater stability. In the case of three stages of R. F. this meant a single circuit tuner and untuned antenna circuit with the consequent loss in selectivity.

It will be noted in Fig. 5 that a radical departure from ordinary practice has been made, resulting in perfect stability combined with a two circuit tuner and a tuned antenna. These three necessary features are obtained by the use of high resistances in the negative C battery connection of the secondaries of the two circuit tuner and the first tuned R. F. transformer. In these experiments a 12,000 ohm resistance was used on the

tuner and a 5000 ohm resistance on the first tuned R. F. transformer. Several values of resistance should be tried for best results. This application of resistance should not be confused with the various methods used to obtain stability by inserting so-called "lossers" in a circuit. The efficiency is in no way impaired as the application of the resistance is in the high resistance grid filament circuit and is a very small proportion of the total resistance of this circuit. This results in the damping out of any parasitic oscillations. Primarily the use of resistance in this way was suggested to me by Mr. Hugo Benioff of Pasadena, and in these experiments proved to be entirely satisfactory.

The tuned R. F. transformers are made by winding 55 turns of No. 24 d. c. c. on a three inch tube with a central tap and a primary of 15 turns wound directly over the secondary. A .0005 mfd. variable condenser is used for tuning. The two circuit tuner is the same as used in Fig. 3. A back panel

view of the three control receiver is shown in Fig. 6 and the general arrangement of parts in Fig. 7.

The construction of this receiver carried out step by step affords one the interesting opportunity of learning just how much sensitivity and selectivity each step of R. F. adds in its turn. The careful testing and adjusting of each step as it is added will result in a very satisfactory receiver.

ADAPTING THE 45,000 CYCLE SUPERHETERODYNE TO LOW WAVE RECEPTION

By E. A. SAHM

The 40 to 80 meter band can be received on the 45,000 cycle superheterodyne by substituting a special coupler for that used on the 200-600 meter band and by reducing the loop to about eight turns tapped in the middle.

The special coupler consists of three basket-wound coils mounted side by side with $\frac{1}{2}$ in. separation for coupling as this narrow band does not require variable coupling. To construct the coils first set up 15 pegs equidistant on a 3 in. circle. Then wind 10 turns of No. 20 d.c.c. wire alternately around the inside and outside of two pegs at a time. The inside coil is used as the grid series coil.

This coupler can easily be added to the set without removing the other so that either may be used at will through flexible leads. The two couplers should be shielded from each other. A short-circuiting lead can also be put on the loop.

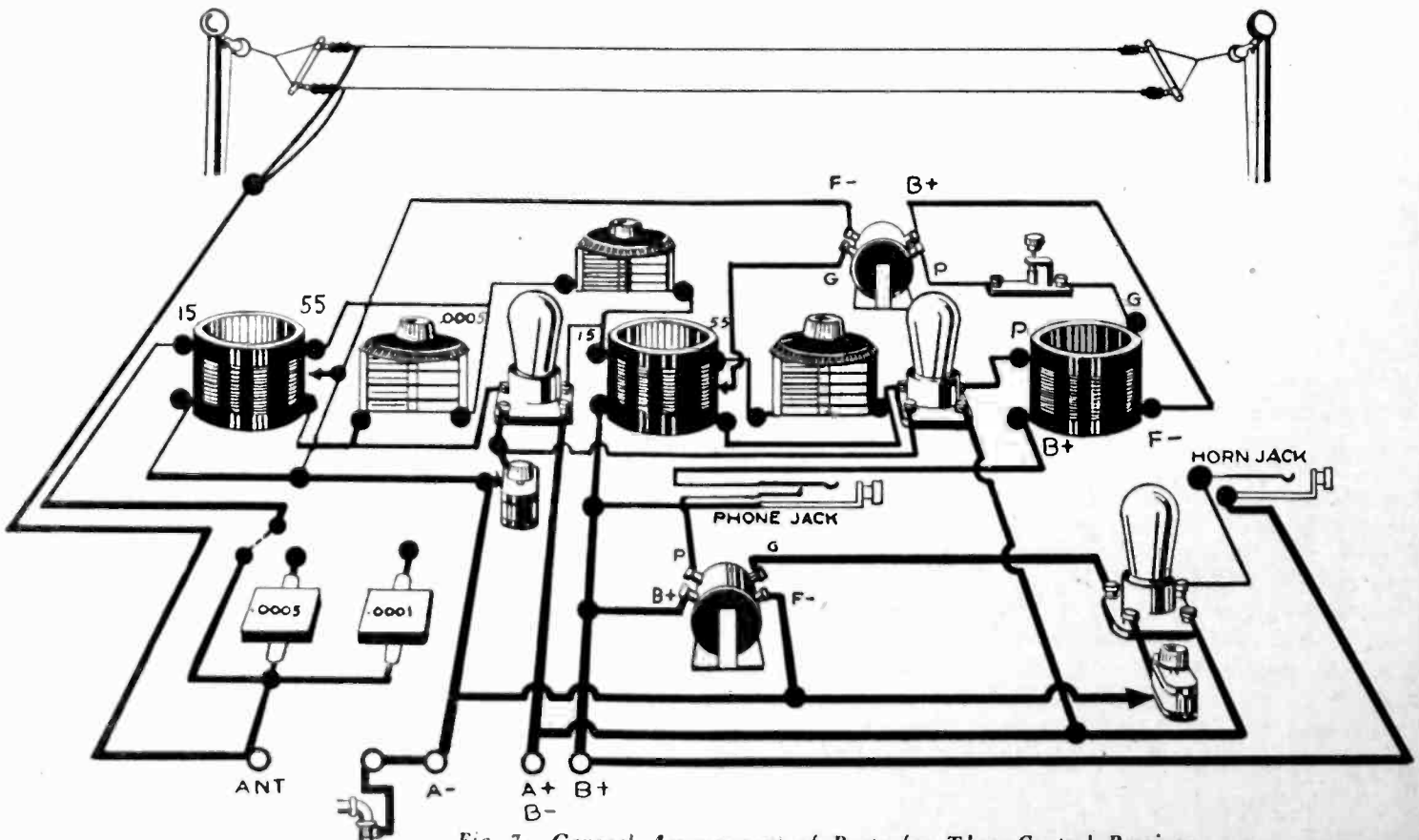

Fig. 7. General Arrangement of Parts for Three-Control Receiver

Superheterodyne or Intermediate Frequency Amplifier Receiving Sets

A Simple Explanation of the Principles Upon Which This Popular Type of Receiver is Based

By C. M. Jansky, Jr.

RECEIVING sets which use several stages of radio frequency amplification to amplify directly the frequency received from an antenna or coil aerial are open to the objection that it is necessary to change the tuning of all of the radio frequency circuits as the set is tuned to stations sending on different frequencies or wavelengths. Thus, a tuned radio frequency amplifier system using two stages of radio frequency amplification with a detector will, in general, have three tuned circuits and three tuning dials. All three of these circuits must be tuned to the incoming signal if satisfactory reception is to be obtained. As has been explained in previous articles this feature is not a serious handicap after the operator has made a record of the tuning adjustments which bring in the various stations.

Several manufacturers have recently made attempts to simultaneously vary the tuning of a number of circuits by gearing a number of condenser controls to a single dial. To satisfactorily vary the tuning of three or four radio frequency circuits in this way and at the same time insure the various circuits being in accurate adjustment for the same frequency requires very careful mechanical construction of the condensers and coils which are used in these circuits. Rather than go to the expense and engineering design necessary to such careful construction most manufacturers place a single plate variable condenser in parallel with the larger tuning condenser. It is necessary therefore to vary the adjustment of the micrometer condensers as well as the single control dial to secure accurate tuning.

It would seem plausible to expect that if a radio frequency amplifier system could be designed to amplify but one frequency or narrow band of frequencies, the number of controls might be reduced and the amplifier system be more efficient than could be the case if it must handle a very wide band of frequencies, as is the case with a system designed to handle the entire radiocast range from 500 to 1500 kilocycles (200 to 600 meters). Sets known commercially as "superheterodyne" or intermediate frequency amplifier receivers provide for reducing the radio frequency signal from any station to a single, com-

paratively narrow, band of frequencies. The radio frequency amplifier system is then designed to amplify this particular band only, after which the signal is detected or rectified and amplified by audio frequency amplifiers.

In RADIO for October, 1924, we discussed the production of beats by combining with an incoming radio frequency an alternating current from a local oscillator producing a radio frequency, such that the numerical difference between f_a and f_b is a frequency somewhere in the range audible to the human ear. The combination of f_a and f_b when rectified or detected and passed through a headset could be heard. This production of beats, as it is called, can be very readily explained to the man with mathematical training by the use of a few simple equations involving trigonometric expansion. It can best be explained to the non-mathematical reader by likening it to the phenomenon which is produced when two keys close together on the piano are struck simultaneously.

cycles per second will be produced. The same beat frequency could be produced by using a local oscillator producing 955,000 cycles. In other words, to produce a beat frequency of 45,000 cycles the frequency of the local oscillator may be adjusted either to a frequency 45,000 cycles above that of the incoming frequency or to one 45,000 cycles below the incoming frequency.

Fig. 1 shows a schematic diagram for a receiving set which might be used for the reception of continuous wave telegraph signals or for radiophone speech and music. If it is assumed that the antenna or coil is receiving a signal at a frequency f_1 of say 1,000,000 cycles per second the first local oscillator might be adjusted to a frequency of f_2 which would give a beat note of 45,000 cycles. This would result when $f_1 - f_2 = 45,000$. Tuning is accomplished by simultaneously varying the antenna tuning unit and the frequency control of the first local oscillator. Two adjustments of the tuning oscillator con-

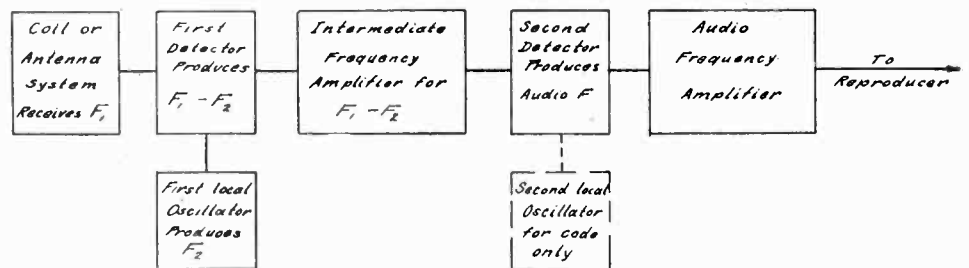

Fig. 1. Schematic Diagram for a Standard Superheterodyne

Due to the fact that the frequencies produced by the two keys are nearly the same, a periodic increase and decrease in the intensity of the sound emitted can be detected as the radiation from one string first adds to, then neutralizes, the radiation from the other.

If the high frequency alternating current from a distant radio telegraph station transmitting a frequency of 1,000,000 cycles per second (300 meters) is combined with the output of a local generator of 1,001,000 cycles per second and the combination passed to a detector there will result an audio frequency alternating current of 1000 cycles per second. If however the same incoming signal were combined with the output of an oscillator producing 1,045,000 cycles per second, and the combination rectified, a beat note of 45,000

cycles per second will be produced. The same beat frequency could be produced by using a local oscillator producing 955,000 cycles. In other words, to produce a beat frequency of 45,000 cycles the frequency of the local oscillator may be adjusted either to a frequency 45,000 cycles above that of the incoming frequency or to one 45,000 cycles below the incoming frequency.

If the set is to be used only for radio telegraph reception the intermediate frequency amplifier may be of the tuned circuit type in which all of the circuits are tuned to 45,000 cycles. This is because a continuous wave telegraph signal does not occupy a very wide band. The amplified 45,000 cycles signal is delivered to the second detector which is adjusted so that the beat note produced by the combination of the two frequencies is audible to the human ear. The audio frequency note can then be amplified if necessary. The intermediate frequency amplifier need not necessarily be designed for 45,000 cycles but may be de-

signed for any satisfactory frequency lower than f_1 .

If the set is intended for the reception of radio telephone signals only, the second local oscillator may be dispensed with. However, due to the fact that a radio telephone signal occupies a much broader frequency band than a radio telegraph signal, certain precautions must be taken in the design of the intermediate frequency amplifier and the detector which is used with it. These precautions will be discussed in some detail.

The voice and instrumental frequencies involved in the satisfactory reproduction of speech and music by electrical methods extend from about 50 to 5,000 cycles per second. While it is true that the ear will respond to frequencies as low as 15 cycles, and with some people to frequencies as high as 15,000 cycles, it will not materially change the quality of reproduction if all frequencies above and below the band from 50 to 5,000 cycles are eliminated. Radio telephone transmitters amplify the speech and instrumental frequencies obtained from the microphone and use them to vary the amplitude of a generator transmitting a high frequency electromagnetic waves. This variation of amplitude is called modulation. The high frequency produced by the generator is called the carrier frequency. The frequencies obtained from the microphone are called the modulating frequencies.

The band occupied by an unmodulated high frequency wave is very narrow. Theoretically it is confined to a single frequency. The wave radiated by a radio telephone transmitting station occupies a band of frequencies twice as wide as the highest modulating frequency obtained from the microphone. Thus if the microphone circuits carry frequencies as high as 5,000 cycles the band occupied by the radiated wave is 10,000 cycles wide. All apparatus designed to amplify high frequency currents modulated by speech and instrumental music must be designed to handle a frequency band of at least 10,000 cycles. It is also fundamentally true that each radio telephone transmitter must be allocated a band 10,000 cycles wide.

Let us assume that a radiophone transmitter uses a carrier frequency of 1,000,000 cycles per second. When modulation is taking place the space occupied by this transmission will extend up to 1,005,000 cycles and down to 995,000 cycles, a total width of 10,000 cycles. To determine the width of band occupied in meters we may make use of the approximate formula:

$$\text{Wavelength in meters} = \frac{300,000,000}{\text{frequency in cycles per second}}$$

The wavelength of the carrier frequency is therefore 300 meters. The wavelength corresponding to 1,005,000

cycles is 298.5 meters. The wavelength corresponding to 995,000 cycles is 301.5 meters. The radiophone transmission therefore occupies a wave band extending from 298.5 to 301.5 meters, a total width of 4 meters.

At 750,000 cycles per second the band would still be 10,000 cycles wide, extending from 755,000 cycles to 745,000 cycles. This figure, converted to wavelengths in meters, shows that the carrier is operating at 400 meters and the side bands extend from 397.3 meters to 402.7 meters. The width of the band occupied in meters therefore is approximately 5.4 meters. *The width of band occupied by a radiophone transmitter in which the modulating frequencies extend up to 5000 cycles is always 10,000 cycles but the width expressed in meters will depend upon the wavelength of the carrier.* The longer the wavelength of

from the carrier frequency. The result of the use of such an intermediate frequency amplifier system would be that the low notes of musical reproduction would receive maximum amplification while the higher notes would be damped out. The higher the modulating frequency the less the amplification.

Because of the principles which have just been brought out it is common practice to use an intermediate amplifying system in which coupling between the tubes is obtained by the use of transformers of special design rather than by the use of coupled circuits. These transformers may be either of the iron or air core type. The same selectivity which makes the tuned circuit amplifier valuable when used for the direct amplification of frequencies lying in the radiocast range prevents the use of this type of circuit in intermediate frequency

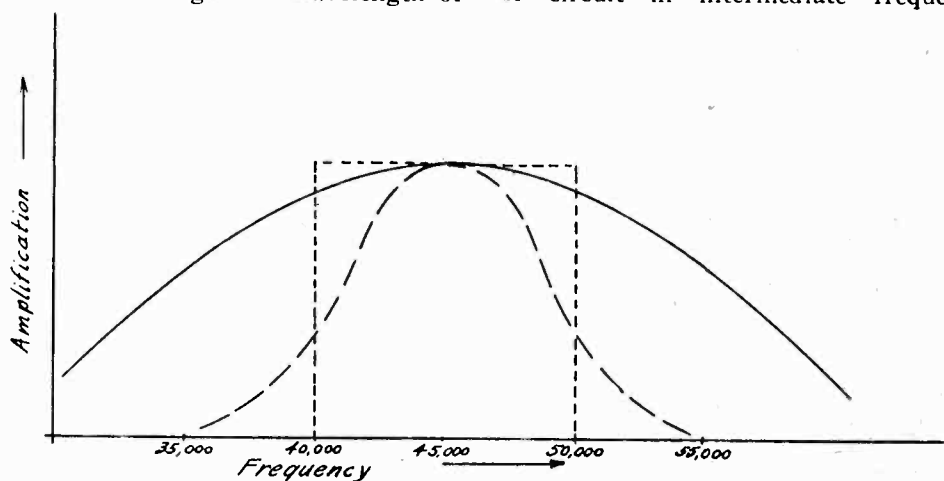

Fig. 2. Frequency-Amplification Characteristics of Three Different Intermediate Frequency Amplifiers
 Theoretical Ideal Amplifier.
 - - - - Tuned Circuit Amplifier.
 ——— Transformer Coupled Amplifier.

the carrier the wider the width of band in meters.

A tuned circuit radio frequency amplifier which is adjusted for an incoming frequency of 1,000,000 cycles will for all practical purposes amplify equally well the entire band extending from 1,005,000 cycles to 995,000 cycles. The ratio of width of band (10,000 cycles) to the carrier frequency (1,000,000 cycles) is 1 to 100.

If, however, we heterodyne the incoming frequency with a local oscillator to produce a carrier of 45,000 cycles a different situation exists. The modulating frequencies still require that the band be 10,000 cycles wide. The band which must be provided for in the intermediate frequency amplifier therefore extends from 40,000 cycles to 50,000 cycles and the ratio of the band width to the carrier frequency is only 1 to 4.5. A low-resistance tuned circuit radio frequency amplifier adjusted to 45,000 cycles would not amplify equally well all frequencies lying between 40,000 and 50,000 cycles. Amplification would be greatest for those frequencies near 45,000 and would be progressively less for those frequencies further removed

amplifiers which must not be so selective as to produce distortion when used for the reception of radio telephone speech and music.

Fig. 2 shows diagrammatically the results which might be expected from three different types of amplifiers. An ideal amplifier would cut off completely all frequencies above 50,000 and all below 40,000 and in addition would give equal amplification to all lying between these two limits. A tuned circuit amplifier would be too selective while the average transformer coupled amplifier will give results like those shown in the third curve. Some selectivity must be sacrificed in order to obtain satisfactory reproduction. The use of a band filter with proper cut off points might increase the selectivity of a transformer coupled amplifier. Resistance coupling might be used in an intermediate frequency amplifier. Such a circuit should give excellent reproduction but would lack selectivity and be open to other objections.

There are certain important points which must be given full consideration in the design of the circuits of the second

(Continued on page 72)

An "A"-Batteryless Audio Amplifier

Practical Directions for Heating the Tube Filaments from a
110-Volt A.C. Supply

By Ferd Humphreys

THERE are many instances where it is desired to add two-stage audio amplifier to a single dry cell tube receiver or even to a simple crystal set. But the most serious obstacle to the idea is the tube and battery question. What kind of tubes will give the best results and how are they to be operated?

If the set to which the amplifier is to be added is of the dry cell tube type, at first thought it seems most practical to employ dry cell tubes for amplification also. The filaments of these tubes may be heated either from a multiple or series multiple connected *A* battery of standard No. 6 dry cells, or from a small storage battery of suitable voltage, if desired. An amplifier might be added to a crystal set in the same manner.

The degree and quality of amplification obtainable with dry cell tubes, however, is hardly comparable to that afforded by larger tubes of the storage battery type which require from 5 to 6 volts and from $\frac{1}{4}$ to 1 ampere. This is especially true in the case of amplifiers consisting of two or more tubes. The storage battery tube has a greater input and output capacity than the dry cell tube and is therefore capable of delivering the greater amount of energy with less distortion to the loud speaker. Thus, storage battery tubes should be used in preference to dry cell tubes whenever circumstances will permit.

The problem of operating the filaments of amplifier tubes from alternating current has a number of practical solutions. Perhaps the safest, simplest, least expensive and most satisfactory of these consists in the use of a bell ringing

transformer in conjunction with a potentiometer and a *C* battery. In the event that the radio constructor wishes to build his own eliminator, he may purchase the necessary parts and incorporate them in the amplifier.

The writer recently constructed a two-stage audio amplifier employing C-301-A or UV-201-A tubes for use with a single dry cell tube regenerative receiver. The filaments of the amplifier were operated from alternating current by means of a bell ringing transformer in accord with the desire to eliminate the storage battery. It was not deemed worth while to go to the expense of incorporating a *B* battery eliminator in

structed appear in Figs. 1 and 2. The following list of parts was purchased for the construction of the amplifier:

- 1 Panel, black, 6x10 $\frac{1}{2}$ x $\frac{3}{16}$ in.
 - 1 Baseboard, 9x7 $\frac{1}{2}$ in.
 - 1 Potentiometer, 200 ohms
 - 1 Rheostat, 10 ohms
 - 2 C-301-A amplifier tubes
 - 2 Tube sockets, panel mounting
 - 1 Phone jack, single circuit
 - 2 Audio transformers
 - 1 Bell ringing transformer
 - 1 *C* battery, 4 $\frac{1}{2}$ volts
 - 4 Binding posts, black moulded
 - 10 ft. lamp cord, twisted pair
 - 1 Attachment plug
 - 1 Cabinet
- Necessary screws, bus bar for connections, and soldering lugs.

The tube sockets are mounted to the

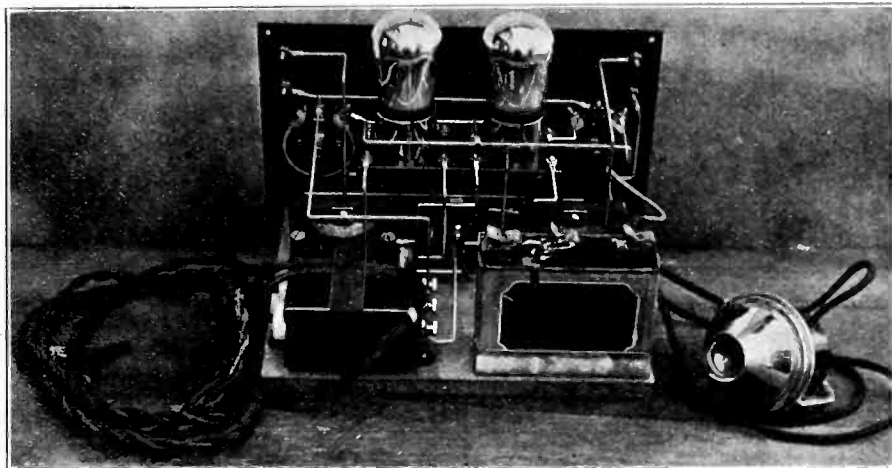

Fig. 2. Back panel view of the amplifier showing the bell ringing transformer for operating the tube filaments. The "C" battery is held to the baseboard by means of a clamp.

the amplifier inasmuch as the *B* battery is not particularly troublesome and will give good service when used with a two-stage amplifier.

Two views of the amplifier con-

center of the panel at equal distances from its ends, the height of the sockets being adjusted to permit the tubes to be inserted therein through holes made in the top of the cabinet. The potentiometer and rheostat are mounted to the ends of the panel at the center of its height. They appear at the left and right, respectively, in Fig. 1 and in the opposite order in Fig. 2. The jack is located at the lower center of the panel. At the upper left and right corners of the panel, Fig. 1, the input and *B* battery binding posts, respectively, may be seen. All of the panel mounted parts are placed to give a well balanced appearance. Oval-headed nickel-plated wood screws are used to secure the panel to the cabinet and to the baseboard. Oval-headed machine screws of similar finish are used to fasten the sockets to the panel.

To the baseboard are mounted the audio transformers, bell ringing transformer and *C* battery. The bell transformer is secured to the left rear corner of the base and the *C* battery is mounted

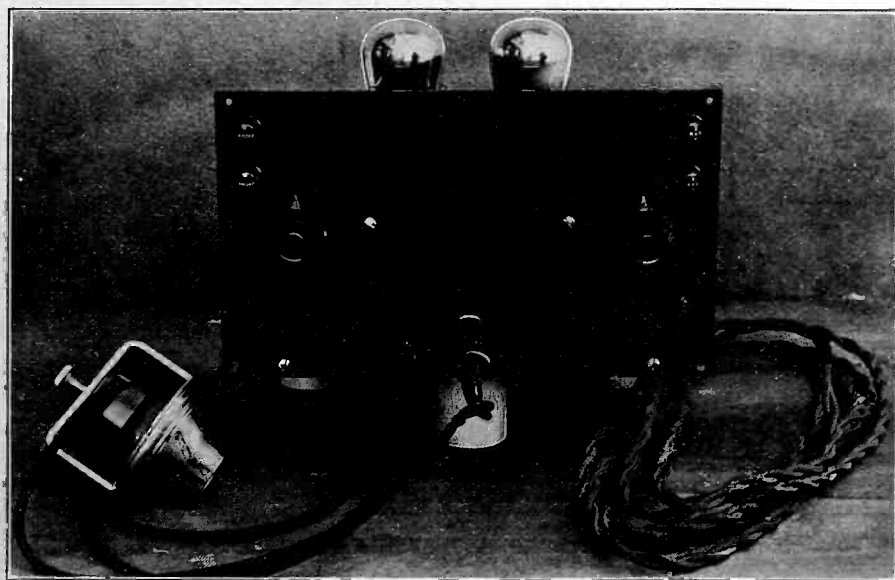

Fig. 1. Front panel view of the "A"-Batteryless two-stage audio amplifier. The amplifier tubes are arranged to project through the top of the cabinet.

to the right rear corner of the same. A clamp, constructed of galvanized-iron and held to the base by flat headed wood screws, accommodates the C battery.

The amplifier was wired in accordance with the circuit diagram of Fig. 3. In the process of wiring, special attention was given to the arrangement of the alternating current leads to and from the bell transformer with respect to the input and output circuits of the amplifier. The leads from the secondary terminals of the transformer to the filament terminals of the tube sockets were kept well away from the audio transformer leads and the grid and plate connections to the sockets. A separation of at least 1 in. was maintained between parallel leads and these were kept short and avoided as much as possible. The wiring was also kept away from the bell transformer. This was done in the interest of preventing any "hum" which might result from objectionable induction between the bell transformer leads and the amplifying circuits.

In an improperly constructed amplifier of this type, a hum is possible because of the rapid reversals of alternating current flowing through the input and output circuits of the bell transformer. The pitch of the hum is double the frequency of the supply current which is generally of the order of 60 cycles per second.

The bell transformer employed has three secondary terminals. These permit of three different voltages for the operation of bells of different sizes. Two adjacent terminals are marked 6 volts, and another adjacent pair are marked 8 volts. By connecting to the two outer terminals of the transformer, a potential of 14 volts may be obtained. When employing this transformer for operating

the 5 volt filaments of an amplifier, the 6 volt terminals are used. One end of the lamp cord is connected and soldered to two flexible leads provided on the transformer and the other end of the cord is connected to the attachment plug. The soldered connection to the transformer is thoroughly taped to prevent short circuit.

The use of a filament control jack for turning the amplifier on and off should be avoided in this instance because of the liability of such a jack to introduce a slight hum by virtue of the intimate association of alternating current with the output circuit of the last amplifier tube. The jack springs act as the plates of a condenser in this respect and serve to couple the alternating current filament circuit to the output circuit.

If the grid return leads of this amplifier are connected directly to one or the other of the filament leads, as is the practice in amplifiers employing direct current on the filaments, the grids of the tubes will be alternately biased positive and negative owing to the flow of alternating current through the filaments. This, of course, would produce a very loud hum in the loud speaker and would render the amplifier operative only when the grids were negatively biased. The necessary negative grid bias for amplification is provided by means of the C battery and potentiometer.

The ends of the potentiometer resistance winding are connected to the filament supply leads and the grid return leads of both tubes are common and connected to the arm of the device through the C battery. The amplifier is adjusted for zero hum by rotating the arm of the potentiometer to the middle of the resistance. When the proper adjustment has once been found, the potentiometer need not be touched again.

The life of the C battery averages about 8 months, as it serves only to place a voltage on the grids of the tubes. The filament rheostat is adjusted to the point above which no additional increase in the brilliancy of the filaments has the effect of improving amplification. A B battery of 90 volts was connected to the binding posts provided.

When tested, the amplifier was used in conjunction with an improvised loud speaker consisting of a phonograph receiver attachment and a Victrola. The amplifier worked with perfect satisfaction and no difficulty was experienced in adjusting the potentiometer for smooth amplification. With the potentiometer out of adjustment, however, the effect of the hum was to modulate to such an extent that the distortion resulting was unbearable. The potentiometer is most easily adjusted for zero hum when no radiocasting is being received.

EXPERIMENTING

By KENNARD MCCLEES

As soon as the radio amateur has progressed beyond the stage of listening-in and begins to want to know more about the hitherto mysterious inner workings, an experimental table will be found invaluable. This table should be in an out-of-the-way corner and can be reserved for the hours of leisure when new hook-ups are tried, the hook-up that just comes into your hands when there is a program on that the family cannot tear themselves away from.

The first essentials are a couple of small panels for the aerial, ground and battery leads. These can be mounted at opposite ends of the table, and should be short strips or insulating material supported by tubes of insulator; broken off bits of porcelain tubing will answer the purpose well. If you can procure some old Fahnstock clips drill places for these in preference to screw binding posts. Appearances will not matter here and they will prove more convenient when many changes are to be made.

If you make up a winding rig and try some coils of your own, remember that the old style loose-coupler is frowned upon today as the best results are had by the simpler method of winding both primary and secondary on the same tube with a short gap between them. It has also been found that it is not essential that the rotor and stator of a variometer be wound in the same directions. Sometimes the opposite will give good results. An excellent experiment is to wind the stator in a given direction, and then the rotor half and half.

Place your grid-leak in a convenient position and test its effectiveness frequently. A coarse pencil and eraser may be tied to one side of the table and reserved for this purpose. It will have to be changed whenever you change tubes

(Continued on page 68)

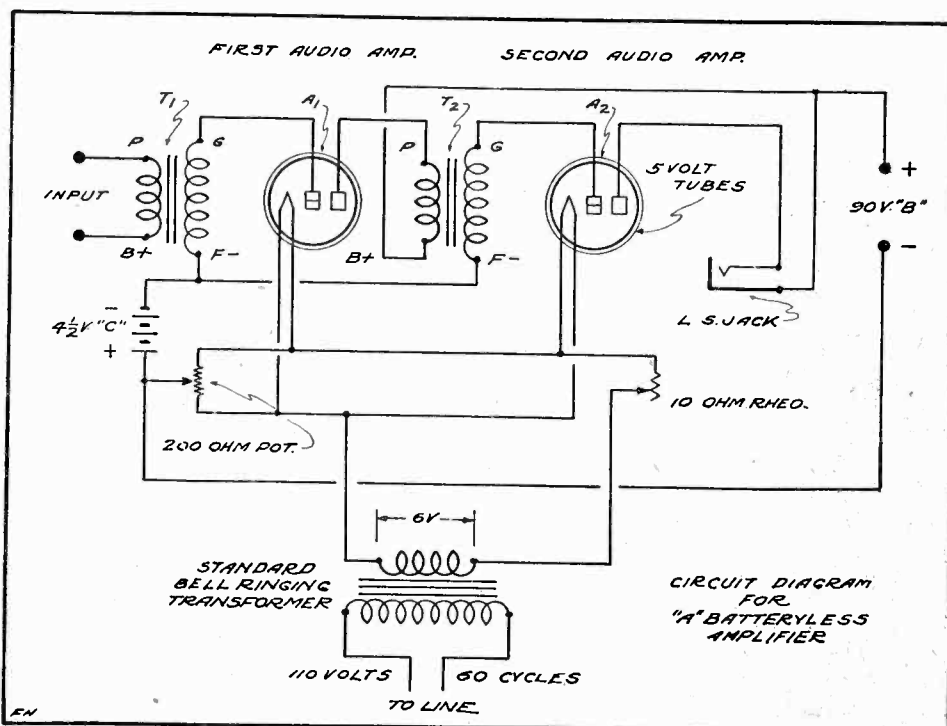
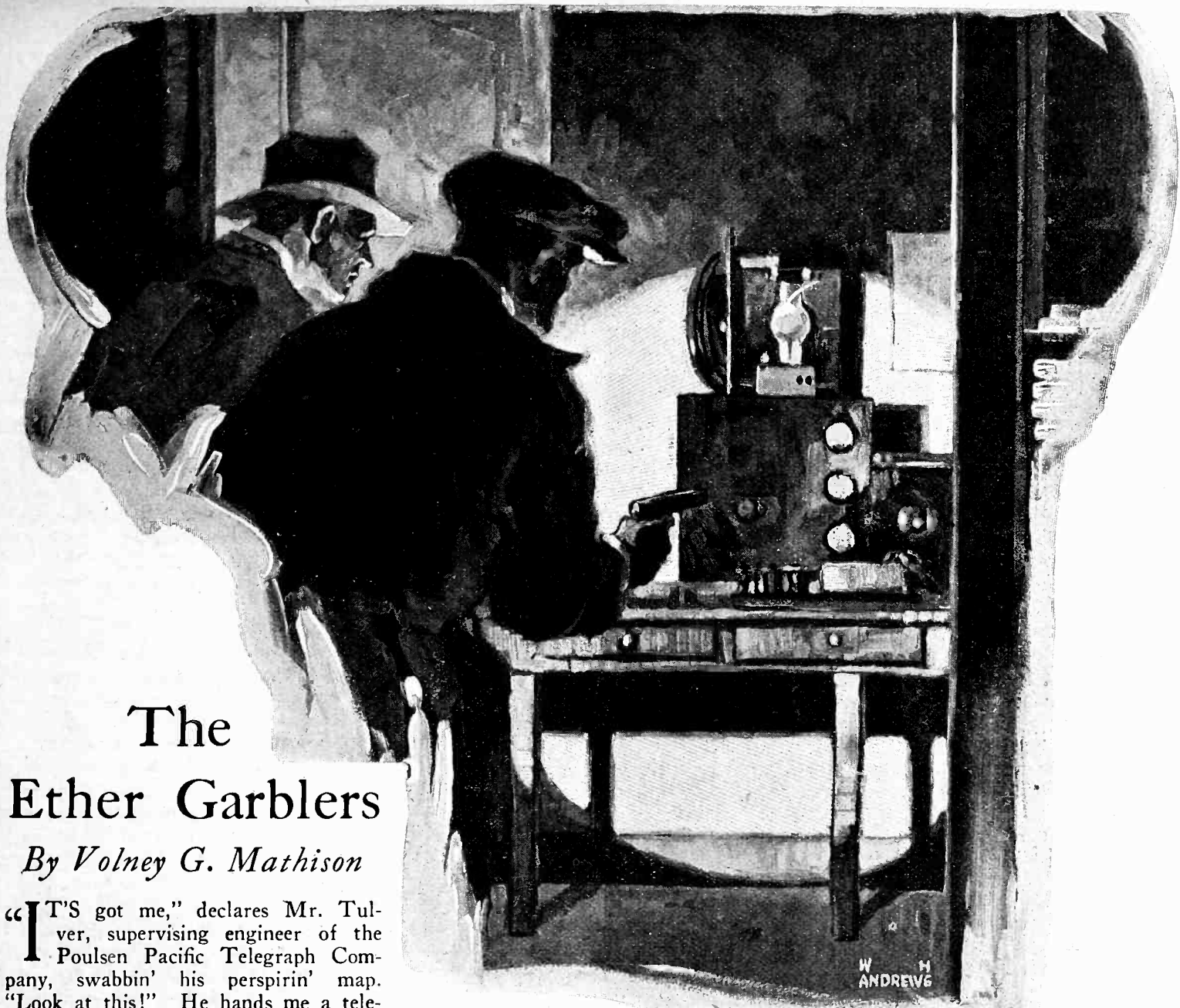

Fig. 3. Circuit diagram. Note the connection of the bell ringing transformer, potentiometer and "C" battery.



The Ether Garblers

By Volney G. Mathison

"IT'S got me," declares Mr. Tulver, supervising engineer of the Poulsen Pacific Telegraph Company, swabbin' his perspirin' map. "Look at this!" He hands me a telegram, filed here in San Francisco, which reads this way:

"Isaac Rosenblum & Son, Los Angeles: Ship us immediately steamer freight one thousand each lot number 6558 assorted sizes up to thirty-eight ladies' chemise slippers and combinations pink and cream silk. Goldberg, Heine, and Jacob Company."

"Now, look at this one," says Mr. Tulver, handin' me another telegram. "Here's the way that message sounded in the ears of the receiving operator at Los Angeles:

"Isaac Rosenblum & Son, Los Angeles: Ship us immediately by fast express one thousand any available lots sizes forty and larger your extra heavy duty or Eskimo brand two-piece undergarments men's red flannel. Goldberg, Heine, and Jacob Company."

"I'm supposed to know something about radio-engineering," declares Mr. Tulver, "but when messages go out correctly on the air from a transmitter and come in on the receiving aerial at the other end with words and numbers entirely altered, then I'm done and I admit it. Every day for the last three weeks, one or more important telegrams have gone wrong. The company is losing business right and left, and we're already threatened with more than a

dozen lawsuits. It always happens on our 4550-meter channel."

"Let's see now," I observes, real thoughtful and Sherlocky like, "there are a lot of places where something can happen to a message. Starting from the beginning, there is the pneumatic tube from the office downstairs to the operating room up here on the eighteenth floor—"

"Wait a minute," interrupts Mr. Tulver. "The messages are going out on the air absolutely correct. We have installed a set of automatic recording receivers tuned to all the different wavelengths of the Palo Alto transmitters; and these receivers record every outgoing dot and dash on a paper tape. The recorders are in our regular receiving house up on San Bruno Mountain, where nobody can come and tamper with the equipment without being caught at it, as there is no house, tree, or bush within a mile in any direction. I have stood watch up there alone with the instruments, and the tapes have recorded the correct message text at all

times, as compared to the originals filed downtown in the city office, showing that every message has gone out into the ether correctly—yet some of those very same messages came in on the Los Angeles receivers entirely altered, such as the one you have read.

"In order to find out whether the Los Angeles receiving circuits were being tampered with, I secretly installed another complete set of recording receivers near that city. These Los Angeles receivers have invariably recorded the messages in their altered form—the very messages the San Francisco recorders show are going out correctly. This proves that there is nothing wrong with our sending and receiving circuits. Furthermore, there is absolutely no break or interference of the signals observable at any time, either in the operators' head-phones or on the tapes of the recorders. The trouble is not in our system; it is something in the ether outside of our system."

"Let's finish lookin' over our ground, then," I resumes. "The next thing for

us to do is to stop and think who would like to see the Poulsen Pacific put out of business—and I fancy there are several. In the first place, you are buckin' three powerful outfits, the Western Union, the Postit Telegraph and the Yell Telephone and Telegraph Company. Then, too, you control the wireless sets on a long string of ocean ships. This brings you face to face with another group of competitors. For instance, there is Greb & Terkelsen—by the way, I've been told that Thomas Greb and Stephen Glass, your president, were buddies in their younger days; but Greb stole Glass' woman an' married her, and they've never spoken since."

"I've heard something of it," replies Mr. Tulver, briefly. "Speaking of Greb & Terkelsen, we have never considered them as competitors. Greb is more of a stock plunger than a radio manufacturer. I hear he has made five million dollars in oil, and is about out of the radio game."

"Well, there are some other concerns who ain't out of it, by a long shot," I persists. "We have the Radio Freezeouters, Inc.; then we also have the Independent Radio Patent-Dodgers Union, and we have the Westover Electric Company. Let me think it all over and I'll see you later."

TAKIN' leave of him, I starts to take the elevator down to the street; then changin' my mind, I stroll down by the stairs and ramble around through the corridors on each floor of the big office building. Roaming along on the fourteenth floor, I hear footsteps and the sound of a door opening and closing around a bend in the corridor—then the sharp, cold voice of Stephen Glass—

"What are you doing down here on this floor?"

"Havin' a smoke," is the thin, shifty-voiced answer.

"Why aren't you up in the operating room?" demands the big chief of the Poulsen Pacific. "Which channel have you?"

"4550 to Los Angeles," replies the operator, in his rattly, nervous voice. "She's clear just now."

"I want you to go upstairs and stay there during shift hours," snaps Glass. "The building superintendent has complained twice about our men smoking out in the corridors. If I catch you again, I'll instruct the chief operator to dismiss you."

Driftin' around the corner, I sees the tall, erect figure of Stephen Glass following a shrimpish, hang-dog-lookin' key-puncher to the elevator.

Strolling along toward the farther end of the corridor, I gets a considerable surprise when I recognizes the Pacific Coast general manager of the Westover Electric Company slippin'

hurriedly in through a door which has lettered on it: "Cleartron Radio Tube Company, Private." Thoughtful-like, I proceeds to size up the outside of this bootleg tube joint when I become aware that somebody is watchin' me. Wheeling about, suddenly, I espies duckin' 'round a corner a white-haired, narrow-jawed, hawk-eyed little gink, who looks to me like one of the "legal investigators" of Radio Freezeouters, Inc. Hearing one of the doors of the Cleartron tube outfit starting to open, I glances back quickly in that direction and sees the short, stocky, nervous, dark-complexioned western branch manager of the Independent Patent-Dodgers Radio Union cautiously peekin' out into the corridor through a crack in the door. When he spots me, he jerks his head back inside and slams the door shut. The next minute, the elevator opens and out steps an engineer of the Yell Telephone Company, an attorney of the Western Union, and a purchasing agent of the Postit Telegraph Company. They are all talkin' together excitedly in a low undertone; and I distinctly hears the words "stock" and "Poulsen Pacific." Seein' me, they instantly freeze up into a guilty silence an' nod briefly; then they hesitate in the corridor, like they don't exactly know what to do next. There bein' no Poulsen Pacific offices on the fourteenth floor for me to step into and get out of the way, I strolls off brisk like and pretend to start to enter a door with the gold lettering, "H. C. Bailey, Real Estate Broker", on it, which is near where the Poulsen Pacific operator got caught catchin' a smoke—whereupon the engineer, the attorney, and the telegraph pole buyer all jump hastily into the Cleartron Tube joint.

"Hum, th' gang's all here, it looks like," I mutters to myself. "All but Greb & Terkelsen."

Down on the ground floor, I espies old Greb himself, a gray-haired, dissipated-lookin' gambler with a long black cigar stuck in his face, filing a telegram in the Poulsen Pacific's city office.

In my whizz-wagon, an hour later, I rambles through the five o'clock downtown crowds, out through the Mission, and up a rocky, narrow, and deserted road leading up onto the top of the San Bruno Mountain, on the southwestern edge of the city. Here, over-looking San Francisco, the bay, and a ship and a flaming sunset in the Golden Gate, stands a small lonely building, surrounded by a big cluster of outdoor loop aerials, each about ten feet square.

Inside, I finds my old pal, Jim Hawkins, the company's chief equipment engineer, who is occupied in hoverin' with a piece of gaspipe an' a murderous-lookin' saved-off shotgun over the maze of inductances and condensers, and long rows of brightly glowing vacuum tubes comprising the twelve big receiving sets

of the Poulsen Pacific's San Francisco terminal.

"Hawkins," I says to the long knight of the shot-gun, who looks more like a Kentucky moonshiner than the cleverest radio-receiver wizard on the West Coast. "I understand you're the designer of most of this gear?"

"Betcherlife!" exclaims Hawkins, stiffenin' up kind of belligerent like.

"Righto," I replies. "Can you fix up a good radio compass tuned exactly to that 4550-meter channel, with your exploring-coil or direction-finder arranged to be swung back and forth through a complete circle about fifteen or twenty times a minute by a small electric motor. Can you hook the compass to one of these recording receivers and set up an interlocking switch controlled by the stylus lever of the recorder and a cam on the compass-swinging mechanism, so that if any 4550-meter waves, outside of those radiated by the Poulsen Pacific arc at Palo Alto, come in on the compass, it will ring an alarm bell and stop the compass-swinging motor, thereby leaving the direction-indicator pointing in the direction of the strange 4550-meter signals?"

"Sure I can!" exclaims Hawkins, his wild eyes lightin' up enthusiastic like. "I'll tell Tulver t' send th' regular watch-crew back up here, an' I'll get down to th' factory right away. How many of them wireless bloodhounds do ya want—one or a dozen?"

"Four," I replies. "Set up one right here, and one somewhere over on the eastern side of the bay, say about at Hayward; take the other two down to Los Angeles and set them up about thirty miles apart, east and west of the city. If there's somebody on the Pacific Coast comin' on the air on the 4550-meter tune of the Palo Alto arc, we have to spot him. Put a good man on watch at each compass, have him sleep an' eat alongside it, an' tell him as soon as he gets an alarm, to stick on his head phones and get a' accurate compass bearing on the strange station. Don't let nobody know what you're doin', don't do any talkin' over Yell Telephone wires, use automobiles to carry your stuff, an' work fast."

While Hawkins is phoning for the crew, I starts back downtown. Upon reaching lower Market Street I am 'roused by a newsboy shriekin' "Wux-tree! Wuxtr-e-e-e! Five million lost by phony telegram!"

Navigatin' in to the curb, I buys a paper, an' finds this glarin' front-page headline streamer an' story:

"THREE WORD TELEGRAM COSTS FIVE MILLION!"

"Mr. Thomas B. Greb, meteoric oil speculator who made five millions in Long Beach deals recently, and well-known manufacturer of the famous 'Radio Ford', is a penniless man tonight. Mr. Greb, through his Los Angeles broker, Philip C. Thornton, last

(Continued on page 50)

Audio-Frequency Amplification

A Comparative Analysis of Amplifiers With Specific Reference to Transformer Characteristics

By G. M. Best

THE design and construction of an audio-frequency amplifier for use with a loud speaker has been the subject of much discussion and some disagreement. It has become of especial interest since many radiocast stations have put out a high quality of speech and music, making it worth while for those who appreciate good music to improve their receiving sets. After the sounds have left the singer's lips or the player's instrument there begins a succession of transformations which carry those sounds ultimately to our ears, and it is these transformations which will make originally perfect music seem either perfect or imperfect according to the degree of accuracy of the transformations.

Speech and music may be analyzed into a large number of separate single frequencies ranging from as low as 30 or 40 cycles per second to as high as 10,000 or more cycles per second. Any given sound is a combination of several of these frequencies in some certain proportions. Changing either the frequencies present or their proportions will change the character of the sound. For example, when a speaker says "ah" and "oh" at the same pitch and with about the same intensity he is combining with approximately equal amounts of some fundamental frequency two different proportions of certain higher frequencies. The result is recognized by our ears as two distinctly different sounds.

If the music originating in the studio is to reach our ears as perfect music, the successive transformations must each obey the following rules:

1. The transformation must introduce no new frequencies except such as will be eliminated in the final result.

2. Exactly proportional energy changes must take place; *i. e.*, if a single sound frequency emitted with 1 unit of energy is received with 1.3 units, another similar sound frequency emitted with 3 units must be received with 3.9 units of energy. Any piece of apparatus in which this condition is fulfilled may be said to have a good *amplitude characteristic*.

3. All frequencies comprising speech and music must be amplified or attenuated exactly alike. The corresponding characteristic of the apparatus is known as its frequency characteristic. Not quite all of these frequencies are necessary to provide music so perfect as to be indistinguishable from the original even by a trained musician but, in general, the frequencies from 50 cy-

cles (important for organ music, piano, drums, etc.) to 5,000 cycles (important because of violins, piccolos, etc.) are necessary to provide good music.

Each of the three rules given must then be obeyed for each transformation taking place, for if, at any one step, the transformation is faulty the final result will also be faulty. It is important to keep this in mind when trying to eliminate distortion in a radio set, since no loud speaker, however perfect, can give out perfect music when used with an imperfect amplifier; and no amplifier, however perfect, can give perfect music with an imperfect loud speaker.

With respect to rule 3 only, it is possible to have one transformation favor the high notes and another the low notes in such a manner that the final result will be impartial to all frequencies, that is, having one frequency distortion balance another. It thus happens occasionally, though rarely indeed, that the frequency characteristic of a poor loud speaker will partly balance that of a poor amplifier so that the poor loud speaker will sound better than a good one when they are alternately tried. Always, however, better results may be obtained by using a good loud speaker with a good amplifier.

If we were to have but one radiocast station and one receiving set it might be economical to use station apparatus which favored the high frequencies and balance it in the receiving set by equipment which favored the low frequencies by a corresponding amount so that the final result would be a uniform reproduction of all frequencies. However, since there are actually many thousands of receiving sets for every radiocast station it would doubtless be more expensive to make the receiving sets compensate for the poor frequency characteristic of the station than to spend the several thousand dollars necessary to improve its characteristic.

To accomplish this the station must have a microphone which is much more faithful in reproduction of sounds than the ordinary type which suffices for telephone use. Such microphones, constructed on the push-pull principle, have been developed and are in use in many stations. The output from these micro-

phones must then be amplified in an amplifier which is as nearly distortionless as possible and then used to modulate the carrier wave of the radiocast station.

Vacuum Tube Amplifiers

EACH stage of a vacuum tube amplifier consists of two essential elements—a vacuum tube and a coupling device. Under proper conditions the vacuum tube itself is an almost ideal amplifier, having, below 5,000 cycles, an almost perfect frequency characteristic and, with the proper *A*, *B* and *C* potentials, a very nearly perfect amplitude characteristic. Coupling devices, however, present a more difficult problem for, while they usually have nearly perfect amplitude characteristics, they cannot be made to have perfect frequency characteristics except at great expense and with some difficulty.

In order to help the constructor build an audio amplifier of any desired degree of perfection in the most economical manner possible and to enable those who already possess imperfect amplifiers to improve them economically, the frequency characteristics of a large number of coupling devices have been measured, a few of which are here presented in tabular form and others as curves.

Those interested in knowing how these measurements were made will find a description of the method in the last paragraphs of this series of articles. The accuracy of these measurements has been found to be better than $\pm 5\%$ for amplification ratios less than 30 and $\pm 7\%$ for greater amplifications. The frequency characteristic for a given transformer could be duplicated with 1% without difficulty.

Three types of inter-tube coupling are now in common use transformer, impedance, and resistance coupling. Of these, transformer coupling is by far the most common, primarily for the reason that 2 stages of transformer coupling may equal in volume 3 or 4 stages of resistance or impedance coupling. It is true also that some good transformers introduce less frequency distortion than some poorly designed impedance or resistance coupled amplifiers. In general, however, transformer coupling introduces a great deal of frequency distortion.

TABLE I.

Amplification Frequency Characteristics of	Typical	Inter-Tube	Couplers				
Frequency	95	200	500	1000	2000	3400	5000
1. Typical Poor Transformer	3.6	9.1	14.1	20.0	25.1	28.2	26.6
2. Very Good Transformer	22.6	23.7	24.2	25.4	26.6	28.8	26.9
3. Impedance Coupled	7.8	8.4	8.2	8.8	8.2	7.8	7.4
4. Resistance Coupled	6.0	5.8	5.8	5.4	6.0	6.2	6.2

Building Sets to Make Money

Some Practical and Helpful Suggestions for the Amateur Constructor of Receiving Sets

By Harry A. Nickerson

MANY amateur set builders fail to realize the difference between "building sets for money" and "building sets to make money." The difference is principally one of system and tools. There are thousands of amateur set builders selling the unlicensed product in violation of no one knows how many patents, but few are making more than a poor day's wage.

At the start there is the element of time to consider. Making radio parts by hand is like cultivating a field of potatoes,—it can be done by hand but it takes machinery to do it at a profit. So one cardinal rule of set building is to use a machine-made product for apparatus assembled in a set, rather than to try to manufacture it. The value of the set builder's time necessary to produce it is greater than the manufacturer's and dealer's profit.

Take a variocoupler as an illustration. One can buy a bakelite tube, a rotor form, bushings for bearings, and a piece of brass tubing for a shaft; but when the assembling and wiring is complete, with the further complication of "stops" and tapping and attachment to panel, the time element has made the expense greater than the cost of the better appearing manufactured instrument.

So with small parts. The city-dweller is of course fortunate because of the great number of radio stores which handle small parts in a city, but the mail order house will supply the deficiency of the small town radio store.

The most useful tools of the set builder are an electric soldering iron and a pair of pliers. It is a good plan to have two irons, one intended for continuous use and the other with a very fine "pencil point" tip for tight places. It pays to buy the higher priced irons with replaceable tips, since the tips generally burn off before the heating element burns out.

The pliers which permit bending of wire to form loops with the end of the pliers, with a cutting device and flat jaws as well, are most convenient, but diagonal end-cutting and "long nosed" pliers are also useful.

By the time the set builder has built a few sets, he has generally seen the necessity for a considerable tool kit, consisting of several sizes of screw drivers, hacksaw, drills, taps and dies, with holders, a drawing board with T square and angles, a scriber, etc. A set of nut drivers for hexagon and round head nuts are a great convenience and save time as well as improve appearance.

Each set should be sold with the thought in mind that it may sell other sets. It is poor advertising to use materials which are not fitted for long and hard use. Save on time but not by buying apparatus that is really cheap in quality as well as in price.

Where the amateur builder often receives little pay, is in the insertion of "extras" in sets. It may take an hour to put a couple of 25c vernier rubber tired "dial adjusters" on a set. Another very common waste of time is the attempt to fit apparatus into cabinets too small to hold it readily. Such sets should only be constructed for the builder's use, where, perhaps he can afford to squander time.

Jacks, especially the filament control type, requires a lot of planning and time in insertion. If customers insist on filament control jacks, the charge should be in proportion. Many manufactured sets, using three or more tubes, have but one jack for the whole set; it is not hard to see where a few dollars is lopped off their selling price.

Engraving on panels, etc, is a matter of difficulty. It is hard to learn to handle an engraving tool. One spoiled panel is more expensive than a lot of expert engraving. A simple line above a dial scratched with a scriber or awl and terminating at the top in a shallow round hole, drilled lightly with a No. 27 or smaller drill, will do for a dial indicator. The placing of transfer engravings is another time-using job. Binding posts with engraved tops (preferably non-detachable) are a solution of the binding-post problem.

The first cost of a cabinet already "finished" may seem high but the reason is obvious to one who has tried to put a "piano finish" on a cabinet. In the large cities, unfinished mahogany cabinets are available at a very low price at the "ten cent" stores, but the usual set builder's finish, is in appearance, what it is in reality, "home made." A "machine sanding" with dustless drying conditions, etc., are needed for real "piano finish." It pays to take lessons in finishing cabinets from an expert. It is no job for a housepainter.

Opinions vary as to the use of bus-bar and soldering lugs, and sphagetti. Probably a judicious use of all three is best. If the bus is to be used with as little sphagetti as possible, it should be "hard drawn." Connections between two posts only can be quickly made by using end loops in the bus wire and dispensing

with lugs. But where a long bus wire must be used with many posts to be connected, the use of soldering lugs makes for speed and ease, rather than trying to make a number of intermediate loops in the long bus. Right angles add to the appearance and should be made for that reason, where but slight increase in the length of the wiring is thereby had, but otherwise short direct leads in a more or less straight line, with bus covered with sphagetti, give better efficiency with good appearance. Round bus is easier to use than square.

Most set builders would like to use resin flux but prefer some sort of soldering paste for quick work. In spite of the hue and cry against "corrosive" paste fluxes, if used sparingly, the paste flux in average hands does better work.

The speed of soldering to lugs varies greatly with the type of lug. Some lugs just won't take solder and have to be individually scraped and "tinned" before being placed under terminal posts of apparatus. One flat type is made of heavy copper heavily tinned and takes solder readily. The use of old discolored lugs is false economy.

A certain amount of system gets to be a habit with most set builders. Thus in most sets, even before the panel is attached to the baseboard, a great deal of the socket wiring may be done, then the panel put in place. Usually the procedure is filament wiring on sockets, placing of panel, wiring of rheos., then jacks, and finally wiring at the rear of baseboard.

The proper placing of tools and small bolts and nuts, etc., is a part of "system." Tools placed in holes drilled in a shelf or supported in leather sockets or on hooks close by the worktable are of course more accessible than when kept in a toolchest and can be put out of the way after temporary use. A cabinet with small drawers helps to keep the large assortment of bolts, screws and nuts necessary for set building, or else several tin "muffin pans" divided into four or six compartments may be used.

The set builder should build so far as possible standard hook-ups in a standard way. The newest reflex set may give fine results under ordinary conditions but be worthless near an alternating electric light circuit with a "60 cycle hum." The attempt to adapt a particular set and hook-up to an odd-shaped panel is a great waste of time. Manufacturers pay heavily for designing

Continued on page 66

Radio and Education

A Suggestive Article
Concerning the Present and
Future Value of Radio for

Class Instruction

By *James A. Ramsey*

ONE of the greatest future functions of radio is its use as an educational force. By this is meant not alone the educational programs intended chiefly for adults in their homes, but especially its use for class-room instruction.

Adult educational work is a feature of many station programs. New York University, with the co-operation of WJZ, created what is called the first "air college." The fall term began in October, 1924. The course consisted of twenty minute lectures on eight subjects and was sent out every week day evening. Washington State College at Pullman is radiocasting its extension courses from its own station, KFAE, and many other colleges are doing likewise. KGO at Oakland, California, has been devoting Monday evenings for nearly a year to educational material, the programs consisting of twenty minute talks on agriculture, economics, English, Spanish and book reviews.

One of the first attempts to use radio in the common schools was made in England. Arthur R. Burrows, Director of Programs of the British Broadcasting Company, wrote an article in the "Teachers World" London, for January, 1924 in which he pointed out that very few schools, public or private, can afford



Miss Myrtle Palmer, penmanship instructor, and her studio class before the microphone at KGO during a recent test radiocast into the Oakland Public Schools.

to hire great authorities to give lectures on their various fields of work, but if all the schools were equipped with receiving sets the lectures could be given to all simultaneously by radio. According to the Journal of the National Educational Association, Mr. Burrows' plan was put into practical operation on April 4, 1924, when lessons in music were given by the famous musician, Sir Walter Davies, to an invisible audience of ten thousand children in the London schools.

A few weeks later, April 30, to be exact, the public schools of Oakland, California began a series of experiments in class-room instruction by radio under the direction of Dr. Virgil E. Dickson, Deputy Superintendent of Schools, who has written an excellent account of the work in the Journal of the N.E.A. The experiments were given with the co-operation of the General Electric Company's station KGO, and consisted of lessons in music, geography, history, arithmetic, penmanship and physical culture. The reports indicated that the lessons in arithmetic and penmanship were the most popular.

Mr. Dickson emphasized particularly that the work in Oakland was actual class-room instruction, in which the pupils continue at work during the progress of the radio lessons and submit the product as tangible evidence of what has been accomplished. In this respect, it is different from all other known attempts at education by radio which consist chiefly of lecture work.

He also stated emphatically that he did not believe the use of radio in the schools would in the least degree affect the number of teachers needed.

I will enumerate some of the results established by Dr. Dickson:

1. There is intense concentration on the part of the pupils who listen in.
2. The need for discipline seems almost negligible during the time of the radio lesson.
3. It offers better training of children in quick, thoughtful obedience to a single direction.
4. It can supplement class room instruction through occasional lessons by the best supervisors and experts.
5. The most perfect planning may be expected for the lesson to be broadcast.
6. The training of radio instructors for planning and delivery will become a new art.
7. Schools in remote or inaccessible districts in the country may come in touch with the best supervision and methods of instruction.
8. Parents and other adult members of the community are intensely interested in the lessons taught in the schools and listen in from places outside the class-room.

Another example of the use of radio in the public schools and one with which you are no doubt familiar is the work proceeding under the direction of Mrs. Grace Stanley, State Commissioner of Elementary Education in California. It was begun on November 3 and con-

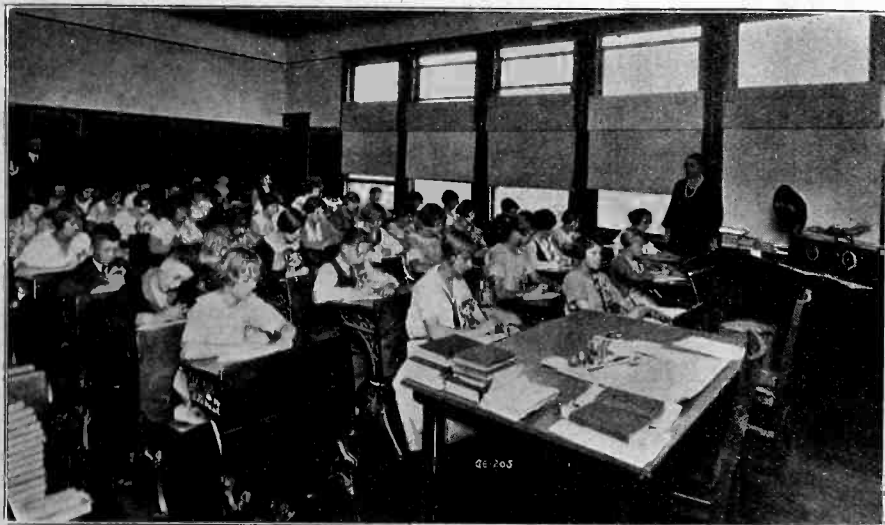

Pupils in the Melrose Heights School, Oakland, California, receiving a penmanship lesson by radio as it is being radiocast from KGO during recent tests made to determine the value of radio in school work.

sists of a series of lectures on geography and history, given by various people of note every Monday morning at 9 o'clock from KGO, Oakland; KF1, Los Angeles; and from KMJ, Fresno. Every school in the state which is equipped with an efficient receiving set is able to tune in on these programs.

Proof of the interest of parents and the general public in the work of the schools is to be found in the experience of some of the Eastern cities. In May, 1924, Rochester received 100,000 replies from those who listened in to their program of Education Week, while Buffalo received 50,000 replies in answer to a definitely organized program designed to give parents and others an understanding of the work and needs of the schools and secure their co-

cannot come to school in person due to home responsibilities or to reticence—and others who perhaps have passed beyond the school age without completing their education and are backward about attending night schools or extension courses or do not do so for other reasons.

The ability of radio to reach isolated individuals and groups must appeal to everyone. People in the lonely homes of the prairies, mountains and deserts, in the logging camps and at the mines, on ships on the high seas, at army posts, with exploration parties in the frozen

broadcast programs for the benefit of these people.

Many school executives have been considering the advisability of providing receiving sets for their schools and some have hesitated to make the purchase thinking that there will be radical changes in equipment. There is no doubt that there will be improvements from time to time just as there are changes in models of automobiles from year to year. I do not believe, however, that anyone should hesitate on that account because satisfactory reception has already been accomplished as is evidenced by the splendid performance of many fine sets on the market today.

RIBBON MICROPHONES AND SPEAKERS

By W. H. WATERMAN

The Siemens-Halske ribbon microphone is a recent German development which is claimed to be unaffected by mechanically transmitted vibration, responding only to the air-borne sound waves which it is intended to catch,—a thing which recommends it immediately to mobile transmission from trains, trucks, planes or, in short, wherever it is extremely difficult to employ the ordinary type of microphone. It is also claimed to cover the audible scale of sounds from the highest violin or piccolo tone to the deepest bass of the drums.

The apparatus is housed in a small, square box with another smaller box mounted upon it. It has no horn nor funnel to gather up minute sound; it is therefore independent of directional sound efforts, which adapts it perfectly to theatrical stage pick-up broadcasting, public-speech pick-up, fights, football games, etc., and this combined with its super-sensitivity leads us to predict that it may have a brilliant future in police work, supplanting the detectaphone.

Mechanically it consists simply of a very thin corrugated ribbon of aluminum, only a few thousands of a millimeter thick, suspended between the poles of a magnet so that the plane of the ribbon, with its corrugations, parallels the magnetic lines of force. The corrugations serve to make the ribbon extremely elastic, with its natural period of oscillation strongly damped and far

(Continued on page 67)

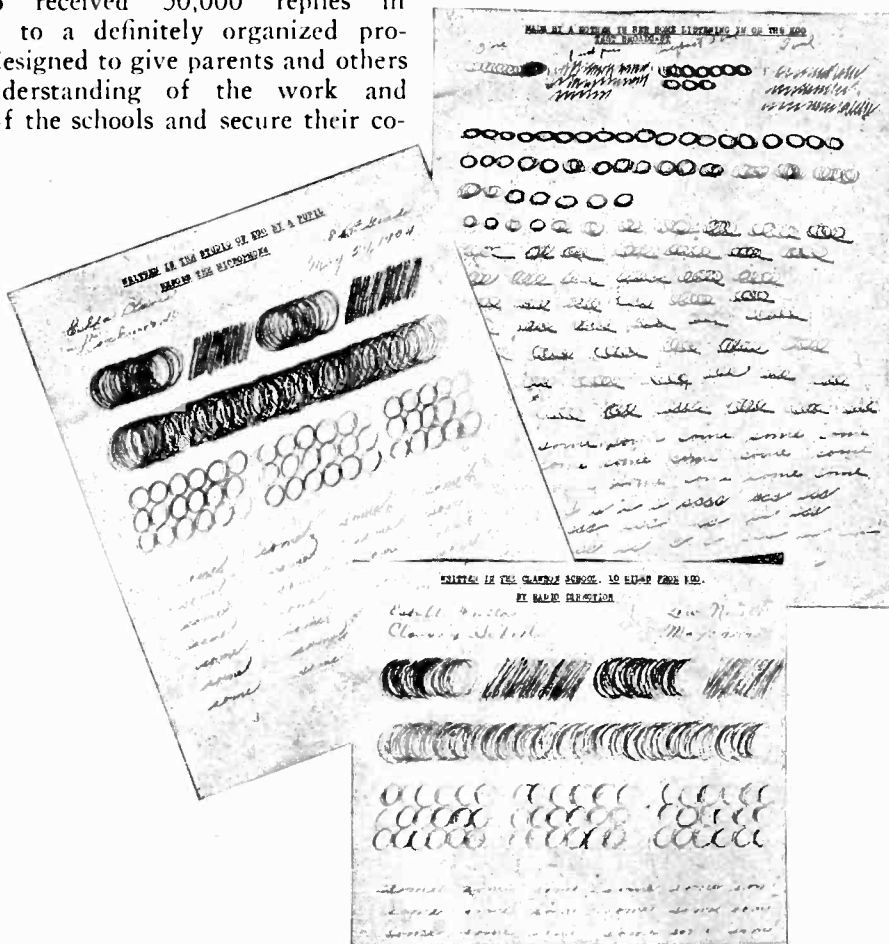

Specimens of Penmanship Taught by Radio

operation and support—a task, which, in the past, has been left to the Parent-Teachers' Associations, Visitors' Days, newspaper items, etc.

Many letters have also been received by KGO from parents saying that for the first time they have been able to get an understanding of the work being done by their children so that they could keep up with their progress and be of assistance to them. Many mothers listen regularly to the lessons and study them in order to help their children in their work. For the first time in history an effective means of educating parents and others along with the children and of enlisting their assistance and sympathetic understanding is now awaiting application.

It seems to me that one of the outstanding benefits of radio instruction in the public schools is that it will be received by outsiders—the parents, who

north, disabled people at home or in hospitals or sanitariums, are all in a receptive mood for education by way of radio. They need something substantial to occupy their minds. It occurs to me that it ought to be considered a responsibility by the educators of the country to make an organized effort to

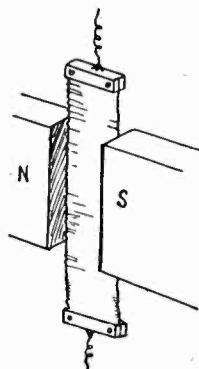

Schematic Plan

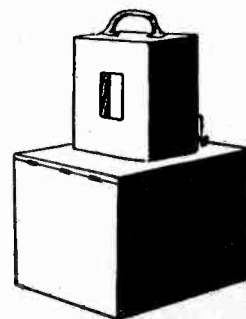

Exterior Appearance

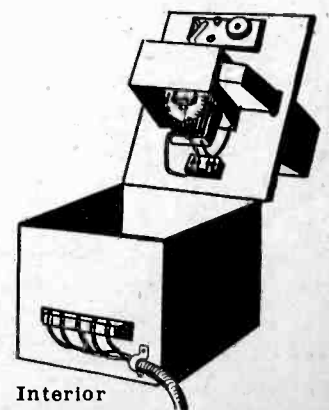

Interior

Siemens-Halske Ribbon Microphone

A Short Wave Loop Receiver

Simple Directions for Building a One-Tube 80-Meter Receiver

By Alexander Maxwell 9BRE-6CKG

THERE is hardly a ham who has not tried his luck with a loop receiver, and as a result there are very few who do not say "bah" whenever one is mentioned. The results fell so far short of expectations that the whole system came to be looked upon as a farce. Some of the more ambitious finally make fairly good records by using a half dozen or so tubes.

But a set which will not hear anything over a few hundred miles on 200 meters, will drag in the DX by the carload on 80 meters, and it is readable stuff too. It was quite a surprise to me when Joe Brubaker of 9DUW called me up and said that he had a loop going and was hearing sixes one right after another, and was only using one tube. I found that he was not over-estimating the set a bit. It seemed to give as great a volume as with an outside aerial, and besides much of the interference and induction was eliminated. I sat and listened to the distant stations without a bit of local interference until early morning.

The circuit is the conventional primary, secondary and tickler which has proved its worth time and again. There is nothing freakish and there are no tricks to the operation. Of course it is understood that to be really efficient the set must be low-loss.

The loop is wound on a wooden frame 18 in. across. The rims are not needed, but if the loop is to be put in a place where it is liable to be bumped they make good fenders. Do not use any patent varnish on the frame. Shellac excludes the moisture and is a fairly good insulator. The wire should be as large as possible. The best way to insure your loop being a failure is to use No. 30 wire. Ribbon antenna is good, but in anything larger than that eddy cur-

rents will detract from the signal strength. On this loop No. 10 enameled wire was used. Five turns spaced $1\frac{1}{2}$ in. apart are about right. The loop is suspended from the end of a bracket arm fastened to the wall and may be swung, by means of a handle at the lower corner.

The rest of the set is standard low-loss equipment. The primary coil consists of 5 turns of No. 12 enameled wire wound on an oatmeal box. They are then slipped off the end of the box and held together with string. The coupling is not critical, and the coil may be fastened permanently, but it makes the set slightly more flexible if it is movable. The primary condenser is an 11 plate. This will tune from 60 to 125 meters.

The secondary is wound on an ice cream carton. These are as nearly a perfect dielectric as can be found. The paper is saturated with paraffin. It is light, moisture proof, and very strong. Have the bottom of the carton at the end facing the primary. The tickler rotates in the open end. The secondary is wound with 15 turns of bell wire. The coil should be placed so that there is a minimum of dielectric in its field. A strip of thin wood screwed to the carton and in turn fastened to the baseboard makes an ideal support—the secondary condenser has 15 plates, giving the circuit the same range as the loop.

The tube is a 201A mounted in a

pyrex glass socket. Later a WD12 without a base was used, and results were slightly better.

The rheostat is a Howard 25 ohm. The make is not important as long as it serves the purpose.

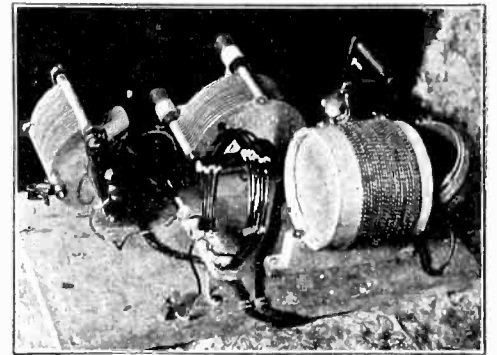

One-Tube 80-Meter Loop Receiver

The unique part of the set is the tickler mounting. A trip was made to the "suregyp" radio and sporting goods emporium around the corner and the mouldiest and highest loss condenser in stock was picked out. It cost \$1.05. As soon as Joe reached home he took it all apart and threw the plates into the garbage can. From a piece of brass curtain rod of the same diameter as the shaft was cut a 9 in. piece. The wreck of the condenser was now reassembled. The tickler coil was wound on a cardboard tube, and the tube fastened to the shaft by means of washers jammed on

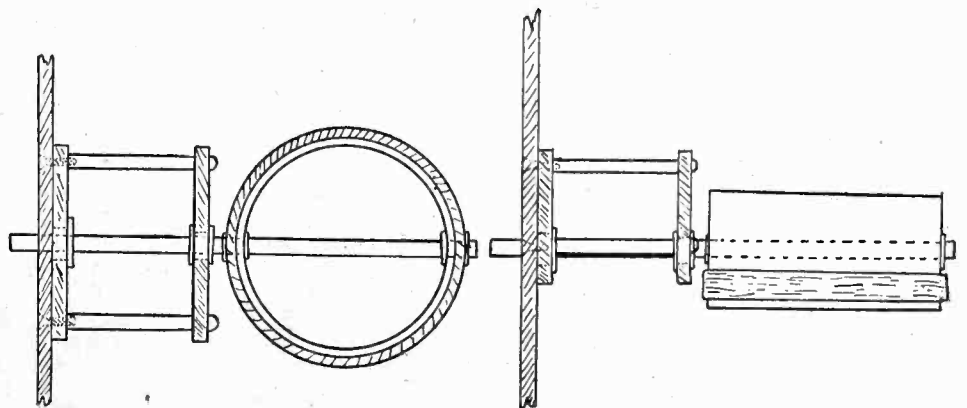

Tickler Coil Mounting

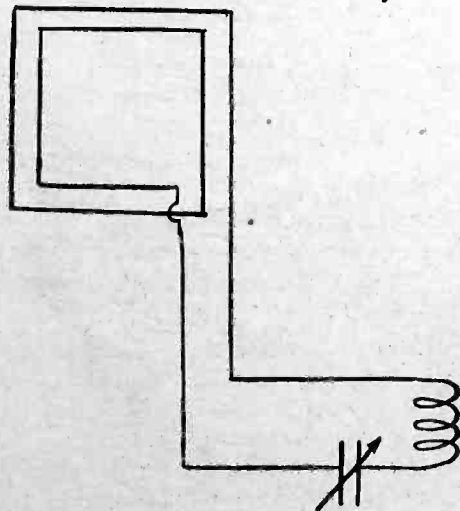

Circuit Diagram of Low-Loss Loop Receiver

and then soldered in place. There is some end play, but not enough to hurt. The bearing runs smooth and all cussing is eliminated for the tickler quits rotating the moment the hand leaves the dial. The number of turns used in the tickler has to be found by experiment. It will be close to twelve.

Don't do too nice a job of wiring. Keep all wires clear of the baseboard and avoid right angles and other fancy

(Continued on page 75)

Testing Electrolytic and Kenotron Rectifiers

Some Interesting Observations of Load Tests and Moduloscope Indications
By Frank C. Jones

PLENTY of theoretical dope on rectifiers has appeared but very few actual tests seem to have been made on any of the various types in general use in amateur stations. Having nothing else to do we ran some load tests on an electrolytic rectifier and on a small kenotron unit, the latter using two of the UV-216 tubes rated at 20 watts.

No filter of any kind was used, the load being merely a variable resistance which in reality consisted of the load resistance and the voltmeter in parallel. As the voltmeter drew from 10 to 20 milliamps it was placed outside of the milliammeter. The power input in all cases was measured by means of a wattmeter in the primary of the step-up or plate transformer so the efficiency curves are for the overall efficiency of the entire unit, transformer and rectifier. The plate transformer was of 500 watts rating and operated at fairly high efficiency except at great overloads, in fact the losses in it were practically negligible in comparison with the losses in the rectifiers.

A glance at the curves will show low efficiencies for the electrolytic rectifier,

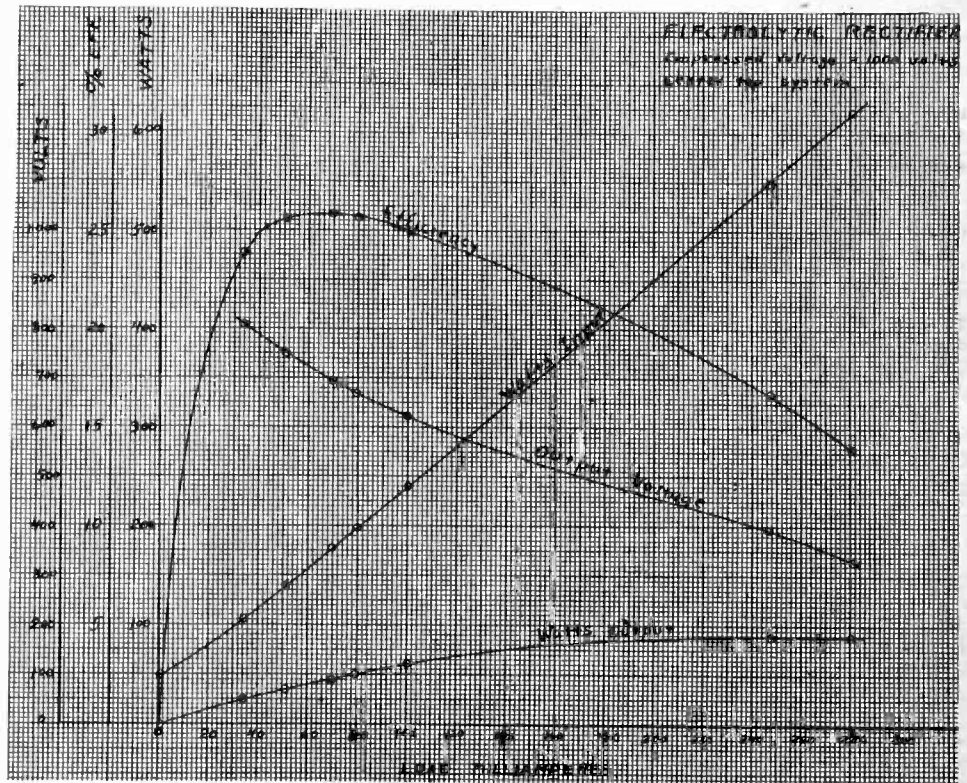

Curves of Electrolytic Rectifier, Center Tap System, with 1000 Volts

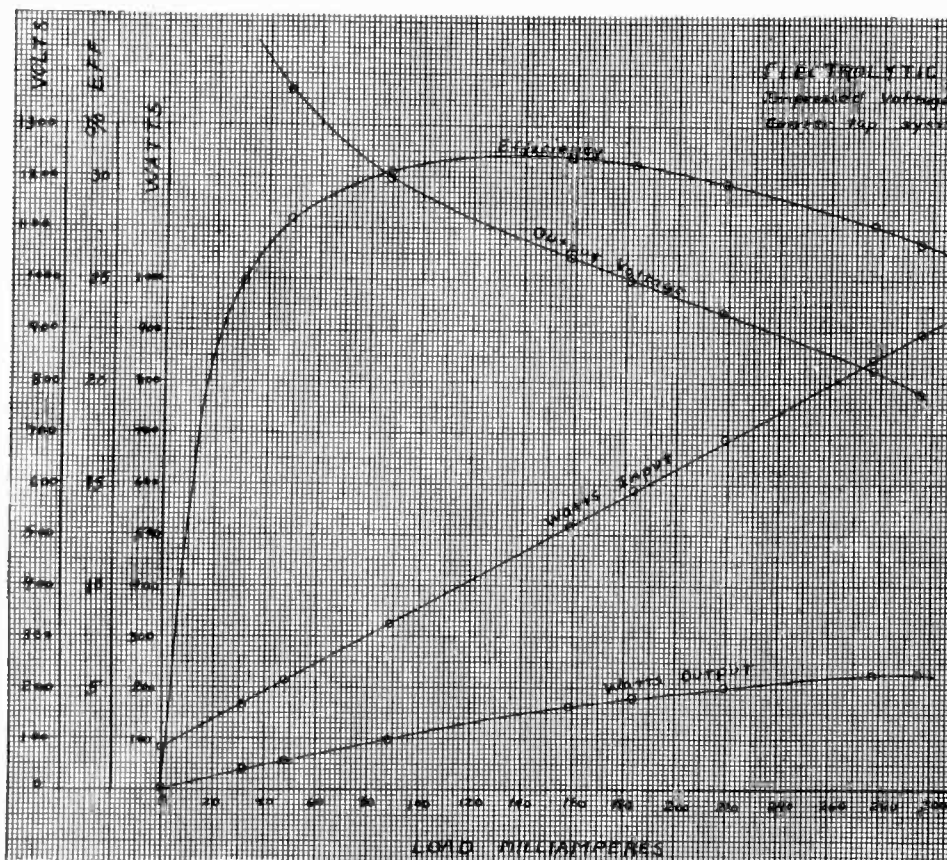

Curves of Electrolytic Rectifier, Center Tap System, with 1500 Volts

the maximum value being about 31 per cent, but this seems to be about the average value for any good chemical rectifier. In the case of impressed voltage of 1500 volts, the rectifier was operating with nearly all of the aluminum plates just showing an even blue glow all over and only 2 or 3 sparking slightly. Whenever the plates began to spark due to high voltage, the efficiency went down quite rapidly.

However the same thing happens if the rectifier is underloaded, as shown by the curves of the tests with the impressed voltage at 1000 volts. The rectifier was originally designed for 1500 volts and 150 milliamps, that is 50 volts per cell and 50 milliamps per square in. of active surface were allowed and the curves prove quite conclusively that these are about the best figures to use in designing a rectifier.

The curves show that neither greater or less than normal load should be used if any degree of efficiency is desired and they also show how poor the voltage regulation is for this type of rectifier. However the voltage regulation of nearly any other kind is just about as poor.

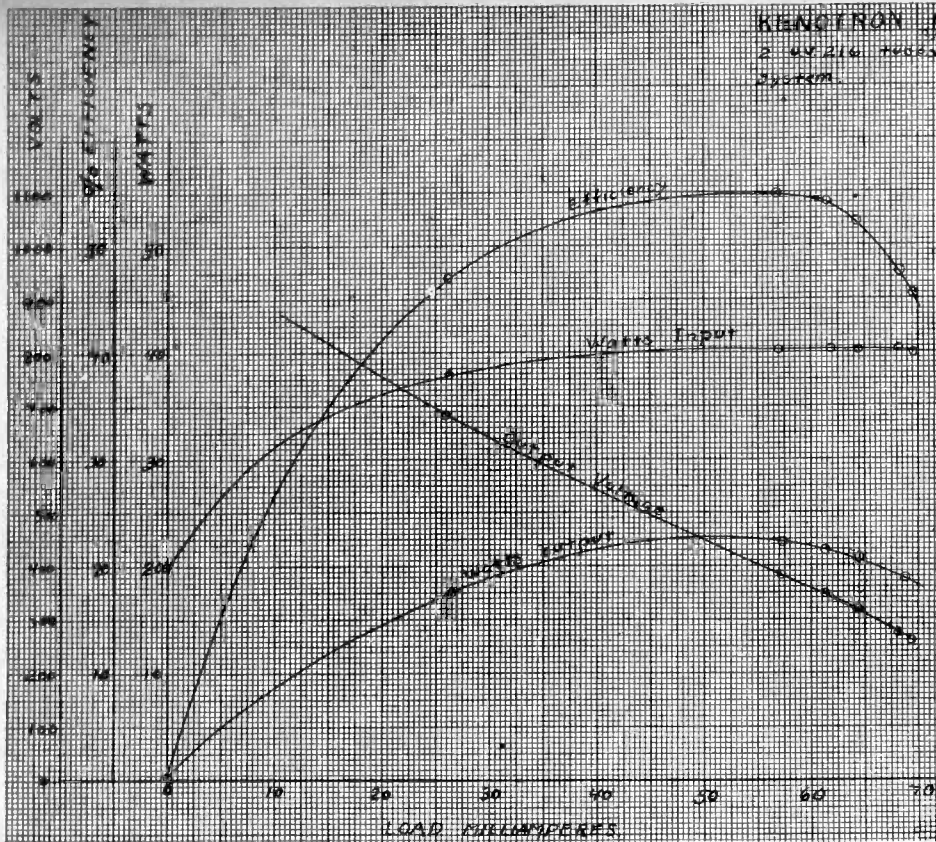

Performance Curves of Kenotron Rectifier. Center Tap System, Using Two UV-216 Tubes

A glance at the voltage curves helps explain a little of the distortion present in so many fone stations because any variation in plate current would change the point of operation on the voltage curve and so cause a greater or less change in the power output than there should be. This would not apply in the case of Heising modulation as that system is practically a constant current system. The use of a large bank of condensers would undoubtedly make the voltage regulation better and increase the output voltage here about 100 volts. However these load tests were run without any filter as it was thought that the characteristics of the rectifier could be better studied in that way.

The curves of watts output show that there is a maximum load which can be drawn from the rectifier and if any greater load current is drawn, the voltage drops so fast that the actual power output decreases. By using more surface of aluminum, this trouble can be cured.

The kenotron rectifier shows a much higher efficiency, reaching about 55 percent, but if the power consumed by the filaments had been taken into account,

very much higher output than that of the normal rating as given by the manufacturers. The voltage regulation appears to be very poor but is not really so because of the fact that the primary voltage was being reduced at the same time. This is apparent from the watts input curve which shows practically constant power input after the first two or three readings and was due to the use of a fixed resistance in series with the transformer primary, the voltage drop across the resistance increasing for increasing loads.

These curves have been presented in hopes of helping to clear up a little of the haziness which seems to be prevalent among the amateurs concerning two of the most popular types of rectifiers now in general use.

An interesting experiment was tried out in conjunction with these tests which gave an indication of the quality of DC given by the rectifier and filter. A Reinartz moduloscope was hastily put together using a 50 watt oscillator in the Hartley circuit with a large variable condenser across the primary coil for tuning purposes. A 250 turn coil of No.

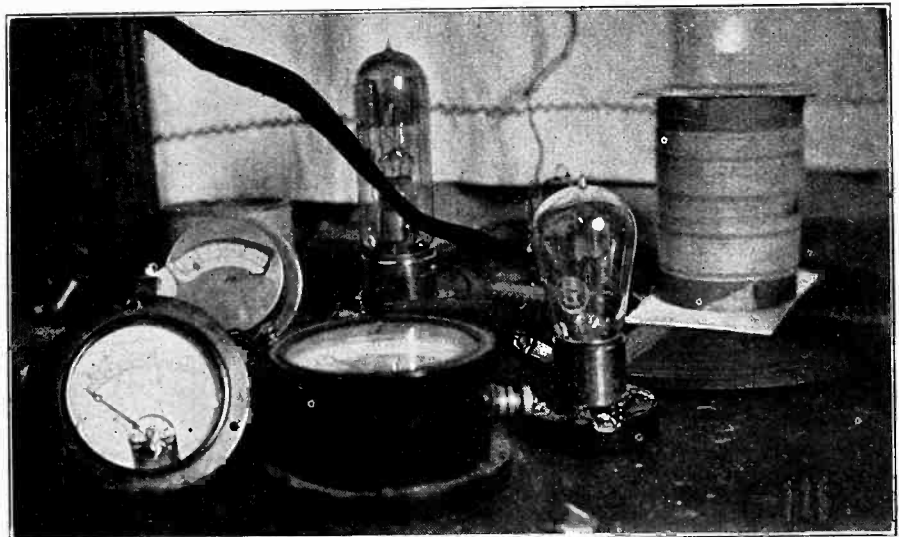

Set-Up for Moduloscope Observations

the efficiency would have been about the same as that of the electrolytic type. The maximum efficiency seems to occur at 32 wire on a 4 in. tube was used and a metal bearing compass needle with copper wire arms soldered on it were used

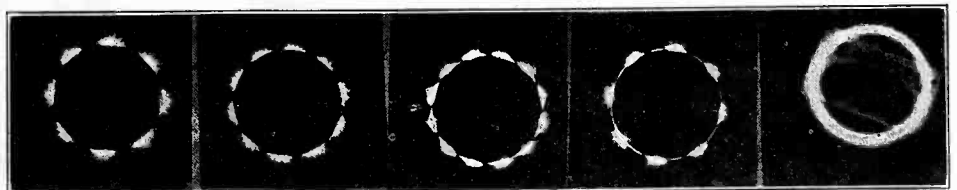

Spark Discharges Observed With Moduloscope

60 cycle A. C. without rectifier	1/2 wave rectified without filter.	Full wave rectified without filter.	1500 volts across one side and 1000 across other.	5 mfd. and 30 henrys in filter.
----------------------------------	------------------------------------	-------------------------------------	---	---------------------------------

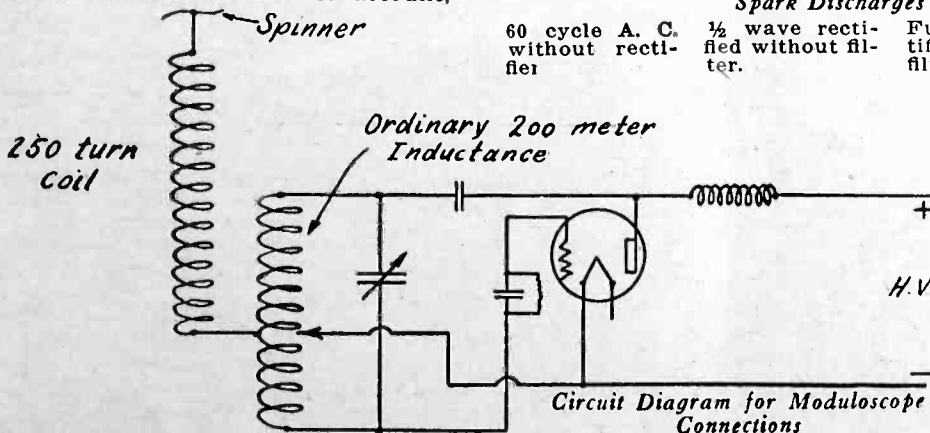

to complete the apparatus. By varying the primary condenser until resonance was reached, the spark discharge from the revolving ring can be so controlled that the dots can be held in one position. It only takes an hour or so to set up the apparatus and a great deal of pleasure can be derived from it in performing various experiments. The results of a few experiments tried out here are shown in the pictures of the spark discharges.

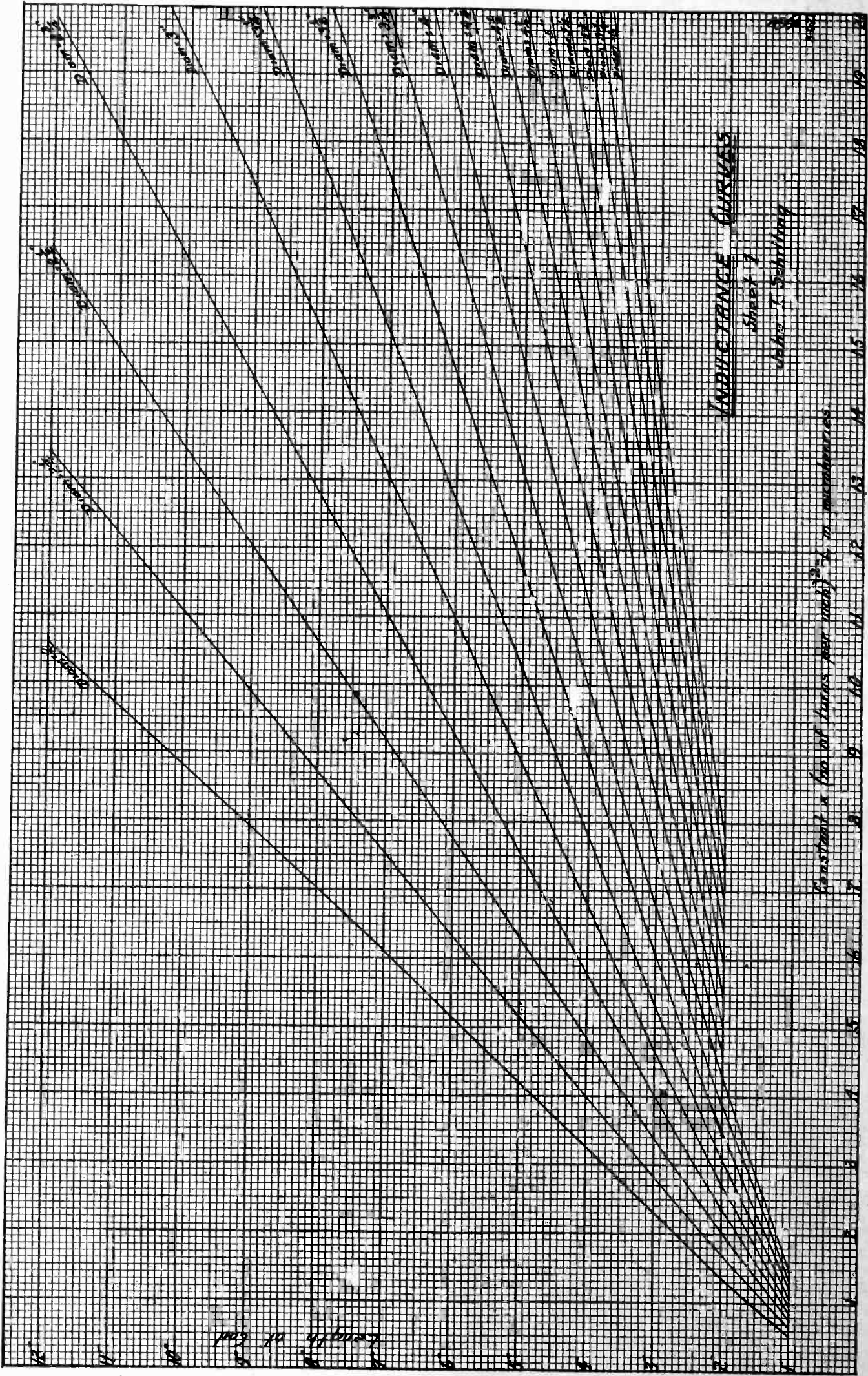

Chart for Calculating Inductance of Different Sized Coils
 (Continued on page 36)

A Short Cut In Calculating Inductance

An Explanation of the Accompanying Charts of Values for Single Layer Coils

By E. M. Sargent

INDUCTANCE, capacity and resistance are the three basic factors that determine the properties of all radio frequency circuits. They are, therefore, the three factors with which the designer of a circuit is most concerned and in order to correctly design either a circuit or a piece of radio apparatus, it is necessary that all three of these factors be determined with reasonable accuracy.

The resistance can be found directly by referring to a standard wire table and multiplying the direct current resistance by a variable which is determined by the frequency at which the piece of apparatus or the circuit is to be operated.

The capacity of a circuit is a little harder to calculate but as the capacity is nearly always a known quantity on account of standard capacity units used, it does not trouble the designer nearly so much as inductance.

Inductance may be defined as the property of a coil to store electromagnetic energy. Its values for any coil depends on several things. The larger the diameter, the greater the number of turns, or the longer the coil, the greater its inductance will be. The ratio of the diameter to the length and the number of turns per inch also affect the value of inductance. It is not the purpose of this article to develop a formula for inductance. There are many of these which will fit the average coil used in a radio set and with which the inductance may be computed within an accuracy of about one per cent. However, all of the standard formulas are rather long and can be simplified so as to make the computation of inductance a very simple matter. The need for such a simple formula is shown in the examples given at the end of this article.

The simplest standard formula for inductance that fits radio coils of the shapes most used in present radio sets is as follows: $L = .000254n^2aK$, in which L equals the inductance in micro henries, n equals the total number of turns, a equals the radius of the coil in inches measured to the center of the wire, and K is a constant whose value depends on the shape of the coil. Values of K for different lengths and diameters are given in many text books.

This formula is a very good one and is fairly easy to use where n , a and K are known quantities and the inductance is unknown. But if the designer tries to use this formula to find the required number of turns for a coil of a given inductance, it becomes a rather compli-

WINDING DATA (Turns per Inch)					
Size B-S Gauge	Enam- eled	S.C.C.	D.C.C.	S.S.C.	D.S.C.
20	29	25	23	27	26
21	32	28	26	31	29
22	36	31	28	34	32
23	41	34	31	38	36
24	45	37	33	42	39
25	51	41	36	47	43
26	56	45	39	52	46
27	64	49	42	57	52
28	71	54	45	63	56
29	79	58	48	70	62
30	88	64	52	77	67
31	100	69	56	85	72
32	112	75	60	93	78
33	125	81	64	102	84
34	140	87	68	112	91
35	156	94	73	120	97
36	173	101	78	130	104
37	201	108	84	141	110
38	225	115	89	151	117
39	256	122	95	163	123
40	288	130	102	178	129

cated matter. By plotting a large number of curves, the formula can be so simplified that only a single calculation is required to find either the inductance, the number of turns, the length, or the diameter of a coil, the other three quantities being known.

In the formula shown above, n equals the total turns or the turns per inch times the length of the coil. Let n_1 stand for the number of turns per inch; then n equals n_1 times l , where l is the length of the coil in inches. When the size and shape of the coil remain the same, the inductance varies as the square of the number of turns. Therefore, L will vary as n_1^2 . Call L_1 the inductance of the coil when there is one turn to the inch. Then to get the inductance of the coil multiply L_1 by n_1^2 squared. n_1 is a quantity that is easily obtained from any standard wire table, such as that given in the accompanying table.

Referring again to the formula $L = .00254 n^2 a K$ and substituting we get $L = .00254 n_1^2 l^2 a K$ and $L_1 = .00254 l^2 a K$.

The formula is now in such shape that it can be plotted on graph paper as shown in Figs. 1 and 2. The length of the coil is plotted along the ordinate and L_1 the inductance for one turn per inch is plotted along the abscissa. A separate curve is plotted for each diameter. The shape of these curves is determined by the constant K which is called the form factor. K , as pointed out before, depends on the ratio of the diameter to the length of the coil. These curves cover nearly every size and shape of coil that is used in the ordinary radio set.

A few simple illustrations will quickly show the reader the advantage of these "short-cut" inductance curves. Assume that a coil is wound with No. 22 double cotton covered wire on a 3 in. tube. The length of the coil is 4 in. and the problem is to find the inductance. The table shows that No. 22 D.C.C. wire winds 28 turns to the inch. Next, find the curve in Fig. 1 that is marked 3 in. diameter, and find the point on this curve for a coil 4 in. long. Reading down from this point, L_1 is found to equal .68. The inductance of the coil is, therefore, .68 times 28², or 533.12 microhenries. Thus, it is seen that the calculation of inductance has been reduced almost to the simplicity of mental arithmetic.

Another example is as follows: Suppose that in designing a circuit, an inductance is needed that will have a value of 200 microhenries. The wire to be used is No. 24 D.S.S.C. The diameter of the coil is always either arbitrary or predetermined by known physical conditions. Assume that the diameter is to be 2 in. The problem is to find how many turns are to be wound on the 2 in. form to get an inductance of 200 microhenries and how long the resulting coil will be. Referring again to the wire table, it is found that No. 24 D.S.C. winds 39 turns to the inch. The square of 39 is 1521. Dividing the inductance, or 200 microhenries, by 1521, gives the value of L_1 equal to 0.13. Refer to Fig. 2 and read up from that value of L_1 to the curve, then over to the left to find the length of the coil. The length is about 1.95 in. Multiplying this length by the number of turns gives 76 as the number of turns that must be put on the coil.

A great deal of labor is necessary to plot these curves. The calculating has been very carefully done and by actual test these curves have shown themselves to be accurate within about one per cent. It is, of course, understood that they apply to single layer coils only.

JOAK are the call letters of the new radiocast station to be started by the Tokyo Radio Broadcasting Co., at Tokyo, Japan. This will be a 1500-watt station operating on 375 meters. Viscount Goto is the president of the company, and N. Shinuryo, who has resigned as director of the Tokyo central telegraph office, is to be the managing director. A similar station is to be installed at Osaka.

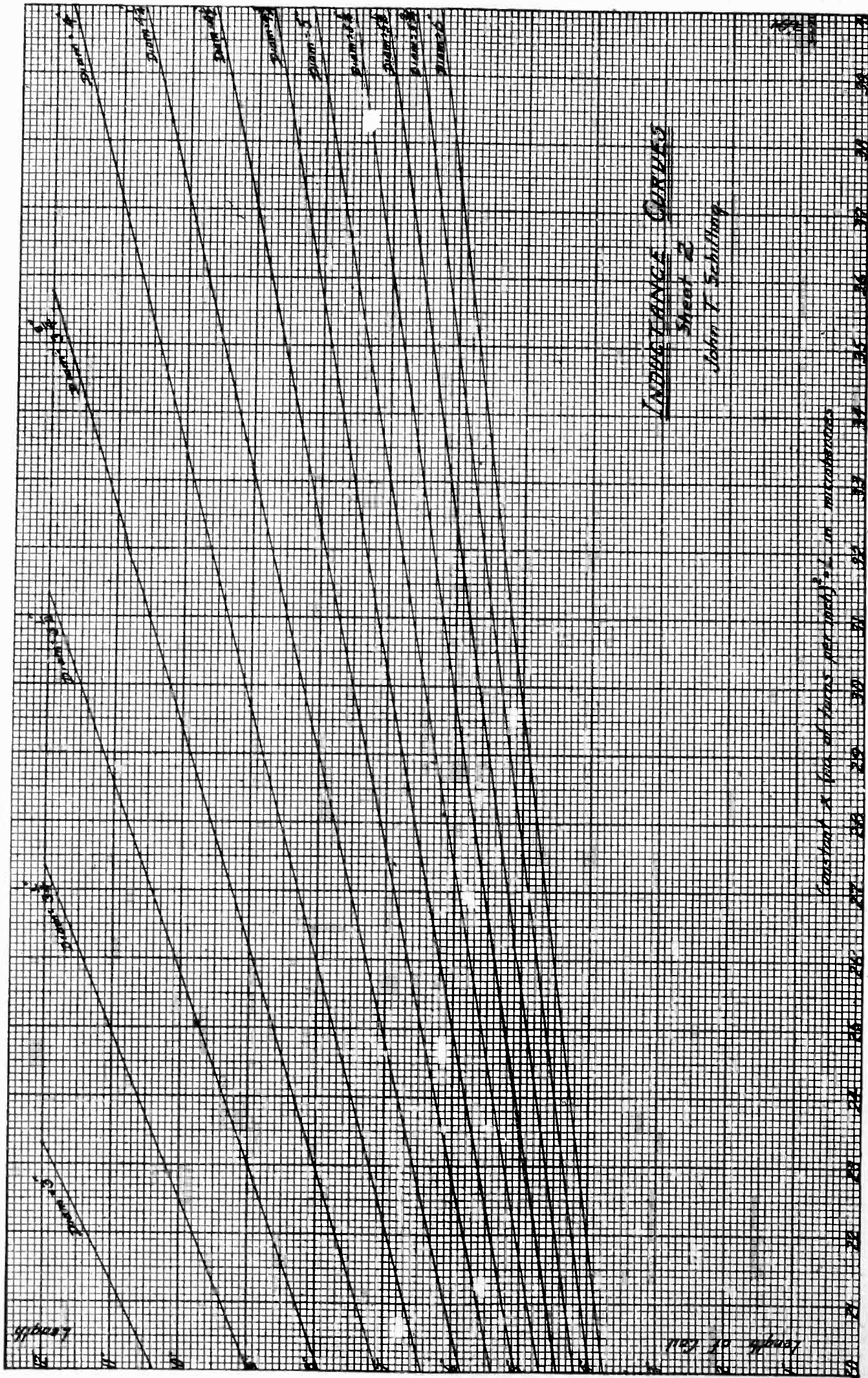

Chart for Calculating Inductance of Different Sized Coils
(Continued from page 34)

Harmonic Interference

An Interesting Explanation of Some Obscure Causes of Interference
for Which Amateurs are Sometimes Wrongly Accused

By *D. B. McGown*

HARMONIC interference, where-
in harmonics from transmitting
or receiving sets are found at fre-
quencies (wavelengths) far removed
from their proper or assigned place, is
one of the most subtle, troublesome, and
uncanny sources of radio disturbances.
A harmonic is a radiation of higher fre-
quency than the fundamental alternat-
ing current which may be produced by
an oscillating vacuum tube and its as-
sociated circuit constants. Harmonics
may be two, three, four or more times
the frequency of the original or funda-
mental wave and are usually of much
less intensity.

The radiation of harmonics is pro-
hibited in the case of a class B station,
special apparatus being installed in the
antenna circuit to prevent it. Many
class A and C stations have also made
efforts to eliminate harmonics. Conse-
quently the main source of trouble is
the radiating receiver, especially the old-
fashioned single circuit sets.

The ordinary regenerative set, includ-
ing the single circuit, may be tuned in
two ways: (1) By first tuning to the
signal, if it can be heard, and then in-
creasing the feed-back until the tube is
just ready to spill over into the oscillat-
ing state, but not allowing it to do so.
(2) By first letting the detector tube
oscillate and then tuning around until
the detector tube frequency heterodynes
or beats with the carrier of the distant
station, giving the familiar audio fre-
quency beat effect called blooming.

This latter method is emphatically the
wrong way to tune. Not only does it
produce the much discussed blooming
oscillations on the wave to which the
set is tuned, but it also causes radiation
of the harmonics of that wave or fre-
quency. While these harmonics are
weak they are capable of creating con-
siderable disturbance.

Suppose that the listener is interested
in receiving on a wavelength of about
450 meters, which is right in the mid-
dle of the radiocast band, and that he
is tuning around on this wavelength by
varying his condenser up and down with
the detector tube oscillating. Although
he is not aware of it, his detector tube
also sets up frequencies of much less mag-
nitude on 225 meters, 150 meters, and
quite possibly on 75 meters, 225 meters
being the second harmonic, 150 the third
harmonic, and 75 meters the sixth har-
monic. It will be seen that the second
harmonic of 225 meters is within the
Class A station wavelength band, and

the other two harmonics are right at the
bottom of two amateur bands. It is
within the bounds of possibility that
there will be stations operating within
a few miles of the receiving set, on each
of these wavelengths—or there might be
a very powerful station on 37.5 meters,
which would be on the 12th harmonic of
the oscillating detector in the listener's
set, which might be some distance away,
but with sufficient power to give a strong
signal on that wavelength. If it so
happened that there were such stations
operating within half mile from the re-
ceiving station, each and every one of
them would be audible on what appeared
to be 450 meters, and the average listener
would be almost certain that the inter-
fering stations were actually on that
wavelength. Possibly the number of
stations is somewhat exaggerated, but
the action as described is entirely within
the bounds of reasonable probability.

Other receiving sets are equally liable
to such interference, as the regenerative
set above described, but that set, for-
tunately, is seldom operated in the con-
dition of continuous oscillation. In fact,
the condition of oscillation is one that is
really undesirable, if for no other rea-
son than that it distorts the received
signal so that it is unrecognizable.

The superheterodyne is especially
troublesome in the production of un-
wanted signals, as it possesses a complete
oscillator, the continuous operation of
which is essential for the operation of
the receiver. For ordinary reception,
this oscillator covers a band from 200
to 600 meters. In some types, the fun-
damental frequency of the vacuum tube
is used to produce radio frequency beats
with the carrier of the incoming signal,
and in some other types the second har-
monic is used for this purpose. In either
of these systems, harmonics are present
in the oscillator as long as the latter is
kept in operation, their frequency being
determined by the frequency of the fun-
damental of the oscillator itself. For
example, if the oscillator is tuned to 200
meters, a harmonic is present at many
odd and even multiples of the fundamen-
tal frequency, which will give them at
100, 66.66, 50, 25, etc. meters. The
amplitude of the lesser wavelengths is
very small, comparatively, but they are
present, nevertheless. As the wavelength
of the oscillator is increased, the wave-
length of the respective harmonics of
course increases, also, and if the wave-
length is increased to the maximum,
which is say 600 meters, we will find

that the second harmonic which former-
ly was on 100 meters, is now on 300,
the third, which was on 66.66 meters,
is now on 200 meters, the fourth, which
was on 50 meters, is now on 150, and
the higher frequency harmonics follow
in the same order.

In the second harmonic oscillator sys-
tem, such as is used in some superhetro-
dynes, the second harmonic is utilized to
give the radio frequency beats. Never-
theless, the third, fourth, and other high-
er harmonics are often present, and may
cause trouble in some cases, by giving
signals where they are not wanted.

In all this discussion, the thought con-
stantly comes up, "How can these sig-
nals on other frequencies be heard, when
using a loop or a selective loose coupled
set which is tuned to the wavelength that
I wish to receive." Generally such inter-
ference cannot and will not take place.
The only condition where it can take
place is where a transmitting station is
close enough to the receiver to force the
antenna to oscillate at the wavelength of
the transmitting and interfering station.
As a general rule, however, such inter-
ference takes place only when the trans-
mitting station is comparatively close to
the receiver, although this will not hold
absolutely, as the writer has observed
serious interference on 320 meters caused
by the transmission of an amateur station
in Los Angeles, while the receiver used
was in San Francisco.

Again the old proposition of amateur
interference crops up, and the amateur
again looks like he was to be the victim,
although this time in a different way.
Formerly the chief complaint was from
listeners-in who were troubled either due
to their receivers tuning broadly, or else
to the spark and tube transmitters of
the amateurs actually interfering, due
to their broad waves. But in the case
of harmonic interference we have the
unique situation of a receiver, intended
for radiocast waves, reaching down into
the amateur bands, and plucking inter-
ference right out of these frequencies.

Thus if an amateur station is tuned
to its lawfully assigned frequency (wave-
length), say on 80 meters in the middle
of the 75 to 85 meter band, and using
a pure direct current source of plate
supply, free from key clicks, and other-
wise complying with every detail of the
law, the radiocast listener's receiver will
receive that amateur on 240 meters, 320
meters, 400 meters, 480 meters, and 560
meters, if there were any radiocasters on

(Continued on page 74)

A Transmitter That's Different

A New Idea in Antenna Tuning With Coupled Circuits

By F. Dawson Bliley, 8XC

AN apparently simple change may alter the whole operating characteristic of the transmitter. First using a series condenser to work below the antenna fundamental, then using the harmonic idea, and finally the following system which probably is no more original than the other two.

In order to fully understand this new method let us refer to the "Lecher wires" used to measure short wavelengths. The

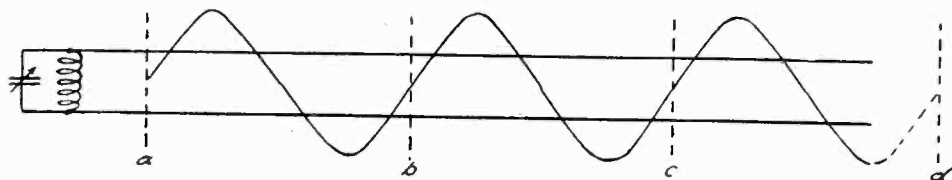

Fig. 1. Lecher Wires

wires are strung as in Fig. 1. In measuring the various wavelengths an ammeter or small bulb is inserted at any point along the wire (preferably at the furthest end) and the variable condenser across the tuning coil is changed until the current in the meter reads at a maximum.

This shows that the current may be found at any point along the wire; *i. e.*, the wires will oscillate at any frequency. In doing this the waves generated will not always come out at even fraction of the total wavelength of the whole "Lecher wires." This may easily be seen by again referring to Fig. 1 and noting the characteristic outlines of the current wave. You may have tried these wires yourself and, in doing so, have noted that each point of highest amperage is the same distance apart and that a length of the wire less than one of these distances was left over at the further end. This "end" wire is then not in use in reality, but the steady drop in current will be noticed starting from the last "hump."

This may very easily be applied to the transmitting antenna with no change other than the insertion of an antenna coil of the right size (about five turns). No variable condenser is necessary, thus simplifying the tuning. Fig. 2 illus-

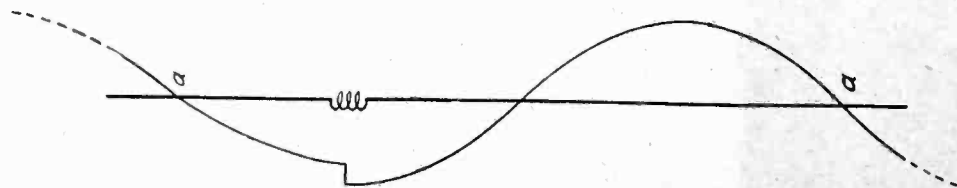

Fig. 2. Antenna Oscillating Just Below the Fundamental

as one of the numerous illustrations which could be drawn. It will be noted that from point *a* to the end of the antenna the wave is incomplete. This wave then either dies out or is completed by the aid of the wave between the two *a*'s. This same may be applied to antennas of greater fundamentals and greater frequencies.

This actually does not begin to work until the third harmonic is reached with

the oscillator. But from the third harmonic to infinity the antenna may be used as a radiator, paying no attention to the harmonics. The thing that would necessarily limit the size of the antenna would be the high frequency resistance involved. Very efficient antennas do not have high antenna current on the even harmonics (this will depend upon the position of the ammeter in the antenna system) below the third so that as we go down we strike the third with maximum current which gradually drops to a minimum at the fourth and again rises to the same maximum at the fifth, etc.

Various tests have been conducted with numerous stations, all over 400 miles, to ascertain the reliability of such a system. All reports showed that it mattered little whether the harmonics were used or not. Bad reports come only from stations at times when such

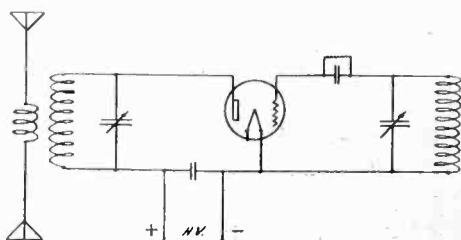

Fig. 3. Coupled Reversed Feed-back Circuit

Fig. 4 is a coupled Hartley which theoretically is similar to the coupled reversed feed-back of Fig. 3. This would make an excellent one-control transmitter for any of the amateur bands using the above method of antenna tuning. The variable condenser should be of the lowest loss obtainable. A 45-plate condenser cut down and triple spaced would be fine in such a case. This would make an excellent transmitter for QSY from QRM.

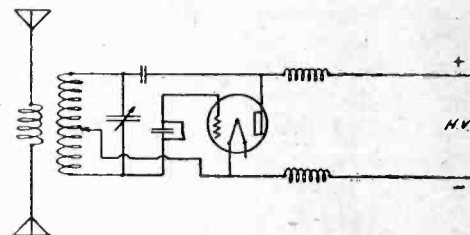

Fig. 4. Coupled Hartley Circuit

As the full description of these two transmitters (differing only in this method of antenna tuning) was given in January RADIO, it is not necessary to repeat any of the description. The radiating system used in these harmonic tests is simple. The antenna and counterpoise are both composed of two wires in a fan shape. The antenna is 20 ft. above the counterpoise and directly over it; not to one side.

Radiocasting in Sweden is done by the government whose Telegraph Administration has been operating temporary stations at Stockholm, Malmo and Gothenburg. A new station has just been erected at Boden, and another is to be installed at Sundewall. Licenses are required for all receiving sets, the fee for a private set being 12 kronen. A set may be inspected at any time by either the telegraph or military authorities. About 40,000 licenses have been issued.

Beam transmission is accomplished by using several aerials so placed that the phases of current in each cause re-inforcement of radiation in one direction and more or less neutralization in all other directions. Less power is needed since all of it is utilized in sending waves in the desired direction instead of in all directions as in the usual method of transmission. The directivity holds for comparatively short distances but is effective in reducing interference from a transmitter.

trates such an antenna oscillating just below the fundamental. This will not work out practically but is given only

reports would be expected—due to the various conditions of the atmosphere on waves below 50 meters.



QUERIES *and* REPLIES



Questions submitted for answer in this department should be typewritten or in ink, written on one side of the paper. All answers of general interest will be published. Readers are invited to use this service without charge, except that 25c per question should be forwarded when personal answer by mail is wanted.

What is the new anti-radiation device recently brought out by Dr. DeForest, and will it be of any help with my single circuit tuner, which occasionally squeals while I am tuning in a station.—J. R. R., Trenton, N. J.

The device developed by Dr. DeForest consists of some additional apparatus of inexpensive nature which may be connected to the set so as to cut out practically all possibility of radiating energy into the air

the detector and the antenna, and hence no squeals will be heard in neighboring receivers. The radio frequency choke should have several taps, in order that the coil will be most efficient at the various radiocast wavelengths, since a value of inductance selected for the middle of the band would not be of much use at the extreme lower or upper ends of the bands. A good coil for the purpose would be one of 150 turns of No. 22 d. c. c. wire wound on a 3 in. tube, with taps at the 40th and 110th turns. Condenser *A* should not be over 15 or 20 micromicrofarads, and will probably be best

frequency signals to some extent, but the presence of the condenser *A* in the circuit produces enough loss to the signal to neutralize the gain of the audio tube, and the set will thus have approximately the same sensitivity as before the change was made.

Please publish the circuit diagram for a three coil honeycomb regenerative set suitable for use on the very short waves as well as the radiocast and long wave telegraph wavelengths.—F. La.B., Los Angeles, Calif.

A suitable circuit is shown in Fig. 2. For the very short waves, care should be taken to build an efficient set of coils. Little or no benefit will result from the use of a honeycomb winding of less than 25 turns, and it would be better to wind special coils having a wavelength range of 50 to 175 meters. As a suggestion, the three coils should be wound basket fashion, on a 4 in. diameter, and fastened to the honeycomb coil mounting plugs with tap or other non-metallic substance. The antenna coil should consist of 10 turns of No. 16 cotton covered wire, the secondary coil 15 turns of the same sized wire and the tickler coil may be the same as the secondary. For the other wavelengths the following table gives the approximate sizes of the coils to use. The primary coils may vary slightly depending upon the antenna used, and the tickler coil may have to be larger or smaller depending upon the excellence of the detector tube used.

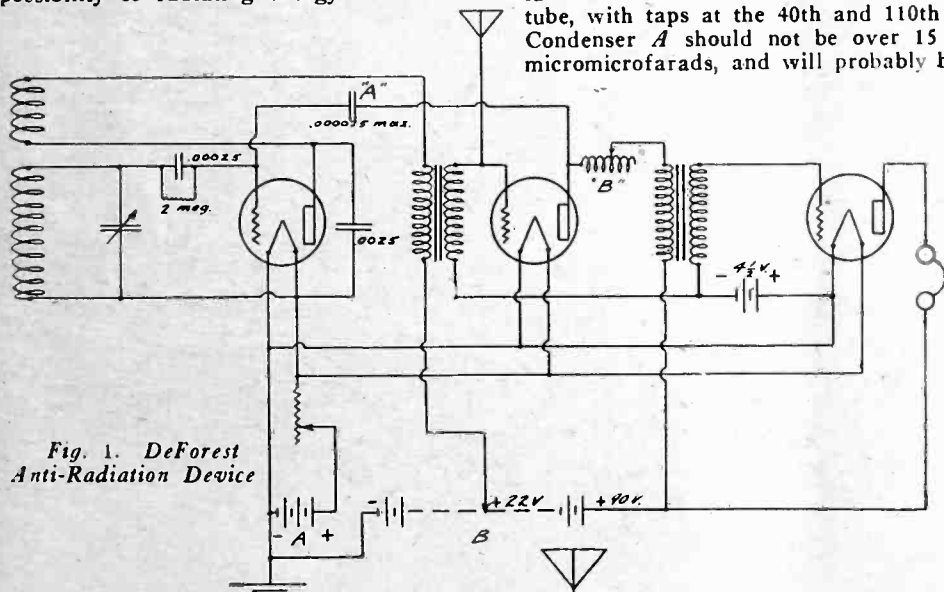
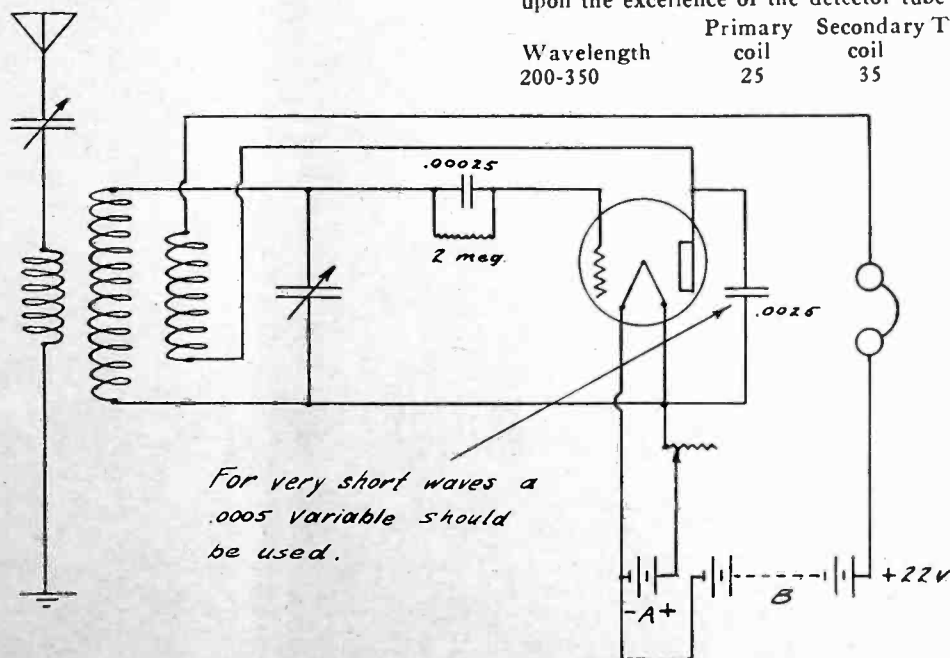

Fig. 1. DeForest Anti-Radiation Device

via the antenna. In Fig. 1 is shown an application of this device to a single circuit regenerative receiver with two stages of audio frequency amplification. The extra apparatus consists of a small condenser marked *A* in the diagram, and a choke coil *B*. Condenser *A* is connected between the plate of the first audio amplifier tube and the grid of the detector tube. Choke coil *B* is placed between the plate of the first audio amplifier tube and the primary of the audio frequency transformer. The antenna connection is removed from the tuned circuit and is connected to the grid of the first audio amplifier tube, the ground connection remaining the same as before the changes are made. The action of the anti-radiation device is somewhat like the action of the reflex circuit. The high frequency signal being received is impressed on the grid of the first audio amplifier tube, and is amplified by this tube. Being prevented from passing through the windings of the second audio transformer, by the presence of the radio frequency choke coil *B* in the circuit, the high frequency passes through condenser *A*, which is of very small capacity and reaches the grid of the detector tube. Since the capacity of condenser *A* is very small, any oscillation of the detector tube will find a very high resistance in the path between

Wavelength	Primary coil	Secondary coil	Tickler coil
200-350	25	35	25



For very short waves a .0005 variable should be used.

Fig. 2. Circuit Diagram of 3-coil All-wave Receiver

determined by adjustment. One of the mid-get type condensers having a maximum capacity of .000025 mfd. will serve the purpose very satisfactorily. The audio frequency amplifier tube amplifies the radio	250-600	35	75	50
	600-2000	75	150	100
	2000-5000	150	300	200
	5000-13000	500	750	500
	10000-25000	1000	1500	1000

What changes should be made in the Best 45,000 cycle superheterodyne, in order to receive the Australian broadcast stations operating on a wavelength band of from 1000 to 2000 meters. Australian 2FC operates on 1100 meters, 6WF on 1250 meters and 3LL on 1720 meters, and I wish to work with these stations.—L.S.L., San Francisco, Calif.

The principal changes in the set would be a larger loop and a different oscillator-coupling coil. The loop, if made the same size as the one described in January, 1925 RADIO, should have 50 turns instead of 12 turns of wire, spaced a little closer together in order to prevent the loop from becoming clumsy. Taps could be provided in the loop to take care of the shorter wavelengths, but this is not an efficient method and it would be better to have another loop of 12 turns only, for the American radiocast band. The oscillator coil should consist of 200 turns of No. 26 single silk or cotton covered wire, wound on a 3 in. tube. The winding should be split into two sections of 100 turns each, and in order to get the windings into a small space, it would be best to employ the bank method of winding, with the bank three layers deep. The grid coupling coil should have 35 turns of No. 26 wire wound on a 1½ in. tube and placed within the oscillator coil, in a manner similar to the coil used for the 200-600 meter band. The two oscillator coils can then be mounted adjacent to each other inside the set, and when the change is to be made from short to long waves, small clips with flexible wires present an easy method of making the change without employing complicated switches.

Does the Improved 45,000 cycle superheterodyne receiver built according to the directions given in January RADIO whistle while tuning in the various stations?—L. M. C., Chico, Calif.

No whistle of any kind is heard when tuning in a station with the superheterodyne, if the set is functioning properly. If a whistle is heard, the feedback condenser has too much capacity in the circuit, and should be re-adjusted. If the set whistles with the condenser cut out of the circuit, the intermediate frequency amplifier is oscillating, probably due to coupling between stages. If the transformers are properly spaced as shown in the baseboard layout, this coupling effect will not occur.

Can you tell me the correct number of turns of wire for the tuned circuit of a 70 meter transmitter? Also the antenna dimensions, with counterpoise.—A. S. C., Honolulu, T. H.

The antenna coil should consist of 8 turns on a 5 in. diameter, the particular style of winding depending upon your other apparatus and your personal preference. The oscillator coil should consist of 15 turns on a 5 in. diameter, arranged for coupling with the antenna coil. A slanting L antenna, or a vertical cage having a length of not more than 60 ft., from the set to the far end of the antenna will give good results on waves below 100 meters. The vertical antenna is by all means the most desirable, where it is possible to erect a single mast 65 or 70 ft. high.

I have been unable to obtain No. 36 S.S. wire for the transformers described in the article on "Best's" 45,000 cycle superheterodyne. Will No. 36 D. S. C. wire do the work equally well? Would No. 24 iron wire be all right for the cores of the intermediate transformers?—H. S., Brocton, N. Y.

If you use No. 36 d.s.c. wire, reduce the number of turns on the secondary of the intermediate transformers to 1800 turns, and wind only 1350 turns on the secondary of the tuned transformer. The No. 24 wire will make a fairly good core, but better results can be obtained with small gauge wire where it is possible to obtain it.

Please publish a circuit diagram of Best's 45,000 cycle superheterodyne, with resistance coupled audio frequency stages instead of the two stage transformer coupled amplifier originally shown in the article.—S. N. P., Van Nuys, Calif.

Fig. 3 shows the circuit diagram of the second detector and three stages of resistance coupled audio frequency amplification. This circuit is almost identical with one published in RADIO a few months ago, and which brought forth considerable criticism from a well-known "resistor" manufacturer because of the use of C batteries and by-pass condensers. The combination of C batteries shown in Fig. 3 is the proper one to use if the amplifier is to function properly without overloading of the tubes with resultant distortion. The C battery is also very necessary in order to preserve the filament emission of the tubes, as the plate current will be much greater without the C battery, with consequent heavy drain on the B battery, and shorter tube life. The by-pass condenser is inexpensive insurance against howling due to defective cells in the dry cell B battery, but may be omitted without impairing the operation of the set if the batteries are known to be in good condition.



By SAGO, Biddle Arthurs, Jr., 3046 Centre Avenue, Pittsburgh, Pa.

1abt, 1kc, 1xam, (1xz), (4uk), 4sa, (4sl), 5ags, 5am, (5ek), 5ew, 5hu, (5qy), 5sd, 5zav, 6aad, 6adt, 6age, 6agl, 6ahp, 6alo, 6ao, 6apw, 6arb, 6ark, 6arx, 6awt, 6bdt, (6bgc), (6bql), 6bqu, 6bw, 6cx, (6cfz), 6cni, 6css, (6cto), 6fh, 6im, 6kw, 6lj, 6ol, 6xad, 7gb, 7mf, 7oy, (9ahq), 9cee, 9cfl, (9cjl), Canadian—1ef, 2ax, 5gf, English—2kf. Confirmations sent on request. Will answer all QSL cards promptly.

By C. A. Weidenhammer, 12L-1AVW, 33 Washington Place, Bridgeport, Conn.

4bl, 4bq, 4bw, 4du, 4eg, 4eh, 4eq, 4fm, 4fs, 4je, 4jr, 4kk, 4kt, 4ku, 4ne, 4oa, 4rh, 4sa, 4sl, 4tj, 4tv, 4tw, 4ua, 4uk, 4wk, 4xe, 5aaq, 5ac, 5aex, 5ade, 5afu, 5agq, 5ahd, 5ahw, 5aj, 5aly, 5akp, 5akz, 5alj, 5ame, 5aot, 5apy, 5arj, 5ash, 5asj, 5atf, 5bj, 5ch, 5dm, 5ei, 5ew, *5 hi*, 5in, 5lg, 5lh, 5lu, 5nw, 5qy, 5rv, 5se, 5ty, 5uk, 5ur, 5vc, 5wo, 6aaq, 6ac, 6afg, 6afh, 6agk, 6alv, 6akw, 6ame, 6anw, 6app, 6ase, 6awt, 6bad, 6ban, 6bdi, 6bgo, 6bhz, 6bjj, 6blw, 6bpf, 6bph, 6bra, 6bul, 6bur, 6coc, 6cej, 6cfs, 6cgo, 6chx, 6cig, 6cky, 6cmu, 6cso, 6css, 6csw, 6cwp, 6dr, 6fy, 6kr, 6ms, 6nx, 6of, 6ol, 6pl, 6ql, 6rr, 6rv, 6ul, 6ut, 6wp, 6wr, 6xy, 6zh, 6zx, 7abb, 7df, 7fq, 7gb, 7gj, 7lj, 7ku, 7lg, 7ls, 7ma, 7mx, 7uj, 7zq, Canadian: 4cr, 4dg, 5ba, Mexican: 1aa, 1k, 1x, 9a, English: 2oo, 2jf, 2kw, 2kz, 2nb, 2od, 2sz, 2wd, 5ma, 5nn, 5pz, 5sz, 6gh, 6lj, 6nf, French: 8bf, 8go, Danish: 7ec, Italian: 1mt, Spanish: EAR6, Netherlands: OBA, ONL, Argentine: LOR, Costa Rica: SJ, Australian: 2bk, yag, 2yl, New Zealand: 2ac, Miscellaneous: PRA, WJL, WJS.

All cards QSL'ed. QRK my 5 watter—(20 watts input)?

By SCP, 233 East 11th St., Holland, Mich. (6afg), (6agk), (6aji), (6ajq), (6akz), (6alw), 6amm, (6amo), 6anw, (6awp), 6ase, 6bez, (6bip), (6bjj), (6bjx), (6bkb), 6blh, 6bmw, (6bql), (6bqr), 6buf, (6bul), (6bur), (6cae), (6cet), 6chl, (6cig), (6cis), 6cni, (6cqd), (6crr), (6crx), (6css), (6csw), (6cto), (6cva), (6cwp), (6xbn), (6ab), (6ea), (6eb), (6ew), 6gx, 6lm, 6mh, (6ms), 6ne, 6of, (6oh), (6oi), (6pl), (6rn), (6rv), (6ts), 6vd, 6ut, 6wp, (7abb), 7afn, (7agf), (7aif), (7akk), (7av), (7bj), 7dd, (7df), (7fm), (7fq), (7fr), 7jf, (7jr), (7ku), (7lg), (7lr), (7mg), (7oo), 7ok, (7to), (7zq), Can. 4fv, (410), (5ba).

Always gld to qsl.

(Continued on Page 44)

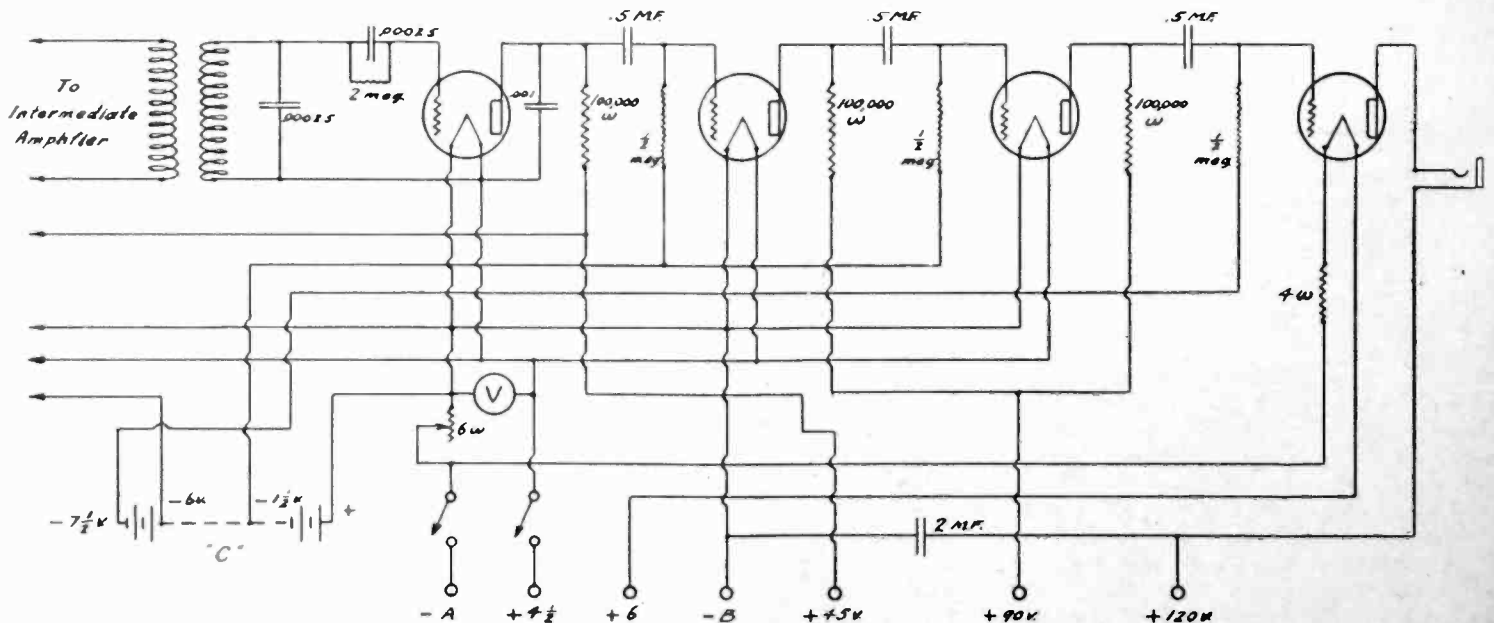

Fig. 3. Superheterodyne Second Detector With Three Stages of Resistance Coupled A. F. Amplification

With the Amateur Operators

6AWT WINS HOOVER CUP

The 1924 Hoover Cup, the highest honor in amateur radio, has been awarded to 6AWT, Bartholomew Molinari of San Francisco. This cup is annually awarded on the basis of the report of a special committee of the American Radio Relay League as to the best all-around amateur station, home designed and constructed.

6AWT has been unusually successful in working with foreign amateurs, signals having been reported heard in Asia, Australia, South Sea Islands, Europe, Africa, Central America and South America as well as in every district in the United States. The list

NEWS OF THE AMATEUR OPERATORS

U-6EA and U-6EB will greatly appreciate reports on their C W signals from any place in the world, including the United States, regardless of distance. Both have 250 watt stations and are on about 85 meters. Please send separate cards to each station giving time, date, etc. Address all communications to 343 South Fremont Avenue, Los Angeles, California, U. S. A. All reports acknowledged without fail.

8CFF, Kenneth Steele, Northumberland, Penna., requests reports on stations strength. 8CHS is a 5 watt set operated by the

will operate on 54-55 meters as well as on 20 and 40 meters.

William H. Slater, ex-2CHZ, died January 11th at Camp Vail, N. J., of pneumonia contracted during his duties with the U. S. signal corps. His well-known fist will be greatly missed as he frequently worked from coast to coast from his home at Port Jarvis, N. J.

Gettysburg College amateur station 3BHY under supervision by E. G. Ports, Instructor of Physics, was in operation during the period of the eclipse and noted the following: At about 8:45 a. m. EST, amateur phone stations from the West began to come through with fair audibility; as the sun became further covered by the moon's disk the signals increased very much in intensity. Several ninth district stations were worked on voice during this period and at the period of totality 9DG, Bellville, Ill., was worked. His signals came in as loud as at night and he in turn reporting 3BM as very loud and clear. As the moon's disk passed off the sun the signals again faded and by 9:12 a. m. EST, Bellville, Ill., had faded so completely that they could not be heard. However 9BSP of Olathe, Kansas continued to come in strong on fone until about 9:24 a. m. EST. The station is to be operated by members of the college radio club of whom several are licensed operators. Using 50 watts, 3BHY has been heard in 36 states. Cuba and Canada on voice.



Bartholomew Molinari, Winner of the 1924 Hoover Cup
Photo by S. F. Bulletin

of two-way workings with Australia and New Zealand has frequently been published in these columns. This station was one of seven selected by the ARRL to transmit press to WNP.

The transmitting equipment consists of one 250-watt tube in a coupled Hartley circuit with 2,000 volts on the plate. The aerial is a 90-ft. L cage.

Mr. Molinari's many friends are extending him their congratulations for the recognition of his industry and ability. He is a modest young man who has been patiently working his way up through the radio ranks for five years. During part of this time he was a student at the Polytechnic High School, but recently he has been assisting his father at his work during the day and spending almost the entire night at his transmitting set. He was only 15 years old when he made his first spark transmitter. Pacific Coast amateurs are particularly pleased with this outstanding recognition of one of their own number.

X. H. S. Radio Club of the Central High School at Xenia, Ohio. All cards answered.

1ZL-1AVW, C. A. Weidenhammer, 33 Washington Place, Bridgeport, Connecticut. A five watt tube is used with an input of from 16 to 20 watts on 75 meters. Reports from the West Coast appreciated and all cards QSL'ed.

Mark Spies of Decatur, Ill., and W. C. Fowler of St. Louis, Mo., worked nine hour watches for two nights in order to give telegraphic news service to the Decatur *Herald* when all telegraphic lines were down during a heavy snow storm in January, thus proving that the amateur is "there" for emergencies.

F. H. Schnell has been given leave of absence from his duties as A.R.R.L. traffic manager at Hartford, Conn. so that he may be with the Pacific fleet during its maneuvers from April 15th to October 1st. He will use a short wave, low power transmitter to communicate with the amateurs so as to compare its efficiency with the regulation high power navy sets. His call is NRRL and he

DX AT 6XAD-6ZW

What with having been in the East for a month and a half, and then, upon returning to Catalina Island, to find that our wonderful fishing is beginning much earlier than usual—both of these situations have kept me off the air, with the exception of a few especially tempting early mornings. The following is the DX list from January 23rd to March 1st. STATIONS WORKED: 1bfl, 1ii, 1bcr, 1acb, 1se, 1bes, 1yb, 1wl, 1zt, 2le, 2kx, 2brb, 3czz, 2cxy, 2cpa, 2ann, 2gl, 3aih, 3bwj, 3ou, 3adq, 3lw, 4fv, c4eo, 5agy, 5ox, 5ls, 5aky, c5an, 5acz, 5ajn (reaches me QSA from Little Rock, Ark., with .1 in the antenna!) 5aqy, 7qd, 7mx, 8adg, 8jq, 8bpl, 8dse, 8dmf, 9dqy, 9dga, 9bdz, 9akn, 9ccx, 9bib, 9dyt, 9no, 9dng, 9sr.

And the usual long list of stations reporting my signals. I am very grateful to their owners. Only lack of time and space prevents my giving a more detailed list. My wavelengths are now 68 meters—on the 500-watt WE set. 78 meters on the 250-watt—also WE. I have not decided what the QRH of the 3KW Western Electric tube will be. Shall report on this matter in the May issue.

NEW DAYLIGHT RADIO TESTS SUCCESSFUL

Further demonstration that short waves are not greatly affected by daylight conditions is offered in the feat of John L. Reinartz, inventor and widely known in amateur radio, in transmitting signals from his estate at South Manchester, Conn., to Wickford, Essex, England, in broad daylight. The American Radio Relay League has verified reports that the American amateur's signals were picked up by F. A. Mayer, an English amateur. In his test Reinartz used a wavelength of 21 meters. Reinartz recently transmitted signals to Berkeley, Calif. in broad daylight.

FROM THE RADIO MANUFACTURERS

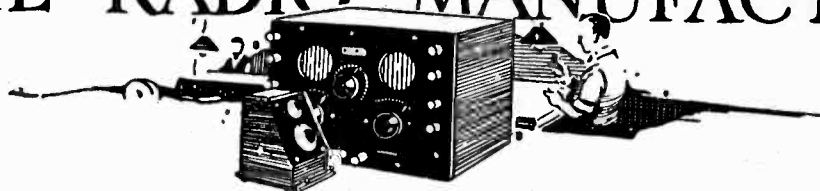

The Klc-O "B" multi-power unit combines a high voltage storage B battery and charger in one unit. The battery is of the nickel-zinc alkaline type and has sufficient

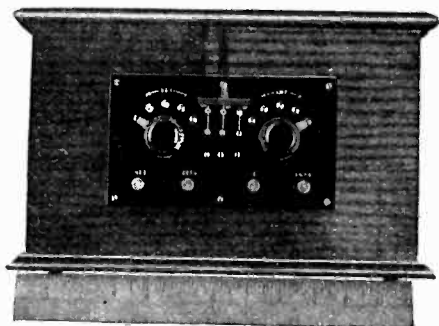

capacity to supply the plate current drain of multi-tube neutrodyne and superheterodyne sets. It delivers current without any chance of a.c. "hum".

The C & C Reachit wrench is designed to pick up and hold a nut while placing it on a screw to tighten it in place, and to reach hard-to-get-at places. Its long, hard-



ened, sliding jaws take hex nuts from size 4 to 10, three sizes of round nuts, as well as machine and wood screws.

The Kellogg low-loss condenser, No. 704, is a .0005 mfd. 23-plate unit built in a novel manner. The stator plates are firmly held at the bottom by two small hard rubber strips in the center of a strong U frame. The rotor shaft is fitted across the top of the U and can be readily removed for cleaning without removing the condenser from the

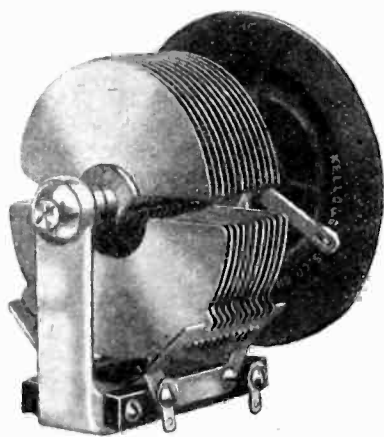

panel. The rotor is grounded to prevent body capacity effects and the bearings are adjustable so as to vary plate spacing. The positive spring connection across the bearing gives four contact points. It is easy to mount on either panel or baseboard. It has a unique vernier dial adjustment which does not affect the general tuning of the condenser. It has a low minimum and correct maximum capacity with a straight line calibration curve.

The General Instrument low-loss r. f. transformer has been designed to have a very low high frequency resistance, a very low distributed capacity, and a very high

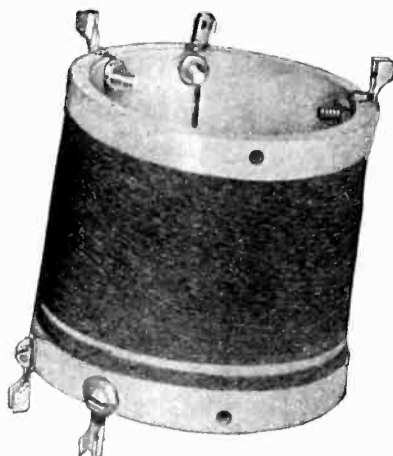

co-efficient of coupling so as to produce a concentrated field with a minimum external field. It is wound with green silk covered "Litz" on an Isolantite form which gives great mechanical strength without sacrifice of electrical efficiency. Both the primary and secondary are periodic at radio frequencies, an ideal condition. The connections are brought to soft copper lugs and means are provided for mounting the transformer to the back of the condenser.

The Andrews Paddle-Wheel inductance is a new form of coil whose compact spiral winding enables the use of large wire and gives a low resistance and a high inductance,

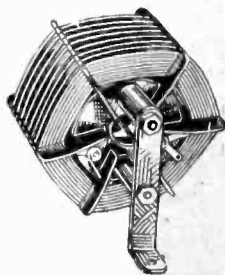

insuring maximum amplification and minimum distortion. Its construction is designed to give a minimum of absorption and eddy current losses. It can be used in any hook-up when a r. f. transformer inductance is required. It tunes from 200 to 600 meters with a .00025 mfd. variable condenser.

The new C-H toggle battery switch has a large wiping contact, positive make-and-break mechanism, wide-spaced terminals, and an attractive appearance which



admirably fit it for the control of A battery circuits. It can be easily mounted on a panel without screws or measurements. A flip of the finger turns the current on or off.

The Remo trumpet, "the wonder loud speaker," has been designed to reproduce radio programs with good volume, uniform



tone value, and clarity. It is small and compact and has an Adam mahogany finish. With its adjustable control it is available either as a phonograph unit, as a trumpet, or a cabinet type of speaker.

The Ampl-Tone headset consists of two balanced 1100 ohm phones with 6 ft., 24-strand cords, polarity indicated. It has a



lightweight head band and comfortable ear-caps. The coils are wound with No. 40 wire on special alloy magnet cores.

Errata Notice:—The Bestone V60, in a recent advertisement of Henry Heyman & Co. in these columns was announced as the Bestone, V\$60, a mistake causing many readers to try to buy the set for \$60, although the prices were stated at the bottom of the advertisement.

You can save about \$60.00 on your radio if you will put a Model "S" Acmeflex Kitset together

Like earning \$60.00 cash for a few hours' fun

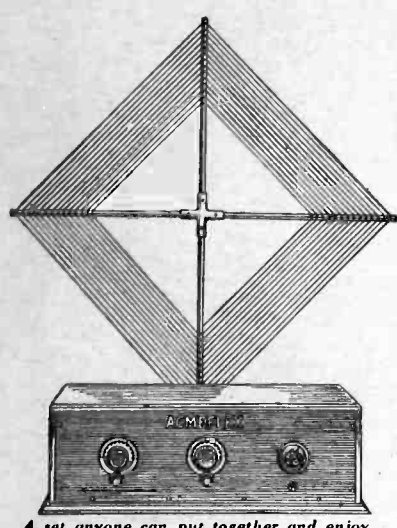

A set anyone can put together and enjoy all-the-year-round radio

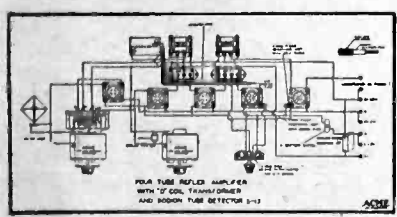

Wiring diagram new Model "S" Acmeflex Kitset

THE radio fan will especially notice the use in the new Model "S" of the D-Coil radio frequency tuning unit and the vacuum tube detector, which together wonderfully improve distance, reception, and selectivity.

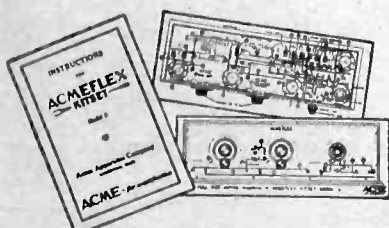

Directions given so simply that anyone can follow them

ABOVE are illustrated the circular of printed instructions and the life-size diagrams of the wiring, which are packed with each Model "S" Kitset. Step by step the making of the set is described in clear, simple language—just simple operations which anyone can easily follow.

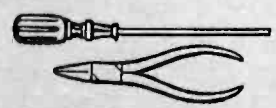

ONLY two tools required—a screw driver and pliers—and they are included in the Kit.

Enthusiastic praise from Model "S" user
 From New York City: "Well, I believe we had every jerkwater station in the U. S. Stations I never heard of before. At 11:45 P. M. I pulled in KFI (Los Angeles, Calif.) on the loudspeaker. At 12:15 A. M. KGO (Oakland, Calif.). I went back and picked up KFI three times. My home is located in what is considered one of the worst sections for radio. The skyline of New York is directly opposite me. I am on the harbor, a mile from the Navy Yard, and have three bridges with electric trains to bother me, but with it all I got the coast. Forgot to mention that two locals were on—WHN and WJZ; some selectivity."

The wonderful new Model "S" Acmeflex Kitset would cost you if assembled complete in our factory, \$150.00. But it costs you only \$80.00 (plus a small cost for a cabinet) if you put it together yourself. You can easily do it. We give complete directions. You save about \$60.00.

THE perfection by Acme engineers of the new model "S" Acmeflex Kitset not only makes it possible for you to get a \$150 worth of radio for only \$80 (plus a cabinet), but it also places in your home the famous Acme 4-tube Reflex (trade mark) now wonderfully improved through the combined use of a D-Coil radio frequency tuning unit and a Sodian S-13 Detector Tube. You get greater distance, greater selectivity and better reception. We could make it for less than \$80, but it would not give results.

Contents of Kitset is complete
 ALL the parts necessary for making the complete set are included in the Kitset. Even the loop is included. There is no antenna to erect. Each part is packed carefully in its own carton and not thrown in a jumbled heap. Each part is fresh, bright, new and well made. Screws, nuts and bolts are in a box of their own. Everything is included; nothing forgotten. The only accessories to get are the tubes, batteries, loud speaker and cabinet. We have put every thing in the kit but the fun.

No technical knowledge or workshop necessary
 You do not have to be a radio engineer in order to put this set together. Anybody can do it. Many have done it easily in three hours—had the set complete and working all in one evening. Only two tools are needed, a screw-driver and a pair of special Acme pliers and they are included in the kit. Good tools which you can use afterwards for other things. The panel is all drilled for you, and no soldering is necessary. If you do not want to assemble the set yourself, there are plenty of amateurs and dealers glad to do it for you at a nominal charge, still saving you a lot of money.

Complete printed directions and diagrams
 WITH each Kitset are included complete printed directions, telling you just how to put the set together, step by step; just simple operations that anyone can easily follow and have a good time doing it. In addition to these printed directions are two life-size printed diagrams, one giving the wiring diagram for the set both from the baseboard view and the panel view, and the other showing, in actual size, exactly how every wire in the set is bent and connected.

More, tube for tube than any other set
 THE finished Model "S" Acmeflex Kitset, a Reflex (trade mark) set, gives two stages of radio frequency amplification, two stages of audio frequency amplification plus a D-Coil radio frequency tuning unit and detector, with only five tubes.

The new Model "S" Acmeflex Kitset will pull in more stations, louder and clearer, on a loop and loud speaker, than any other set using the same number of tubes (five), and more than many sets using from six to eight tubes. It is easy to tune. There is only one tuning dial.

Everything on loudspeaker
 THE selectivity, range and volume of this set make it remarkable for loud, clear reception of stations near and far. The pleasure and the joy of it can be yours at a price only a little more than half what it would cost you to buy the set complete. Anyone can now sit down and put together a set that will perform on a plane with the highest-priced factory-made receivers.

Note these features of Model "S" Acmeflex Kitset
 Complete directions given for putting set together.
 No antenna to erect.
 No technical knowledge or workshop required.
 Only two tools and they are in the Kit.
 No soldering to do.
 Only one tuning dial.
 Excellent reproduction.
 Greater distance, sensitivity and selectivity.
 Non-radiating—won't bother your neighbor.
 Saves you about \$60.00.

ACME APPARATUS COMPANY
 Transformer and Radio Engineers and Manufacturers
 Dept. D3 Cambridge, Mass.

Send coupon now and start putting this wonderful set together

JUST tear out the coupon below; write your name and address on it plainly, mail it to us, and we will send you by return mail a special circular completely describing this set in every detail. Send coupon today.

Send this coupon

ACME APPARATUS CO., Dept. D3, Cambridge, Mass. Send complete information about the new Model "S" Acmeflex Kitset to

Name

Street

City..... State.....

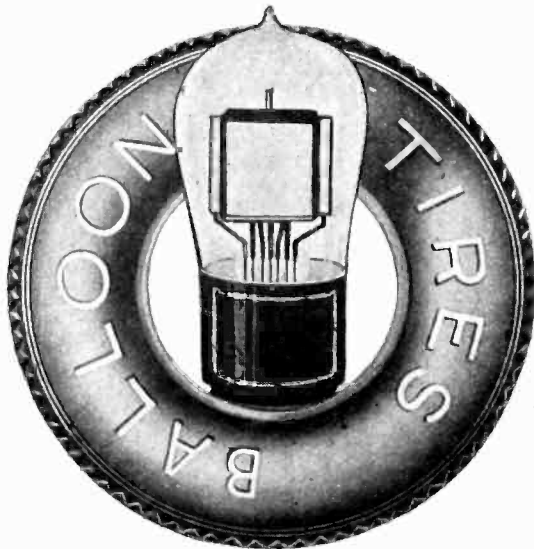

Balloon Tires for Your Tubes!

Delicately adjusted springs, at the base of a Benjamin Cle-Ra-Tone Socket, do the same for the radio tube that balloon tires do for the automobile—absorb jars and shocks.

Outside rumbling traffic, inside footsteps, mechanical and human activities amazingly vibrate floors of buildings—as finely adjusted scientific instruments have proved. This comparatively small shaking of the tube develops a very perceptible noise in the filament, and very often breaks this hair-like wire when it is cold.

Benjamin Cle-Ra-Tone Sockets "float" above their base and the tube filament escapes this ever present trembling. More sensitive experiments are thus possible and distant, faint signals come in much clearer. Stiff bus wiring does not affect the flexibility of Cle-Ra-Tone Sockets. They are adaptable to every hook up and especially desirable in portable sets. There are no rubber parts to deteriorate. Bakelite is used wherever possible to insure sturdiness, long life and high dielectric insulation. Contact points to tube terminals are perfect and permanent. Terminal lugs for soldering. Made in two sizes: standard base, and a base for tubes similar in terminals to the UV-199.

Spring Suspended—Shock Absorbing

Accepted by Leading Manufacturers and Radio Engineers

BENJAMIN

Benjamin Electric Mfg. Co.

120-125 So. Sangamon St.

247 W. 17th Street
New York

Chicago

448 Bryant Street
San Francisco



CARTER New LOOP Aerial

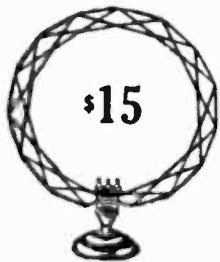

Pat. Pending

Greater Volume
Longer Distance
and
Far More
Selectivity

Coast Distributors
ATLANTIC-PACIFIC
AGENCIES
CORPORATION
204 Rialto Building
San Francisco, California

The new Compound Pentagon winding eliminates the framework and resultant losses. It gives maximum inductance without increasing the distributed capacity. Only 18" in diameter.

Go to your dealer and see this new Carter product. Any dealer can show you



In Canada, Carter Radio Co., Limited, Toronto

Send for Trial Subscription—\$1.00 for Six Months

CALLS HEARD

(Continued from page 40)

By E. W. Thatcher, 87E-8GX, Oberlin College, Ohio

Bermuda: B3ad. Canada: (C5an), C5ba, C5cn, (C5gt). France: F8bo, F8ssc. Finland: Fn, 3gb, (?). England: g2vb, g2kf, g2kz, g2nm, g2od, g2sz, g2yt, g5nn, g5lf, g6nf. Holland: N Onl. Mexico: (mlaa), mlaf, maai, mlk, (min), (mlx), mbx. Porto Rico: 4sa, (40l). Cuba: q2lc, q2mk. New Zealand: Z2ac, Z1ak. South America: WJS. U. S. A.: 6aao, 6ac, 6acl, 6adt, (6afg), 6age, (6agk), 6aha, (6ahp), 6aib, (6aiq), (6aiv), (6ajh), (6aji), 6akw, 6akz, 6alf, 6alk, (6ame), 6amo, 6apj, 6apw, (6aqd), 6arb, (6arx), (6ase), 6ats, (6awt), 6bau, 6bb, (6bdt), (6bgc), (6bhx), (6bjj), (6bjx), (6blw), 6bni, 6bnu, 6bny, (6bph), (6bqr), 6bqu, 6bur, 6bve, 6bvg, 6cae, 6caj, 6can, 6cbb, 6gg, (6cgc), (6cgo), 6cgw, 6cek, (6cel), 6cfe, 6chl, (6cix), 6civ, (6ckw), 6cla, (6cmi), (6cni), 6cqe, 6crx, 6cso, (6cso), (6css), 6csw, (6cto), 6cve, 6cvs, 6cvm, 6cvx, 6cw, 6ea, (6eb), 6gc, (6gt), (6ih), 6lq, 6ne, 6nn, 6nx, (6of), (6oi), (6ol), 6pl, 6pw, 6rn, (6rm), (6ts), 6ul, 6ut, 6ve, 6vo, 6xi, 6xo, (6zh), (6zp), 7abb, (7afn), 7afo, 7agi, 7aha, 7ahi, 7aji, (7bj), 7dj, (7fq), (7gb), 7gr, 7ij, 7ix, 7iy, (7ku), (7lq), 7ls, (7mf), 7mp, (7nx), 7ot, 7nd, 7ry, (7sp), 7sf, 7th, (7zm).
Daylight: (6ame), (6ase), (6oi), 7qd, 7abb.

How about your New Mexico, Nevada, and Idaho stations. Let's QSO. Lack those three of making it 48 straight! Will QSL all cards. Thankz vy—"GX."

By John H. P. Andrews, Lake and Bellona Avenues, Govans, Balto, Md.

6afg, 6agk, 6ahp, 6alw, 6ame, 6awt, 6bir, 6blh, 6boq, 6bph, 6bqr, 6bra, 6bur, 6cbb, 6cct, 6cej, 6chl, 6cmg, 6cmu, 6crx, 6css, 6cwi, 6czx, 6eb, 6kb, 6pl, 6rv, 6zh, 6zp, 7afo, 7mf, 7mp. Can.: 5ba. Foreign: g2jf, g2kf, g2lz, g2nb, g2nl, g2nm, g2od, g2om, g2sh, g2sz, g5nn, g5uo, g6nf, g6vp, f8cz, f8gk, f8gl, f8sm, q2mk, zero re, sj.

By 9BJI, Denver, Colo.

CW—all on 80 meter band—1abf, 1ad, 1acb, 1aea, (1af), 1agg, 1aid, (1ajo), (1all), 1arm, 1ary, 1axi, 1axn, 1axz, 1bdx, 1bqk, 1bvl, 1cab, (1cav), 1ckp, 1cme, 1cmp, 1gs, 1li, 1my, 1ow, 1qm, (1qv), 1rd, 1sf, (1ve), 1xm, 1xu, (1xw), 1yd, 1zs, (1zt), 2aan, 2aco, 2acs, (2axf), 2bbn, (2bgi), 2bn, 2bqb, 2bqu, 2br, 2brc, 2bse, 2byh, 2cel, 2cgi, 2cjb, 2cix, 2cpa, 2cpk, 2csl, 2cst, 2cty, 2cvf, 2cvj, 2cwj, 2cxe, 2gk, 2ha, 2hx, 2ke, 2kf, 2kx, (2le), 2mc, 2mk, (2mu), 2rb, 2xq, 3adb, 3adp, 3adq, (3adt), (3adv), 3ajd, 3aoj, 3aol, (3ava), 3awa, 3bg, (3bjp), 3blp, 3bmn, 3bnu, 3bob, 3bof, 3bwj, 3ca, (3cb), 3cc, 3cdq, 3cdn, 3che, 3dj, 3hj, 3ig, 3mf, 3oq, 3ou, 3qv, 3sm, 3tf, 4al, 4bl, (4bq), 4du, 4eh, 4eq, 4ft, 4fz, 4gw, 4hw, 4ja, 4mb, 4mi, 4pd, 4rm, (4sl), 4tv, (4tw), 4ua, 4wa, (8aa), 8add, (8app), (8apr), 8aol, 8aow, 8atp, 8aul, 8arb, 8awg, 8baj, 8bau, 8bay, 8bbw, 8bbf, 8bce, (8bdk), 8bdq, 8ben, 8blb, 8bhj, 8bp, 8bpl, 8byn, (8ced), 8cel, 8cdt, 8euk, 8enl, 8evf, 8evh, 8eta, 8eyl, 8dal, 8dan, 8dag, 8ded, 8dfo, 8dgp, 8dhs, (8dhw), 8dlf, 8djb, 8dki, 8dma, 8dnf, 8dnv, 8do, 8dse, 8ef, (8fn), 8fy, 8kh, (8pl), 8tr, 8tt, 8xs, 8zah, 8ze. Can.: 1ar, 3nl, 4ch, 4dq, 4fv. Mex.: 1x, 1b 1aa. N. Z.: 2ac. Aust.: 2bk, 2yg, (2yi), (3bd).

By 8DCF, 31 Kingsville Ave., Ashtabula, Ohio

1aao, 1ajx, 1ana, (1ary), 1atj, 1avr, 1aww, 1azr, (1cl), 1erd, (4lw), 4kl, 4sh, 4ua, 4ux, 5aaq, (5acl), 5gq, 5aiy, 5asb, 5bj, 5cn, 5di, 5in, 5ll, 5mz, (5ov), 5qj, 5sp, (5wo), 6aao, 6afg, 6afz, 6bur, 6cbb, 6cto, 6ea, 6pl, 7fq, 9aer, 9akd, 9amx, 9aqf, 9axs, 9blk, 9bmw, (9bnf), 9bwb, 9byv, (9bzk), (9cyr), 9cyz, 9dbz, 9ddk, 9dge, 9dix, (9djs), (9dmj), 9dmz, (9dvw), 9eak, (9er), 9es, 9of, 9qx, 9vc. Can.: c2ax, (c2be), c2cg, (c3kq), (c3gq), c3tf, c3xl.

By 6ALV, Alameda, Calif.

1aao, (1af), 1abs, 1alm, 1ajx, 1ber, 1ban, 1bfl, 1cme, 1or, 1wl, 1xae, 2abt, 2bqb, 2bqt, 2btu, 2cvj, 2cwo, 2xq, (2czr), 3bgl, 3bwj, 3eh, 3hs, (3kq), 3sm, 3te, 3xl, 3xm, 4eg, 4fm, 4xe, (5's, 6's, 7's too numerous), 8ah, 8apr, 8avd, 8bau, 8bz, 8cbp, 8cdt, 8cuk, 8gh, 8gz, 8fm, (too many 9's). N. Z.: (1ao), 2ac, 2ae, 2ap, 4ag, 4ap. Australia: 2bk, (2yg), (2yi), (3bd), (3bq). Mexico: bx, 1aa. Holland: zero nl. Canadian: 4dq, (6ef), nqg, nkt, rvn?? QRA?

By Raymond Oswald, 1046 W. 101st St., Chicago, Illinois

2bbx, 2ctf, 2apa, 3ccu, 3wb, 4dv, 5agn, 5aly, 5an, 5anl, 5apl, 5ek, 5fs, 5ms, 6afh, 6ahm, 6ak, 6ard, 6ase, 6bja, 6bmg, 6bni, 6bxt, 6cab, 6cas, 6ckf, 6cgy, 6dmq, 6jz, 6na, 9add, 9agl, 9bhb, 9bhx, 9bkb, 9bvn, 9bvw, 9cfo, 9ckt, 9cyy, 9ctd, 9cyk, 9cyq, 9dnp, 9dpu, 9drw, 9dar, 9efd, 9fg, 9h, 9hp, 9iz, 9jh, 9ry, 9su, 9tg. Canadian: 9bj.

(Continued on page 46)

Prest-O-Lite

RADIO CHART

Voltage of Tubes	No. of Tubes	Type of Tubes (see foot-note)	Total Amperes Drawn	Recommended Prest-O-Lite "A" Batteries		
				Order by Following Types	Days between Chargeings	
5-Volt Tubes C-100 and UV-200 are interchangeable C-101A, DV-2 and UV-201A are interchangeable	1	UV-200	1	49 WHR 67 WHR	22 16	
	2	UV-201A	1 1/2	67 WHR	33	
	2	1 UV-200 1 UV-201A	1 1/2	63 WHR 69 WHR	22 17	
	3	UV-201A	2 1/4	69 WHR 67 WHR	29 22	
	3	1 UV-200 2 UV-201A	1 1/2	61 WHR 69 WHR	21 14	
	4	UV-201A	1	69 WHR 67 WHR	22 16	
	4	1 UV-200 3 UV-201A	1 3/4	613 RHR 61 WHR	22 15	
	5	UV-201A	1 1/4	611 WHR 69 WHR	22 27	
	5	1 UV-200 3 UV-201A	2	613 RHR 61 WHR	29 13	
	6	UV-201A	1 1/2	611 RHR 69 WHR	21 14	
	8	UV-201A	2	69 KPR 67 KPR	21 15	
	For sets using current at a rate higher than 2 amperes.			1 1/4	69 RHR 67 RHR	22 13
				2 1/4	69 RHR 69 KPR	19 16

60 EPR "B" BATTERY



28 MRR TWIN "B" BATTERY

Copyright, 1929 The Prest-O-Lite Co., Inc.



48 LRR "B" BATTERY

69 WHR "A" BATTERY



Write today for this free booklet

Whether you have a one-tube set or most advanced multi-tube outfit, you'll find a fund of interesting information in our booklet, "How to fit a storage battery to your set—and how to charge it."

This booklet gives you the complete Prest-O-Lite Radio Chart—technically accurate recommendations covering both "A" and "B" storage batteries for every type of set.

In addition, there is much vitally important data on battery care and upkeep—information that any radio fan will find of real value in keeping his set at its maximum efficiency. Write for your copy right now.

How to select batteries that run your set for weeks without recharging

Why select storage batteries by guesswork and risk getting one that requires charging every few days? Buy wisely. Let the Prest-O-Lite Radio Chart guarantee you batteries that fit your set—of ample capacity to bring weeks of fine reception without too frequent recharging.

The above section of the master chart selects Prest-O-Lite "A" Batteries to fit all 5-volt sets. It recommends two sizes for each set, depending upon the days of service you wish between chargeings (based on the average use of your set of three hours a day). The larger capacity battery will be found more desirable unless facilities for frequent and easy recharging are provided. Consult the complete chart

at your dealer's for data on "B" Batteries and also "A" Batteries for low voltage tubes.

In every detail of construction—special structure plates, highly porous separators and superior internal arrangement tops—these batteries are made to get the best out of your set. To supply the dependable, unvarying current essential to fine tuning, efficient tube operation and clarity of reception.

Prest-O-Lite Batteries offer you truly remarkable savings. Though standard in every respect they are priced as low as \$4.75 and up. They last for years and are all easily rechargeable. See them at your dealer's or write for our booklet, "How to fit a storage battery to your set—and how to charge it."

THE PREST-O-LITE CO., INC., INDIANAPOLIS, IND.

New York

San Francisco

In Canada: Prest-O-Lite Company of Canada, Ltd., Toronto, Ont.

Prest-O-Lite



MAR-CO CONDENSERS

RADIO
PRODUCTS

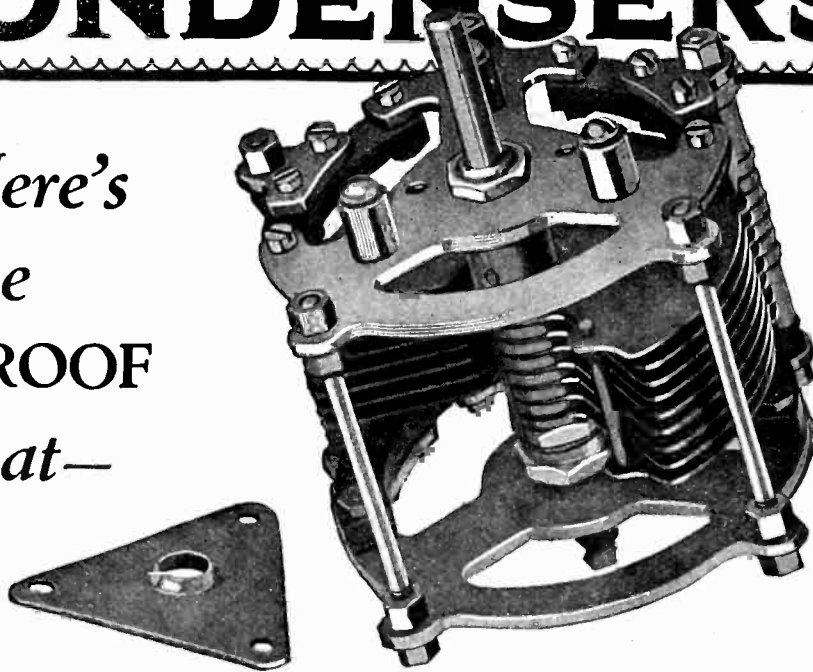

Here's
the
PROOF
that—

“A better condenser
makes any circuit better!”

I have had built an 8-tube Super-Heterodyne and of course bought with care the best parts the market offered. The result was, I tried several well-known condensers which were not satisfactory and by chance tried a pair of “Mar-co Condensers” and was greatly pleased with the performance of my set. So much so I hoped to pick up one of the foreign stations during test week.

On tuning in on 470 meters, picked up “Lyons, France, Station PTT,” which came in as loud and clear as a bell with orchestra music, and held them until they signed off at 12 midnight, Eastern Standard Time.

I am enclosing a confirmed telegram of my reception that you may know Mar-co Condensers proved 100% on a test with an amateur at the dials.

Yours very truly,

(Signed) H. W. DAHL

MARTIN-COPELAND COMPANY · Providence, R. I.

“Elements of Radio Communication”

By Lieut. E. W. Stone

A Book That Every Radio Fan
Should Have.

\$2.50

SENT POSTPAID ANYWHERE

PACIFIC RADIO PUB. CO.
Pacific Bldg. San Francisco

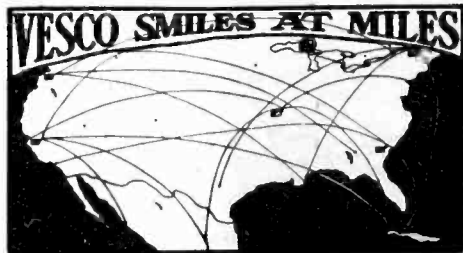

ON ONE TUBE

BIG FREE BOOKLET tells the story. California users of CROSS COUNTRY CIRCUIT hear Atlantic Coast, Canada, Cuba, Mexico and Hawaii. Atlantic Coast users hear England to California. Our new plan makes this set easiest and cheapest to build. One hour puts in operation. One tuning control. No soldering. Any Novice can do it. BIG BOOKLET FREE or complete instructions for 25c stamps or coin.

VESCO RADIO CO.
Box R-117, Oakland, Calif.

(Continued from page 44)

By 7UB, Perry Wonnacott, 536 Liberty St.,
Silverton, Oregon

1aao, 1acb, 1af, 1ajo, 1ary, 1bbe, 1bcc, 1bcr, 1cme, 1cmp, 1cpa, 1cwa, 1er, 1hr, 1ml, 1pl, 1yb, 1yd, 2aav, 2anm, 2aqf, 2atv, 2by, 2cee, 2cft, 2cfx, 2chk, 2cpa, 2cvf, 2dd, 2dlk, 2gk, 2je, 2lc, 2mc, 2rk, 3alx, 3auv, 3blp, 3bpm, 3bnu, 3bta, 3bwj, 3cb, 3cf, 3ckj, 3hw, 3kq, 3ot, 3tf, 4dq, 4eq, 4fz, 4gw, 4kl, 4qt, 4tj, 4tw, 5aad, 5aal, 5aag, 5ahw, 5aic, 5aly, 5adh, 5acl, 5aj, 5ajj, 5ajp, 5aky, 5am, 5an, 5aqr, 5arb, 5aul, 5aux, 5asz, 5afq, 5bx, 5ca, 5dm, 5ew, 5hj, 5in, 5kc, 5ka, 5ll, 5ls, 5ot, 5qh, 5uk, 5wo, 5se, 5sk, 5za, 5zal, 5zas, 8add, 8ajj, 8baj, 8bbi, 8bfg, 8bng, 8bk, 8btr, 8bqp, 8btf, 8cta, 8cva, 8cwp, 8cyd, 8dae, 8bgp, 8bpt, 8doo, 8dse, 8dkt, 8fy, 8vq, 8wa, 8yv, 9aau, 9aks, 9ao, 9amp, 9auw, 9axs, 9ayp, 9bf, 9bhl, 9biz, 9bm, 9bjl, 9bnk, 9bpf, 9bxt, 9ca, 9ccs, 9cgn, 9cic, 9cjs, 9cjj, 9cko, 9col, 9csg, 9ctg, 9cul, 9cvo, 9cuv, 9cyj, 9dad, 9dac, 9diy, 9dix, 9dkk, 9dmj, 9dmz, 9dun, 9duu, 9dyi, 9dtk, 9eak, 9eam, 9efz, 9eg, 9eky, 9emr, 9es, 9na, 9oa, 9on, 9qw, 9xhp, 9zd, 9bku, nfv, nkf, wgh. Canadian: 3ki, 4bb, 4dq, 4fn, 4io. Mexican: 1aa, 1b, 1x, 9a. New Zealand: 2ac, 2ap, 4aa.

By 0APY, 3337 Oak Park Ave., Berwyn,
Illinois

1aao, 1af, 1ak, 1asu, 1avl, 1bdx, (1bhg), (1bub), 1bzq, 1cak, 1pl, 1xa, 2aay, (2aco), 2ahw, (2ale), 2auh, (2bbx), (2bhk), (2bdo), 2box, 2bpg, 2bse, 2bum, (2bjk), 2cor, 2cql, 2cub, (2cxy), (2cuyl), 2gk, 2lm, 3adb, 3adq, 3ans, 3arz, (3awu), 3bhv, 3blp, (3bms), 3bmt, 3br, 3chg, 3cm, 3ly, 3na, (3oe), 3ph, 3qt, 3rs, 3sm, 3dv, 4ml, (4og), 4tw, 4tx, (4vo), 5ail, 5aly, 5ajp, (5apl), 5aqt, 5art, 5asb, 5asf, (5ash), 5att, 5aul, 5ek, 5er, 5ew, 5ex, 5ji, 5lh, 5lr, 5qt, 5sq, 5rw, 5se, 5vc, 5wl, 6afh, 6alw, 6chx, 7ok, 7sb, 8act, 8ase, 8atp, (8azu), (8bjt), 8bmo, 8bmv, 8bn, 8bqa, (8ckf), (8ckp), (8cl), 8dnu, (8dpx), 8eb, 8vo, 8wz. Canadian: (C-3ck), C-3ws, C-4ch. U. S. Fones: 3wf, 8dat. Government: wgh. QRK 9apy's 100 watts?? Card for card.

By George Morrow, 34 North Howard St.,
Salem, Ohio

1ana, 1bdt, 1bkj, 1mo, 1xw, 1xam, 2kc, 2rq, 2cel, 2cow, 3bhy, 3bmn, 3zo, 4ek, 4ik, 4yc?, 5ado, 5amf, 5dw, 5kc, 5qd, 6awt, 6ceu, 6cgw, 6ry, 6kac?, 7ot. Canada: 2do, 2od, 3oo, 3gg, 4bp. Mexican: bx, 1b. New Zealand: 4aa, 4ag. Australia: 2cm, 2ds, 6ac. England: 2kz, 2od, 2sh, 5nm, 5xx. French: 8ab, 8bf, 8ek. Not known: onl, ear2, fain, smm1, chfal, QRA,s pse. A card to all who QSL.

By 2CXY, Bradley Beach, N. J.

5ahw, 5aly, 5ajt, 5aot, 5apm, (5apt), 5asw, 5azg, 5an, (5dm), (5er), 5ka, 5nj, 5ov, 5ox, 5rv, 5ty, (5uk), (5uv), 5xa, (5ox-5uk very consistent), 6abx, (6agk), 6bcp, 6bhx, 6bjj, 6blh, 6bul, 6bvq, 6cgo, 6cgw, 6chx, 6cpw, 6ers, 6eb, 6mg, 6pl, 6vc, 6wp, 6xad, (6zh), 6xo, 6cqe, 6cso, (6zh es 6bjj very consistent), 7acm, 7cy, (7df), 7fd, 7fq, 7gf, 7gj, 7ij, 7ku, (7uj), 7zm, 7zu, (7df-7fq very consistent). Canadian: 4eo, (4io), 4ch, 5ct, 5dq, 5go, 5gf. Mexican: 1aa, 1n, 1x, bx. Britain: (5mm), 5nn, 5uq, 2nm, 6nf, 2fu, 1kf, 2od, 5ma, 5pu, 5nn. Holland: O-nl. Belgium: 3ad. Argentina: CB8. Will QSL on request. Reports on sigs appreciated. 82n hr.

At 6BUR, 340 North Painter Avenue
Whittier, California

1aa, 1aao, 1ajx, 1all, 1amf, 1ary, (1br), 1bdk, (1bgq), (1ble), 1bkq, 1bz, 1cab, (1cme), (1da), 1ez, 1fb, 1hn, 1ml, 1pl, 1qm, 1rd, 1uw, 1wl, (1xz), 1za, 1zt, (2aan), 2aby, (2acs), (2afp), 2aqb, 2aqh, 2axy, 2bg, 2big, (2bkr), 2bqu, 2byk, (2cgb), 2chk, 2cje, 2ctj, (2ctq), (2czt), 3gk, 2kx, (2le), (2pv), 2wl, 2wr, 2xi, 2zk, 3abj, 3adp, 3adq, (3ajd), 3bdo, 3bg, 3jp, 3bmn, 3bng, (3bta), (3bwt), (3bz), (3chg), 3cjin, 3eh, (3kq), 3lg, 3ot, 3qv, 3te, (3tf), 3xm, (4bl), 4bm, 4db, 4do, (4eh), 4eq, (4fz), 4it, (4ku), 4mb, 4oa, (4pk), (4sl), (4tj), 4tw, 4uk, 4wj, 8aa, 8acm, 8afm, (8ame), (8apr), (8avd), (8axn), (8bau), 8baq, 8bbi, (8bbw), 8bcd, (8bf), 8bfe, (8bnh), (8bpl), (8bqa), (8ccf), (8cp), (8cpy), (8cyd), (8czy), 8dae, 8dde, (8dfk), 8dgv, 8dun, 8er, (8fy), 8lh, 8jq, (8lr), 8pk, 8pl, 8tt, (8up). Australia: (2bk), 2cm, (2yi), (2yg), 2yr? (3bd), 3bq. Argentina: 1px. Brazil: (3ad), ur. Canada: 1ar, 2ax, (3gb), (3ly), 3tf, 3vh, 3xl, 9al. Chile: 9tc. Columbia: wjs. Cuba: 2by. England: 2nm, 5nn, 6ry. Porto Rico: 4sa. Navy: nfv, nvl, (nkf), nqg. Mexico: (1aa), 1af, (1b), (1x), (9a), bx. New Zealand: (1ao), (2ac), 2ap, (4aa), 4ag, 4ak.

By Nick Geracimos, 12 Hertzell Street,
Warren, Pa.

6aed, 6agk, 6apw, 6bdv, 6bge, 6bge, 6bln, 6blh, 6bul, 6cae, 6cgc, 6cnn, 6css, 6il, 6ts, 6ul, 6vc, 7adm, 7afo, 7ajv, 7ald, 7cy, 7df, 7dj, 7fg, 7gb, 7ij, 7iu, *7lg*, 7iq, 7mg, 7mp, 7nt. All cards QSL'd.

(Continued on page 48)



You Get This Kit Free!

Without one cent of cost to you and merely in return for a little of your spare time, we will present you with one Baldwin-Pacific Quintet Super-heterodyne Kit. You send us six subscriptions to "RADIO" for one year each, or three subscriptions to "RADIO" for two years each—and the kit is yours. The subscription price is \$2.50 per year. The kit is given to you in return for securing only \$15.00 worth of subscriptions. The kit alone sells for \$15.00. Therefore, you get double value for your money. Why not send "RADIO" for one year to five of your radio friends, let us send "RADIO" to your own address for one year, and get the kit? This big subscription offer is made for one month more due to the heavy demand for kits from our subscribers.

We guarantee this subscription offer to be exactly as represented. There are positively no further payments of any kind to make. Immediately upon receipt of your subscriptions and remittance of \$15.00 we will mail the kit to you, forwarding charges paid. We need more subscribers to "RADIO." Help us get them and we will make it worth your while. It's easy to get subscriptions to "RADIO." Every wide-awake fan should read it. Many people have never seen a copy of this magazine. Show your copy to the radio fans in your vicinity, tell them of the many feature articles published in "RADIO" every month and ask them to subscribe. Many of our readers have secured six subscriptions in a single day and have been awarded a kit. You can build a remarkably efficient 45,000 cycle super by using the parts which make up the Baldwin-Pacific kit.

Use the Coupon ~

ACT NOW. Don't let the other fellow beat you to it. Start today and you will be surprised to learn how easy it is to get six subscribers. Fill in the coupon, send us a list of the subscribers, your remittance of \$15.00 and the kit will be mailed to you on the same day your subscriptions are received.

Pacific Radio Publishing Co.
Pacific Building San Francisco
 —Established 1917—

"RADIO,"
 Pacific Building,
 San Francisco, Calif.

Here is \$15.00 and the names of subscribers for "RADIO." Immediately send me the BALDWIN-PACIFIC SUPER-HET KIT.

Name

Address

City

At DONG, Fergus McKeever, University Heights, Lawrence, Kansas

1aac, 1ah, 1ad, 1aao, 1aap, 1aaz, 1abf, 1acb, 1acd, 1adi, 1aea, 1af, 1agh, 1agg, 1afc, 1aez, (1adb), 1ajh, 1ajp, 1ajt, 1ajf, 1ajx, 1akz, 1anm, (1aid), (1all), 1akp, 1alk, 1aix, 1apy, (1are), 1ary, (1aqm), 1ana, 1ayn, 1avf, (1avr), (1axi), (1awe), 1azy, 1ajo, 1adm, (1air), 1bbh, (1bbe), 1bdx, 1bee, 1bge, 1bgd, (1bhn), 1bkr, (1blx), (1bif), 1bis, (1bdh), 1bv, 1bed, (1bub), 1bvl, 1bzq, 1bx, 1bes, (1cag), 1cak, 1cg, 1ccj, (1cme), 1cmx, 1cjc, 1cpv, (1cx), 1ckp, (1da), 1df, 1dk, (1ef), 1er, (1ez), 1afn, 1de, (1ga), 1gr, 1ge, (1gs), 1li, 1l, 1t, (1ctt), (1lv), (1ld), 1fd, 1gc, 1je, 1kc, 1lw, 1ma, 1ahc, 1ow, 1pl, (1my), (1py), 1rd, 1sf, 1dr, 1km, 1ve, 1vj, 1vk, 1xm, 1xam, 1zw, (1xz), 1yb, 1yd, 1za, 1atj, 1xw, 1xj, 1xu, 1aww, 1azl, 2aan, 2aay, (2abt), 2aoy, 2adf, (2acs), (2ach), 2agb, 2ag, 2ana, 2agq, 2acy, 2anm, 2aix, 2ate, (2at), 2bbn, 2bg, 2gg, 2bkr, 2bm, (2bgl), (2bqb), 2brb, (2bse), 2bro, (2bum), 2byg, 2byk, 2bq, 2cdh, (2cee), (2cgl), (2chk), (2cjb), (2cix), (2csi), 2ctq, 2cty, 2cvf, (2cvu), 2cvs, 2cxw, (2cvi), (2cxy), (2cpa), 2cuj, 2ct, (2czr), 2cwj, 2czq, 2aav, 2aey, 2dd, 2crp, (2eq), 2fc, 2gk, 2agg, 2eb, 2cj, 2cdv, 2kc, 2ku, 2bn, 2bnq, (2kx), 2kf, 2pv, (2pd), 2qs, 2rk, 2mc, 2pu, 2xq, 2xna, 2xi, 2wr, 2wa, 3aac, 3agf, (3adq), 3adp, (3apv), 3afs, 3an, 3adb, 3acj, 3awa, (3bal), 3bhy, 3bel, (3bdo), (3bip), (3blc), (3bob), 3bgg, (3bmn), (3bpm), (3buy), 3bw, 3bjp, (3bma), 3bva, 3bjn, (3bmt), 3bv, 3bwj, 3ca, 3cb, 3cf, 3ccx, (3ccu), (3cdg), 3chc, 3chg, 3chh, (3cf), (3ckj), (3ckl), 3cjj, 3cvu, 3cm, 3dz, 3iu, 3lo, 3lq, (3kd), 3jx, 3my, (3na), 3r, 3hs, 3mf, 3ll, 3ke, (3rr), 3ot, 3mf, (3sm), (3qt), 3yo, (3tp), 3wy, 4al, 4bl, (4bq), 4ch, 4lo, 4eq, 4ft, 4fz, 4eh, 4fm, 4je, 4jr, 4js, 4ku, 4lr, 4mw, 4ke, (4ml), (4mb), 4bx, 4gw, (4tw), (4tl), 4tj, 4tn, (4pd), (4du), (4uk), 4rr, (4pk), (4rm), (4sl), 4sa, 4oa, 4ua, 4xe, 4st, 4vc, 4my, 4vm, 4xc, 6aba, 6adt, (6adb), 6afg, 6agk, 6alb, 6aol, 6alw, 6ajw, 6akz, (6ame), 6amm, 6aww, 6app, (6apw), 6asb, 6ase, (6ahp), (6arx), 6awt, (6ano), 6amo, 6cas, 6ab, 6ac, (6ar), 6aaq, 6bau, (6bav), 6bad, 6bay, (6bdt), (6beb), 6bqb, 6bgc, 6bhw, 6blh, 6blw, 6bni, 6bjj, (6bjx), 6bka, 6bnv, 6bov, (6bql), (6bqu), (6bgo), 6bid, 6bur, (6bve), (6bul), 6bze, (6bhx), 6apj, 6alg, (6cae), 6can, (6ccy), 6cct, 6ceq, 6cgo, 6cgw, 6cge, (6che), 6chl, 6chx, 6clx, (6cmg), 6cnn, 6cso, 6css, 6csw, 6cul, (6clp), (6cje), 6cwl, 6eva, 6czz, 6ase, (6emt), (6cjj), (6cw), 6cto, 6czy, (6cni), 6cux, (6ers), 6erb, 6ctd, 6clz, 6eb, 6ew, (6fy), 6cn, 6cas, 6dl, 6ckf, 6ebb, 6ib, 6lh, 6lr, 6ja, 6gk, 6kr, 6ma, (6me), 6ji, (6jp), 6ms, (6ol), 6pl, 6ql, 6nx, (6rn), 6rv, 6ib, 6tl, (6ts), (6il), 6mi, 6zh, (6wt), 6lh, 6cse, 6ul, 6mo, (6wp), 6vc, 6vd, 6vw, 6ut, 6xby, 6of, (7af), 7alb, 7abb, 7agf, 7av, 7bj, 7cy, 7dc, (7dl), (7df), 7adm, (7gm), 7gr, 7gb, 7ge, (7fr), 7lj, 7lg, 7gu, 7fq, 7js, 7ok, (7mf), 7mp, (7mg), 7gs, 7ls, (7lr), 7se, (7ku), 7qd, 7mx, 7fd, 7ot, (7uj), 7zu, 7zq, (7sp), 7jr, 7dj, 7vm, Canadian: 1ar, 1dd, (1dq), 2cg, 2bn, 2be, (2bv), 2ax, 3adj, (3ly), (3aec), (3ael), 3xi, 3gv, 3qs, 3ad, 3tf, (3ms), 3ach, 3zt, 4aw, (4bb), (4cb), (4fv), (4dq), (4gt), 5go, 5gf, 5ba, 5an, 5bz, 5hk, 5as, Mexican: (bx), 1b, 1aa, 1e, 2ak, 4ag, 2ac, A3bq, nkf, nfv, neg, lpx, wgh, onl. Will try to answer all cards, all reports on my signals greatly appreciated, especially from DEL.

By GVD, 123 Cherry St., Anaheim, Calif.

1aao, 1aeo, 1ckp, 1kc, 1se, 2aan, 2aay, 2bgl, 2bqu, 2brb, 2brc, 2wr, 2xq, 2xb, 3adp, 3avv, 3bb, 3do, 3bdo, 3bhv, 3bnu, 3bpm, 3hg, 3hh, 3te, 3yo, 4eh, 4eo, 4gw, 4hw, 4kl, 4ku, 4tw, 5adh, 5aic, 5ajm, 5akn, 5asb, 5atf, 5bx, 5dw, 5lj, 5kc, 5lh, 5ot, 5ps, 8aa, 8acy, 8apr, 8avl, 8axr, 8bbw, 8bjz, 8bkh, 8blc, 8btf, 8cbp, 8cdt, 8coj, 8dae, 8dal, 8ded, 8doo, 8fu, 8jq, 8pk, 8pl, 8ze, 9aad, 9adg, 9axx, 9bhe, 9bht, 9bjl, 9bkk, 9bm, 9bvw, 9cgy, 9ctg, 9cul, 9cvf, 9czm, 9del, 9dgv, 9dhq, 9dmj, 9dyz, 9eeo, 9eet, 9ehy, 9ekq, 9es, 9fj, 9hn, 9rg, 9vc, 9za. Canadian: 4fn, 4io, 5go, 5ot.

By SRY, Sullivan, Ohio, 65-105 Meters. QSL-QRH 75-QSLL:

C1eb, C1am, C2au, C2be, C2bv, C2eg, C2fo, C2hm, C4er, C4lo, C5ba, C5go, F8bo, F8sm, FN3gb(?), G2kf, G2nm, G2od, G2sz, G2yt, G5kc(?), *G5lf*, G5nn, *G6ry*, Mox, M1b, M1x, M9a, M1aa, P4wj(?), M1af, Qdz, Q2mk, Rcb8, S-LAC, ber, (Lox), lpx, odb, sj, wjs, ur, Z2ac, Z4aa, U-abc, 4je, 6ao, 6eb, 6ew, 6fy, 6gt, 6of, 6pl, 6tl, 6ts, 6vw, 6aa, 6afg, 6afk, 6agk, 6alb, 6aji, 6alg, 6alo, 6alv, 6ame, 6aol, 6ase, 6bad, 6ban, 6bdt, 6bka, 6blr, 6bmw, 6bra, 6bul, 6cbb, 6odn, 6cgw, 6chx, 6cmu, 6cnl, 6cqe, 6oqn, 6cso, 6csw, 6cto, 6cul, 6czx, 7cy, 7df, 7fy?, 7gb, 7ij, 7ku, 7lj, 7mf, 7pz, 7ry? 7sf, 7uj, 7wm, 7zq, 7zz, 7agi.

The By-Pass Condenser

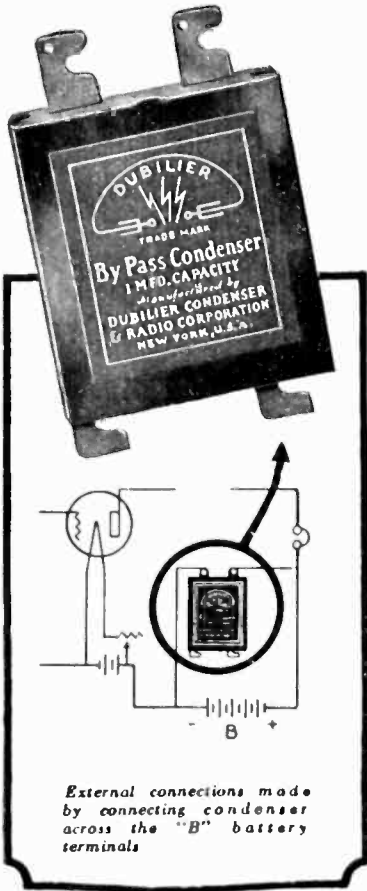

YOU will get the program clearer if you install a Dubilier large capacity By-Pass Condenser in your radio set. Just locate it as the diagram indicates. The result is that the minute fluctuations of the "B" battery are smoothed out into a steady, even flow of current, devoid of all noises.

The result is astonishing! Signal strength is increased—tones purer—volume smoother. The whole program comes in far truer and pleasanter than ever before.

This By-Pass Condenser in quality of material and workmanship measures up to that high standard for which all Dubilier radio devices are famous.

Dubilier

CONDENSER AND RADIO CORPORATION

FILE-KO-LEAK

SCIENTIFICALLY CORRECT VARIABLE GRID LEAK

HAND CALIBRATED IN MEGOHMS—Eliminates distortion; increases volume. Can be read through panel peep-hole and logged. Ask your dealer or write Dept. R325, DX INSTRUMENT COMPANY, Harrisburg, Pa.

HERCULES AERIAL MAST

20 Ft. Mast \$10.00
40 Ft. Mast \$25.00
60 Ft. Mast \$45.00

All steel construction, complete with guy wires and masthead pulley. We pay freight.

S. W. HULL & CO.,
Dept. G5, 2048 E. 79th St.,
Cleveland, Ohio

Write for Literature and FREE Blueprint



HONEYCOMB COILS

The Universal all-wave inductance. Back and front panel mountings. Send 25c for Super Het., R. F. and Honeycomb Coil Circuits and Complete Catalog.

Chas. A. Branston, Inc.
619 MAIN ST., BUFFALO, N. Y.
DEPT. 12

"Built First - Coto - Last"

INSIST ON THE SILVER PLATED AIR CONDENSER FOR YOUR RADIO SET.

At U-6AKW, R. F. D. No. 1, Lancaster, California

1aa, 1aao, 1aay, 1acb, 1amf, 1ana, 1ary, 1avz, 1bz, 1bbe, 1bdh, 1bfi, 1bgo, 1bsd, 1cme, 1da, 1er, 1mc, 1pl, 1py, 2az, 2af, 2asw, 2bgi, 2bkr, 2bqt, 2brb, 2cix, 2cnk, 2cvj, 2czo, 2ds, 2gw, 2mc, 2gk, 2kx, 2xaq, 2adm, 2avj, 2bp, 2bpm, 2buy, 2bwj, 2cb, 2it, 2kq, 2lg, 2ot, 2sf, 2sm, 2wb, 2bb, 2eh, 2eq, 2fn, 2hw, 2io, 2jr, 2kl, 2sb, 2tw, 2ua, 2nkf. Australian: 2bk, 2yg, 2yi, 2bd, 2bq, 2ju, 2bg, *5da.* New Zealand: 1ha, 1ao, 2ac, 2ap, 4aa, 4ag, 4ak. Canada: 2ap, 2ax, 2bg, 3aa, 3ac, 3aw, 3vh, 3xl, 4io, 5an, 5ba, 5bb, 5ct, 5hc, 5ox. Mexico: 1b, 1g, 1x. England: 2nm, 2sh, 6lj. Indo-China: *HVA.* QSO Australia and New Zealand 17 times for January, 1925 during last half month. Handled Australia-New Zealand traffic, 20. 6akw or 6bcl first yanks to QSL. HVA between 7:00 and 8:00 a. m. of February 3rd., 1925.

By H. C. C. McCabe, 71 Holloway Road, Wellington, New Zealand

U. S.: 1abf, 1yb, 1ary, 1kc, 1ow, 1mv, 1pl, 1sf, 1cmp, 2brb, 2anm, 2al, 2bgi, 2xq, 2cqz, 2rk, 2cz, 2bp, 2aha, 2bhv, 2yo, 2bva, 2ot, 2io, 2pk, 2ku, 2oa, 2zav, 2akn, 2aaq, 2vz, 2aex, 2lu, 2ph, 2zai, 2qy, 2cnx, 2ai, 2go, 2amf, 2uk, 2mi, 2za, 2ox, 2dw, 2hl, 2bge, 2zh, 2cni, 2ai, 2ced, 2cjj, 2akf, 2akz, 2bqr, 2bql, 2bvg, 2cmi, 2epg, 2pl, 2csw, 2bip, 2cdc, 2ctc, 2cem, 2cft, 2mme, 2aan, 2amo, 2bjj, 2bhv, 2cct, 2bir, 2aji, 2crx, 2cw, 2ea, 2rn, 2buw, 2ajh, 2ahp, 2akw, 2rk, 2fy, 2ccy, 2gr, 2fh, 2afq, 2ckw, 2cvj, 2ti, 2ts, 2bax, 2czz, 2ne, 2amm, 2cax, 2ame, 2gen, 2hp, 2afg, 2ew, 2eb, 2bur, 2cks, 2xbn, 2lj, 2bcw, 2ao, 2cae, 2cgk, 2awt, 2cfs, 2cgw, 2vc, 2ase, 2cej, 2age, 2bra, 2arb, 2cgo, 2bdt, 2of, 2ij, 2ls, 2mf, 2ku, 2af, 2fq, 2pz, 2wm, 2mgi, 2ry, 2zz, 2afn, 2zm, 2gb, 2cm, 2alf, 2vq, 2ba, 2fm, 2ac, 2cei, 2aa, 2rv, 2alf, 2abs, 2byn, 2bjj, 2bm, 2xi, 2dma, 2cjc, 2eky, 2bcl, 2zi, 2ccm, 2gdv, 2dac, 2dwx, 2dqu, 2bpy, 2dwb, 2bht, 2cip, 2aby, 2bmk, 2acq, 2azp, 2efy, 2bhx, 2zy, 2bhy, 2mm, 2ru, 2na, 2dit, 2egh, 2hk. Mexican: bx, 1bj, 1k(?). Canadians: 2bq, 2dq, 2ba, 2gt, 2go, 2al(?). French: 8sm. English: 2od, 2nm. Special: wgh, 6xi.

By 6CIX, 317 North Friends Avenue, Whittier, Calif.

(1af), 1ar, 1aao, 1ajh, 1ajx, 1ary, 1bv, 1bak, 1bdx, 1bes, 1cme, 1cmp, 1cri, 1fd, 1pl, 1rd, 1wy, 1xu, 1xz, 1yd, 2ag1, 2agq, 2alx, 2azq, 2br, (2by), 2beo, 2bhc, 2bpb, (2buy), 2cee, 2chk, 2cpa, 2cpk, 2cz, 2cvf, 2cwa, 2cxw, 2dd, 2dn, 2hj, 2ke, 2kf, 2kq, 2kx, 2gk, 2mu, 2og, 2rk, 2yo, 2ach, (2adv), 2aew, 2apy, 2aq, 2bco, 2bpm, 2bur, 2ccx, 2chc, 2dh, 2hh, 2lw, 2oe, 2ot, 2te, 2wb, 2an, 2bq, (2eg), 2eh, 2fz, 2fn, 2gw, 2io, 2ka, 2kk, 2kl, 2mg, 2nb, 2ot, 2tw, 2ua, 2xi, 2ap, 2aai, 2aak, 2aaq, 2aay, (2aex), 2ago, 2ahb, 2aic, 2ail, 2aiy, 2ajt, 2akd, 2akn, 2alj, 2alz, 2amw, 2apz, 2aqy, 2arj, 2asj, 2asv, (2axu), 2zas, 2zav, 2ba, 2bl, 2ch, 2co, 2dm, 2dw, 2ew, 2hc, 2hs, 2ka, 2lg, 2lh, (2ls), 2mz, 2ov, 2ox, 2pg, 2ps, 2qx, 2sd, 2se, 2uk, 2ur, 2vf, (2wa), 2xa, 2au, 2adm, 2af, 2afn, 2aha, 2alf, 2aip, 2ajy, (2akh), 2akk, 2cy, 2dc, 2df, 2di, 2dj, 2eo, 2fq, 2gb, 2gj, 2gm, 2gq, (2gr), 2gv, 2ho, 2if, (2iu), 2jf, 2jp, 2jr, 2kr, 2ks, 2ku, 2lg, 2lh, (2lj), 2ls, 2mf, 2mx, 2ok, 2qd, 2rl, 2so, 2sy, 2to, (2uj), (2uq), 2vn, 2wj, 2wq, 2zl, 2zm, 2zr, (2abs), 2acm, 2ade, 2aes, 2atp, 2avd, 2axk, 2bk, 2baj, (2bau), (2bdk), 2cc, 2ced, 2cel, 2cej, 2cud, 2cuk, (2dae), 2fm, 2kc, 2ks, 2pk, 2tt, 2xe, 2ze, 2aw, 2aau, 2aby, (2adk), 2age, 2amb, 2aqr, 2axh, 2axs, 2azi, 2bcj, 2bdf, 2bgn, 2bhx, 2bhy, 2bjj, (2bjl), 2bjy, (2bkk), 2bmv, 2brx, 2bvz, 2bwo, 2bzk, (2bwp), 2cak, (2cbz), 2ccm, (2ccs), 2ccv, 2cdw, 2cej, 2ceu, 2cii, 2cic, 2col, (2csg), 2ctd, 2cvi, 2cyx, 2dad, 2dbz, 2ded, 2dfz, 2dmj, 2dms, 2dmz, 2dqn, 2duj, (2dun), 2dvo, 2es, 2eam, 2eep, 2eeq, 2efy, (2eji), (2eld), 2xpb, 2xib, 2hk, 2kt, (2mi), 2oa, (2of), 2qw, 2ry, 2xe, 2xi, 2zk, 2zy, 2kka, 2kfk, 2ket, 2kgl, 2nke, 2nkf, 2npl, 2npm, 2nerk, 2wgh. New Zealand: (1ao), (2ac). Australia: 2bk, 2cm, 2yl, 2kq. Canadian: 2cg, 2ni, 2dq, 2eo, (2er), (2fn), 2an, 2ak, 2io, 2ba, 2ct, (2ef), 2go, (2gf), 2gt, 2hc, 2hp, 2hs. Mexican: 1a, 2aa, 1af, 1x, 2a. 6CIX is glad to receive repts.

By 6BJX, E. O. Knoch, 2823 East 6th St., Los Angeles, Calif.

1aao, 1abf, 1acb, 1af, 1ajp, 1cak, 1cl, 1cpv, 1gs, 1id, 1ml, 1ow, 1yb, (1zt), (2bgi), 2br, 2brb, 2bsc, 2cee, 2cix, 2cty, (2cvf), 2cxw, 2cyw, (2czr), 2kx, 2mu, 2rk, 2xi, 2abj, 2alx, 2bss, 2bta, 2chg, 2cjin, 2dh, 2jo, 2mf, 2ot, 2pv, 2sm, 2te, 2wb, (2du), 2eb, 2eq, 2gw, 2oa, 2pd, 2sx, 2tj, 2acm, 2acy, 2apr, 2aul, 2axk, (2bau), 2bce, (2bnh), 2bti, 2cta, 2cva, 2cve, 2cvh, 2cwp, 2die, 2dnf, 2dnk, 2doo, 2dph, 2gz, 2pl, 2rv, 2uf, 2uk, 2vq, 2ze, 2zg, 2zk. Canada: 2ax, 2be, 2xl, 2dq, 2fv, 2io, 2ba, 2bf, 2gf, 2go, 2hc. Australia: 2bk, 2ds, 2yg, 2yi, 2bd, 2bg. New Zealand: 1ao, 1ac, 4aa, 4ak. Mexico: bx. Special: 1px, 2nkf.

(Continued on Page 76)

100%
TONE!



Magic Radio Clearness

with this new principle horn—
this Kellogg Symphony Reproducer

This offers a new conception of radio clearness—a recent scientific advance in radio reproduction. It “brings in” the marvels of the air exactly as they were broadcast. With an absolute fidelity of tone that will delight you.

This new way is the Kellogg Symphony Reproducer—now made in quantity production to sell at prices within the reach of every radio owner. It is made by the 28-year-old Kellogg Switchboard & Supply Co., leading specialists in the reproduction of sound. The acoustical engineers of this company worked for years on the problem of clarifying radio reproduction before they finally perfected the Symphony.

The shape and contour—the composition of the horn itself, is one of the principal features. But the theory and design of this “unit” is the secret of its wonderful success.

This “unit” is unlike anything ever offered before for radio. The magnetic feature gives it watchlike precision. The improved results are noticeable instantly to any who hear it.

* * * * *

Hear it today!

Today, hear the Kellogg Symphony. Do not buy any lesser horn until you have heard it. It will increase the value of your set 100% in musical quality—in pleasure to your family and yourself. Any dealer will gladly demonstrate the Symphony for you. Hear it—today!

KELLOGG SWITCHBOARD & SUPPLY CO

CHICAGO, ILL.

Kellogg Symphony Reproducer

Send for Trial Subscription—\$1.00 for Six Months

FREE!— *This Condenser*

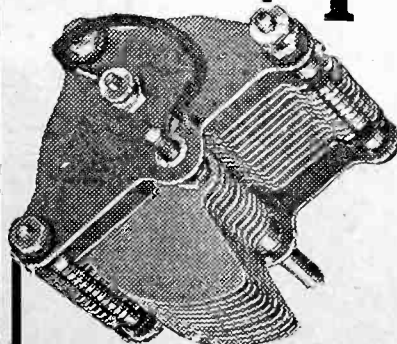

SEND only \$3.00—get this dandy AMERICAN SPECIALTY 23-plate variable condenser and “RADIO” for 15 months. The condenser is given free of cost with your subscription. This offer is positively guaranteed to be exactly as advertised. No further payments to make. The condenser is mailed to you on the same day that your subscription is received.

Guaranteed to be a standard, perfect condenser. Your money cheerfully refunded if you are not entirely satisfied.

This offer good only for the months of March and April. Get your subscription in the mail today, sure.

“RADIO,” Pacific Building, San Francisco

Here's a peculiar fact about radio insulation

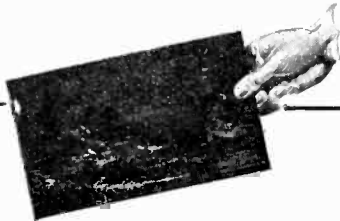

Surface leakage very low with Radion Panel

The high-polished, satin-like finish of Radion Panels prevents moisture from gathering to form leakage paths and cause leakage noise. Surface leakage and dielectric absorption are exceptionally low.

Radion Panels resist warping. They are easy to cut, drill and saw. They do not chip. No special tools needed. Eighteen stock sizes, two kinds, Black and Mahoganite.



Radion Dials match Radion Panels perfectly and make the ideal mounting for your set. Radion Sockets help to eliminate capacity effects.



RADION

The Supreme Insulation

MADE TO ORDER FOR RADIO
PURPOSES EXCLUSIVELY

MATERIAL that is satisfactory for general electrical use often gives poor results in radio-frequency service. Experience has shown that best results come with the use of material and apparatus designed especially for radio's peculiar demands. This is particularly true of insulating material.

Radion IS a special material, developed to order by our engineers to meet the needs of radio. For radio frequency insulation its characteristics are highest, as shown by authoritative laboratory tests.

The use of the most efficient insulation material is important not only for panels, but also for dials, sockets, knobs, binding post panels, rotors, stators, spaghetti tubes, etc. In all these there is a Radion product of the right type and size for your set. Radion is also used by leading set manufacturers who appreciate the superiority of "the supreme insulation."

AMERICAN HARD RUBBER CO.

Dept. M4, 11 Mercer St., New York City

Chicago Office: Conway Building

Pacific Coast Agent:

Goodyear Rubber Co., San Francisco,
Portland

Mail coupon for Booklet,
"Building Your Own Set"

AMERICAN HARD RUBBER COMPANY
Dept. M4, 11 Mercer St., New York City.
Please send me your new booklet,
"Building Your Own Set," giving
wiring diagrams, front and rear
views, showing a new set with
slanting panel, sets with the new
Radion built-in horn, lists of parts
and directions for building the most
popular circuits. I enclose 10 cents.

Name

Address

RADIO INSTITUTE OF AMERICA

TRAINING IN ALL COMMERCIAL BRANCHES OF RADIO

If you cannot attend the Radio Institute of America in person the same instruction can come to you through our recently inaugurated "HOME STUDY COURSE"—Investigate.



Detailed information free on request.

Conducted by

THE RADIO CORPORATION OF AMERICA

28 Geary St.

Phone Garfield 4200

San Francisco, Calif.

98 Worth St.

Phone Franklin 1144

New York City

Tell them that you saw it in RADIO

THE ETHER GARBLERS

(Continued from Page 24)

week arranged with a group of Southern California promoters to purchase jointly for eighteen million dollars the entire properties of the Solar Oil Company, owners of the famous three 'Long-Shot' wells at Long Beach, which have been producing two million barrels a month.

Mr. Greb returned to his home at San Francisco to wait for the promoters to make their funds available, which they accomplished this morning; but as the broker was in the very act of closing the deal news came in from the fields that the three 'Long-Shot' wells had 'gone salt'. Thornton, the broker, hurriedly advised Greb by wire, and Greb filed an answering telegram at the main office of the Poulsen Pacific this afternoon, reading as follows:

"Cancel the deal."

"But when the telegram arrived at Los Angeles, it read:

"Buy the wells."

"Thornton could hardly believe his eyes, but the instructions in the telegram were unmistakable. The Los Angeles promoters withdrew their funds and the broker bought out the Solar Oil Company, lock, stock, and barrel, for Mr. Greb, with Mr. Greb's five million. Mr. Greb is therefore now the owner of four derricks, one partly-drilled well, and three water-gushers, from which a small creek is flowing across the sands into the ocean. The man with the wilted black cigar in the picture to the left is Mr. Greb."

DURING the next six days, I remain encamped in my experimental shop in the basement of the apartment joint where I hang out; and spend my time with a pile of deep radio engineering books, diggin' dizzily into vacuum tube theory, radio compasses, Kolster circuits, and radio frequency phenomena, after which I try a few experiments with some neodyne receiving circuits.

"There's two ways it might be done," I says to myself, when I get through; then in answer to a telegram from Hawkins I puts on my coat an' blinkers, breaks out my whizz-buggy, an' lights out for an all night drive to Los Angeles.

Going through the downtown section, I hears the newsboys yellin' somethin' more about Greb and his oil wells; so I stops long enough to get another paper, an' read:

"GREB, THE SPECULATOR, WINS ON 'LONG-SHOT' WELLS!"

"Six days ago, as the result of an altered Poulsen Pacific telegram, Mr. Thomas B. Greb, speculator of this city and well-known manufacturer of the famous 'Radio Ford', bought three oil wells spouting salt water. This morning, a fourth well being drilled on Mr. Greb's property came in a gusher of rich black oil. At almost the same instant, the salt-water pool under his other three wells came to an end, and they are also gushing forth immense black columns of 'flowing gold'. Last Wednesday morning Mr. Greb was worth five million dollars, Wednesday evening he possessed four second-hand oil derricks and a salt-water creek; this afternoon he sold out to Los Angeles interests for eighteen million. The man with the triumphant smile and the big black cigar in the picture to the right is Mr. Greb."

"Old Greb is havin' a heck of a time,"

(Continued on Page 52)

3 Tubes do the work of 5

In a CROSLEY Trirdyn

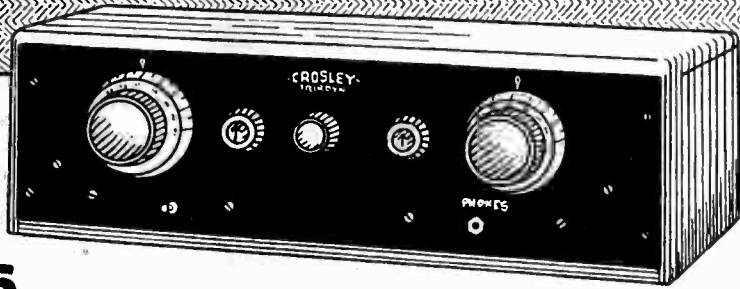
Regular
\$50
Formerly \$65



The famous Crosley Trirdyn with three tubes excels most five or six-tube sets in simplicity of tuning, in selectivity, in volume, in clarity, in economy of operation and in distance getting efficiency.

This remarkable accomplishment in radio engineering is due to the unique combination of Radio Frequency Amplification with Armstrong Regeneration. Many trick circuits have been designed to get around the Armstrong Regenerative feature, hoping to get results "just as good."

Every additional tube means additional expense, an added dial to tune, greater difficulty in operation, more distortion and more tube noises. The Crosley Trirdyn with three tubes has only two dials. These operate but two circuits making tuning and logging easy.

The Trirdyn Regular, the most popular receiver on the market selling at its price or more, was reduced from \$65 to \$50; the

Trirdyn Special from \$75 to \$60. To these have been added two new Trirdyns in beautiful cabinets—the Trirdyn Regular with sloping panel at \$55 and the Trirdyn Special with sloping panel at \$65. Again the demand for Crosley Radios has increased tremendously.

You can't beat the results obtained from a Crosley Radio. Priced from the one-tube 50, "The Little Giant of Radio," at \$14.50, to the new Trirdyn Special with sloping panel at \$65.

Crosley Radios are licensed under Armstrong U. S. Patent 1,113,149. Prices quoted without accessories. West of Rockies, add 10 percent.

For Sale by Good Dealers Everywhere

Write for Complete Catalog

THE CROSLEY RADIO CORPORATION

POWEL CROSLEY, JR., President

419 Sassafras Street

Cincinnati, Ohio

Tune in with the Crosley Broadcasting Station WLW

New Special
\$65
Sloping Panel

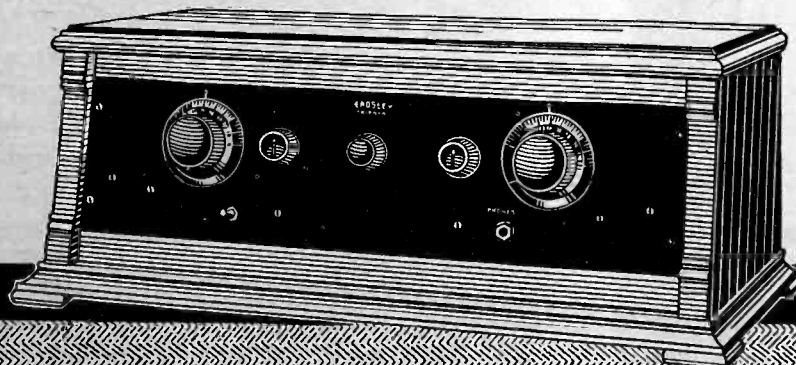

(Continued from Page 50)

I mutters to myself; then I steps on the gas and rambles out of town.

Arrivin' in the City of th' Angels in the glow of early morning, I goes out to Hollywood, where the Poulsen Pacific's Los Angeles receivin' terminal is located. But failin' to see anything suspicious about it, around nine o'clock I lays a course back down-town to the city office, where I finds a note from Hawkins. As I start to read it, he comes in, sleepless an' excited. He grabs me by the arm an' rushes me out into the street.

"Got th' bearin's on him!" he hisses, in a tense whisper. "316 degrees true from one compass in Hollywood and 257 degrees from another at Almiar, up in the Sierra Madre foothills. I've laid the bearings down on a map and they intersect in th' middle of the 1600 block on Cabrillo Avenue in Paraiso Del Tontos, a fine residence section out on the north side of the Santa Monica Mountains."

We gasolines out to Paraiso Del Tontos, twenty-two miles northwest of the Angel City. Arrivin' at Cabrillo Avenue, we finds a' aerial on every house in the 1600 block.

"These people got a' aerial with a bunch of extra big porcelain insulators," I remarks to Hawkins, pointin' to a big quiet-lookin' white-stuccoed house right in the middle of the block, which has a neat, tight antenna at the back. "Let's take a chance at it."

We find the house empty and dark, not a chair or a piece of furniture in it. Somewhere upstairs, I hears the faint whirring of a motor and the clicking of a relay-key. We go through some upper rooms, which are bare and empty like the lower; then we come to a locked door. The whirr of the motor and the click of the relay-key has stopped now.

While Hawkins stands by with his moonshiner's six-gun and a flashlight—for all the blinds are down—I jimmies the door and kick it open. Hawkins sticks his flashlight into the opening, and the rays fall full upon a glittering brand-new one-kilowatt tube transmitter. Above it is a column of pancake coils to get a long wave. On a table beside it is a relay-key and a big distant-control switch. As we stand starin' at all this, the big control-switch flies up with a heavy "click!" that makes me jump half out of my shoes. With a soft humming whistle, a motor-generator set under the transmitter starts up, the tubes light, then the relay-key begins to work—

"—here's a city, San Francisco 10-27 A. M. Nr 45, PK-FL 16 black, Union Oil Los Angeles: Cancel steamer La Brea kerosene to Seattle, load 75,000 barrels fuel oil for Yokohama. Union Oil Company."

Sent on a vibroplex machine by an expert operator, the message flashes through like a shot, the relay-key stops, the con-

Heard Europe on a Home Built Ultradyne Model L-2

Arthur Bender, 116 East 2nd St., Covington, Ky., had no trouble picking up European stations last week on his eight-tube Ultradyne, which he constructed himself.—*Cincinnati Enquirer*, Nov. 30, 1924.

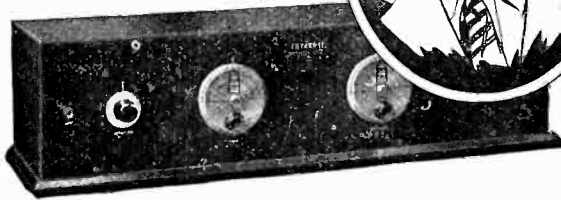

Thousands have built it!

LIKE Mr. Bender, thousands have successfully built the Model L-2 Ultradyne and claim it the most wonderful receiver they have ever known for great distance on the Loud Speaker.

In no other receiver is found the "Modulation System" of radio reception—an outstanding radio engineering development by R. E. Lacault, E.E., A.M.I.R.E., Chief Engineer of this Company and formerly Radio Research Engineer with the French Signal Corps Research Laboratories.

With the application of regeneration to the "Modulation System" the Ultradyne is capable of detecting the faintest broadcast signal, regenerating and making it audible on the loud speaker.

In addition, the Ultradyne is the most selective receiver known. Regardless of close similarity in wave length, it selects any station within range—brings in broadcasting clearly, distinctly, faithfully.

The Model L-2 Ultradyne will do everything better than any super-radio receiver operating under the same conditions.

Write for descriptive folder

ULTRADYNE

MODEL L-2

CARL A. STONE COMPANY
644 New Call Bldg., San Francisco, Calif.
1116 Miner Ave., Seattle, Wash.
429 Insurance Exchange Bldg., Los Angeles, Calif.
PHENIX RADIO CORPORATION
9 Beekman Street
New York

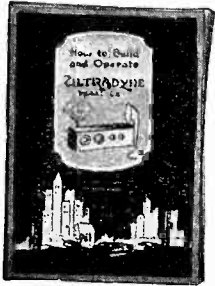

HOW TO BUILD AND OPERATE THE ULTRADYNE

12-page illustrated book giving the latest authentic information on drilling, wiring, assembling and tuning the Model L-2 Ultradyne Receiver..... **50c**

THE ULTRADYNE KIT

Consists of 1 Low Loss Tuning Coil, 1 Special Low Loss Coupler, 1 Type "A" Ultraformer, 3 Type "B" Ultraformers, 4 matched Fixed Condensers. To protect the public, Mr. Lacault's personal monogram seal (R. E. L.) is placed on all genuine Ultraformers. All Ultraformers are guaranteed so long as this seal remains unbroken. **\$30**

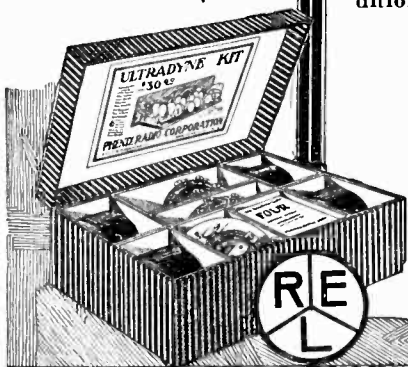

FREE! —

This Rheostat

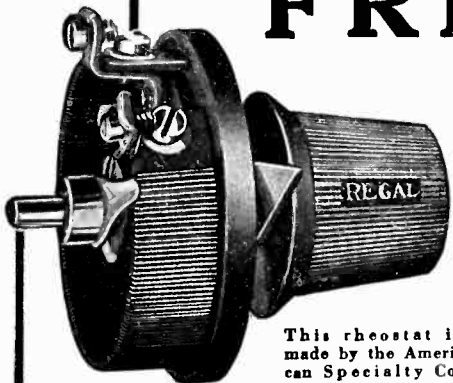

This rheostat is made by the American Specialty Co.

SEND only one subscription to "RADIO" for one year (\$2.50) and we will immediately send you one REGAL rheostat, as illustrated. You may have your choice of either a 6 or 30 ohm type. Why not mail your own subscription today—get "RADIO" for a full year and a dandy rheostat—all for only \$2.50. There are no further payments of any kind.

"RADIO," Pacific Building, San Francisco

trol-switch snaps up again, and the set goes dark.

"Haw! This is th' way th' doped stuff gets on th' Hollywood receivers, sure as you're red-haired—but how in California are th' Palo Alto signals killed out!" exclaims Hawkins. "If we knew where th' other end of th' wires hooked to this relay-key was at—"

"We've seen everything here," I interrupts, briefly. "Have you got those other two compasses installed up at San Bruno Mountain and over at Haywards across the bay?"

"Left 'em with two good men," replies Hawkins. "Guess they got 'em set up by now."

"All right, we're off for Frisco," I announces. "We got to finish up quick, before somebody comes an' sees this busted door."

On the way out of town Hawkins calls up the Poulsen Pacific city office at Los Angeles and has them shoot a service message to San Francisco requesting a repeat on telegram number 45 to Union Oil, Los Angeles.

"It was phony, all right," announces Hawkins, returnin' as I am dumpin' a bucket of water into my hot, thirsty radiator. "Should'a read, 'Cancel Seattle kerosene, load full cargo gasoline for New York.' Would'a been a nice mess if they'd dumped 75,000 barrels of thick black crude in them tanks."

At midnight, we come roaring up the highway into Haywards, on the eastern side of San Francisco Bay, and five minutes later we arrive at Hawkins' radio-compass station, which is located in a small vacant real-estate office. The minute I steps inside the door, Hawkins' compass-man yanks a pair of phones off his head an' slaps 'em violently over my donkey-like ears.

"Th' compass has got him!" he exclaims. "Lissen! First, here's Palo Alto." He swings his direction-indicator to 190 degrees true, or nearly south, and I hears a long banking-house night-letter flying through on the Poulsen Pacific 4550-meter arc. "Now, watch!" hisses Hawkins' buddy. He swings the indicator toward the southeast to 132 degrees, and in comes another transmitter exactly like the Poulsen Pacific transmitter—and sending exactly the same message! As I listen, the end of the telegram is reached; whereupon the mysterious repeating transmitter suddenly goes off the air. I swing the radio-compass direction-indicator back to 190 degrees, and hears the Poulsen Pacific arc still shooting stuff through about forty words a minute—but all alone now.

"The man at the other compass over on San Bruno Mountain spotted him first," says Hawkins' buddy. "He sent word over by a messenger on a motorcycle. He gets the repeater station on 124 degrees. I laid the bearings out on

(Continued on Page 54)

NEW YORK COIL COMPANY'S

Grounded Rotor Low Loss Condenser

New Prices

.0005 — 23 plate, \$4.00; .00035 — 17 plate, \$1.50
\$3.75. Geared Vernier attachment.....

New York Dis-	Tuned Radio	Type
tortionless Audio	Frequency Trans-	Four
Transformer	former with 17	plate condenser
	attached	\$4.00

\$3.75

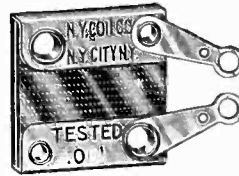
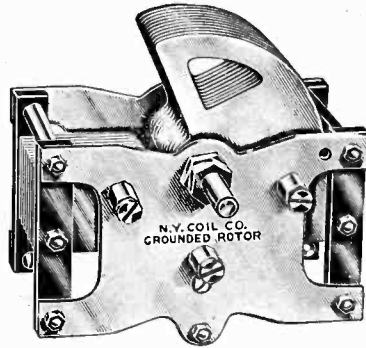

TYPE B

Attention Manufacturers---Our New "Selector" Low Loss Grounded Rotor Condenser with self-balanced coils attached is the exact equipment that you have been waiting for---at a price you can afford to pay.

New York Precision Mica Fixed Condensers, the Standard by Which All Others Are Judged, are more uniform in capacity, the choice of the most prominent set manufacturers and radio engineers.

NEW YORK COIL COMPANY

338 Pearl Street, New York City, N. Y.

Pacific Coast:

MARSHANK SALES COMPANY

926 Insurance Exchange Bldg., Los Angeles, California
Also San Francisco and Portland



FREE! — This Pair of Phones

SEND us \$5.00—get "RADIO" for two full years and a pair of 2000 ohm PENNSYLVANIA HEADPHONES. The phones are given free with your subscription for two years. This great offer will shortly be withdrawn. It is good for March and April only. No further payments to make. Merely send \$5.00 and the phones will be mailed to you on same day your subscription is received. This offer saves you \$3.50. It's worth taking advantage of.

"RADIO"—Pacific Bldg., San Francisco

Now you can UNDERSTAND RADIO!

Take the mystery out of it—build and repair sets—explain the vacuum tube—operate a transmitter—be a radio expert!



**1 VOLUME
514 PAGES**
Leatheroid Edition

Compiled by
**HARRY F. DART
E.E.**

Formerly with the
Western Electric
Co., and U. S.
Army Instructor
of Radio.

Technically Edited by **F. H. Doane**
100,000 ALREADY SOLD

This practical and authoritative I. C. S. Handbook is considered one of the biggest bargains in radio today. Over 100,000 homes rely on the I. C. S. Radio handbook to take the mystery out of radio. Why experiment in the dark when you can quickly learn the things that insure success? Hundreds of illustrations and diagrams explain everything so you can get the most out of whatever receiver you build or buy.

It contains: Electrical terms and circuits, antennas, batteries, generators and motors, electron (vacuum) tubes, many receiving hook-ups, radio and audio frequency amplification, broadcast and commercial transmitters and receivers, wave meters, super-regeneration, codes, license rules. Many other features.

A practical book. Written and edited by experienced engineers, in plain language. Something useful on every one of its 514 pages. The authority that covers every phase of radio, all under one cover in one book at a surprisingly small cost. Don't spend another cent for parts, turn a dial or touch a tool until you have mailed \$1.50 for this I. C. S. Radio Handbook.

Send \$1.50 at once and get this 514-page I. C. S. Radio Handbook—the biggest value in radio today. Money back if not satisfied.

TEAR OUT HERE

International Correspondence Schools
Box 8261-C, Scranton, Penna.

I am enclosing \$1.50. Please send me—post-paid—the 514-page I. C. S. Radio Handbook. It is understood that if I am not entirely satisfied I may return this book within five days and you will refund my money.

Name.....

Address.....

Check here and enclose \$1 if you wish the cloth-bound edition.

REDUCE STATIC

Pat.
Pending
690459



\$10.00
Prepaid in U. S.

by using our super-sensitive
Omni-Directional Aerial
Collapsible, Ornamental,
Mechanically Perfect

Can be used either as a loop or antennae inside or outside. A wonderful value featured at a price within the range of all. Ask your dealer or send order direct

The Portable Globe Aerial Co.
1602 Locust Dept. 45 St. Louis

Send for Trial Subscription
\$1.00 for Six Months

(Continued from Page 53)

this real estate map on the wall here and make the queer guy forty-one miles southeast of San Francisco by air-line, or seven miles northeast of San Jose."

"We're near the end of this thing, it looks like." I announces, with a keen look at Hawkins. "Hawkins, you take your tool-kit out of my whizz-wagon, get a taxi, and make the driver get you to the Oakland mole in time to catch the last ferry. Get over to the Eldridge Apartments on Geary Street, wake up Cecil Blakely in Apartment 15, who is a commercial photographer friend of mine: tell him I said to break out a couple ounces of smokeless flashlight powder and his German detective camera; then hop down to the Holobar Building, lock up the night-watchman in a rag-locker or someplace, take his keys, and search through every office in the building near the Poulsen Pacific's pneumatic tube system from the city office up to the eighteenth floor. In some room, maybe hid in a locker or in a phony filing-cabinet, you'll find a set of dispatch-tubes have been brought in to a connection and so equipped that the up-bound telegram carriers can be intercepted, opened, the messages read, and then sent on up to the operating room. Somewhere in that same room, you'll find a loop-aerial radio receiver, a vibroplex key, and a telegraph relay. Yank off the cylindrical hard-rubber shell of one of the relay magnets, rip out the copper-wire winding, fill the shell with smokeless flashlight powder, put a short piece of the fine wire from the ripped-out winding into the powder, and connect the ends of this piece of wire to the local key circuit; so that as soon as the vibroplex key is touched, it will short the current through the wire, instantly heat it white hot, and set off the powder. Have Blakely set up his detective camera, which looks like a small dusty cardboard envelope box, on top of a locker or somewhere as much out of the way as possible, and connect the fine invisible wire leads of his electric shutter in shunt with your relay circuit, in order that the shutter will operate when the powder goes off.

"Clean up any mess you make carefully; so when the doctored relay explodes, the bird we are after will think a shot of high-tension power current has got on his telegraph wires and blown out the relay coil. I think the plant is in the office of H. C. Bailey, Real Estate Broker, Room 1414; but I may be wrong. If I am, work up and down, until you find the place, because it has to be there; and try to get all set before nine o'clock in the morning.

"When you are through, take possession of the nearest adjoining office, and wait. If the office belongs to somebody and they come in, hold 'em up with your gun and make 'em sit quiet until you

(Continued on Page 56)

Balkite Battery
Charger. Charges 6
volt "A" storage bat-
teries.

Price \$20
East of Rockies \$19.50
In Canada \$27.50

Balkite "B"—replaces
"B" batteries and
dry cells. Operates
from light socket.

Price \$55
In Canada \$75

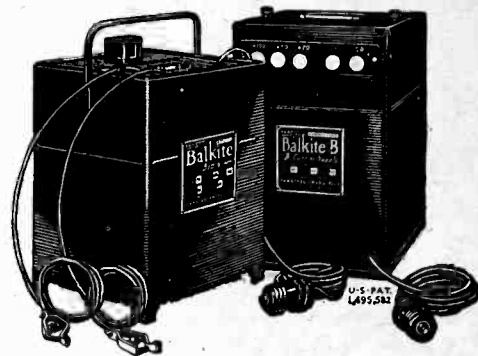

An unfailing power supply for both circuits

Here at last is an unfailing power supply for your radio set. Balkite Radio Power Units furnish constant uniform voltage to both "A" and "B" circuits and give your set greater clarity, power and distance. The Balkite Battery Charger keeps your "A" storage battery charged. Balkite "B" replaces "B" batteries entirely and furnishes plate current from the light socket. Both are based on the same principle, are entirely noiseless and are guaranteed to give satisfaction. Sold by leading radio dealers everywhere.

FANSTEEL PRODUCTS CO., Inc.
North Chicago, Ill.

PACIFIC COAST DISTRIBUTORS:
Seattle, George H. Maire, 95 Connecti-
cut St. San Francisco, A. S. Lindstrom,
274 Brannan St. Los Angeles, Lombard
J. Smith, 324 N. San Pedro St. Portland,
H. A. Killam, 146½ N. 10th St.

FANSTEEL **Balkite** Radio Power Units

BALKITE BATTERY CHARGER
BALKITE "B" PLATE CURRENT SUPPLY

New LeFAX RADIO
HANDBOOK—\$2.00
(Seventh Edition)

in bound form. For sale by
"RADIO," San Francisco

RADIO CATALOG
AND HOOK-UPS FREE

Our great new catalog, fresh from the press, contains the very latest in complete sets, parts and accessories—hundreds of interesting bargains. 250,000 customers testify to our wonderful value and reliability. Complete instructions with diagrams for making most practical popular sets FREE. SEND QUICK for your copy. Urgees include name of friend who is interested in Radio.

THE BARAWIK CO.

Dept. 115

22-40 So. Clinton Street

Chicago

Why It Is Better

"MASTER of Every Note in the Orchestral Range" is the **PROVEN** claim of the Federal No. 65 Audio Frequency Transformer! Volume without distortion is the basis for the beauty of Federal Tone.

From its oversize locking nuts to its heavy brass mounting feet, the Federal No. 65 Transformer incorporates the same engineering skill that has made Federal the recognized leader in electrical communication apparatus since 1890.

Insist upon Federal parts for your "pet" hook-up. There are over 130 standard parts bearing the Federal iron-clad performance guarantee.

FEDERAL TELEPHONE & TELEGRAPH CO.
Buffalo, N. Y.

Boston New York Philadelphia
Chicago Pittsburgh San Francisco
Bridgeburg, Canada



Federal

Standard **RADIO** Products

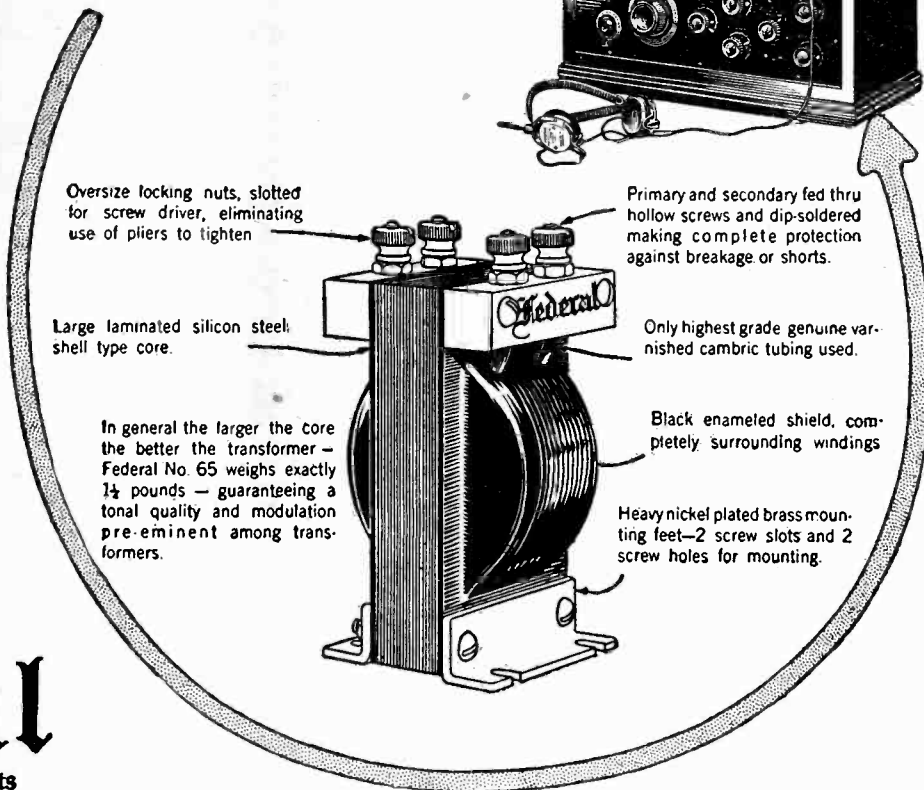
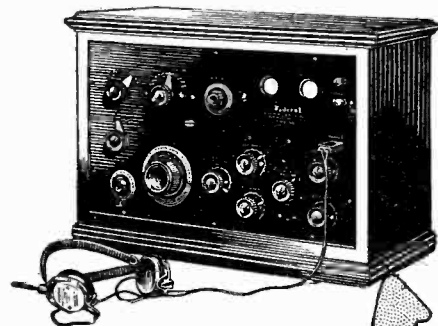

Oversize locking nuts, slotted for screw driver, eliminating use of pliers to tighten

Primary and secondary fed thru hollow screws and dip-soldered making complete protection against breakage or shorts.

Large laminated silicon steel shell type core.

Only highest grade genuine varnished cambric tubing used.

In general the larger the core the better the transformer - Federal No. 65 weighs exactly 1 1/4 pounds - guaranteeing a tonal quality and modulation pre-eminent among transformers.

Black enameled shield, completely surrounding windings

Heavy nickel plated brass mounting feet - 2 screw slots and 2 screw holes for mounting.

YANKEE TUBES

Proven Beyond All Doubt—

"The Ace of Independents"

TYPES **\$3.00**
199-201A



Sold only thru well-established retail dealers

Distributed by
W. E. & W. H. JACKSON
San Francisco
MARSHALL-WELLS
Portland
THE BANTA CO.
Los Angeles
RADIO SUPPLY CO.
Los Angeles

DEALERS—Write to the distributor in your territory as shown below for attractive proposition

BALDWIN PACIFIC & CO., San Francisco
(Pacific Coast Representatives)

TRADE MARK REGISTERED

Tell them that you saw it in RADIO

(Continued from Page 54)

The MOZART Baby GRAND

Radio Reproducer



Another

No piece of radio apparatus in any price class is best because its maker says so—or because its dealer says so. It is only the best when everybody else says so as well.

"Several times I have intended to write you or call on you when visiting Newark. I wanted to let you know of the fine service we have been getting from the Mozart Baby Grand. The clearness of music, voice and other entertainment seems so different from other loud speakers that we have experienced. We also use the _____ Talkers, but we stick to the Baby Grand for Accuracy."

(Signed) R. T. DONOVAN,
5501 5th Street., N. W.,
Washington, D. C.

PRICES (WEST OF THE ROCKIES)

Baby Grand Reproducer, with gold plated unit, black and gold crackle or extra heavy coated all black satin finish.....	\$12.50
Electro-magnetic unit (fits almost any horn or phonograph) with cord,	
Nickel Plated	\$4.50
Gold Plated	\$5.50
Mozart Special Headset	\$6.00
If your dealer cannot supply, order direct.	

West Coast Representatives:

NELSON-RUDE CO., 16 California Street, San Francisco, Calif.
JAEGER RADIO, 4505 Thirty-sixth Ave., N. E., Seattle, Wash.

THE MOZART GRAND CO.

NEWARK, N. J.

Manufacturers of Fine Instruments

U. S. A.

hear the powder flash go off in the plant. Wait a few minutes for our friend the tube-tapper to leave without getting scared and wised up by seeing you spying on him; then breeze in and get the camera. Have Blakely develop and enlarge the picture, and bring it up to Mr. Tulver's office at four this afternoon; also have up there the president and directors of the Poulsen Pacific, and all the main guys. I'm going down to San Jose—I don't think I need to; but I want to make sure I'm right. See you later."

AT TWO o'clock in the morning, I am standing in the barn-like laboratory of Doctor Godfrey Derrold, a few miles northeast of San Jose. At the north end of the laboratory, in a large copper-lined oven-shaped box which is open at one side facing to the northwest, is a Kolster loop-aerial and a part of a complicated seven-step radio-frequency receiving circuit. The fifth tube is a five-watt transmitting bulb, and the sixth, which is outside the copper box, is a 250-watt tube. By means of a radio-frequency transformer made of heavy high-tension cable wound on a bakelite frame, the sixth tube is coupled to a seventh "step" consisting of a bank of eight glittering one-kilowatt power tubes. The high-tension plate circuit of this parallel bank of powerful transmitting tubes is connected in series with a set of spiral copper loading coils and then passes out through a porcelain tube to Doctor Derrold's lofty aerial, which is suspended between two 300-foot wooden towers adjoining the laboratory.

"I have leased my laboratory for six months to a man who through an agent represented himself as, and apparently is, a radio engineer," explains the bewildered Doctor Derrold, whom I have roused out of bed to open up the joint. "I have been obliged to spend a great deal of time in New York and Washington this year testifying in the DeWoods vacuum-tube patent cases; and so I was glad of an opportunity to rent the place for a time—though the man should have been welcome to use it, in any case."

"Do you know what this thing is, here?" I demands.

"Why, I'm not sure that I do," replies the portly doctor, shiverin' a little in his pajamas. "I was told that it is part of a self-driving repeating system which the engineer is developing. I believe he plans to sell his invention to some company who could use it to establish a reliable system of low-powered trans-oceanic telephony and telegraphy, using a number of these automatic repeaters on various islands in mid-ocean."

"What sort of lookin' bird is this engineer?" I queries. "Does he work here every day?"

"I have never seen him—I have seen only his agent or assistant, or whatever

"B" BATTERIES

AN
EVEREADY
PRODUCT

At Standard Prices

43V. Batteries, tapped
22½V. Batteries, Navy Type
22½V. Batteries, Commercial Type
Latter two types especially adapted to
Cunningham and Radlotron Tubes.

Postage Prepaid Anywhere in U. S.

ETS HOKIN & GALVIN

Wireless Engineers

10 Mission Street San Francisco

RADIO

BIG MONEY IN A BIG FIELD

Be a RADIO EXPERT. Make big money. Win success in this new uncrowded field. Trained men needed. Learn quickly, at home in spare time, to construct, install, operate, repair, maintain and sell radio equipment.

RADIO EXPERTS EARN \$3,000 TO \$10,000 a Year!

Short course, low cost, easy terms, money back guarantee.

FREE Wonderful tube receiving set of latest design. Range of over 1000 miles. Write today for "RADIO FACTS."

A. E. Mshup, Radio Eng. Radio Association of America
4513 Ravenswood Ave., Dept. 83 Chicago

Send for Trial Subscription—\$1.00 for Six Months

the gentleman may be," replies the doctor. "While I was east, the engineer installed this apparatus; and he has brought in a pair of leased wires from somewhere and connected them to this distant-control switch, which enables him to start all the generators and tubes and everything from some other laboratory where he is working. He seldom switches on this apparatus more than two or three times a day, and then only for a few moments at a time. I have never attempted to pry into his work in any way, as I presume he naturally wishes to keep it to himself until he has his circuits perfected and securely patented."

"All right, old man, go back to sleep," I tells him. "But if you want to know what you've really got here, drop into Mr. Tulver's office at the Poulsen Pacific in Frisco at four this afternoon. So long."

Getting back into San Francisco at daybreak, I stops by the Holobar Building, where I finds Hawkins and Blakely have successfully spotted the pneumatic tube-tapping apparatus in the 'H. C. Bailey, Real Estate' joint, which has turned out to be a clever layout, consisting of two separate offices with a camouflaged intercommunicating door and about six exits into both front and back corridors. Hawkins and Blakely bein' nearly through setting their trap and needin' no help, I drifts up to my apartment hangout, pulls down my oven-door-type wall-bed, and have a good sleep.

At noon I gets up fer my bath an' toilet in my dog-house boudoir overlookin' a flock of backyard clothes-lines; then wandering down-town for my afternoon breakfast, I finds this in my newspaper:

**"GREB THE SPECULATOR
CLEANS UP AGAIN!**

"Thomas B. Greb, Long Beach oil plunger and well-known manufacturer of the famous 'Radio Ford,' is making the wizards of Wall Street look like pikers. Here is the story—

"The widespread publicity lately resulting from the Poulsen Pacific Telegraph Company's troubles with mysteriously altered telegrams at once caused a slump in their stock, but there was nevertheless a peculiarly strong demand for it, and the rumor was current on California Street that someone was buying control, aiming to sell out to Radio Freezouters, Inc.

"Yesterday, however, the Radio Freezouters announced definitely and authoritatively that they would not buy Poulsen Pacific. Almost instantly the stock returned upon the market in a veritable deluge and was beared down to eight cents a share. At this point, Mr. Greb stepped in and quietly bought all in sight.

"The Poulsen Pacific's traffic has heretofore been confined almost entirely to downtown business houses, since they have never advertised to any extent; but the story of their struggle to use their wonderful radio system in a fight against what are popularly fancied to be the machinations of the Western Union and the Postit has so wrought upon the public mind that a flood of business has

(Continued on Page 58)

CIR-KIT

More Power per Tube brings Greater Radio Most Economically

Triple power is the basis of Erla Supereflex records. Tubes, as used in Supereflex, simultaneously amplify received radio frequency currents, reflexed radio and reflexed audio frequency currents. So 1-tube Supereflex rivals the power of conventional 3-tube circuits. And 3-tube Supereflex readily outclasses the ordinary five!

Only such power can give you the thrill of Supereflex distance and volume; always with Erla crystal-pure tone—and with uncanny selectivity that gets what you want when you want it.

This finer radio is brought within the reach of all by Erla Supereflex *CIR-KIT*, the factory-sealed carton of genuine Erla apparatus for building Supereflex yourself. Anyone can follow the *CIR-KIT* assembly plan perfectly, using only screwdriver and pliers, without the risk of drilling or soldering.

**SEE ERLA
RECEIVERS**

Inherent Erla advantages in power, tone and selectivity are now available in beautiful complete Erla receivers. Retail prices range from \$67.50 to \$225. Both performance and price place Erla receivers among the sensations of radio history.

Pride of workmanship, extreme economy, priceless radio performance, are yours in Erla Supereflex *CIR-KIT*. Select your model at the Erla store. 1 to 5 tubes, antenna and loop types.

Electrical Research Laboratories
Dept. H, 2500 Cottage Grove Ave., CHICAGO
Coast Representatives: Globe Commercial Co., San Francisco



**Make
\$100
a Day**

**FREE INSTRUCTION TELLS
HOW**

Many Sales Are Half Profit When you sell our nationally advertised radio sets and supplies. We guarantee your success, under the "Gould Plan," by allowing you to return goods which you do not sell. It would pay you to get our price list and free instructions.

Write for it.
**Federal Radio Co. 109 East 13th St.
Kansas City, Mo.**

"COMO DUPLEX"

The World's Standard Push-Pull Transformer, \$12.50 per pair. Send for descriptive literature. COMO Apparatus Corp., 446 Tremont St., Boston, Mass. Washington and Oregon Representative

C. E. GAY

166 Lownsdale St., Portland, Oregon

See the New! - - - -

**MONTROSE LOW LOSS
CONDENSER \$2.50**

A new efficient condenser at a new low price. 23 plate, cap. .0005.

**UNITED RADIO LABS. of the Montrose Mfg. Co.
1333 Fulton St., Brooklyn, N. Y.**

The SATURN

Perfect Jack and Automatic Plug. Your order filled by mail promptly. Every article absolutely guaranteed. The SATURN Mfg. & Sales Co., Inc.

48 Beekman Street, New York, N. Y.

Dept. B
Write for Literature



BURGESS BATTERIES

Contribute to
a Radio Miracle



President Coolidge

H.R.H. The Prince of Wales

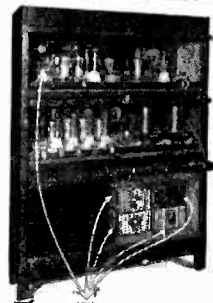

The transmitter that sent photos by radio from London to New York. Batteries for energizing the tubes are shown in the lower shelves of the cabinet.

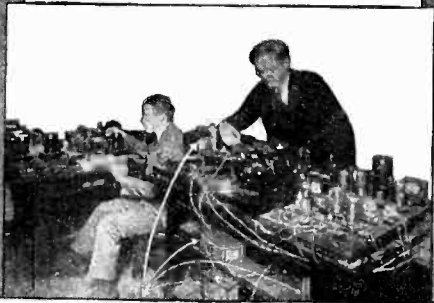

General view obtained through courtesy of the Radio Corporation of America. Captain Richard Ranger of the R. C. A., inventor of the apparatus, is seen placing film upon drum of transmitter. U & U Photos

THAT Burgess Radio Batteries were chosen for this inspiring achievement is a pleasing indication of the confidence placed in them by experienced radio engineers.

Ask Any Radio Engineer

BURGESS BATTERY COMPANY
Engineers DRY BATTERIES Manufacturers
Flashlight - Radio - Ignition - Telephone
General Sales Office: Harris Trust Bldg., Chicago
Laboratories and Works: Madison, Wisc.
In Canada: Niagara Falls and Winnipeg



(Continued from Page 57)

delighted the Poulsen Pacific offices and has congested the company's radio channels to such an extent that they have been compelled to lease twelve wires from the Yell Telephone Company in order to clear their traffic. As a result, Greb's stock is soaring and there is a likelihood of its going to a dollar a share. The man with the big black cigar and the whimsical smile in the picture to the left is Mr. Greb.

I spends the afternoon sitting in a picture show, doing some more thinking. At four 'oclock I roams up to Mr. Tulver's office in the Holobar Building, which I finds jammed. Blakely, waitin' with a big flat brown envelope, gives me a nod and a complacent smile, while Hawkins sits stiff as a gun-barrel an' stares at me with a dumbfounded look on his long seamy face. Stephen Glass is waiting, cold and silent, as usual; Mr. Tulver swabs billows of sweat off his care-worn map, and Doctor Godfrey Derrold sits with a big gold watch-chain draped over his bulgin' stomach, lookin' kind of hurt and curious. A bunch of other chairs are occupied by directors and engineers.

"Now then, fellows," I says, brisk like. "You are all here because you want to know who's jazzin' up the messages of this company, and how they're doin' it. I'm going to tell you the last part first. "What I have found out is that a certain unknown gentleman has rented the San Jose laboratory of Doctor Derrold and installed a kind of Kolster receiving circuit in a copper-shielded box. The seventh step of this circuit is a bank of eight one-kilowatt transmitting tubes, which shoot their power out into a lofty aerial overhead. Now, if you stop to think a minute, you will see that if all the circuits of this instrument are tuned to exactly the same wavelength and all the high-frequency currents are forced to keep in step by proper apparatus, then whenever any waves are received on the circuit, they will cause the eight power tubes to reradiate waves of the same length as the received waves, and the reradiated oscillations will be in synchronism or in step with the incoming oscillations. This is simple so far, but the joker lies in the fact that by a proper connection of the inter-tube radio-frequency transformer circuits, the waves sent out by the power tubes at the end of the seven steps can be made of opposite phase or polarity to the incoming waves. If the power of the opposed outgoing oscillations is adjusted to equal the total effective power of the incoming oscillations, they both will be neutralized; and on any ordinary radio receiver, if placed a reasonable distance from both of the opposing transmitters, you will have a dead silence. The preliminary receiving circuits of the neutralizing transmitter are placed in a copper-lined box, which is open only at one end. This end is adjusted toward the distant primary transmitter to be neutralized, and



Quality
—Based on Perfection
of Parts

A condenser is no more efficient than its weakest feature—a thought borne in mind in designing the U. S. Tool Condensers. As a result, the perfecting of parts has led to the nearest point approaching condenser perfection. Inquire about Type 6 with the micrometer dial.

Factory Guarantee

Write for Literature

Coast representatives:

Radio Electric Distributing Co.
1113 Wall St., Los Angeles, Cal.

U. S. TOOL COMPANY, Inc.
114 Mechanic St. Newark, N. J.

Mfrs. of special tools, dies, jigs,
automatic machinery and sub presses

Send for Trial Subscription
\$1.00 for Six Months



Just what
you need

Valley Battery Charger

Here is just what you need to increase the pleasure and entertainment of your radio. With the Valley Battery Charger as part of your equipment, you need never miss a program because of a dead battery.

The Valley Battery Charger will completely recharge 2-volt peanut tube cells, 6-volt A batteries and from 1 to 4 B 24-volt batteries. It is the only charger necessary for all radio batteries.

Quiet in operation
Full 6-ampere charging rate
No liquids. No bulbs

Plugs into the ordinary light socket like a fan or other household necessity. Just as easy to operate. Takes only about a dime's worth of current to bring your battery up to full charge.

It has grained and engraved Bakelite panel which harmonizes with any radio set. Clear glass top shows the simple, patented working parts at all times.

At radio dealers everywhere

Valley Electric Co.

101 Rialto Bldg., San Francisco, Calif.



**The Famous Truly Portable
TELMACO P-1 Receiver**

Four Tubes Do the Work of 7

Coast-to-coast reception. Aerial, loud speaker, and batteries self-contained. Carry from room to room—take it anywhere. Size 8"x10"x18". Total weight only 26 lbs. Complete with tubes and batteries. **\$125.00**
\$143.50. Receiver only

P-1 KIT SAVES YOU MONEY!

In response to a popular demand we now offer the Telmaco P-1 Receiver in kit form. This contains all parts, as built by us, including case, drilled and engraved panel, and illustrated instructions. **\$80.00**
Complete kit

Ask your dealer or write us. Descriptive folder free.

Radio Division:

Telephone Maintenance Co.
20 So. Wells St. Dept. A, Chicago, Ill.



Quality Radio Exclusively Established 1918

ARE YOU A SUBSCRIBER?
Send for Trial Subscription
\$1.00 for Six Months

**A. C. H. Three-Tube
Concert Receiver**

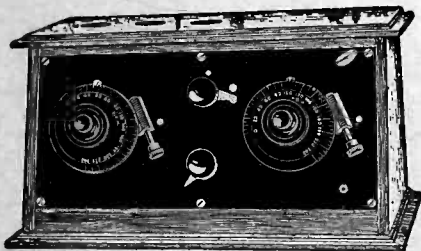

SELECTIVITY

Using sensitive instruments in connection with two A. C. H. Worm Drive Sharp Tuning Instruments. Can be used as one or three tube Receiver. Operates on 199 or 299 dry cell tubes. Batteries Amplifier 90 volt B. Detector 22½ volt B. A battery, three dry cells. C battery, one dry cell. All connections on back. **Installation Plan. No References.**

WRITE US AS FOLLOWS:

A. C. Hayden Radio & Research Co.,
Brockton, Mass.

Gentlemen:

Enclosed please find \$20.00. Send me one A. C. H. Three Tube Receiver. Upon receipt of same I agree to pay you \$1.00 a month for fifteen months until the total amount of \$35.00 is paid. This Receiver is to remain your property until full amount is paid. You guarantee this set to operate on the air.

SIGNED.

Wonderful Value—Limited Production—Mail Orders Only

**A. C. Hayden Radio and
Research Co.**

BROCKTON, MASS., U. S. A.

as the circuit is unidirectional, it is not choked off by the opposing waves of its own radiating power tubes, because the copper box keeps these opposing waves from getting at the loop aerial inside. Not all the local waves are kept out in this way; but enough are kept out to keep them from entirely neutralizing the waves from the distant primary transmitter, and this is sufficient.

"Now, as I have just said, on any ordinary radio receiver within range of the two neutralized transmitters, you will have a dead silence; because the receiver will be equally affected by the two opposing waves; but on a unidirectional radio-compass type receiver you will be able to pick up either of the two transmitters, one at a time, by swinging the direction-finder; because this kind of receiver is acted upon in only one direction at a time. This is how we were able to hear and locate the San Jose neutralizer with a radio compass.

"The Poulsen Pacific receivers at Hollywood, as well as all your other receivers, are of the one-direction radio-compass type; but as you can see by any map, Palo Alto and San Jose both lie in practically the same direction from the Hollywood receivers; therefore the neutralizing waves from San Jose could be adjusted to affect the receiver quite as much as the primary waves from Palo Alto, and the result was a dead silence in the one particular receiver tuned to the wave being neutralized.

"The unknown gentleman who put in the San Jose neutralizer has an office in this building, where he has brought in and tapped some of the Poulsen Pacific's pneumatic tubes from the ground floor to the operating room. He can intercept and read messages, and then send them on up to your operators, without any one being the wiser.

"Suppose he decides to alter a Union Oil Company message which has been given the serial number 45. He quickly copies it and sends it on up to the operating room. Listening in on a loop receiver in his office tuned to the Palo Alto transmitter, he waits until he hears message number 44 go through; then by means of a control-switch on a leased wire he starts his neutralizer at San Jose and kills Palo Alto dead while number 45 is being sent. When he starts his neutralizer, he also starts a small continuous-wave tube transmitter down at Paraiso Del Tontos through a second control-switch, and by means of a vibroplex key, a relay, and a second leased wire, he sends his duly altered copy of message number 45 on his Paraiso transmitter at the same time that the correct number 45 is being sent from Palo Alto. But Palo Alto being neutralized at San Jose does not come in at Hollywood, while the small Paraiso Del Tontos transmitter, which is in nearly the

(Continued on Page 60)

**Apex
Super 5**

This highly efficient tuned radio frequency receiver is the most advanced in design and construction. It is an instrument that meets every critical expectation of the seasoned radio enthusiast.

Buy the Apex Super 5.

You will have a radio receiver that brings in distant stations clear and distinct. Select the station you desire in your log-book, turn the marvelous Apex Vernier Dials to that number, and there you are—perfect reception. No greater selectivity can be had than is easily obtained with the Apex Super Five.

Housed in a highly finished walnut cabinet, complete with Jones Multi-plug Battery Cable. All settings highly gold plated. Sells for \$95 complete excepting accessories.

At All Good Dealers
Apex Elec. Mfg. Co.
1410 W. 59th St.
Dept. 410
Chicago

on
the
dot

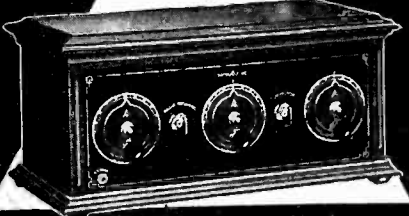

BROWNLIE
CRYSTAL



"REFLEX SPECIAL" \$1.00
QUICK CONTACT
RECTIFIER
GUARANTEED

The Aeme Apparatus Co. says "prevent distortion and howling by using a BROWNLIE CRYSTAL in Reflex Sets"
Order From Your Dealer or Direct.

ROLAND BROWNLIE & CO.
24 Saunders Street. Medford, Mass.

"RADIOCAST
WEEKLY"

A 48-Page Magazine of Programs, Photos, etc., of Pacific Coast Broadcasting Stations
5c per Copy--Radiocast Weekly
433 Pacific Bldg., San Francisco

(Continued from Page 59)

same direction from Hollywood as Palo Alto, does come in with the phony message. As soon as message number 45 is completed, the unknown gentleman cuts off his San Jose neutralizer, and the Los Angeles receiving operator once more gets his stuff from Palo Alto.

"Vibroplex sending at high speed all sounds about the same, and so the difference in the operators' 'fists' is not detected. The Paraiso Del Tontos transmitter must be pretty carefully adjusted to give the same note and signal intensity as the normal Palo Alto arc. I think there is a time-lag of five or six oscillations between the Palo Alto arc and the San Jose neutralizer; but at 4550 meters this represents less than 1/10000 of a second, which is not enough time to move a heavy telephone diaphragm or a tape recorder.

"You will now understand that your recording receivers up on San Bruno Mountain, being also of the one-direction type, recorded the correct message texts going out on the air at all times; because these recorders were very closely adjusted onto the Palo Alto transmitters by Mr. Hawkins here and they consequently were not seriously affected by the San Jose neutralizing waves, since these were coming from a somewhat different direction. On the other hand, the Hollywood recorders were neutralized and got only the altered messages from the local transmitter at Paraiso Del Tontos.

"You will observe that this thing operates without a single actual electrical connection onto your system at any point; therefore it could not be spotted by trouble-shooters and made no suspicious clicks or scratches in the receiving telephones. Furthermore, you will see that the entire apparatus might, in time, be put in and operated by one man working alone; and this man could be holding down a job and do all the preparatory installation work at nights and on Sundays, without being missed from his place of business. It was of course necessary for him to come up into the tube-tapping office on the fourteenth floor of this building, whenever he wanted to work up some altered messages.

"Why the Poulsen Pacific telegrams were altered seems to me to be pretty clear. The unknown gentleman, probably working with some other crooked bank-roll shooters, wanted to destroy for the time being the value of Poulsen Pacific stock, buy control, and then sell out to Radio Freezeouters, Inc. But a crowd downstairs, consisting apparently of a man each from Westover Electric, Patent Dodgers' Union, Yell Telephone, Western Union, and Postit, who I believe have all pooled their personal capital in a bootleg radio tube concern and are therefore being closely spied upon by Radio Freezeouters, Inc.,

CELORON
RADIO PANEL

Size 7 x 12

MANUFACTURED BY
DIAMOND STATE FIBRE COMPANY
BRIDGEPORT (Now Philadelphia), PENNSYLVANIA, U. S. A.

MARKS OF
CELORON - Diamond-Fibre - VULCAWOOD

Office in Principal Cities
IN CANADA, DIAMOND STATE FIBRE COMPANY, OF CANADA LTD., TORONTO, CAN.

How to Work and Finish Celoron Panels

DRILL full size layout of the insulator drilled on a sheet of heavy paper, cut to exact size of panel. Transfer centers of holes through the paper to the Celoron panel with a pointed instrument.

The drilling can be done with a carpenter's brace or a hand drill, but the following conditions should be observed: 1. The drill should be made free. 2. Begin to drill from the front side of the panel. 3. To avoid slipping on back, clamp panel to a board or work bench. 4. Counter-sink holes with a larger size drill. Holes can be threaded with standard machine taps.

If a drill or metal finish is desired, put down the panel with No. 00 sandpaper. The sandpaper should be wrapped around a wooden block and rubbed all over in one direction, not with a circular motion.

Wipe off the panel with an oil cloth.

As popular as radio

As more and more radio novices become seasoned fans, the popularity of Celoron Panels multiplies.

Today Celoron is the accepted standard for radio panels. Sets of many foremost makes are equipped with Celoron panels and parts.

Celoron does not chip or crack. It does not soften, warp or buckle. It is infusible and will stand up under atmospheric changes.

Look for Celoron Panels where you buy your radio supplies. Insist on Celoron insulation in the parts you buy.

Celoron is also made into tubing which has all of the insulating qualities of sheet Celoron. It is used extensively by manufacturers of the best radio instruments. It is made in all sizes and diameters.



This Celoron rack on a merchant's counter means that he wants to give you the best in radio parts. Look for it.

DIAMOND STATE FIBRE COMPANY

Bridgeport, Pa., Toronto, Can. and Chicago, Ill.

The oldest and largest manufacturer of vulcanized hard fibre and laminated technical materials in the world.

Wherever you see a factory chimney there are countless electrical and mechanical uses for Celoron and Diamond Fibre.

Wholesale Distributors of
Nationally Known
RADIO SUPPLIES
DEALERS—Send for price list and discount sheet
COSMOPOLITAN RADIO APPLIANCE CO., Inc.
25 Church Street, New York, N. Y.

NA-ALD

Na-ald DeLuxe Sockets are the only ones with these 3 exclusive features—lowest loss, lowest capacity and positive side-scraping contact. Send for booklet and laboratory test. Aiden Mfg. Co., Dept. G2, Springfield, Mass.

\$50 to \$200 a Week
~and Easy Work

Get your share of the huge Radio Profits. Wanted—Radio Salesmen, Engineers, Executives, Mechanics, etc. Easy home study method qualifies you how in spare time. Earn while you learn.

Big demand for trained men NOW. Easy work. Free book gives complete facts. No obligation. Mail card today.

Send for this FREE Book

NATIONAL RADIO INSTITUTE
Dept. 10FB Washington, D. C.

also saw through the game and tried to buy Poulsen Pacific stock, resulting in the price staying unpleasantly high for the unknown gentleman.

"Then think what a shock it must have been to that gentleman when the Freezeouters unexpectedly announced that they would not buy Poulsen Pacific.

"The unfortunate unknown gentleman, seeing his game ruined, thoughtlessly dumped all his stock back on the market in one chunk for what he could get, and all the other little gentlemen of the bootleg tube combination downstairs, seeing the way things had turned, did likewise.

"Poulsen Pacific stock at once became cheaper than dirt, in which condition it was bought by Mr. Greb, the ubiquitous speculator. Owing to the great amount of publicity the Poulsen Pacific have got out of this thing, the indignant public thinks the company a victim of the hoggish telegraph trusts and is rushing down here with armfuls of business; and so now Poulsen Pacific is going full blast; the unknown gentleman who tried to buy control is probably flat broke; and all the little gentlemen tagging along behind must be badly bent. About the only person who appears to be distinctly ahead of the game is our friend Mr. Greb. This must be the real moldy dog biscuits and sour sardines to the unknown gentleman, for I believe he is nursing a regular Apache Indian grudge against Greb for stealing his woman and marrying her, a good many years ago."

I takes the big envelope from Blakely and pulls out a fine clear-cut enlargement of a man clutching a vibroplex key in one hand and a telegram in the other, and springing back from a blinding white flare, which is evidently the exploding relay-coil. The man's face in the picture is clear and sharp as a movie actor's in a super-feature—the keen, cold, and terrified map of Mr. Stephen Glass, President of the Poulsen Pacific, and one-time crackerjack radio operator for the D'Arcy Wireless Company.

"HOW in the devil did you know it was him?" demands Mr. Tulver, swabbing his haggard face with a soggy towel, in his emptied office, thirty minutes later.

"Well, I didn't exactly know, of course," I replies, "—although Glass's trying to play the lone wolf made it necessary for him to be down on the fourteenth floor, where he didn't seem to have much of any business to be. But just between you an' me an' the sultan of Turkey, I'll tell you real confidential like that I had him spotted from the first by taking him to be the last man in the world who would be suspected—for this is what every regular detective guy and every follower of regular detective guys' stunts has long since learned to do."

Silver-Marshall, Inc.

RADIO EQUIPMENT

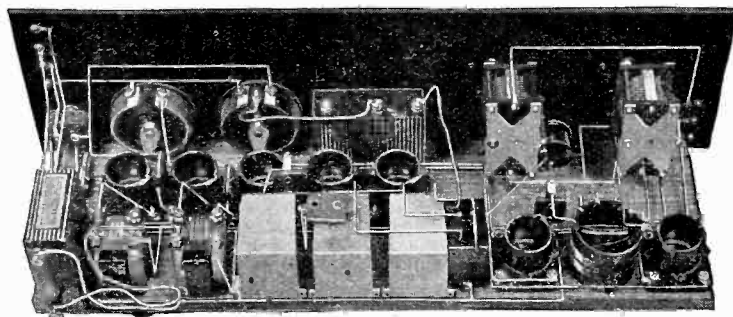

SILVER SUPERS APPROVED by the "WHO'S WHO" of RADIO

The Editors and Engineers who have endorsed Silver Supers constitute a "WHO'S WHO" of Radio. Here they are: Arthur H. Lynch of Radio Broadcast, Capt. John Irwin of Radio Broadcast's "Covered Wagon," Gerald M. Best of Radio Magazine, M. B. Sleeper of Radio Engineering, F. D. Pearne of Radio Age, Iverson C. Wells of Everybody's Radio, R. C. Hughes of the Corn Belt Dailies. Add the Chicago Herald-Examiner, the American Radio Journal, Citizens Radio Call Book. On the Air Magazine, the cautious Christian Science Monitor and WTAS Broadcasting Station . . . then you will know that SILVER SUPERS have been APPROVED, and that by the "WHO'S WHO" of Radio.

SILVER SUPERS are the logical selection of the man who wishes to build the best. Their reception records are unsurpassed, the soundness of the advanced engineering methods embodied in Silver Supers is unquestioned, for simplicity of construction they cannot be equaled. Build your own Silver Super—it's easy—you need just three tools—and your Silver Super will give you up-to-date reception for years.

All Parts \$72.85

Blue Prints and Complete Building Instructions, 50c.

Send 50c for McMurdo Silver's Book "THE PORTABLE SUPER-HETERODYNE."

S-M-4-TUBE KNOCKOUT	On a 70-foot antenna will equal the startling performance of the Silver Supers on a loop. Send 25c for McMurdo Silver's own description of this, his latest circuit. All parts cost.....	\$44.40
S-M DISTORTIONLESS AUDIO AMPLIFIER	A three stage Resistance Coupled Amplifier, giving perfect tone quality on all vocal and orchestral music, and that with greater volume. Cost no more than ordinary two stage transformer coupled amplifiers.....	\$17.65
S-M LOW LOSS CONDENSER	Type 301—straight line, low loss, grounded rotor condenser of the most approved and advanced design. For use in the Silver Super, the 4-tube Knockout, and all sets where extreme efficiency is desired. Cap. .0005 mfd. Price, each	\$4.50
S-M TWO-TENS TWO-ELEVENS	Long wave transformers supplied in sets of 2 or 3 TWO TENS (iron-core interstage) and one TWO ELEVEN (filter for input or output) with identical peaks and separate curves. Curves plotted in our own Laboratory and recorded directly on the transformer's tag. Price of either type, each.....	\$8.00

Circulars on S-M Products Upon Request

SILVER-MARSHALL, Inc., 110 S. Wabash Ave., Dept. B., CHICAGO

HIGH QUALITY — LOW PRICE

The CLARITRON \$2.30

TUBE BY MAIL

FOR BRILLIANCE OF TONE, SHARP TUNING, MORE PEP—
USE CLARITRONS

The Highest Obtainable Quality at the Lowest Obtainable Price. Our price is low because we cut out the jobber-wholesaler's profit—which is YOUR saving.

All types, including our 501A, for 6 volt storage batteries; our 499, for 4½ volt dry cell batteries; and our 112, for 1½ volt dry cell batteries. All made with bases of Pure Bakelite—for superior efficiency. We Guarantee Complete Satisfaction. From your dealer, or direct by mail C.O.D., or prepaid on receipt of Express or Postal Money Order. We Pay Postage. \$2.30 all types. Dealers Write!

**SUPERIOR RADIO COMPANY, Dept. 205
176 Shepard Ave. Newark, N. J.**



Type 499
Detector and Amplifier
3-4 Volts
For Dry Cell Batteries
0.06 Amps.



Type 501A
Detector and Amplifier
5-6 Volts
For Storage Batteries
0.25 Amps.

Send for Trial Subscription—\$1.00 for Six Months

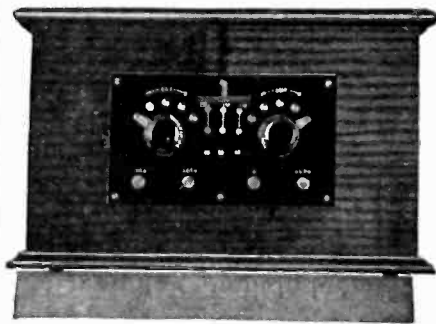

KIC-O--- the permanent power plant for your radio

If you are tired of buying new batteries every little while—if the stations are not coming in as loudly and clearly as you think they should—if you want better reception at lower cost—if you want a real permanent power plant that will last for years—then buy a KIC-O.

These new KIC-O Nickel zinc alkaline storage "B" Batteries are the product of years of research. They are not harmed by standing idle or overcharging. They give a slow, even discharge over a long period of time and by using the KIC-O Double Potential Charger, which can be attached to any electric light socket, you have a permanent power plant. Write for full description, which will tell why KIC-O units are better than dry cells, "B" eliminators and acid "B" batteries.

KIMLEY ELECTRIC CO., Inc.
2661 Main Street Buffalo, N. Y.

Prices

PZ indicates panel type with switches.
CZ is plain type without switches.

VOLTAGE	M. A. H.	TYPE PZ	TYPE CZ
130	2500	\$36.00	\$33.00
100	2500	27.50	24.50
70	2500	21.50	18.50
45	2500	16.00	14.50
22 1/2	2500		7.56

MULTI-POWER UNITS

(No recharger required)

130 volts	\$43.50
100 "	35.00

KIC-O CHARGERS

Type K-1 Single Unmounted	\$1.50
Type K-2 Single Mounted	3.50
Type K-3 Multi-Polar Mounted	5.00
KIC-O Special Charger	
Chemicals (one cell)	.50

LEAVENWORTH STATION

(Continued from Page 10)

wavelengths; from telephone to telegraph and vice versa; and from full power to 20 per cent or 50 per cent output as desired.

The set as installed at Fort Leavenworth occupies a floor space 13x19 feet. The front of this space is the control board, made up of 7 panels. On these are mounted the various meters, and means of operating the switches behind the board. No "live" parts, from which the operators might receive electrical shocks, appear on the front of the board.

The principle of the set is that due to Colpitts and Arnold by which oscillations generated and modulated at a moderate power level, are then amplified to the desired power. This system was originally used in the Arlington-Paris tests of 1915, in which the human voice was first transmitted across the Atlantic. It was again used in the transatlantic tests made in January, 1923, when a group of Bell System engineers and executives talked to people in London. In the present set, oscillations are generated by a 250 watt vacuum tube, amplified first by two other 250 watt tubes in parallel, and again by two water-cooled tubes in parallel. Telegraph signals are sent by starting and stopping the oscillations. Telephone transmission is obtained by controlling the flow of power to the first amplifier tubes in accordance with the voice current waves. This scheme is due to R. A. Heising. While the set is designed to receive power at 220 volts three phase alternating current, the various devices in it require power at several different voltages and of direct current as well as alternating.

It is interesting to follow the path of the voice transmission through the oscillator-modulator unit and then to see how the circuits are modified for telegraph transmission. The voice currents enter through a transformer and are amplified by a 50 watt vacuum tube. They then control the output of two 250 watt tubes in parallel. By the well-known Heising system of constant current modulation, the amount of power available for two 250 watt radio frequency amplifiers is varied according to the changing values of the voice currents. The grid circuit of the last mentioned tubes is controlled by oscillations generated by a 250 watt tube in a Colpitts circuit. Thus the output of the two amplifier tubes is a high frequency "carrier" modulated by the voice current. This method of segregating the oscillating and modulating functions in separate tubes is used instead of the familiar combined oscillator modulator arrangement used in radiocast transmitters because it gives greater stability to the frequency of the oscillator.

When telegraph transmission is desired, the movement of a control wheel

Good Radio Advice

AMERICA'S pioneer instrument maker has prepared a booklet for you showing typical radio receiving hook-ups and how to properly connect instruments in circuit.

Complete information is also given on the Weston Radio Plug and the Weston Radio Table Voltmeter, indispensable to radio pleasure and success. This double range table voltmeter (150 and 7.5 volts) is invaluable for improving reception, for prolonging the useful life of tubes, for locating trouble, and for preventing the discarding of batteries prematurely.

Write for "Weston Radio Instruments" today.

WESTON ELECTRICAL INSTRUMENT CORPORATION

156 Weston Avenue

Newark, N. J.



STANDARD THE WORLD OVER

WESTON

Pioneers since 1888

A Dozen Thrilling Yarns

Read the Story of the Life of a Sea-going Radio Operator—
"THE RADIOBUSTER"

SENT POSTPAID ANYWHERE

PACIFIC RADIO PUB. CO.
Pacific Bldg., San Francisco, Cal.

\$1.00
Per
Copy

\$1.00
Per
Copy

tion, while resistance and impedance coupling on the other hand may be made considerably better than the best obtainable by transformer coupling as yet.

amplification at 95 cycles taken from Table I. The amplification at 200 cycles is 7.1 and the corresponding point is therefore at the intersection of the 200

Frequency	95	200	500	1000*	2000	3400	5000
Amplification	10.6	16.0	26.0	33.3	34.1	30.1	26.4

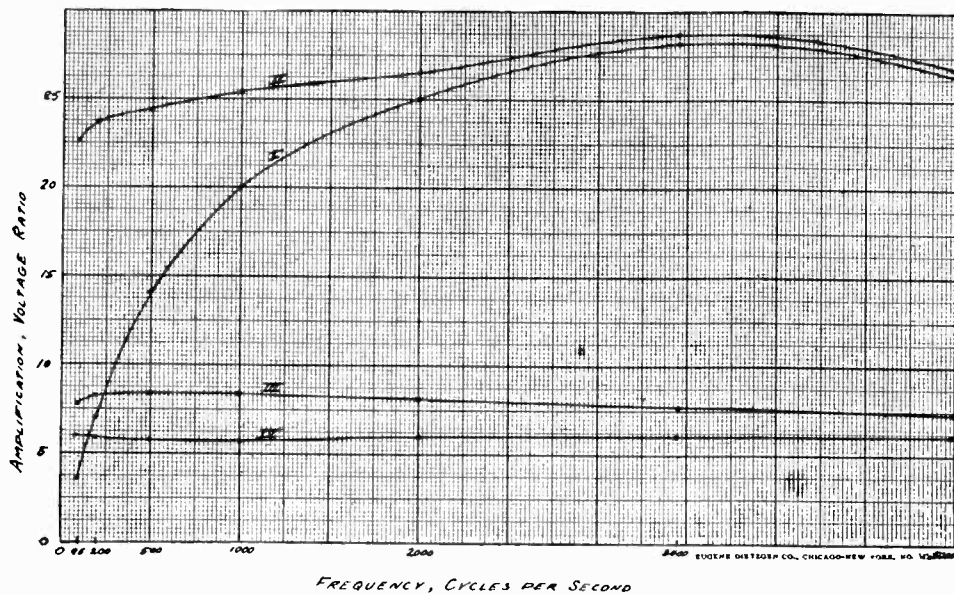

Fig. 1. Voltage Amplification—Frequency Characteristics. I—A Typical Poor Transformer. II—A Very Good Transformer. III—Impedance Coupled Amplifier. IV—Resistance Coupled Amplifier.

Frequency Characteristic Curves and Tables

TO compare the relative merits of any two coupling devices from the standpoint of their frequency characteristics, the latter should be plotted as curves, as shown in Fig. 1. Table I gives the data from which Fig. 1 was plotted. The first point of curve I, representing the frequency characteristic of a typical poor transformer, is found at the intersection of a vertical line at 95 cycles and a horizontal line at 3.6, its

cycle vertical line with a 7.1 horizontal line, and so on. Having plotted the seven points given, a smooth curve is drawn through them with the result shown as curve I.

Tests of some 40 commercial transformers gave the average results shown in Table II.

While the actual performance of each individual make would be interesting, the publication of this information would be obviously unfair as the amplification is largely dependent upon the turns

ratio and as no consideration is here given to the equally important factors of tube impedance and the effects of shunted and inter-winding capacities, as discussed subsequently. In general it is evident that the more expensive transformers give better results than the cheaper ones.

In most cases the data of Table II were taken on one sample only of each type of transformer and it is therefore desirable to know to what extent the frequency characteristic for this sample will be correct for other transformers of the same make, type, and ratio. For this purpose 5 transformers of one kind were measured and the greatest variation at any one frequency found to be about 18 per cent while the average deviation from the mean value at each frequency was about 3 per cent. The variations were greatest in the low frequencies.

Measurements on 3 transformers of one type manufactured in 1922, 1923, and 1924 indicated a continuous improvement in the product of the manufacturer.

Comparisons of two low grade transformers of a given type and of two high grade transformers showed a maximum deviation of 3½ per cent. It is quite possible that this is only a coincidence but the transformers in question appeared to be very carefully made and were the product of reputable manufacturers, so that the uniformity shown may not be accidental.

In Table IV are shown the behaviors of two different transformers with different vacuum tubes. The plate and grid voltages are shown in each case.

(To be continued)

De-magnetization of a radio head-phone can be avoided if it is made in accordance with the A.M.E.S. standards. They specify that each ear-piece be marked with a plus and a minus sign to designate the terminals to which connections should be made. The positive terminal of one ear-piece is connected to the negative terminal of the other by a brown cord with a white thread tracer. A solid brown cord designates the positive terminal and a black thread with brown thread tracer the negative, this connection applying both to head-sets and loud-speakers. Standard plugs, likewise, have a positive mark on or near the terminal that connects to the "sleeve," the tip being negative. Jacks should be wired so that the positive B battery connects to the "sleeve" or body of the plug and the negative to the tip.

Elman B. Myers, one of the pioneers in the development of the vacuum tube, claims to have invented a tube with a renewable filament which operates in the open air and requires no glass inclosure. Tests are said to show an amplification factor of 2 and that the device may be operated directly with alternating current without giving a hum.

Five Samples of Transformer A							
Frequency	95	200	500	1000	2000	3400	5000
1.	17.8	26.6	33.5	34.6	35.5	35.5	35.5
2.	18.4	23.4	32.4	33.4	35.9	36.3	37.2
3.	18.0	22.9	32.7	34.1	37.6	39.4	33.5
4.	16.8	22.1	32.4	33.7	36.7	37.2	33.5
5.	17.4	23.2	32.7	33.7	37.6	37.6	32.7
1922, 1923 and 1924 samples of Transformer B							
1.	4.1	7.9	15.9	21.1	25.1	26.6	26.6
2.	5.0	8.9	16.8	22.4	25.1	25.1	26.0
3.	8.5	8.6	17.2	23.4	27.9	31.6	31.6
Two Samples of a Low Grade Transformer							
Frequency	95	200	500	1000	2000	3400	5000
1.	7.8	11.5	19.7	28.8	28.2	25.4	22.1
2.	8.6	15.8	22.4	28.2	28.2	26.6	25.1
Two Samples of a High Grade Transformer							
Frequency	95	200	500	1000	2000	3400	5000
1.	23.2	24.0	24.3	25.7	27.5	33.9	34.3
2.	22.9	24.0	24.0	25.1	27.5	34.3	35.5

TABLE IV. Effect of Different Tubes

Transformer A		95	200	500	1000	2000	3400	5000
Frequency	$E_B E_C$							
C-301-A	90-4.5	20.	24.8	34.3	33.9	40.7	48.4	50.1
C-301-A	45-1.5	13.6	18.4	30.5	32.4	34.7	28.2	21.9
C-299	90-4.5	11.6	14.6	18.8	18.4	22.1	26.6	26.6
Magnavox	90-4.5	14.6	17.0	21.6	20.9	25.1	29.1	28.8
Transformer B								
Frequency	$E_B E_C$							
C-301-A	90-4.5	13.3	16.4	19.3	19.5	20.4	20.4	20.4
101-D	90-4.5	10.8	12.3	13.2	13.2	13.8	14.6	17.4
C-299	90-4.5	8.3	9.7	10.8	11.1	11.3	11.9	11.9

Power Line Interference

A Discussion of Its Causes and How It May be Located and Remedied

By *Ralph W. Wight*

DUE to the ever increasing number of radiocast listeners with the more universal use of radio as a means of supplying entertainment, the problem of interference becomes a most important one. Of the various sources of such interference, this article deals chiefly with that caused by power transmission and distribution systems.

Contrary to the general impression, the presence of a high tension power transmission line in your immediate neighborhood, does not necessarily indicate that radio reception will be materially disturbed. The writer has made several tests directly under transmission lines of various voltages up to 220,000 and unless serious leaks are actually causing severe sparking, no interference other than an occasional "slop-over" and the regular line inductive "hum" is present. The line "hum" is not present unless the receiving antenna is directly under the transmission line.

In one case a single wire antenna slightly over 1100 ft. long was stretched beneath a 220,000 volt line 17 ft. from the nearest conductor. Due to the inductive relation, approximately 4,000 volts to ground was present. This voltage was drained off through a radio frequency choke coil and very satisfactory reception was secured. This was interrupted occasionally by static discharges.

With this antenna, observations were made on wavelengths ranging from 8,000 to 25,000 meters. The receiver was the usual three circuit regenerative type. With a similar receiver and an antenna varying from a few feet long to 150 ft. placed under the same line, further tests were made over the entire radiocast band. In all cases, no interference of marked amplitude was observed unless leakages were actually present.

The problem of locating these leaks is a difficult one. One method will be outlined which has given very encouraging results although it is far from a faultless system.

After many attempts and careful tests, the directional properties of the loop were finally abandoned as having no real value in locating trouble except in rare cases. Maximum signal strength when using a receiver with directional loop near a noisy line, is always obtained when the loop is parallel with the conductors of the line or any other conductors which tap off the troublesome line. The same is true of wires which are on the same poles but not connected to the circuit from which, it is assumed, the interference radiates. This condition gives many misleading bearings as the proximity and angle of the various outlying leads vary with the location of each observation.

However, we do find that if it is possible to get a considerable distance from all wires and take three or four bearings, the trouble can usually be located within an area, say, of three or four city blocks either side of its source. This will only be true where all bearings are made under like conditions as to distance from other conductors which may be carrying the interference to the receiver in some other direction than its actual bearing from the receiver. It is obvious that bearings will be of no value which are influenced by such conductors. Thus we see that in the case of city distribution systems it is practically impossible to use a loop as a direction finder.

In localities where interference is of such amplitude that it renders radiocast reception impossible, the interfering line can usually be found by placing a portable superheterodyne in an automobile and driving along under several lines in the immediate vicinity, stopping frequently to see which line seems to be carrying noise of the characteristics of the one it is desired to locate.

After picking out the line a systematic survey is made of it. A constant impedance audibility meter is placed in the phone circuit and readings of the audibility are taken at regular intervals. As the observer nears the source of the trouble, the strength of the interference will be of such amplitude that it cannot be balanced out by the impedance of the meter. Record must be kept of all readings and when the amplitude is too great for the scale of the meter, amplification must be decreased to a value which brings the noise back within the range of the meter and tests continued until a maximum is found. The loop should at all times be parallel to the line.

It will be found that there may be stray readings due to slightly different conditions under which observations are made. Where right angle, or other taps are made off the line, they should be followed for a short distance to be sure that the interference decreases as you go from the main line, indicating that the trouble is not on the tap.

This discussion refers to primaries rather than secondaries as the usual 110-220 volt circuits are generally free from trouble.

When it is apparent from the data secured that the peak of the interfering noise is found, a careful inspection should be made of all pole top construction. Various causes of trouble include the following:

1. Dirty or cracked insulators.
2. Tree branches swinging into primaries.
3. Loose contact in pole top switches.
4. Loose contact in primary fuse clips.

5. Charred and arcing fuses.
6. Transformer bushings broken down.
7. Loose ground connection on transformer cases.
8. Loose grounding strip on pole top hardware.
9. Faulty street light cut-outs or bulb loose in socket.
10. Metallic bodies such as "high-voltage" signs which are within the field of the line often pick up a static charge although they are in no way connected to the line. If these bodies are placed too close to ground leads a steady sparking results caused by static leaking off to ground.

These are just a few of the causes. Interference in the radio receiver which sounds like a 50 or 60 cycle roar usually indicates trouble of the above noted nature. In the case of a tree branch swinging into line, it is, of course, intermittent. We also find that varying load conditions will cause leaks to be present only at certain times.

There are a great many other causes of radio interference which we will list separately. Among the well known causes aside from power line noises are as follows:

1. Sparking commutators on direct current machines feeding trolley lines.
2. Sparking synchronous battery charging rectifiers such as are used in many battery stations and garages.
3. Vibrating type of battery chargers.
4. Vibrating frequency chargers such as are used to supply ringing current in telephone offices.
5. Flashing type of electric signs.
6. Railroad wig-wag signals.
7. Sparking at the contacts of main line telegraph relays.
8. Electrically driven sewing machines, vibrators and vacuum sweepers.
9. X-ray machines.

Others almost too numerous to mention also come under these headings and it is apparent that the remedy is to eliminate the source rather than to attempt to filter it out.

There is a great deal of code interference which we are not able to control to an appreciable extent. The transmitting amateur is usually blamed but is rarely, if ever, responsible. The most common cause is ship and coastal station interference; these stations being necessary for the safeguarding of life and property.

In closing we must emphasize the crying need for patience. After the trouble is actually located it is not always possible to repair it immediately. In the case of power lines, they cannot always be taken out of service immediately and with machinery, replacements of parts are sometimes necessary, requiring the expenditure of much time and money.

Building Sets to Make Money

Some Practical and Helpful Suggestions for the Amateur Constructor of Receiving Sets

By *Harry A. Nickerson*

MANY amateur set builders fail to realize the difference between "building sets for money" and "building sets to make money." The difference is principally one of system and tools. There are thousands of amateur set builders selling the unlicensed product in violation of no one knows how many patents, but few are making more than a poor day's wage.

At the start there is the element of time to consider. Making radio parts by hand is like cultivating a field of potatoes,—it can be done by hand but it takes machinery to do it at a profit. So one cardinal rule of set building is to use a machine-made product for apparatus assembled in a set, rather than to try to manufacture it. The value of the set builder's time necessary to produce it is greater than the manufacturer's and dealer's profit.

Take a variocoupler as an illustration. One can buy a bakelite tube, a rotor form, bushings for bearings, and a piece of brass tubing for a shaft; but when the assembling and wiring is complete, with the further complication of "stops" and tapping and attachment to panel, the time element has made the expense greater than the cost of the better appearing manufactured instrument.

So with small parts. The city-dweller is of course fortunate because of the great number of radio stores which handle small parts in a city, but the mail order house will supply the deficiency of the small town radio store.

The most useful tools of the set builder are an electric soldering iron and a pair of pliers. It is a good plan to have two irons, one intended for continuous use and the other with a very fine "pencil point" tip for tight places. It pays to buy the higher priced irons with replaceable tips, since the tips generally burn off before the heating element burns out.

The pliers which permit bending of wire to form loops with the end of the pliers, with a cutting device and flat jaws as well, are most convenient, but diagonal end-cutting and "long nosed" pliers are also useful.

By the time the set builder has built a few sets, he has generally seen the necessity for a considerable tool kit, consisting of several sizes of screw drivers, hacksaw, drills, taps and dies, with holders, a drawing board with T square and angles, a scribe, etc. A set of nut drivers for hexagon and round head nuts are a great convenience and save time as well as improve appearance.

Each set should be sold with the thought in mind that it may sell other sets. It is poor advertising to use materials which are not fitted for long and hard use. Save on time but not by buying apparatus that is really cheap in quality as well as in price.

Where the amateur builder often receives little pay, is in the insertion of "extras" in sets. It may take an hour to put a couple of 25c vernier rubber tired "dial adjusters" on a set. Another very common waste of time is the attempt to fit apparatus into cabinets too small to hold it readily. Such sets should only be constructed for the builder's use, where, perhaps he can afford to squander time.

Jacks, especially the filament control type, requires a lot of planning and time in insertion. If customers insist on filament control jacks, the charge should be in proportion. Many manufactured sets, using three or more tubes, have but one jack for the whole set; it is not hard to see where a few dollars is lopped off their selling price.

Engraving on panels, etc, is a matter of difficulty. It is hard to learn to handle an engraving tool. One spoiled panel is more expensive than a lot of expert engraving. A simple line above a dial scratched with a scribe or awl and terminating at the top in a shallow round hole, drilled lightly with a No. 27 or smaller drill, will do for a dial indicator. The placing of transfer engravings is another time-using job. Binding posts with engraved tops (preferably non-detachable) are a solution of the binding-post problem.

The first cost of a cabinet already "finished" may seem high but the reason is obvious to one who has tried to put a "piano finish" on a cabinet. In the large cities, unfinished mahogany cabinets are available at a very low price at the "ten cent" stores, but the usual set builder's finish, is in appearance, what it is in reality, "home made." A "machine sanding" with dustless drying conditions, etc., are needed for real "piano finish." It pays to take lessons in finishing cabinets from an expert. It is no job for a housepainter.

Opinions vary as to the use of busbar and soldering lugs, and sphagetti. Probably a judicious use of all three is best. If the bus is to be used with as little sphagetti as possible, it should be "hard drawn." Connections between two posts only can be quickly made by using end loops in the bus wire and dispensing

with lugs. But where a long bus wire must be used with many posts to be connected, the use of soldering lugs makes for speed and ease, rather than trying to make a number of intermediate loops in the long bus. Right angles add to the appearance and should be made for that reason, where but slight increase in the length of the wiring is thereby had, but otherwise short direct leads in a more or less straight line, with bus covered with sphagetti, give better efficiency with good appearance. Round bus is easier to use than square.

Most set builders would like to use resin flux but prefer some sort of soldering paste for quick work. In spite of the hue and cry against "corrosive" paste fluxes, if used sparingly, the paste flux in average hands does better work.

The speed of soldering to lugs varies greatly with the type of lug. Some lugs just won't take solder and have to be individually scraped and "tinned" before being placed under terminal posts of apparatus. One flat type is made of heavy copper heavily tinned and takes solder readily. The use of old discolored lugs is false economy.

A certain amount of system gets to be a habit with most set builders. Thus in most sets, even before the panel is attached to the baseboard, a great deal of the socket wiring may be done, then the panel put in place. Usually the procedure is filament wiring on sockets, placing of panel, wiring of rheos., then jacks, and finally wiring at the rear of baseboard.

The proper placing of tools and small bolts and nuts, etc., is a part of "system." Tools placed in holes drilled in a shelf or supported in leather sockets or on hooks close by the worktable are of course more accessible than when kept in a toolchest and can be put out of the way after temporary use. A cabinet with small drawers helps to keep the large assortment of bolts, screws and nuts necessary for set building, or else several tin "muffin pans" divided into four or six compartments may be used.

The set builder should build so far as possible standard hook-ups in a standard way. The newest reflex set may give fine results under ordinary conditions but be worthless near an alternating electric light circuit with a "60 cycle hum." The attempt to adapt a particular set and hook-up to an odd-shaped panel is a great waste of time. Manufacturers pay heavily for designing

Continued on page 66

Radio and Education

A Suggestive Article
Concerning the Present and
Future Value of Radio for

Class Instruction

By *James A. Ramsey*



Miss Myrtle Palmer, penmanship instructor, and her studio class before the microphone at KGO during a recent test radiocast into the Oakland Public Schools.

ONE of the greatest future functions of radio is its use as an educational force. By this is meant not alone the educational programs intended chiefly for adults in their homes, but especially its use for class-room instruction.

Adult educational work is a feature of many station programs. New York University, with the co-operation of WJZ, created what is called the first "air college." The fall term began in October, 1924. The course consisted of twenty minute lectures on eight subjects and was sent out every week day evening. Washington State College at Pullman is radiocasting its extension courses from its own station, KFAE, and many other colleges are doing likewise. KGO at Oakland, California, has been devoting Monday evenings for nearly a year to educational material, the programs consisting of twenty minute talks on agriculture, economics, English, Spanish and book reviews.

One of the first attempts to use radio in the common schools was made in England. Arthur R. Burrows, Director of Programs of the British Broadcasting Company, wrote an article in the "Teachers World" London, for January, 1924 in which he pointed out that very few schools, public or private, can afford

to hire great authorities to give lectures on their various fields of work, but if all the schools were equipped with receiving sets the lectures could be given to all simultaneously by radio. According to the Journal of the National Educational Association, Mr. Burrows' plan was put into practical operation on April 4, 1924, when lessons in music were given by the famous musician, Sir Walter Davies, to an invisible audience of ten thousand children in the London schools.

A few weeks later, April 30, to be exact, the public schools of Oakland, California began a series of experiments in class-room instruction by radio under the direction of Dr. Virgil E. Dickson, Deputy Superintendent of Schools, who has written an excellent account of the work in the Journal of the N.E.A. The experiments were given with the co-operation of the General Electric Company's station KGO, and consisted of lessons in music, geography, history, arithmetic, penmanship and physical culture. The reports indicated that the lessons in arithmetic and penmanship were the most popular.

Mr. Dickson emphasized particularly that the work in Oakland was actual class-room instruction, in which the pupils continue at work during the progress of the radio lessons and submit the product as tangible evidence of what has been accomplished. In this respect, it is different from all other known attempts at education by radio which consist chiefly of lecture work.

He also stated emphatically that he did not believe the use of radio in the schools would in the least degree affect the number of teachers needed.

I will enumerate some of the results established by Dr. Dickson:

1. There is intense concentration on the part of the pupils who listen in.
2. The need for discipline seems almost negligible during the time of the radio lesson.
3. It offers better training of children in quick, thoughtful obedience to a single direction.
4. It can supplement class room instruction through occasional lessons by the best supervisors and experts.
5. The most perfect planning may be expected for the lesson to be broadcast.
6. The training of radio instructors for planning and delivery will become a new art.
7. Schools in remote or inaccessible districts in the country may come in touch with the best supervision and methods of instruction.
8. Parents and other adult members of the community are intensely interested in the lessons taught in the schools and listen in from places outside the class-room.

Another example of the use of radio in the public schools and one with which you are no doubt familiar is the work proceeding under the direction of Mrs. Grace Stanley, State Commissioner of Elementary Education in California. It was begun on November 3 and con-

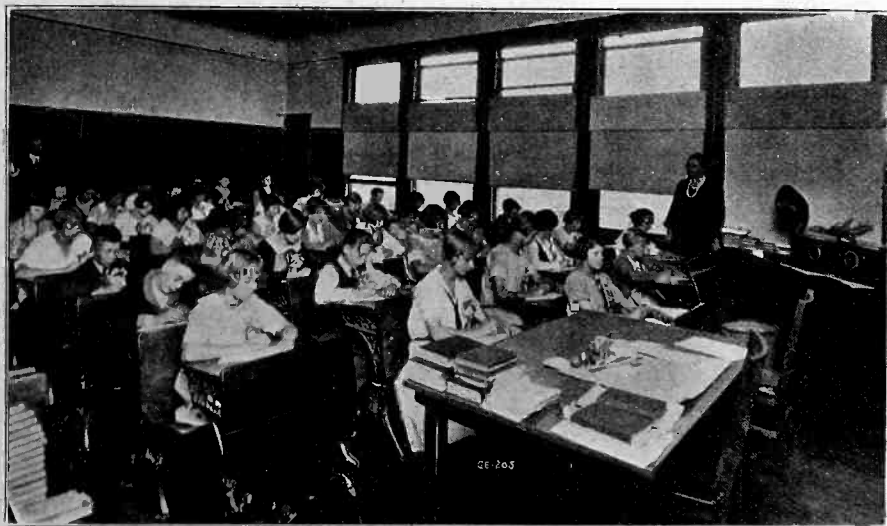

Pupils in the Melrose Heights School, Oakland, California, receiving a penmanship lesson by radio as it is being radiocast from KGO during recent tests made to determine the value of radio in school work.

sists of a series of lectures on geography and history, given by various people of note every Monday morning at 9 o'clock from KGO, Oakland; KFI, Los Angeles; and from KMJ, Fresno. Every school in the state which is equipped with an efficient receiving set is able to tune in on these programs.

Proof of the interest of parents and the general public in the work of the schools is to be found in the experience of some of the Eastern cities. In May, 1924, Rochester received 100,000 replies from those who listened in to their program of Education Week, while Buffalo received 50,000 replies in answer to a definitely organized program designed to give parents and others an understanding of the work and needs of the schools and secure their co-

operation and support—a task, which, in the past, has been left to the Parent-Teachers' Associations, Visitors' Days, newspaper items, etc.

cannot come to school in person due to home responsibilities or to reticence—and others who perhaps have passed beyond the school age without completing their education and are backward about attending night schools or extension courses or do not do so for other reasons.

The ability of radio to reach isolated individuals and groups must appeal to everyone. People in the lonely homes of the prairies, mountains and deserts, in the logging camps and at the mines, on ships on the high seas, at army posts, with exploration parties in the frozen

broadcast programs for the benefit of these people.

Many school executives have been considering the advisability of providing receiving sets for their schools and some have hesitated to make the purchase thinking that there will be radical changes in equipment. There is no doubt that there will be improvements from time to time just as there are changes in models of automobiles from year to year. I do not believe, however, that anyone should hesitate on that account because satisfactory reception has already been accomplished as is evidenced by the splendid performance of many fine sets on the market today.

RIBBON MICROPHONES AND SPEAKERS

By W. H. WATERMAN

The Siemens-Halske ribbon microphone is a recent German development which is claimed to be unaffected by mechanically transmitted vibration, responding only to the air-borne sound waves which it is intended to catch,—a thing which recommends it immediately to mobile transmission from trains, trucks, planes or, in short, wherever it is extremely difficult to employ the ordinary type of microphone. It is also claimed to cover the audible scale of sounds from the highest violin or piccolo tone to the deepest bass of the drums.

The apparatus is housed in a small, square box with another smaller box mounted upon it. It has no horn nor funnel to gather up minute sound; it is therefore independent of directional sound efforts, which adapts it perfectly to theatrical stage pick-up broadcasting, public-speech pick-up, fights, football games, etc., and this combined with its super-sensitivity leads us to predict that it may have a brilliant future in police work, supplanting the detectaphone.

Mechanically it consists simply of a very thin corrugated ribbon of aluminum, only a few thousands of a millimeter thick, suspended between the poles of a magnet so that the plane of the ribbon, with its corrugations, parallels the magnetic lines of force. The corrugations serve to make the ribbon extremely elastic, with its natural period of oscillation strongly damped and far

(Continued on page 67)

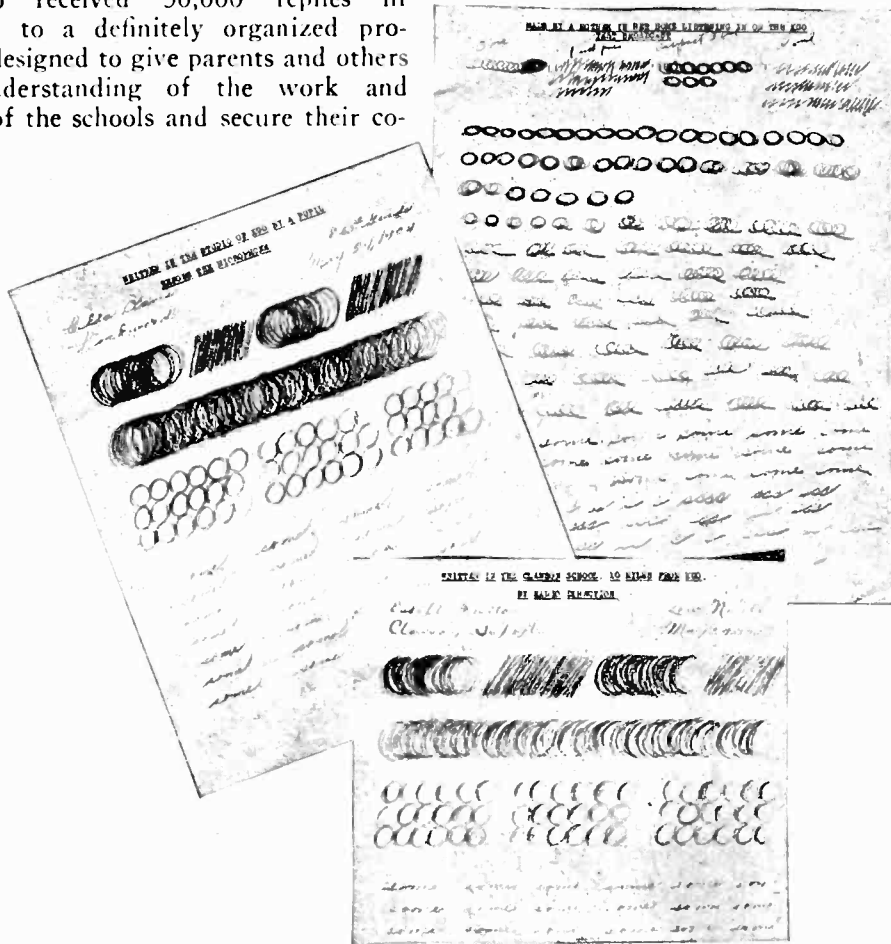

Specimens of Penmanship Taught by Radio

north, disabled people at home or in hospitals or sanitariums, are all in a receptive mood for education by way of radio. They need something substantial to occupy their minds. It occurs to me that it ought to be considered a responsibility by the educators of the country to make an organized effort to

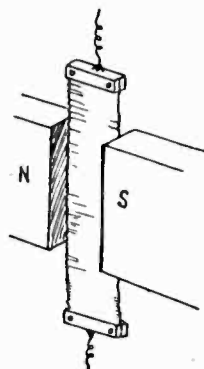

Schematic Plan

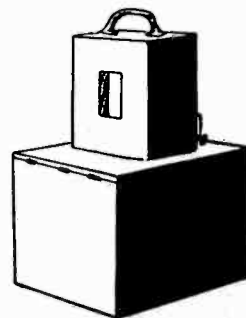

Exterior Appearance
Siemens-Halske Ribbon Microphone

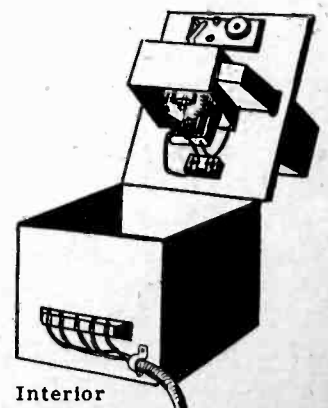

Interior

A Short Wave Loop Receiver

Simple Directions for Building a One-Tube 80-Meter Receiver

By Alexander Maxwell 9BRE-6CKG

THERE is hardly a ham who has not tried his luck with a loop receiver, and as a result there are very few who do not say "bah" whenever one is mentioned. The results fell so far short of expectations that the whole system came to be looked upon as a farce. Some of the more ambitious finally make fairly good records by using a half dozen or so tubes.

But a set which will not hear anything over a few hundred miles on 200 meters, will drag in the DX by the carload on 80 meters, and it is readable stuff too. It was quite a surprise to me when Joe Brubaker of 9DUW called me up and said that he had a loop going and was hearing sixes one right after another, and was only using one tube. I found that he was not over-estimating the set a bit. It seemed to give as great a volume as with an outside aerial, and besides much of the interference and induction was eliminated. I sat and listened to the distant stations without a bit of local interference until early morning.

The circuit is the conventional primary, secondary and tickler which has proved its worth time and again. There is nothing freakish and there are no tricks to the operation. Of course it is understood that to be really efficient the set must be low-loss.

The loop is wound on a wooden frame 18 in. across. The rims are not needed, but if the loop is to be put in a place where it is liable to be bumped they make good fenders. Do not use any patent varnish on the frame. Shellac excludes the moisture and is a fairly good insulator. The wire should be as large as possible. The best way to insure your loop being a failure is to use No. 30 wire. Ribbon antenna is good, but in anything larger than that eddy cur-

rents will detract from the signal strength. On this loop No. 10 enameled wire was used. Five turns spaced 1½ in. apart are about right. The loop is suspended from the end of a bracket arm fastened to the wall and may be swung, by means of a handle at the lower corner.

The rest of the set is standard low-loss equipment. The primary coil consists of 5 turns of No. 12 enameled wire wound on an oatmeal box. They are then slipped off the end of the box and held together with string. The coupling is not critical, and the coil may be fastened permanently, but it makes the set slightly more flexible if it is movable. The primary condenser is an 11 plate. This will tune from 60 to 125 meters.

The secondary is wound on an ice cream carton. These are as nearly a perfect dielectric as can be found. The paper is saturated with paraffin. It is light, moisture proof, and very strong. Have the bottom of the carton at the end facing the primary. The tickler rotates in the open end. The secondary is wound with 15 turns of bell wire. The coil should be placed so that there is a minimum of dielectric in its field. A strip of thin wood screwed to the carton and in turn fastened to the baseboard makes an ideal support—the secondary condenser has 15 plates, giving the circuit the same range as the loop.

The tube is a 201A mounted in a

pyrex glass socket. Later a WD12 without a base was used, and results were slightly better.

The rheostat is a Howard 25 ohm. The make is not important as long as it serves the purpose.



One-Tube 80-Meter Loop Receiver

The unique part of the set is the tickler mounting. A trip was made to the "suregyp" radio and sporting goods emporium around the corner and the mouldiest and highest loss condenser in stock was picked out. It cost \$1.05. As soon as Joe reached home he took it all apart and threw the plates into the garbage can. From a piece of brass curtain rod of the same diameter as the shaft was cut a 9 in. piece. The wreck of the condenser was now reassembled. The tickler coil was wound on a cardboard tube, and the tube fastened to the shaft by means of washers jammed on

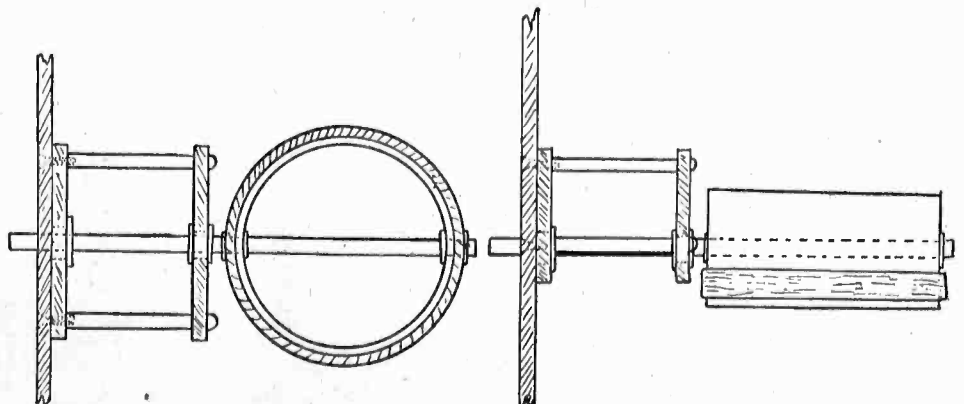

Tickler Coil Mounting

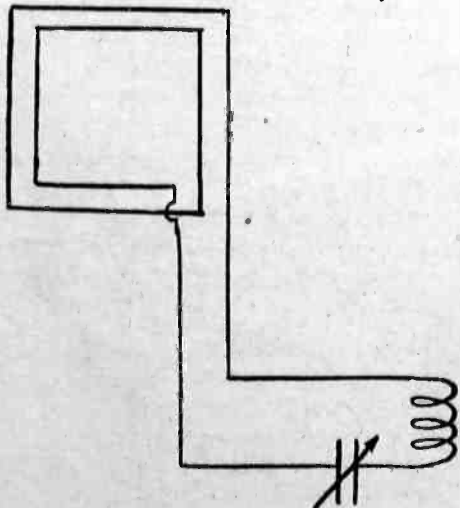

Circuit Diagram of Low-Loss Loop Receiver

and then soldered in place. There is some end play, but not enough to hurt. The bearing runs smooth and all cussing is eliminated for the tickler quits rotating the moment the hand leaves the dial. The number of turns used in the tickler has to be found by experiment. It will be close to twelve.

Don't do too nice a job of wiring. Keep all wires clear of the baseboard and avoid right angles and other fancy

(Continued on page 75)

Testing Electrolytic and Kenotron Rectifiers

Some Interesting Observations of Load Tests and Moduloscope Indications

By Frank C. Jones

PLENTY of theoretical dope on rectifiers has appeared but very few actual tests seem to have been made on any of the various types in general use in amateur stations. Having nothing else to do we ran some load tests on an electrolytic rectifier and on a small kenotron unit, the latter using two of the UV-216 tubes rated at 20 watts.

No filter of any kind was used, the load being merely a variable resistance which in reality consisted of the load resistance and the voltmeter in parallel. As the voltmeter drew from 10 to 20 milliamps it was placed outside of the milliammeter. The power input in all cases was measured by means of a wattmeter in the primary of the step-up or plate transformer so the efficiency curves are for the overall efficiency of the entire unit, transformer and rectifier. The plate transformer was of 500 watts rating and operated at fairly high efficiency except at great overloads, in fact the losses in it were practically negligible in comparison with the losses in the rectifiers.

A glance at the curves will show low efficiencies for the electrolytic rectifier,

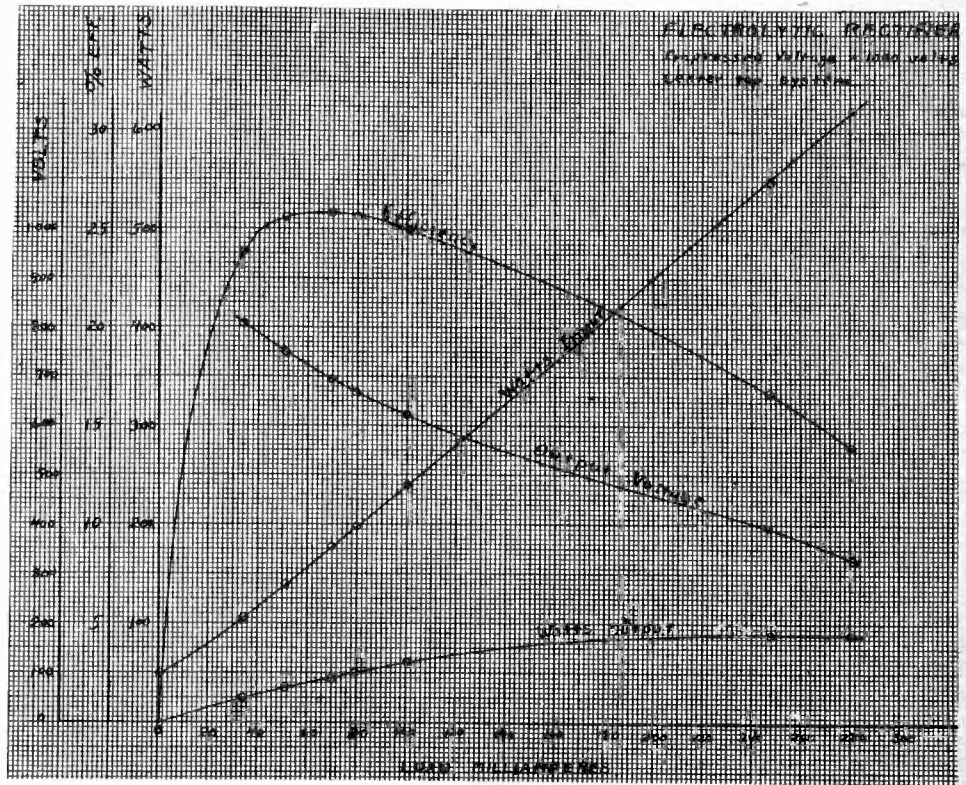

Curves of Electrolytic Rectifier, Center Tap System, with 1000 Volts

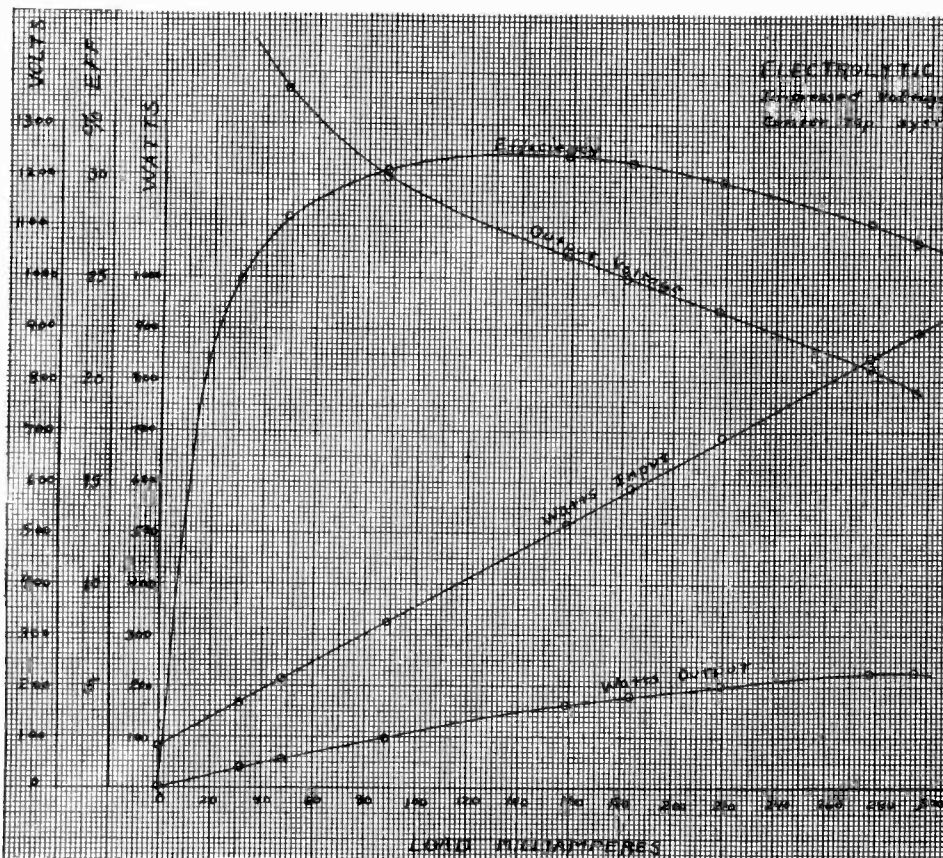

Curves of Electrolytic Rectifier, Center Tap System, with 1500 Volts

the maximum value being about 31 per cent, but this seems to be about the average value for any good chemical rectifier. In the case of impressed voltage of 1500 volts, the rectifier was operating with nearly all of the aluminum plates just showing an even blue glow all over and only 2 or 3 sparking slightly. Whenever the plates began to spark due to high voltage, the efficiency went down quite rapidly.

However the same thing happens if the rectifier is underloaded, as shown by the curves of the tests with the impressed voltage at 1000 volts. The rectifier was originally designed for 1500 volts and 150 milliamps, that is 50 volts per cell and 50 milliamps per square in. of active surface were allowed and the curves prove quite conclusively that these are about the best figures to use in designing a rectifier.

The curves show that neither greater or less than normal load should be used if any degree of efficiency is desired and they also show how poor the voltage regulation is for this type of rectifier. However the voltage regulation of nearly any other kind is just about as poor.

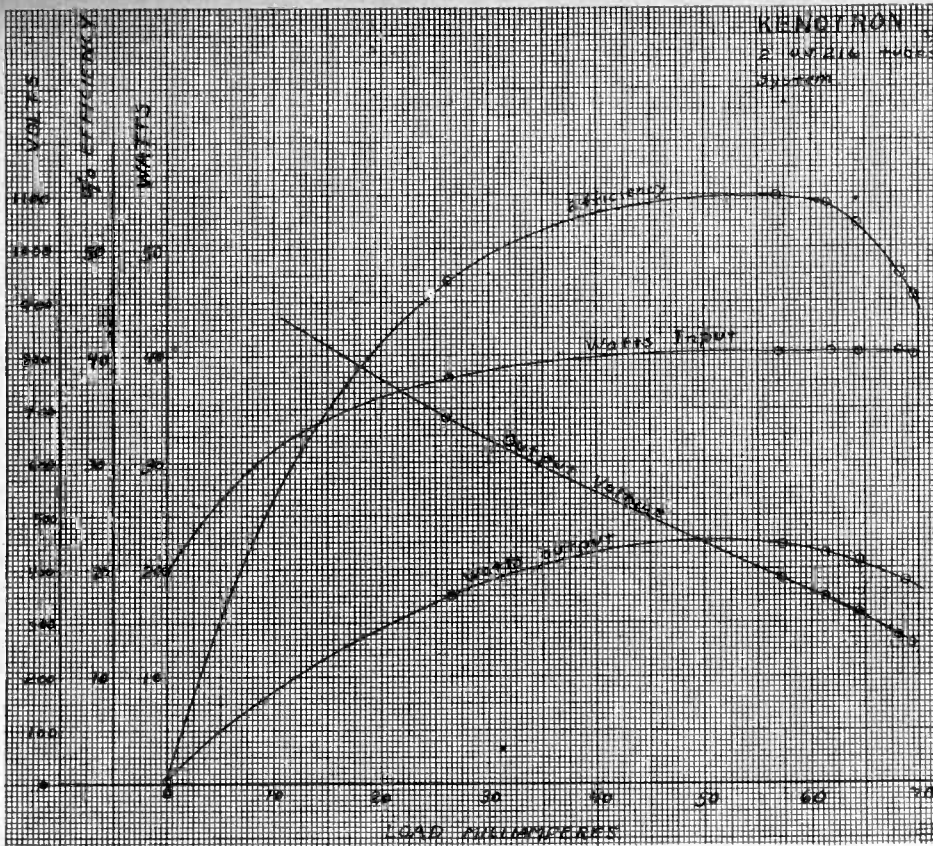

Performance Curves of Kenotron Rectifier. Center Tap System, Using Two UV-216 Tubes

A glance at the voltage curves helps explain a little of the distortion present in so many fone stations because any variation in plate current would change the point of operation on the voltage curve and so cause a greater or less change in the power output than there should be. This would not apply in the case of Heising modulation as that system is practically a constant current system. The use of a large bank of condensers would undoubtedly make the voltage regulation better and increase the output voltage here about 100 volts. However these load tests were run without any filter as it was thought that the characteristics of the rectifier could be better studied in that way.

The curves of watts output show that there is a maximum load which can be drawn from the rectifier and if any greater load current is drawn, the voltage drops so fast that the actual power output decreases. By using more surface of aluminum, this trouble can be cured.

The kenotron rectifier shows a much higher efficiency, reaching about 55 percent, but if the power consumed by the filaments had been taken into account,

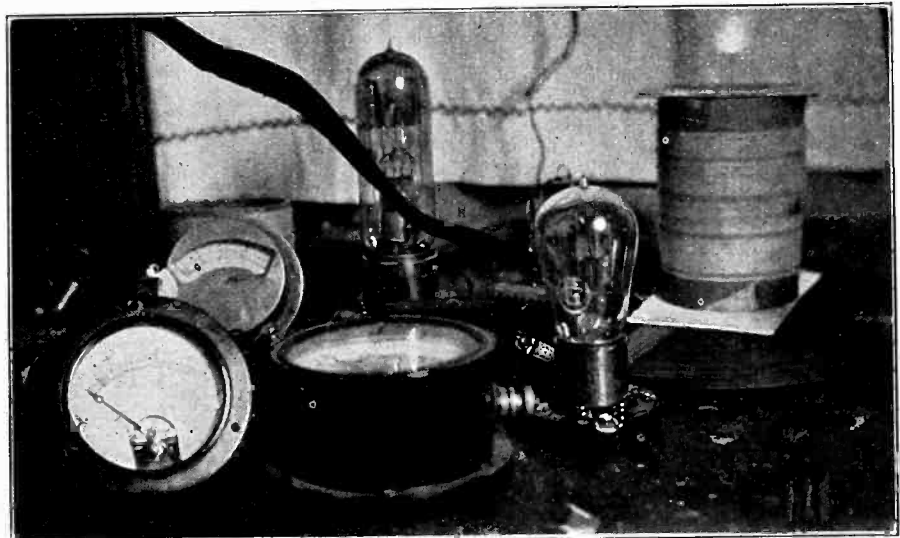

Set-Up for Moduloscope Observations

the efficiency would have been about the same as that of the electrolytic type. The maximum efficiency seems to occur at 32 wire on a 4 in. tube was used and a metal bearing compass needle with copper wire arms soldered on it were used

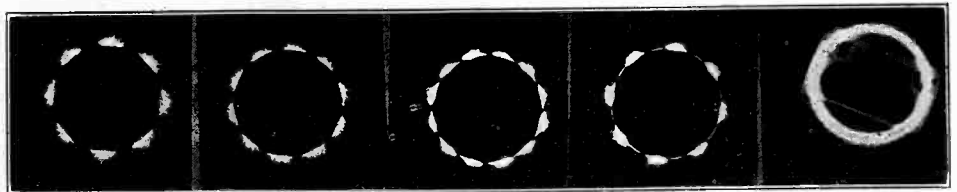

Spark Discharges Observed With Moduloscope

60 cycle A. C. without rectifier	1/2 wave rectified without filter.	Full wave rectified without filter.	1500 volts across one side and 1000 across other.	5 mfd. and 30 henrys in filter.
----------------------------------	------------------------------------	-------------------------------------	---	---------------------------------

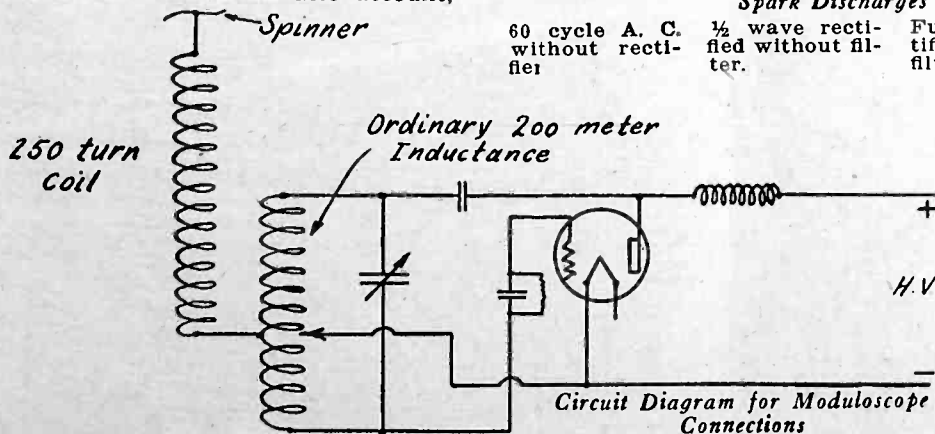

to complete the apparatus. By varying the primary condenser until resonance was reached, the spark discharge from the revolving ring can be so controlled that the dots can be held in one position. It only takes an hour or so to set up the apparatus and a great deal of pleasure can be derived from it in performing various experiments. The results of a few experiments tried out here are shown in the pictures of the spark discharges.

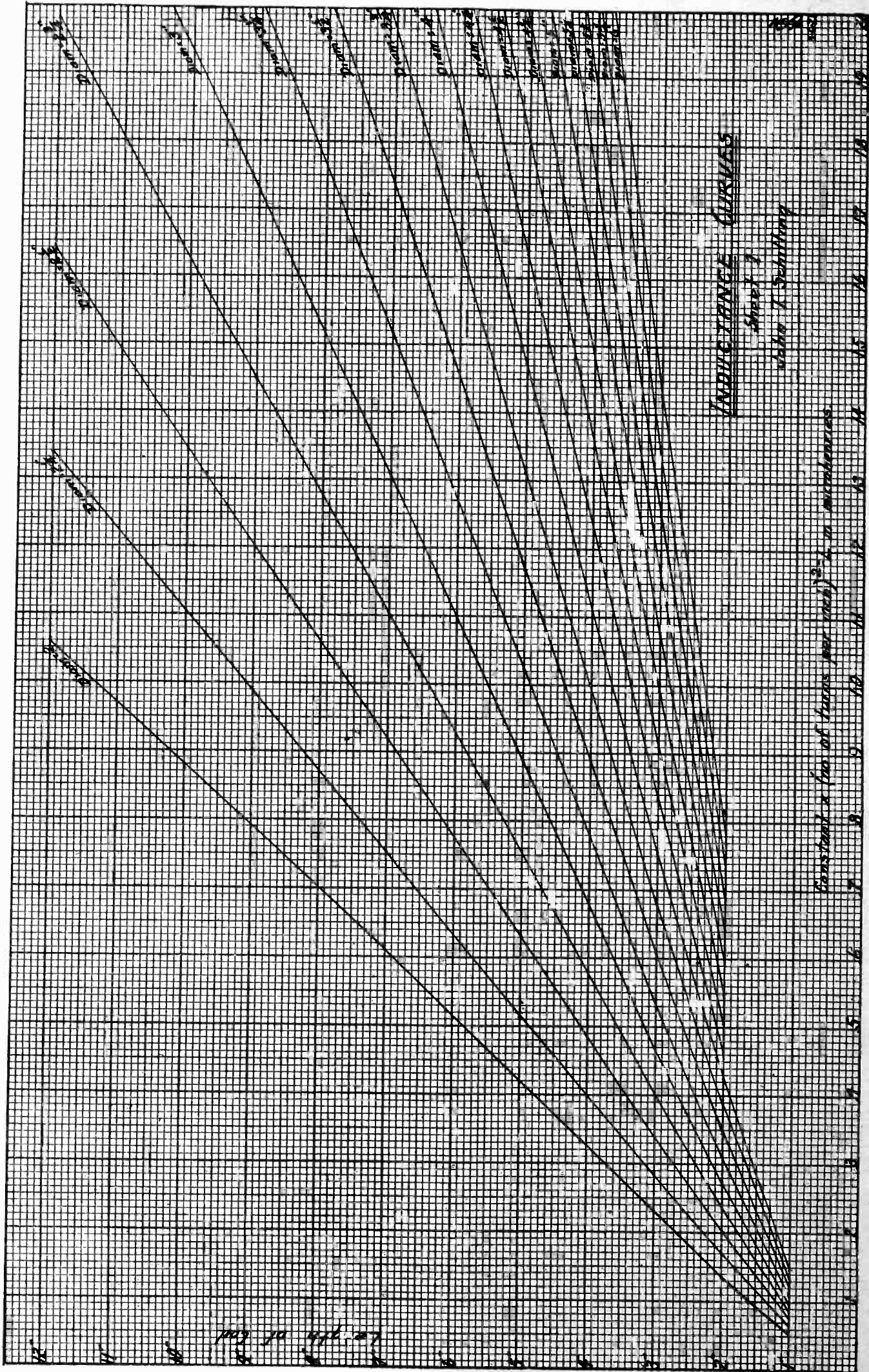

Chart for Calculating Inductance of Different Sized Coils
(Continued on page 36)

A Short Cut In Calculating Inductance

An Explanation of the Accompanying Charts of Values for Single Layer Coils

By E. M. Sargent

INDUCTANCE, capacity and resistance are the three basic factors that determine the properties of all radio frequency circuits. They are, therefore, the three factors with which the designer of a circuit is most concerned and in order to correctly design either a circuit or a piece of radio apparatus, it is necessary that all three of these factors be determined with reasonable accuracy.

The resistance can be found directly by referring to a standard wire table and multiplying the direct current resistance by a variable which is determined by the frequency at which the piece of apparatus or the circuit is to be operated.

The capacity of a circuit is a little harder to calculate but as the capacity is nearly always a known quantity on account of standard capacity units used, it does not trouble the designer nearly so much as inductance.

Inductance may be defined as the property of a coil to store electromagnetic energy. Its values for any coil depends on several things. The larger the diameter, the greater the number of turns, or the longer the coil, the greater its inductance will be. The ratio of the diameter to the length and the number of turns per inch also affect the value of inductance. It is not the purpose of this article to develop a formula for inductance. There are many of these which will fit the average coil used in a radio set and with which the inductance may be computed within an accuracy of about one per cent. However, all of the standard formulas are rather long and can be simplified so as to make the computation of inductance a very simple matter. The need for such a simple formula is shown in the examples given at the end of this article.

The simplest standard formula for inductance that fits radio coils of the shapes most used in present radio sets is as follows: $L = .000254n^2aK$, in which L equals the inductance in micro henries, n equals the total number of turns, a equals the radius of the coil in inches measured to the center of the wire, and K is a constant whose value depends on the shape of the coil. Values of K for different lengths and diameters are given in many text books.

This formula is a very good one and is fairly easy to use where n , a and K are known quantities and the inductance is unknown. But if the designer tries to use this formula to find the required number of turns for a coil of a given inductance, it becomes a rather compli-

WINDING DATA (Turns per Inch)					
Size B-S Gauge	Enam- eled	S.C.C.	D.C.C.	S.S.C.	D.S.C.
20	29	25	23	27	26
21	32	28	26	31	29
22	36	31	28	34	32
23	41	34	31	38	36
24	45	37	33	42	39
25	51	41	36	47	43
26	56	45	39	52	46
27	64	49	42	57	52
28	71	54	45	63	56
29	79	58	48	70	62
30	88	64	52	77	67
31	100	69	56	85	72
32	112	75	60	93	78
33	125	81	64	102	84
34	140	87	68	112	91
35	156	94	73	120	97
36	173	101	78	130	104
37	201	108	84	141	110
38	225	115	89	151	117
39	256	122	95	163	123
40	288	130	102	178	129

cated matter. By plotting a large number of curves, the formula can be so simplified that only a single calculation is required to find either the inductance, the number of turns, the length, or the diameter of a coil, the other three quantities being known.

In the formula shown above, n equals the total turns or the turns per inch times the length of the coil. Let n_1 stand for the number of turns per inch; then n equals n_1 times l , where l is the length of the coil in inches. When the size and shape of the coil remain the same, the inductance varies as the square of the number of turns. Therefore, L will vary as n_1^2 . Call L_1 the inductance of the coil when there is one turn to the inch. Then to get the inductance of the coil multiply L_1 by n_1^2 squared. n_1 is a quantity that is easily obtained from any standard wire table, such as that given in the accompanying table.

Referring again to the formula $L = .00254 n^2 a K$ and substituting we get $L = .00254 n_1^2 l^2 a K$ and $L_1 = .00254 l^2 a K$.

The formula is now in such shape that it can be plotted on graph paper as shown in Figs. 1 and 2. The length of the coil is plotted along the ordinate and L_1 the inductance for one turn per inch is plotted along the abscissa. A separate curve is plotted for each diameter. The shape of these curves is determined by the constant K which is called the form factor. K , as pointed out before, depends on the ratio of the diameter to the length of the coil. These curves cover nearly every size and shape of coil that is used in the ordinary radio set.

A few simple illustrations will quickly show the reader the advantage of these "short-cut" inductance curves. Assume that a coil is wound with No. 22 double cotton covered wire on a 3 in. tube. The length of the coil is 4 in. and the problem is to find the inductance. The table shows that No. 22 D.C.C. wire winds 28 turns to the inch. Next, find the curve in Fig. 1 that is marked 3 in. diameter, and find the point on this curve for a coil 4 in. long. Reading down from this point, L_1 is found to equal .68. The inductance of the coil is, therefore, .68 times 28², or 533.12 microhenries. Thus, it is seen that the calculation of inductance has been reduced almost to the simplicity of mental arithmetic.

Another example is as follows: Suppose that in designing a circuit, an inductance is needed that will have a value of 200 microhenries. The wire to be used is No. 24 D.S.S.C. The diameter of the coil is always either arbitrary or predetermined by known physical conditions. Assume that the diameter is to be 2 in. The problem is to find how many turns are to be wound on the 2 in. form to get an inductance of 200 microhenries and how long the resulting coil will be. Referring again to the wire table, it is found that No. 24 D.S.C. winds 39 turns to the inch. The square of 39 is 1521. Dividing the inductance, or 200 microhenries, by 1521, gives the value of L_1 equal to 0.13. Refer to Fig. 2 and read up from that value of L_1 to the curve, then over to the left to find the length of the coil. The length is about 1.95 in. Multiplying this length by the number of turns gives 76 as the number of turns that must be put on the coil.

A great deal of labor is necessary to plot these curves. The calculating has been very carefully done and by actual test these curves have shown themselves to be accurate within about one per cent. It is, of course, understood that they apply to single layer coils only.

JOAK are the call letters of the new radiocast station to be started by the Tokyo Radio Broadcasting Co., at Tokyo, Japan. This will be a 1500-watt station operating on 375 meters. Viscount Goto is the president of the company, and N. Shinuryo, who has resigned as director of the Tokyo central telegraph office, is to be the managing director. A similar station is to be installed at Osaka.

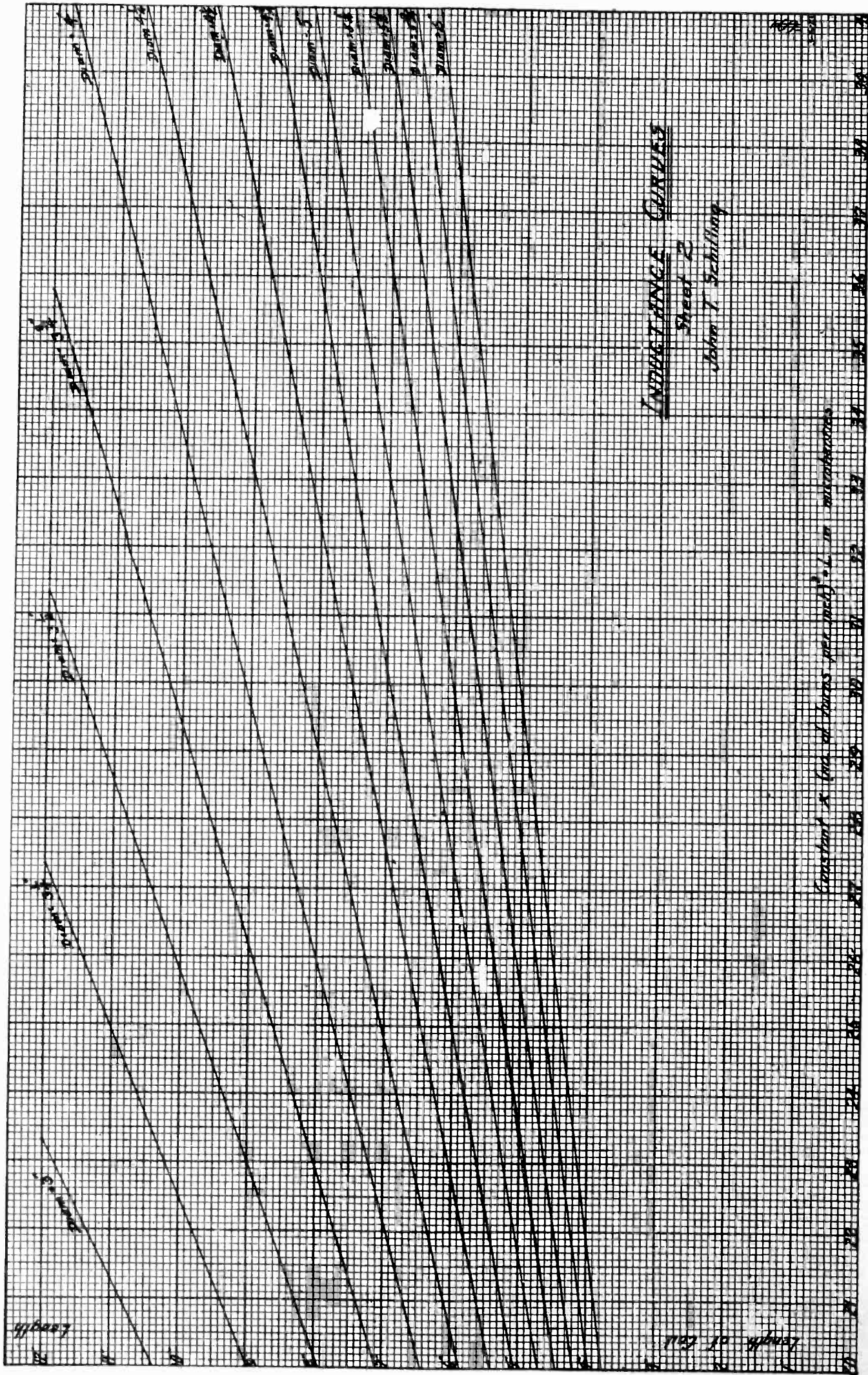

Chart for Calculating Inductance of Different Sized Coils
(Continued from page 34)

Harmonic Interference

An Interesting Explanation of Some Obscure Causes of Interference
for Which Amateurs are Sometimes Wrongly Accused

By D. B. McGown

HARMONIC interference, where-
in harmonics from transmitting
or receiving sets are found at fre-
quencies (wavelengths) far removed
from their proper or assigned place, is
one of the most subtle, troublesome, and
uncanny sources of radio disturbances.
A harmonic is a radiation of higher fre-
quency than the fundamental alternat-
ing current which may be produced by
an oscillating vacuum tube and its as-
sociated circuit constants. Harmonics
may be two, three, four or more times
the frequency of the original or funda-
mental wave and are usually of much
less intensity.

The radiation of harmonics is pro-
hibited in the case of a class B station,
special apparatus being installed in the
antenna circuit to prevent it. Many
class A and C stations have also made
efforts to eliminate harmonics. Conse-
quently the main source of trouble is
the radiating receiver, especially the old-
fashioned single circuit sets.

The ordinary regenerative set, includ-
ing the single circuit, may be tuned in
two ways: (1) By first tuning to the
signal, if it can be heard, and then in-
creasing the feed-back until the tube is
just ready to spill over into the oscillat-
ing state, but not allowing it to do so.
(2) By first letting the detector tube
oscillate and then tuning around until
the detector tube frequency heterodynes
or beats with the carrier of the distant
station, giving the familiar audio fre-
quency beat effect called blooping.

This latter method is emphatically the
wrong way to tune. Not only does it
produce the much discussed blooping
oscillations on the wave to which the
set is tuned, but it also causes radiation
of the harmonics of that wave or fre-
quency. While these harmonics are
weak they are capable of creating con-
siderable disturbance.

Suppose that the listener is interested
in receiving on a wavelength of about
450 meters, which is right in the mid-
dle of the radiocast band, and that he
is tuning around on this wavelength by
varying his condenser up and down with
the detector tube oscillating. Although
he is not aware of it, his detector tube
also sets up frequencies of much less mag-
nitude on 225 meters, 150 meters, and
quite possibly on 75 meters, 225 meters
being the second harmonic, 150 the third
harmonic, and 75 meters the sixth har-
monic. It will be seen that the second
harmonic of 225 meters is within the
Class A station wavelength band, and

the other two harmonics are right at the
bottom of two amateur bands. It is
within the bounds of possibility that
there will be stations operating within
a few miles of the receiving set, on each
of these wavelengths—or there might be
a very powerful station on 37.5 meters,
which would be on the 12th harmonic of
the oscillating detector in the listener's
set, which might be some distance away,
but with sufficient power to give a strong
signal on that wavelength. If it so
happened that there were such stations
operating within half mile from the re-
ceiving station, each and every one of
them would be audible on what appeared
to be 450 meters, and the average listener
would be almost certain that the inter-
fering stations were actually on that
wavelength. Possibly the number of
stations is somewhat exaggerated, but
the action as described is entirely within
the bounds of reasonable probability.

Other receiving sets are equally liable
to such interference, as the regenerative
set above described, but that set, for-
tunately, is seldom operated in the con-
dition of continuous oscillation. In fact,
the condition of oscillation is one that is
really undesirable, if for no other rea-
son than that it distorts the received
signal so that it is unrecognizable.

The superheterodyne is especially
troublesome in the production of un-
wanted signals, as it possesses a complete
oscillator, the continuous operation of
which is essential for the operation of
the receiver. For ordinary reception,
this oscillator covers a band from 200
to 600 meters. In some types, the fun-
damental frequency of the vacuum tube
is used to produce radio frequency beats
with the carrier of the incoming signal,
and in some other types the second har-
monic is used for this purpose. In either
of these systems, harmonics are present
in the oscillator as long as the latter is
kept in operation, their frequency being
determined by the frequency of the fun-
damental of the oscillator itself. For
example, if the oscillator is tuned to 200
meters, a harmonic is present at many
odd and even multiples of the fundamen-
tal frequency, which will give them at
100, 66.66, 50, 25, etc. meters. The
amplitude of the lesser wavelengths is
very small, comparatively, but they are
present, nevertheless. As the wavelength
of the oscillator is increased, the wave-
length of the respective harmonics of
course increases, also, and if the wave-
length is increased to the maximum,
which is say 600 meters, we will find

that the second harmonic which former-
ly was on 100 meters, is now on 300,
the third, which was on 66.66 meters,
is now on 200 meters, the fourth, which
was on 50 meters, is now on 150, and
the higher frequency harmonics follow
in the same order.

In the second harmonic oscillator sys-
tem, such as is used in some superhetro-
dynes, the second harmonic is utilized to
give the radio frequency beats. Never-
theless, the third, fourth, and other high-
er harmonics are often present, and may
cause trouble in some cases, by giving
signals where they are not wanted.

In all this discussion, the thought con-
stantly comes up, "How can these sig-
nals on other frequencies be heard, when
using a loop or a selective loose coupled
set which is tuned to the wavelength that
I wish to receive." Generally such inter-
ference cannot and will not take place.
The only condition where it can take
place is where a transmitting station is
close enough to the receiver to force the
antenna to oscillate at the wavelength of
the transmitting and interfering station.
As a general rule, however, such inter-
ference takes place only when the trans-
mitting station is comparatively close to
the receiver, although this will not hold
absolutely, as the writer has observed
serious interference on 320 meters caused
by the transmission of an amateur station
in Los Angeles, while the receiver used
was in San Francisco.

Again the old proposition of amateur
interference crops up, and the amateur
again looks like he was to be the victim,
although this time in a different way.
Formerly the chief complaint was from
listeners-in who were troubled either due
to their receivers tuning broadly, or else
to the spark and tube transmitters of
the amateurs actually interfering, due
to their broad waves. But in the case
of harmonic interference we have the
unique situation of a receiver, intended
for radiocast waves, reaching down into
the amateur bands, and plucking inter-
ference right out of these frequencies.

Thus if an amateur station is tuned
to its lawfully assigned frequency (wave-
length), say on 80 meters in the middle
of the 75 to 85 meter band, and using
a pure direct current source of plate
supply, free from key clicks, and other-
wise complying with every detail of the
law, the radiocast listener's receiver will
receive that amateur on 240 meters, 320
meters, 400 meters, 480 meters, and 560
meters, if there were any radiocasters on

(Continued on page 74)

A Transmitter That's Different

A New Idea in Antenna Tuning With Coupled Circuits

By F. Dawson Bliley, 8XC

AN apparently simple change may alter the whole operating characteristic of the transmitter. First using a series condenser to work below the antenna fundamental, then using the harmonic idea, and finally the following system which probably is no more original than the other two.

In order to fully understand this new method let us refer to the "Lecher wires" used to measure short wavelengths. The

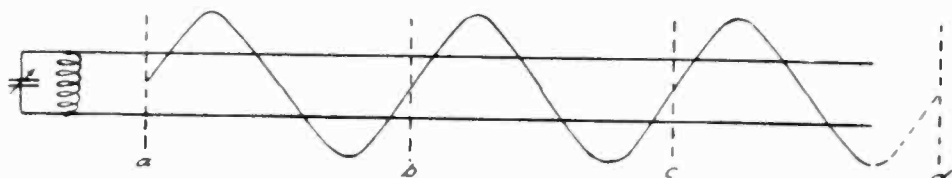

Fig. 1. Lecher Wires

wires are strung as in Fig. 1. In measuring the various wavelengths an ammeter or small bulb is inserted at any point along the wire (preferably at the furthest end) and the variable condenser across the tuning coil is changed until the current in the meter reads at a maximum.

This shows that the current may be found at any point along the wire; *i. e.*, the wires will oscillate at any frequency. In doing this the waves generated will not always come out at even fraction of the total wavelength of the whole "Lecher wires." This may easily be seen by again referring to Fig. 1 and noting the characteristic outlines of the current wave. You may have tried these wires yourself and, in doing so, have noted that each point of highest amperage is the same distance apart and that a length of the wire less than one of these distances was left over at the further end. This "end" wire is then not in use in reality, but the steady drop in current will be noticed starting from the last "hump."

This may very easily be applied to the transmitting antenna with no change other than the insertion of an antenna coil of the right size (about five turns). No variable condenser is necessary, thus simplifying the tuning. Fig. 2 illus-



Fig. 2. Antenna Oscillating Just Below the Fundamental

trates such an antenna oscillating just below the fundamental. This will not work out practically but is given only

as one of the numerous illustrations which could be drawn. It will be noted that from point *a* to the end of the antenna the wave is incomplete. This wave then either dies out or is completed by the aid of the wave between the two *a*'s. This same may be applied to antennas of greater fundamentals and greater frequencies.

This actually does not begin to work until the third harmonic is reached with

the oscillator. But from the third harmonic to infinity the antenna may be used as a radiator, paying no attention to the harmonics. The thing that would necessarily limit the size of the antenna would be the high frequency resistance involved. Very efficient antennas do not have high antenna current on the even harmonics (this will depend upon the position of the ammeter in the antenna system) below the third so that as we go down we strike the third with maximum current which gradually drops to a minimum at the fourth and again rises to the same maximum at the fifth, etc.

Various tests have been conducted with numerous stations, all over 400 miles, to ascertain the reliability of such a system. All reports showed that it mattered little whether the harmonics were used or not. Bad reports come only from stations at times when such

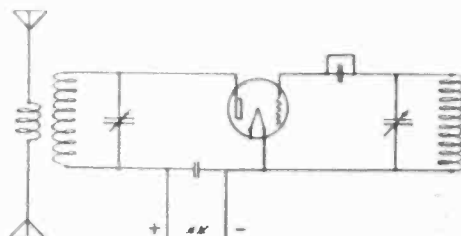

Fig. 3. Coupled Reversed Feed-back Circuit

reports would be expected—due to the various conditions of the atmosphere on waves below 50 meters.

Fig. 4 is a coupled Hartley which theoretically is similar to the coupled reversed feed-back of Fig. 3. This would make an excellent one-control transmitter for any of the amateur bands using the above method of antenna tuning. The variable condenser should be of the lowest loss obtainable. A 45-plate condenser cut down and triple spaced would be fine in such a case. This would make an excellent transmitter for QSY from QRM.

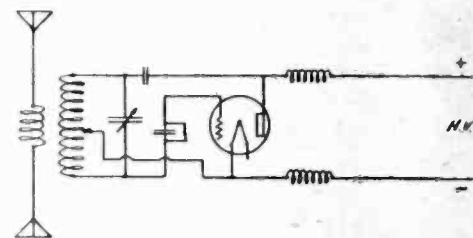

Fig. 4. Coupled Hartley Circuit

As the full description of these two transmitters (differing only in this method of antenna tuning) was given in January RADIO, it is not necessary to repeat any of the description. The radiating system used in these harmonic tests is simple. The antenna and counterpoise are both composed of two wires in a fan shape. The antenna is 20 ft. above the counterpoise and directly over it; not to one side.

Radiocasting in Sweden is done by the government whose Telegraph Administration has been operating temporary stations at Stockholm, Malmo and Gothenburg. A new station has just been erected at Boden, and another is to be installed at Sundewall. Licenses are required for all receiving sets, the fee for a private set being 12 kronen. A set may be inspected at any time by either the telegraph or military authorities. About 40,000 licenses have been issued.

Beam transmission is accomplished by using several aerials so placed that the phases of current in each cause reinforcement of radiation in one direction and more or less neutralization in all other directions. Less power is needed since all of it is utilized in sending waves in the desired direction instead of in all directions as in the usual method of transmission. The directivity holds for comparatively short distances but is effective in reducing interference from a transmitter.



QUERIES *and* REPLIES

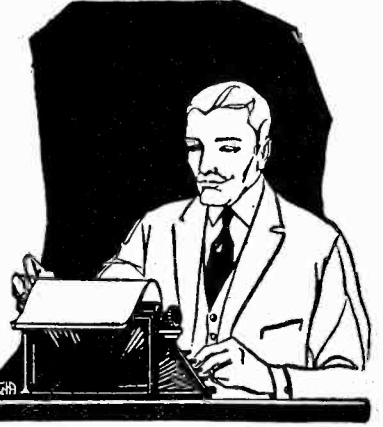

Questions submitted for answer in this department should be typewritten or in ink, written on one side of the paper. All answers of general interest will be published. Readers are invited to use this service without charge, except that 20c per question should be forwarded when personal answer by mail is wanted.

What is the new anti-radiation device recently brought out by Dr. DeForest, and will it be of any help with my single circuit tuner, which occasionally squeals while I am tuning in a station.—J. R. R., Trenton, N. J.

The device developed by Dr. DeForest consists of some additional apparatus of inexpensive nature which may be connected to the set so as to cut out practically all possibility of radiating energy into the air

the detector and the antenna, and hence no squeals will be heard in neighboring receivers. The radio frequency choke should have several taps, in order that the coil will be most efficient at the various radiocast wavelengths, since a value of inductance selected for the middle of the band would not be of much use at the extreme lower or upper ends of the bands. A good coil for the purpose would be one of 150 turns of No. 22 d. c. wire wound on a 3 in. tube, with taps at the 40th and 110th turns. Condenser *A* should not be over 15 or 20 micromicrofarads, and will probably be best

frequency signals to some extent, but the presence of the condenser *A* in the circuit produces enough loss to the signal to neutralize the gain of the audio tube, and the set will thus have approximately the same sensitivity as before the change was made.

Please publish the circuit diagram for a three coil honeycomb regenerative set suitable for use on the very short waves as well as the radiocast and long wave telegraph wavelengths.—F. La.B., Los Angeles, Calif.

A suitable circuit is shown in Fig. 2. For the very short waves, care should be taken to build an efficient set of coils. Little or no benefit will result from the use of a honeycomb winding of less than 25 turns, and it would be better to wind special coils having a wavelength range of 50 to 175 meters. As a suggestion, the three coils should be wound basket fashion, on a 4 in. diameter, and fastened to the honeycomb coil mounting plugs with tap or other non-metallic substance. The antenna coil should consist of 10 turns of No. 16 cotton covered wire, the secondary coil 15 turns of the same sized wire and the tickler coil may be the same as the secondary. For the other wavelengths the following table gives the approximate sizes of the coils to use. The primary coils may vary slightly depending upon the antenna used, and the tickler coil may have to be larger or smaller depending upon the excellence of the detector tube used.

Wavelength	Primary coil	Secondary coil	Tickler coil
200-350	25	35	25

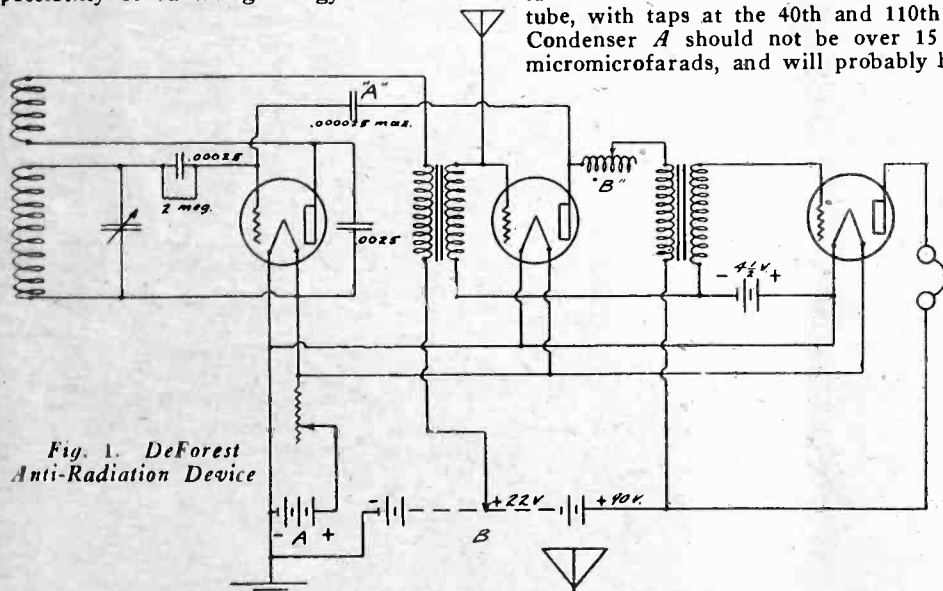
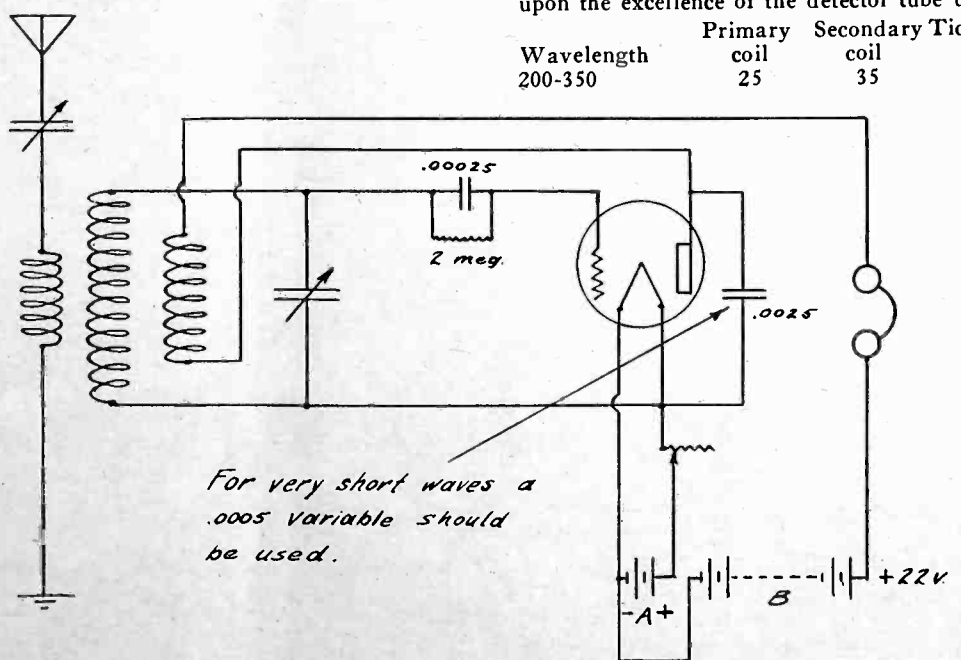

Fig. 1. DeForest Anti-Radiation Device

via the antenna. In Fig. 1 is shown an application of this device to a single circuit regenerative receiver with two stages of audio frequency amplification. The extra apparatus consists of a small condenser marked *A* in the diagram, and a choke coil *B*. Condenser *A* is connected between the plate of the first audio amplifier tube and the grid of the detector tube. Choke coil *B* is placed between the plate of the first audio amplifier tube and the primary of the audio frequency transformer. The antenna connection is removed from the tuned circuit and is connected to the grid of the first audio amplifier tube, the ground connection remaining the same as before the changes are made. The action of the anti-radiation device is somewhat like the action of the reflex circuit. The high frequency signal being received is impressed on the grid of the first audio amplifier tube, and is amplified by this tube. Being prevented from passing through the windings of the second audio transformer, by the presence of the radio frequency choke coil *B* in the circuit, the high frequency passes through condenser *A*, which is of very small capacity and reaches the grid of the detector tube. Since the capacity of condenser *A* is very small, any oscillation of the detector tube will find a very high resistance in the path between



For very short waves a .0005 variable should be used.

Fig. 2. Circuit Diagram of 3-coil All-wave Receiver

determined by adjustment. One of the mid-gage type condensers having a maximum capacity of .000025 mfd. will serve the purpose very satisfactorily. The audio frequency amplifier tube amplifies the radio

What changes should be made in the Best 45,000 cycle superheterodyne, in order to receive the Australian broadcast stations operating on a wavelength band of from 1000 to 2000 meters. Australian 2FC operates on 1100 meters, 6WF on 1250 meters and 3LL on 1720 meters, and I wish to work with these stations.—L.S.L., San Francisco, Calif.

The principal changes in the set would be a larger loop and a different oscillator-coupling coil. The loop, if made the same size as the one described in January, 1925 RADIO, should have 50 turns instead of 12 turns of wire, spaced a little closer together in order to prevent the loop from becoming clumsy. Taps could be provided in the loop to take care of the shorter wavelengths, but this is not an efficient method and it would be better to have another loop of 12 turns only, for the American radiocast band. The oscillator coil should consist of 200 turns of No. 26 single silk or cotton covered wire, wound on a 3 in. tube. The winding should be split into two sections of 100 turns each, and in order to get the windings into a small space, it would be best to employ the bank method of winding, with the bank three layers deep. The grid coupling coil should have 35 turns of No. 26 wire wound on a 1½ in. tube and placed within the oscillator coil, in a manner similar to the coil used for the 200-600 meter band. The two oscillator coils can then be mounted adjacent to each other inside the set, and when the change is to be made from short to long waves, small clips with flexible wires present an easy method of making the change without employing complicated switches.

Does the Improved 45,000 cycle superheterodyne receiver built according to the directions given in January RADIO whistle while tuning in the various stations?—L. M. C., Chico, Calif.

No whistle of any kind is heard when tuning in a station with the superheterodyne, if the set is functioning properly. If a whistle is heard, the feedback condenser has too much capacity in the circuit, and should be re-adjusted. If the set whistles with the condenser cut out of the circuit, the intermediate frequency amplifier is oscillating, probably due to coupling between stages. If the transformers are properly spaced as shown in the baseboard layout, this coupling effect will not occur.

Can you tell me the correct number of turns of wire for the tuned circuit of a 70 meter transmitter? Also the antenna dimensions, with counterpoise.—A. S. C., Honolulu, T. H.

The antenna coil should consist of 8 turns on a 5 in. diameter, the particular style of winding depending upon your other apparatus and your personal preference. The oscillator coil should consist of 15 turns on a 5 in. diameter, arranged for coupling with the antenna coil. A slanting L antenna, or a vertical cage having a length of not more than 60 ft., from the set to the far end of the antenna will give good results on waves below 100 meters. The vertical antenna is by all means the most desirable, where it is possible to erect a single mast 65 or 70 ft. high.

I have been unable to obtain No. 36 S.S. wire for the transformers described in the article on "Best's" 45,000 cycle superheterodyne. Will No. 36 D. S. C. wire do the work equally well? Would No. 24 iron wire be all right for the cores of the intermediate transformers?—H. S., Brocton, N. Y.

If you use No. 36 d.s.c. wire, reduce the number of turns on the secondary of the intermediate transformers to 1800 turns, and wind only 1350 turns on the secondary of the tuned transformer. The No. 24 wire will make a fairly good core, but better results can be obtained with small gauge wire where it is possible to obtain it.

Please publish a circuit diagram of Best's 45,000 cycle superheterodyne, with resistance coupled audio frequency stages instead of the two stage transformer coupled amplifier originally shown in the article.—S. N. P., Van Nuys, Calif.

Fig. 3 shows the circuit diagram of the second detector and three stages of resistance coupled audio frequency amplification. This circuit is almost identical with one published in RADIO a few months ago, and which brought forth considerable criticism from a well-known "resistor" manufacturer because of the use of C batteries and by-pass condensers. The combination of C batteries shown in Fig. 3 is the proper one to use if the amplifier is to function properly without overloading of the tubes with resultant distortion. The C battery is also very necessary in order to preserve the filament emission of the tubes, as the plate current will be much greater without the C battery, with consequent heavy drain on the B battery, and shorter tube life. The by-pass condenser is inexpensive insurance against howling due to defective cells in the dry cell B battery, but may be omitted without impairing the operation of the set if the batteries are known to be in good condition.



By SAGO, Biddle Arthurs, Jr., 3046 Centre Avenue, Pittsburgh, Pa.

1abt, 1kc, 1xam, (1xz), (4uk), 4sa, (4sl), 5ags, 5am, (6ek), 5ew, 5hu, (6qy), 5sd, 5zav, 6aad, 6adt, 6age, 6agl, 6ahp, 6alo, 6ao, 6apw, 6arb, 6ark, 6arx, 6awt, 6bdt, (6bge), (6bql), 6bqu, 6bw, 6cax, (6cfz), 6cni, 6css, (6cto), 6fh, 6im, 6kw, 6lj, 6ol, 6xad, 7gb, 7mf, 7oy, (9ahq), 9cee, 9cfl, (9cjl), Canadian—1ef, 2ax, 5gf, English—2kf. Confirmations sent on request. Will answer all QSL cards promptly.

By C. A. Weldenhammer, 12L-1AVW, 33 Washington Place, Bridgeport, Conn.

4bl, 4bq, 4bw, 4du, 4eg, 4eh, 4eq, 4fm, 4fs, 4je, 4jr, 4kk, 4kt, 4ku, 4ne, 4oa, 4rh, 4sa, 4sl, 4tj, 4tv, 4tw, 4ua, 4uk, 4wk, 4xe, 5aaq, 5ac, 5aex, 5ade, 5afu, 5agq, 5ahd, 5ahw, 5aj, 5aly, 5akp, 5akz, 5alj, 5ame, 5aot, 5apy, 5arj, 5ash, 5asj, 5atf, 5bj, 5ch, 5dm, 5el, 5ew, *5 hl*, 5ln, 5lg, 5lh, 5lu, 5nw, 5qy, 5rv, 5se, 5ty, 5uk, 5ur, 5vc, 5wo, 6aaq, 6ac, 6afg, 6afh, 6agk, 6aiv, 6akw, 6ame, 6anw, 6app, 6ase, 6awt, 6bad, 6ban, 6bdi, 6bgo, 6bhz, 6bjj, 6blw, 6bpf, 6bph, 6bra, 6bul, 6bur, 6coc, 6cej, 6cfs, 6cgo, 6chx, 6cig, 6cky, 6cnu, 6cso, 6css, 6csw, 6cwp, 6dr, 6fy, 6kr, 6ms, 6nx, 6of, 6oi, 6pl, 6ql, 6rr, 6rv, 6ul, 6ut, 6wp, 6wr, 6xby, 6zh, 6zx, 7abb, 7df, 7fq, 7gb, 7gj, 7lj, 7ku, 7lg, 7ls, 7ma, 7mx, 7uj, 7zq. Canadian: 4cr, 4dq, 5ba Mexican: 1aa, 1k, 1x. English: 2oo, 2jf, 2kw, 2kz, 2nb, 2od, 2sz, 2wd, 5ma, 5nn, 5pz, 5sz, 6gh, 6lj, 6nf. French: 8bf, 8go. Danish: 7ec. Italian: 1mt. Spanish: EAR6. Netherlands: OBA, ONL. Argentine: LOR. Costa Rica: SJ. Australian: 2bk, yag, 2yl. New Zealand: 2ac. Miscellaneous: PRA, WJL. WJS.

All cards QSL'ed. QRK my 5 watter—(20 watts input)?

By SCP, 233 East 11th St., Holland, Mich.

(6afg), (6agk), (6aji), (6ajq), (6akz), (6alw), 6amm, (6amo), 6anw, (6awp), 6ase, 6bez, (6blp), (6bjj), (6bjx), (6kbb), 6blh, 6bmw, (6bql), (6bqr), 6bul, (6bul), (6bur), (6cae), (6cet), 6chl, (6cig), (6cls), 6cnl, (6cqd), (6crr), (6crx), (6css), (6csw), (6cto), (6cva), (6cwp), (6xbn), (6ab), (6ea), (6eb), (6ew), 6gx, 6im, 6mh, (6ms), 6ne, 6of, (6oh), (6oi), (6pl), (6rn), (6rv), (6ts), 6vd, 6ut, 6wp, (7abb), 7afn, (7agf), (7aif), (7akk), (7av), (7bj), 7dd, (7df), (7fm), (7fq), (7fr), 7jf, (7jr), (7ku), (7lg), (7lr), (7mg), (7oo), 7ok, (7to), (7zq). Can. 4fv, (410), (5ba).

Always gld to qsl.

(Continued on Page 44)

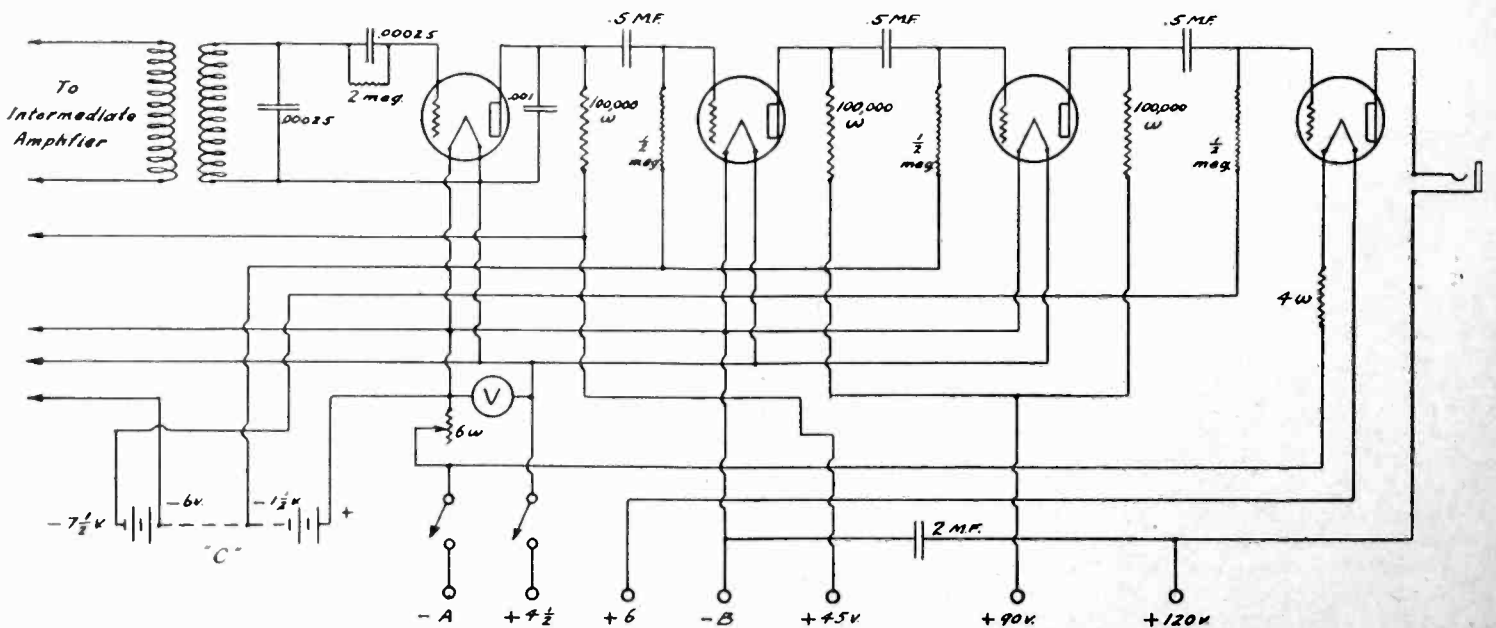

Fig. 3. Superheterodyne Second Detector With Three Stages of Resistance Coupled A. F. Amplification

With the Amateur Operators

6AWT WINS HOOVER CUP

The 1924 Hoover Cup, the highest honor in amateur radio, has been awarded to 6AWT, Bartholomew Molinari of San Francisco. This cup is annually awarded on the basis of the report of a special committee of the American Radio Relay League as to the best all-around amateur station, home designed and constructed.

6AWT has been unusually successful in working with foreign amateurs, signals having been reported heard in Asia, Australia, South Sea Islands, Europe, Africa, Central America and South America as well as in every district in the United States. The list

NEWS OF THE AMATEUR OPERATORS

U-6EA and U-6EB will greatly appreciate reports on their C W signals from any place in the world, including the United States, regardless of distance. Both have 250 watt stations and are on about 85 meters. Please send separate cards to each station giving time, date, etc. Address all communications to 343 South Fremont Avenue, Los Angeles, California, U. S. A. All reports acknowledged without fail.

8CFF, Kenneth Steele, Northumberland, Penna., requests reports on stations strength. 8CHS is a 5 watt set operated by the

will operate on 54-55 meters as well as on 20 and 40 meters.

William H. Slater, ex-2CHZ, died January 11th at Camp Vail, N. J., of pneumonia contracted during his duties with the U. S. signal corps. His well-known fist will be greatly missed as he frequently worked from coast to coast from his home at Port Jarvis, N. J.

Gettysburg College amateur station 3BHY under supervision by E. G. Ports, Instructor of Physics, was in operation during the period of the eclipse and noted the following: At about 8:45 a. m. EST, amateur phone stations from the West began to come through with fair audibility; as the sun became further covered by the moon's disk the signals increased very much in intensity. Several ninth district stations were worked on voice during this period and at the period of totality 9DG, Bellville, Ill., was worked. His signals came in as loud as at night and he in turn reporting 3BM as very loud and clear. As the moon's disk passed off the sun the signals again faded and by 9:12 a. m. EST, Bellville, Ill., had faded so completely that they could not be heard. However 9BSP of Olathe, Kansas continued to come in strong on fone until about 9:24 a. m. EST. The station is to be operated by members of the college radio club of whom several are licensed operators. Using 50 watts, 3BHY has been heard in 36 states, Cuba and Canada on voice.



Bartholomew Molinari, Winner of the 1924 Hoover Cup
Photo by S. F. Bulletin

of two-way workings with Australia and New Zealand has frequently been published in these columns. This station was one of seven selected by the ARRL to transmit press to WNP.

The transmitting equipment consists of one 250-watt tube in a coupled Hartley circuit with 2,000 volts on the plate. The aerial is a 90-ft. L cage.

Mr. Molinari's many friends are extending him their congratulations for the recognition of his industry and ability. He is a modest young man who has been patiently working his way up through the radio ranks for five years. During part of this time he was a student at the Polytechnic High School, but recently he has been assisting his father at his work during the day and spending almost the entire night at his transmitting set. He was only 15 years old when he made his first spark transmitter. Pacific Coast amateurs are particularly pleased with this outstanding recognition of one of their own number.

X. H. S. Radio Club of the Central High School at Xenia, Ohio. All cards answered.

1ZL-1AVW, C. A. Weidenhammer, 33 Washington Place, Bridgeport, Connecticut. A five watt tube is used with an input of from 16 to 20 watts on 75 meters. Reports from the West Coast appreciated and all cards QSL'ed.

Mark Spies of Decatur, Ill., and W. C. Fowler of St. Louis, Mo., worked nine hour watches for two nights in order to give telegraphic news service to the Decatur *Herald* when all telegraphic lines were down during a heavy snow storm in January, thus proving that the amateur is "there" for emergencies.

F. H. Schnell has been given leave of absence from his duties as A.R.R.L. traffic manager at Hartford, Conn. so that he may be with the Pacific fleet during its maneuvers from April 15th to October 1st. He will use a short wave, low power transmitter to communicate with the amateurs so as to compare its efficiency with the regulation high power navy sets. His call is NRRL and he

DX AT 6XAD-6ZW

What with having been in the East for a month and a half, and then, upon returning to Catalina Island, to find that our wonderful fishing is beginning much earlier than usual—both of these situations have kept me off the air, with the exception of a few especially tempting early mornings. The following is the DX list from January 23rd to March 1st. STATIONS WORKED: 1bfl, 1ii, 1ber, 1acb, 1se, 1bes, 1yb, 1wl, 1zt, 2le, 2kx, 2brb, 3czz, 2cxy, 2cpa, 2anm, 2gl, 3aih, 3bwj, 3ou, 3adq, 3lw, 4fv, c4eo, 5agy, 5ox, 5ls, 5aky, c5an, 5acz, 5ajn (reaches me QSA from Little Rock, Ark., with .1 in the antenna!) 5aqy, 7qd, 7mx, 8adg, 8jq, 8bpl, 8dse, 8dmf, 9dqy, 9dga, 9bdz, 9akn, 9ccx, 9bib, 9dyt, 9no, 9dng, 9sr.

And the usual long list of stations reporting my signals. I am very grateful to their owners. Only lack of time and space prevents my giving a more detailed list. My wavelengths are now 68 meters—on the 500-watt WE set. 78 meters on the 250-watt—also WE. I have not decided what the QRH of the 3KW Western Electric tube will be. Shall report on this matter in the May issue.

NEW DAYLIGHT RADIO TESTS SUCCESSFUL

Further demonstration that short waves are not greatly affected by daylight conditions is offered in the feat of John L. Reinartz, inventor and widely known in amateur radio, in transmitting signals from his estate at South Manchester, Conn., to Wickford, Essex, England, in broad daylight. The American Radio Relay League has verified reports that the American amateur's signals were picked up by F. A. Mayer, an English amateur. In his test Reinartz used a wavelength of 21 meters. Reinartz recently transmitted signals to Berkeley, Calif. in broad daylight.

FROM THE RADIO MANUFACTURERS

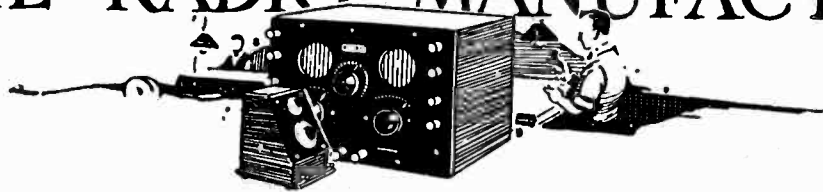

The Klc-O "B" multi-power unit combines a high voltage storage B battery and charger in one unit. The battery is of the nickel-zinc alkaline type and has sufficient

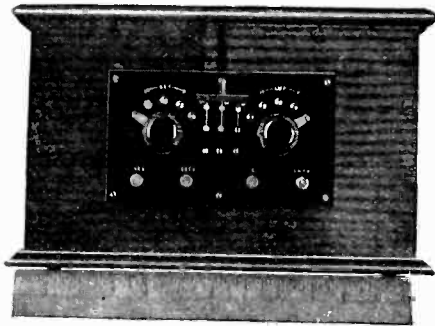

capacity to supply the plate current drain of multi-tube neutrodyne and superheterodyne sets. It delivers current without any chance of a.c. "hum".

The C & C Reachit wrench is designed to pick up and hold a nut while placing it on a screw to tighten it in place, and to reach hard-to-get-at places. Its long, hard-



ened, sliding jaws take hex nuts from size 4 to 10, three sizes of round nuts, as well as machine and wood screws.

The Kellogg low-loss condenser, No. 704, is a .0005 mfd. 23-plate unit built in a novel manner. The stator plates are firmly held at the bottom by two small hard rubber strips in the center of a strong U frame. The rotor shaft is fitted across the top of the U and can be readily removed for cleaning without removing the condenser from the

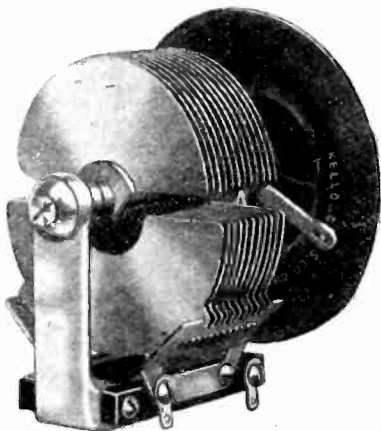

panel. The rotor is grounded to prevent body capacity effects and the bearings are adjustable so as to vary plate spacing. The positive spring connection across the bearing gives four contact points. It is easy to mount on either panel or baseboard. It has a unique vernier dial adjustment which does not affect the general tuning of the condenser. It has a low minimum and correct maximum capacity with a straight line calibration curve.

The General Instrument low-loss r. f. transformer has been designed to have a very low high frequency resistance, a very low distributed capacity, and a very high

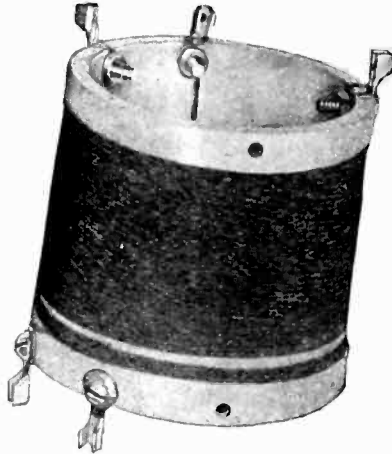

co-efficient of coupling so as to produce a concentrated field with a minimum external field. It is wound with green silk covered "Litz" on an Isolantite form which gives great mechanical strength without sacrifice of electrical efficiency. Both the primary and secondary are periodic at radio frequencies, an ideal condition. The connections are brought to soft copper lugs and means are provided for mounting the transformer to the back of the condenser.

The Andrews Paddle-Wheel inductance is a new form of coil whose compact spiral winding enables the use of large wire and gives a low resistance and a high inductance,

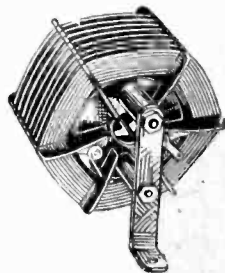

insuring maximum amplification and minimum distortion. Its construction is designed to give a minimum of absorption and eddy current losses. It can be used in any hook-up when a r. f. transformer inductance is required. It tunes from 200 to 600 meters with a .00025 mfd. variable condenser.

The new C-H toggle battery switch has a large wiping contact, positive make-and-break mechanism, wide-spaced terminals, and an attractive appearance which



admirably fit it for the control of A battery circuits. It can be easily mounted on a panel without screws or measurements. A flip of the finger turns the current on or off.

The Remo trumpet, "the wonder loud speaker," has been designed to reproduce radio programs with good volume, uniform



tone value, and clarity. It is small and compact and has an Adam mahogany finish. With its adjustable control it is available either as a phonograph unit, as a trumpet, or a cabinet type of speaker.

The Ampl-Tone headset consists of two balanced 1100 ohm phones with 6 ft., 24-strand cords, polarity indicated. It has a



lightweight head band and comfortable ear-caps. The coils are wound with No. 40 wire on special alloy magnet cores.

Errata Notice:—The Bestone V60, in a recent advertisement of Henry Heyman & Co. in these columns was announced as the Bestone, V\$60, a mistake causing many readers to try to buy the set for \$60, although the prices were stated at the bottom of the advertisement.

You can save about \$60.00 on your radio if you will put a Model "S" Acmeflex Kitset together

Like earning \$60.00 cash for a few hours' fun

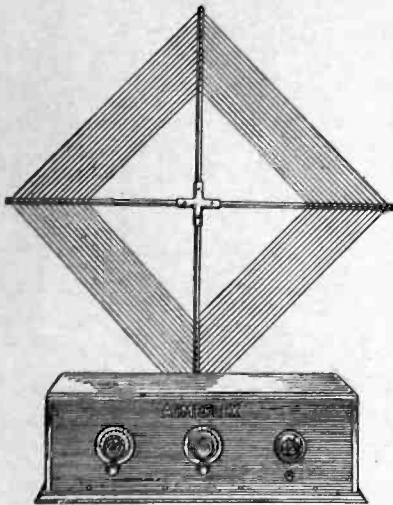

A set anyone can put together and enjoy all-the-year-round radio

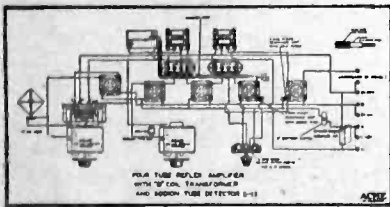

Wiring diagram new Model "S" Acmeflex Kitset

THE radio fan will especially notice the use in the new Model "S" of the D-Coil radio frequency tuning unit and the vacuum tube detector, which together wonderfully improve distance, reception, and selectivity.

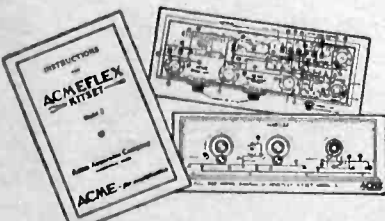

Directions given so simply that anyone can follow them

ABOVE are illustrated the circular of printed instructions and the life-size diagrams of the wiring, which are packed with each Model "S" Kitset. Step by step the making of the set is described in clear, simple language—just simple operations which anyone can easily follow.

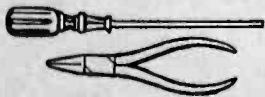

ONLY two tools required—a screw driver and pliers—and they are included in the Kit.

Enthusiastic praise from Model "S" user

From New York City: "Well, I believe we had every jerkwater station in the U. S. Stations I never heard of before. At 11:45 P. M. I pulled in KFI (Los Angeles, Calif.) on the loudspeaker. At 12:15 A. M. KGO (Oakland, Calif.). I went back and picked up KFI three times. My home is located in what is considered one of the worst sections for radio. The skyline of New York is directly opposite me. I am on the harbor, a mile from the Navy Yard, and have three bridges with electric trains to bother me, but with it all I got the coast. Forgot to mention that two locals were on—WHN and WJZ; some selectivity."

The wonderful new Model "S" Acmeflex Kitset would cost you if assembled complete in our factory, \$150.00. But it costs you only \$80.00 (plus a small cost for a cabinet) if you put it together yourself. You can easily do it. We give complete directions. You save about \$60.00.

THE perfection by Acme engineers of the new model "S" Acmeflex Kitset not only makes it possible for you to get a \$150 worth of radio for only \$80 (plus a cabinet), but it also places in your home the famous Acme 4-tube Reflex (trade mark) now wonderfully improved through the combined use of a D-Coil radio frequency tuning unit and a Sodian S-13 Detector Tube. You get greater distance, greater selectivity and better reception. We could make it for less than \$80, but it would not give results.

Content of Kitset is complete ALL the parts necessary for making the complete set are included in the Kitset. Even the loop is included. There is no antenna to erect. Each part is packed carefully in its own carton and not thrown in a jumbled heap. Each part is fresh, bright, new and well made. Screws, nuts and bolts are in a box of their own. Everything is included; nothing forgotten. The only accessories to get are the tubes, batteries, loud speaker and cabinet. We have put every thing in the kit but the fun.

No technical knowledge or workshop necessary You do not have to be a radio engineer in order to put this set together. Anybody can do it. Many have done it easily in three hours—had the set complete and working all in one evening. Only two tools are needed, a screw-driver and a pair of special Acme pliers and they are included in the kit. Good tools which you can use afterwards for other things. The panel is all drilled for you, and no soldering is necessary. If you do not want to assemble the set yourself, there are plenty of amateurs and dealers glad to do it for you at a nominal charge, still saving you a lot of money.

Send coupon now and start putting this wonderful set together

JUST tear out the coupon below; write your name and address on it plainly, mail it to us, and we will send you by return mail a special circular completely describing this set in every detail. Send coupon today.

Complete printed directions and diagrams WITH each Kitset are included complete printed directions, telling you just how to put the set together, step by step; just simple operations that anyone can easily follow and have a good time doing it. In addition to these printed directions are two life-size printed diagrams, one giving the wiring diagram for the set both from the baseboard view and the panel view, and the other showing, in actual size, exactly how every wire in the set is bent and connected.

More, tube for tube than any other set THE finished Model "S" Acmeflex Kitset, a Reflex (trade mark) set, gives two stages of radio frequency amplification, two stages of audio frequency amplification plus a D-Coil radio frequency tuning unit and detector, with only five tubes.

The new Model "S" Acmeflex Kitset will pull in more stations, louder and clearer, on a loop and loud speaker, than any other set using the same number of tubes (five), and more than many sets using from six to eight tubes. It is easy to tune. There is only one tuning dial.

Everything on loudspeaker

THE selectivity, range and volume of this set make it remarkable for loud, clear reception of stations near and far. The pleasure and the joy of it can be yours at a price only a little more than half what it would cost you to buy the set complete. Anyone can now sit down and put together a set that will perform on a plane with the highest-priced factory-made receivers.

ACME APPARATUS COMPANY

Transformer and Radio Engineers and Manufacturers

Dept. D3

Cambridge, Mass.

Send this coupon

ACME APPARATUS CO., Dept. D3, Cambridge, Mass. Send complete information about the new Model "S" Acmeflex Kitset to

Name

Street

City..... State.....

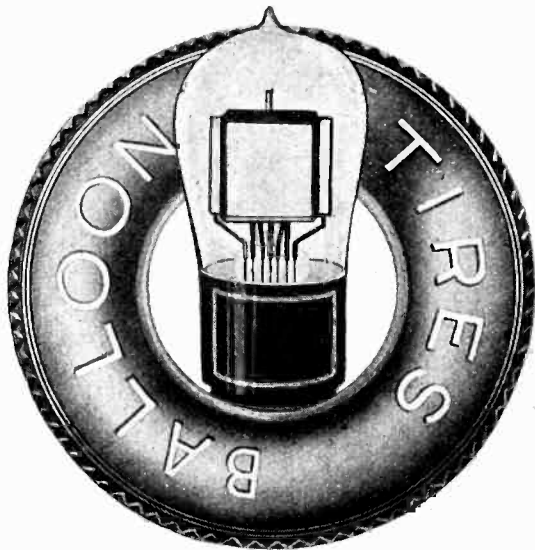

Balloon Tires for Your Tubes!

Delicately adjusted springs, at the base of a Benjamin Cle-Ra-Tone Socket, do the same for the radio tube that balloon tires do for the automobile—absorb jars and shocks.

Outside rumbling traffic, inside footsteps, mechanical and human activities amazingly vibrate floors of buildings—as finely adjusted scientific instruments have proved. This comparatively small shaking of the tube develops a very perceptible noise in the filament, and very often breaks this hair-like wire when it is cold.

Benjamin Cle-Ra-Tone Sockets “float” above their base and the tube filament escapes this ever present trembling. More sensitive experiments are thus possible and distant, faint signals come in much clearer. Stiff bus wiring does not affect the flexibility of Cle-Ra-Tone Sockets. They are adaptable to every hook-up and especially desirable in portable sets. There are no rubber parts to deteriorate. Bakelite is used wherever possible to insure sturdiness, long life and high dielectric insulation. Contact points to tube terminals are perfect and permanent. Terminal lugs for soldering. Made in two sizes: standard base, and a base for tubes similar in terminals to the UV-199.

Spring Suspended—Shock Absorbing

Accepted by Leading Manufacturers and Radio Engineers

BENJAMIN

Benjamin Electric Mfg. Co.

120-128 So. Sangamon St. Chicago
247 W. 17th Street New York
448 Bryant Street San Francisco

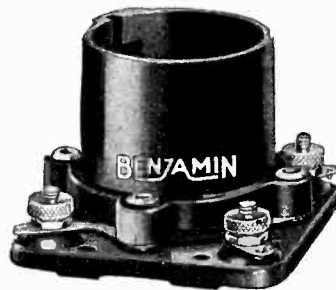

CARTER New LOOP Aerial



Greater Volume
Longer Distance
and
Far More
Selectivity

The new Compound Pentagon winding eliminates the framework and resultant losses. It gives maximum inductance without increasing the distributed capacity. Only 18" in diameter.

Go to your dealer and see this new Carter product. Any dealer can show you

Coast Distributors
ATLANTIC-PACIFIC
AGENCIES
CORPORATION
204 Rialto Building
San Francisco, California



In Canada, Carter Radio Co., Limited, Toronto

Send for Trial Subscription—\$1.00 for Six Months

CALLS HEARD

(Continued from page 40)

By E. W. Thatcher, N7E-8GX, Oberlin College, Ohio

Bermuda: B3ad. Canada: (C5an), C5ba, C5cn, (C5gt). France: F8bo, F8sac. Finland: Fn, 3gb, (?). England: g2vb, g2kf, g2kz, g2nm, g2od, g2sz, g2yt, g5nn, g5lf, g6nf. Holland: N Onl. Mexico: (mlaa), mlaf, maai, mlk, (min), (mix), mbx. Porto Rico: 4sa, (4oi), Cuba: q21c, q2mk. New Zealand: Z2ac, Z4ak. South America: WJS. U. S. A.: 6aao, 6ac, 6acl, 6adt, (6afg), 6age, (6agk), 6aha, (6ahp), 6aib, (6aiq), (6aiv), (6ajh), (6aji), 6akw, 6akz, 6alf, 6alk, (6ame), 6amo, 6api, 6apw, (6aqd), 6arb, (6arx), (6ase), 6ats, (6awt), 6bau, 6bb, (6bdt), (6bge), (6bhx), (6bjj), (6bjx), (6blw), 6bni, 6bnu, 6bny, (6bph), (6bqr), 6bqu, 6bur, 6bve, 6bvg, 6cae, 6caj, 6cah, 6cbb, 6gg, (6cgc), (6cgo), 6cgw, 6cek, (6cej), 6cfe, 6chl, (6cix), 6civ, (6ckw), 6cla, (6cmi), (6cni), 6cqe, 6crx, 6cso, (6cso), (6css), 6csw, (6cto), 6cve, 6cva, 6cvm, 6cvx, 6cw, 6ea, (6eb), 6gc, (6gt), (6ih), 6iq, 6ne, 6nn, 6nx, (6of), (6oi), (6ol), 6pl, 6pw, 6rn, (6rm), (6ts), 6ui, 6ut, 6ve, 6vo, 6xi, 6xo, (6zh), (6zp), 7abb, (7afn), 7afo, 7agl, 7aha, 7ahl, 7ajl, (7bj), 7dj, (7fq), (7gb), 7gr, 7ij, 7ix, 7iy, (7ku), (7lq), 7ls, (7mf), 7mp, (7nx), 7ot, 7qd, 7ry, (7sp), 7sf, 7th, (7zm).

Daylight: (6ame), (6ase), (6oi), 7qd, 7abb.

How about your New Mexico, Nevada, and Idaho stations. Let's QSO. Lack those three of making it 48 straight! Will QSL all cards. Thankz vy—"GX."

By John H. P. Andrews, Lake and Bellona Avenues, Govans, Balto, Md.

6afg, 6agk, 6ahp, 6alw, 6ame, 6awt, 6bir, 6blh, 6boq, 6bph, 6bqr, 6bra, 6bur, 6cbb, 6cct, 6cej, 6chl, 6cmg, 6cmu, 6crx, 6css, 6cwi, 6czx, 6eb, 6kb, 6pl, 6rv, 6zh, 6zp, 7afo, 7mf, 7mp. Can.: 5ba. Foreign: g2jf, g2kf, g2lz, g2nb, g2nl, g2nm, g2od, g2om, g2sh, g2sz, g5nn, g5uo, g6nf, g6vp, f8cz, f8gk, f8gl, f8sm, q2mk, zero re, sj.

By 9BJL, Denver, Colo.

CW—all on 80 meter band—1abf, 1ad, 1acb, 1aea, (1af), 1agg, 1aid, (1ajo), (1all), 1arm, 1ary, 1axl, 1axn, 1axz, 1bdx, 1bqk, 1bvl, 1cab, (1cav), 1ckp, 1cme, 1cmp, 1gs, 1il, 1my, 1ow, 1qm, (1qv), 1rd, 1sf, (1ve), 1xm, 1xu, (1xw), 1yd, 1zs, (1zt), 2aan, 2aco, 2acs, (2axf), 2bbn, (2bgi), 2bn, 2bqb, 2bqu, 2br, 2brc, 2bse, 2byh, 2cei, 2cgl, 2cjl, 2cjk, 2cpa, 2cpk, 2csl, 2cst, 2cty, 2cvf, 2cvj, 2cwj, 2cxe, 2gk, 2ha, 2hx, 2ke, 2kf, 2kx, (2le), 2mc, 2mk, (2mu), 2rb, 2xq, 3add, 3adp, 3adq, (3adt), (3adv), 3ajd, 3aoj, 3aol, (3ava), 3awa, 3bg, (3bjp), 3blp, 3bmn, 3bnu, 3bob, 3bor, 3bwj, 3ca, (3cb), 3cc, 3cdg, 3cdn, 3che, 3dj, 3hj, 3lg, 3mf, 3oq, 3ou, 3qv, 3sm, 3tf, 4ai, 4bl, (4bq), 4du, 4eh, 4eq, 4ft, 4fz, 4gw, 4hw, 4ja, 4mb, 4mi, 4pd, 4rm, (4sl), 4tv, (4tw), 4ua, 4wa, (8aa), 8add, (8app), (8apr), 8aol, 8aow, 8atp, 8aul, 8arb, 8awq, 8baj, 8bau, 8bav, 8bbw, 8bbf, 8bce, (8bdk), 8bdd, 8ben, 8blb, 8bhj, 8bp, 8bpl, 8byn, (8ced), 8cei, 8cdt, 8euk, 8enl, 8cvf, 8cvh, 8cta, 8cyl, 8dal, 8dan, 8dag, 8ded, 8df, 8dgp, 8dhs, (8dhw), 8dif, 8djb, 8dkl, 8dma, 8dnf, 8dnv, 8do, 8dse, 8ef, (8fn), 8fy, 8kh, (8pl), 8tr, 8tt, 8xs, 8zah, 8ze. Can.: 1ar, 3ni, 4ch, 4dq, 4fv. Mex.: 1x, 1b 1aa. N. Z.: 2ac. Aust.: 2bk, 2yg, (2yi), (3bd).

By 8DCF, 31 Kingsville Ave., Ashtabula, Ohio

1aao, 1ajx, 1ana, (1ary), 1atj, 1avr, 1aww, 1azr, (1cl), 1crd, (4lw), 4kl, 4sh, 4ua, 4ux, 5aaq, (5acl), 5gq, 5aiy, 5asb, 5bj, 5cn, 5dl, 5in, 5ll, 5mz, (5ov), 5qj, 5sp, (5wo), 6aao, 6afg, 6afz, 6bur, 6cbb, 6cto, 6ea, 6pl, 7fq, 9aer, 9akd, 9amx, 9aqf, 9axs, 9blk, 9bmv, (9bnf), 9bwb, 9byv, (9bzk), (9cyr), 9cyz, 9dbz, 9ddk, 9dge, 9dix, (9djs), (9dmj), 9dmz, (9dvw), 9eak, (9er), 9es, 9of, 9qx, 9vc. Can.: c2ax, (c2be), c2cg, (c3kq), (c3gq), c3tf, c3xi.

By 6ALV, Alameda, Calif.

1aao, (1af), 1abs, 1alm, 1ajx, 1bcr, 1ban, 1bfl, 1eme, 1or, 1wl, 1xae, 2abt, 2bqb, 2bqt, 2btu, 2cvj, 2cwo, 2xq, (2czr), 3bgl, 3bwj, 3eh, 3hs, (3kq), 3sm, 3te, 3xi, 3xm, 4eg, 4fm, 4xe, (5's, 6's, 7's too numerous), 8ah, 8apr, 8avd, 8bau, 8bz, 8cbp, 8cdt, 8euk, 8gh, 8gz, 8fm, (too many 9's). N. Z.: (1ao), 2ac, 2ae, 2ap, 4ag, 4ap. Australia: 2bk, (2yg), (2yi), (3bd), (3bq). Mexico: bx, 1aa. Holland: zero nl. Canadian: 4dq, (5ef), nqg, nkf, fnv?? QRA?

By Raymond Oswald, 1646 W. 101st St., Chicago, Illinois

2bbx, 2ctf, 2apa, 3ccu, 3wb, 4dv, 5agn, 5aiy, 5an, 5anl, 5apl, 5ek, 5fs, 5ms, 6afh, 8ahm, 8ak, 8ard, 8ase, 8bja, 8bmg, 8bni, 8bxt, 8cab, 8cas, 8ckf, 8cqv, 8dmq, 8jz, 8na, 9add, 9agl, 9hbh, 9bhx, 9bkb, 9bvn, 9bvw, 9cfo, 9ckt, 9cyp, 9ctd, 9cyk, 9cyy, 9dnp, 9dpu, 9drw, 9dsr, 9efd, 9fg, 9h, 9hp, 9iz, 9jh, 9ry, 9su, 9tg. Canadian: 9bj.

(Continued on page 46)

Prest-O-Lite

RADIO CHART

Voltage of Tubes	No. of Tubes	Type of Tubes (see foot-note)	Total Ampere Drain	Recommended Prest-O-Lite "A" Batteries	
				Order by following Types	Days between Chargeings
5-Volt Tubes C-300 and UV-200 are interchangeable C-301A, DV-2 and UV-201A are interchangeable	1	UV-200	1	69 WHR	22
				67 WHR	16
	2	UV-201A	1/2	67 WHR	33
	2	1 UV-200 1 UV-201A	3/4	611 WHR	22
				69 WHR	17
	3	UV-201A	3/4	69 WHR	29
				67 WHR	22
	3	1 UV-200 2 UV-201A	1 1/2	611 WHR	21
				69 WHR	14
	4	UV-201A	1	69 WHR	22
				67 WHR	16
	4	1 UV-200 3 UV-201A	1 3/4	613 RHR	22
				611 WHR	15
	5	UV-201A	1 1/4	611 WHR	22
				69 WHR	17
	5	1 UV-200 4 UV-201A	2	611 RHR	19
			611 WHR	13	
6	UV-201A	1 1/2	611 RHR	21	
			69 WHR	14	
8	UV-201A	2	69 KPR	21	
			67 KPR	15	
For sets using current at a rate higher than 2 amperes.			3 3/4	69 KHL	22
			3 3/4	67 KPR	15
			3 3/4	69 KHL	19
			3 3/4	69 KPR	16

Copyright, 1939
The Prest-O-Lite Co., Inc.

69 KPR
"A" BATTERY



23 MRR
TWIN
"A" BATTERY



46 LRR
"B" BATTERY



Write today for
this free booklet

Whether you have a one-tube set or most advanced multi-tube outfit, you'll find a fund of interesting information in our booklet, "How to fit a storage battery to your set—and how to charge it."

This booklet gives you the complete Prest-O-Lite Radio Chart—technically accurate recommendations covering both "A" and "B" storage batteries for every type of set.

In addition, there is much vitally important data on battery care and upkeep—information that any radio fan will find of real value in keeping his set at its maximum efficiency. Write for your copy right now.

How to select batteries that run your set for weeks without recharging

WHY select storage batteries by guesswork and risk getting one that requires charging every few days? Buy wisely. Let the Prest-O-Lite Radio Chart guarantee you batteries that fit your set—of ample capacity to bring weeks of fine reception without too frequent recharging.

The above section of the master chart selects Prest-O-Lite "A" Batteries to fit all 5-volt sets. It recommends two sizes for each set, depending upon the days of service you wish between chargeings (based on the average use of your set of three hours a day). The larger capacity battery will be found more desirable unless facilities for frequent and easy recharging are provided. Consult the complete chart

at your dealer's for data on "B" Batteries and also "A" Batteries for low voltage tubes.

In every detail of construction—special structure plates, highly porous separators and superior internal arrangement tops—these batteries are made to get the best out of your set. To supply the dependable, unvarying current essential to fine tuning, efficient tube operation and clarity of reception.

Prest-O-Lite Batteries offer you truly remarkable savings. Though standard in every respect they are priced as low as \$4.75 and up. They last for years and are all easily rechargeable. See them at your dealer's or write for our booklet, "How to fit a storage battery to your set—and how to charge it."

THE PREST-O-LITE CO., INC., INDIANAPOLIS, IND.

New York

San Francisco

In Canada: Prest-O-Lite Company of Canada, Ltd., Toronto, Ont.

Prest-O-Lite



MAR-CO CONDENSERS

RADIO
PRODUCTS

Here's
the
PROOF
that—

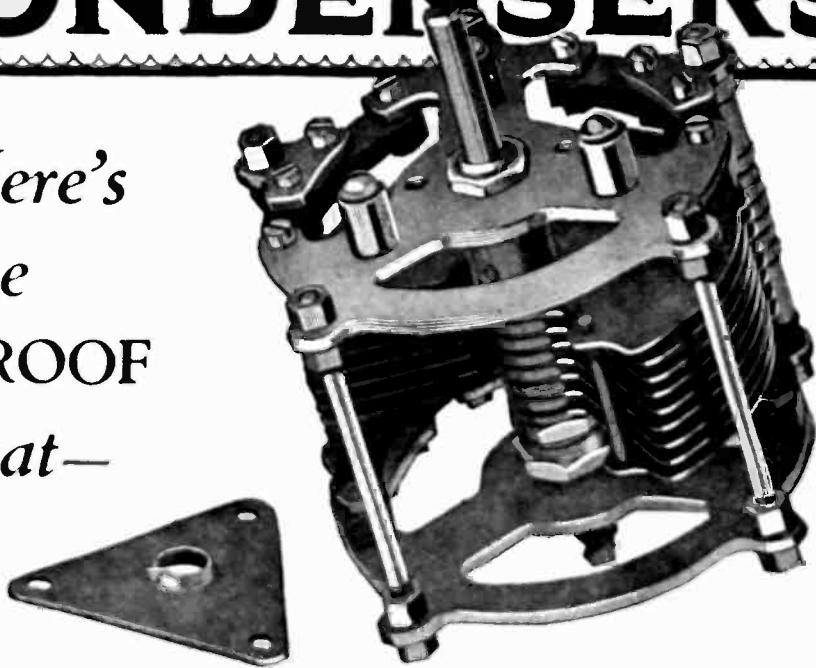

"A better condenser
makes any circuit better!"

I have had built an 8-tube Super-Heterodyne and of course bought with care the best parts the market offered. The result was, I tried several well-known condensers which were not satisfactory and by chance tried a pair of "Mar-co Condensers" and was greatly pleased with the performance of my set. So much so I hoped to pick up one of the foreign stations during test week.

On tuning in on 470 meters, picked up "Lyons, France, Station PTI," which came in as loud and clear as a bell with orchestra music, and held them until they signed off at 12 midnight, Eastern Standard Time.

I am enclosing a confirmed telegram of my reception that you may know Mar-co Condensers proved 100% on a test with an amateur at the dials.

Yours very truly,

(Signed) H. W. DAHL

MARTIN-COPELAND COMPANY · Providence, R. I.

"Elements of Radio Communication"

By Lieut. E. W. Stone

A Book That Every Radio Fan
Should Have.

\$2.50

SENT POSTPAID ANYWHERE

PACIFIC RADIO PUB. CO
Pacific Bldg. San Francisco

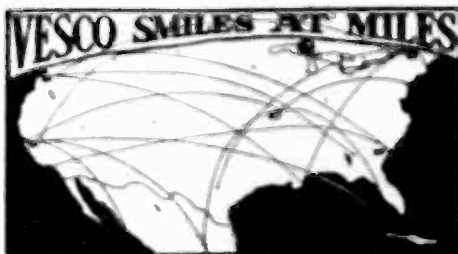

ON ONE TUBE

BIG FREE BOOKLET tells the story. California users of CROSS COUNTRY CIRCUIT hear Atlantic Coast, Canada, Cuba, Mexico and Hawaii. Atlantic Coast users hear England to California. Our new plan makes this set easiest and cheapest to build. One hour puts in operation. One tuning control. No soldering. Any Novice can do it. BIG BOOKLET FREE or complete instructions for 25c stamps or coin.

VESCO RADIO CO.
Box R-117, Oakland, Calif.

(Continued from page 44)

By 7UB, Perry Wannocott, 530 Liberty St.,
Silverton, Oregon

1aao, 1acb, 1af, 1ajo, 1ary, 1bbe, 1bcc, 1bcr, 1cme, 1cmp, 1cpa, 1cwa, 1er, 1hr, 1ml, 1pl, 1yb, 1yd, 2aav, 2anm, 2aqf, 2atv, 2by, 2cee, 2cft, 2cfx, 2chk, 2cpa, 2cvf, 2dd, 2dlk, 2gk, 2je, 2le, 2mc, 2rk, 2aix, 2auv, 2blp, 2bpm, 2bnu, 2bta, 2bwj, 2cb, 2cf, 2ckj, 2hw, 2kq, 2ot, 2tf, 2dq, 2eq, 2fz, 2gw, 2kl, 2qf, 2tj, 2tw, 2aad, 2aal, 2aaq, 2ahw, 2aic, 2aly, 2adh, 2acl, 2aj, 2ajj, 2ajp, 2aky, 2am, 2an, 2aqr, 2arb, 2aul, 2aux, 2asz, 2afq, 2bx, 2ca, 2dm, 2ew, 2hj, 2in, 2kc, 2ka, 2ll, 2ls, 2ot, 2qh, 2uk, 2wo, 2se, 2sk, 2za, 2zal, 2zas, 2add, 2ajj, 2bbi, 2bng, 2bng, 2bk, 2btr, 2bqp, 2btf, 2cta, 2cva, 2cwp, 2cyd, 2dae, 2bgp, 2bpt, 2doo, 2dse, 2dkt, 2fy, 2vq, 2wa, 2yv, 2aau, 2ake, 2ao, 2amp, 2auw, 2axs, 2ayp, 2bfi, 2bhi, 2biz, 2bm, 2bjl, 2bnk, 2bpf, 2bxt, 2ca, 2cca, 2cgn, 2clc, 2cjs, 2cjs, 2cjs, 2cko, 2col, 2csg, 2ctg, 2cul, 2cvo, 2evv, 2cyj, 2dad, 2dac, 2dly, 2dlx, 2dkk, 2dmj, 2dmz, 2dun, 2duu, 2dyl, 2dtk, 2eak, 2eam, 2efz, 2eg, 2eky, 2emr, 2es, 2na, 2oa, 2on, 2qw, 2xpb, 2zd, 2bku, 2fv, 2kf, 2gh, Canadian: 2kl, 2bb, 2dq, 2fn, 2io. Mexican: 1aa, 1b, 1x, 2a. New Zealand: 2ac, 2ap, 2aa.

By 9APY, 3337 Oak Park Ave., Berwyn,
Illinois

1aao, 1af, 1ak, 1asu, 1avl, 1bdx, (1bhg), (1bub), 1bzq, 1cak, 1pl, 1xa, 2aay, (2aco), 2ahw, (2ale), 2auh, (2bbx), (2bhk), (2boo), 2box, 2bpg, 2bse, 2bum, (2bxj), 2cor, 2cql, 2cub, (2cxy), (2cuy), 2gk, 2lm, 2adb, 2adq, 2ans, 2arz, (2awu), 2bhv, 2blp, (2bms), 2bmt, 2br, 2chg, 2cm, 2ly, 2na, (2oe), 2ph, 2qt, 2ra, 2sm, 2dv, 2ml, (2og), 2tw, 2tx, (2vo), 2ail, 2aly, 2ajp, (2api), 2aqf, 2arb, 2asb, 2asf, (2ash), 2att, 2aul, 2ek, 2ew, 2ex, 2ji, 2lh, 2lr, 2qx, 2qz, 2rw, 2se, 2vc, 2wl, 2afh, 2alw, 2chx, 2ok, 2sb, 2act, 2ase, 2atp, (2azu), (2bjt), 2bmo, 2bmv, 2bn, 2bqa, (2ckf), (2ckp), (2cl), 2dnu, (2dpx), 2eb, 2vo, 2wz. Canadian: (C-3ok), C-3ws, C-4ch. U. S. Fones: 2wf, 2dat. Government: wgh. QRK 9apy's 100 watts?? Card for card.

By George Morrow, 34 North Howard St.,
Salem, Ohio

1ana, 1bdt, 1bkj, 1mo, 1xw, 1xam, 2kc, 2ru, 2eel, 2cow, 2bhy, 2bmn, 2zo, 2ek, 2ik, 2yc, 2ado, 2amf, 2dw, 2kc, 2qd, 2awt, 2ceu, 2cgv, 2ry, 2kac, 2ol. Canada: 2do, 2od, 2oo, 2gg, 2hp. Mexican: bx, 1b. New Zealand: 2aa, 2ag. Australia: 2cm, 2da, 2ac. England: 2kx, 2od, 2sh, 2nm, 2xx. French: 2ab, 2bf, 2ek. Not known: onl, ear2, fain, smml, shfal, QRA, s pse. A card to all who QSL.

By 2CMY, Bradley Beach, N. J.

2ahw, 2aly, 2ajt, 2aot, 2apm, (2apt), 2asw, 2azg, 2an, (2dm), (2er), 2ka, 2nj, 2ov, 2ox, 2rv, 2ty, (2uk), (2uv), 2xa, (2ox-2uk very consistent), 2abx, (2agk), 2bcp, 2bhx, 2bjl, 2blh, 2bul, 2bvg, 2cgo, 2cgv, 2chx, 2cpw, 2ers, 2eb, 2mg, 2pl, 2ve, 2wp, 2xad, (2ah), 2xo, 2cgo, 2cao, (2ah es 2bj) very consistent), 2acm, 2cy, (2df), 2fd, 2fq, 2gf, 2gl, 2ij, 2ku, (2uj), 2am, 2zu, (2df-2fq very consistent). Canadian: 2eo, (2io), 2ch, 2et, 2dq, 2go, 2gf. Mexican: 1aa, 1b, 1x, 2x. Britain: (2mm), 2nn, 2uq, 2nm, 2nf, 2fu, 2kf, 2od, 2ma, 2pu, 2un. Holland: O-nl. Belgium: 2ad. Argentina: CB6. Will QSL on request. Reports on sigs appreciated. 22n hr.

At 6BUR, 340 North Painter Avenue,
Whittier, California

1aa, 1aao, 1ajx, 1all, 1amf, 1ary, (1ber), 1bdk, (1bgq), (1ble), 1bkq, 1bz, 1cab, (1cme), (1da), 1ex, 1fb, 1hn, 1ml, 1pl, 1qm, 1rd, 1uw, 1wl, (1xs), 1aa, 1st, (2aan), 2aby, (2ace), (2afp), 2aqb, 2aqh, 2axy, 2bg, 2big, (2bkr), 2bqu, 2byk, (2cgb), 2chk, 2cjc, 2ctj, (2ctq), (2car), 2gk, 2kx, (2le), (2pv), 2wl, 2wr, 2xi, 2ak, 2abj, 2adp, 2adq, (2ajd), 2bdo, 2bg, 2jp, 2bmn, 2bng, (2bta), (2bwt), (2ba), (2chg), 2cjn, 2eh, (2kq), 2lg, 2ot, 2qv, 2te, (2tf), 2xm, (2bl), 2bm, 2db, 2do, (2eh), 2eq, (2fx), 2it, (2ku), 2mb, 2oa, (2pk), (2sl), (2tj), 2tw, 2uk, 2wj, 2aa, 2acm, 2afm, (2ame), (2apr), (2avd), (2axn), (2bau), 2baq, 2bbf, (2bbw), 2bcd, (2bf), 2bf, (2bhh), (2bpl), (2bqa), (2col), (2cp), (2cpy), (2cyd) (2cay), 2dae, 2dde, (2dtk), 2dgv, 2dun, 2er, (2fy), 2ih, 2jq, (2lr), 2pk, 2pl, 2st, (2up). Australia: (2bk), 2cm, (2yl), (2yg), 2yr, (2bd), 2bq. Argentina: 1px. Brazil: (2ad), ur. Canada: 1ar, 2ax, (2gb), (2ly), 2it, 2vh, 2xl, 2al. Chile: 2tc. Columbia: wja. Cuba: 2by. England: 2nm, 2nn, 2ry. Porto Rico: 2aa. Navy: 2fv, 2fv, (2kf), 2gg. Mexico: (1aa), 1af, (1b), (1x), (2a), bx. New Zealand: (1ao), (2ac), 2ap, (2aa), 2ag, 2ak.

By Nick Gernicos, 12 Hertael Street,
Warren, Pa.

2aad, 2agk, 2apw, 2bdv, 2bge, 2bge, 2bin, 2blh, 2bul, 2cao, 2cgo, 2cnn, 2cca, 2il, 2ta, 2ul, 2vc, 2adm, 2afq, 2ajv, 2ald, 2cy, 2df, 2dj, 2fg, 2gh, 2ij, 2ig, 2ig, 2ig, 2mg, 2mp, 2nt. All cards QSL'd.

(Continued on page 48)



You Get This Kit Free!

Without one cent of cost to you and merely in return for a little of your spare time, we will present you with one Baldwin-Pacific Quintet Super-heterodyne Kit. You send us six subscriptions to "RADIO" for one year each, or three subscriptions to "RADIO" for two years each—and the kit is yours. The subscription price is \$2.50 per year. The kit is given to you in return for securing only \$15.00 worth of subscriptions. The kit alone sells for \$15.00. Therefore, you get double value for your money. Why not send "RADIO" for one year to five of your radio friends, let us send "RADIO" to your own address for one year, and get the kit? This big subscription offer is made for one month more due to the heavy demand for kits from our subscribers.

We guarantee this subscription offer to be exactly as represented. There are positively no further payments of any kind to make. Immediately upon receipt of your subscriptions and remittance of \$15.00 we will mail the kit to you, forwarding charges paid. We need more subscribers to "RADIO." Help us get them and we will make it worth your while. It's easy to get subscriptions to "RADIO." Every wide-awake fan should read it. Many people have never seen a copy of this magazine. Show your copy to the radio fans in your vicinity, tell them of the many feature articles published in "RADIO" every month and ask them to subscribe. Many of our readers have secured six subscriptions in a single day and have been awarded a kit. You can build a remarkably efficient 45,000 cycle super by using the parts which make up the Baldwin-Pacific kit.

Use the Coupon ~

ACT NOW. Don't let the other fellow beat you to it. Start today and you will be surprised to learn how easy it is to get six subscribers. Fill in the coupon, send us a list of the subscribers, your remittance of \$15.00 and the kit will be mailed to you on the same day your subscriptions are received.

Pacific Radio Publishing Co.
Pacific Building **San Francisco**
 —Established 1917—

"RADIO,"
 Pacific Building,
 San Francisco, Calif.

Here is \$15.00 and the names of subscribers for "RADIO." Immediately send me the BALDWIN-PACIFIC SUPER-HET KIT.

Name

Address

City

(Continued from Page 46)

At 9DNG, Fergus McKeever, University Heights, Lawrence, Kansas

1aac, 1ah, 1ad, 1aao, 1aap, 1aaz, 1abf, 1acb, 1acd, 1adi, 1aea, 1af, 1agh, 1agg, 1afc, 1aez, 1adb, 1ajh, 1ajp, 1ajt, 1ajt, 1ajx, 1akz, 1anm, 1aid, 1all, 1akp, 1alk, 1alx, 1apy, 1are, 1ary, 1aqm, 1ana, 1ayn, 1avf, 1avr, 1axi, 1awe, 1azy, 1ajo, 1adm, 1air, 1bbh, 1bbe, 1bdx, 1bee, 1bgc, 1bgd, 1bhn, 1bkr, 1bx, 1blf, 1bis, 1bdh, 1bv, 1bed, 1bub, 1bvl, 1bzq, 1bx, 1bes, 1cag, 1cak, 1cg, 1ccj, 1cme, 1cmx, 1cjc, 1cpv, 1cx, 1ckp, 1da, 1df, 1dk, 1ef, 1er, 1ez, 1afn, 1de, 1ga, 1gr, 1ge, 1gs, 1il, 1ll, 1lt, 1cit, 1lv, 1ld, 1fd, 1gc, 1je, 1kc, 1lw, 1ma, 1ahc, 1ow, 1pl, 1my, 1py, 1rd, 1sf, 1dir, 1km, 1ve, 1vj, 1vk, 1xm, 1xm, 1zw, 1xz, 1yb, 1yd, 1za, 1atj, 1xw, 1xj, 1xu, 1aww, 1azl, 2aan, 2aay, 2abt, 2aoy, 2adf, 2acs, 2ach, 2agb, 2ag, 2ana, 2agq, 2acy, 2anm, 2ajx, 2ate, 2at, 2bbn, 2bg, 2gg, 2bkr, 2bm, 2bgi, 2bqb, 2brb, 2bse, 2bro, 2bum, 2byg, 2byk, 2bq, 2cdh, 2cee, 2cgl, 2chk, 2cjb, 2cjk, 2csl, 2ctq, 2cty, 2cvf, 2cvu, 2cvs, 2cxw, 2cvl, 2cxy, 2cpa, 2cuj, 2ct, 2czr, 2cwj, 2czq, 2aav, 2ae, 2dd, 2crp, 2eq, 2fc, 2gk, 2agg, 2eb, 2cj, 2cdv, 2kc, 2ku, 2bn, 2bnq, 2kx, 2kf, 2pv, 2pd, 2qs, 2rk, 2mc, 2pu, 2xq, 2xna, 2xi, 2wr, 2wa, 3aac, 3agf, 3adq, 3adp, 3apv, 3afs, 3an, 3adb, 3acj, 3awa, 3bal, 3bhy, 3bel, 3bdo, 3bip, 3ble, 3bob, 3bge, 3bmn, 3bpm, 3buy, 3bw, 3bjp, 3bma, 3bva, 3bjn, 3bmt, 3bv, 3bwj, 3ca, 3cb, 3cf, 3ccx, 3ccu, 3cdg, 3ch, 3chg, 3chh, 3cf, 3ckj, 3ckl, 3cjj, 3cvu, 3cm, 3iu, 3io, 3lq, 3kd, 3jx, 3my, 3na, 3ns, 3mf, 3ll, 3ke, 3rr, 3ot, 3mf, 3sm, 3qt, 3yo, 3tp, 3wy, 4al, 4bl, 4bq, 4ch, 4io, 4eq, 4ft, 4fz, 4eh, 4fm, 4je, 4jr, 4js, 4ku, 4lr, 4mw, 4ke, 4mi, 4mb, 4bx, 4gw, 4tw, 4tl, 4tj, 4tn, 4pd, 4du, 4uk, 4rr, 4pk, 4rm, 4sl, 4sa, 4oa, 4ua, 4xe, 4st, 4vc, 4my, 4vm, 4xc, 4aba, 6adt, 6adb, 6afg, 6agk, 6alb, 6aol, 6alw, 6ajw, 6akz, 6ame, 6amm, 6aww, 6app, 6apw, 6asb, 6ase, 6ahp, 6arx, 6awt, 6ano, 6amo, 6cas, 6ab, 6ac, 6ar, 6aaq, 6bau, 6bav, 6bad, 6bay, 6bdt, 6beb, 6bqb, 6bgc, 6bhw, 6blh, 6blv, 6bni, 6bjj, 6bjx, 6bka, 6bnv, 6bov, 6bql, 6bqu, 6bgo, 6btd, 6bur, 6bve, 6bui, 6bze, 6bhz, 6apj, 6alg, 6cae, 6can, 6ccy, 6cct, 6ceq, 6cgo, 6cgw, 6cge, 6che, 6chl, 6chx, 6cix, 6cmg, 6cnn, 6cso, 6css, 6csw, 6cul, 6clp, 6cje, 6cwl, 6cva, 6czz, 6ase, 6cmt, 6cjj, 6cw, 6cto, 6czy, 6cni, 6cux, 6crs, 6crb, 6ctd, 6clz, 6eb, 6ew, 6fy, 6cf, 6cas, 6dl, 6ckf, 6cbb, 6ib, 6lh, 6ir, 6ja, 6gk, 6kr, 6ma, 6me, 6jl, 6jp, 6ms, 6oi, 6pl, 6qi, 6nx, 6rn, 6rv, 6ib, 6tl, 6ts, 6il, 6ml, 6zh, 6wt, 6lh, 6cse, 6ul, 6mo, 6wp, 6vc, 6vd, 6vw, 6ut, 6xby, 6of, 7alf, 7aib, 7abb, 7agf, 7av, 7bj, 7cy, 7dc, 7di, 7df, 7adm, 7gm, 7gr, 7gb, 7ge, 7fr, 7ij, 7lg, 7gu, 7fq, 7js, 7ok, 7mf, 7mp, 7mg, 7gs, 7ls, 7lr, 7se, 7ku, 7qd, 7mx, 7fd, 7ot, 7uj, 7zu, 7zq, 7sp, 7jr, 7dj, 7vm, Canadian: 1ar, 1dd, 1dq, 2cg, 2bn, 2be, 2bv, 2ax, 3adj, 3ly, 3aec, 3ael, 3xi, 3gv, 3qs, 3ad, 3tf, 3ms, 3ach, 3zt, 4aw, 4bb, 4cb, 4fv, 4dq, 4gt, 5go, 5gf, 5ba, 5an, 5bz, 5hk, 5as, Mexican: (bx). 1b, 1aa, 1e, 2iak, 4ag, 2ac, A3bq, nkf, nfv, ncg, lpx, wgh, onl. Will try to answer all cards, all reports on my signals greatly appreciated, especially from DEL.

The By-Pass Condenser

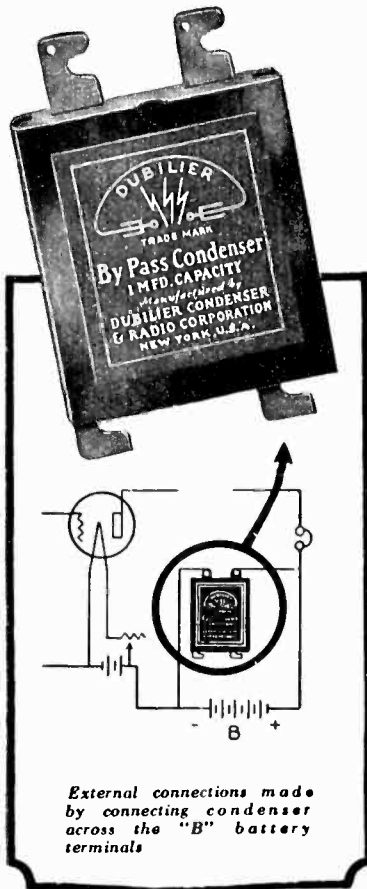

YOU will get the program clearer if you install a Dubilier large capacity By-Pass Condenser in your radio set. Just locate it as the diagram indicates. The result is that the minute fluctuations of the "B" battery are smoothed out into a steady, even flow of current, devoid of all noises.

The result is astonishing! Signal strength is increased—tones purer—volume smoother. The whole program comes in far truer and pleasanter than ever before.

This By-Pass Condenser in quality of material and workmanship measures up to that high standard for which all Dubilier radio devices are famous.

Dubilier

CONDENSER AND RADIO CORPORATION

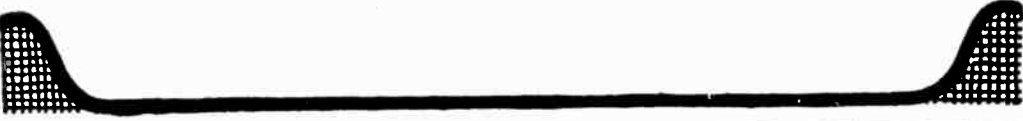

FIL-KO-LEAK

SCIENTIFICALLY CORRECT VARIABLE GRID LEAK

HAND CALIBRATED IN MEGOHMS—Eliminates distortion; increases volume. Can be read through panel peep-hole and logged. Ask your dealer or write Dept. RS25, DX INSTRUMENT COMPANY, Harrisburg, Pa.

HERCULES AERIAL MAST

20 Ft. Mast \$10.00
40 Ft. Mast \$25.00
60 Ft. Mast \$45.00

All steel construction, complete with guy wires and masthead pulley. We pay freight.

S. W. HULL & CO.,
Dept. G5, 2048 E. 79th St.
Cleveland, Ohio

Write for Literature and FREE Blueprint

"Built First - to Last"

Coto

INSIST ON THE SILVER PLATED AIR CONDENSER FOR YOUR RADIO SET.

DeForest License

HONEYCOMB COILS

The Universal all-wave inductance. Back and front panel mountings. Send 25c for Super Het., R. F. and Honeycomb Coil Circuits and Complete Catalog.

Chas. A. Branston, Inc.
818 MAIN ST. BUFFALO, N. Y.
DEPT. 12

By 6VD, 123 Cherry St., Anahelm, Calif.

1aao, 1aao, 1ckp, 1kc, 1se, 2aan, 2aay, 2bgi, 2bqu, 2brb, 2brc, 2wr, 2xq, 2xb, 3adp, 3avv, 3bb, 3do, 3bdo, 3bhv, 3bnu, 3bpm, 3hg, 3hh, 3te, 3yo, 4eh, 4eo, 4gw, 4hw, 4kl, 4ku, 4tw, 5adh, 5alc, 5ajm, 5akn, 5asb, 5atf, 5bx, 5dw, 5hj, 5kc, 5lh, 5ot, 5ps, 8aa, 8acy, 8apr, 8avl, 8axr, 8bbw, 8bjz, 8bkh, 8blc, 8btf, 8cbp, 8cdt, 8coj, 8dae, 8dal, 8ded, 8doo, 8fu, 8jq, 8pk, 8pl, 8ze, 9aad, 9adg, 9axx, 9bhe, 9bht, 9bjl, 9bkk, 9bm, 9bvz, 9cjl, 9ctg, 9cul, 9cvf, 9czm, 9del, 9dgv, 9dhq, 9dmj, 9dyz, 9eeo, 9eet, 9ehy, 9ekq, 9es, 9fi, 9hn, 9rg, 9vc, 9za. Canadian: 4fn, 4io, 5go, 5ot.

By 8RY, Sullivan, Ohio, 65-105 Meters QSL-QRH 75-QSL!

C1eb, C1am, C2au, C2be, C2bv, C2eg, C2fo, C2hm, C4er, C4io, C5ba, C5go, F8bo, F8sm, FN3gb(?), G2kf, G2nm, G2od, G2sz, G2yt, G5kc(?), *G5lf*, G5nn, *G6ry*, Mox, M1b, M1x, M9a, M1aa, P4wj(?), M1af, Qdz, Q2mk, Rcb8, S-LAC, ber, (Lox), lpx, odb, sj, wjs, ur, Z2aa, Z4aa, U-abc, 4je, 6ac, 6eb, 6ew, 6fy, 6gt, 6of, 6pl, 6tl, 6ts, 6vw, 6aao, 6afg, 6afk, 6agk, 6alb, 6ajl, 6alg, 6alo, 6alv, 6ame, 6aol, 6ase, 6bad, 6ban, 6bdt, 6bka, 6bir, 6bmw, 6bra, 6bul, 6cbb, 6cnd, 6cgv, 6chx, 6cmu, 6cni, 6cqe, 6oqn, 6cso, 6csw, 6cto, 6cuf, 6czx, 7cy, 7df, 7fy?, 7gb, 7h, 7ku, 7lj, 7mf, 7pz, 7ry?, 7sf, 7uj, 7wm, 7zq, 7zz, 7agi.

At U-6AKW, R. F. D. No. 1, Lancaster, California

1aa, 1aao, 1aay, 1acb, 1amf, 1ana, 1ary, 1avz, 1bz, 1bbe, 1bdh, 1bf, 1bgo, 1bsd, 1cme, 1da, 1er, 1mc, 1pl, 1py, 2az, 2atf, 2asw, 2bgi, 2bkr, 2bqt, 2brb, 2cix, 2cnk, 2cvj, 2czo, 2ds, 2gw, 2mc, 2gk, 2kx, 2xaq, 3adm, 3avj, 3bp, 3bpm, 3buy, 3bwj, 3cb, 3it, 3kq, 3lg, 3ot, 3sf, 3sm, 3wb, 4bb, 4eh, 4eq, 4fn, 4hw, 4io, 4jr, 4kl, 4sb, 4tw, 4ua, nkf. Australian: 2bk, 2yg, 2yi, 3bd, 3bq, 3ju, 5bg, *5da.* New Zealand: 1aa, 1ao, 2ac, 2ap, 4aa, 4ag, 4ak, Canada: 2ap, 2ax, 2bg, 3aa, 3ac, 3aw, 3vh, 3xl, 4io, 5an, 5ba, 5bb, 5ct, 5hc, 5ox. Mexico: 1b, 1g, 1x. England: 2nm, 2sh, 6lj. Indo-China: *HVA.* QSO Australia and New Zealand 17 times for January, 1925 during last half month. Handled Australia-New Zealand traffic, 20. 6akw or 6bcl first yanks to QSL. HVA between 7:00 and 8:00 a. m. of February 3rd., 1925.

By H. C. C. McCabe, 71 Holloway Road, Wellington, New Zealand

U. S.: 1abf, 1yb, 1ary, 1kc, 1ow, 1mv, 1pl, 1sf, 1cmp, 2brb, 2anm, 2al, 2bgi, 2xq, 2cqz, 2rk, 2cz, 3bp, 3aha, 3bhv, 3yo, 3bva, 3ot, 4io, 4pk, 4ku, 4oa, 5zav, 5akn, 5aaq, 5vz, 5aex, 5lu, 5ph, 5zal, 5qy, 5cnx, 5ai, 5go, 5amf, 5uk, 5mi, 5za, 5ox, 5dw, 5hl, 5gc, 5zh, 5cnl, 5ai, 5v, 5ceq, 5cjj, 5akf, 5akz, 5bqr, 5bql, 5bvg, 5cm, 5epg, 5pl, 5esw, 5bip, 5cdc, 5ctc, 5cem, 5cft, 5mme, 5aan, 5amo, 5bjj, 5bhv, 5cct, 5bir, 5aji, 5crx, 5cw, 5ea, 5rn, 5buw, 5ajh, 5ahp, 5akw, 5rk, 5fy, 5ccy, 5gr, 5fh, 5afg, 5ckw, 5civ, 5ti, 5ts, 5bax, 5czz, 5ne, 5amm, 5cax, 5ame, 5gen, 5hp, 5afg, 5ew, 5eb, 5bur, 5cks, 5xbn, 5lj, 5bcw, 5ao, 5cae, 5cgk, 5awt, 5cfs, 5cgw, 5vc, 5ase, 5cej, 5age, 5bra, 5arb, 5cgo, 5bdt, 5of, 5ij, 5ls, 5mf, 5ku, 5af, 5fo, 5fpz, 5wm, 5mgi, 5ry, 5zz, 5afn, 5zm, 5gb, 5tcm, 5aif, 5vq, 5ba, 5fm, 5ac, 5cel, 5aa, 5rv, 5alf, 5abs, 5byn, 5bji, 5bm, 5xi, 5dma, 5cjc, 5eky, 5bcj, 5zi, 5ccm, 5dgv, 5dac, 5dwx, 5dqu, 5bpy, 5dwk, 5bht, 5cip, 5aby, 5bmk, 5acq, 5azp, 5efy, 5bhx, 5zy, 5bhy, 5mm, 5ru, 5na, 5dlt, 5egh, 5hk. Mexican: bx, 1bj, 1k(?). Canadians: 2bq, 4dq, 5ba, 5gf, 5go, 9al(?). French: 8sm. English: 2od, 2nm. Special: wgh, 6xi.

By 6CIX, 317 North Friends Avenue, Whittier, Calif.

(1af), 1ar, 1aao, 1ajh, 1ajx, 1ary, 1bv, 1bak, 1bdx, 1bes, 1cme, 1cmp, 1crl, 1fd, 1pl, 1rd, 1wy, 1xu, 1xz, 1yd, 2ag, 2agq, 2ax, 2azq, 2br, (2by), 2beo, 2bhc, 2bpb, (2buy), 2cee, 2chk, 2cpa, 2cpr, 2cz, 2cvf, 2cwa, 2cxw, 2dd, 2dn, 2hj, 2ke, 2kf, 2kq, 2kx, 2gk, 2mu, 2og, 2rk, 2yo, 3ach, (3adv), 3aew, 3apv, 3aqr, 3beo, 3bpm, 3bur, 3ccx, 3chc, 3dh, 3hh, 3lw, 3oe, 3ot, 3te, 3wb, 4an, 4bq, (4eg), 4eh, 4fz, 4fn, 4gw, 4io, 4ka, 4kk, 4kl, 4mg, 4nb, 4ot, 4tw, 4ua, 4xl, 5ap, 5aa, 5aak, 5aaq, 5aay, (5aex), 5ago, 5ahb, 5aic, 5all, 5aly, 5ajt, 5akd, 5akn, 5alj, 5alz, 5amw, 5apz, 5aqy, 5arj, 5asj, 5asv, (5xau), 5zas, 5zav, 5ba, 5bl, 5ch, 5co, 5dm, 5dw, 5ew, 5hc, 5hs, 5ka, 5lg, 5lh, (5ls), 5mz, 5ov, 5ox, 5pg, 5ps, 5qx, 5sd, 5se, 5uk, 5ur, 5vf, (5wa), 5xa, 7au, 7adm, 7af, 7afh, 7aha, 7alf, 7alp, 7ajy, (7akh), 7akk, 7cy, 7dc, 7df, 7dl, 7dj, 7eo, 7fq, 7gb, 7gj, 7gm, 7gq, (7gr), 7gv, 7ho, 7if, (7iu), 7jf, 7jp, 7jr, 7kr, 7ks, 7ku, 7lg, 7lh, (7lj), 7ls, 7mf, 7mx, 7ok, 7qd, 7rl, 7so, 7sy, 7to, (7uj), (7uq), 7vn, 7wj, 7wq, 7zl, 7zm, 7zr, (8abs), 8acm, 8ade, 8aes, 8atp, 8avd, 8axk, 8bk, 8baj, (8bau), (8bdk), 8cc, 8ced, 8cel, 8cej, 8cud, 8cuk, (8dae), 8fm, 8kc, 8ks, 8pk, 8tt, 8xe, 8ze, 9aw, 9aau, 9aby, (9adk), 9agg, 9amb, 9aqr, 9axh, 9axs, 9azi, 9bcj, 9bdf, 9bgn, 9bhx, 9bhy, 9bjl, (9bjl), 9bjy, (9bkk), 9bmv, 9brx, 9bvz, 9bwo, 9bzk, (9bwp), 9cak, (9cbz), 9ccm, (9ccs), 9ccv, 9cdw, 9cej, 9ceu, 9cil, 9clq, 9col, (9csg), 9ctd, 9cvi, 9cyx, 9dad, 9dbz, 9ded, 9dfz, 9dmi, 9dms, 9dmz, 9dqn, 9duj, (9dun), 9dvo, 9es, 9eam, 9eep, 9eeq, 9efy, (9ejl), (9eld), 9xpb, 9xib, 9hk, 9kt, (9mi), 9oa, (9of), 9qw, 9ry, 9xe, 9xl, 9zk, 9zy, kdkk, kfkx, ket, kgl, nke, nkf, npl, npm, ner, wgh. New Zealand: (1ao), (2ac). Australia: 2bk, 2cm, 2yl, 3kq. Canadian: 2cg, 3ni, 4dq, 4eo, (4er), (4fn), 5an, 5ak, 4io, 5ba, 5ct, (5ef), 5go, (5gf), 5gt, 5hc, 5hp, 5hs. Mexican: 1a, 2aa, 1af, 1x, 9a. 6CIX is glad to receive repts.

By 6BJX, E. O. Knoch, 2823 East 6th St., Los Angeles, Calif.

1aao, 1abf, 1acb, 1af, 1ajp, 1cak, 1cl, 1opv, 1gs, 1ld, 1ml, 1ow, 1yb, (1zt), (2bgl), 2br, 2brb, 2bsc, 2cee, 2cix, 2cty, (2cvf), 2cxw, 2cyw, (2czr), 2kx, 2mu, 2rk, 2xi, 3abj, 3alx, 3bss, 3bta, 3chg, 3cjin, 3dh, 3jo, 3mf, 3ot, 3pv, 3sm, 3te, 3wb, (4du), 4eb, 4eq, 4gw, 4oa, 4pd, 4sx, 4tj, 8acm, 8acy, 8apr, 8aul, 8axk, (8bau), 8bce, (8bnh), 8bti, 8cta, 8cva, 8cve, 8cvh, 8cwp, 8die, 8dni, 8dnk, 8doo, 8dph, 8gz, 8pl, 8rv, 8uf, 8uk, 8vq, 8ze, 8zg, 8zk. Canada: 2ax, 2bc, 3xl, 4dq, 4fv, 4io, 5ba, 5bf, 5gf, 5go, 5hc. Australia: 2bk, 2ds, 2yg, 2yl, 3bd, 5bg. New Zealand: 1ao, 1ac, 4aa, 4ak. Mexico: bx. Special: 1px, nkf.

(Continued on Page 76)

100%
TONE!



Magic Radio Clearness

with this new principle horn—
this Kellogg Symphony Reproducer

This offers a new conception of radio clearness—a recent scientific advance in radio reproduction. It “brings in” the marvels of the air exactly as they were broadcast. With an absolute fidelity of tone that will delight you.

This new way is the Kellogg Symphony Reproducer --- now made in quantity production to sell at prices within the reach of every radio owner. It is made by the 28-year-old Kellogg Switchboard & Supply Co., leading specialists in the reproduction of sound. The acoustical engineers of this company worked for years on the problem of clarifying radio reproduction before they finally perfected the Symphony.

The shape and contour—the composition of the horn itself, is one of the principal features. But the theory and design of this “unit” is the secret of its wonderful success.

This “unit” is unlike anything ever offered before for radio. The magnetic feature gives it watchlike precision. The improved results are noticeable instantly to any who hear it.

* * * * *

Hear it today!

Today, hear the Kellogg Symphony. Do not buy any lesser horn until you have heard it. It will increase the value of your set 100% in musical quality—in pleasure to your family and yourself. Any dealer will gladly demonstrate the Symphony for you. Hear it—today!

KELLOGG SWITCHBOARD & SUPPLY CO

CHICAGO, ILL.

Kellogg Symphony Reproducer

Send for Trial Subscription—\$1.00 for Six Months

FREE!—

This Condenser

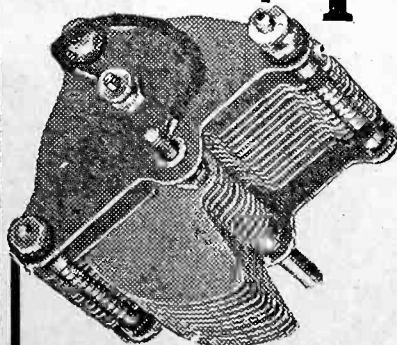

SEND only \$3.00—get this dandy AMERICAN SPECIALTY 23-plate variable condenser and “RADIO” for 15 months. The condenser is given free of cost with your subscription. This offer is positively guaranteed to be exactly as advertised. No further payments to make. The condenser is mailed to you on the same day that your subscription is received.

Guaranteed to be a standard, perfectly condenser. Your money cheerfully refunded if you are not entirely satisfied.

This offer good only for the months of March and April. Get your subscription in the mail today, sure.

“RADIO,” Pacific Building, San Francisco

Here's a peculiar fact about radio insulation

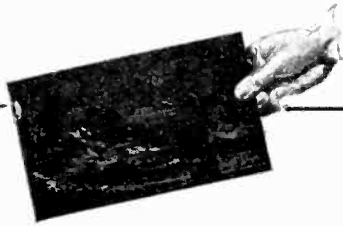

Surface leakage very low with Radion Panel

The high-polished, satin-like finish of Radion Panels prevents moisture from gathering to form leakage paths and cause leakage noise. Surface leakage and dielectric absorption are exceptionally low.

Radion Panels resist warping. They are easy to cut, drill and saw. They do not chip. No special tools needed. Eighteen stock sizes, two kinds, Black and Mahoganyite.



Radion Dials match Radion Panels perfectly and make the ideal mounting for your set. Radion Sockets help to eliminate capacity effects.



MATERIAL that is satisfactory for general electrical use often gives poor results in radio-frequency service. Experience has shown that best results come with the use of material and apparatus designed especially for radio's peculiar demands. This is particularly true of insulating material.

Radion IS a special material, developed to order by our engineers to meet the needs of radio. For radio frequency insulation its characteristics are highest, as shown by authoritative laboratory tests.

The use of the most efficient insulation material is important not only for panels, but also for dials, sockets, knobs, binding post panels, rotors, stators, spaghetti tubes, etc. In all these there is a Radion product of the right type and size for your set. Radion is also used by leading set manufacturers who appreciate the superiority of "the supreme insulation."

AMERICAN HARD RUBBER CO.
Dept. M4, 11 Mercer St., New York City
Chicago Office: Conway Building
Pacific Coast Agent:
Goodyear Rubber Co., San Francisco,
Portland

Mail coupon for Booklet,
"Building Your Own Set"

RADION

The Supreme Insulation

MADE TO ORDER FOR RADIO
PURPOSES EXCLUSIVELY

AMERICAN HARD RUBBER COMPANY
Dept. M4, 11 Mercer St., New York City.
Please send me your new booklet,
"Building Your Own Set," giving
wiring diagrams, front and rear
views, showing a new set with
slanting panel, sets with the new
Radion built-in horn, lists of parts
and directions for building the most
popular circuits. I enclose 10 cents.
Name
Address

RADIO INSTITUTE OF AMERICA

TRAINING IN ALL COMMERCIAL BRANCHES OF RADIO

If you cannot attend the Radio Institute of America in person the same instruction can come to you through our recently inaugurated "HOME STUDY COURSE"—Investigate.



Detailed information free on request.

Conducted by

THE RADIO CORPORATION OF AMERICA

28 Geary St.

Phone Garfield 4200

San Francisco, Calif.

98 Worth St.

Phone Franklin 1144

New York City

THE ETHER GARBLERS

(Continued from Page 24)

week arranged with a group of Southern California promoters to purchase jointly for eighteen million dollars the entire properties of the Solar Oil Company, owners of the famous three 'Long-Shot' wells at Long Beach, which have been producing two million barrels a month.

Mr. Greb returned to his home at San Francisco to wait for the promoters to make their funds available, which they accomplished this morning; but as the broker was in the very act of closing the deal news came in from the fields that the three 'Long-Shot' wells had 'gone salt'. Thornton, the broker, hurriedly advised Greb by wire, and Greb filed an answering telegram at the main office of the Poulsen Pacific this afternoon, reading as follows:

"Cancel the deal."

"But when the telegram arrived at Los Angeles, it read:

"Buy the wells."

"Thornton could hardly believe his eyes, but the instructions in the telegram were unmistakable. The Los Angeles promoters withdrew their funds and the broker bought out the Solar Oil Company, lock, stock, and barrel, for Mr. Greb, with Mr. Greb's five million. Mr. Greb is therefore now the owner of four derricks, one partly-drilled well, and three water-gushers, from which a small creek is flowing across the sands into the ocean. The man with the wilted black cigar in the picture to the left is Mr. Greb."

DURING the next six days, I remain encamped in my experimental shop in the basement of the apartment joint where I hang out; and spend my time with a pile of deep radio engineering books, diggin' dizzily into vacuum tube theory, radio compasses, Kolster circuits, and radio frequency phenomena, after which I try a few experiments with some neutrodyne receiving circuits.

"There's two ways it might be done," I says to myself, when I get through; then in answer to a telegram from Hawkins I puts on my coat an' blinkers, breaks out my whizz-buggy, an' lights out for an all night drive to Los Angeles.

Going through the downtown section, I hears the newsboys yellin' something more about Greb and his oil wells; so I stops long enough to get another paper, an' read:

"GREB, THE SPECULATOR, WINS
ON 'LONG-SHOT' WELLS!

"Six days ago, as the result of an altered Poulsen Pacific telegram, Mr. Thomas B. Greb, speculator of this city and well-known manufacturer of the famous 'Radio Ford', bought three oil wells spouting salt water. This morning, a fourth well being drilled on Mr. Greb's property came in a gusher of rich black oil. At almost the same instant, the salt-water pool under his other three wells came to an end, and they are also gushing forth immense black columns of 'flowing gold'. Last Wednesday morning Mr. Greb was worth five million dollars, Wednesday evening he possessed four second-hand oil derricks and a salt-water creek; this afternoon he sold out to Los Angeles interests for eighteen million. The man with the triumphant smile and the big black cigar in the picture to the right is Mr. Greb."

"Old Greb is havin' a heck of a time,"

(Continued on Page 52)

3 Tubes do the work of 5
In a CROSLEY Trirdyn

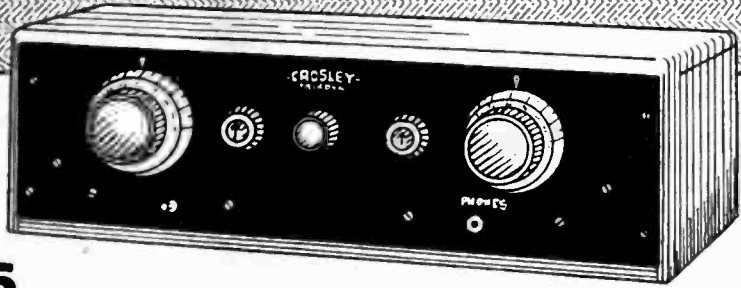

Regular
\$50
 Formerly \$65

The famous Crosley Trirdyn with three tubes excels most five or six-tube sets in simplicity of tuning, in selectivity, in volume, in clarity, in economy of operation and in distance getting efficiency.

This remarkable accomplishment in radio engineering is due to the unique combination of Radio Frequency Amplification with Armstrong Regeneration. Many trick circuits have been designed to get around the Armstrong Regenerative feature, hoping to get results "just as good."

Every additional tube means additional expense, an added dial to tune, greater difficulty in operation, more distortion and more tube noises. The Crosley Trirdyn with three tubes has only two dials. These operate but two circuits making tuning and logging easy.

The Trirdyn Regular, the most popular receiver on the market selling at its price or more, was reduced from \$65 to \$50; the

Trirdyn Special from \$75 to \$60. To these have been added two new Trirdyns in beautiful cabinets—the Trirdyn Regular with sloping panel at \$55 and the Trirdyn Special with sloping panel at \$65. Again the demand for Crosley Radios has increased tremendously.

You can't beat the results obtained from a Crosley Radio. Priced from the one-tube 50, "The Little Giant of Radio," at \$14.50, to the new Trirdyn Special with sloping panel at \$65.

Crosley Radios are licensed under Armstrong U. S. Patent 1,113,149. Prices quoted without accessories. West of Rockies, add 10 percent.

For Sale by Good Dealers Everywhere

Write for Complete Catalog

THE CROSLEY RADIO CORPORATION

POWEL CROSLEY, JR., President

419 Sassafras Street

Cincinnati, Ohio

Tune in with the Crosley Broadcasting Station WLW

New Special
\$65
 Sloping
 Panel



(Continued from Page 50)

I mutters to myself; then I steps on the gas and rambles out of town.

Arrivin' in the City of th' Angels in the glow of early morning, I goes out to Hollywood, where the Poulsen Pacific's Los Angeles receivin' terminal is located. But failin' to see anything suspicious about it, around nine o'clock I lays a course back down-town to the city office, where I finds a note from Hawkins. As I start to read it, he comes in, sleepless an' excited. He grabs me by the arm an' rushes me out into the street.

"Got th' bearin's on him!" he hisses, in a tense whisper. "316 degrees true from one compass in Hollywood and 257 degrees from another at Almiar, up in the Sierra Madre foothills. I've laid the bearings down on a map and they intersect in th' middle of the 1600 block on Cabrillo Avenue in Paraiso Del Tontos, a fine residence section out on the north side of the Santa Mónica Mountains."

We gasolines out to Paraiso Del Tontos, twenty-two miles northwest of the Angel City. Arrivin' at Cabrillo Avenue, we finds a' aerial on every house in the 1600 block.

"These people got a' aerial with a bunch of extra big porcelain insulators," I remarks to Hawkins, pointin' to a big quiet-lookin' white-stuccoed house right in the middle of the block, which has a neat, tight antenna at the back. "Let's take a chance at it."

We find the house empty and dark, not a chair or a piece of furniture in it. Somewhere upstairs, I hears the faint whirring of a motor and the clicking of a relay-key. We go through some upper rooms, which are bare and empty like the lower; then we come to a locked door. The whirr of the motor and the click of the relay-key has stopped now.

While Hawkins stands by with his moonshiner's six-gun and a flashlight—for all the blinds are down—I jimmys the door and kick it open. Hawkins sticks his flashlight into the opening, and the rays fall full upon a glittering brand-new one-kilowatt tube transmitter. Above it is a column of pancake coils to get a long wave. On a table beside it is a relay-key and a big distant-control switch. As we stand starin' at all this, the big control-switch flies up with a heavy "click!" that makes me jump half out of my shoes. With a soft humming whistle, a motor-generator set under the transmitter starts up, the tubes light, then the relay-key begins to work—

"—here's a city, San Francisco 10-27 A. M. Nr 45, PK-FL 16 black, Union Oil Los Angeles: Cancel steamer La Brea kerosene to Seattle, load 75,000 barrels fuel oil for Yokohama. Union Oil Company."

Sent on a vibroplex machine by an expert operator, the message flashes through like a shot, the relay-key stops, the con-

Heard Europe on a Home Built Ultradyne Model L-2

Arthur Bender, 116 East 2nd St., Covington, Ky., had no trouble picking up European stations last week on his eight-tube Ultradyne, which he constructed himself. — *Cincinnati Enquirer*, Nov. 30, 1924.

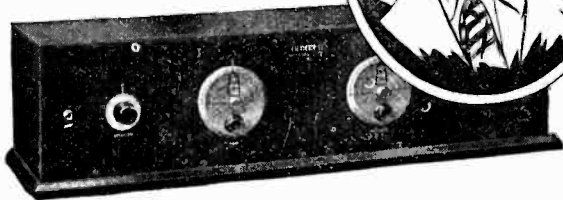

Thousands have built it!

LIKE Mr. Bender, thousands have successfully built the Model L-2 Ultradyne and claim it the most wonderful receiver they have ever known for great distance on the Loud Speaker.

In no other receiver is found the "Modulation System" of radio reception—an outstanding radio engineering development by R. E. Lacault, E.E., A.M.I.R.E., Chief Engineer of this Company and formerly Radio Research Engineer with the French Signal Corps Research Laboratories.

With the application of regeneration to the "Modulation System" the Ultradyne is capable of detecting the faintest broadcast signal, regenerating and making it audible on the loud speaker.

In addition, the Ultradyne is the most selective receiver known. Regardless of close similarity in wave length, it selects any station within range—brings in broadcasting clearly, distinctly, faithfully.

The Model L-2 Ultradyne will do everything better than any super-radio receiver operating under the same conditions.

Write for descriptive folder

ULTRADYNE

MODEL L-2

CARL A. STONE COMPANY
644 New Call Bldg., San Francisco, Calif.
1116 Miner Ave., Seattle, Wash.
429 Insurance Exchange Bldg., Los Angeles, Calif.
PHENIX RADIO CORPORATION
9 Beekman Street
New York

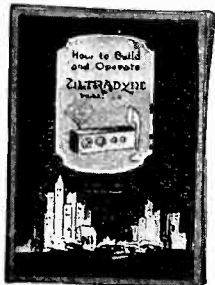

HOW TO BUILD AND OPERATE THE ULTRADYNE

12-page illustrated book giving the latest authentic information on drilling, wiring, assembling and tuning the Model L-2 Ultradyne Receiver. **50c**

THE ULTRADYNE KIT

Consists of 1 Low Loss Tuning Coil, 1 Special Low Loss Coupler, 1 Type "A" Ultraformer, 1 Type "B" Ultraformers, 4 matched Fixed Condensers.

To protect the public, Mr. Lacault's personal monogram seal (R. E. L.) is placed on all genuine Ultraformers. All Ultraformers are guaranteed so long as this seal remains unbroken. **\$30**



FREE! —

This Rheostat

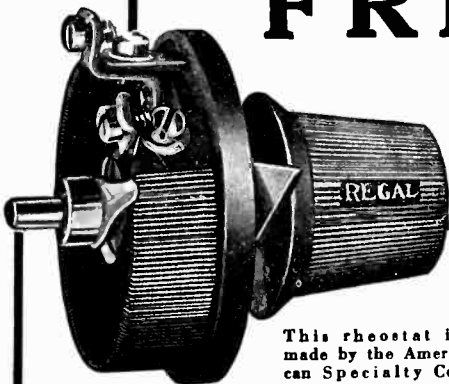

This rheostat is made by the American Specialty Co.

SEND only one subscription to "RADIO" for one year (\$2.50) and we will immediately send you one REGAL rheostat, as illustrated. You may have your choice of either a 6 or 30 ohm type. Why not mail your own subscription today—get "RADIO" for a full year and a dandy rheostat—all for only \$2.50. There are no further payments of any kind.

"RADIO," Pacific Building, San Francisco

Tell them that you saw it in RADIO

and switch snaps up again, and the net goes dark.

"How! This is the way the depot staff goes on the Hollywood mountains, even as you're red-haired—but how in California are the Palo Alto signals killed out?" exclaims Hawkins. "If we knew where the other end of the wire hooked to this relay-boy was!"

"We've come everything here," I interrupts, briefly. "Have you got those other two compasses installed up at San Bruno Mountain and over at Hayward across the bay?"

"Left 'em with two good men," replies Hawkins. "Guess they got 'em set up by now."

"All right, we're off for Frisco," I announce. "We got to finish up quick, before somebody comes and sees this busted wire."

On the way out of town Hawkins calls up the Poulsen Pacific city office at Los Angeles and has them shoot a service message to San Francisco requesting a repeat on telegram number 45 to Union Oil, Los Angeles.

"It was phony, all right," announces Hawkins, returns' as I am dumpin' a bucket of water into my hat, thirsty radiator. "Should've read, 'Cancel 9-cable kerosene, load full cargo gasoline for New York.' Would'a been a nice mess if they'd dumped 75,000 barrels of thick black crude in them tanks."

At midnight, we come roaring up the highway into Hayward, on the eastern side of San Francisco Bay, and five minutes later we arrive at Hawkins' radio-compass station, which is located in a small vacant real-estate office. The minute I steps inside the door, Hawkins' compass-man yanks a pair of pliers off his head and slaps 'em violently over my dusky-like ears.

"The compass has got him?" he exclaims. "Lament! First, here's Palo Alto." He swings his direction-indicator to 190 degrees true, or nearly south, and I hear a long banking-house night-buzzer flying through on the Poulsen Pacific 4550-circuit arc. "Now, watch!" hints Hawkins' buddy. He swings the indicator toward the southeast to 132 degrees, and in comes another transmitter exactly like the Poulsen Pacific transmitter—and sending exactly the same message! As I listen, the end of the telegram is reached; whereupon the mysterious repeating transmitter suddenly goes off the air. I swing the radio-compass direction-indicator back to 190 degrees, and hear the Poulsen Pacific arc still shooting stuff through about forty words a minute—but all alone now.

"The man at the other compass over on San Bruno Mountain spotted him first," says Hawkins' buddy. "He was word over by a message on a cat-antic. He gets the repeater station on 124 degrees. I laid the bearings out on

(Continued on Page 53)

NEW YORK COIL COMPANY'S Grounded Rotor Low Loss Condenser

New Prices

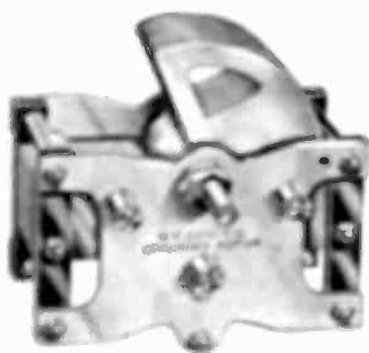

2000 - 25 plate, \$4.00, 2000 - 27 plate, \$1.50
U.S. Patent 1,600,000

New York Co. Grounded Rotor Transformer	\$3.75	Wood Radio Frequency Detec- tor with 27 plate condenser attached	Type Four \$4.00
---	--------	--	------------------------

Attention Manufacturers—Our New "Selector" Low Loss Grounded Rotor Condenser with self-balanced coils attached is the exact equipment that you have been waiting for—at a price you can afford to pay

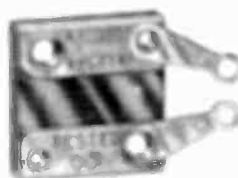

TYPE B

New York Precision Mica Fixed Condensers, the Standard by Which All Others Are Judged, are more uniform in capacity, the choice of the most prominent set manufacturers and radio engineers.

NEW YORK COIL COMPANY

338 Pearl Street, New York City, N. Y.

Pacific Coast:

MARSHANK SALES COMPANY

926 Insurance Exchange Bldg., Los Angeles, California
Also San Francisco and Portland



FREE! — This Pair of Phones

SEND us \$1.00—get "RADIO" for two full years and a pair of 2000 ohm PENNSYLVANIA HEADPHONES. The phones are given free with your subscription for two years. This great offer will shortly be withdrawn. It is good for March and April only. No further payments to make. Merely send \$1.00 and the phones will be mailed to you on same day your subscription is received. This offer saves you \$3.50. It's worth taking advantage of.

"RADIO"—Pacific Bldg., San Francisco

Now you can UNDERSTAND RADIO!

Take the mystery out of it—build and repair sets—explain the vacuum tube—operate a transmitter—be a radio expert!



**1 VOLUME
514 PAGES**
Leatheroid Edition

Compiled by
HARRY F. DART
E.E.

Formerly with the
Western Electric
Co., and U. S.
Army Instructor
of Radio.

Technically Edited by **F. H. Doane**
100,000 ALREADY SOLD

This practical and authoritative I. C. S. Handbook is considered one of the biggest bargains in radio today. Over 100,000 homes rely on the I. C. S. Radio handbook to take the mystery out of radio. Why experiment in the dark when you can quickly learn the things that insure success? Hundreds of illustrations and diagrams explain everything so you can get the most out of whatever receiver you build or buy.

It contains: Electrical terms and circuits, antennas, batteries, generators and motors, electron (vacuum) tubes, many receiving hook-ups, radio and audio frequency amplification, broadcast and commercial transmitters and receivers, wave meters, super-regeneration, codes, license rules. Many other features.

A practical book. Written and edited by experienced engineers, in plain language. Something useful on every one of its 514 pages. The authority that covers every phase of radio, all under one cover in one book at a surprisingly small cost. Don't spend another cent for parts, turn a dial or touch a tool until you have mailed \$1.50 for this I. C. S. Radio Handbook.

Send \$1.50 at once and get this 514-page I. C. S. Radio Handbook—the biggest value in radio today. Money back if not satisfied.

TEAR OUT HERE

International Correspondence Schools
Box 8261-C, Scranton, Penna.

I am enclosing \$1.50. Please send me—post-paid—the 514-page I. C. S. Radio Handbook. It is understood that if I am not entirely satisfied I may return this book within five days and you will refund my money.

Name.....

Address.....

Check here and enclose \$1 if you wish the cloth-bound edition.

REDUCE STATIC

Pat.
Pending
690459

by using our super-sensitive
Omni-Directional Aerial

*Collapsible, Ornamental,
Mechanically Perfect*

Can be used either as a loop
or antennae inside or outside.

A wonderful value featured at a
price within the range of all.

Ask your dealer or send order direct

\$10.00
Prepaid in U. S.

The Portable Globe Aerial Co.
1602 Locust Dept. 45 St. Louis

Send for Trial Subscription
\$1.00 for Six Months

(Continued from Page 53)

this real estate map on the wall here and make the queer guy forty-one miles southeast of San Francisco by air-line, or seven miles northeast of San Jose."

"We're near the end of this thing, it looks like." I announces, with a keen look at Hawkins. "Hawkins, you take your tool-kit out of my whizz-wagon, get a taxi, and make the driver get you to the Oakland mole in time to catch the last ferry. Get over to the Eldridge Apartments on Geary Street, wake up Cecil Blakely in Apartment 15, who is a commercial photographer friend of mine; tell him I said to break out a couple ounces of smokeless flashlight powder and his German detective camera; then hop down to the Holobar Building, lock up the night-watchman in a rag-locker or someplace, take his keys, and search through every office in the building near the Poulsen Pacific's pneumatic tube system from the city office up to the eighteenth floor. In some room, maybe hid in a locker or in a phony filing-cabinet, you'll find a set of dispatch-tubes have been brought in to a connection and so equipped that the up-bound telegram carriers can be intercepted, opened, the messages read, and then sent on up to the operating room. Somewhere in that same room, you'll find a loop-aerial radio receiver, a vibroplex key, and a telegraph relay. Yank off the cylindrical hard-rubber shell of one of the relay magnets, rip out the copper-wire winding, fill the shell with smokeless flashlight powder, put a short piece of the fine wire from the ripped-out winding into the powder, and connect the ends of this piece of wire to the local key circuit; so that as soon as the vibroplex key is touched, it will short the current through the wire, instantly heat it white hot, and set off the powder. Have Blakely set up his detective camera, which looks like a small dusty cardboard envelope box, on top of a locker or somewhere as much out of the way as possible, and connect the fine invisible wire leads of his electric shutter in shunt with your relay circuit, in order that the shutter will operate when the powder goes off.

"Clean up any mess you make carefully; so when the doctored relay explodes, the bird we are after will think a shot of high-tension power current has got on his telegraph wires and blown out the relay coil. I think the plant is in the office of H. C. Bailey, Real Estate Broker, Room 1414; but I may be wrong. If I am, work up and down, until you find the place, because it has to be there; and try to get all set before nine o'clock in the morning.

"When you are through, take possession of the nearest adjoining office, and wait. If the office belongs to somebody and they come in, hold 'em up with your gun and make 'em sit quiet until you

(Continued on Page 56)

Balkite Battery Charger. Charges 6 volt "A" storage batteries.

Price \$20
East of Rockies \$19.50
In Canada \$27.50

Balkite "B"—replaces "B" batteries and dry cells. Operates from light socket.

Price \$55
In Canada \$75

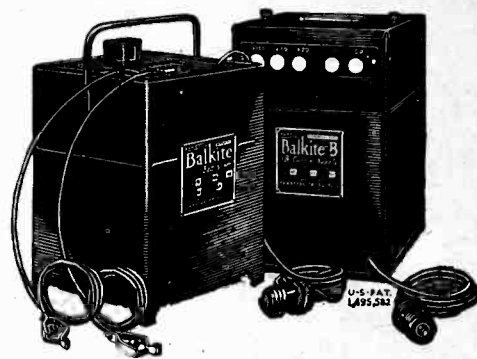

An unfailing power supply for both circuits

Here at last is an unfailing power supply for your radio set. Balkite Radio Power Units furnish constant uniform voltage to both "A" and "B" circuits and give your set greater clarity, power and distance. The Balkite Battery Charger keeps your "A" storage battery charged. Balkite "B" replaces "B" batteries entirely and furnishes plate current from the light socket. Both are based on the same principle, are entirely noiseless and are guaranteed to give satisfaction. Sold by leading radio dealers everywhere.

FANSTEEL PRODUCTS CO., Inc.
North Chicago, Ill.

PACIFIC COAST DISTRIBUTORS:
Seattle, George H. Maire, 95 Connecticut St. San Francisco, A. S. Lindstrom, 274 Brannan St. Los Angeles, Lombard J. Smith, 324 N. San Pedro St. Portland, H. A. Killam, 146½ N. 10th St.

FANSTEEL
Balkite Radio Power Units

BALKITE BATTERY CHARGER
BALKITE "B" PLATE CURRENT SUPPLY

New LeFAX RADIO
HANDBOOK—\$2.00
(Seventh Edition)
in bound form. For sale by
"RADIO," San Francisco

RADIO CATALOG
AND HOOK-UPS FREE

Our great new catalog, fresh from the press, contains the very latest in complete sets, parts and accessories—hundreds of amazing bargains. 250,000 customers testify to our wonderful value and reliability. Complete instructions with diagrams for making most practical popular sets FREE. SEND QUICK for your copy. (Please include name of friend who is interested in Radio.)

THE BARAWIK CO.
Dept. 115 22-40 So. Clinton Street Chicago

Why It Is Better

"MASTER of Every Note in the Orchestral Range" is the **PROVEN** claim of the Federal No. 65 Audio Frequency Transformer! Volume without distortion is the basis for the beauty of Federal Tone.

From its oversize locking nuts to its heavy brass mounting feet, the Federal No. 65 Transformer incorporates the same engineering skill that has made Federal the recognized leader in electrical communication apparatus since 1890.

Insist upon Federal parts for your "pet" hook-up. There are over 130 standard parts bearing the Federal iron-clad performance guarantee.

FEDERAL TELEPHONE & TELEGRAPH CO.
Buffalo, N. Y.

Boston New York Philadelphia
Chicago Pittsburgh San Francisco
Bridgeburg, Canada



Federal
Standard **RADIO** Products

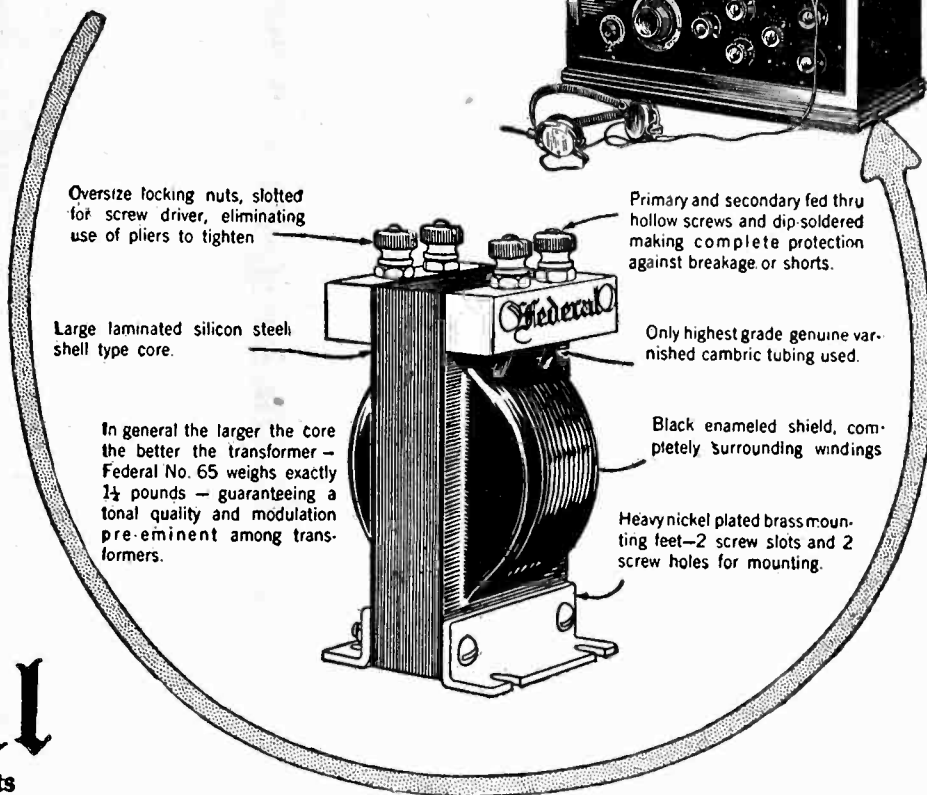
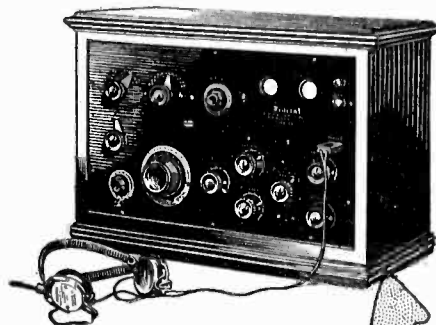

Oversize locking nuts, slotted for screw driver, eliminating use of pliers to tighten

Primary and secondary fed thru hollow screws and dip soldered making complete protection against breakage or shorts.

Large laminated silicon steel shell type core.

Only highest grade genuine varnished cambric tubing used.

In general the larger the core the better the transformer - Federal No. 65 weighs exactly 1 1/2 pounds - guaranteeing a tonal quality and modulation pre-eminent among transformers.

Black enameled shield, completely surrounding windings

Heavy nickel plated brass mounting feet - 2 screw slots and 2 screw holes for mounting.

YANKEE TUBES

Proven Beyond All Doubt—

"The Ace of Independents"

TYPES **\$3.00**
199-201A



TRADE MARK REGISTERED

Sold only thru well-established retail dealers

Distributed by
W. E. & W. H. JACKSON
San Francisco
MARSHALL-WELLS
Portland
THE BANTA CO.
Los Angeles
RADIO SUPPLY CO.
Los Angeles

DEALERS—Write to the distributor in your territory as shown below for attractive proposition

BALDWIN PACIFIC & CO., San Francisco
(Pacific Coast Representatives)

Tell them that you saw it in RADIO

The MOZART Baby GRAND Radio Reproducer

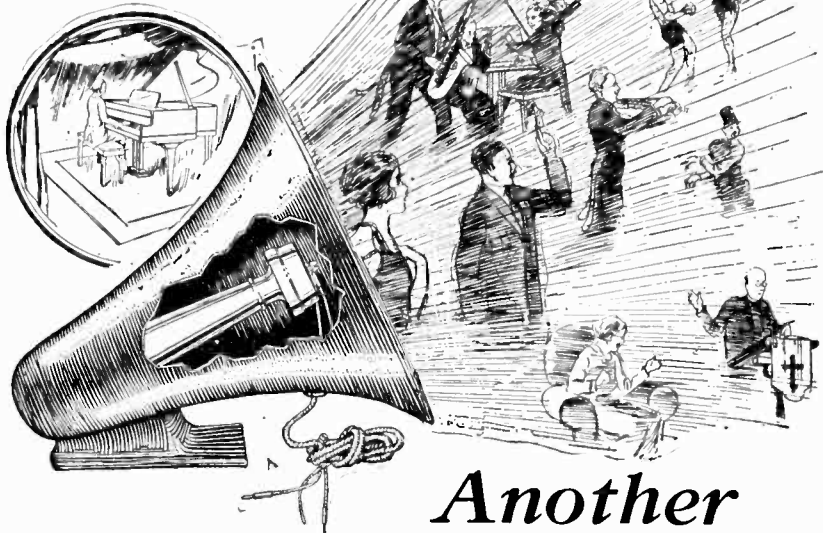

Another

No piece of radio apparatus in any price class is best because its maker says so---or because its dealer says so. It is only the best when everybody else says so as well.

"Several times I have intended to write you or call on you when visiting Newark. I wanted to let you know of the fine service we have been getting from the Mozart Baby Grand. The clearness of music, voice and other entertainment seems so different from other loud speakers that we have experienced. We also use the Talkers, but we stick to the Baby Grand for Accuracy."

(Signed) R. T. DONOVAN,
5501 5th Street., N. W.,
Washington, D. C.

PRICES (WEST OF THE ROCKIES)

Baby Grand Reproducer, with gold plated unit, black and gold crackle or extra heavy coated all black satin finish.....	\$12.50
Electro-magnetic unit (fits almost any horn or phonograph) with cord,	
Nickel Plated	\$4.50
Gold Plated	\$5.50
Mozart Special Headset	\$6.00

If your dealer cannot supply, order direct.

West Coast Representatives:

NELSON-RUDE CO., 16 California Street, San Francisco, Calif.
JAEGER RADIO, 4505 Thirty-sixth Ave., N. E., Seattle, Wash.

THE MOZART GRAND CO.

NEWARK, N. J.

Manufacturers of Fine Instruments

U. S. A.

(Continued from Page 54)

hear the powder flash go off in the plant. Wait a few minutes for our friend the tube-tapper to leave without getting scared and wised up by seeing you spying on him; then breeze in and get the camera. Have Blakely develop and enlarge the picture, and bring it up to Mr. Tulver's office at four this afternoon; also have up there the president and directors of the Poulsen Pacific, and all the main guys. I'm going down to San Jose—I don't think I need to; but I want to make sure I'm right. See you later."

AT TWO o'clock in the morning, I am standing in the barn-like laboratory of Doctor Godfrey Derrold, a few miles northeast of San Jose. At the north end of the laboratory, in a large copper-lined oven-shaped box which is open at one side facing to the northwest, is a Kolster loop-aerial and a part of a complicated seven-step radio-frequency receiving circuit. The fifth tube is a five-watt transmitting bulb, and the sixth, which is outside the copper box, is a 250-watt tube. By means of a radio-frequency transformer made of heavy high-tension cable wound on a bakelite frame, the sixth tube is coupled to a seventh "step" consisting of a bank of eight glittering one-kilowatt power tubes. The high-tension plate circuit of this parallel bank of powerful transmitting tubes is connected in series with a set of spiral copper loading coils and then passes out through a porcelain tube to Doctor Derrold's lofty aerial, which is suspended between two 300-foot wooden towers adjoining the laboratory.

"I have leased my laboratory for six months to a man who through an agent represented himself as, and apparently is, a radio engineer," explains the bewildered Doctor Derrold, whom I have roused out of bed to open up the joint. "I have been obliged to spend a great deal of time in New York and Washington this year testifying in the DeWoods vacuum-tube patent cases; and so I was glad of an opportunity to rent the place for a time—though the man should have been welcome to use it, in any case."

"Do you know what this thing is, here?" I demands.

"Why, I'm not sure that I do," replies the portly doctor, shiverin' a little in his pajamas. "I was told that it is part of a self-driving repeating system which the engineer is developing. I believe he plans to sell his invention to some company who could use it to establish a reliable system of low-powered trans-oceanic telephony and telegraphy, using a number of these automatic repeaters on various islands in mid-ocean."

"What sort of lookin' bird is this engineer?" I queries. "Does he work here every day?"

"I have never seen him—I have seen only his agent or assistant, or whatever

"B" BATTERIES

AN
EVEREADY
PRODUCT

At Standard Prices

43V. Batteries, tapped
22½ V. Batteries, Navy Type
22½ V. Batteries, Commercial Type

Latter two types especially adapted to
Cunningham and Radlotron Tubes.

Postage Prepaid Anywhere in U. S.

ETS HOKIN & GALVIN

Wireless Engineers

10 Mission Street San Francisco

RADIO

BIG MONEY IN A BIG FIELD

Be a RADIO EXPERT. Make big money. Win success in this new uncrowded field. Trained men needed. Learn quickly, at home in spare time, to construct, install, operate, repair, maintain and sell radio equipment.

RADIO EXPERTS EARN \$3,000 to \$10,000 a Year

Short course, low cost, easy terms, money back guarantee.

FREE Wonderful tube receiving set of latest design. Range of over 1000 miles. Write today for "RADIO FACTS."

A. E. Mehaut, Radio Eng. Radio Association of America
4513 Ravenswood Ave., Dept. 83 Chicago

Send for Trial Subscription—\$1.00 for Six Months

the gentleman may be," replies the doctor. "While I was east, the engineer installed this apparatus; and he has brought in a pair of leased wires from somewhere and connected them to this distant-control switch, which enables him to start all the generators and tubes and everything from some other laboratory where he is working. He seldom switches on this apparatus more than two or three times a day, and then only for a few moments at a time. I have never attempted to pry into his work in any way, as I presume he naturally wishes to keep it to himself until he has his circuits perfected and securely patented."

"All right, old man, go back to sleep," I tells him. "But if you want to know what you've really got here, drop into Mr. Tulver's office at the Poulsen Pacific in Frisco at four this afternoon. So long."

Getting back into San Francisco at daybreak, I stops by the Holobar Building, where I finds Hawkins and Blakely have successfully spotted the pneumatic tube-tapping apparatus in the 'H. C. Bailey, Real Estate' joint, which has turned out to be a clever layout, consisting of two separate offices with a camouflaged intercommunicating door and about six exits into both front and back corridors. Hawkins and Blakely bein' nearly through setting their trap and needin' no help, I drifts up to my apartment hangout, pulls down my oven-door-type wall-bed, and have a good sleep.

At noon I gets up fer my bath an' toilet in my dog-house boudoir overlookin' a flock of backyard clothes-lines; then wandering down-town for my afternoon breakfast, I finds this in my newspaper:

**"GREB THE SPECULATOR
CLEANS UP AGAIN!"**

"Thomas B. Greb, Long Beach oil plunger and well-known manufacturer of the famous 'Radio Ford,' is making the wizards of Wall Street look like pikers. Here is the story—

"The widespread publicity lately resulting from the Poulsen Pacific Telegraph Company's troubles with mysteriously altered telegrams at once caused a slump in their stock, but there was nevertheless a peculiarly strong demand for it, and the rumor was current on California Street that someone was buying control, aiming to sell out to Radio Freezeouters, Inc.

"Yesterday, however, the Radio Freezeouters announced definitely and authoritatively that they would not buy Poulsen Pacific. Almost instantly the stock returned upon the market in a veritable deluge and was beared down to eight cents a share. At this point, Mr. Greb stepped in and quietly bought all in sight.

"The Poulsen Pacific's traffic has heretofore been confined almost entirely to downtown business houses, since they have never advertised to any extent; but the story of their struggle to use their wonderful radio system in a fight against what are popularly fancied to be the machinations of the Western Onion and the Postit has so wrought upon the public mind that a flood of business has

(Continued on Page 58)

CIR-KIT

More Power per Tube brings Greater Radio Most Economically

Triple power is the basis of Erla Supereflex records. Tubes, as used in Supereflex, simultaneously amplify received radio frequency currents, reflexed radio and reflexed audio frequency currents. So 1-tube Supereflex rivals the power of conventional 3-tube circuits. And 3-tube Supereflex readily outclasses the ordinary five!

Only such power can give you the thrill of Supereflex distance and volume; always with Erla crystal-pure tone—and with uncanny selectivity that gets what you want when you want it.

This finer radio is brought within the reach of all by Erla Supereflex CIR-KIT, the factory-sealed carton of genuine Erla apparatus for building Supereflex yourself. Anyone can follow the CIR-KIT assembly plan perfectly, using only screwdriver and pliers, without the risk of drilling or soldering.

**SEE ERLA
RECEIVERS**

Inherent Erla advantages in power, tone and selectivity are now available in beautiful complete Erla receivers. Retail prices range from \$67.50 to \$225. Both performance and price place Erla receivers among the sensations of radio history.

Pride of workmanship, extreme economy, priceless radio performance, are yours in Erla Supereflex CIR-KIT. Select your model at the Erla store. 1 to 5 tubes, antenna and loop types.

Electrical Research Laboratories
Dept. H, 2500 Cottage Grove Ave., CHICAGO
Coast Representatives: Globe Commercial Co., San Francisco

ERLA

**Make
\$100
a Day**

**FREE INSTRUCTION TELLS
HOW**

Many Sales Are Half Profit When you sell our nationally advertised radio sets and supplies. We Guarantee your success, under the "Gould Plan," by allowing you to return goods which you do not sell. It would pay you to get our price list and free instructions. Write for it.

Federal Radio Co. 109 East 13th St.
Kansas City, Mo.

"COMO DUPLEX"

The World's Standard Push-Pull Transformer, \$12.50 per pair. Send for descriptive literature. COMO Apparatus Corp., 446 Tremont St., Boston, Mass. Washington and Oregon Representative
C. E. GAY

186 Lownsdale St., Portland, Oregon

See the New! - - - -
**MONTROSE LOW LOSS
CONDENSER \$2.50**

A new efficient condenser at a new low price. 23 plate, cap. .0005.
UNITED RADIO LABS. of the Montrose Mfg. Co.
1333 Fulton St., Brooklyn, N. Y.

The SATURN

Perfect Jack and Automatic Plug. Your order filled by mail promptly. Every article absolutely guaranteed. The SATURN Mfg. & Sales Co., Inc. 48 Beekman Street, New York, N. Y. Dept. B Write for Literature



BURGESS BATTERIES

Contribute to
a Radio Miracle



President Coolidge

H. R. H. The Prince of Wales

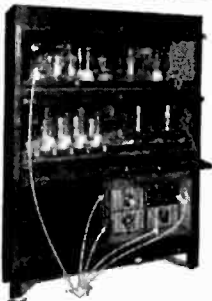

The transmitter that sent photos by radio from London to New York. Batteries for energizing the tubes are shown in the lower shelves of the cabinet.



General view obtained through courtesy of the Radio Corporation of America. Captain Richard Ranger of the R. C. A., inventor of the apparatus, is seen placing film upon drum of transmitter. U & U Photos

THAT Burgess Radio Batteries were chosen for this inspiring achievement is a pleasing indication of the confidence placed in them by experienced radio engineers.

Ask Any Radio Engineer

BURGESS BATTERY COMPANY
Engineers DRY BATTERIES Manufacturers

Flashlight - Radio - Ignition - Telephone
General Sales Office: Harris Trust Bldg., Chicago
Laboratories and Works: Madison, Wisc.
In Canada: Niagara Falls and Winnipeg

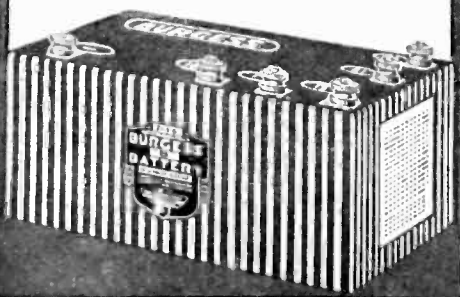

(Continued from Page 57)

deluged the Poulsen Pacific offices and has congested the company's radio channels to such an extent that they have been compelled to lease twelve wires from the Yell Telephone Company in order to clear their traffic. As a result, Greb's stock is soaring and there is a likelihood of its going to a dollar a share. The man with the big black cigar and the whimsical smile in the picture to the left is Mr. Greb.

I spend the afternoon sitting in a picture show, doing some more thinking. At four o'clock I roams up to Mr. Tulver's office in the Holobar Building, which I find jammed. Blakely, waitin' with a big flat brown envelope, gives me a nod and a complacent smile, while Hawkins sits stiff as a gun-barrel and stares at me with a dumbfounded look on his long seamy face. Stephen Glass is waiting, cold and silent, as usual; Mr. Tulver swabs billows of sweat off his care-worn map, and Doctor Godfrey Derrold sits with a big gold watch-chain draped over his bulgin' stomach, lookin' kind of hurt and curious. A bunch of other chairs are occupied by directors and engineers.

"Now then, fellows," I says, brisk like. "You are all here because you want to know who's jazzin' up the messages of this company, and how they're doin' it. I'm going to tell you the last part first. "What I have found out is that a certain unknown gentleman has rented the San Jose laboratory of Doctor Derrold and installed a kind of Kolster receiving circuit in a copper-shielded box. The seventh step of this circuit is a bank of eight one-kilowatt transmitting tubes, which shoot their power out into a lofty aerial overhead. Now, if you stop to think a minute, you will see that if all the circuits of this instrument are tuned to exactly the same wavelength and all the high-frequency currents are forced to keep in step by proper apparatus, then whenever any waves are received on the circuit, they will cause the eight power tubes to reradiate waves of the same length as the received waves, and the reradiated oscillations will be in synchronism or in step with the incoming oscillations. This is simple so far, but the joker lies in the fact that by a proper connection of the inter-tube radio-frequency transformer circuits, the waves sent out by the power tubes at the end of the seven steps can be made of opposite phase or polarity to the incoming waves. If the power of the opposed outgoing oscillations is adjusted to equal the total effective power of the incoming oscillations, they both will be neutralized; and on any ordinary radio receiver, if placed a reasonable distance from both of the opposing transmitters, you will have a dead silence. The preliminary receiving circuits of the neutralizing transmitter are placed in a copper-lined box, which is open only at one end. This end is adjusted toward the distant primary transmitter to be neutralized, and

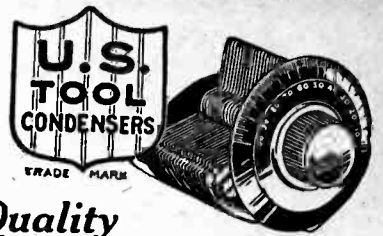

Quality
—Based on Perfection
of Parts

A condenser is no more efficient than its weakest feature—a thought borne in mind in designing the U. S. Tool Condensers. As a result, the perfecting of parts has led to the nearest point approaching condenser perfection. Inquire about Type 6 with the micrometer dial.

Factory Guarantee

Write for Literature

Coast representatives:

Radio Electric Distributing Co.
1113 Wall St., Los Angeles, Cal.

U. S. TOOL COMPANY, Inc.
114 Mechanic St. Newark, N. J.

Mfrs. of special tools, dies, jigs,
automatic machinery and sub presses

Send for Trial Subscription

\$1.00 for Six Months



Just what
you need

Valley Battery Charger

Here is just what you need to increase the pleasure and entertainment of your radio. With the Valley Battery Charger as part of your equipment, you need never miss a program because of a dead battery.

The Valley Battery Charger will completely recharge 2-volt peanut tube cells, 6-volt A batteries and from 1 to 4 B 24-volt batteries. It is the only charger necessary for all radio batteries.

Quiet in operation
Full 6-ampere charging rate
No liquids. No bulbs

Plugs into the ordinary light socket like a fan or other household necessity. Just as easy to operate. Takes only about a dime's worth of current to bring your battery up to full charge.

It has grained and engraved Bakelite panel which harmonizes with any radio set. Clear glass top shows the simple, patented working parts at all times.

At radio dealers everywhere

Valley Electric Co.

101 Rialto Bldg., San Francisco, Calif.



**The Famous Truly Portable
TELMACO P-1 Receiver**

Four Tubes Do the Work of 7

Coast-to-coast reception. Aerial, loud speaker, and batteries self-contained. Carry from room to room—take it anywhere. Size 8"x10"x18". Total weight only 26 lbs. Complete with tubes and batteries, \$125.00 \$143.50. Receiver only

P-1 KIT SAVES YOU MONEY!

In response to a popular demand we now offer the Telmaco P-1 Receiver in kit form. This contains all parts, as built by us, including case, drilled and engraved panel, and illustrated instructions. \$80.00 Complete kit

Ask your dealer or write us. Descriptive folder free.

Radio Division:

Telephone Maintenance Co.
20 So. Wells St. Dept. A, Chicago, Ill.



Quality Radio Exclusively Established 1918

ARE YOU A SUBSCRIBER?
Send for Trial Subscription
\$1.00 for Six Months

**A. C. H. Three-Tube
Concert Receiver**

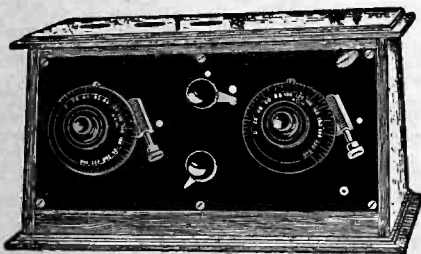

SELECTIVITY

Using sensitive instruments in connection with two A. C. H. Worm Drive Sharp Tuning Instruments. Can be used as one or three tube Receiver. Operates on 199 or 299 dry cell tubes. Batteries Amplifier 90 volt B. Detector 22½ volt B. A battery, three dry cells. C battery, one dry cell. All connections on back. **Installation Plan. No References.**

WRITE US AS FOLLOWS:

A. C. Hayden Radio & Research Co.,
Brockton, Mass.

Gentlemen:

Enclosed please find \$20.00. Send me one A. C. H. Three Tube Receiver. Upon receipt of same I agree to pay you \$1.00 a month for fifteen months until the total amount of \$35.00 is paid. This Receiver is to remain your property until full amount is paid. You guarantee this set to operate on the air.

SIGNED.

Wonderful Value—Limited Production—Mail Orders Only

**A. C. Hayden Radio and
Research Co.**

BROCKTON, MASS., U. S. A.

as the circuit is unidirectional, it is not choked off by the opposing waves of its own radiating power tubes, because the copper box keeps these opposing waves from getting at the loop aerial inside. Not all the local waves are kept out in this way; but enough are kept out to keep them from entirely neutralizing the waves from the distant primary transmitter, and this is sufficient.

"Now, as I have just said, on any ordinary radio receiver within range of the two neutralized transmitters, you will have a dead silence; because the receiver will be equally affected by the two opposing waves; but on a unidirectional radio-compass type receiver you will be able to pick up either of the two transmitters, one at a time, by swinging the direction-finder; because this kind of receiver is acted upon in only one direction at a time. This is how we were able to hear and locate the San Jose neutralizer with a radio compass.

"The Poulsen Pacific receivers at Hollywood, as well as all your other receivers, are of the one-direction radio-compass type; but as you can see by any map, Palo Alto and San Jose both lie in practically the same direction from the Hollywood receivers; therefore the neutralizing waves from San Jose could be adjusted to affect the receiver quite as much as the primary waves from Palo Alto, and the result was a dead silence in the one particular receiver tuned to the wave being neutralized.

"The unknown gentleman who put in the San Jose neutralizer has an office in this building, where he has brought in and tapped some of the Poulsen Pacific's pneumatic tubes from the ground floor to the operating room. He can intercept and read messages, and then send them on up to your operators, without any one being the wiser.

"Suppose he decides to alter a Union Oil Company message which has been given the serial number 45. He quickly copies it and sends it on up to the operating room. Listening in on a loop receiver in his office tuned to the Palo Alto transmitter, he waits until he hears message number 44 go through; then by means of a control-switch on a leased wire he starts his neutralizer at San Jose and kills Palo Alto dead while number 45 is being sent. When he starts his neutralizer, he also starts a small continuous-wave tube transmitter down at Paraiso Del Tontos through a second control-switch, and by means of a vibroplex key, a relay, and a second leased wire, he sends his duly altered copy of message number 45 on his Paraiso transmitter at the same time that the correct number 45 is being sent from Palo Alto. But Palo Alto being neutralized at San Jose does not come in at Hollywood, while the small Paraiso Del Tontos transmitter, which is in nearly the

(Continued on Page 60)

**Apex
Super 5**

This highly efficient tuned radio frequency receiver is the most advanced in design and construction. It is an instrument that meets every critical expectation of the seasoned radio enthusiast.

Buy the Apex Super 5.
You will have a radio receiver that brings in distant stations clear and distinct. Select the station you desire in your log-book, turn the marvelous Apex Vernier Dials to that number, and there you are—perfect reception. No greater selectivity can be had than is easily obtained with the Apex Super Five.

Housed in a highly finished walnut cabinet, complete with Jones Multi-plug Battery Gold. All settings highly gold plated. Sells for \$95 complete excepting accessories.

At All Good Dealers
Apex Elec. Mfg. Co.
1410 W. 59th St.
Dept. 410
Chicago

on
the
dot

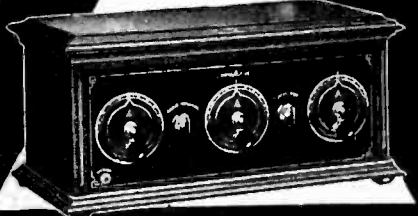

BROWNLIE
CRYSTAL



"REFLEX SPECIAL" \$1.00
QUICK CONTACT
RECTIFIER
GUARANTEED

The Acme Apparatus Co. says "prevent distortion and howling by using a BROWNLIE CRYSTAL in Reflex Sets"
Order From Your Dealer or Direct.

ROLAND BROWNLIE & CO.
24 Saunders Street, Medford, Mass.

"RADIOCAST
WEEKLY"

A 48-Page Magazine of Programs, Photos, etc., of Pacific Coast Broadcasting Stations
5c per Copy--Radiocast Weekly
433 Pacific Bldg., San Francisco

CELORON
RADIO PANEL

Size 7 x 12

MANUFACTURED BY
DIAMOND STATE FIBRE COMPANY
BRIDGEPORT (near Philadelphia) PENNSYLVANIA, U. S. A.
MAKERS OF
CELORON-Diamond-Fibre-VulcaWOOD
Office in Principal Cities
IN CANADA: DIAMOND STATE FIBRE & WOODS, OF CANADA LTD., LONDON, CAN.
Inventors of Celoron in U. S. A.

How to Work and Finish Celoron Panels

DRAW full size layout of panel to be drilled on a sheet of heavy paper, not to exact size of panel. Transfer centers of holes through the paper to the Celoron panel with a pointed instrument.

The drilling can be done with a carpenter's brace or a brace drill, but using a two-flute drill should be used, one regular wood bit. Begin to drill from the front side of the panel. To avoid slipping on back, clamp panel to a board or work bench. Counter-drill holes with a larger size drill. Holes can be finished with standard machine taps.

If a dull or not finish to be drilled on, open the panel with No. 00 sandpaper. The sand paper should be wrapped around a wooden block and the rubbing all done in one direction, not with a circular motion.

Wipe off oil panel with an oily cloth.

As popular as radio

As more and more radio novices become seasoned fans, the popularity of Celoron Panels multiplies.

Today Celoron is the accepted standard for radio panels. Sets of many foremost makes are equipped with Celoron panels and parts.

Celoron does not chip or crack. It does not soften, warp or buckle. It is infusible and will stand up under atmospheric changes.

Look for Celoron Panels where you buy your radio supplies. Insist on Celoron insulation in the parts you buy.

Celoron is also made into tubing which has all of the insulating qualities of sheet Celoron. It is used extensively by manufacturers of the best radio instruments. It is made in all sizes and diameters.

DIAMOND STATE FIBRE COMPANY
Bridgeport, Pa., Toronto, Can. and Chicago, Ill.

The oldest and largest manufacturer of vulcanized hard fibre and laminated technical materials in the world.

Wherever you see a factory chimney there are countless electrical and mechanical uses for Celoron and Diamond Fibre.



This Celoron rack on a merchant's counter means that he wants to give you the best in radio parts. Look for it.

(Continued from Page 59)
same direction from Hollywood as Palo Alto, does come in with the phony message. As soon as message number 45 is completed, the unknown gentleman cuts off his San Jose neutralizer, and the Los Angeles receiving operator once more gets his stuff from Palo Alto.

"Vibroplex sending at high speed all sounds about the same, and so the difference in the operators' 'fists' is not detected. The Paraiso Del Tontos transmitter must be pretty carefully adjusted to give the same note and signal intensity as the normal Palo Alto arc. I think there is a time-lag of five or six oscillations between the Palo Alto arc and the San Jose neutralizer; but at 4550 meters this represents less than 1/10000 of a second, which is not enough time to move a heavy telephone diaphragm or a tape recorder.

"You will now understand that your recording receivers up on San Bruno Mountain, being also of the one-direction type, recorded the correct message texts going out on the air at all times; because these recorders were very closely adjusted onto the Palo Alto transmitters by Mr. Hawkins here and they consequently were not seriously affected by the San Jose neutralizing waves, since these were coming from a somewhat different direction. On the other hand, the Hollywood recorders were neutralized and got only the altered messages from the local transmitter at Paraiso Del Tontos.

"You will observe that this thing operates without a single actual electrical connection onto your system at any point; therefore it could not be spotted by trouble-shooters and made no suspicious clicks or scratches in the receiving telephones. Furthermore, you will see that the entire apparatus might, in time, be put in and operated by one man working alone; and this man could be holding down a job and do all the preparatory installation work at nights and on Sundays, without being missed from his place of business. It was of course necessary for him to come up into the tube-tapping office on the fourteenth floor of this building, whenever he wanted to work up some altered messages.

"Why the Poulsen Pacific telegrams were altered seems to me to be pretty clear. The unknown gentleman, probably working with some other crooked bank-roll shooters, wanted to destroy for the time being the value of Poulsen Pacific stock, buy control, and then sell out to Radio Freezeouters, Inc. But a crowd downstairs, consisting apparently of a man each from Westover Electric, Patent Dodgers' Union, Yell Telephone, Western Onion, and Postit, who I believe have all pooled their personal capital in a bootleg radio tube concern and are therefore being closely spied upon by Radio Freezeouters, Inc.,

Wholesale Distributors of
Nationally Known
RADIO SUPPLIES
DEALERS—Send for price list and discount sheet
COSMOPOLITAN RADIO APPLIANCE CO., Inc.
25 Church Street, New York, N. Y.

NA-ALD

Na-ald Deluxe Sockets are the only ones with these 3 exclusive features—lowest loss, lowest capacity and positive side-scraping contact. Send for booklet and laboratory test. Alden Mfg. Co., Dept. G2, Springfield, Mass.

\$50 to \$200 a Week
~and Easy Work

Get your share of the huge Radio Profits. Wanted—Radio Salesmen, Engineers, Executives, Mechanics, etc. Easy home study method qualifies you how in spare time. Earn while you learn.

Big demand for trained men NOW. Easy work. Free book gives complete facts. No obligation. Mail card today.

Send for this FREE Book
NATIONAL RADIO INSTITUTE
Dept. 10FB Washington, D. C.

also saw through the game and tried to buy Poulsen Pacific stock, resulting in the price staying unpleasantly high for the unknown gentleman.

"Then think what a shock it must have been to that gentleman when the Freezeouters unexpectedly announced that they would not buy Poulsen Pacific.

"The unfortunate unknown gentleman, seeing his game ruined, thoughtlessly dumped all his stock back on the market in one chunk for what he could get, and all the other little gentlemen of the bootleg tube combination downstairs, seeing the way things had turned, did likewise.

"Poulsen Pacific stock at once became cheaper than dirt, in which condition it was bought by Mr. Greb, the ubiquitous speculator. Owing to the great amount of publicity the Poulsen Pacific have got out of this thing, the indignant public thinks the company a victim of the hoggish telegraph trusts and is rushing down here with armfuls of business; and so now Poulsen Pacific is going full blast; the unknown gentleman who tried to buy control is probably flat broke; and all the little gentlemen tagging along behind must be badly bent. About the only person who appears to be distinctly ahead of the game is our friend Mr. Greb. This must be the real moldy dog biscuits and sourardines to the unknown gentleman, for I believe he is nursing a regular Apache Indian grudge against Greb for stealing his woman and marrying her, a good many years ago."

I takes the big envelope from Blakely and pulls out a fine clear-cut enlargement of a man clutching a vibroplex key in one hand and a telegram in the other, and springing back from a blinding white flare, which is evidently the exploding relay-coil. The man's face in the picture is clear and sharp as a movie actor's in a super-feature—the keen, cold, and terrified map of Mr. Stephen Glass, President of the Poulsen Pacific, and one-time crackerjack radio operator for the D'Arcy Wireless Company.

"HOW in the devil did you know it was him?" demands Mr. Tulver, swabbing his haggard face with a soggy towel, in his emptied office, thirty minutes later.

"Well, I didn't exactly know, of course," I replies, "—although Glass's trying to play the lone wolf made it necessary for him to be down on the fourteenth floor, where he didn't seem to have much of any business to be. But just between you an' me an' the sultan of Turkey, I'll tell you real confidential like that I had him spotted from the first by taking him to be the last man in the world who would be suspected—for this is what every regular detective guy and every follower of regular detective guys' stunts has long since learned to do."

Silver-Marshall, Inc.

RADIO EQUIPMENT

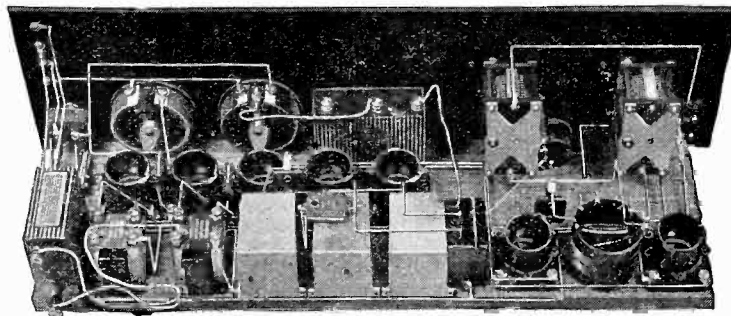

SILVER SUPERS APPROVED by the "WHO'S WHO" of RADIO

The Editors and Engineers who have endorsed Silver Supers constitute a "WHO'S WHO" of Radio. Here they are: Arthur H. Lynch of Radio Broadcast, Capt. John Irwin of Radio Broadcast's "Covered Wagon," Gerald M. Best of Radio Magazine, M. E. Sleeper of Radio Engineering, F. D. Pearne of Radio Age, Iverson C. Wells of Everybody's Radio, R. C. Hughes of the Corn Belt Dailies. Add the Chicago Herald-Examiner, the American Radio Journal, Citizens Radio Call Book. On the Air Magazine, the cautious Christian Science Monitor and WTAS Broadcasting Station . . . then you will know that SILVER SUPERS have been APPROVED, and that by the "WHO'S WHO" of Radio.

SILVER SUPERS are the logical selection of the man who wishes to build the best. Their reception records are unsurpassed, the soundness of the advanced engineering methods embodied in Silver Supers is unquestioned, for simplicity of construction they cannot be equaled. Build your own Silver Super—it's easy—you need just three tools—and your Silver Super will give you up-to-date reception for years.

All Parts \$72.85

Blue Prints and Complete Building Instructions, 50c.

Send 50c for McMurdo Silver's Book "THE PORTABLE SUPER-HETERODYNE."

S-M-4-TUBE KNOCKOUT	On a 70-foot antenna will equal the startling performance of the Silver Supers on a loop. Send 25c for McMurdo Silver's own description of this, his latest circuit. All parts cost.....	\$44.40
S-M DISTORTIONLESS AUDIO AMPLIFIER	A three stage Resistance Coupled Amplifier, giving perfect tone quality on all vocal and orchestral music, and that with greater volume. Cost no more than ordinary two stage transformer coupled amplifiers.....	\$17.65
S-M LOW LOSS CONDENSER	Type 301—straight line, low loss, grounded rotor condenser of the most approved and advanced design. For use in the Silver Super, the 4-tube Knockout, and all sets where extreme efficiency is desired. Cap. .0005 mfd. Price, each.....	\$4.50
S-M TWO-TENS TWO-ELEVENS	Long wave transformers supplied in sets of 2 or 3 TWO TENS (iron-core interstage) and one TWO ELEVEN (filter for input or output) with identical peaks and separate curves. Curves plotted in our own Laboratory and recorded directly on the transformer's tag. Price of either type, each.....	\$8.00

Circulars on S-M Products Upon Request

SILVER-MARSHALL, Inc., 110 S. Wabash Ave., Dept. B., CHICAGO

HIGH QUALITY — LOW PRICE

The CLARITRON \$2.30 TUBE BY MAIL

FOR BRILLIANCE OF TONE, SHARP TUNING, MORE PEP—USE CLARITRONS

The Highest Obtainable Quality at the Lowest Obtainable Price. Our price is low because we cut out the jobber-wholesaler's profit—which is YOUR saving.

All types, including our 501A, for 6 volt storage batteries; our 499, for 4½ volt dry cell batteries; and our 112, for 1½ volt dry cell batteries. All made with bases of Pure Bakelite—for superior efficiency. We Guarantee Complete Satisfaction. From your dealer, or direct by mail C.O.D., or prepaid on receipt of Express or Postal Money Order. We Pay Postage. \$2.30 all types. Dealers Write!!

SUPERIOR RADIO COMPANY, Dept. 205
176 Shepard Ave. Newark, N. J.



Type 499
Detector and
Amplifier
3-4 Volts
For Dry Cell
Batteries
0.06 Amps.



Type 501A
Detector and
Amplifier
5-6 Volts
For Storage
Batteries
0.25 Amps.

Send for Trial Subscription—\$1.00 for Six Months

Tell them that you saw it in RADIO

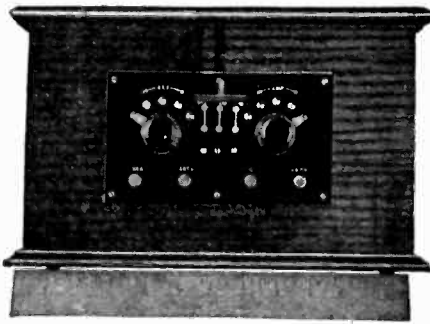

Prices

PZ indicates panel type with switches.
CZ is plain type without switches.

VOLTAGE	M. A. H.	TYPE PZ	TYPE CZ
130	2500	\$36.00	\$33.00
100	2500	27.50	24.50
70	2500	21.50	18.50
45	2500	16.00	14.50
22 1/2	2500		7.50

MULTI-POWER UNITS (No recharger required)

130 volts	\$43.50
100 "	35.00

KIC-O CHARGERS

Type K-1 Single Unmounted	\$1.50
Type K-2 Single Mounted	3.50
Type K-3 Multi-Polar Mounted	5.00
KIC-O Special Charger Chemicals (one cell)	.50

KIC-O---the permanent power plant for your radio

If you are tired of buying new batteries every little while—if the stations are not coming in as loudly and clearly as you think they should—if you want better reception at lower cost—if you want a real permanent power plant that will last for years—then buy a KIC-O.

These new KIC-O Nickel zinc alkaline storage "B" Batteries are the product of years of research. They are not harmed by standing idle or overcharging. They give a slow, even discharge over a long period of time and by using the KIC-O Double Potential Charger, which can be attached to any electric light socket, you have a permanent power plant. Write for full description, which will tell why KIC-O units are better than dry cells, "B" eliminators and acid "B" batteries.

KIMLEY ELECTRIC CO., Inc.
2661 Main Street Buffalo, N. Y.

LEAVENWORTH STATION

(Continued from Page 10)

wavelengths; from telephone to telegraph and vice versa; and from full power to 20 per cent or 50 per cent output as desired.

The set as installed at Fort Leavenworth occupies a floor space 13x19 feet. The front of this space is the control board, made up of 7 panels. On these are mounted the various meters, and means of operating the switches behind the board. No "live" parts, from which the operators might receive electrical shocks, appear on the front of the board.

The principle of the set is that due to Colpitts and Arnold by which oscillations generated and modulated at a moderate power level, are then amplified to the desired power. This system was originally used in the Arlington-Paris tests of 1915, in which the human voice was first transmitted across the Atlantic. It was again used in the transatlantic tests made in January, 1923, when a group of Bell System engineers and executives talked to people in London. In the present set, oscillations are generated by a 250 watt vacuum tube, amplified first by two other 250 watt tubes in parallel, and again by two water-cooled tubes in parallel. Telegraph signals are sent by starting and stopping the oscillations. Telephone transmission is obtained by controlling the flow of power to the first amplifier tubes in accordance with the voice current waves. This scheme is due to R. A. Heising. While the set is designed to receive power at 220 volts three phase alternating current, the various devices in it require power at several different voltages and of direct current as well as alternating.

It is interesting to follow the path of the voice transmission through the oscillator-modulator unit and then to see how the circuits are modified for telegraph transmission. The voice currents enter through a transformer and are amplified by a 50 watt vacuum tube. They then control the output of two 250 watt tubes in parallel. By the well-known Heising system of constant current modulation, the amount of power available for two 250 watt radio frequency amplifiers is varied according to the changing values of the voice currents. The grid circuit of the last mentioned tubes is controlled by oscillations generated by a 250 watt tube in a Colpitts circuit. Thus the output of the two amplifier tubes is a high frequency "carrier" modulated by the voice current. This method of segregating the oscillating and modulating functions in separate tubes is used instead of the familiar combined oscillator modulator arrangement used in radiocast transmitters because it gives greater stability to the frequency of the oscillator.

When telegraph transmission is desired, the movement of a control wheel

Good Radio Advice

AMERICA'S pioneer instrument maker has prepared a booklet for you showing typical radio receiving hook-ups and how to properly connect instruments in circuit.

Complete information is also given on the Weston Radio Plug and the Weston Radio Table Voltmeter, indispensable to radio pleasure and success. This double range table voltmeter (150 and 7.5 volts) is invaluable for improving reception, for prolonging the useful life of tubes, for locating trouble, and for preventing the discarding of batteries prematurely.

Write for "Weston Radio Instruments" today.

WESTON ELECTRICAL INSTRUMENT CORPORATION

156 Weston Avenue

Newark, N. J.



STANDARD THE WORLD OVER

WESTON

Pioneers since 1888

A Dozen Thrilling Yarns

Read the Story of the Life of a
Sea-going Radio Operator—
"THE RADIOBUSTER"

\$1.00
Per
Copy

SENT POSTPAID ANYWHERE
PACIFIC RADIO PUB. CO.
Pacific Bldg., San Francisco, Cal.

\$1.00
Per
Copy

operates certain relays which disconnect the 50 watt and the first two 250 watt tubes. Provision is also made for a relay, controlled by a telegraph key, to insert at will a large negative potential in the grid circuit of the oscillating tube. Pressing a telegraph key at the control point operates the relay and removes the negative potential, allowing oscillation to start. Releasing the key inserts the negative potential and the oscillations are "killed." The lightness of the moving part of this relay, and the fact that it is the only part of the set whose motion must follow the telegraph signals, makes high sending speeds possible.

For either telephone or telegraph transmission, the output of the oscillator-modulator unit is used to control two high power water-cooled amplifier tubes. These tubes are clamped in water jackets through which water is circulated by a pump. Failure of the water supply or excessive temperature would damage the tubes and hence suitable relays are provided to cut off power to the set under such abnormal conditions. This water is cooled by passing it through radiators.

Power for the plate circuit of these amplifier tubes is obtained from the 60 cycle A. C. supply, through a step-up transformer, a three-phase vacuum tube rectifier and a filter circuit. To adjust the power output of the set, a group of relays cut out suitable sections of the transformer primary, allowing three different voltages to be delivered by the secondary.

To secure the maximum efficiency, all high frequency circuits are tuned. The particular arrangement of coils and condensers will prevent the radiation of harmonics of frequencies higher than that of the "carrier," a very important point in avoiding interference with radiocast and other listeners.

In order that the station may change quickly from one wavelength to another, means have been provided by which any one of several groups of coils and condenser taps may be connected at will. To change the wavelength, the operator first pulls forward the large hand wheel on the front of the closed circuit tuning unit. This operates a relay which cuts off the high voltage supply circuits, and unlocks the hand wheel which may then be turned until its pointer indicates that wavelength desired. With it move 15 brush-arms making contact with leads to coil taps and condenser groups. When the handle is released, it locks itself and simultaneously the relay re-applies power to the high voltage circuits.

To change the power input to the antenna, and to change between telephone and telegraph transmission a hand wheel is provided whose rotation changes three separate groups of contacts. By pulling the wheel forward, it is unlocked and the same relay is operated to cut off the

(Continued on Page 64)

MARWOL

BABY GRAND
FIVE TUBE TUNED RADIO FREQUENCY

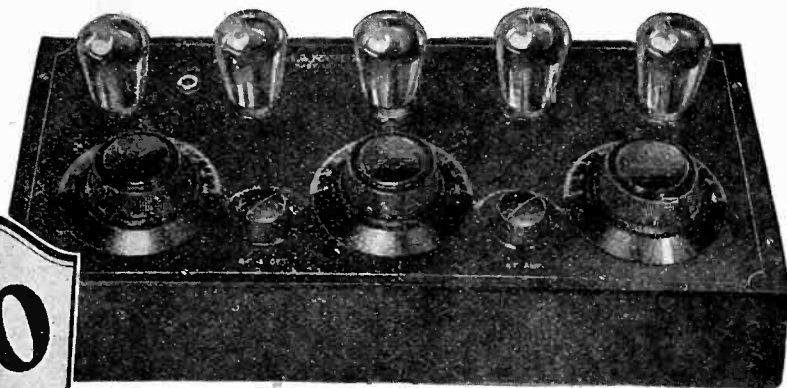

\$40

*At Last
A Guaranteed Set—
Price Beyond Comparison*



MARWOL HOME BUILDER includes three condensers, three radio frequency coils, complete lay-out of front panel, sub-panels and wiring diagram.

\$15.00

The remarkable success of the Marwol Circuit as incorporated in the Marwol Model A-1 is so great that it has made possible a Baby Grand Marwol. This identical famous circuit is now available in a different unique design—a great departure from the conventional model—at considerably lower cost! The Marwol Baby Grand is a 5-Tube Tuned Radio Frequency Receiver which differs from the original Marwol only in design! Offers the same remarkable selectivity and range, with ease of operation, that makes the Marwol today's best radio buy for the money! Write for descriptive folder. At your dealers—otherwise send purchase price and you will be supplied postpaid.

Price West of the Rocky Mountains - \$45.00

MARWOL RADIO CORP.

85-F Mercer Street, New York

DOLLAR FOR DOLLAR RADIO VALUE

Ware
NEUTRODYNE
Receivers
Type T \$65.00 Without Accessories
WARE RADIO CORPORATION, N. Y. C.

IXL RADIO CRYSTALS
The most sensitive long distance Radio Crystal known. Alive all over, no dead spots. Price 50 Cents
U. C. BATTERY AND ELECTRIC CO.
2158 University Ave., Berkeley, Calif.

SHARPEST TUNING
When You Use a **LOPEZ**
Low Loss Tuner
Price \$10.00
At your dealer's or sent postpaid
A. C. LOPEZ & CO.
334 Fifth Avenue, Dept. R-4
New York City

"AIR ROAMER"
A McCall Compensated Circuit set, simple to operate, extremely selective, giving true tones, rugged and economical. Write for details.
KILBOURNE & CLARK MFG. CO.
Seattle, Washington
Branches: Portland, Ore.; Los Angeles; San Francisco. Distributors: Pacific Electrical Company, Sydney, Australia.



DID you ever look the tube question square in the face? Ever stop to realize that the vacuum tube will make or break your receiving set as far as good results are concerned?

Give your set a fair chance to bring in the distant programs. Resolve now that a good set deserves good tubes and decide on MAGNATRONs. The results will pleasantly surprise you.

MAGNATRONs know no superiors. And yet the MAGNATRON DC-201A, the MAGNATRON DC-199 and the MAGNATRON DC-199 with the large base sell for only \$3 each, at your dealer's.

CONNWEY ELEC. LABS., MFRS.,
New York City

MAGNATRONs



\$2.00

All Types
Guaranteed

Send money order plus 10 cents Postage and we will send you a New Tube. No old Tubes required.

C. A. W. Laboratories

608 Chestnut St.
Suite 405 Philadelphia, Pa.

Solicitor of Patents and
Trade Marks
Counsellor in Patent Causes

JOHN FLAM

formerly of the Examining Corps, U. S. Patent Office, also of the Patent Department, General Electric Company. Specializing in Electrical and Radio Inventions. Graduate Electrical Engineer and Lawyer.

Member of the Federal Bar
1009 Merchants National Bank Bldg.
Los Angeles, Calif.

A PAIR OF HEADPHONE FREE

WITH only one subscription to "RADIO" for one year (\$2.50) we will give you a pair of 2000-ohm "PENNSYLVANIA" phones free.

This offer is good for the months of February and March only. Get your subscription and \$2.50 in the mails right now. Phones shipped on day order received.

PACIFIC RADIO PUB. CO., Pacific Building, San Francisco

(Continued from Page 63)

high voltage supply as in the case of the wavelength change switch. To change from telephone to telegraph transmission, the speech amplifier and modulator tubes are cut out of circuit, and the key-controlled grid biasing voltage (previously described) is inserted in the master oscillator circuit.

Actual transmission of voice or signals can be made either from a control desk near the set or from a distant point according to the position of a key at the control desk. The transmitting point can start or stop the set, by throwing a switch at the side of the telegraph key. This switch operates, through relays, to entirely disconnect the set from the power lines. In addition there is a safety push-button on one of the power panels which will prevent either control point from throwing power on the set.

Telegraph transmission may be either by hand or from an automatic sending machine. In this latter case, speeds well above 200 words per minute can be maintained. Telephone transmission is of a quality comparable to that of wire lines. A desk telephone is furnished, whose receiver may be connected to a radio receiving set for two-way conversation.

The antenna, which was erected under the supervision of F. C. Ryan, Signal Corps radio engineer, is of the flat-top "T" type. It contains 10 wires strung between towers 500 feet high and 600 feet apart. The ground lead divides into a number of wires which fan out and run to separate ground connections.

The antenna current at full power carries from 48 amperes to 64 amperes, depending on the wavelength.

So sharply does this set tune that it has been found practicable to install receiving apparatus to receive from Fort Douglas and from Arlington in a building only a mile and a half away. Loop antennas are used, and no interference from the nearby set is reported. High speed automatic tape transmission and reception is used to a large degree. It is possible to use the station as an automatic relay—that is, to allow the received impulses to operate a relay which controls the set—when the incoming signal is enough greater than the static.

In the station at Fort Leavenworth there is in addition to the Western Electric transmitter, a 5 kilowatt arc transmitter for distributing traffic to stations in that vicinity as a reverse against possible failure in the larger transmitter. There will also be a 100 watt tube transmitter for communication with other closeby stations. Two complete antenna systems are provided at Fort Leavenworth so that two transmitters may be operated simultaneously, and the transmitters will be controlled through wire circuits from a receiving station approximately two miles distant.

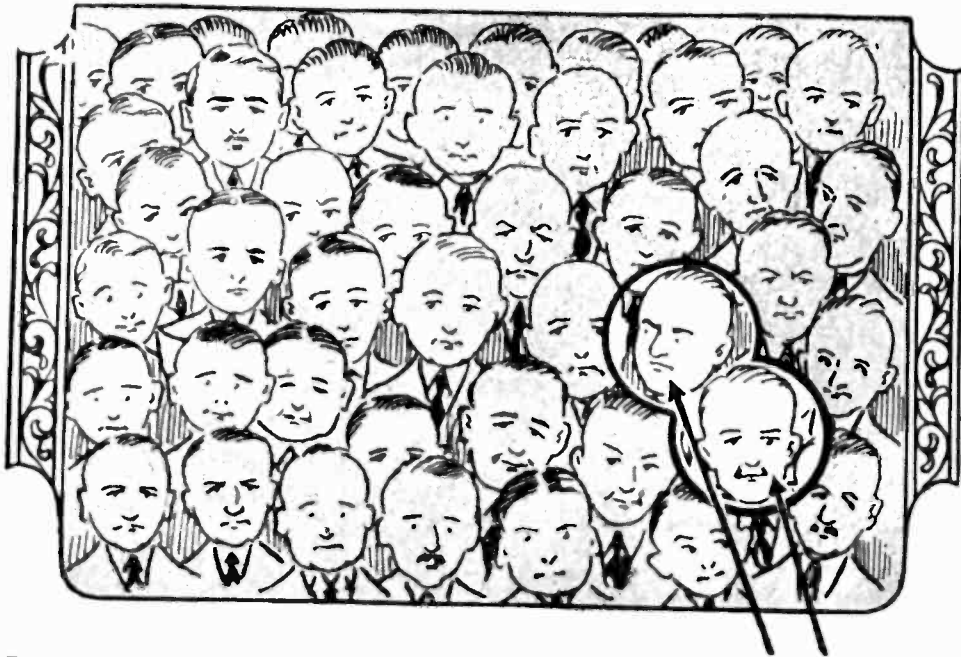

Mr. Manufacturer:

Would you write 100 letters to 100 people to reach just two men?

Then, before you invest your advertising dollars—**THINK!** An analysis shows that publications of general circulation, newspapers and magazines, devote less than 2% of their reading columns to radio—proving that, in the opinion of their own editors, less than 2% of their readers are interested in radio. In fact, many general publications carry no radio editorial matter. Therefore—98% of your investment is lost! On the contrary, the radio magazine offers 100% radio editorial—attracts 100% potential buyers.

Spend your advertising appropriation in Radio Magazines. Be sure of the greatest possible return on your advertising dollar.

Radio Magazine Publishers Association, Inc.

THIS ASSOCIATION IS COMPRISED OF THE LEADING RADIO MAGAZINES

RADIOCAST WEEKLY

48 Pages of
Programs, Photos, Humor
Musical Reviews, Schedules,
Tables, Editorials, Etc.

5c Per Radiocast Weekly
Copy 433 Pacific Bldg.
SAN FRANCISCO

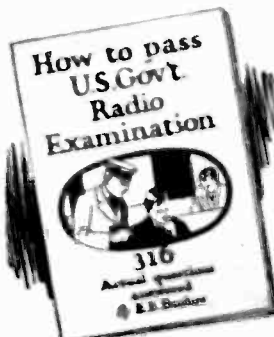

PASS the U. S. Government Commercial or Amateur Radio License examination. This book will help you do it. Send fifty cents in stamps or coin for your copy—postage prepaid to any point in the U. S., Canada or Mexico.

50c

RADIO INSTITUTE OF AMERICA
323 Broadway, New York City

BUILDING SETS TO MAKE MONEY

(Continued from Page 28)

of radio sets,—why should the amateur set builder “design” a new set each time he builds, as so many do? This “figuring” is what takes time,—a “standardized” panel with a template for marking or drilling saves mental worry, and much time.

In the end, where many sets are being built, it will be found a great advantage to make an accurate and full size template of each panel on heavy paper. Different instruments commonly used should also be “templated” to locate the position of mounting screws. If any particular set is often made, one panel properly drilled should be kept for a template and the drilling done through the holes in the panel. A template for two stages of audio with jacks, etc., may be used in making many types of sets with different detector circuits.

A radio clipping book kept indexed and up-to-date is a great help for analysis of unfamiliar circuits. It is frequently required of the set builder, that he “repair” some unfamiliar set. A clipping book will then be first aid.

A useful adjunct to set-building is a so-called “tube tester,” the meters of which are useful for other radio purposes, such as testing of resistances, for partial short circuits, etc. Payment for locating faults and improving the operation of inefficient receivers is generally inadequate. In order to save a lot of time in testing out apparatus and circuits, adequate apparatus should be available for making adequate tests, thereby making a saving in the end.

To make sure of satisfied customers, it is always advisable to make one final test of a set under what is as near as possible to be its actual operating conditions. Preferably, sets should be sold with tested tubes, and with grid leaks, if such are necessary, adjusted to the particular tube used for a detector, remembering that the average purchaser of a complete set knows little about radio and is possessed of but normal intelligence. Every effort possible should be expended to insure initial and continued satisfactory operation of all sets sold, for in order to “make money” through resale, it is essential to make “satisfied customers” with every sale.

“There is a large and growing group of amateurs who pursue radio for the love of the art, and the art to them is not the performance in the studio but the technical art of radio itself. Radio has enjoyed a greater following of amateurs than any other branch of engineering, and it is the thought of these amateurs that molds the future. They are one step closer to reality than the imaginative writers who give us glimpses of the future long before they can be realized. The amateur likes to anticipate what advances in the art may reasonably be expected within the next decade.”—E. F. W. Alexanderson.

A SHORT WAVE LOOP RECEIVER

(Continued from Page 32)

stuff. Bell wire will easily carry all the current, so there is no need of using bus bar. The set may be mounted on a panel or in a soap box. The farther the set is from the cabinet the better it works. Have the battery leads as short as possible. If they are over 2 ft. long place r. f. chokes consisting of 25 turns of No. 30 wire each one as close to the set as possible.

When running the set, the first thing noticed is the grave like silence. This continues until the set is tuned to the wave of a transmitting station, then that signal has the undisputed field, unless the static is very strong, or there is another station in the line of the one being listened to who is on exactly the same wave.

The best procedure in tuning is to set the bulb to oscillating and then swing the loop till a whistle is heard. Stop turning the loop and swing the secondary condenser to resonance, and there is the station. It was noticed that signals were much louder on the same wave as our transmitter. When the aerial switch was opened they decreased in audibility. The set was simply acting as a very loosely coupled receiver with no directional effect whatsoever. The short wave fones come in fine and with a fair audibility. When the loop and secondary circuits are exactly in resonance the set oscillates so violently the tube spills over. Detune the secondary slightly and maximum volume will be obtained.

The advantage of a receiver of this type is that the entire set is low loss. It gets away from coupling a low loss set to a high loss antenna and still higher loss ground.

RIBBON MICROPHONES

(Continued from Page 30)

below the range of audibility. When the ribbon is actuated by sound-waves intended to be broadcast, its motion translates itself into changes of potential, by reason of its cutting the lines of force, and these minute potential changes in the leads from the ribbon ends carried to the amplifier valves, send the broadcast sounds, as oscillations, on their way to the broadcast listeners in the same way that all other microphones do.

The writer was astounded by its quality of modulation, purity of tone and absence of extraneous sounds.

Just as a motor can be made to act as a dynamo so can the ribbon microphone be made to act as a loudspeaker of equal quality and speech-current impressed on the ribbon translates itself into motion which in turn, acting upon the surrounding air, produces sound. Tests with a loud speaker of this type, without a horn, will convince any scoffer that radio can deliver something more than "canned music, uncorked."

—“results are simply amazing”

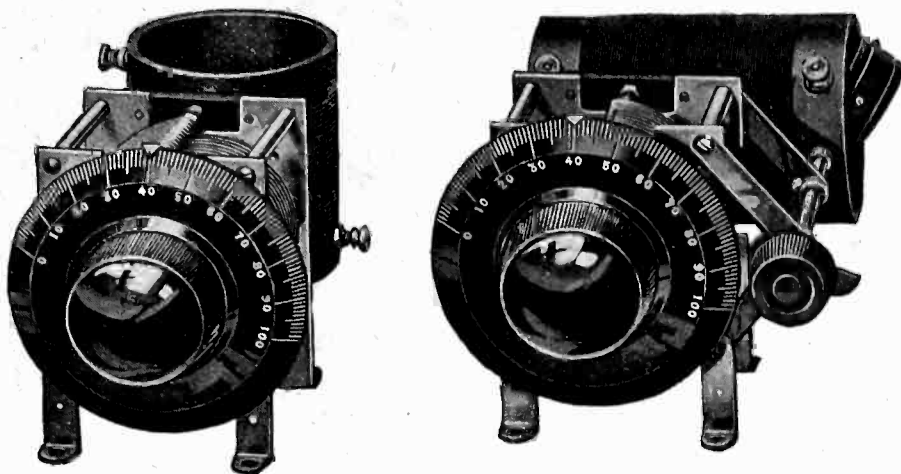

National Velvet Vernier Dial driving a National Condenser upon which is mounted the newest National radio products—

The National Antenna Coil and the National Regenaformer prime requisites of an efficient radio set

THE National Regenaformer is a tuned radio frequency transformer of highest efficiency. When used with a Browning-Drake receiver, the results are simply amazing. Sets using these parts have given transcontinental radio reception with ease.

Send for Bulletin 105R

NATIONAL COMPANY, Inc.

110 Brookline Street, Cambridge, Mass.

Engineers and Manufacturers. Established 1914

Sole Licensees for the manufacture of the National Regenaformer under the Browning-Drake Patents

RADION Black and Mahogany Dials, Tubing, Sockets, Horns PANELS etc.

“That special size for your super, phonograph, portable or odd size cabinet”

ALL STOCK SIZES
WHOLESALE RETAIL

Send for Price List

SPECIAL HARD RUBBER PARTS
MADE TO ORDER

New York Hard Rubber
Turning Co.

212C Center Street New York

Hook-Ups!
Hook-Ups!
Hook-Ups!

of all circuits in
**RADIO
WORLD**

The First Illustrated Radio Weekly
Other Great Features:

Wonderful Question and Answer Department; latest developments in radio art and science; human interest and technical pictures; helps for novice and expert; articles by the best authorities. Full of meat from cover to cover. 15c per copy. \$6.00 yearly (52 issues); \$3.00 six months; \$1.50 three months.

Special: \$1.00 for ten issues.

RADIO WORLD
1430 Broadway NEW YORK

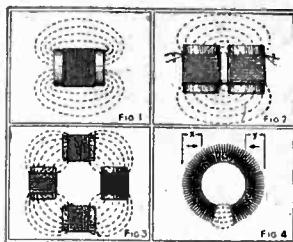
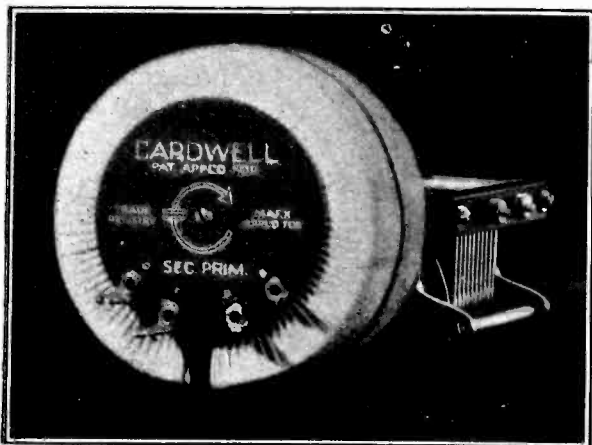

General Theory of the Toro-Tran
 Figure 1 shows how the field of the ordinary coil extends into space and increases losses due to stray field. Figure 2 shows a "double series" winding which restricts the field somewhat. Figure 3 shows a "four series" winding and the field almost enclosed. In Figure 4 (the Toro-Tran) the field is entirely enclosed and the losses due to stray fields are eliminated.
 Note that a stray signal passing through the coil at "X" is not introduced into the aerial or the tube is balanced out at "Y" by the reversed polarity of the winding. This rejects undesirable signals while the concentrated internal field builds up the tuned signal. Hence maximum distance and selectivity.

—and now the TORO-TRAN!

CARDWELL, whose pioneer "low-loss" condenser established new standards of radio efficiency, is now introducing the Toro-Tran*—the ideal balanced coupling inductance for all radio frequency work.

* TRADE MARK
 Registry applied for

The Toro-Tran eliminates signal energy picked up by ordinary coils from nearby stations. It eliminates magnetic feedback in multi-stage radio frequency circuits, thus removing the most active factor in causing howling and distortion and thereby increasing selectivity and distance. It rejects almost entirely the interference effects caused by electrical

power machinery, elevators, door bells, arc stations, etc.

The Toro-Tran winding confines the field to the inside of the coil, a small area, and thus avoids one of the greatest causes of loss known to radio receivers—that of stray magnetic fields which result in the absorption of signal energy and reduce the efficiency of the receiver tremendously.

Note these unusual advantages in assembly and operation

1. Compactness. The coils do not require spacing or angular mounting. They occupy less space than your condensers.
2. Permit exact nullification for tube and stray capacity without guess work or tedious testing.
3. Closed magnetic field eliminates magnetic feedback in tuned radio frequency amplifiers.
4. Low distributed capacity due to air spacing of each winding and to low voltage-drop per turn of small diameter wire.
5. Maximum coupling and high ratio of voltage increase due to concentrated field with zero leakage.
6. Absence of all supporting insulation in the field of the coil. This is one of the greatest

loss factors in the ordinary circuit and is not remedied by "skeleton" or so-called "low-loss" windings.

7. Ease of neutralizing oscillation due to tube capacity by means of rotating control which anyone can "balance."

8. Low capacity between primary and secondary, affording maximum transfer of energy to succeeding grid-circuit.

The Toro-Tran has a lower "circuit resistance" (i. e. effective resistance as assembled in a set and not as isolated in the laboratory for theoretical measurements) than any inter-stage tuned transformer made and has a correspondingly higher amplification factor, its ratio exceeding ten.

To appreciate the many remarkable advantages of the Toro-Tran write for our two free booklets: "The Torodyne Circuit" and "The Most Interesting Radio Frequency Transformer Ever Invented."

Toro-Trans are ready to mount in any tuned radio frequency circuit. Replace your ordinary coils with Toro-

Trans. You will be astonished with the results. Most .00035 mfd. variable condensers will tune them, but by using Cardwell Condensers you get maximum efficiency.

Order from your dealer or direct

CARDWELL TORO-TRAN WITH BALANCING POTENTIOMETER	\$ 4.00
Cardwell .00035 Condenser for tuning	4.75
Cardwell .00035 Vernier Condenser	6.25
Cardwell .00035 Dual Condenser (two-in-one)	8.00
Cardwell .00035 Triple Condenser (three-in-one)	12.00
Cardwell Audio-Trans (compound audio transformers)	10.00

The Allen D. Cardwell Mfg. Corp.
 81 Prospect Street, Brooklyn, N. Y.

Log for Your Radio



NEW 64 page log. Holds 400 stations. Shows calls, cities, wave lengths, dial settings, remarks, etc. TUNING SUGGESTIONS. Station list by wave lengths—by states, etc. Owners' Map. TROUBLE AIDS. Other valuable information. So convenient. Worth many times small cost. A joy to use. GENUINE De Luxe leather cover. Only \$1.

Send No Money. Pay postman after log arrives. Post-paid if pay with order. MONEY REFUNDED if not DELIGHTED. Order today—NOW. Postal will do RADIO PRINTERS, Dept. 3474 Mendota, Illinois

MELCO

SUPREME RECEIVER

BY

AMSCO PRODUCTS, INC.

BROOME & LAFAYETTE STREETS, NEW YORK

EXPERIMENTING

(Continued from Page 22)

and constant experimenting with it will often aid minor noises. It is best not to solder any of the connections between the various instruments, for then they will always be free to change. And remember, while a hook-up may give excellent results on the board, the changed relationships made when placing it in a cabinet may utterly ruin its receptive qualities.

Be sure to try out the various types of rheostats as soon as possible. Acquire one of each type and compare them. The detector tube needs a filament rheostat that will give stepless control if your tube is at all critical, while the amplifying tubes do not have to have such careful adjustment. While experimenting note how the detector tube governs the clarity of a signal; the slightest turn will clear up a message that the average BCL would not even know was on the air.

A small 'phone condenser shunted across the primary of the first amplifying transformer will strengthen the signals. Do not place the several transformers in a line so that the magnetic fields coincide. Keep them at right angles, and a couple of inches apart. The wiring must not run parallel; for if it does the former good work will be undone. In fact, it will be wise to use only flexible wiring on this table and do away with any temptation to make the wiring neater by parallelizing it. Finally, make sure the grid lead from the amplifying transformer comes from the outside of the secondary; there is a great loss of efficiency if it does not.

It is so often that the simplest of things throws the trouble-shooter off that the admonition about socket prongs must be repeated. The tubes may light perfectly and the trouble lie with the grid or plate connections so make certain that all four prongs of the tube are making proper connections.

Have a large variable air condenser on your table, and arrange it so that a switch will throw it into either the aerial or ground circuit. Some stations will come in better on one than on the other, and it is experimenting along these lines that lead to new discoveries. A switch may also be arranged that will place it in parallel with the primary coil, as at certain times this will give added strength to the signals.

Send \$1.00 for a trial subscription to "RADIO" for 6 months.

JANUARY "RADIO"

Per Copy Only a Few Left

25c

"RADIO" SAN FRANCISCO

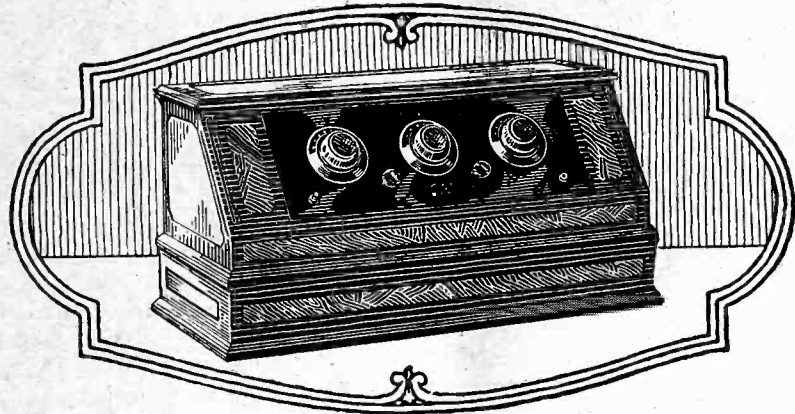

Distinguished for its Musical Excellence!

Refinements had to come before radio could make its true appeal on the basis of musical excellence.

This was the view of the Thompson engineers, who, with fifteen years' experience in manufacturing wireless equipment to their credit, set their ample resources to the task of producing a radio receiver which should be not "just a radio," but a musical instrument.

On every hand the Thompson Neutrodyne is acknowledged as the maestro of radio, a truly fine musical instrument by every standard. The recognition accorded the Thompson is due to Thompson Tone.

Tone that is versatile in its handling of every sensitive shade of music. Tone that falls pleasantly upon the ear of the most orthodox music-lover. Tone that does not and cannot offend the sensibilities of the most critical listener. Thompson Tone!

SIX TUBES GIVE DISTANCE WITH VOLUME

An unique transformer (an exclusive Thompson engineering feat) permits the use of six tubes in the Thompson Neutrodyne — an achievement heretofore confined to the experimental laboratory. Distant programs that come in faintly (if at all!) on ordinary receiving sets are delivered with the volume and brilliance of nearby broadcasts on the 6-tube Thompson.

THREE SETS FROM WHICH TO CHOOSE

The 6-tube Thompson Concert Grand, illustrated above, retails at \$185. This is unquestionably the finest thing in radio today at any price. There is also the 5-tube Thompson Parlor Grand which retails at \$150. Thompson quality throughout, but with one tube less than the Concert Grand. Then there is the 5-tube Thompson Grandette which retails at \$130. This differs from the Parlor Grand chiefly in size and cabinet work.

R. E. Thompson Mfg. Co., 30 Church St., N.Y.

THOMPSON RADIO



The Thompson Speaker

The Thompson Speaker contains over-size magnet and coils, amplifying armature, diaphragm in scientific cone shape. The volume regulator enables adjustment for varying strength of near and far stations. Uses no battery current. For supremely natural home radio — The Thompson Speaker — Retail at \$30.





Best of all

NO ELECTRICAL EXPERT NEEDED

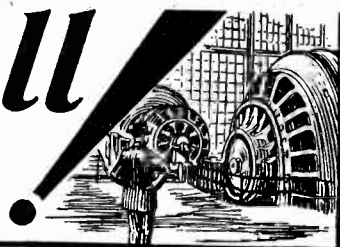

TO OPERATE THE NEW

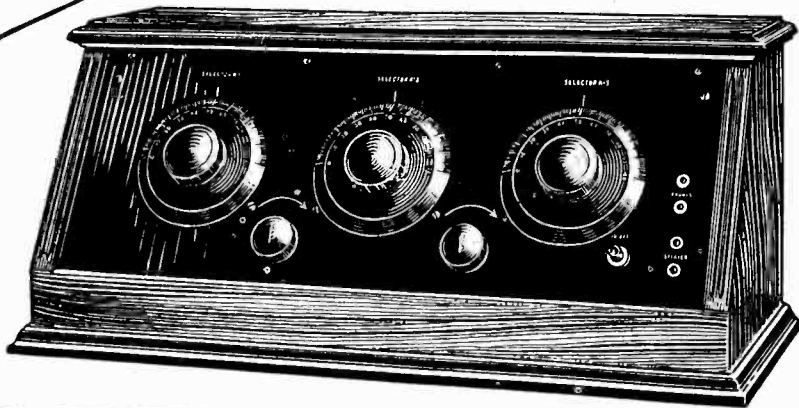

CHELSEA

SUPER-FIVE

5 TUBE RECEIVER \$50.00

West of the Rocky Mountains \$60.00

The name CHELSEA is synonymous with GOOD RADIO, maintaining always a rigid standard of supreme quality. CHELSEA manufacturers have succeeded in embodying in the new SUPER FIVE—all the extraordinary receiving principles of the highest priced sets. Made by one of the oldest radio manufacturers, the New CHELSEA in its mahogany finished cabinet with Bakelite panel, is a most remarkable set to own.

On sale at all good dealers—Catalog sent on request

CHELSEA RADIO COMPANY 179 SPRUCE STREET ~ CHELSEA, MASS.

Chicago St. Louis Seattle Denver Los Angeles San Francisco Cleveland

MATHISON'S POLAR CRYSTAL

Mined North of the Arctic Circle
Gives sharper tuning, more volume and longer life. A solid, sparkling silver ore, not "doped" or coated. The most sensitive radio crystal in the world. A postal card brings you one. Price each.....85c

MATHISON SILVER ORES CO.
OF ALASKA

American Agents

Radio Owners Service Co.
600 Twelfth Street, Oakland, Calif.

NO AERIAL NO LOOP THE Antennaphone INCREASES SELECTIVITY IMPROVES RECEPTION REPLACES THE AERIAL



The Antennaphone will prove a big help to radio reception this Spring and Summer because it reduces static interference and eliminates danger of lightning. No lightning arrester is necessary. Easy to install. The Antennaphone is not attached to, but merely placed under the telephone. Works perfectly with any type receiving set.

Sold with a money-back guarantee

AT YOUR DEALER or sent by mail upon receipt of One Dollar
ANTENNAPHONE CO., 90 West St., New York City

BROWNING-DRAKE RECEIVER

(Continued from Page 15)

night after night reception. Stations from 1000 to 1500 miles are played consistently on the speaker and with exceptional quality, too. The set does not need a publicity campaign to float it. It is not a trick circuit but a good old standard circuit with the weak link in the chain removed. Every builder causes two or three more to be built.

For those who care to experiment with this transformer in a non-regenerative circuit the primary should be increased to 35 turns as previously explained. There is hardly a circuit in use today that cannot be improved through the adoption of this transformer.

Just a few precautions before closing.

1. Mount the coils at right angles to one another so that the center of one is in a direct line with the center of the other or neutralization will be almost impossible.

2. Lack of selectivity is usually caused by the .0001 antenna series condenser being of too high a capacity. They are seldom what is stamped on them. It should be .0001 or less. Resistance caused by bad soldering between the coils and condensers will also cause broad tuning.

3. The set is decidedly critical to grid-leaks. A good variable one with high resistance must be used. Unless the first tube is perfectly neutralized the regeneration in the detector is almost impossible to control and some ear-splitting howls will come out to greet you. Don't blame the leak in this case.

4. Neutralization may be obtained as follows. Turn the tickler to a point where placing a moistened finger on the grid side of the condenser C_2 will give a "pluck." Turn back the tickler until this pluck just disappears. Then rotate condenser C_1 and if, at any setting of this condenser, touching the grid side of it causes a "pluck" the set is not neutralized. Then vary the neutralizing capacity until the test proves satisfactory and the "pluck" disappears.

When tuning the set turn the tickler well up and rotate C_2 until the whistle of a station is heard (The tube ahead prevents radiation so you will not affect your neighbors reception). Then turn C_1 until the whistle is loudest, readjust C_2 until the lowest pitch in the middle setting of the whistle is heard. Now turn back the tickler until this whistle disappears entirely. Again adjust C_1 until the signals are strongest and make a final adjustment with C_2 . With a proper grid leak the set will slide very gradually into oscillation.

ARE YOU A SUBSCRIBER?

Send for Trial Subscription
\$1.00 for Six Months

25 Stations in U.S. from Ottawa

Mr. O. Schoenher, 164 Creighton Street Ottawa, Canada, writes: "Yours are the best tubes I have used. With one Myers Tube I have heard in one night, about 25 stations in the United States. The farthest one was San Francisco." Such results are achieved with Myers Tubes because the leads are not bunched as in the bulbous or incandescent types. They function in any position as detectors, amplifiers or oscillators.

Three types for dry and storage batteries. Complete ready to mount. At your dealer's or sent postpaid for **\$4**
251 Craig Street, Montreal 11

Myers Tubes

Practically Unbreakable

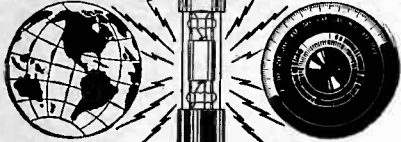

"The World On Your Dial"

Write for descriptive circular

FREE DIALS

Get 3 Four-inch

Bakelite Dials positively free. Send us your subscription to "RADIO" for 1 year (\$2.50) and we will mail you 3 four-inch dials as a premium.

"RADIO," San Francisco

TOWN-CRIER SPEAKER



The Voice that Thrills!

Price \$17.50
WEST OF ROCKIES \$18.50

THE TOWN CRIER

affords clarity, volume, tone range—most natural reproduction. It is vibration-proof . . . without wooden or metallic sounds. Small, compact, sturdy—not easily overturned. Unit of the finest type. It is the Superior Speaker!

Sales Representatives Wanted
WRITE

The TOWN CRIER is a master instrument. It represents the last word in Radio Speakers. It is made right, to sell right, and stays sold. Dealers and Jobbers will find the Gale Sales and Advertising Plan well worth investigating. Write us for complete data and discounts.

DEALERS—JOBBER
Samples sent for your inspection.
Circulars Upon Request.

GALE RADIO LABS.
2514 Irving Park Blvd. Chicago

You will never know the thrills of radio until you own a

FRESHMAN MASTERPIECE



The Greatest Value ever Offered in a Radio Receiving Set

5 tube tuned radio frequency

embodying the 5 big features demanded in a perfect receiver.

- ☑ Built of only the finest low loss material in a beautiful mahogany cabinet (or soft-toned leatherite);
- ☑ It brings in far distant stations,
- ☑ Night after night at the same points on the dials,
- ☑ With real loudspeaker volume,
- ☑ And full throated, true to life tone.

Be sure the serial number is riveted on the sub-panel. It is your protection and guarantee.

Chas. Freshman Co. Inc.
Radio Receivers and Parts
FRESHMAN BUILDING
240-248 WEST 40TH ST.—NEW YORK, N.Y.

\$60

At all dealers

If you want to INSURE RECEIPT of "RADIO" regularly, send \$1.00 today for a special 6 months' trial subscription

DURHAM Grid Leaks

Used by Eagle, Howard, Thompson, Zenith and others. Fit all sets. Sold on guarantee.

50c Metallized Fixed Leaks
18 sizes; under 1/4 meg., 75c; over 1/4 meg., 50c.

Glass Sealed Variable Leaks
3 sizes fit all sets; 75c each for 1/10, 5 and 10 megs. **75c**

At dealers or postpaid

DURHAM & COMPANY, Inc.
1936 Market Street · Philadelphia, Pa.

FROST-RADIO PAN-TAB JACKS ARE BEST for YOUR RADIO SET

The finest radio jacks made, for either panelhung assembly or usual installation. At your dealer's, 70c to \$1.00 list.

HERBERT H. FROST, Inc.
314-324 West Superior Street Chicago

FREE!

Everyone Interested in RADIO Should Write for this FREE Radio Book



The Greatest Bargain Catalogue published. Chuck full of thousands of Radio Bargains at the lowest prices to be found anywhere in the United States.

Parts, Supplies, Sets, Parts for Sets, Latest Circuits.

Send for this catalogue TODAY.

Cotton Super-Het., Complete parts	\$72.50
Gerald M. Best Super-Het., Complete parts	\$69.95

Wholesale Radio Service
Dept. Z
9 Church St., New York City

\$1.00 Brings You "RADIO" for Six Months. Subscribe Right Now!

The DAVEN RESISTANCE COUPLED AMPLIFIER KIT

Those who build their own can easily achieve perfect reproduction. There is nothing to equal Resistance Coupling.

The DAVEN AMPLIFIER KITS are supplied in either three or four stages and come with complete instructions for assembly. They are easy to build and highly efficient in operation.

SOLD EVERYWHERE

Secure from your Dealer, the "Resistor Manual" our complete handbook on Resistance Coupled Amplification. Price 25c; postpaid, 35c.

DAVEN RADIO CORP.
"Resistor Specialists"
Newark, New Jersey

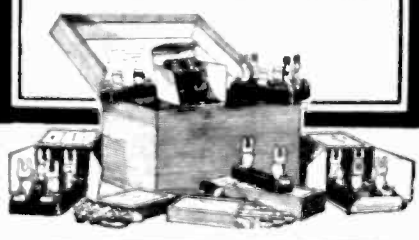

Make Your Own Set at Half Cost!
THE GENUINE SHAMROCK HARKNESS TWO-TUBE REFLEX **\$35**

SHAMROCK

FOR SELECTIVE TUNING

HARMONIC INTERFERENCE

(Continued from Page 37)
the latter wavelength. Furthermore, it will sound just as if the amateur were on this wavelength. While it is true that if the amateur were using absolutely pure direct current, such as is furnished from a storage battery, the listener would not hear him, the fact remains that the instant any radiocast station started up, heterodyning with the latter, interference would result.

It is hard to explain to some people that this is actually the case, but it is a fact that amateur interference is often due to the many harmonics in the receiver used, instead of due to any interference caused by the actual broadness of the amateur transmitter. Fortunately, amateur stations are usually of moderate power, and in but very rare cases are they even making use of the 1,000 watts lawful power input limit, and as a result they do not cause as much interference as might be thought probable at first.

Many commercial stations also, are operating on the lower wavelengths, and new ones will be added constantly to this list. These stations are used for commercial traffic, and are within their rights, legally, and every other way, yet they do cause considerable interference. These short wave commercial and government stations use considerable power, often as much as 15 to 30 kw. plate input, and hence emit quite powerful signals from their antennas. The actual interference is not great, but due to the comparatively large power input, they will excite and interfere on the harmonics of receivers many miles distant.

Again, such interference is very liable to happen, as radiocast stations are established on the lower wavelengths, between 200 and 300 meters: For example, if a 500 watt station were to be established and operated on 254.5 meters, and a listener wished to listen in to the program of a distant station, on twice this, or 509 meters, it might be impossible to do so, as the two stations would come in on exactly the same setting of the oscillator dial, despite the difference in the tuning of the loop. If the lower wavelength station was very weak, this interference might be reduced so as to just be heard, and as the signal strength varied, it would go up, until it might even drown out the distant station entirely.

Nevertheless, all this interference does not exist—in the true sense of the word. It is actually due to the harmonics of the oscillator in the receiver, or else in the harmonics of the oscillating tube in the regenerative receiver. Remember, therefore; if you are troubled by interference from an amateur station, commercial, or government, or similar short wave station, it may be that this is caused in your own receiver, instead of in the mis-adjustment or tuning of the transmitter.

5c

brings you a copy of "Radiocast Weekly"

Photos Programs Schedules Humor Reviews News, Etc.

for Pacific Coast RADIO-CAST WEEKLY 433 Pacific Bldg. San Francisco

DONGAN

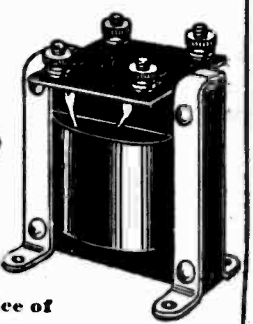

AUDIO TRANSFORMER

Choice of 35 Set Manufacturers

Receiver performance reaches its ultimate through Dongan Audio Transformers, designed and built in the big Dongan plant devoted exclusively to the manufacture of electrical devices for 15 years. Set manufacturers find Dongan the most practical of all Audio Transformers for their purpose.

Fits All Hook-ups Ratio 3 1/2 to 1.0 to 1

Ask our engineering department for facts. Individual set builders, see your dealer or write us direct for information.

DONGAN ELECTRIC MFG. CO.
2961 Franklin Street, Detroit, Michigan

Distributors for Western Coast:
SIERRA ELECTRIC CO.
515 Market Street, San Francisco
443 S. San Pedro Street, Los Angeles
222 Hineckley Building, Seattle
ROBINSON SALES CO.
53 Fourth Street, Portland, Oregon

Transformers of Merit for 15 Years

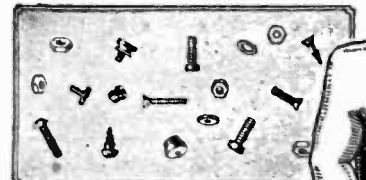

ONE C & C REACHIT WRENCH

TAKES THEM ALL

No necessity to pick over a half dozen wrenches to fit one nut when you use a REACHIT wrench. It not only fits all sizes but automatically HOLDS THEM ALL firmly (with adjustable jaws) while getting into the intricate positions.

NO OTHER WRENCH CAN DO THIS
It assures a tight connection in the hard-to-get-at places.

A REAL TOOL FOR MECHANIC, ELECTRICIAN & RADIO BUILDER
Nickel finish—Hardened Jaws and Fully Guaranteed.

PRICE \$1.00

If your dealer cannot supply, will be sent post paid on receipt of above amount and your dealer's name

CAUFMAN & CLOUGH CO.
Wilmington Delaware

