

March, 1923

25 Cents

RADIO



SPECIAL RADIO FREQUENCY AMPLIFICATION NUMBER

*Immediate Demand
for New*

*Cunningham
Amplifier
Tube*

Type C-301-A

List Price \$9.00

The most efficient vacuum tube ever placed on the market for amateur and experimental use. The engineers of the General Electric research laboratories have at last succeeded in perfecting a tube that every owner of a radio set has been waiting for.

**Greater Power Amplification
Only $\frac{1}{4}$ Amp. Filament Current**

Filament potential 5 volts
Filament current .25 amp.
Plate potential 20 to 100 volts
Plate impedance 16,000 ohms
Amplification constant 6.5

THIS new and improved Cunningham C-301-A Amplifier is a high vacuum tube designed for use as an amplifier and detector, containing a new Tungsten Filament, the characteristics of which are long life, low power consumption, low operating temperature and greater power amplification than any previous amplifier tube. The tube has a standard four prong base, and the glass bulb has the same dimensions as the C-300 and the C-301.

The greatly reduced filament current permits the use of four of these tubes without exhausting the A battery any faster than when using one of the previous type of amplifier tubes.

Complete instructions for the care and efficient operation of this new Amplifier Tube are packed with every tube.

Insert a C-301-A in your amplifier set today. Note the improved quality and increased audibility.

The Cunningham Technical Bureau is at your Service. Address your problems to Dept. K

E. J. Cunningham

248 First Street
San Francisco, California

154 W. Lake Street
Chicago, Illinois

Burgess, the *Radio* Battery

Specified by radio engineers—designed and built by wireless specialists—and recommended by the leading manufacturers of radio equipment.

Burgess Radio Batteries, the result of years of careful experiments are built under exacting manufacturing standards which must meet the requirements of strict laboratory formulae and tests—a supervision that insures their perfect operation.

For professional or amateur radio use, where noiselessness, long life, high capacity and uninterrupted,

dependable service are essential, Burgess has no superior.

Burgess Batteries are built for both "A" and "B" circuits. The Burgess No. 6 is used and found most satisfactory on the "A" or filament circuits equipped with the new type one and one-half volt vacuum tubes. The Burgess "B" Battery is everywhere recognized as the Standard of Quality in the wireless field.

BURGESS BATTERY COMPANY
Engineers — Dry Batteries — Manufacturers
 FLASHLIGHT—RADIO—IGNITION—TELEPHONE

General Sales Office: Harris Trust Building, Chicago
 Laboratories and Works: Madison, Wisconsin

Branches: — New York Boston Washington St. Paul Kansas City New Orleans

In Canada: BURGESS BATTERIES, Ltd.
 Winnipeg, Toronto, Montreal

BURGESS RADIO BATTERIES

"ASK ANY RADIO ENGINEER"

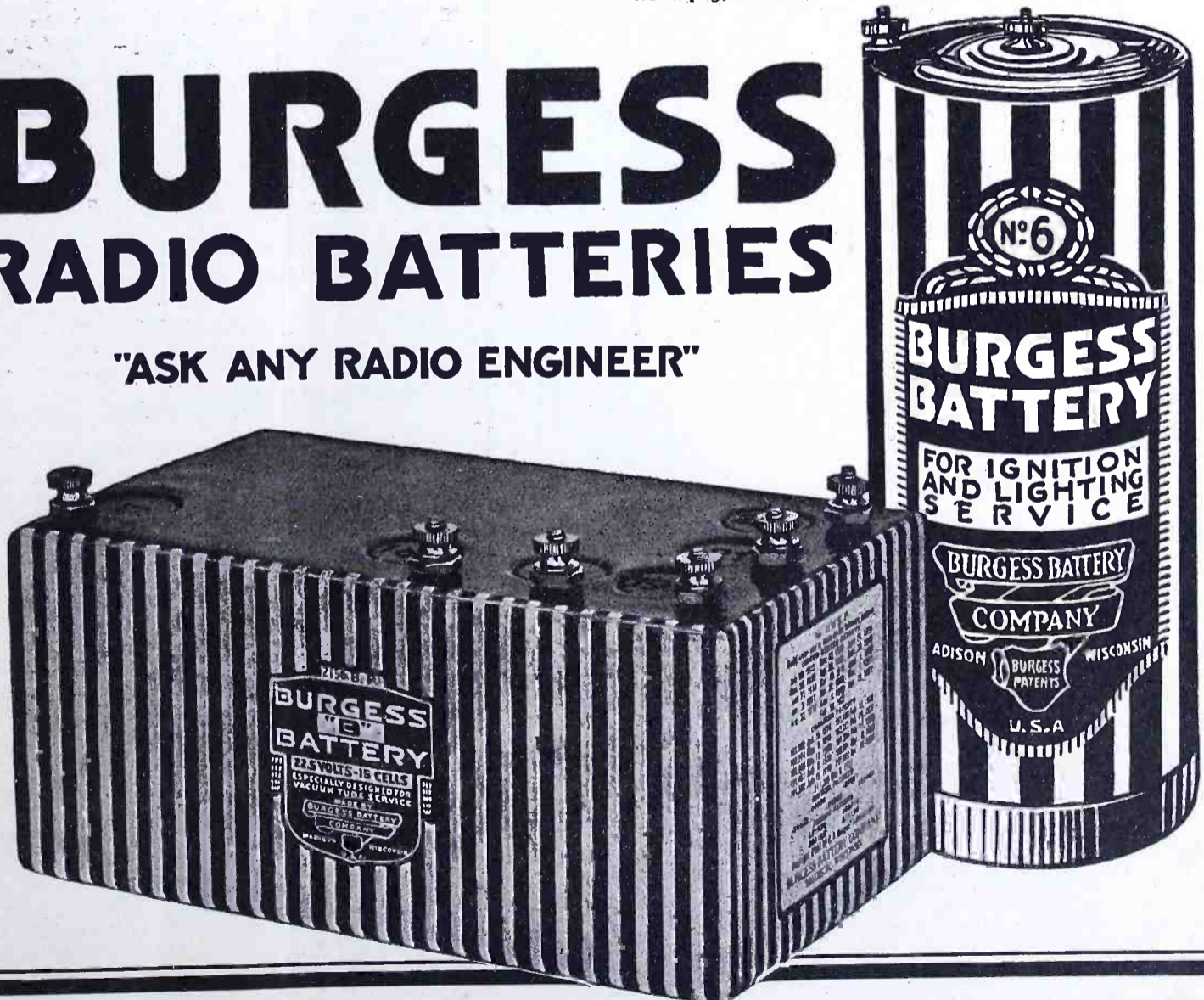

Tell them that you saw it in RADIO

RADIO

Established 1917 as Pacific Radio News

Volume V

for MARCH, 1923

Number 3

CONTENTS for MARCH, 1923

Radiatorial Comment	9
A Simple Radio Frequency Amplifier	10
By SAMUEL G. MCMEEN	
A Simple Radiotelephone That Works	11
By GERALD M. BEST	
A Home-Made D.X. Radio-Audio Frequency Receiver	13
By W. H. WATERMAN	
Regenerative Receiving and Transmitting Circuits	15
By ELLERY W. STONE	
Inside Wiring for Radio Outlets	16
By STANLEY E. HYDE	
More Convenient Honeycomb Coil Mounting	17
By AARON NADELL	
Radio Adventures in Russia	18
By JACK BRONT	
The Martian Marvel	19
By VOLNEY G. MATHISON	
"Sparks" and "Bozo" Make A Call	20
By S. P. WRIGHT	
Some Radio Frequency Theory	21
By DONALD K. LIPPINCOTT	
"Radio Frequency is Great Stuff"	23
By EARL ENNIS	
A. C. Radio Motors and Generators	25
By D. B. MCGOWN	
Successful Trans-Atlantic Radio Telephony	26
The Armstrong Super-Regenerative Circuit	27
By T. N. SLOCUM	
Comparison of Vacuum Tube Characteristics	28
By GERALD M. BEST	
An Efficient Broadcast Receiver	30
By SIX ZEE JAY	
Problems Introduced by Radio Broadcasting	31
By JEROME SNYDER	
News of the Broadcasters	33
Letters to The Editor	34
With The Amateur Operators	35
Digest of Recent Radio Patents	38
Queries and Replies in C. W. Practice	39
New Apparatus and Supplies from the Radio Manufacturers	41
Calls Heard	42

RADIO is Published Monthly by the Pacific Radio Publishing Co., Inc.,
Pacific Building, San Francisco, Calif.

ARTHUR H. HALLORAN	Editor
LAWRENCE MOTT	Associate Editor
LOUIS TREVISO	Art Editor
GERALD M. BEST	Technical Adviser
O. SCHUWENDT	Engineering Draughtsman
H. W. DICKOW	Advertising Manager

Branch Offices: 17 West 42nd St., New York City, Telephone Longacre 8248; 157E. Ontario St., Chicago; 761 Spitzer Bldg., Toledo, Ohio; 52 Irving Street, Boston, Telephone Copley 5107-R; 1102 Republic Bldg., Kansas City, Mo.; Suite 511, 456 So. Spring St., Los Angeles, Cal., Telephone 12050; 2218 Third W., Seattle, Wash., Telephone Elliot 1903.

Advertising Forms Close on the First of the Month Preceding Date of Issue.

Issued Monthly, 25c a copy. Subscription price \$2.50 per year in the U. S., \$3.00 per year elsewhere. Instructions for change of address should be sent to the publisher two weeks before the date they are to go into effect. Both old and new addresses must always be given.

Entered as second-class matter at the Post Office at San Francisco, Calif., under the Act of March 3, 1879.

Copyright 1923, by the Pacific Radio Publishing Co., Inc.

Forecast of Contributions for April Issue

David P. Gibbons contributes another one of his humorous Japanese stories in "Scratchi Publishes Some Third Class Matter," therein taking a fling at sensational radio magazines.

"Making The Set Pay Dividends" is a timely article by C. A. Reberger which may suggest some ideas for getting the money to buy new tubes for your receiving set.

S. P. Wright drops some valuable hints about making a convenient test-board for trying out new hook-ups.

Maurice Buchbinder gives complete details for building a short-range radio-telephone set involving the principles of the C. W. 936 Western Electric model.

"How To Plan Your Set" is the subject of a helpful article by Paul McGinnis, which should be read by anyone contemplating the construction of a receiver.

Every amateur will welcome a four-page article on "Tuning a Double-Circuit Regenerative Receiver." This gives every detail of manipulation so as to produce satisfactory results.

Florian J. Fox describes the construction of a closed core magnetic rectifier for charging storage batteries. This type is electrically more efficient than a tube rectifier, as it rectifies both halves of the cycle.

The thirteenth and fourteenth assignments in the University of California correspondence course in Elementary Radio by Ellery W. Stone will be concerned with tube modulating circuits for radio-telephony and with the operation of a broadcasting station.

Six Zee Jay, whose article on an efficient broadcast receiver appears in this issue, will have a story of an air-core audio frequency amplifying transformer in the next.

"Distributed Capacity: Its Effect and Measurement" is discussed by Jesse Marsten in a simple and interesting manner. It is shown to be the cause of non-regeneration and other coil troubles at low wavelengths. Knowledge of the material in this article will be of great help in designing a set.

An interesting account will be given of the new DeForest Phonofilm, a method for recording sound and pictures simultaneously on a movie film. This will be illustrated by photographs and circuit diagrams.

Carlos S. Mundt gives detailed directions for making a chemical rectifier for a 5-watt C. W. transmitter. His own at 6AJ has been in operation for two months without heating or requiring any attention.

The user of a peanut tube will rejoice in an account of "An Improved 1½-volt Wet Cell for Filament Lighting" by Arthur S. Gordon.

“When happiness or calamity is about to come,
 said Confucius, it can be known
 beforehand.” Insure complete
 radio happiness with
Grebe Receiver.

Doctor Mu.

IF YOU buy inferior radio apparatus
 you must not expect the best
 results.

Its long record of satisfactory serv-
 ice has won for the Grebe Receiver
 the unqualified endorsement of all
 experienced radioists and dealers.

Your copy of “Musings of Doctor
 Mu” sent free upon request.

A. H. GREBE & CO., INC.
 RICHMOND HILL, N.Y.



Licensed under
 Armstrong U. S.
 Pat. No. 1113149



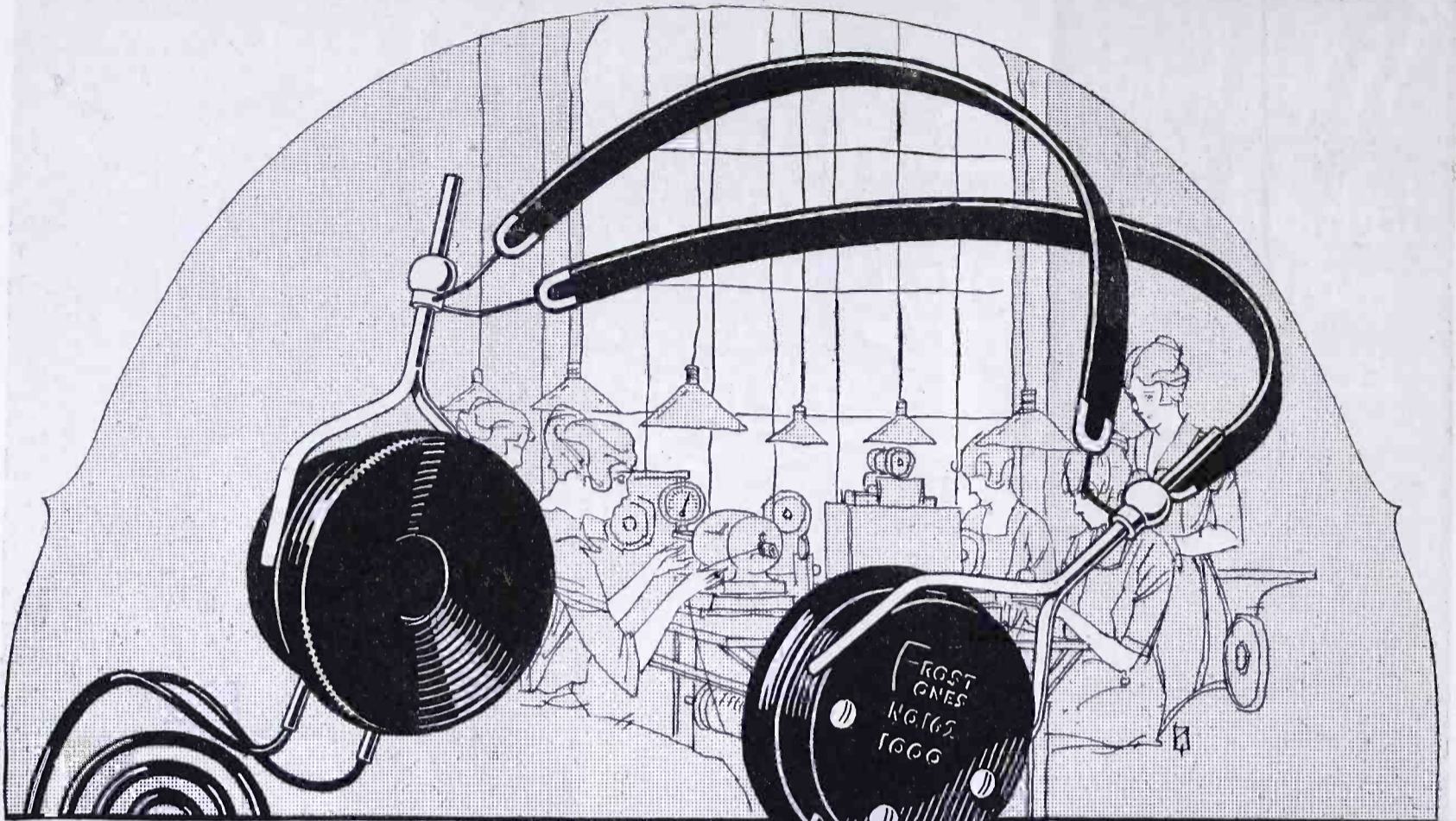

Super-Inspected Quality

Your dealer
Sells Frost Fones
See him today

No. 162
2000 Ohm Set

\$5.00

No. 163
3000 Ohm Set

\$6.00

FROST Fones have always been true to an engineering ideal. Built for precision and sensitivity, they quickly won national repute.

Today Frost Fones are the largest selling head fones in the world. Frost ideals of quality—of precision in manufacture—of rigid inspection during every stage of the making of these famous Fones—insure permanent satisfaction to every one who buys a pair.

Each item in the Frost Radio line is made up to highest standards of radio engineering. You can order Frost Fones, Plugs, Jacks, and other apparatus from your dealer with the certain assurance that your money buys the best that can be made, at prices which only quantity production make possible.



HERBERT H. FROST, Inc.
154 WEST LAKE STREET, CHICAGO, ILLINOIS.

Tell them that you saw it in RADIO

THIS De Forest D-7 Reflex Radiophone* is the famous receiver which has been attracting nation-wide attention by receiving half the Continent on an indoor loop aerial, under most adverse receiving conditions. It is notable for the elimination of extraneous noises and the absence of distortion, and its single-knob control makes it particularly easy to operate. This is probably the most compact, beautiful, and highly selective receiving set in existence. De Forest dealers carry both De Forest and RadioCraft sets.

De Forest Radio Tel. & Tel. Co.
Jersey City, N. J.

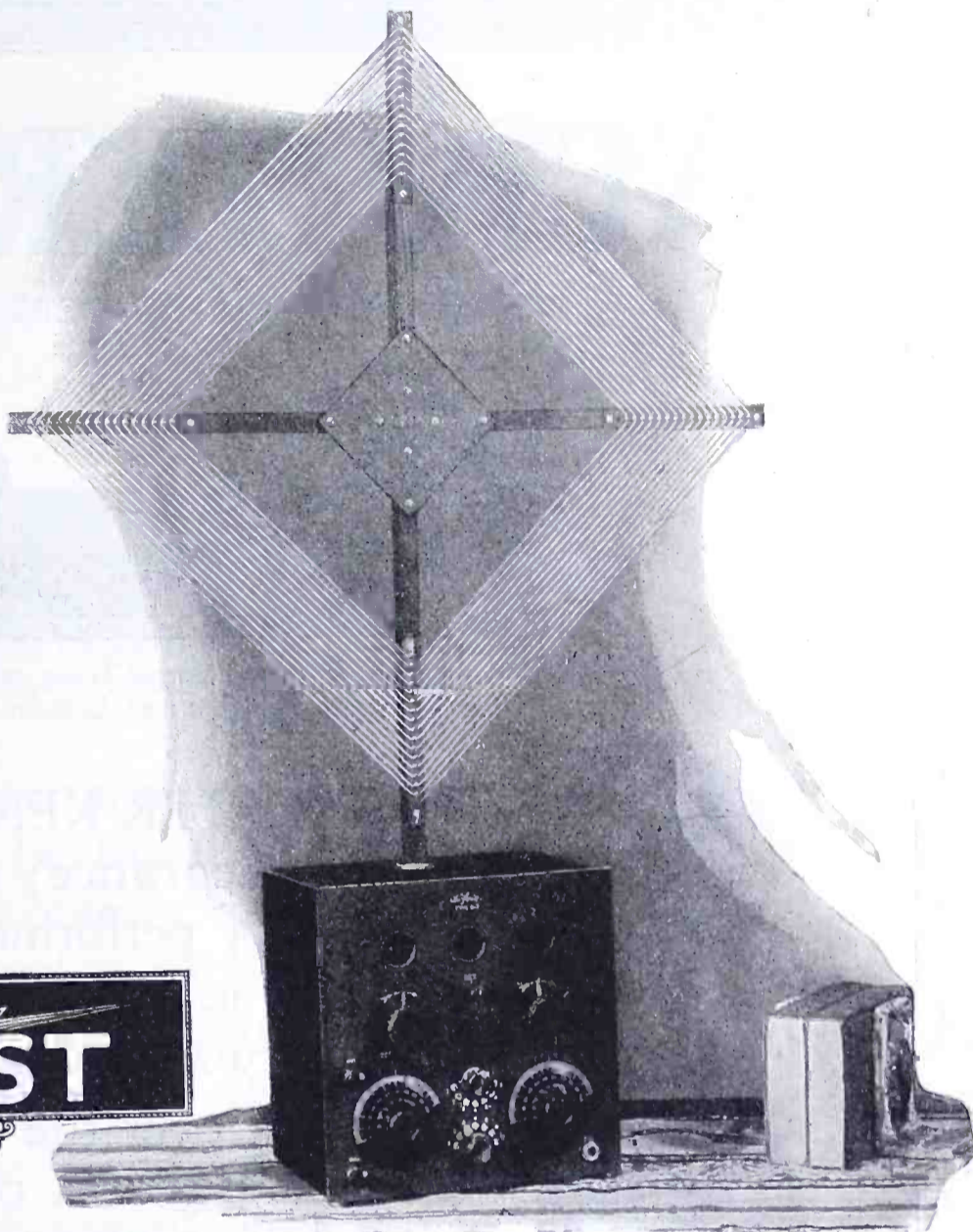

De Forest

His Daddy's Choice



*Reg.
U. S. Pat. Off.



HERE'S the regenerative receiver that has worked a transformation in many a home! RadioCraft's D-4 offers the long-distance reception of the regenerative circuit, and the D-5 2-step amplifier actuates a loud speaker so that the whole room can enjoy the broadcast. When you add to the regenerative principle the long tested reliability of the De Forest parts of which these sets are made, you get a combination which at a low price touches the high spot in present day radio.

RadioCraft

His Daddy's Choice

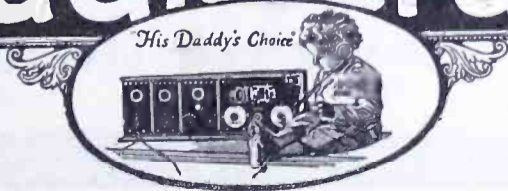

The
RadioCraft Co., Inc.
139 Franklin St.
Jersey City, N. J.

Tell them that you saw it in RADIO

ATWATER KENT

Radio Receiving Sets and Parts

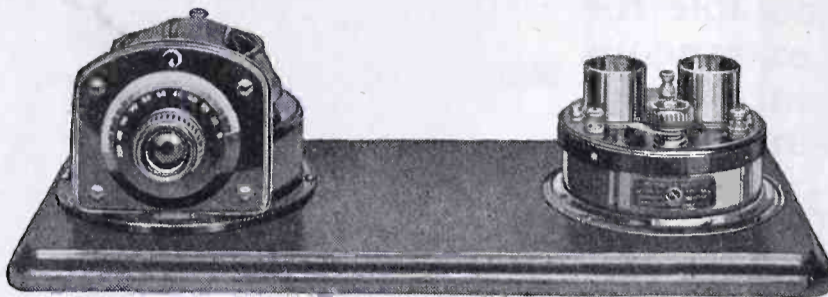

Complete Receiving Set—Coupled Circuit Tuner and Detector 1-stage Amplifier
A similar set is furnished with Detector 2-stage Amplifier

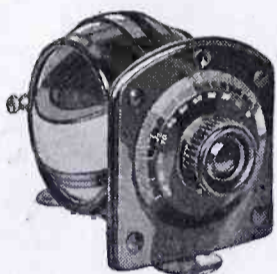

Mounted Variometer

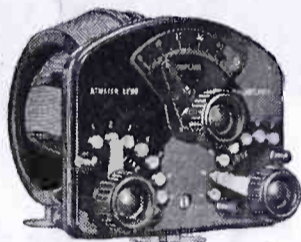

Mounted Variocoupler

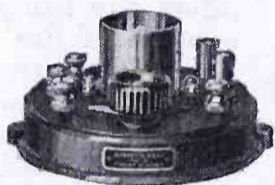

Detector Unit

ATWATER KENT products sell on appearance; they stay sold on quality of performance.

This is the reason for the popularity of ATWATER KENT Radio Equipment.

Look over the illustrations. They show a portion of the line, which includes complete sets, as well as parts from which the radio fan may build his own receiver.

There are various sets all mounted on mahogany bases and wired ready to attach to antenna and battery. No bothering with hook-up.

Use a set as *YOUR* demonstrator

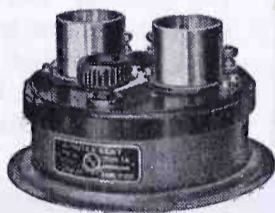

Detector 1-stage Amplifier
A similar unit is furnished in a 2-stage Amplifier



Detector 2-stage Amplifier

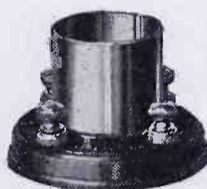

Standard Tube Socket

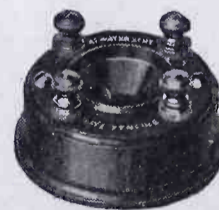

1 1/2-Volt Tube Socket

ATWATER KENT MANUFACTURING COMPANY, PHILADELPHIA, PA.

Radio Department

4947 STENTON AVE.

Write for Literature

Tell them that you saw it in RADIO

ATWATER KENT

Radio Receiving Sets and Parts

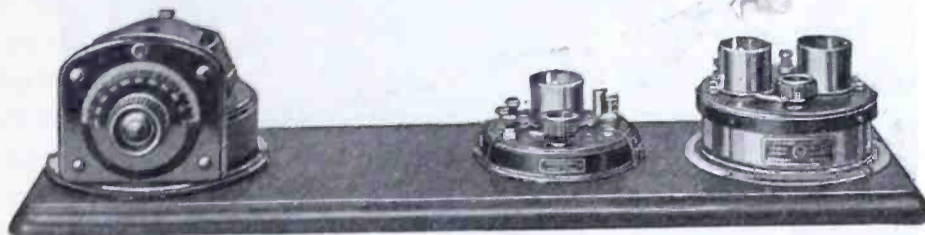

Complete Receiving Set—Coupled Circuit Tuner, Detector Unit and 2-stage Amplifier
This Set is also furnished without Amplifier

THESE sets are attractive enough in appearance to be installed in the most "exclusive" home or club; moderate enough in price to be within reach of anyone; and excellent enough in operating qualities to satisfy the most particular.

For the fan who wants to experiment with varying hook-ups there are parts which will meet every requirement.

ATWATER KENT Radio Sets and Units sell readily and are a very profitable line.

They're always SEEN in the show windows



Unmounted Variometer

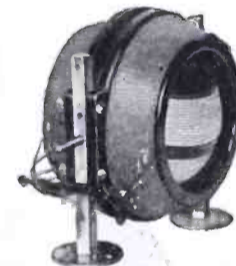

Unmounted Variocoupler



Condense Dials
in 50 or 100 pt. graduations
for $\frac{3}{16}$ " or $\frac{1}{4}$ " shafts



Type L Transformer A.F.

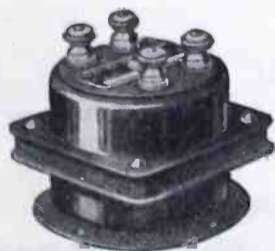

Transformer A.F.

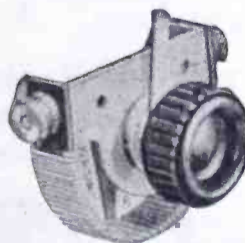

Panel Rheostat

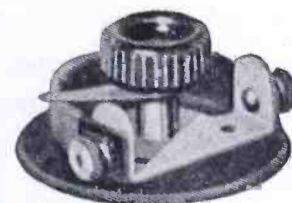
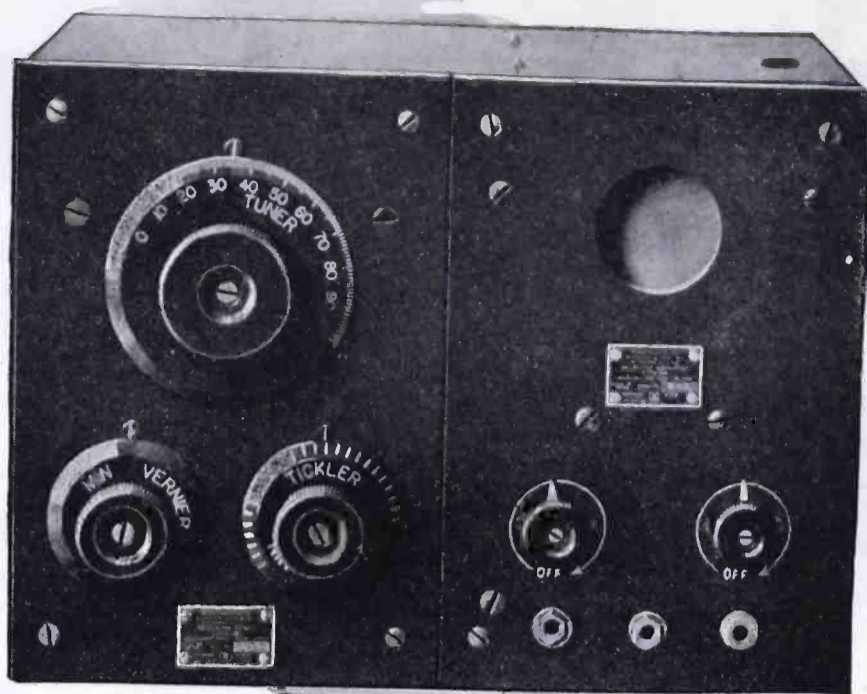

Table Rheostat

ATWATER KENT MANUFACTURING COMPANY, PHILADELPHIA, PA.
Radio Department 4947 STENTON AVE. Write for literature

Tell them that you saw it in RADIO



In TRENTON, he hears stations 1500 miles away with Radiola RC

REG. U. S. PAT. OFF

J. T. K. Hudnut, Secretary and Treasurer of the Trenton Electric Supply Company, recently wrote and said about Radiola RC:

"Just a line to tell you that Radiola RC has given perfect satisfaction. On Tuesday evening between 11:15 and 11:30 I picked up Chicago and Kansas City."

This is but one of thousands of letters received in which owners of Radiola RC have commented on its remarkable range. Half the delight of radio lies in this ability to pick up the far stations.

Radiola RC is a compact, highly-sensitive, long-distance receiver that can be used with a loud-speaker to flood a room with music. Thousands of Radiola RCs are in use everywhere.

The price of Radiola RC is \$132.50. Examine it at any RCA dealer. If there is none near you, write to us and we shall put you in touch with one.



To find out what Radiola will fit your needs and purse, write for free illustrated booklet "Radio Apparatus for Broadcast Reception."



This symbol of quality
is your protection

Radio Corporation of America

Sales Department, Suite 2069
233 Broadway, N. Y.

District Offices:
10 South LaSalle Street, Chicago, Ill.
433 California Street, San Francisco, Cal.

Tell them that you saw it in RADIO

Radiatorial Comment

WHEN standardization becomes necessary in a specialized art or science it has reached an age and importance corresponding to the time that a boy first puts on long trousers. Radio has reached and passed that age, but is still like a big, awkward boy in short pants. It has grown so rapidly that no one has had time to determine standards.

Consequently it is pleasing to note that action has at last been started as the result of a meeting called by the Bureau of Standards in co-operation with the American Engineering Standards Committee. An advisory committee has been formed to name the men who will have the task of standardizing radio under the joint sponsorship of the American Institute of Electrical Engineers and the Institute of Radio Engineers.

These men will realize that the trend of modern progress is toward standardization. Ever since King Henry in 1120 decreed that the yard should be the length of his arm, standards of measurement have been becoming more and more exact, until today the values of the fundamental units are definitely fixed. But this committee's work will be to express comparative performance in terms of these units and to set minimum standards to which equipment should conform.

These standards cannot be too rigid, but must be elastic enough to care for future growth. The danger is indicated by the mythological tale of Proustes, all of whose guests were required to fit one bed. If too tall, enough of their legs were cut off, or if too short they were stretched until they fit. Too much standardization is as bad as too little. Frequent revision will be necessary to care for future developments.

Aside from the fundamental questions of nomenclature, methods of measurement and of testing, there remains the important matter of commercial standardization. There is a crying need for information about the comparative ratings of similar parts manufactured by different companies. Glittering generalities as to excellence of material cannot take the place of exact details as to construction and efficiency. There is usually a good reason why one make of transformer, for instance, costs twice as much as another.

In the past there have been too many special designs for special purposes. High costs of manufacturing have been largely due to a dearth of uniform standards. When these are established costs to the consumer can be reduced.

The buyer is interested primarily in what performance may be expected from a given transformer, coil, rheostat, vacuum tube, telephone receiver, or complete set. Such loose designation as "a 1000-mile receiver," or an "all wave radio frequency transformer" is as misleading as it is untrue. The purchaser is certainly entitled to the protection which can be given by definite standards.

With so much in its favor and so little to its disadvantage, all parties will welcome speedy work on the part of the men who will set standards. Public confidence will be maintained and beneficial results follow the early publication of their findings. The radio industry will be stabilized and many evils eliminated. While not a cure-all, standardization, kept abreast of improvements, is a long step in the right direction.

AT last comes the news that the radio control bill has passed the House of Representatives. 'Tis reported that some opposition has developed in the Senate. But in view of numerous telegrams that have been sent from all over the country there is hope that it will get through during the present session.

The bill places complete regulation and supervision of amateur and commercial operation in the hands of the Secretary of Commerce. It prescribes but little in the way of details as to how this control shall be exercised, leaving it largely to his discretion. It is generally understood that his new regulations will closely follow the recommendations of the Radio Conference at Washington last spring, together with such further recommendations as may be made by the Committee of Fifteen then formed.

With his broad and sympathetic understanding of the entire radio situation, and with the competent advice that he has at his command, there is no doubt but what Secretary Hoover will issue regulations that will do much to bring order out of the present chaos. To the radio inspectors will be given power to enforce, so that instead of depending upon voluntary co-operation the inspectors can definitely suspend the license of an offender. Past experience has demonstrated that this power may be safely entrusted to the Department and that we may soon have a satisfactory solution to present difficulties.

TWO Western amateur radio clubs have recently announced diametrically opposite policies. One well-established club has adopted a resolution forbidding its members to use spark transmitters. Another new club has been formed for the avowed purpose of encouraging spark transmission. The former is, to our knowledge, the first going club to take an unqualified stand in favor of C. W. or I. C. W. The latter represents a large class that chafes under the prospect of restraint.

Fully realizing the unpopularity of such a stand, RADIO cannot refrain from commending the former and condemning the latter. We feel that the one is progressive and that the other is reactionary, that the one is anticipating the inevitable and that the other lacks vision. This stand is taken, not with reference to spark interference with broadcasting, but solely because of spark interference with amateur code transmission.

A Simple Radio Frequency Amplifier

By Samuel G. McMeen

Mr. McMeen here effectively answers the oft-asked question of how to put a simple radio-frequency amplifier ahead of an ordinary receiving set. All that is needed is a 35-turn coil, a condenser and a potentiometer—only two additional controls being needed for tuning up to wavelengths of 400 meters. It is so easy that anyone can do it.

AMPLIFICATION is the one outstanding ability of the vacuum tube, and on that power rests its greatest fame. Detection is itself an amplifying process, wherein the exquisitely feeble alternating currents of the antenna are enabled to create other currents like themselves but of greatly enlarged electrical dimensions.

But having detected those feeble currents from the antenna, and reduced them to hearable form, further amplification after the detector requires means that introduce distortion. A series of amplifiers following the detector has to be limited to two steps if purity of tone is desired, though increase of volume can be attained to any degree by increasing the number of tubes.

A further objection to the exclusive use of amplifiers following the detector tube is that their ability is limited, in that position, to enlarging what the detector has detected. An amplifier located ahead of the detector, however, is not so limited, and this is the form in which the longest distances can be covered by receiving sets, and the faintest signals made audible.

More and more amateurs are finding entertainment in increasing their log entries of distant stations heard, and this is as it should be. The end desired is that at least all the corners of the United States shall be within easy hearing distance of each other at all times of day and night, so everything that leads that way should be developed.

Furthermore, the use of radio frequency amplification permits the use of indoor loops, with the advantages of simplicity and compactness as well as discrimination as to direction.

For all these reasons the use of such amplifiers is most desirable, but many workers have been kept out of the field by the nature of the circuits required. This is partly due to the fact that most radio frequency amplification hookups require the use of tuned transformers, each associated with a pair of variable condensers to accomplish the tuning. This adds at least two controls per step of amplification to those that are otherwise necessary.

All of the annoyances of experimentation in radio frequency amplification for short waves are dispelled by use of the circuit shown in the figure herewith. By short waves is meant up to 400 meters. The circuit requires but one coil in advance of the radio frequency

tube, and that coil is a fixed one of 35 turns, with no taps. It is in series with a condenser of 43 plates. The *A* battery is shunted by a potentiometer, the movable portion of which receives one side of the coil and the grid of the amplifying tube the other side. Thus the only controls of the amplifying portion of the apparatus are a condenser and a potentiometer. For this circuit we are indebted to 6ASE, Hugo Benioff, of Claremont, California.

The units associated with the detector tube are those of the familiar three-circuit regenerative receiving set that has given so good an account of itself, with or without audio frequency ampli-

The primary and secondary coils are each of 80 turns. No. 26 wire is a good size. Each coil has three taps, these being taken out at the first three quarters. The lead which comes from the plate of the amplifier tube shall be the connection to the end of the primary coil that is nearest to the secondary. Similarly, the secondary lead to the detector grid shall be that nearest the primary coil. The grid condenser, of about .00025 microfarad, shall be located as close to the grid terminal as possible. The grid condenser shall be shunted by a two megohm leak, or thereabouts.

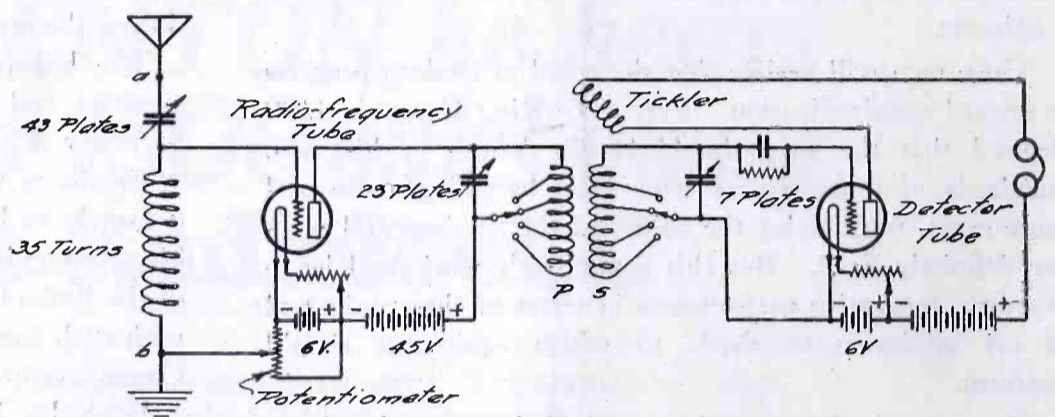

Simple Radio Frequency Amplification Hook-up

fiers. The latter can be associated with it in this form of use with a preceding radio frequency stage.

There are two particulars in which the tuner portion of the set differ from its form when used without the preceding amplifier. The separation between the primary and secondary windings is small, say about 1-in. instead of the 2-in. separation which is best for the use of the set without the preceding stage of amplification. For the purpose of adding general usefulness to the tuner, the ingenious worker may care to devise means whereby the separation between the two coils may be varied at will. This can be done by winding the coils on separate sections of tubing and fitting the primary portion with ends having central holes so that the tube can slide on a wooden rod. The secondary coil must be stationary, as it carries the tickler within itself.

The primary condenser is in parallel with its coil, instead of in series with it, as is the usual form in which the circuit is used when the preceding stage of amplification is not present. The secondary condenser is in parallel with its coil also, but that is the usual practice.

The tickler or tertiary coil shall have 50 turns. This is the winding the writer has used, but if a few more turns get on the form, try it so. There is the possibility that there may be an advantage therein, though the indications have favored the number given above. The tickler coil is mounted to rotate in the secondary coil. Therefore wind the latter in two halves to make a place for the shaft.

The plate voltage of the tubes will of course be those recommended by the makers of the tubes. The same battery may be used for both plate-supply leads, if there are taps for the lesser voltage required by the detector.

An entertaining variation is to substitute a power tube for the amplifier in the first stage. This may be given a plate voltage of several hundred volts with corresponding increase in volume.

In one experimental application of this circuit the detector was followed by three stages of audio-frequency amplification. This had first been used without the radio-frequency stage, and its degree of distortion was enough to be strongly noticeable, and had been

Continued on page 88

A Simple Radiotelephone That Works

By Gerald M. Best

The cost of C. W. equipment as compared with a spark set can no longer be an excuse for not scrapping the spark set. Here is a simple telegraph and phone set combined that costs less than \$50. It has a range of 100 miles, telegraph, and several miles, voice, with 120 volts "B" battery on the plate, using two amplifier tubes.

HOW often have you tuned to 200 meters, after you finished listening to the evening concert program, and wished that you could join the bunch with a real transmitter of your own; not a high-powered noise-maker like the spark set; nor a large battery of fifty-watt tubes; simply a small C. W. or radiotelephone set capable of transmitting a few miles, in order that you could converse either by telegraph or telephone with your friends? Perhaps you had already spent about all you thought you could afford on receiving equipment, and the cost of a radiotelephone would appear to you to be prohibi-

perience in building his receiving apparatus should be able to duplicate this outfit, at a relatively small expense.

As is shown in the illustrations, the set includes two tubes, and employs the reversed feedback circuit, with Heising modulation. This is the best combination that is available at this time for amateur use, and gives the best results, both as to quality of voice, and percentage of modulation of the carrier wave. The circuit diagram will show the detailed arrangement of the various pieces of apparatus, and the correct capacity and inductance values are also indicated. The following list of parts will give the

reader an idea of the cost of the set, and the amount of material required:

One bakelite panel, 9x12 in., 3/16 in. thick	\$ 2.50
One 23-plate air condenser	3.25
Two Remler Junior Rheostats	1.50
One Remler coil mounting—1 No. 43 and 1 No. 42 plug	1.50
One dial	1.00
Two Vacuum tube sockets	2.00
One 250-turn Giblin-Remler inductance—Unmounted	1.10
One 25-turn Giblin-Remler inductance—Mounted	1.50
One 35-turn Giblin-Remler inductance—Mounted	1.50
One Dubilier Micadon—.002 M.F.40
One Dubilier Micadon—.00025 M.F.35
One R.C. of A. Model UP-414 Modulation Transformer	7.25
One R. C. of A. Model UP-415 one henry choke	5.75
One 70,000 ohm resistance65
Two No. 751 Eveready Flashlight batteries70
One 1/2 Megohm resistance65
Two Murdock connecting blocks40
Two Cunningham type C-301 vacuum tubes	13.00
Miscellaneous wire, spaghetti, screws, etc	1.00
	<hr/>
	\$46.00

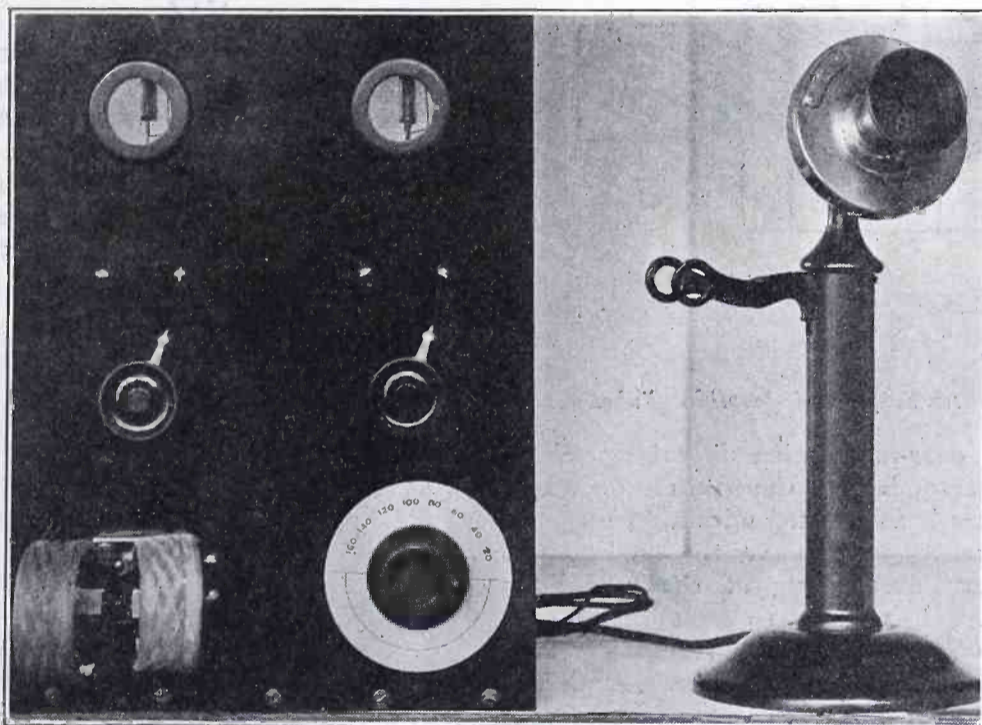

Front View of Phone and C. W. Transmitter

tive. Or perhaps you had an idea that the work of building a real phone set was a little more than you could tackle without a number of tools, and considerable knowledge of radiotelephony in general.

I am going to describe a small set which I recently built, for the express purpose of local communications, since I did not care to jam the air with a 100-watt C. W. telegraph set when I only wished to talk a few blocks, or a few miles at the most. The results obtained with the set so far exceeded my expectations that I am passing the information on to the reader. If I succeed in persuading even one amateur who now owns a spark set, to build such a transmitter for his local work, then I will feel that my efforts have not been in vain. Anyone who has had a little ex-

In laying out the panel, it is best to cut a piece of cardboard or heavy paper the same size as the panel, and mark the position of the pieces of apparatus in pencil on the cardboard. The cardboard can then be laid on the bakelite, and the places for the holes struck through with a center punch. This will avoid marking the panel with lines that are often difficult to remove.

The sockets, rheostats, air condenser and coil mounting are placed on the panel, and holes 1 1/2 in. in diameter are

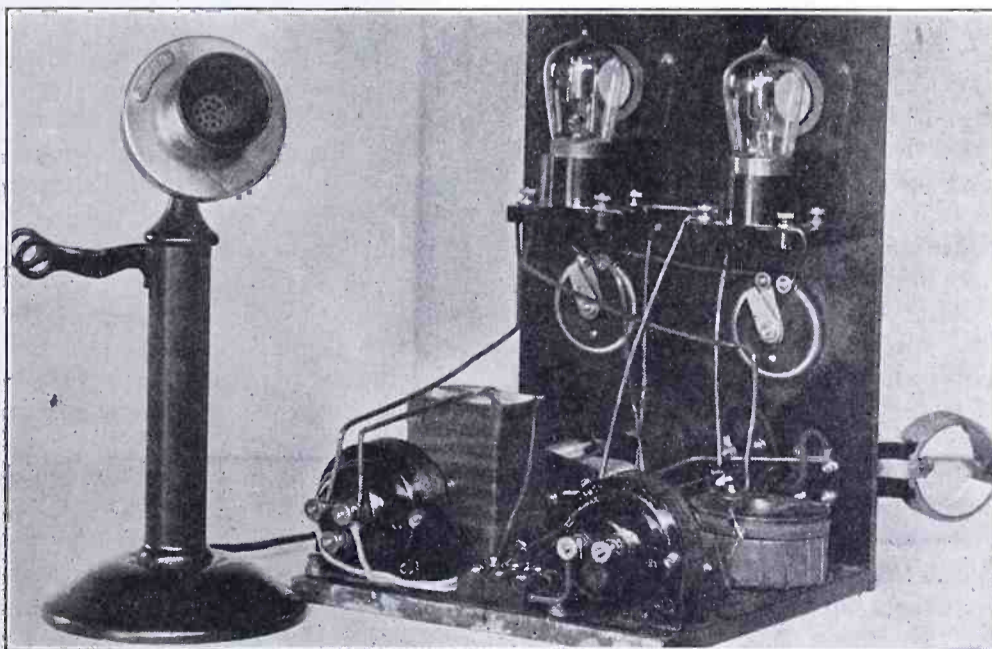

Rear View of Phone and C. W. Transmitter

placed so that the filaments of the tubes may be seen from the front of the panel. The remainder of the apparatus is mounted on a hardwood board 9x9 in., 3/8 in. thick, the base being fastened to the panel by means of five screws at the bottom of the panel.

The modulation transformer and one henry choke are mounted at the rear of the baseboard, and the condensers, resistances, *C* batteries and connecting blocks arranged in such a manner that the connecting leads will be as short as possible. The *A* and *B* batteries are brought to the three-terminal connecting block shown between the transformer and the choke coil, so that no binding posts are necessary on the panel. The carbon grain transmitter is connected to the two terminal connecting block shown between the transformer and the *C* bat-

so. For 200 meters, the 25-turn coil should be in the antenna circuit, and the 35-turn coil in the grid circuit. Tuning is accomplished by moving the grid coil with respect to the antenna coil, and varying the air condenser.

No antenna ammeter is shown in the illustrations, so a small flashlight bulb placed in series with the antenna will serve the purpose of indicating when resonance is taking place. At 120 volts plate, and the proper filament current, a radiation of .3 amperes can be expected, with a good antenna, of course.

The carbon grain transmitter shown in the illustration is a Western Electric 323-W, which was found to give the best quality. Four dry cells will give sufficient voltage to operate this transmitter, and it may be found necessary to reduce this voltage, if it is determined

Using the set for telegraphy, a much greater range than with the voice can be expected. With 120 volts on the plate, a night range, under favorable conditions, of 100 miles would not be unusual. If the plate voltage is raised to 250 volts, a range of 400 miles would be a fair estimate of the set. This is of course using a hard tube capable of withstanding the high voltage, and with the set tuned to maximum efficiency. If it is desired to use some sort of a rectifier, or generator, and employ five-watt tubes in place of the receiving tubes, a much greater distance would be obtained, but the primary object of this set is simplicity, and low cost; hence the use of small tubes, and a low plate voltage. Any amateur who now possesses a small spark set will do well to replace it with the above, so that he can transmit at any time, regardless of the local broadcast restrictions, and at the same time greatly increase his transmitting range.

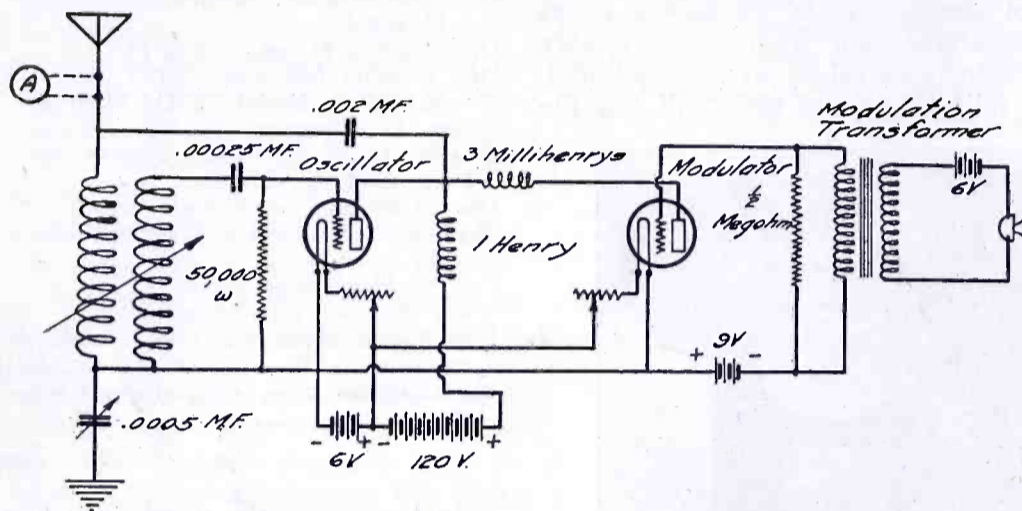

Circuit Diagram of Phone and C. W. Transmitter Employing Amplifier Tubes

teries. The latter were placed in a solid mounting formed by wrapping the cardboard battery cases with okonite tape. The same is true of the radio frequency choke, which is a 250-turn Giblin-Remler coil, wrapped with okonite to keep out moisture and protect it from contact with other apparatus. The wiring is No. 14 bare soft drawn copper, the principal connections being insulated with cambric tubing, or spaghetti, as it is sometimes called.

Returning to the circuit diagram, it will be seen that 120 volts is specified for the *B* battery. This is on the assumption that you have a receiving set or loud speaker requiring that voltage, and while the transmitter will operate on less than 120 volts, it is best to use that amount if any kind of radiation is expected.

The antenna and grid inductances are Giblin-Remler coils, such as are used in receiving sets. These are specified because they were found to have the maximum insulation between layers, and the least distributed capacity of any of the compact wound inductances. They will function in transmitting circuits with voltages up to 250 without breakdown. By using such a coil you can change to any wavelength desired, provided that your license permits you to do

that over-modulation is taking place. The secondary of the modulation transformer is terminated with a 1/2 megohm resistance, to preserve the quality and prevent overloading of the modulator tube. It is better to start out with a low voltage on the hand transmitter, and determine the point where enough energy is produced to properly modulate the carrier wave.

A *C* battery of nine volts is placed in the grid circuit of the modulator, when 120 volts plate is used; if a higher plate voltage is employed, this battery will have to be increased so that the modulator will operate on the proper point of its grid voltage-plate current curve. If only 80 volts *B* battery is used, then the *C* battery should be 4.5 volts.

For C. W. telegraph, a key may be placed in the negative *B* battery lead, and the plate current to the oscillator interrupted as desired, the modulator tube of course being inoperative for this purpose. A switch could be provided to place the grid and plate of the modulator tube in parallel with the oscillator, to double the output power for C. W. telegraph purposes, but this would complicate the wiring, and would necessitate re-tuning the oscillator each time a change from phone to telegraph, or vice versa, was made.

VJZ

VJZ, whose stacatto note is familiar to ship operators in the South Pacific, has been operated by the Australian government since the former German New Guinea was captured by Australian troops in September, 1914. This station was being erected by the German government as a part of a scheme to es-

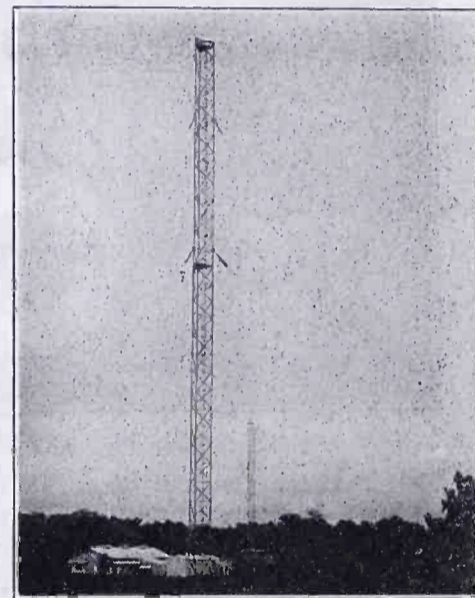

Towers at VJZ

tablish radio communication throughout the Pacific. The Australians completed it and are now operating it in conjunction with their Australian stations. It relays to a number of small stations throughout the Bismark archipelago.

The station is located at Bitu Paka, twenty miles from Raboul, capital of the Northwest Pacific Islands, New Britain, as New Guinea is now known. Power from two semi-diesel engines is used to operate a 65 kw. and an 8 kw. Telefunken quenched gap set. The illustration shows the shack and two steel towers, 315 and 195 ft. high respectively.

A Home Made D. X. Radio-Audio-Frequency Receiver

By W. H. Waterman

Some new ideas in short-wave radio-frequency amplification using honeycombs are here set forth for the guidance of the amateur constructors. The set described is convertible for either audio or radio frequency.

SOONER or later every "crystal" amateur graduates to the "V. T." class—is thereafter promoted to the "audio-amplifier" grade—and, though he may halt there, secretly wishes for the time when he may add radio-frequency amplification. The writer has passed through each stage, experimenting as he went, and passes the results of his efforts along to those who care to reach out for distance—who want to pick and choose their broadcast concerts from afar when distant stations offer better programs than local, and to those who like to make DX records. The set described in this article was entirely assembled at home and, except for panel engraving (non-essential but convenient) all work done by the writer with the ordinary tools found in every household kit, i.e., hand drill, screw driver, pliers and soldering copper.

The cabinet is an old sheet music cabinet from which the shelves and back panel were removed and the door changed from front to rear, the radio panel replacing the front. Similar

cabinets repose in many attics and basement storerooms—and second-hand furniture dealers are overstocked with them since jazz records and player rolls have shoved sheet music into the discard. The

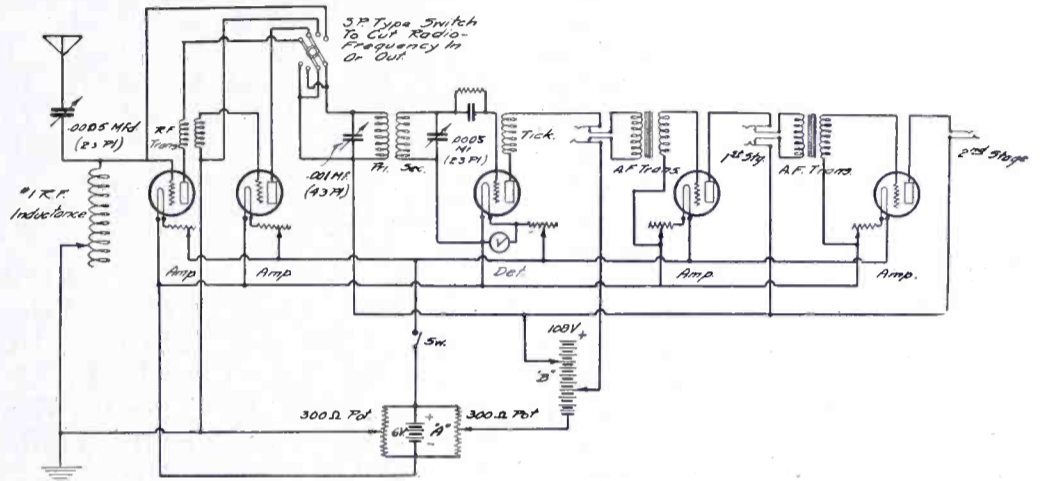

Hook-up for Radio-Audio Frequency Receiver

panel dimensions are not given herewith because the apparatus layout will depend upon the size and shape of the cabinet, if a cabinet be used.

The writer uses and recommends honeycomb inductances because of the convenience in changing to longer wavelengths and with an eye to the future. Certainly the time is coming soon when broadcasting must necessarily be distributed on a broader band of wavelengths instead of the 360-400 meters now allocated.

This set works efficiently up to 600 meters with both radio- and audio-frequency amplification with the 25-35-50 and 35-50-75 turn coils and on all lengths above by the use of larger coils, without the use of radio-frequency amplification above the 600 meter limit. A series-parallel type switch shown in the diagram, but not in the picture, is used for cutting out the radio-frequency tubes when not desired or when it is desired to receive on longer lengths than 600 meters. In this set the short waves only are utilized for radio-frequency amplification. The No. 1 r.f. inductance, (see diagram) for the first tube tuned plate circuit consists of a 4 in. bakelite tube (paraffined cardboard is cheaper and practically as efficient) wound with sixty turns of No. 22 silk s.c.c. wire, tapped every five turns. The antenna condenser in series with this is a twenty-three plate variable, cap. .0025 mfd.

The second tube of the r.f. unit receives its input from a "P. & B." r.f. transformer, a small comparatively in-

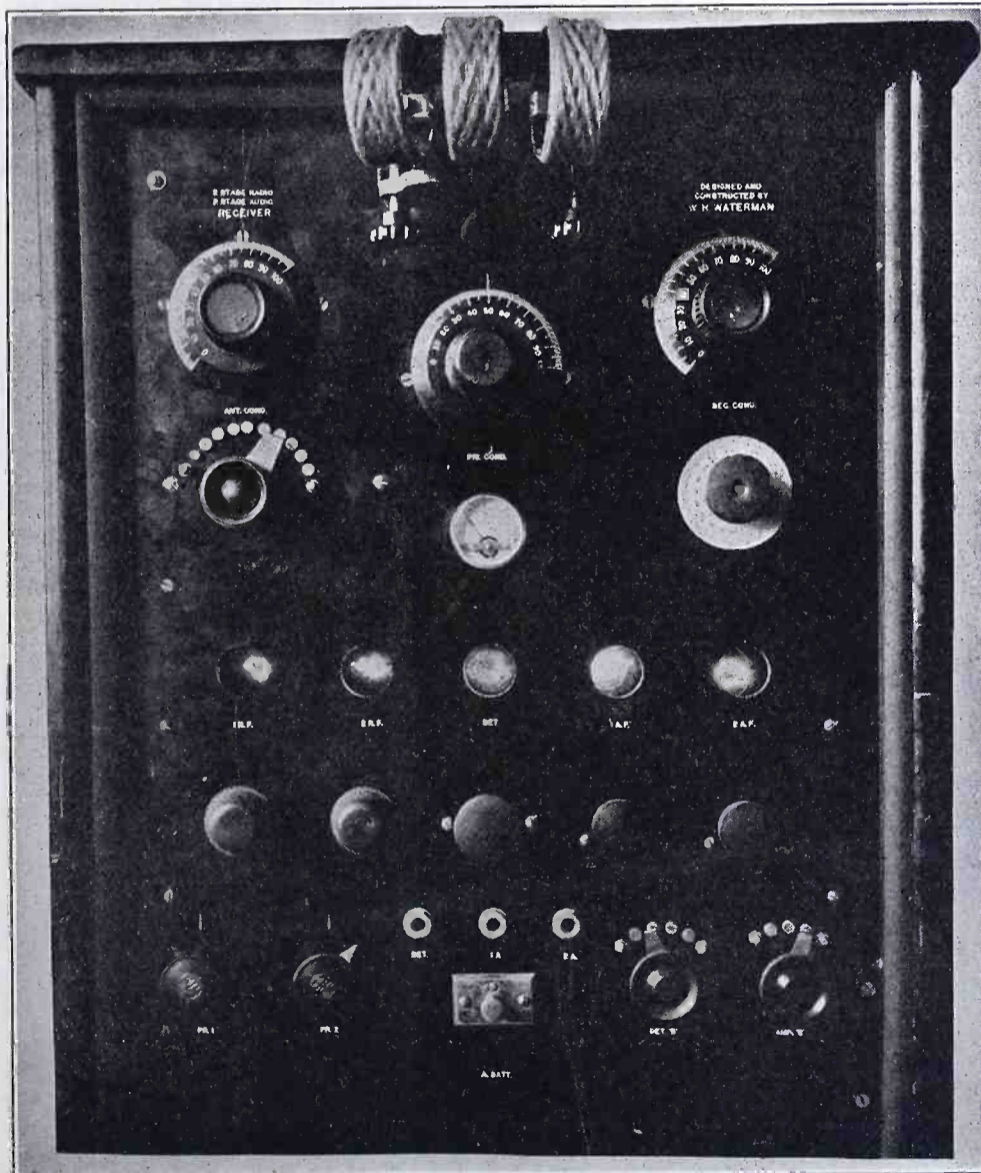

Radio-Audio Frequency Receiver Panel

expensive unit which proved after experimenting with others to be the most efficient of its kind for short waves. From here to the detector the regular honeycomb regenerative or feedback circuit is used with the primary and secondary condensers both in parallel with their respective inductances—and an added three-plate vernier condenser in the secondary circuit, parallel as well. Experimentation proved the secondary circuit tuning to be most critical and therefore the vernier is used here.

The audio-frequency circuits follow common practice in the matter of wiring, but the writer found, after experimentation with various a.f. transformers, that for this particular circuit the greatest amplification, with freedom from howling and distortion, was obtained by use of an Atwater-Kent transformer in the first step of audio, and a Thordarsen in the second, the cores being placed at right angles to each other to avoid the magnetic influence due to parallel fields. (Any two good audio transformers will work in this circuit.)

It will be noticed in the picture and diagram that the detector plate voltage is variable from a point switch. The reason for this is that various tubes are employed as detectors, UV 200, VT 1, and AP, and each works most efficiently with a different voltage which is thus conveniently controlled without changing connections on the B batteries. The potentiometers, Pr_1 and Pr_2 , are essential in this circuit and control the tube oscillations very critically—in fact by their balancing effect on the radio-frequency currents also perform an important function in sharp tuning and the elimination of interfering signals.

It will be noticed also that a voltmeter is used on the panel. This is in shunt across the detector filament—and while not essential, will pay for itself in the prolonged life of tube filaments, as each detector functions best at a determined constant voltage controlled by the detector rheostat and checked by a glance at the voltmeter and calibrated to suit the operator.

A word as to rheostats; any type will do for the amplifier tubes, which are seldom critical, but experience proves that a vernier type of rheostat must be used on the detector. The Klosner vernier or similar type is satisfactory, but the writer uses a Bradleystat. This type has all extremely wide range of limits and very fine adjustment is possible and the voltage appears to remain constant regardless of resistance temperature.

An A battery switch is also provided. This is an automobile dash type switch, with positive-break contact, conveniently placed on the panel.

All five tubes are mounted on a floating shockproof shelf, that is, a shelf suspended on spiral springs, and the transformers are mounted on the underside of

the same shelf. This shortens the inter-tube connections, and the weight assists in stabilizing the suspended tubeshelf, which protects the tubes and does away with microphonic receiver noises.

As to results—The writer, who is located in San Francisco near the ocean beach, is perhaps handicapped in the matter of aeriels, having about a 100 ft. span about 40 ft. from the ground at one end and about 15 ft. at the other, lead-in from the high end, and yet has better than a two thousand mile receiving range to date, which speaks well for the set. In addition to all California stations some of the stations heard outside of California are as follows:

WDAP, (9FU), Chicago, Ill.; WGE, Des Moines, Ia.; WOI, Ames, Ia.; WKAC, Lincoln, Neb.; WJAQ, Topeka, Kans.; WAAP, Wichita, Kans.; WPA, Fort Worth, Tex.; WFAA, Dallas, Tex.; KFAF, Denver, Colo.; KLZ, Denver, Colo.; KFCK, Colorado Springs, Colo.; KDWS, Great Falls, Mont.; CFDN, Calgary, Canada; KZN, Salt Lake City, Utah; KZYL, Salt Lake City, Utah; KNT, Aberdeen, Wash.; KFC, Seattle, Wash.; Walla Walla, Wash.; KQW, Portland, Ore.; KFAD, Phoenix, Ariz.

The following costs of parts are local retail prices which may in many cases have changed, to the advantage of the buyer. They will, however, serve as a guide to anyone who wishes to duplicate such a set:

Antenna Condenser 23 plate .0005 mfd.	\$ 2.50
Primary Condenser 43 plate .001	4.00
Secondary Condenser 23 plate .0005	2.50
Vernier Condenser 3 plate	1.90
Honeycomb Mounting	6.00

Station	Wave Length	Call Letters	Time	Meridian
Washington, D. C.	2,500	NAA	12 M.—10 P. M.	75th
Key West, Fla.	1,500	NAR	12 M.—10 P. M.	75th
New Orleans, La.	1,000	NAT	12 M.—10 P. M.	75th
Darien (Canal Zone)	4,000	NBA	1 P. M.—Undamped	75th
North Head, Wash.	2,800	NPE	12 M.	120th
Eureka, Cal.	2,000	NPW	12 M.	120th
Pt. Arguello, Cal.	1,512	NPK	12 M.	120th
San Diego, Cal.	2,400	NPL	12 M.	120th
San Diego, Cal.	9,800	NPL	12 M.—(Undamped)	120th
San Francisco	2,400	NPG	12 M.—10 P. M.	120th
Great Lakes, Ill.	1,512	NAJ	11 A. M.	90th

Many broadcasting stations also relay these signals on 360 meters.

Honeycomb Coils 25-35-50-75	4.50
R.F. Coil—Tube (Paper .25) Bakelite	.80
60' No. 22 wire s.c.c.	.20
3-1½ in. Switch Levers	1.50
16 Points—6 Stops	.70
3 Condenser Dials	2.25
4 Rheostats	3.00
1 Bradleystat	1.85
2—300 ohm Potentiometers	4.00
1—A Battery Switch	.75
2 Double Contact Jacks	1.50
1 Single Contact Jacks	.60
S. P. Switch and Points	2.00
1 Panel Voltmeter	2.50
5 Tube Sockets	5.00
4 Amplifying Tubes	26.00
1 Detector Tube	5.00
1 P & B—R.F. Transformer	5.00
1 Atwater Kent A. F. Transformer	6.50
1 Thordarsen A. F. Transformer	4.25
1 22-½V "B" Battery	2.50
2 43 V. "B" Battery	10.00
1 6V 100 Ampere Hour Battery	20.00
Bakelite Panel	5.00
Brackets, Machine Screws, Hdwe	...
Spaghëtti Tubing, etc.	2.50

TOTAL.....\$134.80

NAVY TIME SIGNALS

Time signals may be heard by any amateur with a receiving set capable of hearing wavelengths up to 2500 meters. With a honeycomb coil set this can be accomplished with a 500-turn primary and a 250 turn secondary, the primary condenser being in series.

Time signals start five minutes before the time set for the final dash. The signals start as a series of dots at one second intervals, omitting the 29th second of each minute and the last five seconds of each of the first four minutes. The last ten seconds of the last minute are omitted before the final long dash. The schedule is as follows:

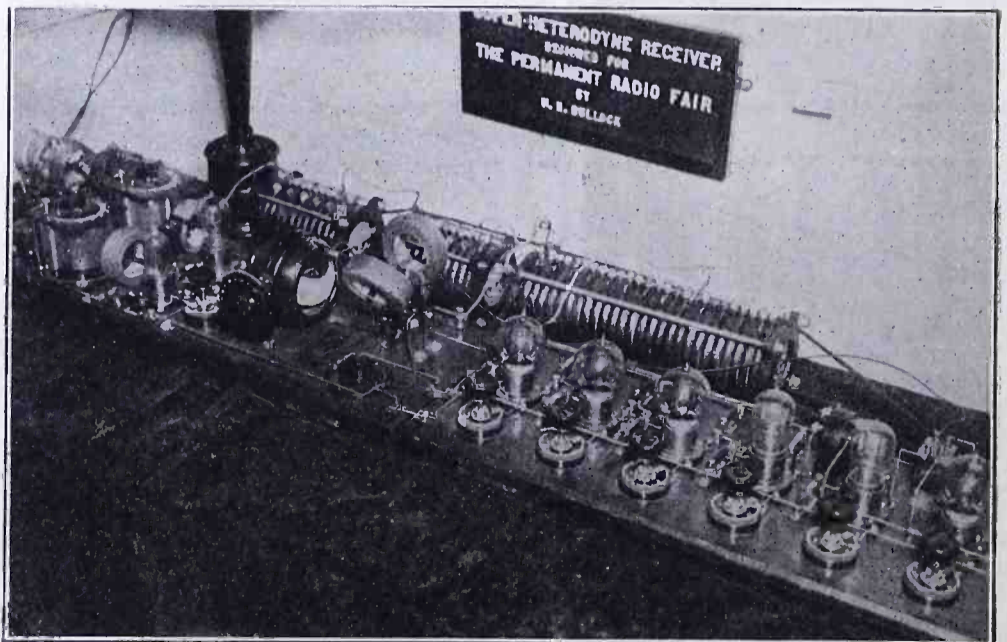

Super-Heterodyne Set on Exhibit at New York Permanent Radio Fair

Regenerative Receiving and Transmitting Circuits

By Ellery W. Stone

This constitutes the eleventh and twelfth assignments in the University of California Extension Division correspondence course on Elementary Radio. It deals specifically with the Armstrong principle of regeneration and tube transmitting circuits for radiotelephony.

IN the ninth assignment, we studied the action of a vacuum tube when used as a detector in a radio receiving set. Fig. 64 in that assignment illustrated the various potentials and currents in the grid and plate circuits of the tube. Referring again to that figure and the accompanying text, you will see that the second curve—showing the radio frequency grid potential—builds up a potential of audio frequency on the grid or stopping condenser as represented by the third curve. This reduction in frequency is due to the rectifying property of the tube and the storing or capacitive effect of the condenser. You will recall that this is similar, in a measure, to the action of the crystal detector which functions as a detector due to its property of rectification.

You also know that the vacuum tube will thus resemble, in principle, an ordinary telegraph relay in the sense that feeble impulses in the grid or input circuit of the tube will be faithfully reproduced in the plate or "local" circuit. Due to this fact, the radio frequency potential on the grid—in addition to storing an audio frequency potential on the grid condenser—"triggers or releases a radio frequency current in the plate circuit." This radio frequency plate current is not shown in Fig. 64. Its characteristics are exactly similar to those of the radio frequency grid potential shown in the second curve of Fig. 64. Due to the amplifying properties of the tube, however, the energy of this radio-frequency plate current is very much greater than that in the grid circuit.

Ordinarily, with the simple detector circuit shown in Fig. 63, no use can be made of this radio frequency current in the plate or telephone receiver circuit, because this current, being of radio frequency, is above the upper limit of audibility and hence cannot be heard. Major E. H. Armstrong of New York, however, invented a novel scheme some years ago which makes it possible to utilize this radio frequency current in the plate circuit so as to increase the strength of received signals or music.

Since no use could be made of this radio frequency plate current in the plate or telephone receiver circuit itself on account of its inaudibility, he conceived the idea of returning the current to the grid circuit. Here it can set up a radio frequency potential which can be added to the radio frequency grid potential that originally generated it. The grid potential will now be much

larger than the original radio frequency grid potential built up by the received radio wave.

This new grid potential, being the sum of the original potential and that built up in the grid circuit by the radio frequency plate current, now "triggers" a large radio frequency current through the plate circuit again. This current is again returned to the grid circuit and an increased radio-frequency grid potential results. The whole process is cumulative and repeats itself many times—up to the carrying capacities of the grid and plate circuits—so that tremendous amplification results. This type of amplification, which takes place with the use of but a single tube, is called *regeneration*. The term is used to denote the mutual action of both the plate and grid circuits in building up a reinforced radio frequency grid potential.

It can readily be appreciated that regeneration would not be possible if the releasing of the plate current were not simultaneous with the induction of the potential on the grid. If the plate current lagged behind the grid potential, so that regeneration could not be instantaneous, distortion would result.

In employing the principle of regeneration, it is essential that means be provided for permitting the radio-frequency plate current to flow without undue hindrance through the plate circuit. To accomplish this result, it is necessary to shunt a fixed condenser, similar to the stopping condenser used in crystal receivers, across the telephone receivers. This by-pass condenser acts as a low resistance path to the radio frequency current so that it is not reduced in amplitude by the high reactance of the telephone receivers. The current which we desire to hear in the receivers, however, is of low or audio-frequency and to this current—on account of its low frequency—the by-pass condenser offers a high reactance. The audio-frequency current is thus diverted through the telephone receivers, as is required.

It is also essential that some means be provided for coupling the plate circuit back to the grid circuits so that the amplified energy in the plate circuit may be superimposed on the original received energy in the grid circuit. This is usually effected by what is known as the *tickler* coil. This is a coil which is connected in series with the plate circuit and arranged to be inductively coupled to the secondary coil of the tuner, to which the grid circuit is connected.

A typical regenerative circuit is shown in Fig. 69.

In the diagram, *P* and *S* represent the primary and secondary of the ordinary loose coupler. *T* is the tickler coil connected in series with the plate circuit and inductively coupled to the secondary; *C* is the fixed by-pass condenser shunted across the telephone receivers to serve as a passage for the radio-frequency plate current; and *A* and *B* are the usual *A* and *B* batteries. With the exception of the addition of the tickler coil and the stopping condenser, it will be seen that Fig. 69 is similar to the simple vacuum tube detector circuit shown in Fig. 63 of the ninth assignment.

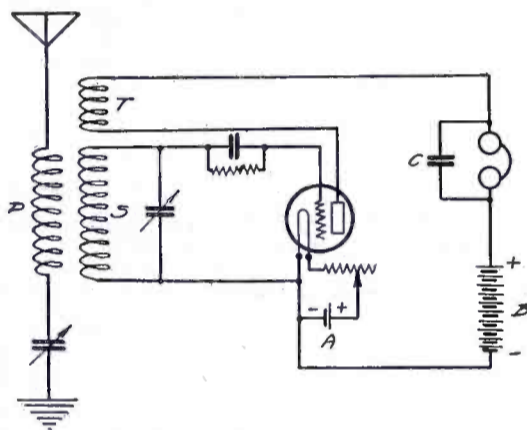

Fig. 69. Typical Regenerative Circuit

One or more stages of audio-frequency amplification may be added to the circuit by replacing the telephone receivers with the primary of an amplifying transformer, as has been previously explained. In addition, radio-frequency amplification may be added between the secondary and the detector tube.

It is essential, in employing a tickler coil for regeneration, that the energy be returned from the plate circuit so that it will *add* to the original, received energy resident in the circuit. If the leads from the plate circuit to the tickler coil be reversed, the potential which it induces in the secondary coil will also be reversed, so that the back potential from the plate circuit may subtract from, instead of add to the original potential on the grid. The correct connection is easily ascertained by trial. If the plate circuit leads are originally connected to the tickler incorrectly, the signals will be reduced in strength, instead of amplified by regeneration.

The tickler coil must be so mounted that the coupling between the secondary and the tickler may be varied. A convenient method for effecting this is a three-coil honeycomb mounting which

Continued on page 48

Inside Wiring for Radio Outlets

By Stanley E. Hyde

A finished job of inside wiring adds greatly to the appearance and safety of a radio installation. By exercising a little care and following the suggestions herein offered any amateur can make a job of which he can be proud.

THE slipshod method of radio wiring is passing. Permanent wiring must take its place. Radio receivers are now assuming as nearly an important place in the home as the telephone. No one would tolerate a mass of tangled wiring hanging around and connected to a desk or wall telephone. Neither should an acid storage battery be brought into a living room where it is apt to ruin rugs or woodwork.

This article is intended for those who install sets of the better class for people

who will use these sets for receiving music, etc., from the broadcasting stations and who have no inclination nor idea of experimenting or trying new "hook-ups." Some kind of an antenna is absolutely necessary, notwithstanding the assertion of certain manufacturers to the contrary. There must be some circuit to pick up the electromagnetic waves and change them into a high frequency alternating current. The more nearly the electrical length or wavelength of the antenna approaches that of

the transmitted wave, the more efficient is that antenna for receiving purposes.

Figs. 3 and 4 show a method of inside wiring for antennas that is being used on construction of new houses, this wiring being an additional cost to the regular contract for the house wiring. The wire for the attic antenna should in no case be smaller than No. 14 rubber covered and should be carried on split knobs its entire length and bushed with porcelain tubes or loom where its passes through stud joist or plate. Where possible it should not be run parallel with grounded plumbing or conduit pipes.

The ground wire is connected with an approved ground clamp to a convenient water pipe and then both antenna and ground wires brought out through the

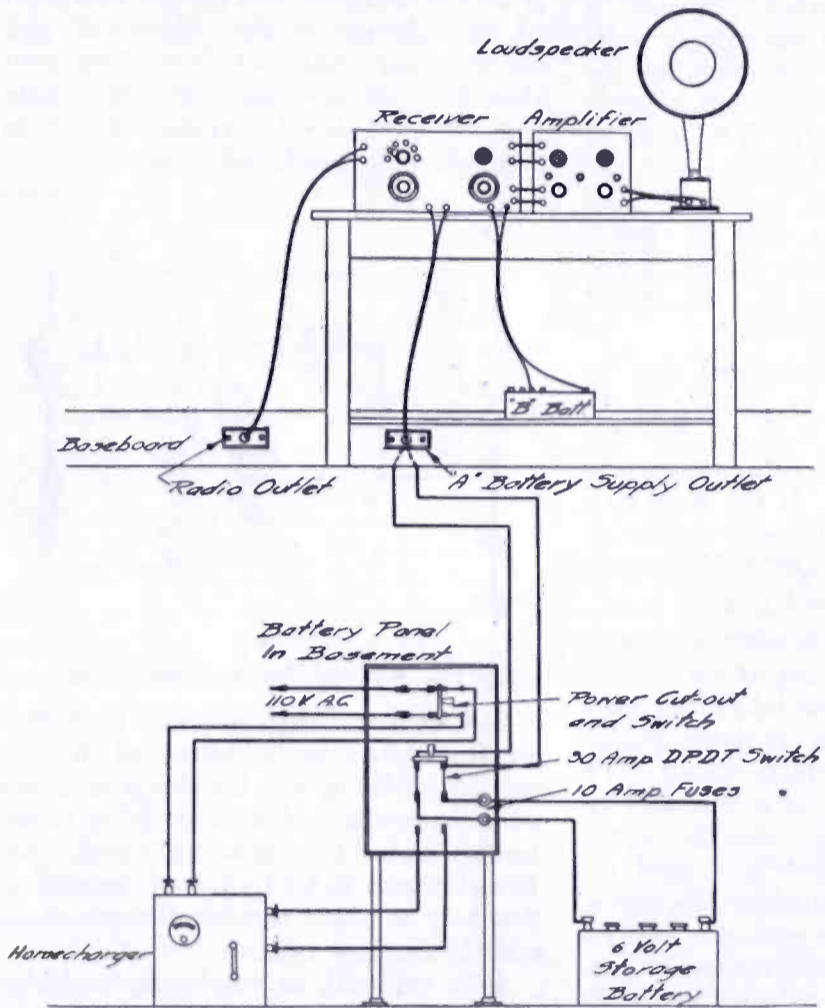

Fig. 1. Use of Radio Outlets

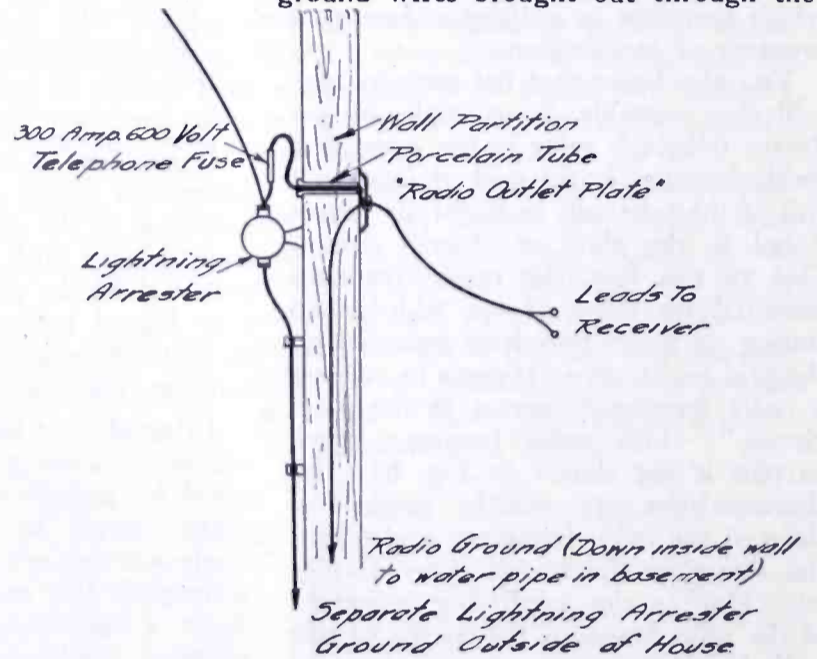

Fig. 2. Outlet for Outside Antenna

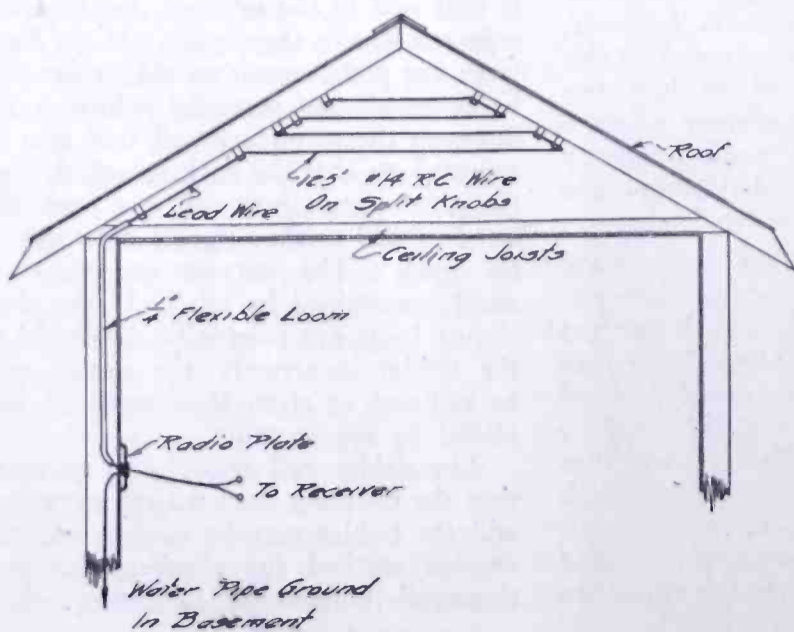

Fig. 3. Inside Antenna in Attic

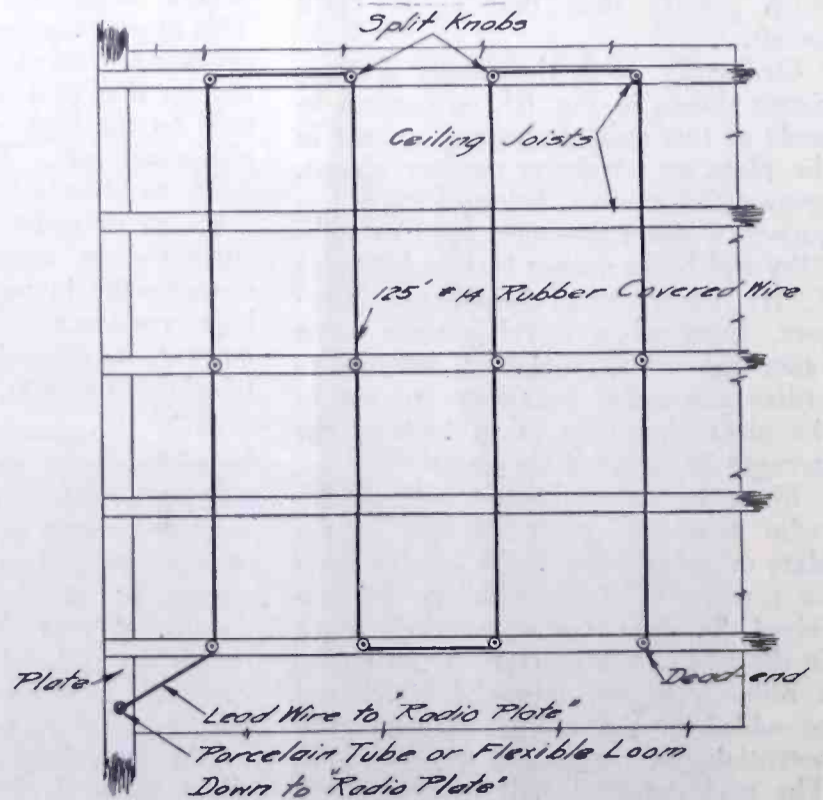

Fig. 4. Antenna Stringing on Ceiling Joists

baseboard or wainscoting through a brass plate with an insulating rubber bushing. These plates are called "telephone plates" and are sold under that trade name. A short length of flexible lamp cord is soldered and taped to the antenna and ground wire respectively, just before they pass through the telephone plate. These two leads may or may not be twisted their entire length. The writer was dubious about their "capacity effect," so while receiving music from a distant broadcasting station, viz KZN, Salt Lake City, he tried both leads twisted and untwisted. With the exception of a slight variation in tuning there was no noticeable decrease in the strength of the received signals.

Fig. 2 illustrates how the leads are brought out from the radio plate in connection with an outside antenna. In this construction, however, a lightning arrester should be installed, as required by the Fire Underwriters. With the attic antenna an arrester is not required.

The plate from which the "A" battery leads are brought out is merely a common convenience outlet, similar to ones that are used to plug in floor lamps, heaters, vacuum cleaners, etc. This outlet does not have to be wired in conduit as it does not come under the classification of power or lighting installation. The wires should not be smaller than No. 14 rubber covered and may be tacked to the under side of the floor joists but it is preferable to run them on split knobs. If the latter method is used the outlet may at any time be connected to the lighting wires and used as a straight convenience outlet, with no danger of shorts or grounds.

It is desirable to have some kind of alternating current rectifier for charging the storage battery, as it soon saves its cost where from 75c to \$1 is the charge for having these batteries recharged at a garage. Fig. 1 shows the arrangement and connections for the charger and battery. The lighting current should be brought to a double pole combined switch and cut-out and fused at 10 amperes. Then the wires from this switch are connected to the charger. The output leads of the charger are led to the bottom binding posts of the double-pole double-throw switch. The two middle binding posts, those attached to the blades of the switch, are connected to the battery, while the top posts are connected to the 110 volt cut-out switch. Care should be exercised in tracing the polarity when connecting the double-pole, double-throw switch. The positive lead should be traced and marked at the convenience outlet. Also one blade of the plug should be marked +, so that the positive battery lead will finally reach the positive binding post of the regenerative receiver. It is also preferable to insert a 10 ampere cut-out in the battery circuit which will protect

the battery in case a short should occur between it and the receiver.

Even with the advent of the "peanut tube" which operates on dry cells, a number of these must be used where a receiver, amplifier and loudspeaker are combined in one set. These dry cells should no more be kept in the living room than the dry cells for the doorbell; which are always installed in the basement.

Fig. 2 shows how the lightning arrester is connected when using an outside antenna. The arrester has a separate ground. This is secured by means of a driven $\frac{3}{4}$ or 1 in. galvanized iron pipe. It can be easily driven into the ground with a large hammer or axe. A wire no smaller than No. 10 rubber covered should connect the arrester and pipe, the latter by means of an approved ground clamp. All sharp bends or kinks should be avoided in this lead. A lightning arrester is a good investment. High tension power wires or even the ordinary 2200 volt primary lighting feeders which pass along our alleys are always apt to carry away in wind storms and may fall across an antenna wire charging it with a destructive potential that would burn out the windings of a receiving set, and cause serious injury to anyone who might be operating the set at the time. It is also good practice to insert a 3 ampere, 600 volt telephone fuse in the lead between the arrester and receiver, as shown in Fig. 2.

In wiring between the receiver, amplifier and loudspeaker, ordinary lamp cord, or ironing cord is suitable. The "B" batteries should be located either directly behind the instruments or on the bottom shelf of the table and the wires tacked neatly up one leg. The antenna-ground leads should not, however, be cabled in with the battery leads, as this changes the tuning of the receiver and causes more or less unnecessary "howling."

Installation of this type of equipment in finished apartment or flat buildings is a problem which can only be solved by having the battery and charger located either directly under the table or else in some nearby closet or cabinet.

MORE CONVENIENT HONEY-COMB COIL MOUNTING

By AARON NADELL, 2PL

We mounted a set of honeycomb coils against our panel, using the flat type DeForest mounting. With this mounting the coils are tuned by tuning two small knobs. Connections go from the coils to eight small binding posts fairly obscure at the bottom of the mounting.

I have never seen a DeForest mounting used any other way. It is the way it is used on the sets the DeForest people put out themselves. Yet everyone who uses it must feel the same discomfort we did, having to hold the elbow stiffly

high to reach around the coils to the knobs on top.

It may be all right for telephone reception, though even then the exaggerated body capacity effects give trouble, but we were using it for arcs and commercial stations, also occasionally for amateurs. We found it practically impossible to tune for any length of time with the elbows held up at the level of the shoulders.

We solved the problem by screwing the mounting to the panel upside down, by which means we could reach up under the coils to the tuning knobs with the elbows resting comfortably on the table. But the row of eight little binding posts, with connections, was too conspicuous that way.

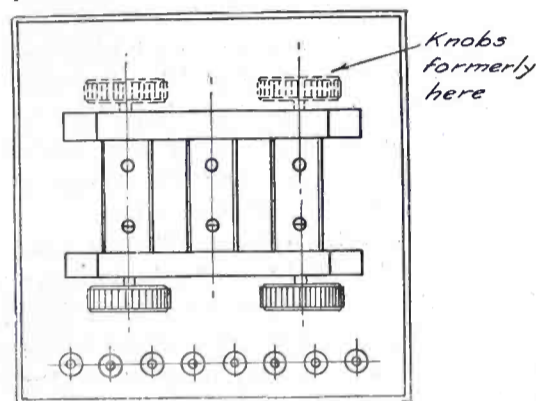

Improved Coil Mounting

We separated the mounting into its two constituent parts, the mounting itself and the small panel which held the row of binding posts. For several reasons we did not want to put the mounting on our own panel direct, so we re-fastened that to its own small panel, leaving it upside down, with the knobs at the bottom, but putting the panel back in its original position, which left the row of binding posts also at the bottom, and more inconspicuous than ever behind the two knobs.

The leads came through a hole at the bottom of the mounting to the eight binding posts, but now this hole was on the top of the mounting, with the binding posts still on the bottom. It was therefore necessary to drill another hole through the bottom of the mounting, and bring the leads through this. The drilling had to be done very carefully, as the mounting is bakelite and showed some inclination to split. But it was done safely, and now the mounting looks exactly as if the DeForest factories had made it with the knobs underneath instead of on top. The only difference is a half-inch hole on the top of the mounting, which, however, looks as if it belongs there. If you will study your own DeForest mounting for a minute you'll have no difficulty in understanding this description.

Radio Adventures in Russia

By Jack Bront

The truth of this thrilling tale is vouched for by the author, who had it first-hand from an acquaintance who went through these experiences. For obvious reasons his name has been changed. The author is a well known ship operator.

JOHN Hanover left for Russia long before the war clouds loomed on the horizon in Europe. The empire of the "Little Father" promised lucrative markets for radio apparatus, and it was upon a survey mission that Hanover was dispatched to that country. The revolution, even the great war, had not yet been made a tangible possibility. However, the unrest and fermenting spore of the antagonists of the imperial government was being nursed beneath the surface. Of this Hanover had been informed upon his arrival at Moscow, and it was with some anticipation that he regarded the possibilities of the radio apparatus market in case the country was thrown into a military camp.

Going about his affairs with painstaking care, he lost sight of the importance of the subsequent entry of Russia into the European wrangle as pertained to his own safety, and it was only when the hordes of what is called Red Russia sprang at the throats of the imperialists and turned the country into a chaotic bedlam that he realized it was high time to leave the country.

Getting to the seaboard after long delays in transit, he found no means of egress from the country. The ponderous machinery of local officialdom promised him nothing and they did nothing in his behalf. He soon perceived that; not only were the local officials unwilling to aid him, but they apparently threw every obstacle in his way. He was arrested on several occasions in the typical Russian way—for no particular reason at all. His protests that he was a national from without the country were of no avail. Officials looked upon his insistent attempts to leave the country as a cause for infinite suspicion. Finally matters came to a head and he was arrested again and thrown into prison, charged with being a secret agent of a foreign country. Upon what basis the charges were founded, he was unable to ascertain. It was very likely that they were based upon nothing.

After long days of delay he was finally brought before local military authorities. They smiled openly at his protests of nationality and they assured him that he had no more chance of leaving the country than the proverbial snowball had of retaining its solid condition in the region made famous by Dante. Upon ascertaining his technical skill, the authorities gave him the choice of two evils: Either to remain in restraint until a "full investigation could be made," or else devote his energies to the service of the czar.

Considering the soul-damning sluggishness of the Russian official machinery, he accepted with bad grace the invitation (veritably a forceful demand) that he serve the "Little Father."

His acceptance of the demand was hailed with satisfaction by the military officials. The radio communication service of the fleet and the land forces, at the time, was a vague quantity, and the whole affair looked like a most ingenious way of obtaining technical skill to augment and accelerate the business of communicating without wires between units of the military and naval forces.

Assignment was made to a ship of the czar's government and, under most difficult conditions, Hanover was able to accomplish some wonderful results. This pleased the officials to such an extent that they heralded his praise even in the ears of the "Little Father." Decorations were bestowed, and the czar himself went so far as to present Hanover with a most valuable watch set with precious stones and bearing the czar's signature engraved in the heavy soft red gold of the case.

It was about this time that all red Russia arose and struck their blows against the imperialists. Subsequently the crew of Hanover's ship turned revolutionists and established the Soviet system. The captain was hailed before the "committee" of the Bolshevist personnel and sentenced to execution for former cruelties to the crew. The other officers were brought before the committee and punished or freed, according to their former conduct aboard ship with regard to the treatment of the crew. Hanover's turn finally came and he was placed on trial.

A small minority voted for his summary execution without delay, for the reason that he was the sole person on board who was familiar with the newly-installed radio telegraph, and that it lay in his power to betray them to the imperialist forces. Being a foreigner and an officer, it was just that more likely that he would deliver them into the hands of the czar's men. This sentiment swayed the men present at the meeting and Hanover's lease on life seemed short, to say the most.

However, several of the crew came to his support and extolled his former kindnesses to them, such as gifts of tobacco, fruit, sugar and cocoa, surreptitiously obtained from the officers' mess. These items were unknown in the crew's mess, which at the best doled out probably the most unsavory mess of material ever dignified by the name of food. On the

other hand, he was favored on account of his knowledge of the radio telegraph, through the use of which the Bolshevist crew could be informed of the approach of the czar's vessels in case of attack, and it was most probable that he would be able to save the day for them many times by this very fact. The outcome of it all was that he accepted the Soviet comradeship as the best way out of a most difficult position. He was hailed as a comrade and held in respect. He was free.

By listening-in to the radio code signals of the czar's ships he was able to locate their positions, and straightway signalled them of the condition of affairs on board. He gave the information that the crew had mutinied and turned over to the Bolshevists. Three gunboats were rushed to the scene and the events which occurred may be discerned from the description given in Hanover's own words as follows:

"It was late afternoon. The radio cabin was cold, as the steam in the heaters was low. I wrapped a fur greatcoat about me and sat down at the radio receiving apparatus.

"A commotion sounded aft. A great hue and cry went up. I was suddenly filled with apprehension.

"The gunboats were in sight!

"Their frowning cannon turrets even then could be dimly discerned against the distant clear skyline. The Bolshevists at once scented their betrayal. Matters looked bad for myself.

"A sharp cry was taken up by the rabble. Running feet sounded along the deck. I looked quickly through the port. They were rushing toward the cabin door in full cry like a pack of wolves, a tall gangling beast in the lead.

"As I shot home the heavy iron bolt on the steel cabin door a rain of blows beat on the outside.

"Open in the name of the committee!"

"A hairy visage appeared at the glass of the port, teeth flashing in a snarl of rage. The thick heavy lips were smeared with saliva and the teeth reminded me of some scavenger carnivora.

"Open in the name of the committee!" came the cry.

"Committee of Hyenas," I shouted as a great wave of anger and nauseating disgust rushed over me. I stood alongside the radio table while blows rained on the door. I mentally estimated how much committee procedure would be gone through if that howling mob of frenzied beasts gained entrance to the

Continued on page 62

The Martian Marvel

By Volney G. Mathison

After many months, here is presented another of the justly popular Samuel Jones stories wherein the author adroitly mixes radio science, imagination and humor to produce an interesting tale. Let it be strictly observed, however, that the editor vouches not for the truth of various statements herein made.

"THERE is a great deal of talk nowadays about wireless with Mars," remarks the goofy lookin' old gazooney who had chosen to come and sit alongside me on the park bench. "It is about time these piffing radio experts were waking up to the fact that Mars has been trying to attract our attention for hundreds of years."

"Humph! There ain't been no signals from Mars bustin' th' diaphragms of my Baldwins yet!" I snorts. "That's only newspaper flub wrote fer th' consumption of half-witted dumbells who don't know th' diff'rance between a Cunningham tube an' a porcelain cleat!"

I gets this off real caustic like, because that was the way I was feelin'. Here I'd been sittin' in Golden Gate Park gulpin' fog for three hours keeping a date with a jane who never showed up—and now comes this queer-lookin' old gink talkin' Mars an' radio. About all you hear talked about nowadays is moonshine an' radio, but this bird's line evidently is Mars an' radio.

"I quite agree with you that the assertions of popular scientific writers in regard to Mars are based upon unproved hypotheses," says the park-roaming mystery alongside me, solemn like. "Nevertheless, some of their suppositions are correct—amazingly correct. *I know!*"

He spits this out sharp—so sharp that I kind of half slide an' half jump around on the bench, runnin' a sliver through my pants an' a good ways into my hide.

"Ouch!" I says; an' I starts to get up to pull the thing out.

"That is no way to speak to a gentleman, sir—especially to me, the great Baron Koubansky!" exclaims the old freak, jumpin' up. "I tell you, I know!" He grabs me by both shoulders an' shoves me back onto the bench so hard that the sliver navigates about another half-an-inch deeper.

"Listen!" he hisses, "I have been there!"

"Where!" I gasps, "Mars!"

"Yes," he answers, tense like. "Yes, I have been to Mars."

Well, when I hears that, I begins to get peeved.

"Look here, old rattlebrains!" I

blows up, "My mental apparatus don't tune them waves you're radiatin'. Anybody that believes they've been up to Mars needs th' same thing them homebrew victims roostin' on lonely coral rocks down in th' South Seas need who hear radiophone music an' signals an' things without no receivin' sets—namely, a nice little sheaf of one-way tickets to th' nuthouse!"

I thought that would shut up the old goof.

"Such a remark, my dear sir, is not in keeping with the broadminded spirit of

"You shall soon perceive your ignorance. Come!"

We get a car to Van Ness Avenue; then another to Ingleside. When I see where we're bound, I begins to get uneasy, because this Ingleside is all dark forests and gullies, with a few woodcutters' shacks here an' there. Besides I had got to thinkin' maybe this old lunatic actually did have some kind of flyin' apparatus after all.

"Say, look here, goofy," I says at last, as we get off the car, "if you really are lookin' for some Boob McNutt to break his neck tryin' to help you navigate some crazy contraption across a few million miles of space, then you can count me out. I went up in a home-made flyin' machine once—

"Your decision, sir, is premature," replies old Koubansky, kind of worried like. "I assure you that my invention has little in common with the generally-accepted principles of aeronautical science."

"I knew it!" I groans. I considers ditchin' the bird right then, but still I had a kind of sneakin' curiosity to see what he had.

Up in a gulch in the wildest and darkest part of Westwood we come to Baron Koubansky's hangout, a small shanty hid among the trees, and back of that a wooden structure about twenty feet square and thirty high, with neither windows nor roof, but with a small padlocked door in one side. The Baron unlocks this, we go in; then he closes the door and switches on a light.

Standing on some large beams and held upright in a heavy timber frame is a kind of cross between a lighthouse and a giant steel torpedo. The thing is about twelve feet in diameter and twenty-five feet high; the top end is pointed like the shell of a big gun, and the base is rounded like the thick end of a' egg. In the side, near the lower end are four heavy glass ports. Between two of these ports I make out the seam of a door, but otherwise the monster is all smooth solid steel.

"Sulphurous saints!" I gasps, clean dazed. "Is this thousand-ton chunk of decarbonized Bessemer supposed to fly!"

Continued on page 68

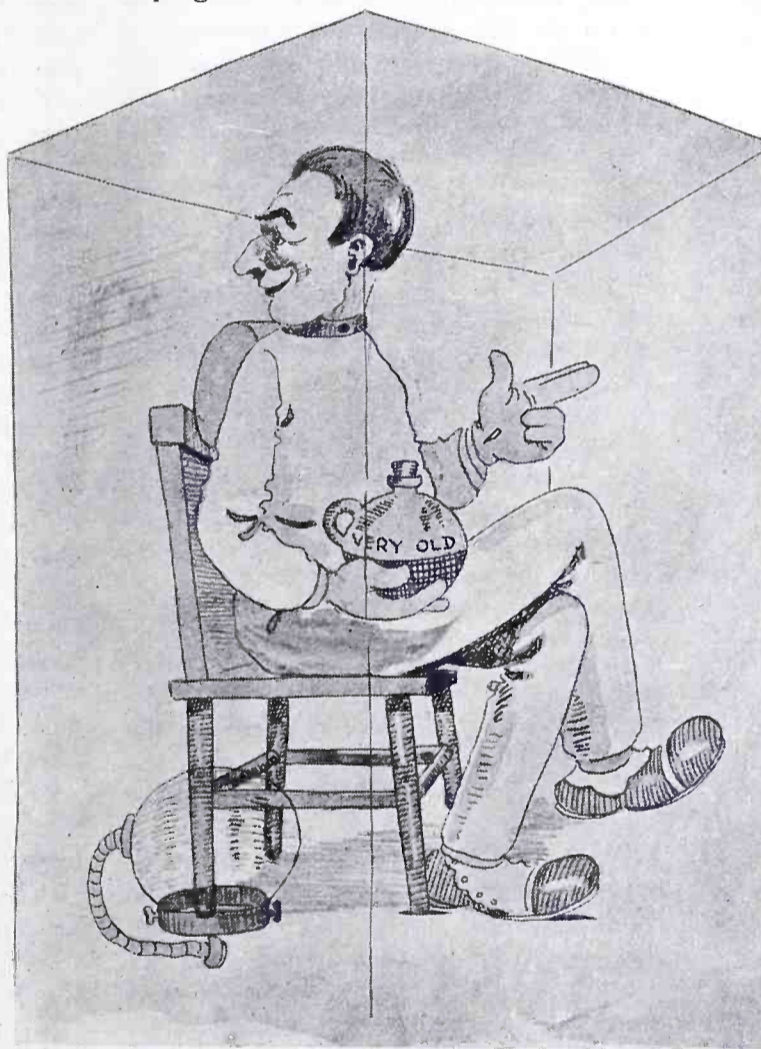

"Well, here goes," I says. "If your Martian wireless ever reaches th' earth, tell 'em I died happy."

the times," he says, quiet like. "In order to convince you of the error of your scoffing words, I shall extend you an invitation that has never before been offered to a human being on this earth. I am going to ask you to accompany me on a short trip to Mars."

"I'm very much obliged to you, my dear Gaston," I responds, sarcastic like. "I shall be delighted to take a little spin with you this evenin' up to th' dear old planet Mars."

"You are ridiculing me, apparently," says old Koubansky with some dignity.

"Sparks" and "Bozo" Make a Call

By Sewell Peaslee Wright

Herein is a good idea in the construction of an electrolytic rectifier. It will prevent the old difficulty of drying up and the consequent ruination of plates.

WILDCAT signed off with a peculiar undulating shriek of his spark, an effect obtained by juggling the rotary rheostat on the final characters (and which, by the way, was responsible for the fearsome nickname that this harmless young gentleman rejoiced in) and turned to greet Sparks McAllister and Bozo Smith, who, with true ham familiarity, had wandered into Wildcat's "shack" without the formality of knocking.

Several years of brass-pounding on the bounding main had given McAllister his title, but how young Smith ever was dubbed "Bozo" nobody knew—least of all himself. Sparks always claimed that Bozo's shock of stubborn black hair, that never would remain combed, and always hung more or less in his eyes, giving him the appearance of a very juvenile wild man, was responsible for the monicker, but this has never been verified. So much for introductions; now let us toddle on.

"Just thought we'd drop in and see you do some of that DX work you claim you can do on that antiquated junk heap of obsolete spark apparatus," said Sparks, picking out the one reliable chair in the shack, and motioning Bozo to a seat on a soap box in the corner.

Wildcat grinned amiably at the insult.

"She reaches out, the old girl does, and she doesn't burn out her filaments or get a red-hot plate on her, either!"—the latter part of this remark being directed at Spark's 20-watt set, which he woefully crowded with the usual results.

"U-m-m-m-m!" remarked Sparks pleasantly. "She never blows a condenser either, I suppose?"

Wildcat's spark went wild in his condenser about once every two weeks. Naturally, it was a sore point with him.

"Maybe she does blow a condenser now and then," he came back, "but it's a pipe she isn't all the time needing new tubes, new adjustments, new meters and new rectifiers!" It was always easy to get Wildcat stirred up; just touch him up on the operation of his precious spark set!

"Yeah! I'll admit all that," conceded Sparks, lazily filling his disgraceful old pipe, "it does take a man of understanding to operate a C. W. set. Spark certainly is the thing for beginners!" He paused to light the pipe.

"But you're all wrong, son, on the matter of rectifiers. I've got a new scheme that prevents them from drying up and ruining the plates."

Bozo leaned forward interestedly.

"Spread it, for the love of good modulation!" he begged. "I've tried oil on the top, and all that does is make an awful mess."

"Verra, verro simple," said Sparks, leaning forward and reaching for pencil and paper. "Just make a little square block for the top of each jar out of $\frac{1}{2}$ or $\frac{3}{4}$ -inch board. Holes are made which will just pass your two electrodes—and now comes the trick." Sparks paused to wave away the cloud of evil-smelling tobacco smoke that hovered over the table.

"Heat some wax or paraffine till it melts, and then allow it to cool till it starts to get thick—but not until a tough skin forms on the top. Soak the top and bottom of your blocks in this paraffine, and allow to harden. Then

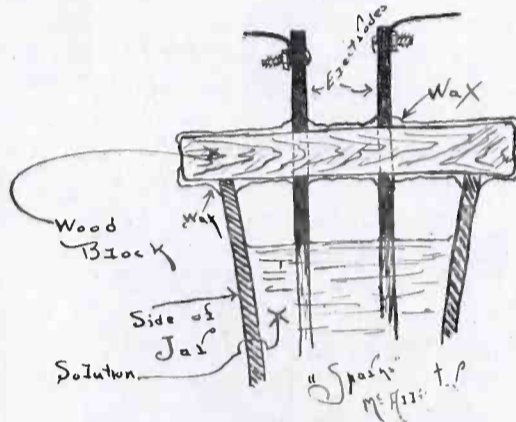

Sparks' Sketch

stick the electrodes through their holes, being careful to insert them from the bottom, so that no wax will get on the parts that are submerged—get the idea?" His auditors nodded, and he went on.

"When the electrodes are properly adjusted, heat the upper ends until the conducted heat melts the wax where they penetrate the wood, and then set them aside to harden. The wax will then seal the electrodes into their slots. Now take a brush and paint the edge of the mouth of each jar with hot wax, and then, with very hot wax, paint the lower side of each block, clapping the block onto the top of the jar in its proper position as soon as possible so that the wax will harden and form a seal. The jar will then be air tight, though, should you want to unseal it, it can be done very easily, and without the slightest muss."

As he talked, he illustrated his points; perhaps his sketch, which was saved by Bozo and is herewith reproduced, will help make it clearer to you.

"Sounds all right," said Bozo, while Sparks lit his pipe again, "but why

couldn't a fellow use shellac instead of wax?"

"Could," admitted Sparks, between puffs, "only thing would be that it would take longer to do the job—and it happened that I was out of shellac at the time I thought of the idea, and the Mrs. was sealing up some jelly, which was what really put the thing in my head."

"Get it patented," advised Wildcat, who was only casually interested in anything pertaining to C. W., and was anxious to start something of more interesting nature, narry a bit awed by the seniority of his older visitor. "May never have another idea; better salt this one down!"

Sparks took a deep, long draw on his pipe, and suddenly exhaled the whole of it in the direction of Wildcat, the blue cloud completely enveloping that young man's head and shoulders.

"Ye gods, Sparks, have a heart! What you think this is, a gas attack?" he spluttered, with tears running down his cheeks, and, sputtering and coughing the while, he waved his log-book fan-wise in a frantic effort to disperse the cloud.

"Don't get flip with your uncle, bub, till you're old enough to come up smiling through a little thing like that, then!" advised Sparks calmly. "Talk about me not having ideas—if your brain pan were analyzed for 'em, the results in figures would exactly coincide with the logarithmic decrement of a good C. W. set!"

Wildcat, somewhat chastened and thinking of no good comeback, turned to Bozo for comfort.

"Good thing somebody in the bunch has got brains, eh, Bozo?" he ventured.

"Thought you'd notice me pretty soon," said Bozo, sticking out his chest. "But, howcome you just recognized the fact that I'm the one that's got 'em?"

Stuff like this passes for humor among hams!

RADIO IN MINE RESCUE WORK

Experiments with a radio receiving set are being conducted on one of the mine rescue cars of the Bureau of Mines. The results thus far show that messages can be received just as clearly when the car is in motion as when it is at rest. An effort is being made to establish whether the radio has a practical application on mine-rescue cars.

Some Radio Frequency Theory

By Donald K. Lippincott

As all intelligent radio practice is based on theory, the radio frequency experimenter may well read this article before attempting any of the hook-ups shown in this issue. The author's treatment is elementary, without mathematics, and has been re-enforced by practical experience.

THE problem of radio frequency amplification is so involved with that of regeneration that they hardly can be considered separately. In emphasizing this recently, it occurred to me that much of the confusion as to radio frequency is really due to a failure to understand some of the fundamentals of "capacity feed-back." I shall try to clear up some of these points here, without, however, attempting to go into the mathematics of the case.

The characteristic of the triode which gives it its unique value is this: Within certain limits, any change in the potential of the grid produces a proportional

change in the current flowing in the plate circuit, this change, however, being many times larger than the original potential change could produce directly.

The only moving elements in the system are electrons, which may move with velocities almost comparable to that of light, so there is no mechanical lag to be considered. It follows that no matter how great the rapidity of change in grid potential, the tube current keeps step with it, and this again means that so far as the tube itself is concerned, its action on radio and audio-frequencies is identical.

Not the simplest, but certainly the best known application of amplification at radio frequency, is in regenerative circuits, of which tickler feed-back is the easiest to understand. Fig. 1 shows the essential elements of such a circuit.

As we are now considering only the radio frequency function, the grid condenser and phones have been omitted as not entering into the action.

Now to follow the happenings in the various circuits:

(1) An incoming wave sets up a radio-frequency current in coil 1.

(2) The magnetic field due to this current links with coil 2, and induces a radio frequency voltage which affects the grid of the tube.

(3) The battery, 4, tends to keep a current flowing between the filament and the plate, but

(4) A negative potential on the grid reduces and a positive potential increases this current, which will flow through coil 3.

(5) The magnetic field due to this current reinforces the field from 1 and intensifies its action.

All this, of course, is elementary, but has been repeated here in order to bring out three points. First, if a decrease in the plate current tends to make the grid negative, the result is a further decrease, i.e., we have regeneration. Second, the tube is an amplifier, and the effect in the coil 3 is much more intense than in the coil 2, and as amplification and re-amplification are simultaneous, the only thing that prevents infinite amplification is the tube itself. If we try to make it give amplification beyond its inherent limits, it "slops over" and starts to set up oscillations itself. Third, the factor

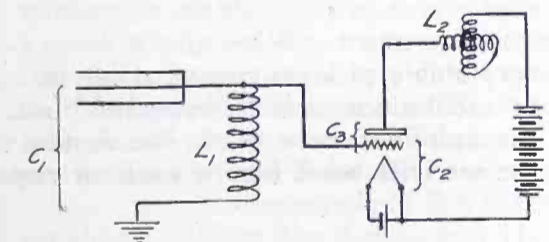

Fig. 1. Essential Elements of a Tickler Feed-Back Circuit

that determines the amount of regenerative amplification is the coupling between the input and output circuits of the tube. Coupling is merely the measure of the effect that a change in one circuit has upon the other. It may be made so "tight" that the tube will oscillate under all conditions, so "loose" that it will not oscillate under any condition, or it may occupy a borderline position where such incidental effects as body capacity or the intensity of incoming signals may make the difference between oscillation or non-oscillation, when the circuit is said to be unstable. Maximum regeneration is always obtained just before oscillation is reached

and necessarily involves a certain amount of instability.

Coupling is not necessarily inductive. Any arrangement which makes a change in one circuit affect another constitutes coupling, and this fact is the basis of the "tuned plate circuit," or "capacity feed-back."

Fig. 2. Radio-Frequency Diagram Showing Aerial and Ground as a Condenser

Consider Fig. 2. Here antenna and ground have been so drawn as to emphasize the fact that together they form a condenser. Plate and grid, and grid and filament of the tube also form condensers, so a radio frequency diagram (neglecting d.c. effects) of Fig. 2 might be drawn as in Fig. 3. This shows

that we have here two resonant circuits. The first consists of the inductance L_1 and the two condensers C_1 and C_2 in parallel across it. The second consists primarily of the inductance L_2 bridged by the condensers C_2 and C_3 in series. Apparently then C_2 is the only element common to the two circuits, but as C_1 and C_2 are in parallel, C_1 must share any charge with C_2 , so the circuit is really rather complex. Supposing the second circuit tuned to some given frequency, the voltage drop across L_2 is equal to the drop across the condensers. Where two condensers are in series, the voltage across each is inversely proportional to the capacity. Therefore the smaller C_1 , the greater the percentage of voltage across L_2 affecting the first circuit, i.e., the closer the coupling.

Now we will return to Fig. 2. The most positive point in this circuit is the positive pole of the B battery, and we will assume that a current is flowing and that there is a steep potential drop across L_2 , making the plate quite negative in comparison. The grid now becomes negative owing to an oscillation in the antenna circuit. Less current then flows in the plate circuit, the drop across L_2 tends to disappear, and the plate becomes more positive. The plate is one half of the condenser C_3 , however, and one-half of a condenser cannot become positive without the other half becoming negative, and we

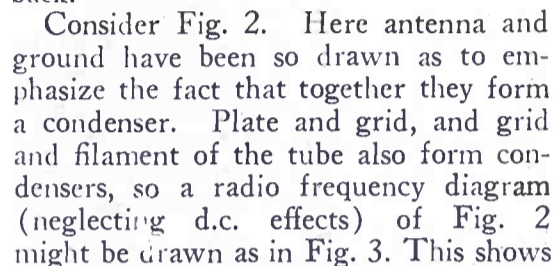

Fig. 3. R. F. Diagram Showing Grid-Plate and Grid-Filament Circuits as Condensers

www.americanradiohistory.com

thus have the same result as in the circuit of Fig. 1, a decrease in plate current making the grid negative—the necessary condition for regeneration.

The facts to be noted here are: (1) The inductance L_2 does not have to be tuned exactly to give some regeneration, but the effect is increased enormously as resonance is approached. (2) The only practical method of increasing the coupling is to decrease the antenna capacity by inserting a series condenser. (3) A positive bias on the grid allows some current to flow in the grid circuit. This current is in phase with the current in C_1 , i.e., a positive bias effectively increases the capacity in the antenna circuit and decreases the coupling.

Suppose now that L_2 is replaced by the primary of a radio-frequency transformer. If this is to function with anything like efficiency, it must be at least approximately in tune with the incoming wave, and will therefore cause the tube to regenerate. This is an effect that cannot be escaped, be the transformer iron core, tuned honeycomb or auto transformer. In practice it gives an additional amplification which compensates for the difficulty in making efficient radio-frequency transformers with high ratios of transformation.

There is one disadvantage about a fixed-tuning transformer. It is impossible to alter the degree of regeneration with it by detuning, and hence some radio-frequency circuits will not oscillate under every circumstance. Still others (and these are perhaps the most maddening of all), are so unstable that they "click" on and off for apparently no reason at all.

The circuits having the strongest tendency to oscillate are those loose coupled ones in which a grid variometer is used for tuning the secondary. Here the only capacity outside the tube itself is the distributed capacity of the windings, and the coupling depends wholly on the capacities between the electrodes of the tube. With some tubes, a potentiometer for procuring a positive grid bias is sufficient to give control, but with others, the only thing to do is either to substitute condenser tuning or else shunt a .0001 mfd. condenser across the secondary of the coupler. In connection with a grid bias the latter will often produce results. The filament of the amplifier tube can also be used to some extent to control the oscillation.

The violent disagreement between authorities as to the best type of transformer is probably due to the fact that almost any kind will work in connection with suitable tubes and pick-up circuits. The essential for a fixed tuning transformer is that primary and secondary have sufficiently close coupling to transfer the greater part of the energy to the secondary, even if resonance between the circuits is not exact. An auto-transformer (or choke), best fulfills this con-

dition, especially if an iron core is provided to broaden out the tuning of both circuits. Tuned transformers are better yet, when the right setting has been found, but the trouble here is in finding it.

Here is the crux of the whole radio frequency problem. The tube itself will do practically anything you ask it to, but the tube is a potential-operated device. In order to produce high radio frequency potentials with the radio frequency current output of the tube, we must have a condition approaching resonance, and at frequencies of a half million and upward, resonance is necessarily comparatively sharp.

A CONVERTIBLE RADIO OR AUDIO FREQUENCY AMPLIFIER

By K. M. BARBIER

General experience has shown that radio frequency amplification gives wonderful results for long distance radio-phone broadcasting but is useless for amplifying local broadcasting. It is possible from the accompanying circuit diagram to make up a set which uses the same tube or tubes for either radio and audio-frequency amplification as may be desired.

The change from one to the other is made by means of a double-throw, five-point telephone switch and fila-

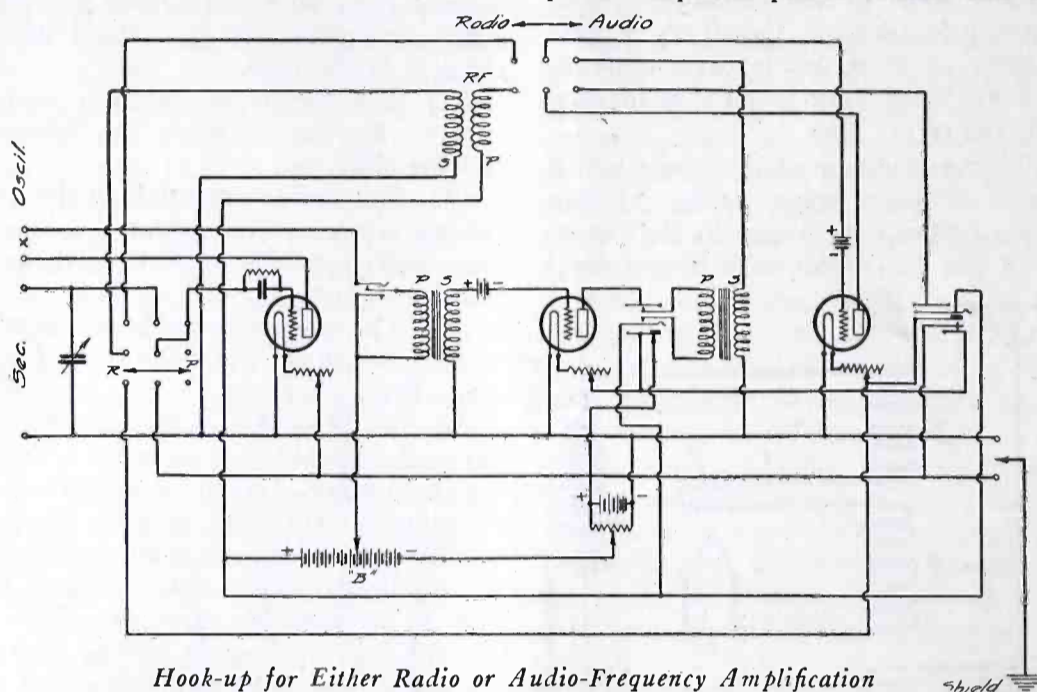

Hook-up for Either Radio or Audio-Frequency Amplification

It is evident from the foregoing that the constants of the pick-up circuit have a great deal to do with the functioning of the radio-frequency amplifier. If regeneration is added to the detector tube as well, the problem becomes still more complex due to the addition of another unstable element. When this is done, a very stable pick-up circuit must be used or oscillations will be reflected back on the amplifier tube with the result that the set will howl like a pack of coyotes at the full of the moon.

If feed-back is not used on the detector, it is well to note that any oscillation is due to the amplifier tube, and is a cause of interference as great or greater than that due to an oscillating detector. Radio frequency should be a cure for this source of annoyance to the neighborhood, but it is not necessarily so.

The most certain results are obtained with an antenna tuner consisting of a variometer in series. By altering the proportions of inductance and capacity any desired degree of stability can be obtained for any given wavelength.

Now for a few conclusions:

(1) The bigger the capacity of the antenna circuit, the less the regeneration, and the greater the stability of the circuit—always remembering that any condenser in series decreases the capacity.

ment control jacks. The filaments are controlled automatically without danger of blowing out the tubes.

The following combinations are available:

1. 1 step radio and detector;
2. 1 step radio, detector and 1 step audio;
3. Detector;
4. Detector and 1 step audio;
5. Detector and 2 steps audio.

The radio frequency amplifier will work better on a single circuit tuner, although it is optional. By all means I advise using a vernier rheostat on the radio frequency amplifier tube.

(2) The percentage of gain due to regenerative amplification is many times that due to any inter-tube amplification.

(3) Multi stage radio frequency hookups are satisfactory with very stable pick-up circuits only.

(4) Intertube transformers must be tuned if maximum efficiency is to be obtained.

(5) Transformers with fixed tuning must have very close coupling to give results over any reasonably wide band of frequencies.

(6) Sloppy construction is fatal to success.

(7 to 20) The only thing that will bring results is careful experimentation.

"Radio Frequency is Great Stuff"

By Earl Ennis

This is a dose to be taken after having tried radio frequency. If you succeed, you won't need it. If you fail, "misery loves company." Anyway, it is better to have tried and failed than not to have tried at all, especially if you can thus appreciate some fun-poking comfort like this.

THERE is something intriguing about radio frequency. It is like psycho-analysis or spirit research. It has the same quality of indefiniteness about it—the same monkeying with mysterious forces. One savveys ordinary radio without difficulty—a pole, a couple of wires, a tuner, and a lamp. But with radio frequency, it is different. There one bumps up against the astral phase of radio.

There had been much in the magazines about radio versus audio frequency. Great men seem divided over the subject. Two great parties exist—the Audio Democrats and the Radio Republicans. There is no tariff in the platforms, but there seems to be a lot of frequency. So I started out to find out what this new thing radio frequency was. If it was worth while I was going to have a bucket of it, or a keg, or however it came.

"What is radio frequency?" I asked an eminent engineer.

He pulled his nose.

"Hum," he said. "Well—you amplify the incoming oscillations at radio frequency before you detect them."

"Oh, yes," I said. "The idea is to let them sneak in on you before you appear to notice them. Then when you are sure you have them trapped, you pounce on them with a detector, magnify them with an audio frequency circuit, and see how they are put together."

"That's the idea," said the expert. "Whereas with audio frequency, you just notice them and there they are."

Very definite and as clear as mud.

"How do you do it?" I asked.

Now that was where I made my mistake. You must never ask a radio man how he radio frequencies. He will tell you anything else but he will never tell you how to radio frequency. It is probably part of some ritual like Masonry. You must never ask a Mason what he does with the goat. That is secret. So with radio frequency. The expert looked at me reproachfully.

"Don't do it," he said. "Let radio frequency alone!"

"Why?" I asked, startled, for his tone was ominous.

"Well, a properly balanced radio frequency circuit works magnificently. But you must have your transformers just right."

"Oh," I said, "there are transformers in this thing, eh? I thought there was a catch somewhere." It looked too easy, the way he said it. When anything looks easy in radio, that is the time you

want to dash out and buy an extra tube, or test your battery, or hire an electrician. Trouble is just ready to begin.

"Oh, yes," said my friend, "You have to have transformers. How else could you get amplification?"

"Of course," I agreed. "How else?"

The conversation lapsed at this point. Naturally I wanted to ask him just how the transformers acted, and where you put 'em, and how much they cost. Maybe I didn't want radio frequency after all. Maybe radio frequency was the Rolls-Royce of the business, not the least suited to my Ford income. But I simply couldn't afford, after being a devotee of radio for two years, to expose myself to his criticism by asking a fool question.

"Of course," he said, "you COULD use variometers if you wanted to."

But the way he said it. The WAY he said it! Utter scorn! A variometer must be pretty low in the social scale of radio frequency I figured. Probably down in the slum class—the common polloi status along with the crystal detector.

"I have no intention of using a variometer," I said with great dignity. "What do you take me for?"

"Well some do," he said.

I knew then I had been right. A variometer was a low instrument of humble birth. It probably cost less than \$200—very cheap and tawdry. I should have none of it, at any cost. No sir. A transformer for me, every day in the week.

"What are you using now?" the expert asked me.

I blushed. The truth had to come out now. I felt my face grow red.

"Just a little temporary set I threw together in a hurry," I said. "You know—detector and two step-audio . . . Hem . . . all right for local stuff, but on distance . . ." (The set cost me \$300.)

He nodded sympathetically.

"I know," he said. "I wasted a lot of time with that type." He leaned forward impressively and tapped me on the chest, "With two steps of radio frequency, you know, you can bring in anything on the Atlantic coast—all over the house—on a loud speaker. Just two steps!"

I gasped! With two steps! All over the house! Radio frequency.

"Well," I said enthusiastically, "I just wanted to get your ideas on the subject. I am going in for radio frequency strong—right up to the hilt. None of this

audio frequency for me. It's all right to play with—you know if you have a kid in the house. But for real stuff, gimme the radio frequency."

They were brave words. But they had their effect. The expert wrung my hand with a God-Bless-You motion, and we parted fast, firm, and irrevocably permanent friends—linked by the common boon of all humanity, greater even than Peruna or Smith Brothers' cough drops—radio frequency.

With the impulse burning hot in my soul, I went into a radio supply store and took unto myself a radio frequency outfit. That is, I bought the makings. I decided that the time had come to build my own stuff. With the pride of a man buying his first villa, I ordered transformers—the best in stock. I got tubes, potentiometers, rheostats, inductances, variable condensers, ohms, volts, amperes, grid leaks and several assorted styles of megohms. I spent one hundred and fifty dollars and went out loaded to the neck like a Christmas tree.

This was on Wednesday. By Friday I had it assembled neatly on a panel. It certainly looked fine. My wife stepped back and forth over me in the kitchen until her patience gave out.

"What is that thing?" she demanded.

"Radio frequency," I replied with great dignity.

"What does it do?" she asked.

I blushed for her ignorance.

"It brings in the Atlantic Coast all over the house," I answered.

"Well, why try to hear the Atlantic Coast where you can't hear the Pacific Coast?" she argued. "We listen and listen and all we hear is something we don't want to hear, or da-te-da-te-da all the time. I'd rather go to a movie."

"Just you wait and see," I countered. "This is the real stuff."

By soldering most of Saturday night, I got the radio frequency set—unit, I believe, is the official term if one wants to be eclat—all ready.

"We'll tap the Sunday morning stuff and try her out," I said.

We did. We hurried through breakfast in order to test out the set on the radio church services. I figured that I would rather waste a sermon, if anything went wrong, than a concert. Right here, I want to say that the unit looked mighty nice when I had it all hooked up.

With all the radio frequency rheostats turned on, and all the radio frequency lamps going full blast, and the radio frequency inductance set at the right tap and the radio frequency condenser

tuned just right, I switched on my regular set which was coupled to the radio frequency unit, and listened. About 4,000 or 5,000 miles away I heard a voice speaking—faintly.

“... and the Lord said unto Moses...”

“Hear anything?” asked my wife, who is very impatient.

“Not yet,” I lied manfully. “Guess we’re a bit early. I’ll just tune around a bit and see what else we can pick up.”

I twisted everything that would turn. The voice grew fainter. I turned some more and fed up the lamps. The voice went out entirely.

“Ah,” I said, mentally of course, “the darned battery is reversed.”

I reversed it back. Then I listened again. Nothing doing. I put the battery back the way it was. Faint voice, this time 6,000 miles away—about where London should be, or Africa.

“Well, let’s hear it,” said the wife.

“Wait a minute,” I urged. “This is a critical circuit. You’ve got to get it just right. Then it booms in.”

“Well, hurry up and make it boom,” said my wife.

I tried. I did everything that a human being could do to make it work. I spent one hour and thirty-five minutes trying to get the speaker to come in out of the fog where I could hear him. There wasn’t a bit of sense in his staying so far away when I wanted to be friendly.

“Well, I think your old set was working plenty good enough,” said the wife.

“Oh, all right,” I growled. “If you want to be behind the times. I’ll connect it up. But you’ll see the difference.”

I jerked off the nice, polished panelled radio-frequency unit and hooked my antenna and ground on the old set.

“... will conclude the service today from the radio church...”

The voice nearly knocked me off the chair. Audio frequency. Good old audio frequency. Old friend!

“There,” said the wife. “What did I tell you? Now let it alone, now that it is working all right.”

Working all right! Ye gods! Sadly I wrapped up my radio frequency set and tucked it away in the closet. It was scientific. It was modern. It brought in the Atlantic Coast all over the house. But somehow—it wasn’t the good, old pal that audio frequency had been. I found myself patting the old set.

“What are you going to do with all that junk you wasted?” asked the wife.

“Oh, it’s not wasted.” I said grandly. “It was an interesting experiment. I can see where radio frequency is destined to supplant audio frequency sooner or

later. But for the present—on this local stuff, audio frequency is good enough. There is no object in trying to hear the Atlantic Coast, anyhow, with all this local interference. I’d rather get the local stuff good. Then you can sit down and enjoy it without always tinkering with the set, tuning in and all that!”

The wife gave me a funny look.

“Huh!” she said.

I met my radio friend again the other day.

“Well, how’s the radio frequency coming?” he asked.

“Oh, so so,” I said. “I prefer audio frequency on the local stuff. Radio works fine on distance, though. Nothing like it.”

“I’ll say it does. We get Atlanta and Schenectady all over the house these nights! Great stuff—radio frequency!”

“It sure is,” I agreed.

We shook hands and parted. I

thought of his words, Atlanta and Schenectady all over the house. Radio frequency! How in heck did he do it?

My wife and his wife got to talking yesterday. Said his wife:

“He spent all Sunday making up some kind of a frequency thing and then threw it away...”

“So did my husband,” said my wife.

As has been said, “radio frequency is great stuff.” It made a liar out of my friend, nearly broke up my family, and shattered my faith in my own ability. Like prohibition, it is sweeping the country. But I wish to announce right here, that, no matter what is said in its favor, or how loud it brings Schenectady all over the house, I am a confirmed audio-bootlegger and shall die with my tubes on.

As for radio frequency, it works best with me on the third shelf of my bedroom closet and I don’t care if Steinmetz and Armstrong both find it out!

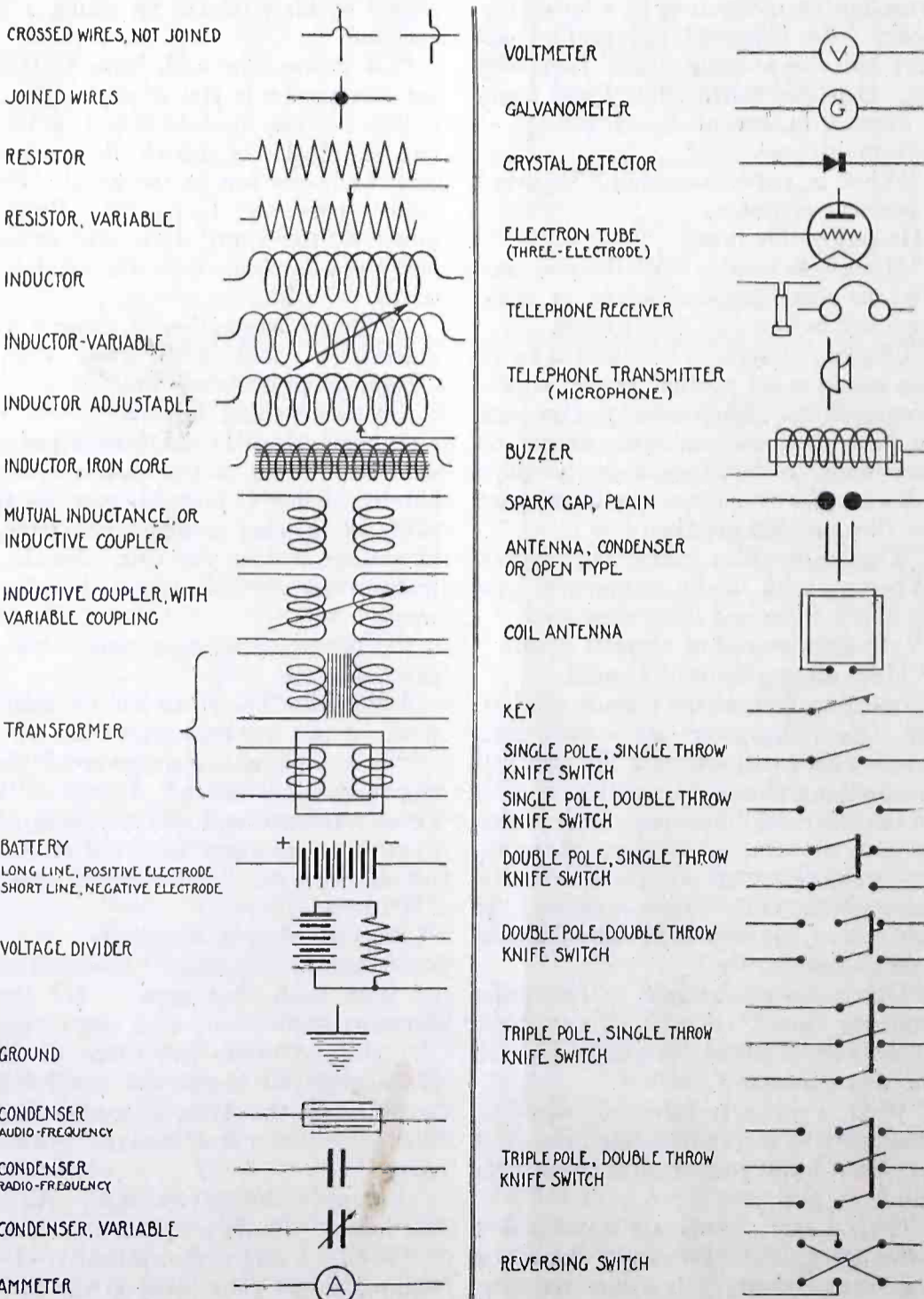

Conventional Signs Used in Radio Diagrams as Prepared by U. S. Bureau of Standards

A. C. Radio Motors and Generators

By D. B. McGown

Herein the author describes in simple terms the fundamental principles of the design of the single-phase a.c. generator and motor, including the synchronous motor. The next installment will deal with induction and commutator motors.

ALTERNATING current motors and generators are simpler and easier to construct than the direct current machines previously discussed. The simplest kind of a generator is the two-pole machine, with a rotor, called the armature, composed of a straight iron core, with a shaft through its center, which is supported on bearings. Two windings are placed on this core, one on either end, as shown in Fig. 1, and their ends connected to "slip rings," which lead the current generated to the outside circuit.

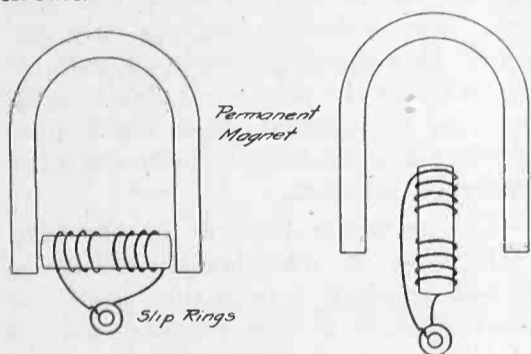

Fig. 1. Two-pole magneto generator, with armature parallel, and at right angles to field poles

The current generated by a machine of this type is indicated graphically in Fig. 2, where we have the well known "sine curve," so called because the current varies directly as the logarithmic function, called the "sine" of the angle which the rotor conductors make with the magnetic field. Thus, this simple generator gives alternating current, i.e., current which reverses itself periodically, without any extraneous apparatus.

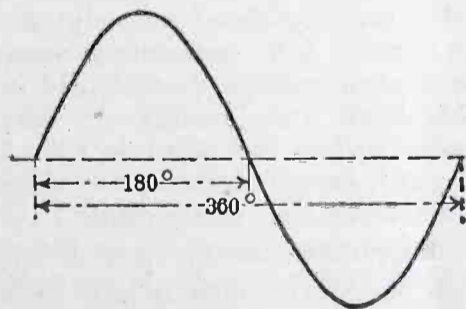

Fig. 2. Sine curve.

The production of direct current can be accomplished by combining the two slip rings into one, and separating it into two halves, insulated from each other. Therefore, although direct current is delivered, the actual electricity generated would be alternating, and rectified, or changed in polarity so that the final action would appear as direct. It would not be a constant current, however, but would be "pulsating," or varying continuously, but in the same direction. A large number of poles on the machine

would result in these pulses becoming overlapping, so we would have the direct current of commercial form, substantially direct, but usually with a "commutator ripple" superimposed thereon, which is true alternating current.

The alternating current generator described above would be rather inefficient, for many reasons. In the first place, a magneto, or machine with permanent magnets, never has a very high density of flux across the ends of the poles. It would, therefore, require a large magnet to obtain very much power. This can be remedied by using electro-magnets with soft iron cores for the fields. It then becomes necessary to supply a direct current from some source to energize, or as it is called "excite," the fields. Another very serious disadvantage would be the excessive speed necessary to drive the machine to obtain a reasonably high frequency. Commercial frequencies are generally 25, 50 or 60 cycles for lighting and power service. For radio work they run higher, 500 cycles being the standard frequency for most ship-board installations, with intermediate frequencies of 240, or 120 cycles used in some cases. It is perfectly possible to drive a two-pole generator at speeds necessary to obtain the relatively low commercial power frequencies; 60 cycles would require a speed of 3600 rpm for the armature, and 25 cycles 1500 rpm. If we wished the higher frequencies, however, we would have to attain the impossible speed of 30,000 rpm for 500 cycles, and even for 120 cycles a speed of 7200 rpm would be needed.

This difficulty is simply remedied by increasing the number of poles. Generators for power supply are usually driven from water power, or from steam, or internal combustion engines, and relatively low speeds are desirable, especially for water power drive. The immense 9000 kva water wheel driven machines at Keokuk, Iowa, deliver 25 cycles, and have 52 poles, but are rotated at the unusually low speed of 58 rpm. The rotor for this machine is 25 ft. in diameter, and weighs 116 tons.

Radio generators are seldom directly driven by the prime mover, except in isolated plants, and so the flexibility of the driving motor is of great value. For example, the highest speed known to the writer, in a 500 cycle generator is 5000 rpm, such a machine being the small 1/4 kva direct-connected machines used by the Navy and Signal Corps on pack sets. This is a 12-pole outfit, and, owing to

its extremely small size, must operate at a high speed to get any kind of power output. Larger types operate at lower speeds, and have correspondingly larger numbers of poles, some typical speeds being 3333, 3000, 2500, and 2000 rpm, for 500 cycle machines, and 2400 rpm for 240 cycle generators.

The 500 cycle generator mentioned is wound on cores built of punchings (laminae) of sheet iron, as shown in Fig. 3. Here the field, (stationary

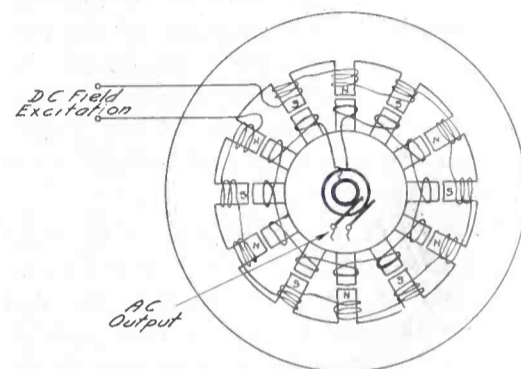

Fig. 3. Diagrammatic sketch showing 12-pole single-phase field and armature, the stator being assumed as the fields

winding) is supplied with direct current from a small d.c. generator on the same shaft (the exciter); the alternating current is obtained from the rotary member, through slip rings, and thence led to the primary of the radio transformer.

Generally, either the rotor or stator may be used as the armature or field, depending on the design of the machine. In power work, especially in polyphase generators, it is almost the universal custom to use the rotor as the field, and supply it with direct current through slip rings. This is due to the greater wind-

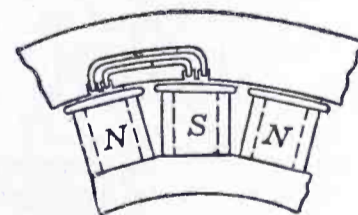

Fig. 4.

ing space offered in the stator, the ease in winding, and also in the lack of moving contacts. For radio work the rotor is usually the armature—radio generators being all single phase, and having wound rotors, with slip rings. One notable type, however, which it is believed has never been used to any extent in power work is the "inductor alternator" (note this is not the induction alternator of the power field). In the inductor alternator we have a single coil, acting as the field coil, and a large number of coils, also stationary, acting as the

armature coils. The magnetic flux is varied by the rotation of a toothed armature, which latter has no windings of any kind. This variation of flux sets up a current in the armature windings, and supplies the alternating current desired.

A simple single phase armature and field is shown in Fig. 4. Here we have the armature windings in slots in the stator, and electro-magnets rotated on a central drum, part of which is shown. There is but one field coil shown, in order not to confuse the drawing. This type of generator corresponds in general to the various types described previously, and, of course, gives (theoretically) the sine wave form of emf, shown in Fig. 2. Actually, this sine wave form may be distorted to give a narrow top, or certain other irregularities in shape, depending on the actual shape of the pole pieces. This sine wave form shows 360 electrical degrees, and corresponds to one complete revolution of the simple two-pole generator, which would be of course 360 degrees.

In a radio set on shipboard we have practically nothing but 110 volt d.c., as described in previous articles. In land stations the use of d.c. is rare and alternating current is used almost exclusively. Usually this current is of 60 cycles.

It is difficult for any of the alternators to be fitted with commutators, which deliver direct current, except at a greatly increased cost, a lowering of the efficiency, and considerably complicating the electrical and mechanical design. The usual practice is to use a separate source of d.c. supply for energizing the fields. On small machines, storage batteries could be used, for intermittent work, but the general practice is to supply a shunt wound generator, which performs no other duty. Generally this is mounted on an extension of the generator shaft, and is rotated by the same driving power, although occasionally belt drive is used. Proper field rheostats are included in the circuit, so that the current in the fields can be varied at will.

Most radio transmitters are supplied with d.c. drive, being used on ships, but when installed on land stations they must, of course, be fitted with external exciters, in the same manner as any machine. A quite common, although inefficient method, sometimes used is to take an ordinary d.c. driven a.c. output motor-generator and drive it externally. If rotated in the proper direction, the d.c. end will act as a generator, and if driven at the normal speed will deliver about its ordinary operating voltage; this is then used to supply the field circuit of the alternator, and operate any auxiliaries in the station, such as relay keys, clapper switches, and the like. This is a rather inefficient method, as

can be easily seen, as the actual load from the driving source is nearly twice that required to operate the a.c. end alone, while the exciter on a normal machine would be a great deal smaller than the 3 hp motor, which, for example, is used to drive a 2 kw motor generator.

If an alternator is supplied with current, of the proper voltage, frequency, and phase, instead of current being taken from it, we will find that the machine itself will continue to run, even if all external power to drive it is removed (assuming it is first brought up to speed). In other words, it is acting as a negative current generator, to state its condition in those terms, or, in plain English, it is absorbing the current from the supply line, instead of delivering it. An analysis of this action will result in it being found that the machine is acting no longer as a generator, in the common sense of the word, but it has become a motor, i.e., a device for converting electrical energy into mechanical energy. If the speed of such a machine be measured it will be found to operate in synchronism with the supply line, i.e., its speed will depend on the frequency of this line, irrespective of its voltage, or current flowing therein, provided sufficient energy exists to prevent a drop of field strength below that necessary to keep the proper magnetizing current in the coils. If the power supply generator happens to speed up, due to some extra amount of power supplied, or if it happens to slow down, due to a large load being taken from it, we will have the same variation in speed of the synchronous motor. Synchronous motors of this type are only applicable to large installations, as a rule, first because they are generally made in large sizes only, and secondly because they are extremely difficult to start and bring up to speed. This factor usually limits its use, and as a rule it is used only in power house service where expert attendance is at hand at all times. In many power houses these motors drive direct connected shunt, or compound wound d.c. generators, and all that is necessary to bring them up to speed is to supply d.c., running the generator end as a motor, until it reaches the desired speed, when it is connected direct to the line, where it at once falls into step. Such a method of starting is absolutely essential in single phase machines, although in poly-phase types, with no load, and on a reduced voltage (to cut down the extremely large currents which would result on full voltage) will start themselves, provided the field circuit is opened. One of the greatest faults with synchronous motors is their tendency to "hunt," i.e., to vary their speed of rotation periodically throughout their rotation, which requires special means to counteract.

SUCCESSFUL TRANS-ATLANTIC RADIO TELEPHONY

Telephone messages from H. B. Thayer, president, and John J. Carty, vice-president of the American Telephone & Telegraph Co. at New York City, were heard on January 14th by G. Marconi and British engineers at New Southgate near London, England. Mr. Thayer and Mr. Carty spoke from their offices at 195 Broadway and used a telephone connected to the radio equipment at Rocky Point, Long Island, by a telephone circuit about 70 miles long. The distance from Rocky Point to New Southgate is about 3,400 miles.

Sending apparatus may be set up in England in the near future to make possible conversations by trans-oceanic radiophone, but months of research and development must elapse before the method can be brought into commercial use. The demonstration was only incidental to a prolonged series of tests undertaken for the purpose of obtaining the accurate information upon which practicable trans-oceanic telephony can eventually be founded.

The technical features of the communication as described in *Electrical World* involved a departure from previous practice in two respects—the use of 10-kw. power tubes and the elimination of carrier currents in transmission.

In the ordinary transmission the voice current, so to speak, is carried along by a carrier current, which usually contains about two-thirds the energy. The carrier current is used to polarize the receiver devices. If the carrier current is, say, 50,000 cycles, the voice current will fluctuate perhaps between 47,000 and 52,000, which necessitates the use of quite a wide ether transmission band.

In the new method twenty 10-kw. tubes are arranged with modulators and filters to radiate into the ether about 100 kw., composed entirely of voice current. The modulating system is similar in principle to that used in wire telephony and consists of balancing tubes against each other in such a way as to balance out the carrier frequency and radiate the voice current.

Suppression of the carrier and one side band occurs directly after the speech currents come from the telephone line which brings them to the radio equipment. The line current modulates the output of a high-frequency oscillator by the balanced modulating equipment, which eliminates the carrier frequency. A filter is then used to suppress one side band, the other side band being applied to a multistage amplifier, the output of whose last stage is the 100-kw. power applied to the antenna. Thus the new method is improved so that a very nar-

Continued on page 88

The Armstrong Super-Regenerative Circuit

By T. N. Slocum

For the amateur who has hesitated to tackle super-regeneration because of lack of information about constants, here are the results of the experience of one who has tried and succeeded. His story gives full details as to construction and operation.

FROM the beginning of wireless transmission of intelligence up to the present time, no one thing has created such widespread interest among the amateurs as the new Armstrong super-regenerative circuit; yet from the large number of inquiries regarding this circuit, it is apparent that few have obtained results worth while.

It is the intention of this article to present a detailed description of a set constructed by the writer that has given most excellent results; and if those who have tried and failed or those who are contemplating building a set will study this article carefully, they will get results that are simply amazing. The

The circuit about to be described is the easiest to construct and operate of any of the circuits for producing regeneration. You will note that no filter circuit is used or required as the amplifying transformer is connected into the plate circuit of the regenerator tube instead of the oscillator tube, which simplifies it very much, as the filter circuit is harder to adjust and is the cause of many of the complaints and failures of those who have tried and given up.

The filter circuit, if used, will give no better results, but if you wish to try it after you have mastered this circuit, you can do so by making a few changes in your connections, and inserting the filter, but my advice is to stay away from it, and let well enough alone, if you want to get real results, and avoid a lot of sleepless nights, in trying to

turns to 1000 turns, or the primary of an audio frequency transformer or any ordinary telephone choke coil. L_5 may be a 1250 turn coil or two 1000 turn coils in series in place of the 1500 turn coil. All of the above substitute values have been used with very good results.

Six condensers are used: C_1 , .0005 mfd. variable; C_2 , .001 mfd. variable; C_3 , .002 mfd. fixed; C_4 , .001 mfd. variable; C_5 , .001 mfd. fixed; C_6 , .002 mfd. fixed.

C_2 and C_3 are connected in parallel across coil L_3 , giving a total of .003 mfd. with a .001 mfd. variation. C_4 and C_5 are connected in parallel and then connected in series with coil L_4 . All of the fixed condensers must be mica insulated such as the Dubilier micadons, and not the paper insulated variety, as the oscillator circuit generates a voltage

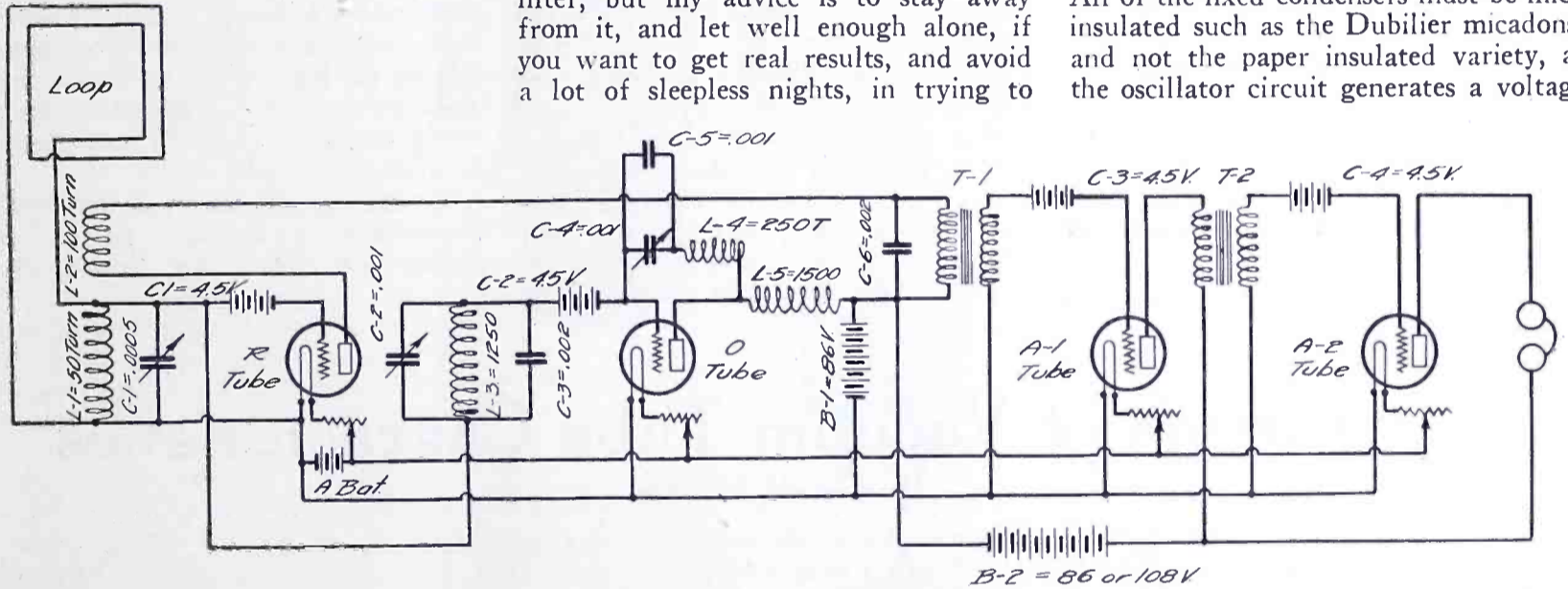

Hook-up for Receiver Using Armstrong Super-Regenerative Circuit

writer has received speech and music loud enough to be heard 100 feet from the instrument through a Westinghouse Vocarola loudspeaker using a 4-ft. loop, from KFC, Seattle (900 miles), KGG and KGW—700 miles; KFAY, Medford, Oregon—400 miles; DN4 Denver; KZN, Salt Lake City; KFI and KHJ, Los Angeles. Also from a loop composed of 7 turns of wire laying flat on the top of an automobile, concerts from the Fairmont Hotel, KDN; KUO, S. F. Examiner and Hale Bros., S. F. were heard clearly a block from the automobile, while in San Jose, a distance of 50 miles from San Francisco.

In constructing this set the writer suggests that the diagram be thoroughly studied before any attempt at assembly is started; then first mount the parts on a flat board and put it in operation this way, until you are perfectly familiar with it. You will find that when you do put it in a case, you will do a much neater and better job, and the chances are you will get quicker results.

figure out why it don't work. As it is you will find this circuit about the liveliest thing you have gotten hold of and it will keep you guessing for some time to keep up with it, as the number of possible adjustments far exceeds the 57 varieties.

Five inductances are used. The Gliblin Remler or honeycomb type are the best. L_1 is a 50 turn, L_2 —100 turns, L_3 —1250 turns, L_4 —250 turns, L_5 —1500 turns. Note carefully that L_1 and L_2 are the only coils inductively coupled, and this coupling must be made variable as L_1 is the tuning inductance and L_2 the tickler. All of the other three coils must be placed at right angles to each other and separated as much as possible to avoid any mutual induction. They should also be kept away from the transformers. An ordinary variocoupler can be substituted for coils L_1 and L_2 , but the rotor, or tickler, must be re-wound with 100 turns, L_3 may be a 1500 turn in place of a 1250 or two 1000 turn coils connected in series may be used. L_4 may be any coil from 250

high enough to puncture any paper insulated condenser. They may last for a while, but the leakage across them will sound like all the stations in the country have turned loose at once, then, when they do puncture, you will spend hours trying to find out what is wrong; don't use them to begin with and avoid trouble. The variable condensers are another important item that can cause a lot of trouble if not right for the same reason as mentioned regarding the fixed condensers. The first condensers used by the writer had the plates spaced very close together. Dust particles would settle on the plates, and cause a brush discharge between them, and at times a continuous arc would take place if a high B battery voltage was used. This was remedied by installing Dayton variable condensers, as they had larger plates, and wider spacing between them, similar to a transmitting condenser.

Most of the circuits described thus far have shown only one stage of amplification. The writer uses two stages

with much better results, as much greater distances can be covered; jacks can be installed to cut out one or both stages if desired. The transformers used should be of the same make and made to withstand heavy plate voltages. The transformers used were Jefferson and as high as 500 volts have been used without any trouble whatever. In mounting the transformers they should be placed at right angles to each other, and away from the inductances. Across the primary of transformer T_1 the condenser C_6 is connected and acts as a bypass for the radio frequency currents.

If there is a slight continuous howl heard all the time when both stages of amplification are used, this may be overcome by adding a fixed .005 mfd. condenser across the secondary of T_2 .

The tubes used must be hard amplifying or power tubes. Most of the time I have used C301 tubes. Five watt power tubes give a little better results. The C301 or UV201 tube is recommended, as the little results gained by using power tubes do not warrant the additional expense for tubes and B batteries.

C or bias batteries of 4.5 volts are placed in series with the grid of each tube, with the negative side of the battery connected to the grid. This is the zinc side of the battery. The small three-cell flashlight batteries are just

right, the longest brass contact on the battery is usually connected to the negative or zinc side; however, it is best to dig into the battery slightly to make sure, as absolute failure will result if these batteries are connected wrong.

The rheostats on the first two tubes should be of the vernier type as a very fine adjustment is necessary to get the best results. Any good make of plain rheostat can be used on the amplifier tubes A .

The amount of amplification depends upon the voltage of the B and C batteries used, but no higher voltage than 200 is necessary to give plenty of amplification. Battery B_1 should be 86 volts and B_2 86 or 108 volts; the 86 volt size will give plenty of amplification, sufficient to rattle the windows. B_1 furnishes the plate voltage of the first two tubes R and O , and is somewhat critical. The full 86 volts may be too much for weak signals. The only way to find out is by changing to the different voltage taps until best results are obtained.

The voltage across the amplifier tubes is not so critical, but if a very high voltage is used, the voltage of C batteries will also have to be increased, but the writer suggests that the voltages specified above be used, as I feel sure you will not desire any greater amplification; in fact ear phones should not be used if

you value your ears; a loud speaker is a necessity.

Now, after you have assembled all the parts required, go over the diagram again carefully. Then proceed step by step to connect it up. After you have made a connection, check it against your diagram; be sure you are right; it may save you much trouble.

Solder every joint and connection as you go along. It is important where wires are connected to transformers and condensers, solder to spades or lugs, and clamp these firmly under nuts, the same where wires are connected to under side of binding posts. I would advise soldering all wires directly to socket binding posts, as these nuts often work loose and cause trouble. Do not use any so-called soldering paste or acid salt solution for soldering flux as they are conductors and also cause corrosion. The best soldering flux is rosin dissolved in alcohol to the consistency of syrup. If any of this should get on the wires or parts where it doesn't belong, it will do no harm, as the alcohol will evaporate, leaving the rosin which is non-corrosive and non-conductive. Shielding the set is not necessary, although no harm will be done if it is used.

Almost any size loop will do for local broadcasting or it may even be used without a loop, but it is much

Continued on page 83

Comparison of Vacuum Tube Characteristics

By Gerald M. Best

These data should prove invaluable to the amateur who contemplates trying radio-frequency amplification as well as for those who wish to know of the relative merits of various tubes for other purposes. With the large number of new tubes now on the market it becomes possible to select one which will be best adapted for a given purpose.

WITH the advent of a number of new vacuum tubes, for general public sale, it is becoming somewhat of a problem for radio fans to digest the information which the manufacturers furnish with their products, and to determine just exactly where each tube

will most appropriately fit into the circuit he is using. With the idea of assembling this information in such a form that comparisons between tubes can easily be made, the table shown on this page has been prepared, the data having

been obtained from the specifications furnished by the various manufacturers.

In this table, reference is made to the illustrations, so that some idea of the mechanical construction of the tubes can be had, in case the reader is not familiar with their appearance. This is particu-

Code No.	Manufacturer	Filament Current in Amperes	Filament Voltage	Normal Plate Voltage	Normal Plate Current in Milliamperes	Normal Negative Grid Voltage	Plate Filament Impedance in Ohms	Amplification Constant	Output Power in Watts	Use
C-300	G. E. Co.	1.0	5	18-25	0.25 to 1.0	10,000	Detector
C-301	G. E. Co.	1.0	5	45-100	1.0-5.0	1.5-4.5	21,000 to 14,000	6.5	...	Amplifier
C-301-A	G. E. Co.	0.25	5	25 as Det.	1.2-8.0	1.5-9	17,000 to 8,000	8	...	Detector
C-302	G. E. Co.	2.35	7.5	45-120 as Amp. 350	45	22	4,000	7.5	5	Amplifier
C-303	G. E. Co.	6.50	10	1000	150	35	3,300	10	50	Oscillator
C-304	G. E. Co.	14.75	11	2000	250	55	3,000	25	250	Amplifier
WD-11	Westinghouse	0.25	1.2	45	0.5	1	20,000	6	...	Detector
215-A	West. Elect. Co.	0.25	1.1	45	0.6	1.15	25,000	6.5	...	Amplifier
203-B	West. Elect. Co.	1.10	2.5	20 as Det. 45 as Amp.	0.5-2.0	1.5	20,000 to 10,000	6.5	...	Detector
216-A	West. Elect. Co.	1.0	6	120	8	9	6,000	6	...	Amplifier
209-A	West. Elect. Co.	1.25	3	120	0.7	1.5	60,000	30	...	Amplifier
205-B	West. Elect. Co.	1.35	7	350	40	20	4,000	7	5	Oscillator
211-A	West. Elect. Co.	3.40	9.5	750	65	30	3,5000	12	50	Amplifier
212-A	West. Elect. Co.	6.25	13	1500	130	60	6,000	16	250	Oscillator
										Amplifier

larly true of the Western Electric tubes used in their broadcast-stations, and the illustrations will give the reader a comparison in size and characteristics between the various tubes. The tubes are grouped according to their use, those intended for transmission or power amplification being separated from those used in reception and low power amplification only.

In order that the reader will not be confused by too many technical details, only those characteristics which are of general use are given. In the table, the filament current values given are those for normal operation, and in many cases the tube will still function at lower current values than the rated normal figure.

In the case of transmitting tubes, particularly, the manufacturers recommend that the tubes be operated at the lowest voltage and filament current that will give satisfactory output for the service desired. Careful observation of this feature will often result in greatly increased tube life. The filament voltage is measured across the terminals of the filament itself, and the voltage of the source of supply will have to be at least 25 per cent higher in order to give satisfactory regulation.

In several cases, the normal plate voltage is shown as variable, in which case the plate current, negative grid voltage and plate impedance is given for the minimum and maximum plate voltages. The normal plate current is given for the condition of normal filament current, plate voltage, and a value of nega-

tive grid voltage such that the tube will operate on the proper section of its grid voltage-plate current curve.

Under the column "Normal Negative Grid Voltage" the values indicate the magnitude of the *C* or "grid biasing battery" which should be placed in series with the grid circuit, as explained above, so that the tube will amplify without distortion. If the tube has no negative grid potential, the plate current will be

a great deal higher in value, and the tube will not function without considerable distortion, unless the input voltage is extremely low. The column headed "Plate-Filament Impedance" indicates the output impedance of the tube, and is valuable in enabling the proper selection of an inter-tube transformer or telephone receivers, to match the output impedance of the tube. This is one of the most important characteristics of the vacuum tube, and is generally the one about which the least is known.

Some of the Western Electric tubes shown in the illustrations, and indicated in the table, are not sold except with apparatus manufactured by that company. The 216-A tube is used in the 10-A loud speaking outfit, and cannot be purchased separately, except for renewal purposes. The 209-A, 211-A and 212-A tubes are used in radio broadcast transmitters and public address systems made by the Western Electric Company, and cannot be purchased separately for amateur or experimental use at this time.

The 203-B tube is known to the public under the code number "VT-1" and stocks of these tubes have been released recently from surplus Army stores. The same is true of the 205-B, which is used under the code number "VT-2" in the Army, and "CW-936" in the Navy, and is available for general sale. The tubes manufactured by the General Electric Company are sold either by E. T. Cunningham, or the Radio Corporation of America, the code numbers given in the table being those used for the Cunningham types.

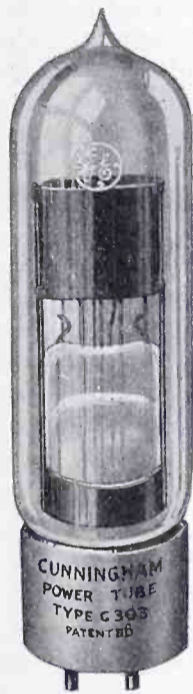

C-303

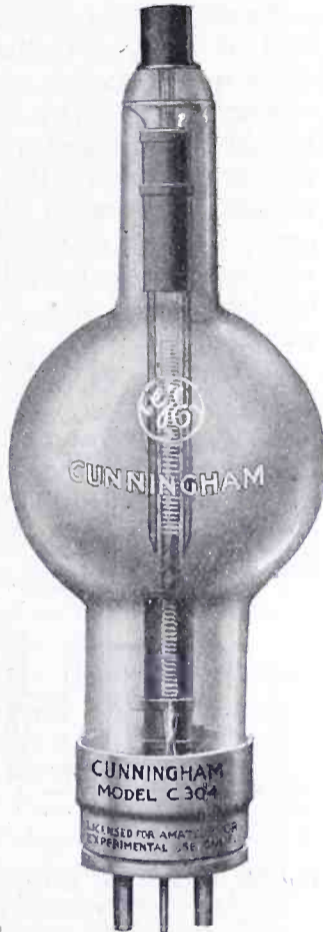

C-304



C-302



C-300 and C-301



C-301A

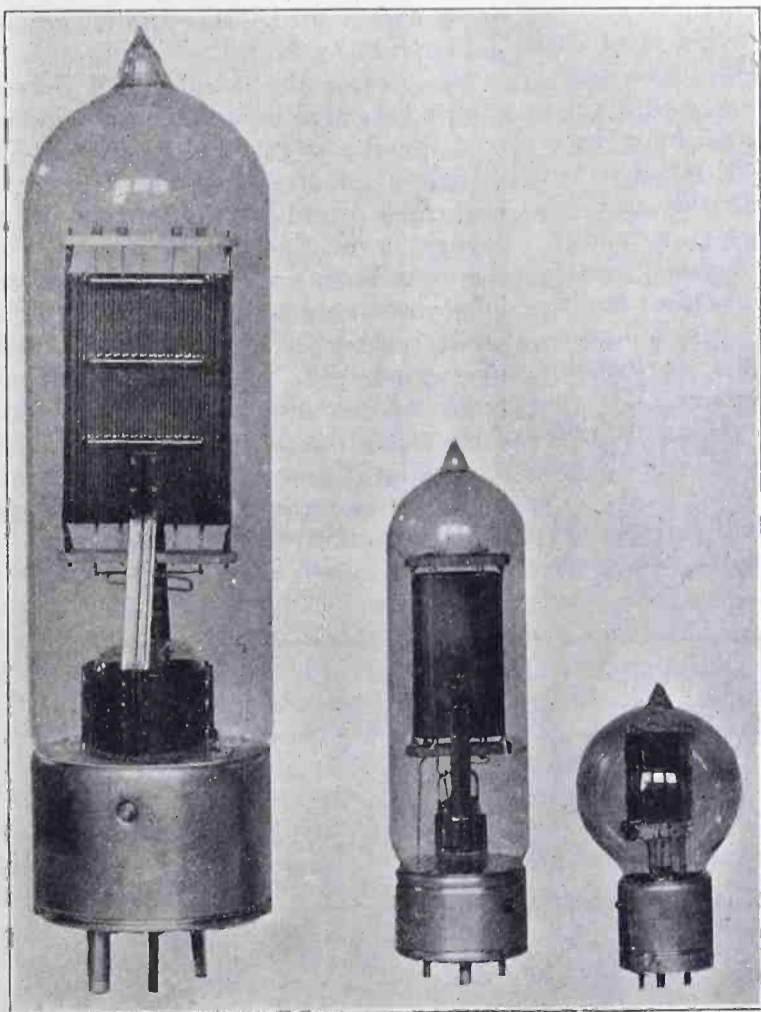

212-A

211-A

205-B

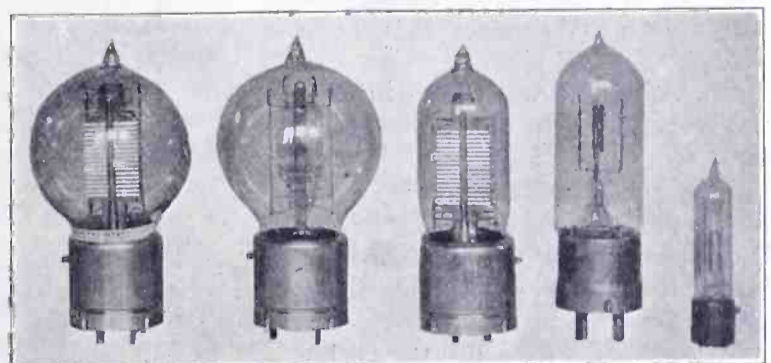

216-A

209-A

203-B

WD-11

215-A

An Efficient Broadcast Receiver

By Six Zee Jay

These directions should enable the amateur constructor to make a single circuit tuner good for wavelengths up to 800 meters. Detailed instructions are given for winding a variometer inductance coil.

THE radio novice, who has just entered into the fascinating game of listening to concerts broadcasted from the many broadcasting stations, usually desires to construct his own receiving apparatus, thereby saving nearly half. Besides a lot of pleasure is derived from constructing your own set and seeing it actually perform. In building or selecting a broadcast receiver there are several points that the experimenter must consider:

First of these is its selectivity; that is, the ability of the set to "sift out" one station from another with a minimum amount of interference. The usual way to realize this is by the use of a three-circuit regenerative receiver, for selec-

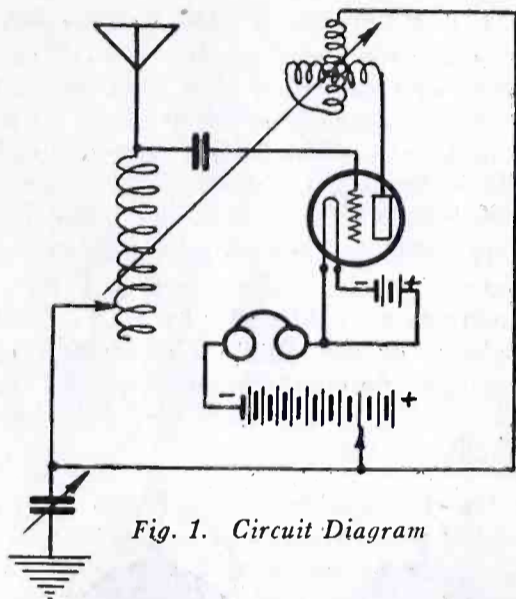

Fig. 1. Circuit Diagram

tivity is not very often found in single-circuit receivers. A third adjustment is then necessary, which constitutes a slight disadvantage to the novice when tuning. Consequently a single-tuned circuit will best fit his requirements if it has a certain degree of selectiveness.

Second—Stability and ruggedness.

Third—Simplicity of arrangement.

Fourth—Ease of adjustment with least number of controls.

Fifth—Efficiency over a wide band of wavelengths.

Sixth—Parts possessed by average experimenter or can be purchased in any radio shop.

Seventh—Sensitiveness that will compare favorably with factory-built instruments.

Now the reader will see that a very efficient broadcast receiver will be the result if the points stated above are observed in his selection of an instrument or constructional data.

With these points in mind, the author wishes to present to the readers of RADIO an efficient broadcast receiver

that is easily constructed and will perform equally as well as any receiver on the market.

From the circuit diagram in Fig. 1 it will be noted that the antenna inductance is in inductive relation to the variometer in the plate circuit. By thus coupling the tuned plate circuit with the grid circuit, the radio-frequency present can be taken advantage of to increase strength of signals and incidently will add selectivity and allow the set to oscillate freely over a wider range of wavelengths.

A bakelite tube $3\frac{1}{2}$ in. in diameter and $4\frac{1}{2}$ in. long will couple on to an ordinary wood form variometer, similar to methods using the rotor of variometer as tertiary coil. This can be more clearly understood by referring to Fig. 2.

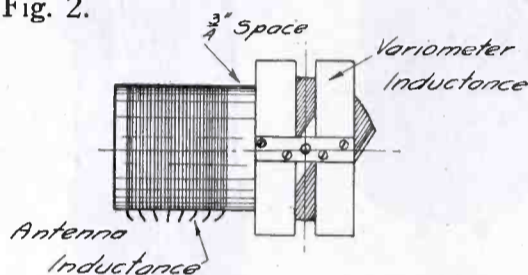

Fig. 2. Coupler of Antenna and Variometer Inductances

Using No. 22 S.C.C. wire, start the winding $\frac{3}{4}$ in. from end of this tube, bringing out a tap at every eighth turn until a total of 80 turns have been wound on. Care should be taken to see that the wire is wound in the same direction as the variometer windings. This coil can be easily fastened to the variometer by means of two brass angles secured to the tube with $\frac{1}{4}$ in. 6-32 machine screws and to the variometer stator with small wood screws.

Those who have no variometer will find the following method equally as efficient:

Wind a 3-in. coupler ball full No. 24 S.C.C. wire. If the reader has never

wound a coupler or variometer ball he will find that it is necessary to start the windings from the outside of each half and wind in, the ends then being thrust through small holes drilled at the center of ball and twisted together on the inside. The coupler ball usually comes drilled with two holes diametrically opposite each other, that will give a tight fit on a quarter-inch round brass rod. So two pieces $\frac{1}{4}$ inches in length are necessary for shafts for the ball to rotate on. Do not insert these as yet.

Next procure a bakelite tube $3\frac{1}{2}$ in. in diameter and 7 in. long. On the right hand end wind 50 turns of No. 24 S.C.C. wire in the same direction as the windings on the coupler ball, leaving a space for the shafts in the center. See Fig. 3. This is the stator winding of

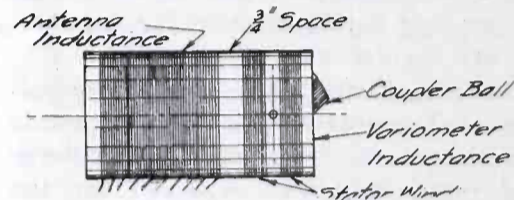

Fig. 3. Alternative Method of Inductance Winding

the variometer. Measuring $\frac{3}{4}$ in. from this winding, wind on 80 turns of No. 22 S.C.C. wire, bringing out a tap at every eighth turn. This is the antenna inductance.

Next place the coupler ball in position, taking care to see that the windings of both the stator and rotor coincide. (This is important because if they do not, their mutual inductance will not change as their position is varied.) Fit the two brass rod shafts through two holes previously drilled diametrically opposite each other in tube and into holes in coupler ball. Solder the start and finish of winding to their respective shafts, the shafts acting as connection terminals. Connect the stator and rotor windings in series using "pig tail" connections to the rotor shafts.

Continued on page 86

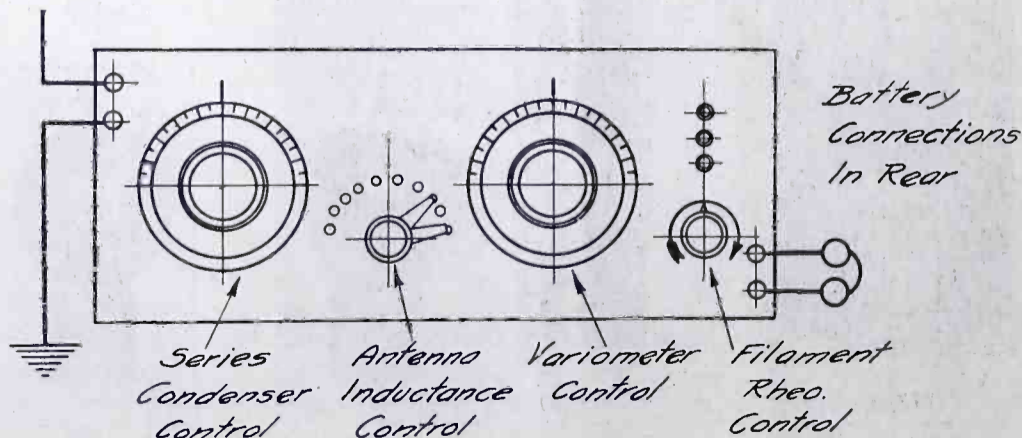

Fig. 4. Panel Layout

Problems Introduced by Radio Broadcasting

By Jerome Snyder

After a brief discussion of the trouble caused by interference, the author suggests the use of C. W. transmitters and better receiving sets. In the latter connection he advocates the use of radio-frequency amplification as a means for preventing re-radiation from a regenerative receiver.

SINCE broadcasting has come into vogue, the amateur no longer has the sole right to the ether. In the old days if there was interference the amateur usually was able to eliminate it on his receiver, for he was skilled enough to do it. Or if the ether was jammed with any number of sparks, both broad and sharp, why—the ether was just jammed, that's all there was to it. They all had spark stations and each one had a right to use it, provided, of course, commercial traffic was not interfered with. However in the case of broadcasting it is different. The people that are primarily interested in broadcasting are in the great majority and they are not particularly keen on hearing spark stations.

These receivers, besides being interfered with by sparks, are being interfered with in another way. They hear the weirdest sort of noises in their phones, noises running up and down the scale. These noises are due to the heterodyne effect that is produced by the radio-frequency carrier wave of the broadcasting station being interfered with by radio-frequency oscillations generated by regenerative receivers used by listeners who are not very skilled in their use. In trying to obtain as much amplification as possible they increase their feed-back coupling to such an extent that oscillations are produced which, heterodyning with the carrier wave from the broadcasting station, produce the beat notes with varying pitches which are generally heard in the receiver phones.

The first cause of interference is that due to the spark stations operated by amateurs. Interference from commercial spark stations cannot here be considered. This interference is due to one cause only, namely *broad tuning* either of the transmitter, the receiver, or both. Suppose you had a very sharply tuned transmitter and receiver, with a percentage selectivity, say of 2%. Thus at 360 meters then, the receiver could distinguish between stations having a difference in wavelength of 7 meters. Obviously then, if he were receiving broadcasting at 360 meters, he would not be interfered with by stations transmitting at 200 meters or 300 meters or 340 meters, for he could work within a limit of 7 meters.

If the transmitters operated by the amateurs had equally sharp tuning and gave an equally sharp resonance curve, it would be quite evident that interference would be negligible. If transmitters and receivers were sufficiently

sharp in tuning to eliminate all undesirable signals, there would be no interference between amateurs and broadcast listeners since their operating wavelengths are so far apart.

Actually, the receivers used by the novice are single circuit receivers having very broad tuning qualities. At one setting of a particular tuner of this type the writer was able to hear any station between 200 and 600 meters. And the spark equipment used by some amateurs is still from the year of one, with a wave as flat as a plateau. As a result, even if the amateur is transmitting at 200 meters, there will be all the interference the devil himself would want to create, and more. Furthermore, it will often be found that some amateurs are not transmitting at 200 meters, and like as not they are above 200 rather than below. This makes the probability of interference still greater.

Now the remedy is obviously, in this particular case, to go to sharper tuning. However, as far as the novice broadcast listener is concerned, this is out of the question. He will positively refuse to plunk down a hundred berries or more for a good selective tuner. What's more, you cannot blame him. He is just beginning to learn the game, and while the amateur who has been at it for years and has learned the ins and outs of the game may be willing to do it, you cannot expect the newcomer, who doesn't know a henry from a hole in the ground, to do it.

The remedy then is for the transmitting amateur to do two things. First get a wave meter by hook or crook and tune his outgoing wave. See that it is 200 meters or less—not more. The farther away you are from 360 meters the less chance there will be for interference. Secondly, get up to date. The day of spark sets is over. In the last two years there have been scrapped more spark sets than you dreamed could exist. The reason is that C. W. transmitters are superior in every way, give sharp tuning qualities which help eliminate interference, and for the same power will carry several times as far as your obsolete spark set can carry. The amateur is always improving his receiving equipment. You read about him adding this or that to his receiver, getting a twenty-stage amplifier, changing his receiver to the new Reinartz circuit, etc. Stop making changes on your receiver, and make a few changes on your transmitter. Scrap that old rock crusher of a spark coil and put in a five-watt tube

transmitter. The writer knows the beauty of the 500-cycle note that comes from a real good quenched gap. He has worked with a quenched gap for a number of years. But the signs of the times are away from sparks of all kinds. The writer also knows ops who used to work with a crystal they would not give away for anything. But that is no reason why they should keep on receiving with a crystal today. As a matter of fact they don't, they use tubes. The same with you fellows that seem to feel sentimentally inclined towards your spark sets. They are getting out of date, do not give the results that C. W. does, and do give more interference than C. W. Scrap your spark equipment, substitute good C. W. apparatus, and part of your interference problem with the broadcast listeners will be eliminated.

The next problem is that of eliminating the interference caused by radiation from regenerative receivers. Of course one method is to prevent regenerative receivers from oscillating into the antenna by not using too much feedback coupling. In single circuit regenerative receivers not employing r/f amplifiers this is the only way. This involves teaching the operator to use his receiver properly, to regenerate up to the point of oscillation and not beyond. This is entirely a problem in educating the newcomer to use his apparatus properly and efficiently and is up to the various radio journals and periodicals. In receiving broadcasting on a regenerative receiver there is no reason why oscillations should be developed. As a matter of fact the broadcasting will be spoiled and the note mushy if oscillations from the receiver interfere. Best results will be obtained if the regeneration is effected up to the point of oscillation and not beyond.

However, there are certain methods of operating sets which prevent the oscillations from a regenerative receiver from getting into the antenna and therefore being radiated from the antenna. These methods will now be taken up in detail.

The following remarks will not apply, of course, to non-regenerative receivers. A non-regenerative receiver cannot oscillate, hence will not produce the interference under discussion. A good non-regenerative receiver with amplification will produce very excellent results for broadcast reception.

However, the regenerative receiver has its advantages and it is therefore in great favor. The following method is

a sure means for preventing the oscillations from a regenerative receiver from being radiated from the antenna, and hence from producing interference. Consider Fig. 1, which is a standard single circuit regenerative receiver. This type of receiver radiates very strong oscillations and produces the maximum of interference, and the reason for this is that the oscillations are generated right in the antenna circuit. A two-circuit receiver such as shown in Fig. 2 will radiate

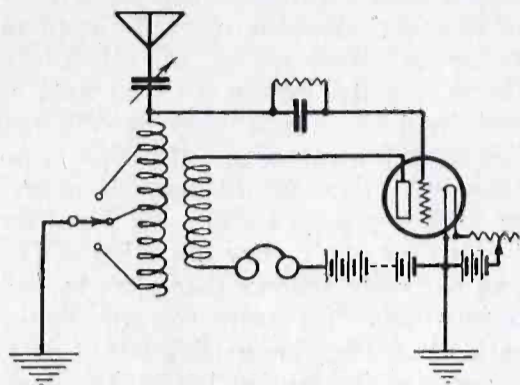

Fig. 1. Standard Single Circuit Regenerative Hook-up

oscillations also, but more feebly. The reason for this is that the oscillations are generated in the circuit containing coil L_2 and are passed by induction to the antenna, thus being weakened. Furthermore, if the receiver is a well designed one, it will be designed so that the transfer of energy takes place most efficiently from antenna to coil L_2 (since this is the direction for received energy). Since the regenerative oscillations are passed in the reverse direction, namely L_2 to an antenna, the transfer is less efficient and hence oscillations due to regeneration are radiated feebly.

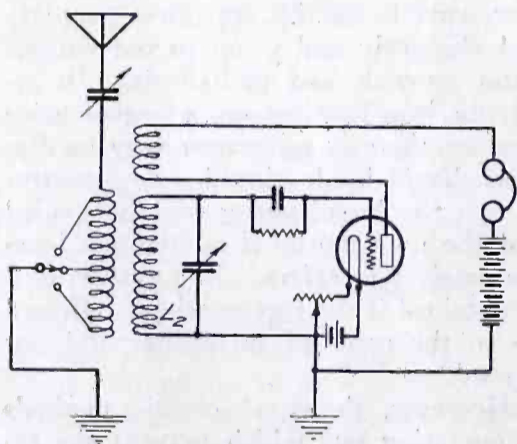

Fig. 2. Two-Circuit Receiver

Thus the first remedy is, if possible, to use two circuit regenerative tuners in preference to single circuit tuners. However, even in this case the oscillations are radiated feebly, and therefore result in bad interference. The problem then is, if regeneration must be had, to confine the regenerative oscillations to a circuit removed from the antenna and to prevent them from passing to the antenna. This can be positively accomplished by the use of radio-frequency amplification, one-stage being sufficient. The method for doing this is shown in Fig. 3. This

circuit shows the single circuit tuner, namely the antenna circuit, feeding directly into the grid of the r.f. amplifier tube. The oscillations are amplified in the tube and passed through the r.f. transformer T , to the grid of the detector tube in which the oscillations are rectified and detected. However, by means of the tickler coil L in the plate

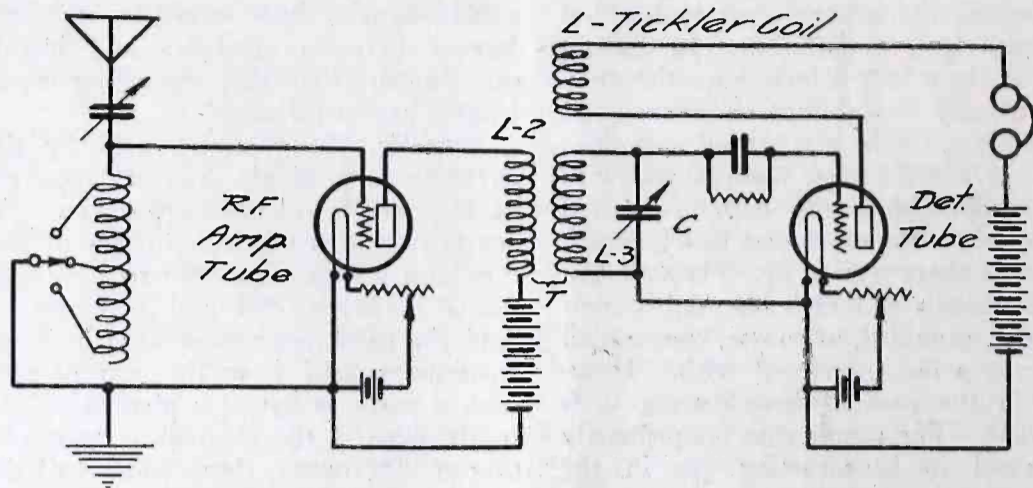

Fig. 3. R. F. Amplifier with Single Circuit Tuner

circuit of the detector tube, regeneration is also effected. Now the oscillations resulting from this regeneration can never reach the antenna and will therefore never be radiated to cause interference.

The reason for this is as follows. Oscillations are generated by the action of the tickler coil, in the circuit comprising $L_3 C$. In order to reach the antenna they must be induced in coil L_2 pass backwards through the r.f. amplifier tube into the antenna. Now these oscillations can be induced in coil L_2 , but they cannot pass backwards through the r.f. amplifier tube because of the unidirectional characteristics of the tube. Currents in a vacuum tube can only pass from filament to grid to plate, but never from plate to grid to filament, as the oscillations would have to pass in order to get to the antenna. Thus it is evident that oscillations from this type of regenerative circuit are blocked and can never get to the antenna to work their harmful effects on other receivers.

The circuits here given are for tickler feed-back regeneration. The particular type of regeneration used makes no difference, the above method applying to any type of regeneration used, so long as the regeneration is effected in the detector circuit after the r.f. amplification. Thus it will apply also to the grid and plate variometer circuits and to the Weagant X-circuit method. If this simple means is utilized the user will find that he will not only get most excellent results but that no interference will be created.

AMATEUR RADIO IN DENMARK

Increased interest has been shown in radio at Copenhagen. The two local radio clubs have combined and the membership of the new club is estimated at

1000, the members of the club being all over Denmark. The aim of the club is, first of all, to have the law of 1907 forbidding the use of amateur wireless apparatus repealed and thereafter to arrange organized broadcasting according to the American standard.

It appears, notwithstanding this law, that many hundred amateurs in this

country have already constructed wireless receiving apparatus or purchased them from foreign countries and in the event that this law is repealed or modified, interest in radio activities throughout the country will increase enormously.

The air traffic commission has decided that wireless telephone apparatus must be installed in all aeroplanes, such installation being made obligatory. In another month it is also expected that wireless telephone connection will be established between Copenhagen and the Island of Bornholm.

A radio exhibition was held at Copenhagen in November. Exhibitions of apparatus from all dealers in this line were displayed. German and Danish equipment predominated while there was a fair showing of American and French equipment and some British apparatus. The German and American equipment appeared to be the best, being more compact and more efficiently constructed. The Danish apparatus, on the other hand, while undoubtedly practical, was of a more bulky appearance. Accessories such as amplifiers and enlargers were mostly of American manufacture. Another feature of the exhibition was the display of hundreds of amateur wireless outfits constructed by young boys and youths; hundreds of such outfits were entered in competition. Some of these amateur receiving outfits were as small as an ordinary match box and could be carried conveniently in one's pocket.

The object of the exhibition was, of course, to stimulate interest in the wireless telephone with the hope that the public would be aroused sufficiently to protest for the bringing about of the repeal or modification of the present laws prohibiting the use of amateur wireless apparatus in Denmark.

NEWS OF THE BROADCASTERS

KPO, the new 500-watt Western Electric transmitter of Hale Bros., San Francisco, came on the air officially on Jan. 16th with a program that was heard in every part of the United States, many points in Canada, in Hawaii, and even in Samoa. An amusing and interesting incident in showing the range of the station was the response to Mayor James Rolph's invitation to telegraph him "collect" as to the reception of his address. As a result he received a bunch of messages that, at last reports, cost him over \$6,000 in telegraph charges.

KPO broadcasts on a 400 meter wavelength as a Class B station from 8 to 10 P.M. on Tuesday, Thursday and Saturday. Broadcasting is also done daily except Sunday between 1 and 1:30 P.M. and on Sunday between 11 A.M. and 12:30 P.M. The station is operated under the direction of E. J. Martineau.

This station represents the vision and public spirit of Hale Bros. in serving the radio public. It is planned that high grade music and entertainment only will be broadcast during the evening hours.

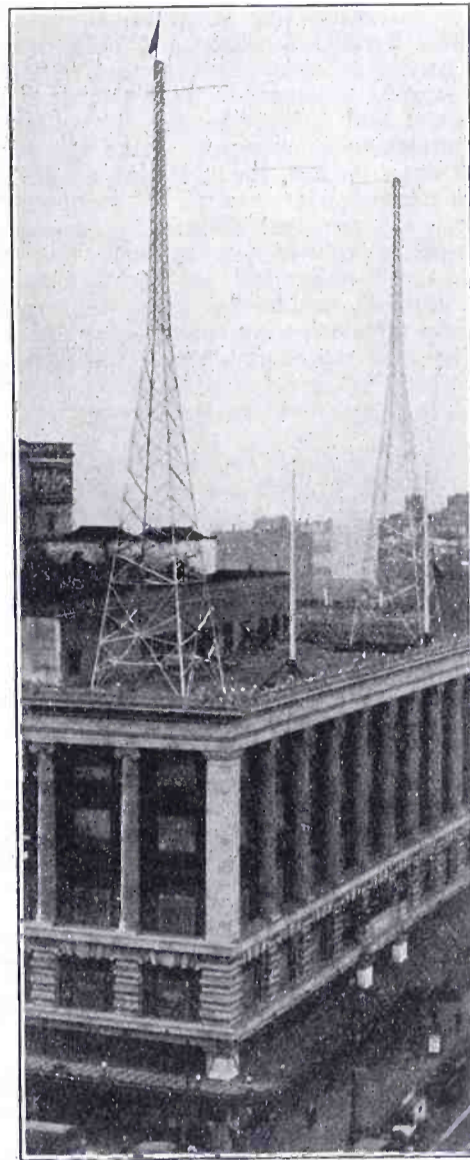

125-Ft. Towers for KPO Aerial

BROADCASTING WITH "WIRED WIRELESS"

The demonstration of a new and unique method of communicating and broadcasting over electric light and power lines, by means of General Squier's system of "wired wireless," at

Continued on page 87



KPO Broadcast Room

The transmitter is the standard Western Electric equipment that has frequently been described in these columns. In addition, two speech amplifiers have been ordered for installation at local hotels, theaters or cafes where orchestral music or speeches can be broadcast. A special microphone is being installed to reproduce the music of the magnificent organ which is to be used in conjunction with the radio church services conducted from this station.

The aerial is of the "T" type, four wires spread 6 ft. apart and 114 ft. long. It is supported by two 125-ft. steel towers erected by the Pacific Coast Steel Co. on the roof of the Hale Bros building. This gives a height of 220 ft. above the street. The station is on the sixth floor of the building and includes a reception room, studio, instrument room and power room.

The studio is 21 x 22 ft. and is constructed so that no echoes will mar the quality of music. The instrument room houses the power panel, instrument panel, speech input panel and charging panel. In the power room is a 5½ h.p. d.c. motor driving a 2kw. 1600-volt generator supplying plate current and a 30-amp. 16-volt generator supplying current for the filaments and for exciting the larger generator.

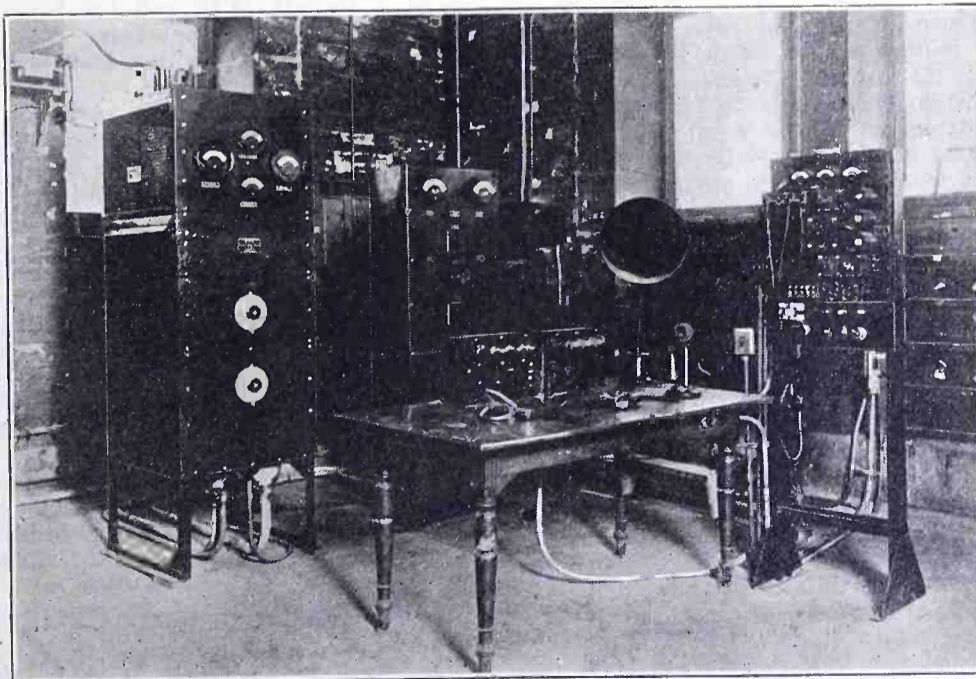

KGW, the Radiophone Station of "The Oregonian," Portland, a 500 Watt, Western Electric Set. Reports of its reception have been received from 30 States, Five Canadian Provinces, Hawaiian Islands, and Remote Parts of Alaska.

LETTERS TO THE EDITOR

Antenna Insulation

Sir: RADIO for February, 1923, at page 23, carries an article by Francis J. Andrews, on antenna construction, in which is stated: "Figs. 1 and 2 illustrate the proper method of insulating an antenna." Had the author said *usual* method, the statement would have been more nearly correct.

It is the principal business of an engineer to specify construction methods that will make most economical use of his materials, all things considered; otherwise, capital charges often wipe out operating profits.

Fig. 1 is reproduced herein for reference.

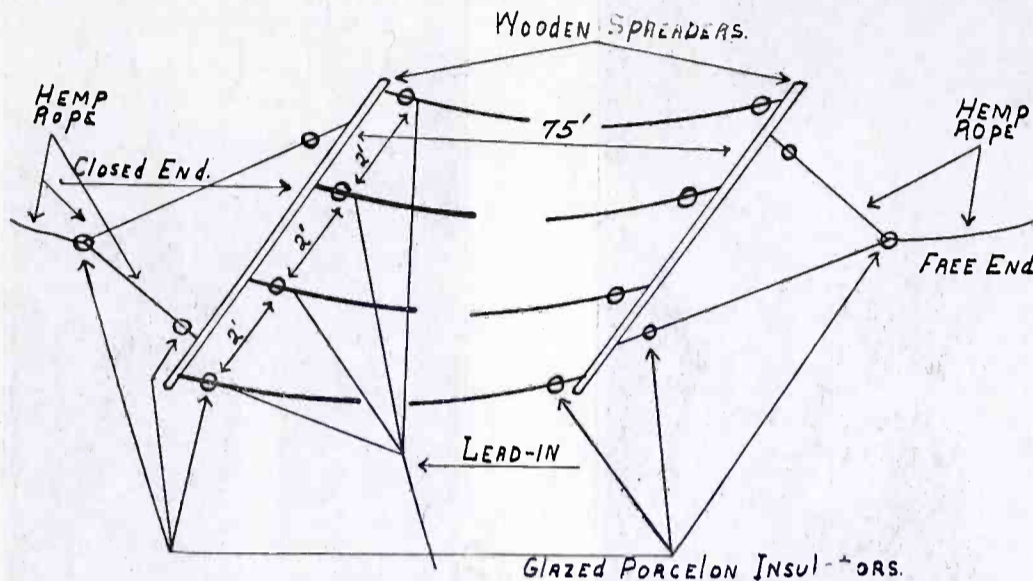

Fig. 1. Inverted "L" Aerial

It shows the conventional method of insulating a 4-wire antenna. Seven insulators are used, in a series-multiple connection; i.e., a multiple of four, in series with a multiple of two, in series with one. Assuming that all four wires are connected electrically and hence are at the same potential, and assuming that the insulators are alike, let us compute the total resistance between live wires and halliard.

Call the resistance of each insulator a ohms; then the joint resistance of the four in multiple will be $a/4$ ohms; of the two in multiple, $a/2$ ohms, and of the one, a ohms; and the combined resistance of the string of 7 will be $a/4 + a/2 + a = 7a/4$ ohms, or $1\frac{3}{4}$ times one insulator. It is easy to see that if two insulators in series had been put in the position of the single insulator, (See Fig. 2), the insulation resistance would have been $2a$ ohms, which is 14 per cent greater than that given by the seven insulators arranged as in Fig. 1, and the cost of ten insulators would have been saved; an item of no small importance to many a young experimenter.

Put all the insulation in the main lead next the part that is connected to ground.

The trouble with most of the present-day radio engineering (for amateurs) is too much "hay wire" guessing and too little engineering thinking, even by the self-styled "Radio Engineer."
A. H. BABCOCK.
San Francisco.

Radio in Great Britain

Sir: I read with interest an article in your December magazine on "Radio in Great Britain." The information it contained, though correct six months ago, is certainly not correct now. In fact, I believe, the London broadcasting station, 2LO, holds the record for broadcasting achievements.

This is briefly what has occurred recently: A British broadcasting company has been

London, Manchester, Birmingham, Newcastle, etc., and excellent programs are transmitted. As they are less than 100 miles apart and cover the whole of England, very powerful sets are not required for reception. For instance London has a population of eight million. For ordinary reception a crystal set is all that is required.

I think the following is a world's record. The London Star is transmitting opera, from England's premier opera house (Covent Garden Theatre), London. The actual performance is transmitted and it is as clear as if it was at the "Co's" own studios. Not

generation. When tuning on the first of the secondary inductance taps this variometer is not inductively coupled to the grid circuit, but is used to tune the plate circuit, thus providing capacity feed-back; while on the remaining taps it acts as a tickler coil.

I heartily agree with Mr. McGown that this is an excellent arrangement, and it may be interesting to your readers to know that it has been used for two years that the writer is aware of on sets manufactured by the Colin B. Kennedy Company. The circuit shown in Fig. 3 of the article in question is nearly identical with that of the Kennedy type 220 receiver.
B. F. MCNAMEE.
St. Louis, Mo.

Crystal Improvement

Sir: I read the article in the December issue on Alfred Crossley and the Spiderweb rotor with much interest, as I have been working for the past four months on a coil of this type to use with the crystal set, and have finally secured volume and clearness. My coil is much larger than any other that I have heard of, and wound to be finally used with the tube set, and in the place of using one spider I am using two, winding with three sizes of wire, the idea being to get both volume and sharpness in smallest space.

The coil and spider on this set are very easily constructed. I have used 5 take-offs on the coil to allow me to tune out the high-power station at Key Port, which is only 9 miles from me, so it gives me very little trouble. I find this outfit much more sensitive than the old straight coil, and the adjustment very close, and as soon as I have more time and funds to spare will finish my experiment with the tube, for I believe that with the Peanut or WD11 it will take all the sending stations in the U.S.

Now a word about crystals on a shunted set. I had lots of trouble at first to get the voice and music—wireless was easy—and I knew that I had good crystals, for I had fine success before, and until I secured a very thin crystal not over $\frac{1}{8}$ -inch thick did I get good results. A crystal that is too thick will not vibrate and allow the voice to pass through, so today I am using the thinnest crystal that I can get and am getting fine results. I am 15 miles from Seattle and using only a single phone of 1000 ohms and most of the time I can get the music with the phone one inch from the ear.
Port Orchard, Wash.
E. D. COSPER.

U. S. BUREAU OF STANDARDS CIRCULARS

Letter Circular 51 from the U. S. Bureau of Standards, Washington, D. C., gives a list of the more important U. S. patents covering the materials and methods of manufacture of insulating materials. Letter Circular 49 describes the construction and operation of a simple audio frequency amplifier unit. No. 40 lists the radio publications of the Bureau. No. 50 gives bibliography on tests, properties and uses of electrical insulating materials.

RADIO TRADE NOTES

A helpful idea for the amateur radio builder is offered by the H. Earle Wright Radio College of San Francisco, who are prepared to furnish a course of instruction on the fundamentals of radio, including the parts to construct a three-stage audio-frequency amplifier set complete with tuner. The student is taught to build this set under competent supervision and at the same time receives a course of instruction in operation.

formed and established stations in various big towns in the United Kingdom, notably only do you hear the opera, but the applause at the end of the acts and the general noise of the audience. Of course opera will be sent out every evening until the season is finished.

We are quite accustomed to the usual news, market reports, weather reports, children's stories, orchestral music, concerts, etc. The Prince of Wales has broadcasted a speech. At present the times of broadcasting are from 5 P.M. until somewhere between 10:45 P. M. and 12 o'clock.

Amateurs are very keen in picking up American broadcasts. The station usually heard is Newark WJZ and has been heard on 3-valve sets and upwards. The other day it was picked up with a seven-valve set with a frame aerial indoors.

There is really very little restriction with regard to radio. A government's license costs roughly two dollars (10/), of which one dollar goes to the B.B.C. and the rest to the State, and is renewable annually. A small royalty is also payable on each set sold, which has to be stamped with the B.B.C. stamp. The royalty, of course, goes to the B.B.C. towards the cost of broadcasting.

A thing that surprises me is the low resistance of your headphones. Here 4,000 and 8,000 ohm phones are in general use. Anything of lower resistance is considered unsuitable.

Your magazine is undoubtedly great, and, although just a few miles away, I'm a regular reader.
Yours faithfully,
(London, England.)
E. JACKSON.

Variometer in Plate Circuit

Sir: I wish to call attention to the circuit arrangement in an article in your January 1923 Issue, entitled "A Portable Radio Receiver" by D. B. McGown. A variometer is employed in the plate circuit to provide re-

WITH THE AMATEUR OPERATORS

DX AT 6XAD

By MAJOR LAWRENCE MOTT
(Signal Corps—ORC—USA)

IN presenting, for the encouragement of others, my DX from Catalina Island, off the coast of So. California—for latter December, '22, and January, '23—I would like to call attention to the following matter:

I have been in receipt of a great many letters, from fellow-operators all over the U.S., who have mistaken the meaning of my former DX lists. That is to say: they could not understand, for some reason, whether the publication of their call letters meant that they had heard *me*—or: that *I* had heard them! I had thought that the matter was clear!

Let me say, therefore, that ALL stations that I have actually WORKED are so marked, either by being bracketted, or by having the letter *w* after the call. Stations NOT so marked have REPORTED HEARING MY SIGNALS!

The receiving apparatus at 6XAD is extremely sensitive, and I hear literally hundreds of DX stations! But were I to attempt to list them *all* several pages of RADIO would contain nothing else! Obviously this is impossible! Nor, unfortunately, have I the time to *write* to all the stations—DX—that I hear, as, should I do so, I should have no time for anything else! Also obviously out of the question!

If a station owner writes and ASKS if I heard him, I take great pleasure in answering his query, but that is as far as I can go!

A phenomenon, in the way of receiving, has been reported to me by Mr. John Haley, 114 Hayward Place, Wallington, N. J., under date of Jan. 7th, that is worth publicity! He writes: "Heard your ICW very QSA Saturday morning at 4:33 EST. Was using Reinartz tuner and 1-step. *The peculiar thing about it was that my aerial was on the snow, having been blown down by the heavy snow-storm*"

A rather remarkable feat of reception, to my way o' thinking! I would also have it noted that, in all my DX work, I have used DETECTOR only, finding any steps of amplification entirely unnecessary—even when working 2's and 3's!

The list:

1AAC (detector only), 1CBJ, 1GV, 1MO, 1RO (Vy QSA), 1RD, 1COH, 1CTX (QSA on detector only), 1BNT, 1BSZ, 1CMP, 1RO, 1GV.

John Haley, Wallington, N. J. (receiver only); E. H. Stofflet, Ridgefield Park, N. J. (receiver only); M. Hein, Westchester, N. Y. (receiver only); 2COR (N.Y. City) detector only, 2BG, 2BSC, 2BFX, 2AXH (Vy QSA), 2CMJ, 2BSC, 2COR, (2EL), 2XK, 2BG, (2FP).

3AMX, Can. 3ST, 3APR, 3BVC, (3ARO), 3APV, 3ALX, (3CAN), 3LR (heard 6XAD three times on Thanksgiving Day between 3 and 5 P.M.—EST—hence—full daylight—copied mags), (3YO), 3BNU, 3PZ, H. Resch, Bayonne, N. J., (Can 3DH), 3BVC.

L. Stollenwerk, Birmingham, Ala.; 4HN (Miama, Fla), (4EB), 4LP, 4LW, 4KL.

5ZAS, (5TJ), (5ABB), 5AER, (5IQ), (5XAJ).

6's too numerous.

(7ZU), (7OM), (7ZS), 7RI.
(8VY), (8AJX), (8CGX), (8BVR), (8ALC), (8LT), (8BDV), (8BXX), (8JJ), 8CCS, (8COO), 8ADZ, 8BRL, 8BKS, (8ASC), (8YN), (8CYU), (8ER), (8MDG), (8CAA), (8ADG), (8BO), (8BEO), (8DV), (8NB), (8BY), John Wile, Wooster, Ohio, 8ABX, 8ADG, 8AEB, 8ADH, 8ANB, 8AWN, 8AKI, 8BEI, 8BIN, 8BNZ,

8BSF, 8CED, 8CKV, 8COO, 8CRZ, 8COX, 8EV, 8BW, 8KW, 8ON, 8BOE, 8AVD, 8BBE.

(9CCM), (9DKQ), (9BLY), (9DUG), (9AAP), (9QF), (Can. 9AL), (9DLF), (9OX), (9KP), (9ZT), (Can. 9BX), (9DUG), 9BTA, 9AWS, 9BZO, 9BMN, 9BLT, 9CPY, 9CUO, 9HK, 9PS, (9BKJ), P. Caramello, Omaha, Neb., 9DMA.

Canadian—C. H. Starr, St. Catherines, Ontario, (9BP, Prince Rupert, B. C.)

At 1:07 A. M. February 1st, 6XAD got into communication with 2FP, without any pre-arrangements, and worked the Brooklyn, N. Y., station for an hour, with the greatest of ease. 2FP was so QSA at 6XAD that on the WE-loud-speaker his signals—500 cycle note—could be read all over the house. His 60 cycle note was also QSA, but not quite as good. No "repeats" in the conversation were required, communication being carried on as though it were local.

S. P. Dalton, 6KY, is at 6XAD for the purpose of installing my two 500-watt British tubes, with which effectual communication with The Wireless Amalgamated, of Sydney, Australia, is fully expected.

I should also like to mention that from 1:44 A. M. to 2:35 A. M. PCT, on January 31st, I worked 2EL—H. H. Carman, Freeport, Long Island, N. Y.—as though he were a local. As a matter of fact he was more QSA than many . . . locals!! On my W-E loud-speaker I could read him 500 ft. from the horn—out of the house, and across two streets! He is using 3-50 watt Radio Corporation tubes. I have worked him before, but not with such marked success as on the date mentioned. It is also worth noting that on the night of Jan. 30th-31st I effectually worked: (whole list), 2EL, 3CAN, 5KP, 6APL, 8BOZ, 9BP (Can), 9AVZ, 9BVY, 9BTT, 9BKK and 9CKS.

Had it not been for some big arc, that "tested" nearly ALL night, I should have been able to work ALL Districts, as I heard several 1's—and that which I *think* was 4JY—calling me, but I could do nothing with them, because of arc QRM. I was so busy that I failed to answer some 7's, too—worse luck!—until too late—or early?—in the A. M.! But I was heard in Every District during one night's effort!

LOS ANGELES—"QSO"—NEW YORK—DIRECT

By HOWARD C. SEEFRED

While "QRX'ing" for eastern amateur "sigs" on a cold and chilly morning with the stars shining brightly in a clear sky and not a bit of "QRN" to be heard in the air, my station 6EA established *direct communication* with station 2FP of Brooklyn, New York, approximately three thousand miles from Los Angeles, on January 15th, from 12:50 to 2:15 A.M.—Pacific Standard time. Both stations reported "QSA" sigs and didn't have much difficulty in reading each other except towards the last on account of "QSS" and "QRM"—buzz from leaky high tension line nearby.

Station 2FP sent a greeting msg as follows: "Nr. 1 fm 2FP. To 6EA Los Angeles.

Greetings fm Bklyn. Sig. Hewitt."

This msg. was rec'd at 12:59 A.M.—P.S.T. at 6EA. I immediately answered with the following reply:

"Nr. 1 fm 6EA. To 2FP, Bklyn, N. Y.

Greetings fm Los Angeles. Sig. Seefred."

2FP OK'ed this msg. at 1:05 A.M.—P.S.T. Both stations asked each other to write and also "chewed the rag" concerning the communication, etc. The communication lasted over one hour. This breaks all my former "QSO" records.

This communication was witnessed and overheard by 6XK, 6KA and 6BVG of this city; also heard and reported by mail by 1BKQ of Worcester, Mass., 6XR; Paul F. Johnson of Pasadena, Calif., and W. J. Roche, mgr. of the Ship Owners Radio Service, Inc., at San Francisco, Calif.

Transmitter at 6EA is a 50-watt transmitter with synchronous rectifier—about 1300 volts on plate (home-made plate supply transformer), reversed feed-back circuit, 170 mills; radiation is 4.5 to 4.6 amps. T.C., using a 9-wire counterpoise. No filter condenser or R.F. and A. F. chokes are used.

I understand that 2FP has a 250-watt tube with 500 cycles on plate, 6000 volts and 6 or more amps T.C.

During December and January my C. W. sigs have been reported by mail and verified by log book as heard by the following: 1BKQ of Worcester, Mass.; 1CMK of Holyoke, Mass.; 2XZ of New York City; 2BIR of Nutley, N. J.; 3ARO of Washington, D. C.; 4EB of Palmetto, Ga., etc.

Antenna at 6EA is 45 and 52 ft. high—45 ft. long on 16-ft. spreaders; 4 wires—7 strands of No. 22 copper, "L" type, 55-ft. lead-in, or 100 ft. total length; counterpoise—9 wires, ditto copper, 60 ft. long and 10 ft. above ground. Same is 23 ft. wide one end and 14 ft. at other end. The DX work *isn't* anything wonderful as compared to the high-powered C. W. amateur stations that reach out to Europe or nearly across the Pacific ocean, but just to show what station 6EA has done with "A pile of Junk" and to boost the West Coast in DX. I am *only* making records for *myself* while I am in the amateur radio game. All my reports heard by on my sigs are all verified by my log-book.

NEWS OF THE RADIO CLUBS

Mystic Order of Owls

The Mystic Order of Owls has been organized at Fort Dodge, Iowa, by C. S. Tunwall, 9UL; C. D. Minogue, 9DAH; C. W. Tennant, 9BSW; A. H. Carlson, 9BLZ; W. G. Davis, 9AXA, L. P. Aldrich, 9DAJ, and W. D. Royer, WEAB. This organization was formed for the improvement of radio communication through the use of C. W. and ICW transmitters only and a general working period to begin after 12 o'clock midnight. Meetings called by the Great Owl for Monday night of each week. All the present members of the Order are dyed-in-the-wool operators and extend a cordial invitation to other Amateur C. W. Operators to affiliate with them.

THE MILWAUKEE AMATEURS' RADIO CLUB

The Milwaukee Amateurs' Radio Club, which was founded in 1917 and became affiliated with the American Radio Raley League, Inc., in 1919, is enjoying an active and successful season. The society meets weekly at 7:45 P.M. on Thursdays in the Trustees' Room of the Milwaukee Public Museum. Meetings have been well attended, and the membership is increasing. At the annual election of the board of direction seven members were chosen, and the chairmanship given to C. N. Crapo, 9VD, local district superintendent for the A.R.R.L. In addition to several committee chairmen the board appointed the following officers: H. F. Wareing, president; E. T. Howell, 9CVI, vice president; H. G. Fawcett, secretary; E. W. Ruppenthal, 9AYA, treasurer; L. S. Baird, business manager.

The meetings and papers committee has arranged for several talks. E. R. Stockle, Ph.D., of the University of Wisconsin spoke on the subject of "the vacuum tube as a radio detector and amplifier." E. D. Nunn, a Milwaukee radio engineer, demonstrated a receptor of his own design and gave a short talk on radio frequency amplification. At a special informal meeting a "ham-fest" was held with F. H. Schnell, traffic manager of the A.R.R.L., as guest and principal speaker. "The Construction of a High Voltage 'B' Storage Battery" was the title of an address by Marian Szukalski, Jr., 9AAP. Ben A. Ott, 9ZY, and K. C. Maas, 9AZA, state officers of the League, recently visited the society and gave talks on state organization. This resulted in the calling of a traffic meeting where several tests were arranged for and seven relay trunk lines within the state of Wisconsin were laid out.

The technical committee, headed by E. T. Howell, Sc. M., and R. E. (radio engineer) Lathrop, 9ATX, vice president of the Waukesha Radio Amateur Club, has submitted several reports on topics of timely interest. The "S" tube has been discussed; super-regeneration explained; an analogy given for oscillating tubes; and the Hartley and reverse feed-back C. W. circuits contrasted.

A spirited spark-C. W. debate was put over with great success. The argument waxed hot, and the sound of the gavel was frequent. A contest in defining technical radio terms caused many lines to be spelled down but resulted in adding a store of words to the members' vocabularies. Several meetings have been devoted in part to discussions of the proper design and construction of aerials in way of collecting data for this club's contribution to the antenna symposium number of QST.

ST. LOUIS, MO., TRAFFIC REGULATIONS

Monday, Tuesday, Wednesday, Friday

From 6 A.M. to 8 A.M.—All stations may transmit or test.

8 A.M. to 7 P.M.—All stations may transmit. No testing unless absolutely necessary.

7 P.M. to 9:50 P.M.—Only straight C. W. and low powered phones on 200 meters may transmit locally or DX.

9:50 P.M. to Midnight—All stations may transmit under the supervision of a traffic officer who will list the stations. The traffic officer will call for DX at 9:50 P.M. and all stations desiring to work will respond. No station will be listed after 10:15 P.M.

Monday—Midnight to 2 A.M. Tuesday—Only C. W. may transmit.

2 A.M. to 4 A.M.—Only spark may transmit.

4 A. M. to 6 A.M.—Only C. W. may transmit.

Tuesday—Midnight to 2 A.M. Wednesday—Only spark may transmit.

2 A.M. to 4 A.M.—Only C. W. may transmit.

4 A.M. to 6 A.M.—Only spark may transmit.

Wednesday—Midnight to 2 A.M. Thursday—Only C. W. may transmit.

2 A.M. to 4 A.M.—Only spark may transmit.

4 A.M. to 6 A.M.—Only C. W. may transmit.

Thursday—6 A.M. to 7:30 P.M.—Same as other days.

7:30 P.M. to 11:30 P.M.—All transmitters, including broadcast stations, must remain absolutely quiet to permit listeners to hear distance broadcast stations.

Thursday—Midnight to 2 A.M. Friday—Only spark may transmit.

2 A.M. to 4 A.M.—Only C. W. may transmit.

4 A.M. to 6 A.M.—Only spark may transmit.

Friday—Midnight to 2 A.M. Saturday—Only C. W. may transmit.

2 A.M. to 4 A.M.—Only spark may transmit.

4 A.M. to 6 A.M.—Only C. W. may transmit.

Saturday—6 A.M. to 9 A.M.—All transmitters may work. No testing.

9 A.M. to 5 P.M.—All transmitters may work and test.

5 P.M. to 7 P.M.—All transmitters may work. No testing.

7 P.M. to 9:50 P.M.—Same as Monday.

9:50 P.M. to Midnight—Same as Monday.

Saturday—Midnight to 2 A.M. Sunday—Only spark may transmit.

2 A.M. to 4 A.M.—Only C. W. may transmit.

4 A.M. to 6 A.M.—Only spark may transmit.

6 A.M. to 9 A.M.—All stations may transmit. No testing.

Sunday—9 A.M. to 12 Noon—All stations may transmit and test.

12 Noon to 7:30 P.M.—All stations may transmit. No testing.

7:30 P.M. to 11:30 P.M.—All transmitters, including broadcast stations, excepting the Kingshighway Presbyterian Church, must remain absolutely quiet. This church being permitted to broadcast its regular Sunday evening services from 8 to 9 P.M.

11:30 P.M. to 6 A.M. Monday—FREE AIR for ALL TRANSMITTERS.

CIVIL SERVICE EXAMINATION FOR RADIO INSPECTOR

The United States Civil Service Commission announces an open competitive examination for radio inspector on March 7, 1923. Vacancies in the positions of radio inspector and assistant radio inspector in the Bureau of Navigation, Department of Commerce, at \$1,800 to \$2,200 a year (plus "bonus," see below), and in positions requiring similar qualifications at these or higher or lower salaries, will be filled from this examination.

The duties will be primarily to inspect the radio apparatus on steamships, to insure its compliance with the law, and to inspect shore stations. The inspectors may also be called upon to examine radio operators. The duties of radio inspectors require some office experience, therefore competitors should outline fully in their applications any office experience they may have had. Assistant radio inspectors will be required to inspect the radio equipment on board vessels and in land stations, which involves the carry of 30 or 40 pounds of testing and measuring instruments. The inspection work requires a knowledge of the installation and operation of the several types of radio installations, including the adjustment and tuning of transmitters and receivers.

Subjects and weights.—Competitors will be examined in the following subjects, which will have the relative weights indicated:

1. Theoretical and practical questions in the construction, use, and adjustment of radio apparatus and auxiliaries (eligible rating required).....	50
2. Education and experience in the line of the required duties.....	50
Total.....	100

Applicants must attain an eligible rating in the first subject. Applicants must have received a bachelor of science degree from a school of recognized standing, such educational training to have included a special course in radio or kindred sciences, or show that they are senior students in such institutions; or have had the equivalent of a high-school education and at least two years' ex-

perience in special radio work, such as the manufacture, installation, or adjustment of commercial or governmental wireless apparatus. It is essential that applicants be wireless telegraph operators. Applicants must have reached their twenty-first but not their fiftieth birthday on the date of examination. Applicants should at once apply for Form 1312, stating the title of the examination desired, to the Civil Service Commission, Washington, D. C., or to the Secretary of the United States Civil Service Board at the city nearest their place of residence.

THE RADIO STANDARDIZATION CONFERENCE

A broad program of radio standardization was agreed upon at a meeting of representatives of forty radio trade associations and national engineering and scientific societies on January 12th. The meeting was held in the Engineering Societies Building, New York City, at the call of the U. S. Bureau of Standards in co-operation with the American Engineering Standards Committee. Dr. F. C. Brown, acting director of the Bureau of Standards, presided.

After full discussion, the conference adopted resolutions providing:

(1) That standards for radio apparatus and service should be formulated;

(2) That a broadly representative national committee on radio standardization should be formed under the leadership of the Institute of Radio Engineers and the American Institute of Electrical Engineers, under the procedure of the American Engineering Standards Committee.

Specifications for quality and performance of receiving apparatus, nomenclature, and methods of testing and of rating apparatus are to be included in the program.

Dr. J. H. Dellinger, chief of the radio laboratory of the Bureau of Standards, showed how the widespread interest in radio had brought with it an increasing demand for uniformity and dependability in radio service and apparatus. The lack of any such standardization has been brought to the attention of the Bureau of Standards by producer, distributor and consumer. There has not previously been a concerted movement to introduce standardization by joint action of all radio interest.

Dr. A. N. Goldsmith, Secretary of the Institute of Radio Engineers, said:

"As every new field of industry passes out of the childhood stage, the need for standardization becomes evident. The main difficulties which at once arise, and which emphasize the necessity for cautious procedure are the dangers of stagnation in an only partly developed art, a possible excessive monotony in the resulting product, and a diversion of the best brains from such a field.

"On the other hand, it is only by a reasonable amount of standardization along wise directions that gross abuses of public confidence can be avoided. As a typical instance, consider the objectionable nature of some of the so-called "information" appearing on name plates and in the advertisements of radio apparatus. We have seen "static eliminators," "thousand-mile receivers," "twenty-plate condensers," and a score of other vague or misleading designations. The purchaser of radio sets, and the dealers who handle them are all entitled to protection against this sort of loose description. And thus we are brought face to face with the necessity for sane standardization."

The following advisory committee was appointed to assist in the organization of the national committee and the necessary technical subcommittees: Major L. B. Bender, Dr. J. H. Dellinger, W. A. Fitzgerald, Dr. A. N. Goldsmith, J. V. L. Hogan, Commander S. C. Hooper, Geo H. Lewis, Max Lowenthal, Donald McNicol, L. T. Robinson, M. C. Rypinski, E. B. Warner and L. E. Whittemore.

RADIO DEVELOPMENT IN GERMANY

While the activities of England, France and Holland in the field of radio have been concentrated since the war on the establishment of communications with their dominions and colonies, Germany, deprived of all overseas possessions, has been building up within her own borders a system of radio-telegraph and radio-telephone stations that is second to none in the world, says Assistant Trade Commissioner W. T. Daugherty, Berlin, in a report to the Department of Commerce. The loss to Germany of her ocean cable system, built up at great cost during the fifteen years preceding the war, made her dependent on neighboring countries for all her international communication except the portion that she could handle by radio. The logical result has been the increased use of high power radio stations for overseas communications, especially to the United States.

At present the central office of the Gosellschaft fur drahtlose Telegraphie, located in the Oranienburgerstrasse, Berlin, controls the two great transmitting stations, Nauen and Eilvese, and the two receiving stations Gelton and Hagen. Both the transmitting stations work on schedule, Nauen with New York, Moscow, Madrid, Rome and Bucharest; and Eilvese with Rome and Madrid. Both have trans-Atlantic press schedules as well.

Extensive changes are now in progress at Nauen, designed to increase its power and the flexibility of its operating plant. Separate antennae are being constructed for the American, the Asian, and African, and the two European circuits; and a special arrangement is planned for the new Buenos Aires circuit which is to be opened to public correspondence within the next few months. The corresponding station at Monte Grande, near Buenos Aires, is to be maintained and operated by a combination of French, English, German and American radio companies.

The German postoffice station at Koenigswusterhausen, near Berlin, transmits to London, Budapest, Sofia and Sarajevo, and its receiving station at Zehlendorf makes up the return circuit. Norddeich, a coastal station used for hydrographic reports, shipping news, and weather reports, completes this group which is known as the Main Stations Group (Hauptfunkstellen). Although communication is maintained with the foreign cities mentioned, the main stations group operate principally within Germany.

The feeder stations of this system operate an interior service as subsidiaries of Koenigswusterhausen. The stations located at Dortmund, Breslau, Duesseldorf, Frankfort-on-the-Main, Hamburg, Hanover, Koenigsberg in Prussia, and Munich, are each equipped with two sending and two receiving installations. Dortmund operates a special service to Rotterdam as well.

"Simple stations" (Funkstellen) supplementing the feeder stations and equipped each with a single sending and receiving set, are located at Bremen, Darmstadt, Elbing, Friedrichshafen, Constance, Stettin, Nuernberg and Mannheim.

Ship to shore stations are 16 in number and were excepted from the system taken over by the postoffice department in 1919.

The distribution of the wireless news broadcast from the interior transmitting stations is effected by 75 receiving stations which have no transmitting sets. Similarly equipped stations receive weather reports in nine of the principal cities.

Public wireless telephony was inaugurated in Germany on September 1, 1922, the postoffice department and the express service (Eildienst G.m.b.H.) uniting to establish the service. Subscriptions, open to the public, are based on the extent of the service rendered, and the only additional cost is the installation charge.

The apparatus used may be employed for either telegraphic or telephonic reception, vacuum tubes being supplied. In accordance with the distance from the broadcasting station, amplification in varying stages is provided.

Koenigswusterhausen is the broadcasting station and subscribers to the service are now located in 176 cities and towns. The material furnished so far has been confined to economic news, such as bank statements, exchange quotations, stock market listings, etc.

DR. FULLER WITH GENERAL ELECTRIC CO.

Dr. L. F. Fuller has accepted a radio engineering appointment with the General Electric Co. at Schenectady, N. Y., and will take up his new duties there as soon as work in California under his direction has been completed. The General Electric Co. is devoting special attention to the possibilities of radio in various branches of the electrical industry. These range from high power stations for trans-oceanic communication to carrier telephone systems for power companies and include the use of large thermionic tubes for power purposes, radio receiving equipment for the home, and the application of radio principles to power work generally.



Dr. L. F. Fuller

Dr. Fuller was for seven years with the Federal Telegraph Co. and particularly during the war as chief engineer of that company did important development work on the high power magnetic arc transmitters which the U. S. Navy now uses for all trans-oceanic work. In this capacity he was also charged with executive duties and personally represented the company in negotiations on technical matters with the Navy Department at Washington, D. C. Stations designed and built under his direction are used for transmission over some of the longest distances spanned by radio communication. Notable among these is the link between Pearl Harbor, Hawaii, and Cavite, P. I., about 7,000 miles, and the high power transmitters located at San Diego, Panama, Annapolis and Bordeaux, France. The last named, which was the last designed and built under Dr. Fuller's direction, has a rated capacity of 1,000 kw.

Later, with C. B. Kennedy, he formed a partnership under the name of the Colin B. Kennedy Co., and has had an active part in the development of the line of radio receiving instruments bearing that name. For several years he has done radio consultation work in the East, as well as on the Pacific Coast, and recently was retained by the Great Western Power Co. and the Pacific Gas & Electric Co., successively, to develop and install complete radio telephone transmitting and receiving systems, using 200-mile, high voltage power lines as carriers. Dr. Fuller was awarded the Morris Liebmann prize for 1919 by the Institute of Radio Engineers in recognition of his research and development work in radio engineering.

BRITISH REGULATIONS GOVERNING RADIO RECEPTION

The British General Post Office has defined the conditions which broadcast receivers should fulfil to obtain post office approval as follows:

1. That all types of Broadcast Receivers may be constructed for the reception of signals of any wavelength.
 2. That the apparatus shall be so constructed that it is difficult to change the arrangement of the circuits embodied in the design by means of external connections.
 3. The following units, each of which must consist of apparatus assembled connected and mounted in a single container, shall be approved:
 - a. Combined Tuner and Rectifier.
 - b. Combined Tuner, High Frequency Amplifier and Rectifier.
 - c. Audio Frequency Amplifier (of Valve or other type).
 - d. Tuner, Rectifier and Audio Frequency Amplifiers.
 - e. Tuner, High Frequency Amplifiers, Rectifier and Audio Freq. Amplifiers.
- In particular, it is intended that each panel must contain all the high frequency circuits and the High Frequency Amplifiers in association with the Rectifier, but there is no limit to the number of high frequency or audio frequency amplifiers that may be included in any unit or set provided the other conditions set forth herein are complied with. Audio Frequency Amplifiers may be added in single, double or multiple units to (a) and (b).

4. No receiving apparatus for general broadcast purposes shall contain a valve or valves so connected as to be capable of causing the aerial to oscillate.
5. Where reaction is used on to the first receiving circuit it must not be adjustable but must be fixed and incapable of causing oscillation.
6. Where reaction is used between a second or subsequent valve on to the anode circuit of a valve connected to the aerial, either directly or inductively, and no specific coupling tending to produce oscillations in the aerial is provided between the first receiving circuit and the first anode circuit the reaction may be adjustable.

7. Tests of sets will be made on two aerials, one 30 feet long and the other 100 feet long. On these aerials the sets should be capable of receiving wavelengths covered by the "Broadcast" band, viz., 350 to 425 meters.

8. The sets will be tested for the production of oscillations in the aerial and for interference properties with a factor of safety, i.e., increasing the high tension battery by about 30%, changing valves, etc., but not by altering any soldered connections.

9. The Postmaster-General must be satisfied that sets containing reaction can be reasonably repeated with consistent conditions.

10. After approval the type will be given a Post Office Registered Number and makers must see that the sets fulfill the non-interfering conditions before they are sold. All sets sold for use under the Broadcasting Receiving License shall bear the registered trade mark of the British Broadcasting Company and the Post Office Registered Number.

11. The unit or set approved as the pattern instrument of a type shall be retained without alteration by the maker. The Postmaster-General shall have the right at any time to select any set of an approved type for test to see that the set is reasonably similar to the approved pattern. In the case of sets of an approved type employing reaction being found to oscillate the aerial, the Post Office may cancel the authorization of the future sale of that type. No change in the design of any set or unit may be made without sanction of the Postmaster-General.

DIGEST OF RECENT RADIO PATENTS



Prepared by White, Prost & Evans, Patent Attorneys, San Francisco, who have been particularly active in the radio field for many years, and from whom may be obtained further information regarding any of the patents listed below.

R. A. Heising, Pat. No. 1,436,252: November 21, 1922. System for Producing Modulated Waves.

In order to vary the amplitude of oscillation of a current produced by an arc 8-9, a variable impedance such as the thermionic tube, 6, is inserted in the system, that is controlled by a microphone 26. The arrangement is such that variations in this impedance have no effect upon the frequency transmitted by the arc 8-9. This result is obtained by using a control circuit for the arc, including a control electrode 12, tuned circuit 13, 14, and the electrode 8. This tuned circuit keeps the arc oscillating at the proper frequency irrespective of the impedance of tube 6 included in a path parallel to or in series with the arc. Variation of this impedance by the microphone merely causes a corresponding variation in amplitude of the arc oscillations.

I. Langmuir, Re-issue Pat. 15,495, Reis.: November 21, 1922. Wireless Signaling System.

A heterodyne receiving system is described, in which the vacuum tube 1 serves both as a detector and as a source of oscillations, the frequency of which differs by a slight amount from that of the oscillations received by antenna 14. The telephone 10 in the plate circuit of the tube 1 is coupled by coil 9, both to the input circuit and to the antenna 14, and thus serves to combine both sets of oscillations.

J. Robinson, Pat. No. 1,435,941: November 21, 1922. Radiodirection Finder.

A radio compass is described in which there are two coils 1-2 and 3-4 rigidly connected at right angles to each other, but rotatable as a unit about a vertical axis. The effect of these coils on a detector 10 is perceived by a device 9. For maximum effect on coil 1-2, there is a minimum effect on coil 3-4, and the bearing of the distant source may be readily ascertained by noting the effect of disconnecting or even reversing coil 3-4. When this coil is disconnected, an equivalent coil 8 is inserted in its place so as

to leave the circuits with substantially the same constants.

E. C. Hanson and W. L. Carlson, No. 1,437,240: November 28, 1922. Apparatus for Detecting Minute Values of Energy.

In order to detect minute values of energy, an arrangement is set up whereby variations in energy cause corresponding variations in frequency of an oscillating tube 30. When no energy is received, this frequency is set to be the same as that of another tube 31, and since the phone 17 is responsive to the combination of both frequencies (which are above audibility), no response is perceived therein. However, upon reception of energy, the frequency of 30 changes and beats are produced in the phone.

J. C. Schelleng, Pat. No. 1,437,021: November 28, 1922. Electron Discharge Device Circuits.

A tube transmitting system is described, in which are utilized the oscillator tubes 0 in parallel, the modulator tubes V in parallel,

Continued on page 90

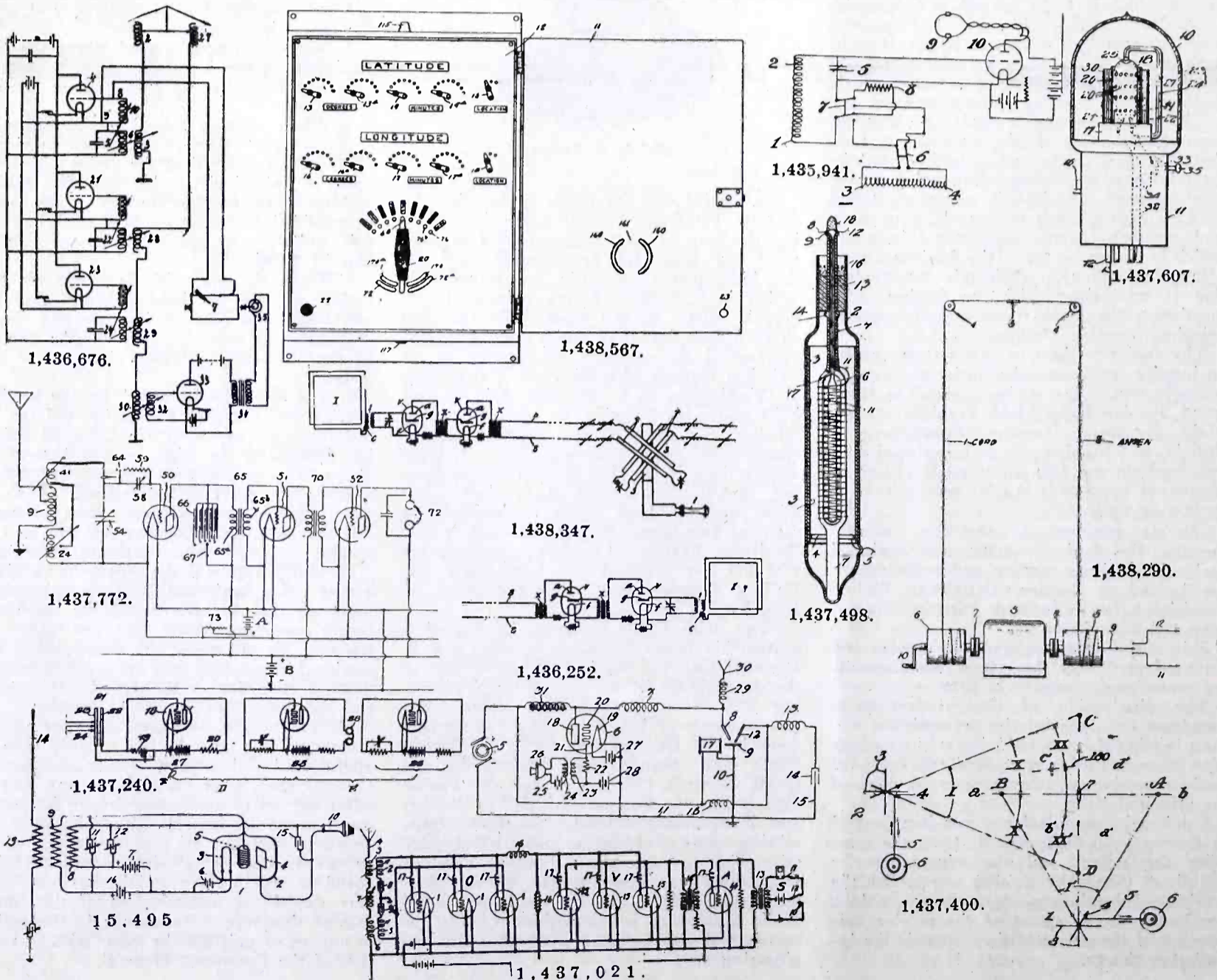

QUERIES & REPLIES

ON C.W. PRACTICE

BY
Gerald M. Best
TECHNICAL ADVISOR



Questions submitted for answer in this department should be typewritten or in ink, written on one side of the paper. All answers of general interest will be published. Readers are invited to use this service without charge, except that 25 cents per question should be forwarded when personal answer by mail is wanted.

Please publish a circuit for using standard spiderweb inductances, showing the necessary apparatus to accompany same. It is intended to use this circuit to receive amateur C. W. and broadcasting, the set having one stage of audio frequency. Please give me the proper dimensions for a four-wire cage antenna, six inches in diameter.

I. C. O., Chicago, Ill.

This circuit you wish is shown in Fig. 1. I have not shown what is known

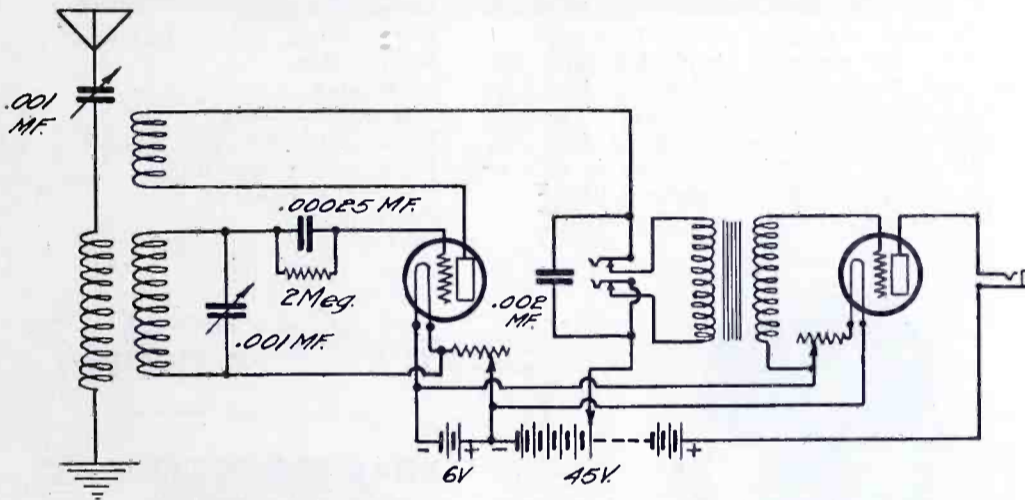

Fig. 1

as the Turney circuit, but rather have indicated a standard regenerative circuit, which I believe will give you good satisfaction on all short waves. For 200 meter reception, as well as on the broadcasting wavelengths, you should not make your antenna more than 75 ft. long, although the height may be as much as 100 ft. above the ground, or roof of building.

Kindly publish a circuit using two steps of radio frequency amplification and two steps of audio frequency amplification, using UV 1714 radio frequency transformers, and a standard compact-wound inductance coil tuning unit, em-

I get increased radiation with one 5-watt tube by using more than the 2.35 amps for which the tube is rated. Will the tube stand up under the extra load? Plate has a tendency to get red hot with about 600 volts on it. Is this proper working condition? What radiation should a person get with one 5-watt tube? Is there anything better than the Hartley circuit?

T. A. C., Campbell, Calif.

If you operate the filament of a Radiotron or Cunningham 5-watt tube at more

than 2.35 amperes, you will materially shorten the life of the tube. 2.35 amperes is the maximum current which should be allowed, and the tube should actually be operated at a slightly lower current to obtain long life. With tungsten filament tubes, you should not measure the filament current, but rather the filament voltage, so that as the filament wears away, in service, you will be able to maintain the voltage constant across the filament terminals. The operating plate voltage of a 5-watt tube such as you are using is 350 volts, and overloading it to the extent of 600 volts is very bad indeed. 5-watt tubes will stand

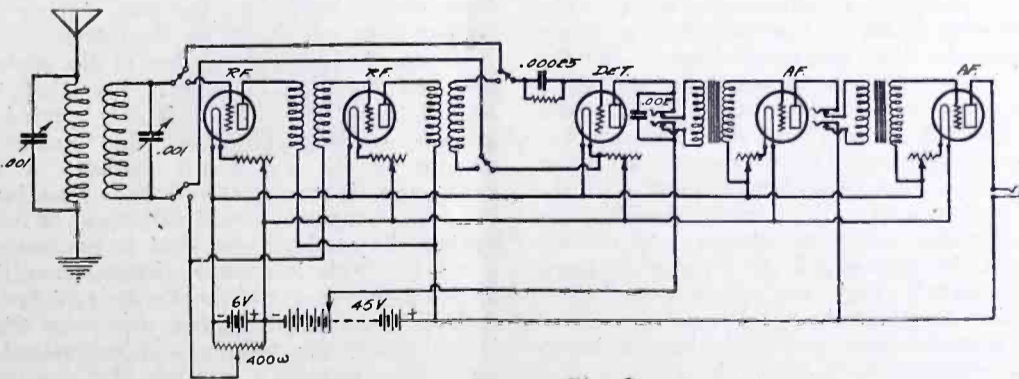

Fig. 2

bodying an anti-capacity switch to cut out the Radio Frequency amplifiers.

V. L. V., Los Hills, Calif.

This circuit is shown in Fig. 2. It is of the non-regenerative type, and will prove more satisfactory than a regenerative receiver for broadcast work.

such a voltage for a few seconds, but you will probably have a burned-out tube on your hands if you subject it to such a high potential for very long. On an average antenna, having a resistance of about 15 ohms, with 350 volts on the plate, and an efficient set, you should

expect about 0.6 ampere radiation. This may vary one way or the other, but .6 ampere is an average. The reversed feedback circuit is more efficient than the Hartley circuit in that it produces a sharper wave, but requires two inductances, whereas the Hartley requires only one.

Please give me a diagram of a regenerative set using an "all wave" coupler and tube detector, with necessary equipment. Am about to build a receiver; would you advise using above-mentioned coupler, or variometers and a different vario-coupler? W. F., Rock Hill, N. Y.

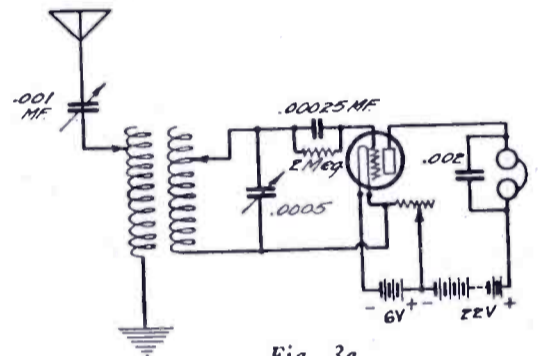

Fig. 3a

The circuit using variometers will be more selective, and easier to control than one using the "all wave" coupler, but would have a much smaller range of wavelength than the latter. Hence I am indicating in Fig. 3 both of the circuits you ask about, "a" being the "all wave coupler" circuit, and "b" the variometer circuit.

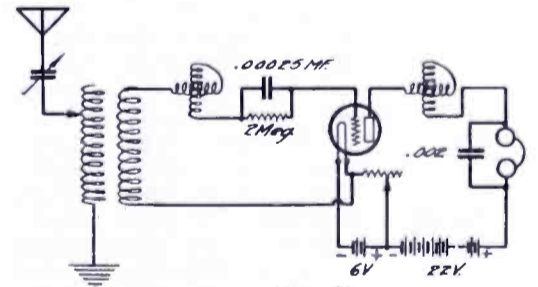

Fig. 3b

What is the reason that I pick up a station which comes in loud and clear, only to gradually fade away, and then come back in again? J. F., Ural, Mont.

This phenomenon is known as "fading." Various theories have been advanced to show the cause of this, but I believe that no conclusive facts have been established. It is sometimes called "absorption," and is believed to be the result of the atmosphere absorbing the energy from the transmitting station. This effect is quite noticeable when receiving station is several hundred miles away, and is one of the inconveniences of radio that you will have to put up with.

In a 10-watt self-rectifying C. W. set, where could a telephone transmitter be placed for telephone transmission?

F. T., Seattle, Wash.

Telephony cannot be employed in a self-rectifying circuit, for this sort of equipment is intended only for telegraph transmission, and due to the 120 cycle note, the voice would be indistinguishable if it were possible to modulate the antenna current. It would be necessary for you to have available a source of direct current for the plate voltage, either in the form of a rectifier, or a motor-generator set. If you will let me know which form you prefer, I would be glad to send you a circuit diagram.

Please give capacity for a grid condenser for the Westinghouse WD-11 tube. A. E. B., San Diego, Calif.

A condenser of .00025 will work satisfactorily with the Westinghouse tube.

In constructing a single circuit with stationary tickler wound on the same tube, how much space should there be between the antenna inductance and the tickler windings? T. E., San Diego, Calif.

About one inch should be sufficient.

I have a receiver using two variometers and variocoupler, with detector and two stages of audio frequency amplification, but find that set howls just on point of tuning in a station. Can you advise me how I can remedy this?

R. V., Greenwich, Conn.

Try grounding the negative of the plate battery, and the cores of your inter-tube transformers. If this does not help, you may have to shield the back of the panel around the grid and plate variometers, as the howl may be caused by the tube oscillating when your hands are close to the tuned circuit.

Enclosed find diagram of the so-called Gibbons hook-up for a one-tube set. My question is "What is wrong with the enclosed hook-up?" J. R., Omaha, Neb.

If you are referring to the set described by Mr. Gibbons in August RADIO, it is not clear why you ask the above question. There is absolutely nothing wrong with the circuit, and the hundreds of letters we have received from satisfied users would indicate that Mr. Gibbons' scheme is O. K. If you have built the set and do not get results, I would advise you to read over his article again, for he describes it so that you should be able to construct the set without difficulty.

Please publish a circuit using a detector and four-stage amplifier, having a jack in each unit including detector.

R. A. M., San Francisco, Calif.

If you intend to build a four-stage audio frequency amplifier, I will say "Don't Do It," for, unless you understand the construction of amplifiers pretty thoroughly, you will get nothing but howls and squeals for your trouble. A scientifically designed four-stage audio frequency amplifier would require a 50-watt tube in the last stage, and possibly more, depending upon the amplitude of the signal. A circuit involving four stages of amplification, two radio and two audio, is shown in Fig. 2.

PANELS NOW IN STOCK SIZES

Fifteen, convenient stock sizes have been brought out by the makers of Radion panels. This is an addition of five stock sizes over the number they have been manufacturing for the past year. Developments in the radio industry have indicated that fifteen stock sizes fulfil almost every demand of the man who builds his own set, and greatly simplifies distribution by jobber and dealer alike. Beginning at the smallest panel, 6x7 inches, they appear in increasing lengths, such as 6x10½, 6x14, 6x21, 7x18, 7x24, 10x12 and

12x14. The smaller sizes are 3/16 inches thick, while the larger sizes, as 14x18 and 20x24, can be had in 3/16 and ¼-inch thickness.

Neither the dealer nor his customer now has the waste and trouble occasioned by sawing panels from large sheets. The exact or approximate size of Radion panel, individually enveloped to protect the highly polished surface, with full directions for sawing, drilling, etc., can be selected and sold over the counter to the buyer. Radion panels are regularly supplied in two colors, black and mahoganite, the latter being a beautiful imitation of genuine mahogany grain. The surfaces of both colored panels have beautiful satin-like polishes. An illustrated booklet may be obtained from the American Hard Rubber Company, 11 Mercer Street, New York City.

A READILY ADJUSTABLE GRID LEAK

The adjustable grid unit that has just been placed on the market by the Central Radio Laboratories of Milwaukee, Wisconsin, consists of an adjustable grid leak and a grid condenser, the latter being mounted between the outer ends of the grid leak binding posts. The high resistance of the leak can be gradually and smoothly changed to any desired value between ½ and 4 megohms merely by turning the operating knob. The point of maximum sensitiveness can be definitely and quickly ascertained. There is no guesswork about its location as there is likely to be in the case of leaks of the pencil-mark type.



Adjustable Grid Leak

Mounted on the bakelite base is a fabric strip, the ends of which are connected to the binding posts shown in the accompanying illustration. The fabric strip is impregnated with a high resistance compound of tested permanence. The current from the grid leak along this strip, the amount being regulated by adjusting the area of contact of the strip with a curved phosphor-bronze spring that is held in place by a compression block. The compression block is operated by the screw attached to the operating knob. As the knob is turned to compress the spring, a larger area of the spring comes into contact with the fabric strip and the resistance between the binding posts is decreased. More current leaks across and the potential of the grid is decreased. Turning the knob in the other direction decreases the area of contact between the spring and the strip, cuts down the current leakage and permits a higher potential between the grid and the plate. The potential that provided the maximum signal strength is thus obtained with ease and certainty.

The convenience of mounting a standard grid condenser on this adjustable grid leak is evident. The entire unit, which is mounted through a single hole in the panel, takes up a space of 2¾ inches long and ¾ of an inch wide—no more than is required for mounting the grid condenser alone.

LISTENING-IN

By C. V. BARTON, KFC D

"Hello— Hello—
 "Hello San Fran.—"
 There are noises whispering, mumbling,
 Rolling, tumbling
 In my ears;
 Whizzing, whanging,
 Rasping, clanging;
 Fourth dimensional tunes are banging—
 Strange, these fourth dimensional tunes;
 Now a stillness — — —
 "This is Calgary, hello!
 "This is Calgary—"
 What makes the static crackle so!
 "This is Calgary,
 "Are you listening, Idaho?
 "Got you fine, old man,
 "I heard you,
 "Coming in a little low
 "Boost her up a notch or so.
 "Come back! Come back!
 "I am listening,
 "Signing off now Idaho."
 Now a palpitating thrumming
 Of colossal insects humming—
 Better buy a "choke," that guy!
 "Sandy hair, blind left eye,
 "Water fronts he may apply—"
 DN4 is on again.
 "Dippy Blues, a foxy foxtrot—"
 No, not that.
 Lucky shot!
 I've got St. Louis,
 He is just announcing who is
 Violin soloist for tonight.
 There, that's perfect,
 Can you hear?
 Gets a fellow—Souvenir — — —
 What's that striking?
 Twelve o'clock?
 Hard luck for a Radio fan!
 Well, let's shut her off, old man.

BRANDES OPTIMISTIC

At the meeting of the district managers and sales department of C. Brandes, Inc., which was held in New York City, on Jan. 8th and 9th, it was the consensus of opinion that the outlook for radio for the coming year is very good. The following offices were represented: Boston, Chicago, Minneapolis, San Francisco, Pittsburgh, Huntington, Atlanta and Washington. With the exception of the West Coast, where broadcasting is not as far advanced as in other territories, the business for the past year has shown a very steady and healthy growth.

It is hoped that the exhibition which it is understood will be held by the American Radio Exposition Company at San Francisco in April will greatly improve the conditions there and that the establishment of further high-power broadcast stations during the coming year will build up the interest.

It was the general opinion of the meeting that the industry is rapidly becoming stabilized and that its mushroom period of growth which, parallels the mushroom growth of the automobile industry a few years ago, is practically over. This being the case, competition will of course be saner during the coming year than it has been in the past. This is a very welcome condition, as it shows that the public is rapidly becoming educated in radio to the point where it will select only products manufactured by reputable concerns.

Radio is building a secure foundation for itself, in the minds of the public for years to come. C. Brandes, Inc., feel perfectly safe in prophesying that the substantial elements of radio industry may look for a 15% increase in business during the year of 1923 over the year of 1922.—M. C. RYPINSKI, Vice President and Sales Mgr.

NEW APPARATUS & SUPPLIES FROM THE RADIO MANUFACTURERS

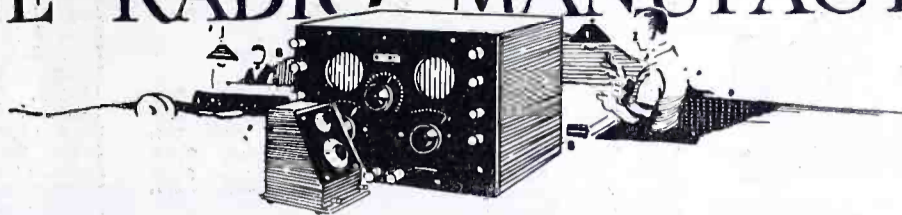

POST ELECTRIC SOLDERING IRON

A soldering iron which is operated in series with any standard electric bulb on an A. C. or D. C. circuit is on the market which is invaluable to the man constructing his own radio outfit at home.

Two tips are furnished with this soldering iron which is sold by the Post Electric Co. of New York City. The small tip is for fine work in soldering connections. The larger point, which is readily attached, is for soldering flat services. The iron would



Post Electric Soldering Iron

better be called of the instrument type since it is so quickly heated and so readily useable for all fine work, making it particularly adaptable for the man constructing his radio set.

NEW VICTORY LOUD SPEAKER

A marked contribution to the radio art is made by the Victory Radio-Electro Co. of San Francisco, in a recently developed combination of an amplifying and loud speaking unit which is now placed on the market under the trade name of Victory-Grantone.

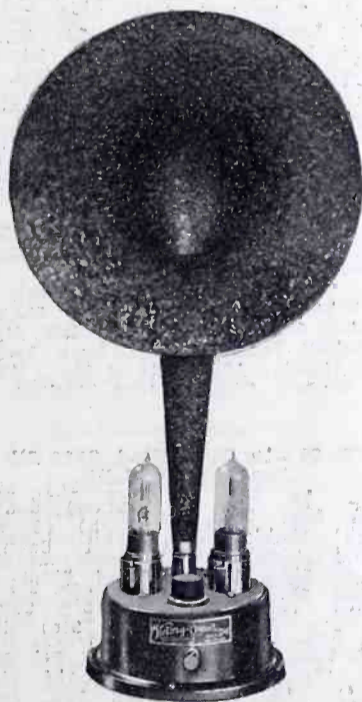

Victory Loud Speaker

The manufacturer has combined in a compact and attractive design the equivalent of two stages of audio frequency amplification with an efficient loud speaking element. The device is designed to operate from the simplest kind of crystal set to any type of vacuum tube detector with a volume ranging at the will of the operator from a mellow audible tone to volume enough to entertain several hundred people.

The aim in developing this device was to fill a great demand for an efficient loud speaking device that can be used with equal efficiency on a home-made \$5 crystal set or the most expensive vacuum tube-sets.

NEW CRYSTAL SET

The Ritter Radio Corp., 232 Canal St., New York City, is manufacturing on quantity production basis, a crystal outfit. It is compact, low-priced and efficient. All connections are so convenient and marked so clearly that no one can possibly make a mistake no matter how new a convert he is to the radio field. Remarkably good results are secured within a 25-mile radius of any broadcasting station sending up to 600 meters. A good idea can be had from the illustrations.

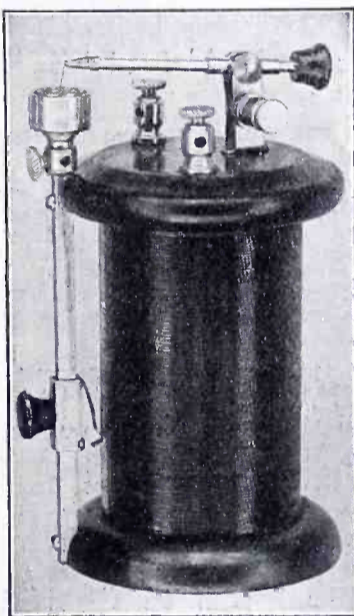

Ritter New Crystal Set

NEW RADIO CATALOGS

The Vesco Radio Shop of Vacaville, Calif., is distributing a treatise on the Phantom Circuit Receiver which employs no aerial or ground. Brief description is given of the construction, operation and results obtained with this set. Included also is an account of the Ves-Co ordinator and of 1, 2 and 3-stage amplifier units.

The Connecticut Instrument Co. of Stamford, Conn., has issued an interesting booklet on "Acoustics of the Telephone." This explains in clear and simple manner the nature of sound in relation to radio telephone reception and how sound engineering principles have been applied in the design and construction of C. I. C. head-sets.

The Automatic Electrical Devices Company, 120 West Third Street, Cincinnati, Ohio, manufacturers of the Homcharger, has recently issued a revised Instruction Book, which will prove quite valuable to any radio fan. This booklet, besides containing the simple directions for operating the Homcharger, contains a paragraph devoted entirely to storage battery maintenance. The novel feature of the Instruction Book is its incorporation of a complete list of all the radio broadcasting stations in the United States, Canada and Cuba. Copies may be secured for 10c to cover cost of postage.

MOUNTED 3-CIRCUIT TUNER

The New York Coil Company of New York City has added to their already extensive line of radio devices, an extremely compact and highly efficient tuner, consisting of one of their standard large variometers,

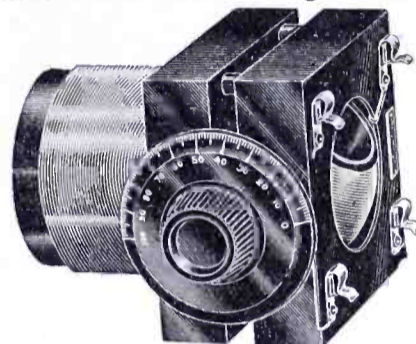

Mounted 3-Circuit Tuner

on one side of which is mounted concentric with the rotor a bakelite tube or primary winding. The winding in the stator of the variometer serves as the secondary. The rotor contains the third winding.

All three circuits have separate connections brought out and they advise that this combination tunes extremely sharp. The selectivity is claimed to be exceptionally good.

RADIO TRADE NOTES

C. Brandes, Inc., has recently appointed Mr. C. E. Brigham as research and designing engineer. Mr. Brigham has taken the course of radio at Harvard. He also took the course in telephony at the Naval School, at in George Washington University in electrical engineering. For two years Mr. Brigham was chief instructor in radio at the National Radio Institute at Washington, D. C. During the war he served for two years in the U. S. Navy Radio Service, and was then transferred to the radio testing laboratories of the U. S. Navy, and put in charge of testing and inspecting all types of radio receiving equipment. For the last two years he was engaged in the radio testing laboratories as designing engineer on amplifiers, receivers and radio and audio frequency oscillators. He has also done considerable research work on high speed reception.

General Insulate Company, No. 1008 to 1024 Atlantic Ave., Brooklyn, N. Y., the well-known moulders of "Insulate" and also of "Hi-Heet" parts for the radio and electrical trades, as well as for a score or more of the mechanical trades, report for the year just passed their volume of business has increased more than 100% over 1921, 1922 being the second largest year in volume of sales and net results since the General Insulate Company was established nearly 20 years ago. In addition to the well-known products of "Insulate" (black shellac composition) and "Hi-Heet" phenol composition, General Insulate Company has shown for the first time at the Radio Show which has just closed in New York, an entirely new product—"Star Insulate"—a material that has great mechanical and dielectric strength—resiliency—can be moulded to almost any shape, either thick or thin, and any color—opaque or translucent.

CALLS HEARD



Readers are invited to send in lists of calls heard from stations distant 250 miles or more from their own station

By 6ZY, 242 Kaulani Ave., Honolulu.
 1adl, 1bkg, 1drg, 1awb, 1baw, 1bas, 2xap, 2el, 2ars, 2fp, 2fm, 2fg, 2nz, 2cmo, 2ayv, 2afp, 3zg, 3cm, 3bz, 3bgs, 3bp, 3ho, 3pa, 3apa, 3bvl, 3bj, 4bv, 4im, 4iz, 4ya, 4ea, 4ck, 5xd, 5my, 5acf, 5zak, 5vo, 5aec, 5hz, 5ft, 5nk, 5uh, 5qi, 5ue, 5ix, 5gr, 5gi, 5hk, 5zas, 5ae, 5za, 5cn, 5xj, 5nz, 5zae, 5ek, 5nd, 5zh, 5be, 5sf, 5zb, 5zaf, 5ek, 6anh, 6bum, 6aso, 6acv, 6gx, 6nx, 6ak, 6aat, 6bel, 6ff, 6ti, 6cc, 6bak, 6bu, 6ka, 6zz, 6biq, 6bjy, 6ptu, 6beq, 6zh, 6bqf, 6zt, 6bob, 6bun, 6can, 6bjh, 6apw, 6bqg, 6bvw, 6bic, 6auy, 6gw, 6cu, 6bmy, 6aoi, 6rm, 6bqj, 6xl, 6ek, 6zn, 6akl, 6bip, 6ang, 6awt, 6bju, 6xxa, 6bnt, 6br, 6bjr, 6bpz, 6zaf, 6apz, 7zu, 7tq, 7aem, 7nn, 7sc, 7na, 7nm, 7mf, 7rr, 7gq, 7bj, 8axc, 8yd, 8sb, 8fa, 8aea, 8cxw, 8bxa, 8pd, 8bde, 8zae, 8bfm, 8ow, 8asv, 8alf, 8qk, 8ml, 8zy, 8ciz, 8byo, 8ii, 8ald, 8ib, 8csp, 8xe, 8boq, 8bx, 8anb, 8cur, 8zz, 8rv, 8ol, 8cf, 8chu, 8cu, 8byo, 8bur, 8brc, 8aqo, 8fm, 8apy, 8wr, 8zaa, 8zy, 9cy, 9aul, 9at, 9aau, 9ar, 9yw, 9al, 9dww, 9dyg, 9ami, 9am, 9djb, 9vk, 9cba, 9aps, 9bzi, 9bap, 9zn, 9uc, 9gk, 9bkw, 9apw, 9bvy, 9bik, 9rc, 9ox, 9byn, 9yah, 9dtm, 9qk, 9cpw, 9dcr, 9rcq, 9bji, 9cr, 9ah, 9xac, 9ahj, 9ctg, 9bri, 9cwc, 9uh, 9vm, 9ccv, 9cz, 9dbl, 9dge, 9bzi, 9dio, 9cp, 9uc, 9bik, 9anq, 9bp, 9edb, ad7, nof, bq3.

By 6AOR, 2319 Ashby Ave., Berkeley, Calif.
 C. W.: 1agh, 1ajz, 1ayz, 1bas, 1bes, 1bdi, 1byn, 1ccz, 1cja, 1cmk, 1xm, 2gr, 2fp, 2nz, 2bf, 2byc, 3fs, 3jk, 3od, 4en, 4ft, 4gh, 4nt, 4oi Cuba, 4pa, 4vk, (5cn), 5di, 5ek, 5kc, 5px, 5tk, 5uo, 5vv, 5xv, 5za, 5zo, 5zae, 5zak; 6 stns too numerous; 6zac, 6zz, 6zo, (6zx), 6boc, (7ba), (7bj), (7dc), 7dp, 7hs, 7cu, 7lr, (7lu), 7mf, 7mc, (7na), 7nf, 7nn, 7ny, 7pb, (7sc), 7af, (7to), (7tq), 7tt, 7ud, 7adf, 7adm, 7adp, (7aea), (7aem), (7afw), 7agu, 7ahi, (7aic), 8ib, 8kg, 8nn, 8uk, 8vd, 8ahr, 8aem, 8aim, 8ago, 8asu, 8awp, 8bcy, 8bxx, 8bef, 8bxx, 8bpl, 8bss, 8cpx, 8erb, 8cpx, 8zg, 8zu, 8zz, 9ao, 9bx, 9dg, 9dr, 9ei, 9fu, 9io, 9ip, 9lz, 9mf, 9ox, 9pw, 9wp, 9uu, 9yf, 9aap, 9afk, 9aig, 9aiy, 9aja, 9amin, 9amb, 9anq, 9aog, 9aon, 9aph, 9aps, 9aq, 9apy, 9arz, 9arr, 9aun, 9aul, 9axv, 9awm, 9awl, 9bch, 9bct, 9bbf, 9bnd, 9bgh, 9bji, 9bju, 9bjk, 9bly, 9bno, 9bri, 9brk, 9bud, 9bxa, 9bxx, 9bxt, 9bve, 9bzz, 9caa, 9cci, 9ccu, 9cfy, 9cfi, 9cgh, 9cln, 9cjk, 9cny, 9cns, 9cxp, 9xab, 9ym, 9yl, 9cln, 9enn, 9cns, 9exp, 9ym, 9yl, 9dnc, 9dpl, 9dsd, 9dtm, 9bzi, 9dyn, 9dym, 9dxn, 9buo, 9dzb, wsy, wjz, fu, poz.
 Will all stations hearing 6aor C. W. pse qsl card.

By B. Overstreet, U. S. S. "Canopus," Colon, Republic De Panama.
 C. W.: 1dq, 1fb, 1xm, 1adl, 1adp, 1aja, 1ajp, 1alz, 1awf, 1bdt, 1bes, 1bet, 1bka, 1bkq, 1ccz, 2el, 2fp, 2fq, 2fu, 2gi, 2gk, 2kl, 2lo, 2om, 2nz, 2zk, 2zl, 2zs, 2aho, 2awf, 2awl, 2ayv, 2azc, 2brb, 2brc, 2cbw, 2cbx, 2ccd, 2cgg, 2cim, 2ckr, 2cql, 2cqz, 2xao, 2xap, 3bg, 3co, 3dh, 3hg, 3jh, 3jj, 3jt, 3xm, 3zh, 3zv, 3zz, 3aby, 3afb, 3aqr, 3auu, 3blu, 3bgt, 3bmn, 3bob, 3btk, 3bvl, 4aq, 4bx, 4dl, 4eb, 4eh, 4ft, 4hk, 4iz, 4km, 4nk, 4op, 5da, 5ek, 5fu, 5mt, 5px, 5sk, 5sm, 5tt, 5xb, 5xa, 5za, 5zav, 6da, 6zi, 6any, 7bh, 7qv, 8ab, 8pd, 8cv, 8cy, 8fg, 8fu, 8hj, 8ig, 8kg, 8ml, 8mz, 8rd, 8qk, 8ue, 8vq, 8xe, 8yd, 8zy, 8za, 8aaf, 8adg, 8agz, 8ayc, 8azq, 8bda, 8bde, 8bdu, 8beo, 8bno, 8boz, 8brk, 8brk, 8bsy, 8bvr, 8bxx, 8cbb, 8cko, 8cql, 8cva, 8czz, 9al, 9ei, 9ej, 9ep, 9ii, 9km, 9uc, 9uu, 9xl, 9zn, 9agc, 9aix, 9ami, 9aou, 9aps, 9ase, 9bbf, 9bed, 9bie, 9cyw, 9djb, 9dky, 9dsm, 9dww, 9xac, 9yaj, 9zac; Canadian C. W.: 3bv, 3dh, 3jh, 3ot, 4aq, 9al; I. C. W.: 2fp, 9zn; spark: 4by; fones: 2el, 5za.

By 6AHP, Pomona, Calif.
 C. W.: 3cq, 3blf, 4bv, 4cn, 4dq, 4va, 5cn, 5cy, 5di, 5ek, 5fv, 5gi, 5is, 5il, 5js, 5kp, 5mt, 5nb, 5nk, 5nx, 5px, 5qy, 5sf, 5sk, 5tc, 5tj, 5uk, 5cc, 5xd, 5xb, 5xqv, 5za, 5zh, (ex5if), 5zai, 5zav, 5zac, (sixes omitted); 7bb, 7bk, 7bj, 7cz, 7dp, 7eq, 7ez, 7fd, 7iw, 7lr, 7lu, 7mf, 7ny, 7od, 7sc, 7th, 7tq, 7ud, 7uu, 7wm, 7ab, 7afw, 7aic, 7xc, 7xl, 7zb, 7zo, 7zv, 8aa, 8ab, 8bk, 8cf, 8da, 8dr, 8ft, 8ib, 8ml, 8qk, 8qk, 8sq, 8sp, 8uk, 8uz, 8uv, 8uy, 8aaf, 8ago, 8aih, 8alm, 8apw, 8any, 8aqo, 8asv, 8awm, 8axc, 8azd, 8azq, 8bfm 8cgp, 8btu, 8bwa, 8bxa, 8byo, 8ciz, 8cko, 8cox, 8cyv, 8xr (or 8xae), 8xj, 8yd, 9bm, 9cp, 9dp, 9qk, 9hk, 9ig, 9pf, 9uu, 9aap, 9abu, 9ahc, 9ajh, 9aip, 9aix, 9amb, 9anq, 9aog, 9aps, 9atz, 9asc, 9asf, 9asu, 9atn, 9aul, 9awm, 9ayu, 9bds, 9bed, 9bfg, 9bfm, 9bik, 9brk,

9bsg, 9bvo, 9bxa, 9bji, 9bjv, 9bxt, 9bxq, 9bzi, 9cde, 9ccu, 9cns, 9dcu, 9dfb, 9dge, 9dkm, 9dkq, 9dtm, 9dte, 9xq, 9xu voice, 9xv voice, 9xac, 9xaq, 9yaj, 9zn; wkd. with 5 watt C.W.: 7bb, 7dp, 7tq, 9dtm, 7fd, 7jw.
 Spark: 7oh, bq3, 7pj, 7kj, 7gq, 7oj, 7abs, 7ve, 9dag?; wkd. with spk.: 7eq, 7th, 7tq, 7aca, 7lw, 6apl, 6zz, 1kw, spk. and 50 watt C. W. lu nw.

By 6BDZ, 831 1/2 N. Heliotrope Dr., Los Angeles, Calif.
 C. W.: 3fn, 4eb, 5cn, 5ek, 5kc, 5ns, 5xa, 5za, 5zb, 5zak, 6's too numerous, 7ba, 7bj, 7lr, 7mc, 7mf, 7na, 7ny, 7om, 7sf, 7sy, 7tq, 7zo, 7zu, 7adf, 8bk, 8ml, 8yd, 8aim, 8awz, 8azd, 8bxh, 9bx, 9fi, 9gk, 9ox, 9rc, 9yw, 9aap, 9aul, 9aza, 9bey, 9bji, 9bjy, 9bly, 9bmr, 9bsg, 9ccv, 9cfy, 9ciz, 9yaj, 9zaa.

By 6ASB, Brea, Calif.
 5zav, 5kc, 5za, 5xd, 5uj, 6bke, 6ku, 6bck, 6acm, 6aih, 6bjy, 6za, 6zh, 6atq, 6cc, 7om, 7dp, 7zu, 7sf, 7zo, 7ny, 7na, 7sc, 7aem, 7zb, 7bj, 7mf, 7br, 7ya, 7nf, 8yd, 8ib, 8aio, 8sp, 8xae, 8zy, 8cf, 8bxh, 8zaf, 8ue, 9bxq, 9yaj, 9ccv, 9cr, 9bzi, 9al, 9dte, 9bik, 9xaq, 9cns, 9ei, 9pi, 9ps, 9bji, 9bbf, 9dww, 9aul, 9ox, 9cfy, 9cmk, 9dtm, 9asf, 9ayu, 9bjv, 9pn, 9dhi, 9aiy, 9rc, 9bsq.
 Music, etc.: kfau, kzd, kzn, kzm, kfaf, kbpt, kdyl, kdd, kfad, kdw, klz, kre, kdym, kuo, kzyf, kfef, kfay.

By 6AJ, Piedmont, Calif., with set described in February RADIO
 4eh, 5ado, 5uj, 5za, 6ael, 6ak, 6amz, 6apw, 6arb, 6atu, 6aun, 6auu, 6bap, 6bcj, 6bel, 6bdf, 6bet, 6bew, 6bfy, 6bip, 6biq, 6bjj, 6bjr, 6bjy, 6bkg, 6boe, 6bow, 6bpil, 6bql, 6brf, 6brm, 6bru, 6bun, 6buu, 6buu, 6bv, 6caj, 6can, 6cbi, 6ek, 6gd, 6jn, 6oh, 6om, 6re, 6te, 6uw, 6xas, 6xx, 6za, 6ze, 6zh, 6zo, 6zt, 6zz, 7adp, 7aft, 7bj, 7hs, 7lr, 7mc, 7mf, 7nm, 7ny, 7om, 7pd, 7sy, 7th, 7bq, 8afd, 8bch, 8fu, 8zy, 9ami, 9ar, 9bji, 9bjv, 9bri, 9bx, 9bxa, 9bzi, 9cns, 9dai, 9lz, 9ox, 9pu, 9yaq.
 All the above heard before 9 P.M., P.S.T., on antenna 30 ft. high, 2 wires 85 ft. long, water pipe ground, one tube.

By 6BNT, 225 Willard St., San Francisco, Calif.
 5za, 5uj, 6ak, (6bz), 6cc, 6ec, 6en, 6ff, 6fh, 6gf, 6ii, (6ku), 6lx, 6ny, (6ok), 6om, 6pi, 6rm, 6tc, 6uw, 6zh, 6zn, 6zo, 6zr, 6zx, 6zz, 6zb, 6abx, 6aeh, 6agp, 6ahq, 6ajg, (6alu), 6aoi, 6aqa, 6ac, 6atq, 6avn, 6avr, 6xad, (6xas), 6bcj, 6bec, 6bet, (6bjj), (6bjq), 6bko, (6bmd), (6bnv), (6bod), (6boe), (6bqb), (6bqe), (6bqf), 6bqh, (6brf), 6bun, 7bj, 7fg, 7ku, 7ly, 7mf, 7ns, 7ny, 7pf, 7sc, 7tq, 7zn, 9pi, 9aul, 9bji.

By 6TI, 414 Fairmount Ave., Oakland, Calif.
 C.W.—1bkq, (1bnl), 4cm, 4oi, 4ot, 4vv, 5cq, 5lo, 5ta, 5uj, (5za), 5zb, 5zak, (6cu), (6rr), (6bf), (6biq), (6bj), (6bnh), (6brs), (6bvg), (6cbk), (7bs), 7gq, 7ke, 7lw, (7mf), 7mc, (7na), (7om), (7sy), (7wx), (7zu), (7adm), (7agi), (7aic), 8bc, 8bo, 8cn, 8cp, 8yn, (8adz), 8avt, 8caa, 8cve, 9kp, 9ps, 9uu, 9yw, (9aap), 9abv, 9aey, 9afo, 9ans, 9asf, 9atn, (9aog), 9aza, 9bbf, 9bb, 9bie, 9bik, 9bkk, 9bqw, (9bri), 9buy—voice, (9bxm), (9ccv), (9cip), 9cfy, (9cns), 9dio, 9dky, 9dlm, 9dng, 9dsd, 9dww, 9xac Can., (5cn), 5ct, 5go, 9bj, 9bx, 6ti. 50-watt C. W. was hrd off coast of Australia. Anyone hearing my C. W. pse. QSL card.

By 8AKI 1432 12th Ave, Altoona, Pa. (Honeycomb Coils—UV-200 detector—Baldwin fones only—No amplifiers.)
 C. W.: 1ap, 1cw, 1fx, 1gv, 1ho, 1ii, 1jj, 1ma, 1my, 1pm, 1rd, 1uj, 1wf, 1xm, 1xu, 1adl, 1ahz, 1ajl, 1asu, 1alz, 1amu, 1anr, 1aol, 1anz, 1bdi, 1ber, 1bhp, 1bqe, 1bv, 1erd, 1cik, 1cmp, 1cwr, 2aw, 2ek, 2el, 2fc, 2fw and others too numerous, 3ab, 3al, 3bz, 3cg, 3cm, 3de, 3fs, 3hg, 3ho, 3ia, 3jj, 3kj, 3kl, 3mo, 3nh, 3of, 3ot, 3sv, 3ta, 3tj, 3tr, 3vw, 3xm, 3ya, 3zh, 3zo, 3auu, 3abw, 3aji, 3akb, 3aqh, 3asi, 3auu, 3axw, 3bdi, 3bhm, 3bho, 3bjr, 3bkl, 3blf, 3blz, 3bof, 3bms, 3bvc, 3bvl, 3cel, 4as, 4bk, 4by, 4cg, 4cy, 4dx, 4ea, 4eb, 4el, 4ia, 4hm, 4jk, 4kc, 4lp, 4ya, 5ek, 5es, 5ig, 5js, 5sm, 5uk, 5xa, 5za, 5za, 5zav, 6xad, 8's too numerous, 9bp, 9cu, 9gk, 9km, 9ko, 9ox, 9pc, 9pf, 9rc, 9wc, 9vk, 9xu, 9ym, 9aap, 9afd, 9ami, 9amu, 9aps, 9arz, 9ase, 9atc, 9aud, 9awf, 9aws, 9aza, 9bak, 9bdb, 9bds, 9bed, 9brk, 9byn, 9ciz, 9cur, 9cya, 9ddy, 9dky, 9dqu, 9dww, 9dyu, 9dzu, wuba, nof, Can. 9nz.
 Spark: 1cix, 2fp, 2om, 3vm, 3bsb, 8byo, 8coa.

By 601 6th St., Petaluma, Calif.
 5acf, 5cn, 5qa, 5zh, 6bq, 6bz, 6rm, 6bf, 6blf, 6bgs, 6bob, 6biq, 6bgh, 6bnt, 6zx, 6boe, 6aag, 6acb, 6bbh, 6xh, 6bqf, 6su, 6bjj, 6xy, 7bj, 7eo, 7adf, 7qe, 7ly, 7ri, 7bk, 7hm, 7qn, (7tq), 7oo, 7ly, 7qf, 7aii, 7bj, 7hm, 7mw, 7ahi, 7afw, 7agu, 7kj, 7hlv, 7pf, 7afw, 7aic, 7vd, 7aca, 7to, 7mc, 8dat, 8ib, 8bwa, 8bcy, 8bhy, 8sf, 8fu, 8bch, 9cc, 9uu, 9bie, 9bji, 9cfy, 9dhi, 9bzi, 9pn, 9dms, 9caa, 9dtj, 9avs, 9cfy, 9dqm, 9abu, 9fu, 9dcr, 9xag, 9fm, 9yw, 9dlm, 9bzi. Have been heard by 7tq, Medford, Ore., 6bob, Placentia, Calif.; Midson, Wash.; Seaside, Ore.; San Diego, Calif., and Tucson, Ariz., with only 5 watts C. W. Who has done better with same power? Anyone hearing 6bmx's 5-watt d.c. C. W. pse qsl.

By 7SC, P.O. Box 511 Aberdeen, Wash.
 C. W.: 1azw, 1xm, 1xu, 2awl, 2bea, 2bgm, 2de, 2fj, 2fp, 2ot, 2zk, 3adp, 3adt, 3blf, 3bv, 3hg, 4cg, 4dh, 4ea, (4eb), 4eh, 4fj, 4kk, 4oi, 4ya, 4yo, 5aby, 5acf, 5aec, 5be, (5di), 5ek, 5fv, 5fz, 5hb, 5hc, 5ir, 5kc, 5lo, 5mo, 5mt, 5mx, 5nk, (5nn), 5nv, 5px, 5qi, 5qy, 5rh, 5rn, 5sf, 5sg, 5sh, 5ak, 5sm, 5ss, 5tc, 5tj, 5tm, 5uj, 5uk, 5uo, 5vy, 5xa, 5xad, 5xaj, 5xk, 5xv, 5xu, 5za, 5zg, 5zah, 5zak, 5zar, 5zas, 5zav, 5zaw, 5zaw, 6aat, (6abx), 6ada, 6agp, 6agu, (6ahq), (6ajf), (6ajr), 6ak, 6akl, 6alv, 6ame, 6amb, (6amz), (6ang), 6anh, 6anp, 6aoi, 6aor, 6apw, 6arf, (6ark), (6asj), 6asy, 6atc, 6atg, 6atj, 6atq, 6atu, 6atx, 6aun, 6auu, 6auy, 6av, (6avd), 6avn, (6avr), 6avv, 6avw, 6awp, (6awt), 6bbh, 6bcd, 6bcj, 6bel, 6bcn, 6bcq, (6ber), 6bdw, 6beg, 6beq, 6bes, 6bet, 6bf, 6bfp, (6bh), 6bic, 6bin, 6biq, 6bj, 6bjq, 6bjr, 6bjy, (6bko), 6bkk, 6blu, 6bm, 6bmd, 6bmn, 6bmx, 6bnt, (6bnu), 6bob, (6bod), 6boo, 6bow, 6bnv, 6bpz, (6bqb), (6bqc), 6bqd, 6bqf, 6bqg, 6bql, (6bqq), 6bqz, 6brf, 6brg, 6brp, 6bru, (6bsa), (6bsj), (6bth), 6bum, 6bun, (6bvq), 6bvw, 6cai, 6ebd, 6cbi, (6cc), 6cp, (6cu), (6dd), (6ea), 6eb, (6ec), 6ek, (6en), 6eo, (6fh), 6gd, 6gf, 6gr, 6gx, 6gy, (6hp), (6if), 6ii, 6iv, (6jd), 6ka, 6ku, 6lo, (6lu), (6lv), 6nh, 6ni, 6nn, 6nx, 6ob, (6pi), 6rm, 6rr, (6sc), 6su, (6sz), (6tc), (6ti), 6tj, 6uw, 6vf, 6vm, (6xk), 6wx, 6za, (6zac), 6ze, 6zg, 6zi, 6zn, 6zo, 6zr, 6zt, 6zx, 6zz, 7aad, (7abb), (7abs), 7aby, 7aca, 7acg, (7acx), (7ad), (7adg), (7adp), 7adq, (7aem), (7afh), (7aft), 7afw, (7agf), (7agv), 7agx, 7agy, 7ahi, 7ahw, 7aic, 7aii, 7ais, (7aim), 7aje, 7ba, (7bj), (7bk), 7c, (7dp), 7du, 7eb, 7en, 7ex, (7ey), 7fd, (7gp), 7ha, (7hj), 7bm, 7iy, 7jg, 7jw, 7ke, 7lr, (7lu), 7lw, 7ly, (7mf), 7na, 7ny, 7oe, 7oo, 7pf, 7qd, 7qf, (7qt), (7ri), 7rn, 7rq, 7sy, (7th), 7to, (7tq), (7tt), 7ud, 7wk, (7wm), (7wx), (7zb), 7zo, (8ab), 8ac, 8ad, 8af, 8ag, 8af, 8ago, 8aio, 8amm, 8anb, 8apw, 8aqo, 8asv, 8atu, 8awp, 8axb, 8axc, 8azd, 8azf, (8azq), 8bce, 8bde, 8bdu, 8bef, 8bfm, 8bfv, 8bho, 8bil, 8bk, 8bke, 8blc, 8bnj, 8boz, 8brk, 8brq, 8bsy, 8buh, 8bvr, 8bwa, 8bxf, 8bxh, 8bzy, 8caa, 8cf, 8cgp, 8cgv, 8cho, 8ciz, 8ckm, 8cko, 8cmi, 8cpg, 8cpm, 8cpx, 8cur, 8cv, 8eva, 8cwr, 8czt, 8dat, 8de, 8er, 8fg, 8ft, 8fu, 8ib, 8ij, 8iq, 8ju, 8kg, 8lt, 8mz, 8ow, 8qk, 8rt, 8rn, 8sg, 8sb, 8sp, 8sz, 8ue, 8pa, 8pd, 8uk, 8uz, 8vq, 8vy, 8xae, 8xe, 8yd, 8yn, 8zy, 8zz, 9aw, 9aap, (9abu) 9ae, (9aey), 9afk, 9ahh, 9ahi, 9ajh, 9ajs, 9alr, 9amb, 9ami, 9amq, 9anf, 9anq, 9aob, 9aod, (9aog), 9aou, 9ap, 9api, 9aps, 9apw, 9aq, 9ark, 9arz, 9asf, 9asj, 9asn, 9atn, (9aul), 9ave, (9avz), (9awm), 9aws, 9axu, 9ayu, 9aza, 9abz, 9bbf, 9bch, 9bcf, 9bds, (9bed), 9bey, 9bgh, 9bhd, 9bhq, 9bie, 9bik, 9bji, 9bjv, (9bkj), 9bkk, 9bkq, 9bly, 9bm, 9bog, 9bri, 9brk, (9bss), 9bst, 9bto, 9bt, 9buw, 9bvl, 9bvy, 9bxa, 9bxq, 9bxt, 9bz, (9bzi), 9bnz, 9bzz, (9cba), 9ccs, 9ccv, 9cde, 9cdr, 9cfi, 9cfy, 9cgv, 9cip, 9ciy, 9cjj, 9cln, 9cmk, 9cns, (9ctr), 9cr, 9cuc, 9cul, 9cxc, 9cxp, 9cdf, 9dcr, 9dge, 9dky, 9dma, 9dmj, 9dnd, 9dqm, 9dqu, (9dr), 9dsd, 9dsm, (9dta), 9dte, (9dug), 9dui, 9dww, 9dxn, 9dyu, 9dze, 9dzq, 9dzw, (9ebt), 9ecz, 9ei, 9ex, 9fk, 9fm, (9gk), 9gl, 9hi, 9hm, 9ig, 9ii, 9ep, 9ja, 9km, 9kr, 9lc, 9lq, 9lr, 9lz, 9mm, 9nu, 9ox, 9pi, (9ps), 9pw, 9qf, (9rc), (9uc), 9us, 9uu, 9pn, 9xac, 9xaq, 9xl, 9yaj, 9yw, 9zaa, 9zaf, (9zn), 9zt, 9zx, (bt3), bq3, ad7.
 Canadian C. W.: 3at, 3bp, 3co, 3ko, 3xn, 4ab, 4bv, 4dq, 4hh, 5ac, (5bq), (5cn), 5ct, (5go), 9ac, 9aj, 9al.
 Spark: 5yg, (6abu), (6abv), (6aca), (6ahp), (6aje), 6akt, (6alv), 6amk, 6apd, 6agu, 6bdu, 6bip, 6blm, 6bpw, 6ic, (6km), 6ot, 6tu, 7aaz, 7abh, (7abs), 7afo, (7aio), (7ry), 7wq, 9aau, Canadian (9ax). 100 watts at 7sc. Would appreciate reports from eastern stations hearing 7sc.

By 6CU, Charles F. Filstead, 2010 6th Ave., Los Angeles, Calif.
 C. W.: 1x, 5hk, 5ir, 5px, 5qy, 5tj, 5xd, 5za, 5zak, 5zav, 5zh, 5zy, (6abx), 6ada, 6adf, 6ajr, (6ak), (6akl), 6amz, (6anh), (6aoi), 6aor, 6arb, 6asj, (6asx), 6atq, 6aub, 6auu, 6awt, 6bbh, 6ber, 6bju, (6bjy), 6bmd, 6bnu, (6bnv), 6bnw, 6boe, 6bow, 6bqf, 6bql, 6bsa, 6cb, (6cc), 6dd, (6fh), (6gx), 6gy, 6ii, 6iv, 6km, 6ku, 6lo, 6lv, 6nx, 6ok, 6rk, 6rm, (6tc), 6ti, 6tw, 6vm, 6xb fone, 6zac, 6zb, (6zh), 6zi, 6zo, 6zt, 6zx, 6zz, (7aem), 7aiy, (7bb), 7bj, 7bk, 7fd, 7fr, (7lj), 7jw, (7lr), 7mf, 7na, 7ny, 7r, 7qn, (7sc), 7sy, 7th, 7tq, 7ud, 7zo, 7zu, 8aqo, 8aqq, 8atc, 8cur, 8cyv, 8ju, 8qk, 8ue, 8vy, 8xj, 8zw, (8zy), 9ajp, 9amb, 9arz, 9aul, 9avz, (9awm), 9ayu, 9bey, 9bhd, 9bik, 9bji, (9bm), 9bpy, 9bsi, 9bzi, 9caa, 9ccv, 9cmk, 9cns, 9dfb, 9dky, 9dte, 9dtm, 9dxa, 9ei, 9gk, 9pi, 9xaq, 9yaj, 9yw, 9zaf, 9zn, mbppk, Can. 4bv, 5cn, 9ac, 9al.
 Spark: 6aoo, 6aqu, 6bak, 6kc, 6km, 6qr, 6tu. These were heard on detector alone and worked on ten watts during Nov. and Dec. 1922.

By Scott Hill, 1513 E. Morrison St., Portland, Ore.
 C. W.: 5za, 6abx, 6acg, 6ajr, 6alv, 6arb, 6ard, 6avd, 6bcl, 6bfg, 6bic, 6biq, 6bob, 6bow, 6bun, 6bwq, 6cc, 6ek, 6en, 6er, 6gr, 6ka, 6ku, 6oh, 6rm, 6vm, 6zh, 6zo, 6zx, 7bk, 7mf, 7ri, 7sc, 7zo, 7zu, 8azd, 8bk, 9bkk.
 Spark: 6tu.
 Phone: kfay, kfc, kfef, kuo, kzn, kzm.
 Continued on page 44

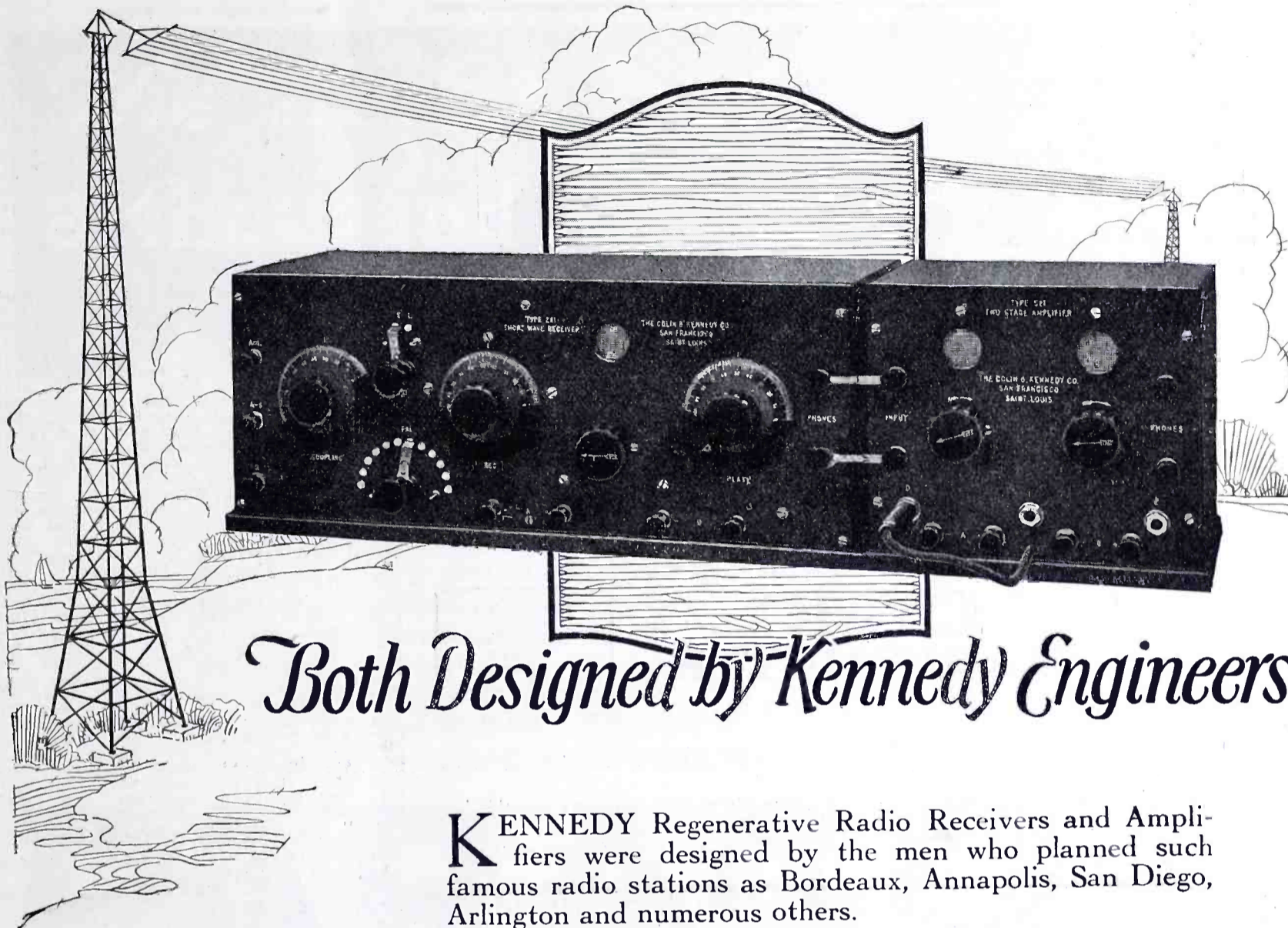

Both Designed by Kennedy Engineers

KENNEDY Regenerative Radio Receivers and Amplifiers were designed by the men who planned such famous radio stations as Bordeaux, Annapolis, San Diego, Arlington and numerous others.

The combined genius of these radio engineers was concentrated on the problem of creating the finest radio receiving sets and amplifiers possible to produce for general use.

They incorporated in every Kennedy receiver the principle of variable inductively coupled circuits, the best method known to insure a high degree of selectivity and freedom from interference.

They designed every element in the assembly—the inductances, variometer, vario-coupler, condensers, etc.—not only in accordance with the most advanced developments, but also to perfectly harmonize in operation. This feature of “balanced design” in Kennedy sets makes for closer tuning, absence of extraneous noises, and assures satisfactory reception.

Three Types

There are three types of Kennedy Receiving Sets. *First*, Type 281 (shown above) specially designed for broadcasting wave lengths. *Second*, the Intermediate, for wave lengths of 200 to 3,200 meters. *Third*, the Universal, an all-wave set.

Write for descriptive literature and prices

THE COLIN B. KENNEDY COMPANY

SAN FRANCISCO

SAINT LOUIS

KENNEDY

KENNEDY
EQUIPMENT

Tell them that you saw it in RADIO

Continued from page 42

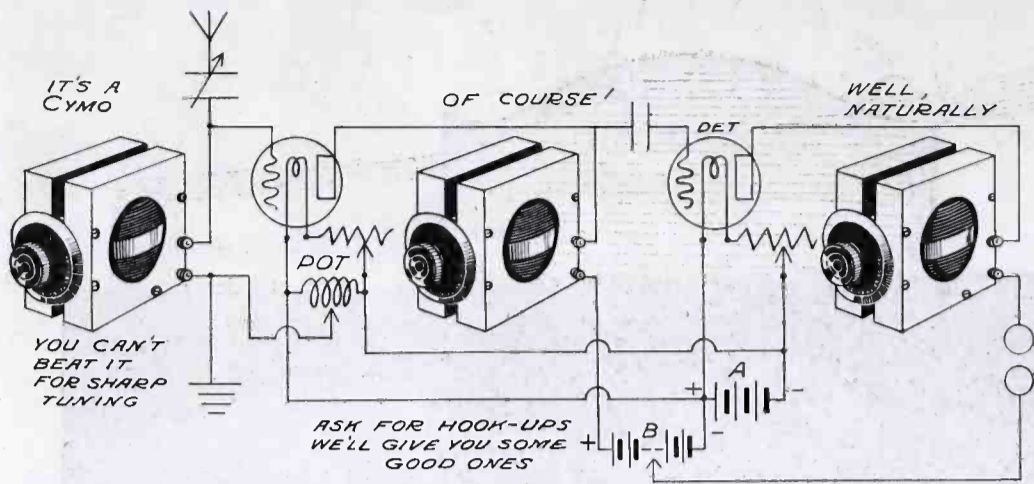

THE STRONGEST LINK IN THE CHAIN OF PARTS IN ANY SET IS YOUR

CYMO VARIOMETER

Every Day They Got Better and Better—Now They're the Best. You'll Say So.

They're Not Molded. That's Why They're Better.

BECAUSE—CYMO has the smallest value of distributed capacity; one-third of that of any molded variometer.
 BECAUSE—CYMO is correctly wound to secure the right proportion of turns between stator and rotor.
 BECAUSE—CYMO has greater wave range; from 150 to 650 meters. For amateurs this is a great advantage, as molded variometers will not go below 200 meters.
 BECAUSE—CYMO perfected design, rugged construction and careful workmanship give greatest efficiency.
 BECAUSE—CYMO at \$5.00 is the best money value on the market. You can't get a better variometer at any price.

Cymo Is Built, Not Assembled

The Part You'll Keep for Your New Set—The Part You Should Order When You Try

RADIO FREQUENCY

If your dealer hasn't got it—order direct, C. O. D., Post Paid. *The price is Five Dollars.* We Build 'em—You Buy 'em. Then we'll BOTH Be Happy. Get the Point

Radio Devices Company

JOBBERS—
Get on the Job

693 MISSION STREET
SAN FRANCISCO
CALIFORNIA

DEALERS—
Don't Delay.
Your Competitor
Will Beat You to It.

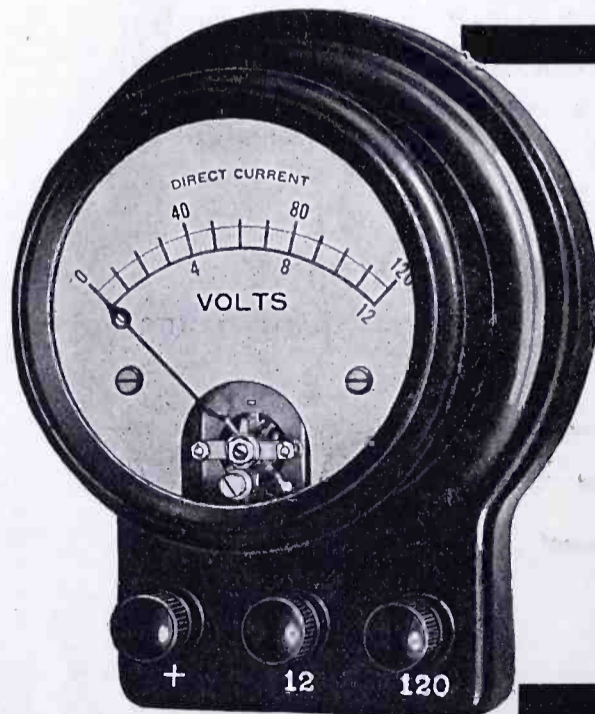

A-B BATTERY TESTER

The Jewell A-B Battery tester fills a need for a low priced but accurate portable instrument for checking battery voltages. Double readings 0-12-120 volts is the range usually supplied, which takes care of the "A" battery under all conditions and the "B" battery up to the highest commonly used for receiving.

Price \$10.00

We were the first to supply a complete line of miniature radio instruments of uniform size. Ask your dealer or write to us for complete radio circular.

JEWELL ELECTRICAL INSTRUMENT CO.
1650 WALNUT ST. CHICAGO

Tell them that you saw it in RADIO

By 7AFF, Lebanon, Oregon
 Canadian—C. W.: 4dq, 4bv, 4hh, 5cq, (5cn), (5ac), 5go, (5ct). Spark: 9bd, 5dx.
 U. S.—C. W.: 5zak, 5zb, 5za, 6ku (buzzer, fone), 6nx, 6fh, 6bmd, (6bum), 6alv, 6pi, 6aat, 6abv, 6awt, (6ea), 6eb, 6zt, 6bsa fone, 6ajr, 6zz, 6if, 6pi, ti, 6arf, 6gy, 6boe, 6bun, 6bin, 6bh, (6biq), 6aoi, (6bdw), 6bnt, (6qm), (6ex), 6ame, (6bru), (6avv), 6bu, 6atw, 6bip, 6lu, 6alv, 7ri, (7tq), 7th, (7adf), (7sc), 7ot, 7to, (7wm), 7fr, 7jw, (7ng), 7nn, (7rn), 7ke, 7abb, 7afw, (7afh), 7eq, 7aic, 7adp, 7bj, 7hj, (7aea), 7om, 7adq, 7wx, (7aif), (7nf), (7qn), (7aiy), (7na), (7nf), 9bif, 8bey, 9zt, 9uu, 9cjc, 9cdf, 9bik, 9bji, 9bzz. Anyone hearing my 10 watts C. W. pse qsl. Will answer promptly by card.

By 7ADF, H. J. Olschewsky, Montesano, Wash.
 C. W.: 1ll, 2afp, 3aro, 4bq, 5ac, 5ado, 5ct, 5ey, 5im, 5ft, 5fv, 5kc, 5mt, 5nk, 5px, 5ql, 5qm, 5qt, 5rh, 5ss, 5tj, 5uk, 5zae, 5zag, 5zas, (6abx), 6abh, 6ahq, 6aiy, 6ajc, 6ajf, 6alu, 6aly, 6alx, 6amz, 6anb, 6ang, 6aox, 6arb, (6ark), 6atc, 6atq, 6atu, 6avd, (6avm), 6avv, 6ax, 6bak, 6bbh, (6bc), 6bcj, 6bc, 6bcv, 6bdf, 6bet, 6bh, 6bia, 6bip, 6biq, 6bko, 6bmd, (6bmn), 6bod, 6boe, 6bof, 6boo, 6bpv, 6bpz, 6bqc, 6bqf, (6bql), 6br, 6brf, 6bru, 6bsj, 6bsw, 6btb, 6bu, (6bum), 6bun, 6bur, 6bvq, 6bv, 6bw, 6bwp, 6bzf, 6cai, (6can), 6cbl, 6cp, 6ct, 6cu, 6dp, 6ea, 6eb, 6en, 6eo, 6fy, 6gh, 6gx, 6ii, (6ku), 6iv, 6lo, 6lu, 6lv, 6nh, 6nn, 6nx, 6qa, 6qm, 6ov, 6rm, 6rr, 6sm, 6su, 6tc, 6ts, 6ud, 6uw, (6vf), 6vm, 6xad, 6xx, 6zb, 6zh, 6zl, (6zo), 6zt, 6zz, 7aad, (7abb), 7aca, 7acf, 7acg, 7acn, 7acx, 7adc, 7adg, (7adm), 7adp, 7ads, 7aea, 7aek, (7aem), (7aff), 7afh, 7afs, 7aft, 7ao, 7at, 7ba, (7bb), (7bj), 7bz, 7cz, 7dp, 7du, 7eb, 7eq, 7ex, 7ey, 7gm, (7hj), 7hm, (7ig), (7ke), 7ks, 7ln, (7lr), (7lu), 7ly, (7na), 7ne, (7nf), 7nr, 7oe, 7oj, 7om, (7ot), 7qy, 7pb, 7pf, 7qe, 7qf, 7qt, (7rn), 7ru, (7sy), 7tf, (7to), 7tt, (7ud), 7ut, 7uu, 7ve, (7vf), 7vx, 7wm, 7wx, 7ya, 7z, 7zu, 8aq, 8asv, 8aws, 8bb, 8bxq, 8cur, 8eu, 8hw, 8ib, 8ju, 8ls, 8ml, 8mz, 8ra, 8sb, 8ue, 8zd, 8zy, 8zaf, 9aen, 9aey, 9afk, 9aja, 9ajw, 9ami, 9ani, 9aoy, 9arz, 9asf, 9aul, 9auu, 9avc, 9avg, 9avs, 9avz, 9awm, 9ax, 9axu, 9bbf, 9bds, 9bey, 9bif, 9bik, 9bji, 9bjk, 9bjv, 9bkw, 9blv, 9bm, 9bri, 9bsu, 9bun, 9bvd, 9bx, 9bxq, 9bxy, 9bzf, 9ccy, 9cfy, 9cns, 9ctf, 9exp, 9dfb, 9dfy, 9dge, 9dgy, 9dkq, 9dlm, 9dpl, 9dsm, 9dvl, 9dy, 9dyg, 9dyn, 9dz, 9ib, 9lf, 9iq, 9oj, 9pi, 9pn, 9ps, 9vm, 9xac, 9xay, 9yaj, 9ym, 9zaf, 9zi, 9zy, bi3, cl8.
 Spark: (6agf), 6ex, 6lv, (6ark), 6om, 6xn, 7abh, (7aff), 7bh, 7ly, 7ry, 7tm.
 Canadian C. W.: 4bv, 4cg, 4hh, (4dq), 5ac, (5cn), (5ct), (5ey), 5ey, 5go.

By 6ARB, 3029 Baker St., Berkeley, Calif.
 C. W.: 1cy, 1xy, 1ccd, 4cg, 4eh, 4kl, 4ya, (5di), 5ek, 5fy, (5ir), 5kc, 5kp, 5ky, 5my, 5nk, (5px), 5qy, 5ru, (5tc), 5tj, (5xa), 5xd, 5xad, 5az, 5zb, 5zak, 6bh, (6cu), (6ea), (6eb), 6ek, 6en, (6gx), 6ny, 6om, (6pi), 6sw, (6tw), 6vf, 6zh, (6zs), 6zz, (6abx), 6ada, 6ajr, 6alu, 6avr, (6awf), (6bc), (6bgh), (6bbe), 6bbh, 6biq, (6bj), (6bjy), (6blu), (6bmd), 6bmx, 6bnv, (6bdd), (6bqc), (6bq), (6bqq), (6brg), 6brk, (6bun), (6bum), 6bv, 6cbi, (6zac), 7bj, 7bk, (7dp), 7du, 7eb, (7eq), 7hm, 7jw, 7ke, 7ln, (7lu), 7mc, 7mf, 7nn, 7nw, 7oo, (7ot), (7pb), 7qe, 7qf, 7qn, 7ri, 7rn, (7sc), 7sj, 7sy, 7th, 7tt, 7uu, 7wk, (7wx), 7xf, —vee, 7zk, 7zo, (7zu), 7abb, 7acg, 7acx, 7adf, 7adp, (7aea), 7aem, 7afs, 7aft, 8bk, 8cf, 8da, 8fu, 8ib, 8ml, 8ow, 8sb, 8sp, 8ue, 8vy, 8xe, 8xi, 8yd, 8za, (8zy), 8axe, 8azd, 8azf, 8azg, 8bnj, 8bti, 8caa, 8ogx, 8cmi, 8zaf, (9bm), 9bp, 9cp, 9co, (9dr), (9gk), 9km, 9kp, 9lq, 9lz, 9ox, 9pi, 9rc, 9yi, 9ym, 9zn, 9aap, 9aey, 9afk, 9afn, 9abh, 9ajh, (9ajp), (9amb), 9ami, 9ani, 9anq, 9aog, 9aon, 9aou, 9aqr, 9arg, 9arz, 9asn, 9aau, 9aul, 9avz, 9awm, 9axv, 9bbv, 9bfg, 9bik, 9big, 9bji, 9bjv, 9bki, 9bom, 9bry, 9bsg, 9bsz, 9btt, 9bvy, 9bxq, 9bzi, 9cac, 9cba, 9ccv, 9cfy, 9cjj, (9cns), vce, cw, 9cmk, 9cpu, 9dfb, 9dge, 9dio, 9dky, 9dpl, 9dtm, 9dui, 9dwb, 9dyg, 9xaq, 9zaa, 9zaf.
 Canadian C. W.: 3co, (4bv), 5bz, 5cn, 5ct, 5ei, (5go), 9ac, 9al, (9bd). Any above wishing qrk, qsl, qrk 6arb.?

By 6APO, Auberry, Calif.
 5aac, 5za, (Can.) 5 cn, 5 ado, 5zak, 5hz, 5nk. Sixes too numerous. 7ahw, 7nf, 7zu, 7na, 7mf, 7aft, 7mc, 7kg, 7adp, 7tt, 7ot, 7hj, 7pf, 8ab, 8ci, 8zc, 8yd, 8tg, 8 bk, 8xae, 8 zy, 8jj, 8cur, 8byo, 8cfo—9avc, 9bm, 9fv, 9bun, 9bji, 9cfy, 9bly, 9dyt, 9byn, 9bed, 9dky, 9bey, 9cgy, 9bvy, 9kp, 9cpu, 9xac, 9ig, 9ccv, 9bxa, 9ccy, 9cfy, 9cvg, 9dhi, 9bzi, 9bri, 9ps, 9fs, 9caa.

By 6BIC W. Martin, 131 N. Pine St., Maywood Sta. Los Angeles, Calif.
 C. W.: 4mb, 5xd, 5oi, 5ya, 5za, 6big, (6bjy), 6agq, 6aiv, (6zt), 6zz, 6ang, 6rm, 6abx, 6bsg, 6nn, 6zh, (6atq), (6bru), 6oh, 6anb, 6arv, (6aoi), (6bin), (6bmn), 7tg, (7aem), 7ey, 7du, 7hj, 7afw, 7hh, 7lu, 7na, 7mc, 8ib, 8fy, 8fu, 8bk, 9bji, (9dcr), 9ejy, 9asu, 9abu, (9ccv), 9dpl, 9avs, 9cfy, 9cwc, 9dtm, 9bzi, 9apw, 9abv. Any one hearing my sigs pse, qsl, to above add.

By 6FY, 144 Sunset Blvd, Modesto, Calif.
 3hg, (can.) 4 bv, 5cn, 5qd, 5uj, 5xd, 5xk, 5ya, 6's and 7's to numerous. 6zz, 8cw, 8ow, 8qk, 8sp, 8vl, 8yd, 8xe, 8zw, 8zz, 8anb, 8btt, 8bf, 8bsy, 8cid, 8cur, 8xae, 9bj, 9bp, 9vh, 9wc, 9yw, 9zn, 9zy, 9aap, 9aix, 9anb, 9anz, 9asb, 9avz, 9baq, 9bbf, 9bji, 9cow, 9dqu, 9dte, 9dtm, 9dun, 9yaj, 9xaq, 9zaa, 9zaf. Any one hearing my five watts pse qsl.
 Continued on page 46



—And they're all talking at once these nights! If you want to hear what you want when you want it, you might as well stop struggling with single-circuit receivers.

Under present-day conditions in radio, with several hundred powerful broadcasting stations all operating on one narrow wave band, the single-circuit receiver is utterly inadequate to give you satisfactory results. Mixed messages and jamming between stations are bound to occur.

The Paragon three-circuit receiver gives you the station you want when you want it—and *no other*. You can tune in accurately and exclusively, on any station you select, and get a clear, complete program without interruption or disturbance.

Ask some experienced amateur what he knows about

PARAGON

Reg. U. S. Pat. Off.

RADIO PRODUCTS

The amateur will tell you that the Paragon three-circuit receiver, because of its greatly superior selectivity and sensitivity, can pick and choose between broadcasting stations of about the same signal strength with less than one per cent differential.

This means that with a Paragon receiver you get what you want when you want it—complete messages and clear music from the station you tune in on, without interruption and jamming. Until you have listened in with a Paragon three-circuit receiver, you cannot guess the real pleasure and fascination of radio.

Paragon receivers are built by the Adams-Morgan Company, which has been a pioneer throughout the modern development of radio. Paragon was the *first* regenerative receiver manufactured. Paragon effected the *first* transcontinental reception (not prearranged) from New York to California. Paragon effected the *first* transatlantic amateur reception. Dur-

ing the war Paragon receivers proved superior to all others in the interception of enemy signals by the United States army and navy.

Long before broadcasting popularized radio with the general public Paragon equipment was the choice of the experienced amateur. He will tell you today that if you want quality and satisfaction, Paragon Radio Products are the best and safest buy on the market.

An Illustrated Catalog of Paragon Radio Products Is Yours for the Asking

DEALERS—The Adams-Morgan Company has an interesting proposition to make to reputable radio dealers who believe in quality merchandise. Details on request.

ADAMS-MORGAN COMPANY
2 Alvin Ave., Upper Montclair, N. J.

Type RD-5 Regenerative Receiver and Detector—\$75.00
Type A-2 Two-Stage Amplifier—\$50.00
(Licensed under Armstrong Patents)



Also Manufacturers of PARAGON	
Radio Telephone	Amplifier
Transmitters	Transformers
V. T. Control Units	Control Dials
Rheostats	Amplifiers
Potentiometers	Receivers
V. T. Sockets	Switches
Detectors	Variometers

Tell them that you saw it in RADIO

Continued from page 44

HOMCHARGE

Your
**RADIO
BATTERY**
for
A NICKEL

Enjoyable concerts and maximum receiving range are obtained only when your battery is fully charged.

**THE
HOMCHARGER**

charges your "A" or "B" battery over night for a nickel without removing it from your living room. No muss—no trouble—no dirt—requires no watching. After the concert connect to any lamp socket, snap the clips on your battery and "turn in." While you sleep the HOMCHARGER is silently charging your battery, the charging rate being governed automatically. In the morning it is fully charged. No OTHER battery charger can boast of such QUICK and ECONOMICAL performance.

The HOMCHARGER is the only battery charger combining all of these NECESSARY HOMCHARGER features—SELF-POLARIZING; FIVE to EIGHT AMPERE charging rate; UNDERWRITERS APPROVAL; beautifully finished in mahogany and old gold; UNQUALIFIEDLY GUARANTEED. OVER 60,000 NOW IN USE.

Sold complete with ammeter, etc., by all good radio and electrical dealers for \$18.50 (\$25.00 IN CANADA).

See the RADIO HOMCHARGERS DE LUXE at your dealer's, or write direct for our FREE circular showing why the HOMCHARGER is the BEST Battery Charger at any price.

MOTORISTS: The HOMCHARGER will also charge your AUTO battery.

Western Distributor:

BERTRAM SMITH

516 San Fernando Bldg.,
Los Angeles, Cal.

**The Automatic Electrical
Devices Co.**

117 West Third St., Cincinnati, Ohio

Largest Manufacturers of Vibrating
Rectifiers in the World

By 5SF, 1616 Worth St., Ft. Worth, Tex.
C. W. only: 1ajp, 1azw, 1cmk, 1gv, 1li, 1on, 2ayv, 2bqd, 2bzw, 2cqq, 2el, 2ud, 2xao, 2xq, 3ajj, 3blf, 3bvl, 3mb, 3ot, 3su, 3yo, 4bg, 4co, 4cy, 4eb, 4eh, 4el, 4hh, 4lw, (4hx), 4hz, 4iz, 4kc, 4kl, (4lj), 4ya. Five too numerous. 6abx, 6ad, 6ak, 6anh, 6awt, 6bic, 6boe, 6bow, 6bqg, 6brf, 6byc, 6cbi, 6cc, 6ft, 6gf, 6if, 6ka, (6zac), 6zh, 6zi, 6zz, 6xad, 7ny, 7sc, (7zo), 7zu, 7zv. 8's and 9's too numerous. Condition: 3gk, 3xn, 4bv, 5cn, 9al.
All stations over 1000 miles.

By 5ADB, El Paso, Texas
C. W.: 1ajp, 1asf, 1aw, 1cnf, 1cra, 1se, 2afp, 2xao, 2zi, 2zs, 3aro, 3ber, 3bfu, 3bgu, 3cg, 3hg, 4sw (qra?) 5aat, 5ado, 5ae, (5aec), 5aeu, 5aht, 5ajj, 5bw, 5ci, 5cy, 5di, 5ek, 5en, 5fo, 5ft, 5fy, 5ga, 5gr, 5gj, 5hh, 5hk, 5hl, 5ho, 5hz, 5ia, 5ik, 5iq, 5ix, 5jm, 5jt, 5jw, 5kf, 5kn, 5me, 5mu, 5nd, (5nk), 5nn, 5nv, 5pb, 5po, 5pv, 5px, 5pz, 5qi, 5qs, 5rh, 5rn, (5sf), 5sg, 5sm, 5sr, 5ss, 5ta, 5tc, 5tj, 5tm, 5uj, 5uk, 5uo, 5vo, 5vy, (5xad), 5xaj, 5xb, 5xd, 5xt, 5xv, 5yk, 5za, 5zae, 5zaf, 5zak, 5zas, 5zaw, 5zb, 5zh, 5zu, 6aag, 6abx, 6ad, 6ada, 6afh, 6aig, 6ajf, 6akl, 6anh, 6apv, 6apw, 6aqq, 6arb, 6arf, 6asj, 6atu, 6avn, 6awt, 6bbe, 6bbv, 6beq, 6bgr, 6bgh, 6bh, 6bic, 6bjc, 6bjj, 6bjy, 6bnv, 6boe, 6bpi, 6bpy, 6bqc, 6bqf, 6brf, 6brr, 6bu, 6bvg, 6bva, 6bv, 6cbi, 6eb, 6ek, 6en, 6ff, 6ku, 6lu, 6om, 6pn, 6rm, 6xad, 6xas, 6xk, 6xxa (qra?), 6zb, (6zh), 6zn, 6zt, (6zz), 7nj, 7lr, 7sc, 7zu, 7zw (qra?), 8azd, 8azj, 8bch, 8bk, 8bec, 8bey, 8byo, 8ft, 8mo, 8uk, 8uzq, 8zw (qra?), 9aau, 9aap, 9abu, 9abv, 9aby, 9aey, 9afd, 9afk, 9aig, 9aix, 9amb, 9ami, 9aod, 9aog, 9aon, 9acu, 9apr, 9apw, 9aqr, 9aqz, 9ar, 9arg, 9ari, 9arz, 9asf, 9asr, 9atn, 9avz, 9ay, 9ayu, 9aza, 9bbf, 9bcf, 9bhd, 9bhi, 9bhq, 9bie, 9bif, 9bik, 9bil, 9biz, 9bji, 9bkk, 9bkw, 9bly, 9bm, 9bog, 9bqw, 9bri, 9brk, 9bsz, 9buh, 9bvl, 9bx, 9bxa, 9bxc, 9bxm, 9bxq, 9bxt, 9byc, 9bzi, 9bzz, 9cac, 9caf, 9cao, 9cem, 9cev, 9ede, 9efi, 9efk, 9efv, 9efy, 9egk, 9egn, 9ehf, 9eig, 9eip, 9ejc, 9ek, 9ekm, 9ens, 9epy, 9er, 9etg, 9evg, 9evo, 9exp, 9daf, 9ddo, 9def, 9dge, 9dgn, 9dgu, 9dgv, 9dja, 9dkq, 9dky, 9dlm, 9dma, 9dn, 9dpl, 9dqm, 9dqu, 9dsd, 9dsu, 9dta, 9dty, 9dwt, 9dxm, 9dxn, 9dy, 9ebi, 9ebt, 9ecr, 9fm, 9fs, 9hk, 9hlh, 9ifo, 9inf, 9lt, 9ps, 9qi, 9rr, 9uc, 9uh, 9uu, 9ve, 9vm, 9xac, 9yb, 9yy, 9zt.
Sparks: 5acq, 5auf, 5au, 5jl, 5nc, 5to, 5tp, 5tu, 5ud, 5wiq (qra?) 5wiz, (qra?), 5xaj, 5yg, 6aah, 9aaj, 9cev, 9fow. Anyone hearing our cw please qsl. to 2117 Grant, El Paso, Texas.

By 7WX, 3825 East J St., Tacoma, Wash.
1bes, 1kkq, 1cy, 3vk, 4bf, 4de, 4fn, 4hi, 4kd, 5ad, 5aec, 5bv, 5ecd, 5da, 5di, 5fv, 5ix, 5kn, 5nn, 5px, 5qn, 5qi, 5ri, 5sf, 5ss, 5wv, 5xaj, 5xv, 5za, 5av, 6abx, (6alx), 6amn, (6aoc), 6aor, 6apl, (6asj), (6arb), (6auy), 6avr, 6avv, 6bar, (6bea), (6bh), (6blh), 6bnh, 6bqh, (6bru), 6bu, 6bum, 6bun, (6buy), (6bwf), 6by, 6bzg, 6ca, (6cbd), 6cu, (6ca), 6eb, (6by), 6ex, (6gx), 6hb, 6ib, (6iy), 6jd, (6jn), 6ka, 6lu, 6ly, 6nt, (6ok), 6rm, 6rr, 6su, (6ti), 6tu, (6wr), (6z), 9abn, 9abu, 9aey, 9ag, 9aog, 9aou, 9apv, 9apw, 9axo, 9ayu, 9aza, 9bgi, 9bju, 9bjk, 9bkk, 9bkk, 9bri, 9btu, 9twa, 9bxm, 9bzf, 9bzi, 9cou, 9cek, 9efk, 9egk, 9ehg, 9elw, 9euc, 9dge, 9dky, 9dpl, 9dsd, 9dta, 9dvw, 9ew, 9lf, 9lwa, 9lz, 9qi, sevens to many Canadian (5cn), (5go), 9lx.

By 6NC, 207 Gacen St., San Francisco, Calif.
4eb, 5en, 5ek, 5fv, 5kc, 5nk, 5px, 5qa, 5za, 5ado, 5zak: 6om, 6bjr, 6xad, 6afn, 6bec, 6atq, 6aeh, 6ea, 6eb, 6en*, 6agp, 6ka, 6bjf, 6gz, 6ft*, 6bjq, 6zh, 6zz, 6ahq, 6cu, 6rm. And many other 6 district stations. 7ta, 7lu, 7vf, 7mf, 7bj, 7ahw, 7adp, 7hm, 7zu, 7asw, 7aem, 7sc, 7zk, 7ba, 7bp, 7jw, 7ke, 7sy, 7wm, 7ny, 7ge, 7aic, 7nf, 7ak, 7zo, 8tc, 8aa, 8af, 8zy, 8kg, 8bk, 8asv, 8yn, 8bch, 8bx, 8er, 8cur, 9asf, 9gk, 9dr, 9awm, 9xac, 9zam, 9uu, 9aul, 9bji, 9bbf, 9bx, 9ami, 9amu, 9zt, 9arz, 9ajm, 9bqk, 9bjv, 9dlm, 9brk, 9bly, 9cwr, 9dlm. The above calls received on one step amplifier audio. Any one heard or hearing my 5-watter please qsl. with card.

By 6AWT, 653 Union St., San Francisco, Calif.
1bkq, 2ckr, 3zo, 4cg, 4lk, 4km, 4ya, 5be, (5di), 5ek, 5fv, 5gr, 5ik, 5jl, 5kc, 5kq, 5mo, (5nn), (5pb), (5px), sqy, 5sb, (5sf), 5sm, 5tc, 5tj, 5uk, (5uo), 5xa, (5xd), 5xv, (5za), 5zl, 5xad, 5zak, 5zav, (5zac), (nr) nw. 6zy. Others 6's too numerous to mention. 7's also too numerous to mention. 8ab, (8cf), (8ib), 8kg, 8lv, 8nb, 8qk, 8sb, 8sp, 8xj, 8yd, (8zy), 8zz, 8aih, 8ajx, (8anb), 8asv, 8axe, 8axc, 8azf, 8azk, 8bdv, 8bch, 8bcy, (8bfl), (8bfm), 8bfp, 8bke, 8blg, 8bnu, 8bvr, 8bxh, 8bxx, 8caa, 8cgp, 8cgz, 8zaf, 8zag, 9az, 9bm, 9bp, 9bx, 9cj, 9ep, (9dp), 9ei, 9ej, (9gk), 9hr, 9ii, 9jq, 9kp, 9lz, 9ox, 9pi, 9ps, (9uh), 9uu, 9xm, 9yi, 9yu, (9yw), (9zn), 9aaq, 9abu, (9afd), 9ajp, (9amb), 9ami, 9anf, (9ang), 9aod, (9aog), 9aon, 9act, (9aou), (9aps), (9apw), 9aqa, 9arz, 9asf, 9aul, (9avz), 9awm, 9aws, 9ays, (9ayu), 9bbf, 9bdb, (9bed), 9bek, 9bey, 9bie, 9bik, (9bji), 9bjv, 9bki, 9bqb, 9bri, 9brk, (9bsg), 9btu, 9bud, 9bvy, 9bxa, 9bxc, 9bxq, 9bzi, 9efy, 9cgk, 9ejc, 9cmk, (9ens), 9epu, 9ctr, 9cuc, 9dfb, 9dge, 9dgv, 9dky, 9dpl, (9dtm), 9dwt, 9dzi, 9xaq, 9yaj, 9zaa, (9zaf). New transmitter here is a 250 watter with 1500 volts rect. ac on plate radiation. 6 Thermo couple amps. All hearing me pse qsl. Any of the above who have not received card reporting their sigs pse let me know and will qsl. one.

By 6BRF 1420 LeMoyné St., Los Angeles, Calif.
3abd, 4bf, 4bw, 5zak, 5zav, 5zaf, 5za, 5xd, 5dr, 5ek, 5ec, 5on, 5or, 5di, 5ak, 5aj, Worked: 6gx, 6ak, 6ti, 6rd, 6re, 6rm, 6fh, 6su, 6zh-v, 6awt, 6avn, 6bak, 6bbh, 6bnt, 6bkk, 6bmd, 6bsq, 6bel, (7hj), 7ey, (7zo), 7om, (7mf), (7tq), 7ny, 7na, 7ot, 7aca, (7bj), 7jw, (7lw), 7aiw, 7mc, 8bx, 8xh, 8bke, 8bsy, 8byo, 8vx, 9cns, 9cev, 9dky, 9zaf, 9amb, 9xaq, (9bji), 9ami, 9awm, 9vaj, 9zn, 9ayu, 9bx, 9avs, 9caa. Anyone hearing my 100 watts pure C. W., pse qsl with card.

Standard Radio Supplies

We offer no cut prices or "junk" merchandise — but we do guarantee you full value for your money, prompt and courteous service, and experienced advice — the result of 15 years in in the radio field.

**Send Us
Your
Mail
Orders**

Everything in stock that's
standard in radio—

Grebe Apparatus—every
model always in stock.

Cunningham Tubes—all
Types.

WD-11 Tubes, Detector and
Amplifier.

Westinghouse Radio Receiving
Apparatus.

Frost Fones and other
accessories.

Magnavox.

All Radio Corporation of
America Receivers.

Remler Radio Mfg. Co.—full
line of parts.

Baldwin Phones—all models.

Tungar and Homcharger
Rectifiers.

Atwater-Kent Radio Parts.

Bradleystat.

Fada Parts.

Western Electric Loud Speak-
ers and Amplifiers.

Eveready Batteries.

And Others too Numerous
to Mention!

**Coast Radio Company
Incorporated**
EL MONTE, CALIF.

Tell them that you saw it in RADIO

Bradleystat Superiority Confirmed by Oscillograph Tests

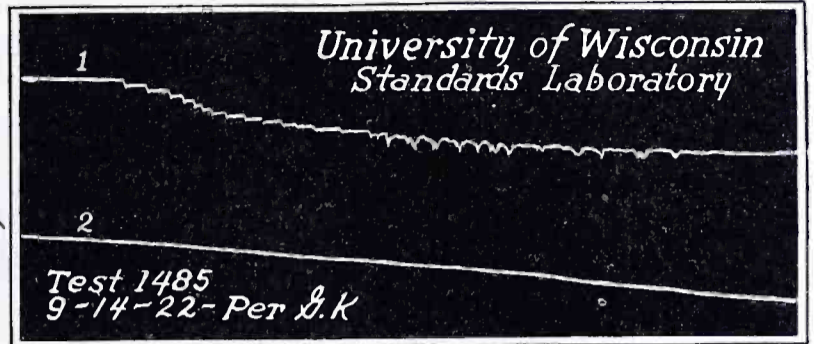
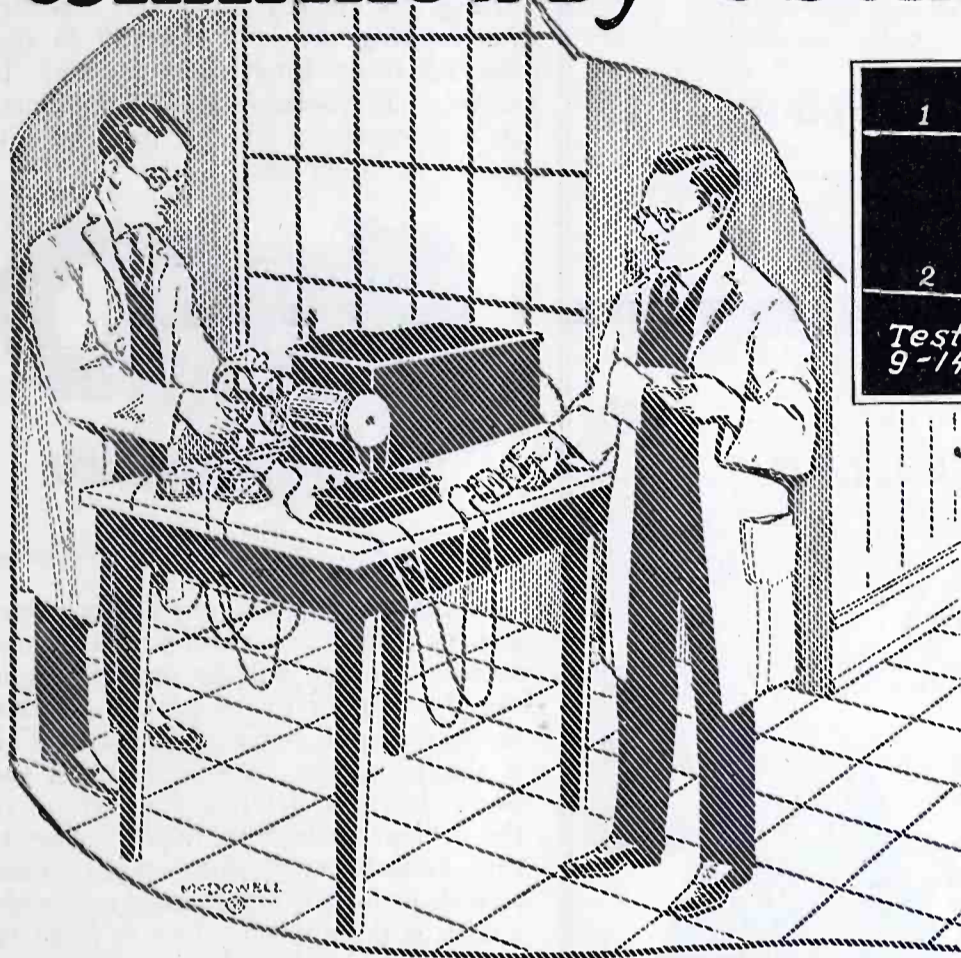

An Important Test

The Oscillograph is a delicate instrument which records on a moving photographic film any fluctuations in electric current flowing through a rheostat connected to the oscillograph.

Test No. 1—See the violent fluctuations, the jerky, noisy control of a regular wire rheostat. Imagine the hissing and whistling such rheostats create in your detector tube.

Test No. 2—Now look at the smooth, stepless control of the Bradleystat. No hissing, no frying nor loss of exact control. Such noiseless, gradual control extends your range immensely.

Fully
Guaranteed

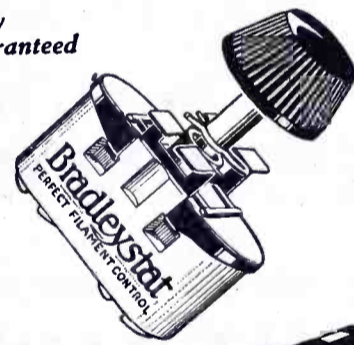

Replace your Rheostats with Bradleystats

Just compare the oscillograph curves above, made in the Standards Laboratory of the University of Wisconsin. The superiority of the Bradleystat is strikingly evident. Thousands are now installing Bradleystats in place of their wire rheostats, and get quicker tuning, greater range and louder detection. Try one, tonight, and note the amazing improvement.

A new Allen-Bradley product is the Bradleyometer, the Perfect Potentiometer. If you use a potentiometer in your set, send for a Bradleyometer bulletin.

Allen-Bradley Co.
Electric Controlling Apparatus.

288 Greenfield Ave. Milwaukee, Wis.
Member of the National Radio Chamber of Commerce

Retail Price
\$1.85
P.P. 10c extra

Bradleystat

REGISTERED

U. S. PAT. OFF.

PERFECT FILAMENT CONTROL

Tell them that you saw it in RADIO

No More Storage Batteries

The new WD-11 vacuum tubes requiring but a single dry cell to heat the filament have opened up a whole new field in radio. Sets are now brought within the reach of vast numbers who could not even consider them before. These new tubes differ in construction from the older types of tubes and require different associated instruments. For this service we announce the following:

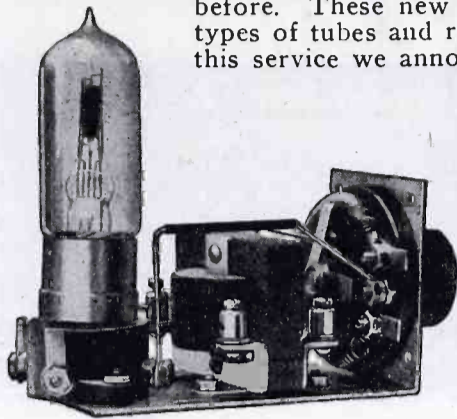

Type 300-A AMPLIFIER UNIT

A compact unit consisting of our Type 231-A Amplifying Transformer, Type 225 Filament Rheostat and Type 282 WD-11 Tube Socket mounted on a nickel finish brass mounting. These parts are all wired ready for the external connections. The mounting is so designed that the unit may be used on a table or mounted behind a panel with only the rheostat knob projecting.

Price \$7.50

TYPE 282 WD-11 TUBE SOCKET

A socket of molded bakelite arranged with positive contact springs to take the WD-11 tubes. This is a socket in itself, not an adapter.

Price 80 cents

TYPE 255 RHEOSTAT

A rheostat of molded bakelite, not a substitute, for panel or table mounting, smooth in operation and attractive in appearance. Resistance 6 ohms, with current carrying capacity of 1.25 amperes.

Price \$1.00

TYPE 247 CONDENSERS

These already popular condensers may now be equipped with gear and pinion providing a vernier adjustment with but a single setting. A low loss condenser with a micrometer adjustment at a fair price. Used in large quantities by such representative organizations as the Western Electric Company. Made in eight types.

Prices \$3.25 to \$7.75

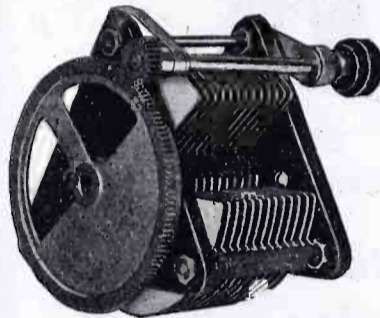

TYPE 231-A AMPLIFYING TRANSFORMER

Remember that this transformer is particularly suited to the WD-11 tubes.

Price \$5.00

Send for NEW FREE RADIO BULLETIN 913-C and learn about these instruments

GENERAL RADIO COMPANY

MASSACHUSETTS AVENUE AND WINDSOR STREET

CAMBRIDGE 39

MASSACHUSETTS

Do not confuse the products of the GENERAL RADIO CO. with those of other concerns using the words "General Radio." The General Radio Co. has been manufacturing radio and scientific instruments for many years. It has no affiliation with any other company.

Standardize on General Radio Equipment Throughout

Try REYNOLDS RADIO Service

9ZAF

from DENVER

KLZ

The exclusive distributors of

KENNEDY EQUIPMENT

IN THIS TERRITORY

If you have a KENNEDY Receiver you have the best in Radio

REYNOLDS RADIO CO., Inc., 1534 Glenarm St., Denver, Colo.

Largest distributors of Radio Apparatus in the West

? Did YOU receive our 68-page Catalogue ?

REGENERATIVE RECEIVING CIRCUITS

Continued from page 15

holds three honeycomb coils—to be used as primary, secondary, and tickler, respectively—side by side, with the coils suspended in a vertical plane as shown in Fig. 70. Geared pinions are provided for rotating the coils laterally so that the distances between them may be varied. The secondary coil is mounted in the center with the primary and tickler on either side.

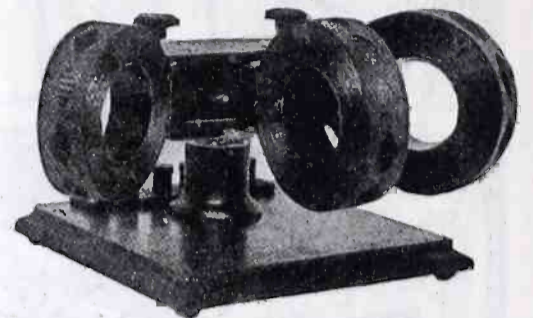

Fig. 70. Three-Coil Honeycomb Mounting

If the coupling between the secondary and the tickler be made sufficiently close, so much energy will be returned from the plate circuit to the grid circuit that the circuits will begin to oscillate. This is similar to the "howling" which can be produced by holding the receiver of the ordinary telephone receiver close to the transmitter. Any slight noise picked up by the transmitter will make a click in the receiver which is, in effect, connected in series with it. This click in the receiver will be picked up by the transmitter and will be heard again in the receiver. The whole process repeats itself cumulatively, the result producing a shrill, high-pitched note in the receiver. In fact, this method is used by telephone operators in attracting the attention of subscribers who have forgotten to replace the receiver on the hook after the conversation is completed. Try it—but don't blame the author for the results obtained.

This phenomenon is identical with that of regeneration. A slight disturbance in the grid circuit is amplified in the plate circuit. This disturbance, much amplified, is returned to the grid circuit and if the coupling between the tickler and secondary is sufficiently close, radio-frequency oscillations similar to the audio-frequency howling of a Bell telephone circuit are produced.

In employing the principle of regeneration, therefore, the set should first be tuned in the usual manner with comparatively loose coupling between the tickler and secondary coils, particularly until complete familiarity with the circuits is gained. The coupling should now be increased; and the strength of signals or music will be increased. If signals grow weaker, it is a sign that the leads from the plate circuit to the tickler

Continued on page 50

Why the Electro-dynamic Principle is Best

To own a good receiving set without Magnavox equipment, is like having your house properly wired and then using only small, feeble candle-power lamps in the sockets!

The Magnavox, in amplifying with extreme sensitiveness every signal supplied to it from the receiver, must necessarily amplify any extraneous sounds which may originate in the receiver or power amplifier itself.

Therefore, the combination of Magnavox Reproducer with Magnavox Power Amplifier (as illustrated) is very desirable. By this equipment, in connection with a good receiver, you get the music or speech with true clearness—and in practically any volume required.

The characteristic of the electro-dynamic principle involved in the construction of the Magnavox Reproducer is such that in operation, no distortional elements can possibly originate in the process of sound amplification.

As electrical engineers appreciate, the sensitivity of the movable coil in an electric field is of a far higher order than that which takes place in the ordinary electro-magnetic reproducer.



This Combination Completes any RADIO RECEIVING SET



Whether placed in the average living room or large dance hall, Magnavox Radio floods the desired area with clear, resonant music or speech—its volume perfectly controlled from the Magnavox Power Amplifier constructed specially for it.

Combination R-3 Reproducer and 2 stage Power Amplifier (as illustrated)

R-3 Magnavox Reproducer with 14-inch curvex horn: ideal for homes, offices, etc.

R-2 Magnavox Reproducer with 18-inch horn: the utmost in amplifying power, for store demonstration, large audiences, dance halls, etc.

Model C Magnavox Power Amplifier insures getting the largest possible power input for your Magnavox Reproducer . . . 2 and 3 stage

Magnavox Products can be had of good dealers everywhere
The Magnavox Co., Oakland, California

New York: 370 Seventh Avenue

Write for booklet illustrating and describing the

MAGNAVOX Radio

Tell them that you saw it in RADIO



Radio Catalogue FREE

One copy of this complete Catalogue of Radio Outfits, parts, Dictionary of Radio Terms, Instruction Book, and Guide to Successful Radio Work—one copy is yours Free.

Simply write us a post card and we will mail the complete book to you Free, by return mail.

It quotes the lowest prices, amazingly low prices on everything for the expert and the amateur. Every improved part, the most up-to-date outfits, everything that is needed of the most modern type—at the lowest possible prices.

It gives a list of broadcasting stations, and gives much information about radio construction and operation. Every one interested in Radio needs this complete catalogue and book of instruction.



Why Pay Higher Prices?

Montgomery Ward & Co. has for fifty years dealt on a Money-Back basis, absolutely guaranteeing everything they sell. With quality absolutely assured, why pay higher prices elsewhere? Write today for this Free Radio Book and see for yourself the Saving it will bring you.

One copy is yours Free. You need only write us a post card.

Write to the house nearest you. Address Dept. 39-R. Chicago Kansas City St. Paul Fort Worth Portland, Ore.

Montgomery Ward & Co.

—The Oldest Mail Order House is Today the Most Progressive—

Continued from page 48

have been incorrectly connected. When they are reversed, it will be found that the signals are greatly intensified. As the coupling between the tickler and the secondary is still further increased, the signals will grow louder and louder until the coupling is close enough to produce oscillations. This results in complete distortion of the signals or music and the coupling should now be decreased to a point just sufficient to prevent oscillation. This is the correct operating adjustment. When the distance between the coils is decreased, the coupling is increased, and vice versa.

When honeycomb coils are used as the primary, secondary, and tickler, as illustrated in Fig. 69, coils of the following sizes should be used for the reception of broadcasted music on 360 of 400 meters:

	De Forest	Giblin-Remler	
Primary	DL	RG	50 or 75*
Secondary	DL	RG	50
Tickler	DL	RG	75

* (Depending on length of aerial, For long aerial, use smaller size).

Fig. 69 shows the use of inductively coupled primary and secondary coils,

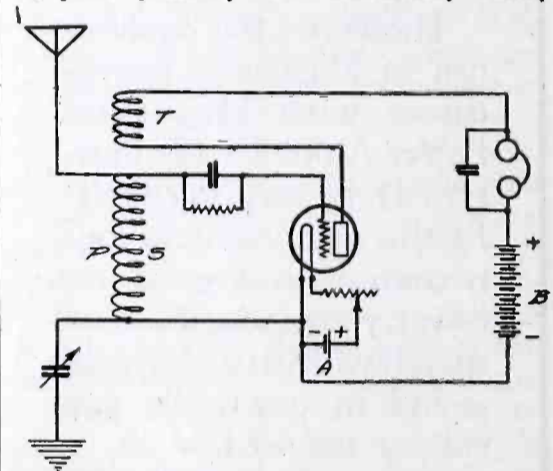

Fig. 71. Conductively Coupled Primary and Secondary

However, it is possible to use an auto-transformer or conductively coupled primary and secondary as shown in Fig. 71.

The coil used as the joint primary and secondary may be a honeycomb coil, preferably of 50 turns. The tickler should have 75 turns. This type of receiver is a regenerative set with an untuned secondary. It is also termed a regenerative, single-circuit receiver, meaning that there is but one tuned circuit (the antenna circuit).

In place of honeycomb coils in a single circuit receiver, it is possible to substitute a vario-coupler as shown in Fig. 72. The stator or stationary coil of the vario-coupler serves as both primary and secondary, and the rotor—ordinarily employed as the secondary—is used as the tickler.

The regenerative single-circuit receiver is very widely used for radiophone

Continued on page 52

Constant, steady voltage.
No battery noise in your V. T.
Easily recharged at home.
A life of from 3 to 5 years.
Jelly electrolyte, no spillage.
Clip on for any required voltage.

—A FEW OF THE REASONS WHY

SNELL CELLS STORAGE "B" BATTERY

should be on YOUR set.
At your Radio Dealer, or

22 v., 11 cells.....	\$ 6.50
44 v., 22 cells.....	12.00
Chemical Rectifier.....	1.25

F.O.B. San Francisco

Order yours now for immediate shipment.

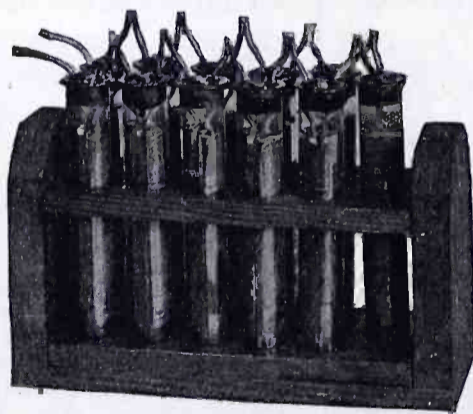

MANN & SNELL 6BQL 4733 Geary St., San Francisco, Ca!

Get a
LEFAX HAND-BOOK free!

See page 51

Investigate!
WESTERN-RADIO DEALERS SERVICE
Wholesale RADIO only
637 50. HOPE ST. LOS ANGELES
1200 FRANKLIN OAKLAND

Tell them that you saw it in RADIO

Lefax Radio Handbook

Distributed in the West by Pacific Radio Pub. Co., Inc.

LEFAX Radio Handbook is the one Book on Radio that keeps abreast of developments. As quickly as the authors learn new facts about the subject, the information is passed on to you. It comes all printed in loose-leaf form, all pages numbered and properly classified. Lefax is the only Book on Radio that doesn't, cannot grow old.

Note the little rings in the center of the book. Those rings are hinged. They are instantly opened—by a slight finger pressure—to receive the perforated pages. Once an ordinary book is bound, it cannot be changed—but Lefax can. You buy Radio information *complete* when you buy Lefax. We furnish, free for a year, pages containing additional information. You need Lefax Radio Handbook.

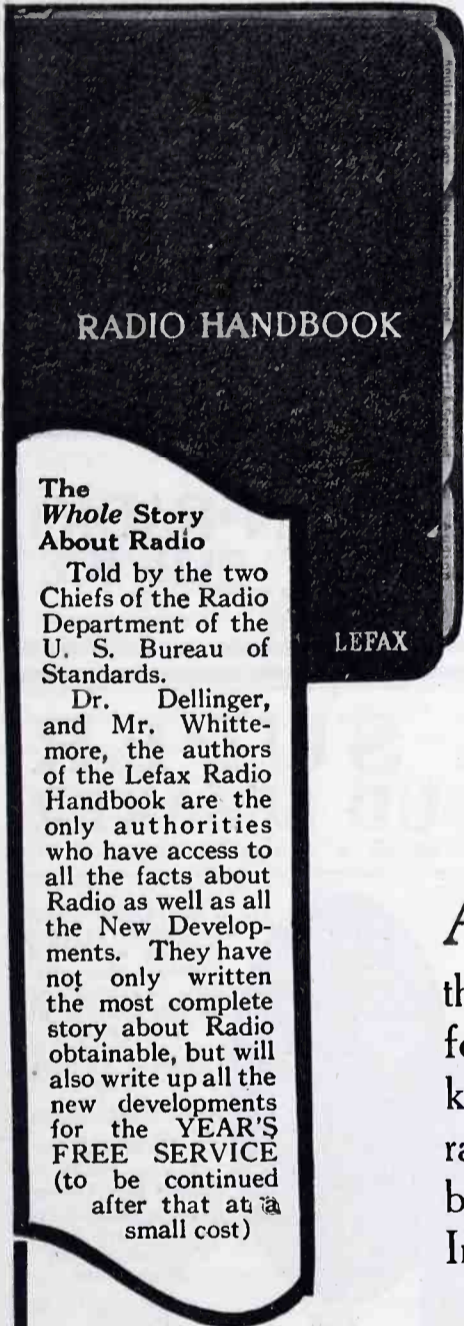

A FREE COPY with one subscription to "RADIO" for 18 months.

The One Best Book on RADIO

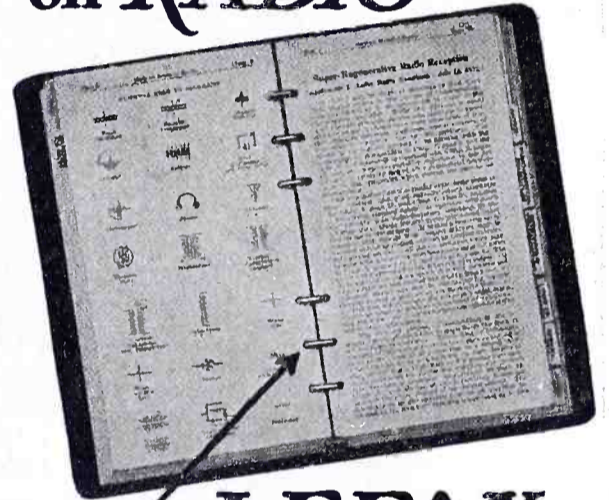

ADDITIONAL loose leaf pages are mailed to you as they are issued — free of charge for one year. Automatically keeps itself up to date. Every radio experimenter needs this book. Send for your copy today. Immediate deliveries.

LEFAX Never Grows Old

\$ 3 50

DEALERS: We are Western Distributors for this Book. Write for trade discounts!

Take Your Choice---Use Either Coupon

FREE LEFAX BOOK

"RADIO"—Pacific Bldg., San Francisco. Herewith is \$3.75. Send me a free copy of LEFAX and "RADIO" for 18 months.

Name

Address

"RADIO"
Pacific Building, San Francisco.

Herewith is \$3.50. Send one Lefax Radio Handbook to:

Name

Address

Tell them that you saw it in RADIO

WELSH PEANUT TUBE
W. T. 501
"The Tube That Cannot Squeal"
 Sold for experimental use as a detector only.

List Price \$2.00

If your dealer has not got his stock in yet send us your remittance and his name and we will see that you are supplied.

Can be used on 3 dry cells or regular 6-volt A-Battery. Wiring diagram packed with each tube showing how to use the W. T. 501 with any crystal set. Nickel-plated socket, moulded base, double spring contacts, 40c extra.

Adaptor for V. T. sockets, 75c extra. Actual size 2 1/4 inches without base. Jobbers and dealers wire for merchandising plan.

Packed 10 in a carton, 10 cartons per case. Orders filled in rotation. Please do not ask us to open an account to ship sample tubes. Samples shipped only at list price which will be credited towards your first stock order.

RADIO RESEARCH GUILD
 9-15 Clinton St. P. O. Box 1 Newark, N. J.

Filament Current less than 1/2 amp. 4-6 volts. Plate voltage 6-22 1/2.



R. C. UNIT
 CHANGES REGENERATIVE TO SUPER. JUST THE THING FOR AUTO RECEPTION. NO AERIAL NEEDED.
 BRING IT IN ON A LOOP
 Diagram for simple electric light socket aerial. Complete instructions with each unit. Send money order for \$1.00.

RADIO RAY
 1545 Pine Street, San Francisco, Cal.

It's the contact that counts

The special phosphor bronze clips of the Na-ald W. D. 11 Socket maintain perfect contact regardless of any variation in tube prongs and bases. Moulded from genuine Condensite, these sockets are made for use with the famous W. D. 11 tubes, operated by a single cell battery.

The Na-ald De Luxe V. T. Socket is of highest quality throughout. Its laminated phosphor bronze strips press firmly with a side wipe action on the contact pins, keeping surface clean and insuring perfect contact.

These sockets retail at 75c each

Send stamp for dial, small-space socket, condenser and R. F. transformer circulars.

Alden Manufacturing Co.
 Formerly Alden - Napier Co.
 Dept. H 52 Willow Street
 Springfield, Mass.

NA-ALD



Continued from page 50

reception. Only two adjustments are required with such a set, rotation of the variable condenser for tuning, and rotation of the tickler for variation of the degree of regeneration. The primary switch is automatically operated in rotating the condenser. For those building their own radiophone receiving sets, the circuit shown in Fig. 72 is recom-

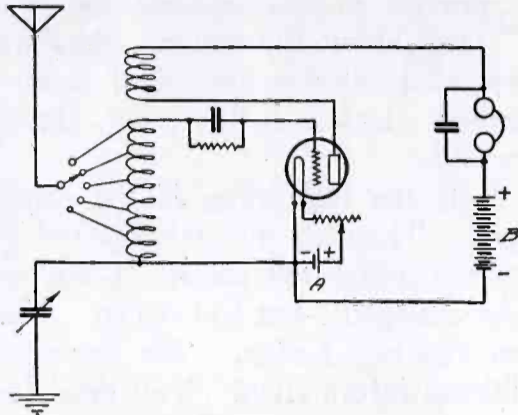

Fig. 72. Hook-up with Variocoupler

mended both for simplicity of operation and signal strength. (It is to be understood, of course, that one or more stages of audio or radio-frequency amplification may be added in the usual manner.)

In the regenerative circuits above described, inductive coupling of the plate and grid circuits through the media of the tickler and secondary coils has been shown. Another method is that of capacitive coupling, through the employment of the inherent capacity existing between the plate and the grid of the vacuum tube. These two elements serve as a condenser of very low capacity. To pass sufficient energy from the plate to the grid circuit through the means of this small capacity, therefore, it is necessary to build up high potentials, relatively speaking, on the plate and the grid.

This is accomplished by tuning the plate and grid circuits to resonance with the incoming waves, just as relatively high potentials are built up on the terminals of the secondary variable condenser of Fig. 69 in tuning the secondary circuit to resonance.

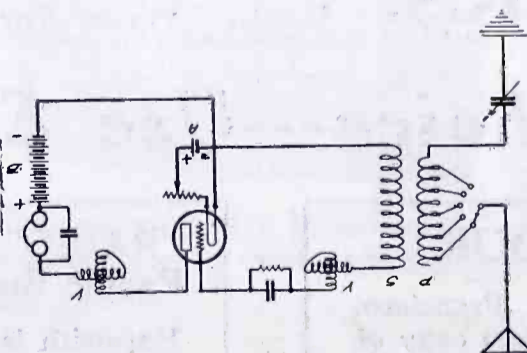

Fig. 73. Capacitive Regeneration

We learned in a previous assignment that variometers serve conveniently for inductively tuning radio circuits. For this reason, they lend themselves favorably to the necessary tuning of the plate and grid circuits for capacitive regener-

DUCON
\$150 Retail
 (By Mail 5c additional)

ROSS RADIO SERVICE
 693 Mission St., San Francisco



FORMICA PANELS
 Cut to order with square and smooth edges from handsome, black, polished sheets 3/16" thick. Price02 per square inch
 Immediate Shipment—Postage Prepaid

DAVID RADIO SUPPLY CO.
 P. O. Box 596 REEDLEY, CALIF.

Investigate!
WESTERN-RADIO DEALERS SERVICE
 Wholesale RADIO only
 837 50. HOPE ST. LOS ANGELES
 1800 FRANKLIN OAKLAND

A SUPER LOUD SPEAKER
 Not merely a head-phone instrument

The Latest Development to produce a loud speaker that surpasses anything on the market at any price.

Powerful Volume Producing Mica Diaphragm Element
 Employed In An Entirely New Manner Assures Maximum Clarity With Total Elimination of Distortion

Patent Pending

THE Gottschalk
 Trade Mark
LOUD SPEAKER
 Will Positively Not Rattle

The Price:
\$22.00

No Metallic Ring—Beautifully Finished Moderately Priced.
 Greater Volume with less energy.
 Supersensitive for Long Distance Reception.

Dealers—Write at once for trade proposition.

GOTTSCHALK ELECTRIC & MANUFACTURING CO.
 992 Howard St., San Francisco



Tell them that you saw it in RADIO

ation. Their use is shown in Fig. 73. *P* and *S* represent the primary and secondary, respectively, of the usual type of vario-coupler, and *V*, *V* the grid and plate circuit variometers, inserted in their respective circuits.

The disadvantage of this type of regenerative receiver is that it requires a complexity of adjustments in contrast to the easily adjusted circuit of Fig. 72. In Fig. 73, not only must the primary and secondary of the vario-coupler be tuned to resonance, but tuning adjustments of the two variometers must also be made. In addition, the adjustments once made, are difficult to maintain.

In the early part of 1922, Major Armstrong disclosed a new principle of regeneration known as *super-regeneration*. In the first part of this assignment, it was shown that as we increase the degree of regeneration by increasing the coupling between the tickler and secondary coils, the signal strength becomes greater since more energy is being returned from the plate to the grid circuits. There is a limit to the amplification of signal strength by regeneration, however, due to the fact that the receiver breaks into oscillation—with deleterious distortion—when the back coupling becomes too great. If a means could be provided to prevent the receiver from oscillating, and at the same time to permit the use of greatly increased coupling between the plate and grid circuits, tremendous amplification would result.

In the super-regenerative receiver, Major Armstrong employs another tube, whose plate and grid circuits are so connected as to set up oscillations. These oscillations are tuned to a frequency just above the limit of audibility—15,000 cycles (30,000 alternations, see first and second assignments)—which is still very much lower than the frequency of the radio wave (750,000 cycles at 400 meters). This 15,000 cycle current is led to either the grid or plate circuit, or both, of the usual regenerative detector tube so as to prevent oscillation at intervals above the limit of audibility. Between these intervals, the regenerative effect builds up to enormous values and tremendous signal strength is obtained.

The super-regenerative receiver is chiefly of interest from the scientific viewpoint. It is by far too complex and unstable a circuit for anyone but the most advanced experimenter to operate and for this reason it has not been put on the market commercially.

Simple regenerative receivers, however, are thoroughly practical and efficient in every way and, in the case of single-circuit receivers, are capable of easy operation by the novice. It should be borne in mind that regeneration secures the benefits of amplification without the use of additional amplifier tubes.

Continued on page 54



The Hit of Radio

New England Products

BUILD YOUR OWN SINGLE CIRCUIT TUNER

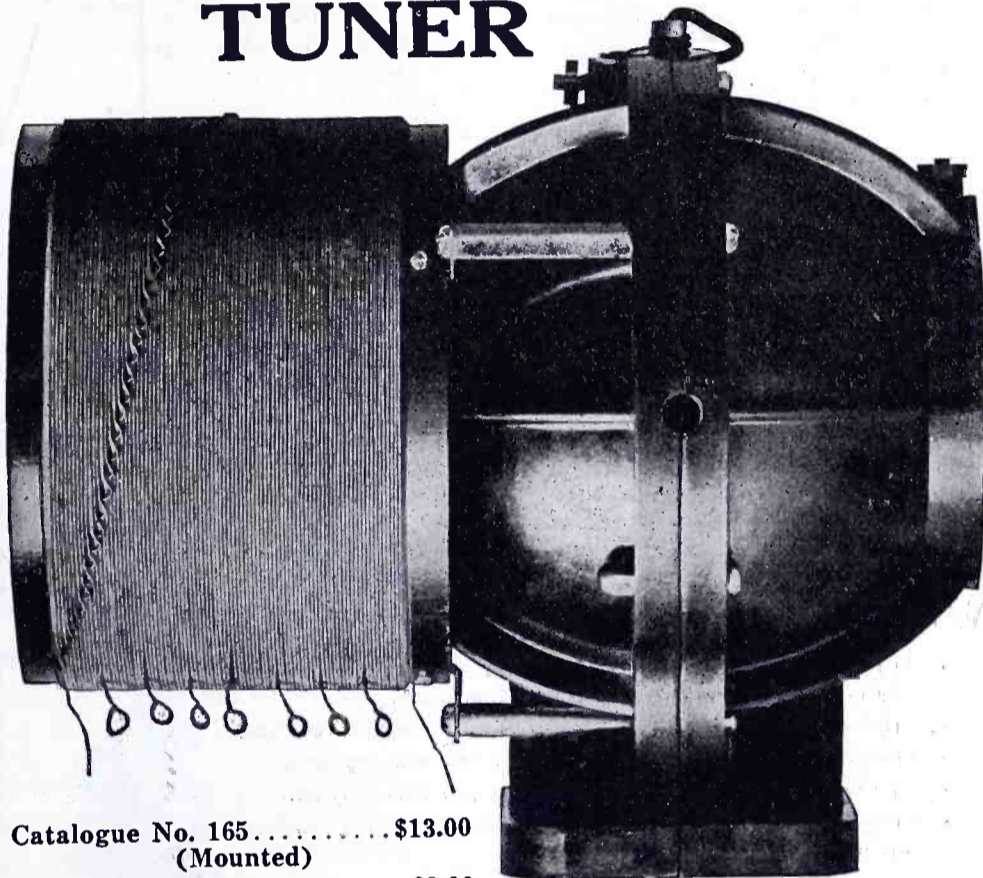

Catalogue No. 165.....\$13.00
(Mounted)

No. 146 Radiometer.....\$8.00

No. 150 B. W. Ind.....\$4.50
(Not mounted)

Wave length range : : 180-3100
Wave length range : : 300-3280

R. MITCHELL & CO.

255 Atlantic Ave.

Boston, Mass.

For 47 yrs. Mfrs. of Scientific and other equipment.
Look for trade mark on every piece.

Jobbers and Dealers, write for discounts

KEEP A DAY AHEAD
of the headlines of tomorrow's newspapers!
Don't be satisfied with the regular broadcasted programs! Get the most out of radiol! Hundreds of radio enthusiasts are doing it!

Equip your vacuum tube set with a **FINCH RADIO RELAY**

and you will automatically receive and at the same time have a permanent record of all the important and interesting news events of the world, whether or not you know the code.

Send Today for Booklet PR 2

FINCH RADIO MFG. CO.
303 FIFTH AVE. N.Y.CITY.

Tell them that you saw it in RADIO

RADIO MAILING LISTS		Per M.
12,422 Radio Dealers, U.S. by States		\$7.50
1,614 Radio Mfrs., U.S. by States		Per list \$15.00
1,760 Radio Supply Jobbers, U.S. by States		15.00
260 Radio Stations		4.00
257 Mfrs. complete Radio Sets		4.00
67 Radio Battery Manufacturers		1.50

Ready to send on receipt of remittance
Trade Circular Addressing Co.
166 W. Adams St., Chicago

Investigate!
WESTERN-RADIO DEALERS SERVICE
Wholesale RADIO only
637 50 HOPE ST. LOS ANGELES
1200 FRANKLIN OAKLAND

Heard with A MU-RAD Receiver

And A 2 Foot Loop Aerial



(The MA-13)

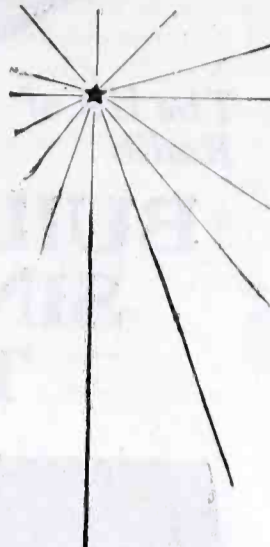

From New York	From Detroit	From Cleveland
Davenport 830 Miles	Fort Worth 1092 Miles	Fort Worth 1050 Miles
Kansas City 1040 Miles	Havana 1680 Miles	Denver 1200 Miles
Fort Worth 1285 Miles	Calgary 1667 Miles	Salt Lake City 1530 Miles
Havana 1567 Miles	Porto Rico 2036 Miles	Havana 1671 Miles
From St. Louis	San Diego 2070 Miles	San Francisco 2180 Miles
Manitoba 900 Miles	Los Angeles 2070 Miles	From Chicago
Montreal 1000 Miles	San Francisco 2210 Miles	Havana 1621 Miles
San Francisco 1820 Miles		Los Angeles 1840 Miles
Honolulu 4278 Miles		San Francisco 1955 Miles

The New
Star in
the Radio
World

They copied all they
could copy,
But they could not
copy our mind;
We left them tear-
ing and swearing
A thousand miles
behind.
—Kipling.



Why MU-RAD Excels

1. **Unequalled Sensitivity**—Exceeds the sensitivity of the average set many times. The above record demonstrates this.
2. **Fine Selectivity**—Permits differentiation of stations 1% off tune.
3. **Simple Operation**—All tuning can be done with one hand.
4. **1,000 Mile Reception**—Guarantee goes with every set.
5. **Distinctive Appearance**—Solid mahogany cabinet, Radion panel, highly polished.

Ask for a Demonstration of
MU-RAD Receivers

The MU-RAD dealer in your town will gladly let
you listen in on either type MU-RAD receiver

Attractive Proposition for Dealers

MU-RAD Laboratories, Inc.

806 Fifth Avenue Asbury Park, N. J.

Two Types MU-RAD SETS	
Type MA-12 3-Stage R-F and De- tector	\$128
Type MA-13 3-Stage R-F, Detector & 2 Stages A.F.	\$160

Continued from page 53

ASSIGNMENT 12.

TUBE TRANSMITTING CIR- CUITS FOR RADIO- TELEPHONY

PREVIOUS assignments have been given over largely to a discussion of the various pieces of equipment which are necessary for the reception of broadcasted music. In the belief that you will find it of interest to consider the nature of the equipment which is used for the transmission of the signals and music which you receive on your radio set, the following assignments will take up the subject of transmitting equipment for radio telephony.

We learned in earlier lessons that for the propagation of the radio wave from the transmitting antenna, it is necessary to have some source of radio frequency current which will produce oscillations in the antenna. Such antenna oscillations are called either continuous or damped, depending upon whether they are unbroken or of equal amplitude, or whether the amplitude of each oscillation is slightly less than the one preceding it—as in the case of the swings of a pendulum. With damped oscillations, the antenna current consists

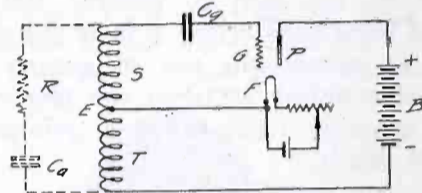

Fig. 74. Hartley Circuit

of a series of wave trains, each train being separated from the one which precedes and the one which follows it and containing a series of oscillations of decreasing amplitude. (See end of fourth assignment).

Obviously, damped waves cannot be employed for radio telephony, since the waves are not continuous—hence to superimpose additional voice currents on such waves would only result in the reproduction of badly broken up and distorted speech.

In the last assignment it was stated that when too much regeneration takes place in a receiving set, the tube circuits break into oscillation, since an over-supply of energy is induced in the grid circuit from the plate circuit. By using vacuum tubes of sufficiently generous dimensions and by supplying adequate power to the plate circuit—a high voltage, direct current generator is used in place of the dry cell B battery employed in the receiving sets—it is possible to utilize the same principle for the production of oscillations at a transmitting station. In fact, all radiophone transmitters today operate on this principle.

The Hartley circuit, the simplest form of tube transmitting circuit, is shown in

Day-By-Day---In-Every-Way

EBY SERVICE

is getting

BETTER

and

BETTER

and

BETTER



Buddy

Ensign



Sergeant

Commander

Notwithstanding the tremendous demands being made upon us from all parts of the country, for our popular line of quality products, we are maintaining 24-hour service.

Anticipate your requirements and be assured of a supply of EBY posts.

The H. H. EBY Manfg. Co., Philadelphia, Penn.

Tell them that you saw it in RADIO

Fig. 74. Compare this figure with the regenerative circuit in Fig. 69 of the last assignment. It will be observed to be very similar in principle. In Fig. 74, the coil *S* in the grid circuit *GC*, *SF* corresponds to coil *S* in Fig. 69. It will be noted that coil *T*, the tickler, is in the plate circuit in both figures. The telephone receivers, of course, are not included in the plate circuit of the transmitter in the above figure. The resistance *R* and the condenser *C*, shown in the dotted lines shunted across the grid and plate coils, represent the transmitting antenna circuit. In order that sufficiently close coupling between the plate and the grid circuits may be obtained and for the production of strong oscillations, coils *S* and *T* are placed close together. In fact, they are generally wound in one coil and are connected together at the point *E*. The *B* battery potential, as previously noted, is usually supplied by a direct current generator, the voltage depending upon the size of the tubes. It ranges from 500 to 2,000 volts.

Due to the very close coupling between the plate and the grid circuits,

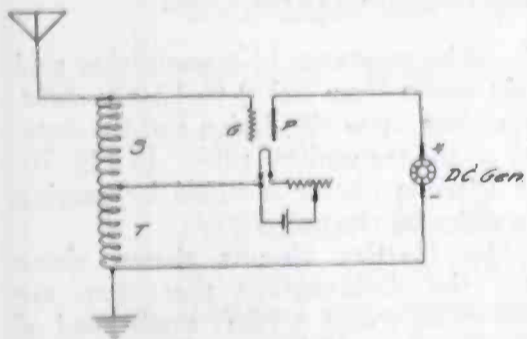

Fig 75. Hartley Circuit with Grid Coil in Antenna Circuit

oscillations are produced in the manner described in the last assignment. You will recall the telephone "howler" analogy given. These oscillations, or radio frequency currents, flow in the circuit *RC*, *TS*. Actually, in the grid and plate circuits themselves, the current is not oscillating or alternating, since the rectifying properties of the tube permit the current to flow in but one direction. The grid and the plate currents, therefore, are actually pulsating direct currents of a frequency with which the circuit in dotted lines, *RC*, *TS*, can be tuned to resonance. The current in this latter circuit may often be many times greater than the currents in the plate and grid circuits.

Fig. 75 shows Fig. 74 redrawn, the antenna circuit replacing the oscillating circuit shown in the dotted lines in the latter figure.

In Fig. 75, the grid circuit coil *S* is shown as being included in the antenna circuit. This means that it would have to be wound with large size wire or copper ribbon in order that the resistance of the antenna circuit may be as low as

Continued on page 56

ONE DOLLAR SPECIALS

Phonograph Attachment

for your head phone. Makes a loud speaker of your phonograph.

\$1.00

Please include 12c for postage charges.

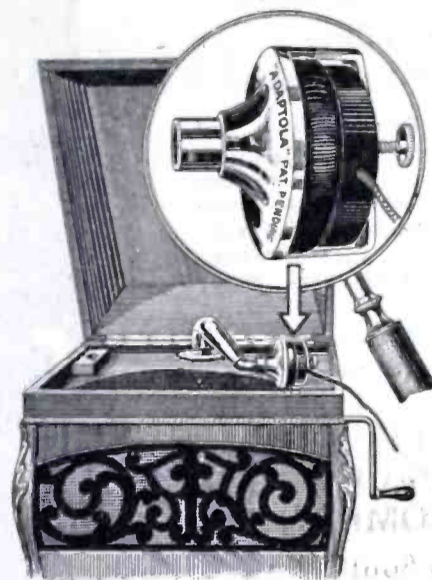

23 PLATE GUARANTEED VARIABLE CONDENSERS \$1.00

Complete assembled. This Condenser has 2 Binding Posts for connections. Aluminum Plates—FORMICA ENDS. Guaranteed On Money Back Basis.

Please send 12c for Postage.

DIALS—

NA-ALD, 2-in. or 3-in., 3 for \$1.00. Postpaid

SOCKETS—

NA-ALD, Condensite, 3 for \$1.00.

Amplifying Transformers,

\$3.00 Postage 12c

Another Special

43 Plate Variable Condensers. Aluminum plates. Formica ends. Binding posts.

Only \$2.00

Guaranteed fully.

Postage, 12c

New and Standard Apparatus only. Our Mail Order Service has gained National Renown!

∴ ∴ TRY US FIRST ∴ ∴

ROSS RADIO SERVICE

693 Mission St., San Francisco, Cal.

SPECIAL DOLLAR ORDER BLANK

ARTICLES

Name

Address

Tell them that you saw it in RADIO

"ESCO" BATTERY CHARGERS

To meet an insistent demand for

**Rugged, Reliable
Neverfailing
Motor-Generators**

For charging Batteries used in wireless operation we have developed a complete line of many sizes. With or without panel boards. "ESCO" quality thruout. You KNOW what THAT means.

Ask for Bulletin 242

**ELECTRIC
SPECIALTY
COMPANY**

**215 South Street
STAMFORD
Conn., U. S. A.**

Pioneers in developing
Quality Wireless Apparatus

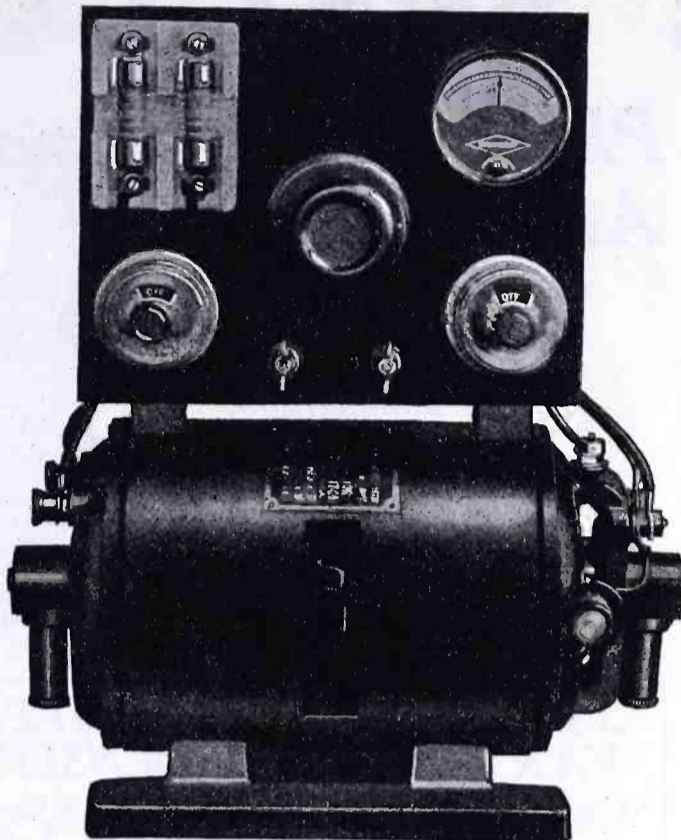

Continued from page 55

possible. The grid current itself, however, is fairly small, and as a matter of economy and convenience, the grid coil, S , is generally removed from the antenna circuit, as in Fig. 76. In this circuit, the grid coil may be wound with smaller wire.

In the study of vacuum tube detector circuits, we observed the necessity for the use of a grid condenser and grid leak. Similarly, in transmitting circuits, a grid leak and condenser must be employed in order to bring the grid to the proper negative potential so that the ensuing oscillations will have a maximum amplitude. See R and C of Fig.

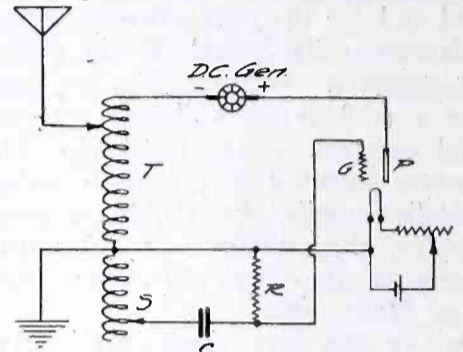

Fig. 76. Hartley Circuit with Tickler Coil in Antenna Circuit

76. The resistance of transmitting grid leaks varies from 5,000 to 12,000 ohms, depending upon the design and the capacity of the transmitter tube. In Fig. 76, the antenna circuit is tuned by varying the slider on the coil T .

The Hartley circuits shown above have the disadvantage that they are efficient only over a fairly small band of wavelengths, which must be chosen in the design and construction of the transmitter. This means that the Hartley circuit does not lend itself to practical adoption at a broadcasting station which, in compliance with regulations of the Department of Commerce, must be capable of operation over a band of wavelengths of from 300 to 600 meters.

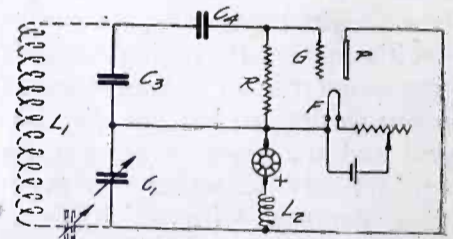

Fig. 77. Colpitts Circuit

The Hartley circuit, as we have seen, employs inductive coupling between the grid and the plate circuits in order to secure the regenerative production of oscillations. The Colpitts circuit shown in Fig. 77 employs capacitive coupling between the grid and the plate circuits to accomplish the same purpose.

In this circuit, the portion in dotted lines represents, as in Fig. 74, the inductance and the capacity of the antenna circuit. The condenser, C_3 , takes the

Continued on page 58



HIGH EFFICIENCY HEAD SETS

- Army and Navy Type:
 2500 ohm, per pair \$10.00
 3200 ohm, per pair \$12.00
- Swedish-American Type:
 2200 ohm, per pair \$8.00
- Victor Type:
 Double pole, single coil, per pair \$6.00

American Electric

COMPANY
CHICAGO, U. S. A.
 For 30 Years Makers of Good Telephones

RADIO SUPPLIES

Mail Orders Promptly Filled
 WE PAY THE CHARGES
 If It Is

RADIO

We Can Supply It.

**U. C. BATTERY
and ELECTRIC CO.**

2158 Univ. Ave. Berkeley, Calif.



Those Broken and
 Burned-Out
**VACUUM
TUBES
Can Be
Repaired**

and Guaranteed Tool
 If your dealer does not
 know send direct to us.

**Harvard Radio
Laboratories**

P.O. Box 1781
 BOSTON, MASS.
 Tubes returned P.P.,
 C.O.D.

Turn to the Inside Back Cover

Tell them that you saw it in RADIO

Two Radio Magazines

for a little more than
the price of one



THROUGH the co-operation of the American Radio Relay League and the Pacific Radio Publishing Co., you can now subscribe to both "QST" and "RADIO" for a full year at the unusually low rate of \$2.70. Your subscription to "QST" also entitles you to membership in the American Radio Relay League.

Amateur Radio is the fad of the day. Join the ranks of the full-fledged experimenter by subscribing to "QST" and "RADIO." These progressive magazines do not feature sensational radio stunts, but they give you the "low down" on anything that's worth-while along the lines of practical radio development.

The very best radio material is published in these magazines. You will get more out of your set if you read "QST" and "RADIO" every month. The publishers will gladly send you a free sample copy of either magazine for your approval.

Save \$1.80

Every progressive Radio experimenter should read both magazines regularly

This is undoubtedly one of the most liberal magazine combinations ever made. Take advantage of it now!

"RADIO," Pacific Building, San Francisco.

Send "QST" and "RADIO" for one year. I enclose \$2.70 in full payment.

Name

Address

Renew your present subscription to either magazine if you are already a subscriber. But get your subscription in by March 1st.

Tell them that you saw it in RADIO

"ILLINOIS" THE RELIABLE

CONDENSER THAT IS MADE RIGHT AND STAYS RIGHT

	Panel	Cased		Panel	Cased
67 Plates	\$7.00	\$8.50	23 Plates	\$2.75	\$4.00
43 "	\$3.50	\$4.75	13 "	\$2.25	\$3.50

Vernier with single movable plate applied to 13, 23 or 43 sizes, \$2.00 extra.

Above list is for our Regular Style with Knob, Pointer and Scale. We also furnish the Condenser with smooth 3/16 inch staff suitable for Dial at 15c off list.

A 3-inch Fine Black Beveled-Edged Dial with Condenser, add 50c to list.

Fully Assembled and Tested. IMMEDIATE SHIPMENT.

Money back if not satisfied. Just return within 10 days by insured Parcel Post.

Sent Prepaid on Receipt of Price, Except: Pacific States, Alaska,

Hawaii, Philippines and Canal Zone, add 10c. Canada add 25c.

No Discounts except 5 per cent on orders of 6 or more. Send for Bulletin.

G. F. JOHNSON

625 Black Avenue

Springfield, Illinois

NON TUNE

Radio Rectifier

Reliable "A" Battery charger for home use

Charging Rate

The Non Tune Radio Rectifier charges at a uniform rate which will maintain a Radio battery yet will not damage the battery plates if neglected for a time greater than regular charging period.

Takes less than a forty watt lamp to operate.

Relay Lock

A most important feature of the Non Tune type of rectifier is the relay lock which will prevent a discharge of any current whatsoever from the storage battery back into the rectifier if power current fails.

Reliability

Thousands of Non Tune Rectifiers are now being operated continuously 24 hours daily in connection with Railway signal batteries where reliability is absolutely essential. In this service contacts of Non Tune Rectifiers operate years without requiring renewals.

Ask your dealer or write giving your dealer's name.

Request Radio Bulletin No. 101D.

LEICH ELECTRIC CO.

Genoa,

Mfrs.

Ill.

Non Tune Rectifiers—Leich Comfortable Headphones

SIXTH DISTRICT
AMATEUR CALLS
appear in "Broadcast Pro-
gram"—\$1.00 for 6 months.

Investigate!
WESTERN-RADIO
DEALERS SERVICE
Wholesale RADIO only
837 50. HOPE ST. LOS ANGELES
1200 FRANKLIN OAKLAND

Tell them that you saw it in RADIO

Continued from page 56

place of the coil S of Fig. 74, since both are connected in the grid circuit. Similarly, condenser C_1 replaces coil T , since it also is connected in the plate circuit. The function of the inductance L_2 is to serve as a choke coil to prevent the radio frequency currents in C_1 from flowing through the generator across which it is directly connected. This choke coil is made of large wire so that it offers little if any resistance to the high voltage direct current from the generator. It contains an iron core, however, which gives it a high impedance to radio frequency currents.

In the eleventh assignment, we learned that it is necessary to have the coupling variable between the plate and grid circuits, in order that the degree of regeneration may be properly controlled. In a regenerative circuit of the type shown in Fig. 69 the degree of regeneration is controlled by varying the inductive coupling between the secondary coil, S , and the tickler coil T , connected in the grid and plate circuits, respectively.

Similarly in a transmitting circuit, it is necessary that the coupling between the plate and the grid circuits be variable in order that maximum regeneration, or the production of oscillations of maximum value, may be secured. In

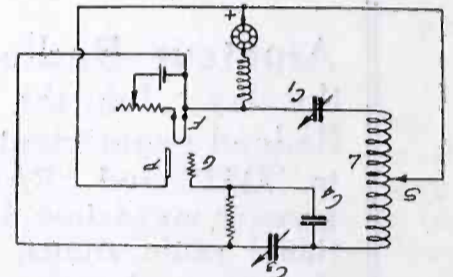

Fig. 78. Heising Circuit

the Colpitts circuit shown in Fig. 77, this is effected by varying the capacity of the condenser C_1 . This condenser, however, is not only part of the plate circuit, PFC_1 , but is also part of the "antenna" circuit $L_1C_2C_1C_3$. This means that if the capacity of C_1 is changed in order to vary the coupling between the plate and the grid circuits, and hence the degree of regeneration, the wavelength of the "antenna" circuit is altered. A compensating change in the capacity of the "antenna" condenser C_2 must therefore be made. This double adjustment is somewhat disadvantageous in actual operation.

The resistance R and the condenser C_4 serve to furnish the capacitive grid leak method of applying a suitable negative potential to the grid as in Fig. 76.

To Heising is due the circuit shown in Fig. 78. This is actually a modification of the Colpitts circuit shown in the last figure. In the Heising circuit, however, the coupling between the grid

Continued on page 60

Kellogg Radio Equipment for Better Results

W
I
T
H
K
E
L
L
O
G
G

U
S
E
I
S
T
H
E
T
E
S
T

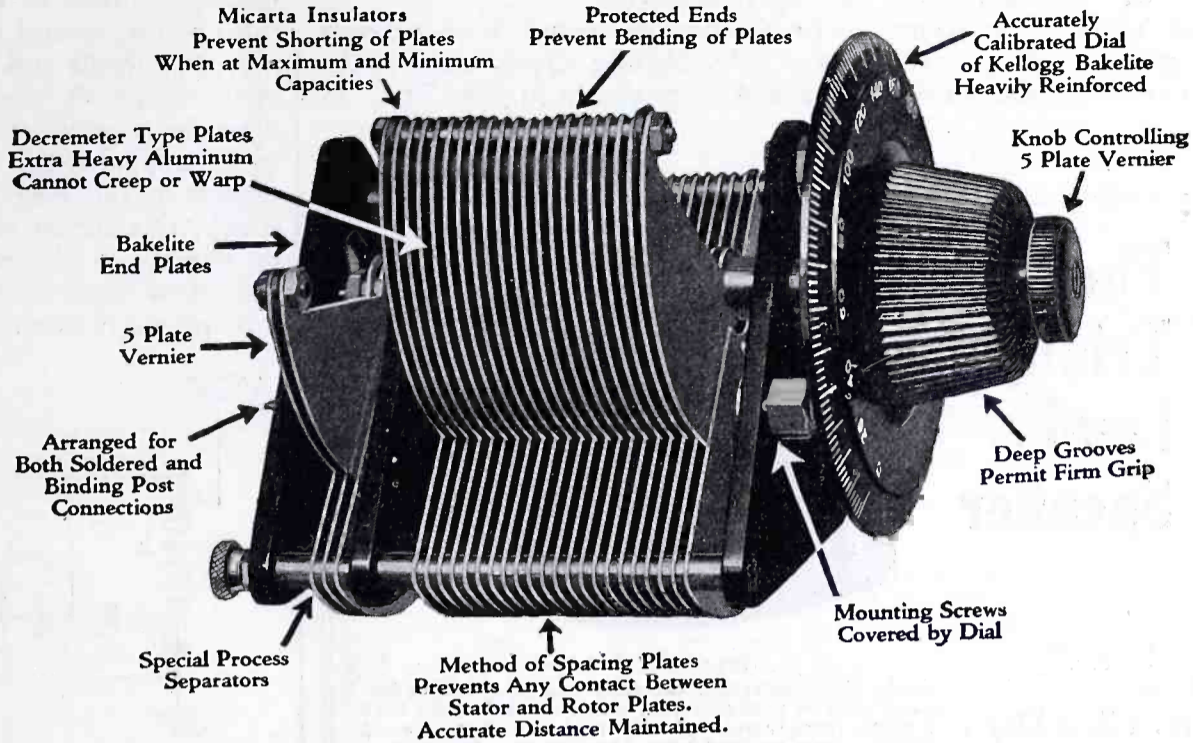

Ask Your Dealer to Show You This Variable Condenser

No. 601—11 plate with 5 plate Vernier. Knob and 4-inch Dial. Each \$6.75
 No. 602—11 plate without Vernier. Less Knob and Dial. Each \$4.50

No. 603—23 plate with 5 plate Vernier. Knob and 4-inch Dial. Each \$7.75
 No. 604—23 plate without Vernier. Less Knob and Dial. Each \$5.50

No. 605—43 plate with 5 plate Vernier. Knob and 4-inch Dial. Each \$8.75
 No. 606—43 plate without Vernier. Less Knob and Dial. Each \$6.50

KELLOGG SWITCHBOARD & SUPPLY CO., CHICAGO

COUNT THE COST—

Two stages with
 2 popular \$5 transformers
 —Total amplification, 36

Equipment cost—
 2 transformers \$10.00
 2 tubes 13.00
 2 sockets 2.00
 2 rheostats 3.00
 \$28.00

One stage with
 1 AmerTran
 —Total amplification, 38.6

Equipment cost—
 1 AMERTRAN \$7.00
 1 tube 6.50
 1 socket 1.00
 1 rheostat 1.50
 \$16.00

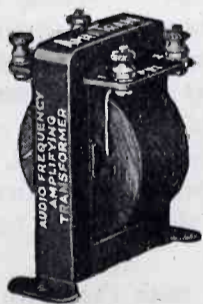

Price, \$7.

Ask your Electrical Dealer, or sent carriage charges collect. (Wt. 1 lb.)

The
AMERTRAN
 super audio frequency
 amplifying transformer

It is doubtful if the substitution of any one thing in a radio set could make such a notable improvement as the installation of an AMERTRAN.

American Transformer Company
 Designers and builders of radio transformers for over 20 years.

174 Emmet St. Newark, N. J.
 W. I. Otis, California Distributor, Rialto Bldg., San Francisco



Dial-Type Rheostat

"The Peak of Perfection"

GUARANTEED to improve both the appearance and operation of any set. Improves appearance because it matches and harmonizes with the other dials on the panel. Improves operation because it assures constant signal strength and prevents resistance overheating. Resistance element recessed in the back of the dial outside the cabinet, also giving more cabinet space. Sold through dealers, or direct if cash accompanies order. Money back if not satisfied. Price—

\$1.50

Mail this FREE Coupon catalog

Parkin Mfg. Co.,
 San Rafael, Cal.

Gentlemen: Please mail me copy of PARKIN Catalog. Name and address of myself and of the dealer I favor, are:

MY NAME.....
 STREET.....
 ADDRESS.....
 DEALER.....
 STREET.....
 ADDRESS.....

Patented Aug. 1, 1922

Tell them that you saw it in RADIO

Continued from page 58

and the plate circuits is varied by moving the slider S along the inductance L . Since L is fixed for any wavelength value desired, the wavelength of the oscillations is not changed for any change in the degree of coupling or regeneration. This circuit eliminates con-

denser C_2 of Fig. 77 and the adjustment is therefore more simple. The other elements of the circuit function the same as their companion lettered elements in the figure preceding.

In practice, connected to an antenna circuit, the Heising circuit assumes the simplified form shown in Fig. 79.

It should be borne in mind that this circuit does not of itself constitute either an undamped wave telegraph (C. W.) or a radiophone transmitter. For telegraphy, it must be supplied with some form of key control for breaking up the antenna current into the dots and dashes of the telegraph code. For telephony, it must be supplied with some form of modulation system, which will be described in the next assignment. As it stands, this circuit simply will generate oscillations in the antenna circuit and additional equipment is required for their proper control.



The Trinity Loud Speaker

TYPE "A1"
\$25.00
21-in. Fiber Horn

The only device of its kind in the Radio field



Type "B" \$12.50

Study the illustration carefully and you will understand why it produces full, clear, natural tones with perfect reproduction of all vocal and instrumental music. May be used with phonograph. No storage battery required.

The Trinity Loud Speaker is an instrument that combines the best qualities of a phonograph reproducer in combination with electro magnetic principles best fitted for radio amplification. Absolutely perfect reproduction of all music and speech without distortion. The volume may be regulated from that required for a room in your home to a tremendous output that can be heard hundreds of feet out of doors by simply increasing "B" battery voltage. No storage batteries required. The instrument is of a heavy duty type and is guaranteed fully by the manufacturers. Ask your dealer for demonstration—if he cannot we can

TRINITY RADIO CO., 168A Dartmouth St., Boston, Mass.

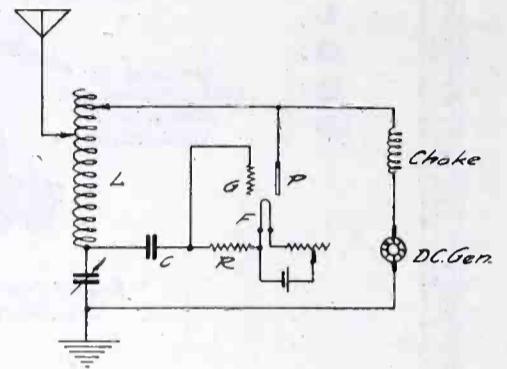

79. Heising Circuit with Antenna

The tubes used in transmitting sets do not differ materially from those employed in receivers. They are more similar in design to amplifiers than they are to detector tubes. That is to say, transmitter tubes are all hard tubes, i.e., are pumped to very high vacuum in order to stand the high potential applied to the plate without ionization or electrical break-down of the space between the plate and the filament. In addition, the filament, grid, and plate of a transmitting tube are made very much larger and more rugged than those of receiving tubes, in order that they will not become unduly heated by the currents which they must carry.

Transmitter tubes are built in three standard sizes, 5 watts; 50 watts, and 250 watts. All of these sizes are used for radiophone transmitting purposes. When more than 250 watts output is required, it is a simple matter to connect two or more tubes in parallel, by connecting the respective filaments, grids, and plates of the various tubes together.

It is interesting to note that late in 1922 announcement was made by the General Electric Co. that its engineers had developed a 1,000 kw. tube. Such a tube, of course, is still in the experimental stage, but it opens up possibilities for the transmission of speech by radiophone to all parts of the world.

In the next assignment, we shall consider the various types of modulation systems by means of which it is possible to control the oscillations generated by the circuits shown in this assignment so as to produce music and speech reproduction at the receiving station.

Delicate Soldering

THE POST SOLDERING IRON

Platinum Heating Unit—Interchangeable Tips—Universal Current
(Large & Small)

\$6

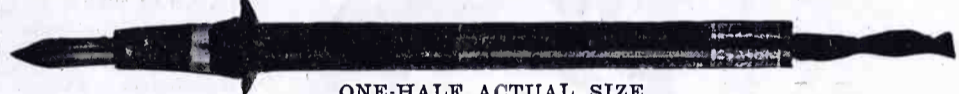

ONE-HALF ACTUAL SIZE

Awarded Certificate of Excellency, N. Y. Evening Mail Radio Institute
From your Dealer, or write

POST ELECTRIC COMPANY (Fifth Division), 30 E. 42nd St., New York

Both the manufacturers' and amateurs' problems on all fine work is readily solved by the instrument constructed for this particular purpose.



JEWELL VERNIER RHEOSTAT

The Jewell vernier rheostat is extremely simple and substantial in construction, employing a new principle of contact which we have patented. Made of the highest grade bakelite and using the best resistance wire obtainable. Very fine adjustments are obtained by a single turn of the knob. Ask your dealer or write to us for special circular.

Price \$1.00

Jewell Electrical Instrument Co.
1650 WALNUT ST. - CHICAGO

Tell them that you saw it in RADIO

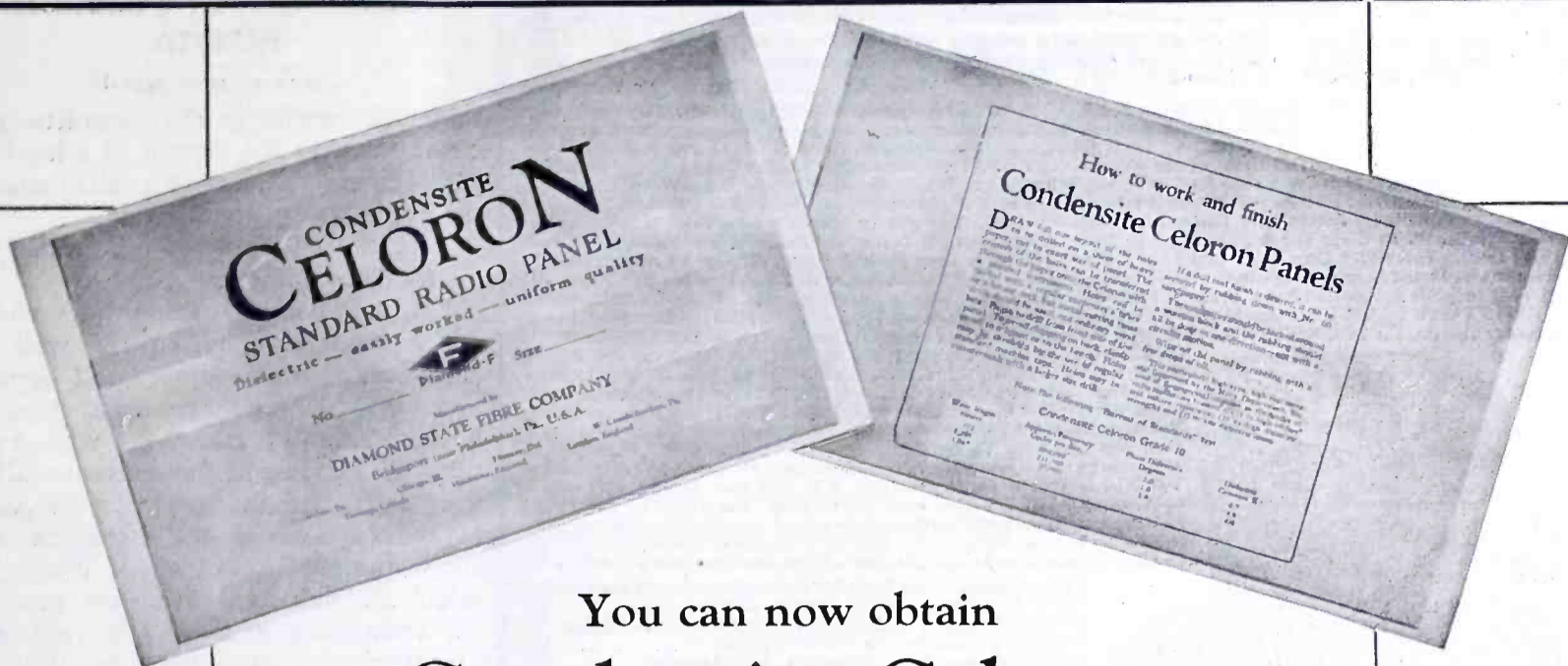

You can now obtain
Condensite Celoron
Radio Panels
 cut in standard sizes

YOU can now get radio panels already cut to a size to fit your needs. For your convenience we are making Condensite Celoron Radio Panels in seven standard sizes. No longer will you have to wait and pay extra cost for having your panel cut to order.

These sizes have been so designed as to meet practically every need of the set-builder. Each panel comes trimmed and wrapped separately in glassine paper to protect the surface. They are all ready for immediate use. On every one are full instructions for working and finishing.

What Condensite Celoron Is

Condensite Celoron is a laminated phenolic condensation product used by many of the leading manufac-

turers of radio equipment. It has high insulation resistance, high dielectric strength, low dielectric losses and is easily worked. Because Celoron has these qualities it has received the approval of the U. S. Navy Department Bureau of Engineering and the U. S. Signal Corps.

You can obtain any of these seven standard sizes:

- | | |
|-------------------|---------------------|
| 1. — 6 x 7 x 1/8 | 4. — 7 x 18 x 3/16 |
| 2. — 7 x 9 x 1/8 | 5. — 9 x 14 x 3/16 |
| 3. — 7 x 12 x 1/8 | 6. — 7 x 21 x 3/16 |
| | 7. — 12 x 14 x 3/16 |

Select the size you need for your set. If your radio dealer has not yet stocked them, ask him to order for you. Or write direct to us, designating by number the size you want. We can make prompt shipment.

To radio dealers: Write for special dealer price list showing standard assortments

Diamond State Fibre Company
 BRIDGEPORT (near Philadelphia) PENNSYLVANIA
 BRANCH FACTORIES AND WAREHOUSES
 BOSTON CHICAGO SAN FRANCISCO
 Offices in Principal Cities
 In Canada: Diamond State Fibre Company of Canada, Limited, Toronto

CONDENSITE
CELORON
STANDARD RADIO PANEL

Tell them that you saw it in RADIO

RADIO "A & B" STORAGE Batteries CHARGED at Home For Few Cents With "PATENTED FULL WAVE" Automatic Magnetic 100-130 Volt 60 Cycle A C

F-F RADIO RECTIFIER

Eventually You Will Buy an F-F RECTIFIER. Why Not Now? The Sooner You Buy It; The More You Save

It CHARGES All 6 Volt RADIO "A" & AUTO Batteries; & All RADIO "B" & LOUDSPEAKER Storage Batteries Up To 120 Volts In Series Inductively At Home Overnight. Disconnecting & Multiple Connections Unnecessary. Charging Circuits Separate. Nothing Like It Made. No Chance For Grounds Or Short Circuits. No Skill Required. AMMETER eliminates Guess Work. It Costs You Less To Buy An F-F RECTIFIER than To Be Without One. You PAY for ONE whether You Buy One Or Not, for It Costs An Average Of \$2. for Charging & Rentals Every Time An Auto Battery Is Charged By Others, but Only A Few Cents When You Charge Your Own From A Lamp Socket With An F-F Battery Boosting RECTIFIER. If You Have Never Known The Delightful Feeling Of Having Your Storage Batteries Always Fully Charged For RADIO & AUTO You Will Experience A New Thrill When You Have An F-F RECTIFIER Which Gives You A Fully Charged Battery Overnight At A Cost Of A Few Cents & A Pleasant Feeling of Things Well Done. Those Who Own Them Feel Their F-F RECTIFIER is Their Faithful Friend. It Charges Automatically & Being Clean Can Be Placed Anywhere. Nothing To Stop Over Be Filled Burn Out Need Attention Or Cause Trouble. Both Waves Are Rectified Thru Infusible Carbon Rectifying Brushes, Maintaining Constant Efficiency Uninterruptedly. While Its FULL WAVE Delivers RAPID TAPER CHARGE recommended By All Storage Battery Manufacturers. The F-F RECTIFIER is A Complete Compact Portably Handy Charging Unit. Delivers Service Day & Night Automatically & Will Charge A Dead Battery. Do Not Think Battery Is Dead & Worn Out Simply Because It Will Not Start Your Car. Buy an F-F RADIO RECTIFIER & Fill It With LIFE. It SAVES MORE than Its Cost & Lasts Lifetime. Leave Your Battery In Car, Or Wherever It is, Without Even Disconnecting It Screw RECTIFIER Plug In Lamp Socket, Snap RECTIFIER Clips on Battery Terminals; Turn Switch & Battery Will Be Charged In Morning At Cost Of Few Cents. Is It Not Gratifying To Be Ready For All RADIOPHONE BROADCAST Music Sermons & News When Friends Call? Never Having To Be Careful Of, or Tell Friends Your Batteries Are Dead & To Feel Your Car Respond Like A Greyhound, Spinning Engine With Power When You Throw in STARTER? Fully Charged Battery Starts Car Quick & Requires Fewer Expensive Replacements. INSIST on The F-F RECTIFIER. Built By A Master Of The Art in 7 TYPES. So Many Thousands Are Being Sold It Has Made Possible These POPULAR PRICES.

They Also Charge AUTO Batteries Overnight Right In Your Car

\$20

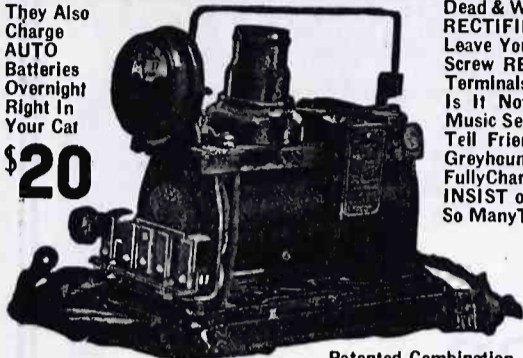

Patented Combination.

CHARGES "A & B" RADIO & AUTO BATTERIES.

The Lower 3 Are Large TYPES Built for Heavy Batteries, or Where Charging Time is Limited. SHIPPING WEIGHTS Complete With AMMETER & BATTERY CLIPS 11 to 15 lbs. Purchase From Your DEALER Or Mail Check for Prompt Express Shipment, If Via PARCEL POST have Remittance Include Postage & Insurance Charges, or WRITE us To Ship TYPE desired C. O. D. Other F-F Battery Boosters Charge Batteries From Farm Lighting Plants & D. C. Circuits & for GROUP CHARGING Economy Use Our 8 Ampere 12 Battery Capacity Automatic Full Wave F-F ROTARY RECTIFIER described in ROTARY BULLETIN 33A. ORDER Now, or WRITE Immediately for FREE Descriptive RADIO & AUTO BOOSTER & ROTARY BULLETINS 33A 33

FRANCE MFG. CO.

General OFFICES & WORKS: CLEVELAND, OHIO, U. S. A. Canadian Distributor: The Jack V. Elliot Co., Hamilton, Ontario, Canada

- TYPE 6 Charges 6 Volt Radio "A" & Auto Batteries At 6 Amperes \$15
- TYPE 12 Charges All 12 Volt Batteries At 5 Amperes \$15
- TYPE B Charges All Radio "B" Storage Batteries Up To 120 Volts \$15
- TYPE A-B is a Combination of TYPES 6 & B \$20
- TYPE 166 Charges All 6 Volt Batteries At 12 Amperes \$20
- TYPE 1612 Charges All 12 Volt Batteries At 7 Amperes \$20
- TYPE 1626 is a Combination of TYPES 166 & 1612 \$28
- ALL TYPES But "B" Also CHARGE AUTO BATTERIES.

RADIO ADVENTURES IN RUSSIA

Continued from page 18

cabin. It would be the committee procedure akin to the descent of a horde of jackals upon the body of a fallen animal, rending, tearing, annihilating.

"Beast! Traitor! Pig!" came the shouts from without.

"A sound came through the phones which were hanging on the wall. I placed them over my ears and listened. Snatching the code callbook from its hook, I scanned the pages with eager eyes. It was one of the gunboats calling me. I grasped the handle of the starting box and heard the motorgenerator climb the scale to a shrill whine. I called the ship and informed them of the transpiring events. The acknowledgement came back slowly but with exquisite precision. They were in the offing and would approach and send launches. I felt better.

"A shot or the blow of some instrument sounded at the port and the glass crashed inwardly to the deck. An unwary head and an arm carrying a pistol was thrust in. I crashed a heavy code-book square upon the leering face. The book was light but it did the work intended. The head of the intruder was knocked down against the ragged projections of the remaining glass. The head and arm was drawn backward and outward, accompanied by a howl of pain. A tiny rivulet of blood ran redly down a sharp projection of the ragged glass and darkened on the port sill in a long trickle.

"I drew back in the corner near the port and kept to the bulkhead. I was weaponless. A hand bearing a pistol was quickly thrust in the port aperture and fired a number of shots over a wide arc. The hand was as quickly withdrawn again. Being well out of the arc of dispersion, I was untouched by the flying lead. It was a clever "coup de feu" meant to floor me. It did no damage except drilling holes in the inner woodwork of the bulkheads.

"I saw part of a head and an eye cautiously thrust above the level of the port in an effort to ascertain results of the volley. I swung a light cane chair and crashed its feeble wood against the port. Apparently it did no damage.

"A shout went up from without. Then the howling voices were stilled and hushed. The mob broke loose and went scurrying about the deck. Three launches were approaching. Their cockpits were black with sailors. Rifles glinted in the sun.

"I looked aft and was staggered. "The czar's colors were running up on the staff! Under the frown and threat of the guns the Bolsheviks had turned reactionaries, but it was morally

Continued on page 64

RADIO SUPPLIES

All Standard Goods
Immediate Deliveries

Distributors for
BALDWIN, BRANDES and FEDERAL
PHONES, FADA, FEDERAL and MONROE
RECEIVING SETS, Erla, Acme, Dubilier,
Chelton, Burgess, Meyers, Tubes, Magnavox,
and many others.

A COMPLETE line. Largest stock in the middle West.
WRITE FOR LATEST 64-PAGE CATALOG
35% Dealers' Discounts

American Radio Mfg. Co.

107 E. 13th St. Dept. N Kansas City, Mo.

KING Rheo-Socket

ANOTHER RADIO SURPRISE
Price \$3, f. o. b. New York City

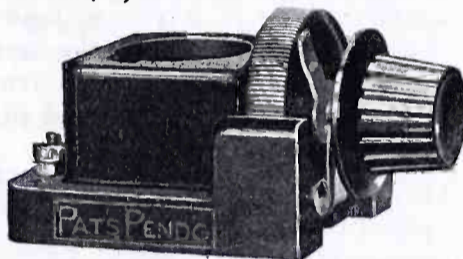

Compact, increased efficiency, shorter connections, less wiring—brings in stations you never heard before. Make this a part of your up-to-date set.

A high grade article in Red Bakelite with Phosphor-Bronze Contacts and Alloy Resistance Wire.

FOR BASE OR PANEL MOUNTING
KING AM-PLI-TONE

82 Church Street New York
Mfrs. of the Famous KING AM-PLI-TONE
Jobbers, wire or write for proposition

Investigate!
WESTERN-RADIO DEALERS SERVICE
Wholesale RADIO only
837 50. HOPE ST. LOS ANGELES
1800 FRANKLIN OAKLAND

—RADIO INSTITUTE—

OF AMERICA

Conducted by the greatest and most experienced radio telegraph organization in the world.

Thorough training given in radio operating, traffic, all systems, including the latest successful commercial radio development of the G. E. Company, which, in one set, combines radio telephony, continuous wave telegraphy, and interrupted continuous wave telegraphy. This apparatus now installed in our school room.

Tuition Ten Dollars per month, for either the day or evening sessions, or both combined.

Prospectus mailed on request

RADIO CORPORATION OF AMERICA

Phone Douglas 3030

331 New Call Bldg., San Francisco

98 Worth St., New York. Phone Franklin 1144

EVERY WEEK
"BROADCAST PROGRAM"
Send for Sample Copy

Published
by Pacific
Radio Pub. Co.

Tell them that you saw it in RADIO



The United States of America
DEPARTMENT OF COMMERCE
BUREAU OF NAVIGATION

LICENSE
RADIO OPERATOR, COMMERCIAL FIRST CLASS

This is to certify that ALFRED HENRY BARTLETT has been examined and passed, pursuant to the Radiotelegraphic Convention, in

(a) adjustment, operation, and care of apparatus;
 (b) transmitting and sound reading at a speed of not less than twenty words a minute, Continental Morse;
 (c) use and care of storage battery or other auxiliary;
 (d) knowledge of international regulations and Acts of Congress to regulate radio communication.

and is hereby licensed, as required by law, a Radio Operator, Commercial First Class for two years. The candidate's practical knowledge of adjustment was tested on a THEORETICAL set of apparatus. His knowledge of other systems is shown below

Code speed 20 WORDS PER MINUTE. Percentage 82.5%

R. G. Carson (Examining Officer) Radio Inspector (Title)
 Here Baltimore, Md. Date June 24th 1922

Herbert Hoover (Notary Public) Secretary of Commerce
D. B. Carson Commissioner of Navigation

Get This First Class Radio License You Can Earn Big Money With It

THE best paid positions in Radio go to the men who hold the Government's Commercial License. The radio men on every ship, in every land commercial station, in every broadcasting station, must have one of these licenses. Every radio inspector must pass the first-class license examinations. Engineers, mechanics, installation and maintenance experts must all of them own a Government First-Class Commercial License. It is every radio man's ambition to get a license, not only because it is the highest mark of honor he can get but because it also opens to him all the wonderful opportunities in this great profession.

Emmett Welch of Peculiar, Mo., Radio Salesman, earns \$300 per month and expenses paid. Merle M. Wetzel, while taking our course, was advanced from a lineman to Inspector in the Engineering Department of a Public Service Co. with a big increase in salary. George Staffa, as operator aboard ship, averaged \$125 a month with all expenses paid. Read in the panel of the fine salaries paid in all the wonderful positions open to you as soon as you get the Government First Class License.

Win Your First Class Government License This New, Easy Way

The National Radio Institute, America's first and largest Radio School, has devised a remarkable new method that makes it easy for you to win your license. No previous experience in electricity or radio is necessary. Lessons, so fascinating they read like an interesting romance, take you step by step through the whole wonderful science of radio. Spare time study at home prepares you in an amazingly short time to pass the government examinations, so you can get one of the fine jobs waiting in this great field. Prominent radio experts give you personal instruction and advice. They grade your papers, answer your questions, give you every help you want so you can qualify quickly. The diploma we give you upon completion of the course, counts for 5 to 10 credits on all government license examinations. The most important requirements for a commercial license is a knowledge of the Radio Code. One of the most extraordinary features of the Institute's comprehensive course is the four patented instruments, invented and owned by the National Radio Institute, give you the practical training in radio operation, installation, maintenance and repair which you must have to become an expert.

National Radio Institute Dept. 10-C
 1345 Pennsylvania Ave., N. W.
 Washington, D. C.

Send me your free book, "How to Learn Radio at Home," with full particulars about the opportunities in radio, and how you will quickly train me in my spare time at home to win a Government First-Class Commercial License. Also tell me how your free Employment Service will help me to a position.

Name..... Age.....
 Street.....
 City..... State.....

Four Radio Instruments Free

Among these instruments is the wonderful Natrometer, said by experts to be the most perfect device ever invented to teach the Radio Code. With this amazing machine you quickly learn how to send and receive code with all the speed, the accuracy and precision of a trained expert operator. No extra equipment is necessary. Simply connect a dry-cell, adjust the head-phone, wind the motor, and for twenty minutes you can listen to a reproduction of the code-work of two of the most expert trans-Atlantic operators.

Interesting Book on Radio Free

Get into this fascinating profession now. The field is wide open; thousands of positions are open. Find out at once your opportunities in radio. Send for the interesting free book, "How To Learn Radio at Home," which gives complete details of the plan by which the National Radio Institute qualifies you quickly in your spare time at home for a Government Commercial License. If you are sincerely ambitious to win success and wealth in radio, send the coupon, or a post card, now.

WARNING!

Ours is the one complete course that prepares you for a first class government license. It is complete in every detail. Necessary practice instruments are supplied free. Don't be confused by cheaper or free courses. They cannot secure for you a government license which is necessary to obtain a good position in Radio.

Pick Out The Job You Want We Will Help You Get It

This is a brief list of the positions in the Radio field today, and the salaries paid:
 Radio Mechanic, \$1,500 to \$2,000 a year.
 Radio Inspector, \$1,800 to \$3,000 a year.
 Radio Auditor, \$1,200 to \$1,800 a year.
 Radio Salesman, \$2,000 to \$5,000 a year.
 Radio Engineer, \$3,500 a year and up.
 Radio Executive, up to \$10,000 a year.
 Radio Aide, \$6 to \$10 a day.
 Radio Draftsman, \$7 to \$10 a day.
 First Class Ship Operator, \$105 a month, all expenses paid.
 Commercial Land Station Operator, \$150 a month and up.
 Broadcasting Station Operator, \$125 to \$250 a month.



SUCCEEDED IN GETTING LICENSE

I have taken the Radio Course from you by correspondence and have finished it. Now I have succeeded in getting a commercial first grade license. I can operate most any spark station and can also operate an arc and tube transmitter.

CHARLES ROSSI,
 31 Runyon Ave., Yonkers, N. Y.

GETS \$165 A MONTH

I am the only operator on board the "Lake Tulare" and receive a salary of \$125 a month, with an additional \$3 a day food allowance while in port, totaling a cash pay of approximately \$165 a month.

LEO A. GOLDBLATT,
 Baltimore, Md.

IN CHARGE OF RADIO DEPARTMENT AND ADVERTISING MANAGER

I presume that you are somewhat interested in the amount of success the graduates of your school attain. The degree of success which your graduates arrive at is a criterion by which the school is judged by others. As you know, I completed your prescribed course in Radio Telegraphy and Radio Telephony on July 21, 1920. At the present time I have complete charge of the Radio Department of True & Blanchard, Inc., of this place. This firm deals both retail and wholesale in Radio Equipment and Supplies. I also have charge of the advertising of The Vermont Radio Company of this city.

REGINALD T. ALBEE,
 Advertising Manager,
 Vermont Radio Company,
 Newport, Vermont.

EASY TO GET GOOD JOB

Only a short letter to let you know that I am still on board and waiting for the ship to sail. Tell your students for me that a man with a license has no trouble obtaining a good position. Believe me, a job like this is worth a good deal of studying.

L. M. WARING, Jr.,
 S. S. Lake Farney, Norfolk, Va.

\$7.00 A DAY AS OPERATOR

Just sailed this morning for Norfolk, where we are to get a load of coal. I haven't much to do on board, and when in port not that much. I get \$7.00 a day when in port, and can sleep on the ship. Not bad at all.

REVERE B. GURLEY,
 On board S. S. "Lake Figart."

NATIONAL RADIO INSTITUTE

DEPT. 10-C 1345 Pennsylvania Ave., N. W. Washington, D. C.

Tell them that you saw it in RADIO

TOO LATE!

With the "Cut" of Our New

"S. R. 25" RECEIVER

— BUT —

We Can Tell You This:

We Challenge the World!

To Outperform It

2 Radio — Detector — 2 Audio

\$150.00—less tubes

And a beauty of finish that we believe unequalled.

WRITE

Hallock and Watson Radio Service

192 Park Street

"KGG"

Portland, Ore.

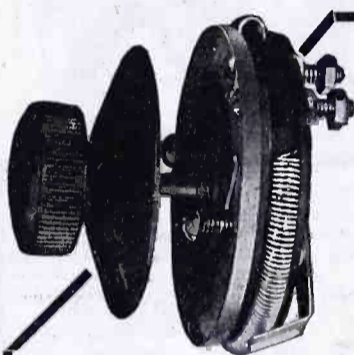

Filament Rheostat

The unusually large number of turns give a fine regulation of current. It will not heat up. Adaptable to either panel or table mounting by mere loosening of set screw.
List Price \$1.00
Trade discounts on application.

Essential for Radio Success!

If you're contemplating building a radio set or if you are not meeting with the best of success with your present set, it will pay you to consider the better grade of radio devices such as STERLING has to offer.

Satisfaction is guaranteed with all

Sterling

RADIO DEVICES

Here we are showing two very important parts to every complete and successful receiving set. A good rheostat is the key to your radio problems, allowing the full reception of clear, loud messages and concerts. The filament volt meter insures the life of your vacuum tube—a protection against premature burn-outs.

Filament Volt Meter

Movement is of the magnetic type, the result of years of manufacturing experience. Flush mounted type. Black satin finish. Lends attractiveness to set. Overall dimension 2 3/8" diam.
0-8; 0-30; 0-100 volt types.
List Prices \$4 and \$5.
Trade discounts on application.

OTHER STERLING RADIO DEVICES

Portable Rectifiers.
Filament Ammeters and Pocket Voltmeters.
Audio Frequency Amplifying Transformers.
Radio Frequency Amplifying Transformers.

The Sterling Manufacturing Co.

2847 Prospect Ave., Cleveland, O.

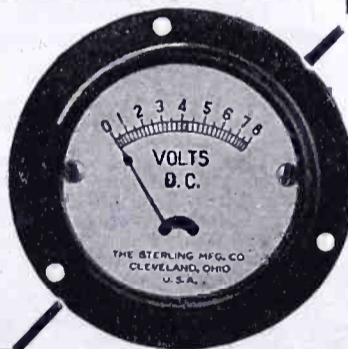

QUALITY PRODUCTS

Instruments 'Phones Loud Speakers

Send for Bulletins AI-10 and AI-20

ROLLER-SMITH COMPANY, 20 Park Place, NEW YORK

WORKS: BETHLEHEM, PA.

Offices in Principal Cities in U. S. and Canada

Continued from page 62

too late for their change of heart so suddenly, and lately, so promiscuously. The czar would brook no subterfuges. Mutiny and treachery would be punished.

"I sat down in the remaining chair and laughed like a woman in hysterics. During the attack I had been deadly calm. It had been a state of calm imbued with the most deadly desire to annihilate the howling beasts who were seeking my life from without. But now I sat in the throes of what—madness probably—a result of the reactions from my late experiences which had been most harassing and wracking.

"The launches scraped alongside. The rail bristled with leveled rifles. The crew had turned back to the czar too late. An officer came toward me as I stepped out on deck. He grasped my hand and was voluble with praise and comment. I sickened and turned away.

"It was homesickness.

"I appealed later and, after several supplications, was finally granted both means and permission to leave Russia, returning home via Sweden. It was a grand and glorious feeling, especially when just about that time Red Russia was sweeping the imperialists across the versts of the country in the east. Little Russia was flaming and White Russia was in the toils as well. The direction of the setting sun was the trail to home."

Investigate!

WESTERN-RADIO DEALERS SERVICE

Wholesale RADIO only

637 SO. HOPE ST. LOS ANGELES 1200 FRANKLIN OAKLAND

How to build the Reinhartz Receiver

is told, complete with illustrations and diagrams, in the latest addition to our FREE looseleaf, handbook catalog.

Amateurs find the Reinhartz hookup by far the simplest yet designed. In efficiency it rivals the Armstrong and other well-known circuits.

Parts necessary for building your Reinhartz receiver are also listed and described in the "Chi-Rad" handbook—your order, no matter how small, will be dealt with the usual "Chi-Rad" assurance of satisfaction.

Write for your copy today—ask for "Chi-Rad" Handbook, Edition RRr.

Chicago Radio Apparatus Co.

415 S. Dearborn St.,

Chicago

Tell them that you saw it in RADIO

Wide Range Proves Crosley Efficiency

Sebring ~
Florida
Hears
Honolulu ~
Hawaii

HONOLULU

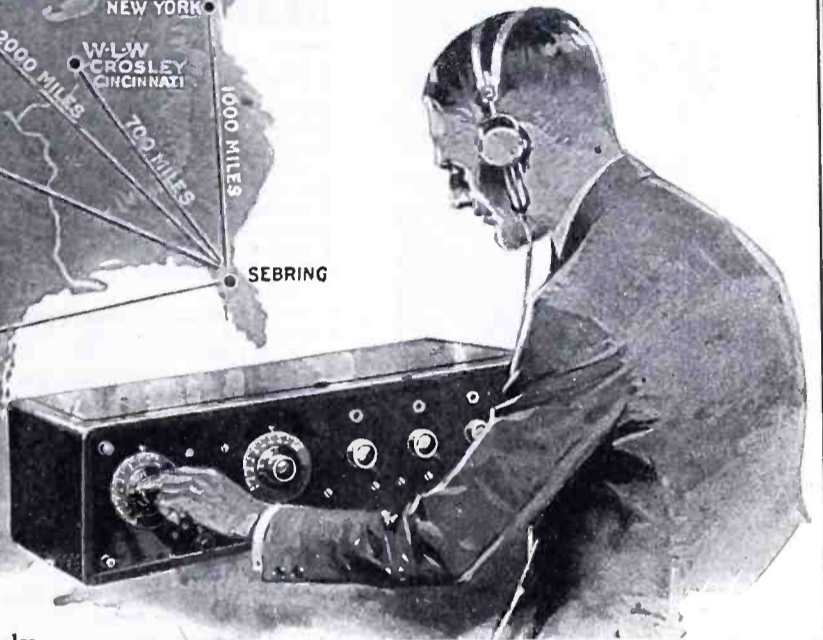

Every day there comes to us unsolicited, new evidence of the remarkable results achieved with various models of Crosley Radio Receiving Sets.

Sebring, Fla., using a Model X Crosley Receiver (price only \$55 for this four tube set) "clearly hears three selections and two announcements from K. D. Y. X. at Honolulu, 4900 miles away!" Centerburg, Ohio, receives 1920 miles from Los Angeles, Calif.; 950 miles from Fort Worth, Tex.; 1200 miles from Havana, Cuba; and 750 miles from South Dartmouth, Mass. A Crosley Model VI, a two tube set that costs but \$28 was used.

With a Crosley Harko Senior—\$20.00—a man from Rock Valley, Iowa, had these very satisfactory results: "I have tested out the Harko Senior and am ready to agree that you made no over statements. We have heard Winnipeg, Canada; Dallas, Tex. and many other points."

These are just a few quotations from among the hundreds that satisfied Crosley users are constantly sending us.

No matter what Crosley Instruments you choose, you may be sure that it will perform everything claimed for it—and more besides. Every Crosley Model, ranging in prices from \$16 to our beautiful console Model XXV at \$150, offers the highest efficiency at the lowest cost.

Listen In on a Crosley and be Convinced.

We also manufacture a complete line of parts for those who wish to make their own outfit. Among these are Variable Condensers, Knobs and Dials, V-T Sockets, Variometers, Vario-Couplers, Rheostats and the well known Crosley Radio Frequency Amplifying Tuner.

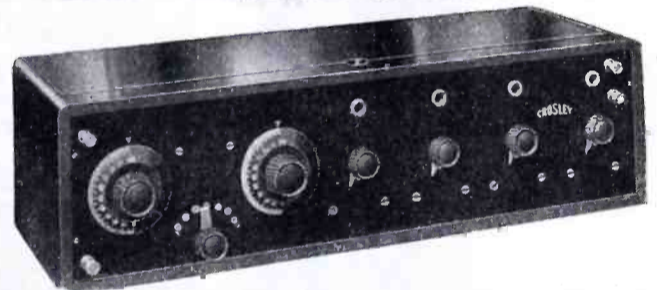

THE THREE MOST POPULAR RECEIVERS ON THE MARKET

CROSLY MODEL X. A four tube set that gives remarkable results. Combines one stage of tuned radio frequency amplification with a tuner, audion detector and the Crosley Two Step Amplifier. Price without bulbs, batteries or phones... \$55.00

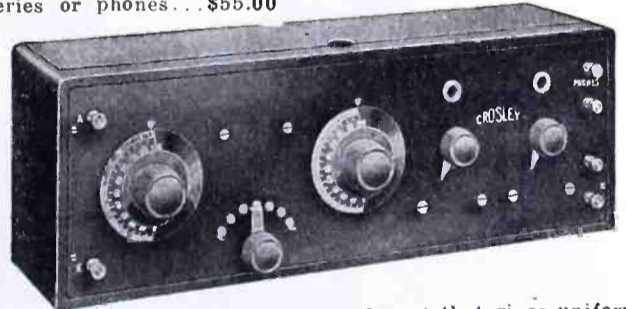

CROSLY MODEL VI. A two tube set that gives uniform satisfaction everywhere. Combines one stage of tuned radio frequency with tuner and audion detector. Price without bulbs, batteries or phones... \$28.00



The Crosley Harko Senior, a one tube non-regenerative receiver, of which thousands have been sold—retail prices, \$14, \$15 and \$16. Similar instruments, but using Armstrong Regenerative Circuit, manufactured under license under Armstrong Patent No. 1,113,149, dated October 6, 1914, can be obtained

from the manufacturers, The Precision Equipment Co., Powel Crosley, Jr., Pres., Cincinnati, Ohio. Write them direct.

CROSLY

Better—Cost Less

RADIO RECEIVERS

CROSLY MANUFACTURING COMPANY

319 Alfred St.,

Cincinnati, Ohio

Tell them that you saw it in RADIO

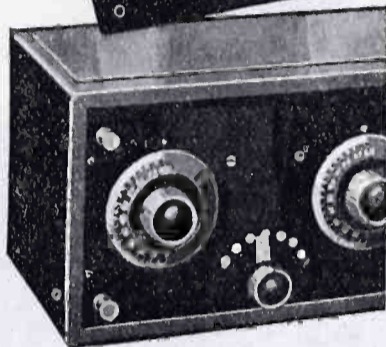

The Leading Radio

Manufacturers of Complete Radio Sets Using Formica

Acme Apparatus Co.
 A-C Electric Co.
 Adams Morgan Co.
 Amateur Radio Supply Co.
 American Radio & Research Co.
 Andrea, Frank A. D.
 Benwood Company
 Beamish Electric Co.
 Boston Scale & Machine Co.
 Bowman Co., A. W.
 Briggs & Stratton
 Bristol Co.
 Canadian Machine Telephone Co.
 Capitol Phonolier Corp.
 Chelsea Radio Co.
 Chicago Radio Apparatus Co.
 Cino Radio Co.
 Clapp-Eastham Co.
 Cleartone Radio Co.
 Cleveland Radio Mfg. Co.
 Cleveland Radio Laboratories
 Cleveland Products Co.
 Consolidated Radio Call Book Co.
 Connecticut Telephone & Elect. Co.
 Corwin Co., A. H.
 Crosley Mfg. Co.
 Central Station Equipment Co.
 DeLancey, Felch & Co.
 Doron Bros., Elect. Co.
 Dryfuss Co., P. M.
 Duck Co., Wm. B.
 Echo Radio Company
 Electric Machine Corp.
 Experimenters Information Service Co.
 Fargo Radio Service Co.
 Fast Feed Drill & Tool Co.
 Federal Institute of Radio Telegraphy
 Federal Telegraph Co.
 Federal Telephone & Telg. Co.
 Freed-Eiseman Co.
 Galvin Electric Co.
 General Apparatus Co.
 Great Eastern Radio Corp.
 Halliwell Electric Co.
 Hartman Electric Co.
 Heslar Radio Co.
 Henry Hyman & Co., Inc.
 Ingersoll Radio Shops
 Kennedy Co., Colin B.
 Klaus Radio Co.
 Kilborne & Clark

Laurence Radio Electric Co.
 Magnavox Co.
 Marshall-Gerken Co.
 Manhattan Elect. Supply Co.
 McCorkel Mfg. Co.
 Meteor Radio Laboratories
 Michigan Radio Co.
 Midwest Radio Co.
 Missouri Radio Co.
 Moon Radio Corp.
 Mutual Purchase Association,
 (Standard Radio Co.)
 National Radio Institute
 Nairsand Radio Mfg. Co.
 New York Coil Co.
 Paramount Radio Corp.
 Premier Radio Mfg. Co.
 Precision Machine Co.
 Precision Equipment Co.
 Radio Apparatus Co.
 Radio Amusement Co.
 Radio Service & Mfg. Co.
 Radio Shop of Newark
 Radio Distributing Co. (Radisco)
 Radio Products Co.
 Radio Electric Company
 Radio Shop of California
 Radio Instrument Co.
 Radio & Scientific Apparatus Co.
 Raymond Radio Corp.
 Ray Mfg. Co., J. A.
 R. T. Radio Corp.
 Reynolds Radio Co.
 Scientific Engineering Co.
 Signal Electric Co.
 Simplicity Mfg. Co.
 Simplex Radio Co.
 Ship Owners Radio Service Co.
 Smith & Smith
 Stanley & Patterson
 States Radio Corp.
 Stern & Co.
 Sleeper Radio Corp.
 Telephone Maintenance Co.
 Tresco
 Tuska, C. D.
 Waveland Radio Co.
 Western Electric Co.
 Western Radio Co.
 Winckler, Frederick
 Wireless Shop, The
 Wireless Mfg. Co.



FORMICA

Made from Anhydrous Redmanol Resins
 SHEETS TUBES RODS

Tell them that you saw it in RADIO

Manufacturers use *and* like

FORMICA

The radio engineers of the leading radio manufacturers all over the United States have approved Formica in the most sincere and convincing way—by adopting it and using it in their production of radio equipment.

No other insulating material for panels, tubes, and other parts can show a list of makers of high grade radio equipment using their material that is comparable to that printed on the page opposite. It is practically a directory of independent radio manufacturers in the United States.

This overwhelming preference for Formica among the men who, among all others, know most intimately the qualities and characteristics of radio insulation means only one thing.

IT MEANS THAT FOR YEARS FORMICA HAS MAINTAINED A QUALITY AND UNIFORMITY THAT IS NOT TO BE HAD ELSEWHERE.

These men like the handsome Formica finish. They like the way it works with ordinary tools. They like its high dielectric strength and the wonderful uniformity of the product. They like the fact that it improves with age instead of deteriorating.

The trained engineers and purchasing agents of these manufacturers can scarcely be mistaken in their judgment of materials. The amateur is perfectly safe in following their lead.

DEALERS: Formica advertising and sales support is the most aggressive and effective in the industry. The Formica Insulation Company treats you right.

The Formica Insulation Company

4616 Spring Grove Ave., Cincinnati, O.



FORMICA

Made from Anhydrous Redmanol Resins

SHEETS TUBES RODS

Tell them that you saw it in RADIO

The Laboratory Technician Says:



Audibility — Plus
 Matching — Perfect
 Volume — Plus

Why Strain Your Ears?

A whisper may be understood at a distance if clearly enunciated.

"T-B-H" Head Sets reproduce clearly and naturally. No "Fuzz" or "Tinny" tone. Extremely sensitive.

Aluminum cases—hard rubber ear caps—6-foot indicated cord—very light in weight, only 12 ounces.

If your dealer does not carry them he will order them for you. : Dealers and Jobbers Write For Discounts

THE TELEPHONE BOOK HOLDER CORPORATION
 Dansville, New York, U. S. A.

District Agent and Warehouse:
 CENTRAL STATES ENGINEERING CO., CHICAGO, ILL.

DO NOT BE CONFINED TO LISTENING IN ON THE NEARBY STATIONS, WHEN BY INSTALLING THE

Genuine and Guaranteed Capitol

"ALL WAVE" COUPLER

(Trade Mark)

Patents Granted

in your set

you can receive remarkably clear and selective broadcast entertainment

From Stations

THOUSANDS OF MILES AWAY

and on any

Wavelength from 150 to 3000 Meters

without the use of variometers, variocouplers, and loading coils.



Eventually—Why Not Now?
 If your dealer cannot supply you, send us your order and remittance together with his name.

Price \$9.00

Beware of Imitations.
 Look for the Trade Mark "ALL WAVE" on the rotor, and the six efficient hook-ups packed in every box.

Six efficient and simple hook-ups sent free upon receipt of ten cents to cover cost of mailing.

Capitol Phonolier Corporation 58 Lafayette St., New York.

THE MARTIAN MARVEL

Continued from page 19

"It does fly, as you term it," replies old Baron Koubansky, calm an' proud like. "Here you see, sir, the first and only reversed-gravity rocket in the world!"

"Reversed what?" I sputters.

"Reversed-gravity rocket, I said," replies Baron Koubansky. "The secret of its flying power lies in a wonderful ray which I have recently discovered—though I find that it has long been known on Mars, where it is called the Zit ray—by means of which the force of gravity can be controlled, reduced to zero, and even completely reversed. In this rocket are five Zit ray generators, the largest one of which acts upon the entire lower part of the steel shell and serves to drive the rocket away from any source of gravity, as for instance the earth. The energy of the other four ray generators is directed into the upper part of the rocket; and through their reacting upon various heavenly bodies other than the one from which the rocket is being propelled, enables the torpedo to be steered in any desired direction. The ray-controlling apparatus is so delicate that this three-hundred-ton shell can be made to weigh less than one ounce, or at will its entire mass can be set in opposition to gravity."

"I don't know if I get you right," I tells him. "Do you mean to say that when you open up them Zip rays full power you can make this steel rocket weigh three hundred tons less than nothin'?"

"That, sir, is approximately the idea," replies old Koubansky. "The action, however, is much more powerful. At full strength, the rays cause this shell to be repelled from the earth with a force of nearly sixty thousand tons. This decreases with the distance, of course, but ample power is always available, because one is constantly meeting other bodies from which additional repulsion may be obtained."

Maybe you don't think I was feelin' pretty dizzy by this time.

Stickin' a kind of socket wrench into a hole in the steel shell, the Baron gives it a couple of turns; whereupon the door in the side of the rocket swings open. This door is about ten inches thick, an' looks like it belongs on some wireless corporation's safe.

"Come," says Koubansky, polite like, "let us be on our way."

"Nothin' doin'!" I exclaims, backin' off, "I ain't goin' in there!"

"Why, my dear sir, is it not yet apparent to you that my reversed-gravity rocket must be perfectly safe!" says the Baron, real pained like. "And think of the possibilities of this trip! You can obtain the constructional details of the wonderful Martian radio system and

Continued on page 70



This official 14 K. gold plated lapel button is now being given FREE to all new Members of the RADIO EXPERIMENTERS' LEAGUE. See special notice in RADIOAD section (page 88) this magazine. Old Members who have not yet received their lapel buttons write at once for one FREE. Get your friends to join RADIO EXPERIMENTERS' LEAGUE (run by Amateurs for Amateurs) 9-15 Clinton St., Newark, N. J.

Investigate!
WESTERN-RADIO DEALERS SERVICE
 Wholesale RADIO only
 637 50 HOPE ST. LOS ANGELES *and* 1200 FRANKLIN OAKLAND

Tell them that you saw it in RADIO

You Can Get **MURDOCK** Receivers

AND OTHER MURDOCK RADIO APPARATUS

--- Why bother with any other kind?

\$5.00

2000 Ohms
No. 56
Double

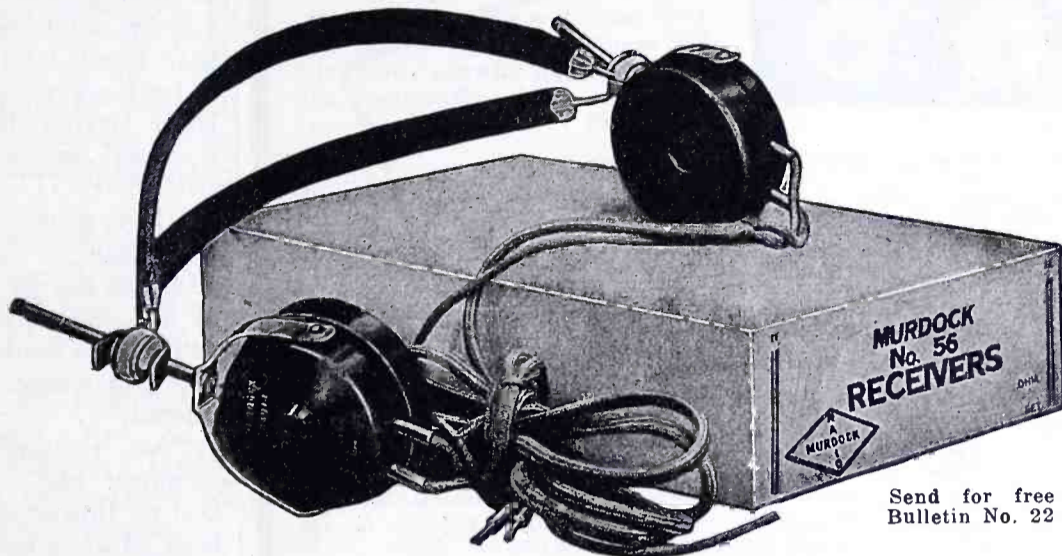

\$5.50

3000 Ohms
No. 56
Double

Send for free Bulletin No. 22

If your dealer is not supplied send remittance direct to us and your order will be promptly filled.

MURDOCK MADE 800,000 TELEPHONE RECEIVERS BEFORE GOING INTO THE RADIO BUSINESS AND HAS MADE THE BEST RADIO RECEIVERS FOR 14 YEARS

We carry a complete stock in our Pacific Coast warehouses. Write for dealer discounts.

KEELER WHITE COMPANY

Pacific Coast Agents—WM. J. MURDOCK CO.—Since 1905

509 Mission Street, SAN FRANCISCO

325 Yesler Way, SEATTLE

211 So. San Pedro Street, LOS ANGELES

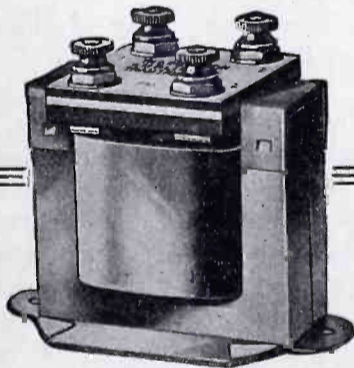

On the First Step

*Thordarson
6 to 1 Ratio
A. F. Transformer*

The ideal two step amplifier has a Thordarson 6 to 1 ratio transformer on the first step.

This is a new product — recently perfected and is distinguished from our 3½ to 1 ratio transformer by the red lettering on the top plate. It gives unusually high amplification without distortion, the core having twice the cross-section of the ordinary transformer.

Remarkably low priced to retail at \$5.00. Good discounts.

Couple up these two for Highest Amplification

We should be able to make better radio transformers for less. And we do!

We have specialized in transformers for the last twenty-five years. That means we know how to make them right! We have the men and the manufacturing facilities to produce them in quantity. That means we can make them economically!

Together they mean the best audio frequency amplifying transformer that can be made, at the lowest possible cost.

Hook up to Thordarson Transformers and see what perfect amplification really means. If you are a dealer, demonstrate to your customers what a perfect combination two Thordarson Transformers make for a two step amplifier—

These transformers can be used with excellent results on low voltage tubes.

And such a demonstration will certainly make sales if results are what your customers are after.

Get a supply of Thordarson Transformers from your jobber now

THORDARSON ELECTRIC MANUFACTURING CO.

500 W. Huron St., Chicago, Ill.

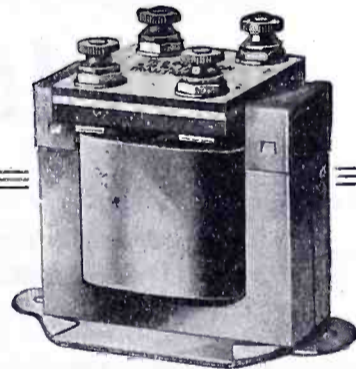

On the Second Step

*Thordarson
3½ to 1 Ratio
A. F. Transformer*

For best results and perfect reproduction of signals, the 3½ to 1 ratio transformer should be used on the second step. Used together in this way, these two transformers give exceptionally loud signals, yet in perfect modulation.

The Thordarson 3½ to 1 ratio transformer is distinguished by the black lettered top plate.

All silk insulated wire used throughout. Unequaled value at \$4.50 list—also with good discounts.

Tell them that you saw it in RADIO

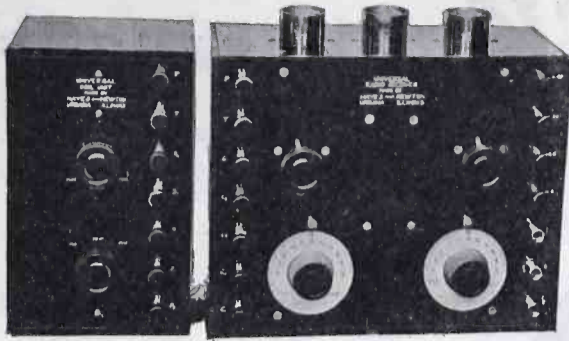

If You Have Never Tuned a Radio Receiving Set by Variable Condensers

You cannot realize the wonderful results possible which this type of tuning affords you in the Universal Radio Receiver and Coil Unit.

By this method of tuning the following desirable features are attained:

- First: The wavelength range possible is approximately four times that attained with variometer tuning.
- Second: The signal strength is exceptionally stronger.
- Third: Interference from other stations is very much less.
- Fourth: By means of the vernier condenser used to tune the Secondary Circuit, extremely sharp signals are possible.

Several other important features incorporated in this set are:

1. Permanent negative potential is automatically applied to the grid of each amplifier tube whenever they are in operation, thus preventing distorted signals.
2. The coupled circuit is used for signals received on waves from 180 to 2400 meters, however, the maximum wavelength possible is 6200 meters with an average antenna.

General Radio parts are used in the construction of the Universal Radio Receiver & Coil Unit. A demonstration of our set will prove conclusively that it is an ideal Radio Receiver for the most discriminating buyer. If your dealer cannot supply you, kindly write us.

Price F. O. B. Factory

Universal Radio Receiver \$90.00

Universal Coil Unit \$10.00

Hayes & Newton

Machinists and Manufacturers of Scientific Instruments and Testing Machines

115 North Market Street

Urban, Illinois

\$10 for \$5

You get a WESRAD AMPLIFYING TRANSFORMER Free for securing only two subscriptions to "RADIO"

Merely Send \$5.00 and Two Subscriptions

"RADIO"—Pacific Building—San Francisco

WIS WIN

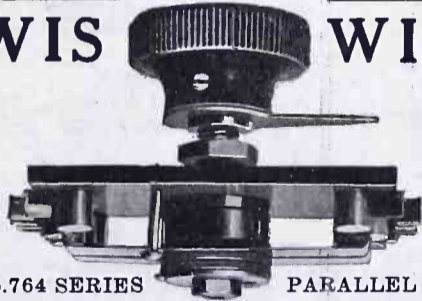

No. 764 SERIES PARALLEL

Concealed type, mounted on formica base \$1.50
No. 754 visible type, switch alone, 65c
Our sheet of diagrams showing the many uses of this popular switch, sent free upon request.

WILLIS SWITCH & INSTRUMENT CO.
8 Kingsbury St., Jamestown, N. Y.

All Under One Cover!

A complete list of all Amateurs, Special Amateurs, and Telephone Broadcasting Stations of United States and Canada; also a large two-color map to record your DX work on, size two ft. by three ft.
MAILED ON RECEIPT OF \$1.00
(No Stamps)

RADIO DIRECTORY & PUB. CO.
45-D Vesey St. New York City

CALLS HEARD

Continued from page 46

By Claude Perkins, 347 So. Fremont Ave., Los Angeles, Calif.

2aa, 3sk, 5cn, 5ir, 5kx, 5xa, 5za, 5zak, 5zat, 5zav, 6cc, 6fh, 6gx, 6lu, 6nx, 6oe, 6om, 6re, 6ti, 6tc, 6xm, 6zh, 6zn, 6zo, 6zt, 6zz, 6adr, 6ajr, 6akl, 6ard, 6ark, 6bih, 6bis, 6bjq, 6boe, 6bqq, 6bqr, 6bum, 6can, 6ced, 6bj, 7gn, 7gs, 7if, 7je, 7jw, 7ln, 7lr, 7mf, 7na, 7nc, 7ny, 7om, 7pf, 7ra, 7rt, 7sc, 7th, 7tq, 7uu, 7wm, 7zu, 7ad, 7af, 7aem, 8bx, 8cf, 8ek, 8qa, 8rr, 8ru, 8xw, 8yu, 8vd, 8abx, 8bxx, 8cou, 9ak, 9bx, 9ey, 9kk, 9la, 9ps, 9ql, 9rr, 9vw, 9zn, 9aap, 9acc, 9ado, 9aic, 9ami, 9any, 9anh, 9anr, 9ans, 9arz, 9azv, 9ave, 9awa, 9awm, 9baf, 9bbu, 9beu, 9bey, 9bjc, 9bji, 9bmy, 9bad, 9bta, 9bxa, 9bxm, 9bxq, 9can, 9ccs, 9cfy, 9cne, 9cou, 9dio, 9dky, 9dsk, 9duk, 9dzm, 9xaq, 9xad.

By 5TA, 329 East D St., Oklahoma City, Okla.
Heard Jan. 30th, 9.55 P.M. to 11.22 P.M., one wire, indoor aerial, 20 ft. long, 6 feet above ground. Detector and one step audio. 1bes, 1cjh, 3xm, 3zk, 4bk, 4by, Fives too numerous. 6bsq, 6re, 8aea, 8anb, 8ben, 8beo, 8bog, 8cso, 8dak, 8eo, 8ex, 8ls, 8qw, 8uf, 8zo. Listed nines, 750 miles or more only. 9aky, 9ato, 9bfm, 9bkj, 9bvy, 9cey, 9dio, 9gu, 9ox. Canadian: 3dh.

By 6BQP, 1928 Crenshaw Blvd., Los Angeles, Calif.
5adh, 5nd, 5nk, 5ns, 5xd, 5xi, 5za, 5zb, 5zh, 5zak, 5if, 7ad, 7bk, 7bj, 7fd, 7kw, 7lr, 7ln, 7ot, 7lu, 7ly, 7hj, 7jw, 7kr, 7mf, 7sy, 7sc, (7tq), 7sp, 7ny, 7mc, 7na, 7dd, 7wm, 7th, 7nr, 7zo, 7zu, 7nf, 7aea, 7aem, 7adp, 7afw, 7abb, 8bk, 8kg, 8ml, 8ue, 8yd, 8zy, 8axc, 8azd, 8bpl, 9dn, 9gs, 9kp, 9pi, 9aey, 9aiy, 9amb, 9awm, 9ayo, 9bey, 9bie, 9bji, 9bxa, 9bxq, 9cfy, 9clm, 9cns, 9dky, 9dlm, 9dte, 9dtm, 9dwk, 9yi, 9ya, 9zn, 9zaf, 9bun, Can.: 9bxqa?

Tell them that you saw it in RADIO

Continued from page 68

patent them in every country on earth—except Japan. Why, you will become the most famous man in the world!"

"Not while old kid C. Chaplin is still able to amble around, I won't," I comes back. "And say, if these here electron magicians on Mars have been signallin' us so long, how come we can't hear 'em? I know a bird with more vacuum tubes than brains who listens every night with a twelve-step amplifier on every wave from twenty thousand to a hundred thousand meters—an' all he gets is mush from N-P-G!"

"The answer is very simple," replies the Baron. "In order to tune in the Martian signals one would require a set of inductances of such—but wait until you see the transmitting station and you will understand. Now let us be getting started."

"No, thanks," I tells him, real determined like. "I don't mind a little trip to Borneo or Copenhagen, but this here Mars is too far."

"Listen!" whispers old Koubansky. "If you knew what they have to drink on Mars—"

"H'm, you didn't mention that before," I says, thoughtful like. "Is it good stuff?"

"It is, assuredly," he answers. "Principally real old rye."

"Well, I don't know," I says, reluctant like. "I've walked twenty miles fer bum home-brew—"

"I am glad you have decided to come," says the Baron. "Step in."

Feelin' like I ought to know better than do such a fool thing, I goes in, passing through another heavy inner door.

"Both these doors close hermetically tight," says the Baron. "This prevents the air inside the rocket from escaping when we get up out of the atmosphere. A simple oxygen generator keeps the air in here in good condition. The rocket also is provided with electric heaters and is lined with a heat-holding material for protection from the fearful cold of interstellar space."

He turns on a light, whereupon I find myself in a round steel-walled room, which is all choked up with motor-generators, high-tension transformers, centrifugal pumps, copper pipes, and steel cylinders. Set in among this complicated apparatus are five strange-looking glass tubes about six inches in diameter and three feet long, with rows of smaller tubes containing silver-like elements branching out on each side like a fish's backbone. In the center of the rocket stands a small table with a U-shaped top; and a leather swivel chair is set in between the legs of the U. This table and the panels it supports are covered with clusters of dials, meters, verniers, gauges, and control wheels, while fitted into six black tubes, one coming from overhead, one from underneath, and

four running horizontally from the sides of the rocket, are six sets of adjustable lenses, in front of which is an elaborate arrangement of tiny mirrors and gold threads mounted over six finely-engraved silver scales.

"Most of the controls you see on the table and panels are for building up the five Zit rays, which are generated in the glass tubes," says the old degravity wizard. "Each ray has two power controls, one of which varies its force in ton units, and the other in pounds. The lenses and mirrors are used in the navigation of the rocket."

"If you will seat yourself here," he continues, pointing to a second chair, which stands over a large glass port in the iron floor, "we shall be getting on the way."

Feelin' right uneasy an' excited like, I sits down.

Old Koubansky switches on a shaded light over his control table, turns off the others; then, taking his seat, he throws in some switches on the panels. There is a clicking of automatic starters, and motor-generators begin to hum. Pretty soon five little blue lights flash up on the control table. As the Baron continues his manipulations, the big glass tubes slowly fill with a glowing silver-colored vapor, which gradually clears away again, leaving half-a-dozen soft rainbow-colored lights flickering and waving in the tubes.

"Now!" mutters old Koubansky—and I hold my breath.

The motor-generators take on a deeper hum; the fluttering colors in the tubes suddenly turn to a hot flaming green; and then I feel the springs in the seat of my chair quiver a little. We were on the way!

Looking down through the port in the floor about a minute later, I see the lights of San Francisco and all the bay cities twinkling below—and getting smaller and farther away every second.

"Sufferin' Jeremiah!" I gasps. "This thing must be travellin' like a speed-bullet!"

"No, only about ten miles a minute," answers old Koubansky, looking up from his controls. "We have to go slow here, otherwise the friction of the air would burn us up. When we get out of the atmosphere we shall come up to our regular running speed, which is about ninety thousand miles a second."

"Oh!" I says, kind of sickly like. "Is that all."

"Why, no," replies Koubansky. "I could double that, if you are in a hurry."

"No, not a'tall, thanks," I replies, hasty like. "I got lots of time."

"The atmospheric pressure indicator has dropped to zero," mutters the Baron; and he reaches for his controls. The hum of the motor-generators again changes to a deeper note, while the

Continued on page 72

Ware

It IS the Most Sensitive Receiving Set on the Market



Actual results count. Testimonials like this pour into us daily.

WARREN R. LIGHTFOOT
METROPOLITAN TOWER
NEW YORK.
February 1, 1923

Ware Radio Corp'n
New York City

Gentlemen:

The WARE AD2 is a revelation. Clear as a bell, without interference of any sort, the programs come in to us nightly from distances I didn't believe possible.

I use a small indoor loop and loud speaker and find it very simple to operate. Its sensitivity and selectivity amaze our friends, several of whom have been interested in radio for years.

I want to thank you for your courteous service and wish you every success.

Yours very truly
Warren R. Lightfoot

The WARE AD 2 Receiver

This 3-step Radio-Frequency Amplifier Detector Set will operate in any location—steel buildings included. It positively solves the problem of "static" and other interferences.

With small indoor loop it reproduces programs with such marvelous tone quality as to amaze the most experienced radio expert. It IS the most sensitive Receiving Set on the market and fully guaranteed.

Price---without accessories, \$1 10

*Order direct, or send for descriptive pamphlet.
DISTRIBUTORS and DEALERS write for proposition.*

WARE RADIO CORP'N

160-162 DUANE ST.

NEW YORK N.Y.



UNEQUALLED SERVICE

"DISTRIBUTING THE BEST IN RADIO"

THE ONLY WHOLESALE EXCLUSIVELY RADIO HOUSE OF SERVICE

ON THE PACIFIC COAST

Western Radio Incorporated

1121 Pine St.

Seattle, Wash.

Tell them that you saw it in RADIO

Warren
Radio
Loop
Un-
Covered

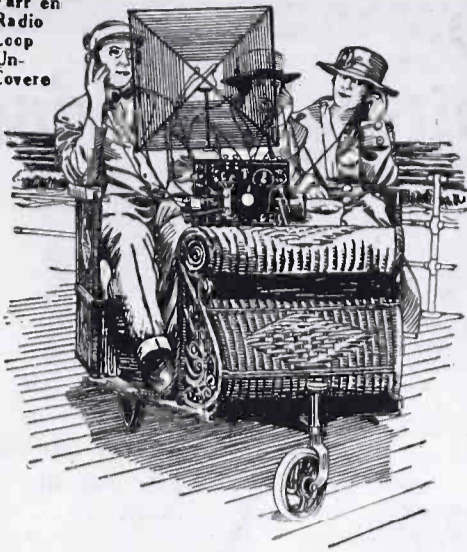

Why You Should Have a Warren Radio Loop

Makes your set portable: no ground outside aerial needed.
Sensitive to direction of wave travel. All interference can be cut out and signals strengthened simply by a turn of the loop.
Saves space. Sets on top of cabinet, under table, or in any odd space. Inconspicuous.
All enclosed away from dust, moisture or any possible harm. New design winding. A Warren Radio Loop for every type set.

Type A-737 (300-700 meters) 6 inches square—non-directional.....	\$10.00
Type A-7236 (175-1000 meters) 6 inches square—non-directional.....	12.00
Type B-2537 (300-700 meters) 18 inches square—directional.....	20.00
Type BL-2520 (200-18,000 meters) with honey-comb cell, 18 inches square—directional....	25.00

Send for Bulletin S. 102

V-DE-CO RADIO MFG. CO.
ASBURY PARK, N. J.
Dept. C



Send 10c for new and complete catalog
Dealers and Jobbers write for our discounts
EMPIRE RADIO CORPORATION
271 W. 125th Street, New York City

Cut Rate Radio

STANDARD APPARATUS ONLY

Write for 54 Page Catalog of Bargains!

Baldwin Type "C" Phones.....	\$10.25
Brandes Superior Phones.....	\$6.45
Radiotron UV200 Detector Tubes.....	\$4.25
Acme Audio Transformers.....	\$4.45
43-Plate Condensers.....	\$1.95
23-Plate Condensers.....	\$1.60
Federal Phones.....	\$6.35

Everything for Radio at less.
Immediate Delivery.

Federal Radio Electric Co.
Dept. N
1233 Grand Ave., Kansas City, Mo.

Investigate!
WESTERN-RADIO DEALERS SERVICE
Wholesale RADIO only
637 50 HOPE ST. LOS ANGELES
1200 FRANKLIN OAKLAND

Continued from page 71

green flames in the tubes grow more brilliant and become shot through with streaks of purple. The needle of a meter which reads from zero to two-hundred slowly begins to rise.

"The influence of the Zit rays practically neutralizes the gravity of our bodies as well as that of the rocket and its parts," says the Baron. "Otherwise we could never withstand this rapid acceleration."

In about a quarter of an hour, the needle of the meter has climbed to ninety-four, where it steadies up.

"Now we are properly started," says old Koubansky, contented like. "It may interest you to know that this cold desolate vastness through which we are shooting at a speed of ninety-four thousand miles a second is not so empty as some imagine, but is quite thickly scattered with pieces of dead rock of every conceivable dimension from mere star dust to hurtling masses weighing thousands of tons. These rocks interfere a great deal at times with the navigation of the rocket, but thanks to the powerful repelling action of the five Zit rays, we can never collide."

Taking a look out of one of the side ports, I see the moon off abeam, her dead volcanic craters and mountains of solid ice showing up plain; then I glimpse down through the floor port at the earth, which has shrunk up to about the size of an ordinary full moon, with the continents of North an' South America lookin' like two ham-shaped shadows. Old Koubansky sits mutterin' over his mirrors an' lenses, while every now and then the rocket takes a kind of sheer—probably dodgin' them flyin' rocks an' interstellar brickbats.

About half-an-hour later, the Baron begins shuttin' down his tubes. Glancing down through the bottom port again, I see a big round disk, which looks about ten miles across, comin' up at us fast.

"Mars!" I exclaims. "I can make out th' canals—"

"No, not canals—cables," says Koubansky. "You have been deceived by the popular supposition that the lines on Mars visible in powerful telescopes are canals. As a matter of fact they are systems of immense cables wrapped around the planet, thereby forming a sort of gigantic dynamo armature producing powerful electrical currents."

"Excuse me," I says, meek like. "I never thought of that."

"The Martians drew power from these cables hundreds of years ago," resumes the Baron. "They soon discovered, however, that the magnetic drag was slowing the planet down and would eventually bring it to a stop; and so they had to abandon the system. At present they produce millions of kilowatts of energy through the disruption

of atoms in peculiarly constructed vacuum tubes. I should explain to you that these people on Mars have been in existence approximately eighteen thousand years longer than the inhabitants of the Earth."

"Then we must still be in th' ring-tailed-baboon stage, alongside of them," I remarks.

"We are coming down in the wrong place," mumbles old Koubansky, suddenly getting busy at his lenses. "I shall have to get reactions on Venus and Jupiter and set over farther."

Looking through the floor port, I see a white, sunlit city shootin' up at us; then in a few minutes we slip down through a hole in the roof of a big building and land inside as soft as if on a velvet cushion.

"We are now in a landing station used by the mail and express flyers from Venus," says Baron Koubansky, shutting off his tubes and generators. "Owing to the small size of this planet, its gravity and atmosphere are only about one-fifth that of the earth, and if we were to venture out into such thin air unprotected, we should instantly bloat and burst open. The opening overhead through which we descended is therefore closed and the chamber containing the rocket is pumped to fifteen pounds. Then we shall go out and put on pressure—maintenance suits."

"You talk about mail trains from Venus," I remarks. "If these birds are fittin' around like that, how come they never call on us?"

"The Earth's gravity would mean instant death to a Martian," replies Koubansky. "A Venus flyer did land several hundred years ago, but he was burnt for a devil by some religious people, and since then the Earth has been boycotted by all interstellar explorers."

Getting out of the rocket a little later, I find Baron Koubansky's pressure suits are sort of armour outfits made of some light transparent stuff like pyralin and fitted with flexible air-tight joints, while on the back is a cylinder of compressed oxygen connected through a reducing valve to the helmet. As we help each other get these rigs on, I discover that we can talk and hear through the transparent stuff almost as easily as if it wasn't there at all.

When we are dressed we pass through a door into another chamber where the air is blown off around us; then we go out into a big room, in which we find about half-a-dozen Martians waitin' for us.

These here Martian gazooneys are about four feet high, heavy set, and yellow skinned. They look like small Japs, only their heads are about twelve inches in diameter, bald, an' round as cannon-

Continued on page 74

Tell them that you saw it in RADIO

RHAMSTINE TRANSFORMERS

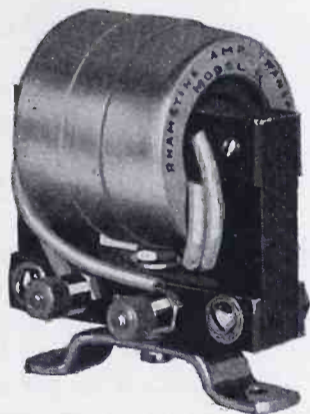

MODEL "B"
(Shielded)

Price

\$4.00



RADIO SETS INSTALLED

423 FARMER STREET

E. M. PAGE

WIRELESS OPERATOR AND MECHANIC

Agent for "Amrad," the Best Known Radio Equipment

Vicksburg, Miss.,

November 20, 1922.

J. Thos. Rhamstine.,
Mf'r. of Radio Apparatus.,
2152 East Larned Street.,
Detroit, Mich..

My Dear Sir:-

I believe that you will be interested in the wonderful results that I have obtained with my receiving set inasmuch as I am using two Rhamstine* audio frequency transformers.

Although not so designed, my set gives good results without the use of an antenna, and I have heard many long distance stations with just the ground connection.

On the evening of Nov. 2nd, I first discovered that my set would operate without an antenna and that evening I tuned in stations, WHB, KSD, WGM, WBAP. Since that time I have often tuned in stations WGM, WDAF, WWJ, KDKA, WSB, WHB, WOC, WHAS, KSD, and WOS. All of these stations have been tuned in clearly and distinctly without any form of an antenna. I have demonstrated my set to many business men of this city and any of them are ready at any time to vouch for the truthfulness of the above statement. Once or twice it was necessary for me to attach a #22 copper wire 18 feet long to the antenna connection, and lay this wire on the floor in order to clearly tune in KDKA and WWJ but ordinarily these stations come in fine.

I attribute this reception solely to the use of Rhamstine* transformers, as I have substituted other transformers that cost more money but my set would not operate without the antenna.

I am always ready and willing to boost the Rhamstine* products, especially the transformers for I am convinced that they are the best.

Yours very truly,

E. M. Page

423 Farmer St.,
Vicksburg, Miss.

**IMMEDIATE
DELIVERIES**

---not just good, but better.

Manufactured by

J. THOS. RHAMSTINE*

2152 E. Larned St.

*Maker of Radio Products

Detroit, Mich.

Tell them that you saw it in RADIO

Continued from page 72

balls. I decides right off I ain't got no use for them.

"We are glad to see you again, Baron Koubansky," they says, bowin' to the old goof. "You have brought a friend with you this time."

"Yes," replies the Baron. "Meet Mr —er—

"Jones," I tells 'em. "Samuel Jones—a hard-boiled brasspounder from Frisco!"

"We are glad to make your acquaintance, Mr. Jones," they says, all makin' a fancy bow.

"Same to you," I says, diplomatic like. "By-the way, would you mind tellin' me what kind of language you speak? I seem to get it all right, but it ain't English."

"It is a universal tongue," replies one of the roundheads. "It can be understood by anybody, even though they have never heard it before. Here on Mars we have one people, one language, and one state. Every one belongs to the state, and every one serves the state in whatever way he is most useful."

"I guess it's a fine system," I replies. "Say, how's chances to get a nip of that famous old Martian rye you got up here?"

"Rye," repeats the roundhead, puzzled like. "What—perhaps you mean liquor!"

"I didn't ask fer soda-water, did I!" I retorts.

But liquor was abolished on Mars almost eighteen thousand years ago!" exclaims the roundhead, astonished like. "Except for a hundred-gallon cask of rye whiskey which has been preserved for thousands of years in a cask in the great museum at Zo-Zonne, the capital city, there isn't a single drop anywhere on the planet!"

"Holy cross-eyed angels!" I groans;—then I turns on Baron Koubansky. "So you put it over on me, huh,—you lousy old skunk—"

"Wait," he interrupts me, troubled like. "I admit and regret having deceived you, but I was anxious for you to see the wonderful Martian radio system; and this appeared to be the only way whereby I could persuade you to come."

I feel like taking a slam at him, but I realizes I ain't in no position to start anything.

"Well, all right then," I growls. "Let's be going."

"Good," says old Koubansky, relieved like. "I shall leave you with one of these gentlemen, who will take you around. I have some private business to attend to, and I will wait for you here at the landing station this evening."

One of the Martians takes me out onto the white noiseless street, which is full of hundreds of busy roundheads passin' back and forth. The first thing I notices is something that looks like a

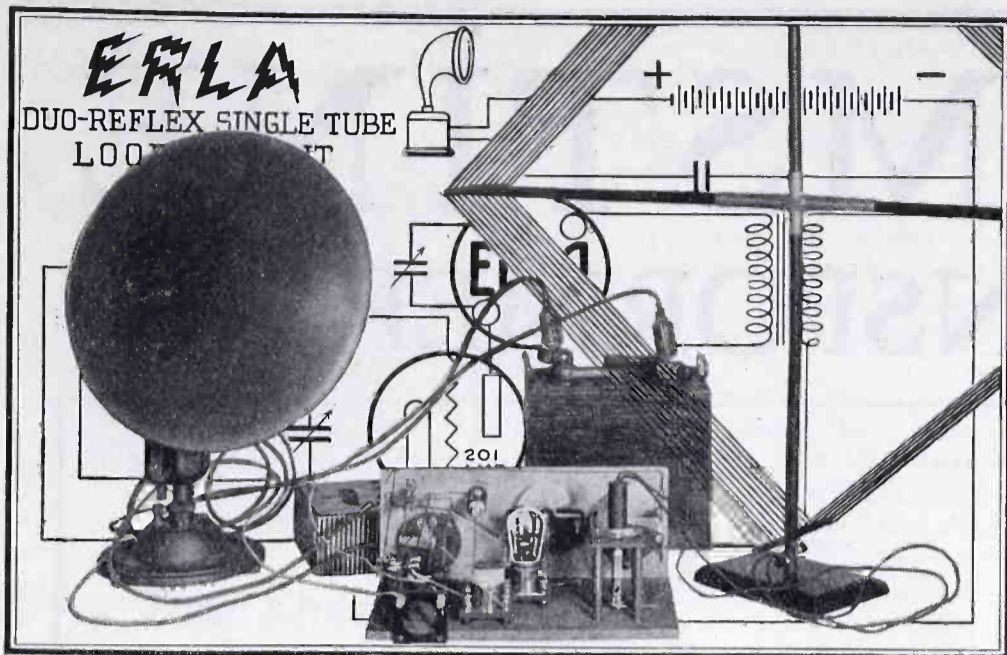

The Most Powerful Single Tube Circuit Ever Built

A single vacuum tube now operates a loud speaker, and this with a loop aerial, using the Erla Duo-Reflex circuit, the most powerful single-tube circuit yet designed.

Two stages of amplification, one radio and one audio, are provided by this circuit, with but a single tube. Further saving in cost results from the elimination of variometers, variocouplers, potentiometers, and ground connection.

Here is an ideal circuit for apartment use, the loop aerial answering most satisfactorily except for extreme long distance work, where an outside aerial is advisable.

Tuning is exceptionally sharp, a movement of only one degree on the control dials serving to cut out undesired stations. Tone volume, with a loud speaker, is surprisingly ample, and the quality of reproduction unusually excellent and clear.

Designed especially for this circuit, and responsible in great measure for its efficiency, is the new Erla Duo-Reflex radio frequency transformer. Overcoming the high capacitance effects of domestic vacuum tubes in unique degree, this transformer provides maximum amplification without distortion.

Blue prints of this new circuit, together with full directions for its construction, are now available. Ask your dealer, or write us, giving your dealer's name.

Manufactured by **Electrical Research Laboratories**, Dept. H, 2515 Michigan Ave., Chicago
 Coast Representative **Globe Commercial Co.**, 700 Mission Street, San Francisco



Unequaled amplification and tone quality are assured by Erla radio frequency transformers. List price \$4.00



Any receiving set benefits 100% in looks by installing Erla bezels. Fit 1 1/2" hole in 3/8" to 1/4" panels. List, 20c

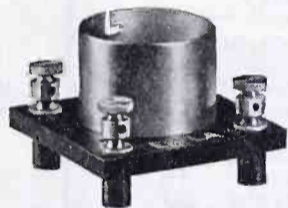

Triple plated nickel parts and polished Radion base of Erla sockets match the finest receiving set. List, \$1.00

JOBBERS—Sales of dependable Erla products are steadily mounting upward, in season and out. Get your share by writing for our liberal terms and discounts.

CARTER "HOLD-TITE" JACKS

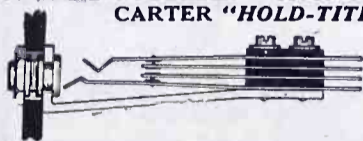

1 to 5 springs; price 70c to \$1.10

New design; heavy phosphor-bronze springs; no spacer washers required. Write for Bulletin on these Jacks, the well-known "TU-WAY" Plugs and other Carter products. CARTER RADIO CO., 209 S. State St., Chicago

"EURACO PRODUCTS"

(Guaranteed)

Compact — Interchangeable — Accurate Most Efficient



Price 60 cents per Unit Mfrs. of

MICA CONDENSEES, GRID LEAKS, MOUNTINGS

Interesting Proposition for Dealers

European Radio Company

1342 East 22nd Street Brooklyn, N. Y.

Investigate!
WESTERN-RADIO DEALERS SERVICE
 Wholesale RADIO only
 637 50 HOPE ST. LOS ANGELES
 1200 FRANKLIN OAKLAND

Tell them that you saw it in RADIO

NOVO
"B"
BATTERIES
FOR RADIO
 22½ - 45 & 105 VOLTS



NOISELESS
DEPENDABLE
GUARANTEED
ASK YOUR DEALER
NOVO MANUFACTURING CO.
 424-438 W. 33RD ST.
 NEW YORK
 531 SO. DEARBORN ST., CHICAGO.

Wave Trap
 TRADE MARK
 PATENT APPLIED FOR

The Missing Link in RADIO



Stops Interference!

Get rid of the interference that is spoiling your evening concert. By using the "WAVE TRAP" you eliminate it.

It is installed in a minute by changing only one connection, and is indispensable on any receiving set with any type of antenna. It is mounted on a formica panel in a handsome mahogany finished cabinet 6x5x6 and is a high grade instrument throughout.

850 Ferbend Electric Co.
 CHARGES PREPAID
 17 E. South Water St.
CHICAGO

Turn to the Inside
Back Cover

Investigate!
WESTERN-RADIO
DEALERS SERVICE
 Wholesale RADIO only
 637 50. HOPE ST. LOS ANGELES
 1200 FRANKLIN OAKLAND

Oklahoma cyclone—a kind of dark cone-shaped cloud—floating high up over the city with a long stem reaching down among the buildings.

"Looks like a friendly little tornado breezin' along," I remarks. "Are they common here?"

"That is not a tornado," answers the Martian. "If you watch a moment, you will see that it is quite stationary. It is the antenna of the great radio transmitter with which we are trying to signal the Earth."

We get into a thing that looks like a cross between a taxicab an' a telephone booth, the Martian shuts the door, turns a numbered dial, sticks a nickel in a slot, pushes a button, opens the door again, and we are in another place.

"That is nice fast work," I remarks, steppin' out. "Where are we now?"

"If you will look up, you will see overhead the gigantic antenna you observed a moment ago," he answers. "This group of buildings before us is the Martian interstellar calling and listening radio station."

The roundhead takes me inside and introduces me to another roundhead, who seems to be the chief engineer of the joint.

"So this is the friend Baron Kouban-sky brought," says the chief; and I sees a queer kind of look pass between the two roundheads. "First I will show you our receiving section, Mr. Jones. It may surprise you to be told that we have been listing to your Earth stations for years."

With this he shows me into a big windowless laboratory made entirely of copper and fitted with copper doors, where the first thing I hear is concert music that sounds like it might be comin' from the Frisco Examiner's broadcastin' station.

"Shut that off!" snaps the chief, clappin' his hands to his ears and glarin' at his gang of assistant roundheads. "How many times have I told you not to listen to those frightful discords. They will eventually give you audio-phobia!"

I observes that the laboratory contains three big tables about thirty-five feet long, all of which are loaded down with receiving gear and masses of silk-cord connections. Here and there on each table are rows and clusters of vacuum tubes, about ninety altogether—and all burning.

"This is only a part of our receiving equipment," says the chief-engineer roundhead. "About thirty miles from here we have a building containing an elaborate apparatus with which we project a powerful radio-sensitive, non-diverging beam, or, as we call it, Zero ray. We can adjust this ray to strike on any desired part of the Earth or other planet, and radio waves impinging upon

Continued on page 76

Tell them that you saw it in RADIO

Unequaled Quality of
Volume and Purity
of Tone

are assured by adding to your Radio Set the newly constructed 100% perfect Audio Frequency Transformer R T-A2. This Audio Transformer is exactly the same shape and size as the R T-6 Radio Transformer, but the color is brown, thus making a neat match when both Radio and Audio transformers are used together. Why build up beautiful tone quality with Radio Frequency and destroy it with inferior Audio transformers? For best results on both tone and distance, use Radio Service Laboratories Radio Frequency (R T-6 and R T-6A) in the black case, retail price \$6.00, and Audio Frequency (R T-A2) in the brown case, retail price \$6.50.

Order by type number, accept no substitute and remember that all Radio Service Laboratories Transformers are individually triple tested and unconditionally guaranteed. For sale at all reliable electrical or Radio Stores or order direct from us.

Send ten cents for new booklet on Radio Frequency with schematic diagrams—a most valuable and helpful publication for the radio amateur and expert.

Rasla Sales
Corporation

National Distributor

10 East 43d St.
 New York City
 Dept. C



The new member of the Rasla Family—in the brown case.

A SUPERIOR AUDIO Frequency Transformer

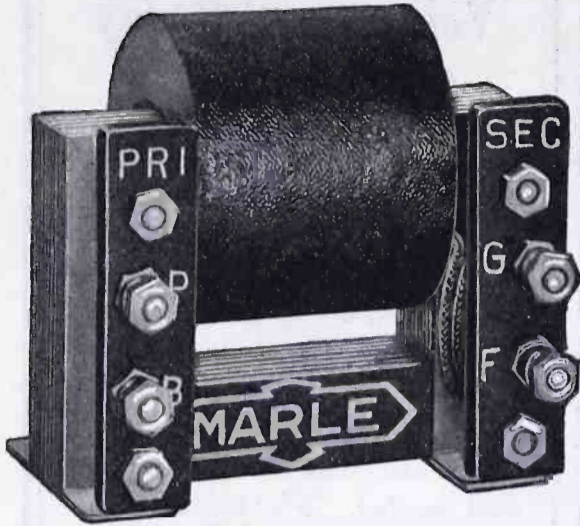

Used and Recommended by Leading Reputable
Manufacturers of RADIO APPARATUS

LIST \$3.75, MOUNTED

Write for information and discounts
Jobbing Concessions Restricted

Manufactured by

MARLE ENGINEERING CO.
Orange, N. J.

Special Prices Quoted on Unmounted Type
to Manufacturers.

Chelsea Condensers

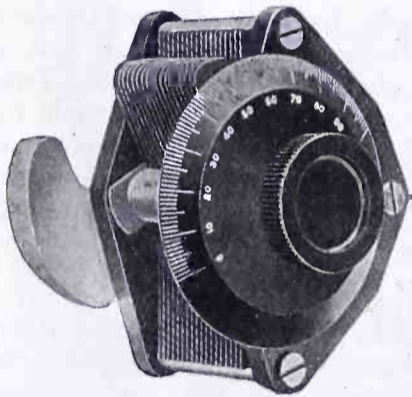

No. 1

PRICES :

No. 1 Table.....	.001	\$5.00
No. 2 Table.....	.0005	4.50
No. 3 Panel.....	.001	4.75
No. 3a Panel without dial..		4.35
No. 4 Panel.....	.0005	4.25
No. 4a Panel without dial..		3.85
No. 5 Panel.....	.00025	3.75
No. 5a Panel without dial..		3.35
No. 6 Panel vernier.....		2.90
No. 6a Panel without dial..		2.50
No. 7 Table with vernier....		6.75
No. 8 Panel with vernier....		6.50

**Genuine Bakelite
Construction**

**The best and most complete
line of condensers in
existence.**

Write for our catalog No. 7

Chelsea Radio Co.

152 Fifth Street
CHELSEA, MASS.

Continued from page 75

the ray are registered throughout its length."

"I wonder if I get you right," I says. "The wireless waves hop onto this here ray and slide up to Mars, like a kid on a banister?"

"That is not precisely the action," replies the roundhead, "but the result is about the same. At this end the Zero ray re-radiates very feeble waves corresponding to those striking its farther end; and these re-radiated waves are detected and amplified by the apparatus you see before you—a multi degenerator and a forty-eight step radio-frequency amplifier."

"Forty-eight step!" I repeats, kind of dazed like. "Your vacuum tubes ain't much like ours, I guess."

"They are pretty good," admits the chief. "Even so, it took us eight years to get all the circuits balanced, and five of our best radio engineers committed suicide doing it, while nine others are still in the mental sanatorium at Zo-Zonne having their brains readjusted."

From the receiving laboratory, the chief takes me out into a kind of central court to look at the transmitting aerial. This seems to consist of a hundred or more cables, each over a foot in diameter, coming down from out of the sky and shackled into four porcelain insulators, which are about eighty feet across. From the insulators the cables are led off in a bunch to a great building of solid brown porcelain.

"This antenna has a circular-shaped flat top," says the chief, pointing upward to where it spreads out, like a giant mushroom. "It is about eighteen miles in diameter, and is supported at an elevation of thirty thousand feet by means of a set of twelve Zit-ray generators, similar to those you have seen on Baron Koubansky's rocket. This cone-shaped system of cables coming down to the insulators keeps the aerial from flying away, and at the same time serves as a lead-in."

We pass into the porcelain building; and I find myself in a vast high-ceilinged hall, perhaps twelve-hundred feet long and half as wide, with big steel-latticed windows in the walls, except at one end, where there are twenty vertical inductance coils about fifty feet in diameter and ninety feet high. Most of the remaining floor space is taken up by eighty gray metal cylinders, maybe a foot in diameter, five feet high, and shaped like the shells of a twelve-inch gun. These are mounted in an upright position on heavy brown porcelain beds spaced about ten feet apart, and are arranged in four rows of twenty.

From each porcelain base two large pipes and three ten-inch cables go down into the floor, and a fourth cable runs up overhead into a system of enormous

Continued on page 78

Tell them that you saw it in RADIO

For

BETTER RESULTS

use

EVEREADY

"A" and "B"

BATTERIES

with your
radio set

Westinghouse
WD-11 Vacuum
Tubes operate
best when used
in connection
with

Columbia

Dry Batteries

—they last longer

Manufactured on the
Pacific Coast—
fresh and full of pep

NATIONAL CARBON COMPANY, Inc.

599 Eighth St.

San Francisco, Calif.

Thordarson Amplifying Transformers

Regular Price \$4.50

Special \$3.50

MYER'S HI MU TUBES

With Receptacles \$5.00

60E

KGO

6XR

I Ship All Over
the United States

"Everything Worth While In Radio"

AT

THE RADIO STORE

OF

PAUL FRANKLIN JOHNSON



560-562 East Colorado Street

PASADENA, CALIFORNIA

If you have not already received one of my RADIO MANUALS, write for one, enclosing 10c in stamps to cover mailing.

Type E-2 3000 ohm Everett Fones

Regular Price \$8.50

Special \$7.00

Type 2-A 2000 ohm Stromberg

Carlson Fones

Regular Price \$8.50

Special \$7.00

Tell them that you saw it in RADIO

Just Consider—

—the essential features necessary to make an audio frequency transformer a good transformer.

1. High Amplification
2. Minimum Distortion
3. Low Interstage Linkage
4. Convenient Mounting
5. Compactness

Cotoco transformers make these ideal features facts. And the finish will please you.

"Built First to Last"

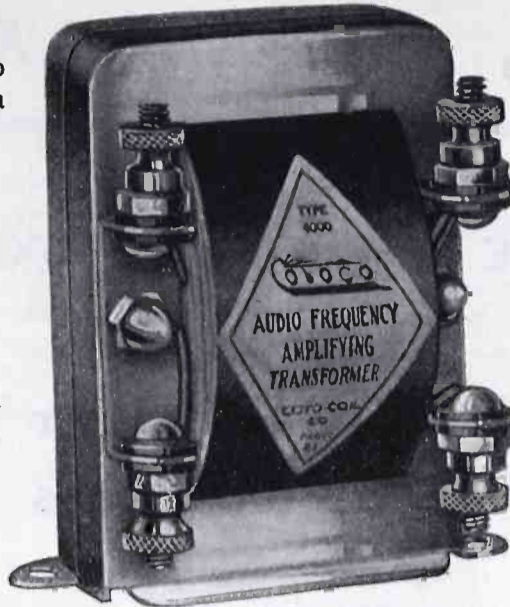

At your Dealer's \$5.00
COTO-COIL CO PROVIDENCE

Tell Your Dealer

"ALL-AMERICAN" or Nothing

when you buy Radio Transformers, and
STICK TO IT—for your own protection

"All-American" Amplifying Transformers Radio and Audio Frequency

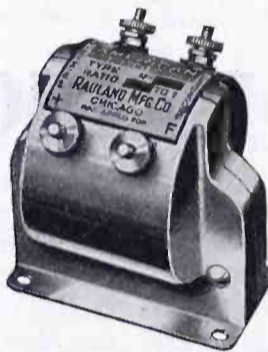

have **PROVED THEIR SUPERIORITY** in every competitive test, and won the approval and adoption by leading makers of sets.

Electrically correct, splendid examples of high-class workmanship, from the best materials; built by experts; rigidly inspected and every one tested singly before leaving our factory.

- R10—Radio Frequency (150 to 550 meters)
- R12—Audio Frequency (Ratio 3 to 1)
- R13—Audio Frequency (Ratio 10 to 1)
- R21—Audio Frequency (Ratio 5 to 1)

Send for circular "Cascading of Amplification."



RAULAND MFG. Co.
 35 So. Dearborn St., Chicago, Ill.



HYGRADE SPECIALS

No. 763 Eveready Variable B Battery.....	\$ 1.25
No. 766 Eveready Variable B Battery.....	2.25
No. 767 Eveready Variable B Battery.....	4.25
Skinderviken Transmitter Buttons.....	.95
2000-Ohm Murdock No. 56 Head Set.....	4.49
3000-Ohm Murdock No. 56 Head Set.....	4.98
Federal 2200-Ohm Head Set.....	6.50
6 Volt 20 Amp. Marko Storage Batteries	8.95
6 Volt 50 Amp. are	11.95
6 Volt 80 Amp. Guaranteed 2 Years	15.45
6 Volt 110 Amp.	18.95

All orders must include Parcel Post charges.

HYGRADE ELECTRICAL NOVELTY CO.
 41 West 126th St. New York, N. Y.

TURN TO THE INSIDE BACK COVER

PHANTOM-CIRCUIT

Build Your Own. This marvel of mystery, using no loop, no aerial and no ground brings in music instead of interference. We have heard stations 950 miles distant on one tube. By using WD-11 tube set can be entirely self contained. Very easy to build from our instructions, use your own spare parts, nothing complicated like radio frequency or super regenerative. Only one tuning control. Complete instructions, with hookup and photo of circuit mailed to you for 60 cents. Stamps accepted.

Vesco Radio Shop Box R-704 Vacaville, Calif.

Continued from page 76

braided copper buses suspended from huge insulators. I noticed that each of the metal shells has a small mica window in one side, through which emanates a hot red glow.

"Burnin' Jerusalem!" I gasps. "Vacuum tubes!"

"Yes, these are our power tubes," says the chief, complacent like. "The water-cooled alloy-metal shell serves as the plate element, upon which is impressed a direct current of approximately fifteen hundred thousand volts. The tubes are each of three hundred and fifty kilowatt input, giving us a total power of twenty-eight thousand kilowatts. This is radiated on a wavelength of five hundred kilometers, or five hundred thousand meters. Yet all this enormous energy is controlled in the final master circuit by one little four-watt tube. Magnificent station, is it not?"

"Yes, it's a real neat little layout," I replies, dizzy like. "You must get several amperes radiation."

"The man who designed and built the station had his license suspended five years and was permanently reduced to a third-grade engineer because he could not bring the radiation up to the required minimum of forty-six thousand amperes," replies the roundhead. "Just at present I am holding the antenna current at fifty-two thousand, but it varies two or three thousand, according to the weather."

"Of course, that would be expected," I says. "A couple of thousand amps more or less don't amount to nothin' anyway."

Just about this time my guide, who has been away some place, joins us again.

"I am sorry to interrupt your inspection of the station, Mr. Jones," he says regretful like, "but the professors of the First National Academy of Anthropology at Zo-Zone wish to see you."

"Well, I s'pose I have to go," I says to the chief-engineer roundhead. "I'll be back in a little while an' get all th' dope on this joint—if it's all right with you."

"Certainly," replies the chief. "Any time you wish." But he glances at the other roundhead with a kind of phony smile which I don't like.

The guide takes me out into another telephone-booth taxi; and a couple of seconds later we arrive at Zo-Zonne. Here we go into a building that looks like the palace of the King of England, and before long I find myself standin' up on a stage in a sort of big auditorium, in which about a thousand roundheads are sittin', lookin' at me. I can see that these are real old birds, because their round domes are glistenin' like billiard

Continued on page 80

Tell them that you saw it in RADIO

DO YOU WANT A REAL HEADSET?

The Dictograph is the Best Headset in the World at ANY Price

This is the same supreme Dictograph Headset that has always sold for \$12—same in quality, same in guarantee, same in everything but the price—\$8 complete. Made by the makers of the world standard Dictograph products—the marvelous "Acousticon" for the Deaf, the famous Detector Dictograph, the Dictograph System of Interior Telephones and Dictograph Radio Loud Speaker for the Home.

Read a few of the many letters we have received from Dictograph Headset users. You, too, can enjoy the utmost in Headsets if you own one.

U. S. Marine Hosp. LaPorte, Ind.
No. 43, "I wish to compliment you on the 3000-ohm headset you now have on the market retailing at \$12.00 (now \$8). I have been experimenting with the Radio game for the past year. In my experience I have tried out 14 different headsets, including one which I purchased for \$16.50. I at last have found the ideal phone where tone quality excels, and harshness is eliminated, and I cannot express myself in words as to the wonderful results I have obtained."

Ellis Island, N. Y.
"The undersigned has for the past sixteen years been an amateur, commercial and government operator, and has used every known make of radio receiver on the market. On April 21st one of your Type R-1 3000 ohm receivers was purchased and it can be safely said without dispute that they are absolutely the best radio receiver on the market today; bar none."

C. H. WEST, U.S.P.H.S.
J. T. BACHMAN

Go to your dealer's today and listen-in with this supreme instrument. Note the difference. Buy two or three Dictograph Headsets and let the rest of the family enjoy your set. Always insist on Dictograph Products. They are Fully Guaranteed.

DICTOGRAPH PRODUCTS CORPORATION
Suite 1303, 220W. 42 St., New York City
Branches in All Principal Cities



The Standard of the World

Type R-1, 3,000 ohms. For all types of crystal and vacuum tube receiving sets.

Dealers:

The Dictograph is the Fastest Selling Headset on the market today. Order through your jobber or write direct for names of authorized distributors.

Sidbenel

LASTS 5

"B"

YEARS

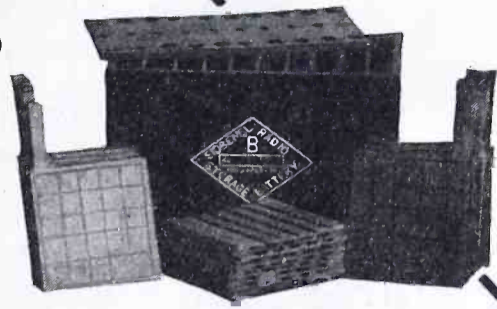

BATTERY

Exceptionally powerful. Makes weak signals strong. A single charge will last six months, recharged (for less than 1/2c) from any lamp socket or farm lighting generator. Patented high ampere plates charged and formed before leaving the factory.

Positively eliminates battery noises often blamed on static. Container will not leak and is made of genuine hard rubber. Size 2 1/2 in. x 3 in. x 4 1/2 in.

You assemble the battery easily and pleasurably in less than ten minutes. Complete illustrated directions with each battery.

Large illustrated circular on request.

- Price 22 1/2 volt, unassembled.....\$4.25
- Price 22 1/2 volt, assembled..... 4.65
- Rectifier for A.C..... .35

Sidbenel Radio Equipment Mfg. Co., Inc.

1663 Jerome Avenue, New York City

BIG NEW STOCK OF RADIO SETS AND PARTS

Grebe CR-5	\$80.00	Grebe CR-9	\$130.00	Kennedy No. 220	\$150.00
Grebe CR-8	\$80.00	Kennedy No. 281	\$90.00	Kennedy No. 110	\$285.00
Grebe Tuned Radio Amplifier				\$60.00	

WE ASSURE YOU OF THE MOST PROMPT SERVICE

Our Radio Mail Order Service is gaining much popularity on account of the FAST SERVICE. We ship your order within four hours of its receipt. After you tire of waiting days—or maybe weeks—for your supplies, try Warner Brothers' Radio Mail Order Service and you will use no other. Following are a few items that we have in stock:

VARIABLE CONDENSERS		AMPLIFYING TRANSFORMERS		RADIO FREQ. TRANSFORMERS	
.0003 11 Plates Signal	\$3.00	ATWATER KENT	\$5.50	UV1714	\$6.50
.0005 21 Plates Signal	3.50	UV-712 Radio Corporation	7.00	Radio Service Co. (RT6 and RT6A)	6.00
.001 43 Plates Signal	4.50	231A GENERAL RADIO	5.00	AEROVOX	4.50
.0015 63 Plates	7.20	A2 ACME semi-mounted	5.00	ACME	5.00
.001 43 Plate Warner	4.00	BRYANT	5.00	STORAGE BATTERIES	
.0005 23 Plate Warner	3.50	All American 10 to 1 Ratio	4.75	6 Volt 70 A. H.	\$15.00
EVEREADY "B" BATTERIES		JACKS AND PLUGS		Philadelphia 6 V. 60 A. H.	16.00
No. 765, 22 1/2 Volts	\$2.00	FEDERAL 1421 Open Circuit Jack	\$.70	LOUD SPEAKERS	
No. 766, 22 1/2 Volts, tapped	3.00	FEDERAL 1422 Single Circuit Jack85	R3 Magnavox Radio Type	\$45.00
No. 774, 43 Volts, tapped	5.00	FEDERAL 1423 Double Circuit Jack	1.00	R2 Magnavox	85.00
No. 746	15.00	FEDERAL 1435 Automatic Filament Control Jack	1.00	Western Electric	55.00
REMLER APPARATUS		FEDERAL 1438 Automatic Filament Control Jack	1.20	VARIO-COUPLERS	
810 Jr. Rheostats	\$1.00	PACENT UNIVERSAL	1.25	REMLER 503 Cario-Coupler	\$5.40
330 Audion Detector Panel	8.50	ERLA	1.00	REMLER 505 Coupler on Unit Panel	12.75
331 Amp. Panel	6.00	RHEOSTATS		OUR OWN TYPE	3.50
333 Amp. Panel	9.00	REMLER Jr.	\$.75	ATWATER KENT	8.00
96 Variable Grid Leak40	FADA—with new Knob75	ATWATER KENT on Panel	13.00
97 Grid Condenser20	GENERAL RADIO No. 214 7 ohm or 2 1/2 Amp. 2 ohm	2.25	DAYTON FAN CO.	8.00
SOCKETS		DEFOREST, new type	1.20	PHONES	
156 GENERAL RADIO	\$1.25	PARAGON	1.00	Murdock, 2000 Ohms	5.00
KELLOGG75	MURDOCK 560	1.00	Murdock, 3000 Ohms	5.50
PARKIN	1.00	KLOSNER	1.50	Western Electric, 2200 Ohms	10.00
HOPEWELL60	JENKINS	1.50	Brandes, Superior	8.00
VARIOMETERS		FRAMINGHAM75	Brandes, Navy	14.00
REMLER 505 Moulded Bakelite	\$7.50	CUTLER HAMMER	1.00	Lincoln, 3000 Ohms	6.00
OUR OWN TYPE	3.50	BRADLEYSTAT	1.85	Frost, 2000 Ohms	5.00
ATWATER KENT	8.00	FRAMINGHAM VERNIER	1.25	Frost, 3000 Ohms	6.00
DAYTON FAN	7.50	CUTLER HAMMER, VERNIER	1.50	Baldwin Type C or E	pr. 12.00
				Baldwin, Type F or G	13.00
				Master Baldwin	pr. 12.00

Now that you have read the list, get that order into the mails without delay. If there is something that you want and don't see it listed here, write us anyway and we will get it for you. Our two stores save still more time in getting your apparatus in a hurry. Enjoy the pleasure of real service for a change. Send us your orders.

San Francisco.
350 Market Street
Phone Douglas 4639

WARNER BROTHERS

TWO STORES

Oakland, Cal.
22nd & Telegraph Ave.
Phone Lakeside 6223

Tell them that you saw it in RADIO



Type 601
Price 35 cents
and 40 cents

Good Enough for Uncle Sam

Dubilier Micadons are little receiving condensers of pressed mica, and are made like the Dubilier condensers ordered by Uncle Sam for the Army and Navy. They are permanent in capacity and, hence, reduce tube noises.

The price ranges from 35 cents to \$1.00 each, dependent on the type and the capacity.



Radio Reception from any Lamp Socket

The Dubilier Ducon does away with troublesome antennae and loops. Simply screw it in any lamp-socket and the music, news and talks come in perfectly. Price at your dealer, \$1.50.

No outside antenna; no indoor loop. Just the Ducon in a lamp-socket

BRANCH OFFICES:

- San Francisco, Cal.—709 Mission Street, Suite 701-704
- Seattle, Wash.—1926 L. C. Smith Bldg.
- Los Angeles, Cal.—337 So. Western Ave.
- St. Louis, Mo.—Syndicate Trust Building, Suite 1409
- Pittsburgh, Pa.—704 Granite Bldg.
- Huntington, W. Va.—1028 Fourth Ave.
- Washington, D. C.—Munsey Building.
- Chicago, Ill.—33 So. Clinton St.
- Atlanta, Ga.—802-3 Forsyth Bldg.

DUBILIER

Condenser & Radio Corp.

48-50 West 4th St., New York

Canadian Distributors:
General Electric Company,
Toronto, Canada

"B" BATTERIES

AN EVEREADY

PRODUCT

- 43V. Batteries, tapped.....\$5.00
- 22½V. Batteries, Navy Type..... 3.00
- 22½V. Batteries, Commercial Type..... 2.00

Latter two types especially adapted to Cunningham and Radiotron Tubes.
Postage Prepaid Anywhere in U. S.

ETS-HOKIN & GALVIN

Wireless Engineers

10 Mission Street

San Francisco

Investigate!
WESTERN-RADIO DEALERS SERVICE
Wholesale RADIO only
637 50. HOPE ST. LOS ANGELES
1800 FRANKLIN OAKLAND

Continued from page 76

balls, an' they all have fancy snow-white goatees.

Pretty soon one old gazooney, who looks like he is the great-grandfather of all the roundheads, comes out alongside me on the stage.

"Fellow scientists and investigators," he begins, addressin' his gang out in front of us. "I take great pleasure in presenting to you this afternoon the first living specimen of the Earth genera *homo saphead* that it has ever been our good fortune to get possession of. Now, at last, we shall be able definitely to settle the long continued and bitter dispute between our good Doctors Zeeno and Zo-Zit regarding the brain and nervous structure of our prehistoric people; for this specimen fairly represents our own imperfect development of eighteen thousand years ago. We are going to remove his cerebellum, medulla oblongata, and spinal cord, to investigate—

"Hey, look here, you old gooney," I breaks in. "Are you talkin' about me!"

"Why, of course," he answers. "It is a perfectly harmless procedure. Your vital spark will be safely preserved in a jar of chemically pure radium, to be afterwards replaced—"

"Well, all I got to say is that it's nothin' doin'!" I informs him and his crew. "I ain't goin' to allow no gang of basketball-headed old freaks to go draggin' my cerebellum an' medullum obligata around like that. You can put that in your pipe an' smoke it!"

"But you have nothing to say in the matter, sir," replies the roundhead. "It is your duty to the state—"

"It is not!" I barks. "I don't owe this state nothin'! I don't belong to it!"

"Oh, yes, you do," insists the old brain butcher. "You have been leased to the Martian State for a period of twenty years by Baron Koubansky."

Now, wouldn't that boil you!

"Oh, he did, huh!" I says, grim like. "How much was *his cumshaw*?"

"Five gallons of the ancient rye whiskey preserved in the cask in the national museum," replies the old roundhead. "He has already taken it and returned to the Earth."

By this time I can see that I am in a hell of a fix.

"Well, I refuse," I declares, ugly like. "I'll bust th' jaw of th' first cerebellum grabber that comes near me! Do you get that!"

"I advise you to submit peaceably," replies the old roundhead. "If you resist, we shall be forced to apply the Zing ray, which will instantly paralyze you."

I begins to realize then that I'm done for.

"All right," I says, "but look here—give me a quart of that old rye in the

Continued on page 82

Tell them that you saw it in RADIO

STANDARD Equipment Prices Can U Beat 'Em?

Every item is guaranteed highest grade and perfect or money refunded.

	Regular	Our Price
Magnavox, R-3.....	\$45.00	\$34.50
WD-11 Peanut Tube—Socket Free	6.50	6.50
Cunningham Detector Tubes.....		5.00
Cunningham Amplifier Tubes.....		6.50
With each Cunningham tube purchased we will give free 1 bakelite base, metal neck socket and 1 high grade rheostat.		
Baldwin Phones	\$12.00	\$ 9.25
Western Electric Aviation Type Army Phones with Headbands Guaranteed New Stock. A Remarkable Value at the price of.....		8.00
11 Plate Variable Condensers.....	3.00	1.45
23 Plate Variable Condensers.....	3.50	1.50
43 Plate Variable Condensers.....	4.50	1.75
Large Size Tapped "B" Battery 22½ Volt.....	3.00	1.75
Large Size Tapped "B" Battery 45 Volts.....	5.00	3.00
All-American A. F. Transformers Shielded 10 to 1..	4.75	3.35
All-American A. F. Transformers Shielded 5 to 1..	4.75	3.35
All-American A. F. Transformers Shielded 3 to 1..	4.50	3.25
Erla Radio Frequency Transformers	4.00	2.95
Carter Radio Jacks—Open Circuit Jack70	.50
Closed Circuit Jack.....	.80	.60
Double Circuit Jack.....	.90	.70
Filament Control 4 Spring.....	1.00	.80
Filament Control 6 Spring.....	1.10	.90
High Grade Filament Rheostats75	.45
Moulded Variometers	5.50	3.75
Moulded Variocouplers 180 Degree	4.50	3.25
Dubilier Micadons and Ducons.....	25% off list	
Switch Lever—Tapered Knob.....	.40	.17
Switch Points..... Special at Per Dz.		.10
Switch Stops..... Special at Per Dz.		.24
Guaranteed Radiocite Mtd....	.30	.20
Guaranteed Million Point Mtd.	.30	.20
3" Bakelite Dial75	.45
Tone Tested Mtd. Galena....	.30	.20
Grewol Crystal Detector	2.00	1.65
Federal No. 226W. Transformers	9.00	5.25
Triple Honey Comb Coil Mounting	5.00	3.50

SPECIAL SPECIAL SPECIAL SPECIAL
TUSKA STANDARD LICENSED REGENERATIVE RECEIVER AND TWO STAGE AMPLIFIER COMPLETE WITH—3 Cunningham Tubes—6 Volt 100 Ampere "A" Battery—2 Large Size "B" Batteries—3000 Ohm Headset—Aerial Equipment—and Arkay Loud Speaker—In Short, Nothing Else To Buy—At The Very Special Price of...\$100.00

Send Your Order In Today!
Shipments made within 24 hours. Please remit by Express or Postal Money Order. Include postage at your zone rate or shipment will be made by Express.

INDEPENDENT Radio Supply Co.

3239 Ogden Ave.
Chicago, Ill.

Build Your Own Set

SAVE 50%

We will send you all of the following supplies, postpaid, for only

\$15.00

- 1 C-300 Tube; 1 Dial
 - 1 Condensite Socket
 - 1 Remler Rheostat
 - 1 Grid Condenser
 - 2 Work-Rite Variometers
 - 1 Work-Rite Variocoupler
 - 1 23-Plate Variable Condenser
- Sent C. O. D. for inspection if \$10.00 accompanies order.

ROSS MAIL ORDER Co.
693 Mission St., San Francisco, Cal.

THIS IS THE SWITCH
that does the trick
Turn it 'till you hear it click
FOUR WAY COMPANY, SPRINGFIELD, MASS. U.S.A.

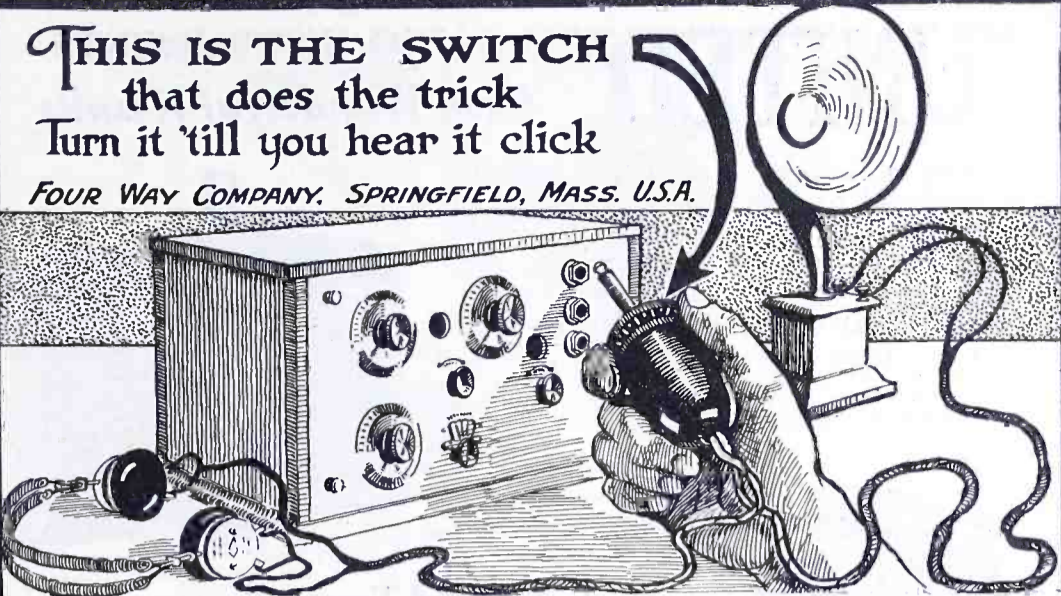



TURN 1: Head Set

TURN 2: Loud Speaker

TURN 3: Both in Series

TURN 4: Both in Parallel



The latest and greatest improvement in Radio!

A switch plug which makes it possible to tune in through head set and switch in loud speaker by turning dial. Two head sets can be readily attached, or one head set and loud speaker. Both can be used at the same time or either one alone.

\$1.50

FOUR WAY COMPANY
Dept. E Springfield, Mass.

A Necessity—

It is annoying—and confusing—to page through a book of “radio facts” in an endeavor to locate a certain long distance station. It is a pleasure to have before you a copy of an authentic schedule that covers stations within your range. It seems good to know what the other fellow hears. Everybody likes to read news while it’s new. The call letters of new amateur stations licensed every week are valued by most amateurs.

The broadcast listener wants the complete programs of the important broad-

cast stations. Your problems have been solved in the form of “Broadcast Program,” a new 32 page weekly magazine devoted to radio broadcasting in Central California. The program is published under the auspices of the Pacific Radio Trade Association—by the publishers of “Radio”. It will be mailed to your address every week for six months in return for a one dollar check, money order or bill. Just write your name and address in the lower margin—pin your remittance to it and enjoy radio as you have never enjoyed it before.

You Will Never Regret It

Tell them that you saw it in RADIO

Continued from page 80

cask in the museum an' let me drink it first."

After some deliberation, the gang of old medullum slitters agree to this. They send out a young attendant round-head, who soon returns with the quart. Then they put me in a big glass box and pump up the air inside, so I can open up my pyralin helmet.

"Well, here goes," I says. "If your Martian wireless ever reaches th' earth, tell 'em I died happy."

With this I takes a big swig out of the bottle.

That eighteen thousand-year-old rye seems to go right down an' bounce against my toes—and then I thought I was a rocket myself. I see explodin' meteors, flamin' helium suns, fallin' stars, spinnin' moons, blazin' comets, an' collidin' planets. The next thing I know, I am lyin' on the bench in Golden Gate Park, while a big cop has me by the shoulders an' is pretty near shakin' th' teeth out of me.

"Holy purple-eyed wildcats!" I gasps, sittin' up. "Some kick to that stuff!"

Gettin' to my feet, I feels a sharp pain in the seat of my pants, whereupon I suddenly remember I still have that big sliver I run onto while I was sittin' on the bench. I reaches around behind to pull it out, an' what does my fingers close over but a big hypodermic needle—a regular hop-gun! Old Baron Koubansky must have dropped it out of his pocket when he came and sat alongside me.

"Some kick to that stuff!" I repeats, yankin' out the needle an' throwin' it away into th' bushes, cautious like.

"Gwan!" barks th' copper. "Git out!"

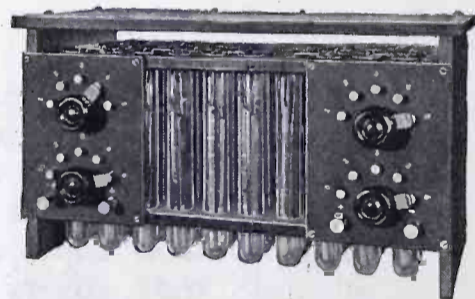

KICO Radio Storage "B" Batteries for EFFICIENT Receiving

1. KICO "B" batteries allow single cell variations by means of switches mounted on panels. (The first in the market with this feature.)
2. Alkaline type.
3. Rechargeable from your 110-volt A. C. line in connection with the rectifier supplied.
4. One charge lasts from three to six months in the detector plate circuit.
5. Neat, efficient and compact.
6. Unlimited life.
7. Your money back if unsatisfied within a 90-day trial.

		(Plain)	(With Panels)
16 cell	22 volt	\$6.50	
24 cell	32 volt	8.00	\$12.00
36 cell	48 volt	10.00	14.00
50 cell	68 volt	12.00	17.00
78 cell	100 volt	16.00	21.00
108 cell	145 volt	21.00	26.00

"A" and "B" Battery Literature gladly furnished
KIMLEY ELECTRIC COMPANY
 1357 FILLMORE AVENUE BUFFALO, N. Y.

"UNITED" RADIO INSTRUMENTS Give Wonderful Results

No set can measure up to its full possibilities of range and tone-quality until it is equipped with "United" Variable Condenser and Audio Frequency Transformers.

United Condensers

Design, material and workmanship combine to produce a valuable condenser that will not "short." Ends are Bakelite plates, hard aluminum; posts and shaft, brass, highly nickeled.

43 plate	\$4.00
23 plate	3.50
11 plate	3.00
5 plate	2.50
3 plate	2.25
		postpaid

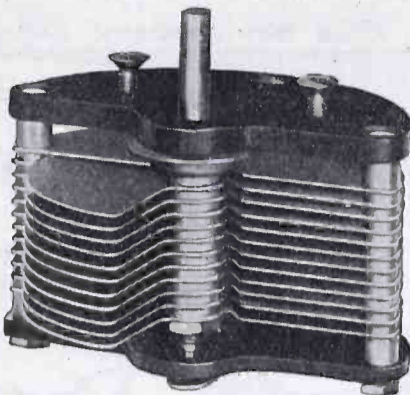

United Transformers

Way ahead of ordinary transformers in design, workmanship, finish. Has Special features on which we have applied for patent. Gives loud, clear signals. Price postpaid \$4.50.

COMING! A wholly new variable condenser with Vernier. Get your name on our mailing list for Bulletin when issued.

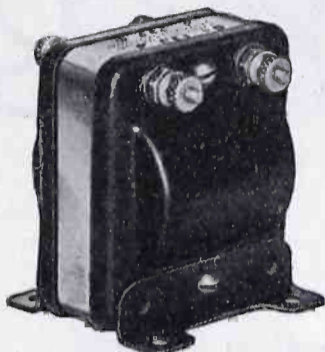

Pat. Appd. For

United Mfg. & Distributing Co.
 536 Lake Shore Drive Chicago, Illinois

The Receiver

which promises to Break All Sales Records



Telmaco Type B. R. Tuner

Manufactured exclusively for us by the Tri-City Radio Electric Supply Co., licensed under Armstrong U. S. Patent No. 1113149, Oct. 6th, 1914, for use in amateur stations and for radio experimental work. Only the best materials are used throughout:

Specifications:

Panel—Formica grained and machine engraved. Vario Coupler—TELMACO special silk wound. Condenser—Special 13-plate with Bakelite ends. Rheostat—Single knob control, Vernier type. Socket—Highly nickeled shell, Bakelite base. Dials—are polished, presenting pleasing contrast with dull panel. Workmanship—manufactured according to TELMACO'S rigid specifications. This guarantees your satisfaction. Remarkable ease in tuning. Either 6 volt or 1½ volt tube may be used.

Price \$25
 The ultimate in value.



Quality Radio Exclusively
 BONA FIDE JOBBERS—If our salesmen have not yet reached you with our proposition, write or wire for it TODAY.

Telmaco Type B. A. Two Stage A. F. Amplifier

Matches the above in size and construction. The greatest Amplifier value on the market. Price \$20.00. Write for our new Free Catalog.

RADIO DIVISION
 TELEPHONE MAINTENANCE CO.
 20 S. Wells Street Dept. A Chicago, Illinois

See the RADIOADS on Page 88

Tell them that you saw it in RADIO

SUPER REGENERATIVE SET

Continued from page 30

more stable with one. For long distance reception the 4 or 6 ft. loop is best; the very best results on 360 meters are obtained with a 6 ft. loop, that is a square loop measuring 6 ft. on each side, wound with 4 turns of any size wire spaced 1/2 in. apart. The reception factor of a 6 ft. loop is nearly 25% greater than a 4 ft. loop; but if you wish to construct a 2 ft. square loop it should have 13 turns spaced 1/10 in. apart; a 4 ft. loop—7 turns spaced 3/10 in. apart; if the spacing is increased, more turns should be added.

The loop should be used with one corner pointing to the ground; also by connecting the filament or *A* battery side to a good ground connection, long distance reception will be improved greatly.

An aerial can be used but it must not be too long, and no ground connection should be used. The loop will give as good results and a great deal less interference.

To Operate the Set.

Turn all filaments up to full brilliancy; turn condensers C_2 and C_3 to full capacity; couple the inductances L_1 and L_2 close. You should now hear a high-pitched whistle in the loudspeaker. This indicates the second tube *O* is functioning. If you do not hear this whistle, you will know the set is not working. All connections should be re-checked again; also *A*, *B* and *C* batteries should be tested to see that they are up to full voltage, and connected in the circuit properly.

If the whistle is heard then vary the coupling between L_1 and L_2 , also vary condenser C_1 until a loud hissing is heard in the loud speaker. This will indicate the first tube *A* is functioning. If you do not get the hissing noise, then go over batteries and connections the same as for tube *O*, also vary the *B* battery voltage.

When both tubes are functioning, then vary the coupling between L_1 and L_2 slowly, also condenser C_1 until signals are heard. Now vary condensers C_2 and C_3 slowly; if signals are accompanied by a lot of noise also vary L_1 and L_2 and condenser C_3 again, and dim tubes *A* and *O* slightly. Keep on varying these different values slowly and you will soon learn how to tune out the noise and get the signals sharp and clear; experience only can teach you this, and patience will bring the results looked for.

Don't forget to change the direction of your loop while tuning, as the signals will be loudest when loop points in the direction of the sending station. Now, if you are able to get telegraph code, but fail to get speech and music, then re-

Continued on page 84

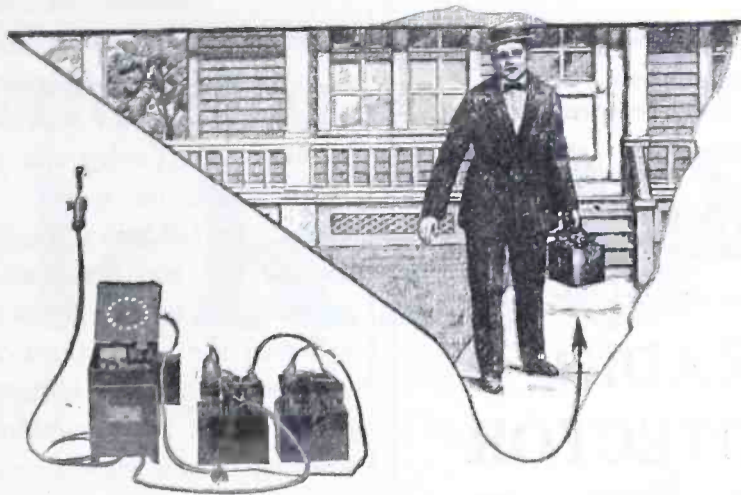

This is the way "B" Storage Batteries are charged with Tungar and attachment.

No Need of Doing This

Is yours a tube set?

Yes? Then you have a storage battery which frequently requires recharging.

Do you carry it to a charging station, wait three or four days, pay from 75 cents to a couple of dollars, and then lug it home again? You don't need to.



Tungar
BATTERY CHARGER

enables you to recharge your storage batteries for either radio or automobile use right at home—easily, quickly, and at little expense. It operates from any a-c. lighting circuit.

Any one can operate a Tungar. Once started, it requires no attention; nor is there the slightest danger of injuring the battery.

The initial cost is low; the operating cost is little. Send for our new booklet on Tungar for radio, if your dealer cannot supply you. Address Merchandise Dept., General Electric Company, Bridgeport, Conn.

General Electric Company
General Office Schenectady, N.Y. Sales Offices in all large cities 35A-79X

Kearny 2778

Pacific Radio School

ARC AND SPARK SYSTEMS

Hours—10 to 12 noon
1 to 4 P.M.
7 to 9 P.M.

Send for descriptive circular

433 Call Bldg.,
San Francisco, Cal.

This school is equipped with KLEINSCHMIDT Automatic Telegraph System

Tell them that you saw it in RADIO

DON'T BE CARELESS —
Protect Your Radio
With the Dependable

BRACH VACUUM

RADIO PROTECTOR

It Lasts For Years

Acknowledged by the most experienced engineers to be the best of all instruments for reducing static interference. In use for over 17 years.



Approved by the National Board of Underwriters

Mend Your Wires and Joints With SOLDERALL A Metal In Paste Form



At All Dealers
or By Mail at
25c a Tube

Insure perfect reception. All you need is a tube of this paste solder and a match to heat it. Results guaranteed equal to bar or wire solder.

L. S. BRACH Mfg. Co.

Newark, N. J.

Coast Representatives:
PACIFIC STATES ELEC. CO.
San Francisco, Los Angeles, Oakland,
Seattle, Portland, Spokane

CRYSTAL FANS

Are you satisfied with your crystal, or do you want better results?

MOLYBDIC GALENA

A new detector just discovered is sensitive even when ground to dust.

Send 50c for one of these wonder crystals. We will refund your money if you are not entirely satisfied.

Phoenix Radio Laboratory
Box 842, Phoenix, Arizona

2-Step Amplifiers \$20.00 (Telmaco)

ROSS—693 Mission St.,
San Francisco, Cal.

PROLONGS LIFE OF TUBES

AMPERITE

AUTOMATIC FILAMENT EXPELS ALL TUBE TROUBLES

ADJUSTER CURRENT ELIMINATES RHEOSTATS

FROM YOUR DEALER OR
RADIALL COMPANY
99 WARREN STREET NEW YORK

\$1.10 WITH MOUNTING

Continued from page 83

verse the connections to your tickler coil L_2 . It took me nearly a week to find this out, as the set functioned properly in every way; telegraph signals would roar in but no music. When I reversed the tickler connections, the code disappeared, and the music came in. If you still fail to get results after you have followed the instructions carefully, then test out all of your inductance coils for open circuit, as it sometimes happens a coil may have a broken connection. This also holds true for transformers; also test all of your condensers for short circuit.

If you have followed the diagram correctly and used the values indicated, you will get results without any doubt, and once you get results you will find it as easy to tune as any set, and not at all critical or fussy.

It is not a set that I would recommend to use in place of a straight regenerative set with a good aerial and ground because it is not as good for real long-distance reception, as it amplifies static and other nearby interference so much that weak signals are drowned out. If you will notice the diagram closely you will see that it is an ordinary regenerative circuit with the oscillator circuit superimposed upon it. By turning out the oscillator tube filament, and connecting to an aerial and ground, you will have a regular regenerative set.

The writer would be glad to hear from any who fail to understand the circuit and will answer any inquiries, and would also like to hear from those who get results.

SAN FRANCISCO TO HAVE COMBINED RADIO AND ELECTRICAL SHOW

To develop radio business and electrical business in general, the American Radio Exposition Company, of New York, N. Y., is to conduct a combined radio and electrical show in the San Francisco Auditorium, April 3-8, inclusive. A similar exposition was conducted in New York recently and the success of the venture prompted the company to prepare for one on the Pacific Coast.

The exposition has been endorsed by the Pacific Radio Trade Association, the San Francisco Electrical Development League, the California Association of Electrical Contractor-Dealers, and the San Francisco Electrical Contractor-Dealers' Association. Space at the show will be open to all branches of the electrical industry.

You should be a subscriber

Tell them that you saw it in RADIO

Page 97 will
Surprise You!

RUSONITE

CRYSTAL RECTIFIER

MULTIPOINT (Patent Pending)

A Synthetic CRYSTAL DETECTOR,
sensitive over its entire surface.

Eliminates all detector troubles. Extraordinary clearness and volume. Endorsed by Radio experts and press. Sold in Sealed Packages only. Join the ever-increasing Rusonite fans.

Price Postpaid, Mounted 50c
Sensitivity Guaranteed

RUSONITE CATWHISKER 25c

14 Karat Gold Multipoint contact. Super-sensitive
Order from your dealer or direct from us.
RUSONITE PRODUCTS CORP.
15 Park Row, N. Y. Dept. "R."

The Best Loud Speaker

IS THE

GOTTSCHALK

WE SELL IT

\$22.00 Postpaid

ROSS-693 Mission St., S. F., Cal.



Loud Speaker for Any Crystal Set

The Steinmetz Amplifying unit selling for \$8.50 will enable you to hear any crystal set all over the room. No storage battery required.

All Steinmetz equipment is thoroughly guaranteed.

STEINMETZ 3000 Ohm Phones.....\$6.50
STEINMETZ 2000 Ohm Phones.....\$5.00
STEINMETZ 1000 Ohm Phones.....\$1.75
Equal to any \$10.00 or \$12.00 Phones made.

"Superior" Crystal Set, \$4.75
Complete catalogue, 5 cents, at your dealer or
STEINMETZ WIRELESS MFG. CO.
5706 Penn. Ave. Pittsburgh, Pa.

Investigate!

WESTERN-RADIO DEALERS SERVICE

Wholesale RADIO only

837 50. HOPE ST. LOS ANGELES and 1200 FRANKLIN OAKLAND

NEW PRICES ON

“WorkRite”

RADIO PARTS

Prices on the WorkRite Super 180° Variocoupler and the WorkRite Super Variometer have been reduced from \$6.00 last spring to \$3.50 now. That is a big reduction and it has brought us in so many orders that we are rushed to fill them. You want WorkRite Radio Parts on your set. In order to get prompt delivery we suggest that you send in your order at once.

Remember that these instruments are WorkRite Quality. Compare the prices with those of unknown inferior instruments and then you will not hesitate to order your WorkRite Parts right away.

WorkRite Super 180° Variocoupler each **\$3.50**
WorkRite Super Variometer each **\$3.50**

WorkRite Super Vernier Rheostat

HERE IS A REAL RHEOSTAT. Indispensable on the detector tube when working long distance concerts. For quick adjustment the knob is pushed in and out, causing the contact arm to slide across the resistance wire. For fine adjustment the knob is turned around and the contact arm feeds along the wire. Our special resistance wire is non-corrosive and does not change in resistance through change in temperature. **POSITIVELY NEVER GETS HOT.** To appreciate this instrument you should use one. Price,

\$1.50

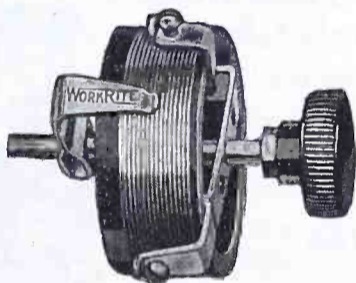

Patent Applied for

WorkRite Concertolas

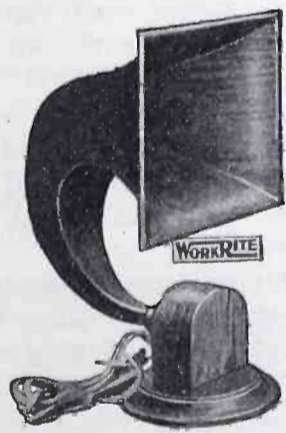

Concertola, Jr.

These Loud Speakers are becoming more popular every day. And no wonder when you consider that they have no metal except in the phone units and, therefore, do away with that “tin-panny” tone entirely.

Read what one of the thousands of Concertola fans writes us:

“Regarding the WorkRite Concertola received some time ago I wish to advise that it is the best \$12.00 worth I have ever bought. Stations in the following cities have all come in very QSA, even on warm nights, with the Concertola: St. Louis, Louisville, Pittsburgh, Detroit, Schenectady, Dallas, Tex.; Fort Worth, Tex.; Atlanta, Ga.; Havana, Cuba; Charlotte, N. C.; Chicago, Cleveland, and many others

“These stations can be heard all over the room with ease on warm nights, and all over the house on colder nights. With every good word for the Concertola, I am,
Earl E. Daesch, 110s Columbia Terrace, Parkersburg, W. Va.”

THREE DAY TRIAL! If after you have tried the Concertola you find that it does not work satisfactorily, return it and we will refund your money. These instruments are designed for use with vacuum tube sets having two-stage amplification.

WorkRite Concertola Jr. With Cord and Phone Unit—\$12.00
WorkRite Concertola Sr. With Cord and Phone Unit—\$24.00

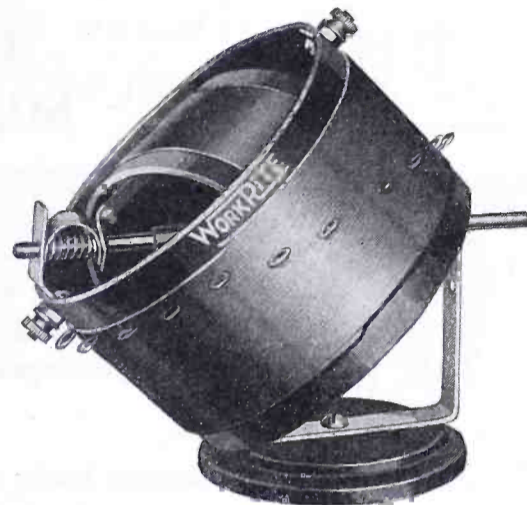

WorkRite Super 180° Variocoupler

Complete List of WorkRite Products

- WorkRite Super Variometer. Very sensitive and sharp to tune. Price...\$3.50
- WorkRite Super 180° Variocoupler. Range 180 to 800 meters. Price...\$3.50
- WorkRite E-Z-Tune Dial. Has a grip on the rim where you can grasp it for fine adjustments. Price.....75c
- WorkRite Concert Headset. Try a WorkRite side by side with any on market. Price\$8.50
- WorkRite Super Vernier Rheostat. Has 50,000 possible adjustments. Price..\$1.50
- WorkRite Type “A” Hydrometer. You need one to keep your “A” Battery in condition. Price75c

WORKRITE CONCERTOLAS. LOUD SPEAKERS OF QUALITY.

- WorkRite Concertola Jr.....\$12.00
- WorkRite Concertola Sr.....\$24.00

WorkRite Radio Parts WorkRite

THE WORKRITE MANUFACTURING CO.

5503 Euclid Ave., Cleveland, Ohio
 (Branch Office, 2204 Michigan Ave., Chicago)

Tell them that you saw it in RADIO

PACENT RADIO ESSENTIALS

Make for convenience and efficiency
in operating your equipment.

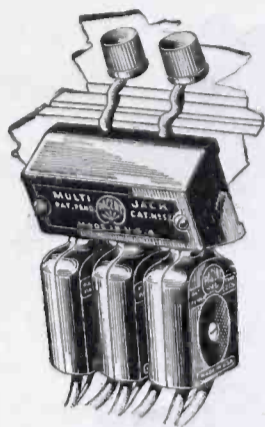

PACENT MULTIJACK

Incorporates three perfect jacks in one moulded unit. Provides connections for three phones or two headsets and loud speaker, etc. Furnished with screws for mounting on set or table. There are many instances where the Multijack will prove an indispensable convenience.

A small investment in Pacent Radio Essentials yields rich interest in pleasure and satisfaction. Ask your dealer to show you the above device, also the Pacent Twinadapter, Universal Plug, Audioformer and other Essentials.

Don't Improvise—"PACENTIZE"

Send for Bulletin R-3

PACENT ELECTRIC COMPANY

I N C O R P O R A T E D

Manufacturers and Distributors of Radio and Electrical Essentials
Executive Offices: 22 Park Place, New York, N. Y.

BRANCH OFFICES

Philadelphia, Bourse Building
Chicago, 33 So. Clinton Street
Minneapolis, 527 Marquette Av.

Members, Radio Section, Associated Mfrs. of Electrical Supplies



Washington, D.C., Munsey Bldg.
San Francisco, Sheldon Bldg.
St. Louis, 704 Pontiac Bldg.
Canadian and British Licensees:
Colonial Radio, Ltd., Hamilton,
Canada

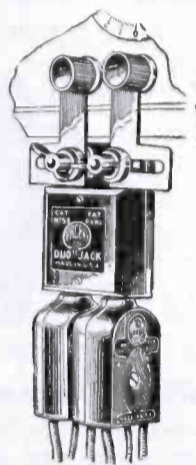

PACENT DUOJACK

Converts awkward binding posts to convenient jack equipment and provides two perfect plug connections.

BROADCAST RECEIVER

Continued from page 30

The measurements given here need not be followed exactly, but they will serve merely as a suggestion, for each experimenter will undoubtedly have different materials. For instance if the experimenter has a variometer rotor ball, then both it and the stator should be wound with No. 20 or 22 S.C.C. wire and the tube would then be about four inches in diameter.

Taken all in all this variometer-inductance is very easily constructed. The only hard thing about it is the placing of the shafts and soldering the leads to them while the rotor is inside of tube. This isn't as hard as it may seem.

The length of tube is entirely optional, depending on what wavelength is desired and the method used in winding; a single layer winding for shorter waves and bankwound for longer.

A bakelite panel 6 in. x 12 in. x 3/16 in. will nicely mount the controls for the inductance-variometer and a vacuum tube detector. Fig. 4 illustrates a practical panel design, the 23-plate variable condenser being mounted to the extreme left with the antenna inductance control between it and the variometer. The detector control is shown here, but can be left off if the experimenter already possesses one and mounted alongside.

Connections should be made with large wire, making sure that all wires cross at right angles or nearly so and avoiding lengthy leads. Capacitance under control is desired—not capacitance distributed over the entire set, as parallel and lengthy leads will surely do.

Solder all connections, using rosin core solder. Acids and pastes spread so easily, making a messy job as well as causing a leakage where the highest insulation is desired.

A good variable condenser is essential and the experimenter should select one embodying heavy plates and good all-around rugged construction.

Results obtained with this type of tuner and circuit have greatly exceeded the writer's expectations and he will not hesitate in recommending it as a vast improvement over all other existing single circuit receivers. Stations were heard that were never heard before and the strength of signals from those previously heard were practically doubled. Used with a two-step amplifier and loud speaker, music can be heard for blocks.

Tiring of concerts, one can shift to commercial wavelengths without any loss of efficiency, the set oscillating and regenerating perfectly up to 800 meters. In conclusion, the writer would like to emphasize the fact that "haste makes waste"—so don't rush yourself in assembling this or any other radio instrument.



Made for All Phones

Ask Your Dealer

THEY ARE GOOD PUT THEM ON YOUR PHONES
Slip out the metal disc and slip in the MICAPHONE. Result: Clearer, better tone, all noises eliminated. Write for circular. Discounts to dealers and jobbers.
RADIO MICA PRODUCTS CO.
156 E. 43d St. New York

C. W. MANUAL
\$1.00 112 Pages
"Radio" S. F.



"COPPERWELD"

THE IDEAL RADIO ANTENNA

COPPERWELD IS 50% STRONGER than Copper, can be strung taut, stays up when other wires stretch and break, and gives 100% electrical efficiency.

COPPER CLAD STEEL COMPANY

BRADDOCK P. O., RANKIN, PA.

Directions for antenna construction on reverse side of carton

BUY IT IN CARTONS

WIRED WIRELESS

Continued from page 33

the bureau of standards in Washington, indicates that within a short time all consumers of electric current may be able to plug in their radio sets to their lamp sockets and receive information and entertainment broadcasted by the large light and power companies. The system is controlled by the North American Company of New York, which owns and operates the lighting utilities of Cleveland, Milwaukee, St. Louis and a number of other cities, and which has secured an exclusive license under General Squier's patent rights for this purpose and is now developing the plan.

With the aid of a small condenser in series with vacuum tube receiving sets, or a special plug, consumers of electricity will be able to receive broadcasts from their electric wires just as they get "juice" to operate the flat iron, electric toaster or hair curler today. The ether will in no way be disturbed by this sort of direct radio broadcasting, and Secretary Hoover will not have to assign wavelengths or worry about interference with other stations using the ether,—there will be no interference as the air is not used.

With the aid of a regulation broadcasting set at a sub-station of the Potomac Electric Power Company, messages have been transmitted over this company's lines, carrying 2400 volts of alternating current, to the signal corps laboratory, Bureau of Standards in Washington, where they were received by means of a tube set coupled with condensers. The sending station was located at Georgetown. The wave which followed the wires was of 5000 meters or 30,000 cycles and a transmitting current of 0.050 amperes was employed.

WORLD-WIDE COMMERCIAL RADIO PLAN

The American public will soon realize the fuller benefits of an international radio service tying in Europe, South America and the Orient, according to Edward J. Nally, who recently sailed for Europe, to attend conferences in Paris, London, Berlin and Rome, where plans to mobilize the interests of American, French, English, German and Italian radio companies will be discussed. Already huge plans for South America are in progress, and a super power station is being erected in Buenos Aires for communication with North America, England, France and Germany. This station will be open about June.

Work has already begun on a similar high power station near Rio de Janeiro, in Brazil, with feeder stations of medium power at Pernambuco and Para. The two great stations will be the

Continued on page 89

Don't Waste Money

Time and Patience on cheap, improperly designed radio parts. Insist on getting New York Coil Company's products, which insures entire satisfaction. Honestly priced, scientifically constructed and engineered to deliver the maximum results.

JOBBER AND DEALERS get our complete literature and worthwhile discounts.

Our 180 degree Variocoupler is a masterpiece, suitable for use in any circuit. Most efficient and best constructed Coupler in existence. Price, \$4.50

Our Combination Mounted Variocoupler for table or back panel mounting has all taps connected and soldered, nothing else like it. Price, \$8.00.

MOUNTED 3 CIRCUIT TUNER. Exceptional selectivity and sharp tuning makes the most easily constructed and highest efficiency Set known. Price without Dial \$6.00. With 3¾ Bakelite Dial \$7.00.

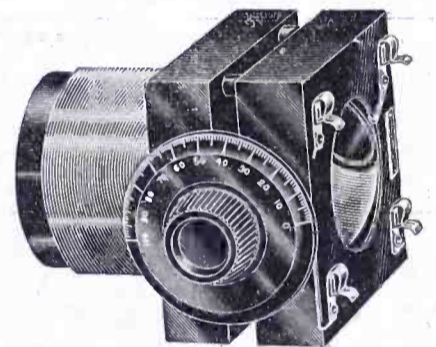

Our Variometers are full size precision instruments. They are not of the "competitive" type. Price \$4.00.

Our Audio Frequency Transformers are the choice of the leading manufacturers and radio engineers. Guaranteed to give high magnification, less distortion and better all around efficiency. No howling. Price \$4.00.

NEW YORK COIL COMPANY'S Variable Condensers are the standard by which others are judged, containing such features as all metal framework, adjustable bearings and positive electrical contact:

- | | | | |
|----------------|--------|----------------|--------|
| 11 Plate | \$1.50 | 43 Plate | \$3.00 |
| 23 Plate | 2.00 | 3 Plate | 1.25 |



NEW YORK ENTERTAIN-APHONE RECEIVING SET No. 2—Complete with detector and two stages of amplification, all in one cabinet. Contains a non-regenerative two circuit hook-up with two stages audio amplification. Results are simply a revelation. It must be operated and heard to be appreciated. Workmanship and design and material of exceptional character throughout. Of unusual interest to the jobber. Price \$50.00, fully guaranteed. DW-11 1½ volt battery lamps may be used if desired.

NEW YORK COIL COMPANY, Inc.

338 Pearl Street

New York City, N. Y.

Tell them that you saw it in RADIO

★ ★ RADIOADS ★ ★

A CLASSIFIED ADVERTISING SECTION READ BY BETTER BUYERS

The rate per word is five cents, net. Remittance must accompany all advertisements.
Include name and address when counting words.

ADS FOR THE APRIL ISSUE MUST REACH US BY MARCH FIRST

WANTED— $\frac{1}{2}$ kw. Amrad quenched gap transmitter complete or five watt C. W. A. C. transmitter complete. W. N. SMITH, 1243 First St., Louisville, Ky.

Vacuum Tube Hospital
We repair and guarantee them.
Agents, Dealers, and Customers Wanted.
George H. Porell Co., Inc.
West Somerville, Mass.

Two-circuit regenerative receiver, with tube \$20.00; Unwired Regenerative Receivers \$15.00; Two-step Amplifiers \$18.00; Type C Baldwins, Single, \$6.50; Double \$12.50; Elwood phones \$6.00; Three-circuit tuners \$8.00; Crystal Sets with receiver, aerial, \$8.00; everything postpaid. Elradio Co., 5667 Fayette St., Los Angeles, Calif.

1000 to 1500 miles on 1 tube, 1 control, 150 to 25,000 meters. No rheostat, storage battery, variocoupler, variometer, 3 coil mounting, variable inductance, taps or radio frequency. Nothing to guess about. Complete hookup \$1. Radio Experimental Laboratory, Box 194D, Berkeley, Calif.

200-20,000 Meter Receiver, including radio-tion, \$35.00. Two-step Amplifier, \$25.00. Box 205, Williamsport, Pa.

Amateur call books 50c. We carry a complete line of receiving and transmitting supplies. Postage paid to any part of U. S. and Canada. Write for prices. Richmond Radio Shop, 421 Macdonald Ave., Richmond, Calif.

110 to 500 volt MG Set 200 watt \$50.00. New Amplifier Tubes \$5.00. Dials, condensers, amplifying transformers, sockets, head sets, binding posts, RF transformers, CW condensers, modulation trans, Magnavox transmitter, HALF PRICE. Two Western Electric Loud Speaking outfits new, CHEAP. Three two-stage amplifiers, with tubes \$40 each. Will send C.O.D. parcel post. C. C. BROWN, MANTON, CALIF.

FOR SALE: 1 pair Connecticut Phones, eighty ohms, three dollars; 2 new Simplex variometers, \$5.00 each; Variocoupler \$2.50; toy transformer \$3.00; 1 pair Brandes phones \$6.00; code practice set \$1.50; \$20.00 worth Chemicals \$10.00; American Model Builder set \$5.00; 2 lbs. Flashlight powder \$3.00. Edward Hunt, 10 N. Indiana Ave., Atlantic City, N. J.

DON'T BUY OR BUILD any Receiver before investigating the ROKAY SIGNAL CONTROL RECEIVER HOOK-UP. ROKAY ELECTRIC COMPANY, INGOMAR, OHIO.

RADIO EXPERIMENTERS' LEAGUE members wear a RADIO EXPERIMENTERS' lapel button (see cut on page 68, this magazine). Be identified as an alert and progressive radio enthusiast. Join RADIO EXPERIMENTERS' LEAGUE, conducted by Amateurs, for Amateurs. Every owner of a radio set is eligible for membership. Every member receives one of the official 14K gold plated lapel buttons, also a membership card and private identification code

number. All members of the LEAGUE are entitled to a ten per cent discount on any approved standard receiving or transmitting radio apparatus. You may also have your choice of any one of the following "DOPE SHEETS": (1) Ten Super-regenerative Circuit Diagrams, every one designed by the famous Major Armstrong himself, together with a complete discussion of their operation by Major Armstrong reprinted by special permission from the Proceedings of the Institute of Radio Engineers. (2) Diagram of Armstrong Super receiver with accurate panel layout, list of parts and where to get them, also three photos. This set actually works. (3) Diagram how to make a simple and inexpensive "WAVE-TRAP" to separate 360 and 400 meter waves and minimize interference. (4) Wiring diagram of the best transmitting set we have seen for C. W., voice or buzzer, with accurate panel layout. (5) Detailed diagram of new "REFLEX" circuit showing how to get two stages of Radio and two stages of Audio frequency amplification using only two bulbs. This also shows the electrical values of the various parts used.

We always have the facts on the latest developments. If you have any hard nut to crack or question to ask, shoot it in, we will send a "DOPE SHEET." We old-timers are sincerely glad to lend a hand wherever possible. This is one of the most valuable features of membership. Send your name today. Enrollment and registration fee 50c includes button, membership card, 10 per cent discount privilege, and choice of any one of the above "DOPE SHEETS." Additional "DOPE SHEETS" in the above list or special "DOPE SHEETS" answering a question, 50c each. We have been able to get a number of the new W.T.501 PEANUT detector tubes while the supply lasts, \$2.00 each; special sockets, 40c extra; adaptors, 75c extra. Radio Experimenters' League, 9-15 Clinton Street, Newark, N. J. More Radio Clubs invited to affiliate.

THE RADIO BROADCASTING CLUB. The only Club of its kind in the world. Be progressive. Keep up with the art. Up-to-date radio news, programs and question box in our free Bulletin to members. Radio sets and parts sold to members at a big discount. Dues only \$1.00 a year. Join now. Write to Radio Broadcasting Club, Room 52, Ryland Bldg., San Jose, California.

RADIO WORLD, THE GREAT NATIONAL WEEKLY—published every seven days with all the latest news, developments and pictures of the radio field. 15c a copy. \$6.00 a year (52 numbers), \$3.00 six months, \$1.50 three months. Special to radio readers. Send \$1.00 and we will send you the next eight issues of RADIO WORLD. Pub. Office, 1493 Broadway, New York. (tc)

Ten per cent discount on all standard radio goods. Prompt service. Superior two step Amplifier \$25.00. QST Radio Service, Williamsport, Pa. (2t)

BUILD YOUR OWN RADIOPHONE. Instruction Book 10 cents. Radio Service Institute, U. S. Savings Bank Bldg., Washington, D. C. (3TC J.F.M.)

TRANS-ATLANTIC TELEPHONY

Continued from page 26

row band in the ether is occupied in transmitting speech.

By the suppression of one of the two side bands it also becomes possible to transmit twice as many messages simultaneously as is now effected, a feature which will become increasingly important as the use of radio grows and especially at the longer wavelengths.

At the receiving end a local oscillator is used to replace the carrier current in rendering audible the received signals. The vacuum tubes used in the present test, while not the largest which have successfully withstood laboratory trial, are the largest that have thus far been applied to radio telephony, and are characterized by means for sealing large copper thimbles to glass in such manner as to hold the best obtainable vacuum.

The radio apparatus and system used in the test are the result of research and experimental work in the laboratories of the American Telephone & Telegraph Company and in the laboratories of the Radio Corporation of America and its associated companies.

GEN'L ELECTRIC'S BROADCASTING HEARD ABROAD

Vice-president Coolidge has received a letter from W. T. Meehan of the General Electric Company informing him that his Christmas address, which was broadcasted on Dec. 24, was heard in both Liverpool and London, as well as in every state in the Union.

RADIO FREQUENCY AMPLIFIER

Continued from page 10

ascribed in part to the large volume. But when the radio stage was added practically all of the distortion vanished, though the volume was greater than before. This is a valuable and interesting phenomenon, which can be utilized in many ways. It is entertaining to speculate on the reasons for that result.

If a loop is used instead of an aerial, connect its ends to the points lettered *a* and *b* in the figure.

As a precaution against the effects of body capacity, see that the stationary plates of the primary condenser are connected to the switch lever.

It is interesting to note that with but slight modification this set can be adapted for use with honeycomb coils. Just how this may be done will be the subject of a short story in April RADIO, which will also contain some ideas for the radio experimenter who wants to play with spiderweb coils.

Radio Bug Emblems

An artistic bronze-finished button to wear on the lapel of your coat. "Tell the world that you're a RADIO BUG." We'll send you this emblem, free of charge, with one subscription to "RADIO" for one year.

RADIO — PACIFIC BLDG. — SAN FRANCISCO

Tell them that you saw it in RADIO.



A high-grade Headset of standard aluminum construction, at a price that appeals to the average purchaser of radio apparatus.

CLARION

RADIO HEADSET

\$5.00

The Clarion Headset is guaranteed to give perfect satisfaction or purchase price will be refunded.

Circular 21-A, mailed free on request, is of interest to Jobbers, Dealers and those desiring a high grade headset at moderate cost.

Radio Supply Company
Hornell, N. Y.

RADIO GOODS AT BARGAIN PRICES

- \$5.00 Detector Tubes (Guaranteed) \$3.00
 - \$6.50 Amplifier Tubes (Guaranteed) 3.50
 - \$6.50 1½ V. Detector or Amplifier (fits standard socket) 5.25
 - \$5.50 Elwood Phones (2000 Ohms) 3.75
 - \$1.75 22½ V. Cyclone Variable "B" Battery 1.00
 - 22½ V. Eveready "B" Battery
 - No. 763 \$1.25 No. 766 2.25
 - \$4.50 Thordarson Transformers 3.59
- Numerous other bargains in our **FREE PRICE LIST** sent upon request. Goods shipped **POST-PAID** promptly upon receipt of money ordered or registered cash.

ALL MERCHANDISE GUARANTEED

Bergen Radio Supply Co.

Mall Order Department
606 Bergen Ave., New York City

\$5.25

Guaranteed 1½ Volt Tube
Operates on Dry Cell

Detectors and Amplifiers, Best Made

- \$5.00 Guaranteed Detector Tubes (6 Volt) \$2.95
 - \$6.50 Guaranteed Amplifier Tubes (6 Volt) 3.45
- Sent post paid anywhere, upon receipt of price
Price list free (containing 100 bargains)

Broadway Electrical Novelty House

Mall Order Department R. O.
134 Third Ave., New York, N. Y.

WORLD WIDE RADIO

Continued from page 87

pivotal center of South American radio communication, and from these two points signals will radiate to all parts of the globe.

According to Mr. Nally, who is now taking up his new duties as Managing Director of International Relations for Radio Corporation of America (with headquarters in Paris and also in New York) this world-wide system of radio will materially assist in stimulating international commerce and bring closer and more friendly relations between all the countries of the world; and with the completion of the plans for world-wide wireless telegraphy there will soon follow a program for perhaps equally stupendous international radio telephone service. In this latter scheme the engineers of the American Telephone & Telegraph Company and those of the Radio Corporation of America are collaborating.

PROGRESS BY FEDERAL TELEGRAPH CO.

Announcement of a new pioneering step in radio is made by the Federal Telegraph Company. This concern, which established the first radio commercial communication with the Hawaiian islands, now has established the first direct private radio communication with China. While this latter service is not on a commercial basis as yet, pending completion of the first of five large stations the company is erecting in China, all its own communication is being carried on over it.

The Federal's Hawaiian service was opened in 1912, between stations at South San Francisco and Heeia, island of Oahu, which virtually are duplicate installations. They since have been sold to the government. Until 1914 communication was carried on only at night, but the service was adequate to supply the island newspapers with their first metropolitan press service and to exchange a number of commercial messages.

The new communication channel with China is from the Federal company's Hillsboro station, near Portland, Oregon, where one of the arc-sending sets used regularly in its Portland-San Francisco service has been diverted temporarily to send to a temporary station located in the Astor House, a Shanghai, China, hotel. Communication is on a wavelength of 8,400 meters and has been carried on thus far with a power input of only 30 kilowatts, less than half the capacity for which the arc was designed.

Tell them that you saw it in RADIO

Fleron's Vernier Adjuster

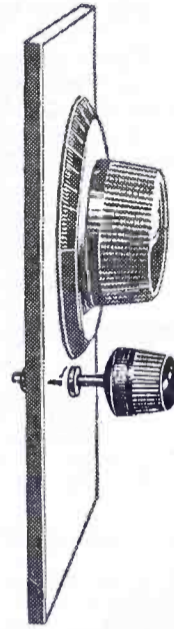

Pat. Appld. For

This ingenious little device is a necessity on every set. Sharp, close tuning is only possible with it.

Easily mounted on any set by drilling only one 5/16" hole. Its normal position is away from the dial as shown.

A slight pressure makes contact with the Dial. Vernier is then turned for accurate tuning.

Price 65c

Sold by Dealers and Jobbers everywhere

Sole Manufacturers

M. M. Fleron & Son, Inc.

Trenton, N. J., U. S. A.

VARIABLE CONDENSERS

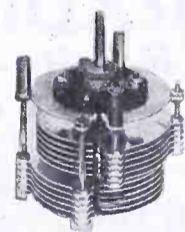

- 3-Plate Vernier \$0.75
 - 23-Plate .0005 Mfd. ... 1.75
 - 43-Plate .001 Mfd. ... 2.25
 - 24-Plate Bal. Cond. ... 3.75
 - 44-Plate Bal. Cond. ... 4.75
- Aluminum Plates, accurate spacing. Get these condensers and improve your set. Shaft runs in bearings. Money back if you are not satisfied.

MONTROSE MFG. CO.
1200 Bedford Ave.,
Brooklyn, N. Y.

Variometers \$3.50

Variocouplers \$3.50

Postpaid

ROSS RADIO SERVICE

Mail Orders

693 Mission St., S. F., Cal.

WEBSTER RADIO APPARATUS

Webster Radio Apparatus — both parts and assembled receiving sets— are built to typical Webster standards of perfection. Our line of parts includes everything from contact points and switch stops to Variometers and Variable Condensers — designed to function perfectly. When building your set, ask your dealer for Webster Apparatus. You are thus assured the utmost value, for Webster parts are designed to perform properly and are priced fairly. If your dealer does not carry Webster Radio Apparatus, write for our 24-page catalog and order direct.

Webster Combination Socket and Rheostat

This unit combines both socket and rheostat together for either panel or table mounting. It is moulded porcelain finished in a brown glaze. Finished with or without vernier.

Webster Variable Condensers

The entire condenser is of improved design. Made of aluminum and accurately spaced. Bearings of ample size with threaded hard rubber bushing for adjustment. Insulated stops limit the arc of rotating plates to 180 degrees. Shaft extension $\frac{1}{4}$ " diameter.

Webster R.-F. Transformer

Iron core type carefully tuned at the factory. Completely enclosed in attractive moulded case. Made in TYPES for 1st, 2nd, or 3d steps of amplification. Range 175-555 meter wave band. Moderately priced.

Other items of Webster Radio Apparatus include Head Sets, Variometers, Vario-couplers, A.-F. Transformers, Rheostats, etc.

Complete line of receiving sets at prices ranging from \$30.00 to \$119.00.

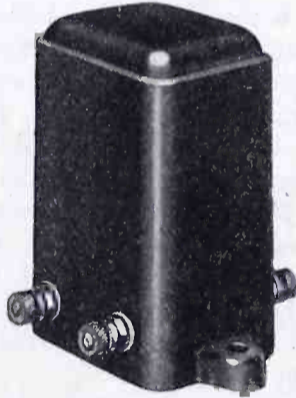
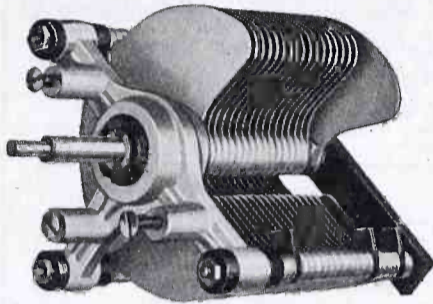
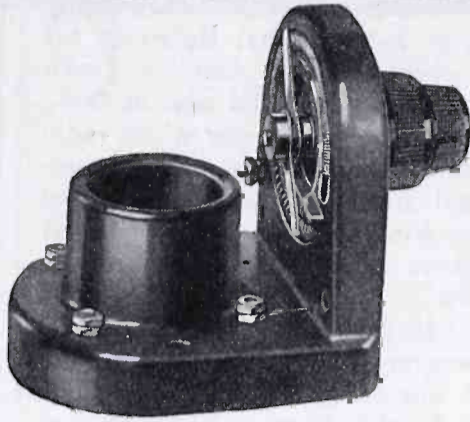

WEBSTER ELECTRIC COMPANY

RACINE, WISCONSIN, U. S. A.
1902 CLARK ST.

Manufacturers of Webster Magneto—over 750,000 in use.

BRECO RADIO APPARATUS

Bring Best Results—They Are Dependable

Listed below are a few BRECO specialties: Owing to our increased facilities, we are able to reduce the prices on some of our manufactured products.

Variometers	\$7.00	Crystal Detectors	\$1.75
Variocouplers	5.00	Inductance switches complete	
Variable Condensers, 43 Plate...	4.50	with 7 points and 2 stops.....	.50
Dials, 3 in. moulded.....	.75	Switch points03
Rheostats75	A. F. Transformers	5.00
Binding Posts, N.P. or insulated knob.....	.08		
Mahogany cabinets, various sizes.....	5.00 up		
Bakelite, sheets and panels.....	per lb. 2.00		
Straight Circuit Tuner	50.00		
Detector and two stage amplifier.....	50.00		
Straight circuit tuner with detector and three stage amplifier.....	115.00		

Write for Catalogue

If your dealer cannot fill your requirements on BRECO apparatus, your order mailed to us will receive prompt attention.

BRONX RADIO EQUIPMENT COMPANY
687 Courtlandt Avenue, "Manufacturers of Quality" Bronx, N. Y. C.

Tell them that you saw it in RADIO

RECENT PATENTS

Continued from page 38

the amplifier tube *A*, and the signaling circuit *S*. It has been found that undesirable oscillations often occur in such systems, and in order to prevent this, impedances *17* are inserted in one or more of the tubes, so as to choke the oscillations.

M. H. Petersen, Pat. No. 1,436,676: November 28, 1922. System for Wireless Transmission of Writing, Pictures and the like.

In order to transmit pictures or writing by the aid of radio, an oscillating tube *10* is arranged to be controlled by contacts on a drum *7* carrying the sign to be transmitted, which is made of insulating material, while the remainder is conducting. The contact describes a helix over the drum, which is driven by a synchronous motor *35*. Whenever the contact touches the sign, the tube *4* is active and may transmit radiations which are used at the receiving station to affect an oscillograph. Whenever the contact rests on the metallic drum, one of the coupling coils *10* of the tube *4* is short circuited, and radiations are interrupted. In order to keep the drum *7* rotating synchronously with the corresponding drum at the receiving station, radiations of energy by the aid of coils *27*, *28* and *29* are effected that produce beats of comparatively low frequency, which beats are utilized to produce low frequency current at the receiving station to drive the synchronous motor. At the transmitting station the same result is obtained by the aid of coils *30*, *32*, which combine the different frequencies produced by tubes *21* and *22*; the beat produced in this manner is transformed into a low frequency current by transformer *34*.

W. W. Conners, Pat. No. 1,437,400: December 5, 1922. Method and Apparatus for Indicating the Geographical Location or Movement of Bodies.

The location of ship or other object *7* with respect to fixed points *A*, *B*, *C* and *D* is determined by the aid of two transmitting stations *1*, *2*. At each of these stations a rotatable transmitting coil *4* is moved over a uniform angle, so as to direct a beam of waves over an arc *I* or *I'*. On ship *7* are located receiving systems that measure the interval of time taken for the beam to travel from the ship to the extreme position and back again to the ship. By noting these values for both sets of waves, the angular position of ship *7* with respect to both stations *1* and *2* may be determined, and its position plotted.

L. DeForest, Pat. No. 1,437,498: December 5, 1922. Oscillation.

A thermionic three-electrode tube especially adapted to supply radio frequency energy of large power is described. The novel structural features include a grid support *7* of glass, the grid *11* forming an interior space within which filament *6* is supported. The plate *3* is in contact with the inside surface of vessel *1*.

E. L. Mueller, Pat. No. 1,437,607, December 5, 1922. Electron Tube.

An electron discharge tube is described, adapted to operate as the usual three-electrode thermionic tube, but without the necessity of a heated filament. Instead, an air-tight glass vessel *18*, arranged to enclose a mercury arc discharge, is utilized; imbedded therein are metal discs *20* that serve to conduct the electrons produced by the arc to the outside portion enclosed by the evacuated vessel *10*. Surrounding the arc vessel *18* are a grid *26*, and a corrugated plate *30*.

J. B. Nowlan, Pat. No. 1,437,772, December 5, 1922. Radio Apparatus.

A highly selective receiving system is described, and results from the use of two variably coupled coils *24* and *41* to the antenna inductance *9*. These coils are directly in series and are independently adjustable,

Continued on page 92

Victory-Grantone

In developing these Victory-Grantone units our aim was concentrated to produce complete self-contained units of highest efficiency and of such design that would permit its production on a large commercial scale. We knew, in this way, we could market them at rock-bottom prices. Simplicity was our watchword, but not to the point of sacrificing efficiency and beauty, but to eliminate useless expensive parts which do not add to the performance of the set. We have finally accomplished our aim and offer to radio buyers the fruits of our efforts at prices of astounding value.

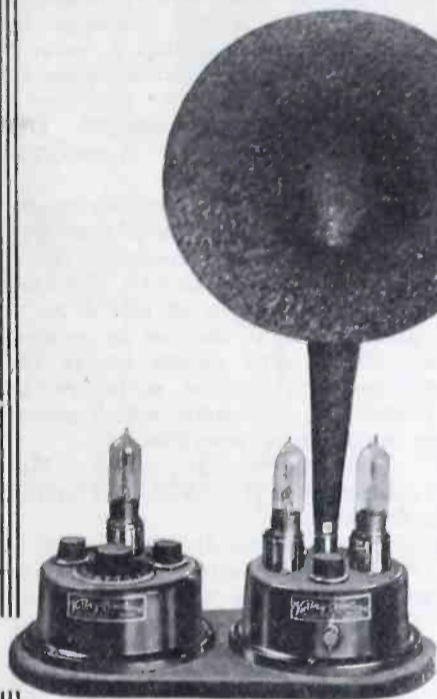

Victory Grantone

Radio Receiver No. 520
A most complete receiving amplifying and loud speaking radio set of compact and attractive design. Detector and Amplifying Loud Speaker units, which are described below, are mounted on a beautiful mulberry colored velour base. Completely wired ready for use.

Efficient receiving radius is conservatively rated at one hundred miles, although reception of over five hundred miles is being regularly accomplished with it with remarkable ease and volume. For long distance receiving, however, we recommend the additional use of our No. 575 DX Unit, which brings in louder signals and increases range of set to over a thousand miles. This unit may be added on at any time. Requires no storage battery, but operates only on two or three dry cells.

Price without tubes..... **\$55.00**
Price complete, with tubes and batteries..... **\$85.00**

Victory Grantone

Radio Receiver No. 550

Truly, this is the most compact, neatest and totally self-contained complete radio receiver yet developed. Embodies everything necessary for its operation. No unsightly loose batteries, wires, parts, etc., but can readily be carried from place to place and ready for instant operation. The Detector and Amplifying Loud Speaker units, which are described below, are mounted on a beautiful leather-covered cabinet containing both "A" and "B" batteries, with space provided for tubes when not in use.

This set has an efficient receiving radius of one hundred miles, although users are reporting continuous reception of over five hundred miles with remarkable clarity. For long distance receiving, however, we recommend the additional use of our No. 575 DX Unit, which increases receiving range to upwards a thousand miles. Operates on two dry cells without storage battery.



Price with tubes and batteries, **\$95**

Victory Grantone

Amplifying Loud Speaker No. 525
This unit has no equal in the entire radio industry.

Enables everybody now to fully enjoy radio entertainment without nuisance of taking turns with head receivers. Operates with equal remarkable efficiency from the simplest kind of crystal set to the most elaborate vacuum tube detector.

Contains besides two stages of audio frequency amplification a super sensitive loud speaking element with heavy mica diaphragm adjusted to give a true natural mellow tone, which can be controlled from a soft audible sound to a mighty volume.

Horn is of durable wood fibre composition designed on best acoustic principles.

A Victory Selector Jack with automatic filament control gives one or two stages of amplification. No storage battery, works on two dry cells.

Price without tubes.. **\$37.50**
Price with tubes and batteries complete.... **\$54.00**

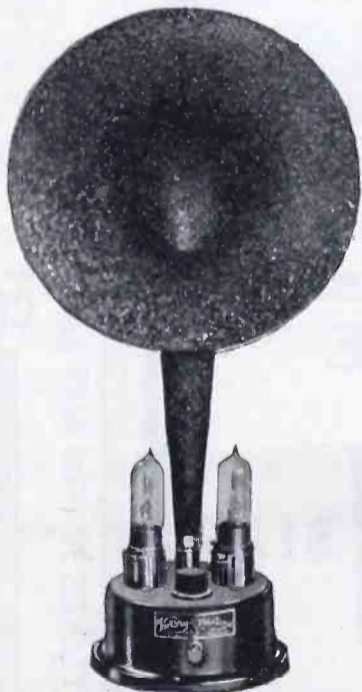

Victory Grantone

Detector Unit No. 500

Tuning is simple, sharp and very selective. Encased in a housing which shields it from all body capacity effects and other external influences, thereby giving maximum receiving efficiency.

Range 175 to 700 meters. Receiving radius conservatively rated at one hundred miles, but used with No. 575 DX Unit increases range to upwards one thousand miles. Operates with one dry cell.

With tube and batteries..... **\$27.50**

Detector and amplifying loud speaker can also be furnished for use with standard 6v. tubes.

DEALERS! Wire or write at once for real merchandising proposition.



Victory Grantone

D X Unit No. 575

By simply connecting this unit to the output binding post of the detector unit creates an efficient regenerative circuit which increases strength of signals and receiving range. Also makes tuning sharper and more selective. Being completely shielded, eliminates all body capacity effects.

Can also be used with any other type of non-regenerative detector.



Price **\$10.00**



Price without tube **\$17.50**

Price without tubes and batteries, **\$65**

Victory Grantone

Loud Speaker No. 530

They are the best value on the radio market.

Has same sensitive heavy mica diaphragm loud speaking element as our Amplifying Loud Speaker. Faithfully reproduces in a natural mellow tone, without distortion or rattling, the finest notes from near and distant stations. Free from all metallic sounds. Designed for use on one or two stages of audio frequency amplification.

The horn is wood fiber composition, designed on best acoustic principles for perfect clarity and maximum volume. Neatly finished with crystallized black enamel. Furnished complete with cord.

Better one cannot be bought for three times the price. Fully guaranteed.

Price complete..... **\$16.50**

Horn with base and phone adaptor..... **\$8.00**

VICTORY RADIO-ELECTRO CO., 559-561 Howard Street, San Francisco

Tell them that you saw it in RADIO

FRESHMAN PRODUCTS—ACCURATE AND DEPENDABLE

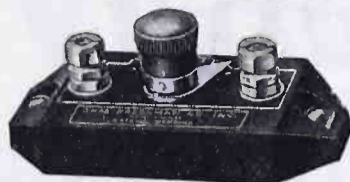

“MICONS”

Tested Mica CONDENSERS

Assure absolute noiselessness—clarity of tone—accuracy—constant fixed capacity.



Antenella

No antenna or aerial needed. Eliminates all the inconveniences in radio; operates from any light socket. Price only... **\$2.00**

At your dealers—otherwise send purchase price and you will be supplied without further charge.

Variable Resistance Leak

With .00025 mfd. Micon Condenser Combined **\$1.00** Without Condenser **75c**

Unbroken range—Zero to 5 Megohms. Clarifies signals, lowers filament current, increases battery life, eliminates hissing.



Size	Price	Size	Price
.00025	\$.035	.0025	\$.050
.0005	.35	.005	.75
.001	.40	.006	1.00
.002	.40	.01	1.50

.006 MICONS and Variable Resistance Leaks especially adapted for New Flewelling Super Circuit.

Chas. Freshman Co., Inc.

97 Beekman Street, New York

DEALERS: Discount 33 1/3% on all orders \$15.00 and over. We pay parcel post, express or freight charges. Literature and display card free on request.

Continued from page 90

one of them, as 41, having relatively few turns. The other elements of the receiving circuit are substantially standard, and include two stages of amplification and a grid leak 59.

W. E. Beakes, Pat. No. 1,438,290: December 12, 1922. Process and Apparatus for Wireless Telegraphy and Telephony.

An adjustable antenna structure is described, whereby the length of conductor 2 forming the antenna may be set at the best value for receiving or sending without the necessity of condensers or inductors for tuning. In this way greater efficiency is obtained. For adjusting the antenna length, a cord 1 of insulating material is wound on a drum 6 and passed over a pulley 4; antenna 2 is similarly arranged and is connected by connector 3 to the cord 1. Either a motor 8 or a handle 10 may be used for winding up the antenna or the cord.

R. A. Weagant, Pat. No. 1,438,347: December 12, 1922. Receiving Apparatus for Radiosignals.

A system for eliminating static disturbances in receiving is described, in which separated loops 1 are made to affect a rotatable coil 5 connected to a translating device t. The idea of so adjusting the position of coil 5 as to minimize static effects is covered in another application; the present patent covers the idea of utilizing amplifiers v, v, before the coil 5 is reached, so that static which affects leads 2 are not likewise amplified.

R. E. Winstanley, Jr., Pat. No. 1,438,567: December 12, 1922. Wireless Signaling Apparatus.

A signaling cabinet is described, that is arranged for use on relatively small ships where a wireless operator would be too expensive. The cabinet is so arranged that by manipulation of switch 20, distress signals of various kinds may be sent out. Furthermore, by proper setting of the switches 13, 13a, 14, 14a, 15, 16, 16a, 17, 17a and 18, the location of the ship may be transmitted. The SOS signal is arranged to be sent as soon as the door 11 is opened, whereby a plunger switch 22 is operated to start the motor-driving brushes over sets of signaling bars.

Hit it anywhere! MAGNETITE RADIO-CRYSTAL

The most sensitive Crystal Detector on the world market. Unaffected by handling or moisture and will render efficient service indefinitely. Price 50 cents at ALL DEALERS—or mailed direct. GUARANTEED by

GIBBONS-DUSTIN RADIO MFG. CO.

OWNERS AND NATIONAL DISTRIBUTORS

518 WEST 9TH STREET

LOS ANGELES, CALIF., U. S. A.

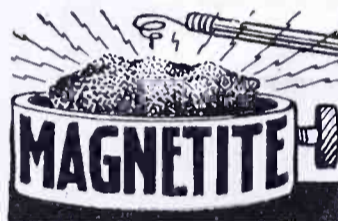

MELCO SUPREME

“Graces any Home”

\$125



\$125

The “Melco Supreme” Radio Frequency Amplifying Receiver can be used with indoor or outdoor aerial, loop or lighting plug—its operation is simplicity itself. Operates over a wavelength of 175 to 500 meters—covering all broadcasting ranges. It is a new departure in radio, non-reflex, non-regenerative, tuned radio frequency.

Amplification of the “Melco Supreme” is extremely high per stage—without the slightest loss of tone quality. It neither distorts the wave nor interferes with other members of the radio audience. Single tuning adjustments, assuring a great degree of program selectivity and long distance reception are permitted by this new system.

At your dealer's—otherwise write for particulars about the “Melco Supreme” and our complete line of parts to any of our offices listed below.

MORTIMER RADIO CORPORATION

114-116 Fulton Street
Huntington, W. Va.,
1028 Fourth Ave.
Philadelphia, Pa.,
636 Victory Bldg.

Pittsburgh, Pa.,
704 Granite Bldg.
Atlanta, Ga.,
Flatiron Bldg.

New York City
San Francisco, Calif.,
709 Mission Street
St. Louis, Mo.,
13 South Fourth St.

Exclusive Canadian Representative, Scott Bros., Ltd., 332 St. Catherine St. West, Montreal, Que.

CRISTAL SET, \$2.50

RITTER GRAND TUNES TO 600 METERS

RITTER GRAND RECEIVES 25 MILES

100 Per Cent satisfaction guaranteed all users of the Ritter Grand Crystal Receiving Set.

SPECIAL OFFER

Ritter Grand with single guaranteed phone and full aerial equipment. Price, complete, \$5.00. We invite dealers' inquiries.

RITTER RADIO COMPANY
232 Canal St. New York City

Tell them that you saw it in RADIO

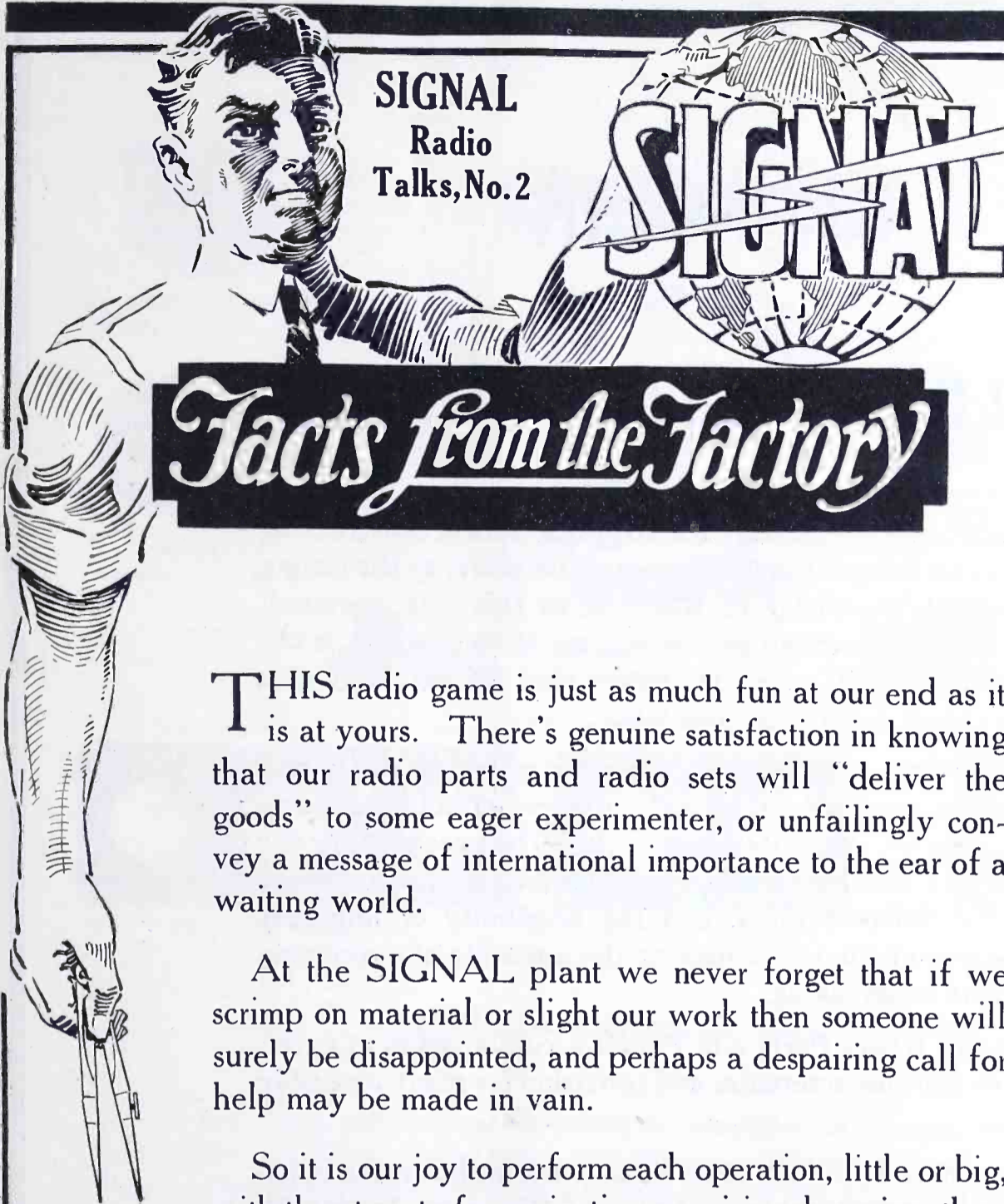

SIGNAL
Radio
Talks, No. 2

Facts from the Factory

THIS radio game is just as much fun at our end as it is at yours. There's genuine satisfaction in knowing that our radio parts and radio sets will "deliver the goods" to some eager experimenter, or unfailingly convey a message of international importance to the ear of a waiting world.

At the SIGNAL plant we never forget that if we scrimp on material or slight our work then someone will surely be disappointed, and perhaps a despairing call for help may be made in vain.

So it is our joy to perform each operation, little or big, with the utmost of conscientious precision, knowing, thus, that no life can ever be charged against defective SIGNAL apparatus.

Radio equipment bearing the name of SIGNAL may safely be depended upon for good honest service.

SIGNAL Electric
Mfg. Co.

Factory and General Offices:
1913 Broadway, Menominee, Mich.

Atlanta
Boston
Chicago
Cleveland

Minneapolis
Montreal
New York
Pittsburg

San Francisco
St. Louis
Toronto

You'll find our local address in your Telephone Directory



**SIGNAL Vernier
Rheostat**

The first successful vernier using a single knob for control. Fine adjustment is easily obtained. Simple in design and sturdy in construction. Furnished with or without knob and pointer, so dial to match others of set may be used.

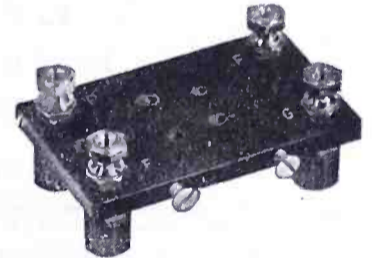

**SIGNAL Tube Base
for WD-11 Tubes**

Adapted for building receiving sets using a single dry cell for filament excitation. Does away with the troublesome 6 volt storage battery but retains the efficiency of the 6 volt tube. Legs insulated for table mounting; screw provided for panel mounting.

(2101-B)

Information Coupon

Signal Electric Mfg. Co.,
1913 Broadway,
Menominee, Mich.

Please send catalog and bulletins giving complete information about SIGNAL Radio equipment to name and address written in margin.

Tell them that you saw it in RADIO



The Building of Radio Sets Simplified

THE enjoyment which every Radio Fan derives in constructing his own receiving set is due, in a large measure, to the feeling that a practical knowledge of Radio is in this way acquired. Naturally, a more thorough understanding of the subject is obtained. It does not, of necessity, follow that the assembly of a receiving set must involve tedious labor.

Heretofore, little consideration has been given, in the design of radio parts, to their adaptability for use by the individual who does not possess an elaborate set of tools. The necessity for the use of panels of insulating material; the lack of provision for mounting the different units, and the possibility of improper wiring have all contributed to making the assembly of a receiving set a laborious undertaking.

In Eisemann Radio Parts and Panels a combination of excellence of electrical characteristics and provision for ready assembly is found.

Aluminum panels, in four stock sizes, with uniform size openings, permit interchangeable mounting of Eisemann Parts. All drilling of holes is eliminated, and the use of shielding made unnecessary. Proper spacing of units—a most important factor—is assured. Binding posts, properly located on each unit, give positive connections and obviate the necessity for crossleads.

The concave dials and bar control, a distinguishing feature of Eisemann Parts, present a most attractive appearance when mounted on the Aluminum Panels, which have a crystal black enamel finish.

The building of a finished receiving set, without turning the home into a work-shop, is made possible.

Send for Descriptive Literature

EISEMANN MAGNETO CORPORATION

WILLIAM N. SHAW, *President*

DETROIT

BROOKLYN, N. Y.

CHICAGO

EISEMANN



BALANCED CONDENSER
Capacity .001 Mfd. \$7.50

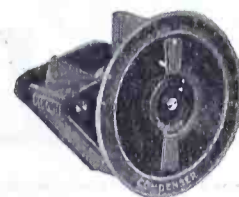

UNBALANCED CONDENSER
Capacity .001 Mfd. . \$7.00
Capacity .0005 Mfd. . \$6.50



VARIOMETER
Price . . . \$8.75



TRANSFORMER
Price . \$6.00



HEAD-PHONES
Price . . . \$8.00



VACUUM TUBE SOCKET
Price . \$.50



VARIOCOUPLER
Price . . . \$10.50

DETECTOR UNIT
Price . \$3.50



AMPLIFIER UNIT
Price . \$8.50

EISEMANN METAL RADIO PANELS

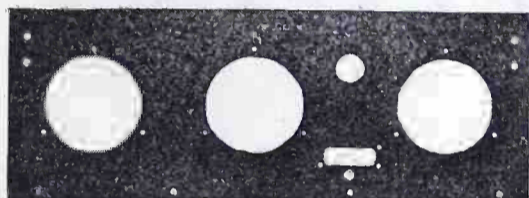

Type TD-3 Price \$3.50

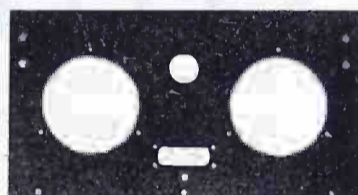

Type TD-2 Price \$2.75



Type T-1
Price \$1.75

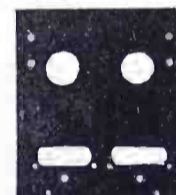

Type A-2
Price \$2.25

The illustrations below show merely the appearance of Eisemann Parts and Panels. The user is unrestricted in the arrangement of units on the panels. Unlimited experimentation with various circuits, without destroying panels, is permitted, by reason of interchangeability of all parts as to mounting.



Front View

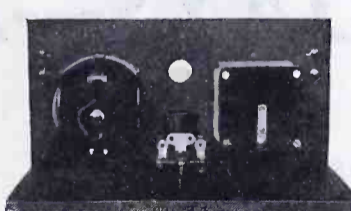

Rear View

EISEMANN MAGNETO CORPORATION

WILLIAM N. SHAW, *President*

DETROIT

BROOKLYN, N. Y.

CHICAGO

Tell them that you saw it in RADIO

P-L-A-N N-O-W!

to attend the
MARVELOUS, THRILLING

RADIO AND ELECTRICAL EXPOSITION

San Francisco---April 3 to 8

Manufacturers!

Jobbers!

Dealers!

Wire now for space reservations. Show open to display by manufacturers, jobbers, dealers, inventors and amateurs in both industries. Booths are 10' by 10', rear wall 8' high; railings front and sides—complete with your company sign—\$65 to \$225. Address J. C. Johnson, manager, American Radio Exposition Co., 687 Mission St., San Francisco.

COME!

COME!

COME!

Newest, most astounding developments in both Radio and Electrical Industries to be shown. Daily demonstrations—lectures—special programs for amateurs—special entertainments—nothing like it ever before attempted.

COME! -- COME! -- COME! -- COME!

SIX FULL DAYS---April 3 to 8

AMATEURS

Write for full details governing home-made set contest for amateurs.

Endorsed by:

Pacific Coast Radio Trade Association
California State Assn., Electrical Contractors & Dealers.
Electrical Contractors and Dealers of San Francisco
San Francisco Electrical Development League

Tell them that you saw it in RADIO

Remarkable Subscription Offer!

We desire to increase the paid subscription mailing list of "RADIO" by at least 5000 during March. If you will help us — we will make it worth your while!

GET THESE INSTRUMENTS FREE!

Free!



Two Subscriptions

Brings you a WORK-RITE Variometer or Variocoupler

Please send 12c to cover mailing charges.

One Subscription

brings you the new WORK-RITE "Ezy-Tune" Dial. Mailing charges, 6c.

Less Than Cost:

This new Victory Loud Speaker selling for \$16.50 given free with only \$12.50 worth of subscriptions. Send us five subscriptions to "RADIO" for one year and it is yours—FREE!



See page 91 for details

Please send 60c for Mailing Charges.

Gottschalk Loud Speaker

that sells for \$22.00 given free with \$20.00 worth of subscriptions.

Free!



Send us Eight Subscriptions and 60c for mailing charges. This is the new instrument that gained such rapid popularity.

Fully Guaranteed

Trutone Loud Speaker

free with 4 subscriptions to "RADIO" for one year each.



Priced at \$8.00 by the manufacturer

Mailing Charges 60c

Fully Guaranteed

RADIO, Pacific Building, San Francisco, Cal.

Enter the following subscriptions to "RADIO" for one year:

Name

Address

Name

Address

Name

Address

Name

Address

Premium desired

Mail Premium to

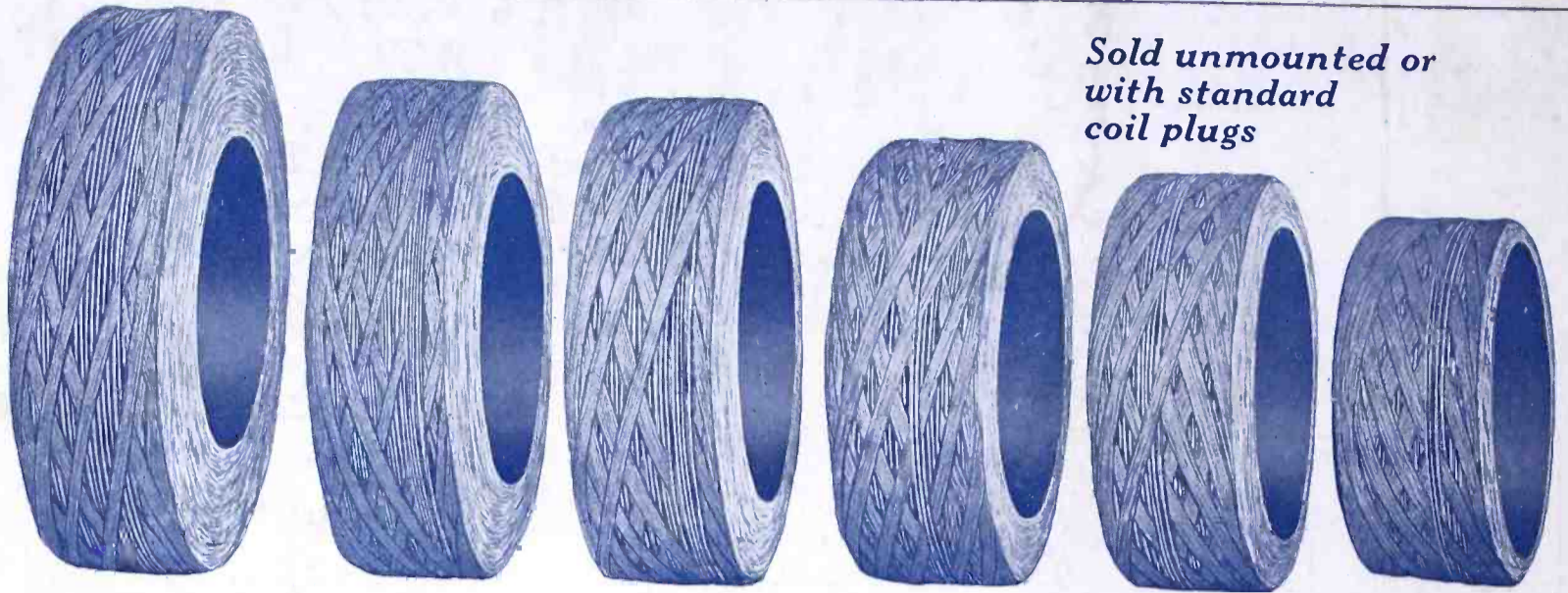

*Sold unmounted or
with standard
coil plugs*

Seventeen sizes between 20 and 1500 turns. Sold unmounted or mounted on Remler coil plugs which fit any standard coil mounting.

Use GIBLIN-REMLER INDUCTANCE COILS

For Maximum Signal Strength With Minimum Interference

DUE to their special features of construction, GIBLIN-REMLER INDUCTANCE COILS have MORE INDUCTANCE, less DISTRIBUTED CAPACITY, and a LOWER HIGH-FREQUENCY RESISTANCE than any other coil, of an equal number of turns, on the market. These are the three features essential in order to obtain MAXIMUM SIGNAL STRENGTH, and MINIMUM INTERFERENCE.

In any receiving set it is always necessary to tune one or more circuits to the frequency of the incoming wave. This is done by adjusting the inductance and capacity of the circuit so that it will have no impedance to an alternating current of that particular frequency. Then, the only resistance to the incoming signal is the high-frequency resistance of the coil. This high-frequency resistance, which depends on the direct current resistance and type of winding, is lower in the GIBLIN-REMLER COIL than in coils employing any other form of winding.

This is explained largely by the fact that resistance is directly proportional to the length of the wire. In the GIBLIN-REMLER COIL all of the turns are parallel and the turns in each layer are wound close together, hence it requires fewer turns, less wire, and lower resistance to obtain a given inductance than with any other type of winding.

The LOW DISTRIBUTED CAPACITY of the GIBLIN-REMLER COIL is a big factor in obtaining MAXIMUM SIGNAL STRENGTH and MINIMUM INTERFERENCE. In a vacuum tube detector circuit the signal strength depends on the potential difference between the grid and filament of the tube. In a coupled circuit receiver the secondary coil is connected to the grid and filament of the detector tube and literally supplies this potential difference. Its distributed capacity, that is capacity between layers of the coil, tends to short-circuit the coil and reduce the potential difference at

the terminals. This is particularly true in the case of the very high-frequency current encountered when receiving the short wave lengths, that is, wave lengths between 200 and 600 meters. The amount of this loss depends upon the amount of capacity and potential across it. Capacity always decreases with an increase in the distance between two conductors. In the GIBLIN-REMLER winding the layers are spaced with a cotton yarn of high dielectric strength in such a manner as to not only reduce the total distributed capacity but also to make it a minimum at the point of greatest potential difference between layers.

A sharply tuned circuit is one that has an extremely low resistance to a current of the particular frequency to which it is tuned, and a high resistance to currents of all other frequency. In any receiving circuit there are two kinds of resistance—one, the straight high frequency of the coil, and the other, the resistance caused by the impedance of the coil and the condenser used with it. The first remains fairly constant over a small range of wave lengths. The second resistance is zero at one particular wave length and increased as the wave length varies in either direction; hence, it is easily seen that when the inductance of the coil is extremely high in proportion to the high-frequency resistance, which is the case in the GIBLIN-REMLER COIL, the circuit in which it is used may be made to have practically no resistance to signals on one particular wave length, and yet have a proportionally high resistance to signals on all other wave lengths. This condition, which is always obtained in circuits using the GIBLIN-REMLER COIL results in a SHARPLY TUNED CIRCUIT, that is, one giving MAXIMUM SIGNAL STRENGTH on the desired wave length, with a MINIMUM OF INTERFERENCE from signals on any other wave length.

Write for price list and table of constants and complete information regarding these coils.

Send 10c for new 40-page Remler Catalogue containing circuit diagrams for Remler Apparatus and other useful information, including a table of inductance, capacity and wave length.

The Remler Technical Bureau is at your service. Address your problems to Dept. R.

REMLER RADIO MANUFACTURING COMPANY

Factory and Home Office
248 First Street, San Francisco, Cal.

Eastern Sales Office
154 W. Lake Street, Chicago, Ill.