

July, 1922

B6

25 Cents

RADIO



~ what might have been

Atlantic-Pacific Radio

Operating (KZY) Rock
Ridge Radio Station

644-650 MISSION STREET
SAN FRANCISCO CALIFORNIA



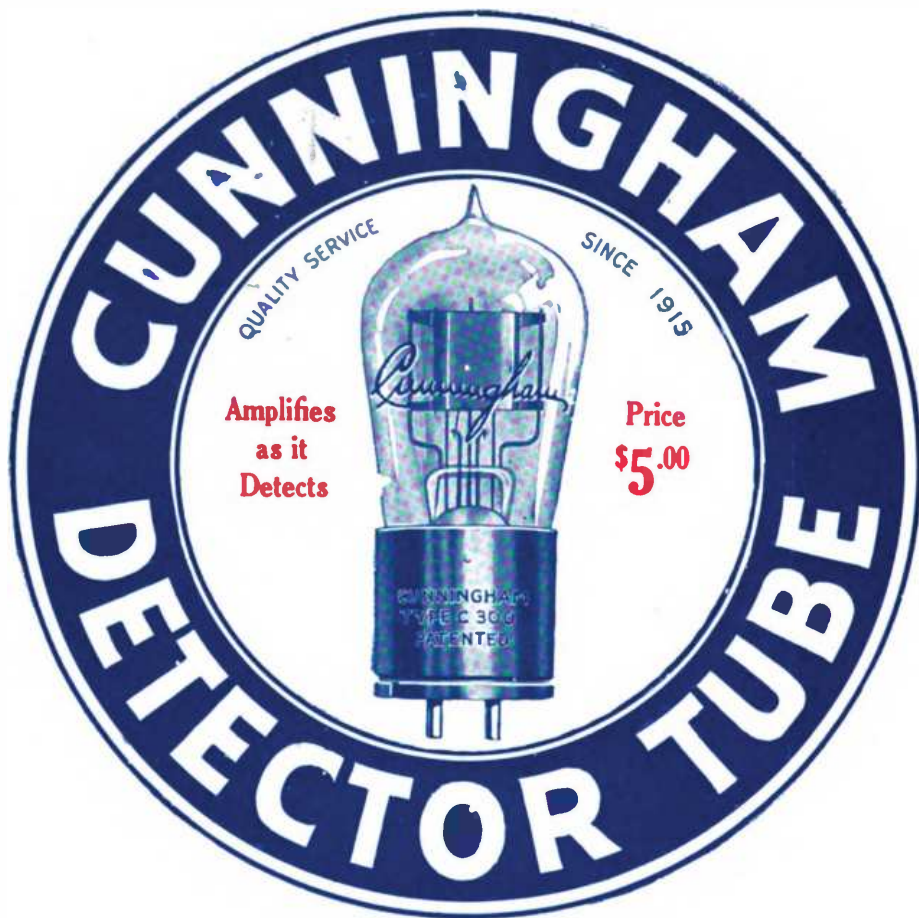

PATENT NOTICE
 Cunningham tubes are covered by patents dated 11-7-05, 1-15-07, 2-18-08 and others issued and pending. Licensed only for amateur or experimental uses in radio communication. Any other use will be an infringement.



The trade mark GE is the guarantee of these quality tubes. Each tube is built to most rigid specifications.

CUNNINGHAM TYPE C-300 GAS CONTENT DETECTOR

*—it gives clearest reception
 for all makes of Home Receiving Sets*

CUNNINGHAM Detector Tubes are built in the great General Electric Laboratories to the most rigid specifications. Years of research work and study, combined with the most scientifically accurate mechanical equipment in the world has made it possible to manufacture these quality tubes that give such remarkably effective results.

The pleasure that your Home Receiving Set will give you depends largely on the CLEARNESS OF RECEPTION of messages, concerts, etc.—therefore, be sure to get CUNNINGHAM TUBES for YOUR set.

For further particulars see or write your nearest dealer; or write us direct.

248 First Street
 San Francisco, Calif.

Trading as
 AUDIOTRON MFG. COMPANY

154 West Lake Street
 Chicago, Illinois

BURGESS "B" BATTERIES

BURGESS "B" Batteries assure clear receiving, increase the efficiency of any receiving set, and they are cheapest in hours of service.

BURGESS "B" Batteries are sold by every progressive Radio Dealer and Jobber. "Look for the Black and White Stripes."

A postal card from you brings full information by return mail. Why not write to us today? Dept. A

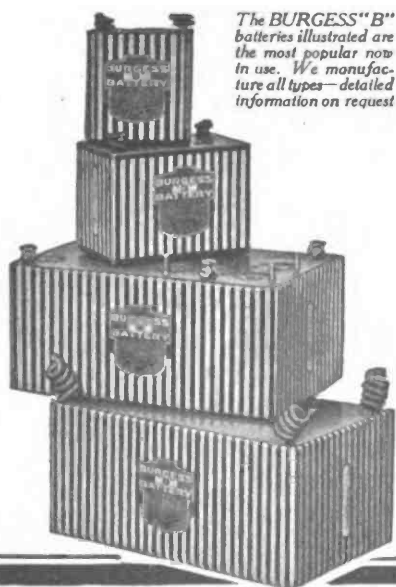

The BURGESS "B" batteries illustrated are the most popular now in use. We manufacture all types—detailed information on request

BURGESS BATTERY COMPANY

Offices and Warehouses:

CHICAGO 111 W. Monroe St.	NEW YORK 50 Church St.	BOSTON 136 Federal St.
MADISON Wisconsin	KANSAS CITY 2109 Grand Ave.	ST. PAUL 2362 University Ave.

*In Canada: BURGESS BATTERIES, Ltd.
Winnipeg Montreal Toronto*

**OVER 300,000 SOLD—WHY?
"ASK ANY RADIO ENGINEER"**

RADIO

Established 1917 as Pacific Radio News

VOLUME IV

SAN FRANCISCO, JULY 1922

NUMBER 7

Contents

	PAGE		PAGE
Radiatorial Comment	9	A Simple Method for Memorizing the Continental Code.....	26
Industrial Uses of Radio.....	10	<i>By</i> DAVID P. GIBBONS	
<i>By</i> R. C. DENNY		A Radio Primer	27
The Design and Construction of a 250 Watt Power Amplifier and C. W. Transmitter.....	12	<i>By</i> H. A. EVELETH	
<i>By</i> J. B. DOW		The Vacuum Tube as an Amplifier.....	29
Variometers	14	<i>By</i> B. F. McNAMEE	
<i>By</i> D. B. MCGOWN		High Frequency Resistance of Inductance Coils.....	30
Eliminating Static by Resonance Wave Coil.....	15	Office Buildings Wired for Radiophones.....	31
How to Design an Iron Core Audio Frequency Choke Coil.....	16	The World's Largest Magnavox.....	31
<i>By</i> A. K. ASTER		Simultaneous Broadcasting on Different Wavelengths.....	31
A New Loud Speaker.....	17	Army Radio Net Saving \$18,000 Yearly.....	32
<i>By</i> G. M. BEST		Broadcasting and Receiving on Light Circuits.....	32
Construction of a Simple Receiving Set and Two Stage Amplifier	18	<i>By</i> CARL H. BUTMAN	
<i>By</i> B. F. McNAMEE		News of the Broadcasting Stations.....	33
\$100 Radio Frequency Amplifier Contest.....	19	Queries and Replies on C. W. Practice.....	34
Reactance and Susceptance Diagrams	20	<i>By</i> GERALD M. BEST	
<i>By</i> G. W. CATTELL		Some Improvements in the Hartley Circuit.....	35
Proposed National Electric Code Revisions.....	23	New C. W. Records Established by 6ZAC.....	35
Scratchi Gets a Broadcast Earful.....	24	Digest of Recent Radio Patents.....	36
<i>By</i> DAVID P. GIBBONS		With the U. S. Radio Inspector.....	37
Harmo Radiopathy	25	<i>Conducted by</i> MAJOR J. F. DILLON	
<i>By</i> EARL ENNIS		New Apparatus and Supplies from the Radio Manufacturers	38
Reception of Short Wave D X Signals in Hawaii.....	26	Calls Heard	40
<i>By</i> T. A. MARSHALL		The New York Radio Show.....	76
		<i>By</i> L. D. MCGEADY	
		Letters to the Editor.....	84

Published Monthly by

Pacific Radio Publishing Co., Inc.

Pacific Building, San Francisco

ARTHUR H. HALLORAN, *Editor.*
 LAWRENCE MOTT, *Associate Editor.*
 GERALD M. BEST, *Technical Adviser.*
 O. SCHUWENDT, *Engineering Draughtsman.*
 H. W. DICKOW, *Advertising Manager.*
 Branch Offices: 147 Sixth Ave., New York City;
 6442 Ingleside Ave., Chicago;
 Suite 510, 456 So. Spring St., Los Angeles, Cal;
 2957 Charles St., Seattle, Wash.

Advertising Forms Close on the First of the Month
 Preceding Date of Issue

25c a copy. Subscription price \$2.50 per year in the U. S., \$3.00 per year elsewhere. Instructions for change of address should be sent to the publisher two weeks before the date they are to go into effect. Both old and new addresses must always be given.

Entered as second-class matter at the Post Office at San Francisco, Calif., under the Act of March 3, 1879.

Copyright, 1922, by the Pacific Radio Publishing Co., Inc.

GREBE RADIO



*"He who has heard but part of the truth
said Chuang Tzu,
thinks no one equal to himself."*

*Compare your present outfit with a Grebe!
Doctor My.*

Licensed under
Armstrong U. S. Patent,
No. 1113149.

RADIO APPARATUS

*Distributors of Reliable Radio Apparatus to Schools,
Colleges, Radio Clubs and Experimenters
All Over the World!*

"PITTSO"

Specializing on RADIO
CORPORATION'S Products



"PITTSO"

Now has three Stores.
Send us your orders.

The present tremendous demand for Radio Apparatus has practically made it impossible for us to render our usual SERVICE.
Reasonably prompt delivery however can be made on the items listed.

AMPLIFYING TRANSFORMERS

No. P-1 General Radio, semi-mounted.....	\$ 5.00
No. 50 Chelsea, semi-mounted.....	4.50
No. A-2 Acme, semi-mounted.....	5.00

ANTENNA WIRE

"Pittsco" No. 14 Hard drawn copper, (80 ft. per lb.) per lb.....	.40
500 ft. (Special value).....	2.25
"Pittsco" 7 strand No. 22 tinned copper, per ft.....	.01
500 ft.....	4.00
1000 ft.....	7.50
"Pittsco" 7 strand No. 20 Phosphor bronze per ft.....	.02
500 ft.....	7.50

ANTENNA INSULATORS

No. P-1 Electrore Ball insulator.....	.35
No. P-2 Electrore 4 inch strain insulator.....	.45
No. P-3 Electrore 10 inch strain insulator.....	.75

"A" BATTERIES (Storage Batteries)

Yale 6 volt 60 Ampere-hour.....	18.00
Yale 6 volt 80 Ampere-hour.....	21.00
Yale 6 volt 100 Ampere-hour.....	25.00

Note.—These batteries are shipped carefully crated and fully charged ready for use.

"A" BATTERY RECTIFIERS

No. P-1 Tungar, 5 ampere type, complete with bulb..	28.00
No. P-2 Tungar, 2 ampere type, complete with bulb..	18.00
No. P-3 F F Battery Booster, 5 ampere type.....	15.00

"B" BATTERIES

No. 763 Eveready, 22.5 volt, small size.....	1.75
No. 766 Eveready, 22.5 volt, large size, 16½ to 22½ volts.....	3.00
No. 774 Eveready, 43 volt, large size, variable.....	5.00

CRYSTAL RECEIVING SETS

Aeriola, Jr., Westinghouse, complete with telephones	\$25.00
Every-man's DeForest, complete with telephones....	25.00

CONDENSERS (Variable)

No. 1 Chelsea, fully mounted, .001 Mf.....	5.00
No. 2 Chelsea, fully mounted, .0005 Mf.....	4.50
No. 3 Chelsea, unmounted with dial, .001 Mf.....	4.75
No. 4 Chelsea, unmounted with dial, .0005 Mf.....	4.25
No. 367 Murdock, fully mounted, .001 Mf.....	4.50
No. 368 Murdock, fully mounted, .0005 Mf.....	4.00
No. 3660 Murdock, unmounted without knob and dial, .001 Mf.....	4.00
No. 3680 Murdock, unmounted without knob and dial, .0005 Mf.....	3.25

JACKS (Radio Type)

No. P-1 Open circuit.....	.70
No. P-2 Closed circuit.....	.85
No. P-3 Two circuit.....	1.00

LOUD SPEAKERS

Arkay, horn only, satin finish.....	5.00
Federal Pleiophone, complete with phone.....	14.00

PLUGS

No. 34-B Firco, round type.....	2.50
No. P-1 Western Electric.....	1.10

SOCKETS

No. 156 General Radio, improved model.....	1.50
No. P-1 Chelsea.....	1.00
No. P-2 Clapp-Eastham, bakelite type.....	1.00
No. UR-542 Radio Corporation.....	1.00

TELEPHONES

No. 56 Murdock, 2000 ohms.....	5.00
No. 56 Murdock, 3000 ohms.....	6.00
No. 2A Stromberg Carlson, 2000 ohms.....	7.50
No. P-1 Holtzer-Cabot, 2,200 ohms.....	8.00

Let "PITTSO" fill your orders for any of the above items.
Our SERVICE on these at the present time will please you.

F. D. PITTS CO., Inc.

12 PARK SQUARE

Woolworth Building,
Providence, R. I.

BOSTON, MASS., U. S. A.

276 Worthington Street
Springfield, Mass.

3 STORES

Tell them that you saw it in RADIO

Make Radio a Profession Instead of a Plaything

IT is said that opportunity knocks but once in a man's lifetime. But there are thousands of opportunities knocking at your door right NOW. Get into Radio as a Big Money Making Profession. Here is how:

Become a Radio-trician

A Radio-trician is a person thoroughly proficient in designing, constructing, installing, maintaining, operating, repairing and selling complete Radio transmitting and receiving stations and outfits, by means of which he may pass U. S. Government Examination and secure a First-Class Operator's License for commercial land or sea service or as Broadcasting operator.

A Radio-trician means to Radio what Electrician means to Electricity.

MILLIONS upon millions of dollars are being invested in Radio by far-seeing business men and manufacturers throughout the world. Nearly a million Radio sets are already in use. Yet the industry is still in its infancy.

Thousands of men are needed in Radio. They are needed—to design Radio sets—to invent new Radio improvements; they are needed to manufacture Radio equipment and to install it; they are needed to maintain and operate the great Broadcasting stations and the small Radio sets; they are needed to repair and sell Radio apparatus; they are needed to operate aboard ship and at the transoceanic land stations.

Hundreds Getting Wealthy

Hundreds of men are already growing wealthy through this new wonder science. The openings for more men are everywhere. Whatever interest you may have in Radio can be turned into gold.

If you are a young man of ambition, anxious to get into a profession with a field that is unlimited, get into Radio—become a Radio-trician. If you are a dealer wishing to become thoroughly familiar with Radio so that you can sell Radio apparatus, become a Radio-trician. If you are an amateur, learn Radio thoroughly from every angle so that you may make money out of this business instead of using it only as a plaything or hobby. Now is the time for men of red blood, men of vision, to become Radio-tricians.

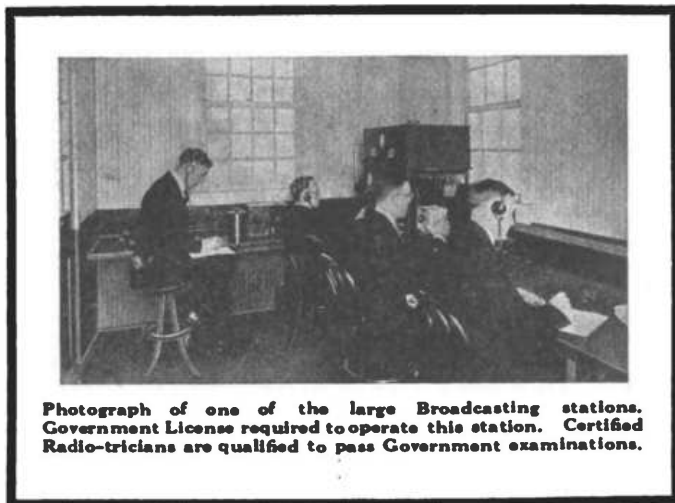

Photograph of one of the large Broadcasting stations. Government License required to operate this station. Certified Radio-tricians are qualified to pass Government examinations.

Radio Headquarters

The National Radio Institute is preparing Radio-tricians by mail in spare time at home. Over eight thousand students and graduates have become proficient in this splendid field through the instruction given by this pioneer school during the past seven years. Every phase of Radio is taught from the ground up. Knowledge is imparted through personally corrected lessons, actual practice and actual assembly of Radio Apparatus.

Through our copyrighted books, diagrams, problems, principles and practice on instruments we send you, the National Radio Institute is making Radio-tricians throughout the country.

WRITE FOR BOOK

Here is a profession which is paying enormous earnings to men all over the country today—a profession that will make hundreds of men wealthy—a profession far more lucrative than that of any other technical or mechanical employment you can secure.

The world is aflame with radio. What are you going to do to "cash in" on the demand for men, for equipment, for experience? Are you going to sit idly by wondering what it is all about, or are you going to make the most of this, the greatest opportunity presented to men of ambition in 50 years?

Write at once for the complete catalog to the National Radio Institute. This is the turning point in your life. Upon your decision *this instant* may depend your entire future. Mail the coupon, or write a letter NOW—for your own sake.

NATIONAL RADIO INSTITUTE

Radio Headquarters

Dept. 1136

WASHINGTON, D. C.

NATIONAL RADIO INSTITUTE
Radio Headquarters
Dept. 1136 Washington, D. C.

Please send me your catalog "How to Learn Radio at Home", describing your Home Study course which will qualify me to become a Radio-trician.

Name.....
Address.....
City..... State.....

\$5,000,000 per Week for Radio

"Do you realize that America is now spending about \$5,000,000 a week for radio equipment? Do you know that the unfilled orders of one radio manufacturing company alone amount to \$50,000,000? Another conservative manufacturer expects to be turning out \$25,000 worth of receiving sets daily.

"It is safe to estimate that in these times of depression, when people were supposed not to have money to spend, the American public has already invested \$100,000,000 in little boxes and tubes and coils of wire whose sole function is to bring entertainment or information into the home. And this is only the start. An annual radio business of \$400,000,000 is confidently expected.

"With the probable establishment of from 12 to 15 powerful broadcasting stations that will cover the entire country—not to mention a host of other public and independent stations—and with the certainty that improvements in apparatus will keep up sales for years to come, it is undeniable that radio has within a period of six months leaped up as a vast national utility on a par in promise with the automobile, the motion pictures, and with public services like the telephone and electric railways."—From *Popular Science Monthly*.

The Book that brings Radio into the home -

WHAT THE BOOK CONTAINS

Section 1. HOW RADIO ENTERS THE HOME. Contains just the information sought by the man who wants to buy a set. What set shall I buy? How much does it cost? What will it do? This section answers a hundred such questions. All types of sets are described from the least to the most expensive. Full installing and operating instructions.

Section 2. HOW TO RECEIVE MOST EFFICIENTLY. Important receiving accessories are described in language that the layman can understand. For the benefit of the amateur, technical data are given on audio and radio frequency amplification, erection of antennae, battery charging, regeneration, etc. Valuable receiving-circuit diagrams are published for the first time.

Section 3. VACUUM TUBE TRANSMISSION FOR THE AMATEUR AND EXPERIMENTER. Everything from A to Z about transmission with new, completely revised transmitting diagrams, incorporating Radiotron transmission and Kenotron rectification. Valuable operating instructions are given, and the use of mica condensers for transmission is emphasized.

Section 4. GENERAL INFORMATION - A VERIFIABLE GUIDE BOOK TO RADIO. Government laws, National Electric Code Radio Rules, vacuum-tube "Don'ts," radio glossary, specifications for a scientifically constructed amateur station, complete price list of all R C A equipment.



Price
35¢

FOR the first time a book is published at a small price which gives the public all that it should know about radio. It is called "Radio Enters the Home," and it is written by experts. It tells how to enjoy popular radio broadcasting, and it gives complete descriptions of apparatus and installation instructions. No book so richly illustrated, so accurate, and yet so understandable has thus far been published.

The book is divided into four sections. Over 200 illustrations, 112 pages, size 8" x 11". The technically uninformed man will find in sections written especially for him the simply presented facts that he seeks; in other sections are data and diagrams that appeal to the trained amateur.

PRICE, AT YOUR DEALER 35 cents

If your dealer has exhausted his supply, send 35 cents to

Radio  **Corporation**
of America

Sales Division, Suite 1804
233 Broadway, New York City

Tell them that you saw it in RADIO.



Stop Buzzing and Sizzling

FORMICA insulation for Radio use is perfect insulation! It prevents buzzing, sizzling and noise that makes it hard to hear over your radio telephone.

There are no weak places in Formica panels. They are not affected by moisture and weather conditions and do not deteriorate. They will give perfect service for years.

Formica is the most widely used radio insulation. It is approved by the Navy and the Signal Corps. It is a thoroughly high quality product—the finest possible insulating material all the way through! It contains no absorbent matter that will take up water and lose its insulating strength through humidity and moisture.

Formica panels have a handsome gloss or satin finish—black and natural brown.

Dealers: We have now in operation an addition to our plant which doubles our previous capacity. Back orders for Formica are being shipped rapidly. We always do our utmost to serve you promptly.

The Formica Insulation Company
4616 Spring Grove Avenue Cincinnati, Ohio

SALES OFFICES

50 Church Street, New York, N. Y.
9 South Clinton Street, Chicago, Ill.
414 Finance Building, Cleveland, Ohio
1042 Granite Building, Rochester, N. Y.
422 First Avenue, Pittsburgh, Pa.

Sheldon Building, San Francisco, Cal.
932 Real Estate Trust Bldg., Philadelphia, Pa.
321 Title Building, Baltimore, Md.
415 Ohio Building, Toledo, Ohio.

FORMICA

Made from Anhydrous Redmanol Resins

SHEETS TUBES RODS

Tell them that you saw it in RADIO



Medal and Diploma received at World's Columbian Exposition, Chicago, 1893



ELECTROSE

INSULATION
MADE IN AMERICA



Medal and Diploma received at World's Fair, St. Louis, 1904



Globe Commercial Co., San Francisco, Cal., Factory representative on the coast.

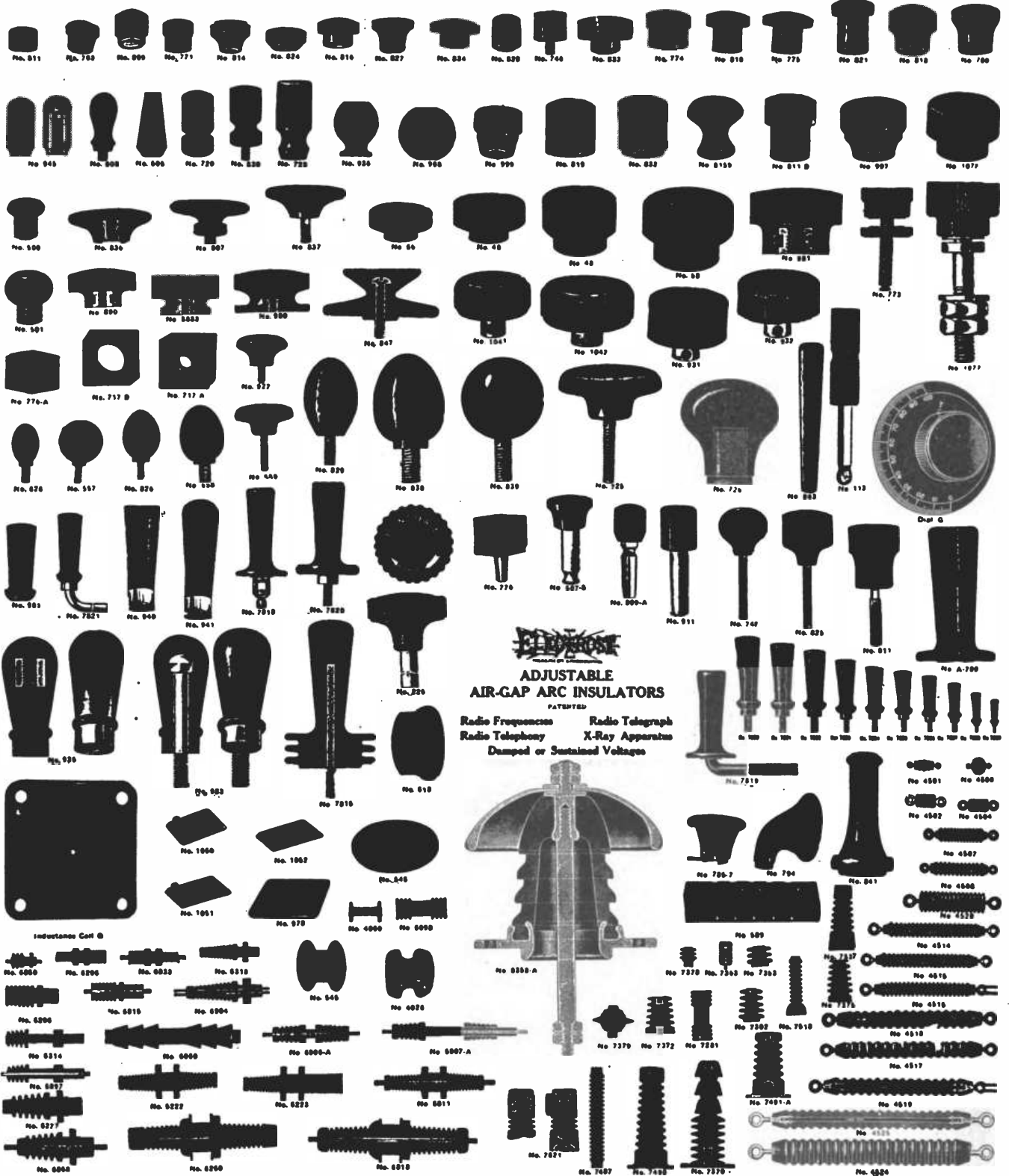

ELECTROSE
ADJUSTABLE
AIR-GAP ARC INSULATORS
PATENTED
Radio Frequencies Radio Telegraph
Radio Telephony X-Ray Apparatus
Damped or Sustained Voltages

"Electrose" is made in a number of grades for various requirements, each grade possessing special characteristics. Insulators and Insulating parts and devices of special sizes and forms, designed and made to order.

SOLE MANUFACTURERS



60-82 Washington St. 27-37 York St.
66-76 Front St. 1-23 Flint St.
Brooklyn, N. Y., America

Tell them that you saw it in RADIO

Radiatorial Comment

IN the course of a recent address, General John J. Pershing expressed his wonderment that the United States was able to achieve victory in the World War, *considering its unpreparedness*. And he strongly made appeal for a sufficient standing force to protect the nation in the future.

On the same date Rear Admiral W. S. Sims also made a speech—in another part of the country, before the graduating class of the Naval War College. He, too, preached a powerful sermon for preparedness. He charged that the nation has ever been UN-prepared in time of emergency and *deplored public indifference in the matter*. Such results can only result in the lowering of the morale of the people, he said. A great many lives were lost in the late war because no branch of our fighting forces was prepared. "The inevitable consequences have been, and now are," he declared, "that once the object of the war is attained, the public loses all interest and forgets the sacrifices entailed by having been unprepared."

Two very much to the point statements by two men at the top of the two branches of our offense and defense! Two truthful statements!

We were discussing citizen radio with the mother of an amateur operator, and a good one. We endeavored to point out that, in case of need, her son—because of his radio knowledge—would be of great service to his flag, adding that it was our ambition to foster citizen radio in every way possible—to this end—as well as that of the all-around development of the youth of the nation.

With a sniff of contempt, this mother retorted that she "did not intend my boy for the Army." We gently made remark that, *IF* the necessity arose, in the future—the same sort of necessity that presented itself not so long ago—"my boy" would have to give his services, in *some branch* of the services, whether she liked it—or no!

Bringing the matter down to a fine point: we have, in this great nation of ours, the finest type of young manhood in the world! Ambitious, keen, resourceful, independent, enthusiastic young manhood! A very great many thousands of "my boys" are first rate radio operators and students. A very great many of them, for one reason and another, have not the opportunities of study, nor the books, nor really any of the facilities at hand for their rapid development! Bless their hearts, these lads dig it out for themselves, as best they may—all the more credit to them!

BUT: When the War Department creates training schools—summer—when it conducts various courses of study—when it *tries* to interest citizen radio, and to *help* its progress—is it not a short-sighted policy to let these advantages slip by—*unheeded*? If the call comes, and "my boy" **MUST** go—is it not better for him to step in to the

branch of the Service where his abilities and his *worth* are at once recognized—rather than to do "K. P."—or be shuffled with a lot of others as one shuffles a pack of cards, and—take what he "draws"—nine times out of ten an congenial position, where his real value is wasted?

This seems to us a logically sane question!

The U. S. is divided into so-called "areas," with a commander over each. Inquiries addressed to the headquarters of each area will be given prompt attention, and enrollment blanks forwarded—that are necessary for the application to the training camps. The Government pays all the expenses—the student being required to bring but his personal, more intimate, apparel—even his uniform being supplied on his arrival at the camp.

We are unhesitating in the remark that it is folly to cast aside the chances for a Signal Corps—and an Army—training, that the Government offers to **ALL** American citizens, below the age of 25 years—and offers it on a silver platter!

BUT lately the eyes of amateur radio were focussed on the Atlantic Coast, where—under the auspices of the ARRL—eminently successful trans-Atlantic tests were made, whose results indubitably proved that the signals from East-Coast amateur stations crossed the Atlantic Ocean.

So far—so good!

But we, of the enthusiastic West, are by no means content to rest at these achievements. It has been shown that a great many Pacific Coast stations—and some from far inland—are being heard (QSA) by that indefatigable worker, Clifford J. Dow, in Honolulu. The question arises in our mind: if Honolulu is hearing many of us, so well, how much *farther* are our signals carrying?

The only answer is to make effort at ascertaining!

And this plan has occurred to us:

With the co-operation and advice of the Radio Inspector of the 6th District, let the Editor appoint an A-1 commercial operator to cross the Pacific on some vessel going to Yokohama—or Shanghai. By prearranged schedules—to be published in RADIO—let this operator—who shall represent the great body of western amateurs—*listen* each night of the voyage out—on the wavelengths used by amateurs, special stations, and those that broadcast music, etc. Let the representing operator keep a careful log of every station heard, together with such data as may seem of effective and interesting use. If the vessel on which he sails stops at Honolulu, let him send, in the most abbreviated form, the call letters of such stations as he has already logged, from that place. He will continue to listen, each night, *after* the ship leaves Honolulu, Orient-bound. We conceive that some

Continued on page 75

Industrial Uses of Radio

By R. C. Denny

HOW far radio can grow out of the stage of a popular parlor toy and take its place as a serious factor in business service is a question which has attracted much interest of late. It is obvious that there are wonderful possibilities latent in this field in the West where such industries as lumbering, mining, stock raising, and fishing often carry on the greater part of their activities in remote regions not reached by the ordinary modes of communication. The power companies, with their mountain plants and distant construction projects, have already experimented with wireless with some success, and their experience will be of interest and value to those contemplating similar installations. The writer, as chairman of the sub-committee on Radio Communication, has embodied his views in a report submitted at the recent convention of the Pacific Coast Electrical Association, as follows:

Among the power companies of this district, it has developed that there is considerable need for an emergency means of communication for system operation or load dispatching in times of storms and line failures, which so affect the telephone lines as to make them inoperative. Radio in such instances should prove a valuable aid to the system dispatcher in restoring conditions to normal. There is no apparent great need for radio for communication with construction camps, but it might be well used in such cases, instead of monopolizing existing lines or building new lines just for this purpose.

Opinion seems somewhat divided as to whether the use of radio for system dispatching should be for emergencies or used as routine. In all probability it would resolve itself down to emergency use, for in the absence of any practical signalling device, the dispatcher would have to be "listening in" at all times, which would very considerably interfere with his routine office work. In an emergency, however, when the telephone line fails, it would be quite the natural thing to turn to the radio set for communication. Construction work would probably justify routine operation, depending somewhat on how extensive the project.

The companies seem unanimously in favor of the undamped or continuous wave system of radio. Recent demonstrations have certainly proven it superior to the damped or spark system in many ways and there is little doubt but that it will entirely supplant the older system. The radio telephone would seem most adapted to system dispatching where speed and accuracy under personal supervision is necessary; while for construction work the radio telegraph should quite well suffice, as the work is not of such exacting nature.

Probably the maximum distance from headquarters that must be reached by any of the companies in order to cover their system, would be 300 miles. On practically all the systems, transmission distances cover all sorts of country, from

level valleys to mountains. The climatic conditions are much the same for similar portions of all systems in this district, so that all would have to contend with considerable atmospheric electricity in the summer months, which are, however, fortunately not the season for line failures. The problem of reliable power supply for remote installations is comparatively simple; as in most cases the hydro plants themselves would be the location of the radio; and in the case of construction camps, reliable power lines must be built in order that work of any magnitude may be carried on at all.

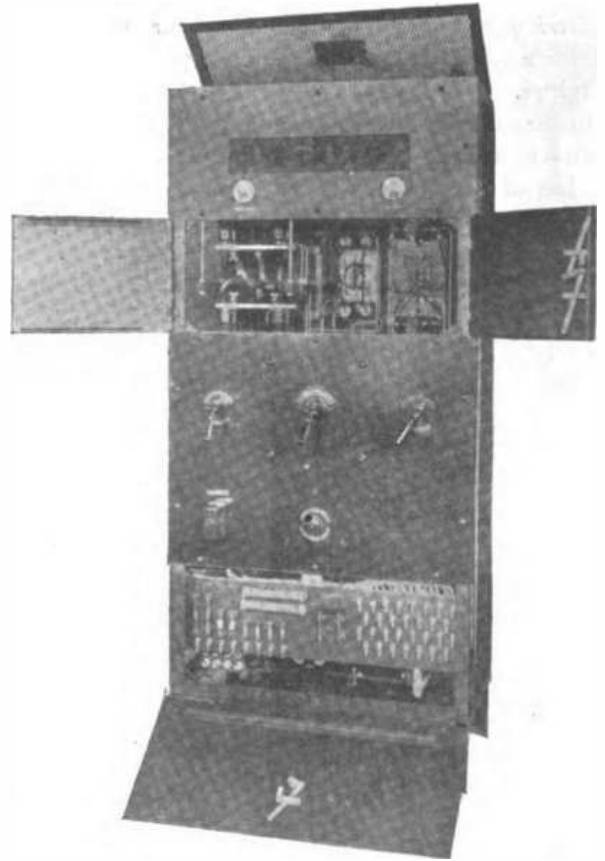

1 K. W. Radio Transmitter Panel for Ocean Telephony. Employing Four 250 Watt Radiotrons as Oscillators and One 50 Watt Tube as Speech Amplifier; Controls Provide for either C. W., I. C. W., or Telephone Transmission on Any Wavelength between 300 and 800 Meters.

The distances between dispatchers' offices of the interconnected companies in this section vary from 5 to 234 miles. Direct communication between these offices is now to be had by means of the Pacific Telegraph and Telephone Company's

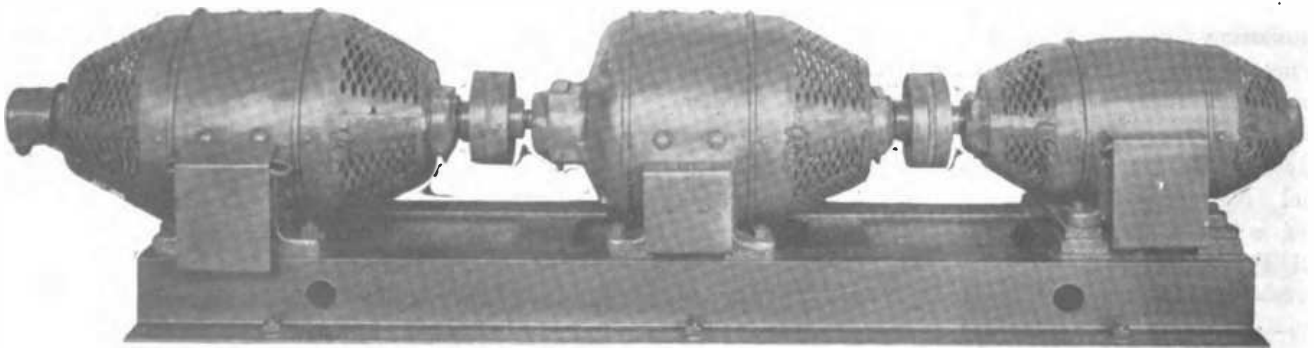

Three Unit Motor Generator Set with 6 1/4 H. P. 115 Volt D. C. Motor Driving 2000 Volt Generator Supplying Plate Circuit and Double Current Generator Supply 4 Amps. at 125 Volts D. C. Exciting Current and 10 Amps. at 88 Volts A. C. for Feeding 12 Volt Filament Heating Transformer.

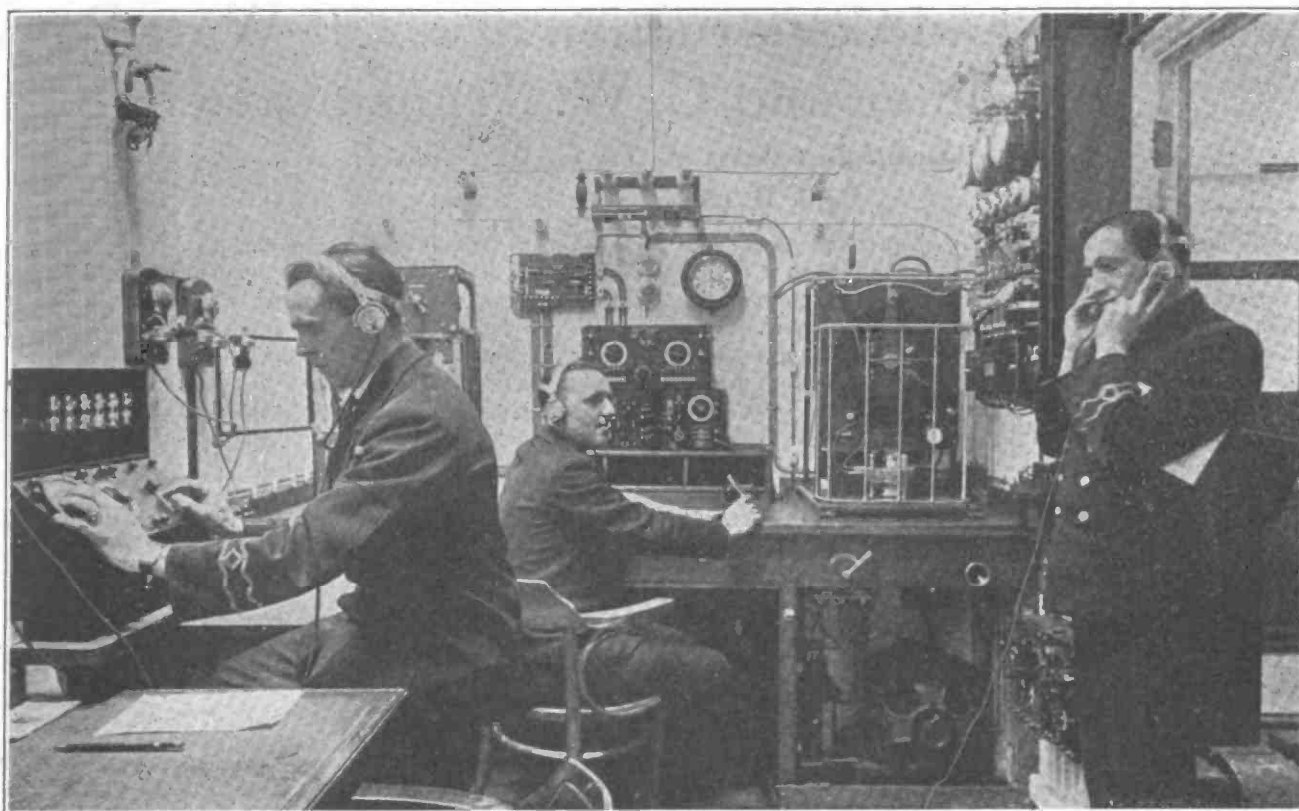

Ewing Galloway, Photo

Radio Room in "Majestic," the World's Biggest Ship, Showing Tube Transmitter at Left Center and Spark Transmitter at Right Center. Radio Compass is Shown at Extreme Left.

long distance service and, indirectly, by relaying phone messages through substation operators over the private lines. The long distance phone is usually quite reliable—but not always, and it is never very rapid. The method of relaying messages is slow and often results in inaccuracies. In several cases the radio requirements of a company in covering its own system have resulted in overlapping the operating headquarters of interconnected systems, which would indicate that the problem of radio communication between dispatchers' offices should not be such a formidable one.

Several of the operating companies have made use of the radio telegraph for construction purposes, with great satisfaction. The Southern California Edison Company makes use of the undamped system and in a typical month's operation, has telegraphed 121,000 words between headquarters and camps. Its operations are over distances of 14 to 25 miles in extremely mountainous country. The San Joaquin Light and Power Corporation utilized the damped system a year ago in connection with the Kern power house job. This operation was over 115 miles of valley country. The Edison Company's sets are rated at ½-kw. and cost \$1,500.00 each; the sets used by the San Joaquin Light and Power Corporation cost \$750.00 each, and although rated at 2 kw., accomplish successful transmission when using not over 6/10 kw.

The stations were all operated under Limited Commercial station licenses, which were obtained without difficulty or cost and were operated by men holding first grade commercial operator's licenses. There was an occasion on each of these systems where the radio telegraph was called in to assist the dispatcher in handling an operating situation. No extensive experiments have been made by any of the companies with "wired wireless," although it is contemplated. The San Joaquin Company are carrying on experiments with a radio telephone set of 50 watts rating and report that they are having considerable success.

The Radio Corporation of America, who practically control the manufacture and sale of tubes and parts for radio

phone sets, have two standard sets on the market rated at 1000 watts and 200 watts, selling for \$7,500.00 and \$6,000.00 respectively, complete in each case with receiving instruments. They have no objection to the power companies buying their tubes and parts for use in experimental work, so long as the work is truly experimental. They go further to say that they probably will be prepared at an early date to take care of limited commercial needs. It is coming to be recognized that if reliable phone sets could be developed at a cost of \$500.00 to \$750.00 power companies would be justified in installing them at remote and important plants for the betterment of the service in emergencies. In conclusion it might at least be said that the outlook is very encouraging, as with the apparatus on the market, and the right to make limited commercial use of it, there is little to stand in the way of applying it to the use of power system operations.



International Photo
Aerial and Radiophone Installation on Buffet Car of Lackawanna Railroad Made by D. W. Richardson and G. D. Murray of Princeton. Complete Conversations to and from the Traveling Train Were Carried on With Stations at Scranton and Binghamton.

The Design and Construction of a 250-Watt Power Amplifier and C. W. Transmitter

Seventh Installment of "The C. W. Manual"

By J. B. Dow, Ensign U. S. N.

FROM a study of the preceding chapter the reader has become familiar with the power amplifier as a device for increasing the output of a previously constructed radiophone or other type of vacuum tube transmitter. The amplifier now under consideration is one employing a single 250-watt tube, and capable of being "driven" from a single 5-watt tube as a master oscillator and another 5-watt tube as a modulator if control of the emitted wave by voice is desired.

This amplifier is also designed to operate as a complete C. W. transmitter. It contains the necessary grid condenser

equipment, and is highly recommended.

Fig. 58 illustrates the circuit used in this combined power amplifier and C. W. transmitter. Reference to this figure will convince the reader of its flexibility and consequent utility. Because of this feature it is a most valuable asset to any radio laboratory.

By merely impressing a portion of the output of a small oscillator or radio phone set (see Fig. 21) upon the grid

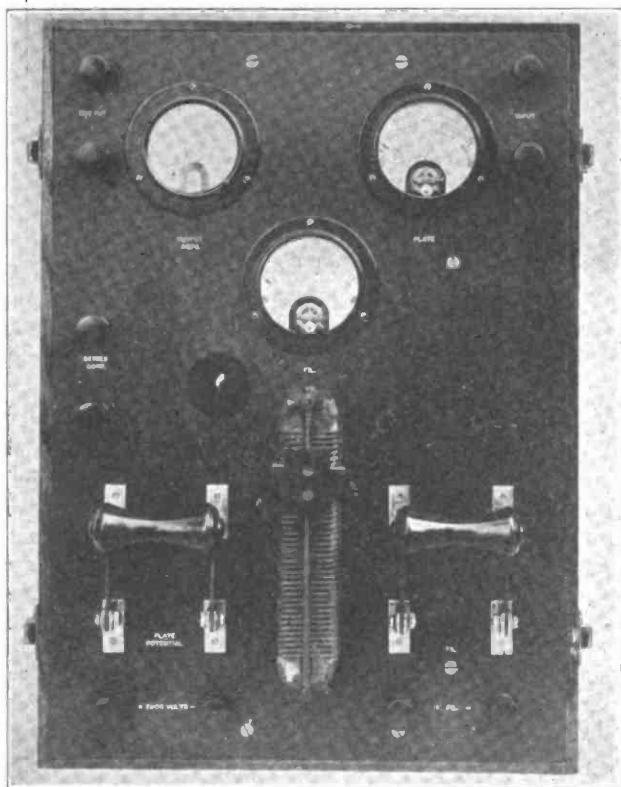

Fig. 54. Front View of 250-Watt Power Amplifier

and grid leak for this purpose as well as the input and output inductances. Figs. 54, 55 and 56 show three views of the completed apparatus (except for the wiring). All non-metallic parts of the completed unit, except the cabinet, which is of oak and 12½ by 11 by 16 in. inside and rabbitted to receive the front panel, are constructed of bakelite. The major dimensions of the various panels and sub-panels may be found by referring to Fig. 57. If the constructor will follow these dimensions carefully in cutting the required material, the expense incurred in manufacturing such a piece of apparatus will not be as great as might be expected and the finished product will be a device well worth the care necessary to construct same.

Since, from Figs. 54, 55 and 56, the details of the assembly are quite clear, it is considered unnecessary to include further detail in connection with Fig. 57. This figure also explains the method of supporting the vacuum tube, wherein standard Radio Corporation end mountings are suspended inside two bakelite rings by means of helical springs. This method of suspension prevents possible damage to the tube from any shock received in handling the

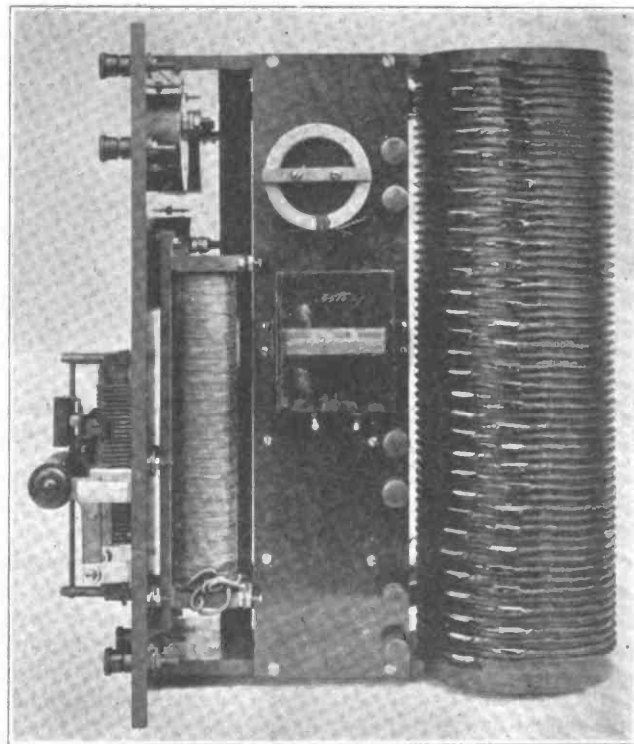

Fig. 55. Right Profile of 250-Watt Power Amplifier

circuit of the amplifier, and, of course, at the same time supplying the latter equipment with the necessary plate and filament energy, the entire output of the amplifier may be controlled with the same precision as the much lower-powered "driver."

If it is desired to use the device as an oscillator for the transmission of telegraph signals only, the master oscillator of Fig. 21 is unnecessary. To do this it is only necessary to connect as shown by the broken lines, these connections being simple post to post operations.

Either alternating or direct current may be used on the filament and plate. The process of shifting is a simple one and will be considered in detail later.

As stated in connection with Fig. 58, binding posts 1, 2, 3, 4 and 5 are located on the vertical sub-panel and are in evidence in Fig. 55. These posts provide a simple, efficient means for operating the device as an amplifier or oscillator. The balance of the binding posts provide exterior connections to the completed apparatus and are located upon the front panel. Some of these are not shown in the original model from which the photograph in Fig. 54 was made, but in all subsequent models the additional posts were provided.

The grid condenser, C_1 , and the grid leak, R_1 , comprises a 0.002 microfarad mica dielectric condenser and a resistance of 5000 to 10,000 ohms. The necessary details for the construction of such a resistance will be found in Fig. 27.

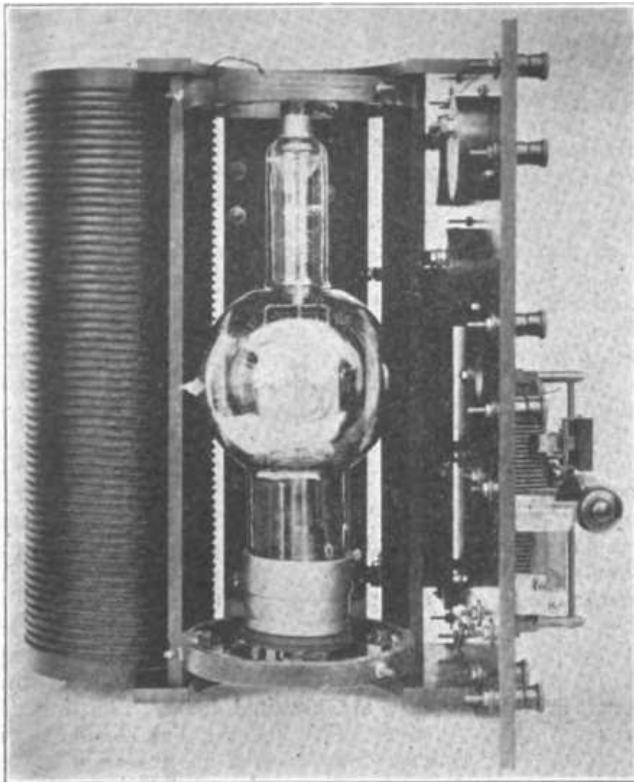

Fig. 56. Left Profile of 250-Watt Power Amplifier

The condenser, C_2 , of Fig. 58, is of the oil dielectric type shown as the left one in Fig. 59 and must be capable of withstanding 4000 volts. Its capacity should be approximately 0.002 microfarad. The smaller condenser of Fig. 59, while admirably suited to use in low power C. W. circuits, cannot supplant the one mentioned above, but is

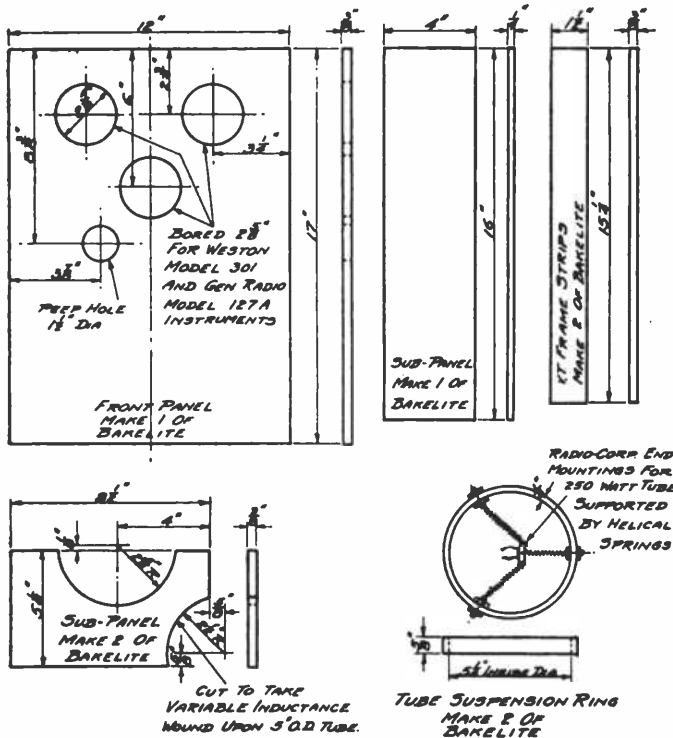

Fig. 57. Panel Dimensions for 250-Watt Power Amplifier

merely shown in this figure for comparison. If an oil dielectric variable transmitting condenser is not available, a mica dielectric fixed capacity may be used in place of C_2 in Fig. 58.

The inductance, L_1 , consists of a 250 turn honeycomb coil and prevents radio frequency energy from entering the

supply circuit by way of the generator leads to the posts, 14 and 15. In series with this radio frequency choke is the audio frequency choke, L_2 , which prevents a damping of any audio frequency signal which is being transmitted. This latter choke also serves the important purpose of maintaining

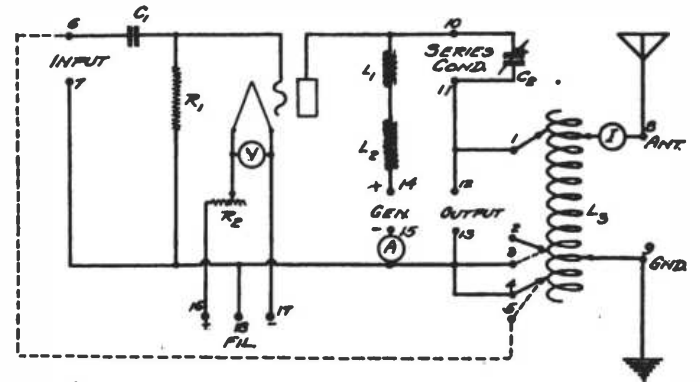

Fig. 58. Diagram of Circuit for 250-Watt Combined Power Amplifier and Oscillator

a steady current flow to the plate from the high voltage generator or other source of supply. If the device is to be used only for the amplification or generation of continuous waves at high frequencies the choke L_2 is unnecessary. The details of construction for L_2 will be found under Fig. 29 of a previous chapter. To smooth out the ripples caused by commutation currents and to provide a bypass for such radio frequency currents as get by the choke L_1 , the posts, 14 and 15, should be bridged with a capacity of 0.5 microfarad. This capacity is not provided for in the instrument itself, because when alternating current of the voltage required is used to supply the tube via the plate, this capacity must be left out of circuit or a much smaller one must be provided. The reason for this is quite obvious.

The inductance, L_3 , which is shown in Figs. 55 and 56, consists of sixty turns of 10 by 30 Litz twisted seven cord, around a 5 in. outside diameter bakelite tube. Different construction for this inductance is permissible, but in designing another type employing solid conductor in place of the above mentioned Litz, the reader is urged to consider the theory of eddy currents, which are very pronounced in power circuits operating within the scope of radio frequencies. It would not be consistent with good engineering policies to use copper tubing less than 5/16 in. in diameter nor copper strip less than 3/4 in. wide. The flexible leads to this inductance terminate at the binding posts provided

Continued on page 87

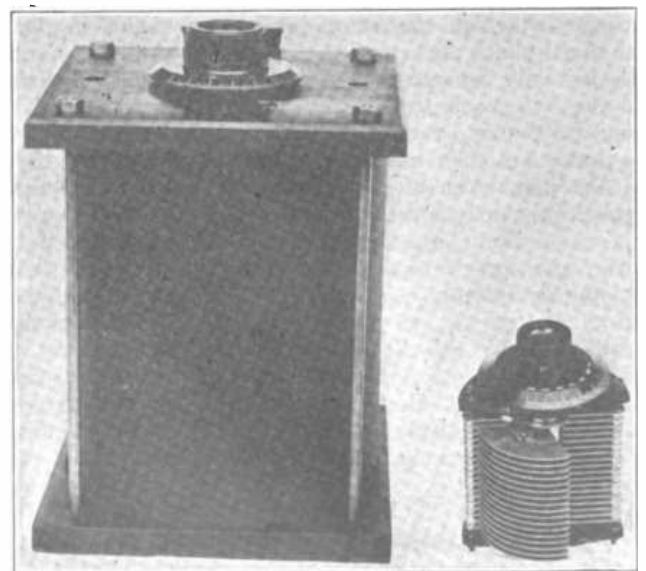

Fig. 59. Transmitting Condensers. Left, Oil Immersed; Right, Air Dielectric Type

Variometers

By D. B. McGown

A VARIOMETER is a type of inductance that is variable, as the name suggests, but differs from the tapped coil, or the coil using a slider, in that no actual variation of the length or amount of wire is made. The inductance of the variometer as a whole is variable, due to its being made up of two coils, which are so placed that they will either add to or oppose each other's magnetic fields, and thus give a variation of the inductance of the total. It might, therefore, be defined as "a continuously variable inductance, varied thru its own mutual inductance."

Variometers are made in several types. The commonest form, and that with which the majority of the radio fraternity are familiar is composed of two spherical windings, one inside the other, which are connected in series.



Fig. 1. Typical Variometer

This type is illustrated in Fig. 1. Here it will be seen that the inner coil or "rotor" is wound on a ball, while the outer coil, or "stator" is wound on the inside of the outer frame, or housing, which acts both as a support for the stator winding, and a support for the bearings in which the rotor revolves. The shaft, which appears to go thru the ball, is really separated in the center, and the two pieces serve as conductors from the center winding. The rotor and stator are then connected together and the inductance of the whole unit depends, as stated above, on whether the coils are "bucking" or aiding each other. This variometer is used exclusively in receiving equipment.

Another type of variometer is the so-called "figure eight" type, which is represented in Fig. 2. This variometer consists of two disks slotted across their diameters at the centers. These disks are wound in the same manner as the tracing of a figure 8, as it is ordinarily made in script figures, as shown in Fig. 2C, which shows the method of winding of one turn, which is shown in order not to confuse the drawing. The additional turns follow in the same or-

der, on both coils. One coil is fixed, and the other is rotated. A rotation of 180 degrees in this, as in the other type of variometer, gives a complete variation from minimum to maximum. The action is the same as in the ball type of variometer, the mechanical construction is the chief difference. However, this instrument takes up less space than the other type, and furthermore, can be made up by anyone with much less trouble than the ball type, which takes considerable skill to make, as well as a lathe to turn out the forms.

The figure eight variometer may be easily made up by taking a flat piece of wood or bakelite, and simply winding as many turns as are desired in the form

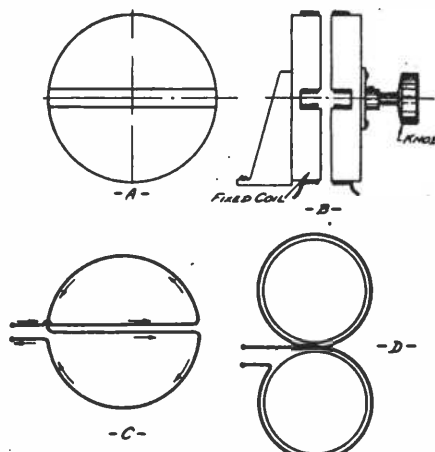

Fig. 2. Details of Figure 8 Variometer

of a true figure 8, on two wooden pegs a couple of inches in diameter, as shown in Fig. 2D. The windings are then removed, fastened with shellac, insulating varnish or thread, and mounted on square pieces of board. They might be also wound on two square blocks of wood, which are fastened to the back before winding, the wire being wound in place and left there. Numerous variations of this type will present themselves to the reader. They may be used for anything and everything that the ball type can be used for, altho they do not possess any particular advantages except that they are easier of construction. The number of turns needed for these instruments will vary with the use to which they are to be put, and the exact number will have to be determined by experiment. For the ordinary receiver about 30 or 40 turns on each coil will suffice.

Another type which is almost exactly similar to the ball type, is the variometer made up of two concentric cylindrical tubes, one rotated inside the other. In fact, this type was the forerunner of the ball type. It is very much easier to construct than the ball type, but does not have as low a minimum, or as high a maximum induc-

tance, as will be explained later. This type is usually made up by amateurs and others who do not have the facilities to make up the other types.

It is not necessary that the variometer be made so that the variation is accomplished by a rotary motion. It may be accomplished by sliding one coil over the other, or the same result may be obtained by two coils which can be brought nearer together, or separated farther apart. The latter system may be represented by two honeycomb coils, one of which is fixed, and the other is movable. The movable one is swung closer, or farther away from the stationary one, and a variation of the inductance is accomplished.

While at the present time the general use for variometers is in receiving apparatus, it must not be thought that they are unsuited for transmitting circuits. The Federal Telegraph Co., in their low powered arc transmitters, use an antenna series variometer called a "note varying variometer." Its function is to change the length of the emitted wave of the transmitter by a small amount, the amount varying on the position of the two coils, and their total inductance. When a receiving operator hears a station calling him he must be just on its exact tune, with an arc set. If it is off tune he will generally hear nothing. If the receiver is set to just 2400 meters, and the ships are also on that wave, well and good, but if the ship happens to be a little above or below, the receiving operator will not hear it unless he is constantly manipulating his apparatus. Now, if the wavelength of the transmitting set is altered so as to "cross" the wave of the receiving station, communication can be established with much greater ease, as is self evident. The variometer used for this purpose is carefully insulated and made up in the form of the ball type, but is wound with wire (litz) which is capable of carrying the total antenna current of the set, instead of the small wire used for a receiving variometer.

Another use for variometers in transmitting is found on the Telefunken transmitters. These sets, like all quenched sets, are extremely critical in the adjustments between the antenna and closed circuits. The Telefunken equipments are supplied with two spiral inductances, one of which is hinged, and the antenna circuit is then tuned by first roughly tuning for resonance, by means of the number of turns and then the actual final adjustment is made by swinging or varying the position of the movable coil of the variometer. The same result could be obtained by the use of a slider, of course, but the use of

such a device introduces a moving contact which is liable at times to prove unsatisfactory—or at least this appears to be the contention of the Telefunken people. It is interesting to note, however, that the modern American quenched set accomplishes the antenna tuning by means of a slider, and no serious effects result, and much greater compactness and convenience is noted.

The so-called "vario-coupler," Fig. 3,

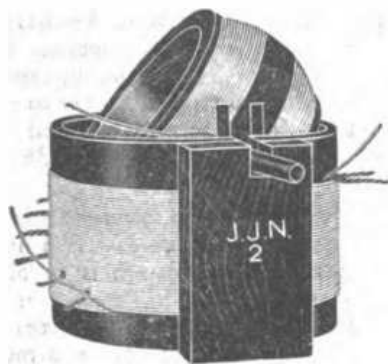

Fig. 3. Typical Variocoupler

is nothing but a special type of variometer, altho it is not connected in the usual variometer manner. It consists of two separate coils, and is really a "coupler," altho it is of the variometer family. It is made up in several types, and may be made on cardboard tubes or on figure 8 coils if considered necessary, altho the present commercially marketed types will answer all purposes as a rule.

Fig. 4A shows the circuit of the popular two variometer receiver, such as has been used and is still used in countless amateur stations. Here we have the grid variometer, A, which serves to vary the secondary C circuit, after the antenna has been properly tuned, and B is the plate variometer. When A is tuned to a given wavelength, B may be adjusted so that the plate circuit is in tune with the grid circuit, and the tube starts to oscillate. Just before the position of oscillation is reached, we have a condition in the tube whereby the incoming signals are greatly amplified. This action is called "regeneration."

A handy use for a variometer is shown in Fig. 4B, where the variometer is used as a "tickler" coil, in the ordinary circuit. The secondary coil is wound on a tube, and is fastened to the side of the variometer. The winding on the secondary depends, of course, on the wavelength range it is desired to receive over, while the tickler, consisting of both the rotor and stator of the variometer, may be varied so the bulb will either act as a detector, a regenerative amplifier, or as an oscillator. It will be found that this system possesses a marked advantage over the tuned plate system. When used as shown, the limit of the wavelength of the secondary depends on the number of turns on the tube. This may, of course, be increased by bank winding, etc. On

the other hand, the tuned plate "two variometer" system will not give a greater wavelength range than is possible to get, due to the maximum and minimum in the variometer, resulting in a comparatively narrow wave band. The usual type of this receiver will only go from about 175 to 400 meters, while if properly constructed, one with a variometer tickler will go up to as high a wavelength as is needed.

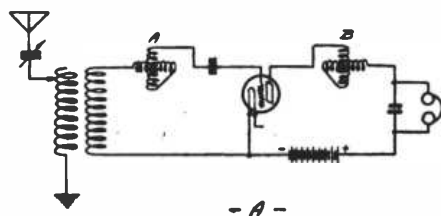

- A -

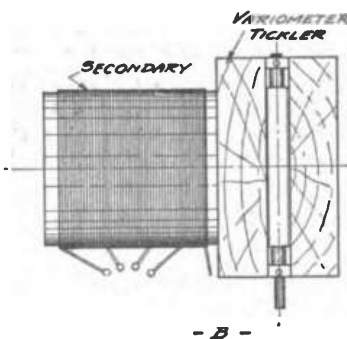

- B -

Fig. 4A. Standard Tuned Plate Circuit
Fig. 4B. Tubular Secondary Fitted to End of Ordinary Variometer

For general results there will be found to be little difference in the efficiency of the various types of variometers on the market. The moulded type, in which the rotor and stator windings are made up on bakelite, are probably better than those made of wood, altho a variometer made of good hardwood, well seasoned, should not give any trouble.

Besides the uses mentioned above a single variometer may be used as a simple receiver, of the single coil type, either for a crystal or a vacuum tube detector. This possesses, as all single coil receivers, reasonable sensitivity, but with but little selectivity, altho if the listener does not have any local interference with which to contend, he will be able to obtain very good results.

The best variometers are those that have a minimum clearance between the rotor and stator, and which have exactly equal coils for both the rotor and stator. By this is meant that the two coils both have the same inductance. If they are then adding, their total inductance will be very high, while if they are bucking, it will theoretically approximate zero. In general, a variometer fills the place of the clumsy, crude tapped tuning coil, or inductance, shunted by a condenser, as the variometer is itself continuously variable, and as fine adjustment can be had

with it as with any condenser, and, furthermore, no loss will be introduced, as always exists in a condenser. It also eliminates the use of the multi-tapped coils which were sometimes used when it was not possible to use a shunt condenser, and, in fact, which would be absolutely useless for the reception of continuous waves of any kind.

ELIMINATING STATIC BY RESONANCE WAVE COIL

Plans for the perfection of the resonance wave coil method recently demonstrated at Chicago as a static eliminator in radio receiving, and the design of a standard instrument for general use, are being worked out, according to Dr. Louis Cohen, consulting engineer of the War Department. At present this instrument is only in the form of special laboratory apparatus, Dr. Cohen pointed out and as such demonstrated by him and Major J. Mauborgue, Chief Signal Officer of the Sixth Army Corps Area in Chicago.

At the suggestion of Major General Geo. O. Squier, Dr. Cohen and Major Mauborgue undertook a study of combining their developments in the use of resonance wave coils with line-wire broadcasting, with the result that they found a means of eliminating a large amount of the static ordinarily encountered. For some time Major Mauborgue and Dr. Cohen have been experimenting with their resonance coils method used in the reception and transmission of radio signals, and upon combining the theories of General Squier with their own, were able to get most satisfactory results in eliminating static interference. A number of patents have already been filed on circuit arrangements for use with wave coils.

Commenting on the recent experiments in Chicago, Dr. Cohen said that two important things were accomplished: First, they broadcasted by means of "wired wireless" on the mains of the Edison Company in the city of Chicago, plugging in a transmitter on the line through condensers and sending with a 50-watt lamp. The messages transmitted were received at one point on the circuit six miles from the transmitting station and at another point twelve miles distant. This was the first time that a practical demonstration of General Squier's line broadcasting system had been given in public.

Second: Messages were also received from a distance on the Edison system, it was said, showing that besides the signals put on the circuit messages sent from a distance could be received, the city lighting circuit serving in the place of an aerial. During the demonstration, signals from Government transmitting stations in Washington were picked up and heard clearly, the Chicago city

Continued on page 82

How to Design an Iron Core Audio Frequency Choke Coil

By A. K. Aster, Ph. D., University of California

THE design of a choke coil may be determined from five factors, namely: the inductance of the coil, the length of the magnetic field, the area of the core, the permeability of the iron, and the number of turns of wire. As two or more of these factors are likely to be unknown at the outset, it is necessary to assume certain values for them, so that we may determine approximate values for the other factors. To design a coil for a definite inductance, we must proceed more or less by trial, making reasonable assumptions and trying them out in the formula. If the desired result is not obtained, we make some changes and try again, until after several trials the desired value is obtained.

Let us therefore proceed to work out the design for a 100 henry choke coil to be wound on a rectangular closed core, having a cross sectional area of one sq. cm. and a magnetic path of 15 cm. Thus we have three of the five required factors and have only to determine the permeability of the iron in the core and number of turns in the coil.

The permeability depends upon three things: the kind of iron, the magnetic flux, and the frequency.

Only the best kind of silicon steel should be used for the core. Curves or tables giving values of permeability for differences in magnetic flux are furnished by the manufacturers. For instance, Fig. 1 shows the magnetization curve for Apollo special electrical steel, made by the American Tinplate Co.

Let us therefore assume a magnetic flux of 12 lines per sq. cm. From Fig. 1, it will be seen that the corresponding permeability is 1000. But this value is for low frequency and must be multiplied by a factor to give the correct value for a higher frequency of, say, 1000 cycles, which we will adopt as a standard, because it is the average frequency of the human voice and so is suitable for both telephone and telegraph work. For No. 29 gauge sheet steel, this correction factor is 5/8. Therefore, the effective permeability is $1000 \times 5/8 = 625$ for a frequency of 1000 cycles.

Consequently our problem now reduces itself to finding out the number of turns necessary for a 100 henry choke coil, having a one sq. cm. core area and 15 cm. magnetic path, assuming that the iron has a permeability of 625 for 1000 cycles. This may be found from the equation $t = 8944 \sqrt{L/1/a\mu}$ where t = number of turns, L = inductance = 100 henries, l = length of magnetic path = 15 cm., a = cross sectional area of core = 1 cm., and μ = permeability = 625. Substituting these values in the equation, we have $t = 8944 \sqrt{100 \times 15 / 1 \times 625} = 8944 \sqrt{2.4} = 13,823$ turns.

So now we know that 13,823 turns will give an inductance of 100 henries, if wound on a rectangular core 1 cm. in area with a magnetic path of 15 cm.,

as shown in Fig. 2, if we have a magnetic flux of 12 lines per sq. cm.

The next question that arises is how many amperes in such a coil will cause a magnetic flux of 12 lines. This may be found from the equation $A = .8HL/t$, where A = current in amperes, H = magnetic flux = 12, L = inductance = 100 henries, t = number of turns = 13,823. Substituting these values and solving, we get $A = .8 \times 12 \times 100 \div 13823 = .07$ approximately.

The next thing to determine is the size of wire to be used. The usual rule in transformer design is to allow 1000 circular mils per ampere. Since the rating of this coil is .07 ampere, 70 circular mils should be allowed. Therefore No. 36 B. & S. gauge wire will be ample, this value being determined from the ordinary wire table.

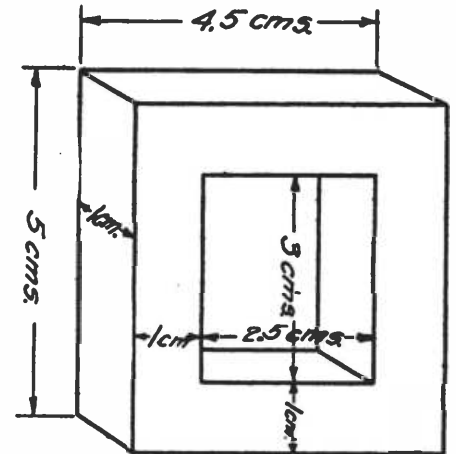

Fig. 2.—Choke Coil for Audio Frequency Amplifier.

Fig. 2 shows the general details of the core discussed. All joints should be lapped. A butt joint must never be used, as the magnetic leakage of this type is very high. The details of the actual method of winding the coil have been omitted, as it was assumed that the reader is familiar with them.

There are probably some readers who have not the equipment or time to make their own coils, and who would like to know what standard apparatus is available on the market, as there are no choke coils actually being made especially for use in amplifiers. After testing a number of standard coils, the writer believes that the smallest size Wayne bell ringing transformer will be satisfactory for amplifier work. This coil has an inductance of about 30 henries. The 110 volt winding should be used as a choke coil, and the 12 volt winding should be left open. This transformer can be purchased from any dealer in electrical supplies.

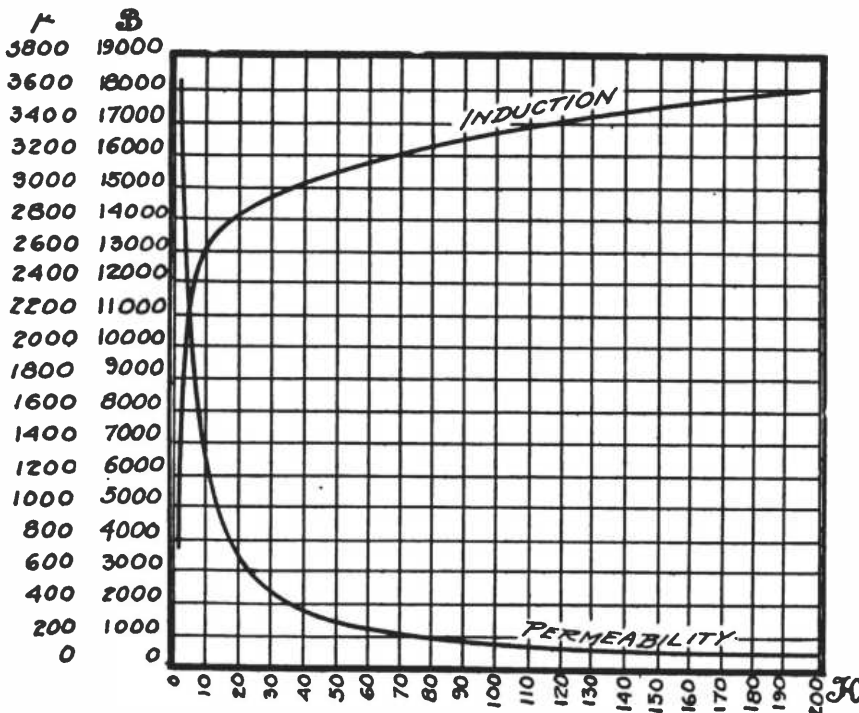

Fig. 1.—Magnetization Curves for Apollo Special Electrical Steel. Read left column μ as permeability in lines per sq. cm.

A New Loud Speaker

By G. M. Best

TO meet the ever increasing demand for high grade radio equipment, the Western Electric Company has recently introduced a new loud speaking unit, for use in the home, or in fact any place where a reproduction of speech or music is desired in moderate amount.

The complete outfit consists of a two stage amplifier enclosed in a cabinet, and a loud speaker with horn attached, ready to connect to the output of any standard vacuum tube detector and receiving set. The amplifier is the principal part of the set and embodies some principles that are new to the radio art, although previously used in other fields.

The outstanding feature of the amplifier is the second stage, which consists of two tubes of like characteristics, both being connected in the circuit in the same manner as the first stage, but each tube having only one-half the voltage variations impressed upon its grid. This is accomplished by constructing the in-

the Western Electric type 216-A, which require 120 volts on the plate and 6 volts on the filament. Due to the rather wide range of filament current values through which the 216-A tube will

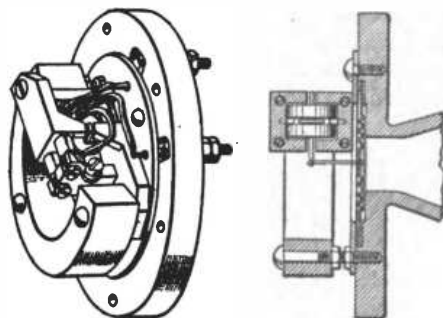

Sketch of Loud Speaker Mechanism.

operate, filament rheostats are not necessary provided that not more than 6 volts is supplied to the filaments. This eliminates annoying adjustments and simpli-

received from the amplifier into useful magnetic vibrations, a soft iron armature placed in the center of the coil and connected to a composition diaphragm by means of a rigid lever. This loud speaker will reproduce all the voice frequencies, from 200 to 3500 cycles, without distortion and by its simplicity of operation and ease of adjustment should fill a long felt want in the radio field.

THE SET

*Did you ever put on your head-set,
And start copying NSS,
When your mother calls, "Oh, Charlie!
Show these folks your wireless?"*

*With a frown you let them enter,
And provide each with a chair,
And they say, "Oh, my! How wonderful!
What's that thing over there?"*

*So you begin explaining
From the beginning to the end,
About audions, and vacuum tubes,
And the distance you can send.*

*You show them your transmitter,
And explain things through and through,
And they say, "Oh, my! How wonderful!
Wish I knew as much as you."*

*And after careful explanations,
Which leave you in a sweat,
They rise and say, "Well, thanks, Charles,
For showing us your set."*

*And just as they are leaving,
And are pausing at the door,
Someone pointing at your aerial says,
"Hey! What's those wires for?"*
—L. W. P.

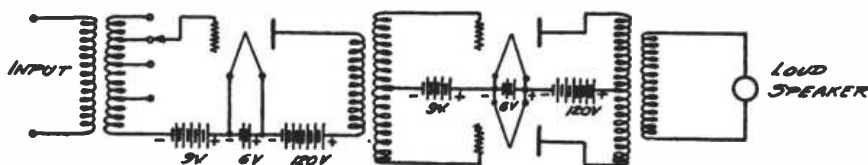

Circuit Diagram

put transformer with a center tap for the connection to the filament of the two tubes. As the input voltage divides equally between the two grid circuits, input voltage equal to twice the amount allowable with a single tube may be employed, with a correspondingly greater output into the loud speaker. As the loud speaker is of much lower alternating current resistance than the output of the last stage of the amplifier, a step down transformer is necessary. This transformer also keeps the plate current in the last stage from flowing through the windings of the loud speaker, and thus avoids the distortion which is so often present where the direct current is allowed to pass through the loud speaker.

A unique feature of the set is a volume, or output control, which enables the operator to regulate the volume of sound coming from the loud speaker without having to resort to any of the customary methods of control such as reducing or increasing the filament current, changing the tuning of the receiver, etc. This is accomplished by bringing taps from the secondary of the first amplifying transformer to a variable switch mounted on the panel. By means of this switch the connection to the grid of the first amplifying tube is varied to increase or decrease the input voltage into the first stage.

The tubes used with the amplifier are

fies the operation to a considerable degree.

The loud speaker itself, as shown in the accompanying sketch while built along the same principles as the already well known Baldwin receiver, is much more rugged in design, and will carry a much greater amount of power without distortion. It consists mainly of a permanent magnet mounted on a heavy frame, a coil to transform the energy

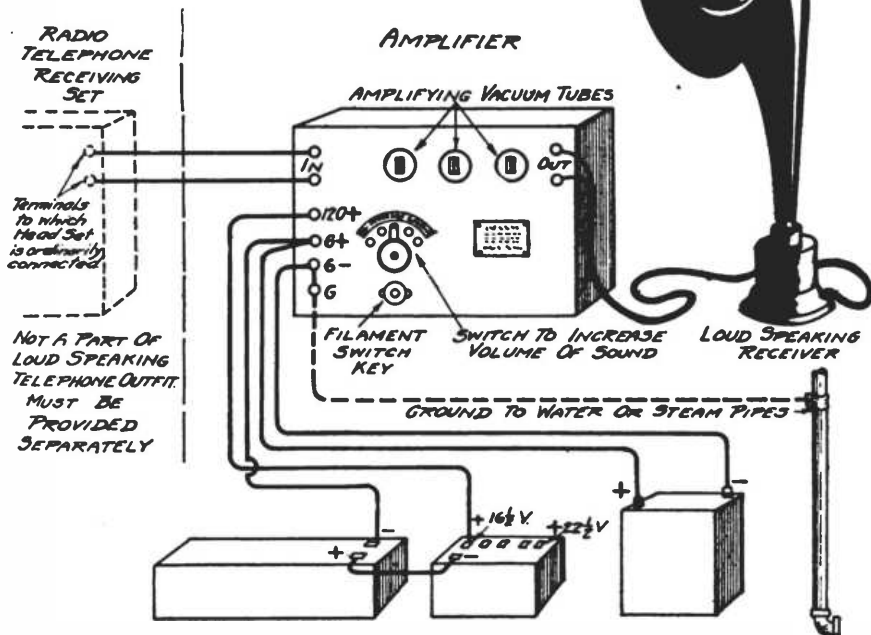

Western Electric Amplifier and Loud Speaker

Construction of a Simple Receiving Set and Two-Stage Amplifier

By B. F. McNamee

THE object of this article is to describe a simple receiving set, consisting of tuning apparatus, detector, and two-step amplifier. The chief novelty lies in the fact that without an expensive Bakelite panel and cabinet we obtain an extremely efficient set. The arrangement is such that good insulation is used where required so that the leakage losses are cut to a very small amount.

The switch on the left-hand end of the rheostat board may be any form of single pole double throw switch for changing from one to two steps of amplification. A two-point rotary switch will suffice.

as shown. This can be made by winding a primary and a secondary coil end to end on a 2½ in. cardboard tube, separating the ends by about ¼ in. space. The primary consists of about 60 turns of No. 22 enamel wire and the secondary of 140 turns of the same wire. This is in effect a fixed coupler, suffi-

A Universal Tuning Transformer is secured to the base at the right-hand end,

SUGGESTED LIST OF MATERIAL AND PARTS

- 3 Remler Sockets.
- 2 Wesrad Amplifying Transformers.
- 9 Binding Posts.
- 1 Universal Tuning Transformer.
- 3 Fada Rheostats.
- 1 Rotary Switch with two contacts.
- 1 Grid Condenser. (.0003 mfd.)
- 1 piece hardwood, 8" x 14¾" x 5/8".
- 1 piece hardwood, 2¾" x 10" x 12".
- Connecting wire.

The wooden parts should be cut and drilled as shown in the drawings. They should be made of some good hard wood, preferably Spanish cedar or mahogany. The base board may be 5/8 or ¾ in. thick, while the rheostat board should be ½ in. After drilling, they should be very carefully finished with fine sand paper, then dusted and stained. After the stain has had ten or twenty minutes to soak in, wipe the boards with a soft rag to remove the surplus stain. Apply one or two coats of orange shellac, being careful to get the shellac on the insides of the holes. This will serve as insulation between the binding posts and the wood.

When properly shellacked, the wood will not absorb moisture. If it is dry to begin with, there will be practically no losses due to leakage through the wood since further insulation is used where especially needed.

The place for mounting the rheostat board can be seen from the picture of the set. The three tube sockets are mounted directly over the ¾ in. holes in the base board.

Use some type of socket in which the contact springs will not make contact to the wooden base. This is necessary for proper insulation. The ¾ in. holes immediately beneath the sockets are for the purpose of rebending the springs if they should fail after a time to make good contact to the base prongs on the tubes.

The two amplifying transformers are placed immediately behind the tubes and as far apart as possible to prevent howling from interaction. They are placed at right angles for the same purpose.

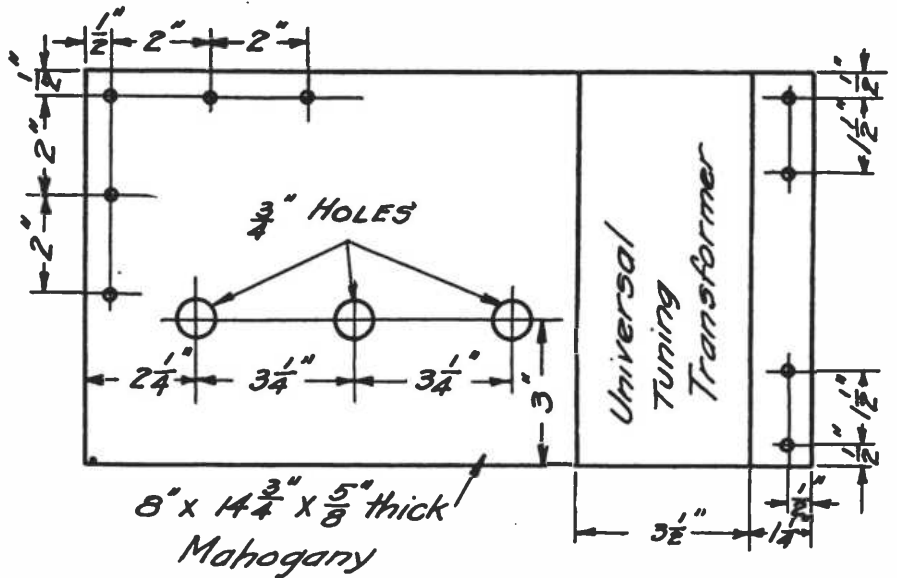

DRILLING FOR BASE

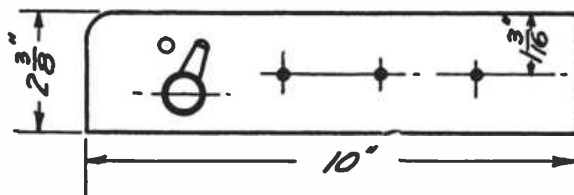

DRILLING FOR RHEOSTAT BOARD.

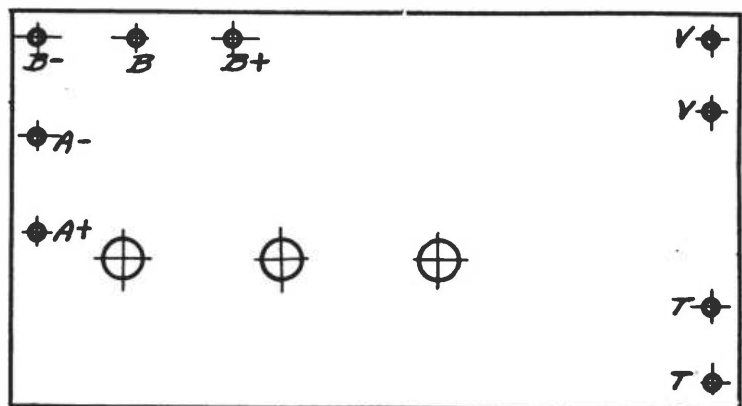
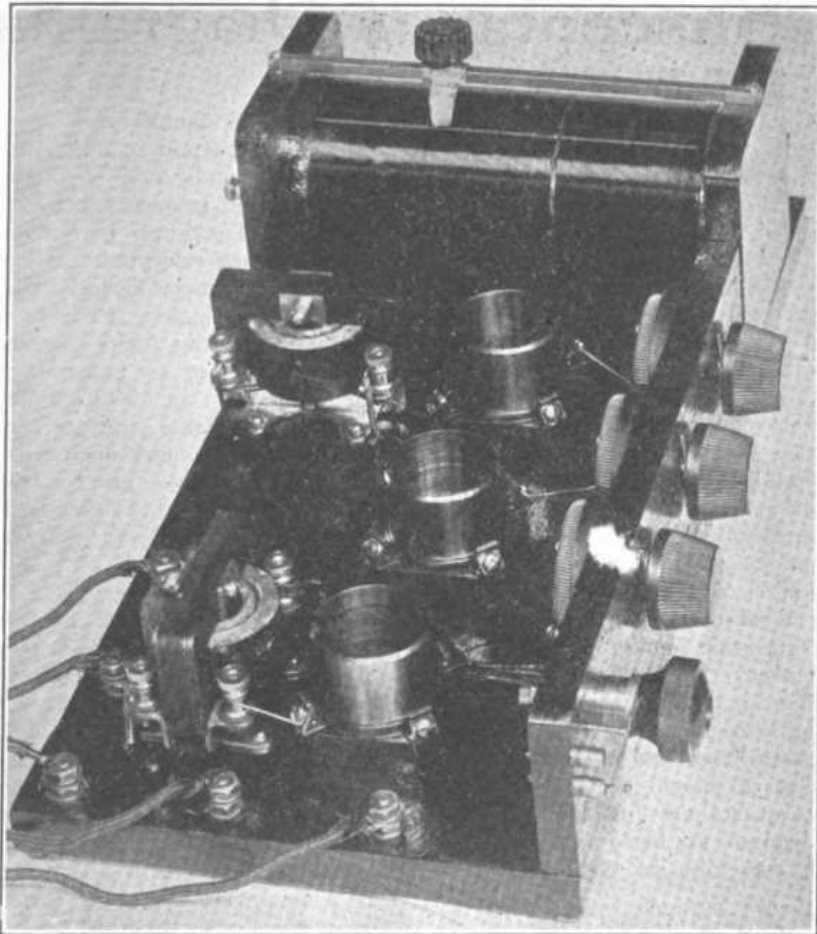

DIAGRAM TO SHOW LETTERING ON BINDING POSTS.



Completed Receiver and Amplifier Set

ciently loose to eliminate interference and doing away with the necessity for a variable condenser. Tuning of both the primary and the secondary is accomplished by means of a slider.

A small, fixed grid condenser (.0003 mfd.) is connected between binding post *C* of the tuning transformer and the grid terminal of the right-hand tube socket. The tube sockets commence with a detector at the right-hand end and end with a second step at the left-hand end. Binding posts *A* and *B* on the tuning transformer are for connection to the aerial and ground respectively, and binding post *D* or *E* to the positive end of the filament battery. Binding posts *TT* are for the receivers, and binding posts *VV* may be used if the receivers are desired in the plate circuit of the detector tube. In order to make the set regenera-

tive, use the receivers in binding posts *TT* and connect a variometer to binding posts *VV*. If the variometer is not used, the binding posts *VV* should be connected together.

The storage battery should be connected to binding posts *A+* and *A-*. Binding post *B-* goes to the negative end of the *B* battery. *B* should have a wire terminating in a spring clip so that any desired potential of *B* battery may be selected for the detector tube. Binding post *B+* is connected to the plate circuits of the amplifier tubes, and for best results should be connected to the positive end of a 90-volt *B* battery.

A very convenient arrangement is to have flexible lamp cords from these 5 binding posts, terminating in spring clips for connection to the batteries.

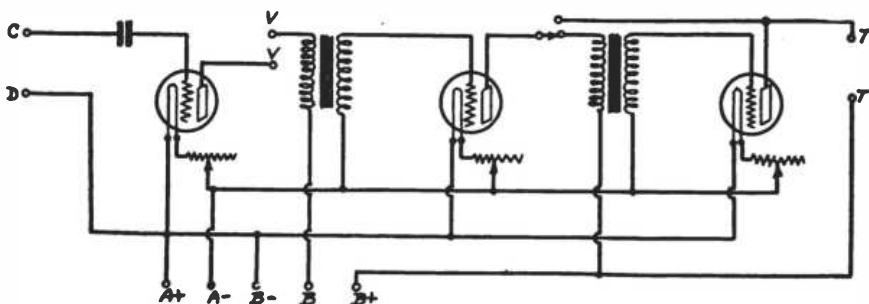

Circuit Diagram

\$100 RADIO FREQUENCY AMPLIFIER CONTEST

Every progressive amateur is interested in radio frequency amplification. Many of our readers have been experimenting with this method of bringing in more distant stations that can not otherwise be heard or in making local broadcasting louder. Many other readers are anxious to try out these methods.

In order to bring out these ideas the publishers of RADIO are offering four prizes for the best description of the design, construction and operation of a radio frequency amplifier. There will be a first prize of \$50, a second of \$25, a third of \$15 and a fourth of \$10, totaling \$100.

Contestants are requested to submit manuscript written on one side of the sheet and with all diagrams and sketches in ink on separate sheets. Photographs of completed equipment should accompany the manuscript. It is requested that no description that has been previously published be considered and also that no description be submitted of designs that have not been tried out in practice.

The publisher reserves the right to print all worthy ideas, not prize winners, at the usual space rates. No manuscript entered in this contest can be returned. The contest is open to everyone, radio clubs included, except manufacturers of radio equipment. Prizes will be paid upon publication.

This contest closes at noon, August 15, at San Francisco, by which time all entries must be received. Address all communications to the Editor, care of this publication.

NAVAL RADIO COMPASS STATIONS

It has been unofficially reported to the Navy Department that during the past winter fourteen large merchant vessels were saved from destruction by the Navy's radio compass stations. Due to the severe storms in the Atlantic, ships were often unable to determine accurately their positions on approaching the coast. By simply calling by radio the nearest fixed compass station and asking for bearings, they were given their positions accurately and it is estimated that fourteen ships thus aided would otherwise have been wrecked.

Reactance and Susceptance Diagrams

By G. W. Cattell

REACTANCE and susceptance diagrams afford an easy and quick method of analyzing complex circuits consisting of inductance and capacity, and are especially useful in radio work.

With the use of such diagrams it is possible to ascertain how many resonance points the circuit has, the frequencies at which they occur, whether they are for zero or infinite reactance and the nature of the reactance (positive or negative) for other than resonant frequencies. By "resonant point" is meant a value of frequency which will make the reactance either zero or infinite.

All these quantities may be calculated mathematically, but the equations involved are often difficult of solution.

Complex circuits are merely combinations of simple circuits. In the present consideration of the subject, the simple circuits will be treated first and then the more complex.

Reactance is that property of an electrical circuit which tends to stop or reduce the magnitude of an alternating or radio frequency current. Susceptance is that property of an electrical circuit which tends to accept or allow an alternating or radio frequency current to flow. Obviously, one is the reciprocal of the other. The symbol usually applied to reactance is "X" and that applied to susceptance is "b". Reactance due to inductance (L) is called positive,

and that due to capacity (C) is called negative.

Mathematically, the reactance of an inductance is expressed by the equation $X_L = 2\pi fL$, the susceptance of an inductance by $b = 1/X_L = 1/2\pi fL$, the reactance of a capacity by $X_C = -1/2\pi fC$ and the susceptance of a capacity $b_C = 1/X_C = -2\pi fC$.

Reactances of circuits in series can be added directly and the result will be the algebraic sum of the component reactances. The corresponding susceptance will be the reciprocal of the resultant reactance.

The reactances of circuits in parallel can not be added directly. Susceptances of circuits in parallel, however, can be added directly and the result will be the algebraic sum of the component susceptances. The corresponding reactance will be the reciprocal of the resultant susceptance.

The reactance and susceptance diagrams of a simple inductance and a simple capacity are fundamental. All other diagrams are based on them. They should, therefore, be clearly fixed in mind.

For clearness, definite values of inductance and capacity have been assumed and the diagrams drawn accordingly. Let $L_1 = 150$ micro henrys, $L_2 = 100$ micro henrys, $C_1 = 0.001$ microfarads

and $C_2 = 0.0006$ microfarads.

The upper portion of Fig. 1 shows the reactance of L_1 and L_2 plotted as ordinates against frequency in kilo-cycles as abscissa. The lower portion of the figure shows the susceptance of L_1 and L_2 plotted as ordinates against frequency in kilo-cycles as abscissa. It will be noted from a study of this figure that the reactance diagram of an inductance is a straight line with an upward slope, the larger the inductance the steeper the slope. The susceptance diagram of an inductance is a curved line concave upward, the larger the inductance the lower the curve and the sharper the curvature.

The upper portion of Fig. 2 shows the reactance of C_1 and C_2 plotted against frequency. The lower portion of the figure shows the susceptance of C_1 and C_2 plotted against frequency. A study of this figure shows that the reactance diagram of a capacity is a curved line, concave downward, the larger the capacity the higher the curve and the sharper the curvature. The susceptance diagram of a capacity is a straight line with a downward slope, the larger the capacity the steeper the slope.

For convenience, a reactance or susceptance diagram will be designated as X or b with a subscript corresponding to the figure number in which it first

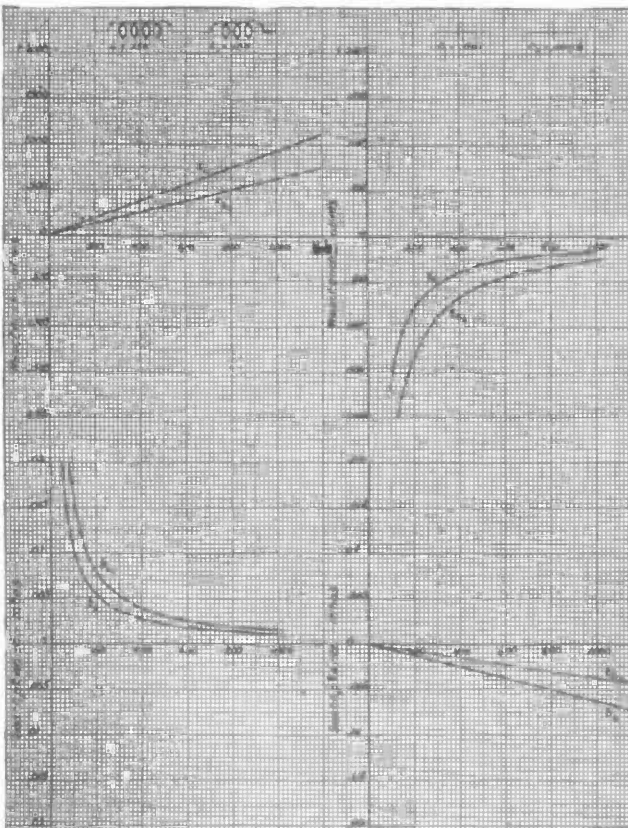

Fig. 1

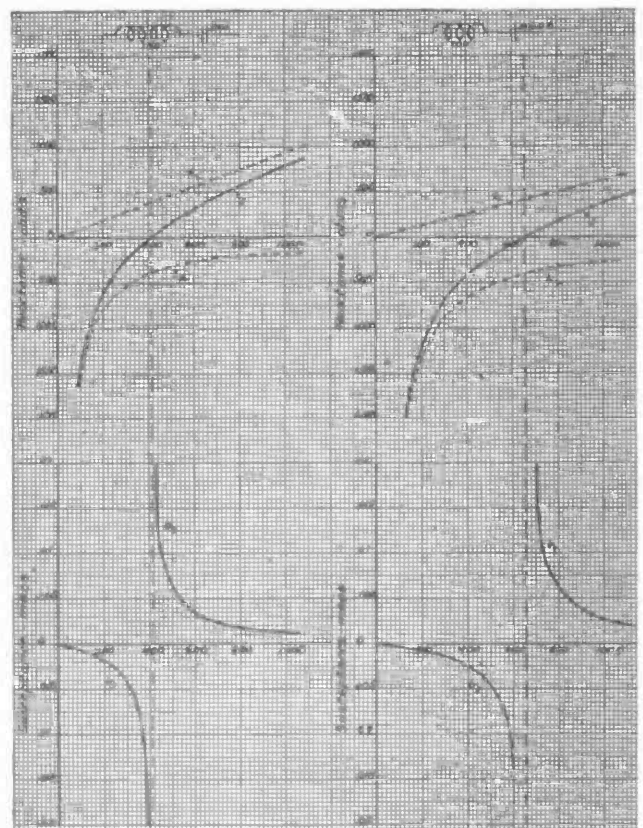

Fig. 2

Fig. 3a

Fig. 3b

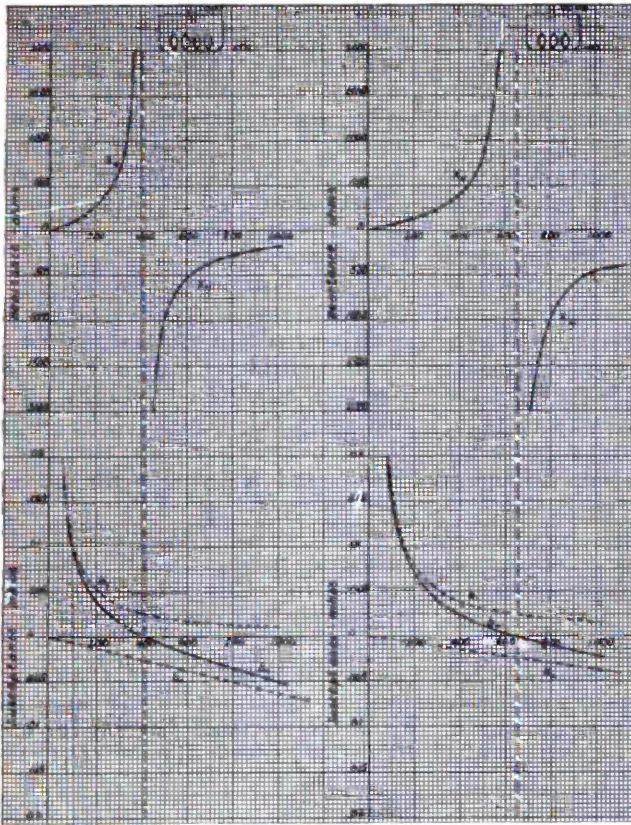

Fig. 4a

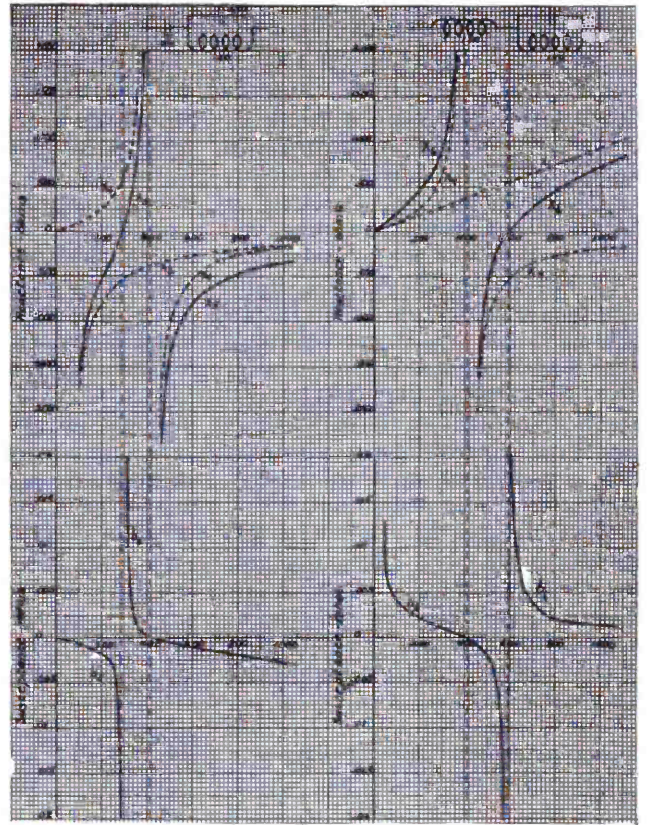

Fig. 4b

Fig. 5

Fig. 6

appeared. For example, the reactance diagram of a capacity would be referred to as X_2 etc. When diagrams are used as parts of other circuits, they are shown in dotted lines.

Fig. 3 shows the reactance and susceptance diagrams of an inductance and

capacity in series (frequently called a parallel resonant circuit). Fig. 3_a is for L_1 and C_1 while Fig. 3_b is for L_2 and C_2 .

X_1 is the reactance diagram of the inductance and X_2 is the reactance diagram of the capacity. The reactance of

the entire circuit is the algebraic sum of X_1 and X_2 and is shown as X_3 . The corresponding susceptance diagram is obtained by plotting the reciprocal of X_3 and is shown as b_3 .

The simple series circuit has one resonance point, that is, for one particu-

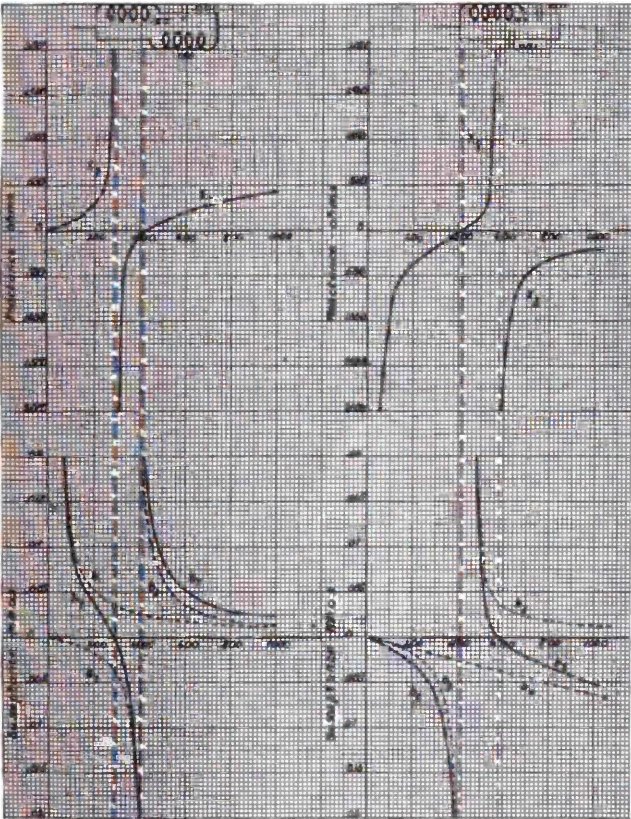

Fig. 7

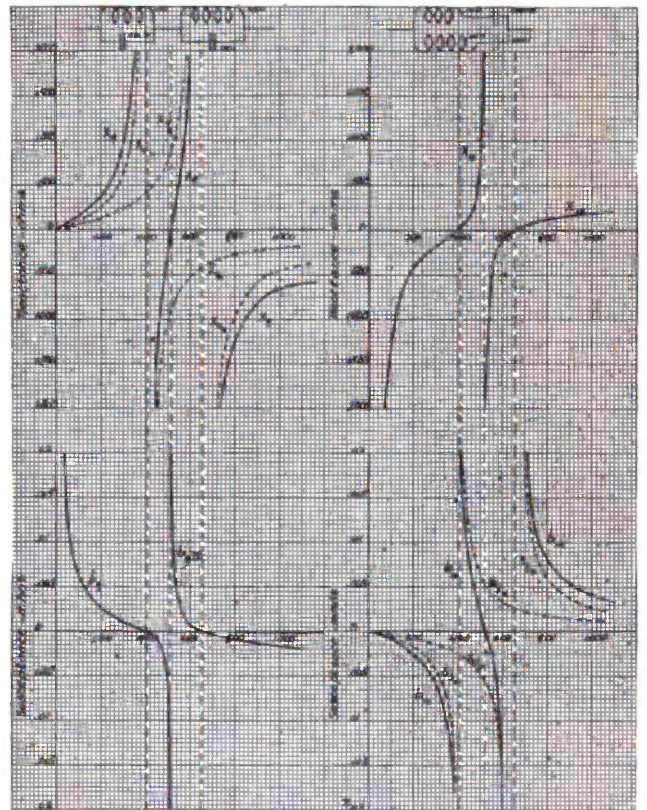

Fig. 9

Fig. 8

Fig. 10

lar value of frequency the reactance is zero. With L_1 and C_1 in series, the circuit will have zero reactance for 410 kilo-cycles. With L_2 and C_2 in series the circuit will have zero reactance for 650 kilo-cycles. It will be observed that when the reactance is zero the susceptance is infinity.

Fig. 4 illustrates the reactance and susceptance diagrams for an inductance and capacity in parallel. Fig. 4_a is for L_1 and C_1 while Fig. 4_b is for L_2 and C_2 . Such a circuit is frequently called a parallel resonant circuit.

Since reactances of circuits in parallel can not be added directly, susceptance diagrams can be used, for susceptances of circuits in parallel can be added directly. b_1 is the susceptance diagram of the inductance and b_2 is the susceptance diagram of the capacity. The susceptance of the entire circuit is the algebraic sum of b_1 and b_2 and is shown as b_4 . The corresponding reactance diagram was obtained by plotting the reciprocal of b_4 and is shown as X_4 .

The simple parallel circuit has one resonance point, that is, for one particular frequency the reactance is infinite. With L_1 and C_1 in parallel, the circuit will have infinite reactance for 410 kilo-cycles. With L_2 and C_2 in parallel, the circuit will have infinite reactance for 650 kilo-cycles.

Fig. 5 illustrates the reactance and susceptance diagrams for a circuit consisting of a capacity in series with a parallel resonant circuit. X_4 is the reactance diagram of the parallel resonant

circuit (L_1C_1) and X_2 is the reactance diagram of the series capacity (C_1). The reactance of the entire circuit is the algebraic sum of X_2 and X_4 and is shown as X_5 . The corresponding susceptance diagram is shown as b_5 . This circuit has two resonance points, one of infinite reactance for 410 kilo-cycles and one of zero reactance for 290 kilo-cycles.

Fig. 6 illustrates the reactance and susceptance diagrams for a circuit consisting of an inductance in series with a parallel resonant circuit. X_4 is the reactance diagram of the parallel resonant circuit (L_1C_1) and X_1 is the reactance diagram for the series inductance (L_1). The reactance of the entire circuit is the algebraic sum of X_1 and X_4 and is shown as X_6 . The corresponding susceptance diagram is shown as b_6 . This circuit has two resonance points, one of infinite reactance for 410 kilo-cycles and one of zero reactance for 590 kilo-cycles.

Fig. 7 illustrates the diagrams for an inductance in parallel with a series resonant circuit. b_3 is the susceptance diagram of the series resonant circuit (L_1C_1) and b_1 is the susceptance diagram of the inductance (L_1). The susceptance of the entire circuit is the algebraic sum of b_1 and b_3 and is shown as b_7 . The corresponding reactance diagram is shown as X_7 . This circuit has two resonance points, one of zero reactance for 410 kilo-cycles and one of infinite reactance for 290 kilo-cycles.

Fig. 8 illustrates the diagrams for a capacity in parallel with a series resonant circuit. b_3 is the susceptance diagram

for the series resonant circuit (L_1C_1) and b_2 is the susceptance diagram for the capacity (C_1). The susceptance of the entire circuit is the algebraic sum of b_2 and b_3 and is shown as b_8 . The corresponding reactance diagram is shown as X_8 . This circuit has two resonance points, one of zero reactance for 410 kilo-cycles and one of infinite reactance for 580 kilo-cycles.

Fig. 9 illustrates the diagrams for two parallel resonant circuits in series. X_{4a} is the reactance diagram of one parallel resonant circuit (L_1C_1) and X_{4b} is the reactance diagram of the other parallel resonant circuit (L_2C_2). The reactance of the entire circuit is the algebraic sum of X_{4a} and X_{4b} and is shown as X_9 . The corresponding susceptance diagram is shown as b_9 . This circuit has three resonance points, two of infinite reactance for 410 and 650 kilo-cycles respectively and one zero reactance for 520 kilo-cycles.

Fig. 10 illustrates the diagrams for two series resonant circuits in parallel. b_{3b} is the reactance diagram for one of the series resonant circuits (L_1C_1) and b_{3a} is the susceptance diagram of the other series resonant circuit (L_2C_2). The susceptance of the entire circuit is the algebraic sum of b_{3a} and b_{3b} and

Continued on page 62

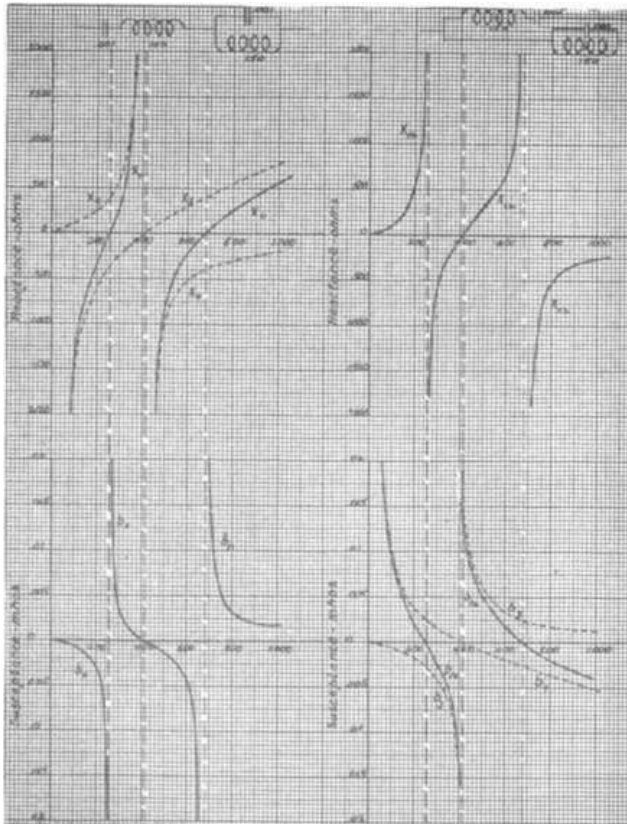

Fig. 11

Fig. 12

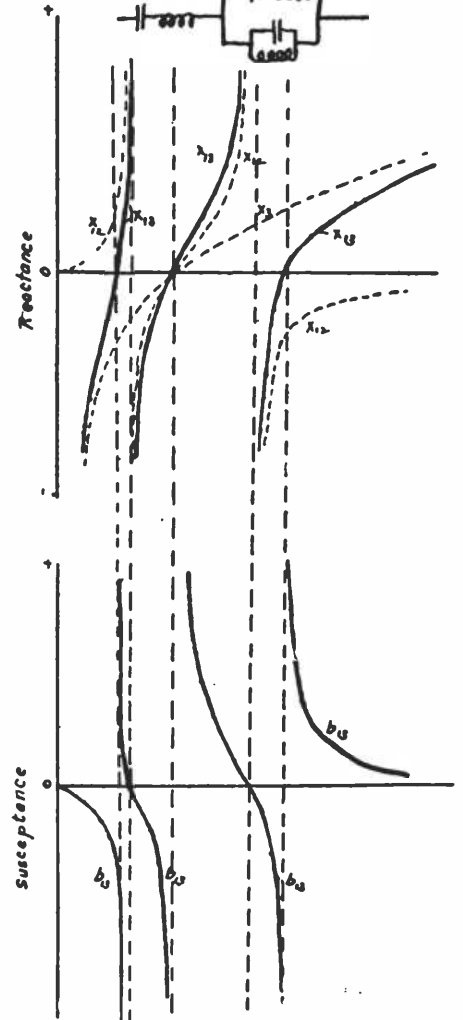

Fig. 13

Proposed National Electric Code Revisions

With Comment by Bureau of Standards

THE proposed revisions of Rule 86 of the National Electrical Code, as applied to receiving stations only, were published in June RADIO. Here-with are the proposed changes of rules for transmitting stations, together with a discussion and explanation of the proposals for both receiving and transmitting stations by the radio laboratory of the U. S. Bureau of Standards.

Suggestions for improvements in these proposed rules should be sent to William S. Boyd, Chairman, 175 W. Jackson Boulevard, Chicago, not later than September 1, 1922.

FOR TRANSMITTING STATIONS

g. Antennae outside of buildings shall not cross over or under electric light or power wires of any circuit of more than six hundred (600) volts or railway trolley, or feeder wires nor shall it be so located that a failure of either the antenna or of the above mentioned electric light or power wires can result in a contact between the antenna and such electric light or power wires.

Antennae shall be constructed and installed in a strong and durable manner and shall be so located as to prevent accidental contact with light and power wires by sagging or swinging.

Splices and joints in the antenna span shall, unless made with approved clamps or splicing devices, be soldered.

h. Lead-in wires shall be of copper, approved copper-clad steel or other metal which will not corrode excessively and in no case shall they be smaller than No. 14.

Antenna and counterpoise conductors and wires leading therefrom to ground switch, where attached to buildings, must be firmly mounted 5 in. clear of the surface of the building, on non-absorptive insulating supports such as treated wood pins or brackets equipped with insulators having not less than 5 in. creepage and air-gap distance to inflammable or conducting material. Where desired approved suspension type insulators may be used.

i. In passing the antenna or counterpoise lead-in into the building a tube or bushing of non-absorptive insulating material shall be used and shall be installed so as to have a creepage and air-gap distance of at least 5 in. to any extraneous body. If porcelain or other fragile material is used it shall be installed so as to be protected from mechanical injury. A drilled window pane may be used in place of bushing provided 5 in. creepage and air-gap distance is maintained.

j. Protective Grounding Switch. A double-throw knife switch having a break distance of 4 in. and a blade not

less than $1/8$ in. by $1/2$ in. shall be used to join the antenna and counterpoise lead-ins to the ground conductor. The switch may be located inside or outside the building. The base of the switch shall be of non-absorptive insulating material. Slate base switches are not recommended. This switch must be so mounted that its current-carrying parts will be at least 5 in. clear of the building wall or other conductors and located preferably in the most direct line between the lead-in conductors and the point where ground connection is made. The conductor from grounding switch to ground connection must be securely supported.

k. Protective Ground Wire. Antenna and counterpoise conductors must be effectively and permanently grounded at all times when station is not in actual operation (unattended) by a conductor at least as large as the lead-in and in no case shall it be smaller than No. 14 copper or approved copper-clad steel. This ground wire need not be insulated or mounted on insulating supports. The ground wire shall be run in as straight a line as possible to a good permanent ground. Preference shall be given to water piping. Gas piping shall not be used for the ground connection. Other permissible grounds are the grounded steel frames of buildings and other grounded metal work in buildings and artificial grounding devices such as driven pipes, plates, cones, etc. The ground wire shall be protected against mechanical injury. An approved ground clamp shall be used wherever the ground wire is connected to pipes or piping.

l. Operating Ground Wire. The radio operating ground conductor shall be of copper strip not less than $3/8$ in. wide by $1/64$ in. thick, or of copper or approved copper-clad steel having a periphery, or girth (around the outside) of at least $3/4$ in. (for example a No. 2 wire) and shall be firmly secured in place throughout its length. The radio operating ground conductor shall be protected and supported similar to the lead-in conductors.

m. Operating Ground. The operating ground conductor shall be connected to a good permanent ground. Preference shall be given to water piping. Gas piping shall not be used for ground connections. Other permissible grounds are grounded steel frames of buildings or other grounded metal work in the building and artificial grounding devices such as driven pipes, plates, cones, etc.

n. Power from Street Mains. When the current supply is obtained directly from street mains, the circuit shall be

installed in approved metal conduit, armored cable or metal raceways.

If lead covered wire is used it shall be protected throughout its length in approved metal conduit or metal raceways.

o. Protection from Surges, etc. In order to protect the supply system from high-potential surges and kick-backs there must be installed in the supply line as near as possible to each radio-transformer, rotary spark gap, motor in generator sets and other auxiliary apparatus one of the following:

1. Two condensers (each of not less than $1/2$ microfarad capacity and capable of withstanding 600 volt test) in series across the line and mid-point between condensers grounded; across (in parallel with) each of these condensers shall be connected a shunting fixed spark gap capable of not more than $1/32$ in. separation.

2. Two vacuum tube type protectors in series across the line with the mid-point grounded.

3. Non-inductively wound resistors connected across the line with mid-point grounded.

4. Electrolytic lightning arresters such as the aluminum cell type.

In no case shall the ground wire of surge and kick-back protective devices be run in parallel with the operating ground wire when within a distance of 30 ft.

The ground wire of the surge and kick-back protective devices shall not be connected to the operating ground or ground wire.

p. Suitable Devices. Transformers, voltage reducers, keys, and other devices employed shall be of types suitable for radio operation.

DISCUSSION AND EXPLANATION

These rules do not apply to radio equipment installed on shipboard, but have been prepared with reference to land stations.

RECEIVING EQUIPMENT

a. Antenna. Indoor receiving antennae are not included within the requirements of this proposed rule, which provides for the protection of radio equipment against lightning. Indoor receiving antennae and auxiliary apparatus are, however, included in the general requirements covering the wiring of signal systems, for it is obviously desirable to insure, for example, the freedom of all receiving apparatus from contact with electric power circuits either inside or outside of buildings.

It is desirable that electrical construc-

Continued on page 72

Scratchi Gets a Broadcast Earful

By David P. Gibbons

To Editor RADIO (which endeavor to tune all the jangly notes into harmonic chorus.)

Sir Dear:—

In recent bout which my Cousin Scratchi engage with Hon. Radio Inspec., you remember mightbe, Mr. Editor, he got knocked for row of Mexican bean-pots. He are complete mentally wreck, capsized, bottom-up, waterloggy menace to navigators, so for rest cure he decide to rig up very simple receiver described by trained expert of the Daily Yowl and listen to musical strains which ether are full up with.

For three days and four nights he strew highly confused messup from kitchen to roof and back again. Grand jumble consist greatly of henry coils, black chew-gum which hold same asunder in box, paper fasteners, clothespins, catswhishers and other ends and odds which expert have sniggsted for set that all children can build. "Must mean oldish children of Methusalem," mutter Scratchi, while making pigstail splicings with knotty wire around Faker Oats box.

When I see that my cousin are on edge of another nervy smashdown, I visit honest retail friend and purchase latest model Barko Receiving Set, Type 000. New style tube which come along with this fitout, he inform me, have no filament, no grid and no plate but are not yet on market, owing to vast volume of something or another, and in meantime he design that I use the RAZ4 Type Audion, which operate on half per cent of one volt and not very critical about that. After he burn up several of these Scratchi go out and buy regular tube and at last we hear KPH quite plain. He jiggle around some more and then we hear loud burr-r-r and swishh-h-h noises and we know sweet phoney music are about to pour fourth into many listening earpieces, so we prepare for jolly eventide of high-classy programs.

First voice which ramble down aerial are quite feeble as we strain eardrums to grab any, but we soon give them resting spell, as it denounce rapidly, "This are station Glub Glib Blaa brawcassin'. First slecshun t'ni' are violin solo by Fritz Pieface——" But Scratchi turn out filament to save juicy battery as we hear Humoresque many, many times and violin soloist never execute anything else. Next six slecshuns are foxytrotting pieces played by Royal Jazziola Troupe, direct from extensive run in Congo, and Scratchi save more current as he say he can obtain same defect by making very loosely connection on "B" battery and pounding table with fists. When we light up again denouncer are saying for eleventeenth time, "This sta-

tion are owned, controlled, managed and operated by the Blump-Blomp Radio Co. We are in debt for the musiky numbers to the Tynpani Orgañ House, needles are kindly loaned by the Victory Funnygraft People, the table is furnished by the Mary Ann Period Furniture Society and the chair are donated by the Maison de Fromage. You will confer fine favor on us by writing letters and telegrams to those gents thanking them for great crusty and how muchly you have enjoyed this splendor program. That will be all from Glub Glib Blaa this evenin'. Goo' ni'."

Quite soonly after him we hear some more swooshing and whiffing and thickish voice say, "Hello! Hello! (18 times) Zee Kee Zoo callin' (12 times). How you gettin' me, ole man? (10 times). Come back ole man (8 times)." Scratchi say, "He come in like farm-boy making Spanish speech down empty well. Hope that ole man gone where they never come back from."

After 15 or so minutes of this QRM he start his program. First number he produce as special treat are lecture by Hon. Traveling Professor from Leavenworth University, Rufus J. Whoozat, entitle, "How I made my pile." Next special treat which he donate are exhibition of flapper language and flipper costumes by denoted Oaklander, Miss Muriel O'Kavnaw, in person, who are visiting America for first occasion. "This are a screech!" Scratchi slang me as new tube turn blue around gills.

Number after this, he propose, are piano reciting by Ignatz Polaxski and Scratchi are much ticklish, as he highly enjoy piano recitings, but not for long, as he discover this are not a really piano at all, but machine like that formally used to accept continuous input of nickels, while helping old soaks pass pleasing hours in back room. Scratchi say, "Better shut off quickly before he begin reciting 'The Sheik' by populous request," and we save 3 or 4 additional amps.

When we pick him out again he are taking slight exercise for imagination as he say, "Hello! Mr. Spring Bock of South Africa! Hello! Mr. Shammy of Patagonia! Hello! Mr. Kang Aroo of Australia! Glad to know you are all getting us so well over there! Hello! Mr. John Doe of Honolulu! Thank you for nice lemons you sent, and Hello! Mr.——" but Scratchi have hanged up fones on hook and slapped airy switch as bedtime signal.

While he are hiding new triode in obscure recess under pillow I demand to know if we shall continue to improve our intelligences next eventide in similar manner.

"Tomorrow night," he tone back, "I require mentally relief from such and shall read few volumes of Einstein or so. These are lighter drains on nervy system, and only effect one victim simultanely."

He are recovering very gradually, Mr. Editor, and hoping you are likewise, I enclose myself, Verily yours,

HILOLI NOGO.

Radio equipment is being sold by all sorts of stores, everywhere. "Jellio-meters" are sold by delicatessen stores, bakelite by bakeries, ground clamps by florists, sockets by plumbers, aerials by milliners, tuners by music dealers, detectors by Burns, receivers by banks, plates by crockery stores, but the prize story is told by W. E. Lufkin, former president of the San Francisco Radio Club. While he was in a Powell St. jewelry shop trying to pawn a wedding ring, a youth tried to buy a crystal, saying that he was told he could buy one in any jewelry store.



Why Not a Tongue for the Sphinx?

Harmo-Radiopathy

By Earl Ennis

IT was toward the end of 1950—in October to be exact—that the world was suddenly jarred out of a condition of peace and normalcy by the development of a critical situation at the International Musical Epicentrum on the Island of Yap. On a Saturday night of that month, at 8 o'clock in the evening, universal meridian time, the lights in the wireless receivers in millions of homes all over the world twinkled in unison. Almost immediately thereafter, the voice of the announcer-general at the international broadcasting station at Berne was heard.

"Ladies and gentlemen," he said. "We regret to announce that there will be no music from Yap . . . tonight."

The words fell upon startled ears. No music from Yap? Impossible! There must be some mistake. There was a moment of hushed silence as men and women fronted each other with whitened faces. The next instant, the universal query disk at the Berne station burst into sudden brilliance as millions of fingers all over the world reached for the third button of the Automatic Radio Language Questionnaire and pressed it—hard. The button bore on its surface the word "Bjorbllcm," which in the condensed stenographic speech of the period meant: "Are you certain of your facts and being so can and will you inform me concerning the reasons leading up to and responsible for such a state of affairs?"

The announcer-general shook his head sadly and turned to his transmitter. "I have no information at present," he said wearily. "I hope you will all be patient until . . ."

He left the sentence unfinished and snapped off his transmitter. He and the chief engineer of the big news station faced each other before the intricate switch board that controlled the powerful bulletin waves.

"There is only one way," said the chief engineer.

The announcer-general nodded.

"And if that fails . . . ?"

The chief engineer shook his head.

"If that fails—we can do nothing!" he said.

He walked to a tiny, nicked lever at the far end of the switch board, over which burned a perpetual crimson pilot-light. It was the lever which controlled the sinuous, coiling, undulating exploration wave, from which nothing could be concealed. Above it was the great chart

the powerful exploration wave, swirling around the conical radiators over his head, raced forth into the night, seeking the solution to the mysterious silence from the Island of Yap.

"Yoo-hoo!" wailed the wave. "Oh, Yap—yoo-hoo!"

It whipped among the ice-floes of the northern sea and a hollow reverberation was the only response. It swirled down among the typhoons of the tropic waters, and only the breadth of a whisper returned.

It whined through mountain passes, it sped over jungles, it poked behind continents, it gyrated around the Japanese coast, encircling the Island of Yap and making more noise than a Democratic convention conducting a secret ballot. Tired and exhausted, it returned again to Berne—back into the wave recharger—with not a scrap of success to mark its flight. Yap was as silent as the grave.

By 8:30 that evening every man, woman and child knew that some sinister calamity was overhanging the world. Business suspended. Cafes shut down. Opera stars cancelled contracts and went home, throwing whole acres of impresarios into hysterics. Into many minds crept the almost forgotten prophecy of Peccan—greatest musician of his time—he who had played the monster steam ukulele at the peace jubilee in '42—that some day this very thing would transpire.

"Comes it—some day—silence!" he had said.

The world had scoffed at him, steeped in the drunken revelries of its noise-maddened existence—scoffed until his ashes had been placed in a silver shell and fired out into the eternal spaces by the magnetic planetary defense gun, whose projectiles, by the law of centrifugals, were destined to whirl among the asteroids for all time. Was Peccan, now, after all these years, to be vindicated?

Continued on page 44

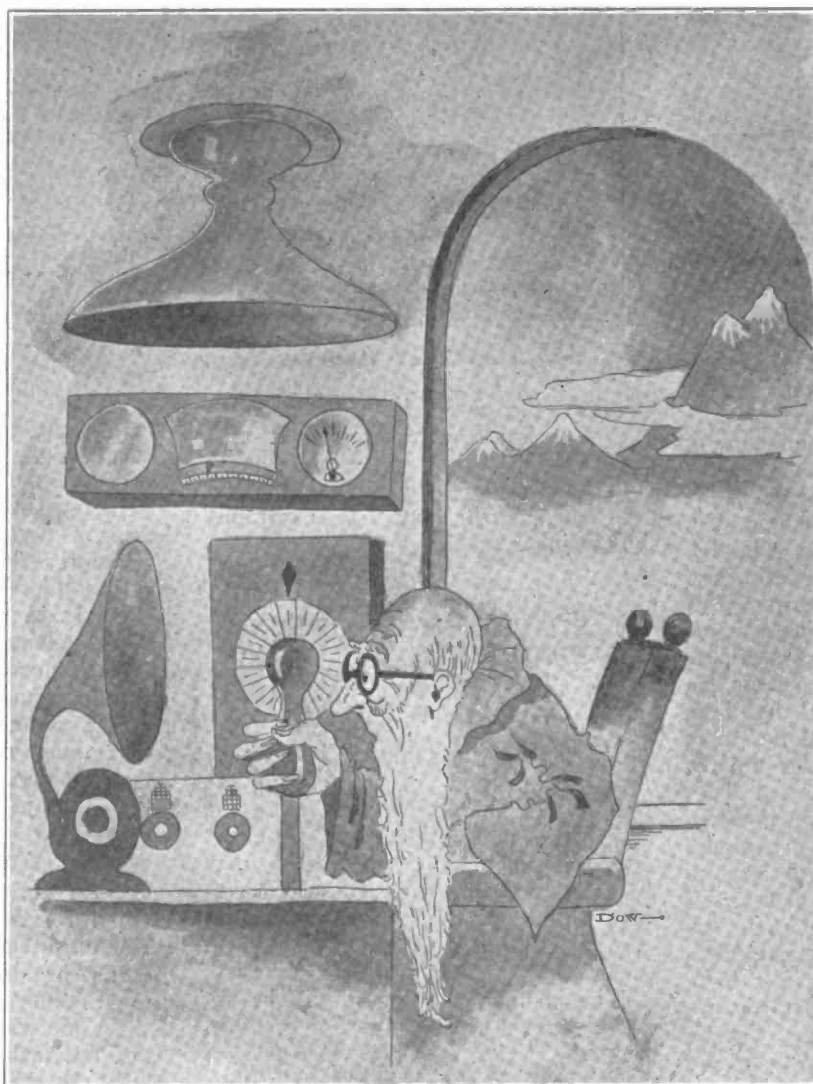

"Static!" he whispered and again, "Static!"

of magnetic decrements—the chart on which was noted the resident magnetic value of every important spot on the earth's surface. His eye sought out Yap—the tiny spot near the Japanese coast—taking in the close-written numbers of the decrement. He touched the buttons of the control—setting the destination points in the code designation of Yap—G-51 south 9x. As the last button slipped into place, he reached for the lever and thrust it home. Instantly the meters over his head began to dance and

RECEPTION OF SHORT WAVE DX SIGNALS IN HAWAII

By T. A. MARSHALL

LONG distance transmission of radio signals at short wavelengths is dependent mainly on the choice of the receiving apparatus, if due consideration is not given to locality in which the receiving station is located. This is the general opinion of the radio fans of Honolulu. Amateurs here consider a variocoupler, such as the Remler type, tuned regenerative set with a detector and two stage amplifier as the most efficient type of receiver for receiving Coast amateurs.

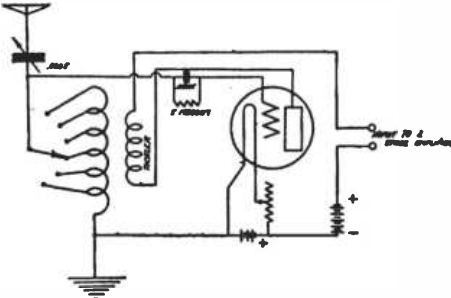

Fig. 1.—Variocoupler Tuned Regenerative Receiver

In Fig. 1 is shown a variocoupler tuned regenerative receiver. Heretofore the reason for failure of amateurs of this district in receiving coast amateurs is due to the location and type of receiving apparatus. This has been definitely proven by the writer, who has carried on considerable experimental work in receiving coast amateurs.

Some time ago an invitation was extended to the writer to make a trip to Makapuu Point, which is the most distant point from QRM. It has been often said that Oahu Island has more QRM than any other place in the world. Makapuu Point is located about 25 miles from the Navy high powered arc station, and about the same distance from the big set of the Radio Corporation of America at Kahuka. On April 22nd a truck was secured and a trip was made to Makapuu Point. Shortly after our arrival we had erected a 55 ft. bamboo mast and a four-wire flat top, inverted L antenna, 75 ft. long. The receiving equipment was placed in an old wash house where a water pipe served for a good ground. For long wave reception duo-lateral honeycomb coils were used. Every arc station under the American flag was logged. I might add right here that most of those who think that good work cannot be done on honeycomb coils have never learned to use them correctly.

After enjoying a good campfire meal and inspecting the lighthouse, a watch was started on short waves. At 9:10 p. m. 6ZX was picked up. His signals were so steady and so seemingly dependable that I wished for a transmitter with which to make a real record.

Nothing further was heard until we changed bulbs. A UV-200 brought in 6KY, 6ZB, 6TQ, and 6EX. Many calls were lost on account of jamming and harmonics from Heeia arc station. 6ZZ came in very QSA. Finally at 9:57 p. m. 6ZI came rolling thru in good style as he worked with Dow, 6ZAC. The stations heard up to 12:30 a. m. follow: 6ZG, 6ASJ, Chas. L. Elvin, Oakland, Calif.; 6ZAC, 6SY, GP, 6KI, 5BG, 7AC, 6NB, 6NY.

The most remarkable feature was the strength of the signals from 6ZI and 6ZG. The latter station was easily



Antenna and Shack

read 25 feet away from the receiver. Three messages were intercepted from 6ZG. If the editor will tolerate us we will have more to tell about our next trip and amateur hunt. It is certainly interesting work.

A SIMPLE METHOD FOR MEMORIZING THE CONTINENTAL CODE

By DAVID P. GIBBONS

No extravagant claims are being made for this method of committing to memory the characters representing the alphabet in the Continental Morse Code. It is believed however, that its use may be of considerable value to such beginners as have unusual difficulty in this respect. In other words it may "help some."

The manner of using it will be apparent after a brief study. For example, take the letter L. The word used is "linoleum," in which the letter itself occurs twice. The first syllable (lin) has a short accent, the second (ol) a long accent, and the two final syllables (e, um) short accents, thereby reproducing the dot-dash-dot-dot, which form the Morse character representing the letter.

Again take the letter Q. Here three words are used to obtain the proper accents and at the same time include the letter itself. The first two words (quite, queer)—of one syllable each—are long, the third syllable (in-) is short, and the final syllable (-deed) is long, thus giving the dash-dash-dot-dash, which represents Q in the Continental Code.

Similarly the connection between the other letters and the corresponding words will be seen on inspection, and the correct combination of SOUNDS for any given letter be more readily impressed on the memory.

- A Away ---
- B By Billiken's ----
- C Crowded Cloister ----
- D Dangerous ----
- E Eggs -
- F Fifi Foolish ----
- G Good Gracious ----
- H Hilly Billy ----
- I Izzie --
- J Jerome Jay Jones ----
- K Kokomo ----
- L Linoleum ----
- M Mile-long ---
- N Nailer ---
- O Ozone blows ----
- P Persuades Peter ----
- Q Quite Queer indeed ----
- R Reported ----
- S Sensitive ---
- T Tube ---
- U Undertaker ---
- V Visible glow ----
- W With White Wire ----
- X Hoax silly jokes ----
- Y Yearly told yarns ----
- Z Zero weather ----

If the student find any particular difficulty in memorizing the various words selected he might connect them together to form sentences like the following: Away by Billiken's crowded cloister the dangerous eggs made Fifi foolish. "Good gracious!" said the hilly-billy to Izzie, "look at Jerome Jay Jones laying linoleum with a mile-long nailer, while the ozone blows and persuades Peter he is quite queer indeed, as it is reported that a sensitive tube will undertake to make a visible glow with white wire, but such hoax, silly jokes and yearly told yarns are a sign of zero weather."

Radio control of ships was discussed by Max Laubeuf, formerly chief engineer of the French Navy, in his presidential address before the Society of Civil Engineers. Reference was made to the fact that "the battleship Iowa with nobody on board was driven with the utmost ease by the battleship Ohio, which kept at a distance of five miles behind. The experiment lasted three hours and no mishap whatever happened." M. Laubeuf further explained that the water and oil taps of the Iowa were opened and closed by the radio waves emitted from the Ohio in order to increase or diminish at will the speed of the driven crewless battleship. The helm was also maneuvered from a distance, and the Iowa avoided with great accuracy the air attacks made upon her.

A Radio Primer

By H. A. Eveleth

THE VACUUM TUBE

BEFORE we consider in detail the operation of the vacuum tube detector and vacuum tube amplifier as employed in modern receiving apparatus it may be well to bring out what an important electrical development is the three-electrode vacuum tube which is used to detect and amplify radio signals. It is claimed by some that this device is the most important electrical development of the twentieth century so far.

A long time ago Edison made a two electrode tube containing a filament and a plate. Later Fleming, one of Marconi's engineers, used this two electrode tube as a detector of "wireless" waves. Finally DeForest, about the time the war broke out, added a third electrode, the grid, and since then wonderful things have been accomplished.

Credit for long distance telephone communication over land wire between San Francisco and New York belongs to the vacuum tube. It will relay and amplify or magnify the voice perfectly, without distortion when properly adjusted, which enables telephone communication to be carried on over great distances.

Using a series of tubes the human voice can be magnified a million times. If one tube amplifies ten times two will amplify one hundred times, hence six will amplify a million times.

When services were held over the grave of the Unknown Hero near Washington, D. C., every word uttered was understood by a large audience in the San Francisco Auditorium. The vacuum tube relay and amplifier made this possible.

The combination of detector and amplifier tubes makes it possible to detect, in radio communication, much smaller values of electrical energy than can be detected with the crystal detectors. Not only does this greatly increase the range and efficiency of radio communication, but makes possible the use of small portable aeri-als such as are used for compass work and on aeroplanes and submarines.

When properly connected these tubes will generate a high frequency current of constant amplitude which may be used for both radio code and telephone work and a tube may be used to modulate current in telephony. Also the C. W. (continuous wave) permits much sharper tuning and practically eliminates interference between stations.

The detecting and amplifying actions of the vacuum tube depend primarily on the electron flow between two elements of the tube called the filament and the plate. The metallic plate surrounds the

filament, but is insulated from it and is connected to a terminal on the base of the tube. The filament is connected to base terminals and operates from a six volt storage battery. A rheostat is connected in series to control the current flow and hence the temperature of the filament. A flow of electrons, or negatively charged particles, takes place between the heated filament and the comparatively cold plate.

To explain this action let us consider briefly the composition of matter, that is, what goes to make up material or objects. Consider a piece of ordinary yellow brass. We might attempt to divide it into the smallest particles possible by using a very fine file. This would give us brass dust. Now each particle of this dust would consist of millions of still smaller particles of brass called molecules, but we could never hope to divide the brass into its molecules nor see them with the most powerful microscope. Molecules are the smallest particles which combined make up a visible object.

Now this yellow brass is made by mixing two elements, 67 parts of copper and 33 parts of zinc. Copper and zinc are called elements because they are not a mixture of two or more other substances. These elements are in turn composed of extremely small particles called atoms and the size and other properties of these atoms determine the kind of element. Thus an atom of copper differs from an atom of zinc, but all copper atoms and all zinc atoms are alike.

The atom is supposed to consist of particles of negative electricity called electrons. It is assumed that these electrons revolve about a positive central point within the electron like the planets revolve about the sun and it is the number and group arrangement of these electrons which determine the nature of the atom, that is, whether it is a copper atom or a zinc atom. There are many kinds of atoms besides these two.

Also there are electrons moving about between the different atoms called free electrons.

The particles of matter are supposed to be in a state of motion or vibration. The molecules are vibrating within the piece of brass and the atoms of copper and zinc which compose the brass are vibrating within the molecules.

If heat is applied to the brass the molecules vibrate faster and through a greater amplitude or space. Naturally they take up more room and we say the brass expands. On the other hand if the brass is cooled the amount of vibration is decreased and the metal is said to contract.

We said in the last letter that there are free or extra electrons moving about between the atoms. Now if we increase the vibration of the atoms by applying heat there will be more space between the atoms and hence the free electrons will have more room in which to move about. If the metal is made very hot the atoms will vibrate so much that the free electrons will escape from between them and leave the surface of the metal.

This is just what happens in the vacuum tube. We heat the tungsten filament by passing an electric current through it and the result is that free electrons or negative charges of electricity pass from its surface and we can control the amount of electrons which pass by adjusting the temperature of the filament.

The object is to secure a flow of negative particles or electrons from the filament to the plate so a second battery called a "B" or plate battery is connected with its positive terminal to the plate and its negative terminal to the filament. The plate will then be charged positively and will attract the negative particles or electrons emitted from the filament and the result is an electron flow in the vacuum tube from the filament to the plate.

A third electrode, called the grid, is inserted between the filament and plate. When connected properly with external circuits the grid will regulate the electron flow so that the tube will detect or amplify electric currents.

GRID ACTION

Picture in your mind the three-electrode vacuum tube in operation: the lighted filament from which a stream of electrons is flowing to the positively charged plate and the grid or wire screen interposed between the filament and plate, through the meshes of which the electrons must pass.

This electron flow constitutes a current of electricity in the plate circuit, the dry "B" battery being connected by its negative and positive terminals respectively to those two electrodes of the tube.

If the grid receives a negative charge of electricity from an outside source it will repel to a certain extent the negative charges of electricity or electrons which are passing through its meshes to the plate because charges of similar polarity repel each other—positive charges repel positive charges but attract negative charges and vice versa. If the negative potential or negative charge of the grid is increased the point will be reached where the repulsive effect of the grid on the electrons will neutralize or

equal the attractive force exerted by the positively charged plate. The electron flow will stop and the current flow in the plate circuit will cease.

On the other hand if the grid is given a positive charge it will attract electrons emitted from the filament and the combined attraction exerted by both plate and grid will result in an increase of current flow in the plate circuit. However, since the grid is charged positively some of the electrons will remain with the grid instead of passing through the grid to the more positively charged plate beyond. This will result in a current flow in the grid circuit from grid to filament which will act in part toward limiting the current flow that can take place in the plate circuit.

As the positive charge on the grid is increased the electron flow and hence plate circuit current increases at a rate more rapid than the positive grid potential and finally the point of saturation is reached when no further increase of plate current will result because the attractive effect of the positive grid on the electrons is neutralized by the excess of negative electrons flowing through the tube.

DETECTOR AND AMPLIFIER ACTION

To explain the detector action let us consider a hook-up using a loose-coupler, a grid condenser and grid leak, telephone receivers, vacuum tube, storage battery and plate or "B" battery. The primary winding of the coupler is connected to aerial and to ground. The secondary winding is connected to one terminal of the grid condenser and to the negative terminal or side of the storage battery which heats the filament of the tube. The other side of the grid condenser is connected to the grid element in the tube. The grid condenser is therefore in series with the grid and one terminal of the secondary winding of the coupler. Connected to the terminals of the grid condenser (in shunt with it) is a high resistance called the gridleak. The positive terminal of the plate or "B" battery is connected to the plate element within the tube with the telephone receivers in series.

When no oscillations are taking place in the aerial circuit and the filament of the tube is heated, an electron flow takes place and permits a definite current to flow through the telephone receivers. When the aerial "picks up" a station and an alternating current at radio frequency is set up in the aerial circuit a current at like frequency is set up by induction in the secondary winding of the coupler (when the secondary circuit is tuned to the primary circuit) and the alternating current passing through the condenser alternately charges the grid within the tube positively and negatively. When charged positively it attracts the negative electrons passing from filament to plate and becomes negatively charged itself; then

the grid leak permits this negative charge to leak off from the grid which then assumes its normal potential or original state. Since a change in grid potential causes a change in amount of current flow in the plate circuit a sound will be produced in the telephone receivers, the frequency of which will correspond to the frequency of the groups of oscillations or "wave trains" sent out by the transmitting station. The grid acts as a relay to control the plate current flow much as you could control the flow of a powerful stream of water by manipulating a mechanical valve.

A very slight amount of energy acting on the grid element produces a comparatively large variation of current in the plate circuit; the grid acts as a relay, as it were, to control a larger amount of energy. It is an electron relay. Referring again to the water analogy, the expenditure of a comparatively small amount of energy in operating the mechanical valve would control a very much larger amount of energy represented by the powerful stream of water. It is therefore apparent that the vacuum tube will amplify as well as detect.

Several vacuum tubes may be connected in circuit with transformers interposed and the combination of two amplifier bulbs and two transformers will give an energy amplification of about ten thousand times. The primary winding of the transformer is connected to the plate of one tube and positive terminal of the plate battery and the secondary winding is connected to the grid of the next tube and negative terminal of the plate battery. The pulsating direct current set up in the plate circuit of the first tube passes through the primary winding of the transformer and sets up an amplified alternating current in the secondary winding which acts on the grid of the second tube.

Amplification may be at audio frequencies or at radio frequencies. In the former case the energy received is amplified after it has been rectified by the detector bulb and rendered audible. In the latter case the energy is amplified before it is rectified by the detector. Several stages or steps of radio frequency amplification will enable the detector to function on signals it otherwise would not pick up and the audio frequency current may then be put through several stages of audio frequency amplification and the combination of the two kinds of amplification gives more satisfactory results than can be obtained with an equal number of stages all at audio frequency.

When the plate voltage of a tube is increased a greater current will flow in the plate circuit. Detector bulbs are usually designed for 22½ to 35 volts plate potential. If the voltage is increased much a blue glow will be observed around the plate and a hissing noise will be heard in the receivers. If

the degree of vacuum in the tube is not correct and the blue glow occurs at normal plate voltage the tube is said to be *soft* and less plate voltage should be used. Tubes which operate at a definite plate voltage and degree of filament temperature are said to be critical. Most amplifier bulbs are non-critical and while they will function at low plate voltages the addition of sufficient "B" battery to bring the plate voltage to 100 and over will greatly increase the amount of amplification. Amplifier tubes are therefore made *hard*, the degree of vacuum being sufficient to prevent the plate glow at comparatively high plate potentials.

Amplifier circuits must be designed carefully to prevent induction effects between adjacent wires which will cause howling and distortion. Furthermore, three stages of audio frequency amplification are about the practical limit because any sounds not desired are brought out so strong that they are very objectionable, especially when music or speech is being received.

A human antenna was accidentally discovered by Captain D. H. Muse of Cincinnati, Ohio, while listening to a concert broadcasted by the Crossley Mfg. Co. The ground wire of the set had been disconnected to demonstrate that the set still would receive. Then Captain Muse, his hands slightly moist with perspiration, unhooked a 3 ft. insulated copper wire leading to his outside aerial and by accident held the bare, exposed end of the metal strand in his fingers. To his surprise, music, faint but audible, continued to reach his ears through the head phones. Captain Muse clamped a pair of head phones on his phonograph, so the horn would act as an amplifier. Then he held the bare wire in his hand and the room was filled as if with distant music. He transferred the copper strand to his mouth and the harmony instantly was intensified by this more perfect connection. He asked another officer to take hold of the wire with him, and learned that the music came in stronger by virtue of the dual aerial. A third, fourth and fifth man attached himself to the wire at its non-insulated surface and the music became so strong that the doors of the phonograph had to be closed. When all the men let go the wire so that it dangled in midair the sound stopped entirely.

The Vacuum Tube as an Amplifier

By B. F. McNamee

THE type of vacuum tube used as an amplifier is the "hard" or high vacuum tube. The vacuum is so nearly perfect that there is no noticeable effect of gas molecules; in fact, for practical purposes it may be considered a perfect vacuum. The "soft" tube, that is one containing a certain small pressure of gas and intended for use as a detector, can be used to a certain extent for amplification purposes. However this almost always results in distortion which would prohibit its use as an amplifier in radio telephone work, and its use is also restricted because it will not work with high plate voltage, thus limiting the strength of signals that can be obtained.

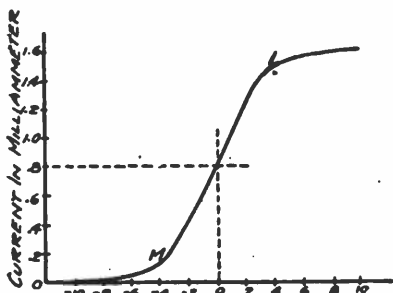
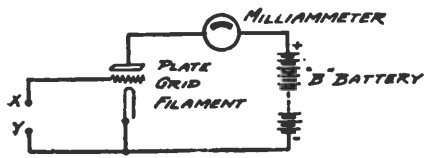

Fig. 1 and Fig. 2

The hard tube therefore is the only one that will be considered in this article.

In the soft tube we have both electrons and gas molecules acting as carriers of electricity, but in the hard tube the electrons are the only carriers and the action is thus simplified. When the filament becomes incandescent it throws off negative electrons. The B battery is connected with its positive end toward the plate and this positive charge on the plate attracts the negative electrons. There is, therefore, a flow of electrons across the tube from filament to plate and returning to the filament through the meter and B battery shown in Fig. 1. As long as no charge is placed on the grid this current will remain at a steady value of about one or two milliamperes with ordinary B battery voltages.

The grid is a sort of screen interposed between the filament and the plate. The electrons in going from the filament to the plate pass through the openings in this screen. When electric charges are placed on the grid it acts like the faucet in a water pipe since it controls the flow of current through the tube. When a negative charge is placed on the grid,

it repels the electrons coming from the bulb and a smaller number of them will reach the plate. If this negative charge is sufficiently great all the electrons from the filament will be repelled and driven back to the filament, and the meter which shows the plate current will read zero. If, on the other hand, a positive charge is placed on the grid, it will accelerate the electrons, and larger numbers will reach the plate. This will increase the current through the meter.

The grid is charged positively or negatively by connecting the battery between the points X and Y in Fig. 1. If points X and Y are connected by a wire, and Y is connected to the negative end of the filament, the grid is said to have zero charge. By changing the voltage of the battery connected between X and Y and marking down the corresponding values of current shown by the meter we obtain the curve of Fig. 2. We note that when X and Y are connected by a wire, that is, when there is zero charge in the grid, there is a current of .8 of a milliamper in the plate circuit. This value of current of course holds good for only one particular adjustment of filament and B battery on one particular tube; we might make this current almost anything we pleased.

Note that as the voltage is increased in the negative direction the current in the plate circuit falls very suddenly until we have reached a negative charge on the grid of 4 volts, corresponding to point M on the curve. As the voltage is increased in the positive direction beyond this point the plate current falls very gradually to zero at about 10 volts.

On the other hand, if the plate voltage is increased in the positive direction the plate current rises suddenly at first until about 4 volts positive has been reached, corresponding to a plate current of 1.5 milliamperes. If we increase the positive charge of the grid beyond this point there will be hardly any corresponding increase in plate current. This is because all the electrons given out by the filament are now reaching the plate and consequently no further increase in plate current can take place except the filament is made hotter. This is known as the saturation part of the curve.

Suppose that a small alternating voltage is connected between points X and Y in Fig. 1. If the voltage on the grid is made to fluctuate from 2 volts positive to 2 volts negative it will be seen that the needle of the milliammeter will show that the plate current is rising and falling between the values 1.2 to .6 milliamperes.

The usual method of supplying an alternating voltage to the grid of a vacuum tube is by means of a trans-

former, as shown in Fig. 3. The primary of the transformer may be connected to a telephone line and the alternating current in it will in that case consist of voice currents. The transformer is usually of the step-up type in order to supply as great a change of voltage on the grid as is practically possible. Since the grid requires little or no current we can have large voltages from a source supplying very little power. This is the case in long telephone lines where nearly all the power is expended in overcoming resistance losses in the line.

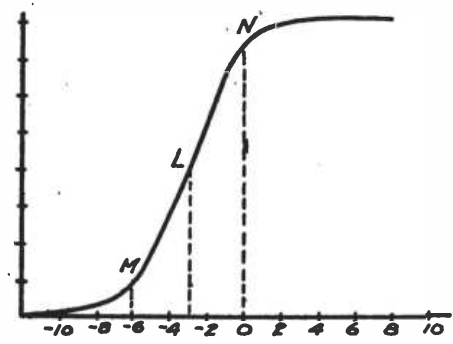
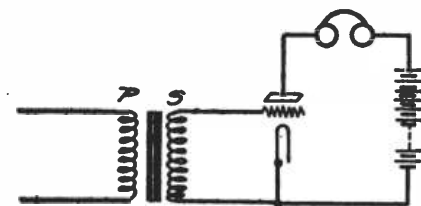

Fig. 3 and Fig. 4

With such a voice-controlled voltage applied to the grid, the current in the plate circuit of the tube will fluctuate accordingly, and if a pair of telephone receivers are used in place of the milliammeter in Fig. 1, the speech of the telephone line will be clearly heard. The result will be much stronger than if the telephone receivers are connected directly in the telephone line, because the energy now used to produce the sound waves comes from the B battery and is simply controlled by the minute amount of energy in the telephone line. The grid circuit of the vacuum tube is for this reason called the control circuit or input circuit, and the plate circuit is known as the output circuit. A very small amount of energy in the control circuit will release in the output circuit a comparatively large amount from the B battery.

In telephone work another transformer would be connected in place of the telephones and this would supply the energy to the continuation of the telephone line. Of course this would provide for one way communication only, but a rather complicated hook-up has been devised, generally using two tubes

which provides for amplification in both directions and is used in all long distance telephoning today.

Fig. 4 shows the curve obtained from some types of amplifier tube with certain adjustments of filament and B battery. If this tube were used with the connections shown in Fig. 3, the amplified sounds would be distorted, because a positive charge of let us say two volts would increase the plate current but very little, while a negative charge of the same amount would cause a comparatively large decrease. In order to amplify without distortion it would be necessary that the increase in this case should equal the decrease. This could be brought about by connecting a battery of about three volts between the filament and the secondary of the transformer with its negative end toward the latter. This would bring the plate current to point L on the curve of Fig. 4. If the grid voltage now fluctuates two or three volts in either direction, the corresponding increase and decrease in plate current will be equal and there will be no distortion. Such a battery connected in the grid circuit is called a "C" battery or "bias" battery. Since it supplies little or no current it may consist of the smallest size of flashlight cells.

If more amplification is required than that given by one tube, the telephones of Fig. 3 may be taken out and the primary of another transformer connected in their place. The secondary of this transformer is connected to the grid and filament of another tube, which will amplify the results of the first tube. This action may be continued through four or five tubes in succession, and is known as cascade amplification. Very careful design is necessary in such multi-stage amplifiers in order to prevent distortion.

The matter of "howling" in amplifier circuits can be entirely avoided. This subject will be taken up in the next article of this series, which will deal with the vacuum tube as an oscillator.

SWEDEN AND FINLAND TO GET RADIOPHONE BOND

A radio telephone system to take the place of the contemplated telephone cable between Sweden and Finland now is being investigated by officials of the two governments involved. Estimates place the cost of the cable from 20,000,000 to 40,000,000 marks and the radio station at 10,000,000 marks.

HIGH-FREQUENCY RESISTANCE OF INDUCTANCE COILS

An "inductance coil" is simply a coil of wire wound in any one of a number of different familiar forms. The behavior of such coils in circuits carrying direct current or alternating cur-

rents of low frequencies, such as 60 cycles, has been studied for many years and is well known. When the attempt is made to predict the behavior of an inductance coil at radio frequencies by extending the relations which are sufficient to predict its behavior at low frequencies, it is found that other effects are present at the radio frequencies which do not require consideration at the low frequencies. At low frequencies the same number of amperes flows in every part of the wire constituting the inductance coil, and the distribution of the current over a given cross section is practically uniform. At high frequencies the current density is not uniform over a given cross section of a wire, nor is it the same for different cross sections of the wire. The current flow is modified by induction effects of magnetic as well as electrostatic nature. For direct current the resistance of inductance coils can be determined by Ohm's law, but at radio frequencies Ohm's law by no means gives complete information regarding the resistance of a coil. The study of non-uniformity of current density in a particular cross section is the subject of "skin effect," on which various investigators have already done considerable work. The difference in the current flowing across different cross sections of the wire forming a coil is caused by the capacities distributed along the winding of the coil.

An inductance coil behaves in an electric circuit primarily as an inductance. The potentials of the different parts of the coil are, however, different from each other and from the potentials of the ground. For this reason the coil behaves also to a certain extent as an electric condenser, or rather a system of condensers. The impedance of these capacity paths is low at radio frequencies, and the capacities constitute shunt paths for the radio frequency current and cause charges to collect at various points of the coil, thus creating back electromotive forces. There are several effects of the non-uniform distribution of current along the wire, of which the most important is the increase in the resistance of the coil with the frequency. At radio frequencies the resistance of an inductance coil depends upon the point of the coil at which an e.m.f. is inserted and the current measured.

On account of the importance of inductance coils in radio communication, careful studies, both theoretical and experimental, have been made at the Bureau of Standards on capacity effects and other effects in inductance coils at radio frequencies. Some of the results of these investigations are contained in a new publication, Bureau of Standards Scientific Paper No. 430, "The High-Frequency Resistance of Inductance Coils," by Gregory Breit. In this paper a formula for the resistance of an in-

ductance coil is derived which takes into consideration both the skin effect and the capacity effect for the case of a short single-layer solenoid, and the results of experiments are given which check this formula. Other more general formulas for current distribution and resistance are also derived. A copy of this paper may be purchased for 5 cents from the Superintendent of Documents, Government Printing Office, Washington, D. C.

NAVY VACUUM TUBE BIDS REJECTED

Seventeen bids received by the Navy Department for its 30,000 surplus vacuum transmitting tubes were rejected, and new bids called for June 1. The best bid received was at \$3.17 $\frac{3}{4}$ each. These tubes, although originally purchased for transmitting tubes, can be reslotted and used as receiving tubes. When these tubes are retailed, they must be sold in their original cartons to licensed amateurs only, for experimental or entertainment use. The fact that they are several years old and that they were originally purchased by the Navy as transmitting tubes, must be shown on the label. In case the retailers fail to comply with the regulations of the Navy Department, the tubes will be seized and the payments forfeited.

NORWAY MAY RADIO UNITED STATES

With a new and powerful radio telegraph apparatus being installed on Rundemanden, a 2500 foot mountain at Bergen, Norway, it is believed that direct communication with America will be possible. The radio telegraph will have a 3000 kilometer radius. An 800 kilometer radius wireless phone for communication with England and Continental Europe will also be established. The improvements represent an investment of about \$25,000, and are expected to be completed by June 1, according to Consul George Nicolas of Bergen.

A pale blue glow in a detector vacuum tube is due to the ionization or electrical breakdown of the gas in the tube and is generally caused by too high a voltage on the plate from the B battery. The tube usually will not detect until the voltage is reduced.

The detecting efficiency of a three electrode vacuum tube increases with the square of the signal voltage.

OFFICE BUILDING WIRED FOR RADIOPHONES

For the first time in the history of Pacific Coast office building construction, a 15-story skyscraper in San Francisco, the new Matson Navigation Co. building, will be wired throughout for radiophone installation, so that tenants wishing to put in a receiving set will only have to "plug in" the same as for a desk lamp, to a socket in the wall, to be connected up with antennae on the roof and receive broadcasting programs from stations in San Francisco and vicinity.

The building is now in process of construction and will be ready for occupancy next March or April.



Matson Navigation Co. New Building to be wired for Radio.

Not only will the new building be completely wired as a convenience to tenant radiophone enthusiasts, but the company intends to install a powerful sending and receiving set, with which it is expected it will be possible to give orders to the captains of the company's nine freight and passenger ships, all of which maintain a weekly service from San Francisco to all Hawaiian Island ports.

Within the next year the Matson Line hopes to be able to talk by radiophone with its agencies in Honolulu, Hilo and other Hawaiian ports. Only recently a radio amateur at Kahului, Island of Maui, 90 miles from Honolulu, was able to hear with distinctness broadcasting sent out from the Rockridge station in Oakland, 2000 miles away.

THE WORLD'S LARGEST MAGNAVOX

As a means for employing the great drawing power of radio many publicity stunts are being carried out at the pres-

ent time. One of the very latest is that of building a huge Magnavox and setting it up in an amusement park, thus providing free radio concerts and entertainment for all those who may wish to listen.



The World's Largest Magnavox

The Magnavox here illustrated was designed and built by the engineering department of the Magnavox Company for Idora Park, at Oakland, California. The horn contains 1000 running ft. of clear airplane spruce one inch thick. It has an opening 12 ft. in diameter and is 35 ft. over all. An interesting comparison is that while the bell or opening has an area of 144 sq. ft., the smaller end has an area the exact size of a buffalo nickel.

Connecting to the enormous horn there is a standard Magnavox radio telemegafone energized by one of the latest developments in the audio frequency amplifier science—a super power amplifier, capable of giving to the horn and telemegafone about 1/16 horse power in modulated voice current or sound producing energy, under the influence of the average radio signal. The enormous sound produced can thus be imagined, for only an infinitesimal amount of current is necessary to produce an audible sound in head receivers. The radio concerts are daily heard all over the large amusement park and people have reported hearing the music for over three miles. This use of radio as a drawing card for an amusement park is one which is new in its design, and one which can profitably be used by many other resorts with equal success. The idea for the huge Magnavox must be credited to Mr. York, manager of Idora Park, who is always on the lookout for new and unique methods of amusement.

SIMULTANEOUS MULTI-WAVE BROADCASTING

Within a few months it will probably be possible for a representative of the Government to talk to anyone in the world, or to all people at one time, on the new Naval radiophone transmitting set at NAA, the Arlington station on the Potomac. This statement was made by a high-ranking officer of

the Navy Department, who said that the Navy could now send code messages practically around the world, by the use of relays.

Speaking into any ordinary telephone in Washington connected with the Arlington broadcasting station, an official could talk to a Pacific Coast station, which would automatically relay the message within a sixtieth of a second to Pearl Harbor, thence to Guam and Cavite, where the message would arrive only one-quarter of a second after it left Washington. The further routing he did not explain, but it is known that other big stations are in prospect overseas.

The simultaneous broadcasting of a single spoken message from two stations on different wavelengths has been successfully conducted by the Navy, for the purpose of making sure that plans for broadcasting the headquarters dedication program of the National Woman's Party were satisfactory. Through the co-operation of the American Telephone and Telegraph Company, direct wires were strung from the Woman's Party headquarters to the Naval air station at Anacostia and the Naval radio station at Arlington. Test messages spoken at the headquarters were transmitted by wire to these stations and put on the radio broadcasting circuits. At Anacostia, NOF, a 412-meter wave was used, with about 13 amperes radiation, and at Arlington, NAA, on a 2650 meter wave, with 40 amperes.

The system worked perfectly, serving two classes of receiving stations at once, the 412-meter wave furnishing many amateur stations within from 400 to 700 miles, while the long wave served stations equipped with larger receiving sets, between 800 and 1500 miles distant.

The actual broadcasting of the speeches Sunday afternoon, however, was prohibited by Naval officials Saturday, on the ground that the meeting was of a political nature such as previously ruled against by Secretary Denby.

The experiments in simultaneous broadcasting from two stations on different wavelengths have been so successful that it is believed that several stations, not too greatly separated, will soon be able to broadcast a single phone message on a number of different wavelengths at one time, reaching receiving stations nearby and at great distances, even crossing oceans.

With the perfection of this system and the necessary apparatus, the President, for example, could address practically the whole world, or at least all the people provided with suitable receiving apparatus who understand English. This would furnish an excellent method of issuing official verbal statements of serious import or bearing on the policies

Continued on page 60

ARMY RADIO NET SAVING, \$18,000 YEARLY

While the Naval Communication Service handles all official trans-oceanic radio messages, and most of the shore to ship communication, the Army is far from idle in its radio activities. A great radio "net" now stretches practically all over the United States, with 43 large sending stations located in the nine corps areas of the Army.

This net is controlled by the Signal Corps, under the direction of Major General George O. Squier, an eminent soldier and scientist, credited with many of the inventions and devices which have made radio and "wired wireless" practical. At present the Signal Corps is clearing practically half of the Government communications, and only the signature of Secretary Weeks is needed to make the Signal Corps radio headquarters the message center of the Army.

In two months the radio communication system has saved the Government \$3354, by carrying over 20,000 words in messages, which would have cost that amount if sent in the old manner by commercial rates on land lines. For April, 3249 messages, comprising 136,316 words, were handled by Signal Corps radio stations, estimated as a saving of \$2167. The saving would approximate \$18,000 a year.

With the installation of a powerful radio station at Fort Douglas, Salt Lake City, on May 9th, which is now communicating with the Presidio station at San Francisco, and the completion of a similar station at Fort D. A. Russell, Cheyenne, Wyoming, the main transcontinental radio circuit will be completed. With stations already operating at New York and Washington, communication on the cross country circuit is routed as follows: Fort Benjamin Harrison, Indiana; Chicago; Forts Omaha, Douglas and Russell, to San Francisco. Stations have also been installed at Jefferson Barracks, Mo., and at Fort Leavenworth, Kansas.

Some of the Army stations are sending 1000 miles with an antenna input of 1000 watts, but as a number of the new stations are to be higher powered with an input of 5000 watts, a distance of 5000 miles may be reached.

In the event of a collapse of the commercial wires and radio stations or in an emergency, great possibilities are seen in the growing Army net, as practically every section of the country could be reached through it and the nine corps area local nets. Every branch, even the field detachments of the Army, is in constant communication with headquarters at Washington. No commercial work is handled, only official Army and Naval dispatches being carried, but all commercial traffic could be handled in time of need, and a large amount regularly in dull hours.

Smaller stations are going in daily; recently a station was opened at the Airship Field, Aberdeen, Md., and another at the Morgan Ordnance Depot, South Amboy, N. J. The Signal Corps plans shortly to have a fifty-station service in operation.

ment houses and private dwellings, meeting with the disapproval of architects and community beautifiers. The elimination of aerials also precludes certain dangers from possible contact with high power electric lines.

It is believed by experts that one of

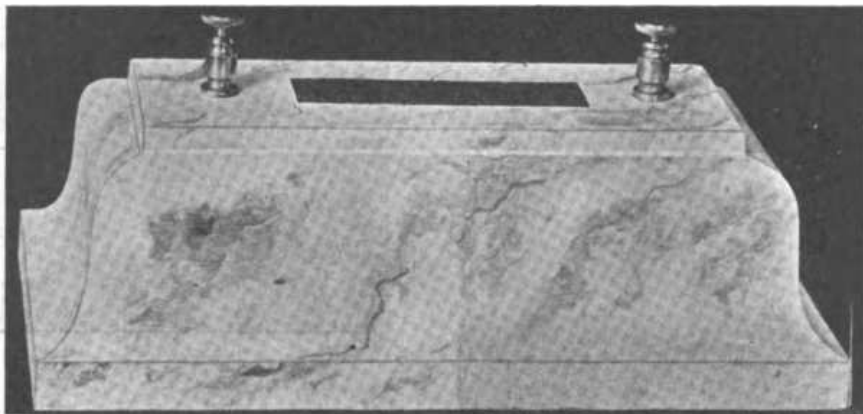

Marble Antenna Invented by W. J. Cormey of Minneapolis To Utilize House Wiring System as Aerial.

BROADCASTING AND RECEIVING ON LIGHT CIRCUITS

By CARL H. BUTMAN

Major General George O. Squier, Chief Signal Officer of the Army, has recently extended his experiments with "wired wireless," using the wires of an electric light system as a receiving antenna. The ordinary commercial electric light lines always have a return wire running in close proximity throughout the circuit, giving a distributive capacity and such a line may be considered as a reservoir comprising all values of antennae. The receiving instrument when plugged into a socket possesses the power of "picking out" or choosing from this reservoir the particular antenna necessary for resonance at any particular wavelength. This may be called the "fish pond" theory, General Squier says, in which one can either take from the pond a whale or a minnow, depending on the particular wavelength being received. The longer wavelengths might be considered whales and the shorter ones minnows, the receiving operator adjusting his instrument to maximum loudness, as usual.

The use of the lighting circuit—eliminating unnecessary wires—instead of aerials for receiving broadcasted messages, serves to reduce the static very materially. In the summer this static becomes very much more active than in the winter, and makes receiving with aerials difficult throughout the East and South, though it does not bother much in the West.

There is no necessity for any wires except the lighting circuit and the usual flexible lamp cord to the ordinary socket. This method will be a benefit to our skylines, as it will eliminate the necessity of all receiving antennae which now literally cover the roofs of apart-

the most practical improvements will come in the very near future, by which the broadcasting service, whether from a distance or upon the wires themselves, will utilize in the receivers the electrical energy necessary to operate these receivers, taken directly from the same plug in the lighting circuit.

Once the whole apparatus is condensed and operated directly from the lamp socket, and maintained indefinitely therefrom, we have reached the point where the installation of home sets on a practical basis can go ahead on a big scale.

RECEIVING ON STEAM RADIATORS AND PIPE LINES

The latest scheme for receiving radio messages involves the use of a good steam radiator, or a hot-water radiator, for that matter, according to a report reaching the radio section of the Army. This system, said to have been evolved and tested out satisfactorily by a former electrical engineer of the Signal Corps, has evidently a market value, as the inventor is reported to have sold out his circuits and patents to a big corporation.

Many curious forms of receiving apparatus have already been used in lieu of the usual aerials, some of them with remarkable success by well-known experts. Among the unusual types of aerials employed are: the "tree antenna," demonstrated some time ago by Maj. Gen. Squier; the bed-spring antenna used by several experimenters, a trough of water and a cake of ice employed in Signal Corps experiments a year ago, and smaller and more handy devices such as umbrellas and fish poles. But the latest device for this purpose should interest many fans, as it is so readily available and should prove most useful, if practical.

News of the Broadcasting Stations

NEW BROADCASTING STATIONS

WBAE—Bradley Polytechnic Institute, Peoria, Ill.
 WBAH—Dayton Company, Minneapolis, Minn.
 KZN—Deseret News, Salt Lake City, Utah.
 WBAG—Diamond State Fibre Co., Bridgeport, Pa.
 KTW—First Presbyterian Church, Seattle, Wash.
 WBA—Marshall-Gerkin Co., Toledo, Ohio.
 WBAF—Fred M. Middleton, Moorestown, N. J.
 KZC—Public Market and Department Stores Co., Seattle, Wash.
 WBAD—Sterling Electric Co. & Journal Printing Co., Minneapolis, Minn.
 WBAN—Wireless Phone Corporation, Paterson, N. J.
 WIZ—Cino Radio Mfg. Co., Cincinnati, Ohio.
 KUY—Coast Radio Company, El Monte, Calif.
 WBAK—Pennsylvania State Police, Harrisburg, Pa.
 WBAM—I. B. Rennysen, New Orleans, La.
 WAAC—Tulane University of Louisiana, New Orleans, La.
 KNN—Bullock's, Los Angeles, Calif.
 KSC—Hale & Company, San Jose, Calif.
 WBAO—James Millikin University, Decatur, Ill.
 KNT—North Coast Products Company, Aberdeen, Wash.
 KYF—Thearle Music Company, San Diego, Calif.
 WBAY—American Telephone & Telegraph Co., New York, N. Y.
 WBAV—The Erner & Hopkins Co., Columbus, Ohio.
 WGM—Georgia Railway & Power Co., Atlanta, Ga. (Atlanta Constitution.)
 WBAQ—Myron L. Harmon, Y. M. C. A., South Bend, Indiana.
 WGI—Iowa State College, Ames, Iowa.
 WBAW—Marietta College, Marietta, Ohio.
 WBAU—Republican Publishing Co., Hamilton, Ohio.
 KNI—T. W. Smith, Eureka, Calif.
 WBAX—John H. Stenger, Jr., Wilkesbarre, Pa.
 WCX—Detroit Free Press, Detroit, Mich.
 WCAE—Kaufmann & Baer Co., Pittsburgh, Pa.
 WCAB—Newburgh News Print & Pub. Co., Newburgh, N. Y.
 WBAZ—Times-Despatch Pub. Co., Richmond, Va.
 KLX—Tribune Pub. Co., Oakland, Calif.
 KOJ—University of Nevada, Reno, Nevada.
 KZV—Wenatchee Battery & Motor Co., Wenatchee, Wash.
 WBAP—The Star-Telegram, Wortham-Carter Pub. Co., Fort Worth, Texas.
 KYI—Bakersfield Californian, Bakersfield, Calif.
 WCAG—Daily States Pub. Co., New Orleans, La.
 KNX—Electric Lighting Supply Co., Los Angeles, Cal.
 WCAC—John Fink Jewelry Co., Fort Smith, Ark.
 WCAD—St. Lawrence University, Canton, N. Y. (Only weather.)
 KQI—University of California, Berkeley, California.
 WCAR—Alamo Radio Electric Co., San Antonio, Texas.
 KDYO—Carlson & Simpson, San Diego, Calif.
 WCAP—Central Radio Service, Decatur, Ill.
 WCAK—Alfred P. Daniel, Houston, Texas.
 KDYN—Great-Western Radio Corporation, Redwood City, Calif.

WCAJ—Nebraska Wesleyan University, Lincoln, Nebr.
 KDYQ—Oregon Institute of Technology, Portland, Ore. (weather only.)
 WOC—Palmer School of Chiropractic, Davenport, Iowa.
 KDYR—Pasadena Star—News Publishing Co., Pasadena, Calif.
 WCAU—Philadelphia Radiophone Co., Philadelphia, Pa.
 WCAL—St. Olaf College, Northfield, Minn.
 WCAO—Sanders & Stayman Co., Baltimore, Md.
 KDYM—Savoy Theatre, San Diego, Calif.
 WCAN—Southeastern Radio Telephone Co., Jacksonville, Fla.
 WCAT—South Dakota School of Mines, Rapid City, S. D. (weather only.)
 WCAQ—Tri-State Radio Mfg. and Supply Co., Defiance, Ohio.
 WCAM—Villanova College, Villanova, Penna.
 WCAS—William Hood Durwoody Industrial Institute, Minneapolis, Minn.
 WCAZ—Robt. E. Compton & Co., Quincy Whig Journal, Quincy, Ill.
 KDZV—Cope & Cornwell Co., Salt Lake City, Utah.
 WCAV—J. C. Dice Electric Co., Little Rock, Ark.
 WDAD—William Louis Harrison, Central Kansas Radio Supply, Lindsborn, Kansas.
 KDYU—Herald Publishing Co., Klamath Falls, Ore.
 WDAI—Hughes Electrical Corp., Syracuse, N. Y.
 WDAC—Illinois Watch Co., Springfield, Ill. (weather only.)
 WDAF—Kansas City Star, Kansas City, Mo.
 WCAY—Kesselmen O'Driscoll Co., Milwaukee, Wisc.
 WDAG—J. Laurence Martin, Amarillo, Texas.
 WDAK—Mine & Smelter Supply Co., El Paso, Texas.
 WAAD—Ohio Mechanics Institute, Cincinnati, Ohio.
 WCAW—Quincy Herald and Quincy Electric & Supply Co., Quincy, Ill.
 KDYW—Smith-Hughes & Co., Phoenix, Ariz.
 WDAB—M. C. Sumner & Son, Portsmouth, Ohio.
 WKB—Sweeney School Co., Kansas City, Mo.
 WDAE—Tampa Daily Times, Tampa Fla.
 KDYS—The Tribune, Inc., Great Falls, Mont.
 WCAX—University of Vermont, Burlington, Vt.
 WDAW—Ward-Belmont School, Nashville, Tenn.
 KDYY—Rocky Mt. Radio Corp., Denver, Colo.
 WDAJ—Atlanta & West Point R. R. Co., College Park, Ga.

NEW YORK MUNICIPAL STATION

An appropriation of \$50,000 has been made by New York City for a broadcasting station to be erected on the Municipal Bldg., in City Hall Park. The purpose is to send out musical programs, news information and educational lectures on health, fire and crime prevention, municipal government, etc. It is planned to have this new station on the air about August 1st.

MUNICIPAL STATION FOR SAN JOSE, CALIF.

The first municipal radio broadcasting stations on the Pacific coast has been authorized for the city of San Jose by the city council. It is indicated that the new station will cost \$6000 to be raised by private subscription. The committee appointed by the combined Chamber of Commerce and Commercial Club to handle this work consists of H. F. Parsons, District Engineer of the Standard Oil Company, Chairman; Prof. Chas. D. Herrold; A. L. Anderson, former Asst. Chief Engineer of the Federal Telegraph Co.; Roscoe D. Wyatt, Manager of the San Jose Chamber of Commerce; Stanley Hiller, manufacturer, and W. T. Rambo, broker. This means the providing of high class broadcasting, free from any bias of politics or religion, or the direct advertising of individuals or firms.

WHB, one of the largest inland stations in the United States, has just been erected by the Sweeney Automobile School in Kansas City. The aerials are 325 ft. high and the station is equipped at a total cost of \$20,000. The transmitter is a 500 watt W-E set. Mr. Sweeney has also installed a sound-proof studio where concerts will be rendered and arrangements are being made to install a pipe organ.

KQI, a new station established by the University of California at Berkeley, will be used for broadcasting educational matter and special events at the university.

Warner Bros. station at Oakland, Calif., has been transferred to the Daily News Bldg., at San Francisco, where it will broadcast music and news supplied through the cooperation of "The Daily News."

CKAC, the station of "La Presse," the French newspaper at Montreal, Quebec, has been installed by the Canadian Marconi Company. Broadcasting schedules are now being arranged for transmission in both French and English.

The *Advertiser*, Honolulu, H. T., started broadcasting service May 11th from a station erected by M. A. Mulroney, Naval Radio Aid.

WEW, St. Louis University, St. Louis, Mo., is broadcasting U.S. market and weather reports at 10 a. m., and 2 p. m., daily, on 485 meters. The first anniversary of this regular service was celebrated April 26th.

KLN, the new station of the Noggle Electric Works at the Hotel Del Monte, Calif., is broadcasting concerts daily between 12 and 1, and 6 and 7 p. m.

NOTES FROM THE OPERATORS

Call 4MN has been assigned to J. V. Settle at Winder, Ga.—using two 5-watters, acme 200, rect. A. C., rad. 1.6 amp.

The call 7FK has been reassigned to George W. Chinn, 263 East 50th St., Portland, Oregon.

6AOR, Sid Glasson, is radio operator at the Y. M. C. A. camp at Lakeport, Calif. for the summer months.

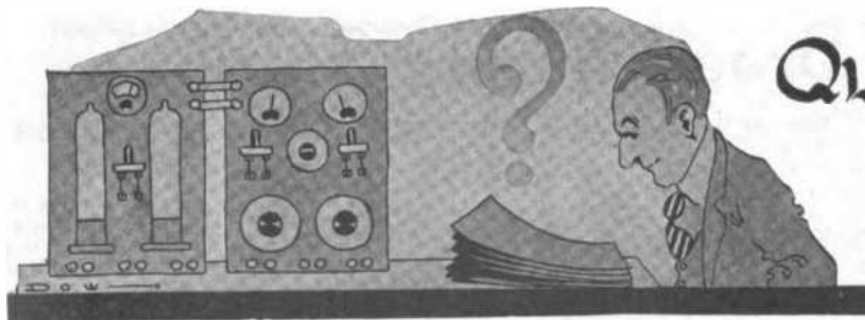

Queries & Replies

on C.W. practice

by

Gerald M. Best,

Technical Advisor.

Questions submitted for answer in this department should be typewritten or in ink, written on one side of the paper. All answers of general interest will be published. Readers are invited to use this service without charge, except that 25 cents per question should be forwarded when personal answer by mail is wanted.

Please publish a diagram showing how a crystal detector may be inserted, with necessary switch, in place of the audion detector shown in Fig. 1 on page 29 of March RADIO.—D. N. S., Belleville, N.J.

The switch for this operation is shown in Fig. 1.

Would the volume of signals coming from a detectaphone receiver, where the microphone is coupled to a Baldwin phone be as great as with the Baldwin phone alone?—W. B., Holtville, Calif.

The volume might be greater, but the quality would certainly suffer in passing from the Baldwin receiver to the sensitive microphone, and thence to the detectaphone receiver. Such an arrangement would probably overload your detectaphone circuit, if the signals were of very great volume, and the concerts or speech would be greatly distorted.

Can I use a wooden panel for an audion control mounting?—C. R. E., Hornell, N. Y.

Yes, provided that the wood is dry and well seasoned. For a receiving set, where no high voltages are used, a high degree of insulation is not necessary.

Please publish a diagram of a 10 watt C. W. set using an electrolytic rectifier, with Acme C. W. transformer.—E. C. P., Owatonna, Minn.

The circuit is shown in Fig. 2.

Please publish a circuit for a two stage amplifier with filament control jacks, to be added to the single coil set as described by D. B. McGown in March RADIO. Can I use a 5 watt tube in the second stage, with 350 volts on the plate, for a power amplifier?—J. F. A., Grand Forks, N. Dak.

If you will turn to page 29 in March RADIO, you will find the amplifier with filament control jacks. A 5 watt tube can be used as you describe provided that the Magnavox you expect to use has a step down transformer suitable to withstand such a high potential.

Can a short wave regenerative set be used in connection with a three step Radio Frequency amplifier.—F. C., New Albany, Ind.

A circuit employing a regenerative set as well as radio frequency amplifiers is shown in Fig. 3.

Is there any possible way to lengthen the wavelength of the set described on page 24 of March RADIO?—W. C., Miami, Fla.

Yes, by adding more turns to the loading inductance, or bank wound coil, as it is called.

I use my automobile storage battery to light the filaments of my vacuum tubes, by running wires from the garage to the set, a distance of 35 feet. Cannot receive the music or short wave signals until I bring the battery close to the set. How can I overcome this difficulty? How can the wavelength of a set be shortened without shortening the antenna?—W. J. P., Vallejo, Calif.

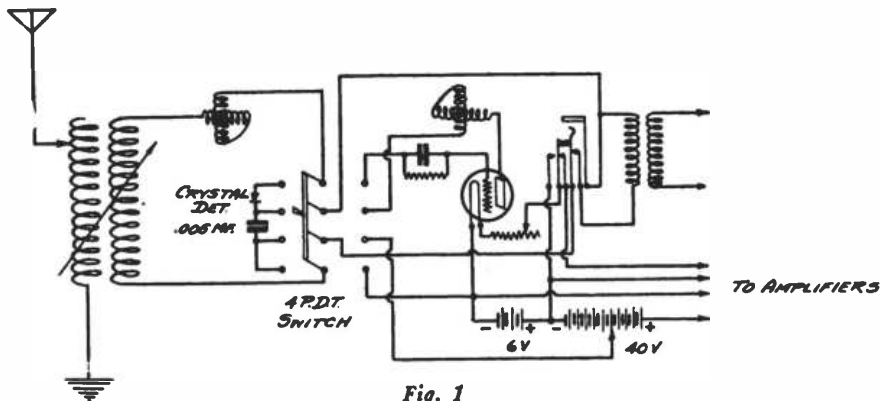

Fig. 1

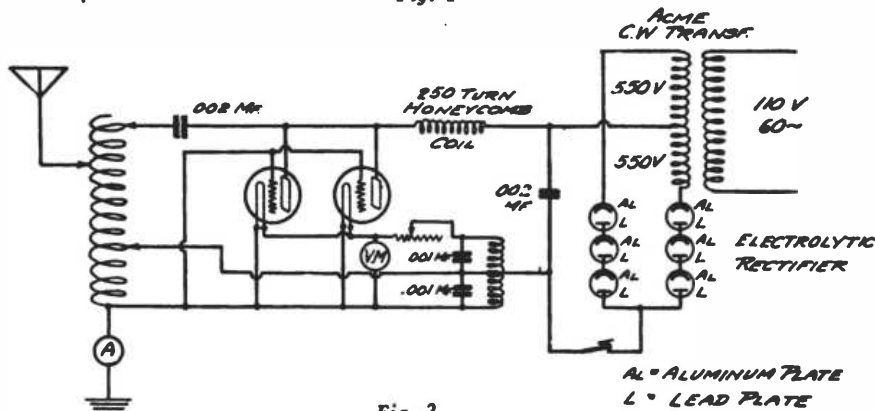

Fig. 2

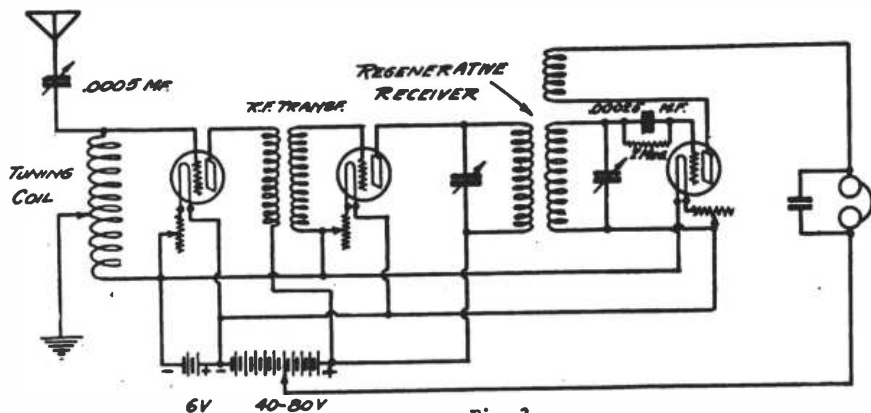

Fig. 3

Your trouble probably lies in the capacity and inductance of the battery leads. Try bridging a 1 or 2 microfarad condenser across the filaments, at the set. This will serve to by-pass the radio frequency, and neutralize the effect of the capacity in the leads.

You can shorten the wavelength of your set by placing a series air condenser in the antenna circuit.

Please advise if enclosed hook-up will work efficiently as a radiophone. Why is it that I get better results without grid condenser and grid leak?—A. D. S., La-Crosse, Wis.

The circuit you enclosed will not work as a radiophone. See Fig. 33 of the C. W. Manual, on page 14 of April RADIO. In the Hartley circuit, which you are using, does not require a grid condenser, as the grid is connected directly to one side of the helix.

Could the C. W. set described on page 13 of May RADIO, be used as a radiophone?—A. C. K., Elgin, Ill.

Not without a great many changes, including the addition of either set of rectifying tubes, or a motor generator set. This set was designed for telegraph work only, and is not easily adapted to radiotelephone work.

Continued on page 80

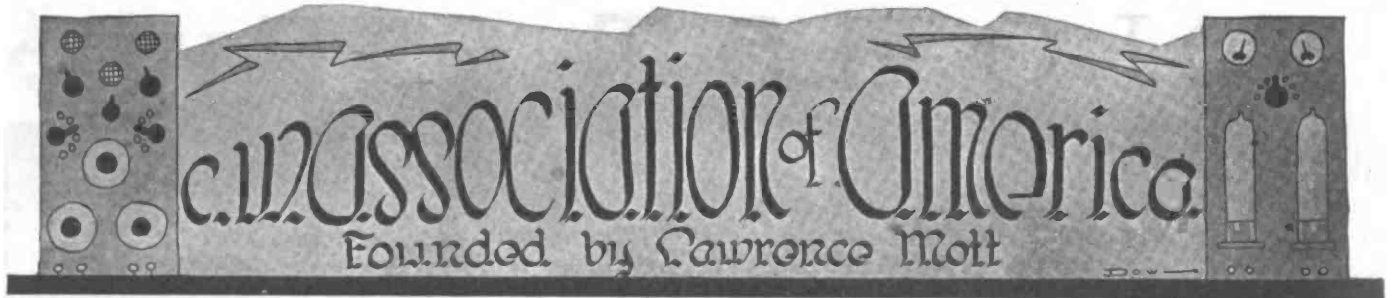

Lawrence Mott, 6XAD, President

G. G. Griffith, 6AA, Secretary

H. O. de la Montanya, 6AUL, Treasurer

SOME IMPROVEMENTS TO THE HARTLEY CIRCUIT

Considerable trouble is experienced in high powered C. W. circuits using A. C. as a source of filament and plate potential, from sparking at the key contacts, and recent development along the lines of mitigating this source of trouble will prove of interest to all C. W. experimenters. Credit for this work is due to A. H. Babcock, 6ZAF, who has

By the method shown in Fig. B., the high frequency is allowed to pass through the two bridging condensers "a" and "b" which are paper condensers of 1 microfarads each, and the only current passing through the key is the plate current being supplied from the transformer. A small radio frequency choke is placed in series with the lead from the high voltage winding to the key, to keep out undesirable high frequency that often finds its way from the antenna circuit through to the transformer, and thence to the ground via the 110 volt house lighting circuits. Hook-ups have been published occasionally to show condensers of .001 or .002 mf. each, bridged across the filament to by-pass the radio frequency, but we believe that the circuit as shown in the sketch is a new wrinkle that will prove of assist-

Hawaiian Islands, continues to set the pace for C. W. telegraphy, by reaching out to almost unheard of distances during the month of May, in that this station has been heard several times at Oil City, Pa., Cleveland, Ohio, and numerous other intermediate points. The distance to Oil City, from Honolulu, is roughly 5000 miles and when it is considered that the signals, after traveling

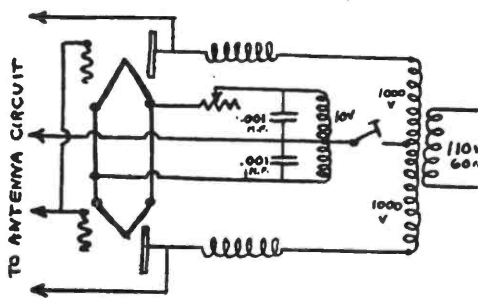

FIG. A

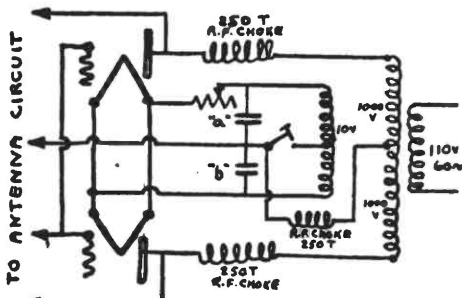

FIG. B

Improvements in the Hartley Circuit

succeeded in entirely eliminating key arcing by the method shown in the circuit diagram, Fig. B.

Fig. A shows a self rectifying 100 watt transmitter, using the same transformer to supply the filament and plate circuits, keying being accomplished by connecting the center tap of the filament and plate windings. The connection from the filament to the tap on the oscillation transformer was tied to the center tap of the filament winding of the power transformer, and as a result, the high frequency energy passing from the tube to the antenna circuit found a path through the key. This produced a disagreeable spark which necessitated a large key, and in the case of sets employing 500 watts or more of power, a relay was necessary.

ance in getting the most out of C. W. By its use, an ordinary small telegraph key can be employed to successfully break the plate circuits of four 250 watt tubes, with no more than a tiny spark at the key contacts.

NEW C. W. RECORDS ESTABLISHED BY 6ZAC

6ZAC, located at Wailuku, Maui,

2300 miles over water, were able to cross the Rockies and the lesser mountain ranges in between and could be heard in Pennsylvania, it can be realized what really remarkable results Mr. Dow is obtaining.

The illustrations on this page will give an idea of what Mr. Dow's installation comprises, and show his antenna

Continued on page 64

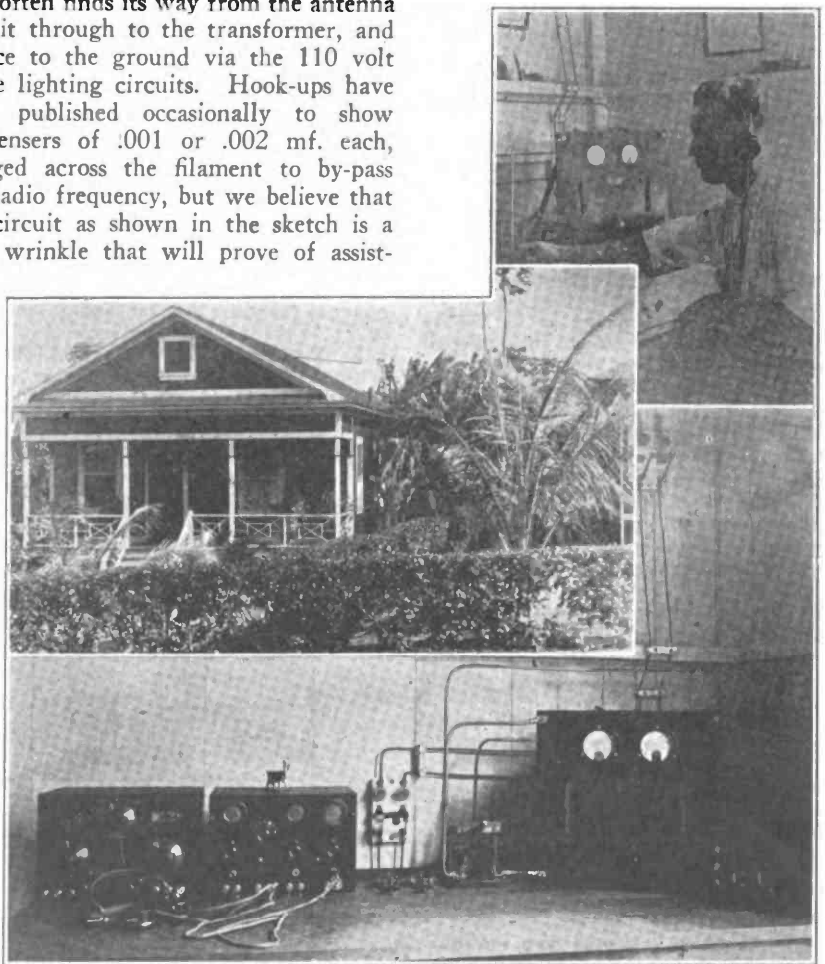

Clifford J. Dow. His Aerial. His Transmitter and His Receiver



Prepared by White, Prost & Evans, Patent Attorneys, San Francisco, who have been particularly active in the radio field for many years, and from whom may be obtained further information regarding any of the patents listed below.

J. R. Carson, Pat. No. 1,410,890; March 28, 1922. Method of and means for modulating carrier oscillations.

Signals radiated from antenna 15 are supplied with energy from a constant source 13. Modulation is effected by varying the amount of energy absorbed from this source by the thermionic tube circuits. The tube 1 affects the energy of one polarity, while tube 2, that of the other polarity. The controlling circuits of these tubes are coupled to a transmitter circuit 20, 21, 22, in such a way that the potentials of grids 7 and 8 are varied equally so that they remain equal and of the same sign. In this way half waves of both polarity radiated from antenna 15 are equally affected.

J. Mills, Pat. No. 1,412,567; April 11, 1922. Means for and method of wave transmission.

Static disturbances received by the receiver D are substantially eliminated by passing the received signals and disturbances successively through the wave filters F₁, F₂, F₃, and F₄. These filters are tuned to audio frequencies and the impulse currents produced in them by the static disturbances are highly damped by the insertion of resistances 8, 9, 10 and 11. The signaling currents being in the nature of sustained oscillations, are but little affected by the filters.

A. H. Taylor and L. C. Young, Pat. No. 1,414,232; April 25, 1922. Method of receiving radio-signals with the compound heterodyne.

The antenna A receives signals to which is added the effect of the heterodyning circuit H. The detector D transmits waves of frequency equal to the difference between the signaling and heterodyning frequencies, to amplifiers A₁ and A₂. The amplified waves are again passed through another detector D₂ tuned to be responsive to the frequency equal to the difference between the heterodyning frequency and the frequency detected by D₁. In this way the heterodyning frequency is used twice, and it may be used a still greater number of times, since some energy at heterodyne frequency passes through the successive detectors and amplifiers. By proper choice of heterodyning frequency, great selectivity is obtained, and the signal may be brought to audio frequency to affect the telephones T.

M. M. Dolmage, Pat. No. 1,414,629; May 2, 1922. Wireless duplex signaling system.

A single antenna 1 is used both for transmitting and for receiving. The transmission of modulated waves by the aid of elements 6 to 12 causes relay 17 to operate, due to the arrangement of the two branch circuits 2, 3, in the antenna circuit. The operation of this relay short circuits the receiving elements so that no signals can be received at 26. The reception of signals does not affect the relay 17, due to the symmetrical arrangement of the branch circuits 2, 3, through which the received signals must pass. Therefore, with this arrangement the system is in condition to receive except when modulated waves are transmitted, and there is thus no interference between the sending and receiving circuits.

Pupin and Armstrong, Pat. No. 1,415,845; May 9, 1922. Selectively opposing impedance to received electrical oscillations.

The receiving antenna circuits are so arranged that impulses of duration shorter than a predetermined time are greatly damped, while signals, which last many times longer than this short limiting value, are received with substantially no damping. A highly damped antenna 1 is used, the damping being effected by resistance 1^a and 2. The signals and impulses must travel over an artificial line consisting of inductances 12, 13, 14, etc., and capacities 15, 16, 17, etc. The constants of this line are so chosen that it takes a short period before the detector 6 is affected by the signal. This detector controls the circuits for the amplifier 8 which re-impulses, by means of coils 11, 3, sufficient energy upon the antenna so that the effect of resistances 1^a and 2 is overcome. This effect, however, is not of any benefit except for signals which persist long enough to affect the antenna 1 and the detector 6 simultaneously; that is, the impulse must be of longer duration than the time required to traverse the artificial line. To detect the signals, it is merely necessary to connect a detector circuit, such as 19, 20, 21, in the last amplifier stage.

E. T. Jones, Pat. No. 1,415,179; May 9, 1922. Radiocontrolling device.

A change-over switch is described, whereby antenna may be used either for receiving or transmitting. The connection between clip

4 and blade 5 completes the circuit for the source of the sending set, and permits spring clip 3 to engage connection clip 2 so as to complete the antenna circuit. As the switch is moved in a counter-clockwise direction, first the connection between 4 and 5 is broken, then the spring 3 is forced from contact with clip 2, and lastly blade 1 engages with clip 2. This connects the receiving set. The gap formed between 2 and 3 in this position serves as a protective gap against lightning. It is this feature which is an essential element of the invention.

NEARLY 20,000 TRANSMITTING STATIONS

The Department of Commerce has issued nearly 20,000 transmitting licenses, of which 16,000 are for amateurs, 3,000 for American ships, 500 for experimental and technical training schools and 500 for commercial stations, the greater part of which are broadcasting. It is conservatively estimated that there are 1,500,000 receiving sets in use.

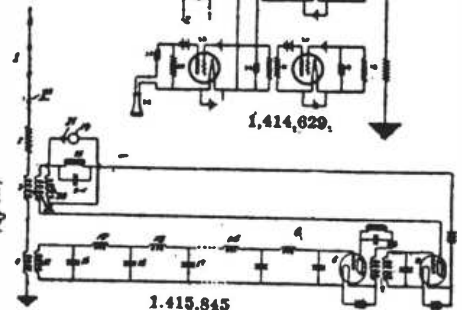
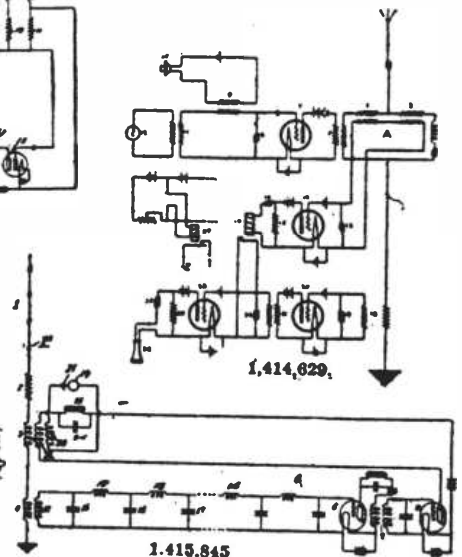
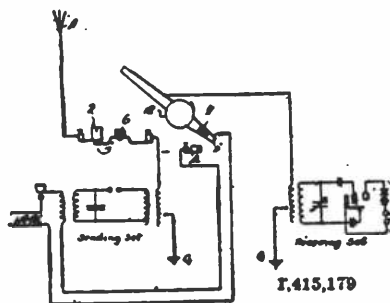
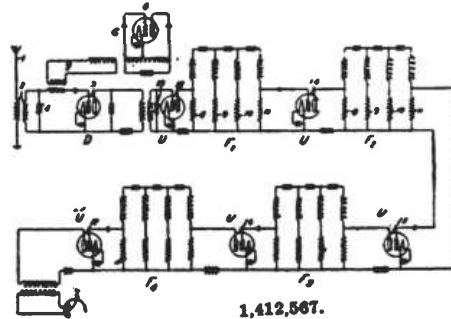
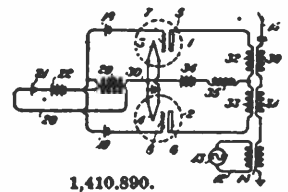

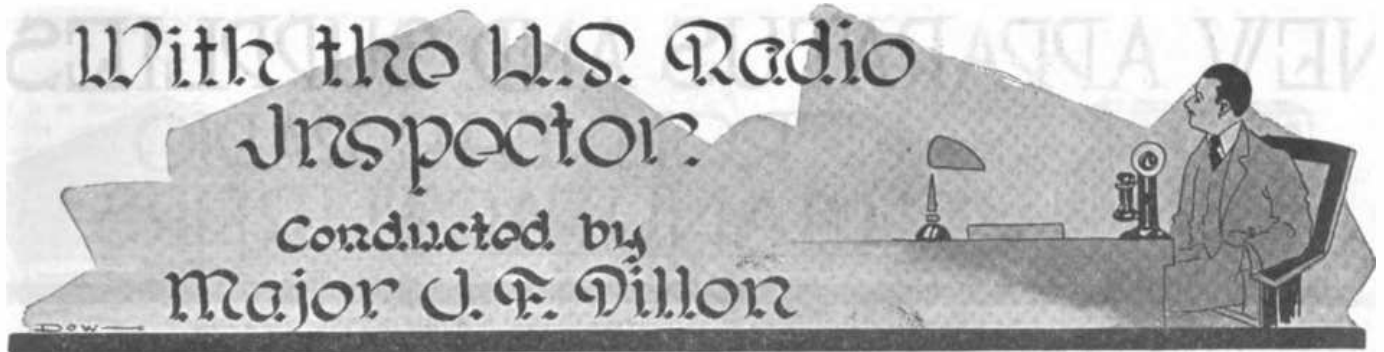

QUESTIONS AND ANSWERS

How may I calibrate a wavemeter without having a standard one available to check against?—H. K., Reno.

No entirely satisfactory method occurs off hand. This may be done with fair accuracy by erecting a long pair of evenly spaced wires, and then calculating their exact wavelength, or you might make up a standard coil and inductance, and calculate their exact values, and then make up a coil of half this value, etc. (see Bur. Stds. Circular 74 for details.) The best and simplest way is to have it calibrated in comparison with a standard. This can be done by the Bureau of Standards, at Washington, who will guarantee accuracy, or it may also be done at the offices of the various Radio Inspectors of the Department of Commerce, altho they will make no claim as to the absolute accuracy of the measurements. If you have access to an electrical laboratory they may be able to measure the frequency direct, which can, of course, be transposed to read wavelength.

Are the standard 5-watt tubes capable of much overload, or not?—H. K., Reno.

Yes, they seem to give good results in many amateur stations despite the fact that they are very seriously overloaded. This doubtless shortens their useful life a great deal, however.

What is the minimum code speed required for a commercial license?—J. G. F., Kansas.

The lowest commercial license is second class third grade. This requires a code speed of at least 12 words per minute, International Morse.

Why do radio telephone transmitting stations require operators to be familiar with the Morse Code, when such stations only wish to use voice transmission?—H. U. T., New Jersey.

Because the law requires, first, that the operators of all transmitting stations be licensed. This is necessary, because unlicensed operators would be very liable to cause serious interference with the work of other stations, and if they did not know the code as in a telephone station, they would not be able to tell whether or not they were causing such interference.

Why do the local broadcasting stations break off every now and then, and say they will stand by in compliance with the regulations?—P. R., San Francisco, Cal.

These stations are licensed as coastal stations, and all coastal stations are required to listen in on 600 meters, at least two minutes out of every 15, to determine if they are causing interference with ships who may be in distress.

I have noted that many ships send personal notes and messages from one operator to the other as a service message, prefixing it "SVC". Is this correct?—Ship Operator.

No, decidedly not. Service messages are messages connected with the handling, routing of messages, the charges or tariffs on them, etc., or other matter connected with the actual handling of telegraph business. For example,

a ship may send a service message to ask the shore station rates plus landline charges thru a station it wishes to handle business, or it may send a service correcting the check in a message already sent, etc. It is decidedly not a service message, on the other hand, to ask if Operator Bill Jones is on watch, or if Mate Olaf Olafsen is still on the S.S. Blank. If the latter business is to be handled, it must be in the form of a regular paid message.

NEW RADIO RECORDING DEVICE

The necessity of an experienced radio operator to receive code messages may be eliminated by the recent development of a radio relay recorder at the Bureau of Standards by F. W. Dunmore. Applications of the new device include the recording of radio telegraph code messages on a tape at fairly high speed, so they can be read by an average operator visually instead of audibly. The elimination of a constant watch at stations may be effected by the installation of a call system, and in line-radio telegraphy a sounder may be operated from a signal transmitted by radio frequency currents, making it unnecessary for the Morse operator to use a telephone receiver.

Wire telegraph recording instruments have been employed for many years, but it is only within the past few years that they have been applied to radio telegraphy, on account of the fact that the exceedingly small amount of energy found in an incoming radio signal—ordinarily only a few microwatts—made it difficult to construct a radio recorder. Such devices as had been developed required such sensitiveness and so careful an adjustment, besides being very delicate and expensive, that they hardly proved practical.

Reports on this recording relay, which is more rugged than devices hitherto developed and using larger currents of the nature of 5 milliamperes or more, indicate that any form of mechanism may be operated by radio for remote control of moving bodies, such as automobiles, boats or airplanes. The simultaneous records of two messages received on the same antenna may also be secured by means of two recorders of this type connected in series.

Currents of 5 milliamperes or more are obtained, according to experts of the Bureau of Standards, by increasing the feeble signals received through the

use of the electron tube amplifier. Electrical tuning to the audio frequency which is being received, is employed. The operation of the newly developed relay has been made possible by the development of the electron tube amplifier as a reliable instrument for engineering practice. With a current of 5 milliamperes or more, a strong and positive action is obtainable, and it is possible to use an ordinary telegraph relay of rugged construction which does not require careful and repeated adjustment in operation, it is explained.

The radio relay is constructed so that the electron tube circuits can be operated on 110 volt, 60 cycle alternating current from lighting circuits, or the relay can also be operated by batteries properly connected.

After amplification, the received radio signal is delivered thru a tuned audio-frequency transformer to the plate circuit of an electron tube in which is connected the windings of a high-resistance telegraph relay. A condenser with a capacity of about one microfarad is shunted across the relay windings. The movement of the armature of the relay may be made to operate any desired mechanism, such as the ordinary ink-tape register or other apparatus, or for the remote control of boats and vehicles.

The selectivity in this apparatus is greatly increased by the use of audio-frequency tuning of the secondary circuit on the input transformer, making duplex operation possible. Interference from strays is also reduced somewhat.

INTERFERENCE WITH CONCERT RECEPTION UNJUSTIFIED

Complaints of interference from amateur transmitters are frequently made to the radio inspector by radio concert fans. These complaints are often due to poor receiving equipment rather than to any fault of the sender. Amateurs operate on a 200-meter wavelength, while concerts are broadcasted on a 360-meter wavelength. Except for near-by stations there should be no difficulty in tuning out undesired signals with a properly designed receiving set. If the concert fan has purchased an "all wave" receiver, his only recourse is the dealer who sold him the stuff or else a few lessons on how to operate his set.

NEW APPARATUS AND SUPPLIES FROM THE RADIO MANUFACTURERS

HOMECARGE RADIO B BATTERIES

Miniature storage battery cells are being offered by various manufacturers for supplanting the small dry B battery used with vacuum tube receiving sets. These batteries consist of from 8 to 50 small cells, and the recharging of such batteries has presented quite a serious problem to the user and is largely responsible for their not being more readily adopted by the wireless enthusiasts.

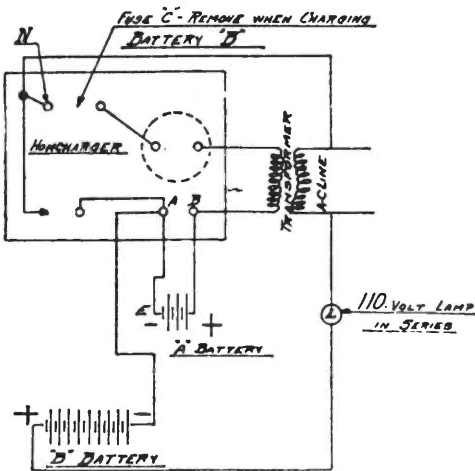

SCHEMATIC DIAGRAM

Fig. 1.—Schematic Diagram

These small cells require a very low charging rate, varying from 1/10 to 1 ampere, depending upon their size, but due to the number of cells employed, the charging voltage required is quite high.

Where direct current is available, it is a very easy matter to charge these batteries by connecting them in series with a 40 watt lamp. When charging in this manner it is quite essential that positive battery terminal be connected to positive line, as otherwise batteries will discharge instead of charge.

As 90% of the homes wired with electricity in the United States are supplied with alternating current, the charging of any type of storage battery has presented a much more complicated problem than were direct current available.

Various types of chargers are now on the market for charging the 3 cell "A" battery used for heating the lamp filaments, and practically every wireless enthusiast has one of these machines in order to eliminate the inconvenience and expense of having to lug his battery to a service station every time it requires recharging.

Through a very simple scheme of connection it is possible to recharge any radio B battery with the same homcharger that is used for charging the A battery. Fig. 1 illustrates the connections employed.

The Homcharger Fuse-C is removed, so as to open normal charging circuit. One side of the 110 volt alternating current line is connected to the Homcharger armature at N, the other going to positive terminal of the B battery through a 110 volt lamp—L

in series, which acts as a current reducing resistance.

Charging circuit is completed from negative terminal of B battery to terminal A of the Homcharger.

The 3 cell 6 volt A battery is connected to the terminals A and B in the usual manner. As soon as alternating current supply is turned on, the armature should start to vibrate and act as a rectifying valve, completing the B battery charging circuit during the proper part of the A. C. cycle, thereby delivering to the B battery a series of intermittent unidirectional current impulses.

It is necessary that either the positive or negative pole of both A and B battery be connected to the terminal A. If this is not done B battery will discharge instead of charge, the same being indicated by the series lamp L glowing with intense brilliancy. When connections have been properly made, and B battery is charging, this lamp burns quite dull.

A very simple method of making the proper connections is shown in Fig. 2. The material required can be purchased at a cost of less than \$2.00 from any electrical dealer, and consists of:

- 1—Two-way Socket Plug or Duplex
- Current Tap\$1.00
- 1—Attachment Plug25
- 1—Porcelain Wall Receptacle..... .25
- 1—10 ft. Lamp Cord..... .50

The two-way socket plug is screwed into lamp socket and the standard Homcharger attachment plug screwed into one side thereof. Another attachment plug is inserted in the other side of current tap, one lead being connected in series with the 110 volt lamp L of the proper size, the other lead running direct to screw N of the vibrator assembly. The other terminal of lamp L is connected to the positive terminal of B battery and the other side of B battery running to terminal A.

It is impossible to charge both A and B battery at the same time, as with fuse C in place the B battery will discharge through transformer secondary.

As the ammeter is not connected when fuse is out, this instrument does not indicate charging rate of B battery. However, when Lamp L burns dull the batteries are charging properly and no other indication is required.

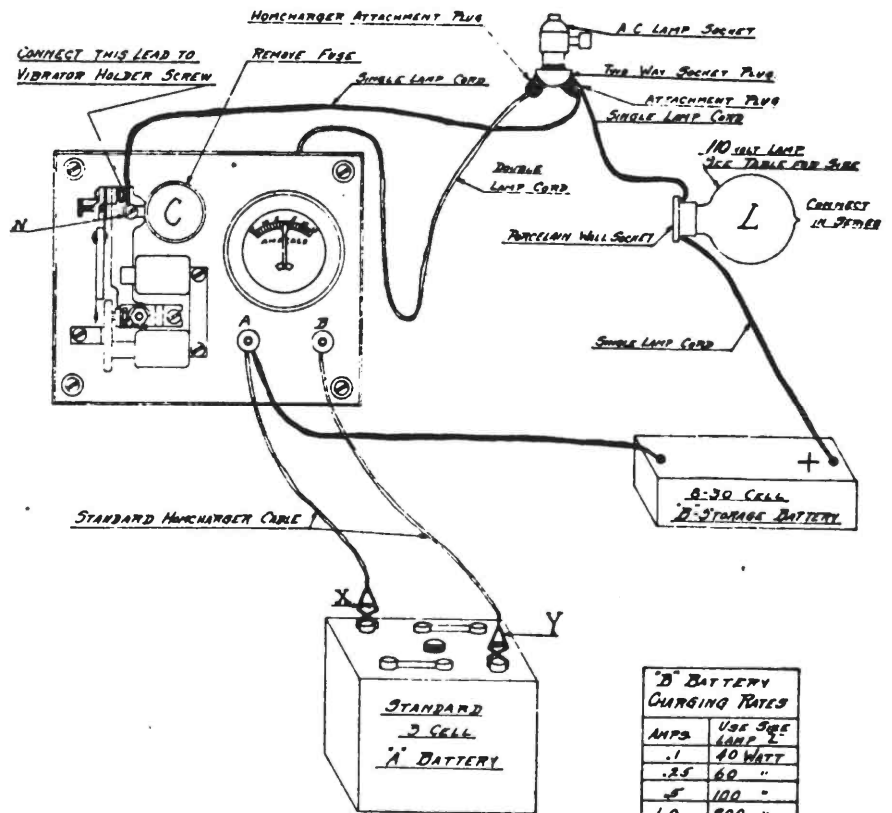

Fig. 2.—Method of Connecting

B BATTERY CHARGING RATES	
AMPS	USE SIZE LAMP L
.1	40 WATT
.25	60 "
.5	100 "
1.0	200 "

RADIO INSTITUTE OF AMERICA

The purpose of the Radio Institute of America is to teach the radio enthusiast, as well as the commercially inclined operator, the theory and practice of this most interesting art. Classrooms are located at 331 Call Building, San Francisco and instruction is conducted by the Radio Corporation of America, which has behind it the splendidly equipped research laboratories of the General Electric Company, the American Telegraph and Telephone Company, the Western Electric Company and the Westinghouse Electric and Manufacturing Company, where eminent physicists conduct investigations that result in new radio advances. Therefore students at the Radio Institute can avail themselves of the splendid opportunity to become familiar with the latest type of modern radio equipment.

The transmitting equipment includes several types of apparatus such as are used aboard ships and aeroplanes. Installation of the latest 3 way combination vacuum tube transmitter for CW, ICW and telephony will shortly be added to the present equipment.

Each month students are taken on a tour of inspection to the plant department of the Radio Corporation and also aboard various ships so as to become familiar with the apparatus as commercially installed.

A post-graduate course is provided for students, who, having been enrolled at least 3 months at the Institute, qualified and have obtained a U. S. Government first class license. The course consists of one month's free training at the High-Power Trans-Pacific station of the Radio Corporation located at Marshall, California. The student "listens in" with the regular operator, both on

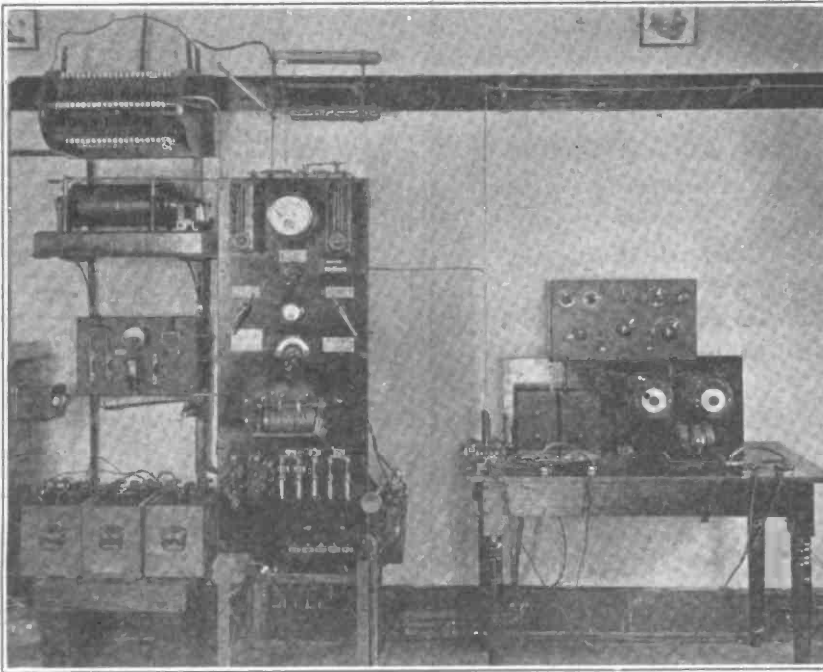

The Institute has been an established and successful institution for over fifteen years and during that time more than 6000 men have been trained in this new branch of science and industry. The course consists of instruction in spark, arc and vacuum tube transmitters and receivers, storage batteries and modern auxiliary equipment, U. S. and International Radio Laws and Regulations, commercial traffic and accounting.

Theoretical lectures and practical instruction regarding the adjustment, maintenance and operation of the various types of transmitters and receivers in connection with amateur and commercial operation are regularly given.

For receiving practice the Institute is supplied with two Wheatstone automatic transmitters having a speed capacity of 5 to 75 words per minute. The receiving practice speed varies from 5 to 35 words per minute depending on the students ability. The tapes for these machines are punched by expert RCA operators on a Kleinschmidt perforator.

A complete receiving set is in operation at the Institute and advanced students keep an accurate watch and log during school hours, copying the Trans-Atlantic RCA high power station at "Radio Central," Long Island, New York, and also the Trans-Pacific RCA circuit at Bolinas, California and Kahuku, Hawaii on the most modern vacuum tube receiver. The students also copy the Radio Corporations Coastal Station at Marshall (KPH) working with the many vessels off shore.

marine and high power circuits, and therefore becomes acquainted with the handling of commercial traffic on a large scale.

The Institute is in charge of T. L. O. Fassett who has been a radio man both ashore and afloat for many years. Mr. Fassett until recently was in the U. S. Navy and made several trips across the Atlantic as Junior Lieutenant in the capacity of Radio Officer and Engineer Officer on the U. S. S. "Cuyama," engaged in the transportation of troops and supplies.

Department continued on page 66

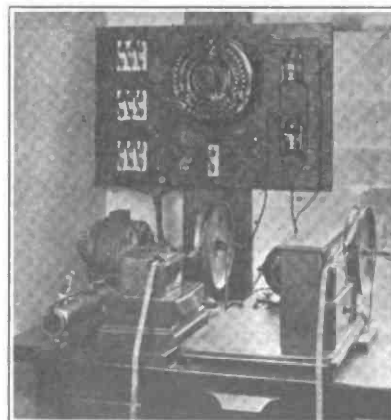

Tell them that you saw it in RADIO

Your Last Chance

The Subscription Price of "RADIO" has been increased to \$2.50 per year. Single copies on the news stands now sell for 25c.

You Can Still Save a dollar if you Act Now

As previously announced, we will accept your subscription at the old rate of \$2.00 a year, provided that you send it to us before June 30th. We have extended this period to July 15th in order that our many new readers may benefit by subscribing at the old rate.

Our New Editorial Policy

will be based on the results of the Questionnaire that we published in our May number. We will give you just what you want, to the best of our ability.

"RADIO" is getting better every month. Be sure of getting your copy regularly by subscribing right now.

Present Subscribers may extend their subscription for one year at this special rate.

Be Sure To Mail This Coupon Before July 15. It Will Save You \$1.00.

COUPON

RADIO,
465 Pacific Bldg.,
San Francisco, Cal.

Herewith is \$2.00 for which you will send "RADIO" for one year to:

Name

Address

.....

IMMEDIATE DELIVERY

The Peerless Radiofonograph

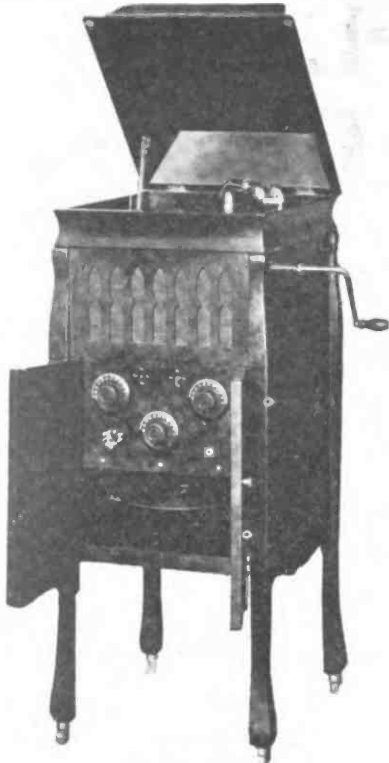

The Radiofonograph utilizes the silvery tones of the fine phonograph horn and reproduces radio broadcasted music without distortion; is instantly available as phonograph or radio concert receiver.

The Radiofonograph comprises besides a fine phonograph the Peerless Type PR. 75 Detector and Peerless Type PA. 60 Two Stage Amplifier with or without Magnavox.

Cabinet Mahogany highly polished.

Equipment furnished with the radiofonograph Willard Special Radio 50 hour A Battery; 86 Volt Battery Eveready B. Battery; high grade phone head-sets; aerial and ground wire, insulated and clamped; one detector tube and two amplifying tubes.

Dealers—This is the liveliest and newest popular priced Radio set on the market. We will protect you on territory.

There will be a big demand for this number and this is the first announcement. We are now in quantity production. Immediate delivery.

Complete
\$225.00

With Magnavox \$250.00

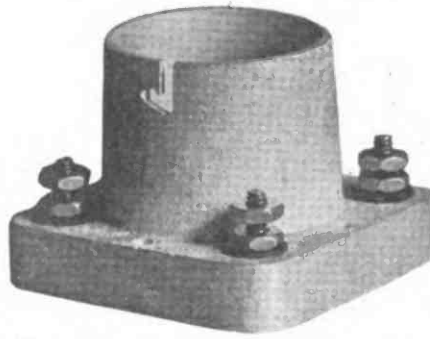
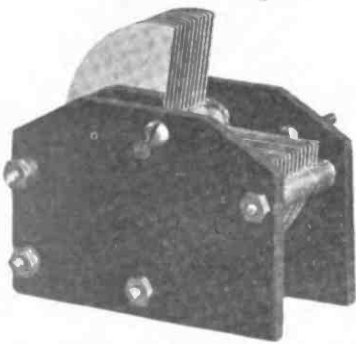

- We manufacture the following Radio Equipment:
- The Peerless Non-breakable all metal heat-resisting V. T. Socket..... \$1.50
 - The Peerless 23 plate .0005 Variable Condenser..... 3.50
 - The Peerless indestructible heat-resisting Rheostat..... 1.50
 - The Peerless Audio-Amplifying Transformer made to our specifications..... 5.00
- We also carry a complete line of Radio parts and can supply Jobbers and Retailers.

PEERLESS RADIO LABORATORIES

Prompt Attention to Mail Orders

50 SECOND STREET, SAN FRANCISCO

Phone Douglas 1490

—approved!!

Our type H-B-1 Receiver has met with instant approval. Single tuned regenerative, enclosed in handsome mahogany cabinet. Price

\$70.00

Dealers' Propositions

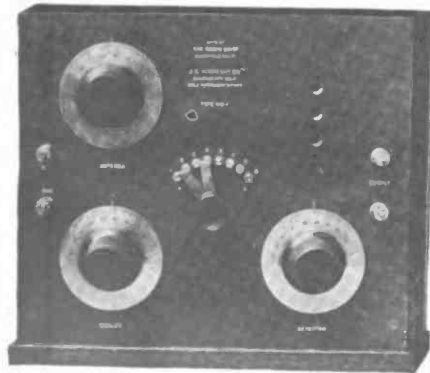

Licensed Under "Armstrong" Patents

Hobrecht's Operating KVQ
Broadcasting Station

1014 6th SACRAMENTO, CALIF. Phone Main 654

Tell them that you saw it in RADIO

CALLS HEARD



Readers are invited to send in lists of calls heard from stations distant 250 miles or more from their own station.

AT 6EA

C. W.—5za (buzzer), 6ak (voice), 6gl, 6gy, 6km, 6ku, 6ni, (600), 6rm, 6zq, (6zi), 6zs, 6zx, (6zz), 6aat, (6arb), 6asv, (6awt), (6bcd), 6xac (voice and music), 6xat, 6zac, (7dp), 7mf, 9amb, 9ayu, 9dva, 9wd, (9zaf), dma, wv6 (voice and music).

Spark—5xd, 5yq, (6as), 6cc, 6ex, 6fn, (6gf), 6gr, 6hc, (6hp), (6ib), (6ic), 6im, 6km, 6ng, 6po, 6qr, (6tu), 6vk, (6vx), (6wg), 6xb, 6zd, 6zi, 6zk, (6zz), 6aau, 6abu, 6abw, 6acr, 6afp, 6agf, 6ain, (6ajr), 6ala, 6amk, 6aqu. (San Francisco now), 6ark, 6atq, 6atu, 6bak, 6bnn, 6zam, 7jd, (7kj), (7mf), 7ya, cl8.

Best 5 watt A. C.—C. W. reported heard was by 6zac at Wailuku, Hawaii (2100 miles).

AT 6LV ON ONE TUBE

6bj, 6cu, 6ec, 6ef, 6en, 6ea, 6ft, 6fh, (6cd), (6jj), 6jd, 6ka, (6ku), 6tw, (6aat), 6abx, 6ajh, 6akw, 6atp, 6avd, 6bes, 6bcd, 6za, 6zb, 6zs, 6zn, 6zr phone, 6zf, 6zz, 6qt, 7mf, 7rn, 7op, 7sc, 7zm, 7zu, 8lx, 9amb, 9ayu, 9zaf, cl8, wvy.

AT 7MF, EUGENE, OREGON

C. W.—2xb, 2om, 3fs, 4gl, 4bq, 5an, 5za, (6ak), (6cu), (6fh), (6ft), 6gd, (6gy), 6hc, 6ka, 6kbl, (6nx), (6oo), 6ti, 6vx, 6vm, 6xad, 6wz, 6xh, 6za, (6zf), (6zi), 6zz, 6ak (fone), (6aat), (6zx), (6bcd), 6bd, 7ad, (7ce), (7dm), (7dp), 7go, 7hs, 7hw, 7kb, 7lr, 7qe, 7tj, 7rn, 7aag, 7aav, 7ack, 8bk, 8jl, 9aav, 9aao, 9ayu, 9dva, 9rv, 9aja, 9zn, xfl, (6awp), 6jd, (6aif), Can. (4cb), 9ax, 9bd, 5ct, 9aw.

Anybody hearing 7mf's C. W. or Spark, please qsl, and give check on sigs.

AT 9DSW

C. W.—2ba, 2fp, 2hg, 2zk, 3aay, 3any, 3ba, 3bij, 3bz, 3cc, 3fm, 3la, 3qz, 3rf, 4bq, 4by, 4cc, 4ds, 4gh, 4eb, 4iv, 4ya, 5aab, 5aw, 5bm, 5cb, 5do, 5ek, 5ga, 5hb, 5jb, 5jd, 5kp, 5la, 5mt, 5nk, 5np, 5nz, 5oi, 5qb, 5wo, 5za, 5zy, 6ka, 6zz, 7zf, 7zu, 8acf, 8aed, 8ago, 8ahr, 8nio, 8alb, 8am, 8anb, 8apt, 8aso, 8awm, 8awx, 8awy, 8azf, 8azh, 8bdo, 8bdu, 8bfx, 8bke, (8blw), 8ho, 8bol, 8box, 8bur, 8bas, 8caz, 8cz, 8cql, 8cfp, (8dv), 8dw, 8ea, 8gv, 8jm, 8ow, 8pt, 8sp, 8uc, 8vv, 8vq, 8wr, 8xe, 8xu, 9aap, 9aay, 9aly, 9aja, 9ajh, 9akd, 9amb, 9aog, 9aqe, 9ark, 9asf, 9aal, 9axf, 9axa, 9bdp, 9bed, 9bjb, 9bok, 9bsd, 9ct, (9dqq), 9dqq, 9dsm, 9dta, 9dtf, 9dtm, 9dub, 9dun, 9dva, 9el, (9fm), 9gl, 9io, 9km, 9kp, 9ps, 9uc, 9vk, (9wa), 9wd, (9wu), 9xaq, 9yan (fone), 9ze.

Spark—5aq, 5fo, 5hk, 5xm, 7zv, 8afb, 8aq, 8ea, 8ug, 8ve, 9abv, 9aaw, 9ahz, 9anp, 9aso, 9avh, 9axm, 9ca, 9dsd, 9sv, (9tv), 9zc.
Canadian—(4cb), 2rz, 9bd, wsb, vaw, wvu.

AT 6AWF, LOS ANGELES

Spark—6ak, 6as, 6bn, 6cp, 6ex, 6gf, 6gr, 6gt, 6hc, 6ib, 6ic, 6im, 6ng, 6oh, 6pj, 6po, 6qk, 6qr, 6tc, 6to, 6tu, 6tv, 6vk, 6vx, 6wz, 6xh, 6zb, 6zd, 6zk, 6zu, 6zx, 6zz, 6aah, 6aak, 6aau, 6abu, 6abx, 6acr, 6ada, 6aeh, 6aei, 6afn, 6agf, 6agp, 6ahf, 6aif, 6ajh, 6ajr, 6akl, 6ala, 6alv, 6amk, 6anp, 6aoe, 6ape, 6aqu, 6ark, (6aud), 6awh, 6zam, 6bjv, 7bh, 7gj, 7mf, 7ya, 7zt.

C. W. and I. C. W.—5za, 6ak, 6gy, 6jj, 6pj, 6pk, 6pt, 6tw, 6xi, 6za, 6zf, 6zi, 6zx, 6zz, 6aif, 6alv, 6arb, 6asj, 6asv, 6bcd, 9wd, 9ayu, 9zaf.

AT 6FZ, BERKELEY, CALIF.

Spark—6ea, 6eb, 6gd, 6hy, 6kc, 6lc, 6mh, 6od, 6ol, 6qr, 6up, 6xu, 6zd, 6aak, 6aeh, 6aei, 6agp, 6ahq, 6aif, 6ajh, 6ajr, 6akl, 6alu, 6amn, 6aqx, 6ark, 6avd, 6awx, 6baj, 6bbv, 6bdz, 6bjv, 7bh, 7bk, 7cu, 7fi, 7gj, 7gk, 7hf, 7kj, 7mf, 7oh, 7ot, 7ox, 7oz, 7ui, 7xh, 7ya, 7yg, 7ys, 7zj, 7zk, 7zm, 7zt, can-9bd, cl8.

C. W.—4gl, 5za, 6ea, 6eb, 6en, 6gd, 6ka, 6ku, 6ky, 6pt, 6tw, 6agp, 6apw, 6awp, 6awv, 6xad, 6zb, 6zf, 6zn, 6za, 6zx, 6zz, 6zac, 6bes, 6bmd, 7dp, 7gk, 7mf, 7nn, 7sc, 7xg, 7zu, 9wd, 9wu, 9amb, 9ayu, 9zaf, can-9bd, kdpw, kdpv.

AT 6ASN, BERKELEY, CALIF.

6ak, 6av, 6op, 6dd, 6en, 6gr, 6gt, 6lc, 6oh, 6ol, 6od, 6ot, 6qr, 6rc, 6aak, 6acr, 6ahq, 6ain, 6ajh, 6aln, 6ald, 6amw, 6ane, 6ano, 6anw, 6ark, 6ars, 6avr, 6bly, 6zah, 7bh, 7mf, 7nz, cl8.
Anyone hearing 6asn s 500 cycle please QSL.

**KENNEDY
EQUIPMENT**

▼▼
Type 110
Regenerative Receiver
with Type 525
Two stage amplifier



**KENNEDY
EQUIPMENT**

▼▼
All Kennedy
Regenerative Receivers are
Licensed under
Armstrong U. S. Patent
No. 1,118,149

KENNEDY

Universal Regenerative Receiver Type 110

is designed to meet the requirements of those who wish to cover the entire field of Radio. It permits of reception on all wave lengths in use today by Government, commer-

cial, amateur, special and all broadcasting stations. Coupled with Kennedy Amplifier Type 525 it affords the user access to every field of Radio.

Type 110 Receiver can be made to detect, regenerate, or oscillate at will, with high efficiency, over its entire range of 175 to 25,000 meters.

Kennedy Radio Equipment is sold by good dealers everywhere

Write for Latest Bulletin C-3

THE COLIN B. KENNEDY COMPANY

INCORPORATED

RIALTO BUILDING

SAN FRANCISCO

Tell them that you saw it in RADIO

CHOOSING YOUR APPARATUS

The spread of radio enthusiasm over the country has brought in its wake a host of new companies and instruments. Radio products of all kinds and qualities are flooding the market. The new purchaser, not being familiar with the names of the old established radio companies, has little to guide him in his choice.

We, accordingly, ask you to weigh the fact that the General Radio Company was one of the earliest manufacturers in the field of high-grade radio instruments. It has for years maintained a research laboratory for the development of new apparatus. Our instruments are in daily use at the Bureau of Standards radio laboratory, the radio laboratories of the Army and Navy, the principal college and commercial research laboratories throughout the country, as well as by thousands of citizen radio enthusiasts.

We have not allowed the enormously increased demand to cause us to discard our rigid inspection system or to lay aside our development work. We have a reputation to maintain.

When you purchase radio instruments, we ask you to give consideration to these facts. Every instrument we make is guaranteed. When you think of Radio, think of GENERAL RADIO.

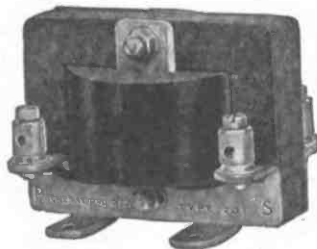

TYPE 231A
AMPLIFYING TRANSFORMER

A noteworthy example of our instruments is the amplifying transformer illustrated in the cut. This transformer is designed to give the maximum amplification possible, using a Radiotron UV-201 tube. It has an impedance ratio of 15 and an energy amplification of 400.

PRICE, COMPLETELY MOUNTED \$5.00

Send For Free Radio Bulletin 911C

GENERAL RADIO COMPANY

Massachusetts Avenue and Windsor Street
CAMBRIDGE 39 MASSACHUSETTS

Standardize on General Radio Equipment Throughout
CARRIED BY LEADING DEALERS

BRACH vacuum LIGHTNING ARRESTER

This is the arrester that is approved and recommended by official action by the Underwriters' Laboratories. It is the arrester that is insisted upon by all who seek safety for radio and home—the skilled radio engineer down to the little amateur.

It is, the arrester that is fool-proof, takes care of itself, works automatically, requires no switching on and off.

Why take chances with any other, when you can get the Brach Vacuum Lightning Arrester that has long been recognized by the United States Army, by the big railroad and telegraph companies, by fire departments—and, finally, is included in the List of Inspected Electrical Appliances published by the Underwriters' Laboratories?

Your Dealer Will Supply You.

L. S. Brach Mfg. Co., Newark, N. J.

Sixteen Years Specialists in Lightning Protective Apparatus

Tell them that you saw it in RADIO

AT 9BJI, F. L. HICKS, 3935 W. 30TH AVE., DENVER, COLO.

C. W.—4bq, 4fe, (5kp), 5za, 5ak, 5ho, 5ms, 5sz, 5nz, 5ir, 5ci, 5ek, 5su, 5mt, 5mf, 5nk, 5ic, 5oi, 5iv, 5cu, (6zz), (6awp), (6aqp), (6xad), (6za), 6av, (6ag), 6xaq, 6zs, 6pd, 6zf, (6en), 6aif, 7hs, 7jd, 7mp, 7zn, 8agz, 8bz, 8bx, 8bf, 8yv, (9ar), (9dz), (9bjv), 9jl, (9bbf), 9kp, (9bjb), (9im), (9dz), 9bl, 9ps, 9dt, 9dme, 9ex, (9bv), (9qe), 9akr, 9blo, 9aje, 9zac, 9dym, 9dts, 9aja, 9aav, 9bri, 9akd, (9sl), 9aeq, (9pi), 9dv, 9wu, 9atu, 9dts, 9rv, (9aw), 9bmd, 9zg, 9bad, 9wa, 9se, (9bow), (9awm), 9hl, (9dof), 9jg, 9ays, 9xi, 9xm, 9avn, 9amu, 9agn, 9sj, 9bum, 9asp, 9bey, (9nx), 9aou, 9amq, 9wq, 9brh, 9aas, 9aay, 9dqm, (9bik), (9yam), 9bno, (9ajh), (9aua), (9ajp).

Spark—5lb, 5hk, 5ew, 6aah, 6es, 7zv, 9dse, (9ayw), (9yak), 9agz, 9avz, (9aj), 9aeg, 9wi, 9pi, kyj and kic tones. Canadian 4cb. Would appreciate a card from any station hearing me.

CALLS HEARD AT GAPP

4xf, 5ec, 5lk, 5mg, 5fo, 5os, 5cu, 5re, 5ak, 5fk, 5hk, 5ek, 5qe, 5eb, 5nk, 5za, 5tl, 5ln, 5xb, 5xc, 5xe, 5xj, 5xu, 5xy, 5yc, 5as, 5sb, 5sf, 5sj, 5sl, 5sm, 5so, 5sr, 5zs, 5zab, 5zak, 5saf, 6ak, 6yv, 6tz, 6hw, 6ayh, 6bf, 6awh, 6awk, 6iv, 6aif, 6ij, 6fu, 6aer, 6ka, 6by, 6bal, 6as, 6ir, 6aph, 6tv, 6za, 6ab, 6zf, 6sk, 6sl, 6zm, 6zn, 6so, 6ar, 6sa, 6xt, 6su, 6zy, 6sz, (6zz), 6sab, 6sak, 6saf, 6aay, 6aaw, 7kv, (7zu), 7si, 7ya, 7um, 7zv, 7ej, 7la, 7ry, 7zt, 7as, 7hf, 7ah, 7jt, (7jd), 6jt, 7ln, 7uk, 7za, 7ar, 7lv, 7nr, 6xd, 6zac, 6xad, 7ds, 6apj, 6sp, 6ot, 7sj, 9aey, 9yal, 9dp, 9ny, 9dy, 9aey, 9ar, 5if, 9yo, 9fx, 9auq, 9ax, 9ke, 9oc, 9pl, 9ff, 9arv, 8saf, 9ym, 9tg, 9ix, 9afv, 9aza, 9ds, 9em, 9vv, 9yg, 9aw, 9atn, 6wv. A card to 1258 W. Pierce St., Phoenix, Ariz. will be appreciated by Herschel Rawls, from any hearing this call. All correspondence answered.

BY 6AWP, EVERETT W. THATCHER, 407 WEST FIRST ST., SANTA ANA, CALIF.

C. W.—2fp, 3fs, 3aln, 4bq, 4ft, Can. 4cb, (5za), (6aif), (6ak), (6akw), (6ale), (6asj), (6aun), (6df), 6ek, 6gh, 6ib, 6ku, 6nz, (6tw), 6zh, (6za), 6zac, 6zae, 6zaf, (6zf), 6zg, 6si, (6zt), (6zz), (7dp), 7zf, (7oz), 7xf, (7zu), 8agz, 8bri, 8jl, 8xv, 9aav, 9aeg, 9alg, 9ajs, (9amb), 9arj, Can. 9bd, (9bji), 9bsg, (9dth), (9dtm), (9dva), 9dxx, 9dzj, 9nx, (9ps), (9wd), (9wu), (9xac), 9xm, 9yae, (9zac), 9zaf(voice), cl8, dd5(music), xfl.

Spark—5if, 5hk, 5xd, 5yq, (5za), 6's too numerous, 7bs, 7cb, 7ck, 7gl, 7gt, 7hf, 7im, 7in, 7jd, 7kb, (7ly), 7mf, 7mp, 7nf, (7ot), 7tj, 7vo, 7wj, 7zv, (7ya), 7yg, 7yj, 7ys, 7za, 7zm, 7zo, (7zu), 9aeg, 9aog, 9ayy.

These stations were worked on two 5-watt tubes in a modified Hartley circuit. The radiation is 1.7 amps on 215 meters. Have reports from 6zac, Hawaii; 8agz, East Cleveland, Ohio; S. S. McKevey off Key West, and S. S. Admiral Watson at Yakutat, Alaska. Best 'QSO' with 9wu, Ellendale, North Dakota, 1400 miles. Would appreciate card QSL's and will promptly answer all.

BY 6ACM, 1551 EMERSON ST., PALO ALTO, CALIF.

C. W.—4ua, 4va, 5xd, 5za, 6cu, 6cv, 6en, 6ka, 6kc, 6ku, 6ky, 6ny, 6pe, 6tw, 6aag, 6aat, 6aby, 6agp, 6aif, 6alu, 6akw, 6aur, 6awp, 6awv, 6bcd, 6bjc, 6bmn, 6xad, 6xaq, 6zb, 6zf, 6zz, 6zac, 7ab, 7dp, 7na, 7nn, 7xz, 7zu, 8bdb, 9db, 9dva, 9zaf, Can. 9bd, cl8.

Spark—5xd, 5xu, 5yq, 6bv, 6ec, 6fh, 6gt, 6hy, 6ic, 6iv, 6kc, 6kd, 6km, 6lc, 6od, 6ol, 6ud, 6up, 6aak, 6aau, 6abm, 6acy, 6adl, 6adg, 6adp, 6aeh, 6agt, 6agp, 6ain, 6ajh, 6ajr, 6ald, 6amn, 6ans, 6ark, 6asq, 6ayd, 6avr, 6awi, 6awx, 6bak, 6bbc, 6bds, 6bfr, 6bjv, 6bjy, 6bmp, 6bnf, 6bnu, 6cz, 6zal, 6zam, 7bk, 7ck, 7ed, 7gj, 7iw, 7ju, 7kj, 7mf, 7nw, 7nz, 7ot, 7wg, 7oz, 7ya, 7ys, 7yl, 7yj, 7zj, 7zk, 7im, 7an, 7ap, 7za, 7zt, 7zy, 8cmi, 9avz, 9ye, Can. 9bd, cl8.

AT 9BJI, F. L. HICKS, 3935 W. 30TH AVE., DENVER, COLO.

C. W.—4bq, (5za), 5oi, 5mt, 5la, 5jb, 5yg, 5fv, 5aac, 5bm, 5zv, 5hb, 5ku, 5lj, 5un, 5af, 5ic, 5nk, 5zu, 5ci, (5kp), 6vm, 6zx, 6tw, (6za), 6zb, 6xa, 6zi, 6xh, 6zg, 6df, (6zz), 6zs, (6awp), (6xad), 6xaq, 6ada, 6bge, 7zo, 8uk, (8vy), 8agz, 8arw, 8bke, 8xak, 8aiv, 8box, (9sl), 9zl, (9pi), 9dv, 9jk, (9wn), 9qf, 9iz, 9kp, 9ze, 9oa, 9vk, 9ve, 9yf, 9wa, 9uu, 9xi, 9xm, (9fm), 9il, (9qe), 9wq, 9hl, 9sg, 9ps, (9nx), 9jl, 9oo, 9zy, 9bey, 9aou, 9aeg, 9bsg, (9awm), (9ajh), 9aas, 9aay, 9amu, 9avs, 9aap, 9agn, 9aaf, (9dof), 9aau, 9aka, (9ar), 9akd, 9abf, 9aog, 9axf, 9arz, (9aua), (9ajp), 9asl, 9aiy, 9apw, 9avn, 9aic, 9ari, 9anz, 9axa, 9avf, 9bad, (9bow), 9bum, 9boq, (9bbf), 9baz, 9bdy, (9bik), 9blo, 9bri, 9bmd, 9dqm, (9dsq), (9dzj), 9dts, 9dta, 9dsm, 9dky, 9dix, 9dys, 9dun, 9dug, 9dhh, 9dgg, 9bv, 9cao, (9yak), (9yam).

Spark—5xu, 5xd, 5xb, 5fo, 5hk, 5ew, 6zam, 7lu, 7zv, 9drw, 9arq, 9amq, 9aig, 9wi, (9yak), 9ayw, 9aeg, 9avz, 9dse, Can. (4cb)-cw.

AT 7BC, MYRTLE POINT, ORE.
6ac, 6af, 6al, 6an, 6cc, 6dd, 6dp, 6ek, 6en, 6ex, 6go, 6gl, 6ib, 6pi, 6ala, 6ale, 6amb, 6amk, 6ars, 6asj, 6xia, 7bh, 7fu, 7fl, 7bi, 7iw, 7km, 7mf, 7ma, 7mu, 7nn, 7nu, 7nz, 7st, 7sc, 7vo, 7wg, 7ys, 7nl.

Announcing the new RASAC "Puretone"

—TUNER and
AMPLIFIER
comprising
the new RASAC
PURETONE

receiving set

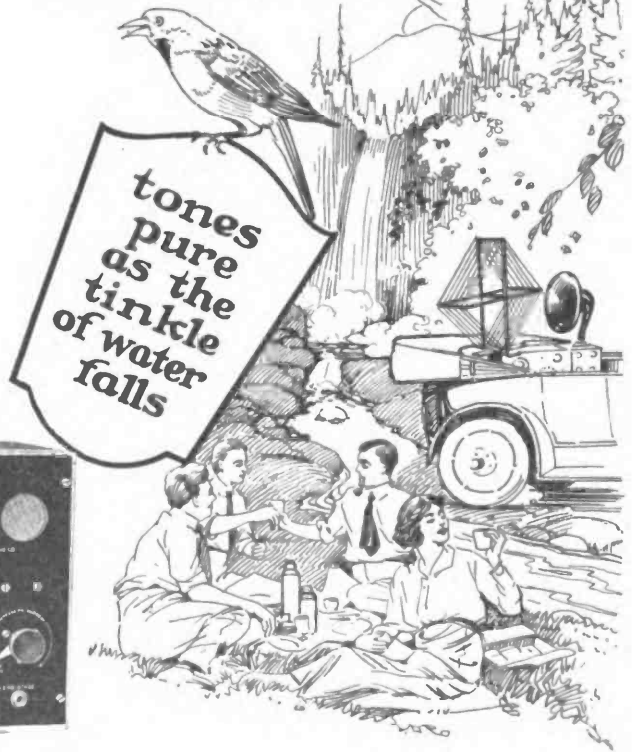
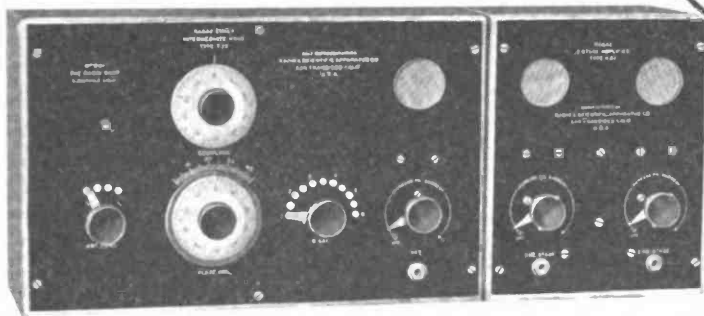

Designed by Ralph M. Heintz. Licensed under the Armstrong Patent No. 1,113,149. Manufactured by the Radio Shop, Sunnyvale, Calif. Distributed exclusively by the RADIO & SCIENTIFIC APPARATUS CO., 606 MISSION STREET, SAN FRANCISCO, CALIF.

With recent improvements that minimize "mush"

The most outstanding advantages possessed by the new RASAC TUNER are its ability to eliminate the aggravating scratches, hisses and clicks which usually accompany the reception of "radio," its extreme selectivity, and the purity and resonance of its tone.

These advantages are made possible through improvements recently devised by Ralph M. Heintz, upon which patents are pending, and which are incorporated exclusively in the RASAC Type T-22 receiving set. This set will not only eliminate the interfering noises, but will tune out with fine precision, all wave lengths except that which is desired.

The RASAC Type T-22 will, with equal ease and facility, receive on either short or intermediate wave lengths, affording a range of from 150 to 3000 meters. Because of these important advantages, and the beautiful finish of the set, it is ideally adapted for home use, where it will be an ornament as well as a source of constant enjoyment to the entire family.

IMPORTANT—The new RASAC apparatus described above is now available for delivery. Dealers are invited to write us for prices and full particulars. Retail purchasers are invited to write us for new RASAC folder describing this apparatus more in detail. Such requests should include the name of some radio dealer through whom they desire to purchase.

Prices and Specifications

The new RASAC Type 22 receiving set is composed of the new RASAC tuner and its companion piece, the new RASAC amplifier.

THE NEW RASAC PURETONE TUNER
.....Price \$85

Panel—of heavy formica, highly polished and engraved. *Cabinet*—your choice of solid mahogany or solid walnut, both with beautiful lustrous finish. *Dials*—engraved, silver finish. *Condenser*—mica dielectric. *Antenna Inductance*—space—lattice basket weave. Tubes and batteries extra.

THE NEW RASAC PURETONE AMPLIFIER—Price \$60. A 2-stage amplifier designed and finished as a companion piece for use with the new RASAC tuner.

Radio & Scientific Apparatus Co.

606 MISSION STREET—SAN FRANCISCO, CALIFORNIA

Tell them that you saw it in RADIO

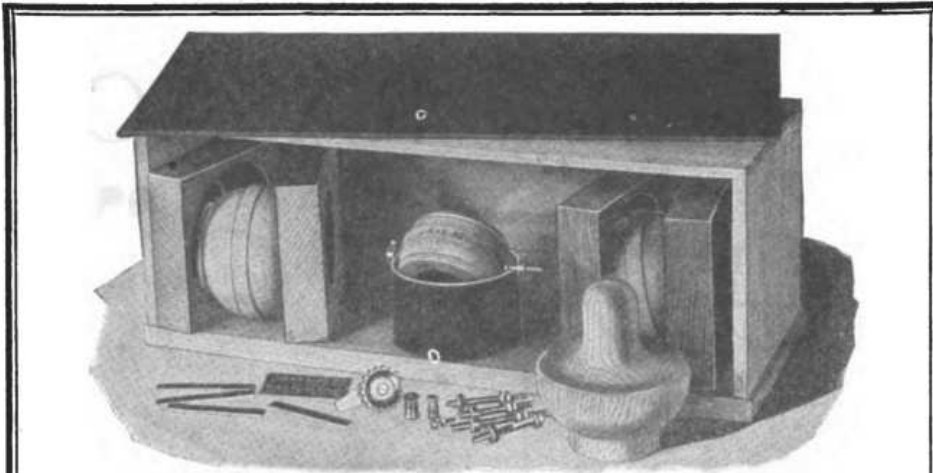

J-RAY UNASSEMBLED RECEIVING APPARATUS

Self Assembling Saves You 50 to 75 Per Cent.

JR-1. \$19.00 Unwound. \$23.00 With All Windings.

We herewith present our new line of Radiophone Receivers, Vacuum Tube Detectors and Amplifiers in knocked-down or un assembled form.

Each set comes with all holes drilled, directions furnished, etc., making it a very simple and at the same time highly interesting and instructive process assembling the various parts. Each piece of apparatus mounts directly to the drilled Formica Panel, by means of the screws and nuts provided. Wire supplied for making connections.

- JR-1—Unassembled Receiver. Consists of the following parts: Hand rubbed Oak Cabinet, 18 1/4 x 7 x 7 inches, hinged top; 6 Binding Posts; Polished Formica Panel to fit (all holes drilled); 7 Contact Points; Grid and Plate Variometers and Varicoupler, complete ready to assemble; 3 J-Ray White Enamelled Dials (not shown); 1 Switch Lever; 2 Stops; all necessary brass parts, screws, etc., for completely assembling the set with directions. Price (with winding form for stator windings)..... \$19.00
- JR-2—Same as above, but with all Vario Windings in place..... 23.00
- JR-3—Unassembled Receiver with V. T. Detector and 1 Stage Amplifier, all in one cabinet. Consists of the complete set of parts for JR-2, plus 2 Crosley or J-Ray Sockets; 2 Fada Rheostats, 1 Amplifying Transformer, 1 Grid Condenser; extra Binding Posts; brass parts, etc., complete with directions. Extra holes provided in panel for mounting Rheostats and Sockets. Price..... 33.00
- JR-4—V. T. Detector and 1 Stage Amplifier. (Consists of Stained Oak Cabinet, 9 1/4 x 7 x 5, hinged top; drilled Formica Panel to fit; 2 Sockets; 2 Rheostats; Grid Condenser; Amplifying Transformer; Binding Posts, etc.)..... 16.50
- JR-5—V. T. Detector and 2 Stage Amplifier. Same as JR-4, but with extra Tube Socket, Rheostat and Transformer..... 22.50
- JR-6—Two Stage Amplifier, without Detector..... 20.00
- Receiver Cabinet only..... \$5.50. Panel..... 2.25
- Detector and Amplifier Cabinet..... 2.85. Panel..... 1.15
- 2 Variometers, (Grooved Stators) and 1 Coupler, K-D, with all hardware..... 10.00
- Our new Amplifying Transformer, 5 to 1 ratio, unmounted..... 3.75
- Crystal Receiving Set, complete, without Phones..... 7.50

Write for bulletins.

J-RAY MFG. CO. 1618 Chestnut St., St. Louis, Mo.

**“ILLINOIS” THE RELIABLE
MADE RIGHT - STAYS RIGHT**

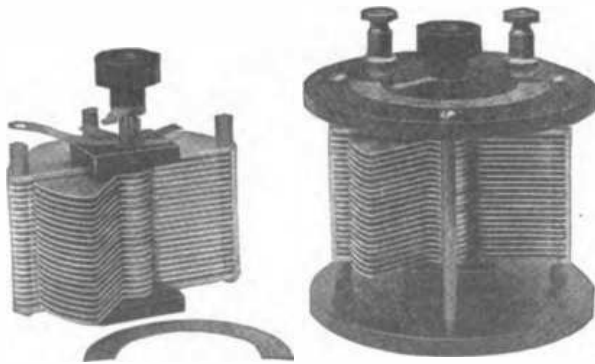

Three Styles: No. 1, Panel; No. 2, Open Type as shown; No. 3, Fully Encased. Anti Profiteer. Less than pre-war prices. Fully assembled and tested.

	Style No. 1	No. 2	No. 3
67 Plates,	\$7.00	\$8.00	\$8.50
48 "	3.50	4.50	4.75
28 "	2.75	3.75	4.00
18 "	2.25	3.25	3.50

Money back if not satisfied. Just return condenser within 10 days by insured Parcel Post.

Options:—With Style No. 1—Instead of Scale and Pointer, a 3. inch Metal Dial at 50 cents extra, or a 3. inch Bakelite Dial at \$1.00 extra. Large Knobs. Both excellent values. Or we will, if desired, supply the Condenser with smooth 3/16 inch center staff, without Scale, Knob and Pointer, at 15 cents off the list to those who prefer to supply their own dial.

Vernier with single movable plate applied to 18, 28 or 43 plate condenser, \$3.00 extra.

We allow no discounts except 5 per cent on orders of 6 or more.

Sent Prepaid on Receipt of Price
Except: Pacific States, Alaska, Hawaii, Philippines and Canal Zone add 10c. Canada add 25c.
Foreign Orders other than Canada not solicited.

G. F. JOHNSON, 625 Black Ave.

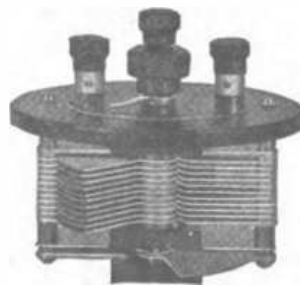

VERNIER

Springfield, Illinois

Tell them that you saw it in RADIO

HARMO-RADIOPATHY

Continued from page 25

THEIR thoughts sped back to the historic crisis in the earth's harmonic affairs, many years before when, driven almost insane by hideous jazz and its ramifications, it had sought a sane solution. Hawaiian orchestras of Carolina negroes had taken to fox-trotting, Swiss Yodlers, born of Swedish parents in Cincinnati, essayed Scottish folk songs. The conglomeration of vibrations, beating upon defenseless brains, was producing endless confusion of ideas and emotions. Something had to be done and that quickly. So said the great men—savants, psychologists, and alienists of that day.

The famous Musical Demobilization Conference, held at Fort Said, in 1940, had been the result. The nations of the world at that congress had mutually agreed to disarm their musicians. In the interest of world sanity, a League of Harmony was formed, whose principals would control the tonic output of the globe. Yap, a former cable station, was taken as the broadcasting center for international music. From there, day and night, an orchestra composed of players from the best musical circles of each country, would send forth by wireless, a fundamental theme to be received by the separate countries and translated into national programs.

There was wild rejoicing when the results of the conference became known. Great bon-fires of grand pianos were built in public squares. Riotous mobs smashed phonographs in the streets. The gutters of cities ran with harmonicas, concertinas, flutes, saxophones and ukuleles. Even in far off Palestine, camels were loaded down with tons of jewsharps and driven into the Red Sea. There was universal enthusiasm. It was felt that a great stride forward toward the goal of human happiness had been achieved.

In France, on the nights that the Yap orchestra played the patriotic motif, the French people would tune their instruments to the fundamental wave and "Le Dernier Centime" would burst forth to send them into ecstasies of appreciation. In England, the same motif wave would render "God Save the British Manager." In America, the wave would be read as "The Coin Spangled Wall Street"—a melody that brought every school child to attention.

Did the citizens of Germany, listening to the love motif wave from Yap which above the Rhine was interpreted as "The Swan Song of Solvig The Chiropodist" from "Das Blunderbuster," desire to find the same thought in Italian environment, they had but to touch the international transposition key of the receiving instrument, and instantly the lyric

Continued on page 46

Science is Explaining the delicate action of the audion bulb

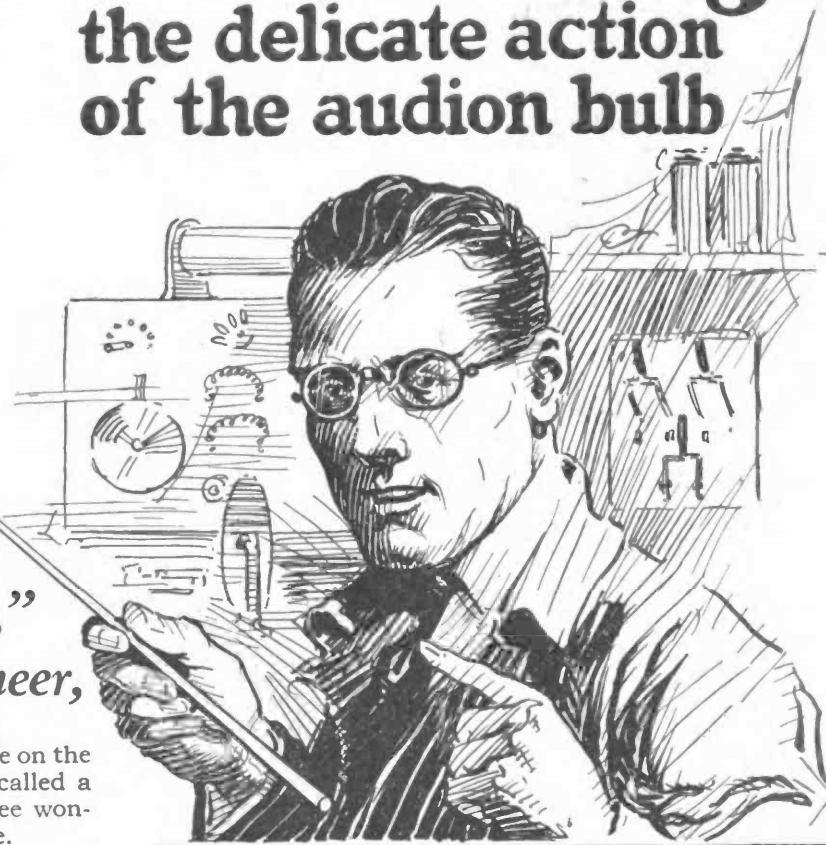
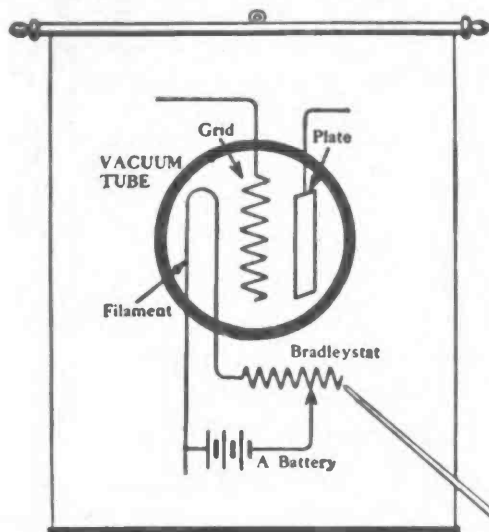

*“This is the vital part,”
says the radio engineer,*

“of the receiving set. The heavy circle on the chart is the audion bulb, sometimes called a detector or vacuum tube. It has three wonderful parts—filament, grid, and plate.

“The filament becomes white hot when connected to the “A” battery, and sends out a fairy rain of invisible, electrified particles, which pass through the grid and strike the plate just as a spring rain is driven through the bare twigs of a hedge fence.

“The telephone receivers detect the slightest variation in the rain upon the plate. The broadcasting waves run from the antenna to the grid and interfere with the fairy rain like the leaves on a hedge interfere with a summer shower. So you see, by interfering with the fairy rain, the broadcasting waves make the telephones sing and talk.

“Since it is the fairy rain from the filament which does the trick, it is all-important that you provide noiseless, stepless, and extremely accurate control of filament current. The success of your set will depend upon the quality of your filament rheostat.”

For further information, address

Allen-Bradley Co.

Electric Controlling Apparatus

288 Greenfield Ave., Milwaukee, Wis.

Manufacturers of graphite compression rheostats for 20 years

Bradleystat

REGISTERED U. S. PAT. OFF.
PERFECT FILAMENT CONTROL



Retail Price

\$1.85

Postage 10c extra

A single knob applying pressure upon graphite discs provides the amazingly accurate and noiseless control of the Bradleystat. No wire coils, no sliders, no verniers, and no loose contacts to “fry.” And above all, the most precise control is available.

The Bradleystat is without equal for filament control of ½ and 1 ampere receiving tubes and sending tubes up to 2½ amperes. A guarantee of one year against factory defects is back of every Bradleystat.

Tell them that you saw it in RADIO

BRYANT TRANSFORMERS

FOR AUDIO FREQUENCY



PROMPT DELIVERY

A better transformer for music and speech is not made. We leave the appearance to you.

Designed to amplify all audio frequencies in voice range with equal intensity. Takes up less panel space, is extremely rugged, has beautifully blued steel mounting frames, insulation resistances all above 10 megohms.

Both windings of heavy wire—will not burn out.

Ratio 3½ to 1 **\$5.00**

Excellent Proposition to Dealers

BRYANT RADIO COMPANY
459 HOMER AVE. PALO ALTO, CALIF.

75c
Ea.



KELLOGG V-T SOCKET

the durable socket

Kellogg molded lamp sockets fit all standard four prong based vacuum tubes. Extra heavy solid base 7/16 inches thick. Four German silver springs with rounded ends firmly held in position in deep grooves, cannot touch mounting surface. Double end nickel plated binding posts. Connections can be made under the socket as well as above. A practically indestructible construction. 75c each, postpaid.

COMPLETE RADIO EQUIPMENT
The item above is merely a sample of the excellent line of radio equipment that is handled by the Apex Radio Company, Inc. All orders for sockets or other standard equipment will be filled the day received. Send two cent stamp for our new price bulletin.
APEX RADIO CO., INC. 1105 W. 69th St. Chicago, Ill.

RTS

The New RTS Standard Detector Panel will please all amateurs. Sent complete without tube two batteries for only **5.95** Postpaid by Insured Parcel Post
Send for complete circulars, now
Radio Testing Stat'n, Dept. A, Binghamton, N.Y.

CONNECTICUT

RADIO EQUIPMENT

Variable Condensers, Transmitters, Head Bands, Panel Switches, Etc.

Connecticut Tel. & Elec. Co., Meriden, Conn.

THE CLASSIFIED ADS ON PAGE 94 WILL INTEREST YOU!

Do You Want REAL SERVICE?

Let us have your order, learn what REAL SERVICE means. Shipments made within 24 hours.

SEND FOR YOUR COPY OF
CATALOGUE No. 22

THE SERVICE RADIO EQUIPMENT COMPANY

DESIGNERS — MANUFACTURERS -- DISTRIBUTORS
225 Superior Street Toledo, Ohio

Tell them that you saw it in RADIO

Continued from page 44

strains of "El Piccalo del Manuel" from "La Blowedor" came pleasantly to their ears. It seemed that the dreams of universality were to be realized.

There was one shadow, however, which overhung the perfect understandings of the musical conference. That was the split-tone demands of the Far East—China, Japan and India, over which the delegates had argued for many days without arriving at any satisfactory decision. The Occidental world had held out for a tonic scale of fifths and sevenths. The Orientals demanded a chromatic arrangement. Being of a lazy temperament they had consistently refused to straddle the distances between fifths and sevenths, preferring to slide along from note to note, up and down the scale.

The Far East claims for harmonic recognition were overridden however, toward the close of the Congress, by an agreement that after ten years there should be a readjustment, and the chromatic scale given a hearing in the musical world. With this amendment the great ten-power musical pact had been signed. Thereupon, the world entered upon an era of peaceful, jazzless routine that had satisfied beyond all expectations.

SUCH was the status of things, on this particular night as, with all the world tense with expectancy and puzzlement, a little group of men sat in the conference room of the world's international musical center at Yap, their faces grim with the sinister import of the problem confronting them. For, while the rest of the globe had laughed, and played oblivious to impending trouble, the Orient had demanded its tithes of blood. On this night, the ten-year armistice had expired!

At the head of the table sat the international manager-general of Yap. At the foot was the chief operator of the Allied Harmonic Power Council. Beside him was Wang Yu Yuck, ambassador of the Fu-Suffragette dynasty, his expressionless face masking his inner thoughts—on his head his vanadium thought insulator that kept his mental processes from registering on the collectograph of the World Press Association's cylinders at Berne.

"Gentlemen!" The director general broke the silence. "Wang Yu Yuck has something to say to us!"

The emissary of the Far East bowed politely. High over his head the great sun-flower spirals of the massive projector through whose pyramided antennae the vast waves of harmony were thrown to a listening world, yawned silent and expectant. Behind closed doors in the great orchestral hall, adjoining, two hundred famous musicians

Continued on page 48

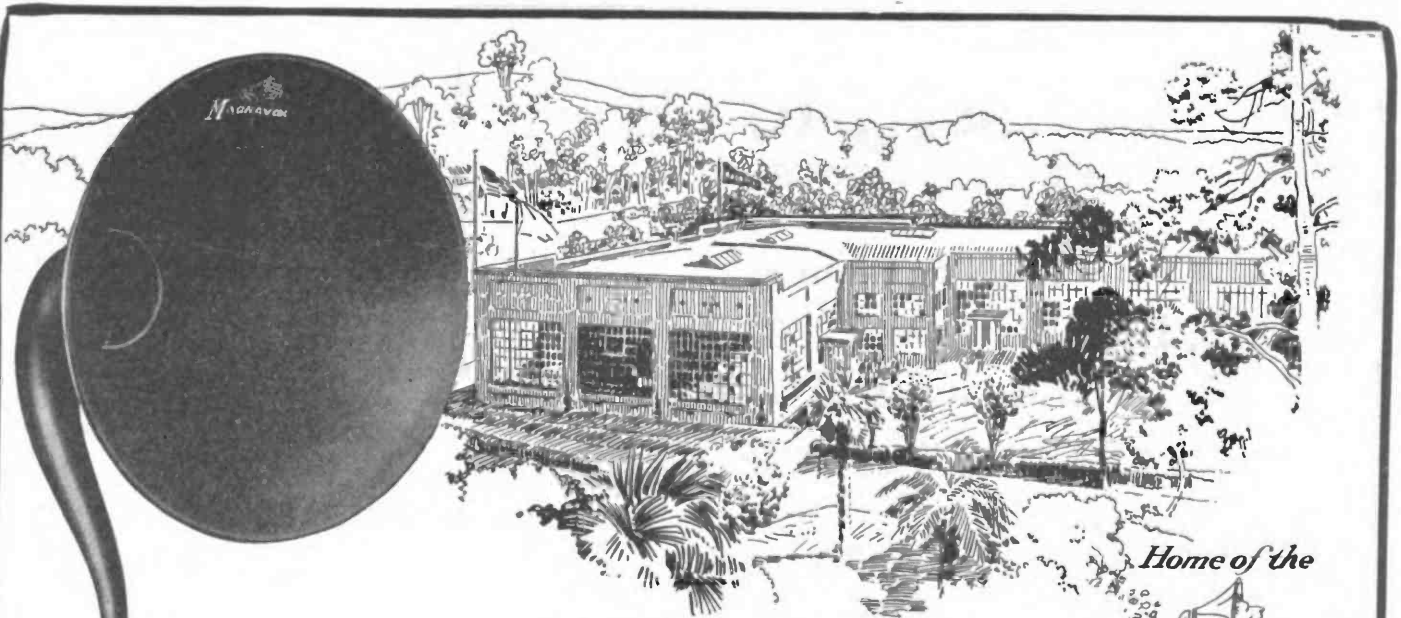

The Plant of the Magnavox Co., Oakland, California—one of the show factories of the Pacific Coast.

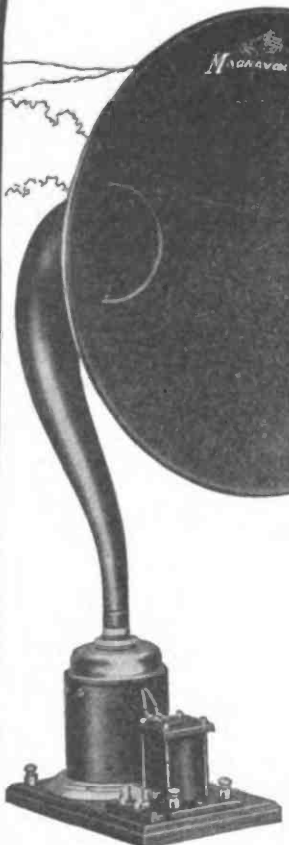

**Type R-2
Magnavox Radio**
with 18-inch Horn

THIS instrument serves the requirements of professional use for large audiences, dance halls, etc. Price, \$85.00

**Type R-3
Magnavox Radio**
with 14-inch Horn

THE same in principle and construction throughout as Type R-2, and is ideal for use in homes, offices, amateur stations, etc. Price, \$45.00



3-Stage

**Magnavox
Power Amplifier
Model C**

INSURES getting the argest possible power input for the Magnavox Radio. Can be used with any "B" battery voltage which the power tube may require for best amplification.

AC-2-C, 2-Stage..... \$80.00
AC-3-C, 3-Stage..... 110.00

Essential to the full enjoyment of your wireless receiving set is the MAGNAVOX RADIO

A FEW months ago the Magnavox Radio occupied a relatively unimportant position in the list of Magnavox products—today even our greatly increased production facilities are taxed to supply the demand for Magnavox Radio, the reproducer supreme.

It is the Magnavox Radio which gives every receiving set its greatest enjoyment and use—doing away with the restrictions and limitations of the *individual headset*. The receiving set only *brings* the message, while Magnavox Radio *tells* it clearly and in full volume to all within reach of its voice.

Unlike the *telephone receiver* used on headset and some forms of "loud speaker"—which are constructed on the electro-magnetic principle—the Magnavox Radio exclusively is constructed on the *electro-dynamic* principle and is thus a most efficient

converter of electrical energy into sound waves.

The Magnavox Radio operates with any good type of receiving apparatus, and was not designed for any one particular make. Without the Magnavox Radio no receiving set is complete.

Any radio dealer will demonstrate; or write us for descriptive booklet and name of nearest dealer.

THE MAGNAVOX CO.

Home Office and Factory:
Oakland, California

New York Office: 370 Seventh Ave.

MAGNAVOX Radio



Tell them that you saw it in RADIO



Insist on Getting

U. S. EAGLE GALENA, 25 Cents

U. S. EAGLE GOLDENA, 35 Cents

MOUNTED U. S. EAGLE GALENA and GOLDENA, 2-in-1, 50 Cents

Patent Applied For.

Marvelous Crystals of sensitivity; Improve your Radio Reception by the use of these Crystals. No better on the American Market. Each Crystal is packed in a container and labeled U. S. Eagle Galena or U. S. Eagle Goldena.

Attractive proposition for dealers and jobbers. Immediate shipment. Will use your own labels on request. Also in bulk.

EVERYTHING IN RADIO SUPPLIES SEND FOR CATALOGUE

U.S. RADIO CO. of PENNA., Inc.

Distributors and Manufacturers of Radio Apparatus
Corner Ferry and Diamond Streets
Pittsburgh, Pa., U. S. A.

HOMCHARGE YOUR BATTERY for A Nickel



No fuss, trouble, dirt—no moving of batteries—loss of time—no effort on your part—no technical or professional knowledge needed.

THE HOMCHARGER

successfully meets all charging conditions, and is the only rectifier combining the following essential Homcharging features.

1. Self polarizing. Connect battery either way and it will always charge. No danger of reverse charging, ruined battery or burnt out Rectifier.
2. No delicate bulbs to break or burn out. Only one moving and two wearing parts. These are replaceable as a unit, after thousands of hours use, at small cost. Cannot be injured by rough handling.
3. Operation stops and consumption of current ceases immediately upon disconnecting battery.
4. The only charger costing less than \$100.00 that will fully charge a battery over night. Gives battery a taper charge—exactly as recommended by battery manufacturers. Guaranteed not to harm your battery even though left connected indefinitely.
5. Highest efficiency of any three or six cell charger made.
6. No danger of fire. Approved by the Underwriters.

THE AUTOMATIC ELECTRICAL DEVICES CO.
117 West Third Street, Cincinnati, Ohio
Branch Offices — New York — Chicago — Pittsburgh —
Los Angeles — New Orleans — Detroit
— Toronto — Philadelphia — Baltimore
— Dallas.

Largest Manufacturers of Rectifiers in the World

ATTENTION MOTORISTS

Will charge your auto battery as well as radio battery. Send for Bulletin No. 58 for further information. For sale by all radio, electrical and accessory dealers or shipped express prepaid for purchase price. \$18.50 \$20 west of the Rockies.

Tell them that you saw it in RADIO

Continued from page 46

sat with poised instruments—awaiting the verdict from within. Two billion people in the outer world were waiting—tense, nervous. Silence within the marble halls of Yap for the first time within a decade. It was a dramatic moment!

"Gentlemen," began Wang Yu Yuck in his faultless English, "please do not think me greedy, but we of the East have waited patiently for this hour—the moment of our triumph. We have receded much before the stride of Western civilization—given in cheerfully to the caravan of progress. Tonight we come before the world seeking our reward—justice."

He paused and a slight shudder ran through the concourse of assembled delegates.

"From this spot," he went on inexorably, "there has been played the motif of love, of adventure, of joy, of sorrow, of passion and discord. These and the motifs of the Occident—purely. But they are not the motifs of the Orient. To the Far East alone, from ancient times, belong the motifs of insinuation, of seduction, of allurements, of suggestion and fantasy. Their only expression is the half and quarter tone, unknown to the music of the Occidental world."

He paused and for a moment seemed overcome with feeling. Then in a steady voice he continued:

"For ten years, gentlemen, we have had no expression for our emotions. Try as we would, the genius of our great men of science has been wholly unable to translate the motif of the Occident into the feeling of the Orient through the existing scale. Our instruments, tuned to the finer themes of the chromatic scale, do not respond to the fundamental wave sent out from this station. We have been a race cut off from the benefits of harmony—pariahs from the realm of melody. We stand alone—musicless!"

There was something terrible in his words that brought a chill into the heart of every listener. As though unaware of this Wang Yu Yuck went mercilessly on.

"The East is in open revolt," he said. "In Bagdad, a sailor was found manufacturing a hornpipe in an attic. In Cairo, a dancing girl was caught strumming the woof of a carpet machine. In Burmah, a holy fakir was detected beating upon the ribs of a starving pilgrim, and singing an ancient verse of "The Alimony Blues." In China a seven-year-old child was seen to nail a hair across a crack in a window to obtain an aeolian harp in spite of the law."

His voice went up.

"Such," he challenged, "is the effect of the ten-power harmony pact. Sedition is everywhere. My people are in

Continued on page 50

Stop that Leakage!

The Willard All-Rubber Radio "A" Battery (shown at the right) is not an automobile battery adapted for Radio use, but is a special radio battery built for the reception of C W and spark messages. The reduction of the weight of connectors, the increase in thickness of plates, the special radio type of Threaded Rubber Insulation are all features that are necessary to an efficient, economical battery of this type.



You'll have to admit it's annoying to have a radio concert or a conversation interrupted by noises that sound as if all the animals in the zoo had cut loose at once.

Some of these noises can't be stopped by even the most careful tuning. They can be ended only by removing the leaky cell or the leaky battery that's responsible for them.

One of the most important features of the Willard All-Rubber Radio Battery is that it is absolutely leak-proof. Battery case and jars are cast in one solid piece of

rubber, eliminating the possibility of leakage either from cell to cell, or to ground. Every case is tested at 24,000 volts.

The Willard All-Rubber Radio Battery has the same Threaded Rubber Insulation as the Willard Threaded Rubber Automobile Battery. The Willard Radio "B" Battery is a 24-volt rechargeable storage battery, with leak-proof glass jars and Threaded Rubber Insulation. Assures freedom from frying and hissing ground noises. Ask for particulars from your dealer, or at the nearest Willard Battery Station.

WILLARD STORAGE BATTERY COMPANY, Cleveland, O.

Made in Canada by the Willard Storage Battery Co. of Canada, Limited, Toronto, Ontario

Willard THREADED
RUBBER
BATTERY

Tell them that you saw it in RADIO

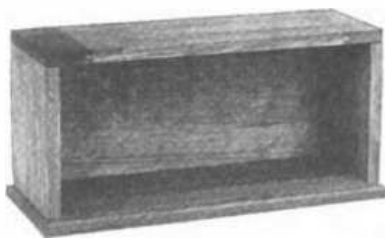

Mitchells Radio Cabinets

We manufacture a complete line of Radio cabinets, in American Black Walnut, Quartered White Oak and Genuine Mahogany. Quick deliveries—quantity production prices.

Some of our latest refinements:—Lock joint construction, 110 degree stop butts, felt pad bottoms. *Write for prices.*

The Robert Mitchell Furniture Company
CINCINNATI, OHIO

Cabinet woodwork since 1836.

DELAWARE HARD FIBRE The Incomparable Insulation

DELAWARE HARD FIBRE today enjoys the distinction of being the leading product of its kind, being superior to hard rubber, porcelain and composition materials for insulating purposes. It is the best insulation that can be secured for your radio apparatus. It should be used for panels, coil cases, end plates, knobs, bushings and other insulating parts in your wireless outfit. Let our Development Department help you solve your insulating problems. Further information and samples gladly furnished on request to our main or branch offices.

BRANCH OFFICES:

New York, 50 Church Street	
Pittsburgh, 1st Nat'l. Bank Bldg.	Boston, 170 Summer Street
San Francisco, 235 Pine Street	Philadelphia, Fuller Bldg.
Toledo, 415 Ohio Bldg.	Rochester, 1040 Granite Bldg.
Chicago, 564 West Monroe Street	Dayton, 314 Dayton Savings & Trust Bldg.
New Haven, 209 Plymouth Bldg.	

MAIN OFFICE AND FACTORY

DELAWARE HARD FIBRE CO.
WILMINGTON DELAWARE

KEYSTONE

Variable Condensers have a greater capacity than any condenser on the market. We use 24 gauge copper. Our 28 Plate has a capacity of .0002. Price \$8.00; 48 Plate .001, \$4.50. We give 24 hour service on VARIOCOUPERS @ \$4.50, CRYSTAL SETS, RADIOPHONES.

KEYSTONE RADIO SERVICE CO.

138 SO. BROADWAY Manufacturers of Radio Equipment LOS ANGELES, CAL.

MAILING LISTS

FOB SALE

2919 Radio Dealers Retail..	\$20.00
812 Radio Manufacturers..	4.00
652 Radio Supply Jobbers..	7.50
4000 Amateur Radio Users..	7.50 Per M.

TRADE CIRCULAR ADDRESSING CO.
166 W. Adams St. Chicago, Ill.
Phone Franklin 1182

RADIO SUPPLIES

Large Stock of Crystal Sets, Audion Sets and Parts, Howard Rheostats.

B. W. FRANK, Jobber
107 S. El Centro St. Holly 6446 Los Angeles

Continued from page 48

open revolt. We can no longer hold them back with empty promises. They have grown restless, and uncontrollable. Their's is the cry of stifled hunger—an innate thirst for harmonic expression. Revolution is smouldering at our doorsteps, and we sit calm and indifferent."

Dramatically he waved both arms over his head.

"Gentlemen, I tell you unless we are given the latitude promised by the treaty of Port Said—unless the people of the East can have that which they crave, that for which they have patiently waited, that for which they are aflame with desire, there will be heard for the first time in half a century the thunderous tread of marching men, sweeping down from the barbaric heights of self-denial upon the voluptuous indifference of civilization."

He clinched his hands.

"I alone cannot hold them back. Only you—trustees of the great harmonic station of Yap, here assembled, can do this thing. Choose! On the one side—chaos and disaster. On the other—peace. In the name of Twang, our ancestral God of Music, I demand the fundamental Motif G.-777—the motif of split tones, half tones, quarter tones, eighth tones and sixteenth tones. I ask this in the name of my people, who stand, tense and menacing on the border. I can hold them back until 4 o'clock of next week but no longer!"

There was a deathly silence as Wang Yu Yuck sank into his seat. The international manager ran his eye around the circle. Before him sat the dictators of the world's music—men within the hollow of whose hands rested the harmonic fate of the globe. Would they see this thing as Wang Yu Yuck saw it? Would they grant the claims of the Far East, guaranteed under the treaty of Port Said?

"Gentlemen!" He put the question quietly. "What is your will?"

The representatives of the plutocracy of Greenland arose. He was the Esquimos of the North—the leader of Refrigeration party and a patron of wireless thinking.

"There is no other way," he said slowly, "What Wang Yu Yuck has said is the truth. The East is aflame. Itinerant musical critics have stirred the people into revolt. Besides, there is the promise of 1940. It must be done. I move the request be granted."

The international manager raised his gavel.

"Unanimous?" he queried.

A nod ran around the table. For a second there was silence. Then came the crash of the gavel in the quiet room like the thud of an executioner's knife upon a headsman's block. Wang Yu

Continued on page 52

Tell them that you saw it in RADIO

AEREO

RADIO RECEIVER

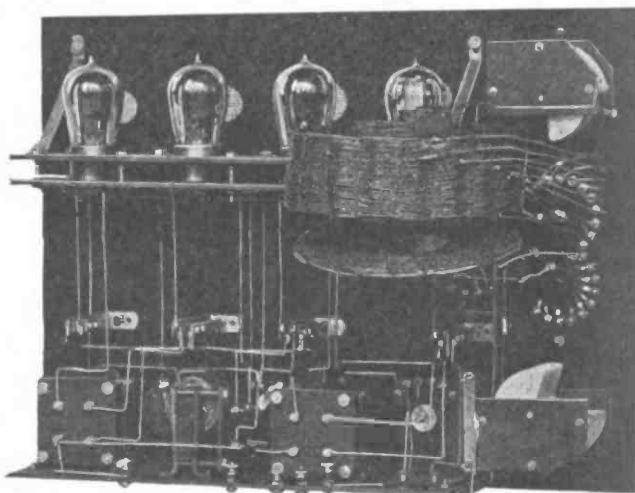
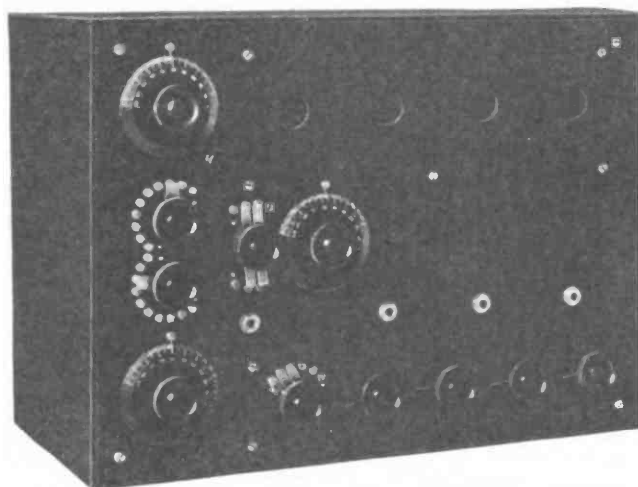

Front and Inside of the "AEREO" Showing Solid Mahogany Cabinet—Panel of Grained Formica—Detector and 3 Stages of Amplification—Size Over All 18½' x 13½' x 11'

The set you have waited for

The Aereo Radio Receiver is the result of eight years research work and experimentation in both America and Europe. It is nothing short of marvelous in its simple operation. It is extraordinarily clear in reception.

The Aereo is a non-regenerative receiver possessing regenerative tuning features. Due to the special type of windings and mechanical arrangement of the highly efficient basket wound inductance coils, extremely sharp tuning can be accomplished.

A special coupling device allows very close adjustment between the primary and secondary coils thereby reducing interference to a minimum.

Special Amplifying Transformer

The Aereo amplifying transformers are not of

the ordinary type. Specially constructed, the windings are so designed as to work most effectively with the remainder of the circuit. A correct balance has been obtained in the Aereo transformers resulting in maximum signal strength with a minimum of howling.

See your Radio Dealer today about this wonderful new Receiving Set. If he cannot give you the desired information write to us direct giving us the name of your nearest Radio Dealer. Circular on request.

Jobbers: We have a very attractive and profitable proposition for live jobbers. A few territories are still available. Wire or write for particulars.

It is built right
It is priced right
\$142.50
Less Tubes and Batteries

AMERICAN RADIO ENGINEERING COMPANY
240 California Street San Francisco, Calif.

T. H. CAMP, General Manager

Tell them that you saw it in RADIO

Immediate Delivery on Quality Condensers!

THE NORTHRAD VARIABLE

Plates of polished half-hard aluminum; end pieces of milled Bakelite sheet. Soldered pig-tail connection to movable plates—no wiping contacts. Navy type knob with polished nickeled pointer. Curved entering edges minimize hand capacity effects. Dielectric losses negligible.

23-Plate, .0005 Microfarads \$3.60 43-Plate, .001 Microfarads \$5.25
Add postage one pound

NORTHERN RADIO & ELECTRIC CO.

Operating
Post-Intelligencer
Radio Broadcast

606 Pine Street
Seattle, Wash.

Phone
Elliott
2512

NOVO "B"



Batteries

NOISELESS — DEPENDABLE — GUARANTEED

19 Sizes — Plain and Variable

22½—45 and 105 Volt Sizes

NOVO MANUFACTURING CO.

424 W. 33rd St.
NEW YORK

531 So. Dearborn St.
CHICAGO

10c. Charges Radio & Auto Batteries WITH AN F-F Booster

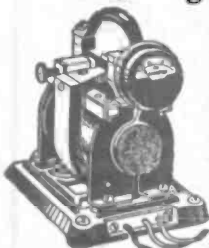

Which is an Automatic Full Wave Magnetic RECTIFIER for 105-125 Volt 60 Cycle A. C. Is it not gratifying to feel that Your Batteries will Always be Ready for All Radiophone Broadcast Music, Sermons & News, never having to tell Friends Your Batteries are dead. The F-F Battery Booster is a rugged Charging Apparatus, unailing in its ability to deliver Service Day & Night & Requires No Skill, as it Charges Automatically & Operates Unattended. Screw Plug in Lamp Socket, Snap Booster Clips on Battery Terminals & watch gravity rise. AMMETER shows amount of current flowing, eliminating all Guess Work. Everything being Complete in One Compact, Self-Contained, Rugged & Conveniently Portable CHARGING UNIT. In these F-F BATTERY BOOSTERS, which are the Pioneer Full Wave Rectifiers, Infusible Carbon Electrodes Rectify the current, while the Full Wave Design Delivers Rapid Taper Charge, which Saves You 90 cents a charge & They Last a Lifetime. REDUCED PRICES:
Type 6 Charges A 6 Volt Battery at 6 Amperes, \$15. Type 12 Charges 12 Volt Battery at 5 Amperes, \$15
Type B Charges Radio "B" Batteries Up to 100 Volts, \$15. Type A-B Charges Both "A&B" Batteries, \$20
Type 166 Charges 6 Volt Batteries at 12 Amperes, \$24
Type 1612 Charges 12 Volt Batteries at 7 Amperes, \$24
Type 1626 is a Combination of 166 & 1612 & Charges Both 6 & 12 Volt Batteries at 12 & 7 Amperes, \$36

The Larger Types are recommended for Large Batteries, or where time is limited. Shipping Weights Complete With Ammeter & Battery Clips 11 to 15 lbs. Order from Your Dealer, or Send Check for Prompt Express Shipment. If via Parcel Post have remittance include Postage & Insurance Charges, or Order us to ship Type desired C. O. D. Order Now, or Write Immediately for Free Descriptive BOOSTER & GROUP Charging ROTARY Bulletins 33 & 33A.

FRANCE MFG. CO. General OFFICES & WORKS: CLEVELAND, OHIO, U. S. A.
Canadian Rep.: Battery Service & Sales Co., Hamilton, Ontario, Canada.

Tell them that you saw it in RADIO

(Continued from page 10)

Yuck raised his head. His eyes were brimming with tears, his features illuminated.

"My people!" he murmured. "My people!"

IN the great orchestral room, the leader of the world orchestra jumped to attention as a gong clanged in his ear. Far beneath him in the huge resonance pit, the whole orchestra sat upright. Into the intense stillness came the vowelless syllables of an order from the international manager, spoken in the secret code of the Harmonic Conference.

"Czkrpqmx!" rang the words from the noiseless annunciator.

The leader's face paled.

"My God!" he exclaimed. "Motif G-777!"

He stood with ashen face as the significance of the order was borne home. Then remembering his oath of office, remembering the great trust imposed in him by those who had elected him to his office, remembering the money he had spent to achieve that distinction, buying votes, corrupting election officials, and padding returns the night he defeated his British opponent, he raised his baton and with all the great courage of a soldier going over the top, gave the signal that plunged the orchestra into the devilish insidious, mal-harmonic allocation of hoots, jeers, cat-calls, wails, squeals, clamors, roars, bawls, whoops, howls, bellows, screams, shrieks, squeaks, squeals, squalls, whines and yaups that stood for Oriental music. In other words the orchestra played Motif G-777 in all its ravishing beauty!

There are two parts to the awful motif of G-777. The opening prologue covers the entire gamut of Oriental misery. But the second portion—the main theme—deals with the battle spirit of Klam Chow, the great warrior epic of the Bamboo era. It fairly sizzles with excitement and dynamics. It effervesces with explosives. It concusses the ear with the native enthusiasm of a playful volcano. To hear it is like listening at the keyhole of an interdenominational hell.

As the first crash of sound went hurtling from the radiators of the Yap station into every crack and crevice of the earth with its terrific, ear-splitting cadences, millions of listeners who had been patiently awaiting the meaning of the unusual silence, jumped to their feet aghast. Wives clutched at husbands. Mothers hugged children. Animals lit out for the foothills, and a convention of Orthodox and Bonded Prophets and Soothsayers who had just passed a resolution abolishing the Almighty as a non-taxable utility, laid down their rabbits-feet and hurried into Kansas, U. S. A., where comfortable cyclone cellars could be bought on the installment plan.

Continued on page 54

QUALITY

The one thing you pay for in the end
Why not get quality when you buy

Your First Radio Instruments
Buy

Wireless Shop Apparatus
AND BE ASSURED OF THE QUALITY

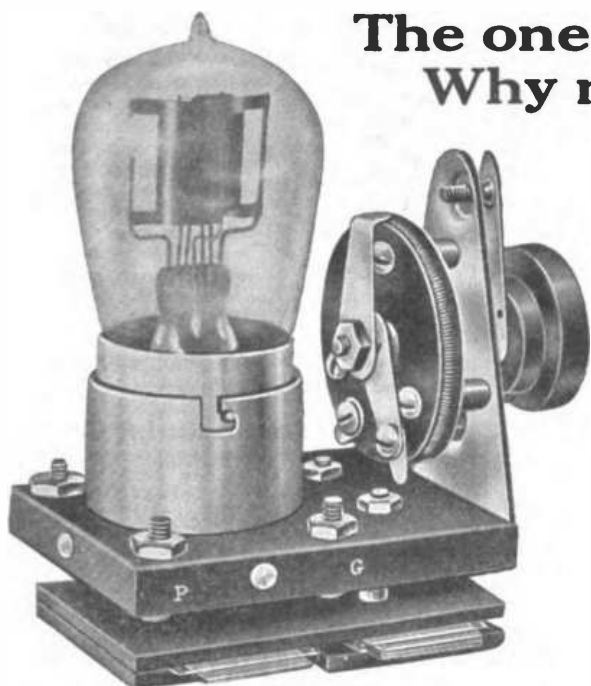

NO. 40 WIRELESS SHOP DETECTOR UNIT

A complete detector control, designed for back of panel mounting. By using this new unit it is very easy for the novice to build up a receiving set. All that is necessary is to drill three holes in your front panel, mount the unit and wire it to your tuner. Unit consists of socket for tube,

rheostat, mica grid condenser and mica by-pass condenser. The bulb is not included. And the price is so low that you cannot afford to assemble the separate instruments yourself. A knob and pointer is supplied. Price (postage extra)..... \$5.00

The No. 40 detector unit and No. 41 amplifier unit is fully described in our bulletin No. 3, which will be mailed for the asking.

Variable Condensers

When you buy a variable condenser, you want the product of a real instrument shop. Of the many different instruments used in radio work, the variable condenser and head receiver are two that must be made right, by men that know, and have passed through the experimental stage. "Wireless Shop" variable condensers have an enviable reputation for "QUALITY", and this reputation has been honestly earned by strictly high grade material and workmanship. We have been manufacturing

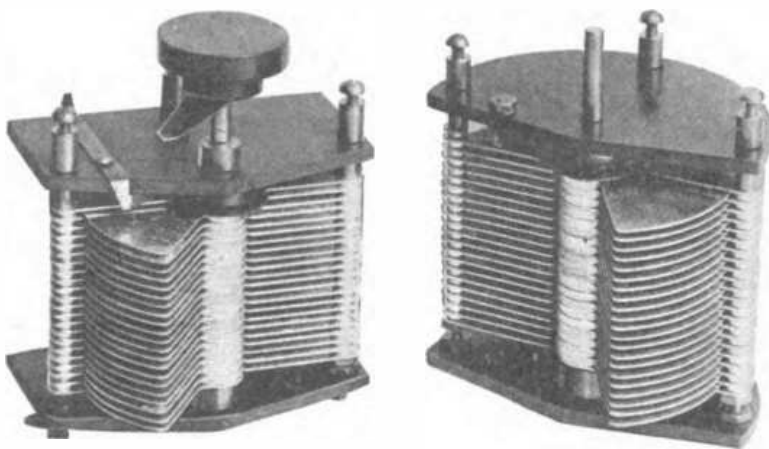

variable condensers for nearly eight years, and have developed a special line of equipment for performing each and every manufacturing operation required. "QUALITY" not "PRICE" is our slogan. The "PRICE" is as low as is consistent with "QUALITY". The 23 plate, No. 230, sells for \$3.60. The 43 plate, No. 430, for \$5.25. Twelve other sizes are fully described in our bulletin No 1. Ask for it.

THE WIRELESS SHOP
A. J. EDGCOMB

1262 West Second Street

Los Angeles, California

Tell them that you saw it in RADIO

LATEST IN RADIO

Sweeney's Line of Radio Supplies

Personal service, information and instruction for all radio users together with immediate supply of the most complete and very latest equipment. Keep in touch with newest scientific development by getting our catalog. Among new items: See the Variometer for \$5.50 and Variocoupler \$5.00; designed by electrical engineers and finished by instrument maker. Sweeney Battery, 80 ampere hour, made of hard rubber, (can't leak) \$22.00. Variable condensers \$3.75. Phone condensers 35 cents; Grid condensers and leaks 50 cents.

SWEENEY RECEIVING SET—5 tube receiver (two stages of radio frequency amplification) detector and two stages of audio frequency amplification. Wave length 175 to 1000 meters. This is a wonderful set; price \$150. SEND 15c for illustrated instruction book, hook-up diagrams and complete catalog. Lowest prices and latest radio developments.

Write Dept.



FOR RELIABLE BROADCAST RECEPTION Use a "Master Radio Broadcast Receiver" Handsome in appearance, simple in control, highly efficient in operation, it receives concerts with remarkable clarity. Fulfills every desire of those who are particularly exacting in their requirements. Price, without receivers, batteries and tube, only \$85. Prompt shipment.

Order One Today or Send for Circular
Master Engineering Co., Omaha, Neb.



SPECIAL INSTRUCTION OFFER to readers of "Radio"

Here is your opportunity to get the most reliable, complete, up-to-date radio instruction course under a special arrangement if you take advantage of this offer within 30 days.

By this special offer you can get The Radio Reading Course which gives all the technical details in easily-understood, non-technical language by a foremost radio engineer, inventor and a "father" of radio telephony. Five Lecture Books with over 100 graphic drawings give you the knowledge you need to intelligently buy, design, build, operate and maintain radio receiving apparatus. It will add new pleasure to your hobby and save you large sums of money needlessly spent in the wrong apparatus. Its study will tell you how to build your own apparatus, locate and correct troubles, discriminate between the various types of apparatus, to make your apparatus more efficient and in a hundred ways give you a thorough knowledge of radio science.

Not a re-written left-over from radio of years ago, but of radio as it is known and practised today in the great radio research laboratories. And all in such a way that its reading will be your chief recreation.

Make This Investment

If you want to really enjoy Radio and get the utmost in results, make this small investment which will be returned many times over—you will quickly save \$50 to \$100 that you would needlessly spend for the wrong apparatus. Costs only \$10.00, and if you act quickly you can take advantage of a special easy plan. Send the attached order form and only \$3.50 and the first Book will be forwarded at once. Then send balance (\$6.50) and you get the complete course. But act quickly.

COUPON

RADIO COURSES, Inc., Dept. A7,
15 E. 40th St., New York, N. Y.

Gentlemen: Herewith \$3.50 money order (or check), for which send the first Lecture Book of the Radio Reading Course. Upon receipt I will then send balance (\$6.50) for the complete course of Five Lecture Books.

Name.....
Street.....
City and State.....

Continued from page 52

Like a Banshee with its tail caught in a wringer, Motif G-777 with all its exquisite chromatic suffering went shrieking and cavorting through Domesticatoriums, Religioriums, Concertariums, Cabaretoriums and Operariums. It broke the Windillium, Stringilium, and Vocalium controls on the great Temperamentoriums. It set towers to vibrating as in a wind. It rocked skyscrapers as does an earthquake. Its screech drove milling crowds into a frenzy. In the space of a few seconds, the world had changed from a haven of peace into an abode of insanity to the degree that an opera singer rushed into the street in Vienna and offered to sing for nothing.

HARDLY had the world begun to realize the awful thing that had leaped at it out of the silences when a new note intruded itself into the ensemble—a roar, a rumble—like the growl of distant surf. Within the Arctic Circle, where the University of The North had its polar laboratories, a little bent spectacled man—Professor Credo Nemo—raised his head and listened. He alone, of all the earth's startled, frightened millions, knew the answer.

He was the wizard of all known science. For nearly a century he had spent his time stealing ideas and developing them as his own. He knew the width of the fourth dimension, the thickness of the inch, and the ultimate parking place of Time. He had lived on the top of the earth for years to be next to Infinite Space in case anything went wrong with Creation and the services of an expert were needed. To him the growl that had crept into the awful Motif G-777 meant but one thing.

"Static!" he whispered. And again—"Static!"

It was even so. The great carrier wave, flung from the giant projectralia of the Yap station, carrying in its bosom the frequency of Oriental chromatics, was taking in every known vibration. It was heterodyning with the inner forces of Nature, the other force of the Universe, the surf beat of planetary oceans. Now it had become intuned with static, the great ocean of all Time and not even Professor Credo Nemo could predicate the result.

Acting on an impulse, the professor reached for his Vocophone, an invention of his own. The twist of a knob and a sound ray, more powerful than any known wave, raced toward the assembly had at Yap, where the international trustees clung to each other with staring eyes, paralyzed by the terrible bedlam they had started.

"Beware!"

The words were those of Professor

Continued on page 56

Tell them that you saw it in RADIO

"All-American" Type R-10 Radio Frequency Amplifying Transformer 150-550 Meter

\$4.50



For amateur and commercial receiving instruments. Sharp enough for the most discriminating and so simple the laymen can easily tune. Efficient, effective and well made. Can be used with Radiotron.

Cunningham, Moorehead, A. P. or Meyer tubes.

Attractive discounts to jobbers. Send for illustrated folder.

Rauland Manufacturing Co.
Successors to All-American Electrical Manufacturers

35 So. Dearborn St. Chicago, Illinois

Also manufacturers of "All-American" Audio Frequency Amplifying Transformers—50 Watt. Power Tube Sockets. Grid-condensers. Send for folder.



Firco Radio Apparatus

For sale by all prominent dealers

JOHN FIRTH & CO., INC.

Pioneers since 1901

709 Sixth Ave.

New York

"SHAMCO PRODUCTS"

Amateurs: Send 5c in stamps today for our new Catalog L showing complete line of parts, raw materials and high grade apparatus.

Dealers: Write for our attractive proposition.

THE SHOTTON RADIO MFG. COMPANY, INC.

8 Market St.

Albany, N. Y.

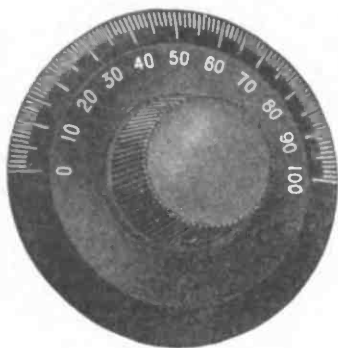

"R-E-M-C-O" DIALS



"ANTI-CAPACITY"

Metal Shield Moulded in Back, Registered U. S. Pat. Office. (Pat. Pending)

With Grounding Contact Brush.

Brush travels in a depressed Groove or Track and acts as a stop. Eliminates all body capacity effects.

Also "REMCO" Standard Dials

All with Stop Track Moulded in Back Tapered Knob and Dial Moulded in One Piece.

Licensed under "GREBE" Design Pat. 57900

Beautifully Engraved with Brilliant White Scale and Figures.

Moulded of "REDMANOL", the same phenol synthetic material as used by the U. S. Govt. for its Aeroplane, Field and Ship Wireless Sets.

ELECTRICALLY PERFECT

"REMCO" Dials retain their shape indefinitely and turn true on projecting moulded shaft hub.

Scientifically tapered knurled knob allows fingers to release without disturbing fine adjustment. Above features exclusive with "REMCO" Dials.

"REMCO" Dials made 3 1/4" and 4" diameter—For either 1/8" or 1/4" Shafts. Separate tapered knurled knobs to match.

"REMCO" No. 500 Standard Dials	3 1/4" Diam	List \$1.00
"REMCO" No. 502 Standard Dials	4 "	" \$1.50
"REMCO" No. 501 Anti-Capacity Dials	3 1/4" "	{ Metal Shield Moulded in Back—Pat. Pending and G'nd'g Contact Brush }	" \$1.50
"REMCO" No. 503 Anti-Capacity Dials	4 "	" "	" \$2.00
"REMCO" No. 510	{ Tapered Knurled Knob For Rheostat or Switch }	8/32 Bushing " 30c

QUANTITY PRODUCTION NOW PERMITS ABOVE REVISED PRICES

RADIO EQUIPMENT AND MFG. CO., 564 Atlantic Ave., Brooklyn, N.Y.



HERE THEY ARE

LOOK THEM OVER AND ORDER FROM BELOW LIST

Volts	type	kind	taps	price
22.5	Large	varia.	5	\$2.50
22.5	Large	plain	.	2.10
22.5	Small	varia.	5	1.50
22.5	Small	plain	.	1.25
45	Parl 45	plain	.	4.00
45	Parl 45	varia.	6	4.50

All about our mystery ad next month

PORT ARTHUR RADIO LABORATORY
PORT ARTHUR, TEXAS

IN STOCK

Holtzer-Cabot Head-phones. Navy head-band, nickel plated case, carefully made. \$8.00

Murdock type 56 headset
2000 ohm - \$5.00
3000 ohm - 6.00

Federal Radiophone Receiver

The leading low-priced radio set. Complete ready to connect to your aerial. It works! \$25.00

Special—100 ft. of aerial wire with the set during June.

Aerial Wire

7 strands of No. 22 pure copper. Only 65c per hundred ft. \$6.00 per thousand.

WE HAVE THE AMPERITE

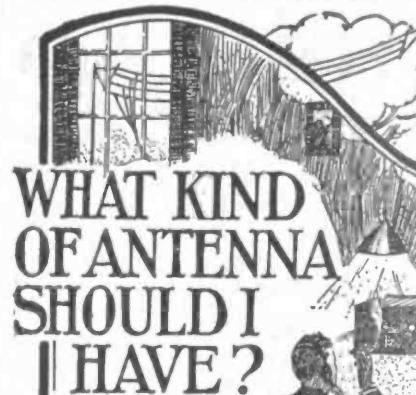

WHAT KIND OF ANTENNA SHOULD I HAVE?

How long should I

make it? Is a cage aerial as good as an inverted "L"? What are the latest developments in loop aerials? How can I build a good amplifier? What equipment will I need to receive longer wave lengths? How can I hook up my apparatus differently to get 50% better results?

These, and thousands of other important questions are analyzed in



Lefax Radio Handbook is the first real authority on all radio subjects. Lefax knows all—tells how—in every phase of radio.

Its authors are Dr. J. H. Dellinger, Chief of the United States Bureau of Standards Radio Laboratory and L. E. Whittemore, Alternate Chief. It has been officially examined and approved by the Bureau of Standards to insure absolute accuracy.

Lefax is technically correct, yet written in everyday language. It insures success in radio for the novice and provides a reliable source of data for the experimenter.

It contains *not* opinions, *not* hearsay, but tried and tested facts—and always the newest.

Knows all—Tells how

Lefax (Leaf facts) is loose leaf. By using the Lefax service, you can add new pages every month and keep your handbook perpetually up to date.

The price of Lefax is \$3.50 in a handsome six-ring binder. It is the cream of radio research in pocket size. Ask your radio or electrical dealer for your copy. If he has not yet secured a supply, order it through him or mail us \$3.50 for your copy, postpaid.

LEFAX, Inc.
Room 153-A 9th & Sansom Sts., Philadelphia, Pa

Publishers of loose leaf handbooks on scores of scientific and technical subjects which are used as authorities by engineers, scientists, universities and technical schools throughout the country.



Always ready~
Always new!

HAVE YOU SUBSCRIBED?

YOU CAN SAVE A DOLLAR BY MAILING US YOUR SUBSCRIPTION TO "RADIO" BEFORE JUNE 30TH.

THE RADIO STORE

90 North Los Robles Avenue
After July 1st, 562 East Colorado Street
PASADENA, CALIFORNIA

Alta-Robles Receiving and Loud Speaking Outfit	\$ 537.00
Kennedy Intermediate Receiver—type 220.....	\$125.00
Kennedy Two Stage Amplifier—type 525.....	85.00
Western Electric Headset—type 1002-C.....	15.00
One Detector and Two Amplifier Tubes.....	18.00
Magnavox Loud Speaker—type R-3 with 14" horn.....	45.00
Magnavox Two Stage Power Amplifier—type AC-2.....	80.00
Amplifying Transformer.....	7.00
Two 5 watt Power Amplifying Tubes.....	16.00
B Batteries.....	24.00
Edison Storage Battery—6 cell B-4 75 amp. hr.....	78.00
Tungar Rectifier—5 ampere 50 cycle.....	36.00
Antenna Equipment.....	8.00
Alta-Robles Outfit with 60 cycle Tungar Rectifier	\$531.00
Pasadena Receiving and Loud Speaking Outfit	\$440.00
Kennedy Short Wave Receiver—type 281.....	\$ 80.00
Kennedy Two Stage Amplifier—type 521.....	55.00
Western Electric Headset—type 1002-C.....	15.00
One Detector and Two Amplifier Tubes.....	18.00
Magnavox Loud Speaker—type R-3 with 14" horn.....	45.00
Magnavox Two Stage Power Amplifier—type AC-2.....	80.00
Amplifying Transformer.....	7.00
Two 5 watt Power Amplifying Tubes.....	16.00
B Batteries.....	24.00
Two Willard Wireless Storage Batteries—6v. 80 amp. hr.....	56.00
Tungar Rectifier—5 ampere 50 cycle.....	36.00
Antenna Equipment.....	8.00
Pasadena Outfit with 60 cycle Tungar Rectifier	\$434.00
Pasadena Outfit with 50 cycle Homcharger Rectifier	\$424.00
Pasadena Outfit with 60 cycle Homcharger Rectifier	\$424.00
Alta-Universal Receiving Outfit	\$450.00
Kennedy Universal Receiver—type 110.....	\$250.00
Kennedy Two Stage Amplifier—type 525.....	85.00
Western Electric Headset—type 1002-C.....	15.00
One Detector and Two Amplifier Tubes.....	18.00
B Batteries.....	9.00
Edison Storage Battery—5 cell B-4 75 amp. hr.....	65.00
Antenna Equipment.....	8.00
Alta-Universal Outfit with Willard Wireless Storage Battery	\$413.00
Alta-Universal Outfit with Edison Battery & Magnavox R-3	\$495.00
Alta-Universal Outfit with Willard Battery & Magnavox R-3	\$458.00
Alta-Intermediate Receiving Outfit	\$325.00
Kennedy Intermediate Receiver—type 220.....	\$125.00
Kennedy Two Stage Amplifier—type 525.....	85.00
Western Electric Headset—Type 1002-C.....	15.00
One Detector and two Amplifier Tubes.....	18.00
B Batteries.....	9.00
Edison Storage Battery—5 cell B-4 75 amp. hr.....	65.00
Antenna Equipment.....	8.00
Alta-Intermediate Outfit with Willard Battery	\$288.00
Alta-Intermediate Outfit with Edison Battery & Magnavox R-3 ...	\$370.00
Alta-Intermediate Outfit with Willard Battery & Magnavox R-3 ..	\$333.00
Alta-Broadcast Receiving Outfit	\$213.00
Kennedy Short Wave Receiver—type 281.....	\$ 80.00
Kennedy Two Stage Amplifier—type 521.....	55.00
Western Electric Headset—type 1002-C.....	15.00
One Detector and two Amplifier Tubes.....	18.00
B Batteries.....	9.00
Willard Wireless Storage Battery—6 volt 80 amp. hr.....	28.00
Antenna Equipment.....	8.00
Alta-Broadcast Outfit with Magnavox R-3	\$258.00

Prices subject to change without notice.

Paul Franklin Johnson

Tell them that you saw it in RADIO

Continued from page 54

Nemo whose voice was familiar to every man in that vast auditorium.

"Beware," he said, "of the . . . Aurora Borealis!"

He had no need to finish. Stark staring horror clutched the trustees by the throats. The Aurora Borealis! Dull, sodden terror gripped them as the full significance of his words was suddenly driven home. If the awful thing they had started—that climbing, chromatic of Oriental harmony, mounting upward through a crescendo vibration scale ever heterodyned with the oscillation of the giant aurora as it crashed its great streamers of static hundreds of miles into the infinite spaces of the polar night.

. . . if that titanic exhaust from the earth's magnetic dynamos was tapped, the terrible aurora would become a destructive agent, turned upon its parent. There would be annihilation . . . complete extinction.

The international manager mopped his brow and for the first time in twenty-five well-guarded years, the perspiration trickled down his face unheeded.

"Nemo!" he gasped — "Professor Nemo . . ." He went stumbling across the room, clawing at the radiophone of the Polar Exchange. He jerked the receiver from the hook with a shaking hand.

"Nemo, Nemo!" he shrieked into the transmitter.

There was a whirr, heard faintly above the awful grind of the ascending Oriental theme . . .

"Yes?" It was the calm voice of the professor speaking.

"For God's sake, man . . . tell us . . . tell us what to do!"

The international manager's tone reflected something of the terror that gripped them all—masters of the world's music yet in the great lap of science—children all. "Tell us!" he pleaded.

For an instant there was silence, although no one present was in the least conscious of it. Then . . .

"The Fundamental Note—that is your only hope!"

The international manager repeated the words dully.

"The Fundamental Note . . . !"

With a scream of delirious joy he dropped the radiophone. In one stride he crossed the room and stood before the huge iridiscium vault—the burglar-proof, processed safe, built from an improved formula for restaurant pastry, in which the fundamental note of all music, placed there by the Association for the Betterment of Harmonic Standards and Melodic Welfare, reposed in a plush case—the most precious and vital possession in the world.

"It shall be done!" he exclaimed.

The others did not hear his words, on account of the din without. But

Continued on page 57

they sensed his meaning. Wang Yu Yuck sprang to his feet.

"Not that!" he screamed, "not that!"

This was the one thing he desired to prevent—the use of the fundamental note. It was the note upon which the entire tonic scale of the Occidental theme was built. Once that note was sounded—once its clear purity was sent forth into the world, there would be a revulsion against Oriental chromatics and the great cause of the East would be lost. And yet . . . the Aurora Borealis!

Even while he stood with outstretched hands, seeking a solution for this awful dilemma, feeling as he struggled for an answer that there was none, the international manager twirled the knob on the front of the vault, flung back the doors and from a shelf within removed the plush case. For a second he fumbled with the catch. The next instant he fronted the room, a tiny silver pitch-pine at his lips. In that instant Wang Yu Yuck made his decision.

Thrusting aside the detaining hands spread before him he jumped toward the international manager. But he was too late. Even as he poised, the clear, flute-like note of the whistle cut sharply through the room. The monster projectors overhead caught up the tiny vibration, magnified it, amplified it, regenerated it, patted it on the back, and shot it forth, cavorting around the globe through the storm of discords that raged and screamed in all corners of the sphere.

For an instant no change could be noticed and the international trustees, their faces white, their hands clenched, leaned forward and waited. Then there came a slack in the hideous crash of sound without. Gradually it began to die away, to slow down, to dissipate. A moment more, one could hear himself talk in the room. Another moment, the racket had died away all together. The next — there was silence — complete — unanimous!

With a great sigh the international manager walked to a huge auditorium where the world's great musicians clung to each other in bunches and wept. He spoke sharply to the leader, leaning against his music rack, his baton twisted into splinters.

"Give me that Oriental theme!" he said.

Without a word the leader turned and handed his music to the speaker. From player to player went the latter, collecting every scrap and atom of the awful chromatic music—with all the variations for piccolo, flute, organ, harp, harpischord, piano, banjo, ukulele, horn, violin, cello, viola, jews-harp and zither as well as the eighty-four copies held by the drummer. With the heap in his arms he returned to the trustees' room where a fire burned cheerfully in the grate.

Continued on page 58



HESLAR Equi-Tone PHONES
Durable, comfortable and efficient. Outside noises eliminated. Register most delicate sounds.

TRADE MARK
HR
C

Keeping FAITH!

You radio enthusiasts have heard of the many improvements and the unusually fine appearance of Heslar products. NOW YOU CAN SEE THEM! We present Heslar Radio Equipment knowing positively that it will please you.

Every Heslar product shows last minute improvements that are exclusive. We stand back of every one of them. Go to your dealer NOW. Ask for HESLAR RADIO EQUIPMENT, or—

Write for Catalog and Literature



HESLAR VARIABLE CONDENSERS
23 Plate and 41 Plate. Designed by engineers with 14 years experience. Special plates, rounded to enable perfect adjustment at lowest capacity.



HESLAR SOCKETS
Four distinct improvements. Formica post, assure perfect insulation. Blades locked by counter-sinking in Formica base. Admits all steel base tubes.

HESLAR

RADIO CORPORATION
INDIANAPOLIS U.S.A.

With Heslar Radio the World's your Neighbor

Radio Frequency Transformers

The R. T.—1 Transformer Works on All Standard Makes of Tubes

For Amateur and Broadcasting
Range 175-500



Type RT-1,
Price \$6.00

Mr. Amateur: Hook up a radio transformer ahead of your detector and get acquainted with stations you have not heard before.

The Type RT—1
Transformer of special R. F. iron core construction. (Patent pending.)
Transformer having complete shielding.
Transformer covering the amateur wave-length efficiently.
Transformer giving maximum amplification per stage.
Transformer designed by former Government radio engineers
Commercial and special range R. F. transformers supplied

RASLA SALES CORPORATION Inc.
National Distributors for Radio Service Laboratories
10 EAST 43rd STREET NEW YORK CITY

Tell them that you saw it in RADIO

IMMEDIATE DELIVERY

WESRAD

MOUNTED

Amplifying Transformer

AUDIO FREQUENCY

*It brings in those Weak Signals
Latest and Most Efficient Design*

\$5 JOBBER • DEALER **\$5**
Write for Attractive Proposition
USE OUR NEAREST STORE

WESTERN RADIO ELECTRIC CO.

1200 Franklin St., Oakland, Cal.

637 So. Hope St., Los Angeles, Cal.

**COMPLETE WITH HEAD PHONES
AND
MATERIAL FOR ANTENNA**

Puget Type "F"

Now

Crystal Receiving Set \$16.50

Excellent for camps and homes within twenty to twenty-five miles of a broadcasting station.

EVERY RADIO NEED



Times Square
Building

Main 5388

ADVANCE UNIT CHARGER

A perfected device guaranteed for one year. Will charge 6 volt radio or auto battery over night. Self polarizing, automatic. The only charger that will stand rough use. We also manufacture the Advance Motor Rectifier for service stations. Capacity 24-6 volt batteries 1-15 amperes. Fully automatic and highest efficiency. Ask for particulars.

\$18.50 Complete

ADVANCE ELECTRIC CO.

1260 W. 2nd St.

LOS ANGELES Phone Pico 5990

Continued from page 57

Without a word he hurled the mass into the flames, watching the fire lick them up greedily. When the last scrap had been burned, when the pile of what had almost marked a millenium in world affairs had been reduced to a grey ash, the international manager turned back to the guardians of the world's musical destiny. His voice was a bit shaky, but he did fairly well, considering what he had been through.

"Gentlemen," he said, "that was a narrow escape. Five minutes more and we would have been responsible for the grandest display of fireworks this world has ever seen." He paused and his eyes fell on Wang Yu Yuck, his head pillowed on his arms on the great mahogany table.

"Wang Yu Yuck," he said sternly. "Go back to your people!"

The delegate from the Far East raised his head. He was aged and broken—a crumbling remnant of a man. He lifted his arms.

"Yes—I will go back," he said. There was infinite sadness in his voice. "Back . . . empty handed!"

The international manager shook his head.

"No," he said. "You shall not go back empty handed. You will go back with this!"

He held out—the little silver whistle. Wang Yu Yuck stared at him, uncomprehending.

"Go back to your people," repeated the international manager. "Bring them the message of the Occident—of pure harmony. Tell them that the theme of the Orient is gone forever. Tell them that trying to impose it on the Western world missed converting the earth into a hell by a margin of seconds and a couple of oscillations. Become a prophet and a teacher of your people. And whenever you see an enthusiast from Thibet to the Ganges who seeks to revive anything resembling Chinese music, take this little silver whistle out of your pant's pocket and blow—blow for the peace of humanity and salvation of your race!"

His words rang with dramatic force throughout the room. Slowly Wang Yu Yuck staggered to his feet, clutching the whistle in his hand. For a moment he seemed about to speak, and then with his face working convulsively, he turned from the little group of men around the table and staggered to the door and so out into the yawning maw of the Far East—a quivering, palsied exponent of a decadent epic.

As the door closed behind him, the international manager touched a button on the table. In the great auditorium, the splintered baton of the world's orchestra leader clicked for attention. He semaphored a design in the air. In-

Continued on page 60

Tell them that you saw it in RADIO



TRESKO

Seven Years in Radio
—Think What That Means!

TRESKO SECTIONAL UNIVERSAL

Licensed Under Armstrong U. S. Patent No. 1,118,149

The Tresko Tuners were among the first ever made under the Armstrong Patent. They are found in all parts of the world, giving satisfactory service. The sectional idea is original with us.

The instruments are identically the same as those we have been manufacturing for seven years—but we have made their casings on the plan of the sectional bookcase—each a separate unit which, when put together with a top and base, forms one complete section.

The set consists of three units :

1. Tuner and Detector.
2. Two-Stage Amplifier.
3. Case for "A" Storage Battery.

The sections are of oak, finished in French gray, making an extremely attractive piece of furniture—something you will be proud to have in your home, beside your phonograph or piano. No wires or battery on the floor.

PRICES

Tuner and Detector Unit without vacuum tube, head set or "B" Battery	\$ 50.00
Two-Step Amplifier Unit without vacuum tubes or "B" Battery	35.00
"A" Battery Unit for holding "A" Battery	9.50
Top and Bottom, which, when added to the three other units, make a complete section all in one. Each, \$5.00; both	10.00
Complets set of five units—Total	\$104.50

The units when assembled make a cabinet 40 inches wide, 15 inches high and 10 inches deep.

We do not furnish vacuum tubes, batteries or head sets.

TRESKO SECTIONAL UNIVERSALS are being supplied to dealers and jobbers just as fast as possible. Order from your local dealer. If he cannot supply you, we will fill your order upon receipt of prices as given.

Dealers and jobbers are rapidly finding out that TRESKO is one of the very few manufacturers who is actually in position to take care of large volume orders for immediate shipment. Liberal discounts are given to jobbers and dealers for quantity orders. We do not furnish vacuum tubes, batteries or loud speakers.

Tresko

RADIO

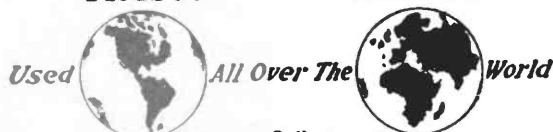

J. Matheson Bell, Sales Mgr. Davenport, Iowa, U.S.A.

Tell them that you saw it in RADIO

"M.P.M." STANDARD

Nature's Finest
Tested

MINERAL

Mail \$1 Bill, M. O., or
Check to

Million Point Mineral Co.

San Francisco Office
1254 CLAY STREET

Pacific Radio Exchange

439 Call Building
SAN FRANCISCO

Manufacturers and Jobbers

Write for
trade proposition

"PARADEX"
Vacuum Tube
Receiving Set

"PARADIO"
Crystal
Receiving Set

BUILD YOUR OWN

Build your own the way you want it. Buy your panels from me already drilled, ready to mount your instruments. I also have rheostats, sockets, jacks, plugs, binding posts, switches and switch points in stock at all times.

3/16" Formica, per sq. in. 2 1/2 c
1/4" Formica, per sq. in. 8 1/2 c

GEO. F. MARTIN
RADIO PANEL SHOP

1108 S. 3rd St.
Evansville, Indiana

Continued from page 58

struments swung to position. The next instant, there burst from the giant oscillators—far-flung into the waiting instruments of an anxious world, a message of confidence from the dictators of music to their subjects—the popular paean of universal peace and harmony—"Middle E Uber Alles!"

The crisis of October, 1950, had passed!

Continued from page 51

of the country. The broadcasting of a direct personal message such as President Wilson made to Congress on the day we declared war would have made America's position immediately known to the world. It is unlikely that any international broadcasts will be sent out by the Naval stations except experimentally or in the event of a declaration of vital national importance.

Radio time signals sent out from the Annapolis station have been heard at the Antipodes, or half-way around the world. According to C. E. Adams, official astronomer and seismologist at the Hector Observatory, Wellington, New Zealand, time signals sent by radio from the Naval station at Annapolis, Md., were heard distinctly by him. Another report received by the Naval Observatory from Australia stated that the time signals had been heard there within a fraction of a second after their transmission, apparently coming both ways around the world.

Of course the electric light lines are the property of the lighting and power companies, and objection may be registered by these companies if their lines are used as antennae for receiving without their permission, but in the event that they do, it is possible that they may themselves establish broadcasting stations.

CALLS HEARD

AT 1PB, NEWTON, MASS.

C. W.—1aco, (1adl), 1agi, 1aip, 1ajp, (1ary), (1awo), 1azw, (1axz), 1bdc, 1bdi, (1bet), (1bkq), 1bpz, 1bqe, 1bql, (1brq), 1bsd, 1bym, (1cak), 1cct, 1cik, (1cpn), 1csc, (1ec), 1ii, (1lz), 1on, 1pb, (1qp), (1uj), (1vt), 1xz, (1yb), 1ze, (2aab), 2aif, 2aja, 2alw, 2aqh, 2aqi, 2awf, 2awl, (2axk), (2ayv), (2azz), 2bcf, 2bca, 2beb, (2beh), 2bgi, 2bgl, 2bjq, (2blp), (2bnz), 2bqd, 2bqu, 2brb, 2btj, 2caw, 2cft, 2ciz, 2dk, (2dx), (2fc), 2fp, 2kp, 2lo, 2lh, 2nz, 2ry, 2sq, 2wxm, (2zk), 2zk(ph), 3ajd, (3all), (3alu), (3aln), (3any), 3aqh, 3atg, 3aj, 3ba, 3wt, (3bec), (3bij), (3bnu), (3btk), 3buv, (3bz), 3cc, 3em, (3fm), 3gh, 3il, 3ir, (3iw), 3nh, 3qz, (3vw), 4by, 4gl, 4ili, nx4, 4za, 4zc, 5da, 5fv, 5la, 5nz, 8afj, 8agk, 8ago, 8ahq, 8ahk, 8alt, (8amk), 8anb, 8aqf, 8aqz, (8ark), (8asv), 8aub, (8avl), (8awm), 8awx, 8axb, 8axc, 8axy, 8bel, 8bdu, (8beo), 8bef, 8bgd, 8bil, 8bja, 8boo, (8blx), 8blt, 8bnv, 8bqv, 8bsy, 8bso, 8bu, 8buq, 8bux, 8ebj, 8cfp, 8chz, (8cmm), 8cnn, 8cql, (8coo), 8cpc, 8cpg, 8ctz, 8dv, 8ev, (8hj), 8jj, 8ks, 8nb, 8oz, 8pn, 8pt, 8uc, 8uk, 8vj, (8vv), 8xe, 9aap, 9adx, 9aly, 9aja, 9ajh, 9ark, 9avg, 9ayh, (9axf), 9blc, 9ct, 9dax, 9dky, 9drq, 9dzq, 9fs, 9km, 9pf, 9wu, (9uh), 9zl, Canadian 2bg, (8bp), 8iz, 9al.

Daylite—(1ary), 1bdc, (1lz), (1bkq), (1qp), (2aab), (2azz), (8bec), (8iv), (8amk), (8awm), (8beo), 8xe, (9blc).

Spark—1adc, (1ary), 1azk, 1bhr, 1bop, 1boq, 1bpz, (1brq), 1fm, (1yb), 1yd, 2aje, 2aqi, 2awf, 2ct, 2dn, 2fp, 2jz, (2pv), (2sz), 2ts, 2wb, 8aj, 8ba, 8wt, 5fd, 8acf, 8ahq, 8axo, 8axy, 8bsy, 8ms, 8vq, 8xe, 8zo, 9awg, 9arg, (9axf), 9asa, 9dsi, Canadian (8bp), 3fo, Daylight 1ary, (2pv), 8zo.

Tell them that you saw it in RADIO

Nationally Advertised



G-W Sliders and Rods

G-W sliders make perfect electrical contacts due to a patented bow spring which presses firmly against the slider rod, and a spiral tip contact spring which tunes on a single wire and slides across the coil easily in either direction without cutting the wire.

3/16" 25c

1/4" 30c

Plenty of Other Sliders But None
With the Advantages of G-W

More G-W Sliders sold than all other makes combined.

The G-W Improved Detector

Corrects the faults common to most detectors. Position will not loosen after setting. Entirely new design of crystal cup—no screws—locks automatically. Mechanically and electrically perfect. Up to the usual G-W Quality Standard.

Distributors Wanted

Gehman & Weinert

Manufacturers of G-W Radio Products
42 Walnut St., Newark, N. J.
Address inquiries to Dept. C.

BERKELEY CALIF.

RADIO FREQUENCY TRANSFORMERS
MURAD

T-11 \$6.00
T-11A \$6.50
T-11B \$7.00

For 1st, 2nd and 3rd stages respectively
U. C. BATTERY
and ELECTRIC CO.

2158 University Ave.

Vacuum Tube Detector \$5.50

Including complete cabinet with all instruments wired ready for use
Detector and Two Stage Amplifier \$22.50



With transformers and all other instruments in cabinet, ready for operation. This equipment is of high quality, and distances of as high as 3,000 miles has been obtained with ease.

Batteries and Tubes extra
2000 Ohm Receivers \$5.00
Superior Crystal Receiving Set
\$4.75

Attractive dealers' proposition

STEINMETZ WIRELESS MFG. CO.
5706 Penn Avenue, Pittsburgh, Pa.

Magnet Wire

AT SPECIAL PRICES

Send For Our Prices
IZENSTARK RADIO CO.
509 S. State St., Chicago

Better Radio Receiving

Improve the Reception of Your Radio Set



Every radio enthusiast desires to get the most out of his set, and feels unusually proud when he is able to secure better results than his neighbor. A radio receiving set is only as good as the receivers used with it. To secure maximum results, use a set of Kellogg radio receivers, which are built by the Kellogg Switchboard and Supply Company for radio use only.

Kellogg radio receivers are unusually sensitive and require minimum of pressure on the ears, resulting in clear, distinct transmission. The extreme lightness in weight is a noteworthy feature to any one listening to a radio concert. Heavy, bulky receivers become most disagreeable. The head band is strong, of neat construction, and the receivers easily ad-

Listen in—On the World—with Kellogg

justed for the most comfortable position. Kellogg sets will not disarrange a lady's head dress. Kellogg radio receivers are the choice of the professional, as well as the amateur, due to their many points of superiority.

Order a set today. If your dealer does not have them, write us.

Kellogg Microphones



vice. This product is so arranged as to prevent the mouth being placed inside the transmitter mouthpiece, thus assuring perfect modulation.

Kellogg No. 21 Microphone is a hand microphone with a switch in the handle and made up to government specification and will stand extraordinary severe service.

Kellogg Tube Sockets



Kellogg molded tube sockets fit all standard four prong vacuum tubes. Four German Silver springs with rounded ends are firmly held in position in deep grooves. Cannot touch mounting surface. Binding posts plainly marked for wiring.

Kellogg sockets are 2 3/16 inches square with round corners, with a total depth of 1 1/4 inches.

Kellogg Insulators



Kellogg No. 3 strain insulators consist of Bakelite rods in which are firmly inserted metal end rings. These insulators stand a direct pull of approximately 350 pounds.

Nos. 4, 5 and 6 are the same as No. 3 except the length. The lengths are: No. 3, 3 inches; No. 4, 2 inches; No. 5, 4 inches; and No. 6, 6 inches.

Dealers and Jobbers
Write for Your
Discounts

We also manufacture
radio jacks, plugs,
condensers and other
radio accessories

Kellogg Switchboard and Supply Company

Manufacturers of Standard Telephone Equipment

CHICAGO, ILLINOIS

Tell them that you saw it in RADIO



When you see the name Teagle on a radio instrument you know that it is a BETTER piece of apparatus. Send for catalog.

THE NEWMAN-STERN CO.-CLEVELAND, OHIO

IMITATIONS!

NAA Arlington Tested Detector Crystals have won their reputation through sheer goodness—through their marvelous and uniform sensitiveness—by the honesty with which they are tested, packed and guaranteed.

That there should be imitations of these nationally famous minerals is to be expected. We welcome fair competition. But unscrupulous imitations are unfair both to you, the user or dealer and to us, the pioneer producers of tested crystals.

Certain unscrupulous manufacturers are marketing imitation tested minerals in packages closely resembling the famous NAA containers. We have obtained and tested dozens of these so-



called tested crystals—some are without a sensitive spot on their surface—others are of mediocre quality—not one meets the rigid requirements of our testing laboratories.

We sell sensitiveness, not bulk minerals. Pounds of crystals are worthless—Galena for instance, is cheap—the market price is less than 8c a lb. For crystals worthy of efficient radio use insist upon the genuine NAA (Arlington tested) Detector Crystals. For your own protection look for the signature of J. S. NEWMAN the originator, on every container. It will insure guaranteed sensitiveness. Each is packed in lithographed metal container. The mounted crystals are set into brass cups and packed in enameled turned wood boxes.

NAA Galena Silicon or Goldite, price per crystal, post paid, \$0.25. Mounted, set in Woods Metal in brass cup, price per crystal, post paid, \$0.40.

We will gladly replace without charge any NAA Crystal that does not function to the entire satisfaction of the user. Send for complete 80 page radio catalog describing these crystals, The Teagle Line, "Red-Head" Radio Receivers and all the leading makes of Radio Equipment. The Newman-Stern Company, Cleveland, O.



"RED-HEADS"
THE LAST WORD IN
RADIO RECEIVERS
at your dealers or
send direct to
The Newman-Stern Co.
CLEVELAND, OHIO.

FREE THIS MONTH
VACUUM TUBE

WIRELESS RADIOPHONE & CODE SET

Also the Wonderful OMNIGRAPH Set for learning the Code, best Theory and Text Books given FREE with our Simplified Spare Time Professional Home Course

LEARN WIRELESS

The demand for experts exceeds supply. Pays \$125 to \$250 monthly up to \$10,000 a year or more

COURSE FOR AMATEURS
SHORT—LOW COST
Non-technical, qualifies you for Amateur License.

FREE
LEARN-O-GRAPH

Code Sender and Text Books with Amateur Course Free Booklet—"How to Become a Wireless Operator."

New York Wireless Institute
154 E-Nassau St., New York City

REACTANCE AND SUSCEPTANCE DIAGRAMS

Continued from page 22

is shown as b_{10} . The corresponding reactance diagram is shown as X_{10} . This circuit has three resonance points, two of zero reactance for 410 and 650 kilocycles respectively and one of infinite reactance for 520 kilocycles.

Fig. 11 illustrates the diagrams for a series resonant circuit and a parallel resonant circuit in series. X_3 is the reactance diagram of the series resonant circuit (L_1C_1) and X_4 is the reactance diagram of the parallel resonant circuit (L_2C_2). The reactance of the entire circuit is the algebraic sum of X_3 and X_4 and is shown as X_{11} . The corresponding susceptance diagram is shown as b_{11} . This circuit has three resonance points, two of zero reactance for 260 and 680 kilocycles respectively and one of infinite reactance for 410 kilocycles.

Fig. 12 illustrates the diagrams for a series resonant circuit and a parallel resonant circuit in parallel. b_3 is the susceptance diagram of the series resonant circuit (L_1C_1) and b_4 is the susceptance diagram of the parallel resonant circuit (L_2C_2). The susceptance of the entire circuit is the algebraic sum of b_3 and b_4 and is shown as b_{12} . The corresponding reactance diagram is shown as X_{12} . This circuit has three resonance points, two of infinite reactance for 260 and 680 kilocycles respectively and one of zero reactance for 410 kilocycles.

While all the foregoing diagrams have been drawn to scale and the results are more or less accurate, one of the greatest advantages of this method of analysis is that qualitative results may be obtained by drawing the diagrams roughly. For example, consider the circuit illustrated in Fig. 13. The shape of the reactance diagram for the first portion of the circuit is the same as X_3 (see Fig. 3). The shape of the diagram for the rest of the circuit is the same as X_{12} (see Fig. 12). The reactance of the entire circuit will be the algebraic sum of X_3 and X_{12} and is shown as X_{13} . This circuit will have five resonance points, three of zero reactance and two of infinite reactance. The exact points at which resonance occurs cannot be determined from such a rough diagram, but the general characteristics of the circuit can be clearly seen.

A study of the foregoing figures reveals many interesting facts. For instance, connecting any type of circuit in series with a parallel resonant circuit will not change the resonant frequency of the latter (See Figs. 4, 5, 6, 9 and 11), while connecting another circuit in series with a series resonant circuit will change the resonant frequency. Connecting any type of circuit in parallel with a series

Continued on page 64

Tell them that you saw it in RADIO

Prompt Service

We have the stock and facilities to ship your order within 2 hours after receipt. We carry all standard apparatus at list prices.

Radio Maps 50c

Something you need right now. Gives Broadcasting Stations, location, schedules, etc.

Send for your copy now.

Standard Radio Co.

59 East Adams St.
CHICAGO, ILL.

LOS ANGELES

The Busiest Radio Store
in California

The Radio Concert Equipment Co.

WILL BRENNAN - MANAGER

Mail orders given prompt attention

"The Finest in Radio"

734 West Sixth St. Los Angeles

"B" BATTERIES

AN

EVEREADY

PRODUCT

48V. Batteries, tapped.....\$5.00
22½ V. Batteries, Navy Type..... 3.00
22½ V. Batteries, Commercial Type..... 2.00

Letter two types especially adapted to Cunniffham and Radiotron Tubes.

Postage Prepaid Anywhere in U. S.

ETS-HOKIN & GALVAN

Wireless Engineers

10 Mission Street

San Francisco

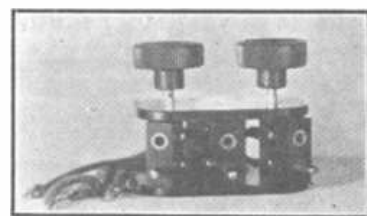

Precision Shop
Adjustable Coil Mount.
\$7.00

Made of highly polished Formica, flexible cord connections, suitable for table or panel mounting. A handsome addition to any receiver.

Attractive Proposition to Dealers

Manufactured by
The PRECISION SHOP
Gridley, Calif.

B. M. SPENCER, Prop.

We build radio receivers, transmitters and apparatus of any description to order—prices reasonable—best of workmanship.

Operating Broadcasting Station KFU

C — THE — MANUAL W

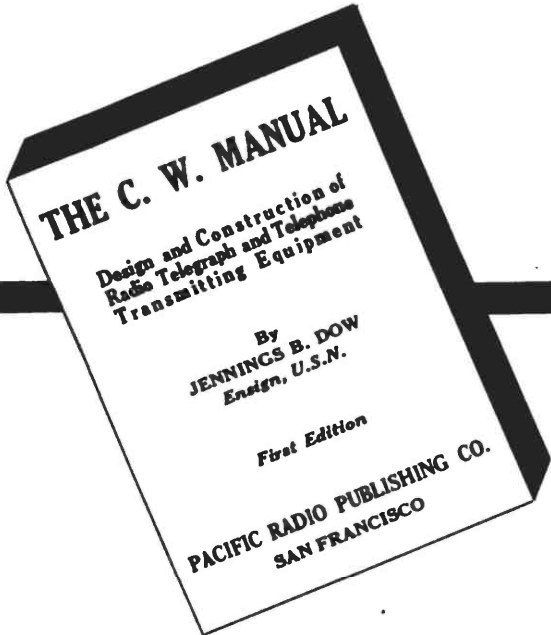

Jennings B. Dow, U. S. N.
AUTHOR OF THE C. W. MANUAL

The Only Complete Textbook
Of Its Kind on the Market

*Tells You How to Construct
Any Type of Tube Transmitter*

EVERY radio experimenter should have a copy of The C. W. Manual. Don't be content with a receiving set. Install a transmitter and talk—by voice or telegraph—to your radio friends. It's fascinating and simple. Anybody can construct a small vacuum tube transmitter by following the directions outlined in this book. Discard that troublesome and noisy spark transmitter and install one of the highly efficient transmitters described in The C. W. Manual. Everything in C. W.—from the smallest tube set to the transmitter that employs 250 watt tubes—is described in detail. A small, inexpensive tube transmitter will outdistance the expensive spark and assure you of reliable communication under almost any atmospheric conditions.

The C. W. Manual contains 112 pages of the most timely data on the vacuum tube transmitter and power amplifier. There are eleven chapters—profusely illustrated, and detailed drawings accompany every phase of the subject. The book is substantially bound in board and is just the right size to fit your pocket. The author of The C. W. Manual has many years of C. W. experimenting to his credit and all apparatus described in the book has been thoroughly tested to his entire satisfaction.

\$ 1.00
Per Copy Postpaid
Anywhere in the
United States.

Profit from the experience of those who know. Put your transmitter in the better class. Experience the joy of long distance communication and record breaking that is not possible with the obsolete spark transmitter. Get your C. W. or telephone set on the air before the static season is here. Work right thru the summer without a break.

DEALERS: Write for attractive proposition.

CONTENTS

- Chapter I—The Vacuum Tube Transmitting Circuit.
- Chapter II—C. W. Circuits to Date.
- Chapter III—Experimental Phone Circuits.
- Chapter IV—Ten Watt C. W. Transmitter, I. C. W. Transmitter and Phone Set Using Direct Current.
- Chapter V—Design and Construction of Ten Watt C. W. Transmitter for Use on A. C.
- Chapter VI—An Inexpensive 50 Watt C. W. Transmitter.
- Chapter VII—A Ten Watt Power Amplifier.
- Chapter VIII—Design and Construction of a 250 Watt Amplifier and C. W. Transmitter.
- Chapter IX—Rectifiers of Plate Supply Current for Transmitting Vacuum Tubes.
- Chapter X—Design of a Low Powered Circuit for Duplex Operation.
- Chapter XI—Notes for the Experimenter and Constructor.

THE FIRST EDITION IS NOW
READY FOR DISTRIBUTION
MAIL THE COUPON TO—
DAY and we will immediately send you
a copy.

RADIO
465 Pacific Bldg.,
San Francisco.
Herewith is \$1.00
for which you will send
The C. W. Manual to—

Name

Address

6-22

Tell them that you saw it in RADIO

For

BETTER

Results

USE

EVEREADY

'A' & 'B'
BATTERIES
 With Your
RADIO SET



FOR SALE

By Better Radio Sup-
 ply Dealers
 everywhere



Made on the Pacific Coast

By

National Carbon
Co., Inc.

599 Eighth Street
 San Francisco, Cal.

resonant circuit will not change the resonant frequency of the latter (See Figs. 3, 7, 8, 10 and 12); while connecting another circuit in parallel with a parallel resonant circuit will change the resonant frequency. If a circuit has two or more resonant frequencies, points of zero and infinite reactance will alternate (See Figs. 5 to 13, inclusive).

There are many other things of interest which may be learned from a careful study of these figures. While one can construct his own diagrams, those shown here for several typical circuits will be found to be useful, particularly when only qualitative results are desired.

NEW RECORDS BY 6ZAC*Continued from page 33*

system as well as his apparatus layout. The antenna is directly back of his home, and is unobscured, in the direction of the United States. The transmitter, which was described in detail in the May issue of RADIO, is shown mounted on the table, to the right of the receiver, which is of the regenerative type, with detector and two stage amplifier. The whole arrangement of the apparatus is with the purpose of obtaining the greatest possible efficiency, and the lowest possible antenna radiation resistance, which he appears to have accomplished in a very satisfactory manner.

Mr. Dow maintains a regular schedule with such stations as 6ZQ, Oakland, Calif., 6ZAF, Berkeley, Calif., 6XAF, Piedmont, Calif., 6ZZ, Douglas, Ariz., and 7ZU, Billings, Montana and numerous others. Since the summer static season has already arrived, it is indeed remarkable that such low power as is represented by the above stations, none of whom employ more than 100 watts, is able to cover the distance to Hawaii. Mr. Dow is now after the scalps of those who won the recent Transatlantic tests, and hopes soon to be reported in England and Western Europe, when the long cold nights of Fall and Winter roll around.

C. W. ASSOCIATION NOTES

Due to the press of business, practically the entire C. W. Association staff has been absent for the past few weeks, with the result that considerable correspondence has remained unanswered. However, with the return of Mr. Griffith, correspondents can expect replies to their queries in a very short time. Great interest has been expressed by many in the plans of the C. W. Association for Transcontinental and Transpacific tests in the near future, and those desiring to participate in these experiments are invited to write to Mr. G. G. Griffith, Secretary, The C. W. Association, 602 California St., San Francisco, Calif.

Tell them that you saw it in RADIO

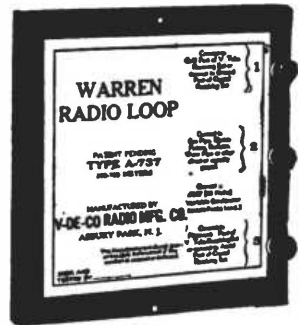
Warren Radio LoopNO
A
E
R
I
A
LLESS
S
T
A
T
I
C

If Dad says—

"NO AERIAL ON THIS HOUSE"
 don't allow his QRM to worry you, but purchase a

WARREN RADIO LOOP

The LOOP that made the Radio Roller Chair famous on the Boardwalk at Asbury Park, N. J.

Is just the thing for an apartment or den.
 Is light in weight and easily portable.
 Is produced under a new principle.
 Is wholly enclosed, thereby protecting the winding.

Is used in place of an outside aerial.
 Is a regular indoor aerial.
 Is adapted for receiving in moving vehicles.
 Takes the "tic" from static.
 Eliminates all danger from lightning.
 Can be used with any receiving instrument.
 Can be used without tuner.



This picture of the Radio Roller Chair showing the Warren Radio LOOP was used as cover designs on "Wireless Age" and "Radio News" and featured in many other magazines and newspapers in the United States.

Send your order through your dealer or direct to us with his name.

Type-A-737 (300-700 meters) \$10.00
 Type-A-7236 (175-1000 meters) 12.00

V-DE-CO RADIO MFG. CO.

DEPT. C, ASBURY PARK, N. J.
 Send for bulletin—No. 8101

FORMICA PANELS

Black Sheets, Both Sides Polished
 You can get panels cut to order from this high quality material and it will cost you only .02½ per sq. in. 3/16" thick.
 Immediate Shipment - Postage Prepaid
DAVID RADIO SUPPLY CO.
 P. O. Box 596, Reedley, Calif.



New design "TU-WAY" Plugs—Jacks—Variable Condensers—Hand Sets—Rheostats—V-T Sockets
 If your jobber does not carry our products, write us direct.

RADIO MANUFACTURERS

Attention! For Efficiency—

SHAW

Moulded Insulation

PRODUCTS

Moulded insulation to fit your every need Exactly. For we manufacture it according to *your own* specifications and moulds. That's the SHAW way. Try it—"for efficiency." We neither retail nor wholesale. We manufacture only. Submit your specifications for a SHAW estimate.

SHAW INSULATOR COMPANY

Henry M. Shaw, President

Frank H. Shaw, Vice President and Gen'l. Manager.

638 MISSION STREET, SAN FRANCISCO

5 KIRK PLACE, NEWARK, NEW JERSEY

DE FOREST Dependability is an inbuilt quality that only years of experience in the building of radio apparatus and a thorough knowledge of radio science can give. It is not a tangible element that one can grasp or point out yet its presence is essential to satisfactory performance.

To those who are looking for satisfactory performance, De Forest Radiophones also present technically correct design, handsome appearance and unequalled efficiency. De Forest Reputation and Prestige insure the quality of the workmanship and materials used being of the highest.

The Everyman Receiver is for 30 mile reception; the Radio-home Receiver is a vacuum tube set efficient up to 100 miles; for use with either of these sets there is the "DT-800" Two-Stage Amplifier. MR-6 Receiver includes an unsurpassed tuner, tube detector and two-stages of amplification. Ask your friends who use them.



DE FOREST RADIOPHONES

"The Standard of Dependability"

Tell them that you saw it in RADIO

Radio Frequency Amplifier

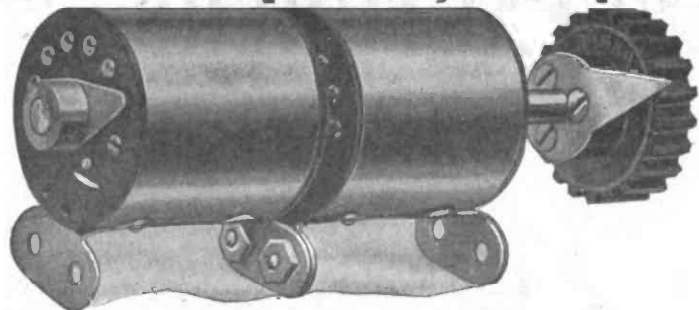

Two Type 5000 Transformers in Tandem for 2 stage control
Pat. Applied For

There is nothing that opens up a wider field on the receiving end for the amateur and experimenter, than radio frequency amplification.

After an extensive investigation of the various types of tube couplings possible for radio frequency amplification, we have developed the above units (two are shown) with a view to giving maximum efficiency and greatest ease of control, at a reasonable price.

Tuning each stage is not necessary. Only one adjustment necessary to cover fairly wide bands of wave-lengths with several stages.

Transformers for several stages can be mounted in tandem with single control which greatly simplifies the manipulation of the set.

Remember that radio frequency amplification will increase the range, the selectivity and the satisfaction you can get from your receiver. A loop antenna will be far more effective with radio frequency amplification.

These units will cover wave-lengths from 180 to 750 meters.

TYPE 5000 RADIO FREQUENCY AMPLIFYING TRANSFORMERS, PRICE \$5.50

For Single Stage (without Knob and Pointer)

COTO-COIL CO. 87 WILLARD AVE., PROVIDENCE, R. I.

WITH THE RADIO MANUFACTURERS

Continued from page 34

TWO NEW RADIO ESSENTIALS

Those who use radio receiving outfits know how troublesome and unsatisfactory it is to pass a single pair of phones about so that more than one person can listen in. If two sets of phones are available with only one jack on the receiver, the phones can be placed in the circuit only after much trouble and

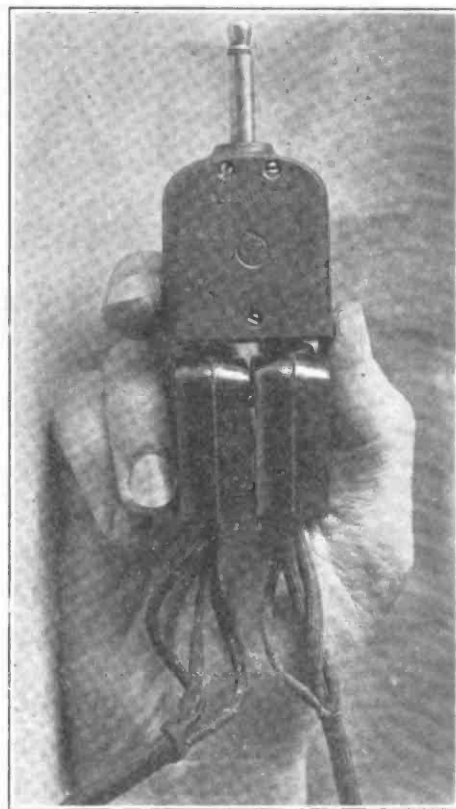

Patent Twin Adapter

Radio Concert Equipment Company

WILL BRENNAN, Manager

The largest and most complete stock of radio goods in California. Buying in large quantities—low profits—with quick turnover—low overhead expense, enables us to give the buyer goods at minimum prices.

A square deal and courtesy—always!
Mail Orders Promptly Filled.

734 WEST SIXTH STREET

LOS ANGELES

SOMETHING NEW

Made to Please You and Priced to Please
Your Pocketbook

By departing from conventional design in audion sockets we have combined the advantages of all, the disadvantages of none and a price lower than any. Think of it—a sturdy, easily mounted socket that is heat proof, has bakelite-dilecto insulation, handy binding posts, etc., all for 75c.



Type 126, Tube Socket
Price 75c Postpaid

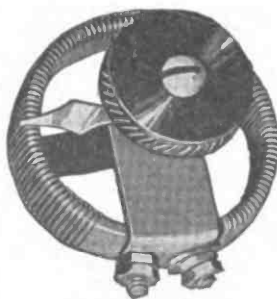

Type 122 Rheostat
Price 90c Postpaid

And here's a smooth running rheostat that takes panel space 2 inches in diameter, needs one hole to mount, has six ohm resistance, all off and all on positions and a brass panel bushing. Priced at 90c.

THE WILCOX LABORATORIES

LANSING, DEPT. J., MICHIGAN

Binding Posts, Contact Points, Switch Levers, Etc.

Quality goods only. For Manufacturers and Dealers

— Made by —

PREMIER DENTAL MFG. CO.

Get our literature

56 N. Second St., Philadelphia, Pa.

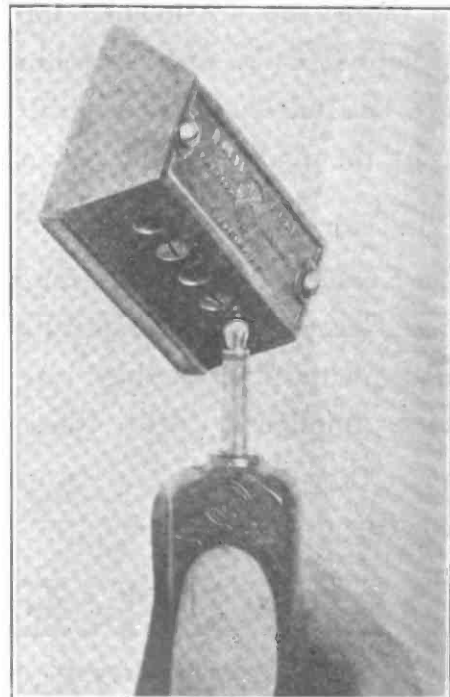

The Patent Multijack

Tell them that you saw it in RADIO

inconvenience. This problem has brought about the need of a Twin Adapter which will allow two phone connections or a phone and a loud speaker connection to be made with a single jack. To fill this need the Pacent Twin Adapter has been brought forth by Louis G. Pacent and with it one jack can be made to serve the purpose of two. Thus the receiver can be tuned with the phones and the loud speaker can be plugged in. The Twin Adapter will also be found very serviceable when making rapid connections and changes in C. W. work. The Pacent Twin Adapter is provided with heavy phosphor bronze spring connections and it is beautifully finished in polished brass and velvety black composition. The Pacent Twin Adapter, although made especially to accommodate Pacent Universal Plugs may be used with plugs of other make.

The Pacent Multijack is really three jacks built into one. This new development followed closely on the heels of the Twin Adapter and it may be used in connection with the Twin Adapter and the Pacent Plug. The three jacks which make up the Multijack are built into a beautiful composition base that may be attached to the side of a receiving cabinet or to a testing board or table. The ends of the Multijack are flat so that a number of them can be placed end to end where a large number of connections are necessary. If three Pacent Twin Adapters are used in connection with a single Multijack as many as six connections can be made. Both the Pacent Twin Adapter and the Pacent Universal Plug fit into the Multijack. Like the Twin Adapter, the Multijack is provided with heavy spring contactors that are sure to form low resistance connections.

DAVISTONE HORNS

Davistone is a patented composition which is claimed to be non-susceptible to vibration and therefore well adapted for a horn which will not distort sound waves. Tests made with Davistone horns in comparison with horns made of other materials prove its superiority in radio work, both as to the quality and volume of what was transmitted, just as it had in the phonograph. A small Davistone horn 1 ft. long produced far clearer and more satisfactory reproduction than a wooden or metal horn four times its size.

A company has been organized to market Davistone for radio loud speakers, phonograph tone chambers and for the many other uses to which it can be put. Their factory is already in production and it looks as though the company will have a tremendous growth from the start. The Davistone horns will be sold in attractive cabinets or mounted on metal bases. They will come equipped with or without receivers. Davistone horns will also be furnished unmounted to firms who desire to assemble their product with these horns at their factory. The Davistone Company's temporary address is 4037 Harrison Street, Chicago, Illinois.

The Central Radio Laboratories, at 303 Sixteenth St., Milwaukee, has established production on one of its initial products, a filament rheostat, at the rate of 1000 per day. The president of the company, E. R. Stockle, Ph.D., has resigned as physicist of The Cutler-Hammer Mfg. Co., in order to assume active charge of the business. Mr. Stockle was formerly associated with the Western Electric Laboratories on research and development work in connection with vacuum tubes for radio telephony. He was also at one time connected with the Physics Department of the University of Wisconsin. C. R. Hammond is the sales manager of the new company.



The end of a perfect howl—

THE squalls of a two year old are as music to the ear beside the howling demonstration put up by a fractious radio set. And how a set can howl unless one offers the soothing influence of the proper amplifying transformer.

Most any transformer can amplify sound, but it will also amplify the stray fields which produce howling and distortion. It takes the Acme Amplifying Transformer with its specially constructed iron core and coil to put an end to the howls and yowls. Only when you add the Acme do you get the realistic tone and volume so markedly absent in the ordinary radio receiving set.

The Acme Radio Frequency Transformer greatly increases the range of any receiving set, either vacuum tube or crystal detector type. The Acme Audio Fre-

quency Transformer produces not only volume, but reality of tone. It is indispensable to the satisfactory operation of loud speaking devices. The combination of one or more stages of Acme Radio and Audio Frequency Transformers assures the maximum of range, of volume and of reality in tone.

The Acme Apparatus Company, pioneer radio engineers and manufacturers, have perfected not only Radio and Audio Frequency Transformers as well as other receiver units and sets, but are recognized as the foremost manufacturers of Transmitting Apparatus for amateur purposes. Sold only at the best Radio stores. The Acme Apparatus Company, Cambridge, Mass., U. S. A. New York Sales Office, 1270 Broadway.

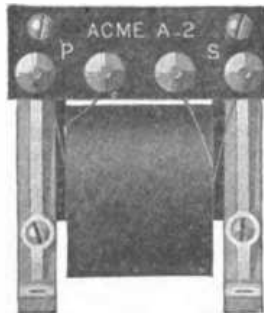

Type A-2 Acme Amplifying Transformer

Price \$5 (East of Rocky Mts.)

ACME
for amplification

Tell them that you saw it in RADIO

Protect
your VTS

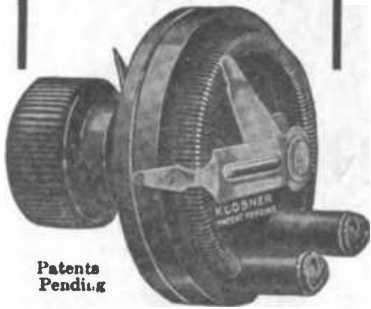

Patents
Pendii.g

KLOSNER VERNIER RHEOSTAT

EVERY TUBE you have deserves a Klosner Vernier Rheostat. The Klosner wire wound feature produces a low starting current, preventing sudden strain and thereby prolonging the life of the tube.

The Klosner provides micrometer adjustment for your critical detector tubes. One single knob controls both the rough and vernier adjustments. It is unsurpassed for loudest reception of telephone and CW, and is essential for detector tubes of radio frequency amplification. Awarded the New York Evening Mail's Certificate of Excellence. Insist on the genuine—made only by the originators. Look for the name "Klosner" moulded on the base. The cost is no more than for other Rheostats without these exclusive features. At your dealer or send for interesting literature.

Klosner
Improved Apparatus Co.
Dept. R
2024 Boston Road

Dealers: This is the fastest moving rheostat on the market. It is stocked by all leading jobbers. Get your supply from them.

ONE SINGLE KNOB
NO SUDDEN STRAIN
\$1.50

TRACO

Loud Speaker

Price **\$40**

Complete F. O. B. San Francisco

Vernier Controls \$1.15

Radio Appliance Co.
INC.

158 Fifth Street
San Francisco

BONE DRY "B" STORAGE BATTERY

A radio "B" storage battery with rubber gasket seal and threaded rubber insulation, which can be shipped to dealers bone dry, thus insuring a brand new battery for the radio operator, is the latest product of the Willard Storage Battery Company of Cleveland. This latest "B" battery, besides being unusually quiet and overcoming several of the present difficulties most commonly attributed to "B" battery, resembles the more rugged, heavy duty automobile batteries made by the same company. It is said that none of the noise due to polarization in dry cells occurs in a liquid electrolyte battery. Electrical leakage between cells has also been overcome by wide separation of the cells and the use of individual glass containers.

The cells used are miniatures of the heavier types in many points of construction. The plates are insulated with threaded rubber insulation and the whole group assembled on a hard rubber rest which holds plates and insulator tightly in place at the same time affording ample space for the accumulation of sediment.

The plate posts pass through the covers in close fitting, soft rubber gaskets, similar to those recently adopted by the Willard Company for all of its batteries. The gaskets fit into a deep well on the under side of the cover and are firmly cemented to the posts making a tight leak-proof joint which can be easily removed when occasion arises. Shipping bone dry makes possible the delivery of a perfectly fresh, fully charged "B" battery, one which has not been slowly deteriorating during the interval between manufacture and purchase by the user.

This feature made possible solely by these threaded rubber insulators has met with a very favorable reception in connection with automobile batteries and there is every reason to believe it will be appreciated by the radio operator also.

WESTERN ELECTRIC

Loud Speaking Telephone
Outfits as Illustrated
KENNEDY RECEIVING SETS
Remler Apparatus

Distributed by
H. F. HAVERKAMP
1148 Market St., San Francisco

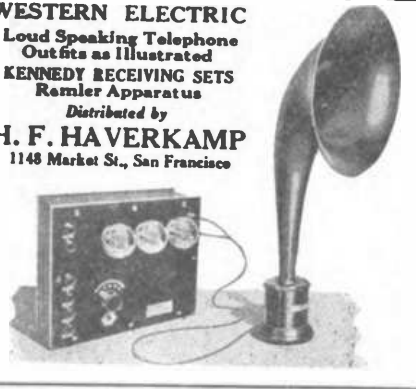

Pearland Rotary Lever Switch



A well made lever switch designed for radio. Has moulded knob with switch bolt screwed in. Tension spring holds switch in position. Bearing fits 3/8 inch hole. Nickel finish. Three sizes—1, 1-3/8 and 1-1/2 inch radius. Each 60c.

Ask about our variable condenser with venier attachment—one minute to tune up. Liberal discount to jobbers and dealers.

PEARLAND RADIO & ELECTRIC CORP.
184 W. Washington St., Dept. C, Chicago

Jacks,
Dials,
Switch Points,
Binding Posts,
Etc.

Don't Miss this Big Radio Offer
1 Mounted Tone Perfect Detector Crystal, 12 Contact Points and Nuts, Inductance Switch Stops, 4 Binding Posts and Copy of wonderful Radio Information "How to Make Your Home-Made Radio Sets for Long and Short Wave Reception at Greatly Reduced Cost." All 50c. Bargain Radio List 10c. Free with 50c Order.

Jaynxon Radio Laboratory
646 Sixty-fourth St., Brooklyn, N. Y.

RADIO CONCERTS RECEIVED WITHOUT OUTSIDE AERIAL

by
Converting Light Wires into suitable Antenna
with

THE WOLF AERIAL ATTACHMENT

This attachment enables you to use any electric light socket in your home and eliminates use of outside and inside wires. No danger of any kind. Save cost of all aerial construction. The attachment comes complete and ready to connect to your receiving set.

Price \$1.50 Postpaid

The Wolf Radio Co.

206 Scherer Bldg., Dept. R Detroit, Mich.

\$1.00 SECOND EDITION
QUIZ BOOK

JUST OUT

You Can't Buy a Better Book
"RADIO" San Francisco

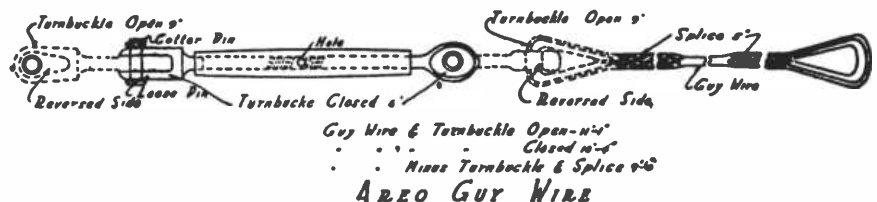

Until our supply is exhausted, we are offering the above GUY WIRES for ANTENNA CONSTRUCTION. The turnbuckle is forged and machined and the wire, twisted and tinned 5/32 inch diameter. A WONDERFUL BARGAIN.

Price each, parcel post paid \$ 1.25
Per dozen, parcel post paid \$12.50

Special quotation for large quantities.

ASK FOR PRICES ON HARD DRAWN COPPER AND MAGNET WIRE.

HAVERSTICK & COMPANY, 125 S. 5th St., Philadelphia

Tell them that you saw it in RADIO



Peerless "Radiofonograf," Combining a Phonograph and Detector with Two-Stage Amplifier and Using Common Phonograph Horn.

ERRATA NOTICE

The announcement of G. M. Proudfoot in May RADIO should have given the price of the Proudfoot detector and two stage amplifier, non-filament control, as \$45, and of the detector and one stage amplifier as \$35. G. M. Proudfoot is now engineer and manager of the radio department of the Cruver Mfg. Co., 2456 W. Jackson Blvd., to whom his business was recently sold because additional manufacturing facilities were needed to meet the demand for the Proudfoot instruments.

RADIO NEW CATALOGS

Bulletin C-3 from The Colin B. Kennedy Co. of San Francisco is an attractively printed publication giving illustrated descriptions, specifications and prices on Kennedy receivers, amplifiers and radio accessories.

The National Radio Institute of Washington, D. C. has discontinued the publication of "National Radio News" in connection with their correspondence course in radio and are advising their students to subscribe to RADIO as a desirable supplement to the N. R. I. instruction.

American Hard Rubber Co., of New York City, has issued a booklet on "Ace" hard rubber sheets, tubing, rods and moulded parts for all radio purposes.

Bulletin No. 22 from the Burgess Battery Co., of Chicago, is devoted to "B" batteries for wireless. Illustrations and descriptions are given of 4.5 volt, 18 volt, 22.5 volt and 113 volt dry batteries.

Give Your Radio Set the Advantage of
WESTINGHOUSE
 RADIO
BATTERIES



Westinghouse "A" Batteries are especially built for the peculiar requirements of radio work. They deliver a constant, dependable flow of low voltage current. They are built to give long, low-cost service. They demand a minimum of attention.



In the Westinghouse "B" battery you have a storage battery for "B" work—the latest development in radio practice. It has all the reliability and dependable performance of a storage battery and none of the disadvantages of a dry cell. The Westinghouse "B" gives a steady, continuous, noiseless service. It lasts indefinitely. When exhausted it is easily recharged. The first cost is the last cost.

Don't lose the enjoyment of your Radio by operating under unsatisfactory conditions. Get Westinghouse "A" and "B" batteries from your radio dealer or the nearest Westinghouse Service Station.

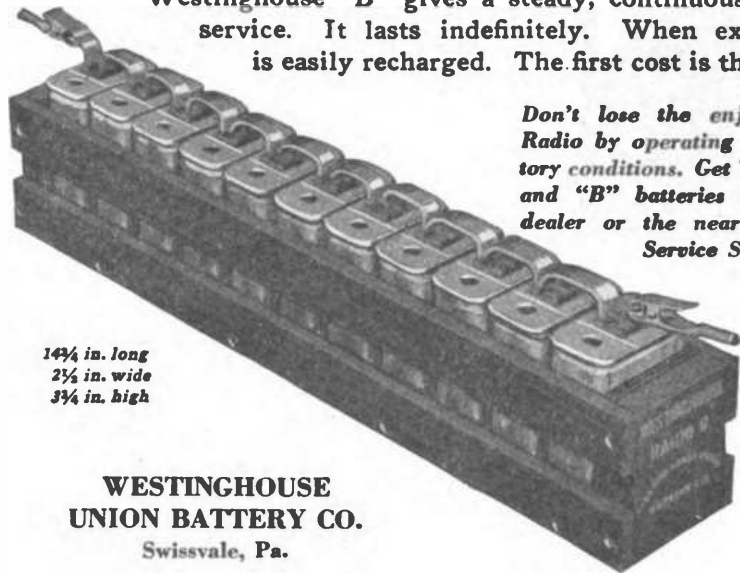

14 1/4 in. long
 2 1/2 in. wide
 3 1/4 in. high

The best Westinghouse can build."

**WESTINGHOUSE
 UNION BATTERY CO.**
 Swissvale, Pa.

This loud speaker has many unusual features, first and foremost being the swivel adjusting device which allows the horn to be swung into any desirable position. Secondly, it is constructed in such a manner that a simple turn of an adjusting screw will allow almost any kind of a head phone being used for the loud speaker.



HEAVY PAPER HORN
 Will Fit Any Phone

It will be a valuable addition to your station as the workmanship is excellent. The stand is of Mahogany finished wood.

RICHMOND
 Loud Speaker

Price without phone

\$7.00

F. O. B. Richmond

Patent Applied For

429 BARRETT AVENUE
 RICHMOND, CALIFORNIA

RYAN RADIO COMPANY

Tell them that you saw it in RADIO



DUDLO MAGNET WIRE

put up in the new fractional pound package offers you the opportunity to obtain Dudlo high grade wire in the insulation and amount you need to wind those new coils or to complete your hook-up.

All wire is of the regular Dudlo high standard of quality wound on a light weight attractive metal spool and is packed in a distinctive carton on one side of which is listed a table of wire diameters.

Sold by leading jobbers and dealers everywhere.

Look for the yellow carton and the Dudlo trademark.

DUDLO MANUFACTURING CO.

FORT WAYNE, INDIANA

WESTERN REPRESENTATIVE
A. S. LINDSTROM
111 New Montgomery St., San Francisco, Calif.



FRONT VIEW

PROUDFOOT AUTOMATIC FILAMENT CONTROL DETECTOR 2 STAGE AMPLIFIER

\$55⁰⁰

**CAN BE USED
WITH ANY TUNER**

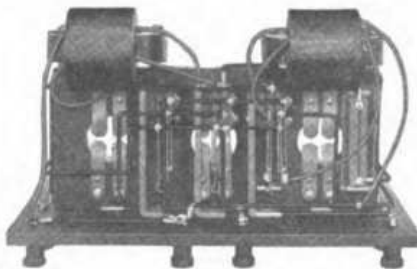

BOTTOM VIEW SHOWING AUTOMATIC
CONTROL CIRCUITS

EXACT DUPLICATE
WITHOUT
FILAMENT CONTROL CIRCUITS
\$45.00

CRUVER MFG. CO.
2456 W. JACKSON BLVD.
CHICAGO, ILL.



WE USED OUR BEAN

IN DESIGNING

THE PARKIN DIAL RHEOSTAT (pat. pending) and by mounting the resistance element in a circular groove in the back of a 3" molded Bakelite dial eliminated one part and saved you the cost of a dial. The groove being recessed, allows the dial to clear the panel by the usual distance of 1-16". An off position is provided and a stop on the dial engages the stationary contact at the extreme positions. The 360-degree rotation insures fine adjustment. A brass bearing insures a true running dial and smooth action.

All figures and graduations are filled with brilliant white enamel. All brass parts nickel plated. Bakelite knob. Resistance is 5 ohms, carrying capacity 2 amps.

No. 77 Parkin Dial Rheostat, postpaid.....\$1.75

FOR SALE BY ALL LEADING DEALERS
Send for free catalog, No. 3, describing our complete line.
Dealers: Write for proposition.

PARKIN MFG. CO.
SAN RAFAEL, CALIF.

Tell them that you saw it in RADIO

BOOK REVIEWS

"Radio Handbook," by J. H. Dellinger and L. E. Whittemore. Published by Lefax, Incorporated, Philadelphia. Price \$3.50.

The compilers of this handbook have succeeded in assembling in one handy volume, every detail which applies to modern radio in the home. The authors are Dr. J. H. Dellinger, Chief of the Radio Laboratory of the U. S. Bureau of Standards, and L. E. Whittemore, Alternate Chief. These men, with all the resources and information of the U. S. Government at their command, would be expected to turn out an excellent piece of work, and they certainly have succeeded in producing a comprehensive source of accurate data, which at the same time is in no way complicated. Everyday language is used throughout, and all technical terms are so clearly explained that any average individual will experience no trouble whatever in understanding them.

The handbook is pocket-size and carefully indexed for easy reference. The fundamental principles of both radio telephone and telegraph are treated in an unusually interesting way. Actual practice of both receiving and transmitting sets of various types is explained in detail, and the exact functions of every piece of apparatus is excellently explained. This last point, especially, is something of great interest to almost everyone who is interested in improving their radio results. Different types of antenna are contrasted in one chapter in a way that shows an excellent grasp of this important subject.

The handbook is loose-leaf and new pages which can be added will be issued every month, free of charge, to all owners up till July 1st, 1923.

BIG STOCK

Detector Tubes	\$5.00
Amplif. Tubes	6.50
Magnavoxes	45.00
Phones	\$7.50 to 15.00
Radio Shop Receiver.....	70.00
2 Stage Amplifier.....	55.00
Kennedy Receiver	80.00
Kennedy 2 Stage Ampl.....	55.00

The only Real Radio Store in
San Joaquin Valley
Broadcasting Station KJQ

GOULD THE LIGHT MAN
615 E. Main Street Stockton, Calif.

We have the best equipped shop on the coast for the manufacture of:—

High Grade Radio Apparatus

We make the following standard lines:—

- Variable and fixed Condensers.
- Vario Couplers.
- Variometers.
- Filament Rheostats.
- Vacuum Tube Sockets.
- Switch Contacts and Levers.
- Crystal Detectors.
- Binding Posts.

Write for prices to:—

Office and Works. Phone: Douglas 145.
**BUTTE ELECTRIC and
MANUFACTURING CO.**
534 Folsom St. San Francisco, Calif.

Federal HEAD TELEPHONES

Light In Weight—
Extremely Sensitive—
Durably Constructed—
Carefully Matched In Tone—
Will Perfectly Reproduce
Radio Sounds—



Made by a Company With 22
Years Successful Experience in
the Manufacture of High Grade
Telephone Apparatus

The
FEDERAL COMPANY
With Its Rating of \$1,000,000.00
and Over Guarantees the Effi-
ciency of all Federal Apparatus

DEMAND
From Your Dealer **GENUINE**
FEDERAL APPARATUS
Accept No Substitute

Prices—Per Pair:
No. 53-W, Total Res. 2200 ohms,
\$8.00
No. 52-W, Total Res. 3200 ohms,
\$10.50

**ABSOLUTELY THE BEST ON
THE MARKET
REGARDLESS OF PRICE**

Federal Telephone and Telegraph Company
BUFFALO, N. Y.

“Fifteen Years in Radio”

“HALOWAT”

Hallock & Watson

“Radio Service”

Radio, Telephone and Telegraph Equipment

Distributors for

NORTHWESTERN RADIO MANUFACTURING COMPANY

J. H. HALLOCK

C. H. WATSON

formerly

formerly

RADIO CONSTRUCTION ENGINEER IN CHARGE U. S. NAVAL RADIO LABORATORY
U. S. NAVY AND FEDERAL TEL. CO. MARE ISLAND, CAL.

Operating Stations KGG and 7X1

192 Park Street, Portland, Oregon - Main 5677

“Experience Tells”

\$ 1.00 Brings you a copy of the *second* edition
of the License Quiz Book. Every radio ex-
perimenter needs a copy. Limited supply
on hand. Send us your order today.

For Sale by “Radio,” Pacific Building, San Francisco

THE RADIO “IF”

By W. T. BURFORD

(With apologies to Mr. Kipling.)

If you can keep your nerve when all about
you
Are stations jamming hard and blaming
you;
If you can “hold the air” though others flout
you,
Until you get the longest message
through;
If you can send, and not grow weary send-
ing,
Nor over-tire the man who has to read;
If your mistakes are rare, but prompt their
mending,
If you believe that haste is never speed:

If you can calmly contemplate the chatter
Of greenhorn operators fresh from
school;
If you can sit with messages that matter,
And wait until they’ve finished—and be
cool;
If you can read through half a dozen stations
The weaker signals that are meant for
you,
And pick ‘em out, with few interrogations,
Yet never feel ashamed to ask those few:

If you’re a jack-of-all trades, tinker, tailor,
If there is scarce a thing you cannot do;
If you’re an electrician and a sailor,
Telegrapher, accountant, lawyer, too;
If you’re propelled by energy that’s tireless,
If you don’t fear a job that’s never done:
Then, take my word, you’re fit to work at
wireless,
And anything you get you’ll *earn*, my
son.

Tell them that you saw it in RADIO

"CHELSEA"

No. 50 Amplifying Transformer

was designed for use with the present day models of vacuum tubes, and when so used produces remarkable amplification, with minimum noise. It is well adapted for table mounting or may be panel mounted in any position.



Terminals are marked for best connection. Only highest grade materials and workmanship employed. Its high efficiency together with its neat appearance and compactness, makes it a predominating feature in any radio receiving equipment.

Price as shown.....\$4.50
Unmounted\$3.75

Bulletin sent upon request. Purchase from your dealer. If he does not have it, send to us.

CHELSEA RADIO COMPANY

150-156 FIFTH STREET

CHELSEA, MASS.

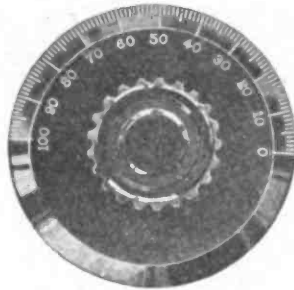

Immediate Deliveries

ON OUR

- No. 23 Quality Dial List \$1.00
- No. 124 Composition Dial List \$1.00

Made to fit $\frac{1}{4}$ " or $\frac{1}{8}$ " Shafts

Dealers write for Special Prices



HOW'S YOUR STOCK, MR. BUSY DEALER?

ORDER NOW
DELIVERIES FROM STOCK

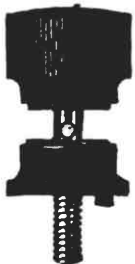

COMMANDER H



ENSIGN H



SERGEANT



CORPORAL

The Four Posts Shown Are Especially Suitable for Use on Radio Apparatus. Manufacturers, Jobbers, Dealers—Write for Our Proposition.
THE H. H. EBY MANUFACTURING CO., 605 Arch Street, Philadelphia, Pa.

CODE REVISIONS

Continued from page 23

tion companies install radio antennae and apparatus for persons who are not familiar with electric wiring. This will tend to insure the installation of antennae and apparatus in a strong and durable manner. It is important that antenna wire be used in such size and tensile strength as to avoid its coming in contact with any electric power wires whatsoever.

The size and material of which the antenna is made should depend, to some extent, upon the length of the span which the antenna must bridge. It is suggested that for the ordinary receiving antenna about 100 ft. long No. 14 soft drawn copper wire can safely be used. If other materials are used, the size which is chosen should be such as to insure tensile strength at least equal to that of the No. 14 soft copper wire suggested above.

The requirements covering splices and joints in the antenna span are for the purpose of avoiding accidental falling of such wires upon light or power wires, of less than 600 volts where it is found necessary to cross such lines. The rules, it will be noted, permit crossings with lines of 600 volts or less, if they do not happen to be trolley wires or feeders to trolley wires. In such a case, it is desirable to use wire of a larger size than No. 14 in order to minimize the chance of accidental contact of the antenna with the power wires.

The interchangeable use of copper and of approved copper-clad conductor is suggested on account of the fact that these two kinds of wire are practically equivalent in their conductivity for high-frequency current.

b. *Lead-in Wires.* No mention is made of the insulation from the building of the receiving antenna or lead-in wire except that this lead-in wire should be run through a bushing. The latter provision is chiefly to protect the wiring against the possibility of short-circuiting with electric power lines which many run in the wall and whose location may be unknown to the persons installing the radio equipment. This requirement serves also to protect the antenna lead-in wire against contact with metal lath or other metal parts of the building.

From a signaling standpoint, it is desirable to use insulators for receiving antennae in order that wet weather may not cause the antennae to become partly short-circuited to the ground.

c. *Protective Device.* The requirement for a protective device to be connected between the antenna and ground terminals of the receiving set is for the purpose of carrying lightning discharges or less violent discharges caused by in-the ground with a minimum chance of

Tell them that you saw it in RADIO

duction or by atmospheric electricity to damage to the receiving apparatus, building, or operator. A fuse is not required as a part of the protective device, though lightning arresters which are provided with fuses will not necessarily fail to receive approval. If a fused lightning arrester is used, it makes it less likely that the antenna terminal of a receiving set will be put at a high voltage in case the antenna falls upon an electric light or power wire. The absence of the fuse, on the other hand, makes it possible for the antenna, if it accidentally falls across the power wires, to become fused at the point of contact and thus fall to the ground and eliminate the hazard. The antenna terminal of the receiving set should be connected to the point of junction of the fuse with the arrester.

Lightning arresters may be used inside the building, and in such a case they will receive better protection from moisture and mechanical injury than lightning arresters placed on the outside of a building wall.

Protective devices of reliable manufacture are approved by the Underwriters' Laboratories, and can be depended upon to operate at the required voltage. The use of a cheaply constructed home-made arrester, is not recommended, since it may easily get out of order and fail to operate at the low voltage which is desirable. Arresters should be inclosed in such a way as to protect the breakdown gap from dust. One disadvantage of the vacuum tube type of arrester is that it may cease to function without giving warning that it is inoperative. A list of the approved protective devices and ground clamps is contained in the "List of Inspected Electrical Appliances," published by the Underwriters' Laboratories. This list is revised semi-annually and may be consulted upon application to the principal office of the Underwriters' Laboratories, Inc., 207 East Ohio St., Chicago, Ill., and at offices and agencies throughout the United States and Canada.

While an arrester connected between the antenna and ground is regarded by many as sufficient protection, it is somewhat safer to install a switch in parallel with it as an added protection. Particularly if the arrester is inside of the building and the ground connection is made to a radiator, it is desirable to use in addition the outside ground connection.

If the antenna is properly connected to the ground, such connection prevents the antenna from becoming a hazard to the building and its contents and may act to supplement the protection given by lightning rods. The arrester should have the most direct connection to the ground which it is feasible to make, otherwise the antenna may become a

"Benwood" Apparatus—Higher Efficiency Finer Tuning

Signals Louder and Clearer



"Benwood" Variometer

A PROPERLY designed variometer brings in signals very much louder and clearer than the various other types of inductances on the market. With this fact in mind we have designed the "last word" in variometers—the "Benwood." Inductances are wound with double cotton covered wire and no shellac, paint or varnish is allowed to cover the wire and diminish the effectiveness.

The "Benwood" features are—minimum distributed capacity, minimum distance between stator and rotor, large size wire on both coils, positive contact bearings and proper design. This variometer will get splendid results on wave lengths from 150 to 650 meters with the average variocoupler. Price, each... **\$5.00**

"Benwood" Vacuum Tube Socket Solid Bakelite—Panel or Base Mounting

HERE is the very latest and best improvement in vacuum tube sockets—the new "Benwood." Solid, highly polished, molded Bakelite, specially designed for either base or panel mounting—the only one of its kind. Firmly holds any standard four-prong detector or amplifier tube. Eliminates ground hum and noises in operation of amplifiers. Terminal posts plainly marked. Base is 2 1/4 x 2 1/2 inches, height 1 1/2 inches. A good buy at..... **90c**



"Benwood" V. T. Socket

The New, Improved "Benwood" Dial Controls

THE "Benwood" controls all have solid Bakelite knobs of extra large diameter, which minimize all body capacity effects, and the new tapered design fits the fingers perfectly. The knurling is particularly fine and sharp.

Solid Bakelite Knob and Dial

Graduated 0° to 100°—all markings clearly defined in white and stamped into the solid Bakelite—won't wear off. Ribs on reverse side prevent turning too far. Set screw deeply countersunk and easily reached.

	Diam.	Depth	Knob	Each
BC-7 "Benwood" Control	4"	1 1/4"	2" at base	\$1.75
BC-8 "Benwood" Control	3 1/4"	1 1/4"	1 1/2" at base	1.50

Specify whether 1/16" or 3/16" drilling is required



"Benwood" Dial Control

CATALOG—Send 10c in stamps for the Benwood catalog and price list, also complete catalog and price list of DeForest Radio Equipment.

DEALERS—We manufacture high grade radio apparatus in our own factory and have stock ready to ship. Write or wire for our liberal dealers' discounts.

Bakelite Binding Post

THESE "Benwood" binding posts have the same style tapered, knurled solid Bakelite grip which fits the finger tips and matches the "Benwood" dial controls. Diameter 5/8 in. with two washers, each..... **25c**



The **BENWOOD** Co. INC.
RADIO
"WORLD-WIDE MAIL ORDER SERVICE"
1113 OLIVE STREET, ST. LOUIS, MO.

"Sign of **ACE** Long Life"



THEY LIFT YOUR RADIO SET ABOVE THE ORDINARY



ACE Batteries are constructed to give the utmost "B" battery service. By reason of special manufacturing process they solve the "B" battery problem.

Get them at your dealer
and write for catalog

ACE BATTERY MANUFACTURING CORP.

Gen. Offices 495 Broome St. New York City Factory 359 W. Bdway

Tell them that you saw it in RADIO

**CROSLY
HARKO SENIOR RADIO RECEIVER**

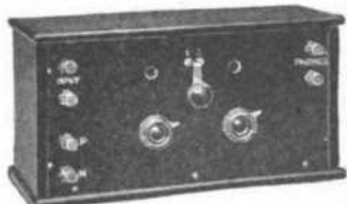

Complete tuner and audion detector assembled on a formica or other high grade dielectric panel, mounted complete in mahogany finish cabinet. Range, 150 to 600 meters, non-regenerative hook-up. Price without battery, tube or phones.....\$16.00

CROSLY TWO-STEP AMPLIFIER

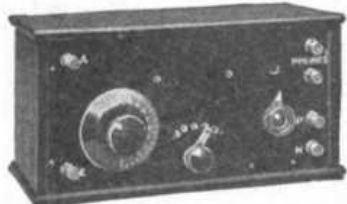

Complete with amplifying transformers, sockets, rheostats, switch, binding posts, etc., mounted on formica panel in mahogany finished cabinet. Price complete as shown in illustration.....\$25.00

We make a complete line of radio apparatus. "It's better—and costs less" Send for circulars.

CROSLY MFG. CO.

Radio Dept. P-5 Cincinnati, Ohio

RAY-DI-CO RADIO SUPPLIES

for Service and Satisfaction

Write, wire or phone us for prices and information.

RAY-DI-CO ORGANIZATION

1547C N. Wells Street Chicago, Ill.

HANCOCK RADIO

Real quality—Lowest price.

APPARATUS — PARTS — DIAGRAMS

Orders filled same day received.
EVERY ARTICLE GUARANTEED
Catalog and Bulletins for stamp.
Hancock Radio Galena, 20c Silver.

HANCOCK RADIO

908 Congress Austin, Texas



Mica Grid Condenser and Grid Leak Mountings
From .00005 to .00025 MFD.....\$.50
From .0008 to .0005 MFD..... .65
Grid Leak Mounting only..... .25
Triple Coil Mounting..... 5.00

Variable Condensers
.0005 MFD.....\$4.50
.00075 MFD..... 5.00
.001 MFD..... 6.00
.0015 MFD..... 7.50

MONTROSE MFG. CO.

619 St. John's Place, Dept. B. BELYN. N. Y.

hazard with respect to lightning.

d. *Protective Ground Wire.* While it is desirable to run the protective ground wire in as direct a line to ground as possible, it is more important to provide a satisfactory contact at the ground itself than to avoid a few bands in the ground wire.

f. *Receiving Equipment Ground Wire.* If the ground wire of a receiving set passes through a wall, it should be insulated for the same reasons as the antenna lead-in wire referred to in paragraph a above.

If the ground wire is exposed at all to mechanical injury it should be of larger size than the minimum permitted under the rules and certainly not smaller than No. 10 B. & S. gage. It should, for mechanical protection, be enclosed in wood moulding or other insulating material. Ground wires should not be run through iron pipe or conduit because of the choking effect at radio and lightning frequencies.

TRANSMITTING EQUIPMENT

j. *Protective Ground Switch.* On account of the larger size of the ordinary transmitting antenna, it is more likely to be subject to damage from lightning; and on account of the high voltages produced by radio transmitting equipment, it is desirable to provide for the use of a double-throw switch for connecting the antenna either to the transmitting apparatus or to the ground. The use of this switch makes it possible to entirely disconnect the antenna from the transmitting apparatus when not in use.

The objection to slate-base switches is chiefly from the radio engineering viewpoint, on account of the absorption of water by many kinds of slate and the presence of conducting streaks.

Under this rule one has the choice of the standard 100-ampere 600-volt single-pole, double-throw switch or a special antenna switch using 60 ampere copper

which has an air-gap distance of at least four inches.

o. *Protection from Surges, etc.* On account of the difficulty which has been experienced by the induction of voltages in the supply lines of a transmitting station, it is advisable to use a protective device across the terminals of each machine or transformer connected to this power line. It would also seem desirable to connect a similar protective device across the power line and near the point of its entrance to the building and on the house side of the meters.

It is desirable that research on the performance of protective devices and the means for avoiding surges and "kick-backs" in the power supply lines be promoted.

Tuning Coils

Cross Weave Tuning Coils, the heart of a receiving set—just the coils for bringing in the Radiophone broadcasting stations. 180 to 500 meters. Price \$1.25 each, or set of three coils, Primary, Secondary and Tickler coils, \$3.50 per Set with circuit diagram.

CONDENSERS

Grid and Phone condensers made of the best material obtainable, \$1.00 each.

PANELS

Of Gumwood Black Finish

Treated with a special process made by us. Will not Warp or Shrink and is not affected by Temperature changes. Waterproof and possesses High Dielectric properties. Easily machined and will not Crack or BREAK. Looks as good as Bakelite. We are prepared to ship promptly the following sizes:

6"x 6" 1/4" thick.....\$.60	8"x12"x1/4" thick.....\$1.80
6"x 7" 1/4" thick..... .75	8"x14"x1/4" thick..... 1.75
6"x10 1/2"x1/4" thick.....1.00	12"x14"x1/4" thick..... 2.20
6"x12" 1/4" thick.....1.25	12"x21"x1/4" thick..... 3.00
Strips 3 1/2" x 8; 3 1/2" x 6; \$4.00 each; 3 1/2" x 10, 3 1/2" x 12, \$3.00 each; 3 1/2" x 14, \$2.75 each.	

Add Postage for 1 lb. for Panels up to 6 x 12 1/4"; and 2 lbs. for larger sizes.

We will be pleased to quote prices on these panels sent to a different size on receipt of your specifications. NO FREE SAMPLES.

NATIONAL RADIO CO.

Marshall, Minn.

Dealers: Write for our proposition

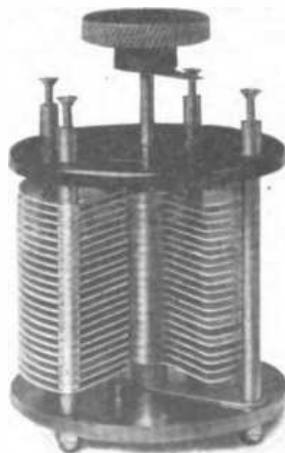

"HITON"

Variable Condensers

Ends, moulded bakelite—Plates, half hard aluminum—Large knob—Positive rotor stop—Soldered pigtail connections—Adjustable tension on rotor.

43 Plate .001 mfd.....	\$5.25
23 Plate .0005 mfd.....	3.60
13 Plate .0002 mfd.....	2.75
7 Plate .0001 mfd.....	2.35

Hiton Radio Laboratories

641 No. Bronson Ave. Los Angeles, Cal. U. S. A.

If your dealer does not stock we make IMMEDIATE DELIVERY

Tell them that you saw it in RADIO

—it far surpasses any loud speaker on the market

Manufactured by Western Electric Co.



Here is the new Western Electric 2 Step Power Amplifier. It is without question the most perfect reproducer of voice and music, giving a clear non-metallic reproduction. It operates on 6 volt storage battery for lighting the filaments and uses standard B-Battery for the plate circuit. There is no distortion of signals and for true reproduction it has no equal.

It would be well to place your order with us now to assure early delivery.

Circular on request

LEO J. MEYBERG CO.

Operating the Fairmont Hotel Radio Station **KDN**, San Francisco
Operating Hamburger's Radio Station **KYJ**, Los Angeles

428 Market Street
San Francisco, Cal.

950 South Flower Street
Los Angeles, Cal.



Complete as shown
\$161.00

RADIOTORIAL COMMENT

Continued from page 9

astounding records will be made—especially in the carrying powers of C. W. and I. C. W.! The return voyage will be conducted in the same manner.

We feel sure that the shipping companies, operating vessels to the Orient, would be glad to co-operate in this effort at obtaining further scientific data, for the good of radio progress in the U. S.

We also think that there are many manufacturers of receiving and amplifying apparatus, who would be willing to loan a complete equipment for this test—that would become historic in the annals of amateur radio effort.

Arrangements could doubtless be made whereby the representing operator would be given permission to put up a single wire, of proper length, on board—for the test—in order that he should, in no way, interfere with the regular radio operations of the vessel.

There are many little details to be filled out, of course, but we believe the test to be very well worth while, and—to this end—we ask that all operators who desire to ascertain JUST how far they are reaching out, notify the Editor. We suggest that all stations who are interested, contribute to the expenses of sending an operator, say \$5—or \$10—each, for a first class passage to the Orient and return, to-

gether with a sufficient sum for incidental expenses, and so forth.

We furthermore propose that the receiving equipment shall NOT consist of “super-heterodyne’s”—nor shall it have more than 3 steps of amplification—at the most! This for the reason that the test is not to be made for any *especially-built* apparatus! Rather is it one that is undertaken for the purpose of showing that which amateurs can accomplish with such apparatus as lies within the financial reach of the majority.

In the first available number of RADIO—after the representing operator’s return—will be published, in full, all details of the test, together with the names of all who have contributed toward making the effort possible.

It is urged that those who think well of the idea, so inform the Editor at the earliest possible moment. And be it understood that the proposition is by NO means limited to Pacific Coast stations! Any operator, who has cause—by his former DX results—to believe that he can reach out over Pacific waters—is *welcome!*

LET’S GO!

MAJOR LAWRENCE MOTT.

Tell them that you saw it in RADIO

SHIP OWNERS RADIO SERVICE INC.

80 Washington St., New York City

RADIO DISTRIBUTORS

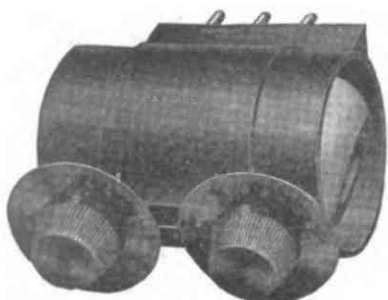

SORSINC "TUNIT"..... \$15.00

The "Tunit" is a balanced primary attachment for use with the standard triple coil mounting allowing ultra efficient reception on wave lengths from 160 to 600 meters.



"FRAMINGHAM" RHEOSTAT... \$1.00

The only rheostat incorporating a panel brushing to give rigidity. The detail of construction and design makes this a highly desirable instrument. For table or panel mounting.

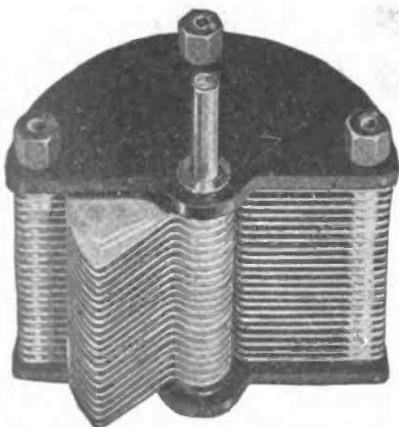

"ELITE" VARIABLE CONDENSER.. \$4.75

43 plates, panel mount, .001 mfd. capacity. Plates accurately spaced, bakelite ends, metal end brushings, and spring tension adjuster at base. A well made condenser at an attractive price.

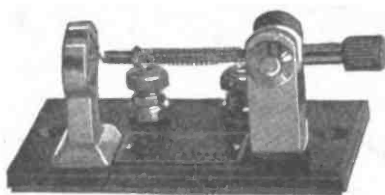

"SORSINC" CRYSTAL DETECTOR.. \$2.50

The Sorsinc Crystal Detector is sold for amateur, experimental and amateur entertainment use. This detector represents careful design and manufacture and incorporates a ball-joint arm. The spring tension is carefully adjusted and the crystal is guaranteed to be super-sensitive and dependable. Manufactured and licensed by the Wireless Specialty Apparatus Co.

Purchase from your dealer

Variometers Couplers \$3.75 Each

Wound but unassembled
\$3.00 Each

These instruments embody best workmanship and materials, all wooden parts genuine mahogany, coupler primary wound on Formica tubing. Wound to assure maximum results for short wave work. Shafts 3/16 inch. With Chelsea Dial and Knob \$1 extra. Send for bulletin describing panels, parts and other apparatus.

FREDERICK WINKLER, JR.

304 Columbus Av., New York, N. Y.

WIRELESS CATALOGUE

WHETHER you are interested in a complete radio receiving outfit, or a half a dozen binding posts, you'll find the particular instrument, best for your needs, in Corwin's catalogue. Send 10 cents, (credited to your first order) for your copy today! Where's the nearest mail box?

A.H. CORWIN & CO.
4 West Park St. Dept. G
Newark New Jersey

Tell them that you saw it in RADIO

THE NEW YORK RADIO SHOW

By L. D. McGEADY

Z-Z-Z — Br-Br-r-r — Screech —
— Yow-Yow. That is a somewhat harsh sound to convey to the reader's mind, but it is a fairly accurate reproduction of the noise made by most of the receiving sets before the exhibitor shut off his set at the late Radio Show, at the 71st Regiment Armory, running from May 22nd to 27th. The show was the fourth this year to be held in New York City, making an equal break between Brooklyn and Manhattan, each having had two of their own.

The first New York Radio Show early in the year brought out all of the amateurs in the Second and Third Districts. The last Radio Show succeeded in attracting all of the Finale Hoppers within a hundred miles radius; and some even brought their poodles.

The event of the week was the wireless telegraph receiving contest held Wednesday evening, May 24th, in the Armory. All honors were carried away by Theodore R. McElroy, of Boston, an employee of the Western Union Telegraph Company, with an official receiving record of 57½ words a minute for two minutes with one error, which error, as it later developed, may have been the faulty machine used in sending. This is setting up a new world's record. Mr. McElroy carried away a twelve inch loving cup representing first prize.

The man to carry off second honors was also a Western Union man, J. R. Smythe, of New York City, with a record of 49 words a minute to his credit. Third at the finish of the contest was E. G. Seutter of the New York Times staff with 46 words a minute officially credited him. These three men are ready to defend their records, so any amateur getting his receiving record up above the record should not fail to arrange a contest.

New radio attachments and devices in large numbers were shown at the show. Many of these were of wide interest; some of less general interest, but of great importance.

Another event which aroused the interest of the fans at the show was the amateur construction contest. All amateurs were invited to take part in constructing a set which would receive radio. The results were gratifying. Some of the sets were built into a lobster's claw, a ring finger, and all sort of small contraptions which made them look like the weavings of a spider more than the handiwork of an amateur. The smaller sets, however, did not come in for the big prize money. The first prize of \$100 for construction, originality and effectiveness went to Rudolph Knopp, of Cedar Grove, N. J. Second prize money of \$75 was awarded to A. Fasko, of Brooklyn, N. Y., third prize of \$50

Radio panels and radio parts

Start right. The panel is the very foundation of your set. High volume and surface resistance are essential factors. Make sure that you get them in both the panel and parts that you purchase. To make doubly certain look for the dealer displaying this sign

CONDENSITE CELORON *Radio Panel Service*

Condensite Celoron Grade 10—approved by the Navy Department Bureau of Engineering—is a strong, handsome, waterproof material, high in resistivity and dielectric strength. It machines easily, engraves without feathering and is particularly desirable for panels. It is also widely used for making many other important radio parts such as tube bases, platform mountings, variable condenser ends, tubes for coil winding, bases, dials, knobs, bushings, etc. We are prepared to make these various parts to your own specifications.

Where economy is a factor we can supply panels of Vulcanized Fibre Veneer made of hard grey fibre veneered both sides with a waterproof, phenolic condensation product. This material has a hard, smooth, jet black surface, machines and engraves readily and will give excellent service where very high voltages at radio frequencies are not involved.

Shielded plates (patent applied for) are made with a concealed wire shield. This shield, when properly grounded, effectively neutralizes all howl and detuning effects caused by body capacities.

Send today for our Radio Panel Guide

Are you an enthusiast? This Guide describes our panels in detail—gives tests—and tells just how much the panel you want will cost.

Are you a Radio Dealer? Let us tell you how easily and profitably Celoron Radio Panel Service enables you to supply your customers with panels machined and engraved to their specifications. Write today for our Dealer's Proposition covering panels, dials, knobs and tubes.



CONDENSITE
CELORON

Diamond State Fibre Company

Bridgeport (near Philadelphia), Pa.

Branch Factory and Warehouse, Chicago.

Offices in principal cities.

In Canada: Diamond State Fibre Company of Canada, Ltd.
Toronto.

Tell them that you saw it in RADIO

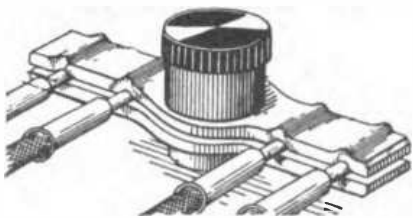

FOUR SETS OF PHONES!

25c will buy a set of Multiple Binding Post Connections (patent pending) which provide the only practical means of attaching as many as 4 pairs of telephone receivers to a pair of ordinary binding posts.

Dual connection set provides same connection in attaching Magnavox and outfit to storage battery.

Either set will be sent postpaid upon receipt of 25c in coin or stamps. Satisfaction guaranteed or money back.

Portable Wireless Telephone Co.

Dep't A, Commercial Bank Building
STOCKTON, CALIFORNIA

Attractive Dealer's Proposition.

NEW MOTORS

FOR ALL PURPOSES
STANDARD MANUFACTURERS
PROMPT DELIVERY

ALL SIZES UP TO 5 H.P.

We Specialize In Small Motors & Generators

ALL PHASES AND FREQUENCIES IN STOCK AT ALL TIMES

Largest exclusive Mail Order Small Motor dealers in the world.

CHAS. H. JOHNSTON, Box 38, West End, Pittsburgh, Pa.

WIRELESS, TELEPHONE GENERATORS
500 VOLT - 100 WATT - 3400 R.P.M.
FOR MOUNTING MOTOR GENERATOR SETS.

\$28.50
each

WRITE FOR
CATALOG

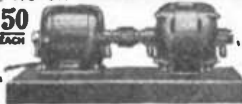

DUPLEX Victrola Attachment \$5.00

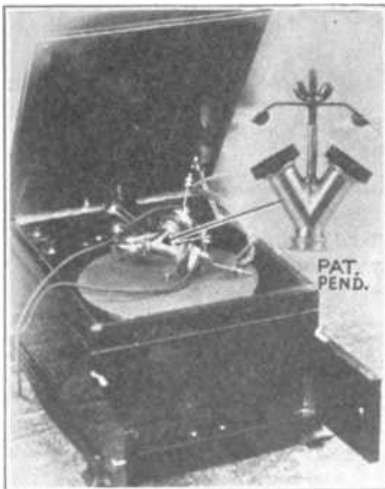

Make a first class loud speaker of your head phones and Victrola with a Duplex. Highly polished aluminum and nickel plate. Take any size head phones. Just what every one has been looking for.

If your dealer does not have the Duplex we will ship postpaid on receipt of price. State make of Talking Machines when ordering.

Mfg. by
W. B. McMASTERS
WHEELING, W. VA.

Solder Your Connections

for best results. Get the "Welder" a Self Heating Iron. Use it anywhere without stove. No workshop complete without it. Cheap to operate. Generates own vapor in two minutes. Absolutely safe. So simple a child can operate. Nothing to get out of order. Use it as blow torch size. Boxed complete with solder. Balancing and full soldering directions. Send \$2.00 cash or money order. Shipped prepaid anywhere in the U. S. Send order now.

Dealers—a big seller. write for proposition.

North Shore Radio Works, Dept. B-602
810 Davis Street, Evanston, Ill.

going to Walter Ostman, Ridgewood, N. J. Besides these there were fifteen other smaller prizes.

Another record set at the show was in the number of aerials on the roof of one building, there being 20 receiving aerials of exhibitors at the show and three permanent aerials belonging to the service men occupying the armory and used for both sending and receiving practice and instruction.

Grasp the proportions of the show from the following data: There were nearly one hundred individual exhibitors' booths. An estimated figure of the number of visitors to the show is over sixty thousand. The exhibition building covers in all one entire block facing on four streets. This probably sets a record for the country as the largest radio show ever given.

One of the interesting exhibits was the one maintained by the United States Navy Radio service. Through working models and maps it was shown just how a ship is brought from the three mile limit, right up into the lower bay of New York. When a ship reaches the three mile limit, the navigator sends out the call "NAH" (the compass control station at New York City), and requests "QTE," "What is my bearing?" NAH replies with K. The navigator then sends his own code letters signal test and within one minute four separate compass stations are taking their turns sending him reply messages, which by turning his wave direction compass on he can safely guide himself into port. The four compass stations are located at Amaganssett, Fire Island, Sandy Hook, and Mantoloking.

COMMERCIAL BROADCASTING IN CANADA

Radio broadcasting on a large commercial scale will soon be in progress in Canada. John Lowry, telephone commissioner, announces that the Manitoba government telephone system is now preparing facilities with which to carry on a substantial business throughout the province. Similar steps are being taken by other provinces. Laws governing the activities of amateur radio machines so that best results may be obtained by commercial sending and receiving stations will be sought at the next sessions of the Western Canada legislatures.

Agricultural economists declare that the radio is destined to work wonders for Western Canada. Hundreds of settlers are pouring into the rich mixed farming districts of the prairie provinces. While Western Canada is noted for its telephone service, which forms a network of wires across the prairies, there is an inevitable delay in wiring new districts. With the rapid advancement of the radio science, the farmer in the most remote section may for a few dollars

throw up a small receiving set that will keep him linked continuously with the broadcasting stations at Winnipeg.

RADIO RECEIVING PHONES

We Repair and Rewind Them

If you have a pair of telephone receivers we can rewind them to any ohms you desire. We have a few pairs of rebuilt receivers on hand. Write for our prices.

THE RADIO SHOP

321 West 40th St., Indianapolis, Ind.

Your storage battery

IS NOT A POWER PLANT;
IT MUST BE RECHARGED.

The Riggs Rectifier

\$12.50

postpaid, anywhere, is the cheapest and best way to do it.

W. H. RIGGS

Box 304, Everett, Wash.

THE RIGGS MFG. CO.

Urbana, Ohio

Liberal discount to dealers

A POSTAL CARD

Will Bring Our Latest
RADIO FOLDER

THORDARSON ELECTRIC MFG. CO.
600 W. Fulton St. CHICAGO

Our 3 Factories

are dedicated to building only the finest radio apparatus. Every one of our complete outfits and separate parts carries our unqualified guarantee.

MARVEL Receives wireless telephone, music and speech in 30 miles radius. telegraph 300. With antennae and insulated wire. \$15 complete
headphone, switches, etc. Range 180 to 2600 meters. Nothing additional required

MARVEL In cabinet, providing greater selectivity and range, with double headphones, antennae, switches, etc. Complete \$25.

Also a complete line of high grade separate parts guaranteed unconditionally as best
FREED-EISEMANN RADIO CORPORATION
255 Fourth Avenue New York, N. Y.

RADIO PANELS

Cut exactly to size and shipped within 12 hours. ¼ inch thick \$.01 ½c per square inch, ½ inch .02c. Made of the highest grade black fibre. This material possesses high dielectric strength, is inexpensive, unbreakable, easy to work and takes a nice finish. Special offer 6x6 ¼ .50c. We pay postage.

RADIO INSTRUMENT & PANEL CO.
26 North Desplaines St., Chicago, Illinois

Tell them that you saw it in RADIO

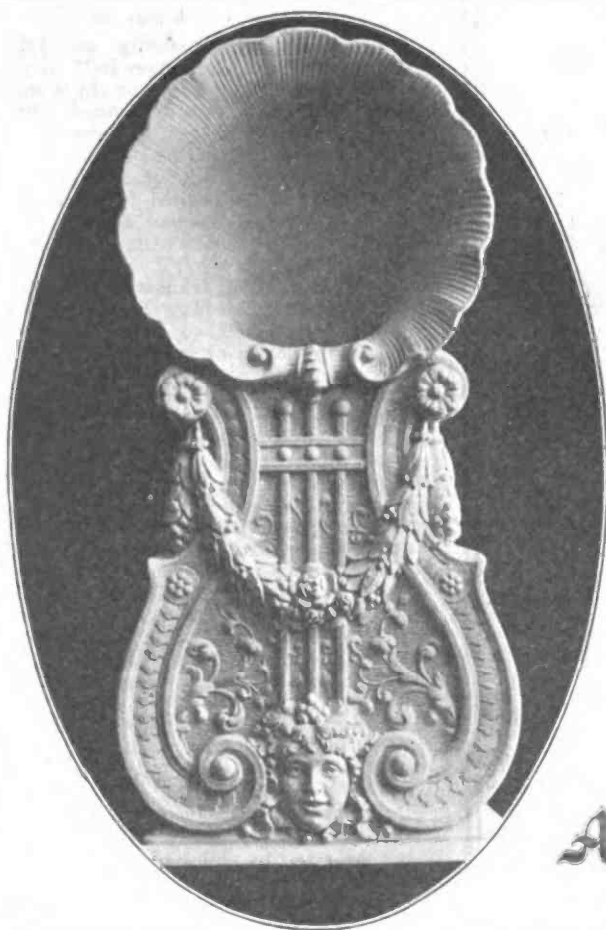

'MADERA' Clear Speaking Horn and Cabinet

Made of Die-cast Wood—A Delight to Both Eye and Ear

Brings out the soft, distinctive semi-tones of the human voice and lends to music a rich, full tone quality impossible with metal horns. It absorbs and destroys all jangling sounds and makes clearly audible messages that are otherwise unintelligible.

Horn is separate from, and sets loosely in, the Cabinet. Is equipped with attachment for holding any type of Phone Receiver. Wire connections enter back of Cabinet out of sight. Both Horn and Cabinet are die-cast from wood fibre under great pressure; accompanied by an electric baking process. This forms thin walls of a very dense wood, possessing remarkable acoustic properties. So thin are these walls that the entire Cabinet and Horn weighs only 5 lbs.; yet so strong it will bear a man's weight.

Height over all—20 in. Horn 10 in.
in diameter. Price, boxed—ready **\$25**
for shipment.....

Send for an outfit. It will add a new and unexpected joy to your Radio parties. Send cash with order. Money will be refunded on return of outfit if found unsatisfactory. Circular for the asking.

American Art Mache Co.

6313 No. Clark St., Chicago.

RADIO DEALERS.

We offer you complete stocks, fair prices, and prompt service.

We want your business—send us your orders

WHOLESALE ONLY

We do not retail anything—Wholesale Only—which is fair play to you, Mr. Dealer.

If we have it in stock, you can buy it—nothing held back for Retail Sale.

GORTON ENGRAVING

Our Gorton Engraving Machine is working 24 hours a day—we assure you prompt service on engraving, drilling, and polishing panels.

DEALERS—Get in touch with us for action!

Coast Radio Company

An organization of Radio Electricians with 15 years Radio Experience

Old Time Radio Men—Do You Remember Us?

C. R. PARKER E. G. ARNOLD HALL BERRINGER
G. S. CORPE T. L. CORPE

EL MONTE, CALIFORNIA
Los Angeles County

Tell them that you saw it in RADIO

TRADE **ESCO** MARK
 HIGH VOLTAGE MOTOR-GENERATORS
 STAND PRE-EMINENT IN WIRELESS FIELD

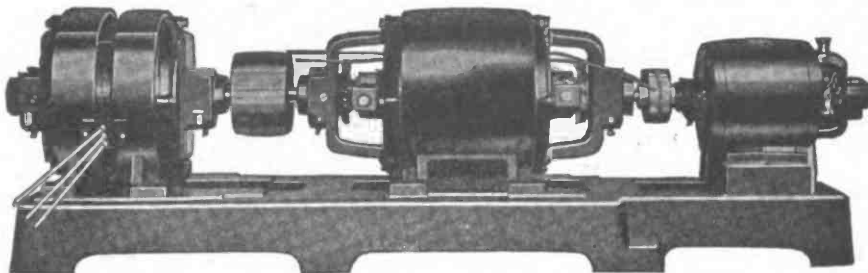

USED BY LEADING EDUCATIONAL INSTITUTIONS, U. S. GOV'T. RESEARCH LAB'S., NEWSPAPERS, DEP'T. STORES, ETC.

ESCO

Manufactures over 200 different combinations of windings for wireless, and develops special apparatus for special requirements. Send us your problems.

Write for Bulletin No. 237—Complete Information
 MOTORS — DYNAMOTORS — GENERATORS
 MOTOR-GENERATORS

SOLD BY PRINCIPAL DEALERS
 EVERYWHERE

ELECTRIC SPECIALTY CO.

215 South Street

STAMFORD, CONN., U. S. A.



TELMACO

Thousands of Unfilled Orders
 FOR THE
TELMACOPHONE

What's The Reason?

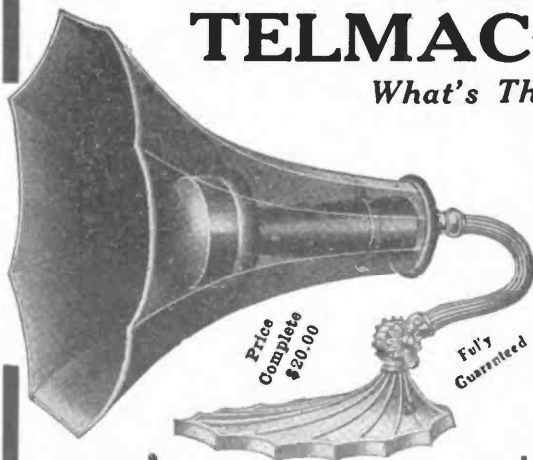

Much to our regret we have been unable to fill all orders for the Telmacophone promptly. The demand has been far beyond our expectations. When we first advertised the Telmacophone, we felt confident that it was the greatest value ever offered.

Our own confidence has been sustained by the public which has taxed our manufacturing facilities to the limit.

All unfilled orders will be taken care of just as soon as possible. To those who have not yet ordered the Telmacophone, we want to assure you that it is well worth waiting for. Do not be satisfied with an inferior substitute.

DEALERS: We are distributors for nearly all standard lines. Full discounts on the Telmacophone. Write for proposition on our complete line.

RADIO DIVISION

TELEPHONE MAINTENANCE CO.

Note New Address

20 S. Wells Street, Dept. A, Chicago, Ill.

Tell them that you saw it in RADIO

QUERIES AND REPLIES

Continued from page 34

The circuit accompanying an article entitled "The D. X. Bringer-in," on page 23 of April RADIO, does not show where the loading coils should be placed. Please show the correct place for these coils.—B. O., Youngstown, Ohio.

The small crosses at the places where loading coils should be inserted for long waves were omitted on the original diagram, so we are reproducing it herewith, in corrected form. See Fig. 4.

(a) In the C. W. transmitter for C. J. Dow, described in May RADIO, is the rheostat connected so as to place the windings in series or in parallel, and will either of these arrangements carry the current of the two tubes? (b) Will the rheostat, when connected in parallel, have sufficient resistance to keep the voltage of the tubes at ten volts? (c) What is the purpose of the binding post on the upper right hand side of the panel of the transmitter?—J. P., Staten Island, N. Y.

(a) The rheostat windings are in parallel, in order to carry the current of the two tubes, without heating. (b) Yes, the rheostat is sufficient to bring the voltage down to eight volts if necessary. (c) This binding post is not used, being merely placed there to preserve the symmetrical proportions of the panel.

Please inform me how the limit of power from an amateur C. W. transmitter is reckoned.—R. J. B., Pine Knot, Calif.

Until the new regulations now being prepared by the Dept. of Commerce are put into effect, the rule of 1 K. W. maximum input into the transmitting apparatus is still in force.

A chemical rectifier for charging storage batteries can be made by filling a pint mason jar to within an inch of the top with a concentrated solution of borax and by suspending a 1-in. strip of $\frac{1}{8}$ -in. sheet aluminum and a similar strip of lead on either side of the jar. The solution is made by stirring about half a pound of borax into a pint of warm water until no more can be dissolved. The metal strips should be long enough to just clear the bottom of the jar and should be bent at the top so as to hang over the edge of the jar and thus be suspended in the jar. The aluminum strip should be connected to the positive battery terminal and to one of the alternating current wires, being sure to have a 100-watt lamp or equivalent resistance in series. The other ac. wire is connected to the negative battery terminal. Before using the rectifier cut the battery out of the circuit and turn on the juice for five hours so as to "form" the plates.

ORANGE COUNTY RADIO
 CLUB

The Orange County Radio Club of Fullerton, Calif. has elected as president—Malcom Atherton, vice-president—Cecil Yates, Sect'y treasurer—Ray Hancock, and traffic officers—J. E. Waters (6EC) and (6AHA).

Every meeting is taken up by a lecture or moving picture. A debate is in progress on "Whether Spark is better than C.W."

The spark set and the telephone set at 6BIK (Club Set) is now in operation, and advice as to modulation, etc., will be appreciated. All letters answered. No regular operating hours have been assigned yet. Laurance Babize, ex-commercial operator, Cecil Yates, Ray Hancock and Walter Bruce are the operators for the Club Set.

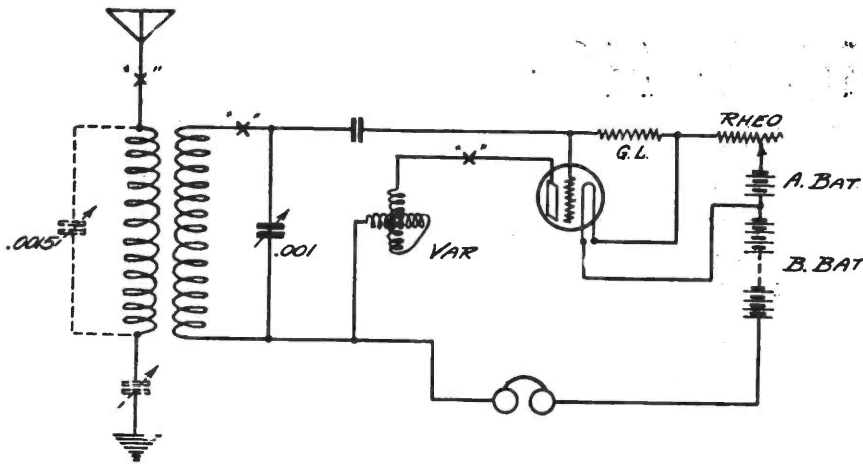

The 'QSA' Line of Radio Equipment

Larger business has made necessary larger space and larger stock. So we have moved into new quarters where we will be better able than ever to supply your wants. Items listed below are in stock for immediate delivery.

- Radiotron UV 202 5 Watt Power Tube...\$8.00
 - Federal No. 226-W Amplifying Transformer..... 7.00
 - Paragon VT Socket No. 80..... 1.00
 - FADA Panel Mounting Rheostat..... 1.00
 - Eveready No. 776 Variable "B" Battery 3.00
- Catalog of "QSA" equipment sent for 10 cents which will be refunded on initial purchase or FREE with order from this advertisement. Get on our mailing list. We have something interesting to say to you each month.

INDEPENDENT RADIO SUPPLY CO.
3239 Ogden Ave., Chicago, Ills.

RHAMSTINE* Rheostat

The Rhamstine* Rheostat conveys instant and vivid conviction of value.

It is a new Rhamstine* Product and aside from its original design and attractive appearance, it possesses these valuable features:

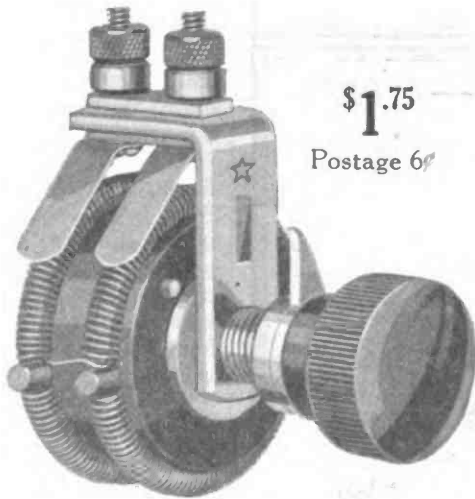

1. Compactness—the element ring is only 1 1/4 inch in diameter.
2. One hole for mounting—the bearing for the shaft also holds the rheostat frame.
3. Brush Contact — two stationary brushes make contact with the resistance element.
4. Air cooled.
5. Noiseless.

It is exceptionally well made, dependable and durable and quite advanced in design.

Ask your dealer to show you how it works.

Circulars upon request.

Manufactured by

J. Thos. Rhamstine*

2152 E. Larned St.

Detroit, Mich.

*Manufacturer of Radio Products

Hook Up With a WIZARD BATTERY

A special made "moisture proof" "B" battery of guaranteed long life—a veritable power house. As high in quality as it is low in price.

No.	Size	Wgt., Lbs.	Volts	Price
1623 Plain.....	2x3 1/4 x 2 1/4	1	22 1/2	\$1.00
1623 Variable....	2x3 1/4 x 2 1/4	1	22 1/2	1.20
1625 Plain.....	4x6 1/4 x 3	5	22 1/2	1.85
1625 Variable....	4x6 1/4 x 3	5	22 1/2	2.25
1626 Plain.....	8x6 1/4 x 3	10	45	8.75
1626 Variable....	8x6 1/4 x 3	10	45	4.15
1630 Variable....	3x6 x 2 3/4	2 1/4	27	1.80
1632 Variable....	5x6 x 2 3/4	3 1/4	45	2.80

At your dealer or write direct

WIZARD BATTERY CO.
173 Lafayette Street, New York City

Special

- Empire Variometers.....\$3.00
- Empire Variocouplers... 4.00
- Chelsea Variable condensers, 23 plate..... 3.75
- Variable condensers, 23 plate..... 2.50
- Variable condensers, 43 plate..... 3.25
- Vernier condensers, 3 plate..... 1.25
- Moulded sockets..... .60
- Fada rheostats..... .75
- Klosner vernier rheostats 1.25
- Small 22 1/2 V "B" Battery .90
- Large 22 1/2 V "B" Battery 1.75
- Large 45V "B" Battery.. 3.25
- Federal amplifying transformers..... 5.50
- Audiotrons..... 5.00
- Audiotron adapters..... 1.25
- Dictograph headsets..... 9.85
- Turney headsets..... 6.00
- Federal Jr. crystal sets... 20.00

EMPIRE RADIO CORPORATION
271 West 125 Street
New York City

Phone Kearny 2778

PACIFIC RADIO SCHOOL

ARC & SPARK SYSTEMS

Hours:

1 to 5 P. M.
7 to 9 P. M.433 Call Bldg.,
San Francisco, Cal.

Send for descriptive circular.

Try	REYNOLDS RADIO	Service
(Old) "9ZAF"	<i>from DENVER</i>	(New) "KLZ"
Distributors for		
KENNEDY	CLAPP-EASTHAM	
GREBE	CHELSEA	
REMLER	PROST	
MURDOCK	DeFOREST	
MAGNAVOX	ELEC. SPECIALTY	
		We are now located in our NEW STORE, with the largest stock of Radio Apparatus in the West.
		Our facilities for serving you have been greatly increased.
		When you think of RADIO, think of "REYNOLDS RADIO."
REYNOLDS RADIO CO., Inc. 1534 Glenarm Pl. DENVER, COLO.		
THE LARGEST DISTRIBUTORS OF RADIO APPARATUS IN THE WEST		

WHAT YOU HAVE BEEN LOOKING FOR—A REAL

AMATEUR

RADIO

DIRECTORY

Complete List of all Amateur Stations in the United States, including Special Stations and Broadcasting Stations.

— also —

Notes on the construction of a complete receiving set.
Calibration of a receiving set without the use of a wavemeter.

Price \$1.00 Per Copy

Order from your dealer—if your dealer hasn't them, send direct.

PUBLISHED BY

Radio Directory and Publishing Co., Dept. "B" 45 Vesey St. New York City, N. Y.

Do not send stamps. Dealers—write for proposition.



—RADIO INSTITUTE—

OF AMERICA

Conducted by the greatest and most experienced radio telegraph organization in the world.

Thorough training given in radio operating, traffic, and in damped and undamped systems.

Tuition ten dollars a month for either the day or evening sessions or both combined.

Prospectus mailed on request

RADIO CORPORATION OF AMERICA

Phone Douglas 3030

331 New Call Bldg., San Francisco

Tell them that you saw it in RADIO

ELIMINATING STATIC

Continued from page 15

electrical system acting as a huge receiving antenna.

In receiving by this method, Dr. Cohen pointed out, the interference of static is less, although much static is still present, but by connecting in the resonance coils in combination with certain circuit arrangements perfected by him and Major Mauborgue, it was found that the static was practically all eliminated. The resonance wave coil method, he added, had also been found applicable for use as an ordinary aerial, through experiments conducted last summer.

Describing the device, known as resonance wave coils, briefly, Dr. Cohen said that it was practically a long coil, the length of the wire used being comparable to the length of the wave which is being received. The coil which stands vertical is enclosed with short metal tubes which slide up and down the coil, and are grounded through certain circuit arrangements which act like a drain for the static currents but permit the signals desired to be received to pass through to the detecting instrument. The device can be used either with a lighting circuit used as a receiving antenna as described by General Squier, or in connection with a regular receiving aerial.

According to the Bureau of Standards, a great deal of work has been done by radio engineers and scientists in an effort to reduce the interfering noise caused by static and strays. Certain devices are in use by means of which strays are considerably reduced, but the apparatus now employed is usually too elaborate to be used at the ordinary amateur station.

One method which the amateur will find helpful in reducing certain types of strays, is to use, instead of the usual elevated antenna, a coil antenna and a more sensitive receiving set. A coil antenna may be constructed by winding a suitable number of turns of wire with proper spacing on a square wooden frame about 4 feet square. Certain types of strays seem to come from a particular direction, but many strays have no directional properties. The coil antenna has the property of receiving a strong signal when pointed in the direction from which a signal is approaching, and receiving only a weak signal when pointed at right angles to that direction. Thus by rotating a coil antenna to the proper position the directional types of strays can be greatly reduced. The strength of signals picked up by a coil antenna is much smaller than the strength of signals picked up by the ordinary elevated antenna, and good results should not be expected from a coil antenna unless three or more stages of amplification are used.

Some relief can also be obtained by persons having good amplifiers by using a "ground antenna." This is a long insulated wire run in a shallow trench or on the surface of the ground. The ground wire should be run in the direction of the station from which the most signals are to be received, and should preferably be several hundred feet long.

RADIO COMPASS STATION

The Navy maintains along the coast of the United States 62 radio compass stations, the total cost of which is not more than \$1,000,000. It is estimated that during peace times the value of ships saved from destruction during three months of bad weather will more than offset the total cost of installation and maintenance of all the radio compass stations of the Navy.

These stations are not only of immense value during peace times but of the greatest assistance during war. Every time an enemy ship within 500 miles of the coast sends a radio message the coast compass stations can immediately determine the direction of this message. This direction in degrees is sent to a central office where the exact position of the enemy can be plotted.

The radio compass is also used continuously by aircraft flying up and down the coasts. In bad weather the aircraft frequently finds its base by asking the radio compass station there for a bearing, and upon receiving the bearing of the station the pilot flies directly toward it.

**GALENA
ORE**

Exceptionally fine
Specimens of Galena
Ore carefully selected
and prepared, direct
from the mines

Fully guaranteed
Money refunded if not satisfactory

Send **\$1.00** for
Generous Supply

Mineral Supply Co.
1227 47th Avenue
SAN FRANCISCO, CALIFORNIA

*It Took 14 Years to Perfect
This Set*

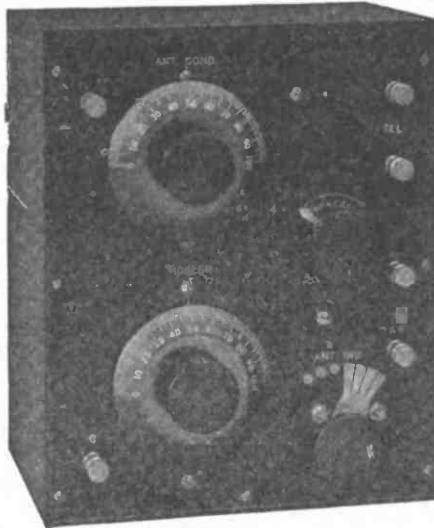

(Licensed under Armstrong U. S. patent No. 1,113,149)

SPECIFICATIONS

- CABINET:** Solid mahogany, dull finish.
- PANEL:** Condensite, dull finish, machine engraved, white lettering.
- DIALS:** Indestructible metal, black with white lettering.
- CONDENSER:** Balanced type, built as a Vernier; 2 rotary, 3 stationary plates.
- ANTENNA INDUCTANCE:** Wound on formica tube.
- PLATE INDUCTANCE:** Wound on molded ball.
- BINDING PARTS:** Black rubber covered.
- SWITCH:** Fan blade.
- RHEOSTAT:** Clapp-Eastham type H 400.
- CIRCUIT:** Single circuit regenerative.
- "B" BATTERY:** Contained in inside compartment or external, as desired.
- PRICE:** \$40.

WE have specialized exclusively in radio for more than fourteen years. Every one of those years has contributed something important to our latest Type H. R. Regenerative Receiving Set. We sincerely believe it to be the best set of this type on the market today—regardless of price.

Novices and experienced radio men alike praise its simplicity of operation, its sharp, clear tones, its wide range, its careful workmanship, its neat appearance. And invariably they express surprise at its unexpected performance. Regenerates perfectly wave lengths of 180 to 825 meters.

N. B. If, owing to the phenomenal demand, your dealer is out of Clapp-Eastham sets, write us. 6c stamps will bring you our new Radio Catalog—containing full information regarding this set and other radio equipment.

Oldest and Largest Exclusive makers of Radio Equipment

Clapp-Eastham
Type H R
Regenerative Receiving Set

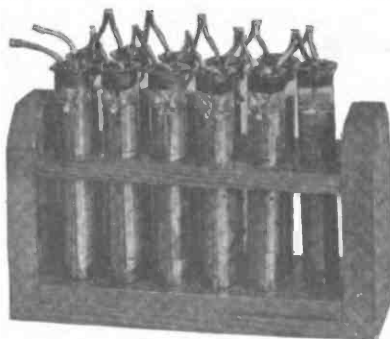

Permanence of Performance is
Assured by the use of
SNELL CELLS

- 22 v., 11 cells.....\$5.50
 - 44 v., 22 cells.....10.00
 - 88 v., 44 cells.....20.00
- F.O.B. San Francisco

**THE STORAGE "B" BATTERY THAT DELIVERS
THE PROPER VOLTAGE FOR FROM 3 to 5 YEARS**

MANN & SNELL

4733 Geary St.

San Francisco, Cal.

Tell them that you saw it in RADIO

The ADAPTOLA

"Radio Through Your Phonograph"



The ADAPTOLA may be attached to the tone arm of any phonograph. It amplifies the sound between the head-phone and the tone chamber of your phonograph and insures the finest possible rendition of music or spoken voice. The ADAPTOLA offers those who own phonographs the most perfect loud speaker obtainable. Fits any standard phone and all makes of phonographs.

Price \$3.50

On sale by dealers. If your dealer has none in stock, send us \$3.50 and name of your phonograph. We pay postage in U. S.

(Discounts to Jobbers and Dealers)

The Radio Supply Co.

111 New Montgomery St. San Francisco

LETTERS TO THE EDITOR COMPRESSIBILITY OF WATER

Sir: I wish to call your attention to an error which occurs in a technical article in your May issue. Charles K. Fulghum, in his article on "The Radio Wave," page 17, states:

"If a point is chosen beneath the surface of the water and a careful study made under the conditions which take place in this medium during such a disturbance as cited above, we find that the water is not moved along, but is merely *compressed and rarefied*, corresponding with the wave motion which takes place on the surface."

The author probably had in mind the compression and rarefaction of the air caused by a sound wave in it, as mentioned in the next paragraph of his article.

The fact is that water is practically incompressible, an enormous pressure being required to produce any apparent decrease in volume. The particles of water in a water wave have been found to move in circular orbits which become smaller and smaller as one goes further below the surface.

Yours truly,
EDWARD W. KIMBARK.

Evanston, Ill.

Sir: In reply to Mr. Kimbark's letter of May the third, concerning the error in my article on the Radio Wave, I have this to state.

Mr. Kimbark is in error when he states that water is practically incompressible. That is the popular belief, but the fact is that it is compressible and this property is being made use of in a very novel manner at the present time. (See May issue of Scientific American, "Transmitting Power in Fluid Waves.")

Were water not compressible a sound propagated at a point beneath the surface of a body of water would be heard simultaneously at any point no matter how far distant it was from the source of sound. (This is considering the use of proper microphonic instruments as detectors beneath the surface of the water.)

In the case of a disturbance such as was referred to in the article, viz., a stone dropped in a pool of still water, the writer was not referring to the surface waves but to the waves which are formed that are points of rarefaction and compression. Mr. Kimbark's statement that the particles of water, presuming he has meant molecules, move in circular orbits, is proof in itself that there must be differences in the density of the water as the wave progresses through it, for no matter how small, these particles have a certain inertia which is the cause of the formation of these waves which are characterized as points of rarefaction and compression.

I trust that this letter will clear up any question which has occurred in the minds of any readers over this point which is here discussed.

Very truly yours,
CHAS. K. FULGHUM.

Delta, Colo.

TRANSMITTING ON GALENA

Sir: In your May issue of RADIO, on page 20, is an article by L. F. Seefred on "Transmitting on Galena."

This article is very interesting as it shows that Mr. Seefred's antenna was able to absorb enough energy from the two receiving stations heterodyning each other to be able to modulate their beat frequency by pure absorption. Please have Mr. Seefred give a little data on this phenomena such as distances between the three stations and plane of each antenna. I imagine his station was located quite close to one of the other stations in order to absorb enough energy to modulate its output.

Continued on page 36

Head Sets That Give Service

Western Electric Head Sets

Tested and designed by experts, very light and sensitive \$15.00

Brown Phones 16.00

Seibt Phones 14.00

Auth Phones 8.00

Federal Phones 8.00

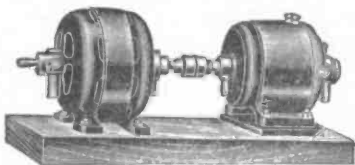

Special Motor Generator

For charging storage batteries—110 volts A. C. or D. C. Generator output—8 to 10 volts. 8 Amperes D. C. \$40

AETACO Heavy Rotary Switch with special bearing and Bakelite Knob—75c each

Lightning Switches, 600 Volt, 100 Amp \$3.60

Arkay Horns 5.00

King Am-pli-tones 12.00

Cabinets—all sizes and prices

Everything for Radio - Send 10c. for Catalog R-7

Dealers' inquiries invited

AMER. ELECTRO TECHNICAL APPLIANCE CO.
227-229-235 Fulton St. New York



"COPPERWELD"

TRADE MARK REG. U. S. PAT. OFF.
Made by the Molten Welding Process

No. 14 Copperweld Wire is 50% STRONGER than No. 14 Copper or 7-No. 22 Stranded Copper

Has Underwriters' OK.

Used and recommended by largest radio concerns in the world.

(Extract from New Fire Underwriters' Rules, Par. 86.)

Lead-in wires shall be approved copper clad steel: not less than No. 17 B & S gage may be used.

The ground wire may be approved copper clad steel: not smaller than No. 17 B & S gage.

The ground conductor may be approved copper clad steel, not less than No. 17 B & S gage.

Buy Copperweld Wire in Cartons

ANTENNA WIRE,
LEAD-IN and
GROUND WIRE
GROUND RODS,

No. 14 Bare (100 ft., 150 ft. and 200 ft. cartons)
No. 17 Rubber-Insulated (25 ft., 50 ft. and 100 ft. cartons)
Pointed, Non-Rusting (6 ft. long, 1/2 inch diameter)

COPPER CLAD STEEL COMPANY
OFFICE AND WORKS: RANKIN, PA.
NEW YORK CITY OFFICE: 30 CHURCH ST.



WESTERN SALES REPRESENTATIVES:
STEEL SALES CORPORATION, CHICAGO, ILL.

Radio Dept.—Braddock P. O., Rankin, Pa.

BIG SUPPLY LATEST APPARATUS ON HAND READY FOR PROMPT DELIVERY
4 HOUR MAIL ORDER SERVICE

WE ASSURE YOU OF THE MOST PROMPT SERVICE

Our Radio Mail Order Service is gaining much popularity on account of the **FAST SERVICE**. We ship your order within four hours of its receipt. After you tire of waiting days—or maybe weeks—for your supplies, try Warner Brothers' Radio Mail Order Service and you will use no other. Following are a few items that we have in stock:

VARIABLE CONDENSERS

.0003 17 Plates K & C Type.....	\$3.00
.0005 23 Plates K & C Type.....	3.50
.001 43 Plates K & C Type.....	5.00
.0015 63 Plates.....	7.20
.001 43 Plate Warner.....	4.00
.0005 23 Plate Warner.....	3.50

LOUD SPEAKERS

E3 Magnavox Radio Type.....	\$45.00
E2 Magnavox.....	85.00
36 inches long	

EVEREADY "B" BATTERIES

No. 765, 22½ Volts.....	\$2.00
No. 766, 22½ Volts, tapped.....	3.00
No. 774, 43 Volts, tapped.....	5.00

REMLER APPARATUS

810 Jr. Rheostats.....	\$1.00
811 Rheostats.....	1.75
813 3 Amp. Rheostats.....	1.75
330 Audion Detector Panel.....	8.00
331 Amp. Panel.....	6.00
333 Amp. Panel.....	9.00
400 3 Coil Mounting.....	6.50
96 Variable Grid Leak.....	.80
97 Grid Condenser.....	.35

SOCKETS

156 GENERAL RADIO.....	1.50
550 MURDOCK.....	1.00
DEFORST Moulded Bakelite.....	1.10
CEOSLEY Porcelain.....	.60
KELLOGG.....	1.00
PARKIN.....	1.50

AMPLIFYING TRANSFORMERS

UV-712 Radio Corporation.....	\$7.00
231A GENERAL RADIO.....	5.00
226W FEDERAL.....	7.00
A2 ACME, semi-mounted.....	5.00
Thordarson.....	4.00
BRYANT.....	5.00

VARIOMETERS

REMLER 505 Moulded Bakelite.....	\$6.50
OUR OWN TYPE.....	4.00
ATWATER KENT.....	8.00

JACKS AND PLUGS

FEDERAL 1421 Open Circuit Jack.....	\$.70
FEDERAL 1422 Single Circuit Jack.....	.85
FEDERAL 1423 Double Circuit Jack.....	1.00
FEDERAL 1425 Automatic Filament Control Jack.....	1.20
FEDERAL 1425 Automatic Filament Control Jack.....	1.30
WESTERN ELECTRIC Plugs.....	1.30
FEDERAL Plugs.....	2.00
PACENT UNIVERSAL.....	1.25
NEW FEDERAL Universal Plug.....	1.75
FEDERAL PLEIPHONES.....	14.00

RHEOSTATS

REMLER Jr.....	\$1.00
FADA—with new Knob.....	1.00
GENERAL RADIO No. 214 7 ohm or 2½ Amp. 2 ohm.....	2.50
DEFORST, new type.....	1.20
PARAGON.....	1.00
MURDOCK 560.....	\$1.00

KLOSNER.....	1.50
JENKINS.....	2.00
FRAMINGHAM.....	1.00
HOWARD.....	1.25
OUTLER HAMMER.....	1.00

RADIO FREQUENCY TRANSFORMERS

MURAD T-11, 160 to 500 meters.....	\$6.00
MURAD T-11A.....	6.50
MURAD T-11B.....	7.00
RADIO ENGR. CO.....	6.00
UV1714.....	6.50
Radio Service Co.....	6.00
Radio Instrument Co.....	8.00

STORAGE BATTERIES

6 Volt 70 A. H.....	\$16.00
Philadelphia 6 V. 60 A. H.....	16.00

VARIO-COUPPLERS

REMLER 503 Vario-Coupler.....	\$5.40
REMLER 505 Coupler on Unit Panel.....	12.75
OUR OWN TYPE.....	3.50
ATWATER KENT.....	8.00

PHONES

Federal, 2200 Ohms.....	\$8.00
Federal, 3200 Ohms.....	10.50
Cory.....	8.00
Western Electric, 2200 Ohms.....	12.00
Dictograph, 3000 Ohms.....	12.00
Manhattan, 2000 Ohms.....	6.00
Manhattan, 3000 Ohms.....	7.00
Brandes, Superior.....	8.00
Lincoln, 3000 Ohms.....	8.00
Frost, 2000 Ohms.....	5.00
Frost, 3000 Ohms.....	6.00

Now that you have read the list, get that order into the mails without delay. If there is something that you want and don't see it listed here, write us anyway and we will get it for you. Our two stores save still more time in getting your apparatus in a hurry. Enjoy the pleasure of real service for a change. Send us your orders.

WARNER BROTHERS

TWO STORES

San Francisco.
350 Market Street
Phone Douglas 4639

Oakland, Cal.
22nd & Telegraph Ave.
Phone Lakeside 6223

MISSOURI WILL SUPPLY YOU MARKET CONDITIONS ARE IMPROVING EVERY DAY. SO IS OUR SERVICE. TRY IT.

THE MAN WHO KNOWS BUYS IT FROM



REGENERATIVE RECEIVERS

No. CR-4 Grebe 175-680 meters.....	\$65.00
No. CR-5 Grebe 175-8000 meters.....	80.00
No. CR-8 Grebe 175-1000 meters.....	80.00
No. CR-9 Grebe 175-8000 meters with det. and two stage amplifier, complete.....	130.00
No. RA Westinghouse 150-700 meters.....	68.00
No. RC Westinghouse 150-700 meters.....	132.50
Aeriola "Jr.".....	25.00
Aeriola "Sr.".....	75.00

SOCKETS

No. 550 Murdock.....	\$1.00
No. UP-552 Radio Corp.....	1.50
No. UR-542 Radio Corp.....	1.00
No. UT-541 Radio Corp.....	2.50
No. 80 Paragon.....	1.00

AMPLIFYING TRANSFORMERS

No. A-2 Acme, Semi-mounted.....	\$5.00
No. UV-712 Radio Corp.....	7.00
No. 281 Gen. Radio.....	5.00

JEWELL METERS

No. 54 for D. C. Standard readings.....	\$8.00
No. 54 for D. C. 500 volts.....	16.00
No. 54 for D. C. 1000 volts.....	23.00
No. 54 for D. C. 1500 volts.....	29.00
No. 64 Radio Frequency.....	12.00
No. 74 A. C. Standard reading.....	8.00

VACUUM TUBES

No. UV-200 Detector.....	\$5.00
No. UV-261 Amplifier.....	6.50
No. UV-201 5 watt transmitter.....	8.00
No. UV-208 50 watt transmitter.....	30.00
No. UV-204 250 watt transmitter.....	110.00

ATLANTIC-PACIFIC

A. P. Detector.....	\$5.00
A. P. Amplifier.....	6.50

LOUD SPEAKERS

No. A-3 Magnavox, new type.....	\$45.00
VOCALOID, station type.....	30.00

TELEPHONES

Type C Baldwins.....	\$12.00
Type E Baldwins.....	13.00
Type F Baldwins.....	14.00
No. 56 Murdock 2000 ohm.....	5.00
No. 56 Murdock 8000 ohm.....	6.00
No. 2500 Meaco 2000 ohm.....	6.00
No. 2501 Meaco 8000 ohm.....	7.00

RHEOSTATS

No. 25 Paragon.....	\$1.50
No. 214 General Radio.....	2.50
No. 560 Murdock.....	1.00
No. 120-A FADA, new type.....	1.00
No. 810 Remler, 4 ohm.....	1.00

"B" BATTERIES

No. 763 Eveready 22½ volts.....	\$2.25
No. 766 Eveready 22½ volts tapped.....	3.00
No. 5156 Burgess 22½ volts tapped.....	3.00
No. 2156 Burgess 22½ volts, extra large.....	4.50

BOOKS

C. W. Instructions.....	\$0.25
Practical Wireless, by Bucher.....	2.25
Experimenters' Manual, by Bucher.....	2.25

Please include sufficient postage with all C. O. D. orders.

"We give all we can for what we get—Instead of—Getting all we can for what we give"

MISSOURI RADIO SUPPLY COMPANY
 4623 Maryland Ave. SAINT LOUIS MISSOURI

Tell them that you saw it in RADIO

6 "Ledox" Volt

Storage Batteries

Efficiency
economy
durance

Radio Special

Guaranteed Two Years

60	AMPERE	NINE PLATES	\$ 15⁰⁰
	HOUR	PER CELL	
90	AMPERE	11 PLATES	\$ 17⁵⁰
	HOUR	PER CELL	

Manufactured by—

LARSON & ZINNAMON

439 Golden Gate Ave., San Francisco, Calif.

Dealers—Write For Proposition

Mail Orders Promptly Attended To

He states that just as soon as one of the stations would turn off its bulb, his (Mr. Seefred's transmitter) would be dead. I think that is not quite the case as I believe he could still modulate the output of the other station by absorption, but as he was using galena he of course could not get a beat without the third station heterodyning.

I see no reason why Mr. Seefred could not accomplish voice transmission by putting a microphone in series with his antenna and modulating the output of the near station by voice. This would require a fourth station with a non-oscillating receiver to hear the voice, or the third station could hear it with a straight detector.

Yours truly,

V. H. BROWN.

Brooklyn, N. Y.

Sir: Mr. Brown is correct in saying that one of the stations must have been close to mine as I will admit that he was approximately 50 or 60 feet from me, while the other was two blocks away. Both antennas were at right angles with mine. No doubt voice could be accomplished in this form as per Mr. Brown's letter. I have not had the opportunity to try voice modulation as yet, but would like very much to see published in RADIO, some experiments carried out by others along this line. I know of two amateurs in this city now who claim to be talking to each other at a distance of four blocks by making their sets oscillate and inserting a microphone in the ground lead, altho Mr. Brown's idea is a different experiment, and should prove successful to my estimation.

I have a friend in Texas who claims that he picks up quite a lot of the long undamped wave stations on both the Pacific and Atlantic Coasts. Also hearing POZ, and all this done on galena and a long antenna. There probably were two stations heterodyning on each other to make the third one audible on crystal at the fourth station.

I remember on one occasion when we copied the Great Lakes Naval Radio Station (undamped wave) on crystal, Saturday, Sept. 16, 1916, at 1:05 A. M.—P.S.T. NAJ was calling NPL on 6,000 meters. I have some very rough sensitive galena that is not seen at any of the stores and which probably accounts for the success I have had with receiving and transmitting on galena.

Very truly,

LYNDON F. SEEFRED.

Los Angeles, Cal.

The Altadena Radio Laboratory, operated by Paul F. Johnson at Pasadena, Calif., has outgrown two stores during the past year and on July 1st will move to 562 East Colorado St., where they will have twice their present room.

The Northwest Radio Service Co., of 1637 Westlake Avenue, Seattle, has expanded its activities to include large-scale manufacturing of instruments, under the trade name of "Puget." Shops in the Flatiron Building, adjacent to the store headquarters in the Times Square Building, have been completely fitted out, and are now engaged in working to capacity on three types of receiving sets and on Puget headphones. A large corps of radio mechanics have been put to work, and the demand is so strong that additional men are being added practically every day. The Northwest Radio Service Co., will extend the scope of its business to include wholesale relations with western and national dealers, according to V. I. Kraft, manager of the company. The company resumed broadcasting schedules early in May, when it reopened its station, KJR, with a 100-watt set.



RADIO ESSENTIALS

CONVENIENCES YOU NEED

PACENT PLUG and JACK COMBINATIONS

The Only Complete Line of Radio Jacks and Plugs
Adapted as Standard Equipment by largest Radio Manufacturers



Pacent Twin Adapter
Makes one jack take two
plugs.
Cat. No. 51... Price \$1.50



Pacent Universal Plug
The original radio plug
Cat. No. 50... Price \$1.25

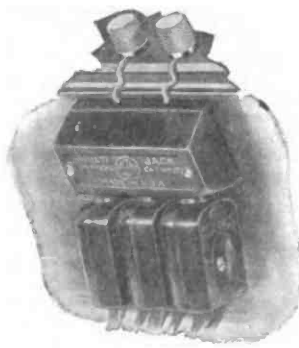

Pacent Multi-Jack
Three Jacks in one molded unit
Attachable to single pair binding posts
Cat. No. 52... Price \$1.50

The above and other Pacent Radio Essentials are distributed
by foremost jobbers and dealers.

Bulletins send upon request. Outline of sales plan for dealers and jobbers.

PACENT ELECTRIC COMPANY, Inc.

LOUIS GERARD PACENT, President

33 So. Clinton St.
CHICAGO, ILL.

150 Nassau St.

New York, N.Y.

Bourse Building
PHILA, PA.

Member Radio Section, Associated Manufacturers of Electrical Supplies

ATTENTION AMATEURS!

7 strand No. 22 Antenna Wire, 75c per 100 feet.

Enamel Wire No. 22 to No. 30 B. S., 85c per pound on 1 pound spools.

THE QUAKER LIGHT SUPPLY CO.

728 Arch St., Philadelphia, Pa.

Tell them that you saw it in RADIO

250 WATT POWER AMPLIFIER

Continued from page 13

on the vertical sub-panel. The process of soldering Litz is considered in detail in a subsequent chapter.

The filament voltmeter, V, which has a scale reading to 12, the milliammeter, A, with a scale reading to 250, and the radiation ammeter, I, with a scale reading to 10, are standard equipment.

It will be seen in Fig. 58 that there are three posts marked "FIL." These provide for filament heating by either alternating or direct current and, of course, the former is to be preferred because of the resulting greater tube life. When alternating current is employed for this purpose, post number 18 is the mid tap to the filament transformer secondary. To eliminate the impedance of the transformer secondary to the high frequency pulsating currents flowing from the filament, a 0.5 microfarad paper dielectric condenser should be bridged across posts number 16 and 18, and 18 and 17. When direct current is used for filament supply, connect posts 17 and 18 together and apply the filament heating current to posts 16 and 17.

Neglecting the broken lines of Fig. 58, the device is connected for use as an amplifier of any high frequency pulsating or alternating current impressed upon the input terminals. It will be noted that the flexible leads to the variable output inductance are connected to posts numbered 1, 2, 4, 8, and 9. Post number 2 is a blank, and serves merely to support the flexible lead when its use is not desired.

To use the instrument as an oscillator or C. W. transmitter, shift the flexible lead from post number 2 to 3 and the one from post number 4 to 5 and connect posts 5 and 6 together. This will form a Hartley oscillating circuit which will be found to operate most efficiently.

HORNE Radio Products

**Short Wave Receiving Sets
Tuners, Detectors and Amplifiers**

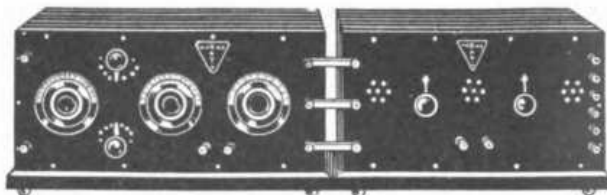

"NEPTUNE" HM-1 Receiving Tuner "SATURN" HM-7 Detector Amplifier

Other bright stars on the armament of HORNE Products are the:

- "JUPITER"—Combined Tuner and Detector.
- "VENUS"—Two-stage Amplifier.
- "MARS"—Detector Tube Control Cabinet.

The famous HORNE receiving sets are enclosed in highly polished, handsome ebony cabinets. Each unit attached by brightly nicked connection bars. All battery terminals concealed. These magnificent receiving sets may also be obtained with cabinets covered in beautiful shades of close-grained leather—dark green, brown, deep blue and glossy black.

Distributed Nationally by Leading Jobbers

HORNE MANUFACTURING COMPANY

General Offices:
Hudson Terminal Bldg.
30 Church Street
New York City



Two
Factories in
Jersey City,
N. J.

THE < **STANRAD** > FAMOUS



\$5.00 VARIOMETERS & \$5.00 VARIOCOUPLERS

OF PROVEN MERIT

STANRAD Variometers and Variocouplers have stood the test of time. Two years of conscientious endeavor have brought Stanrad apparatus to a point where they are unsurpassed as real short wave instruments.

SPECIFY STANRAD AND BE ASSURED OF SATISFACTION
See your dealer or direct

Standard Radio Company

KJC 1048 South Olive Street KJC
Los Angeles, Calif.

Manufacturers of STANRAD INSIDE AERIALS

If experience means anything to you, your choice of receivers will be influenced by Murdock's fourteen years of delivering satisfaction on a money-back basis. Murdock Phones bring in the concerts clearly and distinctly. They stand years of rough usage. They are priced as low as fourteen years' experience and tremendous quantity permits with due regard for quality.

Prices: 2000-ohm. \$5.00; 3000-ohm. \$6.00

Wm. J. Murdock Co.

342 Carter Street

Chelsea, Mass.

**MURDOCK
PHONES**

Tell them that you saw it in RADIO



and save 25% on high-grade assembled sets

THERE are two parts in the building of radio apparatus; first the actual panel drilling and assembling, and second, the wiring.

The first is essentially machine work which you could not duplicate. At the same time, because it is machine work, it is really the less expensive part of the entire assembly.

The wiring, which is hand work, is the expensive part and also the part which you can do just as well yourself. The Standard Plan gives you an opportunity to secure commercial grade correctly assembled apparatus at prices only slightly more than you would pay for the individual instruments.

The STANDARD Plan
"assembled but not wired"

The Standard Assembling Company makes a complete line of apparatus—fully ASSEMBLED but not WIRED. The actual machine work is done in a splendidly equipped factory. The workmanship is not excelled anywhere. The individual instruments and parts are of the highest quality obtainable and are bought in tremendous quantities at big discounts.

The wiring, which is expensive hand work, is left for you to finish.

Take advantage of the Standard Plan and save the expensive wiring costs. Only in this way can you get fully assembled high quality apparatus at such low prices.

STANDARD
ASSEMBLING COMPANY
Dept. A, 19 Bridge St., N. Y. C.

OUR new 12-page booklet, explaining the Standard Plan in detail and illustrating Standard instruments in actual colors, is just coming off the press. Send 5c for your copy at once. This coupon is for your convenience. We suggest that you fill it in now in time to save money on your next purchase.

Standard Assembling Company,
Dept. A, 19 Bridge Street, N. Y. C.
Gentlemen:—I enclose 5c. Send me your new booklet by return mail.

Name.....
Address.....
City.....
State.....

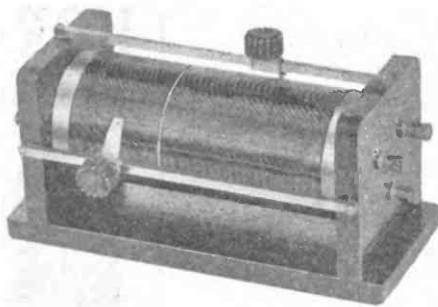

Complete directions with each instrument for using it in several ways including radio-frequency transformer work and regenerative circuits.

THE UNIVERSAL TUNING TRANSFORMER

EFFICIENT TUNING without variable condensers—
LOOSE COUPLING to avoid interference—
A COMPLETE HIGH-CLASS TUNING OUTFIT
for the price of a simple tuning coil—
DESIGNED for both Vacuum Tube and Crystal detectors.

\$4.25

At your dealer or write to

RADIO DEVICES COMPANY
693 MISSION STREET, SAN FRANCISCO

Can You Beat These?

- A Loud Talker for \$1.00
- A Short Wave Cabinet Receiver 9.75
- A Duo-Lat. Cabinet Receiver 7.75

Plan Bureau R-Series Blue Prints with separate printed instructions show you exactly how to make these and many other instruments for amounts ridiculously low. Give full details for every modern receiver part so that you can make each and every one from raw material. 24 blue prints in the set. Here is the list of parts shown:

- | | | |
|---------------------|------------------------|-----------------------|
| Loop Aerial | Knob | Duo-Lateral Coil Plug |
| Flat Top Aerial | Dial | Triple Coil Mount |
| Single Wire Aerial | Switch Lever | Duo-Lateral Coils |
| Cage Aerial | Switch Points | Phones |
| Umbrella Aerial | Rheostat | Loud Talker |
| Variometer | 1 Stage Amplifier | Series Par. SW. |
| Varicoupler | 2 Stage Amplifier | Anti-Cap. SW. |
| Short Wave Receiver | 3 Stage Amplifier | Switch Stops |
| Long Wave Receiver | Amplifying Transformer | Binding Posts |
| VT Detector Cabinet | Variable Condenser | Short Wave Hookup |
| Tube Socket | Grid Leak | Long Wave Hookup |
| Storage Battery | Grid Condenser | Loop Set Hookup |
| Storage "B" Battery | Plug | Det. Cab. Hookup |
| | Jack | Vacuum Tube |

You save the cost of the entire set if you make only the Loud Talker.

THE BIGGEST VALUE IN RADIO

Complete Set 24 Blue Prints and Instructions \$3.00 Postpaid. (No stamps.)

THE PLAN BUREAU

1929 McCausland Ave.

ST. LOUIS, MO.

"PRMCO" SERVICE WHY

Come in and see us, inspect our stock. We have it if it is Radio. If you live out of town, send for Bulletin. We will check what we have in stock to avoid delay. Postage paid.

QST RADIO SHOP

3305 BELMONT AVE.

FRESNO, CALIF.

FRESNO'S PIONEER RADIO STORE



Tell them that you saw it in RADIO

International Radio Co.

San Francisco, California

Announcement

Mr. I. H. McCarty A. I. E. E. will personally supervise the manufacture, testing and completion of our High Grade Radio Receiving Sets, having complete charge of our Engineering Department.

The "Toy Stage of Radio" has passed. This has prompted us to add to our Staff, Experts of proven ability and experience.

Mr. McCarty is a pioneer in the Radio Field, having in 1903 given the **FIRST** demonstration on the Pacific Coast of the Wireless Telephone. Mr. McCarty was Engineer for the North American Wireless Corporation, and during the World War designed special dictagraph and amplifying equipment for the U.S. Government.

Nineteen years practical experiments in Radio by Mr. McCarty will enable us to turn out "up-to-the-minute-Radio-Equipment." Mr. Carroll Shipman A. I. E. E., No. 58 Sutter Street, San Francisco, has accepted our appointment as Consulting Engineer. His long years of experience with great Electrical Engineering problems and his reputation is too well known to require introduction from us. Our Factory at the corner of Annie and Jessie Streets, San Francisco, is being equipped in line with the idea that Radio is here to stay. It will be a credit to San Francisco and the gentlemen who have become identified with it. First thought has been given to efficiency and a high class product.

A glance at the photograph of our Receiving Set will convince anyone that it will be a credit to any home, one you would be proud to have in your parlor or office. All material entering into its construction is the best obtainable. Before shipment every set is tested and inspection certificate attached carrying our guarantee.

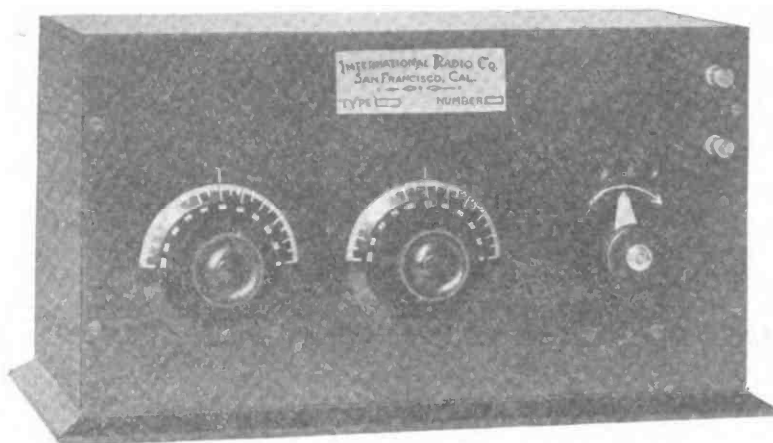

Specifications

Polished solid mahogany box, 13 x 7½ x 6½. Satin finished Bakelite ⅜ inch panels. Bakelite Dials. No wires in front. Binding post connections in rear. 2,400 ohm. Kellogg Receivers. Batteries, etc., everything complete. No parts to buy. Ready for use and installation in 30 minutes after receipt. **TOTAL COST \$75.00.**

Dealers: Price upon application. All questions cheerfully answered. Our service department can help you.

Reference: Anglo London & Paris National Bank.

International Radio Co.

Phone Douglas 422

1 65 JESSIE STREET

San Francisco, Cal.

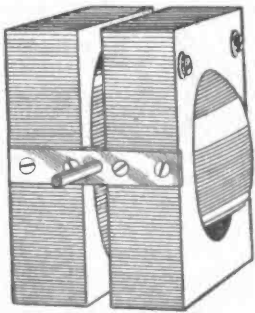

Complete Postpaid \$5.00

Make Your Own Receiving Set

These Variometers are specially designed for the reception of wavelengths of 150 to 650 meters. Two of them—used with any standard variocoupler—will make a regenerative receiver that will bring in loud, clear and properly tuned signals. Brass bearing plates are sunk flush so that you can mount the variocoupler tight against your panel. Complete, ready to use, postpaid, only.. **\$5.00**

Variometer Parts—At Factory Prices

For the amateur who wants to wind his own variometer, we furnish the wooden parts and all necessary wire, screws, hardware, etc.

Wood Rotors—4" diameter, 2" wide, grooved for windings, postpaid, each **90c**

Wood Stators—4 3/4" square, with slots for bearing plates, postpaid, per pair **\$1.00**

Wire, etc.—Complete set of all wire, screws, and hardware needed to wind and assemble the complete variometer as shown in illustration above, postpaid, per set **70c**

Send us your specifications for cabinets, panels, or any other wood parts wanted. Be sure to get our prices.

DEALERS: These variometers are made in our own factory and are ready for immediate shipment. Write for our very attractive offer.

NATIONAL RADIO CO., Inc. 1302 S. Vandeventer, St. Louis, Missouri.

PATENTS PENDING



KING "Am-pli-tone"

For Summer Concerts, News and Dancing, use the KING "Am-pli-tone;" the accepted standard. It has true tone and volume—no sheet metal is used—the "tinny" sound is left out. Polished cast aluminum body with nickel-plated base and bell. The volume is doubled because TWO head phones are blended into one POWERFUL tone. Scientifically correct.

It speaks for itself

At all leading dealers

Price \$12.00, f. o. b. New York City

KING "AM-PLI-TONE"

82 Church Street

New York City

(Warning: All infringers of this device will be vigorously prosecuted)

Immediate Delivery

on all standard makes of Radio Apparatus. No matter what instrument you desire, send us your order for quick shipment. Chicago Amateurs: Come and inspect our new apparatus. Open all day Saturday.

Chicago Radio Apparatus Co.
Inc.

415 South Dearborn St. Chicago, Ill.
New Ground Floor Salesroom

Universal Radio Co.

121 Prince St., New York, N. Y.

Manufacturers of

V. T. SOCKETS

Single, Double, Triple

VARIABLE CONDENSERS

JACKS

Double, Single

CRYSTAL SETS, Etc.

Radio Equipment of the Better Kind



Dependable
Noiseless
Durable

Edison Radio Batteries

Assure Finest Results For All Radio Battery Requirements.

Write Dept. O
for Radio Bulletin

Edison Storage Battery Co.
Orange, N. J.



WANTED:—Subscription solicitors to solicit subscriptions to this Publication in all states east of the Mississippi. Good pay to the right parties. Address, Eastern Sales Director, Room 306, 413 Fourth Ave., Pittsburg, Pa.

RADIO DEALERS

We have in stock for immediate delivery Crystal Sets complete with Phones and full Aerial Equipment

List Prices \$15.00 \$18.00 \$25.00

Sockets	Knobs and Dials
Rheostats	Head Phones
Condensers	Tuning Coils
Variometers	Insulators
Variocouplers	Vernier Condensers
Transformers	Binding Posts
Galena	Magnet Wire
Switches, etc.	No. 14 Copper Wire, etc.

WE SELL TO DEALERS ONLY

B. Lichtig & Son, Inc.

Wholesale Distributors

582 Sixth St. Oakland, Calif.

Tell them that you saw it in RADIO

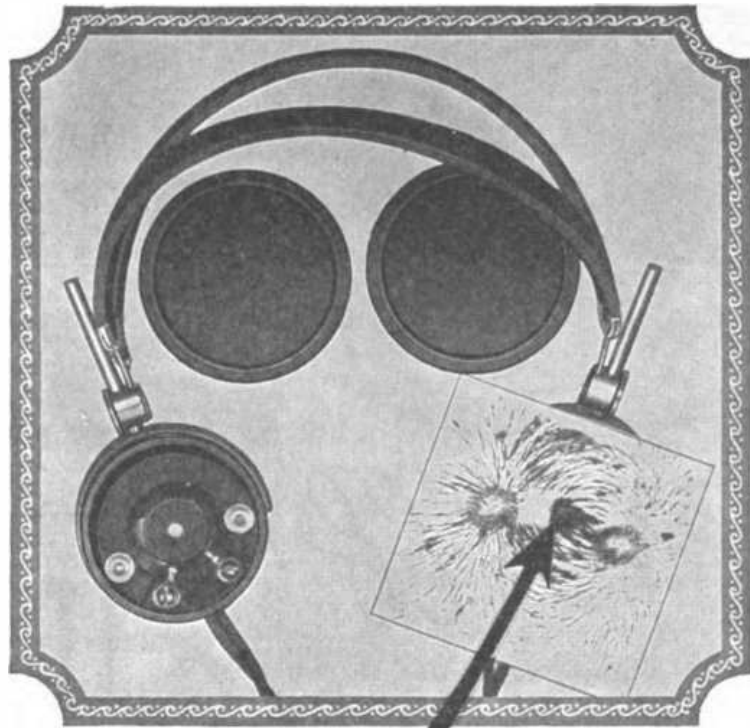

A STRONG PULL AT THE ONE PROPER POINT

WHEN the forces exerted on the diaphragm of a telephone receiver are applied at two points, there is a tendency for the diaphragm to vibrate in sections, producing false overtones and distortion to sound waves.

The PERFECTED AUTOMATIC ELECTRIC (LONG RANGE) RADIO HEAD SETS are designed with a powerful single pole electro-magnet. The pull is at the exact center of the diaphragm, which vibrates as a unit, reproducing clearly and accurately every shade and inflexion of tone.

Automatic Electric Head Sets have been designed by a staff of engineers of over thirty years' experience in developing better telephone equipment. It has taken many months to produce these receivers. But when you try them, you will say here is an accomplishment which justifies the time and study.

When Automatic Electric Head Sets are used, both strong and weak signals are reproduced with maximum loudness and clearness. Results are equally good whether used with crystal or vacuum tube detectors, multi-stage amplifiers or loud speakers. The strongest signals are reproduced with no distortion.

Remember this! High resistance does not necessarily mean high efficiency. The things that count most are number of turns of wire, magnetic strength and scientific construction. In the design of Automatic Electric Receivers, these factors have been given first attention. The resistance is just sufficient to give the best results.

Automatic Electric Head Sets are of standard size, but are light and comfortable. They weigh but 12 ounces complete. The shells and caps are of bakelite. The magnets are of the best grade of tungsten steel, carefully selected. The cords and webbing are of the highest grade material obtainable.

PRICE
\$ **10**⁰⁰
COMPLETE



Dealers who specialize in highest grade Radio Equipment should be able to supply you. Such dealers know the reputation of this company for its telephone equipment of finest quality. If your dealer cannot fill your order for the genuine Automatic Electric Head Set, we will ship it postpaid to any address in the U. S. A. for \$10.00.

Automatic Electric Company

ENGINEERS, DESIGNERS & MANUFACTURERS OF THE AUTOMATIC TELEPHONE IN USE THE WORLD OVER
HOME OFFICE AND FACTORY: CHICAGO, U. S. A.

Tell them that you saw it in RADIO

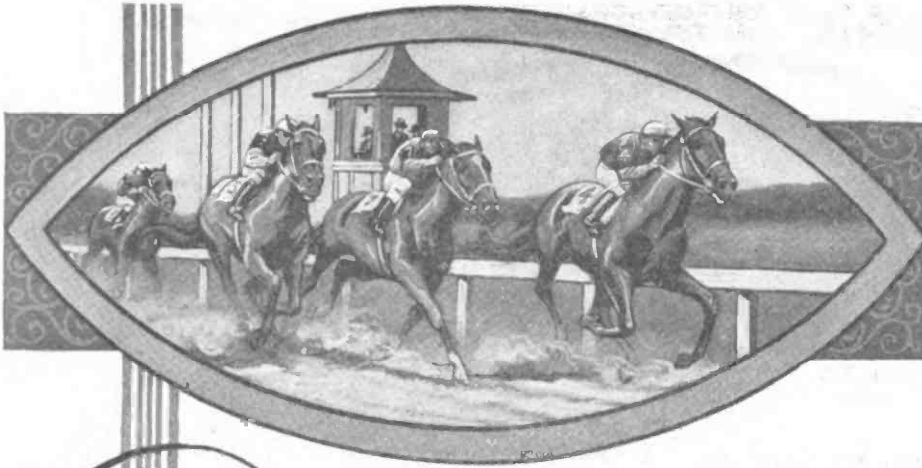

Here off!!!



OFF the beaten path and on the trail to a worthwhile goal. "Thoroughbred Apparatus" has been constantly winning new friends and has hung up some enviable records as a quality leader in radio apparatus.

Our goal is *unwavering superiority* and we intend to come under the wire *with* "Thoroughbred Apparatus" in the lead of the radio field.

On June 1st we moved into our new factory. Now, with greatly increased facilities, we are prepared to handle your orders as they come. Write for our interesting offer to reliable dealers.

"Thoroughbred Apparatus" consists of: Moulded Variometers, Vario-couplers, "Read 'em" Binding Posts, 17 styles, Amplifier panels, Detector panels, Variable Condensers, Fixed Condensers, Binding Posts, Contact points and stop pins, Switch Levers, Dials, Single Sockets Rheostats, Crystal Detectors.

THE MARSHALL-GERKEN CO.
Jackson and N. 12th Street
TOLEDO, OHIO

Thoroughbred Apparatus

TRADE MARK
"Q-R" The VERNIER ADJUSTER

Price \$1.50

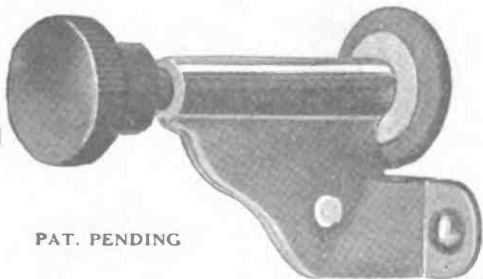

Type 100

PAT. PENDING

MANUFACTURERS — JOBBERS — DEALERS

Let us send you our unusually interesting proposition. Our advertising campaign is producing results and hundreds of dealers and thousands of satisfied customers are enthusiastic over this absolutely necessary radio accessory.

Your Order Will Receive Our Prompt Attention

ROBINSONS PECIALTY COMPANY "Q-R" RADIO PRODUCTS
15 Walnut St., Kewport, N. J.

CALLS HEARD

BY 7KP, SEATTLE—ONE TUBE

C. W.—4bq, 5za, 6aat, 6aif, 6alu, 6awt, 6ber, 6bdz, 6cu, 6en, 6fh, 6gy, 6ka, 6ky, 6nx, 6oo, 6ym, 6xad, 6za, 6zad, 6zb, 6zf, 6zq, 6zz, 8agz, 9kp, 9ps, 9wd, 9wq, 9amb, 9yae, 9zac. Can. 4bt, 4cb, 5bi, 5ct, 9bd. Spark—5cn, 6ajh, 6ajr, 6ark, 6avr, 6ex, 6gr, 6ib, 6im, 6mh, 6qr, 6tu, 6uo, 6oh, 6xh, 6zam, 6zu, Can. 9bd.

AT 600, 88 PEBALTA AVE., S. F.

C. W.—5za, (6ak), 6bk, 6cu, 6df, 6ea, 6en, 6fh, 6ft, 6ga, (6gd), (6gy), 6ka, (6ku), 6pi, 6akw, 6bkb, 6bka, 6bjq, 6bjr, 6bes, 6biv, (6bcd), 6xad, 6zf, 6zg, 6zw, (6zx), 6zz, 7cp, 7dp, 7fl, (7mf), 7na, 7oz, 7zu, 9wd, 9amb, 9ayu, 9dtm, 9dva; qrn getting bad now.

RADIO

CATALOG

FREE

Our corps of Radio experts are now designing and building improved Radio apparatus and we want every Radio fan on our mailing list so that we can send literature covering our apparatus as developed. Kindly state the type of set you have or contemplate installing and give us the names and addresses of your Radio friends so that we may place their names on our mailing list.

**Maxum
Radio Company**

5837 Woodland Avenue
Philadelphia, Pa.

Tell them that you saw it in RADIO

The Business Journal of the Radio Industry

Issued the First of Every Month for the Radio
Retailer, Jobber and Manufacturer

If you're a Dealer, send us a card or letterhead to prove it for a Free Sample Copy. Subscriptions \$1 the year.

If you're a Manufacturer let us know what you make so that we can list you in our Service Bureau —without cost.

Advertising Rates are Low and will be
 Furnished on Application

THE RADIO DEALER

HARRY M. KONWISER, *Publisher*
 LAURENCE A. NIXON, *Editor*

1133 Broadway,
 New York City.

Immediate Delivery UNITED PRODUCTS

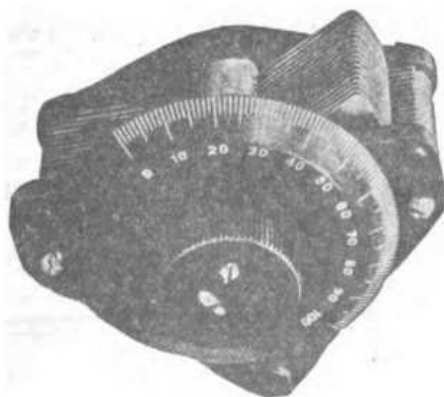

With Dial, \$3.75
 Without Dial, \$2.75

We would be glad to hear from
 reputable Dealers.
 We have a real proposition.

United Dial Indicators

The knob is of real Bakelite and will retain shape and finish. The dial is of brass, heavily plated with real silver. The special method of assembly assures a dial which runs true on the shaft. The dial is insulated and when grounded acts as a shield from capacity effect from body. Insist on the original and best.



3 1/8 inch, \$1.25
 Drilled for 1/8 and 1/4
 inch shafts

United Variable Condensers

Made of aluminum movable and fixed plates. Affords delicate adjustment on starting engagement of plates because of logarithmically curved shape of movable plates, as well as insuring positive operation throughout the range. Double end bearing of movable plates and lock nut on substantial spindle maintains constant and exact spacing between fixed and movable plates, preventing short circuiting. End plates of polished fibre.

THE UNITED RADIO LABORATORIES

DETROIT

313 Lissner Bldg., LOS ANGELES, California

CHICAGO

Tell them that you saw it in RADIO



"If You Want the Best"

CRYSTAL RECEIVING SETS

Patents Appl'd. For

Compact, self-contained, very selective and efficient. Bus bar method of wiring. Attractive mahogany finished cabinet, with lid arranged to close without disconnecting wires.

Responds to Wavelengths up to 900 Meters

Receives speech and music from broadcasting stations within 50 mile radius, and radio telegraph messages for several hundred miles.

DEALERS—Write for Special Proposition.

No. 340—"LEMCO" Receiving Set.....	\$12.00
No. 340-A—No. 340 Outfit and Couch 3000 ohm Head Set.....	20.00
No. 340-B—No. 340-A Outfit and Complete Good Antenna Outfit.....	24.00
No. 340-BX Outfit—Same as No. 340-B, but with Lightning Arrestor.	

LEE ELECTRIC AND MFG. CO.

Sierra Electric Company

Distributors
515 Market St., San Francisco.
Roberts Bldg., Los Angeles

LISTEN IN PHONES

Retailed at Factory Prices



Enjoy your Radio Concert with Century Specialty Phone
Absolute Satisfaction Guaranteed or Money Refunded

**PRICE \$5.85
IMMEDIATE DELIVERIES**

Three reasons why we highly recommend these phones.
1—Highest quality of material used throughout.
2—Highly sensitive, matched tone.
3—Well built to stand hard service, easily adjusted to head.

ORDER DIRECT

CENTURY SPECIALTY COMPANY
1221 Pennsylvania Ave. Washington, D. C.

★ ★ **RADIOADS** ★ ★

A CLASSIFIED ADVERTISING SECTION READ BY 60,000 BUYERS

The rate per word is five cents, net. Remittance must accompany all advertisements. Include name and address when counting words.
ADS FOR THE JULY ISSUE MUST REACH US BY JUNE FIRST

RECEIVING APPARATUS

FOR SALE: Short wave regenerative receiver \$15. E. Gassmann, 782 North Second St., Fresno, Calif.

FOR RELIABLE BROADCAST RECEPTION buy a "Master Radio Broadcast Receiver." Write at once for complete circular. Master Engineering Company, Omaha, Nebr.

FOR SALE—200-20,000 Meter Receiver including Radiotron Detector, \$35.00. Box 205, Williamsport, Pa.

FOR SALE—Custom built audion detector short wave length apparatus including variometers, variocoupler and variable condenser, \$55.00 without phones or batteries. Mortimer Harris, 50 21st Ave., San Francisco, Calif. Phone Pacific 6242.

FOR SALE: Variable condensers: plates 4c, rotary washers 10c dozen, stationary 5c. shafts 25c, supporting rods 5c, tops and bottoms 25c pair, knobs 15c. Parts 28 plate \$1.85; 48 \$2.85. Assembled \$1.00 extra. Tool and die work. Gravenstede, 84 Hancock Ave., Jersey City, N. J.

MURDOCK PHONES. With each pair of No. 56 type Murdock Phones we will give as premium one Dubilier mica by pass condenser, suitable for either regenerative or crystal circuits. No. 56 Phones 2000 ohms \$5.00 each. 3,000 ohms \$6.00 each. Twelve hour service or your remittance returned. Postpaid and insured. The Kehler Radio Laboratories, Dept. R, Obilene, Kansas.

TRANSMITTING APPARATUS

For this month only, anything standard or if it's radio, less 15 per cent. Moulded Bakelite socket 50c, 7/22 tinned antenna wire 65c per 100 ft. Detector panels \$4.50 each. Amrad crystal sets \$13. Rush your list of apparatus wanted today. Dealers write. Henry Kull-kavaski, Ansonia, Conn.

FOR SALE: \$35 for 6Z2 one kilowatt DX spark set all complete. Perfect performance. Box 175, Douglas, Arizona.

MISCELLANEOUS

RADIO SPECIAL: Switch lever, knob, 12 contacts, 2 stops, 2 binding posts, \$1.00; those excellent Eveready B Batteries all sizes, postpaid; a neat sturdy 28 plate variable, .0005, \$3.75; moulded and nickel plated sockets, 90c and \$1.00. Immediate delivery. Also a receiver-detector with 2 step \$125.00 and a single circuit receiver-detector 1 step in same cabinet, \$50. Pacific Radio Equipment Co., Box 27, Station "A", Berkeley, Calif.

SWAP: Good bicycle; loose coupler, for Magnavox or other equipment. W. McCartney, Box 168, San Jose, Calif.

CABINETS. We manufacture all sizes, from any variety of wood desired. No lock-box corners. Only high grade tongue and groove or double tongue joints employed. Prices low. Prompt delivery guaranteed. Boxtoy Company, 2000 E. Vernon Ave., Los Angeles, Calif.—(2T-J&A)

FOR SALE—Phone condensers 25c; contacts 30c dozen; binding posts 6c each. Jennison, 83 Russell Street, Waltham, Mass.

SALE or TRADE for RADIO apparatus. \$50 concert receiver, two \$6 variometers. R. W. Haynes, 1236 American, Long Beach, Calif.

FOR SALE: Used bare copper wire, 20 cents per pound. (Good as new.) 481 88th St., Oakland, Calif. Phone Piedmont 6945W.

RADIO BOOKS

"Arc Radio Manual," published by the engineers of the Federal Telegraph Company of San Francisco, and written in simple, interesting manner. Well illustrated with diagrams and photographs of the various types of arc radio apparatus used on shipboard and in shore stations. Price \$2.50 per copy, postpaid in the U. S. For sale by Pacific Radio Pub. Co., Pacific Bldg., San Francisco.

Tell them that you saw it in RADIO

"License Quiz Book," for passing the U. S. Government radio examinations. The most popular selling radio book. Contains 106 pages of radio information. 80 illustrations. 250 questions and answers. Deals with every new radio development. Price \$1.00 per copy, postpaid anywhere in the U. S., or given free with a one year subscription to "RADIO." Pacific Radio Pub. Co., Pacific Bldg., San Francisco.

Build your own Radiophone. Instruction book ten cents. Radio Service Institute, No. 2000 14th Street, Washington, D. C. —3t

Send 10 cents for our new large 32 page catalog describing our course entitled "How to Learn Radio at Home." National Radio Institute, Dept. 1831, 1345 Penn. Ave. N. W., Washington, D. C.

Remember—

You paid the news dealer 25c for this copy of "RADIO." Twelve issues will cost you \$3. Subscribe at the \$2.00 a year rate before June 30th and save a dollar.

Time to Broadcast "CAUTION" to Radio Fans—



Quoting from "Radio" of May:

"America has gone wild over radio.

*"There has been 'created' an overwhelming demand for any old thing that will receive radio-
phone speech and music.*

"Manufacturers, jobbers and dealers were unprepared for the onslaught of orders.

"Manufacturers have doubled, trebled and quadrupled production facilities.

*"Meanwhile men who know little or nothing about radio are busily making Chinese copies of
old stuff to be sold to an unsuspecting public, at fabulous prices.*

"Such a time of wild, crazy enthusiasm calls for cool heads and words of caution."

You who are in radio for profit or pleasure realize this; you know the very future of the industry, and possibly your own business, depends greatly upon the ability and stability of radio equipment to GIVE SERVICE. Therefore, keep a "cool head." Investigate, analyze, compare before you tie yourself to any one make or manufacture.

RADIO EQUIPMENT MARKED "SIGNAL"

is not new, nor untried. It has stood the test of time. SIGNAL Wireless Equipment served the United States Signal Corps efficiently and well. SIGNAL Radio Materials have been developed by SIGNAL Radio Specialists in SIGNAL Laboratories, and are built in the SIGNAL Factory, according to the best commercial and government standards. It is Radio Insurance to specify "SIGNAL."

SIGNAL ELECTRIC MANUFACTURING COMPANY

Menominee, Michigan

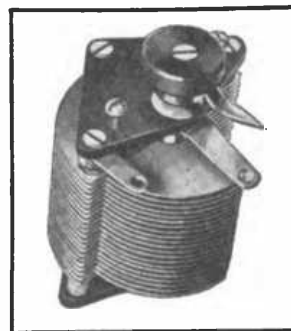

"Signal Variable Condenser"

SIGNAL BACK MOUNTED VARIABLE CONDENSER

A typical "SIGNAL" product built for service. For example; where ordinary amateur construction calls for plates only .015" in thickness, SIGNAL plates are .026" thick. You can drop SIGNAL Condensers No. 76 and 77 from a considerable height without injuring plates or spoiling adjustment.

This request-coupon makes it easy to secure all "SIGNAL" latest Wireless Bulletins, without any obligation. Simply fill out and mail now.

CUT OUT AND MAIL COUPON NOW

COUPON

Send me the new Signal Wireless Bulletin W.

Name

Company

City

State



Announcing
the formation of the
Rock Ridge Radio Corporation

Incorporated under the laws of the State of California

THE personnel of the organization includes men who are well known in the field of Radio and a staff of Engineers of national, even world-wide reputation.

The Rock Ridge Radio Corporation will engage in the manufacture and sale of Radio Equipment. In addition, it will maintain a corps of engineers second to none.

Particular attention is to be given to the perfection of existing Radio Receiving devices and the development of such new apparatus as increased knowledge of the art may warrant.

Within a few days the Rock Ridge Radio Corporation will have ready for delivery the first of its Receiving Units—the

Rock Ridge Special

Other equipment will be announced as soon as manufacturing facilities, now in preparation, are completed.

*The Rock Ridge Radio Corporation will operate the
Rock Ridge Radio Studios in Oakland, California*

ROCK RIDGE RADIO
Corporation

Consulting, Designing and Construction Engineers

Oakland, California

SAN FRANCISCO

Newark, New Jersey

REMLER

APPARATUS
THAT RADIATES
QUALITY

No. 810



REMLER Jr. Panel Type RHEOSTAT

REMLER Jr. Rheostat No. 810. Resistance unit of 4 ohms with a carrying capacity of 1½ amperes mounted on a bakelite disc 2" in diameter. It is especially designed for filament control of vacuum tubes operating on 4 or 6 volts. The resistance unit is a non-corrosive alloy and can be readily renewed—an exclusive Remler feature. All metal parts are nickel plated and those showing in front of panel are bright polished nickel. An off position is provided, obviating the necessity of a filament switch.

No. 810—Remler Jr., Panel Rheostat, 4 ohms resistance..... \$1.00
No. 810—RU Resistance Unit Renewal..... .20

No. 92

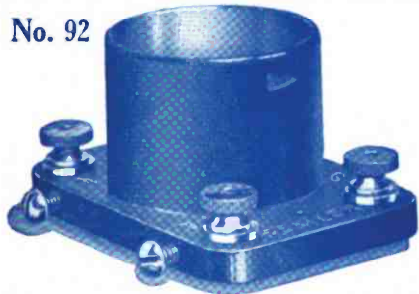

REMLER VT TUBE SOCKET

Panel or Table Mounting

THIS receptacle is designed for all standard 4 prong based vacuum tubes, including the new Cunningham Tubes.

The entire socket is molded from black Bakelite, with a highly polished surface. The base of the socket is of sufficient depth to allow clearance between contact fingers and table.

The contact fingers are nickel plated spring brass. Nickel plated binding post terminals are marked. Nickel plated screws are provided for panel mounting and holes drilled for table mounting. When mounted on panel the tube is set vertically, insuring maximum filament life. Base is 2¼" x 2¾", and the height 1½".

No. 92—Remler VT Socket, Panel or Table Mounting.....\$1.00

No. 100



REMLER BAKELITE DIAL

THIS Remler 3" bevel edged dial is molded and ground true from genuine bakelite and will not warp or discolor. It is not brittle like composition. The surface is highly polished. The engraving is filled with white enamel and the 100 division scale reads from right to left for clockwise rotation.

The knob is molded bakelite 1¾" diameter. The bushing is drilled for ⅜" or ¼" shaft, and the set screw passes through both knob and bushing. The construction insures an absolutely true running dial.

No. 101—Remler 3" Bakelite Dial only..... \$0.75
No. 100—Remler 3" Bakelite Dial with knob and bushing, specify ⅜" or ¼" shaft..... 1.00

No. 93



Patent Applied For

REMLER A-BATTERY POTENTIOMETER

THE plate voltage of any detector tube must be carefully adjusted for maximum sensitiveness and signal audibility. Potentiometer control provides close adjustment with ease of operation. This new Remler Unit with metal inserts provides positive definite electrical contact and eliminates the uncertainty of carbon to graphite contact. This Remler Unit is not brittle and is connected across the A-Battery to control the plate potential over a six volt range by half-volt steps. Circuit diagram furnished with each unit.

No. 93—Remler A-Battery Potentiometer Unit only, with studs for panel mounting..... \$0.75
No. 94—Remler Rotary Lever Switch for use with No. 93 Unit..... .45

Remler Radio Apparatus

THE remarkably high quality of every Remler item is not accidental, but the final result of years of research work, painstaking study and perfection of manufacturing processes. The uniformly handsome appearance of the Remler line—the accuracy and precision of each individual item—the truly wonderful results that are obtained from the use of this "Apparatus That Radiates Quality"—these facts have made REMLER the choice of those who really know radio apparatus.

DEALERS: There is a very profitable proposition for you on Remler Apparatus. Write for full particulars.

REMLER RADIO MANUFACTURING COMPANY

248 FIRST STREET
San Francisco, Cal.

E. T. CUNNINGHAM
General Manager

154 W. LAKE STREET
Chicago, Ill.

new A-P apparatus now ready for delivery

New AP-4 Radio Receiver



A new A-P set of typical A-P quality throughout, designed to meet the increasing demand for a receiver that will produce radio telephone music and speech efficiently for home entertainment and instruction. The set is complete, ready for installation, including one 6 volt 60 ampere-hour storage battery, one Eveready 43 volt B battery, one detector tube, one 2000 ohm radio head set, 160 ft. of copper antenna wire, aerial insulators, ground clamp, instructions, etc. Cabinet made of highly polished gumwood, genuine bakelite panels, and moulded dials. Wave length range 175 to 500 meters. Price complete, \$80 f. o. b. San Francisco. Price of set without equipment, \$45.

New AP-3 Two Stage Amplifier



Finished to harmonize with new AP-4 Radio Receiver and particularly designed and adapted for use with it. Furnishes two stages of amplification to enable music and speech to be reproduced sufficiently loud to be enjoyed by many people simultaneously. Utilizing specially designed Transformers to give maximum amplification without distortion, the AP-3 reproduces volume of sound with clearness of tone. Price complete with tubes \$63.00. Without tubes, \$50.00.

Announcing

New Type A P-2 and A P-5 Regenerative Receivers

Licensed under Armstrong U. S. Patent No. 1113149, October 6th, 1914. For Amateur and Experimental use only.

New type A P-2 Regenerative Receiver, designed to operate efficiently over all broadcasting wave lengths in use in the United States. It oscillates and regenerates freely and easily over its entire range of 175 to 1600 meters. Simple to operate and handsome in appearance. Cabinet of solid mahogany with a highly polished light Walnut finish. All terminals in rear. Price complete with detector and two-stage amplifier in one cabinet, \$135.00 f. o. b. San Francisco.

The new Type A P-5 regenerative receiver has the same beautiful lustrous finish, and is otherwise identical with Type A P-2 except that it is made without the two-stage amplifier included in Type A P-2. For an instrument so carefully constructed and so efficient in operation the price is very low—\$85 f. o. b. San Francisco.

Manufactured by Oard Radio Laboratories, Stockton, California. Atlantic-Pacific Radio Supplies Co., sole agents.

The above apparatus is now ready for delivery. In writing for folder and further information, mention the name of your dealer. Dealers are invited to write us for complete information.

Atlantic-Pacific Radio Supplies Co.

**Operating (KZY)
Rock Ridge Radio Station**

648-650 MISSION STREET
SAN FRANCISCO, CALIFORNIA

**Radio
Supplies**