

July, 1924

THE JOHN CRE
JUL 23 1925
LIBRARY.

RADIO IN THE HOME

TWENTY CENTS

by HENRY M. NEELY

In this Issue :

GRIMES

HARKNESS

NEELY

GOODREAU



Photograph courtesy of Operadio Company, Chicago, Ill.

A Poet's Dream Come True!

"He touched his harp, and nations heard entranced," sang Robert Pollock a century ago.

The dream has come true. Through Music Master, radio's perfect reproducer, the actual tones of a single harp are brought to listening nations.

As the harp depends on wood for its purity and richness of tone, so Music Master owes to an amplifying bell of wood its fidelity in reproducing the same glorious music.

Go to your radio dealer at an hour when your favorite music is broadcast. The full, rich resonance of the tones—a lifelike re-creation of the original—will prove a revelation to you.

Dealers Everywhere

Connect MUSIC	14-inch Model, \$30
MASTER in place of headphones.	for the Home
No batteries required.	21-inch Model, \$35
No adjustments.	for Concerts and Dancing

Music Master Corporation

Makers & Distributors of High-Grade Radio Apparatus

10th and Cherry Streets

Chicago PHILADELPHIA Pittaburgh

Music Master

RADIO REPRODUCER



CROSLLEY

Announcing — The New Models — each a leader in its line



Crosley Trirdyn 3R3, \$65.00

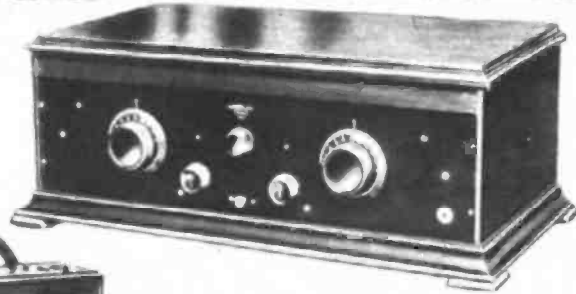

Crosley Trirdyn 3R3 Special, \$75.00

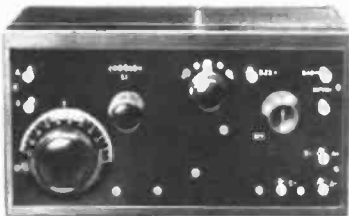

Crosley 51, \$18.50



Crosley 51-P Portable, \$25.00



Crosley 52, \$30.00



Crosley 51-A, \$14.00



Crosley 50, \$14.50



Crosley 50-A, \$18.00

Guaranteed Satisfaction At A Reasonable Price

CROSLLEY 50. A new one tube Armstrong Regenerative Receiver. We believe this to be the most efficient one tube receiver ever put on the market. Like our present Model V, which it supersedes, it will bring in, under average conditions, on headphones, broadcasting stations at a distance of one thousand miles or more. Uses any standard storage battery or dry cell vacuum tube. PRICE \$14.50.

CROSLLEY 50-A. A new two stage Audio Frequency Amplifier to match the new Model 50 receiver. This unit is equipped with a filament switch for shutting off the current from the "A" and "B" Batteries. When used in connection with the Crosley Model 50 Receiver, it gives the equivalent of a three tube regenerative receiver. PRICE \$18.00.

CROSLLEY 51. In twenty-four days this receiver became the biggest selling radio receiving set in the world, and it holds that position today. It uses two standard storage battery or dry cell tubes, regenerative detector and one stage of

audio frequency amplification. Will bring in local stations on the loud speaker at all times, and under average conditions will also bring in distant stations on the loud speaker. PRICE \$18.50.

CROSLLEY 51-A. A new one stage Audio Frequency Amplifier to match the Model 51 receiver. When used in connection with the Crosley Model 51 Receiver it gives the equivalent of a three tube regenerative receiver. PRICE \$14.00.

CROSLLEY 52. A new three tube Armstrong Regenerative Receiver, has phone jack to plug in on two tubes and filament switch to turn off the "A" and "B" Batteries. It is unusually efficient, will provide loud speaker volume on distant stations under practically all conditions, and is in every way an ideal receiver for the home. PRICE \$30.00.

CROSLLEY 51-P. This is our new portable set. It is the Crosley Model 51 two tube receiver mounted in a leatherette covered carrying case, has a compartment for a pair of headphones and one to hold an ample power plant for the popular

dry cell vacuum tubes. This receiver can be used as a stationary set in the home or as a portable. PRICE \$25.00.

CROSLLEY TRIRDYN JRJ. This three tube receiver gives the efficiency and volume of a five tube receiver. Incorporating Radio Frequency Amplification, Regenerative Detector with one stage of reflex and one stage of straight Audio Frequency Amplification. Can be calibrated accurately—stations logged and returned to at will. Used on outdoor or short indoor antenna and is, we believe, the most efficient and sharpest tuning receiver on the market at any price for bringing in long distance stations. PRICE \$65.00.

CROSLLEY TRIRDYN JRJ SPECIAL. This receiver is exactly the same as the Trirdyn JRJ except the solid mahogany cabinet is larger, and more handsomely designed to harmonize with the most beautiful furniture settings. There is sufficient space inside for all the "A" and "B" Batteries required when standard dry cell tubes are used. PRICE \$75.00.

WRITE FOR DESCRIPTIVE CIRCULAR

FOR SALE BY GOOD DEALERS EVERYWHERE

THE CROSLLEY RADIO CORPORATION

POWEL CROSLLEY, JR., President

760 ALFRED STREET

CINCINNATI, OHIO

Licensed under Armstrong
U. S. Patent No. 1,113,149

Crosley Owns and Operates
Broadcasting Station W L W

CROSLLEY
Better - Cost Less
Radio Products

Editorially Speaking

A SEEMINGLY inoffensive clause in a bill now pending in Congress threatens to disorganize the entire radio industry. It furnishes a remarkable situation and one in which the framer of the bill probably had no such intentions. Indeed, it is believable that Mr. Hawes did not even think of radio when he drew up House Bill 5850.

On the face of it, the bill is merely intended to clear up a confused situation left on our hands by the war. At that time, all of the patents owned in this country by enemy aliens were taken over in the natural course of events and were placed in the hands of the Alien Property Custodian. That was routine. It was a thing that had to be done and was perfectly proper.

All during the war, these patents were owned by our Government, or at least controlled by us, and were used by us in prosecuting our side of the conflict.

Now that the war is over, nothing is more natural than that we should get back to a friendly footing with our late enemies, and one necessary part of this resumption of cordial relations is the return of all such property as was confiscated under war conditions. Patents of all kinds are included in this property.

Section five of the Hawes Bill says, "That all privately owned patents seized and taken over as the property of the United States or any official thereof shall be returned to their owners except in so far as the United States Government may desire to take over any particular patents by eminent domain on payment of compensation."

This is perfectly regular and as a general proposition it is the proper thing to do. Unfortunately, there are included in the patents dealt with in this clause certain patents granted to German subjects covering basic ideas in radio development. These basic ideas include the entire right to radio fre-

By

Henry M. Neely

following the war, when radio made such an amazing advance in so short a time, the widespread demand of listeners-in for receiving sets that would tune in great distance made it absolutely necessary to use radio frequency, tuned radio or reflex or a combination of all. This was perfectly easy to do. The enemy patents covering these things were in the hands of the Government and so any manufacturer was at liberty to go ahead and develop his circuit along the lines laid down in those patents.

Virtually all other important patents were owned by the Radio Corporation of America, and therefore competing manufacturers were unable to use them and almost all development by independent researchers has been along the lines covered by the German patents.

This independent development has been of tremendous value in the spread of radio interest and in the efficiency of receiving sets. Without it, we would still be confined to the use of simple regenerative sets, consisting probably only of a detector and two or three stages of audio frequency amplification. The entire industry would be in the hands of a single corporation and all development would be subject to the necessary considerations of corporation management, finances and such things. The free use of these German patents has resulted in the most astonishing growth of an industry that history has yet given us. Babson estimates that the public will spend more than three hundred million dollars next year in radio. Such an amazing figure could not have been reached in many years without the free and unhindered use of these German patents.

Personally, I regard the neutrodyne idea as perhaps the most valuable development that the recent history of radio has shown. Next to that comes the inverse duplex, and I am

(Continued on Page 6)

This Shows the Trend of Radio



HERE is the radio set of next season. This shows the trend that we are taking in radio and proves what this magazine said in its very first issue—that radio is entitled to a place of dignity in the home on an equality with the piano and the finest type of phonograph.

This photograph shows not only the radio set but the loud speaker, the aerial, the ground, the A and B batteries and all chargers.

You don't see them?

Well, you won't see them next season in the up-to-date radio sets either. That is because this set does not use either A or B battery—and why should it? Why should any radio set use a battery?

It is scientifically wasteful and uneconomical to have 110 volts of perfectly good electricity in our house lighting system and then have to go out and buy an expensive battery to produce only six volts to light the filaments of our tubes and more expensive batteries to produce only 90 or 100 volts

(Continued on Page 40)

Photograph courtesy of Timmons Talker, Inc.

quency amplification, tuned radio frequency and reflex.

These basic patents were owned by Schloemilch and Von Bronk. They were assigned by their owners to the German Telefunken Company and it is to that company that they would be returned under the provisions of this clause. Immediately

management, finances and such things. The free use of these German patents has resulted in the most astonishing growth of an industry that history has yet given us. Babson estimates that the public will spend more than three hundred million dollars next year in radio. Such an amazing figure could not have been reached in many years

RADIO IN THE HOME

Published Monthly by the Henry M. Neely Publishing Company, 606 Chestnut St., Philadelphia, Pa.
Bell Telephone—Lombard 9481 Experimental Station (2KP), Dolanso, N. J.

<p>HENRY M. NEELY.....President and Editor G. W. KRAFT.....Secretary and Treasurer W. L. DUDLEY.....General Manager NORMAN NEELY.....Art Director MERRIL NEELY.....Laboratory Assistant</p>	<p>DAVID GRIMES.....Associate Editors KENNETH HARKNESS.....Contributing Editors BRANARD FOOTE..... W. FRANCIS GOODREAU.....</p>
---	---

Radio in the Home is sold at 20c per copy at all newsstands, radio shops and bookstores. Subscription in the United States and Canada \$2.00 per year.

Printed on the rotogravure process of the Public Ledger, Philadelphia, Pa.
Copyright, 1924, by the Henry M. Neely Publishing Company
Entered as second-class matter May 28th, 1922, at the Postoffice, Philadelphia, Pennsylvania,
under the act of March 3, 1879

Build your Harkness Reflex With Genuine Radio Guild Parts

You can get cheaper imitations of Radio Guild parts for the Harkness Reflex, but don't forget they are cheap imitations and cannot give you the results you will expect. Only the genuine parts can and will give you the results. Ask for RADIO GUILD parts and see that you get them. Look for the Radio Guild Seal on every package. Don't be cheated!



35⁰⁰

Complete 2-Tube Kit

Flexoformers

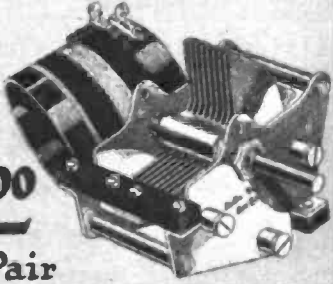

\$12⁰⁰
Per Pair

This Complete Kit Contains All Parts For 2-Tube Set

The parts in this Kit were designed by Kenneth Harkness, Chief Engineer of the Radio Guild, and are manufactured under his direct supervision. You may be certain, therefore, that the receiver you build with these parts will be perfect in every detail. You will find, too, that each part is specially prepared to simplify the work of construction. The panels are drilled; the terminals are numbered; the kit contains every necessary item—right down to the last screw. With only a screwdriver and a soldering iron you can put the whole set together in just a few minutes.

But be careful; don't let anybody sell you a bunch of cheap junk and tell you you can build the "Kenneth Harkness" Reflex with it. You can't, any more than you can build a Packard with Ford parts. Get the genuine RADIO GUILD parts and you'll save yourself real money.



Crystal Detector

\$2⁰⁰

Audio Transformer



\$4⁸⁵

JOBBERs, DEALERs
Write for Our
Proposition



Distributors
Radio Stores Corp.
222 West 34th Street,
New York City

Distributors
Trilling & Montague
40 North Seventh St.,
Philadelphia, Pa.

Mail this Coupon for Illustrated Book

THE RADIO GUILD, Inc.,
256 West 34th Street, New York, N. Y.

RIH 7-24

Please send me your 36-page book with colored illustrations, photographs, wiring diagrams, blueprints of panel layouts and complete instructions for building the 2-tube Harkness Reflex, together with full descriptions of Radio Guild products, for which I enclose ten cents. Mail at once.

Name

Address

Editorially Speaking

(Continued From Page 4)

not quite sure that the inverse duplex will not ultimately prove to be the popular solution of the problem of developing an economical set with all of the efficiency which we now have with our most expensive ones. The combination of the neutrodyne principle with inverse duplex seems to be to present the ideal toward which we are striving in the immediate future.

Both of these systems will be put out of business if the German patents are returned to their owners.

These German patents also cover the super-heterodyne and it might be thought that the super-heterodyne would suffer in the same way, but I do not think that it would. The German patents are in the name of the Telefunken Company and would be returned to them and the American super-heterodyne patents are owned by the Radio Corporation. It is quite generally understood that the Telefunken Company and the Radio Corporation are on very friendly terms in a business way, and there would be little difficulty in arranging a licensing agreement. This would mean that all of the radio frequency and reflexing patents would, through the Telefunken Company, probably be turned over to the Radio Corporation so far as American rights were concerned, and that would place the entire radio industry in the hands of this one company.

Such a development would be most unfortunate. I do not mean that the Radio Corporation is not competent to handle these patents, but I believe that it would be a fatal blow to radio to have this development centralized in the hands of any one corporation. I believe that the possibilities of radio are so great that its legiti-

mate development can be obtained only through keen competition.

The present status of these patents seems to be somewhat doubtful. Since Mr. Grimes wrote his article, I have been informed that E. S. McDonald, Jr., of Chicago, has received a statement from the Alien Property Custodian saying that the patents in question have been sold outright to the United States Navy and that no patent sold outright can be returned to the German owners. If that is so, such a sale

In any case, it seems to me a very vital thing for all of us radio listeners-in to get together and let Congress know that the clause already spoken of in the Hawes bill threatens a great popular industry and that these particular patents should come under the provision in that clause which permits the United States Government to take over "any particular patent by eminent domain on payment of compensation."

This crisis brings up the very great need which we have of some central contact point or clearing house between the great body of listeners-in and our Congress and our manufacturers. There have been a number of attempts made to form such an organization, but to be really effective and influential an organization for this purpose must have behind it the recognized leaders of the industry and be in a position to act effectively at a moment's notice.

Within the last few months, such an association has come into existence. It is called the American Radio Association and its headquarters is at 50 Union Square, New York, N. Y. Alfred M. Caddell

would remove these patents from the danger list. On the other hand, I get information from two well-informed sources that there has not been a really definite sale, but that the Navy has simply been the custodian of these patents so far and that the patents will really come under the provision of the Hawes bill.

is the secretary, and I strongly urge every one of my readers to send Mr. Caddell \$1.00 for membership in this association. It is only by building up an extremely strong organization of this kind we can protect the interests of the radio industry and the radio family in times of crises such as this one brought about by a seemingly unintentional threat.

With adequate popular support, this association will be in a position to keep in very close touch with all such situations as this and will have the authority and power to act for the benefit of the radio family.



Radio in the home of Edward I. Pratt, of the Kellogg Switchboard & Supply Company. Mr. Pratt's home is in Evanston, Ill. The radio set pictured above was built by Mr. Pratt entirely of Kellogg parts

Photo courtesy of the Kellogg Switchboard & Supply Company





MAGNAVOX

The Reproducer Supreme with a Human Throat

BETWEEN Magnavox and ordinary "loud speakers" there are certain essential differences hidden away in the base of the instrument, insuring for Magnavox utmost clearness of tone.

The quality of radio speech or music is largely determined *before* the sound enters the horn—which makes it so important to select a Reproducer on account of its scientific construction, not merely its outward appearance. The strongest guarantee of mechanical excellence is the Magnavox trade mark on your Reproducer. Look for it when you buy—

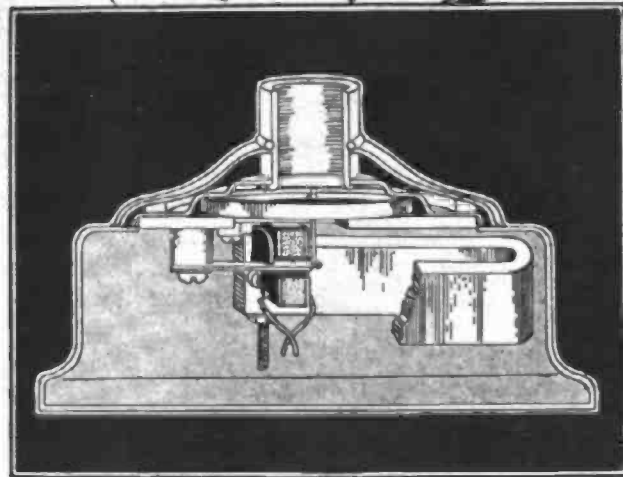

As marvelous as the vocal chords of a great singer is the mechanism of the new M4 Magnavox, shown in sectional view above.

Reproducers

- M4—the latest Magnavox achievement: requires no battery \$25.00
- M1—also constructed on the semi-dynamic principle, requiring no battery \$30.00
- R3—famous electro-dynamic type: new model with Volume Control \$35.00
- R2—same as R3 but larger size: new model with Volume Control \$50.00

Combination Sets

- A1-R and A2-R—the only instruments combining electro-dynamic Reproducer and Power Amplifier in one unit \$59.00, \$85.00

Power Amplifiers

- A1, AC-2-C, AC-3-C—the most efficient audio-frequency Amplifiers: one, two and three stage \$27.50 to \$60.00

To obtain the fullest enjoyment from your receiving set, equip it with the Magnavox—for sale at good dealers everywhere.

THE MAGNAVOX COMPANY, OAKLAND, CALIFORNIA

New York Office: 350 West 31st Street

Canadian Distributors: Perkins Electric Limited, Toronto, Montreal, Winnipeg



M4



R3

EVEREADY
Radio Batteries
-they last longer

The Story of
EVEREADY
DRY CELL
RADIO
"A" BATTERIES
for
DRY CELL
VACUUM TUBES

EVEREADY
STORAGE
"A"
BATTERY

How to
get the most
out of your
"B"
BATTERY

No. 771
EVEREADY
"TRIPLE"
RADIO BATTERY
THREE
CELLS

EVEREADY
BROADCASTING
HOUR GLASS
An Aid in Determining
by Hours
THE LOCATIONS
CALL LETTERS
& WAVE LENGTHS
of Principal Stations
NATIONAL CARBON CO., INC.
MAKERS OF EVEREADY BATTERIES
NEW YORK SAN FRANCISCO

FREE!

Informative and money-saving booklets on radio batteries sent free on request. If you have any questions regarding radio batteries, write to G. C. Furness, Manager, Radio Division, National Carbon Company, Inc., 120 Thompson Avenue, Long Island City, N. Y.

Every radio user should have these books

THEY contain battery facts that it is important for you to know. They are *not* catalogs, *not* advertising pamphlets, but each one tells the story of one kind of battery, what it is, what it does, how to connect it and how radio users can get the utmost in satisfaction and long service out of it.

Do you know why a "B" Battery is necessary? Do you know how much "B" Battery current your tubes use? Do you know what a "C" Battery can do for you? All these things and many more are told in these informative booklets. Many of these facts you can secure

EVEREADY HOUR GLASS

When you wonder what that station is, turn to this list of Class B broadcasters and their schedules of transmission without waiting to hear the call letters. You can pick the station from its wave-length and the time at which you hear it. Sent FREE.

elsewhere only by digging through several different works on radio engineering. These booklets present battery facts, in plain language, with a few simple diagrams.

These pocket-size pamphlets cost you nothing. They are sent free on request, part of our service to the radio user. Whether you use Eveready Radio Batteries or not, these booklets will interest you, assist you, answer your questions.

To take the mystery out of radio batteries, read these four booklets. Write for them to-day. Remember, they are FREE.

Eveready Radio Batteries are manufactured and guaranteed by

NATIONAL CARBON COMPANY, INC., New York—San Francisco

Headquarters for Radio Battery Information

Canadian National Carbon Co., Limited, Toronto, Ontario

RADIO IN THE HOME

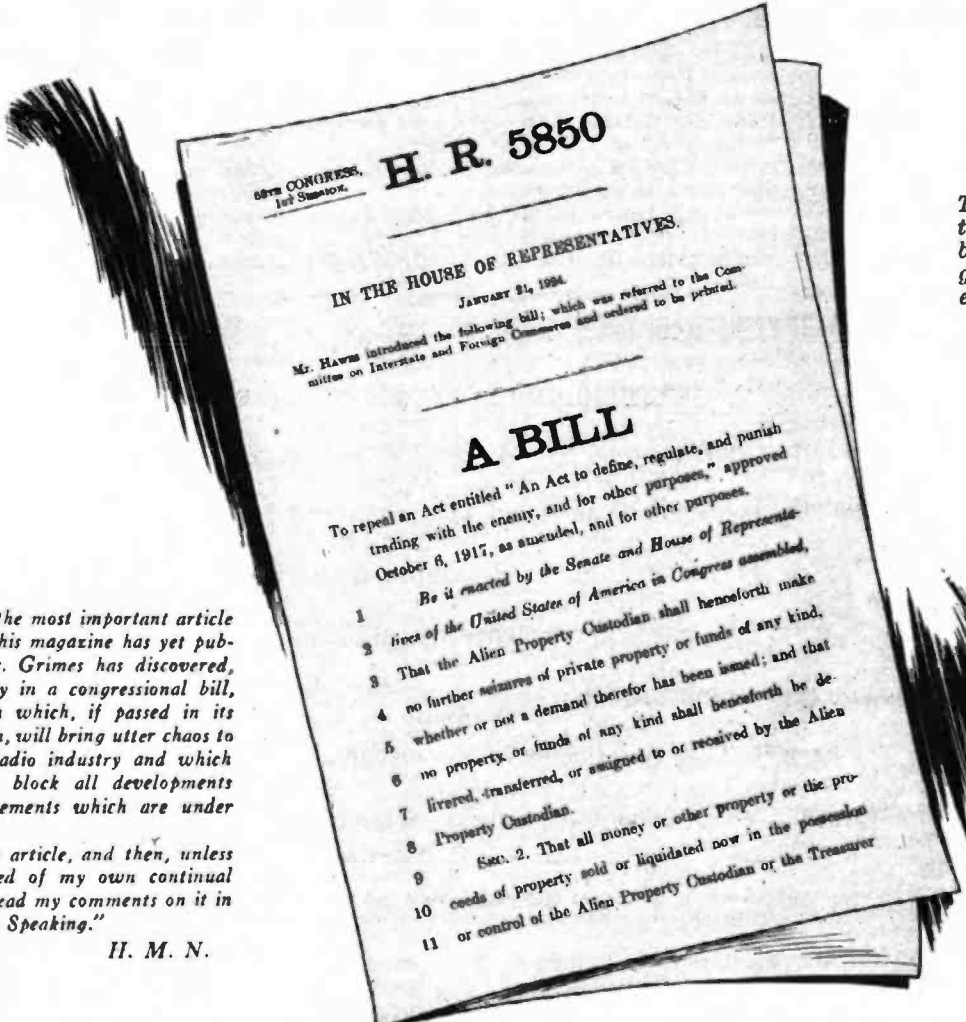

This is a reproduction of the first page of House bill No. 5850, one paragraph of which threatens chaos to the entire radio industry

THIS is the most important article that this magazine has yet published. Mr. Grimes has discovered, hidden away in a congressional bill, a paragraph which, if passed in its present form, will bring utter chaos to the entire radio industry and which will totally block all developments and improvements which are under way today.

Read this article, and then, unless you are tired of my own continual preaching, read my comments on it in "Editorially Speaking."

H. M. N.

EVERY developed industry has been the result of the combined efforts of many hundreds of inventors. Many minds attacking a problem from many angles are required for the best possible answer. The public rewards such individuals in the form of patents, or government monopoly grants. These licensed monopolies are allowed to exist for a period of seventeen years. A rapidly developing art will have many such patent grants covering its important improvements. It is peculiarly significant that most of these patents are granted to a widespread group of workers, and rarely do more than two important inventions fall to one individual. A little casual thinking will indicate the chaos that exists when an inventor, owning an important patent, refuses to co-operate. The patent law in

STOP THIS BILL! It means Chaos

By **DAVID GRIMES**
Chief Engineer Sleeper Radio Corporation

America grants to the inventor the right to prevent others from making, using or selling his own particular contribution to society. It does not say that he himself may make it. It may be merely an improvement on another's patented article. He could not, then, make it without the consent of the first patentee, although he can prevent the first inventor using his specific improvement. This frequently results in detrimental "deadlocks."

In many of the foreign countries these "deadlocks" are avoided by compulsory agreements before a court. This court has the power to decide the benefit accruing to the public if the original invention incorporated the improvement. If it is decided that the improvement is worthy of adoption, a licensing agreement is demanded so that the greatest good

VOLUME III	CONTENTS FOR JULY, 1924	NUMBER II
EDITORIALLY SPEAKING		Page 4
THIS SHOWS THE TREND OF RADIO		4
STOP THIS BILL! IT MEANS CHAOS		9
TAKE YOUR RADIO WITH YOU		11
HARKNESS WRITES ABOUT SELF-OSCILLATION		13
TROUBLE SHOOTING IN THE GRIMES 3XP		15
THE RADIO—KINDERGARTEN		20
FACTORY REFINEMENTS IN HOME-BUILT SETS		21
BRINGING THE WORLD TO THE FARM		22
LEVIN'S NEW COIL MAKES A DX PORTABLE		24
RADIO FREQUENCY AND THE GOODREAU SPLIT VARIOMETER		25
TUBE TESTING OUTFIT AS USED IN "RADIO IN THE HOME" LABORATORY		31
WHAT SIZE GRID LEAK SHALL I USE?		43
THE SLANT OF THE TRADE ON RADIO		44

shall result to the greatest number of people. An inventor, under this system, is unable to jeopardize an entire industry.

We have no such system of compromise in the United States. Of course, the inevitable happened. Such cases as the Seldon patent did great harm to the early commercial development of the automobile—and the courts are full of similar cases less prominent but no less regrettable.

When the World War came, it found just such a state of chaos in the radio industry. The Government accordingly passed the necessary wartime emergency legislation to permit the use of any and all inventions for the common defense. Radio received a powerful impetus and grew from infancy to manhood in a few months. Tremendous possibilities and startling accomplishments dawned on the horizon. At the conclusion of the war and the termination of the emergency legislation, radio slipped back once more into a state of patent stagnation.

The controlling inventions reverted to their uncompromising owners—many of them in foreign countries.

This was so discouraging that the Government at Washington undertook to rectify the situation. As a result, a new company was formed called the Radio Corporation of America. It was the object of this company to include as its stockholders the owners of the several important interlocking radio patents. These were held by the Marconi Company, the General Electric, the Westinghouse and the American Telephone and Telegraph Company. The Marconi Company's interest was purchased by the others to enable the Radio Corporation to be American owned.

One of the Government requests was that this tolerated patent monopoly should be entirely in American hands.

So far so good! No one at that time had given any serious thought to the subject of broadcasting. It hadn't been commercially born. No one dreamed of its possibilities. And therein lies the point of this story.

Every patent that was thought to have any bearing on the American radio situation was included in the above combine. Receiving, transmitting and equipment patents were apparently all there. It was impossible to imagine a more ideal and complete American monopoly.

Subsequent developments in radio broadcasting, however, entirely changed the situation. Many new inventions have now appeared that are not under the jurisdiction of the Radio Corporation of America. From the viewpoint of the American public, the situation is more humorous than serious, because the new improvements are fortunately the results of American invention.

Any one of our readers who has been following the broadcasting development

during recent months must realize that different systems of radio frequency amplification and reflexing have constituted the major portion of the present trend. *Our whole present radio art leans strongly in this direction.* Hundreds of patents have been issued and hundreds more are pending on radio frequency and reflexing. The Neutrodyne and the Inverse Duplex are only two of the many.

Now all of these developments are merely improvements, in the patent sense, on an earlier basic patent that at one time wasn't considered important. It was so insignificant as not to be included in the combination of American patents united under the Radio Corporation.

This patent is owned by *foreign interests.* It is the famous Schloemilch and Von Bronk patent No. 1,087,892 covering radio

6 or is still to be returned.

7 SEC. 5. That all privately owned patents seized or
8 taken over under authority of the United States or any
9 official thereof shall be returned to their owners, except in
10 so far as the United States Government may desire to
11 take over any particular patents by eminent domain on
12 payment of compensation.

13 SEC. 6. That the owners of the privately owned ships,
14 cargo, and other maritime property, which under the pro-

Here is the pernicious Section 5 of the Hawes bill which would rob radio fans of all forms of radio frequency amplification, including reflex, inverse duplex, neutrodyne and super-heterodyne

frequency and reflexing. This patent was shown and discussed in the May issue. The group which owned this patent before the war was the German Telefunken interests.

On October 6, 1917, our Government confiscated this patent along with other alien property belonging to the enemy. This was made possible by a congressional act, entitled "An act to define, regulate and punish trading with the enemy, and for other purposes." The Navy Department has had control of it since that time, and because of the public control the independent manufacturers, as well as the Radio Corporation, have been able to use it without molestation.

Congress now has before it several bills providing for the return of enemy property taken over by the United States during the war under the Act of October 6, 1917. These bills, naturally, cover everything from tin cans to church organs.

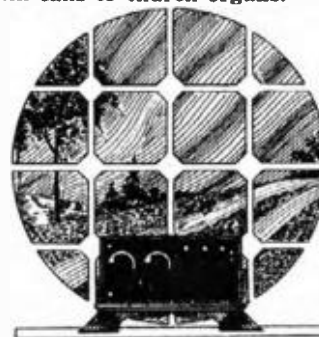

One of them specifically mentions the enemy patents acquired during the emergency. This is House Bill No. 5850, shown herewith. It was introduced in the House of Representatives on January 21, 1924, by Mr. Hawes and was referred to the Committee on Interstate and Foreign Commerce. The part of the bill that particularly concerns us is section 5 on page 3. This is also shown. This bill, at this writing, has not been reported out of Committee.

Needless to say, if this bill should pass and become a law, great damage would be done to our present radio industry. *It would give all radio frequency and reflex back into the control of foreign hands.* A situation similar to that at the end of the war would again exist, and instead of the Government accomplishing its purpose as it thought at the time of the organization of the Radio Corporation, the radio patent situation in this country would again be out of our control.

This is a serious situation and must be met with prompt action. We must all work together.

The bill specifically permits the United States to retain, if it desires, "by eminent domain on payment of compensation" any of the many patents confiscated. The patents affected by this bill cover many things—radio and otherwise. Most of this miscellaneous "junk" may and should be returned.

In view of the earlier policy to retain American radio for Americans, it does not seem likely that Congress will deliberately return such a dominating factor in the industry. We believe that it merely remains for Congress to be sufficiently impressed with the importance of the Schloemilch and Von Bronk patent to retain and pay for it.

This will cost the Government some money, but can be justified in two ways. First, it would permit the wide and continued increase of radio—a valuable force in uniting and educating the American public. Second, the independent manufacturers, as well as the Radio Corporation, would probably be only too glad to pay a combined royalty sufficient to make it well worth while to the Government.

Every independent radio manufacturer is vitally affected by this situation. It means his very existence.

The Radio Corporation should also be interested and anxious for the Government to retain this patent. It was organized to keep American patents in American hands! Here is the chance to justify its existence!

This patent, if returned, goes into German hands! So let's all get behind the wheel and push. Any inactivity on the part of the smaller companies will indicate gross negligence, while any inactivity on the part of the Radio Corporation means a drifting away from the high ideals that inspired its formation.



Take Your Radio With You



And don't forget that this photograph also shows a Kodel Portable Receiving Set

NOTWITHSTANDING a very widespread campaign of propaganda, the public has been very slow to take up the idea of special portable sets for summer use during the last two years.

This season, for the first time, there has appeared a noticeable stir in this direction, and manufacturers are beginning to feel that there may really be a good future in the sale of sets designed especially for the vacationist.

So far, the reaction of the dealers all over the country seems to be that the public is not yet sufficiently educated in radio to feel justified in spending the money necessary for two sets—an elaborate installation for the home and a more modest one for portable use in the summer time.

In fact, many dealers have told our correspondents in different sections of the country that they did not believe that the public would ever take to the idea of having two sets. They seem to overlook the fact that the public is very well sold on having one kind of clothes for winter time and

another kind of clothes for summer time, a house in the city for winter time and some sort of a place to spend their vacation in the summer time.

It takes effort and slow education to bring the general public around to a realization of things of this kind. The automobile did not sell itself all at once, and when it did the first people who bought automobiles thought that the first car they bought would last them the rest of their lives. They soon, however, became educated to the fact that they should buy a new automobile every so often, and this education came after the business had so arranged itself that there was a considerable resale value for their old car.

The same thing will happen in radio. We must arrange the business in such a way that there will be a resale value for an old set, even though this value may be not more than twenty or twenty-five per cent of the original price.

Portable sets are going to come into quite general use; it seems to me that there

is no doubt of that. This season we have some sets that are really entitled to be called portable. In past seasons we called a set portable if two or three men could gather up its various appurtenances and manage to drag them out to an automobile.

Nowadays, we demand that the entire set with batteries and loud speaker and everything be packed into a case no bigger than a suitcase and that it be not too heavy for one man to carry.

This standard has been achieved in a number of very excellent and efficient sets, and as the efficiency and satisfaction furnished by such sets increase so will the public interest in portable sets increase.

Boonton "Light Four" Receiver: Truly portable, yet entirely adequate for the home.

General design: Instrument case 12¾ inches long x 4½ inches high x 8 inches deep; lock-corner wood case covered with genuine pebble grain leather. Extra long hinges. Snap catches. All hardware nicked brass. Shoulder-length leather sling strap. Weighs only 7 pounds. Can be slipped into bag or suitcase. Weatherproof.

Battery Case: Same as instrument case. Holds three No. 6 cells and two small or medium 22½ B blocks. Connectors arranged to assure proper connections. Weight up to 20 pounds according to size of batteries used. Not included in \$75, as owner may wish to use own case. Has room for head phones.

Circuit: Two straight stage radio frequency, tuned with Ballantine variotransformers tube detector; one-stage audio. Tuning element, two-circuit aperiodic primary and condenser-tuned secondary. Potentiometer for grid return.

Apparatus: Tuner coils on bakelite tube. Condenser, 23 plate with dial vernier. Potentiometer, 400 ohms. Four UV199 tubes in special mold, any socket supported on four springs like Navy type. Rheostat common to all tubes and will handle 6 volts. Ballantine variotransformers in radio

Getting the Bedtime Stories on a Kennedy Portable Receiver





stages with shielding cases ground to filament. Hedgehog audio mica grid condenser with finex leak. Anti-capacity jack. All wiring of rigid bus, except flexible leads to floating tube socket assembly.

Collector requirements: Collector wire included with insulators and carrying spool. Ground wire ditto. Any convenient support may be used for collector. Ground wire need not be actually buried or grounded may be used as counterpoise. May be used with any antenna and ground.

Operation: Condenser is main control. Intensity control is added convenience. Rheostat not critical. Variotransformer dials give refinement for weak signals. Calibration curve in lid of case gives settings good for any collector system. Tuning range, 250 to 550 meters.

Sensibility: Operates a good loud speaker up to 50 or 100 miles on collector wire supplied. Consistent work up to 500 miles with well-constructed antenna. With head set, 1000 miles plus, according to antenna and local conditions.

Selectivity: Will separate strong signals from weak signals of ratio 8:1 differing by 20KC or more, using collector system supplied.

Tone quality: Variotransformers ahead of detector give timbre equal to best victrola reproduction. Marked freedom from audio resonance.

As a set for the home: Receiver placed on top of battery box presents a rich appearance entirely self contained, with no loose battery wires. Hinged cover keeps out dust. Loud speaker performance with greatest simplicity. Results on a par with any other four tube set of equal stability.

As a real portable set: Small size (about same as 5x7 camera with plates) goes into suitcase, grip duffle bag under auto seat, in canoe, or the like. Weight divided for ease in carrying. Will withstand heaviest jolts and any fall that wouldn't break a camera. Tubes on special spring suspension. Leather covering protects against weather and can be washed.

Advantages over other receivers: The

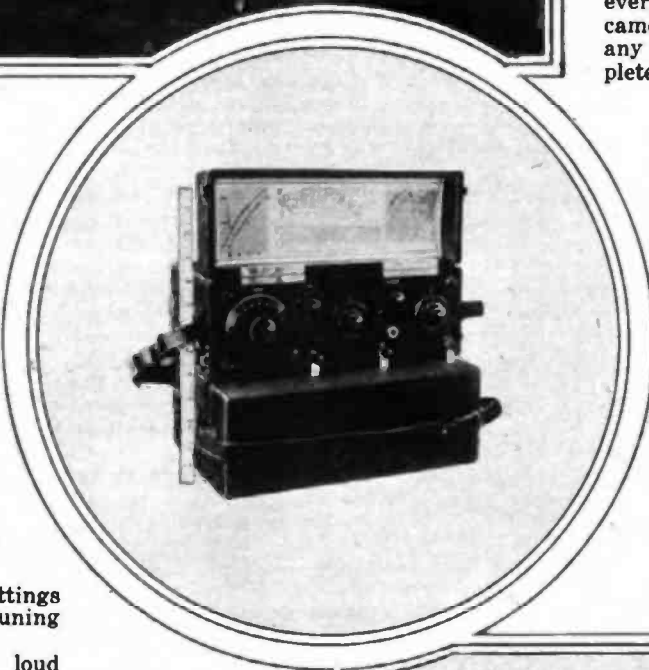

At the top of the page is shown a party of campers enjoying a concert. The radio set in this photo is an Ozarka Portable

The radio set pictured in the circle is a Boonton Portable. To the right is shown the Crosley Portable Set

only one of its kind, so far as we know, that has real portability comparable to a camera, or even a camp type victrola. Results extraordinary compared tube for tube and pound for pound. Battery capacity for actual measured average of 110 house service. Simple control permits operation by touch, if necessary, in poorly lighted camp. Calibration curves sufficiently close under all conditions for easy pickup. Can be used on auto or boat battery.

The Crosley 51T: This is a neat little portable outfit put out by the Crosley Radio Corporation. It is a regenerative detector and one stage of audio amplification, contained in a strong leatherette, nickel-trimmed, portable cabinet. Loud-speaker volume is obtained on nearby stations and excellent phone reception on distant stations. The Crosley 51T is 12½ inches wide x 7¼ inches high and 7½ inches deep and weighs only 21 pounds with batteries, phones and aerial equipment. Space is provided in the cabinet for these accessories.

The Kodol Portable: Here is a neat little set with batteries, phones, tubes and everything included in an ordinary hand-camera case. It would be hard to imagine any radio set more compact or more complete than this.

The Kodol has all of the controls mounted in the front, and at the bottom of the front is a compartment for the head phones. In the back the upper compartment holds the tubes and one battery and the lower compartment holds the other battery.

Naturally, it must not be expected that such small batteries as this will last long under constant use, but allowances of this kind must of necessity be made for portable sets. These batteries are cheap, however, and can be purchased anywhere, so that the replacement is not a serious question.

Benson Portable Superflex: This is a portable reflex set using two UV201A or C301A tubes with 90 volts of B battery. The batteries fit into the (Continued on Page 40)

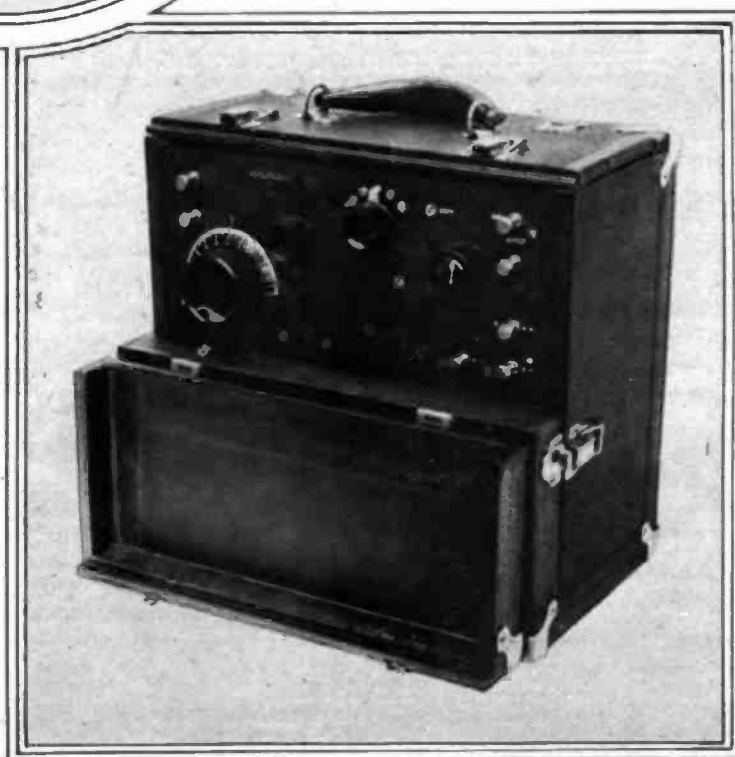

HARKNESS

Writes on Self Oscillation

THE entire trend of radio today seems to be toward some form of radio frequency amplification. Mr. Harkness is peculiarly fitted to deal with this problem and we have felt that our readers would probably value his discussions of it more than anything else about which he could write.

Necessarily, the consideration of radio frequency amplification presupposes a certain amount of radio knowledge upon the part of the reader. If you are just beginning in radio, you will probably not be able to understand these articles thoroughly just at present. However, let me advise you to save them because you will undoubtedly soon reach the point where you can understand all the terms and the theories involved.

To any one who has been experimenting in radio for a reasonable time, these articles will be perfectly plain and they will be of inestimable value because they will explain simply and clearly the fundamental problems of a subject which is not very widely understood by amateurs.

H. M. N.

By KENNETH HARKNESS

Chief Engineer, The Radio Guild

THE majority of radio receivers today use radio-frequency amplification to increase their sensitiveness. By amplifying the minute oscillating currents induced in the receiving antenna before rectification and detection, the efficiency of the receiver is enormously increased. In these receivers, however, some provision is usually necessary to control what is known as "self-oscillation." For instance, some receivers use small neutralizing condensers for this purpose; others use a potentiometer, etc.

To the student of radio science and to the designer and builder of a radio-frequency amplifying receiver, a thorough knowledge of the causes of self-oscillation, the precautions which must be taken to prevent it and the means which may be adopted to control it, is of the utmost importance. I find, however, that these impor-

tant subjects are not very well understood by many amateur constructors of receivers. In this article, therefore, I will explain how continuous oscillations are self-generated in a radio receiver, why it is necessary to control these oscillations, and will outline the best methods of controlling them in different types of receivers.

The term "self-oscillation" is used to describe the action which takes place in a

sound is heard, changing in pitch as the tuning elements are varied; moreover, it is then almost impossible to detect such signals without considerable distortion. In a reflex receiver self-oscillation is unmistakable; it is usually accompanied by a rasping howl in the telephones.

To comprehend fully how continuous oscillations are self-generated in a radio receiver, one should really possess a knowledge of oscillatory currents in general, including particularly the effect of resistance upon the current in an oscillatory circuit. The following explanation of how self-oscillation takes place, however, is only of a superficial character, intended merely to give the layman a general understanding of the subject.

Figure 1 illustrates one of the simplest receiving circuits in which self-oscillation may be produced. A receiver using this circuit is generally known as a "single-circuit regenerative receiver."

In this system the antenna circuit comprises the antenna A, the inductance coil L1, the variable condenser C1 and the ground connection E. The terminals of the coil L1 in this oscillatory circuit are connected across the grid and filament of the vacuum tube, the condenser C2 being inserted to produce a rectifying action. The plate circuit, which is separate and

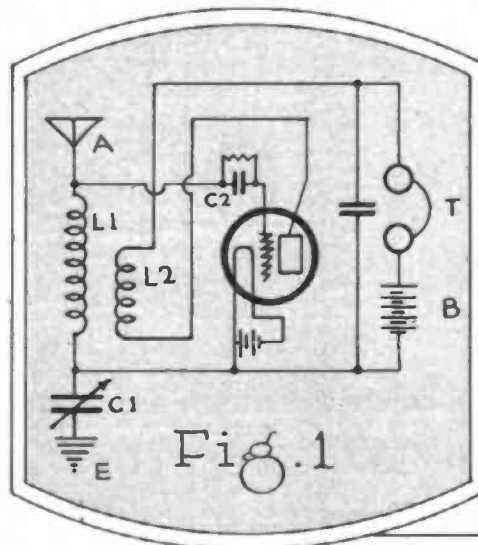

Fig. 1

radio receiving (or transmitting) system when the vacuum tube self-generates continuous oscillations in the circuits of the system.

The owner of a regenerative or radio frequency amplifying receiver continual-

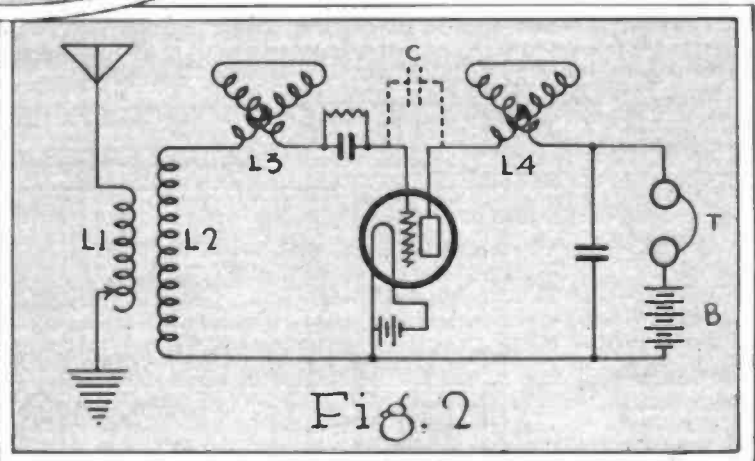

Fig. 2

ly hears the audible manifestations of this action when tuning his receiver. A hollow click is heard in the telephones when the action begins; if, while the tube is "oscillating," an attempt is made to detect the signals of a radio broadcasting station, a whistling

distinct from the antenna circuit, although coupled to it, comprises the coil L2, the telephones T and the high potential battery B.

L1 and L2 form what is known as a vario-coupler; that is to say, provision is made for inductively coupling the plate and grid circuits and for varying the degree of coupling between them.

Now, it is a fundamental characteristic of the three-electrode tube that variations of the grid voltage produce corresponding amplified variations of the current flowing in the plate circuit. For instance, if a radio wave induces oscillations in the antenna circuit of Figure 1, an oscillating

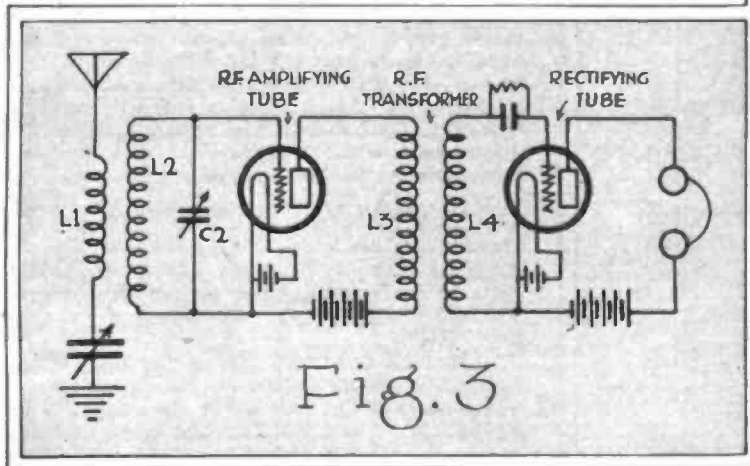

Fig. 3

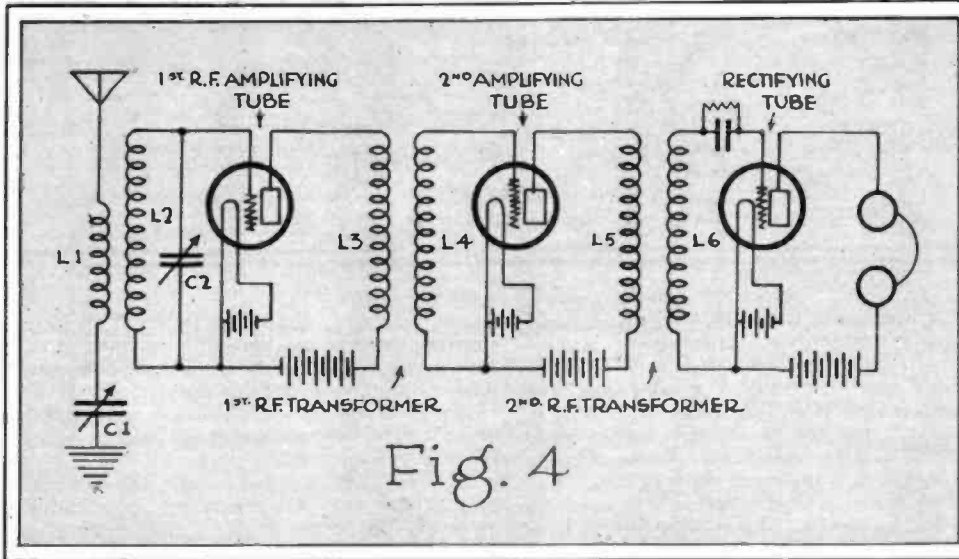

Fig. 4

tenna circuit and the plate circuit, the radio frequency current variations of the plate circuit induce an oscillating e. m. f. in the antenna circuit. This induced e. m. f. tends to offset the effect of resistance in the antenna circuit, aids the signal oscillation and increases the amplitude of the original oscillation impressed on the grid. Proportionately more energy is released in the plate circuit and an amplifying effect is thereby obtained.

The amount of energy fed back from the plate circuit to the antenna circuit, which governs the extent of the amplification, depends, of course, upon the degree of coupling between the two circuits. If the coupling is loose, the amplification is slight. If the coupling is close, the amplification is large. There is, however, a decided limit to the amplification which is obtainable. The audibility of a signal can be greatly magnified by increasing the coupling between the plate and grid circuits, but if the

electro motive force (E. M. F.) is set up across the coil L1; these oscillations vary the voltage of the grid of the vacuum tube and corresponding amplified variations of the plate current are produced.

Furthermore, since the plate circuit is inductively coupled to the antenna circuit, any variations of the plate current will induce oscillations back into the antenna circuit and reinforce the original oscillations. It is in this way that regenerative amplification may be obtained.

To study the operation of this circuit more closely, let us presume that the coupling between the antenna and plate circuits is zero, the coils L1 and L2 being turned at right angles to each other.

If a signal oscillation is then induced in the antenna circuit, and this circuit tuned to resonance, the amount of energy released in the plate circuit, and consequently the loudness of the signal in the telephones, depends upon the amplitude of the e. m. f. oscillations impressed on the grid. The latter amplitude, in turn, is limited only by the resistance of the antenna circuit.

Now, if the coil L2 is revolved so that there is a slight coupling between the an-

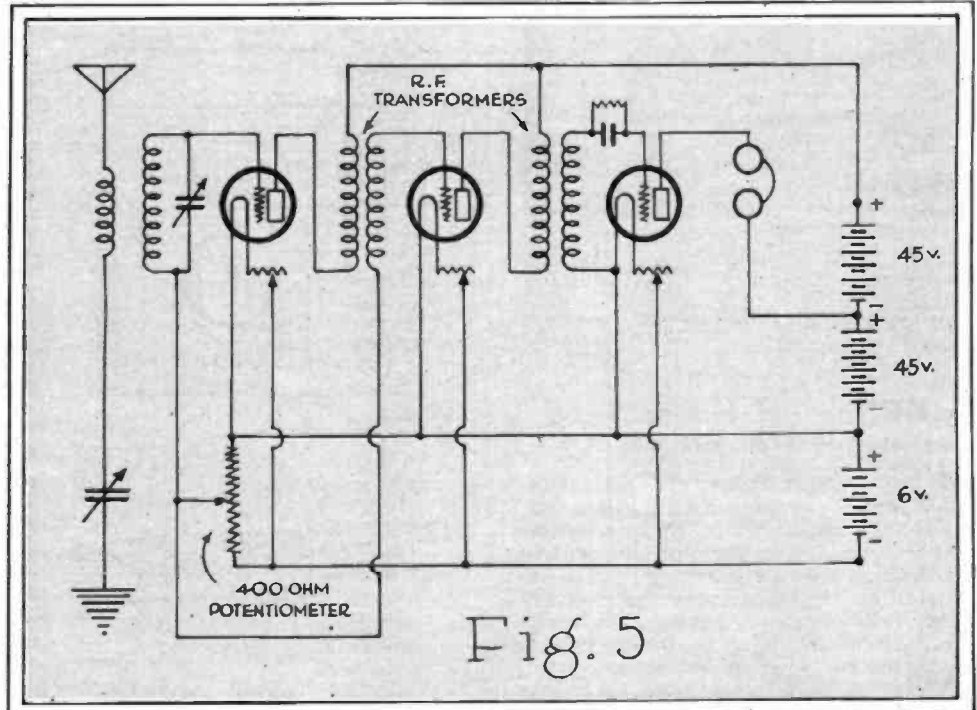

Fig. 5

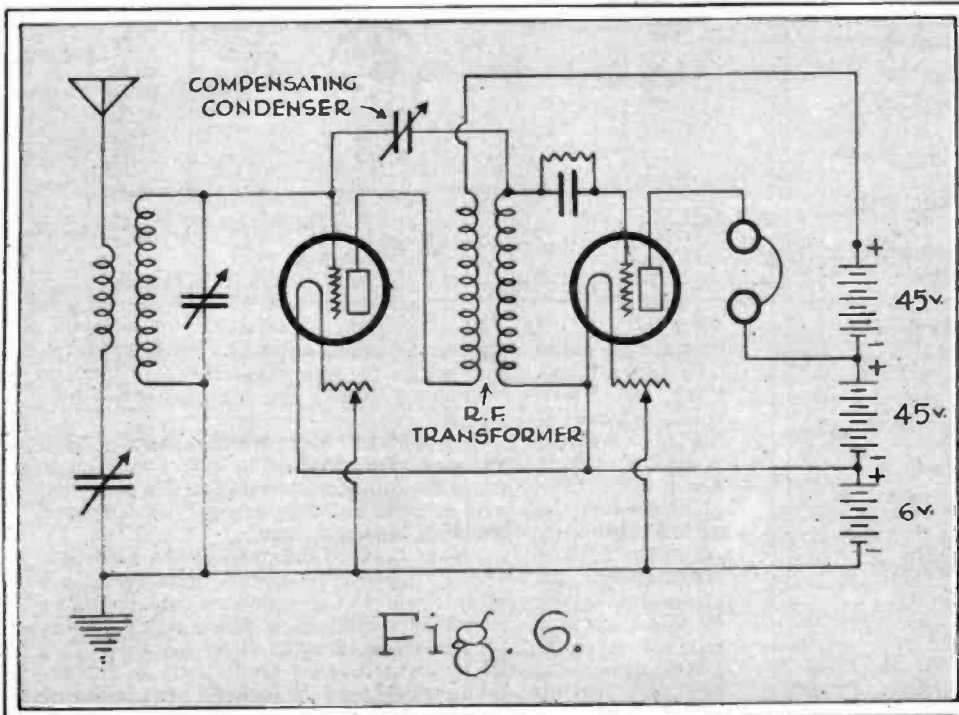

Fig. 6.

coupling is increased beyond a certain degree, a click is heard in the phones, the signals become distorted and no further amplification is obtainable. The tube is then said to be "oscillating."

The action of self-oscillation which takes place may be explained, in a general way, as follows:

When the coupling between the plate and the grid circuits is sufficiently close to enable the transfer from the plate circuit to the grid circuit of an amount of energy equal to the amount consumed by the resistance of the grid circuit, the tube becomes a generator of continuous oscillations; some slight impulse, such as an atmospheric disturbance or an irregularity in the electron emission of the tube, sets up a weak oscillation which builds up until it reaches a certain amplitude and then continues steadily at this amplitude as long as the coupling between the plate and grid circuits is sufficiently close to sustain the oscillation against the resistance of the grid circuit.

This self-generated continuous oscillation is quite separate and distinct from the signal oscillation; if, while the tube is oscillating, a signal (Continued on Page 38)

Trouble Shooting in the Grimes 3XP

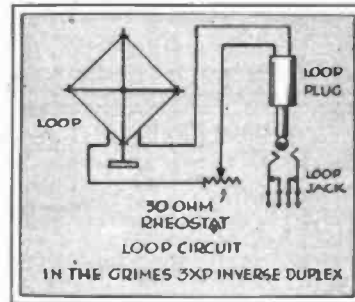
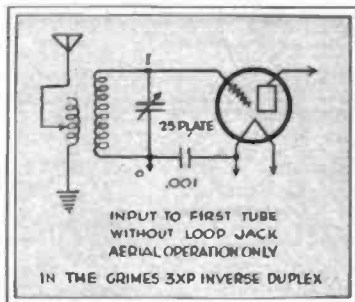

THOSE of you possessing sufficient perseverance to complete the 3XP circuit shown in last month's issue were undoubtedly puzzled by certain noises emanating from your set. We certainly were puzzled the first few times that we seriously experimented with the Inverse Duplex. The various noises caused many an earlier enthusiast to drop by the wayside; but now, for the first time, we will outline most of the common difficulties, give their symptoms, and prescribe their cures.

Before going further, let us defend ourselves to this extent—these noises are not inherent (except in one instance) in the Inverse Duplex arrangement. They are troubles that might arise in any type of radio or audio frequency circuit.

You see, the 3XP circuit is a combination of both radio and audio amplification and, therefore, must be working perfectly in its component parts to insure satisfactory operation of the whole. But do not become discouraged. It is very easy to locate trouble when you know how.

Most of our readers who have written in their grievances have been set straight by simple suggestions covering less than three sentences. Of course, to do this we must know as many of the symptoms as possible. In some cases, we could prescribe no remedy because of insufficient data. It is rather hard, you know, to answer such a question as this:

"Dear Editor: I have hooked up your 3XP circuit and it doesn't work. Please tell me what my trouble is."

So, in order to avoid all this, we have built up the 3XP circuit, backward and forward, right-side up and upside down—even blindfolded. Furthermore, many different kinds of equipment were used. Well, you should have heard the shrieks and howls and the moans and groans—to say nothing of the grunts. We never realized before that mere inanimate objects would express themselves so humanly. The worst squawks seem to occur when combining the Radio Cor-

By DAVID GRIMES
Chief Engineer Sleeper Radio Corporation

THE Grimes-3XP circuit published last month certainly seems to have made a big hit among our readers.

In this article Mr. Grimes takes up some of the more common troubles which seem to have been encountered by readers, and on succeeding pages I am showing a brand-new style of hookup diagram.

This diagram is a result of very long and careful thought and discussion and I should be very much interested to hear how our readers like it and whether they think it is better than the old style of diagram. It means a great deal more work for us, but a great deal less work for the novice. If you think it is an improvement, please let me know and we will go ahead with it in future issues. H. M. N.

poration parts with those of the various independents. They didn't seem to want to stoop to such indignities.

A record of all such protests was diligently made and now they have been fairly well classified. They fall under three main heads and are as follows:

1. Oscillation Squawk.
2. Audio Howl.
3. Overload Howl.

These three are absolutely separate in their causes, although it is quite likely they may all occur together. They are easily recognizable, having very distinctive features that will enable you to pick them out in the dark. By studying the symptoms and their causes and remedies, you should be able to adjust your own difficulties. We will be anxious to hear from all of you who discover and correct your troublesome sets.

Oscillation Squawks—The first classification of "oscillation squawks" includes all difficulties experienced through radio oscillation. These troubles are inherent in a radio frequency circuit. One system of avoiding them is the Neutrodyning method, although, of course, there are many other available schemes.

When either one of the two radio frequency stages oscillates, a choking of the grid occurs. This choking is caused by the audio equipment in the same grid circuit. Ordinarily, in a straight radio frequency circuit, a radio oscillation can be recognized by a high, clear-pitched whistle that changes tone as the tuning condenser is rotated. In a Duplex circuit, a periodic choking of the grid takes place, preventing whistle and causing a noise like an air hammer.

You have, no doubt, neglected to place your tuned, air core, radio transformers at right angles to each other and on the same line of centers. The centers of all three coils should fall on the same straight line. If this has been done and "air hammer" noises are still experienced, the source of trouble probably lies in long B battery leads or a close assembly of ap-

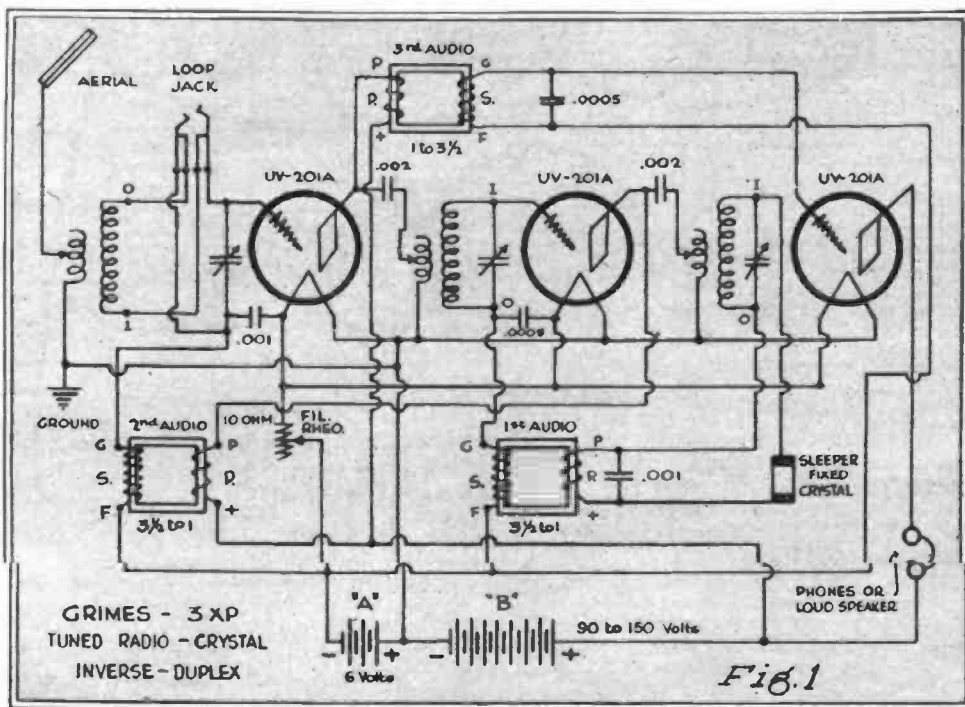

(Continued on Page 26)

Let's Hook Up the Grimes-3XP

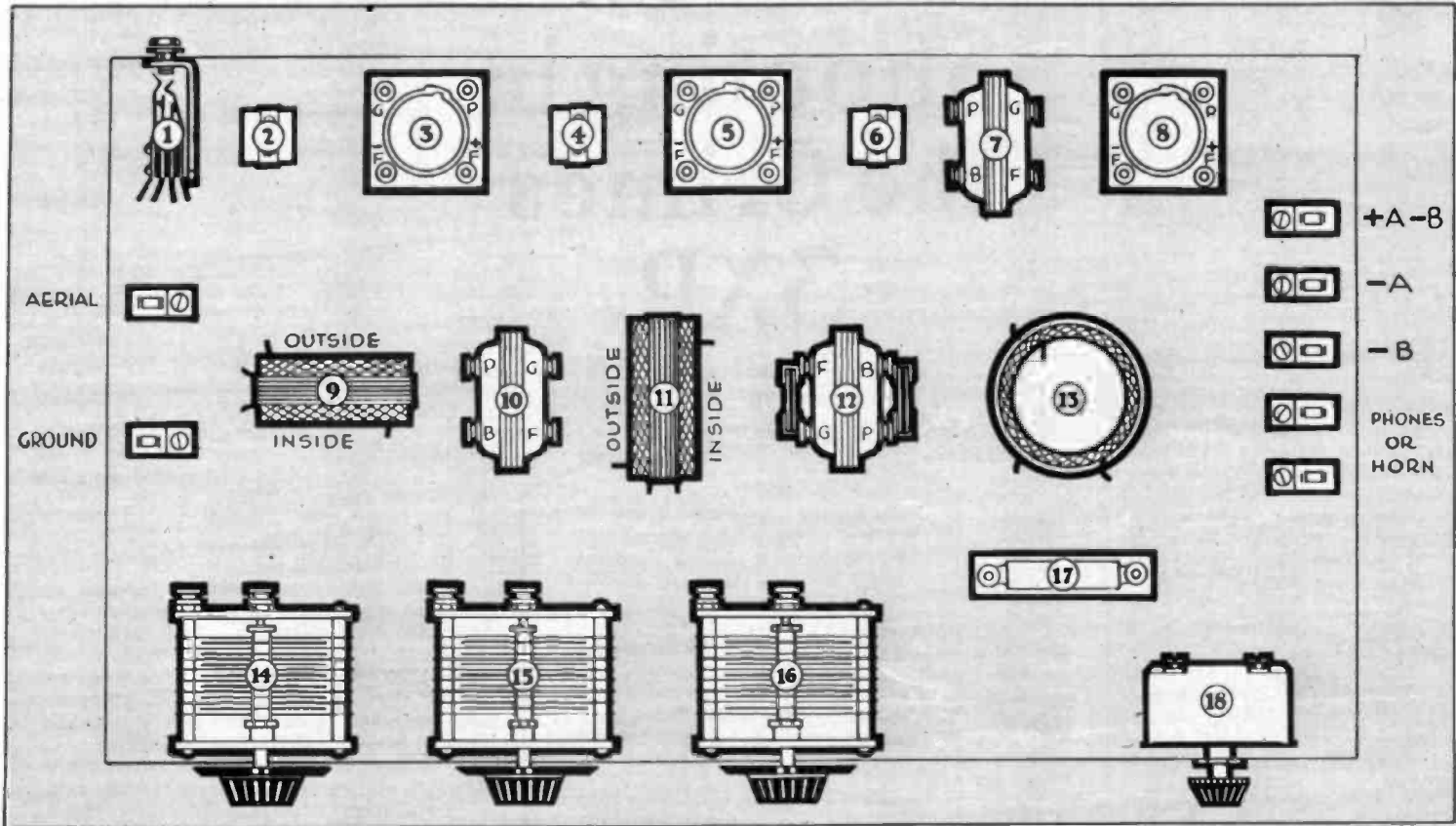

Fig. 1—Above is layout of the apparatus

Figure 1 shows the various pieces of apparatus just as they are laid out on the baseboard as recommended in last month's article. No. 1 is the double circuit jack, No. 2 a .001 condenser, No. 3 the first tube socket, No. 4 a .002 condenser, No. 5 the second tube socket, No. 6 a .002 condenser, No. 7 the last audio frequency trans-

HERE is a brand-new form of wiring diagram for the novice. We have worked it out carefully, and it seems to me that anybody ought to be able to put a set together from a series of diagrams such as these.

This hookup is the Grimes-3XP circuit which was described in last month's issue,

and in order to get the values of the various instruments and learn something about it, I would advise you to read that article first and then try this hookup.

Fig. 2—Below, the negative filament leads

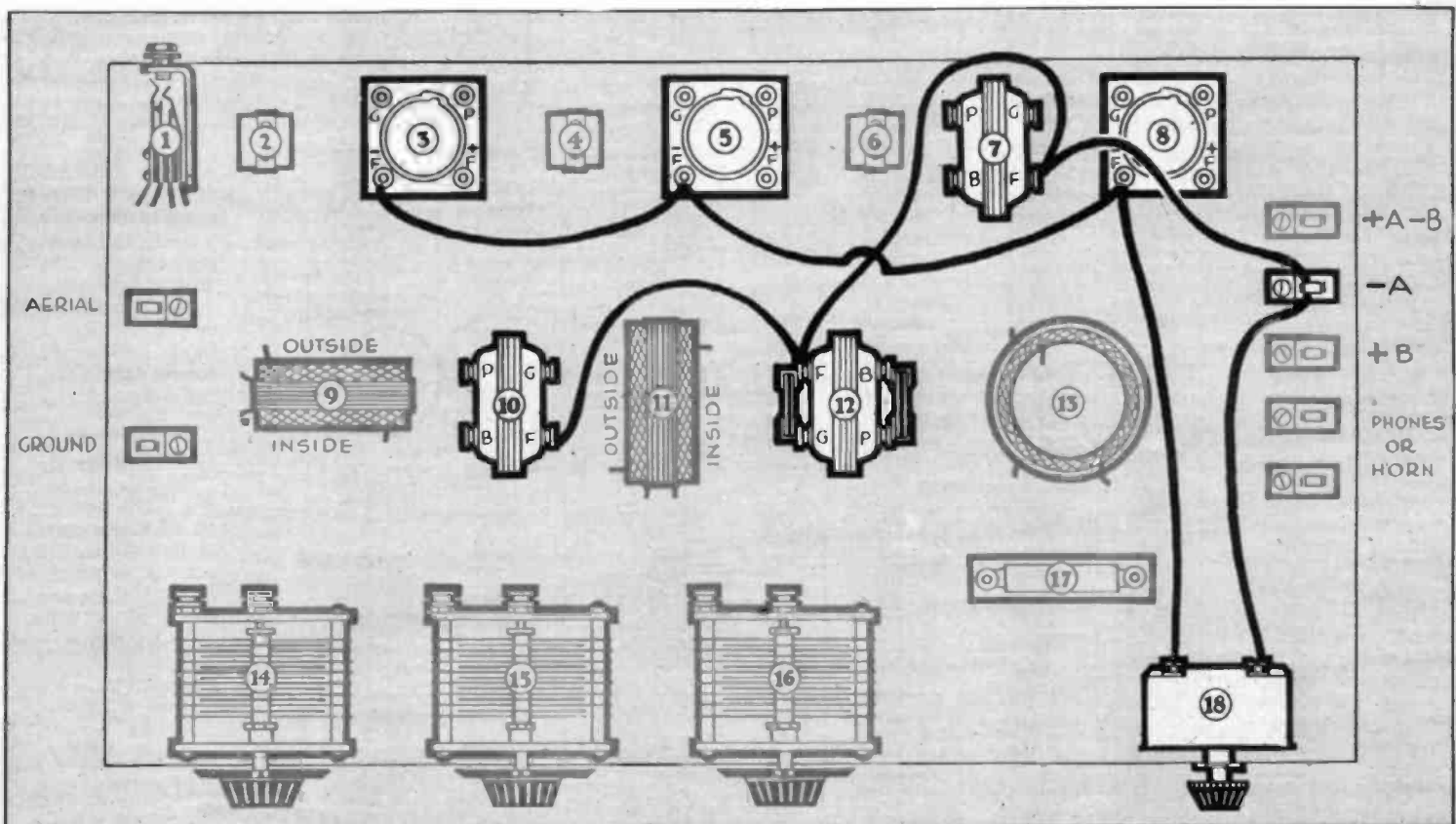

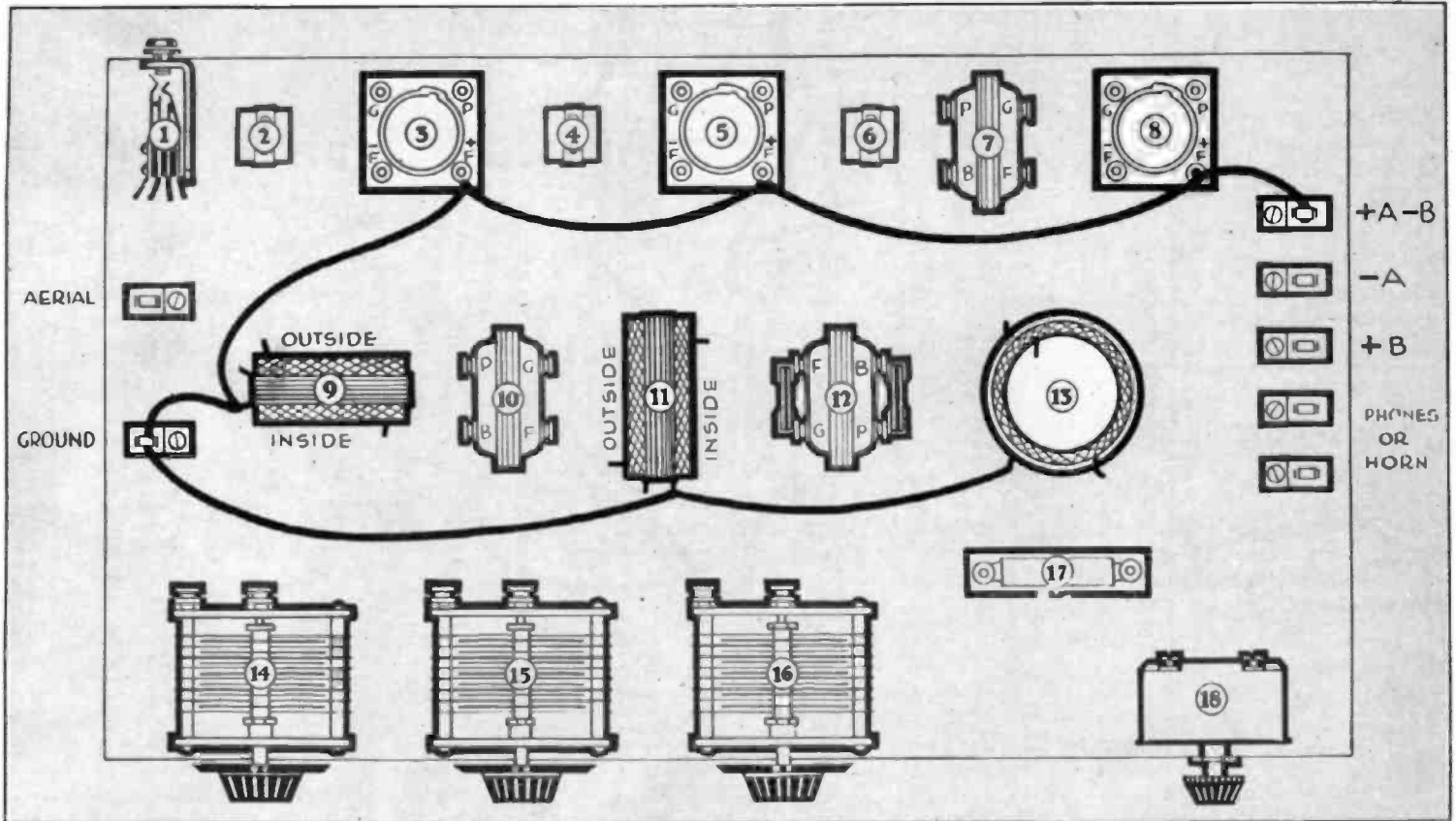

former, No. 8 the third tube socket, No. 9 the first honeycomb coil with the primary wound around the outside, No. 10 the second audio frequency transformer, No. 11 the second honeycomb coil with a primary wound around the outside, No. 12 the first audio frequency transformer with a .0005 condenser connected from the filament to the grid post and .001 fixed condenser connected from the B to the plate post, No. 13 the third honeycomb coil with the primary wound around the outside, Nos.

Fig. 3—Above, the positive filament leads 14, 15, 16 three .0005 variable condensers, No. 17 the crystal detector, either fixed or adjustable, and No. 18 the Bradleystat.

Place all of these instruments upon the board as shown here and then we are ready to start with the wiring. Use ordinary bell wire or annunciator wire, as it is called. I advise you not to attempt to make the reg-

Fig. 4—The radio frequency primary leads

ular square bends that most people recommend, because this set will function perfectly well without them.

Come on; let's get ready now and put on the first wires that are necessary.

Figure 2—Negative Filament Leads— Here we have seven wires, if you are going to use short pieces, but personally I prefer to use only two pieces and do it this way; attach one wire under the minus filament of the binding post of the first socket (No. 3), measure to the minus filament binding

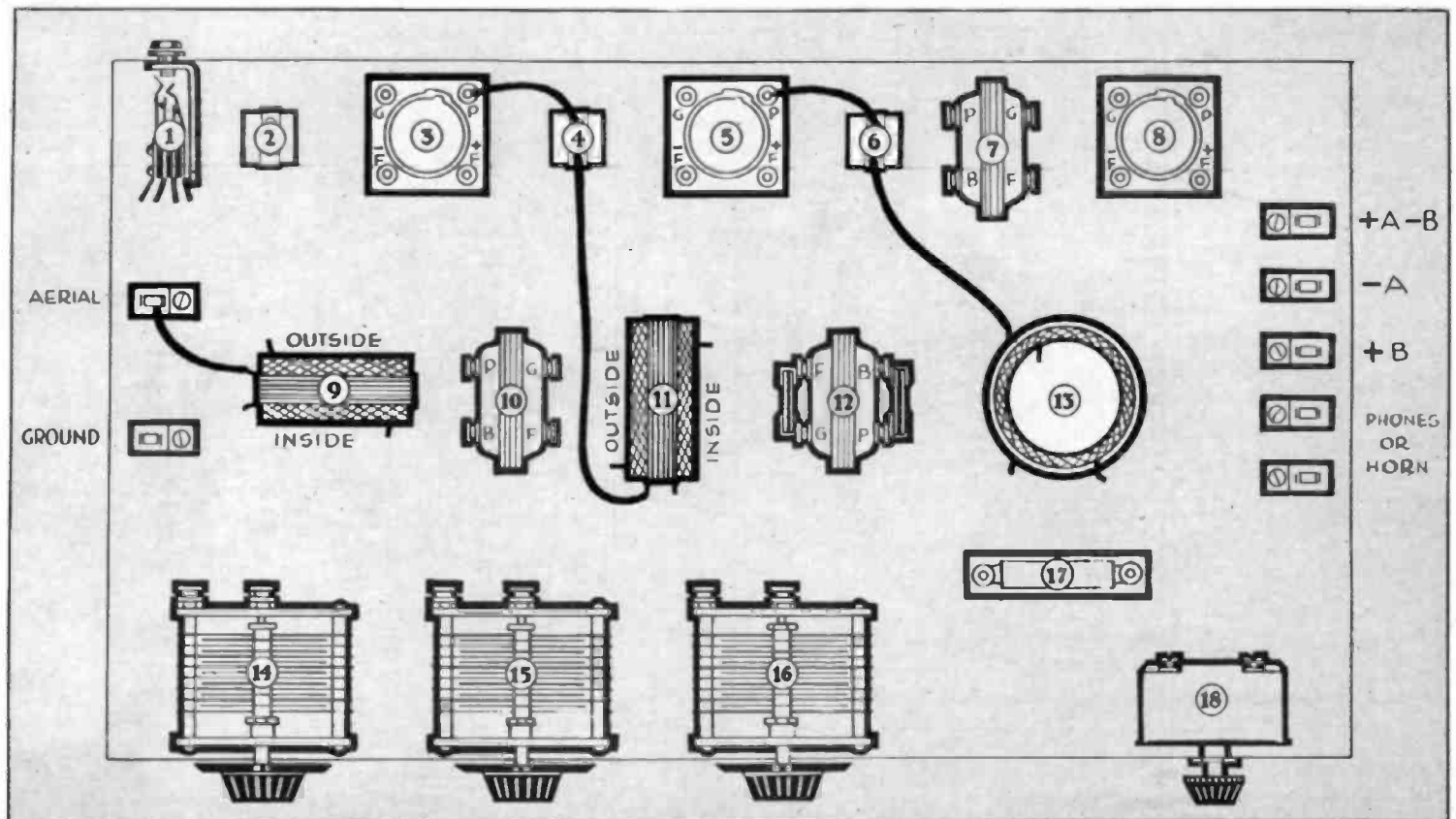

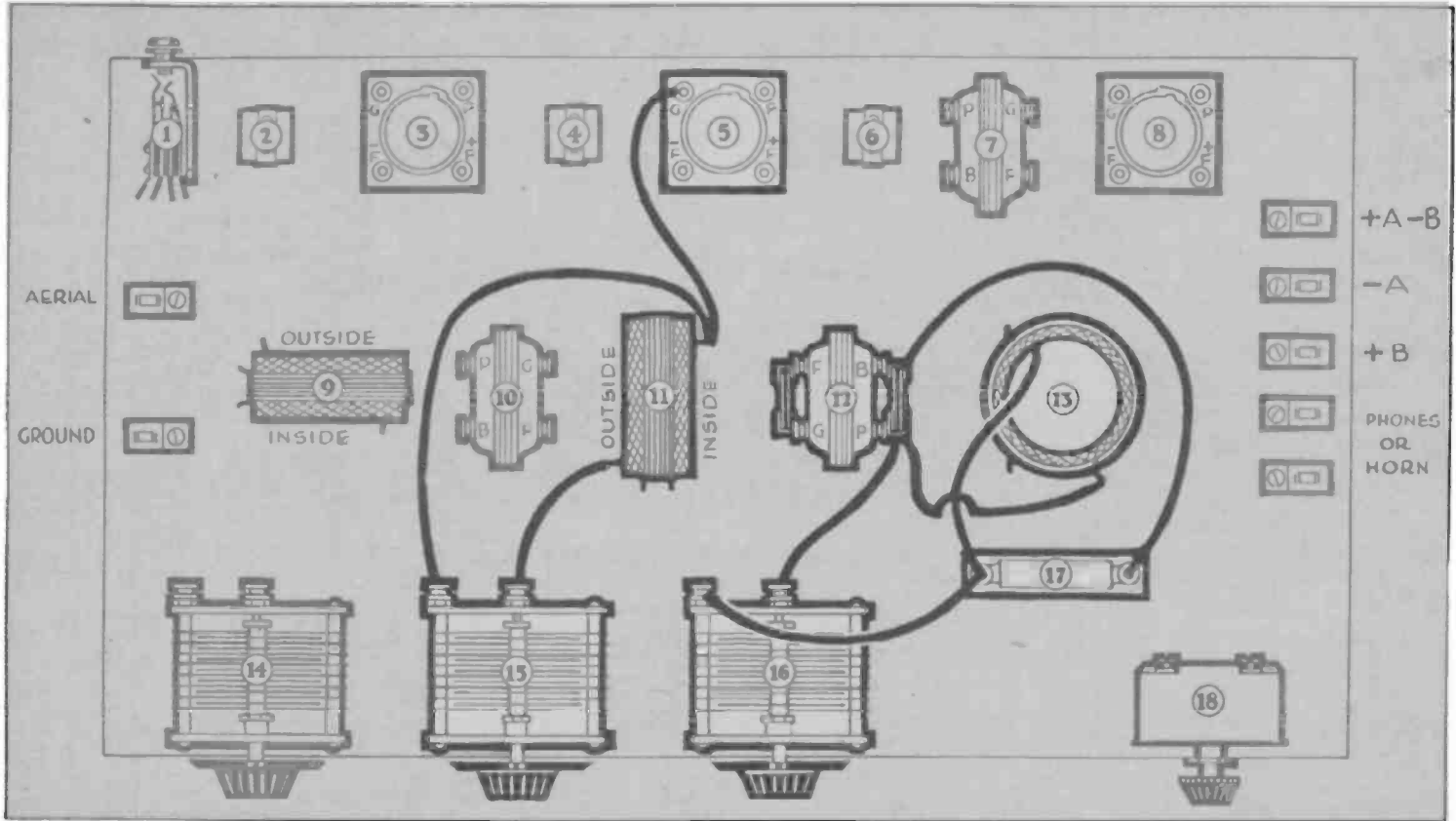

Fig. 5—This diagram shows the radio frequency secondaries

post of the second tube socket (No. 5), scrape off some of the insulation, twist the wire under and screw down, then measure over to the minus filament binding post of the third socket (No. 8), scrape off some insulation, twist the wire under and screw down, and then go over to one side of the Bradleystat, where the wire is cut, the end scraped and soldered fast. The other wire should then begin at the other connection on the Bradleystat, go over to the clip marked minus A, scrape off some of the

insulation and twist it around the screw and screw down the clip on it, measure over to the filament binding post on the third audio transformer (No. 7), screw down tight, measure over to the minus filament binding post of the first audio frequency

transformer (No. 12), scrape off some of the insulation, twist around the binding post and screw down tight, and then measure over to the filament binding post of the second audio frequency transformer (No. 10), scrape off the insulation and make fast. This completes the negative leads and we are ready for the next diagram.

Figure 3—Positive Filament Leads— Here again we have seven connections if you are going to use short pieces of wire, but in this case I would recommend one

Fig. 6—The audio frequency primaries and connections to phones or loud speaker

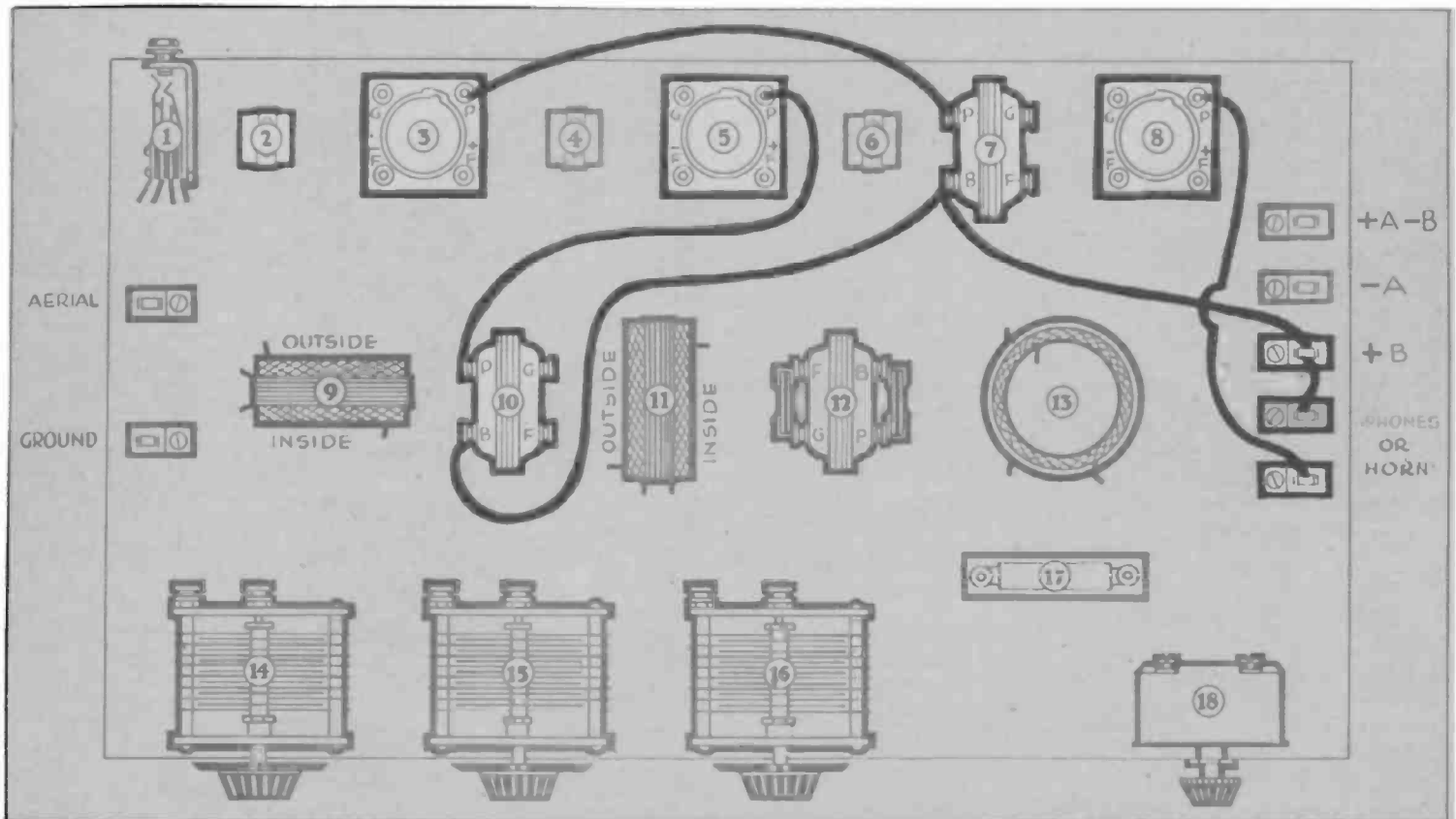

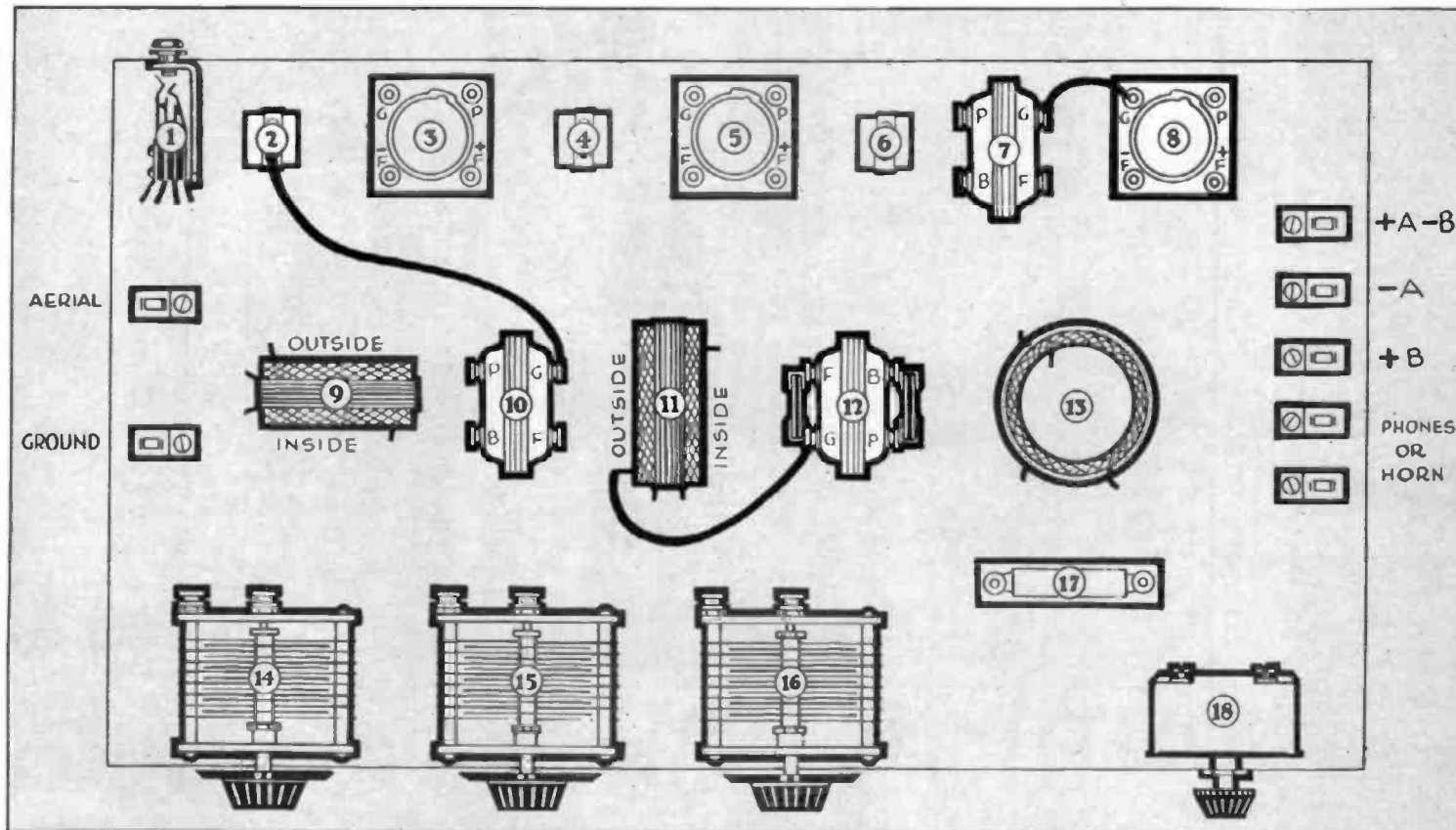

Fig. 7—The audio frequency secondaries

long piece in the same way that we used the pieces in number two. Scrape the insulation off one end of the wire, twist it around the screw of the clip for the plus A and minus B, screw down on it, measure over to the positive filament binding post of the third socket (No. 8), scrape off insulation, twist wire around binding post and screw down, measure over to positive filament binding post of second socket (No. 5), repeat scraping and screwing down, measure over to positive binding post of first

socket (No. 3), repeat scraping off insulation and screwing down, measure over to the last end of the primary winding over the first honeycomb coil (No. 9), scrape insulation and solder fast, measure over to ground clip, scrape insulation, twist around screw, and screw down fast, measure over to the last end of outer winding over second

honeycomb coil (No. 11), scrape insulation and solder and then measure over to last winding around outside of third honeycomb coil (No. 13) and solder the end there. This completes the positive filament leads.

Figure 4—Radio Frequency Primary Leads—Run a short wire from the aerial clip to the first end of outer winding on the first honeycomb coil (No. 9). Run a short wire from plate binding post of the first socket (No. 3) to one side of the fixed condenser (No. 4). Run (Continued on Page 35)

Fig. 8—The connections to the loop jack

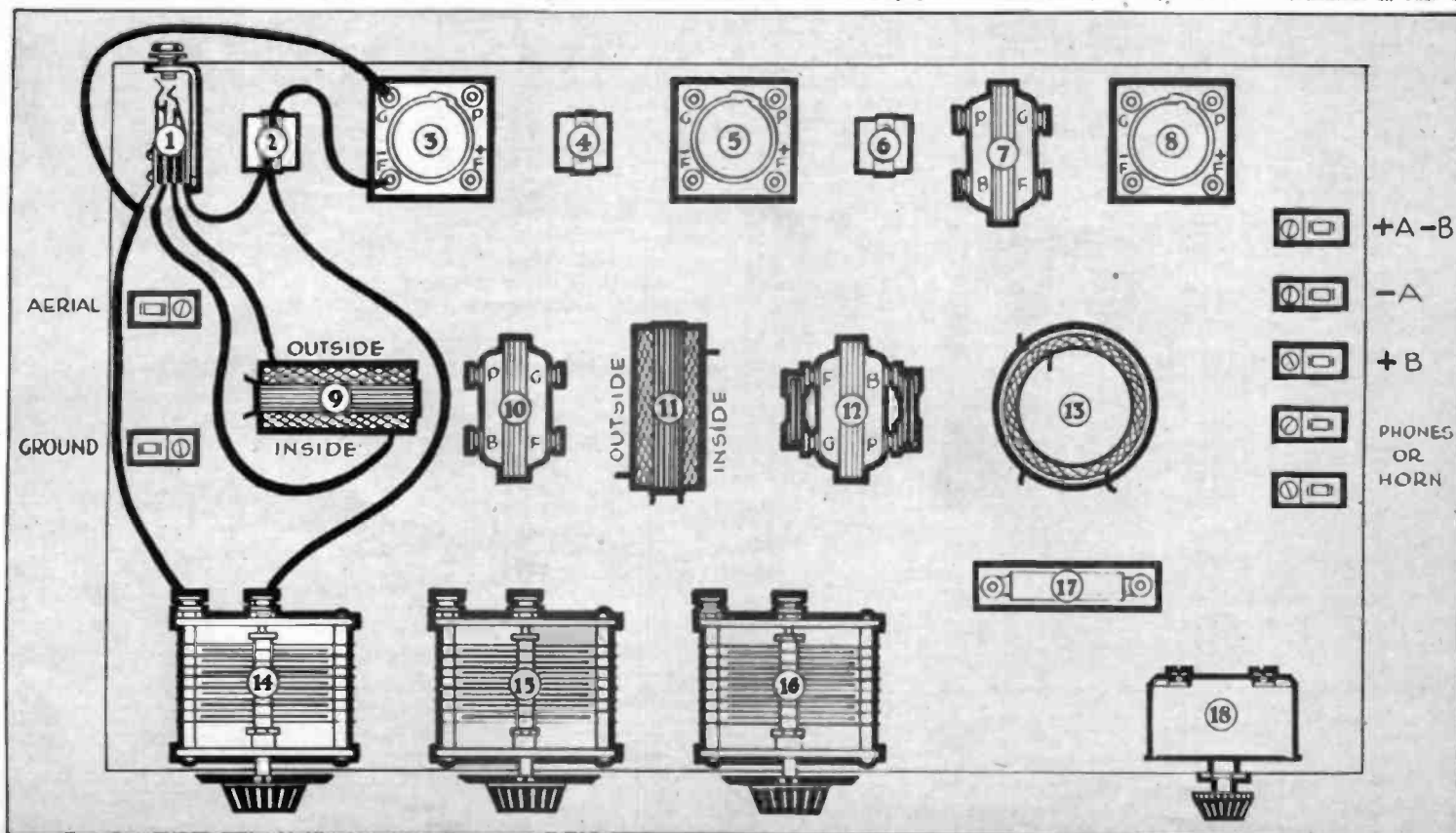

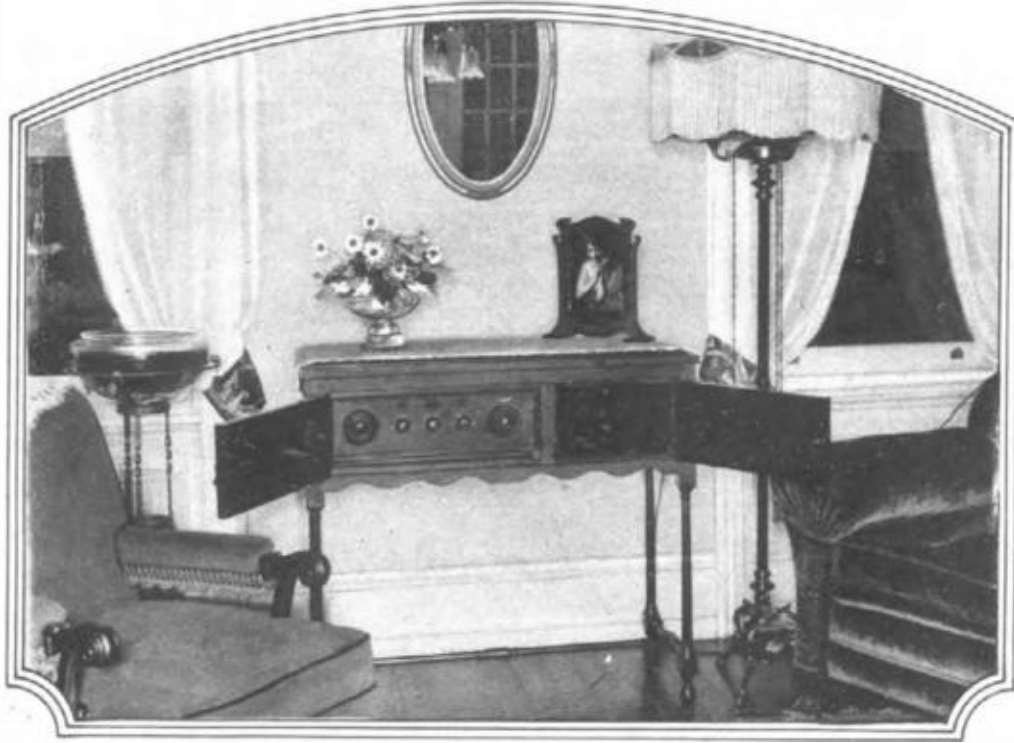

LESSON TEN

*Radio in the home
of Harry Polk, 311
West Susquehanna
avenue, Phila., Pa.
Photograph by
Henry S. Tarr*

The RADIO KINDERGARTEN

By HENRY M. NEELY.

IN THIS lesson of our Kindergarten, I am going to take up a subject upon which I feel very free to speak, for the simple reason that nobody really knows anything certain about it. Therefore one man's theories are just as good as another's and any writer is at liberty to explain it in his own way, confident that any other writer's contradiction will be just as lacking in authoritative basis as his own.

The subject is static. It is a timely one now, because we are in the midst of the static season, and every listener-in has a direct personal interest in it.

We really know very little about static. Scientists are satisfied that static is caused by electrical discharges in the air, but just exactly what these discharges are—that is, exactly what *all* of them are—is still a disputed question. Part of it we do know about in considerable detail. But there are other forms of static which are still open to investigation.

A discharge of lightning is the extreme form of static. This is one form with which everybody is familiar. The vivid flash of fire, oscillating between a cloud and the earth, is nature's form of wireless transmission by means of the spark method.

In our early days of wireless, this was the only form which man had for transmission. He could not make a spark so powerful as a lightning discharge, but he was able to make sparks in his wireless machinery which would cause sufficient disturbance in the surrounding ether to enable receiving sets many miles away to receive this disturbance and to translate it into dots and dashes of the wireless code.

Just as the man-made spark was received by wireless operators, so the discharge of lightning is received by all sets within hundreds of miles of it, only the signal received from lightning is naturally very much more powerful than a signal from a man-made spark.

With the man-made spark produced in

a transmitting set, there were other pieces of apparatus which were designed to keep the disturbance centralized on or about a certain definite wave length and this resulted in the ability to tune the signal in or out. Consequently, the man-made spark is not so likely to disturb the receiving sets which are tuned to some other wave length.

With the lightning discharge, there is no tuning apparatus and the signal, tremendous and powerful as it is, is sent out on all ordinary wave lengths, so that it is impossible for any receiving set to tune it out.

It is fairly generally agreed now that this discharge of lightning is typical of all static. That is to say, all of the static noises which we hear are a lesser degree of actual lightning.

The genuine bolt of lightning is a vivid flash of millions of sparks passing through many hundreds or thousands of feet of atmosphere. From this gigantic discharge down to its minimum form, which might be considered merely the passage of one tiny electron from a little particle in the atmosphere to another, we can get a fairly clear picture of all static by remembering the lightning flash.

We have already learned in a previous Kindergarten lesson that a lightning discharge is caused when a strong charge of positive or negative electricity accumulates in a cloud and an equally strong charge of the opposite kind of electricity accumulates in the earth underneath it. These two charges, being unlike, naturally attract

each other and when sufficient energy is accumulated in both clouds and earth, the tendency to rush together and neutralize each other becomes so strong that the air gap in between is broken down and electrons rush back and forth between cloud and earth until an equilibrium is established. It is this rushing back and forth that forms the flash that we see in the air.

Whenever a positively charged body gets near enough to a negatively charged body, there will be this tendency for the electrons to rush from the negative to the positive one until an equilibrium is established and the two bodies become neutralized or, in other words, until they have no electrical charge at all. In this case, the positive and negative charges exactly equal each other.

This tendency of oppositely charged bodies to neutralize each other is true, no matter how large or how small those bodies may be. It is true of a great cloud extending over many square miles and the earth beneath it. It is also true of the tiniest little atoms in the air—so tiny that even the most powerful microscope would not reveal them to us. It is true if there is only one more electron in one of these bodies than there is in the other.

We know that the atmosphere is always full of billions and billions of atoms of various kinds. We also know that there are many causes which will result in electrons being disrupted from some of these atoms and either being stolen and attached to others or else being freed in space, virtually seeking some other atom to which to attach themselves.

Now, an atom is always a particle which has just exactly as many electrons, or negative charges, as it has protons, or positive charges. The minute this equal number is disturbed, the atom becomes what we call an "ion" and if it has more electrons, or negative charges, than it ought to have, it is a negative ion, but (Continued on Page 22)



"Factory" Refinements in Home-built Sets

THIS is the concluding article by Mr. Loeb outlining for the novice the various considerations which enter into the purchase and mounting of radio apparatus.

I feel sure that these two articles will prove of great value to the non-expert builder, and Mr. Loeb will be very glad to write further articles dealing with any questions which readers may care to send him.
H. M. N.

COMING now to the instruments having moving parts (which are subject to mechanical wear and breakage) we must consider those that govern inductance (coils), capacity (condenser), resistance (rheostat) and conductance (tap switch, etc.).

Movable inductances include the loose coupler, the variocoupler, the variometer and pancake or honeycomb coils. Space will not be here devoted to the loose coupler, as it has been superseded almost everywhere by the variocoupler and flat coils.

In the choice of a variocoupler there is considerable leeway. It may be of the ball-secondary type, which gives variations through a range of ninety degrees, or of the cylinder-within-a-cylinder type, which gives a range of 180 degrees of inductance and is called 180-degree coupler.

Some variocouplers are constructed of cardboard tubing for the stator and have a wooden rotor; others are of dielectric material throughout and are well worth the additional money which they cost. Lattice-wound inductances, in which little or no supporting material is used for the wire, are perhaps the best of all. In any inductance, beware of excess of shellac used to hold the wire in place; and if you wind your own and feel that you must shellac the wire to keep it in place, use a colloidal shellac very sparingly.

Attention should also be given to the bracket of the coupler or means of fastening it to the panel or baseboard—for if this is poorly designed, this instrument may wobble about after the receiver has been completed.

The same consideration of materials holds true of variometers, molded or lattice type being preferable to those of wood. In both couplers and variometers, means must be provided for taking the current from the secondary coil, and this is accomplished either by "pigtail" connections or by brushes which act on the shafts. The pigtail or flexible wire connection is generally considered to be the better of the two, as it is said to provide more positive contact. The brush principle, however, permits the rotor being turned indefinitely in either direction without danger of breaking any wires. With either type, when wiring the set, connections should, if pos-

sible, be made from the rotor shaft which enters the dial to the ground or the filament circuit, to prevent hand-capacity effects.

Certain circuits now call for a split variometer, which means simply that rotor leads and stator leads are utilized independently. Obviously, any standard variometer can readily be separated and connected as a split variometer.

Thought the primaries of variocouplers are tapped and the stators of variometers are not tapped, certain firms have produced spherical molded variocouplers and variometers which are alike in external ap-

pearance. When so utilized, these instruments will reach the higher wave-lengths.

Pancake and honeycomb coils usually have lower internal or self-capacity than couplers and variometers and are therefore at times more efficient in bringing in the distant stations. They are, however, usually harder to adjust precisely when mounted in or on the set, unless they have some mechanism for operation by a dial.

Recently a number of "tuners" of various types have appeared on the market under various trade names, and for these great feats of distance-getting are claimed by their manufacturers. If they are better than the older types of inductances, the improvement can be attributed largely to the superior workmanship entering into them, particularly the winding of the wire, its gauge, insulation and the like.

Variable condensers are of three types—the so-called book type, the circular plate type and the mercury condenser. The book type has the advantage of low price, but it gives the least uniform variations of capacity. The circular plate type is the one most generally used, the mercury condenser having only recently been put on the market in any quantities. This latter would seem, however, to have marked advantages over the others.

In choosing a condenser of conventional design, one should observe first that its plates are of rugged construction; second, that it is smooth-running; and, third, that the movable plates are well insulated from the stationary ones.

Vernier condensers, or condensers capable of fine as well as coarse adjustment, will improve almost any radio receiver. The vernier adjustment is accomplished in one of two ways: Either by moving all the rotor plates through an exceedingly small space by means of reduction gears or wheels, or by the use of one or more supplementary plates whose position in relation to the stator may be changed. This latter method perhaps gives the finer adjustment in the hands of the average operator. Such verniers are also made as separate units, known as two or three plate and

midget vernier variable condensers. Electrical leakage in a condenser, as has been said, is most likely to occur at the point where the shaft of the rotor passes through the bushings or end pieces of the stator, and for this reason these should be heavy and of the best dielectric material. Dust between plates and plates bent so as to form contact with plates of the opposite element also destroy the efficiency of the condenser. The book type condenser consists of two leaves



MR. TONEY PETERS, manager of the Ashcroft, Young Manufacturing Company, of Clarendon, Ark., built a Grimes single-control inverse duplex set which exemplifies excellently the points brought out in these two articles by Mr. Loeb.

Mr. Peters has sent us photographs of his installation showing what a neat and complete job he made of it. Mr. Peters writes:

"The set is copied from *Radio in the Home* and is the Grimes Monotrol described by yourself in your magazine, I think last June, but I wore the issue out when building the set and then loaned it to another bug.

"There are a few novel features about the set that would interest you but are rather hard for me to explain here. You will note that the loop sets on top. It really goes through a large four-inch dial into a socket made up of cartridge fuse shells with the leads running down through the center to the brass ends of these shells. This fits into a socket in the set and three strong spring blades make contact with the strips on the plug. With this arrangement the loop may be turned around without twisting the wires and it has no exterior leads. Then you can lift the loop off the set and attach the coil shown in one of the photographs and attach a short aerial or a long aerial and ground as

(Continued on Page 27)

pearance, and these are most attractive when used together in any set. Miniature variocouplers and variometers are said to cover the same range of wave length as the larger type, and are handy to use in building portable receivers. In most circuits, couplers and variometers having sixty turns of wire each on stator and rotor are standard, though some variocouplers have a much higher number of turns on the stator, and some variometers are designed for coupling with a loading coil of addi-

(Continued on Page 27)



Bringing the World to the Farm

Left—George D. Hay (with locomotive whistle), announcer of the Sears-Roebuck Agricultural Broadcasting Station WLS. Ford Rush, studio artist and director of musical programs. Robert Northrop, assistant announcer. Below—Left, Samuel R. Guard, director of the Sears-Roebuck Agricultural Foundation, and to the right is Edgar L. Bill, director of the station

RADIO is the ideal companion on the farm. Nothing that the farmer can install in his home will prove of more value, both in actual dollars and in home comforts, than a good radio receiving set.

Several big broadcasting stations have recently been put into operation for the express purpose of supplying exactly the kind of information and entertainment that the farmer wants. I feel that this step is extremely valuable to the whole radio industry.

The farmer is rather hard to sell on anything new, but, once he has been sold, he is about the best customer there is to have upon your books. The farmer is slowly but surely being sold on radio.

Here is a story about the new Sears-Roebuck station, which is being operated primarily for farmers. There are perhaps a half a dozen other stations operated with the same end in view and we will take them up in later issues.

H. M. N.

By VERA BRADY SHIPMAN

FOR many years, Farmer Brown has ordered his cornbinder, and his wife has purchased her serge dress, sister's hats and brother's hobnailed shoes from the Middle West mail order house.

Everything from Christmas presents to portable houses may be had from within that great volume which comes semi-annually through the overloaded rural mail delivery—that farmer's Bible, as it has been facetiously called—the mail order catalogue.

With the coming of radio, the logical advance step of the advisory committee on farm needs was the opening of a broadcasting station in Chicago, the heart of the farming lands of America, under the auspices of the Sears-Roebuck Agricultural Foundation, a financial bloc which has been used in advancing to the farmer ideas of theory and practice. Samuel Guard is the business director of the Foundation and through his vision and that of Julius Rosenwald, president of the Sears-Roebuck Company, the radio station WLS became a reality.

WLS won its call letters from government assignment, which is translated into *World's Largest Store*. And then—the farmer's store began its daily programs



Left—Elizabeth Weirick, textile chemist of the Sears-Roebuck Agricultural Foundation, who is in charge of a course in textiles and clothing being conducted during the "Home Maker's Hour"



early in May with its direct appeal to the entire farm family.

WLS is a 500-watt station, Class B, operating on 345 meters. Curtis Peck is the operator in charge. Its main studio is atop the Sears-Roebuck building in the Chicago west-side factory district. A 130-foot aerial mast on one side of the roof is balanced by a fourteen-story tower on the other. The studio is on the eleventh floor and from here are broadcast talks of valuable farm information. From here, too, the afternoon home maker's hour is broadcast. Ellen Rose Dickey, head of the Food Advertising Department of Sears-Roebuck,

Elizabeth Weirick, textile chemist for the store and a former instructor of Pratt Institute, Brooklyn, and occasionally Katherine Blunt, of the Home Economics Department of the University of Chicago, give the farm woman constructive talks on food preparation, home economics, materials and how to buy them, and essentials of farm food and clothing production and manipulation.

This afternoon broadcast is timed for the busy farm wife whose rare leisure hours may fall between three and five in the afternoon, after the dinner dishes (the farm dinner is always noon) and before supper and the evening chores.

In this midafternoon hour, the farm housewife can sit down with her mending and adjust her headphones, or, if she be fortunate enough to have a good loud speaker, she can assemble a few neighbor friends for the afternoon radiocast from WLS. Over the radio she hears how to make over Stella's last summer's frock, she hears of a new pudding made of apples (which are plentiful on the farm) or a

To the right is a photograph of the operating room of Station WLS, while below is a view of a corner of the broadcasting studio on the eleventh floor of the Sears-Roebuck Company



Right—Mrs. Charles Sewell, of Otterbein, Indiana. Mrs. Sewell is the head of the woman's work of the Indiana Farm Bureau Federation

short talk on music or women's clubs. She hears a short review of Gene Stratton-Porter's new book, which may be had at the circulating library, and a recipe for softening the hands after Monday's washing. She learns, by listening, practical hints for making farm living better, and she listens in each day when she is able, and finds the habit growing into a part of the day's routine.

Daily farm news bulletins, as well as weather and stock reports, are a part of the regular day's program. At the noon hour, when the farmer is in from the field for dinner, he can tune in on WLS and get a practical talk by some farmer like himself



who tells over the radio how they keep books in Woodford county, how the Wisconsin Guernsey Association accomplished its last year's goal, or how to use that new tractor adjustment. Perhaps the editor of a farm journal may talk for a few minutes, or an instructor from the agricultural college will give a few pointers on the theory and practice of better animal husbandry. These talks are interspersed with music, generally popular, for the radio farm survey of Illinois recently showed that among the Illinois farmers who owned radio sets, the majority preferred popular music.

In the evening, at the Hotel Sherman, within Chicago's downtown loop, musical programs of all kinds are given by the reigning orchestras within the hotel dining-room, or vocal and instrumental soloists.

With the opening of WLS station, Edgar E. Bill, formerly publicity director of the Agricultural Foundation, became director. Equipped for this work by farm journal editorship, farm homestead filming and Holstein-Freisian Association publicity work, Mr. Bill entered the radio field with a knowledge of the farmer's viewpoint, better prepared to give the farmer what he actually could use.

And then along came George Hay and his famous hushpuckiny steamboat whistle, named for the Chickasaw Indian whistle made of sunflower stalk—the announcer whose toot was a familiar sound on the Memphis Commercial-Appeal programs—for a visit to Chicago (Continued on Page 32)

Levin's New Coil Makes a DX Portable

I KNOW of no radio experimenter more persistent than Moe Levin. Long ago he tackled the problem of developing a set that would get DX efficiently without an aerial and he has stuck at the job ever since.

I have published each development that he has made and the letters from readers have shown how popular these circuits have been. Then the other day, Mr. Levin walked into my office with this set, clipped it on to my desk telephone, turned on the rheostat—and we heard the music all over the room with only a single earphone unit lying face down on my desk.

There are several very original and unique features about this circuit. One is the way the third winding on the coil is used both as a tickler and as a radio frequency choke. The other is the way the detector positive B battery voltage goes both to plate and grid and is also tuned by the variable condenser. This is something I had not seen before.

I took this set out to Station 3XP and tested it pretty thoroughly. It's a good one. That's why I'm glad to publish it here.

H. M. N.

By MOE LEVIN

WELL, Radio Engineers, here I am again. Does that make your chest swell?

For every fan who builds his first set, admits that he is a Radio Engineer.

My previous circuits have proved so successful, that I am going to give you another one to try. This has the others beaten.

I have a date with Matilda and while I am waiting for her to come downstairs, I will tell you all about my new circuit.

The last time I waited for her I built a super-heterodyne, before she came down, but as she is almost ready now, I won't have much time.

Recently there has been a great demand for portable sets, and although a number of them have been published, they are all



Mr. Levin makes a neat and compact portable 3-tube set with only one control. Circle:—Here is the new Levin No-Rotor Coil with its three windings

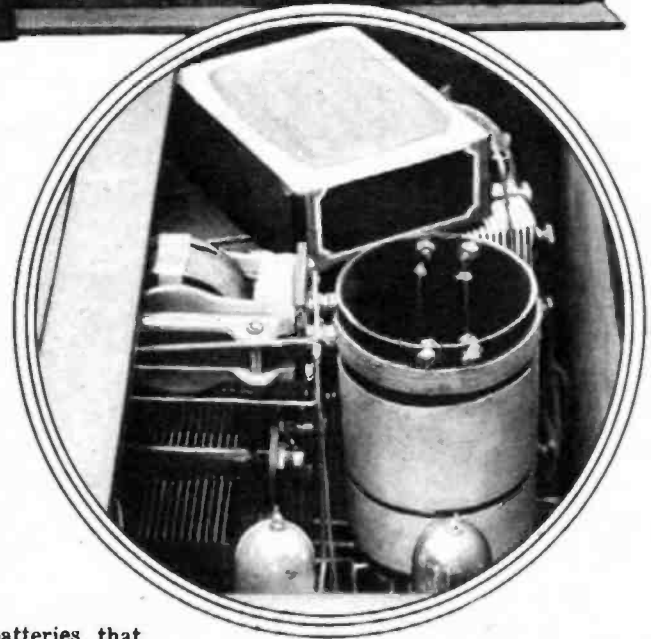

reflexes. As soon as the average fan sees a drawing of a reflex, he becomes shy and steers clear of it. It seems too complicated for him. Another drawback of reflexes is the crystal. There seems to be such difficulty in finding the sensitive spot.

Some time ago I asked one of my customers what his conception of a portable set was. He replied "A three-tube set, in a 7 x 14 cabinet, including A and B batteries, that could be carried about with a handle, that has one control and that could be used with a short aerial, but no ground. Something that I could take in my car when I go

out visiting." I looked at him and asked him if he knew any more jokes. With a shrug of his shoulders and a mocking smile, he made for the door. "Let me know when you get up something like it and I will buy it," he called back.

Oh! that made me so mad.

That night I told Matilda about it and she said, "Well, why don't you do it?"

That got me worse than mad; it got me good and sore, and when I'm sore, I do a lot of funny things, so I made up my mind that I would get even with them and do it.

Two months have elapsed. Result of experimenting: A 3-tube set in a 7 x 14 cabinet, including "A" and "B" batteries, has one control, is selective, does not depend on aerial and ground, can be used with short piece of wire for aerial and no ground or ground alone, and operates a loud speaker. Can be used in a car, using a short piece of wire under the car! Well, what do you think of those?

Now, don't crowd. Give me air and I will tell you all about it.

The heart of this circuit is the coil. I call it the "No-Rotor Coil," (Continued on Page 29)

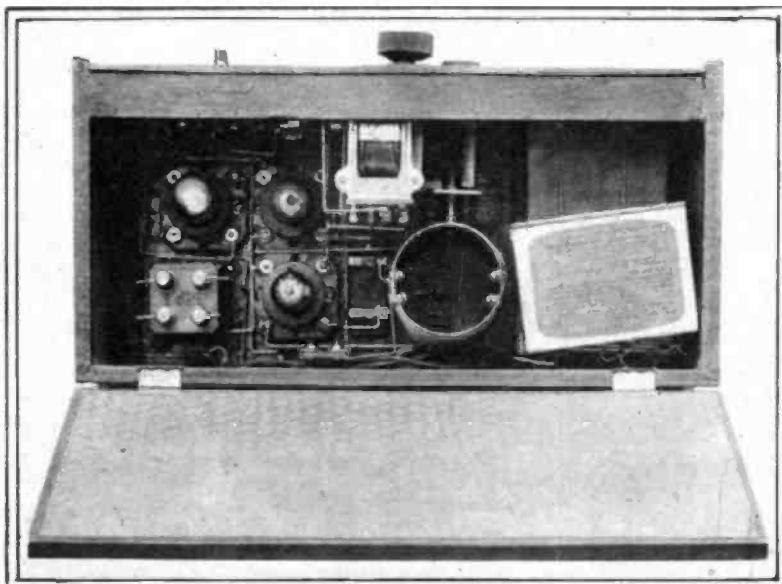

Looking straight down into the case, we see the placing of the batteries and the instruments



Radio Frequency *and* the Goodreau Split Variometer

By W. FRANCIS GOODREAU

TO MOST of the readers of this magazine, the Goodreau Split Variometer Circuit is well known. Many of you have built it, most of you have been very generous in your praise of it.

Soon after the publication of the article describing this receiver I began to receive letters from all over the United States and Canada. Letters asking questions of all kinds, some of which were answered in a personal letter and the rest in another article which appeared in a later issue of the magazine.

One of the questions most frequently asked was: "Can radio frequency be added to this receiver, and if so how?"

The answer has always been the same, namely, "At the present time there is no method by which radio frequency can be added to this circuit." The reason for this was that this circuit uses regeneration, and radio frequency amplification and regeneration do not get along well together.

However, in spite of the fact that nothing was accomplished, after many trials, in adding radio frequency to this set, I still continued to work on it, because the letters continued to come in, and also I desired to add radio frequency to this receiver for the satisfaction of doing it. You know how it is, I just hated to let this receiver get the best of me, and I was determined to add radio frequency to it or know the reason why.

Well, it's done, and so I am giving you the information on how to do it, and what results to expect when it's done.

You will need a few more parts for the set if you are going to use radio frequency, and you will also have to discard your split variometer and use in its place a variocoupler. I am sorry that this must be done, but because of the close coupling of

the rotor and stator on the variometer good results could not be had. With the variocoupler, however, it was quite different. This variocoupler *must* be of the 180-degree type, such as a Remler or Simplex.

For one stage radio and detector you will need the following parts:

- 1 Variocoupler.
- 1 Variable Condenser, cap. .0005 mf. (Vernier).
- 1 Acme Radio Transformer, type R2.
- 2 Sockets.
- Grid condenser, cap. .00025 mf. (Dubilier or Freshman or a "Grid-Denser," which is variable.)
- Daven grid leak, 2 megs.
- 2 Rheostats, one 6 ohm, one 30 ohm (Kellogg, Pacent or Carter).
- 1 Open circuit jack.
- 1 Potentiometer, 350 or 400 ohms. (Federal, Pacent, General Radio.)
- 1 Inductance switch (Marco back-mounted)
- 6 Binding posts (Eby).
- 1 Radion or Mahoganite panel baseboard.

Mount the parts on the panel in the following order, from left to right, looking at panel from front of set. First, the vario-

coupler, next tap switch, next variable condenser, next two rheostats. Sockets, radio transformer, grid condenser and leak, and binding posts may be mounted on baseboard. The potentiometer can be mounted near rheostats.

After all parts are mounted, the set is ready to be wired. In wiring this set proceed as follows:

Connect the taps on the primary of the variocoupler to the tap switch. Connect a wire from the antenna post to the tap on the coupler, which is connected to the top of the primary winding. This same wire is now connected to the stator plates on the variable condenser, and is also connected from the same plates on the condenser to the post marked G on the first tube socket.

The tap switch is connected to the rotary plates of the variable condenser, and from there a wire is connected to the center post of the potentiometer.

The potentiometer is connected across the A battery, that is, one of the outside connectors is connected to the positive A and the other outside connector to the negative A. A cut-out switch should be inserted in either one of these lines to open circuits when not in use. The rheostats of both tubes are connected in the negative filament leads.

One end of the rotor of the variocoupler is connected to the plate of the first tube, the other end is connected to the post on this transformer marked P. From the post on this transformer marked B, a wire is connected to the binding post marked B, 67½ volts positive.

From the post marked F minus on this transformer a wire is connected to the post marked F minus on the second or detector tube socket. From the post on

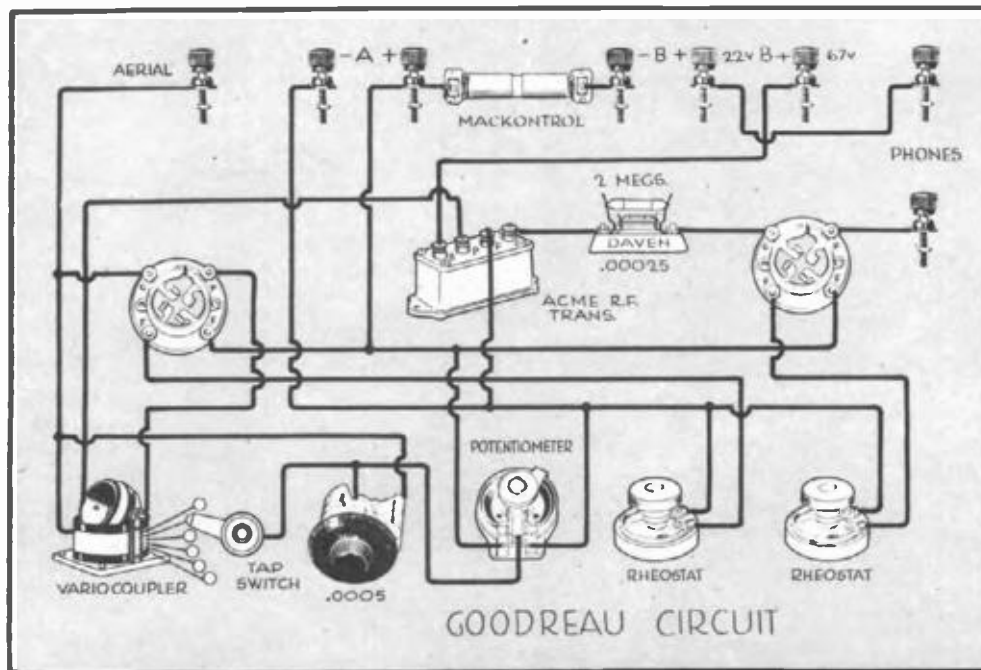

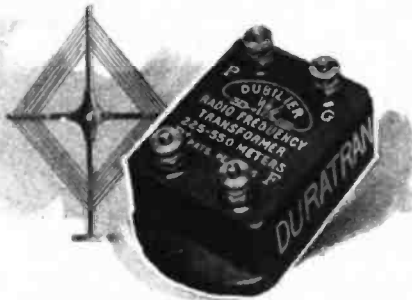

FREE BLUEPRINTS OF R. F. HOOK-UPS Ask your dealer for free blueprints of Duratran hook-ups. If he has none write for them to us and give us his name.

For Unrivalled Summer Reception— The Dubilier Duratran and a Loop

The indoor loop and one or two stages of Duratran radio-frequency amplification—the combination can't be beaten for summer reception.

You overcome DX summer reception obstacles.

The Duratran amplifies powerfully and uniformly over the entire band of broadcasting wave lengths. The Duratran dampens the longer static waves and amplifies the waves sent from the broadcasting station. Broadcast music and speech predominate over static.

Dubilier Condenser and Radio Corporation
46-48 West 4th Street New York

Brandes



More than 100,000 Table-Talkers were purchased in the first ninety days after production began.

Table-Talker \$10

this transformer marked G, a wire is connected to one side of the grid condenser and leak, and from the other side of the grid condenser and leak a wire is connected to the post on the detector tube socket marked G.

From the post on this socket marked P a wire is connected to the binding post marked B, 22½ volts.

From the binding post marked B minus a wire is connected to the posi-

with one tube and the distance range was increased somewhat. It was much sharper in tuning than the original, and should prove useful to those who are having trouble tuning out local stations.

I shall be glad to hear from all who build this receiver whether they are successful or not. Please address me in care of the editor of Radio in the Home.

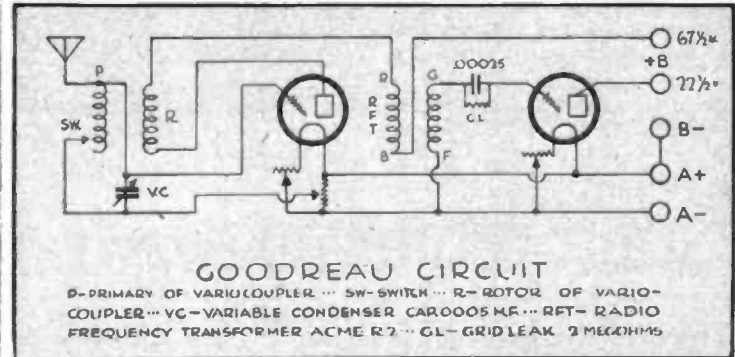

tive A battery post. It is wise to insert a Mackcontrol in this lead to protect the tubes. This is shown in the picture diagram. From the positive A battery post a wire is connected to the post on detector tube socket marked F plus, and from there it is connected to one side of potentiometer and from there to post on first tube socket marked F plus. This completes the wiring.

In tuning this set you will find very little difference. It tunes just about like the original, except that more care is required, and the addition of a tap switch. This switch is used for selective tuning and need not be varied unless you wish to do so. You will find it helpful in cutting out local stations.

Keep the rotor of the variocoupler at right angles to the stator when tuning and vary it but slightly. If you bring the rotor too close to the stator you will lose the station you are trying to tune in. Handle this control carefully. It is the only critical control on the set.

The potentiometer needs very little adjustment—just a slight turn once in a while.

If you are at present using the original circuit and are satisfied with it, I would advise that you leave it alone, and not tackle this unless you have had a little experience with radio frequency amplification. It is not suitable for the novice and this article was not intended for them, but is given in response to requests from many readers who have some experience with this type of amplification.

In tests with this receiver it was found that signals were louder than

Trouble Shooting in the Grime's 3XP

(Continued From Page 19)

paratus. To overcome the effect of long battery leads, a .005 mf. condenser should be placed across the negative B and the 90-volt binding posts at the set. To reduce the feedback oscillation tendency in closely mounted equipment, reduce the number of turns on the primary windings of the tuned radio transformers. The last remedy is least desirable but is sometimes necessary.

The trouble may also appear if you have the windings of one of your radio frequency transformer coils in too close coupling with the windings of an audio frequency transformer.

There are other ways to recognize the "air hammer" noises than by their mere sound. To make certain that the noise is really a radio oscillation and is to be treated accordingly, remove the antenna wire from the set. The "air hammer" noise should then occur at certain settings of the tuning condensers and only at those settings.

Audio Howl—Audio howl is often experienced in an audio frequency amplifier, especially if the amplifier has three stages of amplification. The 3XP Inverse Duplex has three audio stages. The greatest tendency toward audio howl comes from the feed-back between the audio transformers or in the B battery circuit.

To prevent audio feed-back between the transformers, care should be exercised in placing them at right angles to each other, mounting their

(Continued on Page 34)

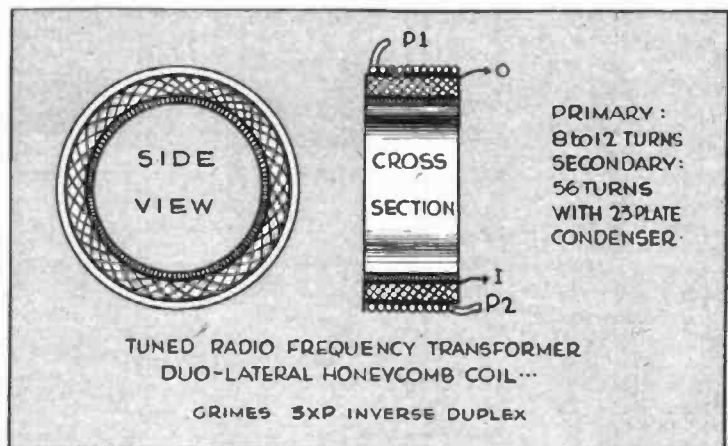

A Fine, Complete Home-Built Set

(Continued From Page 21)

you prefer. The B batteries are all in the bottom; the A battery is directly behind the set and the Balkite charger is inside the window seat with the connection through the lid.

"We have had from WGY to KFI on the loud speaker using the loop—loud enough to hear all over the room—and it is a rather large room. I use a Bradleystat on the detector tube, making it silent in operation. I use a VT2 tube on the first stage and you cannot make it howl. I use 135 volts on the amplifier with four volts C battery bias and the rheostat in the negative lead also.

"This is the most sensitive set that I have tried and has more real power than any of them. I can take it in between the back and front seat of a Lissy, plug the A lead into the dash light and set the loop on it and can hear WBAP announce for four blocks and understand every word.

"I am sending these photographs to you mainly that you may have the satisfaction of knowing that you have one set built in Arkansas by your plans; that is more than the builder

Factory Refinement in Home-Built Sets

(Continued From Page 21)

opening like the letter V, capacity between their metal inner faces being reduced or increased as the leaves are spread apart or brought together by a cam. Capacity of the mercury condenser is varied by the action of mica plates in passing through a trough of mercury. Thus in this type, the area of the plate themselves is varied.

Like condensers, rheostats are either coarse or vernier, and are ordinarily of two types—wire resistance and carbon resistance. The vernier adjustment of a wire rheostat generally consists of a small additional length of wire whose resistance may be introduced into the circuit in whole or in part, much as the capacity of additional plates is introduced into a vernier condenser. Carbon rheostats usually give micrometer adjustment due to the very nature of their design.

The principal desideratum in a rheostat is that it shall run smoothly, increasing or decreasing the voltage by imperceptible steps.

While vernier rheostat adjustment is an advantage in most circuits, in others it is of no material advantage,

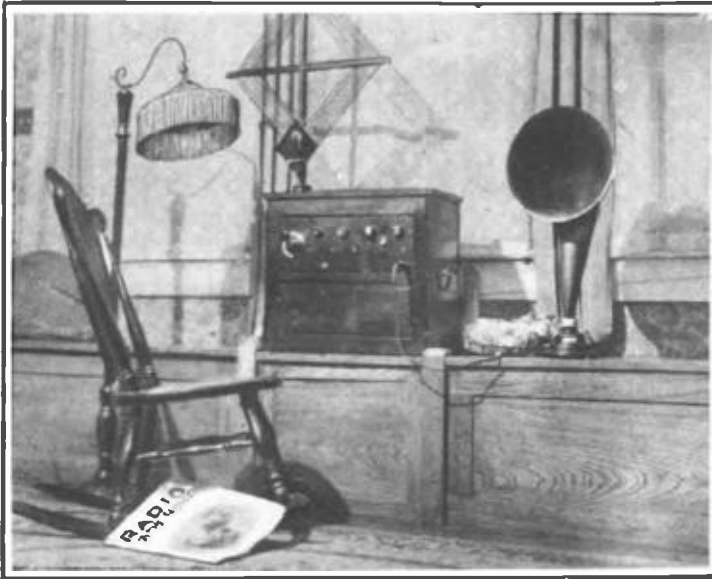

The loop fits in a' jack in the lid

ever expected it to be. I built the first Grimes that you described and never got a murmur, but I can look back and see the assortment of parts I used and am not at all surprised, and I think that the best step taken this year in radio design is your method of naming the parts used, regardless of their advertising connections.

"In my set I used an Acme variable condenser, Acme radio transformers, Kellogg audio transformers, Carter jacks, Na-Ald sockets and Dubilier fixed condensers, and the combination is hard to beat.

"The cabinet is solid walnut built from an old table top.

"The loop is barely twenty inches on the side and is wound from common bell wire and tapped every turn to a Carter inductance switch, making a very desirable volume control, especially on the loud stations.

"In closing, I wish to express my thanks to you for your magazine and to Mr. Grimes for the system and assure you that you have brought happiness to several family groups many, many nights through the medium of the inverse duplex."

and in such circuits a fixed resistance or a ballast for the tube will serve, thus eliminating one control. This is particularly true where amplifier tubes are used as detectors, as these tubes are not as critical of filament adjustment as the soft ones. Rheostats should always be inserted in the proper A battery lead, as shown in the directions accompanying various makes of tubes.

The grid resistance, or grid leak, also is sometimes made variable through the introduction of more or less graphite or carbon into its circuit, or by a choice of cartridges of various known fixed resistance values, which may be clipped into special containers. The pencil-mark type of grid resistance should be avoided as inaccurate. To determine whether to use a fixed or a variable grid resistance, one should consult the instructions from which he is building his set, although variable grid resistances are always desirable.

In certain circuits, small resistances are also used as impedances, and these resistances, usually made of lavite, should be purchased in the ohmage specified.

It may be said here that howling,

Improve your set with an ACME "lowest loss" condenser

Because of low losses and sharp tuning practically all the currents on the antenna can now be used.

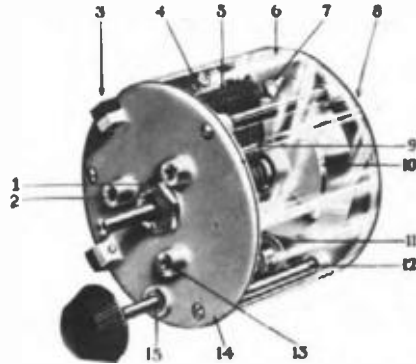

Which one is your tuning circuit —the hump or the peak?

HERE are the curves of two tuning circuits. The hump has a high loss condenser and the peak a low loss condenser. Both receive broad-casting, but the peak receives local and distant stations without interference, while the hump receives only the nearby stations with interference. The new Acme Condenser will change your tuning circuit from a hump to a peak.

The Acme engineers have been working for two years to bring out a condenser which would give to Radio experimenters sharp tuning and minimum losses. The new Acme Condenser has these fundamental advantages and also has many new improvements in structure and equipment. See the illustration with explanation, and, for more information, write to us for booklet—"Amplification Without Distortion," which contains many diagrams and helpful hints on how to build and get the most out of a set.

ACME APPARATUS COMPANY

Dept. 137

Cambridge, Mass.

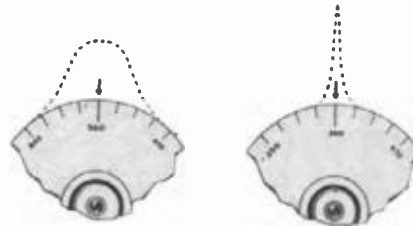

- 1—Steel-brass cone bearings adjustable.
- 2—Lock nut for bearing.
- 3—Highest grade hard rubber Dielectric in that part of the field to prevent losses.
- 4—Brass separator to which both rotary and stationary plates are soldered, making continuous circuit for each.
- 5—Brass silver-plated plates; rotary plates log-arithmetic.
- 6—Dustproof covering.
- 7—Stops at extreme end of movements.
- 8—Coiled connection between shaft and heads allowing lubrication of bearings.
- 9—Brass separator, to which both rotary and stationary plates are soldered, making continuous circuit for each.
- 10—Counterweight which balances rotary plates.

- 11—Noiseless friction Vernier control, seven to one ratio.
- 12—Brass separators to prevent twisting and to take strain off Dielectric.
- 13—Panel mounting holds for 120 degree spacing.
- 14—Metal heads.
- 15—Steel bushing to prevent wear on Vernier shaft. ALL parts are non-rusting metal, except steel bearing, which is covered with nickel-plated protective surface. End plate capacity is .000016 m.f., full capacity is .0005 m.f. Price \$6.50.

Cut out and send this coupon

ACME APPARATUS COMPANY
Dept. 137, Cambridge, Mass., U. S. A.
Gentlemen: I am enclosing 16 cents (U. S. stamps or coin) for a copy of your book, "Amplification without Distortion."
Name
Street
City State

ACME ~for amplification



UNIFORM CROSS SECTION OF THE NA-ALD DE LUXE SOCKET



Look for the socket board

In leading radio stores you will find the Na-ald Socket Board, displaying the five standard Na-ald Sockets: For the 200 and 201 tubes, the De Luxe at 75c, and also the Small Space at 35c; For the UV-199, No. 499 at 50c and adapter at 75c; For WD-11, No. 411 at 75c. Ask your dealer to show you the self-cleaning arrangement of contacts in Na-ald De Luxe, No. 400. These dual-pressure contact strips cut into the sides of tube terminals, keeping their surface clean and bright, and resulting in perfect contact.

These sockets have the highest dielectric properties, obtained by the thorough cure of the Bakelite used, and made possible by uniform cross-section.

There can be no noisy circuits due to poor contact with these sockets in use.

New retrospective booklet "What to Build," now packed with each Na-ald product. If your dealer's stock doesn't have this booklet, send cover of Na-ald carton or life for it.

SPECIAL DIPPED BRIGHT PHOSPHOR BRONZE CLIPS, LAMINATED AND EXERTING DUAL-WIPE PRESSURE.

THIS ILLUSTRATION SHOWS HOW THE CONTACT STRIPS CAN BE MADE TO CLEAN TUBE TERMINALS AUTOMATICALLY BY ROTATING TUBE SEVERAL TIMES.

NA-ALD

ALDEN MANUFACTURING CO.
DEPARTMENT T SPRINGFIELD, MASS.

"whistling and other freak operation of the receiver will be reduced to a minimum if all grid-regulating instruments are placed as far back from the panel as is practical, and if the grid lead is kept as short as possible. For this latter reason, the grid condenser and leak in factory-made apparatus are usually mounted directly on the grid terminal of the socket, and the whole set is planned so as to make the other lead short.

Another resistance unit is the potentiometer, used in some circuits to bias the grid voltage of the tube. Like a rheostat, the potentiometer may be of either the wire or the carbon-resistance type, and is offered to the public by at least one manufacturer combined with the rheostat into a single instrument. When a potentiometer is introduced into a set, some form of cut-out switch or current breaker should always be employed, otherwise the potentiometer will slowly drain the A battery when the receiver is not in use.

In circuits utilizing a tapped coil, a switch and set of taps to regulate the inductance is necessary. The writer strongly favors the type made as a unit for mounting behind the panel, as this is likely to give better contact than the home-made assembly, and also necessitates drilling only one hole in the panel. In one factory-made receiver, selection is accomplished by a metal finger or brush bearing upon the desired sector of a commutator. This would seem to be an ideal arrangement where space is at a premium.

In all tapped coils, one should avoid excess turns and taps, because of the "dead-end losses" which occur in them; in fact, the trend of modern designing is toward "aperiodic" tuners—that is, a coil of a fixed number of turns in the neighborhood of thirty-five or fifty, in which the filtering capacity is "varb" by means of a variable condenser shunted across it.

In all these variable instruments, the diameter and the length of the shafts should be carefully noted, so that there will be no difficulty about fitting the dials to them when the receiver is assembled.

Phone jacks should be examined for good contacts, as more trouble is likely to arise in these instruments than the average amateur suspects. Particularly is this true of filament-control jacks, because of the current passing through their electrodes. Phone jacks also introduce capacity into a set, so their relation to other instruments should be considered.

Binding posts also can cause much annoyance if they do not grip the wires readily and hold them securely. When the receiver is built, the clamping element of the post should be drawn up very tightly on its screw, so that the whole unit will not turn when the thumb-screw is tightened. Terminals which are engraved are worth the few cents additional which they cost. Always use binding posts with insulated caps.

Taking up last the instruments which do not have moving parts, we shall consider fixed condensers, radio and audio frequency transformers and wire of various kinds.

Fixed condensers ordinarily employ either waxed paper or mica as an insulating medium, the mica being far

preferable because of its greater dielectric strength, and also because the capacity is more likely to be as rated in these slightly higher priced units.

Fixed condensers, before introduction into the receiver, should be tested by short-circuiting them across a battery. If a spark occurs when this is done, the condenser is obviously defective. Excessive heat from a soldering iron or an excess of flux will also ruin a condenser, and some of the paper condensers deteriorate with age.

In some circuits a so-called "built-up" condenser, or other means of varying the capacity of a fixed condenser until just the right point is found, is an advantage. Neutralizing condensers employed in the Neutrodyne circuit must be variable, and a variable grid condenser is coming to be considered an adjunct to any set.

Several commercial manufacturers have cleverly introduced into their receivers a fixed condenser to be used if desired in series with the tuning (variable) condenser where a short antenna is employed. This condenser is so wired as to be thrown into or out of the circuit, two binding posts marked Antenna being found on such receivers.

An inherent feature of fixed radio frequency transformers is that they can operate only over a limited band of wave lengths, and in purchasing them, the home worker should note their ratings and be governed accordingly. Virtually all radio frequency transformers have, however, a peak efficiency at certain frequencies.

Similarly audio frequency transformers usually have a definite range of pitch, and some of the poorer ones will be found to distort high and low notes. The new push-pull audio transformer undoubtedly gives clearest reception, but it necessitates the use of two transformers and two tubes for each stage of amplification.

It is well known that audio frequency transformers should be mounted at right angles to each other and as far apart as possible to avoid howling and various other troubles in reception, and it is a good plan to "ground" their cores. Radio frequency transformers also should be spaced as far apart as possible, particularly the so-called air-core type, when at least six inches of space should separate the units.

Wire for coils and inductances of all kinds may be had either in enameled insulation, single cotton or silk covered, or double cotton or silk covered. As a general rule, the wire specified in the diagram from which the builder is working should be used, but it may be mentioned that enameled wire, unless carefully handled, is liable to chip and give rise to short-circuiting.

Wire also comes in various gauges or thicknesses, and these are generally specified in the diagram. Where the gauge is not specified, No. 22 double cotton-covered wire may be considered average. Wire that is too heavy may give rise to undesirable "skin" or capacitative effects, and wire that is too fine may introduce unwanted resistances into the circuit.

Litzendraht or "litz" wire consists

(Continued on Page 30)



The New All-American Long-Wave Radio Frequency Transformer, \$6

The MASTERPIECE of Amplification

for Super-Heterodyne, Ultradyns and all radio frequency and reflex circuits

Facts you should know about this new All-American and why it leads: (1) Highest amplification, without distortion, of any transformer on the market; for wave lengths 4,000 to 20,000 meters. (2) Quiet in operation; shielded to prevent inter-stage coupling or reaction. (3) Stable; free from any tendency to oscillate. (4) Windings specially designed to eliminate capacity; properly treated to exclude humidity. (5) Every transformer "circuit-tested" for accuracy and precision to insure uniformity and highest efficiency. (6) The best long-wave transformer that can be made. Fully guaranteed. All the better dealers recommend the All-American. Built by pioneers in the industry: Rauland Mfg. Co., 2666 Coyne St., Chicago.

ALL-AMERICAN

AMPLIFYING TRANSFORMERS

Largest Selling Transformers in the World



Levin's New Coil Makes DX Portable

(Continued From Page 24)

because it does not require a rotor for a tickler, thereby eliminating one control and making it easier to build. This can be made as a one or three tube set. I will give the specifications of the three-tube set. Parts required are:

- 10 ft. No. 18 D. C. C. wire.
- ¼ lb. No. 22 D. C. C. wire.
- 35 ft. No. 10-38 Litz wire.
- 1 pc. fiber tubing, 2½ inches diameter by 4½ inches long.
- 1 23-plate variable condenser with vernier. (I suggest the new Pearico condenser.)
- 1 Variable grid leak and condenser, .00025.

long distant stations, as well as sets employing three and four controls. On ground alone connected to post I I have heard stations several hundred miles away.

It is very simple to tune. Turn detector rheostat on nearly full, then turn condenser dial until a sharp whistle is heard. This is the signal of a station. If the signal is being interfered with by the whistle, slowly turn down the rheostat until the whistle disappears.

That's all there is; there ain't no more! Very simple. Even Matilda can work it.

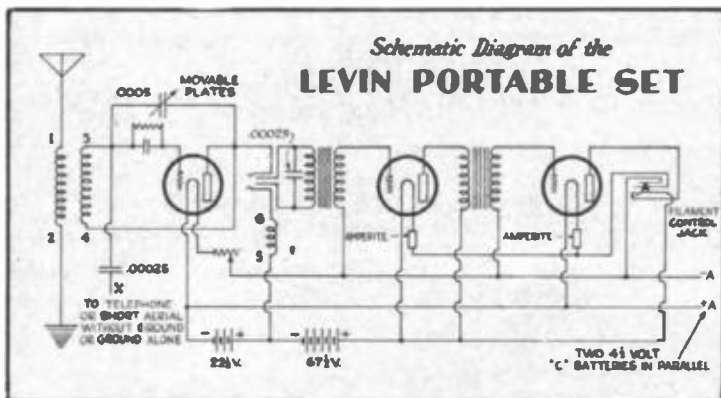

- 3 UV199 sockets (rubber base).
- 1 30-ohm rheostat.
- 2 Amperites for UV199 tubes.
- 2 3YQ audio frequency transformers.
- 2 .00025 Micadon fixed condensers.
- 1 Double circuit jack.
- 1 Single filament control jack.
- 2 4½-volt C batteries (connected in parallel).
- 4 Small 22½-volt B batteries.
- 3 UV199 tubes or C299.

In wiring this circuit the most important thing is to get the radio frequency coil (No. 3) connections right. If the tube does not oscillate, reverse the connections.

A word about this coil. This is not a tickler coil, but the third winding acts as a choke coil, and is to eliminate any radio frequency current from passing that circuit, which is part of the audio frequency connection.

Be sure and connect the rotary plates of the variable condenser to this coil.

As to the parts, I strongly advise using absolutely the best. The better the parts, the better the results. Another important part is the variable condenser. Be sure it is a good one and of the low loss type. Though there are several on the market, I have chosen the new type Pearico "Low Loss" condenser, as it has some novel features which others lack. This does not mean that the circuit will not function with any other condenser. It will.

The transformers should also be standard makes. Use a 5 to 1 ratio in the first step and a 3 to 1 ratio in the second step.

The grid leak should be variable, and should be adjusted for best results.

The amperites I am using to replace the rheostats, which enables me to make the set more compact. A filament control jack is necessary when using amperites, as when the plug is inserted in the jack it lights the tubes. A rheostat must be used for the detector tube.

This set when properly constructed, using aerial and ground, will bring in

For those who do not wish to make a portable set, I would advise using UV200 tube for detector and UV201-A tubes for amplifiers with rheostats in place of the amperites.

Better results can be obtained with storage battery tubes than with the low voltage tubes. This holds true, regardless of the circuit you use.

In case the set oscillates too freely, reduce the detector plate voltage, or else remove the .00025 fixed condenser across the first transformer.

Should you want to use this as a portable set and just use the telephone as your aerial, simply connect

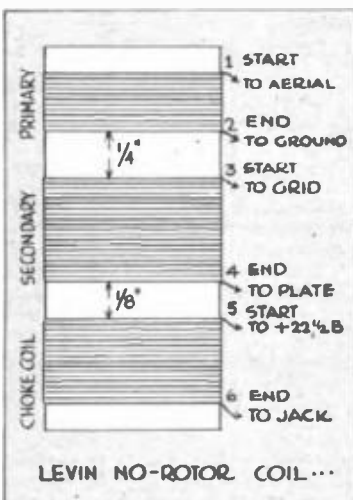

a piece of wire from post X with a fixed .00025 condenser in series, and with a large clip on the other end, clip it on to the large metal screw of the telephone. No ground is necessary. Try it. You will be surprised.

Use the same post, minus the .00025 condenser, should you want to

Beauty and Modern Performance in the Goldcrest Clear-O-Dyne

\$75

Buys a 4-tube set.



Selective and Non Critical. Logable Loud Speaker Volume.

Narrow selectivity, easy non-critical tuning, loud speaker volume and perfect distortionless tone, are yours in the Goldcrest Clear-O-Dyne. It is a non-reradiating set, and it logs accurately.

Tuned and balanced radio frequency amplification; high-grade parts made complete in the Cleartone plant; competent design and the most rigidly tested production are responsible for this unsurpassed modern performance.

At \$75, Model 70 Goldcrest Clear-O-Dyne is an astonishing value—how great you will appreciate only when you have seen the etched gold-finished panel and the solid mahogany cabinets. It harmonizes with the most luxuriously furnished home.

Write now for literature on Cleartone sets including the beautiful cabinet console models.

Dealers and Jobbers: Test Cleartone yourself and let it tell you how well it will sell. Send for sample and details of our proposition.

Model 60.....\$60.00	Model 71.....\$90.00
Model 61.....75.00	Model 72.....135.00
Model 62.....120.00	Model 80.....120.00
Model 70.....75.00	Model 82.....190.00

THE CLEAR-TONE RADIO COMPANY, Cincinnati, O.



Get a "close-up" of the radio stage with Murdock's HEADPHONES

are your ticket to the Theatre of the Air. If you make a poor selection, you'll find yourself in the rear row of the balcony, straining to catch the fun on the radio stage. Voices and music sound "over the hill and far away."

Plug in a pair of Murdock Radio Phones—and note the difference. It's just like being in fifth row center. High and low notes, loud and soft tones—come in round, mellow and true.

Get a pair of Murdock's today. The new improved flat headband permits you to wear them for hours without discomfort. They are fully guaranteed.

WM. J. MURDOCK CO.,
356 Washington Ave., Chelsea, Mass.
Branch Offices: Chicago and San Francisco

MURDOCK
RADIO PHONES
Standard since 1904

WM. J. MURDOCK CO.,
356 Washington Ave., Chelsea,
Mass.
Gentlemen: Please send me, without obligation, your free booklet, "The Ears of Radio."

Name

Address

THOROPHONE

TRADE MARK REG. U.S. PAT. OFFICE

Makes Distant Stations
LOUDER



High Power Type Model S-5 \$45.00

"The THOROPHONE'S capacity to amplify makes it possible to bring in on the loud speaker distant stations that would otherwise have to be received on the head set," says W. D. Lest, Chicago, Ill.

The THOROPHONE uses a powerful solenoid, whose intense force is added to that of the signals, giving maximum volume of tone.

Second only to the THOROPHONE is the new THOROLA, just introduced to meet the demand for an instrument which does not require a storage battery, but which is built with the same precision as the THOROPHONE. Here you have the same controlled mica diaphragm which gives the finest possible shadings of tone.

Due to the exclusive method of adjustment found only on the THOROLA, together with the Double Push and Pull Principle of amplification, this instrument will reproduce at highest volumes with the same accurate fidelity as at lowest volumes.

Thorola Three, 12-inch bell horn, \$20
Thorola Four, 14½-inch bell horn, \$25

Ask your dealer about THOROPHONE and THOROLA—each the best of its type—or write for booklet.

WINKLER-REICHMANN CO.
1725 West 74th Street Chicago, Ill.

EVERY RADIO FAN SHOULD HAVE THIS BOOKLET



PRICE 15c

Daven Radio Corp.

"Resistor Specialists"
9-11 Campbell Street
Newark, N. J.

use just a short piece of wire (about 20 feet) for an aerial.

In using the set with this kind of aerial, do not expect too much. That is, do not expect to get distance, and as much volume as you would with aerial and ground. It can't ever be did!

Using the set as I described will prove invaluable to those wishing for such a set.

When I go visiting, I carry this set with me and as there is a telephone in most any house, I simply clip it on to the phone and we have a concert.

Great sport, I call it! Now, to make the coil. Read carefully and follow all details.

Take a piece of tubing. The best to use would be bakelite, hard rubber or good fiber. Do not use any shellac. The dimensions are 2½ inches diameter and 4½ inches long.

Start at the extreme top and wind 9 turns of No. 18 D. C. C. wire and bring both ends to top of coil. This is the primary.

Next wind the secondary. Start

specified in the instructions for the circuit being built. There is usually, however, a gain to be had in using good dielectric material for the form on which the wire is wound, and, as has been said before, to eschew shellac or use it sparingly.

Tinned copper wire, known as bus wire, is generally utilized for wiring the set or connecting the various instruments. Its principal advantage over ordinary copper wire is the ease with which it may be soldered and its rigidity. Whether the bus wire shall be round or square is a matter of personal preference, as is also the use of the non-use of spaghetti tubing for insulating.

Spaghetti is convenient where wires are in proximity to one another and in danger of touching; it does not, however, insulate the wires in any degree against capacitative or electro-magnetic effects.

Recently there has come on the market an insulated wire called Acme Celatsite which makes a good job. The insulation is in various colors



The binding posts come through a slit in the back and around them is wrapped the flexible wire with its clip for quick connection to telephones, bedspring, electric light fixture or wire fence

one-quarter inch from primary and wind on 61 turns of No. 22 D. C. C. wire in same direction.

Now comes the choke coil. Start this next to secondary and also separate by one-eighth inch. Wind on 39 turns of No. 10-38 Litz wire. Bring the ends of the secondary and choke coil to the bottom of the coil.

Study diagram carefully before wiring. This set will tune from about 200 meters to over 600 meters.

Don't forget to reverse the leads of the choke coil if the set does not work properly.

Here comes Matilda now, so I am compelled to sign off. Station MOE signing off. I shall be pleased to answer all questions. Just send them to me in care of Radio in the Home.

Factory Refinement in Home-Built Sets

(Continued From Page 25)

of a number of very fine strands braided and insulated from each other, and is highly efficient in certain circuits. There is no advantage to be gained in using it, however, in the average inductance coil.

Likewise in winding a coil no advantage will ordinarily be found in bank winding, lattice winding or other special forms, unless these are

and a distinctive color can be used for positive leads, negative leads and different circuits. This makes it easy to trace wires in case trouble develops.

As a general rule, it is well to make all wires as short as possible, bend them where necessary at slightly rounded angles, avoid running them parallel, and solder all connections.

Soldering is not so difficult as many persons imagine, particularly if a soft solder is used. "Soft" is not meant to imply the kind of solder that is melted with a match—which is very likely to cause trouble—as is also soldering with an iron barely hot enough to make the joint. In soldering, a minimum of flux should be used, and after the connection is made all trace of excess flux should be scrupulously cleaned away with alcohol applied with an old tooth brush. Flux is both corrosive and electrically conductive.

If these suggestions enable the reader to build a set which equals similar receivers made in a factory, they will have served their purpose well. Indeed, the home worker has an advantage over the average commercial institution, for the manufacturer is hedged about by patent limitations and the necessity for economy which quantity-production necessitates—considerations which need not trouble the man who "builds his own."

The "Levin No-Rotor Coil" and Pearlco Low-Loss Condenser

Used in the new Levin circuit.

Read about it in this issue.

We carry complete parts for this circuit.

All information answered personally by Mr. Moe Levin.

Levin No-Rotor Coil... \$3.00

Pearlco Low Loss Condenser .0005 mfd... \$5.00

Special Prices to Dealers

We are sole distributors

SPIRO BROS.

218 No. 13th St., Phila., Pa.

RATHBUN

(SINGLE-HOLE MOUNTING)
SUPERIOR CONDENSERS

"Extremely Low Losses"

Tests by "Lefax" and other recognized laboratories report losses in Rathbun Condensers "negligible." Mechanically and electrically as perfect as fine engineering can make them. See these Rathbun "points of superiority"—single hole mounting, self-wiping contacts, anchored stator plates, non-magnetic materials and other advantages.

PRICES

Plain Types	
3 Plate Vernier, .00003\$1.00
11 Plate Variable, .0002 3.00
13 Plate Variable, .00025 3.00
16 Plate Variable, .0003 3.25
23 Plate Variable, .0005 3.50
43 Plate Variable, .001 4.50

Combination—Vernier Types	
3-11 Vernier Variable\$4.50
3-23 Vernier Variable 8.00
3-43 Vernier Variable 6.00

Combination Types include Knob and Dial

RATHBUN MFG. CO., Inc.
Jamestown, N. Y.

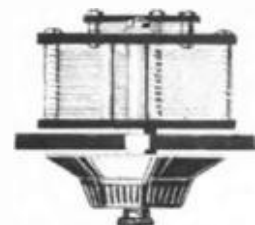

Tube Testing Outfit as Used in "Radio in the Home" Laboratory

By HENRY M. NEELY

THIS outfit is shown with jacks instead of measuring instruments because in this way only two instruments are necessary, whereas, if permanently hooked up, an expensive instrument would be necessary in place of each jack.

The two necessary instruments are a good direct current milliammeter reading up to about twenty milliamperes with fractional or decimal divisions of the milliampere if possible and a Weston type 489 direct current voltmeter reading up to 7½ volts on the low side and 150 volts on the high side.

Weston plugs should be used so that the polarity of wires from the instruments can be easily changed. The Federal rheostat shown here is the one with three windings so that it can be used with any type of tube.

The 200-ohm potentiometer shown in the positive B battery circuit is merely for an exact adjustment of the B battery.

The C battery may be a 45-volt B battery, with the 22½-volt tap connected to the middle binding post as a neutral connection, or else two or more ordinary C batteries may be used, so that there shall be from 7 to 10 volts or even more on each side of the neutral C battery binding post.

The method of procedure is as follows:

Set the A battery switch tap on the correct contact point to get the proper filament voltage for the particular type of tube to be tested. Insert the tube in the socket. Plug in the low reading side of the voltmeter to the jack marked "Filament Voltage" and adjust the rheostat for the correct voltage for the particular tube. For the 11 or 12 tube this will be 1.1 volt; for the 199 or 299 it will be 3 volts, and for the 200 or 300 or the A tubes it will be 5 volts. Remove the voltmeter plug once it has been set.

Set the arm of the C battery potentiometer at about the center and then adjust the B battery voltage by plugging the high reading side of the Weston voltmeter into the jack marked "Plate Voltage." Vary the positive B bat-

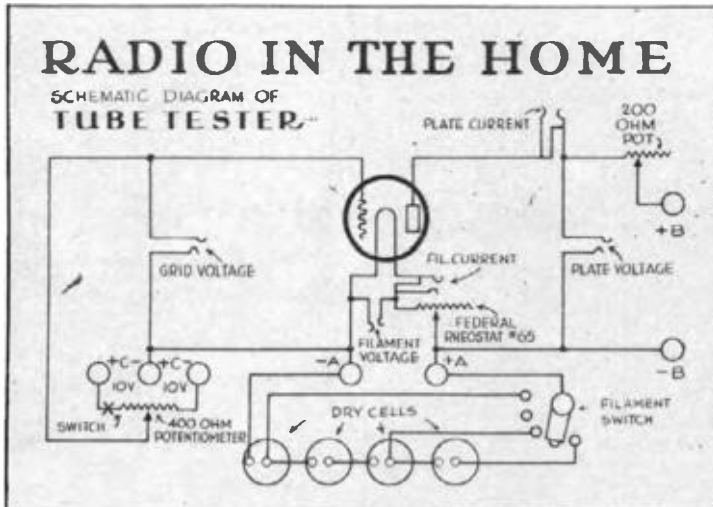

tery tap to get a rough adjustment and then use the 200-ohm potentiometer to get an exact adjustment. For the 11 or 12 tubes, use 45 volts of B battery, for the 199 or 299 use 60 volts, for the 200 or 300 use from 18 to 22 and for the A tubes use 90 volts of B battery.

Insert the plug of the milliammeter in the closed circuit jack marked "Plate Current" and leave it there during the entire operation.

With the A and B battery voltages correctly set, swing the arm of the C battery potentiometer all the way over to the negative side. Insert the plug of the low reading side of the voltmeter into the open jack marked "Grid Voltage," being careful to reverse the terminals in the plug, because you will now be reading a negative voltage.

It is always wise when inserting any of the plugs of these instruments to do it very quickly with a light touch in order to see that the needle does not fly backward. If it does fly backward, the terminals should be reversed.

Adjust the arm of the potentiometer until the grid voltage reads 7 volts; then remove the voltmeter from the grid voltage jack and take a reading on the plate current milliammeter. A dot should be placed on the graph paper, as explained in our Radio Kindergarten in the June issue. With this reading taken, once more insert the plug in the grid voltage jack and move the potentiometer arm over towards the positive side until there is one volt change. In other words, if you take the first reading at minus 7 volts grid potential, the next one should be taken at minus 6, the next at minus 5, the next at minus 4 and so on, a reading being taken from the plate milliammeter at every point of grid voltage. Always remove the grid voltmeter plug from the jack before taking a reading on the milliammeter, as you will find that the milliammeter will be different with the plug in the jack.

Readings are thus taken all the way up from the negative through zero (and here you must once more reverse the wire tips in the plug) up to maximum positive on the C battery. You will find that the series of dots which you make on the graph paper will make a fairly smooth curve as shown in our Radio Kindergarten. We refer you to the May and June issues of the Radio Kindergarten for a full explanation of the correct reading for various tubes.

It is rather difficult to get a good curve from the UV200 or the C300 tubes because, as every one knows, these tubes are inclined to be "spotty"—that is, there is just one point on the

(Continued on Page 32)

Bristol Single Control Radio Receiving Set, together with Bristol Senior Audiophone Loud Speaker as used in one of the Finer Homes.



Radio Reception Simplified to Single Control Dial

IT IS AN easy matter for any member of the family to operate a set like this. A good illustration of the absolute simplicity of

BRISTOL SINGLE CONTROL RADIO RECEIVER

Using Grimes Inverse Duplex System (Patents Pending)



is the fact that a set is installed in the home of a blind woman who operates it herself and is able to bring in station after station at her will.

Powerful enough to get long distance reception. It is a four-tube set using Grimes Inverse Duplex System, which makes it equal to six tubes because the first two tubes are utilized for both Radio and Audio Amplification.

Non Reradiating—will not disturb your neighbor's reception when you tune in.

Many refinements, including panel with telephone jacks on back of the case for making connections.

Used with Aerial or loop, and in some locations short Inside Antenna will give good results. When Aerial and Loop are both provided it is only necessary to operate a lever to change from one to the other.

The case is solid mahogany finish with walnut stain. It is handsome in appearance, and at the same time provides a rugged protection for the working parts.

Price of Bristol Single Control Radio Receiver without accessories \$190.00.

BRISTOL TRADE MARK AUDIOPHONE REG. U. S. PAT. OFFICE LOUD SPEAKERS

made in three models. Senior \$30.00, Junior \$22.50, Baby \$12.50.

The most recent development in these models is the fibre horn with which the Baby Audiophone is now furnished, as illustrated below.

Write for Bulletin No. 3013-Q



MADE AND SOLD BY THE BRISTOL COMPANY Waterbury, Conn.

ENJOY A RADIO SUMMER

RADIO will play a wonderful part in your summer pleasures.

At home or vacationing—seashore—north woods or mountain nook, radio will be a friendly, convenient companion.

Music from far distant hotel orchestras will play for your dances and beach parties. Through head phones and loud speakers will crash the roar of the ball game. Religious services from metropolitan churches will add to your further enjoyment of the Sabbath. During and after the presidential conventions the country's foremost orators will address you.

Broadcasting stations are increasing their sending power. The bugaboo of summer static is no longer feared, and so remarkable has been the improvement and simplification of receiving sets that you will find their cost much lower than you might expect.

Give thought now to summer radio. Replace your worn out batteries with Burgess 'A,' 'B' and 'C's, which are recognized by expert and amateur alike as the best obtainable.

"ASK ANY RADIO ENGINEER"

BURGESS BATTERY COMPANY
Engineers DRY BATTERIES Manufacturers
Flashlight - Radio - Ignition - Telephone
General Sales Office: Harris Trust Bldg.,
Chicago.
Laboratories and Works: Madison, Wis.

BURGESS RADIO BATTERIES



Bringing the World to the Farm

(Continued From Page 23)

and to try WLS announcing for a week or so.

George stayed, but he sent hushpuckiny back to Memphis, for it belonged to the South and river traffic. He made another whistle, however, of red cherry wood like hushpuckiny, but with a short toot, like a railroad train, and now every trip on the WLS unlimited special is preceded and followed by this whistle.

Every one on the air knows Hay, "the solemn old judge," and his lilting "WLS, Chicago," sings itself right into your heart. Auxiliary announcers, staff artists and accompanists are Ford Rush, musical director,

farm child who has won the prize in his community for the best animal of its kind will have a chance to tell other farm children over WLS how it was done. Oratorical contests, debates and musical numbers are given by farm children as well as professional talent.

Each week, a nationally known farm woman is brought to Chicago by WLS to take charge of the week's program for home makers. She, from her practical farm experiences, tells others of her kind how things are accomplished.

One week Mrs. Charles Sewell, of Otterbein, Indiana, gave her series of



John Goodrich, assistant operator of Station WLS

and Robert Northrop, always ready to perform should any of the talent fail to put in an appearance.

Saturday nights in rural communities are dance nights. The farm boy dons his Sunday best, and with the modern substitution of a fivver for time-honored Dobbin, takes his girl to the country dance.

WLS met this custom with a regular dance program, made up of an intermingling of old-fashioned fiddling tunes with modern fox trots and waltzes. And father and mother wired in to WLS that they all danced now, that the whole family enjoyed the varied program. An old-time fiddling contest has resulted and fiddlers are sent by their communities to take part in the Saturday night contests over WLS, Chicago, and are voted on for their respective popularity. You tune in on either a bow-scraping "Turkey in the Straw," or "You Know You Belong to Somebody Else," with equal alacrity, for both are as good as the best on the air.

Children's pig and calf clubs are receiving due consideration. The

talks over WLS, and you can see by her kindly face that her heart lay in her work of contact with other real farm women.

While the farmer goes to his community church on Sunday mornings, the afternoon or evening chapel services are not neglected if he tunes in on WLS. Each Sunday the chapel services, conducted from the Hotel Sherman studio, are in charge of a minister of some large denomination. If this Sunday you listen-in to a Presbyterian minister and his own church quartette, next Sunday you may hear a Catholic priest and his vested choir, and last Sunday you might have heard a Jewish rabbi. Each Sunday's service is complete in its denominational entirety and each succeeding Sunday another denomination holds forth.

A personality week broadcast musical numbers of the highest order. Charles Wakefield Cadman and Princess Tsianina gave their wholly Indian musical hour, soloists from Chicago churches and Henry Purnmort Eames, a "musical esthetics" author-

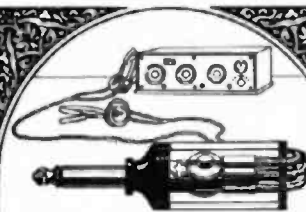

Nothing Complicated About the DUOPLUG!

It takes two head sets, four phone tips, and yet is so simple that no tools are necessary to make the connections. Unscrew the handle and look inside—you can tighten the special thumb-nut connectors with your fingers—or a dime, and be assured of a secure and perfect contact.

A substantial plug—with genuine bakelite handle heavily nicked metal parts. Good radio shops have it at \$1.00.

Write for Catalog H-7

Pacent Electric Co., Inc.
22 Park Place, N. Y., N. Y.

Philadelphia Sales Office
221 N. 11th Street

Pacent
RADIO ESSENTIALS

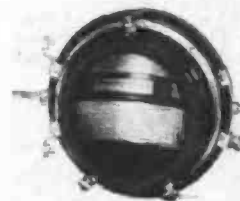

Amplify with

**LANGBEIN & KAUFMAN
TUNED RADIO FREQUENCY
VARIOTRANSFORMERS**

TYPE VT25 LIST \$8.50

Connected same as a fixed radio-frequency transformer, but continuously adjustable to the peak of the wave.

MAXIMUM AMPLIFICATION
AT ALL WAVE LENGTHS

The Home of Moulded
Tuner Specialties

LANGBEIN & KAUFMAN
654 Grand Avenue
NEW HAVEN CONN.

QRM!

If you could read the dots and dashes you would constantly hear this frantic call. In wireless parlance it means that signals cannot be received because of

Interference

Interference! The bane of the listener-in! QRM—QRM—Everywhere!

Pfanstiehl has made interference as inexcusable as small-pox. Here's how:



Silencer
Price \$8.00

The Nineteenth Amendment to the Constitution of the United States—Prohibition of Interference. It doesn't require a law: It requires just one of these SILENCERS.

Pfanstiehl made and still makes:
The original no-less Reinartz coil.
The original no-less pure inductances.
The original no-less pure inductance universal TUNING UNIT. And now
THE PHANSTIEHL SILENCER
PFANSTIEHL RADIO SERVICE CO.
Highland Park, Ill.

TUNE HIM OUT!

Just a touch—and it's done.

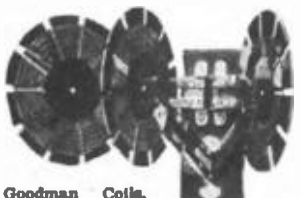

Goodman Coils, in their beautiful mount, are an ornament to any panel. Their sharp tuning is a joy to any radio fan. They can be used in any of the standard hook-ups, and improve them all. Diagrams given in our pamphlet. Send for one. **\$6.00** and P. P. one pound

L. W. GOODMAN
Manufacturer
Drexel Hill, Pa.

NEW

EBY
Tip-Top
Post, 50c



It takes 3 pair of phones. You can mount it in a jiffy. See them at your dealer's.

THE H. H. EBY MFG. CO.
Philadelphia, Pa.

ity, lectured during this period. The personality of the musical artist was given the listeners in a series of great value.

Distance records from WLS are coming in from Porto Rico to British Columbia, joining the farmers of the surrounding country who listen-in regularly.

WLS belongs to the farmer. It was built solely for the purpose of giving to rural America a cross section of every line of thought on the national of interest. It is giving a new type of program, wholly unlike any other in the United States.

Other stations have farm programs, hours of lectures and occasional afternoon woman's programs, but to give every moment of thought direct to the farmer and his family is a departure which only the great financial appropriation of the farm-



Ellen Ross Dickey, food specialist and announcer for the "Home Maker's Hour," Station WLS

er's store can adequately give. The programs are of agricultural woof and warp, woven from experiences with the dirt farmer, colored with talks by the great farm leaders, and made to fit the interests of every member of the farm family.

The radio has abolished the isolation of the farm. The receiving set in the farm home is the connecting link with the outside world. The farmer can hear Broadway favorites as well as the village soprano. Drama, music and politics are within his active discussion. He is a part of the listening world.

Radio has brought the world to the farmer's door, and the great Sears-Roebuck radio station WLS is giving its programs directly to him and his family.

Tube Testing Outfit as Used at 3XP Laboratory

(Continued From Page 31)

rheostat where they will operate efficiently. We have all noticed that in our receiving sets. Beyond this point, the tube will oscillate and plate current will be high and fairly steady so that you cannot get a curve on it.

In testing a 200 or 300 tube, we usually turn the tube up to the regulation 5 volts and there we find that the milliammeter in the plate current

will read rather high—somewhere around 10 or 11, with little variation.

We then bring the C battery potentiometer over to minus 7 and turn the rheostat down until the milliammeter needle drops to zero. That is usually found to be the best operating point on the rheostat. Then bringing the C battery potentiometer over to the positive side will make the plate milliammeter needle go up to 5 or 6 or 7 milliamperes. There will be one point where there will be a sudden jump and this quick jump from something less than one milliamperere up to something more than 5 usually denotes an excellent detector tube.

Unless you are drawing characteristic curves for scientific purposes, the exact setting of the B battery by the potentiometer is not important and an approximation of the voltage will show whether the tube is in good condition or not.

For ordinary testing purposes, it is also unnecessary to measure the exact C battery voltage. If this outfit is to be used by a radio dealer to show a customer that a tube is good, all that is required is to prove that swinging the C battery potentiometer from negative to positive produces a wide variation in the reading of the plate current milliammeter. A good 200 or 300 tube will produce a variation of about 5 to 7 milliamperes, the 11 or 12 tubes about 4 to 6, the 199 or 299 from 5 to 7 and the A tubes from 10 to 15 milliamperes difference. Less variation than this indicates a poor tube.

Out at station 3XP, we usually remove the grid-volt meter plug from the jack before taking a reading on the millimeter, and we have several times advised others to do this same thing. The chief engineer of the Weston Electric Instrument Company, however, takes issue with us on this matter and calls my attention to the fact that he believes under certain circumstances the method of removing the plug may be misleading. He says that errors may become very large in this way. For instance, in adjusting a UV199 tube filament by means of a voltmeter and then removing the voltmeter, says that the error might be as much as 3.5 filament voltage since the instrument itself requires eight millimeters, and the tube about sixty millimeters at the proper working voltage.

Furthermore he says that measuring the grid voltage after adjustment by means of 400 ohm potentiometer, and then removing the voltmeter may result in error to 20 per cent so he believes that for such measurements the voltmeter should not be disconnected. I only want to say that he knows a whole lot more about it than I do and so it is probably better to take his advice.

Radio Kindergarten

(Continued From Page 30)

if it has fewer electrons, and therefore more protons, or positive charges, it becomes a positive ion. Any process by which the equalization between the protons and electrons is disturbed is called "ionization."

Scientists are fairly well satisfied now that sunlight has the effect of ionizing a vast number of the atoms in the atmosphere. So long as the sun is shining steadily on a summer day this process of ionization goes on and atoms are constantly being disrupted and turned into either positive or negative ions.

Then, after sunset, with the influence of the sun's rays gone, there comes a natural tendency for the various ions to readjust themselves so that they will become atoms again

Every Question ANSWERED for only \$1

At last you have under one cover a Complete Radio Handbook



JUST OUT 514 PAGES

Compiled by HARRY F. DART, I.E.

Formerly with the Western Electric Co., and U. S. Army Instructor of Radio. Technically edited by F. H. Deane.

40,000 ALREADY SOLD

NO more need you turn from book to book, hoping to find what you want. It is all here, in 514 pages crammed full of every possible radio detail. Written in plain language, by engineers for laymen. Clears up the mysteries, tells you what you want to know. A complete index puts everything within your reach in a few seconds.

IT EXPLAINS: Electrical terms and circuits, antennas, batteries, generators and motors, electron (vacuum) tubes, every receiving hook-up, radio and audio frequency amplification, broadcast and commercial transmitters and receivers, super-regeneration, codes, license rules. Many other features.

Under one cover. Yes, it is all in one volume of 514 pages of clear type with hundreds of diagrams and illustrations. Takes the place of eleven or more specialized texts, each costing from two to ten times the dollar you pay for this single book. Belongs, in every radio-equipped home, on every amateur's table.

Send \$1 to-day and get this 514-page I. C. S. Radio Handbook—the biggest value in radio to-day. Money back if not satisfied.

TEAR OUT HERE

INTERNATIONAL CORRESPONDENCE SCHOOLS
Box 8233-C, Scranton, Penna.

I enclose One Dollar. Please send me—post-paid—the 514-page I. C. S. Radio Handbook. It is understood that if I am not entirely satisfied I may return this book within five days and you will refund my money.

Name.....
Address.....

Radio Safeguards

STORM KING LIGHTNING ARRESTER

Approved by the National Board of Fire Underwriters



\$100 at all dealers

Solderall Solders All Joints Permanently. SOLDERALL CO. NEWARK, N.J.



BOONTON PORTABLE RECEIVER

"THE LIGHT FOUR"

Designed by Radio Engineers for head-phone reception of Broadcast, wave lengths 250 to 550 meters; 1000 miles and over. Will operate Loud Speaker properly at distances of 50 to 500 miles, depending on local conditions and the antenna used. Built by Manufacturers with Thirty years' experience in the Electrical Industry.
Beautiful Workmanship - Rigid Construction



SIZE
4 1/4" x 8" x 12 3/4"

WEIGHT
7. POUNDS

\$75

Price does not include tubes, dry batteries or phone

SPECIFICATION: Genuine leather covered case and strap. Multiple socket for four U.V.199 vacuum tubes with damped spring suspension U. S. Navy type. Solid bus bar and lock washer connections. Two Ballantine Variotransformers. Special Tuner with Vernier on 3" dial. Engraved Panel and uniform Knob control.

VERY COMPACT AND EASY TO OPERATE

Go To Your Dealer—Order your set today—if he can't supply you, or if there is no Dealer in your vicinity—write us. Bulbs. tin sent on request.

BOONTON RADIO CORPORATION

RADIO HOME, 724 FANNY ROAD
BOONTON, NEW JERSEY

with no predominance of either positive or negative charge.

In other words, if a positive and a negative ion get near enough to each other in the atmosphere, the surplus on the negative ion will have a tendency to rush over to the positive ion and attach itself there until a balance is established.

There are all conceivable degrees and shades of static between these two extremes of the lightning flash and the exchange of a single electron.

Aside from the actual lightning storm, static probably is most annoying on very cloudy nights and this can be easily understood by following this same line of reasoning.

Let us assume that there is a cloud drifting across the sky from one direction and another cloud drifting across from the other direction. Just as soon as they get near enough to each other to have an electrical effect, all of the positive charges on one cloud will rush toward the inside and all of the negative charges on the other cloud will rush to its inside in an effort to get together and equalize the charges.

As the clouds come nearer and nearer, electrons escape and begin leaping across space or else begin exchanging places with electrons in the atoms in between and so the entire stretch of atmosphere between the two clouds begins a process of rearrangement and disruption which causes the crackling and the frying in our receiving sets.

This process is going on everywhere throughout the atmosphere all of the time. During the summer time, it is more pronounced because the disruptive effect of a hot summer sun is greater than the effect of a winter sun. Consequently we hear more of this static in the summer than we do in the winter.

There is, however, always a certain amount of this static in the air. When it is very faint it does not disturb the radio receiving set very much, but when there has been a great deal of this disruption, the readjustment becomes so great at times that we will hear in our receiving sets a constant crackling and frying that will totally destroy our concerts.

Scientists speak of the "static level." By this they indicate whether there is a great deal of readjustment going on or only a little. With a great deal, they say that the static level is "high," and with very little they say that it is "low," but there is always a "static level."

One of the great faults of having too sensitive a receiving set is that, while it does undoubtedly reach out and pick up extremely faint signals, this very sensitivity enables it also to pick up this static even when the static level is low—or when there is a minimum amount of this readjustment of electrons going on in the air.

In order for a radio signal to be heard satisfactorily, it must be considerably stronger than the static—also called "strays"—which is picked up at the same time by the same set. This is what we call "signal-stray ratio." If the signal-stray ratio is very low—if, for instance, the strays (or static) are just as strong as the signals—our reception will not be satisfactory. If the strays (or static) are stronger than the signals, we might just as well shut down our receiving sets, because we will get nothing but frying and crackling and crashing through them.

You will hear many people tell you that a loop aerial, on account of its directional effect, will eliminate static. This is not true.

It is true that, with certain forms of static that originate in lightning storms some hundreds of miles away from us, we will not pick up so much of that particular static if the loop is turned away from the direction of the storm. But with this other kind of

static that I have been speaking about—the readjustment of the atoms in the atmosphere all about us—there is no directional effect and the loop aerial will pick it up no matter in what direction it is pointed.

Most of our static over the Eastern seaboard comes from the South, because, even when there is no definite lightning storm there, there is more of this atmospheric readjustment around the Gulf of Mexico and the tropical waters than there is up in the North. Consequently, a loop aerial, if not turned toward the South, will eliminate this part of it to a very large extent.

Many scientists are working on devices to eliminate static entirely. Personally, it does not seem to me that this is possible and yet I know of several very fine radio engineers in whose judgment I have the most implicit confidence, who tell me that the problem really is going to be solved and that there are already several devices which have reached the successful laboratory stage and which eliminate all forms of static almost entirely.

While I am still skeptical, I am hopeful. A genuine static eliminator would be a Godsend to all of us and would do more to make radio an all year around pastime than any other one thing.

The elimination of static, the entire suppression of radiating receivers, and a cutting down of the number of broadcasting stations so that the wave lengths may be spread farther apart—these are the things which we should all work and pray for in radio.

Trouble Shooting in the Grime's 3XP

(Continued From Page 28)

centers all on the same straight line. Do not place them too closely together. The audio howl caused by feedback in the common B battery circuit may be done away with by reversing the primary connections on the audio transformers. Reversing the two primary connections on the last audio transformer is usually all that is necessary to clear the howl.

If the above means fail, the bypass condenser across the secondary of the second audio transformer should be increased to .005 mf. It is best to operate with this as small as possible, but some types of audio transformers require larger value bypassing condensers. An "audio howl" may be easily recognized by the fact that neither removing the aerial nor adjusting the tuning condensers has much effect on it. If there is an audio howl with the detector removed, but none with the detector in place, you need not worry. This occurs quite often.

Overload Howl—The "overload howl" is inherent in the duplex circuit and is caused by combining strong radio with strong audio currents. It occurs only on a nearby, powerful station. There are many ways of controlling this, but the simplest is merely detuning the first condenser slightly.

The whole subject of overloading is exceedingly complex and we will not have the space this issue to go into detail regarding it. It is enough to say that it occurs only when you are tuned into a powerful nearby station that, aside from the noise, it does no damage to equipment or tubes.

The overload howl does not radiate. If you do not obtain such an overload noise when all dials are exactly tuned in to a strong local station, you can very nearly make up your mind that your set is not giving you the amplification it should. This whole story of overloading will be revealed in a later issue.

There is a tendency for all classes

Sterling

Especially Designed for Equalizing Radio Frequency Circuits

N 311 MICROCONDENSER

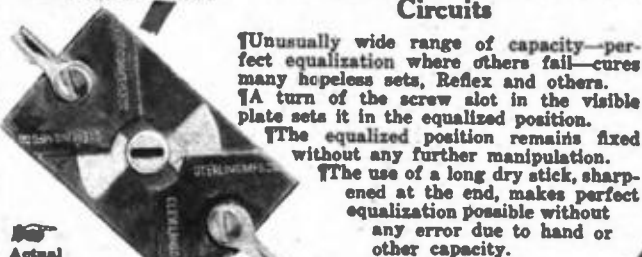

Unusually wide range of capacity—perfect equalization where others fail—cures many hopeless sets, Reflex and others.
A turn of the screw slot in the visible plate sets it in the equalized position.
The equalized position remains fixed without any further manipulation.
The use of a long dry stick, sharpened at the end, makes perfect equalization possible without any error due to hand or other capacity.

Actual Size

PRICE, including Legs and Screws, **\$1.00**

THE STERLING MANUFACTURING CO.
Cleveland, Ohio

Built Up to a High Standard, Not Down to a Low Price

The New CARTER "ONE-WAY" Plug



50c

FASTEST — EASIEST — SIMPLEST

Plug to attach or detach. Heavy phosphor-bronze springs "hug" the cord tips the entire length, making a positive contact and sure connection.

The original Carter design prevents the terminals from twisting together and causing trouble by short circuiting.

Any Dealer Can Supply

Carter Radio Co.
1811 REPUBLIC BUILDING
CHICAGO

Write for Catalog

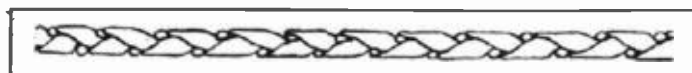

of reflex or duplex sets to pick up noises from adjacent power lines. These disturbances are called "induction noises." They are pure audio noises and would ordinarily be shut out by a radio amplifying stage or a detector tube.

But with means for amplifying audio currents in the same tubes, the induction energy is amplified from the aerial into the horns. The Inverse Duplex arrangement has a decided advantage in this respect. It has been shown before that the mere balancing of loads in the tubes is not the only feature possessed by this system. For instance, should the 3XP circuit be reflexed in the ordinary manner, three stages of successive audio amplification would exist between the aerial and horn.

By inverting this circuit there will be only two stages of audio amplification between the aerial and the horn, although the set still will employ three audio tubes between the detector and the reproducer. The reduction of one audio amplification stage between the aerial and the horn very materially reduces the "power noise."

This "power noise" only occurs in some localities and only when the set or aerial is quite close to an electric line. We have sought out known "bad spots" for trying the 3XP and have never been seriously troubled with this class of disturbance.

When trying the ordinary garden variety reflex under such conditions, the hum made reception well-nigh impossible.

It is fairly easy to recognize this "power noise" or hum. It gives one the impression of an open circuit. It is in no sense an "air hammer" effect; but rather approaches, in tone, the noise heard on a telephone line that has been grounded by lightning or is otherwise out of order.

Usually it can be reduced or changed by opening and closing the main lighting switch in the house. This affords a good clue to the trouble but scarcely a desirable remedy.

The "microphonic hum" is perhaps one of the most baffling troubles in any type of radio set. It is most noticeable on sets employing several stages of audio amplification and loud speaker.

It generally starts with a low subdued hum and gradually builds itself up into a roar—the whole procedure taking several seconds. There are several remedies to be tried before the best one can be determined for the particular trouble. The cause is invariably a loosely mounted filament in one of the tubes.

If the "microphonic hum" is experienced in the 3XP circuit, change the tubes about in the sockets. A loose filament in the first audio stage will cause no end of trouble, while this same tube in the last audio stage may be quite satisfactory.

Removing the horn away from the set will sometimes help, while mounting the entire apparatus in a cabinet will often relieve the situation. New tubes help some, too, but these cost money.

Many experimenters have mounted their tubes on sponge rubber. This seems to be the best remedy, if properly done. A tube well mounted on sponge rubber rarely becomes microphonic.

All of these, of course, are makeshift remedies. The real solution lies in the proper manufacture of tubes, which we hope will be an accomplished fact some day.

Meanwhile, the above outline will help you to clear up your doubtful points or, at least, to give us some data regarding your troubles so that we can suggest intelligent changes.

Let's Hook Up the Grimes-3XP

(Continued From Page 19)

another wire from the other side of that fixed condenser to the first end of the outer winding of the second honeycomb coil (No. 11). Run a wire from the plate binding post of the second tube socket (No. 5) to the .002 condenser (No. 6). Run another wire from the other side of condenser (No. 6) to the first turn of the outer windings of the third honeycomb coil (No. 13). This completes the wiring of the radio frequency primary leads.

Figure 5—Radio Frequency Secondaries—Here we have five wires, although there are apparently eight. That is because three of the wires make double connections. The first one goes from the grid binding post of the second tube socket (No. 5) to the inside end of the second honeycomb coil (No. 11), where the insulation is scraped and a soldered connection is made, and the wire then goes over to the stationary plates of the second variable condenser (No. 15). Another wire goes from the rotor plates of the second variable condenser (No. 15) to the outer end of the second honeycomb coil (No. 11). A wire goes from the stationary plates of the third variable condenser (No. 16) to one side of the crystal detector (No. 17), where the insulation is scraped and a connection is made and the wire is continued on to the inside end of the third honeycomb coil (No. 13). Another wire goes from the rotor plates of the third condenser (No. 16) to the plate binding post of the first audio frequency transformer (No. 12), where the insulation is scraped and a connection made and the same wire continued on to the outside end of the third

honeycomb coil (No. 13). A wire goes from the other side of the crystal detector over to the B battery post of the first audio frequency transformer (No. 12). This completes the wiring of the radio frequency secondaries.

Figure 6—Audio Frequency Primaries and Horn—Here we will begin to place wires upon connections where we have already fastened other wires, but it need not worry you. First run a wire from the plate binding post of the third socket (No. 8) to the clip for horn nearest to the front of the mounting board. Then connect the other horn clip to the plus B clip and connect that plus B clip by a wire to the B battery binding post on the third audio frequency transformer (No. 7), scrape the insulation and screw it fast and then run the wire over to the B battery binding post on the second audio frequency transformer (No. 10). From the plate binding post of that second audio frequency transformer (No. 10) run a wire over to the plate binding post of the second socket (No. 5), where you will already find a wire connected. Then from the plate binding post of the first socket (No. 3), where you will also find a wire already connected, run another wire over to the plate connection of the third audio frequency transformer (No. 7).

Figure 7—Audio Frequency Secondaries—Run a wire from the front side of the first fixed condenser (No. 2) to the grid binding post of the second audio frequency transformer (No. 10). Run a wire from the outer terminal of the second honeycomb coil (No. 11), where you will already find a connection, over to the grid binding post of the first audio frequency transformer (No. 12). Run another wire from the grid binding post on the third audio frequency transformer

Announcing the B-Limiter

Which takes the place of "B" batteries and operates from your house current.

Engineers have spent thousands of hours, and consumed hundreds of thousands of dollars in experiments, trying to make house current available for operating your radio. This has now been accomplished absolutely so far as your "B" batteries are concerned. The Timmons B-Limiter supplies all plate voltages from 1 to 120 by simply plugging into any electric light outlet.

This Is the First of the New Timmons Products

Before making the B-Limiter available to the public, we tried it out in many localities and in several states for a period of months. We wanted to be sure that the B-Limiter would operate under the most unfavorable conditions. It did, even where the power company's generators were known to be especially "noisy" so far as 60 cycle hum was concerned. This hum was completely filtered out.

After these tests, we called in outside men, technically versed in Radio. It was only after these men had passed on it that

We Decided to Market B-Limiters

Shipments of B-Limiters are being made as fast as they can be manufactured, assembled and tested. Your dealer is now taking orders.

Meanwhile, we will be glad to send a folder describing and illustrating the B-Limiter. Its title is "Eliminating the 'B' Battery." In writing for this folder, please state whether you use alternating or direct current. You might also mention your dealer's name.

All Timmons' Products Are Guaranteed

TIMMONS TALKER, Inc.
339 E. Tulpehocken St., Philadelphia, Pa.

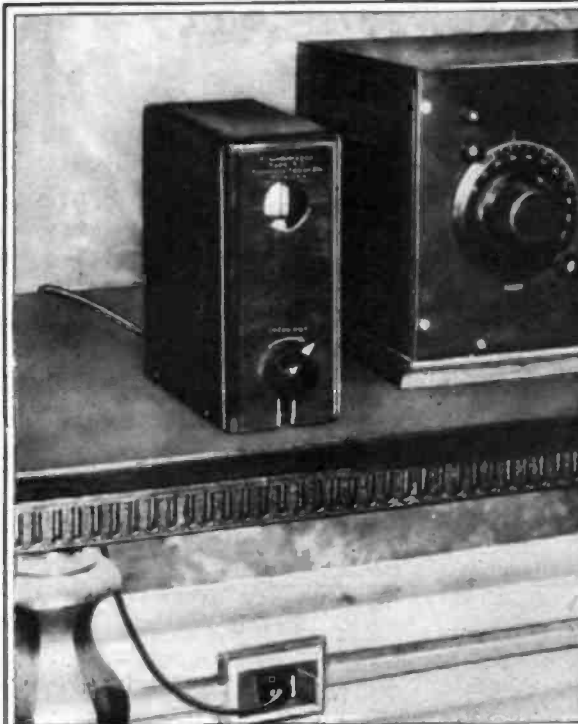

TIMMONS B-LIMITER

IT TAKES THE PLACE OF "B" BATTERIES

MODERN LONG-WAVE 30 K. C.

Transformers

for

Super-Heterodyne and Ultradyn



- Core** Special silicon steel 36 gauge, .007 thick.
- Coils** Wound with D. C. silk wire specially wound in our own plant.
- Range** Practically uniform amplification over from 20 to 35 kilocycles.
- Stages** Three or four stages in Cascade.
- Price** \$5.00 each

MODERN
"Push-Pull" Trans-
formers for power
amplification—
\$12.50 Set
of 2

MODERN
Standard Audio
Transformers for
Cascade amplifica-
tion—
\$5.00 Each

MODERN
famous one-tube
Reflex Audio
Transformer—
\$5.50 Each

Jobbers and Dealers

We are manufacturers of transformers exclusively, every coil being wound in our own plant. Modern engineers devote their entire time to keeping MODERN Transformers modern. Those facts mean a lot. Write us. Some territory still open for live distributors.



The Modern
Electric Mfg. Co.
Toledo, Ohio

(No. 7) to the grid binding post on the third tube socket (No. 8). This completes the wiring of the audio frequency secondaries.

Figure 3—The Loop Jack—From the grid binding post of the first tube socket (No. 3) a wire goes to the top blade of the double circuit jack (No. 1), where the insulation is scraped off, a soldered connection made and the wire continued to the stationary plates of the first variable condenser (No. 14). A wire is run from the jack blade next to the top over to the inside terminal of the first honeycomb coil (No. 9). A wire is run from the blade next to the bottom on the jack over to the outside terminal of the first honeycomb coil (No. 9). A wire is run from the bottom blade of the jack over to one side of the first fixed condenser (No. 2), where you will already find a connection, and the wire is continued on over to the rotor plates of the first variable condenser (No. 14). A wire is run from the other side of the first fixed condenser (No. 2) to the minus filament binding post of the first socket (No. 3), where you will also find another connection.

This completes the wiring of the set and we are ready to insert our tubes and hook up the ground and batteries. Let's go!

Harkness Writes on Self-Oscillation

(Continued From Page 14)

oscillation is impressed on the grid circuit, there are two separate oscillating currents flowing in the circuits of the receiver—the signal oscillation and the self-generated oscillation, the latter being of a continuous nature.

Now, whereas the system of Figure 1 uses inductive coupling to obtain regenerative amplification and, if desired, to produce continuous oscillations, the system of Figure 2 uses capacitive coupling to feed back energy from the plate circuit to the grid circuit; moreover, in the system of Figure 2, regenerative amplification is controlled, and self-oscillation produced or prevented, as may be desired, by varying the resonant frequency of the external plate circuit.

In Figure 2, which represents the so-called "short wave regenerative" circuit, L1 and L2 form, respectively, the primary and secondary of a variocoupler. L3 and L4 are variometers. The capacity C represents the natural capacity which exists between the plate and grid of the vacuum tube.

The manner in which regenerative amplification is obtained by this system may be explained as follows:

If oscillations are induced by a signal in the grid circuit, formed by the coil L2 and the variometer L3, corresponding variations of the plate current are produced. The plate current variations have the same frequency as the signal oscillation which produced them. These radio frequency plate current variations cause a self-induced oscillating e. m. f. to be set up across the variometer L4 in the plate circuit, in accordance with the law of induced e. m. f. As long as the signal oscillation is impressed on the grid, oscillations of the same frequency are set up across the variometer L4 in the plate circuit and consequently the plate potential rises and falls at this frequency.

If the plate of the tube is then capacitively coupled to the grid, an oscillating e. m. f. is impressed on the grid in phase with the signal oscillation. In other words, energy is fed back from the plate circuit to the grid circuit to produce an amplifying effect.

The plate and grid may be capacitively coupled by means of a fixed or variable condenser, but, if the circuits are tuned to a high frequency to re-

ceive a low wave length signal, the inherent capacity existing between the plate and grid inside the tube itself is sufficiently large for the purpose; no external capacity is then required.

Presuming that the capacitive coupling between the plate and grid is a fixed value, the degree of amplification may be controlled by varying the resonant frequency of the external plate circuit; that is to say, by revolving the rotor of the variometer L4. The amplification depends upon the extent to which the plate potential rises and falls, which in turn depends upon the amplitude of the oscillations across the variometer L4. The latter can be increased by varying the self-induction of L4 so that, with its distributed capacity, its resonant frequency approaches the frequency of the oscillations produced across it by the radio frequency plate current variations.

However, once again the amplification obtainable is limited by the continuous oscillations which are self-generated if the conditions for self-oscillation are fulfilled. If the external plate circuit is tuned to exactly the same resonant frequency as the grid circuit, the self-induced oscillations across L4 have their maximum amplitude, but the amount of energy transferable from the plate to the grid circuit is then sufficiently large to sustain continuous oscillations in the circuits.

Without an external means of capacitively coupling the plate and the grid of the vacuum tube, the system of Figure 2 will generate continuous oscillations only when the grid and the plate circuits are tuned to a high frequency. If the circuits are tuned to a low frequency, it becomes necessary to increase the capacitive coupling by means of an external condenser. However, in the ordinary short wave or radio broadcast receiver, using the circuit of Figure 2, self-oscillation invariably takes place when the grid and plate circuits are tuned to approximately the same frequency.

From the foregoing explanations we may conclude that continuous oscillations may be self-generated by a vacuum tube—

(1) By inductively coupling the plate and grid circuits.

(2) By capacitively coupling the plate and grid circuits (either by the inherent internal capacity of the tube or by outside means) and tuning the grid and plate circuits to approximately the same resonant frequency.

In connection with the second conclusion, however, it is not always essential for the plate and grid circuits to be tuned to the same resonant frequency to cause self-oscillation. The oscillations set up across a non-resonant plate circuit are sometimes strong enough to sustain continuous oscillations.

There are, of course, methods of producing self-oscillation other than those specifically outlined above, but these are the most important methods and are chiefly responsible for the continuous oscillations generated by radio frequency amplifying receivers.

Figure 3 represents the fundamental circuit of a standard radio amplifying system. This, of course, is not intended to be a practical circuit; it merely depicts the fundamental principle. We will learn from a consideration of this circuit the general principles of radio frequency amplification and why continuous oscillations are generated in a radio frequency amplifying receiver.

In Figure 3 the first tube is the radio frequency amplifier, while the second tube is the rectifier, or detector. The object of this and other radio frequency amplifying systems is to impress on the grid of the detector tube an oscillating e. m. f. of the same form and frequency as the



KELCOIL

The Wonder Tuning Coil
Most-Talked-About Coil on the Market

SELECTIVE



SENSITIVE

THIS IS THE ORIGINAL AND ONLY KELCOIL
DISTANCE—VOLUME—CLEARNESS
SIX DOLLARS

"The very easiest sort of a circuit for DX listings is the three-circuit with untuned antenna coil described recently in radio in the Home as the Kelcoil."

From "RADIO IN THE HOME," June, Page 19.

SYCO WAVE TRAP
USE WITH ANY CIRCUIT OR RECEIVING SET
ELIMINATES INTERFERENCE—MOST SELECTIVE

\$8

GUARANTEED
SAME STANDARD
THAT HAS MADE
KELCOIL FAMOUS



FOR HOOK-UPS AND
WIRING DIAGRAMS
SEND US
TWENTY-FIVE CENTS
MAILING EXPENSE

SYCO RADIO PRODUCTS CORPORATION
440 Drexel Bldg. Philadelphia, Penna.

oscillations induced in the receiving antenna, but having a much larger amplitude than the original oscillations. Whereas the audio frequency amplifier increases the audibility of signals *after* they have been rectified, the radio frequency amplifier magnifies the high frequency oscillations of incoming signals *before* they are rectified; it makes possible the detection of signals which might not otherwise be heard; it increases the sensitivity of the receiver.

Figure 3 illustrates how this is accomplished. Incoming signals induce oscillations in the grid circuit L2 C2, which produce corresponding variations of the current in the plate circuit. These plate current variations, by self-induction, set up across the coil L3 an oscillating e. m. f. having the same form and frequency as the original signal oscillation but a much larger amplitude. The oscillations across L3 induce corresponding oscillations in L4, which is connected across the grid and filament of the rectifying tube. The amount of amplification secured is represented by the amplitude of the oscillations finally induced in L4 as compared with the oscillation impressed on the grid of the amplifying tube.

It will be evident that the efficiency of the system largely depends upon the coils L3 and L4, which form what is known as a radio frequency transformer. Radio frequency transformer design is a subject for separate consideration.

Compare now the circuit of Figure 3 with that of Figure 2. Notice that the arrangement of the amplifying circuit of Figure 3 is similar to the circuit of Figure 2. A variable condenser is used to tune the grid circuit of the former, while a variometer is used for this purpose in the latter; but they both achieve the same object. In Figure 2 the variometer L4 forms, with its distributed capacity, the plate oscillatory circuit. Similarly, the coil L3 in Figure 3 forms the plate oscillatory circuit of the amplifying tube. The only difference lies in the fact that the resonant frequency of the plate oscillatory circuit of Figure 3 cannot be varied.

Now, whereas it is the object of the system of Figure 2 to obtain amplification by regeneration and, on occasion, to generate continuous oscillations for the reception of undamped wave signals, these are not the primary objects of the system of Figure 3. The amplifying tube of Figure 3, to receive radio broadcast signals, must amplify signals *without* generating continuous oscillations. But if any of the standard types of radio frequency transformers are used in this circuit the amplifying tube will, when the grid circuit is tuned to certain frequencies, generate continuous oscillations in exactly the same manner as described in connection with Figure 2 and for the same reasons. At certain frequencies the oscillations set up across the coil L3 are strong enough to feed back sufficient energy through the capacity of the tube to generate and sustain continuous oscillations. To make the system practical it is necessary to use some method of controlling self-oscillation.

As the number of stages of radio frequency amplification employed in a radio receiver is increased, the tendency toward self-oscillation is proportionately increased. In a multi-stage radio frequency amplifier any or all of the radio frequency amplifying tubes may become generators of continuous oscillations.

For instance, in the "two-stage" amplifying system of Figure 4 continuous oscillations may be generated by either the first or second amplifying tube as the result of either inductive or capacitive coupling between the numerous oscillatory circuits. At certain frequencies the oscillations

KELLOGG RADIO



This Kellogg Radio Kit saves time and money ~ Say the Radio Bugs.

Everything complete for assembling two stages of audio frequency amplification. The panel is drilled for three tuning units,

which together with this No. 501 Kit will complete a radio set using your favorite hook-up, or most any other that you may desire to try.

This universal panel makes the changing of from one circuit to another an easy matter. Every piece is standard Kellogg radio equipment and guaranteed.

"Build Your Own" with this Kellogg No. 501 Radio Kit. At your dealers for \$43.00.

KELLOGG SWITCHBOARD & SUPPLY COMPANY
1066 W. Adams Street · CHICAGO, ILL.

GRIMES *and his famous* INVERSE-DUPLEX SYSTEM

are found exclusively in "Radio in the Home." David Grimes is one of our Associate Editors and writes for no other publication.



RADIO IN THE HOME

is devoted entirely to better class radio—the only kind that is fit to go into the American home.

RADIO IN THE HOME

is not in the market for general radio advertising. We make our own tests of apparatus and our own investigations of the financial and commercial reliability of firms, and we solicit advertising only from those manufacturers whose products we ourselves are willing to guarantee in the light of these researches.

This is to assure our readers that they can depend on the things they see advertised in our columns.

IT IS A READER SERVICE

By Subscription
Two Dollars the Year

set up across the coils L3 and L5 will be large enough to feed back sufficient energy through the capacity of each tube to generate continuous oscillations in all the circuits of the amplifier. Furthermore, continuous oscillations may be generated by inductive coupling between the coils and transformers themselves, for it must be realized that the oscillations are so greatly magnified by the amplifier that comparatively loose inductive coupling between any of the circuits may be sufficient to generate continuous oscillations; for instance, there may be sufficient inductive coupling between L2 and L5 to generate continuous oscillations.

The operator of a radio frequency amplifying receiver is well aware of the fact that it is necessary to control self-oscillation, because as soon as self-oscillation takes place signals become hopelessly distorted. The reason the signals are distorted by this action may be explained as follows:

The frequency of a self-generated continuous oscillation is governed by the resonant frequency of either the

grid circuit is excited by oscillations of two different frequencies. This results in the production of an oscillation of varying amplitude with a "beat frequency" equal to the difference in frequency between the two separate oscillations. Radiophone signals are thereby completely distorted. For the reception of radio broadcasts, therefore, it is invariably necessary to prevent the generation of continuous oscillations in the circuits of the receiver.

In the foregoing paragraphs we have explained that it is necessary to provide some means of controlling self-oscillation in a radio frequency amplifier because continuous oscillations are invariably self-generated. It is extremely important to realize, however, that the designer of a radio frequency amplifying receiver should arrange his apparatus to avoid, as much as possible, inductive or capacitive coupling between the oscillatory circuits and thus minimize the tendency toward self-oscillation, not merely relying upon some outside means of preventing self-oscillation.



Radio in the Home of Carl H. Chaffee, Swarthmore, Pa., cashier of the First National Bank, Philadelphia. The radio set is a Grebe with Western Electric Loud Speaker
Photo by J. E. Green, Chester, Pa.

MACKONTROL Saves Your Tubes!

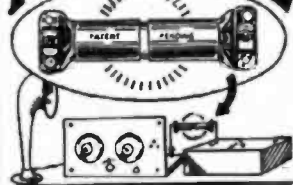

An everlasting insurance against burnt-out tubes. One protects all the tubes in a set. Gives notice of a short circuit instantly. Lasts a lifetime. Does not interfere with operation of a Set. \$2.50 Price

More than a fuse

Your Dealer Will Demonstrate It

Mackline
of Superior RADIO PRODUCTS
MACK Company
1810 Market St., Phila.

P. W. AIRKORE SUPER EIGHT

Identically the same as tested by Henry M. Neely

Our Transformer is the heart of the AIRKORE Super Eight, absolutely prevents distortion and results in sharp tuning. Set of four transformers, including panel layout, base board layout and circuit diagram..... \$25.00

Complete package of parts, including everything necessary to build your Super Eight identically as illustrated by Mr. Neely. Drilled engraved panel, base board and all parts ready to put together, even including the solder.. \$85.00



PHILADELPHIA WIRELESS SALES CORP.
133 N. 11th Street, Philadelphia, Pa.

Formerly 1533 Pine St., Philadelphia

grid or plate oscillatory circuit of the oscillating tube. The original impulse which starts the oscillation produces a current in either the grid or plate circuit and the current oscillates at the frequency to which the circuit is tuned.

As explained previously, when a signal oscillation is impressed on the grid circuit of an oscillating tube there are two separate oscillations in the circuits of tube—the signal oscillation and the continuous self-generated oscillation. If the latter has the frequency to which the grid circuit is tuned, it should theoretically be possible to tune the grid circuit to the frequency of the incoming signal oscillation so that the continuous oscillation will have the same resonant frequency as the signal oscillation, in which case the continuous oscillation would not distort but greatly amplify the signal. In practice, however, it is extremely difficult to tune the grid circuit so accurately that the continuous oscillation and the signal oscillation have both absolutely the same frequency, especially when the frequencies are high.

If the resonant frequency of the grid circuit is only slightly different from that of the signal oscillation

No matter what method of preventing self-oscillation is used, the effect is to increase the resistance of the circuits; in other words, the only way to control self-oscillation in a radio frequency amplifier is to diminish the amplification. It is evident, therefore, that the more easily continuous oscillations are generated the more the amplification must be reduced to stop them. Conversely, the smaller the tendency toward self-oscillation, the greater the efficiency of the amplifier.

The ideal radio frequency amplifier would be one in which the coupling between the circuits (other than the coupling which repeats the signal oscillation from tube to tube) is so small that continuous oscillations could not be generated. Then there would be no necessity for introducing resistance into the circuits to control self-oscillation. The amplifier would operate with full efficiency, and controllable regeneration could even be added to magnify signals still further.

In a multi-stage radio frequency amplifier with efficient transformers, however, this is impossible of accomplishment. Even though inductive coupling between transformers and coils is entirely eliminated, the ca-

passive coupling between the plate and grid of each amplifying tube is inherent and cannot be avoided; this coupling is usually sufficient to generate continuous oscillations.

The designer of a radio frequency amplifier should, however, bend every effort to reach as close to the ideal arrangement as possible. All sources of coupling in the amplifier should be reduced to an absolute minimum. All inductance should be mutually at right angles to each other and separated, or "astatic" coils with closed magnetic fields should be used to minimize inductive coupling. The apparatus should be arranged so that it may be connected together with very short wires, particularly the plate and grid leads, which should, if possible, run at right angles to each other.

The leads connecting to the batteries should be as short as possible to avoid direct magnetic coupling. If good amplifying tubes with low internal capacity are obtainable they should be used in preference to tubes with high internal capacity. The efficiency of the amplifier can thus be greatly improved and even though self-oscillation may be entirely prevented by these precautions the tendency toward self-oscillation is reduced and the amplification need not be reduced to the same extent to prevent the generation of continuous oscillations.

Generally speaking, there are two methods employed to prevent the self-generation of continuous oscillations in a radio frequency amplifier. The first method was developed by the British and the diagram of Figure 5 shows how the system is used. The grid returns of the radio frequency

amplifying tubes instead of being connected to the negative side of the filament circuit are connected to the sliding contact of a potentiometer in parallel with the filament circuit. By moving the potentiometer contact, the normal potentials of the grids with respect to the negative end of the filament can be varied from a negative value to a positive value.

If self-oscillation takes place when the potentiometer contact is at the negative end of the resistance, the oscillations can be damped out by moving the contact toward the positive end. As the grids become more positive with respect to the filaments the impedance of the grid filament circuits is lowered; the amplification is diminished; more energy is consumed in the grid circuits; in other words, the resistance of the grid circuits is increased. By balancing the resistance of the grid circuits against the feed-back, self-oscillation can easily be controlled.

The second method of controlling self-oscillation was devised by French engineers during the war. It is based on the principle of coupling two circuits of a radio frequency amplifier together to produce a feed-back which is out of phase with the signal oscillation, thereby damping the signal oscillation, tending to neutralize the positive reaction of the feed-back through the capacity of the tubes, the latter feed-back being in phase with the signal oscillation. To obtain the neutralizing effect the two circuits are generally capacitively coupled through a small condenser, although a high variable resistance can also be used. There are many applications of this general principle, one of them being shown in the diagram of Figure 6. In this circuit self-oscillation can be controlled by adjusting the small compensating or neutralizing condensers.

There is some difference in opinion as to the respective merits of the two methods of controlling self-oscillation. When more than one stage of radio frequency amplification is used, the potentiometer method is certainly more stable and easier to adjust. The potentiometer system, however, can not be used in a reflex receiver. To obtain good audio frequency amplification it is absolutely essential that the grid of the amplifying tube be maintained at a normal potential which is negative with respect to the negative side of the filament. If a potentiometer is used to control self-oscillation in a reflex system the audio frequency amplification disappears when the grid of the amplifying tube is given a positive potential to stop self-oscillation. If it is necessary to use some means for preventing self-oscillation in a reflex receiver the negative reaction method should be used.

In last month's article describing the Harkness reflex system in detail, we mentioned that no potentiometer or compensating condenser was used to control self-oscillation. The two-tube circuit is again shown in Figure 7 for the purposes of reference.

No special means is used to control self-oscillation in this circuit because the apparatus and receiver are designed to render this unnecessary. Inductive coupling is eliminated by turning Flexoformer T1 and T2 at right angles to each other. Moreover, the Flexoformers and audio frequency transformer are designed so that the resistance of the circuits prevents the generation of continuous oscillations. Flexoformer T2, particularly, is designed so that the oscillations set up across the primary of this transformer are not large enough to cause self-oscillation.

This Shows the Trend of Radio

(Continued From Page 4)

for the plate supply of our tubes. Why should we buy these batteries when we have 110 volts already in the house supplied at a most reasonable price?

Of course, this house lighting system gives us what we call alternating current and our tubes require direct current, but that is merely a difficulty which we have every right to ask science to overcome, and science is now overcoming it.

The set shown in the photograph uses a Ducon or Antenella plug for both aerial and ground and uses another plug to provide both filament lighting and plate current. With such a set as this, it is necessary only to screw a triple socket into the base-board socket and use one of these triple openings for the Ducon or Antenella, one for the current supply and one for the cords going to a neat table lamp which can be stood alongside the set.

Next season there will be half a dozen devices placed upon the market, all designed to convert the 110 volts of our house lighting current into the direct current needed for lighting the filaments and supplying the plates of our tubes.

Last season we had several of these devices introduced upon the market, but they did not seem to succeed very well in catching the popular enthusiasm and many people have asked me why this was.

It is a perfectly simple thing to explain. The makers of these devices designed them to work upon the particular electric light systems which they had in their own laboratories, and assumed that, because the devices

(Continued on Page 42)

SLEEPER MONOTROL

REG. U.S. PAT. OFF.

With the Grimes Inverse Duplex Circuit

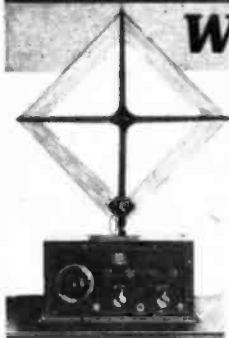

Dealers Please Note
Absolutely dependable in operation at any time of year, you will find the Sleeper Monotrol particularly suitable in Summer.

Through the Summer With a Loop

The Sleeper Monotrol is free to rove with you this Summer. It is not fixed in any spot—moored by aerial or ground connections. You can move it out upon the porch for Summer evening concerts. You can carry it and listen-in while riding in your car—set it up on mountain top or beach—

point the loop towards stations that you want to hear and hear them with that sweetness, clarity and purity of tone that you get *only* through a loop in sets especially built for loop reception. Your dealer will be glad to put a Sleeper Monotrol into your home on trial. Try it.

Send for Booklet—Free on Request

SLEEPER RADIO CORPORATION, 88 Park Place, New York



MAHOGANITE Dials that match the set

Like all other distinctive products, Mahoganite has its imitators. But these imitations are on the surface only. Mahoganite is not a surface finish. The electrical values of RADION Mahoganite extend through the material.

The only way to assure yourself of genuine Mahoganite Panels, or Dials which match the panels, is to make sure that the RADION Trademark is on every one that you buy.

RADION

The Supreme Insulation

PANELS



Look for this stamp on every genuine RADION Panel. Beware of substitutes and imitations.

21 Stock Sizes
Mahoganite and Black

6 x 7	7 x 14	8 x 26
6 x 10 1/2	7 x 18	9 x 14
6 x 14	7 x 21	10 x 12
6 x 21	7 x 24	12 x 14
7 x 9	7 x 26	12 x 21
7 x 10	7 x 30	14 x 18
7 x 12	7 x 48	20 x 24

At all good Radio Shops everywhere or write to

AMERICAN HARD RUBBER CO., 11 Mercer St., N. Y.

We repair the following RADIO TUBES and Guarantee Them



WD-11 \$2.50	DV-4 \$2.50	UV-301A \$2.50
WD-12 2.50	DV-1 2.50	C-301A 2.50
UV-200 2.50	DV-2 2.50	Marcant 2.50
UV-301 2.50	DV-4A 2.50	Moorhead 2.50
C-300 2.50	UV-100 2.50	6 v. Plate Amp. 2.50
C-301 2.50	C-300 2.50	6 v. Plate Det. 2.50

Mail Orders filled and promptly attended to. Dealers and Agents write for Special Discount.

H. & H. RADIO CO.

P. O. BOX 22-K NEWARK, N. J.

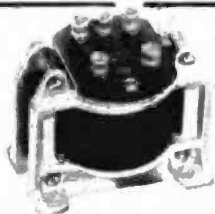

Summer Success — RUBICON DUPLEX

When Radio entertainment these long summer twilights needs something greater than the usual "straight audio"—add a stage of RUBICON Duplex. Then you can depend upon the loud speaker at all times.

This folder tells why

"The Inside Story" takes you beneath the surface. From turn ratios and other data, it points out the right type for every purpose—RUBICON Audio, Radio and RUBICON Duplex.

Just write for "The Inside Story"

RUBICON COMPANY

918 Victory Building Philadelphia, Pa.

Duplex, pairs tested for balance **\$12**
Audio Frequency...\$6.00
Radio Frequency...\$6.00

Take Your Radio With You

(Continued From Page 12)

case. One of the unique features of the Benson portable is the fact that the panel may be lifted out of the portable case completely and inserted in your victrola, using a phonograph unit on the phone in place of the ordinary loud speaker.

The Colin B. Kennedy Corp. is also putting out a very fine portable set

radio fan to be as enthusiastic over radio in the summer as he is in winter, because, besides being a radio fan, he is probably an ordinary human being, and the call of the great outdoors during the long days of summer is as irresistible to him as to any one else. The portable set will undoubtedly interest him, however, and

This photo shows a Benson Melody Portable Set with a loud speaker attached

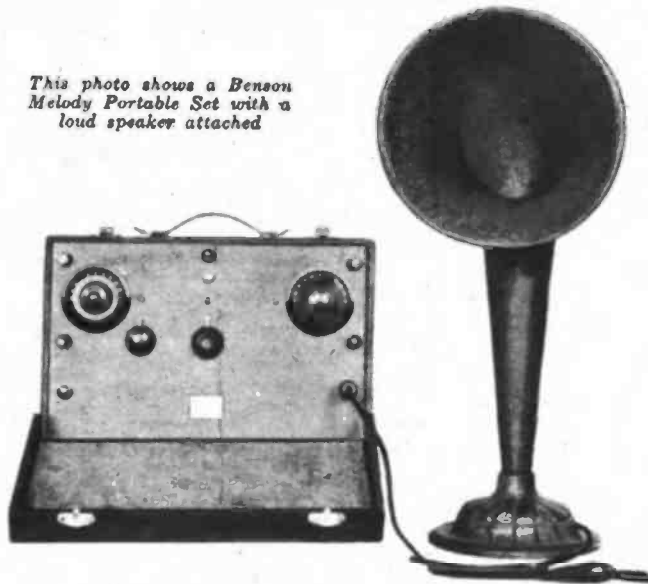

of which we are reproducing in photograph. This photograph was taken in the home of Mrs. Vera Brady Shipman, the Chicago correspondent of *Radio in the Home*, and shows Mrs. Shipman's two daughters, Mary Jule, eight years old, and Sally, three years old. Mrs. Shipman tells us that the children have no difficulty in operating this set themselves, and they are becoming quite enthusiastic radio fans on account of the results which they have been getting.

Other portable sets which are coming prominently to the front now are the Ozarka and the Operadio. These, with other small sets which are being developed, are likely to solve the problem of the dealer in keeping his sales moving during the summer time.

Naturally no one can expect the

this will make radio an all-the-year-around business for the up-to-date dealer.

We are showing with this article a few of the more prominent portable sets which are on the market at the present time. They show an extremely interesting trend in the development of radio and they have been developed to fill a very real need among the radio fans who feel that they can't afford the luxury of a permanent installation in the home and another receiver to be taken with them on trips.

Simplex type RFB portable receiver: A four-tube receiver furnished in a leatherette-covered carrying case with a handle having the appearance of a neat suitcase. It is the tuned radio-frequency type with one stage

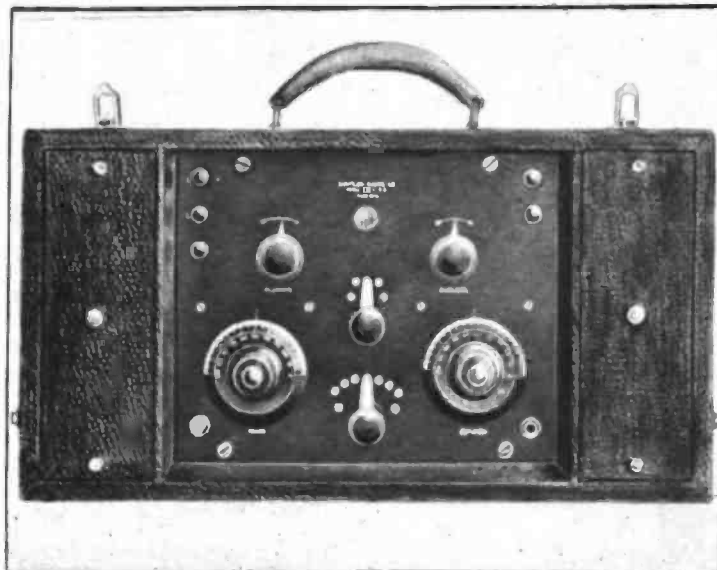

Here is the Simplex Portable Receiving Set in its neat case

of tuned radio frequency, detector and two stages of audio-frequency amplification, using four UV199 tubes lighted by three number six dry cells.

The receiver is entirely self contained with a compartment at the left for the three number six dry cells which when placed horizontally fit snugly into the space and a compartment on the right for three medium-sized B batteries, two placed upright and one horizontal, with a total plate voltage of 67½. For best results it is advisable to use some form of outdoor aerial with this receiver, but an elaborate antenna is not at all necessary. It will work very well with a Ducon plug in the electric socket or a clip on to a screw on the telephone, or will even give considerable satisfaction with a bed spring, although undoubtedly a wire stretched well above the ground will give better results. A loop aerial can be used but will not give the distance nor the volume that the other kind of aerial will.

latest type armature driven sound unit, coupled to an acoustically correct, dead-material, vibrationless horn, reproducing faithfully all audible frequencies with satisfactory volume.

The carrying case contains necessary space for installing six standard No. 6 dry A batteries and four standard medium size B batteries. Connection to the batteries are made easy by a color code on the wires making wrong connections impossible.

A voltmeter, in series with a push button, gives the A battery voltage at any time, indicating the condition of the batteries.

Only two controls are used for all tuning, one selecting the station desired, and the other giving volume control of that station. A third control, used only when starting or finishing use of the set, controls the power supply, allowing the minimum necessary battery consumption.

An outside aerial and ground may

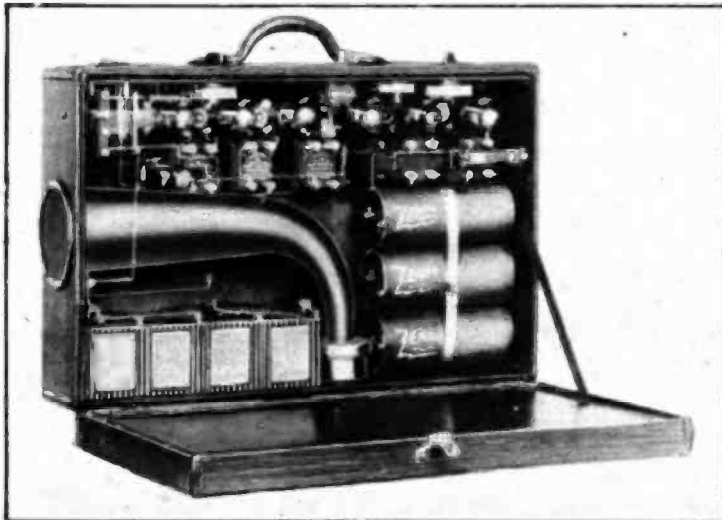

Here is shown a side-view of the Zenith Portable Set with the lid dropped, showing all the "works."

The set produces plenty of volume for loud-speaker use, and it also has a jack for the head sets to be plugged into if the user prefers phones.

This receiver, when fully equipped with batteries, tubes, and everything which are all contained in the carrying case, will not overburden any one who is going camping, motoring, yachting or picnicking. No other accessories are necessary for the operation with the exception of a roll of aerial wire and some form of loud speaker, which in a makeshift may be a phonograph unit attached to some form of horn, and the wire and unit will fit nicely in the lid of the carrying case between the panel of the receiver itself. The weight of the portable set is only 25 pounds fully equipped or 14 pounds net. The size is 10 inches x 19 inches x 8½ inches.

Another good portable set for the vacation is the Operadio-two illustrated in this article. This set is contained in a carrying case, measuring 17 inches long, 12 inches high and 9 inches deep.

For wave interception a patented wave-bridge is built into the removable front and top sides, which are hinged together, allowing them to be straightened into one flat surface.

The circuit used employs three stages of radio-frequency amplification, a detector, and two stages of audio-frequency amplification, affording loud-speaker reception on far-distant stations, using 199 tubes throughout.

The loud speaker consists of the

be used if desired through proper connections to the wave-bridge.

Ear phones may be used through a jack on the control panel.

The New Zenith Radio Companion: Here's a six-tube radio set that's en-

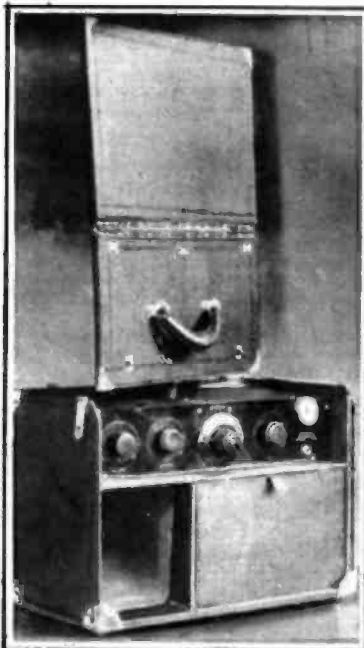

Above is the Operadio-2 Portable Set. Notice the horn in the left-hand side of the case

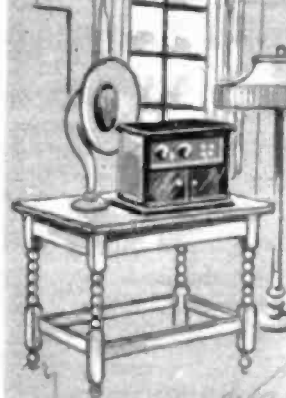

Open the Door of
Radio Entertainment
with
ONE DIAL

AMRAD reputation was built first upon the technical efficiency of our radio sets—efficiency manifested in marvelous distance records and wondrous purity of tone.

Then came beauty—AMRAD Sets encased in lovely period cabinets.

And NOW—simplicity! By the turning of ONE DIAL the AMRAD Inductrole will give you measureless days and nights of pleasure, culture, entertainment drawn from the whole world of Radio.

We ask this favor—will you please send us a post card giving your name and address?

If you add that you'd like a demonstration we'll give you one, in your own home, without cost to you. And anyway we'll be glad to send you booklets fully describing the various AMRAD models for all kinds of homes and at a wide range of prices.

The Inductrole is illustrated above, encased in hand-rubbed mahogany, with special battery compartment, operates four tubes, extremely selective and a supreme value at..... \$100

AMERICAN RADIO AND RESEARCH CORPORATION

Department RH, Medford Hillside, Mass.
New York Chicago Philadelphia Boston

AMRAD
"The Voice of the Air"

A NEW CIRCUIT AND A LICENSING AGREEMENT THAT MEANS MONEY TO MANUFACTURERS AND DEALERS

For the past few years, scores of new circuits, new ideas and new designs have been brought to the attention of the radio public. Many had merit, but few survived.

This condition has been brought about mainly because sufficient finances have not been available for extensive exploitation.

The Callworth Radio Corporation realizes that consumer acceptance and endorsement cannot be had without consistent and intelligent advertising effort, and with this in mind, has agreed to spend for advertising 20 per cent of all royalties received from manufacturers. This policy will do much to further public interest in the McCall Compensated Circuit.

The McCall Compensated Circuit is practical, not only from the standpoint of the radio fan, but also from a manufacturing angle. In offering the McCall Compensated Circuit license to six manufacturers, the Callworth Radio Corporation feels that it is offering not only a really new and important circuit, but what is even more necessary, an assurance of its favorable reception by the public.

We would like to submit our proposal to interested manufacturers and suggest immediate inquiry.

Callworth Radio Corp'n.

GRAND RAPIDS, MICHIGAN
NEW YORK OFFICE, 500 FIFTH AVE.

Gotham Wireless, Inc.

131 West 14th Street, New York City

Licenses and manufacturers of the

Royal Knight Receiver

tirely self-contained—tubes, "A" batteries, "B" batteries, loud speaker and loop antenna complete.

This set is packed in a small, beautifully finished traveling case—much smaller than the average suitcase, and the set complete weighs only 24 pounds.

In order to operate the new Zenith Radio Companion you simply turn the controls to bring in the station you want—then for maximum volume you swing the case so that the loop is facing that particular station.

The Ozarka Portable Set: This wonderful little instrument is not only for use on vacation; when you come home you will set it up and use it. More than this, your home aerial and ground connection will be much better and therefore the results will be better.

The Ozarka Portable is made to receive results and yet operate under very adverse conditions.

The aerial consists of about ninety feet of flexible wire. This is simply stretched out and the other end tied to a tree or post. The ground connection is made either to the frame of your automobile, to an iron rod in the ground, or a pump, or possibly a windmill tower which is not resting on concrete, or if you are anywhere

fronted this problem have assumed the same thing in the beginning.

But it is an unfortunate fact that while virtually all electric systems are theoretically 60 cycle to 110 volt alternating current, there are, as a matter of fact, as many individual characteristics of the lighting systems as they are lighting systems.

Faulty operation of generators, dirty contacts, imperfect brushes in the power house, "induction" noises picked up along the line, all of these things are fed into our converting units when we attempt to use the house lighting circuit for our radio sets.

Consequently, it is essential that the successful unit of this kind be capable of adjustment to meet the individual requirements of the circuit upon which it is going to be used.

When I first discussed this matter with Mr. Timmons during the preliminary stages of his experimentation, he declared that he would not put anything on the market until this problem of individual peculiarities was solved. He sent his chief engineer and some of his laboratory assistants on a tour of the South and the Middle West, under instructions to hunt out the most antiquated and least efficient lighting systems that they could find and to stay with these



Radio in the Home of Mr. F. Atlee, 2321 DeLancey St., Philadelphia
Photo by Henry S. Tarr

near water you would simply put one end into the water.

The instrument requires three 199 dry cell tubes, and these are operated by two 3½-volt "A" batteries, which are carried in the left-hand side of the instrument. The capacity of these batteries is from 12 to 18 hours. If you are going on a trip that you will use them longer than this, take along an extra set. In addition to the "A" batteries are two 22½-volt "B" batteries, and the capacity of these is from 25 to 30 hours. The instrument is made to operate one or more sets of head phones. If more than one set are used they are connected in series by a connector, and as many as four sets can be used successfully.

This Shows the Trend of Radio

(Continued from Page 39)

worked upon their system, they would work upon any system. Mr. Timmons, whose set is shown in the picture, assumed the same thing with the first device he built in his laboratories, now a good many months ago. In fact, most people who have con-

systems until these units were able to tune out all of the various noises which the system would ordinarily introduce.

At the end of a three months' trip these men came back to the laboratory and Mr. Timmons designed his present unit. He brought it out to our experimental station, 3XP, at Delanco, N. J., where we happen to have as difficult a problem as there is anywhere, and there, for the first time, I heard a genuinely satisfactory demonstration of a device to use the alternating current lighting system for both A and B current in our radio sets.

I am pointing out the difficulties in the way of designers of such units not only for the benefit of our readers, but particularly for the benefit of dealers who are not quite familiar with the technical features of such units. These dealers are going to be besieged by many salesmen within the next month or two, and these salesmen will give all kinds of assurances that their particular devices are absolutely perfect.

I want to give both readers and dealers a word of warning right now. Don't under any conditions buy one

of these units unless there is an absolutely cast-iron guarantee that money will be refunded if the unit does not work successfully in the particular place where it is to be used.

We have tried at least a dozen of these devices at Station 3XP. We have tried all that have been put on the market and every one of them failed. That was not because the device would not work perfectly on a system identical with the one on which it was developed, but it was because the unit had not been developed with the idea of adjusting it to any system on which it might be employed. Consequently, it failed to work at Station 3XP.

Mr. Timmons has led the way in designing a unit which can be tuned by any novice until all extraneous noises are eliminated. He will undoubtedly be followed by a great many manufacturers next season and I only wish to suggest to all dealers that they refuse to consider any of these devices without the guarantee of money back if not satisfied.

The development of a successful device of this kind seems to me to be about the most important thing that has happened for a long time in radio. Any dealer will agree with me when I tell you that in 30 or 40 per cent of his best prospects, the sale has not been made because the woman of the house has refused to permit the installation of storage batteries or of a set which required a lot of wires exposed to catch dust and almost impossible to clean.

The device shown in the photograph eliminates all of these difficulties. The photograph shows the set absolutely complete in every respect and the only wires are those running from the set to the baseboard plug.

What Size Grid Leak Shall I Use?

By G. N. Garrison, I. R. E.

Much has been said in the press during the past relative to the proper size grid leak to use with a certain vacuum tube in a specific circuit. The Radio Corporation of America incloses a circular with each of its tubes, telling the range of grid leaks that will give the best results for the tube with which the circular was packed. It will be noted that these circulars give a comparatively broad range of grid leak resistances that will prove satisfactory.

If the specification for a certain tube called for a grid leak of 2-5 meg. ohms, it would simply mean that a grid leak somewhere between 2 and 5 meg. ohms resistance with that particular type of tube would probably be satisfactory for giving clear reception on most stations.

However, there is quite a difference between 2 and 5 meg. ohms, and it is my intention to show that it is absolutely essential to employ a variable grid leak, if maximum results are to be obtained.

A detector tube rectifies by virtue of the fact that it allows the incoming wave to pass more readily in one direction than in the opposite direction. Understand, the incoming radio wave passes through the detector tube in both directions, but in one direction it is much stronger than in the other. When the radio wave strikes the grid of the detector tube and before it is rectified, both the negative and positive half of the cycle are of equal strength. In most circuits there is a small fixed condenser, called the "grid condenser," connected between the secondary coil and the grid of the tube. This effectively prevents any direct current from reaching the grid, at the same time allowing the negative and positive half-cycles of the incoming wave to freely strike the grid. All the time the tube is in

(Continued on Page 47)



WorkRite Radio-King, a five tube G radio amplifier, 1 detector and 2 audio amplifier, super neutrodyne receiver. Beautiful mahogany cabinet, 22 in. x 20 in. x 14 in. This set operates with outdoor or indoor aerial and is highly selective. Long distance stations come in full and clear on the built-in loud speaker. Complete except tubes, batteries and aerial wire - \$225.



Now You May Choose Your Set With Certainty of Satisfaction

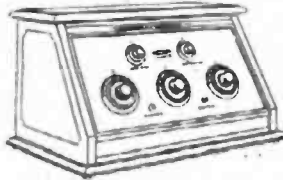

WorkRite Air-Master, same as Radio-King except without built-in loud speaker. Mahogany cabinet 21 in. x 14 in. x 14 in. Without batteries and loud speaker, tubes or aerial, \$160.

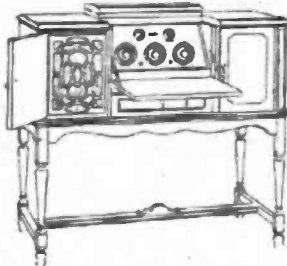

WorkRite Aristocrat, a most beautiful mahogany console model 42 in. x 40 in. x 20 in. This set employs the same super-neutrodyne receiving apparatus. The cabinet contains a built-in loud speaker and space for A and B batteries. Not only a wonderful receiving set but also a charming piece of furniture. Complete except tubes, batteries and aerial - \$350.

THESE new WorkRite super neutrodyne receiving sets bring an assurance of lasting satisfaction in every phase of radio performance.

Combining ease of operation and remarkable selectivity these sets receive clear across the continent with full volume on the loud speaker. Even over extremely long distances music is heard with striking clearness and freedom from distortion.

And, because these receivers are neither experimental sets or playthings, they have been built into beautiful cabinets of genuine mahogany. You will be as proud of the appearance of a WorkRite set as you are of its performance.

See these sets at your dealer, or write for the new illustrated literature

Licensed under Hazeltine Patent Nos. 1,350,080-1,450,228
The WorkRite Manufacturing Co., 1800 E. 30th St., Cleveland, O.

BRANCHES:
New York City, 1023 Knickerbocker Bldg. Chicago, 539 Lake Shore Dr. Los Angeles, 239 So. Los Angeles St.

WORKRITE

SUPER NEUTRODYNE RADIO SETS

HARKNESS REFLEX

The circuit that put efficient radio within the reach of all. All developments of this system are now found exclusively in "Radio in the Home."

KENNETH HARKNESS

is one of our Associate Editors and writes for no other publication.

The Slant of the Trade on Radio

NEW WAVE LENGTH OF 423 METERS ASSIGNED TO CROSBY STATION

WLW to Divide Time With WBAV
of Columbus—WSAI and WFBW
to Remain on 309

WLW, the radio station of The Crosby Radio Corporation, is now broadcasting on its new wave length—423 meters—final plans for the change having been made as a result of a special request made by Powel Crosby, Jr., owner of the station, to officials of the Department of Commerce.

This wave length is the same as is used by KPO, at Oakland, Calif., but because of the great distance between the two stations and the difference in time, there will be no interference. It also is the same as will be used by WBAV, of Columbus, O., but that station and WLW will divide operating time. Friday night will remain silent night so far as Cincinnati is concerned.

This change was necessitated by the addition of a third Class B broadcasting station in Cincinnati, which had been assigned a wave length of 309 meters, the same as was used by WLW and WSAI. It had been suggested that a three-way division of time be worked out, but Mr. Crosby realized the fact that there is but one other instance of three stations dividing time on the same wave, and that the others involved also were in Ohio, the Columbus station being one of them. He immediately suggested that a new wave length be assigned to WLW, and asked for the same as is used by KPO, declaring that if the Columbus station were assigned the same "two birds could be killed with one stone."

As soon as the final plans were completed, he "went on the air" at WLW and announced the change to the thousands of radio listeners. His message follows:

"When there was talk of a third Class B broadcasting station being assigned the same wave length—309 meters—up to that time used by WSAI and ourselves, we felt sure that such an arrangement could not work out, knowing full well that there is only one other place in the United States where an attempt has been made to operate three broadcasting stations on the same wave length with a division of time, and as that experiment has not worked out satisfactorily we felt it would not be feasible to attempt to work such a plan in Cincinnati.

"We visited Washington and requested the Department of Commerce to assign us to a different wave length. Officials there appreciated the difficulties involved in an attempt

of a three-way division of time, but showed us that there were no other wave lengths available. They suggested that an additional wave might be worked out in the course of the National Radio Conference, which, at that time, was planned to be held in June, and suggested we do the best we could until that time. However, it was decided to postpone the conference until later in the year.

"In the meantime, a rather unpleasant condition became evident in Cincinnati, which required some immediate action. Now remember that there is only one other place in the country where three Class B stations are attempting to divide the same wave length; there are two stations in Cleveland, WTAM, the Willard Storage Battery Company, and

stations would be asked to divide time on the same wave length, with such a condition not existing in any other State in the Union. The Department of Commerce recognized this condition.

"They did not like it any better than we did, but they had no other wave lengths available. However, about a week ago I visited Washington again, and it was finally decided to assign this station the same wave length used by KPO, Oakland, Calif., namely, 423 meters. Heretofore the department has not assigned any station west of the Allegheny Mountains on the same wave length as a West Coast station.

"However, as station WCAP, of Washington, D. C., is operating on the same wave length as KFI in Los

where any three local stations are attempting to divide time. We have not as yet taken up in detail with the Columbus station the matter of division of time, but there is no question but that this can be worked out very satisfactorily. This matter will be arranged within the next few days, so that we can go on our new wave length as soon as possible.

Now the question has been brought up as to interference between any two Cincinnati stations operating at the same time on different wave lengths. You will notice that there is a wave length separation of 114 meters between the 309 meters—the wave length at which the other stations in Cincinnati will operate—and 423 meters—the wave length on which we will be operating shortly. With

such a wide separation there should not be any serious interference where non-selective receivers are used.

"We believe that with even the simple type of receivers, located at a point where the two Cincinnati stations operating simultaneously are of equal volume, that either station can be tuned in. On the other hand, if the owner of a non-selective receiver is located very close to one or the other station, the user will probably be unable to hear that station located at the greater distance. However, we believe that on the whole there will be very little interference. You will be able to hear one station or the other, and in some instances you will be able to choose which station you wish to listen to. Even though you are unable to choose, the condition will be exactly the same as if the attempt to have three stations divide time had been carried through, when you would be able to listen to one station at a time. Things will simply be bettered to this extent: Under some conditions you will be able to make your choice of two stations, where otherwise you would be able to hear one.

"We feel sure that this matter has been worked out to the satisfaction of all, and that the other two stations will have no difficulty in working out their own division of time. We are certain that we will have no difficulty in a division of time between our station and the station in Columbus, O. There will, of course, be no necessity for Columbus to maintain the same 'silent night' that we will, namely, Friday, but we ask the radio public to bear in mind that this whole matter has been worked out in the fairest possible way—the same way that has been done in every other place in the country.

"We wish to add that our efforts to bring this about have been at no time designed to embarrass any other station, nor to prevent the operation of any other station in Cincinnati."

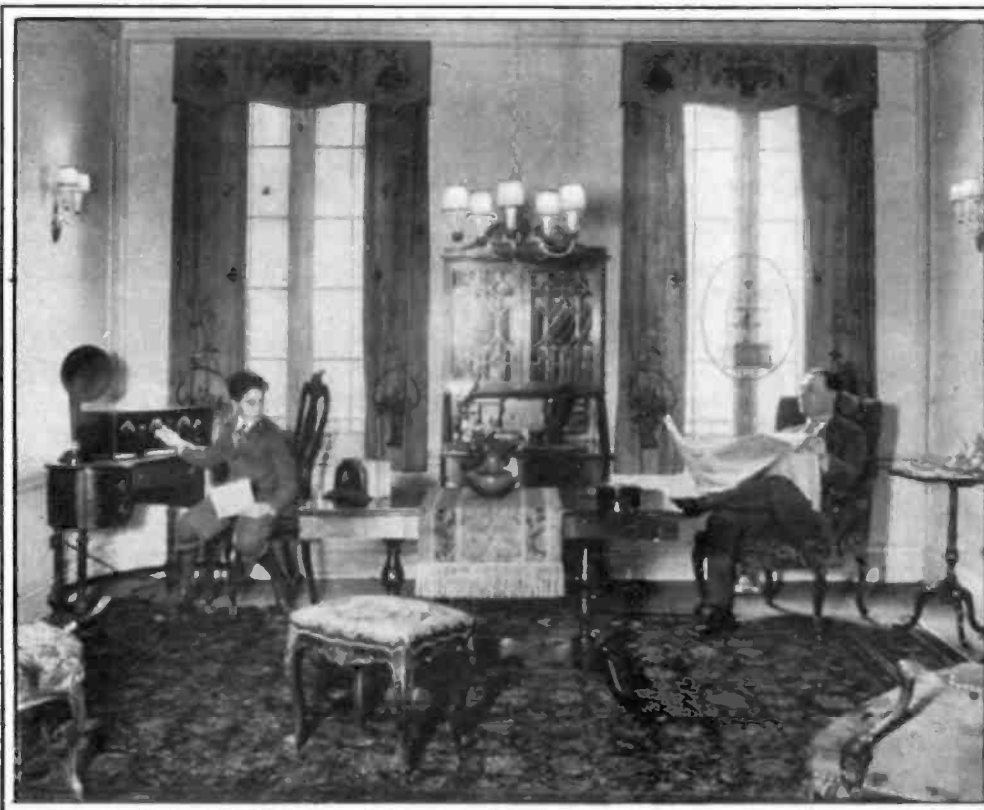

Radio in the home of Bernard Beck of Newark, N. J. Mr. Beck and his son are both enthusiastic radio fans, and not even the evening paper can hold "Dad's" attention when "Junior" tunes in his favorite station

WJAX, the Cleveland Trust Company, who are assigned the same wave length as WBAV, Erner-Hopkins Company, of Columbus, O. These three stations are dividing time, but but it has not worked out at all satisfactorily for any of the stations. Chicago has five different Class B wave lengths, with seven broadcasting stations.

"One station in Chicago has a wave length all to itself, and the others divide time with not more than two stations on any one wave. The same condition is true in New York. Pittsburgh has two Class B broadcasting stations, neither of which is dividing time with the other.

There are many other Class B stations in the country that do not divide time with any other station, and yet, here in the State of Ohio, there seemed the possibility that there would be two localities in which three

Angeles, and there is very little, if any, interference between the two stations, on account of the great distance apart, even in the winter time, it was felt that this arrangement might well be made to put us on the same wave length as KPO, especially during the summer months, with the probability of a different arrangement before the winter.

"So 423 meters was assigned to WLW, with the understanding that we would divide time with the Erner-Hopkins Company, of Columbus, O., thus, it was possible for the Department of Commerce to 'kill two birds with one stone.' It is no longer necessary for the two Cleveland stations to work with a third station in Ohio on the same wave length, and it is no longer necessary for any attempt to be made for a division of time between three stations in Cincinnati.

"There is no place in the country

The Slant of the Trade on Radio

¶ Fans in every city want to know the favorite sets and circuits in other cities.

¶ Dealers everywhere want to keep in touch with the trade trend everywhere else.

¶ All this is given in "The Slant of the Trade on Radio." It is an exclusive feature of

RADIO IN THE HOME

Burned Out or Broken Radio Tubes Repaired

Including
WD-11 or C-11
WD-12 or C-12
UV-199 or C-299
UV-201A or C-301A
UV-200 or C-300
UV-201 or C-301
DV-1 or DV-2
DV-6 or DV-6A

\$2⁵⁰

All Tubes Guaranteed to Work Like New

Radio Tube Exchange

220 S. State Street, CHICAGO, ILL.
Department A
Mail Orders Given Prompt Attention

KEYSTONE RADIO LIGHTNING ARRESTERS

The new Keystone, made of genuine Bakelite, approved by Underwriters. Absolutely weather proof, damp proof and has no vacuum to lose.

At Your Dealers, \$1.60 each
ELECTRIC SERVICE SUPPLIES CO.
Manufacturers of Over a Million Lightning Arresters
17th & Cambria Streets, Philadelphia
Monadnock Bldg., Chicago

The Most Efficient Vacation RADIO



SIMPLEX RFB PORTABLE

For camping, picnics, auto trips or any of those "in-between" hours of every vacation. Loud speaker volume, distance and clearness. 4 tubes on 3 dry cells. All concealed in handsome case. Price without accessories. **\$80**
At Most Reliable Dealers
SIMPLEX RADIO CO. (Mfrs.) Phila., Pa.

RADIO, THE SUPER WEATHERMAN

By Lloyd S. Graham

We think of the weatherman as doing two things: He forecasts the weather and then distributes the information which he has obtained.

From the early days of the weather service, the problems of quick distribution of weather information has always been a puzzling one. The best that any of the forecasters could do with any degree of accuracy in the early days was to forecast the weather a few hours in advance.

Even now predictions are only made with reasonable accuracy about twenty-four hours in advance and the problem of distribution is an important one.

Obviously the weather information is of no use unless it can be distributed, and its value is considered in direct ratio to the swiftness of its distribution.

But really swift distribution of weather information was really an impossibility, comparatively speaking, until a short time ago. The government used the telegraph. It used the daily papers. It used the postal service. It established in each district many storm warning stations, and any one who was near enough to a storm warning station or a weather bureau could get the information over the telephone.

Still distribution was a problem. And then, in came radio.

One never reads about the weather broadcasting of radio. This is one of the great unrecognized, unheralded, radioly despised services of radio. Hundreds of thousands of people listen once or twice a day to the radio information "on the air." They listen and pattern their daily lives accordingly.

It is one of those things taken for granted, like eating and sleeping, but of the utmost value to those who receive the information. They listen, they plan their shopping trip or they give it up for the day; they take their ships to sea or they remain in the shelter of harbors; they cut their harvest plans to fit the weather information; the aviator flies or he does not fly.

In a recent statement, C. F. Marvin, chief of the weather bureau at Washington, said: "Meteorology and radio communication have literally transformed the navigation of the sea from a great peril to a state of relative safety, especially in coastal waters and on the high seas in reach of the daily broadcasts of weather reports from coastal stations.

"Cargo and even passenger ships now shape their movements on weather reports. During the hurricane season of the southern seas we may safely say a captain would not leave port without the latest weather advices."

Mr. Marvin tells how important the service is to shipping on the Great Lakes. This is evidently one of the locations where radio broadcasting is of greatest value. Tying up a ship means a loss of \$50 to \$100 per hour unless the delay can be justified by accurate weather information, right up to the minute, predicting inclement weather.

David Cuthbertson, meteorologist of the Buffalo district, in this connection, says that there has been no invention in years which has meant so much for increasing the effectiveness of the weather bureau operation in the Great Lakes. This applies not only to the shipping interests but to the farmer.

"It is a poor farmer, indeed, in this part of the country who does not have a radio receiving set capable of obtaining reports from the nearest forecasting station. The public does not realize the value of the service

and never will unless it should somehow be suddenly taken away from it. "Before the days of popular broadcasting, there were many stations established by the government throughout the country for spreading weather information, but many of these, including the one at Buffalo, have been discontinued since the big broadcasting stations have taken up the broadcasting of weather reports."

Mr. Cuthbertson is one who knows. He is a veteran of the weather service. He came to Buffalo in 1884 as meteorologist, which position he has held since that time. He had been in the weather bureau service for many years prior to that time. And if you think you know any thing about the weather, well, you don't know "nothing" yet, as compared with Mr. Cuthbertson.

The writer interviewed all sorts of people on the value of radio in broadcasting weather information. Chamber of Commerce secretaries, farmers, farm bureau secretaries, steamship captains, officials of shipping companies, aviators and aircraft experts, fruit growers and many others.

Perhaps the class which considers the weather information of the greatest value is the farmer. The farmers used to get their weather information a few hours old by the rural free delivery, both in their newspapers and on franked postal cards from the weather office. Now he gets his weather information hot off the griddle by radio. And apparently the farmer is more appreciative than any other type of broadcast listener for the weather information which he receives.

Let's look at it a moment from the standpoint of the broadcasting studio. In a large number of studios, weather broadcasting is considered the studio killjoy. It is the Jonah that drags tired announcers out on silent nights to go to the studio and broadcast a weather report, when otherwise they could be at home resting up for the next concert night, reading a book or at a movie.

Broadcasting weather reports is not what you might call popular in most studios. It is generally considered as an unappreciated service, a service which the government should be paying for. No studio ever gets any fan letters complimenting it or thanking it for broadcasting weather reports.

Yet many stations attend to this service religiously, as regularly as the rising and falling of the sun; holidays, silent nights, Sundays, morning and night, the weather has the right of way.

And hundreds of thousands of people who literally gush over this singer or that piano player, listen for the weather reports more often than they do to the concerts and never think of the expense and care that is necessary for the broadcasting station to take in issuing these reports on time and with uninterrupted regularity.

HOW SOME PROBLEMS IN RADIO HAVE BEEN SOLVED

By E. F. W. ALEXANDERSON
Consulting Engineer, General Electric Co.

The real romance in any development lies in the pioneer stages. When long-distance radio communication was first put to important use, during the war period, many thrilling episodes occurred.

One of these took place in a station that had been hastily reconstructed and forced into the service of maintaining communication with France while we were yet building and experimenting in radio. Originally, the station had been of the Marconi type, but had become obsolete, and its reconstruction primarily consisted in setting down a high-frequency alternator and building a primitive trans-

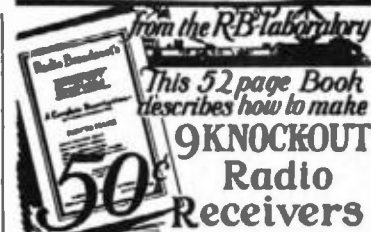

B. R. Linton, Hapeville, Ga., using the 1-tube Knock-out set described in this book, hears KFI, Los Angeles and many other distant stations regularly on his loud speaker.

YOU, too, can build a Knock-out distance-getter. This book tells you how! No "trick" circuits; each of the sets has been built and tested in the Radio Broadcast laboratory—where all new circuits are tried out—under the personal direction of Arthur H. Lynch. The 9 Knock-out sets described in this book were chosen because of the exceptional results obtained with them by hundreds of Radio Broadcast readers. You can buy all of the parts from your nearest dealer.

The first edition of Radio Broadcast's Knock-out series was sold in less than 10 days. The second edition—more data, more photographs—is going fast. If your dealer cannot supply you, use the coupon today. If dissatisfied we will refund your money.

RADIO BROADCAST, Doubleday, Page & Co., Garden City, N. Y.
I enclose \$0 cents in payment for a copy of Radio Broadcast's Knock-Out Series to be sent to
.....
R. H.

MUSIC that IS music!



THE thrilling voices of great singers—the magic touch of instrumental artists—the vibrant eloquence of famous speakers—free from discordant noises—gripping—REAL!

KENNEDY

MODEL VI (Four Tubes)

gives you radio music reproduction that is music. Tunes with a single dial. Other dial controls volume. When a dial setting is once determined, that station will always "come in" at its own setting. Beautifully constructed throughout. Price \$120, without tubes, batteries or phones. Ask your dealer for demonstration.

Kennedy Receivers are licensed under Armstrong, U.S. Patent, No. 1,111,100

THE COLIN B. KENNEDY CO.
SAINT LOUIS, MO.



Write for a copy today



A new twenty-four page booklet will be sent, gratis, to those interested in building their own receiving sets.

A simplified method of construction is described. Illustrations and diagrams.

On Request

EISEMANN MAGNETO CORPN.
William N. Shaw, President
165 BROADWAY, NEW YORK

Of course you want to improve your summer reception.



USE
TURN-IT
ADJUSTABLE
GRID LEAK
Price \$1.00

National Distributors
TURN-IT RADIO SALES, Inc.
30 Church St., N. Y. City

Manufactured by
CHARLES E. BONINE
20 S. 15th St., Phila., Pa.

MAR-CO

PROBABLY you touch your plug oftener than any other single part of your set. And if it's a MAR-CO STA-PUT plug, you congratulate yourself on a wise purchase, every time you use it.

You need never use tools for quick tip changes and positive connections, and you always get "leak-proof" service



40¢



mitting plant around it. Trouble soon developed in the antenna insulation. Usually an insulator would blow up with an explosion, but sometimes it would give warning by a flickering light. The station was strongly guarded by marines who were quick on the trigger, and one dark night the guard saw a flickering light in one of the wooden shacks which was used to house the outdoor tuning coils. He thought it was an enemy spy and would not take any chances so he peppered the shack with his automatic rifle. After a little while the insulator exploded and the station was dead. This gave the marine convincing proof that somebody had planted a bomb.

Firearms played no part, however, in the final solution to this problem of insulator breakdown. It was technical knowledge acquired by scientific investigation that furnished the means of eliminating the trouble. This is but one such incident.

The development of commercial radio in all its phases has afforded an unusual opportunity for the application of scientific engineering methods. In most other branches of engineering there are many precedents to help or hinder the engineer in his choice of methods. In radio communication there were but few such precedents; practically every problem was a new one and had to be solved by new means. In addition to this element of newness, there was the additional complication of having to deal with forces of Nature which are not under control, and therefore subject to the law of chance. At the outset, these laws of Nature were very little understood and all of them are not yet entirely known. For instance, what are the causes of fading and exceptional increase of signal strength, or periodic fluctuation of signals? It can only be stated that these phenomena are observed to have something to do with the change from daylight to darkness, and that they are more pronounced at the shorter wave lengths. The hypothesis of the Heavyside layer has been introduced as an explanation, but it is not altogether convincing.

That great enemy of radio communication, atmospheric disturbance, so-called "static," is by this time well understood and under control. It is really this fact that makes commercial radio communication at all possible.

To bring about order and dependability in the transmission of radio signals, it has been necessary to take into account the law of probability and averages. This can be readily understood by those who are radio amateurs or broadcast listeners. When a clear signal is received from across the continent, this interesting fact is related to friends. Similarly, when the sportsman catches a big trout, he makes mention of it as an event. Nevertheless, professional fishermen succeed in providing fish for the market with great regularity.

The transoceanic radio station is a power station. Its input is kilowatts and its output is words. The problem of radio engineering is to establish the relation between kilowatts input and words output. This relation between kilowatts and words is a chain comprising four separate links which are being studied by specialists in the following subjects:

- (1) Efficiency and cost of radiation.
- (2) Wave propagation, absorption and fading.
- (3) Atmospheric disturbances.
- (4) Speed of commercial signaling.

Efficiency and cost of radiation: The first subject deals with the radio power station and the antenna. Four types of antennas are used in the system of the Radio Corporation of America. Three of these are adaptations of old structures, but the fourth, the Radio Central antenna, is designed

from the ground up. The radiation efficiency of an antenna depends upon the effective height, the ground resistance and the wave length. In antennas for long waves, most of the energy is absorbed locally and only a small proportion is radiated.

The object of modern antenna design has been to get maximum radiation for a given antenna investment as well as a maximum radiation for a given power consumption. These two requirements are contradictory, and, as usual in design, a compromise must be arrived at. A high radiation efficiency can be obtained only by the use of a very expensive antenna. There is a third requirement that the operating potential must be kept within practical limits. The best compromise between these requirements has been obtained in the long multiple-tuned antenna, with moderately high towers operated at high potential. The Radio Central antenna has twelve ground connections distributed over a distance of three miles, and has 300 miles of wire buried in the ground. Through these devices the ground resistance has been reduced to 1-20 ohm. Antennas of types previously used had ground resistances of about 2 ohms. The losses in the ground have thus been reduced to a different order of magnitude.

The second subject is wave propagation. The longer the wave length the greater is the cost of antenna structure and the lower is the radiation efficiency. From this point of view it would seem that long waves would be undesirable. If communication were desired only during the hours of darkness, this would be so, but in commercial communication the daylight hours are the most important and during those hours the absorption of the short waves is so great that better and more economical communication is obtained by the long waves. For each distance there is a certain wave length, which gives the best compromise between absorption and radiation efficiency.

Atmospheric disturbances: "static": The third subject deals with the atmospheric disturbances. Our modern receiving system eliminates about nine-tenths of the disturbances, but the residual which is not eliminated determines the speed of reception by the law of inverse proportionality.

Sufficient knowledge has now been accumulated on these subjects to enable new radio communication circuits to be designed with the same deliberateness as we design a dynamoelectric machine. The designer starts at the receiving end and gathers his facts and reasons backward in order to determine what power, wave length, etc., the transmitting station should have in order to serve the purpose most economically.

This can best be illustrated by an example. The first step in planning a radio circuit is to make measurements of atmospheric disturbances at the places where the signals are to be received. These measurements should extend throughout the season of the year when reception is most difficult.

At this point it may be of interest to explain the modern conception of atmospheric disturbances and the means devised to control them.

Any such disturbance was originally called "static" because it was assumed to be of the nature of static electricity. The hypothesis which is the basis of modern work is different, however. The ether is imagined to be a disturbed ocean with waves of every length rolling in from all directions. These waves are of the same nature as the signal wave. Those disturbing waves which are of different wave length from the desired signals can be shut out by the same means as is used for shutting out other signals, that is, by tuning. But

FREE

To Each Purchaser of a **World Battery**

A 24-Volt "B" Storage Battery positively given FREE with each purchase of a WORLD "A" Storage Battery. The WORLD Battery is famous for its guaranteed quality and service. Backed by years of successful manufacture and thousands of satisfied users. You save 50%.

Prices That Save and Satisfy

Auto Batteries		Radio Batteries	
6-Volt, 13 Plates \$24.25	6-Volt, 13 Plates \$14.25	6-Volt, 13 Plates \$11.00	6-Volt, 13 Plates \$11.00
6-Volt, 13 Plates \$14.25	6-Volt, 13 Plates \$11.00	6-Volt, 13 Plates \$11.00	6-Volt, 13 Plates \$11.00
12-Volt, 7 Plates \$17.00	12-Volt, 7 Plates \$11.00	12-Volt, 7 Plates \$11.00	12-Volt, 7 Plates \$11.00

Shipment Express C. O. D. subject to examination. 4 per cent discount for cash in full with order.

2-Yr. Guarantee Bond in Writing With Each World Storage Battery

proves satisfactory World performance. Hold this ad with your money and tell us — we will ship battery day after day until you are satisfied. If you are not satisfied, we will return your money and give you your choice of 75¢ cash, 25¢ in World Storage Batteries, or 25¢ in World Batteries. **FREE** is yours today.

WORLD BATTERY COMPANY
1219 So. Wabash Ave. Dept. 35 - CHICAGO, ILL.

The FREE "B" Storage Battery takes the place of the old "A" battery. (Can be recharged and run just as long.) To be sold only for \$2.25. It is the only battery of its kind equipped with a built-in rubber cap — 1 in. extra — against acid leakage. To take advantage of this offer, call for a copy of our offer NOW. (It shows why you will save 50% — a bonus you can't get elsewhere.)

GIVEN FREE

To introduce the new and improved World Storage Battery to the

The Perfect Reflex Crystal

Whether you are building a reflex or crystal set or already have one it will pay you to get a Foote Perfected Variotector. No chance of electrical leakage or short circuiting. Assures maximum volume and greatest clarity. And it's built to last as long as your set. Absolutely mechanically and electrically perfect. Get a Foote Perfected Variotector and hear the improvement in your set. \$1.50 at Reliable Dealers.

Perfected Variotector

FOOTE CRYSTALS

FOOTE MINERAL COMPANY, Inc.
104 N. 19th St., Philadelphia, Pa.
Mineral Pioneers for nearly 60 years

Use **DURHAM** Price 75¢

Variable Grid Leak

At all dealers or postpaid
Fits all sets, home made or factory built. Snap a DURHAM in place of present fixed leak. Send for Folder H.

Satisfaction Guaranteed
DURHAM & CO., Inc.
1930 Market St., Philadelphia

the disturbing waves which have the same wave length as the desired signal are in all respects of the same nature, and pass through the tuning system like the signal.

Elimination of "static": It is thus apparent that if some ground for discrimination can be found other than wave length, we would have a higher order of selectivity than is obtainable in the ordinary tuned receiver. Such a principle has been found, and has proved to be one of the most important developments in radio communication. If a receiver is constructed which is sensitive to waves coming from only one direction, then waves from any other direction can be shut out even if they have the same wave length. This is the principle of directive reception on which the receiving stations of the Radio Corporation are based.

Each successive step in increasing directivity of the receiving system has shown marked improvement in its capacity for handling traffic. The development of the central receiving station at Riverhead, Long Island, has already reached the point where the signals from Europe are received on an antenna system 30 miles long, and the signals from South America on another antenna system 20 miles long. The antenna consists of two telegraph wires mounted on telegraph poles.

Selection of receiving site: Static usually originates from the land side and thus if the signal comes from the ocean, it is possible to design the receiving system so that it eliminates the static and retains the signal. In one exceptional case, it was found after sending an expedition to the place which had been planned for a radio station that static and signal came from the same direction and that radio communication would have been impossible for several hours a day. A new receiving site was then investigated where conditions were found to be favorable. The adoption of this location necessitated the re-design of the whole system in such a way that the signal reached the ultimate destination after passing two sides of a triangle, the relay station being situated at one of the points of this triangle. Two lines of favorable direction were thus substituted for one line of unfavorable direction; just like a sailboat which requires two tacks to arrive at a point straight to the windward. This is a very unusual case but it shows that a practical solution can be found even under the most unfavorable circumstances.

Speed of commercial signaling: The fourth subject deals with the speed of reception. It has been observed in radio telegraphic communication that the maximum signalling speed is directly proportional to the ratio between the wave amplitude and the amplitude of the atmospheric disturbances.

Measuring instruments have been developed by which charts can be made to show by polar curves the intensity of the static in all directions. Such charts are made for every hour of the day. Their examination will show that portions of the static can be eliminated by unidirectional reception, and what the intensity will be of the static which cannot be eliminated. Assume that this investigation shows that the total static for the afternoon hours of the summer is 500 microvolts per meter. Reception under such conditions without the unidirectional receiving system would be totally impossible. Assume, however, that the polar charts show that only 10 per cent of the static falls within the quadrant from which the signals are to be received. The portion of the static which cannot be eliminated has then an effective intensity of 50 microvolts per meter. A transmitting station that can give a signal intensity of 50 microvolts per meter could then

be expected to handle traffic at a rate of twenty words per minute during those worst hours of the day, and at a higher rate during the remaining hours. If this is not sufficient to handle the expected volume of traffic, it may be decided to use a signal intensity of 100 microvolts per meter, with the expectation of receiving at a rate of forty words per minute during the worst hours.

The fact that radio telegraphy has now definitely attained the commercial stage does not mean that the end of its development has been reached. By the continued application of scientific engineering principles to the solution of its problems, as they arise, radio telegraph service will grow to fill a greatly extended field of utility. But this is not all. The knowledge which has been gained in making radio telegraphy dependable is now available for application to broadcasting. There is reason to believe that the utilization of the same principles will go a long way toward eliminating the uncertainty that today attends the daily reception, over long distances, of educational and entertaining programs.

What Size Grid Leak Shall I Use?

(Continued From Page 48)

operation there is a small amount of negative current constantly accumulating on the grid. Since this negative charge, in itself, cannot pass back through the grid condenser, some means must be provided of allowing it to "leak" off as fast as it accumulates on the grid. If it did not, the accumulated negative charge would become so great that it would "block" the tube and it would cease to operate. A grid leak is usually provided for this purpose, and it is connected either across the grid condenser or between the grid of the tube and its filament. If the negative charge on the grid leaked off very slowly, and not so fast as it accumulated, the action of the tube would become erratic, accompanied by clicks and knocks in the head telephones.

If the negative charge leaked off too rapidly—that is, faster than it accumulated on the grid, less of the incoming wave would be rectified and the signals would be weak.

Now, since all broadcasting stations are not the same distance from your receiving set, nor of the same power, each station received will have a different intensity. This means that each station received will place a different amount of alternate positive and negative charges on the grid of our detector tube—different for every station received. A local station, in a given fraction of a second, will place a larger negative charge on the grid than will a station, say, 50 miles away. In fact, this charge will vary inversely as the square of the distance between transmitting and receiving stations.

Since the local station places a larger negative charge on the grid than does a distant station, it stands to reason that the leak used for the local station must have a lower resistance than it would have for a station further away, to allow the charge to leak off in the same length of time.

If we use a grid leak whose resistance is fixed and of the proper value for a certain station, it will be entirely unsuited for a station that is much nearer or much further away.

Since it is impracticable to change grid leaks for each different station we wish to receive, our only solution is the use of a grid leak whose resistance is continuously variable. This is an ideal solution if a variable grid leak of reliable manufacture is selected, and the added improvement in signal strength, clarity and distance will more than compensate for the slight additional first cost.



FADA

Transformers and Variable Condensers



FADA Audio Frequency Transformer No. 171-A, \$6.00

FADA Variable Condensers No. 142-A (15 plates .0003 mfd), \$3.00 No. 144-A (23 plates .0005 mfd), \$3.50

More volume—finer tuning

POOR condensers absorb radio power—that cuts down volume. Poor condensers add resistance—that broadens tuning. You can sharpen your tuning, increase selectivity and get greater volume with the new FADA "low-loss" variable condensers. Use them. The low power factor and low equivalent series resistance prove their superiority. FADA "low-loss" condensers are more efficient than many of the so-called precision condensers and have a capacity ratio of 40 to 1 as compared with 30 to 1 which is usually encountered. Two sizes—No. 142-A (15-plate .0003 mfd) at \$3.00 and No. 144-A (23-plate .0005 mfd) at \$3.50.

Performs as well as it looks

The new FADA Audio Frequency Transformer is encased in bakelite with nicked binding posts and soldering lugs. It looks "quality" all over. And it performs up to its appearance. It has a high average amplification over all the broadcasting wave-bands and reproduces voice and music with a volume and tonal fidelity that is surprising. A wonderful addition to the audio frequency stages of Neutrodyne receivers and equally efficient in other types. This new transformer, No. 171-A, is made possible by correct FADA engineering principles and by uniform production methods. Ratio 4 to 1. Price \$6.00.

Ask your dealer for FADA Transformers and Variable Condensers

F. A. D. ANDREA, INC.

1581 Jerome Avenue, New York



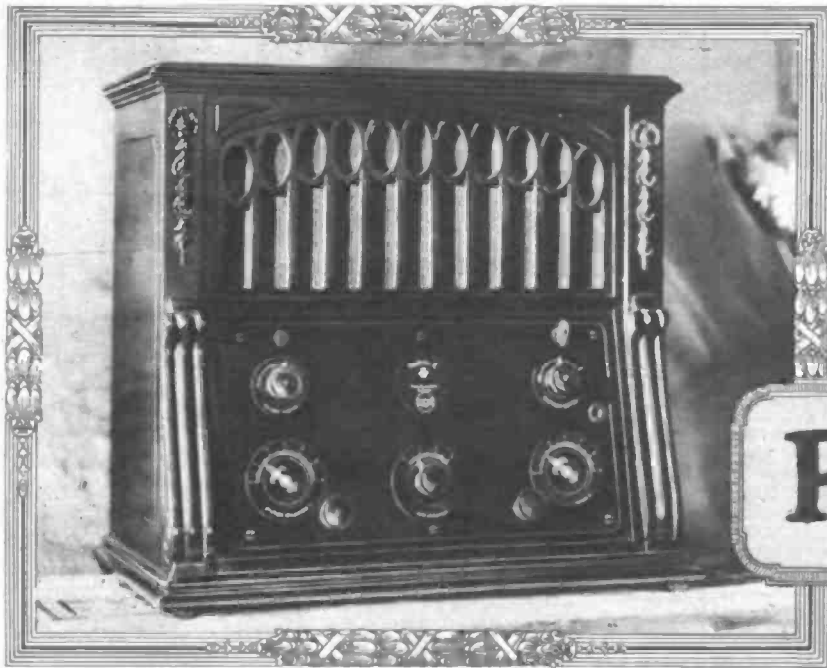

Radiola X

Radiola X—ultra refined receiver of the antenna type, selective and NON-RADIATING. Space for batteries inside. Complete with four WD-11 Radiotrons—everything except batteries and antenna \$245

Uses Only
Dry
Batteries

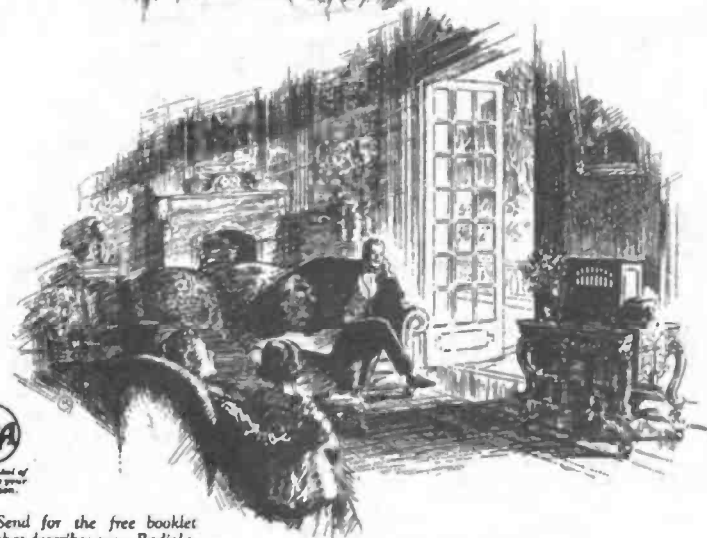

This symbol of quality is your assurance.

Send for the free booklet that describes every Radiola.



To the inspiration of music—add the fun of sports news—lectures—dance! To the beauty of violin and voice and organ, as true and mellow in reproduction as in their rendering in the studio, add the vigorous life of the nation—the urge of national politics—momentous religious debates—the thrill of sports as they're played in the field.

New improvements for long distance receiving, selectivity, simplicity and perfect tone make the Radiola X an outstanding radio achievement of the year. And the same quality in *appearance* makes it the Radiola for the finest of city and country homes. It combines the joy of radio—and pride of possession!

"There's a Radiola for every purse"

Radio Corporation of America
Sales Offices:

233 Broadway, New York 10 So. La Salle St., Chicago, Ill.
433 California St., San Francisco, Cal.

RADIO CORPORATION OF AMERICA
Dept. 277. (Address office nearest you.)
Gentlemen: Please send me your free Radio Booklet.

Name _____

Address _____

Radiola

REG. U. S. PAT. OFF.

YOU DON'T NEED AN OUTDOOR AERIAL

Put the DUBILIER DUCON in the electric-light fixture and tune in. Tunes so sharp you can easily separate two stations on nearby wave lengths.



NOVELTY ELECTRIC COMPANY
30-34 North Fourth Street, Philadelphia
Dubilier Condenser & Radio Corp.,
48 W. 4th St., New York, N. Y.

Gentlemen:

Just a few words of appreciation for your Ducan Plug. We had a recent case where we installed a 4-tube radio set under the most difficult and unusual conditions. Several forms of antenna were tried with results which were not very pleasing. The writer suggested the use of a Ducan in this instance and we are pleased to advise that it has solved the problem for us. The reception over this set using the Ducan was extremely satisfactory. We would not hesitate to recommend your plug for use in this connection.

Very truly yours,
C. E. Mason, Purchasing Agent

The above is one of hundreds of similar testimonials.

BUY A DUBILIER DUCON FOR RESULTS
\$1.50 at all good dealers.

DUBILIER CONDENSER AND RADIO CORPORATION
48 West Fourth St. New York City

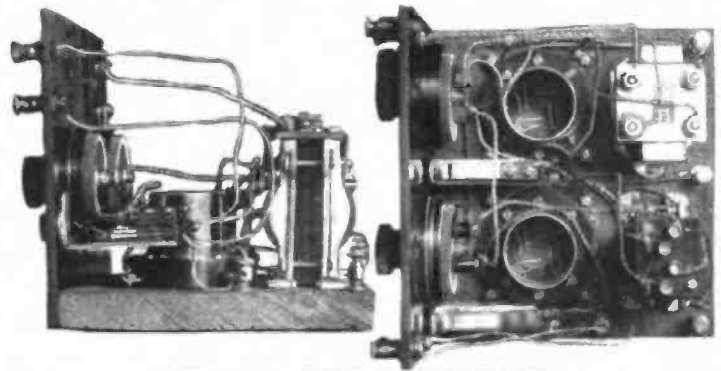

These views show the complete panel for two stages of audio frequency amplification. Above is the side view.

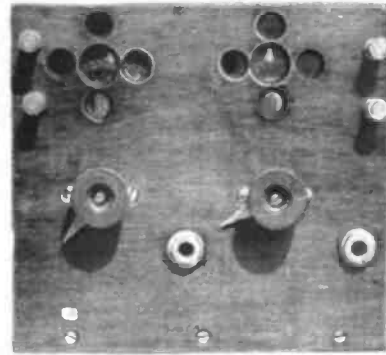

The cut above this shows the panel looking straight down upon it and into the tube sockets. To the left is a front view of the panel.



ACTUAL SIZE OF INSTRUMENT

This Clever Instrument Tells You the Correct Distance of Every Call! And Does it Instantly!

When you tune in on a "DX" call and the tones come over clear and resonant, the first thing you want to know is HOW FAR those waves traveled. You hear a human voice or music hundreds of miles away—and half the thrill is knowing the exact distance those sounds came.

McNeary's Scalometer, Official Radio Map and Broadcasting Directory answer this

question instantaneously. It's simple! Place the Scalometer at your home station (keep it mounted there always), extend the tape to the station received—and there before your eyes, in clear, legible type—you've got your answer.

McNeary's Scalometer is a wonderful little device, and should be in the home of every radio owner.

McNEARY — RADIO
SCALOMETER
together with RADIO MAP and BROADCASTING DIRECTORY **\$1.00**

See this SCALOMETER at any radio shop
IF YOUR DEALER CANNOT SUPPLY YOU COMPLETE
SEND ONE DOLLAR TO

EMBLEM MANUFACTURING CORP.
261 Middle City Bldg., Philadelphia, Pa.

- Q. J. A. Johnson, Jr., Phila.—Wants to know where the minus post of the 45-volt B battery goes in hook-up shown on page 36 of the March issue of E-Z Radio.
- A. The minus 45 is connected to the plus 22½. Yes, WD11 tubes may be used. By using a variocoupler in place of the loop you can use an outdoor antenna.
- Q. S. T. Sutor, Baltimore, Md.—Wants to know about taps shown on page 2 of the November issue of E-Z Radio on the Lindh hook-up.
- A. Don't let a small thing like a few taps worry you. Wind your coil so that there are ten taps taken off, then you will be able to use ten switch points on your panel. The drawing as shown was made from another of my sets.
- Q. G. S. Kleinman, Wildwood, N. J.—Has a single circuit regenerative set that interferes with the neighbors.
- A. You have the same trouble that everybody has who owns a single circuit set. To remedy this is to stop your set from oscillating, then the set is not sending out a wave of its own and it can not interfere with others.
- Q. F. L. Mathewson, Henry Clay, Del.—Adding one stage radio frequency to a single circuit set.
- A. On page 29 of this issue of "Radio in the Home" you will find the circuit you want.
- Q. Robert McCracken, Jr., Cynwyd, Pa.—Has Atwater-Kent set that gets him as far as Kansas City and Canada, and wants to know if he should make a better set.
- A. You have a very good set, and if you get that far, I don't see why you want to change.
- Q. H. W. Handy, Troy, N. Y.—Mounting for honeycomb coils.
- A. You can use the standard De Forest honeycomb mounting.
- Q. R. S. Haws, Collingdale, Pa.—Wants a hook-up of one-stage radio, detector, two-stage audio.
- A. The hook-up you want is shown on pages 24 and 29 of the October issue of E-Z Radio.
- Q. W. H. Kleinberger, Phila.—Sends in hook-up of two-stage radio, detector, two audio.
- A. If I were you I would use the circuit that came with the DX transformers. I know what will work. The DX transformers are very good and work well.
- Q. Thomas A. King, B. S. of A., Troop 40, Washington, D. C.—Wants to know if it is possible to use a crystal with the Lindh hook-up.
- A. If you use a crystal, the range of your set is limited only to local reception, as you have no method of regeneration. The crystal will work on local stations. Your idea of using a variable condenser between the antenna and ground is very good.
- Q. Charles Grow, Darby, Pa.—Wants a hook-up for three stages of radio, detector, two stages of audio.
- A. This will be found on page 26 of the October issue of E-Z Radio. This diagram shows only two stages of radio, but you can put in another transformer the same way as shown for the first two. The audio side is shown on page 29 of the same issue.

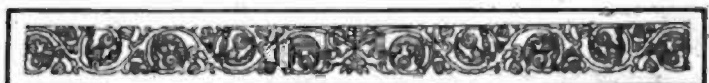

Some Broadcasting Headliners



Above is Harry E. Ehrhart, director of station WDAR. Mr. Ehrhart was the original Uncle Wip of station WIP and is now the Dream Daddy of station WDAR, as well as in charge of the station.



Mr. Ehrhart's kiddies send in many pictures, but he prizes none more highly than the one to the left, which shows a family on a lonely farm way up in Vermont, where the children listen nightly to the Dream Daddy stories.



The "Ten-Million-Dollar Voice" in a broadcasting studio. Dr. Russell H. Conwell has twice delivered his famous lecture "Acres of Diamonds" from station WOO. He has given his lecture more than 6100 times and has raised with it and other lectures more than \$10,000,000, virtually all of which he has spent for the education of poor boys in the Temple University at Philadelphia.



Station WFJ sent a radio-equipped automobile through the streets to carry speakers and the speakers were introduced by radio from the station through the loud-speaking horn on the car.



The grand organ recitals from station WOO are a feature of its broadcasting. The photograph shows Miss Mary E. Vogt at the console.