

SEVEN METAL TUBE RECEIVERS

# RADIO WORLD

REG. U. S. PAT. OFF.

THE HOW-TO-MAKE-IT MONTHLY 14th Year 25c Per Copy

**FEBRUARY**

**HANDFUL FOR ALL WAVES**

1936

**CORRECT  
LINE CORDS  
OR A.C.-D.C.  
RECEIVERS**

**DELAYED  
AUTOMATIC  
VOLUME  
CONTROL**

**TWO  
POWER  
AMPLIFIERS**



Layout  
for Simple  
All-Wave  
Receiver.  
See page 32.

THE NEW CORNELL-DUBILIER

Operates effectively  
on either AC or DC.



List  
Price

**\$5.00**

RADIO INTERFERENCE FILTER

Sh-h-h

that's what  
**QUIETONE**  
does to  
Radio Noises

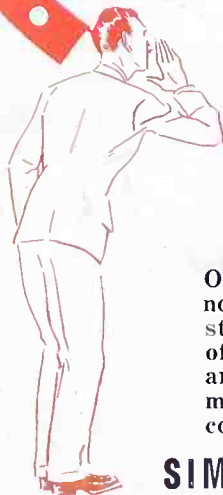

The Cornell-Dubilier IF-1 Quietone climaxes many years of research and study, utilizing a principle that has been employed successfully in radio engineering for more than a score of years.

Of the 26,000,000 radio receivers now in use, whether S. W. or the standard broadcast radio—most of them are in one way or another affected by either "man made static" or atmospheric conditions.

The extensive use of electrical appliances, the house elevator—nearby trolley and high voltage transmission lines, have greatly increased the need for a filter, that would satisfactorily eliminate interference.

**SIMPLE TO INSTALL—NO TOOLS REQUIRED—  
COSTS NOTHING TO OPERATE—EFFICIENT IN  
PERFORMANCE**

*Now you too can enjoy the evening's program, without annoying and aggravating background noises.*

MAIL THIS COUPON

Find out more about this double filter. Now! While this ad is at hand clip the coupon and send for free descriptive booklet.

Cornell-Dubilier Corp.  
4343 Bronx Boulevard, New York, N. Y.

Gentlemen:

Please forward to me the free descriptive booklet on the functions and installation of the IF-1 Quietone. Enclosed please find check ( ) money order ( ) for one IF-1 including full instructions.

I understand that if I find the Quietone not to my liking within five days, my full purchase price will be returned.

NAME .....

ADDRESS .....

CITY..... STATE.....

**CORNELL-  
DUBILIER**  
CORPORATION  
4343 BRONX BOULEVARD  
NEW YORK

# NEW "RACO" DIRECT READING SIGNAL OUTSTANDING — ALL WAVE — GENERATORS

## MODEL 339 A. C. and D. C. OPERATED

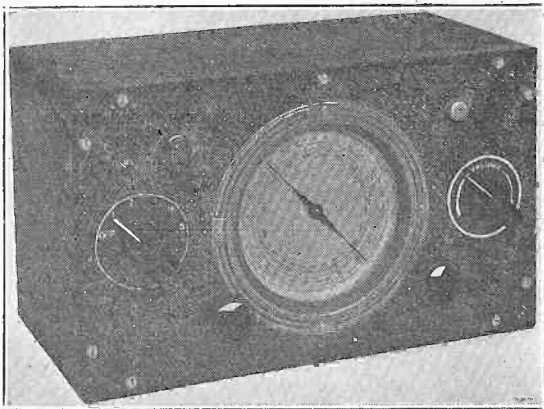

MODEL 339. A 5-band Signal Generator, 54 to 17,000 kc, all on fundamentals, switch operated, direct reading in frequency and wavelength; universal operation. Modulation on-off switch and attenuation. Electron coupled. Wired, tested, calibrated, with three tubes (6D6, 37 and neon). Shipping weight, 8 lbs. **\$16.00**

measurements of frequencies up to 100 mcg (down to 3 meters) simplified harmonic system to the 5,400 to 17,000 kc fundamental band. The 339 has a 6D6 r.f. oscillator, a 37 rectifier tube, so that d.c. is used on the plate, while modulation is provided by a neon tube relaxation oscillator at a frequency of about 1,000 cycles. Model 339, wired, calibrated, adjusted, complete with three tubes, ready to operate; instructions (shipping weight, 8 lbs.) **\$16.00**

**Model 339K, complete kit, instructions, less only tubes. \$12.50**

THE highest requirements of precision and convenience for all-around work are met in the Model 339 Signal Generator that works on a.c. or d.c. of 90-125 volts, to measure frequencies from 54 to 17,000 kc and line up channels. It also serves for determining the frequency of a station that is being received. Model 339 is outstanding because though all-wave, switch type, with airplane dial, attenuator and removable modulation, it is priced at only \$16.00 net.

The frequencies are in five bands, all on fundamentals:  
(1)—5,400 to 17,000 kc. (2)—1,700 to 5,400 kc.  
(3)—540 to 1,700 kc. (4)—170 to 540 kc.  
(5)—54 to 170 kc.

It can be seen from the above that the calibration is decimal repeating, by noting left-hand column alone, then right-hand column alone. Thus two calibrations afford maximum spreadout, each at outside of dial scale. The two inside scales are for reading wavelengths, 18 to 5,500 meters.

Coincidence of generated frequency and scale reading is 1 per cent. This high order of accuracy obtains in no other instrument selling at less than twice the cost of the 339.

Many, no doubt, have been somewhat confused by the numerous types of signal generators, but will note that the best of them cover wide ranges on fundamentals, have an attenuator, and permit of presence or absence of modulation. Also they have a vernier dial and are direct-reading in frequencies, accurate to at least 3 per cent. The 339 has all these advantages, besides affording wavelength determinations as well, and operation on 90-125 volts a.c. (any commercial frequency) or d.c. And the accuracy is three times as great. Moreover, the 339 is well built, for lifetime use, and covers all waves fundamentally, besides permitting by resort to a slight calculation method, applying

## MODEL 339B BATTERY OPERATED

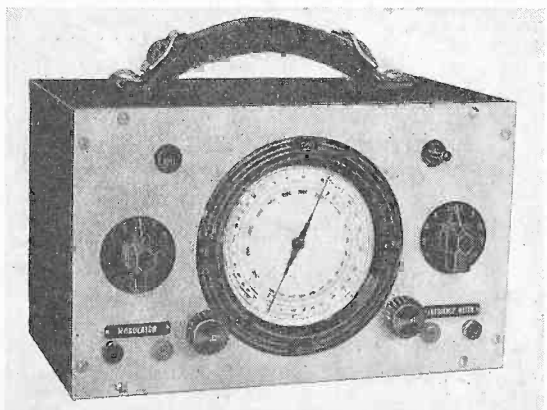

The Model 339-B Portable Signal Generator in a handle-equipped black wrinkle finish shield cabinet, the front panel finished in "Raco Wrinkle Illuminite," wired, complete with A and B batteries, two 30 tubes, r.f. attenuator, variable audio frequency control, selector switch, r.f. and a.f. output jacks, and "Frequency Meter" and "Modulator" nameplates. (Shipping weight, 11 lbs.)... **\$15.10** NET

**Model 339 B Kit, less tubes and batteries ..... \$11.50**

### OUTSTANDING FEATURES

- (1)—Frequencies are direct reading to an accuracy of 1 per cent., using Raco's own calibrated dial and precision inductances, and a precision variable condenser (54 kc to 17,000 kc).
- (2)—Radio frequency output has an attenuator that does not molest the frequency generated, no matter where the attenuator is set.
- (3)—A tone is impressed on the radio frequency generated, or not, as you prefer, to allow for both methods of alignment. A throw of a switch introduces or removes the tone.
- (4)—The audio frequency generated may be varied by adjustment of a control marked in arbitrary graduations, 1 to 10. This enables measurement through interference.
- (5)—Besides the radio frequency output jacks, there are separate jacks for the audio frequency output, and since this audio frequency may be adjusted, tests may be made of response characteristics of audio amplifiers.
- (6)—Stabilization of the radio frequency oscillator.
- (7)—Stabilization of the audio frequency, and independence of the audio frequency from any setting of the radio frequency tuning condenser.
- (8)—Modulation is about 50 per cent., when introduced in the r.f. oscillator, double peaks are thus completely avoided.

THE NEW CORNELL-DUBILIER

Operates effectively  
on either AC or DC.



List  
Price

**\$5.00**

RADIO INTERFERENCE FILTER

sh-h-h

that's what  
**QUIETONE**  
does to  
Radio Noises

The Cornell-Dubilier IF-1 Quietone climaxes many years of research and study, utilizing a principle that has been employed successfully in radio engineering for more than a score of years.



Of the 26,000,000 radio receivers now in use, whether S. W. or the standard broadcast radio—most of them are in one way or another affected by either “man made static” or atmospheric conditions.

The extensive use of electrical appliances, the house elevator—nearby trolley and high voltage transmission lines, have greatly increased the need for a filter, that would satisfactorily eliminate interference.

**SIMPLE TO INSTALL—NO TOOLS REQUIRED—  
COSTS NOTHING TO OPERATE—EFFICIENT IN  
PERFORMANCE**

*Now you too can enjoy the evening's program, without annoying and aggravating background noises.*

MAIL THIS COUPON

Find out more about this double filter. Now! While this ad is at hand clip the coupon and send for free descriptive booklet.

Cornell-Dubilier Corp.  
4343 Bronx Boulevard, New York, N. Y.

Gentlemen:

Please forward to me the free descriptive booklet on the functions and installation of the IF-1 Quietone. Enclosed please find check ( ) money order ( ) for one IF-1 including full instructions.

I understand that if I find the Quietone not to my liking within five days, my full purchase price will be returned.

NAME .....

ADDRESS .....

CITY..... STATE.....

**CORNELL-  
DUBILIER**

CORPORATION  
4343 BRONX BOULEVARD  
NEW YORK

# NEW "RACO" DIRECT READING SIGNAL OUTSTANDING — ALL WAVE — GENERATORS

## MODEL 339 A. C. and D. C. OPERATED

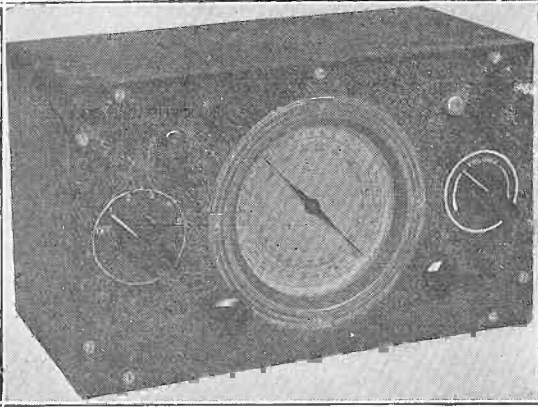

THE highest requirements of precision and convenience for all-around work are met in the Model 339 Signal Generator that works on a.c. or d.c. of 90-125 volts, to measure frequencies from 54 to 17,000 kc and line up channels. It also serves for determining the frequency of a station that is being received. Model 339 is outstanding because though all-wave, switch type, with airplane dial, attenuator and removable modulation, it is priced at only \$16.00 net.

The frequencies are in five bands, all on fundamentals:  
(1)—5,400 to 17,000 kc. (2)—1,700 to 5,400 kc.  
(3)—540 to 1,700 kc. (4)—170 to 540 kc.  
(5)—54 to 170 kc.

It can be seen from the above that the calibration is decimal repeating, by noting left-hand column alone, then right-hand columns alone. Thus two calibrations afford maximum spreadout, each at outside of dial scale. The two inside scales are for reading wavelengths, 18 to 5,500 meters.

Coincidence of generated frequency and scale reading is 1 per cent. This high order of accuracy obtains in no other instrument selling at less than twice the cost of the 339.

Many, no doubt, have been somewhat confused by the numerous types of signal generators, but will note that the best of them cover wide ranges on fundamentals, have an attenuator, and permit of presence or absence of modulation. Also they have a vernier dial and are direct-reading in frequencies, accurate to at least 3 per cent. The 339 has all these advantages, besides affording wavelength determinations as well, and operation on 90-125 volts a.c. (any commercial frequency) or d.c. And the accuracy is three times as great. Moreover, the 339 is well built, for lifetime use, and covers all waves fundamentally, besides permitting by resort to a slight calculation method, applying measurements of frequencies up to 100 mc (down to 3 meters) simplified harmonic system to the 5,400 to 17,000 kc fundamental band.

The 339 has a 6D6 r.f. oscillator, a 37 rectifier tube, so that d.c. is used on the plate, while modulation is provided by a neon tube relaxation oscillator at a frequency of about 1,000 cycles.

Model 339, wired, calibrated, adjusted, complete with three tubes, ready to operate; instructions (shipping weight, 8 lbs.)..... **\$16.00**

MODEL 339. A 5-band Signal Generator, 54 to 17,000 kc, all on fundamentals, switch operated, direct reading in frequency and wavelength; universal operation. Modulation on-off switch and attenuation. Electron coupled. Wired, tested, calibrated, with three tubes (6D6, 37 and neon). Shipping weight, 8 lbs. .... **\$16.00**

Model 339K, complete kit, instructions, less only tubes. **\$12.50**

## MODEL 339B BATTERY OPERATED

### OUTSTANDING FEATURES

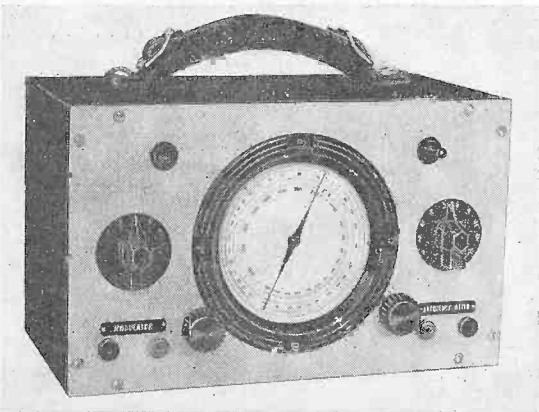

The Model 339-B Portable Signal Generator in a handle-equipped black wrinkle finish shield cabinet, the front panel finished in "Raco Wrinkle Illuminite," wired, complete with A and B batteries, two 30 tubes, r.f. attenuator, variable audio frequency control, selector switch, r.f. and a.f. output jacks, and "Frequency Meter" and "Modulator" nameplates. (Shipping weight, 11 lbs.)... **\$15.10** NET

Model 339 B Kit, less tubes and batteries ..... **\$11.50**

(1)—Frequencies are direct reading to an accuracy of 1 per cent., using Raco's own calibrated dial and precision inductances, and a precision variable condenser (54 kc to 17,000 kc).

(2)—Radio frequency output has an attenuator that does not molest the frequency generated, no matter where the attenuator is set.

(3)—A tone is impressed on the radio frequency generated, or not, as you prefer, to allow for both methods of alignment. A throw of a switch introduces or removes the tone.

(4)—The audio frequency generated may be varied by adjustment of a control marked in arbitrary graduations, 1 to 10. This enables measurement through interference.

(5)—Besides the radio frequency output jacks, there are separate jacks for the audio frequency output, and since this audio frequency may be adjusted, tests may be made of response characteristics of audio amplifiers.

(6)—Stabilization of the radio frequency oscillator.

(7)—Stabilization of the audio frequency, and independence of the audio frequency from any setting of the radio frequency tuning condenser.

(8)—Modulation is about 50 per cent., when introduced in the r.f. oscillator, double peaks are thus completely avoided.

# RADIO WORLD

*The How-to-Make-It Monthly—Fourteenth Year*

ROLAND BURKE HENNESSY  
Editor

HERMAN BERNARD  
Managing Editor

HERBERT E. HAYDEN  
Advertising Manager

## Table of Contents for FEBRUARY, 1936

<b>Six Tube Communication Receiver</b> 5	<b>Signal Generator Calibration</b> . . . . . 29
<i>How to Wind Your Own Switch Type Coils</i>	<i>Accurate Method, Using Broad- casting Stations</i>
By Edwin K. Butler	By Louis Kranz
<b>10 to 1,500 Meters, Two Metal Tubes</b> . . . . . 9	<b>A Portable Amplifier</b> . . . . . 31
<i>Simple Universal Set, With Pic- torial Diagram</i>	<i>For Phonograph, Radio or Micro- phone Use</i>
By Harry Cisin	By M. N. Beitman
<b>Latest Metal Tubes in Small Super</b> . . . . . 12	<b>One Tube All Wave Set</b> . . . . . 32
<i>25A6 and 25Z6 in Five Tube Design</i>	<i>It's a Metal Tube at That, the 6J7</i>
By Jack Goldstein	By Herbert E. Hayden
<b>A Battery Superheterodyne, 10 Microvolts</b> . . . . . 16	<b>Line Resistors for A.C.-D.C. Sets</b> 36
<i>New 1B5 Second Detector and A. V. C.</i>	<i>How to Compute for Them and Pilot Lamps</i>
By Lee F. Woolsey	By Adam Blackford
<b>A Compact All Wave Receiver</b> . . . 19	<b>Beats in Superheterodynes</b> . . . . . 41
<i>Six Metal Tubes and Commercial All Wave Coil Assembly</i>	<i>Phenomena Analyzed by Expert</i>
By Robert G. Herzog	By J. E. Anderson
<b>A Grounded Cathode Metal Tube Set</b> . . . . . 22	<b>Specialized Meter Uses</b> . . . . . 46
<i>Two Band Receiver—Coil Wind- ing Data in Full</i>	<i>Discussion of Theory as Basis of Individual Application</i>
By Spencer L. Woods	By Clair E. Ballard
<b>Delayed A.V.C. in a Broadcast Super</b> . . . . . 24	<b>Originality in a Commercial Re- ceiver</b> . . . . . 53
<i>Eight Tubes, Some of Them Metal, in High Class Design</i>	<i>Regenerative All Wave Metal Tube Set with Improvements</i>
By Herman Bernard	By William X. Black
	<b>Universal Phonograph Amplifier</b> . 55
	<i>Push Pull 48's in Output</i>
	By Maxwell M. Hauben
	<b>Radio University</b> . . . . . 57
	<i>Readers' Technical Questions</i>
	<i>Answered</i>
	By the Technical Staff

Vol. XXVII, February, 1936. No. 13. Whole No. 689. RADIO WORLD, published monthly by Hennessy Radio Publications Corporation, 145 West 45th Street, New York, N. Y. Editorial and executive offices, 145 West 45th Street, New York, N. Y. Executives of RADIO WORLD: Roland Burke Hennessy, editor and business manager; Herman Bernard, managing editor; Herbert E. Hayden, advertising manager. Officers of corporation: Roland Burke Hennessy, president-treasurer; Roland Burke Hennessy, Jr., vice-president; Herman Bernard, secretary. Entered as second-class matter March, 1922, at the Post Office at New York, N. Y., under Act of March 3d, 1879.

### SUBSCRIPTION RATE

Price 25 cents per copy. Subscription \$2.50 per year (12 issues), postpaid in United States and Possessions; \$3.00 per year postpaid in all other countries. Remittance for foreign subscription should be by International money-order (postal or express) or draft against or discountable at New York bank.

RADIO WORLD is distributed by the American News Company and its Branches

# Communication Type Set, Using Home-Made Coils

By Edwin K. Butler

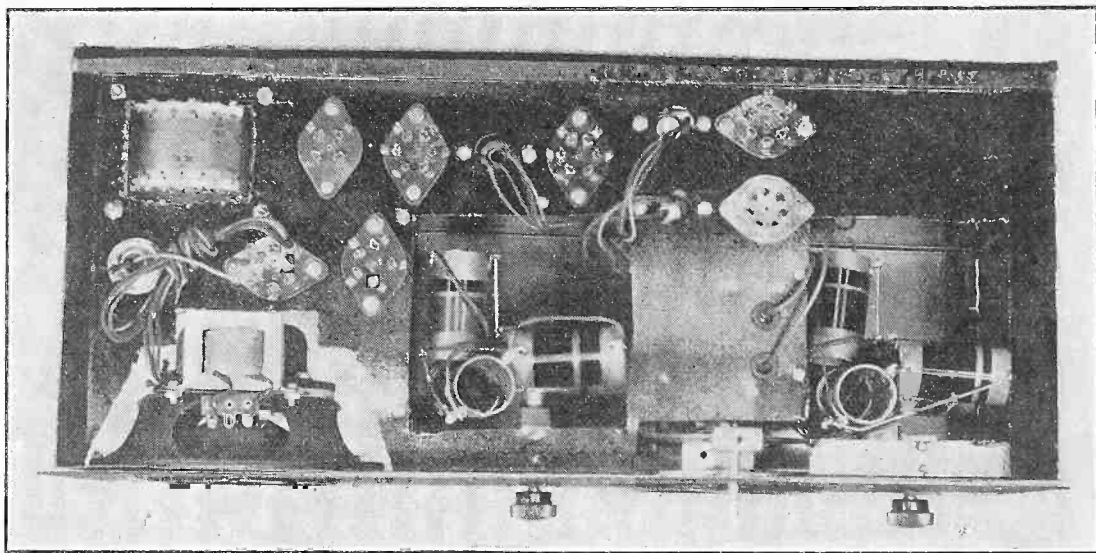

Bottom view shows cutouts for coils, coil assemblies and speaker. As there are large shields atop of these openings, you are looking into the interior of these shields. The two 8 mfd. condensers for the filter happen to be in one cylindrical container, but whether physically separated condensers are used or not, the negative leads must be independent, not common for use with this circuit. The reason is explained in the text.

**A** DESIRE to possess a communication type receiver of the coil switch type was gratified by building one consisting of six tubes. The 2A7 was used as mixer, two 58's as intermediate frequency amplifiers (465 kc), a 55 was used as second detector and diode biased triode, and a 2A5 as output tube. The rectifier was an 80.

The tubes were selected because they fitted into the general requirements, and were on hand. The tuning coils were wound by the author.

Besides certain basic requirements of the circuit, a few refinements were introduced. For instance, each of the coil switches was separate, and there was a small celluloid disc dial of the direct drive type on each. The 0-100 calibration was erased, using kitchen scouring powder, and for each position the bands were marked No. 1 to No. 5. If the constructor has a signal generator these markings may be made in terms of end frequencies.

Another refinement was the symmetrical disposition of the parts and adherence to a definite mechanical plan in carrying out the wiring. The electrical wiring precautions were satisfied by short leads for "hot" current, and then the

mechanical arrangement was perfected as the photograph on this page shows.

As stated, switch type coils were used, and there was a total of ten coils, two windings on each, one set of five for the signal carrier level, one set of five for the oscillator level. The five coils were wound on three forms.

The circuit diagram shows the coils included for one band only, for simplification, but the switch arrows are indicated, and these go to the tabs for the four moving members. Two separate two deck, three position switches are used.

## Coil Information

Coils for any one band being wired in, the coils for the other bands are connected the same way, the only precautions necessary being that there be minimum coupling between coils for the same circuit, the leads be short as practical to the switch, the primaries be not confused with the larger winding secondaries and that the tickler of the oscillator coils be connected in that way that provides oscillation.

If the coils are wound in the same direction, then if the grid winding is considered as being

*(Continued on page 7)*

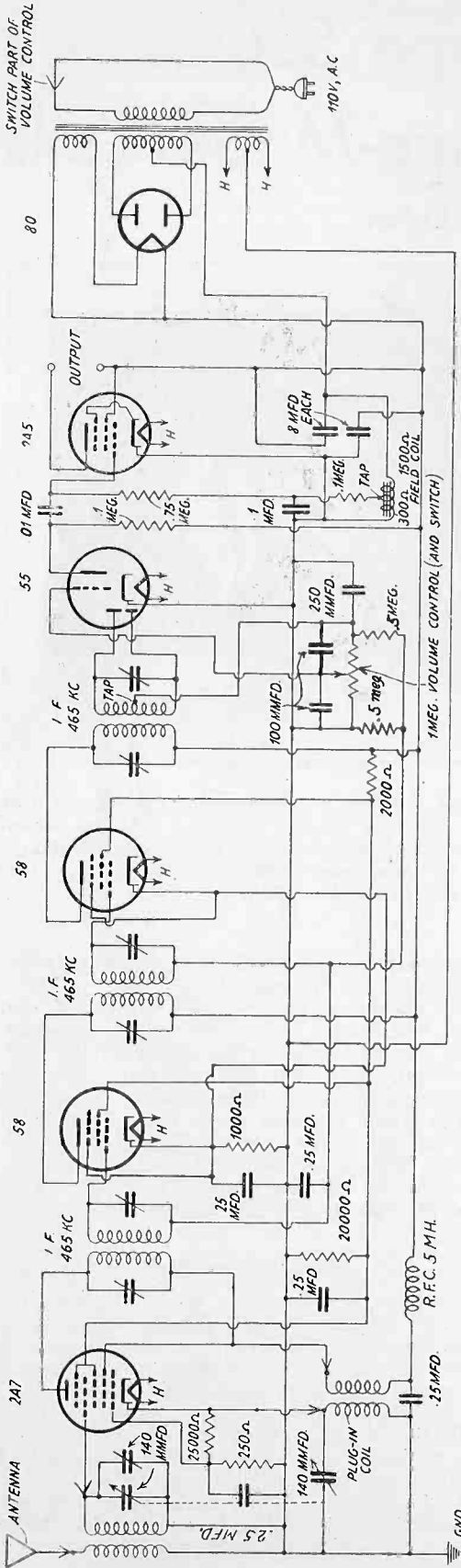

The four points of switching are indicated, but only one coil for each circuit is shown, for simplicity of diagram.

**Coils**

- Ten tuning coils, five for detector, five for oscillator, wound according to directions given in the text.
- Two 465 kc shielded intermediate frequency transformers, primaries and secondaries tuned.
- One 465 kc center tapped intermediate transformer.
- One radio frequency choke, 5 millihenries.
- One power transformer with four windings: Primary, 115 volts, 50-60 cycles; secondary, 2.5 volts center tapped; high voltage winding, center tapped. Known commercially as type for six tube set.
- One dynamic speaker, with 1,800 ohm eId. tapped at 300 ohms; equipped with output transformer, 7,000 ohm load.

**LIST OF PARTS**

**Condensers**

- One two gang .00014 mfd. tuning condenser.
- One single .00014 mfd., knob controlled, for making the modulator frequency lower than the oscillator frequency, and thus dispensing with padding the oscillator.
- Two .0001 mfd. (100 One .1 mfd. mmfd.).
- Four .25 mfd.
- Two 8 mfd.
- One .00025 mfd.
- One .01 mfd.

**Resistors**

- One 250 ohm.
- One 1,000 ohm.
- One 2,000 ohm, 2
- One 1 meg. potentiometer, a.c. switch attached.
- Two .1 meg.
- Two .5 meg.
- One 1 meg.
- One 20,000 ohm.
- One .75 meg.

**Other Requirements**

- One four hole, one five hole, four six hole and one medium, seven hole sockets. (The five hole socket is for speaker plug).
- Four tube shield and bases.
- One chassis and front.
- Four grid clips.
- One dial and escutcheon.
- Seven knobs.
- One speaker grille and escutcheon.
- Antenna-ground posts, and name plates therefor.
- Two small window escutcheons for switch index viewing, and two 3 inch disc dials with celluloid scales from which numbers may be erased for putting in band data.
- Two shields to cover openings above the coils.



(Continued from page 5)

on top, connect upper grid terminal of the larger secondary winding to grid, other end of that winding to ground, upper end of tickler to B plus and lower terminal of tickler to plate. That is the direction of connection, or polarity, for assuring oscillation.

The number of tickler turns of course must be sufficient to provide oscillation at the low

**No. 4:** Primary, 22 turns of No. 26 enamel, wound close. Secondary, 49 turns of No. 26 enamel, wound 36 turns to the inch.

### The Single Difference

The detector coil for the lowest frequency band, which includes most of the broadcast band, starting at 550 meters and going down

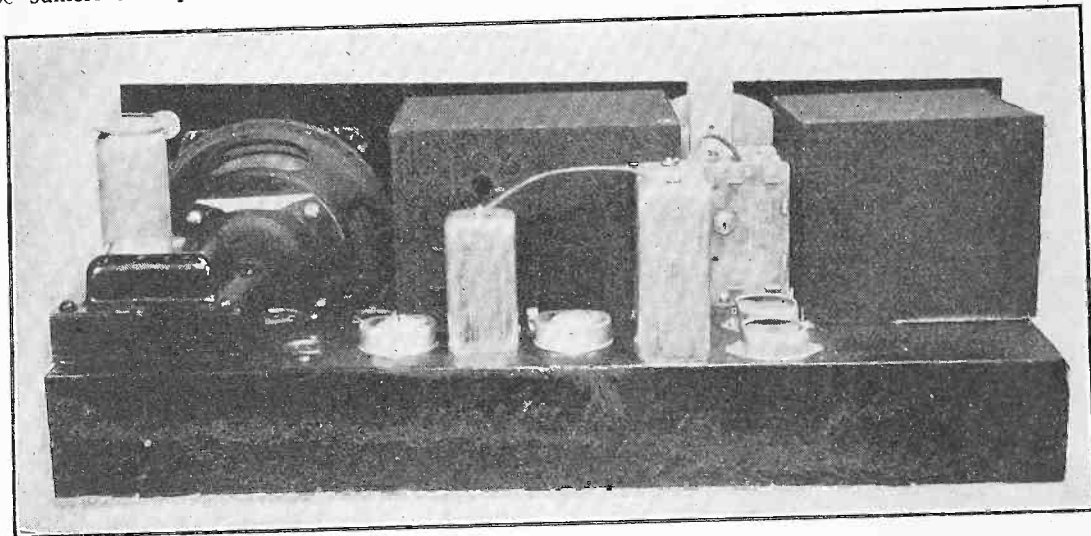

Location of the power transformer, electrolytic condensers (two in one container), intermediate coils, one being behind the other in the taller showing, tuning condenser and shield cans on either side of them. The speaker plug socket is just to the right of the power transformer. Front of the six tube receiver. The window openings for coil switch indexing are the small ones to left and right of the tuning dial. Below these windows are the coil switch knobs.

frequencies as well as at the high frequencies of any band, but that is taken care of in the coil winding tabulation.

### The Sockets Explained

The underneath view of the receiver, which was photographed before the wiring was completed, shows seven sockets instead of six. The seventh one is for the speaker plug and is the socket nearest the speaker (lower left).

The angulation of the coils is shown in the diagram. The coil kit to the right is for the broadcast band, the oscillator coil kit being at center of the chassis. For tuning with .00014 mfd. capacity (a two gang condenser is used) four of the bands are covered by identical coils wound as follows on 1 1/4 inch outside diameter Bakelite tubing:

**No. 1:** Primary, 6 turns of No. 26 enamel wire, wound close. Secondary, 6 turns of No. 20 enamel wire wound 6 turns to the inch.

**No. 2:** Primary, 11 turns of No. 26 enamel wound close. Secondary, 22 turns of No. 20 enamel, wound 12 turns to the inch.

**No. 3:** Primary, 9 turns of No. 26 enamel, wound close. Secondary, 12 turns of No. 24 enamel, wound 24 turns to the inch.

(in meters), has a primary of 30 turns of No. 30 enamel, close wound, and a secondary of 123 turns of No. 30 enamel, close wound also. The oscillator coil for this band, the only one different from the detector coil for a particular band, has a tickler of 40 turns of No. 30 enamel, and a secondary of 70 turns of No. 30 enamel, both close wound.

The spacing between primary and secondary (including oscillator coil where primary is called the tickler) is 3-16 inch on all coils, both circuits.

The circuit diagram is close to standard. The only deviations are that full wave second detection is used and that instead of the full signal rectified voltage being applied as automatic volume control to the two i.f. tubes, only half of this voltage is used. That is the reason for the two .5 meg. fixed resistors across the volume control potentiometer.

### The B Filter

The B supply choke is the speaker field and is located in the negative leg of the rectifier, so that bias for the output tube is obtained from the total B current flowing. This condition may be described as semi-fixed bias, since it is not self bias, nor is it fixed bias, there being a change of B current with the intensity of the signal, hence is in between.

(Continued on next page)

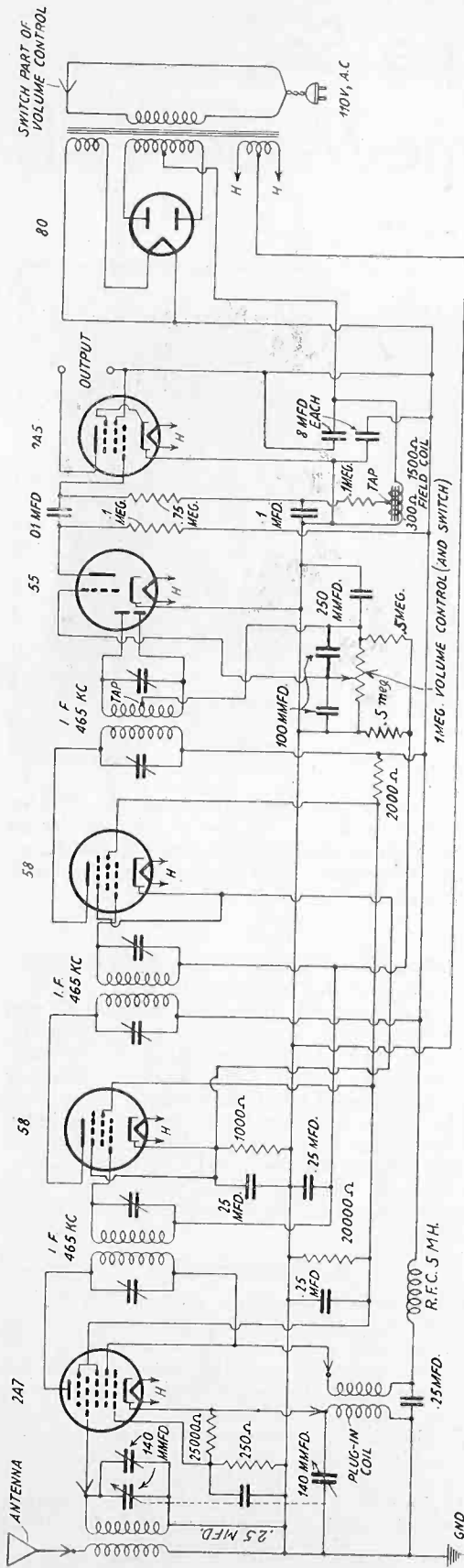

The four points of switching are indicated, but only one coil for each circuit is shown, for simplicity of diagram.

LIST OF PARTS

Coils

Ten tuning coils, five for detector, five for oscillator, wound according to directions given in the text.  
 Two 465 kc shielded intermediate frequency transformers, primaries and secondaries tuned.  
 One 465 kc center tapped intermediate transformer.  
 One radio frequency choke, 5 millihenries.  
 One power transformer with four windings: Primary, 115 volts, 50-60 cycles; secondary, 2.5 volts center tapped; high voltage winding, center tapped. Known commercially as type for six tube set.  
 One dynamic speaker, with 1,800 ohm eld. tapped at 300 ohms; equipped with output transformer, 7,000 ohm load.

Condensers

One two gang .00014 mfd. tuning condenser.  
 One single .00014 mfd., knob controlled, for making the modulator frequency lower than the oscillator frequency, and thus dispensing with padding the oscillator.  
 Two .0001 mfd. (100 mmmfd.)  
 One .00025 mfd.  
 One .01 mfd.

Resistors

One 250 ohm.  
 One 1,000 ohm.  
 One 2,000 ohm, 2 watt.  
 One 20,000 ohm.  
 One .75 meg.  
 Two .1 meg.  
 Two .5 meg.  
 One 1 meg. potentiometer, a.c. switch attached.

Other Requirements

One four hole, one five hole, four six hole and one medium seven hole sockets. (The five hole socket is for speaker plug).  
 Four tube shield and bases.  
 One chassis and front.  
 Four grid clips.  
 One dial and escutcheon.  
 Seven knobs.  
 One speaker grille and escutcheon.  
 Antenna-ground posts, and name plates therefor.  
 Two small window escutcheons for switch index viewing, and two 3 inch disc dials with celluloid scales from which numbers may be erased for putting in band data.  
 Two shields to cover openings above the coils.

(Continued from page 5)

on top, connect upper grid terminal of the larger secondary winding to grid, other end of that winding to ground, upper end of tickler to B plus and lower terminal of tickler to plate. That is the direction of connection, or polarity, for assuring oscillation.

The number of tickler turns of course must be sufficient to provide oscillation at the low

**No. 4:** Primary, 22 turns of No. 26 enamel, wound close. Secondary, 49 turns of No. 26 enamel, wound 36 turns to the inch.

### The Single Difference

The detector coil for the lowest frequency band, which includes most of the broadcast band, starting at 550 meters and going down

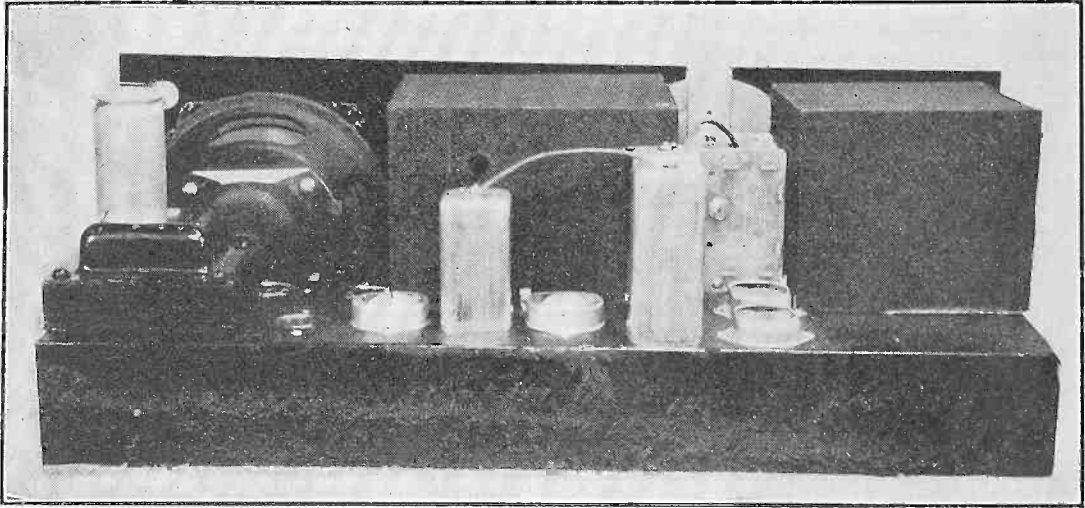

Location of the power transformer, electrolytic condensers (two in one container), intermediate coils, one being behind the other in the taller showing, tuning condenser and shield cans on either side of them. The speaker plug socket is just to the right of the power transformer. Front of the six tube receiver. The window openings for coil switch indexing are the small ones to left and right of the tuning dial. Below these windows are the coil switch knobs.

frequencies as well as at the high frequencies of any band, but that is taken care of in the coil winding tabulation.

### The Sockets Explained

The underneath view of the receiver, which was photographed before the wiring was completed, shows seven sockets instead of six. The seventh one is for the speaker plug and is the socket nearest the speaker (lower left).

The angulation of the coils is shown in the diagram. The coil kit to the right is for the broadcast band, the oscillator coil kit being at center of the chassis. For tuning with .00014 mfd. capacity (a two gang condenser is used) four of the bands are covered by identical coils wound as follows on 1 1/4 inch outside diameter Bakelite tubing:

- No. 1:** Primary, 6 turns of No. 26 enamel wire, wound close. Secondary, 6 turns of No. 20 enamel wire wound 6 turns to the inch.
- No. 2:** Primary, 11 turns of No. 26 enamel wound close. Secondary, 22 turns of No. 20 enamel, wound 12 turns to the inch.
- No. 3:** Primary, 9 turns of No. 26 enamel, wound close. Secondary, 12 turns of No. 24 enamel, wound 24 turns to the inch.

(in meters), has a primary of 30 turns of No. 30 enamel, close wound, and a secondary of 123 turns of No. 30 enamel, close wound also. The oscillator coil for this band, the only one different from the detector coil for a particular band, has a tickler of 40 turns of No. 30 enamel, and a secondary of 70 turns of No. 30 enamel, both close wound.

The spacing between primary and secondary (including oscillator coil where primary is called the tickler) is 3-16 inch on all coils, both circuits.

The circuit diagram is close to standard. The only deviations are that full wave second detection is used and that instead of the full signal rectified voltage being applied as automatic volume control to the two i.f. tubes, only half of this voltage is used. That is the reason for the two .5 meg. fixed resistors across the volume control potentiometer.

### The B Filter

The B supply choke is the speaker field and is located in the negative leg of the rectifier, so that bias for the output tube is obtained from the total B current flowing. This condition may be described as semi-fixed bias, since it is not self bias, nor is it fixed bias, there being a change of B current with the intensity of the signal, hence is in between.

(Continued on next page)

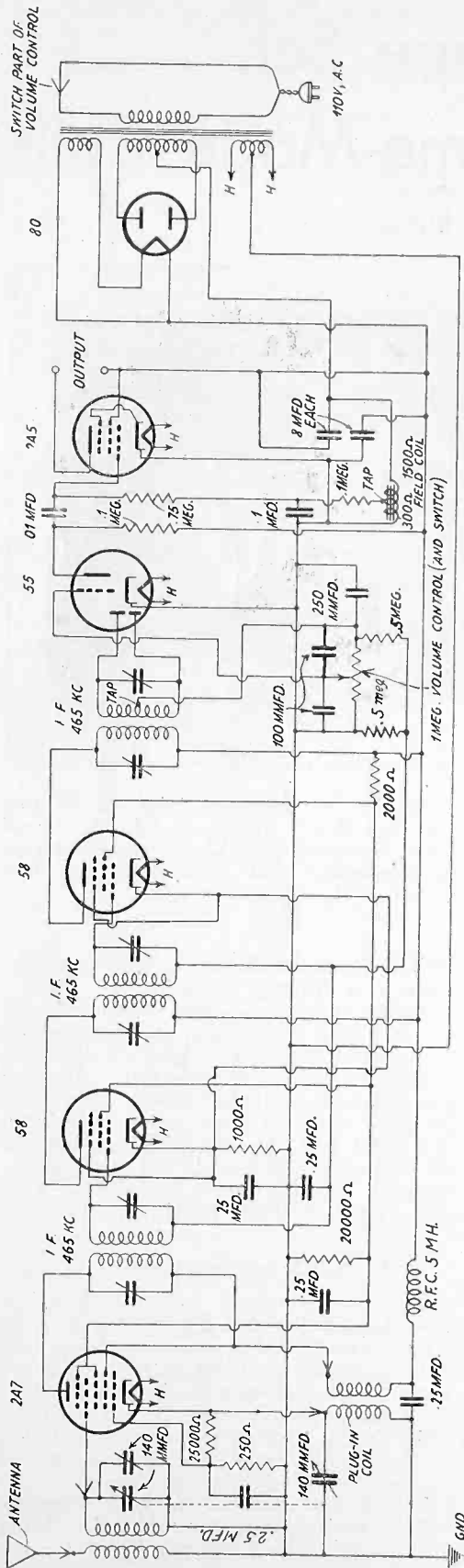

The four points of switching are indicated, but only one coil for each circuit is shown, for simplicity of diagram.

LIST OF PARTS

Coils

- Ten tuning coils, five for detector, five for oscillator, wound according to directions given in the text.
- Two 465 kc shielded intermediate frequency transformers, primaries and secondaries tuned.
- One 465 kc center tapped intermediate transformer.
- One radio frequency choke, 5 millihenries.
- One power transformer with four windings:
  - Primary, 115 volts, 50-60 cycles; secondary, 2.5 volts center tapped; high voltage winding, center tapped. Known commercially as type for six tube set.
  - One dynamic speaker, with 1,800 ohm e.l.d. tapped at 300 ohms; equipped with output transformer, 7,000 ohm load.

Condensers

- One two gang .00014 mfd. tuning condenser.
- One single .00014 mfd., knob controlled, for making the modulator frequency lower than the oscillator frequency, and thus dispensing with padding the oscillator.
- Two .0001 mfd. (100 mmmfd.)
- One .1 mfd.
- Four .25 mfd.
- Two 8 mfd.

Resistors

- One 250 ohm.
- One 1,000 ohm.
- One 2,000 ohm, 2 watt.
- One 20,000 ohm.
- One .75 meg.
- Two .1 meg.
- Two .5 meg.
- One 1 meg. potentiometer, a.c. switch attached.

Other Requirements

- One four hole, one five hole, four six hole and one medium, seven hole sockets. (The five hole socket is for speaker plug).
- Four tube shield and bases.
- One chassis and front.
- Four grid clips.
- One dial and escutcheon.
- Seven knobs.
- One speaker grille and escutcheon.
- Antenna-ground posts, and name plates therefor.
- Two small window escutcheons for switch index viewing, and two 3 inch disc dials with celluloid scales from which numbers may be erased for putting in band data.
- Two shields to cover openings above the coils.

(Continued from page 5)

on top, connect upper grid terminal of the larger secondary winding to grid, other end of that winding to ground, upper end of tickler to B plus and lower terminal of tickler to plate. That is the direction of connection, or polarity, for assuring oscillation.

The number of tickler turns of course must be sufficient to provide oscillation at the low

No. 4: Primary, 22 turns of No. 26 enamel, wound close. Secondary, 49 turns of No. 26 enamel, wound 36 turns to the inch.

### The Single Difference

The detector coil for the lowest frequency band, which includes most of the broadcast band, starting at 550 meters and going down

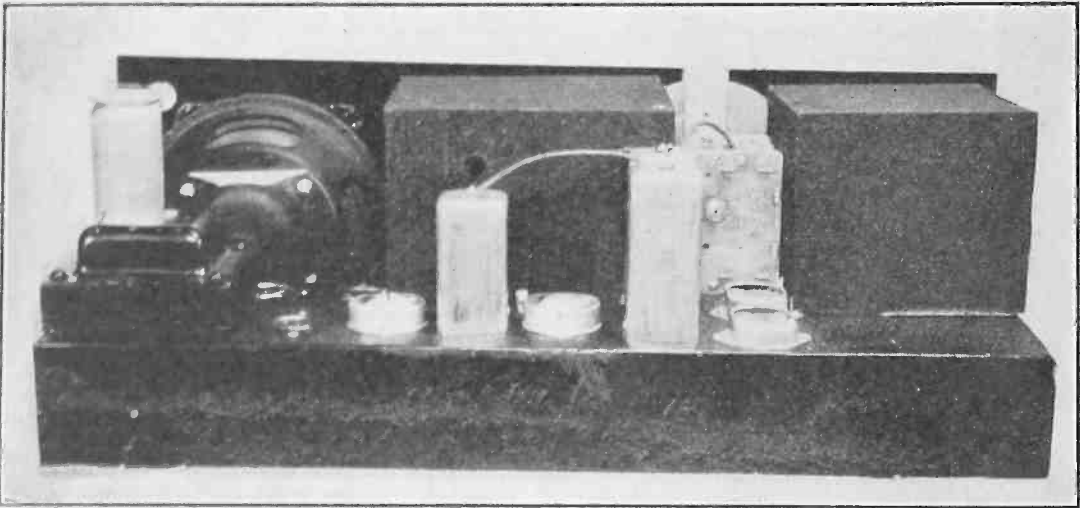

Location of the power transformer, electrolytic condensers (two in one container), intermediate coils, one being behind the other in the taller showing, tuning condenser and shield cans on either side of them. The speaker plug socket is just to the right of the power transformer. Front of the six tube receiver. The window openings for coil switch indexing are the small ones to left and right of the tuning dial. Below these windows are the coil switch knobs.

frequencies as well as at the high frequencies of any band, but that is taken care of in the coil winding tabulation.

### The Sockets Explained

The underneath view of the receiver, which was photographed before the wiring was completed, shows seven sockets instead of six. The seventh one is for the speaker plug and is the socket nearest the speaker (lower left).

The angulation of the coils is shown in the diagram. The coil kit to the right is for the broadcast band, the oscillator coil kit being at center of the chassis. For tuning with .00014 mfd. capacity (a two gang condenser is used) four of the bands are covered by identical coils wound as follows on 1 1/4 inch outside diameter Bakelite tubing:

No. 1: Primary, 6 turns of No. 26 enamel wire, wound close. Secondary, 6 turns of No. 20 enamel wire wound 6 turns to the inch.

No. 2: Primary, 11 turns of No. 26 enamel wound close. Secondary, 22 turns of No. 20 enamel, wound 12 turns to the inch.

No. 3: Primary, 9 turns of No. 26 enamel, wound close. Secondary, 12 turns of No. 24 enamel, wound 24 turns to the inch.

(in meters), has a primary of 30 turns of No. 30 enamel, close wound, and a secondary of 123 turns of No. 30 enamel, close wound also. The oscillator coil for this band, the only one different from the detector coil for a particular band, has a tickler of 40 turns of No. 30 enamel, and a secondary of 70 turns of No. 30 enamel, both close wound.

The spacing between primary and secondary (including oscillator coil where primary is called the tickler) is 3-16 inch on all coils, both circuits.

The circuit diagram is close to standard. The only deviations are that full wave second detection is used and that instead of the full signal rectified voltage being applied as automatic volume control to the two i.f. tubes, only half of this voltage is used. That is the reason for the two .5 meg. fixed resistors across the volume control potentiometer.

### The B Filter

The B supply choke is the speaker field and is located in the negative leg of the rectifier, so that bias for the output tube is obtained from the total B current flowing. This condition may be described as semi-fixed bias, since it is not self bias, nor is it fixed bias, there being a change of B current with the intensity of the signal, hence is in between.

(Continued on next page)

*(Continued from preceding page)*

Be careful to connect the 8 mfd. filter condensers as follows: both have their positives to B plus, one has its negative to B minus, other has its negative to ground. Common negative in paired condensers cannot be used. The different connections of negative of these condensers is applicable because B minus is not grounded. So if there is hum check back on the filter condenser connections, for you probably

#### BEST TRANSMISSION LINE

The best transmission line is one constructed of concentric conductors. One reason for its superiority is that the electromagnetic field is completely enclosed by the outside conductor. This prevents radiation from the line and makes the effective resistance low. Whereas the ultimate object is to radiate the power transmitted by the line, any power that the line itself radiates is lost because it is not radiated where

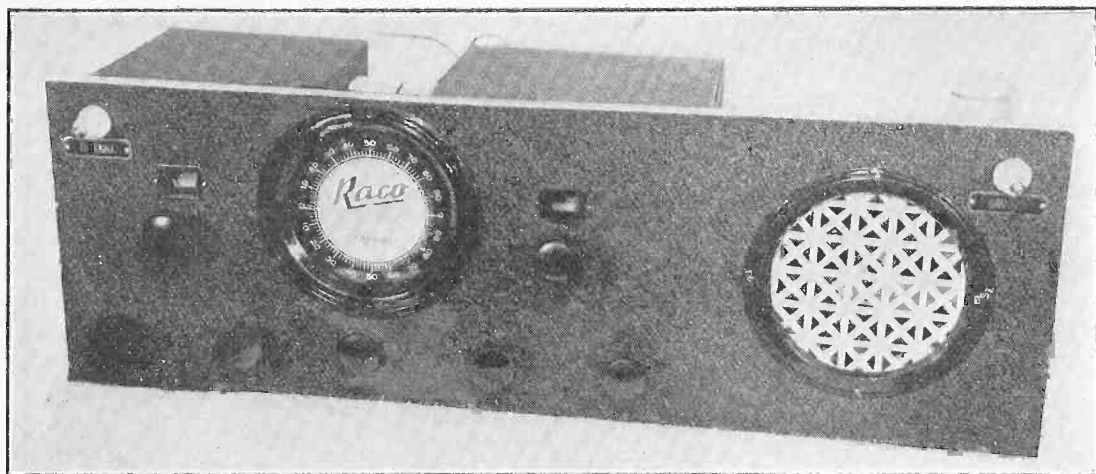

The small windows are for observation of the band in use, as there are two separate coil switches.

have one of the condensers across the total speaker field.

The total d.c. resistance of this field, by the way, is 1,800 ohms, the power tube grid being connected through the resistor of a filter to tap, the 300 ohm section of the choke being between tap and ground and the difference, or 1,500 ohms, between tap and B minus of the power transformer.

In noisy locations it is advisable to connect two .05 mfd. condensers in series, joint to ground, two remaining extremes to the respective sides of the primary of the power transformer.

#### METAL GLASS TUBES

Instead of an all metal tube a metal-glass tube may be used with no change of socket or circuit. Such a tube has a glass envelope in a metal container, so the size is larger than that of the all-metal 6K7. No difference in results was noted. Metal-glass tubes were not tried in the two other positions.

#### FRAMEWORK AS AERIAL

In large buildings there is usually iron framework that has considerable area and thus picks up radio waves and may serve as an antenna. It is not an effective one, usually, but is a good makeshift. The heating system of a loft building, office building or apartment house is an example. The fire escape is another. Such an aerial usually produces broad tuning.

it should be radiated and in the manner required.

#### HOW RESISTANCE CHANGES

The resistance of a tuning condenser, and also that of the coil it tunes, increases with frequency. However, vacuum tubes in usual circuits operate more gainfully at the higher frequencies of a band, as a rule, and therefore the somewhat regenerative effect may more than atone for the drop in tuning efficiency that otherwise would arise. If the tubes are made too gainful by the circuiting, there may be unwanted oscillation in an r.f. or i.f. amplifier.

#### IRON CORES FOR COILS

Iron cores are being introduced in commercial coils for short waves, broadcast waves and for intermediate frequency levels. These cores are made of iron reduced to a powder, mixed with a binder, and baked at such a high temperature that the purified iron flows, and is allowed to cool in a mould. The inductance and the Q, or efficiency, of the coils are increased by use of these cores.

#### RADIO PROSPECTING

Many efforts have been made to find a reliable method of radio prospecting, so that with the use of a generator one may locate ores and minerals, but there are serious drawbacks to all known systems, and the solution can not be deemed to have been reached yet.

# 10 to 1,500 Meters, Two Tubes

## Very Simple Set, Metal Tubes, Picture Diagram

By Harry Cisin

Allied Engineering Institute

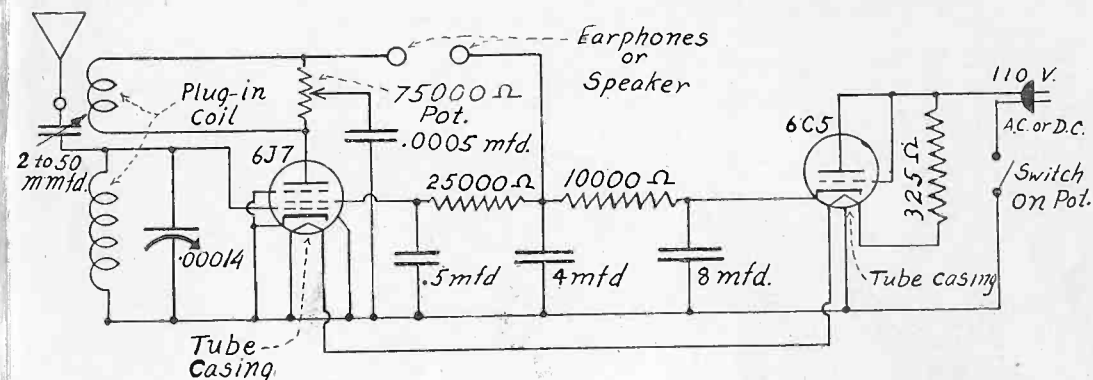

This is a circuit that the beginner always welcomes, because it uses few parts and is easy to wire. In the schematic diagram above a grid leak and condenser may well be included in the detector circuit for improving the results somewhat. They are included in the picture diagram on page 11.

NO doubt many have noticed that, using the same capacity condenser, the frequency ratio is different in different receivers. For instance, with .00014 mfd. for tuning, which is popular for ranges that include short waves, the frequency ratio may be around 2 to 1 for each band and may reach even 2.5 to 1. What is the reason for the difference? The reason is simply the capacity in circuit, the fixed amount that, hunting the tuning condenser, reduces the frequency ratio the more, the larger the shunt capacity. Usually this large capacity is due to loose coupling of a large number of primary or tickler turns to a secondary.

In the present two tube receiver, using plug-in coils especially made for low capacity of the nature just described, the range from 10 to 200 meters is accomplished with four coils, two more coils take in the broadcast band, and it is practical to use a long wave coil to get results from 550 to 1,500 meters.

### Few Parts Used

It can be seen from the schematic diagram above that few parts are used, the wiring is simple and that metal tubes are included. The 6J7 is the regenerative detector and the 6C5 is the rectifier. Uniformity of tube types alone dictated the choice of the metal tube rectifier. This tube is simply used as a diode.

Standard commercial plug-in coils may be used, but without assurance of full coverage of the range, although this of course could be checked, and especially note should be taken

that the tickler is not a large one, compared to the secondary.

The circuit works best when there are a grid leak and condenser in the 6J7 circuit, and these should be in parallel, and run from grid of the tube to common connection of stator of the tuning condenser and socket prong of the coil receptacle that picks up the intended grid connection. The leak and condenser are not in the schematic diagram. The so-called grid end of the coil does not go directly to grid but to grid leak and grid condenser. The leak is 1 meg. and the grid condenser .0001 mfd. and they are included in the pictorial diagram on page 9.

### Letter Designations

The letter M as used for designation of resistance values on the pictorial diagram denotes "thousands of ohms," while the Greek letter omega on the schematic diagram above denotes units of ohms.

The circuit is well established, needs no particular comment, and the construction can be done by anybody who can read the diagrams, especially as the picture diagram will appeal to all, even the experienced. And then there is on the following page (folio 10) a realistic reproduction of a photograph of this simple but dependable receiver.

There are two resistors in the B leg. One is 10,000 ohms and should be that value. The other is marked 25,000 ohms (above) but may be any value between 20,000 and 40,000 ohms. Also the potentiometer may be 50,000 to 75,000 ohms maximum.

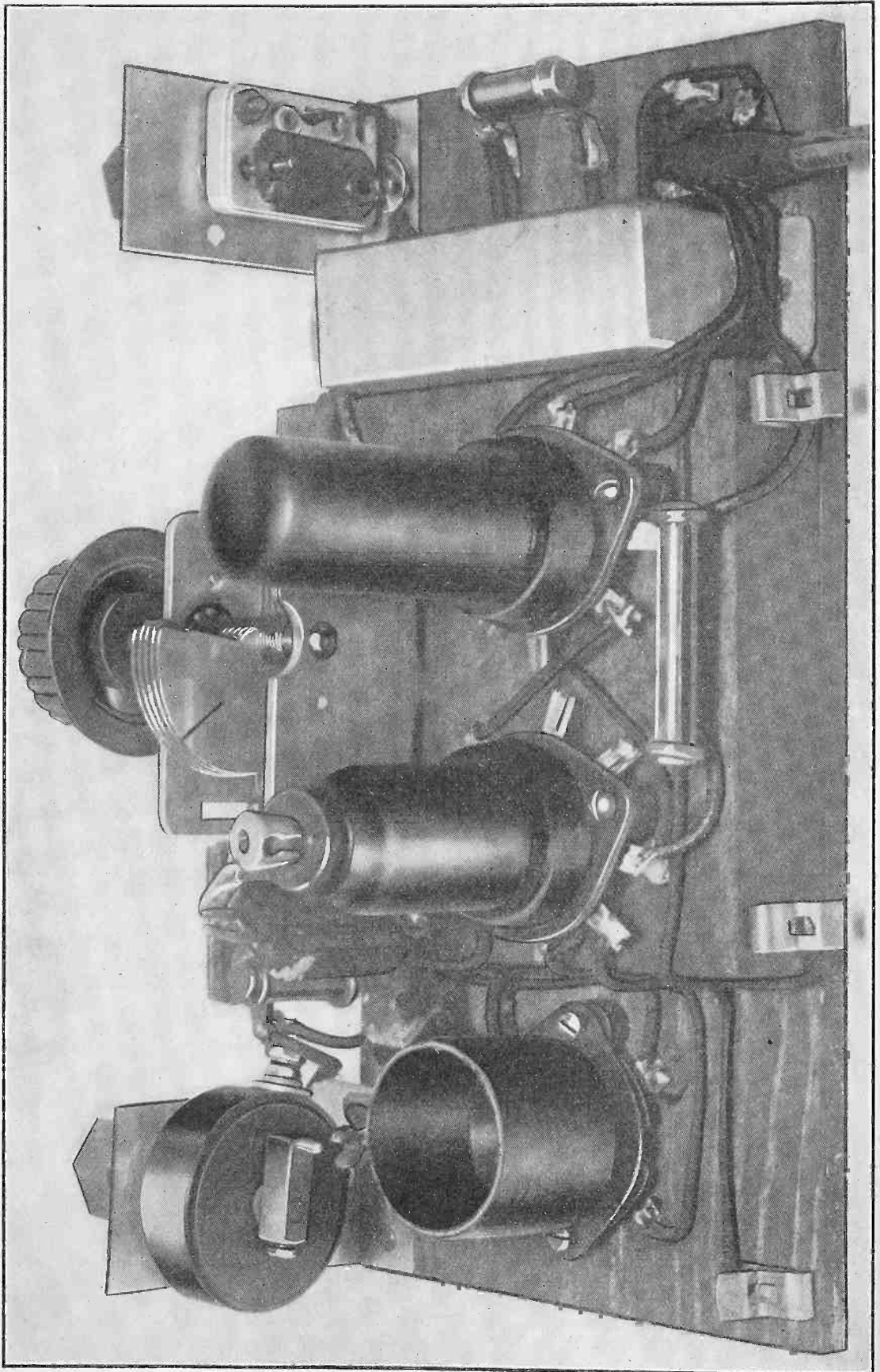

Picture diagram of two-tube multi-range receiver, using plugin coils, and representing extreme simplicity of wiring.



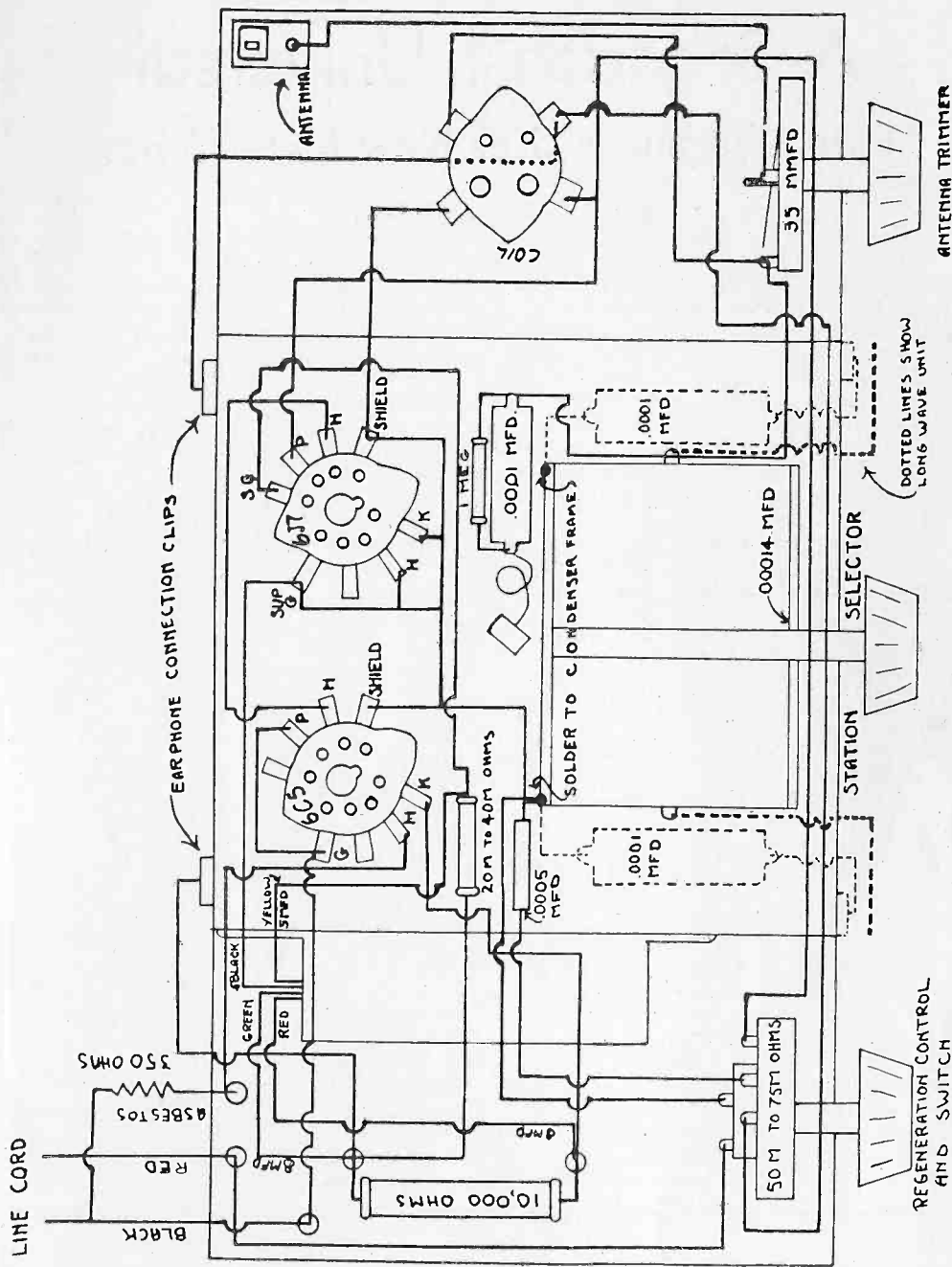

Picture diagram of the wiring of Cisin's set, that covers from 10 to 1,500 meters, using seven plug-in coils. Some optional values are included, e.g., the potentiometer and one of the B lead resistors.

LIST OF PARTS  
Coils

One set of four plug-in coils for the short wave bands, two additional coils required for the broadcast band, and one additional coil for the long wave bands.

Condensers

- One 2 to 50 mmfd. postage stamp type condenser. This may have to be adjusted once for each band.
- One .00014 mfd. tuning condenser.
- One block of three filter condensers of 8, 4 and 5 mfd. voltage rating, 175 volts d.c. continuous working.
- One .0001 mfd. mica grid condenser.
- One .0005 mfd. mica fixed condenser.

Resistors

- One 350 ohm, 30 watt resistor, built into line cord, and represented by the third or asbestos covered lead.
- One 75,000 ohm potentiometer (may be 50,000 to 75,000 max.).
- One 10,000 ohm fixed resistor.
- One 25,000 ohm fixed resistor (may be 20,000 to 40,000 ohms).

- One 1 meg. grid leak.
- One baseboard.
- One miniature grid clip.
- Two octal sockets.
- One four prong socket to be used as coil receptacle.
- One 6C5 tube and one 6J7 tube.
- Three connection clips (Ant. and earphones).

# A Broadcast Universal

## Five Tube Super Uses New Metal Tubes

By Jack Goldstein

NO sooner had the first group of metal tubes been put on the market than engineers felt the need of additional types for the design of economical universal type superheterodynes. The tubes are now available. There is the 6A8 for oscillation and mixing, the 6K7 for super-control amplifier, the 6J7 for bias detection, the 25A6 for pentode power amplification, and the 25Z6 for rectification. All these tubes are similar in their electrical characteristics to the corresponding tubes in the glass tubes.

It will be noticed that two of the tubes re-

quire 25 volts on the filaments or heaters. The other three tubes require only 6.3 volts each. Thus the five tubes in the circuit require a total heater voltage of 68.9 volts. Since the line voltage will on the average be 115 volts, an additional voltage drop of about 46 volts is necessary. This is taken care of by a 30 watt resistor of 150 ohms, which may be built into the line cord.

### Heater Connections

Since the current through this resistor will be

## LIST OF PARTS

### Coils

- One unshielded honeycomb antenna coil for 370 mmfd. condenser.
- One unshielded oscillator honeycomb coil for 456 kc and 370 mmfd.
- Two doubly tuned i.f. transformers tuned to 456 kc.
- One 375 ohm filter choke, small size.
- One small loudspeaker with a 3,000 ohm field coil.

### Condensers

- One two gang variable condenser of 370 mmfd. capacity and trimmers.
- One 200-600 mmfd. padding condenser.
- Two .00025 mfd. mica condensers.
- One .006 mfd. mica condenser.
- Two .01 mfd. condensers.
- Four .1 mfd. condensers.
- One dual 5 mfd., 35 volt electrolytic condenser.
- One 8 mfd. electrolytic condenser.
- One 16 mfd. electrolytic condenser.

### Resistors

- One 300 ohm bias resistor.
- One 700 ohm bias resistor (at least one watt rating).
- One 150 ohm ballast resistor, from 15 watts up.
- One 10,000 ohm potentiometer.
- One .02 meg. resistor.
- One .025 meg. resistor.
- One .05 meg. resistor.
- Two .5 meg. resistors.
- One 1 meg. resistor.

### Other Requirements

- Five standard wafer type octal sockets.
- Three small grid clips.
- One line cord and plug (may contain the 150 ohm ballast).
- One line switch (may be attached to the volume control potentiometer).
- One airplane type dial.
- One small chassis.

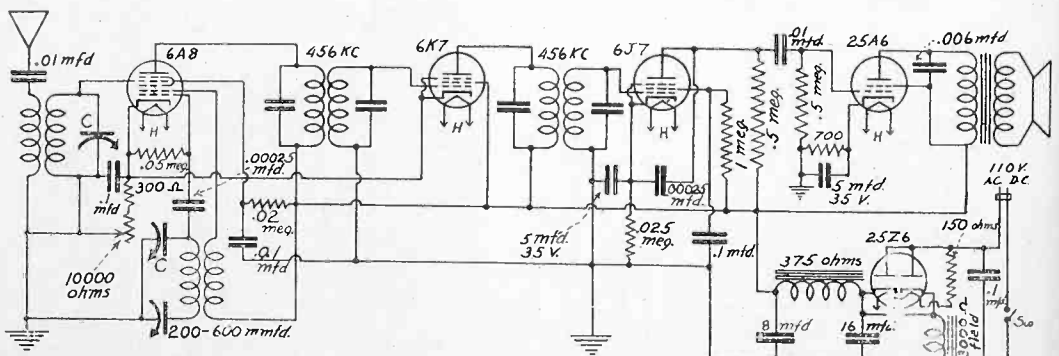

The fundamental circuit of a well tried midget superheterodyne which has been improved greatly by the use of metal tubes throughout. There is sensitivity to spare and no lack of selectivity.

.3 ampere, the rating of the resistor should be at least 15 watts. A resistor of greater rating is desirable, say, one of 30 watts. The order of connecting the heaters is not shown in the circuit diagram of this receiver, except that the heater of the 25Z6 is connected to the 150 ohm ballast resistor. The next tube in the heater series may be the 25Z6, then the 6K7, the 6A8, and finally the 6J7. One side of the heater of

The tuner consists of the radio frequency selector and the oscillator. A two gang condenser, therefore, is required. In the diagram three variable condensers are indicated, but one of these is the adjustable padding condenser. Only the two condensers marked C belong to the gang. The capacity of each section of the dual condenser is 370 mmfd.

If the radio frequency coil is an unshielded

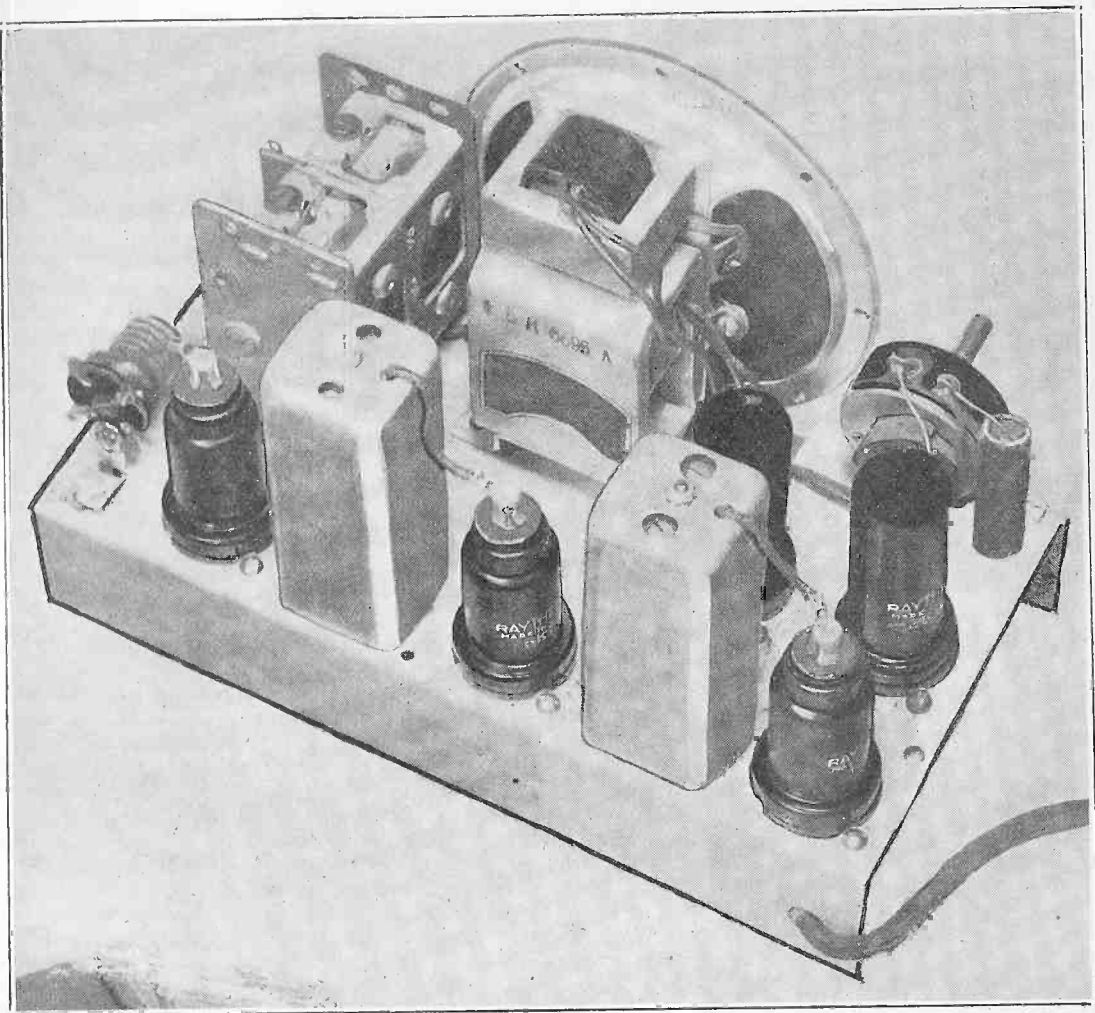

This shows how the five tubes and chassis-top parts are disposed.

the 6J7 may be connected to the chassis, unless a pilot light is used, which may be between the 6J7 heater and the chassis.

### What the Tuner Is

The circuit proper in this receiver is that which is often used for universal type midget superheterodynes. However, as the metal type tubes are somewhat more effective than the older glass tubes, this receiver, properly wired and adjusted, is superior to the older types of midgets. Moreover, the metal tubes are much smaller and require no tube shields, and these facts make smaller and more efficient assemblies possible.

honeycomb and also if the tracking of the oscillator with the radio frequency circuit is close, the selectivity in the radio frequency level will be good because the tuner is required only to suppress image interference, which is not difficult for the broadcast band when the intermediate frequency is as high as 456 kc.

### The Intermediate Amplifier

It should be pointed out that it is not necessary to shield either the radio frequency or the oscillator coils. They should not, however, be placed too close together. A good way of mounting the two coils is to put the radio fre-

*(Continued on next page)*

# A Broadcast Universal

## Five Tube Super Uses New Metal Tubes

By Jack Goldstein

NO sooner had the first group of metal tubes been put on the market than engineers felt the need of additional types for the design of economical universal type superheterodynes. The tubes are now available. There is the 6A8 for oscillation and mixing, the 6K7 for super-control amplifier, the 6J7 for bias detection, the 25A6 for pentode power amplification, and the 25Z6 for rectification. All these tubes are similar in their electrical characteristics to the corresponding tubes in the glass tubes.

It will be noticed that two of the tubes re-

quire 25 volts on the filaments or heaters. The other three tubes require only 6.3 volts each. Thus the five tubes in the circuit require a total heater voltage of 68.9 volts. Since the line voltage will on the average be 115 volts, an additional voltage drop of about 46 volts is necessary. This is taken care of by a 30 watt resistor of 150 ohms, which may be built into the line cord.

### Heater Connections

Since the current through this resistor will be

## LIST OF PARTS

### Coils

- One unshielded honeycomb antenna coil for 370 mmfd. condenser.
- One unshielded oscillator honeycomb coil for 456 kc and 370 mmfd.
- Two doubly tuned i.f. transformers tuned to 456 kc.
- One 375 ohm filter choke, small size.
- One small loudspeaker with a 3,000 ohm field coil.

### Condensers

- One two gang variable condenser of 370 mmfd. capacity and trimmers.
- One 200-600 mmfd. padding condenser.
- Two .00025 mfd. mica condensers.
- One .006 mfd. condenser.
- Two .01 mfd. condensers.
- Four .1 mfd. condensers.
- One dual 5 mfd., 35 volt electrolytic condenser.
- One 8 mfd. electrolytic condenser.
- One 16 mfd. electrolytic condenser.

### Resistors

- One 300 ohm bias resistor.
- One 700 ohm bias resistor (at least one watt rating).
- One 150 ohm ballast resistor, from 15 watts up.
- One 10,000 ohm potentiometer.
- One .02 meg. resistor.
- One .025 meg. resistor.
- One .05 meg. resistor.
- Two .5 meg. resistors.
- One 1 meg. resistor.

### Other Requirements

- Five standard wafer type octal sockets.
- Three small grid clips.
- One line cord and plug (may contain the 150 ohm ballast).
- One line switch (may be attached to the volume control potentiometer).
- One airplane type dial.
- One small chassis.

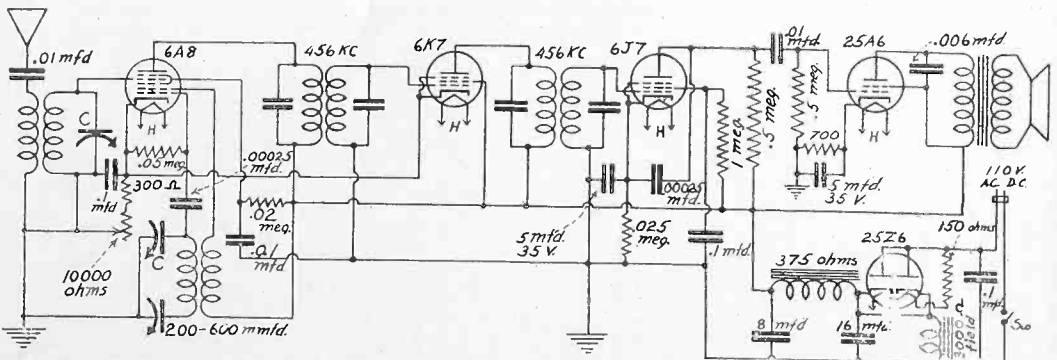

The fundamental circuit of a well tried midget superheterodyne which has been improved greatly by the use of metal tubes throughout. There is sensitivity to spare and no lack of selectivity.

.3 ampere, the rating of the resistor should be at least 15 watts. A resistor of greater rating is desirable, say, one of 30 watts. The order of connecting the heaters is not shown in the circuit diagram of this receiver, except that the heater of the 25Z6 is connected to the 150 ohm ballast resistor. The next tube in the heater series may be the 25Z6, then the 6K7, the 6A8, and finally the 6J7. One side of the heater of

The tuner consists of the radio frequency selector and the oscillator. A two gang condenser, therefore, is required. In the diagram three variable condensers are indicated, but one of these is the adjustable padding condenser. Only the two condensers marked C belong to the gang. The capacity of each section of the dual condenser is 370 mmfd.

If the radio frequency coil is an unshielded

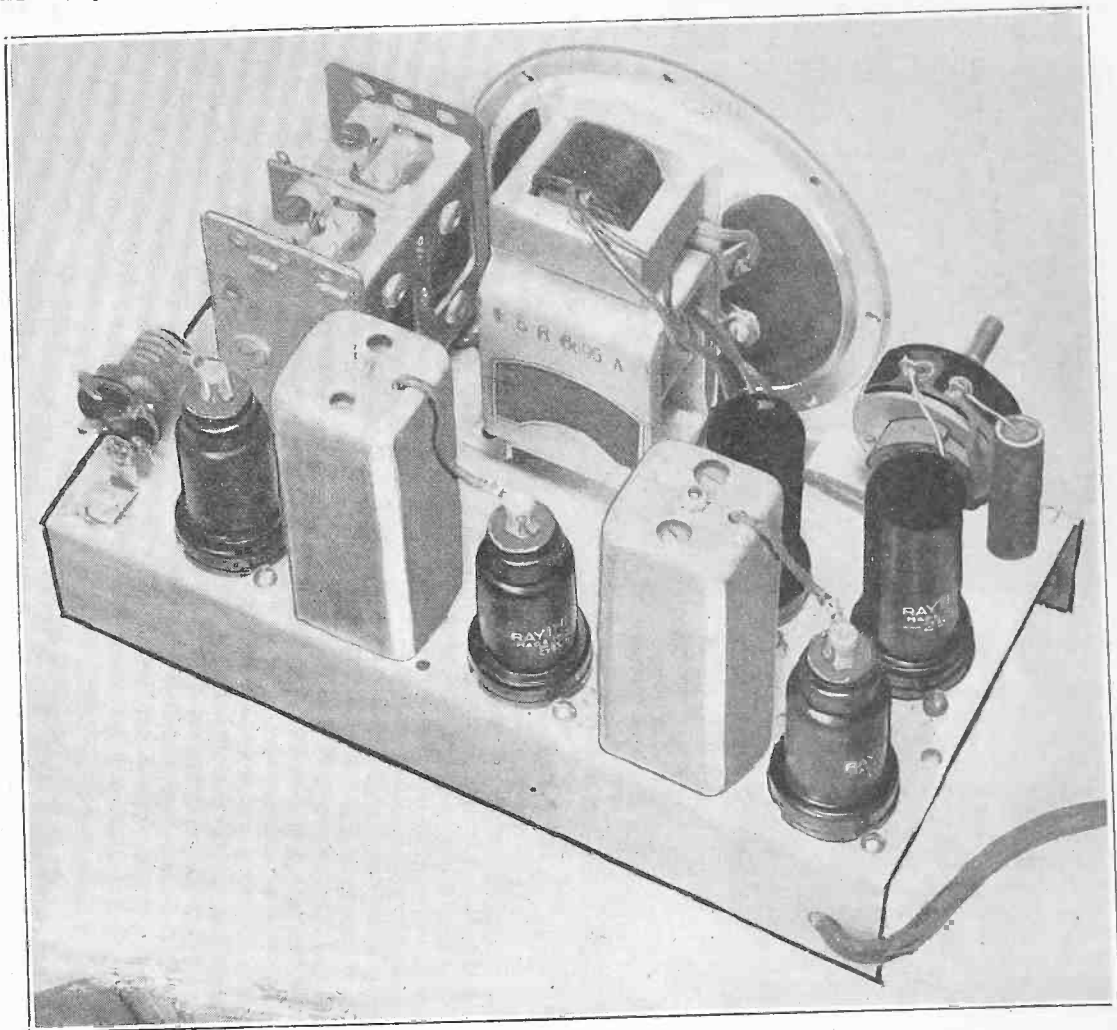

This shows how the five tubes and chassis-top parts are disposed.

the 6J7 may be connected to the chassis, unless a pilot light is used, which may be between the 6J7 heater and the chassis.

### What the Tuner Is

The circuit proper in this receiver is that which is often used for universal type midget superheterodynes. However, as the metal type tubes are somewhat more effective than the older glass tubes, this receiver, properly wired and adjusted, is superior to the older types of midgets. Moreover, the metal tubes are much smaller and require no tube shields, and these facts make smaller and more efficient assemblies possible.

honeycomb and also if the tracking of the oscillator with the radio frequency circuit is close, the selectivity in the radio frequency level will be good because the tuner is required only to suppress image interference, which is not difficult for the broadcast band when the intermediate frequency is as high as 456 kc.

### The Intermediate Amplifier

It should be pointed out that it is not necessary to shield either the radio frequency or the oscillator coils. They should not, however, be placed too close together. A good way of mounting the two coils is to put the radio fre-

*(Continued on next page)*

(Continued from preceding page)

quency coil on top of the chassis and the oscillator coil below it. Neither coil should be placed closer than one radius to the chassis.

One tube, a 6K7, is used in the intermediate amplifier. This is the usual number in small superheterodynes. This is especially the case when the second detector is a high efficiency transrectifier, as in this case.

To obtain a high order of selectivity between adjacent channels two doubly tuned intermedi-

is shunted by a 5 mfd., 35 volt electrolytic condenser. Because of the high bypass capacity used the degeneration on the lowest essential audio notes is negligible.

### The Power Supply

As a means of eliminating a certain type of squeal and also to cut down somewhat on the gain of the highest audio notes, a .006 mfd. condenser is connected between the plate and the screen of the pentode.

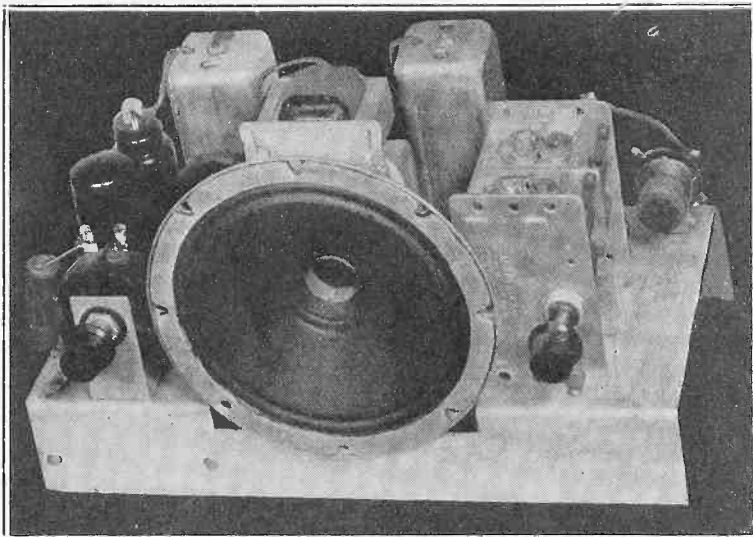

Volume control at left, tuning control at right, speaker in center, its output transformer above, in this front view of Jack Goldstein's set.

ate transformers are used. Each of these has two tuned circuits and the coupling between them is close to the critical value. Therefore the optimum combination of selectivity and gain is secured. The assumption is made, of course, that all the resonant circuits in the intermediate are tuned accurately to the same frequency, namely 456 kc.

The 6J7 detector is operating on the negative bias principle. The bias is obtained from the drop in a 25,000 ohms resistor in the cathode lead. This resistor is shunted by a 5 mfd., 35 volt electrolytic condenser. The large value of the capacity is used to insure freedom from degenerative effects on the lowest audio frequencies.

### Screen Voltage for Detector

The appropriate screen voltage for this detector is obtained by connecting a one megohm resistor between the screen and the high voltage line. The actual screen voltage is steadied by means of a .1 mfd. condenser connected between the screen and the cathode.

A single audio tube follows the detector, and that is a power pentode. The coupling between the two is by means of resistance-capacity. The plate coupling resistor has a value of .5 megohms, the stopping condenser a value of .01 mfd., and the grid leak a value of .5 megohm. This combination is favorable to the amplification of the low audio notes as well as of the high. The pentode is biased by means of a 700 ohm resistor in the cathode lead. This resistor

The 25Z6 tube is able to supply sufficient rectified current not only for the tubes in the circuit but also for the field of the dynamic speaker used with the set. The field coil, which should have a resistance of 3,000 ohms, is connected between the combined cathodes and ground. A 16 mfd. electrolytic filter condenser is also connected between these two points. In series with the positive lead is a 375 ohm filter choke and then there is an 8 mfd. electrolytic condenser across the line. The filtering is quite sufficient.

The volume in the set is controlled by means of a 10,000 ohm rheostat in series with the cathodes of the first two tubes. There is a 300 ohm limiting resistor in series with the rheostat to prevent the bias from going to zero when the rheostat is turned. If there should be a very strong station near the receiver, it is possible that the range of the volume control is not sufficient. In that case one of higher value may be used, or else a 10,000 ohm potentiometer with one end connected to the antenna end of the coil in place of being left open.

### RAY INDICATOR METER

The 6E5 tube may be used as a vacuum tube voltmeter. It is necessary to bias the tube nearly to cutoff, so that a.c. may be measured. Then there would be two calibrations, one for a.c., the other for d.c. As the difference in voltage is in terms of a shadow angle, the a.c. calibration may be on one side of neutral and the d.c. calibration on the other side.

# Sliding Oscillator in Neutral

## How to Locate Zero Axis for Leakage Prevention

By Carter Allen

**I**N a signal generator it is generally assumed that the point that is grounded, usually represented by a metal chassis to which a grounded post is conductive, represents the neutral point of the oscillator, but this is far from true. The neutrality is subject to diverse locations, depending on various factors in the oscillator, although for any single oscillator as constructed, the neutrality is nearly permanent.

If the zero axis of the oscillation voltage is considered, then the neutral represents that axis, for it is the zero level, and nothing connected to that level will result in any output. Connection for output has to be made to some elevated potential, easy enough, since the neutral point is not so easy to find as some unneutral level.

In a battery operated signal generator, for instance, if A minus is grounded, and whether or not there is a filament limiting resistor, it has been found in various circuits that ground is not the neutral level, or zero axis, and naturally oscillation voltage can be taken from the chassis, even if that is grounded, too. This sounds like strange doctrine but is a fact nevertheless.

Once the neutral is found, bypassing to that point stops leakage, and there is no feeding

through the line, if the bypassing and other filtering includes the line. A simple test, not complete, however, is to put a high resistance potentiometer across the total supply voltage, A and B, and connect a .0005 mfd. condenser to the arm, using other side of the condenser as output to a sensitive receiver. As the arm is moved a position will be reached where there is no response in the set, or very little, and moving farther response increases. Go back to minimum, use this as neutral, and do all bypassing to this level.

The condition is made permanent by connecting, measuring the resistance between arm and one extreme, and between arm and other extreme, of the potentiometer, and then inserting fixed resistor of these values, leaving them there, except for battery sets, where a switch should remove them from circuit when the generator is not in use. Therefore a double pole single throw switch may be used, to disconnect the A supply, and to remove the resistors that otherwise would bleed the B batteries, even when the set is not in use.

In an a.c. installation the resistors need not be cut out, because there is no voltage across them when the line switch is open, hence the resistors draw no current.

## De Luxe All Wave Superheterodyne

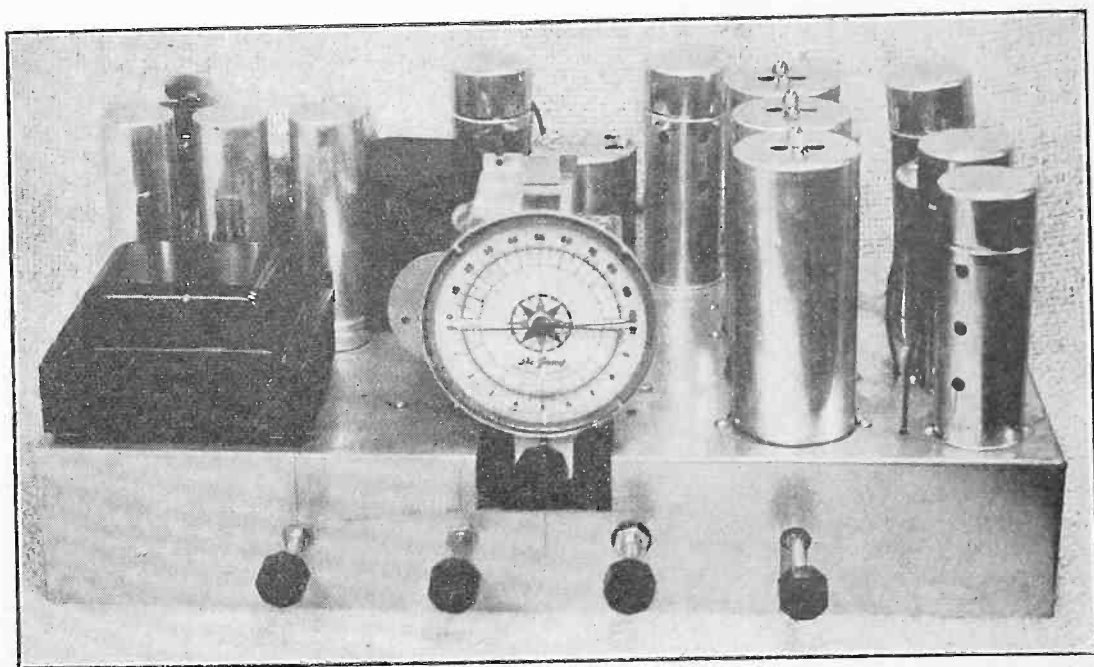

An 8-tube all wave superheterodyne, to be described next month.

# High Sensitivity, Using Batteries

## Voltaging Problems Stressed in Six Tube Super

By Lee F. Woolsey

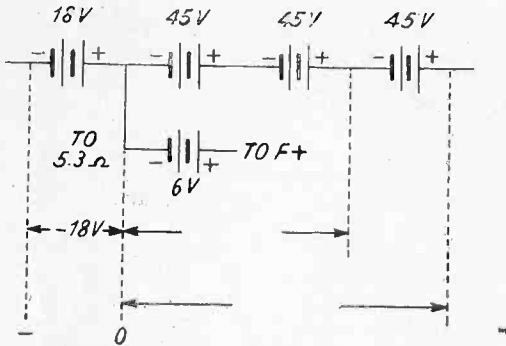

Battery connections to 135 volts of B. Add another 45 volt battery for 180 volts of B. A minus connects to 5.3 ohms.

USING a six volt storage battery, four 45 volt B batteries and a biasing battery, a six tube superheterodyne of a sensitivity high enough to reach the noise level may be built, following the accompanying diagram.

The battery circuits are somewhat simpler than the a.c. models, but there are some pointers that apply to the battery receivers particularly and bear watching.

Extreme care must be exercised not to connect any high voltage to the filament, because then the tubes will burn out. In a.c. sets this peril seldom is present, except as to power some tubes, because of the heater type cathode, that is, the emitter itself is not directly connected to the heater, and the heater is sturdy. This is no recommendation, however, to try high voltage tricks with a.c. heaters.

### Negative Filament Reference Point

Voltaging has to be watched carefully in a battery set, besides safeguarding against accidental connection of high voltage to filament. Therefore the voltaging will be discussed.

The point from which reference is made is the negative filament. The grid is biased negatively in respect to negative filament, the plate and screen positively. Therefore the bias is not reckoned from A minus.

If a six volt storage battery is used, and the tubes require only two volts across the filaments, then the excess, or four volts, must be dissipated in a limiting resistor. The value of filament resistor for this circuit is 5.3 ohms, and a 10 ohm rheostat may be adjusted until the voltmeter reading across the filament is just two volts. It is splendid practice to build the voltmeter into the set, so that if the fila-

ment voltage is wrong—and it is likely to become a bit lower in time—the rheostat may be reduced in resistance to permit the filaments to have the two volts at which they work best. The rheostat at first should be at full resistance setting, or, if in doubt which arm position represents this, use a rheostat of not less than 10 ohms, with pointer at center of the resistance circle. Then adjust to make the filament voltage what it should be.

### The Detector Circuit

If the rheostat is on the front panel, then the limiting resistor should be 4 ohms, and the rheostat 6 ohms. Otherwise some unthinking turn of the rheostat knob in the wrong direction might result in overvoltageing the filaments, even application of the full six volts, which would damage the tubes, if not burn out the filament.

Since the grid in the example of the two 34 tubes and the 1A6 is returned to negative A, which is grounded, and since the reference point, negative filament, is four volts positive in respect to A minus, the grids are automatically negatively biased by four volts. This is the situation when there is no signal.

A carrier will develop a voltage across the detector, a diode of the 1B5 duplex diode triode tube. The detector may be located as the diode on the positive filament side, as seen in the diagram, and as connection is correspondingly present in the tube pin location, the identity is made doubly safe.

A fixed condenser is connected from this diode to the other, hence passes considerable of the a.c. voltage at the intermediate frequency, for separate rectification for automatic volume control, permitting an individual return to ground through a load resistor, .5 meg.

### Four Volts A.V.C. Delay

The diode located about the negative filament is therefore the one used for automatic volume control supply voltage. As this diode is returned to a d.c. voltage point four volts negative compared to the side of the filament associated with it (negative), the diode plate is negative in respect to the filament by four volts, and there is consequently voltage delay, so that on weak signals, when sensitivity is most needed, it will not be reduced by a.v.c.

The signal detector diode, the one on the other side, has no delay circuit. The pulsations in the rectified voltage of this circuit are communicated as audio frequencies to the grid of the amplifier part of the 1B5 tube

(Continued on page 18)



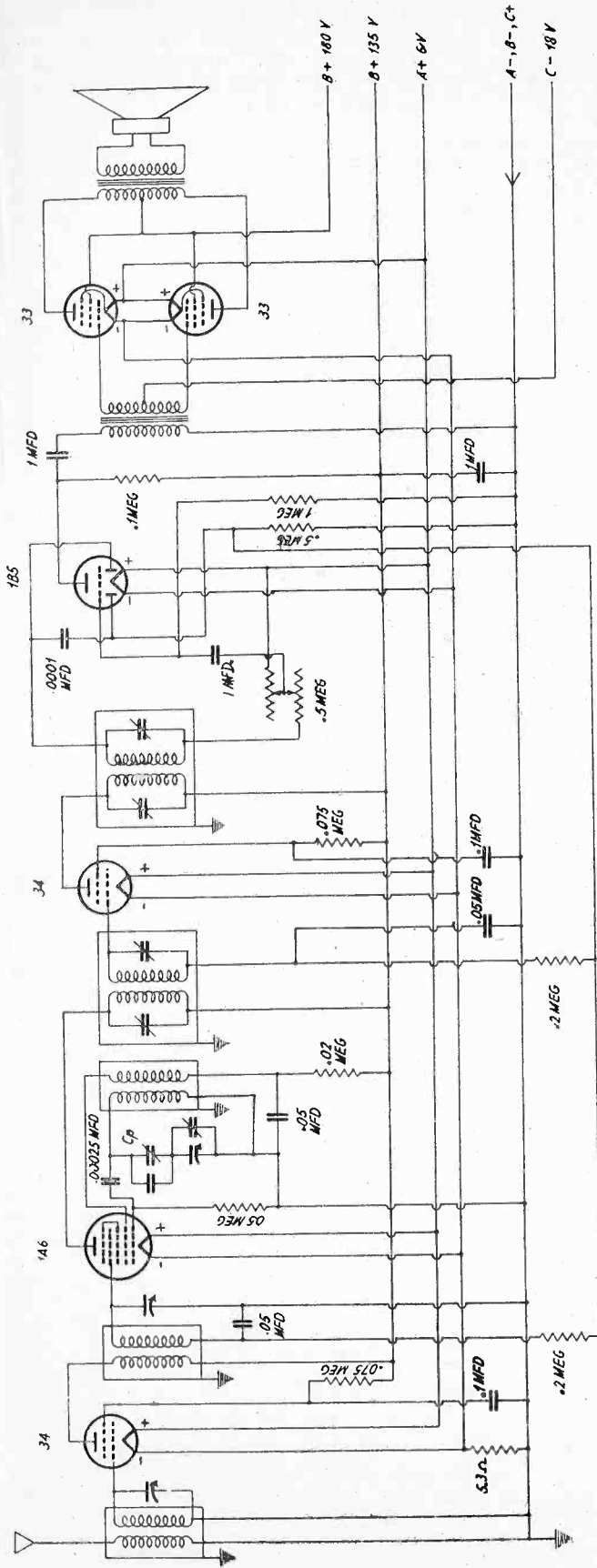

**LIST OF PARTS**

wide-open or removed from r.f. stages so as to reduce capacity changes.  
 One .0001 mfd. mica fixed.  
 One .00025 mfd. mica fixed.  
 One .0008 mfd. fixed condenser and one 140 mmfd. air dielectric variable, together comprising Cp.  
 Three .05 mfd. tubulars.  
 Two 1 mfd. tubulars.  
 Two 1 mfd. paper dielectric.  
 One air dielectric 35 mmfd. trimmer for oscillator (remove compression trimmer). An air dielectric condenser is highly advisable here.

**Coils**

Two shielded radio frequency coils and one shielded oscillator coil for 175 kc i.f.  
 Two 175 kc intermediate frequency transformers, primaries and secondaries tuned.  
 One push pull input transformer, ratio, primary to one-half of secondary, 1 to 1.5.  
 One magnetic speaker for push pull 33 output, with output transformer built in.

**Condensers**

One three gang .00035 mfd. tuning condenser (up to 400 mmfd. allowable). Trimmers

**Resistors**

One 5.3 ohm filament resistor, or 6 ohm rheostat adjusted to give 2 volts across the tube filaments.  
 One .02 meg. (20,000 ohms).  
 One .1 meg. Two .2 meg. One .5 meg. One 1 meg.  
 One .5 meg. L pad, with switch attached.  
 One .075 meg. (75,000 ohms).

**Other Requirements**

Chassis, panned, six sockets.  
 Dial, two knobs, batteries, tubes.

(Continued from page 16) through a 1 mfd. condenser. The grid leak, returned to A minus, is 1 meg.

In the power tube circuit the B voltage actually in circuit is 176 volts, because the negative filament is four volts positive in respect to B minus, and the maximum of the B supply is 180 volts positive in respect to B minus, not in respect to filament minus. The real supply is therefore the difference.

### Making B Voltage Higher

These four volts may be added to, instead of being subtracted from, the 180 volts, by connecting negative of the B feed to positive of the A battery. The full A battery voltage is not added to the B voltage because of the negative filament reference point, or, the two volt drop in the filament.

The recommended bias for the output tubes

volts, or drop in the 5.3 ohm resistor. Literally 14 battery volts would be required, the other four arising from the filament resistor, but 15 would be the nearest battery voltage obtainable, since the cells are 1.5 volts each.

It is satisfactory to leave the bias arrangement at 22 volts actually, as in the diagram, especially as 18 volts are readily obtainable at a tap from a 22.5 volt C bias battery, otherwise two 7.5 volt C batteries could be used in series for 15 volts.

The battery voltage diagram shows three of the four B batteries, also 18 volts of C battery, and the A supply. Positive A goes to positive filaments, negative A to one side of the 5.3 ohm resistor, other side of that resistor to all negative filaments. The B voltages for 90 and 135 volts are shown by the arrows. For 180 volts another B battery would be hooked up in the same series fashion, which causes the volt-

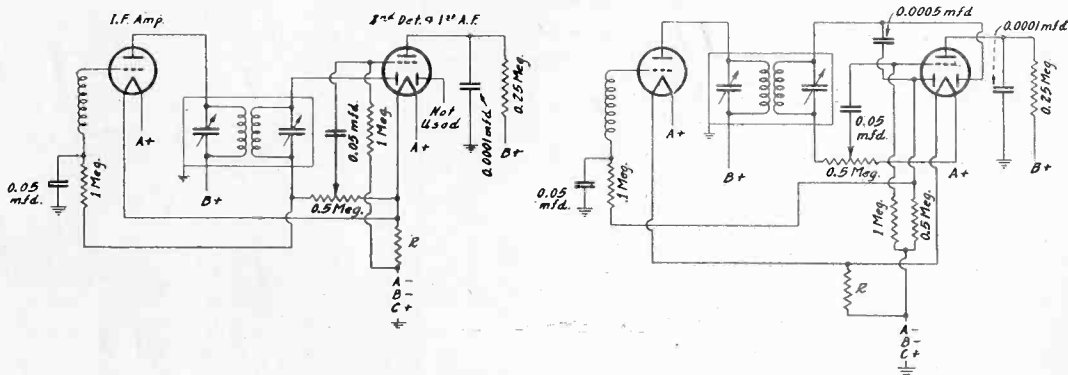

At left, diode nearest positive filament not used, but other diode works without delay of a.v.c. At right, the method of delay used in the six tube set.

is 18 volts negative, for 180 plate volts applied, but this bias is exceeded in the diagram, if it is assumed from the drawing that with C plus connected to A minus, the designation "minus 18 volts" applies to negative of a battery of that voltage. The excess is of course the same four

age to add up. The zero reference point in the battery diagram applies only to the batteries, not to the actual circuit biasing.

## Short Wave Booklet

"Short Wave Travel Tips" is the title of a booklet by H. G. Cisin. It contains a list of short wave stations of the world, except amateur, that use voice transmission, alphabetically arranged by call letters, giving locations (cities of origin), wavelengths in meter and frequencies in kilocycles.

A feature is a special Travel Tip call letter list of important short wave stations to try for in Europe, Asia, Africa, North and South America, Central America and Australia. The booklet is published by Allied Engineering Institute, 98 Park Place, N. Y. City.

### MARKED OCTAL SOCKETS

Some manufacturers now make octal sockets for metal tubes with no lugs on sockets for unused elements, and mark the sockets for the very tubes to go in them.

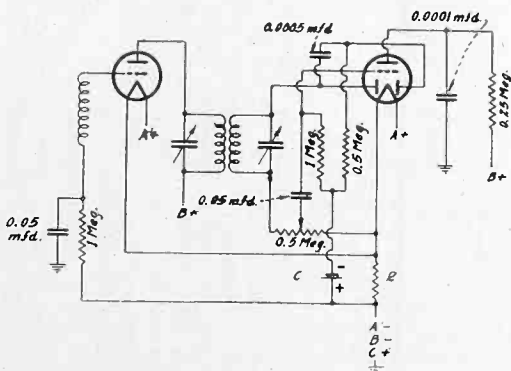

Auxiliary biasing battery to increase the delay of a.v.c.

# A Compact All Wave Set

## Six Metal Tubes and Commercial Coils

By Robert G. Herzog

*Thor Radio Company*

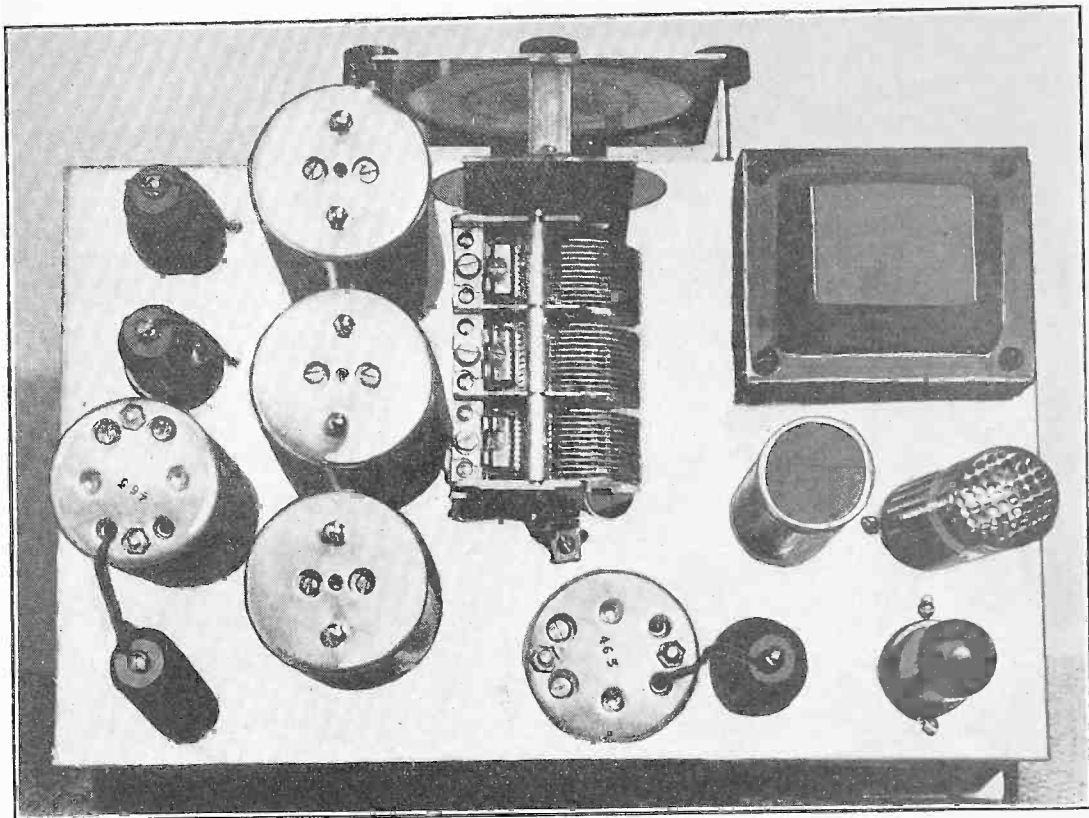

Top view of the chassis of the six tube, all wave superheterodyne. The three shields left of the condenser contain the coil assemblies. The other two shields contain the intermediate transformers. At the right are the power supply and the audio amplifier.

**F**OUR tuning bands, three tuned circuits in the radio frequency level, and four tuned circuits in the intermediate frequency level—that in brief describes the selector in the six tube superheterodyne. By three tuned circuits is not meant that there are only three in the r.f. level. It is meant that three are used at a time, for there are actually twelve tuned circuits in the selector. A six pole, four stop switch is employed for selecting the particular set of three coils required to bring in a station of given frequency. The four tuned circuits cover the frequency range from the lowest broadcast frequency to the highest frequency ordinarily received with circuits of that type.

The coils employed in the radio frequency tuner are standard commercial coils designed for use with regular 370 mmfd. gang tuning

condensers. The radio frequency coils used in the receiver, as may be seen from the chassis layout picture, are encased in metal shields similar to those used for the intermediate coils.

### Each Oscillator Band Padded

In each of these shield cans is a set of four inductances. It will be noticed that in each are two trimmer condensers. Two others on each coil may be seen at the other ends of the coil under the subpanel. These are enough to trim each of the circuits independently of the trimmers on the tuning condensers.

It should be noticed that there is a series padding condenser for each oscillator coil. The capacity of the condenser for the first coil is .0042, that for the second coil, .0022 mfd., that

*(Continued on next page)*

# A Grounded Cathode Set For Two Bands, with Low Note Fidelity

By Spencer L. Woods

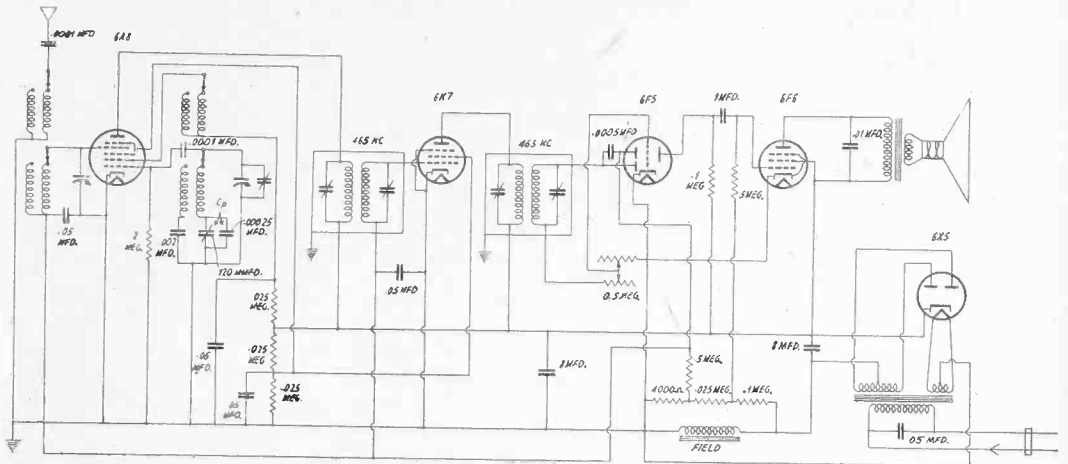

The control grid of the 6A8 (first tube at left) and that of the 6K7 intermediate amplifier are subject to automatic volume control. Therefore the line from the secondaries feeding the first tube should pass over the ground line, on the way to the a.v.c. circuit, a fact not clearly brought out in the diagram.

**A** TWO band metal tube set is shown. The new tube is the 6X5 rectifier, of the cathode type. Therefore a single 6.3 volt winding may be used for all tubes.

The receiver is for a.c. operation. The tube arrangement does not lend itself readily to universal operation, as the rectifier draws .6 ampere, the power tube .7 ampere and the

other tubes .3 ampere each of heater current.

All cathodes, except for the rectifier, are connected directly to ground. Minimum bias for the control grid of the mixer tube and for the intermediate amplifier, both of which are automatically volume controlled, is obtained from the drop across one unit of the network of three resistors across the speaker field. Nor-

## LIST OF PARTS

### Coils

- Four coils, two each for each of two bands, wound as described in the text.
- Two 465 kc intermediate frequency transformers, primaries and secondaries tuned.
- One dynamic speaker with pentode output transformer and 1,800 ohm field. (Field used as B choke in negative rectifier leg.)
- One power transformer with three windings: 115 volts, 50-60 cycles; 6.3 volts, 5 amperes; high voltage winding for five tube set.

### Condensers

- One two gang .00035 mfd. tuning condenser (trimmer on antenna section wide open).
- Two .0001 mfd. mica.
- One .00025 mfd. mica.
- One 120 mmfd. or higher air dielectric condenser (across .00025 mfd. fixed).
- One .002 mfd.
- Five .05 mfd.

Two 8 mfd. electrolytics, 500 volt continuous working voltage rating.

- One 1 mfd. paper condenser.
- One .01 mfd. (any type).

### Resistors

- One 4,000 ohms.
- Four .025 meg. (25,000 ohms).
- Two .1 meg.
- One .2 meg. (may use .25 meg.)
- One .5 meg.
- One .5 meg. L pad with a.c. switch.
- One 5 meg.

### Other Requirements

- Five octal sockets and one four hole socket for speaker plug.
- Three miniature grid clips.
- One chassis and front panel.
- One dial and escutcheon.
- Two knobs (one for volume control, other for dial).
- One a.c. cable and plug.

mally this field would be 1,800 ohms and drop around 110 volts.

### The Three Biases

B minus is not connected to ground but to one side of the field, the other side of the field to ground, so that all the voltage developed from ground to B minus is in a negative direction. Hence if a cathode is grounded, and grid is returned to a voltage derived from the field, then the tube gets a negative bias. The 6F5 high mu duo-diode triode gets three different values of bias. First, the lower diode works at once. Second, there is no bias on the control grid until rectification takes place, whereupon the grid becomes negative to an amount just equal to the rectified voltage. This circuit is represented by the lower diode in the diagram, the secondary feeding it, and the L pad return to cathode. As soon as the lower diode is positive to a.c. (intermediate frequency carrier) there is rectification, and there is enough without any station being tuned in to develop a small negative voltage for the grid.

### The Delayed A.V.C.

The third condition affects the other diode. The voltage for this diode is taken through the stopping condenser connected to the other plate, and the load resistor is a fixed one of .5 meg., connected to a point on the resistor network representing about 3 volts negative from ground.

This of course is the same negative point that develops the bias for the controlled tubes, but it also causes the upper diode to be maintained that much negative in respect to the other diode.

Since the diode will not rectify until it is positive to a.c., the i.f. carrier has to overcome this bucking voltage before there is any a.v.c. rectification, although the real detection takes place in the other diode at once. So there is a 3-volt delay, recommended for diode biased tubes of this type, assuring high sensitivity to weak signals, and a.v.c. only on relatively strong ones.

### Cutoff Considered

The plate load resistor is purposely made .1 meg. rather than the higher values sometimes recommended, so that the plate current will be adequate for strong signals. As is well known, the intensity of the rectified voltage easily may become so great on the diode that the negative bias resulting will practically cut off the plate current. The cutoff point therefore is moved farther over, and if any trouble develops due to premature cutoff, the plate load resistor should not be reduced. It is essential that a short antenna be used with such a set, as the selectivity is improved, and also the peril of cutoff is removed.

The bias for the power tube is obtained in the same general manner as is the fixed portion of the bias for the tubes subject to a.v.c., only the return is made to a more negative point.

The stopping condenser between the triode plate and pentode grid is 1 mfd. and should be of the paper type. No smaller capacity

should be used for the present purpose, and at the same time the leak should be maintained at a high value. The specification is for 5 meg., and this will greatly improve the low note reproduction, and also the general sensitivity.

It is true that so high a value of resistance is the subject of specific warning in tube manuals, in conjunction with such a tube, and .5 meg. is usually put as the maximum value. The reason given is that the tube loses bias on strong signals. However, low note fidelity is also a consideration, and if one will put up with shorter power tube life, he can have the low notes in the manner described. It is well to have the tube biased a bit more negatively than usual as a safeguard against too early a loss of bias.

### A Listening Test

It is easy to test for this low note fidelity. First, tune in an orchestra, especially one that has a bass viol. Listen carefully to the low notes. Then put a .5 meg. leak across the 5 meg. and note the difference. You may hardly be able to hear the bass viol. Maybe that musician happens not to be tiddling at the moment. Wait a while. Listen. Keep on waiting. If there is little if any sign of a viol by the time the orchestra signs off, you can ascribe the results to the low load on the grid circuits.

If a potentiometer of the usual type were used as volume control there would be loss of low note response at low volume settings also due to insufficient loading of the grid circuit, this time the grid of the triode of the 6F5.

### Coil Information

The intermediate frequency used is 465 kc. The r.f. and oscillator tuning sections are .00035 mfd. but capacities, larger up to .0004 mfd., may be used, with the following coils:

<b>R.F. Broadcast Band</b>	<b>R.F. Short Wave Band</b>
Primary, 20 turns, 32 enamel	Primary, 25 turns, 32 enamel
Secondary, 127 turns, 32 enamel	Secondary, 9 turns, 24 enamel
<b>Osc. Broadcast Band</b>	<b>Osc. Short Wave Band</b>
Primary, 35 turns, 32 enamel	Primary, 5 turns, 24 enamel
Secondary, 78 turns, 32 enamel	Secondary, 8½ turns, 24 enamel
<b>Padding capacity, .00025 mfd. fixed, with 120 mmfd. variable across it (cp.).</b>	<b>Padding capacity consists of a fixed condenser of .002 mfd.</b>

In each instance the primary is wound over the secondary. In the broadcast coils, both oscillator and r.f., the tickler is put near the bottom of the secondary, some insulation between, either Empire cloth, wrapping paper or the like. For the short wave coils, both r.f. and oscillator, the tickler is put on at center of the secondary, so that the length of winding is about the same for primary and secondary. The short wave band in frequencies will be ten times as high as the standard broadcast frequencies. All directions are for tight winding on one inch diameter tubing.

# Broadcast Superheterodyne with 12 Watt Push Pull Output

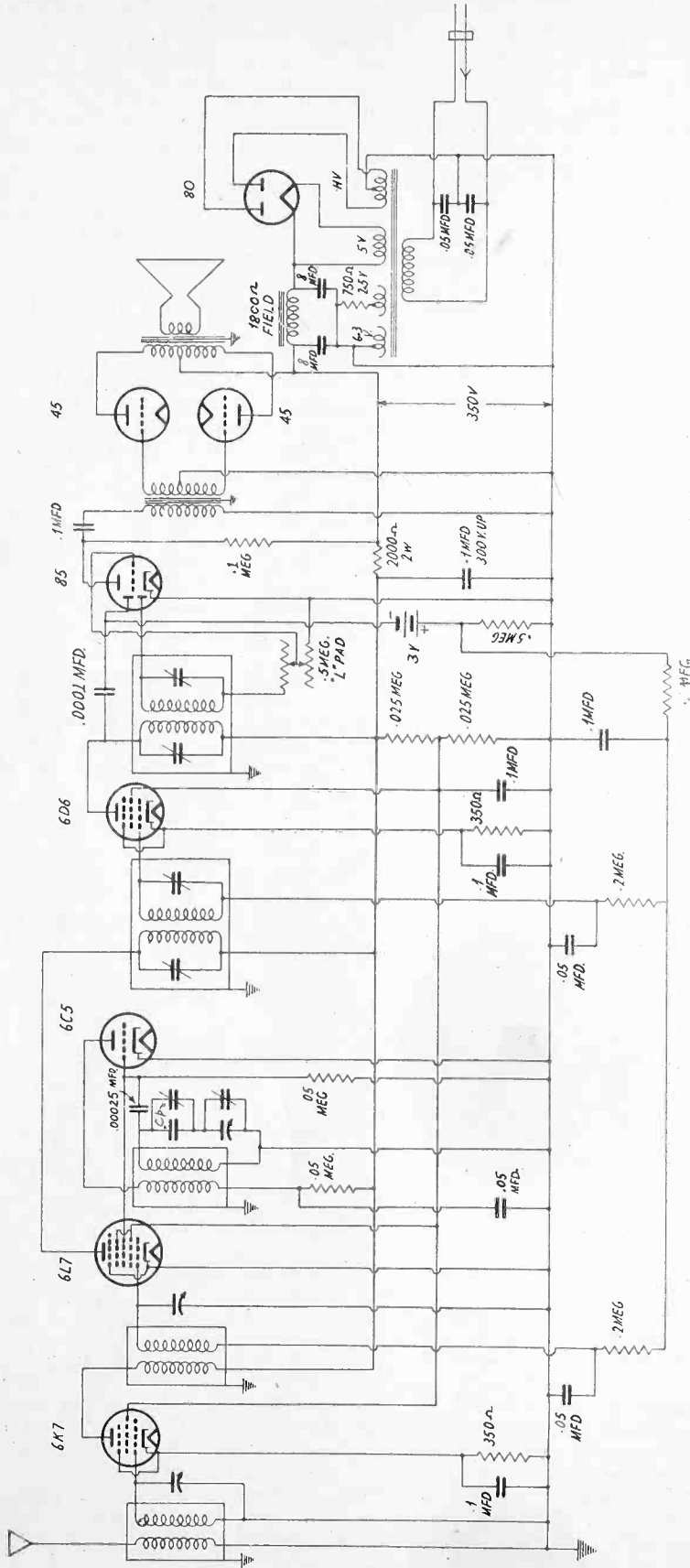

The 6L7 r.f. control grid, and the grid of the first i.f. tube (6D6) are returned to ground through a .5 meg. resistor. The same lead from the controlled tubes goes to positive of a 3 volt battery, negative of which connects to a.v.c.

This delays the a.v.c. by about 3 volts, as not until the bucking voltage of the battery is overcome does rectification for a.v.c. take place. Thus weak stations are not subject to reduction of sensitivity.

## LIST OF PARTS

## Coils

Two shielded radio frequency coils and one shielded oscillator coil (see text).  
 Two 175 kc intermediate frequency transformers, primaries and secondaries tuned.  
 One power transformer: primary, 115 volts, 50-60 cycles; secondaries: 6.3 volts, center tapped; 2.5 volts, center tapped; 5 volts, high voltage, center tapped, rating 100 milliamperes. (High voltage 400-0-400 satisfactory.)  
 One dynamic speaker, with 45 push pull self biased output transformer built in, ohms load, 5,000 plate to plate; field, 1,800 ohms.  
 One push pull input transformer, low ratio. (Primary to one half of secondary, 1 to 1.5 satisfactory.)

## Condensers

One three gang tuning condenser (maximum of .00035 to .0004 mfd. satisfactory).  
 One air dielectric 35 mmfd. trimming condenser to be shunted across oscillator tuning condenser section and adjusted. (See text.)  
 Series padding capacity consisting of a fixed condenser and a variable across it, total comprising Cp. (See text.)  
 One .0001 mfd. fixed mica  
 One .00025 mfd. fixed mica  
 Five .05 mfd. tubular  
 Five .1 mfd. tubular (one of these 300 volt rating or more)  
 Two 8 mfd. electrolytic condensers, 500 volt rating or more.

## Resistors

Two 350 ohm  
 One 750 ohm, 5 watts  
 One 2,000 ohm, 2 watts  
 Two .05 meg.  
 One .5 meg. L pad, with a. c. switch attached

## Other Requirements

One chassis  
 One dial  
 Nine sockets: three octal for metal tubes; two six hole for 6D6 and 85; three four hole for 45's and 80; ninth one to match speaker plug  
 One a. c. cable and cord  
 Two tube shields and bases, for 6D6 and 85  
 Antenna-ground posts

Super with Delayed  
A.V. C.

By Herman Bernard

THE principal object of automatic volume control is to have the quantity of sound output from the speaker about the same for all stations, assuming a given setting of the manual volume control. One limitation is that some stations lay down such a weak carrier that the intended sound level is not reached. The situation is made worse if the a.v.c. action is simultaneous, that is, becomes effective as soon as there is any detection in the detector tube. Then even the weak stations are subject to some reduction of volume, and that is exactly what is not wanted.

So the process of delaying the a.v.c. action is introduced. This means that a.v.c. does not become effective so soon as there is detection in the detector tube, hence no additional negative bias is provided by the a.v.c. action until the amplified intensity at the radio frequency or intermediate frequency level is high enough to justify inclusion of a.v.c.

## Delay with Single Cathode

With simply a diode second detector in a superheterodyne, for instance, the connection of the return circuits of the controlled tubes to the high side of the diode load resistor has the effect of wiping out the weak stations, and the set has less sensitivity where it needs more.

The delay is perhaps more simply established with separate cathodes, hence the 6H6 metal tube has been introduced, but delay can be worked successfully with single cathode tube, also. One way of doing this is to use the two diodes of a duplex tube separately, one connected as usual to the secondary of the i. f. transformer, load resistor of this diode returned to cathode, the other diode connected to plate of prior tube through a fixed condenser, with a separate load resistor that is returned through a biasing element, cell or battery. In the circuit herewith a 3 volt dry cell is shown, so that when approximately 3 volts of signal (a. c.) appear across the primary of the transformer, the bucking voltage of the cell is neutralized, carrier voltages higher than 3 volts produce rectification, and a.v.c. applies.

The cell may be raised to 4.5 volts or more, for increasing the sensitivity for signal levels at the primary below 4.5 volts or more, instead of below 3 volts. Around 6 volts delay are commonly used.

## Lag Must Be Avoided

The signal voltage across the primary is usually about the same as that across the secondary, so that the feed to the a.v.c. diode would be about the same, due to 1 to 1 transformer ratio, but the a.v.c. voltage actually

(Continued on next page)

# Broadcast Superheterodyne with 12 Watt Push Pull Output

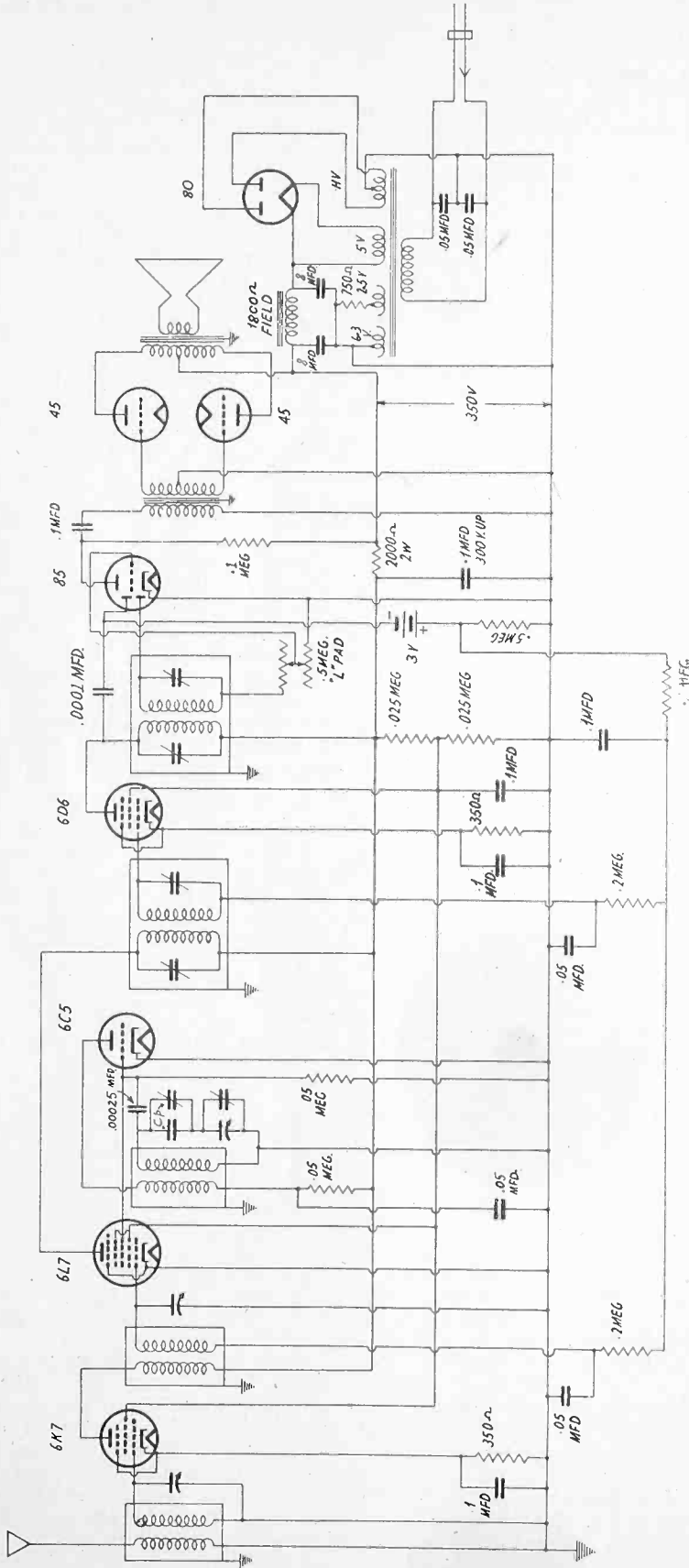

The 6L7 r.f. control grid, and the grid of the first i.f. tube (6D6) are returned to ground through a .5 meg. resistor. The same lead from the controlled tubes goes to positive of a 3 volt battery, negative of which connects to a.v.c. diode plate. This delays the a.v.c. by about 3 volts, as not until the bucking voltage of the battery is overcome does rectification for a.v.c. take place. Thus weak stations are not subject to reduction of sensitivity.



## LIST OF PARTS

## Coils

Two shielded radio frequency coils and one shielded oscillator coil (see text).  
 Two 175 kc intermediate frequency transformers, primaries and secondaries tuned.  
 One power transformer: primary, 115 volts, 50-60 cycles; secondaries: 6.3 volts, center tapped; 2.5 volts, center tapped; 5 volts, high voltage, center tapped, rating 100 milliamperes. (High voltage 400-0-400 satisfactory.)  
 One dynamic speaker, with 45 push pull self biased output transformer built in, ohms load, 5,000 plate to plate; field, 1,800 ohms.  
 One push pull input transformer, low ratio. (Primary to one half of secondary, 1 to 1.5 satisfactory.)

## Condensers

One three gang tuning condenser (maximum of .00035 to .0004 mfd. satisfactory).  
 One air dielectric 35 mmfd. trimming condenser to be shunted across oscillator tuning condenser section and adjusted. (See text.)  
 Series padding capacity consisting of a fixed condenser and a variable across it, total comprising Cp. (See text.)  
 One .0001 mfd. fixed mica  
 One .00025 mfd. fixed mica  
 Five .05 mfd. tubular  
 Five .1 mfd. tubular (one of these 300 volt rating or more)  
 Two 8 mfd. electrolytic condensers, 500 volt rating or more.

## Resistors

Two 350 ohm  
 One 750 ohm, 5 watts  
 One 2,000 ohm, 2 watts  
 Two .05 meg.  
 One .5 meg. L pad, with a. c. switch attached  
 Two knobs  
 Two small grid clips  
 Nine sockets: three octal for metal tubes; two six hole for 6D6 and 85; three four hole for 45's and 80; ninth one to match speaker plug  
 One a. c. cable and cord  
 Two tube shields and bases, for 6D6 and 85  
 Antenna-ground posts

## Other Requirements

Two knobs

Two small grid clips

Nine sockets: three octal for metal tubes;

two six hole for 6D6 and 85; three four hole

for 45's and 80; ninth one to match speaker

plug

One a. c. cable and cord

Two tube shields and bases, for 6D6 and 85

Antenna-ground posts

# Super with Delayed A.V. C.

By Herman Bernard

THE principal object of automatic volume control is to have the quantity of sound output from the speaker about the same for all stations, assuming a given setting of the manual volume control. One limitation is that some stations lay down such a weak carrier that the intended sound level is not reached. The situation is made worse if the a.v.c. action is simultaneous, that is, becomes effective as soon as there is any detection in the detector tube. Then even the weak stations are subject to some reduction of volume, and that is exactly what is not wanted.

So the process of delaying the a.v.c. action is introduced. This means that a.v.c. does not become effective so soon as there is detection in the detector tube, hence no additional negative bias is provided by the a.v.c. action until the amplified intensity at the radio frequency or intermediate frequency level is high enough to justify inclusion of a.v.c.

## Delay with Single Cathode

With simply a diode second detector in a superheterodyne, for instance, the connection of the return circuits of the controlled tubes to the high side of the diode load resistor has the effect of wiping out the weak stations, and the set has less sensitivity where it needs more.

The delay is perhaps more simply established with separate cathodes, hence the 6H6 metal tube has been introduced, but delay can be worked successfully with single cathode tube, also. One way of doing this is to use the two diodes of a duplex tube separately, one connected as usual to the secondary of the i. f. transformer, load resistor of this diode returned to cathode, the other diode connected to plate of prior tube through a fixed condenser, with a separate load resistor that is returned through a biasing element, cell or battery. In the circuit herewith a 3 volt dry cell is shown, so that when approximately 3 volts of signal (a. c.) appear across the primary of the transformer, the bucking voltage of the cell is neutralized, carrier voltages higher than 3 volts produce rectification, and a.v.c. applies.

The cell may be raised to 4.5 volts or more, for increasing the sensitivity for signal levels at the primary below 4.5 volts or more, instead of below 3 volts. Around 6 volts delay are commonly used.

## Lag Must Be Avoided

The signal voltage across the primary is usually about the same as that across the secondary, so that the feed to the a.v.c. diode would be about the same, due to 1 to 1 transformer ratio, but the a.v.c. voltage actually

(Continued on next page)

(Continued from preceding page)

is smaller than the true detection voltage, because the coupling method, through a condenser, is not as efficient, nor is the resistor loading as effective.

Besides the delayed a.v.c., which is highly advisable, it is imperative not to delay the a.v.c. effect in another direction, by having filter return circuits of too high a time constant, representing too low an inherent frequency, whereby stations become audible an appreciable time after the dial positions have been reached for tuning them in. For instance, a dial is turned to bring in WOR, but the station is not heard at once, rather a fraction of a second later. This is objectionable.

Besides a.v.c. being marred by too sluggish a filter circuit, represented by the condensers and resistors in connection with returns of the controlled tubes, it may be marred by too fast an action, that is, the inherent frequency of the filter circuits is too high, time constant too low. If the time constant were so low as to produce filter resonance at 10,000 cycles, then the modulation would be removed from the signal.

### Limits Prescribed

Hence somewhere between these two extremes, and safely within them, the time constants should be established. These are commonly recommended as between .04 and .09, inclusive, and represent respectively frequencies of 25 and 11.1 cycles. These are frequencies below those reproduced in receivers, hence removal of reception of these frequencies is of no importance.

The time constant is equal to the resistance in megohms multiplied by the capacity in mfd. Thus if the resistor is 100,000 ohms, express it in megohms as .1, and if the capacity is .5 mfd., then the time constant is the product of these two (.1 x .5) or .05, which falls within the prescribed limits. The frequency is the reciprocal of the time constant, that is, 1/.05 or 20 cycles. It will be remembered that the frequencies should fall between about 11 and 25 cycles.

In considering the time constant and its proper evaluation one should consider the total circuit.

### Time Constants Evaluated

So far as resistance is concerned the cathodes of the controlled tubes may be taken as grounded, and the biasing resistance ignored. The d. c. resistance of coils is too small to warrant attention, either, therefore the resistance to be considered is that amount between grid and ground.

Take the first controlled tube, the 6L7. Grid No. 1 goes to a resistor of .2 meg., but before the final return, or ground, is reached, there are one more series resistor, .2 meg., also another of the .5 meg. constituting the a.v.c. diode load resistor. Therefore the total is  $.2 + .2 + .5 = .9$  meg., by passing which is .05 mfd., hence the time constant of the circuit is .045, and the inherent frequency is 22 cycles. The other controlled tube is the 6D6, with .2

and .5 meg between grid and ground, hence .7 meg., across which is .1 mfd., and the time constant is .07, frequency 14.4 cycles.

There is some support for the theory of thus staggering the time constants, so that there will not be any accentuation of a given rapidity of response, which might give a fluttering effect in the speaker.

### Local Oscillator Bias

No automatic volume control is applied to the first or radio frequency amplifier tube, as it is the general experience that there is reduction of sensitivity without comparable control benefit, as compared with the 6L7. However, experience has shown that the control is satisfactorily included at the intermediate frequency level.

The grid leak in the local oscillator circuit also establishes a form of automatic volume control of internal generation, as the amplitude of the oscillation is limited by the voltage developed across the leak due to grid current. This d. c. passes through the resistor, but not through the grid condenser. For each micro-ampere of grid current there is developed .5 volt negative bias.

The polarity is such because the cathode is always positive to d. c. when rectification takes place. Also, the negative bias developed represents an average value, applicable to both alternations of the cycle, because during the negative cycle the grid condenser is discharging. Therefore during the negative cycle the negative bias is maintained by displacement current.

### Padding the Oscillator

Minimum bias is used on the first tube because the noise level is less when the plate current is substantial, and as low carrier are handled the actual plate current does not change much.

The change is greater in the 6L7, and in addition oscillation voltage is introduced, therefore the total input to the tube is considerably greater than if carrier alone were to be considered. The steady negative bias is maintained at around 6 volts, to prevent overloading of the modulator tube even on weak signals, and also to improve selectivity, because of the increased input impedance.

The sensitivity is less than if the bias were lower, say, 3 volts, but the reduction is advantageous for the reasons stated.

The oscillator is padded for 175 kc by using a little more than .008 mfd. The oscillator secondary inductance is 200 microhenries for a tuning condenser of 400 mmfd., with r. f. secondaries of 236 microhenries for the same tuning capacity, unpadded, however. The effective capacity in the oscillator should be about 265 mmfd., and to pad for this, build up parallel fixed capacity to .0008 mfd. and then put an air dielectric trimmer across, of 75 to 100 mmfd., compression type.

### Reason for Using 175 kc

The adjustment is made at a low broadcast frequency, 600 kc usually, while for padding

(Continued on page 28)



A metal-glass tube was tried out as r.f. amplifier (left).

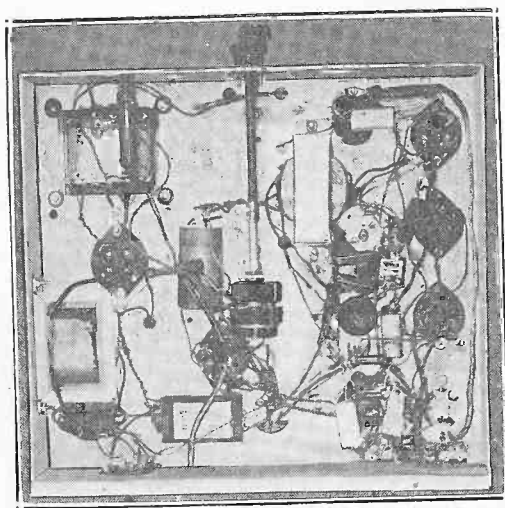

Short leads result from shaft extension of the L pad.

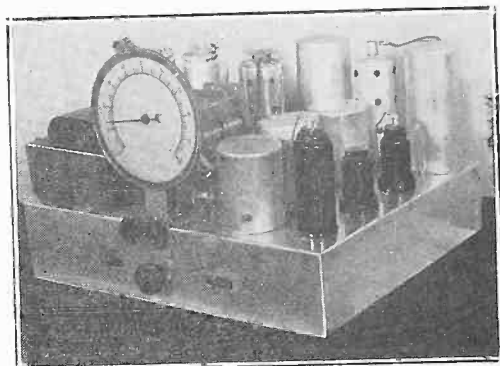

The three informative views on this page show the author's construction of his personal receiver. The dial pointer turns 270 degrees for 180 degree condenser rotation, for better visual spreadout. The oscillator coil is between the two coils that are frequency marked. Caps were put on the i.f. and second detector tubes after the photographs were taken. The power transformer may run warm but not hot.

(Continued from page 26)

near the opposite end of the dial, use 1,450 kc, and turn the trimmer that is across the oscillator tuning condenser. Full directions for padding superheterodyne were printed in last month's issue (January). However, in the present instance no trimmers are used across the coil at the r. f. level, because it is desired to tune to 2,000 kc at one end and 530 kc at the other to encompass some police and amateur transmission frequencies.

### Another Difference

At the extreme frequency of 2,000 kc the local oscillator frequency differs from the r. f. by more than 9 per cent which is satisfactory. There are greater gain and selectivity at the 175 kc i. f. level than if a higher i. f. were used, such as 456 kc or 465 kc, advisable only if much higher frequencies than 2 mc are to be tuned in. Then an i. f. even a bit higher than 500 kc might be used, and it would not be surprising to see such a vogue set in for all wave superheterodynes.

The lower diode in the diagram represents the second detector, the upper diode the rectifier for a.v.c. Both diodes are returned to ground, but the a.v.c. load resistor has the cell or battery in series. Since the diode will not rectify unless it is positive to a. c. the cell or battery, though providing d. c., requires that the signal overcome the bucking voltage before rectification will take place, hence before any voltage can develop across the a.v.c. diode load resistor.

### Use of an L Pad

For the second detector the load resistor may be a potentiometer of .5 meg., but if two potentiometers are connected in tandem opposing, and are matched for the purpose, an L pad is introduced, so that the total resistance in circuit remains about the same, regardless of knob position, although the amount of rectified signal voltage taken off changes of course with knob position.

This pad constitutes a great improvement over a simple potentiometer because the grid circuit is sufficiently loaded at low volume settings, and the low note reproduction is maintained at the same relative value, whereas otherwise low volume settings of the manual control would leave insufficient resistance in the grid circuit to support low note reproduction.

At the r. f. and oscillator levels metal tubes were used, because of their advantages. The 6K7 does not make so much difference for broadcast band use, but the separation of the local oscillator and the modulator, with high impedance electron coupling, and support of the separate identities of the input voltages, instead of them pulling together, make the selection of the metal tubes of some consequence even for standard broadcast band use.

### Notation on Tubes

The i. f. tube, the 6D6, is of the glass type, as are the 85, the 45's and the 80.

The 85 is the equivalent of the 55 of the

2.5 volt series, but takes 6.3 volts on the heater. The similar 6.3 volt tube, the 75, does not suit the present purpose so well, because plate current cuts off at a small signal input, and the loading of the plate with a suitable impedance becomes difficult, due to the high plate resistance, as the triode is a high mu tube.

### Audio Frequencies

The plate load of the 85 looks into the transformer as a device permitting frequencies to 50 cycles to pass along, but actually the primary itself of the audio transformer likely will limit this to a higher frequency, depending on the calibre of the transformer used. At least, the input is filtered, so that no d. c. flows through the primary, hence the primary inductance is supported, whereas otherwise it would be reduced, due to the steady magnetization that provides no benefit, and very greatly reduced for transformers having high permeability cores. A high permeability core is one that speeds up the response to electro-magnetism, so that small input produces a larger effect. In other words, there is greater flux density, greater inductance for a given number of turns, but the saturation point is reached much more quickly, for the very same reason of sensitivity, so that all the lines of force are utilized early. But with d. c. kept out of the primary the premature saturation is avoided.

### Power Transformer

The power transformer is of the 100 milli-ampere type, the rating applied to the high voltage secondary, although less than 100 milliamperes actually will be taken out. Besides the primary and the high voltage secondary, there are three filament or heater windings, one of 5 volts for the rectifier, one of 6.3 volts for the amplifier and detector tubes, and one of 2.5 volts for the two 45's. Commercial transformers with 100 milliamperes high voltage secondary nearly always have filament and heater secondaries of sufficient power capacity to take care of the requirements of a circuit like this.

The speaker field is used as the B filter choke, and may have a resistance of 1,800 to 2,500 ohms, depending on the high voltage secondary. Normally around 100 volts d. c. would be dropped in the field. The limiting resistor, to reduce the B supply voltage on the prior tubes, may be raised beyond 2,000 ohms, to whatever is necessary to establish a voltage of between 225 and 250 volts across the .1 mfd. 300 volt condenser bypassing the resistor.

### EXPLANATION OF FADING

Fading is generally believed to be due to the arrival of different components of the radiated waves at different times. Thus, the sky wave may reach maximum at one instant, and if the ground wave, or a reflection or refraction of the sky wave, is minimum at the same time, and the intensities are equal in amplitude though opposite in phase, then the signal momentarily would be cancelled out.

# Precision Calibration of Generators

## Identification of Low Frequencies by Higher Ones

By Louis Kranz

THE method of calibrating a signal generator, even where the generator frequencies are lower than standard broadcast frequencies, may be applied accurately by any one. As far as and including the broadcast band, where equal frequencies of generator are compared to station frequencies, a complete run may be made.

The method of calibrating your own generator, and there is nothing to stop you from protracting your own scale and pasting it on a metal disc, is to beat harmonics of the generator with broadcasting stations of known frequencies, whereby fundamentals of the generator are identified. The beat is caused by mixture of the station frequency and an harmonic of a generator frequency.

### Identification of Fundamentals

To find out what the generator fundamental frequencies are requires some knowledge of harmonic technique. As a first approximation, assuming use of a condenser of about .00035 to .0004 mfd. maximum capacity, no trimmer, or trimmer wide open, the frequency ratio will be about 3.2 to 1. So no fundamental generation ever can be four times as high as any other fundamental generation in a single band. Therefore set up the signal generator, beat with some local station of low frequency (800 to 530 kc for instance), and preferably some station that enables a response at or near one end or the other of the generator tuning.

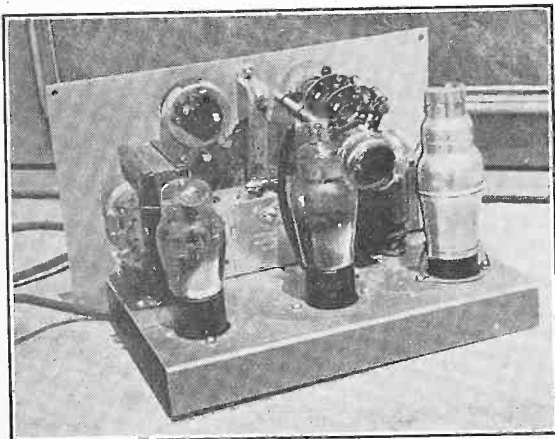

Before any calibrating is attempted the coils should be permanently in the positions they will occupy, especially if a metal chassis and cabinet are used. The reason is that the inductance is increased as the coil is put nearer the chassis, especially for low frequencies.

All we know so far is: (1) we have a generator working; (2) it is beating with a broadcasting station of known frequency tuned in on a receiver.

Suppose the station frequency is 570 kc. Suppose that near the generator's full capacity setting we hear a response due to an assumed generator harmonic beating with the station. We hear three responses for the span, therefore at least two must be due to harmonics. They give us our bearings. We divide 570 by 1, 2, 3, 4, 5, getting 570, 285, 190, 142.5 and 114. The generator's low terminal frequency can not be 114, because 570 is 4 times 114, and we have been assured that the high frequency extreme can not be as much as four times the low frequency extreme, otherwise the maximum capacity in circuit would have to be at least 16 times the minimum, hence at less than full capacity of the condenser the impossibility is even greater, if degrees of impossibility are permissible.

### Was It 142.5 KC?

So the response near full capacity could not have been 114 and may have been 142.5 kc. Divide some other local station frequencies and see if you get a number close to 142.5 without dividing by more than 5. Take 710 kc. The divisions yield 355, 236.67, 177.5 and 142. So if it is true that the estimated frequency really is 142.5 kc on the generator fundamental, then a beat—not zero beat, but in this instance a note—will be distinctly heard when the receiver is tuned to the second station. If this materializes, then the frequency is set down as 142.5 for the position obtained when beating with 570 kc, also two other positions are known, 190 and 285 kc.

### Easy from Now On

Now one has his bearings. The rest is an easy matter of selecting different stations, dividing their frequencies by 2, 3, 4, 5, etc., and locating the fundamentals of the generator on the generator dial.

Cross harmonics become very useful, indeed; that is, a certain harmonic of the generator equals one station frequency, another harmonic of the same generator frequency equals another station frequency. This is the same kind of check as before, but the beats used are now all zero. For instance,  $190 \times 3 = 570$  kc, also  $190 \times 4 = 760$  kc, and for two such stations the 190 kc verification is complete, especially since the stations themselves are 190 kc apart. Hence, the generator fundamental always is equal to

(Continued on next page)

(Continued from preceding page)

the difference in frequencies read on the receiver when the generator is left unmolested.

But perhaps the calibration is too much for the prospective builder of a generator, especially as the mechanical work of accurate registration, etc., requires considerable draughting skill, and the rigidity of the dial as a whole and as a rotating device on a condenser shaft becomes important.

### Better Something Than Nothing

Even the very simplest types of generators have their values, since it is better to have a fair generator than no generator at all. Nothing has been said of an attenuator, that is, a means of adjusting the intensity of the input to the circuit to be measured, and besides the universal type feeds through the a. c. or d. c. line, which serves as a transmitting antenna. It is very difficult to stop this, in any universal model, the method costing nearly as much as the generator.

There is no trouble whatever from this otherwise nuisance if the local oscillator in the superheterodyne is made to stop oscillating, which may be done in nearly all instances by grounding the oscillator grid with a shorting wire. Then no confusion arises from multiplicity of responses due to harmonics of the generator coming in as if carriers, when adjusting intermediate channels. Or antenna and ground posts of receiver may be shorted when peaking i. f. channels.

### Method of Silencing

In some sets the local oscillation may be silenced by removing the oscillator tube, but the practice does not apply well if the tube is a pentagrid converter type, for though the i. f. from generator will come through, the modulator tube or mixer tube should be in the socket

so that the tube's output capacity figures in the peaking. This capacity is relatively large in all tubes used in such positions in receivers, of the order of 12 mmfd.

In the universal type oscillators it is virtually standard practice to use a three-lead line cord, two leads going to the line directly, the third indirectly through a heater cord. Thus the wrapper of the combination becomes warm, which should not be alarming. The heat is waste but unavoidable unless a transformer is used, and a transformer precludes universal operation. The heater cord for a 6.3 volt tube is 350 ohms. That value serves sufficiently for two tubes, also.

### Capacity Coupling

The coupling for output of the small generators consists of capacity resulting from wrapping a few turns of the output wire to the plate return leg, then connecting to output post. Some diagrams show the condenser effect, but do not emphasize the twisting, although if the wire is made 3.5 inches or so, no twisting is needed, and spaghetti may be used to hold the two leads in constant but insulated impact.

A battery model, to include modulation, ought to be raised to two tubes, or a combination tube (two in one envelope) may be used, although it is better to have separate tubes so as easily to avoid overmodulation.

### Frequencies to Expect

Normally two bands would be something like 140 to 500 kc and 540 to 1,600 kc. The output is purposely small, thus enabling the attenuator to be almost fully effective, for if violent oscillation were permitted, and as much of it taken out as possible, there would be a high order of feeding through the line.

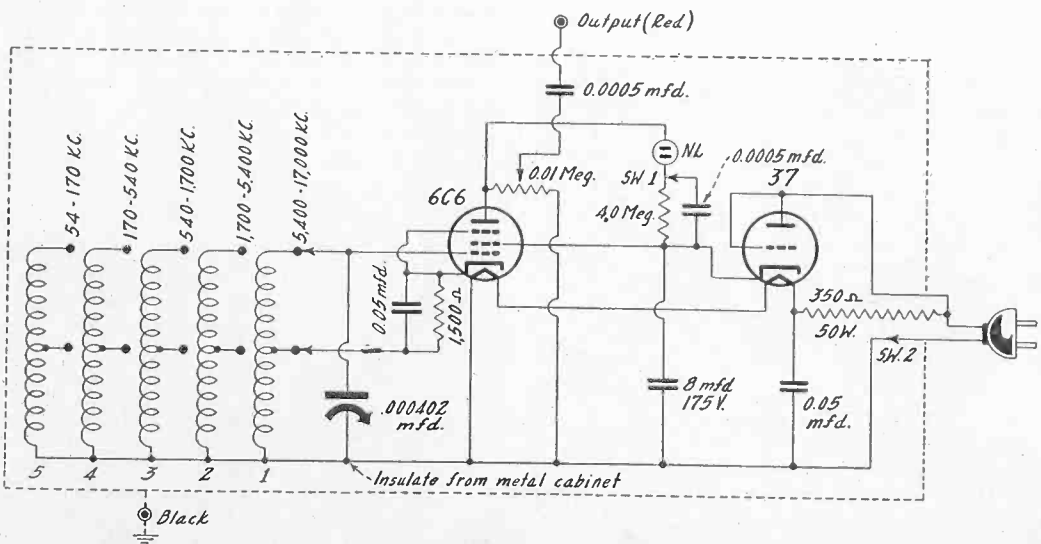

A five band signal generator for universal use. This may be accurately calibrated by the method set forth in the text. A neon tube is used as audio oscillator to modulate the 6C6. The attenuation is almost complete but there is a little leakage.

# A Powerful Mobile Sound System

## Radio, Phonograph and Microphone Input

By M. N. Beitman

*Allied Radio Corporation*

FOR mobile public address application, a powerful compact sound system obtaining all its operating power from a 6-volt automobile battery is the ideal set-up. The 20-watt mobile sound system described, because of these characteristics and many other additional features, is excellent for use on a car or truck for advertising purposes. With the Presidential election this year and the general realization of the possibilities of sound advertising, an investment in a powerful mobile sound system is timely and will repay itself in a short time.

The amplifier used in this system is housed in a steel cabinet together with a dynamotor for B voltage supply, electric phonograph motor and pickup, and a control panel

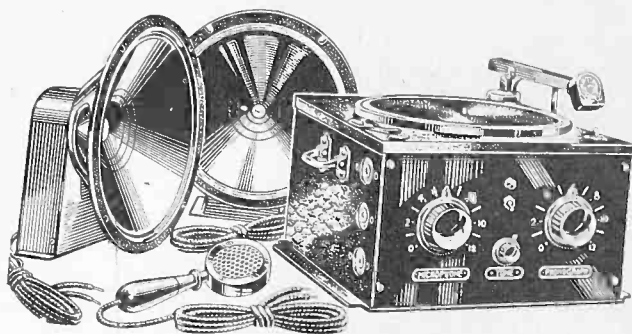

Dual speakers used with a phonograph in a motor generator installation for a portable sound system.

having provisions for mixing and blending the phonograph music and microphone input in the  
(Continued on next page)

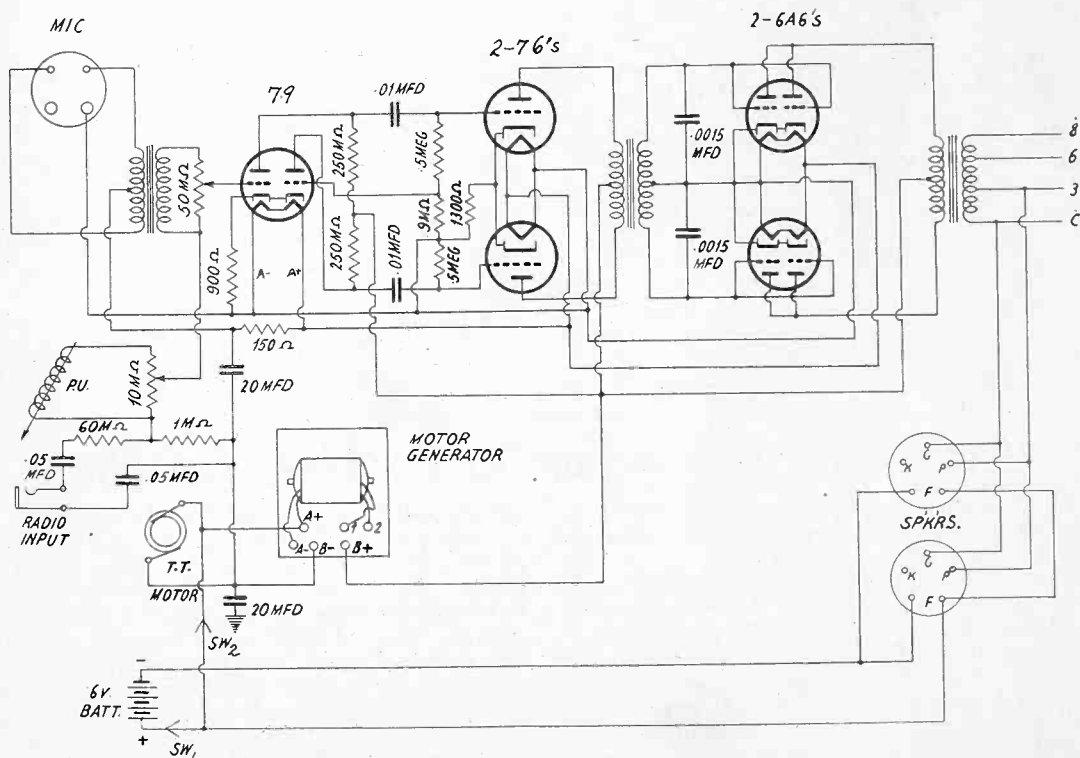

In the diagram T.T. represents turntable, P.U. phonograph pickup. A 6 volt storage battery is used for power. The heaters are connected across the battery, positive picked up from right hand side of SW1. A motor generator supplies the B voltage. The output transformer has a common connection and leads for 3, 6 and 8 ohm voice coils.

# All Wave One Tube Set

## Simple Regenerator Uses Metal Tube

By Herbert E. Hayden

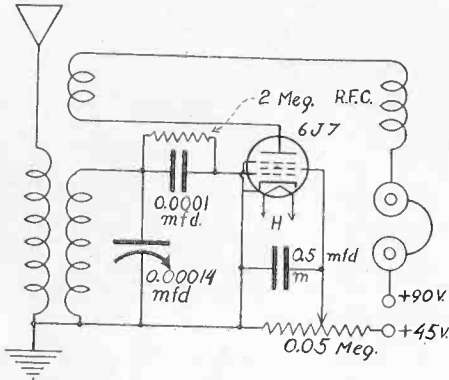

Close control of the regeneration and a high efficiency tube make this circuit sensitive and selective. It regularly brings in stations from overseas.

A ONE TUBE set has always been a favorite with short wave listeners who are satisfied with headphone reception. Such a set, if regenerative, is remarkably sensitive, and regular reception of overseas stations is usual. Of course, the signals are not strong, but they are strong enough for headphone reception, and that is all that is required.

Almost any tube can be used in such a receiver, but it is, naturally, best to use a tube that has been designed especially for detection, because the lone tube must function as a detector.

One of the best tubes of all is the 6J7, the detector tube in the new metal series. As a radio frequency amplifier this tube is excellent, and that makes it a good regenerative tube. As an

### LIST OF PARTS

#### Coils

- One set of short wave plugin coils with six prong bases and three windings.
- One 2.5 millihenry radio frequency choke (optional)
- One pair of high impedance earphones.

#### Condensers

- One .00014 mfd. variable condenser.
- One .0001 mfd. mica fixed condenser.
- One 0.5 mfd. bypass condenser.

#### Resistors

- One 2 meg. grid leak.
- One .05 megohm potentiometer, switch attached.
- One 350 ohm ballast resistor (unless six volt storage battery is used).

#### Other Requirements

- One six-contact wafer type socket, preferably low loss type.
- One octal socket.
- One small grid clip.
- Two knobs.
- Front panel and baseboard.

audio amplifier it is also first rate, provided it is loaded up properly. Since a detector of the grid leak type must function simultaneously as a radio frequency amplifier, a diode detector, and an audio amplifier, the 6J7 is the ideal tube for a one tube set.

The readiest way of covering the entire short  
*(Continued on next page)*

## Microphone Connection to Portable Amplifier

*(Continued from preceding page)*

desired proportion. The cabinet has carrying handles for easy portability.

The 20-watt amplifier uses five new type tubes in a powerful, efficient three-stage circuit developing a gain of 70 decibels.

A type 79 dual triode serves the double application of a voltage amplifier and phase inverter. A pair of 76's is used in a push pull arrangement as drivers for a pair of 6A6's in a Class B final stage. The frequency response of the amplifier is flat within 2 db. from 40 to 10,000 cycles per second.

The phonograph motor operates on six volts D. C. and is a constant speed type. A high impedance pickup possessing excellent fre-

quency response characteristics is employed.

Provisions are incorporated to supply microphone current to a double button hand microphone. Two large dynamic speakers are used to handle the large power output of this mobile system. The fields of these dynamic speakers are energized from the same six volt source as used for power. The microphone and speakers are connected to the amplifier by means of cables with polarized plugs. The system may be installed or disconnected in a few minutes.

The extra current taken by this amplifying system from the car's storage battery may be compensated for by slightly increasing the charging rate of the car or truck's generator.



(Continued from preceding page)

Wave band is to employ plugin coils. Such coils were used in the present one tube receiver. They are of the six terminal type, for one winding is used for the antenna, another for the tuned circuit, and still another for regeneration. Such coils are available commercially for all the short wave bands and also for the broadcast band or bands.

The second winding is tuned with a variable condenser of .00014 mfd. maximum capacity, suitable for short wave reception.

Control of regeneration is one of the most important features in a one tube regenerative receiver because if the operator does not have complete control of it at all settings of the variable condensers and for all coils that may be plugged in, excellent results are impossible. In this set the regeneration is controlled by varying the voltage on the screen, by means of a potentiometer of 50,000 ohms connected across 45 volts of the B supply. Thus the screen voltage may be varied between zero and 45 volts. To insure freedom from reaction between the screen and the other elements of the tube, a condenser of 0.5 mfd. is connected between the screen and the cathode.

### B Voltage Options

The voltage in the plate circuit is 90 volts. This is supplied through a high resistance head-set and a radio frequency choke, and, of course, through the tickler. The effective voltage on the plate is very close to 90 volts because the current is so small that very little drop occurs in the phones, the d.c. resistance of which will be of the order of 2,000 ohms. The voltages have been determined experimentally to be the best for this type of detector. The 90 volts may be obtained from two 45 volt B batteries, or 110 volts d.c. of the line may be used. The heater is connected to a six volt storage battery.

The radio frequency choke in series with the tickler and the headphones may seem superfluous or even undesirable. Certainly there would be regeneration if it were not used. Indeed, there would be more regeneration, for without the choke the capacity in the phone leads would offer a low impedance path to ground for the radio frequency currents. Excessive regeneration without the choke was just the reason for its use in this instance. The coil employed had an inductance of 2.5 millihenries. If the regeneration can be controlled well without any choke, omit the choke. If the circuit will not oscillate with the choke in the circuit, omit the choke.

### Power Supply

The 6J7 requires 6.3 volts and .3 ampere on the heater. The power may be supplied from a six volt storage battery, in which case the heater may be connected directly across the heater. The heater current may be obtained from a 110 volt line, a.c. or d.c., provided that a ballast resistor of 350 ohms, 30 watts or more, is used. Line cords with 350 ohm resistances built in are available. The plate and screen voltages may be provided by a 90 volt battery, or a small

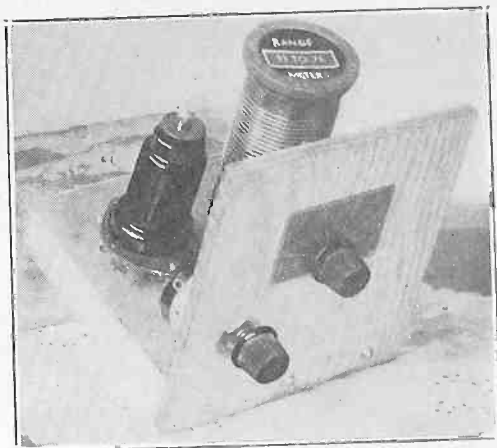

Corner view of the one tube all wave receiver.

rectifier for a.c. use., when 2.5 volts a.c. are put on the heater.

## Connectors That Connect Improve the Workbench

A workbench where several connections to the a.c. or d.c. line have to be made on occasion may be equipped with theatrical type connectors, which require special plugs, but these connections stay put, as compared to the cheap receptacles, single and multiple, which can not support any weight, and finally do not even hold satisfactorily a single plug. The result is that one has to hang the plug in a particular position, to make contact. But the more professional method is a time saver and an economizer, despite the considerably higher cost of the installation.

Whenever any connecting is done, remember that the male plug, the one with the prongs, always must go toward the line, and that the female type, or socket, must convey the electricity to the work circuit. In other words, do not make any installation that makes possible the exposure of prongs that carry current.

## Rule for Wattage

The wattage rating of a resistor to be used in a given circuit is determined by the resistance in ohms multiplied by the current squared in amperes. Many tubes now draw .3 ampere. The square of this is .09. This is not greatly different from .1. Therefore a handy rule for determining the wattage rating of drawing .3 ampere is to divide the resistance by ten. The error thus committed is in the direction of safety since the result calls for a slightly larger resistance than the wattage dissipated in it. As an illustration of the use of this rule, suppose we have determined that the ballast resistance in a .3 ampere circuit is 350 ohms. The rating of the resistor to be used is therefore 35 watts or more. The rule holds strictly true only when the current is .316 ampere.

# All Wave One Tube Set

## Simple Regenerator Uses Metal Tube

By Herbert E. Hayden

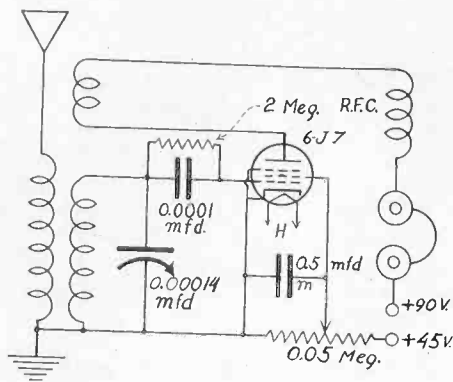

Close control of the regeneration and a high efficiency tube make this circuit sensitive and selective. It regularly brings in stations from overseas.

A ONE TUBE set has always been a favorite with short wave listeners who are satisfied with headphone reception. Such a set, if regenerative, is remarkably sensitive, and regular reception of overseas stations is usual. Of course, the signals are not strong, but they are strong enough for headphone reception, and that is all that is required.

Almost any tube can be used in such a receiver, but it is, naturally, best to use a tube that has been designed especially for detection, because the lone tube must function as a detector.

One of the best tubes of all is the 6J7, the detector tube in the new metal series. As a radio frequency amplifier this tube is excellent, and that makes it a good regenerative tube. As an

### LIST OF PARTS

#### Coils

- One set of short wave plugin coils with six prong bases and three windings.
- One 2.5 millihenry radio frequency choke (optional)
- One pair of high impedance earphones.

#### Condensers

- One .00014 mfd. variable condenser.
- One .0001 mfd. mica fixed condenser.
- One 0.5 mfd. bypass condenser.

#### Resistors

- One 2 meg. grid leak.
- One .05 megohm potentiometer, switch attached.
- One 350 ohm ballast resistor (unless six volt storage battery is used).

#### Other Requirements

- One six-contact wafer type socket, preferably low loss type.
- One octal socket.
- One small grid clip.
- Two knobs.
- Front panel and baseboard.

audio amplifier it is also first rate, provided it is loaded up properly. Since a detector of the grid leak type must function simultaneously as a radio frequency amplifier, a diode detector, and an audio amplifier, the 6J7 is the ideal tube for a one tube set.

The readiest way of covering the entire short  
(Continued on next page)

## Microphone Connection to Portable Amplifier

(Continued from preceding page)

desired proportion. The cabinet has carrying handles for easy portability.

The 20-watt amplifier uses five new type tubes in a powerful, efficient three-stage circuit developing a gain of 70 decibels.

A type 79 dual triode serves the double application of a voltage amplifier and phase inverter. A pair of 76's is used in a push pull arrangement as drivers for a pair of 6A6's in a Class B final stage. The frequency response of the amplifier is flat within 2 db. from 40 to 10,000 cycles per second.

The phonograph motor operates on six volts D.C. and is a constant speed type. A high impedance pickup possessing excellent fre-

quency response characteristics is employed.

Provisions are incorporated to supply microphone current to a double button hand microphone. Two large dynamic speakers are used to handle the large power output of this mobile system. The fields of these dynamic speakers are energized from the same six volt source as used for power. The microphone and speakers are connected to the amplifier by means of cables with polarized plugs. The system may be installed or disconnected in a few minutes.

The extra current taken by this amplifying system from the car's storage battery may be compensated for by slightly increasing the charging rate of the car or truck's generator.

(Continued from preceding page)

wave band is to employ plug-in coils. Such coils were used in the present one tube receiver. They are of the six terminal type, for one winding is used for the antenna, another for the tuned circuit, and still another for regeneration. Such coils are available commercially for all the short wave bands and also for the broadcast band or bands.

The second winding is tuned with a variable condenser of .00014 mfd. maximum capacity, suitable for short wave reception.

Control of regeneration is one of the most important features in a one tube regenerative receiver because if the operator does not have complete control of it at all settings of the variable condensers and for all coils that may be plugged in, excellent results are impossible. In this set the regeneration is controlled by varying the voltage on the screen, by means of a potentiometer of 50,000 ohms connected across 45 volts of the B supply. Thus the screen voltage may be varied between zero and 45 volts. To insure freedom from reaction between the screen and the other elements of the tube, a condenser of 0.5 mfd. is connected between the screen and the cathode.

### B Voltage Options

The voltage in the plate circuit is 90 volts. This is supplied through a high resistance headset and a radio frequency choke, and, of course, through the tickler. The effective voltage on the plate is very close to 90 volts because the current is so small that very little drop occurs in the phones, the d.c. resistance of which will be of the order of 2,000 ohms. The voltages have been determined experimentally to be the best for this type of detector. The 90 volts may be obtained from two 45 volt B batteries, or 110 volts d.c. of the line may be used. The heater is connected to a six volt storage battery.

The radio frequency choke in series with the tickler and the headphones may seem superfluous or even undesirable. Certainly there would be regeneration if it were not used. Indeed, there would be more regeneration, for without the choke the capacity in the phone leads would offer a low impedance path to ground for the radio frequency currents. Excessive regeneration without the choke was just the reason for its use in this instance. The coil employed had an inductance of 2.5 millihenries. If the regeneration can be controlled well without any choke, omit the choke. If the circuit will not oscillate with the choke in the circuit, omit the choke.

### Power Supply

The 6J7 requires 6.3 volts and .3 ampere on the heater. The power may be supplied from a six volt storage battery, in which case the heater may be connected directly across the heater. The heater current may be obtained from a 110 volt line, a.c. or d.c., provided that a ballast resistor of 350 ohms, 30 watts or more, is used. Line cords with 350 ohm resistances built in are available. The plate and screen voltages may be provided by a 90 volt battery, or a small

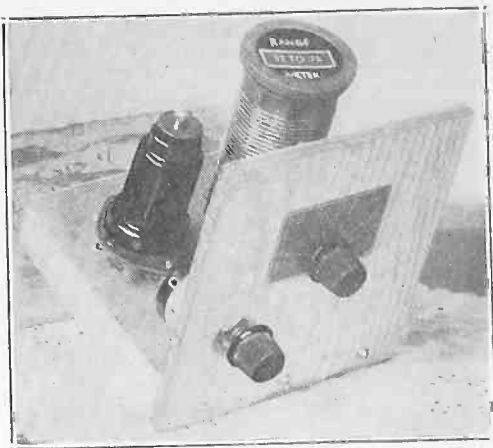

Corner view of the one tube all wave receiver.

rectifier for a.c. use., when 2.5 volts a.c. are put on the heater.

## Connectors That Connect Improve the Workbench

A workbench where several connections to the a.c. or d.c. line have to be made on occasion may be equipped with theatrical type connectors, which require special plugs, but these connections stay put, as compared to the cheap receptacles, single and multiple, which can not support any weight, and finally do not even hold satisfactorily a single plug. The result is that one has to hang the plug in a particular position, to make contact. But the more professional method is a time saver and an economizer, despite the considerably higher cost of the installation.

Whenever any connecting is done, remember that the male plug, the one with the prongs, always must go toward the line, and that the female type, or socket, must convey the electricity to the work circuit. In other words, do not make any installation that makes possible the exposure of prongs that carry current.

## Rule for Wattage

The wattage rating of a resistor to be used in a given circuit is determined by the resistance in ohms multiplied by the current squared in amperes. Many tubes now draw .3 ampere. The square of this is .09. This is not greatly different from .1. Therefore a handy rule for determining the wattage rating of drawing .3 ampere is to divide the resistance by ten. The error thus committed is in the direction of safety since the result calls for a slightly larger resistance than the wattage dissipated in it. As an illustration of the use of this rule, suppose we have determined that the ballast resistance in a .3 ampere circuit is 350 ohms. The rating of the resistor to be used is therefore 35 watts or more. The rule holds strictly true only when the current is .316 ampere.

Six tube battery Portable Standard Broadcast and Police Calls. Completely self-contained. Batteries, tubes, set and speaker in leatherette covered wood case, size 11" wide, 7" deep and 17" high. A rugged and dependable set. Licensed by R.C.A. and built for economical use. Complete with tubes and batteries, ready to play, fully guaranteed. Shipping weight, 25 lbs. Actual "carrying" weight about 20 lbs..... **\$19.95**

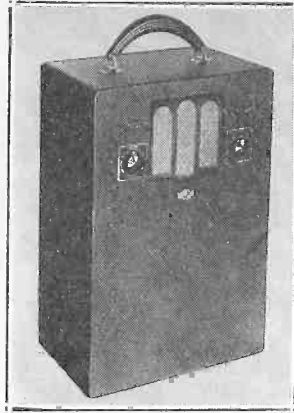

**Speaker Field Supply.** Delivers 100 volts at 100 mills. Excitation for 2-25.00 ohm fields or for 1-1000 ohm speaker. Absolutely no hum. Shipping weight, 2 lbs. Complete with RCA tube, in black crystalized finish metal case.. **\$2.49**

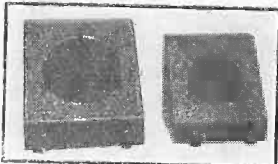

**Universal Meter Cases,** finished in oven-baked lifetime scratchless black crinkle lacquer.

For all 2" meters.....49c  
 For all 3" meters.....59c  
 For all 3 1/4" meters.....59c  
 Shipping weight, 3 lbs.



**Ambassador phones,** sturdy and efficient, full size adjustable bands, impedance 3000 ohms. Shipping weight, 2 lbs.. **\$1.19**

**24-Hour Service**

We are fully equipped to give you the finest and quickest service. We ship everywhere.

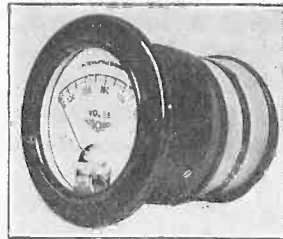

**Surplus Stock, Jewel and Weston Meters**

(Fully guaranteed)

- #476-W-0.750 v. A.C., \$3.95
- #476-W-0.600 v. A.C., \$3.49
- # 74- J-0.300 v. A.C., \$2.49
- # 74- J-0.150 v. A.C., \$2.49
- #476-W-0.5 v. A.C., \$1.95
- #476-W-0.3 v. A.C., \$1.75
- #476-W-0.2 v. A.C., \$1.95
- # 74- J-0.3A A.C., \$1.95
- # 74- J-0.2A A.C., \$1.95
- # 74- J-0.15A A.C., \$1.95
- # 74- J-0.1.25A A.C., \$1.95
- # 74- J-0.1. A A.C., \$1.95

Shipping weight, 3 lbs.

J-Jewel  
 W-Weston

**1936 PA**

**THE LARGEST**  
**IN NEW Y**  
**DEVOTED TO**  
**EXPERIMENT**



**Efficient Noise Filter.** To eliminate noise reaching the receiver thru the power line. Connects between the line and the set. AC or DC operation. The metal case is finished in black crystalline lacquer. Shipping weight, 5 lb..... **\$1.69**



**Practical Soldering Irons** with heat proof handles.

- Nicknack, 55 watts..... \$ .95
  - Mercury, 50 watts..... 1.15
  - Esico Midget, 65 watts. 1.39
  - Esico Junior, 85 watts.. 1.89
- Shipping weight, 3 lbs.

All C.O.D. \$10 required deposit C.O.D. on U. S.

**RED HOT**  
 Genuine \$7.

3 Purpose complete antenna aerial and wire. Shipping weight, 5 lbs.....

Todd Batt Dry Disc 2 Elkon units 5 amp. r with wire. Shipping weight, 8 lbs.....

**Rola Hi-Fi** Ohmages and 1800. 12 inch range, 30 carries 18 ously. Shipping weight, 26 lbs.....

Output Tr match .....

Limited items fully



**PROMPT SERVICE**

**167 GREENV**  
**near CORTLANDT STR**

# PARTS LEADERS

RADIO STORE  
 NEW YORK CITY  
 PARTS AND  
 SUPPLIES

Orders over  
 minimum  
 20%. No  
 outside

## SPECIALS!

Crystal Aerial

Kit,  
 set and  
 transformers,  
 weight,  
**\$2.29**

Charger!  
 uses  
 charges at  
 complete  
 clips.  
**\$4.75**

Speaker!  
 675, 1000  
 line G-12,  
 frequency  
 100 cycles,  
 weight,  
**\$8.75**

Transformer to  
**\$1.25**  
 varieties, all  
 guaranteed.

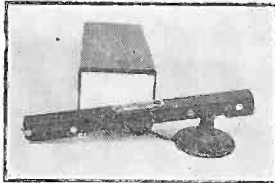

**Crystal Pickup.** Real Hi-Fidelity Reproduction. The most efficient agent known for converting motion into electrical energy. Extremely light in weight, plus ball-bearing construction makes possible the playing of either slow speed of 78 R.P.M. records without the use of additional counter balances. Uses 1/2 meg. volume control, output feeding direct to grid. Shipping weight, **\$6.19**  
 5 lbs.....

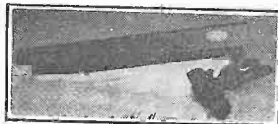

**Audak Pickups, Model No. 100** Hi-impedance unit feeds direct to grid. No matching transformers needed. Frequency response covers entire tone range. Shipping weight, 2 lbs..... **\$3.65**

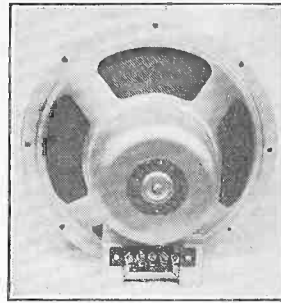

## Rola Speakers

5 inch, specify output desired, 6 or 3000 ohm. Shipping weight, 3 lbs..... **\$1.79**

6 inch, 6, 1800 or 2500 ohm, specify output. Shipping weight, 4 lbs..... **2.45**

8 inch, 1250, 1800 or 2500 ohm, specify output. Shipping weight, 6 lbs..... **2.95**

10 inch, 1000, 1250, 1800 or 2500 ohm, specify output. Shipping weight, 12 lbs. **3.45**

12 inch, 1000, 1250, 1800 or 2500 ohm, specify output. Shipping weight, 13 lbs. **3.95**

## C.O.D. Orders

Receive prompt attention. All packages insured, please include postage to cover. Print your name and address plainly!



**Hi-Fidelity Amplifier.** Pure Class A, delivers 16 watts continuously, 20 watts peak, less than 2 d.b. variation from 20, 14000 cycles. Rated gain 75 d.b. Uses 1-83V, 2-2B6's, 1-57, 1-56 Heater type rectifier delivers voltages only when tubes are fully warm. Manual volume and tone control. Black oven-baked scratchless finish on chassis and cover. Double input with selector switch, finest hi-fidelity reproduction from tuner, mike or pickup. Completely wired, less tubes and speaker. Ship. **\$14.95**  
 ping weight, 30 lbs.

Full size protecting screen, completely enclosing tubes and transformer, in finish to match chassis.  
 Extra .....**\$1.00**

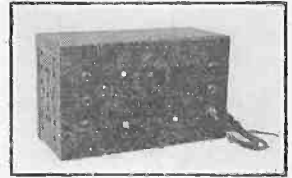

**Input Stage Mixer.** Black crystalized finish metal case containing mike transformer battery and volume control plus filter. Selector switch for pickup or mike. Complete with battery. Shipping weight, 8 lbs. **\$3.49**

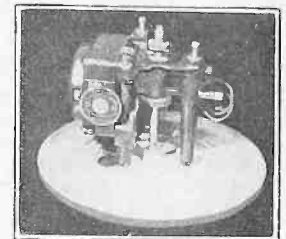

**Blue Flyer Motor.** An outstanding value in A.C. phonograph motors. Single speed set at 78 R.P.M. Spiral cut gears, quiet operation. Complete with 10 inch turntable. Shipping weight, **\$1.89**  
 15 lbs. ....

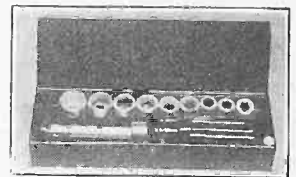

**Handy Wrench Set.** Contains 9 different size wrenches with offset handles, for working in difficult positions. Complete in metal container. Shipping weight, **\$ .85**  
 3 lbs.....

# RADIO

W 5TH STREET  
 NEW YORK CITY

## QUALITY PARTS

# Line Resistors for A.C.—D.C. Sets

## How to Compute Them—Pilot Lamp Problem

By Adam Blackford

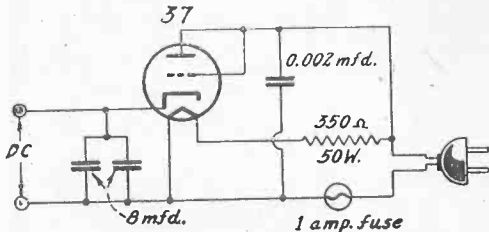

If the current through the heater is to be of a certain value the type of tube does not matter, and the voltage to be dropped externally simply affects the required line cord resistance.

THE problem of inserting a pilot lamp in a universal receiver came up the other day in a radio store. The customer was addressing one of the clerks, the service man having gone out for luncheon:

Customer: I want to put a pilot lamp in my universal set. How can I do it?

Clerk: You can put a 110 volt lamp across the line. That won't interfere with the current to the heaters at all. That's the way it's usually done in commercial sets.

Customer: There's no room for such a bulb. All I can spare is room for a radio type pilot bulb. What resistance shall I use, or can I put the tube in along with the heaters?

Clerk: You'd need a separate resistor of 700 ohms, in series with the pilot lamp, the total across the line.

Customer: What would happen if I put a pilot lamp in series with the heaters? It's a five tube set, two tubes with 25 volt heaters, rest with 6.3 volt heaters.

Clerk: The voltage would be cut down too much.

Now, just what is the answer to the question?

### Establishing Current Suffices

Evidently the clerk had in mind a pilot lamp that would draw 170 milliamperes. Remembering that lamp and a 700 ohm resistor were to be put across the line, the fixing of the current on the assumed basis of 115 line volts would and the limiting resistor be right, because the limiting resistor was so large compared to the lamp resistance.

If a 6 volt type of pilot lamp were supplied of course the illumination would be adequate with a drop of 5.1 volts. This drop is based on the lamp resistance of 30 ohms, multiplied by the current, .17 ampere.

If the current supposed to flow through the pilot lamp is known, the limiting resistance

being very large compared to the lamp resistance, which would be true of all radio pilot lamps, then fixing the current suffices. The voltage takes care of itself, because it is developed by the established amount of current flowing through the lamp. Actually the resistance of the lamp is different for different values of current put through it, or voltages applied to it, but in regard to pilot lamps this is immaterial.

However, when we come to a consideration of the voltaging of the heaters, then there must be some pretty close adherence to recommended values.

### Tolerance 10 Per Cent

If the heater voltage is too low the tubes have different characteristics, true also if the voltage is too high. Tube life may be shortened whether the voltage is too high or too low. So working within 10 per cent tolerances is advisable.

One consideration that rises to defeat this very end is the use of the universal receiver on a. c. in localities where the regulation is poor. That means the voltage changes considerably with load. I remember one night last Summer when a block party was being held at a residential seaside resort overlooking Coney Island, the line voltage, due to a string of powerful street lights put up by kindly neighbor, dropped to 83 volts. Ordinarily the voltage would be average 112 volts, at night, whereas during the morning, after breakfast for instance, it might be 130 volts. Now, 83 to 136 volts is quite a difference. In d. c. use, however, such wide fluctuation is not generally encountered.

However, 115 volts are used as the general basis of reckoning. For the present let us consider only tubes with series heaters that draw .3 ampere, and also assume that the customer's set had five tubes of that current in the heater legs.

### Conflicting Requirements

The 6.3 pilot lamp at that voltage application may be expected to have a resistance of 30 ohms, approximately, as around .2 ampere flows.

The voltage drop will be greater across the lamp, and the current through the lamp too high, if it is put in series with the heater chain, where .3 ampere now flows. If addition of the lamp will reduce the heater current to .2 ampere, that would be intolerable for the radio tubes; if the current stays near .3 ampere the pilot lamp can't take it.

However, accepting the overbright lamp for the moment, and putting it in series with the

heaters, let us discover whether too much voltage will be dropped, as the store clerk said.

The voltage dropped by the five tubes totals 75 volts, approximately, and if the line voltage is 115 volts, then the limiting resistor, which may be in the line cord as a third lead, would have to drop the excess, or 40 volts. For a current of .3 ampere the resistance required is  $40/.3$  or 133 ohms.

If the pilot lamp of the so-called 6.3 volt type is connected in series any place, it will be in series within the line, it will be in series with the limiting resistor, which now becomes let us say  $133+30$  ohms or 163 ohms. Assuming that the resistance of the heaters does not change as the current is reduced, what is the current now?

### Resistance Across Line Always Same

A fact now confronts us that should be controlling in our consideration of the series line for uniform current of .3 ampere, assuming 115 volts, and that is, *the total resistance across the line always must be the same*, 383.3 ohms, because only when the voltage, 115, is divided by 383.3 is the current .3 ampere.

The five tubes present a heater resistance of 250 ohms, because resistance equals voltage, 75 volts, divided by current, .3 ampere. The line cord in the case just considered constituted 133 ohms and the lamp 30 ohms, total 163 ohms, so the total resistance becomes 413 ohms. Since the required resistance for a current of .3 ampere is 383.3 ohms, and we have 413 ohms, we have too much resistance and too little current.

The former .3 ampere has been reduced to .278 ampere, as found by dividing the voltage in volts by the resistance in ohms, a reduction of 22 milliamperes. For the set tubes with heaters totalling 250 ohms the total voltage reduction is 5.5 volts. Therefore the reduction is not equal to the rated voltage of the pilot lamp that has been introduced, because that very introduction reduced the current.

### Can Get By With This

The percentage voltage reduction on the set tubes is  $7\frac{1}{3}$  per cent, which is not serious and is less than changes that other causes might introduce, and so the pilot lamp actually could be put in series with the heaters and line without harm, or even without excess loss of heater voltage.

However, there is a simple expedient that improves matters. We should like to have the current through the heaters closer to .3 ampere, the voltage across the heaters nearer normal, and still have the pilot lamp in series. This may be done by putting less current through the lamp, but enough through a resistor across the lamp, so that the sum of the two currents is close to .3 ampere.

If the resistance is 21 ohms, as presented by the lamp and the parallel or shunting resistance, then at .3 ampere the drop would be 6.3 volts.

### There's a Catch

But there's a catch. Under no circumstances can we shunt the pilot lamp with a resistor and maintain the current at .3 ampere, since only

a short circuit of the lamp would do the trick, and then we would not have in circuit the very lamp on which we are almost staking our lives.

So we do the next best thing. We need precious little illumination from the lamp. We can compromise by putting the lamp in series, and across the lamp a 10 ohms resistor, so if

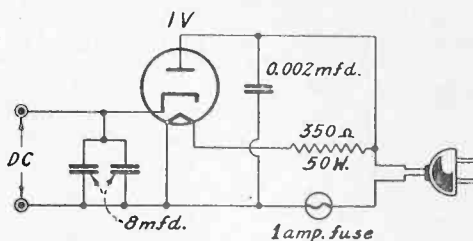

While computation yields close values of resistance for limiting the heater current, in practice the nearest value in steps of 10 ohms is selected, and sometimes (as above) tolerance is even greater. The computed value for the above is 362 ohms.

the lamp were 30 ohms, the shunt 10 ohms, the effective resistance would be the product divided by the sum, or  $300/40$  or 7.5 ohms. The voltage drop would be  $.3 \times 7.5$  or 2.2 volts. That would strike a dim light on a 6.3 volt lamp. But we discover that we could put a 2.5 volt lamp in that very position, the resistance of which is 10 ohms at rated service current of .25 ampere, the effective resistance due to 10 ohm shunting is 5 ohms, the voltage across the lamp is about 1.5 volts, an improvement, and we finally notice that what we want more than a lamp of low resistance is one that draws little current, so we can shunt it, and thus take care of the excess to equal a total of .3 ampere.

### Arrival at Solution

So we select the 60 milliampere 2 volt pilot lamp. The required current expressed in amperes is .06, compared to .3 in circuit, or the ratio is 1 to 5. The lamp resistance then would be  $2/.06$  or 33 ohms. So low an additional resistance will be presented by the shunted lamp that we may safely compute on the basis .3 ampere will flow finally, and if we put a resistor of 8.3 ohms across the new pilot lamp we will have an effective resistance of 6.6 ohms, or a voltage drop of 1.98 volts for the 2 volt lamp. Then that would do the trick nicely. We could use 10 ohms to get an effective of 7.7 ohms, a voltage drop of 2.2 volts, but we prefer the lower shunting resistor until the drop across the pilot lamp circuit is 2 volts.

Now let us see how much the current through the heaters has been reduced when an effective 6.6 ohms is added.

This is the resistance resulting from shunting the 2 volt pilot lamp, .06 ampere type, with 8.3 ohms. The 383.3 ohm resistance has been increased to 391.6 ohms and the current is  $115/391.6$  or .294 ampere, a reduction of 2 per cent, which is negligible.

With the serious problem of the pilot lamp  
(Continued on next page)

(Continued from preceding page)

put aside we may now concern ourselves with the general problem of selection of the correct limiting resistance, which seems to bother some of the customers.

It has been stated that for the example of all tubes of the .3 ampere variety, regardless of the required voltage drop across the heaters, the total resistance, consisting of the sum of the heater resistances and the limiting resistor, should be 383.3 ohms. Of course such a close figure is not necessary in practice, so use 380 ohms as the figure, and solve for the limiting resistor. Line cords have resistance differences of 10 ohms, usually, so our decimal points are not going to do as much good.

Considering only the .3 ampere class of tubes, the resistance of the heaters for the required voltage drops are:

- 21 ohms for 6.3 volts
- 40 ohms for 12 volts
- 83 ohms for 25 volts
- 100 ohms for 30 volts

### Specific Examples

So all we have to do is to note the tubes used, add up the heater resistance they represent, subtract this value from 380, and we have the required line cord resistance. For a single tube, 6.3 volt heater, the limiting resistor should be 359 ohms, so a 360 ohm value is used. For a 12 volt tube of the .3 ampere type the limiting resistor would be 340 ohms. If there are two tubes, one of 6.3 volt the other of 25 volt rating, the sum of the resistances of the heaters is 104 ohms, and the difference between 380 ohms is 270 ohms, so the limiting resistor would be 280 ohms in a practical case.

The reason for doing the problem this way is to emphasize the fact that the total resistance must always be the same across the line, that we must establish a specified current, more or

less closely, and that the voltage drops take care of themselves.

### Different Currents Through Tubes

If all the tubes to be series connected at the heaters had the same heater current requirement the case would be just as easy as outlined. However, the current requirements are various. Besides .3 ampere we have .4 ampere and .6 ampere in heater type tubes, and in general the higher currents apply to power tubes and rectifier tubes, and when there are more than 6.3 volts to be dropped across the heater (which takes care of itself when the current is rightly established), again rectifier and power tubes usually are concerned, although there are 6.3 volt rectifier tubes, as well as power tubes.

The outstanding fact to consider is that if there are different current requirements, the highest current requirement is controlling. That much current must flow through the circuit, because there is only one fundamental circuit, and if tubes requiring less current are used, their heaters must be appropriately shunted by resistors, so that the total current, adding that through the heater to that through the shunt across the particular heater, equals the fundamental current.

### The Resistances for 0.4 Ampere

Again, the total resistance must be the same for the same current, using the 115 volt assumption. For .4 ampere the total resistance across the line, the sum of heater and limiting resistors, and even with shunting effects across some heaters considered, must be 287.5 ohms.

The resistance values of the heaters of .4 ampere tubes for specified voltages are:

- 15.75 ohms for 6.3 volts
- 30 ohms for 12 volts
- 62.5 ohms for 25 volts
- 75 ohms for 30 volts

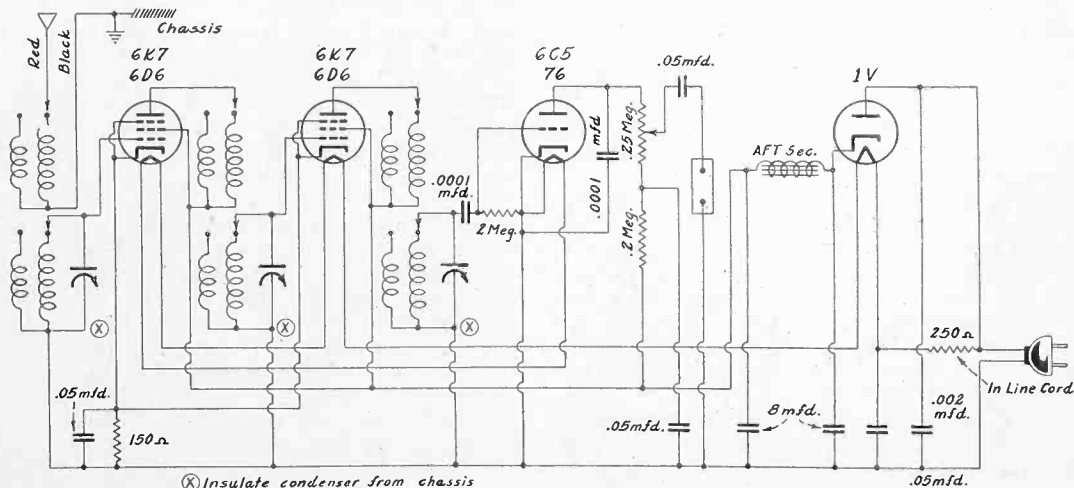

Using the resistance method, see if 250 ohms are correct. Each tube's heater has 21 ohms resistance, total for four tubes is 82 ohms, subtracted from 383 equals 301 ohms. So 250 is too far off. Use 300 ohms. The heater of the 6C5 detector is properly connected to one side of the line. Always do that with the detector tube. In the case of supers it's the second detector.



The foregoing applies to .4 ampere type tubes. But if .3 ampere type tubes are to be used also, when shunted, the heater resistance will appear as if the ohmage were the same as just tabulated, that is, the .4 ampere classification applies, the only problem being to find the right shunt value. The .6 ampere tubes need not be considered, as they would not likely be used in any series circuit connected to the electric line, but would be used in parallel connection, where the current differences of tubes does not matter, since the voltage supplied across the heaters is rather constant.

### Shunt Values Found

The shunting solution can be obtained by applying a formula. The higher current being the consideration, the heater is to be shunted to take care of the excess, that is, the effective resistance reduced to that required for the higher current, to maintain the specified voltage difference across the heater terminals.

For instance, at 6.3 volts, .3 ampere, what shunt is required across such a heater for a 4 ampere circuit? (Other tubes establish the 4 ampere requirement).

The circuit to be shunted is .1 ampere, the voltage drop is to remain 6.3 volts, so the shunt resistor should be equal to the voltage in volts divided by the current in amperes or  $6.3/.1$  or 63 ohms.

Solving for the effective resistance of two resistors in parallel, put to check up, the heater has 21 ohms, the shunt 63 ohms, the net resistance is the product divided by the sum, or  $1,323/84$  or 15.75 ohms. The current is the voltage in volts divided by the resistance or  $6.3/15.75 = .4$  ampere

### Case of Chain Shunting

If there is a chain of lower current tubes,

a single shunt may be used. Suppose there are four 6.3 volt .3 ampere tubes. The total heater voltage is 25.2 volts for these tubes at .3 ampere. Still the shunt is to carry .1 ampere. So the required shunt is  $25.2/.1 = 252$  ohms. See if the current is .4 ampere. The effective resistance due to shunting is  $(252 \times 84) / 252 + 84 = 63r$ . The current is  $25.2/63$  or .4 ampere.

So get the shunt resistance by dividing the shunt current into the voltage drop required across heaters.

A common method of solving for the limiting (series) resistor only is to take the current of the highest current drawing tube (if the different currents are to go through heaters), accept 115 volts for the line voltage, add the heater voltages, and subtract this from the line voltage, giving to the limiting resistor the value in ohms of voltage it must drop divided by current it must pass. Thus, five .3 ampere tubes, total heater voltage drop 50.2 volts. Subtract from 115, yielding 64.8 volts. Divide .3 ampere into this, if all tubes are of that current capacity, answer is 216 ohms. Use 220 ohms. If the current to be considered is .4 ampere then the limiting resistor should be  $64.8/.4$  or 162 ohms, the .3 ampere tubes (if any) shunted as explained.

### EFFECT OF DISTRIBUTED CAPACITY

The frequency bands covered by short wave coils, with a given condenser, vary considerably, due to the capacity effect of the tickler on the secondary. To support oscillation at high frequencies a large tickler winding is common, and coupling is close, so that the span of frequencies covered with the same condenser is smaller. If this distributed capacity were the same on each coil the frequency ratio of each and every band would be the same.

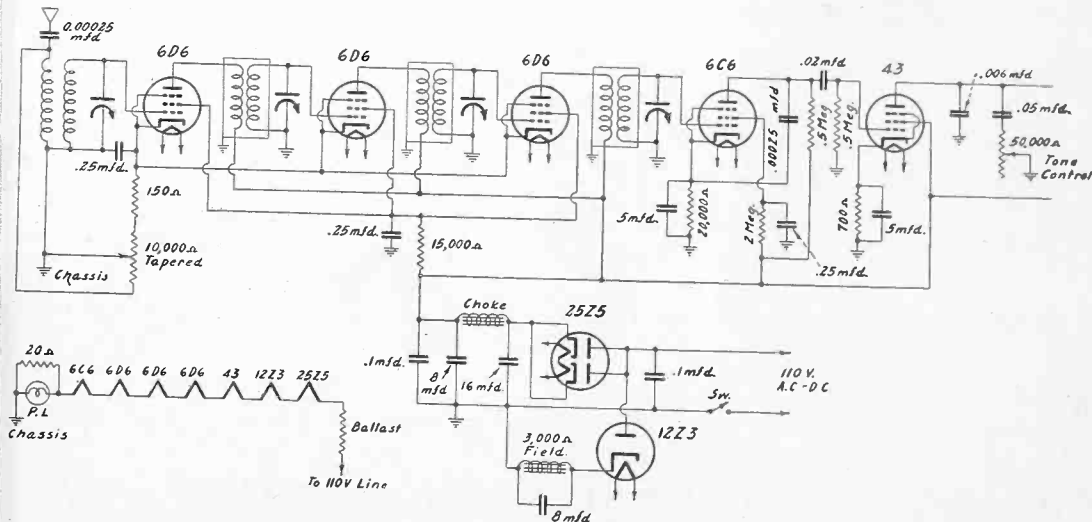

The limiting resistor is here referred to as a ballast. Speaker field is separately excited (by 12Z5). A 6 volt, 200 ma pilot lamp is shunted by 20 ohms. How much current flows through the lamp in .3 ampere circuit? The lamp resistance is taken as 61.2 or 30 ohms, the shunt is 20 ohms, so the lamp gets two thirds of .3 or .2 ma, which is correct. However, the effective 12 ohms requires that much less resistance on the ballast.

## Three Different Tuning Characteristics

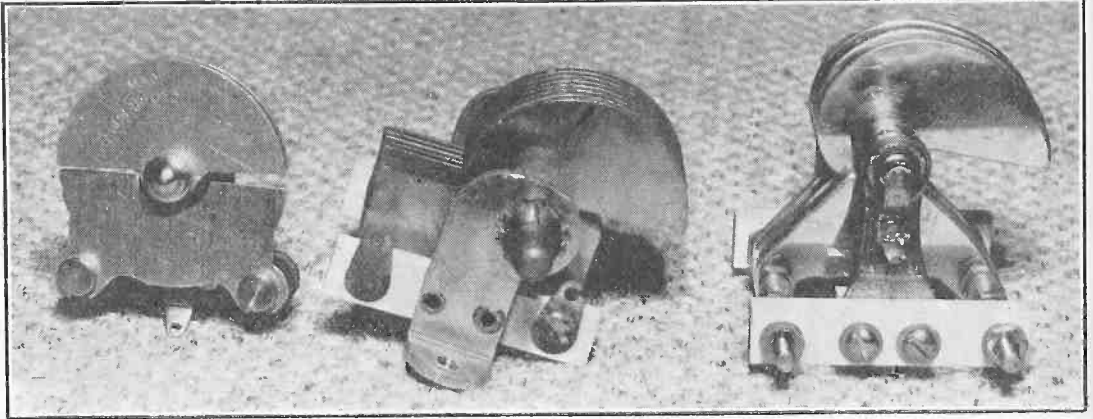

Three object lessons in tuning characteristic. Left, straight capacity line; center, midline; right, straight frequency line.

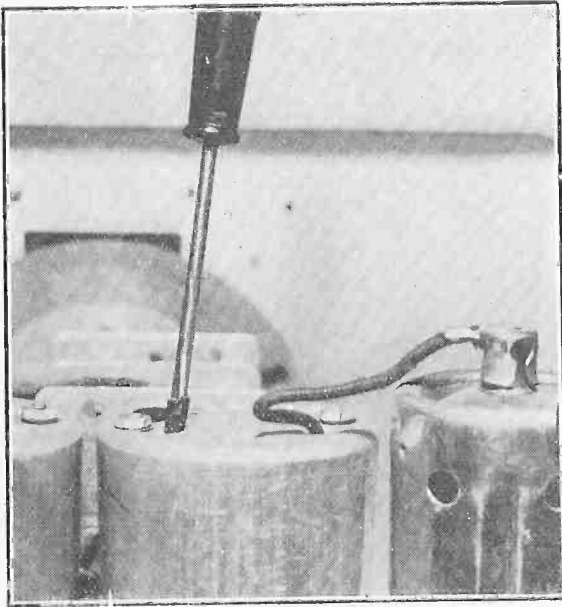

Spaghetti on screwdriver safeguards against short circuit.

### TUNING CHARACTERISTICS

Selection of the tuning condenser as to rate of capacity variation determines the relative separation of frequencies on the dial. Straight capacity line type (left) spreads out the frequencies at the higher capacities but crowds them badly at the lower capacities. So such a condenser could be well used for regeneration control, antenna tuning and the like, but is not so suitable for the tank circuit. At center is shown a midline type. At right is the straight frequency line type, which gives equal separation for equal frequency differences at any and all dial positions. The midline effect is between that of straight capacity line and straight frequency line.

### INSULATING A SCREWDRIVER

When peaking intermediate frequency transformers, if you have no insulated screwdriver, use an ordinary small screwdriver, and press a small piece of spaghetti over the end, far enough down to expose the working surface of the driver. Then a short circuit of B plus to shield when adjusting the plate condenser will not result.

## DIRECT CURRENT ALWAYS FLOWS SAME WAY

When a circuit is closed so direct current flows, the direction of flow is always the same. It is said current flows from negative to positive in the load circuit, from positive to negative in the supply. This is true, the sign has to be

changed for convenience, but the current moves like the hand of a clock, always the same way. If the hour hand is considered, take 9 o'clock as minus and 3 o'clock as plus, and current travels clockwise over any part of the "dial."

# Beats in the Superheterodyne

## Six Guiding Principles for Circuit Performance

By J. E. Anderson

**W**HETHER a superheterodyne is superior to a tuned radio frequency receiver depends on design. It is not necessarily the most selective, but with ordinary care in the design it is likely to be. Indeed, it can easily be excessively selective for good quality. Neither is the circuit necessarily the most sensitive. Its sensitivity, too, depends on the design. It is not a great feat of design to get an extraordinarily high sensitivity, but this is not accomplished by adding a large number of tubes. Many superheterodynes have failed to give satisfactory results because the amplification in the circuit was too high, making the set unmanageable. Others have failed because they were so selective that stations were too difficult to find.

It is a fallacy to attribute great output volume to a superheterodyne. The volume that can be obtained depends on the audio frequency amplifier, and particularly on the last stage in the circuit. If the last tube in the circuit is a little 9, no more volume can be obtained if this tube is preceded by a ten tube superheterodyne than if it is preceded by an ordinary radio frequency receiver, provided, of course, that there is sufficient amplification ahead of the tube in each instance to load it up. Likewise, the tone quality does not depend so much on the radio frequency circuit, whether superheterodyne or not, as it does on the type of audio frequency amplifier used. The excessive selectivity which may occur in the superheterodyne will mar the tone quality to an extent depending on the value of the selectivity.

### Principles Guiding Design

In designing a superheterodyne one should be guided by the following principles:

(a)—The sensitivity should be great enough to bring in signals which are just below the noise level.

(b)—The selectivity should not be any greater than is absolutely necessary to separate the signals of distant stations from those of strong local stations.

(c)—There should be adequate selectivity ahead of the first detector or modulator so that image interference may be reduced as much as possible.

(d)—The intermediate frequency should be higher, the greater the frequency span of the i.f. level.

(e)—The coupling between the local oscillator and the first detector or modulator should not be close.

(f)—The coupling should be such that only the fundamental frequency of the oscillator is

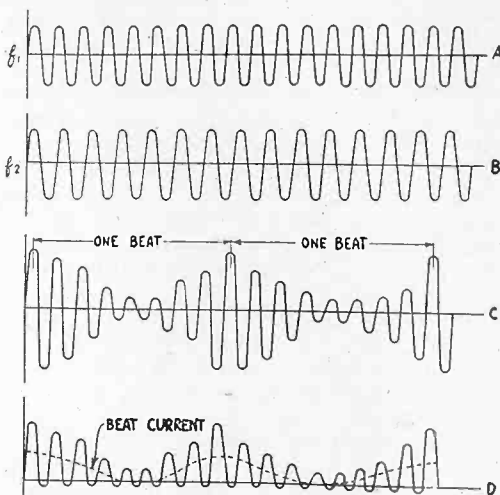

FIG. 1

Graphical representation of beats  $F_1$  is one frequency,  $F_2$  is another, but lower. The axes are A and B. In C two cycles of the resultant beat are shown, while D depicts the composite current, the dotted line representing rectified pulses.

introduced into the modulator, that is, the coupling should be selective.

The reasons for these will be brought out in the following discussion of the principles of the superheterodyne:

### Origin of the Word

The word *superheterodyne* is made up of three different words, namely, *super*, meaning higher; *hetero*, meaning other or different, and *dyne*, meaning force. This compound word, a hybrid of Latin and Greek elements, is supposed to describe what the circuit is, but it does not do this well, for it is not very illuminating to call a receiver "a higher other force." However, the name fits as well as many other accepted radio names and there is no reason for changing it to a more descriptive term, even if one could be found.

The term *heterodyne* was introduced into radio by Prof. Reginald Fessenden to describe a method of reception of continuous waves whereby a local radio frequency which differed only slightly from the frequency of the signal to be received was impressed on the detector simultaneously with the incoming frequency. Later when regenerative tube receivers came

(Continued on next page)

(Continued from preceding page)

into use the term was applied to the whistling sounds generated by the circuit when the tube oscillated and when the locally generated frequency differed only slightly from the frequency of the signal.

Most fans who have operated such a regenerative receiver no doubt have noticed that when the tuning condenser is turned slowly the pitch of this whistle varies throughout the whole gamut from the very lowest audible sound to the very highest. The whistle is caused by the interaction between the frequency of the oscillating detector and the frequency of the signal.

### Audibility and Superaudibility

There is present in the plate circuit of the detector tube a current having the frequency of the whistle. This current obviously does not stop when the whistle ceases to be heard. The frequency simply passes the upper limit of audibility. As the tuning condenser is turned in the direction of increasing pitch, the frequency continues to increase indefinitely. As soon as the frequency is above the upper limit of audibility it is called a superaudible frequency, or a superaudible heterodyne. It is this superaudible frequency which is used in a superheterodyne.

Heterodynes are not limited to electrical currents but occur whenever two periodic motions take place simultaneously. The most familiar example is the throbbing phenomenon which occurs when two musical tones of slightly different frequencies are sounded at the same time. The two tones are not heard separately but as a single tone, the intensity of which waxes and wanes at a rate depending on the difference in the pitch of the two separate tones.

The phenomenon is called a beat, and two tones which are interacting in this manner are said to be beating. The phenomenon is best observed when the two tones are sustained and when both are pure, that is, free from harmonics or overtones. But it can also be observed when two piano strings in the bass, and both close together, are struck simultaneously. The sound can both be heard and felt when one tries to whistle in unison with any sustained note.

If one of the beating tones is held at a fixed pitch and the pitch of the other is varied continuously from unison, the rapidity of the beats will increase gradually.

### Slow Beats at First

At first the beats are very slow, then they increase until they can no longer be heard as separate beats, but rather as a tone. This occurs when the rapidity is about 16 per second. When the difference between the two tones is greater, the two tones can be heard separately as well as the subjective beat tone. This in acoustics is exactly similar to the electrical heterodyne previously discussed, and for that reason the term beat is applied to the electrical case quite as often as the term heterodyne. Thus two currents are said to beat with each other

and to produce a beat current. The frequency of this beat current is limited only by the frequencies of the two currents which beat.

The coexistence of two currents of different frequencies, or of two tones of different pitch, is not sufficient for the production of a beat current or a beat tone. There must be distortion in the medium in which the action takes place. In the case of two weak tones, the distortion takes place in the ear of the listener.

In the case of two very intense tones, the distortion may also occur in the air. In the electrical case the distortion takes place in the vacuum tubes. A detector tube is only a vacuum tube which has been adjusted so that the distortion is large and so that the beat current produced by the interaction between the two currents is large. The first detector in a superheterodyne, the modulator tube, is a tube adjusted in this manner.

### Beats Made Graphical

A graphical representation of the production of beats is shown in Fig. 1. At (a) is represented a simple harmonic disturbance of frequency  $f_1$  and at (b) a similar disturbance of a lower frequency  $f_2$ . These simple harmonic disturbances may represent either pure alternating currents or pure tones. At (c) is represented the combined effect of these two simple harmonic disturbances when they are occurring simultaneously in the same medium. The amplitude of the curve in (c) varies regularly from maximum to minimum. The distance between one maximum to the next maximum represents the time or period of one beat, and the number of such periods per second is the beat frequency. This is equal to the difference between the two frequencies represented in (a) and (b), that is, to  $f_1 - f_2$ .

As was pointed out above, the beat frequency does not represent a tone or a current of this frequency when the two beating frequencies occur in a distortionless medium. The condition for the production of such a beat current or beat tone is that the displacement in one direction is greater than that in the other. This is met in detector circuits where the operating point is on a curved portion of the characteristic of the device, and it is also met in rectifier circuits in which one side or the other of the current is wiped out entirely, provided there is an additional device which averages the resulting unidirectional pulsations.

This average current varies as the amplitude of the composite current (c). Curve (d), Fig. 1, shows approximately the shape of the composite current in the plate circuit of a grid bias detector resulting from two voltages of slightly different frequencies impressed on the grid. The negative loops are nearly wiped out, while the positive loops are proportional to the voltage impressed. The dotted line through the positive loops is the average current and represents the beat current. This current can be selected by a suitable tuner and amplified.

Curve (d), Fig. 1, can also represent the output of a rectifier in which the rectification is not perfect, and since practically no rectifier

is perfect at radio frequencies, it represents the output of any rectifier operating at radio frequency.

### Representation of Current

When a pure tone strikes the microphone in a broadcast station an electric current having the frequency of the tone is generated. This current is impressed on the radio frequency wave generated by the oscillator in the transmitting station, that is, an audio frequency and a radio frequency current are mixed. The resulting current is one of radio frequency having a variable amplitude, and it is essentially of the same form as curve (c), Fig. 1. Analytically, this current can be represented as composed of

the three components will cause heterodynes with a suitable local oscillation.

The sound that falls on the transmitting microphone is rarely a pure tone, but in general consists of all audible tones, or combinations of many different tones. Hence there will be many side frequencies. If the highest audible frequency transmitted is 10,000 cycles per second and the lowest is 16 cycles per second,  $f$  in the formulas above may have any value from 16 to 10,000 cycles per second. Therefore, the superior side frequency may have any value between  $F + 16$  and  $F + 10,000$ . This band of frequencies is called the upper or superior sideband. Likewise the band between  $F - 10,000$  and  $F - 16$  is called the lower or inferior side-

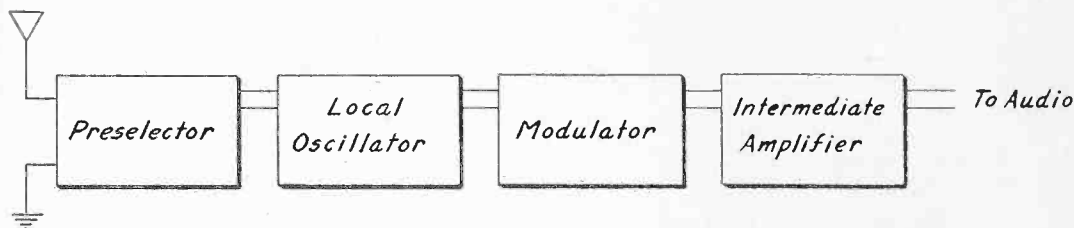

FIG. 2

The three superaudible frequency levels of a superheterodyne: (1), r.f. tuner or preselector; (2), local oscillator, and modulator that combines the station and generator frequencies; and (3), the intermediate amplifier.

three different currents, one having the frequency of the radio current generated by the oscillator, a second having the frequency of the sum of the oscillator frequency and the tone frequency, and a third having a frequency equal to the difference between the oscillator frequency and the tone frequency. All three are radio frequency currents.

If  $f$  is the frequency of the tone current and  $F$  the frequency of the radio current, the frequencies of the three products of the mixture, or modulation, are  $F$ ,  $F + f$ , and  $F - f$ .  $F$  is called the carrier frequency, and the corresponding current the carrier current.  $F + f$  is called the upper or superior side frequency and  $F - f$  is called the lower or inferior side frequency.

When this composite radio frequency current is impressed on an antenna, a radio wave is radiated into space, and this wave has the same form as the current. In free space this wave does not exist as three separate entities, unless we are willing to admit that the "ether" is incapable of following the variations accurately. It exists as a single complex wave in which the amplitude varies according to the tone impressed on the carrier.

### When Wave Strikes Antenna

This complex wave strikes a receiving antenna and induces therein a voltage which has the same form as the wave transmitted. In the receiver the three components may exist as separate entities because of the distortion which occurs in the tubes and in other parts of the receiver. It is for this reason that either of

band. In ordinary receivers the circuit is tuned to the carrier frequency  $F$  and never to the side frequencies. However, when the carrier frequency is high compared with the highest side frequency, and when the circuit is tuned to  $F$ , it is also approximately tuned to all the side frequencies, both upper and lower. There are exceptions, notably in superheterodynes, and these will be discussed further on.

The object of any receiver is to retrieve from the complex radio wave all the original sounds that fell on the microphone, and this is done in the detector. This device inverts the process of the modulator, and consequently the detector is often called a demodulator.

### The Modulator Tube

The so-called first detector in a superheterodyne does not detect in the sense that it makes the signal audible. Electrically, it functions in the same manner as the modulator in the transmitting station, and therefore it is desirable to call it a modulator rather than a detector. The difference between a detector, or demodulator, and a modulator is really only in the point of view. Both function because of the same property of a vacuum tube.

For the purpose of explaining the operation of the superheterodyne it will be convenient to assume for the time being that the signal to be received is unmodulated, or that it consists of the carrier frequency alone. Let this frequency be  $F_1$  and let the frequency of the local oscillator be  $F_2$ . Voltages having these two frequencies are impressed simultaneously on the modulator

(Continued on next page)

(Continued from preceding page)

tube in the receiver. The product of this modulation contains the frequencies  $F_1 - F_2$  and  $F_1 + F_2$ , the two side frequencies. The first of these is a difference between two radio frequencies, and is, therefore, a beat or heterodyne frequency. The second is a sum of two radio frequencies, and is, therefore, itself a radio frequency.

In practice these two frequencies are so widely different that they cannot be selected by the same tuning system. Receivers employing either of these frequencies can be built, and many have been constructed of both types. Every superheterodyne employs the beat frequency  $F_1 - F_2$ . However  $F_2$ , the local frequency, does not have to be the fundamental of the local oscillator frequency. One commercial superheterodyne made use of the second harmonic, though practical difficulties are introduced.

The difference frequency  $F_1 - F_2$  will be referred to as the intermediate frequency, or simply IF, unless there is some reason for retaining the terms beat or heterodyne. Let the intermediate frequency be designated by  $f$  so that  $f = F_1 - F_2$ .

### The Intermediate Coils

The intermediate frequency filter or tuner is simply a selective arrangement which is tuned to the intermediate frequency  $f$ . It may consist of transformers with tuned secondaries, or with tuned primaries, or again it may consist of filters having both tuned primaries and secondaries. Again, it may consist of more complex filter systems which respond to a definite band of frequencies rather than a single frequency. Some of these filters are only variations or refinements of the simple tuned transformer system which in no way alter the principle of operation of the superheterodyne.

The selectivity of the superheterodyne depends primarily on the properties of the intermediate frequency filter. If this is selective, the receiver is selective; if it is broad, the receiver is broad. The lower the intermediate frequency, as a rule, the greater is the selectivity. However, high selectivity in the intermediate frequency amplifier is not at all a guaranty against interference from stations not desired. If the intermediate frequency is equal to one half the separation between two stations and the oscillator is set half way between the two carriers the signals of both come through the filter. The choice of intermediate frequency for any superheterodyne is always a compromise among several conflicting factors, and the exact value chosen in any case depends on the relative importance the designer attaches to these various factors.

### The Main Tuning Device

Some may think that the oscillator determines the intermediate frequency. This is erroneous because it has nothing to do with what the intermediate frequency is to be. It is merely one of the factors which jointly produce the frequency that is acceptable to the tuned filter system.

Yet the oscillator condenser is the main device for bringing in desired signals. When this condenser is turned the radio frequency generated by the oscillator changes continuously. Beats between this frequency and any other frequency that may be impressed on the modulator also change.

Whenever the beat frequency between any signal frequency and the oscillator frequency happens to be that which is acceptable to the filter, the signal comes through and is amplified. Beats of all other frequencies are rejected.

The oscillator is the heart of the superheterodyne, and as long as it beats the receiver is alive. The sensitivity of the receiver depends to a large extent on how vigorously the oscillator works and how much energy it pumps into the modulator. The signal received is directly proportional to the product of the voltages impressed on the modulator by the carrier frequency of the signal and by the oscillator. If either is reduced the signal received is reduced also; and conversely, if either is increased, the output of the receiver is increased.

### Coupling Governs Intensity

The intensity of either of these voltages depends on the degree of coupling between the source and the modulator. If the oscillator, for example, is closely coupled to the modulator the output of the receiver is strong for a given signal strength. If the coupling is loose, the output is weak. Indeed, if the coupling between the oscillator and the modulator is zero, the receiver is dead just as if the oscillator were not functioning and as if no carrier were present. The method of coupling the two frequencies with the modulator constitutes a major problem in design.

When the two beating frequencies are coupled too closely to the modulator, there are many repeat points, also growling. Beats of sufficient intensity to produce audible tones and noises are produced between harmonics of the oscillator and the signal carrier frequencies. If the multiplicity of repeat points and the growling are to be avoided, it is essential that harmonics be eliminated from the modulator as much as possible. This requires loose, selective coupling between the oscillator and the modulator, or it requires an oscillator which does not produce harmonics of appreciable intensity. Moreover, it is necessary to prevent generation of harmonics of the signal carrier frequency, which can be done by tuning and by adjusting the r.f. amplifier so that there is the least amount of detection in the circuit.

When the intermediate frequency is low and the tuned circuits of the oscillator and the signal selector are coupled closely, the frequency of oscillator is not completely determined by the oscillator tuned circuit, but is partly determined by the constants of the signal selector. Under certain conditions the two selective circuits act as one, when they are said "to pull together." Reception is not possible when this occurs. The looser the coupling between the two resonant circuits, the less the likelihood of this occurring, and also the higher the inter-

mediate frequency, the less the tendency for the two circuits "to pull together."

### Stray Coupling

The intentional coupling in any superheterodyne between the oscillator and the modulator is not necessarily the only coupling. The two tubes will be served by the same batteries or voltage supplies. These will have resistance which will act as a coupling medium. In order to minimize this coupling bypass condensers should be used liberally across the supply leads. No condenser is shown in any of the modulator arrangements because the only purpose of the circuits is to show some of the possible methods of modulation. Stray coupling must be kept down to the lowest possible minimum if the receiver is to work properly.

We assumed previously for the purpose of explaining the production of the intermediate frequency that the signal was unmodulated, or that it consisted of the carrier alone. But a broadcast wave is modulated with audio frequencies whenever it brings in an audible signal, and these audio frequencies may lie, as we found, anywhere in the band between about 16 and 10,000 cycles per second. For simplicity let us assume that the carrier is modulated by a single audio frequency. We have found that the modulated wave can be regarded as composed of three different radio frequencies, namely, the carrier itself and two side frequencies.

When a locally generated frequency is mixed with this complex wave, the local wave becomes modulated by it, or what amounts to the same thing, by the three components of it. Of the products of the local modulation we are interested only in the inferior side frequency, since the intermediate frequency filter accepts this only. The local frequency is subtracted from each of the three components of the complex signal wave, or each of the three components is subtracted from the local frequency, depending on whether the locally generated frequency is lower or higher than the signal component frequencies. The result is an intermediate frequency which is modulated by the original audio frequency, and this intermediate frequency wave can be regarded as composed of three intermediate frequencies, one equal to the difference between the carrier frequency and the local frequency, and the other two being greater and less this difference by the amount of the audio frequency.

### Three Frequencies Per Group

Let us summarize this in symbols. Suppose the carrier frequency is  $F_1$  and the local oscillator is  $F_2$ . Let the audio frequency be  $f$ . Then the complex signal is composed of  $F_1$ ,  $F_1 - f$ , and  $F_1 + f$ , all of which are radio frequencies. When these are mixed with  $F_2$  and the difference frequencies only are taken, we have  $F_1 - F_2$ ,  $F_1 - F_2 - f$ , and  $F_1 - F_2 + f$ , if the local oscillator frequency is less than the carrier frequency, and  $F_2 - F_1$ ,  $F_2 - (F_1 - f)$ , and  $F_2 - (F_1 + f)$ , if the oscillator frequency is greater than the carrier. All of these are intermediate frequencies.

In each of these two groups there are three frequencies, the intermediate carrier and the two side frequencies. In the two groups the value of  $F_2$  is not the same for any particular value of  $F_1$  and  $f$ . In fact,  $F_2$  in one group differs by twice the intermediate frequency from the  $F_2$  in the other group, and the two values of  $F_2$  represent the two points on the oscillator at which any given signal comes in on a superheterodyne, or more exactly the two principal points.

### Side Frequencies Tuned In

The value of  $f$  in the above formulas may be any from 16 to 10,000 cycles per second, and it may have one or more values at the same time, depending on the complexity of the sound that is being transmitted. In fact, it may have as many different values as there are different frequencies in the sound of orchestral music. No matter how complex the sound may be, each component frequency can be treated separately as  $f$  was treated above.

The value of the difference  $F_2 - F_1$ , or  $F_1 - F_2$ , is determined by the tuning of the intermediate frequency filter, and the value accepted by the filter is selected by varying  $F_2$ . This is done by turning the oscillator dial. If we designate the difference between  $F_2$  and  $F_1$  by  $IF$ , we may express the three intermediate frequency components by  $IF$ ,  $IF - f$ , and  $IF + f$ . These expressions include both groups given previously.

### Low IF Avoided

When a circuit is tuned to a carrier, as has been stated, it is also tuned approximately to the side frequencies provided that the frequencies do not differ much relatively. Suppose, for example, that the carrier frequency is 1,000,000 cycles and that the highest audio frequency impressed on it is 10,000 cycles. The side frequencies are 990,000 and 1,010,000 cycles, and the ratio of the lower side frequency to the carrier is .9. This is so nearly equal to unity that when the circuit is tuned to the carrier it is almost as well tuned to the side frequencies. But suppose the carrier is 30,000 cycles, as it is in certain superheterodynes. The side frequencies corresponding to a 10,000 cycle tone are now 20,000 and 40,000 cycles. The ratio of the lower side frequency to the carrier is now  $2/3$ . This differs so much from unity that when the circuit is tuned sharply to the carrier the side frequencies are practically tuned out. Not only are the high side frequencies tuned out, but frequencies corresponding to tones as low as 1,000 cycles are greatly suppressed.

This is one of the reasons why a low intermediate frequency should not be used in a superheterodyne, and excessive selectivity must be avoided if the quality of broadcast signals is to be good.

\* \* \*

[The action of the voltages of the two frequencies, that of the station and of the carrier, and the resultant beat or intermediate frequency, will be analyzed by J. E. Anderson in the March issue.]

# Special Ranges for Meters

## How Particular Needs are Met, Using Standard Instruments

By Clair E. Ballard

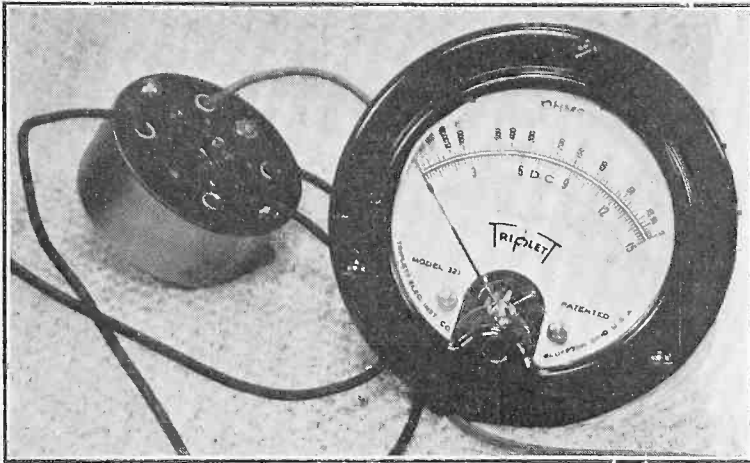

The rectifier type meter consists of a d.c. microammeter, with which, for a.c. measurements, a copper oxide rectifier is used. The meter is not used at its maximum sensitivity but is shunted with a resistance for d.c. measurements always, and usually with a separate shunt for a.c. measurements. The purpose is to coincide the current, so that the same series resistors, or multipliers, serve for d.c. and a.c.

**M**ANY persons have specialized uses for meters and therefore have to build their own equipment, using standard meters. Even though a diagram of some already engineered circuit may be followed to a large extent, it is well to have some understanding of the apparatus connected to the meter and the purposes served. Moreover, often one may desire to introduce some service not provided for in the diagram and this he may do, when fortified with an understanding of the fundamental meter principles.

All meters measure current. But the calibrations may be in current, volts, ohms, resistance, capacity, etc. The effect of introducing various voltages, resistances, capacities and the like always is registered as a current difference, hence it is practical to ascribe the other values. Remember, they express themselves, but that the differences depend on current.

### The Rectifier Type Meter

Take as an example a popular meter, the rectifier type. This consists of a sensitive d.c. current meter, in series with which for a.c. purposes is a copper oxide rectifier. When the meter is considered only as a d.c. current meter and as a d.c. voltmeter, the current ranges are extended by introducing parallel resistors across the meter, called shunts, and represented by  $R_{sh}$  in the first diagram. If the voltage is to be read, a limiting resistor is used, and this one is in series with the meter, instead of in shunt with it. Shunting and multiplying apply to all current drawing meters.

The series resistor, or multiplier, is  $R_s$  in the first diagram. It can be seen therefore that a common meter terminal, C, may be brought out, and of two other posts or connections, one may be used with the common for measuring currents of ranges greater than the meter alone would provide, while the other, with the common, serves for measuring voltages greater than the meter alone would enable.

The common point, or positive, of the meter is marked C. Either side of the meter may be used as common, and the series resistors may be in either leg, if the common terminal is transposed, that is, negative side is used. No difference in performance or safety obtains as between one option or the other.

### Rating of Sensitivity

Let us see why the meter range is extended as to current by shunting, and why the voltage range is enlarged by an entirely different process, that is, increasing the circuit resistance.

Considering current first, the meter has a certain sensitivity. This is established by the full scale deflection current. There can be no better way of describing the sensitivity of a meter than by stating its full scale deflection current. If that current is 1 milliampere, one one thousandth of an ampere (.001 ampere), then such is the sensitivity. The sensitivity rating thus made applies to the instrument when used as a current indicating or voltage indicating device.

It is impossible to increase the sensitivity of



the meter, therefore in the example just cited, of a 0-1 milliammeter, no more than 1 milli-ampere must flow through the meter. So if we desire to measure 5 milliamperes, say, we would like to have an apparent full scale deflection of 10 milliamperes. This can be done very easily, since if another resistance is put across the meter, which always has an internal resistance of its own, the selection of the parallel or shunt resistor may be on the basis of

through the shunt, as well as that through the meter. That is why the calibration, in respect to the meter current, is stated as being "apparent" current. The real current through the meter at full scale in this example is only one-tenth of the total current flowing, though the meter reads the total current.

Now, why do we use a series resistor for voltage range extension? To produce exactly the same effect, that no more current is put

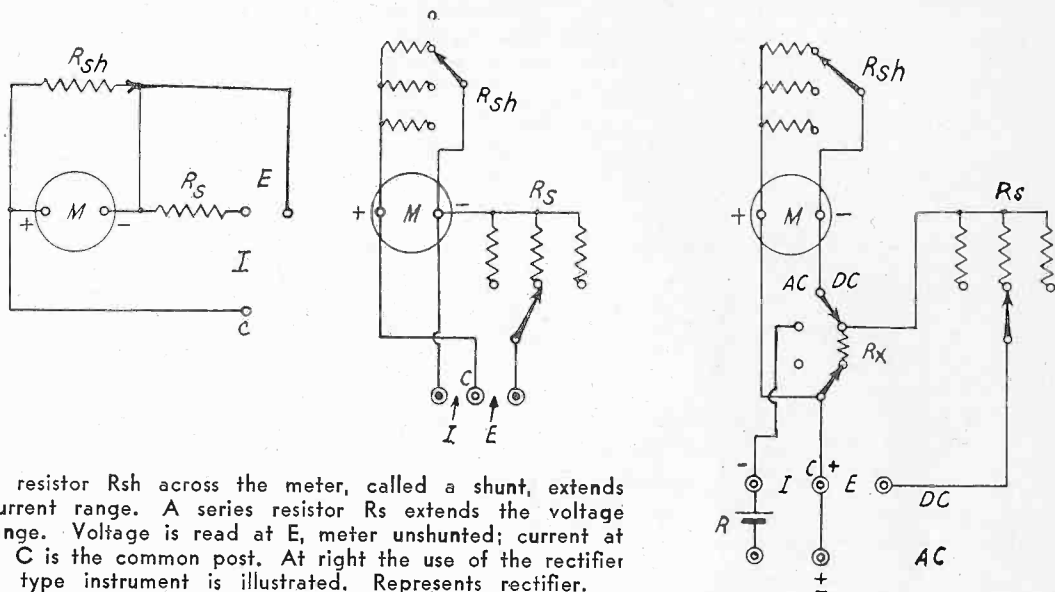

A resistor  $R_{sh}$  across the meter, called a shunt, extends current range. A series resistor  $R_s$  extends the voltage range. Voltage is read at E, meter unshunted; current at I. C is the common post. At right the use of the rectifier type instrument is illustrated. Represents rectifier.

only 1 milliampere flowing through the meter itself, therefore the shunt must exactly carry the difference, or 9 milliamperes.

It is not possible to solve for the desired shunt unless the meter resistance is known, since the problem is to find out what unknown resistance must be put across a known resistance so that the current divides as we decided. But the manufacturer reveals in his catalogue, and in an instruction sheet, what the meter resistance is, or will inform you, so the meter resistance is considered known.

### How Current Is Divided

If .001 ampere is to flow through a meter of 100 ohms resistance the voltage drop will be .1 volt, and since the shunt is to drop the same voltage, because across the same e.m.f., then the shunt resistance for the 10 ma example would have to be the shunt voltage in volts divided by the shunted current in amperes. This current was .009 ampere, so the shunt resistor should be the voltage divided by the current, or  $.1/.009$  or 11.1 ohms.

The effective resistance of these two in parallel is 10 ohms, which is one-tenth the meter resistance, so the total current flowing is ten times as great, which is what we want.

So we know why we put a resistor across the meter to increase the meter reading range, without ever increasing the full scale deflection of the meter itself. The calibration on the meter really reflects the current flowing

through the meter than full scale deflection will permit. We use series resistance because resistance in a series circuit also reduces the current through the meter for any one voltage. The shunt was a parallel circuit and also limited meter current. Therefore it must be remembered that series resistors limit current through a meter and so do resistors across a meter. The meter circuit is in parallel with any voltage to be measured, but in series with any current to be measured.

### How Much Series Resistance?

Another way of looking at it is to remember that if the voltage applied is fixed, the current is determined by the resistance in the circuit, a fact that is the basis of the ohmmeter. If the resistor is fixed, as for a given range, and the voltage applied is varied, the current will vary directly in proportion to the voltage. Only d.c. use is meant now, remember. So as we desire to go to ascending orders of voltage ranges we must introduce more and more resistance. How much?

Again we revert to two factors: (1) the sensitivity of the meter, and (2) the internal resistance of the meter, usually resulting from the resistance of the wire of which the meter magnet coil is wound.

The sensitivity of voltmeters is commonly expressed in terms of ohms per volt, because when this term is used the resistance to be

*(Continued on next page)*

(Continued from preceding page)

put in series is the resistance in ohms per volt multiplied by the full scale deflection voltage desired. Otherwise the rating in terms of ohms per volt is not a very good one, particularly as it applies only to full scale deflection, all readings taken at less than full scale being of higher ohms per volt, e.g., at half a scale the ohms per volt are doubled, since the same resistance is used for half the voltage.

### Determining Ohms Per Volt

The ohms per volt are determined by dividing the full scale deflection current of the meter

would represent 1.1 volts, an error of 9 per cent. No consideration need be given to the effect of the meter resistance for external resistors at least 50 times as great as the meter resistance.

### Switching Introduced

The second diagram shows the selection of shunts  $R_{sh}$  and multipliers  $R_s$  by switching, with C the common post, current being read between C and the left hand post and voltage between C and the right hand post. For voltage purposes the meter is always used at maximum sensitivity, if it is a 0.1 milliammeter, on

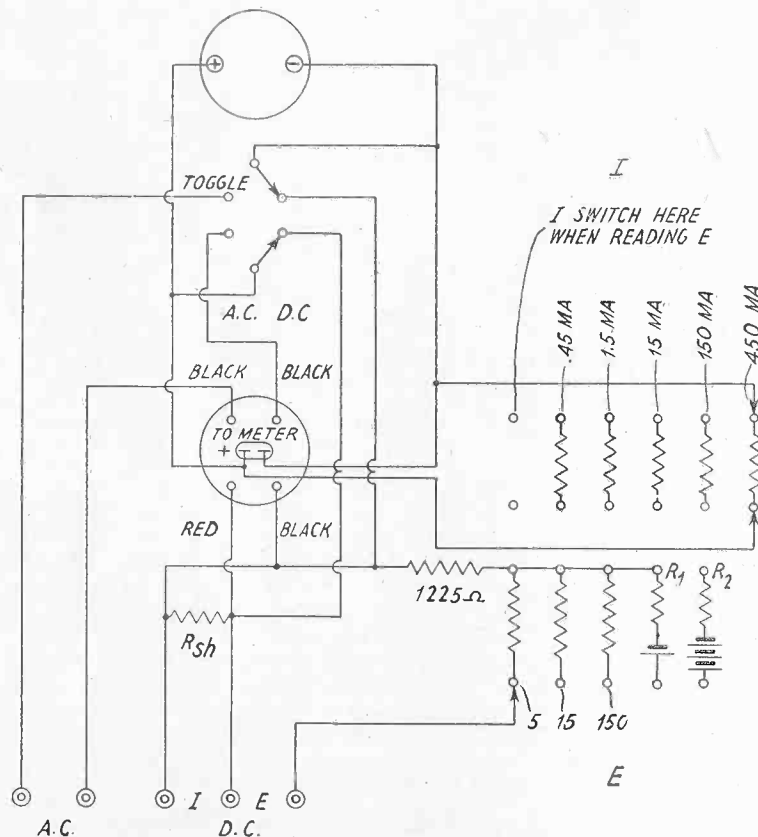

One example of application of the d.c. microammeter (top circle) to d.c. measurements and, by use of the copper oxide rectifier (other circle) to a.c. measurements. The connections for the Triplett rectifier are shown. Rsh, just above the lower posts, is the permanent meter shunt for all d.c. use. Shunting the meter, with different value, for a.c., is also standard practice (not shown). In the diagram the idea of using a series resistance, marked 1,225 ohms, equal to the rectifier resistance, is illustrated. The resistors, upper right, are shunts for current extension, the resistors below are series ones for voltage extension while  $R_1$  and  $R_2$  are for medium and high resistance measurements, respectively. A.c. current as well as voltage is read at a.c., but for larger currents accuracy may not be so high. This applies to all rectifier type instruments.

expressed in amperes, into the number one. Thus for .001 ampere full scale deflection (0.1 milliammeter) the ohms per volt rating is  $1/.001$  or 1,000. If we want a range of 50 volts, then we use  $50 \times 1,000$  or 50,000 ohms series resistance, for 100 volts 100,000 ohms series resistance, etc.

There is one point to watch closely, however, and that concerns any low voltage range.

Since the meter has resistance, which in good meters used in radio practice will be 100 ohms or less, if a low voltage range is to be used, such as 1 volt, requiring 1,000 ohms total resistance, the meter resistance being in the series circuit must be subtracted, to determine the value of the external series resistor, which on the example discussed (100 ohm meter) would be 900 ohms. Otherwise at full scale the apparent reading of 1 volt

the basis of 1 milliamper full scale deflection to denote the maximum voltage of the range, hence it should be possible to cut out any and all shunting for voltage readings, as the dead post at top right indicates. For shunting it is not necessary to have a dead post for the multiplier switch arm, because the current posts give access to the meter directly, and when currents are read the voltage adjunct is automatically out of circuit.

The letter I is used for denoting current and the letter E for denoting voltage.

### Introducing the Rectifier

Modern practice requires that one possess a meter that will read a.c. as well as d.c. and therefore the rectifier type instrument has gained great popularity. The third diagram represents such an instrument, which is a d.c.

meter used directly when d.c. is to be measured, either current or voltage, and d.c. also when resistance is to be measured, while for a.c. purposes the rectifier is cut in series with the meter.

The principle of the rectifier type meter is that the a.c. is passed through a rectifier, a device for passing current only one way, so that the output is direct current, which the d.c. meter reads. The needle deflects because of the d.c. thus flowing, although the scale for a.c. purposes is calibrated in a.c., always root

illustrated in the photograph was 1,225 ohms. For multiplying, the d.c. resistance may be taken as pure, although the rectifier has reactance due to capacity, e.g., current depends on frequency somewhat, as well as on voltage.

### Extreme Sensitivity

The d.c. meter had a measured sensitivity of .000407 ampere (407 microamperes) and if used as a voltmeter would have an ohms per volt rating of 1/.000407, or about 2,500 ohms per volt. This would be fine for those who

If a meter is set up for d.c. use only, if one of the series resistors ( $R_{m2}$ ) is for a full scale voltage deflection equal to a battery voltage, then the same resistor may be used in the ohmmeter. Three voltage and five current ranges are shown, also a resistance range. The doubling of the switch below is to atone for nonsimultaneous contacting, the "quicker" contact being applied to the meter, by transposition if necessary, so the meter will be protected.

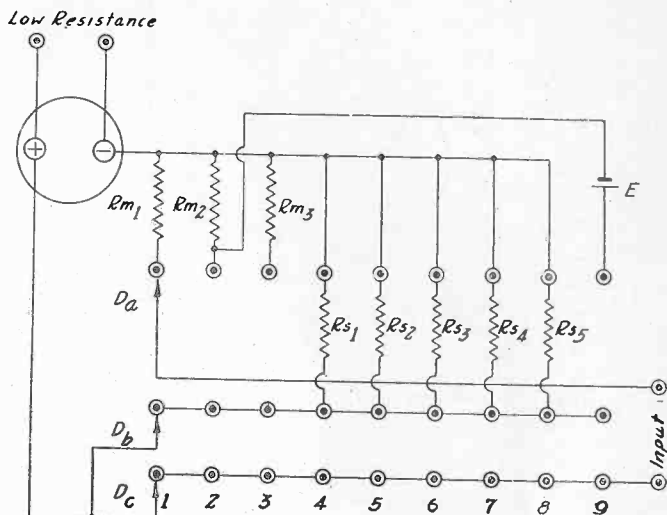

mean square, unless otherwise specified. The other specification, for special practice, is peak volts, or crest volts.

The a.c. and d.c. scales are never identical, hence separate calibrations obtain.

We need a switch to change from d.c. to a.c. use. A single switch could take care of everything, but is complicated, whereas a double pole double throw switch, on one side for a.c., the other for d.c., will simplify the wiring and reduce the cost. The arms of the switch are connected to the meter itself. When the switch is thrown to the right, as shown in the third diagram, the measurements are for d.c. When switch is thrown to the left the readings are for a.c. The symbol that looks like that for a battery and is marked R represents the rectifier.

### Rectifier Problem

Since every rectifier has resistance, and since this resistance will be large compared to the meter resistance, we are at once confronted with a problem. We desire to use the same shunts and series resistors, and not require a second set of them for a.c., because precision wire wound resistors are used for accuracy and permanency, and it is advisable to economize on them.

In some instances the rectifier resistance is 5,000 ohms or more. A particular meter, the Triplett Model 321, uses a Triplett copper oxide rectifier of a resistance of roughly 1,000 ohms. That is an approximation, as stated, and the d.c. resistance of the particular rectifier

need equipment of such special purpose, and the meter could be shunted to coincide the 0-15 scale with 450 microamperes for convenient reading, enabling close reading to 10 microamperes, as there are 45 divisions, but the multipliers would have to be on the basis now of 2,220 ohms per volt, or for the extreme voltage range of 750 volts, let us say, 1,665,000 ohms.

Using the meter at such extreme sensitivity also prevents the use of the same multipliers all the way through for a.c. as for d.c. The meter resistance is 100 ohms, the rectifier resistance is 1,225 ohms, the total is 1,325 ohms, and limiting resistance of 50 times that would be 66,250 ohms, the minimum at which the internal and rectifier resistances would not have to be considered. For a full scale reading of 15 the voltage selected may be 30 volts, so that 66,600 ohms would be used externally in series. For lower voltage ranges on a.c. separate series resistors would have to be used, to compensate for the rectifier resistance particularly, although there is further rectifier compensation to be considered.

Since the rectifier is always in series with the meter on a.c. use it limits the current through the meter. However, a shunt resistor across the meter also limits the current through the meter. This enables use of the same series resistors for both a d.c. and a.c. by shunting the meter for d.c. use only, and removing the shunt when a.c. is to be measured,

(Continued on next page)

## Measuring Medium and Low Values of Resistance

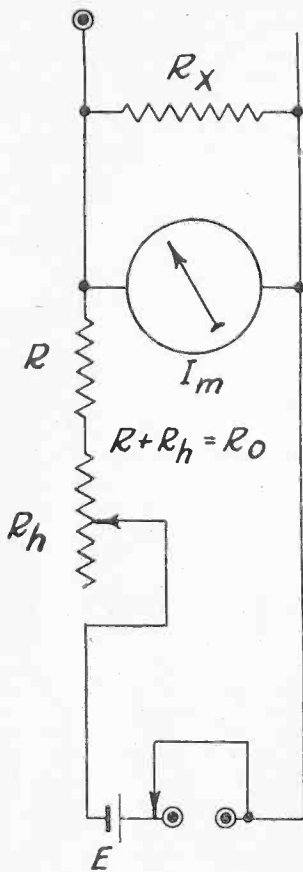

Measure low resistance,  $R_x$ , at top posts by shunting an otherwise unshunted meter.  $R$  is the limiting resistor and  $R_h$  is the rheostat for adjustment to exactly full scale deflection.  $E$  is the battery voltage. The switch is included for closing the circuit when  $R_x$  is to be measured. When the switch is open medium resistance may be measured at the posts below. A formula for  $R_x$  is that it equals  $[I_m / (I_{max} - I_m)] R_m$ , where  $I_m$  is the current through the meter during the measurement,  $I_{max}$  is the full scale deflection current, though not present in the measurement, and  $R_m$  is the meter resistance.  $R$  is in ohms and values of  $I$  are in microamperes. For a 0-1 milliammeter  $I_{max}$  is 1,000.

(Continued from preceding page)

or shunting more for d.c. than for a.c. if double shunting is to be used.

For the particular rectifier that had a resistance of 1,225 ohms, the shunt may be selected on the basis of a given current through the parallel circuit. The Triplet rectifier type meter previously mentioned has scales intended for a total flow of 1 milliampere. The meter itself will take .000407 ampere or 407 microamperes, and the shunt will have to take up the difference of .000593 ampere or 593 microamperes. Considering the meter resistance alone, of 100 ohms, and using the figure .0004 ampere for meter current and .0006 ampere for shunt current, we find the voltage drop across the meter when this current flows will be  $100 \times .0004$  or .04 volt. The same drop is to take place across the shunt. The shunt current is .0006 ampere, so the required shunt for this particular example is  $.04 / .0006$  or 66.7 ohms.

Now the meter circuit and shunt pass a total of 1 milliampere and the multiplier resistors for d.c. will be on the basis of 1,000 ohms per volt, e.g., 5,000 ohms for 5 volts, 15,000 ohms for 15 volts, 150,000 ohms for 150 volts, etc.

### Rectifier Considerations

The reactance of the rectifier is no serious drawback at commercial frequencies, and simply means that high frequencies can not be accurately measured, using the scale as it is, although a correction factor could be introduced to enable readings on frequencies up to 25 kc or so.

To reduce the effect of the reactance of the rectifier it is permissible to shunt the rectifier with practically pure resistance, and a total of 2,000 ohms, consisting of two separate 1,000 ohm units, is used in commercial production of measuring units, with the Triplet meter. This results in an effective resistance of about 760 ohms, to be considered instead of the 1,225 previously mentioned.

Besides, one of the voltage multiplier resistors may be shunted by a condenser, the usual practice being to select a multiplier in the tens of thousands of ohms range and put across it .05 mfd., to offset considerably the capacity reactance of the rectifier.

Using resistance across the rectifier reduces the rectification efficiency, but makes the resultant d.c. more uniformly related to the a.c. Also, higher a.c. currents may be measured with greater accuracy.

### 1 Ma Current Repeated

Measurement of a.c. voltages depend on the reactance of the rectifier, the benefiting safeguards introduced for straightening the resultant current curve, and on the rectifier efficiency.

Various methods may be used for coinciding the meter with the scale for a.c., all based on a certain amount of a.c. current flowing through the meter. Since the multipliers have been selected on the basis of 1 milliampere, naturally in this instance the total current is that, the meter taking .0004 ampere (400 microamperes) and another meter shunt, put on the

a.c. side permanently, that is, across left hand posts of the toggle switch, the difference. If any shunt is to be used this way for a.c., it is a good plan temporarily to get a precision a.c. meter, set the a.c. voltmeter you are constructing to a certain voltage range, say, 15 volts, using a total of 15,000 ohms, and apply one-tenth that voltage, or 1.5 volts, adjusting the shunt until the a.c. meter reads about 1.5 volts. Then increase the voltage applied until it is 15 volts on the test meter and readjust the shunt until full scale is exactly established on your construction job.

Another plan is to introduce a fixed wire wound resistor equal in value to the d.c. resistance of the rectifier, so that when d.c. is measured this resistor is always in the voltage circuit, and on a.c. it is not, because the identical rectifier resistance supplants it. However, the a.c. post points on the toggle switch should be shunted, if the meter so requires, as will be found from the experiment outlined above.

**Special Purposes Served**

Both current and voltage may be read from the same a.c. posts, although the usual segregation must be introduced for d.c. purposes. These facts are shown in the diagram.

So for special purposes it is practical to bring out high sensitivity connections for the d.c. meter, say, .00045 ampere (450 microamperes), where each scale division represents 10 microamperes; introduce as many voltage and current extensions as desired, always preferably having the full scale deflection equal the terminal integer (15), or a multiple or submultiple thereof, applicable to voltage or current; provide for resistance measurements of greater values by increasing the B voltage and the limiting resistor proportionately to the desired increase of range; measure low resistance, closely to say, 1 ohm, by shunting the meter circuit; and correlating the current scale (or voltage scale, for they are the same) to capacity and inductance measurements at a particular frequency, say, 60 cycles, and establishing a high order of accuracy on the a.c. voltage and current measurements.

**Capacity and Inductance**

The measurement of low resistance is done by shunting the meter at the d.c. position, leaving the permanent d.c. shunt in circuit. The effective resistance (considering 66.7 and 100 ohms) is 40 ohms. The meter current, if shunted by the unknown, will yield the value from a formula. Note the following designations:

- R<sub>x</sub> is the unknown resistance.
- R<sub>m</sub> is the net resistance when meter has d.c. shunt across.
- R<sub>o</sub> is the limiting resistor.
- E is the battery voltage.
- I<sub>m</sub> is the sum current through the meter and shunt.

Then the formula is

$$R_x = \frac{R_m (R_o + R_m)}{\frac{E}{I_m} - R_o}$$

**Simple Ohmmeter Without External Shunt Resistor**

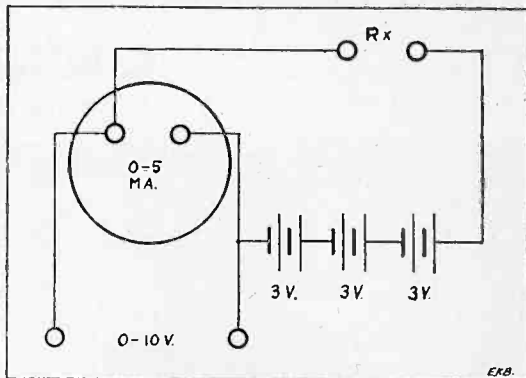

A very inexpensive ohmmeter circuit may be set up without external resistor, using a Readrite 0-5 milliammeter, which has an internal resistance of 2,160 ohms, with 9 volts applied. Full scale may be obtained by using 12 volts and shunting the meter with 22,000 ohms.

A simpler formula for the unknown shunt is given in the caption on the opposite page, although it ignores the equivalent series resistance change due to shunting. This is permissible.

**Capacity and Inductance**

If an a.c. voltage is introduced to yield full scale deflection, then the capacity put in series to determine its value will reduce the current and the values are assignable because the current for each capacity is computable.

Let the frequency be 60 cycles, determine the capacity reactance from the formula

$$X_c = \frac{10,000,000}{3768 \text{ Cmf.}}$$

The answer is in ohms.

For 1 mfd., 60 cycles, the capacity reactance is 2,650 ohms, and higher capacities have proportionately lower reactance, lower capacities proportionately higher reactances, so from these facts the current scale may be interpreted for capacity measurements.

Inductance is measured by applying the formula for inductive reactance in ohms is:

$$X_L = 376.8L \text{ (for 60 cycles).}$$

**Proportion Holds**

Hence 1 henry has a reactance of 376.8 ohms, higher inductance higher reactance, lower inductance lower reactance, in proportion to 376.8 for one henry (60 cycles).

When the solutions are obtained from the X<sub>c</sub> and X<sub>L</sub> formulas, the meter scale current values on 60 cycles a.c. are self-revealing in capacity and inductance values.

# Originality of Design

## In a Commercial Six Tube All Wave T.R.F. Set

By William X. Green

*Harrison Radio Company*

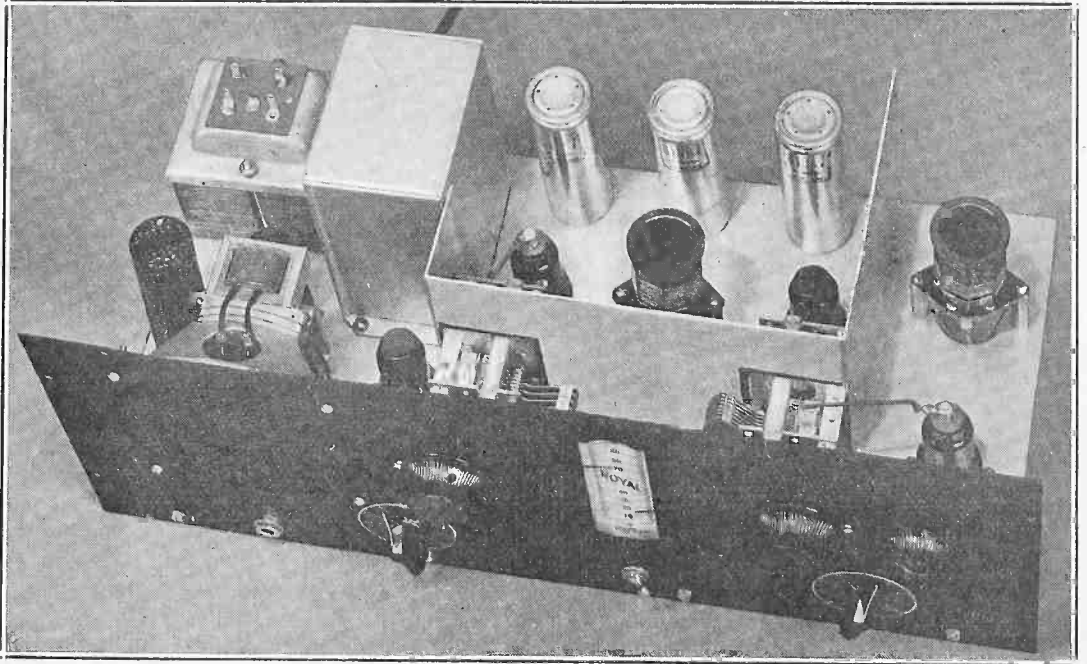

An attractive layout of an effective circuit in which much originality is shown.

**T**HE long felt need for a receiver that is easy to construct and operate and at the same time low in cost and smart in appearance urged the writer to construct this set. After considerable experiment it was decided that a well built t.r.f. receiver would do the job. The circuit and wiring deviate from usual practice to result in sharper tuning than normally experienced with anything but a good superheterodyne.

The shielding system is unusual. The large triple shield not only separates the detector and r.f. stages but it has been so shaped that it cuts through the center of each of the dual tuning condensers, thus placing each of the four condenser sections in its own compartment. The parts are laid out with all important units well placed so that no feedback results between stages.

### Regeneration Control

Metal tubes are used for their close fitting individual shields which are part of the construction of the tubes. The shell of each tube is bonded to the header. Better short wave results are obtained.

An advantage of the superheterodyne over

the ordinary t.r.f. is that the regeneration control is absent. This was considered an important enough point to merit consideration. The old bothersome autodyne detector has been eliminated. The 6K7 detector in this circuit is only a detector and nothing more. It is not used for regenerative feedback. Instead a separate oscillator tube, a 6C5, beats with the detector circuit. It has the usual advantages of regeneration, but what a difference in operation and control!

The oscillation control on the front panel, although somewhat similar to the ordinary regeneration control in its effect, is actually hardly a control at all. It is calibrated, and by a simple movement the set can be left permanently in or out of oscillation, as desired. It can be set right at the point below oscillation and be completely disregarded while the receiver is tuned with the large knob.

### Scientific Volume Control

The volume-sensitivity control is also calibrated. It is a tapered rheostat in the cathode circuit of the r.f. tube, and its high end is connected through a resistor to high voltage. This

*(Continued on next page)*

effect is familiar to experienced operators as the best and practically only way to obtain real control of volume to complete cut-off.

Due to the high efficiency of the circuit, no trouble whatever is experienced in tuning the receiver to high frequencies as well as to the lowest. Consequently, six pairs of coils have been resigned covering the complete desirable radio spectrum from  $9\frac{3}{4}$  up to 625 meters (31 megacycles to 480 kc). The individual coil ranges are:

10 meter coil	$9\frac{3}{4}$ to 18 meters	31 to $16\frac{2}{3}$ mc
20 meter coil	17 to 38 meters	$17\frac{1}{2}$ to 8 mc
40 meter coil	36 to 78 meters	$8\frac{1}{3}$ to $3\frac{3}{4}$ mc
80 meter coil	74 to 158 meters	4050 to 1900 kc
160 meter coil	148 to 350 meters	2025 to 850 kc
Broadcast coil	325 to 625 meters	925 to 480 kc

### How the Coils Look

The coils themselves are interleaved high gain inductances. Here again efficiency is the most important consideration. The secondaries are space wound with the heaviest wire possible in each case. One winding, close wound, is spaced a short distance away, the other is interleaved in the center of the secondary. The coils are plugged into isolantite sockets raised  $\frac{1}{2}$  inches above the chassis with pillars. A matched pair consists of a 5 prong and a 6 prong coil for the r.f. and detector stages respectively.

Two separate two gang tuning condensers are used. One is a dual .000235 mfd. condenser for tuning and range, and the other is a dual 40 mmfd. condenser for bandspread. By the use of separate dual condensers for each of these functions, tracking of the r.f. and detector stages is assured. The equalizer condenser is the knob to the right of the main tuning controls. It is a .0001 mfd. variable condenser connected across the primary winding of the r.f. coil. Its capacity is made equivalent to that of the r.f. plate in the detector coil primary, thus equalizing the two stages.

### The Quest of the Clusters

It is at this point that the sharpness of the receiver becomes really apparent. With a signal tuned in, turn the equalizer slightly to the left or right. The signal disappears. In the average t.r.f. set, throwing the stages off track-

ing will have little effect, thus exposing low efficiency. Even on the broadcast band, where difficulty in separating stations is encountered with some superheterodynes, the PR-SIX sends each signal through to the speaker crisp and clean of interference.

It is well known that important signals on short waves are found in small clusters throughout the spectrum. Witness the amateur bands, the foreign station, police, airplane bands, etc. Therefore bandspread plays an im-

portant role in short wave reception. The method selected provides real spread of all the bands. Of the ham bands, for example, each occupies from 70 to 100 degrees of the dial, even for the narrowest band.

Provision is made for using the receiver in conjunction with a transmitter. A "Send-Receive" standby switch is placed in the center of the front panel, just below the main tuning scale. It cuts off the signal but leaves the heaters of the tubes connected so that the receiver can be immediately snapped into action when ready.

The average person at some time or another wants to use headphones with his receiver. A headphone jack has been placed beneath the speaker on the panel, that cuts in on the first audio stage. It provides comfortable headphone volume, and at the same time completely cuts off the speaker.

### Some Nice Refinements

It was decided that, in order that the receiver have the greatest possible appeal and utility, the power supply and speaker must be built in. In fact, the receiver must be a complete unit in itself, with the exception of the antenna and the 110 volt power line. This is exactly what has been done. The disadvantages previously found in such units have been completely eliminated. Hum and speaker feedback are absent.

*(Continued on next page)*

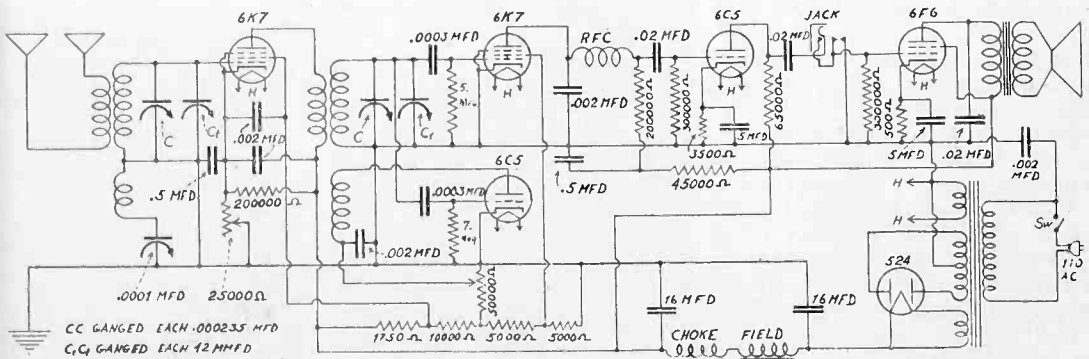

Metal tubes are used in the receiver.

## Small Range Audio Oscillator

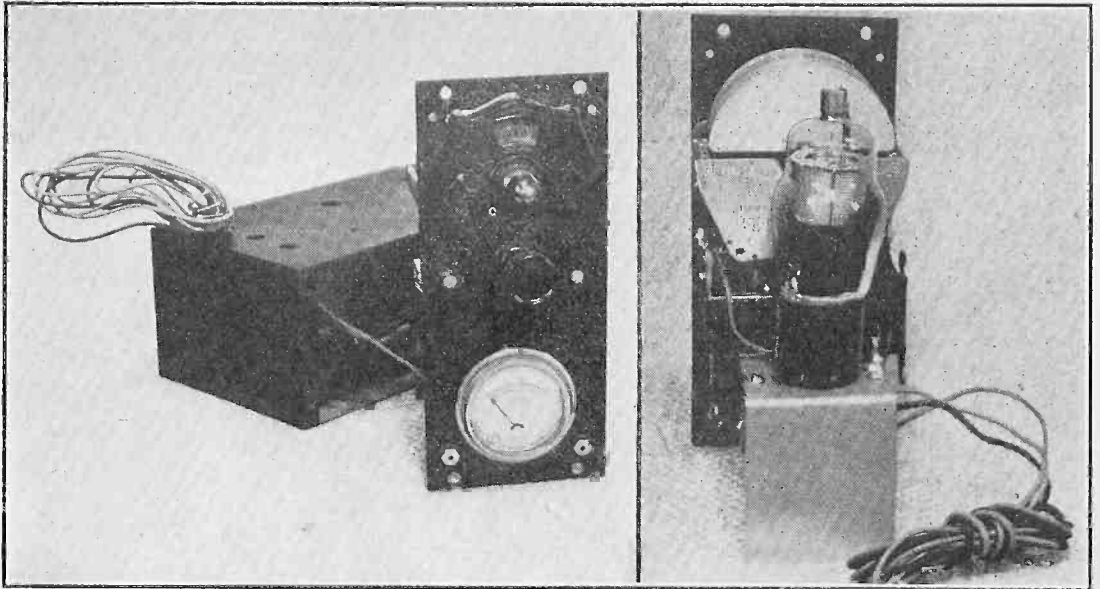

An audio oscillator with small frequency range may be constructed by using an audio transformer as the coil, small winding for feedback, and putting a .0005 mfd. variable condenser across the secondary. A 34-tube is used in a battery model (above), current meter in the plate leg for oscillation indication.

## Refinements in a T.R.F. Receiver

*(Continued from preceding page)*

The speaker is mounted so that it does not touch the chassis. It is secured against the front panel with tiny rubber blocks. In addition, the speaker field is not the only choke used. A large double choke in series with the field comprises the inductive portion of the filter system. A total of 24 mfd., 16 before the chokes, and 16 after, completes this portion of the filter.

### Filtering

An examination of the diagram will reveal many other small points of filtering. Numerous small resistors and bypass condensers serve

to eliminate the last trace of hum and tunable hum, making reception with this set a decided pleasure. Even with a pair of sensitive headphones, not a trace of hum can be heard.

### Antenna Remarks

Provision is made for operating the set with either a single wire antenna or a doublet. Three binding posts are used for this purpose. The power transformer used as a universal winding on the primary for 110, 120, 220 and 240 volts a.c., 25, 50, 60 or 133 cycles. This feature means that the receiver can be taken anywhere there is a.c. and operated perfectly.

A smart looking front, with original provisions, including fixed regeneration for each band, if one desires to operate William X. Black's set that way, since the regeneration is supplied by a separate tube. The speaker is behind the grille at left, and below is the jack for earphone listening. The receiver represents an unusual degree of attainment.

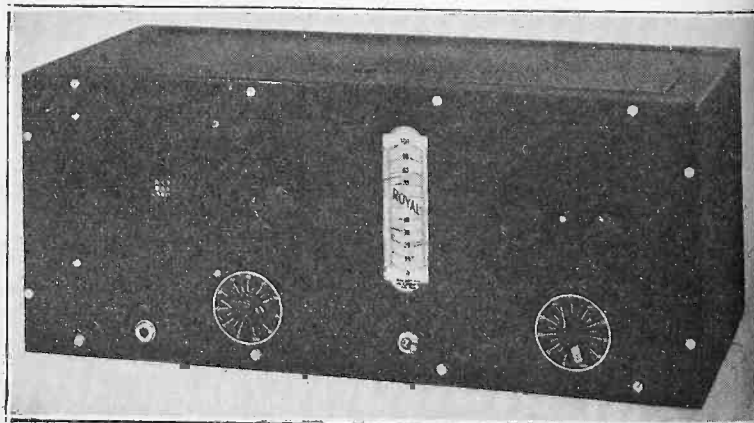



# 10 Watt Phono-Amplifier

## 48's in Push Pull for Universal Use

By Maxwell M. Hauben

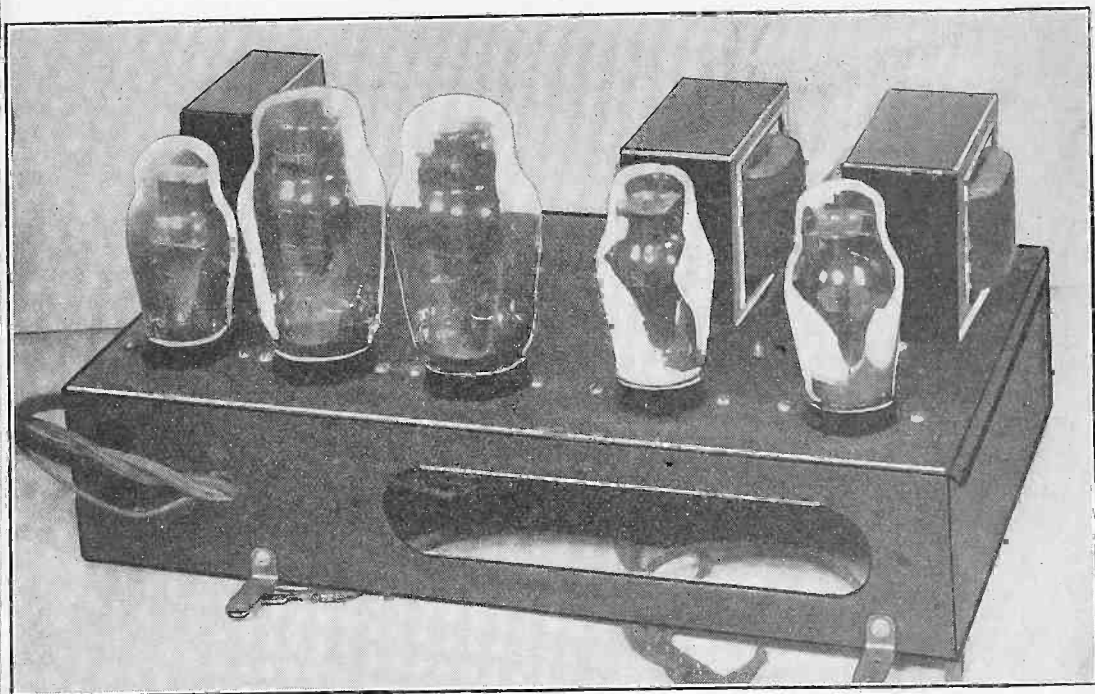

Top rear view of the power amplifier. The rectifier tubes and the filter chokes are on the right, and the three amplifier tubes and the input transformer on the left.

**H**ERE is a simple, universal type power amplifier capable of large undistorted output. It may be used after a radio tuner when great volume is desired, or it may be used either with a phonograph pickup or a microphone.

The high power output is due to the use of a pair of 48's in push-pull in the second stage. Each of these tubes when operating alone is capable of delivering an output of nearly 5 watts  
(Continued on next page)

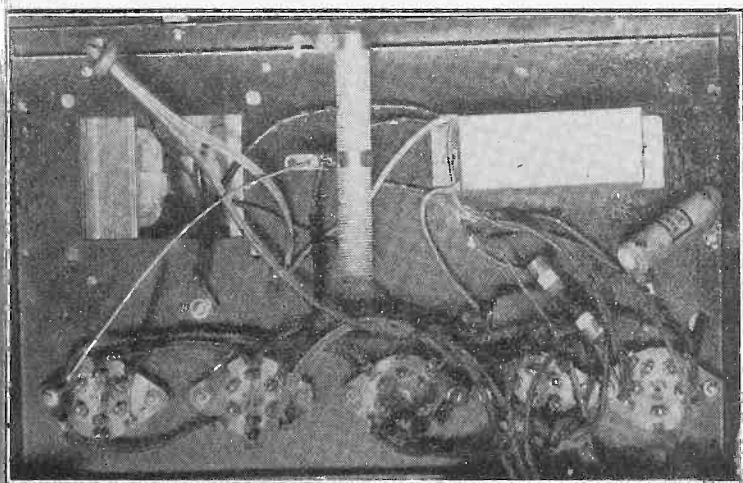

Bottom view of the chassis of the power amplifier, showing the locations of all condensers and resistors. Most of the wiring between these parts and the sockets is also indicated. The voltage divider has a sliding contact that is left put in the position that yields the required bias voltage for the 48's. It is used as a rheostat.

(Continued from preceding page)  
and two in push-pull are capable of putting out more than twice, the total distortion remaining the same.

### Two 48's in Push-Pull

The 48 tubes require a great deal of plate current. For this reason two 25Z5 tubes are used in parallel as rectifiers. Each of these is rated at 100 milliamperes, and this is ample, not only for the plates of the 48's but also for the screens of the same tubes and the plate of the first tube in the circuit.

As the total current drawn from the rectifier is very heavy, an ordinary filter is not effective in removing the hum. The chokes must have low d.c. resistance if the available voltage is not to be wasted, yet the inductance must be high under the special conditions of heavy d.c. current. Thus the coils used should have large cores and the wire should be a heavy gauge.

In the circuit two 75 ohm inductances are indicated. Practically, the inductance of each may be around 10 henries.

### Filter Capacities

Most of the filtering should be done by means of capacities. Three condensers are indicated in the diagram, one at each end of the coils and one at their junction. Usually 8 mfd. for each will suffice. Yet a capacity of 16 mfd. is not too large for each of these condensers. Such large values, of course, call for electrolytic condensers.

Note that the first stage is well filtered as a means of eliminating degenerative feedback on the low notes. Thus there is a 10 mfd. condenser across the 2,500 ohm bias resistance and another 10 mfd. condenser across the plate supply. The 25,000 ohm resistor in the lead to the plate of the 76 is used primarily as a filter for it helps reduce hum.

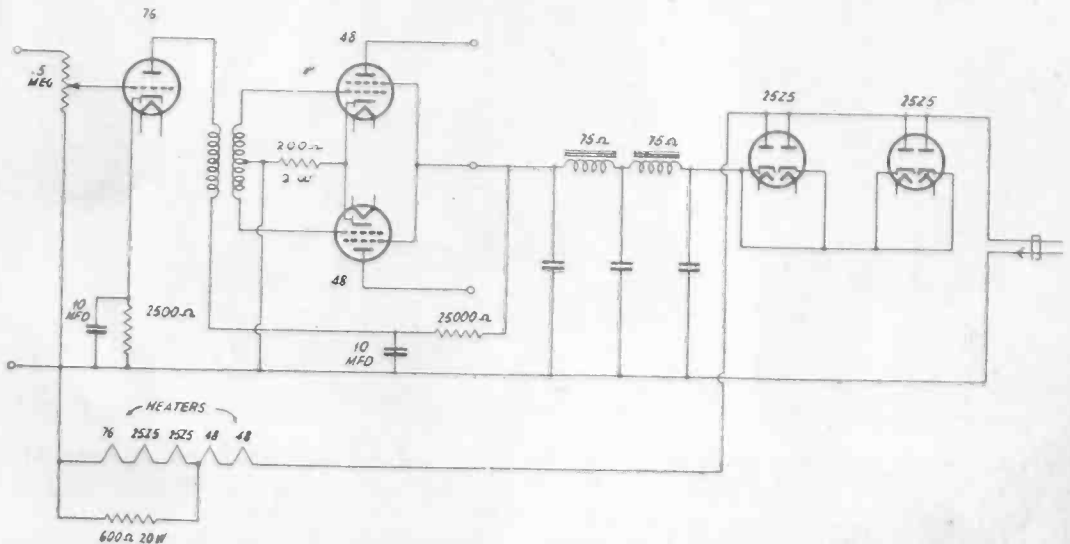

The diagram of a universal type power amplifier utilizing 48's in push-pull. Two 25Z5's are required to supply the needed plate current.

### LIST OF PARTS

#### Coils

- One audio frequency push pull input transformer.
- Two 75 ohm, heavy duty filter chokes (200 mill rating or more).

#### Condensers

- Two 10 mfd. electrolytic condensers, 100 volts rating or more.
- Three 8 or three 16 mfd. electrolytic condensers, 175 volts rating or more.

#### Resistors

- One .5 megohm potentiometer.

- One 2,500 ohm bias resistor.
- One 200 ohm, bias resistor, 2 watts at least (25 watts illustrated).
- One 25,000 ohm resistor.
- One 600 ohm, 20 watt resistor.

#### Other Requirements

- Four six prong wafer type sockets.
- One five prong wafer type socket.
- One control knob for potentiometer with line switched attached.
- One line cord and plug.
- A short length of three lead cable to speaker.
- Two short input leads.
- One chassis.

# RADIO CONSTRUCTION UNIVERSITY

Answers to Questions by Readers on the Building of Radio and Allied Devices. Readers Should Address Questions to Radio Construction University, Radio World, 145 West 45th Street, New York, N. Y.

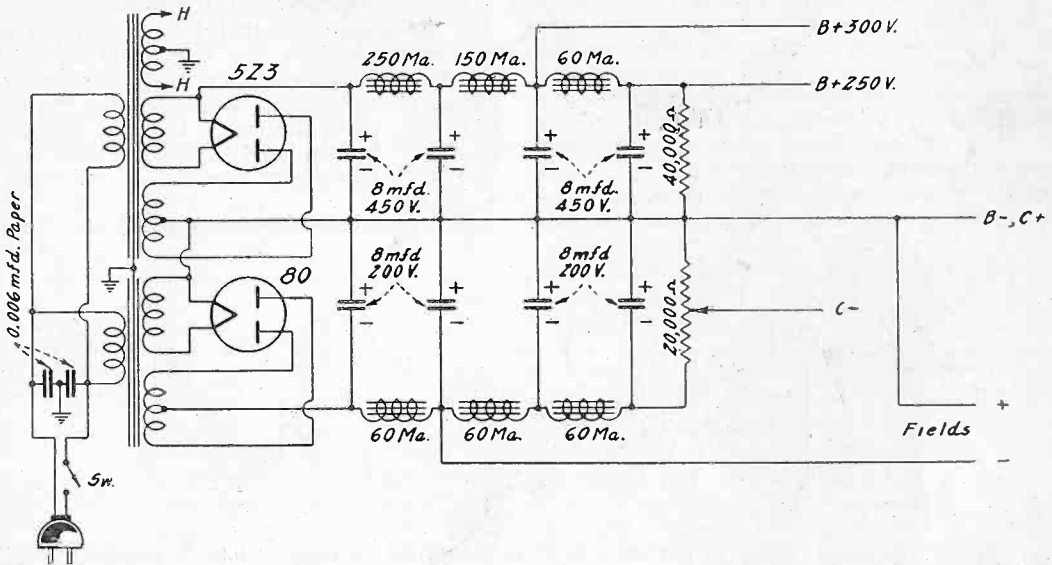

Design for a high powered B rectifier with C supply. The C bias voltage is adjustable. The joint between the 250 and 150 ma rating chokes may be used for power tube voltage above 300 volts, if desired.

## B and C Rectifier

YOU would oblige me by showing a diagram of a high powdered B supply, with auxiliary C supply, so that power tubes could be worked in push pull with applied plate voltage up to nearly 400 volts, also intermediate B voltages of 300 and 250 volts obtained.—O.O.E.

The resultant high voltages will depend on the voltage supplied by the high voltage winding of the power transformer, and on the load. It is assumed that low resistance filter chokes are used, say, a few hundred ohms resistance each. The 5Z3 is used as the B rectifier, the 80 as the C rectifier, and the C voltage is adjustable, being intended principally for the power tubes, hence will have to be suited to the tubes and the B voltage used. Since there is so much interdependence in a circuit like this, adjustments will have to be made until the correct operating conditions obtain. What these conditions are may be found in tube manuals.

\* \* \*

## Pentode Screen Voltage

NOTICE that the screen voltage limiting I resistor in pentode power output tubes is now practically universally omitted, while in

the beginning its inclusion was suggested. Will you please state the reason?—L.W.

The inclusion of the limiting resistor, to maintain the screen voltage slightly lower than the applied plate voltage, in other words, compensate for the d. c. drop in the primary of the output transformer, did not prove sufficiently needful. The difference between inclusion and omission is small. A matter of about 8 volts is concerned. In practice, then, the effective screen voltage is higher than the effective plate voltage, and this slightly limits the power output, but the difference has not proved sufficient to make inclusion of the limiting resistor essential.

\* \* \*

## Tubes Unbalanced

TWO 2A3 tubes used in push pull draw different plate current. The measured voltage drop across the halves of the primary of the output transformer is 9 volts across one half and 11 volts across the other half. The same biasing is used, the same plate voltage, on both. Is the transformer primary unbalanced, do you think?—P.W.

No, it is more likely that the tubes have

(Continued on next page)

(Continued from preceding page)

different mutual conductances. The conductance is so high that independent biasing of each tube to equalize the current at no signal is recommended, which requires, in the simplest case, two 2.5 volt secondaries, one for each tube. Then each biasing resistor must be bypassed by a condenser of 8 mfd. or more, preferably much more. If you have means of selecting from an assortment of these tubes, pick out two that are closely the same.

\* \* \*

### 6L7 Converter Practice

**K**INDLY show how to insert a biasing battery for the 6L7 tube, Grid No. 3, in an a. c. receiver. I connected G3 to the high side of the oscillator coil, with poor results.—O.W.K.

The diagram at left shows insertion of the biasing battery in series with a grid leak of .05 meg. (50,000 ohms), with a .0001 mfd. stopping condenser between coil and G3. The diagram at right shows insertion of the battery in series with the coil, but puts the bat-

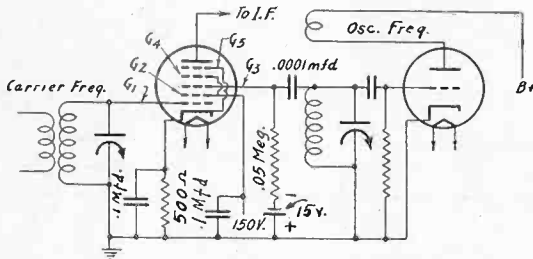

ohms, it would not do to use 2 ohms, as the filament voltage would be more than .3 volt too high. Perhaps the best advice is that the actual filament voltage should be very close to the requirement. If an air cell is to be used the limiting resistor must be critically close. For maximum performance and longest tube life, a lower than required filament resistor should be used, and a rheostat put in series, a voltmeter connected across the filaments, so that it remains in circuit, and the voltage adjusted to the correct value each time the set is to be used.

\* \* \*

### Improving a Transceiver

**I**N the transceiver that I have there is fixed regeneration for the five meter band, plus the interrupter frequency, since the receiving circuit is super-regenerative, but the sensitivity is by no means uniform. Can not some form of volume control be established, besides making the sensitivity about equal over the band?—L. K.

Put a variable resistance of about 25,000 to

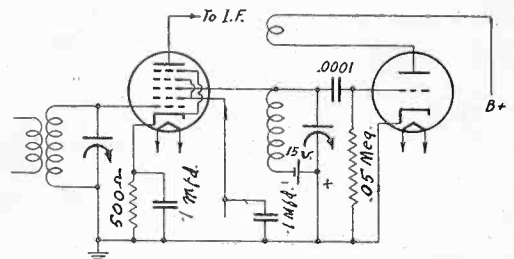

Proper use of a biasing battery to put 15 volts negative on G3 of the 6L7 tube is shown at left. The insertion of the battery in series with the oscillator secondary, as at right, is not productive of such good results. If desired, the biasing voltage may be obtained directly from the oscillator leak, as diagrammed below.

tery in the tuned circuit, and does not provide a high enough d. c. load for G3, which may be the reason for your poor results. Use the method shown at left, or diode biasing, as shown below, which omits the battery.

\* \* \*

### Filament Limiting Resistor

**W**HEN a resistor is to be used for dropping the higher A battery voltage to the required filament voltage, must it be such a close resistance as the computation requires, or would it be sufficient if the resistance were approximately right?—K.L.

Factors not mentioned in the question enter into a consideration of this subject. If the current through the resistor is small, say, one tube drawing 60 milliamperes is served, then the small variation between computed value and commercial value may be tolerated. Thus if a 3 volt battery is used for a 2 volt tube that should draw 60 milliamperes filament current, the computed resistance value is the voltage difference in volts divided by the current in amperes, 1/.06, hence 16.67 ohms. A commercial value of 15 ohms would do, especially since the battery resistance would increase with age and use, and not decrease. However, suppose six such tubes were served, requiring 2.77

50,000 ohms in series with the plate leg of the super-regenerative detector and bypass it with a mica condenser of .0005 mfd. capacity. In series with the grid leak, which is usually of

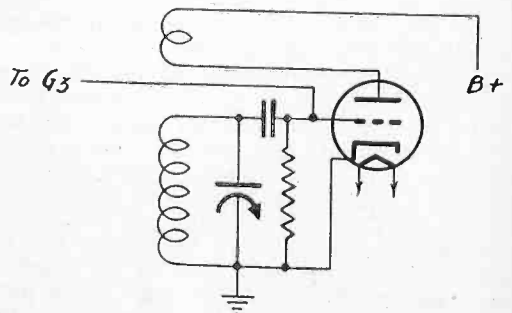

Use of diode biasing of G3 of the 6L7, dispensing with the need of the battery, but reducing the sensitivity just a little. Grid current in the oscillator flows through the .05 meg. leak to provide the bias, so that G3 of the 6L7 and G of the 6C5 are at the same d.c. potential, always negative. The diode mentioned is the circuit from G to K grid to cathode of the 6C5, and the a.c. that is rectified is the oscillation voltage.

low value, put a rheostat, or potentiometer hooked up as a rheostat, value around 500,000 ohms. If the coils are made of very heavy wire for purposes of rigidity, try using much finer wire, winding it on a form of  $\frac{3}{4}$ -inch diameter or even less.

\* \* \*

### Effect of Shield

**H**OW can I determine the effect that a particular shield has on inductance and on capacity?—K. D.

If the coil is used with shield full on, the total distributed capacity may be determined by using across it a calibrated variable condenser and loosely coupling a wire from the stator connection to a coil in an oscillator. Some frequency is generated by the oscillator that the external coil-condenser combination can reach near the low frequency extreme, then twice that frequency is generated, and external circuit condenser turned. In both instances the trap circuit will or should stop the oscillation from oscillating. Read the calibrated capacities. The distributed capacity is obtained, the method detailed in the December, 1935, and January, 1936, issues. Then with the shield removed the test is repeated. The difference between the determined distributed capacities is equal to the capacity contributed by the shield. Also the coil capacity alone becomes known. Therefore with shield off add the coil capacity to the calibrated condenser capacity, and compute the inductance from a known frequency setting. Now add the sum of the coil and shield capacities and repeat the inductance computation and the effect of the shield on inductance is represented by the difference between these two values. The shield will increase the capacity and reduce the inductance.

\* \* \*

### Polarity of Coil Connections

**D**OES it make any difference which way a two winding radio frequency transformer is connected? For instance, suppose that the coil consists of two windings, a primary and a secondary, beside each other, small separation between. Suppose one outside extreme of the primary is connected to plate, other primary terminal to B plus, then the secondary terminal adjoining primary's B plus goes to grid and the other secondary terminal to grid return. Now suppose that either or both of the coils are connected the opposite way, that is, the lead that went to plate now goes to B plus, that which went to grid now goes to grid return, etc. Has this anything to do with gain and oscillation?—W.D.C.

In general, it makes small difference which way the connection is made, but it is advisable to have all the coils connecting amplifiers and detectors connected in the same manner. Assuming the same direction of the winding, and

the terminals as given by you, it is usual to connect secondary terminal equivalent to top of the winding to grid, bottom of this winding to grid return, top of primary to B plus and bottom of primary to plate. There is smaller capacity coupling this way, and theoretically less danger of feedback, although when there is unwanted oscillation the reversal you mention does not produce enough of an effect to constitute a cure. In an oscillator, however, the connection should be in a given way, and it happens to be the same as the direction for polarities just laid down for the r. f. coils. Considering unidirectional wound coils from top to bottom, the same relative terminals go to opposite r. f. potentials, because the tube to which the windings are connected reverses the phase just about 180 degrees, and the reversal of phase due to the oppositely polarized connections outlined puts the grid and plate currents in phase and thus supports oscillation. Even the wrong polarities may result in oscillation at the higher frequencies of tuning, considering any band, particularly the broadcast band and higher frequencies, due to sufficient feedback through the capacity between the windings. This capacity may in certain instances be large, of the order of 15 mmfd.

\* \* \*

### Rule for Parallel Resistors

**W**ILL you please give me a simplified form of finding the net resistance when two or more resistances are connected in parallel?—I. R. J.

For the case of two resistors in parallel, if they are equal, the effective resistance is half that of either. For any number of equal resistors in parallel, the effective resistance is equal to the resistance of any one divided by the number of resistors. Of course it seldom happens that equal resistors are used. For two resistors of unequal value in parallel divide the product of the two resistors by their sum.

$$R_2 \times R_1$$

Thus  $R_x = \frac{R_2 \times R_1}{R_2 + R_1}$ . If there are three un-

equal resistors, then the effective resistance of any two may be obtained as just described, the effective value then may be treated as one resistance, and the next resistor as the other. For instance, if there are two resistors of 1,800 ohms and 900 ohms in parallel the effective resistance

$$1,620,000$$

is  $\frac{1,620,000}{2,700}$  or 600 ohms. If there are three

$$2,700$$

resistances in parallel, of 1,800, 900 and 400 ohms, then the first two may be reduced to one effective, as above, equalling 600 ohms, and the solution applied to 600 and 400 ohms, the answer being 240 ohms. The same system may be used for more than three resistors. Thus, for four, take a pair, reduce to effective value, then other pair and solve for the two semi-final effectives. Always the resultant resistance is smaller than any one of the parallel resistors alone. The current divides through individual parallel resistors inversely as the resistance, i. e., higher resistance, less current.

(Continued on next page)



As shield is removed distributed capacity rises, inductance drops.

(Continued from preceding page)

### Coils for T.R.F. Set

**I**N a tuned radio frequency set I desire to build, kindly let me know whether the high impedance primary types, having large inductance honeycomb coil noninductively coupled, with a few turns therefrom for capacity coupling around the secondary, would be preferable to the usual type with 25 turn primary next or over secondary.—P. O. L.

The high gain coils with the honeycomb primaries are inadequate for any selectivity requirements, although providing tremendous gain. What you probably need is selectivity, therefore the more usual coil, as you mention, is the preferable one. There is often trouble from crossmodulation and intermodulation, using the high gain primaries, and such coils are found mainly in midget sets of the t.r.f. type, for use in country districts, or anywhere else where there are no strong stations nearer than 50 miles.

Layout for short wave experimental work, using a 6L7 and a 6C5, as shown, or other metal tubes may be substituted by changing the socket wiring. Rectifier tube would be behind the lower transformer.

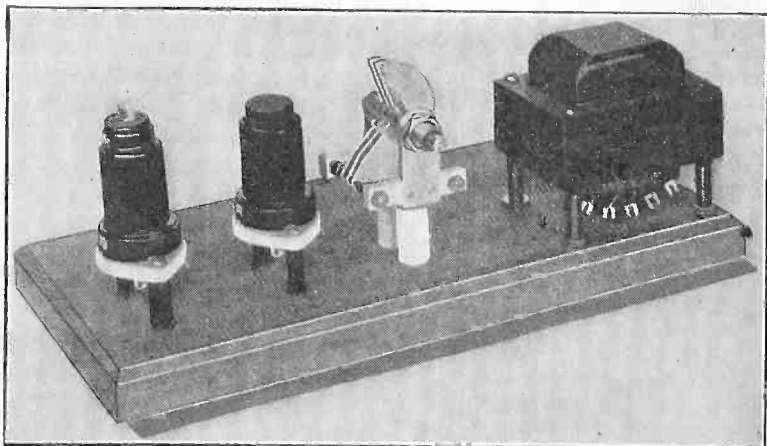

### Short Wave Layout

**G**IVE me a simple breadboard layout for some short wave experiments in an a.c. circuit, using the 6C5 and the 6L7.—P.E.

The layout is shown, rectifier tube omitted, but it would be behind the power transformer. The dial may be attached to the National Company tuning condenser and held down at the front elevation of the breadboard. It is well to use high insulation sockets to prevent excess leakage.

\* \* \*

### Signal Generator Responses

**I**N a signal generator that I built I find that there is a response from a generator fundamental compared to equal frequency station tuned in on a set, and again other responses, set left as it is, generator turned to higher frequencies of the band. Let me illustrate. WOR is tuned in at 710 kc on the receiver, and the generator is turned to 710 kc, producing a beat. Then the dial of the set is turned and there is a response around 1,400 kc, audible due to modulation in the generator, and another around 1,500 kc. Please explain why this is, also state remedy.—L. C.

The fundamental of the generator beating with the station of equal frequency is of course well understood. The receiver being left intact, the generator is turned to around 1,400 kc. There is a beat with the 710 kc station. The generator is really at 1,420 kc, which is the second harmonic of 710 kc. This second harmonic content in the detector of the receiver is fairly large, because the detector is not of the linear type or is overloaded. For response to result the input to the set must be strong from the station, and from the generator at twice the receiver frequency. Usually nothing would be heard if the generator were turned to a frequency equal to the third harmonic of the station frequency, in this instance 2,130 kc, because the third harmonic content in the receiver's detector is very small compared to the second harmonic. The receiver is not very selective, or not completely shielded, hence some energy from another station gets into the de-

detector when the receiver is tuned to 710 kc. In your instance this other station is evidently 760 kc (WJZ) and the response that results when generator is read at around 1,500 is due actually to generator's 1,520 kc beating with WJZ's second harmonic produced in the set ( $760 \times 2 = 1,520$ ). There is a great deal of unjust criticism of stations, that they send out second harmonics, but in practically every instance it is the receiver, not the station, that produces the harmonics, and it is actually against the law for the station to send out a second harmonic of more than a very feeble amplitude when measured not far from the station, so always suspect the set, since the stations are obliged to obey the law and the sets are not. Use looser coupling between generator and set, say smaller output condenser, and the trouble will disappear.

\* \* \*

### Capacities Considered

**C**ONSIDERING the up-to-date coil switches, what would be a fair estimate of the capacity of the switch?—L. W.

The switch capacity for the skeleton type switches now so popular may be neglected, it is so small.

## LITERATURE WANTED

Readers whose names and addresses are printed herewith desire trade literature on parts and apparatus for use in radio construction. Readers desiring their names and addresses listed should send their request on postcard or in letter to Literature Editor, Radio World, 145 West Forty-fifth Street, New York, N. Y.

Reid Radio Shop, James B. Reid, Box 294, Houston, Mississippi.

Fred Shanley, 3055 Gough St., San Francisco, Calif. —parts and apparatus for use in radio construction.

J. Th. Deitert, 298 High St., Webster, Mass.

F. M. Scott, 1418 E. 10th St., Long Beach, Calif.

W. T. Smith, 172 Lawn Ave., Stamford, Conn.

J. Davis, 740 Mechanic St., Jeffersonville, Ind.

E. A. Juselius, 3049 Crescent St., Astoria, L. I., N. Y.

Irving Londa, 366 Hunterdon St., Newark, N. J.

William Sauer, Herr Court R. R. No. 3, Benton Harbor, Mich.

C. M. Wadman, 953 Mass Ave., Cambridge, Mass.

Carl J. Willhide, E. E., Huntingdon, Penna.

Peter N. Kramer, 22A Zengele Ave., Aurora, Ill.

Dr. G. F. Rogers, 1612 West 30th St., Los Angeles, Calif. Literature and prices on wire coil testing apparatus, etc., especially desired.

Laxmidas & Dvarkadas, 466 Sandhurst Road, Bombay 4, India, require information from makers of radios and components, mostly 240-250 volts in 50 cycles AC as well as DC current, with special insulated and impregnated parts to withstand tropical conditions.

W. E. Hodver, New Castle, Indiana.

Peter N. Kramer, 224 Zengle Ave., Aurora, Ill.

Robert C. Travis, 408 N. Dean St., Bay City, Mich.

Albert E. Walters, c/o Morley Weaver, R.R. No. 1, Glanford Station, Ontario, Canada.

Frank E. Goss (on parts and apparatus), 7420 Indiana Ave., Chicago, Ill.

Harry Beigar, 78 Florence Ave., Brooklyn, N. Y.

Sr. D. Jose Riera (sets, parts, etc.), Borrell, 162, Barcelona, Spain.

S. Ziller, 978 Union Ave., New York, N. Y.

O. W. Bussert, Refrigerating Engineer, Box 437, R. 3, Tulsa, Okla.

Ralph Minock, "Radio Service," 203 High Ave., S.W., Canton, Ohio.

Saul Schaffer, 404 East 78th Street, New York City. (Diagrams on radios from 1 to 10 tubes. Also diagrams on television Transmitters and Receivers).

Raymond G. Tessmer, 599 Ward Road, North Tonawanda, N. Y.

W. Cox, 3925 S. Washington St., Marion, Ind.

C. B. Rainbolt, 3925 S. Washington St., Marion, Ind.

Archie Bernstein, 1461 Long Ave., Hillside, N. J.

Ernest Morlock, 16 Franklin Street, Franklinville, N. Y.

Henry Jackson, Route 4, Box 475-A, Bessemer, Ala.

V. F. Daidone, 212-214 Fairmount Ave., Newark, N. J.

A. H. Nutkis, 1219 - 45th St., Brooklyn, N. Y.

Roy Brown, Madison, Ga.

A. E. Kuehn, Carrington, N. Dak.

C. L. Johnson, 1975 Navarro Ave., Pasadena, Calif.

Joe A. Krajcovic, Empire, Ohio.

Hosea E. Decker, 376 N. Sandusky St., Delaware, Ohio.

Jim English, 4207 N. Jefferson, Spokane, Wash.

Carl Chase, Burrton, Kans.

John Rau, 1460 W. 54th St., Cleveland, Ohio.

Henry Pardon, 111 W. 3rd St., Owensboro, Ky.

Smallwood Electric Co., 517 Minnesota Ave., Kansas City, Kans.

L. Clifford Praeger, 216 E. Hoffman St., Baltimore, Md.

Harold F. Beck, Butler, Ohio.

Paul Lawrence, R. No. 1, Swannanoa, N. C.

A. Zeitzer, 200 E. 3rd St., Brooklyn, N. Y.

Sam Samuels, 4031 - 48th St., Sunnyside, L. I., N. Y.

Kelley Radio Service, 36 California Ave., Hempstead, L. I., N. Y.

The ONLY TWO Companion Devices for Reducing Noise on ALL Waves

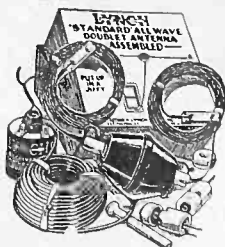

### LYNCH HI-FI Assembled Antenna

All ready to hang. Saves 90% of installation time. Any novice can install it—quickly, easily, correctly. Makes every set perform better. Results are amazing.

LYNCH HI-FI ASSEMBLED ANTENNA **\$6.75** list

## NOISE REDUCING TWINS

### LYNCH FILTERADIO

Cuts out objectionable noise from the light line. Makes interference from circuit breakers, motor generators, etc., practically negligible. Easy to install; simple to adjust. One type serves all purposes. **\$5.00** list

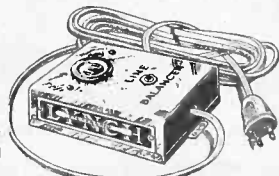

Be sure and see these NOISE-REDUCING TWINS at your jobber's or dealer's. If they cannot supply you, order direct. Write for folder.

ARTHUR H. LYNCH, Inc., 227 Fulton St., New York  
Pioneer of Noise-Reducing Aerials

## METAL CHASSIS

We can supply chassis for any make receiver, experimental or otherwise.

Inquiries should be accompanied with sketch and complete details enabling us to give quick service as to prices and delivery.

KORROL MFG. CO., Inc. Dept. R.W.-236  
232 GREENWICH ST. NE WYORK CITY

## A COMBINATION OFFER! RADIO WORLD and "RADIO NEWS"

# \$3.50

Canadian and Foreign, \$1.50 extra on this offer.

You can obtain the two leading radio technical magazines that cater to experimenters, service men and students, for one year each, at a saving of \$1.50. The regular mail subscription rate for RADIO WORLD for one year is \$2.50. Send in \$1.00 extra, get "Radio News" also for a year—a new issue each month for twelve months. Total 24 issues for \$3.50.

RADIO WORLD, 145 West 45th Street, N. Y. City

## "THE MUSIC GOES 'ROUND and AROUND."

The smash sheet music hit of the year.  
Postpaid ..... .40  
Also "The Broken Record." Postpaid..... .40  
Also "Boots and Saddle." Postpaid..... .40

RADIO WORLD, Dept. A.  
145 West 45th Street New York City

# The New ROYAL PR-SIX METAL TUBE COMMUNICATIONS RECEIVER

REASONABLY  
PRICED

YET IT HAS  
EVERYTHING  
YOU COULD WANT  
IN A MODERN  
COMMUNICATION  
TYPE RECEIVER!!

✓ CHECK THESE  
FEATURES

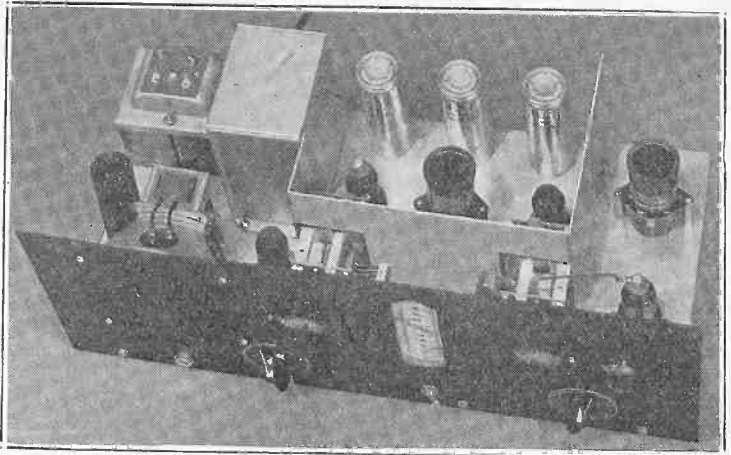

- > SIX ALL METAL TUBES
  - 6K7 Tuned Screen-grid RF
  - 6C5 Regenerator
  - 6K7 Tuned Detector
  - 6C5 High Gain Audio
  - 6F6 Power Pentode Output
  - 5Z4 Rectifier
- > Real Continuous Bandspread
- > Isolated Regenerator Tube
- > FIVE Tuning Sections
- > 480 Kc to 31 Mc. Full Range (625 to 9¾ Meters)
- > Self-contained Humless Power Supply
- > Positive Triple Shielding
- > Works on 115 to 240 Volts, 25 to 133 Cycle AC Current
- > Sturdy Battleship Construction
- > Phone Jack on Front Panel with Automatic Speaker Cutoff
- > Smart Professional Appearance
- > Unconditional Guarantee
- > FREE FIVE DAY TRIAL

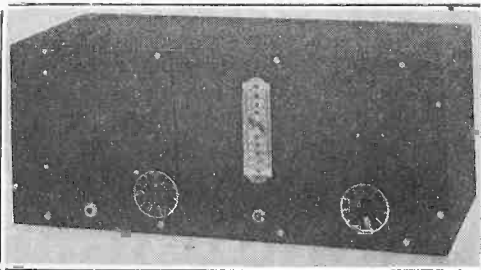

Utilizing to the fullest extent the tremendous advantages of the new All METAL Tubes—using a sensational new circuit—and incorporating scores of remarkable features—the NEW 1936 “ROYAL PROFESSIONAL RECEIVER SIX” definitely outstrips all other receivers in performance, dependability, and downright honest value!

Check over the features, one by one. Each is a definite step toward the ultimate in radio reception! Many are exclusive with ROYAL. No other set offers them all!

Continuous Bandspread that is really b-a-n-d-s-p-r-e-a-d! Not just a trick dial pointer. Selectivity that only a tuned radio frequency stage can give. Sensitivity that only a tuned detector, freed from the restrictions of self-regeneration and operating under optimum conditions, can produce. Smoothness of control obtained only by the use of a separate regenerator tube. Power that comes from SIX full sized metal tubes, operating at high voltage. Quietness that metal tubes, positive shielding, massive power filter, and low background noise, alone can give. Added to this is the highest quality of workmanship and the genius of engineering design that is synonymous with the name of ROYAL—

THIS IS THE “PR-SIX”—for Amateur or Short Wave Fan—“Oldtimer” or Beginner!

#### CONVINCE YOURSELF!

So confident are we that the “PR-SIX” will win your enthusiastic approval that we have arranged a FREE TRIAL OFFER. Order a Royal “PR-SIX.” Tune in foreign stations—try it in the crowded Ham bands—listen to its full rich tone—turn up the volume and feel its dynamic power—in fact, give it every conceivable test to satisfy yourself that here is the finest in radio! Really remarkable value! Try it for five days. If, for any reason, you are not entirely satisfied—do not hesitate to ship the set back to us! We don’t want you to keep it! We will immediately return your full purchase price without any deduction what-so-ever. FAIR ENOUGH?

ORDER TODAY!—You’ll never regret it!

#### Complete “PR-SIX” Receiver

with tubes, cabinet, and all twelve coils. NOTHING ELSE TO BUY!  
Ready to plug in and operate.....

**\$31.45**

ON DEMONSTRATION! At our new large store—the ROYAL PR-SIX, as well as the Super Skyrider, FB-7A, Hammarlund Comet “PRO,” RME-69, Patterson PR 16, and many other new Amateur Communications receivers. TIME PAYMENTS arranged. \$5.00 down payment. Come in for details.

VISIT THE NEW HARRISON HAM HEADQUARTERS!

Complete stock of all Amateur Apparatus and Short Wave Supplies—Lowest wholesale prices.

## HARRISON RADIO COMPANY

12 WEST BROADWAY

Dept. RW-2

NEW YORK CITY

Between Barclay and Vesey Streets

Telephone WOrth 2-6180



## QUICK-ACTION CLASSIFIED ADVERTISEMENTS

7 cents a word. \$1.00 minimum.

### ELECTRICAL AND RADIO SUPPLIES

**SMALL POCKET RADIO**, complete; nothing more to buy, \$1.99. Dixie Radio, Box 21, Topeka, Kansas.

**POSITIVE NOISE REDUCTION—SIMPLE**. Tested booklet with complete drawings, 25c. Alworth, 757 Ferkle Marion, Ohio.

**WILLCOX AUTO ELECTRICIAN'S WIRING MANUAL**—Complete wiring diagrams for all U. S. cars made in 1928-1929-1930-1931-1932. Complete data on ignition systems, generators, starting motors, batteries and lighting. Printed on tough, wear-resisting paper that can be washed with gasoline without injury to print or paper. Loose-leaf style in sturdy covers. Size 11 x 12". 10 wiring diagrams. Price \$10.00. RADIO WORLD, 145 W. 45th St., New York City.

**MAKE** Batteryless pocket radios. Full instructions with 24-page illustrated radio beginners handbook catalog. 10c. Melomite, Dept. EP, Fairmount, Kansas City, Mo.

**WINDING** Data, 100 AC motors, various horsepower and voltage, \$1.00. Motor Data Co., 3002 Monroe, Kansas City, Mo.

**WESTINGHOUSE** Power generators. Output 200 watts, 110 volts a.c., \$8.00 each. National Electric Tool Co., 560 Washington, Chicago.

**EXTREMELY** Simple wind charger governors, blueprints, 25c. Propellers, \$2.45 postpaid. Emil Magnuson, Backoo, N. Dak.

**ELECTRIC** Drills. Brand new, \$5.95 up. Descriptions sent. Shaw, 31-A Winchester St., Boston, Mass.

**ELECTRIC** Tube plates with attachment for rubber valve stems, \$5.95. Haywood Company, 709 So. Kolmar Avenue, Chicago, Ill.

**RADIO WORLD AND POPULAR MECHANICS MAGAZINE**—Radio World is \$2.50 a year, and Popular Mechanics Magazine is \$2.50 a year. Popular Mechanics Magazine does not cut rates, but Radio World will send both publications to you for one year for \$3.75. RADIO WORLD, 145 West 45th Street, New York City.

**LAMINATIONS**—for experimental power transformers of all types ten cents a pound minimum order one dollar. We also make one year guaranteed duplicates of any audio or field if you send us the bad one.

**RUSSELL LABORATORIES, PORT ARTHUR, TEXAS**

**TWENTY** practical and low cost changes converting old generators into new generators and motors 100-500 watt capacity, d.c. or a.c. current, with 6 to 400 volts, for radio operation, power, light, or welding. Also instructions for rewinding armatures. 350 definitions of electrical terms, etc. All in new, revised book with simplified instructions. Endorsed by thousands. Only \$1.00 postpaid. Autopower, 414-A S. Hoyne Ave., Chicago.

**GOOD** Acetylene welding generators cheap. Use any torch. Do any job. Minor Portable Generator Company, Brookfield, Missouri.

**NEW** Farm radio—\$7.95. No-cost sample. J-20th Century Co., Kansas City, Mo.

**ENTIRELY** New million point supersensitive DX radio crystal. Full instructions for set included. 50c postpaid. Radio Supply Co., Edmonton, Alberta.

### MANUALS AND BLUEPRINTS

**MAKE** Your own blueprints! Inexpensive, simple, quick process. Homemade equipment. Guaranteed instructions \$1.00. Allen Blueprinting Co., Perryton, Texas. Established 20 years.

**LEARN** Diesel engineering. Rapidly expanding field. Good pay for Diesel-trained men for next 25 years. Home training possible. Get latest and right up-to-date Diesel Handbook. Authentic, \$5.00 postpaid. Popular Mechanics Press, Room C35, 200 E. Ontario St., Chicago.

### WOODCRAFT

**WOOD** Turning on the lathe. Interesting and fascinating. Send for Milton & Wohlers Course in wood turning. It gives you quickly a complete mastery of this manual art. 200 pages. Cloth. 141 plates. \$1.50 postpaid. Popular Mechanics Press, Room C35, 200 E. Ontario St., Chicago.

**BUILD** a power saber saw for less than \$2.00. Does work of jig saw. No arm to limit diameter of work. Saws up to one inch lumber. Complete instructions and drawings. 50c. Western Shops, Box 475, Chickasha, Okla.

### MUSICAL INSTRUMENTS

**EARN** Your own musical instrument. Get free details and free attractive savings bank at your music store or write Fred Gretsch Mfg. Co., 521 So. Wabash, Chicago.

**USED**—Rebuilt nationally known instruments. Bargain prices. Supply limited. Write at once for information. Tom Brown Music Company, 315 South Wabash, Chicago.

### PATENTS

**PATENTS**. Instruction "How to Establish Your Rights" and form, "Evidence of Conception"—sent Free! Lancaster, Allwine & Rommel, 414 Bowen Building, Washington, D. C.

### MISCELLANEOUS

**AUTHORS** invited forward MSS of all descriptions for publication. Fiction specially required. £50 for Poems; particulars free. Stockwell, Ltd., 29, Ludgate Hill, London, England.

**200 NEW AND UNUSUAL MONEY-MAKING IDEAS**; many from Government records. 35c (stamps accepted). Enterprise Bureau, Syracuse, N. Y.

**PARACHUTES, NAVY SURPLUS**, 18 ft. white silk, like new; have many uses, \$4. each, prepaid and insured. Remit with P.M.O. No stamps, no C.O.D.'s Supply limited. Thompson Bros. Balloon & Parachute Co, Aurora, Ill.

## COIL KIT

for 5-tube metal tube A.C.-D.C. Superhet consisting of Antenna Coil, Osc Coil and 2 high gain Litz D.T.I., 456 K.C. Special \$2.75 postpaid. Coils for all radio circuits and a complete supply of radio parts.

## RADIO DESIGN CO.

1353 STERLING PLACE  
BROOKLYN, N. Y.

# VERY LATEST RADIO BOOKS

## A Complete Course in Itself

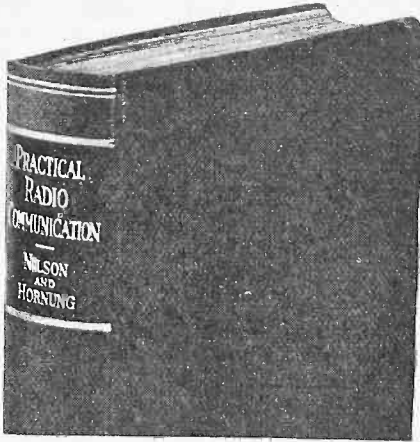

**M**OST up to date of all the comprehensive books on radio theory and practice, "Practical Radio Communication," just published, is the work of Nilson and Hornung, and as its name implies, it stresses the practical side. Moreover, although a certain amount of mathematics is necessary for any complete and authoritative treatment of the subject, the authors have simplified this very considerably, and offer a treatment that makes no sacrifices yet establishes full revelation. All the latest types of receivers, transmitters and oscillators are set forth, with no neglect either of the traditional information that is still the backbone of any radio discourse. This book is outstanding, and it constitutes a complete, practical course in radio, requiring only the barest minimum of knowledge on the part of the reader. This attitude of taking practically nothing for granted lends to the new volume a tone of detail and completeness that few other radio books possess. 745 pages 6 x 9, 435 illustrations. flexible cover. Price, \$5.00 postpaid.

## RIDER'S CATHODE RAY BOOK

**T**HE first book dealing with the commercial cathode ray tube as used in testing, lining up, constructing and servicing receivers and ham transmitters is now ready, John F. Rider's "The Cathode Ray Tube at Work." Everybody realizes that the cathode ray tube in this use is outstanding, and every service man and experimenter knows he must have such a testing device some day, if he hasn't one now, so the groundwork for proper use should be laid, and Rider's book reveals all that you need to do, and reveals it expertly and clearly. For many the cathode ray tube has mysteries, but these Rider dispels, one by one. 320 pages, 6 x 9. Price, \$2.50, postpaid.

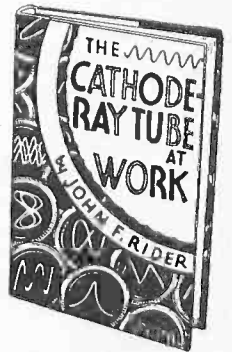

## INDUSTRIAL ELECTRONICS

by **F. H. Gulliksen and E. H. Vedder**  
Both *Electronic Development, Design and Application Engineers, Westinghouse Manufacturing Co.*



This new book covers most of the important types of industrial applications in which electronic devices are now being used and shows how this apparatus may be useful to them. The book is based on the authors' first-hand experience in the design, installation and servicing of electronic equipment since industrial electronics became active.

245 pages 6 x 9 \$3.50  
Postpaid

## MODERN RADIO SERVICING

(2nd Revised and Greatly Enlarged Edition of Radio Servicing Course)

by **ALFRED A. GHIRARDI**

**JUST RELEASED.** The greatest text ever published on Radio Servicing. 1300 pages, 700 illustrations, hundreds of practical facts on the most up-to-date methods, construction and operation of all kinds of equipment; servicing of all forms of receivers; auto radio, all wave, high fidelity; locating and eliminating noise and interference; special servicing problems; construction and use of new Cathode-Ray Oscillographs for aligning superhets.

Written in clear, simple style.  
Price, \$4.00, Postpaid



## RADIO FIELD SERVICE DATA AND ANSWER BOOK

(Supplement to "Modern Radio Servicing")  
by **A. A. GHIRARDI and B. M. FREED**

A handy time-saving reference data book, 240 pages, 41 illustrations, for service men to keep in their tool kits. Data for use on the job, such as listing of intermediate frequencies of over 3000 models of superhets; comprehensive Trouble Shooting compilation of Symptoms and Remedies for troubles in over 750 models of broadcast and all-wave receivers; remedies for ignition interference in various makes of cars (with electrical diagrams of all cars); complete tube charts; wire tables; RMA Color Codes; and a comprehensive collection of other useful charts, diagrams and tables. Price, \$1.50  
**SPECIAL OFFER:** Supplement Book in combination with **MODERN RADIO SERVICING**, \$5

Book Department

**RADIO WORLD**

145 WEST 45th STREET  
NEW YORK, N. Y.



# UNIVERSAL

## 5-METER HAND SET

A new, 15-ounce, compact hand set—Designed for 5-meter transmitters and 5-meter receivers—Highly polished, moulded bakelite units—2000 ohm uni-polar receivers—High output, single-button Universal microphone of 200 ohms—6-ft. 4-conductor cord with color-coded phone tips—List Price, Single-Button microphone, \$8.00.

UNIVERSAL MICROPHONE CO., Ltd.  
424 Warren Lane Inglewood, Calif., U. S. A.

# HIT AS A MONTHLY

## SPECIAL 2-FOR-1 OFFER

### RADIO WORLD

The How-To-Make-It Magazine.

In Its New Monthly Form.

Radio World is \$2.50 a year (12 issues), 25c per copy. Canada and foreign, \$3.00 yearly. Offers of Radio World and other worthwhile publications for the full year on each, (NET):

- RADIO WORLD and SHORT-WAVE CRAFT, \$3.50.
- RADIO WORLD and POPULAR SCIENCE MONTHLY, \$3.50.
- RADIO WORLD and RADIO-CRAFT (12 issues) \$3.50.
- RADIO WORLD and RADIO INDEX (monthly, 10 issues) stations, programs, etc., \$3.50.
- RADIO WORLD and SERVICE (monthly) \$3.50.
- RADIO WORLD and EVERYDAY SCIENCE AND MECHANICS (monthly) \$3.50.
- RADIO WORLD and BOYS' LIFE (monthly, 12 issues) \$3.50.
- RADIO WORLD and MOTION PICTURE MAGAZINE (monthly) \$3.50.
- RADIO WORLD and MOVIE CLASSIC (monthly) \$3.50.
- RADIO WORLD and PICTORIAL REVIEW (monthly) \$3.00.
- RADIO WORLD and SCREENLAND (monthly) \$3.50.
- RADIO WORLD and TRUE STORY (monthly) \$3.00.
- RADIO WORLD and LIBERTY (weekly) \$3.00 U. S. only.

Select any one of these magazines and get for an entire year by sending in a year's subscription for RADIO WORLD at the regular price, \$2.50, plus a small additional amount, per quotations above. (Add \$1.50 for extra foreign or Canadian postage for both publications.)

Name .....

Address .....

City and State.....

- If renewing an existing or expiring subscription for RADIO WORLD, put cross in square.
- If renewing an existing or expiring subscription for other magazines, put cross in square.

Special Trial Offer for Radio World only: \$1.00 for 5 months, postpaid. Mail order with remittance to Radio World Office. NET.

RADIO WORLD, 145 W. 45th St., New York

# NEW! H. G. CISIN'S Metal Tube ALL ELECTRIC AIR SCOUT

Only Set of Its Kind in the World  
Pat. Pending U. S. Serial No. 592,586. Operates on A. C. or D. C. Self-Contained Power Supply.

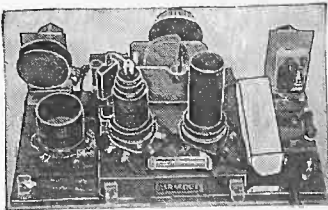

Rear view showing New Metal Tubes

**GREATER SENSITIVITY.** Four plug-in coils cover 10 to 200 meters. Extra coils for Broadcast Reception, also Special long wave unit. Operates several headsets simultaneously. Speaker on strong stations.

Complete, Assembled Kit, with instructions and picture diagram, and all four short wave coils, ready to \$3.95  
wire .....

Set of Matched Metal Tubes .....\$2.50  
Special Long Wave Unit w. Coil, 550 to 1500 meters ..... .95  
Broadcast Coils (Two) .. 1.45

Earphone (single)..... .50  
Total .....\$9.35

**SPECIAL COMBINATION OFFER**—Assembled Kit, metal tubes, 7 coils, including Long Wave Unit, \$8.40

earphone ..... Above: Custom-Built, wired and laboratory tested, ready to use, \$1.00 extra.

10c to cover printing, etc., brings copy of new booklet, "SHORT WAVE TRAVEL TIPS," including valuable world short wave log and all-wave data! Order at Once!

**H. G. CISIN** Chief Engineer Allied Engineering Institute  
98 Park Place, Dept. 2C, New York, N. Y.

## Radio World Advertising Rates

### GENERAL ADVERTISING

	1 time	12 times
Full Page—5 1/8 x 8" .....	\$75.00	\$60.00
1/2 Page—5 1/8 x 4" or 2 1/2 x 8" .....	37.50	30.00
1/4 Page—2 1/2 x 4" .....	18.75	15.00
1/8 Page—2 1/2 x 2" .....	9.38	7.50
One inch, single column....	5.00	4.00
Agate line .....	.38	.34
Classified—7c. per word, minimum	\$1.00.	

### Color Pages (2 colors):

Inside front cover.....	\$90.00
Inside rear cover.....	90.00
Back cover .....	90.00

## A Birthday Gift for HIM

Is your husband, son or nephew interested in radio? Why not send him RADIO WORLD for the coming year? We will send him, at your request, a letter so that he will receive it the day before his birthday telling him of your generosity and thoughtfulness. For \$2.50 a year in the United States he will be reminded of your unselfishness every time the magazine arrives.

# Coil Winding Made Easy

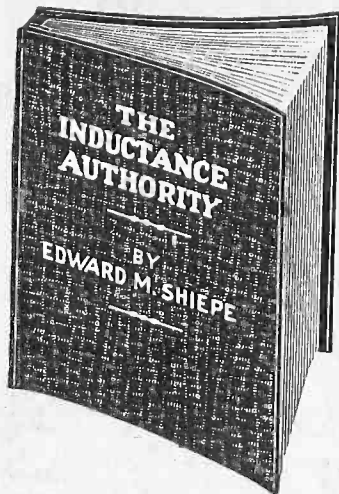

The biggest help anyone can get who desires to wind radio-frequency coils for any frequency from just below the audio range to the fringe of ultra frequencies is to have a book that tells just what inductance is required for the condenser one possesses, and just how many turns of any kind of wire on any sensible diameter are needed to produce that inductance. "The Inductance Authority," by Edward M. Shiepe, gives you all that information, to an accuracy of 0.1 per cent. Send \$2.00 and book will be mailed you postpaid; or send \$5.00 for a two-year subscription for Radio World and this valuable book will be sent free.

RADIO WORLD

145 WEST 45TH STREET, NEW YORK CITY

## All Circuits We Print Can Be Readily Duplicated

ALL parts for circuits described in RADIO WORLD constructionally are obtainable. Most of them stocked by regular supply sources. We are always glad to identify the trade names of any parts, and tell where any parts are stocked. Address questions to Trade Editor, RADIO WORLD, 145 West Forty-fifth Street, New York.

WHEN WRITING TO ADVERTISERS  
PLEASE MENTION THAT YOU SAW THE  
ADVERTISEMENT IN RADIO WORLD.

## You need these 2 books MATHEMATICS of Radio Servicing

Introduces and explains the use of arithmetic and elementary algebra in connection with units, color code, meter scales, Ohm's Law, alternating currents, ohmmeter testing, wattage rating, series and parallel connections, capacity, inductance, mixed circuits, vacuum tubes, curves, the decibel, etc., etc., and has numerous examples.

Plainly written and easy to understand. Only useful data included. M. N. Beitman, author. Size, 8½ x 11 in.

## PRINCIPLES of PUBLIC ADDRESS SYSTEMS

A practical handbook, full of useful information, fully illustrated, written by M. N. Beitman, an engineer and noted authority on audio amplifiers.

Considers in detail various microphones, radio and phonograph inputs, acoustic feedback, mixing and volume controls, use of vacuum tubes, interstage coupling, power amplifiers, output coupling, loud speaker placement, the decibel, P.A. measurements, power level, and other points of importance, including actual circuit diagrams of tested P.A. systems.

Price, 50c each book.

**SUPREME PUBLICATIONS**

3727 West 13th St.

Chicago, Illinois

## SUBSCRIBE NOW!

RADIO WORLD, 145 West 45th St., New York City. Enclosed please find my remittance for subscription for RADIO WORLD, one copy each month for specified period.

- Two years, 24 issues, \$4.50.
- One year, 12 issues, \$2.50.
- Trial sub., 5 issues, \$1.00.  
(50c extra per year for Canadian and foreign postage.)

- This is a renewal of an existing mail subscription (Check off if true).

Name .....

Address .....

City .....



® National offers a thoroughly engineered part for nearly every radio purpose. The entire line cannot be compressed into our twenty-page catalogue, much less a single page. But look over the group above. Transmitting condensers from the little 1000 volt TMS in the foreground to the 12,000 volt TMA at the rear. Low loss ceramic coil forms for every amateur band. Low loss sockets for nearly every tube type, from acorns to power pentodes. Flexible couplings from the little TX-12, which will work around a corner, to the big fellows for heavy condensers, high voltages, and low-losses. Strain insulators, spreaders, lead-ins for the antenna; stand-offs, chokes, dials for the rig. National has what it takes.

NATIONAL



COMPANY

# Coil Winding Made Easy

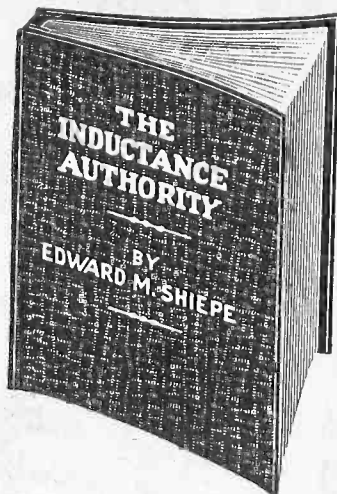

The biggest help anyone can get who desires to wind radio-frequency coils for any frequency from just below the audio range to the fringe of ultra frequencies is to have a book that tells just what inductance is required for the condenser one possesses, and just how many turns of any kind of wire on any sensible diameter are needed to produce that inductance. "The Inductance Authority," by Edward M. Shiepe, gives you all that information, to an accuracy of 0.1 per cent. Send \$2.00 and book will be mailed you postpaid; or send \$5.00 for a two-year subscription for Radio World and this valuable book will be sent free.

RADIO WORLD

145 WEST 45TH STREET, NEW YORK CITY

## All Circuits We Print Can Be Readily Duplicated

ALL parts for circuits described in RADIO WORLD constructionally are obtainable. Most of them stocked by regular supply sources. We are always glad to identify the trade names of any parts, and tell where any parts are stocked. Address questions to Trade Editor, RADIO WORLD, 145 West Forty-fifth Street, New York.

WHEN WRITING TO ADVERTISERS  
PLEASE MENTION THAT YOU SAW THE  
ADVERTISEMENT IN RADIO WORLD.

## You need these 2 books MATHEMATICS of Radio Servicing

Introduces and explains the use of arithmetic and elementary algebra in connection with units, color code, meter scales, Ohm's Law, alternating currents, ohmmeter testing, wattage rating, series and parallel connections, capacity, inductance, mixed circuits, vacuum tubes, curves, the decibel, etc., etc., and has numerous examples.

Plainly written and easy to understand. Only useful data included. M. N. Beitman, author. Size, 8½ x 11 in.

## PRINCIPLES of PUBLIC ADDRESS SYSTEMS

A practical handbook, full of useful information, fully illustrated, written by M. N. Beitman, an engineer and noted authority on audio amplifiers.

Considers in detail various microphones, radio and phonograph inputs, acoustic feedback, mixing and volume controls, use of vacuum tubes, interstage coupling, power amplifiers, output coupling, loud speaker placement, the decibel, P.A. measurements, power level, and other points of importance, including actual circuit diagrams of tested P.A. systems.

Price, 50c each book.

**SUPREME PUBLICATIONS**

3727 West 13th St.

Chicago, Illinois

## SUBSCRIBE NOW!

RADIO WORLD, 145 West 45th St., New York City. Enclosed please find my remittance for subscription for RADIO WORLD, one copy each month for specified period.

- Two years, 24 issues, \$4.50.
- One year, 12 issues, \$2.50.
- Trial sub., 5 issues, \$1.00.  
(50c extra per year for Canadian and foreign postage.)

- This is a renewal of an existing mail subscription (Check off if true).

Name .....

Address .....

City .....

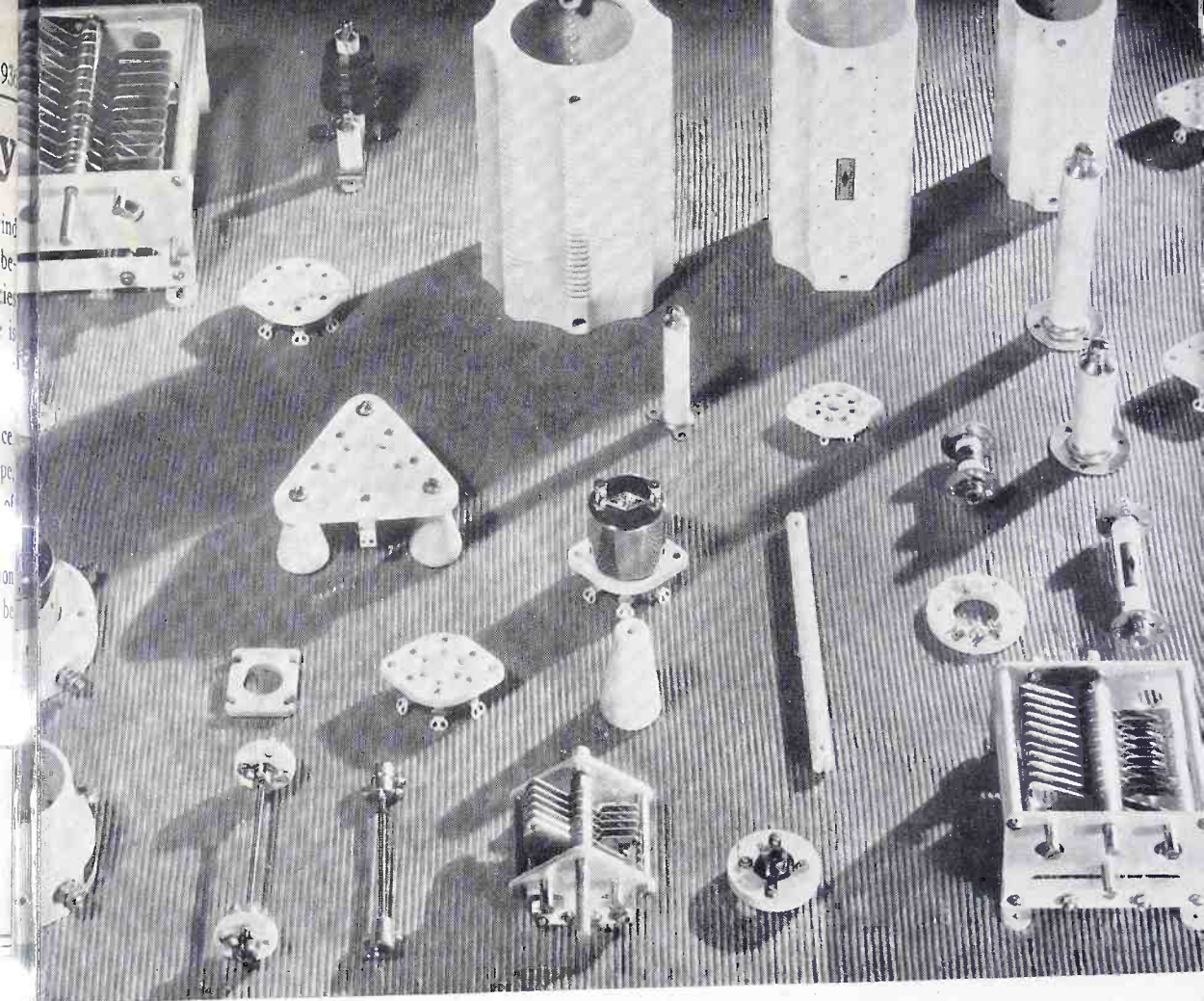

● National offers a thoroughly engineered part for nearly every radio purpose. The entire line cannot be compressed into our twenty-page catalogue, much less a single page. But look over the group above. Transmitting condensers from the little 1000 volt TMS in the foreground to the 12,000 volt TMA at the rear. Low loss ceramic coil forms for every amateur band. Low loss sockets for nearly every tube type, from acorns to power pentodes. Flexible couplings from the little TX-12, which will work around a corner, to the big fellows for heavy condensers, high voltages, and low-losses. Strain insulators, spreaders, lead-ins for the antenna; stand-offs, chokes, dials for the rig. National has what it takes.

NATIONAL



COMPANY

# TRY THIS TESTER AT YOUR JOBBERS



**CHECKS  
ALL PARTS  
OF RADIO  
CIRCUITS  
USING  
GLASS OR  
METAL TUBES**

MODEL 710-A

**DEALERS NET PRICE *Only* \$16.50**

This popular three meter set tester checks all parts of radio tube circuits by plugging directly into the receiving set sockets.

- D.C. Voltmeter Scale 20-60-300-600
- D.C. Milliammeter Scale 15-150
- A.C. Voltmeter Scale 10-140-700

## OTHER READRITE PRODUCTS

Readrite also manufactures all types of testers used for servicing radio sets, including: Set Testers, Tube Testers, Oscillators, Resistance, Continuity and Capacity Testers, Point - to - Point Testers and inexpensive Indicating Meters.

**Model 710-A**, in Black Leatherette Case, complete with all necessary connections. Dealer Net Price,..... **\$16.50**

**Model 712-A**, Same as 710-A but having Tripplett moving coil, Model 223, 2" D.C. Voltmeter. (1,000 ohms per volt). Dealer Net Price ..... **\$22.50**

MAIL THIS COUPON

READRITE METER WORKS  
227 College St., Bluffton, Ohio

Please send me more information on

.....Model 710-A .....Model 712-A

.....New Catalogue

Name .....

Address .....

City..... State.....

**TESTERS AND METERS**