

# RADIO WORLD

REG. U. S. PAT. OFF.

THE HOW-TO-MAKE-IT MONTHLY — 14th Year — 25c Per Copy

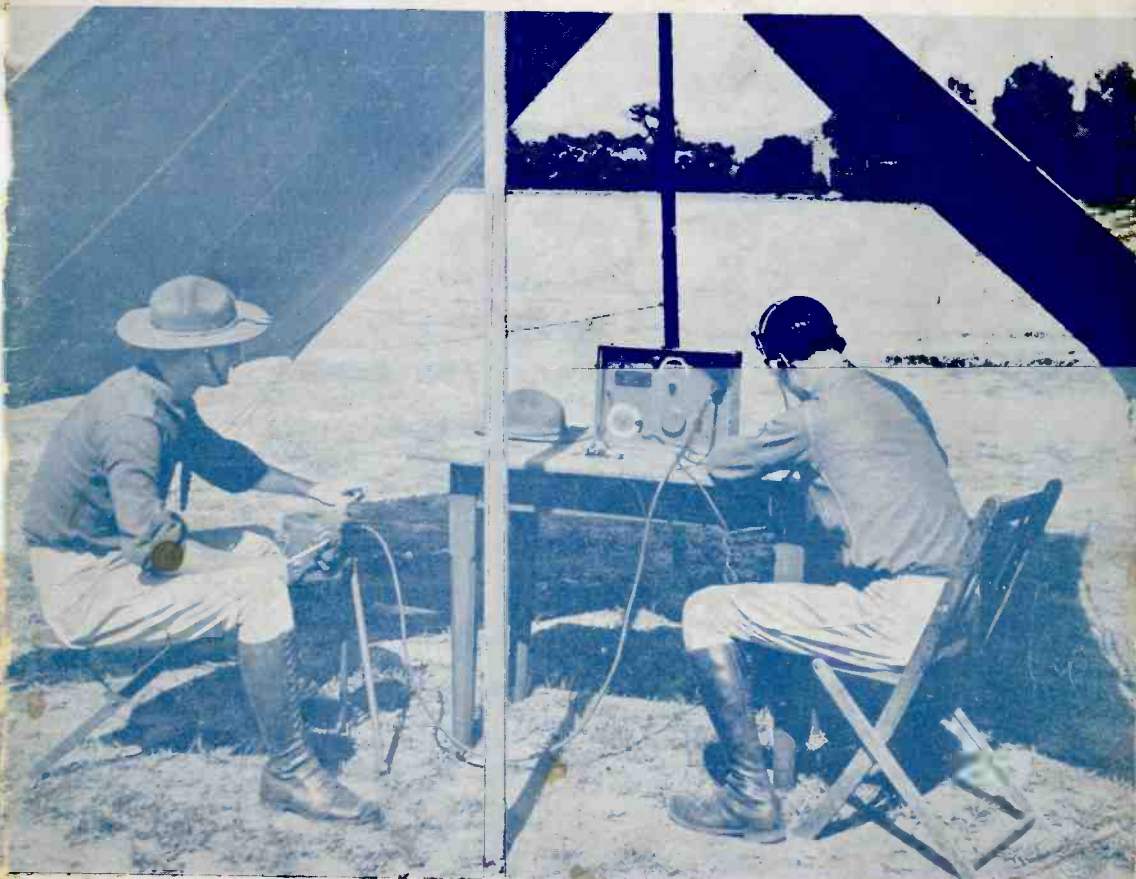

*Publishers' Photo Service, N. Y.*

## SEPT.

1935

Field units carry on communication by radio, for 50 miles or so, using a hand operated generator as voltage supply, and a short wave receiver and transmitter. Aerial can be seen at rear guy pole. Cadets are giving the demonstration at West Point.

# BUILD WITH

## CORNELL-DUBILIER CONDENSERS

Are you building your set with parts that will stand up—  
or are you going to be continuously repairing your set?

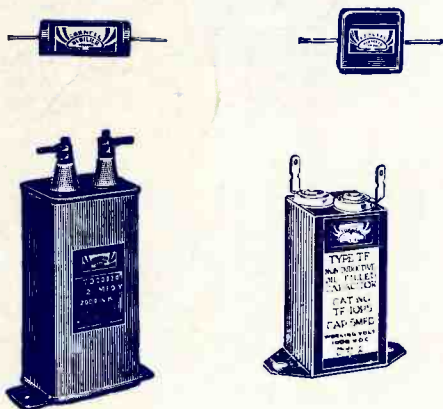

Condensers specified by the United States Navy *must* be good. Uncle Sam doesn't use parts that go blooey at the most unexpected times. That's why C-D DYKANOL, ELECTROLYTIC, PAPER and mica condensers are in most of the specifications of the radio industry.

They are good — because there is a creed of quality behind each condenser, whether it is a ten-cent tubular or a thousand-dollar mica unit. A creed that dates back twenty-five years — that is backed by the greatest engineering skill ever assembled in one organization, devoted exclusively to the manufacture of condensers.

You can't afford to substitute. Cornell-Dubilier *guarantees* you absolute satisfaction.

*Write for your copy of Catalog 128*

THERE IS NO CIRCUIT, THE EFFICIENCY OF WHICH CANNOT BE IMPROVED BY THE USE OF C-D CONDENSERS.

OVER  
ONE BILLION  
CONDENSERS SOLD  
SINCE 1910

# CORNELL-DUBILIER

C O R P O R A T I O N

4343 BRONX BOULEVARD • NEW YORK

# I WILL TRAIN YOU AT HOME IN SPARE TIME FOR A GOOD RADIO JOB!



J. E. SMITH, Pres.,  
National Radio Institute

**HERE'S  
PROOF**

### \$18 a Week in Spare Time

"Although I am doing only spare time Radio work, I have averaged \$18 a week. I recommend N. R. I. training. It is certainly a complete course." STEPHEN J. DRAPCHATY, 407 Wunderlich Ave., Barberton, O.

### Nets about \$50 a Week besides Sales

"I have been getting along fine. I average ten calls a week, which nets me about \$50, not counting profits on sales I have serviced almost every make of set and have earned more than I ever expected." BEITNARD COSTA, 150 Franklin St., Brooklyn, N. Y.

### Get my FREE LESSON on Radio Servicing Tips

I'll prove that my training is practical, money-making information, that it is easy to understand—that it is just what you need to master Radio. My sample lesson text, "Radio Receiving Troubles—the Cause and Remedy" covers a long list of Radio receiver troubles in A. C., D. C., battery, universal, auto, T. R. F., super-heterodyne, all-wave, and other types of sets. And a cross reference system gives you the probable cause and a quick way to locate and remedy these set troubles. A special section is devoted to receiver check-up, alignment, balancing, neutralizing, and testing. Get this lesson Free. No obligation. Just mail coupon.

## FREE BOOK TELLS HOW MAIL COUPON

Act today for better pay. Act today to break away from a low pay, no-future job. Act to get away from having to skimp, scrape to pay your bills. Mail coupon for my free 64-page book. It tells you how I will train you at home in your spare time to be a Radio Expert; about my training that has doubled and tripled the pay of many.

### Many Radio Experts make \$40, \$60, \$75 a Week

Consider these facts—think of the good jobs they stand for. Over 16,000,000 Radio sets in use, over 600 broadcasting stations, over 40 large manufacturers of Radio sets, over 3,000 manufacturers of parts, over 100 Police Departments Radio equipped, airplanes and airports Radio equipped. Thousands of ships touching every seaport of the world, Radio equipped. Over 35,000 stores selling sets and parts, about 2,000,000 autos Radio equipped and about 20,000,000 unequipped. Loud speaker systems wherever people gather, indoors and outdoors. Commercial Radio stations dotting our coast lines. Radio a big industry—is growing bigger fast. A few hundred \$40, \$60, \$75 a week jobs, have grown to thousands.

### Get ready now for Jobs like these

A spare time or full time service shop; installing, maintaining, operating—broadcast, aviation, commercial, ship, television and police stations. A Radio retail business of your own. Installing, maintaining, servicing, loud speaker systems. A service or sales job with a store or jobber. I'll train you for good jobs in every branch of Radio.

### Many make \$5, \$10, \$15 a week extra in Spare Time almost at once

Every neighborhood can use a good part time serviceman. I'll start giving you special instruction material, plans, ideas, the day you enroll, for making money in spare time. Get my book—read how many of my students make \$200 to \$1,000 in their spare time while learning.

### Your money back if not satisfied

I'll make this agreement with you. If you are not entirely satisfied with my Lesson and Instruction Service when you finish. I'll refund your tuition.

### Find out what Radio Offers

Mail the coupon. My book of information on Radio's spare time and full time opportunities is free to any ambitious fellow over 15. Read what Radio offers you. Read about the training I offer you. Read letters from graduates—what they are doing and making. There's no obligation. Mail coupon in an envelope or paste it on a postal card—NOW.

J. E. SMITH, President  
National Radio Institute, Dept. 5JM4  
Washington, D. C.

**The Tested Way to BETTER PAY**

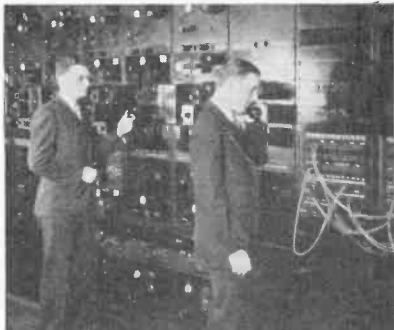

### SAVE MONEY—LEARN AT HOME

#### Special Equipment Gives You Practical Experience

Hold your job. No need to leave home and spend a lot of money to be a Radio Expert. I'll train you quickly and inexpensively right at home in your spare time. You don't need a high school or college education. Many of my successful graduates didn't finish grade school. My practical 50-50 method of training—half with lessons, half with Radio equipment—gives you broad practical experience—makes learning at home easy, fascinating, practical and rapid. There is opportunity for you in Radio. Old jobs are becoming more complicated—many need better trained men. New developments are making new jobs. Short waves, loud speaker systems, police Radio, auto Radio, aviation Radio, television—Radio's newest uses are covered by my training. Here's a field that's growing. It is where you find growth that you find opportunity.

I have doubled  
and tripled  
the salaries  
of many



## MAIL THIS NOW!

J. E. Smith, President  
National Radio Institute, Dept. 5JM4  
Washington, D. C.

Dear Mr. Smith: Without obligation, send me the Sample Lesson and your free book about spare time and full time Radio opportunities, and how I can train for them at home in spare time. (Please print plainly.)

Name ..... Age .....  
Address .....  
City ..... State ..... 14X-1

# RADIO WORLD

*The How-to-Make-It Monthly—Fourteenth Year*

ROLAND BURKE HENNESSY  
*Editor*

HERMAN BERNARD  
*Managing Editor*

HERBERT E. HAYDEN  
*Advertising Manager*

---

## Table of Contents for SEPTEMBER, 1935

---

<b>Television Race Gets Hotter....</b> 5 <i>Stations Building in U. S., Much Activity Abroad</i> By Herman Bernard	<b>Filter Design and Application...</b> 28 <i>Simple Circuits for Audio Systems</i> By Morris N. Beitman
<b>Farnsworth Demonstrates Progress</b> ..... 11 <i>His Cathode Ray Television System is Striking</i> By Neal Fitzalan	<b>Small Rectifiers for B Supply...</b> 31 <i>Handy for Testing and for Powering Small Sets</i> By Jack Tully
<b>Elementary Tube Voltmeter.....</b> 14 <i>The 6C6 in a Universal Circuit</i> By Jack Tully	<b>Experiences with 12-Tube All Wave Super</b> ..... 33 <i>Gain Is Upheld at the High Frequencies</i> By Samuel Miller
<b>The Multivibrator</b> ..... 16 <i>Audio Oscillator Rich in Harmonics</i> By Morris N. Beitman	<b>A High Fidelity Power Amplifier</b> 34 <i>Multiple Speakers and Fixed Bias</i> By Roy L. Smith
<b>Power Amplifier Taxes Ingenuity</b> 19 <i>Artistic Amphitheatre with No Emplacement for One</i> By Herbert E. Hayden	<b>Diode Amplifiers in T.R.F. Set..</b> 37 <i>A Way Out of a Common Difficulty</i> By Henry Bullitt
<b>Full Scale "On the Nose".....</b> 20 <i>Necessary for Correct Ohmmeter Practice</i> By Ambrose Bishop	<b>Directional Transmission</b> ..... 38 <i>How It Is Applied to Ultra Waves</i> By J. E. Anderson
<b>Underwriters' Rules for Transmitters</b> ..... 23	<b>A Little More Meter Insurance..</b> 42 <i>Switch's "Lag" Turned to Safety Method</i> By Edward B. Nelson
<b>The 6B5, a Tube with Built-in Circuit</b> ..... 24 <i>Held the Most Interesting Valve Since the Vari-Mu</i> By K. N. Satterwhite	<b>A Balanced Detector.....</b> 44
<b>Installation in a Console.....</b> 26 <i>Some Pointers on Putting Set into Place</i> By Herbert Irwin	<b>A 5 Meter Pilgrim's Progress...</b> 46 <i>Detailed Report of an Adventurous Ham</i> By Arthur H. Lynch
	<b>The New Metal Tubes in Practice</b> 52 <i>Higher Mutual Conductance, Smaller Grid-Plate Capacity</i> By George Dubuc
	<b>Radio Construction University..</b> 55

---

Vol. XXVII, September, 1935. No. 8. Whole No. 634. RADIO WORLD, published monthly by Hennessy Radio Publications Corporation, 145 West 45th Street, New York, N. Y. Editorial and executive offices, 145 West 45th Street, New York, N. Y. Executives of RADIO WORLD: Roland Burke Hennessy, editor and business manager; Herman Bernard, managing editor; Herbert E. Hayden, advertising manager. Officers of corporation: Roland Burke Hennessy, president and treasurer; Herbert E. Hayden, vice-president; Herman Bernard, secretary. Entered as second-class matter March, 1922, at the Post Office at New York, N. Y., under Act of March 3d, 1879.

---

### SUBSCRIPTION RATE

Price 25 cents per copy. Subscription \$2.50 per year (12 issues), postpaid in United States and Possessions; \$3.00 per year postpaid in all other countries. Remittance for foreign subscription should be by International money-order (postal or express) or draft against or discountable at New York bank.

---

RADIO WORLD is distributed by the American News Company and its Branches

# Television Race Gets Hotter

## World Trails America, Which is Getting Experimental Transmitters Ready—Unsolved Problems Knotty

By Herman Bernard

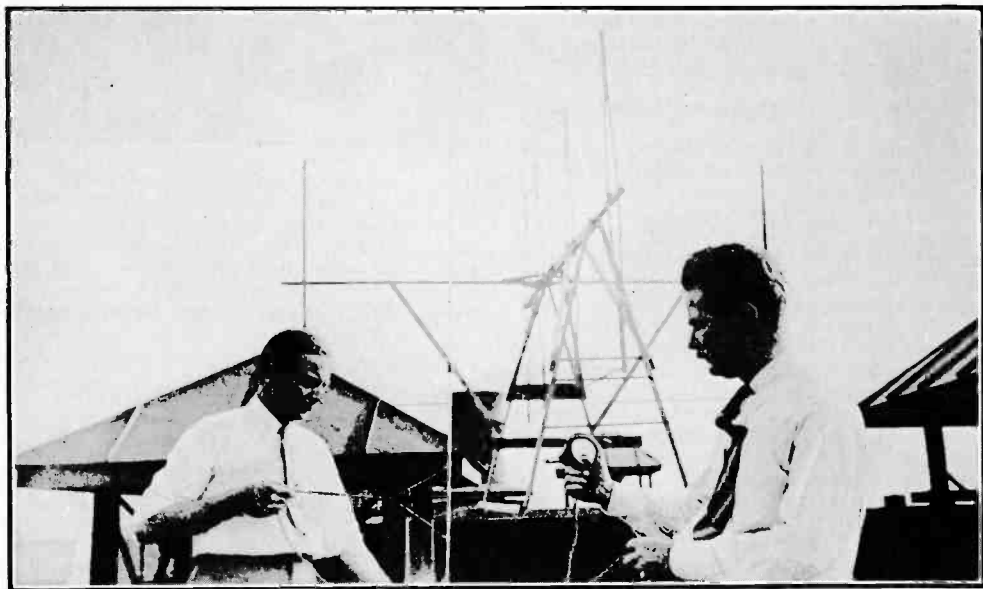

In the background is shown the Yagi transmitting antenna erected by VE9AK, Montreal, Can., for transmitting television on 6 meters. The system consists of critically placed and selected reflecting antennas and a directing antenna, all in addition to the energized radiator itself. In the foreground are J. Francis Dusek (left) and J. Lawrence Cassell, engineers of Peck Television of Canada.

**T**ELEVISION is moving at a faster pace toward commercialization than at any previous time in history, and the advance is being made in several countries. Sizeable pictures are now being produced with definition and illumination that give promise of real entertainment value, the test being whether these laboratory demonstrations can be duplicated in large scale co-ordinated service, or, as the engineers say, "in the field."

In the world wide aspect, arrangements have been made between television development companies in different countries for the exchange of patent rights. In the domestic field, however, there is great rivalry, not only among different systems of accomplishing television, but also concerning the course that television development should follow. Some, like Radio Corporation of America, hold that each developing agency should be permitted to carry out its experimental and field work along its own lines, while others favor Government insistence on

standardized transmissions, so that a separate receiver will not be necessary to pick up each system's propagation.

### The Four Out Front

From each country come reports that, in effect, tend to create the impression that television there is of the highest quality anywhere. Some "scouts" for investing interests do nothing but go about the world, investigating television development, and, though they are not all Americans, they report that systems they have seen here surpass anything they have seen elsewhere.

In a recent report to the stockholders of his corporation David Sarnoff, president of R. C. A., said "the results obtained by R. C. A. in laboratory experiments go beyond the standards accepted for experimental television service in Europe."

The four corporations in the United States  
(Continued on next page)

(Continued from preceding page)

that are out front in television are R. C. A. and Farnsworth Television, Inc., with electrical systems without moving parts; Peck Television Corporation and National Television Corporation, which have mechanical systems.

All have been introducing improvements for several years and are showing better and larger pictures. R. C. A. uses a 343 line picture, compared to 30 lines of a few years ago when it was intensely developing mechanical systems, and now has 60 pictures per second, compared to 12 pictures then. Farnsworth uses a fine lineage and high picture frequency, too. Peck and National at present have 60 lines per picture and 24 pictures per second.

### Scanning Is Common to All

All television today is on the basis of scanning, which consists of breaking up the picture into elements, and transmitting the equivalent values of the elements for recomposition at the receiving end. The light values are changed at the transmitter into current values, by using some photo electric agency, and the frequencies of these currents modulate the carrier. In mechanical systems a disc or drum revolves, reflecting surfaces at different angles picking up bits of the picture one by one. In the electrical system a camera and tube do the work, and this system lends itself readily to direct pickup, use of so-called "live subjects," compared to movie film or stills.

The two advanced exponents of the electrical systems feel that theirs are respectively superior to mechanical methods, whereas the inventors of mechanical systems believe they can produce results that the others can not match. As to actual demonstrations, although few of these are given, and mostly in private, observers who say they are impartial find defects in both systems, advantages in both, tell their adverse

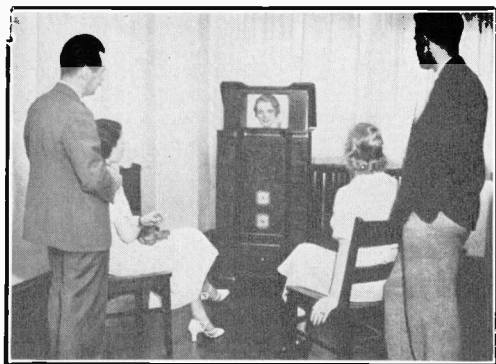

The women are shown at minimum distance from the television viewing screen for enjoyment of 60 line pictures, the men at the greater distance from which 180 line pictures may be viewed with equal resolution of the lines of the picture. A wash drawing is on the television screen to emphasize where the picture appears.

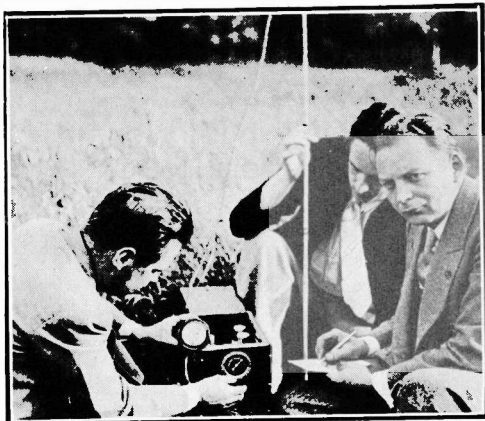

With a dipole antenna and a receiver the strength of the transmission from VE9AK is measured at various distances from the source, up to about 60 miles. By using greater power, around 600 watts, it is expected that more than 100 miles of reliable service will be attained on 6 meters. Transmissions are now conducted daily.

criticisms of one system to the backers of the other, and confine their praise to the system of the men to whom they are talking.

### No Claims of Perfection

None of those developing television asserts that anything approaching perfection has been achieved. It is also pointed out that since much has to be accomplished before a co-ordinated service of consequence can be instituted, that there will be rapid and costly obsolescence, one of numerous reasons for not bringing out receivers now, for sale to laymen. However, experimental television stations will be operating on a high definition basis within a year or so in this country, particularly one that R. C. A. is about to erect, probably in New York City, and experimenters may be able to do some uninvited viewing with apparatus of their own that may be changed from time to time to meet new requirements.

Considerable impetus was given to television progress from a psychological viewpoint by the report of the British Television Committee to the Government, advocating immediate inauguration of television. The word "immediate" or the phrase "at once" has a delayed significance when applied to television.

### Trying Our System Over There

What has been shown in Britain generally has been low definition television, usually 30 lines, but now electrical systems are being tried, particularly the one developed in R. C. A.-Victor laboratories in this country under Dr. Vladimir K. Zworykin. Electrical Musical Industries (known as E. I. M. in Britain) has a working agreement with R. C. A., while Baird Television, Ltd., of Britain, has a similar agree-

ment with Farnsworth. At present Germany is going it alone, and seemingly doing better than England, while France is trying to keep up with Germany, but so far with little success in the television line.

In Germany, as in England, television is Government sponsored, whereas in the United States and Canada the work is undertaken solely by private initiative. Germany, for instance, has viewing places, where interested throngs flock to look at the short distance television. The system is one of movie-filming a scene, developing the film in less than a minute, and putting the film through the transmitting scanner. There is no public sale of television sets, and the results as yet do not encourage the officials to permit such sale.

From France very little is heard about television developmental work, while from England come rather frequent reports, some of which sound like impossible dreams come true,

That somewhat the same problems of policy exist in all countries is suggested by the decree of the British Broadcasting Company that the emissions of two rival companies, Baird and Electrical Musical Industries, alternating in propagation from the Crystal Palace plant, be receivable on the same set.

### The First Television "Election"

Evidently the public is to be at least one of the judges of the results. Thus perhaps in Eng-

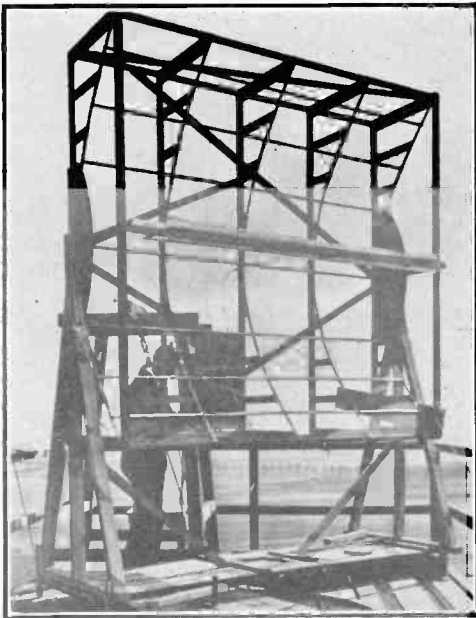

(W. de World)

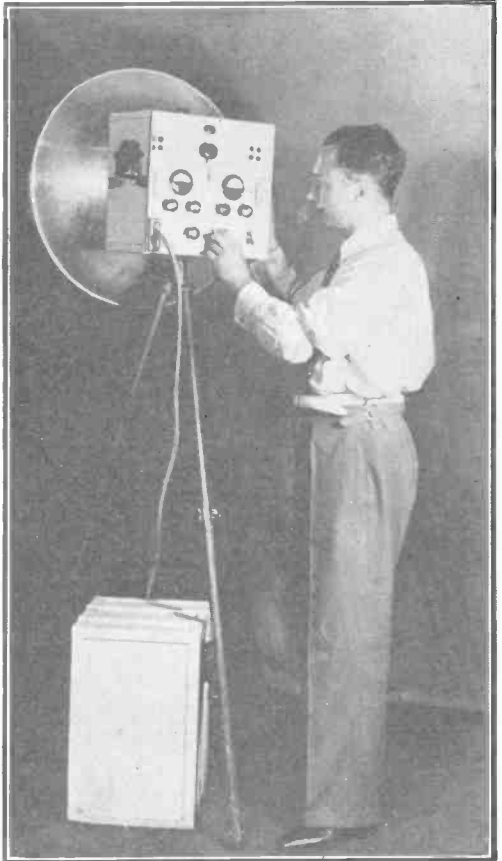

A reflecting transmitting antenna system used by Telefunken for centimeter waves. Installations for from 10 to 90 centimeters have been made. Much more power is radiated when the wave is beamed by this method. At the receiving end, for short enough waves, a parabolic reflector is used (at right). The receiving aerial is a small wire at the focal point of the parabola.

but the realities turn out to be something less than a prudent person would regard as outstanding. The policy in England is to attempt to produce high definition television, as a public service, as soon as practical, without regard to the nationality source from which the development springs. Thus foreign systems are welcome, and are being tried out, invitations to several more having been issued.

land there may be a decision in the bout between the R. C. A. and the Farnsworth systems, both American, before there will be such a determination in the United States. The Farnsworth Corporation is arranging to put up a transmitter, and expects that several will be going full blast within a year.

All interests are agreed that television trans-

(Continued on next page)

mission will have to be on low waves, because then the modulation band width is a small percentage of the carrier frequency, and well accommodated. For high definition systems the band width might run into millions of cycles per second. At present the reliable range for waves around 6 meters is around 25 miles or less, and with this limitation is grouped the necessity of providing links for any system co-ordinated to a large geographical area like the United States, and a medium for establishing such links.

### The Coaxial Line

Here another laboratory development enters, the coaxial transmission line of the Bell Telephone Laboratories. While the Laboratories are primarily concerned with voice transmission as part of the regular service, and the coaxial lines now readily enable sixteen messages compared to standard practice of four messages per carrier, the company also leases lines for broadcasting purposes, and if it could develop in the field the use of a system to include television modulation band it would endow television with a real benefit. It is confidently expected that the field experiment with the coaxial lines to be erected between Philadelphia and New York will confirm the utility of this device in practice, for in the laboratory it was a great success. In fact, the coaxial line in the laboratory is far ahead of television in the laboratory. And the line can carry a 1,000,000 cycle frequency readily, and even far higher

*(Continued on next page)*



*(Wide World)*

Operators atop motor trucks go about the streets of Berlin shooting scenes with a movie camera. The exposures are developed in about a minute and thus made ready for scanning by a television transmitter. The public is permitted to see the reception results in booths about the city.

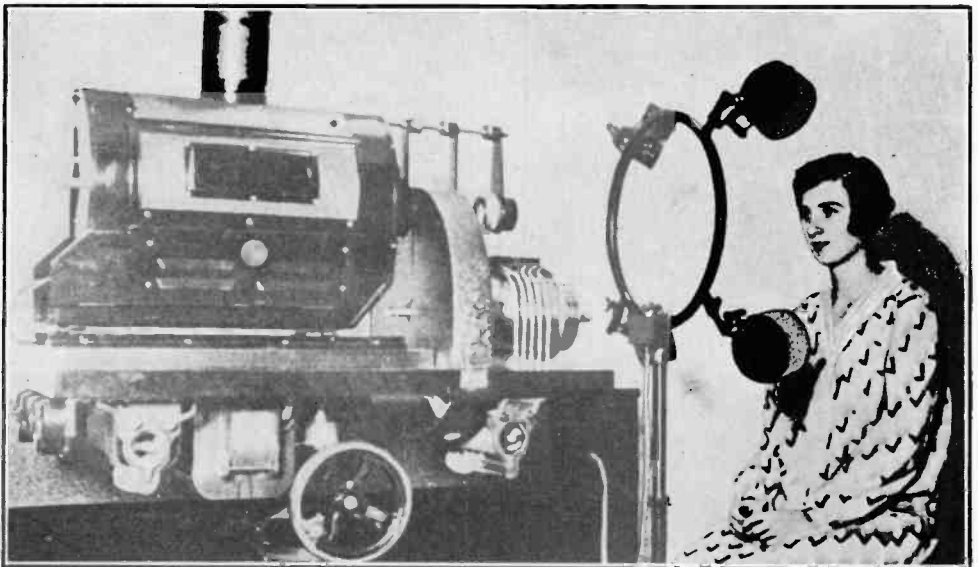

*(Wide World)*

Direct pickup, using live subjects instead of film, is under experiment in Germany, also. A woman with a contrasty dress is shown before the microphones and the pickup. Contrasts are what are particularly studied in the experiments.



# RCA and Philco Negotiating for Coaxial Television Line

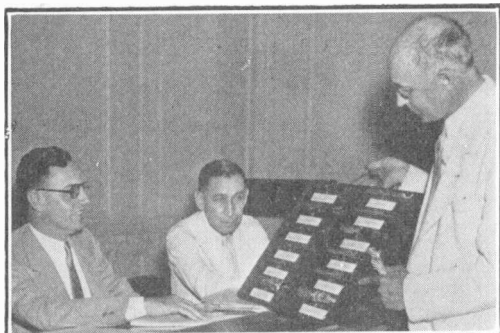

(Wide World)

Samples of coaxial transmission line cable as developed by Bell Telephone Laboratories were exhibited by Dr. Frank B. Jewett, president of the Laboratories, at a hearing before the Federal Communications Commission on the application for permission to install the line between New York and Philadelphia. Left to right, Commissioners Irwin Stewart and Eugene O. Sykes, and Dr. Jewett.

Washington.

Opposition having been withdrawn by the Western Union Telegraph Company and the Postal Telegraph and Cable Company to the institution of an experimental coaxial line by Bell Telephone Laboratories between New York and Philadelphia, the Federal Communi-

cations Commission announced that the request for permission to install the line would be granted. The assurances of the experimental nature of the installation overcame the objection.

Dr. Frank B. Jewett, president of the Laboratories, said that the service would be experimental for at least a year. It was denied there would result any disruption of existing communications systems, which fear had also led some broadcasting stations to offer opposition. Finally all opposition was withdrawn, excepting that of one lawyer, representing sound movie interests.

Dr. Jewett said that no attempt would be made to monopolize the coaxial service, but that reputable concerns would be welcome to rent the service for television that met standard requirements. Already negotiations have been started with Radio Corporation of America and Philco Radio and Television Corporation. It was denied A. T. & T. is perfecting a television machine.

The cost of the New York-Philadelphia installation is estimated at \$580,000.

Quiet operation of the line is attained by introducing just enough reverse feedback. It is extremely novel to introduce reverse feedback in a repeater, which is of course an amplifier, but by discarding some of the possible gain this way the ratio of signal to noise was greatly increased.

(Continued from preceding page)

frequencies. Thus the television current variations that are to be mixed with the short wave television carrier—that is, the modulation or video frequencies—could be sent by wire just as well as audio messages. A central studio then could send television pulsations to various transmitters for propagation and thus the problem of local service, due to short-range of the low

radio wave, could be solved by the wire intervention.

## Coaxial Impedance Computable Easily

The coaxial principle is an old standby in physics, but the contribution of the Laboratories consists of the utilization of the principle along practical lines of the modern need. The prin-

(Continued on next page)

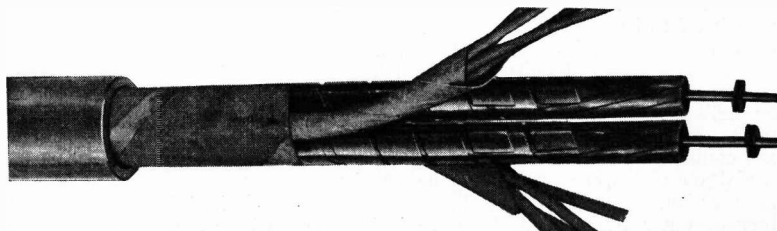
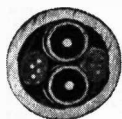

Bell Telephone Laboratories

The outer covering of the coaxial line is a lead cable  $\frac{7}{8}$  inch in diameter. Inside are two copper tubings and eight usual type telephone wires, paper insulated. Each of the two copper tubings has inside it a small copper rod, insulating spacers between rod and inside wall of the tubing, so that the dielectric is mostly air, to avoid losses. Cross section view is shown at left.

**DAVID SARNOFF**, president, Radio Corporation of America: "The results attained by RCA in laboratory experiments go beyond the standards accepted for the experimental television service in Europe. We believe we are further advanced scientifically in this field than any other country in the world."

(Continued from preceding page)

ciple is based on the transmission properties of two conductive tubings, one inside the other, that is, the two have the same axis.

For short distances the coaxial principle is applied to a transmission line in the strict sense of conduction from source to destination without loss, familiar in radio practice. It is difficult, certainly at high radio frequencies, to measure the impedance of a transmission line. More accurately the impedance can be computed, and the coaxial feeders of radio practice represent the selection on that basis. The circular symmetry makes things easy for the mathematician, and since practice is based on the computation, which is highly accurate, the coaxial feeders are accepted as being unsurpassed, that is, as lead-ins do not pickup to annoy a receiver or transmit to confound a transmitter.

Where the coaxial line is to run any considerable distance, say, 20 miles, it is necessary to have a repeater.

"The attenuation of copper wire lines always varies with temperature—overhead lines being perhaps 10 per cent. higher than average on the hottest day in Summer and 10 per cent. below average on the coldest day in Winter. On a transcontinental coaxial circuit this variation would reach tremendous proportions, and even on a circuit from New York to Philadelphia the variation would be sufficient to make the conversation impossible unless the transmission were regulated in some manner. Since most of these repeater stations would be unattended, their regulation must be automatic."

What applies to telephone conversations also applies to television.

Mr. Strieby continues:

"The coaxial line is also well adapted for transmitting over long distances the extremely broad frequency bands required for television. Since the frequency range for high grade television extends from the neighborhood of zero up to a million or more cycles, special modulating apparatus is required at the terminals to

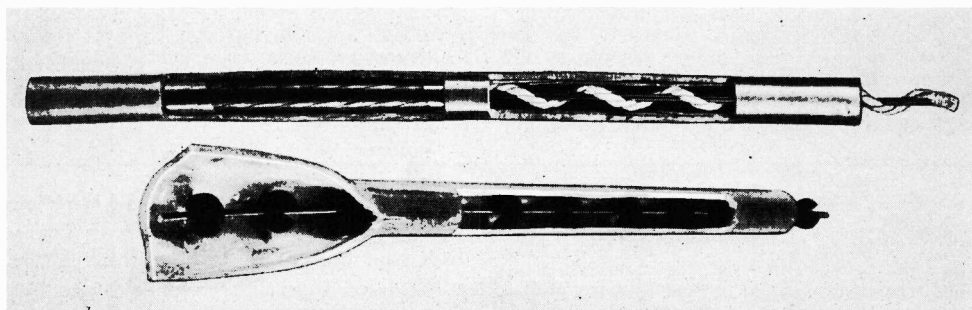

Bell Telephone Laboratories

Two types of Western Electric coaxial conductor that have proved very satisfactory under test.

The coaxial line, Bell Laboratories found, lends itself to broad band transmission, and the repeater could amplify the whole band.

Tests were made of built up coaxial lines, in a check on theory, the line consisting of a copper tubing 2.5 inches outside diameter within which was mounted a smaller tubing, which in turn contained a small copper wire. Thus two coaxial circuits were produced, one consisting of outer tubing and next adjacent one, the other of outer tubing and the wire inside the smaller diameter tubing.

M. E. Strieby, carrier transmission research engineer, reports in an article entitled "Coaxial Conductor Systems," in "Bell Laboratories Record," for July issue (1935):

lift the entire band to a range which can be transmitted over a coaxial system."

As for voice telephony alone, a million cycle coaxial line would carry more than 200 voice channels.

## WIRED RADIO TESTS RESUMED

Cleveland  
Wired Radio, which tried out sets in homes, where the programs were sent over light wires, stopped the experiment, after three months, for a study of the results. More than 700 families had metered sets in their homes and the average use per day turned out to be four hours. Service then was resumed.

# Farnsworth Demonstrates Progress

## His Television Clear, Luminous, in Black and White

By Neal Fitzalan



(Wide World)

The Farnsworth television studio in action. The direct pickup was transmitted by cable to a room about 40 feet away, where the reproductions were viewed and heard in a recent demonstration in Philadelphia. Musicians played and stage girls danced and sang. Note the powerful light source at right, announcer at microphone at left rear.

**T**ELEVISION of good quality, with both direct pickup and movie film used for the program, was demonstrated by Television Laboratories, Inc., in its studios at Chestnut Hill, Philadelphia, recently. The pictures were of small size,  $5\frac{1}{2} \times 7$  inches when projected, but the definition and illumination were much better than at a previous demonstration of the same general system at Franklin Institute.

The inventor, Philo T. Farnsworth, not only used both direct and indirect program sources, but also sent the results of one by radio, for reproduction in a console type receiver, with greenish lighting, and the other by wire, shown on an external screen in black and white. Sound effects were reproduced in both instances. He explained he can increase the size of the projected picture materially, with adequate light left.

The principal objection that some of the observers had to the results was that the picture

would wobble occasionally, but Mr. Farnsworth explained that this took place during the part of the demonstration dealing with transmission by radio, that the power used was small, and that increased power cured that trouble.

He said that though the transmissions were put on only about 40 feet from the receiver, the clarity would be the same for distances up to 30 miles.

The studio was fitted up in approved style, with a small stage, faced by a powerful light source. On the stage girls sang and danced, while an orchestra played, and the usual formalities were observed, with William Eddy serving as announcer. The group of guests in another room in the same building heard and saw the antics of the human participants, and also, in the case of the indirect pickup demonstration, heard and saw Mickey Mouse in a television screen reproduction of a movie reel.

(Continued on next page)

*(Continued from preceding page)*

Farnsworth uses an electrical scanning system having no moving parts. He has his own developmental form of cathode ray oscilloscope tube, one with hot cathode for receiving purposes, another with cold cathode for economical operation of a transmitter. His pickup tube he calls the "oscillight." In purpose this corresponds to the iconoscope used by R.C.A.

### Shows Black and White

The direct pickup scene to be shown is picked

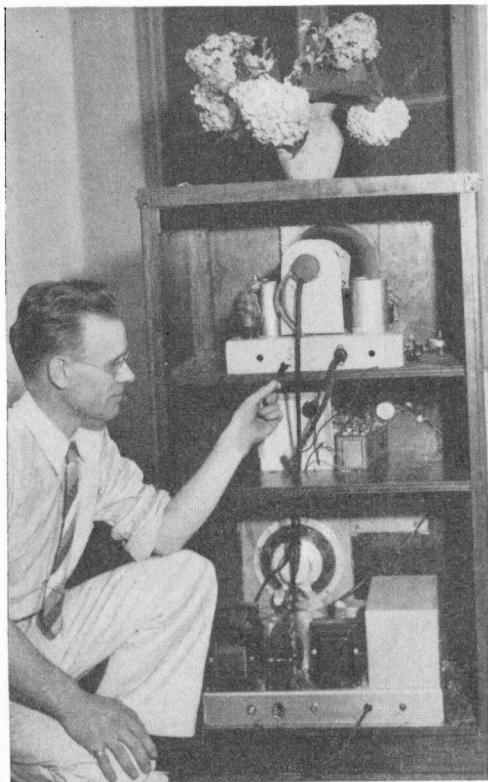

*(Wide World)*

Philo T. Farnsworth holds a small neon lamp near the transmission line feeding the cathode ray tube at his receiver. If the line is not truly a transmission line, that is, radiation takes place, the field will light the lamp. Purposeful unbalance would accomplish this, but the lamp does not light, because the line is balanced. The speech amplifier and the sound reproducer are shown in the bottom compartment.

up on a camera and the equivalent ground glass is scanned by the Farnsworth method and the light values converted into electrical values for modulation of a carrier, in the case of radio, or sent directly on special wires, in the case of wired television.

The conducting wires, once a problem, have

been developed to such a point that carrier television, and wired television results could not be told apart, except that in this instance they were shown on different screens, and the fluorescence of the receiving tubes was of different color. The greenish results familiar to cathode ray tube users was due to zinc orthosulfate. The wired television was received on a tube target composed of calcium tungstate and other substances, the ingredients being held secret, as getting black and white results with a tube of that kind is considered an achievement.

During one of the stage shows there were sixteen persons in the scene, including chorus girls, and it was possible to distinguish them clearly. In fact, among the guests were friends of the stage folk who recognized them instantly, and applauded. This was not taken by the inventor as the compliment that probably was intended, since television several years ago passed the point when mere recognition of identity constituted proof of progress. But now there were more numerous participants than formerly, and the distinctness with which everything could be seen was well appreciated by the viewers.

### 24 Pictures, 240 Lines

The modulation band was about 2 mc. Such a wide band, or close to it at least, is regarded as necessary for high definition, and requires that if a carrier is used that its frequency be high, so that the modulation or electrical impulses that constitute the picture elements shall be a small percentage of the carrier frequency. Hence Farnsworth's television, like that of others, is necessarily intended for short waves, say, not more than 7 meters.

The net effect of the operation of the scanning system is that a very fine spot of light is made to move over the picture area 5,760 times a second. There are 24 pictures per second, to create the illusion of motion without flicker due to low picture frequency, the same repetition rate as used in the talkies, and there are 240 lines per picture.

### How the Spot Moves

The spot of light is moved across the screen, as if starting at the top left hand corner of the picture, traveling to the top right hand corner on a straight horizontal line, then being carried to the left in an unobserved return sweep, to start going from left to right again, one twenty-fourth the distance from the top of the picture, and next time one twelfth the distance down, etc., until the picture is scanned vertically this way by a light spot occupying what may be compared to rung positions on a closely formed ladder, and moving from left to right on each rung, in a top to bottom progression. There was no trace of the lines observable, as even at a distance of seven feet or so the lines are so close as to be invisible, due to the resolving power of the eye, that is, multiples appear as a unit.

The military and naval branches of the Gov-

ernment are following developments at Television Laboratories, Inc., as they are at R.C.A. and other places, because of the great possibilities that television holds forth as a defensive and offensive weapon in warfare.

The goal of being able to see distant objectives for directing explosives toward particular

targets has not yet been reached, but that possibility exists at least in theory, and is the prime reason for the deep interest the armed forces have in television in this country, just as the fighting branches of foreign governments exercise the same watchfulness over television progress at home. The American Army officers

are cooperating with other branches of the government in keeping close tabs on television progress.

Opinions still differ as to when television will be here as a commercial proposition of entertainment value. David Sarnoff, president of RCA, is said to lean to "10 years", but Farnsworth says it will be much sooner than that.

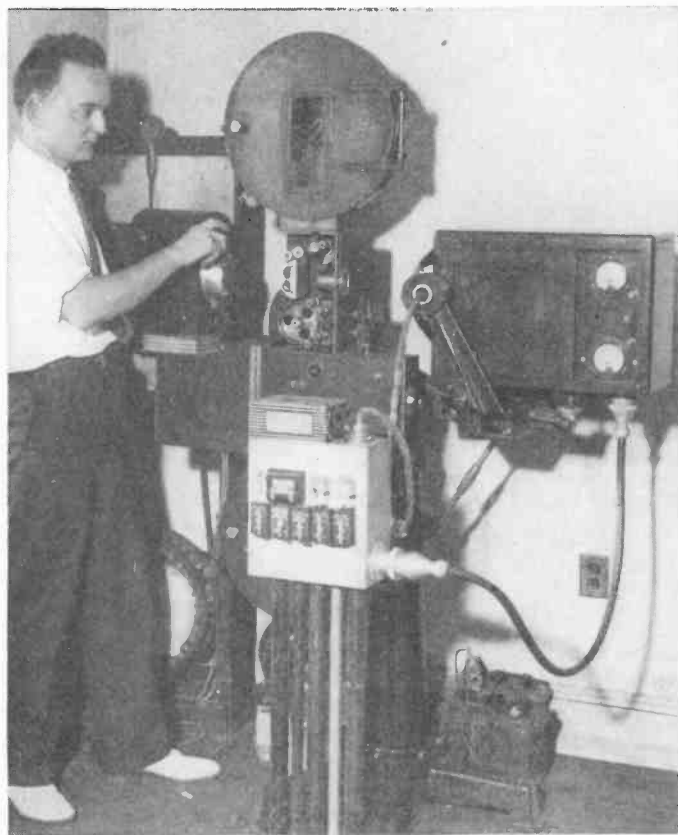

(Wide World)

Operator is shown at the Farnsworth transmitter. An entirely electrical system is used for scanning, both at transmitter and receiver, based on the principles of the cathode ray oscilloscope. Hence moving parts are omitted.

## Germany First, Britain Second Abroad

A. W. Cruse, chief of the electrical division, Department of Commerce, has returned to the United States with a report to the National Association of Broadcasters, who had asked him to make a survey of television conditions and results in Europe. The following is a summary of the report:

ENGLAND: British Broadcasting Company offers low definition television now, half to three quarters hour, twice a week. Television on 261 meters, sound accompaniment on 398 meters. Flicker is bad, picture indistinct, but program technique excellent. Great variety of "live subjects" scanned, vaudeville and condensed operas included in offerings. Number of television sets on British Isles said to be about 100. British radio manufacturers fighting television as hurtful to set sales, but sales this year may exceed those of last year. Some

movie folk see no threat by television to theatres.

GERMANY: Berlin crowds flock to television viewing places. Using 180 lines, Germany lays down an excellent picture, of high entertainment value. License fees on sets, plus a Government appropriation, finance television experiments. Germany moving along at a swift pace, with thorough technique.

FRANCE: Realization exists in that country that it is behind Germany and efforts are being made by the Ministry of Posts and Telegraphs to catch up. Transmissions now being tried irregularly, 60 lines, 25 pictures per second, on 17.5 meters. Trying to get 90 lines for early experiments and expect to settle on 180 lines as quickly as they can, but will take more than six months.

# Elementary Tube Voltmeter

Measures A.C. Potentials,  $\frac{1}{4}$  to 2.8

By Jack Tully

For measuring small a.c. voltages this circuit may be used. Ungrounded external systems, such as power transformer secondaries, may be measured without the input current flowing through the 1 mfd. condenser. All other measurements are made through the condenser.

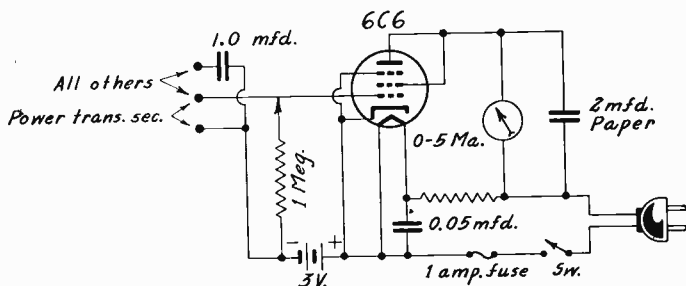

A SIMPLE vacuum tube voltmeter is shown, for measurements from 0.25 volt to 2.8 volts. The curve is given, showing a.c. volts related to d.c. plate milliamperes, when a 0-5 milliammeter, having a d.c. resistance of 2,160 ohms, was used (Readrite No. 305).

A 6C6 tube has screen tied to plate, as the mutual conductance is higher that way, also suppressor to cathode, for the same reason, although the difference when connecting suppressor to C minus is negligible.

A line cord is connected to the a.c. line. There is a resistor of 350 ohms built into the line cord (third lead), to drop the line voltage to the required heater voltage. Grid of the tube, represented by the head, is brought out to a binding post. C minus 3 volts is brought out to a separate binding post and the connection is made to a similar post through a condenser of 0.01 mfd. or higher mica capacity, from the aforementioned ground lead.

## The Input Connections

Between the grid post (center) and the direct connection to battery are put low voltages from secondaries of ungrounded power transformers, or low a.c. voltages from any other source not directly related to the a.c. line or actual ground. Between grid and the upper post are put all radio frequency voltages, because many of them will be taken from receivers, generators, etc., where chassis and coil returns are grounded. The 0.01 mfd. condenser avoids shorting the line, since otherwise the tube voltmeter could communicate to grounded chassis the ungrounded side of the line and cause the short.

The plotting of a.c. volts against d.c. plate current shows that the curve is linear from the minimum, 0.25 volt, to 1.5 volts, or 1.3 to 2.35 ma, after which the curvature is obvious. For the linear part the change is 0.2 milliamperes in d.c. plate current for 0.25 volt a.c., on

the grid, or, expressed as a resistance, 125,000 ohms, or as a conductance, 400 micromhos.

Across the meter is a paper dielectric bypass condenser, to keep as much a.c. out of the meter as that capacity will accomplish, although at 60 cycles the job is not done completely, and 8 mfd. would be preferable. That, however, would be by way of bringing the small device into more serious dimensions.

## Needle May Kick Down

A leak is included with switch so that the grid can have a return, without depending on the load for d.c. continuity, which in some instances it will not have.

Thus the grid may be operated at the condition at minimum plate current, leak switch closed, except that when an unknown a.c. is connected other than in the intended direction, the negative alternation drives the grid negative and decreases the plate current. The curve starts at more than 0 plate current, in fact, 1.3 milliamperes, and if the needle kicks backward, reverse the connections of the unknown, using the same posts as before, but now the positive alternation is toward the grid and drives the plate current up. This increase in plate current is what enables the determination of the a.c. voltage from the curve.

## Calibration Holds for All Frequencies

Nearly all systems that will be measured will have one side grounded, and if not, the a.c. grounding will be accomplished through the tube voltmeter. Thus 0.01 mfd. grounds radio frequencies sufficiently, and in other examples cited, for the direct connection to C minus, hence to line, the same condition of grounding as to the a.c. exists for the tested circuit. For power transformer secondary measurements

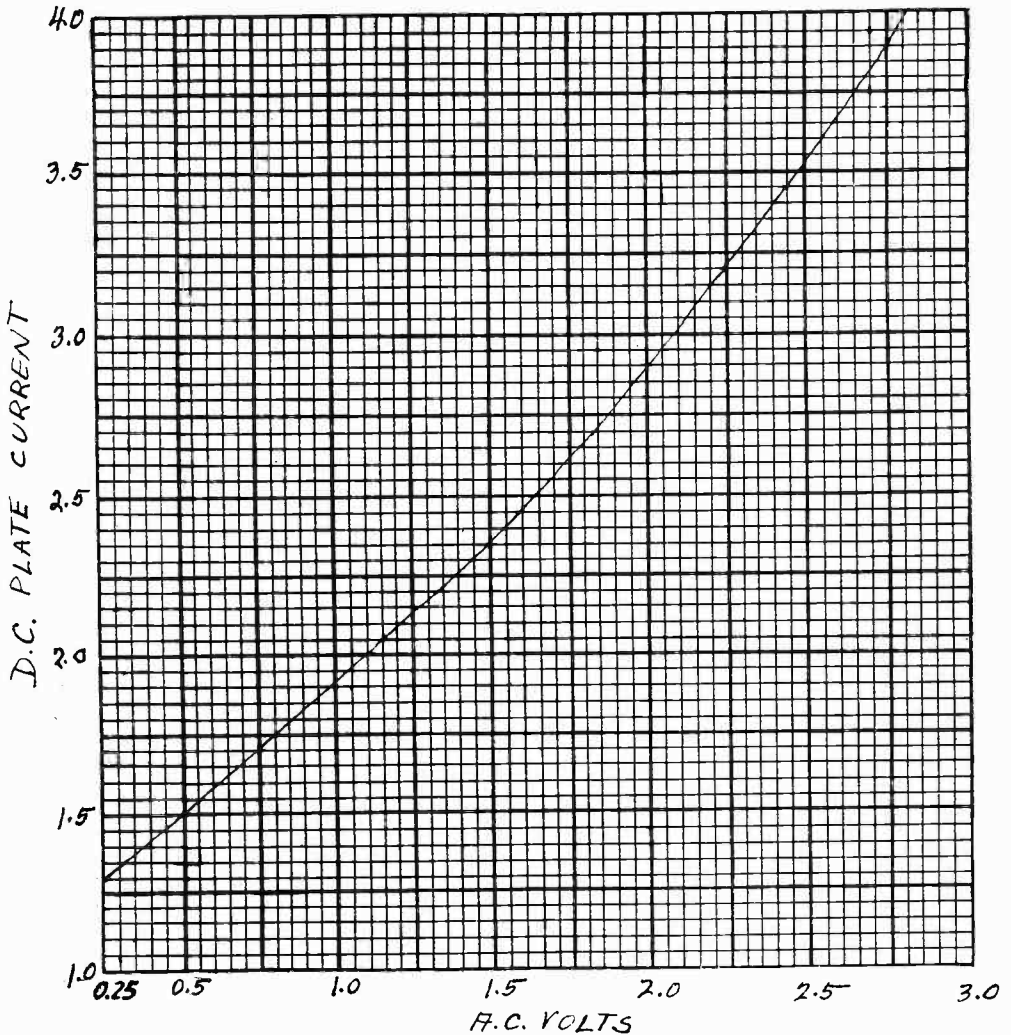

The plate current is read in the perpendicular column of figures at left, and equals 0.05 milliamperes per division, or, two divisions for each 0.1 milliamperes. The meter used has division bars for each 0.25 milliamperes, but the readings can be taken sufficiently for the present purpose. Carry plate current line across until the curve is intersected, and then come down to the a.c. volts line.

(low voltages, of course) the condition is obvious, since the secondary may add to or subtract from the grid voltage. Hence the two voltages should be in phase. A correction may be introduced by reversing the connection to the wall socket. For radio frequencies the difference in frequencies is so great that the condition will not likely obtain, though any effects, if noticed, should be corrected either at the input posts or, if more convenient, at the wall socket.

While the calibration was made at 60 cycles, it is substantially correct at all frequencies, say, to 10 mc., not being critical to line voltages within the variations encountered in large centers of population. The line voltage was 116

volts when the calibration was run, and at 110 volts the 2.5 volts reading might be expected to be reduced to 2.37 volts, but was nearer 2.47 volts.

### Leave Leak Switch Open

With connections properly made to input, the measurement of relative values of radio frequency voltages as found in receivers, etc., at levels above 0.25 volt, to 2.8 volt, may be made, with high accuracy, in respect to establishing the same voltage in two different circuits, and also of course absolute measurements, by using

*(Continued on next page)*

# THE MULTIVIBRATOR

## Construction, Operation and Application

By M. N. Beitman

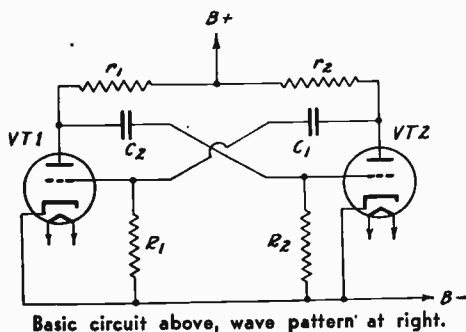

Basic circuit above, wave pattern at right.

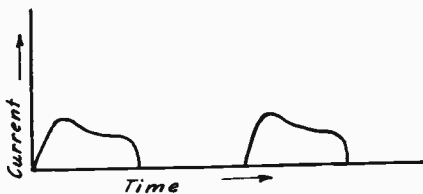

The wave pattern.

**A**LTHOUGH a multivibrator is finding extensive application in station monitoring and laboratory equipment, it is a little known device. In this article the author will attempt to explain the operation of a multivibrator, mention some of its more common applications and give plans for construction of a small multivibrator from spare parts found in any radio workshop.

The multivibrator is one form of a relaxation oscillator. One of its simpler forms is nothing more than two capacity-resistance coupled amplifiers, so connected that the output of one is coupled to the input of the other, while the output of the second is coupled to the input of the first. This oscillator employs no inductance and was originally due to Abraham and Bloch as described in "Comptes Rendus" of 1919.

### The Basic Circuit

The basic circuit of such a simple vibrator is shown in Fig. 1. On the first examination it would seem that upon connecting the filament

and plate supply, the two tubes would draw steady current. However, this is far from what actually takes place. The circuit oscillates violently, producing waves that approach a square shape, as illustrated in Fig. 2. This represents sudden rise and fall of current and is exactly what might be expected from a closer examination of the circuit in Fig. 1.

Once the circuit is connected a steady current will begin flowing through the two vacuum tubes and the associated plate resistors  $r_1$  and  $r_2$ . Suppose that through some outside disturbance (no matter how minute) the current through  $r_1$  is increased. Since the voltage drop across this resistor is equal to the product of the resistance by the current, the voltage across  $r_1$  will increase, because of the increase in current. The condenser  $C_2$  will act as a short circuit for the sudden change of voltage, and a higher negative voltage will be placed on the grid of VT-2, reducing the current through it.

### How the Action Repeats Itself

Now we have seen that the increase of current in one tube will decrease the current in the  
(Continued on next page)

## Vacuum Tube Voltmeter

(Continued from preceding page)

the plotted curve, although with somewhat lesser accuracy.

It will be noticed that with the 2 mfd. across the meter there is not quite enough capacity to remove the wobble due to residual a. c. from the line, which removal larger capacity would accomplish, but it is very easy to estimate with the eye the average of the small displacement, and read the direct current accordingly. That this condition is also associated with the shape of the curve seems to be borne out by the fact that no such wobbling occurred where the curve was straight, but only over the curved portion.

The device does not draw current from the measured source, with leak in open position, and this use is recommended provided the tested circuit affords d. c. continuity to the grid circuit of the tube voltmeter. Where stopping condensers intervene, as in grid condenser practice in oscillators, there is no d. c. continuity for the tube voltmeter when the leak is in parallel with the grid-cathode leakage of the oscillator tube, and then the 1 meg. of the tube voltmeter may be cut in. The current drawn by the 1 meg. resistor even at maximum of the plotted scale is only 0.0000028 ampere, or 2.8 micro-amperes.



(Continued from preceding page)  
 other, so that the reduction of the plate current in VT-2 will further increase the current in VT-1 and  $r_1$ , since this action works both ways. This action repeated again and again will finally reach a point where, in this case, VT-1 will have a maximum current going through it limited only by the emission, while VT-2 will have such a high negative potential on its grid that it will be entirely blocked.

### What Determines the Frequency

This action takes place during but a fraction of the total cycle and accounts for the sharp rise of the plate current. At this stage, when one tube is blocked and the other is passing maximum current, the circuit is no longer symmetrical and the condenser begins to discharge. This discharge continues until the blocked tube

kc., i.e., exactly within the same relative error possible for the crystal oscillator. Changes in the multivibrator circuit elements or voltages will have no effect upon the frequency within wide limits. Under this operating condition the multivibrator is under the absolute control of the crystal oscillator.

### The Decimal Fundamentals

It is necessary for broadcasting stations to keep their operating frequency within 50 cycles of the assigned frequency. Usually a carefully calibrated quartz bar is used to generate some exact frequency (within about 0.003%). Bars having a natural frequency of about 100 kc are commonly employed. By utilizing three separate multivibrators, one generating 100 kc and its harmonics, the second generating 10 kc and

The author's multivibrator for 60 cycles, using four tubes, including the rectifier. This is the circuit used in the constructed device shown in the photographs on next page. From grid of first 45 to ground is a 100,000 ohm resistor. From grid of first 45 to plate of second 45 is a condenser of 0.1 mfd. By increasing either or both the frequency is lowered, by decreasing either or both the frequency is increased. For 600 cycles use 100,000 ohms and 0.01 mfd. For 6,000 cycles 50,000 ohms and .002 mfd.

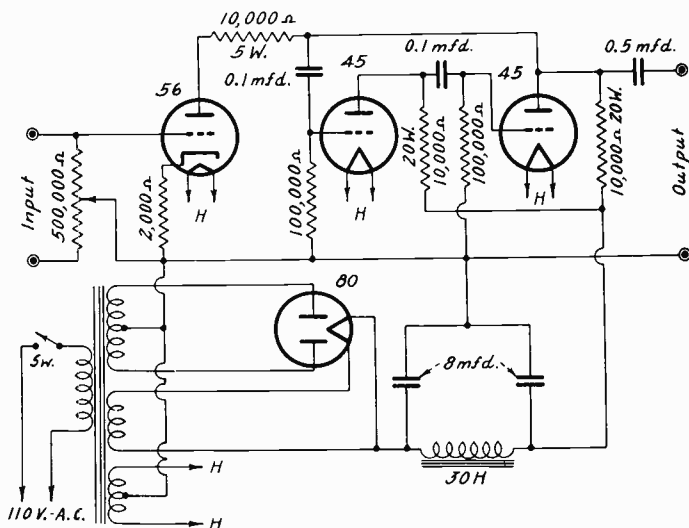

begins to draw current and then the entire action repeats in the second tube.

These oscillations by proper design may appear of any frequency between 50 kc and 1/50 of a cycle per second. The period is proportional to the product of the capacity and resistance of the circuit.

The sharp corners of the plate current curve, of course, indicate the presence of a large number of harmonics. As high as the fiftieth harmonic is detected with ease. This presence of a great number of harmonics and the fact that a multivibrator locks in step with any frequency that is a multiple of its own approximate frequency, makes a multivibrator adaptable to many applications.

Suppose a multivibrator, natural frequency about 10 kc, but not exactly this, is so connected that it is influenced by a 100 kc crystal controlled exact oscillator. Once this connection is made the frequency of the multivibrator will be noticed to shift a little, but upon careful measurements will be found to be exactly 10

its harmonics, and the third generating 1 kc and its harmonics, any radio frequency commonly used by broadcasting stations may be obtained. This frequency will be almost as exact as the frequency of the quartz bar.

As a check of the frequency a 1,000 cycle precision electric clock is run from a 1 kc multivibrator. The clock's time is checked frequently against standard time obtained from astronomical observations and broadcast by government stations. If the clock's time corresponds to the standard time within the allowed limits, the station may be considered to be operating within permissible frequency variations. On the other hand, a drift of the crystal frequency and, thereby the station frequency, will result in an error difference in time. The amount of gain or loss of the clock's time will indicate in what direction and how much the station frequency is off the assigned figure.

This application of multivibrators as station frequency monitors suggests a laboratory use  
 (Continued on next page)

(Continued from preceding page)

of one or more multipliers as exact frequency checking devices. Accuracy may be carried to a satisfactory degree with an ordinary 60 cycle electric clock and using a good watch as the standard of time. Fig. 3 and the photographs show a 60 cycle multivibrator constructed from spare parts. Other tubes may be used and the circuit is not critical.

This unit in connection with an ordinary electric clock\* may be used to test any frequency between about 60 and 2,000 cycles. For exam-

ard watch. What is the frequency of the source?

The nearest multiple of 60 close to 1,000 is 17, so that if the source's frequency were 1,020 cycles the electric clock would show true time. But since one minute was lost, the frequency must be less than 1,020 cycles. One minute is 1/60 of an hour, the time the clock ran, so that the frequency of the source is 1/60 of 1,020 less (17 cycles less). This gives us as the frequency of the source 1,003 cycles, a figure reliable to

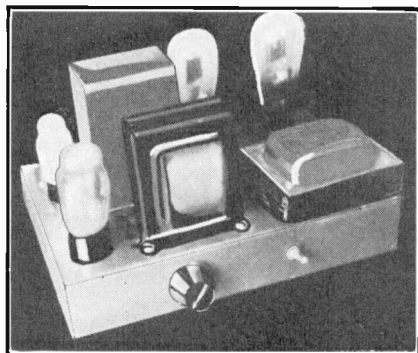
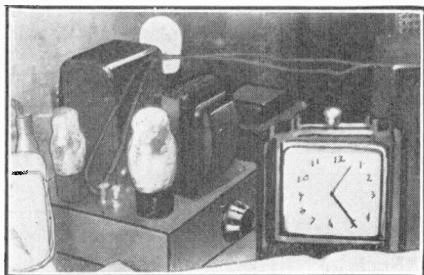

Two views of the multivibrator constructed by the author, using the diagram shown on previous page.

ple, suppose the source to be analyzed is about 1,000 cycles. The source is connected to the input terminals and the control is adjusted until the clock runs at about the right speed. After a period of time has passed, let us say one hour in this case, it is noticed that the electric clock has lost one minute as compared to the stand-

about the extent that clock scales can be read.

The testing method outlined above may be extended to higher ranges with the aid of one or more additional multivibrators. Each additional multivibrator will multiply the upper frequency limit by about ten. The application of a number of multivibrators would enable amateurs to grind their own crystals with laboratory precision, for the method outlined is exactly the one used in commercial laboratories.

\* If the clock requires considerable power, an amplifying unit will have to be made.

## Short Wave Battery Portable Circuit

The 19 will amplify fairly well, and certainly will oscillate, at 1.5 volts on the filament, instead of the standard rating of 2 volts. Since it is advisable to have an A supply that will last some time, a No. 6 dry cell is used, and the reason for confinement to one is that these cells are large, and in a portable short wave circuit there may not be room for the extra cell.

The input lead is a radio frequency choke coil, value not critical. L1 is the primary in the plate leg of the first triode, L2 is the grid coil for the second triode, and L3 is the tickler affecting that grid coil. The large tuning condenser is used for "rough" setting, the

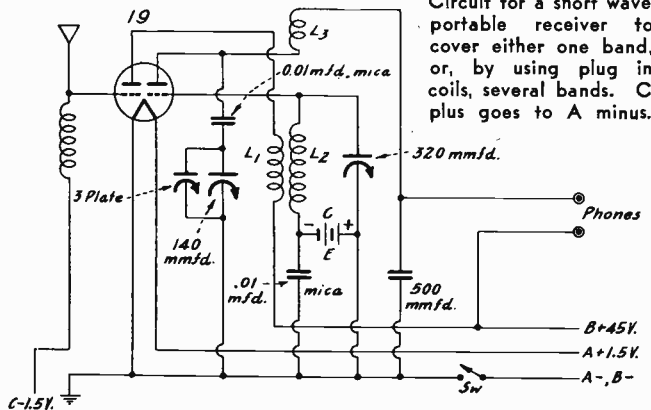

Circuit for a short wave portable receiver to cover either one band, or, by using plug in coils, several bands. C plus goes to A minus.

smaller one for finer setting, and the trimmer across the smaller main tuning condenser for close regeneration control.

# Power Amplifier Taxes Ingenuity

By Herbert E. Hayden

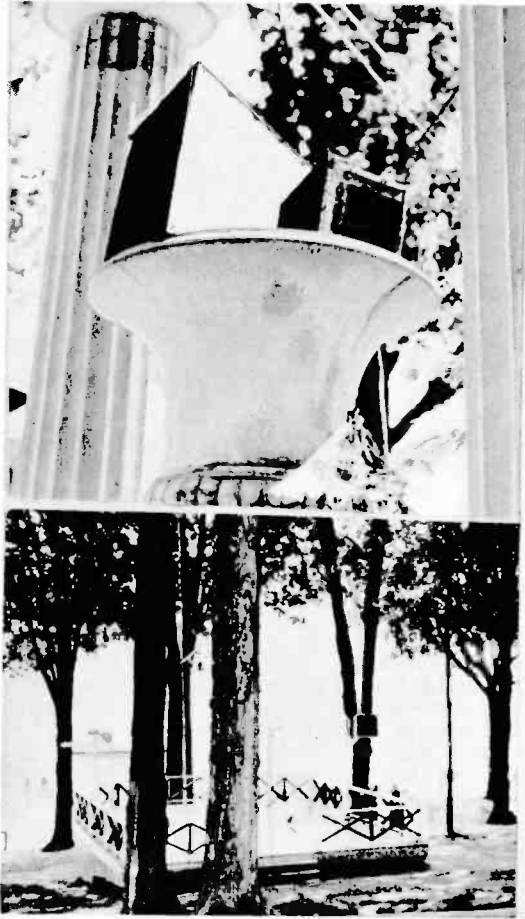

Opportunity exists for the consistence of public address systems with beautiful surroundings. Often a makeshift installation is necessary if crowds are to hear what is going on.

**T**HERE are some fine architectural creations, conceived with the idea of creating a beautiful setting to commemorate some celebrity's achievements. The vogue for public address amplifiers, and boosting the volume of radio programs for enjoyment by a large assemblage, taxes ingenuity in making an harmonious installation.

At right is shown a small part of the Edward M. Shepard Memorial Amphitheatre at Lake George, N. Y., and amid the fluted columns and the landscape gardening there has to be placed some means of rendering sound audible to large assemblies, for whom there are the "naturalized" stone steps serving as seats in the ancient amphitheatre manner, as well as benches. The reproducer is shown perched on an urn, a contrast to the placid lake behind it, and the rolling hills of the distance. At upper left is a closeup of the speaker, showing how the urn actually serves as support and container.

At lower left is shown a wooded scene in the same Memorial, with a speaker attached to the trunk of a forked tree.

The use of amplifiers amid landscaped and architectural creations imposes a requirement of conforming the electrical installation to the graces of the civic art. Artificial trees for such purpose may be used for artistic attainment, and architects will have to consider creating emplacements for speakers of large size and power, that do not suggest an intrusion upon the scene.

# Full Scale "On the Nose"

## Necessary for Correct Ohmmeter Practice

By Ambrose Bishop

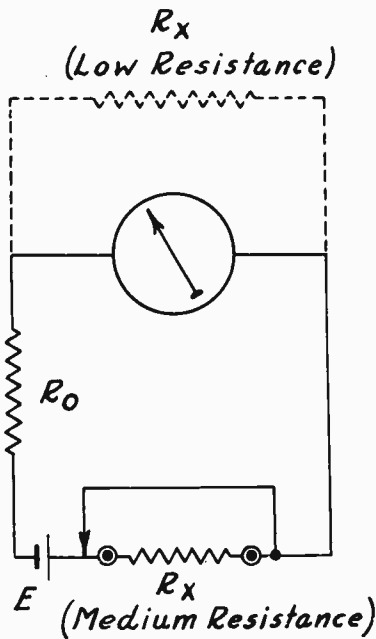

Disregarding the dashed lines, the series circuit is shown. The shunt across the meter is represented by the dashed lines.

IN ohmmeter practice full scale deflection is established in the meter, as a preliminary check, by closing the open terminals where later the unknown is to be connected, and then when the unknown is inserted its resistance is read directly, or computed, on the basis of the new current reading. For the tests that include the unknown as a series resistance, the accuracy is not affected when the current through the meter is changed, because this change is calibrated in ohms. However, for the low resistance shunt method of measurement, current through the meter changes also, and if not considered, as sometimes it is not, reduces the accuracy.

One diagram shows the conventional unknown series resistor circuit. For such service the meter scales are direct reading in ohms. There are hardly any commercial meters using the shunting method of low resistance with calibration in ohms. Since computation is used

often, the correction factor should be introduced. If the calibration were on the scale the error referred to could be eliminated by including the differential in the calibration. The formula in its accurate form is given separately herewith, while on page 49 of the May issue was printed a full-page curve for a typical meter, 0-1 milliammeter having 30 ohms internal resistance, readings obtainable from about 0.3 ohms to 250 ohms.

### How the Shunt Method Works

Another diagram herewith shows the meter shunting method. The basis of application is that putting the unknown across the terminals of the meter itself diverts part of the current through the unknown, the remainder going through the meter.

A calibration can be prepared, on the basis of the highly accurate formula, for the values of the unknown in terms of the current through the meter.

Incidentally, the needle moves in the opposite direction when the shunting method is used, compared to the series method, because the higher the unknown resistance, the less current through the unknown and the more current through the meter, whereas in the series example, the higher the unknown resistance the less current through the meter, because the unknown limits the current.

Consider the shunt method to be applied. The circuit is checked for full scale deflection. Whether full scale will be attained depends on the voltage of the source and the resistance in the circuit.

### The Voltage of a Cell

In general the voltage source is a dry cell or battery. Actually the voltage is not known accurately. The commercial rating is 1.5 volts per cell. Tests made of two popular brands of cells showed that the voltage at no drain was higher than 1.5 volts and averaged just under 1.6 volts. These tests may not be controlling as to voltages that will be supplied by cells in general, but they do show that 1.5 can not be accepted as a sure thing.

Fortunately, the actual voltage is close to the rated voltage, and besides full scale deflection always can be controlled by resistance, even though the source voltage itself is beyond control for any given cell or bank of cells.

The resistance is in three parts.

First consider the resistance of the battery or cell. This is not a constant. The resistance is

low when the cell or battery is fresh. With use and age the battery resistance increases. Since some voltage will be dropped in the resistance of the cell or battery, the voltage reading when current flows will be less as time goes on. This is because the reading is taken at the terminals, which now have an equivalent series resistance in circuit. In ohmmeter practice it is well to replenish the cell or battery when the reading at 1 ma drain is 10 per cent. less than the rating. This is approximately an average battery resistance of 150 ohms.

### Rheostat Takes Up Differences

To take up differences of this sort a series rheostat is used, and it should be large enough to enable exact full scale deflection when the cell voltage is higher than expected or rated, and also to afford reduction of resistance, that is, work in the opposite direction, when the cell resistance rises. It would be satisfactory, for instance, to have 100 ohms between the full scale point established when the cell is fresh, and zero resistance terminal of the rheostat in respect to arm, so that when one had to turn the arm to that terminal one knew that the cell should be replenished.

The other resistors in the constructed outfit are the fixed series limiting resistor and the internal resistance of the meter itself. It is not wise to ignore the meter's resistance, which for popular makes of 0-1 milliammeter is around 30 ohms.

If the shunting method of low resistance measurement is used, of course a series circuit is present, too, composed of the limiting resistor, the cell, and in fact the effective series resistance of the meter-shunt circuit.

### The Limiting Resistance

Suppose that a meter of 30 ohms internal resistance is being used in the series leg, the cell actually is 1.5 volts, and a limiting resistor of 1,500 ohms is used. The assumption, false though it be, is that all the resistance is in the limiting leg, but the meter has 0.02 per cent. of the resistance of the limiter. But with 1,500 ohms limiter, plus the meter resistance, total 1,530 ohms, the full scale deflection current is not established under the stated voltage condition, because only 980 microamperes flow, instead of 1,000. Hence the sum of the meter resistance and limiting resistance should be less than the total required resistance by an amount somewhat smaller than the series rheostat's total resistance. Since it is desired to have this rheostat work in both directions, using, say, rheostat center as datum, then the rheostat should have a total resistance at least twice as great as previously mentioned.

As has been said, with the proper rheostat and smaller fixed resistor there is no difficulty in establishing full scale deflection exactly.

### Small Shunted Resistors

Taking now the example of 1,500 ohms fixed  
(Continued on next page)

## Highly Accurate Resistance Formula

This is the circuit for measuring the unknown low resistance  $R_x$ , when full scale deflection is established first on the sensitive d.c. milliammeter, due to relationship of the cell or battery voltage  $E$ , and the series resistors  $R$  and  $R_h$ , likewise the meter's own resistance. The designations coincide with those used in the formula set forth below.

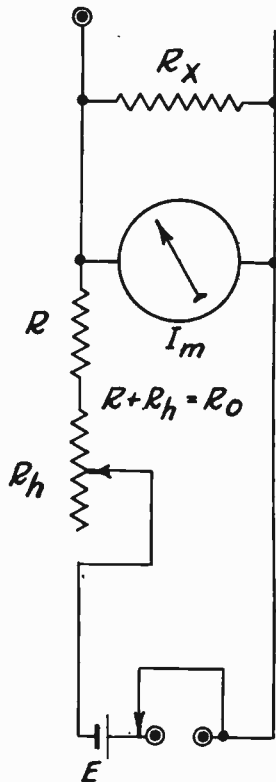

For highly accurate determination of unknown low resistances by the meter shunting method the following formula, which considers the decreasing series resistance when meter shunts decrease in resistance, applies:

$$R_x = \frac{R_m (R_o + R_m)}{\frac{E}{I_m} - R_o}$$

in which

$R_x$  is the unknown resistance.

$R_m$  is the internal resistance of the meter itself.

$R_o$  is the limiting resistor and would include a rheostat, if used.

$E$  is the battery voltage.

$I_m$  is the current through the meter alone.

When the meter is checked for accurate full scale deflection the fact that  $E$  and  $R_o$  may not be accurately known does not affect the result, if  $E$  and  $R_o$  are taken at standard ratings. The meter error in practice would be larger than the calculation error, by far.

(Continued from preceding page)

limiting resistor, plus the meter resistance, total 1,530 ohms for the specified conditions, and 980 microamperes instead of full scale, if we put some very small unknown resistance across the meter, the current increases almost to full scale, because the forgotten meter resistance is practically eliminated, and 1,500 ohms becomes sensibly right.

For instance, suppose the unknown is 0.3 ohm, about the lowest ohmage readable by the system on usual meters, for reasons of definition of current on the scale, this is almost a short to the original 30 ohms, and the meter current is 996 microamperes. This would read as full scale. A difference of 0.4 per cent. can not be closely determined on such meters, and besides the guaranteed accuracy of the meter, applicable to full scale only, is 2 per cent.

The condition, however, does point to the fact that the shunting method changes the equivalent series resistance.

The change is exponential. By resorting to computation the error is eliminated, using the separate formula. Most persons do not desire to work a formula, preferring direct reading. In the absence of direct reading a chart might be prepared and consulted. The point is that unless full scale deflection is accurately attained, the results as determined from the chart will be somewhat inaccurate at some settings. So it is very important to establish full scale deflection "on the nose." Then, say, if the meter resistance is 30 ohms, the series resistance added, including rheostat, is 1,470 ohms, and for 1.5 volts, the current is 1,000 microamperes.

#### Fairly Accurate Accuracy

When the unknown is so small that the meter resistance is practically cancelled out, the theoretical full scale deflection would be 1,002 microamperes. This is established by testing with 1,440 ohms series resistance, and using the 30 ohm meter resistance to total 1,470 ohms, when the case becomes practical rather than theoretical.

Ignoring the change of series resistance introduced by shunting the meter the unknown may be determined on the basis of this simple formula:

$$R_x = \frac{R_m I_m}{I_{max} - I_m}$$

Where  $R_x$  is the unknown,  $R_m$  is the resistance of the meter alone,  $I_m$  is the current through the meter alone, and  $I_{max}$  is full scale deflection current.

Taking the full scale as 1 milliampere and using its equivalent in microamperes, we might test for a few unknowns, say, for (a) 15; (b) 30; (c) 50; (d) 100; and (e) 500 microamperes.

$$\begin{aligned} R_x &= 30 \times \frac{15}{985} = 0.45 \text{ ohm} \text{---(a)} \\ R_x &= 30 \times \frac{30}{970} = 0.93 \text{ ohm} \text{---(b)} \\ R_x &= 30 \times \frac{50}{950} = 1.575 \text{ ohms---(c)} \\ R_x &= 30 \times \frac{100}{900} = 3.33 \text{ ohms---(d)} \\ R_x &= 30 \times \frac{500}{500} = 30 \text{ ohms---(e)} \end{aligned}$$

It can be seen that the resistance is not linearly related to the current read, simply by observing that the 50 microampere example yielded 1.575 ohms, and the 500 microampere example yielded 30 ohms, not  $10 \times 1.575$  or 15.75 ohms. Also, when the shunt resistance exactly equals the meter resistance, the meter reads half scale. This fact is used as a basis of obtaining a shunt resistance, then measuring the resistance of the shunt externally in a high current circuit, the answer being the resistance of the meter, for it is the same as the resistance of the shunt. This was done and shown in detail in the May issue.

#### Higher Accuracy

If it is desired to have still greater accuracy, although it is a fine point and will not prove of much value to most experimenters, the rheostat in the series leg may be set for some definite value required by the cell, etc., for full scale exactitude, and resistance differences calibrated on a scale to be affixed to the pointer of the knob. These differences would represent ohmage from the prescribed full scale setting.

#### Linear Rheostat Used

A rheostat with linear characteristic would be necessary. The scale would have to be rotatable, so as to follow the so-called zero setting, which in respect to the rheostat would change from period to period. The calibration could be in steps of 5 ohms from reference point (taken as 0), to 30 ohms, if that is the meter resistance. Then when any very small resistance value is being tested, if the reading is in tenths of an ohm the rheostat is moved to higher ohmage to include 30 ohms more, as if the meter had been shorted by the unknown. For 1 to 3 ohms the knob could be turned to read at the estimated equal distance between 0 and 5 ohms.

As a comparison, the more accurate method as derived from the separate formula gives (a) as 0.456 ohm and (d) as 3.324 ohms, compared to 0.45 and 3.33 ohms. For readings from half scale to higher currents the correction factor becomes smaller and may be ignored, i. e., the simpler formula above the tabulation is ample.

### Glad to Answer Questions on Who Makes the Parts

IF you want to know who makes any radio product shown or mentioned in these columns, a quick reply is yours for the asking. Address Trade Editor, RADIO WORLD, 145 West 45th St., N. Y. City.

## UNDERWRITERS' RULES FOR TRANSMITTERS

The following paragraphs apply to amateur transmitting stations.

a. Antenna and counterpoise conductors outside buildings shall be kept well away from all electric light or power wires of any circuit of more than 600 volts, and from railway, trolley or feeder wires, so as to avoid the possibility of contact between the antenna or counterpoise and such wires under accidental conditions. Antenna and counterpoise conductors where placed in proximity to electric light or power wires of less than 600 volts, or signal wires, shall be constructed and installed in a strong and durable manner, and shall be so located and provided with suitable clearances as to prevent accidental contact with such wires by sagging or swinging.

b. Antenna conductor sizes shall be not less than given in the following table:

Material	Stations to which power supplied is less than 100 watts and where voltage of power is less than 400 volts	Stations to which power supplied is more than 100 watts or voltage of power is more than 400 volts
		Material
Soft copper ....	14	7
Medium - drawn copper .....	14	8
Hard-drawn copper .....	14	10
Bronze or copper clad steel ....	14	12

c. Splices and joints in the antenna and counterpoise span shall be soldered unless made with approved splicing devices.

d. Lead-in conductors shall be of copper, bronze, approved copper-clad steel or other metal which will not corrode excessively and in no case shall be smaller than No. 14.

e. Antenna and counterpoise conductors and wires leading therefrom to ground switch, where attached to buildings, shall be firmly mounted five inches clear of the surface of the building, on non-absorptive insulating supports such as treated pins or brackets, equipped with insulators having not less than five inches creepage and air-gap distance to inflammable or conducting material, except that the creepage and air-gap distance for continuous-wave sets of 1,000 watts and less input to the transmitter, shall be not less than 3 inches.

f. In passing the antenna or counterpoise lead-in into the building, a tube slanting upward toward the inside, or a bushing of non-absorptive insulating material shall be used, and shall be so insulated as to have a creepage and air-gap distance in the case of continuous wave sets of 1,000 watts and less input to the transmitter, not less than three inches, and in all other cases not less than five inches. Fragile insulators shall be protected where exposed to mechanical injury. A drilled window pane may be used in place of a bushing provided the creepage and air-gap distance, as specified above, are maintained.

g. Adequate lighting protection either in the form of a grounding switch or suitable lightning arrester shall be provided. The grounding conductor for such protection shall be at least as large as the lead-in and in no case smaller than No. 14 copper, bronze, or approved copper-clad steel. The protective grounding conductor need not have an insulating covering or be mounted on insulating supports. The protective grounding conductor shall be run in a straight line as possible to a good permanent ground suitable for the purpose. The protective grounding conductor shall be protected where exposed to mechanical injury.

h. The operating grounding conductor where used shall be of copper strip not less than  $\frac{3}{8}$  inch wide by  $\frac{1}{32}$  inch thick, or of copper bronze, or approved copper-clad steel having a periphery, or girth, of at least  $\frac{3}{4}$  inch, such as a No. 2 wire, and shall be firmly secured in place throughout its length.

i. The operating grounding conductor shall be bonded to a good permanent ground. Preference shall be given to water piping. Other permissible grounds are grounded steel frames of buildings or other grounded metal work in the building, and artificial grounding devices such as driven pipes, rods, plates, cones, etc. Gas piping shall not be used for the ground.

j. The transmitter shall be inclosed in a metal frame, or grill, or separated from operating space by a barrier or other equivalent means, all metallic parts of which are effectually connected to ground.

k. All external metallic handles and controls accessible to the operating personnel shall be effectually grounded.

No circuit in excess of 150 volts should have any parts exposed to direct contact. A complete dead-front type of switchboard is preferred.

1. All access doors shall be provided with interlocks which will disconnect all voltages in excess of 750 volts when any access door is opened.

m. Under the conditions noted in paragraphs 1, 2 and 3 below, wiring may be grouped in the same conduit armored cable, electrical metallic tubing, metal raceway, pull-box, junction-box or cabinet.

1. Power-supply wires are introduced solely for supplying power to the equipment to which the other wires are connected.

2. Wires other than power-supply wires run in conduit, armored cable, electrical metallic tubing, metal raceway, pull-box, junction-box or cabinet with power-supply wires are insulated individually or collectively in groups by insulation at least equivalent to that on the power-supply wires or the power and other wires are separated by a lead sheath or other continuous metallic covering.

3. Terminals for the power supply conductors and the other conductors provide spacings of all other terminals from the power terminals at least as great as the spacing between power terminals of opposite polarities and also suitable means are provided to guard against connecting other conductors to the power supply terminals.

# THE 6B5 :: Most Interesting Tube Since the Variable Mu

By K. N. Satterwhite

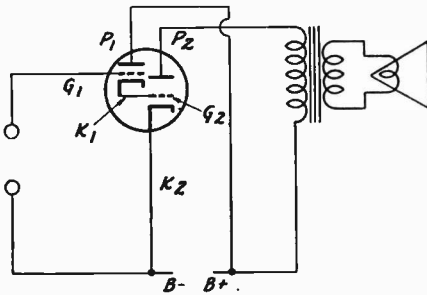

The 6B5 in a single sided circuit is shown, with the elements identified by subscripts. The input triode consists of P1, G1 and K1. It can be seen K1 is not accessible externally. The output triode consists of P2, G2 and K2. P, G and K refer respectively to plate, grid and cathode. The diagram does not show heater. Refer to the underneath view of socket. A load resistor or transformer secondary may connect to binding posts.

THE most interesting tube to come out since the variable mu tube appeared a few years ago is the 6B5, consisting of two triodes in one envelope, one of which is a signal voltage load supply tube, the other the output tube. It is practical to use two of the tubes in push pull and obtain large power output under circumstances of unusually low distortion.

One of the fascinating facts about the tube is that the input load on the first tube serves as grid to cathode impedance of the second tube. This is made possible by tying the grid of the second tube to cathode of the first tube, done in the manufacturing process. Thus direct coupling prevails. The manufacturing process also establishes the correct phase relationships, so that the tubes work together, and their entire performance should be regarded as that of a single tube, although for technical dissection it is necessary to consider the tubes separately. The intimacy of one triode to the other makes it difficult to consider the final result as that of two separate tubes, especially as a strikingly linear relationship is established because of the unified variation.

### Grid Runs Positive

In fact, the curves show that the tube is closer to a diode detector, as to linearity, than any other amplifier tube, so that harmonics due to curvature of the characteristic are almost absent, and such harmonics as are present then

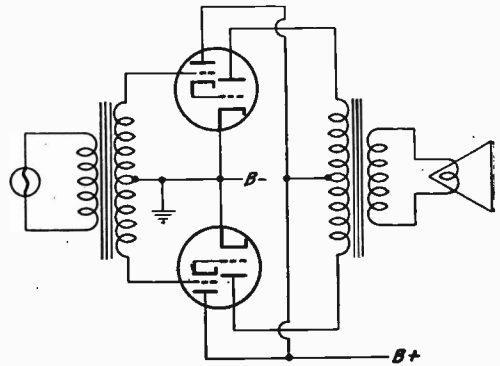

For push pull this circuit may be used, if only 300 volts are applied. The power output then would be 15 watts. For 20 watts output the B voltage should be raised to 400 volts, and a bias applied. Either a 140 ohm resistor or a 12-volt dry battery would be connected between common cathode and the joint of the ground lead, battery plus to cathode. Thus the 6B5 gets into the 2A3 class for output capabilities

would be due largely to effects of output loads (for instance, speakers), and working the tubes far beyond the intended limits.

Another interesting point about the 6B5 is that it runs a positive grid. This formerly was taken somewhat in the sense of a patient running a high temperature, but when Class B amplifiers of consequence came along, equipped with special purpose tubes, operated at zero bias at no signal input, and running grids in the only direction possible, the world became cured of positive grid phobia. It is therefore prepared to hear of a tube that not only runs a positive grid, but has a straighter characteristic on the positive than on the negative slope, so is worked as Class B would be, in usual practice, at zero operating bias, and with 300 volts on the plate, too.

### What Class? A, B, AB or What?

It is not intended to say that the operation is that of Class B. It is Class—well, it is hard to say just what the class is. What shall be the criterion? During what part of the cycle the tube is functioning?

Taking efficiency as a basis, the new tube is equal to a pentode.

Taking power output capabilities as the standard, the performance of the new tube is equal to Class B.

(Continued on next page)



**CHARACTERISTICS OF 6B5**

Heater Voltage (a.c. or d.c.)...6.3 volts  
 Heater Current .....0.8 ampere  
 Bulb .....ST-14  
 Base .....Medium 6 pin

**Single Class A Amplifier**

	<i>Input</i>	<i>Output</i>
Plate Voltage	300 volts	300 volt.
Grid Voltage	0	0
Plate Current	6 ma	45 ma
Plate Resistance	.....	24,100 ohms
Amplification Factor	.....	58
Mutual Conductance	.....	2,400 micromhos
Load Resistance	.....	7,000 ohms
Total Harmonic Distortion	.....	5 per cent.
Power Output	.....	4 watts

**Push Pull Class A Amplifier**

	<i>Input</i>	<i>Output</i>
Plate		
Plate Voltage	400 volts	400 volts
Grid Voltage	13 volts	13 volts
Plate Current	4.5 ma	40 ma
Load Resistance		10,000 ohms
Total Harmonic Distortion		5 per cent.
Power Output		20 watts

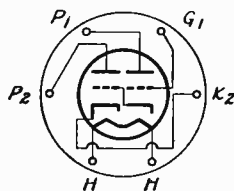

The socket connections as seen from the bottom. The symbols correspond to those shown on the diagram of the single sided Class A amplifier. Just where the heater is to be grounded will depend on the type of circuit used. For a.c. operation the center of the heater winding is usually grounded.

*(Continued from preceding page)*

Taking performance as a comparison the new tube ranks Class AB.

Taking distortion level, the tube is comparable to Class A.

From the foregoing it may be assumed that the strictly technical classifications are put aside for the moment, efficiency, power, performance and distortion being considered, that is, the effects of the different classes, rather than the cyclic operation that determines the A, B, AB classification.

**Portable  
 6B5  
 Amplifier**

The photographs show the constructional factors of a small portable amplifier, the diagram revealing the circuit, with the new 6B5 combination tube. As very small impulses may have to be amplified at times, a driver is used in this instance, although in receiver practice it would not be strictly necessary to provide a driver for the new tube. At right, the flap is to be pulled up when speaker behind it is in operation.

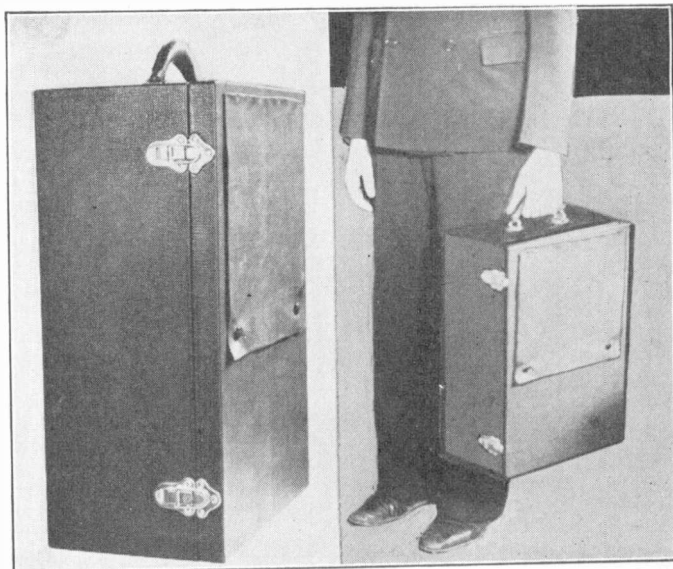

**Opportunity Exists for Stable Oscillator**

Since the 6B5 tube is one that may be operated at zero bias, resulting in practically a straight line on either side, that is, for negative or positive pulses applied to the grid, the tube may be used as an otherwise unbiased oscilla-

tor, with promise of frequency stability. This is true because if the amplitude is held low the plate current change will be small and linear, both considerations fully consistent with stability.

# Utilizing an Old Console

## Tuner, Power Amplifier and Speaker Installation

By Herbert Erwin

IT was decided to install a high fidelity tuned radio frequency tuner and amplifier, together with its dynamic speaker, in a console cabinet that had previously been used to house a standard set. Since holes had been left in the cabinet by the previous fittings, such as protruding metal shafts and dial openings (in this case the opening was rectangular) it was desirable to construct the new unit so that it could match up with these holes as nearly as possible.

This was accomplished by placing a sheet of cardboard across the face of the cabinet, covering all openings, and with a lead pencil, marking these positions on the cardboard, including the dial opening, then transferring this pattern to the chassis, and moving the controls over to fit on the same holes. The airplane dial, being circular, was centered over the section formerly occupied by the rectangular opening, the cardboard pattern then being transferred to the cabinet again, and the surplus wood cut away.

### Shelf Inside Cabinet

All that remained was to build a little shelf inside the cabinet to hold the tuning unit, which was then slid forward and the controls shoved through the holes in the cabinet. The amplifier is connected through a two wire cable which is sheathed with a metallic covering and grounded to prevent pickup. The amplifier rests on the floor of the cabinet alongside the Rola G-12 speaker.

The combination of the three circuits, high fidelity tuner, amplifier and high fidelity speaker, result in extremely satisfactory performance, although some will prefer a superheterodyne for the tuning if better selectivity is needed. For all practical purposes and actual operation, the combination described is very satisfactory.

It is useless, however, to design a flat top high fidelity tuning element that delivers a faultless signal into an amplifier that is poorly designed, and in turn brings forth a jittery signal, or to put it different, it cannot be expected that a good tuner and a good amplifier will deliver a final pleasing sound through a loudspeaker that is constructionally bad or electrically imperfect.

The speaker can only reproduce the energy that is delivered into it, and no matter how nearly perfect this signal may be if the speaker will not reproduce it, if the speaker has not sufficient signal scale response, then the resultant output in sound waves can scarcely be considered high fidelity.

### Three Considerations

Three things therefore must be correlated: the tuner, the amplifier and the speaker. Power is a later consideration.

A set designed for average home use does not need 15 watts output. This has 4 watts.

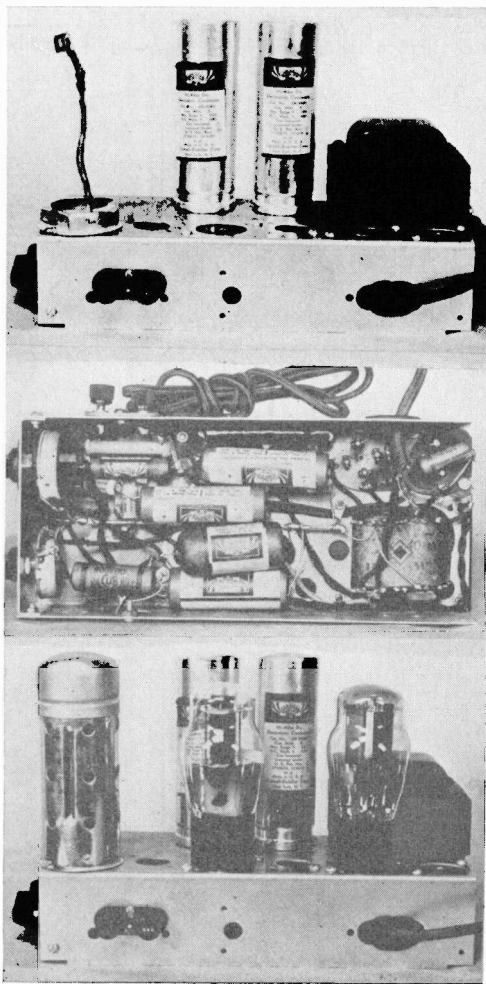

A tuner and separate power supply-amplifier were built to be fitted into a console the author had. The first view is of the side of the amplifier, with the tubes (57, 2A5 and 80) removed. Next is shown the bottom view. Note how the medium capacity Cornell-Dubilier condensers are neatly arranged to permit of splendid symmetry of wiring. Bottom picture shows tubes in place on amplifier chassis size 10 x 4 x 1.5 inches.

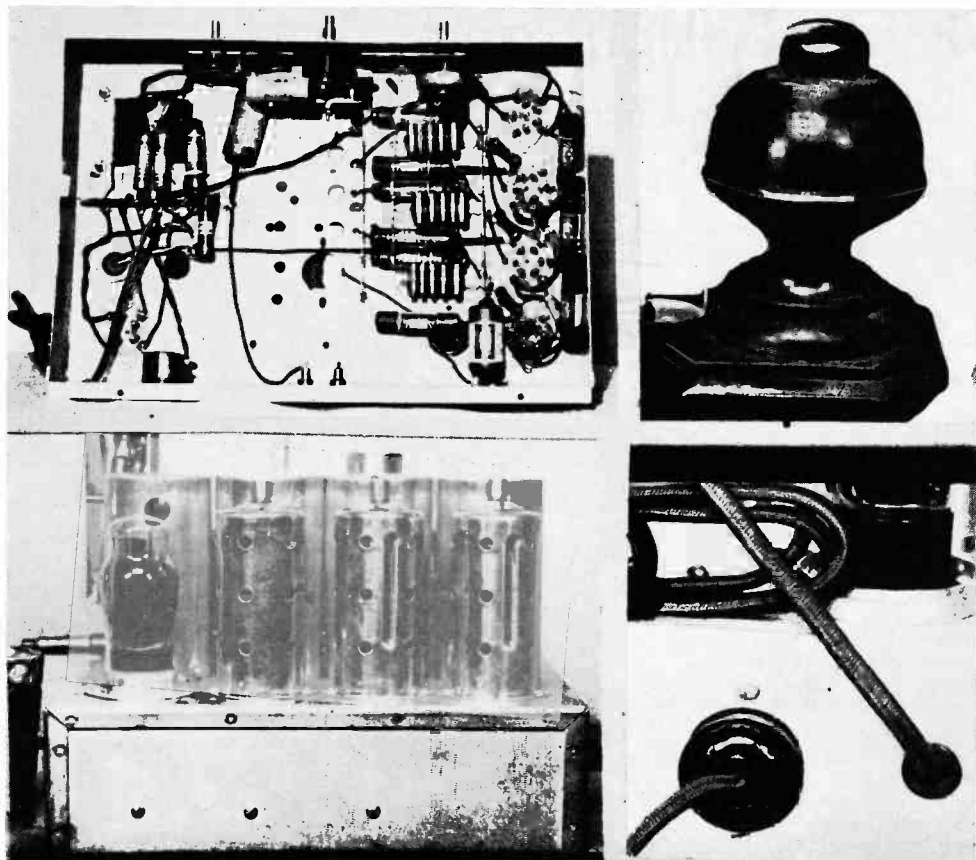

The two views at left are of the receiver side and bottom. At top right is a wooden caster, with rubber bed just below the polished metal cap at top (the caster is shown upside down). The reason for replacing the simple metal caster (lower left of same picture) was that tone was improved, the console being freed of certain jarring effects due to acoustical resonance because of the liveness of the sprung rubber. Immediately below are shown the a.c. cable outlet for connecting to wall socket, (right) and the lead from amplifier to set with male plug attached, so the set switch also turns the amplifier on and off.

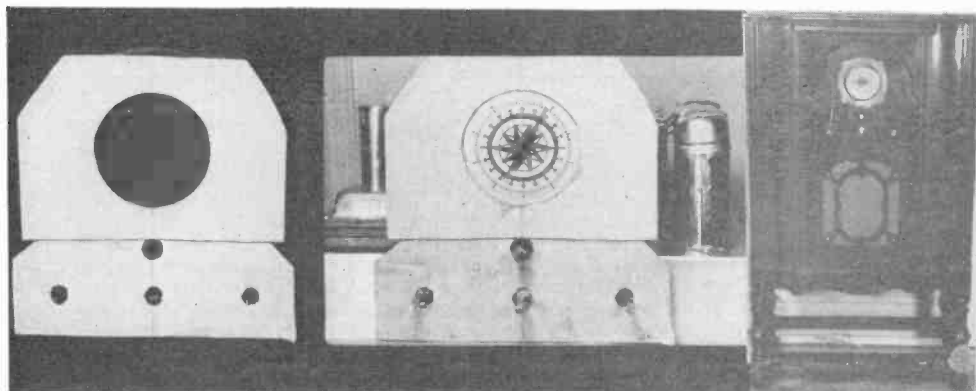

A template was prepared from cardboard as shown at left, so that the control and airplane dial positions could be closely located, for communication of markings to the console front, preparatory to drilling. Center view shows templates on set. At right is the finished installation, front view.

# Filter Design and Application

## Simple Circuits for Audio Systems

By Morris N. Beitman

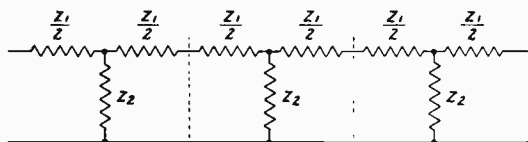

FIG. 1

A filter diagram illustrating T section division between dotted lines.

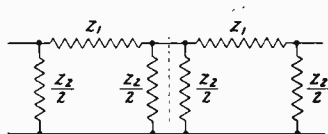

FIG. 2

A filter diagram illustrating pi section division between dotted line.

**F**ILTERS are electrical devices that show varied "shut-out" discrepancy to different frequencies. In other words, filters change their impedance to different frequencies. By utilizing capacity, inductance and resistance in various circuit combinations it is possible to vary the amount of suppression of any frequency group. By combining a number of similar sets of filters much sharper and more exact results may be obtained.

### How Filters Are Classified

The use of filters in radio and allied fields is great and varied. All tuning units are one form of filter. Bypass condensers across bias resistors, detector radio frequency chokes, and power chokes and condensers are only a few more examples of filters found in radio.

In one manner filters may be divided into four categories depending upon the function they are called to perform. Each one of these four classes will be considered as to circuit details, application, and design.

Filters may be low pass, high pass, band pass, and band elimination relative to the frequencies passed or attenuated. Each of these filters may be divided into a number of either T or  $\pi$  sections. Which division is chosen is immaterial, for there is a simple group of

mathematical formulas that enables interchange at any single frequency of a three element T filter with a three element  $\pi$  filter, and vice versa.

The reason that one of these divisions is used is because the analysis and calculations are greatly simplified. For example, with the aid of this interchangeable theory, any network composed of linear impedances for any given frequency can be simplified to a single T or  $\pi$  section. If we begin with a  $\pi$  section it can be reduced to a T section; two T sections can be reduced to a  $\pi$  section with extra arms; and this  $\pi$  section can be further reduced to a T and the arms are added on. In this manner complicated networks can be greatly simplified.

### The Low Pass Filter

A low pass filter with no resistance losses in its elements will pass, without attenuation, currents of all frequencies from zero to the cutoff value and will greatly attenuate frequencies beyond this value. Of course resistance is always present in the inductance or condensers that go to make up the filter. This resistance has the effect of making the cutoff point less sharp; i.e. frequencies near the cut-

*(Continued on next page)*

## Barkhausen Theory Undergoing Revision

When Barkhausen and Kurz announced that they had made conventional tubes oscillate on centimeter waves, by making the grid positive, plate either zero or slightly negative, and tuning by altering the voltages of the supply, their discovery was hailed as representing a new form of generator. It was considered an "electron" oscillator, different from the usual kind. The circuit as devised by the two Germans was modified by two Englishmen, Gill and Morrell, who used tank circuits. The Barkhausen oscillator then began to look theoretically somewhat more like any other oscillator.

Now F. B. Llewellyn, noted oscillator author-

ity, writes in the Bell Telephone "Record" that the Barkhausen is in fact much like any other oscillator, and he details the electron path and activity on which his conclusion is based. Moreover, in other quarters the theory that the distance between elements limits the frequency, due to the transmit time of the electron movement between these parameters confining the upper frequency, is under fire, if not already disproved. And the limits of oscillation are under other forms of iconoclastic study, so that the early theory of the Barkhausen circuit has been partly upset and is due to meet further amendment.

off point but below it are attenuated to a limited extent, and the frequencies slightly above the cutoff point are passed with relative freedom. For this reason the units of a high grade filter should always possess the least resistance possible. For the cutoff frequency

$$f = \frac{1}{\pi \sqrt{LC}}$$

where  $L$  is the inductance in henries and  $C$  is the capacity in farads, of the low pass filter shown in Fig. 3, both as a  $T$  and  $\pi$  types.

If the input and output impedances are known and are equal to  $Z$ , the inductance and capacity of the filter may be computed for the cutoff frequency  $f$ :

$$L = \frac{Z}{\pi f}$$

$$C = \frac{1}{\pi f Z}$$

### Reason for More Sections

If need arises to cutoff all frequencies above 1,000 cycles, where  $Z$  is 500 ohms, these values substituted in the equations above will give:  $C = 0.64$  mfd., and  $L = .159$  henries. Commercial units close to these values are obtainable.

If a certain frequency is suppressed a certain amount by a single section, two such sections will suppress exactly twice this amount. Therefore by utilizing a number of sections any degree of attenuation may be attained. By reducing the circuit resistance to a low figure, the same results may be obtained with fewer sections.

### High Pass Filter

A high pass filter freely passes all frequencies above the critical or cutoff frequency and greatly attenuates the currents below this frequency. One high pass filter is shown in Fig. 4, both  $T$  and  $\pi$  sections. The capacity  $C$  and inductance  $L$  are computed from the formulas:

$$L = \frac{Z}{4 \pi f_0} \text{ henries}$$

$$C = \frac{1}{4 \pi f_0 Z} \text{ farads}$$

### Band Pass Filter

A band pass filter passes a given band of frequencies and attenuates those above and below this band. The object in designing a good band pass filter is to have little loss in the band to be passed, high attenuation in all outside frequencies, and a sharp turn from band pass to attenuation regions. These objectives can be accomplished by reducing the d.c. resistance to a minimum, and using a sufficient number of well designed units.

From the discussion of a high pass and a

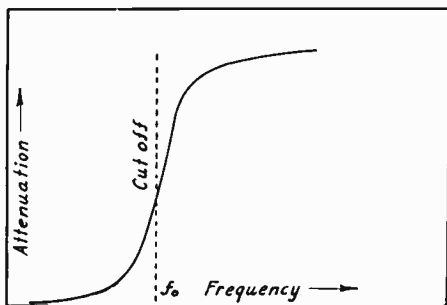

FIG. 3

Low pass filter with a cutoff frequency  $f_0$ , showing attenuation variations with rise in frequency.

low pass filter it becomes evident that if the two are combined and if they have cutoff frequencies that differ, the band that is passed will be between the two cutoff frequencies. For example, if a low pass filter will attenuate all frequencies above 5,000 cycles, and a high pass filter will pass frequencies above 4,000 cycles, then if the two are combined only the band between 4,000 and 5,000 cycles will be passed.

In practice, however, the two filter sections are combined into one structure as illustrated in Fig. 5. A more complex structure is possible and is used for some special applications. But for most ordinary needs of a band pass filter the type illustrated would serve the need excellently. At some group of frequencies, corresponding to the band to be passed,  $C_1L_1$  combination will be resonant and  $C_2L_2$  combination anti-resonant, so that  $C_1L_1$  will offer negligible resistance and  $C_2L_2$  will offer infinite resistance, theoretically. The values of the condensers and inductances may be computed from the formulas given below, where  $f'$  is the lower limit of the band to be passed, and  $f''$  is the upper limit.

$$L_1 = \frac{Z}{\pi (f'' - f')} \text{ henries}$$

$$C_1 = \frac{(f'' - f')}{4 \pi f' f'' Z} \text{ farads}$$

$$L_2 = \frac{(f'' - f') Z}{4 \pi f' f''} \text{ henries}$$

$$C_2 = \frac{1}{\pi (f'' - f') Z} \text{ farads}$$

### Band Elimination Filter

A filter of the band elimination type is designed to pass freely currents of all frequencies except those within a given band. A structure such as illustrated in Fig. 6 is commonly

(Continued on next page)

used. The curve in Fig. 7 shows the characteristics of this type filter. This type of filter is quite efficient for ordinary application and is quite simple in design. Fig. 6, of course, illustrates a single section of an L type filter

incorporate in the phonograph line a band elimination filter that will eliminate the band slightly above and below 4,000 cycles. Let  $f' = 3,900$  cycles and  $f'' = 4,100$  cycles. Substituting these figures in the formulas above we get the

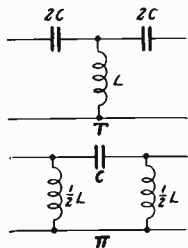

FIG. 4

A T and pi type high pass filter.

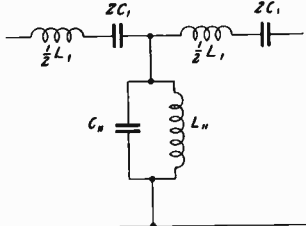

FIG. 5

A T type band pass filter.

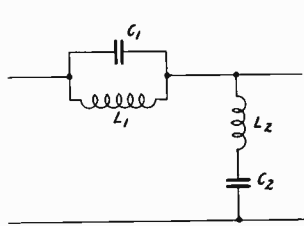

FIG. 6.

Band elimination filter. Single L section.

for this application. The values of the different parts used may be computed from the formulas given below, where  $f'$  is the lower frequency of the band to be eliminated, and  $f''$  is the upper limit of the band, since there are only two limits to be considered for such simple filters.

following values (assuming input and load impedance 17,000 ohms):

$$L_1 = \frac{(f'' - f') Z}{\pi f' f''} \quad \text{henries}$$

$$C_1 = \frac{1}{4\pi (f'' - f') Z} \quad \text{farads}$$

$$L_2 = \frac{Z}{4\pi (f'' - f')} \quad \text{henries}$$

$$C_2 = \frac{f'' - f'}{\pi f'' f' Z} \quad \text{farads}$$

- $L_1 = 0.068$  henries
- $C_1 = 0.023$  mfd.
- $L_2 = 6.8$  henries
- $C_2 = 0.0025$  mfd.

Commercial units close to these sizes will of course serve the purpose.

In certain engineering procedure need arises for more specialized filters, but the types described should prove satisfactory for the usual radio and public address practice.

### Application of Scratch Filter

For example, we may consider the need of filtering out the needle noise of a phonograph pick-up. Usually this noise is of one frequency, about 4,000 cycles. In other words, all that is needed to eliminate this undesirable noise is to

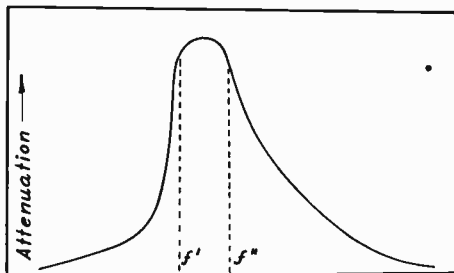

FIG. 7

Characteristics of a band elimination filter. It is intended to eliminate the frequencies between  $f'$  and  $f''$ .

## Glow Indication of Zero Beat

Under some circumstances it is advisable to get exactly zero beat, or at least closer to zero than by the usual ear test, and in that instance a visual index fills the need. One oscillator beats with another to produce the audio from the two radio sources. Therefore if the outputs are united and put into another tube—a detector—the output of the detector can be sufficient to actuate an indicating device, such as a regular d.c. milliammeter or the new ray indicating tube, 6E5. The oscillator being varied

is brought as close to zero as practical, meaning the needle will stand still, or indicating tube stay steadily lit or out, or movement will be so slow that the number of cycles a second can be counted accurately against the second hand of a synchronous motor clock. Then even "how far off from zero" is known, but not on which side. The "side" may be determined by slightly turning the oscillator dial. If the movement increases the former "offness" is to be subtracted from the true frequency.

# Small Rectifiers for B Supply

## Handy for Testing and for Powering Small Sets

By Jack Tully

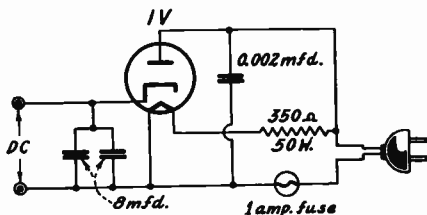
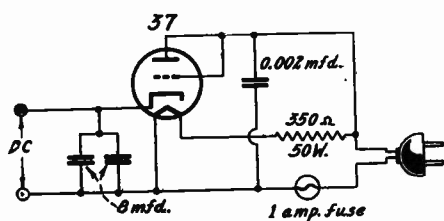

Substitution of the IV rectifier tube for doubling the current drain. The d.c. output voltage is unchanged, about 105-125 volts.

A 37 or 76 tube may be used as rectifier. The two electrolytic condensers, 175 volt peak rating, are in one cardboard container.

**O**FTEN in experimental work the need arises for a source of d.c. voltage up to around 100 volts or so, and this may be obtained from a small rectifier. A diagram shows such a rectifier that has been in use for several weeks, the appearance being revealed in the photographs. In that time on scores of occasions the rectifier has been put to handy service, for supplying the d.c. voltage to small high frequency generating circuits and for making meter shunts and multipliers and measuring resistance. Resistances 2 to 10 meg. have been measured, a range not covered by a battery operated ohmmeter on hand.

The circuit shows the use of a 37 tube. The other tube that may be used in the same socket without any change is the 76. The grid is tied to the plate for this type of rectifier, that is, where the current is relatively high, compared with detecting diode use, for up to 50 ma may be drawn on short occasions, although around 25 milliamperes steady drain is about the safe limit, consistent with long tube life.

### Precautions Against Shorting

If 50 ma are to be drawn for regular service, that is, if it is desired approximately to double the safe current drain, instead of a five hole socket a four hole socket is used, and the IV rectifier tube is inserted instead of the 37 or 76. A diagram shows the connections.

The line cord has a third lead built in, and this third lead contains the limiting resistor. This lead has to be so placed that during that alternation when the plate is positive to a.c. the cathode is negative to a.c. and full a.c. is applied to the plate. During the other alternation, since the plate is then negative, there is no conduction, as these are half wave rectifiers. Hence the a.c. has to appear between cathode return and plate, so cathode is necessarily connected to the line to provide a return

circuit, and any grounded line presents the danger of a short if connected to a grounded system, since "hot" side of the line could be connected to the grounded side through such external connection. This is a zero potential difference or short, hence the line fuse is included for safety. This may be an automobile cartridge type, supported on an insulated clip type holder. There are stamped end pieces obtainable which, when insulated from the chassis, permit safe insertion of the fuse. The chassis itself, if of metal, is never connected to any part of the circuit.

Usually the "hot" side of the line can be distinguished by touch. It can be felt as a tingle, whereas the other side can not. Negative d.c. output post may be used for the test.

### How to Test Line Cord

The line cord just mentioned may not follow familiar color coding. It is common to expect that black represents ground, red represents plus, and white would be the third connection. The cord used had the resistor tied at one end to the black cord side of the plug. Therefore at this plug prong black and white (the resistor) were common, so to follow the circuit connect red to cathode and one heater side, black to plate and white to other heater.

The line cord should be given a continuity test to confirm the correctness of intended connections. Laying the cord on the table, connect an indicator between the two plug prongs. No reading should obtain. Connect indicator between two cord terminals other than the one obviously representing the resistor lead, which is usually white. No reading should obtain. Between one of these leads and the resistor wire no reading should result, while between resistor and the other free terminal wire there will be a reading. The two cord terminals

*(Continued on next page)*

(Continued from preceding page)

that show this reading are to be connected as follows: resistor lead to either side of heater, other wire to plate. Cathode is to be connected to the remaining lead. This was red in the cord used in the rectifier.

### Low Efficiency Yet Low Cost

The two diagrams for transformerless operation represent what must be admitted to be an efficient method, since to work the simple rectifier around 40 watts power dissipation is required. This would be enough to operate a

the current drain may be safely 50 ma at all times, and on occasion may be raised to 100 ma for brief intervals, for some special test requirement.

### Choice of Voltages

While the earlier circuits may be used for voltages less than maximum by introducing a series resistor, say a rheostat of a few hundred thousand ohms, and the voltage measured at the test circuit, the more elaborate rectifier might well have adjustable resistors built in. One fixed resistor should be included, marked R, so that under no circumstances could the

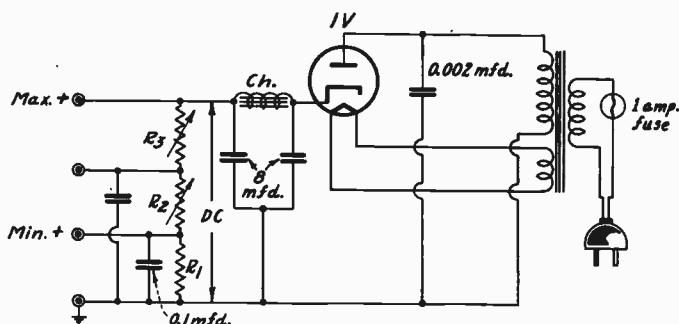

Small rectifier, using a transformer. In this way the voltage output is greater, depending on how much stepup ratio exists between primary at right and high voltage secondary; the shorting danger is removed, because of isolated grounding; the B choke, which may be an audio transformer winding, improves filtration; and the rheostats afford ready voltage selection.

six tube receiver. The trouble lies in the limiting resistor, where nearly all the power is spent, mostly in the form of heat for which there is no use. Since the resistor wire is in the a.c. cord covering, the cord will get warm, but not hot. No danger attaches to the fact that this device warms up.

Of course the 40 watt power consumption is not financially ruinous, simply representing a poor efficiency, about 0.16 per cent. output compared to 100 per cent. input, at full working output current, 50 ma, but in cost, at 10c per kilowatt hour, and the rate is less in cities, this is only 0.4 cents an hour.

### Use of Transformer

A single voltage output is obtained, as the d.c. circuit is brought out to two binding posts, but if a more elaborate rectifier is to be built, it may be done as shown in another diagram, where a small power transformer is included, having 115 volt primary, 350 volt secondary (or lower voltage secondary) and a heater winding, 6.3 volts. Not only is the maximum d.c. output voltage higher, which also requires higher rating filter condensers, but the filtration is made better by inclusion of the choke, Ch, and the d.c. output is freed from danger of short due to connection of external grounded circuit to ungrounded side of the line. Hence the first two diagrams represent a use for ohmmeter, shunt, multiplier and other similar purposes, without danger, but for wider application the third diagram is better. Also,

rectifier output be completely shorted to d.c., hence R may be 2,000 ohms, 5 watts. Then R2 and R3 may be two equal rheostats of a few hundred thousand ohms each, or, if unequal, R3 may be the larger. The resistors' bypass condensers should all be rated at maximum B voltage, which is about the same as the a.c. voltage on the secondary feeding the plate.

### Follow Line Voltage

The transformerless rectifier circuits shown herewith give a d.c. voltage output at 10 milliamperes drain or less that is equal approximately to the r.m.s. line voltage, and so may be used with d.c. meters for the a.c. measurement. If the drain is substantially increased above 10 ma this condition no longer holds.

## All Circuits We Print Can Be Readily Duplicated

ALL parts for circuits described in RADIO WORLD constructionally are obtainable. Most of them stocked by regular supply sources. We are always glad to identify the trade names of any parts, and tell where any parts are stocked. Address questions to Trade Editor, RADIO WORLD, 145 West Forty-fifth Street, New York.



# A HIGH FIDELITY POWER AMPLIFIER

## Provision for Multiple Speakers and Fixed Bias

By ROY L. SMITH

FOR my personal use I have constructed the amplifier and power supply illustrated in the photographs, using the best parts and standard circuiting, so that with a faithful reproducer the result is high fidelity.

Since it may be desirable to use more than one speaker for commercial use of such an amplifier, provision is made for powering such extra dynamics, the negative bias for the amplifier output tubes being adjusted to meet the conditions imposed by the extra current drain of an additional speaker on the 80 rectifier circuit. This bias may be made of such value as to serve Class A, Class AB or Class B purposes. It is derived from a C supply rectifier.

### Meters Described

The front panel of the amplifier shows also the meters for the mixing circuit, which meters were included because on hand, not being really necessary. These are the 0-4 voltmeter and the 0-25 milliammeter, as shown in the diagram of the mixer on the next page. The three other meters are two 0-100 milliammeters and a d.c. voltmeter, the latter not in the diagram on page 36.

There are five tubes in the amplifier, a single 56 input, push pull 56 drivers and push pull 2A3 output tubes. Various output tubes have been used, and if the filament voltage and plate voltages are suitably selected, the substitution may be made quickly. The output transformer is tapped for three voice coil im-

pedances, 4, 8 and 15 ohms, with 500 ohms as the maximum, for use if desired with a transmission line, a popular impedance for which is 500 ohms.

The power supply has two tubes, an 80 for the C bias voltage and a 5Z3 for the B voltage. The photographs at right on this page show three sockets that are not used, as the particular chassis happened to be on hand.

The mixer provides for input from a two button carbon micro-

tube without any matching devices.

Since the power supply is rather elaborate, it is well to point out again the load across the output of the 280 will vary according to the number of speakers used, so the 20,000 ohms bleeder (marked "10,000 ohms each") is tapped to provide C bias of such value as never to exceed 100 volts, preferably not to exceed 80 volts.

### One Battery Used

The small potential required for carbon microphone excitation is obtained from a C battery, all other voltages being taken from the power supply.

Diagrams of the mixer, amplifier and power supply are printed on the next page. There is a 25 mfd. condenser across the 1,250 ohm biasing resistor in the push pull 56 stage. Ordinarily no condenser is required, because with true balance there is no signal across the resistor. However, in service, if a 56 should get "sour" or go dead, the presence of the condenser permits continued operation without immediate tube replacement, and with excellent tone preserved.

For the output stage, separate bias is applied to each tube, so that static balance can be readily accomplished. This is of particular importance when 2A3 tubes are used, because they have such a terrifically high mutual conductance that a small grid voltage difference makes a large plate current difference.

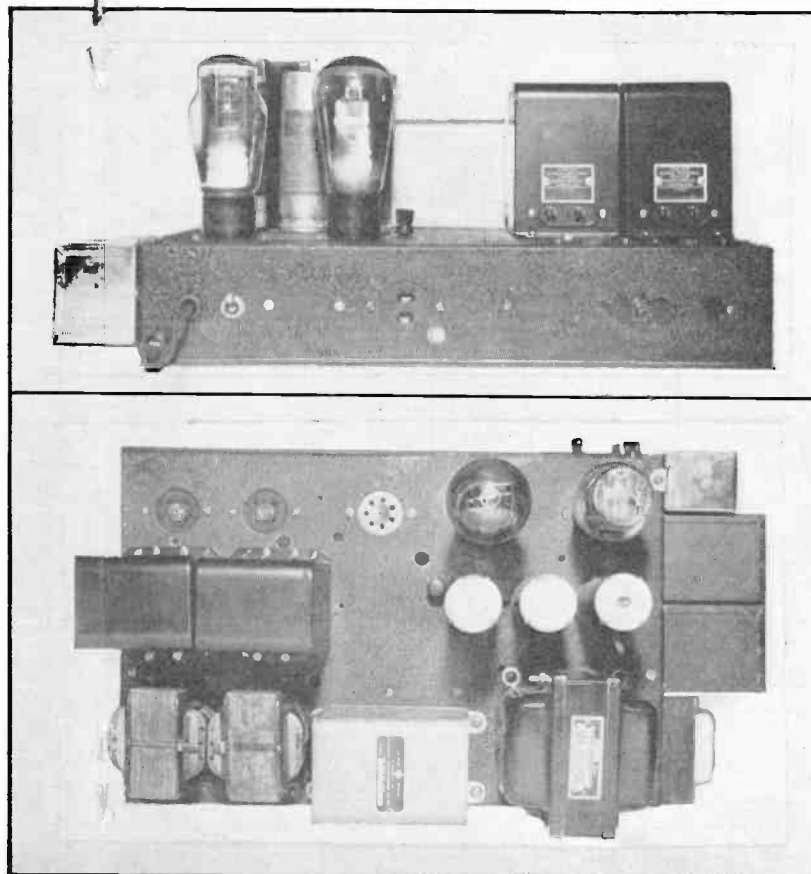
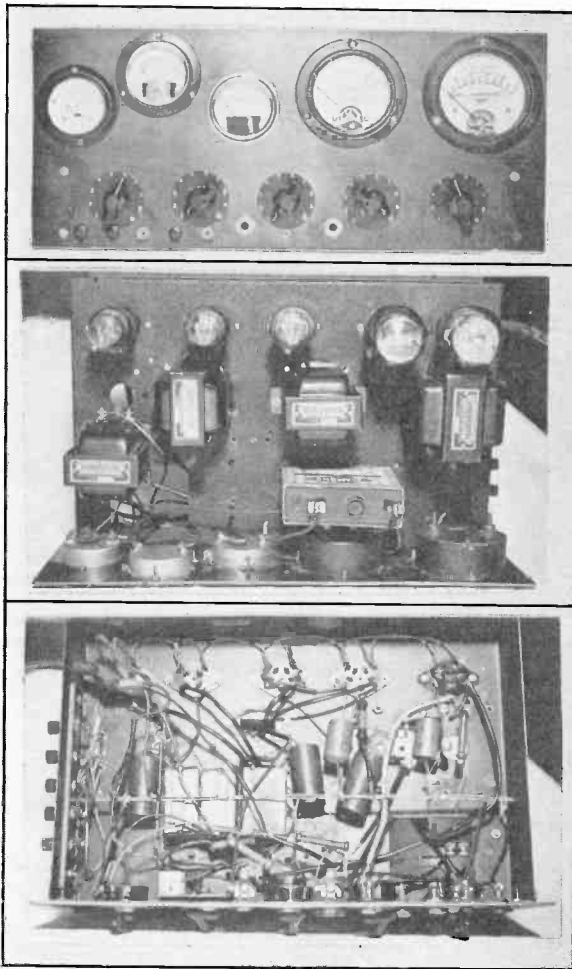

The mixer-amplifier is shown at left in three views and the dual power supply in two views above.

phone, or a high impedance phonograph pickup. If a low impedance type pickup is to be used, then, unless the impedance is close enough to that of the primary intended for the microphone, a special matching transformer would be needed, and the pickup manufacturers have the proper coupling coil for this purpose. The speech or music, or both, may be faded out at will.

The amplifier gain is not sufficient for a crystal microphone, although one may be connected across the grid load of an input

# 12 Tube Super Experiences

## Constructional Guidance from Designer of a Precise Set

By Samuel Miller

THE 12 tube all wave receiver on which I have been working for more than three months was developed along standard lines, but a few specialties had to be introduced to improve the performance, and where involving constants these are shown. They consisted principally of the following:

(1)—Use of minimum bias on the first tube on the highest frequency band, to reduce noise and raise sensitivity.

(2)—Medium voltage on the screens of the output tubes, to improve the tone, bringing the functioning nearer to that of triodes.

### Doing Better with the Trimmers

(3)—Use of trimmers across secondaries of selector tuning coils far from their full capacity, e.g., for 35 mmfd. condensers less than 15 mmfd. is ever used, as thus the tension is less, and the compression trimmers then will stay put quite well.

(4)—Use of a separate oscillator, and coupling to modulator made inductive so that in coil design coupling can be controlled and thus accommodated to the frequencies concerned, the coupling being different for all bands.

(5)—Use of a light limiting resistor in the oscillator plate leg, bypassed by 0.1 mfd., so that the frequency stability of the tube is greatly improved, due mainly to the resistor.

### The Oscillator Grid Condenser

(6)—Use of a small grid condenser capacity in the oscillator, to avoid an objectionable time constant that otherwise might introduce high pitched modulation (scream) at high radio frequencies, yet enabling maintenance of a fairly high leak value, 0.1 meg., for stability aid, sharpness, and good bias control of the oscillator.

(7)—Use of semi-fixed bias under audio regeneration conditions elsewhere in the circuit that dispense with the need of a bypass capacity across the biasing section of the voltage divider (200 ohms).

(8)—Separate tube for working the tuning meter, so that closeness of indicating resonance is independent of the setting of the controls other than the tuning control.

### Where the Peaks Are High

To the circuit output is connected a high fidelity speaker. The power output is brought to considerably higher level than usual by purposeful increase of the B voltage and bias.

Therefore two of the usual 500 volt type electrolytic condensers are connected in series,

with protecting resistor across each, instead of condensers in parallel, or simply one condenser next to the rectifier, where the peaks run high. The circuit can be worked at 15 watts at 7 per cent. total harmonic distortion, or at about 10 watts, 5 per cent. total harmonic distortion.

The construction of such a receiver is a very considerable undertaking. Save for the X hand coils (low frequencies) all were wound by hand, the X coils being universal wound (honeycombs). The range is from 140 kc to 30 mc. in five steps, and the dial is frequency calibrated. The coincidence of dial reading to actual frequency received is always better than 1 per cent.

The coil assembly is very interesting and it is planned to present details of the structure in the October issue.

## Design for 6B5

### Portable Amplifier

The amplifier described herewith has an output of about 4 watts with one single 6B5 tube, which is plenty of power. Better quality can be obtained with other and more expensive types of amplifiers, but this is another story, since the purpose of this construction was to build an entire circuit, all in one package that could reasonably be called good fidelity, and at low cost. For adherence to the closer requirements of high fidelity a triode here is used as output.

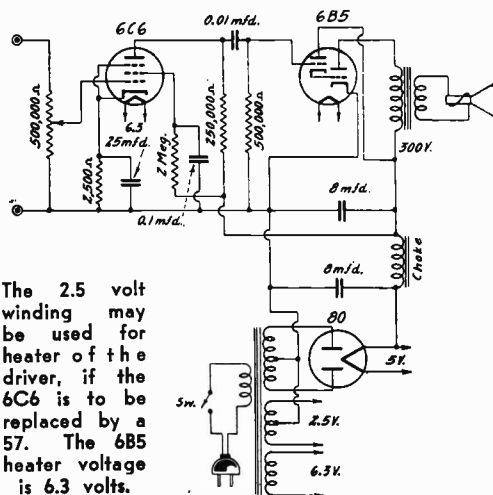

The 2.5 volt winding may be used for heater of the driver, if the 6C6 is to be replaced by a 57. The 6B5 heater voltage is 6.3 volts.

[These diagrams illustrate article on preceding two pages]

The author used a double button carbon microphone, and to excite it a 4.5 volt C battery. The meters shown to right were included largely for decorative purposes (he had them on hand) and may be omitted.

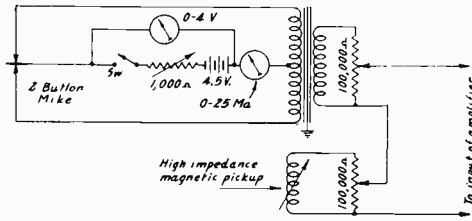

The lower coil with arrow through it represents a high impedance phono-graph pickup. The double potentiometer system represents a T pad, which presents practically a constant impedance to the circuits it connects.

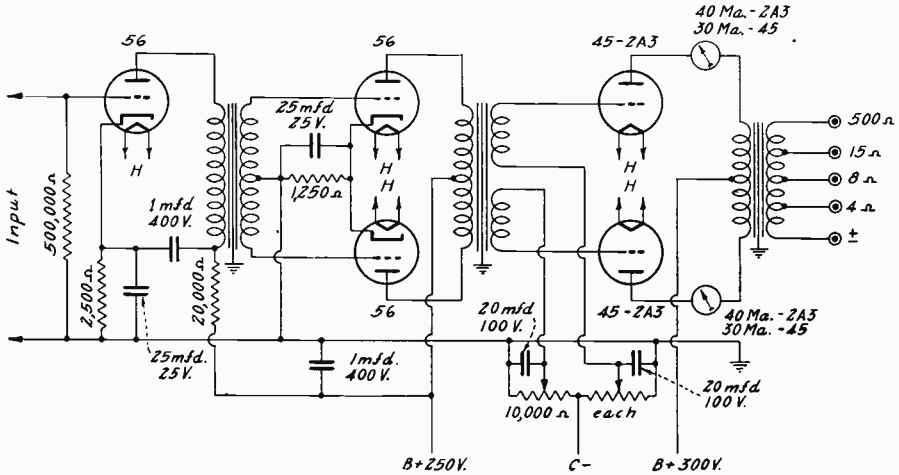

A 25 mfd. condenser is connected across the biasing resistor of the push pull 56 stage so that if one of the tubes goes dead the circuit will work well. Otherwise the condenser could be omitted. This is the diagram of the amplifier.

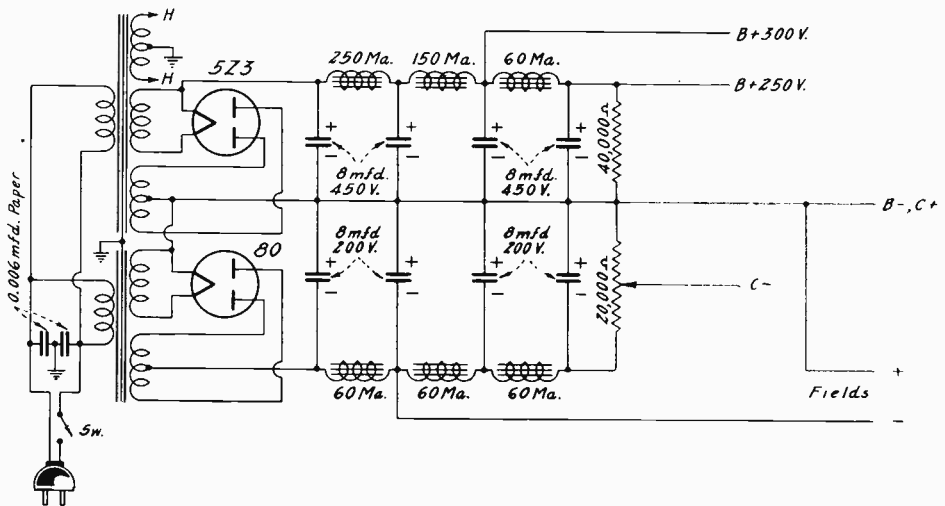

One 80 and one 5Z3 are used in the power supply, the 80 for C bias voltage and speaker excitation, and the 5Z3 for the B voltage.

# Diode-Amplifier Tube in T.R.F. Set

## A Way Out of the Difficulty Presented by Grounded Rotor

By Henry Bullitt

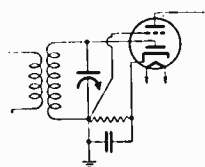

Won't work.

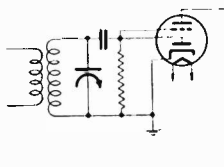

Doesn't solve problem.

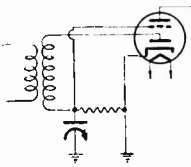

Not hot, either.

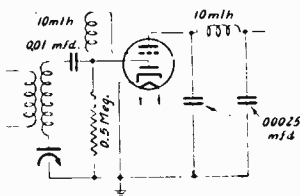

Ah!

THE use of a diode detector as found in the multiple tubes presents a problem in connection with tuned radio frequency sets, because the tuning condenser rotor is grounded naturally, so return to cathode through a resistor, in nearly all circuits, prevents grounding the cathode directly. Also, the load resistor for the rectifier is the biasing resistor for the triode or pentode amplifier in the same envelope. This resistor has to be so high, to support the rectifier, that the bias is high, and the bias has to be overcome by the signal before rectification takes place, an impractical attainment, considering the simple t.r.f. set. The first diagram (at left) shows the situation.

Then we might consider grounding the secondary as well as the condenser and the cathode, and have the circuit as shown in the second diagram.

### Series Tuning Condenser

This has an objection, in that radio frequencies get into the triode grid, indeed that grid is in parallel with the diode anode, so the diode may be taken out of circuit, for we have grid leak detection anyway, whether we want it or not.

Another scheme is the third one, with the tuning condenser in series with the coil. This change may be made because series and parallel connections produce the same frequencies, or, rather, the formulas for both are practically identical. But the tuning condenser becomes a variable bypass condenser, and so we have tone control of a pronounced sort, more high audio frequency attenuation at the higher wavelengths (lower frequencies).

### A Practical Case

The fourth diagram, however, offers a practicality, because a choke coil of 10 millihenries inductance is introduced between the anode and the control grid of the amplifier, and this keeps out a sufficient percentage of the radio frequencies to prevent a feed for grid leak detection.

The remaining radio frequencies are wiped out by the filter in the plate leg.

The diagram represents diode biasing of the triode, but is applicable also to self biased amplifier, by interposing the biasing resistor between common lead and the ground symbol, bypassing that resistor with 0.1 mfd. up. Connect the choke to the diode anode through a stopping condenser, say, 0.01 mfd., and put a leak of 0.5 meg. or more from grid to ground. The biasing resistor for audio transformer in the plate leg may be 1,000 ohms, and for a resistor of 0.1 to 0.25 meg. in the plate leg, bias with 5,000 ohms, bypassed by 0.1 mfd. up.

The point may be considered that the variable bypass effect of the tuning condenser is present in the fourth example as in the third. However, the tuned coil may have sufficient d.c. resistance to bring the coils' distributed capacity into play, so the tuning condenser might have little effect on tone.

### Selection of Bypass Condensers

The selection of bypass capacities across biasing resistors like those discussed may be on the basis of actual regeneration in the audio channel. Where resistance coupling is used there must be some regeneration expected, and when there are two transformer stages there may be considerable regeneration, also. This condition changes the requirements of high bypass capacities, because regeneration is at some low audio frequency, usually, and small condensers take care of protection of the high audio frequencies, even capacities as low as 0.05 mfd.

### Capacity Compensation

The bypass capacities therefore may be increased to that point where the low note reproduction is strong, or, if motorboating or hum sets in, then the capacities may be decreased just until the trouble-stops. By tuning in an orchestra the test may be made with sufficient assurance of a good standard. Listen for the bass viol and the drums.

# DIRECTIONAL TRANSMISSION

## How It Is Applied to Ultra Waves

By J. E. Anderson

THE advantages of directional transmission of radio waves, especially of those now called ultra short, have been recognized since the beginning of radio technique. Hertz, the discoverer of electric waves in space, produced ultra short waves and employed directional devices for studying their properties.

Directional transmission of the longer waves is not practical because of the large dimensions required of antennas, reflectors, and special antenna arrays. For this reason little has been done about beam transmission until the last few years, when technique was developed to the point where very short waves could be produced simply and efficiently. At present the greatest progress in radio is being made in ultra short waves and their directional transmission and reception.

The general idea back of directional transmission is to send as much of the available energy as possible in the direction in which it is desired, and none at all, if possible, in any other direction. The transmission may be such that the energy is confined in a narrow beam, which is most desired in point to point communication, or it may be such that the energy is spread out over an angle of 180 degrees, practically nothing going in the opposite direction. In ordinary broadcasting the available energy is spread out over the full 360 degrees with almost equal intensity in all directions.

The simplest device that will send out a beam in one direction is a parabolic reflector. The radiating antenna is located at the focus of the parabola and the energy is sent out in a beam just as light is sent out from an auto-

## Basis for Constructing a Parabolic Reflector

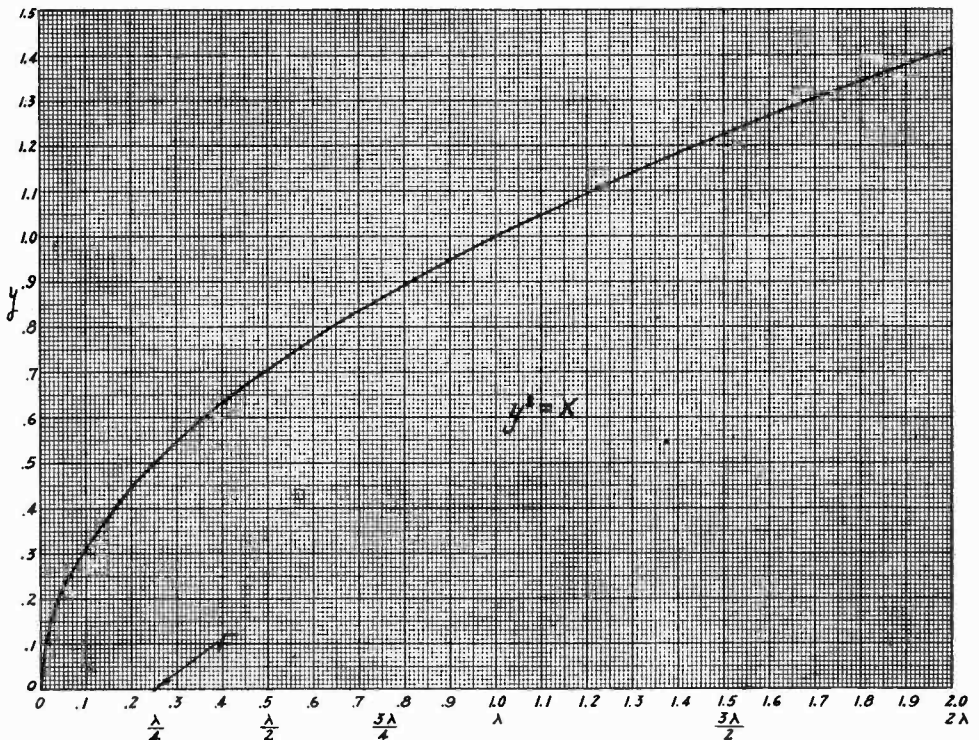

FIG. 1

One half of a parabola having an axial depth of two wavelengths. The focus, F, is one quarter wave from the origin. To get actual distances for the construction of a parabolic reflector multiply the coordinates by the desired wavelength.

mobile headlight. There is a difference, however. The mirror surface in a searchlight is a paraboloid of revolution. The reflecting surface in the beam transmitter is a parabolic cylinder. It is produced by bending a flat sheet of copper, or of other metal of very good electrical conductivity, into the form of a parabola.

### The Wave Front Considered

The special property of the parabolic reflector is that if a plane wave (plane wave front) enters the parabola so that the wave front is at right angles with the axis of the parabola, or so that the direction of propagation is parallel with it, all the waves will converge at the focus.

Conversely, if a point source of wave motion is located at the focus, the wave front of the waves emerging will be plane. This means that the light, or sound, or other wave motion, will not attenuate. It will be as strong ten miles

half of the parabola is given, for it is exactly the same below the x-axis as it is above it. This half parabola has been carried to a point where x is equal to two wavelengths in case it is desired to construct it that length. The focus of this parabola is at F, on the x-axis, and therefore on the axis of the parabola, and it is located one-quarter wave from the origin. At the focus the distance y is one-half wave, or the total width of the parabola is one wave.

It is not necessary to make the depth in the x direction much greater than one-quarter wave, but a sharper beam will be obtained if it is made deeper. This effect will be discussed later.

### Looks Like a Cradle

When the two wooden parabolas have been shaped properly the sheet of copper may be tacked to the edges of the wood. The finished

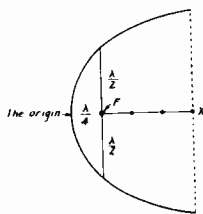

FIG. 2

A cross section of a parabolic cylinder having an axial depth of one wavelength from the origin to the termination X. The right angle solid line is the same length as the axis, since each half is half a wavelength.

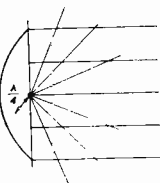

FIG. 3

A parabolic reflector terminating at the focus, axial depth quarter wave. One half of the radiated energy is reflected into a beam and the other half is radiated radially, as shown by divergent lines.

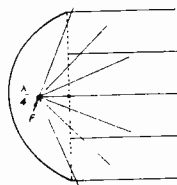

FIG. 4

The depth of this reflector is one half wave. In this case 39 per cent of the energy is radiated divergently and 61 per cent in a parallel beam. Greater depth than this does not much increase the parallel beam.

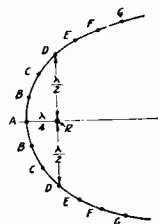

FIG. 5

A parabolic reflector may consist of resonant conductors spaced less than one quarter wave apart in the parabola. Each conductor should have the same natural frequency as the radiating antenna.

away from the source as it is close to that source, excepting for losses by absorption in the transmission medium.

This is the great advantage of the parabolic reflector. Without the reflector an electric wave from a vertical antenna would decrease directly as the distance. Ten miles away from the source it is only half as strong as at five miles. Actually it is less than half, due to absorption.

### Construction of a Reflector

The construction of a parabolic cylinder for waves of less than one meter is not difficult. The principal material required is a long rectangle of sheet copper one-half wavelength wide and at least 1.3 wavelengths long. This sheet of copper is bent over two equal wooden forms previously cut into the shape of parabolas of the proper dimensions.

As an aid in laying out the parabolas on the wooden boards previously to cutting, a parabola of the proper shape is given in Fig. 1. Only

structure will be in the shape of a cradle or round bottom trough. The radiating antenna, which should be one-half wave long, can be fastened to the wood pieces at the two foci of the wooden parabolas. Provision should be made for varying the position of the antenna in the axial direction by a slight amount. Therefore oblong holes, or slots should be cut about the foci so that the position of the antenna may be varied closer or farther away from the origin than one-quarter wave. The antenna should occupy that position which gives the greatest forward radiation, and this can best be determined by trial. Only a slight shift from the focus, if any, should be required.

It should be pointed out that a half wave antenna is never one-half wave long, as the wave is measured in free space. Thus an antenna for a one meter wave will be slightly less than one-half meter. The reason for this is that the electric wave travels at a slower rate on the wire than it does in free space. The same does

(Continued on next page)

(Continued from preceding page)

not apply to the quarter wave distance between the focus and the origin, nor to any other dimension of the parabola, because these distances are free space. It would apply to the width of the sheet of copper out of which the reflector is made, but there is no harm in making this a little greater than one-half wave. Indeed, it is advantageous.

### Sharpness of Beam

As has been said, the sharpness of the beam depends on the depth of the parabola, that is, on the distance between the origin and the point X in Fig. 2. The waves starting out from the antenna at F will be circular but only that part of the wave front intercepted by the reflecting surface will be reflected in a parallel beam in the direction X. That part which is not intercepted will be attenuated just as if there were no parabola present. The deeper

is 61 per cent. Thus doubling the length of the reflector has increased the sharpness of the beam considerably, since only 39 per cent of the energy is allowed to spread out and attenuate.

If we add another quarter wave to the depth of the reflector we make the reflected portion of the energy 2/3 and the divergent portion 1/3. The improvement in the sharpness of the beam is not proportional to the increase in the depth of the reflector, and we suspect that little is gained by increasing the depth still further. This is borne out by the figures, for if we make the depth a full wave the direct forward transmission is 30 per cent of the total and the reflected portion 70 per cent. As the reflector becomes unwieldy as it is made deeper, and also as the increase in sharpness is not rapid, it may be impractical to make the depth greater than one half wave. Of course, it depends on whether the reflector is to be moved or rotated or whether it is to remain in a fixed

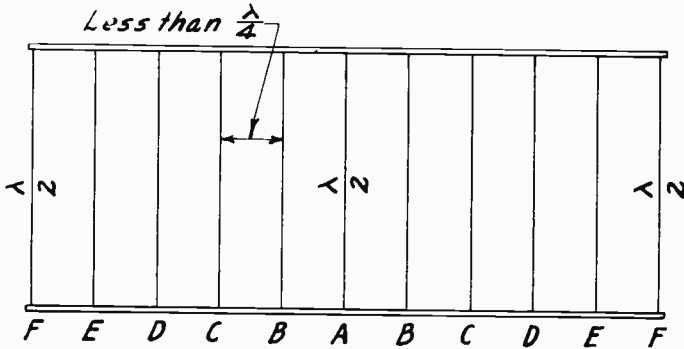

FIG. 6  
A reflector of the type shown in Fig. 5 can be made by stretching wires between two supports and then bending these into the form of a parabola. Or a single support can be used at the center.

the parabola the greater will be the percentage intercepted.

Suppose the parabola is terminated at the focus. This case is illustrated in Fig. 3. Only one-half of the total energy from the antenna is intercepted by the reflector and sent out in a straight line beam. The other half is radiated radially. The first part is represented by the parallel lines and the other part by the lines diverging from the focus. That half which is reflected is not attenuated but the other half decreases directly as the distance increases. Therefore at no great distance from the antenna the reflected portion of the energy will dominate, since that does not decrease. Still, the beam produced by this transmitter is broad and not sharply defined.

### Diminishing Returns

Now suppose we double the depth of the reflector and make the distance from the origin to the end, measured along the axis, equal to one half wavelength. This case is illustrated in Fig. 4. The divergent radiation is now 39 per cent of the total and the reflected radiation

position. Small reflectors are often rotated so that the beam will be directed not only in the desired direction in respect to the meridian but also in respect to the horizontal.

### Relatively Long Waves

It is not necessary to have a solid sheet of metal for the reflector. The solid sheet may be replaced by a number of half-wave rods all placed parallel with the antenna and in the parabola, provided that the distance between the rods, measured along the curve, is less than one quarter wave. The arrangement is illustrated in Fig. 5. The half wave rods are indicated by A, B, C, and so on, and the distance between any two, as between A and B, must be less than one quarter wave. As in the case of the solid reflector, the radiating antenna, R, is placed at the focus.

Each rod in this case should be a duplicate of the radiating antenna, for each must be tuned to the same frequency. Thus the length of any one rod is slightly less than the length of the wave radiated, as measured in free space.

If the wavelength to be radiated is long, say several meters, it would hardly be practical to

use rods. Wires of the proper length, placed in the correct positions, would be more practical.

A simple way of constructing a radiator of this type for short waves, say less than 2 meters, would be to lay out a parabola on a flat wood structure like a table top and drill holes at uniform distances along the curve of the proper diameter to hold the rods that are to be used.

### Why Rods Reflect

Of course, these holes must be drilled with the tool at right angles to the surface so that they will all be perpendicular to the same plane. As in the case of the solid reflector, provision should be made for moving the radiating antenna by a slight amount in the axial direction.

The reason why the resonant rods, or wires, reflect the waves is that the waves induce currents in the rods and these currents are such that they oppose the wave. That is, they send out waves of their own in the opposite direction to the incident waves. In this respect they act as the secondaries of transformers. The resonating reflectors must be spaced less than a quarter of a wave length or some of the energy will pass through the spaces between them. These reflectors are especially effective because they are resonant to the incident wave.

### Flexible Supports Used

Fig. 6 shows another way in which the resonant rod or wire can be constructed for reflection. The half wave resonant wires are stretched between two flexible supports, the distance between any two adjacent conductors being less than one quarter wave. When this has been done the supports are bent into the shape of a parabola. A reflector of this type has also been made by using a single support in the middle, the conductor then bent into the correct shape. This arrangement perhaps is superior to the ladder type of construction because when the support is in the middle it is placed at the current maximum and voltage minimum. Under these conditions the losses in the dielectric will be a minimum. When the supports are at the ends of the reflecting rods they are at the voltage maximum, and consequently dielectric losses will be greater.

## LITERATURE WANTED

Readers whose name and addresses are printed herewith desire trade literature on parts and apparatus for use in radio construction. Readers desiring their names and addresses listed should send their request on postcard or in letter to Literature Editor, Radio World, 145 West Forty-fifth Street, New York, N. Y.

- Elwin Marg, 159 19th Ave., San Francisco, Calif.  
 J. Babin, 323 Beaver St., North Adams, Mass.  
 Shailer A. Peterson, Head of Science Dept., University High School, University of Oregon (186 East 14th St.), Eugene, Oregon.  
 John Adams, 340 Ruggles St., Fond du Lac, Wisc.  
 Arthur Lillwitz, 836 N. Cicero Ave., Chicago, Ill.  
 H. J. Greenspan, Radio Service, South Haven, Mich.  
 N. C. May, 1421 W. 77th St., Cleveland, Ohio.  
 S. H. Evans, Esq., Weaversville, No. Car.  
 S. W. Case, 198 Woodlawn Ave., Jersey City, N. J.  
 Chas. H. Bost, 1014 Euclid Ave., N.W., No. 204, Washington, D.C.  
 William Settles, Legion Bldg., No. 2, Owensboro, Ky.  
 Sr. D. Antonio Lopez, Espronceda 11, Linares (Jaen.), Spain  
 Stanley Lewis, 512 Union St., Portsmouth, Ohio  
 Milton J. Schreiber, 256 Westfield Ave., Elizabeth, N. J.  
 J. Ginger, c/o Lattio, 269 West 12th St., New York City  
 Sylvan Elencweig, 343 McKee Place, Pittsburgh 13, Penna.  
 Charles Rome, c/o Bonano, R.D. No. 2, Nassau, New York  
 Carl von Herrmann, 1424 - 49th Ave., San Francisco, Calif.  
 Bernard Croninger, 1062 Divisadero St., San Francisco, Calif.  
 Afsar Mooraj & Co., Taj Villa Souter Street, 8, Bombay, British India  
 C. A. Coolidge, Kentfield, Calif.  
 Irwin Creedon, Box 271, Route No. 1, Arlington, Wash.  
 Carl S. Taylor, Dubois, Penna.  
 S. S. Bradley, Ayden, No. Car.  
 Luther M. Cope, Box 505, Connellsville, Penna.  
 Allen T. Simmons, Station WADC, Tallmadge, Ohio  
 Everett Clutter, RR. No. 2, Blacklick, Ohio  
 W. W. Cook, 2313 East 60th St., Kansas City, Mo.  
 M. R. Purlee, Seymour, Ind.  
 C. V. Patterson, 2348 Tipperary Road, Kalamazoo, Mich.  
 J. M. Corey, Bellaire, Mich.  
 T. H. Cox, 522 - 9th Ave., So., Columbus, Miss.  
 Charles Walter Greenley, Station KGCA, Decorah, Iowa  
 T. F. S. Cushine, 349 Worthington St., Springfield, Mass.  
 D. C. Akers, 181 Greenwood Ave., E. Orange, N. J.

## Separate B Supply for Short Waves

In quite a few short wave sets it will be noticed that the power supply and the speaker are external. One important reason for this is the elimination of hum. Short wave receivers are much more sensitive to hum than broadcast receivers, and for that reason extraordinary precautions must be taken against it. Perhaps the greater sensitivity of short wave receivers to hum is in large measure due to the higher gain necessary in order to bring in the short waves, since most of them are weak. But it is also due to the fact that short waves stray around more than longer waves. They will get through a small capacity where a long wave

would not get through. Likewise they stray by virtue of the greater effectiveness of induction fields for the higher frequencies. Also, if hum frequencies are present in the set, grids in the leads to which there is a small condenser and a high grid resistance will pick up the hum. Thereafter it will be amplified as a modulation on the high frequency signal, or directly as an audio signal. In many instances it has been found that by moving the power supply a few feet away from the set all hum disappears, whereas if the supply is built into the same chassis with the tuner and audio amplifier the hum may be intolerably loud.



# A Little More Meter Insurance

## Can't Fuse Sensitive Device, So Watch the Switch

By Edward B. Nelson

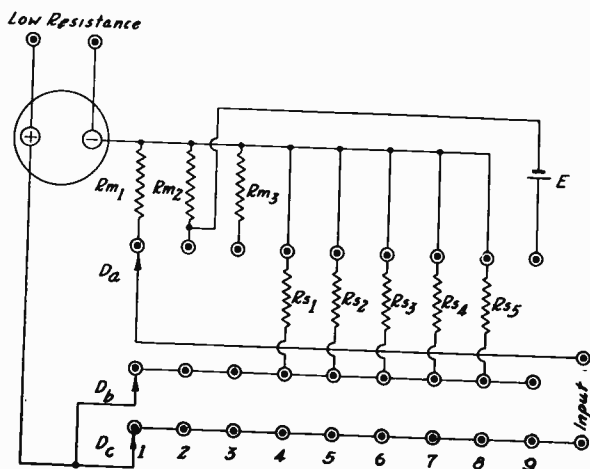

A three deck switch is used in this volt-ohm-ammeter, so the faster connecting tab on deck  $D_b$  or  $D_c$  may be connected to the meter, to insure the shunts being in place before the output binding post is picked up. This prevents exposing the "raw" meter to high current.  $R_{m1}$  etc. are voltage multiplier resistors and  $R_{s1}$  etc. are shunt resistors. If the battery voltage  $E$  is proportioned to one of the resistors ( $R_{m2}$  above) a separate ohmmeter resistance is not required.

IN the construction of volt-ohm-ammeters the experimenter may select more current ranges than voltage ranges, the total number of ranges being governed in general by the number of switch positions. Switches ordinarily obtainable have nine positions maximum. So three voltage ranges, five current ranges and a high resistance range may be selected. If it is desired to have low resistance measurements to less than an ohm, then the meter shunting method may be employed. This does not require an extra switch position, as the meter terminals simply are brought out to extra binding posts or jacks. So, too, the meter is accessible for its maximum sensitivity on current measurements.

### Computation of Voltage Drop

The reason for more current ranges than voltage ranges is that often a current condition is critical, whereas seldom is a d.c. voltage so critical. Since current in modern receivers, particularly small current, flows through high resistances, a small difference in current may mean a large difference in effective voltage. Sometimes the current is so small the meter one is likely to have does not enable the measurement of effective voltage, so B plus to cathode voltage is measured, then the current through the plate leg resistor, and the effective plate voltage computed, it being the difference between the applied voltage and the voltage drop in the load.

That drop is determined by Ohm's law, voltage in volts equals current in amperes times re-

sistance in ohms. The voltage and resistance are units, but the current is a fraction represented decimally by milliamperes, that is thousandths of an ampere, or microamperes, or millionths of an ampere. The values 1 milliampere and 1 microampere are written, respectively, 0.001 and 0.000001 in ampere terms.

Commercial devices usually have the same number of current ranges as voltage ranges, because the two are linear and the same calibration may be taken for volts or current purposes, simply by selection of the proper accurate multiplier resistors for voltage and shunts for current, and applying decimal or other integral scale multipliers.

Meters are very strongly built these days, and while it must not be taken as a recommendation to be careless, they often stand terrific overloads. An example is that of a 0-500 microampere galvanometer, used in constructing the volt-ohm-ammeter as diagrammed. Accidentally shorting of an external resistor used for voltage dropping purposes caused 100 volts d.c. to be momentarily connected across the meter. The resistance of the meter is 16 ohms, so the current for that brief moment was at least 6 amperes, yet there was no burnout.

### Hit the End Hard

The needle hit the end stop so hard that the pointer was bent, and the whole needle was jammed against the scale and would not move. So the meter seal had to be broken to remove a screw at top of the case side wall, one of three screws holding meter to case, and then the

needle was straightened on the removed meter. After that everything was just as fine as before.

While such a condition is not to be expected in ordinary practice, it is nevertheless possible with a switching arrangement to have the input binding posts intended to complete a series circuit for current measurement, and then when one moves the meter connections from one range to another in this condition, expose the meter alone to the current, which may be 100 times the current for which the meter is rated, a dangerous condition, and moreover always introducing the risk of bending the needle.

### Reason for Extra Deck

The danger is present when a two deck switch is used, as then one side of the meter is permanently connected to an input binding post. The switch action may be such, and with cheap switches this is not uncommon, that the riders do not leave the tabs at exactly the same time. The difference may ruin the meter, or damage the needle at least, because one side of the meter is connected to one binding post, hence one side of a shunt, so one side of the meter goes to the current source, while the other side, though contacting the other meter terminal, may not quickly enough pick up the shunt. The result is that for a brief period at least, and if the condition is not watched the period might be ruinously long, large current is passed through an unshunted meter.

An extra deck on the switch will enable one to free the meter from permanent connection to an input binding post. The diagram shows how this is done. Unfortunately, a schematic diagram, not being literal, fails to convey the complete picture of the operation. Consider the three decks, Da, Db and Dc. Da is unchanged. Db contacts the other side of the meter to a common branch, the voltage positions, 1, 2 and 3, not requiring service now. For the current five positions of the meter are shown picking up the shunts, one at a time, while Dc communicates the meter to the otherwise open side of the shunts.

### Speed Is Apportioned

However, if there is an opening it is in the external circuit. The method reduces the danger of unshunted meter one-third, as there still might be the same condition as before, but if so the delayed contact lug can be spotted, and the slower lug made to pick up the meter instead of picking up the binding post.

This is possible because the two switch decks, Db and Dc, are tied to the common meter terminal, but one is a shunt pickup and the other an input binding post pickup. If the shunt is picked up before the binding post is, then the problem is solved. Of course, another answer would be to get a better switch. The better type of switch for this purpose lists at \$7.50.

Mention has been made of the schematic diagram not quite telling the full story. Thus a line is drawn from switch tab to switch tab and seems to be a continuity to the moving arm. Of course this is not so. The arm contacts only

the tabs, and not the full stretch of the wire connecting the tabs, hence arm can be out of circuit completely, that is, simply in space. Hence the long line between switch tabs denotes the tabs themselves are connected together without reference to whether the rider really makes contact.

### Meter Shunting Method Simplified

In the May issue was a detailed article on "Measuring Low Resistance," using the meter shunting method, and in the present issue there is a discussion of a sidelight on accuracy. Since the same method is used in the diagram herewith, measurement made by putting the unknown across the meter posts, a simplified calculation is proposed for those who would not care to prepare and consult a chart. The meter resistance must be known. The manufacturer's catalog usually discloses this resistance value.

The meter is set for full scale deflection, done at the high resistance setting of the switch by closing the input terminals at right. If the unknown across the meter terminals at top is of less resistance than the meter the needle will swing to less than half scale. If the unknown is higher than the meter resistance the needle will not move as far as midway. Hence if the needle is midscale the unknown is equal to the meter resistance. In general, the lowest resistance is easily determined, due to needle definitely above zero, is say 0.5 ohm, and the maximum 200 ohms, so a general idea of the unknown is determined this way. For a 30 ohm meter, as most of the 0-1 milliamperes are, then an unknown is found to be between half an ohm and 30 ohms or between 30 ohms and 200 ohms.

### Computation from Scale

To get the value closely enough, get full scale deflection, note whether the needle is moved to less than half scale or above half scale when the unknown is shunted across the meter, and get the proportion the unknown bears to the meter resistance by using the fraction developed from the current calibration on both sides of the needle indication. Thus, if the needle reads 250 microamperes for a 0-1 milliammeter (0-1,000 microammeter), 250 is the numerator and the difference between 1,000 and 250, or 750, is the denominator. So the unknown is  $250/750$  or  $1/3$  of 30 ohms, equals 10 ohms. If the unknown is greater than the meter resistance the needle will rest on the high side of midway, and the fraction will have to be inverted. Thus, if the reading is 750 microamperes, the unknown is  $750/250$  of 30 ohms, or  $3 \times 30$  ohms, equals 90 ohms. Nearly all computations can be done by mental arithmetic.

The high resistances will have to be computed each time, too, unless the meter has a resistance scale, which it may have, or such a scale can be put on, that has the other readings, too. However, there are no such replacement scales for the shunting method of low resistance measurement, nor is this method used commercially, so far as the author knows.

# A New Balanced Detector

## Using the 6H6 in Nonreactive Circuit

By Edward C. Sturgis

Lower left, positive grid on right push pull tube, so that's out; center, stopping condensers are reactive; right, something to think about.

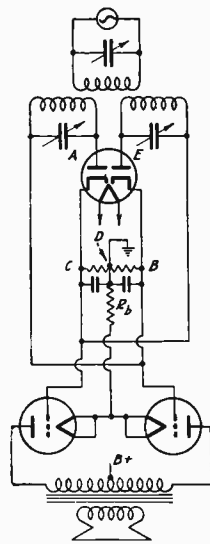
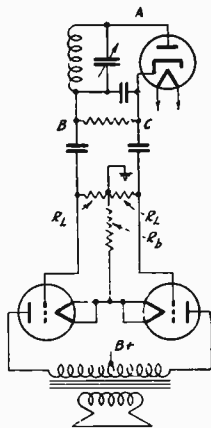
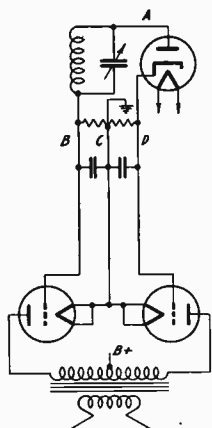

THERE has been a strong desire among experimenters for direct coupling and preferably nonreactive direct coupling. Whenever two circuits are united by a single load the coupling is direct, and when the coupling medium has a constant impedance, despite variations in frequency, hence behaves as a pure resistance, the coupling is said to be nonreactive. It is inductance that largely introduces reaction in audio amplifiers, for stopping condensers may be sufficiently large to make the reaction relatively small, but there are leakage and phase shift conditions that have to be considered with condensers and it is therefore especially interesting to follow the path of resistance, though not necessarily least resistance.

### Why Push Pull Is Included

Since the object of a nonreactive amplifier is strictly one of quality, to attain which certain sacrifices of gain are made, it will be assumed that a diode detector is to be used, as this has the closest to a straight line characteristic, meaning that the changes in current through the load resistor are directly proportionate to the applied voltage.

Push pull is selected for quality, too, because it frees the output from the even order harmonics, second, fourth, etc. Since second harmonic distortion is the strongest, as a rule, the push-pull circuit is favored for output.

So we combine the requirements of a nonreactive circuit with push-pull output.

For several years we have brought up now and again for discussion the first and second circuits illustrated, the first of which does not work, while the second does, though none too well. They are shown now to set forth the theory. The interconnection of both filament leads in the output tubes is simply a habit when dealing with symbolic rather than constructional circuits.

A modulated r.f. voltage (at left) is developed across the tuned circuit AB, one side of which circuit goes direct to anode of a diode rectifier, the other side to cathode through the load resistor BD. Ignore C and grounding for the while. When A is actuated by the positive alternation of the cycle, rectification takes place, because only when the anode is positive to a. c. will current flow. Note that the cathode may be floated. The tube's action is unilateral, or the tube is like a one-way street. During the alternation when A is negatively voltaged by a. c. there is no rectification. Nothing happens. No current flows through BD. The tube, then, is a single wave rectifier, and the alternation that it rectifies is the positive one.

### The Grounded Center

When the tube conducts there is direct current flowing through the load resistor BD. The potential relationship never changes. B is always negative in a d. c. sense, and D may be regarded as positive, or zero, depending on the viewpoint.

Now take the center of BD and call it C.

If C is used as the datum or reference point, then B is always negative in respect to C, and D is always positive, else there is no voltage difference between them, i. e., the tube is not conducting, or nothing is being put into the tube and nothing put out.

If we now connect B and D to the grids of intended push-pull tubes, we introduce to the grids a theoretically symmetrical circuit, for the voltages at B and D, hence at grids, are equal in value but opposite in polarity at any instant, and this is a push-pull requirement.

Unfortunately, we encounter bias trouble or unbalance right away. The tube at lower left in the first diagram has grid at zero (no rectification) or negative (rectification), but the tube at right has grid at zero or positive. So one of the tubes runs a positive grid and we run into very serious distortion right away. The circuit therefore may be said not to work. You hear something, of course, but you would not want to hear it long.

### Cathode May Be Floated

Compromise might be provided by inserting a biasing battery, but even if the battery is not objectionable, the precise bias required for balance would be hard to find, that is, there is difficulty in ascertaining the identical operating points for the two tubes. The tube curve itself would have to be linear, that is, or possess a special symmetry.

Aside from the fact that the circuit is no good, it does consist of direct coupling, and if one fails to look too seriously into the output tubes, and forgets the speaker load, the word nonreactive might be applied.

The circuit is shown because it demonstrates the practicability of diode detection with folating cathode, that is, cathode independent of any connection anywhere else in circuit save to load resistor. Afterward use of a ground interposes half of BD in each grid circuit and in this way cathode is returned to ground.

### R. F. Driver Needed

Another point is that there is no audio amplification, except as is present in the output tubes, and the detector thus is moved as near to the speaker as is practical. There is no present equipment for performing the detecting work in one tube or push pull pair and still getting enough power out to drive a speaker.

The circuit therefore suggests that, due to the absence of the customary audio amplifier, it is necessary to supply a strong voltage, at good power, to the detector tube. The diode as previously found, even consisting of a triode with plate and cathode interconnected, will not yield a straight line on high voltage, and will not stand the current. So an r. f. driver and more capable detector are needed.

### Is It a "Converter"?

Next we come to the second illustration, which provides a solution to the bias objection raised against the first diagram, by including stopping condensers. Now BC is the diode load

resistor, the detecting work being done this time the same way as before, according to exactly the same rules, but the stopping condensers become charged by the audio voltage equally and oppositely. Only direct current flows through BC, except for some residual radio frequency which may be ignored in the present consideration, but this d. c. is pulsating at the rate dictated by the original modulation of the carrier. The discharge is through the load resistors  $R_L$  in the grid circuits that follow. The condenser thus acts somewhat like a converter, fed by pulsating d. c. and delivering at its output actual a. c. of single alternation, the d. c. "line" across BC being the zero axis. This "converter" explanation, by the way, is not the orthodox one.

### This One Not So Hot, Either

To the power tubes in the second circuit we may apply a negative bias, as the circumstances are exactly the same in this respect as in any other push-pull output.

The circuit does not work very well, as previously stated, and the reason may be due mostly to the capacity unbalance. The location of the cathode in respect to the grounded heater of the diode, and the coupling between heater and cathode by thermal radiation, account for part of the unbalance. Of course, it might be suggested that this could be counter-balanced capacitatively, but again, as with bias, it is a tricky feat, and the very capacities may change, for instance the cathode capacity effect may be a variable, not balanceable by any fixed capacity in the other branch.

### This Is Different

It is assumed the load resistors  $R_L$  in the grid circuits are equal. They are grounded at center for grid return, to effectuate the bias, through the resistor  $R_B$ . There are probably other reasons for unbalance, judging from results, hence the circuit is deemed too tricky to be worth while.

Something to think about is the third circuit, which represents a theory only. One of the metal tubes, the 6H6, is a double diode, with separate cathode for each anode, symmetrically constructed, and offering the opportunity of a balanced detector.

It will be observed that the modulated radio frequency is fed to a pair of secondaries, each secondary a separate winding, that is, no center tap. It is assumed that the windings are equal, are in such direction, or connections so made, that the phases are right for the diodes, that is, the instant that one diode is positively supplied by voltage E from the source the other diode is negatively voltaged by the same potential E, of opposite sign, of course. Also the coupling from primary is equal in respect to both secondaries. Hence the diodes take turns at rectifying and we have full wave rectification. But what else happens?

*[Readers are invited to send in solutions of the problem and an analysis of the third circuit. More data next month.—EDITOR.]*

# A 5 Meter Pilgrim's Progress

## Adventurous Experimenter Who Risked Life for "Cause" Reports Results

By Arthur H. Lynch (W2DKJ)

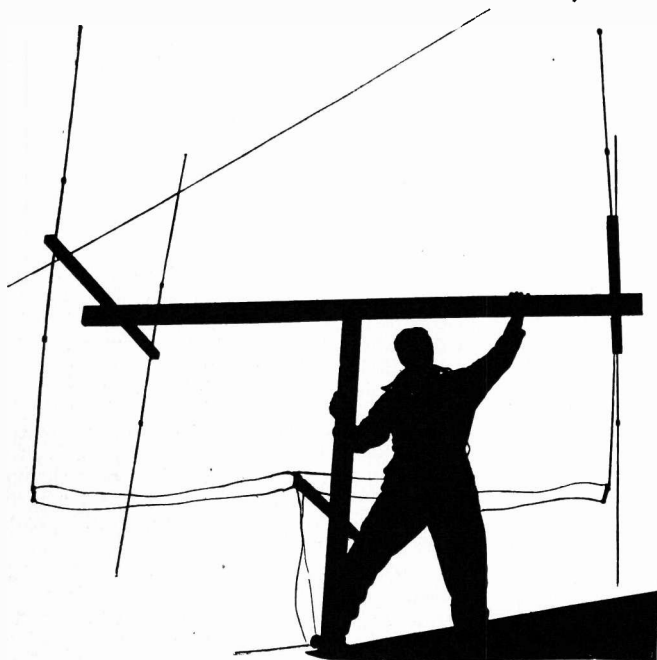

A silhouette of the author adjusting the rotary beam atop the Hotel New Yorker, some 600 feet above the street, where an earlier experimental station was erected. This beam was arranged so that it could be rotated without difficulty, but the arrangement had to be abandoned because of the high winds encountered. Moreover, the author had to be warned by personal friends not to risk life and limb in his enthusiasm for radio experimental activities.

**T**HE ultra high frequency activity of the Garden City Radio Club during the past year and a half has been productive of such interesting results that there seems to be some real reason for a more or less complete and accurate record.

The club itself is unique in that there are no officers, no dues, no by-laws, no regular meeting place and no regular meetings. When a general meeting is called, arrangements are generally made over the air and the meeting takes place in the home of one of the members. The discussion of any radio subject is looked upon with great disfavor. All this seems rather foolish, doesn't it?

A great deal of the incentive to really accomplish things which are a bit out of the ordinary is brought about by such members as "Doc" Dunn, W2CLA, former American Radio Relay League director for the Hudson Division, and Al Williams, the aviator, who has long been using radio in connection with private flying. Frank Hawks, the aviator, is a member of the club by virtue of his operating out of Roosevelt Field, which is in Garden City, N. Y.

The club's work on the really high frequen-

cies—waves just a few centimeters long—has been under the direction of Ed Glaser, W2BRB, also a former director of the League for the Hudson Division.

When the ultra high frequency bands were just in their infancy there were just four of the club's members who were seriously interested. They were Dunn; S. P. McMinn, W2WD; Jim Tynan, W2BRI, and Glaser. All of them got rigs working and the neighborhood gossip which passed during their QSO's was the subject of much comment among five meter eavesdroppers. Later Dick Depew, W2SB, made himself a transceiver which was used at his ground station as well as in several of his airplanes. The present author was then induced to get going on "five" with some kind of an outfit. A National transceiver was put to work as a ground station as well as in the air. We had permitted our license to lapse and had to take another examination. The Federal Communications Commission issued the new license with our old call. In the meantime it was necessary to have some other ham around when we were on the air, either at home or in a 'plane. One of the most accommodating, particularly in connection with 'plane tests, was

Kenneth Stanford, W2KE, and our little transceiver made quite a name for itself in connection with several test flights.

### Airplanes Work Duplex

Some time later a regular rig was made up for us. It was designed by W2WD and was built by Ed Ruth, W2GYL. The original arrangement is shown in an accompanying illustration. In the club's air tests, at Roosevelt Field, it was operated as the ground control station by Harry Steenberg, W2AOL. Two airplanes took part in the test, Dunn piloting one and "Sonny" Tronck piloting the other. McMinn operated the five meter rig in Dunn's ship and Depew operated the outfit in the other ship. Very satisfactory two way communication was maintained between the ground and both of the ships, during the entire flight, which lasted about an hour. Communication between the two ships was not quite so successful, although they did manage to work each other on voice, when about twenty-five miles apart.

Last winter W2BRI, Garden City, was heard in Cincinnati, on five meters. And last summer we were invited to address the Provincetown Radio Club, of Cape Cod, Mass., on the subject of noise reducing antennas for the regular ham bands. Among those who attended the hamfest were K. B. Warner, editor of "QST," and Ross Hull, his associate editor, as well as G. W. Bailey, W1KH, the A.R.R.L. director for the First District. A paper was delivered by one of the engineers of the telephone company which described the ultra high frequency radio telephone link between Provincetown and Green Harbor, across Massachusetts Bay. The whole thing seemed so satisfactory that a group went up to visit the station and witness a demonstration. It worked beautifully. Warner, Hull and the present author breakfasted together the next morning and they decided right there to get some real work going among the league members on the ultra short wave bands. On the way home from Provincetown we dropped off to see James Millen, W1HRX, Malden, Mass., and discussed the entire matter with him.

### Station at Hotel New Yorker

What Millen and Hull have done on the high frequency bands since that time is now history. The great success which accompanied their two way tests, between Hartford and Malden, was directly responsible for our own interest in experimenting in the same field. All the members of the Garden City Radio Club jumped into the thing with great enthusiasm.

Through the good auspices of Eli M. Iurie, W2DLG, engineer in charge of radio for all the hotels under the management of Ralph Hitz, permission was obtained to set up a station on the roof of the Hotel New Yorker, in the heart of New York City. A room was provided on the 46th floor and several different antennas were put upon various parts of the roof, some hundred and twenty-five feet higher.

Our rig was moved from Garden City to the hotel. Just about that time George Shuart, W2AMN, published the information on his

"long lines" oscillator and the idea was incorporated in our outfit.

### 40 Mile Service Area

The way in which W2DLG "got out" soon became the talk of the entire metropolitan area. We were getting reports of R9 and R9 plus—whatever that is—from nearly all the stations we worked and our normal coverage was something like forty miles. Our difficulty in covering greater distances was not in getting out but in hearing the stations on the other end. The



Richard Depew, Jr., W2SB, and his home-made transceiver. The National transceiver on five meters is about half the size of the ordinary tool boxes used to house the dry cells and B batteries, required for power.

evolution of our transmitter is shown in accompanying illustrations.

Naturally, after finding out how the circuit set up by Millen and Hull operated and actually holding a rather long QSO with Hull, from Millen's station one day last summer, with R8 signals at each end of the 125 mile circuit, we were of the impression that all we needed to do was to set up a suitable beam antenna on the New Yorker and that we would have no trouble in squirting a good signal into Hartford, about 85 miles away.

Even though the hotel management was most patient and offered no complaint about the "spinach" with which we adorned the roof, we ran into some unforeseen difficulties of an entirely physical nature. At an altitude of some 600 to 700 feet we met with an entirely different wind condition than one meets on terra

(Continued on next page)

(Continued from preceding page)

firma. Then, too, there are certain physical limitations to roofs on high buildings.

But it was "Hartford or Bust." We put up as much of a sky wire as safety would warrant and we aimed it at Hartford. In all this work we had the hearty co-operation of another former A.R.R.L. director for the Hudson Division, "Doc" Walsh, W2BW. He proved himself to be quite an aerialist.

### Five Meter Chain Idea

Well, when everything was in readiness, we telegraphed Hull, at Hartford and made a schedule with him. Nearly all last winter some of our gang was on the job several nights a week, in an attempt to hear from and be heard

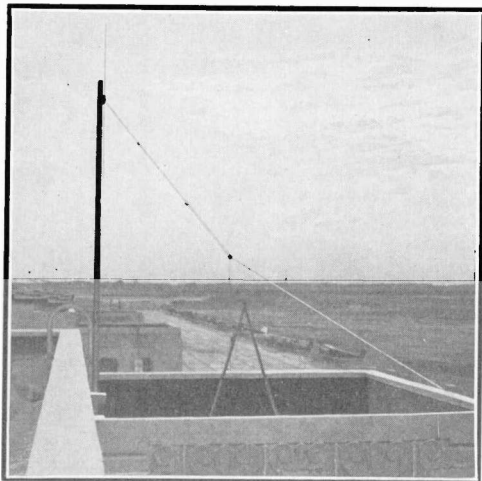

The aerial at the ground station at Roosevelt Field, where first tests conducted by the Garden City Radio Club, between the ground station and two airplanes, were conducted on five meters. The antenna actually was attached to one side of a wooden ladder, which in turn was fastened to the steps leading to the roof by means of a couple of trunk straps.

at Hartford. Many other New York stations joined us in the attempt and while several of them got through, they were never able to do so with regularity and the entire matter was thought to be a flop. We were never heard at Hartford nor did we ever hear Hartford.

We had had visions of a five meter chain of stations, joining Boston and Washington, through Hartford, New York, Philadelphia and Baltimore. Our dream seemed shot to pieces. We continued to do very well locally but the thrill was practically gone. We cut out the beam antenna and went back to the vertical half wave radiator with a matched impedance transmission line. We saw Hull and he was of the opinion that our efforts had been unsuccessful due to his station being behind a rather large hill with relation to New York, while that condition did not exist with relation to Millen's station, some 25 miles north of Boston.

It was thought that there was little use in at-

tempting the stretch to Philadelphia, since the Hartford link had proved to be such a failure. We were about to dismantle the station and bring it back to Garden City, when Herb Gordon, W11BY, popped in on us one day with the information that we were being heard more or less regularly by W3AZG, of Riverton, N. J., which is just across the river from Philadelphia. That, indeed, was good news.

According to W11BY, the five meter gang in Philadelphia wanted us to organize the crowd in the metropolitan New York area and put on a series of tests. We agreed to do so and the manner of going about it was this.

### Five Meter Radio Association

In New Jersey some of the old timers in the ham ranks get together now and then in the name of the Bloomfield Radio Club. Some of the more progressive in that outfit were rather active on the ultra high frequency bands. They, in conjunction with some other fellows in the same area do their stuff under the caption of the Five Meter Radio Association of Northern New Jersey. Frank Lester, W2AMJ, is president of the outfit. They hold meetings on the air every Tuesday night. The meetings are conducted just as if the members were actually attending a group gathering in a single place instead of being spread out all over the State.

At W2DLG we have listened to these meetings and, on occasion, because all the members could hear our station satisfactorily and the hotel was more convenient for out of town visitors than some ham's Jersey location, we have had the pleasure of introducing speakers who have had a message for the Jersey gang.

Among those who have addressed them, from W2DLG, are Ken Hill, W2AHC, the present director of the Hudson Division; Arthur A. Herbert, W1ES, from A. R. R. L. headquarters, at Hartford; F. Edward Handy, W1BDI, also of the A. R. R. L. headquarters staff and Capt. Horace L. Hall, the retired sea captain, who is, at the same time, famous short wave broadcast listener.

### Schedule Is Set Up

So, at one of the weekly meetings we passed the news along to the club and received their suggestions concerning a schedule. The schedule was set up and the information passed along to the fellows in Philadelphia.

On the appointed night the tests came off. They began at midnight. Earlier in the evening we had been receiving reports from stations we contacted more or less regularly, to the effect that we were not putting out a signal quite as well as usual. Static was rather bad and when Doc Walsh and Percy Collison left us we had come to the conclusion that there was but little chance of getting through, but we'd keep the "sked" anyway.

At the end of our first transmitting period, which lasted ten minutes, we listened. Sure enough, there was W3AZG, on interrupted continuous wave. What a kick!! By the end of our listening period we had been able to hear him on voice, as well as on the i.c.w. Well, we went back at him with great gusto. On the

next receiving period we didn't hear a tap from him.

However, Herbert Snow, W2ETU, who was operating a portable outfit, in his car, at the highest point on Staten Island, called us to say that he was picking up Anthony Repici, W3FGN, City Hall, Philadelphia, who in turn was hearing us and reported our signals as R6. W2ETU told us where to look for him and we tuned our head off with no success. So our first Q S O with Philadelphia was accomplished by talking directly to W3FGN and getting his replies through W2ETU. If the information we have is correct, and we believe it is, W2DLG was the only station heard in Philadelphia during that test. Also, our signals were

bands. While W3FGN was heard by Stanley Oehmen, W2HG, in Brooklyn, N. Y., and several fellows in Jersey, we were the only station on Manhattan Island which could pull him through. We had been experimenting with all manner of receivers and all manner of aeriels and had just about decided that when we were in for a serious job we could always depend upon our National SRR ultra high frequency receiver. It did the trick for us on this as well as many other occasions.

The one important point brought to our attention by this contact was the great improvement in the signal we could lay down in Philadelphia as a result of the installation of our beam. Incidentally, the beam we were using

The complete transmitter and receiver, stalled in one of the hangars at Roosevelt Field, being operated by Harry Steenberg, who was able to maintain contact with both airplanes for the entire time that they were in the air.

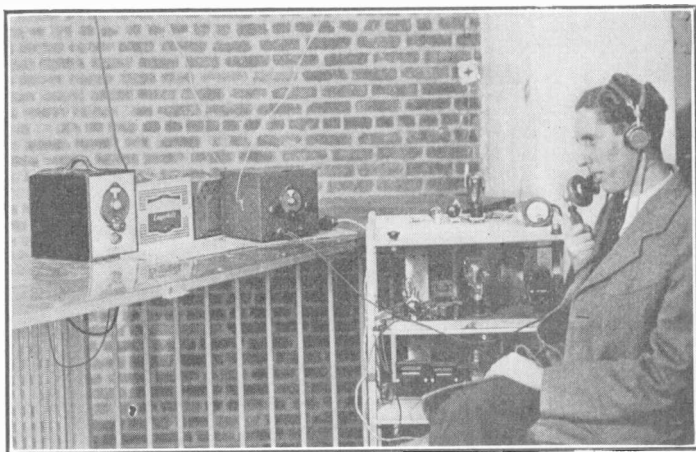

reported by air as well as by post from quite a number of ham stations in the Philadelphia area.

### Two Way With Philadelphia Direct

Well, from that rather humble beginning we went ahead, encouraged by our first real DX contact. We put up a new beam, at risk to life and limb. We tuned it accurately and we put on another test with the gang in Philadelphia. Before the test we drove over and had a little chat with W3FGN and made a definite schedule with him. We phoned W2ETU and he agreed to stand by, on Staten Island, as he had done during our first QSO. Everything was all set and we went to work, with but a few of the local crowd knowing what we were about.

At the appointed time we called Philadelphia and sure enough we picked up W3FGN, during our first listening period. From that point we went right into a two way conversation. W3FGN told us we were being heard at R9 at W3AZG and that his own conservative report on our signal was R8. There was as much kick in that 100 mile QSO as we would have derived from a chat with an Aussie on any of the other

was a very simple affair, in comparison to the swell arrays used by Millen and Hull.

### Strong Local QRM

While W2DLG was generally known to put out a "swell" signal, in the metropolitan New York area, nearly all the local hams credited most of the Garden City Radio Club's success to the height of the antenna above ground. We had a hunch that this was not entirely so. We put the transmitter in a car and took it to the home location. Garden City is a few miles further from the Bronx than the Hotel New Yorker is. We got a report from W2APV, in the Bronx, that we were a little better, at his station than we had been from the hotel. We worked W2AZB and W2DX, both located at Summit, N. J., and they gave us an R8 report, while we were R9 with them from the hotel, which was about one-third the distance to Garden City.

As we have said, we were putting out such a whale of a signal that a few of the fellows who called us and got no response thought we were

*(Continued on next page)*



(Continued from preceding page)

not anxious to work with them. They did not know the adverse receiving conditions we had to overcome. There was local QRM of a sort not common in amateur stations. This difficulty could not be realized by anyone who did not actually visit our station at the New Yorker. Some of the fellows who did come up to see us threw up their hands and said they knew that we were in a tough spot from what we had said about it on the air, but they had no idea that it could be as bad as it really was.

### Working Under Difficulties

Our radio shack was on the same floor as all the hotel's elevator control apparatus. It was

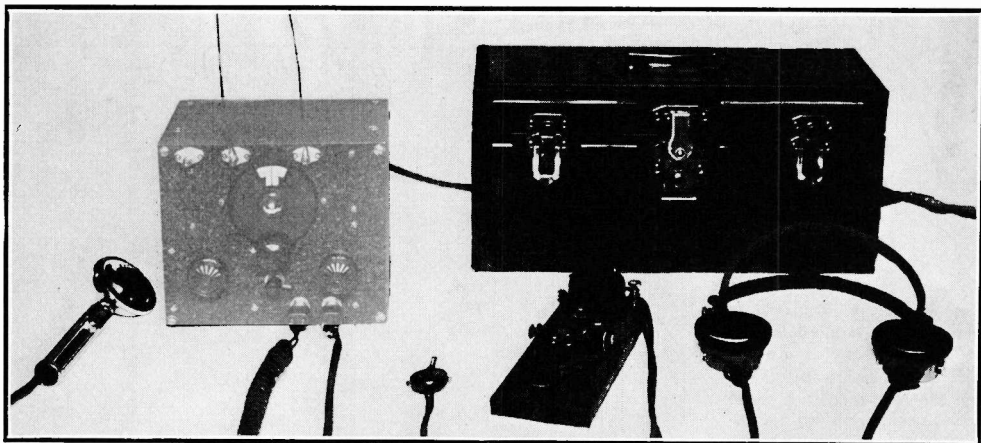

The Depew transceiver and accessories. The hand microphone at the left is of the "close talking" type. This type is used to avoid picking up the noises from the motor when the transceiver is used in open cockpit airplanes. In the center are key and buzzer. At left is National Company transceiver.

an ideal spot to experiment with noise reducing antenna systems. The current in the building is d.c. and juice for our outfit had to be piped up by a shielded line from a motor generator outfit, located four floors below. The results of our receiving tests with various types of antenna systems and the manner in which we licked the local interference are summarized in the sketches and captions. We were of the opinion that we would be able to do much better if we could get a location which would be free from the electrical interference set up by the elevator control apparatus. Incidentally, the acoustic racket which this type of machinery kicks up is just about as bad as is the electrical noise.

Through the auspices of a good friend we were able to lease the tower of the Manhattan Company building, at 40 Wall Street, New York City. We now operate there under the call of W2DKJ, portable. We are more than 900 feet above the street and our antenna systems are entirely in the clear with respect to Philadelphia, on the one side, and Hartford and Boston, on the other. There is no acoustic noise and practically no electrical interference. Even

automobile and motor bus interference seems to be totally absent at such a height.

### Three Pickups From Philadelphia

W2AOE, Dana Griffin, of the Leeds Radio Company, helped us to move the gear from the New Yorker to our new New York headquarters. Then he helped us to get it set up and the first night we were on the air, we worked thirty different stations and *three of them were in the Philadelphia area.* One of them, W3DRA, is located in Strafford, Pa., twenty-five miles west of Philadelphia, or 115 miles from our own station. When he is not on the air W3DRA keeps busy as a Justice of the Peace.

When he can tear himself away from his five

meter rig, W3FGN spends his time keeping the radio equipment of the Philadelphia Police intact. His boss, M. Gault, who has charge of Philadelphia's Electrical Bureau, told us that he is much interested in the application of ultra high frequency radio to police work. He has authorized the erection of a beam, on the city hall, which, it is thought, will remove the necessity for "Billy" Penn talking through his hat, which is what he has been doing for the past few months. The antenna, which sticks up from his hat now, is 547 feet above the street.

### So, Now It's Chicago

At a recent hamfest held at Syracuse, N. Y., we ran into Willard Wilson, W3DQ, of Wilmington, Del. He told us that the night we opened up at 40 Wall Street he heard both sides of our QSO with W3FGN. Recently we received the following telegram from W9CVO, Chicago:

W1XG, W2AMJ, W2HG, W2KG, W2HHW and about 12 other five meter phone stations have been heard in Chicago during the time between 10:00 a.m. and 12 noon Central Daylight time stop At 10 a.m. Chicago five meter stations

Frank Lester, showing he can tune the Lafayette superheterodyne 5 meter receiver with his left hand, without even looking at the dial. Though he is the designer, he says anybody else can tune it the same way. The receiver was used at W2DKJ, Arthur H. Lynch's station, nearly 1,000 feet above Wall Street, where the photograph was taken. Other sets were used, too.

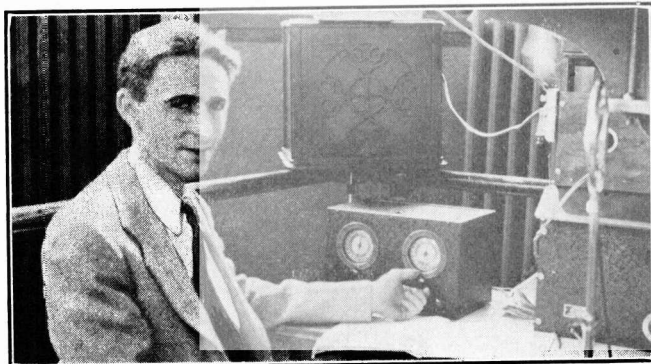

will call the East Coast for 10 minutes stop At 10:10 a.m. will listen for 10 minutes, etc., until 12 noon stop W9RLA has been heard in Philadelphia so there is a chance for someone to have a 900 mile five meter contact

W9CVO and Fritz Franke

The schedule was kept and more than a hundred five meter outfits in the New York area pegged away at Chicago and then listened their heads off. The net result was zero success.

Because the tests with Chicago have been unsuccessful, up to now, is no reason for discouragement. Many stations in the East have been heard there, even though ours was not among them. Worse luck! As the telegram from W9CVO indicates, several have been heard and since that time, we heard W2HG, of Brooklyn, N. Y., carry on a twenty minute QSO with W9CYE, at Dayton, Ohio.

We can't say that we are too optimistic over the possibility of a regular contact with Chicago.

We are of the opinion that the changing condition of the atmosphere has contributed much to the five meter long distance QSO's which have been made recently, but something must also be said for the real improvement which has been made in receiver design as well as the great strides which have been made in the design and the use of beam aerials.

### Buffalo First?

At the Syracuse hamfest we ran into some of the five meter hams from Buffalo and Rochester. Dr. Burton Simpson has done noteworthy work on this service.

At Syracuse we had a session with Edward A. Roberts, W8CH, A.R.R.L., director for the Central Division. He and Irving Cassidy, W8MAN, told us they would get the gang in their vicinity busy in an attempt to contact us. They have the towers of a discontinued broad-

casting station at their disposal. Their present plan is to set up a beam on one tower, headed toward Chicago and another beam on the other, headed toward Buffalo and New York.

Up in New England, in addition to the beam array which Millen keeps aimed at the New York area and which is being fed by a pair of 852's, we have obtained the enthusiastic cooperation of A.R.R.L. Director Bailey, W1KH, who is going to instal a beam on two and a half meters and aim it in our general direction. On the other hand we will do the same thing on our end and trust that we will be able to contact him direct, or, at least via Hartford.

### Plenty of Opportunity

The accompanying map indicates the routes over which regular communication has been established and the dotted lines indicate the routes which should offer no insurmountable difficulty for regular working during the coming winter on 5 meters. In these plans we are not laying stress upon the more or less undependable contacts which have been made over distances in excess of 200 miles, although we are not prone to discount them entirely and they may become quite regular as we learn more about using the ultra high frequencies. We are of the belief that so much has been said and written by "authorities," which has been take as orthodox and which has later been found to be unsound, that there is still plenty of room for real experiment and research. Few fields offer so much romance.

*[The foregoing completes the narrative to date of the 5 meter activities of Arthur H. Lynch and cronies. Some experimental findings likewise hold interest and will be discussed next month, when circuits used by the author will be shown. A coast to coast 5 meter relay league is being formed and prospective members will be particularly interested in the transmitting circuits.—EDITOR.]*

---

**PHILO T. FARNSWORTH, inventor of the Farnsworth television system:** "Television should come in less than a year. Receiving sets can be put on the market at any time. The obstacle is the erection of transmitting stations. Some work along that line is now going on in this country."

---

# The Metal Tubes in Practice

## Give Big Lift to Short Waves—Some Problems Met

By George Dubuc  
Comet Radio Company

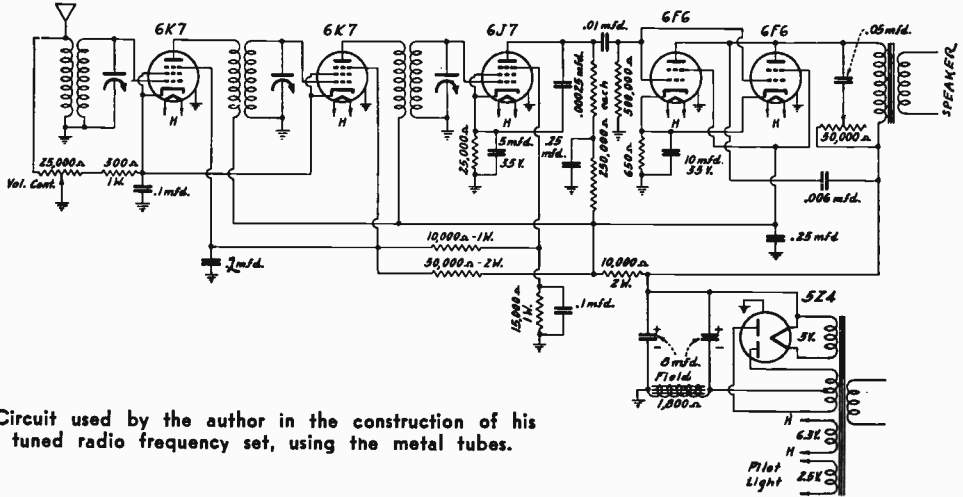

Circuit used by the author in the construction of his tuned radio frequency set, using the metal tubes.

**E**VEN persons who have only a mild interest in the technical side of radio are asking about the new metal tubes. Are they better than the glass tubes? Can they be put into existing sets instead of glass tubes already there?

The metal tubes obviously are intended to be better than the glass tubes, otherwise there would be no point in bringing out the metal tubes. They are smaller than the glass ones, thus providing space economy, also they are externally more durable, but these would be less than vital reasons for bringing out new tubes.

Since there is a growing interest in short waves, it was believed important to produce tubes that, while functioning very well on the standard broadcast band, also would carry over much of that efficiency to short waves, where circuit losses accumulate at such a fast pace that every bit of advantage is appreciated and valuable. To that end the tubes were made with smaller grid-to-plate capacities. The output capacities in general still run around 12 mmfd. in all tubes. Especially with multielectrode tubes it is difficult to keep down the output capacity, as it is the capacity of the plate to all other electrodes.

### Case of Mutual Conductance

Also the superheterodyne circuit is practically the exclusive one in commercial production, so the tubes for oscillation were made with higher mutual conductance than their glass equivalents. The main example is a comparison

of the companion 76 and the 6C5, with respective mutual conductances of 1,450 and 2,000 micromhos. Where oscillation is a likely use the mutual conductance will be found higher, but for the general run of tubes it is about the same as for the glass models, and in some instances just a bit lower.

It is the mutual conductance that is the figure of merit of the tube as to how well it will oscillate, and indirectly as to how high the frequency may be with oscillation still supported. It is notorious of tubes with low mutual conductance, like 700 micromhos, that they stop oscillating too soon. Perhaps this was the reason that the battery glass tube 1A6 was supplanted with the glass 1C6, which has twice the emission of its predecessor, and supports oscillation to 25 mc., whereas the other was hardly good for much beyond 10 mc. Thus, too, as a makeshift in the absence of substitution, the addition of an extra tube in parallel with the oscillator for the higher frequencies was recommended, this being the equivalent of increasing the mutual conductance of the net single tube in circuit.

### Shorter Wiring Length

Also, the amplification factor was raised for the 6C5, so that there would be larger output voltage, the comparison being 13.8 factor for the 76 and 20 factor for the 6C5. Also, if the tube is used as an audio amplifier the circuit gain becomes higher, due to the greater amplification factor, and the higher mutual conduc-

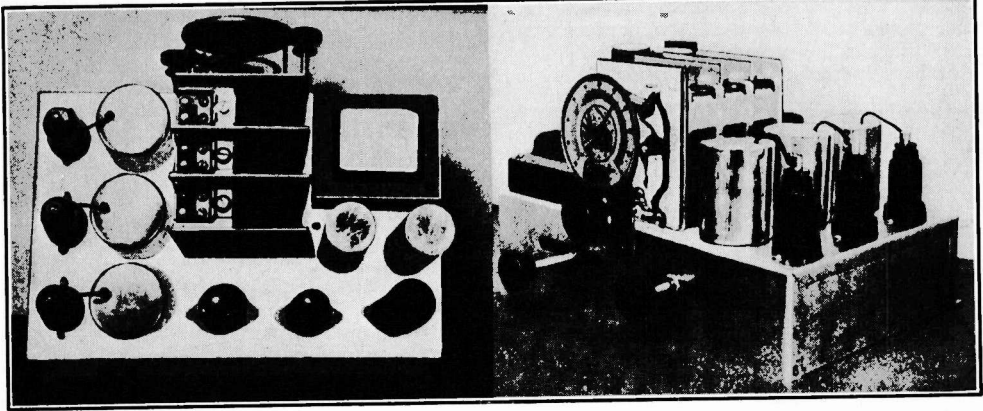

Top and front views of the receiver. A precision 12 tube superheterodyne, the frequency calibrated dial of which tracks better than 1 per cent. Rear and bottom views of author's t. r. f. set.

tance in general permits larger input signal, so there is improvement in both directions.

The smaller size of the tubes enables shorter wiring lengths and less stray coupling, important on short waves, while the much smaller vital elemental capacity, between control grid and plate, enables loading the tube so as to uphold gain, without running prematurely into unwanted oscillation that ruins reception.

### Elemental Capacities Compared

The following tabulation gives a comparison of the interelectrode capacities in mmfd:

	<i>Pentagrid</i>		<i>Mixer-</i>
	<i>Mixer</i>		<i>Amplifier</i>
	6A8 6A7		6L7 ..
G4-P .....	.03 .3	G1-P ....	.0005 ..
G4-G2 .....	.10 .15	G3-P ....	.25 ..
G4-G1 .....	.09 .15	G1-G3 ....	.12 ..
G1-G2 .....	.8 1.0	G1-A0 ..	8.0 ..
Mod. Input	12.0 8.5	G3-A0 ..	11.5 ..
Osc. Output	5.0 5.5	Output ..	12.5 ..
Osc. Input.	6.5 7.0		
Mod. Output	12.5 9.0		
	<i>Amplifier</i>		<i>Triode</i>
	6J7 6D6		6C5 76
G-P .....	.005 .01	G-P .....	1.8 2.8
Input ...	7.0 4.7	Input .....	4.0 3.5
Output ..	12.0 6.5	Output ...	13.0 2.5
	<i>Detector</i>		<i>Power</i>
	6K7 6C6		<i>Triode</i>
G-P .....	0.005 0.01		6D5 45
Input ...	7.0 5.0	G-P .....	3.5 7
Output ..	12.0 6.5	Input .....	4.0 4
		Output ...	7.5 3
		[Note: 6D5 and 45 not	
		close duplicates.]	

### Effect of Shell on Heat

The foregoing classification shows that the grid to plate capacity is maintained lower in every cited instance, compared to the equivalent glass envelope tube, but that in general the output capacity is the same, and the input capacity may be higher. The input capacity is of

small importance at the frequencies considered, say, to 25 mc, because much more capacity is added, both intentionally by trimming, and unintentionally, due to the distributed capacity of the coil, the minimum capacity of the tuning condenser, and the capacity of the wiring.

Enclosure in the metal housing, with no perforations, causes the heating problem to become serious at times. For the rectifier tube there is a perforated shell.

The effect of the heat on frequency stability has been noted. Even with the glass tubes it is no secret that frequency stability has not yet been achieved in commercial receivers for high frequencies where this stability is of importance. That is, the oscillator changes its frequency slowly, or drifts.

### Effect of Sharp I.F.

For a sharply tuned intermediate amplifier, oscillator drift causes a form of fading, because small change in frequency of the oscillator produces large change in output. Also there are phase shifts that injure tone. It is not surprising therefore that the same problems arise with metal tubes, but correction for drifting is practical, and some means probably will be adopted other than the makeshift of tolerating the drift and widening the band passed by the i.f. to hold the station.

A few suggestions may not be amiss. The problem of frequency constancy arises elsewhere and solutions found in comparable fields may be tried. One of them is to use a saturated pentode as a plate load resistor. Thus a pentode tube would be so voltaged that if the plate voltage were increased there would be no increase in plate current, for saturation has been attained, that is, all the electrons originating at the cathode already have been drawn to the plate, so increasing the plate voltage has no effect. The behavior of the circuit becomes the same as that of a pure resistance of constant

(Continued on next page)

(Continued from preceding page)

value. The method is used for producing a linear sweep in the cathode ray oscilloscope.

Another approach to the problem lies in

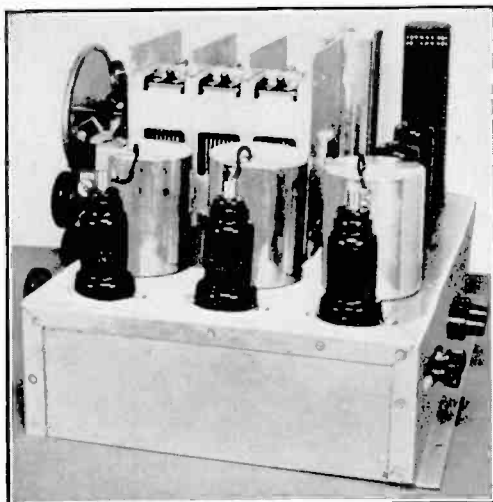

Comparative size of the metal tubes is shown off against the coils

establishing the local oscillator as a feeble one, worked on the straight portion of its characteristic curve. An amplifier tube could be included to increase the oscillation voltage, and also buff the local oscillator from the modulator.

Frequency change is related to the violence of the oscillation, because of the harmonics introduced when the grid voltage swing hits the ends of the curve particularly. So operation at the center of the straight portion of the curve tends to improve stability.

Part of the trouble no doubt lies in the fact that the change causes a corresponding expansion of the metals of the electrodes, and thus increases the capacity, or, for metals that work the other way, the change is in the opposite direction. Bimetallic trimming and similar plans offer an opportunity for curing that aspect of the difficulty.

The new metal tubes are intended for circuits designed for them, as coupling and other factors are selected on the basis of the somewhat different performance of these compared to the glass companions. Therefore the introduction of the new tubes into old sets, by use of adapters, is not being pressed, and so far no announcement has been received of any such adapter in existence or in preparation.

The formal uses to which the new tubes are to be put are represented by the receivers now on the market, using these tubes. The first such commercial receivers put on the market comprised the General Electric line, from the laboratory where the tubes were designed, closely followed by nearly all the other manufacturers, except notably Philco, who printed advertisements voicing confidence in glass tubes, because of the long manufacturing experience behind them, and something less than confidence in the metal tubes of the hour. Also the fact that metal tubes were used abroad with no revolutionary advantages was cited.

The present line of metal tubes differs from the foreign metal tubes, one significant comparison being that the American tubes use the metal shell as a shield, whereas in the foreign tubes the shell is used as an active element, and is even the anode (plate).

It usually takes about a year for the technique on a new tube to become settled, it is true of all tubes, and there never would be any new ones if there were hesitancy about facing the consumer proving period. Recently in that period the technique has been changed but little, proving that tubes as produced at first, and circuits to go with them, are close to consumer requirements.

A notable advantage in a transmission line for a lead-in is that it does not pick up any noise or unwanted signals on the way down from the antenna to the receiver. If it is of the concentric type it can run through all kinds of electrical noise without picking up any of it. This is a boon to those who live in large apartment houses where the antenna must pass several floors, each floor contributing a bedlam of crackles, before it reaches the receiver. The antenna itself can be placed high up, away above the sources of the noise.

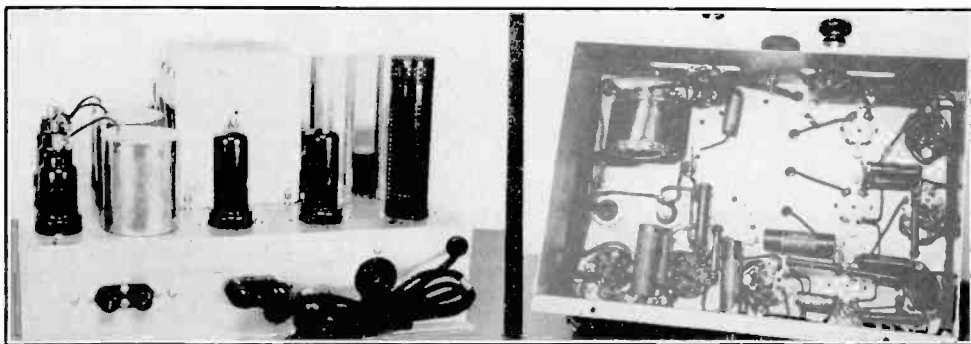

Rear and bottom views of author's t. r. f. set.

# RADIO CONSTRUCTION UNIVERSITY

*Answers to Questions by Readers on the Building of Radio and Allied Devices. Readers Should Address Questions to Radio Construction University, Radio World, 145 West 45th Street, New York, N. Y.*

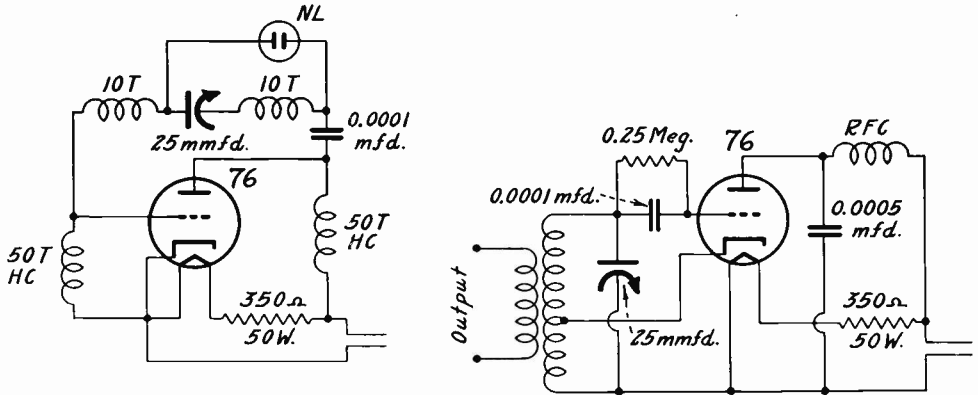

The circuit at left oscillates at frequencies much lower than, wavelengths much higher than, the questioner expected. The circuit at right may be used for 5 and 10 meter work, being constantly modulated by the line frequency (hum). The tuned coil consists of 10 turns of No. 16 bare copper wire wound on 3/8 inch outside diameter, winding length 3/4 inch, with tap at 4 turns from grounded end. The radio frequency choke consists of 15 turns of No. 30 insulated copper wire, wound on 1/4 inch outside diameter. The output coupling winding may consist of two turns, slightly spaced, 1/2 inch from the grounded end of the tuned winding. With 25 mmfd. the wavelengths are 5 to 3 meters, approximately.

## Right Track But Wrong Direction

RECENTLY I became interested in 5 and 10 meter work and realized that some measurement device would be necessary, so that I would know the frequencies or wavelengths. As yet I have not calibrated the wavelengths, but I have built an oscillator that seems to work violently. I put a neon tube across the circuit as shown and it lights from radio frequencies, so the r.f. must exceed 60-odd volts. This fact is checked by stoppage of illumination if the coil system is touched with the finger. I reduced the tuned inductance one might say almost to zero and still there was oscillation. Do you think this circuit is satisfactory for a generator and should I go ahead calibrating it? Diagram is enclosed.—I. B.

If the supposed inductance that you consider in the tuned circuit were shorted entirely, oscillation would still endure, as you are not working at 5 or 10 meters but at a much higher wavelength, the tuning coils being the 50 turn honeycombs. If you omit these coils, or even one of them, there will be no oscillation, which should prove the assertion. Omit the so-called tuned circuit windings (as you suppose them to

be) and put them in the position now occupied by the chokes. Oscillation may or may not be present, but the circuit could be made to oscillate, that is, if the voltages are high enough and the coupling large enough. The modified Hartley circuit shown herewith will be found satisfactory and will oscillate under the diagrammed conditions at 5 and 10 meters, with suitable inductances. A tuning capacity of 25 mmfd. is ample. You might calibrate a few points on your present oscillator just as verification of the higher wavelengths actually covered, say 30 meters or so, rather than 5 meters with one coil system and 10 with another. Then rig up the Hartley and try it with 5 and 10 meter coils.

\* \* \*

## Carrier and Sideband Suppression

WILL you please explain transmission of carrier and both sidebands, transmission of carrier and one sideband, and transmission of one sideband only, carrier and other sideband suppressed?—I. K. M.

When an oscillator is producing a constant  
(Continued on next page)

(Continued from preceding page)

radio frequency there may be impressed on it audio frequencies, to change the amplitude of the radio frequency at the audio frequency rate and intensity. This effect of modulation appears on both alternations, and in both it consists of the upper sideband and the lower sideband. If the carrier is to be maintained, a filter may be inserted so that one sideband is suppressed, just as a single sideband filter of the crystal variety is now popular in communication type receivers. Then the other sideband and the carrier are propagated. The receiver is of the usual type for both examples. However, if the carrier as well as one sideband, is to be suppressed, an oscillator is set up and coupled to a balanced modulator, a push pull affair, which develops no r.f. voltage across the output winding when no modulation is introduced, but when the modulation appears across the input circuit it is a total voltage across grids and upsets the balance, causing only sidebands to be propagated. If one of the sidebands is suppressed then only the other is sent out. Otherwise carrier is suppressed and the two sidebands transmitted. All carrier suppression systems require an oscillating receiver to supply the carrier at the set, and the constancy of this oscillator must be of an exceedingly high order. The tuning must be to within 50 cycles.

\* \* \*

#### Extra Shielding for Metal Tubes

**A**RE the metal tubes sufficiently shielded by their metal cover for all purposes, and if not, what remedy could be applied?—W. S.

The metal tubes are sufficiently shielded for nearly all purposes. The exception exists in the case of some extremely sensitive circuit, where one or two tubes might have to be given a little extra attention. This consists of shielding the top cap of the critical tubes. Also, the lead from circuit to the cap may be shielded and shield grounded. Receiver stability may be increased by these extra precautions, but, as stated, the necessity seldom arises. It is not necessary to enclose the entire tube to provide shielding for the small top cap. A thimble shaped shield with the proper diameter to grip the dome of the tube and with sufficient length to house the top cap and its terminals meets the requirements. Since there is paint on the tube, a part of the top cap shield has flange bent in, so that the protrusion will scrape off the paint and thus make suitable ground connection.

\* \* \*

#### Measuring an Harmonic Frequency

**W**ILL you please give me a simple method of determining higher frequencies than the fundamentals of my direct frequency reading signal generator? I understand that harmonics are confusing but that you have a method that eliminates this confusion.—H. T.

The method to be given is one that enables the determination of the frequency of the unknown (receiver) when that frequency is higher

than the fundamentals of the signal generator, but does not enable presetting the receiver to some desired frequency by use of the method, without additional calculation. The method is as follows: Read a frequency on the signal generator that creates a response in the receiver, then slowly turn the generator dial, but do not molest the receiver dial, until the next consecutive generator setting is reached that also causes a response with receiver. Having read the two generator frequencies, subtract to obtain the difference, divide this difference into each of the two read frequencies, and multiply the difference by the two quotients. The answer is the unknown. It is a very simple method though the statement of it in words sounds a little complicated. For instance: Suppose one read frequency is 100 kc and the other is 120 kc. The difference is 20 kc. Divide 20 into 100, get 5. Divide 20 into 120, get 6. The unknown is the original difference, 20, times 5 times 6, or 600 kc. \* \* \*

#### Value Seen in Metal Tubes

**D**O the metal tubes have any real advantage over the glass tubes, or are they just something new, to stimulate sales?—W. D. A.

The metal tubes represent a real development. What you have possibly heard is that there is trouble with some of the tubes. However, nothing is produced without some trouble, and it is foregone that any difficulties will be ironed out. Really tubes are tested more in customers' homes than in factories and laboratories, for the tube makers have to be governed by public acceptance. There is every indication that the metal tubes will be extremely popular and worthwhile. With one exception the list so far announced is not exclusive as to general characteristics, and two glass tubes will do what that other metal tube does, but this is scarcely a criterion. The tubes seem to be largely intended to produce an extra need of service, particularly on short waves, for the interelectrode capacities are very small, compared to those of glass tubes, except the output capacities, which are about the same in both instances. More gain at the high frequencies may be expected. The fact that dozens of set manufacturers are out with metal tube sets shows that they were convinced of a value present in the tubes beyond mere novelty.

\* \* \*

#### Ordinary Tubes for Below 1 Meter

**W**HAT is the accurate statement about the highest frequencies in general that normal tubes will tune to? I understand that such tubes are scarcely much good for anything below five meters, and in fact the five meter oscillators as found in transceivers do not seem to be particularly good.—K. C.

The statement about 5 meters or a bit lower being the limit is a conservative one indeed, as it has been possible to use normal tubes in a straight oscillator circuit (no superregeneration) to approximately the conservatively rated limit of the acorn tubes, 70 centimeters. The

76 has been used in our laboratories in a 2.5 meter signal generator, and also frequencies so high as to yield no harmonic or response from a 1 meter test source have been obtained. The technique of the use of normal tubes for very high frequencies, somewhere in the centimeter range perhaps, has not been fully developed along conventional circuit lines. The method usually introduced is that contributed by two Germans, Barkhausen and Kurz, with positive grid and negative or zero plate, the wavelength being voltage controlled, or an amendment to this scheme, where a tank circuit actually is present. We do not refer to these methods but to Hartley and other familiar oscillators at or below 1 meter.

\* \* \*

### Accuracy Desired

**C**AN you suggest some accurate method of measuring frequencies? I am interested in both audio and radio, but it seems difficult to make any progress along precision lines without very expensive equipment that I can not afford. I could rig up circuits if you would outline some procedure.—W. E. C.

You should build a tuned radio frequency receiver, using plug in coils or otherwise, or fixed tuned to three selectable frequencies, so that you can pick up the frequency standards sent out by the National Bureau of Standards, through WWV. These standard frequencies are 5, 10 and 15 megacycles. In conjunction with this receiver you should have a modulated-unmodulated test oscillator (signal generator) to cover the bands of radio frequencies you will desire. By approximately calibrating this signal generator for these various bands, say, 50 to 15,000 kc, you can check against the standard transmissions up to generator frequencies equal to the standard. From the approximate calibration it is simple to get the accurate results, by tuning in the standard on the receiver, combining signal generator and standard in a single detector, and putting a bypassed d.c. plate milliammeter in the detector, to watch the needle movement. The beats when close to zero will represent medium movement of the needle, too far from zero will be shown by fast movement, and sometimes you can make the needle move so slowly that you can count the beat frequency, or difference. If you can count the beats, say, four a second, denoting frequency of difference of 4, you are lucky, because your accuracy is splendid. The generator's true frequencies then are referred to the standard on the basis of dividing the standard by whole numbers, e.g., if 5,000 kc is being received, generator at 50 kc will beat its 100th harmonic with the standard, the higher generator frequencies will be represented by lower harmonic orders, 5,000/99, taken as 50.5 kc, next 5,000/98, taken as 51, etc. As the frequencies of the generator become higher the points are less numerous and you would have to wait for a higher standard frequency, and thus complete your calibration, which may be checked regularly against the standard. If now you will set another low r.f. generator going, and calibrate that, you can use closer figures for the audio tones produced

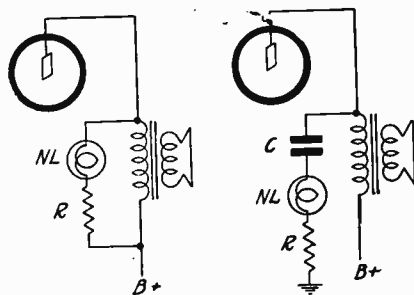

Neon tube output indicators.

by the difference in a detector tube into which the two radio frequencies are fed. Actually two of the frequencies mentioned above are 50.505 and 51.0204, and an audio beat oscillator may be fed into another detector along with the audio tone from the two low frequency r.f. generators. The difference frequency is 515.4 cycles for zero beat, which is not hard to establish in this instance, because the resultants are low frequencies. If there is a difference the meter will enable one to tell what it is but not the direction of difference, e.g., whether 5 cycles too high or too low, to register zero beat certainly, although indirectly even this could be checked. The beat between 50 and 50.0204 yields 20.4 cycles, as low as you could calibrate the audio device, probably. By these methods you can proceed along the whole gamut and also refer both radio and audio systems to a standard of frequencies accurate to 5 parts in a million.

\* \* \*

### Uses for Neon Lamp

**C**AN the neon tube be used so that only modulation will light a lamp attached to a set's output tube? What about the direct current through the primary winding?—I. L.

The tube may be used in either of the ways shown. At left the lamp is NL, and its limiting resistor is R, usually built in, and 100,000 ohms. The voltage drop due to the d.c. through the primary will not be nearly enough to light the lamp. However, assume that it is enough, more than 65 volts, purposely accomplished by grounding. Put a condenser in series with the lamp, as C at right, and no d.c. will pass through the lamp, only a.c. The condenser should be of the paper dielectric type, however, otherwise there might be sufficient leakage to nullify the intended result.

\* \* \*

### "Straightening" the 6E5

**T**HE 6E5 electron ray indicator tube, as I understand it, has an illuminated screen, and the width of the illumination is controlled by the bias voltage, the more negative that voltage, the narrower the shadow angle. Since the action is not quite linear, due to an amplifier characteristic of the triode part of the tube, could not some external impedance be used to make the curve linear, so that the difference between 6 and 7 volts, or even 7 and 8 volts,

(Continued on next page)



# NOISE REDUCING TWINS

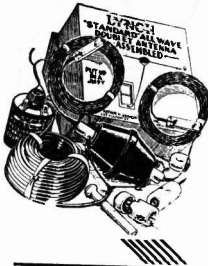

## LYNCH HI-FI Assembled Antenna

All ready to hang. Saves 90% of installation time. Any novice can install it—quickly, easily, correctly. Makes every set perform better. Results are amazing.

LYNCH HI-FI  
ASSEMBLED  
ANTENNA **\$6.75**  
list

The ONLY TWO Companion Devices  
for Reducing Noise on ALL Waves

## LYNCH FILTERADIO

Cuts out objectionable noise from the light line. Makes interference from circuit breakers, motor generators, etc., practically negligible. Easy to install; simple to adjust. One type serves all purposes. **\$5.00**  
list

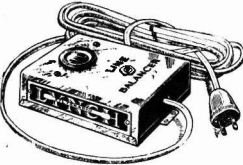

Be sure and see these NOISE-REDUCING TWINS at your jobber's or dealer's. If they cannot supply you, order direct, or write for folder.

ARTHUR H. LYNCH, Inc., 227 Fulton St., New York  
Pioneer of Noise-Reducing Aerials

# LEARN THE FASCINATING PRINCIPLES ON WHICH TELEVISION IS BASED

It is by no means difficult to learn the fundamentals of television, to get a real insight into the processes and methods, for they are revealed, simply but expertly, in "A B C of Television, or Seeing by Radio."

Raymond Francis Yates, author of the book, is a famous interpreter of scientific topics, and makes everything perfectly clear.

The book is very practical and gives constructional data for experimental television arrangements of the low fidelity type, excellent on which to learn, and reveals facts which may be used as the basis of construction of high-class receivers and scanners. With television on the air in Canada, and television stations now building in the United States, everyone should be prepared to get in on the ground floor, and knowledge is the magic key. This book enables attainment of that knowledge. 210 pages. Freely illustrated. Price: **\$3.00**, postpaid. Prompt shipment.

BOOK DEPARTMENT

RADIO WORLD

145 West 45th Street, New York, N. Y.

(Continued from preceding page)

would be as wide as that between 1 and 2 volts?—I. B.

The triode has been loaded with a very high resistance as it is (1 meg. recommended, see August issue), although principally for purposes of limiting the current through the triode plate, and there does not seem to be any ready way to straighten this out. Whether there is much need for linearity is debatable, as from 0.5 to 6 volts there is fairly even division, and the limit is 8 volts, with crowding between 6 and 8. The tube is intended for visual tuning purposes mostly, but other applications, such as tube voltmeter and the like, will have to be made to subscribe to the performance enabled by the geometry of the tube. If it is desired to shift the spreadout from the low to the high voltage extremes, this may be done by biasing the tube 8 volts negative, thus reversing the significance of the change of shadow angle, that is, zero voltage would be closest angle, and 8 volts would be maximum shadow angle. By a switching arrangement it would be practical to use the tube one way, then the other, to shift the spreadout from one extreme to the other. It should be remembered that it is in the measurement of small voltages that tube voltmeters are most important.

\* \* \*

## Reversed Tickler Oscillates

IS IT possible that the tickler that I connected in reverse, that is, in the opposite direction to that which it should be for oscillation, nevertheless will cause oscillation? I seem to have had that experience and was wondering if there was anything within your own experience to confirm this?—W. D.

Yes, the condition you mention is not an oddity at all. The oscillation or feedback is the result of the capacity coupling between primary and secondary. Usually the oscillation prevails for the higher frequencies in tuning any particular band, and then the oscillator goes dead. The phenomenon, if such it may be called, is particularly present on high frequencies (short waves). In fact, when the frequencies become high enough there may be almost a complete phase shift in the grid circuit, requiring for the support of oscillation all over the band that the tickler be connected seemingly the "wrong" way, but actually of course it is the right and only way. With regenerative receivers this condition may be noted indirectly, in that the throttle condenser (if feedback is capacity controlled) has to be turned the opposite direction than for lower frequency bands to increase regeneration. It is also true that as frequencies become very high the nature of the oscillator changes, that is, a Hartley turns into a tuned grid oscillator, or other such unintentional circuit swapping takes place.

\* \* \*

## Amateurs on 5 and 10

WHAT methods do the amateurs use to be sure that they are inside the bands on 5 and 10 meters, as I have not seen any information about devices for measuring such fre-

(Continued from preceding page)  
 quencies, for ham purposes, only laboratory instruments of considerable cost.—J. R. D.

We do not know what method they use. Many no doubt depend on other amateurs as guide posts, by tuning them in, but on whom these guides depend we don't know. From measurements we have made we would assume that much of the frequency selection is the result of hit or miss, even allowing for considerable bootlegging of call letters by poachers who wouldn't care what the frequency was. The requirement for adherence to frequency pertains in this band as to others and no doubt in due course ready methods will be perfected for enabling hams and others accurately to determine such frequencies.

## HIGH-CLASS PRINTING

PREPAID IN UNITED STATES

1,000 Business Cards, fine vellum, free case.....\$1.35  
 1,000 Letterheads, standard size, 20 lb. bond.....\$3.65  
 1,000 Envelopes, Statements or Billheads.....\$2.75  
 1,000 Veri Cards (six lines maximum).....\$1.35

Wonderful values. Trial order will convince you.  
 Let us quote on your other printing requirements.

### MAIL ORDER PUBLISHERS

954 8th AVENUE

NEW YORK

### Radio Noises and Their Cure

Complete information on distribution, interference and suppression.

288 diagrams - 76 pages.

Price \$1.00 while they last.

GETZ, 127 Brick Street, Dickson, Pa.



### PROTECT YOUR VALUABLE KEYS!

A Polished Metal Key Check with your name and address stamped on will identify and usually insure prompt return of keys if lost. Send 25 cents today and Key Check with a Key Ring will be sent to you postpaid. Agents wanted.

IRVIN BUSCHKOWSKY

508-N Oak Street - Chaska, Minnesota

## METAL CHASSIS

We make Chassis and Metal Cabinets for any make receiver. Experimenters and others who want neat metal bases or housings for assembled apparatus, will find our workmanship superb. Inquiries should be accompanied with clear drawings, blue prints and other details concerning size and bends in metal if any, enabling us to give quick service as to prices and delivery.

Dealers and Jobbers: Write for special prices.

**KORROL MFG. CO., Inc., Dept. R. W.**  
 232 GREENWICH ST. NEW YORK CITY

## DOCTORS!

We will gladly send you  
 Reprints and Literature on  
**Ultra-Short-Wave Therapy**

with details of the new Lelap  
 Ultra-Short-Wave Machine

If you will write to

Dept. R. W.

**LELAP HIGH FREQUENCY LABORATORIES**

Inc.

39 West 60th Street, New York City

## Royal Air-Cooled Pipe

"Smoke with a Breath of Air"

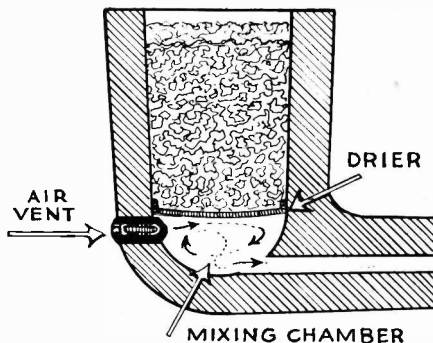

### Get the Full Flavor of Your Favorite Tobacco

Three good reasons why the Royal Air-Cooled Pipe has gained so rapidly in popularity:

1. **No more burning bite**, because it is cooled by the exclusive Royal air feature.
2. **No more unpleasant dampness or wet heel**, because the perforated disc placed just above the vent allows the tobacco moisture to drop into the mixing chamber where the air mixing with the smoke dries it away.
3. **No more disagreeable odor** to cling to your clothes, because this beautiful Algerian briar pipe styled by experts is ventilated!

If your local dealer cannot supply you, write for illustrations of models, or send \$1.50 to

**ROYAL PIPE COMPANY, Inc.**  
 Chrysler Bldg., New York City

## New HIGH FREQUENCY SOCKETS by HAMMARLUND

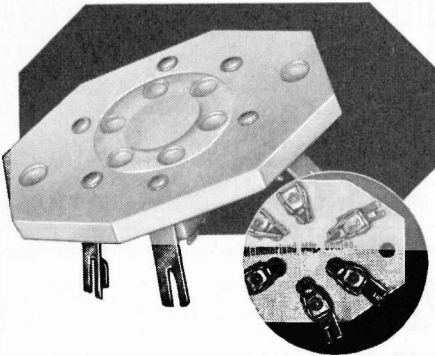

Hammarlund originated low-loss wafer-type sockets, and they have never been excelled for high-frequency work. Only Grade "B-100," the lowest, strongest Insulante material is used—glazed on top and sides—and "Ceresin"—treated underneath to prevent moisture absorption. Long leakage paths between new-type, positive side-gripping contacts. Due to a square inset anchorage, Hammarlund contacts cannot twist, loosen or shift position, with changes in temperature and humidity. The new circular Guide-Groove makes insertion easier. For 4, 5, 6 or 7 prongs—60c each, list.

Write for RW-9 for Complete Catalog

**HAMMARLUND MFG. CO., INC.**  
424 WEST 33RD STREET NEW YORK, N. Y.

## PEAK Regenerative Pre-Selector

IMPROVE your  
S. W. Reception  
with PEAK  
Products.

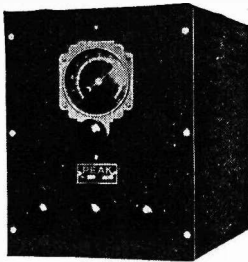

The Peak P-11 is the only Pre-selector guaranteed to give unconditional satisfaction to the most critical S. W. listeners.

Tremendous increase in signal strength.  
Absolute rejection of image.  
Increased selectivity.  
Decrease of noise level to signal ratio.

PEAK Q-5—the last word in design of 5 meter Super-het receivers.

PEAK X-4—10-watt, 5-meter x-mitter. A quality transmitter at a price within the reach of all, now available.

For further data on PEAK Products  
see your dealer or write to Dept. R.W.

## Eastern Radio Specialty Co.

Manufacturers of PEAK Products

1845 BROADWAY

NEW YORK, N. Y.

## QUICK-ACTION CLASSIFIED ADVERTISEMENTS

7 cents a word. \$1.00 minimum.

**FILMS DEVELOPED**—Any size, 25c coin, including 2 enlargements. Century Photo Service, Box 829, La Crosse, Wisconsin.

**"RADIO TROUBLE SHOOTING,"** Second Edition, by E. R. Haan. Contains the latest on A.C. receivers, dynamic speakers and television. A practical book for practical men. Contains a special chart showing all possible radio troubles and the way to detect them. Size, 6 x 9 inches, 361 pages, 300 illustrations. Flexible binding. Price, \$3.00. RADIO WORLD, 145 W. 45th St., New York City.

**WANTED: ORIGINAL POEMS, SONGS** for immediate consideration. MMM Publishers, Studio Bldg., Portland, Ore.

**"WILLCOX AUTO ELECTRICIAN'S WIRING MANUAL"**—Complete wiring diagrams for all U. S. cars made in 1928-1929-1930-1931-1932. Complete data on ignition systems, generators, starting motors, batteries and lighting. Printed on tough, wear-resisting paper that can be washed with gasoline without injury to print or paper. Loose-leaf style in sturdy covers. Size 11 x 12". 300 wiring diagrams. Price \$10.00. RADIO WORLD, 145 W. 45th St., New York City.

**"RADIO TROUBLE SHOOTING,"** Second Edition, by E. R. Haan. Contains the latest on A.C. receivers, dynamic speakers and television. A practical book for practical men. Contains a special chart showing all possible radio troubles and the way to detect them. Size 6 x 9 inches. 361 pages, 300 illustrations. Flexible binding. Price \$3.00. RADIO WORLD, 145 W. 45th St., New York City.

**RADIO WORLD AND POPULAR MECHANICS MAGAZINE**—Radio World is \$2.50 a year, and Popular Mechanics Magazine is \$2.50 a year. Popular Mechanics Magazine does not cut rates, but Radio World will send both publications to you for one year for \$3.75. Radio World, 145 West 45th St., New York City.

**THE ART OF INVENTING AND WHAT TO INVENT**—By Raymond F. Yates, an inventor of numerous devices. 297 pages and 68 illustrations. Invention is not the exclusive property of genius. Often it is the property of the ordinary tinker—in fact, it has been said that every man has in him at least one useful invention. This book is intended for just ordinary people who do not know how to turn their creative ideas into profit. It assists them by imparting fundamental scientific and technical knowledge, by providing suggestive lists of needed inventions, and by describing how to patent inventions and what inventions are unpatentable or unprofitable. Sent postpaid for \$3.00. Book Dept., Radio World, 145 W. 45th St., New York City.

**HAVE YOU A SOUND, PRACTICAL INVENTION FOR SALE,** patented or unpatented? If so, write Chartered Institute, Dept. 70, Barrister Building, Washington, D. C.

**KNOW STAMPS**—"Stamp collecting" in ten easy lessons, to approval applicants, 25c. Havert Stamp Company, Dept. D, Milford, Kansas.

# Pep on 17 mgc.

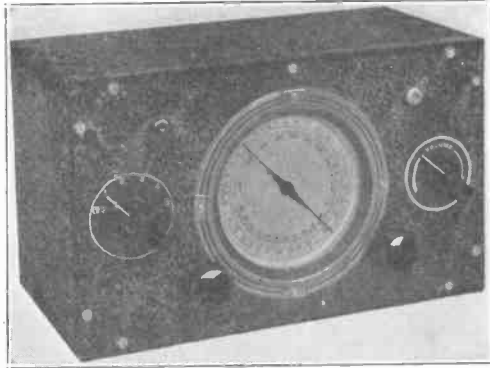

**T**HE Racó All-Wave Signal Generator, using Racó's own decimal repeating vernier airplane dial, covers from 54 kilocycles to 17 megacycles, a frequency ratio of 315-to-1, and all on fundamentals. Moreover, wavelengths are read directly from the dial scale, and so are frequencies, of course. And on the highest frequency, 17 mgc. in a region where some other signal generators lose their strength, the Racó Signal Generator has plenty of PEP.

The five wave bands are selected by a low-resistance, low-capacity panel switch. The bands are: (1)—5,400 to 17,000 kc (5.4 to 17 mgc). (2)—1,700 to 5,400 kc (1.7 to 5.4 mgc). (3)—540 to 1,700 kc. (4)—170 to 540 kc. (5)—54 to 170 kc.

By close attention to exacting requirements we are able to produce this Signal Generator, and track the scale to 1 per cent. accuracy, without the use of compression type trimmers, which notoriously *do not stay put*. In fact, no external trimming capacity is used at all, the required adjustment being taken care of in the coil winding, so that the capacity between plate and grid windings is properly established for each band. This capacity is held to very close tolerance.

The Racó 339 Signal Generator works on a.c. or d.c., 90-125 volts, is electron coupled as to output and also as to audio tone, has a separator modulator tube to create that tone, and is equipped with attenuator, on-off a.c. switch, and on-off modulation switch. Model 339, wired, calibrated, adjusted, complete with 6D6, 37 and neon tubes; instructions (shipping weight, 8 lbs.)

**\$16<sup>00</sup>**

## FOR INTERMEDIATE FREQUENCIES ONLY

**T**HOSE whose work does not require that they have an all-wave Signal Generator may use the Racó Model 341 for direct reading of intermediate frequencies, 109 kc to 500 kc. As is our invariable practice, the frequencies and wavelengths are directly read from the dial scale. This model is universal, also (works on 90-125 volts a.c. or d.c.). On a.c. the line hum constitutes the modulation. On d.c. there is no modulation.

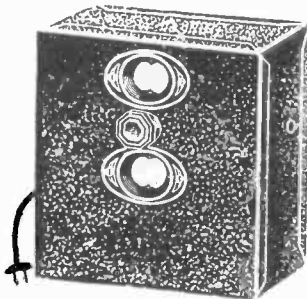

**M**ODEL 341 is housed in a black crinkle-finish box and is a compact handful that meets the requirements of those otherwise at loss for proper means of peaking an intermediate amplifier. This model requires a 37 tube (not supplied). Otherwise everything is complete—wiring, adjustment, calibration. Though the price is exceedingly low, the service is high, and the instrument's life practically unlimited. Model 341, \$4.50.

(All prices quoted are net.)

**RADIO CONSTRUCTORS LABORATORIES**

136 LIBERTY STREET Dept. W-208 NEW YORK, N. Y.

# 1/2% Accuracy

## Attainable in Build-Your-Own SIGNAL GENERATOR

**L**ABORATORY perfection of a new type precision inductance meter has enabled us to hold our signal generator coils to even a higher accuracy than formerly, so that they are literally precision coils. Used with a particular tuning condenser of 406 mmfd., in series with which is to be put a 0.0065 mfd. fixed condenser, the tracking of our direct frequency reading dial enables coincidence to be within 1/2 per cent., the limit of accuracy of reading determined by mechanical conditions. That is, the electrical circuit is super-plus accuracy, and only the difficulty of reading the calibration closer than 1/2 per cent. limits the accuracy to that quantity.

And you can build at low cost a battery operated signal generator (as the one diagramed on page 59 of the August issue of Radio World) or a universal signal generator, operating on a.c. or d.c. (as diagramed on page 24 of the same issue). We have coils for three bands, to be shifted by switching. The frequencies are: 140-500 kc; 540-1,600 kc; 1,400-5,000 kc.

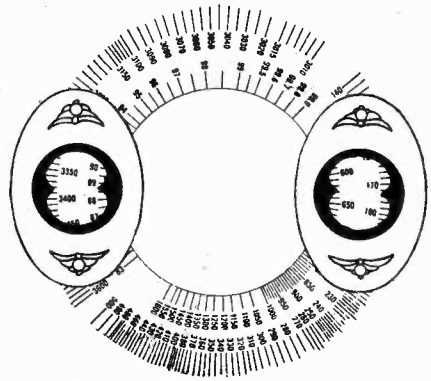

Scale and Escutcheons for 333 Series

### THE 333 SERIES

**FOUNDATION KIT 3332-N** consists of etched metal dial scale, escutcheon, two Isolantite coils for intermediate and broadcast frequencies, tuning condenser (remove trimmer) and precision fixed series condenser 0.00065 mfd. (Shipping weight, 2 lbs.)..... **\$2.20**

**FOUNDATION KIT 3333-N** consists of dial scale, escutcheon, two Isolantite coils for intermediates and broadcasts, one intermediate short wave solenoid coil, tuning condenser, series condenser. (Shipping weight, 2 lbs.)..... **\$2.75**

**FOUNDATION KIT 3334-N** consists of the same as 3333-N, except that a 0.0008 mfd. precision fixed condenser is supplied, and two escutcheons instead of one, so that by using a three deck switch, or extra switch to cut this fixed condenser in parallel with the intermediate coil, frequencies 83-100 kc are read, and cutting it across the 1,400-5,000 kc coil, frequencies 830-1,000 kc are read, both with enormously wide spreadout, and with wavelength readings for these bandsreads present as well as frequency readings. The low frequency use enables checking old sets with i.f. around 92 kc, as Victoreen and Magnaformer. The bandsread at the middle of the broadcast band enables closer use directly or by harmonics for very high frequency determinations. The bandsread method requires the extra escutcheon to reveal the other half of the dial on which the 83-100 kc or 3,010-3,600 meter calibrations are imprinted. Trimmer to be removed from tuning condenser (Shipping weight, 2 lbs.)..... **\$3.55**

**FOUNDATION KIT 3335-N** consists of 3334-N plus the shield cabinet for building either universal or battery model (room inside for batteries), and two chrome finished face plates, one for output attenuation (volume), other for 0-100 for percentage modulation, as generators have separate modulators. And both are electron coupled and stable. Remove trimmer from tuning condenser. (Shipping weight, 7 lbs.)..... **\$5.59**

### INTERMEDIATE FREQUENCY SIGNAL GENERATOR

**SPECIAL:** Single coil, escutcheon, tuning condenser (do not remove trimmer, as adjustment is to be made with it for this use) and 0.0001 mfd. fixed condenser to go across tuning condenser, for covering 109-220 kc fundamentally, all important higher intermediate frequencies also direct reading, with harmonic confusion elimination by two spot location of these important i.f. Cat. PR-6-K. (Shipping weight, 2 lbs.) **\$1.89**

**SHIELD CABINET FOR "SPECIAL"**  
(Cat. PR-6-SC) **92c**

### PRECISION COILS

Our precision coils of the 333 series may be used by those who desire to tune them with a 0.00035 mfd. single gang condenser, and calibrate the frequencies themselves. The ranges will be close to 140-500, 540-1,600, 1,400-5,000. No series condenser would be needed, because of independent calibration.

- Intermediate Frequency Isolantite Coil (Cat. L-140)..... 65c.
- Broadcast Frequency Isolantite Coil (Cat. L-540)..... 60c.
- Intermediate Short Wave Solenoid Coil (Cat. L-1400)..... 55c.
- Output Coupling Coil, for use with signal generators having an amplifier stage. Connect large winding in plate circuit, small winding as output. Frees generators from molesting the sensitivity of receivers, and enables measurements on sets using doublet antenna posts (Cat. L-OP)..... 50c.

**Precision — Quality**

**CUSTOM SET BUILDERS SUPPLY CO.**

135 LIBERTY STREET, NEW YORK, N. Y.

Telephone: REctor 2-6650

When ordering, please request the particular circuit diagram you want, whether a.c., universal or batteries. Any individual features you prefer should be specifically mentioned and will be included in a special diagram at no cost to customer.

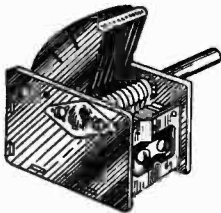

# Servicemen, Experimenters and Set Builders!

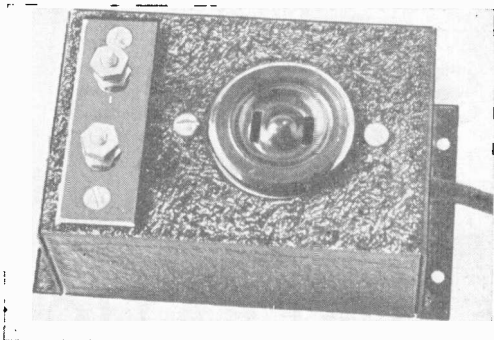

Line filter that reduces line noise and eliminates need for antenna.

Build better new receivers, make old receivers better with new coils of the latest and most advanced types. These improved coils make sets more selective, more sensitive, and quieter in operation.

## RADIO DESIGN LINE FILTER AND ANTENNA ELIMINATOR (illustrated)

List price, \$3.00. **Special introductory price, \$1.50.**

**I.F. TRANSFORMERS**, 465, 456, and 175 kc, doubly tuned by high grade mica trimmers—3-pie windings with Litz wire—High Q—The very latest development in coils.....List price, \$2.50. **Our price, \$1.00**

**ALL-WAVE SUPERHETERODYNE COIL KIT**, for three-gang variable condenser, tuning bands, 16-50 and 66-200 meters, 540-1, 500 kc, consisting of 6 high frequency coils and 2 Litz-wound I.F. transformers. Circuit diagram included.....List price, \$8.00. **Our price, \$4.00**

**TWO-BAND SUPERHETERODYNE TUNING KIT** for B.C. and foreign short-wave bands (530-1, 600 kc and 16-53 meters), consisting of 4 coils and 2 Litz-wound special I.F. transformers, for two-gang condenser. Complete with coil switch and circuit diagram.....**Price, \$3.00**

**T.R.F. BROADCAST COIL KIT** for 3 or 4-gang condensers. Shielded coils. Three coils for three-gang condenser, four for four-gang. Circuit diagram included.....**Price each coil, \$0.50**

**SUPERHETERODYNE COIL KIT** for broadcast receiver, consisting of two B.C. coils and two special Litz-wound 456 kc, I.F. transformers. For two-gang variable condenser. Diagram included.....**Price, \$2.50**

We can supply wide choice of radio parts at lowest prices.

## RADIO DESIGN COMPANY

98 PARK PLACE, NEW YORK, N. Y.

Free technical advice given by J. E. Anderson, if self-addressed and stamped envelope is included with questions.

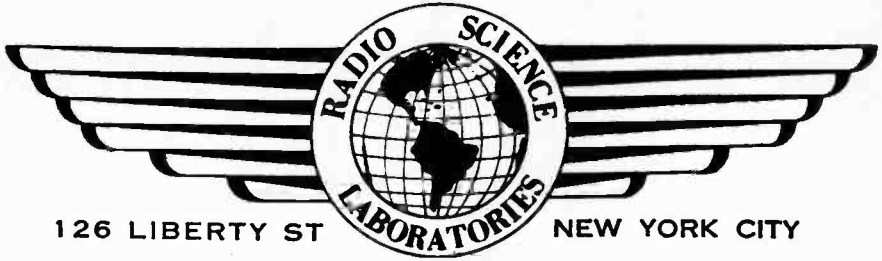

126 LIBERTY ST

NEW YORK CITY

# SOUND SYSTEMS

**PRESENTING A COMPLETE LINE  
OF AMPLIFIERS READY FOR  
IMMEDIATE OPERATION**

## MODEL 6-A

### 6-Watt Hi-Fidelity Portable Amplifier

INCORPORATING 3 Tubes — 1—57, 1—2B6, 1—5Z3 — High Impedance Input—Gain 85.5 dcbls.—Fader Mixer—Microphone—Microphone Battery—Unit built into a strong, durable carrying case.

**Complete—F. O. B. New York \$29.50 Less Tubes**

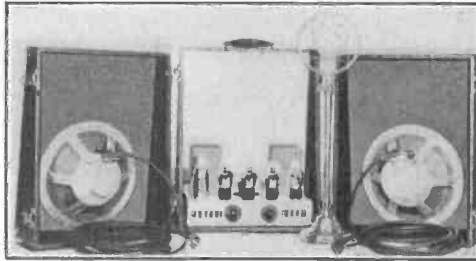

#### MODEL 12-A (Illustrated)

#### 12 WATT HI-FIDELITY PORTABLE AMPLIFIER.

Incorporating—5 tubes—1—57, 1—53, 2—2A5s, 1—5Z3—Phase inversion—Gain 105 dcbls.—High impedance input—Fader mixer—microphone and full sized stand—microphone battery—Two 11½ in. hi-fidelity speakers, each with 25 foot cable and plug—Built in speaker field supply—Entire unit built into a sturdy carrying case 15"x15"x18½".

**Complete—F.O.B. New York—\$55.00 less tubes**

#### MODEL 30-A

#### 30 WATT HI-FIDELITY STATIONARY AMPLIFIER.

Incorporating—8 tubes, 1—57, 2—53s, 4—45s, 1—5Z3—Phase inversion—Gain 94 dcbls.—High impedance input—Fader mixer—Microphone and full sized stand—Microphone battery—Volume, and Tone control—Built in output transformer—Two heavy duty Hi-Fidelity speakers.

**Complete—F.O.B. New York—\$59.50 less tubes**

**RADIO SCIENCE LABORATORIES**  
126 Liberty St. New York City

# P. A. S.

5 Tube - High Fidelity - 15 WATTS

Uses one 57, one 56, two 2A5, one 83V.

Sold complete with case, speaker, microphone, stand, input stage, phono pickup, phono motor and connecting cables—ready to operate, nothing else to buy.

## \$42.50

**THOR RADIO**



167 GREENWICH ST. **CORP.** NEW YORK CITY

## P. A.

### PRINCIPLES of PUBLIC ADDRESS SYSTEMS

A practical handbook, full of useful information, fully illustrated, written by M. N. Beitman, an engineer and noted authority on audio amplifiers.

Considers in detail two-button and condenser, microphones, radio and phono input, acoustic feed back, mixing and volume controls, use of vacuum tubes, interstage coupling, power amplifiers, output coupling, loud speaker placement, the decibel, P.A. measurements, power level, and other points of importance, including actual circuit diagrams of P. A. systems. (Size, 8½ x 11 in.)

## MATHEMATICS of Radio Servicing

Introduces and explains the use of arithmetic and elementary algebra in connection with units, color code, meter scales, Ohm's Law, alternating currents, ohmmeter testing, wattage rating, series and parallel connections, capacity, inductance, mixed circuits, vacuum tubes, curves, the decibel, etc., etc., and has numerous examples.

Plainly written and easy to understand. Only useful data included. M. N. Beitman, author. Size, 8½x11 in.

*Either book, price only 50c, post free.*

**SUPREME PUBLICATIONS**

3727 WEST 13th STREET  
CHICAGO, ILLINOIS

# Coil Winding Made Easy

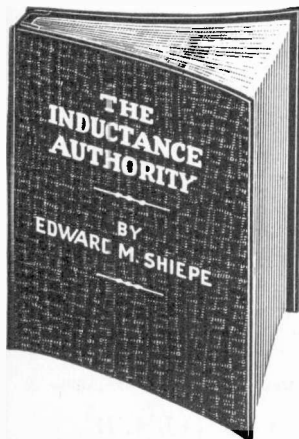

The biggest help anyone can get who desires to wind radio-frequency coils for any frequency from just below the audio range to the fringe of ultra frequencies is to have a book that tells just what inductance is required for the condenser one possesses, and just how many turns of any kind of wire on any sensible diameter are needed to produce that inductance. "The Inductance Authority," by Edward M. Shiepe, gives you all that information, to an accuracy of 0.1 per cent. Send **\$2.00** and book will be mailed you postpaid; or send **\$5.00** for a two-year subscription for Radio World and this valuable book will be sent **free**.

**RADIO WORLD**

- 145 WEST 45TH STREET, NEW YORK CITY



# GENERAL SHORT-WAVE AND PUBLIC ADDRESS MANUAL

Bound in cardinal red leatherette, this manual includes articles on the construction of short-wave receivers from one to nine tubes, inclusive, and all values between, supers and t-r-f, with the clearest imaginable illustrations, both photographic and draughting. Besides the usual plain circuit diagram there is a pictorial diagram for each circuit. And all the photographs are informative. Portable short-wave sets, design and winding of coils for short waves and broadcasts (intimately illustrated).

List of short-wave stations, with meters and kilocycles and hours on the air; trouble-shooting, and forty other topics, all done well.

The public address section contains data on different systems, how to use them, and offers opportunities to turn public address work to profit. Besides, there are articles on testing and servicing not encompassed by the title of the manual—signal generators, broadcast home and portable sets, analyzers, formulas, capacity data. Everything plainly told, simple language, from microphones to speakers.

## PARTIAL LIST OF CONTENTS

Amplification Factors .....	95
Amplifiers .....	115
Analyzer Unit, How to Make .....	129
Antenna Design .....	80
Antenna Lead-in Cable .....	86
Antenna Wire .....	85
Antenna, 5-Meter .....	71
Broadcast Receivers .....	88
Coil Design .....	23, 24, 25
Construction of Short-Wave Receivers .....	22
Condenser Data Sheet .....	13
Condensers, Proper Replacement .....	12
Converting Meters to Kilocycles .....	19
Condenser Microphone .....	110
Crystal Microphone .....	114
Converters:	
"Regent" Two Tube A.C.-D.C. ....	64
"Paramount" Two Tube A.C.-D.C. ....	65
"Adam's" Four Tube A.C. Superhet. ....	66
Curves, Explanation .....	100
Hum Elimination .....	98
Interference Elimination .....	79
Morse Code .....	75
Modern Microphone Trends .....	109
Oscillator, Battery-Operated .....	134
Oscillator, A.C.-D.C. ....	138
Phonograph Combination .....	128
Power Transformer Design .....	105
Public Address Installation .....	94
Servicing Formulae and Data .....	103
Short-Wave Tuning Instructions and Data .....	20, 21
Short-Wave Station Log .....	14 to 18
Short-Wave Receivers starting .....	page 26
Short-Wave Power Pack .....	46
Transceiver, Federal .....	70
Transceiver, Powertone .....	68
Transmitter .....	141
Tuner, Three Tube T.R.F. ....	125
Tuner, Four Tube T.R.F. ....	126
Tuner, Superhet .....	127
Velocity Microphones .....	111
Volume Controls, Electrad Replacement .....	132

PRICE 50 CENTS

Send stamp for technical book catalog.

**RADIO WORLD** 145 WEST 45th ST  
NEW YORK CITY

## CONTENTS OF MONTHLY ISSUES OF RADIO WORLD

MAY NO., 1935

**Metal Shell Tubes**—By Conrad L. Morrow.  
**More Gain from New Tubes**—By Harry Miller.  
**Try a Whisk Broom on Your Soldering Iron**—By Jack Tully.  
**Plain Talk on Aerials**—By Connie Andover.  
**Boondoggling.**  
**Alignment, All Levels**—By Martin A. Gobin.  
**Getting the Harmonic Habit**—By Albert J. Pierce.  
**Armchair Portable**—By J. C. Wall.  
**Tuned Radio Frequency Set with Pentode or Triode Output**—By Henry L. Maks.  
**Portable for All Waves**—By Tom Bidwell.  
**What Air Condensers Do**—By John Braden.  
**What Pep**—By Jack Sullivan.  
**Neon Gadgets**—By Will Ellington.  
**B-u-z-z-e-r**—By Leon Wolf.  
**Organizing A Meter**—By B. M. L. Ferris.  
**Fundamentals Most Useful**—By Herman Bernard.  
**A Filter for High Fidelity**—By Sidney Wald, E.E. Radio University.

JUNE NO., 1935

Illus. features in that issue: Coil Switch Assembly—Ultra Frequency Measure with Photocell and Lamp—Seventh Metal Shell Tube—Pin Numbering on Octal Bases—Finding CX Easily—Equal Gain on T.R.F.—A Beat Oscillator—High Fidelity Tuning—It's the Set, not the Car—New Police Radio-Car Sets on Peak Road—False Alarms with Universal Sets—Dual Range Super—Wave Trap Does the Trick—Measuring Low Resistance—Three Tube S.W. Set—An Effective Transceiver—A Battery Signal Generator—War on Static Succeeding—Circuits We Print Readily Duplicated—Straight Frequency Liner—The Velocity Microphone, etc., etc.

JULY NO., 1935

Illus. features in that issue: Television in Natural Colors—Technique for 'Phone Tip Soldering—T.R.F. Tuner Made High Gain—A 5 Meter Sending Aerial—Getting Things Into Places Where They Don't Fit—A Four Tube Portable—A Transmitter Class \$750—The Saturated Pentode—A Service Wand for Light—A Marine Radio Compass—VTVM Capacity Meter—Pretuned I. F. Amplifiers—Compact Four Tube Set—Neon Tube's Average Current, etc. Radio University Dept.—Harmonic Practice for Calibrating or Checking a Generator—Articles by Capt. V. O'Rourke, Herman Bernard, J. E. Anderson, Louis Pouy, Jack Goldstein, Harvey E. Sampson, B. Herbert Russ, Earle Branker, etc., etc.

AUGUST NO., 1935

Illus. features in that issue: An Electron Ray Indicator, Ultra Wave in Wall Street; Graphic Help to Constructor; Shield Effect on Inductance; All Hail the Grid Leak; Receiver Detuning Avoided; Short Wave Converter Factors; How to Use the New Tubes; An Experimenter's Supe 4; High Fidelity R.F. Tuner; Television on Six Meters; The Thyatron Tube; Radio Construction University: Articles by Neal Fitzalan, J. E. Anderson, Herman Bernard, Lionel Rivers, Arthur H. Lynch, Morris N. Beitman, L. M. Loughboro, S. G. Brady, Maxwell M. Hauben, etc. etc.

**25c A COPY. \$2.50 YEARLY IN U. S.**  
Include as part of New Subscription if you wish.

**RADIO WORLD**

145 West 45th Street

New York City

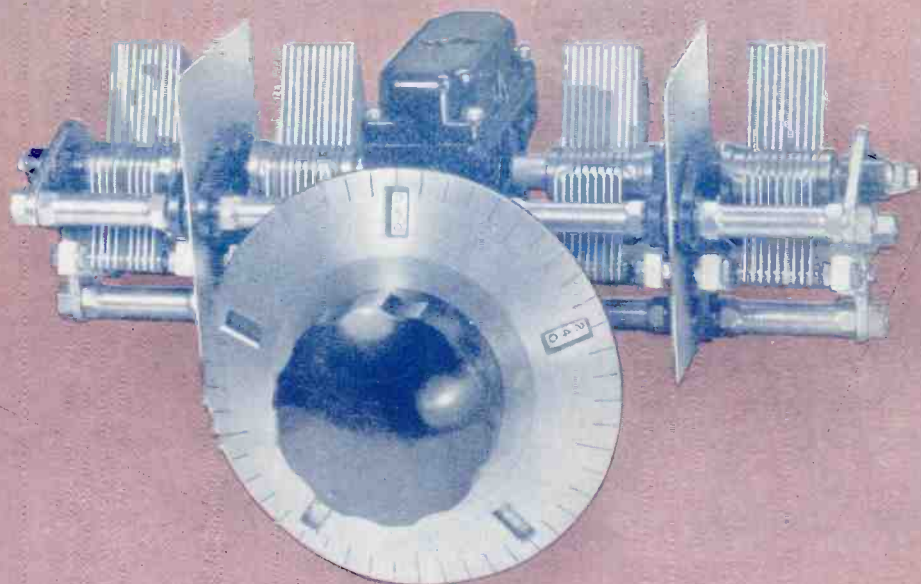

**THE MICROMETER DIAL.** The dial on the PW Precision Condenser is of an entirely new type, being direct reading to 1 part in 500. It is read exactly like an ordinary dial. Fifty division lines are engraved on the rim of the dial shell, and each tenth division is numbered in the usual way. However, the dial revolves ten times in covering the tuning range. Each revolution the numbers change automatically, giving continuous readings to 500. The numbers turn with the division lines, and change rapidly at the bottom of the dial when they are out of the operator's line of sight.

**THE PRECISION CONDENSER.** The condenser is of extremely rigid construction, with four bearings on the rotor shaft. The drive is through a preloaded worm gear of great accuracy. Each rotor is individually insulated from the frame by bakelite; each stator is individually insulated by low-loss Steatite. End bearings are insulated for quietness. The condenser is mounted rigidly to the chassis by bosses on the base of the gear housing. Neither the frame nor the dial touches the chassis or panel at any point, making the assembly immune to bending of the chassis.

**RANGES.** The PW condensers are available in 1, 2, 3 or 4 sections with 150 or 225 mmf maximum per section. A new single section model now in preparation will provide capacities up to 500 mmf. The plate shape of all ranges is designed to give straight line frequency tuning when the frequency range is exactly 2 to 1.

**NATIONAL COMPANY, INC. - MALDEN, MASS.**

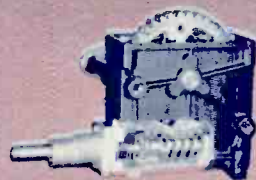
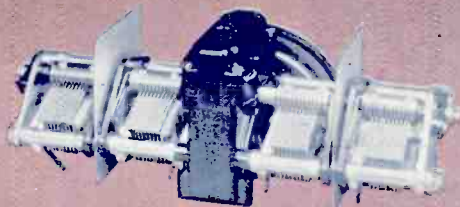
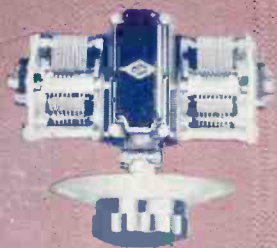

# Readrite SENSATIONAL New Tube Tester



Model No. 430

## FEATURES:

1. Tests both metal and glass tubes.
2. Applies proper load values to tube under test.
3. Tests for slightest leakages and all shorts.
4. But four simple operations required.
5. Uses Triplett Model 221 meter with GOOD-BAD scale.
6. Meter especially protected against damage.
7. Shadow type A.C. meter for line volts adjustment.
8. Has double grid cap for metal and glass tubes.
9. Sloping, all-metal lithographed panel.
10. Furnished in handsome quartered oak case which you must see to really appreciate.

**E**VERY serviceman will want this new Readrite Model 430 because it speeds up jobs and makes money on every service trip. Ruggedly built, and designed especially to withstand the harshest treatment and all weather conditions.

Don't be caught short because of inadequate test equipment. Be sure you have the Readrite Model 430 to meet all tube testing requirements. Be prepared! See the Readrite Model 430 at your jobber's, and write immediately for catalog describing this and other outstanding Readrite equipment.

## WATCH FOR OTHER NEW ITEMS

### READRITE METER WORKS

180 COLLEGE AVENUE

BLUFFTON, OHIO, U. S. A.

#### RUSH COUPON FOR DETAILS

READRITE METER WORKS

180 College Avenue, Bluffton, Ohio

Gentlemen:

Please rush immediately catalog describing the new, 1936 Readrite line.

Name .....

Street .....

Town ..... State .....

*See  
Your  
Jobber*