

# PUSH-PULL DETECTOR FOR SHORT WAVES

# RADIO

REG. U.S. PAT. OFF.

# WORLD

The First and Only National Radio Weekly

**15¢**

Per Copy

628th

*Consecutive Issue*

*Thirteenth Year*



## A SENSITIVE SHORT WAVE CONVERTER

—  
Super-Regeneration  
for Ultra Frequencies

# NOISE REDUCING ANTENNA INSTALLATION

APRIL 7th, 1934

# POWER TONE

## "ROUND THE WORLD" UNIVERSAL AC-DC SHORT WAVE RECEIVER



15-200 Meters

This circuit features the new 25Z5 tube as rectifier for the power supply. The 43 tube is a splendid power pentode output for universal circuit.

With a pair of headsets there is no limit to the amount of S.W. stations this set will receive. All short-wave bands are successfully covered with the 4 coils sent with the receiver. The bands included are amateur, police, C.W. ship-to-shore, foreign broadcasts, etc.

Complete kit of parts, including cabinet, blueprints and 4 coils, 15-200 meters. **\$8.95**  
Completely wired and tested ..... **\$10.95**

Complete set of Sylvania tubes (1-78, 1-25Z5, and 1-43). Net Price..... **\$3.25**  
Broadcast Coil (200-550 meters) ..... **79c**

## The "SCOUT" ONE-TUBE SHORT WAVE RECEIVER

15 to 550 Meters—Described in Radio World, Feb. 10, 1934

A Receiver that will cover the entire short wave and broadcast band. Amazing the way it intercepts short wave signals, police signals, ship-to-shore signals, airplane conversations, amateurs, etc. An inexpensive short wave receiver.

Kit of parts with Bruno coils, **\$3.95**; wired and tested, **\$1.00**; set of batteries, **\$1.50**; matched headphones, **95c**.



**HANDY**  
Serviceman's  
Manual, 25c

**TRY-MO RADIO**  
COMPANY, INC.  
85 Cortlandt St., N. Y. City, N. Y.  
DEPT. R.W.  
Visit Our Bargain Basement in  
179 Greenwich Street

**FREE!**

New handy - sized  
catalog now ready.  
Send for your copy.

### COMBINING THE TECHNICAL AND EDUCATIONAL

"RADIO AND EDUCATION, 1933," edited by Levering Tyson. Proceedings of the Third Annual Assembly of the National Advisory Council on Radio and Education. **\$2.50**

"EDUCATIONAL BROADCASTING." A Bibliography by Robert Lingel. The best and most complete on the subject. **\$1.50**

"A DECADE OF RADIO ADVERTISING," by Herman S. Hettinger. From nothing to \$90,000,000 in ten years. **\$3.00**

Book Dept., **RADIO WORLD**  
145 West 45th St., New York, N. Y.

### "SERVICING RECEIVERS BY MEANS OF RESISTANCE MEASUREMENT"

by John F. Rider

The new printing is ready for delivery. Right in line with the latest type of testing equipment offered by Weston, Supreme, Hickok and Radrige. All interested in resistance measurement method of servicing and who use their ohmmeter or who are purchasing the new type of point-to-point testing equipment produced by Weston and the other manufacturers, and the selective-reference-point type of testing equipment as produced by Supreme, can make very good use of **SERVICING RECEIVERS BY MEANS OF RESISTANCE MEASUREMENT.**

Still selling at **\$1.00**

Book Dept., **RADIO WORLD**  
145 West 45th Street New York City

"AUTOMOBILE REFINISHING," by C. E. Packer, Member of S.A.E. For the car owner and professional refinisher. A practical handbook on the materials, methods and equipment used. 148 pages, 41 illustrations. Price **\$1.50.** **RADIO WORLD.** 145 W. 45th St., New York City.

**RADIO WORLD AND RADIO NEWS.** Both for one year, **\$7.00.** Foreign, **\$8.50.** Radio World, 145 W. 45th St., N. Y. City.

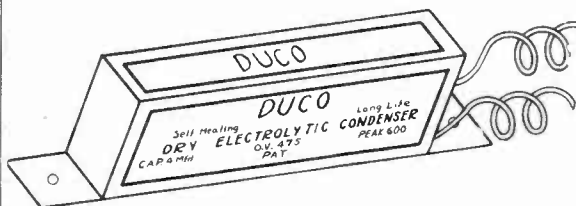

## DUCO

"Best by Test"

All DUCO Condensers fully guaranteed for one year.

### In No Other Condensers Do You Find These Features:

1. DUCO condensers are positively self-healing, even up to 3000 volts.
2. Better and longer life than the wet electrolytic condensers.
3. Smaller in size than any other make on the market.
4. For economy in costs it has no equal.
5. DUCO condensers in use over six years showing long shelf and use life.
6. All condensers are rated very conservatively.
7. Growing faster than any other make.
8. Used by best service men in the world.
9. Adopted by finest engineers of set manufacturers.
10. Guaranteed for one year.

DUCO CONDENSERS are fully protected by patents and patent applications all over the world. The response since we introduced our new condenser has been remarkable.

You, too, will be surprised at its performance.

Send for Free Catalog  
Sales and Jobber Territory Open

Mfd. by

**Dumont Electric Co.**

453R Broome Street  
New York City, N. Y., U. S. A.

## The World Is Yours!

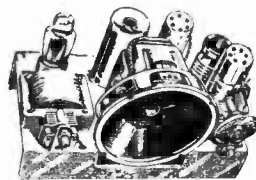

**Four-Tube  
A-C  
Short-Wave  
Receiver  
with Built-  
In Speaker**

Will tune in short-wave stations from all parts of the world with ease. Uses four plug-in coils to cover the entire short-wave band from 15 to 200 meters. The built-in power supply is entirely free from hum or disturbing line noises. Uses an ultra-sensitive dynamic speaker which aids in tuning in the weaker signals.

Cat. 4TK. Kit of Parts, less cabinet, less tubes..... **\$17.50**

Cat. 4TW. Above, completely wired and tested ..... **\$19.50**

Cat. 4TCB. Cabinet only... **\$1.50** extra

Cat. 4TTU. Complete set of licensed tubes..... **\$2.50** extra

## Reliable Radio Company

145 West 45th Street  
NEW YORK CITY

## DIAMOND of the AIR SHORT-WAVE POWER PACK

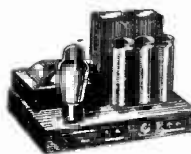

Supplies clear hum-free power regardless of circuit sensitivity. Especially designed for use with the "Diamond of the Air" Short-Wave receivers, but can be

used on any short-wave battery-operated receiver for B supply.

Contains a brute-force filter, employing two heavy-duty 30-henry chokes, specially-designed power transformer, and three electrolytic condensers. These factors assure pure d.c.

Will deliver 180 volts. Supply your own taps, 135, 90 and 45 volts. Supplies 2 1/2 volts at 10 amperes for filament drain. All taps terminate at binding posts on the side of the pack. Employs an 80 rectifier. Will stand up to 75 ma. drain for B current.

All parts are mounted on a sturdy metal base finished in silver.

Cat. DAPP. Price, including 80 tube ..... **\$5.95**

Shipping Weight, 20 Lbs.

## RELIABLE RADIO CO.

145 West 45th Street  
NEW YORK CITY

## NEW PRICES TROUBLE SHOOTER'S MANUAL, Nos. I, II and III

Having assembled 2,000 diagrams of commercial receivers, power amplifiers, converters, etc., in 1,200 pages of Volume No. 1 of his Perpetual Trouble Shooter's Manual, John F. Rider, noted radio engineer, has prepared Volume No. 2 on an even more detailed scale, covering all the latest receivers. Volume No. 2 does not duplicate diagrams in Volume No. 1, but contains only new, additional diagrams, and a new all-inclusive information on the circuits covered.

Volume No. 3 (Recently issued). Order Cat. RM ..... **\$7.50**  
Volume No. 2—Perpetual Trouble Shooter's Manual, by John F. Rider, Shipping weight 6 lbs. Order Cat. RM-VT @ ..... **\$8.50**  
Volume No. 1 (6 lbs.). Order Cat. RM-VO @ ..... **\$7.50**  
Rider's Trouble Shooter's Manual, No. IV. Brand new, up to 1934..... **\$7.50**

We pay postage in United States on receipt of purchase price with order. Canadian, Mexican and other foreign remittances must be in funds payable in New York.

**RADIO WORLD**  
145 West 45th Street New York City

ROLAND BURKE HENNESSY  
Editor

HERMAN BERNARD  
Managing Editor

# RADIO WORLD

REG. U.S. PAT. OFF.

The First and Only National Radio Weekly  
THIRTEENTH YEAR

J. E. ANDERSON  
Technical Editor

J. MURRAY BARRON  
Advertising Manager

Vol. XXV

APRIL 7th, 1934

No. 4. Whole No. 628

Published Weekly by Hennessy Radio Publications Corporation, 145 West 45th Street, New York, N. Y.

Editorial and Executive Offices: 145 West 45th Street, New York

Telephone: BR-yant 9-0558

OFFICERS: Roland Burke  
Hennessy, President and  
Treasurer.  
M. B. Hennessy, Vice-  
President.  
Herman Bernard, Secre-  
tary.

Entered as second-class matter March, 1922, at the Post Office at New York, N. Y., under Act of March 3, 1879. Title registered in U. S. Patent Office. Printed in the United States of America. We do not assume any responsibility for unsolicited manuscripts, photographs, drawings, etc., although we are careful with them.

Price, 15c per Copy; \$6.00 per Year by mail. \$1.00 extra per year in foreign countries. Subscribers' change of address becomes effective two weeks after receipt of notice.

## The Best Means of Applying A Noise-Reducing Antenna

### ALSO AN EXPOSITION OF THEORY AND PRACTICE, SO ALL MAY GRASP THE SIGNIFICANCE OF THIS VITAL AID TO SHORT-WAVE RECEPTION

By Paul L. Bradley

**D**URING an observation tour of Cortlandt Street, where I go occasionally to ascertain what the new things in radio really look like, I happened to be in a store. A customer asked a clerk:

"What are these noise-reducing antennas? How do they work?"

And the clerk replied:

"The noise-reducing aerials bring in the signals louder and clearer."

"Why?"

"Wait a minute," admonished the clerk.

He went looking for some one—nobody in particular, but just some one who could supply the answer. Nobody in the store knew the answer. The customer evidently was ready to spend some money on a noise-reducing antenna system, if he could be convinced that it would do what was expected. He did not even ask for a demonstration. An adequate exposition of the theory would have clinched the sale. And what is more important, the customer would have been doing himself a favor, for his reception would be improved, especially as he had an all-wave receiver.

#### What Does It Do?

So I journeyed outside and asked some questions of supposedly technically-minded folk who were window-shopping. Just casually I asked: "What is the principle behind these noise-reducing antennas?" But I could not get a satisfactory reply from any of the fourteen persons I asked. Two of them said they didn't know anything about radio technique. Assumptively, a dozen did.

Still, radio magazines have been giving considerable space to the topic, manufacturers of matching couplers, transposition blocks, aerial wire and the like have been stating the message in their advertisements and circulars, and engineers have been addressing service men's meetings and short-wave clubs on this very subject. But perhaps the subject has not been effectively presented as yet, and at the risk of being rash, an attempt to make such a presentation will begin right now.

The noise-reducing antenna!

It is an antenna! It reduces noise! What else does it do, or how does it do what it does do?

There are three things to think about: the aerial, the lead-in and the matching. The aerial is a doublet, meaning a straight flat portion halved, that is, two unidirectional straight wires separated by

an insulator. It is also called a dipole antenna. The system works by virtue of the capacity to ground. But there is no ground connection actually used in the wiring, and one reason for the doublet is avoidance of the necessity of a direct ground at a roof location, where it would be difficult to find a good one, another that two leads may be readily taken off.

#### Length Determined

The doublet is a half-wave antenna. It is directional, also it is reactive. By directional is meant that it receives best in the directions from which it points, say, North and South, East and West, Northeast and Southwest, etc. By reaction is meant that it is more sensitive to some particular frequency or frequencies. In general, considering wavelength now, the greatest sensitivity is at the wavelength equal to the sum of the two halves in meters.

Considering only the theoretical values, suppose we have an all-wave receiver, and that it tunes to 13.5 meters. We know that the sensitivity declines with frequency, as part of the inevitable performance of the receiver, and therefore to help make up for this we favor the highest frequency in the antenna installation. If each half of the doublet is 21 feet long the total length is 42 feet. In inches this is 504. In meters this is 504/37.39, or nearly 13.5 meters.

Actually the frequency would be a little lower than this, or wavelength higher, so that wire length would be decreased a bit, the reason being that the capacity to ground lowers the frequency. It is not necessary, however, to have the selection exactly equal to the highest frequency to which the receiver responds, and the general value of length as stated may be approximated as best conditions permit.

#### Two Inverted L Antennas

As an instrument of pickup the doublet does not differ much from the inverted L type antenna, and of course may be considered as a tandem arrangement, in which two inverted L types are used instead of one, and a high radio-frequency potential taken from both.

Experience has shown that man-made static, the chief contributant to noise in receiving systems, is strongest somewhere near the ground. Actually, there may be a heavy interference area a few feet above ground, but the point is that the closer the antenna is to

(Continued on next page)

# Installation of All-Wave Antenna

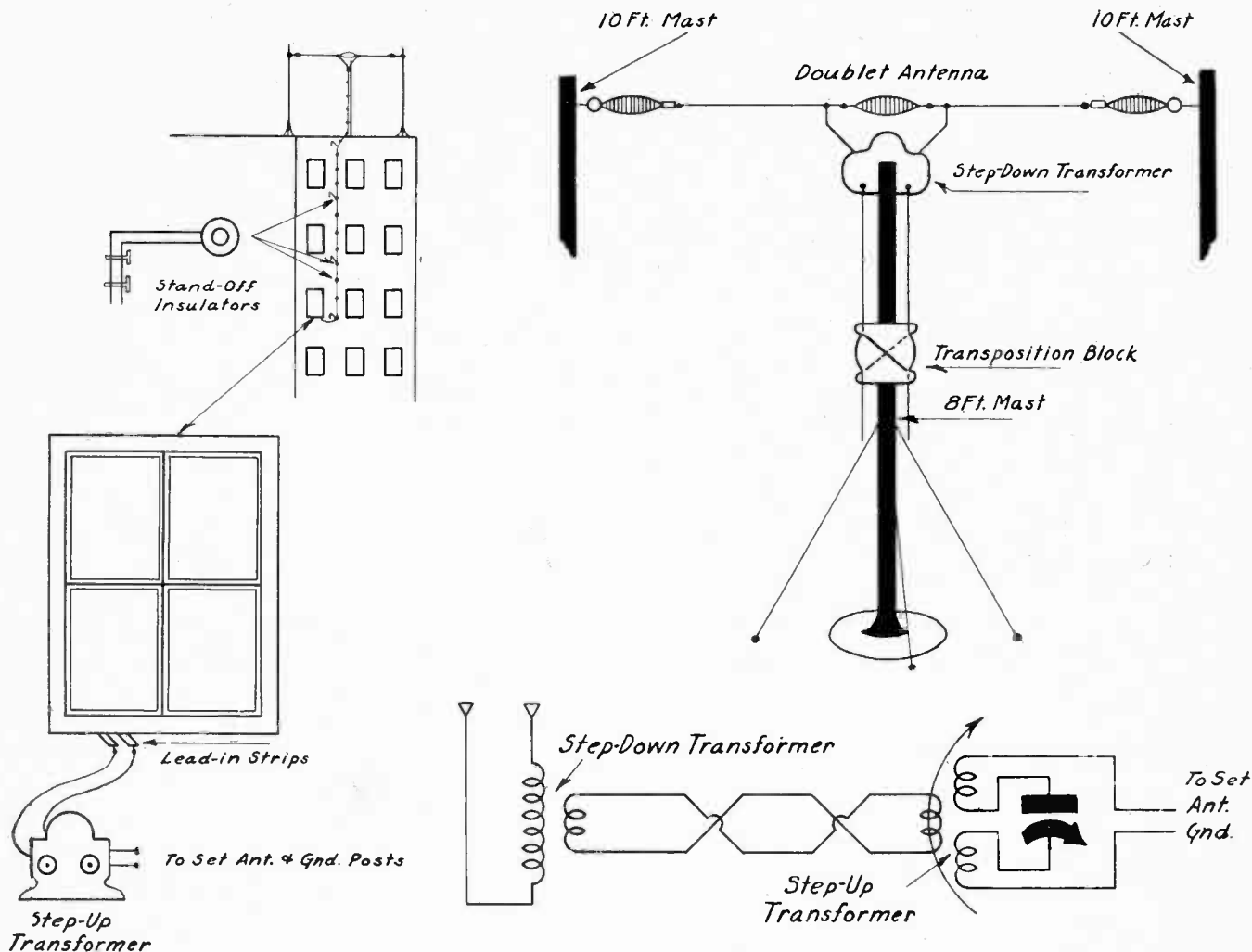

FIG. 1

The doublet or dipole antenna is illustrated at upper left, with step-down transformer (exaggerated in size) located on an auxiliary mast which also holds the first few transposition blocks rigid. Two wires are brought down, though they appear here as one. Upper right, detail of the doublet, transformer and first block. Lower left, bringing the leads into the house. Lower right, the wiring diagram.

(Continued from preceding page)

ground, as a matter of height, the greater the amount of noise picked up. Therefore it follows that the antenna should be elevated as much as possible. Elevation of the antenna changes its natural period also, that is, the frequency to which it is most sensitive. The higher the aerial, the higher the natural period in kilocycles, or the lower the wavelength, so that the necessity of a correction factor to be applied to the simple rule just stated for approximating the desired length becomes much smaller.

If an ordinary leadin is used, simply No. 14 weatherproof wire soldered to aerial and brought down to an insulator for introduction into the home and thence to the set's antenna post, the frequency is lowered the higher the aerial, because the antenna inductance has been increased greatly. In fact, the leadin then is more of an antenna or instrument of pickup than is the aerial proper, having more inductance and capacity, and since the leadin traverses the noise area, it picks up the very interference we seek to avoid. So the device of elevating the aerial has come to naught, or, the remedy may be worse than the ailment.

### Use of Transposition Blocks

When a sensitive receiver is used, naturally the noise is worse than in the instance of an insensitive receiver, for there is great am-

plification of the stray impulses. The object is to raise the input voltage to such a value that it will more than overcome the noise, sort of out-ride the noise, just as the sound of some one tapping a pencil on a desk (interference) may be masked when a boiler-maker starts his trip-hammer going (signal). In this example what we want to listen to is the boiler-maker, strangely enough, for he is the broadcasting station, and what he produces is the signal we want. The interference or noise is the desk-tapping.

So far we haven't accomplished a thing. We have introduced, if anything, more noise, and possibly spent some time and money to do it, and if we had no further means we would have to stop and confess defeat. But we have a means, in fact, a selection of several means, but as one is better than the others we shall select and discuss that.

We want an antenna as high above the noise field as possible, and say we have it, even though there would be still more noise nearer ground if the leadin had to go that far down, as for instance if we lived on the ground floor. But suppose we live on the third story below the roof.

Instead of using the single-wire leadin, since we have purposely provided a double-wire outlet from the antenna, we may use transposition blocks, and cross the two wires every foot or so.

### What the Crossing Does

The transposition block may be regarded as a good insulator, approximately square, say 5 inches on each side, with notched corners, and so constructed that the wires may be crossed without touching, thus enabling the use of bare wire, if desired, and also providing spacing for any wire. The object of the transposition block is to enable killing off the pickup of the leadin, and this is done by neutralization through phase reversal. The two branches of the leadin pair within the same transposition block are so close together that they pick up the same signal in the same phase, but since the connections are reversed, and the currents in the respective

(Continued on next page)

FIG. 2  
Transposition is effected by twisted pair a-c cable, but the capacity is too large, as with shielded wire.

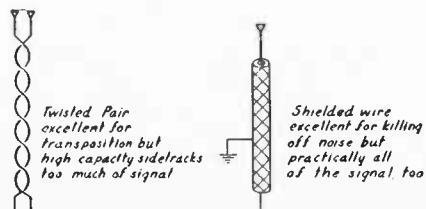
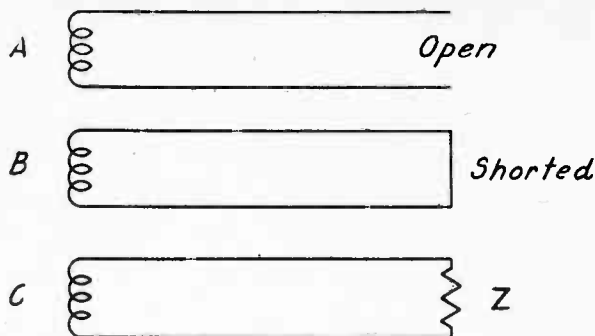

FIG. 3

A. A uniform transmission line with the source at the left and open circuit at the right. Reflection occurs at the open end. B. A uniform transmission line with the source at the left and short circuit at the right. Reflection occurs in this case also. C. In this case the right end of the line is terminated by an impedance Z. If this impedance is equal to the characteristic impedance of the line there is no reflection, and energy is absorbed by Z as fast as it comes up. This is the optimum condition.



(Continued from preceding page)

wires on one block are 180 degrees out of phase, there is zero pickup, and the total leadin acts as a transmission line. That means a link that connects a source of voltage or current to a destination without loss or gain. The two factors are usually called "source" and "sink."

So we have a high aerial that feeds a substantial voltage, and a leadin that is not an aerial but intended to be a transmission line, and we could connect the two wires in the house, coming from the doublet, to primary of the first r-f transformer in our set.

Matching Helps Greatly

However, most sets have one side of the primary grounded, hence we would have an unbalanced system, in fact, the whole effort would be severely handicapped, if not made fruitless. We could isolate the present ground post, as is done in some short-wave sets to enable use of dipole antenna systems, and we would have gained our end in part.

We have discussed the aerial, and the leadin, and now we have to consider the matching.

Since a no-loss purpose attaches the idea of a transmission line, naturally we have not reached a completely acceptable goal if we connect an aerial of little-known constants to a coil system in the receiver of absolutely unknown constants. The transmission line becomes significant only when the source works into the sink in the most efficient manner, that is, practically all of the energy from the source is delivered to the sink. Therefore we may as well consider now the idea back of impedance-matching, especially as applying to antenna installations and connections.

The subject of matching impedances is an important one, and radio engineers are always talking about it. Just what does matching mean? Generally it means that devices are so proportioned that there is no reflection of waves. In a battery or generator it means that the load resistance is equal to the internal resistance of the source. We may have a battery with an internal resistance of R ohms. What should the load resistance be in order that the greatest power be obtained from the battery, that is, the greatest power in the load resistance? It can be proved by calculus, or by plotting curves, that the load resistance should be equal to the internal resistance. That is, the load resistance should be R also.

Radio-Frequency Matching

But now we are more interested in matching in conjunction with alternating-current devices, especially as related to high frequencies. In Fig. 3A we have a transformer winding supposed to be coupled to a coil in which radio-frequency current flows. There is a certain voltage induced in the secondary, the coil shown. To this winding a long line is connected. When the far end is open, how much power is delivered to the load? There is no load and therefore there can be no power delivered. Perhaps we should say that the load is infinite.

The device is perfectly efficient, yet no power is delivered because there is no current. We might say that the wave travels down the line, is reflected back, and causes a back voltage equal to the e.m.f. induced. Now look at B. The far end of the line is shorted. In this case no power is delivered to the load, for there is no load at all. Plenty of current flows but it has nothing to act on. There is reflection in this case, too, but in an opposite sense. All the energy involved is now lost in the transformer. We all know that when we short a transformer winding, the transformer gets hot.

Now let us look at C in Fig. 3. The end of the line is neither open nor closed, but has an impedance Z across it. It might be a

pure resistance. There is only one possible value for Z at which no reflection occurs, and at that value the power delivered to Z is greatest. Energy is then used up in Z just as fast as it comes up. The value of Z which causes no reflection is that for which there is a match—Z is equal to the resistance looking into the transformer winding, or rather looking into the line in that direction. If we have a transmission line with uniform characteristics all the way, that line has a certain characteristic impedance. Z should be equal to this impedance. Likewise, the transformer used for delivering energy to the line should be such that it matches the impedance of the source to the characteristic impedance of the line. If the match is right there is no reflection at the transformer.

Acoustic Analogies

For every electrical case we can find an acoustic, hydraulic, or mechanical analogy. In Fig. 4A we have a pipe, which we might say is full of air. At the right is a diaphragm actuated by a loud-speaker element. If the diaphragm is set into vibration, the air will also be set into vibration. If the far end is closed mechanically, this pipe is equivalent to an electric circuit in which the far end of the line is open, because when the end is closed no air can go in or out. No sound energy will be delivered to the air outside. In Fig. 2B we have the opposite case. The pipe is actually open. This corresponds with the case in Fig. 4B. There is reflection at the open end (shorted) and very little sound power passes the boundary.

In Fig. 3, cases C, D, and F, we have three different conditions of load, representing three different values of Z in Fig. 3C. In Fig. 4C the pipe suddenly opens up into a larger pipe. The pipe is now under-loaded and some energy is reflected and some transmitted. If we had an acoustic step-down transformer to place at the junction between the two types of different diameter, we could prevent the reflection. We could then transmit the sound at lower air pressure but with greater motion.

In D, Fig. 4, we have the opposite case. The large pipe suddenly narrows down to a smaller one. Now the large pipe is over-loaded. There is reflection at the junction and all the energy coming up is

(Continued on next page)

FIG. 4

A. An air line with source at left and closed end at right, equivalent to an open-end electric line. B. An air line with open end at right, equivalent to a shorted electrical line, as in B, Fig. 1. C. An air line opening up into a line of larger diameter. Part reflection occurs because of underload. Z is too small. D. An air line working into a smaller line. Part reflection occurs because of overload. Z is too large. E. An air line working into an equal line. No reflection occurs and the lines are matched. Z is just right.

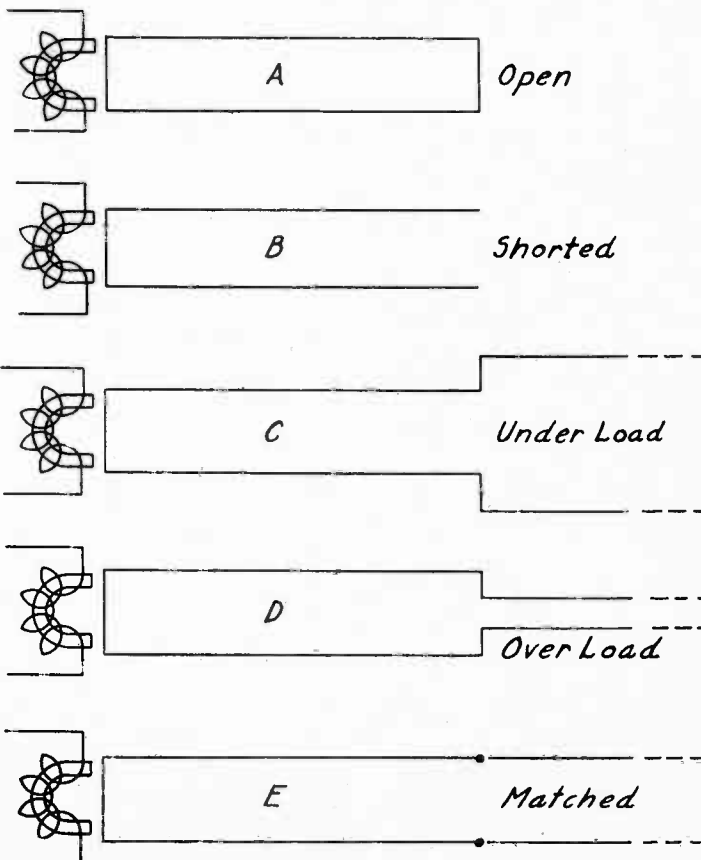

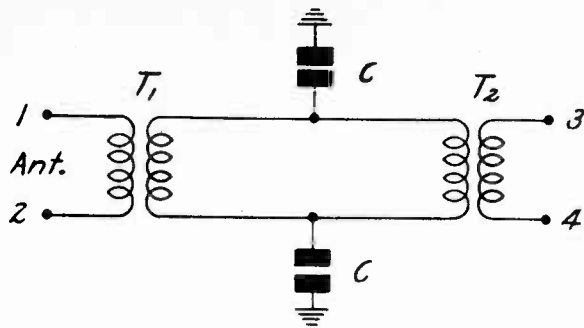

FIG. 5

An electrical transmission line with a step-down transformer at left and a step-up transformer at right. Energy is transmitted effectively at low voltage and high current. The transformers are used to match different impedances, or lines of different "diameters."

(Continued from preceding page)

not transmitted. At this point we need a step-up transformer, one that would transform the power from much motion and low pressure to little motion and high pressure.

In E, of Fig. 4, we have a case of perfect match. Two pipes of equal diameter are joined together. Now there is no reflection at the junction. All the power that comes up to the junction leaves it without change of direction.

### Acoustic Transformers

There is no acoustic transformer in the same sense as an electric transformer. One possible way of matching is to place an exponential section between the two pipes. This was done during the early years of broadcasting. The entire pipe was an exponential horn and the flare was made so large that there could be relatively little reflection at the end.

Another possible way would be to have a rigid but freely moving piston of the same diameter as the pipe in each pipe, the two being coupled mechanically by a lever having the same ratio of transformation as the ratio of diameters of the pistons.

With either of these transformers there would be little reflection at the junction, and power would be transmitted with little loss.

We have not considered resonance in any of these cases, either in the electrical or the acoustical cases. Resonance cannot occur unless there is reflection, for resonance really means the tossing of sound back and forth by reflection. It is called resonance in radio by analogy, although there is no sound involved. But sound is made up of pressure and air displacement waves, and there are similar phenomena in an electric circuit, potential, or electric pressure, and displacement of electric quantity.

### Line Matching

The question of matching becomes of great importance when transmission lines are used for the transmission of radio or audio power over considerable distances. As a rule, a transmission line is operated a low potential and high current. If the source has a high impedance, a step-down transformer must be used between the source and the line; and if the sink has a high impedance, another transformer must be used, and in this case it must be of the step-up kind. Even when the signal is delivered to the grid of a tube and that grid does not draw any power, it is necessary to have a sink that will take the energy that comes up, for a transformer with an open secondary will not act as a resistance. A resistance should then be connected across the secondary, and the transformer must match this resistance with the characteristic resistance of the line.

There are at least two reasons why the line should be operated at low voltage and high current. The first is that if the line is open and the wires are placed far apart, there will be radiation losses. The second is that there is a certain capacity between line conductors and ground; and if there is a high voltage between the conductors and ground, much energy is lost to ground through the capacity.

That the losses to ground increase as the voltage increases becomes clear after a little thought. The current through the capacity to ground is given by  $CwV$ , where  $C$  is the capacity to ground,  $w$  the radian frequency, and  $V$  the voltage. Thus for a given capacity and frequency the current that escapes is directly proportional to the voltage. For a given power, the current in the line is inversely proportional to the voltage. Therefore the current lost to the total current decreases as the square of the voltage. It is not all gain, however, as the current in the line increases, the power lost in the line resistance increases as the square of the current. But resistance losses are usually negligible. The case of the transmission line is illustrated in Fig. 5,  $T_1$  is the step-down transformer,  $C$  the capacity between ground and either side of the line, and  $T_2$  is the step-up transformer. Terminals 1 and 2 are supposed to be connected to the source, that is, the antenna or oscillator, and terminals 3 and 4 to the sink, that is, the load. This may be a grid leak of an amplifier, which is not needed for the leakage but to establish a definite impedance for determining the ratio of  $T_2$ .

The characteristic impedance of a uniform transmission line in

which the conductance across and the resistance in series are negligible is  $(L/C)^{1/2}$ , where  $L$  is the inductance per unit loop length and  $C$  is the capacity per unit length. This is a pure resistance. To make this low in value  $L$  should be small and  $C$  should be large. That is, the two conductors should be close together. This impedance can be computed by well-known formulas provided the line is uniform. The value of the impedance might vary from 50 ohms to 1,000 ohms depending on the size of the conductors and the distance between them.

The difficulty of matching is not so much a matter of not knowing the characteristic impedance of the line as not knowing the impedances between which it is to work. The load impedance, of course, can always be chosen arbitrarily, but not so the impedance of the antenna. For these reasons it is not easy to say off-hand what the ratio of the either transformer should be. In any case it is best to make the adjustment experimentally. While the load resistance across terminals 3 and 4 may be known, if the frequency is very high, the input capacity of the tube must also be taken into account, and for that reason an experimental determination of the optimum ratio of  $T_2$  should also be made.

In line with the foregoing discussion of impedance matching, we need only apply the principles. We know that the system inevitably will have some capacity to ground, meaning the capacity between one side of the transmission line and ground and the other side of the transmission line and ground. We also know that a mere closely-shielded wire, with ordinary antenna feed through the conductor, sheath grounded at several points along the line, kills pickup, but also kills signal, and that twisted pair is to the same effect as transmission blocks, for the reversals are there, but again the loss to ground is altogether too much. We are seeking a system of minimizing the loss. Let us set a goal of reducing the loss by 99 per cent.

### How Loss Is Almost Eliminated

There is a certain carrier voltage in the antenna that we want to conduct to the receiver. If we put a step-down transformer right at the connections from antenna, large winding to the adjoining ends of the doublet, small winding to the two feed wires of the transmission line, we shall reduce the voltage delivered to the line. Suppose the transformation ratio is 10 to 1, primary to secondary. Suppose we use an identical but step-up transformer at the receiver end. Now the ratio is 1 to 10, transmission line to receiver's antenna coil. So there is no difference now between the voltage taken off at the antenna and the voltage delivered to the receiver, unless there has been some loss in between, so let's investigate.

When the step-down transformer is used, while the antenna voltage  $E$  is reduced to  $E/10$  at input to the transmission line, the current has been increased to  $10E$ , because the power in the primary and the secondary is the same, so as the voltage is reduced the current is increased to the same degree.

Hence we have a ten-fold current in the transmission line, compared to what we would have had without the first transformer, and since the voltage is only one-tenth of what we would have had, the effect of the inevitable capacity to ground, which is proportional to the voltage, is only 10 per cent. of what it would be without these precautions.

### 100 Times Better

So with the energy from the antenna distributed in the form of an increased current and decreased voltage, we have a very favorable circumstance, one that gives us 10-fold current compared to one-tenth the loss to ground. Figuring both as gains, we have a current gain of 10 and a loss-preventive gain of 10, or a total improvement of 100. This means the input to the receiver will be 100 times as great as it would be without these precautions, provided no other loss is incurred.

Prevention of that other loss is accomplished by having the source and sink impedances equal, where the source is considered as the secondary of the step-down transformer and the sink the primary of the step-up transformer.

Mention has been made of the sensitivity of a doublet antenna system to some frequency or frequencies. There can be a perfect match for only one frequency. In a broadcast receiver we could use some acceptable frequency, and with a total span of 1,000 kc to be covered we would get satisfactory results without further adjustments, but for short-wave or all-wave tuning it is advisable indeed to have two variable factors, one the inductive relationship between primary and secondary of the step-up transformer, where the primary is rotated, the other a variable condenser as auxiliary to the adjustment for the various bands, put between adjoining secondary terminals. For any one band experience proves that a single adjustment of each will suffice abundantly, and therefore the settings of both the inductive and capacitive branches may be calibrated.

### Practical Considerations

Aerial installations of practically any kind present practical problems. Avoidance of a mast of any sort is a frequent device, but to gain sufficient elevation a mast should be used on any roof for support of both extreme ends of the flat portion of the antenna. Tension on the mid-insulator will provide sufficient support here. But the use of transposition blocks makes it advisable also that some support be given to them, and the down-leads, so a third mast is in order. It may be somewhat lower than the two others. It is customary to use 10-foot masts for the extremes.

Then, on the way down, places must be found for supporting the

wires as well as keeping them a reasonable distance from the house itself. A foot or so will prove sufficient. Stand-off insulators will provide this spacing, also contribute support.

Often one sees transposition blocks installed in such a manner that the wires are permitted to swing. This is bad practice, because swinging wires cause capacity changes, and thus introduce "variable constants," which at the highest frequencies of short-wave tuning may have a considerable effect.

### Into the House

On reaching the window through which the wires are to be brought it is preferable to use two porcelain tubings and conduct the wires separately through two tubings. However, many persons live in houses owned by others, and hesitate to drill two holes for the tubing insertion, as well they should hesitate, unless the landlord has given explicit consent. This he may not do, and in that instance the thick, flat, weather-proof-covered lead-in insulators may be used, as shown in the diagram.

A small hole in the window pane also is good device. This hole may be drilled, one for each of the two wires, using plenty of oil on the drill, and carborundum powder. A steel drill is not as good for this purpose as a brass one, and even a brass pipe the diameter of the hole to be drilled may be used. The size will depend largely on that permissible by the chuck. Holes only large enough to pass the insulated wires are all that is needed.

Many attempt to drill the glass when the pane is in the window, but this is difficult and awkward and also increases the danger of breaking the glass. The drilling can be done without breaking the glass if the speed of rotation is slow and the work is conveniently at hand, which means that the pane should be removed and worked like any other piece, in a comfortably accessible position.

### "Not To Be Disturbed!"

If the window consists of two sections, upper and lower, the hole is drilled high in the upper section, and that part of the window is locked tight, so that it will not be opened. By locating the holes high on the upper section the lower section may be opened, and raised as high as usually desired, without interfering with the incoming wires. Once an installation is made, every precaution should be taken not to create or leave any conditions consistent with disturbance.

When the window strips are used, as in the diagram, naturally the frame can not be brought down all the way to the jamb, because of the intervention of the strips, but there is enough overlapping of the inside window ledge with the bottom of the frame to prevent rain or snow from coming in.

The window must be wood, for use of the lead-in strips. If the frame and jamb are metal, as in a small percentage of houses, and more frequently in office buildings, then considerable loss of signal results.

## WLW Making Day Tests On 500 kw As Opening Nears

The fear that 500-kw power at WLW, Cincinnati, would cause dial-blanking has proved groundless, said Powel Crosley, president of the Crosley Radio Corporation, owner and operator of the 700-kc station. Night tests, representing periods of greatest penetration, have proved that no such interference resulted from high power, said Mr. Crosley.

Now the station is making day tests at this high power, the highest used in the United States. After the completion of the day tests the station will be prepared to go on the air regularly with its great power, intended originally to make WLW the equivalent of a "single-station chain," by virtue of wide service area, practically from coast to coast.

While no definite word has been given as to actual coverage achieved, it is now stated that service of high quality will be enjoyed by tens of thousands of persons too remote from stations operating even on 50,000 watts. This is quite different from coast-to-coast coverage, or anything faintly resembling it, but the use of such large power is experimental, and in the past, when 50,000 watts were expected to produce wonderful results, the increase in the dependable service range was not nearly as great as had been expected. There were plenty of advantages, but the hopes of the most optimistic were not realized. Nor did the higher power cause dial-blanking then. The vices fell short as well as the virtues.

## TUNE IN FOR THESE ON SHORT WAVES

[Time Given is Eastern Standard]

- VE9JR, Winnipeg, Can., 7 to 11:30 p.m., 25.6 meters, 11,760 kc.  
 FYA, Pontoise, France, 8 to 11 a.m., 19.68 meters, 15,230 kc; 11 a.m. to 2:15 p.m., 25.63 meters, 11,700 kc.  
 COC, Havana, Cuba, 4 to 5 p.m., 49.9 meters, 6,008 kc. (Power being increased).  
 GSB, Daventry, Eng., 11:30 a.m. to 12:30 p.m., 1 p.m., to 5:30 p.m. and 6 p.m. to 8 p.m., 31.53 meters, 9,510 kc.  
 RNE, Moscow, USSR, 8:30 to 10 a.m., 24.99 meters, 12,000 kc.  
 RKF (RV59), Moscow, USSR, 2 p.m. to 5 p.m., 49.97 meters, 6,000 kc.  
 CP5, La Paz, Bolivia, 7:30 to 10 p.m., 32.89 meters, 9,120 kc.  
 KFZ, Little America (Byrd Expedition) Thursdays and Fridays testing 9 p.m. to 11 p.m., 22.68 meters, 13,210 kc; 25.36 meters, 11,840 kc; 31.57 meters, 9,500 kc.

## Pick-Up Is Less, But Signal Itself By Transposition Is Favored Against Noise

THE installation of a noise-reducing antenna system does not mean that the signals will be made louder, but that they will be stronger compared to the noise, and therefore the results will be better.

For instance, suppose an ordinary aerial is used. The pickup consists of that from the flat portion of the aerial, the stretch that runs parallel to the rooftop, and also that from the downlead. Suppose the receiver were moved to the roof and the antenna connected there, directly to the set. That would be the equivalent of the noise-reducing antenna situation. Naturally, the pickup of the downlead has been removed, and the effectiveness of the noise-reducing antenna is directly proportionate to the percentage of removal of this pickup. The effort is to make the removal or eradication of such pickup complete, but in actual practice it can not be totally complete. There will be just a little pickup from the downlead, though it is immaterial.

### Provides Looser Coupling

So if the volume control of a receiver is at a given position, and the noise-reducing antenna installation is compared to the ordinary antenna installation, there will be louder signals with the ordinary antenna, but much more noise, too, and in some instances the noise will be practically as great as the signal, and that impairs or spoils reception. What the noise-reducing antenna does is to provide, incidentally, looser coupling between the receiver and the transmitting aerial of the station, and that makes for less noise and also for greater selectivity. So the volume control is turned up, and the receiver is expected to be sensitive enough to enable this method of utilizing the benefits of the noise-reducing aerial. If the receiver does not perform satisfactorily when the noise-reducing antenna is used, this is an indication that the receiver can stand some improvement in the line of sensitivity, and is not to be taken as something derogatory of the noise-reducing antenna.

The new system has been given a wide variety of trials by many persons, including experimenters, retail store keepers, amateurs, short-wave lay listeners and scientific laboratories, and has justified

itself. However, the system should be one that works in the right direction, and the method outlined in the preceding article is consistent with that requirement.

### Tuning Highly Advisable

Some so-called noise-reducing antenna systems do not go quite all the way, because they rely too much on aperiodic effects, hence omit all tuning systems in conjunction with the device, but this is not the soundest practice, as the disparity in the sensitivity in the various bands is too great. The tuning should be included as a vital part of the installation, and the inclusion of the two transformers is just as important.

As a verification of the improvement, it need only be cited that many retail dealers have to contend with the requirements of particular customers that certain stations be tuned in. For instance, somebody of French lineage may desire proof that Pontoise can be tuned in on a certain set the prospective customer desires to buy. The right time of the day is selected, if possible. Usually, early in the afternoon is not so favorable, but around 5:30 p.m. the signal strength picks up, and a better demonstration can be given.

As it is hard to convince any one that just any old kind of reception will do, a noise-reducing antenna will enable bringing the signal into focus, as it were, and obscuring the noise in the background of the reception pattern. The signal may not be as loud as before, but it is much clearer, and the intelligibility of speech, for instance, becomes of a sufficiently high order to convince the customer that he should buy the set.

### General Requirement

The same type of reception or high order of results is required by every one, whether he builds his own set or uses a commercial or laboratory type receiver, and therefore the benefits are not special but apply to all users of short-wave receivers of any kind whatever.

Measured only in results, the noise-reducing antenna justifies itself fully, and results are what the short-wave enthusiasts are after.

# Listener Exodus to Short Waves Threat to American Broadcasting

By Herman Bernard

**A** GREAT many persons who until a few months ago hadn't much appreciation of the existence of short waves have come to realize they are important means of transmitting programs over great distances.

The original plunge into the short waves must be credited to the amateurs, those radio-minded folk who converse with one another by voice and code, and who have national and international organizations, and are recognized in international radio agreements and treaties. The amateurs were pushed into short waves when broadcasting demanded it, but the amateurs developed the first short-wave technique, and led the way to the present conquest.

Experimenters and radio technicians, encouraged by laboratories that produced special short-wave equipment, built up the vogue among the non-amateurs, as well as giving a hand to the amateurs, until the popularity increased to surprising proportions last year. Then the manufacturers of commercial sets took heed, especially as they saw a means of intriguing the lay public with the appeal of foreign programs received direct over great distances. At first only dual-band performance was offered—the broadcast band for one, then turn a switch and hear amateurs, police calls, some relay broadcasting, a few foreign broadcasts and numerous plane-to-plane and ship-to-ship talks—but a satisfied public encouraged greater coverage. So now all-wave sets are popular.

## Exaggerated Claims in Advertising

Broadcast reception has had its ups and downs, including in the crescendo the upbuilding of a gigantic industry in the shortest space of time in American history, and including in the decrescendo the hard times most set manufacturers had in 1930, 1931 and 1932. The improvement came in 1933, only last year, and with it an increase in the sale of receivers and of parts to build receivers. But short waves had to be a part of the scheme, generally, and the result is that to-day there is a growing interest in short waves that offers something of a menace to moneyed broadcasting.

Since American broadcasting is, after all, a system of advertising, where the price of the benefits must be paid by the listener almost without choice, the foreign programs, which carry no advertising, are welcomed by many who object to American advertising blurbs, object to them not so much because they are advertising, but because in the form of advertising they are offensive.

A great amount of the "credits" in American broadcasting consists of claims made by the sponsors that evidently are not investigated by any save the expose specialists, for many claims don't hold water.

## Beauty, Coughs and Colds

Beautiful women did not acquire their pulchritude by using the face powder they indorse, which wasn't even manufactured at the time they acquired their beauty. Tooth pastes and powders do not have the medicinal and remedial qualities claimed for many of them. Coughs are not cured by cough drops, nor colds by sniffing-liquids, for science has not isolated the cold germ, hence does not know what to use, save nature, to kill that germ. Even the perfection of tone claimed for all radio sets is a myth.

Many find it a relief to turn to something far from perfect in the form of entertainment, but at least free from blurbs.

So far there has been no solution to the problem of repulsive advertising over the air. The Federal Radio Commission felt itself without authority. The stations could not cope with the problem, either, as so many of them were unable to reject the sponsored programs that made station existence possible, while the large chains have established rules to eliminate the worst features of exaggeration and falsity, but more than enough of the incredible is sent over the kilocycles, despite the rules.

## Quasi-Appaisal of Wanderlust

The blurb-objectors are a minority, but the distance-seekers are not. The chief attraction of short waves is that programs from great distances are received, that the preferred points of origin are foreign countries, and listening to the programs from these sources is the substitute for world travel, denied to practically all listeners. The wanderlust is there, but the means of appeasing it is lacking. And so the short-wave or all-wave set somehow fits in between the frustration and the satisfaction.

Meanwhile an important structure, American broadcasting, built up as an institution of great importance, and affording utter reliability of quality reception, with an industrial standing high in the ranks of American endeavor, is feeling at least a temporary shock, due to more and more listeners preferring the foreign short waves to the American broadcast waves. A dash of the different is a relish

to the listening appetites of the set-owner, who may have become fed up on the more or less standardized and routine programs of the stations of his own country. While he maintains his favorites, and will tune them in on broadcast waves, he may virtually exclude American broadcasting in favor of the programs from overseas that present novelty, if not a refinement over American practices.

## Attractive Mystery of Origin

From the American viewpoint, American programs are better than programs from any other country, particularly as ours were built up to our own tastes, and as existing now are the result of a process of rejection and selection. Offensive blurbs may be considered as an evil, but advertising is our preferred way of paying for our own programs, and private operation of broadcasting is also our preference, whereas in foreign countries broadcasting is government owned and operated, or closely controlled by a Government corporation, and fees are charged for having a receiver.

Still, it is a fact that the program alone is not the exclusive appeal, nor is the absence of advertising or the unfamiliar nature of the program. It is hard to account for the delight any listener takes in hearing a speech from a foreign country in an alien tongue he does not understand. Yet thousands listen to such talks. Perhaps all they are waiting for are the call letters. There is a fascination perhaps in listening to a program from no one knows where, for the mere satisfaction of finding out at least where it does originate, and even marking up a record of having "caught" Java or Hindustan or Morocco.

## What Does the Future Hold?

Take as an example an American program, sent over a chain, and also sent by short waves from a transmitter auxiliary to the chain. An American listener will tune in this program at around 50 meters and hold it, though on the broadcast band he would pass up the very same program. This must be due to the assumption that there is something more mysterious about short waves than about broadcast waves, or that the receiver is being tested in an uncertain spectrum. At least the short waves are compelling.

If more and more persons continue to tune for foreign short waves and keep passing up the broadcast band, the effect will be felt economically in this country. There are thousands of employes, including technicians, announcers, publicity agents, repair men, operators, program directors, artists, hostesses and pages, who depend on the continued existence of American broadcasting at its present scale and hope for an enlargement of operations.

Besides, there are many millions of dollars invested in plant and equipment, the outstanding example being Radio City. On this alone the Rockefellers have expended hundreds of millions of dollars, and the National Broadcasting Company, Radio Corporation of America and others have committed themselves to leaseholds and other obligations, consistent only with the growth of American broadcasting. If their listeners decrease instead of increase, these stations and chains will diminish, and so will jobs.

It is really the tariff question all over again. Those who favor free trade ask that every nation be enabled to sell its goods anywhere it sees fit, in competition with domestic and with other foreign suppliers, without tariff or duty of any kind. This is comparable to the all-wave situation as existing to-day. The listeners are becoming the free traders of the air.

## The Other Groups

Others in the tariff debate believe in "America Self-Contained," whereby everything needed in this country will be grown or manufactured in this country, with utter exclusion of foreign products, a situation almost possible at present in a land of such abundance. No parallel exists in radio listening, as nobody asks that there be an American law against tuning in any program coming directly from any foreign country.

Between the extreme are those who favor some tariff, in one case a tariff to protect American industry, in the other a tariff for revenue only. The class favoring a tariff to protect American industry has a parallel among listeners—the majority, who have receivers that respond only to the wavelengths or frequencies of American broadcasting. These would be in the class of the self-contained, except that there are foreign stations on broadcast-band waves, for instance Canadian, Central American, South American and Cuban, and many listeners get these foreign stations. There is some importing, so to speak, not self-containment.

The tariff-for-revenue-only group is not represented among listeners, as broadcasting is not the subject of special taxation, except to

(Continued on next page)





# Heigh-ho! Pulses from Outer Space Received Constantly on 14.6 Meters

By J. E. Anderson



FIG. 1

A record showing the variation of the intensity of the horizontal component of electromagnetic waves of unknown origin covering one-half day. The record shows the bearings at which the waves are strongest as well as the time maximum occur.

WE ARE inclined to say that all noise that is heard in a radio receiver originates in the atmosphere, in the set, or in electrical circuits in the neighborhood of the receiver or the transmitter. But in view of studies made by Karl G. Jansky\* of the Bell Laboratories, at Holmdel, N. J., during 1932, we must attribute some of the noise, on 14.6 meters, at least, to an extraterrestrial source. The noise appears to be coming from a definite direction in space, not far from the point toward the entire solar system is moving in respect to the stars.

### Peaks Shift

The method by which the direction from which the waves come was determined is interesting. An antenna array having a sharp horizontal directivity was rotated on a vertical axis at a definite rate. A short-wave receiver and an automatic intensity recorder were connected to this antenna and the entire system tuned to 14.6 meters. The recording mechanism was synchronized with the rotation of the antenna array so that at any instant the record showed the intensity of the horizontal component of the signal and the direction. A sample record for one-half day is shown in Fig. 1. The humps in the curve indicate when the horizontal component was strongest, that is, when the array was pointed directly toward the source of the waves as far as it could be pointed in that direction, and the scale at the top in-

dicates in which direction the array pointed.

The first peak occurs at 12:15 p.m., when the array points east. The next one occurs again when the array points approximately east. As we follow the peaks as time goes on, there is a progressive shift in the direction. By 6:50 p.m. the peak occurs when the array points due south. The last peak occurs at 11:46 p.m., and then the direction is nearly west. Thus in twelve hours there has been a shift of nearly 180 degrees. If the record had continued for the complete day, the shift would have been nearly 360 degrees.

Another fact shown by the records, taken from month to month, is a progressive shift in the position of the maxima which had such a value that at the end of the year they were back to where they started.

All these facts indicate that the origin of the waves is extraterrestrial and outside the solar system, as well. Whence do they come? Insufficient data prevent a precise determination of direction, for a rotating antenna array, however directional it may be, is a poor instrument as compared with an astronomical telescope with precise means attached to it for measuring angles. But enough data have been obtained with the rotating antenna array to show that the waves come approximately from the point in the celestial sphere having a right ascension of approximately 18 hours and a declination of minus 10 degrees. The possible error in the measurement of the declination is plus or minus 30 degrees.

If a line be drawn from the sun to the

center of the galaxy of stars and nebulae of which the sun is a member, that line would strike the celestial sphere at a point having a right ascension 17 hours, 30 minutes and a declination of minus 30 degrees. Therefore that point is not far from the apparent direction from which the waves come.

Another possibility is the point toward which the solar system is moving in respect to the stars. That point has a right ascension of 18 hours and a declination of plus 28 degrees. That is even closer to the point from which the waves seem to come. It is possible that they come from both directions, inasmuch as the observed point lies between these two points.

### Other Experiments Expected

No doubt, other experiments, in other parts of the world, will be made on these waves, using apparatus especially designed for the purpose. And as soon as more data, especially more accurate, have been collected, the point of origin will be determined much more accurately.

But even when the precise point from which the waves come has been determined, there is no way of determining the source of the waves. Is there some cosmic activity in the Milky Way, or beyond, which generates these waves and of such intensity that they reach the earth? Or is the solar system passing through a stratified region of some kind where the intensity of electric and magnetic forces varies? If so, would the stratification be so regular that the resultant is a wavelength of definite length? Perhaps

\*"Electrical Disturbances of Extraterrestrial Origin," Proceedings, IRE, October, 1933.

these longer waves are of the same kind and origin as the cosmic rays. Cosmic rays, however, are supposed to come from all directions with equal intensity, and they are of infinitely shorter length.

In Fig. 2 is shown the position of the earth at the four critical positions in its orbit around the sun, together with the direction from which the waves come, as seen from Polaris. Directions of rotation and revolution are shown by appropriate arrows. The location of the receiver is indicated by a dot in each position of the earth and the direction from which the waves came at the different times is shown by short arrows. This figure shows how the direction of arrival should vary with the time of year.

The curve in Fig. 1 represents a record taken near the autumnal equinox. The curves show that the direction is from the south at 6 p.m. At the winter solstice, December 22d, they should come from the south at midday; at the vernal equinox, March 20th about, they should arrive from the south at 6 a.m., and at the summer solstice, June 21st, at midnight. The various records showed just such variation.

These electromagnetic waves of extra-terrestrial origin recall the long-time echoes which were the subject of study and discussion a few years ago. They were first observed in Norway but were later reported elsewhere. The time elapsed between the sending of the waves and their arrival apparently ruled out the possibility that the waves had been reflected from the Heaviside-Kennelly layer, for it required minutes instead of small fractions of a second.

It was suggested that the waves had gone around the earth a number of times before they were finally received. This suggestion did not meet with universal favor. As far as time was concerned, it appeared that they went out into space, approximately near the position of the moon, and then were reflected. Obvious objections abound. Again, it was suggested that they were delayed in the ionosphere (another name for the layer). For such delay there are optical parallels, so this explanation is by no means impossible. The waves were supposed to be delayed particularly by the decrease in speed due to the presence of free electrons.

Other suggestions were that the Martians were trying to communicate with the earthians, but, of course, it was known that the waves had a terrestrial origin—Holland as we recall it. Just the same, the possibility of communicating with the Martians, at least one way and either way, was revived. Radio engineers of renown tried it. So far as we are aware, no one has yet become a master of the Martian language, nor has any one received any evidence of the existence of any such language or of any who might be using it.

The waves detected and measured at Holmdel are of a different nature from the waves to or from Mars. They are real and concrete, for evidence of their existence has been obtained. Not only has the direction from which they come been established with fair accuracy, but their intensity and wavelength have been determined.

## \$700,000 Cited as Cable Users' "Noise Quantity"

Washington. In a letter to Senator Dill, Chairman of the Senate Interstate Commerce Committee, G. M.-P. Murphy, chairman of the Radio and Cable Users' Protective Committee, replied to a statement made before the Senate committee by J. C. Willever, vice-president of Western Union. Mr. Willever had charged that Mr. Murphy represented a small but "noisy" group, but this group, according to Mr. Murphy, paid radio and cable companies \$700,000 in rates during 1933. The group consisted of brokers who had constant business abroad.

**FIG. 2**  
The sun and the earth at the four critical periods of the year. The direction from which the unknown waves come is also indicated. All the data point to a fixed point in space.

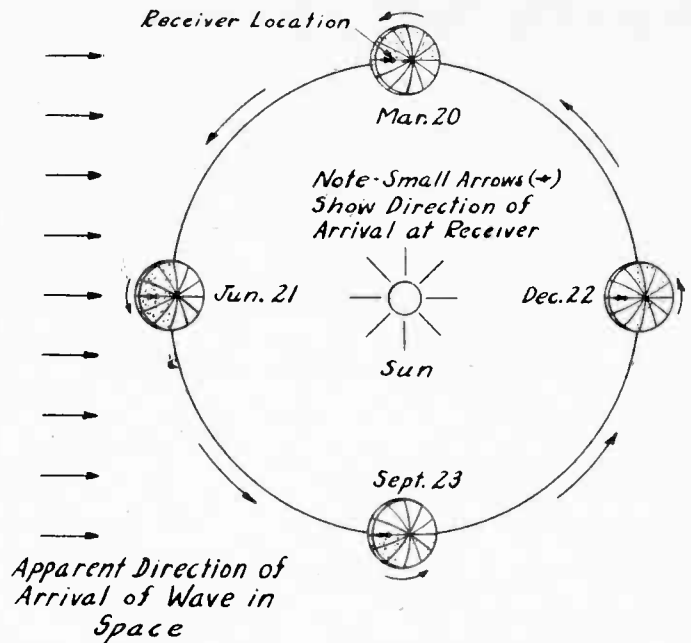

# Attack Communications Bill

Washington. Walter S. Gifford, president of the American Telephone and Telegraph Company, R. B. White, president of Western Union, and David Sarnoff, president of Radio Corporation of America, appeared before the Senate Interstate Commerce Committee and severely criticised the proposed Communications Bill. Mr. Gifford said, "The bill proposes to so largely place the power to manage in the commission as to set up a regime of public management of private property. It is my opinion that this is the most extensive public power ever granted." He also pointed out that A. T. & T. is not a closely-held corporation but is practically publicly owned, since there are 681,000 stockholders not one of whom owns as much as one-fifth per cent. of the total stock. More than half of the stockholders are women.

Mr. White said that "we can conform

with the President without much difficulty," but he suggested technical changes in the bill and a clause guaranteeing avoidance of labor disputes under an arrangement satisfactory to labor.

Mr. Sarnoff, speaking for the Radio Corporation of America, said:

"We are heartily in accord with President Roosevelt's recommendation for the creation at this time of a unified Federal Communications Commission. We believe that this commission should take over functions of the Federal Radio Commission and those of the Interstate Commerce Commission so far as the latter relate to communications. We suggest that there also be transferred to the proposed new commission the functions of the Postmaster General relating to certain telegraphic rates and the functions of the executive department concerning granting and revoking of cable-landing licenses."

## Elders Share Fun with Youngsters in Tuning Short-Wave Stations

By ENOCH MURDOCK

Every one with short waves in his head, but without a short-wave set in his home, should realize that the youth of this land are taking to short waves with a vengeance and getting a great deal of fun out of them, yet it is the kind of fun that even grandfather and grandmother can participate in (as it requires toting no one on your neck, no Humpty-Dumpty and no piggy-back), and persons of all ages call in the neighbors to have them duly impressed with the reception of foreign stations on the new set. And sooner or later these formerly unsophisticated neighbors are themselves telling about hearing Big Ben at 7 p.m. local time and calling in other neighbors. This forging of an endless chain is giving new birth to radio.

And do not forget amid all the excitement that the young folk are getting lessons in geography, meteorology, horology, and physics generally, and the elders may be spurred on lest they know less than their juniors. But knowing less than the children has long been an adult accomplishment.

## Literature Wanted

Readers desiring radio literature from manufacturers and jobbers should send a request for publication of their name and address. Address Literature Editor, RADIO WORLD, 145 West 45th Street, New York, N. Y.

- Raymond C. Resseguie, 79 Fountain St., Springfield, Mass.
- D. L. Davis, Jr., V-P-4-F Fleet Air Base, Pearl Harbor, T. H.
- C. C. Carver Radio Service, 8015 S.E. 13th Ave., Portland, Ore.
- Chas. B. Tator, 6212 S. E. 21st Ave., Portland, Ore.
- Arthur Matthews, Holliday's Cove, W. Va.
- Jos H. Stephenson, 140 N. Butler St., Madison, Wisc.
- W. V. Kincaid, Ramsey, W. Va.
- M. K. Clementson, Ensign, U. S. Navy, United States Ship Indianapolis, Long Beach, Calif.
- Bernard Grubbe, Oakland, Ore.
- C. W. Bourne, Box 32, Council Grove, Kansas.
- Leonard F. Boto, 800 Pratt Ave., Huntsville, Ala.
- Bruce H. Denney, Chief Operator, Soboba Theatre, San Jacinto, Calif.
- Adelard H. Lanoie, Box 168, Northbridge, Mass.
- Jos. Belick, 65 Front St., Box 133, Coplay, Pa.
- E. B. Pipes, 2601 Linson St., Beaumont, Texas.
- Ernest Towler, Co. 1337, P. 70, Fort Union, Va.
- Oscar N. Long, R.F.D. 2, Mt. Morris, Mich.
- F. W. Bouska, 1526 S. State St., Chicago, Ill.

### ASSIGNMENTS

Milton B. Raynow, radio parts, 169 Washington St., New York, N. Y., and 167-17 Hillside Ave., Queens, L. I., N. Y., assigned to Harry Mesnard, 277 Broadway, New York, N. Y.

# R-F Regeneration in a Boosting the Incoming Wave A Between Frequency Cl

By Chester

## LIST OF PARTS

### Coils

One 10-millihenry choke coil.  
Seven 85-millihenry choke coils.  
Two 300-turn honeycomb coils.  
One set of five plug-in coils for r-f tuner.  
One set of five oscillator plug-in coils.

### Condensers

Two 0.00014 mfd. S.L.F. variable condensers.  
Three 0.0001 mfd. variable condensers.  
One 0.00035 mfd. variable condenser.  
Five .01 mfd. mica condensers.  
One 0.0001 mfd. mica condenser.  
Three 0.005 mfd. mica condensers.  
Eight 0.002 mfd. condensers.  
One 0.00015 mfd. mica condenser.

### Resistors

One 50,000-ohm variable resistor.  
One 5,000-ohm variable resistor.  
One one-megohm grid leak.  
One 50,000-ohm fixed resistor.  
One 25,000-ohm fixed resistor (may be lower).

### Other Requirements

Three six-prong sockets.  
Three five-prong sockets.  
One aluminum cabinet, 14 x 6 x 6 inches.  
Two National Type B dials.  
One power supply to furnish A and B voltages.  
Three pieces of aluminum for partition shields.  
Nuts, bolts, screws, and hook-up wire.

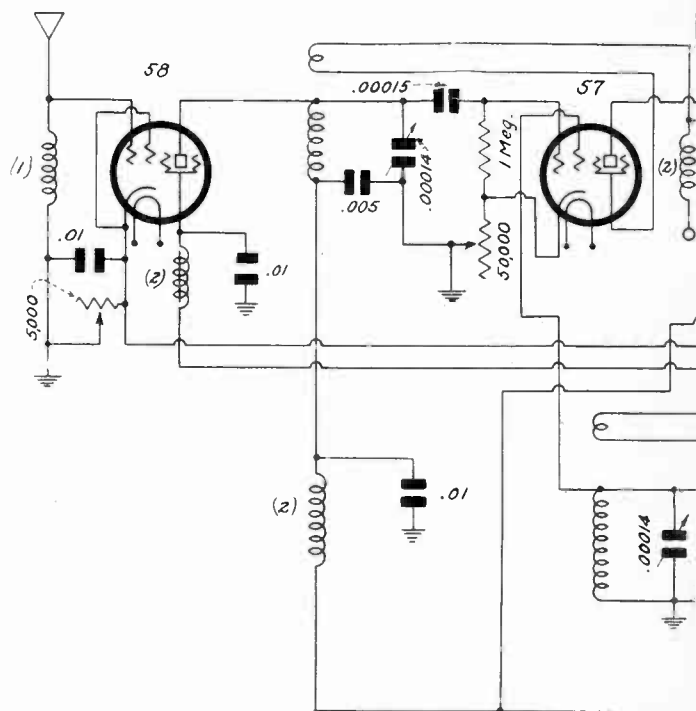

FIG. 1  
The circuit diagram of a four-tube regenerative short-wave suppressor

FROM time to time articles on short-wave sets and converters appear in your magazine. These I have read thoroughly and have derived many ideas from them. I have also been experimenting a good deal along this line and as a result reading and experimenting I have designed a short-wave converter which has given me and my friends, for whom I have built it, very good service. I submit a description of it in case you may wish to publish it.

The converter uses plug-in coils, space wound on a five-prong form  $1\frac{1}{2}$  inches in diameter. The feedback winding is placed in a slot at the base of the form. The two coils, that is, the oscillator and the input coil to the mixer, are mounted in top of the cabinet about six inches apart and directly over the tube. The cabinet is a stock aluminum box 14 x 6 x 6 inches which can be purchased in any radio store. The dials are Type B, National Company, and a separate dial is used for each condenser. The condensers are of 0.00014 mfd. capacity, and no attempt was made to pad nor to gang them.

Four tubes are used in the converter proper. One functions as a radio-frequency amplifier with choke coupling between it and the antenna. A 58-tube is used in the first stage.

### The Mixer Tube

For mixer, a 57 is employed, and it is coupled to the radio-frequency amplifier by a tuned impedance. Regeneration has been introduced in this place, the tickler being connected in the screen circuit of the 57. The regeneration is controlled by means of a 50,000-ohm variable resistor in the cathode lead of the tube. This is connected so that the bias on the tube is not affected but only the effective values of plate and screen potentials.

For oscillator a 56-tube is used, a stopping condenser and a grid leak being used to assist in stabilizing the frequency. It will be noticed that the oscillator is of the tuned grid type. An unusual

feature of the connection between the oscillator and the mixer tubes is that the top of the oscillator circuit is connected to the suppressor of the 57. In view of this connection the suppressor bias voltage is variable and depends on the setting of the 50,000-ohm regeneration control. On top of this bias is impressed the alternating voltage generated by the oscillator. This is an effective way of modulating the radio-frequency signal and of producing a strong intermediate-frequency output.

The final tube in the circuit is a 58, and it functions as an intermediate-frequency amplifier. The output tube is coupled to the mixer tube's plate by means of a tuned impedance adjusted to the intermediate frequency. This frequency can be controlled from the panel. There is a second intermediate-frequency coupler in the output, and this is also tuned from the panel. Indeed, the two intermediate tuners are controlled by the same knob, the two condensers being ganged.

The fact that the intermediate tuner is adjustable to any broadcast frequency is advantageous in that it provides a means for selecting the intermediate frequency at which best results are obtained. It need not interfere with broadcast signals, for if there should happen to be a broadcast signal that comes through on one particular setting, it is only necessary to readjust slightly. Moreover, the variable intermediate provides a means for compensating to some extent the lack of tracking on the high frequency side of the circuit. Again, it provides a means for band spreading, for if the radio-frequency and oscillator tuners require very critical adjustment, that adjustment can be done with the intermediate tuner and the tuner in the broadcast set.

The coils used in the intermediate tuners are 300-turn honeycomb choke coils and they are tuned with two 0.0001 mfd. condensers. While these are small, they are large enough to cover the broadcast band, or at least enough of it to allow ample choice of intermediate frequency for the converter. The small size of capacity and the

# Short-Wave Converter Tones for Relaxed Coupling Changer and Receiver

L. Masser

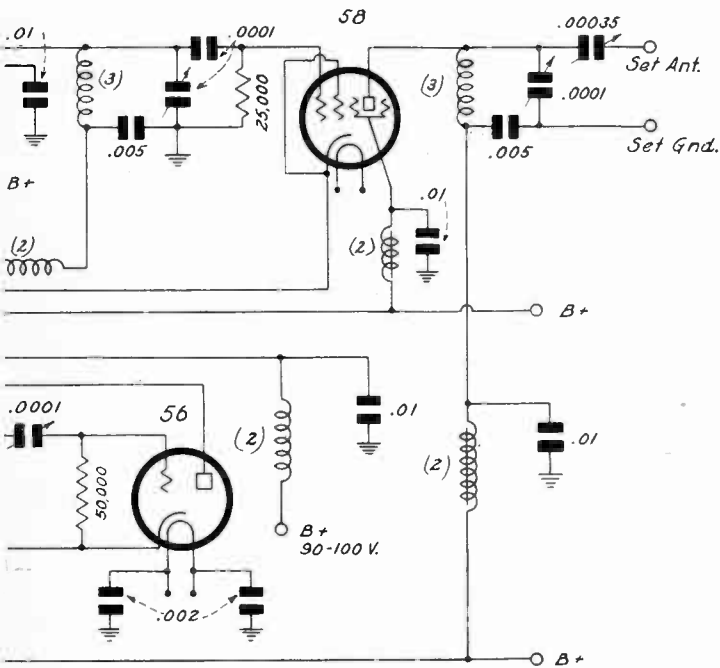

Short-wave converter. Impressing oscillation on the mixer is a feature.

comparatively large inductances are advantageous in that the L/C ratio is favorable for a high gain.

The converter has been used with both t-r-f and superheterodyne type receivers, but better results, as a rule, are obtained with the t-r-f type.

It will be noticed that at the output side there is a 0.00035 mfd. stopping condenser. The object of this is to prevent a short of the B supply through the ground connection. In view of the fact that the input to the receiver is connected in shunt with the last tuned circuit, there will be a considerable change in the natural frequency of that circuit unless the stopping condenser has a low value, or unless the input impedance to the receiver is high. In general it may be better to have the last tuning condenser separate from the other intermediate tuning condenser, for then the two circuits are adjustable to the same frequency for a larger range of the impedance that may be connected across the two output terminals.

The last tuning condenser apparently is left ungrounded as far as the set is concerned, but if the same ground connection is used for both the receiver and the converter, the two intermediate-frequency tuning condensers are actually connected together on the rotor sides, and they may, of course, be ganged without insulation between them.

The regeneration in the modulator increases both selectivity and sensitivity considerably and is a well worth-while feature. The degree of effectiveness of the regeneration depends on the number of turns on the tickler and on the closeness with which the tickler is associated with the tuned winding. Best results can usually be obtained only by trial, although the tickler is by no means critical as long as the 50,000-ohm variable resistance is available for varying the performance of the tube.

It is important to have complete control over the regeneration in this circuit, for if the regenerator oscillates, no satisfactory results can be obtained.

A separate power supply is used to furnish the plate and screen voltages for the tubes in the converter, and also to supply the filament currents for the tubes. This supply is not shown but it is standard in all respects. Of course, it is permissible to use the same supply as is used for the broadcast set, if suitable leads are brought out. It is much better, however, to use a separate supply, for then there is no chance of upsetting the balance in the broadcast set. Moreover, it is more convenient than to bring out filament and high potential leads from the receiver.

In each of the four plate and screen leads is a radio-frequency choke (2) for filtering, and for each choke there is a mica type, 0.01 mfd. by-pass condenser connected from the high radio-potential side of the choke to ground. Thus there is no way in which the signal can stray into the power supply. A by-pass condenser of 0.002 mfd. is also connected from each side of the heater winding to ground. These condensers are shown at the oscillator only but each tube is treated the same way and the condensers are connected directly to the socket springs to the nearest grounded conductor. These condensers are necessary in high-frequency circuits in order to remove hum, especially of the tunable variety. This converter is free from hum even on the highest frequency covered by the tuner.

### Bias

The bias on the grids of the two 58s is variable and is obtained from the drop in a 5,000-ohm variable resistor placed in the common cathode lead. It is placed near the first tube and the 0.01 mfd. by-pass condenser that goes with it is also mounted next to this tube. This variable provides a means for controlling the volume aside from the regeneration control. If there is any tendency to oscillate in the two amplifiers, the control provides the means for stopping it.

There is no difficulty in making the 56 oscillate down to 10 meters and to control the circuit at the high frequency represented by 10 meters.

The coils are wound to cover the range from 10 to 200 meters. The number of coils required to do this depends on the overlap allowed between adjacent coils. I am using 5 sets of coils to do the job, for in my case the condensers are not quite 0.00014 mfd.

### Suggested Antenna

As an aerial I am using 25 feet of hook-up wire placed behind the picture moulding inside the room. For a ground I have a water pipe and this is connected to the converter by a wire about 10 feet long.

At present the converter is used with a midget, six-tube superheterodyne of the a-c, d-c type. The connecting link between this superheterodyne and the converter is a wire two feet long, measured from the output posts of the converter to the input posts of the receiver.

An arrangement is provided for switching the antenna either to the broadcast set or to the converter. This is accomplished by means of a plug and jack. As a rule, it is not necessary to switch the antenna to the broadcast set when broadcast signals are to be received.

When the converter is to be used, I usually set the broadcast set at about 530 kc and then tune the converter circuits to that frequency. With this intermediate frequency, which is just below the lower broadcast limit, I have had no difficulty in getting loud-speaker reception on various short-wave stations throughout the world.

### Construction

The top of the cabinet serves as the bottom of the converter. The tubes are upside down, and the leads in the converter are extremely short. Aluminum shields separate the stages so that coupling through the air as well as through the supply leads is reduced to a vanishing minimum. Notwithstanding the shielding, the converter is very compact and it is easy to assemble, or to take apart when for any reason that becomes necessary.

# For Ultra Frequencies

## The Super-Regenerator Gives Excellent Results

By Harry Gessen

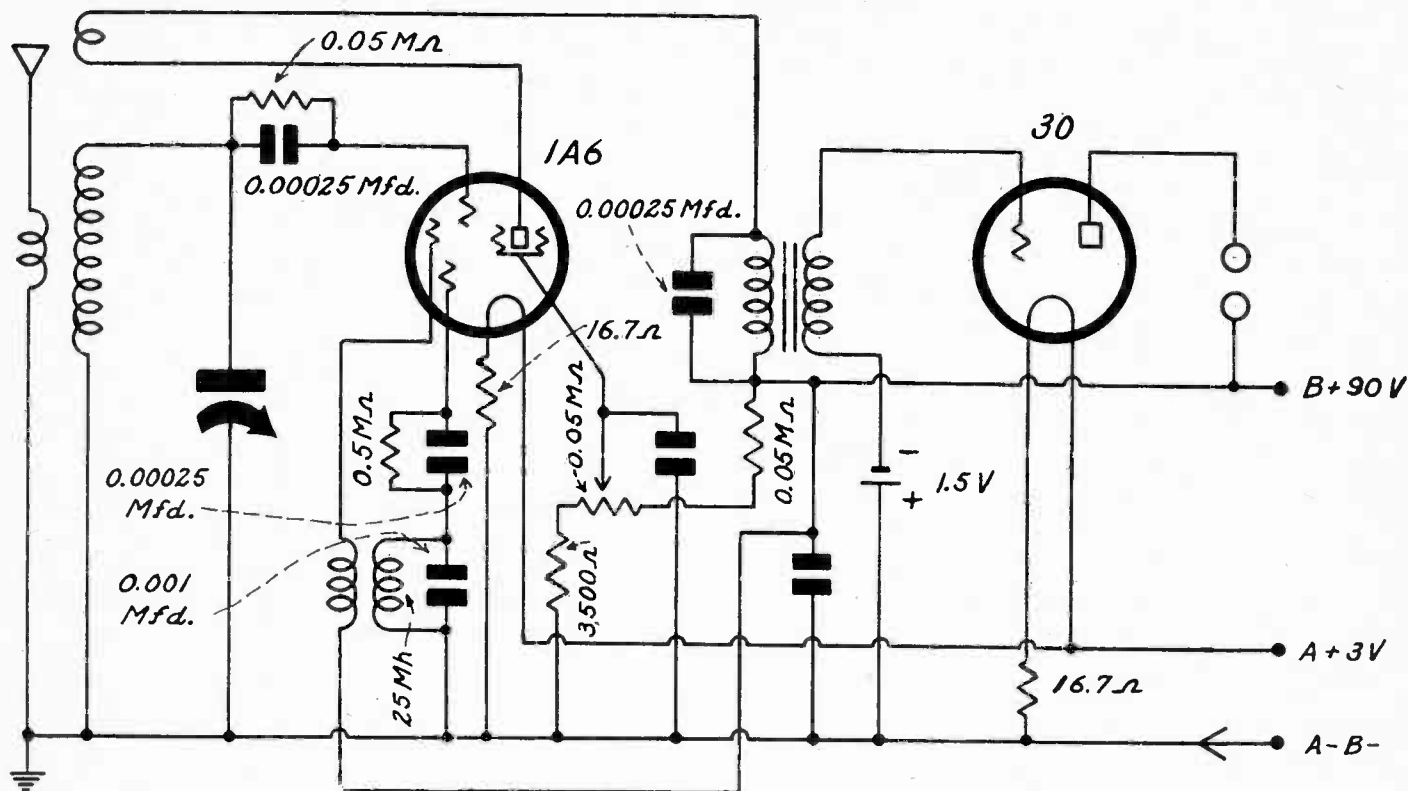

FIG. 1

The circuit of a two-tube super-regenerative short-wave circuit. Excessive regeneration is provided by the tickler but the effect thereof is controlled by the auxiliary oscillator.

THERE has been little interest in the super-regenerative circuit the last few years, or ever since the Neutrodyne receiver came on the stage. But this lack of interest is only in respect to broadcast reception. When a receiver is used for ultra-high frequencies, those below ten meters, and especially those in the neighborhood of one meter, there is no other type of receiver that is really sensitive.

Since the original super-regenerative receiver was built many new tubes have been made available, and some of those are much more suitable for super-regenerative circuits than the old models. This is particularly true of the multi-grid tubes, the 1A6, for example.

In Fig 1 we have a two-tube super-regenerative circuit employing one 1A6 and one 30-tube. The second tube is nothing but an audio amplifier, and the super-regenerative feature is associated with the first tube.

### Principle of Super-Regenerative Circuit

The theory of the super-regenerative circuit is about the same as that of the ordinary regenerative circuit, but as the name suggests, the regeneration is stronger. It is well known that as the tickler is advanced the sensitivity of the circuit becomes greater and greater. But at a certain value of the regeneration the circuit breaks into uncontrolled oscillation and then the sensitivity drops to nothing. The problem to be solved in connection with the super-regenerative circuit is to allow the regeneration to be increased without the circuit's breaking into uncontrolled oscillation. Armstrong, who was the originator of both the ordinary regenerative and the super-regenerative circuits, argued that if the circuit could be prevented from oscillating freely after the tickling had been advanced well beyond the point where the signal could control the action, the circuit could be made exceedingly sensitive.

If the oscillation is allowed to build up to a certain value and then is stopped, and if this starting and stopping is done periodically, a high amplification can be obtained. The stopping was done in the original circuit by another oscillator which changed the characteristics of the regenerator periodically. One moment the regenerative circuit could build up an oscillation. The next, due to the action of the auxiliary oscillator, regeneration was not possible, and the oscillation had to die down.

Therefore during one-half cycle, approximately, of the auxiliary oscillator the regenerator able to build up a very high amplitude and during the next it will partly lose this amplitude. If the rate and intensity of oscillation of the auxiliary oscillator are chosen correctly there will be a super-regenerative effect in so far as the

regenerative circuit is concerned, and the amplitude will never increase to a value so that the tube cannot handle it.

### Frequency of Auxiliary

It was customary in the early regenerators to make the frequency of the auxiliary oscillator 10,000 cycles, because this was so high that it did not materially interfere with the operation of the receiver, that is, with the audio signal. It is a fact, however, that the 10,000-cycle frequency could be heard in the background. When it was made so high that it could not be heard, it ceased to be effective in stopping the oscillation.

A necessary condition is that the difference between the frequency of the auxiliary oscillator and the frequency of the signal must be great. When we are dealing with ultra-high frequencies, the frequency of the auxiliary oscillator can be much higher than the upper limit of the audible frequencies.

In the present circuit the inner grid and plate are used for the auxiliary oscillator. A 25-millihenry is connected in the grid lead and a similar coil in the plate lead, that is, the lead to the inner grid. A 0.001 mfd. condenser is connected across the grid winding. Thus an oscillator generating a frequency of about 32,000 cycles per second results. This is much above the upper audio limit, yet it is low compared with any ultra-high radio frequency that may be tuned in. A 0.5-megohm grid leak and a 0.00025 mfd. stopping condenser completes the oscillator.

### The Regenerator

The regenerator is typical of all regenerative one-tube detectors. It has a tickler winding connected to the plate circuit in the usual way. It also has the tuned winding, which is tuned with a small variable condenser, say 140 mfd. There is a grid leak of 0.05 megohms and a stopping condenser of 0.00025 mfd. The tuned circuit is coupled loosely to the antenna by a small winding in series with the antenna-ground leads. The tickler is supposed to be coupled so closely to the tuned winding that vigorous oscillation will result when it is not interrupted. To make the tickler effective a 0.00025 mfd. condenser is connected across the primary of the audio-frequency transformer. This condenser may also be connected directly to B minus.

Provision is made for varying the voltage on the screen and thus to control the intensity of the regeneration. This is the only regeneration control in the circuit. Another control might be used advanced

(Continued on next page)

# For Short Waves Try the So-Called "PUSH-PULL DETECTOR"

By Emerson Hardy

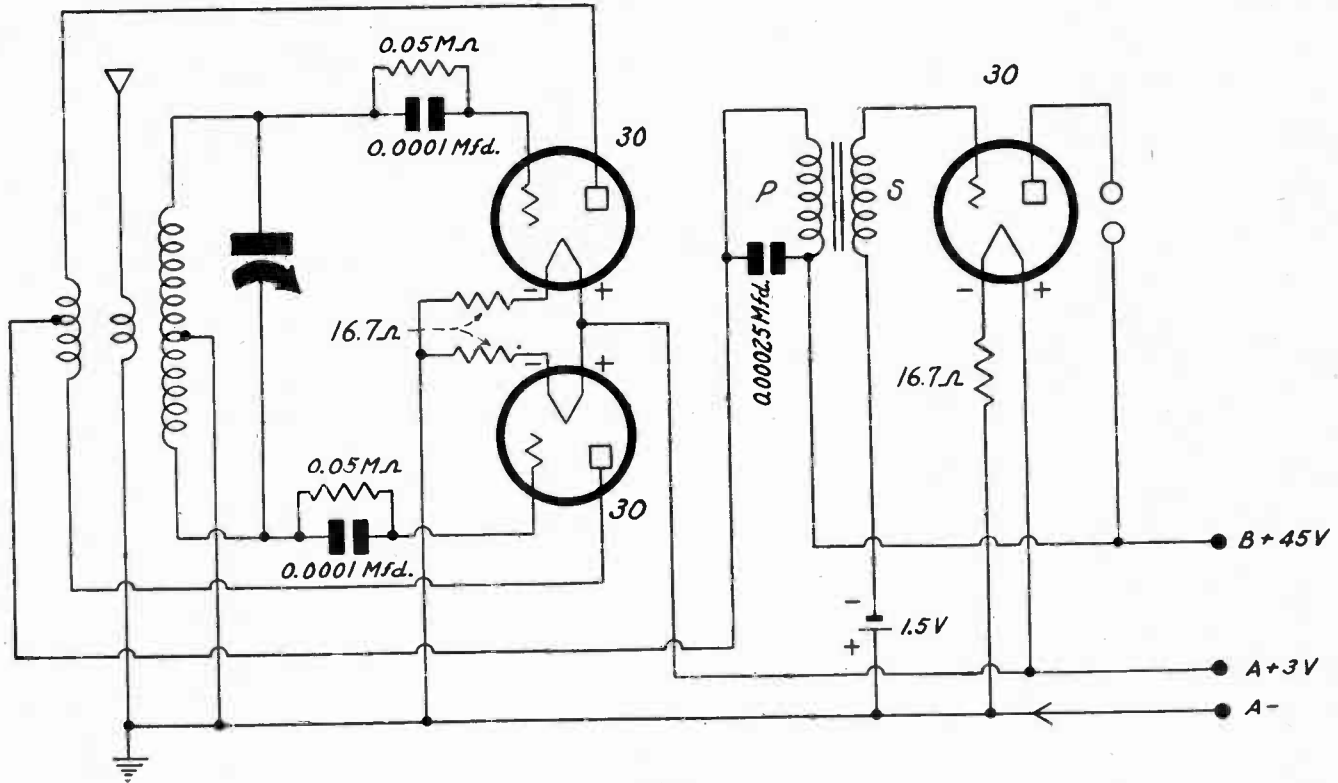

FIG. 1

Although this is commonly called a "push-pull detector," and yields splendid results on short waves, it is really just a full-wave detector. To be push-pull it would have to provide duo-directional rectified output current (plate circuit). However, all the pulses are in the same direction.

THE so-called push-pull detector gives somewhat better performance on short waves than does the more familiar single tube. The tone is improved, also the reception may be pressed to higher frequencies than by the other method, because the tube capacities are in series and the circuit as a whole is a readier regenerator.

It is not pretended that the phrase "push-pull detector" is literal. Full-wave detector would be more like it. Of course the input voltage is halved, compared to the normal method, but this is not serious, as "twice as much voltage" has little significance in terms of audible results.

### No Such Thing as "Push-Pull Detector"

A detector really can not be push-pull, because the output pulses are always in the same direction. Here the rectified component is led through the primary of an audio transformer, and although the input voltages on the two grids are equal and opposite in phase at any given instant, and only one tube is rectifying at a time, and no matter which one it is, the direct or rectified current is flowing from B plus 45 volts to B minus.

If it were possible to establish true and perfect balance or symmetry the 0.00025 mfd. condenser across the primary of the audio transformer would not be necessary, for then there would be true

push-pull operation. But the fact that the condenser improved detection, by offering a high impedance to audio frequencies, and a low impedance to radio frequencies, and thus enables the plates to work into a distinctively audio load without putting any radio frequencies in the audio amplifier tube, is experimental proof of single-sided output.

Some attempt to balance the circuit statically should be made, provided tests show any unbalance. For instance, two 30 tubes are used as the detectors. They may not be of equal mutual conductance. It is desirable that the static performance be equal. So if under otherwise equal conditions of same value grid condenser, same value grid leak, and same value of supply voltages, (all measured) the plate currents differ, a little more resistance may be added in the filament leg of the tube that has the greater emission, until the two tubes have equal plate current.

### Indication of a Faulty Tube

Or, if the other method is preferred, the resistor in the filament leg of the tube having lower emission may be paralleled with a much higher resistance than 16.7 ohms, say, 100 to 200 ohms, until the right value is found for equalization.

The first or voltage reduction method may be preferred by some, (Continued on next page)

## The Super-Regenerative Ultra Wave Set

(Continued from preceding page)

tageously for the auxiliary oscillator, which may take the form of a 25,000-ohm variable resistor in series with the plate supply of the oscillator.

Whether or not the auxiliary oscillator will control the regeneration in the high-frequency circuit depends on the coupling between the elements. Well, in the 1A6 the coupling is very close so the oscillator will have complete control. It is for that reason that the added oscillation control is suggested.

The voltage applied to all the plates, including that of the oscil-

lator is 90 volts. For the screen of the 1A6 this is dropped by a voltage divider, which consists of a fixed resistance of 50,000 ohms, a potentiometer of 50,000 ohms, and another fixed resistance of 3,500 ohms, all connected in series, with the potentiometer between the two fixed resistors. Since the total resistance is 103,500 ohms and the voltage across the total is 90 volts, the minimum voltage that may be applied to the screen is 30 volts and the highest is 46.5 volts. This division assumes that the current to the screen is negligible in comparison with the bleeder current, which it is likely to be.

(Continued from preceding page)

that is, added series resistance of a few ohms, because then there is no danger of increasing the filament voltage on the adjusted tube to above 2 volts.

It is harmless if the voltage for any special reason is reduced below 2 volts, so long as no circumstance requires that it be dropped to 1.5 volts, for that would indicate the disparity between the tubes, present originally, would be due to a fault or defect in the low-emission tube.

The circuit at top of the page is intended for use of a three-winding coil on one form, with condenser across the total secondary. This represents the simpler method, for the question of coupling of the secondary halves does not enter.

### Drum Dial Recommended

However, the rotor of the condenser is not grounded, which practically precludes the use of a disc dial, and requires that a drum dial be used, and preferably a large one. There would be capacity effects from the hand to the "hot" rotor even if an insulated type disc dial were used, that is, no metallic connection between hand and dial face and condenser shaft, yet the conduction would be through the dielectric of the insulating material. A drum dial presents such a large separation between the shaft and the hand that this trouble does not then arise.

But if grounded rotor connection is to be used, a double condenser should be selected. Then the center-tapped coil will have tap grounded, as usual, rotor grounded also, and the two stators connected to the high sides. Then any type of dial might be used without troublesome effects.

### Inductance Considerations

The two windings for the double-condenser example are assumed not to be coupled. If that be true, then the total winding for the first example is one-half the inductance of the total winding for the second example, assuming that the single condenser in the first example is equal in capacity to that of each of the separate two condensers in the second example, and the frequency coverage is to be the same. Let us assign values. The capacities are identical. A single condenser of 140 mmfd. is used, and, again, a double condenser, each section of 140 mmfd. But the inductances are dissimilar. That in the second example—double condenser—has twice the inductance of the other, grid to grid. The rule, then, may be reduced to this: double condenser, double inductance. That is for covering the same frequency range in both instances.

It is apparent that the single condenser with drum dial offers a simpler solution. How to have two windings not related to each other, as in the second example, yet related to a common primary, even if ticklers are separate, does not then arise.

If the double-condenser example were applied to a continuous secondary, with tap for ground, three would be no objection at all, only the inductance would be larger for the same number of turns, compared to isolated windings, due to the mutual inductance.

So any who will build this circuit, if they select the diagram at top of this page, may wind or rewind standard plug-in coils, so that the secondaries have the same number of turns as for any other use, but the secondary tap is introduced. The primary may be a few turns wound the length of the secondary, and the tickler wound over the others, centered on the secondary, insulating fabric between, twice as many turns as otherwise would be provided for the tickler, since effectively only half the inductance is in use at a time.

### Twice as Many Pulses

The earphone volume will be found adequate, but if it is desired to increase it without adding another tube, the B voltage on the audio amplifier may be raised to 90 volts, and the bias increased to 3 volts or so, or even raise the B voltage to 135 volts and increase the negative bias to 6 volts or so. The detector B voltage

**FIG. 2**  
In the other diagram the rotor is not grounded, so a drum dial should be used. If rotor is to be grounded use a double condenser (at right).

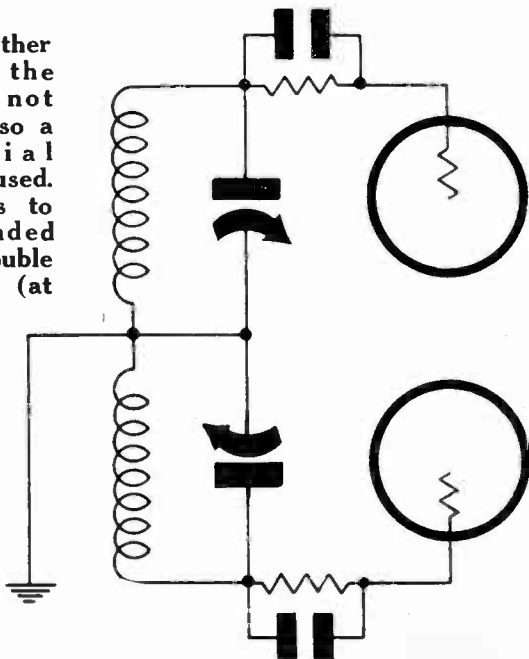

## Coils for Wave Switching Need Careful Placement

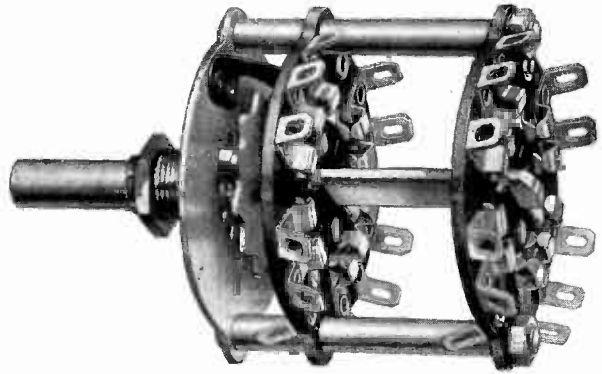

This represents two sections of a short-wave switch. For best results the highest frequency coils should be so located that leads are shortest, next lower-frequency coils so leads are second from shortest, etc.

The usual neatness of coil arrangement as found in exclusively broadcast receivers is not to be expected quite yet in switch type short-wave and all-wave receivers, and in fact, although the sets work well, a view at the coil-switch assembly of the completed set usually is uninspiring.

It is best practice to keep the leads shortest for the highest-frequency band, leads next shortest for the next lower frequency band, and thus on until the lowest-frequency band is accommodated.

Naturally, there will be some coupling among the various coils, and the object is to keep this as low as possible. Where the tuning ratio in frequencies is more than 2 to 1, as it practically always is, there is danger of introducing dead spots, due to the trapping out of a frequency at a higher frequency band by the natural period of the coil intended for the lower frequency band, when condenser is moved from the low-frequency coil.

The position of the index connection becomes important, and there are several types of switches to accommodate the respective needs. One type will have the index to the left, close to the condenser stator outleads, so that coils at right can be picked up, the coils near the tubes they are to serve. Another type will have the index and throw connections practically in successive rotation. An examination of the type of switch and a realization of the purpose to be served are necessary.

may remain at 45 volts, unless in special cases of 67.5 volts giving a better response.

It should be kept in mind that when full-wave detection is used the number of unidirectional pulses is doubled. The voltage of each is halved, thereby cutting down the value of each current pulse, but there will be twice as many pulses. Hence the mean current in the output is not greatly changed. If the question is merely a matter of getting a high output voltage across a very high load resistance, one drawing practically no current, it is preferable to have a single-wave rectifier, utilizing the full voltage, but when the discharge is through a low resistance device, the effectiveness of full-wave is fully equal to, if not actually greater than the output when the full signal-voltage is applied to a half-wave rectifier.

It will be noticed that the outputs of both tubes are combined, since the two plates are connected in parallel in respect to the audio amplifier. Detection does not occur in the plate circuit. The real detection occurs in the grid circuits. Therefore we have two separate detectors sharing the signal voltage across the coil in such a manner that one rectifier is idle while the other is working. There are also two separate audio frequency amplifiers. It is not until the half-signals have been detected and amplified once that the two outputs are combined. This is because we happen to be using grid circuit rectification. The principle would not be any different if we used plate circuit detection.

### Resembles Present Super Use

It is well to recall that an arrangement not unlike this present is used in most superheterodynes employing full-wave diode detection. In this case, however, the outputs of the two detectors are combined before amplification in the single load resistance.

When the diode tube is used in this manner there is no chance for obtaining regeneration. We could not connect a tickler to the plate of the diode tube's triode and lead it back to the input coil the way it has been done in this instance. The current would be out of phase for one rectifier and in phase for the other.

Of course, it might be possible to use two coils in parallel and connecting them in opposite directions, but to make this reasonably effective we would have to use a split tuning system as in smaller illustration. It would not be practical. The better arrangement is that shown in the large diagram.



# Radio University

*Answers to Questions of General Interest to Readers. Only Selected Questions are Answered and Only by Publication in These Columns. No Correspondence Can be Undertaken.*

### Paralleled Oscillators

WHAT IS the object of using two tubes in parallel in the local oscillator circuit of a superheterodyne, especially if short waves are to be received? I do not see the sense of such practice, since the capacity contributed by the tube is doubled, particularly the input capacity, and where the gain comes in is more than I can understand.—P. W. D.

The object of paralleling the oscillator tubes, as in the diagram herewith, is to increase the mutual conductance. The figure of merit of an oscillator is the mutual conductance. The higher the Gm the larger the oscillation amplitude, other factors equal. The inequality you mention, of increased capacity, is not more than unity compared to the minimum capacity of the tuning condenser, and becomes small or even trivial compared to the higher capacity settings of the condenser when striking lower frequencies. For numerous reasons the sensitivity of receivers today generally falls off considerably at the higher frequencies, and around 20 mc. meters the trouble is serious. However, by paralleling the tubes as shown the oscillation amplitude may be sufficient even around 10 meters, whereas oscillation otherwise would fail long around 15 meters. Hence, if any one desires to reach higher frequencies, where present failure is due to the oscillation stoppage, he may resort to the parallelism.

### Conditions for Oscillation

IT HAS BEEN STATED by persons supposed to know that an oscillator cannot function unless grid current flows. Is that a fact? If it is, how is it possible to have oscillators in which no grid current flows, as is required in certain stabilized circuits?—W. B. L.

The supposed authority is wrong. There can be oscillation in a circuit if no grid current flows, and no grid current will flow if the circuit is adjusted correctly. With the ordinary voltages applied to the plate, grid and filament it is not possible to prevent grid current flow. The nearest approach is to use a grid stopping condenser and a grid leak. Grid current must flow in this circuit also, for it is only because of this grid current that there is any improvement. But the grid current is very small, and, what is important in respect to frequency stability, the effective plate and grid resistances are very large.

### Amplitude of Oscillation

IS IT A FACT that the amplitude of oscillation in an oscillator is limited by the cut-off voltage and the saturation current in the tube? If so, where do the high voltages come from in an oscillation circuit?—W. B. L.

No. But this assertion must be qualified to some extent. First of all we must decide on what voltage or current amplitude we mean. Is it the voltage in the plate circuit or the voltage in the resonant

circuit that in in question? Or the respective currents? The maximum current in the plate circuit is limited by the saturation current of the tube. The amplitude is not. In fact, if the plate current varies between zero and saturation, the amplitude of the fundamental must be considerably higher than the saturation. This fact follows directly from Fourier analysis. The voltages are not limited, either. The only limitation on the oscillator is the power supplied. No more power can be expended than is supplied. That is, energy cannot be dissipated in the circuit any faster than it is supplied, but only at the same rate. That condition limits oscillation throughout the circuit. Since the saturation current limits the power supplied to the set, it also limits the amplitudes indirectly. But by this limitation is not meant that the amplitudes of the fundamentals in the various meshes cannot exceed the saturation current.

### Diode Detection Explained

CAN YOU GIVE us a mechanical analogy of what goes on in a diode detector which will help to explain the principle?—R. K.

We have previously given an explanation in connection with the grid leak detector, and it might bear repeating. Suppose we have a large water tank (condenser) with a small hole in the bottom (leak across filter or grid condenser). Let a pump pour water into the tank at a definite rate. (This represents the signal e.m.f.) The pump will deliver water in pulses (current pulses). If the water leaks out at the same rate as the pump delivers it, on the average, there will be no change in the water level (voltage across load resistance or across condenser remains constant). Now suppose that the pump takes longer strokes. It will gain on the leak and the water rises. After the length of the strokes has increased to a certain value it begins to decrease again. The leak begins to gain. Finally the strokes are very short and the leakage is much faster than the water delivery. The level of the water is low, not at the same time as the stroke is shortest but sometime after. Therefore, if the length of the stroke varies regularly (the stroke is modulated) the water level will rise and fall according to the average value of the strokes. Thus the variation in the strokes is detected. There will be a small ripple in the water level, but this will be greatly reduced if the tank is large, in cross-section area. There will be only a slight ripple in the current flow, or in the level of water. This is about as close an analogy as can be found for grid leak or diode detection.

### Sensitivity of Galvanometers

WHAT IS the sensitivity of the most sensitive current-measuring devices of the moving coil type? In other words, how small currents can be measured?—W. B. N.

The most sensitive moving coil meters are usually mirror galvanometers, and some of these are extremely sensitive. These have a scale in front of the instrument and light is reflected from the scale by the mirror on the moving coil into a telescope. Frequently the scale is placed a distance of one meter (37.39 inches) in front. The sensitivity is given in terms of microamperes per millimeter deflection. One commercial galvanometer of this construction has a sensitivity of 0.0005 microampere per millimeter. Since it is possible to read one-half millimeter, or even less, it is possible with this instrument to detect a current of 0.00025 microampere. That means that the smallest current that can be measured, or rather detected with some degree of precision, is one-quarter of a billionth of an ampere. If such a current flowed through a 0-1 milliammeter, or even a 0-1 microammeter, we would say that the current was zero.

### Using 57 in Resistance Coupler

IF A 57 TUBE is to be used in a resistance-capacity coupled circuit what should the voltages and coupling elements be? Is it practical to use this tube in a resistance-capacity coupled circuit?—W. R. T.

The 57 or any similar tube may be used in a resistance-capacity

**A short-wave mixer, consisting of a stage of t.r.f. (left), a modulator and a pair of 56 tubes in parallel as oscillator to increase the mutual conductance, so that keener response will be enjoyed in the highest-frequency band.**

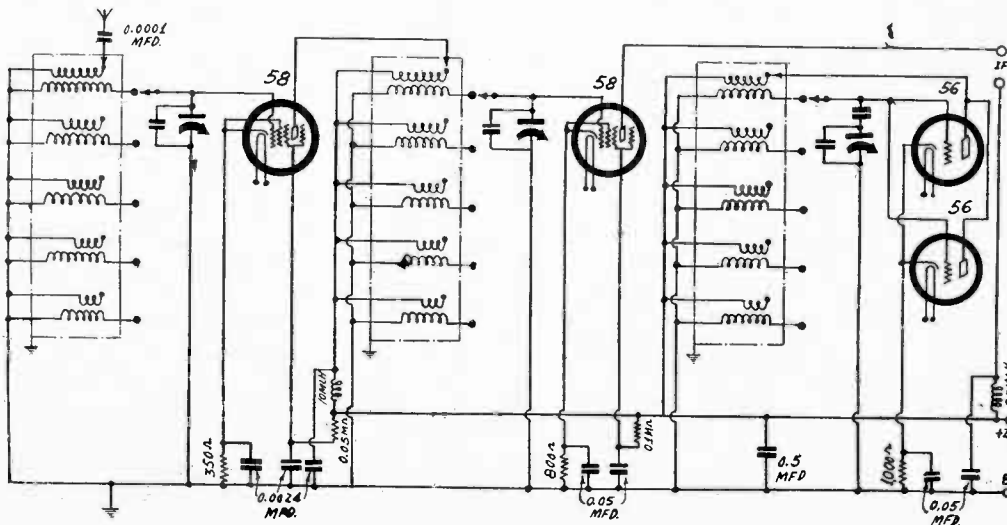

A postage-stamp type midget condenser at rear of receiver may be used in a short-wave set like this and need be adjusted once for each band. This merely avoids the extra expense of a variable condenser of around 50 mmfd. which would be adjustable from the front panel.

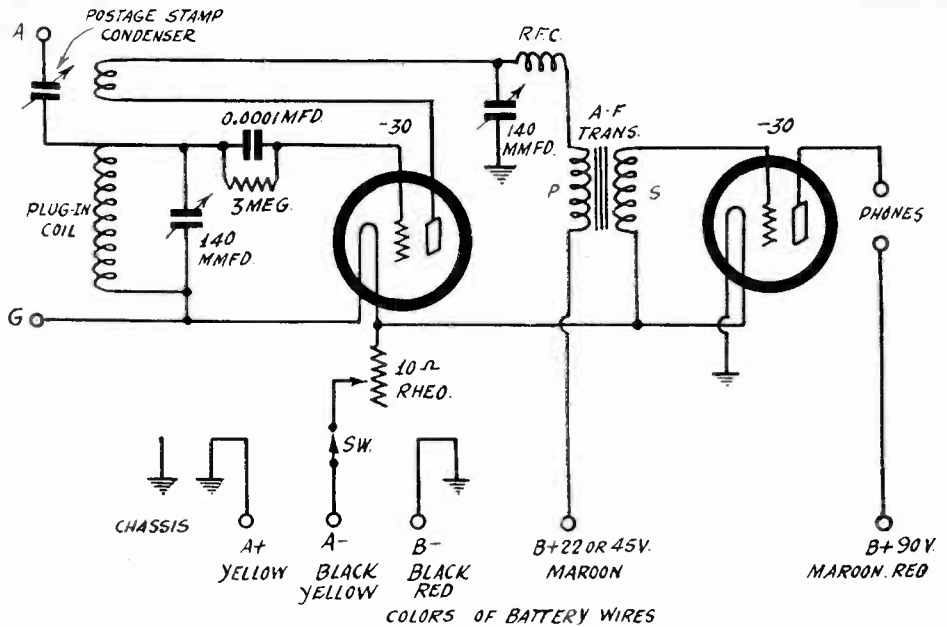

coupled amplifier provided that the suppressor is grounded. When that is done it will function satisfactorily with moderate voltages on the elements. Since the tube has a high internal resistance it should have a high resistance load, say 1.0 meg. or more. It should also have a high voltage in series with this resistance. The effective voltage on the plate should be high. The grid bias should be the same in this case as for other uses of the tube.

**Lissajou Figures**

IN A RECENT ISSUE you discussed Lissajou figures. I wonder why this idea of measuring frequencies by harmonic ratios is something new or old? If it is old, why has it been neglected?—G. W.

Lissajou figures are very old, for they have been used in physics many, many years. Usually they are produced by double reflection from two mirrors attached to tuning forks. They have been used for comparing frequencies of tuning forks. It was only when the cathode-ray tube was devised that they could be applied to radio. With the cathode-ray oscillograph they form a very sensitive and exact means for comparing frequencies.

**Matching of Impedances**

WILL YOU KINDLY give an explanation of the matching of impedances, why it is necessary, and how it is brought about?—W. E. M.

You will find this subject treated in the article on noise-reducing antennas elsewhere in this issue.

**A-C on Filament Tubes**

IS IT PRACTICAL to use a.c. on filament-type tubes? I have a four-tube receiver using 2-volt battery tubes but I wish to change to a.c. I was wondering if it would be all right to heat the filaments with a 2.5-volt transformer, using a rheostat to cut down the excess voltage.—R. E. L.

The hum will be excessive and it is almost impossible to remove it. It is much better either to retain the batteries or to substitute heater-type tubes. There is a tube in the 2.5-volt series that corresponds with every tube in the 2-volt filament series.

**Range of Volume Controls**

ABOUT HOW GREAT is the range that a volume control, either manual or automatic, should have in a sensitive receiver? Let us assume that the sound output is to be varied from about 15 watts to a small fraction of a watt and that the set is sensitive enough to pick up stations 3,000 miles away.—N. B. R.

If the weakest signal to be received is one microvolt and the strongest is one-tenth volt, the ratio of the strongest to the weakest is 100,000. This represents a difference of 100 db. If the lowest output power is one-tenth watt and the highest is 15 watts, the power ratio is 150. This represents a difference of 21.76 db. Therefore, the total range is 121.76 db. If it is a question of voltage ratio control, the volume control should be able to vary it in the ratio of 1-222,500 to one. That is a very wide range, indeed.

**Electromagnetic Mass**

WHAT IS MEANT by electromagnetic mass, especially as applied to an electron? Is this mass the same as the ordinary mass of the electron, considered as a particle of matter?—P. S. A.

There is a difference of opinion whether or not the mass of an electron is all electromagnetic or part ordinary mass. The electron appears to be heavier when it is moving at a high rate of speed, and

it is this apparent increase in the mass that is called electromagnetic. The latest opinion, we believe, is that all the mass of an electron is electromagnetic, that is, that it exhibits inertia only by virtue of motion.

**Postage-Stamp Series Condenser**

IN THE REGENERATIVE detector and stage of audio you have shown for short-wave reception, where a postage-stamp type condenser is used in series with the aerial, how is this located at the front panel and adjusted?—I. W. C.

The condenser is located at left rear of the chassis, not at front. Adjustment is made with a screw driver. For each band it should be adjusted once. As these adjustments are the same for each band, the points to which to turn the setscrew may be memorized by the number of turns to the left from maximum capacity. The reason for including that type of condenser is economy. The kits and receivers are very low-priced, though results are good, and the expense of a regular variable condenser of, say, 50 mmfd., is avoided. To be sure the difference is not so great that you can not include the front-panel type condenser for this purpose, but be sure to insulate it from any metal panel. With the regular variable condenser of the midget type it will be unnecessary to reach behind to make the adjustment, and also the proper position of the condenser rotor for each band may be marked on the panel, or indicated by a pointer knob referring to a numerically-scaled face plate. Such plates are commercially obtainable. The diagram of such a receiver as you discuss is printed on this page.

**Measuring Beats**

SUPPOSE the intermediate frequency of a superheterodyne is measured with a calibrated oscillator by observing the two points at which the same signal comes in, how accurate is the measurement? Let us assume that the accuracy of the calibration of the oscillator is 2 per cent.—W. G. H.

The difference between the two frequencies on the calibrated oscillator is equal to twice the intermediate frequency. If the calibrated oscillator is 2 per cent. accurate, one setting may be  $0.98F_1$  where  $F_1$  is the lower setting. The other may be  $1.02F_2$ , where  $F_2$  is the higher. The difference between  $F_2$  and  $F_1$  is  $2f$ , where  $f$  is the intermediate frequency. Let  $df$  be the error and let  $F$  be the signal frequency. The error then is  $df/f = 0.02F/f$ . If  $F$  is 550 kc and  $f$  is 175 kc, the error would be 6.3 per cent. This is the maximum. Of course, it is different for different values of frequencies. If the calibrated scale is linear, the percentage error, however, is about the same for other values of  $F$ . By the signal frequency  $F$  is meant the geometric mean of the two frequencies  $F_2$  and  $F_1$ , assumed to be correctly measured. Wherever a measured quantity depends on the difference between two other measured quantities, the percentage of error is large. For this reason this method is useful only when the difference is large. Suppose, for example, that the intermediate frequency is 465 instead of 175. The error then becomes 2.37 per cent. The absolute error, however, is the same in both instances.

**Secondary Emission**

AT WHAT VOLTAGE does secondary emission from the plate of a tube begin? I understand that it is a function of voltage entirely and that if the critical voltage is not exceeded there is no danger of secondary emission.—T. J. O'B.

There are several factors determining the voltage at which secondary emission begins. One is the condition of the plate, or rather (Continued on next page)

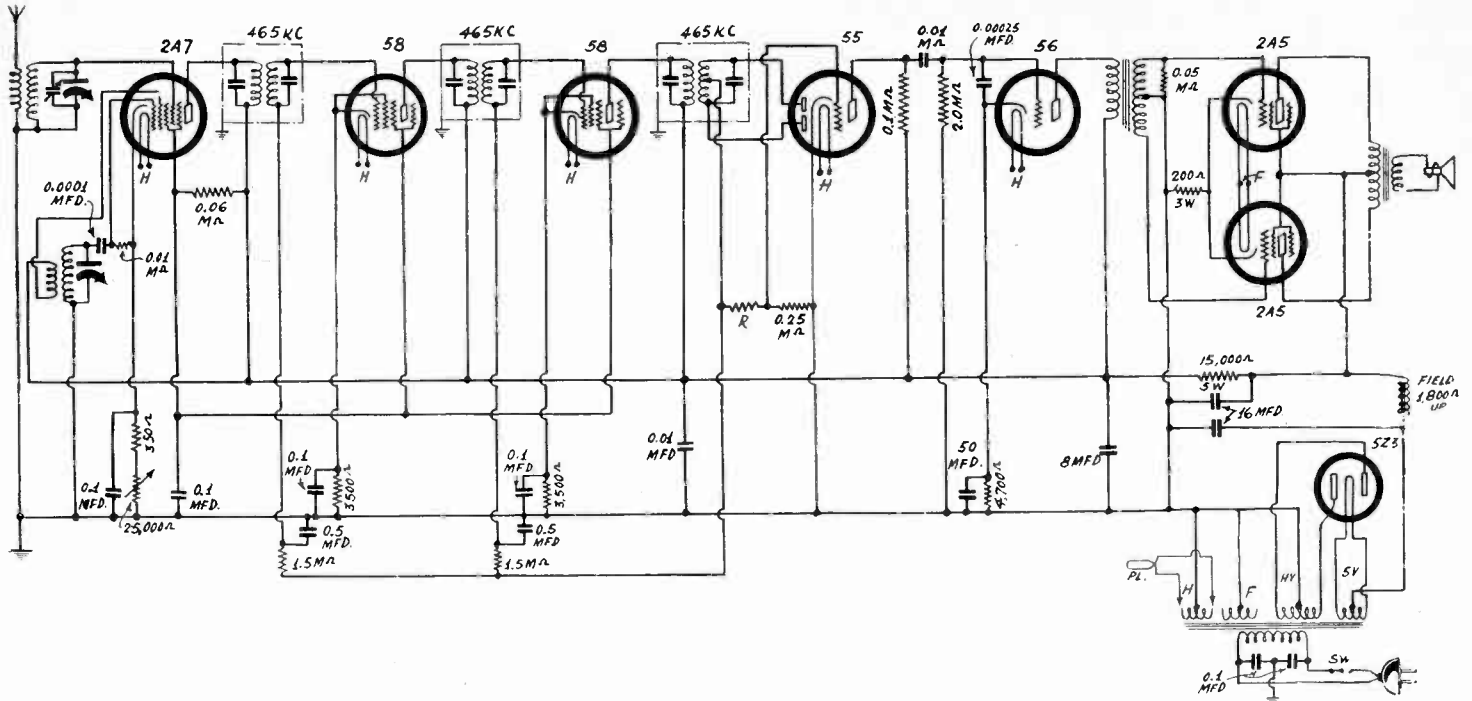

**A circuit of this type, a superheterodyne using a two-gang condenser, is satisfactory only if a very short aerial is used, say, not more than 10 feet of wire indoors, and provided also the intermediate amplifier is stabilized.**

(Continued from preceding page)  
of the surface of the plate. If the surface is clean—free of foreign substances, there should be no secondary emission. But it is obviously impossible to have a perfectly clean surface. About 20 volts is the practical limit, but, of course, at that low voltage there is very little secondary emission. The effects of secondary emission on higher voltages are eliminated by the suppressor grid which is placed near the plate. When that is present and the plate is positive with respect to the suppressor, electrons that are emitted by the plate cannot escape through the suppressor but fall back into the positive plate as fast as they are emitted. When the suppressor is not present and when it is not at low potential, say zero or slightly negative, the electrons emitted by the plate are attracted to the positive screen, and thus they will cause a reduction in the plate current, or an actual reversal of that current.

\* \* \*

**Two-Tuned Mixer Circuits**

KINDLY enlighten me regarding the following: Are two tuned circuits enough in a broadcast superheterodyne, for the mixer? Are they enough for short waves? Also, must I use three intermediate coils, for two i-f stages, or would two coils for one stage of such amplification be sufficient?—R. D. W.

A two-gang condenser is used in the circuit at top of this page, which is for broadcast reception, but there are two intermediate-

frequency stages (three i-f coils). If the antenna is very short, or a very small series antenna condenser is used though the aerial is long, passable results will be obtained. However, the circuit is not one that just can be put down in any location with the assurance that reception will be satisfactory. The usual practice with such a receiver if it is of the manufactured type is for the maker to supply a stranded, silk-insulated antenna wire, the customer being advised to let out as much wire as is necessary for loud enough signals, but not so much wire as to cause interference (birdies). When a very short antenna, or any antenna in conjunction with a series condenser of 20 to 50 mmfd., is used at broadcast frequencies, the natural period of the antenna is far higher than the highest frequency to which the set responds, and this may be cited as a purposeful instance of mismatching, to restrict the pickup and in that way indirectly increase the apparent selectivity. The two-gang-condenser tuning system for short waves is exceedingly attractive, because the introduction of t.r.f. renders difficult the sustaining of sensitivity above 10 mc. One factor is the output capacity of the tube, which is high. If, in respect for this large capacity, the primary inductance of an interstage coupler is made small, still the transfer is slight, as the tube circuit calls for a high inductance in the plate for effective transfer. It is a safe rule to follow, that two tuned stages will do for short waves, but scarcely will do for broadcast waves. As for the number of intermediate stages, one stage is sufficient for practically all purposes.

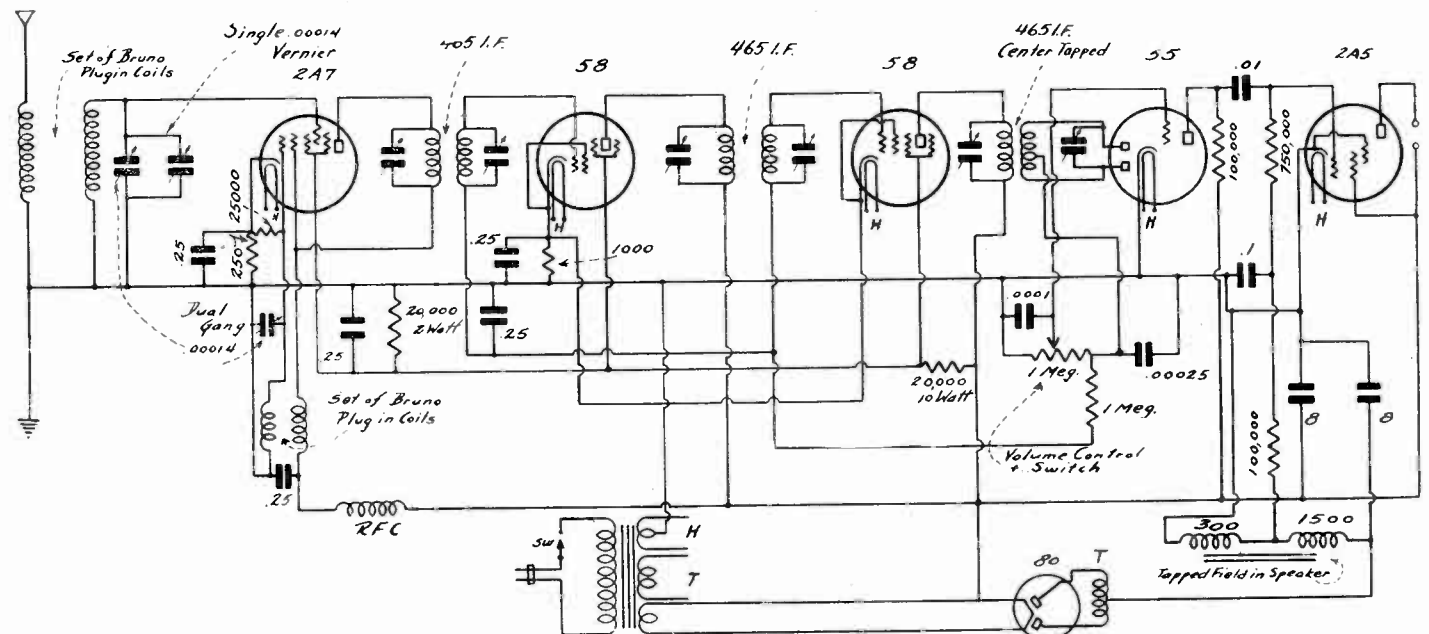

**A six-tube superheterodyne for short waves. This circuit also uses a two-gang condenser, but for short waves this is sufficient, if the aerial is short.**

# The Review

## Questions and Answers Based on Articles Printed in Last Week's Issue

### QUESTIONS

1. If a multi-wave tuning system uses the same capacity for tuning throughout the bands, and the frequency ratio is 3 to 1, how much greater is the crowding in the fourth or highest band than in the broadcast band?
2. If a condenser has a split stator, maximum capacity 500 mmfd., maximum capacity of the smaller sub-section 150 mmfd., how many maximum capacities are available, and what are they? Approximately what would be the frequency ratio of each when used with any given inductance?
3. If the capacity ratio is known, and it is desired to have an inductance to cover the next highest band of frequencies with the same condenser, what is the relationship between the second and the first inductance?
4. What is an advantage of using a condenser that rotates 270 degrees instead of 180 degrees?
5. What are two methods used for manually controlling volume by grid bias shifts?
6. What is an advantage of a blocking tube in a regenerative short-wave receiver? What is a disadvantage?
7. State two methods of effecting loose coupling between the antenna and the regenerative short-wave detector, the effect on regenerative action and discuss loose coupling in respect to calibration.
8. Give the effects of various values of grid leaks in a regenerative detector and state what limits the allowable capacity of the grid condenser when high leaks are used.
9. Is the sensitivity of a receiver determined by the amount of radio-frequency, intermediate-frequency or audio-frequency amplification, or any of these? State which and tell why.
10. To convert wavelength in meters to frequency in kilocycles, and frequency in kilocycles to wavelength in meters, what formula is used? Is the answer strictly correct, or is there a slight error? Why?
11. The velocity of a wave of 11.2 meters is 186,000 miles per second. What is the velocity of a wave of 22.4 meters? Is the answer the same if the weather conditions are different for the two waves?
12. If B voltage available is excessive for a particular tube, state two methods of reducing the voltage, and which method is preferable, and why.
13. For a high-powered set, is a second detector such as the 55 preferable to a 2B7 or 2A6. What are these tubes?
14. Is the inductance of leads used in wiring appreciable on very short waves, for instance at ultra frequencies, and is there a steady means of computing this inductance? If not, why not?
15. What is meant by the distortion factor? Can it be measured at audio frequencies? How does the distortion depend on the load resistance?

### ANSWERS

1. If the ratio is 3 to 1 in the broadcast band, the lowest frequency being 540 kc and the highest therefore 1,520, the difference is 980 kc. In the fourth or final band the frequencies would be 13,680 to 41,040 kc, a difference of 27,360 kc. The comparison of "crowding" is  $27,360/980$ , or 27.91. Hence, the crowding is nearly 28 times as bad in the fourth band.
2. If a condenser of 500 mmfd. has a stator split at 150 mmfd. the resultant maximum capacities are three: 500, 350 and 150 mmfd., which may be selected for use by switching. That is, the total is available separately, as are the larger and smaller divisions. The frequency ratios of tuning with any inductance would be: for 500 mmfd., 3.5; for 350 mmfd., 3; and for 150 mmfd., 2.2.
3. The lower inductance is related to the higher one by the capacity ratio of the tuning condenser. If this ratio, maximum capacity divided by minimum capacity, is 9, then the smaller inductance should be one-ninth of the larger.
4. Since a condenser that rotates 270 degrees has a displacement of one-half more than a 180-degree condenser, there is 50 per cent. better spread-out.
5. The two methods are: By varying the amount of resistance in the self-biasing resistor to B minus in cathode leg of the tube, and by grounding the cathode and varying the amount of resistance through which the rectifier current flows in the B minus leg.
6. An advantage of a blocking tube in a short-wave regenerative receiver is that the detector may be calibrated and the calibration not be disturbed by antenna conditions. A disadvantage is that since a fixed form of coupling or load is used in the antenna input, the circuit will be more sensitive at some radio frequencies than at others.
7. Two methods of effecting loose coupling between the antenna and the first tube are: (a) a small primary, distantly placed from the secondary; (b) a small series antenna condenser. The effect of both methods is to make the regenerative action keener. The loose coupling minimizes the detuning effects of the antenna, hence favors calibration systems.
8. The higher the grid leak resistance, the greater the sensitivity. However, if the leak is very high, of the order of megohms, and a relatively large grid condenser is used, audio oscillation may be produced, the grid-blocking modulation used in some oscillators. Hence, the capacity should be small, around 250 to 100 mmfd. Also, if the leak is large, and since the capacity then can not be comparatively large, selectivity will be lowered, especially at the higher frequencies of tuning in any band, because of inadequate bypassing of the high resistance.
9. The sensitivity of a receiver is determined by the amount of amplification generally, no matter at what level or levels the amplification takes place. This is true because the output compared to the input defines the sensitivity.
10. The number 300,000 is divided by either the wavelength in meters to produce frequency in kilocycles, or by frequency in kilocycles to produce wavelength in meters. This is not strictly accurate, but the error is only part part in 10,000. The speed of the wave is slightly less than 186,000 miles (or 300,000,000 meters) per second.
11. The velocity of a radio wave is the same for all frequencies and all weather conditions.
12. One way to reduce the B voltage on a tube is to insert a series resistor, so that the B current feeding the tube causes a voltage drop in the resistor, which resistor should be bypassed to cathode. Another way is to use a voltage divider, or resistance across the total B voltage, and take off a tap at the desired voltage value. The bleeder method is better because the B voltage then does not change much even when the signal is strong.
13. The 55 is preferable because it will

stand much greater triode input. The 55 is a double diode triode. The 2B7 is a double diode pentode and the 2A6 is a double diode high-mu triode. The use of the 2B7 or 2A7 is restricted to receivers providing small voltage input to detectors.

14. The inductance of the leads is appreciable at high frequencies, and at ultra frequencies there may be no other inductance to consider. To compute these inductances from the shape and length of the leads, however, is beyond practical possibility. The inductance of a short, straight length of wire quite isolated from other conductors can be computed easily. So can the inductance of a pair of parallel wires of given length and distance apart. In fact, the inductance of any regular arrangement of the conductors can be computed by well-known formulas. But it is seldom that the conductors are placed regularly so that they can be brought under the formulas. To reach short waves the best practice is to make the leads as short as possible and then hope that the interelectrode capacities are small.

15. The ratio of the sum of the squares of all the harmonic components except the fundamental to the square of the fundamental gives the square of the distortion factor. Thus the square root of this ratio is the factor. The sum of the squares is the square of the current that would be measured with an a-c milliammeter after the fundamental has been removed by filtering. The current measured with an a-c meter before the filtering would give the total. For small distortion this is not greatly different from the fundamental alone. In other words, the current measured when the fundamental has been removed divided by the distortion factor. The distortion is least when the optimum load resistance is used. At zero load the distortion is practically all second harmonic. It decreases rapidly as the load resistance is increased until a certain load value is reached, when it increases to high values. The third harmonic distortion begins to be considerable after the optimum load resistance has been exceeded.

## Stabilized Oscillator Enables Measurement of Receiver Sensitivities

The value of amplitude stability in a test oscillator is well illustrated in the use of the oscillator in conjunction with the determination of the sensitivities of a receiver at different radio frequencies. It is well known that receivers do not have constant sensitivity values over their ranges, though superheterodynes may come close to that achievement. Anyway, the problem is to find out.

When the stability is constant the output is constant at all the generated frequencies, therefore measurements of a tested circuit (say, a receiver) may be made for sensitivity at all frequencies to which the tested circuit responds, including harmonics of the test oscillator, for the input voltage is the same to the tested device for any and all fundamentals and for any equal order harmonics. Moreover, with constant output voltage from the test oscillator there will be a constant output current, and relatively constant impedance output may be taken from a simple potentiometer of relatively high resistance (50,000 ohms). Also, when high harmonics are used and large output desired, a low harmonic order is selected, and were not stability general, the relatively high fundamental used would be wobbly, hence the harmonic frequency would be uncertain, particularly as the higher the harmonic order, the greater the absolute deviation from the desired or expected frequency, due to multiplication of the fundamental's error or instability by the harmonic order.

It is also to be noted that when there is amplitude stability there is also frequency stability, a valuable asset the higher the frequencies tuned in.

# Station Sparks

By Alice Remsen

## BILL WHITLEY GETS A BREAK

"Airbreaks," the new program presided over by Ernest J. Cutting, has already "discovered" one promising young artist warranting more than one performance on this proving plant program. His name is Bill Whitley, and he is a baritone. Whitley sang on the first "Airbreaks" program, and although Cutting's idea was to present a new group of artists each week, he has decided to give a second "break" to those who earn it.

### RAY WITH EDDIE DUCHIN

Ray Heatherton, the handsome young singer, got his real start in radio when Paul Whiteman happened to hear him singing at a Long Island tavern. Paul asked the youngster to sing for him at an audition and Ray became vocalist with Paul's band. Ray has a new three-time-a-week commercial, Pepsodent, with Eddie Duchin's band. He also plays the lover in the "Castles in the Air" program, which has been changed to WJZ and network, twice weekly, Tuesdays and Thursdays at 10:15 a.m. . . . April 19th brings the first NBC reports of the Boston Marathon. There will be two broadcasts, the first at 11:45 a.m. covering the start and the second at 2:15 p.m. covering the finish. A number of other important racing events will be broadcast during the coming season, including the Kentucky Derby on May 5th, followed a week later by the equally famous Preakness. . . . Howard Phillips is getting a good break over the NBC networks, starred as the Romantic Troubador of the Mohawk Treasure Chest program, over an NBC-WEAF network each Tuesday and Thursday at 10:30 a.m. . . .

### AUDIENCE WOULDN'T LET HIM

Carlos Gardel, the young South American baritone, was homesick, so he tried to cancel his microphone appearances, but his air-audiences wouldn't let him, in fact, they objected to his departure so strenuously by letter, that Carlos canceled his sailing instead and stayed here to further delight his listeners with those langourous Argentine love songs. . . . Martha Mears, the newest NBC contralto star, gives credit to numerology for her success on the radio; her name was spelled Meers, but she changed it to Mears, the new vowel is supposed to give her financial success, and the old one just gave her artistic success, anyhow, Martha is lucky—she doesn't know how lucky—to crash the great radio doors of NBC in such a short time; surely this means that Lady Luck is riding with you, Miss Mears, and I hope she continues to do so. . . . Shirley Howard now has a long-term exclusive contract with the Molle program, on which she is featured with the Three Jesters, three times weekly. . . . Lillian Buckman, new NBC soloist, has a range of three octaves. Miss Buckman was with Columbia a few years ago. She is tall and stately and a real prima-donna type. . . . Jimmy Burdette, member of the NBC quartet in Chicago, was in the Navy band which helped to introduce "jazz" into England. The band played a two-hour "pop" concert in front of Buckingham Palace.

### JESSICA AND THE BOB

To bob or not to bob is the question which is now agitating the Jessica Dragonette fans. Jessica proposed bobbing her lovely long blond hair, but the fans object; that is, some do and some don't; but Jessica is not worrying; she'll probably bob it if she feels like it. Personally, I should think Jessica would be much better off without her long hair; she is such a small person, and hair takes away a lot of strength and energy; I'm speaking from experience. . . . Hollywood-on-the-Air has shifted its spot from Tuesdays to Mondays, midnight is the

time, over an NBC-WEAF network from the Coast. . . . The budding romance between Bradley Kincaid, the Mountain Boy, and Minnie the Stooze, of the Landt Trio and White's act, is developing rapidly. Bradley writes poems to Minnie, and Minnie vows undying love for Bradley. Of course, it's all in fun, as Minnie is really one of the Landt Boys speaking in a falsetto voice. . . . And now I find that Theodore Webb is the new Ipana Troubador, taking Ray Heatherton's place in the new line-up, with Fred Allen, Portland Hoffa and Lennie Hayton's orchestra, the two products, Ipana and Sal Hepatica, have merged into an hour's program, WEAF and network, each Wednesday night at 9:00 p.m. EST. . . . At last Gene and Glenn will be heard over an extensive NBC hook-up, including New York (WEAF) in an evening program; each week-day except Saturday, at 6:45 p.m. EST. Gene and Glenn, with Jake and Lena, the two laughable characters created by Gene Carroll, have been popular in the Middle-West for several years. They were heard in New York on an early morning broadcast for Quaker Oats a few years ago. The programs will emanate from the studios of WTAM, in Cleveland, and will be sponsored by the Gillette Razor Company. . . . The Madame Sylva spring series changes time. The famous beauty expert will now be heard each Friday afternoon at 5:00 p.m. EST., under the sponsorship of the Ralston Purina Company. . . . Jack Benny heads the cast for the new General Tire Series. He will be assisted by his wife, Mary Livingstone; Don Bestor and his orchestra, and a soloist to be selected. One half hour each week, Fridays at 10:30 p.m. NBC-WEAF network. . . . Emilio de Gorza, famous Spanish baritone, will be heard in a series of song recitals over an NBC-WJZ network, commencing Tuesday, April 10th, at 10:30 p.m. EST., and three consecutive Tuesdays thereafter, at the same hour. De Gorza, who is a Metropolitan Opera star, will be accompanied by Frank Black and the NBC Symphony Orchestra. . . . WABC announces that the Bard of Erin now has a regular schedule over the Columbia network; each Saturday evening at 8:45 p.m. EST. The Bard presents authentic Irish legends and folk songs, translated from the original Gaelic. . . . Commencing on April 15th, Wayne King will augment his present Lady Esther series over WABC with a Sunday broadcast at 10:00 p.m. EST. The Monday night programs will be continued as usual. . . . Congratulations are in order for Tom Neely, who has been named as Peter de Lima's successor, now the latter has been sent out to Los Angeles to supervise the CBS programs emanating from there. So Tom is the new assistant to Ralph Wonders, and I know of no one more competent to fill that position than Tom. Congrats and good luck! . . .

### WHY CUT IT OUT?

Among the programs closed down for the summer are Alexander Woolcott's "Town Crier" series, which I shall miss extremely; could always count on "Woolly" handing me a smile, or mayhap a tear—either one welcome from him; the Seven Star Revue closed April 1st; and Helen Morgan made her final bow on March 25th. The glamor-

### A THOUGHT FOR THE WEEK

CHARLES HANSON TOWNE is the latest columnist to join the ranks of radio. Mr. Towne, who is taking off enough time from his Hearst newspaper activities to do his Wednesday evening bit over station WNEW, is quite different from Edwin C. Hill or Alexander Woolcott, for he has a style of his own, and is neither so high brow that he is boring nor so low brow as to be common. Incidentally, one of these days we'll probably hear that a radio news commentator has turned newspaper columnist, thus reversing the usual order of things.

ous Helen is due shortly in California to make a picture. . . . A series of novel broadcasts has been arranged by Columbia engineers, cooperating with various communication companies, designed to illustrate the wonders of world-wide communication. The first program will be heard on April 5th, at 4:00 p.m. WABC and network. It will be entitled "Spanning the Globe," and should prove mighty interesting. Other dates and details will be announced later. . . . It is Jimmy Grier's Orchestra which is now heard with Bing Crosby on those programs from the Coast each Monday evening at 8:30 p.m. Grier is one of the Pacific Coast's foremost dance maestros. He replaced Carol Lofner and his band. . . . The Dramatic Guild has returned to the Columbia networks; Wednesday at 9:00 p.m. . . .

### NEW DRAMA ON THE AIR

And there is a new historical serial drama on CBS, "Peter the Great," which originates in the studios of KHJ, Los Angeles, and is heard every Saturday at 11:30 p.m., over WABC. The series is under the direction of that capable young man, Kenneth Niles. . . . On April 12th, the tenth anniversary of Station WLS, Chicago, will be celebrated, over a Coast to Coast NBC network, with a forty-five minute program. . . . One of the most popular programs at Station WSM, Nashville, Tennessee, is the "Slip-Up Court," Sunday nights at 10:30 p.m. It has a big cast, which includes 'Lasses an' Honey, the Vagabonds; The Waller Brothers; Ruth and Red; Freddie Rose, George D. Hay, who plays the solemn old judge; Tiny Stowe, who is the bailiff, and Freddie Russell as Stagnat, the village nitwit.

### THE INTERESTING AUXILIARIES

Adjuncts to radio receivers are always a subject of experimenting and production. "Selectifiers" or wave traps came first. Short-wave converters came six years later. Now devices to flash set-owners by a radio-controlled light system if big news is to be sent, and methods of counting the listeners and getting their votes on programs by pushing buttons on a set are being tried.

## SUBSCRIBE NOW!

York City. Enclosed please find my remittance for subscription for RADIO WORLD, one copy each week for specified period.

- \$10.00 for two years, 104 issues.
- \$6 for one year, 52 issues.
- \$3 for six months, 26 issues.
- \$1.50 for three months, 13 issues.
- \$1.00 extra per year for foreign postage.
- This is a renewal of an existing mail subscription (Check off if true)

Your name.....

Address.....

City.....

# TRADIOGRAMS

By J. Murray Barron

The General Electric Company has announced three new model sets. One is a six-tube superheterodyne table model receiver, with a tuning range of 540 to 2,800 kc. The tuning dial is calibrated accurately. The receiver has a maximum undistorted output of 1 3/4 watts. Another is a deluxe radio phonograph combination composed of a twelve-tube superheterodyne receiver and an automatic record-changing phonograph of improved design. The tuning range is from 540 to 2,800 kc.

The third, 6 1/2 inches high, 9 5/8 inches wide, and 4 5/8 inches deep, and weighing only 1/2 pounds, is a "personal" universal set, 540 to 1,710 kc.

General Electric Company has a dual-purpose receiver designed to adapt itself to almost any transitory conditions. This new receiver will operate from an automobile battery or from the usual 110-volt, 60-cycle household current. The B-battery eliminator is of the sealed vibrator type. With its five-tube superheterodyne circuit the receiver has a dynamic speaker, tone control, automatic volume control, airplane-type illuminated dial, silent tuning, and noise suppression. The set is not fixed in an automobile and can be moved into any desired position.

A new photo-electric relay for general industrial use and much lower priced than former light-operated relays of comparable reliability is announced by the Westinghouse Electric & Manufacturing Company. The heavy-duty contactor in the new "LE" relay interrupts 20 amperes, 115 volt a.c. non-inductive load or 3 amperes, 115 volt d.c. In such applications as counting, the operating speed is extremely fast, ranging from 200 to 600 objects per minute depending upon the amount of light change available and the resistance of the contacts.

Bud Radio, Inc., 1923 East Fifty-fifth Street, Cleveland, O., has developed an Easy

Starting Screw Holder which enables the serviceman to insert screws with ease. There have been screw-starting tools on the market but they have all been higher in price.

The 1933 receiver sales increased nearly 50 per cent. over 1932. The percentage gain is being maintained for the second quarter of 1934, having been at least equalled during the first quarter. The dollar volume is up nearly 15 per cent., 1933 against 1932. Auto sets showed the biggest 1932 rise, midsets were still most numerous, and all-wave and short-wave table and console models advanced.

A new battery-operated all-wave receiver is announced by the Philco Radio & Television Corp. The new set, Model 34, is furnished in two cabinet styles, baby grand and lowboy. All-wave reception has been provided. A tuning range of from 530-22,000 kc is divided into four bands. Model 34 Philco is provided with a heavy duty combination B and C dry battery and, at the purchaser's option, with either a heavy-duty new type dry A battery or a heavy-duty Philco storage A batter. The heavy-duty B and C unit uses a quick-change plug-in connection which makes it impossible to connect the battery wrongly. Class B audio is used.

The annual May Convention for Philco Radio distributors will be held aboard the new turbo-electric liner Queen of Bermuda, leaving New York on May 15th and bound for Bermuda and Nassau. The entire liner will be occupied by the 600 distributors and salesmen from all over the country. It has been a practice most every year for the Philco Company to conduct its annual convention aboard ship in order to provide its distributors with relaxation as well as information as to its advertising and sales plans for the new radio season. The announcement of this year's cruise states that special arrangements are being completed to make this the outstanding cruise in Philco's history.

The New York Chapter of the International Short-Wave Club, which meets every other Friday at the Stuyvesant High

School, Fifteenth Street and First Avenue, New York City, announces that the meeting scheduled for April 20th at 8 p. m., will have as speakers F. M. Coperthwait, of the Weston Electrical Instrument Corp., who will speak on sensitive relays and the new camera-exposure meters, and V. E. Jenkins, who will speak on small instruments associated with radio.

With the advent of Spring we notice an increase in interest in motor car radio. The serviceman who has not made his contact with the manufacturer should realize that the real fine weather will soon be with us, and he should be ready for the business.

## Short-Wave Switches Announced by C.R.C.

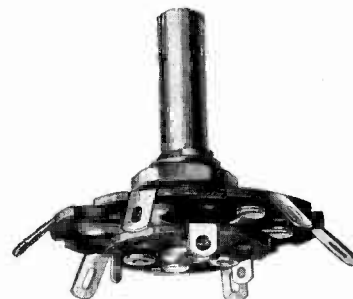

The Single-Pole C.R.C. Switch

A small short-wave switch is now being made by C. R. C., Incorporated, at Beloit, Wisconsin (Central Radio Corporation).

Heavy silver-plated wiping contacts, positive indexing action, low contact resistance, noiseless operation, low capacity between circuits and to ground, and single-hole mounting are among the important features.

Any circuit combination from single-pole, twelve-position to four-pole three-position can be furnished.

This article is being added to the corporation's line of tube sockets.

C. R. C. also announces an all-wave switch, diameter 1 9/16 inches, single 3/8 inch hole mounting; the indexing mechanism prevents stopping between positions; biting contact with 1/1000 ohm resistance. This switch can be built up to as many sections as desired, each section being an independent unit allowing any switching combination from eleven position single pole to two position six pole, including combinations.

See page 16 for this switch.

## Paley Sends Congratulations on Twelfth Anniversary

I congratulate RADIO WORLD on the celebration of its twelfth anniversary. A dozen years in the history of radio is comparable to double or triple that time in the life of any other important industry, and I am happy to send a word of greeting on so significant a birthday anniversary.

Broadcasting has been particularly fortunate in its progress throughout the trying years of the depression, and all indications point to continued improvement in conditions in the radio industry. I trust that RADIO WORLD will share both in the larger field of service and the resultant benefits.

WILLIAM S. PALEY, President Columbia Broadcasting System.

## CORPORATE ACTIVITIES

### FINANCIAL REPORTS

Weston Electrical Instruments Corp.—Net loss for year 1933, after deduction of depreciation, taxes and other charges, \$24,369. For 1932 the net loss was \$153,353. For the quarter ended December 31, 1933: Net profit, after same charges, \$45,696, which, after dividend requirements on 34,800 class A shares, equals 17 cents a share on 160,583 no par common shares, as compared with a net loss of \$9,120 in preceding quarter, and \$14,114 loss in quarter ending Dec. 31, 1932.

# Two Almost for the price of One

Radio World is \$4.00 a year (52 issues). Read the following Combination Offers for Radio World and other worth-while publications for one full year on each offer.

- RADIO WORLD and POPULAR SCIENCE MONTHLY \$6.50.
- RADIO WORLD and RADIO-CRAFT (monthly, 12 issues) \$6.50.
- RADIO WORLD and RADIO INDEX (monthly, 10 issues), stations, programs, etc., \$6.35.
- RADIO WORLD and RADIO (monthly, 12 issues; Short Wave and Experimental) \$6.60.
- RADIO WORLD and EVERYDAY SCIENCE AND MECHANICS (monthly) \$6.50.
- RADIO WORLD and RADIO LOG AND LORE. Bi-monthly; 5 issues. Full station lists, cross indexed, etc., \$6.25.
- RADIO WORLD and AMERICAN BOY — YOUTH'S COMPANION (monthly, 12 issues; popular magazine) \$6.50.
- RADIO WORLD and BOYS' LIFE (monthly, 12 issues) \$6.50.
- RADIO WORLD and MOTION PICTURE MAGAZINE (monthly) \$6.50.
- RADIO WORLD and MOVIE CLASSIC (monthly) \$6.25.
- RADIO WORLD and SCREENLAND (monthly) \$6.50.
- RADIO WORLD and SILVER SCREEN (monthly) \$6.25.
- RADIO WORLD and THE PATHFINDER (weekly) \$6.25.
- RADIO WORLD and TRUE STORY (monthly) \$6.50.
- RADIO WORLD and LIBERTY (weekly) \$6.50.

Select any one of these magazines and get it for an entire year by sending in a year's subscription for RADIO WORLD at the regular price, \$6.00 plus a small additional amount, per quotations above. Put a cross in the square next to the magazine of your choice, in the above list, fill out the coupon below, and mail the quoted price by check, money order or stamps to RADIO WORLD, 145 West 45th Street, New York, N. Y. (Add \$1.50 for extra foreign or Canadian postage for both publications.)

Your Name.....

Your Street Address.....

City..... State.....

- If renewing an existing or expiring subscription for RADIO WORLD, please put a cross in square at beginning of this sentence.
- If renewing an existing or expiring subscription for other magazines, please put a cross in square at the beginning of this sentence.

RADIO WORLD, 145 West 45th Street, New York. (Just East of Broadway)

DOUBLE  
VALUE!

## Matched Condenser and Coils for Dual-Band Tuning

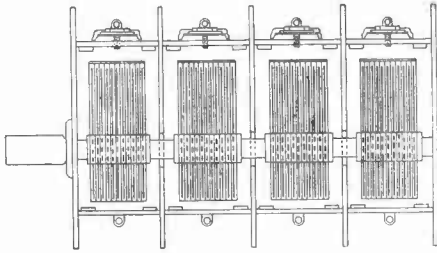

A four-gang tuning condenser of the semi-precision type. Small in size, exact in adjustment and construction for precise tuning, it ranges in capacity from 18 to 406 mmfd. Was built-in trimmers, 8 to 35 mmfd. With standard coils intended to be tuned with a 0.00035 to capacitance, this condenser will cover the band from 200 to 600 meters. The sections are separated by half shields, while a shield as high as the maximum height of the rotor plates is at each end. The rotors are turned by a common shaft,  $\frac{1}{8}$ " diameter which is mounted on ball bearings. Condenser closes to the left and is equipped with mounting spades. Overall size 5x3 $\frac{1}{2}$ x2 $\frac{1}{2}$  inches (not including shaft for dial in measurement). Noted for its extreme compactness. 4-gang condenser Cat. No. 48G @.....\$2.95  
Set of four shielded coils for this condenser, for 485 kc super, includes three r-f and oscillator coil. Tapped for police calls. DLC.....\$1.50

**RELIABLE RADIO COMPANY**  
145 WEST 45TH STREET NEW YORK CITY

## F & H Capacity Aerial Eliminator



Completely Eliminates Aerial—Fully Concealed Within Receiver

Produces results equal to regular 75 ft. aerial 50 ft. high. Each instrument factory tested on actual 1127 mile reception. Chosen by U. S. Government Navy Hospital for their numerous bed-side radio installations. Attached by anyone in a moment's time. Radio can then be moved from place to place as easily as a piece of furniture. Adapted for AO Sets only. Nationally Advertised List Price \$1.

Net Cost, Each - 60c

An attractive Colored Counter display furnished with each order for a carton of six.

Per Carton of Six - \$3.60

**RELIABLE RADIO CO.**

145 West 45th Street  
New York, N. Y.

## "JIFFY 3" Short Wave Set

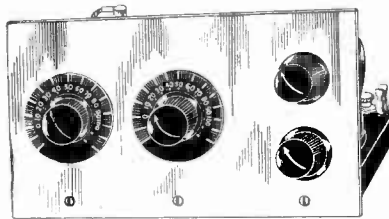

### Worldwide Earphone Reception

3 Tube self-containing BAKELITE base RESISTANCE COUPLED thru-out so that it can be ASSEMBLED in a JIFFY. Almost no wiring needed. Wonder set for amateurs and experimenters. 2-30's and a 32; the latter tube controls both regeneration and

detection. Smooth, clear, quiet performance assured. Offering complete BAND-SPREAD TUNING and LOW CURRENT drain.

**KIT** including 4 short wave coils wired, \$7.75; tubes extra, \$1.50. **\$6.25**

We welcome inquiries and comparison.

Leotone Radio Company 63 Dey St. New York City

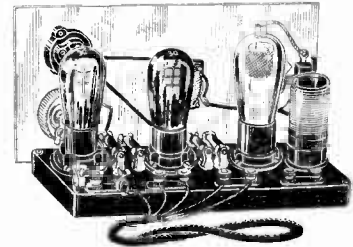

## Receivers and Oscillators Calibrated!

Any receiver, any oscillator, any frequency range or ranges, calibrated to an accuracy of 0.5 per cent., and the results expressed in quickly-readable charts. Broadcast, short-wave, all-wave receivers, ultra-frequency receivers and oscillators, Barkhausen Kurz oscillators, Gill-Morell oscillators, super-regenerators, and anything else.

Price, \$2 for one band for a 20-point complete curve. Three bands for \$5. Four bands for \$4.50. Five bands for \$5. Prompt service.

**Reliable Radio Company**  
145 WEST 45TH STREET  
NEW YORK, N. Y.

## Vest Pocket Size Flashlight for Radio Repair Work—FREE

Great for getting right down into your set!

Obtain one free with 3 months' subscription for Radio World at the regular rate of \$1.50. Send postpaid.

Sub. Dept.  
**RADIO WORLD**  
145 West 45th Street New York, N. Y.

## A COMBINATION OFFER! RADIO WORLD and "RADIO NEWS" \$7.00

Canadian and Foreign, \$1.50 extra.

You can obtain the two leading radio technical magazines that cater to experimenters, service men and students, the first national radio weekly and the leading monthly for one year each, at a saving of \$1.50. The regular mail subscription rate for Radio World for one year (52 weeks), is \$6.00. Send in \$1.00 extra, get "Radio News" also for a year—a new issue each month for twelve months. Total 64 issues for \$7.00.

RADIO WORLD, 145 West 45th Street, New York, N. Y.

## Quick-Action Classified Advertisements

7c a Word—\$1.00 Minimum

**YOUNG MAN 26 YEARS OF AGE, R.C.A. Institutes, Inc., and Capitol Radio Engineering Institute, Inc., graduate, desires moderate position as assistant in either Radio Laboratory or Radio Service Shop; has done some experimental work at home and speaks and writes Spanish correctively. Write Michael A. Alvarado, 322 W. 113th St., New York City.**

**YOUNG MAN WOULD LIKE POSITION** as assistant in Radio or Electrical Laboratory or Radio Service Shop. Two years electrical school education. Attended Milwaukee School of Engineering. E. Reckentine, 703 Union St., Rome, N. Y.

**MODERN TUBE INDEX**, all tubes, all the dope, all manufacturers, socket connections, everything. Most complete of all. Sheet 21 x 27 inches. Price 25c. RADIO WORLD, 145 West 45th Street, New York, N. Y.

**"INVENTIONS, PATENTS AND TRADE-MARKS,"** by Milton Wright, Attorney and Counselor-at-Law. How to make your inventions pay—how to secure the utmost in legal protection. Second Edition, 310 pages. Price, \$2.50. RADIO WORLD, 143 West 45th St., New York City.

**"THE RADIO HANDBOOK,"** including Television and Sound Motion Pictures. By James A. Moyer and John F. Wostrel, both of the Massachusetts Department of Education. For engineers, designers, operators, service men, experimenters. 886 pages, 650 illustrations, flexible. Price, \$5.00. RADIO WORLD, 143 West 45th St., New York City.

**"SWOOP'S LESSONS IN PRACTICAL ELECTRICITY,"** 17th Edition, Revised by Erich Hausmann, E.E., Sc.D. Requires no previous technical knowledge; fully explains every question about the entire subject of electricity. New chapters on vacuum tubes, telegraphy, telephony and radio signalling. 709 pages, 542 illustrations, 5 $\frac{1}{4}$  x 8, Cloth, \$2.50. Radio World, 145 W. 45th St., New York, N. Y.

## Selected Quality Tubes FREE With Subscriptions for Radio World

Here is your opportunity to subscribe for RADIO WORLD and get just the tube or tubes you want, made by a very large, reliable, licensed tube manufacturer; picked tubes you'll appreciate. On this offer you have five days after receipt to put the tube to any logical test, and if not entirely satisfied with its performance, return it for replacement.

For an 8-week subscription (8 issues, one each week), at the regular price, \$1.00, you may select any one of the following tubes as free premium, or more at the same rate (\$2, 16-weeks subscription for two tubes, etc.), from this particular list: 01A, 01AA, IV, 12Z3, 112A, 24A, 26, 27, 30, 31, 35, 36, 37, 38, 39, 45, 47, 51, 56, 71A, 80, 82.

With a 13-week subscription (13 issues), at the regular price, \$1.50, any one of the following tubes, or more at the same rate, from this particular list (two for a 26-week \$3.00 subscription, three for 39-week \$4.50 subscription, four for 52-week, yearly \$6.00 subscription, etc.), 1A6, 5Z3, 2A5, 2A6, 2A7, 2B7, 6A4, 6A7, 6B7, 6F7, 25Z5, 22, 32, 33, 34, 41, 42, 44, 46, 49, 53, 55, 57, 58, 59, 67, 75, 77, 78, 83, 83V, 84, (6Z4), 85, 89, 483, 485.

For a \$4.00 subscription, 34 weeks (34 issues), one No. 10 tube or one No. 50 tube may be obtained.

You may select any assortment of tubes desired and send in a subscription amount for the total required under the above classifications.

Obtain one free with 3 months' subscription for Radio World at the regular rate of \$1.50. Send postpaid.

Sub. Dept.  
**RADIO WORLD**  
145 West 45th Street New York, N. Y.

# Power Transformer for a BIG SET

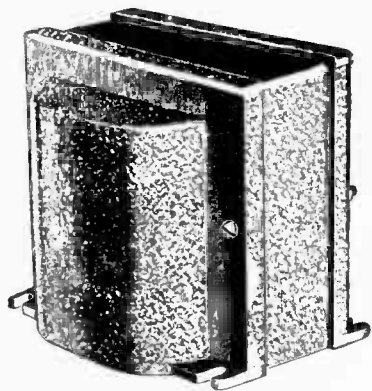

**I**NSTEAD of using undersized, overheating, inefficient power transformers for a big set, why not use a cool-running, efficient transformer and pay the little extra? The Reliable transformer, Model 104-SP, will work an 18-tube set. Provides also the voltage for a 2Z5 rectifier.

- Primary = 115 v., 60 cycles
- Secondary X = 14 amp., 2½ v., ct.
- Secondary Y = 6 amp., 2½ v., ct.
- Secondary R = 5 v., ct.
- Secondary HV = 400-0-400 v., 200 ma.
- Secondary Z = 25 v., 0.6 ma.
- Lug terminals at bottom
- Price, \$3.95
- Shipping weight, 13 lbs.
- Immediate Delivery

**RELIABLE RADIO CO.**  
145 W. 45th St., New York, N. Y.

## SOLDERING IRON FREE!

Works on 110-120 volts AC or DC, power, 50 watts. A serviceable iron, with copper tip, 5 ft. cable and male plug. Send \$1.50 for 13 weeks' subscription for Radio World and get these free! Please state if you are renewing existing subscription.

**RADIO WORLD**  
145 West 45th St. N. Y. City

## Subscribers! Important!

Note subscription expiration date on wrapper containing your copy of RADIO WORLD. If nearing expiration date, please send in renewal so that you will not miss any copies. Subscription Dept., RADIO WORLD, 145 W. 45th St., New York City.

## 'Radio Broadcast Stations in the United States' (Edition January 1, 1934)

Prepared by the Federal Radio Commission. 70 pages and paper cover. Contents: Full data on U. S. broadcast stations (a) alphabetically by call letters, (b) by frequencies, and (c) alphabetically by zones and States. Three listings in one volume. Official government document. Send 10 cents for a copy. List of corrections and amendments in March 31st issue of Radio World, 15c extra.

**RADIO WORLD,**  
145 West 45th Street, New York, N. Y.  
Enclosed please find 10 cents, for which please send a copy of "Radio Broadcast Stations in the United States" (January, 1934, edition).  
Enclosed please find 25c, for which send the station list with March 31st issue of Radio World containing the corrections and alterations in the list for the first quarter of 1934.

NAME .....  
ADDRESS .....  
CITY ..... STATE .....

## Select the Gift You Want from An Inviting Array!

### Kit for One-Tube Short-Wave Set

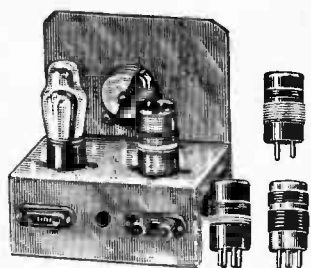
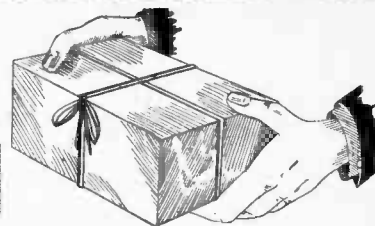

**A**MID the present furor over direct reception of short-wave foreign stations you don't want to be left, nor need you be, for a one-tube set will give you results that will amaze you. We offer the complete kit of parts for a one-tube battery-operated receiver (less 30 tube, less batteries, less earphones), and give you a clear wiring diagram, and at the same time welcome you to our list of yearly subscribers, whereby you will get in RADIO WORLD the short-wave data, including frequent station lists, that will enable you to improve your tuning technique and glory in thrilling foreign-station "catches." Coverage, 13 to 200 meters. Here's what your gift will consist of:

- One punched chassis metal.
- One punched metal front panel.
- Four small-diameter plug-in coils (not the large ones shown below).
- One 50,000-ohm potentiometer.
- One 10-ohm rheostat.
- One switch.
- One 0.0005 mfd. fixed condenser.
- One output binding post assembly (for phones).
- One battery cable.
- One dial.
- Two knobs.
- One tube socket.
- One coil socket.
- One Hammarlund 0.00014 mfd. tuning condenser.
- One 0.0001 mfd. grid condenser.
- One 5.0-meg. leak.
- One 0.0001 mfd. adjustable series antenna condenser (adjust with screw-driver at rear for keenest response once on each hand).

(Two ½-volt dry cells, 10c type, 22.5-volt B battery, 30-tube and phones not supplied.)

Order PR-SCK and remit \$6.00 for one full year's subscription (52 issues, one each week) and kit of parts will be shipped promptly, small transportation charge collect.

For the expert short-wave enthusiast precision type plug-in coils, wound on special forms, of special silver ribbon wire, prove valuable. Coverage, 12 to 200 meters, using 0.00014 mfd.

The four-prong coils illustrated reveal the special precaution of ribbed forms, so that the wire will touch only a minimum amount of the form, to reduce losses to a minimum. Diameter, 1.25 inches. Order PR-FPBC and send \$4.00 for a 33-week subscription for RADIO WORLD. Postage prepaid.

### DE-LUXE SHORT-WAVE PLUG-IN COILS

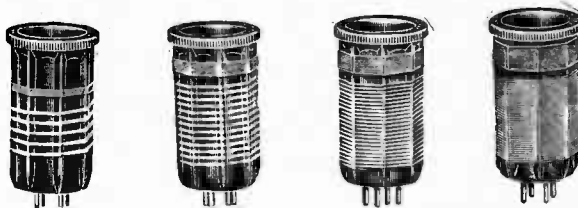

Often an expert short-wave set constructor or operator desires precision coils for use as interstage couplers to a regenerative detector. It has been found by vast experimenting that the three-winding coil is far superior for this purpose than the two-winding coil with any of the makeshifts, like choke and stopping condenser. We offer a set of four 6-prong, 1.25-inch diam. coils (otherwise same as the four-prong illustrated at left). Ask for PRE-SPBC and send \$6.00 for a full year's subscription (52 issues, one each week). Mailed postage prepaid.

The precision type, silver-ribbon-wound plug-in coils are obtainable as gifts in either the four-prong or six-prong varieties.

#### SPECIAL!

Both sets of coils (four 4-prong and four 6-prong) free with a \$9 subscription, 78 issues. Order PRE-FPSPBC.

### DUAL-BAND TUNING UNIT

**F**OR broadcast reception, plus coverage to higher than 4,000 kc, thus yielding a total span of 540 to higher than 4,000 kc. We have an exceptionally precise combination, consisting of three r-f coils, one of which is used as antenna coupler, and one oscillator coil, also the necessary four-gang condenser and the correct padding condenser (Hammarlund adjustable type). The tuning coils for the r-f level have secondaries tapped so that the condenser stator may be switched from full inductance to just enough inductance to pick up the broadcast band where the full inductance left off. The oscillator coil is appropriately tapped, also, for this purpose. A four-pole, double-throw switch would be required (not furnished). Coils aluminum shielded, 2-1/16" outside shield diameter by 2.5 inches high. The four-gang condenser is very compact (5 x 2.25 x 2.75 inches). All material is specially made for this premium offer and is of highest calibre.

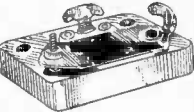

Order Cat. PR-BCTU-465 for use with 465 kc intermediates, and enclose \$7 for 14-month subscription (60 issues, one each week), and four-gang condenser, four coils, and 350-450 mmfd. padding condenser, but no switch, will be sent, small transportation charges collect. Same as above, same terms, except oscillator is for 175 kc and padder is 850-1,350 mmfd. Order PR-BCTU-175.

#### WHAT RADIO WORLD IS

RADIO WORLD, now in its thirteenth year, offers the super advantage of very latest news of circuits, tubes and station lists, covering ultra frequencies, short waves and broadcast waves. RADIO WORLD is written and edited by experts whose daily laboratory work is reported in the authentic columns of this first and only national radio technical service. Knowledge gained from RADIO WORLD enables you to improve the performance of the sets you build or repair. Subscribe now!

**RADIO WORLD, 145 WEST 45th STREET, NEW YORK, N. Y.**

## LAPEL MICROPHONE

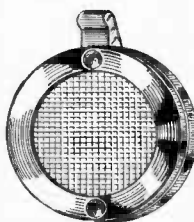

A single-button carbon-granule lapel microphone, impedance 200 ohms, requiring 4.5-volt excitation, of good frequency characteristics, and both handy and inconspicuous. Outside diameter, 1¾ inches. The case is chromium-plated brass. The excitation may be provided by introducing the microphone in a cathode circuit carrying around 20 to 25 milliamperes, or a 4.5-volt C biasing battery may be used. Net price, \$2.95.

**RELIABLE RADIO COMPANY**  
145 West 45th Street, New York, N. Y.

## NEW EDITION (1934) "THE RADIO AMATEUR'S HANDBOOK"

published by the American Radio Relay League, just out (eleventh edition). Almost completely rewritten and re-illustrated. Changes in technique introduced during 1933 fully covered. Several chapters entirely new.

PRICE, \$1.00, POSTPAID  
RADIO WORLD, 145 West 45th Street, New York, N. Y.

### BOOKS AT A PRICE

"The Superheterodyne," by J. E. Anderson and Herman Bernard. A treatise on the theory and practice of the outstanding circuit of the day. Special problems of superheterodynes treated authoritatively. Per copy. (Cat. AB-5H), postpaid...25c  
"Foothold on Radio," by Anderson and Bernard. A simple and elementary exposition of how broadcasting is conducted, with some receiver circuits and an explanation of their functioning. (Cat. AB-FH), postpaid .....25c  
**HENNESSY RADIO PUBLS. CORP.**  
15 45th St. N. Y.