

JAN. 3  
1931

All-Wave Screen Grid Converter

15 Cents  
Per  
Copy

# RADIO

REG. U.S. PAT. OFF.

# WORLD

The First and Only National Radio Weekly

458th Consecutive Issue—NINTH YEAR

SHORT-WAVE  
TROUBLE-SHOOTING

RESISTANCE AUDIO  
WITH SG TUBES

DIAGRAMS OF NEW  
MAJESTIC SUPER, ALSO  
WESTINGHOUSE TRF SET

## A \$25 MIDGET RECEIVER

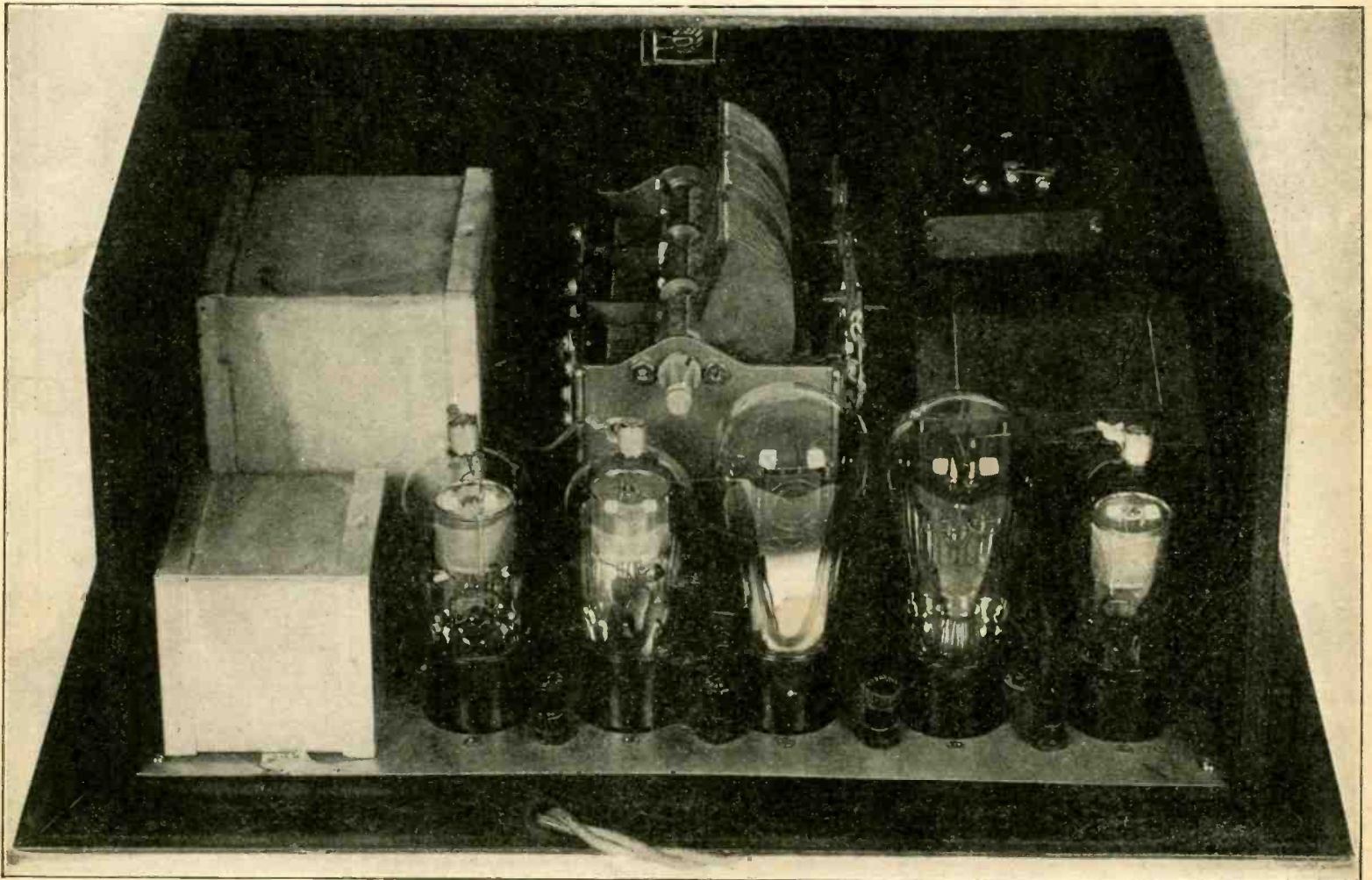

Built into a shielding steel cabinet, of parts costing less than \$25, this screen grid TRF set gave excellent results, tone quality being especially fine.

RADIO WORLD, Published by Hennessy Radio Publications Corporation, Roland Burke Hennessy, editor; Herman Bernard, managing editor and business manager, all of 145 West 45th Street, New York, N. Y.

# RADIO'S GREATEST BARGAINS

**THIS** month we are offering a great variety of battery sets at such ridiculously low prices that they cannot fail to astonish you. These sets are so-called store demonstration models and are not sold as brand new. However, all sets have been carefully tested and put into good shape and we guarantee them to be in good working order. All other merchandise listed on this page is brand new and is shipped in

original factory sealed cartons and carries the same guarantee of absolute satisfaction. Act immediately as the supply is limited and we reserve the right to return remittances as soon as items are sold out. In many instances, our sale prices are lower than the actual manufacturer's cost. For terms, see bottom boxes.

## Radiola 25 Superheterodyne



The "25" is a loop-operated set requiring 6 "X-199" tubes. No outside aerial is needed. The receiver has "10-ke selectivity. Tuning of this receiver is accomplished through large "thumb-operated" tuning drums, so designed that stations may be "logged" directly on the drums. The small center knob controls a multiple contact switch which changes the circuit to include one or two stages of A.F. A two-tone mahogany veneer cabinet of original pattern houses the chassis and batteries. Its overall dimensions are 28x19x12 inches high. Shipping weight, 55 lbs. List Price \$265.00. **YOUR SPECIAL PRICE ..... \$10.95**

## Radiola 28 Superheterodyne



is a "Second Harmonic" superheterodyne. However, the circuit of the "28" includes 7 type X199 tubes and 1 type X120 tube. The Radiola 28 includes 3 S.L.F. condensers, 2 1-m. safety lamp by-pass condensers; center-tapped loop (necessitated by the stage of neutralized R.F.); 1 off-on switch; 2 filament rheostats; 1 4-coil R.F. inductance; 2 jacks; and the special 8-socket "catcomb" containing the I.F., R.F. and A.F. transformers. Coast to coast reception is a rather usual accomplishment! Uses 2 drum dials—space for station logging thereon. Many easy ways of electrifying this receiver. Revolving loop—greatly assists tuning. Access to battery compartment obtained by raising receiver on hinge. The mahogany cabinet imitates a secretary. List Price \$295.00. **YOUR SPECIAL PRICE ..... \$24.95**

## Radiola Superhet. AR-812



One of the most famous radio sets in America. This set placed on a table, the battery switch turned to "on," and music will be heard—without an outdoor antenna; it works with a loop aerial built inside the cabinet. The set is super-sensitive and, in certain localities, it is possible, on the east coast, to hear west coast stations. The cabinet holds all the batteries for the six "dry-cell" tubes required. Some experimenters tune in short wave stations and use the AR-812 as the INTERMEDIATE FREQUENCY AMPLIFIER. In that way the tremendous amplification obtainable from this receiver is used to the fullest extent. A push-pull switch (center) turns the set on and off; another, (lower left) cuts in either one or two stages of A.F. amplification. Although the cabinet is 35 inches long, 11 1/2 deep and 17 1/2 high, the panel of the receiver is only 19 inches long and 9 inches high. The difference lies in the two end compartments for "A" and "B" batteries. Six type UV199 tubes are required for this receiver. Dry-cell power tubes, the type "20," may be used in this set if a Naald or similar adapter is used. Shipping weight 45 lbs. List Price \$220.00. **YOUR SPECIAL PRICE ..... \$10.95**

## The Radiola 20



Two stages of tuned frequency amplification, a regenerative detector, and two stages of A.F. amplification, using 4 type X-199 tubes and a X-120 for the last audio stage, is the arrangement of this receiver. The A.F. transformers used in this set are perfectly designed for the required performance. Heavy, soft iron encases the windings, and the frequency characteristic is exceptionally good. Cabinet is mahogany. Overall dimensions are: 19x16x11 inches high. Shipping weight 35 lbs. List Price \$102.50. **YOUR SPECIAL PRICE ..... \$12.50**

## Stromberg-Carlson 523



This fine set uses 4 201A and 1 200A tubes. The cabinet is one of the finest ever made for radio sets. A standing, beautifully grained wooden panel carries the tuning es-cutechons. The panel controls include a "Long-Short Antenna" switch; 3-ohm and 20-ohm rheostats; "On-Off" snap switch; audio output jack; and a Weston 0-7 voltmeter. The jack on the panel is for phonograph pickup. A neutrodyne circuit is used. 26 long x 14 deep x 13 inches high. Shipping weight 75 lbs. List Price \$160.00. **YOUR SPECIAL PRICE ..... \$24.95**

## Utah Dynamic A.C. Power Speaker—Model 33A



110-volt, 60-cycle A.C. light socket supply for field excitation with Westinghouse dry rectifier. 9 in. high, 9 1/2 in. wide, 7 1/2 in. deep. Speaker comes packed in wooden crate. Weight 19 lbs. It is one of the most powerful as well as best reproducers in the market. 9-inch cone. List Price \$50.00. **YOUR SPECIAL PRICE ..... \$7.50**

## A.C. Phonograph Motor



SYNCHRONOUS—revolves EXACTLY 30 turns per minute despite any voltage variations. Most compact made—only 1 1/4 in. thick—mounts in any limited space. For 110 volt, 60 cycle, A.C. Complete with turntable. Shipping wt. 10 lbs. List Price \$15.00. **YOUR SPECIAL PRICE ..... \$4.25**

## 245 A.C. Power Transformer



For five 224 (or five 227), two 245, one 380 A.C. tubes, OR ANY COMBINATIONS OF 2 1/2-VOLT TUBES. All secondary windings CENTER TAPPED. 600-VOLT HIGH VOLTAGE SECONDARY. 75 WATT CAPACITY. Size 5 1/4 x 4 1/4 x 3 1/4 inches. For 110 volt, 60 cycle, A.C. Shipping weight 12 lbs. List Price \$15.00. **YOUR SPECIAL PRICE ..... \$3.40**

## 2 1/2 Volt A.C. Fil. Transformer



Two windings, both center tapped. One "lights" six 227 or six 224 2 1/2-volt tubes, and the other lights two 245 tubes. Total: 14 amps. For 110 volt, 60 cycle, A.C. Size 4 1/2 x 2 1/2 x 3 1/4 inches. Shipping weight 6 lbs. List Price \$10.00. **YOUR SPECIAL PRICE ..... \$2.75**

## 600 Volt Condenser Sections

Impregnated in pitch. Flexible lead terminals.

.5 mfd. .... 25c	2 mfd. .... 40c
1 mfd. .... 30c	4 mfd. .... 60c



**FREE**

We have just issued our new "RADIO SERVICE TREATISE. It's red hot all the way through. 52 new hookups and circuit diagrams. 110 illustrations. Partial contents: Modernizing old radio sets. How to convert battery to power set. Selection of tubes. The detector tube. The power tube. Changes in grid or "C" bias circuits. Push pull amplifiers. Replacing audio transformers. Phono attachments. How to choose power transformers. Voltage dividers. Wattage of power transformers. Selecting and installing replacement parts in radio sets. Filter condensers. Repairing "B" eliminators. ALL BRAND NEW DOPE—NOT A REPRINT. Chuck full of REAL radio information all the way through. Even the catalog section has dozens of hookups—never found anywhere before. WRITE TODAY. A postal card brings it by return mail.

## Ware Type T. Neutrodyne



This is the most economical in operation of all radio sets. The circuit is that of a REFLEXED NEUTRODYNE incorporating 3 UV-199 tubes. The mahogany cabinet is 14 in. long and 13 in. deep. This design provides room for the "A" supply of 3 dry cells, 2 "B" and 1 "C" battery. There are 2 15-plate variable condensers, 2 neutrodyne-type R.F. transformers, 2 A.F. transformers, rheostat, 2 jacks, R.F. choke, 2 tuning dials, shock-absorbing mounting for the 3 tubes. Shipping weight 10 lbs. List Price \$65.00. **YOUR SPECIAL PRICE ..... \$5.95**

## Atwater Kent Model 35



One of the most compact receivers ever offered to the public. 3 stages R.F., 3 variable condensers are used. Overall dimensions are: 17 1/2 x 8 1/2 x 1 1/2 inches. The chassis is housed in a brown crackle-finish metal cabinet. This is a "one-dial control" receiver. Incorporated in this set is a 6-wire cable, each wire of which is rubber insulated and very high "gain" and may be used with antennas of any length, without in the least affecting the tuning. The variable condensers are of the "single bearing rotor" type. This set takes the following tubes: 5 type-201A and one type-112A or 171A tubes. Shipping weight 16 lbs. List Price \$65.00. **YOUR SPECIAL PRICE ..... \$14.95**

## R.C.A. Double Filter Chokes (No. 8336)



This heavy-duty, extremely strong, double filter choke can be used for all types of filter circuits, experimental work, power amplifiers, receivers, eliminators, power packs, converted sets, etc. Known as R.C.A. replacement part for all Radiola models, particularly Nos. 33, 17 and 18. Each choke D.C. resistance, 500 ohms. Connected in parallel, these double filter chokes have a rating of 15 Henries at 160 Mills; connected in series, 60 Henries at 80 Mills. Fully shielded in heavy metal case with special insulating compound. Size 5 1/4 x 3 3/4 x 2 1/2. Shipping weight 6 lbs. List Price \$10.05. **YOUR SPECIAL PRICE ..... 95c**

## Earl Power Transformer



Make money revamping the old battery set. This power transformer used in Earl Model 22 receiver supplies "A," "B" and "C" potentials for: two '27's (or screen grid '24's), three '20's, two '71A's and one '80 rectifier; total current output of high-voltage winding at maximum output (about 200 volts) is 80 ma. High-voltage secondary, filament winding for '27's, and for '71A's are center-tapped. May be used in any number of combinations. Suitable resistors, a couple of 4-mfd. filter condensers, two 30-henry chokes and by-pass condensers complete fine power pack. Size 3 3/4 x 3 x 2 1/4 inches. 16 long leads and full wiring directions. Shipping weight 5 lbs. List Price \$7.50. **YOUR SPECIAL PRICE ..... \$1.75**

## Atwater Kent 20 Compact



Five 201A tubes are used in this very sensitive and selective tuned radio frequency set. Dimensions: 20x6 1/2 x 6 1/2 inches high. A six-wire cable, "color coded," 6 ft. long, is included. Cabinet is finished in walnut. The panel is metal, finished in flat brown. Variable condensers having 16 plates are used. The variable condensers are independent of the receiver chassis. 3 brown molded "full vision" dials are used. A 3-point switch on the panel selects taps on the first R.F. coil, for "local" or "distance" reception. Non-oscillating. Easily re-wired for A.C. operation. Shipping weight 20 lbs. List Price \$60.00. **YOUR SPECIAL PRICE ..... \$10.95**

## Freshman "Masterpiece" A



It is of the tuned Radio Frequency type. Requires 4 201A, 1 171A tube. Has 2 F.T. transformers, and 3 variable condensers. Overall dimensions are: 20 1/2 x 12 x 9 1/4 inches; mahogany bakelite panel. The cabinet is finished in mahogany. 3 19-plate variable condensers used. The dial settings are read through recessed windows, 2 jacks mounted on panel. Shipping weight 25 lbs. List Price \$80.00. **YOUR SPECIAL PRICE ..... \$7.00**

## Allen Hough ROTROLA



This remarkable new instrument enables you to play phonograph records through your radio loud speaker. Plugs into any radio set, whether same uses batteries or A.C. Connected to your radio in a jiffy. Equipped with fine electric motor operating only on A.C., 60 cycles, 110 volts. New Webster pick-up; volume control; special constant speed electric motor. Beautiful portable cabinet. Full bronze trimmings. In factory sealed case. Shipping weight 18 lbs. List Price \$45.00. **YOUR SPECIAL PRICE ..... \$13.50**

## Replacement Power-Pack Condenser Blocks



Exact duplicate, physical size, placement of connection terminals, and electrical specifications of original blocks. For Majestic 171 type receivers ..... **\$5.00**  
For Majestic 250 type receivers ..... **\$5.00**  
For Majestic 245 type receivers ..... **5.00**  
For Atwater Kent 37 ..... **4.95**  
For Freshman M-12 ..... **5.00**  
For Majestic "B" Eliminator ..... **2.90**  
For Majestic Master "B" Eliminator ..... **2.90**  
For Majestic Special Master "B" Eliminator ..... **3.00**  
For Majestic "A" Eliminator ..... **3.25**

WE ARE A WHOLESALE HOUSE AND CANNOT ACCEPT ORDERS FOR LESS THAN \$3.00. If C. O. D. shipment is desired, please remit 20% remittance, which must accompany all orders; balance on delivery. If the full cash amount accompanies the order, you may deduct 2% discount. Send money order—certified check—U. S. stamps (any denominations.)

**Radio Trading Co.**  
25R West Broadway  
New York, N. Y.

Should you wish goods shipped by parcel post, be sure to include sufficient extra remittance for same. Any excess will be refunded. Order from this page; you will find special offers from time to time in this magazine. Get our big FREE catalog for the greatest Radio Bargains in the U. S.

# High-Grade Parts of Great Utility

## FILTER CONDENSERS

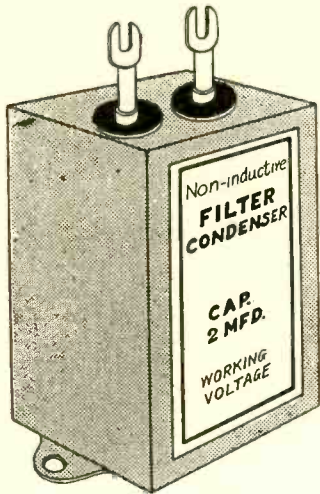

Flechthelm filter condensers for circuits using 245 output tubes, singly or in push-pull, or other circuits using lesser B voltage. Illustration is actual size. Capacities are 1 mfd. and 2 mfd. Continuous working voltage, 800 volts DC, 400 volts AC root mean square. Tested at 1,000 volts DC. Breakdown voltage 1,500 volts DC. Equipped with mounting feet.

Two condensers of 1 mfd. sent free with each 6 months' subscription at \$3.00. Order PR-HVD-1.

One condenser of 2 mfd. free with 6 months' subscription at \$3.00. (26 issues). Order PR-HVS-2.

## HAMMARLUND 100 MMFD. EQUALIZERS

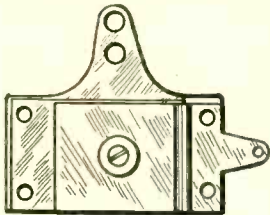

## Your Choice of NINE Meters!

To do your radio work properly you need meters. Here is your opportunity to get them at no extra cost. See the list of nine meters below. Heretofore we have offered the choice of any one of these meters free with an 8-weeks subscription for RADIO WORLD, at \$1, the regular price for such subscription. Now we extend this offer. For the first time you are permitted to obtain any one or more or all of these meters free, by sending in \$1 for 8-weeks' subscription, entitling you to one meter; \$2 for 16 weeks, entitling you to two meters; \$3 for 26 weeks, \$6 for 52 weeks, entitling you to six meters. Return coupon with remittance, and check off desired meters in squares below.

## SOLDERING IRON



Works on 110-120 volts, AC or DC; power, 50 watts. A serviceable iron, with copper tip, 5 ft. cable and male plug. Send \$1.50 for 13 weeks' subscription for Radio World and get these free! Please state if you are renewing existing subscription. Order PR-SO.

## AMER-TRAN AUDIO

First stage, de luxe (illustrated), primary, in detector circuit, has 200 henrys inductance at 1 milliamperes; turns ratio, 1-to-3. Order PR-AMDL, free with 1 1/2 years' subscription at regular rate ..... \$9.60

Push-pull input transformer, turns ratio, 1-to-2 1/2; single primary; two separate windings for secondary. Order PR-AMPP, free with 2 1/2 years' subscription @ \$15.00.

These audio transformers are recognized as being predominant. They afford tone realism unexcelled and deliver fully adequate volume. You can never go wrong with Amertrans. And remember that RADIO WORLD circuits show how best to use these transformers. Read RADIO WORLD weekly.

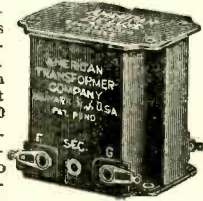

## THREE-GANG SCOVILL .0005 MFD. WITH BRASS PLATES

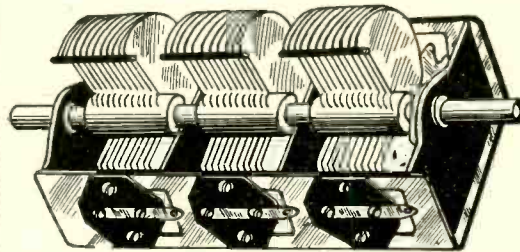

One of the best three-gang condensers made. Plates, utterly rigid and expertly aligned, are of brass, the most expensive metal used for this purpose. Capacity of each section, .0005 mfd. Shaft, 3/8" diameter of genuine steel, protrudes at both ends. For 1/2" diameter dial use at extension shaft (Cat. XS-4 @ 12c extra). Trimming condensers not built in, but mounting holes are provided for them. Condenser should be mounted on narrow side for drum dial operation. Rotor tension adjusters are built in. Frame is steel. Total shaft length overall 8 1/2", total frame width overall, 4 1/2". Order PR-3G, free with 26 weeks' subscription @ \$3.00

The most precise and rugged equalizing condenser made, with 20 mmfd. minimum and 100 mmfd. maximum, for equalizing the capacity where gang condensers are used that are not provided with built-in trimmers. Turning the screw alters the position of the moving plate, hence the capacity. Cross-section reveals special threaded brass bushing into which screw turns, hence you can not strip the thread. If you turn the screwdriver down with

accidental excess of force the screw simply stops, no injury results, as this special equalizer does not rely on the delicate thread in bakelite. The screw receptacle is strong brass. Useful in all circuits where trimming capacity of 100 mfd. or less is specified. Maximum capacity stamped on the condenser. Order PR-EQ-100, and three condensers will be shipped; subscription, three months @ \$1.50 regular rate.

# BOOKS THAT BUILD UP YOUR RADIO KNOWLEDGE TWO GREAT STANDBYS

## AUDIO POWER AMPLIFIERS

An understanding of audio amplifiers of all types, and of the use of tubes in audio channels, is a prerequisite today, when audio amplification is to the fore in radio, in public address systems and in the talkies.

"Audio Power Amplifiers" is the first and only book on the important subject. The authors are J. E. Anderson, M.A., former instructor in physics, University of Wisconsin, former Western Electric engineer, and for the last three years technical editor of "Radio World"; Herman Bernard, LL.B., managing editor of "Radio World." The book begins with an elementary exposition of the historical development and circuit constitution of audio amplifiers and sources of powering them. From this simple start it quickly proceeds to a well-considered exposition of circuit laws, including Ohm's laws and Kirchhoff's laws. The determination of resistance values to produce required voltages is carefully expounded. All types of power amplifiers are used as examples: AC, DC, battery operated and composite. But the book treats of AC power amplifiers most generously, due to the superior importance of such power amplifiers commercially. Tube characteristic tables and curves profusely included. Cloth cover, 193 pages. Order Cat. PR-APAM with one year's subscription (52 issues) @ \$6.00

## THE SUPERHETERODYNE

This is a new volume by Anderson and Bernard dealing with the principles and practice of the Superheterodyne method of receiving. It explains the function of the oscillator, the modulator, the pre-modulator selector, and the intermediate frequency amplifier. It explains the cause of repeat points and gives methods for avoiding them or minimizing their effect. It expounds the relative advantages and disadvantages of high and low intermediate frequencies, and shows the effect of selectivity on the quality.

It illustrates various forms of oscillators and tells of the advantages of each. Different types of modulators and pick-up systems are explained and their advantages stated. Different methods of coupling in the intermediate frequency amplifier are shown. Order PR-ABSA, free with 6 months' subscription (26 issues) @ \$3.00

## FOOTHOLD ON RADIO

In simple English that any one can understand, the technical side of radio is presented by Anderson and Bernard in their book, "Foothold on Radio." Any one who can read English can understand this book. It is intended for the sheer novice. The treatment is non-mathematical. Order PR-FOR free with 16 weeks' subscription @ \$2.00

## BOOKS BY J. F. RIDER

"Practical Radio Repairing Hints," by John F. Rider, just published. A handbook for the radio worker. No theory. No formulae. Explanations of the modern radio systems, automatic volume control circuits, new forms of voltage distribution—automobile radio sets, public address systems, etc. Order PR-PRRH, free with 26 weeks' subscription @ \$3.

"Practical Testing Systems," the first complete collection of accurate and practical testing circuits of interest to the service man, professional set builder and experimenter. Order PR-PTS, free with 3-month subscription @ \$1.50.

"Principles of Radio Communication," by Prof. John H. Morecroft, second edition. Prof. Morecroft, of the Electrical Engineering Department of Columbia University and past president of the Institute of Radio Engineers, is a noted authority. Prior electrical and mathematical knowledge required. 1,001 pages and 831 illustrations. Cloth-bound. Order PR-MPRN, free with subscription for 1 year and 34 weeks (86 issues) @ \$10.00

"Elements of Radio Communication," written in plain language, requiring little foundation knowledge of radio, is another fine Morecroft book. The book is a complete course on the elements of radio, containing much material never before published. 226 pages, 170 illustrations and a complete index. Cloth bound. This is one book you must have in your library. Order PR-MELEM, free with 26 weeks' subscription @ \$3.00

## PLEASE USE THIS COUPON

RADIO WORLD, 145 West 45th Street, New York, N. Y.  
I hereby take advantage of your extra-special premium offers and subscribe for RADIO WORLD for the number of weeks specified in the list below. Please send indicated premium. My remittance of \$..... is enclosed.

- |   |   |
|---|---|
| <input type="checkbox"/> PR-HVD-1 (26 wks., \$3.00)     | <input type="checkbox"/> PR-326-0-6 Voltmeter D.C.  |
| <input type="checkbox"/> PR-HVS-2 (26 wks., \$3.00)     | <input type="checkbox"/> PR-327-0-50 Voltmeter D.C.   |
| <input type="checkbox"/> PR-AMDL (1 1/2 yrs., \$9.60)   | <input type="checkbox"/> PR-23-6-Volt Charge Tester D.C.  |
| <input type="checkbox"/> PR-AMPP (2 1/2 yrs., \$15.00)  | <input type="checkbox"/> PR-338-0-10 Amperes D.C.   |
| <input type="checkbox"/> PR-EQ-100 (3 mos., \$1.50)     | <input type="checkbox"/> PR-325-0-25 Milliamperes D.C.  |
| <input type="checkbox"/> (Three condensers supplied.)   | <input type="checkbox"/> PR-350-0-50 Milliamperes D.C.  |
| <input type="checkbox"/> PR-APAM (1 yr., \$6.00)        | <input type="checkbox"/> PR-380-0-100 Milliamperes D.C.   |
| <input type="checkbox"/> PR-ABSH (26 wks., \$3.00)      | <input type="checkbox"/> PR-399-0-300 Milliamperes D.C.   |
| <input type="checkbox"/> PR-FOR (16 wks., \$2.00)       | <input type="checkbox"/> PR-394-0-400 Milliamperes D.C.   |
| <input type="checkbox"/> PR-PRRH (26 wks., \$3.00)      | <input type="checkbox"/> (One for \$1, 8 wks. Two for \$2, 16 wks. Three for \$3, 26 wks. Six for \$6, 52 wks.) |
| <input type="checkbox"/> PR-PTS (13 wks., \$1.50)       |   |
| <input type="checkbox"/> PR-MPRN (1 yr., 34 wks., \$10) |   |
| <input type="checkbox"/> PR-MELEM (26 wks., \$3.00)     |   |
| <input type="checkbox"/> PR-3G (26 wks., \$3.00)        |   |

State here how many meters.....  
 PR-SO (13 wks., \$1.50)

NAME .....

ADDRESS .....

CITY ..... STATE .....

Put cross here if renewing an existing RADIO WORLD subscription, as this facilitates speedy service.

# Hammarlund SFL

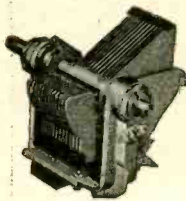

Hammarlund's precision .0005 mfd. condenser, with removable shaft; single hole panel mount. Excellent for calibrated radio frequency oscillators, short-wave converters and adapters and TRF or Superheterodyne broadcast receivers. Lowest loss construction; rigidity; Hammarlund's perfection throughout.

Order Cat. HAM-SFL. list price \$3.50; net price.....\$3.00

**GUARANTY RADIO GOODS CO.**  
143 West 45th St., New York, N. Y.

# Songwriters Service Co.

6719 Hollywood Boulevard, Dept. R. W.  
Hollywood, California

Talking Pictures offer new opportunities. Your songs personally submitted to Picture Studios, revised for publication by Hit Writers. Words, Music, Arranging, everything pertaining to songs.

# RF Choke in Copper Shield

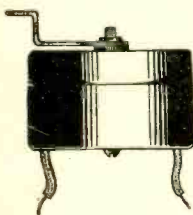

A 50-millihenry radio frequency choke coil, in a copper shield, with mounting screw and bracket attached. This choke is excellent for the plate lead of a detector, placed in series with the plate and the load impedance, for keeping RF out of the audio channel, broadcast receivers. Also excellent for RF plate lead, between the end of the plate load and B plus, and for screen grid leads, between screen grid and B plus, for thorough filtering and stabilizing. This choke will pass 25 ma. In all cases ground the shield. Order Cat. SH-RFC. List price, \$1.00; your price.... 57c

For short waves, an unshielded RF Choke, 1/4 millihenry, with mounting lugs. Order Cat. QMH, list price 80c; your price.... 47c

**GUARANTY RADIO GOODS CO.**  
143 West 45th St., New York, N. Y.

# DIAMOND PAIR, \$1.20



Antenna coil and three circuit tuner (single hole panel mount) for .0005 mfd. tuning. Wound on bakelite. Official coils for all models of Diamond of the Air. Pair for .00055 mfd. - - - \$1.20

**GUARANTY RADIO GOODS CO.**  
143 W. 45th St. New York, N. Y.

# NATIONAL

## Velvet B Eliminator \$16.13

180 Volts (250 Tube Free)  
Latest Model National Velvet-B, Type 3530, in handsome crackle finish black metal casing, for use with sets up to and including six tubes. Input 105-120 volts AC, 50 to 60 cycles. Output, 180 volts maximum at 35 milliamperes. Three variable output intermediate voltages. (Det., RF, AF). Eliminator has excellent filter system to eliminate hum, including 80 henry choke and 12 mfd. Mersham condenser. No motorboating! (Eliminator Licensed under patents of the Radio Corporation of America and associated companies.)

**Guaranty Radio Goods Co.**  
143 W. 45TH STREET  
(Just East of Broadway)  
NEW YORK CITY

# RADIO WORLD and "RADIO NEWS"

BOTH FOR ONE YEAR @ \$7.00

You can obtain the two leading radio technical magazines that cater to experimenters, service men and students, the first and only national radio weekly and the leading monthly, for one year each, at a saving of \$1.50. The regular mail subscription rate for Radio World for one year, a new and fascinating copy each week for 52 weeks, is \$6.00. Send in \$1.00 extra, get "Radio News" also for a year—a new issue each month for twelve months. Total, 64 issues for \$7.00.

□ If renewing Radio World subscription, put cross in square.  
RADIO WORLD, 145 West 45th Street, New York, N. Y.

# A L L - W A V E CONVERTERS

15-600 METERS—  
REMOTE CONTROL OPTIONAL

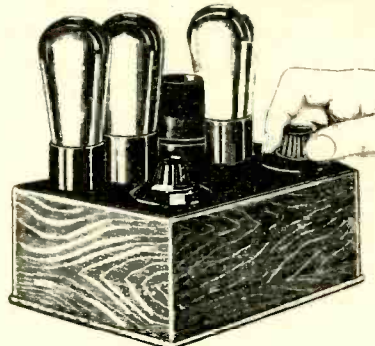

ESSENTIALLY a short-wave converter, 15 to 200 meters, using only a total of two plug-in coils, the model illustrated, Cat. 3-FS, works in conjunction with any broadcast receiver. Only four connections to receiver, without molesting the set. Requires a non-critical B voltage, 45 to 180 volts, from receiver. Tune the broadcast set to 1,500 kc (200 meters) or thereabouts, unless more sensitive elsewhere. Enjoy single tuning control, without body capacity, on short and broadcast waves. Converter uses Hammarlund .0002 mfd. condenser. Order Cat. 3-FS (all parts as specified by Herman Bernard, including filament transformer, cabinet and instructions; less three 222 tubes) at \$9.58.  
Remote control adapter, 24-foot radius, for control of tuning and switching at a distance (extra). Order Cat. RCAD at \$3.23.

UNIT NO. 1A

All parts for Unit No. 1-A, as described this week by Herman Bernard, less cabinet, less three 224 tubes, but with filament transformer, order Cat. U-1A, at ...\$19.87 For remote control order Cat. RCAD extra.

## SHORT-WAVE PARTS

Polo filament transformer for 50-60 cycles, 105-120 volts; secondary (thick leads) 2 1/2 volts, 8 amps. Order Cat. SW-FLT at .....\$2.50  
New Hammarlund short-wave midjet condenser; turns in 1/2-inch diameter; frame depth 2 7/16 inches; capacity is .0002 mfd. Order Cat. H-20 at.....\$1.35  
Supertone short-wave plug-in coils for 15-600 meter mixer when used with .0002 mfd total of two coils used. Use 5-prong tube base as coil receptacle. Order Cat. L-156 (both coils) at .....\$1.20

Polo 245 power transformer. Cat. 245-PT at .....\$9.50  
Polo B supply, choke, 30 henrys, Cat. 245-CH at ...\$4.00

**Polo Engineering Laboratories**  
Exclusive Distributors  
125 West 45th Street, New York, N. Y.

# The New Jiffy Tester

## Chromium-Plated Case and Accurate Meters

A NEW and improved Jiffy Tester, improved in both performance and appearance, is Model JT-N. The meters are of the moving iron type. Tested on precise batteries, they show errors not exceeding 2%. As for appearance, the case is first copper plated, then nickel plated, then chromium plated, giving a lustrous, permanent, non-peeling non-rusting finish. It is the same finish found on hardware in fine automobiles. The handle and lock strap are genuine leather.

Jiffy Tester, Model JT-N, consists of three double-reading meters, with cable plug, 4-prong adapter, test cords and screen grid cable, enabling simultaneous reading of plate voltage, plate current and filament or heater voltage (DC or AC), when plugged into the socket of any set. The ranges are filament, heater or other AC or DC: 0-10 v, 0-140 v; plate voltage: 0-60, 0-300 v. It makes all tests former models made. Each meter is also independently accessible for each range. The entire device is built in a chromium-plated case with chromium-plated slip-cover. Instruction sheet will be found inside. Order Cat. JT-N.

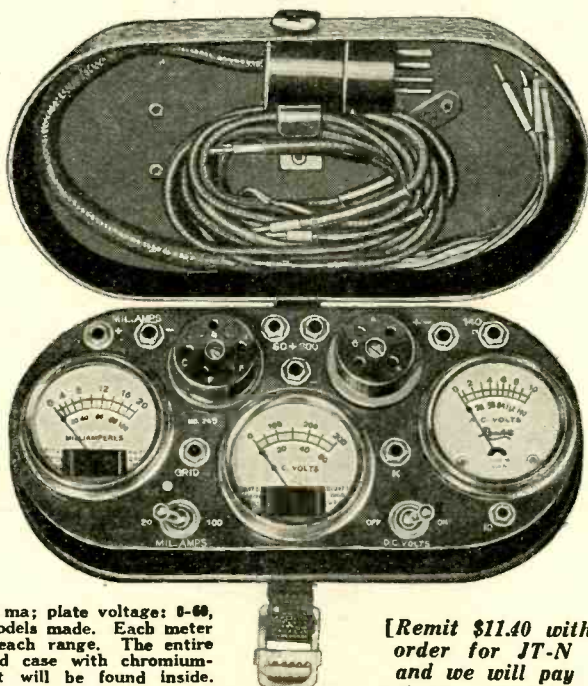

[Remit \$11.40 with order for JT-N and we will pay transportation]

# GUARANTY RADIO GOODS CO.

143 WEST 45th STREET (Just East of Broadway) NEW YORK, N. Y.

# HAYDEN'S DANDY MIDGET!

All parts, complete, as specified by Herbert E. Hayden, including cabinet (less tubes) ..... \$22.46

**Guaranty Radio Goods Co.**  
143 West 45th Street  
New York, N. Y.

The inductor dynamic offers high sensitivity and true tonal response. It requires no exciting field current, unlike other dynamics. Order model B for 112 or 112A, and Model G for all other output tubes.

Cat. 9-G (9" extreme outside diameter) \$8.49  
Cat. 9-R .....\$8.49  
Cat. 12-G (12" extreme outside diameter) .....\$10.03  
Cat. 12-R .....\$10.03

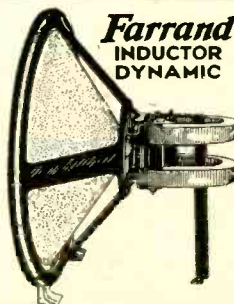

**GUARANTY RADIO GOODS CO.**  
143 W. 45th St., New York, N. Y.

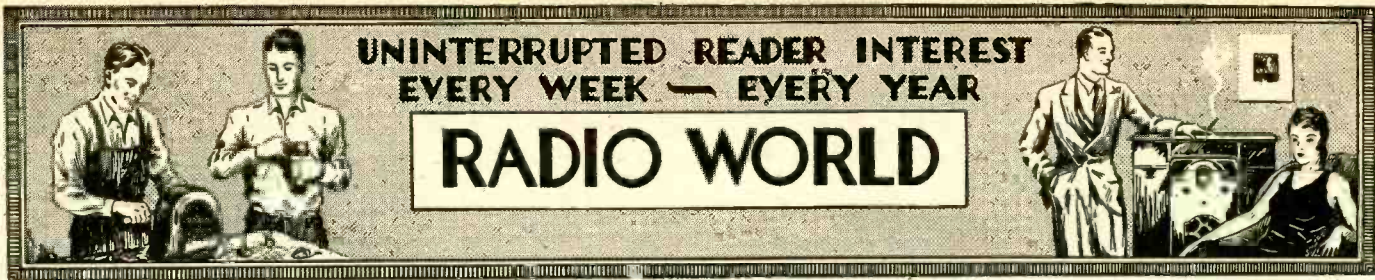

Vol. XVIII, No. 16 Whole No. 458  
 January 3d, 1931  
 [Entered as second-class matter, March, 1922, at the Post Office at New York, N. Y., under act of March, 1879]  
 15c per Copy, \$6.00 per Year

**NINTH YEAR**  
 Latest Circuits and News  
 Technical Accuracy Second to None

A Weekly Paper published by Hennessy Radio Publications Corporation, from Publication Office, 145 West 45th Street, New York, N. Y. (Just East of Broadway)  
 Telephone, BRyant 9-0558 and 9-0559

RADIO WORLD, owned and published by Hennessy Radio Publications Corporation, 145 West 45th Street, New York, N. Y. Roland Burke Hennessy, president and treasurer, 145 West 45th Street, New York, N. Y.; M. B. Hennessy, vice-president, 145 West 45th Street, New York, N. Y.; Herman Bernard, Secretary, 145 West 45th Street, New York, N. Y.; Roland Burke Hennessy, editor; Herman Bernard, business manager and managing editor; J. E. Anderson, technical editor

# A Dandy Midget

By Herbert E. Hayden

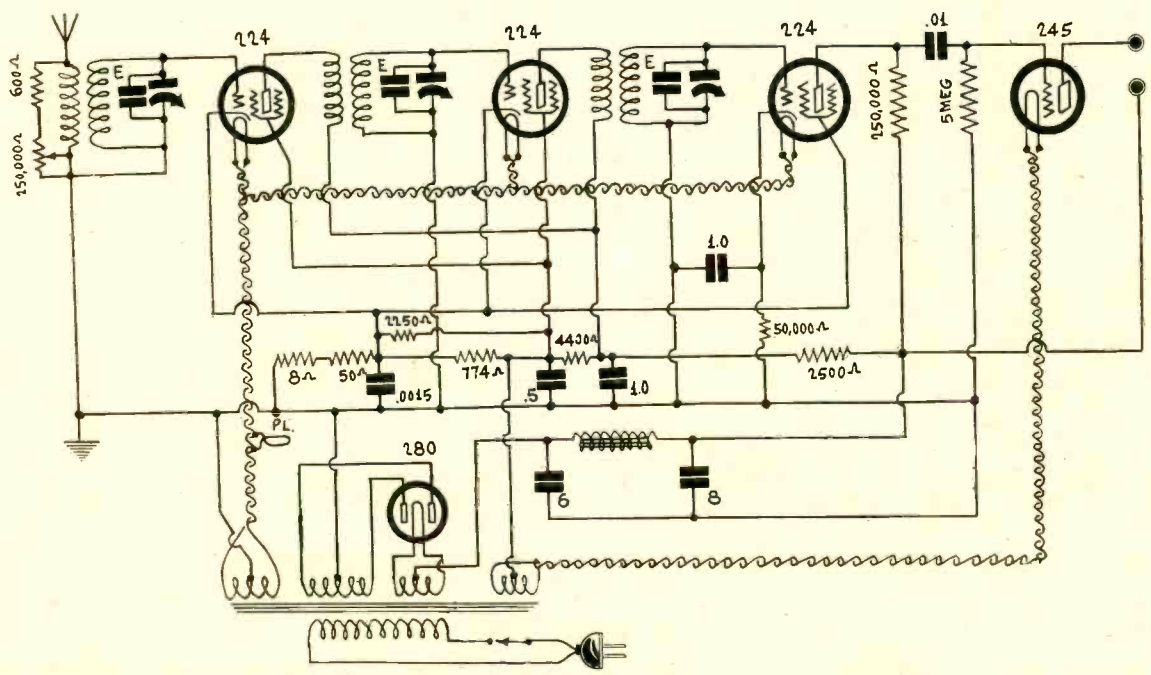

Fig. 1.

A midget receiver was built from the diagram herewith, and housed in a small steel cabinet. Results were excellent, due to the careful design, despite rigid economies practiced, so that parts would cost less than \$25.

**I**N building a midget receiver if you desire to use an external reproducer, perhaps one that you have, your set will be the better for it, because of more room afforded for the receiver proper. Therefore the design shown in Fig. 1 was selected, embodying a circuit that renders excellent performance, and yet yields to requirements of compactness without adverse crowding. One of the first thoughts that will strike a person who looks at the diagram is that there is only one stage of audio frequency amplification, and that it is resistance-coupled at that. One might assume that there would not be enough volume to work the reproducer.

### The Gain Analyzed

Yet consider the gain factor of two high-quality audio transformers of low ratio, using general purpose tubes. The overall gain of such a system is about 500. The gain from a screen grid tube with a plate load resistor of 250,000 ohms is around 400. The human ear usually is not able to distinguish differences in volume unless they exceed 25 per cent. Therefore the circuit as shown, while not as loud as the two-stage transformer circuit discussed, falls short of the other by only 25 per cent., a difference not distinguishable by the ears that most of us wear.

Moreover, the maximum voltage of 290 volts is applied to the end of the plate resistor. The bias on the detector is 10 volts. Thus the 300 volts are accounted for. In this way the output of the detector, provided the radio frequency gain is high enough, will be sufficient to load up the 245 tube. The bias on the output tube is about 50 volts, and therefore the swing accommodated is 100 volts, due to the positive and negative halves

of a cycle. Hence the detector signal voltage drop in the resistor need be only 100 volts, and it may be several times that, depending on the radio frequency amplification ahead and in-  
 (Continued on next page)

### LIST OF PARTS

- One power transformer (OS-FPS)
- One B choke coil (OS-SCH)
- One condenser block, 6, 8, 1, 1, 0.5 mfd. (F-CB)
- One steel subpanel with five sockets built-in (SBPL-1-3)
- One voltage divider (VD-6732)
- Two brackets, two insulating washers, 7" threaded screw with two bolts.
- One 2,250-ohms resistor (R-2250)
- One .0015 mfd. fixed condenser.
- One steel cabinet, removable back; crinkle brown finish.
- One 250,000-ohm potentiometer.
- One 600-ohm wire resistor.
- Four binding posts.
- Three RF coils (UNSH-40-70) with two brackets.
- Three Hammarlund 100 mfd. equalizers (E.)
- One 250,000-ohm pigtail cartridge resistor.
- One 5 meg. pigtail cartridge resistor.
- One 50,000-ohm pigtail cartridge resistor.
- One 0.1 mfd. condenser.
- One dial and two knobs.
- One AC cable with plug.
- One pilot bracket with lamp and window.

# Economy in a Midget

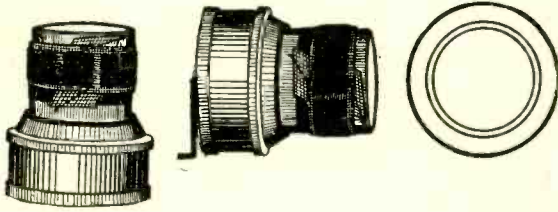

Fig. 2.

The three coils are placed at mutual right angles as illustrated.

(Continued from preceding page)

identally on the bias allowance on the detector. The RF amplification is not so enormous as to overtax the detector, while the bias on the detector is purposely high enough to accommodate even the loudest signal attainable with the radio amplifier system.

It is usual to have a lower screen voltage on the detector than on radio frequency amplifier screens, with equal plate voltage, but another way of arriving the same proportion, of course, is to increase the detector plate voltage, leaving the screen voltages the same, which was done in this instance. The screen voltage is about 50 volts in all instances, which makes for simplicity, as well.

The total resistance in the detector plate circuit will be of the order of 1,550,000 ohms, with a plate current of about .0002 ampere (0.2 milliampere). The total resistance is made up of a tube plate resistance of 1,250,000 ohms, a plate load resistor of 250,000 ohms and a biasing resistor of 50,000 ohms. Across the biasing resistor is a 1 mfd., bypass condenser, one of the capacities built into the condenser block used.

All three radio frequency coils are alike, with 40 turns on the primaries and 70 turns on the secondaries. The large primaries are necessary so that the radio frequency amplifiers will have a high impedance plate load.

One of the primaries, however, is in the antenna circuit, where it is usual to have a "skinny" primary. But it helps the synchronization of the tuned circuits to have the inductances identical, even if a large primary is in the antenna circuit. The voltage input to the receiver is better capitalized that way, the selectivity is just as good as with any other method, although it only seems not to be quite as good. The reason is that the greater the capitalization of the antenna voltage the less the apparent (but not the actual) selectivity. Therefore the volume control is placed in the antenna circuit, so that the input voltage may be reduced to decrease the volume and increase the apparent selectivity.

If you use a large antenna primary, as recommended, you can get as much volume, at the same apparent selectivity, with an aerial less than half the length and height, as compared with conditions where a "skinny" primary is used.

## Voltage Divider Economy

Compactness requires that as few parts be used as are compatible with excellent performance. One method of arriving at this result is to depend on the voltage divider very heavily for biasing voltages—the negative grid biases of all tubes save the detector, the positive screen and positive plate biases of all the tubes, save the 245, which has no screen.

The bias on the two radio frequency amplifiers is 4.64 volts negative, which is more than the usual recommendations, but is purposely so, due to the increase in actual selectivity resulting.

The special voltage divider, which is ample in wattage rating to take care of the needs of the circuit, has a total resistance of 7,732 ohms. This is a relatively low value, but was chosen so that the bleeder current would be high, and the voltage of the power transformer high-tension secondary would be correct, despite the rather low drain of the receiver proper. The bleeder current will be about 40 milliamperes, while the receiver itself will draw 10 amperes for the two radio frequency amplifiers (plates and screens), next to nothing for the detector, and 32 milliamperes for the power tube stage. Thus the total B current drawn by the set will be 42 milliamperes. Adding the bleeder, the total overall current will be 82 milliamperes.

The sections of the voltage divider are: 8 ohms (top not used); 50 ohms, equalling 4.64 volts for negative bias of the radio frequency amplifiers; 774, 4,400 and 2,500 ohms. Through the 774-ohm section, named below, the power tube current, 32 milliamperes, and the bleeder current, 40 milliamperes, a total of 72 milliamperes, yielding about 74 volts. Add the 4.64 volts of the lower section, the total would be over 78 volts. This is all right as a positive bias on the screens, but not as a negative bias on the power tube, so the power tube requirements of 50 volts negative bias are met by the introduction of parallel resistor of 2,250 to 2,500 ohms. The one used was 2,250 ohms, of the wire-

wound type. This changes the effective value of the voltage bleeder to about 7,500 ohms.

As the same voltage is used for other purposes, the negative bias on the power tube and the positive screen biases are all about 50 volts.

## Coil Data

The coils are placed under the three-gang tuning condenser, each adjoining coil at right angles to the other. How three coils are thus put at right angles to reduce back coupling is shown in Fig. 2.

The tubing on which the coils are wound is 1¼-inch diameter bakelite. The wire is No. 28 enamel. Only 70 turns are put on the secondaries, for .0005 mfd., tuning, as no shielding is used. Shields reduce inductance.

The primary is wound over the secondary, with a layer of insulating material, such as cabric or Empire cloth, in between. The purpose of the separator is principally that of affording insulation, as there is a voltage difference of about 180 volts.

A steel cabinet is used for housing the set. The cabinet has a flange at bottom, so that the extreme dimensions, as measured on this flange, are 17¼ wide x 12 inches front to back. The front is elevation, equivalent to the size of a front panel, if one were used, is 7 inches high x 15 inches wide. The front of the cabinet is used instead of a panel. However, inside a sub-base is needed, 9½ inches front to back x 14¼ inches wide. This is obtainable in steel, with the sockets built in, and nearly all the necessary holes pre-drilled. A few small parts, like the .00015 mfd. condenser, and cartridge resistors, may go underneath, where the depth between under side of the sub-base, and the plane on which the cabinet rests, is ½ inch.

## Condenser Mounting

On the front the three-gang condenser is mounted. There are three holes at one end of the condenser frame, and these take 6/32 machine screws. Drill for these holes in respect to the already drilled shaft hole, as shown in Fig. 3. Close work is necessary here, so that the lower hole will register properly. It is not at all difficult to drill through the front of the cabinet.

This mounting will be secure enough to maintain the condenser rigid when the dial is turned.

The other devices on the front are a 250,000-ohm potentiometer, at left, used as volume control, and, at right, an AC switch of the shaft type, made by Hart & Hegeman.

The coils are put under the condenser, as stated, but they are not in the center, but to the right, as one regards the set with front elevation toward him. At extreme right is the power transformer, and the coils should be at least one inch from this. Behind the power transformer is the B choke coil.

At extreme left front is the filter-bypass condenser block. To the right of this, running at right angles to the front elevation, is the voltage divider. To secure the voltage divider to the sub-base, use two right-angle brackets, separated from the divider by insulating washers. A threaded screw is run through the voltage divider. Nuts are used at the screw extremes to fasten the divider and brackets tightly together.

## Filter Circuit

Filtration is good, due to large capacity used. Next to the rectifier 6 mfd. are used, and at the end of the filter choke, in the reservoir position, 8 mfd. These are paper dielectric condensers. The 1 mfd. and one .5 mfd. capacities are in the block, too.

The color designations of the leads emerging from the condenser block are: black, to grounded B minus; white, 6 mfd., to red center lead of 5-volt winding of the power transformer and to one terminal of the B choke; vermilion, 8 mfd. to other terminal of the B choke; two maroon, 1 mfd. each, respectively to detector cathode, and to first tap after the high end of the voltage divider; green, 0.5 mfd., to second tap after high end of the voltage divider.

The high end, of the divider, which goes to the positive B voltage, is the end where there is considerable space between lugs, for at the low end, beginning at grounded B minus, the lugs are much closer together.

(Other illustration on front cover.)

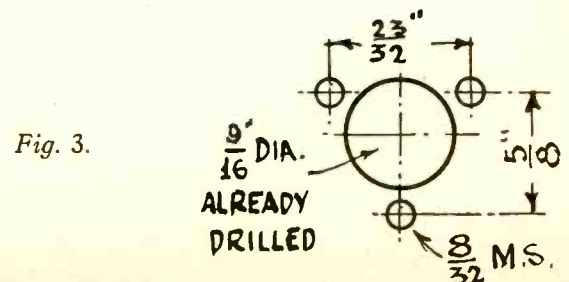

Fig. 3.

# The Unitary All-Wave Set

By Herman Bernard

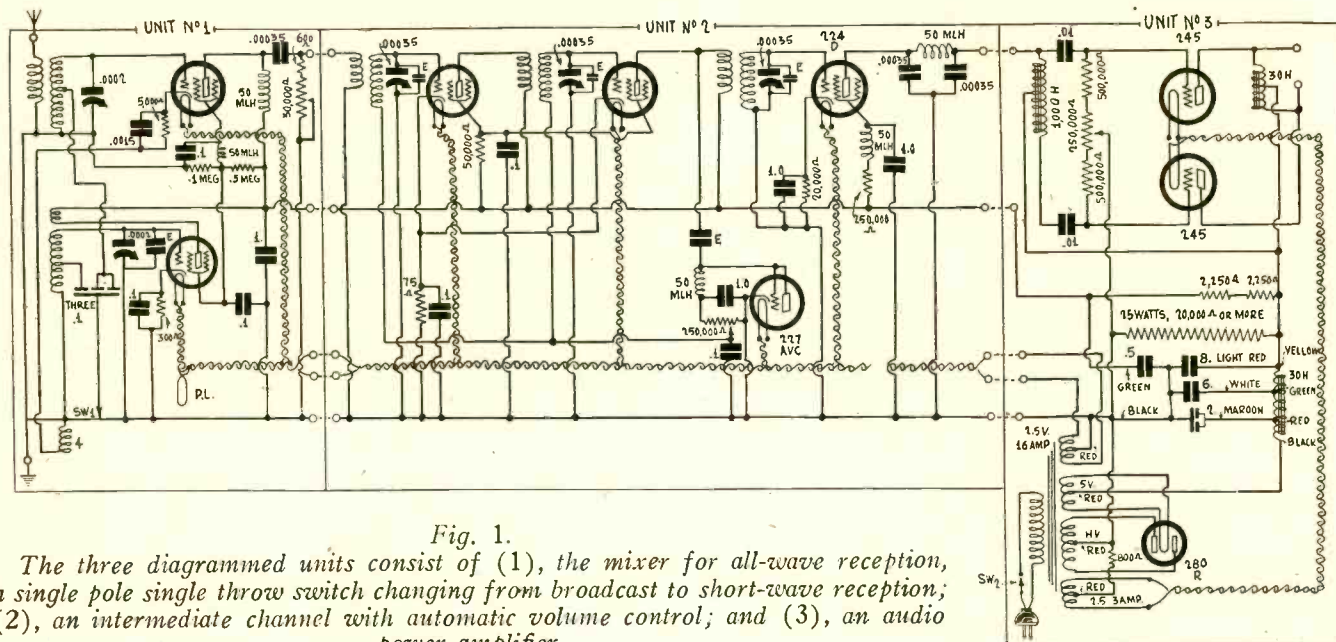

Fig. 1.

The three diagrammed units consist of (1), the mixer for all-wave reception, a single pole single throw switch changing from broadcast to short-wave reception; (2), an intermediate channel with automatic volume control; and (3), an audio power amplifier.

**A**N all-wave receiver is diagrammed in three units. No. 1 is the mixer, and comprises two screen grid tubes, with a single pole single throw switching arrangement to shift from broadcast wavelengths to short waves. No. 2 is the intermediate frequency amplifier, with automatic volume control tube. No. 3 is the audio power amplifier.

The arrangement is such that Unit No. 1, by the mere addition of a filament transformer and the introduction of a positive B voltage of from 45 to 180 volts, preferably the highest of these, from the receiver, becomes an all-wave converter when used in conjunction with a broadcast receiver.

When Unit No. 1 is put to such use, for broadcast reception, turn the set dial to tune in the lowest frequency, round 550 kc. (545 meters), and to tune in short waves, use the highest receiver frequency for intermediate amplification, about 1,500 kc. (200 meters). Throw the switch S1 to tune in still shorter waves.

However, when the receiver is built in its entirety from the diagram shown as Fig. 1, then the intermediate frequency is fixed, and the switch alone changes reception from the broadcast band to the short-wave band.

### Problem Avoided

Unit No. 1 has a main tuning condenser, which is across the oscillator grid coil, with rotor of the condenser grounded, so that only physical proximity of the hand to the coil would cause a body capacity, and the layout of parts affords ample safeguarding separation.

The other condenser is across the modulator coil grid, and is a rough tuner, except on extremely distant signals, so may be used for volume control. When the broadcast band is worked a big problem, in any ganging of the tuning capacities, is to make both circuits tune to the same difference in frequency over the scale. This can not be done unless specially cut condenser plates are used on the oscillator, although there are makeshift methods of approximating the result. None of the makeshifts is anywhere nearly so good as using a separate condenser across the modulator grid coil.

### Where Equal Coils Suffice

The system still remains single tuning control, in a sense, because, with the modulator condenser set at minimum capacity, the oscillator tuning condenser may be relied on to tune in the stations. What the other condenser does is to improve the sensitivity and selectivity. If volume is too great this condenser therefore may be used for volume control, by detuning, which is an excellent method, provided the rest of the system sustains the selectivity needs, which it does. Prof. John H. Morecroft, in his new book, "Elements of Radio Communication," expressly states that detuning is a good method of volume control, and it is one that does not change the tone quality.

Unit No. 1 has a triple fixed condenser, used as a double, for shorting out a large percentage of the number of turns on the two grid windings. Since the intermediate frequency to be chosen may be a little below the lowest broadcast frequency, say, 450 kc., when short waves are to be tuned in the frequency difference between

the oscillator and modulator tuning circuits will not be a large percentage of the original carrier frequency. Therefore the two circuits differ little from each other, capacitatively, when the frequencies concerned are high.

Take 80 meters as an example, 3,750 kc. The original carrier frequency therefore is about 8.5 times as great as the intermediate frequency, and in dial positions the disparity is only a few degrees even if the coils are equal. So it is practical to short the unequal windings used in the grid circuits for broadcast reception, so that the remaining inductances are equal, the difference in frequency readily being taken up by the tuning capacities.

On strong signals, or indeed, for the greater part of all domestic reception, it is not necessary to bring the modulator condenser to resonance with the carrier frequency to produce reception, but when such resonance is established, the response is stronger. On stations strong anyway, the ear can detect small difference at resonance.

### Image Interference

The modulator tuning condenser is a valuable asset in getting rid of any image interference that might present itself. Image interference is peculiar to the Superheterodyne, and consists of the reception of another station, rather weakly, at the same setting that brings in the desired station more strongly. The reason for image interference is that the intermediate frequency is established in the modulator output by reason of difference in frequency between the oscillator and the original carrier frequency.

Assume again 80 meters, 3,750 kc. Using the higher frequency of the oscillator, as it is the preferable one, the oscillator would be tuned to 4,200 kc. to produce an intermediate frequency of 450 kc. But the same difference in frequency, 450 kc., would arise from the same oscillator setting for an original carrier frequency of 3,200 kc. (108.3 meters), for in that instance the oscillator frequency would be lower than the original carrier frequency by the amount of the intermediate frequency. The modulator tube therefore is an electrical adding and subtracting machine, and it does both operations at once, sometimes against our will.

### Must Limit Oscillator Range

However, the remedy, and the only remedy, for getting rid of image interference, where present, is modulator tuning, or in addition pre-modulator tuning. Here we use modulator tuning whenever the occasion arises. It will arise very seldom at an intermediate frequency of 450 kc. for the broadcast band tuning.

For 1,500 to 550 kc. broadcast coverage, at 450 kc. intermediate, the oscillator would have to tune from 1,000 kc. to 1,950 kc., but if the tuning condenser had the usual ratio, say, 1-to-10, minimum to maximum capacity, with a suitable coil, the oscillator would tune from the chosen low frequency of oscillation, 1,000 kc. to 3,500 kc., so to restrict the scope and distribute the broadcast band over virtually the entirety of the oscillator dial, a fixed condenser is placed across the tuning condenser. This parallel capacity is referred to as fixed, although a Hammarlund adjustable equalizer, because it need be set only once. Its purpose is to reduce the ratio

(Continued on next page)

# Direct-Coupled

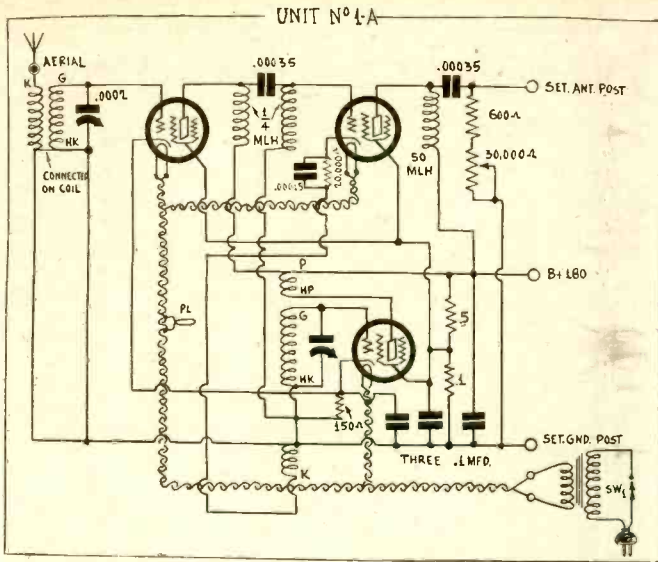

Fig. 2

Circuit for an all-wave converter, triple screen grid. A stage of RF is advisable, since the receiver amplification is an undetermined quantity.

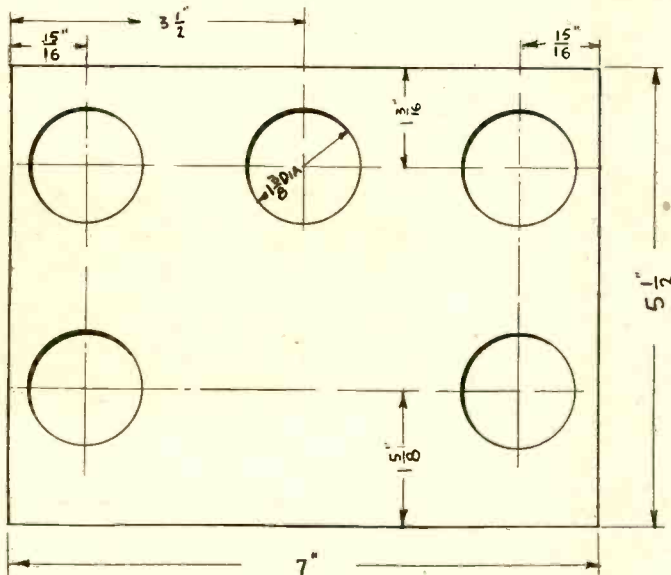

Fig. 3

Plan for subpanel, with location of socket holes. The coil sockets are at rear, extreme left and right. RF tube is left front, modulator center rear, oscillator right front.

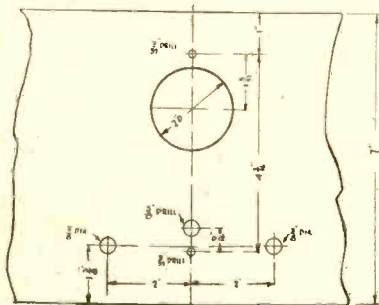

Fig. 4 Dimensions for front panel. The width of the panel may be 8 inches or more, as installation requirements demand. The pattern is for National type of dial.

(Continued from preceding page)

of minimum to maximum capacity by establishing a high minimum. The coupling between modulator and oscillator is at a medium value in the broadcast band. This coupling arises from connection of the cathode return of the modulator through a 4-turn winding. The coupling is by mutual induction. For short waves the same four turns constitute much tighter coupling, but the effect of this is to make the modulator tuning condenser perform as a trimmer for the oscillator tuning condenser, which is handy and desirable on short waves.

### Only Two IF Stages

The modulator tuning range is the same regardless of what the intermediate frequency may be. With the oscillator quite the opposite is true. Change the intermediate frequency and you change the oscillator log.

Intermediate frequencies of 1,700 kc. and 450 kc. were used, and good results obtained on both, but with stability more readily

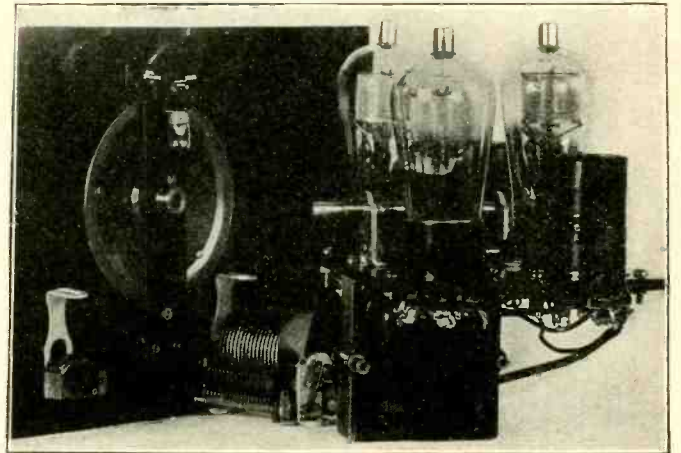

Fig. 5

The filament transformer acts as sub-panel support. The front and sub-panel plans result in exact coincidence of parts.

obtained at the lower, as would be expected. However, choice of an intermediate frequency may be left to the constructor, as oscillation in the intermediate amplifier, where no oscillation is wanted, may be suppressed by any of the approved methods, for instance, inclusion of grid suppressors.

Unit No. 2, the intermediate frequency amplifier, detector and automatic volume control, consists of four tubes. Two of them are screen grid intermediate amplifiers, one the screen grid detector, and the other being the 227 automatic volume control tube.

Only two intermediate frequency stages seem a modest number, but with screen grid tubes worked at a high amplification level, with large primaries in the plate circuits, the gain is greater than with four stages of intermediate frequency amplification using general purpose tubes, as were called for by at least one super-heterodyne design in 1927. In a word, the amplification, with two screen grid tubes worked at high gain, is abundant.

### Automatic Volume Control

The automatic volume control tube is a three-element valve worked as a simple rectifier, grid and plate "tied together." The input is some of the radio frequency taken from the plate of the second intermediate tube, through a small condenser. (All the capacities marked E are Hammarlund equalizers, 20-100 mmfd.)

The two intermediate tubes have a common biasing resistor of 75 ohms, so that there will be a steady bias of half a volt negative, even at no signal. This prevents operation at zero bias at no signal, and is a safety factor. As the carrier amplitude rises, the rectified current through the 250,000-ohm arm of the automatic volume control circuit increases, the voltage drop across the resistor increases, and as some of this drop is used for additional bias on the two intermediate tubes, their bias increases, and the volume decreases. Then when the carrier amplitude is weak, or reduces, then the bias is lowered and the volume increased. This team work produces a leveling effect, and is handy indeed in short-wave work, because it tends to offset the fading effects otherwise bound to be experienced on many short-wave stations, particularly from overseas. The arm of the potentiometer in this circuit is set only once.

There are three coils tuned at the intermediate level, although only two stages, because one coil simply couples the final intermediate amplifier to the detector, which in this instance is a screen grid tube.

### The Audio Power Amplifier

Unit No. 3 is the audio power amplifier. It is direct-coupled push-pull. The maximum B voltage, 300 volts, is applied to the detector. The plate load is a special high impedance choke, of the order of 1,000 henries, with a DC resistance of around 15,000 ohms, as contrasted against the usual choke of 30 henries and 200 to 400 ohms DC resistance for other uses.

The principle of operation is that the voltage drop across the upper part of the center-tapped choke in the detector plate is equalled in the lower half because of the inductive coupling. The high potentials are connected to the grids of the 245 output tubes, with stopping condensers between to keep the direct positive voltage off those grids.

Since the voltage from detector plate to B plus, in the upper half of the choke, is in a particular phase, the voltage in the lower half is in opposite phase. The current flows in the same direction



# Push-Pull Audio

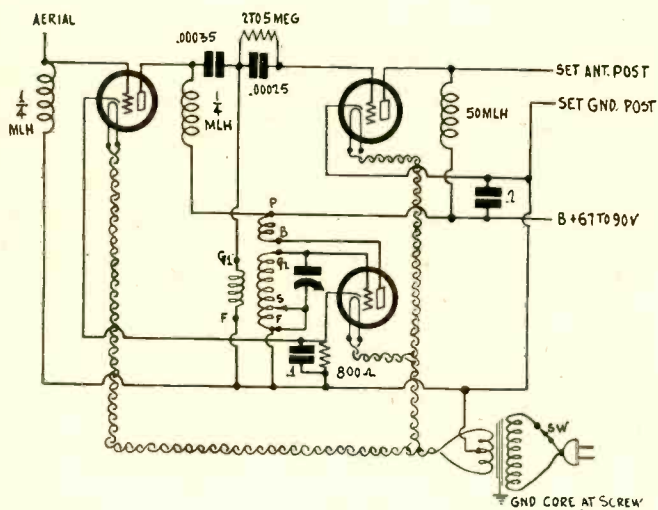

Fig. 6

A contrast to Fig. 2, with three 227 tubes and one tuned circuit.

to opposite polarities at the same instant, if you attempt to read the circuit diagram literally. Electrically, the voltages at any instant are equal, but opposite in phase.

If by any chance there is a voltage inequality, the push-pull system would be upset, for to have push-pull you must have symmetry. Hence, a potentiometer is used between the fixed resistors in the grid leaks. Any unbalance of the signal may be corrected this way, including elimination of hum that might rise from such unbalance.

### Data on Speaker Connections

The output is taken through a center-tapped choke coil, which permits connection of any type speaker, dynamic or magnetic, whether equipped with an output transformer or not. However, if you have a dynamic speaker with a special push-pull transformer built in (three connections at input), you may omit the center-tapped choke. This omission also holds good if you use the Farrand inductor, e.g., model 12-G, which is recommended as an especially good one. The magnet coil is center-tapped, and a lug on the assembly represents this center. Connect the lug to B plus and the two other leads to plates directly. If there are three wire leads on the speaker, as is true of some Farrand inductors, the yellow goes to B plus, the tipped cords to plates, with the center-tap choke shown in the output in Fig. 1 omitted.

The B supply is standard, with a choke input, which means no condenser next to the rectifier, but enough taps on the choke coil to permit the usual sequence of filter capacities. The ones used here are high, yet they may be paper dielectric. The capacities are in one block, the leads being identified from the diagram.

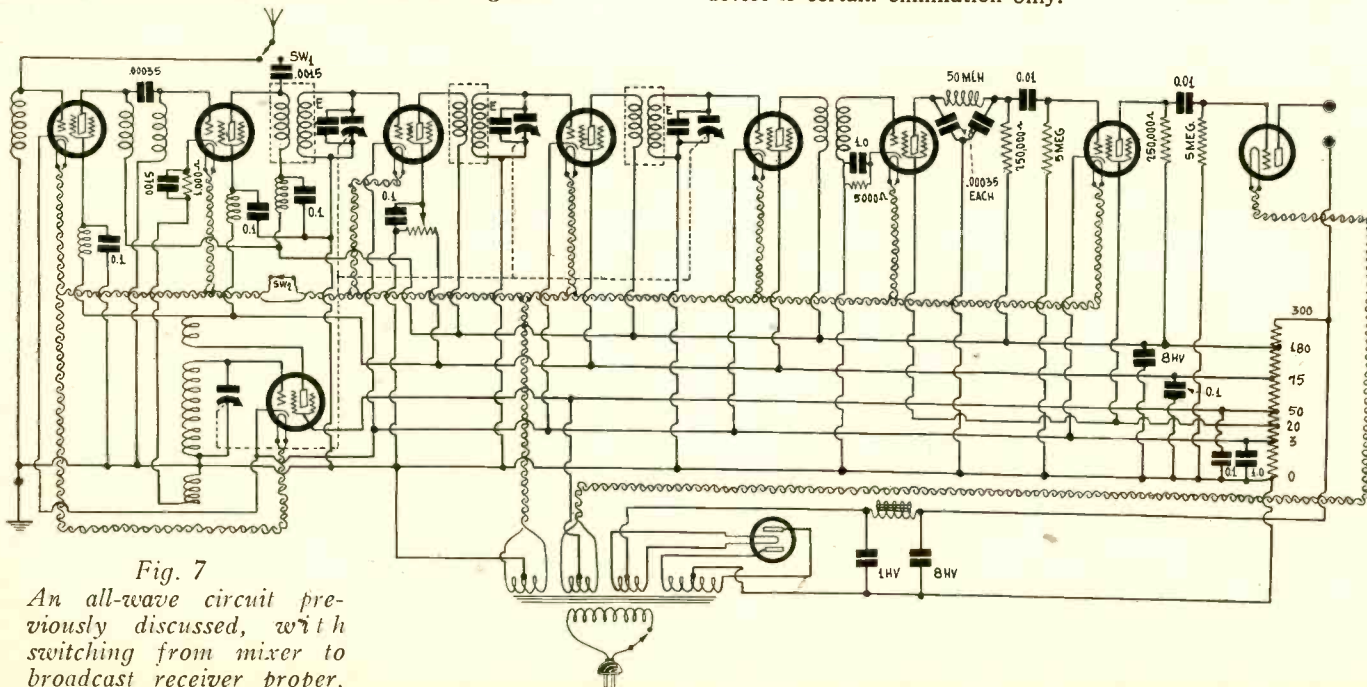

Fig. 7

An all-wave circuit previously discussed, with switching from mixer to broadcast receiver proper.

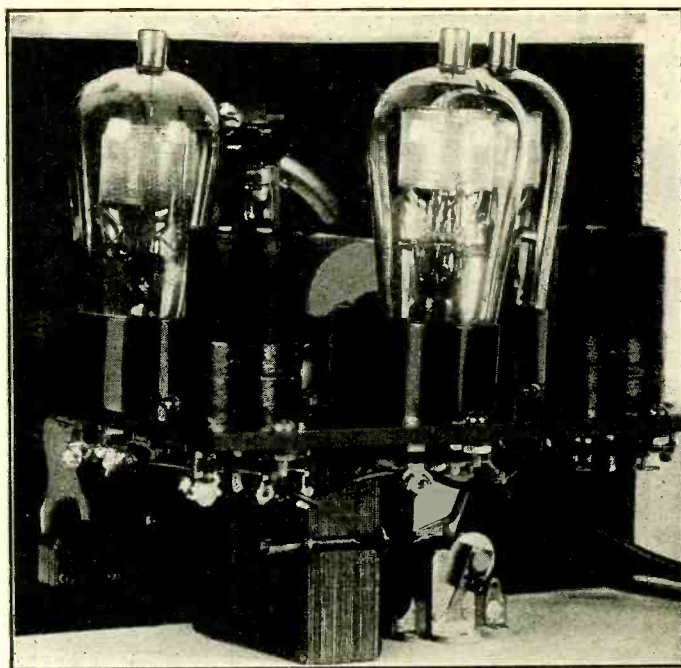
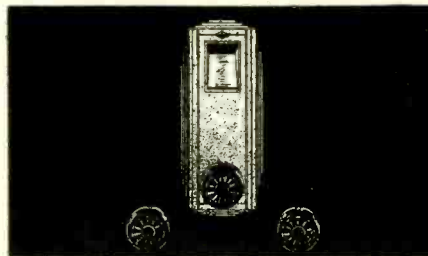

Fig. 8

Two brackets are common to the front panel and sub-panel, at the side openings at front, thus attaching panels without any extra holes on the front.

Fig. 9

General appearance of the front panel. At left is the modulator capacity control, at center the National dial, and at right the switch - volume control unit.



## Place to Kill Noise Is at the Source

If you are troubled with noises from electrical instruments or devices, remember that the best place to stop electrical noise is at the source.

No other method is nearly as effective.

Changes in the aerial, line noise filters at the set, or any other methods, may prove helpful, but the attachment of a suitable condenser or filter system right AT the offending motor or other device is certain elimination only.

# Remedies for Converters

By Stuart McMillan

**"I** BUILT a short-wave converter and it does not work. All it brings in is code, code, code. Some nights I get even that only weakly. Under 20 meters the converter stops oscillating, although I try on several hours a night to get reception under 20 meters."

Such was one young man's "complaint."

The fact that the converter brings in code proves that the converter is very much alive and not that it "does not work." One thing a converter will not do. It will not provide programs for its own reception. Stations have to provide programs. There are 19,000 amateurs, a greater number than ever before in history; about a dozen stations sending broadcasts on short waves, in the United States, and maybe a hundred foreign short-wave program-senders. So that's that.

Rule No. 1. Find out where the broadcast stations are, that send short waves, and tune for them with some relationship to their frequency.

Short waves, much more so than broadcast wave-lengths, are erratic. One might find reception. Some other day or night, very poor reception.

Rule No. 2. Do not expect uniformly great reception.

Tuning in under 20 meters at night is little better than a waste of time. The brand in that realm works in daylight but poorly if night intervenes anywhere between sender and receiver.

Rule No. 3. Tune in higher than 20 meters at night. Don't assume the oscillator isn't oscillating simply because you're not receiving below 20 meters.

## Low Impedance Choke Short-Circuits Output

The construction of a short-wave converter is usually done with expectation that the device will tune in European stations any time, from one end of the dial to the other.

I recently came across a converter correctly wired and therefore presumably all right to use. But on connecting it up not a single station radiating short waves responded to dial twisting. The broadcast receivers that served as intermediate amplifiers were a tuned radio frequency type and a Superheterodyne used for comparison. Both of these were checked over for this particular converter test and were found to respond to a local 1,500 kc transmitter, but with the addition of the converter to the set at this checked setting the results were nil. The output from the converter was through a radio frequency choke but on disassembly this was found to be a short-wave choke, and as such its impedance might easily bypass most of the output of the converter, at 1,500 kc. This choke was replaced with a 50-mlh choke, and the setup was tried again. This time there were promising results, as one short-wave station came in where there were at least three within sensitivity range, on the air, according to schedule.

The converter was inspected again to try to find another loophole. A test with a source of high potential across the series connection formed with the output condenser and a low range milliammeter showed slight leakage. This was sufficient reason to substitute another condenser. The converter was tried again, without any special improvement being noticed. Then it was decided to try to find out how much was the signal from a given broadcast station, now received apparently as a harmonic to do this the given harmonic was tuned in on the converter, then the antenna lead was removed from the converter binding post and touched to the 1,500 kc input lead to the set, with the result that the station came in with full volume, this proving that the harmonic heard was of the regular broadcast wave.

But this same station also operates a short-wave transmitter

on 58 meters and there it appeared at another place on the dial, not far removed from the place where we are now at. By repeating the aforesaid experiment the result when the antenna lead was touched to the set input lead connection should be nil, proving that this time we were resonating to the higher frequency.

This simple analysis then showed that evidently there was pickup directly from the broadcast station on one or more of the connecting leads, and to find out which lead was the offender was easy.

The procedure consisted of operating the converter as above described and observing the effect of removal of first the antenna clip connection and then the ground lead.

Then a length of metal mesh shielded wire was substituted on this converter output circuit rather more to observe the effect than anything else. It detuned the circuit slightly. Grounding of the shielded coating seemed of no avail.

The only other thing left to do was to bypass the B plus supply lead. A 1 mfd. paper condenser was connected across B plus and the ground terminal of the converter.

The results were as expected. The disturbing pickup was reduced to a minimum, with a large increase of volume of the short-wave signals. The oscillator was thus given a chance to function properly.

## Adapting Different Forms of Input Coupling

There is usually a greater diversity of type of input coupling employed with broadcast receivers than in the case of converters, but in the event that you have a set with which a converter will not work "as is," the trouble can be overcome in either of the following ways. If the set will not respond specially well to 1,500 kc, the output tube of the converter may be fed into a tuned stage whose resonant frequency is 1,500 kc. The added stage of amplification consists of a 227 tube, a variable condenser (either .0005 mfd. or .00035 mfd.) and an air-core inductance coil, which can be tuned to 1,500 kilocycles or so. The output circuit of this tube may be similar to that of the converter output.

On the other hand, the aperiodic primary of a tuned radio frequency set need not be used. It is presumed here that the fan has previously assured himself that he knows what the connections are, so that he can act in accordance with the general instruction given.

There are some sets provided with a resistance type of antenna input that consists usually, of a variable series resistance between antenna and ground, the first stage input tube grid circuit being shunted between ground and the slider. The resistance in this case may act as the grid return at the same time.

The scheme to follow in such event is to locate the grid terminal of the first stage tube, removing the junction of the resistor slider, attach a separate lead to the grid terminal, which is brought out to be connected to the RF air core coil, that is to be condenser-tuned as before.

Ready-made unshielded or shielded coils and tuning condensers are available with which to make the suggested modifications. The author has succeeded in clearly resolving short-wave signals emanating from a seven-watt amateur transmitter at a distance of 1,000 miles, with the aid of the foregoing corrections, and passes the information along for those whom it may help. It seems that the outstanding requisite is to reduce the pickup of broadcast station harmonic to a minimum, by the use of adequate bypass condenser, so that by contrast the prevailing short-wave signal intensity is stronger.

## Rectifiers for Dynamic Speakers

**T**HE magnetic type loudspeaker used a large permanent magnet, not powerful enough for satisfactory volume, especially for low tones. So the dynamic type was evolved, using an electro-magnet energized by current derived from a storage battery or the house socket.

To convert this field current into direct current, in place of alternating, a rectifier is required. The original type dynamic speaker used the dry metal disc type of rectifier. In this system, the voltage is first "stepped down" from 110 volts to about 15 volts by means of a transformer. Then the dry disc rectifier converts it into direct current. The current, however, is not always smooth, and a hum may result.

Two plans are employed to combat this hum. Some manufacturers use a hum coil, which is a special small coil so installed and connected that it produces an equal and opposite magnetic effect to that which causes the hum. A disadvantage of this, despite its inexpensiveness, is the fact that it may interfere with the proper musical tones of 60 cycles and 120 cycles.

The second plan is to use an A condenser, a specially-built condenser having an enormous capacity, about 1,500 mfd., connected across the field coil to smooth out the fluctuations. This is a better method, but care must be used not to connect the condenser to a circuit higher than 15 volts, and not to connect it with reversed polarity.

The other method of rectifying is by a tube of the full-wave style, e.g., the 280 tube. With this a much higher voltage is used on the field coil, and it is much easier to filter and rectify the alternating current into a smooth and satisfactory direct current.

Furthermore, when the tube wears out, it is a simple matter to install a new one. On very large speakers, two rectifier tubes are used, for obtaining full-wave rectification at higher voltages, such as 500 to 700 volts. Regulation condensers and filter chokes are used on this style speaker, so from many standpoints, the tube rectifier type of dynamic speaker will become more and more widely adopted.

# The Screen Grid Tube

By Brainard Foote

**M**ORE than any other radio development in recent years, the screen grid tube has proved of unusual public interest. Some of this interest is due, undoubtedly, to advertising, but there is much to be said in favor of this type of tube, especially when it comes to reception from distant points.

If you have more than a passing interest in radio, you should have a working knowledge of the screen grid tube, because it is so much talked about and so generally used. Just how does it differ from the regulation radio tube? Is it better or worse?

## Two Main Points

Two two principal things which the screen grid tube does, in contrast to ordinary tubes, are (1) to eliminate capacity feedback in the tube, and (2) to provide amplification many times that of ordinary tubes.

Let's consider a general purpose tube. The current from the A battery or transformer passes through the filament of the tube and makes it red or white-hot. From this hot filament particles of electricity are given off. These particles are called electrons. They are negative electricity. The plate of the tube is a cylinder of nickel. A B battery or eliminator is connected outside the tube between the plate and the filament. This battery is connected with the positive end to the plate, thus charging the plate with positive electricity. Then the negative electrons are attracted to the positive plate, so we have a regular stream of millions of electrons flying across from the filament to the plate.

## Amplification Factor

Between these two we have a coil of wire or a screen, called the grid. It is quite close to the filament and any electrical charge on the grid has a very great effect on the stream of electrons, for the stream has to pass the grid to get to the plate. Since the grid is much closer to the filament than it is to the plate, a slight electrical change on the grid has a much greater effect on the plate. In the ordinary 201A type tube this proportion (i.e., amplification factor) is about 8. The grid of the tube is connected to the aerial, or to the preceding radio circuit and in this way the amplification is carried along.

The space surrounding the filament is always filled with negative electrons, as they leave to go to the plate. Accordingly, these electrons act as a damper on more electrons attempting to leave the plate, since negative repels negative. If this space charge could be eliminated, the amplification of the tube would be 30 to 35 rather than 8, without any other alteration in the tube.

The amplification may be increased in certain ways. In the high mu tubes the grid is a much finer mesh and it is much closer to the filament. However this plan is not very successful in radio frequency circuits, and is not entirely satisfactory for other purposes, except with special circuits.

## Reduced Space Charge

The space charge surrounding the filament may be partly done away with, however, by inserting an additional element nearby, which is charged positively, so as to neutralize the negative space charge. This fourth element looks like a grid, because it is of openwork construction and surrounds the filament. It may be located either between the filament and grid, or between the plate and grid. The fourth element is charged with a positive voltage, much less than that of the plate of the tube, and this is done by a connection to a lower voltage point on the B supply.

In the screen grid tube, this fourth element is located between

the grid and the plate, and in this way it screens the grid. By keeping the screen grid (the fourth element) charged at a certain positive voltage, the space charge is neutralized to a considerable extent. Thus the control grid is far more effective in controlling the flow of electrons from the filament to the plate, and the amplification is raised tremendously. The screen grid is usually referred to simply as the screen.

## Series Capacity Effect

The second important difference between the former tubes and the screen grid tubes is in the capacity between the elements. The elements act toward one another as the plates of a condenser and in this way minute radio frequency currents may feed back from the plate to the grid, causing the tube to oscillate or generate electrical wave. With the screen grid inserted between the grid and plate the capacity effect between grid and plate is reduced.

In effect, there are two separate capacities one between the plate and the screen grid, the other between the screen grid and the control grid.

Electrical students will know that when two capacities are in series, as in this case, the resulting capacity is much smaller than either of the two. So in the screen grid tube, the capacity as reduced to a very low amount, and there is so little feedback through the tube that greater transfer of energy between the various circuits of the set may be realized without oscillation.

In the very center of a screen grid tube you find a straight wire, stretched tightly, and that's the filament. Closely surrounding that is a spring-like wire, in a coil, and that's the control grid. Next you find another coil of wire, which is the screen grid, or screen. Outside of that, you have a metal cylinder, or plate.

## Why Control Grid is Outside

Then outside of that, you find another spiral wire coil, and that is simply an outer screen grid which is connected to the inner screen grid so that both act together so dissipate the negative space charge. There is a metal cap on top of the tube, and to this the control grid is connected. It is done in this way to avoid any capacity effect which would be encountered should the connection be made down through the base and to the socket.

It is important to note that when the capacity of the tube is so greatly reduced, the presence of inductive feed back possibilities is much more serious, if the full amplification ability of the tube is to be realized. Accordingly, in screen grid circuits it is desirable, and practically necessary, to enclose each separate section of the radio frequency amplifier in a metal container, and to use other methods to avoid capacity effects between the grid and plate circuits.

The 222 and 232 screen grid tubes are battery-operated, but for regular radio service with AC sets the 224 is used, with heating element similar to that employed with the 27 tube, so that the cathode is heated by thermal radiation from the AC-operated heater.

## Effect on Reception

The screen grid tube has definite advantages for long-distance reception, but in order to realize these, conditions must be good. During the Summer, for example, not so much advantage is usually noticed in using the screen grid tube. During the Fall and Winter there are frequent occasions when the sensitiveness of this tube is fully realized.

## "Sacred" Angles for Coil Placement

**I**N a set where the radio frequency coils are not shielded it is very important that they be placed so that there will be stray coupling among them.

In the Neutrodyne system, the coils are placed parallel, but at such angles to each other that hardly any coupling exists. This is a very difficult position to locate, for it depends upon the size of the coils, the distance between them and other factors.

Another way to avoid coupling is to mount all three coils mutually at right angles. This is not hard to do. The exact centers of the three windings (the wire itself, not the tubing) must be on an exact line, and it may be necessary to mount one or two of the coils on brass supports to place them in this manner. The first coils may be placed vertically, standing on one end. The next coil may be placed horizontally, with the ends toward the panel and the back of the set. The third coil may be placed horizontally, with the ends toward the ends of the cabinet. There is then scarcely any possibility of coupling between any two of the coils.

## He Suffers Throbs of Interference

**O**N several occasions I have listened to the rebroadcast of programs originating in London and each time I have noticed a certain throbbing sound. What is the cause of this?—A. B. L.

If the throbbing sound to which you refer is accompanied by a rise and fall in the amount of noise, it is probably due to fading and the use of an automatic volume control. As the signal intensity decreases, due to fading, the amplification increases to offset it, and as the amplification increases the noise increases with it. There could also be disturbances of this general nature due to land lines. The international signals pass through at least two land lines, once on the other side to the broadcast station and again on this side from the short-wave receiver to the rebroadcast station from which it passes through other controlling circuits before going on to you.

# The Majestic Super, Westingh

The 1931 Models Shown

**T**HE Majestic Model 50, the latest model of this line of receivers, is a radical departure from the earlier models. It is of the superheterodyne type and contains seven tubes, exclusive of the 280-type rectifier tube. The first tube is a screen grid radio frequency amplifier with a double resonant tuner in front of it. The second tube is the oscillator, which is of the 227 type, and the third is a 224 type modulator or detector. The fourth tube is also a 224 type operating as an intermediate frequency amplifier, and the next tube is a 227 type detector, which operates on the high bias, high plate voltage principle, and works into a 245 push-pull amplifier. The circuit diagram is shown in Fig. 1.

Between the radio frequency amplifier and the modulator is an untuned transformer so that all the radio frequency tuning is done ahead of the first tube. There are two intermediate frequency couplers, in each of which both the primary and the secondary are tuned to a frequency of 175 kilocycles.

There are three variable condensers on one control, two of which are in the double tuner ahead of the first amplifier and the third is in the oscillator. Tracking of the oscillator and RF tuning condensers is accomplished by a special treatment of the oscillator capacity, which consists of four condensers in series parallel, one of which is a fixed condenser of .001 mfd., another the variable condenser in the gang, and the remaining two are trimmers, one in parallel with each of the others. This arrangement of capacities makes it possible to adjust the circuits so that the oscillator and the modulator input circuits are tuned alike at two different settings. If these settings are suitably selected there can only be a small deviation at other places, and this deviation can be taken up by adjustments of the rotor plates of the oscillator variable condenser.

### Type of Pick-up

The oscillator and the modulator are coupled by connecting a condenser of .04 mfd. from a tap on the oscillator tuned coil to the cathode of the modulator, so that a small portion of the oscillator inductance is in parallel with the 12,500 ohm bias resistor of the modulator tube.

A dual volume control is used in the circuit, one part being a 10,000 ohm variable resistance across the input and the other part a 645 ohm potentiometer which varies the bias on the RF and the modulator tubes.

The grid of the oscillator is maintained somewhat negative by means of a 100,000 ohm grid leak in the grid circuit of the tube, the condenser being shunted by a .001 mfd. condenser. The second detector grid is maintained negative by means of a 35,000 ohm resistance placed in the cathode lead. This resistance is shunted by a 1 mfd. condenser.

A low pass filter is put in the plate circuit of the second detector, and it consists of a radio frequency choke and two .001 mfd. condensers. Note that one of these condensers goes to the cathode of the tube and the other to ground.

### The B Supply

The B supply contains one 280 type rectifier, one tuned filter coil, the field winding, the usual by-pass condensers, and a voltage divider. The entire current drawn by the tubes flows through the field winding as well as the current that flows through the voltage divider.

The full voltage output is impressed on the power tubes and also on the intermediate frequency amplifier tube. This voltage is 256 volts, measured from ground. Therefore the effective plate voltage on the power tube plates is considerably less, since there is an 800 ohm bias resistor for these tubes. The plate return of the detector is made through a 25,000 ohm resistor to the 256 volt point. Since the normal plate current in the detector tube is very low, the effective plate voltage on the detector is not much less than that on the intermediate frequency tube.

The voltage applied to the plates of the RF and modulator tubes is 180 volts, being taken from a tap on the voltage divider 2,680 ohms from the highest tap. The plate voltage on the oscillator and the screen voltages on the three screen grid tubes is practically the same and is 90 volts. It is taken from a point on the voltage divider 4,170 ohms below the 180 volt tap.

### Westinghouse WR-4 Receiver

This is a six-tube screen grid receiver utilizing four 224 type tubes and two 245s. In addition there is a 280 type rectifier.

The unusual feature in this circuit is that the screen grid high voltage detector works into a special high impedance audio coupler which has a mid-tapped winding so that the same voltage is impressed on the two power tubes, but in opposite phase. The coupler does not act as a choke coil, but rather as an autotransformer.

The radio frequency filter in the plate circuit of the detector consists of two 320 mmfd. condensers in shunt and two 90-ohm RF chokes in series with the line, so that only the audio frequency

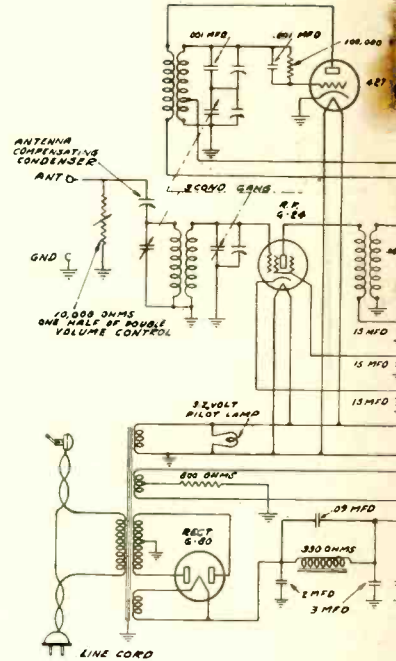
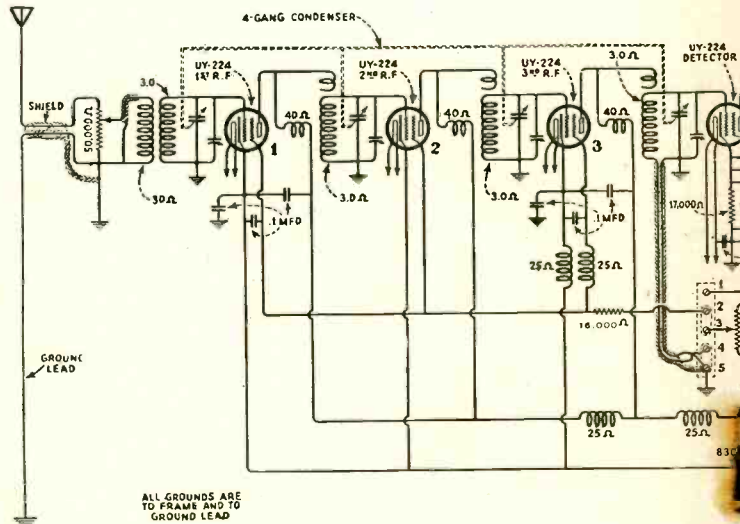

Fig. 1

The circuit diagram of Model 50 Majestic superheterodyne receiver. There is only one intermediate frequency amplifier and only two couplers tuned to the intermediate frequency.



ALL GROUNDS ARE TO FRAME AND TO GROUND LEAD

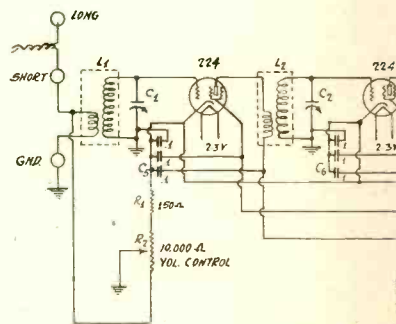

Fig. 3

The diagram of Model 440 Sentinel receiver, which contains three 224 type screen grid tubes, two 227 and one 245 power tube.

# Westinghouse WR-4 and Sentinel Sets

## in Schematic Diagrams

MODEL 50 CHASSIS  
110 VOLT 50-60 CYCLE

component of the detector output is transmitted to the power amplifier. Since the mid-tap of the high impedance coupler is connected to the high positive voltage, the same as the plate returns of the power tubes, it is necessary to isolate the grids of the power tubes from the high voltage. This is done by means of a .025 mfd. condenser in the grid lead of each power tube. A grid leak resistance of 430,000 ohms is used in each grid circuit to maintain the grids at the proper negative voltage.

### RF Couplers

The couplers between two successive tubes in the radio frequency amplifier is no less unusual than that between the detector and the power stage. In the plate circuit is a high impedance choke coil which matches the impedance of the tube. This coil is mounted inside the tuned coil in the grid circuit of the tube that follows and it is at right angles to that coil. The orthogonal relation is used to insure that the inductive coupling between the plate coil and the following grid coil to be a minimum. A single turn of wire, connected to the plate of the tube ahead and placed at one end of the grid coil provides capacitive coupling between the two circuits. This method of coupling is used because the inductance of the plate coil and the distributed capacity resonate at about 350 kc., making the receiver more sensitive at the low frequency end of the tuning range than it would be with the ordinary arrangement of coils and condensers. Since the coupling between the single turn and the grid coil increases with frequency, this coupler causes the circuit to be more sensitive at the high end. The combination of the two results in practically uniform sensitivity from one end of the range to the other.

The input coupler is an ordinary radio frequency transformer, the secondary of which is tuned with one section in the four-gang condenser. The primary of this transformer has a comparatively high resistance, being 30 ohms.

The volume is controlled by means of two 50,000-ohm potentiometers, one placed in the antenna circuit and the other in the screen circuits. The high voltage end of the primary of the first RF transformer is connected to the slider of the first potentiometer so that any fraction of the signal voltage developed across the resistance by the antenna current can be applied to the transformer. The second 50,000 potentiometer varies the screen voltage on the first three tubes. Both are controlled by the same knob.

### Phonograph Pick-up

Provision is made for connecting a phonograph pick-up unit in the grid circuit of the detector tube. The terminals for the phonograph unit are (4) and (5) on the terminal strip under the detector in Fig. 2. It will be noticed that the pick-up unit is cut into the tuned circuit between ground and the coil.

The filter in the B supply is put in the negative lead instead of in the positive, as is usual. The filter consists of a 0.1 mfd. condenser in shunt with the line to take out high frequency ripple that may be present. Then there is a 315 ohm choke coil in series. This is tapped at a point 300 ohms from the negative end and to this tap the field coil of the dynamic speaker is connected. The 15 ohm section of the coil is connected to a 2 mfd. condenser, the other side of which goes to the positive side of the line. Finally there is a 1.5 mfd. condenser from the positive side to ground. The small 15 ohm section of one of the filter coils and the 2 mfd. condenser connected in series with it across the line form a tuned circuit which is adjusted to the hum frequency. At the resonant frequency the only impedance is the 15 ohms. Hence the line is virtually short-circuited to the hum frequency.

### Sentinel Receivers

Fig. 3 and 4 give the circuit diagrams of two of the models of the Sentinel line, namely, Models 440 and 104. Both are screen grid receivers, each incorporating three 224 type tubes. Both also utilize power detection, but in Model 440 the detector is a 227 tube working into a resistance coupler and in Model 104 the detector is a 224 type tube working into the same type of coupler. Model 440 contains a single 245 power tube, whereas Model 104 contains two in push-pull. (Fig. 4 will be published next week.)

In both models the field coil of the dynamic speaker is one of the filter coils in the B supply. In Model 440 the first filter coil is tuned by means of a 0.25 mfd. condenser and in Model 104 choke unit is used.

The volume controls in these circuits are somewhat different from those used in other receivers. Referring to Fig. 3, R2 is a 10,000 ohm potentiometer, used both in the antenna and the cathode circuits. As the slider of the potentiometer is moved toward the antenna the primary is short-circuited and at the same time the 10,000 ohms in the potentiometer is cut into the cathode leads of the first two tubes, thereby increasing the bias. In most circuits the same thing is accomplished by means of two potentiometers on the same control.

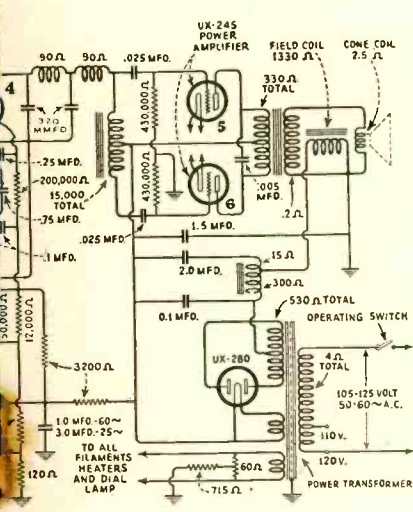
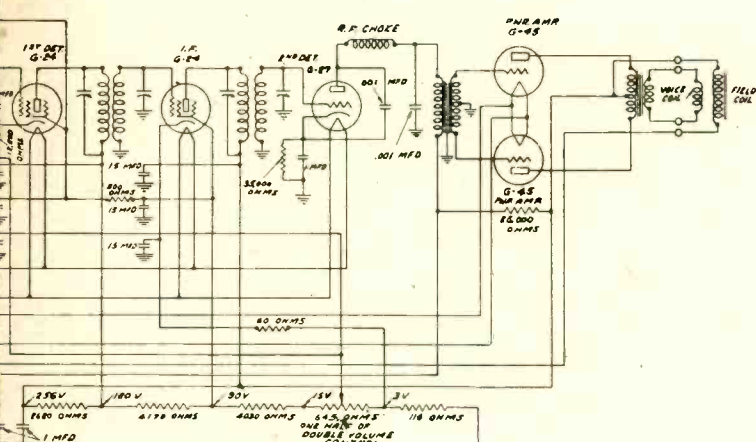
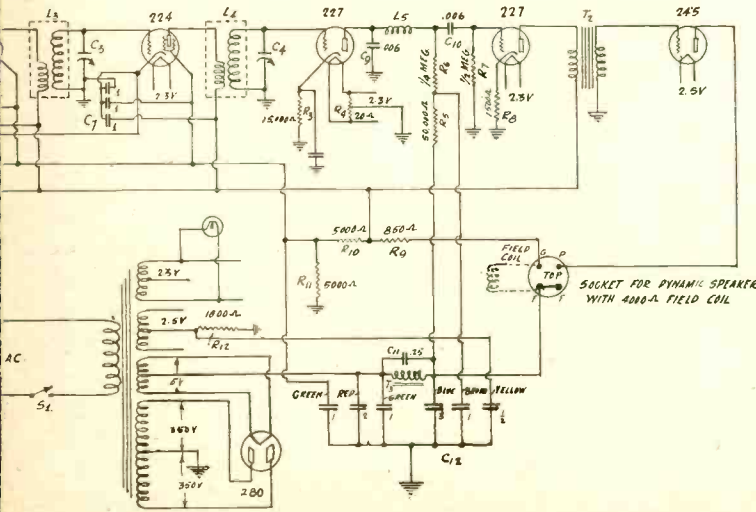

Fig. 2 (Left)  
The diagram of Westinghouse Model WR-4 receiver. A screen grid power detector ahead of the push-pull power stage is made possible by a special high impedance coupler.



# How to Avoid Grid Bias

By J. E.

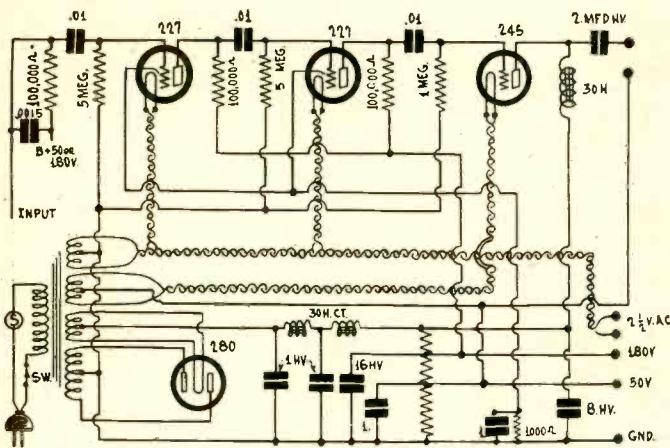

Fig. 1

The circuit of a resistance-coupled amplifier in which 227 type tubes are used. There will be some high frequency cut-off because of the capacity between the plate and the grid of each tube.

SCREEN grid tubes seem to have been made to order for resistance-coupled amplifiers, yet they are not popular for this purpose, possibly because resistance coupling is not popular. Many experimenters have built all kinds of amplifiers in the quest for the best possible quality, but few have settled on resistance coupling. Indeed, it seems that most of them have sworn never to try resistance coupling again.

One reason given for not using resistance coupling is that the amplification per stage is not so great as when transformer coupling is used. This was a good excuse before the high mu tube was developed, but it is no longer true, now that we have not only the high mu three-element tube, but also several screen grid tubes.

Another reason given for not using resistance coupling is that the circuits are unstable. This objection is valid to some extent, but not when the amplifier is designed properly.

Still another objection is that the quality is poor. There never was any good reason for this opinion of resistance-coupled amplifiers.

## Troubles With Resistance Amplifiers

There are two principal difficulties with resistance-coupled amplifiers. One is their tendency to instability and oscillation. The other is their tendency to drift, or the tendency of the grid bias to assume a zero or positive value. When either of these troubles occurs the amplification is poor and the quality is very bad, if anything at all can be obtained from the amplifier. These difficulties may occur no matter what tubes are used in the circuit, but screen grid tubes are less likely to the drifting trouble than three-element tubes, because of the structure.

The cause of the drifting is too much current leakage from the positively charged conductors around the control grid to that grid, and insufficient leakage through the regular grid leak. This might be expressed as the insulation of the control grid from the positively charged conductors, such as the plate of the tube itself and the plate of the tube ahead of it.

In the screen grid tube the control grid is so located that there can be very little leakage from the plate, or the screen, to the control grid, and it may be neglected in considering the operation of the tube in a resistance-coupled amplifier. The leakage from the plate ahead of the tube, however, is just as serious in this instance as in any other because it takes place through the stopping condenser and the external insulation.

In assembling a screen grid resistance-coupled amplifier it is therefore only necessary to insure that the stopping condenser be of good quality, preferably mica dielectric, and that any conductor to which the control grid is connected touches only the highest class of insulators, and as little insulating material as is practical.

## Don't Use Too High Leak Values

A grid leak, of course is necessary, and since it offsets the leakage from the positively charged conductors, it should not have too great a resistance value. If it has, the leakage will not be sufficient to maintain the grid at the proper negative operating potential and distortion or blocking will result. A value of 1.0 meg. should be sufficient, although in many instances values as high as 5 meg. may be used successfully. Try the highest value

first. If drift occurs it is necessary to use a lower value of resistance.

The best method of determining whether the bias drifts toward the positive is to put a milliammeter in the plate circuit of the suspected tube, which in nearly all cases is the power tube, and note what happens. If the plate current gradually increases, a lower grid leak resistance is necessary.

In cases of drifting bias, the amplifier works all right for a while after the set is turned on but the quality gets worse and worse until the output is badly distorted. Turning off the power for a while restores the set to operating condition.

## Relation Between Quality and Grid Leak

It is desirable to use the highest value of grid leak resistance that will make the amplifier function without any drifting, because the higher the resistance the greater is the amplification, particularly on the low notes. The amplification at the low frequencies is also related to the value of the capacity of the stopping condenser, being greater the larger the capacity. In fact, the amplification at the low notes depends on the value of the product of the capacity of the condenser and the grid leak resistance.

If the capacity is measured in farads and the resistance in ohms, the product should not be smaller than .02 second. A much larger value would be desirable if it can be used without upsetting the stability of the amplifier, both in respect to oscillation and grid drift.

## A Simple Remedy

If the amplifier is unstable in either of these respects a simple remedy is to reduce the time constant, and it may be done by reducing either the stopping condenser capacity or the grid leak resistance. It must be remembered, however, that stability is achieved in this manner only at the expense of amplification of the low notes and hence at the expense of quality.

To get a high degree of amplification from each tube in a resistance-coupled amplifier it is essential that the load impedance on that tube be as high as possible. This does not mean that the plate resistance alone should be a high resistance, but that the plate resistance shunted by the grid leak should have a high resistance value. As long as the plate coupling resistance is as low as 100,000 ohms, and the grid leak resistance effectively in parallel with it is 1.0 meg., we need consider only the plate coupling resistance, but when the plate resistance is of the same order of magnitude as the grid leak, we must consider both. It is especially important in screen grid circuits to have high resistance values.

## High Note Loss

When the resistance load on a three-element tube is increased there results a decrease in the amplification of the high notes and therefore an impairment of the quality. This is directly due to the capacity between the plate and the grid, which causes a great increase in the effective capacity between the grid and the filament. It partly short-circuits the input to the tube at high frequencies. This effect occurs only when the load on the tube is resistive. Since the load on the power tube is inductive in most instances, there is no high note loss in this tube. Indeed, the inductive load may cause an increase in the amplification on the highest audio frequencies.

When screen grid tubes are used in resistance coupling there is very little high note loss, because the effective plate to control grid capacity is negligibly small. This is one marked advantage of using screen grid tubes for this purpose, but the main advantage, of course, is that the amplification on all notes is much greater.

The screen grid tubes are so well suited to resistance coupling that it seems unnecessary to consider any other types. But screen grid tubes cannot be used successfully without certain precautions. For one thing, the various voltages must be adjusted much more carefully than is necessary for three-element tubes.

## Must Keep Up Plate Voltage

It is absolutely necessary to insure that the applied plate voltage is so high that the effective plate voltage never is smaller than the screen voltage. If this is not observed the screen grid tube will not function properly as an amplifier.

There are several methods of adjusting the circuit to prevent this situation. In this first place, the resistance in the plate circuit may be made low so that the voltage drop in the resistance will be low. But this defeats the main object of the tube, a high degree of amplification.

A better way is to use a high value of plate resistance and to boost the applied plate voltage to a very high value. This allows the use of a moderately high screen voltage and a comparatively high input voltage so that a high signal voltage may be taken off

# Drift in Resistance AF

Anderson

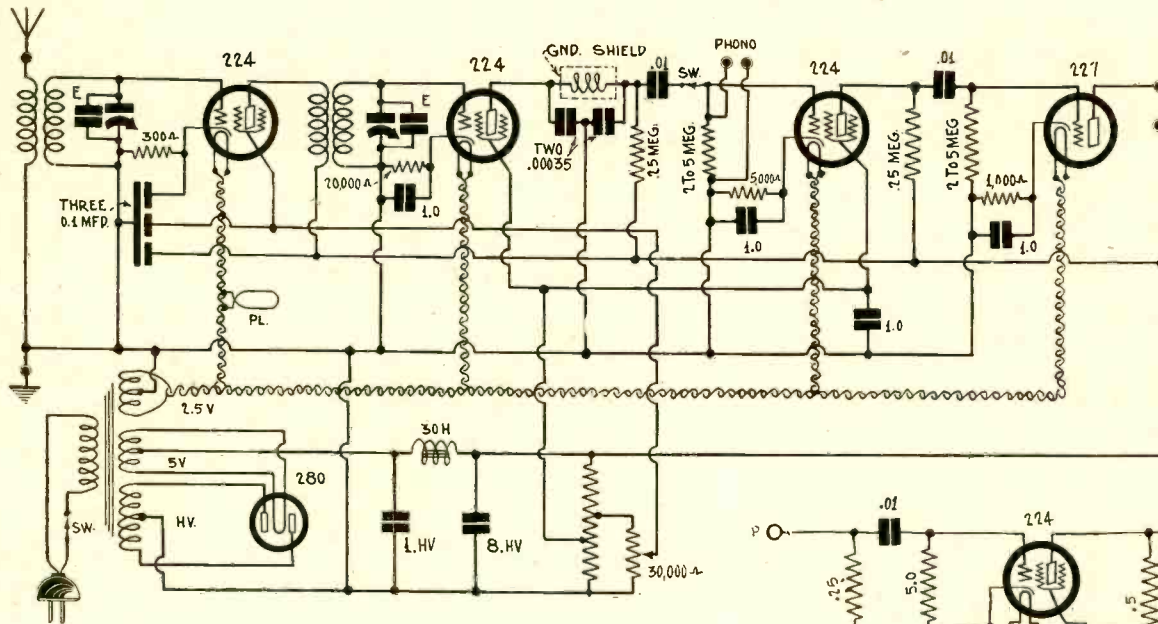

Fig. 2  
In this circuit the 224 screen grid tube is used as detector and first audio amplifier. No screen circuit resistance is used but the applied screen voltage is low.

the tube. But if the plate load resistance is as high as it should be, say 250,000 ohms or more, the required applied plate voltage would have to be impractically high.

### Use of Low Screen Voltage

In place of boosting the voltage in the plate circuit to insure that the effective plate voltage is always greater than the screen voltage, the screen voltage may be lowered. In practical cases the screen voltage is usually one-fifth or one-fourth the value of screen voltage that would be used when the same tube is used in a radio frequency amplifier with transformer coupling. For example, when the applied plate voltage is 180 volts, the grid bias 1.5 volts, and the plate coupling resistance around 500,000 ohms, the proper screen voltage is in the neighborhood of 15 volts.

Lowering the screen voltage in this manner does not appreciably change the degree of amplification that can be obtained from the screen grid tube. This is evidenced by the fact that curves between the output voltage and the control grid voltage are similar for different screen voltages over the allowable operating range of grid voltages.

If the screen voltage should happen to be a little too high for a given combination of plate load and applied plate voltage, the tube will function, provided that the grid voltage is not allowed to go too close to the zero bias point. If the screen voltage is as high as that recommended for the tube when used in a radio frequency amplifier it is practically impossible to get any undistorted output from the tube.

### Resistor in Series with Screen

Another method of preventing the screen voltage from ever assuming a value higher than the effective plate voltage is to put a high resistance in series with the screen lead. When this is done it is permissible to apply a voltage in the screen lead equal to that applied when the tube is used in a radio frequency amplifier. The reason why this works is that there is a screen current as well as a plate current and that the two rise and fall together. Hence when the plate current increases and causes an increase in the drop of voltage in the plate load resistance, the screen current rises also and causes an increase in the drop in the screen circuit resistance. Thus the effective values of the plate and screen voltages fall together. They also rise together.

The resistance in the screen circuit is equally valuable whether the screen grid tube be used as an amplifier or as a power detector. In either case it stands guard against distortion of the waveform. If the screen circuit resistance is to be equally effective at all audio frequencies it should not be by-passed by any condenser. However, even when it is by-passed it serves a useful purpose in cutting down the average effective screen voltage to a value it would have if the applied voltage were lower as was previously suggested.

### Suggested Values

Suitable plate and screen resistance for a tube like the 232

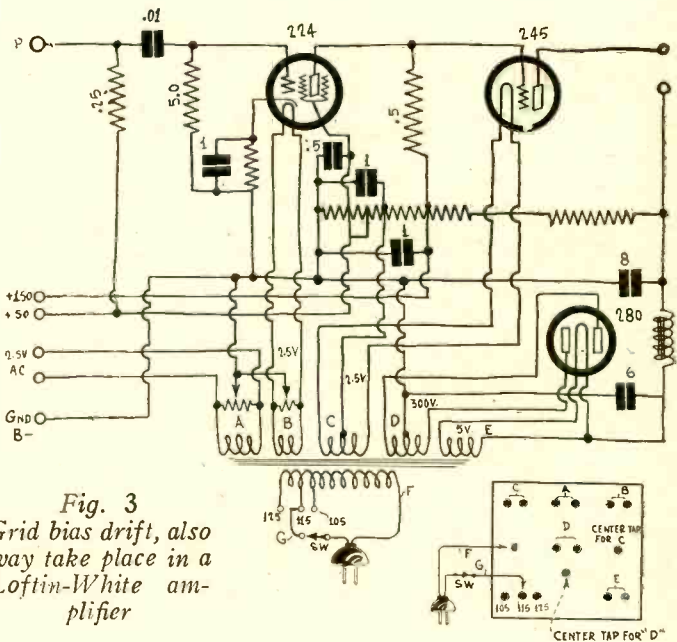

Fig. 3  
Grid bias drift, also way take place in a Loftin-White amplifier

are 200,000 ohms for the plate and 100,000 for the screen, the applied plate voltage being 135 volts, the applied screen voltage being 45 volts and the grid bias being 4.5 volts negative. About the same values hold for the 222 screen grid tube. In case of the 224 the applied screen and plate voltages should be 75 and 180 volts respectively and the grid bias 3 volts negative. The plate coupling resistance can well be 250,000 ohms and the screen circuit resistance 100,000 ohms.

### Favor High Plate Voltages

These values do not mean that higher applied plate voltages on any of these tubes cannot be used. It is always well to use high plate voltages because the higher they are the higher will be the amplification and the greater will be the output voltage before distortion sets in. Plate voltages as high as 300 volts have been used on the 224 in series with a coupling resistance of 250,000 ohms.

### Capacity Coupled Band-pass Filters

In most TRF band pass filters the two tuned circuits are coupled together by means of a .04 mfd. condenser shunted by a 500 ohm resistance. Why is .04 mfd. used in place of some other value and why is the resistance used at all?—S. G.

The resistance is used to provide a grid leak across the condenser and .04 mfd. is used because that gives the desired band pass characteristic. If a narrow band is desired the capacity is made large and if a broad band is desired the capacity is made small. The size of condenser for a given band width also depends on the values of the tuning capacities.

# Right or Wrong?

## QUESTIONS

- (1)—Condenser type microphones are used in nearly all broadcasting stations in this country and in Europe.
- (2)—Short-wave converters usually don't work effectively with superheterodyne receivers in which there is no radio frequency amplification ahead of the modulator tube.
- (3)—A carbon microphone works on the same principle as a compression type, carbon rheostat.
- (4)—A B supply filter having series tuned circuits across the line and parallel tuned circuits in series with it, can be made more effective at a given cost than the ordinary filter consisting of shunt condensers and series chokes.
- (5)—When the volume is controlled by means of varying the grid bias on the radio frequency tubes, modulation hum usually results.
- (6)—When the tone quality of a radio receiver suddenly goes bad it is usually necessary to put in a new set of tubes.
- (7)—When a radio receiver is equipped for the playing of phonograph records and the pick-up unit is connected in the grid circuit of the detector, it makes no difference whether the grid bias on the detector is changed or not.
- (8)—A resistance is usually connected across the terminals for the field winding of a dynamic speaker when the field is connected in series with the B supply because without the resistance there would be too much current through the field.
- (9)—A large by-pass condenser wound inductively may be entirely valueless at short waves, whereas it may be all right at audio frequencies.
- (10)—A loudspeaker can be used as a microphone by connecting its terminals to the input of a sensitive amplifier and then talking to the speaker diaphragm. The more sensitive the speaker as a speaker, the more sensitive it will be as a microphone.
- (11)—When the grid bias in radio frequency amplifiers utilizing the 224 tube is made very high for the purpose of reducing the volume, hum results due to modulation.

## ANSWERS

- (1)—Wrong. While microphones of this type are used in most stations in this country, a special carbon type microphone is used more frequently in Europe.
- (2)—Right. When there is no radio frequency amplification ahead of the modulator in a superheterodyne there are two frequency changes in succession without any amplification in one of

the frequency levels, and it seems that satisfactory results are not obtained with converters under these conditions. Modern superheterodynes now have at least one stage of RF ahead of the modulator.

(3)—Right. When carbon is compressed its resistance to electric current is reduced. It is on this principle that the compression type rheostat works. The carbon microphone works on exactly the same principle. As the diaphragm vibrates under the influence of the sound that impinges on it, it causes changes in the pressure on the carbon granules.

(4)—Right. If a parallel tuned circuit is put in series with the line and adjusted to the hum frequency, the impedance to that frequency will be much greater than that of a choke having the same inductance as the choke in the tuned circuit. Likewise, if a series tuned circuit is put across the line and adjusted to the hum frequency, the impedance of that circuit to the hum frequency current will be much smaller than the impedance of a condenser of the same size as used in the series circuit. Indeed, it will amount to a short-circuit at that frequency.

(5)—Right. This is due to the fact that when the bias has been increased to the point where amplification is poor, the tubes are good detectors or modulators.

(6)—Wrong. If the tone is poor on loud signals, it is indicative of bad tubes, but the probability is that only the output tubes are bad, because these give out first under normal operation.

(7)—Wrong. If the detector operates on the negative bias principle it will not function as an amplifier of the phonograph signals unless the bias is reduced to the value it would have in an amplifier stage.

(8)—Wrong. The main object of the resistance in shunt with the field winding is to insure some current even if the field is disconnected, accidentally or intentionally. If the current should stop entirely the voltage might rise so high as to endanger the condensers.

(9)—Right. A condenser in which the two electrodes are wound so that there is inductance may act as a choke coil for high frequencies and such a condenser would do more harm than good.

(10)—Right. This does not make a very sensitive microphone but it does make one that works. Low sensitivity in the microphone can easily be offset by high amplification in the audio amplifier.

(11)—Right. If there exists any hum voltage in the grid circuits, as is usually the case, it intermodulates with the carrier and passes through the tuners as part of the signal. This condition is manifested by the appearance of hum when the circuit is accurately in tune.

# FREE AID TO A NEW JOB!

SITUATIONS WANTED AND HELP WANTED ADVERTISEMENTS WITHOUT COST!

RADIO WORLD will publish, FREE, under the heading of Radio Situations Wanted or Help Wanted, advertisements for those who are seeking radio situations or for employers who are adding to their working forces.

Address: Industrial Dept., RADIO WORLD, 145 W. 45th St., N. Y. C.

## SITUATIONS WANTED

**EXPERIENCED** radio service and custom building man wants position. A. J. Norman, Geneva, N. Y.

**YOUNG MAN 24**, desires position with broadcasting station. Has had experience in studio work, office work; musical and dramatic ability. Can furnish references. R. E. Fuller, Box 284, North Conway, N. H.

**WIRING AND ASSEMBLING MAN** on radio sets desires prompt connection. Good character. Ben Schurman, 196 Bristol St., Brooklyn, N. Y.

**YOUNG MAN 30 YEARS OF AGE** wishes position in service and installation work. J. Hamilton, 329 So. 6th Ave., Mt. Vernon, N. Y.

**NATIONAL RADIO INSTITUTE STUDENT** wishes position with store or factory. M. J. Palmer, 10733 Lafayette Ave., Chicago, Ill.

**RADIO SERVICE MAN**, 35 years old, desires position in southwest. Been actively engaged in radio in all forms since its beginning. Just recently disposed of own shop. Would like to get in the sound engineering game. Address, D. W. Pickett, 917 No. Washington St., Kokomo, Indiana.

**YOUNG MAN WISHES CONNECTION** with a Radio Research Laboratory which is interested in the reduction of received static only. Write S. Stella, 958 How Ave., Bronx, New York City.

**EXPERIENCE FIVE YEARS**, custom set builder and designing. 25 years old, single, reliable. Knew radio when Electro Importing Co. was the only supply house available to amateurs. Would like factory or laboratory work—go anywhere. Floyd Hoskins, Jr., care Hotel Atlantic, Bay and Hogan Sts., Jacksonville, Fla.

**RADIO MAN, 3 YEARS EXPERIENCE**, desires work. Write Frank Lavallee, 218 Baxter St., Pawtucket, R. I.

**NATIONAL RADIO INSTITUTE GRADUATE**, with three years' experience in building and repairing receivers. Would like to obtain position. William B. Floyd, Box 22, Monroe, Virginia.

**RADIO SITUATION WANTED**. Radio Repair and serviceman, 21 years old, High School education, three years experience, would consider radio position of any kind, anywhere in United States. Kenneth P. Henderson, 115 Honeoye St., Shinglehouse, Pa.

**EDITORIAL or CORRESPONDENCE** position desired by woman experienced in newspaper Editorial and Radio Departments; also has had sales experience. Steady worker. Phone Havemeyer 8996-J.

**COMPETENT RADIO SERVICEMAN**. Weston test equipment. Go anywhere. Casey, 325 E. 4th St., Jacksonville, Fla.

**YOUNG ELECTRICAL ENGINEER** wishes job in a radio laboratory or engineering department. Will work for small starting salary. Location preferably in the middle west. D. Zimmerman, 1720 W. Harrison St., Chicago, Ill.

**YOUNG MAN 19, TECHNICALLY INCLINED**, desires position as assistant in radio laboratory. Formerly connected with Pilot experimental tube laboratory. Write August L. Oechsli, 280 Linwood St., Brooklyn, N. Y., or phone Applegate 8631.

**RADIO SERVICE-MAN** wishes position in either store or factory. Have three years outside experience. Am now student of National Radio Institute, Washington, D.C. L. Schudde, 155 Meserole St., B'klyn, N. Y.



# Placement Problems

By John C. Williams

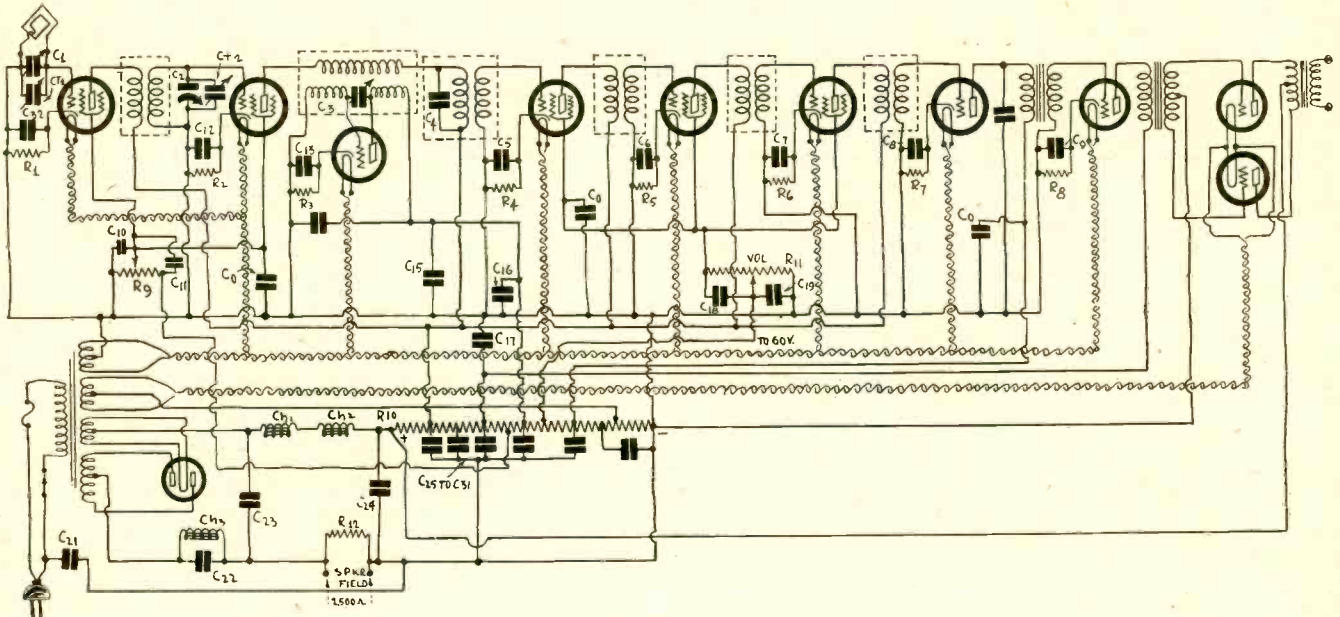

FIG 1

A SUPERHETERODYNE FOR AC OPERATION WITH MANUALLY OPERATED SENSITIVITY CONTROL THAT STAYS PUT FOR ANY GIVEN ADJUSTMENT, OBVIATING THE NEED FOR A SEPARATE LOCAL-DISTANCE ADJUSTMENT.

THE wiring layout of Fig. 1 perhaps does not look so very different from one that appeared recently, but close inspection will reveal that there are some differences in the wiring, as well as the addition of a tuned radio frequency stage which will add to the amplification.

One of the first things that will doubtless strike the eye of the fan is the number of tubes that are to be operated. This suggests that a power transformer of generous proportions will be necessary, perhaps larger than usual. There is seen to be a tuned choke, and in this case it will have to be carefully adjusted, due to the increased sensitiveness of this circuit.

### Load Distribution Important

It is sometimes the practice when the plate load is likely to be more than 90 milliamperes to employ two rectifiers, one for the set, and the other for the field of the dynamic speaker, which field may be of high impedance, having upwards of 50,000 turns of No. 34 enameled wire. The operative voltage would be of the order of 300 to 350 volts, the impedance being so high that hum is absent.

The field wattage is of the order of from six to eight watts, depending on the dimensions of the pot magnet (field coil) parts. In this set the expected plate load will be of the order of seventy milliamperes. This current flows through the field coil of the dynamic speaker.

The voltage divider is of 24,000 ohms resistance, which results in a bleeder current of 15 milliamperes, or lower than what is used with some tuned radio frequency sets, but it has been found to be of sufficient intensity in this case.

### A Substantial Gain

There are more tubes used, it is true, but due to the manner in which they are to be worked, the final result will be a substantial gain over a TRF receiver. In fact, the secret of being able to work so many tubes without overloading the rectifier may be said to be due in large measure to the manner in which the 280 tube is loaded, it is well known that in mechan-

ical systems that excessive strains may be avoided if the distribution of the load is done scientifically. The same is just as true of the voltage divided system.

This set is equipped with two control circuits which have proven their merit amply in recent Superheterodyne sets. When the listener desires to enjoy the local program to the fullest extent, it is not essential for the set to be in condition to receive stations thousands of miles distant, and on the other hand when great distances are expected with the adjustment that provides ample local reception volume, the result would be inadequate.

The fact that this kind of compensation can be obtained readily by the mere turning of a knob, is sufficient justification for such. The set, at the option of the constructor, may be so laid out that the sensitivity control can be either at the left or the right-hand of the front panel.

### Sometimes Too Much Shielding

The set is laid out more or less on the plan of the letter H. The RF coils that compose the intermediate amplifier, the oscillator and the tuned RF stage, are in shield cans.

The builder may have the choice of either a metal front panel or a wooden one. The chassis is of stamped angle, with the tube sockets mounted on a suspended bakelite strip. An unusual variety of shield treatment consists of the use of shielded wire, in a manner not usually employed, the braces and the side arms of the chassis are so assembled that chassis eddy currents do not adversely affect the operation of the receiver.

But the assembly of this chassis is relatively simple. The power pack apparatus is mounted on a shallow chassis. In relatively close proximity to it are the components for its operation. The power transformer is placed so that its external field will have no appreciable effect on the reproduction at the speaker.

It is felt that shielding in the past on some sets has been carried to excess. The results of a new kind of shield treatment provide latitude for the desired sensitivity without the degree of aberration due to excessive shield effects.

(Continued next week)

## + NEW BOOKS +

Practical Testing Systems. By John F. Rider.

The function of this book is to present a number of practical testing systems suitable for application to the measurement on radio receivers, mainly with apparatus which the radio experimenter can either make himself or can procure at moderate cost.

The contents are divided into eight sections covering Measurement Instruments, Resistance Units, Oscillators, Tube Testers, Vacuum Tube Voltmeters, Capacity Tests, Inductance Tests, and

Audio and Output Systems. Under each heading many circuit arrangements are given and the principle of each test and each system is carefully explained.

Mathematical explanations are confined to the simplest algebraic and arithmetical expressions and are only used when they make the subject matter more easily understood. There are many circuit arrangements never found in text books or in other published literature.

A Question and Answer Department conducted by Radio World's Technical Staff. Only Questions sent in by University Club Members are answered. Those not answered in these columns are answered by mail.

# Radio University

Annual subscriptions are accepted at \$6 for 52 numbers, with the privilege of obtaining answers to radio questions for the period of the subscription, but not if any other premium is obtained with the subscription.

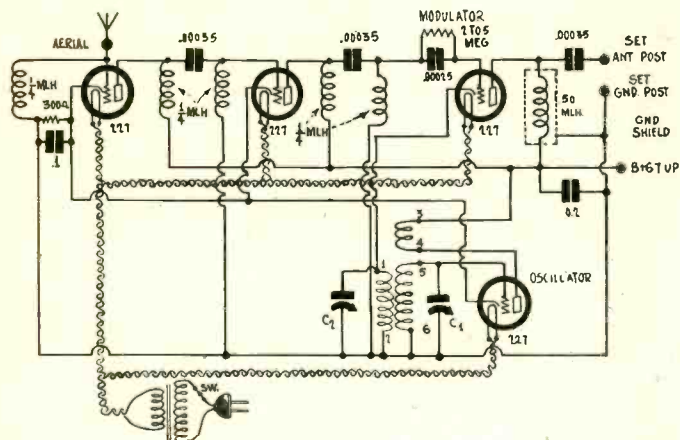

Fig. 873

Diagram of a three-tube, short-wave converter. The choke in the plate circuit of the modulator should have at least the designated value.

## Taking Curves on Push-Pull Amplifiers

WILL you kindly explain a method of taking curves on push-pull amplifiers for the purpose of determining whether or not they are balanced?—L.C.D.

Rig up the circuit with a grid battery common to the two tubes and of the correct value. Put a milliammeter in the circuit in the common plate return so that the plate currents of both tubes flow through it. Then provide another grid battery so arranged that when the effective bias on one tube is increased by 1.5 it is decreased by the same amount in the other. Take observations at every 1.5 volts, or at every cell. Plot a curve with plate current against the differential grid bias. The curve should be a nearly straight line. The circuit may be arranged so that a battery having a total voltage approximately equal to the common grid bias is connected with the positive to one grid and the negative to the other. The negative terminal of the common battery can then be moved from one grid to the other, one cell at a time. At one extreme the bias on one tube is approximately zero while that on the other is about twice the value of the bias battery, or is equal to the sum of the voltages of the two batteries. The differential battery should then be reversed and another curve taken. The readings should be averaged, point for point, and then plotted. The result should plot into a straight line and any deviation from that indicates distortion. The straight line should be parallel to the current axis because if the circuit is truly balanced there should be no change in the total plate current. Of course there will be some.

## Loud Hum in Speaker

MY receiver has developed a loud hum the cause of which I have been unable to locate. I wonder if there is something wrong with the filtering in the B supply. The condenser is of the electrolytic type and I have heard that these sometimes develop a trouble of this type. If that is so, will you kindly suggest a remedy?—F. W. C.

It is quite likely that the trouble is in the electrolytic condenser because in many instances trouble of this kind have been traced to it. A possible remedy is to put a fixed paper dielectric condenser across the section of the electrolytic which is suspected. This often cures the trouble even if the paper condenser is not left permanently across the other. If this does not cure the trouble a new condenser should be put in.

## Poor Matching of Transformers

I HAVE a first class radio receiver which gave fine results as long as I used it on a dynamic speaker. When a defect developed in this speaker I was induced to get an inductor dynamic but this does not give the results that the dynamic did. I have heard the inductor on other sets and know that it can do better than it is doing for me. What would you suggest as the trouble?—B. C. Q.

Very likely there is nothing wrong except improper matching of impedances. The output transformer was made for a dynamic speaker of low impedance and the inductor has a high impedance. Get the proper output transformer and the inductor will give you splendid results. If your power amplifier is of the push-pull

type just connect the inductor from plate to plate of the two output tubes and you will not need any transformer.

## Screen Grid Tube As Detector

WHAT is the best adjustment for a 224 tube when it is to be used as a power detector, if it is practical so to use it? I mean the voltages on the grid, screen, and the plate and the type of load on the tube?—G. W. F.

The first thing to do is to insure that the load impedance is very high, and the only way to get a really high impedance is to use a resistance. This can well be a resistor of half megohm or even greater. Next, the applied plate voltage should be high, and by high is meant 180 volts or more. If the load resistance is half megohm it is perfectly safe to put as much as 250 volts on the plate. When the load resistance and the plate voltage have been fixed it is only a question of fixing the grid bias and the screen voltage. Both depend on the applied plate voltage and on the resistance in the plate circuit as well as on each other. If a potentiometer of fairly high resistance, say 30,000 ohms, is connected from the screen return to the grid return and the cathode is connected to the slider, it is always possible to find the best combination for either best detection or best amplification. If this method is adopted the high voltage end of the potentiometer and the screen might be connected to 75 volts. If the potentiometer method is not used it is best to give the screen a voltage of about 15 volts and then adjust the grid bias until the detecting efficiency is the best.

As far as detecting efficiency is concerned, the same may be obtained with a large number of combinations, even when the voltages are very low, say 45 volts on the plate with correspondingly lower voltages on the other elements. But for power detection is necessary to make them high as suggested above. A by-pass condenser of about 2 microfarads should be connected across that portion of the potentiometer which is in the grid circuit and one of about 1 mfd across the other portion. If a by-pass condenser is connected across the load resistance it should be very small because a small condenser is very effective across a resistance of half megohm.

## Usual Bias Resistor

WHAT is the average value of the grid bias resistor for detection with a 227 tube? I have seen many diagrams in which values all the way from 2,000 to 25,000 ohms have been used. I presume that somewhere between the correct value lies.—W. H. J.

The correct value depends on the type of load in the plate circuit. If the load is a high resistance the bias resistor must be higher than when the load is a transformer or a choke coil. A common value when the load is either a transformer or an audio frequency choke is 20,000 ohms, and this value is all right. If the load is a high resistance of the order of 250,000 ohms the bias resistor must be much higher. As a matter of fact, it is not practical to depend on the plate current alone in this case to establish a bias, but the current must be augmented by a current through a resistance connected from the plate return lead to the cathode of the detector. When this method is used almost any value will do provided that the auxiliary resistance is chosen properly. Suppose the detector is adjusted for power detection and the load resistance is 250,000 ohms. The plate voltage might be 180 volts and the required grid bias 20 volts. We might neglect the plate current through the tube and assume that the current through the auxiliary resistance alone flows through the bias resistor. We may take a bias resistance of 10,000 ohms. How large should the auxiliary resistance be? The total voltage across the 10,000 ohm bias resistor and the auxiliary resistor is 180 volts and the current is to be such that the drop in the 10,000 ohm resistance is 20 volts. By proportion we get that the auxiliary resistance should be 80,000 ohms.

## Charger For A Supply

IN building a receiver like that described by Herbert E. Hayden in the Dec. 6th issue would it not be possible to use a battery charger rated at about 0.75 ampere for A supply? If so, how should the voltage be dropped to 2 volts, and what precautions would be necessary to prevent hum?—C. F. M.

It is quite feasible because the circuit only takes 0.31 ampere. Put a rheostat in series with the charger, say in the positive line, and simply adjust the resistance until the voltage across the filaments is 2 volts, as measured with a good voltmeter across the F terminals, or until the current is 0.31 ampere, as measured with a good ammeter in series with the charger output. Be sure that the series resistance is high enough when the charger is

first turned on for it if it is not the tubes might burn out. If the charger has provision for making the output either 0.75 or 0.5 ampere by moving a fuse, set it for half ampere. To drop four volts, the difference between the 2 volts required and the 6 volts of the charger output, you will need a rheostat of at least 13 ohms. A 20-ohm rheostat should be enough to give a good margin of safety.

To take out the hum you can connect an electrolytic condenser of very high capacity across the charger output. You can get one of 1,000 mfd. You can also put a heavy duty, low inductance choke in series with the supply line. This choke must not have a resistance higher than 13 ohms because if it has you will not be able to get enough voltage on the filaments of the tubes.

**Amplifier for Phonograph**

IS it necessary to have a radio set in order to play records with a loudspeaker? We have a good phonograph of the old kind, but the radio set is run on batteries and we are told it will not do for phonograph records. What do you advise that we do?—C. L. O.

You may obtain a power amplifier, using one amplifier tube such as the 210, or 250, and also containing a B eliminator that may also supply B voltage for the radio set. A dynamic loudspeaker is required for full satisfaction from the records. Old-style records will not prove very pleasing—the new electrically-recorded kind are needed. The new loudspeaker and amplifier are available in separate units, and your radio may be connected to them. The present power (or last) amplifier tube of your radio will not be used in that event.

**Use of 32-Volt Plant**

UNDERSTAND that there is some system which enables us to run a radio without a storage battery where there is a 32-volt plant in the house. We have a storage battery set, giving good results, but the battery is played out.—N. J.

Yes, you may obtain a resistor of the correct size, which is screwed into a socket and connected in series with the A terminals. Your dealer can order one for you, but he must know exactly how many and what kind of tubes you use, in order to obtain one of the correct resistance value. Otherwise the tubes may light too brightly and soon burn out, or they may not be lighted brightly enough. Describe your set fully, and I will be glad to send a diagram of the connections. Address this paper, sending a stamped return envelope.

**Inquiry on Television**

WHAT form of set is best to receive television broadcasts?—A. P. O.

A short-wave set is used, with a resistance-coupled amplifier. Transformer amplification will not amplify the extremely wide frequency variations found in television. It is not possible to see well by radio with a short-wave set used in conjunction with a broadcast outfit. A special short-wave set made for the purpose, is necessary. Then disc and screen are necessary.

**Wants Hum Eliminated**

HAVE constructed an AC set but would like some advice on eliminating hum. The speaker does not hum, as I tested it on a friend's set and it is almost silent.—M. L.

It is difficult to suggest causes of hum. Here are a few: Magnetic interaction between power transformers or filter chokes and audio transformers in the set; grid leads too long, especially in detector and first audio tube; first stage audio transformer too near AC wires or filter system or power transformer; AC wires not twisted; faulty tubes or rectifier; nearness of set to speaker, to lamp cords, power wiring, speaker cord; detector grid circuit near other wires.

**"Bucking" Speakers**

OUR local theatre, using the phonograph record system, maintains it cannot place a loudspeaker at the rear of the auditorium. Yet, many are unable to hear when they have to sit at the back. I cannot understand why loudspeakers could not be located both in front and back, so all could hear better.—A. C. S.

The theatre is right, but should have no trouble obtaining satisfactory volume if the amplifier and speakers are big enough. If a loudspeaker were placed in the rear as well as in front, every one in the house would get a fuzzy reproduction, because the sound from one speaker would reach his ears before the same sound from a speaker farther away. It has been tried and proved very objectionable.

**Twisted Pair Necessary**

WILL you kindly explain whether it is absolutely necessary to twist the filament wires of a set? I am remodelling my set into an all-electric one, and would rather not rip out the filament wiring.—M. N. P.

Yes, it is necessary to prevent magnetic coupling effects which would reach out from ordinary straight wires and induce hum in the sensitive wires and parts of the set. In rewiring, provide heavy filament wire, as AC tubes draw many times the current required for ordinary storage battery tubes.

**Receiver Has Developed Hum**

A BAD hum has developed in my radio receiver. What do you think is the cause of it?—W. O. H.

There are so many kinds of hum and so many causes that it is impossible to express an opinion on the subject. It is necessary to proceed by elimination until the cause is found. Sometimes the hum occurs when one of the power tubes in a push-pull amplifier goes bad. At other times it develops when a condenser in the B supply opens. In some instances the trouble is in the loudspeaker.

**Throbbing in Phonograph Music**

I HAVE a receiver equipped for playing records. As a radio receiver it works all right but as a phonograph reproducer it does no longer give good results. There is a peculiar throbbing sound which seems to be synchronous with the rotation of the record. I have tried new motors and turntables without change. What do you suppose is the trouble?—B. F.

It may be that the motor driving the turntable is not strong enough to drive it uniformly. This might be the case when an induction motor is used. If the turntable has any tendency to wobble, the load on the motor would vary cyclically with the rotation of the record. Even if the motor is strong enough a wobble in the turntable might cause a noise like you experience. Possibly the trouble may be remedied by counterbalancing the pick-up unit so that the weight on the needle is reduced. Leave enough weight on it just to hold the needle in the groove.

**Extending Converter Range**

IF the oscillator coil in a short-wave converter is designed to cover a certain range with an intermediate frequency of 550 kc, will it cover the same range if the intermediate frequency is 1,500 kc? If not, will the change in the intermediate frequency raise or lower the range?—B. L. F.

The change in the intermediate frequency will change the tuning range of the coil. Suppose the coil is designed so that it will cover the range from 1,500 kc to 3,000 kc, when the intermediate frequency is 550 kc. The oscillator then will cover the frequency 2,050 to 3,550 kc. Now if the IF is changed to 1,500 kc the range will be from 550 to 2,050 kc. The change in the intermediate frequency therefore makes the circuit tune to lower frequencies. That is the case when the upper oscillator setting is used.

**Converter Brings in Code**

I BUILT one of the converters which you described and I was led to believe that it would bring in short-wave broadcast stations. I am very much disappointed because I have not been able to get anything but code signals. Why does the converter not work on voice and music?—W. A. C.

If you can get code stations on the converter you can also get voice and music, if there are any stations around sending out these signals.

Join  
Radio World's

# University Club

And Get Free Question and Answer Service for the Coming 52 Weeks. This Service for University Subscribers Only

Subscribe for RADIO WORLD for one year (52 numbers). Use the coupon below. Your name will be entered on our subscription and University Club lists by special number. When sending questions, put this number on the outside of the forwarding envelope (not the enclosed return envelope) and also put it at the head of your queries. If already a subscriber, send \$6 for renewal from close of present subscription and your name will be entered in Radio University.

**NO OTHER PREMIUM GIVEN WITH THIS OFFER**

[In sending in your queries to the University Department please paragraph and number them. Write on one side of sheet only. Always give your University Club Number.]

RADIO WORLD, 145 West 45th Street, New York City. Enclosed find \$6.00 for RADIO WORLD for one year (52 nos.) and also enter my name on the list of members of RADIO WORLD'S UNIVERSITY CLUB, which gives me free answers to radio queries for 52 ensuing weeks, and send me my number indicating membership.

Name .....  
Street .....  
City and State .....

# 400 KW PERMIT IS GRANTED TO WESTINGHOUSE

Pittsburgh. The Federal Radio Commission has licensed the highest power radio transmitter of the United States, if not of the world. This experimental transmitter, W8XAR, at Saxonburg, Pa., may use 400,000 watts, eight times the prevailing maximum. This station will operate on 980 kilocycles, the operative frequency assigned to KDKA, but the high power will only be used between the hours of 1 a.m. and 6 a.m.

The application for permission to use this high power was filed by with the Federal Radio Commission by H. P. Davis, vice-president of the Westinghouse Company, who has charge of radio transmitting development.

The purpose of this high power is determine its effect on reception throughout the country. To make this test the Westinghouse Company shortly will station engineers at listening posts at selected points. These men will make the necessary technical observations, recording the effect of the increased power, noting how it blankets the prevalent static, the fading, etc. The station will be located about 30 miles from Pittsburgh.

## Board Creates a New Division

Washington. Consistent with its policy of improving administrative processes, the Federal Radio Commission announces the creation of an Examiners' Division, which will be headed by Chief Examiner Ellis A. Yost. Associated with the Chief Examiner will be Examiners Elmer W. Pratt and R. H. Hyde.

The function of the new division will be to hear and pass on cases that are the result of applications submitted. The examiners thus will prepare cases for presentation to the Commission, submitting testimony and recommendations for the final disposition of petitions.

## Pleas to the Board Average one a Day

Washington. Recent statistics completed by the Federal Radio Commission show that applications received by the Commission for all classes of broadcast petitions average at least one a day.

There were 308 applications for new stations. Of this total the Commission has granted licenses to 201 applicants. All these are broadcasters operating within the 1,500 to 500 kc frequency range. The grand total for all classes of applicant was 1,616.

# SNAG STRUCK ON EQUALIZATION

Washington. The Federal Radio Commission has been deliberating several plans with a view to attempting to redistribute the broadcasting facilities of the nation in accordance with the provisions of the Davis Equalization Act, which is an amendment to the Radio Law.

The Commission has finally decided that it will have to shelve the whole matter temporarily, as the plans now before it are incapable of application.

The original plans prepared by Chairman Charles McK. Saltzman and Commissioners W. D. L. Starbuck, Ira E. Robinson, are among the ones that were under consideration. The Robinson plan was later amended at the suggestion of Commissioner Sykes. It provided for a gradual increase of the facilities of under-quota States with a corresponding decrease of the facilities of the over-quota States. In all there were four separate proposals before the Commission.

Approximately one-half the States have more than their proportional share of broadcasting facilities. The law provides that there shall be an equal distribution of facilities among the five radio zones into which the nation is divided, and that there shall be an equitable distribution among the States, within each zone, according to population.

# STATIONS GET NEW STATUS, CHANGING LIST

The Federal Radio Commission has announced the following list of changes in a list of broadcasting stations, as published in the December 13th issue of RADIO WORLD. All the corrections are in bold type. The stations are listed in order of descending frequency.

- 1500 KC. Time Sharer Watts
- KUJ—Longview, Wash. .... 1/4 time 100
- C P to move Station and Transmitter to Walla Walla, Washington, and change frequency to 1370 kc.**
- 1480 KC.
- WKBW—Buffalo, N. Y. .... 5 kw.
- Special authorization to synchronize with WHK & WABC-WBOQ on 860 kc. until 1/31/31.**
- 1440 KC.
- WOKO—Poughkeepsie, N. Y. WEHC-WABO 500
- C P to move Station and Transmitter to Albany, N. Y.**
- 1420 KC
- KGFF—Alva, Okla. .... 100
- C P to move Transmitter and Station to Shawnee, Okla.**
- KGVO—Missoula, Mont. .... 100
- C P only.**
- WHDL—Tupper Lake, N. Y. .... 10
- C P to increase power to 100 watts, daytime only.**
- 1390 KC.
- WHK—Cleveland, Ohio. .... 1 kw.
- Special authorization to synchronize with WABC-WBOQ on 860 kc. until 1/31/31.**
- 1380 KC.
- KOH—Reno Nevada. .... 500
- 1380 kc. new frequency.**
- 1370 KC.
- WRAC—Williamsport, Pa. .... 50
- C P to increase power to 100 watts.**
- KMAC—San Antonio, Texas. .... 100
- This was formerly Station KGGI.**
- 1350 KC.
- WAWZ—New York, N. Y. .... 250
- WCDA, WKBO, WMSG
- This is former Station WBNY, and it has a C P to move Transmitter and Station to Zarapeth, N. J.**
- 1310 KC.
- WEXL—Royal Oak, Mich. .... 50
- Unlimited time.**
- WMBH—New Bedford, Mass. .... 100
- C P to move Transmitter to Fairhaven, Mass.**
- WROL—Knoxville, Tenn. .... 100
- Power formerly 50 watts.**
- WTEL—Gastonia, N. C. .... WHAT 50
- Formerly WSOC.**
- 1300 KC.
- WIOD-WMBF—Miami, Florida. T.—Miami Beach, Fla.—New locations. .... 1 kw.
- 1290 KC.
- WJAS—Pittsburgh, Pa. .... 1 kw.
- C P to increase power to 2 1/2 kw.**
- 1270 KC.
- WFBR—Baltimore, Md. .... 250
- C P to increase power to 500 watts**
- WJDX—Jackson, Mich. .... 1 kw.
- Power increase granted.**
- 1250 KC.
- WDSU—New Orleans, La. .... 1 kw.
- T.—Gretna, La.
- 1210 KC.
- WRBQ—Greenville Miss. .... 250
- Granted increase in power.**
- WSOC—Gastonia, N. C. .... 100
- Formerly WRBU.**
- 980 KC.
- KDKA—Pittsburgh, Pa. .... 50 kw.
- Special authorization to synchronize old and new transmitters; combined power not to exceed 50 kw.**
- 860 KC.
- WABC-WBOQ—(see WKBW under 1480 kc.
- 580 KC.
- WIBW—Topeka, Kansas ..... KSAC 1 kw.
- Experimental Only.**
- 550 KC.
- KFYR—Bismarck, N. D. .... KFDY 1 kw.
- Permit to use 2 1/2 kw. daytime.**

## WWVA REMOVAL HALTED

Washington. The Federal Radio Commission has announced that WWVA, to which it had previously granted permission to move equipment, has withdrawn its application. This action is due to the granting of a stay order obtained in the Court of Appeals of the District of Columbia, by WBOU, Charleston, W. Va., which restrained the Commission.

## LITERATURE WANTED

- L. J. Furlong, c/o Standard Fence Co., 1936 First Ave. South, Seattle, Wash.
- Ebenezer B. Peebles, 2059 W. Roosevelt Rd., Chicago, Ill.
- Vernon Hullinger, 1100 South Oakes St., San Angelo, Tex.
- Vernon Estelle, 6424 Rhodes Ave., Chicago, Ill.
- Irving J. Toner, Shinglehouse, Pa.
- Reinhardt Electric Co., 12151 Findlay St., Detroit, Mich.
- Walter Ashbecker, R. R. No. 4, Marion, Iowa.
- Joseph F. Monahan, 6756 S. Irving Ave., Chicago, Ill.
- Thomas Dunn, 245245 Nelson Avenue, Saratoga Springs, N. Y.
- H. F. Rones, 190-18 89th Ave., Hollis, L. I., N. Y.
- A. T. Gaulke, 444 N. 18th St., Kansas City, Kans.
- Josephine W. Shutt, 3222 N. Carlisle St., Philadelphia, Pa.
- Mrs. C. L. McFall, 1109 Lick St., Scranton, Pa.
- L. A. Schwartz, 225 Meeker St., Newark, N. J.
- Fred Lange, Fayette City, Pa.
- A. C. Alexander, 335 Leflang Bldg., Omaha, Nebr.
- Mrs. Harry W. Carpenter, P. O. Box 519, Cheshire, Conn.
- T. Thos. Pitts, 2124 Kenmore Ave., Charlotte, N. C.
- James A. Johnson, Essenwein & Johnson, 781 Elliott Sq., Buffalo, N. Y.
- D. O. Green, Apt. 3W, 7346 Kingston Ave., Chicago, Ill.

- J. A. LeConte, 1044 Cleburne Ave., N. E., Atlanta, Ga.
- Geo. F. Schreiber, 116 Parker St., Mobile, Ala.
- Geo. E. Sullivan, 340 S. St., N. W., Washington, D. C.
- Stephen Kaveak, 6 Dexter House, Nazareth, Pa.
- Chester C. Robinson, 3159 Blair Ave., Tyrone, Pa.
- C. D. Stone, 109 Court St., Plymouth, Mass.
- Raymond L. Walker, 967 Chestnut St., Union City, N. J.
- Edw. Toohy, 129 Edgevale Ave., Detroit, Mich.
- C. Weingartner, 1824 Cleveland Ave., Chicago, Ill.
- Herman C. Gemmer, 318 W. Louis St., St. Joseph, Mo.
- Calvin S. Daniel, 803 Talbot St., Jacksonville, Fla.
- Virginia B. Walls, 12 E. Division St., Chicago, Ill.
- J. L. Connell, Box 335, Athens, Ga.
- J. F. Burnett, R. F. D. 4, Baton Rouge, La.
- C. A. Kneckenmeister, 1120 Maryland Ave., Crosse Pointe Park, Mich.
- W. M. Moffitt, 508 5th St., Altoona, Pa.
- J. E. McBride, Apt. No. 1, San Francisco, Cal.
- Clayton A. McCarter, 16 Olmstead St., Hartford, Conn.
- G. Howarth, Box 178, Kenora, Ont., Can.
- Melvin Garner, 230 W. 107th St., New York, N. Y.
- T. C. Waite, Jr., 146 Union Trust Bldg., Pittsburgh, Pa.
- F. J. Hauser, R. F. D. No. 1, Rensselaer, N. Y.

# 1,000 KC BAND HAILED AS BOON TO TELEVISION

Washington.

By granting permission to WTMJ, of Milwaukee, Wis., to use a channel width of 1,000 kilocycles, or 43,000 to 44,000 kc, for experimental visual broadcasts, the Federal Radio Commission has made possible for exploration of little known higher frequency channels.

The present television broadcasting is being carried on with frequencies in the continental short-wave band. These channels are 100 kc wide, but are regarded as too limited for successful commercial use, according to J. V. L. Hogan, consulting radio engineer, appearing for the Milwaukee station. He said that on the basis of present indications bands of modulation considerably wider than 100 kilocycles will be necessary for satisfactory picture definition, and such bands are available only in the higher frequency regions of the spectrum.

Moreover, it was declared the information obtained from experiments will be of great value to designers and engineers in the development of television apparatus.

## N. Y. Harbor Phone Asked in Petition

Washington.

An application is pending with the Federal Radio Commission, which if granted will mean that various commercial New York Harbor craft will be equipped with radiophone transmitting and receiving equipment. The application requests, in addition, that permission be granted for the erection of a 400-watt land transmitter for this service.

At present there is no mention of frequency assignment, but the equipment is intended to operate in much the same manner as that now used in communication with liners at sea.

The necessity for such service was shown according to the petitioner, by a survey conducted by the American Railway Association, which is interested because of the numbers of railroad tugs operating in New York harbor. The radiophones would permit railroad officials to keep in constant touch with their boats and would save time and other expenses. At present the tugs must get to the nearest land point if shipmasters want to get orders.

The fireboat John Purroy Mitchel, already radiophone-equipped can be called when it is in the harbor.

As soon as the application for construction of the station is granted and a site is selected the petitioner will start to build.

### A THOUGHT FOR THE WEEK

**L**ET'S look forward with optimistic anticipation to the time when television shall have become of practical entertainment and scientific value and of world-wide use. In the meantime, let's keep on replacing the worn out tubes in our sets and make up our minds that in radio as it is we have something worth while. While we're dreaming of the wonderful things to come we also should not be scornful of the marvels now at our elbow.

## WABC Prepares To Send Pictures

WABC's experimental television transmitter will be ready for operation early this year, according to W. S. Paley, president of the Columbia Broadcasting System. He said:

"Installation of the transmitter is going forward at the Columbia Broadcasting System Building, 485 Madison Avenue, New York, where an additional floor is being occupied for this and other expansion. The antenna will be on the roof of this twenty-four-story building. The 500-watt transmitter will broadcast on an experimental basis." It will operate in the 2,750-2,850 kilocycle band.

"It must be recognized that television still is in the experimental stage. We believe that the public will not get television in the form they expect it for some time to come. However, in our experimental television broadcasting we hope to contribute largely to the development of this important field of the future."

## CANADA SEEKS HIGHER PLANE

Ottawa, Canada.

There has been recently established an organization within the Dominion known as the Canadian Radio League. The first meeting resulted in the election of temporary executives.

The object of this organization is to further interest in the development of radio broadcasting in Canada by Canadian stations, and to seek to establish a National Canadian Chain of broadcasters.

One of the plans of the League is to seek to improve the economic position of the Canadian broadcaster generally, with a view to reducing the quantity of American radio station advertising matter put on the ether.

### Contrasts Situation

Contrasting the present situation as between Canada and the United States, the Canadian Radio League points out that Canada's seventy broadcasting stations have only 33,000 watts in all, while the American stations reaching Canada radiate 700,000 watts power, reaching sections of Canada which cannot hear Canadian programs, while the largest Canadian station can afford only two hours of national broadcast a week.

The League deplores the present domination of Canadian stations by American advertising programs and lack of attention by Canadian stations to educational work, said to be due to "the necessity of radio stations using as much of their time as possible for advertising."

### Sees Opportunity

"The solution the Radio League sees of the present radio problem is that of making the radio a great instrument of entertainment, education and national unity, and is to be accomplished by the establishment of a national broadcasting company, with the powers of a private enterprise, and the functions of a public utility."

The national council of the league is comprised of a large number of prominent Canadian public men and women, representative of English and French speaking Canadians.

# REALLOCATION IS INSTITUTED FOR TELEVISION

Washington.

The Federal Radio Commission has instituted the new allocations of frequencies for television broadcasters, the outcome of the recommendation of a recent engineering conference called by the Commission. The new reallocations went into effect as follows:

	<b>2,000—2,100 kc.</b>
W3XK	5,000...Wheaton, Md.
W2XCR	5,000...Jersey City, N. J.
W2XAP	250...Portable.
W2XCD	5,000...Passaic, N. J.
W9XAO	500...Chicago, Ill.
W2XBU	100...Beacon, N. Y.
	<b>2,100—2,200 kc.</b>
W3XAK	5,000...Bound Brook, N. J.
W3XAD	500...Camden, N. J.
W2XBS	5,000...New York, N. Y.
W2XCW	20,000...Schenectady, N. Y.
W8XAV	20,000...East Pittsburgh, Pa.
W9XAP	1,000...Chicago, Ill.
W2XR	500...Long Island City, N. Y.
	<b>2,750—2,850 kc.</b>
W2XBO	500...Long Island City, N. Y.
W9XAA	1,000...Chicago, Ill.
W9XG	1,500...West Lafayette, Ind.
	<b>2,850—2,950 kc.</b>
W1XAV	500...Boston, Mass.
W2XR	500...Long Island City, N. Y.
W9XR	5,000...Downers Grove, Ill.

Other proposals of the conference now being considered by the Engineering Division of the Federal Radio Commission, will probably be recommended for approval within a brief period.

This realignment of visual broadcasting stations is expected to aid experiments and to hasten the day when the art will be ready for public entertainment on a commercial scale.

## Physicians Hear Flexing of Muscles

London.

A new application of radio frequency transmission was demonstrated here recently when a lecturer on animal electricity showed the possibility of rendering audible the flexing of muscle fibres within the body. The lecturer, with apparatus in full view of his audience, flexed the muscles of his arm, about which was clamped a pickup device connected to a sensitive amplifier and a loudspeaker.

The loudspeaker emitted sounds resembling static, the volume of which varied accordingly with the rapidity with which the flexing took place. The demonstration was attended by physicians, who were enthusiastic over the success of the demonstration. Interest was stimulated to carry on further research. One auditor, a dentist, recalled earlier efforts to diagnose forms of dental infection by means of high frequency radiations.

### NO LIQUOR TALKS ALLOWED

Washington.

The Federal Radio Commission has recently approved an opinion that it shall be unlawful for a radio broadcasting station to transmit advertisements relative to the method of manufacture of intoxicating liquors. It is pointed out that this is specifically banned by the prohibition act.

**Orders-Inquiries**

60 pages  
Send for FREE

Can be Secured by MAIL

**POLK'S REFERENCE BOOK and Mailing List Catalog**

Gives counts and prices on over 8,000 different lines of business. No matter what your business, in this book you will find the number of your prospective customers listed.  
Valuable information is also given as to how you can use the mails to secure orders and inquiries for your products or services.

Write for Your FREE Copy  
R. L. POLK & CO., Detroit, Mich.  
Largest City Directory Publishers in the World  
Mailing List Compilers—Business Statistics  
Producers of Direct Mail Advertisiz

**RADIO MAP OF NORTH AMERICA**

22 x 22 inches, printed in two colors, bound in cover.

Shows every city from Balboa to Edmonton which has a broadcasting station.

Indexed by states, provinces and cities with key for instant location on map.

Call letters, power and frequency given for each station.

**Accurate; up-to-date**

Scale in miles gives distances between any two cities. Time zones correctly marked.

Just what you have been wanting.

**25 cents**

**THE RADEX PRESS**

1368 E. 6th St. Cleveland, Ohio

**BRACH RELAY**

**ONLY 99c**

List price, \$4.50

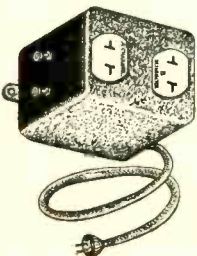

Connect relay's cable plug to 105-125 volt AC line. Connect B eliminator cable plug to relay socket so marked; connect trickle or other charger's plug to relay socket so marked; connect one side of A battery to binding post, other side to A set. Then turning on your set turns on B eliminator and turns off charger, turning off set turns on charger and turns off B eliminator.

**GUARANTY RADIO GOODS CO.**  
143 West 45th Street  
New York City—Just E. of B'way

**DEALERS and SERVICE MEN!**  
STANDARDIZE ON



For Permanent Replacement—Accurate—Guaranteed  
Write for descriptive catalogue "W"  
**LYNCH MFG. CO., INC., 1775 Broadway, New York**

**FOUR-GANG .00035 MFD. WITH TRIMMERS BUILT IN!**

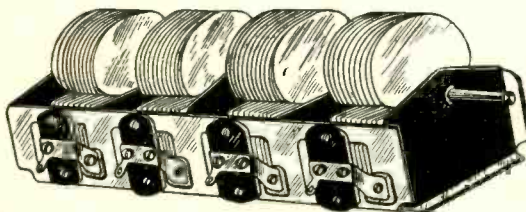

This condenser, each of four sections .00035 mfd., has aluminum plates that are removable and adjustable, also a 1/4" diameter steel shaft that is removable. It is sturdy and is suitable for popular four-circuit screen grid tuners. Trimming condensers are built in. The condenser may be mounted on its bottom or side. Total overall length, including shaft, 1 1/2". Overall width, 4". The frame is steel Order Cat. 4-G @.....

**\$3.95**

(Between 46th and 47th Streets)

**RELIABLE RADIO COMPANY**  
Room 504, at 1562 Broadway, N. Y. City

**Two for the price of One**

Get a FREE one-year subscription for any ONE of these magazines:

- CITIZENS RADIO CALL BOOK AND SCIENTIFIC DIGEST (quarterly, four issues).
- RADIO (monthly, 12 issues; exclusively trade magazine).
- RADIO ENGINEERING (monthly, 12 issues; technical and trade magazine).
- RADIO INDEX (monthly, 12 issues) Stations, programs, etc.
- SCIENCE & INVENTION (monthly, 12 issues; scientific magazine, with some radio technical articles).
- AMERICAN BOY—YOUTH'S COMPANION (monthly, 12 issues; popular magazine).
- BOYS' LIFE (monthly, 12 issues; popular magazine).

Select any one of these magazines and get it FREE for an entire year by sending in a year's subscription for RADIO WORLD at the regular price, \$6.00. Cash in now on this opportunity to get RADIO WORLD WEEKLY, 52 weeks, at the standard price for such subscription, plus a full year's subscription for any ONE of the other enumerated magazines FREE! Put a cross in the square next to the magazine of your choice, in the above list, fill out the coupon below, and mail \$6 check money order or stamps to RADIO WORLD, 145 West 45th Street, New York, N. Y. (Just East of Broadway).

Your Name .....

Your Street Address .....

City ..... State.....

- If renewing an existing or expiring subscription for RADIO WOKLD, please put a cross in square at beginning of this sentence.
- If renewing an existing or expiring subscription for other magazine, please put a cross in square at the beginning of this sentence.

**RADIO WORLD, 145 West 45th Street, New York, N. Y. (Just East of Broadway)**

**DOUBLE VALUE!**

**Parts for the Best Circuits**

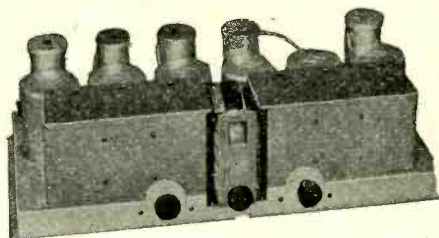

**NEW NATIONAL DE LUXE MB-30 SCREEN GRID TUNER**—This is one of the most sensitive tuners ever developed, averaging 1 microvolt per meter, and at some frequencies attaining 1/4 microvolt per meter. Its selectivity is most remarkable, and without material sideband cutting, due to use of Vreeland band pass filter and pre-selector circuits. Six tuned circuits, perfectly aligned and tested with laboratory equipment that cost more than \$1,000. The circuit, which is for AC only, uses four 224 and one 227 tubes and requires a power amplifier that will power the heaters as well. All parts mounted on chassis, ready for wiring. Steel chassis, 2 1/2"x10"x1 1/4". Order Cat. MB-30-P, list price \$85 less tubes; net price.....**\$48.87**  
**WIRED MODEL, Cat. MB-30-W, list price \$95 less tubes; net price.....\$54.86**

**MB-29-A TUNER**, a smaller version of the MB-30, using four instead of six tuned circuits, but including also the pre-selector and band pass filter circuits. Uses three 224 and one 227. Aluminum chassis 15 1/4"x10 1/4"x1 1/4". Order Cat. MB-29-AP, list price \$69 less tubes; net price.....**\$40.88**

**WIRED MODEL, Cat. MB-29-AW, list price \$79.50 less tubes; net price.....\$46.74**

**NATIONAL VELVETONE Push-Pull Power Amplifier**, using one 227, two 245's and one 280; two stages of transformer coupling, with output transformer; heater voltage for five extra tubes; plate voltage for tuner. A matched unit for the MB-30 or MB-29-A. Phonograph jack built in. Velvetone comes completely wired. Licensed by RCA. Order Cat. PPPA, list price \$97.50, less tubes; net price.....**\$57.53**

**HI-Q 31**

**HAMMARLUND HI-Q-31**—The latest development in custom-set building, a 9-tube circuit, using a 5-stage band-pass filter pre-selector, three stages of 224 RF, 224 power detector, 227 first audio, two 245's for push-pull output, and a voltage regulator tube. Chassis is 2 3/4"x12". Order Cat. AC-31-B, list price of complete parts, \$159.80, less tubes; net price.....**\$91.00**

**WIRED MODEL HI-Q-31**—Order Cat. AC-31-BW, list price, \$184.80, less tubes; net price.....**\$111.86**

**HI-Q AC TUNER WITH POWER SUPPLY** (less audio)—Order Cat. AC-31-TPS, list price \$148.55, less tubes; net price.....**\$82.79**

**HI-Q-AC TUNER ONLY** (for use with external power supply)—Order Cat. AC-31-T, list price, \$107.20, less tubes; net price.....**\$61.09**

**HI-Q-31 FOR BATTERY OPERATION**—Order Cat. BAT-31-B, list price, \$119.55, less tubes; net price.....**\$68.14**

**HI-Q-31 TUNER FOR BATTERY OPERATION** (less audio)—Order Cat. BAT-31-T, list price \$102.95, less tubes; net price.....**\$58.89**

**Short Waves**

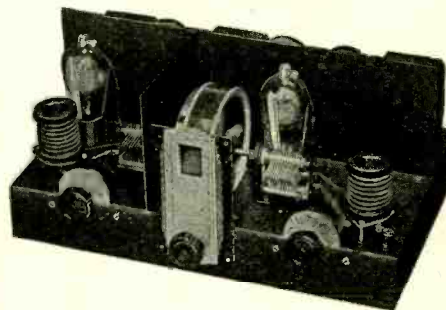

**NATIONAL 5-TUBE THRILL BOX**—A remarkably sensitive short-wave outfit, noted for reception of foreign stations. Uses 224 RF, 224 detector, 227 first audio, 227 push-pull second audio. A separate A and B supply is required. See below. Standard set of four pairs of coils included (21.2 to 2.61 megacycles). Hissless operation, even on earphones. Single tuning control. No grunting, no backlash, no hand capacity. Order Cat. AC-SW-5, list price, less tubes, less B supply, \$79.50; net price.....**\$48.74**

**NATIONAL SW POWER UNIT**—Furnishes heater voltage and B voltage for the AC Thrill Box. Uses 280 rectifier. Comes in wired form only. Licensed under RCA patents. Order Cat. 5880, list price, less tube, \$34.50; net price.....**\$20.28**

**BATTERY MODEL THRILL BOX**—This uses the new 2-volt tubes; two 232 screen grid, three 230 and one 231, in same general circuit. Order Cat. DC-SW-5, list price \$75; net price.....**\$44.10**

**WIRED MODEL AC THRILL BOX**—Order Cat. AC-SW-5-W. List price, \$89.50, less tubes, less power unit; net price.....**\$52.82**

**WIRED MODEL BATTERY THRILL BOX**—Order Cat. DC-SW-5-W. List price, \$85, less tubes; net price.....**\$49.98**

**Guaranty Radio Goods Co.**

143 West 45th Street,  
New York, N. Y.

# SCREEN GRID COILS

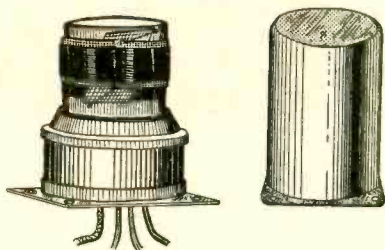

**H**IGH-GAIN shielded radio frequency transformers for screen grid circuits using 222, 224 or 232 tubes for RF, and any kind of detector. The primary has a high impedance—45 turns—and is closely coupled to the secondary over which it is wound, with an insulating wrapper in between, 42/10,000 inch thick. The diameter of the bakelite tubing is 1 3/4 inches.

Each coil form is solidly set in a veneer base, to support and elevate the coil, and equalize the distance from the shield walls. The base is secured to an aluminum template over which the drawn aluminum shield fits snugly, so that the coil is utterly rigid inside at all times. The coils are packed in matched sets of fours, tested for identical inductance on a bridge circuit. Thus they are of precision type, necessary for full effectiveness from gang tuning.

Shield size is 2 1/8" x 2 1/8" x 3/4".

The same type coil is used as antenna input and as interstage coupler and will feed into any type of detector, screen grid or otherwise.

For .00035 mfd. tuning order Cat. 40-80 @ \$2.25  
Matched set of four for .00035 mfd.  
Cat. 40-80-MF ..... 9.00

[The matched four for .00035 mfd. may be used for intermediate frequency amplification at frequencies below 550 kc, by putting a .00035 mfd. fixed condenser across the secondary and a 100 mmd. equalizer across the same circuit. We can supply the .00035 mfd. fixed condensers @ 15c each and the 100 mfd. Hammarlund equalizers @ 35c each.]

For .0005 mfd. tuning order Cat. 40-70 @ \$2.25  
Matched set of four for .0005 mfd.  
Cat. 40-70-MF ..... 9.00

Remit with order for coils and we pay transportation. C.O.D. orders filled.

## SCREEN GRID COIL COMPANY

143 West 45th Street  
New York, N. Y.

[Just East of Broadway]

# Save Money on Tubes!

## Get a Guarantee Just the Same!

**Q**UALITY tubes at enormously reduced prices enable you to save money and obtain full satisfaction. Any tube will be replaced on request within thirty days of its sale!

These tubes are made by a manufacturer of national reputation and are not "distress merchandise." No tube is shipped until it is carefully checked on a Readrite No. 9 Radio Test Kit.

Type	List Price	Your Cost	Type	List Price	Your Cost	Type	List Price	Your Cost
<input type="checkbox"/> 201A	\$1.25	49c	<input type="checkbox"/> WD-12	\$3.00	59c	<input type="checkbox"/> 245	\$2.00	59c
<input type="checkbox"/> 226	1.75	49c	<input type="checkbox"/> 200A	4.00	59c	<input type="checkbox"/> 280	1.90	59c
<input type="checkbox"/> 199-UX	2.50	59c	<input type="checkbox"/> 171A	2.25	59c	<input type="checkbox"/> 224	3.30	59c
<input type="checkbox"/> 199-UV	2.75	59c	<input type="checkbox"/> 171AC	2.25	59c	<input type="checkbox"/> 222	4.50	95c
<input type="checkbox"/> 120	3.00	59c	<input type="checkbox"/> 112A	2.25	59c	<input type="checkbox"/> 281	7.25	95c
<input type="checkbox"/> WD-11	3.00	59c	<input type="checkbox"/> 227	2.20	59c	<input type="checkbox"/> 210	9.00	95c

250, List \$11.00, your cost, 95c.

[Remit with order for tubes and we pay postage]

## DIRECT RADIO CO.

Room 504, at 1562 Broadway, New York, N. Y.  
(Between 46th and 47th Streets)

**Subscribers: watch the date line on your wrapper**  
If the expiration date line on your wrapper indicates that your subscription has expired or is about to expire, please send in renewal so that you will not miss any copies of the paper. Subscription Dept., Radio World, 145 W. 45th St., N. Y.

## PHONOGRAPH PICK-UP \$3.32

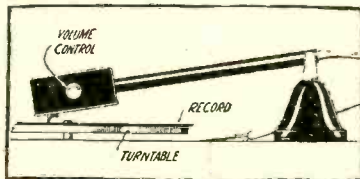

The famous Phono-link, made by Allen-Hough, enables playing phonograph records electrically, on your set. Volume control is built in.

Adapter, free with each order, enables immediate connection to your set. Instruction sheet enclosed. Order Cat. PHL @ \$3.32.

## SHIELDED LEAD-IN WIRE

No. 18 solid wire, surrounded by a solid rubber insulation covering, and above that a covering of braided copper mesh wire, which braid is to be grounded, to prevent stray pick-up.

Also used to advantage in the wiring of receivers, as from antenna post of set to antenna coil, or for plate leads.



This wire is exceptionally good for antenna lead-in, to avoid pick-up of man-made static, such as from electrical machines.

leads, or any leads, if long Order Cat. SH-LW. List 9c, net, 5c per ft.

143 West 45th St., New York, N. Y.  
GUARANTY RADIO GOODS CO.

## CIRCUIT DIAGRAMS

115 Circuit Diagrams of Latest Commercial Receivers and Power Supplies, by John F. Rider. Each in black and white on separate sheets 8 1/2 x 11. Send \$3.00 to RADIO WORLD for 6 months' subscription and get this FREE.

# Quick Action Classified Ads

## Radio World's Speedy Medium for Enterprise and Sales

7 cents a word—\$1.00 minimum—Cash with Order

**GOOD VOLUME**, 4 tube, loop Auto Radio blue print 50c. Parts cost \$12 complete. Write me. C. C. Burge (Radio Engineer), 301 E. Park Blvd., Villa Park, Ill.

**SILVER MARSHALL 712 TUNER** with tubes \$25.00, complete. J. D. Avery, 245 Federal St., Greenfield, Mass.

**EXPERT CONSTRUCTIONAL DATA** — Power transformers 245 and 250, .50 each. Cores supplied. Radio Power, 1028 Forest Road, Schenectady, N. Y.

**"MATHEMATICS OF RADIO."**—A great help to everybody interested in radio. \$2 postpaid. Radio World, 145 W. 45th St., N. Y. City.

**MICROPHONE LIGHTERS**—For cigars or cigarettes, with button switch at top. Press switch, and lighter acts instantaneously. \$1.00. Model B lighter on tray, \$1.50. Radio World, 145 W. 45th St., N. Y. C.

**FOR SALE HiQ 30 CHEAP.** F. L. Hanson, Iliou, N. Y.

**IMPORTED NOVELTY OF MYSTERY.** Fascinating and amusing, sample 15c, Ray-Hud Co. Box 471, West Tulsa, Okla., Dept. R.

**OUR CONVERTER** makes your radio public address system. Bay Laboratories, Box 1183, San Francisco, Calif.

**POWERS PACKS**, 110 volts, 60 cycle. Supply 1 1/2, 2 1/2 and 5 volts AC, 165 volts DC. Complete with 280 tube \$6.25. Cash Radio, 1013 N. McDonel St., Lima, Ohio.

**"FORD MODEL 'A' CAR."** Its Construction, Operation and Repair, By Victor W. Page, M.E. 545 Pages, 251 Specially Made Engravings. \$2. postpaid. Radio World, 145 W. 45th St., N. Y. City.

**POWER UNIT CONSTRUCTION**—The book that enables you to wind your transformers, chokes, and figure correct size resistors for the voltage control, and other valuable information. Price .50. Shipped C. O. D.. Ralph B. Davis & Co., Prestonsburg, Ky.

**RADIO COURSES**, sets, books, bargains. Stephen Plavetich, 1597 East 47th St., Cleveland, Ohio.

**SONG WRITERS**—Poems, Melodies. Opportunity. Tommie Malie, RW-4215 North Ave., Chicago.

**BARGAINS** in first-class, highest grade merchandise. B-B-L phonograph pick-up, theatre type, suitable for home with vol. control, \$6.57; phono-link pick-up with vol. control and adapter, \$3.32; steel cabinet for HB Compact, \$3.00; four-gang .00035 mfd. with trimmers built in, \$1.95; .00025 mfd. Dubilier grid condenser with clips 18c. P. Cohen, Room 1214, at 143 West 45th Street, N. Y. City.

# A Complete Line of Radio Books!

SERVICE MANUAL

RAMSAY

HAAN

RADIO MANUAL

ANDERSON and BERNARD

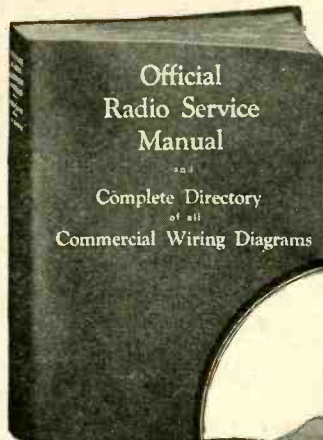

"Official Service Manual," by Gerns-bach and Fitch. 1,000 illustrations; diagrams of commercial receivers and power amplifiers; 222 pages; includes course on servicing. Weight, 3 1/2 lbs. Complete 6-page index. Flexible leatherette cover, loose-leaf binding. Order Cat. ORSM @ \$8.50



The index to the commercial wiring diagrams takes up five pages alone. The index is an alphabetical array of the manufacturers' names, with model names and numbers stated.

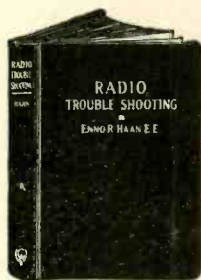

"Radio Trouble Shooting," by R. Haan, passes over theory, tells what to do to cure troubles. 300 illustrations, flexible binding 361 pages 6x3". Order Cat. HAAN... @ \$3.00

"Experimental Radio" by R. R. Ramsay, Ph.D., Prof. Physics, Indiana University. 255 pages, 168 illustrations. Cloth cover. Order Cat. REX... @ \$2.75

"Fundamentals of Radio," by Ramsay, 374 pages, 402 illustrations. Order Cat. RFM @ \$3.50



The new edition of "The Radio Manual" answers questions about the principles, methods, or apparatus of radio transmitting and receiving. A complete course in radio operation in a single volume. 30 big chapters include: Elementary Electricity and Magnetism; Motors and Generators; Storage Batteries and Charging Circuits; The Vacuum Tube; Circuits Employed in Vacuum Tube Transmitters; Modulating Systems and 100% Modulation; Wave-meters; Piezo-Electric Oscillators; Wave Traps. Nearly 900 pages, 369 illustrations; flexible fabricoid cover. Order Cat. MAN @ \$6.00

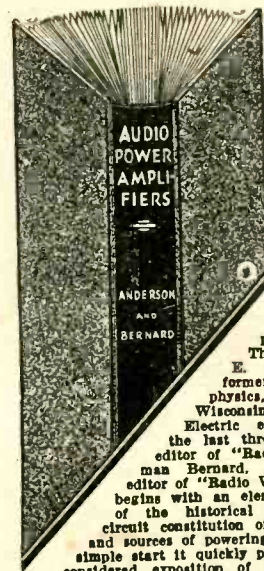

An understanding of audio amplifiers of all types, and of the use of tubes in audio channels, is a prerequisite today, when audio amplification is to the fore in radio, in public address systems and in the talks.

"Audio Power Amplifiers" is the first and only book on the important subject.

The authors are J. E. Anderson, M.A., former instructor in physics, University of Wisconsin, former Western Electric engineer, and for the last three years technical editor of "Radio World"; Herman Bernard, LL.B., managing editor of "Radio World." The book begins with an elementary exposition of the historical development and circuit constitution of audio amplifiers and sources of power for them. From this simple start it quickly proceeds to a well-considered exposition of circuit laws, including Ohm's laws and Kirchhoff's laws. The determination of resistance values to produce required voltages is carefully expounded. All types of power amplifiers are used as examples: AC, DC, battery operated and composite. But the book treats of AC power amplifiers most generously, due to the superior importance of such power amplifiers commercially. Tube characteristic tables and curves, profusely included. Cloth cover, 193 pages. Order Cat. APAM... @ \$3.50

## BOOKS BY JOHN F. RIDER

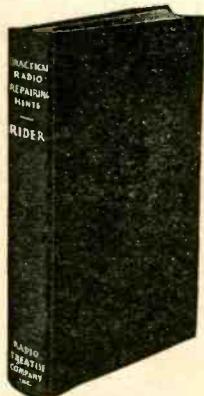

Two new books by Rider are:  
(1) "Practical Radio Repairing Hints," a handbook for the radio worker. Replete with facts and figures, hints and kinks. No Theory. No Formulas. In it you will find explanations of the modern radio systems, automatic volume control circuits, new forms of voltage distribution in automobile radio sets, public address systems, etc. Order Cat. PRRH... @ \$2.00

(2) "Practical Testing Systems," the first complete collection of accurate and practical testing circuits of interest to the service man, professional se builder and experimenter. Among the many testing systems described in this book are tube testers, capacity measuring systems, signal generators, radio frequency oscillators, audio oscillators, vacuum tube voltmeters, resistance testers, continuity testers, etc. Material for the man who wants a simple test unit or desires a laboratory arrangement. Order Cat. PTS... @ \$1.00

Other books by Rider are:  
"Trouble Shooter's Manual," the first comprehensive volume devoted exclusively to the topic. It is not only a treatise for service men, telling them how to overcome their most serious problems, and diagramming the solutions, but it is a course in how to become a service man. It gives details of servicing and includes more than 100 actual factory-drawn diagrams of commercial receivers. 240 pages, 8 x 11", 300 illustrations. Order Cat. TSM... @ \$3.50



"Supplement No. 1," containing 115 diagrams of commercial receivers, supplementing the diagrams in "Trouble Shooter's Manual," but not duplicating any. These 115 diagrams are supplied loose. They are a necessary adjunct to those in "Trouble Shooter's Manual." Order Cat. SUPP-1... @ \$1.20  
"Mathematics of Radio," by Rider, 128 pages, 8 1/2 x 11", 119 illustrations, bridges the gap between the novice and the college professor. It gives a theoretical background so necessary for a proper understanding of radio and audio circuits and their servicing. Formulas for capacity, inductance, impedance, resistance, etc., are explained. Flexible cover. Order Cat. MOR... @ \$2.00

## TWO MASTERPIECES BY PROF. MORECROFT

"Principles of Radio Communication," by Prof. John H. Morecroft, second edition. Prof. Morecroft, of the Electrical Engineering Department of Columbia University and past president of the Institute of Radio Engineers, is a noted authority. Prior electrical and mathematical knowledge required. 1,001 pages and 831 illustrations. Cloth-bound. Order Cat. M-PRIN... @ \$7.50

"Elements of Radio Communication," written in plain language, requiring little foundation knowledge of radio, is another fine Morecroft book. The book is a complete course on the elements of radio, containing much material never before published. 226 pages, 170 illustrations and a complete index. Cloth bound. This is one book you must have in your library. Order Cat. M-ELEM... @ \$5.00

## THREE BOOKS BY MOYER AND WOSTREL

The need for an up-to-date book on radio tubes that answers all the important questions has been filled by James A. Moyer, Director of University Extension, and John F. Wostrel, instructor in radio engineering. Division of University Extension, Massachusetts Department of Education. This book is a complete discussion of tube principles, functions and uses. The essential principles underlying the operation of vacuum tubes are explained in as non-technical a manner as is consistent with accuracy. The book covers the construction, action, reactivation testing and use of vacuum tubes as well as specifications for vacuum tubes and applications for distant control of industrial processes and precision measurements. 297 pages, cloth bound. Order Cat. MWT... @ \$2.50  
"Practical Radio," including the testing of radio receiving sets. 378 pages, 223 illustrations. Cloth bound. Order Cat. MWP... @ \$2.50  
"Practical Radio Construction and Repairing," 319 pages, a companion volume to the above. New edition. Order Cat. MWC... @ \$2.50

## THE SUPERHETERODYNE

This is a new volume by Anderson and Bernard dealing with the principles and practice of the Superheterodyne method of receiving. It explains the function of the oscillator, the modulator, the pre-modulator selector, and the intermediate frequency amplifier. It explains the cause of repeat points and gives methods for avoiding them or minimizing their effect. It expounds the relative advantages and disadvantages of high and low intermediate frequencies, and shows the effect of selectivity on the quality.

It illustrates various forms of oscillators and tells of the advantages of each. Different types of modulators and pick-up systems are explained and their advantages stated. Different methods of coupling in the intermediate frequency amplifier are shown.

Audio interference is discussed in detail and methods given by which it may be reduced.

A special method of ganging the oscillator to the radio frequency condensers is explained, a method which allows either the high or the low oscillator setting to be selected by means of a variometer in the oscillator circuit.

One section is given over to coil design for the radio frequency tuners, the oscillator, and the intermediate frequency filter.

Audio amplifiers suitable for Superheterodynes are also described. These include transformer, resistance, and push-pull amplifiers both for AC and DC.

While the book is primarily intended to expound the principles of the Superheterodyne, the practical phase has not been neglected. Detailed descriptions of AC and DC Superheterodynes, designed in conformity with best practice and sound applications of the principles, have been included in the book. These descriptions are well illustrated. Order Cat. ABSH... @ \$1.50

## FOOTHOLD ON RADIO

In simple English that any one can understand, the technical side of radio is presented by Anderson and Bernard in their book, "Foothold on Radio." Any one who can read English can understand this book. It is intended for the sheer novice. The treatment is non-mathematical.

The origin of the broadcast wave, its radiation, reception, amplification are set forth in clear language. Side bands are explained simply. The types of receiving circuits are illustrated, described and contrasted. A chapter is devoted to loudspeakers, explaining the different kinds and the principles of their operation. Performance is compared. Audio coupling is fully explained, also the action of the vacuum tube, with a special analysis of plate current and its behavior. Those who have been thirsting for a book that readily reveals the marvels of the radio science will appreciate this little volume. Paper cover 60 pages, fully illustrated. Order Cat. For... @ \$1.00

## "A B C OF TELEVISION"

"A B C of Television, or, Seeing by Radio," by Raymond Francis Yates, editor of "Television," formerly editor of "Popular Radio." 210 pages (5 1/2 x 8 1/2"). 100 illustrations. Cloth bound. This book is not a dull, technical treatise. Rather, it is a popular, easily understood and practical book containing descriptions of television systems, and also detailed information concerning many fascinating, television experiments that may easily be conducted with modest equipment. It is not a book for engineering "high-brows" nor is it a superficial treatise written merely to entertain and amaze the novice. It is an intensely practical volume written for those who want to do things. It stresses the "how" of the art as well as the "why." In its essence, it is an academic treatise brought down to the level of the lay mind. Engaging in its simplicity, penetrating and wide in its scope, it stands as the first popular American book devoted to television and telephotography. The book contains two hundred fifty pages profusely illustrated. The reading matter is arranged in simple stepping stones dealing with the problems of scanning, amplification of light modulated signals, photo-electric cells and neon lamps. The book has been written especially for those who wish to build and use television receivers and transmitters for entertainment and research purposes. It is written for amateurs and experimenters who crave action and results rather than high-sounding theory. Order Cat. TEL... @ \$3.00

"Drake's Encyclopedia," new edition, 2 1/2" thick, weighs 3 1/2 lbs., 920 pages, 1,025 illustrations. Order Cat. DBA... @ \$6.00

"Principles of Radio," by Keith Henney, M.A., former director, laboratory, Radio Broadcast. 477 pages, 305 illustrations. Order Cat. PRK... @ \$3.50

"Radio Telegraphy and Telephony," by Rudolph L. Duncan and Charles E. Drew, of Radio Institute of America. Order Cat. RTT... @ \$7.50

Radio World, 145 West 45th Street, New York, N. Y.

Enclosed please find \$..... for which please send at once, postpaid, books indicated by my crosses

<input type="checkbox"/> Cat. ORSM @ \$3.50	<input type="checkbox"/> Cat. PRRH @ \$2.00
<input type="checkbox"/> Cat. HAAN @ 3.00	<input type="checkbox"/> Cat. PTS @ 1.0
<input type="checkbox"/> Cat. REX @ 2.75	<input type="checkbox"/> Cat. YSB @ 3.5
<input type="checkbox"/> Cat. RFM @ 3.00	<input type="checkbox"/> Cat. SUP-1 @ 1.20
<input type="checkbox"/> Cat. MAN @ 6.00	<input type="checkbox"/> Cat. MOR @ 2.00
<input type="checkbox"/> Cat. APAM @ 3.50	<input type="checkbox"/> Cat. M-PRIN @ 7.5
<input type="checkbox"/> Cat. FOR @ 1.00	<input type="checkbox"/> Cat. M-ELEM @ 3.0
<input type="checkbox"/> Cat. ABSH @ 1.50	<input type="checkbox"/> Cat. MWT @ 2.5
<input type="checkbox"/> Cat. TEL @ 3.00	<input type="checkbox"/> Cat. MWP @ 2.50
<input type="checkbox"/> Cat. DBA @ 6.00	<input type="checkbox"/> Cat. MWC @ 2.50
<input type="checkbox"/> Cat. PRK @ 3.50	<input type="checkbox"/> Cat. RTT @ 7.50

Name.....  
Address.....  
City..... State.....  
 Check here if C. O. D. is desired.

Remit with Order for Books and We Pay Postage