

HOLIDAY GIFTS NUMBER

DEC. 8th, 1928

15 CENTS

RADIO

REG. U.S. PAT. OFF.

WORLD

The First and Only National Radio Weekly

350th Consecutive Issue—Seventh Year

The Sargent- Rayment



In This Issue — *Dr. E. F. W. Alexanderson, Dr. John H. Dellinger, J. E. Anderson, Leslie G. Biles, Perry S. Graffam, Herman Bernard, F. Edwin Schmitt, Orestes H. Caldwell, James H. Carroll, Herbert E. Hayden, M. V. Wallach.*

TRUVOLT
ALL-WIRE
RESISTANCES



U. S. Pat.
1,676,869 and
Patents Pending

**Seven
Big Reasons**

THE Truvolt Variable Resistor is the superior Resistance for your Eliminator because it has seven big advantages; 1—Entirely made of wire; 2—Permanently accurate; 3—Long life; 4—Potentiometer control; 5—Noiseless; 6—Positive metallic contact at all times; 7—Nichrome wire—very low temperature coefficient.

Electrad Specializes in a Complete Line of Resistances for All Radio Purposes, Including Television.

Write for FREE Circuit Data and Description of Truvolt Resistances.

175 Varick Street
Dept. 32-B
New York

ELECTRAD

Manufacturers of highest quality condensers and resistors that are—
Built to Endure!

AEROVOX
"Built Better"
72 WASHINGTON ST., BROOKLYN, N.Y.

Write for the Research Worker, a free monthly publication.

SM

BUILD and OWN
The Boss of the Air
The Sargent-Rayment Seven

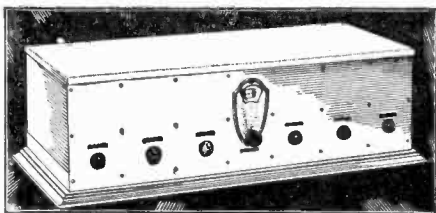

With its single-dial control, it is not out of place in the finest console—but it sells on results. A station on every 10-kilocycle channel is its regular record. California listeners report getting Japanese and Australian stations with good speaker volume. New Yorkers get Fort Worth and other distant stations with "local volume" in the heart of Manhattan.

Get your order in early!

Five sharply tuned circuits, all controlled by a single illuminated dial (with individual verniers in each stage for hair-line tuning) are here built to a standard of precision that brings out, to a degree never before approached, the marvelous possibilities in the new screen-grid tubes—four of

which are used. Tone quality is of the unequalled S-M Clough-system standard. The complete kit, exactly as authorized by the designers, comes with the heavy satin-finished aluminum shielding which builds up into the trim cabinet shown. Price, \$130.00. Custom-built and fully wired, \$175.00.

SILVER-MARSHALL, Inc.
878 W. Jackson Blvd., Chicago, U. S. A.
...Send your complete catalog, with sample copy of the Radiobuilder.
...For enclosed 10c, send five sample S-M Data Sheets, including No. 8 (Sargent-Rayment).

Name.....
Address.....

Are you receiving "The Radiobuilder" regularly? Every month it gives you all the earliest S-M news, operating hints and kinks. To S-M Authorized Service Stations, it comes free of charge, with all new constructional Data Sheets. If you build professionally, write us about the Service Station franchises.

SILVER-MARSHALL, Inc.

878 W. JACKSON BLVD. CHICAGO, U. S. A.

SM

Demonstrated Superiority Over All!
Sargent-Rayment Seven

Specialists on this Wonder Set and All S-M Equipment.
All Silver-Marshall Sets, Power Amplifiers and Eliminators are always on demonstration at our showroom. Testing—Consulting—Construction

IMMEDIATE DELIVERY ON ALL S-M PRODUCTS
Write for details of Technical Service for set builders with maximum discounts.

ROSSITER, TYLER & McDONELL, Inc.

136 Liberty Street

New York City

SM

The Peer of all receivers
Sargent-Rayment Seven

Unmatched in Radio at Any Price
THE NEW SARGENT-RAYMENT SEVEN IS UNBEATABLE
IF IT'S SILVER-MARSHALL, WE HAVE IT!

Dealers Write for Our New Big Catalog

CLARK & TILSON, Inc.

122 Chambers St., New York City

SM

The Greatest Achievement of Radio's
Greatest Engineers—

Sargent-Rayment Seven

ROUND THE WORLD FOUR 720 SCREEN GRID SIX

675 A.B.C. POWER PACKS

Official Silver-Marshall Service Station—Custom Set-Builders' Headquarters
MAIL ORDERS FILLED TECHNICAL INFORMATION FREE

S. HAMMER RADIO CO.

142 Liberty Street

New York City

RADIO WORLD, a weekly paper, published by Hennessy Radio Publications Corporation, from Publication Office, 145 West 45th Street, New York, N. Y. Phone: BRyant 0558 and 0559. 15c per copy, \$6 per year. This issue is dated December 8, 1928, and is Vol. XIV, No. 12. Whole Number 350. Entered as second-class matter, March, 1922, at the post office at New York, N. Y., under Act of March, 1879.

SM

LEADS ALL 1929 CIRCUITS

Sargent-Rayment Seven

Sets a new standard for distance getting ability

Dealers, we can make Immediate Delivery on all Silver-Marshall Kits

Write for Big New Catalog with maximum discounts.

ROYAL-EASTERN ELECTRICAL SUPPLY CO.
16-18 West 22nd Street, N. Y. City

SM

METROPOLITAN DISTRIBUTORS

The Greatest Development in Radio!

SARGENT - RAYMENT SEVEN

IMMEDIATE DELIVERY

Largest Silver-Marshall Stock in New York
We Distribute Over 100 National Standard Radio Lines
Dealers, Write for Our Catalog Listing Standard Parts

GRAYMORE RADIO CORP.
142 Liberty Street New York City

SM

The Boss of the Air

Sargent - Rayment Seven

**Tone Quality that is unequalled—Volume that is startling—
Distance that is unbelievable—**

IMMEDIATE DELIVERY ON ALL LATEST S-M CIRCUITS

*Write for our new big Catalog with maximum discounts to
dealers and set builders*

WHOLESALE RADIO SERVICE CO.
6 Church Street, New York City

SM

*A Circuit That Can Honestly Be
Recommended for Consistent, Outstanding Performance.*

Sargent-Rayment Seven

Superheterodyne Service in All Branches

POWER AMPLIFICATION MODERN RADIO

H. & F. RADIO LABORATORIES, Inc.
Under Personal Direction of Paul R. Fernald

72 CORTLANDT STREET ROOM 303 NEW YORK CITY

SM

SEND 10¢ in Stamps or Coin for BLUEPRINT of the Silver-Marshall

Sargent-Rayment Seven

GUARANTY RADIO GOODS CO.
145 West 45th Street New York City



VICTOREEN
Super Coils

Write for Free Blueprints of New Victoreen Circuits

Geo. W. Walker Co.
2825 Chester Avenue
Dept. B Cleveland, O.

RUN YOUR radio set through the horn of your phonograph by attaching the Loud Unit, price \$3.53. Gives fine volume and tone. Just the thing for those desiring compactness. Use a pickup attached to your set to play the phonograph. Philip Cohen, 236 Varet St., Brooklyn, N. Y.

NEXT WEEK—Issue of December 15th
—David Sarnoff will discuss television from an optimistic viewpoint.

Individual METERS

For Portable or Panel Use



\$4.50

High resistance 0-300 Voltmeter, accurate to 1%. Measures any DC voltage to 300, including B eliminators. Provided with 30" cord, with luxurious jack tips and hanger. Meter full nickel de luxe finish. No. 846.
No. 847, same as above, but 0-500 volts, \$6.00

POCKET AND PORTABLE VOLTMETERS

No. 8—For testing A batteries, dry or storage, 0-8 volts DC scale.....\$1.00
No. 10—For testing A batteries, dry or storage, 0-10 volts DC scale..... 1.00
No. 13—For testing A batteries, dry or storage, 0-16 volts DC scale..... 1.00
No. 50—For testing B batteries, dry or storage, but not for B eliminators, 0-50 volts DC scale..... 1.00
No. 39—For testing B batteries, dry or storage but not for B eliminators, 0-100 volts DC scale..... 1.25
No. 40—For testing A and B batteries, dry or storage, but not for B eliminators; double reading, 0-8 volts and 0-100 volts DC scale... 1.75
No. 42—For testing B batteries, dry or storage, but not for B eliminators; 0-150 volts DC scale..... 1.50
No. 348—For testing AC current supply line, portable, 0-150 volts..... 4.00

PANEL AC VOLTMETERS
(Panel meters take 2-5/54" hole)

No. 351—For reading 0-15 volts AC.....\$2.25
No. 352—For reading 0-10 volts AC..... 2.25
No. 353—For reading 0-6 volts AC..... 2.25
(See No. 348 under "Pocket and Portable Voltmeters.")

PANEL VOLTMETERS

No. 335—For reading DC voltages, 0-8 volts, \$1.00
No. 310—For reading DC voltages, 0-10 volts, 1.00
No. 318—For reading DC voltages, 0-16 volts, 1.00
No. 328—For reading DC voltages, 0-6 volts, 1.00
No. 337—For reading DC voltages, 0-50 volts, 1.00
No. 339—For reading DC voltages, 0-100 volts, 2.25
No. 342—For reading DC voltages, 0-150 volts, 2.25
No. 340—For reading DC voltages, double reading, 1-8 volts, 0-100 volts..... 1.50

VOLTMETERS

No. 18—For testing amperage of dry cell A batteries and voltage of dry or storage A batteries, double reading, 0-8 volts, and 0-40 amperes DC.....\$1.25
No. 35—For testing amperage of dry cell A batteries and voltage of B batteries (not B eliminators); double reading, 0-50 volts, 0-40 amperes DC..... 1.50

PANEL MILLIAMMETERS

No. 311—For reading 0-10 milliamperes DC..\$1.75
No. 325—For reading 0-25 milliamperes DC.. 1.00
No. 350—For reading 0-50 milliamperes DC.. 1.00
No. 390—For reading 0-100 milliamperes DC.. 1.00
No. 399—For reading 0-300 milliamperes DC.. 1.00
No. 394—For reading 0-400 milliamperes DC.. 1.00

VOLTAGE REGULATOR

No. 218—For preventing excess voltage on the filament and cathode of AC tubes, by compensating for excess line voltage.....\$5.00

POCKET AMMETER

No. 1—For testing dry cells, 0-50 ampere DC scale pocket meter.....\$.75

6-VOLT A BATTERY CHARGE TESTER

No. 23—For showing when 6-volt A battery needs charging and when to stop charging; shows condition of battery at all times.....\$1.00

PANEL AMMETER

No. 338—For reading amperage, 0-10 amperes DC.....\$1.00

Immediate Shipment

GUARANTY RADIO GOODS CO.,
145 West 45th Street, New York City.
Just East of Broadway

Send me the following individual meters (quantity in square):

Cat. No. Cat. No. Cat. No.
 Cat. No. Cat. No. Cat. No.

NAME

ADDRESS

CITY..... STATE.....

TEN-DAY MONEY-BACK ABSOLUTE GUARANTY!

De Luxe Carrying Case **FREE**

With Each Jiffy Tester Combination!

This Meter Outfit Makes Thirteen Vital Tests in Only 4½ Minutes!

The Jiffy Tester in its Case is a Testing Laboratory All by Itself. Leave the meters in the case. Simply lift out the plug, attaching the four-prong adapter, if testing a four-prong tube. Put plug in socket of receiver to be tested; put tube in Tester socket. The B voltmeter automatically connects to the proper points when its tipped leads are inserted in the two binding posts at rear.

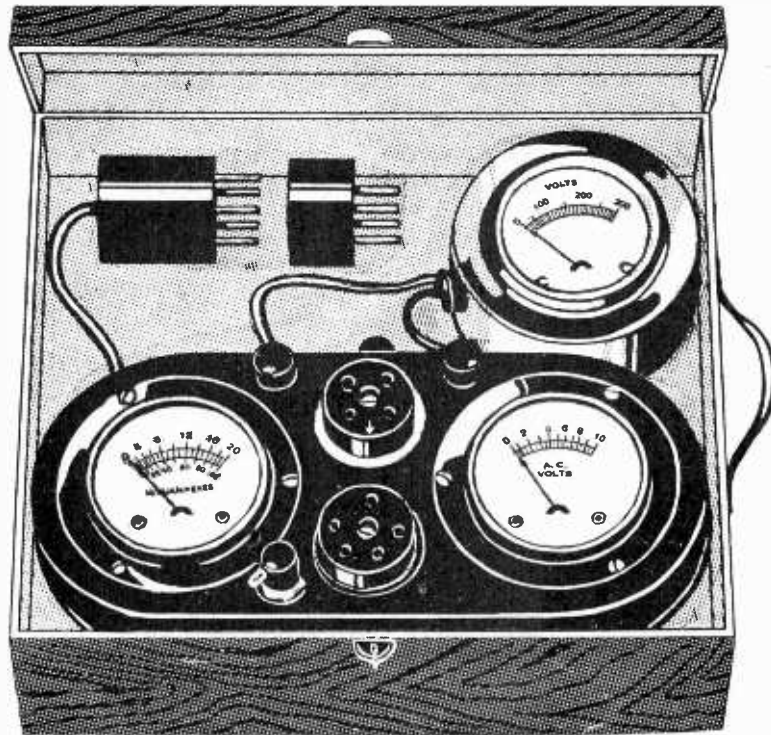

This housed Jiffy Tester, with high resistance voltmeter for measuring B voltages, including those of eliminators, is a service kit of the highest value. The case is furnished in a de luxe finish, with handle. A patented snaplock makes it impossible for the lid to open accidentally. The Tester and high resistance meter fit so snugly in place that they will not jar in transportation. A 5-day money-back guaranty attaches to each sale.

Jiffy Tester Combination, shown one-third size. Includes 0-10 voltmeter reading AC or DC (same meter reads both); 0-20, 0-100 milliammeter, with change-over switch; cord and plug with 4-prong adapter; 0-300 high resistance voltmeter. Price \$13.50. Complete instruction booklet and de luxe carrying case FREE with each order.

Jiffy Tester a Scientific Trouble Shooter

Every service man, custom set builder, home experimenter, student or teacher needs one of these Jiffy Tester Combinations. Ample accurate for this class of work. You will be well satisfied with assured 5% plus or minus accuracy. Jiffy Tube and Set Tester, consisting of 0-20, 0-100 combination milliammeter, 0-10 AC and DC voltmeter and 0-300 high resistance voltmeter. De luxe carrying case and instruction booklet FREE with each order. Jiffy Tester Combination A. **\$13.50**

The 0-300 high resistance voltmeter in "Jiffy Tester Combination A" is accurate to 5% plus or minus, so that at maximum reading it is not more than 15 volts off. Those desiring a more accurate 0-300 high resistance meter, never more than 3 volts off, at maximum reading, should order "Jiffy Tester Combination B," which has a 0-300 meter accurate to 1%, at a cost of \$1 extra. Order "Jiffy Tester Combination B." De luxe carrying case and instruction booklet FREE. **\$14.50**

Here Are the Thirteen Vital Tests!

- (1) to measure the filament voltage, up to 10 volts, of AC and DC tubes;
 - (2) to measure the plate current of any one tube, including any power tube, from less than 1 milliamperes up to 100 milliamperes;
 - (3) to measure the total plate current of a receiver or amplifier, up to 100 milliamperes. (Hardly any set draws more);
 - (4) to measure the B voltage applied to the plate of tube; the voltage across B batteries or B eliminators, up to 300 volts;
 - (5) to determine the condition of a tube, by use of the grid bias switch;
 - (6) to measure any tube's electronic emission;
 - (7) to regulate AC line, with the aid of a power rheostat, using a 27 tube as guide;
 - (8) to test continuity of resistors, windings of chokes, transformers and circuits generally;
 - (9) to find shorts in bypass and other condensers, as well as in inductances, resistors and circuits generally;
 - (10) to read grid bias voltages, including those obtained through drops in resistors;
 - (11) to determine the presence of distortion and overloading;
 - (12) to test for correct bias;
 - (13) to determine starting and stopping of oscillation.
- [Note—Instruction booklet fully informs you how to make each and every one of these tests in a jiffy.]

Note All That You Get!

For \$13.50 you receive:

- (1) One Two-in-One 0 to 10 voltmeter for AC and DC. Same meter reads both. Scale especially legible at 1½ to 7½ volts. This meter reads the AC and DC filament voltages.
 - (2) One DOUBLE reading DC milliammeter, 0 to 20 and 0 to 100 milliamperes, with changeover switch. This reads plate current, which is always DC in all sets.
 - (3) One 0-300 volts high resistance voltmeter, No. 346, with tipped 30" cord to measure B voltages.
 - (4) One 5-prong plug with 30" cord for AC detector tubes, etc., and one 4-prong adapter for other tubes.
 - (5) One grid switch to change bias.
 - (6) One 5-prong socket.
 - (7) One 4-prong socket.
 - (8) Two binding posts.
 - (9) One handsome moire metal case.
 - (10) One instruction sheet.
 - (11) One de luxe carrying case.
- If 0-500 volt 5% accuracy high resistance meter is preferred to 0-300 volts, add \$1.00, and order Combination C at \$14.50.
If 0-500 volt 1% accuracy high resistance meter is preferred to 5% accuracy 0-500 voltmeter, add \$2.00, and order Combination D at \$15.50.
[Note—A pair of adapters for UV199 tubes, Cat. No. 999, at \$1.00 extra. These are not sold except with Jiffy Tester Combination.]

GUARANTY RADIO GOODS CO.,
145 West 45th Street, New York City.
(Just East of Broadway.)

- Please ship at once your Jiffy Tester Combination for which I will pay post-man advertised prices, but no shipping charges. (Check off below.)
- One Jiffy Tester Combination A (0-10 v., 0-20, 0-100 m. a., 0-300 v., carrying case, instruction booklet FREE).....\$13.50
 - One Jiffy Tester Combination B (same as above, but with 0-300 voltmeter accurate to 1%). Price.....\$14.50
 - One Jiffy Tester Combination C (same as A, except 0-500 voltmeter replaces 0-300). Price.....\$14.50
 - One Jiffy Tester Combination D (same as C, except 0-500 voltmeter is accurate to 1%). Price.....\$15.50
 - Set of 199 adapters. Price.....\$1.00

NAME.....

ADDRESS.....

CITY..... STATE.....

5-DAY MONEY-BACK GUARANTY



Vol. XIV. No. 12 Whole No. 350
 DECEMBER 8th, 1928
 15c per Copy, \$6.00 per Year
 [Entered as second-class matter, March
 1922, at the Post Office at New York,
 N. Y., under Act of March, 1879]

**Latest News and Circuits
 Technical Accuracy Second to None**

A Weekly Paper published by Hennessy
 Radio Publications Corporation, from
 Publication Office, 145 West 45th Street,
 New York, N. Y.
 (Just East of Broadway)
 Phone: BRyant 0558 and 0559

Station Complaints Futile

RCA IS LOSER IN LAST STAND ON TUBE WRIT

Washington.

The Supreme Court of the United States denied a petition for a review of the decree of the lower court in the case of the Radio Corporation of America vs. Arthur D. Lord, receiver for the De Forest Radio Company et al.

The case involves the validity of a license agreement under which vacuum tubes are to be sold, supplied and used in radio receiving sets.

The District Court for the District of Delaware granted an injunction pendente lite, requested by the respondents (De Forest et al.) under Section 16 of the Clayton Anti-trust Act, restraining the Radio Corporation from continuing to operate under or from enforcing Clause 9 of the license agreements.

Review Denied

The decree of the District Court was affirmed by the Circuit Court of Appeals for the Third Circuit.

The Supreme Court has now denied the petition of the Radio Corporation for a writ of certiorari to review the judgment.

The clause of the license agreement in question provides that vacuum tubes to be used as part of the circuits and apparatus of the radio receiving sets licensed and sold by the agreement, and necessary to make them initially operative, are to be bought only from the Radio Corporation.

Injunction Stands

It further provides that the sale of such tubes shall not be construed as granting any licenses except the right to sell such tubes for use in the radio receiving apparatus sold under the agreement.

The refusal of the Supreme Court to review the case leaves the injunction granted by the District Court and affirmed by the Circuit Court of Appeals in force.

UNIDIRECTIONAL BEACONS

Washington.

Possibilities of unidirectional radio beacons for guiding aircraft are being studied by the Bureau of Standards, according to a statement made public by the Department of Commerce.

Market for Tubes

Open, Says Lawyer

Samuel Darby, Jr., of the New York law firm of Darby & Darby, De Forest representatives, said:

"The Supreme Court has declined to review the case of De Forest and others brought against the Radio Corporation of America for violation of Section 3 of the Clayton Anti-Trust Act, where the District Court of Delaware and the Court of Appeals for the Third Circuit held that the R. C. A. had violated the Clayton Act by Clause 9 of their license agreements entered into with twenty-five set manufacturers.

"The independent tube manufacturers who were damaged by the operation of Clause 9 of these agreements are now in a position to demand a sum equal to the amount of their damages, which sum will be trebled under the provision of the Clayton Act. The suit was filed a year ago this month, but was stayed pending the appeal to the Circuit Court of Appeals and the Supreme Court. Now the injunction will issue restraining the R. C. A. from enforcing Clause 9 of their agreement.

"The import of the decision is that the R. C. A. cannot legally monopolize the manufacture and sale of audion tubes by contract with the set manufacturers who are their licensees, thereby absorbing the market for tubes.

"From a practical viewpoint, this will assure a varied supply of tubes to the users of radio sets where the tubes will be on a purely competitive basis as to efficiency and price."

COURT IS ASKED TO BLOCK WGY

Washington.

The Federal Radio Commission, through counsel, requested the Federal District Court to vacate the temporary injunction obtained by WGY, Schenectady, N. Y., prohibiting the Board from disturbing WGY's bulletins on its 790 kc. frequency. The reallocation retained the frequency for WGY but curtailed the hours on the air.

The Board asserted that the court was without jurisdiction, as no order had been issued by the Commission that prevented WGY from broadcasting day and night. The station is operated by the General Electric Company, which also owns KGO, Oakland, Calif., which got 790 kc. as a clear channel.

PROTESTS ARE TURNED DOWN; REALLOCATION HELD SACRED

Having spent many trying months over the reallocation structure, the Federal Radio Commission has decided to give it a fair test and a long trial, and meanwhile is turning down virtually all requests of stations for complete redress of grievances.

Encouraged by the considerable improvement in average reception since the reallocation became effective, the Commission is loath to disturb the structure.

The adherence to the structure as put into effect November 11 is deemed of vital importance by the Commission, and this despite obvious defects, one of which proved to be the selection of only forty channels for national service, the so-called clear channels.

Results in Some Inequality

This left some large stations with inadequate time on the air and gave to some considerably lesser important stations much more important transmission frequencies and privileges.

An analysis of the effect of the reallocation shows that in the larger broadcasting centers there has been a great restriction in the number of different local stations that can be tuned in on a given day or night.

Thus in New York City the radio listener, who previously had a choice of nearly thirty stations, now may choose from eight or ten. But the reduction has been one of quantity. The stations to which the majority of listeners turned habitually for fine entertainment are still on the air nightly.

There are many listeners who are not yet aware that a great revolution has taken place in the radio set-up, except that their favorite local stations are now found at different dial settings.

DX Increased

Many listeners have taken a renewed interest in distance reception. They now turn with increasing frequency to stations 1,000 miles or more away and find that these can be brought in with a quality and loudness of local stations, due partly to increased power of the distant

stations and partly to less interference from other stations.

When they tire of the local programs, excellent though these may be, they turn to a distant station for a fresh note and an unfamiliar voice. In New York stations like KDKA, Pittsburgh, WPG, Atlantic City, and WRVA, Richmond, Va., are like locals, and the larger stations in New England, Michigan, Canada, the Southeast, and Chicago are fully as strong as many of the smaller local stations. And in other well-populated sections of the country the DX situation is equally favorable.

Farmers Benefited

The improved DX situation greatly benefits the farmers and all others who live far away from the large cities where the larger broadcast stations are located, provided that these listeners are equipped with receivers which will reach out 1,000 miles or more. Therefore possessors of non-sensitive receivers in rural districts find the reallocation disastrous to them.

But the listeners in small communities have been deprived of much of their local entertainment, because the small local stations, previously on the air every night, have either been curtailed in power or in hours of operation. In compensation for the lack of local programs the listeners have the opportunity of hearing stations of national importance and appeal without any interference from smaller stations.

While the listeners in the large cities have been deprived of some of the quantity of radio service, the listeners in the country have not received a greater quantity because of the general curtailment of power and hours of operation necessary to eliminate heterodyning. But throughout the country there has been an improvement in the quality of service, in view of the reduction of heterodyning.

Frequency Stabilization Necessary

Beyond the full value of the new radio set-up can be realized it is necessary that all stations get on their assigned frequencies and stay on them. At this time there are still some stations which have not "found" their frequencies and they cause interference by heterodyning. But they are gradually overcoming their difficulties and the situation is clearing up.

Heterodyning causes little interference in the evening because many of the stations are not permitted to broadcast after sundown, local time.

Aside from a few cases of apparent injustice to high-class stations and their large bodies of listeners, the new allocation is in general an improvement from the viewpoint of the listening public. Better programs can be received with less disturbance by practically all listeners in the United States, except by those resident in the small densely populated districts which had more than their share before the reallocation went into effect.

The injustice to some large stations, like WGY and WSAI, which suffered curtailment of hours, arose from the Commission choosing only forty cleared channels, instead of fifty recommended by the engineers. This choice of eight clear channels for each of the five zones made the reduction in power and time less for small stations than otherwise would be the case.

THE RAYTHEON Manufacturing Company, of Cambridge, Mass., has established a patent and legal department under the supervision of LeRoy Williams. Mr. Williams has been associated with the Cadillac Motor Company and with the Westinghouse Electric & Mfg. Co., as patent counsel. He is an authority on radio patents and litigation. Mr. Williams has been elected secretary of the Raytheon organization and a member of the board of directors.

KSL and KLZ

Join New Chain

Extension of the American Broadcasting Company's Pacific Coast chain to include KSL, Salt Lake City, and KLZ, Denver, was announced by G. A. Coats, vice-president of the Allied Broadcasting Companies, Eastern representative of this system.

The network now includes KJR, Seattle; KEX, Portland, Ore.; and KGA, Spokane, Wash., on 5,000 watts, and KYA, San Francisco, with 2,500 watts, and also the independent station KMTR, Los Angeles, using 1,000 watts, all stations having been granted preferential channels under the reallocation.

KSL also uses 5,000 watts. KLZ, pioneer Rocky Mountain station, is on 1,000 watts.

It is expected that many programs originating in New York will be radiated through this system. KJR, KEX, KGA and KYA are equipped for 20,000 watts transmission, and are owned by the American Broadcasting Company, of which Adolph F. Linden, Seattle banker, is president.

Eastern offices of the ABC are at 551 Fifth Avenue, New York City.

WOBLERS FACE 60 QUIET DAYS

Washington.

Captain Guy Hill, engineer for the Radio Commission in charge of broadcasting, has recommended to the Commission that the licenses of the following stations be suspended for sixty days for failure to adhere to their assigned frequencies:

WKQB, the Bronx, New York City; WEVD, Woodhaven, New York City; WOKO, Mount Beacon, N. Y.; WHAZ, Troy, N. Y.; WCLB, Long Beach, N. Y.; WNJ, Newark, N. J.; WAFD, Detroit; WKAR, East Lansing, Mich.; KWKH, Shreveport, La., and WDSU, New Orleans, La. These stations, Captain Hill told the Commission, had been from 2,000 to 73,000 cycles off their assigned frequencies. He further said:

"In order to put an immediate stop to such destruction of the programs of stations which are faithfully adhering to their frequency, I recommend that in each case where stations have been measured and found to be deviating from their assigned frequency by more than one kilocycle, which is twice the allowable deviation, that the licenses of such stations be immediately suspended by the Commission, this suspension to be for a period of sixty days.

"I also recommend that stations which deviate from their frequency by more than one-half kilocycle, but not exceeding one kilocycle, should be notified that they must make adjustments to their apparatus immediately to operate within the limits set by the Commission or the Commission will be forced to suspend their licenses."

THE FEDERATED Radio Trade Association has decided on Buffalo, N. Y., as the scene of the next convention, to be held February 18th, 19th and 20th. Buffalo has been chosen because its location makes it accessible to radio tradesmen throughout the United States and Canada.

NO HOPE LEFT FOR WAVE GAIN IN ANY ZONES

By Orestes H. Caldwell

Reports reaching the Radio Commission as well as independent surveys of national conditions, indicate that the November 11th broadcasting changes have been followed by improved radio reception generally throughout the Nation and by an increased number of stations available on the average listener's dials.

Complaints are, however, coming to the Commission from several cities regarding the reduced number and periods of local or nearby radio programs which are to be heard since the redistribution of wave lengths. The reason for such reductions will be very clear upon a reading of the 1928 Radio Law.

Followed Davis Law

Under this 1928 Radio Law (Davis Amendment), the Commission is ordered to redistribute the wavelengths and other radio facilities equally among the citizens of the Nation, that is, to States according to population.

Of course, this has meant that from certain sections heretofore enjoying an excess or high degree of radio service provided by enterprising broadcasters, wavelengths have had to be withdrawn from these sections.

The reallocation of November 11th faithfully carried out this redistribution and all parts of the Nation now have their proportions of the radio total, based on population, in strict compliance with the mandate of Congress.

Each State and section, moreover, now also has its appropriate share of the various positions on the dial, from 200 meters to 543 meters.

Cites Massachusetts

For example, Massachusetts, which formerly had the advantage of using chiefly the upper or longer wavelengths, now has its State channels fairly spread across the dial, and has necessarily witnessed the transfer of certain of its stations "down," where they are finding themselves able to give equally good (or better) service on relatively cleared channels, as rapidly as their transmitters are adjusted to the new assignments.

While the reduction of local radio service in certain parts of the Atlantic Seaboard will occasion some inconvenience, as compared with the former excess of broadcasting enjoyed by Eastern listeners, it is believed that citizens thus deprived will cheerfully accept this equalization and redistribution, knowing that the facilities thus lost by them are being made, by Act of Congress, available to other American citizens in other parts of the country which formerly had little or no radio service.

ALL

in Next Week's Radio World

How to make a few simple changes in the 1926 Model Diamond of the Air, a 5-tube circuit, so as to incorporate the screen grid tube as radio frequency amplifier, will be described in next week's issue of RADIO WORLD, dated December 15th. In that issue, also, David Sarnoff, vice-president and general manager of the Radio Corporation of America, will discuss television. Remedies for motorboating will be outlined by J. B. Anderson, Technical editor. A 3-tube circuit, using only one tuning condenser, with fixed regeneration, will be discussed, also. The final instalments on the Hammarlund-Roberts Hi-Q29 (five tubes) Master and the Sargent-Raymont (seven tubes) will be published in that issue. Besides, there will be thirteen other "lucky" features.

WNAC'S PLIGHT LAID TO STEEL IN BUILDINGS

Washington.

The inability of WNAC, operated by the Shepard Stores, Boston, to perform as good radio service on its new assignment of 1,230 kilocycles as it did prior to the reallocation, is held due to "steel-building absorption" of its signals, a condition that can be corrected by readjustment or removal of its transmitter, it was suggested by Commissioner O. H. Caldwell, of the Radio Commission, in a letter to Senator David I. Walsh, of Massachusetts. Commissioner Caldwell wrote: "Since your call at the Commission's office this week, on behalf of your constituents who are listeners to Station WNAC of Boston, I have been giving careful investigation to the arguments presented by you in urging a different assignment for that station, so that it may be better heard with its present transmitter arrangement.

"At your request, I have also had our engineers check over the situation thoroughly again, because, like yourself, I want to exert every personal effort to get Station WNAC and its very popular network programs in position to best serve the people of Boston and New England.

"First, let me explain that the channel (1,230 kilocycles), to which WNAC was assigned by the Commission on September 11 (to become effective November 11), was not of the Commission's voluntary choosing, but resulted from the application of the 1928 radio law, requiring the Commission to redistribute the wave lengths equitably among all the States in proportion to population.

Spreadout Necessary

"For you will recall that under the former radio arrangement (which the 1928 Act of Congress was designed to amend), Massachusetts and other eastern States had been enjoying the use of the upper scale or longer wavelengths almost exclusively. In assigning Massachusetts' new quota of wavelengths, according to population, therefore, it was necessary for the Commission to spread these wavelengths across the dial (since to have assigned to Massachusetts all upper-dial positions only, would have meant lower-dial positions for some other State or States).

WNAC Jumped Wave

"In spite of the complex problem of interlocking channels, both national and regional, the Commission has, therefore, sought to distribute the larger Boston stations equally across the dial (which extends from 550 to 1,500 kc.), as follows: WEEI, 590 kilocycles (508 m.); WBZ, 990 kilocycles (303 m.); WNAC, 1,230 kilocycles (244 m.); WBET, 1,360 kilocycles (220 m.).

"It was felt that WNAC could use this 244-meter channel satisfactorily, since it was near the channel (280 m.) on which WNAC had successfully operated for years under Mr. Hoover's assignment, and from which, when the law broke down in 1926, WNAC 'jumped' to its higher position, when the restraining hand of Governmental authority was temporarily removed.

Given Chance to Test

"Moreover, to make sure of the operating results to be expected by WNAC of 1,230 kilocycles, the station was during

Quota is Full, Bay State Told

Washington.

The State of Massachusetts is assigned its full quota of channels proportional to population and these channels are equitably distributed across the broadcasting spectrum under the new allocation, Commissioner O. H. Caldwell informed Frank Jenkins, radio editor of the Boston "Herald," in a telegram. The telegram was in reply to complaints against the arrangement of Boston stations of the allocation. The full text of the telegram follows:

"Answering inquiry, members of Commission have sought to give each section and State maximum possible good radio service consistent with the 1928 act equalizing radio facilities throughout nation.

"Massachusetts is assigned its full quota of channels proportional to population and these channels are equitably distributed across broadcasting spectrum. Any Massachusetts station dissatisfied may contest for any other suitable Massachusetts channel at public hearing.

"Your report, difficulty WNAC reception, indicates WNAC's transmitter arrangement on building not yet properly adapted for new channel which, with neighboring channels, is giving excellent transmission in case of many other stations suitably designed. Commission will welcome any suggestions to improve radio reception to Boston listeners consistent with existing law and requirements, good radio to rest of nation."

October authorized by the Commission to make after-midnight tests on its new channel, in preparation for the November 11 change-over.

"Whether such preliminary tests were made during October or not, I do not know. But it is certain that when actual operation of WNAC on 1,230 kilocycles was begun on November 11, reduced signal-strength was observed by many listeners.

"The engineers whom I have consulted all attribute this to the absorption of the steel-building area, in which the WNAC transmitter is located. Like a huge sponge these steel structures seem to reach up and absorb radio waves of frequencies higher than 900 to 1,000 kilocycles, although having little effect on frequencies around 600 kilocycles.

Laid to Steel Buildings

"This difficulty with the higher frequencies is purely a matter of steel-building absorption, for the channels of 1,200 to 1,500 kilocycles are being used entirely successfully by more than a hundred important stations in other localities (many of these stations far larger than WNAC, and representing investments up to \$150,000 per station). In fact, the high-frequency channels seem to reach out across country better than channels at the top of the dial, and every radio listener knows the distance records being obtained by certain 200-meter stations.

"This is further confirmed in your own States by the recent experience (since November 11) of two Boston stations allocated to positions below WNAC. These two stations are now covering Massachusetts and New England in a way never before attained, and are very much pleased with their results.

"The engineers seem unanimous that when Station WNAC readapts or removes its transmitter from the steel-building area the absorption it is now suffering will cease, and that on its present excellent wavelength the station will reach out with an intensity equal to or greater than it has ever enjoyed."

TARGET FOR DX IS COSTA RICA NRH ON 30.3 M.

Short wave fans throughout the United States and Canada who delight in receiving far-away stations will find it interesting to tune for the broadcast station NRH of Amando Cespedes, Marin, Heredia, Costa Rica, Central America. Mr. Cespedes broadcasts every evening between 9:30 and 10:30 Eastern Standard Time on a wavelength of 30.3 meters. His power is 7.5 watts but he is so favorably located that his station has been heard throughout Central America, Cuba, Colombia and in many other South American countries. He has also been reported in Philadelphia Pa., and in Providence, R. I. He broadcasts Spanish music and talks in Spanish, and his programs have been enjoyed by the American soldiers in Panama.

Special Test

Mr. Cespedes will make a special effort to reach RADIO WORLD from December 3rd to 9th, inclusive. This is a real opportunity for American short wave DX fans to establish a long distance record for reception of a low power station. He uses phone.

Wants Letters

Mr. Cespedes will appreciate hearing from those who succeed in receiving the signals from NRH. Since the wavelength of this station is 30.3 meters it will tune in just below Eindhoven, Holland, which is 30.4 meters and 2XAF, the General Electric 30.4 meter station in Schenectady.

23 Dance Orchestras Are Booked by N.B.C.

Twenty-three popular dance orchestras, including many of the leading ones in New York City, are now under the exclusive management of the National Broadcasting and Concert Bureau, said George Engles, managing director.

The bureau has also added nine artists and six artist groups to its list. The new artists include Betsy Ayres, soprano; Adelaide de Loca and Leslie Frick, contraltos; Franklyn Baur, James Melton and Morton Downey, tenors; John Mitchell and Phil Cook, specialty acts. The new artist groups are the American Singers, the Smith Brothers, the Pickard Family, the Landt Trio, the Piano Twins and Torre and Viviano.

Orchestras and their leaders under contract with the bureau include B. A. Rolfe and his Palais d'Or Orchestra, Ben Bernie and his Hotel Roosevelt Orchestra, Hal Kemp and his Hotel Manger Orchestra, Lucky Strike Dance Orchestra, Ben Pollack and his Park Central Orchestra, Frank Winegar and his orchestra, Howard Lanin and his Music, the Detroiters, Red Nichols and his Five Pennies, Harry Salter and his orchestra, Charles Fry and his Million-Dollar Pier Orchestra, Peter Van Steeden and his orchestra, Harry Reser and his Cliquot Club Eskimos, Jack Albin and his Hotel Bossert Orchestra, Johnny Johnson and his orchestra, Sam Lanin and his Ipana Troubadours, George Hall and his orchestra, Hugo Mariani and his Mediterraneanans, Carroll Cooney and his orchestra, Jean Goldkette and his orchestra, Oscar Adler and his orchestra, Don Marcotte and his Vagabonds, and Larry Brier's Orchestra.

BROADCASTERS STILL WORRIED ON COPYRIGHTS

By William S. Hedges

Of WMAQ, Chicago, president of the National Association of Broadcasters, Inc.

There is perhaps no industry which has its foundation on such uncertain ground as the broadcasting business.

The very fundamentals of existence as broadcasters cannot be definitely determined. No broadcaster can be certain of the power he may use, the frequency of his transmitter, his time on the air or his very tenure of life as a broadcaster beyond the ninety day period of his present license.

He may have huge investments in broadcasting equipment but there is nothing definite about the manner or the time that he may make use of that investment.

Must Meet Situation

This condition must be expected at a time when the government, as the representative of the people, may be reasonably expected to proceed slowly in permitting the use of the new medium of communication, which is supposedly the property of all the people.

It is nevertheless a situation that must be confronted if real stability is ever to come in broadcasting.

There is still another element of uncertainty and that is the cost of the "raw materials" of the broadcaster—the music itself. At the present time there is no standard charge for the use of copyrighted music. Broadcasters in similar circumstances may be paying entirely different amounts. Not only is the commodity-music sold for a variety of prices, but there is no certainty of the price for next year or the year following.

The copyright proprietors can charge about as much as they think the traffic will bear and can, conceivably, keep "jacking up" the price until the broadcaster is wrung dry. The copyright proprietors don't really want to do that. They want to see the broadcaster make enough money to pay his license fee without hurting so much that he will quit and thereby drop from the list of revenue producers.

Radio Potent

The lack of standard prices and the uncertainty of how much the copyright proprietors may levy on the stations are not the only discomforts that rise to plague the broadcasters, for there is always the likelihood that new groups of copyright proprietors will organize and also demand license fees.

These are but a few of the reasons why the broadcasters of the United States should maintain a strong association for it is only by concerted action that we can hope to establish conditions which will place the business of broadcasting upon a stable basis, which, after all, is necessary if the public is to be served best.

I anticipate a busy year. Radio is likely to play a conspicuous role in legislative halls of Washington.

Certainly the Presidential campaign has opened the eyes of many a legislator to the potency of radio. As the law now stands the Commission adverts to a judicial status next February and the terms of the present Commissioners come to an end. The present radio law needs clarifying and amendment, according to views expressed in the annual convention.

German Records Sound on Coil

Paris.

A new device, consisting mainly of a sensitive steel wire, was demonstrated here by a German inventor, Dr. Stille, who claims he has discovered a new medium of recording and transmitting sound. If he is successful in substantiating his claim the new invention will probably influence telephonic transmission and the development of talking motion pictures.

The instrument embodying the invention is said to consist of a coiled steel wire on which speech can be recorded in much the same manner as speech is recorded on dictaphones and on phonograph records. It is possible to use the device for sending a recorded speech over a telephone line at highly increased speed and for receiving the high-speed message for later reproduction at normal speed. The advantage besides increased speed of transmission is that the sender may transmit and the receiver may accept the message at their convenience. The method is capable of synchronization of sound with motion pictures.

STATIONS WAR IN BROOKLYN

Representatives of WLTH, WBBC, WSGH and WCGU, and Eric H. Palmer, Brooklyn radio arbitrator, had a difficult time trying to arrange a schedule of operation on the 214-meter wave assigned to these stations. Two of these stations, according to the Federal Radio Supervisor for New York and many radio listeners, were on the air at the same time for half an hour one day, thus ruining each other's transmissions. Previously WMCA and WNYC, both 526 meters, were on the air a short while "together."

In the war between the stations Mr. Palmer, who was appointed by Borough President Byrne of Brooklyn at the suggestion of the Federal Radio Commission, has the backing of the Federal authorities as well as of the residents of Brooklyn.

CIVIL SERVICE

The United States Civil Service Commission announces an open competitive examination for Assistant Radio Inspector. Applications must be on file with the Commission at Washington, D. C., not later than December 31st. The entrance salary is \$2,400 a year. Competitors will be rated on theoretical and practical questions on radio and electrical engineering and on their education, training and experience.

The duties are primarily to assist the radio inspector in the enforcement of the Radio Act. The assistant radio inspector will be required to inspect radio equipment on vessels and at land stations, which involves the carrying of 30 to 40 pounds of testing and measuring instruments to make high frequency and field intensity measurement; to assist in the examination of radio operators, and to perform such office work as is required.

Full information may be obtained from the United States Civil Service Commission, Washington, D. C., or from the secretary of the United States Civil Service Board of Examiners at the Post Office or Custom House in any city.

THREE DICTION MEDALS TO GO TO ANNOUNCERS

A medal for good diction on the radio will be awarded by the American Academy of Arts and Letters, according to an announcement made by the Academy at 633 West 165th Street, New York City.

Three gold medals for good diction on the stage already have been awarded by the Academy to Walter Hampden, Edith Wynne Matthison and Otis Skinner.

The decision of the Academy to award a medal for good diction on the radio rests on the theory that the announcers for the programs of the various radio stations have an enormous effect upon the speech of the American people.

The winner will be chosen from among the official announcers of the radio stations of this country.

Complete details for the contests are in the hands of Hamlin Garland, chairman of the Academy committee for the award. Announcement of the details will be made from the Academy on Sunday evening, December 16, at 10:30 o'clock, Eastern Standard Time, over a nationwide hook-up through the courtesy of the National Broadcasting Company and the Columbia Broadcasting Company.

Award in April

At that time Mr. Garland will present Dr. Nicholas Murray Butler, president of the Academy, who will be the chairman of the evening. Other speakers will be Mr. Hampden, Miss Matthison and Mr. Skinner. Professor George Pierce Baker, head of the Yale Dramatic School, Robert Underwood Johnson, secretary of the Academy, and Augustus Thomas, playwright, also will speak.

The art committee of the Academy, of which Gass Gilbert is chairman, has selected as the designer of the medal John Flanagan, a member of the National Institute of Arts and Letters and a former student of Augustus Saint-Gaudens, who was one of the first seven members of the American Academy of Arts and Letters.

The award will be made in connection with the celebration of the twenty-fifth anniversary of the Academy next April.

The committee in charge of the plan includes the following Academicians: Mr. Garland, Mr. Johnson, Mr. Thomas, Mr. Baker and Dr. John H. Finley.

Commenting on the plan, Mr. Garland said:

"Recognizing the enormous power of the radio as it is today, and believing that it is to be still more influential in the education of the nation, the Academy hopes to be of service by establishing a fund for a medal to be awarded to that announcer who employs the finest tone, the best diction, and the most agreeable accent while engaged in the regular discharge of his duties."

ALL

in Next Week's Radio World

How to make a few simple changes in the 1926 Model Diamond of the Air, a 5-tube circuit, so as to incorporate the screen grid tube as radio frequency amplifier, will be described in next week's issue of RADIO WORLD, dated December 15th. In that issue, also, David Sarnoff, vice-president and general manager of the Radio Corporation of America, will discuss television. Remedies for motorboating will be outlined by J. B. Anderson, Technical editor. A 3-tube circuit, using only one tuning condenser, with fixed regeneration, will be discussed, also. The final instalments on the Hammarlund-Roberts Hi-Q29 (five tubes) Master and the Sargent-Raymont (seven tubes) will be published in that issue. Besides, there will be thirteen other "lucky" features.

NEW TYPE SET IS DEVELOPED FOR AIRPLANES

Washington.

Two notable contributions to aircraft radio have been developed by the Signal Corps during the past year, according to the annual report of the Chief Signal Officer of the Army, Major General George S. Gibbs. The two contributions are, first, a new radio receiver for use with aircraft radio sets, that will supersede the standard receivers now in use, and, second, a double voltage direct engine driven generator for use in aircraft.

Cites Advantages

A summary of General Gibbs' annual report sets forth:

"It is to be expected that the most astonishing progress will be found in the radio field. So it is that the Signal Corps announces the completion of a new radio receiver for use with aircraft radio sets that will supersede the standard receivers now in use.

"The new receiver is considerably lighter in weight, occupies much less space, is rugged, receives continuous wave signals, as well as tone modulated and radio telephone. It is a distinct advancement and should contribute much to the success of signal communication involving aircraft.

"Another important contribution to aircraft radio operation has been the joint development by the Signal Corps and the Air Corps of a double voltage direct engine driven generator for use in aircraft. It eliminates the necessity of supplying dynamotor with each radio set and effects a saving in weight and cost and increases the dependability of operation.

The Only Flying Laboratory

"These two notable accomplishments have been effected at the Signal Corps Aircraft Radio Laboratory at Wright Field, Ohio, and have been greatly facilitated by the action of the Air Corps in making available as a flying laboratory three-motored Fokker transport airplanes.

"So far as known, this is the only flying laboratory of its kind in existence, and by its use the characteristics of radio equipment for all air uses can be tried out practically in a few hours, and results obtained that would otherwise require weeks.

"Another notable radio achievement has been the redesign and improvement of the 500-watt, crystal controlled, high frequency reduction transmitter. This set is used for medium long-range operation at stations on War Department net and in Alaska."

Aerovox Wins Suit On Condenser Patent

In an opinion handed down by Judge John C. Knox of the United States District Court for the Southern District of New York, the patent claims upon which the Dubilier Condenser Corporation based its suit against the Aerovox Wireless Corporation, for alleged infringement of Dubilier patents on mica condensers, were held invalid and a decision was rendered in favor of the Aerovox Wireless Corp.

Commenting on the evidence, Judge Knox said:

"There is no patentable novelty in the claims on which suit is brought."

Domestic Study Of Music Suffices

Dave Schooler, formerly known as "The Boy Paderewski," who recently began an engagement as guest conductor of the Capitol Theatre's stage band, the "Capitolians," now plays piano over the air with Major Edward Bowes' Capitol "Family" on Sunday evenings.

A native of Rochester, N. Y., Mr. Schooler was a pupil, in his early youth, of an interpreter of the old Italian School, and later of Raphael Joseffy. Mr. Schooler is proud to have received all his musical education in this country. He contends that it is no longer necessary to go to Europe to obtain the best musical training, as the large cities of the United States now offer the greatest teachers of both Old World and New.

CALL LETTERS NEED STRESSING

Washington.

More frequent announcement of call letters by radio broadcasting stations is suggested by the Federal Radio Commission in a circular to all broadcasting stations. The full text of the notice follows:

"That listeners, Government supervisors, and inspectors may readily identify broadcasting stations now operating on the November 11 assignments, it is suggested that all broadcasters announce their call letters, or identify their stations briefly, more frequently than once during the 15-minute period, as directed by General Order 8.

"The Commission does not desire that programs be interrupted or interfered with by such announcements, but feels that, in view of the fact that thousands of listeners are endeavoring to identify stations heard, and because the Department of Commerce field men are checking stations as to their frequencies, the frequent announcement of call letters will permit the logging of stations on their new assignments."

U. S. Barges Depend On the Short Waves

Washington.

The dependence of the Inland Waterways Corporation, the Government-owned barge transportation organization on the Mississippi and Warrior Rivers, upon radio communication to maintain schedule operation was explained to the Federal Radio Commission by Maj. Gen. T. Q. Ashburn, chairman and executive of the Corporation.

Urging the Commission to renew the licenses of four of the short wave stations now being operated along the rivers, General Ashburn said that the operations of the service are "as regular and dependable as train operation and only because of radio communication between operating points and between boats and shore."

The Corporation has four separate applications before the Commission, asking for renewal of licenses originally issued by the Department of Commerce before the Commission was formed. They are for the Corporation's stations at Birmingham and Mobile, Ala., Memphis, Tenn., and Minneapolis, all terminal points of the Mississippi-Warrior service.

TEN STATIONS APPROVED IN CHICAGO VOTE

Chicago.

Radio fans are backing up the Federal Radio Commission in its attempt to clear the air of interference. Listeners go even further than the Commission in expressing the opinion that there should be fewer stations on the air.

This information is contained in a survey made by an independent agency for WBBM, Chicago. Inquiries were sent to the following classes of listeners: executives, professional men, members of labor unions, clerks and radio dealers.

856 Satisfied with Ten

A total of 1,275 answers was received on the question, "Would your enjoyment of radio be less or greater if there were only ten Chicago stations?" Exactly 856 replied that they approved of only ten stations. Only 252 thought that Chicago should have more than ten stations. On the question, "If, because of less time on the air, your favorite stations could not present the programs they now do, would you be displeased?" 1,144 answered "Yes" and 164 answered "No." The third question was, "Would you want your favorite station silent after 10:30 P. M.?" 1,010 answered "No" and 226 "Yes."

Four Stations Preponderate

More important, however, from the viewpoint of a Chicago survey, is the fact that out of 1,257 answers received on the question, "Which are the favorite radio stations in Chicago?" 996 declared for four stations. These stations, with reference to the order in which they stood in the contest, were KYW-KFKX, WMAQ-WQJ, WGN-WLIB, WBBM-WJBT.

Of interest is the fact that WMAQ led among the executives; WGN among professional men; KYW among union labor; WBBM among clerks, and KYW among radio dealers. In each instance, however, the vote was so close that there was little difference between the first four stations. Eleven stations of those in the Chicago area did not receive a single vote.

Two Missouri Stations Suffer Cut in Power

Washington.

The Federal Radio Commission has reduced the power of KMBC-KLDS, Independence, Mo., and WHB, Kansas City, from 1,000 watts to 500 watts for causing interference with WRC, Washington, D. C., which was operating on 500 watts.

Listeners to WRC heard a heterodyne squeal, which was first thought to be caused by beating with CNBU, 5,000 watts, at Bowmansville, Canada. It was thought that WRC had strayed from its assigned frequency far enough to heterodyne audibly with the wave of the Canadian station. But listeners found that WHB was causing the interference when WRC signed off and the signals from WHB were brought in with loudspeaker volume without changing the tuning. Captain Guy D. Hill, broadcasting engineer for the Commission, dispatched a telegram to the Missouri stations as follows: "Authorized power of your station changed to 500 watts after local sunset. This change effective immediately and modification of license being mailed. Reduction of power necessary to reduce heterodyne interference."

How High is the Plane?

A New Radio Echo Method of Measuring Craft's Altitude

By *Dr. E. F. W. Alexanderson*

Consulting Engineer, General Electric Company

ONE of the most important aids to navigation of the sea is depth sounding. By means of his soundings and his chart the sailor can usually find his way in foggy weather. We are told that a corresponding aid is needed in aviation and many suggestions have been made. One of these proposals is to make use of the echo or reflection of a radio wave. Depth and distance measurements are sometimes made by sound waves in water and in air. In that case the time is measured for the return of the reflected wave. With radio waves travelling at the velocity of light, this time interval is extremely short and indirect methods of measurements must be adopted.

I am going to describe one such method that has proven successful.

Phase Varies

If we decide to measure the time interval in units equal to the time of one oscillation or cycle of the antenna current, the time interval of the echo is equal to the number of wavelengths the reflected wave has travelled on its way from the antenna to the ground and back again.

If this distance is varied by an amount which is a fraction of a wavelength this variation will manifest itself in a variation of phase of the returning wave relatively to the phase of the transmitted wave.

If this distance is varied by an amount of several wavelengths, then the phase of the returning wave will go through the corresponding number of cyclic changes of phase.

Thus, if we have means for ascertaining the phase of the returning wave and are able to count the number of cyclic changes, we are thereby able to make absolute measurements of the height over ground.

Phase Detection Necessary

The problem thus resolves itself into finding means for detecting the phase of the reflected wave in relation to the transmitted wave.

A direct measurement of phase under these circumstances is difficult and we are therefore taking advantage of a fact which we discovered during tests made from an aeroplane, that the reflected wave modifies the frequency of the original wave.

This change in frequency is dependent on the strength as well as the phase of the reflected wave. These cyclic changes in frequency are used to detect the phase of the reflected wave. The cause for these changes of frequency will, however, need some further explanation.

Ordinarily, we assume that the frequency of an electrical oscillator is determined by the inductance and the capacity of the circuit, in the same way as the frequency of a mechanical oscillator is determined by the inertia and the restoring force.

Outside Forces Cause Upset

From these considerations we are tempted to draw the conclusion that the transmitted wave has the natural frequency of the antenna and that the reflected wave which has the same frequency as the transmitted wave, will only modify the phase but not the frequency of the original oscillations.

This conclusion is, however, a fallacy, as we discovered when we started to make practical tests. The reason for this fallacy is that an oscillator will swing at its natural period only when the restoring forces which are contained in the oscillator itself are the only ones that exist.

When the oscillator is acted upon by forces from outside, these forces may add to or subtract from the inherent restoring forces. It is, however, the resulting restoring force which determines the actual period of the oscillator.

Thus, if the force coming from outside is in phase with the inherent restoring force and increases it, the oscillator will swing with a higher frequency, and conversely, if the force from outside is in opposition to the inherent restoring force, the oscillator will swing at a lower frequency.

This relation between the phase of the force impressed upon the oscillator from outside and its actual frequency can be demonstrated with mechanical as well as electrical models.

As soon as it is understood that the cyclic change of phase of the reflected wave manifests itself in a corresponding change of frequency of the antenna oscillator, a basis has been established for the design of a practical altitude meter.

Distance to Be Measured

The object is to measure the distance that the reflected wave has travelled when it returns to the antenna. This distance may be measured in two ways, by the strength of the returning wave which in its turn determines the amount of frequency change; and by the number of cyclic changes in phase which the wave has passed through before it returns.

The indications may be oral, graphic or visual or in the nature of a warning which would call the operator's attention when certain limiting values had been exceeded.

In the measurements so far made, we have used an instrument that traces a graphic record of the frequency variations. Quite a number of such records have been taken. Up to altitudes of 4,000 feet the cyclic nature of the frequency variations is unmistakably shown by one of the records.

Barometric Method Tried

Observations were also made on a barometric altitude meter and the observations were written down on the graphic record, during the progress of the flight. We have thus observations of altitude by two independent means set down side by side on the graphic record. Two logs of the flight were reconstructed, one from each set of observations. The wavelength was 95 meters from which is deduced that each cycle of the wavy line in the graphic record represents an altitude change of 155 feet. The barometric log gives altitude over the starting point whereas the radio echo log gives actual altitudes over the ground. The results should therefore not necessarily be identical.

Still Something to Ascertain

The agreement of the general shape of these curves is, however, quite convincing that we have in the radio echo a basis for absolute altitude measurements of height over ground.

How this principle may be best applied for practical aerial navigation we are not yet able to say. Continuous graphic records may be used on larger craft and it may thereby be possible to positively identify the course flown with the maps and previous experience. Such graphic altitude logs may also be used for surveying.

A very desirable development will undoubtedly be an instrument which permits of positive determination of altitude over the ground at any time desired.

Some suggestions of how this can be accomplished may be sufficient at the present time. Suppose that an aviator is flying in a fog and he wishes to reset his barometric altimeter for the actual level of the ground. The navigator will put the graphic radio echo meter in operation and start to climb.

The amplitude of the wavy line will give an immediate indication of height over ground but he may desire a more accurate determination.

Let us then assume that he can change the wavelength of the instrument 8 per cent. by pressing a key. By periodically pressing the key he may then trace two graphic curves, one at 100 meter wavelength and one at 92 meters.

Susceptible of Calibration

The phase relation of these two curves will be clearly shown by the record.

If the two curves are in phase it means that the distance travelled by the echo wave may be measured in exact whole wavelengths for both frequencies of the transmitter. Thus, the 100 meter wave may have travelled 12 wavelengths and the 92 meter wave 13 wavelengths.

In this case the distance over ground would be 600 meters (2,000 ft.). If, on the other hand, the cyclic variations of the two records are 180 degrees out of phase it may be concluded that the altitude is either 300 meters (1,000 ft.) or 900 meters (3,000 ft.). The amplitude of the echo indication will indicate with sufficient accuracy which of the two figures should be accepted.

A definite calibration of the barometric instrument with reference to ground may therefore be made at 1,000, 2,000 or 3,000 feet altitude.

Another suggestion for the development of direct indicating instruments is to use two antennas with an oscillator in each antenna. One antenna may have a wavelength of 10 meters and the other 11 meters. The beat frequency between these two oscillations is detected and observed. This beat frequency will be of the magnitude of three million cycles, but the frequency will change cyclically when the plane changes altitude.

Successive Scale Uses

It will pass through maxima when the echo wave tends to decrease the frequency of the 11 meter oscillator at the same time as it increases the frequency of the 10 meter oscillator.

If these radio indications of height and position are combined with a mechanical landing device touching the ground at 10 to 15 feet, it is conceivable, at least we are told so by our associates who are skilled aviators, that safe landings may be made in fog without any vision of the landing field.

Uncle Sam, Radio Bug

Government Regulates and Participates in Big Way

By Dr. John H. Dellinger

A FRIEND told me the other day that on looking over the newspapers of a number of cities he found the radio programs either on the humor pages or with the obituary notices. He said he did not know whether this really meant that radio is defunct, or a joke.

The pessimist will tell you that radio has not fulfilled some of the high hopes that were raised in the early days of broadcasting. I admit that the millennium has not yet arrived, but radio as a service to mankind is in fact making a brilliant advance. I hope to show you what part the Government has in this.

The Government participates in the advance of radio in three principal ways: through regulation, scientific research, and extensive use of every application of radio.

In the Navy alone the Government is one of the largest users of practically every kind of radio service, including ship and aircraft communication, broadcasting, transoceanic telegraphy, direction finding, etc. It is constantly improving its radio facilities, and many of the improvements find their way into every-day use.

Standards Bureau the Bulwark

The radio research of the Government is carried on mainly by the Bureau of Standards by measurement, which enables all stations to operate with the least possible interference. It includes determination of the effects and causes of fading and static and other natural phenomena which determine just what service the listener receives.

The research work also includes the perfecting of radio systems for the Government's use, as for instance the radio beacon system to aid the navigation of ships and airplanes.

Radio is regulated or controlled by our Government, but in a very limited way in comparison with other countries. Radio has to have both national and international regulation, for two principal reasons: first, radio waves spread out everywhere, stopping at no boundaries, and capable of great mutual interference; and, second, the demand for the privilege of using radio frequencies is greater than the supply.

Government Encourages

These basic reasons for regulation are well illustrated in broadcasting. Because the number of broadcasting stations was increasing to the point where the listener could hear nothing except a station very near him or else whistles and interference. Congress enacted the Radio Law of 1927. This put stern control of the privilege of broadcasting and indeed all radio transmission in the hands of a commission of five men.

In other countries the control of radio is generally exercised through direct operation of the radio stations by the Government. Broadcasting is financed by a special tax on all owners of receiving sets.

Why U. S. Advanced Fast

The more liberal policy of our Government encourages the operation of stations by private owners, promotes radio by scientific research and development, and imposes the necessary minimum of



regulation through the Federal Radio Commission.

This policy has resulted in a radio advance in the United States unparalleled in any other country.

The Federal Radio Commission has the duty of examining every application for a radio license to operate a station and of deciding between applicants when more than one apply for the same frequency or in a given locality.

It must grant or refuse a license in accordance with a principle set forth in the law, defined by the words "public interest, convenience, or necessity."

The interpretation and application of that phrase is one of the most interesting features of the Commission's work.

The phrase is borrowed from legal terminology used in the regulation of public utilities, such as street car lines, gas companies, etc. Most users of radio are not public utilities, and yet the test of a public utility must be applied to them for the two basic reasons I have already mentioned. The legal profession is looking on with great interest while a new branch of jurisprudence is being founded in radio.

Applied to Radio

Applied to broadcasting, the legal test of "public interest, convenience, or necessity" insures that the rights of the listeners are of superior importance to those of the broadcasting stations. This means that as far as possible interference, heterodyning, etc., must be avoided.

It means that both rural listeners and city listeners must be given service.

It means that too much duplication of programs can not be permitted, the high-power stations can not be located in the midst of cities, and, finally, that the total number of broadcasting stations must be reduced if undue interference can not otherwise be eliminated.

A Trip to Bureau

I stated that the Government carries on scientific research work to perfect its own uses of radio. I can perhaps illus-

trate the ways in which this is done if I invite you to go along as the observer in a trip of the Bureau of Standards' experimental airplane.

You step into a small cabin containing only two seats and a table full of apparatus. There is a metal pole projecting eight feet above you from the cabin.

This is the antenna and you have before you the airplane instrument board, a receiving set, a pair of phones, and some electrical measuring instruments.

The engine is started and as the plane roars into the air, you glance at the course indicator on the instrument board in order to be sure that the pilot has started to go in the right direction.

Best Angle Found

You adjust the currents in the receiving set to a fixed value and then instruct the pilot to fly across your course at various angles and you put in a notebook the indicator deflections each time.

You then adjust the antenna to a different angle and repeat the process. The result of the day's work is the determination of the best angle to set the antenna to give greatest accuracy when a pilot flies in fog by the aid of the radio beacon service which is to be installed on the airways next year by the Department of Commerce.

To tell you fully the story of the Government's part in the advance of radio, I would have to relate much of the history and activities of such diverse bodies as the Commerce Department's Radio Division, which polices the ether; the Lighthouse Service, which maintains radio beacons to aid the navigation of ships and airplanes; the Army, the Coast Guard and Coast Survey, and the Forest Service, and many other branches which use radio telegraphy and telephony. I would have to tell you of the activities of the Interdepartment Radio Advisory Committee, which correlates the radio work of the various Government departments and aids the President in his legal duty of assigning frequencies to all Government stations.

Fine Public Service

There is an extensive interlinking of bureaus and boards concerned with the Government's operation and control of radio. It must be apparent from all this that the Government's part in the development of radio is of pretty vital concern to the public. As seen from the inside, the public's concern is a very real thing. As an example, the Federal Radio Commission has received as many as 547,000 letters from radio listeners in a single day.

There is some very fine service being rendered in connection with the radio work of the Government.

I have been in close touch with the development of radio in the Government for many years, and I know that the possibilities of radio furnish an inspiration which attracts loyal service and keeps the Government's radio workers alive to the responsibility of their task.

What the Government is doing to advance radio is the sum of the intelligence and devotion put into their jobs by those persons in the Government radio service who have caught the vision of the value of radio to humanity.

You Can Get M

Author Expounds Five Require

By M. U.

Associate, Institute

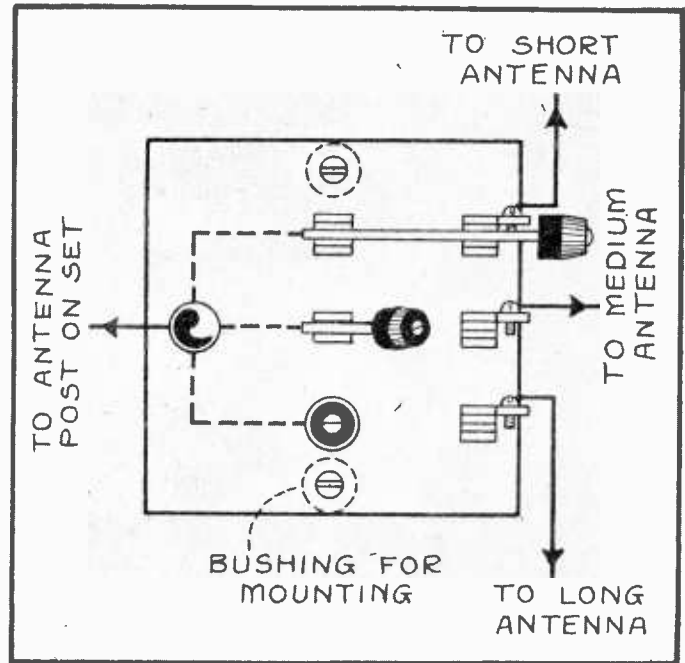
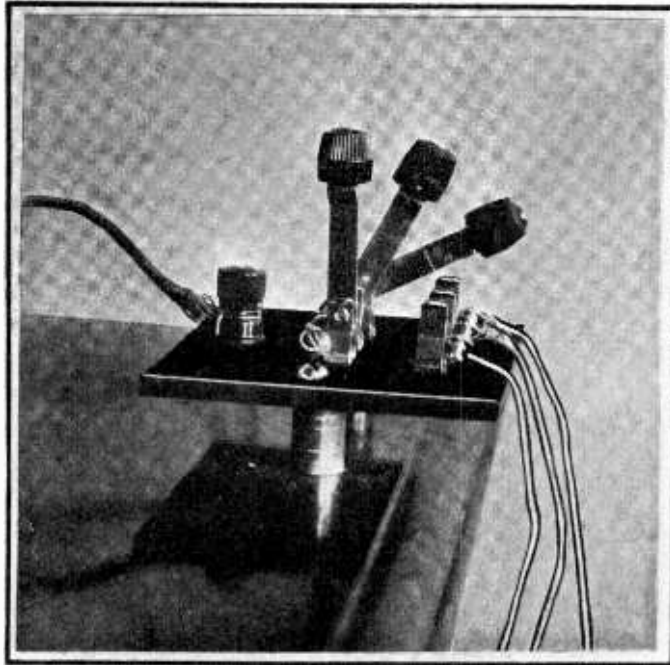

FIGS. 1 AND 2

THE SWITCH, FOR SELECTING ONE OR MORE OF THE THREE RECOMMENDED ANTENNAS, IS SHOWN AT LEFT, WITH THE WIRING DETAIL AT RIGHT.

This switch is easily constructed by purchasing two double pole, double throw knife switches mounted on porcelain. Remove the switch blades and contacts and use the porcelain base as a template for remounting the switches on a Bakelite base 4 x 4 inches. While porcelain is a good insulator, Bakelite will be found better for this type of switch. By using a larger base any number of additional blades and contacts may be used.

HAS quality local reception supplanted the old time, and still new, thrill of hearing far-away broadcasters? In my opinion, it has not.

You will invariably hear the purchaser of a new radio set ask his dealer:

"Will this set pick up distant stations?"

The dealer knows that his prospect is interested in this phase of radio and guarantees reasonable reception. If the purchaser would study his new receiver he would discover, to his amazement and joy, that a new world of thrills awaited him. There isn't a single owner of a radio set, in the East, who would not get a "kick" out of hearing an announcer say, "KFI, Los Angeles, California." Yet to tune in far distant stations is not difficult for the owner of a manufactured set, or the fan who "rolls his own" if a bit of advice is carefully followed.

Set's Coast-to-Coast Reception

A receiver can be made very sensitive, if properly operated, and will in no way affect the tone quality on local or distant stations.

The writer lives in the heart of Manhattan, a conceded "bad spot," and does not experience any difficulty in hearing West Coast stations with good loud-speaker volume. The exquisite tone quality of the receiver used is not affected by its sensitivity and the fact that only indoor antennas are used, to receive far away broadcasters, is an indication that even better reception can be expected in a better locality.

Nothing is more important than a good antenna and a good ground. The say-

Five Requirements for Getting Distance

The author gives the following requirements on DX.

1. **SUITABLE** antenna and ground systems. One or more aeri-als. Switching control.

2. **PROPER** position of tubes by testing them in the receiver. Extra care in selecting the detector tube.

3. **PROPER** plate voltages on plates of R.F. and detector tubes. Grid bias on R.F. Test voltages with a high resistance meter to make sure of them. Try several grid leaks.

4. **CAREFUL** tuning of the receiver. Study your set and know the location of your local stations on your dials.

5. **THE** use of "trimmers" or auxiliary tuning units where gang tuning is used. There are several manufactured and are very reasonable in cost.

ing goes that "a good antenna is an extra stage of radio frequency" and it holds true. The writer employs three aeri-als—one short, about ten feet, of metallic tape, and two others, also of tape, each thirty-five feet long. The longer aeri-als are strung around the picture moulding and by a switching control, shown in Fig. 1, any, or all, of these indoor aeri-als can be used. This switch is very useful. It enables the operator to use a short antenna for locals, a longer one for distant reception, and a still longer one for volume on distant stations or, when conditions warrant, the entire combination.

Fig. 2 shows how this switch is mounted and dotted lines show connections under base of switch.

Suggests Multiple Aerials

An excellent antenna system consists of one or two outdoor aeri-als in combination with indoor. If local stations are broad the shorter one may be used. If there are favorable spots on the dial, or dials, the entire antenna system may be employed.

This is done at the will of the operator by merely opening or closing the switch blades. Now that the new allocations are in effect this system will be advantageous. It is desirable to solder all antenna connections, and lead-ins, whether indoor or outdoor. A poor joint is a prey to corrosion and in time the aerial may cease to function. If soldering is not possible then wrap the joint with clean tin foil—not lead foil—and bind it securely with a good weatherproof tape. This extra care will pay large dividends.

Great care should be taken in making

More DX This Way

ments He Followed Successfully

Wallach

of Radio Engineers

the ground connections. Without a good ground stations that are otherwise easy to hear never will come through. For the benefit of those who live in apartment houses the writer ventures that a properly installed radiator ground will give the same results as a water pipe ground.

Connect Carefully

In selecting the water, or steam, pipe make your connection at the point where the pipe comes through the floor. Avoid pipe joints. There is already enough resistance in them to add to what you have. Remove all paint, rust, nickel plate, etc., by using rough emery cloth.

Use the "shoe shining" motion until the pipe is clean and finish the job with fine emery cloth until the pipe shines. Then attach your ground clamp and if possible solder the ground lead to it.

If this is not possible then treat it in the same manner as the antenna lead-in. A water or steam pipe joint will quickly corrode and will become worse with age if not properly treated.

Now that the antenna and ground problems are disposed of let us go to the next step:

A good set of tubes is like a tonic to a run-down system. One poor tube, up to and including the detector, will cause a sufficient decrease in sensitivity to warrant its quick removal. So we will only discuss the radio frequency and detector tubes as they alone will, or will not, bring in the station.

There are a number of tube testers on the market.

Tubes are supposed to be uniform, but let us see if they are. Out of fifty tubes tested in the receiver, twenty-seven were found to be very good, sixteen were fairly good and seven were poor. The twenty-seven good tubes were tested for position; that is, first, second and third RF stages and detectors.

Out of all these tubes only seven were selected for detectors.

Now we'll go about the testing method, which anyone can do, and which I have found, after using almost every other possible means, to be practical.

Getting a Tube's "Number"

Have a number of tubes on hand and with the present tubes in their sockets tune in some distant or near distant station. Reduce your volume control until the station is just heard. Then remove the first RF tube and try another in its place. Continue to do this until you have selected a tube for that particular stage which will increase the volume with the volume control set in its low position. Then go to the next RF stage and repeat. Continue to do this until good tubes have been selected for all RF stages.

In making this test I have found, in many cases, that the increase in volume and selectivity ran as high as 30 per cent. After proper tubes have been selected, mark them by scratching their position numbers, 1, 2, 3, etc., on the base of each and do the same with spare tubes so that you will have a quick replacement if necessary.

Then go to the detector tube and proceed in the same manner, but use care with this tube. Be sure that it is not microphonic or you will get plenty of

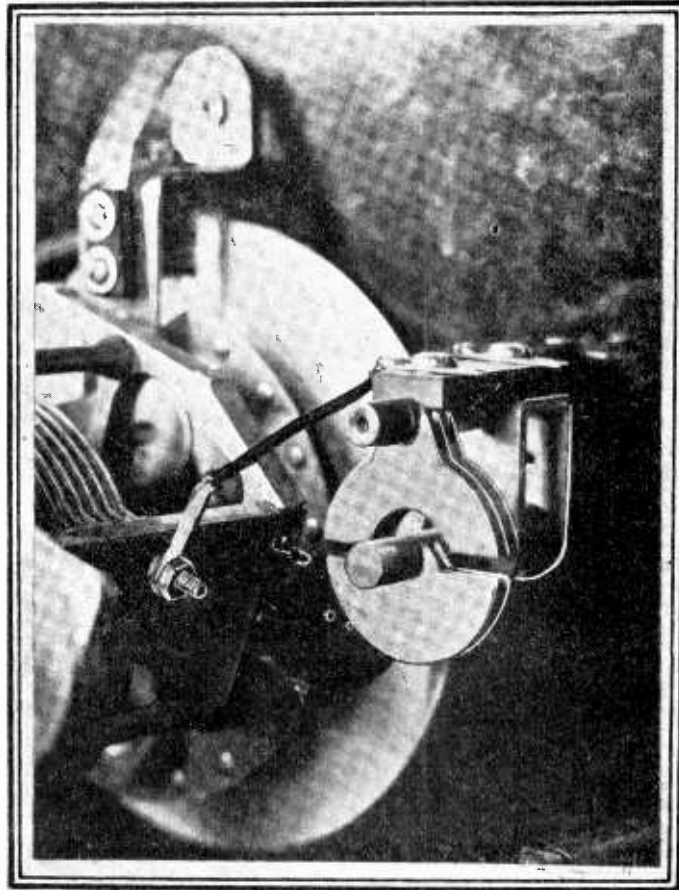

FIG. 3
CONNECT THE TRIMMER CONDENSER WITH ROTOR PLATES TO ROTOR OF THE MAIN TUNING CONDENSER, AND STATOR TO STATOR. THE HAMMARLUND JUNIOR CONDENSER IS SHOWN, MODEL MC5.

noise when the distant station is on.

This "position test" for tubes has enabled me to cure some very bad ills in receivers operated by my friends and has made it possible for them to hear stations they never heard before.

As all locations are different and as no two receivers are alike, your own receiving conditions are the only ones you can consider. A good test for tubes, therefore, is right in your own receiver.

A few other suggestions, in regard to tubes, can be made at this point. Tubes in RF stages should have the proper amount of grid bias, especially if high voltages are used. The writer uses 120 volts on the plates of the RF tubes with 1½ volts of C battery. This prevents, to a great degree, overloading. From 45 to 55 volts can be used on the detector.

Let me add a word about detector tubes. Every type of tube has been used in my receiver and I still find the 201A type the most efficient. The value of the grid leak will vary, but from two to three megohms is most satisfactory.

112A and 171A as Detectors

The 112A type, which of late has been prominently mentioned as a detector, will sharpen tuning a bit and will perform satisfactorily with about 67 volts on the plate,

but after considerable experimenting with this tube I do not believe that it is more sensitive than a good 201A.

An interesting experiment was recently made by using a 171A as a detector. With 90 volts on the plate, this tube performed very well, with a much better passing of bass notes noted. However, a grid leak of about five megohms must be used with this tube. This leak will give much more volume than the 201A type, but will broaden tuning a bit. I would suggest using this tube to those who have time to listen after the locals have signed off. The increased volume on distant stations will be worth the effort.

Now that I believe we have an excellent aerial and ground system and a fine set of tubes, to begin with, let us proceed.

No matter what kind of a receiver the reader operates, it is necessary to tune it carefully for faint signals. Tuning is an art and as such must be practised. I have patiently watched people tune radio sets and have wondered how they could receive anything but the most powerful locals. In a single dial receiver tuning is reduced to a minimum, but even here a little care will produce better reception.

Always locate your local stations and log them. This will fix in your mind their exact position, in kilocycles, and will per-

(Continued on page 25)

Some Gift Suggestions

By James H. Carroll

Contributing Editor

EACH year, as the Christmas season approaches, radio assumes a more prominent part in the gift field, offering as it now does, a wider, highly diversified choice. It is also much easier to select a radio Christmas present for a friend or relative. A radio present carries more joy than any other, except jewelry, in the case of women. And the recipient will remember the radio donor a long while, for the radio gift will be in constant use.

I remember when RADIO WORLD started the movement for radio Christmas gifts, six years ago. At that time, the idea was more or less smiled on and met with very little backing among the trade, but it has been carried on until now it is generally accepted and Christmas packing and boxing is now quite general among the purveyors of radio merchandise.

After all, what is more worth while to the true radio fan, than a real radio Christmas gift, from the tube that one wanted to try out for so long, to the latest kit of parts.

What to Give

Well, someone might rise to remark, what can I give in radio for Christmas? There are hundreds of things to choose. For instance, any one would be made happy by the gift of a good magnetic unit, a fine unit such as the B. B. L., which has been well proved by universal use. If the speaker be a horn, a good air column unit such as the Fairfax will also make a good present. If the purse is low, the gift of a table model volume control Clarostat, which will also fill a number of other useful purposes, will carry joy.

If a friend has never had an Airplane speaker, a kit for this speaker which can be purchased at a wide range of prices, according to the size and quality, with a B. B. L. unit to install in it, makes a good gift. Then there are tubes, one special purpose tube that you know some one has been hankering for, and never has had the money therefor will please them better than anything else that one could think of. A set of tubes makes a handsome gift.

Electrify a DC Set

If you know an elderly couple who get all the joy in life from their old-fashioned radio, you can electrify it for them at small cost. There are two ways of doing this, depending on the convenience, the set and the results required. The simplest and easiest way of electrification is by means of an A and B eliminator, both of these appliances being now perfected and foolproof. The Tobe Deutschman Company now has on the market a small, rugged, handsomely finished A filter. Several good makes of B powers that will work well and deliver the right voltages are now on the market at varying prices. Among them are the new National, medium priced, and the Greene-Erla, both with voltages up to 180.

Other Suggestions

Another means of electrification is by using an adapter harness for AC tubes with a small step-down transformer for the tube voltages. These are perfectly devised and constructed and work well. Several manufacturers make good harnesses of this kind for five and six tube sets and Thordarson makes a fine step-

Wide Range for Presents

Kino lamps and photo-electric cells will prove highly acceptable gifts to those who like to play with television experiments and film-recorded music and speech.

A battery charger for D. C. installations will prove a useful and appreciated gift, particularly if it is of the trickle and automatic variety. It will be useful every day of the year.

A particularly handsome gift is a Victoreen Duplex amplifier and power supply. This falls in the de luxe class and its appreciation by the recipient will be in proportion to the performance of this exceptional combination.

A set of Screen Grid coils for the S. G. Universal, with an aluminum subpanel on which to build the circuit could not fail to strike an appreciative chord in the recipient.

If you have a friend who is deeply interested in the technical, practical and news phases of radio you will gain his everlasting appreciation by giving him a year's subscription for RADIO WORLD.

down transformer for this purpose. Making a present of this kind and doing the job gives one an added glow and thrill.

For those who have set builder friends, a set of Hammarlund coils and condensers, special Hammarlund parts, or the new Hammarlund four-gang "battleship" condensers, or a complete kit for the new Hammarlund-Roberts "Hi-Q" 29 Master will be more than welcome.

Another fine gift for set-builders would be an entire set of Clarostats complete from the baby Clarostat up to the giant power Clarostat, including the volume control Clarostat, the grid-leak Clarostat, the duplex Clarostat and the antenna socket plug Clarostat. These will all fill a multitude of uses and help the recipient in many ways to better radio reception.

In the speaker field we come to the dynamic speaker as a gift. This type of speaker is all the rage at the present time and on that account will be all the more appreciated. If the friend has a dynamic, the gift of a scientifically constructed and handsome "open baffle box" will enable him to bring out the fine tone. Such boxes are now being manufactured and are available at a low price.

This same baffle box may be used with a pin drive motor, such as the B. B. L., making a handsome gift and one that will give splendid results on tone quality.

Pacent Affords Fine Choice

Allied to these gifts is the phonograph pick-up. Many people have heard of this useful apparatus and longed to have one. Such a gift will surely please. A good apparatus of this type is made by the Pacent Electric Co., and one need not fear to make this a choice, results will be fine, because Louis G. Pacent designed and executed the pick-up.

Many persons would like to have an all-electric phonograph and many others would like to make presents of them. The Pacent company makes a portable electric machine that is within most anyone's means. It comes equipped with the

de luxe phonograph pick-up and just plugs into the light socket. No winding of the motor is necessary. With a good set and amplifier playing through a good speaker the results are hard to beat by any high-priced phonograph on the market. This makes a good present for any custom set builder as it gives him a fine means of demonstration when no stations are on the air, and one that will sell the set, nine times out of ten.

For the Builder

If one is skilled in building sets, a new angle to Christmas giving is to give a complete set of parts for one of the new out performing sets just coming on the market and then build it for the recipient. There should be a great kick in this. There are several worth-while kits of this type now available at reasonable prices. Among them the new Silver-Marshall Sargent-Rayment Seven, the S-M "Coast-to-Coast Four" and the S-M "Around-the-World Four." These are all proven circuits that will give the results claimed for them.

Silver-Marshall also makes a wide range of amplifier kits for power packs, giving every conceivable combination of uses for AC and DC requirements. These can be given as kits or the donor can have all the fun of building them and then cashing in on the joy of giving something worth while that he has constructed with his own hands.

Also short wave kits or adapters are popular and fascinating. National has a splendid foundation kit. Radio Supply Co. makes a fine, simple plug-in Adapter.

A new device on the market is the Power-Driver, an unusual type of rectifier that takes the place of a tube and comes in models for the -71, -10 and -50 type tubes, making a useful gift.

A set of good meters is most acceptable to any radio fan or a fine meter test set for the service. The Jiffy Tester with 0-500 high resistance voltmeter is an exceedingly popular item.

A set of Amperites will prove a pleasant surprise, one for each tube in the set, also for the power tube. The fellow who is making power amplifiers will be tickled to death with a set of Electrad Truevolt dividers or some of the other Electrad precise devices.

Even if "He Has a Book"

A good radio book such as Drake's Encyclopedia will hit the mark every time, even for the fellow who is a bookworm. This is one book he will value for years. A pair of Ferranti transformers will make a decided hit.

The new Nova electric clock and radio control will be a novel, useful and unusual Christmas present.

A Yaxley catalog will reveal a hundred fine presents in small parts for little money if one has a flock of presents to make among his radio friends. The Yaxley outlets for all radio purposes are unusually handsome and efficient, making a present that will look like a million dollars.

These are only a few of the thousands of radio presents that one can make at prices ranging from a few cents to as many dollars as one has to spend.

These are all guaranteed joy producers as well as fine friendship cementers. Let's all get together, then, and make it a real Radio Christmas.

Resistance AF Improved

The Screen Grid Tube Gives Best Frequency Curve

By J. E. Anderson

Technical Editor

AS is well known, the amplification on high audio frequencies in resistance coupled circuits is not satisfactory under certain conditions. For example, with high mu tubes and high coupling resistors the amplification at 10,000 cycles, and even at 5,000 cycles, is considerably "down" as compared with the amplification at 100 cycles. It is true that amplification on the high frequencies is "down" relatively because it is "up" at the lower frequencies. But this makes the frequency curve far from the ideal.

What is the main reason for the lower amplification on the high notes than that on the low and medium? It is the effective input capacity to a tube, which partly short circuits the input to the high frequencies. A simple expression can be given which shows the manner in which the input capacity varies with the constants of the tube and its associated circuit. Suppose that C is the effective capacity between the grid and the filament, C1 the actual capacity, C2 the plate to grid capacity of the tube, and A the voltage amplification of the tube and circuit at low frequencies. Then the effective capacity is given by the equation $C=C1+C2(1+A)$.

If μ is the amplification constant of the tube, R1 its internal plate resistance for AC, and R2 the load resistance, $A=\mu R2/(R1+R2)$. From the first equation it is clear that as the low frequency amplification A increases, the effective input capacity increases. For large values of the amplification the increase is practically proportional to the amplification, for A is large compared with unity. That is, the formula for the effective input capacity takes the approximate form $C=C1+C2A$.

Numerical Example

Let us take a numerical example to see how the effective input capacity is increased by the amplification and the grid to plate capacity. In a high mu tube C1 is about 6 mmfd. and C2 about 12 mmfd. The low frequency amplification obtainable can be taken as 20 as a conservative value. Then the input capacity becomes $C=6+12(1+20)$, or 258 mmfd. This is high enough to effect a considerable reduction in the amplification at the higher audio frequencies.

Now let us compare effective input capacities for different plate load resistances. First let R2 equal 100,000 ohms. The mu of the tube is 30 and the internal resistance R1 is 40,000 ohms. Substituting these values in the second formula we have $A=30 \times 100,000 / (100,000 + 40,000)$, or $A=21.4$. Putting this in the first formula we have $C=6+12 \times 22.4$, which equals 274.8 mmfd.

Now let R2 equal 500,000 ohms. The low frequency amplification becomes 27.8, and the effective input capacity becomes nearly 340 mmfd. If higher plate load resistors are used, the higher the amplification becomes, and so does the effective input capacity.

Capacity Shunts Grid Leak

The effective input capacity is in shunt with the grid leak, or with the secondary of the transformer feeding the tube. Hence because of the capacity the input to the tube will be lower than if no ca-

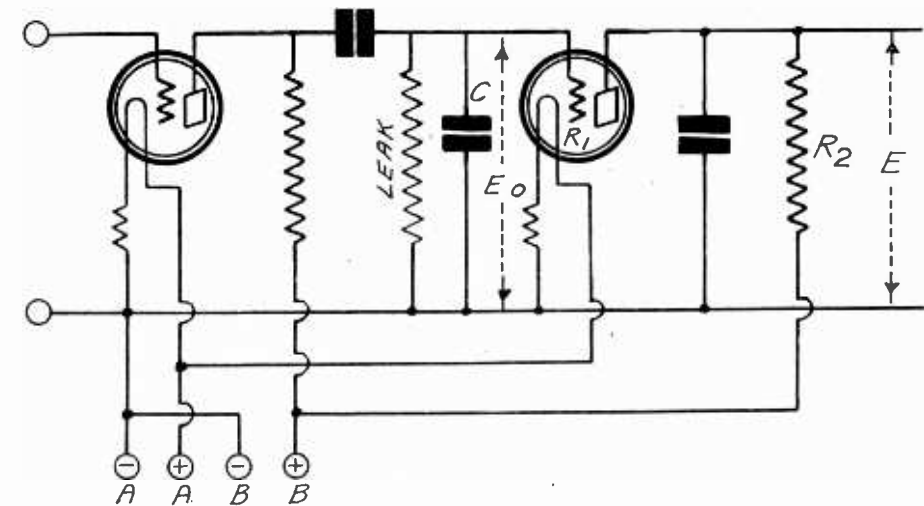

FIG. 1

A CIRCUIT DIAGRAM SHOWING HOW THE EFFECTIVE INPUT CAPACITY OF A TUBE IN RESISTANCE COUPLING CUTS DOWN THE INPUT VOLTAGE BECAUSE OF THE POOR VOLTAGE REGULATION OF THE VOLTAGE SOURCE.

capacity were present, and this decrease is greater the greater the effective input capacity.

Let us take an example of resistance coupling with a grid leak of 2 megohms and an effective input capacity of 340 mmfd. The effective impedance of the 2 megohm grid leak and the 340 mmfd. capacity at zero frequency is 2 megohms, the same as the resistance of the leak. At 5,000 cycles the impedance is about 100,000 ohms and at 10,000 cycles it is but 50,000 ohms. Thus 50,000 ohms compared to 2 meg. shows that at the higher audio frequencies the input to the tube is practically short-circuited.

It is clear from the first formula that if the grid to plate capacity of the tube could be reduced the effective input capacity would be reduced also. Thus in a screen grid tube the effective capacity is relatively very small. With such a tube it is possible to get a low frequency amplification of 60. The grid to plate capacity in this tube is not more than .02 mmfd. Hence assuming that the grid to filament capacity is no greater than in the high mu tube, the effective input capacity is only 7.22 mmfd. This is not high enough to cause any appreciable reduction in the amplification on any audio frequency.

An Ideal Tube

The effect of the input capacity C may be illustrated with the aid of Fig. 1. It is assumed there that the second tube is "ideal," at least as far as inter-elemental capacity is concerned. The effective input capacity C is placed across the grid leak. The input voltage to the "ideal" tube is the voltage drop Eo across either the grid leak or the condenser C. The output voltage is the drop across the plate resistance and is indicated by E. The amplification is the ratio E/Eo.

From this construction it appears that the decrease in the high frequency gain is not so much due to a decrease in the amplification in the tube itself as it is in the input voltage. This decreases because

of poor voltage regulation in what precedes the grid leak and condenser C rather than because of anything that follows. The voltage regulation is more potent in cutting the input voltage on high frequencies than on low because the condenser C draws more current on the high frequencies.

The tube is essentially an AC voltmeter and its output voltage is the reading. As in all voltmeters drawing current the reading is lower the greater the current that is drawn, provided the regulation of the voltage source is poor. Thus the reduction in the amplification on high frequencies because of the grid to plate capacity is not an isolated phenomenon but a special example of a general proposition.

Raytheon Announces Line of Foto Cells

For television and other applications calling for photo-electric or light-sensitive cells, the Raytheon Manufacturing Company, of Cambridge, Mass., announced a comprehensive line of Raytheon Foto Cells. These cells are made in the hard-vacuum and the gas-filled types, as well as in bulb and tubular shapes.

The hard-vacuum Raytheon foto cell has the characteristics of instantaneous response—no lag; response directly proportional to illumination; maximum photo-active surface; permanent characteristics; no leakage or "dark current." The gas-filled Raytheon foto cell has the characteristics of super-sensitivity; instantaneous response—no lag; response directly proportional to illumination; no damaging effect from ionization; low operating voltage; no leaking or "dark current."

The Raytheon Foto Cells are available in two spherical bulb types and three tubular types, to meet a wide variety of uses in television, daylight recording, photometer, fire alarm system, laboratory, experimental and other applications.

The Sargent-Rayment

By Edwin

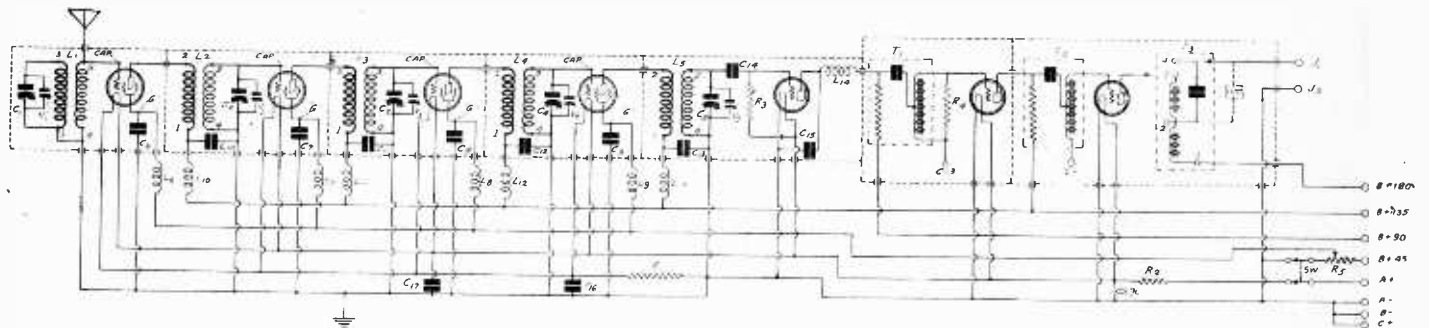

FIG. 1

THE CIRCUIT DIAGRAM OF THE SARGENT-RAYMENT SEVEN RECEIVER IN WHICH FOUR SCREEN GRID TUBES ARE USED FOR ULTRA-SENSITIVITY AND THE CLOUGH SYSTEM OF AUDIO AMPLIFICATION FOR TONE QUALITY.

PART I

"I HAVE tried all DX receivers which have come to my notice," writes O. D. Brown, a Connecticut man, "but the Sargent-Rayment Seven is the only receiver which I have found that will pull in KFI, Los Angeles, with ample loud-speaker volume at any time, night or day, Summer or Winter."

This man lives on the Atlantic coast and the station is situated on the Pacific coast. The distance between the receiver and the transmitter is almost the longest line that could be drawn across the United States. And the receiver covers the distance with ample volume. That means that no distance can be found in the United States over which the signals cannot be pulled in with the receiver.

Indeed, few places can be found in the inhabited North American continent which have a greater air line distance to Los Angeles. If a few such places can be found, the "ample" qualification of the loudspeaker reception in Connecticut amply takes care of the difference in the requirements. Therefore one is justified in assuming that the Sargent-Rayment Seven placed anywhere in the North American continent will pull in any broadcasting station in that huge territory, if that station has approximately the same power as KFI. All the more desirable stations have as much power as, or more, than KFI had at the time the tests were made in Connecticut.

Birthplace of Great Circuits

The Sargent-Rayment circuit was designed by two gifted radio engineers in the laboratories of Silver-Marshall in Chicago, the birthplace of many of the greatest receivers and parts that have been presented to American radio fans. These engineers received the co-operation of the research staff of the S-M laboratory, and consequently the outstanding developments originating there have been incorporated in the circuit. The result is a circuit of phenomenal sensitivity, unique selectivity and unsurpassed fidelity of tone.

Fans often ask whether it is possible to use the Sargent-Raymond circuit for phonograph record playing, and if so, the quality is as good as the quality when used for radio reception. It can be used. Whether or not the quality is as good depends entirely on the record and on the pick-up used. The audio amplifier, which alone is used for phonograph work, is the

same as when it is used for radio reception. The quality remains the same.

When the amplifier is used for phonograph work there is no volume control in the circuit. But one must be used if the pick-up is at all efficient, for the amplification of the audio amplifier is enormous. The volume control usually supplied with the pick-up unit will serve the purpose very nicely.

There are two places at which the phonograph pick-up may be connected to the audio amplifier. One is across the grid leak of the detector. The other is across the input of the first audio transformer. The volume will be greater when the pick-up is connected across the grid leak, but the probability is that it will be loud

enough when it is connected across the input of the first audio transformer. In fact it may be so loud as to require considerable cutting down by the volume control.

Magneto pick-up units are usually supplied with a plug which is to be inserted into the detector socket of the set. In most cases, these connect the pick-up output across the first audio transformer and the plate voltage for the detector. This causes a steady current to flow through the pick-up. This is not desirable, and the connection across the first transformer alone is preferable.

In some cases, the plug-in adapter is arranged so that the pick-up is connected between the grid and the filament of the detector. This is a good arrangement and should be used provided that the volume does not become so great that it cannot be controlled satisfactorily by the volume control provided with the pick-up. It only takes a few moments to test this.

Should the volume prove to be too great, the pick-up terminals should be connected across the input of the first transformer, as was explained above. For convenience two binding posts or tip jacks might be provided at the back of the set, that is tip jacks just like those used for the loudspeaker terminals. Leads are run from these jacks to terminals (1) and (2) on the first transformer T1. In the event there is considerable needle scratch noise in the output of the speaker, some of this can be eliminated by making a slight change in the connection one of the tip jacks. Instead of running one of them to (2), it should be run to the plate of the detector tube. This puts the low pass filter L14C15 in series with the output of the pick-up, and this suppresses much of the high frequency noise which may be present. A temporary connection should be made while deciding which of the two places gives better results.

The sensitivity of the circuit is obtained from the use of four screen grid radio frequency amplifiers, precise tuning of the four tuned circuits and the use of RF coupling transformers designed for the screen grid tubes. The radio frequency amplification is enormous. This RF amplification, with perfect stability of the circuit, has been achieved by very thorough shielding of the individual stages and of the set as a whole, as well as by thorough filtering of the individual supply leads. Thus there is a radio frequency choke coil in each of the four screen grid

LIST OF PARTS

- L1—One S-M 141 antenna coil
- L2, L3, L4, L5—Five S-M 142 RF transformers
- C1, C2, C3, C4, C5—Five S-M 32OR variable condensers
- V1, V2, V3, V4, V5—Five S-M 340 midget condensers
- L6, L7, L8, L9, L10, L11, L12, L13, L14—Nine S-M 275 RF chokes
- T1—One S-M 225 first stage transformer
- T2—One S-M 256 second stage transformer
- T3—One S-M 251 output transformer
- C6, C7, C8, C9, C10, C11, C12, C13—Eight Polymet ¼ mfd. condensers
- 14—One Polymet .00015 mfd. condenser
- C15—One Polymet .002 mfd. condenser
- C16, C17—Two Polymet 2 mfd. by-pass condensers
- R1—One Carter H3 three ohm resistor
- R2—One Carter H1 1 ohm resistor
- R3—One Polymet 2 megohm grid leak
- R4—One Durham 150,000 ohm resistor (optional)
- R5—One Yaxley 53,000 P (3,000 ohms) potentiometer
- SW—One Yaxley 740 Junior switch, double pole single throw
- J1, J2—Two Yaxley 420 insulated tip jacks
- One S-M 705 aluminum shielding cabinet
- Seven S-M 511 tube sockets
- One S-M 708 lead cable
- One National type "F" velvet vernier dial with illuminator
- Two insulated binding posts
- One knob for V1 to match knob of R5
- Twenty-five feet of S-M hook-up wire
- One S-M 706 walnut base moulding
- One set of assembly hardware

for Extreme Distance

F. Schmitt

FIGS. 2 AND 3
The arrangement of the parts in the Sargent-Rayment Seven receiver. A completely shielded compartment is used for each of the five tuned circuits and one for the audio frequency amplifier. The supposedly missing audio transformer is hidden by the output transformer. The other view is the front.

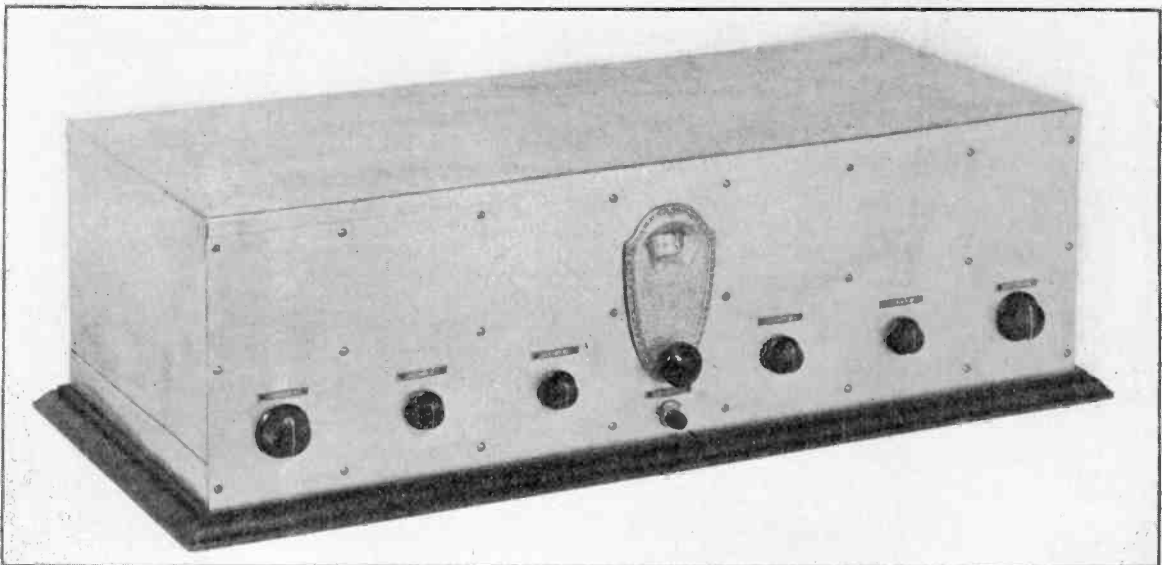
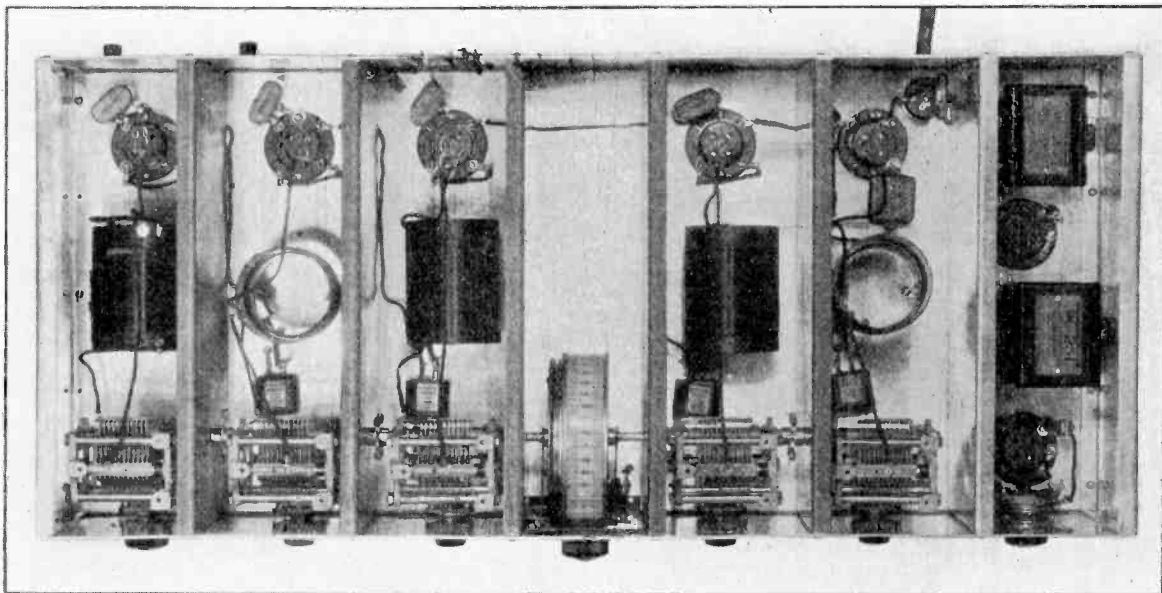

leads and one in each of the four plate leads for the screen grid tubes. For each choke coil there is a by-pass condenser of adequate capacity to provide a short path for the radio frequency currents.

Uniform Volume Level

One might suppose that the enormously high amplification in this circuit would result in terrific volume on local stations, since the receiver will bring in transcontinental stations with loudspeaker volume. But this is not so. There is relatively little difference between the volumes from a local and a distant station. The reason for this near equality under such widely divergent conditions is that the screen grid tubes act as automatic volume controls. That is, the amplification is not so great on local stations as it is on the distant ones. This, of course, is a result of the limited volume handling capacity of the tubes.

In addition to the automatic volume equalizer there is a very effective explicit volume control incorporated in the circuit. This is the high resistance voltage

divider R5, Fig. 1, connected between ground and plus 45 volts, to the slider of which the screen grids of the four RF amplifiers are connected. By adjusting the position of the slider any screen grid voltage from zero to 45 volts may be obtained. The amplification of a screen grid tube depends on the screen grid voltage as well as on the other voltages applied to the tube. Hence by moving the slider on R5 the volume of the receiver can be adjusted from zero to maximum. This variation is entirely independent of the tuning.

The selectivity necessary for unique transcontinental reception is obtained by the use of four tuned circuits and aided by the use of a rejector or wave trap circuit. The four tuned circuits select the signal desired and the wave trap circuit rejects any one interfering signal which may be so close to the desired signal that it is impossible to tune it out by the four acceptor circuits. This adds a very powerful device to the circuit for sharpening the tuning.

We have spoken of unique selectivity

and unique reception. Perhaps a definition of the meaning of this term is in order, especially in view of the fact that it has not been used often in connection with radio receivers. Of course, by unique reception is meant the reception of one station at a time, without any interference from any station. And by unique selectivity is meant the capability of the circuit to receive one station, and only one, at a time. When the noise from a jazz orchestra from a local station is heard in the background while listening to a program of a station two or three thousand miles away the reception is dual and the selectivity is far from being unique. Uniqueness of reception is an outstanding characteristic of the Sargent-Rayment receiver.

And it is the proper manipulation of the trimmers which makes the selectivity unique no matter what the interference conditions may be.

[Part II, the concluding instalment of Mr. Schmitt's presentation of the Sargent-Rayment receiver, will appear next week on page 15 in the December 15th issue—Editor]

SG Short Wave Adapter

National Converter Got London and Holland on Speaker

By Perry S. Graffam

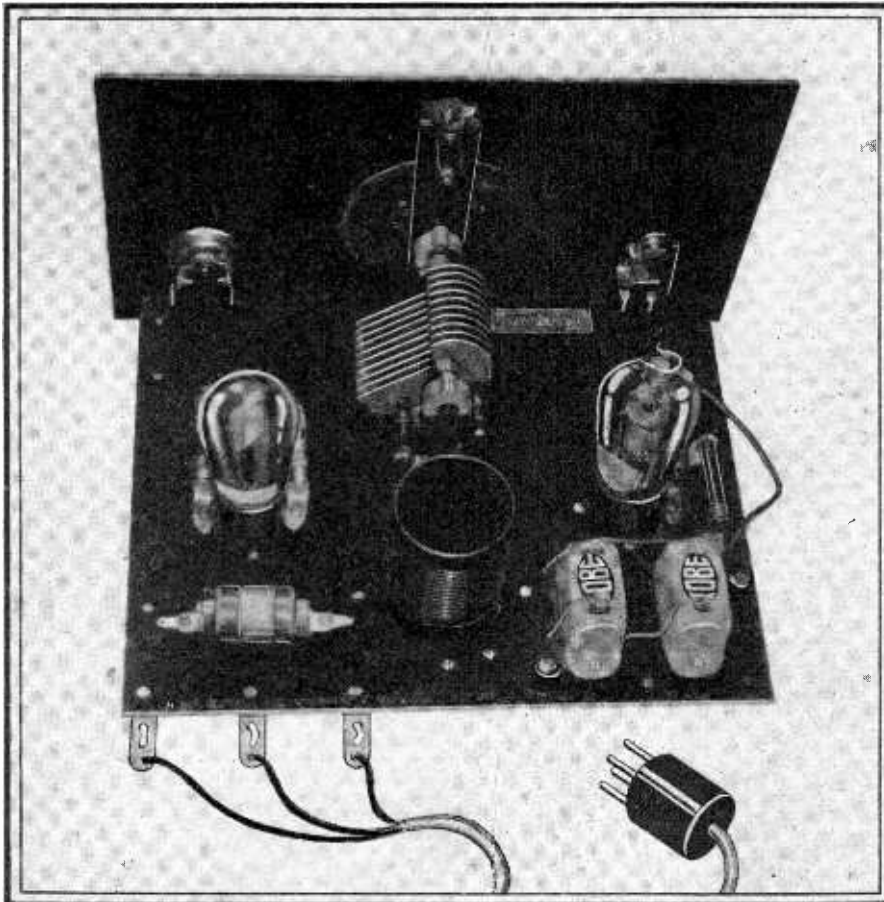

THE REAR VIEW SHOWS THAT NOT MUCH IS NEEDED TO "PUT THE WHOLE WORLD AT YOUR COMMAND." THE PLUG AND CABLE ILLUSTRATED IS THE GUARANTY RADIO GOODS CO. PRODUCT

AS the one-stage radio frequency amplifier with regenerative detector rapidly became the outstanding circuit arrangement in home-built receivers during the great broadcast building era, so has a similar circuit taken the short wave field. With this type of set just beginning to be appreciated, vast numbers of parts have been sold for these receivers.

The circuit used in short waves, however, uses an untuned input rather than a tuned antenna circuit, and in this way differs from the accepted broadcast practice.

The first tube has several purposes. It permits the use of an antenna of any length without adjustment. It gives some amplification to the incoming signal. Most important, it prevents radiation.

Non-Radiation Important

Those who listened in two or more years ago will never forget the "blooping" that characterized every evening's entertainment. With the great increase in the number of short wave receivers, this same condition will occur up in those frequencies unless a blocking tube is used to prevent radiation.

A general impression among many not familiar with short waves is that a completely new receiver must be built to get the programs. The short wave receiver differs only in the tuning section. From

the detector on, the arrangement is identical with any other receiver.

A simple converter which will permit one to use this most popular of short wave circuits, in connection with the receiver now in the home, is the National Short Wave Adapter. After completing it, one merely has to remove his detector tube and insert the plug of the adapter in its place. The detector tube is then placed in the adapter's second socket.

Only few parts are needed and the placing of these is illustrated.

Making a Plug

The base of an old tube may be used in making a plug. The glass should be broken, and the other material in the base cleaned out. The four brass tips will come into view, and the necessary connecting leads should be soldered to these. The plug may then be filled with wax. This takes care of three of the four external leads to the set. You can identify the leads by a continuity test with a meter. The 135-volt connection is made on to a binding post at the rear of the adapter.

Many have little idea of the radio sport that lies in wait for them down on the shorter waves. Up until this year there was so little to listen to except code that a set hardly seemed worth while, but now any number of stations are broadcasting

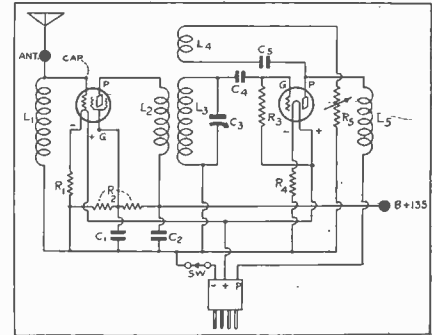

on these wavelengths. Stations all over the North American continent are heard during daylight hours, some of which cannot be heard even at night time on a good broadcast receiver.

But the real thrill comes in the trans-oceanic reception. 5SW, the British Broadcasting Corporation's station at Chelmsford, England, can be picked up from 5 p. m. to 7 p. m. Eastern Standard Time, and under favorable conditions may be brought up to loudspeaker strength. This station usually closes with an hour of dance music, and when you can clearly hear the music, dancers' voices, the hand-clapping for encores from the Savoy Hotel in London, right from your own loudspeaker, you are getting a real radio thrill!

Germany on the Job

Now Germany is just completing a powerful short wave station with which to send excellent programs to the whole world. A particularly strong station is the one in Eindhoven, Holland, which puts on regular programs for the British colonies and other remote points. This station is more widely heard than any other short wave station in the world, according to many reports.

The thoughts of getting distant places like these usually conjure up visions of high-priced receivers using fourteen tubes. But, thanks to the gift of short waves, this is not the case. Just build up the little simple unit described herewith; connect it to your present radiocast receiver, and, like Monte Cristo, you say, "The world is mine!"

(See page 23 for picture diagram)

LIST OF PARTS

- L1, L2, L3, L4, L5, C3—One National Short Wave Kit (consisting of front and sub-panels, set of plug-in coils, tuning condenser and choke).
- R5—One Clarostat grid leak.
- R3—One Tobe 8 meg. Tipon leak.
- C1, C2—Two Tobe .5 mfd. by-pass condensers.
- R2—Two 10,000 ohm resistors.
- C4—One Tobe .00025 vacuum fixed condenser.
- C5—One Tobe .001 vacuum fixed condenser.
- R1—One 622 Amperite.
- R4—One 1A Amperite.
- Sw—One Yaxley switch.
- One plug and cable.

The Hi-Q 29 Master

By Leslie G. Biles

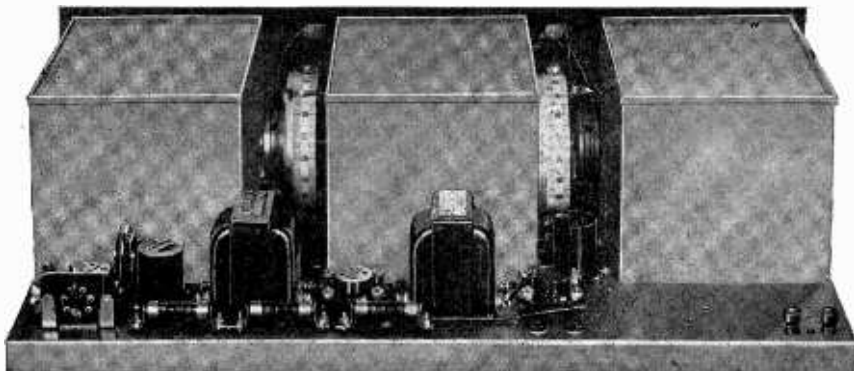

FIG 3

BACK VIEW OF THE HAMMARLUND-ROBERTS MASTER HI-Q 29 RECEIVER SHOWING THE POSITIONS OF THE SHIELDING CANS AND THE TUBES.

[Part I of Leslie G. Biles' lucid description of The Hammarlund-Roberts Hi-Q 29 Master receiver was published last week, issue of December 1st. Herewith is the second instalment.]

PART II

MANY of the so-called "neutralizing" schemes designed to overcome the effect of the plate-to-grid capacity were not entirely satisfactory, because they were not equally effective throughout the tuning range. The neutralization was satisfactory in a certain band of radio frequencies, which could be selected at will, but failed outside this band. Thus many so-called neutralized circuits often oscillated at the high frequency, or low wavelength, end of the dials.

The schemes depending on losses in the tuned circuits were not satisfactory because they decreased both sensitivity and selectivity. Many such circuits having two and three apparently sharply tuned circuits were not much more selective than a crystal set.

Therefore, the appearance of the screen-grid tube with a capacity so small that neutralization is unnecessary was welcomed by set designers, and many circuits using them made their appearance. Many of these sets did have enormous amplification, making possible quite satisfactory reception on short antennas. The selectivity of these sets, however, left much to be desired, so much, in fact, that the tube acquired the reputation of causing broad tuning.

Capitalizes Inherent Virtues

The natural advantages of the screen grid tube were carefully considered, also various methods of overcoming the apparent disadvantages were investigated.

Two stages of radio frequency amplification were decided upon as sufficient, as they could reasonably be expected to produce an overall voltage gain of over one thousand.

To achieve a high degree of selectivity with this amount of amplification some special form of tuning is necessary.

The conventional antenna coupler and two interstage tuned-radio-frequency transformers were found to be wholly inadequate in selectivity, although the amplification was good.

The tuned-plate impedance, coupling condenser and grid leak arrangement specified by the manufacturers of the tube was passed up for the same reason.

Calculation showed that it was quite feasible to tune both the grid and the plate circuits of these screen grid tubes. This is one of the marked advantages of this type of tube, since an attempt to

tune both the grid and plate circuits of an ordinary amplifier tube invariably results in uncontrollable oscillation.

When both grid and plate circuits are tuned, a two-stage radio frequency amplifier has a total of five tuned circuits, including the grid circuit of the first tube. This increased number of tuned circuits would naturally provide a marked increase in selectivity.

Performance Remarkable

The radio frequency gain in an experimental set was very high; enough to bring in many distant stations in New York City, including one on the Pacific coast. The selectivity was such that more than a dozen of these distant stations were received while the local stations were operating. This test was made using a 75-foot antenna, located in midtown.

The remarkable performance of this receiver can best be understood by a con-

List of Parts

- Five Hammarlund No. ML-17 .00035 mfd. Midline Condensers.
- One Hammarlund No. "Hi-29" Coil Set.
- Two Hammarlund No. SDW Knob-Control Drum Dials (walnut).
- Three Hammarlund No. RFC-85 Radio Frequency Chokes.
- Five Benjamin Cle-Ra-Tone Sockets, No. 9040.
- One Sangamo .00025 mfd. Fixed Mica Condenser.
- One Sangamo .001 mfd. Fixed Mica Condenser.
- One Carter No. 11S "Hi-Pot" Potentiometer with switch, 100,000 ohms.
- Two Thordarson No. R-300 Audio Transformers.
- Four Parvult 5 mfd. Series 200 By-pass Condensers.
- One Durham Metallized Resistor, 1½ megohms.
- Two Amperites No. 1-A.
- One Amperate No. 112.
- One Yaxley No. 660 Cable Connector and Cable.
- One pair Yaxley No. 422 Insulated Phone Tip Jacks.
- Two Eby Engraved Binding Posts.
- One "Hi-Q 29" Master Foundation Unit

Recommended Accessories:

- Three CX322 or UX222, two CX301A or UX201A or UX171.
- Corbett, Fritts or Superior cabinet.
- One Hi-Q 29 BC eliminator, one Raytheon BH MA tube, one Sterling Dri-A eliminator or storage A battery.
- One Belden Aerial Kit.

sideration of the principles involved in its design. The interstage radiofrequency transformers are unique in that they consist of two exactly similar coils. One constitutes the primary of the transformer and is connected in the plate circuit of the preceding tube. The other coil acts as a secondary and is connected to the grid of the following tube. Each coil is tuned to resonance with the desired signal by means of a .00035 mfd. variable condenser.

Small Feedback

While there is a small capacity between the control grid and the plate of a screen grid tube through which some feedback will occur, this is so small that it does not induce oscillation. But the capacity between the elements of a tube is not the only capacity which contributes to the regeneration. The capacity between the tuned circuits and the leads to them also contribute some. But this can be nullified completely without any adverse effects by shielding the parts in the plate circuit from the parts in the grid circuit of a tube.

The shielding should be effective against both electric and magnetic coupling. Furthermore, the effect of conductive coupling must be reduced to practically zero by carefully isolating the several tuned circuits.

Tuning the Plate Circuits

It will be remembered that when the plate circuit of a screen grid tube is tuned the greatest possible selective load is put on the tube, making the amplification the greatest, provided that the proper coupling arrangement is used between the tuned plate circuit and the grid circuit of the next tube. If the grid circuit is tuned also, and if the coupling coefficient between the two coils is made optimum, a very great signal transfer is effected from tube to tube. And this transfer is highly selective.

It might be supposed that the high selectivity obtained by tuning both the primary and the secondary, and by coupling them loosely, would result in a great suppression of the higher audio frequencies, thus impairing the quality and timbre of the signal. But that is not the case at all. In fact, the double tuning prevents this suppression of the higher frequencies. It produces a flat-top tuning characteristic with extremely steep sides, approaching the ideal characteristic for broadcast reception. This point will be discussed more fully.

[The third and concluding instalment of Leslie G. Biles' interesting article on the Hi-Q 29 Master will be published next week, issue of December 15th.—Editor]

RADIO WORLD AS A CHRISTMAS GIFT

Why not give him a year's subscription for RADIO WORLD as a Christmas gift? This would serve as a reminder of your thoughtfulness every week for the coming fifty-two weeks.

We will, if you wish, send a special letter to the name and address that you send us on the subscription order, and inform the new subscriber that you have ordered us to send the paper to him for the coming year. We will time this letter so that he will receive it the day before Christmas.

\$6.00 a year, 52 issues.
Subscription Department, Radio World
145 W. 45 St., New York City

Antenna Coupling Vital

Select the Method that Suits Your Conditions Best

By Herman Bernard

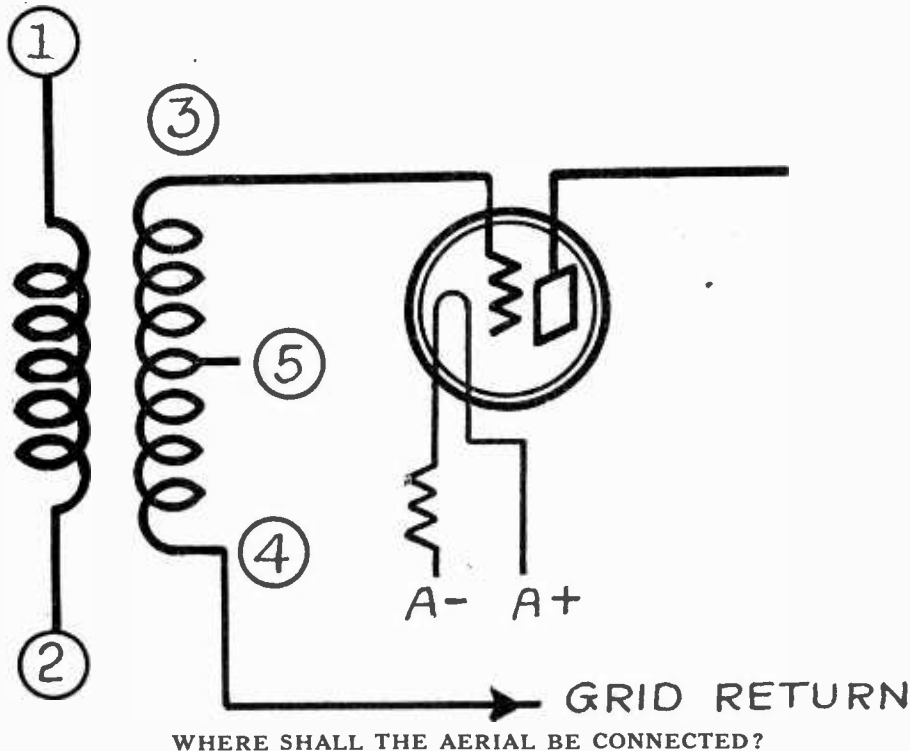

PART II

SOMETIMES a receiver works beautifully in one location, but, taken to some other place, it disappoints. The reason usually is that a given type of antenna coupling is well suited to one location and wholly unsuited to another.

Therefore welcome a receiver that permits about all the existing options on antenna connection, and select that method which you find works out to your greatest satisfaction, as measured in distance, if that's what you especially desire, or selectivity, if such is your greatest need, or more volume, if such is in your heart.

The receiver described last week, named the Screen Grid Universal, is a four tube design that accommodates itself to almost any condition. If you live "on top" of a broadcasting station, you can so arrange the circuit at the antenna coil to give you the necessary selectivity for tuning out that station. If you live in what is termed a dead spot—where few stations come in, and those few weakly, while many other stations that should be within easy reach are never heard at all—you may so connect the antenna as to bring in the whole bloomin' lot of stations, and some more that you never expected to get.

Always the Same Coil

To obtain this great option asset, including not only the method of connection but also accommodation to the physical length and location of the aerial, you need a two-winding antenna coil with a center tapped secondary.

Fig. 1 shows this coil with its essential terminals numbered from 1 to 5. The following discussion concerns the connection of the aerial to meet your requirements, using only this coil in all instances except one, and that one relates to the addition of a fixed condenser in series

with the aerial and in conjunction with the same coil.

It is assumed that the circuit was built according to the schematic design published last week, issue of December 1st, and in conjunction with the blueprint which shows the same connections in picture diagram form. That network calls for the connection of the antenna to one end of the primary coil (1) and the ground to the other (2), while the grid is connected to (3) the grid return to the midtap (5), while (4) is connected only to the rotor of the tuning condenser. This is slightly different from Fig. 1, and the reasons will be explained.

The hookup for a degree of selectivity more than ordinary is the one shown last week. It was adopted as the standard for the Screen Grid Universal, because it represents the higher requirements of large centers of population, where stations are numerous. But the builder may depart from the blueprint to suit his needs as will be explained.

Tuned Circuit Always the Same

Connecting the antenna and ground to the primary or small winding of the coil is the familiar fashion. Mid-tapping the secondary, and making the grid return to the midtap, is unusual, except in the Universal hookup, where it has been a feature for nearly four years. The only substantial change in the Universal, as represented by the present model, is the use of a screen grid tube as a radio frequency amplifier.

The tuned circuit remains the same—it is always the complete secondary. The grid return to the center tap causes half of the voltage across the secondary to be impressed on the grid, and moreover reduces considerably the capacity effect of the antenna-ground system upon the

tuned secondary. Therefore selectivity is higher and the dials will read more nearly alike than otherwise.

Now, a great many persons who live in rural places would like to have greater sensitivity and volume, but are not interested in high selectivity, for their problem is to get stations rather than to keep stations apart. Each one knows his own situation, and governs himself accordingly, but he must have a receiver and a coil system that permit an extensive range of choice, the Screen Grid Universal (as you may have inferred) being such a one.

Up Goes the Volume!

For greater volume and sensitivity, at a sacrifice of some selectivity that one may well afford to miss under the circumstances, connect the end of the secondary (point 4 in Fig. 1) to the grid return, as illustrated. The diagram therefore is to be read as one providing a means of increasing volume and sensitivity at a more rapid rate than it reduces selectivity.

A still greater increase in the same direction, and a vast decrease in selectivity, are obtained by leaving the points (1) and (2) unconnected, and joining antenna to the grid post (3) of the tube and putting ground to the A minus end (4) of the same coil. Also of course, leave (5) unconnected.

This scheme is not practical for two reasons: first, one cannot tune in the entire wave band, because the full capacity effect of the antenna-ground system is introduced into the tuned circuit, adding about .00025 mfd. average. Therefore, with a 50 mmfd. minimum capacity of the tuning condenser, you may have a minimum effective tuning capacity of .0003 mfd., and a maximum, with a .0005 mfd. tuning condenser, of .00075 mfd., or a ratio of 2½ to 1, which is far too little to permit covering the wave band with any fixed coil.

The other reason, as if any other were needed, is that the selectivity is too low even for the most meagre needs in that direction.

Turns-off Plus Midtap

Suppose you want increased selectivity even over what was obtained from the circuit built after the design published last week. There are two ways of improving selectivity that are easily adopted. One is to remove turns from the primary winding (1) and (2). There are 14 turns on the primary of the Screen Grid Coil, Model RF5 or Model RF3, which were specified as antenna coils for this circuit, one being for .0005 mfd. and the other for .00035 mfd. tuning. Reduce the primary turns to 7 by removing half the winding. But remove the turns from the end of the primary that adjoins the beginning of the secondary, so that while removing turns you are increasing the distance between the two windings at the same time.

You will notice that the dial reading will change slightly, due to the reduced coupling between primary and secondary, also reducing the effect of the antenna-ground capacity on the tuned circuit or secondary.

You may connect the grid return to the center tap, as shown in last week's diagram and in the blueprint, or you may connect the grid return to (4), as diagrammed. (Continued on page 26)

Bad Contacts Puzzle

Ingenuity Required to Locate Cause of Sputtering

By Herbert E. Hayden

Does your radio set crackle and sputter at certain times of the day? Or does it do so regularly? Whether it does so regularly or irregularly, the chances are that the trouble is caused by a loose connection somewhere. This loose connection may be in your own set, in your neighbor's, in the electric light circuit, or it may be between two pieces of metal not in any particular circuit.

In one case there was an irregular crackle and sputtering in one receiver. It appeared at certain times of the day and it so happened that it was coincident with noise made in the apartment above. The children were running around, jumping off chairs, and bouncing a ball. All this caused the building to vibrate.

It was obvious that the crackling in the set was due to a loose contact somewhere in the building. But where was it? Was it in the receiver in which the crackling was heard or was it elsewhere? If the noise was in the receiver it should have ceased when the antenna was removed from the set. If the noise persisted when the antenna was off, the loose contact was either in the set or in the power line which supplied the set.

Noise Removed

In this instance the noise disappeared when the antenna was removed. Hence the crackling came in over the antenna. Still the loose contact might have been in the light circuit in the house. Or it might have been in the antenna itself. Again it might have been in the neighbor's antenna. Wherever the place, it was where the contact could be jarred by the racket in the apartment above.

As soon as the receiver had been acquitted by removing the antenna, and also by jarring the receiver without crackling, the antenna was inspected as the most probable source of the trouble. As it was an indoor antenna this was easily done. There were two possible places where the noise could have originated. At each place the antenna wire was wrapped around door hinges. These

hinges were isolated and insulated pieces of metal, and it did not seem likely that they could have caused all the crackling in the set. But they were located where there was appreciable vibration when there was a racket up stairs. Hence they could not be acquitted without a test.

On inspection it was found that the insulation on the wires had been rubbed off at both of these places and that the bare wire was in contact with the hinges. As soon as one of these contacts had been fixed an appreciable improvement was noted. Insulation of the other point effected still more improvement. But not all the crackling was removed. And what remained was still coincident with the racket in the apartment above.

Found in the Kitchen

The location of the remaining crackling was at first baffling. Apparently it was outside the apartment in which the set was located. But by accident it was located in the kitchen. An aluminum boiler was hanging on a nail so that it was in contact with a water pipe, which was grounded. When the building was set vibrating by the racket upstairs the aluminum vessel made irregular contacts with the grounded pipe. For each contact the electric charge which had accumulated on the aluminum discharged into the pipe and set up an electric disturbance. This was picked up by the antenna and caused much of the crackling.

The remedies for electrical disturbances of this nature are obvious. First set your own house in order, or don't have neighbors around who shake the house like an earthquake.

It should not be supposed that objects as large as dishpans and water pipes are required to set up disturbances of this nature. Even tacks in the wall may be responsible under certain circumstances. Suppose there is a tack in the wall and another tack is suspended from a string near it so that a vibration of the building or a gust of wind will bring the two tacks in contact. The two tacks will not be at

the same electric potential except when they are in contact. When apart they form the two plates of a small condenser, which becomes charged whenever the two plates are apart. When the tacks touch each other there is a discharge which may be heard in a sensitive receiver. There are countless such possibilities in the average home, and when they occur in the antenna circuit, or very near it, they give rise to the greatest disturbance.

A Serious Case

A more serious disturbance in the same receiver was traced to the power line. This was so severe that it interfered with the reception over a considerable area. The power company was running a new line in the neighborhood. At night the workmen would leave wires dangling from the poles. Although the wires were not alive they caused irregular discharges of electricity either between the ground directly or through metal pieces in the poles. For two weeks the dangling wires ruined reception in the neighborhood and did not cease until the line was completed.

EXTRA SPECIAL OFFER!

Many readers of this special gifts number are seeing RADIO WORLD for the first time.

To these new readers, we make the following special offer:

SEND \$1.00 FOR A TRIAL SUBSCRIPTION OF EIGHT WEEKS. WE WILL IMMEDIATELY PLACE YOUR NAME ON OUR MAILING LIST, AND SEND YOU, WITH OUR COMPLIMENTS AND ABSOLUTELY FREE, ANY OF THE FOLLOWING BLUE PRINTS—FIVE TUBE DIAMOND, FOUR TUBE SCREEN GRID DIAMOND, S-M 720, S-M ROUND THE WORLD FOUR OR SARGENT-RAYMENT.

Address Subscription Department, Radio World, 145 W. 45 St., New York City.

Use Affects the Rating of a Resistor

The rating of fixed and adjustable resistors is subject to revision, if the resistor is to be used under conditions different from those upon which the rating was based, says Ward Leonard Electric Co. In cases where ventilation is poor, or where several units are mounted in close proximity, it is found advisable to use resistor units at only about 50% of their watt rating or 70% of their current rating.

Three of the most common changes in conditions are: first, a lack of free air space around the resistor units, which naturally causes lack of ventilation; second, the proximity of other apparatus and the use to which the entire apparatus is put; third, the addition of taps.

The watt rating of a resistor is the number of watts which will cause the temperature of the unit to increase to a specified figure (250 degrees Centigrade) when suspended in air at least one foot away from the nearest object. This condition is one of good ventilation and free-

dom from close contact with surrounding material. Assuming this condition of free ventilation, the unit may be run continuously at this rise if the surrounding air is not over 40 degrees C.

It should be pointed out that when the circulation of air is obstructed, or when several resistor units are mounted together, the load which will cause this same temperature is markedly decreased. Thus it becomes obvious that the application limits the load which a unit will dissipate.

Poor ventilation is likely to be the rule rather than the exception, so it is generally recommended that units be used at about 50 per cent. of their watt rating.

May Hurt Other Parts

The second important factor is proximity of other apparatus which might be injured by a temperature which is much higher than the 250 degree C. rise which the resistor will stand. The apparatus

may necessitate a lower rating of the resistor than would be imperative were the unit used in isolation.

The third point to be considered in the revision of resistor rating is the introduction of taps. The introduction of a terminal band, made imperative whenever a tap is added to the resistor, reduces the effective heat radiating surface of the unit. Take the case of a resistor of 100 ohms, wound on a four-inch tubing, normally rated to dissipate a load of 44 watts. If this resistor is made in steps of 50 ohms, it is necessary to introduce a terminal band or connection at the center of the tubing to provide for the extra connection.

Lowers Rating

This terminal requires some space on the tubing which is then not entirely available for the resistive element. The total possible effective dissipation of the resistor is thereby reduced to some value less than that of the untapped resistor.

Literature Wanted

THE names and addresses of readers of RADIO WORLD who desire literature on parts and sets from radio manufacturers, jobbers, dealers and mail order houses are published in RADIO WORLD on request of the reader. The blank at right may be used, or a post card or letter will do instead.

RADIO WORLD,

145 West 45th St., N. Y. City.

I desire to receive radio literature.

Name

Address

City or town

State

Raymond Burgos, 131 Roosevelt St., New York, N. Y.
 Franklin E. Kuhn, 3401 West 41st St., Cleveland, Ohio.
 E. E. Yetter, Nazareth, Pa.
 R. S. Northe, Room 206, City Hall, Cleveland, Ohio.
 G. R. Bausum, L. Box 35, Oshkosh, Wis.
 E. Roach, Oak Island, Revere, Mass.
 F. S. Bordner, 444 East 141st St., New York, N. Y.
 Robert Kazragis, 4429 S. Fairfield Ave., Chicago, Ill.
 Robert Gardiner, 1183 N. Michigan, Pasadena, Calif.
 U. L. Ritter, 300 S. Arken Ave., Pittsburgh, Pa.
 J. H. Morgan, 149 S. Elm St., Hagerstown, Md.
 Fred Shatzer, 1933 Trumbull Ave., Detroit, Mich.
 G. A. Prodrer, Pall Mall No. 575, London, Ont., Can.
 Lyle Sanders, Box 415, Sinton, Texas.
 William C. Hodgson, 3642 HineLine Road, Violets-ville, Baltimore, Md.
 Howard Ketz, 936 Alder St., Scranton, Pa.
 Chas. S. Hazard, 29 Glen St., Worcester, Mass.
 Masashi Harano, 2152 Dwight Way, Berkeley, Calif.
 Frank Thylla, Claressa, Minn.
 G. H. Landry, 185 St. Julie, Three River, Que., Can.
 Walter Bartell, 2135 Lyndale St., Chicago, Ill.
 Edwin Jurkowski, 581 Mineral St., Milwaukee, Wis.
 Orville Pugsley, Maryville, Mo.
 B. Belsky, 1923 Webster St., San Francisco, Calif.
 Carl Ledbetter, Box 334, Livingston, Tenn.
 George G. Barger, Raynoldsville, Pa.
 Myron Doner, 258 N. Oak St., Garnett, Kan.
 James J. Watson, 1117 Fulton Ave., N. Y. C.
 G. E. Hills, H. F. D. No. 3, Ft. Edward, N. Y.
 Clark Collins, 691 Orange St., Chillicothe, Ohio.
 R. Hornek, 70 Nassau St., N. Y. C.
 Wm. R. King, 414 N. Eighth St., Barberton, Ohio.
 J. A. Bail, 410-6 Ave., Verdun, Quebec, Can.
 Robert Rott, 161 Martin St., Milwaukee, Mich.
 Ed. Schroeder, 76 Charles St., Englewood, N. J.
 Alexander Smith, 1935 E. Lippincott, Philadelphia, Pa.
 Frank Brunson, Bicknell, Calif.
 F. Ruehl, 5215 Tennessee Ave., St. Louis, Mo.
 C. S. Smith, 312 W. Frambes Ave., Columbus, Ohio.
 Bert Reed, 416 W. Elizabeth St., Paris, Ill.
 Will H. Brueggeman, 740 Milton Ave., Janesville, Wis.
 Frank Schweers, 44 Block I (eye), Pueblo, Colo.
 Russell Dennison, 466½ Dufferin Ave., London, Ont., Can.
 Scout Clifford Marstad, 197-16 Central Ave., St. Albans, N. Y.
 B. H. Hill, 266 Montgomery St., Jersey City, N. J.
 J. H. Sale, 726 Loughe St., New Orleans, La.
 W. Le Roy Heim, 675 Penning Ave., Wood River, Ill.
 B. Byron, 11 Wright Ave., Toronto, Ont., Can.
 Geo. Allinger, 902 Woodside St., South Bend, Ind.
 H. Dieterich, 570 Jefferson Ave., Brooklyn, N. Y.
 Gerald B. Fitzgerald, Sta. L., Washington, D. C.
 James Izzo, Box 84 A, Silver Sands Rd., East Haven, Conn.
 Henry J. Tilden, Montauk, Long Island, N. Y.
 Florida Radio Co., Box 35, Bartow, Fla.
 Grandy Sales Co., 1306 Cherry, Los Angeles, Calif.
 William H. Cook, 431 Myrtle Ave., Clearwater, Fla.
 Henry E. Lewis, 1312 E. 9th St., Kansas City, Mo.
 C. A. Bollen, 1100 O'Farrell St., San Francisco, Calif.
 George Laird, 34 Garfield St., N. W., Hamilton, Ont., Can.
 Chas. E. Lowers, R. D. No. 3, Box 305, Marietta, Ohio.
 W. S. Williams, Box 105, Salamanca, N. Y.
 L. N. Parent, 23 Grant St., Newark, N. J.
 Geo. H. Cooper, 248 W. 4th St., Riverside, Calif.
 Bell Radio Service, 222 Monticello Ave., Jersey City, N. J.
 R. W. Bebb, 1563 Main St., Peckville, Pa.
 C. A. Walden, R. F. D. No. 3, Gulf Island, Auburn, Maine.
 Richard L. Lewis, 5 Union Court, Annisquam, Mass.
 H. V. Griffin, Albany, Ga.
 A. A. Stephenson, 1-2-03 32nd Ave., Corona, N. Y.
 Stanley Stevenson, 418½ W. 40th Place, Los Angeles, Calif.
 Earle Goodson, 1701 Erie St., Utica, N. Y.
 Chas. C. Leonard, 1164½ N. Westmoreland, Los Angeles, Calif.
 Harry Benninger, 56 Matlock St., Paterson, N. J.
 T. J. Corley, Care City Hall, Vancouver, B. C., Can.
 Thomas Reid, 1333 Fifth Ave., New York, N. Y.
 George Teeps, 2426 Midland Ave., Syracuse, N. Y.

John Smithson, 140 Smithies St., Fall River, Mass.
 A. J. Nicholson, Drawer No. 8, Eastland, Texas.
 Philip Florio, 1416 N. Monroe St., Herrin, Ill.
 Donald Norgaard, 5243 Richard Ave., Dallas, Texas.
 Home Radio Service, Homer H. Ordnung, R. Eng., 723 Cleveland Ave., South Bend, Ind.
 Jay Spoelstra, 829 Oakland Ave., Grand Rapids, Mich.
 Chas. W. Black, 281 Union Ave., Paterson, N. J.
 Fred P. Wilkins, 15709 Vine Ave., Harvey, Ill.
 J. A. Miller, Radio, 1321 Fairmount St., Ft. Worth, Texas.
 Ralph B. Martin, 654 Chestwood St., Oakland, Calif.
 H. L. Benson, R. D. No. 1, Drummond, Idaho.
 Joseph Gillespie, 186 Savannah Ave., E., Detroit, Mich.
 H. C. Clark, 800 Ave A, Dodge City, Kan.
 J. H. Hamilton, 420 Somerville Ave., Philadelphia, Pa.
 T. J. Corley, Care City Hall, Vancouver, B. C., Can.
 L. Cohen, 4221 Ft. Hamilton Parkway, Brooklyn, N. Y.
 A. E. Lane, Box 356, Sealy, Texas.
 Ernest Fleck, 2842 N. Albany Ave., Chicago, Ill.
 A. S. Price, The Gables, Belvedere Rd., Quebec, Can.
 H. S. Black, 1210 Monterey St., Pittsburgh, Pa.
 Charles H. Breese, Cos Cob, Conn.
 Thos. Connell, 405 Butternut St., Syracuse, N. Y.
 J. D. Keiser, P. O. Box 194, Mahanoy City, Pa.
 Harry Durlin, High St., Cameron, W. Va.
 S. W. Bettigrew, P. O. Box 345, Florence, S. C.
 C. D. Roach, 153 High St., Woodbury, N. J.
 Eugene Hise, 216 E. Clayton St., Brookfield, Mo.
 Rev. Georges E. Poirier, Drawer N, Springvale, Maine.
 A. A. Bishop, Bishop Electric Co., Hobart, Okla.
 Bert M. Johnson, 1935 Broadway, Denver, Colo.
 Arthur Cartu, 234 Alfred St., Detroit, Mich.
 J. Lasada, 1 Coleridge St., San Francisco, Calif.
 R. R. Hartill, Box 219 A, Toms River, N. J.
 Harold Hill, Mgr. Marks Stores, Inc., Albion, Mich.
 John Player, Radio, Dunkirk, N. Y.
 Ralph Iremonger, Electric Contractor, Richford, Vt.
 D. O'Meara, 1 Arden St., New York, N. Y.
 John A. Haley, 1410 Bosart Ave., Indianapolis, Ind.
 M. Wisnowski, New York State Highway, Poughkeepsie, N. Y.
 Earle H. Brown, R. F. D. No. 1, Middletown, N. Y.
 O G Bergen, 855 Deppe St., St. Paul, Minn.
 LeRoy Doellner, New City, Rockland Co, N. Y.
 Hans A. Zonff, 7403 Orchard Ave., Fordson, Mich.
 Earl G. DeHaven, 5136 Victoria Ave., Los Angeles, Cal.
 W. A. Wright, 162 Arlington St., Winnipeg, Can.
 W. Lewandowsky, Carlstadt Radio Shop, 334 3rd St., Carlstadt, N. J.
 M. M. Lytton, 1163 Cleveland Ave., Wyomissing, Pa.
 Harry Benninger, 56 Matlock St., Paterson, N. J.
 Thos. J. Magner, 37 Boylston St., Pittsfield, Mass.
 C. H. Brown, Box 136, Grand Forks, N. D.
 J. E. Henderson, 421 N 2nd St., McAlester, Okla.
 Fred Davis, 1515 Lackawanna Ave., Superior, Wis.
 Chas. Allison, 1317 Roache St., Indianapolis, Ind.
 H. H. Drake, 1002 Walnut St., Elmira, N. Y.
 William Dummer, The Radioshop, 15 State St., Newburyport, Mass.
 Robert F. Gowan, Hudson Radio Laboratories, Ossining-on-Hudson, N. Y.
 W. F. Carpenter, 26 Knapp Ave., Middletown, N. Y.
 Lt. A. L. Mains, 4th F. A. Bn., Ft. Robinson, Nebr.
 J. R. Mullen, Hq. Co 14 Brigade, Ft Omaha, Nebr.
 A. C. Stewart, Waterloo, Iowa.
 O. Johnson, Kanawha, Iowa.
 E. Ingram, 428-15 St., Oakland, Calif.
 Guillermo Ibanez, Apartado 739, Barranquilla-Columbia, S. A.
 L. F. Cyphers, 512 Olive St., Evansville, Ind.
 W. Emory, 712-25 St., Moline, Ill.
 Frank Herrman, Box 23-Parkville, P. O., Baltimore, Md.
 M. M. Oberlin, Brantford, Ont., Canada.
 A. A. Stephenson, 102-02, 32 Ave., Corona, N. Y.
 Edwin Larson, Martinsburg, Ohio.
 Saro Fagi, 212 W. Everett St., Falconer, N. Y.
 John David, 2915 Evering Ave., Lyons, Iowa.
 J. T. Fettes, 92 Corsby St., Lowell, Mass.
 Doc. Browne, 1115 Union St., Bklyn, N. Y.
 E. K. Wallace, 820 Mass. Ave., Cambridge, Mass.
 Paul Klug, 4714 Carlos Ave., Cleveland, Ohio.
 C. H. Toellner, R. F. D. 1, Bunceton, Mo.
 R. E. Fischer, Farmville, Va.
 R. B. Ottey, 508 Third St., West Fairview, Pa.
 E. O. Tanke, 3016 Jackson Ave., Ogden, Utah.

S. B. Gardner, Utica, Ill.
 Wm. Cameron, 2709 S. 9th St., Phila., Pa.
 Ryan's Radio Shop, 315 E. Grand, Hastings, Mich.
 Gus Helming, 578½ San Jose Ave., San Francisco, Calif.
 Rowland Bros. & Co., 4594 Evans Ave., St. Louis, Mo.
 Frank E. Yakeley, Quincy, Mich.
 Jay Spoelstra, 829 Oakland Ave., Grand Rapids, Mich.
 A. Geiler, 1072 E. 40 St., Bklyn., N. Y.
 Chas. Breesa, Cos Cob, Conn.
 Wm. Wheat, 1017 Linwood Blvd., Kansas City, Mo.
 Fred Dawlton, 112 E. Ave., Lawton, Okla.
 Geo. Selholzer, 94-38 St., N. Milwaukee, Wis.
 E. C. Woodward, 113 E. Commerce St., High Point, N. C.
 H. W. Gould, 711 W. St. Peter St., New Iberia, La.
 O. G. Bergen, Bergen Radio Service, 855 Deppe St., St. Paul, Minn.
 E. F. Walters, 475 Monroe St., Brooklyn, N. Y.
 Erie Whiting, 100 W. Kingsbridge Road, New York City.
 W. G. Adams, Highland, Calif.
 Ben Lewis, P. O. Box 363, Forest City, N. C.
 F. Baker, P. O. Box 206, Grand Junction, Colo.
 Radio Supplies, Las Vegas, N. Mex.
 G. Dreyer, 293 Stuyvesant Ave., Newark, N. J.
 Wm. D. Otto, 364 Greene Ave., Brooklyn, N. Y.
 B. R. Balsis, 1617 Peoples Gas Bldg., Chicago, Ill.
 C. Smith, Care Coast Guard Station, Charlevoix, Mich.
 W. Steinmann, 184 Utica Ave., Brooklyn, N. Y.
 Harold W. Duley, Upper Dam, Maine.
 R. G. Alquist, Radio Owners' Service Shop, Eureka, Calif.
 Theodore L. Maslar, 13932 Chippewa Ave., Burnham, Ill.
 W. R. Winslow, Rouzerville, Pa.
 A. Gunderson, 214 S. Main St., Rockford, Ill.
 B. Roberts, Care Mrs. T. McLaughlin, 40 Elizabeth St., River Rouge, Mich.
 William E. Ehlers, 66 Halleck St., Newark, N. J.
 H. W. Forster, 4219 Ivanhoe Ave., Baltimore, Md.
 Fred Shatzer, 1933 Trumbull Ave., Detroit, Mich.
 Geo. L. Burger, 905 Wisconsin Ave., North Fond du Lac, Wis.
 Sam Arons, 5210 Columbia Ave., Dallas, Texas.
 George T. Klein, Jr., 8849 202nd St., Hollis, L. I.
 C. J. Jeveret, 2449 W. 60th St., Chicago, Ill.
 M. J. Flicker, 114 Williston Ave., Waterloo, Iowa.
 Leo P. Kitchen, P. O. Box 888, Jacksonville, Fla.
 Joseph D. Copeland, 85 Main St., S. Portland, Me.
 A. S. Caldwell, Box 488, Davidson, N. C.
 Arthur W. Beem, Operator, K. G. H. I., Marion Hotel, Little Rock, Ark.
 John H. Schulken, 1038 44th St., Brooklyn, N. Y.
 Joe Pascorella, 441 Lansing Ave., Youngstown, Ohio.
 A. R. Sylvester, 2716 Baker St., Baltimore, Md.
 Harold Torgerson, Box 266, Maddock, N. Dak.
 D. K. King, 3119 Marne Ave., Norfolk, Va.
 Claude Humphreys, 5045-A Delmar Ave., St. Louis, Mo.
 Joe Randall, Mgr., Fulton Theatre, 806 W. Fulton St., Grand Rapids, Mich.
 Wm. J. Stein, 66 N. E. 3rd St., Miami, Fla.
 John J. Ryan, 442 Sackett St., Brooklyn, N. Y.
 Herbert McClure, Mac's Radio Shop, 2909 Kosuth Ave., St. Louis, Mo.
 F. E. Roller, 634 S. 8th St., Cambridge, Ohio.
 C. Hibbard, 917 Paynes Ave., N. Tonawanda, N. Y.
 Alfred E. Duprer, "Old Citadel," Meeting St., Charleston, S. C.
 Geo. Volz, 1121 Champion Ave., Columbus, Ohio.
 Y. Porton, 267 Piaget Ave., Clifton, N. J.
 Frank Peterson, 1941 53rd St., Brooklyn, N. Y.
 Prof. Ricardo Moran Pereira, Director Cure of Radio, Guayaquil, Ecuador.
 John F. Roberts, Phoenix, Md.
 Ethan M. Turley, Box 216, Windfall, Ind.
 Meyer Steinhurst, 64 Herzl St., Brooklyn, N. Y.
 J. MacKie, 22 Corley Ave., Toronto 13, Ont., Can.
 Ed. Breault, Jr., P. O. Box 1476, Sarasota, Fla.
 W. Roy Schweibing, 7218 Race St., Homewood Sta., Pittsburgh, Pa.
 C. Archer, Box 23, Goderich, Ont., Can.
 Frank R. Patke, 4171 W. Archer Ave., Chicago, Ill.
 Joseph Korosec, P. O. Box 61, Yukon, Pa.
 W. W. Butts, Auto Repairing, Parts, etc., Athens, Pa.
 R. W. Hartman, 115-19 Farmers Ave., St. Albans, L. I., N. Y.
 John A. Stang, 3071 33rd St., Astoria, L. I., N. Y.
 Albert E. Turner, 1612 Kiesel Ave., Ogden, Utah.
 Alex. Schneider, 226 S. 13th Ave., Maywood, Ill.
 Jas. W. Gage, 913 W. 6th St., Lawrence, Kans.
 Sam Sergi, 12 Marion St., Cambridge, Mass.
 Arthur Racicot, Major, U. S. M. C., P. O. Box 580, Parris Island, S. C.
 Mr. Hacker, care The French Shoppe, 1605 Kings Highway, Brooklyn, N. Y.
 C. W. Houger, 5106 W. 22nd Place, Cicero, Ill.
 Lieut. John W. Childs, 197 Carlton Road, Athens, Ga.
 F. C. Wissinger, care F. James, 56 Ft. Washington Ave., New York, N. Y.
 Ray G. Pruner, Box 1124, Cristobal, Canal Zone.
 John Hies, Farrell, Pa.
 H. R. Judson, Box 432, Balboa Heights, Canal Zone.
 J. W. Lawrie, 9000 Sherwood St., Detroit, Mich.
 J. B. Emmal, care Sanborn Map Co., 640 California St., San Francisco, Calif.
 Oscar Hanson, Oscar's Radio Shop, 119 Pleasant St., Worcester, Mass.
 Geo. E. Davis, 3089 Potter St., Philadelphia, Pa.
 Anton Lassen, Susanville, Calif.
 J. L. Hill, 1034 E. State St., Rockford, Ill.
 Lester Foley, 92 Thorne St., Jersey City, N. J.
 Lawrence J. Ryan, 288 Washington St., Taunton, Mass.
 W. Hartman, 1144 Lois Ave., Camden, N. J.
 Henry W. Woodward, 15 Winchester St., Springfield, Mass.

Radio University

A QUESTION and Answer Department conducted by RADIO WORLD, by its staff of experts, for University members only.

When writing for information give your Radio University subscription number.

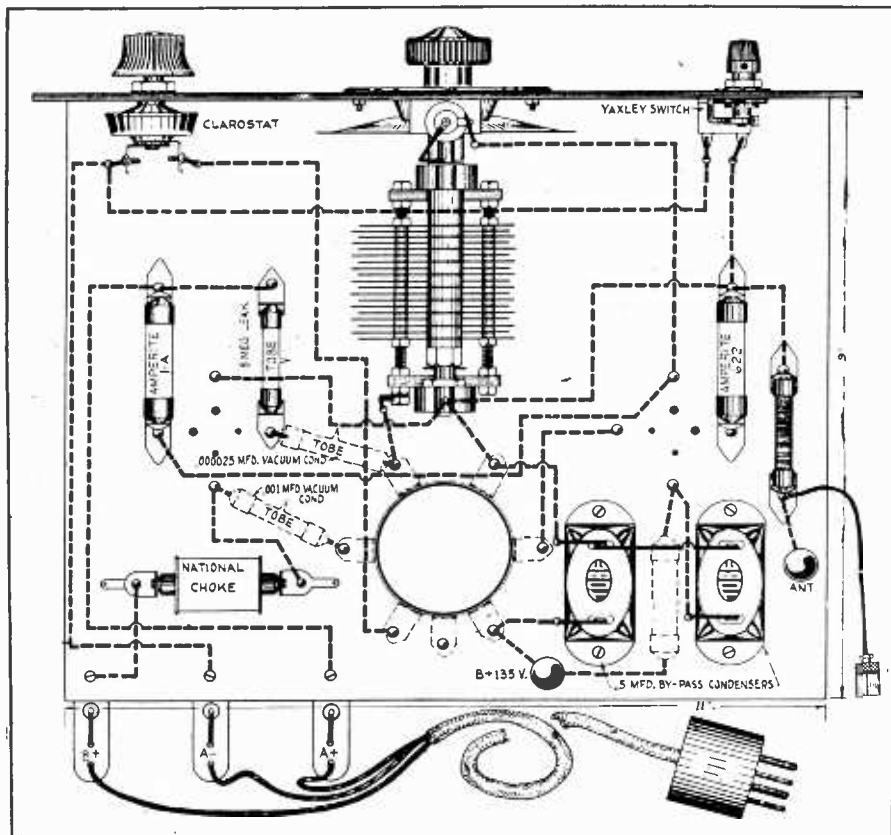

FIG. 720

THE CIRCUIT ARRANGEMENT OF THE NATIONAL SCREEN GRID SHORT WAVE ADAPTER IS SHOWN IN PICTORIAL AND SCHEMATIC FORMS

PLEASE let me know whether the National short wave tuner can be utilized as an adapter.

(2) If so, please show picture diagram of the wiring.

ADAM FOSTER,
Atlanta, Ga.

(1) Yes. See page 18 of this issue for Perry S. Graffam's article on the National short wave adapter.

(2) See Fig. 720 for the picture diagram. The list of parts is given on page 18.

IS THERE a device which can be put in the line supplying the eliminator which will cut down the AC hum?

(2)—I have a voltmeter with a resistance of 200 ohms per volt and a range of 0-500 volts. How much current does it require at full scale reading?

(3)—Does it take the same current for all voltage readings?

(4)—How can I determine the total resistance of a meter when the resistance per volt is known? How the current?

WILLIAM A. COTTRELL,
Harrisburg, Pa.

(1)—There is no such device and there never will be.

(2)—The meter requires 5 milliamperes for full deflection.

(3)—No, it takes a current proportional to the voltage.

(4)—Multiply the maximum reading by the ohms per volt. Thus the total resistance of a 0-500, 200 ohms per volt meter is 500 times 200, or 100,000 ohms. The current is the reciprocal of the resistance per volt.

HELP! I tried to improve my receiver, but succeeded only in making it inoperative. Following some articles that were published in RADIO WORLD, I re-

sorted to grid bias detection, instead of the leaky-condenser method I had been using. I had been getting pretty good results, but thought that tone quality might be improved by using grid bias detection. Instead, I lost all signals and here's what happens now. When I turn the detector tuning condenser I get a howl that varies in pitch as the dial is rotated. This howl is loudest at any point in resonance with the first tuning dial, but changes in pitch as the detector dial is varied. The howl is lowest in pitch at resonance and at both sides rises in frequency. All I did, mind you, was to remove the grid condenser and leak and connect the detector grid return to C minus on the first audio transformer,

which was about five volts, which should have done nicely, with the 100 plate volts on the first AF and detector. Will you please rush me directions for curing my troubles.

EDWARD FORD MANNING,
Toronto, Canada.

You made a misconnection that converted your receiver into an audio oscillator, and your tuning of the detector stage to resonance with the AF gives you the loudest and howl, with lowest pitch, and when you get away from resonance you get the higher-pitched and softer howls. Your trouble lies in a mistake in connecting to the first audio transformer secondary. Instead of bringing the detector grid return directly to C minus at the audio transformer secondary you connected it to grid post of that winding, thereby making an oscillator of your receiver and preventing reception by shorting the radio frequencies. Move the detector grid return from grid of the first audio to C minus (the opposite post on the same winding), as you had really intended, and your troubles will be over. But try various negative grid biases for detection, even more than five volts.

I HAVE a six-volt storage battery which is supposed to have a capacity of 100 ampere-hours. I have to charge it every few days or the voltage will drop to about 5.5 volts. What is the trouble with the battery?

(2) KDKA and WBZ, on 980 and 990 kilocycles, come in only half a division apart on my dial. Should not these come in one whole division apart on a 100-degree dial? What is wrong?

EDWIN FRANKLAND,
Nyack, N. Y.

(1) The plates of the battery probably have become sulphated. Have the battery repaired or get a new one.

(2) These stations should be one full division apart on a straight line frequency condenser. On other condensers they will be closer.

I HAVE a DYNAMIC speaker which requires 40 milliamperes at 90 volts for the field. When I connect the winding in series with my power supply the current is about 60 milliamperes. Is this current safe? If not, how can I cut down the current in the winding without cutting it down in the power supply?

MYRON BOWMAN,
Toledo, Ohio.

(1) The current is excessive.

(2) Connect a variable high resistance across the field winding. One having a range of from 0-10,000 ohms and a current carrying capacity of 50 milliamperes will serve. When adjusted properly so as to divide the 60 milliamperes between the field and the resistance the value of resistance used is 4,500 ohms.

Join RADIO WORLD'S University Club

And Get Free Question and Answer Service for the Coming 52 Weeks
This Service for Yearly Subscribers Only

Have your name entered on our subscription and University lists by special number. Put this number on the outside of the forwarding envelope (not the enclosed return envelope) and also put at the head of your queries. If already a subscriber, send \$6 for renewal from close of present subscription and your name will be entered in Radio University. No other premium given with this offer.

[In sending in your queries to the University Department please paragraph them so that the reply can be written under or alongside of each query. Write on one side of sheet only. Always give your university number.]

RADIO WORLD, 145 West 45th Street, New York City.

Enclosed find \$6.00 for RADIO WORLD for one year (52 nos.) and also enter my name on the list of members of RADIO WORLD'S University Club, which gives me free information in your Radio University Department for 52 ensuing weeks, and send me my number indicating membership.

Name

Street

City and State

A THOUGHT FOR THE WEEK—If our American broadcasting stations keep on offering their excellent musical programs it is quite possible that the w. k. man in the street will soon be able—even if blindfolded in accordance with the cigarette advertising formula—to tell the difference between a Beethoven sonata and a Strauss waltz. American listeners-in are receiving a liberal education in the understanding of good music.

RADIO WORLD

The First and Only National Radio Weekly

Radio World's Slogan: "A radio set for every home."

TELEPHONES: BRYANT 0556, 0559
PUBLISHED EVERY WEDNESDAY
(Dated Saturday of same week)
FROM PUBLICATION OFFICE
HENNESSY RADIO PUBLICATIONS CORPORATION
145 WEST 45TH STREET, NEW YORK, N. Y.
(Just East of Broadway)
ROLAND BURKE HENNESSY, President
M. B. HENNESSY, Vice-President
HERMAN BERNARD, Secretary
Kansas City, Mo.: E. A. Samuelson, 300 Coca Cola Bldg.
Los Angeles: Lloyd Chappel, 611 S. Coronado St.
European Representatives: The International News Co.,
Brema Bldg., Chancery Lane, London, Eng.
Paris, France: Brentano's, 8 Avenue de l'Opera.

EDITOR, Roland Burke Hennessy
MANAGING EDITOR, Herman Bernard
TECHNICAL EDITOR, J. E. Anderson
ART EDITOR, Anthony Sodare
CONTRIBUTING EDITORS:
James H. Carroll and Capt. Peter V. O'Rourke

SUBSCRIPTION RATES
Fifteen cents a copy. \$6.00 a year. \$3.00 for six months. \$1.50 for three months. Add \$1.00 a year extra for foreign postage; Canada, 50 cents.
Receipt by new subscribers of the first copy of RADIO WORLD mailed to them after sending in their order is automatic acknowledgment of their subscription order. Changes of address should be received at this office two weeks before date of publication. Always give old address; also state whether subscription is new or a renewal.

ADVERTISING RATES
General Advertising
1 Page, 7 1/2 "x11" 462 lines.....\$300.00
1/2 Page, 7 1/2 "x5 1/2" 231 lines..... 150.00
1/4 Page, 8 1/2 " D. C. 231 lines..... 150.00
1/4 Page, 4 1/2 " D. C. 115 lines..... 75.00
1/4 Page, 4 1/2 " S. C. 57 lines..... 37.50
1 Column, 2 1/4 "x11" 154 lines..... 100.00
1 Inch 10.00
Per Agate Line75
Time Discount
52 consecutive issues 20%
26 times consecutively or E. O. W. one year..... 15%
13 times consecutively or E. O. W. 12 1/2%
4 consecutive issues 10%
WEEKLY, dated each Saturday, published Wednesday.
Advertising forms close Tuesday, eleven days in advance of date of issue.

CLASSIFIED ADVERTISEMENTS
Ten cents per word. Minimum 10 words. Cash with order. Business Opportunities, 10 cents per word. \$1.00 minimum.
Entered as second-class matter March 23, 1922, at the Post Office at New York, N. Y., under the Act of March 3, 1879.

Buffalo Stations Warned by Board

Washington.
The Federal Radio Commission, through its broadcast engineer, Captain Guy D. Hill, has notified two Buffalo, N. Y., stations that unless they correct their transmission faults their power will be reduced. WKBW was notified by telegram that the station is so broadly tuned that it was causing serious interference and that unless it took immediate steps to prevent the interference the power would be reduced from 5,000 watts to 1,000 watts or less.
WGR was similarly notified that its transmitter was not properly adjusted and that it was causing interference because of broadness. If the condition persisted the engineer would recommend to the Commission that the power of the station be reduced from 750 watts to 250 watts or less.

Table for Converting Kilocycles to Meters

The station lists under the reallocation often give only frequency. Herewith is the conversion table, so you can determine the wavelength of any United States or Canadian broadcaster, if you know the frequency:

kc.	m.	kc.	m.	kc.	m.	kc.	m.
1500	199.9	1260	238.0	1020	293.9	780	384.4
1490	202.6	1250	239.9	1010	296.9	770	389.4
1480	202.6	1240	241.8	1000	299.8	760	394.5
1470	204.0	1230	243.8	990	302.8	750	399.8
1460	205.4	1220	245.8	980	305.9	740	405.2
1450	206.8	1210	247.8	970	309.1	730	413
1440	208.2	1200	249.9	960	312.3	720	416.4
1430	209.7	1190	252.0	950	315.6	710	422.3
1420	211.1	1180	254.1	940	319.0	700	428.3
1410	212.6	1170	256.3	930	322.4	690	434.5
1400	214.2	1160	258.5	920	325.9	680	440.9
1390	215.7	1150	260.7	910	329.5	670	447.5
1380	217.3	1140	263.0	900	331.1	660	454.3
1370	218.8	1130	265.3	890	336.9	650	461.3
1360	220.4	1120	267.7	880	340.7	640	468.5
1350	221.1	1110	270.1	870	344.6	630	475.9
1340	223.7	1100	272.6	860	348.6	620	483.6
1330	225.4	1090	275.1	850	352.7	610	491.5
1320	227.1	1080	277.6	840	356.9	600	499.7
1310	228.3	1070	280.2	830	361.2	590	508.2
1300	230.6	1060	282.8	820	365.6	580	516.9
1290	232.4	1050	285.5	810	370.2	570	526
1280	234.2	1040	288.3	800	374.8	560	535.4
1270	236.1	1030	291.2	790	379.5	550	545.1

SHORT WAVES TO CARRY NEWS

Washington.
The American Publishers' Committee, through its trustees and chairman, Joseph Pierson, presented to the Federal Radio Commission its plan of organization and allocation of the twenty transoceanic high frequency channels recently assigned it for use of the press as a whole in dissemination and gathering of news.
The committee also has pending applications for channels in the continental short wave band to gather and distribute news within the United States.
The plan presented to the Commission contemplates the assignment of the twenty transoceanic channels to eleven newspapers and press associations, Mr. Pierson told the Commission. Under the authorization the Commission must approve such assignments, and the American News Traffic Corporation, the parent organization, must agree that the radio network will be open to all the press as a "public utility."
The organizations to which the channels will be allocated, Mr. Pierson said, are the American News Traffic Corporation; Consolidated Press Wireless, Inc.; New York Times Wireless, Inc.; New York Herald-Tribune Wireless, Inc.; Press Publishing Company Wireless, Inc. (New York World); San Francisco Chronicle Wireless Corporation, Ltd.; United Press Wireless, Inc.; Scripps-Howard Wireless, Inc.; Universal Service Wireless, Inc.; Los Angeles Times Wireless, Inc., and Chicago Tribune Wireless, Inc.
Mr. Pierson, who called at the Commission with L. M. Loeb, counsel for the New York "Times," explained that the Consolidated Press Association had not yet submitted its charter of organization

KWK AND WIL ON FULL TIME

Washington.
The application of KWK, St. Louis, for full time operation on the 1,350 kilocycle channel was granted by the Federal Radio Commission, which at the same time assigned WIL, also of St. Louis, to full time on the 1,420 kilocycle channel, but restricted its power to 100 watts. The two stations, under the allocation, shared time on the 1,350 channel on alternate days.
In announcing its decision, the Commission informed the stations that it feels that the public interest, convenience and necessity will best be served if KWK is given full time operation, pursuant to its request. The station has 1,000 watts power.
On the other hand, the Commission informed WIL that, after investigation, it has decided that reducing the station's power from 250 to 100 watts, and placing it on another channel would be in the public interest. This station recently was given a construction permit for a 1,000 watt transmitter, which is revoked by the Commission in its decision.
PETER L. JENSEN was present at a recent demonstration in New York City of the new auditorium model Jensen dynamic. James A. Kennedy, Jensen sales representative, made the demonstration. Thomas A. White, general manager of Jensen, was present.
THE H. & F. Radio Laboratories, 72 Cortlandt Street, New York City, under the personal supervision of Paul R. Fernald, has selected the Sargent-Raymont Seven, the newest Silver-Marshall production, as one of the outstanding receivers of the season.

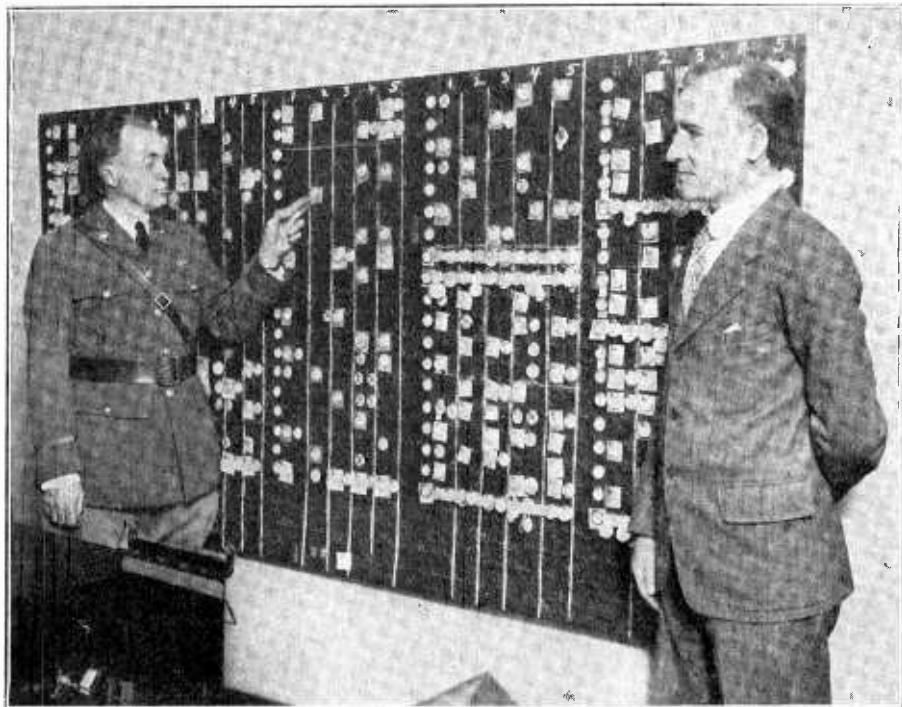

CAPT. GUY D. HILL AND DR. JOHN H. DELLINGER AT THE FEDERAL RADIO COMMISSIONS REALLOCATION BOARD. (Acme)

How to Get DX

(Continued from page 13)

mit you to "fish" for stations near them rather than use the haphazard method of falling upon them.

Then note how much leeway (selectivity) you have on either side of the local stations and experiment by turning the volume control on full and moving the dial slowly towards, or away from, the station. Many people "pass" distant stations in their haste to get away from locals.

If a station is broad, try the antenna switch until you have found the best combination.

One of the greatest aids in tuning is pictured in photograph No. 3. This is an auxiliary condenser of .000015 mfd. (5 plate) capacity, shunted directly across the main tuning condenser, or condenser gang, and is commonly known as a "trimmer." The tricks performed by this apparently insignificant accessory are so astounding that special mention must be made of them. I employ two trimmers in my circuit, one across each condenser unit. The manner in which they are connected is shown in the photograph, but to make it clear refer to Fig. 3.

These trimmers are easily installed in most receivers in a short time. Be sure to solder the leads. The contacts and connections must be perfect.

As an example of what can be done with trimmers, perhaps this will be of interest to the reader.

One night, a few weeks ago, I was listening to WRC, Washington, D. C., operating on 468 meters. I increased my volume control and heard an unmistakable heterodyne on WRC. By slightly turning the knob, which controls the left trimmer, I separated WRC and KFI, Los Angeles, operating on apparently the same frequency. There is no doubt that either WRC or KFI was slightly off its assigned frequency, but at that it could have been only a few kilocycles. I defy any expert in tuning to accomplish a similar feat without the aid of some auxiliary device. Dial gear ratios are too low to permit such fine tuning.

The proper use of these midget condensers will enable the user of a gang-tuned set truly to get ten, or even five, kilocycle separation. I have found them invaluable and would not think of con-

structing any receiver without incorporating them into the circuit. It may be true

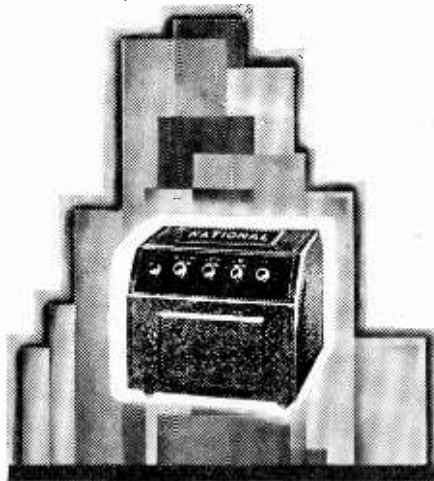

A REALLY FINE PRODUCT AT A POPULAR PRICE

An entirely new Development in B-Eliminators, of advanced simplicity of design.

Velvet Silent Hum-Free Output.
Safety Voltage Adjustments that Protect your Tubes.

Using the same rectifier tube as the highest priced A.C. sets; the U.X.-280.

Runs set up to six tubes and gives full 180 volts for 171 Power Tube.

Licensed under  Patents

List Price (less tube) \$26.50

NATIONAL VELVET-B

Type 3580

Write us for Bulletin 132-RW

NATIONAL CO. INC.

ESTABLISHED 1914
W. A. READY, PRES.

MALDEN, MASS.

that it means an extra control or two, but then the results are worth it.

YEARS

Ahead



Radio condensers come and go—but the Hammarlund "Mid-line" keeps ahead. Built with watch-like precision and embodying every feature demanded of a modern tuning instrument, the Hammarlund "Mid-line" Condenser has won world-wide renown.

If you know radio, you know Hammarlund. If you are a beginner, ask any radio engineer his estimate of Hammarlund Products. Follow his advice.

HAMMARLUND MFG. CO.
424-438 W. 33rd St., New York

Write for
Folders

For Better Radio
Hammarlund
PRECISION
PRODUCTS

The "Best" Christmas gift—

is one that affords the greatest amount of lasting pleasure.

This year give the



U. S. Pat. No. 1,667,531

- 1.—It eliminates distortion.
- 2.—Operates on all type speakers.
- 3.—Installed in a few minutes.
- 4.—Extreme tone sensitivity.

Be sure that you get the genuine—in the red box with the yellow label.

\$10 complete with 10 ft. of cord, at all good radio dealers.

Mfd. and guaranteed by
Best Manufacturing Co.
1200 Grove St.
Irvington, N. J.

'Dead Spot' Alive with DX Reception

(Continued from page 20)

grammed this week, whichever suits your objective. The center-tapped grid return of course is a selectivity increaser under these circumstances as well as under any others.

For uniformity of tuning, and independence of capacity effects of antenna length, you may omit the primary winding and connect (3) to grid, (4) to grid return, and aerial to one side of a .00005 mfd. fixed condenser, the other side of this capacity to the midtap (5) on the secondary. Be your indoor aerial 50 feet long or your outdoor one 150 feet long, the tuning of the left-hand dial will be the same, and also it will be nearly like the tuning of the other dial. The fact that the two will not tune absolutely alike is due to the difference in the elemental capacities of the screen grid tube and the tube, usually 401A or 201A, used as detector. On the high wavelengths (low

frequencies) this difference scarcely shows up, but on the low wavelengths (high frequencies) it will amount to a few degrees on the dial.

The tuning condenser in all instances is connected between the points (3) and (4).

The foregoing therefore gives the several options of antenna connection, based on requirements more or less independent of the physical and electrical size of the antenna.

Long Aerial Louder

The long aerial will provide louder signals and greater sensitivity, with lowered selectivity. The short aerial will give less sensitivity and volume, but more selectivity. Therefore the antenna connections may be determined by aerial circumstances or location or, generally, pickup.

For weak reception resort to the strengthening means. For strong recep-

tion, with absence of sufficient selectivity for the specially severe circumstances, resort to a shorter aerial, even an indoor one around the picture moulding, or adopt the .00005 mfd. series condenser method, or remove turns from the primary, or connect the grid return to the midtap, or combine all these.

Got DX in "Dead Spot"

The Screen Grid Universal therefore gives you a wide range of choice, which amounts to suitability to any location, for if any receiver works well in that location, the Universal will behave superbly, while if you can scarcely get a peep out of any set in a given location, try the Universal with that high-gain screen grid tube and high impedance coupler, 3TP or 5 TP and your troubles will be over. For this receiver was taken to a "dead spot" in the Park Avenue district of New York City, where millionaires live, and where one person thus endowed had a 10-tube set that brought in nothing on a loop, whereas the Universal brought in all the locals on an indoor antenna 40 feet long, stuck behind picture moulding, and besides afforded audible signals from KDKA, Pittsburgh, 980 kc., 45; WOC, Davenport, Ia., 1,000 kc., 43; WBAL, Baltimore, 1,060 kc., 39; WBT, Charlotte, N. C., 1,080 kc., 38; WPG, Atlantic City, 1,100 kc., 32.5; WCB, Zion, Ill., 1,100 kc., 32.5; WRVA, Richmond, Va., 1,110 kc., 34; WFBR, Baltimore, 1,120 kc., 33; KFKB, Milford, Kansas, 1,130 kc., 32; WHAM, Rochester, N. Y., 1,150 kc., 30; WOWO, Fort Wayne, Ind., 1,160 kc., 29; WCAU, Philadelphia, 1,170 kc., 28.

The numbers other than kc refer to the setting of the antenna dial.

FILL OUT AND MAIL NOW

SUBSCRIPTION BLANK

RADIO WORLD

RADIO WORLD

145 West 45th Street, New York City
(Just East of Broadway)

Please send me RADIO WORLD for months, for which

please find enclosed.....

SUBSCRIPTION RATES:

Single Copy\$.15
Three Months 1.50
Six Months 3.00
One Year, 52 Issues..... 6.00
Add \$1.00 a Year for Foreign Postage; 50c for Canadian Postage.

The Merry Go-Round

Oakland, Calif.

Very few of the radio stars at KGO give over their leisure moments to the interest of anything else but radio.

They can be found chatting about and listening to radio while breakfasting, lunching, dining, or while waiting their turn to go on the air. In between radio dates most of them attend musicales, or haunt the music publishers, constantly on the quest for brand new or long forgotten hits.

New Powertone Unit Brilliant to Eye and Ear! 1929 Model Far Excels Anything Else in Its Price Class!

Having won highest repute last season, the Powertone Unit, which gave maximum volume and quality reproduction at lowest price, again wins leadership because, without any increase in price, it assures still better performance.

The coil is wound a new way, with double the former impedance, giving remarkably faithful low-note reproduction, a region in which many units are deficient. The middle and high notes are faithfully reproduced, too.

GOLD AND VAN DYKE

The magnet is gold-dipped, giving it a rich and handsome appearance. The dipping is done before the "horseshoe" is magnetized, so there is no detrimental effect on flux. The back frame is sprayed with a Van Dyke finish—deepest brown, a splendid color combination. Imagine gold against Van Dyke! Use this unit for its superior performance and fetching appearance!

WHAT YOU GET:

At \$3.75 each, this unit represents the utmost you can obtain at anywhere near this price. Not only do you get the unit, but also a mounting bracket, apex, chuck, thumb-screw nut and 5-foot cord.



This unit will drive any type of cone, airplane cloth, linen or similar speaker, but will not work a horn. The Powertone Unit will stand 150 volts without filtering and is fully guaranteed against ALL defects for one year. The armature is adjustable to power tube impedance. Order a unit NOW!

SEND NO MONEY!

Just order one new Powertone Unit with equipment. It will be mailed at once C. O. D. You will pay postman \$3.75 plus a few cents extra for postage.

Try it for five days. If you don't think it superb, simply return the unit with a letter asking for refund, and your purchase money will be returned immediately! You run no risks! All you can do is win!

36" OR 24" KIT

You can use this unit on any type cone or other diaphragm speaker you prefer. If you want to build a 36" or 24" cone yourself, specify which, and unit, paper, bracket, apex, nut, thumbscrew, cement, pedestal, cord and instructions will go forward at \$6.00 C. O. D. plus small cost of cartage.

You will be overjoyed with the new 1929 model improved Powertone Unit. Order one TO-DAY!

GUARANTY RADIO GOODS CO., 145 W. 45th St., New York City. Just East of Broadway

NEW CORPORATIONS

Dunbar Radio Engineering Co., radios—Atty., C. A. Johnson, 2313 Seventh Ave., New York, N. Y.
 Graybar Management Corp.—Atty., Breed, Abbott & Morgan, 15 Wall St., New York, N. Y.
 Kew Radio Electric, Kew Gardens—Atty., A. H. Courtenay, Hempstead, N. Y.
 Vitatron Radio Corp., Newark, N. J.—Atty., F. D. Masucci, Newark, N. J.
 Jenkins Television Corp., Wilmington, Del.—Atty., Corporation Trust Company of America, Wilmington, Del.
 Authorized Radio Specialists—Atty., Basch & Kulkin, 1265 Broadway, New York, N. Y.
 Television Corp. of America, Wilmington—American Guaranty and Trust Company, Wilmington, Del.
 General Broadcasting System—Atty., Stanchfield & Levy, 120 Broadway, New York, N. Y.
 Press Publishing, wireless radio transmission—Atty., Jackson, Fuller, Nash & Brophy, 15 Broad St., New York, N. Y.
 The City Radio Shop of Paterson, Paterson, N. J.—Atty., David Cohn, Paterson, N. J.
 Collway Radio Laboratories, Inc., Newark, N. J.—Atty., Charles Hood, Newark, N. J.
 L. & L. Radio Stores—Atty., Schlesinger & Schlesinger, 17 East 42nd St., New York, N. Y.
 Elbee Radio and Electric Co., Atty., E. Finger-man, 551 5th Ave., New York, N. Y.
 Livingston & Milibauser, radios—Atty., H. H. Livingston, Rockaway Park, N. Y.
 Nassau Broadcasting Corp., Farmingdale—Atty., F. C. Dowd, Farmingdale, N. Y.
 Symphonic Corporation of America, Wilmington, radios, phonographs—Atty., Delaware Charter Co., Wilmington, Del.

BUILD YOUR OWN DYNAMIC SPEAKER

Complete set of blueprints and instructions for building your own Dynamic cone speaker. Easy and inexpensive to build at home with few tools. Guaranteed to work; thousands now enjoying Dynamic reproduction. Mail \$1.00 today and you will receive complete set, postpaid.

FANSPEAKER RADIO COMPANY
 74 Dey Street - - - New York, N. Y.

SOCKET WRENCH

FREE

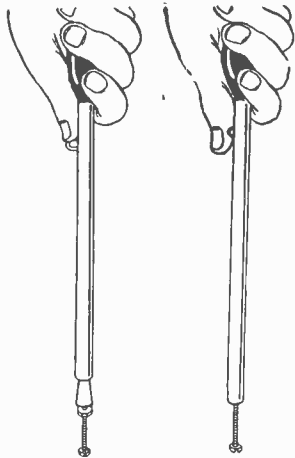

Push out control lever with knob (as at left) and put wrench on nut. Push down on handle only (at right), then turn nut left or right.

ONE of the handiest tools for a custom set builder, service man or home constructor is a BERNARD socket wrench.

It consists of a 6 1/2" long metal tubing in which is a plunger, controlled by a knob. The plunger has a gripping terminal (called a socket, hence the name "socket wrench") that may be expanded or contracted to fit 6/32, 8/32 and 10/32 nuts, the most popular sized nuts in radio.

Use the knob to push out the plunger, press down on the handle to grip the nut, then turn the nut to left for removal or to right for fastening down. Total length, distended, including stained wooden handle, 10". Gets nicely into tight places. Send \$1 for 8 weeks' mail subscription for RADIO WORLD and get this wrench FREE.

No other premium with this offer. Present subscriber may extend subscription by stating he is one, and entitle himself to this FREE premium, making \$1 remittance.

RADIO WORLD
 145 WEST 45TH ST., N. Y. CITY
 A few doors east of Broadway

SAVE THOSE TUBES!

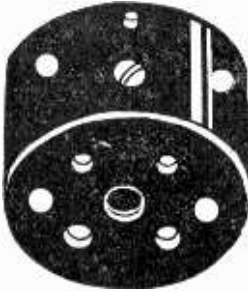

Many persons have sets with Navy type sockets—the kind with the collar on and the bayonet hinge for the pin on the base of the tube. If you put a UX base tube in a Navy type socket a short may blow out all the tubes. Play safe and have fine contact besides. Use adapter that fits UX tubes into Navy sockets (Cat. No. UX). Price 20 cents each.

GUARANTY RADIO GOODS CO.
 145 West 45th St., N. Y. City

SHORT WAVE ADAPTER \$10.17

Completely built-up, ready to receive; includes three plug-in coils, also built-in plug and cable and tunes 18 to 78 metres. Requires no extra tube. Chart tells just where each wavelength comes in DC model (for all sets except AC tube sets). List price, \$18.50; our price, \$10.17 AC model for AC sets. List price, \$19.50; our price, \$10.72.

Order One Now C.O.D.
Ten-Day Money-Back Guarantee!
RADIO SUPPLY COMPANY
 217 Havemeyer Street, Brooklyn, N. Y.

An Extraordinary Speaker

THE super-sensitive and acoustically faithful twin magnet POLO UNIT in a deluxe housing, with moulded metal front piece, makes a first-class table model speaker. It will stand the heaviest load—even two 250 tubes in push-pull without rattling—yet is so sensitive it will work well from any output tube, even a 201A!

Compact and handsome, this table model graces any living room or parlor, is inconspicuous to the eye but alluringly predominant to the ear.

The unit is mounted on a special bracket that makes it impossible for the unit to get out of adjustment. The table model, of the free-edge cone type, is furnished completely built-up, ready to play.

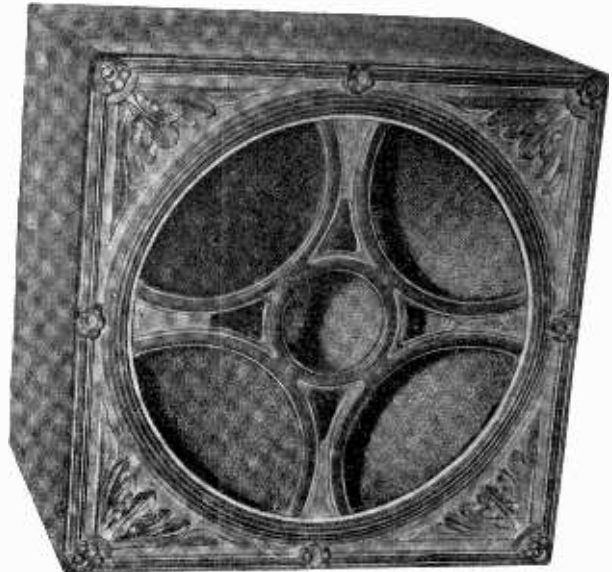

The Table Model Polo Speaker, an outstanding example of the magnetic type of speaker, is shown one-third actual size.

The grill or front piece is moulded, while the rest of the housing is wood. Both grill and housing are furnished in rich, conservative two-tone brown spray.

Table Model Polo Speaker, Cat. TMP, consisting of de luxe housing and moulded grill, with sprayed finish; mounted Polo Unit, with cone and special bracket; also 10-ft. cord
 All built-up, ready to play.....\$13.50

[Note.—Those who possess a Polo Unit and desire the housing, special bracket and cone, may obtain these by ordering Cat. HO at \$5.00.]

THE Polo Unit, using two magnets, to double sensitivity, is regarded by many experts as the best magnetic unit. It weighs three full pounds—almost three times as much as an average unit—and will stand the strain of even two 250 tubes in push-pull without rattling. It works well out of any type tube. The pole pieces are laminated and the armature can't get out of adjustment. The two magnet coils are housed in bakelite. This unit will stand 180 volts without filtering, due to the large diameter wire used on the special coils. All Polo Units have a bronze-green casing and black twin magnets.

Polo Unit, shown one-half actual size. Furnished complete with unit, apex chuck, nut, 10-ft. cord, bracket and hardware. Cat. PU\$10.00

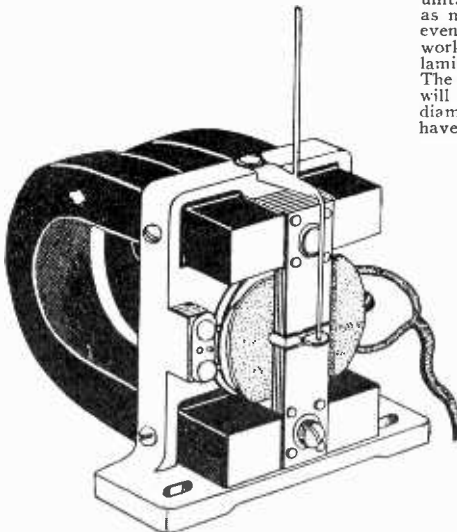

Acoustical Engineering Associates,
 143 West 45th Street, N. Y. City.
 (Just East of Broadway)

Please ship at once C.O.D.:

- One Cat. TMP at \$13.50.
- One Cat. PU at \$10.00.
- One Cat. HO at \$5.00.

[Put cross in proper square above.]

Name

Address

City State.....

Ten-day Money-back Guarantee.

JUST TURN KNOB



to switch from one speaker to another, or to operate both together! Instantaneous Convenience!

Those who have two loudspeakers in their home or store have been without a simple method to switch from one to another. When they wanted two loudspeakers to play at the same time, they had to make certain connections. And then when they wanted only one speaker to play they had to change the previous connections.

This new Speakerelay (illustrated) is enclosed in a bakelite case and is so constructed as to make two loudspeakers operate separately or together from your radio set, without any loss in volume. By merely turning a small knob to the left one loudspeaker operates, when the knob is turned to the right, the other loudspeaker operates, disconnecting the first one. When the knob is placed at position marked "2" both loudspeakers operate together. Price **\$2.00**

Send no money! Order C. O. D. Five-day money-back guaranty!

Guaranty Radio Goods Co.

145 W. 45th St., N. Y. City
(A few doors east of Broadway)

BUILD A 36-INCH CONE—LOWEST COST FOR FINEST TONE!



NEW
POWERTONE
UNIT
with 5-ft. cord
Designed Front Sheet
Plain Rear Sheet
Radio Cement
Mounting Bracket
Apex
Chuck
Nut
Tri-Foot Pedestal
Instruction Sheet
ALL FOR ONLY

\$6.00

Note: If 24" kit is desired, order Cat. No. 24; same price.

Cat. No. 36

REMARKABLE GUARANTY!

This 36" Cone Speaker Kit is sent complete, as listed, carefully packed. Order one sent C. O. D.

SEND NO MONEY!

Build the speaker. If not overjoyed, at results, return the built-up speaker in five days and get ALL your money back!

GUARANTY RADIO GOODS CO.

145 WEST 45TH STREET
N. Y. City Just East of Broadway

COMPLETE ADVANCE STATION LIST—Nov. 3d issue of RADIO WORLD contained complete advance list of stations compiled according to the new allocation plan of the Federal Radio Commission, effective Nov. 11. Mailed for 15 cents a copy, or send \$1.00 for trial subscription of 8 weeks, including Nov. 3d issue. RADIO WORLD, 145 W. 45th Street, New York City.

EXCELLENT unit for phonograph attachment, to play records. Connects to speaker terminals, gozette to phonograph. \$4.20. P. Cohen, 236 Varet St., Bklyn., N. Y.

BLUEPRINT OF SCREEN GRID 4-TUBE UNIVERSAL - - \$1.00

Connections Doubly Clear Because Wiring Done on Top of the Subpanel is Shown Separately, and wiring done underneath the subpanel is shown separately. All leads shown in the same direction in which they are physically connected. You don't have to reverse the blueprint mentally to visualize the practical connections. Crystal-clear blueprint safeguards against error. Order your print today. Prompt delivery. Price of complete kit, \$35.00 (less tubes, cabinet and speaker).

PHILIP COHEN, 236 Varet Street, Brooklyn, N. Y.

Cash in on This Offer Now!

ONE full year's subscription for any TWO of the following magazines given to you—**RADIO NEWS** or **SCIENCE AND INVENTION** or **RADIO** (San Francisco) or **BOYS' LIFE**.

Select any TWO of these four publications, each of which will be sent to you (at only one address, however) each month for twelve months—in other words, 24 issues—if you will send in now your subscription for **RADIO WORLD** for two years (104 numbers) at \$10.00. **RADIO WORLD'S** subscription price for one year is \$6.00, so you gain the extra dollar by taking advantage of the liberal offer for two-year subscriptions; and, besides, you get a subscription for each of the TWO other magazines selected from the enumerated list, making a total of 128 numbers for \$10.00.

If you want to select only one from among the four other magazines, you may obtain this one for TWO years, so that you will be subscribing for **RADIO WORLD** for two years and for the other magazine for TWO years, all for only \$10.00 (both mailed to one address only).

These offers are rightly regarded as among the most liberal ever made, but as they are limited as to expiration date (see notice below) you must act now.
Please use the attached coupon.

SPECIAL TWO-FOR-PRICE-OF-ONE COUPON

RADIO WORLD, 145 West 45th Street, New York City (Just East of Broadway):
Enclosed please find \$10.00, for which send me **RADIO WORLD** each week for two years (104 numbers), and also send me, without extra cost, each month for one year each of the following TWO magazines—total, 24 issues—grand total, 128 numbers:

- | | |
|-------------------------------------------------------|-------------------------------------------------------|
| <input type="checkbox"/> RADIO NEWS | <input type="checkbox"/> RADIO (San Francisco) |
| <input type="checkbox"/> SCIENCE AND INVENTION | <input type="checkbox"/> BOYS' LIFE |

If you want one of each, put a cross in a square next to the name of each of the two other magazines. If you want a two-year subscription for ONE of the above magazines, with the two-year subscription for **RADIO WORLD** (same grand total of 128 numbers), put two crosses before the name of one magazine.

If you prefer to pay \$6.00 for only one year's subscription for **RADIO WORLD** (52 numbers) and get one of the other magazines for one year, without extra cost, put one cross in one square in front of the name of one magazine.

Present **RADIO WORLD** subscribers may renew under this offer. If renewing, put a cross here .

Name.....
Address.....
Street Address.....
City..... State.....

THIS OFFER EXPIRES AT NOON ON JANUARY 15TH, 1928

ELIMINATE BATTERIES!

NO Change in Set Wiring
NO Change in Tubes

"B" Eliminator, Using Raytheon Tube. Replaces "B" Batteries and Gives Great Satisfaction.



No. B16—"B" Eliminator for 50 to 60 cycle, 105 to 125-volt AC house current. Max. voltage, 180, with one variable detector and one variable intermediate voltage. Weight 16 lbs. Size, 6 x 6 1/2 x 11 1/2". Quiet, economical. Requires no attention. Sold only with Raytheon tube. Price, including Raytheon BH125 mil. tube and built in connector cord and plug. **\$16**

Famous Raytheon Tube With Each "B" Eliminator

"A" Eliminator, Using Dry Plate Rectification, Current Well Filtered. Replaces "A" Battery.



No. A22—"A" Eliminator. Supplies up to 2 1/2 amperes at 6 volts. Variable resistance permits adjustment to number of tubes in set. Supplies A current and voltage to sets using from 4 to 10 quarter ampere tubes, or equivalent current drawn by any other combinations. Tip jacks for voltmeter readings. Receptacle for "B" eliminator plug. Pendant switch controls everything. Set switch need not be touched. Device requires no attention. Uses no tube. Size: 10 1/2" high, 6 1/2" wide, 11 1/2" long. Shipping weight, 27 lbs. **\$22**

POLO ENGINEERING LABORATORIES, 57 Dey St., New York City.
Please ship at once—

- One 180-volt maximum "B" eliminator, with variable detector and variable intermediate voltage (three different voltages in all); equipped with one Raytheon BH tube, 125 milliamperes rating. I will pay \$16, plus a little extra for freight, on receipt of goods, which are to be approved for ten days (money back, if desired after 10-day trial)
- One "A" eliminator, 2 1/2-ampere maximum at 6 volts, using dry plate rectification, large choke and large capacity condenser, AC switch, receptacle for any "B" eliminator plug, variable resistor, all built in for which I will pay \$22 plus a little extra for freight.
- Both the "B" eliminator and the "A" eliminator, at total of \$36, on same approval basis.

Note: If fast express shipment is preferred, rather than slower freight, put a cross here .

Name.....
Address.....
City..... State.....

ALL SHIPMENTS MADE ON APPROVAL FOR TEN DAYS

All prices quoted are NET!

For That Increased B Voltage—

Need more detector or intermediate voltage from that B-eliminator? If so, just connect a STANDARD CLAROSTAT or a DUPLEX CLAROSTAT across B maximum tap and the tap to be increased. You can adjust the Clarostat to provide any desired voltage. And there are many other applications for these Clarostats in bettering your radio.

Your dealer will gladly show you the Clarostat line and furnish literature. If you prefer, write us for same.

CLAROSTAT MFG. CO., Inc.
Specialists in Variable Resistors
291 N. 6th St. Brooklyn, N. Y.

CLAROSTAT
REG. U. S. PAT. OFF.

FREE BOOK



New Hook-ups. This book shows how to make Short-Wave Receivers and Short-Wave Adapters.
How to use the new screen-grid tube in D.C. and A.C. circuits.
How to build Power Amplifiers, and ABC Eliminators. Up-to-the-minute information on all new radio developments.
Set Builders, Fans, Dealers, send for it today!

Write for it!

KARAS ELECTRIC COMPANY 4039-L2
4039-L2 N. Rockwell St., Chicago, Illinois
Please send me your Free Book:

Name
Address
City State

SPEAKERELAY

Cat. No. 121

\$2



For connecting two speakers by turn of knob so that at No. 1, left, you operate one speaker alone; at No. 2 you operate both speakers together; at No. 1, right, you operate the other speaker alone. Excellent for store demonstrations or home use. Earphones may be substituted for one speaker.

GUARANTY RADIO GOODS CO.
145 WEST 45TH STREET
NEW YORK CITY Just East of Broadway

RADIO WORLD, published every Wednesday, dated Saturday of same week, from publication office, Hennessy Radio Publications Corporation, 145 West 45th Street, New York, N. Y., just east of Broadway. Roland Burke Hennessy, President; M. B. Hennessy, Vice-President; Herman Bernard, Secretary. Roland Burke Hennessy, Editor; Herman Bernard, Managing Editor; J. E. Anderson, Technical Editor; Anthony Sodaro, Art Editor.

More Profits To Set Builders

One good radio idea may be worth millions. Barawik has thousands of ideas for radio set builders to make more money. Barawik's Big Radio Book will help you while elections are on and big national events stir the world.



Send for your copy today - NOW.
BARAWIK CO. 1312A Canal Station,
CHICAGO, U. S. A.

LYNCH

equalizers for filament control make rheostats unnecessary. Complete with mount **\$1.00**

ARTHUR H. LYNCH, INC.
1775 Broadway New York City
Send for free Lynch radio manual

AIR COLUMN HORNS ARE SPLENDID!

Especially Those Made of Molded Wood

EVERYBODY who uses a horn loud speaker of the latest type, consisting of an air column design, with long tone travel, agrees that the tone is splendid. Our Model 595 has a travel distance of 8 feet from the unit to the large end of the "bell." If you must economize on space, use

Model 570, with a 6-foot tone travel, with not quite as

strong reproduction of low notes.

But No. 595 is better and, if you've the room (21 1/4" high, 18" wide, 15" deep), choose that one. Every purchaser is a delighted customer.

Order one of these specially moulded wood horns. Try it for 90 days. If not delighted, return it and get back your money, including any shipping charges you paid! (Note: Not a single one of these horns has ever been returned to us, though we've sold many hundreds!)

Model 570, with a 6-foot tone travel, with not quite as strong reproduction of low notes.

But No. 595 is better and, if you've the room (21 1/4" high, 18" wide, 15" deep), choose that one. Every purchaser is a delighted customer.

Order one of these specially moulded wood horns. Try it for 90 days. If not delighted, return it and get back your money, including any shipping charges you paid! (Note: Not a single one of these horns has ever been returned to us, though we've sold many hundreds!)

Model 570, with a 6-foot tone travel, with not quite as strong reproduction of low notes.

But No. 595 is better and, if you've the room (21 1/4" high, 18" wide, 15" deep), choose that one. Every purchaser is a delighted customer.

Order one of these specially moulded wood horns. Try it for 90 days. If not delighted, return it and get back your money, including any shipping charges you paid! (Note: Not a single one of these horns has ever been returned to us, though we've sold many hundreds!)

Model 570, with a 6-foot tone travel, with not quite as strong reproduction of low notes.

But No. 595 is better and, if you've the room (21 1/4" high, 18" wide, 15" deep), choose that one. Every purchaser is a delighted customer.

Order one of these specially moulded wood horns. Try it for 90 days. If not delighted, return it and get back your money, including any shipping charges you paid! (Note: Not a single one of these horns has ever been returned to us, though we've sold many hundreds!)

Model 570, with a 6-foot tone travel, with not quite as strong reproduction of low notes.

But No. 595 is better and, if you've the room (21 1/4" high, 18" wide, 15" deep), choose that one. Every purchaser is a delighted customer.

Order one of these specially moulded wood horns. Try it for 90 days. If not delighted, return it and get back your money, including any shipping charges you paid! (Note: Not a single one of these horns has ever been returned to us, though we've sold many hundreds!)

Model 570, with a 6-foot tone travel, with not quite as strong reproduction of low notes.

But No. 595 is better and, if you've the room (21 1/4" high, 18" wide, 15" deep), choose that one. Every purchaser is a delighted customer.

Order one of these specially moulded wood horns. Try it for 90 days. If not delighted, return it and get back your money, including any shipping charges you paid! (Note: Not a single one of these horns has ever been returned to us, though we've sold many hundreds!)

Model 570, with a 6-foot tone travel, with not quite as strong reproduction of low notes.

But No. 595 is better and, if you've the room (21 1/4" high, 18" wide, 15" deep), choose that one. Every purchaser is a delighted customer.

Order one of these specially moulded wood horns. Try it for 90 days. If not delighted, return it and get back your money, including any shipping charges you paid! (Note: Not a single one of these horns has ever been returned to us, though we've sold many hundreds!)

Model 570, with a 6-foot tone travel, with not quite as strong reproduction of low notes.

But No. 595 is better and, if you've the room (21 1/4" high, 18" wide, 15" deep), choose that one. Every purchaser is a delighted customer.

Order one of these specially moulded wood horns. Try it for 90 days. If not delighted, return it and get back your money, including any shipping charges you paid! (Note: Not a single one of these horns has ever been returned to us, though we've sold many hundreds!)

Model 570, with a 6-foot tone travel, with not quite as strong reproduction of low notes.

But No. 595 is better and, if you've the room (21 1/4" high, 18" wide, 15" deep), choose that one. Every purchaser is a delighted customer.

Order one of these specially moulded wood horns. Try it for 90 days. If not delighted, return it and get back your money, including any shipping charges you paid! (Note: Not a single one of these horns has ever been returned to us, though we've sold many hundreds!)

Model 570, with a 6-foot tone travel, with not quite as strong reproduction of low notes.

But No. 595 is better and, if you've the room (21 1/4" high, 18" wide, 15" deep), choose that one. Every purchaser is a delighted customer.

Order one of these specially moulded wood horns. Try it for 90 days. If not delighted, return it and get back your money, including any shipping charges you paid! (Note: Not a single one of these horns has ever been returned to us, though we've sold many hundreds!)

Model 570, with a 6-foot tone travel, with not quite as strong reproduction of low notes.

But No. 595 is better and, if you've the room (21 1/4" high, 18" wide, 15" deep), choose that one. Every purchaser is a delighted customer.

Order one of these specially moulded wood horns. Try it for 90 days. If not delighted, return it and get back your money, including any shipping charges you paid! (Note: Not a single one of these horns has ever been returned to us, though we've sold many hundreds!)

Model 570, with a 6-foot tone travel, with not quite as strong reproduction of low notes.

But No. 595 is better and, if you've the room (21 1/4" high, 18" wide, 15" deep), choose that one. Every purchaser is a delighted customer.

Order one of these specially moulded wood horns. Try it for 90 days. If not delighted, return it and get back your money, including any shipping charges you paid! (Note: Not a single one of these horns has ever been returned to us, though we've sold many hundreds!)

Model 570, with a 6-foot tone travel, with not quite as strong reproduction of low notes.



Model 595 (illustrated above) Baffle board (not shown) FREE with each order. List price \$18.00. Our price (40% and 2% off list price) —

\$10.58

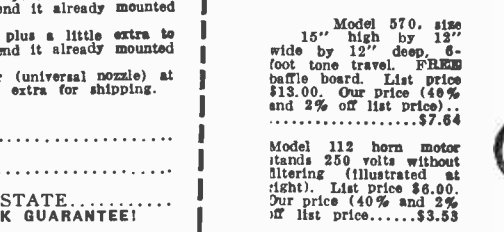

Model 570, size 15" high by 13" wide by 12" deep, 6-foot tone travel. FREE baffle board. List price \$13.00. Our price (40% and 2% off list price).....\$7.64



Model 112 horn motor stands 250 volts without filtering (illustrated at right). List price \$6.00. Our price (40% and 2% off list price).....\$3.53

ACOUSTICAL ENGINEERING ASSOCIATES,
143 West 45th St., New York City.
(Just East of Broadway)

Please ship me at once the following (check off):

- One No. 595 at \$10.58, plus a little extra to defray shipping costs; send it already mounted in FREE baffle board.
- One No. 570 at \$7.64, plus a little extra to defray shipping costs; send it already mounted in FREE baffle board.
- One No. 112 horn motor (universal nozzle) at \$3.53, plus a few cents extra for shipping.

NAME.....
ADDRESS.....
CITY..... STATE.....
90-DAY MONEY-BACK GUARANTEE!

Quick Action Classified Ads

Radio World's Speedy Medium for Enterprise and Sales

10 cents a word — 10 words minimum — Cash with Order

FREE BLUEPRINTS! GET YOUR SHARE!
National Short Wave Circuit blueprint, exact circuit used by James Millen for tuning in television, voice, code, music, programs. National Screen Grid Five (broadcast receiver circuit) blueprint FREE also. John F. Rider's B Eliminator blueprint free. Send separate request for each of the above free blueprints you desire. Custom Set Builders Supply Co., 57 Dey Street, N. Y. City.

Recent Issues of RADIO WORLD, 15 cents each. Any number published in 1928 available for a short while. Six issues 75 cents, 10 issues \$1.00. Send stamps, coin or money order NOW, before the issues are sold. RADIO WORLD, 145 West 45th Street, New York City.

POSITION WANTED by licensed radio operator. Ivan Fry, Minerva, Ohio.

QUICK SERVICE. Order radio goods now, shipments made day following receipt. All merchandise pre-tested. Set of Screen Grid Coils for Bernard's Economy Three, consisting of antenna coil Model 2A and High Impedance Tuner, Model 5 HT, \$4.75. One screen grid tube, one high mu tube, one -12A tube, total for three tubes, \$7.00. Blueprint for Bernard's Economy Three, \$1.00. Front panel and subpanel for 4-tube Screen Grid Diamond of the Air, \$5.00. All merchandise guaranteed on five-day moneyback basis. Send remittance and I pay carrying and shipping charges. Philip Cohen, 236 Varet Street, Brooklyn, N. Y.

ARTISTS and Art Students are printing 250 signs or pictures an hour without machinery. Sample and particulars 10c. Straco, 1014 Mulberry, Springfield, Ohio.

TAKE Your Choice of 4 Other Publications for New Radio World Subscribers Ordering Now. Radio World has made arrangements to offer, with one year's subscription for Radio World, a year's subscription for any one of the following publications FREE: Radio News or Science and Invention or Boys' Life or Radio (San Francisco).

Send \$6.00 —now. State which other listed publication you desire. Radio World, 145 W. 45th St., N. Y. City.

The New HBH

Irish-Linen Diaphragm Speaker

DeLuxe Finish; Built-up, Ready to Play

(Cat. A No. 1DLB)

\$19.50

Beautiful to Eye and Ear

Enjoy the *Big Thrill!*

THE new HBH Irish-Linen Diaphragm Loud-speaker, using the new Polo Unit, is designed to produce *more volume* and handle *more power* than any other electro-magnetic type speaker! The volume is so stupendous as to be utterly amazing. You would think you had added a couple of more audio stages, whereas all you did was to substitute the HBH Speaker for some other type.

The tone is pure throughout the audio range, and the low notes get specially favorable treatment, to equalize their final intensity with that of the higher audio frequencies.

Matching the finest unit with the finest diaphragm, tightly stretched on a rigid baffle and properly "doped," produces the outstanding results.

Listen to this speaker and *enjoy the big thrill of your radio life!*

If the results are not louder, clearer, better than anything else you have heard in this line, using your own individual judgment, in five days return the speaker, and we will refund your money at once. No delay! No questions asked!

GUARANTY RADIO GOODS CO.
145- W. 45 St., N. Y. City.
(Just East of Broadway)

Please ship at once C.O.D. express, at advertised price plus little extra for cartage, the following, on 5-day money-back guaranty, including refund of cartage cost:

Cat. A No. Cat. A No.
 Cat. A No. Cat. A No.

Name

Address

City State

SEND NO MONEY!

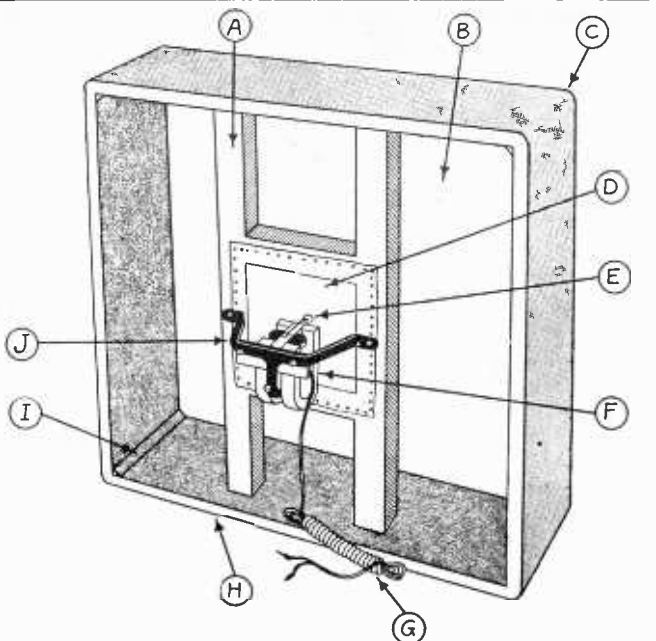

Symbolic Rear View of the New HBH Speaker

A—Upright "H" Support
B—Front Cloth (thinnest linen).
C—Rounded Edges.

D—Rear Cloth (airplane cloth).
E—Apex.
F—Pole Unit.
G—10-Foot Cord.

H—Rigid De Luxe Frame, 24x24"
I—Splice Jointed Metal
J—Moulded Metal Bracket.

Strikingly Beautiful

THE mottled finish on the splice-jointed (not nailed) frame, in mellow tones, with conservative gold edging, plus the gracefully rounded corners, makes the speaker beautiful to behold. A thrown-together appearance characterized such speakers in the past, but here is one so different you'll be proud to exhibit. The woman of the house will appreciate its beauty, too.

The mechanical construction is perfect.

PARTS PRICE LIST

Cat. A No. 1. DLNB. Entirely complete kit for same speaker, with Polo Unit, dope, constructed de luxe frame, linen, etc. \$17.50
Cat. A No. 1. DLF. Built-up, high-grade, rounded de luxe frame, splice-jointed, not nailed; size 24x24 inches with moulding; also H-shaped upright support, splice-jointed; also hardware for attaching upright to frame. 5.50
Cat. A No. 5. Thinnest Irish linen for front diaphragm, 26x26 inches. 2.00
Cat. A No. 6. Airplane cloth 8x8 inches for rear piece.25
Cat. A No. 7. Polo Duo-Magnetic Unit, with factory-adjusted and sealed armature, apex, thumbscrew, chuck, nut, 10-foot cord, moulded mounting bracket. 10.00
Cat. A No. 9. One can finest "dope" (good for three thin coats). 1.25
Cat. A No. 10. Two cans "dope" (for five good coats). 2.00
Cat. A No. 11. Apex, chuck, thumbscrew, nut.25



LONGER LIFE
BETTER TONE
MORE VOLUME

A guarantee slip is contained in each carton. Fill this out and earn FREE tube insurance. Built to excel, KELLY TUBES open new vistas of radio reception.

401A	\$1.00
4X Special Detector	2.00
412A	2.00
471A	2.00
UX499	1.25
426AC	2.00
427AC	3.50
440 (high mu)	1.50
422 (screen grid)	3.50
480	3.50

422 SCREEN GRID

Our 422 stands up.

440 HIGH MU

great for resistance or Impedance audio

KELLY TUBE COMPANY

8718 Ridge Boulevard, Brooklyn, N. Y.

SUBSCRIBERS!

Look at the Expiration Date on Your Wrapper

Please look at the subscription date stamped on your last wrapper, and if that date indicates that your subscription is about to expire, please send remittance to cover your renewal.

In this way you will get your copies without interruption and keep your file complete.

SUBSCRIPTION DEPARTMENT

RADIO WORLD

145 WEST 45TH ST., N. Y. CITY

A few doors east of Broadway

PLUG AND CABLE for any SHORT WAVE ADAPTER

Handiest thing for ANY short-wave adapter. socket of any short-wave adapter you Put detector tube of your present set in build, put plug in detector socket of your broadcast receiver. Cable, 34". Leads identified both by color scheme and tags. 5-prong plug and 5-lead cable for AC short wave adapter. May be used as 5-lead battery cable plug with UY socket. (Cat. No. 21AC) \$1.50. 4-prong extra plug only, necessary addition to other for DC short-wave adapter (Cat. No. 21DC) \$0.50.

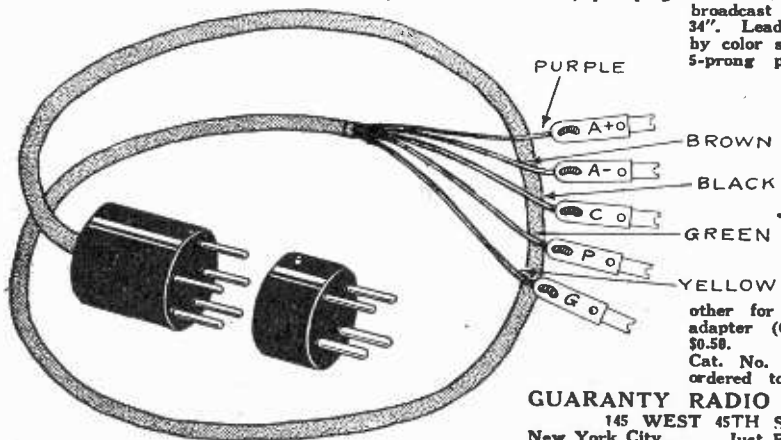

GUARANTY RADIO GOODS CO.
145 WEST 45TH STREET
New York City Just East of Broadway

Cat. No. 21AC and 21DC ordered together \$1.75.

BLUEPRINT FREE!

4-Tube Screen Grid Diamond of the Air Blueprint, full sized picture wiring diagram; also schematic diagram and panel layout.

At 15c per copy RADIO WORLD costs you 60c for four weeks. But if you send 50c NOW you get the first and only national radio weekly for four consecutive weeks and this handsome official blueprint FREE!

This blueprint is life-sized and shows in easy picture diagram form how to mount parts and wire this super-sensitive receiver. One screen grid tube is used as radio frequency amplifier. The rest of tubes are two-01A and one 112A.

This circuit gives you distance, tone quality, ease of performance. No shielding, no neutralizing required!

Radio World, 145 West 45th Street, New York City

Enclosed please find 50 cents (stamps, coin, check or money-order) for which send me RADIO WORLD for four weeks, and free Diamond S. G. blueprint.

Name

Address

City State.....

Renewal.

If you are already a mail subscriber for RADIO WORLD you may extend your subscription four weeks and get free blueprint, but put a cross in the square.

DYNAMIC BAFFLE

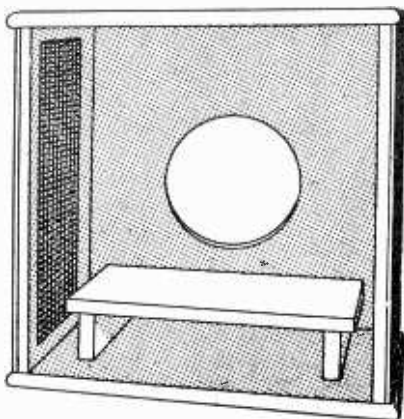

Completely built up, for any type dynamic chassis. State what make dynamic you want it for. One side, open back. Do luxe finish. Size, 24x24 inches..... **\$12.00**

GUARANTY RADIO GOODS CO.
145 West 45th Street, New York City

NEW LINEN DIAPHRAGM speaker, superior tone quality, no details as yet published in radio press, but to alert inquirers the whole absorbing story will be enfolded. Uses new super-sensitive unit, beautiful splice-jointed frame, 18x24", with decorative moulding; absolutely a wonderful speaker. Put together in ten minutes. Rich-looking job. Write for details. Guaranty Radio Goods Co., 145 West 45th Street, New York City.

Bakelite Front and Aluminum Subpanel

for the
4-Tube Screen Grid
Universal; also

\$5.00

DIAMOND OF THE AIR - -

Five-Day Money-Back Guaranty

Finest eye appeal results from construction of the 4-tube Screen Grid Diamond of the Air when you use the official panels. The front panel is bakelite, already drilled. The subpanel is aluminum, with sockets built-in, and is self-bracketing. Likewise it has holes drilled in it to introduce the wiring, so nearly all of it is concealed underneath set. Make your set look like a factory job.

Front panel alone, bakelite, drilled..... **\$2.35**
Aluminum subpanel alone, drilled, with sockets built-in..... **3.00**

GUARANTY RADIO GOODS CO.

145 WEST 45TH STREET

NEW YORK, N. Y.

YOU MUST GET THIS BOOK!

DRAKE'S RADIO CYCLOPEDIA (New Edition)

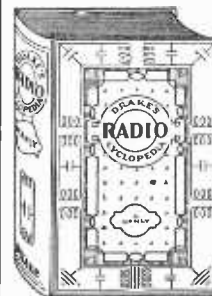

has been developed to answer the questions of service men, custom set builders and home constructors, students, salesmen and operators of receiving equipment and to allow all these to have instant access to the information they want. The author, Harold P. Manly, has collected and translated into plain English the material formerly obtainable only from dozens of scattered sources.

BOOK IS 2 1/2" THICK. WEIGHS 3 1/2 LBS., 1,025 ILLUSTRATIONS.

name under which the information might be classed.

This alphabetical arrangement lets the experienced worker refer directly to the one thing in which he is interested at the moment without hunting through non-essentials. The needs of the beginner are cared for.

The important articles deal primarily with receivers and reception. They do not stop with the electrical end, but go also into the mechanics of construction. Every new thing in radio is covered in detail.

1,680 Alphabetical Headings from A-battery to Zero Beat
1,025 Illustrations, Diagrams, Layouts and Graphs
920 Pages, Each 6 by 9 inches
240 Combinations for Receiver Layouts

OF THE PRINCIPAL ARTICLES

158 concern service men, 129 help the set builder, 162 help the experimenter, 155 interest the student, 75 assist in sales, 73 interest set owners.

Radio World: "The most suitable volume for those who want the facts as far as possible of intricacies. Useful to any library."

Radio Broadcast: "The reviewer does not believe that a more satisfactory addition to the experimenter's library in any one subject can be made."

QST: "The information is so put as to be of most immediate use to the constructor and repair man, and, remarkably enough, includes apparatus of most recent origin."

Radio: "Seldom is a subject so comprehensively and practically explained."

GUARANTY RADIO GOODS CO.,
145 W. 45th St., New York, N. Y. (Just E. of B'way)
Gentlemen: Please mail me at once the new (second) edition of Drake's Radio Encyclopedia," by Harold P. Manly, just published, with all the latest technical information it contains. I will pay the postman \$6.00 plus a few cents extra for postage. If I am not delighted, I may return the book in five days and you will promptly refund my purchase money.

Name

Address

City State.....

5-DAY MONEY-BACK GUARANTY!

AC DYNAMIC CHASSIS

110 volt 50-60 Cycle Model, with Built-in Rectifier and Output Transformer

\$23.52

YOU simply must get a dynamic speaker. There's nothing more important to your radio installation. Everybody's getting one. Why deny yourself the advantages of most superior tone realism? Your set can't over-tax a dynamic speaker. You can't buy anything at anywhere near our prices that will give you such satisfaction.

All you need is the chassis. It plays splendidly just as it is. You may put it in a baffle box, or in a cabinet, if you like.

If your home is wired for electricity of the alternating current type, 110 volts, 50 to 60 cycles, then get the AC model at \$23.52. It has a plugged cord for connection to the lamp socket or convenience outlet. The two extra leads, with tips on, go to the output posts of your receiver—the speaker posts.

The AC model has a built-in rectifier that changes the AC (alternating current) to DC (direct current) and filters it. The rectifier is

shown at right in the illustration. Also there is a built-in output transformer, (at left in illustration). Your receiver therefore needs no output transformer—there is one in the dynamic chassis.

For best results use as the output tube of your receiver any of the following power tubes—120, 171, 171A, 210, 250, or two in push-pull. If your set has a 112 power tube put in a 171 and increase the negative grid bias. If your set has a 112A or a 201A for the output tube, put in a 171A and increase the negative grid bias. No other changes are necessary.

Remember that the dynamic is this year's supreme contribution to radio, and you must share in this fine advantage to enjoy the best and be thoroughly up-to-date.

6-VOLT MODEL

If you have a 6-volt storage battery to heat the filaments of your tubes you may use the 6-volt model dynamic chassis with equal results. The current drain is low. But if you have AC house supply of electricity, even if you use a storage battery, the AC model dynamic chassis is recommended, because if you decide at any time to have an AC set you'd have to retain the storage battery just to run the 6-volt model. If you have no electricity in your home, then you must use the 6-volt model. It looks exactly like the other model, except that the rectifier is omitted as unnecessary. The current used is already direct. The output transformer is built-in, however. Both models perform alike.

\$17.64

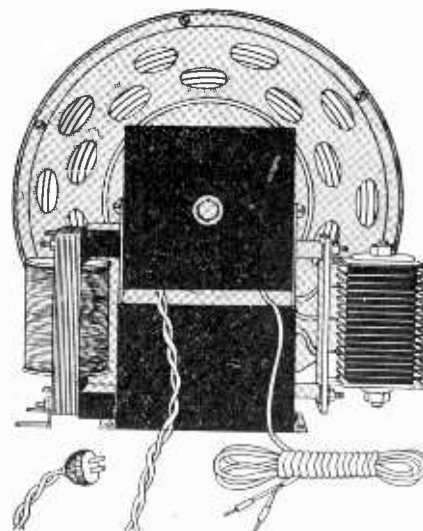

The AC model, 110 volts, 50 to 60 cycles, is illustrated. It has built-in rectifier and filter and built-in output transformer. Price, \$23.52

Acoustical Engineering Associates,
143 West 45th Street, N. Y. City
(Just East of Broadway)

Please ship C.O.D. at once.
 One 110 volt, 50-60 cycle AC Model dynamic speaker chassis at \$23.52, plus cartage cost.
 One 6-volt Model dynamic speaker chassis at \$17.64, plus cartage cost.

Name

City..... State.....

Address

HOW TO USE SCREEN GRID COILS

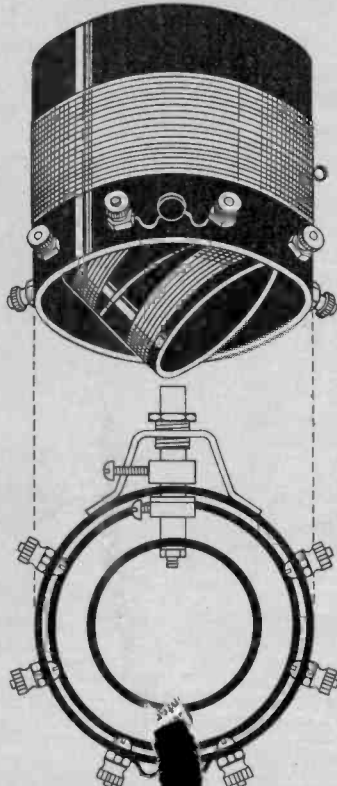

Model 5HT. High impedance 3-circuit tuner, to work with screen grid RF tube. For .0005 mfd.\$3.00
Model 3HT. Same as above, but for .00035\$3.25

WHEN a screen grid tube is used as a radio frequency amplifier, the maximum gain, the best amplification, the most volume and the most DX are obtained by tuning the plate circuit. Then this enormous amplification is itself doubled by providing a secondary with twice as many turns as the primary has. The secondary is not tuned. The high impedance 3-circuit tuner at left (Model 5HT) is an example, as is the two-winding coil (Model 5TP) at lower left. The primary in these two instances is the outside winding and the tuning condenser goes across it. The secondary is wound on a separate form that is riveted inside the primary form. Preferably mount coils with binding posts at bottom for short leads. Then the connections for Models 5HT, 3HT, 5TP and 3TP are, from right to left as you look at the back of the coil: B+135, near front panel; plate of screen grid tube; two rotary leads (for tuner only); grid and (next to panel) grid return.

The antenna coil to use in screen grid circuits is 5A or 3A (upper right), because it is so designed as to equalize tuning. The low, almost zero, capacity between grid and filament of the tube is compensated by extra turns of wire, so that if the tube following the screen grid is of another type, for instance a regular detector, the elemental capacity difference is nullified. The antenna coupler has a continuous winding in shaded colors. The end with the larger number of distinctive turns goes to grid, the opposite end to ground. Either of the two remaining binding posts goes to antenna.

For single control screen grid sets the inductive trimmer type of antenna coupler (Model 5AS or 3AS, at right) should be used. The inductive trimmer coil for interstage coupling is Model 5TPS or 3TPS (not illustrated), but its connections are shown in the diagram at lower right. An inductive trimmer adds to or subtracts from the reactance, which is very important for resonance in single control sets. Trimming condensers only increase reactance, hence fail where decrease is needed.

Model 5TPS Interstage coupler to screen grid tubes, with inductive trimmer. For .0005 mfd.\$2.25
Model 3TPS, same as above, except it is for .00035.....\$2.50

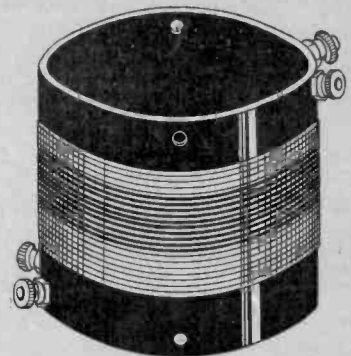

Model 5A. Conductively coupled antenna coil for input to screen grid radio frequency amplifier. For .0005 mfd. condenser. Price\$1.75
Model 3A. Same as above, but for .00035\$2.00

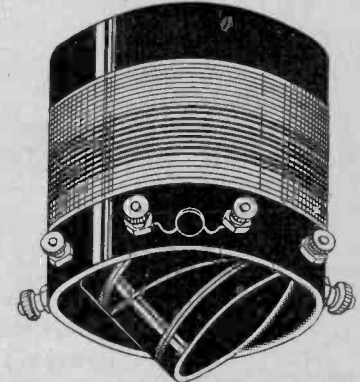

Model 5AS. Conductively coupled antenna coil for single tuning control screen grid sets. Rotor is an inductive trimmer. For .0005 mfd.\$2.75
Model 3AS. same as above, but for .00035\$3.00

ALL ROTOR COILS HAVE SINGLE HOLE PANEL MOUNTING FIXTURE

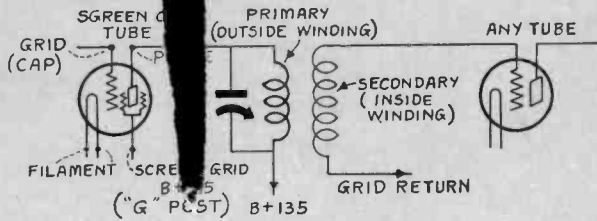

How tuned primary in plate circuit is wired for a screen grid tube. This illustrates the use of Model 5TP or 3TP, also Model 5HT and 3HT, except for the rotor coil connections.

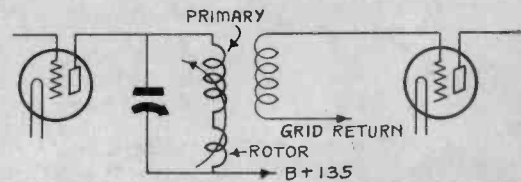

In single control circuits Model 5TPS is used as shown, for interstage coupling. The rotor is an inductive trimmer. The tube at left is a screen grid.

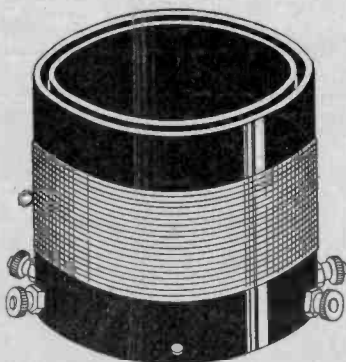

Model 5TP, the wiring of which is shown in the diagram directly above, is an interstage coupler for screen grid tubes. For .0005 mfd.\$2.00
Model 3TP. Same as above, but for .00035\$2.25

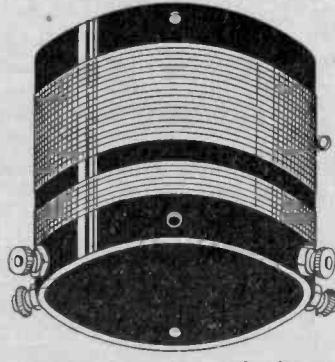

Model R5. Interstage coupler for replacing present coil in existing receiver when screen grid tube is substituted. For .0005\$1.50
Model R3. Same as above, but for .00035\$1.75

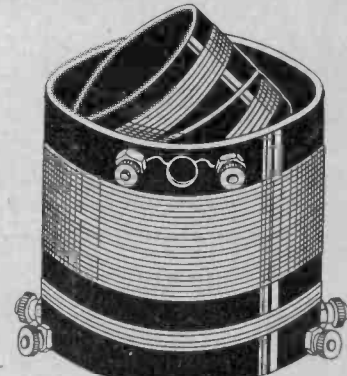

Model T5, standard 3-circuit tuner, not for screen grid tubes, but for all others. For .0005\$2.50
Model T3, same, but for .00035. \$2.75

Coils for Other Than Screen Grid Tubes

When any tubes other than screen grid tubes are used as radio frequency amplifiers, standard coils are used, for instance Models T5 and T3, the three-circuit tuner shown above at right.

For the antenna coil in such a circuit use one with two separate windings, the familiar radio frequency transformer, with about 14 turns on the primary. This RF transformer is therefore used as antenna coil and as an interstage coil. The resultant loose coupling of antenna reduces the capacity effect of the antenna and thus the standard TRF coils, with 201A, 112A, 226, 227, 199 or 240 tubes, providing the same RF tubes are used throughout, may be used in single control sets without trimming devices. This is true if the coils are absolutely matched, as Models RF5 and RF3 are.

The small winding (primary) is connected in the antenna-ground circuit, or, for interstage coupling, in the plate circuit. The large winding (secondary) is tuned and is put in the grid circuit.

Model RF5. Antenna coil or interstage coupler for any and all tubes. excepting only screen grid tubes. For .0005\$1.00
Model RF3, same as above, but for .00035\$1.25
Model T5, standard 3-circuit tuner for .0005\$2.25
Model T3, standard 3-circuit tuner for .00035\$2.50

USE THIS COUPON

Screen Grid Coil Co., 143 W. 45th St., N. Y. C. (Just East of Broadway)

(Specify Quantity in the Squares)

Please mail me at once your following coils, for which I will pay postman the advertised prices, plus a few cents extra for postage.

Model..... Model..... Model..... Model..... Model.....

Name

Address

City State

SEND NO MONEY!