

RADIO WORLD

REG. U.S. PAT. OFF.

America's First and Only National Radio Weekly

New Notions on Audio

♦ ♦ ♦ ♦

The Phonograph Pickup

♦ ♦ ♦ ♦

Machine Counts Megacycles

♦ ♦ ♦ ♦

Drum Control Powertone

AUGUST 20

1927

Vol. XI, No. 22. Whole No. 282

15 CENTS

HERE YOU SEE "THE FOUR AC"

No Batteries at All—AC Tubes Employed—

New Victoreen Audio

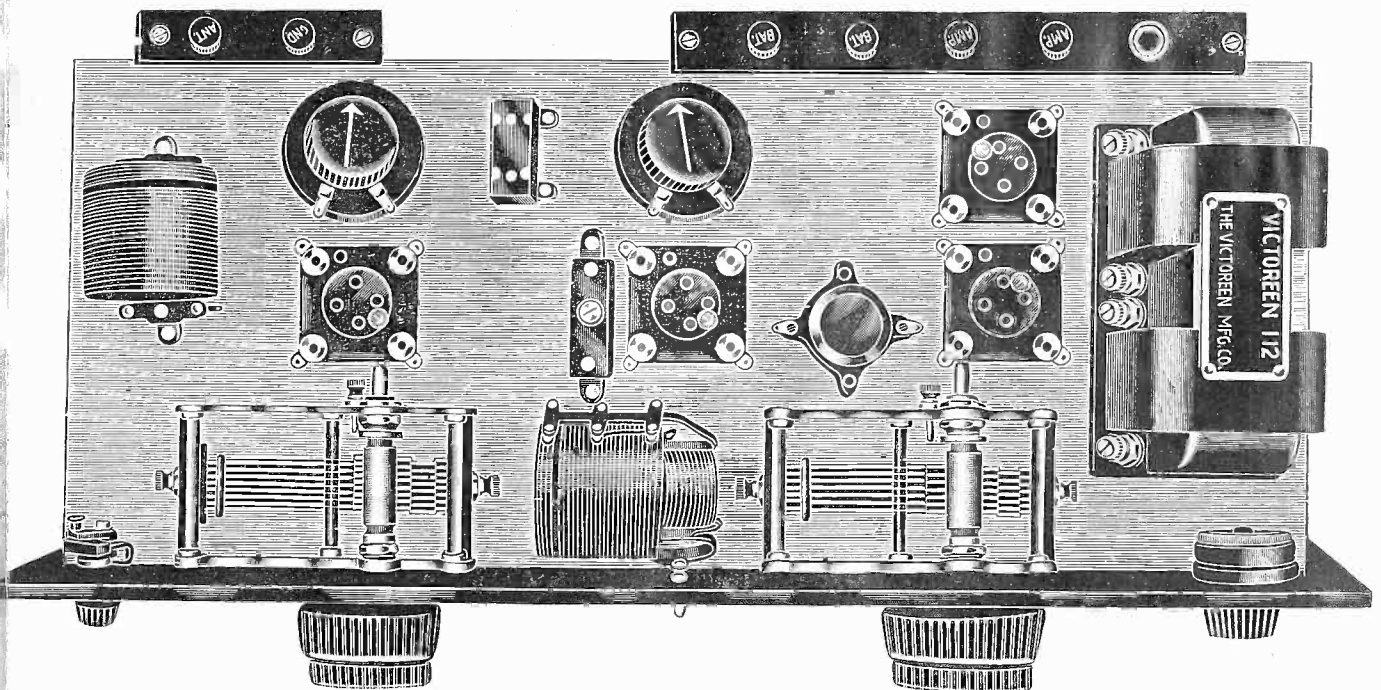

A Thing of Beauty, Besides an Efficient Set, is the
Four AC, which operates without batteries.



TELEVISION

Picture Transmission—the Marvel of the Century

Newest and greatest authority, just published, gives History, facts and complete instruction to build a home television set

THE marvel of Radio Broadcasting, the transmission of the voice and music over the air is no longer the greatest achievement of this precocious 20th century.

We now have TELEVISION—the transmission of events over land wires or by radio. A tremendous step ahead of even Radio.

For many years experiments on television have been diligently made by many famous inventors and engineers. Step by step machines have been corrected, improved and simplified—until today—practical machines

are in constant operation, annihilating distances in picturing events to the eager public.

Here is the first and only book in print that gives you the complete story of television from earliest experiments to the present day machines.

The book is the most complete publication of its kind. It gives you the history, the facts and the full instructions on how to build, in your own home, an up-to-date model Television apparatus.



Like Radio in 1921

Television is ready for the world. Like Radio in 1921, it waits only for you experimenters to invent, develop and perfect the apparatus. You may be fortunate enough to develop an idea that will be worth many dollars—start now with a copy of this book.

Great Future for practical Experimenters

Television will be as popular as Radio. Even now the public is showing great interest in telephoto pictures from Europe and elsewhere. Get your apparatus together. You are in for many days of fascinating experiments that beat anything you've ever tried. 4 special chapters in this book deal exclusively with how to construct an experimental set.

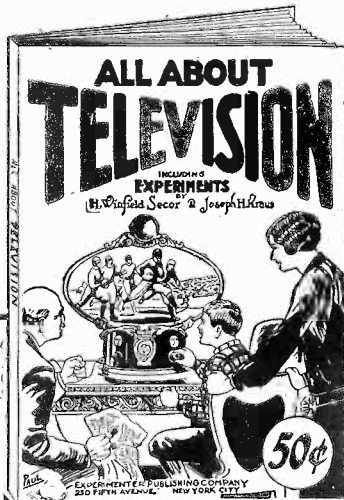

**COPIES 50¢ EACH
AT ALL
NEWSSTANDS**

If Your Newsdealer Cannot Supply You—Order Direct
EXPERIMENTER PUBLISHING CO.
230 Fifth Ave., New York, N.Y.

1000 Hours of Fun with SAM LOYD

THERE are more than one thousand hours of truly amazing fun and frolic—in Sam Loyd's "Tricks and Puzzles." There is only one Sam Loyd, the Puzzle King, the incomparable, a true master mind, and he has crowded in this new volume, "Tricks and Puzzles," the best work of his lifetime.

In this book are thousands of puzzles of every conceivable nature, games, tricks, conundrums. Hundreds of illustrations. Scores of real brain-teasing puzzle stories, dozens of humorous anecdotes.

With this inexhaustible gold mine of lively entertainment at hand you need never be at loss for an evening's party program or a rainy day's delight.

It's a book for young and old folks alike—Riddles for the youngsters—Brain teasers for the grown-ups.

The kind of a book every home should have in its book-rack. 116 pages, 100 or more illustrations, large size, 9 x 12 inches with beautiful 2-color cover.

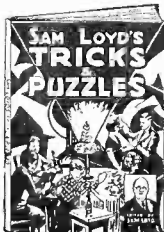

50c THE COPY EVERYWHERE

or you can order direct

EXPERIMENTER PUBLISHING CO., Inc.
230 Fifth Ave. New York, N. Y.

SECRETS of your HANDS

96 page Book on the revelation of character, fortune, etc.--in Hands

FINGERPRINTS are used throughout the world as a means of apprehending criminals—but fingerprints are but a small portion of the secrets of your character that your fingers, your palm, even your handshake reveals.

Every inch of your hand has been charted by the experts of this highly developed science, and so simply and accurately that anyone can learn the telltale signs by heart.

Here is a brand new book with all the latest information—written in such a way that you can quickly master "Palmistry."

Everything is simplified, easy to understand, the book contains 96 pages, hundreds of illustrations and is the large size 9x12 inches.

50c THE COPY EVERYWHERE

or you can order direct

EXPERIMENTER PUBLISHING CO., Inc.
230 Fifth Ave., New York, N. Y.

RADIO WORLD

REG. U.S. PAT. OFF.

Vol. XI
No. 22Whole No. 282
August 20, 1927

15c per Copy. \$6.00 per Year

A Weekly Paper Published by Hen-
nessy Radio Publications Corporation
from Publication Office, 145 W. 45th
Street, New York, N. Y.

Phones: BRyant 0558 and 0559

[Entered as second-class matter, March, 1922, at the post office at New York, N. Y., under Act of March, 1879]

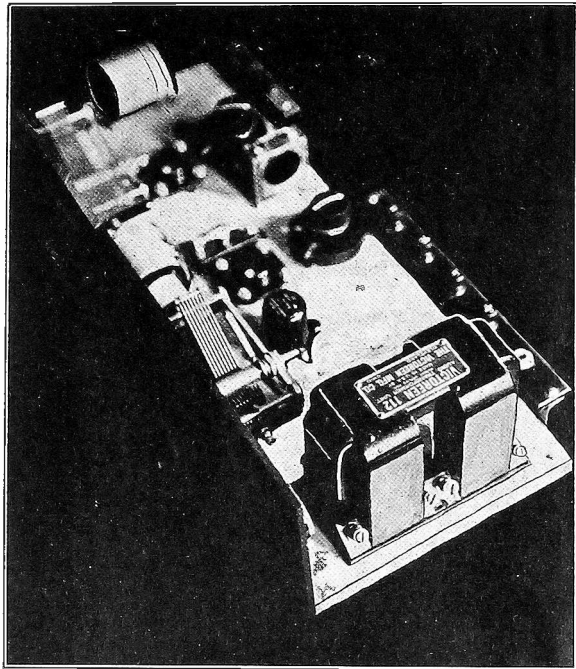

A STUDY IN HIGHLIGHTS

THE AC RECEIVER in shadowland with the Victoreen audio unit in front position (Fig. 2).

The Four AC

A Batteryless Set
Using the AC Tubes for RF
and Detection and Two 112s
for the New Victoreen Audio

A SET to be PROUD OF

By *Herbert E. Hayden*

Photographs by the Author

A CERTAIN peace of mind comes to the radio fan who installs a completely electrified receiver. He does not worry about the possible exhaustion of the A battery during an interesting program, because the filaments are all heated with AC. He does not worry about the exhaustion of the B battery because the B eliminator keeps the voltage up to optimum value all the time. He does not worry about replacing his C batteries, because there are none in his set and the grid bias voltage are obtained from voltage drops in resistances strategically placed in the set. He turns his switch and he knows that his set will work, barring a breakdown of the power plant, the transmitting station, or an SOS.

Four tubes of three different types are used in this receiver. The first is an AC tube requiring 1.5 volts on the filament, the second is a special 5-element detector tube requiring $2\frac{1}{2}$ volts on the filament, and the two audio tubes of the 112 type which require 5 volts on the filaments.

The filament power for all the tubes is obtained from three separate windings on the power transformer. One of these supplies the first tube with 1.05 amperes at 1.5 volts, the second supplies the detector with $1\frac{3}{4}$ amperes at $2\frac{1}{2}$ volts, and the third supplies the two audio tubes with a total of one ampere at 5 volts.

Grid Returns

As a means of eliminating hum the grid return of the RF tube must be made to the midpoint of the filament winding. It is not practical in this case to bring a tap out from the apparent mid-point, as this

would not be accurate enough. It is necessary to employ a potentiometer across the secondary winding and then return the grid to the slider. This can then be set experimentally at the point which gives no hum. A somewhat similar arrangement is necessary for the detector tube, although the grid in this case returns to the 5th element, or cathode. The connection to the slider of the potentiometer is necessary in order to complete the plate circuit. The midpoint of the potentiometer should be located experimentally very carefully for minimum hum.

The coupling between the two audio amplifiers is by means of a 112 double Victoreen transformer unit. This unit has an even amplification from about 16 cycles to 5,000 cycles, and it is effective as low as 5 cycles per second and as high as 10,000 cycles. It gradually falls off in

amplification at the higher frequencies to compensate for the rising characteristic of most loudspeakers at the high notes. The uniformity of the amplification at the lower end of the scale can be seen from the characteristic curve. See page 10.

A feature of this transformer unit is that it is able to handle the load without introducing wave form distortion. This means that the core area is so large that magnetic saturation of the core does not take place for any values which the primary current is likely to take.

Point Often Slighted

This is a feature often overlooked, or if considered is often dismissed by the statement that the primary current never becomes high enough in practice to cause saturation. That may be true at the higher frequencies, where only a small signal amplitude is ever encountered, but

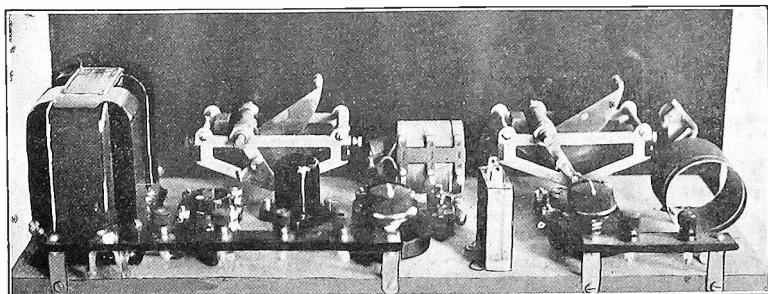

FROM the back this is what you see. (Fig. 3)

LIST OF PARTS

(Receiver)

V,V—One Victoreen 112 audio transformer unit.
 C1,C2—Two Karas .0005 mfd. Orthometric condensers.
 C3—One XL variometer (type G, .0001 to .0005 mfd.)
 C4—One Electrad 1 mfd. by-pass condenser.
 P1,P2—Two 200-ohm potentiometers.
 P3—One Frost 500,000-ohm potentiometer.
 Ch—One General Radio 65 millihenry choke coil.
 OPJ—One output jack.
 L1L2—One Genwin radio frequency transformer.
 L2L4L5—One Genwin three circuit tuner.

Two Karas Micrometric dials.
 Three Benjamin sockets.
 One UY227 five-prong Benjamin socket.
 One tickler knob.
 One snap switch, 110-volt rating.
 Six binding posts.
 One Micarta panel 7x21 inches.
 One wooden baseboard 7x20 inches.
 Two hard rubber strips for binding posts ($\frac{3}{4}$ x2 $\frac{1}{2}$ inches and $\frac{3}{4}$ x 10 inches).

(A Power and Grid Bias)

PT—One National power transformer for AC tubes.
 R1,R2—Two 2,000-ohm Frost resistors.
 R3—One Centralab 10,000-ohm heavy duty variable resistor.

(Accessories)

One battery eliminator, 200 volts.
 One UX-226 or CX-326 amplifier tube.
 One UY-227 or CY-327 detector tube.
 Two UX or CX 112 tubes.
 One lb. of No. 18 wire for wiring the filament leads of the set for AC.
 One cabinet.

may not be so at the low frequencies where a very great amplitude is necessary to give loud response.

Many transformers previously deemed adequate in respect to core area did not amplify the low notes and saturation was not encountered for that reason. But such transformers were not capable of the best quality.

The use of transformers capable of amplifying the low notes as they should be amplified demands that power tubes be used in the amplifier, not only in the output stage but also in the stage preceding. There would be no point in using transformers of adequate dimensions to prevent wave form distortion and then use small tubes which would introduce it.

Of great importance in a quality circuit is to have a volume control by means of which the signal level can be kept within desired limits. This control must not be such as to affect the plate and grid potentials or currents. This condition is so broad that it leaves only one method of control and that is a high resistance potentiometer across the secondary of the first section of the audio transformer unit. The manner in which it is connected is shown at P3 in Fig. 4.

Uses a B Eliminator

Since this set is AC operated, a B battery eliminator should be used. This is not shown in the drawing but it should be connected to the B terminals as shown.

The grid bias for the radio frequency amplifier is obtained from the voltage drop in resistor R1 placed in series with the lead to the slider of the potentiometer P1. This resistance should be 2,000 ohms when the applied voltage at the plate is 90 volts. The grid bias on the detector is negative in respect to the cathode unless

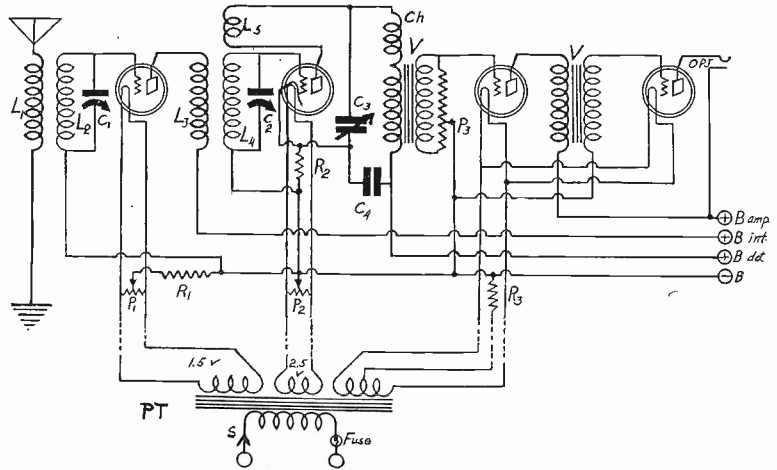

THE DIAGRAM (Fig. 4) of the Four AC Set

one desires to try the leaky condenser method of detection.

The grid bias on the two audio amplifiers is obtained from the resistance R3 connected between the midtap on the 5 volt winding and the grid return. The value of R3 with 160 volts on the plates of the tubes should be 2,000 ohms. Note that the plate voltages on the two tubes should be the same and the tubes should be of the same type. It is desirable to have R3 variable so that adjustments can be made for different plate voltages. An instrument which is variable between zero and 5,000 ohms is suitable. It is not necessary to use a potentiometer across the filaments of the last two tubes in order to eliminate hum. The midtap on the winding serves excellently.

A radio frequency transformer and a three-circuit tuner made to match .0005 mfd. condensers are used in the circuit.

A General Radio choke coil Ch of 65 millihenrys is connected in series with the tickler and the primary of the first audio transformer to stop radio frequency currents from entering the transformer. A by-pass condenser C3 is connected as shown to provide a more direct path for the RF currents back to the cathode.

The Dotted Lines

C4 is a condenser of 1 mfd. connected between the B plus detector binding post and the cathode element for the purpose of keeping radio frequency currents out of the eliminator.

It will be observed that some of the leads in the circuit are dotted. This indicates a separation between the set proper and the transformer which supplies the filament power. The transformer can be placed under the set in the same cabinet, provided a metal shield, preferably iron, is placed between the set and the transformer. This shield should be grounded or it should be connected to the B minus bus bar.

The arrangement of the parts in the receiver can be seen from the photographs of the set. In Fig. 3 we have a back view of the set showing the disposition of the RF transformer at the right,

the three circuit tuner in the middle and the two-stage Victoreen audio assembly at the left. The two Karas condensers can be seen on the panel. The General Radio choke coil is in front of the left condenser. Condenser C5 can be seen in the foreground toward the right. The various binding posts are distributed along the edge of the baseboard and are mounted on strips raised above the board. The positions of the two potentiometers P1 and P2 can also be seen in Fig. 3.

Fig. 2 gives another view of the set looking from the audio transformer end.

Fig. 5 shows the panel view of the receiver. The two Karas Micrometric dials are most prominent. The volume control potentiometer can be seen at the right, and is immediately in front of the audio amplifier. In the middle of the panel between the two dials the tickler knob can be seen. At the left is a filament switch. This is not used for turning on and off the filament current alone but for turning on or off all the power. This should include the eliminator as well as the filament transformers. A 110 volt switch should be used, not just any ordinary switch.

Use Heavy Filament Wire

The use of the proper size wire in the AC operated set is of importance. The filament currents are large requiring heavy wire to carry them. The first tube in the receiver requires a current of 1.05 ampere and the filament leads from the transformer to the filament should not be of smaller wire than No. 20. No. 18 would be preferable. The detector draws $1\frac{3}{4}$ amperes. No. 18 will carry this current safely but a greater margin of safety will be obtained with No. 16 wire. The two 112 tubes in parallel draw a current of one ampere. No. 20 or No. 18 wire should be used. In any of these cases it will do no harm to use very much heavier wire than the sizes specified. For example, No. 12 can be used if desired, and this wire will safely carry up to 20 amperes.

[Other illustration on front cover]

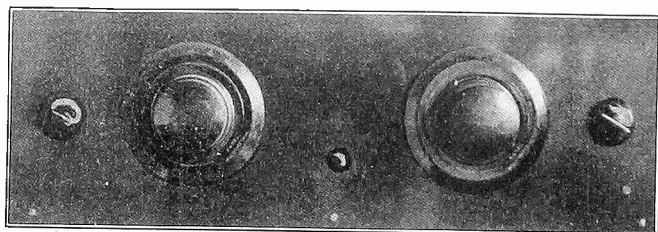

THE PANEL VIEW (Fig. 5).

New Notions on Audio

Two 112 Tubes in Line Give Volume with Quality

By Capt. Peter V. O'Rourke

SOME radio engineers of standing maintain that it is necessary in the interest of undefiled output to have a semi-power tube ahead of the final tube in the receiver, particularly when the last tube is a -71, a -10 or a still larger tube. They usually recommend that this tube be a 112. Other engineers of equally good standing maintain that it is entirely useless to employ a large tube to feed the final power tube. They say that a little -99 type tube is large enough to overload a -71 or a -10 before it becomes itself overloaded. Can both of these groups be right or is one of them barking up the wrong tree?

Not so long ago the engineers of the General Electric Company published a paper on the performance characteristics of various types of tubes in common use. It was shown in this paper that the maximum undistorted output from a tube could be had when the load resistance was twice as great as the internal AC resistance of the tube. The value of the maximum undistorted output was given in watts for the different tubes for various plate and grid voltages. For example, it was shown that the maximum undistorted output of a UX-199 tube with 90 volts on the plate and $4\frac{1}{2}$ volts on the grid, is 7 milliwatts.

A Porous Argument

This tube has an amplification constant of 6.5. Suppose this tube be used to feed a -71 output tube, and that a transformer having a ratio of 4-to-1 be used between the two. Now some of those who ridicule the idea of using a semi-power tube to feed the last tube argue in this fashion. The ratio of the transformer is 4-to-1 and the amplification constant of the -99 tube is 6.5. Hence the secondary voltage in the transformer is 26 volts for every volt impressed on the grid of the -99 tube.

Now, according to the data given out by the manufacturers of that tube, the maximum input voltage allowable on the -99 is $4\frac{1}{2}$ volts. Then the maximum undistorted voltage in the secondary of the transformer when the -99 tube is worked to capacity is $26 \times 4\frac{1}{2}$ or 117 peak volts. The -71 power tube can only stand a maximum of $40\frac{1}{2}$ volts input peak voltage. Thus the little -99 tube will deliver to the final tube an undistorted voltage which is three times as great as what last tube will stand.

Question of Allowable Distortion

The argument which leads to that result is as full of holes as a sieve. In the first place the 4-to-1 transformer does not deliver 26 volts for every volt impressed on the grid of the -99 tube preceding it. Suppose that the transformer is a fairly good one, that is, one which has a high inductance primary at low frequencies. We might assume that the primary impedance of the transformer is equal to

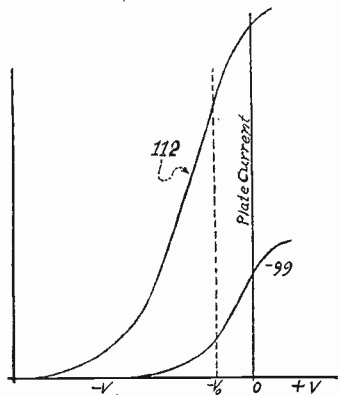

CURVES showing the relative performance of -99 and 112 type of tube. The curve for the 112 is steeper than that for the -99, showing that the amplification constant for the 112 is greater. The straight portion of the curve for the 112 is longer, showing that it can take a greater voltage swing before appreciable distortion enters into the signal.

the output impedance of the -99 tube at 50 cycles per second.

In that case the effective step-up of the tube and transformer will not be 6.5×4 , but it will only be half of that. Hence the maximum undistorted voltage delivered to the power tube will not be 117 but just half of it. But even 58.5 volts is more than the -71 will take.

It would seem that the -99 protagonists can concede that point without greatly endangering their cause.

The semi-power tube adherents will counter by saying that there should be a greater margin of safety and that the assumed conditions were optimum. That is, in many cases available voltage across the secondary will not be nearly 58 volts under the conditions assumed, particularly on the lower frequencies.

But the -99 tube protagonists take the expression "maximum undistorted output" at face value. There is where they err. They forget that in the very paper from which they got the idea, considerable distortion has been admitted. That is, the so-called "maximum undistorted output" contains from 5% to 15% of second harmonic, and a goodly percentage of other harmonics.

The expression "maximum undistorted output" means the maximum output that can be obtained from the tube with the percent second harmonic less than a specified value. In some cases the maximum allowable second harmonic was as high as 15% of the fundamental. The -99 tube protagonists entirely overlook this fact and assume no distortion after

such a high percentage of second harmonic has been admitted. They confuse distortion-free output in fact with distortion-free by tolerance.

Actual Practice Ignored

The rule which gave a maximum input voltage swing of $4\frac{1}{2}$ volts for maximum undistorted output in the -99 tube applies to the case when that tube is delivering power into a pure resistance, not necessarily when the tube is functioning as a voltage amplifier. If the inductance of the primary of the coupling transformer is high so that the impedance in the load of the tube at very low frequencies is high compared with the internal resistance of the tube, then the grid voltage can have a maximum value of $4\frac{1}{2}$, and yet there will be very little distortion and the step-up will be higher than the 58.5 volts stated above.

But where can a transformer of such specifications be obtained?

There are many good transformers available but all of them have comparatively low impedances on the lower frequencies, and even if they are suitable for use with a tube which has a low output impedance, they are not suitable for use with a tube which has as high an output impedance as a -99 type.

The amount of distortion introduced into the signal by any amplifier tube depends on the relative voltage swing for that tube. A swing of one volt for a -99 tube will be about three times as great relatively as a one volt swing for a 112. The amount of second harmonic will vary as the square of the voltage swing. Hence, the amount of distortion introduced by the -99 will be about nine times as great as the amount introduced by the 112 tube when the input voltage is the same.

Smaller Input Suffices

But that is not all. The amplification constant of the 112 tube is greater than that for the -99. The ratio is 8 to 6.5. Hence for equal output, or for equal voltage across the secondary of the transformer, the input to the 112 need not be as great as the input to the -99 tube. In fact a voltage of .8 volt will give the same output with the 112 as one volt the -99 tube.

Again, the transfer of voltage from the tube to the transformer for any given transformer will be better with the 112 than with the -99 tube.

Taking all into consideration, it is safe to estimate that the distortion will be twenty times greater with a -99 than with a 112 when the voltage across the transformer secondary is $40\frac{1}{2}$ volts.

Those who favor the use of two 112 tubes for the audio channel or a 112 tube preceding a -71 power tube, certainly have a stronger argument than those who favor the -99 tube. It is a case of quality against economy.

Saintly Patience Wins

Success for the Hard-Driven Service Man

By Jasmine Bibble

A THOROUGH knowledge of radio principles is not the only essential requirement of the service man. Indeed not, for he must also be a philosopher, a statesman and educator and an ace-high salesman. However, only with the aid of few practical cases, can this fact be appreciated.

A certain party had purchased a standard five-tube receiver for use with batteries and outdoor antenna. When the set was installed it worked remarkably well. Months passed with the set working well. The owner now noticed that the signals were very much weaker than previously. He looked over the batteries, the tubes and the set and found everything to be all right. He was baffled as to the sudden cause of the inefficiency. After his own personal inspection, which was not a very thorough one, he phoned the owner of the store, from whom the set was purchased and explained the trouble. The store owner replied that he would send up his installation man. I received the assignment.

The trip was a long one and finally after three hours of riding, I arrived.

"What's the trouble, old man?" I queried.

"Oh gosh, I don't know. The set was working great until last week, but it seems to have lost its kick. I looked everything over, the batteries, the tubes and the set, but I'll be darned if I can find anything wrong with it," he replied.

"Do you think there could be anything wrong with the antenna?" I asked.

"Well, I don't know, it looks all right from here," he replied. "I didn't look up there."

We both looked up at the leadin which seemed to be all right, but I was a bit doubtful though. So up to the roof I went, and sure enough, the antenna wire had snapped near the leadin. The insulation covering camouflaged the break. It was soon repaired. The set was then turned on and the signals again rolled back with the old-time pep.

"That service will cost you \$5.00, old chap," I stated.

Service Cost Argument

"What? Why, that's outrageous! When I bought this machine, your boss told me that the service was free," angrily ejaculated the set owner.

"But my dear sir, the set was all right, and that was all that was to be serviced free. The leadin wire, you must remember was broken. How it broke, I cannot say. It was probably an accident, and may have been caused by a heavy wind, or someone leaning up against it."

"Hm—well, that sounds reasonable enough. I guess you are right. Oh, well you know how peeved one becomes. I work hard all day long and just don't get free to give out such money."

"We all work hard, old man. If it were not for these little difficulties occurring, I wouldn't have a job."

He then reluctantly drew out the five dollars from his wallet and handed it to me.

Such simple cases as the above are welcomed by service men. The next is typical of the cases which tries the patience of the service man to the limit.

A More Difficult Case

A set had been purchased by a young couple. The woman was a radio fan as

well as her husband, but she considered the beauty of cabinet as much as the tone quality, the selectivity and the sensitivity. The husband didn't have very much to say in the matter except to pay the bill. And so, she picked out a super-sensitive receiver built in a very handsome cabinet. The receiver pleased her and so it was bought. Oh, yes, it used a loop antenna.

"When would you like to have the installation engineer call and install the set, madam?" my employer asked.

"Why, tomorrow morning. I am going to give a house warming and of course want to use the set to furnish the music."

And the next morning, I went up with the set.

"Good morning. I have come to install the radio, which you purchased last evening."

"Oh, yes, come right in."

"Thank you. Where do you wish to place the set?"

"In the living room," she replied.

Installation of the Set

The room was quite a large one. The hooking up of the set was very simple. The operations were soon complete and the set was turned on. Being very skeptical, I always make it a point to listen to the signals on the phones, before connecting the speaker. The results were satisfactory to me and therefore put the speaker plug in the jack.

"Oh, my goodness," she cried, "that is awful. Why that doesn't sound anything like the set I listened to in the store."

"It's the same set, madam," I explained.

"Oh, that will never do. My goodness, no! Why, that music sounds as if it were hashed up," she replied angrily.

I could see no reason for her statement. However, I thought that if I tried switching the speaker about, she would be pleased. But all I heard was, "That will never do."

I sat there for two hours, making attempts to please her by tuning in different types of programs, but all in vain.

She would listen to none of my arguments, and demanded that the set be taken back. I told her that that would not be possible at the present moment, as I had several other calls to make, but would gladly call the next morning. To this, she agreed. I hastened back to the store and told the owner about it. He asked me what could be done. "Nothing," I said, since the set was O. K.

Her husband called at the store the same evening.

"Good evening," said my employer. "How do you like the set?"

"I think it's great. My wife is not so tickled with it, though," he remarked. "Why, I cannot say."

"Yes," replied the boss, "my installation man said the set worked beautifully, but for some reason or other, your wife did not think so. As a matter of fact, he was going to call tomorrow and replace it with another type."

"What? Say that set remains in my house if I have to get a divorce," he replied to my employer's delight.

"Well, what would you suggest doing?" I inquired.

"Just call every other day, listen to the set and remark how good the reproduction is," he replied. "I think she needs some one to convince her that the set is good.

She will not listen to me, not in this case at least."

Couldn't Be Convinced

After repeated calls she still insisted that we had faked her into a duplicate set, remarking that her husband did not know what he was talking about. Well, to satisfy her, we brought in another set, leaving the one she had in the house. But it still didn't sound well to her. Her husband was still pleased. I did not give up hope though, because I learned that she liked sopranos and other high pitched notes.

"Here's where I play my trump card," I thought to myself.

Across the output of the receiver was a .001 mfd. fixed condenser. This in conjunction with a cone speaker allowed greater response on the low notes than on the high. It was the high notes which she had heard in the set in the store and which had pleased her. On questioning the store inspectors, I learned that the fixed condenser across the output had not been in the demonstration set in the store at the time that she had heard it.

"There is the whole thing in a nutshell," I told my employer. "I am going to take another set up to her house without one of those condensers, and then we shall see what happens."

My employer was agreeable to anything that would satisfy the customer. Hence, I took another set to the house and connected it up. What a difference in the woman's facial expression! Her face was wreathed in smiles.

"Well, well, that is wonderful," she happily exclaimed. "That is what I call true reproduction."

"Thank God, for that!" I mumbled to myself.

Greatly relieved at the successful solution to the problem, I picked up my tools and returned to the store.

"It worked; it worked!" I shouted to my boss, on my arrival in the store.

India Joins Fold with Native Talent

Washington.

Using domestic talent exclusively because it is not deemed feasible as yet to begin the rebroadcasting of programs from England, the Indian Broadcasting Company is making every effort to establish radio broadcasting on a firm footing in India, according to a report to the Department of Commerce by the American Vice Consul at Calcutta, Robert L. Buell.

The full text of the announcement follows:

"The Indian Broadcasting Company is continuing its efforts to establish broadcasting stations at Calcutta, Bombay and Madras.

"Programs, to begin with, are planned to be made up of material available in India. It is not thought practicable at the start to relay programs from England and the Continent.

"There will be a minimum of three hours' broadcasting daily consisting of news bulletins, market reports and weather forecasts, which will be carried on in as many languages as is demanded by the public."

Machine Counts Millions of Cycles!

An Exposition of the Workings of A Frequency Meter

By J. M. C. Dess

RADIO engineers are now talking in kilocycles and megacycles, referring of course to currents and voltages of such high frequencies. These are just a bit too fast to be counted like the number of cars in a train that is passing. But every wave must be counted if the engineer is to know just how many there are in every second. Just how can they be counted?

There are many indirect methods of counting the waves per second. One of these is to measure the length of the wave and make use of the fact that the frequency is equal to the velocity of the wave divided by the length of one wave. The length of the wave, if not too long, can be measured quite easily. The velocity is known very accurately, if we assume that the velocity of the radio wave is the same as the velocity of light.

Many comparison methods are used for measuring the frequency or wavelength. These are all based on comparing the unknown frequency with a known and previously counted frequency. The various boxed-up frequency meters and wave meters are of this type.

Actual Count Made

But measuring the length of the wave or comparing one frequency with another are not absolute methods of measuring frequency. The number of cycles per second is not counted.

There is one absolute method of counting the number of waves that pass a given point every second, or of measuring frequency, which is simple, accurate and ingenious. It is now used for calibrating standards. In this method the unknown frequency is compared with the rotation of the earth, which gives us our unit of time. The number of cycles occurring in 24 hours is counted by a mechanical counter.

Suppose we have an oscillation, either acoustical or electrical, the frequency of which we wish to determine very accurately. The first step is to make the unknown oscillation drive a synchronous motor, which is not a difficult step at all, now that amplifiers are available. Then

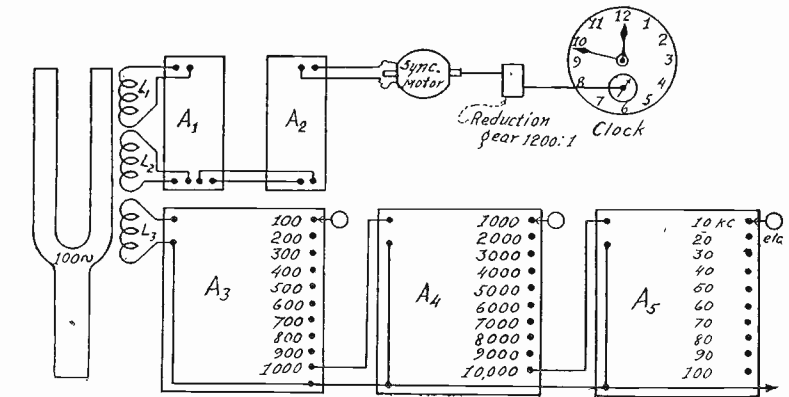

AN ARRANGEMENT for counting the number of cycles per second in an unknown frequency.

A1 is an amplifier which delivers its output through coil L1 and drives the tuning fork. L2 picks up the vibrations of the fork. The voltage picked up by this coil is amplified by A1 and returned to drive fork. The fork and A1 constitute an oscillator. Part of the output of A1 is amplified by A2 until it is strong enough to drive the synchronous motor, which drives the clock. From the rate of the clock the rate of the fork is accurately known. L3 picks up part of the vibrations of the fork and A3 produces the first ten harmonics of the frequency of the fork. A4 takes the tenth harmonic of A3 and produces the first ten of that. A5 then produces the first ten harmonics of the tenth harmonic of A4. The process is continued as far as is desired. Any unknown frequency can be measured with the arrangement to within 100 cycles, or the frequency of the fork, by suitable combination of the various harmonics.

the synchronous motor drives a clock-work. This clock will either gain or lose on the astronomical clock. The rate at which it gains or loses can easily be determined. From the rate of loss or gain of the oscillation driven clock over the astronomical clock the frequency of the unknown oscillation can be determined accurately.

Concrete Example

This can be made a little more definite. Suppose that the unknown vibration is 100 cycles per second. The synchronous motor can be designed to rotate 20 times every 100 cycles. Then if the vibration driving the motor is 100 cycles per second the rotor will revolve 20 times a second. The second hand on the clock rotates once every 60 seconds. Hence the rotor is 1,200 times faster than the shaft of the second hand. If the synchronous motor is coupled to the second hand shaft by a reduction gear having the ratio 1,200:1 the synchronous motor will drive the clock at the correct rate. That is, the oscillation driven clock will keep the same time as the astronomical clock.

If the oscillation driven clock deviates one second per day from the astronomical clock, the frequency of the oscillator differs from 100 cycles per second by one part in 86,400. If the oscillation driven clock differ from the astronomical clock by one second in thirty days, the oscillation would differ from 100 cycles per second by one part in 2,592,000, or roughly by one part in 2.6 million.

Of course it is not possible to keep the frequency of any oscillator to such a high degree of constancy over a long period of time, and what the counter would give is the average rate. This might be considerably different from the instantaneous rate of the oscillation.

Other Methods, Too

But there are other methods of comparing the rate of the oscillation driven clock with the astronomical clock which can be done with about the same accuracy in a small fraction of the time.

An oscillation driven clock like the above has been built in which the accuracy was one part in 1,500,000 and the rate remained constant over long periods of time. The 100 cycle oscillator was a vacuum tube driven tuning fork made of

special steel to give high constancy. To increase the constancy of rate the fork was placed in a specially constructed box in which the temperature was kept constant at zero degrees centigrade with melting ice, in which the barometric pressure was kept very low and constant with a pump, and in which the humidity was continually removed by chemical means. The amplitude of vibration of the fork, which greatly affects the frequency, was automatically kept constant at a very low level by electro-magnetic means.

Great Accuracy Assured

With this 100 cycle oscillator, or with some other accurately known frequency, it is possible to measure the frequency of any other unknown oscillation to a very high degree of accuracy. And there is no practical upper limit. It is possible to get any harmonic of the 100 cycle frequency up to about the 400th, which would be 40,000 cycles. This can be amplified and its harmonics taken up to the 400th again. This would put the frequency up to 16 million cycles per second.

In practice the stepping-up of the standard 100 cycle frequency does not proceed by multiples of 400 but by multiples of 10. Thus the first ten harmonics of the 100 cycle frequency gives all the even hundreds up to 1000. The 1000 cycle harmonic is amplified and the first 10 harmonics of this frequency give the even thousands up to 10,000. The same process is repeated.

Having all the hundreds, thousands, ten thousands, and so forth, they can be combined in any desired manner so that any number which is an even multiple of 100 can be obtained. Thus a frequency of 897,364 for example can be measured to within 100 cycles. The result that would be obtained in this case would be 897,400 cycles. Any other frequency, either higher or lower, could be obtained in the same way.

The comparison of any unknown frequency with a frequency known by the above method can be made to a fraction of a cycle per second. This is done by the process of visual beats on a meter. Thus there is no difficulty in telling when two frequencies are equal. The difficulty enters when we wish to know the absolute value of either one. The fork driven clock solves the problem.

How Does She Pick Up—?

Not Your Car But Your Set

The Combination Radio Receiver and Phonograph Installation
Raises the Question

By Herman Bernard

Associate, Institute of Radio Engineers

[This is the first of a series of articles on how to utilize radio and phonograph conjunctively. The series is built up around the phonograph pickup, the new device that supplants the phonograph sound box and makes the phonograph music come out of your speaker. Subsequent articles will be constructional. The following strikes the keynote and paves the way for one of the big novelties of radio this season.]

THE onward march of radio this season is going to be made with the considerable help of the phonograph. Mere receiver design has taken second place, and the audio channel, volume controls, battery eliminators, filtered outputs and high voltages on power tubes occupy the center of the stage. Thus is the quest for quality stressed, while distance-hunting, still popular, receives less attention, and all eyes are focused on what comes after the detector. Of course the audio channel does that, and if it is a good one it may well be used not only for amplification of the rectified radio wave but also for amplification of phonographic music, played from records in your home.

There is no reason to radio in this, for every sensible person recognizes the value of a phonograph, and impartially states that both the radio and the phonograph have their popular and proper place. It is conceivable that the radio orchestras tonight may fail to include in their program "The Doll Dance," although such is highly improbable. Then the popular music lover, whose particular fancy this rhythmic piece has caught, can

troop out his electrically recorded record and play it as it reproduces it electrically, as it should be reproduced.

Needs a Good Speaker

Virtually all phonograph records are now electrically recorded, through a microphone, for better quality, and they should be played electrically, that is, by means of a pickup feeding an audio amplifier. Have a carefully selected speaker of the Balsa Wood, Western Electric, Fada or equivalent merit, and you let the faithful reproduction come bursting forth in such fashion that the Caruso records seem to give the tenor his natural life back again, and render unto the reproduction of instrument or voice a fine measure of improvement.

Throughout this land there are many thousands of the old-style phonographs, consisting of upright cabinets, atop of which are the turntable, next the tone chamber with horn in it, and below the record compartment. There are Victors, Aeolian Vocalions, (as in the top phonograph), Sonoras, Brunswicks, Pathes and the like, not with orthophonic or panatropic qualities, but having the essentials—the crank, the motor and the turntable. With only these, plus a phonograph pickup, you can deliver into your present radio receiver, with its abundantly equipped audio channel, the phonograph music, and get results that sound as thrilling as those from a \$500 or \$1,000 phonograph model, as the saying is.

The pickup is vastly important, so much so that of the half dozen radio manufacturers who recently entered the

business of producing such devices, most have failed so far to produce anything worth listening to, exceptions including the American Bosch Magneto Corporation, with its Recreator, and Louis G. Pacent with his Phonovox. The Bosch product is much louder than Pacent's, under average conditions, and costs nearly twice as much. Bosch's volume control box and socket plug and pickup itself are as exquisite to the eye as the Recreator's functioning is to the ear. A pedestal is included. The Phonovox has none, the existing tone arm being used for support.

Method of Operation

Having selected a pickup, preferably from test on a radio with audio channel similar to your own, remove the detector tube, insert the pickup plug with its two tinsel leads, put a needle in the pickup receptacle, turn on the record, placing the needle point upon it, light the tubes and listen to the music come from your radio speaker.

Between the pickup and the plug the volume control, furnished with the phonograph device, may be placed. But if the volume control in your receiver is after the detector then you do not need the extra volume control.

Now, instead of doing merely this much, you may not have a radio set, or if you have one in a cabinet you may want to put a different one inside the phonograph cabinet, indeed include the power supply therein, also, whereupon the phonograph, the radio set, power supply and the means

(Concluded on next page)

LAYOUT FOR AN ABC ELIMINATOR FOR SERIES FILAMENT CIRCUITS

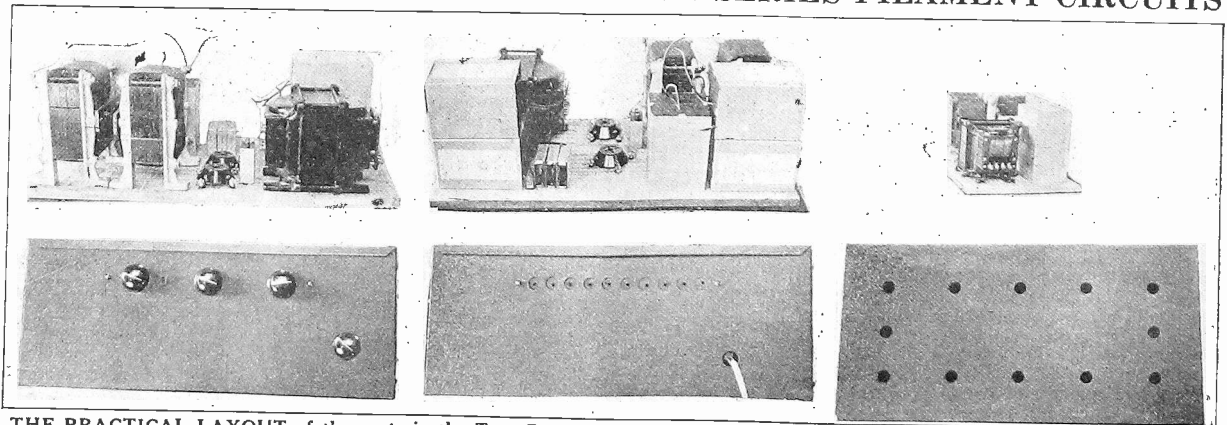

THE PRACTICAL LAYOUT of the parts in the Toto Power Well described in the Aug. 6 and 13 issues. At upper left is the view of the transformer and choke coil side of the circuit. The two chokes are at the left, the power transformer to the right and the two sockets are in the middle. The top center picture shows the assembly from the Flechtheim condenser side. The top right photo shows another view of the arrangement with the power transformer in the foreground. The lower left picture shows the rear side of the case showing the terminal strip and the power lead-in cord. The middle picture in the lower row depicts the front of the case. The right photo in the lower row shows the ventilating holes in the top of the case. The circuit is an ABC eliminator, with an extra audio stage, using the Raytheon BA tube (350 mls) as rectifier.

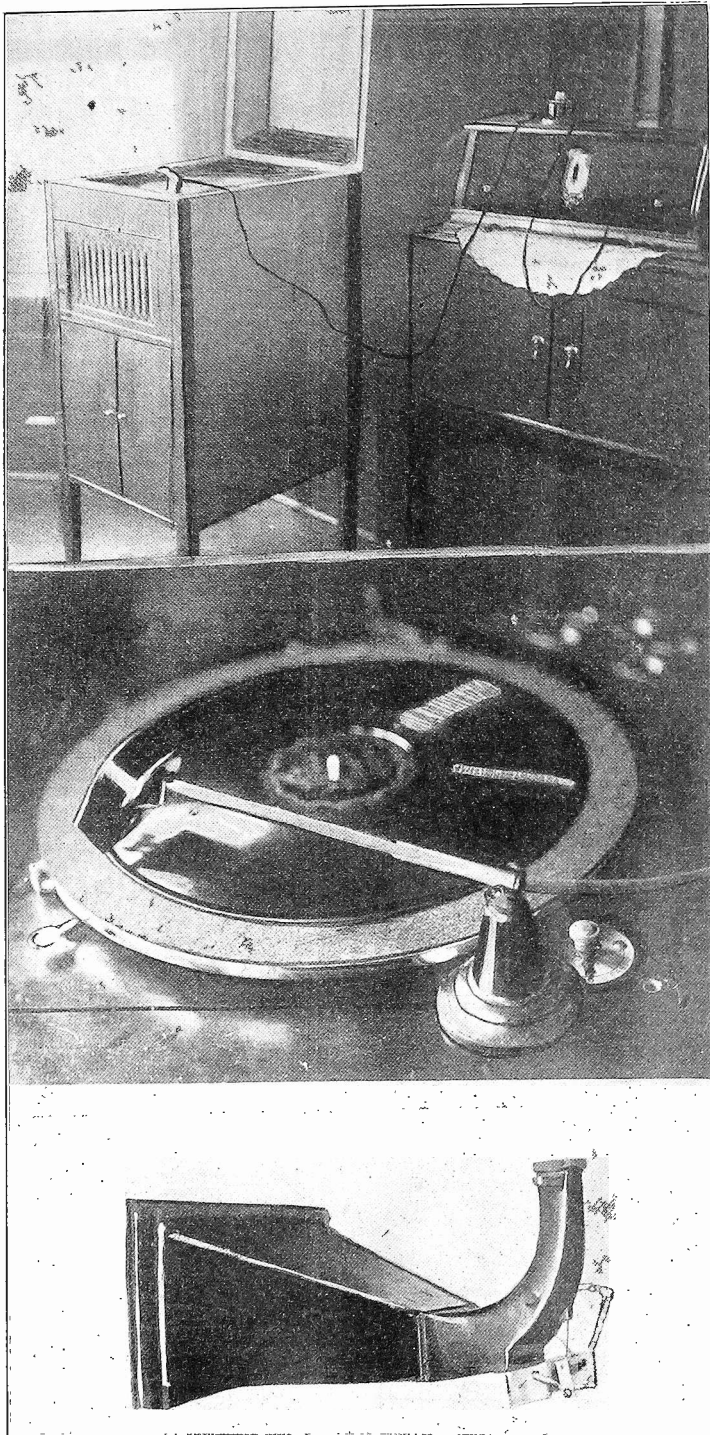

HERE are some scenes such as present themselves in many American homes today and which will be duplicated with many times greater popularity in the months to come. The public will be schooled in the art of turning the old style phonograph into a modern tone quality phonograph that works through the audio channel of the radio receiver. At top is a remodelled installation. At center is a close-up of the Bosch Receptor. The bottom picture shows the horn taken from the Vocalion shown in the top photograph, for discard of all except the neck, necessary for affording security if the tone arm is to be preserved.

(Concluded from preceding page)
of using any or all of them are right inside that oblong box you thought only yesterday was wasting useful space in the storeroom.

Well, it is easy enough to equip the phonograph cabinet with all these. You remove the horn from the phonograph,

because that always takes up considerable room. You need room, but with the pickup will not need the horn. In the case of the Victor models of the approximate size and shape of the phonograph pictured, room will be provided for the receiver, when the horn is taken out, but not for the power supply. You will have

MUST REVEAL CANNED MUSIC

Washington.
 While there is "nothing reprehensible" in the broadcasting of so called "canned music," the Federal Radio Commission has taken the stand that any mechanically reproduced music sent out over the air must be announced as such.

This was the statement made orally by Commissioner H. A. Bellows of the Federal Radio Commission, in making public a general order (General Order No. 16) on this subject. The full text of the order follows:

"The Federal Radio Commission finds that while the broadcasting of music performed through the agency of mechanical reproductions, such as records or perforated rolls, is not in itself objectionable, the failure clearly to announce the nature of such broadcasting is in some instances working what is in effect a fraud upon the listening public.

"The Commission, therefore, hereby orders that, effective August 21, 1927, all broadcasts of music performed through the agency of mechanical reproductions shall be clearly announced as such with the announcement of each and every number thus broadcast, and that proved failure to make such announcement shall be deemed by the Commission cause for action under Section 32 of the Radio Act of 1927."

Three N. Y. Stations To Use Same Plant

Stations WBBR, WBJ and WLTH have all been assigned to operate in the 256 meter wave on a time division basis. They will also use the same transmitting station, that of WBBR on Staten Island, as soon as the WLTH studios in the Leverich Towers Hotel, Brooklyn, are finished.

A. R. Goux, Secretary of the People's Pulpit Association, which operates station WBBR, said yesterday that neither station would lose its identity by the arrangement, but would use its own call letters.

"As soon as facilities can be arranged," he explained, "wires will be strung from the WLTH studios to our transmitter. We have agreed to share 75 per cent. of the transmitting on our allotted wave in this district and WBJ will use the balance. Separate studios will be used and we will be known by different call letters. The only consolidation will be in transmitting apparatus and use of wave."

to remove the record grooves, and in the place they occupied put your eliminator, storage battery and trickle charger, or what have you. With the Vocalion removal of the horn affords enough space for everything.

Good for All

If you make the set sensitive enough to work from a loop, and put the speaker at the rear, or, if the cabinet legs are high enough, at bottom, you will have a self-contained radio-phonograph combination that needs only the turning of a switch and a dial, or a switch and a crank, for musical rendition.

Besides the renaissance of old phonographs there is the task of putting radio sets in radio-phonograph table models where sets now are lacking. There are thousands of such outfits with the aching void that ought to be filled, and the pickup will help to fill it.

All in all the pickup will help both the radio and the phonograph record business, and the net result will be better business and music better worth hearing.

100,000-Watt Transmission!

WGY Uses Record Power in Broadcast Tests

HIGH powered radio broadcasting reached a new peak when a program of WGY was put on the air at midnight from the new 100 kilowatt developmental transmitter, located at the South Schenectady transmitter laboratory of the General Electric Company. This test marked the first time that 100 kilowatts of power have been modulated and put on the antenna for broadcast service.

The Federal Radio Commission issued a provisional license to the General Electric Company to operate on 100 kilowatts, on the application of Martin P. Rice, manager of broadcasting for that company. The commission limited the license to 30 days and specified the period midnight to one A.M. eastern standard time.

Special programs were offered nightly by WGY, from midnight until 1, standard time, and listeners had an opportunity to report on the quality and volume of the signal.

Comparisons Made

During the week of August 14, comparison tests were made of transmissions on the 100 and 30 kilowatt transmitters. Trained observers, located at distant points, made measurements on signal strength, audibility and modulation. By means of this investigation, which is part of an extensive developmental program, the radio engineers hope to improve the broadcast service.

The South Schenectady transmitter laboratory covers 54 acres. Facilities are available for suitable antenna and counterpoise systems and for the power and cooling requirements of a large number of transmitters or for a very large transmitter. There are, for example, four steel antenna towers, three 300 feet high and one 150 feet high, in addition to a large number of smaller masts. There is a rectifier capable of supplying 750 kilowatts of direct current power at 15,000 volts.

Tube Hastened Transmitter

The development of the 100 kilowatt transmitter has been hastened, to some extent, by the production of a 100 kilowatt power radiotron by the General Electric Company. The new transmitter occupies less than half the space taken by the 50 kilowatt transmitter, heretofore the highest powered equipment. Two 100 kilowatt tubes are used in the amplifier unit, and three more tubes operate in the modulator unit. The 50 kilowatt transmitter, now operated at 30 kilowatts, in accordance with the Federal license, uses seven 20 kilowatt tubes in the amplifier and twelve tubes of the same size for modulators.

The 100 kilowatt transmitter consists, essentially, of a radio power amplifier whose frequency is controlled by a quartz crystal, and a modulator bank, together with its modulation reactors and speech input equipment.

100 Kilowatt Tubes

Two 100 kilowatt tubes are used in the power amplifier unit. These radiotrons are of the conventional metal anode construction. The anode is of copper, approximately three feet long by $3\frac{1}{4}$ inches in diameter. The filament and grid leads are brought out through a glass cylinder at the top. The glass cylinder is approximately 19 inches long by 5 inches in diameter. The radiotron is 50 inches long. For filament excitation the radiotron requires 210 amperes at 33 volts. Two of the radiotrons are used in parallel for normal operation. They work into a tank circuit which is inductively coupled to the antenna by means of coupling coils and a transmission line.

The antenna is of the vertical type, consisting of a cage two feet in diameter and 240 feet high. The wires of the cage are combined to form a single conductor for the lower part of the antenna. A counterpoise, consisting of a radial wire system 240 feet in diameter, is used instead of a ground connection.

Quartz Crystal Frequency Control

The frequency of the transmitter is controlled by a quartz crystal. The output of the crystal is amplified by five stages of radio frequency amplification to a power which is sufficient to completely excite the grids of the 100 kilowatt radiotrons, in the power stage. All of the amplifier stages are completely neutralized so that there is little possibility of independent oscillations in the amplifier chain. Thus the quartz crystal determines the radio or carrier frequency of the transmitter. This frequency is the same as that used by WGY, 790 kilocycles.

Speech or music to be broadcast is sent from the WGY studio over the telephone cable, at a power approximately equal to that used for ordinary telephone conversations. This voltage is then amplified 1,000 times by an audio frequency amplifier chain, the last stage of which employs a 20 KW water-cooled radiotron. It is then impressed on the grids of a bank of three 100 KW radiotrons used as modulators. These tubes operate directly in the plate circuit of the radio power amplifier tubes and vary the plate potential in accordance with the speech frequency.

Power Rectifier

Power for the plate circuit of the trans-

mitter is obtained from a rectifier which employs six vacuum tubes of the two element type. These tubes are of the same size as those employed in the transmitter but have no grid structure. The rectifier is capable of supplying 750 kilowatts of direct current power at 15,000 volts. Several large filter units remove all objectionable 60 cycle ripple from the output. Power for the rectifier is taken directly from the 13,200 volt 3 phase supply for the station. A motor-operated voltage regulator enables the operator to vary the output voltage at will, under load. This rectifier is probably the largest of its type in use by a broadcasting station. It is capable of supplying a transmitter having an output of 250 kilowatts. Although such a transmitter is not now available it is now considered as practical.

Methods of Cooling Tubes

In order to keep the anodes of the large tubes used in the transmitter properly cooled, it is necessary to circulate 12 gallons of water per minute through the water jacket in which each tube is mounted. For the transmitter proper, exclusive of the rectifier, a flow of 60 gallons of water is required per minute. This is obtained from a centrifugal pump which obtains its supply from a cistern of approximately 20,000 gallons capacity. On its return from the tubes this water is required to flow through a radiator unit where it is cooled by a current of air supplied by a large blower. The water is then returned to the cistern. This type of cooling system is termed a closed system since it is not dependent upon an actual contact between the water and air for removing the heat contained in the water. The water is protected from dust and other impurities and may be used for long periods without replenishment.

The cooling water actually comes in contact with the plate or anode of the tubes, which is at a high radio and DC potential above ground. It is well known that pure water is a fairly good insulator. By using a fairly long section of rubber hose between the water connection to the tube jacket and the supply pipe it is possible to secure a sufficiently high resistance in the column of water to prevent excessive loss of power due to the conductance of the water.

Operation Simplified

The operation of a 100 kilowatt transmitter is made quite simple through the use of remotely controlled electrical apparatus and protective devices. The operator has before him two major controls. One switch controls a small rectifier which supplies the plate circuit of a small metal tube which supplies the excitation for the main power amplifier.

A second switch controls the large rectifier which supplies the plate circuit of the main radio power amplifier tubes and the plate circuit of the modulator tubes. In getting the set ready to go "on the air" all motor generator equipment (including the water cooling system and blowers) rectifiers and low power amplifiers, both audio and radio, are started. The set is finally put on the air for the use of the two major control switches which, at the will of the operator, send 100 kilowatts of radio frequency energy into the antenna. Protective devices are employed to trip off the power supply in case of a tube failure, also to give warning to the operator in case of failure of the water supply. The operator is constantly checking the degree of modulation by means of an oscillograph. The quality of transmission is also checked by means of a suitable loud speaker.

CONSTANT AMPLIFICATION SHOWN

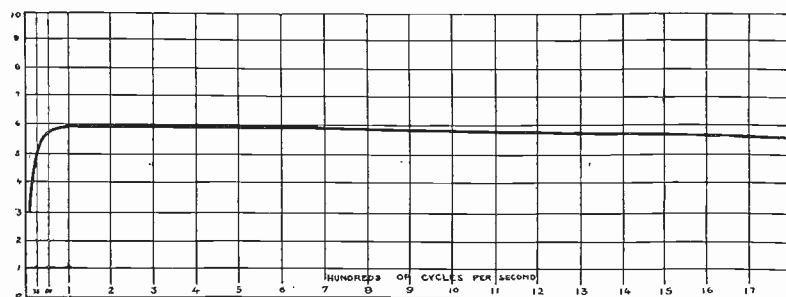

THIS GRAPH shows the characteristic curve of one of the sections of the Victor-112 audio transformer unit. The voltage gain is plotted against the frequency. Note that the gain at 25 cycles is 5 and at 100 cycles it is 6. Beyond the 300 cycle mark the gain decreases as the frequency increases but the fall is slow. The amplification is virtually constant over the entire audible range.

Tim Turkey Says—

“I Do Not Choose to Run My Set with Rheostat As the Volume Control In 1928”

By Tim Turkey

A VOLUME control is as necessary in a radio receiver as a brake is on an automobile. Without a control the loudspeaker is likely to “run away” when a loud signal comes crashing in. But if I can't have the right control I would rather not have any at all. I would let the speaker take care of itself and take a chance on finding it again if it should shimmy out of the house.

By the right volume control I do not mean a device which changes the output of the set by changing the filament current in the amplifier tubes. No, that is a wrong control. There are many reasons why volume tampering with the rheostat is wrong. In the first place, there will be a tendency on the part of the operator to turn the filament current up to get that last mile while DX hunting. That shortens the life of the filament more than it shortens the apparent distance to a transcontinental broadcaster.

Point About Squeals

In the second place, when the filament is turned down to limit volume on local stations, the thing the operator really succeeds in doing well is to ruin the quality of the signal. These effects were pointed out in an article from the Information Bureau of the Radio Corporation printed in RADIO WORLD on page 12, Aug. 6 issue:

“Turning the filaments of the receiver up or down does not constitute an efficient volume control. It should be noted that filaments must be operated at the proper voltage at all times, irrespective of the volume desired. Dimmed filaments may result in severe distortion, while excessively lighted filaments lead to greatly shortened life of tubes.”

A point worth mentioning is that RF rheostat volume control is often only a squeal control. Who wants any squeals?

It seems strange to me that a few well-meaning persons even today put a rheostat in the filament of the last tube to control the output of the set.

The Worst Place

It is apparent to a novice that that is not only the worst method of control but it is the worst place to put it. Every tube in the circuit introduces some distortion into the signal, and this is proportional to the square of the amplitude of the signal voltage. This distortion is cumulative. If the volume control is placed in the last stage, no matter what type of volume control is used, the accumulated distortion for any given signal strength is the greatest possible. Then if the volume is cut down in the last stage with a rheostat, not only is the accumulated distortion retained but a vastly greater distortion is introduced in the last tube by cutting down the power handling ability of the tube.

Chances are that the signal voltage on

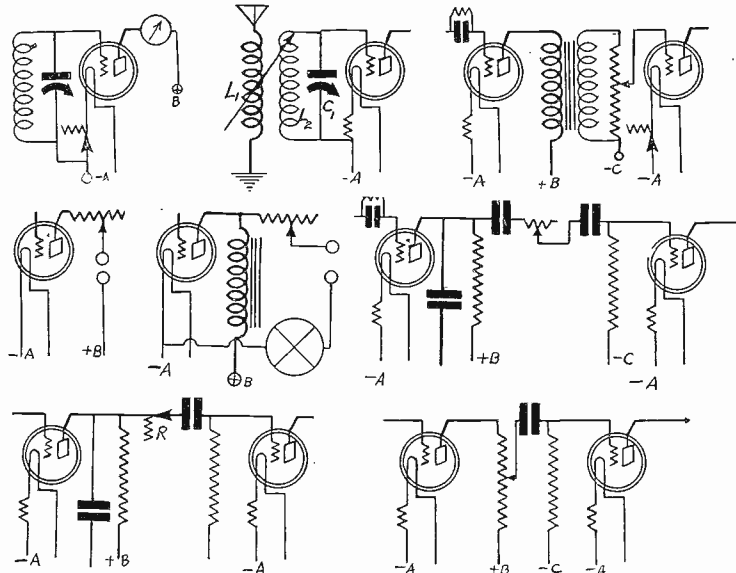

Upper Row—A rheostat in the filament circuit of the first tube for volume control. (At left). Varying this varies the plate current. The middle drawing shows how the volume can be varied by varying the coupling between the antenna coil and the first tuning coil. At right is the best method of volume control as far as the audio amplifier is concerned. A high resistance potentiometer is placed across the secondary of the first audio transformer.

Center row—How the volume can be varied by varying the resistance in the plate circuit of a tube. (At left). It can be placed in the plate circuit of any tube but it is more effective in a radio frequency tube. The middle drawing differs from the preceding in that the effective plate voltage is not altered when resistance is put in series with the loudspeaker. This method of control is effective and it has the effect of improving the quality. The resistance introduced in series with the speaker must be equal to the effective resistance of the loudspeaker before the sound output is cut in two. At right, a method of volume control by means of a resistance placed in the grid lead to the first audio tube. The resistance in the rheostat must be equal to the resistance of the grid leak following before the volume is cut in two. Quality does not suffer when this control is used provided that the two condensers used are very large and the grid leak resistance is high. Either the first or the second stopping condenser can be removed without adversely affecting the action.

In bottom row, at left, the first condenser has been removed. At right is a method which should not be used because it is noisy.

reaching the grid of the last tube is so great as to overload the tube when the filament temperature is normal. With the filament temperature cut down to a dull glow the overloading will be vastly greater. The horribly mutilated sound emitted from the average radio store is raucous evidence of the fact that volume control by rheostat in the last tube is effective in introducing distortion.

Rheostat volume control in the radio frequency tubes has been a favorite method with many writers and engineers. It is a good enough makeshift as long as the plate voltage source has negligible resistance. It might be said that it is good so long as storage or dry cell B batteries are used. But as soon as an eliminator of any kind is used the method is no longer a good one, because it affects the effective plate voltage on all the tubes. Hence it is likely to introduce distortion

into the signal even if it is placed in the filament circuit of a radio frequency tube.

The reason that the rheostat affects the plate voltage is that it directly affects the emission from the radio frequency tube filament. That is, it changes the plate current in this tube. Automatic change in grid bias helps along this plate current change. Now the regulation of the plate voltage source comes in. As the plate current in any one tube changes the effective voltage on all the tubes changes. It decreases when the current increases. As the voltage changes on all the tubes the plate currents in all the tubes change also. Therefore a change in the filament current in a single tube will change the plate currents in all of the tubes in the circuit and will generally upset the operation. The set will be erratic and the amplification uncertain.

(Concluded on page 15)

Four Wave Protests Win; Board Denies 6 Others

Washington.

Decisions in ten cases in which broadcasting stations sought changes in the conditions of operation were made by the Federal Radio Commission.

Four of the applications for changes in frequencies were approved and six denied by the decisions, which were issued in the form of special orders effective on the new license date, August 15.

The Commission granted the application of WLTH (formerly WFRL), Brooklyn, for a shift to the 1,170 kilocycle frequency, on which it was ordered to share time with WBBR, Rossville, N. Y., and WEBJ, New York. The order in this case (Special Order No. 57) follows in full text:

"The application of the Flatbush Radio Corporation, Brooklyn, N. Y., Radio Station WLTH (formerly WFRL), to be assigned to a frequency of 1,170 kilocycles, was heard before the Commission on July 26, 1927.

Why Grant Was Made

"After consideration of the testimony, the Commission found that public interest, convenience and necessity would be served by granting this change in frequency. Station WLTH is hereby authorized to operate on a frequency of 1,170 kilocycles, sharing time on this channel with Stations WBBR and WEBJ. The time division on this channel will be as follows: WBBR will use 50 per cent, WEBJ 25 per cent, WLTH 25 per cent.

"In view of many complaints received regarding blanketing by WLTH (formerly WFRL) on 500 watts power at its present location in a congested section of Brooklyn, a power reduction to 250 watts will be imposed by the Commission pending the station's contemplated move to an outside location remote from residence.

Shift for WJBI

"New licenses specifying the changes indicated above will be issued as of August 15, 1927."

WJBI, Red Bank, N. J., was shifted from 1,170 to 1,140, in accordance with its application, but its power output was limited to

First 20 Years Hardest

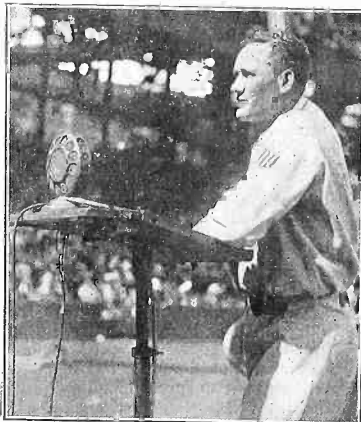

(Acme)

WALTER JOHNSON, famous pitcher of the Washington Senators, shown before the microphone as he thanks the thousands of fans who crowded the Griffith stadium in Washington to honor him at the celebration of his twentieth year with the Washington club.

150 watts by the following decision (Special Order No. 58):

"In order to promote public convenience or interest, or to serve public necessity, it is hereby ordered that Station WJBI, Robert S. Johnson, Red Bank, N. J., be changed from operating on a frequency of 1,170 kilocycles to a frequency of 1,140 kilocycles, and that said station's power output be limited to 150 watts. A license specifying the above frequency and power will be issued as of August 15, 1927."

Assigned to Frequency Asked

WMBG, Richmond, Va., seeking a place on 1,360 kilocycles, was assigned that frequency in the following order (Special Order No. 62):

"The application of Havens and Martin, Richmond, Va., Radio Station WMBG, to be assigned a frequency of 1,360 kilocycles, was heard before the Commission on July 29, 1927.

"After a consideration of the testimony, the Commission finds that public interest, convenience or necessity will be served by assigning this station to the frequency requested, namely, 1,360 kilocycles. Station WMBG is, therefore, assigned to a frequency of 1,360 kilocycles, effective August 15, 1927."

The Commission granted the request of Station KFNF, operated by the Henry Field Seed Co., Shenandoah, Iowa, for a change from 1,110 kilocycles to 650 and authorized it to increase its power from the present 500 watt output to 2,000 during the day. The decision follows (Special Order No. 64).

"In order to promote public convenience or interest or to serve public necessity, it is hereby ordered that Station KFNF, Henry Field Seed Company, Shenandoah, Iowa, be changed from operating on a frequency of 1,110 kilocycles, to a frequency of 650 kilocycles, with a power output of 2,000 watts from 6 a. m. to 7 p. m. only.

"A new license effective August 15, 1927, will be issued in accordance with this order."

Church Plea Refused

KLDS, Independence, Mo., owned by the Reorganized Church of Jesus Christ of Latter Day Saints, was refused its application for a change in frequency to 650 kilocycles and the use of 5,000 watts power. The decision (Special Order No. 63) follows:

"The application of the Reorganized Church of Jesus Christ of Latter Day Saints, Independence, Mo., Radio Station KLDS, to be assigned to a frequency of 650 kilocycles with 5,000 watts power output, was heard before the Commission on July 29, 1927.

"After a consideration of the testimony, the Commission does not find that public interest, convenience or necessity would be served by the granting thereof.

"The application is hereby denied."

Four Requests are Denied

In one order (Special Order No. 61), the Commission decided against the applications of four Pacific Coast broadcasting stations for changes, as follows:

"The applications of the Western Broadcasting Company, Portland, Oregon, Radio Station KEX, to be assigned to a frequency of 770 kilocycles with a power output of 20,000 watts; the Pacific Broadcasting Company, San Francisco, California, Radio Station KYA, to be granted an increase in power to 1,000 watts; and the Northwest Radio Service Company, Seattle, Washing-

THE MEDIUM OF K



THE PRINCE OF WALES performing the official opening of the International and Ontario. This was the first time that audience over the radio. In his address he has endured for more than a century," "would serve "as a continual reminder to seek and pursue it is the first and highest that are yet to come." At right is shown principal address at the official opening of the causes for the failure of the recent Geneva of the participants



(Herbert Photos)

KING ALBERT of the Belgians delivering of the Menin Gate Memorial Church on structure is a memorial to the 56,000 Brit during the World War. The speech was microphone standing

ton, Radio Station KJR, to be assigned to a frequency to 550 kilocycles with a power output of 20,000 watts, and the Northwest Radio Service Company, Spokane, Washington, Radio Station KGA, to be granted an increase in power to 20,000 watts, were heard before the Commission on July 28, 1927.

770 kc. Denied to KXL

"After a consideration of the testimony, the Commission does not find that public interest, convenience or necessity would be served by the granting thereof.

"The applications are hereby denied."

KINGS AND PRINCES



part of the ceremonies which marked the opening of the new bridge at Niagara Falls, New York, the Prince of Wales spoke to an American audience and dwelt entirely on the "peace that the bridge will bring to the people who will use it, and all of us, that to the benefit of both of this generation and of those to come." President Dawes delivering the principal address. Mr. Dawes said that one of the purposes of the conference was lack of preparedness to discuss the subject.

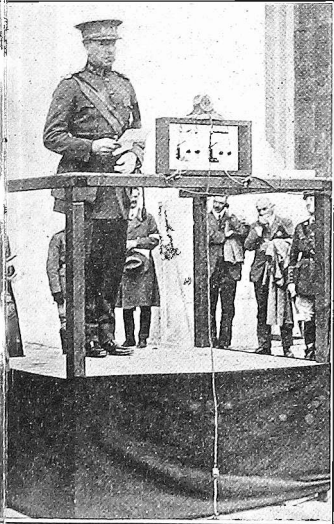

dedication address at the inauguration of the new battlefield of Ypres in Belgium. The speakers who fell on the Flanders front broadcast, as will be observed from the front of the king.

The fifth Pacific Coast station to seek a license was KXL, Portland, which was also granted a place on 770 kilocycles (Special Order No. 60):

The application of the KXL Broadcast Station of Portland, Ore., Radio Station KXL, was assigned to a frequency of 770 kilocycles, was heard before the Commission on July 28, 1927.

After a consideration of the testimony the Commission does not find that public interest, convenience or necessity would be served by the granting thereof. The application is hereby denied."

Legal Attacks on Board End as WGL Withdraws

Washington. Withdrawal of the test suit instituted by WGL, New York City, against the Federal Radio Commission, in the form of an appeal from a decision of the Commission to the Court of Appeals of the District of Columbia, was announced by representatives of the International Broadcasting Corporation, operators of the station, who were in Washington to attend a hearing before the Commission. The action is significant in that it marks the end of legal attacks upon the Board's rulings.

The attorney for WGL, Lewis Landes, who is also chairman of its board of directors, in a statement to the press said that in his opinion the Radio Act of 1927 is "utterly impregnable" and that it would be "impossible to upset the Radio Act of 1927." He adds that it is his opinion that the Supreme Court would find the law constitutional, and that no court would attempt to upset any of the acts of the Commission.

Wanted WOR Wave

This statement is acknowledged by Judge Sykes in a letter to Mr. Landes in which he expressed his gratification that WGL has decided to withdraw or dismiss its appeal.

WGL filed suit in the Court of Appeals of the District of Columbia in June, following the Commission's decision denying it the use of the frequency of 710 kilocycles (422.3 meters), on which WOR, Newark, had been assigned to operate.

The operators of WGL objected to its allocation to 1,020 kilocycles (293.8 meters) last June 15, the frequency on which it is now operating with 500 watts of power. These objections were voiced before the Commission at a public hearing held in Washington.

Constitutional Point

The appeal was taken to the Court of Appeals on constitutional grounds, WGL contending that the Radio Act was unconstitutional because it circumscribes the use of facilities, such as transmitting apparatus, on which large sums of money had been expended. It also claimed the Commission was vested with an undue power in its assignment of frequencies without preliminary hearings.

WGL, its managers announced, is about to remove its transmitting apparatus from the present location on the roof of the Hotel Majestic, New York City, to a site at Secaucus, N. J.

Following is part of the statement by Mr. Landes:

"I believe that the best interests of all concerned will be met by withdrawing our proceeding in the District Court of Appeals. We believe, too, that the best interests of the Commission and all manufacturers who have millions of dollars invested in their business will be best served by this step.

Fear of Chaos

"For, if the Radio Act were declared unconstitutional at this time, chaotic conditions certainly would be created all over the country and this we are anxious to do our share in avoiding.

"With successful negotiation for the purchase of a site at Secaucus, N. J., and the establishment of a transmitting station which is now in the course of construction there, the officers and directors of the International Broadcasting Corporation have decided to withdraw the lawsuit now pending in the Court of Ap-

peals of the District of Columbia, in which the constitutionality of the Radio Act of 1927 was to be tested before the court.

"We feel that the future demonstration of WGL will justify the Commission in broadening the field of our usefulness. The Commission has pointed out in a letter that our position on the dials is in their opinion the best."

China Requires Owners of Radio Sets to Register

Washington.

Advices to the Department of Commerce from the office of the American Commercial attache at Shanghai state that regulations in China require that all Chinese who desire to have radio receiving sets in their homes must register at one of the offices in charge of radio broadcasting recently established in Peking and Tientsin.

The advices also stated that regulations governing installation of receiving sets require that all equipment must be purchased from licensed shops. Importers and sellers of radio equipment must register with the superintendent of the Northeastern Long Distance Wireless Telephone Service, which issues the licenses.

WHO in Big Chain

WHO, owned and operated by the Bankers Life Company, Des Moines, Iowa, will become a member of both the Red and Blue Networks of the National Broadcasting Company in the early fall, said W. H. Heinz, manager of WHO. It is expected, the announcer states, that wire line facilities will be ready for the addition of WHO to the N. B. C. Networks at the same time that WOW, Omaha, is to be added, which according to a recent statement by officials of the National Broadcasting Company approximated the date as October 1.

Sharkey Enjoys This

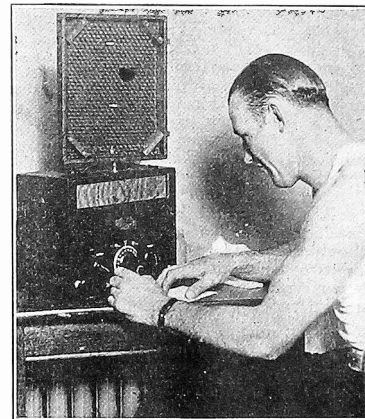

JACK SHARKEY finds pleasure in tuning in on the broadcasts of boxing bouts. Well may he smile as he hears the ringside announcer tell of a "sock to the jaw" just landed on a boxer's jaw.

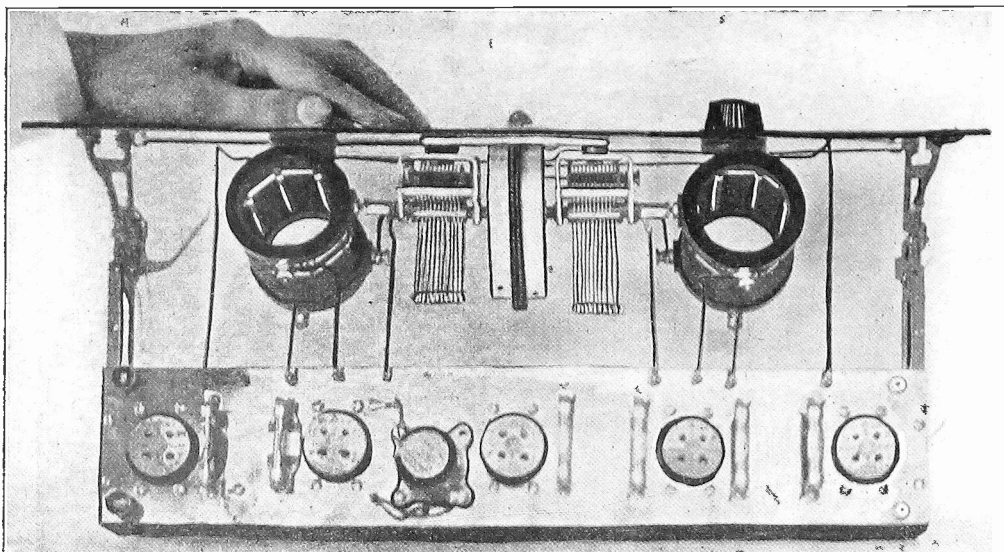

FIVE tubes, simplicity, economy and tone quality characterize the Drum Powertone, shown at left in top view, at extreme right in end view. The circuit diagram and the front panel view are presented, also.

The High at

WITH your eye on top of the set here is the view you get. A five-gang socket strip is supported by a pair of adjustable brackets. The leaks are placed a top the socket shelf, while the other parts, excepting those for front panel, go underneath. The coils are mounted on the condenser assembly.

By Fred Madagascar

SIMPLICITY and quality are the two outstanding characteristics of the drum control model Powertone receiver. It is simple in construction and simple to tune, because it employs collated drum tuning controls and standardized parts. It is capable of good quality. It contains one transformer AF stage and two resistance coupled stages.

In the tuning system Bruno coils and condensers are employed. L1L2 and L3L4 have secondaries tuned with .0005 mfd. Bruno condensers. The coils have 10-turn primaries and 55-turn secondaries, using No. 24 wire, silk covered.

The two condensers are placed centrally in the set and each is tuned with a drum. The two drums are placed side by side on the panel so that the two condensers can be turned simultaneously with one hand. They are not mechanically connected, so they can also be turned independently. This fact obviates the necessity of using midget condensers.

The Choke System

The detector is non-regenerative. It employs a standard tube requiring a positive grid return. The grid condenser C5 is of .00025 mfd. and the grid leak R3 is of 2 megohms. A radio frequency by-pass condenser C6 is placed in the plate circuit of the detector to facilitate detection and to help to keep the radio frequency currents out of the AF amplifier. The condenser is of .0005 mfd. capacity and it is connected between the plate and the positive end of the filament. A radio frequency choke coil Ch is placed in the plate lead of the circuit to complete the filtering of the RF currents from the AF. This coil is a General Radio of 65 millihenry inductance. No greater inductance should be used.

There are two coupling resistors, R4 and R6, in the circuit. Each of these is of .1 megohm resistance. There are also

two grid leak resistors in the amplifier, R5 and R7. Each of these should be of 2 megohm resistance, but other values can sometimes be used to advantage. The two stopping condensers C7 and C8 have a value of .006 mfd.

Rheostat Volume Control

The volume is controlled in the circuit by means of a rheostat R1. It controls the filament current in the radio frequency and detector tubes. R2 controls the filament current in the audio frequency tubes. It should be used for adjusting the filament current in the amplifier tubes to

normal, and then left thus. The rheostat system permits use of -01A or -99 tubes, with 112 or 220 in the output, if desired.

The resistance of R1 should be 10 to 20 ohms and that of R2 need not be more than 10 ohms.

There is a by-pass condenser C1 connected between the negative end of the filament circuit and the ground connection. This should have a value of at least .01 mfd. Its purpose is to ground the filament circuit and the rotors of the tuning condensers at RF, and yet isolate them from the ground at direct current. This arrangement is a convenience in

Why Reflexed Stage

[The reflex was formerly a very popular type of circuit, but due to distortion it fell out of the lap of popular favor. The distortion was deemed due to overloading and

audio and radio frequency oscillations. But since the advent of the tube, scientific research has been conducted with reflex sets, with a view towards curing these vices.]

By H. Coster Forbes

In some reflex receivers the first tube in the set is also the last. In other words, the first radio frequency amplifier is also used as the final power amplifier.

It is apparent when this is done that the load on the tube is greater than if it were used for one purpose only.

It is therefore well to use a power tube in the reflexed stage.

This would not only give greater undistorted output but it would greatly improve the quality of the receiver.

It would also make the set more sensitive, since the power tube is an excellent radio frequency amplifier, particularly

when high plate and grid voltages are used on it.

Recommended in All Cases

The use of a power tube like the -71 or -10, had these tubes been available when the reflex circuits were popular, would probably have retained public interest in the reflex.

The use of a power tube in a reflexed stage is recommended no matter where that stage may be in the circuit.

If beneficial results can be gained when the first and the last stages are combined into one tube, similar results can be gained when the second radio and the first audio are combined.

Important Considerations

The sum of the impressed voltages is approximately the same in both cases. In the first case the radio frequency voltage is very small but the audio frequency voltage is very high.

In the second case the radio frequency voltage is moderately high and so is the audio frequency voltage.

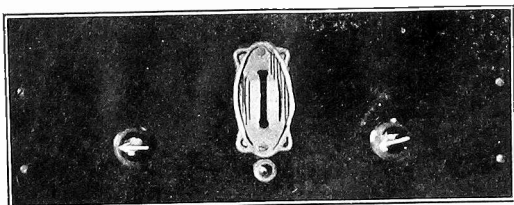

AT LEFT the front panel view, with the drum control in the center, and the rheostats on either side. The pilot light window is under the drum.

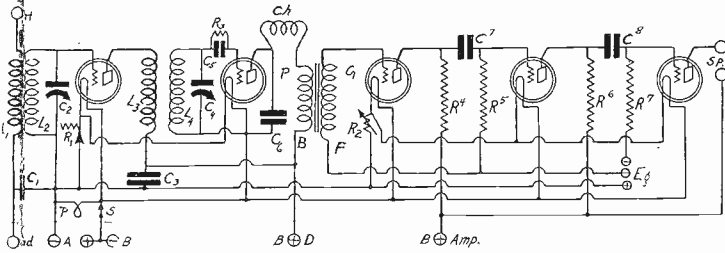

Drum Powertone Quality of Tone Low Cost

many cases, particularly when the plate voltage for the tubes is obtained from a DC power line in which the positive side is grounded. If C1 were replaced by a metal strap the ground binding post could not be used, for then both sides of the house line would be grounded. Fuses would blow. Even if the ground is not used and the ground binding post is metallicly connected to the filament, short circuits often occur through the antenna. While such shorts are not dangerous they are sometimes unpleasant when taken through the body.

A grid bias equal to the voltage drop in

rheostat R1 is used on the RF tube. This bias is one volt on the average. When the volume is throttled down the bias is increased and when it is turned up the bias is decreased.

Grid Battery for Last AF

The bias on the audio frequency amplifier tubes is obtained from a grid battery. Eg. This battery should be tapped so that a bias of from 1½ to 4½ volts can be obtained for the first two audio tubes. The voltage of the battery should be high enough so that adequate bias can be obtained for the last tube.

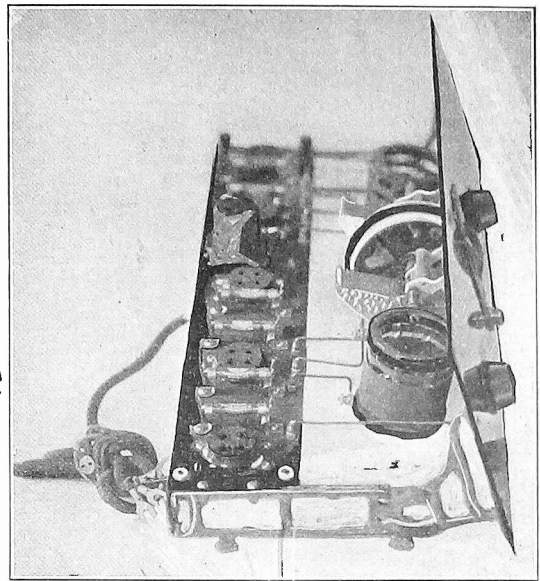

WITH the output nearer you, represented by phone tip jacks.

There is another by-pass condenser C3 across that portion of the B voltage supply which feeds the RF and the detector tubes. Its value should not be less than .01 microfarad.

A filament switch S is placed in the positive leg of the filament circuit. This is a Bruno switch of the turn on-push out type. This has a pilot light socket built in, permitting the use of a pilot light if desired, to shine through the red window on the panel.

The applied plate voltage on the detector and RF tubes is 45 volts, at the binding post marked D. The plate voltage on the remaining tubes can vary between 135 and 180, depending on the tubes used.

If this set is used with a dry cell plate battery a condenser of about 4 mfd. should be connected between the negative of the A battery and the binding post for the highest B plus voltage. If an eliminator is used this condenser is a part of the filter, but an additional condenser may have to be used.

The final tube, if a power tube is desired, may well be a 112 or a 220, their characteristics (except as to grid bias and filament rating) being about the same.

Needs Power Tube

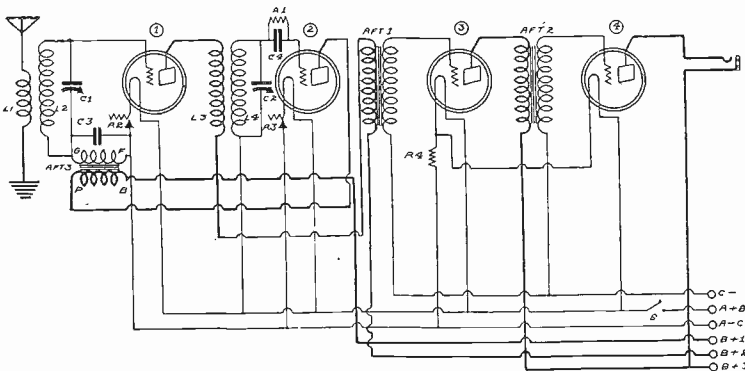

IN socket (1), reflexed stage, one may use a power tube.

Tim Turkey Does Not Choose

(Concluded from page 11)

I will not even listen to a receiver in which the volume is controlled by means of a rheostat in the audio amplifier. In my set volume used to be controlled by a rheostat in the radio frequency tubes. Therefore I have built myself a new set, my 1928 model. I do not choose to run my set with a rheostat to control volume.

In the audio frequency amplifier the best volume control is a high resistance potentiometer across the first audio transformer secondary. The next best is a

variable resistance across the secondary in place of the potentiometer. These methods of volume control do not affect the filament and plate currents directly. There is a minor effect due to rectification, but this is reduced to a minimum when these methods are used.

Other good ways to control volume are: by a variable primary in the antenna circuit and by a variable primary in an inter-stage RF couples. Both methods presuppose that varying the coupling does not produce squeals, not always true.

LIST OF PARTS

- L1L2, L3L4—Two Bruno No. 99 RF transformers
- Ch—One General Radio 65 millihenry choke coil
- C2, C4—Two Bruno .0005 mfd. tuning condensers, with drum control.
- C1, C3—Two .01 mfd. by-pass condensers
- C6—One .0005 mfd. by-pass condenser
- C5—One .00025 mfd. grid condenser
- C7, C8—Two .006 mfd. stopping condensers
- R1—One 10 to 20-ohm rheostat
- R2—One 10-ohm rheostat
- R4, R6—Two metallized plate resistors of 100,000 ohms
- R3—One Turnit leak variable.
- R5, R7—Two 2-megohm grid leaks.
- Sp—One Bruno filament switch with pilot light
- PBGF—One Bruno Trutone audio transformer, 3½-to-1
- Twelve binding posts
- Two Bruno adjustable brackets.
- Five standard sockets.
- One 7 x 18 inch front panel
- One subpanel, with mountings.

A THOUGHT FOR THE WEEK

SUITS, suits and more suits! But radio continues along the more or less even tenor of its way and marches onward to an Autumn and Winter which, according to all signs worth noting, will be the busiest and most successful that radio science, business and entertainment ever has known.

SIXTH YEAR

RADIO WORLD

The First and Only National Radio Weekly

Member, Radio Publishers Association

Radio World's Slogan: "A radio set for every home."

TELEPHONES: BRYANT 0558, 0559
PUBLISHED EVERY WEDNESDAY

(Dated Saturday of same week)

FROM PUBLICATION OFFICE

HENNESSY RADIO PUBLICATIONS CORPORATION
145 WEST 45th STREET, NEW YORK, N. Y.

Just East of Broadway

ROLAND BURKE HENNESSY, President

M. B. HENNESSY, Vice-President

HERMAN BERNARD, Secretary

European Representatives: The International News Co.

Brema Bldg., Chancery Lane, London, Eng.

Paris, France: Brentano's, 8 Avenue de l'Opera

EDITOR, Roland Burke Hennessy

MANAGING EDITOR, Herman Bernard

TECHNICAL EDITOR, Lewis Winsor

CONTRIBUTING EDITORS:

J. E. Anderson, Capt. Peter V. O'Rourke, and
James H. Carroll

SUBSCRIPTION RATES

Fifteen cents a copy, \$6.00 a year, \$8.00 for six months, \$1.50 for three months. Add \$1.00 a year extra for foreign postage. Canada, 50 cents.

Receipt by new subscribers of the first copy of RADIO WORLD mailed to them after sending in their order is automatic acknowledgment of their subscription order. Changes of address should be received at this office two weeks before date of publication. Always give old address; also state whether subscription is new or a renewal.

ADVERTISING RATES

General Advertising

1 Page, 7 1/2" x 11"	462 Lines.....	\$300.00
1/2 Page, 7 1/2" x 5 1/2"	231 Lines.....	150.00
1/4 Page, 8 1/2" x D. C.	231 Lines.....	150.00
1/4 Page, 4 1/2" x D. C.	115 Lines.....	75.00
1 Column, 2 1/2" x 11"	154 Lines.....	100.00
1 Inch.....		10.00
Per Agate Line.....		.75

Time Discount

52 consecutive issues.....	20%
36 times consecutively or E. O. W. one year.....	15%
9 consecutive issues.....	10%

WEEKLY, dated each Saturday, published Wednesday. Advertising forms close Tuesday, eleven days in advance of date of issue.

CLASSIFIED ADVERTISEMENTS

Ten cents per word. Minimum 10 words. Cash with order. Business Opportunities ten cents per word, \$1.00 minimum.

Entered as second-class matter March 23, 1922, at the Post Office at New York, N. Y., under the Act of March 3, 1879.

FALSITY ON AIR CHARGED BY U. S.

Washington.

A complaint charging the Omaha Tanning Company and W. C. Kalash, of Omaha, Nebr., with making false statements over the radio in representation of the company's products, was made public by the Federal Trade Commission.

This is the first trade practice involving the radio which has come before the Commission, the Commission stated orally.

Representations by the respondents to the effect that the company eliminated "needless profits" by manufacturing the products and selling them direct to the consumer, are false, it is alleged.

HOW TO BUILD RADIO WORLD'S Four-Tube Universal Receiver fully described by Herman Bernard in the March 12, 19 and 26 issues of RADIO WORLD. Send 45c and get these three numbers. RADIO WORLD, 145 West 45th Street, New York City.

Radio Guiding Channel for Aircraft Invented

Washington.

Development of a radio guiding channel which will enable aviators to keep on a definite course, irrespective of weather or topographical conditions, was announced by C. Francis Jenkins, of Washington, D. C., as the fourth of a series of inventions which he has recently evolved for the improvement of aviation conditions. The invention is receiving the consideration of some of the leading commercial aviation executives in the country preliminary to the adoption of the plan.

The radio guiding channel is brought about through the installation of a series of radio transmitting stations at intervals of 25 miles over any given course. These make use of short wavelengths. By the use of vertical antennae, of a height and separation bringing them one-half a wavelength apart, the waves are radiated in one direction. The use of the short wavelength limits the waves radiated by one station to approximately forty miles. The location of the stations causes this directional radiation of waves to overlay somewhat.

Uses Simple Receiver

The airplane traversing this route is equipped with a simple receiving device which uses the power from this radio-energized channel to light a small indicator lamp on the instrument board of the plane. The aviator, by noting the intensity of this lamp, can tell at once when he is not keeping in the channel, for as he gets off the course, the light from the little bulb becomes dimmer. As he returns to the course, the light becomes brighter.

The constant transmission of radio waves from these stations along the radio channel makes it unnecessary for the airman to even know the course which he is flying, it is stated.

"The radio guiding channel," Mr. Jenkins explained today, "is especially suited to commercial or government uses, such as the air mail, where flying must go on through rain, fog, snow and sleet. The present system of beacon lights along the air mail courses serve their purpose well for night flying in clear weather, but when storms come or fog lowers, these are blotted out to a large degree. Then is when the radio channel guide will be most helpful."

Transmitter Costs Only \$250

Mr. Jenkins declared that the transmitting stations of his radio channel guiding

system could be installed at a cost of about \$250 each, and that they could be located at the same points as the present light beacons, where they could be cared for by the same forces as now care for the beacon lights. The beacon light towers, he said, could also be used for the antennae supports.

"The advantages of this radio guiding channel," Mr. Jenkins said, "include the ability to change the direction of the course, so as to take the airplane through mountain passes or other rough ground.

"Another important advantage is that the channel will serve many planes traveling in either direction at the same time. Planes going East, for instance can fly at 2,000 feet and planes going West at 3,000. Along with this is the simplicity and automatic character of the transmitting and receiving devices.

Like Submarine Cable

"This might be compared with the submarine cable which is used to guide ships coming into New York in a fog, through the use of which ships' officers are able to determine whether they are in the proper channel. The great difference is that we do not have to have a cable with its expensive initial cost and right of way. Another difference is that the distance from the ship to the cable is far less than that of the plane from the ground making the radio channel the better for guiding airplanes.

"The area covered by the radio waves is sufficiently high that the aviator may fly far above buildings, hill and trees which might cause them to crash."

The other devices Mr. Jenkins has recently patented for the improvement of aeronautics include a launching runway which will enable a plane to get into the air in a second's time; a propeller-reversing device which permits a plane to be stopped in twice its own length on landing; and a landing altimeter, which will keep an aviator constantly informed as to the distance of his ship from the ground in gliding to a landing when weather conditions would prevent him from seeing the landing field.

Mr. Jenkins is both an experienced airplane pilot and a radio engineer of recognized ability. His unqualified endorsement of this radio trail-finding device would therefore seem to be worthy of serious consideration by aviation interests generally as a practical means of guiding airplanes when confronted by the pilot's worst enemy, fog.

Socialists Acquire Station in New York

The Debs Memorial Radio Fund has purchased station WSOM in Woodhaven from the Union Course Laboratories to be used as "a militant voice of the American Labor movement to give expression to the aspirations of the millions of men and women who toil for a living." Application has been made to the Radio Commission for permission to change the call letters of the station to WDEBS.

A Debs Memorial Fund of \$250,000 is sought by the backers to support the station. The Board of Trustees includes Morris Hillquit, John Haynes Holmes, Victor L. Berger, Theodore Debs, Roger Baldwin, Upton Sinclair and Sidney Hillman.

"With radio as now privately owned," said G. August Gerber, Secretary of the fund,

"a station like WDEBS is the only cry in the wilderness. But WDEBS assures to the American labor movement and to all the forces of progress a rallying ground from which to capture the imagination of the American public.

"We promise that, as soon as we can proceed with full operation, WDEBS will be not merely a chronicler of events or a vehicle of music and entertainment, but a fighting, militant champion of the rights of the oppressed, of all those who toil by hand or brain to produce the wealth of the country. It will be a tireless agent in telling the radio audience that the giant of labor in this country has found another means of articulation."

The statement aroused much interest.

Radio University

A FREE Question and Answer Department conducted by RADIO WORLD for its yearly subscribers only, by its staff of Experts. Address Radio University, RADIO WORLD, 145 West 45th St., New York City.

When writing for information give your Radio University subscription number

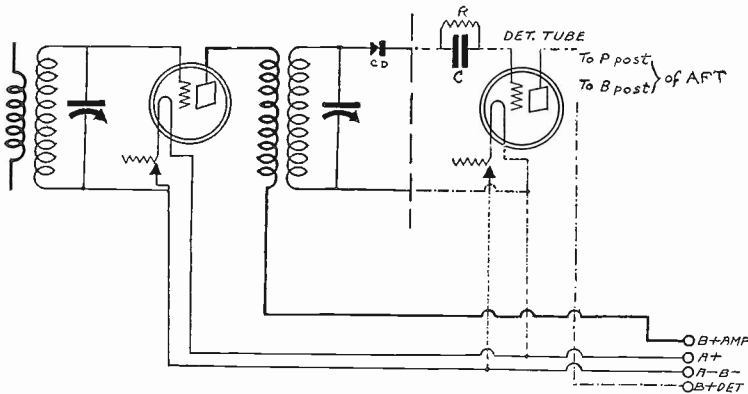

FIG. 559

The circuit showing how to insert a tube in place a crystal is herewith shown.

WHEN INSTALLING a tube in place of a crystal, is that portion of the coil connected to the crystal, connected to the grid leak and condenser and then on to the G post of the socket?

(2)—Does the other terminal of the winding go to the filament post? I am not very clear on both these points and therefore, think a diagram illustrating these points would help me greatly. I wish to use a -01A tube as a detector tube.—KENNEDY RALPHAEL, Houston, Tex.

(1 and 2)—Yes, See Fig. 559 for this diagram. The dotted lines indicate the new connections.

I HAVE a three-tube set, using a regenerative detector with a variometer in the plate circuit and two stages of transformer coupled audio frequency amplification. I would like to insert a radio frequency choke coil in this set. How and where should it be inserted?

(2)—I now have an antenna which is 100 feet long. I can very easily increase its length to 200 feet. Would it pay?—FRANK YOLEMAN, Valparaiso, Ind.

(1)—One terminal of the RF choke is connected to the terminal of the variometer that formerly went to the P post on the transformer. The other terminal of the choke is brought to the P post on the transformer. From the variometer connection on the choke, a lead is brought out to one terminal of a .001 mfd. fixed condenser. The other terminal of the condenser is brought to the minus A post.

(2)—The long antenna will increase your signal intensity, but at the same time the decrease the selectivity. Therefore, if you live quite close to a broadcasting station, the long antenna would not be advised.

IN WHAT issue did you publish a diagram showing how to connect up a loop to a standard five-tube receiver, using binding posts for connections?

(2)—I have a regular two-ampere charger. I have a wall socket near the floor and close to the radio set. From this outlet, I obtain juice for a bridge lamp. I would like to know if it is possible to use this source, by means of some type of plug, to supply the juice for the lamp at the same time it supplies juice for charging my battery. In other words, have the lamp lit at the same time the battery charges.—LESTER MYROWSKY, Dayton, O.

(1)—See page 19 of the July 9 issue of RADIO WORLD.

(2)—Yes. Use a double plug. This can be purchased in any electrical store.

I HAVE the circuit diagram of a two-tube reflex set, using a regenerative RF and AF amplifier, a crystal detector and a single stage of transformer coupled audio frequency amplification. Would I get better results if I switched the regeneration to the detector circuit using a tube, leaving the RF-AF tube non-regenerative? —ARTHUR KING, East Pittsburgh, Pa.

The results would be greatly improved. Don't forget the grid leak and condenser, which are connected in series with the grid of the detector tube. The leak can have a resistance of 2 to 8 megohms, while the condenser has a capacity of .00025 mfd.

I HAVE the circuit diagram of a six-tube receiver, using three tuned radio frequency stages, a non-regenerative detector and two stages of transformer coupled audio frequency amplification. Would this type of receiver be difficult for a novice to construct?

(2)—Would I get good results if I left out one stage of radio frequency amplification?

(3)—In this hookup single condensers are used. Could a triple condenser be em-

ployed instead with balancing condensers across each section?

(4)—If so, would a 50 mmfd. midget condenser do?—HARRY STRACKS, N. Y. City.

(1)—Yes.

(2)—Yes, the tuning would become less critical. You would also have less trouble in neutralizing the set.

(3 and 4)—Yes. The balancing condensers will greatly aid the tuning. Be sure you bring the rotary plate sections of all the condensers to the grid return leads of the coils.

IN THE Jan 20 issue of RADIO WORLD there appeared a circuit diagram of a single tube set using a special selector circuit system. This was described in the Radio University columns. I built this set and it worked out great. Is it feasible to employ this same system in a five-tube set, the special selector coil being placed in inductive relationship to the grid coil in RF and detector circuits. I realize, of course, that if the standard winding is used, the large variable condensers will have to be used, which will complicate tuning. It is not, therefore, possible to use the midget type of condenser with coils consisting of several hundred turns?

(2)—Could 1A Amperites be used to control the filament temperature of each of the tubes?—ABBOT DIAMANT, Kansas City, Mo.

(1)—It is only necessary to use this system in the first RF stage. The larger condenser works out better. No shielding is necessary.

(2)—Yes.

I CONSTRUCTED the circuit diagramed on page 18 of the July 2 issue of RADIO WORLD. It works remarkably well. Could another stage of audio frequency amplification be added to this set using a power tube such as the -71?

(2)—At times I have trouble in controlling the first radio frequency tube, which oscillates. Could I remedy this by placing a 2,000-ohm variable resistance in series with the B plus lead going only to the plate of this tube? Or, would a 400-ohm fixed resistor in series with the grid work better?

(3)—In installing the power tube, which by the way will get its plate and grid voltage from a B eliminator, will it be necessary to install a choke coil and condenser in the output? If so, how would a 60-henry choke and 8 mfd. fixed condenser work?—LEON BURSHOWITZ, Atlantic City, N. J.

(1)—Yes.

(2)—Both systems will work satisfactorily.

(3)—The choke coil and condenser should be used. The apparatus you have will work all right.

Join RADIO WORLD'S University Club

And Get Free Question and Answer Service for the Coming 52 Weeks
This Service for Yearly Subscribers Only

Have your name entered on our subscription and University lists by special number. Put this number on the outside of the forwarding envelope (not the enclosed return envelope) and also put at the head of your queries. If already a subscriber, send \$6 for renewal from close of present subscription and your name will be entered in Radio University. No other premium given with this offer.

[In sending in your queries to the University Department please paragraph them so that the reply can be written under or alongside of each query. Write on one side of the sheet only. Always give your university number.]

RADIO WORLD, 145 West 45th Street, New York City.

Enclosed find \$6.00 for RADIO WORLD for one year (52 nos.) and also enter my name on the list of members of RADIO WORLD'S University Club, which gives me free information in your Radio University Department for 52 ensuing weeks, and send me my number indicating membership.

Name

Street

City and State.....

Code of Ethics Adopted; First One in the Field

The following Code of Ethics was adopted by the Radio Manufacturers Association:

Experience has shown that a formal statement of principles embodying correct standards for business relations are essential to the development, and orderly conduct of every industry. The R. M. A., recognizing its responsibility to the radio industry and to the public has, therefore, adopted as a rule and guide for the conduct of its members, the following code of ethics:

1. Statistics

Knowledge—thorough and specific—and unceasing study of the facts and forces affecting this industry are essential to lasting individual success, and the members of this association should co-operate in the collection and dissemination of facts relating to the industry, for the benefit of all.

2. Standards

The standardization of parts, manufacturing methods, terminology, rating and types are of great assistance to the industry and to the public and the members of this association pledge themselves to make all reasonable efforts toward this end, provided, however, that attempts to standardize should not be pressed to such a point as to discourage or limit the development of the industry.

3. Mutual Relations

Recognizing that the radio industry will benefit by the existence of harmonious and friendly relations between its members, no member of this association shall make statements or take action calculated to injure, directly or indirectly, the business reputation, product, or personal standing of a competitor.

4. Duty to the Public

The nature of the radio industry is such that there is a well-defined duty and obligation to the public. Their interest demands that the members of this association use every honorable means to uphold the dignity and honor of this industry, to raise its standards, and to extend its usefulness.

5. Piracy of Design

A company gaining an advantage by reason of superiority in designing skill, electrical or mechanical, is under no obligation to share such advantage with other companies. Such a company cannot, however, expect to retain exclusive use and benefit of unpatentable features of construction; but specific construction and designs of one company should not be appropriated by its competitors.

6. Piracy of Appearance

The duplication in color, description or designation of product or package which would tend to deceive the buyer or the public, that in purchasing the imitation they were getting the original article, is a form of unfair competition which this association condemns in the strongest terms.

7. Production Costs

Realizing that only through exact knowledge of the cost of production can the manufacturers sell on a fair margin of profit, this association specifically urges every member to adopt an intelligent check on their business operations, and to know accurately the cost of management, production, and distribution of their product. This association distinctly leaves to the determination of each member, however, all questions of selling prices, labor, hours, and wages, and avows its position in such matters to be that of the strictest observance of the law.

8. Advertising

Advertising should at all times be fair and honest. It is not discreditable to become enthusiastic in print, but to criticize a competitor, directly or indirectly, in a paid advertisement, or to convey to the public your opinion of your competitor or

his products, or to include statements in advertising which through actual misrepresentation, through ambiguity or through incompleteness are likely to be misleading to the public is unjust to competitors, and should not be permitted.

9. Subsidizing Buyers Representatives

We are opposed to any manufacturer offering in any way special compensation of any type or kind as an inducement to the individual who acts as buyer for his employer.

10. Jobbers Catalogues

We discountenance the furnishing by the manufacturer of inserts for jobbers trade catalogues without charging for same at full cost, or the making of any allowance upon the part of manufacturers to the jobber for illustrating the manufacturer's goods in such catalogues.

11. Cash Discounts

A cash discount is given in return for payment within a specified time after shipment. The terms given should be adhered to or the transaction ceases to be of the nature intended.

12. Returned Goods

We recommend the following as standard practice with reference to return of goods where orders have been correctly filled:

A. The customer should be required to obtain consent of the manufacturer before returning such goods for credit.

B. The goods thus returned may be credited subject to a service and rehandling charge including the shipping expense.

C. Such returned goods may be sold as new goods, if in salable condition.

13. Guarantees

We disprove of any unreasonable guarantee, believing such to be detrimental to the manufacturer and to the industry. Apparatus should be guaranteed free from defects in material and workmanship, for a reasonable time, but this should not apply to apparatus which has been subjected to misuse, neglect, or accident. Defective material should be repaired or replaced at the option of the manufacturer upon the return of the same, transportation charges prepaid.

14. Unethical Acts

(a) Formal complaint:

Should any member of the Radio Manufacturers Association believe that a serious unethical act has been committed against him by another member of this Association the procedure to be adopted by the complainant in entering his complaint shall be to file with the Executive Secretary a writ-

ten statement duly sworn to, specifying the cause of complaint.

The Executive Secretary shall thereupon refer such complaint to the Fair Trade Practice Committee who shall review the charges that have been made, and if they are of sufficient gravity in their judgment to warrant such action, they shall cause to be served upon the accused member, a certified copy of the charges with a written notice that a period of fourteen days will be allowed in which to file with the Fair Trade Practice Committee their answer to the charges in the complaint.

The complainant shall submit for the consideration of the Fair Trade Practice Committee, all evidence he shall have in his possession and likewise the accused member upon receipt of his notice from the Fair Trade Practice Committee shall prepare all the evidence at his disposal and submit it in the form of the sworn affidavit.

If the Fair Trade Practice Committee shall find probable guilt the case shall be referred to the Board of Directors with a report of their findings for careful consideration and appropriate action.

(b) Informal complaint:

1. The complaining member may communicate, either verbally or in writing to one or more members of the Fair Trade Practice Committee, stating his complaint in full, and submitting whatever evidence he may have.

2. If the complainant so requests, the Fair Trade Practice Committee must not reveal the name of the complainant to the party complained of. In the event of a report by an unnamed complainant, it shall be incumbent upon the Fair Trade Practice Committee and all of the members thereon as individuals to not reveal to any one outside of the Fair Trade Practice Committee, any of the facts or anything about the complainant so long as the complainant remains anonymous.

3. The Fair Trade Practice Committee, as such, or one or more of its members, will then advise the member against whom the complaint is made, of the nature of the complaint, and will give the accused full opportunity to present its side of the case.

4. The Fair Trade Practice Committee, or a member of the Committee, will then report back to the complainant. The complainant may then prefer formal complaint, if such action is warranted in his judgment, or he may do nothing further.

5. The Fair Trade Practice Committee may make formal complaint itself, if the original complainant does not care to do so, and if in the judgment of the Fair Trade Practice Committee such formal complaint should be made.

Leipzig Fair Opens at End of the Month

The great international Trade Fair, which has been held for centuries at Leipzig, Germany, will be open this year from August 28 to September 3. More than twenty countries will display their newest products, and buyers will be attracted from over forty countries, thus making Leipzig the most important industrial exchange in the world. America is taking great interest in the Fair this year since it presents a unique opportunity to enter world markets both as exhibitor and buyer.

Germany has recently sent hundreds of its leading scientists and business men to the United States to study methods of manufacture and market conditions, and is making a special effort to develop business relations with America. A great variety of industrial products have been prepared in Germany to appeal to American demands at attractive prices. The Fair will include some 7,000 exhibits.

Farrand Announces Line for Season

The new line of Farrand speakers and eliminators, the products of the Farrand Mfg. Co., Long Island City, N. Y., has been announced by George H. Kiley, vice-president and sales manager of the company. The speaker models this season will be manufactured in four different models. The design is oval.

Two new models of the Farrand B eliminator are also announced. The new products are model 180, for sets up to six tubes and model 220, for sets of seven tubes or more.

NEW MOUNTFORD DISTRIBUTOR

C. E. Mountford, formerly an advertiser, announces the appointment of Radio Jobbers, Inc., 142 Liberty St., New York City, as exclusive Metropolitan distributors for the Mountford line of Kroblak resistors.

THE RADIO TRADE

Powertone Makes New Wire Strippers Giant Cone Kit Function Ingeniously

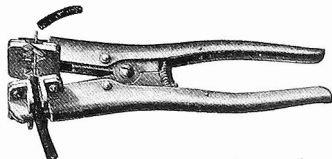
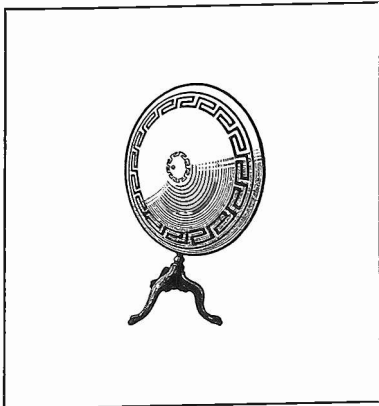

The E-Z wire stripper, shown above, is a new and ingenious tool for removing the insulation from the wire. The piece to be stripped is placed in the appropriate recess in the jaws of the tool and a light pressure is applied to the handle. The insulation comes off without leaving any ragged edges and the wire is not nicked in the process. There are recesses for three different wire sizes.

The device will strip insulation from all sizes solid conductor wire from 10 to 20 gauge inclusive. When stripping stranded wire a rather exact size corresponding to the stranded wire gauge is necessary. The size of any of the holes in the cutters can be increased with the point of a small round file to correspond with the size of the stranded wire to be stripped. For solid conductor wire the precision is not necessary, as any of the holes will strip several sizes smaller. The mechanical action is all that is necessary to strip insulation from any electric wire. It is merely a question of centering the wire and using the proper size hole.

The device is manufactured by the Pyramid Products Co., 2311 South State Street, Chicago, Ill.

COMMISSION DECLAINS CENSORSHIP

Washington.

The Radio Commission has no authority to impose any censorship on broadcasting and any abuse in that regard must be dealt with by other agencies. Chairman Admiral Bullard of the Commission has informed W. R. Keagan of St. Louis, who had complained that abusive and profane language had been used by announcers in the Middle West.

AUTOMATIC SOS RECEIVER

An apparatus which will automatically pick up, discriminate and then call attention to the fact that a ship within range of the apparatus is sending distress calls has been developed by the engineers of the Marconi Company of London. This will relieve operators from the necessity of always being on the alert for such signals.

Walter E. Bathgate, formerly executive head of W. E. Bathgate Co., Inc., manufacturers of the famous "WEB" wave trap, has now become affiliated with the Powertone Electric Co., 220 Fulton Street, New York City. This connection will bring about greater production, new ideas and finer apparatus, with a saving in production which will be passed on to the consumer in the form of lower prices.

The Powertone Electric Co. will continue to market the efficient Powertone Wave Trap and other Powertone apparatus and in addition is now placing on the market the new Powertone 36-inch cone kits, using the new and improved Powertone Giant Cone Units. These units are of the approved horseshoe magnet type, direct drive, and are built to operate on the 90 and 135 volt outputs such as are now used on the average set, while also being capable of operating on as much as 500 volts for use in speakers for large halls, dance halls and open air work with filtered output.

The best Alhambra Fonotex paper is used for the kit. Metal baffle rings and the stand are included in the kit, which embodies everything necessary to make the complete speaker. These kits can be assembled by anyone in less than an hour. Literature on this speaker will be sent upon application to the above concern.

WILLSON WITH COLUMBIA

R. Meredith Willson, of the New York Philharmonic Orchestra, has joined the Columbia Broadcasting System's radio musical ranks.

Pooling Possibility of Radio Patents Investigated

A special committee appointed by the Radio Manufacturers Association will begin immediately an investigation of the patent situation in the radio field, according to L. S. Baker, Vice President of the association.

"Radio today is in a situation somewhat similar to that which once confronted the automobile industry," said Mr. Baker. "That crisis was solved through the pooling of virtually all automotive patents and the inauguration of a system to cross-license manufacturers, under the auspices of the National Automobile Chamber of Commerce. Our committee has been charged to investigate the full details in the automotive field

to determine how the radio industry may be benefited thereby.

"The report of our show committee, which has been enlarged upon by comments coming from many outside sources, indicated clearly that the association, with its 309 manufacturing members, is adequately caring for the needs of the industry in merchandising and public responsibility.

"H. B. Richmond, director of the engineering division of the association, whose work on radio standards has been held up pending a conference with other interested organizations, reported that the standards situation has reached a point where the division can proceed without further delay."

Literature Wanted

THE names and addresses of readers of RADIO WORLD who desire literature on parts and sets from radio manufacturers, jobbers, dealers and mail order houses are published in RADIO WORLD on request of the reader. The blank below may be used, or a post card or letter will do instead.

RADIO WORLD,
145 West 45th St., N. Y. City.

I desire to receive radio literature.

Name

Address

City or town

State

Robert Lange, 3004 Bering St., Houston, Tex.
Roy O. White, 4752 Columbus Ave., Minneapolis, Minn.

Henry H. Luther, 830 Sixth Ave., South, St. Petersburg, Fla.

I. Seider, 793 Sterling Place, Brooklyn, N. Y.

Jerry Potter, 4125 Drake Ave., Chicago, Ill.

Dr. W. F. Thurston, 1334 3rd St., Los Angeles, Calif.

Karl Hermansen, 275 Limbeck Ave., Jersey City, N. J.

V. C. Deterich, 861 7th Ave., N., St. Petersburg, Fla.

Firmino Botelho, Rua Santa Cruz 10, V. Mariana, Sao Paulo, Brazil.

J. B. Foreman, 1631 East Lewis St., Philadelphia, Pa.

I. O. Pritt, 870 Concord Ave., Akron, O.

Harold E. Davis, Box 1162, Tulsa, Okla.

Balsa Unit Employs Balanced Armature

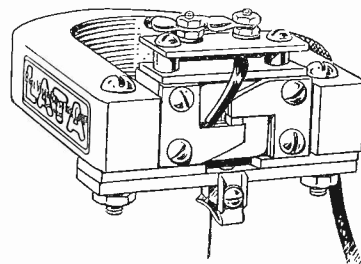

The Balsa Unit, for driving any cone or flat type speaker, is now in full production. It is manufactured by the Balsa Wood Reproducer Corporation, 331 Madison Ave., New York City, makers of the famous Lata Balsa wood reproducers and kits.

The unit is of the balanced armature type. It has a powerful permanent magnet to maintain an intense magnetic field across the armature and soft iron pole pieces. The armature itself is of soft well-annealed iron to prevent any residual flux or hysteresis. The assembly of the pole pieces, the coils and the armature is very compact. A mechanical transformer, or lever, is used to match the mechanical impedance of the armature to that of the speaker.

The unit handles strong power very well and is itself voluminous.

New Mohawk Speaker

The Mohawk Corporation of Illinois has developed a new speaker. This addition to the Mohawk line is the result of almost a year's work.

The new speaker has been named the Mohawk Pyramonic Speaker because the internal construction is shaped similar to a pyramid. It consists of four units in one.

NEW CORPORATIONS

Radio Blue Book, Corp., New York City; magazine, \$25,000. (Atty. A. Homig, 25 West 43rd St., N. Y. City.)



Play Safe!

Wherever a variable resistance is specified use CLAROSTAT, the greatest variable resistor.

"THE GATEWAY TO BETTER RADIO." 32 pages covering the latest angles in radio. Send 25c to Dept. R.W., American Mechanical Lab., Inc., 285 N. 6th St., B'klyn.

World "A" Power Unit--\$12.75

Automatically provides even, unvarying "A" current from your light socket. Absolutely noiseless. Assures full tone quality from your set and wider D. X. range. Famous WORLD quality—at less than half the cost of any similar equipment. Shipped complete, subject to inspection on receipt of price, or C.O.D., if you wish. 25 amp. unit for sets of 4 tubes or less, \$12.75. 60 amp. unit for sets of 5 tubes or more, \$15.75. 5% discount if cash in full is sent with order. Send order today. World Battery Co., 1219 So. Wabash Ave., Dept. 82, Chicago, Ill.

Adapter Devised For Set

By S. Ruttenberg
Chief Engineer, Radiall Co.

With the remarkable uniformity achieved in the production of present-day vacuum tubes of the better kind, the unified control of tube filaments now makes its bow to progressive radio enthusiasts. This new practice not only simplifies the operation of the usual radio receiver to the utmost by automatically maintaining tube filaments at the correct filament temperature, but, what may be of even greater interest to those not seeking the last few hundred hours of service from their tubes, it permits of changing about to various types of tubes without alterations of any kind in the receiver itself.

The Amperite Adapter System, which brings about the unified control of tube filaments, is applicable to any existing factory-built receiver without change in the usual arrangements.

The system comprises a pair of Amperites (self-adjusting rheostats) on a compact block which may be conveniently mounted inside or at the rear of the receiver cabinet, and connected in series-parallel with the

Everybody *OR* Nobody?

If It's a Product You Manufacture, the Answer Is "Everybody"—If It's the Extent of Your Personal Financial Resources, the Answer Is "Nobody."

Secrets Should Be Imparted to Nobody. You Would Not Spend Any Time, Much Less Any Money, Arousing Anybody's Interest in What Is Nobody's Business. For Instance, How Old Your Wife Is, or How Much Money You Have in the Bank.

If You Have Something to Sell You Want EVERYBODY to Know It. Perhaps you have a new product this season, and your first real problem is to ESTABLISH it as an entity. Or you may have the same excellent line this season as you had last. But you don't want the radio buying public to forget you, as it quickly will, unless you keep your name and product constantly in the foreground.

You Must Sell the Consumer—The Jobber Will Fill the Dealer's Orders When the Public Demand Makes the Dealer Send in the Orders, Therefore—

Create that public demand. Advertise your product in the

Fourth Annual Radio World's Fair Number

of Radio World, which will be published September 17, two days before the Fair opens, and will be circulated throughout the entire United States by that date, as well as being distributed to thousands upon thousands who attend the Fair, at Madison Square Garden, New York, September 19 to 26, inclusive.

Radio World is America's First and Only National Radio Weekly, dated every Saturday and Published every Wednesday, and circulating among home builders of sets, purchasers of factory-made sets, and also among the retail, jobbing and manufacturing trade.

"Tell It to Everybody"

Magnetize Your Dollar.

Give It a Pulling Power It Never Had Before.

Advertise in the Fourth Annual Radio World's Fair Number.

Advertising forms for the Fourth Annual Radio World's Fair number—the predominant issue—dated September 17, close Tuesday, September 6, at noon. For rates, see editorial page.

**RADIO WORLD (Advertising Manager), 145 West 45th Street
New York, N. Y.**

Write or Telegraph for Reservations—or Telephone BRY ant 0558 or 0559

**RADIO WORLD'S
QUICK-ACTION
CLASSIFIED ADS
10 CENTS A WORD
10 WORDS MINIMUM
CASH WITH ORDER**

EIGHT-TUBE VICTOREEN for \$55.00. Need money for college. For particulars, write Joe Malysiak, 531 Brighton St., La Porte, Indiana.

REAL OPPORTUNITY. Book orders for our nursery products in the Eastern and New England States. Write for offer. Good pay. Pequot Nurseries, Yalesville, Conn.

HOW TO BUILD RADIO WORLD'S Four-Tube Universal Receiver fully described by Herman Bernard in the March 12, 19 and 26 issues of RADIO WORLD. Send 45c and get these three numbers. RADIO WORLD, 145 West 45th Street, New York City.

THOUSANDS OF RADIO BARGAINS. Write, OMAN, 156 Concord, St. Paul, Minn.

NEW DE LUXE BST RECEIVER—5-Tube Set, resistance coupled audio, built-in C eliminator, genuine mahogany cabinet. Price, \$60. Five-day money-back guarantee. **GUARANTY RADIO GOODS CO.**, 145 W. 45th St., N. Y. City.

VALET AUTOSTROP RAZOR—The only razor that sharpens its own blades. Highly polished, nickel-plated, self-stropping Valet AUTOSTROP Razor, with one blade, in velvet lined metal case. Leather strap especially prepared, and complete outfit in neat, lithographed carton. Mailed post-paid on receipt of 50c. **SPECIAL:** Send \$2 for one-third of a year subscription for Radio World (yearly price \$6), mention this particular ad, and complete "Pal" set will be sent as a premium. If already a subscriber, your subscription will be extended three months. **THE COLUMBIA PRINT**, 145 West 45th Street, New York City.

LINDBERGH PLANE SPEAKER. Pictures and explanatory article appeared in Radio World dated June 25, 1927. Sent on receipt of 15 cents or start your subscription with that number. Radio World, 145 W. 45th St., N. Y. C.

COMPLETE AND LATEST LIST OF STATIONS appeared in Radio World, dated Aug. 6. Sent on receipt of 15c., or start your subscription with that number. **RADIO WORLD**, 145 West 45th St., New York City.

minus or negative side of the filament battery or A-battery.

Two Amperites are employed, connected in parallel, for the purpose of gaining greater flexibility of control as well as better distribution of the current-handling capacity. The cartridges employed must be of the voltage rating of the battery or power supply source, and of the current-carrying capacity represented by the combined amperage requirements of all the tubes in the receiver. Thus for a three-tube receiver employing standard 201-A or other 3/4-ampere, five-volt tubes throughout, the correct unified control will consist of one No. 1A and one No. 112 cartridge, or a current-passing capacity of 3/4 ampere irrespective of the A-battery voltage fluctuations. In the case of a five-tube receiver using four 201-A type tubes and a 112 or 171 type power tube, with a total amperage of 1 1/2, the satisfactory combination will consist of one 4A and one No. 112. A seven-tube receiver with six 201-A type tubes and a 171 power tube, representing a current drain of 2 amperes, will require two No. 4A cartridges. And so it goes. It is only necessary to figure out the total current requirements of the tubes in the receiver, operating off the same battery, and then to secure the proper combination of Amperites, stick them in the adapter and the unit in series with the minus A lead, for the desired unified filament control.

In the case of the receiver being built, the rheostats are, of course, dispensed with entirely through the use of Amperites in the circuit. Since there is no drop in voltage at the individual tubes due to rheostats or separate resistances, there is no grid biasing effect to worry about.

In the case of the existing receiver, the Amperites are placed in the minus lead to the A battery or power supply, while the existing hand rheostats are short-circuited, or kept full on, since they have no useful function with the adapter system once installed.

FLECHTHEIM

Superior Condensers for Socket Power Circuits Are

UNCONDITIONALLY GUARANTEED
Not to Break Down in Use if Operated At or Below Their Rated Voltages

Flechtheim Quality Condensers, in compact aluminum cases, are designed for Socket Power Sets and Power Amplifiers, with a working voltage up to 600 volts D.C., and in Filter Circuits for plate supply. Accurate when made and remain accurate within 5% of their rated capacities. Inquiries from the Trade Solicited

Manufacturers Supplied
A. M. FLECHTHEIM & CO., Inc.
275 BROADWAY NEW YORK
Telephone: WORth 7150

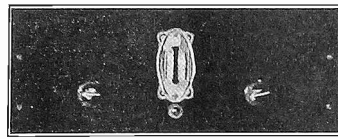

POWERTONE DRUM CONTROL

Complete Kit, \$23.50

Built to Order, \$1.50 Extra

- Diamond Kit..... \$37.50
- Streamline Wave Trap... .75
- Diamond Eng. Panel..... 1.95
- Web Cone Unit..... 3.45

Write and Get Our New and Low Price on Complete Bruno and Other Lines

B. C. L. RADIO SERVICE CO., Inc.
220 Fulton St., N. Y. City

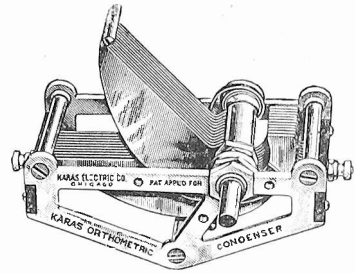

KARAS CONDENSERS AND DIALS AGAIN ARE SPECIFIED BY RADIO WORLD

In the Radio World "Four A. C." Receiver described and illustrated in this issue, 2 Karas Orthometric Straight Frequency Variable Condensers and 2 Karas Micrometric Vernier Dials are specified. You naturally wish to get maximum volume, purest tone and greatest ease of tuning when you build this receiver, and to make absolutely sure that you achieve these results use the 2 Karas

Condensers and the 2 Karas Dials that the specifications call for. Karas Condensers are true S. F. L. type—the finest variable condensers made—and Karas Micrometric Dials are so carefully made that they enable you to tune to within 1-1000th of an inch. Your dealer can supply you with these Karas parts. Build this receiver today—start building it NOW.

KARAS ELECTRIC CO.
4039-H No. Rockwell Street Chicago

COMPLETE DETAILS on what ohmage resistances may be used with B eliminators to also obtain C bias, were given by Frank Logan in the March 12 issue of RADIO WORLD. Either send 15c for his issue or begin your subscription with this issue. RADIO WORLD, 145 West 45th St., New York City.

ANNOUNCING THE NEW

Powertone

36" Giant Cone Speaker Kit, including \$1200 stand.....

using the new
POWERTONE UNIT
List, \$6.50

Used in 18", 24" and 36" Speakers. Kit includes 1 front sheet (designed), 1 back sheet, 2 metal Baffle Rings, 1 mounting bracket, 1 set Apex fittings, 1 POWERTONE UNIT, 1 stand, 1 tube cement, 1 set screws, nuts, etc.; full instructions. Can be assembled by anyone in half hour.

At Your Dealers or Direct on Receipt of Check or Money Order
Jobbers and Dealers, Write!

Powertone Electric Co.
220 Fulton Street, New York City



FLECHTHEIM CONDENSERS

BEST BY TEST
Dealers! Write for Attractive Proposition!
VENUS RADIO CORP.
142 LIBERTY STREET, NEW YORK CITY
Sole distributors of Flechtheim Condensers and Imperial "B" Cases for these states:
N. Y., N. J., Conn.

ONLY A QUARTER! 25 CENTS, GENTLEMEN!

Buys a blueprint of 5-tube Diamond of the Air and booklet on how to build it! Radio World, 145 West 45th Street, New York City.

WATCH EXPIRATION OF YOUR SUBSCRIPTION

Subscribers will note that the end of their subscriptions is indicated on the labels on wrappers. If your wrapper shows a date earlier than the current issue, please send payment for renewal. Changes in expiration dates on wrappers appear two weeks after receipt of renewal. PLEASE ALWAYS INDICATE WHEN SUBSCRIPTION IS A RENEWAL.

RADIO WORLD, 145 West 45th Street, New York City (Phones: Bryant 0558-0559)

Take Your Choice of 7 Other Publications!

For NEW RADIO WORLD Subscribers Ordering NOW

Radio World has made arrangements
—To offer a year's subscription for any one of the following publications with one year's subscription for RADIO WORLD

RADIO NEWS or POPULAR RADIO or SCIENCE AND INVENTION or BOYS' LIFE or RADIO DEALER or RADIO (San Francisco) or RADIO AGE.

This is the way to get two publications

- for the price of one:
- Send \$6.00 today for RADIO WORLD
- for one year (regular price)
- for 52 numbers)
- and select any one of the other
- nine publications for twelve months.
- Add \$1.00 a year extra for
- Canadian or Foreign Postage.
- Present RADIO WORLD subscribers
- can take advantage of this offer by
- extending subscriptions one year
- if they send renewals NOW!

Radio World's Special Two-for-Price-of-One Subscription Blank
RADIO WORLD, 145 West 45th Street, New York City.

Enclosed find \$6.00, for which send me RADIO WORLD for twelve months (52 numbers), beginning.....and also without additional cost, Popular Radio, or Radio News, or Science and Invention, or Radio Dealer, or Radio (San Francisco), or Radio Age or Boys' Life (or \$10.00 for a two-year subscription to one address). No other premium with this offer.

Indicate if renewal. Name

Offer Good Until Street Address

Sept. 10, 1927 City and State.....

The NEW
3 Ft. Cone
Loud
"ENSCO"
Wall Type
Speaker



Complete "ENSCO" Kit

\$10.00 With Hardwood Wall Frame, \$11.00

It contains "ENSCO" Direct-drive unit, designed and patented by Clyde J. Fitch. Beautifully decorated Alhambra FON-O-TEX Cone Material; Metal Apertures; Extension Cord and 12-page illustrated Book of Instructions for easy assembly of any of six sizes of Cone or Roll shape, Wall, Pedestal or Console speaker. You can build it in less than an hour. Stattle materially reduced—winter results all summer.

The "World's Finest Loud Speaker"

Now within the means of every one. At your dealer's or direct from any of the offices listed below. Send check, money order or C.O.D. Shipping charges paid. Absolute (money-back) guarantee

Engineers' Service Company

25 Church Street, New York
73 Cornhill, Boston
28 E. Jackson Blvd., Chicago
331 Bay Street, Toronto

25 Cents
Brings ALL THIS!

One Official Blueprint of the Five-Tube Diamond of the Air

One official booklet describing in detail how to build this famous set, wind coils, etc.

Act Now! Send That Quarter to
RADIO WORLD

145 West 45th Street, New York City

COMPLETE LIST OF STATIONS appeared in Radio World, dated Aug. 5, on receipt of 15c., or start your subscription with that number. **RADIO WORLD**, 145 West 45th St., New York City.

Be sure to take **RADIO WORLD** along with you on your vacation, or read it while you are at your summer home so that you will not miss a copy; send \$1.50 for three months subscription and **RADIO WORLD** will be sent to you all summer. **RADIO WORLD**, 145 W. 45th St., N. Y. C.

FILL OUT AND MAIL NOW
SUBSCRIPTION BLANK

RADIO WORLD

RADIO WORLD

145 West 45th Street, New York City
(Just East of Broadway)

Please send me **RADIO WORLD** for months, for which

please find enclosed

SUBSCRIPTION RATES:

Single Copy \$.15
Three Months 1.50
Six Months 3.00
One Year, 52 Issues 6.00
Add \$1.00 a Year for Foreign Postage; 50c for Canadian Postage.

Wire Resistors Wound New Way for Power Duty

With the demand for power resistances for battery eliminators and electrified receivers, much interest was provoked in engineering circles relative to the best method of obtaining a resistance capable of dissipating a large amount of energy; one which would possess a negligible temperature coefficient, positive, if present, and one which would not require a large amount of space. It was generally admitted that the first two requirements would be easily fulfilled by the use of

wire for the resistance element, but the conservation of space called for much more ingenuity.

It was up to Henry G. Richter, chief engineer of Electrad, Inc., to devise a new method of winding wire for power resistances, since this organization was one of the most interested in the development of power resistances, and was greatly in need of a new type of power resistor. Having decided that wattage dissipation and negligible temperature coefficient could be obtained with wire wound resistance, he set himself to the task of devising a new method of winding the wire so that a large value of resistance could be obtained in a small space. After a great deal of experimentation, he thought of the system now employed in their variable power resistor, known as Truvolt.

Why not wind the resistance wire around a very thin, round flexible support and then wind the support around the final winding form.

By first winding the resistance wire around the thin winding form he could obtain a far greater value of resistance in a certain amount of space. Whereas the periphery of one turn around the large winding form, when the wire was wound in the conventional manner, would possess resistance value of 20 ohms, the new arrangement would possess 20, 40 or even 50 times as much resistance. This was tried. It proved to be an immediate success. The result was a 50,000-ohm resistance rated at 25 watts, with a total length of only 2 inches and an outside diameter of only 9/16 inch; a 25,000-ohm resistance rated at 50 watts with a total length of 4 inches and an outside diameter of only 9/16 inches; and a 25,000-ohm resistance rated at 75 watts with a total length of 6 inches and an outside diameter of only 9/16 inch.

VICTOREEN
Super Coils
Send for Folder
Geo. W. Walker Co.
6528 Carnegie Avenue
Dept. B Cleveland, O.

2100 intelligent questions
2100 correct answers
Ratings of 62 celebrities
and
THE SUPER-TEST
Ask Me Another
2
Series
The second question book
THE VIKING PRESS

Sent, postpaid, for \$1.60

THE COLUMBIA PRINT

145 West 45th St., New York

Table Gives Rating of the Trickle Charger

The type of charger to use depends on the average number of hours per day or other unit that the set is to be used. Taking the average number of hours of use per day, the charger requirements would be as set forth in the following table for 1 3/4 amp. set:

Daily Hours	Trickle Charge Rate
5	1/2 ampere
7	3/4 ampere
9	1 ampere
11	1 1/2 amperes
13-15	2 amperes

Make any Good Receiver

BETTER

CC
TUBES

C.E. MFG. CO.
Providence R.I.



TELL YOUR NEWSDEALER

to save you a copy for each week you are away on your vacation, so that when you return you will have a complete file of Radio World. If you require any summer numbers of this paper, send 15c for each issue desired to Circulation Manager, Radio World, 145 West 45th St., N. Y. C.

A Great Deal for a Very Little!

Ordinarily This Seems Too Good to Be True, But Here Is An Instance of Complete Verification



The New De Luxe Model Bretwood With Condenser Attached

WHEN you are deciding on what parts are to go into the receiver you are about to build, under no circumstances dismiss the grid leak with only casual consideration. Respect the grid leak as something well worthy of expert choice.

The best course is to select a variable grid leak with an ample resistance range, one that may be mounted on baseboard, sub-panel or front panel, as you prefer.

Such a leak is the BRETWOOD VARIABLE GRID LEAK, which is now on the market in new de luxe model, representing improvements in mechanical strength, electrical efficiency and utility.

Higher Efficiency

You should use a variable grid leak like the

North American Bretwood Co.,
145 West 45th Street, New York City.

Gentlemen: Enclosed find \$1.75. Send me at once one De Luxe Model Bretwood Variable Grid Leak on 5-day money-back guarantee. (Or \$2.25 for leak with grid condenser attached.)

NAME

ADDRESS

CITY STATE.....

Inquiries Solicited from the Trade

BRETWOOD VARIABLE GRID LEAK in a set you are about to build, or should put one in your present receiver, because it will enable you to get highest operating efficiency from the detector tube. As nearly all tubes used as detectors draw grid current, the resistance value of the leak is important for biasing and discharge purposes. Not only can exactly the right degree of flow be established to discard excess electrons, but the grid-to-filament impedance is so affected as to afford best selectivity under the circumstances. Only a variable leak gives this precision choice.

You prevent overloading of the detector tube by correct leak setting. This improves tone quality considerably. Often if your set sounds distorted, this is immediately and permanently remedied. Hence you reap greater volume, better selectivity and purer tone quality—all by the simple insertion of a BRETWOOD DE LUXE MODEL VARIABLE GRID LEAK.

Selected by Bernard

This efficient instrument so struck Herman Bernard that he prescribed it for his latest and most popular circuit, Radio World's Universal Four-Tube Receiver.

The BRETWOOD DE LUXE MODEL VARIABLE GRID LEAK costs \$1.75—a small enough price for so much efficiency. If desired, a .00025 mfd. BRETWOOD BULLET CONDENSER is supplied, mounted on the leak, at 50 cents extra.

Note: The Bretwood Leak's range is .25 to 10 meg.

Dealers: Send in your orders direct!

B. S. T. CONE SPEAKER

Guaranteed to give Satisfaction in
Tone, Volume and Appearance
Adjustable to Volume Desired

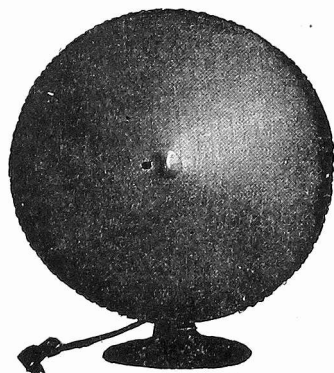

18 inches in diameter edged in Gold Braid, Art Metal Base can be placed on highly polished surface without danger of scratching.

Immediate
Delivery

\$7.50

Shipped Direct
from Factory

Satisfaction Guaranteed or Money Back

GUARANTY RADIO GOODS CO.

145 West 45th St., New York

Your Light Socket
 supplies
 all the Power

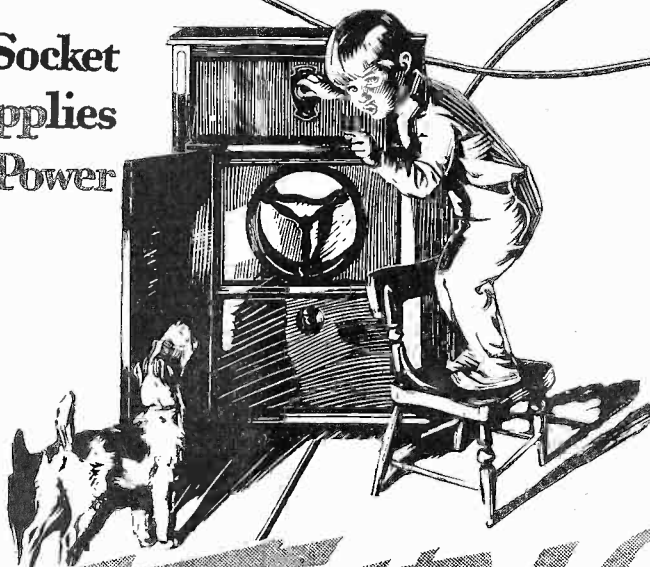

THE
ELECTRIC
RADIO

THE RADIO YOU'VE BEEN WAITING FOR

The Thrill of a Life-time!

Always Ready ~ Always Right

NO EXCUSES — NO BATTERIES — NO ACIDS
 NO MAKESHIFTS — NO WATER — NO TROUBLE

The *New AC Tubes* and scientifically developed circuit allow you to merely

plug in your light socket and listen

The cabinet, panelled entirely of genuine mahogany, contains a large cone speaker mounted on a Baffle Board, which is placed in a remarkably resonant tone chamber, rendering exceptionally fine tone quality and "true-to-life" reproduction.

\$175.00

COMPLETE
 READY TO
 OPERATE

A Freshman development—licensed under patents;
 RCA—General Electric Co.,—Westinghouse
 Electric & Mfg. Co. and American Tel. & Tel. Co.

Sold on Convenient Terms
 by Authorized Freshman Dealers

Six tubes ~ One Control
FRESHMAN
MASTERPIECE

CHAS. FRESHMAN CO. Inc., Freshman Building, New York