

JAN. 30 *Diamond of the Air Stirs the Nation* **15 CENTS**

RADIO WORLD

Vol. 8. No. 19 *Illustrated*
**EVERY
WEEK**



POWELL CROSLLEY JR.

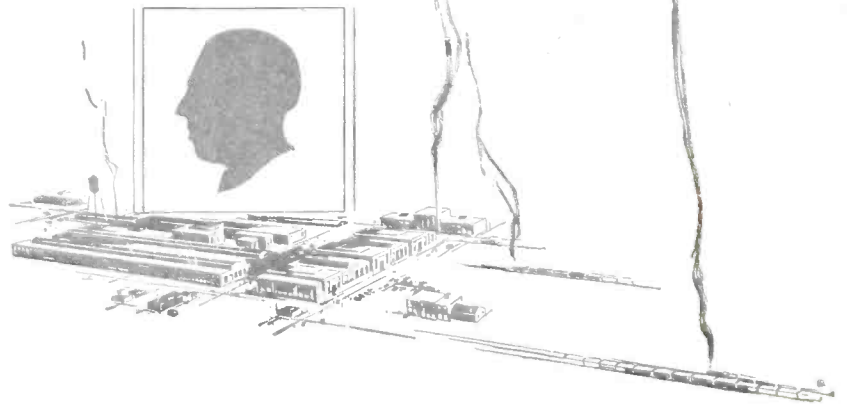

INDUSTRIALIST *Pioneer Radio Builder*

At a time when products of his manufacturing genius were already known to millions, Powell Crosley, Jr., boldly diverted his energies to the development of radio reception, then scarcely known beyond the laboratory walls.

Pioneering both in engineering trends and manufacturing practices, Mr. Crosley has been a vital factor in making radio and broadcasting as much a part of American life as motion pictures and the motor car.

There is scarcely a milestone in the development of popular radio on which his shadow has not been the first to fall. And his announcement of December 26th concerned a milestone that dwarfed all others in its importance — *four entirely new radio receiving sets:*

The Crosley 4-29 (4-tube).....	\$29.00
The Crosley 5-38 (5-tube).....	38.00
The Crosley R.F.L.-60 (5-tube)..	60.00
The Crosley R.F.L.-75 (5-tube)..	75.00

These are now being demonstrated by Crosley dealers and will be completely described in a forthcoming issue of the Saturday Evening Post.



RADIO WORLD

[Entered as second-class matter, March, 1922, at the post office at New York, N. Y., under the Act of March 3, 1879.]

A Weekly Paper Published by Hennessy Radio Publications Corporation from Publication Office, 145 West 45th St., New York, N. Y. Just East of Broadway. Phones: BRYant 0558 and 0559.

Vol. VIII. No. 19. Whole No. 201

January 30, 1926

15c per copy, \$6.00 a year

An Individual AF Amplifier

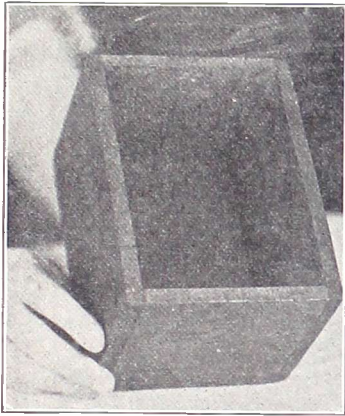

FIG. 1—Get some small boards, about $\frac{3}{8}$ " thick, and make a little box about $6\frac{1}{2}$ " long by $5\frac{1}{2}$ " wide by $4\frac{1}{2}$ " high. The size need not be exactly as given, but do not make it any smaller than this. After the box has been finished and suitably stained the desired color mount the parts.

By *Herbert E. Hayden*
Photographs by the Author

A 2-STAGE transformer-coupled audio-amplifier that can be added to any detector circuit is diagrammed on this page. This may be housed in a box $6\frac{1}{2}$ " long, $5\frac{1}{2}$ " wide and $4\frac{1}{2}$ " high. When the parts are assembled and the wiring completed the audio-amplifier will afford speaker reception on any signal that is audible in the earphones at the detector output.

To hook up a 1-tube set, which is in separate cabinet, to operate a speaker with this amplifier, connect the top of the detector tube to the P or Plate post of the audio-transformer, the B or Pos. B. post of which goes to B plus detector voltage.

Use the Same Type of Tubes

You will naturally desire to use tubes in the audio-amplifier of the same kind as the detector tube, because you will want to employ the same A battery source. If you are using the 99 type of tube as the detector, with a $4\frac{1}{2}$ -volt source, then you may easily employ the 120 type tubes in both audio sockets. This is all right, even though the tube is marked "last audio stage." No matter what type of tubes you use probably you will want to include a C battery, and this is shown in Fig. 1. The battery may be contained inside the cabinet of the amplifier, or if more C bias is needed than battery space permits inside the cabinet, introduce flexible leads through the rear cabinet wall and thus connect to the C battery.

The audio-amplifying tubes are (1) for first audio and (2) for second audio. Across the phones at the speaker con-

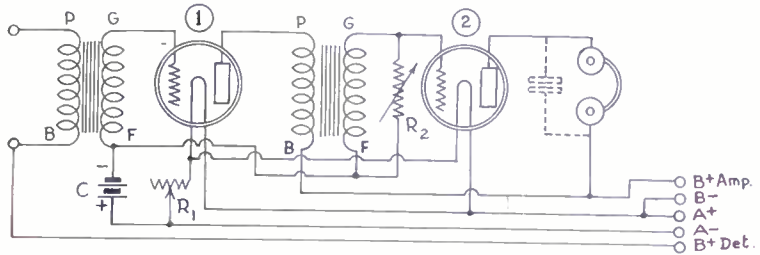

THE WIRING DIAGRAM of a 2-stage audio-frequency amplifier, using transformers. R2 is a volume control.

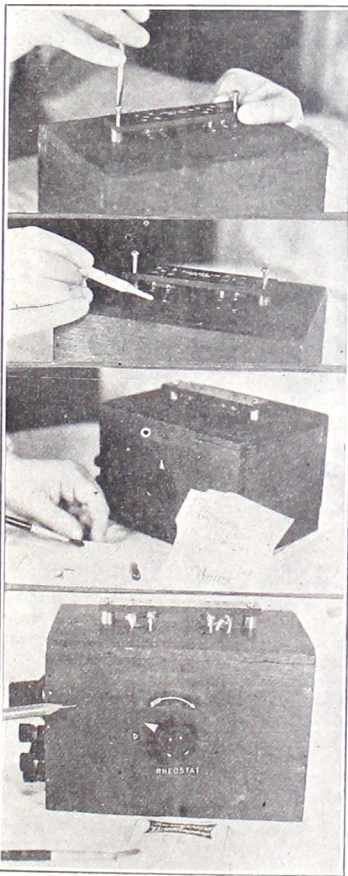

TOP TO BOTTOM, Figs. 2, 3, 4 and 5.

nection, symbolized by earphones in the diagram, one may use a fixed condenser, the value depending on the speaker, but usually .001 mfd. will suffice. With cone speakers .05 mfd. has often proven excellent in avoiding rattling.

Volume Control Used

A volume control is included in the hookup. It is R2, a variable resistance,

which may be a Clarostat, as shown in the photographs. One rheostat, R1, controls both audio tubes.

The audio-transformers may be of any sensible ratio, the characteristic of a transformer being more important than the ratio. As a rule, the more you pay for the transformer, the better the quality of the amplified signal. Transformers that cost next to nothing are worth less than that.

If different ratios are used, put the higher ratio in the first stage. Many manufacturers are making transformers of only one ratio for any stage. In constructing the amplifier shown in the photographs I used a 6-to-1 in the first stage and a $4\frac{1}{2}$ -to-1 in the last stage.

Constructional Data

As for the construction, make the cabinet first. Then mount the parts.

The first thing to mount is the 2-gang UX socket strip, as this little amplifier is desired to give a powerful smooth amplification, and the new UX 120 Tubes are employed, using the same A battery (dry cells) that is used to energize the filaments of the tube used in the tuning unit. The strip socket is very easily mounted (Fig. 2) using the two wood screws supplied for the purpose, and likewise the two thick washers also shown in the photograph. The washers raise the socket strip up from the surface of the box about $\frac{1}{2}$ ".

Holes For Socket Leads

Next drill eight holes with a No. 27 drill right alongside the socket terminals. (Fig. 3). This is done to allow the connecting wires to be brought down neatly in the interior of the box, to be connected to the other parts of the apparatus, as shown in the wiring diagram. The pencil points to the proper place for drilling.

Select one side of the box (Fig. 4) and after locating the center, drill a $\frac{3}{8}$ " hole, and mount the volume control.

Just underneath the volume control mount the binding posts for connection to the necessary batteries as shown, and also the two input binding posts, which are to be connected to the phone posts of the receiver by the use of a 2-conductor flexible connecting cord. Then up a little bit, and to the right, two more posts marked phone, or they may be marked Amp.

This photo also shows how the UX 120
(Continued on page 33)

Eleven Notables at the Convention

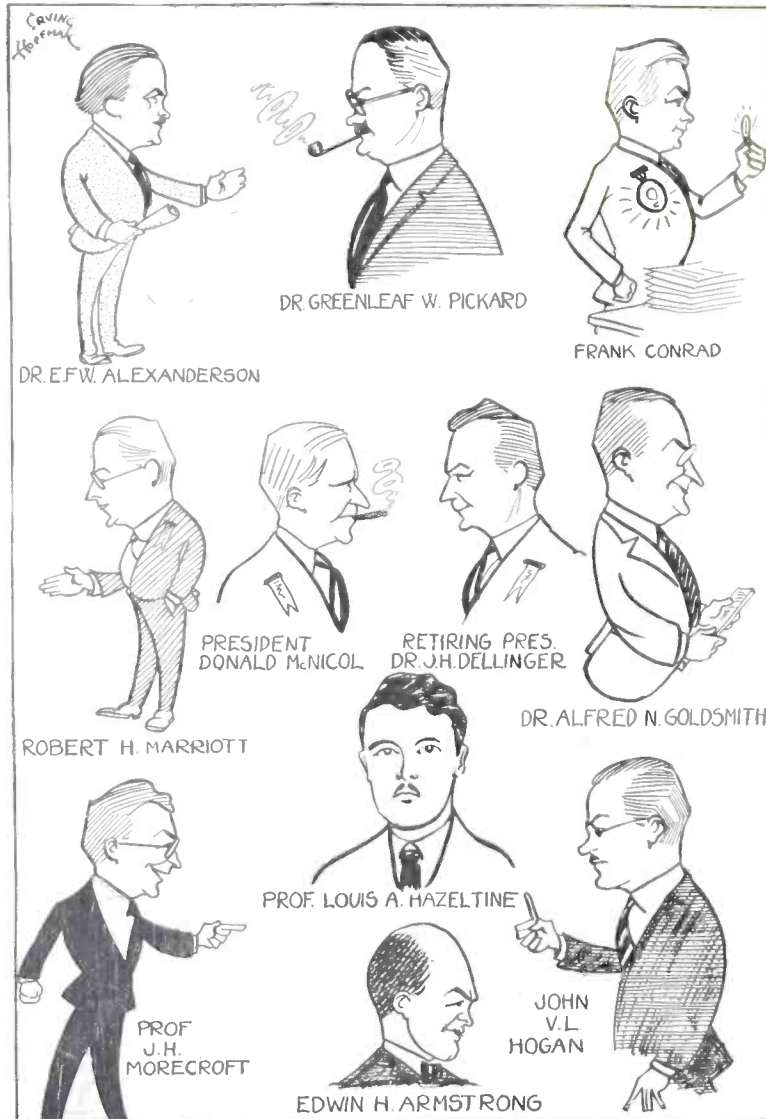

Radio Institute Hears Alexanderson, Dellinger, Pickard

Frank Conrad, of KDKA, received the \$500 Liebmann Memorial prize for pioneer work in short-wave transmission, at the annual convention of the Institute of Radio Engineers in New York City. Dr. John Howard Dellinger, retiring president, spoke. He is chief of the Bureau of Standards Radio Laboratory. Then Donald McNicol was installed as president.

The prize consisted of a year's income from a \$10,000 fund created by Morris Liebmann to be awarded "for the best contribution to the advancement of radio during the past year or in recent years."

Tribute by Dellinger

Dr. J. Dellinger said the prize was "a tribute to the amateur and his pioneering spirit." Mr. Conrad's work, he declared, constituted "the most important step since the discovery of radio itself, because upon it rests the whole structure of present-day broadcasting."

From his amateur experimenting, Mr. Conrad went to the Westinghouse Company in Pittsburgh, where he had charge of the erection of KDKA, said to be the first broadcasting station in the world.

Only two great problems remained in radio today, Dr. Dellinger told the 500 delegates. They were the perfection of broadcasting and "the solution of the mystery of wave phenomena."

Working toward the latter, Greenleaf W. Pickard, consulting radio engineer, in a paper on "Polarization of Radio Waves," outlined experiments which indicated that the direction of waves as obtained by radio compass could not be relied upon.

Goldsmith Honored

Dr. E. F. W. Alexanderson said that Dr. Pickard's work and experiments of his own all indicated that radio waves "twisted" in the ether, which might explain many of the annoying phenomena that handicap radio today.

A framed testimonial in appreciation of his work in radio was presented to Dr. Alfred N. Goldsmith, of the R. C. A.

Mr. McNicol said that "the present demand for radio channels far exceeds the present available channels. The ether, like the ocean, is there to be used, and the engineer's task is to invent and develop carriers which may traverse the element independently, safely and without causing damage to each other."

Other newly elected officers were Dr. Ralph Brown, Vice President; Dr. Dellinger, Junior Past President; Dr. Goldsmith, Secretary, and W. F. Hubley, Treasurer.

Stations Want

More Power WASHINGTON.

Since the Fourth National Radio conference there has been a big increase in applications for increased power among stations. The policy of the Department in dealing

with these applications is to grant an increase of power when it would be beneficial to the public and not result in interference. In large cities where there are a number of stations of high power already in operation, the power increase is not likely to receive favorable conditions unless experiments definitely prove that interference would not result.

Radio Movies Wait Only on Speed Kink, Says Bowles

CAMBRIDGE, MASS.

The near future holds forth the prospect of radio movies, said Prof. Edward L. Bowles of the Massachusetts Institute of Technology.

Prof. Bowles, who won wide recognition for his research in electrical communications, particularly radio, told an audience at the institute that motion pictures in silhouette already had been transmitted successfully by radio.

It remained, he said, for engineers to

perfect the process so that movies as seen on the screen might be broadcast from studio to home.

The greatest difficulty to overcome, he said, was the speeding up of the present process. Reproduction of all light and shade values was necessary, and in perfecting the process it would be necessary to transmit one "still" every sixteenth of a second to produce the effect of motion, Prof. Bowles declared.

He is experimenting himself.

Cleaning Up Soldering Job

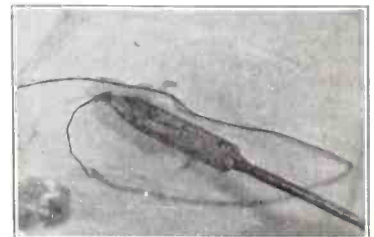

WHEN soldering a wire outside a set, if the flux is too plentiful, put a piece of blotting paper underneath, and this will take up excess oil. Note the resulting stain on the blotter.

High Mu and Power Tubes

Why Resistance and Impedance Coupled Audio Hookups Give More Volume When High Mu Tubes Are Used—This Type Never Suitable in the Last Stage—Voltage and Power Amplification Compared and Applied to Tube Characteristics.

By F. R. Jolin

THE advent of the resistance coupled audio amplifier has brought about the development of a type of tube different than that to which the fan has been generally accustomed. This is the high mu tube, the tube with the high amplification constant. ("Mu" does not stand for mutual conductance). That this type of tube is superior to the standard, so long the favorite, has been conclusively demonstrated, but the reason for this superiority is a matter of conjecture among radio fans. And since the utility of the tube is definitely limited to resistance and impedance coupled amplifiers in all stages except the output, the enigmatism is still further increased.

Tube Characteristics

Now, to make possible the comprehension of this tube design it is necessary to dwell upon the operating characteristics of the three element vacuum tube as an amplifier. It is a well known fact that the tube is an amplifier; that an alternating electromotive force impressed across the grid-filament circuit will be amplified in the tube, and an amplified emf and current be noticeable in the plate-filament circuit. These two circuits are shown in Fig. 1. The extent of this amplification is equal to the amplification constant of the tube, usually expressed by the term "mu." Continuing, the operating characteristic of the tube is such that in the amplified alternating emf current in the plate circuit, we can obtain either a preponderance of amplified current or voltage, depending upon the resistance or impedance in the plate circuit. As the resistance or impedance in the plate circuit is increased towards in-

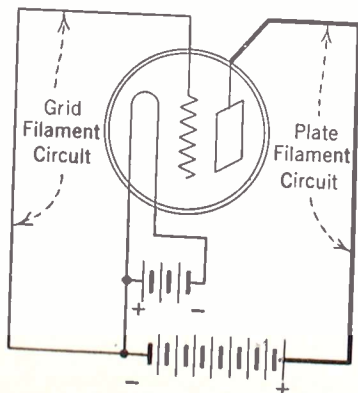

FIG. 1

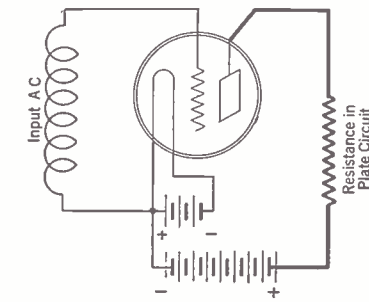

FIG. 2

finity, the voltage amplification obtainable with the tube increases.

The Infinite Impedance

That is the preponderance of voltage in the combination of amplified alternating voltage and current in the plate circuit gradually increases until the maximum voltage amplification and minimum current amplification is obtained. This condition exists when the external plate impedance is infinite. The fluctuations of the applied grid voltage will cause the maximum amplitude of amplified alternating voltage in the plate circuit, the value of the amplification being equal to the maximum amplification constant of the tube. The closer the value of the plate impedance to infinity the higher the voltage amplification obtainable with the tube, until the external impedance is infinite, when the voltage amplification is maximum.

For example, if we have two tubes, one with an amplification factor of 8.5, and another with an amplification factor of 20, and we apply the same value of alternating emf to both grids with infinite external impedance in the plate circuits of both tubes the amplified alternating voltage in the plate circuit of the 20 tube will be greater than that in the plate circuit of the 8.5 tube. The amplified alternating current in both instances will be minimum.

Needs of High Mu

Hence when the design of an amplifying unit is such that a high resistance is in the plate circuit of the tube, and we are to amplify a certain signal, it is most advantageous to use a tube with a high amplification constant value, for in this way we obtain the maximum voltage amplification. Obviously the use of a tube with a low amplification constant value under these conditions is inferior.

Furthermore since we obtain the maximum voltage amplification only when the external plate impedance is infinite, we can obtain only a certain percentage of the maximum amplification when the external plate impedance is finite, hence the tube with the highest amplification constant will afford the greatest voltage amplification when the resistance in the plate circuit is finite, of a certain value, and voltage amplification is desired. This condition is existent in the present-day resistance coupled audio amplifier, the coupling resistor in the plate circuit being the finite external plate resistance. So the high mu tube is superior to the standard tube with a low mu when used in a resistance coupled audio amplifier. Hence the development of the high mu tube for resistance coupled amplification. (Fig. 2).

No High Mu for Output

Fans have no doubt noticed that high mu tubes are never used in the output

Bulb Functions As a Power Amplifier When the External Plate Impedance Is Decreased Until It is Equal to the Internal Plate Impedance.

stage of any audio amplifier; that a power tube with a low mu is usually recommended. Also that a standard tube with a mu of 8 or 8.5, other than the semi-power or full power tube, affords greater output in the last stage than the high mu tube. This, too, is puzzling and its explanation brings us back to the operating tube characteristics again. This time we are concerned with power amplification rather than voltage amplification.

There is in addition to the amplification constant of a tube factor which enters into the design of the tube and amplifier. This is the internal plate to filament impedance or resistance of the tube, or the internal resistance between the filament and plate when certain potentials are applied to the grid, filament and plate. We made mention in a previous paragraph that the load impedance in the plate circuit was a governing factor in determining the preponderance of the alternating voltage or current in the plate circuit.

Unequal Results

As the load impedance is decreased the voltage amplification decreases and the grid voltage fluctuations cause an increase in the alternating plate current amplitude. And if we continue to decrease the external plate impedance until it is equal to the internal plate impedance, the alternating voltage and current in the plate circuit will reach certain proportions relative to the amplification constant of the tube, the plate current being maximum, but the greatest amount of power within the tube will be transferred from the tube to the external circuit. Under these conditions the tube is functioning as a power amplifier rather than a voltage amplifier (Fig. 4). In this diagram R is the internal plate to filament impedance and Z is the external impedance, which under operating conditions in the output stage of an audio amplifier is equivalent to the impedance of the loud speaker winding.

The Boosting Effect

Now, the transfer of power between two circuits is such that if the impedance of the source is much greater than the impedance of the load, a very small percentage will be transferred, the transfer curve being very steep, as the load increases until it reached that of the supply.

(Continued on page 31)

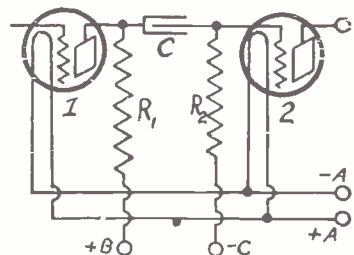

RESISTANCE-COUPLED audio. R1 is the plate resistor, R2 the leak. C is the coupling condenser. Tube 1 requires a high mu tube, while tube 2 if the last stage, should have a low-mu tube. (Fig. 3).

Litz O. K.,—All But the Price

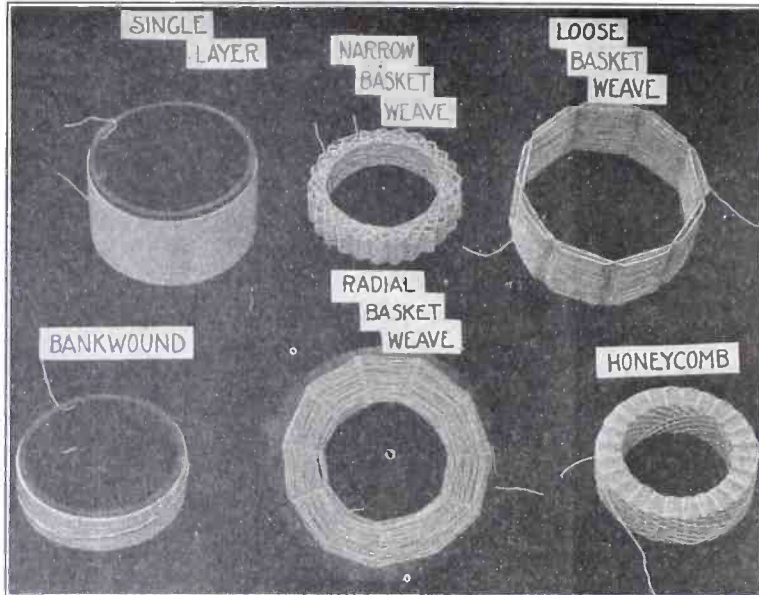

THE six types of coils tested and compared by the Bureau of Standards. The radial basketweave is more commonly known as the honeycomb. Note the difference between the loose basketweave and the narrow basketweave.

No. 24 DCC Wire Costs Less Than One-Fifth As Much and Is of About the Same General Usefulness—RF Resistance of 32-38 Litz Compared with That of No. 28 DCC Wire.

By *Sidney E. Finkelstein*
Associate, Institute of Radio Engineers

GR^{EAT} interest was manifested by radio fans in the coil report of the Bureau of Standards, fully reviewed in the January 16 issue of *RADIO WORLD* by Herman Bernard. The tests were made from 1,500 kilocycles to a little less than 300 kilocycles, as the curves on the opposite page show, but the object was mainly to reach determinations for the broadcast range, 550 to 1,500 kilocycles (about 545 meters to about 200 meters).

Litz Finding is Outstanding

An outstanding point is the analysis of the effect of litz. This wire was 32 strands of No. 38 enamelled double silk covered wire. It was found best for broadcast use, but only a shade better than No. 24 double cotton covered. As the litz wire costs \$2.50 for a quarter of a pound, list price, and the 24 wire costs 35 cents, list price, there will be no rush to use litz. For the coils as tested (60 turns) virtually the entire quarter pound is consumed in winding one loose basketweave coil.

It will be noticed (Fig. 2) that a coil wound on hard rubber tubing, using litz, has a lower high-frequency resistance from about 1,260 kilocycles to 1,500 kilocycles, than has the loose basketweave for that span, using the same kind of wire. But on the higher waves (1,261 to 550 kilocycles) the LBW has a lower resistance, though the difference is scarcely more than 1 ohm at any point therein. At 1,500 kc., however, the difference is 4 ohms in favor of the SLHR.

Two Kinds of Wire Compared

Now, to compare the two kinds of wire (litz and No. 28 DCC), rather than the shape of the coil.

Litz, on a LBW, has a lower resistance at all points than No. 28 wire, LBW, but the resistance difference begins to contract at the lower waves, and at 1,500 kc there is practically no difference. At higher frequencies than 1,500 kc, therefore, the resistance of litz would be greater on this type of winding, although all through the broadcast band it is less. The same advantage of litz prevails, although to a somewhat greater extent, on the SLHR winding form. These are the only two forms necessary to compare to establish the superiority of litz over No. 28.

Another good form of winding is the spiderweb, where litz again shows less resistance at all points than No. 28.

The narrow basketweave also is serviceable, litz showing up much better than No. 28.

It must be remembered that No. 28
(Concluded on next page)

"Hour" Named for Artists, Who Supply the Talent

Station WBPI, Warners' Theatre, New York City, inaugurated a new stunt in honoring artists who appear before its microphone by dedicating an hour's program each week for their own use. The hour will be known under the name of the artist, who is expected to assemble his or her own talent for the special program.

The first to be honored was Joseph Turin, tenor. Turin, besides giving his own renditions, had his own artists. Through this plan, according to Frank Mallen, the director, Station WBPI hopes to increase the quality of radio music.

Cuban Station Asks Vote On Its Wave

WASHINGTON

A new Cuban station, 7SR, at Elia, is now broadcasting every Tuesday and Thursday night at 8:30 p. m. The station is licensed in the name of Salvador C. Rionda and uses 500 watts power. No definite wavelength has been assigned, but the station has the authority to use any wavelength between 200 and 360 meters. Listeners are requested to suggest a wavelength that will not interfere with their local stations. Those hearing the station may cooperate by writing direct to Mr. Rionda.

He will answer all letters.

U. S. to Broadcast Farm Facts Through Peppy Personalities

WASHINGTON.

The vast fund of popular and scientific agricultural information that originates on the farms and in the laboratories of the United States Department of Agriculture will soon be tapped in a new place. This is the announcement made by Sam Pickard, chief of the newly created radio service in the department. Steps will be taken immediately, he said, to furnish a variety of agricultural program material to commercial broadcasting stations serving farmer audiences.

Much of the material furnished by the radio service will be prepared for presentation in a radically different manner than the present almost universal practice of reading manuscripts. Broadcasting stations cooperating will be asked to provide personalities who have unmistakable qualifications to voice the information and material which in most cases will be presented in popular style and in the form of dialogue or questions and answers.

"Uncle Bert," the garden expert, one of Mr. Pickard's phantom characters, will

entertain and instruct the boys and girls of the Radio Order of Junior Gardeners with nature-study information. Some of the juniors themselves will be heard over the radio as they ask questions of Uncle Bert.

"Fifty Farm Flashes" will soon be offered as a regular feature on the air. The "flashes" will consist of interesting current information sought by farmers through the several thousand letters received each week by the department.

Other special feature programs are under consideration, among which are the "Housekeeper's Half-hour," and the "National Farm School." In the latter the farm will be considered as the student's laboratory. Timely lecture courses which dovetail with the daily farm work will be developed, and laboratory assignments will be made which necessitate putting into practice the subject matter taught. These will be supplemented with a file of bulletins dealing with the subject matter broadcast.

The service starts forthwith.

Resistance of Litz Compared with 28 DCC

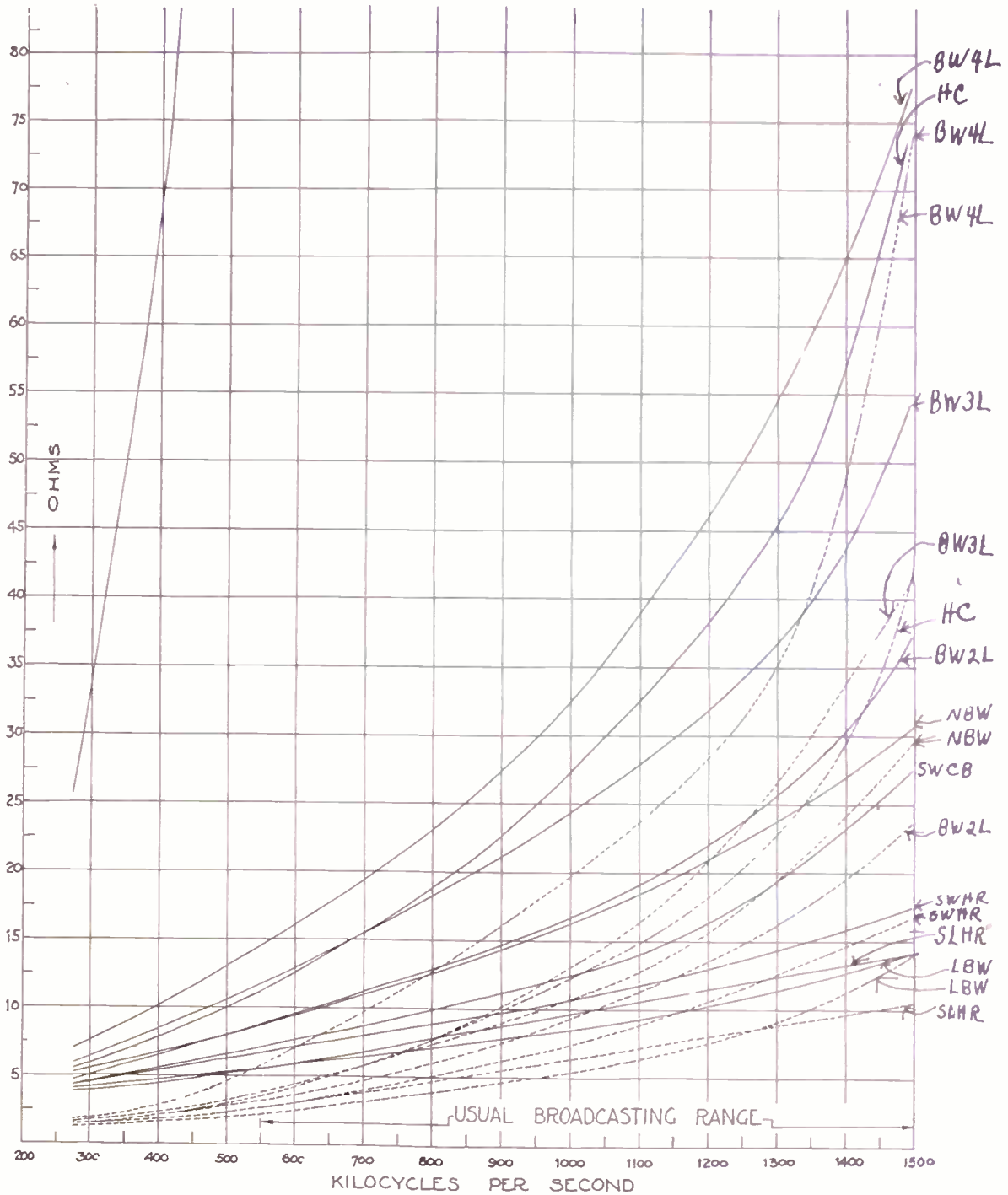

LITZ, 32-38, is contrasted with No. 28 DCC wire in the above curves, the wires being compared in different forms of winding. SLHR = single layer hard rubber; LBW = loose basket weave; SWHR = spiderweb on hard rubber; BW2L = bank wound, 2-layer; SWCB = spiderweb on cardboard; NBW = narrow basket weave; HC = honeycomb. The 2-layer solenoid is shown at extreme left. Dotted lines indicate Litz wire. (Fig. 2.)

(Concluded from preceding page)
 wire is used for comparison with litz and that if No. 24 is used the difference will not be so great. The 32-38 litz corresponds to No. 23 wire in cross section, but No. 23 is not readily procurable.

A Bad Coil

The two-layer solenoid, the curve of which is shown at left in Fig. 2, is a bad

kind of coil. Note how high its resistance is, even at 425 kc (nearly 90 ohms).

The honeycomb coil makes a poor showing for broadcast work. The resistance is about 73 ohms at 1,500 kc where No. 28 DCC wire is used, although at the lower frequencies the showing is very much better. For long-wave work (above the broadcast waves) honeycomb coils

are efficient. Where litz honeycomb is used, the showing is better for broadcast work.

The findings in respect to litz contradict previous reports of the Bureau of Standards in fixing the points where litz resistance is higher than that of solid wire. Within the broadcast band litz always shows a lower resistance.

Trapping Out Super-Power

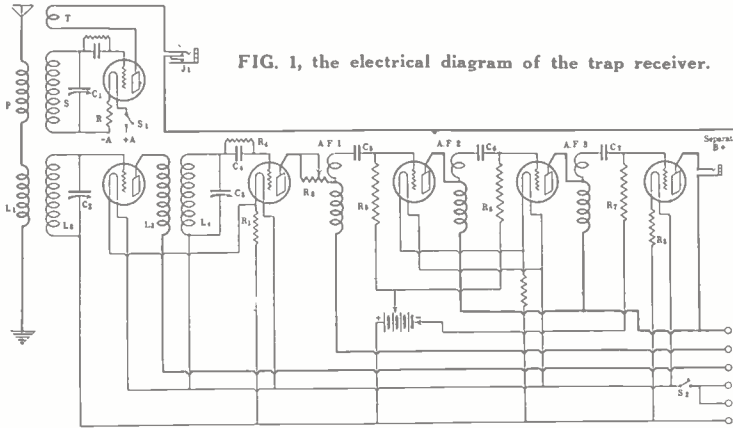

FIG. 1, the electrical diagram of the trap receiver.

By Capt. P. V. O'Rourke

IN Fig. 1 we have the schematic electrical diagram of a receiver designed for eliminating the signals from an interfering local station using high power, such as using 50 KW is often very troublesome as WJZ, Bound Brook, N. J. This station to some fans in and near New Jersey. A regenerative wavetrap designed by John F. Rider and described in the December 26 issue of RADIO WORLD, is used as the eliminator unit. The receiver proper employs five tubes. The detector and the radio-frequency amplifier tubes are non-regenerative. The autotformer method of coupling is used in the audio-frequency amplifying circuit, but any other desirable audio hookup may be substituted. Instead of rheostats, ballast resistors are employed to control the filaments of the tubes. A C battery is on the grids of the audio-amplifying tubes. A resistance is placed in series with the plate of the detector tube, so that the voltage may be regulated, hence volume controlled. There are only two major controls on the master receiver, while there are two controls on the trap unit.

Beside the fact that the trap unit is used to rid the receiver of interfering signals, the same unit may be used as an individual receiver. This unit employs a 3-circuit tuner. A receiver of this type is great for earphone reception of DX signals. The 5-tube set is so arranged that only the loud speaker can be used. When all the locals are off the time for listening to DX is best. However, if you do not wish to disturb any one at that late period of the night or probably that early period of the morning with the loud speaker going, the phones plugged in the trap unit plate circuit serves the purpose. Of course the 5-tube master receiver is a good DX getter.

The Coils

L1 and P the primaries contain 6 turns. The secondaries L2, L4 and S each contains 45 turns. To wind these coils a form $3\frac{1}{4}$ " in diameter and 4" high is required. No. 24 double cotton covered wire is to be used. Between the primary and the secondary windings, leave a $\frac{3}{8}$ " space. The tickler, T, contains 30 turns of No. 26 single silk covered wire. This is wound on a form $2\frac{3}{4}$ " in diameter and 2" high. When winding the tickler leave a $\frac{3}{8}$ " space between the 15th and 16th turns. This is for the tickler shaft. The primary winding L3 of the second radio-frequency transformer consists of 12 turns. When winding these coils be sure that all the windings are in the same direction.

The number of turns on all the second-

aries holds true, only if .0005 mfd. variable condensers are shunted across. These .0005 mfd. condensers may be of the SLW or SLC type. If they are of the SLF type, then place 5 more turns on these secondaries.

Placing the Parts

A 7x21" cabinet should house the master receiver while a 7x10" cabinet may house the 3-circuit tuner trap receiver. To combine in one unit use 7x24". It is feasible to place the trap circuit in the same cabinet with the master receiver, the only point being that this prevents the use of this unit in connection with any other receiver, should such be your preference.

As to the master receiver it is not advisable to use a socket strip to mount the autotransformers, sockets, condensers, etc., as the material is too heavy for such support. Therefore a baseboard nearly as long as the panel, and 8" deep should be used. Now, as to the drilling of the panel which automatically places the condensers. The holes for the variable condensers are 3" from the respective ends of the panel, or one at the right and one at the left hand side of the panel. The rheostat and switch are at the center, or $10\frac{1}{2}$ " from both the right and the left hand side of the panel. The hole for the variable resistance, R8, is $3\frac{1}{2}$ " from the bottom of the panel. The hole for the switch is $\frac{3}{4}$ " from the bottom of the panel. This means that there are only four major holes to be drilled on the panel, beside the small holding holes. The radio-frequency transformers should be placed in back of the condensers, which shunt their secondaries, of course, at right angles to each other. The autotransformers, grid resistances and blocking condensers may be placed according to the discretion of the builder. There is no special manner in which these parts have to be placed.

Now as to the trap unit. The best way in which to mount the condenser tuner and switch, is to have the condenser and tuner holes about 2" from the ends, with the switch in the center, $3\frac{1}{2}$ " from the bottom and the top.

Wiring the Receiver and Trap

The wiring of the master receiver will be first attended to. The beginning of the tuner primary, P, goes to the antenna post on the terminal strip. The end of this winding goes to the beginning of the primary winding, L1, of the radio-frequency transformer. The end of this winding goes to the ground binding post on the terminal strip. The beginning of the secondary winding, L2, goes to the rotary plates of the variable condenser, C2, and to the A- post on the terminal

LIST OF PARTS

- Two tuned radio-frequency transformers, L1L2, L3L4.
- One 3-circuit tuner, PST.
- Three .0005 mfd. variable condensers, C1, C2 and C3.
- Two .00025 mfd. grid condensers.
- Two 2-megohm grid leaks.
- Three 500,000 ohm fixed resistances, R5, R6 and R7.
- Three .25 mfd. fixed condensers, C5, C6 and C7.
- Three autotransformers, AF1, AF2, AF3.
- Two $\frac{1}{2}$ ampere ballast resistors, R1 and R2. (Amperite No. 112).
- One $\frac{1}{4}$ ampere ballast resistor, R3. (Amperite 1A).
- One 200-ohm potentiometer, R8.
- Five sockets.
- One 7x10" panel and cabinet.
- One 7x21" panel and cabinet.
- Three 3" dials.
- One 2" dial (for tickler).
- Two filament switches, S1 and S2.
- Two single-circuit jacks.
- One terminal strip with binding posts.
- Accessories: A, B and C batteries, connecting wire, baseboards, solder, etc.

strip. The beginning of this winding goes to the stationary plates of the variable condenser, C2 and to the G post of the first socket, which will hold the radio-frequency amplifier tube. The F- post on this socket goes to the F- post on the socket which will hold the detector tube. The F+ post of this socket goes to the F+ post on the detector tube socket. The P post on the RF socket goes to the beginning of the primary winding, L3. The end of this winding goes to the B+ 67 $\frac{1}{2}$ post on the terminal strip. The beginning of the secondary winding of the second radio-frequency transformer, L4, goes to the rotary plates of the variable condenser, C3, and to the A+ post on the terminal strip. The end of this winding goes to the stationary plates of the variable condenser, C3 and to one terminal of the fixed grid condenser and leak, C4 and R4 respectively. The other terminal of this combination goes to the G post on the socket which will hold the detector tube. One terminal of R1 goes to the F- post on this socket. This connection also goes to the F- post on the RF socket. The other terminal of this resistance goes to the A- post on the terminal strip. The F+ post on this socket goes to F+ post on the socket which will hold the first AF amplifying tube. You will notice that one resistance controls the filament of both the detector and the RF tubes. The P post on the detector tube socket goes to the arm of a variable resistance, R8. The other terminal of this resistance, which is the post carrying the resistance wire, or whatever the resistance substance may be, goes to the P post on AF1. The B+ post on AF1 goes to the B+ 22 $\frac{1}{2}$ -volt post on the terminal strip. The G post on AF1 goes to one terminal of the blocking condenser, C5. The other terminal of this condenser goes to the G post on the socket which will hold the first AF amplifying tube and to one terminal of a fixed resistance, R5. The other terminal of this resistance goes to a clip, which will connect to a minus post on the C battery. The P post on this socket goes to the P post of AF2. The B+ post goes to the B+ post of AF3 and to the B+ 135 volt post on the terminal strip. This last connection also goes to the bottom terminal

(Concluded on page 30)

Completing the Antennatrol

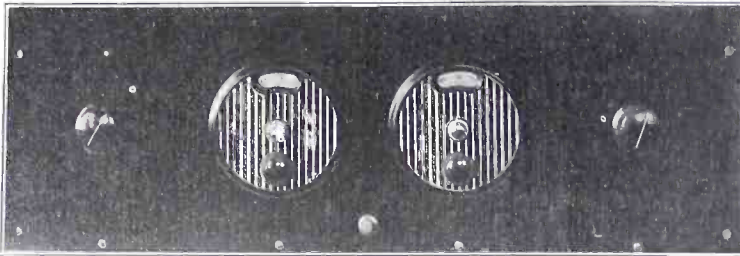

FIG. 2, the panel view. The knob at left turns the rotor plates of condenser C of Fig. 1, published last week (issue of January 23). The knob at right is on the rheostat. The switch is at lower center, while the two main tuning controls are Bruno "Slo-Moshen" vernier dials, actuating two of the three Hammarlund SLF condensers.

PART II.

THE Antennatrol, a 4-tube receiver, the diagram of which was published last week, issue of January 23, tunes the aerial with a variable condenser across a series-connected coil in the aerial lead, while the rotary plates of the condenser are connected to one terminal of the aperiodic primary of the first radio-frequency transformer, L1. The end of that primary goes to ground.

The idea of tuning the aerial is to get maximum signal response. One slight difficulty to be met is getting the coil to have the correct inductance, so that the condenser tuning the aerial, C in Fig. 1 of last week's issue, will be effective over the entire wavelength band. The inductance normally would be less than that of an ordinary secondary in a condenser tuned circuit, for the capacity of the aerial system has been made effective upon the antenna tuner. Therefore if you are using a coil designed for a particular value of condenser, say .000375 mfd., you will find that by using the neutralizing tap on such a coil you will get all the necessary inductance between that tap at the farthest terminal of the coil. The small winding represented by the turns between the other terminal of the coil and the tap may be short-circuited, as may be the small primary winding, if any, which is then ignored.

As aerial capacities differ, no general statement of inductance will suffice. The solution lies in using a coil that, for the highest receivable wavelength, necessitates having rotary plates of the condenser C totally in mesh with the stator plates, that is, full capacity is used. Then the antenna condenser will be effective on the lowest receivable wave, but otherwise it might not be.

Any one who has a coil that proves of too small inductance may alter the wiring as diagrammed, so that the rotor of C connects, not to the end of L, but to the ground.

As a Separate Unit

If the Antennatrol system, as the Fig. 1 method of improving reception is called, is to be installed in conjunction with an existing set, it may be built in on a separate 5x5" panel in a cabinet 5x5x5½". Two binding posts on the rear cabinet wall would suffice for the connections, one post going to aerial and the other to the antenna post of the set. The ground post of the set is joined as usual to ground.

The tubes used in the set were of the 01A type, excepting the last tube (4), which was a power tube, UX112, hence the separate ballast, R41, which was No. 112 Amperite. The use of the power tube accounts for the two flexible C battery leads, one to C minus 4½ (F of first audio transformer), the other to C minus 9 (F of second audio transformer). The

set should be quite free from the oscillation vice at any setting of the condensers, this being due in no small measure to the placement of the parts, particularly the coils.—H. E. H.

(Trouble Shooting next week)

LIST OF PARTS

Three Hammarlund low-loss .000375 mfd. straight-line frequency condensers, C, C1, C2.

Three Hammarlund radio-frequency coils, L, L1L2, L3L4.

One 20-ohm rheostat, R1.

Two No. 112 Amperites, R2, R4.

Four Air-Gap sockets.

Two Modern Symphony audio transformers.

One 7x21" panel.

One 8½x23" baseboard.

Three brass angles to mount baseboard.

Two 4" Bruno "Slo-Moshen" Vernier dials.

One knob, to match rheostat knob, and to be used on C.

One .00025 mfd. Dubilier fixed grid condenser, C3.

One 2-megohm Amsco grid gate, R3.

One pair of phone tip jacks, PTJ.

One A battery switch.

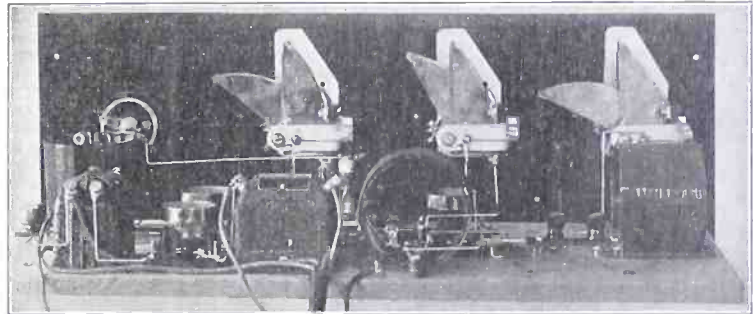

FIG. 3, the rear view. Note how the coils and audio-transformers are mounted. These transformers are modern symphonies.

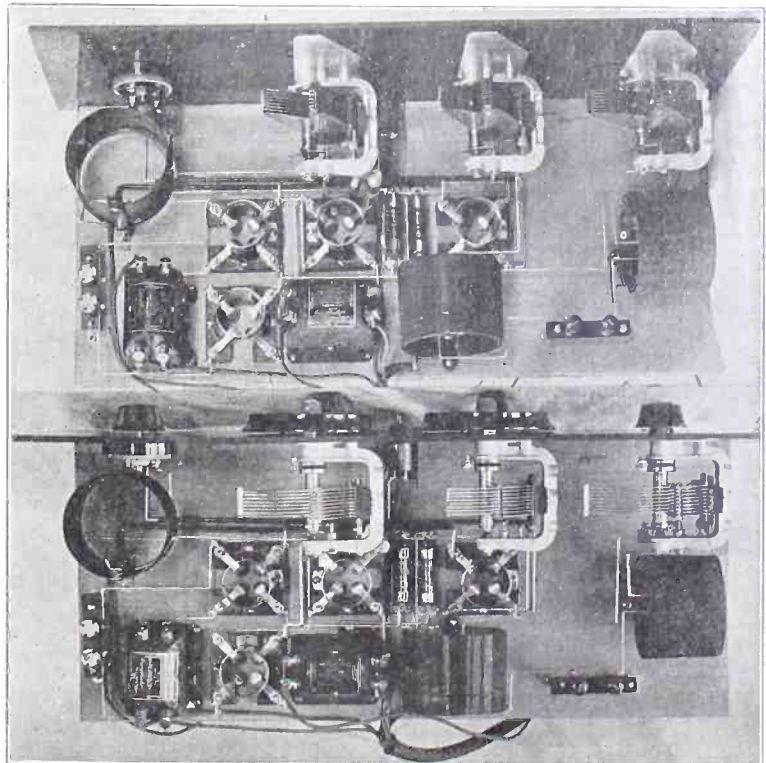

FIG. 4 (top), the top view, disclosing the baseboard layout and neat wiring. Fig 5 shows how the condensers are shielded against body capacity. Note the two amperites (center) and the space in each Airgap socket.

RADIO WORLD'S

Laboratory

Reports for the Guidance of Its Readers

Address problems to Laboratory Director, RADIO WORLD, 145 West 45th Street,
New York City.

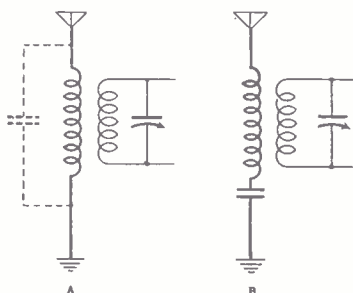

FIG. 1.

A TOPIC of frequent discussion is the series antenna condenser. In fact so often is this remedy prescribed that it would seem to be put forth as the panacea for all radio ills. Poor selectivity, insufficient oscillation, excessive oscillation, instability of operation, distortion and what-not, are remedied instantly by the insertion of the series antenna condenser! Really a wonderful remedy—if it works. But so varied are its effects, that the majority of its users cannot attribute any one phenomena to it.

Now, its application is very simple and the comprehension of its action is just as simple, when considered from the proper angle. Let us forget the condenser for a moment and analyze the circuit wherein the condenser is usually located. We have a primary circuit as shown in Fig. 1 (A). Ignore the secondary circuit that is shown to make more prominent the primary circuit.

Analysis of Primary Circuit

The primary circuit consists of the aerial and lead in, primary inductance and the ground. Since every wire possesses an inductance value the inductances in an aerial circuit consists of what is known as the distributed inductance of the aerial and lead-in proper and the lumped inductance of the primary coil. The differentiation between the distributed and lumped inductance should not be difficult. In a simple way, the inductance of the aerial and lead-in are known as distributed in view of the large distribution of the wire forming that inductance, whereas the wire and inductance of the primary coil are lumped into a small space. The electrical components of the aerial circuit, however, do not consist only of the distributed and lumped inductances, but also of the capacity between the aerial and ground, with the aerial forming one plate and the ground the other plate. This capacity, too, is designated as distributed for the same reason. This distributed capacity is indicated as a condenser, by means of the dotted lines between the aerial and ground.

And since the aerial circuit is composed of inductance and capacity we can illustrate that circuit as in Fig. 2 (A). This is possible in view of the fact that both the distributed inductance of the aerial and lead-in and the distributed capacity between the aerial and ground have definite values. The distributed inductance

of the average single wire receiving aerial approximates 20 to 30 microhenries, and the distributed capacity is often about .00025 mfd. So we can assume C1 in Fig. 2 (A) to be a condenser of .00025 mfd. and L1 a coil of 20 microhenries. L2 is representative of the lumped inductance, the primary coil, which of course possesses its own inductance value. Let us assume this to be 80 microhenries. And as inductances in series add, we can assume the total inductance of 100 microhenries to be one lumped inductance, the circuit then evolving itself into an inductance shunted by a fixed capacity.

The Resonant Frequency

We are all aware that an electrical circuit consisting of a coil and condenser is resonant to a certain frequency, or is tuned to a certain wave length, the exact value of which is dependant upon the inductance and capacity values. Hence the aerial circuit as illustrated in Fig. 1 (A) and theoretically in Fig. 2 (A), is tuned to a definite wavelength by virtue of its inductance and capacitance values.

Let us now insert fixed capacity into the aerial circuit as in Fig. 1 (B), the condenser being connected between the ground and the primary inductance. Theoretically we have effected the change shown in Fig. 2 (B). In this circuit diagram the inductance marked L is the sum of the two inductances L1 and L2 of Fig. 2 (A). The capacity C1 is the capacity C1 of Fig. 2 (A) and the capacity C2 is the series condenser as shown in Fig. 1 (B). Now we have an inductance shunted by two fixed capacities in series, since the insertion of the series aerial condenser is the equivalent of placing another condenser in series with the capacity of the aerial-ground system.

The electrical resonance phenomenon still holds true, but the frequency to which circuit B in Fig. 2 is resonant is different than that of the circuit in Fig. 2 (A). In other words the wavelength of the circuit has been changed, because the capacity shunting the coil L is not of the same value as previously. This is so because the resultant capacity when two capacities is different.

Application to Effects

If we imagine C2 to be of .00025 mfd., the resultant capacity will be .000125 mfd. Accordingly the inductance L is now shunted by a capacity of .000125 mfd., and the wavelength of the circuit has been reduced, or the resonant frequency increased. And so we find that when a series condenser is added to the aerial circuit the wavelength of the aerial circuit is reduced. A reduction in wavelength range should not be associated with a reduction in wavelength, because at this time we are concerned solely with the resonant wavelength of the aerial circuit, all capacity and inductance values being fixed and not variable.

Having determined the action taking place when a series condenser is inserted into the aerial circuit, let us apply this action to the various effects noted by fans when series antenna condensers are added to receiving installations. The most pronounced phenomenon noted is the de-

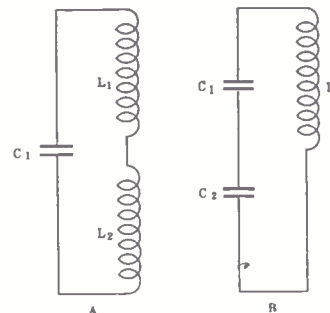

FIG. 2.

crease in signal intensity. Just what causes this reduction in output signal intensity? The tuning circuits of the receiver have not been touched, insofar as changes in equipment are concerned, and even the most critical tuning fails to bring the old output back. Although the shortcoming designed to be remedied has been overcome, say, selectivity has been increased. Incidentally the reason for obtaining the increased selectivity will be discussed later in this text. Why should the volume decrease?

The Untuned Primary

It is a known fact in electrical circuits that the greatest current and voltage will be induced when the two circuits are in tune, that is when the circuit being fed is tuned to resonance with the supply. This is experienced in everyday radio receiving. The greatest signal intensity is obtained when the receiver is tuned to resonance with the transmitter. As the aerial circuit without the series condenser is tuned to a certain wavelength, if a signal of that same wavelength strikes that antenna system, the maximum energy would be induced, and signals of different wavelengths would not induce as much energy. This fact should be borne in mind. In normal receiver operation where the aerial is of the untuned type as used in fully 90% of the receiver installations, the aerial is apparently responsive to all wavelengths within the tuning band of the receiver, since various stations within the band can be tuned in at will. But the aerial becomes most responsive as the incoming signal is on a wavelength approximating that of the aerial circuit, usually known as the fundamental of the aerial circuit.

As an example, let us consider our theoretical aerial without the series condenser, and with a fundamental wavelength of 150 meters. When operated with an average broadcast receiver, the aerial itself, not the receiver, would increase in responsivity as the wavelengths of the incoming signals would be decreased from 550 meters to 150 meters. And if the receiver were capable of tuning as low as 150 meters, and a signal on that wavelength were received, the the fundamental the less the induced energy of the aerial circuit. Now, suppose that with this aerial circuit we tuned in a station on 345 meters and the output signal intensity reached a certain value.

Effect of Difference

Due to the difference in wavelength between 150 meters, the fundamental, and 345 meters the incoming wave, there would be a corresponding decrease in the induced energy in the aerial circuit from that obtained if the incoming signal were on 150 meters. For a signal of unit strength the further the wavelength from the fundamental the less the induced energy. Now if we add the series antenna condenser the fundamental of the aerial is carried to a still lower level, say to 60 meters with the .00025 mfd., hence volume drop will result.

Dah—Dit—Dah—Dit—Dah!

By Irving Philip Wolfe

ZAPJ

The Short-Wave Receiver of 2BW

THE front view of the short-wave receiver of 2BW who has done some of the best DX work in the 2nd district. The right-hand condenser is used for tuning and the other condenser for regeneration control. (Walsh).

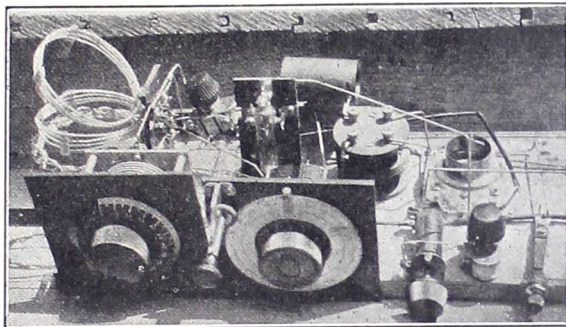

6 BUR won the Modesto Wouff-Hong Trophy. The four points that the award was based on were the station log, percentage of home-made apparatus used, distance in "miles-per-watt," the regularity of operation, and the neatness of the whole "works." A synchronous rectifier produces his famous note and the usual lo-loss receiver make up the other two most important things excluding the "valve" which is a UV 204A.

Don't mistake the Naval tactical call FBZ for 8ZF. Poor 8ZF was being reported from all parts of the world until he realized that it was the Navy and not he that was being heard.

The railroad distress call QRR may be heard this winter so QRX as soon as you hear it, OM.

I am including in this issue a picture of the receiver of U2BW. In explanation I wish to say that this detector tube is a Marconi Osram type DEQ. The filament voltage is 3.5 and the plate voltage is about 45-60. This tube is one of the most sensitive detectors known and is one of the biggest reasons for BW's DX reception. The audio transformer now in use is the General Radio No. 285.

The Yonkers, N. Y., bunch have all gone over to the Hertz antenna system. Some say it's great, but then again some say it's not so great. Like every other antenna system it seems to work better in some locations than in others.

IAOA, the "Newport Noise," on the air with a 250 watt. He is a new Army Amateur station and expects to be QSO the world over with his new WNP type transmitter.

LAID was reported in France. She sure puts out a mean kick.

The Britishers worked so many U's that as soon as they were QSO in Australia they forgot all about us. They can be heard working the Aussies at about 4 to 5 A.M. EST.

The Honolulu station 6BUC sure has a nice tone and plenty of pep. The wavelength used is about 36.5 meters.

Holland PB3 is now operating on 50

meters. His peculiar AC note can easily be read at about 11 P.M. EST.

During the New Year's test G5XX, located at Daventry, England, was received on the loudspeaker at ZAPJ. The British Broadcasting Station was clearer by far on 1600 meters than on the 455 meter rebroadcast wave.

2BW was in communication with rFH4 for an hour on the night of Dec. 30. The QRA of rFH4 is 1926 Brown St., Rosario, Argentina. The time of starting was 9 P.M. EST., right in the middle of the broadcasting hours. The wave of rFH4 is 31 meters.

Calls Heard

Radio 2BW. 319—33rd St. Woodcliffe-on-the-Hudson, N. J. (rFH4), rFB5, BA1, kY5, NTT, (iGW), iICO, iIAU, iINO, bz1AF, bz1BD, bz1IA, bz1AB, MIE, f8YOR, Chile 2 LD, Holland PB3, (Zero A6N).

A new ham is now on the air with a 5-watt on 40 meters. His name is Carl Holtz and his QRA is 30 Spencer Ave., Brooklyn, N. Y. 2AJE has been assigned to him.

7GS and 7DD are now experimenting on the 20 meter band on Sunday afternoons on PST. They want to get QSO with some twos and ones.

2CRB in Brooklyn worked IIAV and IICO with a UV 210 with 24 watts input.

Another ham will soon be returning to the radio game. 2CUA is having his home inspected by the fire underwriters and as soon as the place is OK'ed he will be on 40 meters with a fifty.

NTT is now cruising about the Mediterranean and manages to keep in communication with the world due to his great note.

Correct your call books; Chas. Whiteley, 2AGT has moved to 506 W. 178 St., New York City; and 2AD, Nathan Pomeranz, is now located at 1324 Forty-ninth St., Brooklyn, N. Y.

A new station on 40 meters is XPPA. He is on a ship in the South Seas and

Amateurs to Hold Show and Convention

The Sixth Annual Radio Show and Convention of the Executive Radio Council of the Second District, an organization composed of representatives of amateur radio clubs in and about New York City, will be held at the Hotel Pennsylvania the week of March 8. The announcement was made by Capt. George T. Droste, president of the Council, from headquarters at 74 Cortlandt Street, New York City.

More than fifty of the most prominent radio manufacturers will display their latest wares in the grand ballroom of the hotel. Amateurs of the district will arrange exhibits of amateur activities on the ballroom balcony, and will participate in a general fraternal convention which will run through the week.

The officers of the show are: Capt. George T. Droste, general manager; Frank Frimmerman, show manager; Earl Peacock, convention manager; Edward Fink, banquet manager; Robert T. Morris, finance director; Paul C. Oscanyan, advertising manager, and Robert Hertzberg, publicity director.

WJZ's New Location Changes Loop Setting

Station WJZ is no longer broadcasting from New York City, but is using its high power experimental station 2XAR in Bound Brook, N. J. If you are using a loop antenna, which is directional, unless you are located on a direct line which passes through New York City and Bound Brook, you will not receive maximum signals on the old loop setting. Try turning your loop when tuned in on WJZ and see if you cannot turn down your filament rheostats, thereby reducing battery consumption.

Roxy in New Office

S. L. Rothafel, the genial Roxy of radio and motion picture fame, has taken permanent quarters at Steinway Hall, 113 West 57th Street, room 605, New York City, where he not only holds his rehearsals for the concerts at WEA, but presides over the destinies of the new Roxy Theatre.

His new studio is equipped as an up-to-date rehearsal room and here the gang is put through their paces preparatory to their weekly radio program. Roxy has a thousand and one demands on his time, these numerous details to be attended to in connection with the \$8,000,000 enterprise which will be the crowning achievement of his career. His multifarious duties keep him on the jump from 7 a. m. till 2 a. m. the next day and since he left the Capitol Theatre some months ago, Roxy has divided his time between his radio activities and plans for the new Roxy Theatre for which ground has already been broken at 50th Street and Seventh Avenue.

has been worked by many Second District hams. At present he is between Samoa and Australia.

3UT located at Pleasantville, N. J. reports working a 7 in Oregon. He is using 2 VT. 14's and was given an R5 report. That's FB om, keep it up.

A letter notifies us that 8BRC of Van, Penna., is rebuilding his transmitter and will be on the air within the next week. QRH-40 meters.

BLUE PRINT FOR 1926 DIAMOND OF THE AIR, sent on receipt of 50c. Radio Division, The Columbia Print, 145 W. 45th Street, N. Y. C.

Gernsback Goes London One Better



DANCING to music coming from a radio set, that no one else but the dancers hear, is London's latest. Above we have Iris Gray and Robert Andrews showing how dancing is done with the above mentioned method. Jack Luden is operating the receiver. The earphones are connected directly to the set. But America is farther advanced than that. The brilliant Hugo Gernsback has a scheme for omitting the telephone wire leads, hence permitting freedom in dancing. (Kadel & Herbert)

U. S. Stops WJAZ in Suit Alleging Wavelength Piracy

By Thomas Stevenson

WASHINGTON.

HAS the Secretary of Commerce the authority under the present radio law to prevent a broadcasting station from operating on any wavelength it chooses? The action against E. F. McDonald, Jr., president of the Zenith Radio Corporation of Chicago, and the threatened confiscation of his station, WJAZ, has centered interest on this point.

Some months ago, Mr. McDonald applied for a license for WJAZ to share time with KOA, Denver, on 322.5 meters. KOA is silent every Thursday evening between 10 and 12 o'clock, and Mr. McDonald wanted to use the Denver wavelength during those two hours. A license was granted Mr. McDonald authorizing him to operate WJAZ on 322.5 meters between 10 and 12 o'clock every Thursday evening.

Shortly thereafter, Mr. McDonald became dissatisfied and wanted more time on the air. He applied to the Department of Commerce for another wavelength. He was informed that there was no additional wavelength available for use around Chicago.

Mr. McDonald, it is asserted, then began broadcasting on 330 meters, which had been used exclusively by seven Canadian stations. Thereupon, the Department of Commerce requested the arrest of Mr. McDonald and the confiscation of his station for violation of the law.

Mr. McDonald feels that he has just as much right to broadcast as the 535 stations already in the field. He was sure that if he took the case to the courts, the Department of Commerce would be required to give him a wavelength. But that would

have involved a long-drawn-out legal battle and he wanted to broadcast immediately.

Mr. McDonald knew that there were no American stations operating on 330 meters and that his station, if operated on 330 meters, would not interfere with other American stations.

The wavelength upon which Mr. McDonald elected to broadcast, however, is being used by seven Canadian stations. The operation of Mr. McDonald's station on that wavelength might cause interference in Canada.

There is no specific agreement between the United States and Canada in regard to wavelengths. But as a matter of international courtesy, the United States has refused to assign to United States stations wavelengths in use by Canadian stations. The Canadian government has likewise refused to permit Canadian stations to operate on American wavelengths when interference would result.

In the band between 200 and 550 meters there are 95 wavelengths. Of these, 89 are used exclusively by United States stations and 6 by Canadian stations.

Unless International courtesy were observed by the American and Canadian governments in assigning wavelengths, there would undoubtedly be considerable interference between the stations of the two countries, from which the listening public would suffer.

If Mr. McDonald were permitted to continue broadcasting on 330 meters it might result in a broadcasting conflict between the United States and Canada.

Recognizing the seriousness of the situation, the U. S. acted promptly.

(Copyright 1926 by Stevenson Radio Syndicate.)

Charms with Violin



CECILIA HANSEN charmed listeners by her fine violin playing during a recent Atwater-Kent music hour from WEF and fourteen allied stations. (G. M. Kessler.)

Station Range Measured

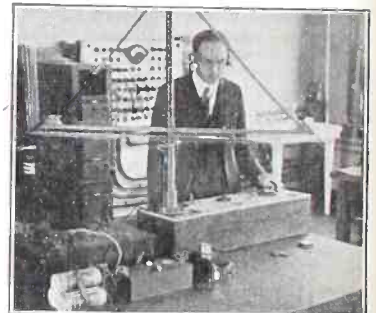

"COMPLETE Service Area," is a new phrase for the enrichment of radio terminology. It means the distance or radius over which radio reception is possible the year around, day and night, without fading and static. This photograph shows apparatus devised by the Radio Laboratory of the Bureau of Standards for determining the distance over radio receiving sets may be expected to give service under all kinds of conditions. (Harris & Ewing.)

Bloom Has New Plan For Copyright Fees

Representative Sol Bloom, New York, suggests that the copyright payment by broadcasters be based on the density of the population within steady range of a station.

WIOD, Florida, Opens

WASHINGTON.

A new 1,000 watt station, Nautilus Island, Miami Beach, Fla., has been licensed experimentally by the Department of Commerce. The station is owned by Charles G. Fisher, Inc., and operates on 248 meters with 1,000 watts power. The call letters of the new station are WIOD.

Joe Moore Speaks Up



JOE MOORE, Olympic champion and probably one of the best known ice skaters of the world, had a few cold words to say before the microphone with a few of his thousand medals as a background. (Foto Topics.)

Ford's Old-Timers Inspire Memories



FORD'S OLD TIMERS' dance orchestra which plays old-fashioned dance music, broadcast frequently in N. Y. City. They will be on the air over the whole American Telephone and Telegraph circuit. Let to right: William Hallup, cymbalom; Clayton Perry, violinist; Maurice Castell, Sousaphone, and Edwin Baxter, dulcimer. (Fotograms).

Beauty Lends a Hand



DOROTHY KNAPP, winner of a beauty contest that landed her a stage job, exhibits cups that figure in the International Tests. (Foto Topics.)

Smiling Send-off to Eric Palmer



PROMINENT figures in radio snapped at the send-off dinner to Eric Palmer, radio explorer, at the eve of his departure for Europe in conjunction with the International Tests. In foreground, at the microphone of WMCA, left to right, Clay T. Erwin, director Radio World's Fair; L. Smith, Billy Jones, Jos. Freed, Eric Palmer, Major J. Andrew White, L. A. Nixon, Ernest Hare, Thornton Fisher, Leo and J. D. R. Freed. (Foto Topics.)

Rickard Buys a Station; Garden to Send Fights

A broadcasting station will be erected atop the new Madison Square Garden, New York City. Tex Rickard has bought a station license and call letters, said to be those of WWGL, Radio Engineering Corporation, Richmond Hill, N. Y., 212.6 meters. Events at the Garden will be broadcast, including boxing.

Arthur Batcheller, Radio Supervisor of the Department of Commerce in the New York District, said that he could not release information regarding the station transfer at this time because the matter was not completely settled and final action must come from Washington.

It has been understood that Tex Rickard was opposed to broadcasting of sporting events since he announced a ban on the broadcasting of boxing bouts in the old Madison Square Garden in November, 1924. The reason given at that time was that broadcasting reduced the attendance

when the matches were fought before microphones into which expert critics described the fights blow for blow.

When asked whether or not he had changed his attitude toward broadcasting, Rickard refused to make a statement.

"The fact that the station and studio will be in the garden ought to explain Tex Rickard's attitude toward radio," said E. K. James, representative for Mr. Rickard. "It has never been a question of Tex Rickard being opposed to broadcasting on the grounds that people did not go to the fights because they could hear them over the radio. He believes broadcasting of sporting events is all right, if they are properly handled. What he opposed was the propaganda started by some factions in radio that listening-in was just as good as seeing the fight.

"Work has already started on the station."

Complaints Against WJZ Power Drop

WASHINGTON.

Complaints of interference through the use of super-power by WJZ, the Radio Corporation station at Bound Brook, N. J., have shown a decrease, according to the Radio Division of the Department of Commerce. It is the intention of the Radio Division to allow a good test of superpower at Boundbrook before making a decision on whether or not undue interference will result.

According to David Sarnoff, Vice President and General Manager of the Radio Corporation, most of the trouble experienced by fans in the locality of the station has been due to non-selective receivers. If there to be an international broadcasting service, super-power must be used, Mr. Sarnoff asserts.

Diamond's Audio Extolled

One Transformer and Two Resistance Stages Splendid For Volume and Quality, Says Rider

By John F. Rider

Member, Institute of Radio Engineers

ONE sometimes wonders about the trend of audio amplification. Despite the apparent popularity of resistance and impedance coupled audio amplifying systems, transformer manufacturers are not despairing, in fact they are what we would term "bucking" the market by producing bigger and better transformers. And judging from the new products offered the public, one would be prone to say that previously transformer design and construction had been deliberately withheld, not with intent to impair the progress of the art, but because of the limitations imposed by the purchaser's pocketbook. But with the realization that the fan will pay, and keener competition in the audio amplifying field, transformer manufacturers are producing super-units.

The variance between these new units and the older ones, exclusive of the amplifying characteristics, is simply size and cost. That quality output was being sacrificed in an endeavor to meet the individual's purse is manifest by the present production of high ratio transformers with flat amplifying characteristics, an action thought to be impossible. But with the decision to charge a price commensurate with the value and cost, the seeming impossibility was met. And the units are daily increasing in popularity.

As to the future type of amplifier, whether transformer, impedance or resistance coupled, one would be on precarious ground to choose. But being concerned with the present rather than the future, we can compare existing types with security.

Three Types Compared

We have three types of audio amplifiers. First the old and still popular transformer coupled arrangement; second, the newer resistance coupled units, and the most recent to strike the public's fancy, the impedance coupled system. The difference between the last two mentioned is very small. As to the degree of amplification, that is, the trueness of tone, there is little to choose. One is as good as the other. However, with a certain value of applied plate potential the impedance coupled amplifier will afford greater volume than the resistance coupled unit, due to the higher dynamic voltage amplification obtainable with any one tube. This is due to the higher external plate

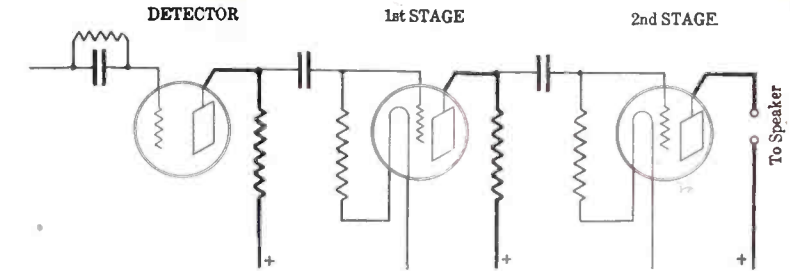

FIG. 2

impedance obtainable with the impedance coupled amplifier with a low direct current resistance. This is obtained by means of the choke. The impedance is high but the direct current resistance is low. With the resistance coupled unit, the impedance is equal to the resistance of the coupling resistor and the direct current resistance is also of the same value. With the choke coil the only increase is volume, whereas the initial cost is higher and also the maintenance, the plate current drain being greater.

As to comparing resistance or impedance coupled audio amplifiers with transformer coupled units, it just cannot be done. In operating efficiency the transformer coupled unit is far superior to the choke coil, being much more economical and superior in certain ways to the resistance coupled unit. In the past the quality of the output has not been so good with transformers, but the future bids well to reach the highest levels. In the majority of instances the defect of every transformer coupled amplifying unit was found to be in the second stage, even with the best of transformers. Very seldom was a complaint registered against the first stage. Hence why not replace the second stage of transformer coupled audio with two stages of resistance coupling and retain the first stage of transformer coupling?

Praise for Diamond Audio

This arrangement has been carried out in many instances and found to be not only very satisfactory but in some aspects superior to the regular three stage resistance coupled system. The excellent amplification obtainable in the audio side of RADIO WORLD'S Diamond of the Air is attributable directly to this audio combination. (Figure 3). In fact this arrangement is becoming more and more popular, with the advent of even high ratio transformers which afford a flat operating characteristic. In the first place, the output of a unit of this type is much greater than that of a straight resistance coupled unit, such as is illustrated in Fig. 4. The reason for this is very simple if we calculate the amplification obtainable with each tube. And with this increased output we have eliminated

distortion to the point where the quality output from the first stage may be considered as equal to that of a resistance coupled stage of amplification.

As to the voltage amplification in each stage, the values given herewith are theoretical and while the output is not directly in proportion, an idea of the magnitude of the increase can be obtained. Assume an AC voltage output of .11 volt from the detector in Fig. 4. The AC voltage output of the first stage amplifier will be equal to the input multiplied by the dynamic amplification constant of the tube. In exact figures this is .11 times 13 for the average high mu tube with 100,000 ohm coupling resistances. This means that the output voltage from that tube will be 1.43. The amplification progression theoretically for the succeeding tubes is the input times the dynamic voltage amplification constant of each tube. The next tube output will be 1.43 times 13 or 18.59. This value can be assumed to be the input voltage to the output tube.

Superiority Noticeable

Now what have we with the transformer-resistance combination? The output from the detector tube is still .11 volt. The transformer ratio is about 4 to 1, so for all calculations the voltage step-up may be considered as 4. This means that the voltage applied to the grid of the first amplifying tube is the output of the detector multiplied by the voltage step-up value of the transformer, or .11 times 4 or .44. The output of this amplifying tube is the .44 times the dynamic mu, which with the average 8.5 mu tube is approximately 7 or 7.5. Let us consider it as 7. Accordingly the output voltage is .44 times 7 or 3.08. Using the same method of progression previously applied, since resistance coupling is being utilized now, 3.08 would be multiplied again by 13, the product being the output voltage of the second audio stage. This is 40.02. The difference between this output and the one obtained with the straight resistance coupled amplifier is so great that discussion is out of the question. And while the increase in actual volume output is not as great, the superiority is noticeable with ease.

Thus with the same number of tubes, but a stage of transformer coupling instead of resistance coupling, we obtain an advantage which is beyond dispute. It is true that the initial cost is greater, since the price of the transformer is at least double that of the complete coupling resistance-blocking condenser and grid leak combination, but the operating cost is not greater. The transformer primary is connected into the plate circuit of the detector tube. Due to the low DC resistance of the primary of the transformer a low value of plate potential may be applied, say between 37 and 45 volts. At this value the normal plate current varies between .8 and 2 milliamperes. If the transformer primary is replaced by

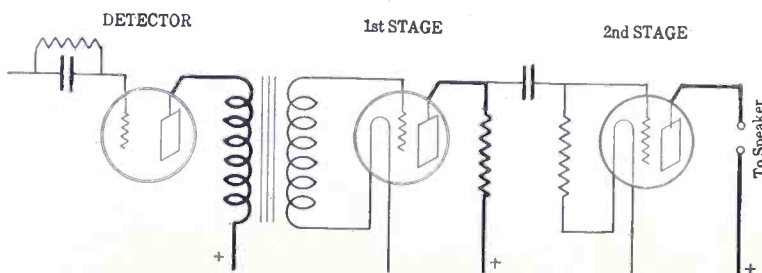

FIG. 1

A Comparison of AF Results

a resistance, which action takes place when the transformer is replaced by the coupling resistor, it is necessary to increase the applied plate voltage, so that the effective plate voltage reaches a satisfactory value. Under normal conditions the plate current drain with this satisfactory voltage varies between .5 and .8 of one milliamper, not a radical reduction by any means. As to the plate current consumption of the other tubes, they are in no way affected by the use of the transformer. Thus where a three stage resistance coupled audio amplifying unit is employed a feasible change is the replacement of the first stage with a good transformer.

May Use High Ratio

This transformer need not be a low ratio unit. In one of the new high ratio units is available it can be used to good advantage, as high ratio amplifying transformers with flat amplifying characteristics are available. The higher the ratio the greater the voltage increase, consistent of course with a flat amplifying characteristic.

There is another consideration which must be discussed. This is the primary impedance of the transformer. As the turn ratio is decreased, the primary impedance is increased and vice versa, hence the transformer must be of the type which would permit of the greatest energy transfer between the tube and the transformer. The choice of the transformer therefore must be made with these two items in mind.

In instances where only two stages of audio frequency amplification are being used, it is very impractical to use two stages of resistance coupling. (Fig. 2). A combination such as Fig. 1, using one stage of transformer coupling and one of resistance, will afford practically twice the volume of two resistance stages.

Now, in our computations of voltage amplification progression in the three stage amplifiers we considered the use of a regular low mu tube in conjunction with the transformer, whereas this tube may be a high mu tube. With the average dynamic mu of 13 the voltage output from that tube would be equal to the input .44 x 13 or 5.72 in place of 3.08. Thus the gain due to the use of one stage of transformer coupling is even more pronounced.

Divers Broadcast from Undersea at Sydney

WASHINGTON.

A recent novelty, so far as Australia was concerned, was the broadcasting of the experiences of a couple of divers on the bed of Middle Harbor, Sydney, seventy feet under water, according to a report to the Department of Commerce. One of the divers was a professional and the other a member of the Royalty Society who took the dive in the interests of scientific knowledge.

A description of the dress of the divers was broadcast prior to their descent, and showed that each of them carried 142 pounds. Diver Jack carried a knife and a spear in case of an attack by sharks. Diver Jack explained the work done by divers in laying the sewer pipes across the harbor bed. The amateur diver merely told of the scene on the ocean bed

Next week's star attraction will be the marvelously efficient FENWAY Super-Heterodyne (issue of Feb. 6).

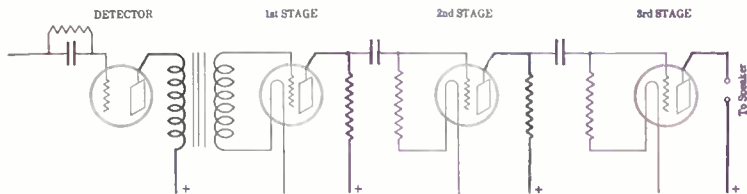

FIG. 3

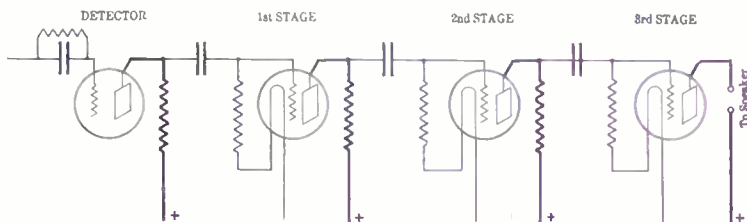

FIG. 4

Diamonds Cover the World; Enthusiasm Is Tremendous

THOUSANDS of letters have been received from fans who built the Diamond of the Air and obtained highly satisfactory results. Of course, there are hundreds of Diamonds in every state in the Union. Indeed, no city or town of more than 15,000 population is without a generous share of them. The Diamond has been constructed by fans in every civilized quarter of the globe (and in some barbarian sections, too). Letters have been received from delighted owners living in every country, except Switzerland and the Republic of Georgia. Here are some of the domestic letters:

His First Set a Success, Due to Text and Diagrams

DIAMOND EDITOR:

As I have not read of any results of any of your good hookups from this city, I am writing to let you know of the wonderful results I have obtained from The Diamond of the Air. I have had several sets but have never had as good results as from my Diamond. I also want to say that I had never built a set in my life, but often wished I could, but being a regular buyer of RADIO WORLD my wish came true. Your picture diagrams are sure great for the novice. I used to buy three other magazines but RADIO WORLD is my standby now.

We have three local stations here, WMBF, WQAM and WGBU. It is very simple to cut through and get several outside stations. I have no outside aerial. I am using inside Talking Tape, 100 feet in length.

It is run around the walls of three rooms. All stations are received on the loud speaker with very good volume.

I wish to thank RADIO WORLD and Herman Bernard for putting such good hookups before the radio fans and join the thousands of other fans as a booster of RADIO WORLD.

ROBERT E. LEWIS,
2603 N. W. 26th Street,
Miami, Fla.

Expectations Exceeded, Canadian Fan Reports

DIAMOND EDITOR:

I have built the Diamond and find it to be all and more than I expected of it.

JOHN I. HALDOM,
40 Ashburnham Road,
Toronto, Ontario, Canada.

"Wonderful Receiver," Says Experienced Man

DIAMOND EDITOR.

I am just another Diamond of the Air booster. I have been in the radio game since 1909 and was kind of skeptical of building this set, but I took a chance and I was certainly rewarded. It is a wonderful receiver. All the distant stations that one could wish to hear are pulled in. I built the 1926 model. Congratulations to RADIO WORLD.

GEORGE J. SCIVILL,
1218 Marlborough St.,
Detroit, Mich.

More Than Forty DX Stations Tuned In

DIAMOND EDITOR:

I have built the Diamond of the Air and am so proud of the set that I am writing to tell you of the results. The set cannot be beat for distance. Over 40 distant stations were heard. Many thanks to Herman Bernard for contributing this circuit to RADIO WORLD fans.

CLARENCE H. BROWN,
1550 South Lambert St.,
Philadelphia, Pa.

With One AF He Gets 2,500 Miles on Speaker

DIAMOND EDITOR:

It is a pleasure to be able to tell you that I am the proud owner of the 1926 Model Diamond of the Air. It ought to be named the Peerless of the Air. I tuned in KFJ, Los Angeles, Cal., on the loud speaker within two days after I completed this set. I kept this station for two hours. The wonderful feat about receiving this station was

Diamond Results Stir Nation

that I used only one stage of audio-frequency amplification. The signals were so loud that the phones could not be used. I have heard about 30 other DX stations.

J. P. HOLLOWAY,
170 Marsden St.,
Hazelwood,
Pittsburgh, Pa.

Doubts About RF and Tickler Dispelled

DIAMOND EDITOR:

I have built the 1926 Model Diamond of the Air and have obtained marvelous results. I was always dubious about placing a stage of RF ahead of a regenerative detector, but it certainly works out great. The set sure is a knockout.

ROY SMITH,
2638 12th Street,
Detroit, Mich.

Virginia Fan Gets Pacific Coast Stations

DIAMOND EDITOR:

After reading what other fans have done with the 1926 Model Diamond of the Air, I concluded that I would let you know of my success. I have heard more than 23 distant stations, a great many of which are Pacific Coast stations.

H. C. LIGGAU,
2108 E. Leigh St.,
Richmond, Va.

Stable and Simple to Tune, Says Another

DIAMOND EDITOR:

I am very grateful to RADIO WORLD and Herman Bernard for devising so clever a circuit as the 1926 Model Diamond of the Air. It certainly is a hard set to beat for volume and quality of signals both from distant and local points. It is very stable and simple to tune.

AUG. B. JORNSEN,
1602 N. 4th St., W.,
Cedar Rapids, Ia.

Loop User Proclaims the Hookup Wonderful

DIAMOND EDITOR:

Just a few lines to let you know how my 1926 Model Diamond of the Air is working. I have been using it for about a week now and have received 30 stations. I am using a loop antenna. It is a wonderful set.

ELDON SEITZ,
1280 E. 112th St.,
Cleveland, O.

DX Feature Stressed by Camden Enthusiast

DIAMOND EDITOR:

I wish to inform you of the results that I have obtained with the Diamond of the Air, which name it rightfully deserves. I have received 20 distant stations to date, KOA, Denver, Col., being one of them.

HARRY CAWOOD,
817 South 6th St.,
Camden, N. J.

WGY, 3,000 Miles Off, Heard by Californian

DIAMOND EDITOR:

I have just completed building the 1926 Model Diamond of the Air and wish to say it is a wonder. It is better than any other 5-tube set that I have ever heard, and

even than a super-heterodyne. I have received 35 DX stations, WGY being one of them. This station is about 3,000 miles from my home, as you know. Best regards to Messrs. Bernard, Warren, Winner and O'Rourke.

ANDREW HOWAT,
Berkeley, Cal.

Never Has to Use Phones, Even on Remote DX

DIAMOND EDITOR:

I have built the 1926 Model Diamond of the Air, as described by Herman Bernard, and it is the finest set I have ever seen, which includes a 7-tube super-heterodyne. It beats this super, as to distance and volume. The volume on distant stations is so great that I never use the phones. I wish to thank Mr. Bernard for this circuit.

ERNEST L. SHEPARD,
Box 52, Bath, Me.

"Shines" Where Stations Are Few and Far Between

DIAMOND EDITOR:

I have just completed the Diamond of the Air and must say it sure is a wonderful set. Down in this portion of the country the stations are very scattered, so that a set that is capable of receiving DX stations with volume is wonderful.

GEORGE BRADBEE, JR.,
c/o St. Luke Hospital,
Jacksonville, Fla.

Fan Likes Clear Way of Describing Hookup

DIAMOND EDITOR:

I have built the Diamond of the Air and my praise and enthusiasm for the set are beyond bounds.

I made a loop antenna and take pleasure in telling you that WLW, WSB, WQAM and CNRO came in loud and clear enough on the speaker to be heard throughout my 5 room apartment.

I have built most of the popular sets, but find that the Diamond gives me more distance on an outdoor antenna than any other receiver that I have ever made. I am more than pleased with the results. I thank Herman Bernard for the clear, descriptive manner in which the construction of the set was described.

WILLIAM B. SIMPSON,
301 West 107th St.,
N. Y. City

Bates Hears 105 Stations; Coast-to-Coast, Too!

DIAMOND EDITOR:

I have constructed 1926 Model Diamond of the Air.

The big fault I find with this type of set is that I can hear only one station at a time. Can you tell me how to remedy this? (I dare you to try.)

The first night I heard 42 stations, not counting those within 300 miles. I have heard 105 different stations in eight evenings.

Remember now that I live in California, not in the east where the stations are thick and handy.

A few of the more distant stations heard were WJZ, WGY, WMAK, WGR, WHAZ, WAHG, KDKA, CICA, PWX, WRVA, WPG, WBZ, WGHB, WMBF, WGBU, WJAX.

O. J. BATES,
344 Yale Ave.,
Claremont, L. A. County, Cal.

Diamond Wins in His Test with a "Super"

DIAMOND EDITOR:

I have built the 1926 Model Diamond of the Air and have received the following stations on the loud speaker: WENR, WLIB, WOC, WCBD, WTAM, WSAI, WSB, SNRO, WOAN, WELW, KDKA, WLS and many others. I compared this receiver with a Super-Heterodyne that I have, the same evening that the above mentioned stations were received, and could not get WSB or CNRO at all, while with the Diamond they came in with ease. I congratulate RADIO WORLD for this wonderful hookup.

THEODORE E. RHODE

More Than 60 Stations on Speaker, His Record

DIAMOND EDITOR:

I have built the 1926 Diamond of the Air and find it the best, by far, of any I have ever built before. I get KOA, WMBF, WTAD, WDAF, WOAW, CNRM and about 60 others, all on the loud speaker with plenty of volume.

P. DIEHL,
6210 Huntress St.,
Pittsburgh, Pa.

"Truly Remarkable Set" Built by Son for Father

DIAMOND EDITOR:

I have tried quite a few radio sets but have as yet found none that was really satisfactory. At present, a Diamond built for me by my son is giving results which are as near perfect as can be expected. It cuts clearly through powerful local stations. It brings in Chicago and other Western stations with clarity and volume unapproached by any radio set I have ever heard. It is a truly remarkable set.

MRS. EDWIN SHEPPARD,
c/o The Worrick Inn,
Nantasket, N. Y.

"Best Set I Ever Had," Another Fan's Eulogy

DIAMOND EDITOR:

I have built the Diamond of the Air and it is by far the best set that I ever had. With head phones I have received Calgary, Vancouver, Mexico City, New Orleans, San Antonio, Des Moines, Davenport, Chicago and Pittsburgh stations.

FRED BULL,
44 South Fair Oaks Ave.,
Pasadena, Cal.

Gets 800 to 1,000 Miles On Speaker, Using Loop

Diamond Editor:

I have just completed my third Diamond of the Air receiver. It is the best all-round receiver I have ever constructed. The reception is perfect, with plenty of volume and DX. On a loop I can receive stations on the speaker within a radius of 800 to 1,000 miles. The tuning is extremely sharp.

I wish to thank RADIO WORLD for publishing such efficient hookups.

SIDNEY NORDEN,
42 McGovern Ave.,
Ashtabula, O.

The Diamond University

Questions on the 1926 Model Diamond of the Air Answered Free by RADIO WORLD,
145 West 45th Street, New York City. Address Diamond Editor.

By Herman Bernard

Associate, Institute of Radio Engineers

CAN I use a Bruno 77 pancake tickler coil for the 1926 Model Diamond of the Air? (2) Also a Bruno 55 radio-frequency transformer? (3) Need I change the primaries or secondaries in any way?—George Roberts, 1937 Ogden Ave., Chicago, Ill.

(1) Yes. (2) Yes. (3) No.

I HAVE made several sets but they are all of the 1-tube variety. Now I want to build the 1926 Model Diamond of the Air. Can I use a basket-weave 3-circuit tuner, primary 16 turns, secondary 48 turns, tickler 32 turns, the primary and secondary having 3" inside diameter and the tickler 1 3/4"? (2) What size tubing shall I use for the aerial coil, which would be a solenoid? (3) Can I use BCL vernier

transfer energy that is flowing in the primary L0, whereas a short, where the circuit should not be in metallic contact, would produce the same failure of signals. Test your RF tube also. (2) This is due to incorrect manner of wiring up the leak. The lug or connection to the leak which is right at the back of the panel, hence nearer the hand as the knob is turned, should be connected to the end of the secondary, L3, at the terminal designed H in the diagrams. The other lug of the leak goes to the grid post of the detector tube socket. As your body is at ground potential, the howling will not result if the low potential side of the leak-condenser combination, R0C2, is at back of the panel, while if the high potential (grid post of socket) is placed there, you can scarcely avoid body capacity effect. (3) This may be due to any of the causes set

decline set in. I checked and rechecked the wiring time and again. I tried a power tube of a different make and oh, what a wonderful set the Diamond proved to be! It is sure named right.—Sam L. W. Gourley, 4511 Higgins Ave., Bayside, N. Y.

One of the filaments of the first power tube you used probably was shorted and tapping the tube simply disestablished the short until the two filament sections sagged together again.

I DO NOT get enough volume on the high wavelength stations on my Diamond. (2) I do not get signals from the detector jack.—Arthur C. Brek, Crandon, Wisc.

(1)—Place a .001 mfd. fixed condenser across the tickler coil, one side of the condenser to I and the other side to J. The coil referred to is L4. If that does not cure the condition, then the regeneration is not at fault (granting efficient tubes), but there may not be enough inductance on the secondaries, L1 and L3. Put on four more turns. (2) This is due to defective jack or erroneous wiring of the jack. Follow the diagram. If your jack is so constructed that its respective lugs do not correspond to those shown in J2 of the diagrams, then inspect the jack to determine which are the two prongs

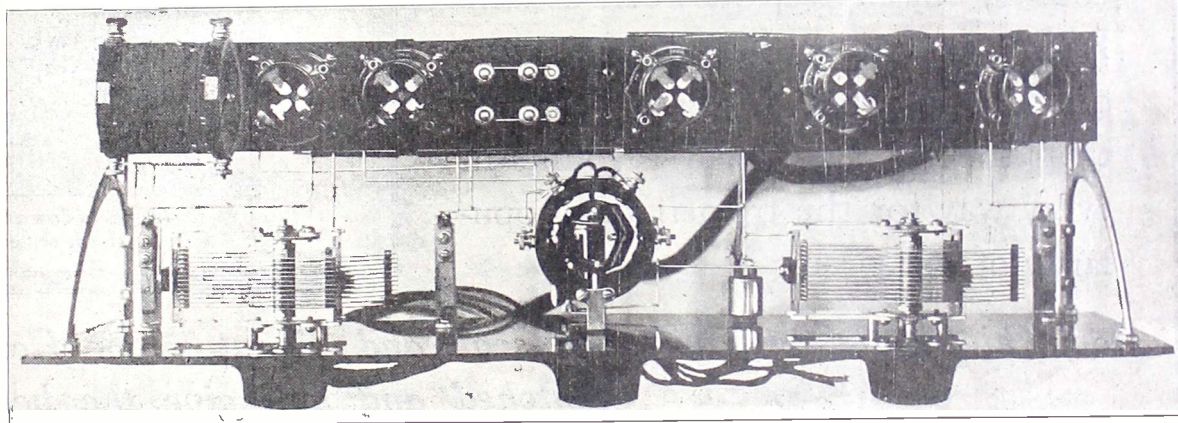

TOP VIEW of the 1926 Model Diamond of the Air.

dials on this set?—C. A. Isaacson, c/o Gates Dry Goods Co., Doud Block, Fort Dodge, Ia.

(1) Yes. (2) You may use 3/8" diameter tubing, with 8 turns on the primary, 3/8" space, and then 45 turns on the secondary, the wire being No. 24 silk over cotton, or No. 24 double cotton covered. (3) Yes.

I HAVE TROUBLE in getting the 1926 Model Diamond of the Air to work just right. In changing aerial and ground I had the earphones on and the ground wire happened to touch the plate lead of the radio-frequency tube. I then heard WJZ plainly. When the ground lead was touched to the bottom of the loop jack signals came in a little louder. (2) Please tell me why the set squeals when you touch the grid leak. (3) I can not hear on the detector jack at all.—Emile J. Snyder, c/o Bridgeport Boys' Club, Bridgeport, Conn.

(1) There is an open circuit or short-circuit in the wiring connected with the radio-frequency tube. See if the insulation is scraped off the secondary winding of the radio-frequency transformer, causing a short in adjacent turns. See that the variable condenser C1 is connected to the secondary, as failure to establish the two connections would produce the result you describe. An open circuit, where a closed one should exist, would cause a failure to

forth in the answer to your first question, or besides there may be some fault in the wiring of the detector jack. The outside frame or right angle of this jack goes to the B plus lead, while the outside hooked spring goes to the tickler terminal other than the terminal of that coil that went to plate of the RF tube. This coil is L4 and the terminal thereof referred to is I in the diagrams. Be sure that the inside prong of the jack J2 that contacts with the B plus goes to Pos. B. of the audio-transformer and the other inside prong of the jack to the plate post of that transformer. These connections to the transformer are made from one pair of binding posts (W and Y) to another pair of binding posts (X and Z), bus bar straps being used for this purpose. See that the battery cable leads are fully conductive and not partly or wholly shorted, especially the B plus leads.

I BUILT the 1926 Model Diamond of the Air, using high-mu tubes on the first two audio stages and a low-mu in the last stage. I found that the low-mu tube would light brightly at first but then the tube would go down and glow dully, volume decreasing all the while, until suddenly the set would sound like a boiler shop working overtime. By tapping the low-mu tube with my finger the tube would again light brightly and volume would be fine again, until the inevitable

that contact respectively to the outside prong and wire accordingly.

THE VOLUME is wonderful on all locals on my Diamond of the Air, but I do not get much distance. (2) When I touch the second socket shell, which is metal, there is an awful squeal. (3) The 3-circuit coil has 54 turns on the secondary while the RF coil, on the same diameter, using the same wire, has 49. Is this correct?—Bert Williams, 122 Fifth Ave., Brooklyn, N. Y.

(1) In the absence of local conditions which would prevent getting distance on any receiver, your failure to obtain far-off stations with the Diamond may be due to insufficient coupling between the primary and the secondary of the 3-circuit coil or wrong B battery voltages or too short an aerial. The set will stand an aerial of even 200 feet, including lead-in. (2)—Sever the common lead of the B+ detector and B plus RF (if your set is wired that way), so that you can reduce the detector plate voltage to between 45 and 22 1/2, and use 90 volts on the B plus RF. This can be done with the usual 5-lead battery cable by running a separate wire from B minus to A plus, battery to battery, and using the former B minus cable lead as the B plus RF lead. Thus you will require only the original five leads, but you will have six battery con-

(Continued on page 26)

Weekly recognized by the public

sale of the boxed and sealed 1926

AIR KIT - - \$35.00

(Blueprint)

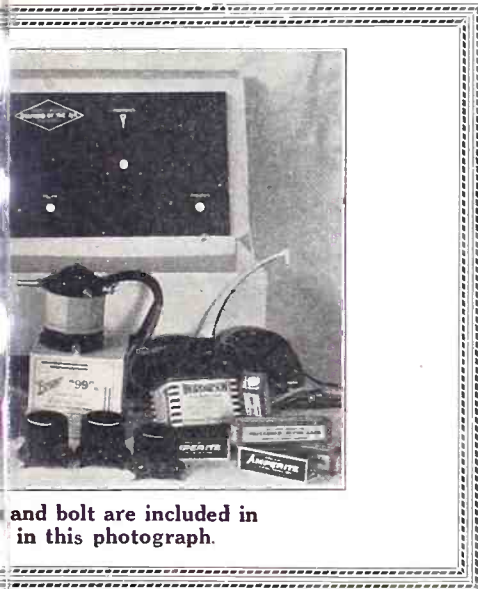

and bolt are included in this photograph.

Each kit is comprised of parts which were specially chosen by Mr. Bernard only after months of experimentation. The boxed and sealed kit contains parts which function in complete harmony giving a balanced receiver that has proven its worth to thousands of builders all over the world. Each unit is carefully tested before being packed for shipment so as to avoid any annoyances on the part of the purchaser.

ernard which is your guarantee that all parts are perfectly s. Accept no kit without this seal.

Press

BOOKLET
print on the
e, trouble-
operation of

H's 1926
the AIR

Edited by
ELSTEIN

50c

list.

tribution

30.

OUR MONEY-SAVING SPECIALS

Garod Bakelite 4".....	\$0.45	Bezels 1" Nickel.....	\$0.05	Dayfan Potentiometer 400	
Pathe 2", 3", 4".....	.25	Bezels 1" Gold.....	.10	ohm.....	\$0.35
TUBES					
R. C. A. 201-A.....	2.25	Glass Insulator.....	.20	3" Dayfan Dial.....	.20
Cunningham.....	2.25	Toggle Switch.....	.20		
DeForest.....	2.25	Bruno Inductance Switch		HARD RUBBER	
New Venus Blue, 201-A.....	1.50	(14 Point).....	.35	PANELS	
Schickering.....	2.25	Bruno "66".....	2.25	7x10.....	\$0.50
MISCELLANEOUS					
Cutler-Hammer 6-ohm		Hydrometers.....	.60	7x12.....	.60
Ver.....	\$0.59	Bell Wire (Half Pound).....	.40		
Turn-It Grid Leak.....	.65	Na-ald UX Adapters.....	.35	7x14.....	.75
U. X. Adapter.....	.30	Aerial Kit (Complete).....	2.50	7x18.....	.95
Patent Plug.....	.25	Crystal Detector.....	.50	7x21.....	1.25
Soldering Iron.....	.95	Double Jacks.....	.40	7x24.....	1.35
"A" Battery Switch.....	.25	Single Jacks.....	.30	7x26.....	1.50
Jones' Single and Double		Westinghouse R. C. Set		SOCKETS—BAKELITE	
Jacks.....	.40	(2 only).....	29.50	Federal.....	\$0.65
Bruno Binding Post (per		Neutralizing Cond.....	.35	Naald De Luxe.....	.45
plge. of 12).....	.40	Steinite Eliminator.....	.95	Hoosick Falls.....	.50
Lightning Arrester.....	.40	Continental Midget Cond.....	1.10	Hoosick Falls 199.....	.35
Battery Cable.....	.45	Continental Neutralizer.....	.45	Hoosick Falls Triple 199.....	.95
Patent Rheostat.....	.60	Single Mount.....	.15	Eby UX.....	.60
Dubiller By-Pass Con.,		Double Mount.....	.30	Patent UX Universal.....	.55
0.25 mfd.....	.70	Extension Plug.....	.40		
D. P. D. T. Switches.....	.50	Voltmeter Leader 0-50			
WD-11 Adapters.....	.50	Volts.....	.75		
S. P. E. T. Switches.....	.45	Voltmeter Ammeter Com-			
Phone Plugs.....	.25	bination.....	1.10		
Triple Standard Sockets.....	1.00	Tower Scientific Headset.....	1.95		
		Tower Scientific Headset.....	2.95		
		Triple Coil Mount.....	.95		
		Amrad Variometer.....	1.25		
		Betts & Betts Loop.....	2.50		
		Bruno WD-11 Socket.....	.25		



Herman Bernard
Managing Editor of Radio World,
who designed the Diamond
Circuit.

We Can Save Money
for You on Any
Apparatus You May
Require. Let Us Know
What You Need.

ing Manufacturers in the Diamond of the Air Kit

1 Fulton St., N. Y. C., N. Y.

SHIPMENTS ON DIAMOND KIT SENT
THE DAY RECEIVED TO ALL PARTS OF
THE WORLD.



MacMillan received and sent with Thordarson Transformers

If you were commissioned to explore the polar regions, you too would be very particular to select the best equipment — especially in radio, your sole means of communication.

- ZENITH
- KENNEDY
- Radiodyne
- Pfanstiehl
- Howard
- Thermodyne
- GLOBE
- Deresnadyne
- ADLER-ROYAL
- MURDOCK
- MU-RAD
- Valley
- Silver-Marshall
- OZARKA
- ULTRADYNE
- Newport
- LEICH
- NUNN-LONDON
- KUSTOMBILT and many others use

THORDARSON Super Amplifying Transformers — the identical transformers sold by dealers everywhere and used in a majority of quality sets—have been the exclusive choice of MacMillan on his Arctic expeditions.

Surely no greater tribute can be paid to the actual supremacy of Thordarson Transformers, product of the world's oldest and largest exclusive transformer specialists. Faultlessly they amplified programs and messages from great distances on the 1923-1924 expedition — and came back "as good as new." Equally successful was their performance on the last expedition.

The wisdom of MacMillan's choice is further confirmed by the fact

The Thordarson "Autoformer" All Frequency Amplifiers are our latest development. They amplify clearly the lowest as well as the highest notes of any instrument. An adaption of impedances, resistances and capacities. Write for the Autoformer Hook-up Bulletin—it's free.



Autoformers are \$5 each. Other Thordarson Radio Transformers: Audio Frequency (subpanel or top mounting types), 2-1, \$5; 3 1/2-1, \$4; 6-1, \$4.50. Power Amplifying, \$13 the pair. Interstage Power Amplifying, each \$8. If dealer cannot supply, order from us.

THORDARSON ELECTRIC MANUFACTURING CO.
Transformer specialists since 1895
WORLD'S OLDEST AND LARGEST EXCLUSIVE TRANSFORMER MAKERS
 Chicago, U.S.A.

that year after year, leading builders of fine sets — makers of fine instruments especially noted for distance and superb tone qualities—use more Thordarsons than all competitive transformers combined.

Standard in the "Diamond of the Air" Kit

Thordarson Super Amplifying Transformers have also been chosen for the "Radio World's" famous 1926 DIAMOND OF THE AIR kit, described by Radio World as "the best receiver for home construction"—and, therefore, worthy of the finest audio frequency amplification to be had.

Thordarsons cost more to build — but no more to buy. Dealers everywhere. Interesting bulletins on amplification mailed free.

THORDARSON

Super
AMPLIFYING TRANSFORMERS
Standard on the majority of quality sets

"Bruno" Quartzite Inductances

PATENT PENDING



Trade Mark
Reg. U. S.
Patent Office

The most efficient coils of their type made. The heart of the 1926 Diamond of the Air, chosen by Herman Bernard for his circuit after exhaustive tests for comparative efficiency.



This is the matched pair of Bruno Coils used in the Diamond of the Air Circuit

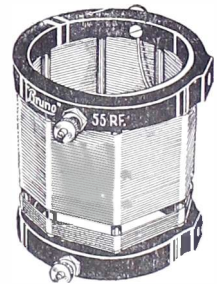

Bruno "99" interstage coupler wound on quartzite glass rods with newly designed tickler, giving maximum efficiency on all wavelengths. Tunes with .0005 condenser and covers range of from 175 to 575 meters.
Price\$5.50

Bruno "55" or "99" R.F. coil, which is matched to tune with the Bruno "99." Also wound on quartzite glass rods, which insures minutely small losses. The primary is green colored and the secondary is of orange color, giving this coil a handsome appearance.
Price\$3.00

The inventive genius, Mr. William A. Bruno, is busy in his laboratory, which is a sure sign that new and far more efficient apparatus than has appeared on the market up till now will be produced. Among the items upon which Mr. Bruno is devoting much of his time is a new condenser which is bound to make an instant "hit" with the radio fans who appreciate efficient apparatus. It will pay you to watch closely the developments of Mr. Bruno's work, and these will be announced in advertisements which will appear shortly.

In order to keep the fans who are interested, informed more closely of Mr. Bruno's work, a monthly bulletin, known as RADIO RESEARCHES, will be issued at 10c per copy.

BRUNO RADIO CORP., 223 FULTON STREET., N. Y. C.

Philadelphia Office:
611 Widener Building

Detroit Office:
159 E. Elizabeth Street

Chicago Office:
337 W. Madison Street

274 Bannon Street
San Francisco Office:

KURZ-KASCH *Aristocrat*

Chosen for DIAMOND OF THE AIR KIT



More manufacturers have adopted Kurz-Kasch product than all others combined.

The world over Kurz-Kasch Aristocrat E-Z Toon is recognized as the real "Key to Simplified Tuning"



KURZ-KASCH ARISTOCRAT DIAL

The supremacy of Kurz-Kasch Aristocrat dials is further exemplified by the choice of Aristocrat Dials for the famous "Diamond of the Air" kit. The beauty of workmanship—the care in moulding—the expert mould making—all combine to make Kurz-Kasch Aristocrat dial the choice of the big majority. The famous Kurz-Kasch split bushing method of mounting is an exclusive feature found only in Kurz-Kasch Aristocrat dials. Kurz-Kasch dials "Align Rite"—"Hold Tite."

KURZ-KASCH ARISTOCRAT E-Z TOON

Gives that close tuning so necessary, with stations numerous and close together. Simple to install, remove your present dial and slip on an E-Z Toon. Kurz-Kasch workmanship and quality brings in stations you never heard before. Famous Kurz-Kasch split bushing method of mounting. You'll never realize how simple it is to tune your set until you use Kurz-Kasch Aristocrat E-Z Toon.

KURZ-KASCH *Aristocrat* E-Z-TOON

(EASY TUNE)

GROUP CONTROL



For the Set
You Have!



For the Set
You Build!



Tunes two or more units by means of one Master Control and at the same time provides vernier adjustment for each separate unit. All the advantages of single control, with none of the disadvantages.



\$7.50

LIST
Complete

Simple to install, comes complete, nothing else to buy. No panel to drill, complete instructions with each kit. Nothing to get out of order. Simplifies tuning without loss of efficiency. Any dealer can supply. Write for illustrated folder.



Manufactured by

THE KURZ-KASCH COMPANY

Largest exclusive Moulders of Bakelite

FACTORY and OFFICE:

:::

DAYTON, OHIO

AMPERITE

REG. U.S. PAT. OFF.

The "SELF-ADJUSTING" Rheostat

A BASIC Need in Every Circuit

BECAUSE—AMPERITE not only modernizes any set—it keeps it modern.

- 1—Eliminates Hand Rheostats, thereby simplifying control.
- 2—Permits use of the latest types of tubes or any combination of tubes.
- 3—Simplifies and reduces set-wiring, thereby making for greater compactness and avoids losses.
- 4—No moving parts, hence no grinding noises; clear and full tones.
- 5—Prolongs tube-life by keeping filaments at a constant temperature.
- 6—No filament meters needed.
- 7—Brings the most out of each individual tube—automatically—no guessing.
- 8—Makes every set-owner a master operator, no knobs to turn.

Write today for
FREE
Hook-Ups



Sold Everywhere
\$1.10 complete with mounting

Amperites are used in the
1926 DIAMOND OF THE AIR
because it simplifies the construction and operation of this famous receiver. The amperite used in the last stage permits the use of any type of power tube.

For the new tubes :

Amperite No. 112—for the UX-112 and CX-112
Amperite No. 120—for the UX-120 and CX-120

Radiall Company

Dept. R.W. 16,50 Franklin Street, New York City
Be sure that the set you buy or build is equipped with
AMPERITE.

Manufacturers of
TUNE-RITE
5% STRAIGHT-LINE FREQUENCY DIAL



Obsolete

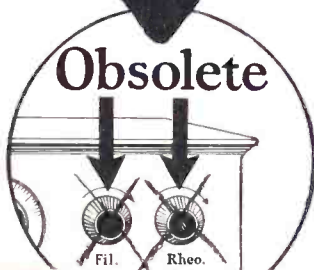

VEBY TUBES WILL GIVE YOU GREATER SATISFACTION IF YOU ARE USING RESISTANCE COUPLED AMPLIFICATION FOR YOUR RECEIVER



Increased volume without distortion and lower plate voltage are some of the advantages obtained by using VEBY AF20 Tubes for resistance coupled amplification. They are especially designed for this purpose and have an amplification factor of 20 as compared to 7 or 8 of ordinary tubes.

VEBY POWER TUBE

While designed for use in the last stage of a resistance coupled amplifier, the VEBY AF6 Power Tube is guaranteed to give more volume and eliminate distortion on any receiver, regardless of type of amplification used.

VEBY AF20 AMPLIFIER TUBE—\$3.00

(FOR RESISTANCE COUPLING)

VEBY AF6 POWER TUBE—\$4.50

VEBY RADIO COMPANY

47-51 MORRIS AVENUE

NEWARK, N. J.



VEBY Resistor No. 100

VEBY RESISTORS ARE SPECIFIED BY HERMAN BERNARD FOR USE ON THE

“DIAMOND OF THE AIR”

Manufactured in a Complete Range of Values From 2,500 Ohms to 10 Megohms.

B GRID LEAK T W O D

The Best Grid Leak in the World, is the contribution of Britain's finest craftsmen to the 1926 Model Diamond of the Air.

The Bretwood leak is variable, its efficiency is not. Price... **\$1.50**

NORTH AMERICAN BRETWOOD CO.

145 WEST 45TH STREET

NEW YORK CITY

Preferred By Those Who Know

Better Products— Lower Prices

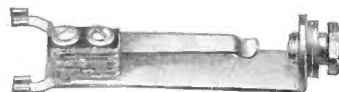

Preferred single jack



Preferred double jack

This pair of Jacks is used exclusively in the 1926 **Diamond of the Air Kit**, because of their durable construction and high efficiency. In actual tests these jacks proved better than makes of much higher price. The contact points are of a special alloy insuring long life.

Contributed to the new Diamond of the Air Kit by

Preferred Radio Products Co.

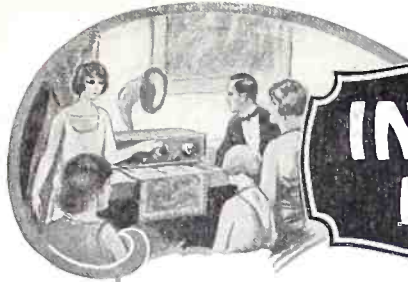

INSULINE PANELS

Pride of Ownership

IF the panel is of "Insuline" you can point to your set with justifiable pride. This beautiful panel material imparts a touch of distinction which instantly places your set in the "exclusive" class.

Insuline comes in three finishes; "Frieze," Black, and Mahogany, characterized by their high lustre, which does not grow dull with age.

Clearer reception—finer selectivity—and immunity against leakage losses are assured where Insuline is used, due to its great dielectric strength and moisture-repelling qualities. Insuline gives you a *better* set as well as a *better looking* set.

Insuline Panels are chosen for the 1926 Diamond of the Air Kit because of their durability and fine appearance. The drilled and engraved panels as used in each kit represent the highest type of workmanship possible to obtain.

RADIO PANEL & PARTS CORP.
 (Insulating Company of America)
 Insuline Building, 59 Warren St., New York
 Branches in Principal Cities

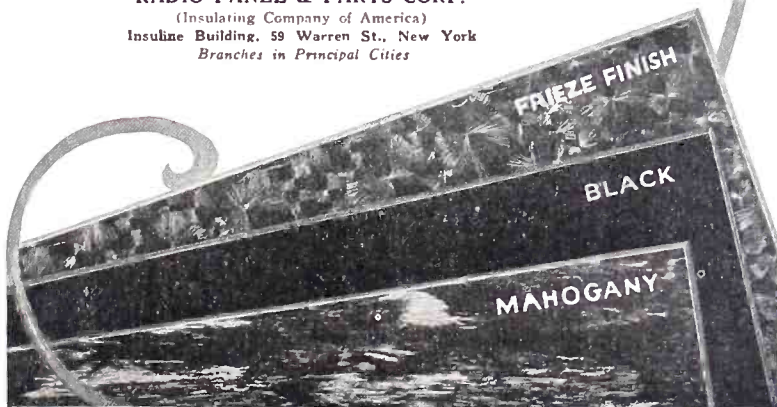

De Luxe Cable

The finishing touch to the Diamond of the Air



Facilitates the connection of set to batteries. About six feet long with large lugs permitting easy attachments.

Multi-Colored Battery Cable
 Supplied by

De Luxe Sales & Mfg. Co.
 NEW YORK

those who know recommend



Fixed Condensers

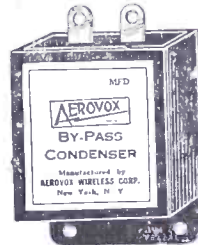

Used in the 1926 Diamond of the Air Kit because of its high standard of efficiency.

*Tested and approved by M. I. T., Yale, Radio News, Radio World, Popular Radio and Popular Science. Used by over 200 of America's leading set manufacturers. Made in all capacities. Also manufacturers of Grid Leaks, Resistors, Resistofomers and Rheostats.

another reason why you should insist on them

Chicago Office: 53 W. Jackson Boulevard
 Cincinnati: 304 Palace Theatre Building
Aerovox Wireless Corporation
 491 Broome Street New York City

STREAMLINE

The Straight-Line Frequency Condenser of Unfailing Performance. Enables tuning from 175 to 560 meters. Logging is Made Easy. Even a Baby Can Tune a Set That Uses Streamline Condensers.

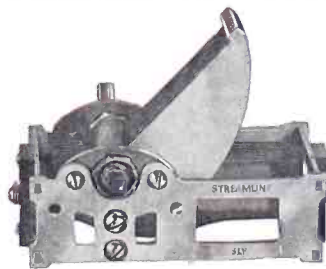

(The Streamline Condensers are officially certified for use in RADIO WORLD'S 1926 Model Diamond of the Air.)

Streamline Radio Co., 223 Fulton St., N. Y. City
 Enclosed find \$..... for which send me by return mail..... Streamline SLF condensers, capacity.....
 NAME.....
 ADDRESS.....
 CITY..... STATE.....

.0005 mfd. **\$2.50**
 .00035 mfd. **\$2.25**
 .00025 mfd. **\$2**

STREAMLINE RADIO CO.
 223 FULTON STREET
 New York City

DIAMOND UNIVERSITY

(Continued from page 17)

nections, one of which will be made by a separate piece of wire from B minus to A plus. (3) This is due to the proximity of your hand to either plate or grid post or lead from this socket. Inspect the grid and plate leads of the detector tube and see that they do not touch the socket shell or run near it, and that the grid and plate leads are kept apart from each other. Occasionally this howling results because of capacity within the tube itself, due to the elements, and the radio waves come through the base and are affected by your hands. Change tubes about to test this. This is not serious. If your tuning condensers do not tune nearly in step, and you desire them to do so, you may remove the extra five turns from the 3-circuit secondary. But before you do this make sure that the other condenser brings in the highest wavelength station within range with good volume, as it should under the conditions you describe.

WHEN I TUNE in a station on my Diamond, using the variable condensers, and then adjust the tickler for volume, the signal will build up to a certain point and then drop off with a click. I also get this click when I move the condensers off the station tuned in. The set is noisy when doing this. KDKA is 30 miles away. I bring in this station with fine volume, but this is not DX. (2) Can I get the design for the 1925 Model 4-tube set, using single condensers, as I built my set from the 1926 Model, using the RF and detector tube hookup to that point, and the rest of the set from another diagram.—K. E. McCowin, c/o Daubenspeck Auto Supply, 122 West Mifflin St., Butler, Pa.

(1) The most likely causes for the sudden pop when the saturation point in regenerative action has been reached are incorrect grid leak setting, too much or too little B battery voltage, or improper filament heating. Vary the grid leak until the signal comes in loudest without moving the tickler from a low-regenerative position which enables reception. Then leave the grid leak in that position and tighten the tickler coupling very slowly. The grid leak setting then need not be changed except when you are receiving a far-distant station and desire to clear up the signal and increase volume. If a common lead is used for B plus RF and B plus detector, the voltage may be 45, and this is a satisfactory voltage under most conditions. The common lead may be placed even at 67½ or even 75 volts, but if you can not remedy your trouble by following these suggestions, sever the common connection, as explained in the answer to Mr. Williams' question (2) The 4-tube Model was described in the January 23 issue of RADIO WORLD, but the 5-tube 1926 Model has a better audio hookup, and if you prefer excellent quality, with adequate volume still preserved, you should build the 1926 Model. Unless you are thoroughly familiar with radio hookups it is not safe for you to attempt to piece two diagrams together in the fashion that you describe and expect maximum results.

I HAVE BUILT the 1926 Model Diamond of the Air and am very much pleased with it, except that the tuning is rather broad. I have tried reversing the leads on the radio-frequency transformer and also on the 3-circuit coil, without improvement. (2) I find that I get about the same volume by disconnecting the B plus and negative filament sides of the audio-

transformers. (3) Distant stations are received, but I do not believe the volume is great as it should be.—A. W. Beeson, 149 South Wade Ave., Washington, Pa.

(1) This is an unusual complaint, because the set is very selective and was designed to be so. Therefore it must be assumed, in view of the great selectivity of all 1926 Diamonds constructed in the laboratory, that you have poor A or B battery supply or that your tubes are not permitted to function properly. If the B batteries are run down selectivity and volume will be small and this is true also if the A battery is exhausted. Test these. If the test shows the batteries are in good condition, remove three turns from the primary of the RF transformer, at the point adjacent to the beginning of the secondary winding. This will not only cut down the number of turns but will reduce the coupling also on account of the increased separation between primary and secondary. (2) This should impel you to test both the primary and the secondary of the audio transformer for an open circuit. Use a 1½-volt dry cell, connecting one earphone tip to one of the posts of the dry cell, while the other phone tip and the remaining post of the cell are connected respectively to the two leads of the test circuit. While volume may still be supported without the Neg. Fil post of the audio transformer being connected, there should be a very noticeable effect in respect to the B plus lead being disestablished. (3) Increase the B battery voltage in the audio circuit. Adjust the variable leak to proper setting when receiving distant stations. Test the plate resistors and audio leaks by putting in others.

I HAVE been reading with much interest the articles describing the 1926 Model Diamond of the Air. I expect to build this receiver, but would like to know if another stage of tuned radio-frequency amplification is added ahead of the one-stage already in the set, would increase the efficiency of set.—K. F. Rausch, 61 East 6th St., N. Y. City.

Another stage of tuned radio-frequency amplification would not increase the volume of signals from local stations. The signals from distant stations would be increased to a slight extent, only if extreme expertness in arrangement is practiced. If you live in a district where the interference from local stations, due to the high power used, is great, then an extra stage of tuned radio-frequency amplification may be attempted, but the danger of riotous oscillation is great.

I HAVE built the 1926 Model Diamond of the Air and have not had much success by Herman Bernard, but am having some trouble. The tickler does not control the oscillatory action of the tube. Due to this effect, the stations are difficult to tune in. I am using 45 volts on the plate of the detector and RF tubes and 90 volts on the plate of the audio-frequency amplifier tubes.—S. J. Avery, N. Y.

Change the tubes around. Separate the B+ voltage leads of the detector and RF tubes. At least 135 volts should be placed on the plates of the audio-frequency amplifier tubes. Reverse the tickler leads. Be sure that the plate and grid leads of the Det. and the RF tubes do not run parallel to each other. Also see that these leads are short. Test the flexible leads of the tickler coil for continuity, with a small battery and phones.

I HAVE built the 1926 Model Diamond of the Air and have not had much success with it. (1) I do not get stations over 365 meters with any volume. (2) I have a 3-foot loop with 12 turns of No. 18 double cotton covered wire on it. When I plug

in the loop the signals are barely audible. (3) When I pull out the filament switch, the signals will come in for a moment and then fade away. They will then come back again and stay until the tube is turned off. I am using the UX201A tubes throughout. There are 135 volts on the plates of the audio-frequency amplifier tubes. On the detector and the radio-frequency amplifier tubes, 45 volts are placed. I put a 9-volt grid bias on the last tube.—E. P. Grant, Box 531, Albany, Tex.

(1) Put 6 turns on the secondaries of both the RFT and the tuner. (2) Add 4 turns to the winding. Be sure that the plug makes perfect contact with the jack, so that the antenna, the ground and the RFT are completely out of the circuit. (3) Reduce the length of your A battery leads. Look at the leads which make contact with the switch and see that the contact is perfect. The contact may be poor due to the paste falling in between the two pieces of wire instead of the solder. Push the filament prongs of the sockets up. Lengthen your aerial.

I WOULD like to build the Diamond of the Air. (1) Would two SLF .0005 mfd. variable condensers be O. K.? (2) I have a 180° variocoupler. The stationary tubing is 3½" in diameter and 2¼" height. The rotor is 2¾" in diameter and 1½" high. I am desirous of having the number of turns so as to make the 3-circuit tuner. The radio-frequency transformer is to be made on a tubing 3½" in diameter and 2¾" high. (3) I would like to use dry cell tubes of WD12 type. Is there any change to be made in the filament wiring? (4) Is this receiver good for portable use?—J. F. Forens, Latrobe, Pa.

(1) Yes. (2) Wind 10 turns to constitute the primary. Wind 45 turns to constitute the secondary. There is a ¾" left between the primary and the secondary windings. The tickler consists of 26 turns of No. 26 SCC wire. The primary and the secondary are wound with No. 24 silk over cotton covered wire. The number of turns on the primary and the secondary will be the same as on the primary and the secondary of the tuner, using the same kind of wire, with a ¾" space left between the primary and the secondary windings. (3) There is a small change to be made in the filament wiring of the set. There will be only one ¼ ampere ballast resistor required, which should be placed in series with the negative leg of filament of the detector tube. All the filaments of the other tubes can be operated directly from the A battery source, 1.5 volts. (4) Yes.

I HAVE tried to build the 1926 Model Diamond of the Air, but have failed. I used .00035 mfd. variable condensers, instead of .0005 mfd. variable condensers. I can never seem to get the number of turns on the secondary correct. Now how many turns should be placed on the secondaries so that the broadcast band is covered and the dial readings on the condenser will read alike. The diameter of tubing is 3¼", using No. 24 DCC wire.—I. M. Jacobs, c/o Westgater Hotel, St. Louis, Mo.

There should be 58 turns on the secondaries of both the tuner and the RFT.

ABOUT SIX weeks ago I constructed the 1925 Model Diamond of the Air, using two stages of transformer coupled audio-frequency amplification. In constructing the coils I used the Goodman Spider Web Coil Form with an inside diameter of 1". I wound 10 turns to constitute the primary and 50 turns to constitute the secondary of both the RFT and the 3-circuit tuner. The tickler consists of 35 turns. I used No. 24 DCC wire. The secondaries of the RFT and the 3-circuit tuner are shunted

by .0005 mfd. variable condensers of the SLF type. The trouble that I encounter is that I cannot get both dials to read alike. On approximately 225 meters, the condenser shunted across the secondary of the RFT is 15 degrees ahead of the condenser that is shunted across the secondary of the tuner. On approximately 525 meters, the condenser across the secondary of the RFT reads 2 degrees ahead of the other condenser dial. What could I do to make these dials match?—H. K. Mansfield, c/o Martin Brothers & Co., Barker Block, 15th and Farnum Sts., Omaha, Neb.

The condensers are not of the same variation of capacity.

I PUT the 1926 Model Diamond of the Air together with a batch of old parts lying around the house and have obtained over 25 DX stations, all of which are located in Wis., Neb., Tex. and Mich., but I cannot get stations west of Iowa and Nebraska. Some folk tell me that I am in a dead spot to the stations in that locality. Is that true?—G. H. Thomas, c/o People's Bank, Hartsville, S. C.

Your friends are probably right. Point your antenna in the direction of the most desired station or group of stations.

I WOULD like to have a diagram of the Diamond of the Air, using 3 stages of transformer coupled AF. (2) What types of tubes should be employed?—H. Fremont, Toulon, Ill.

(1) It would not be advisable to use three stages of transformer coupled AF with this hookup. (2) 5-volt type, a power tube in the last stage.

I HAVE built the 1926 Model Diamond of the Air and am pleased with the results. However, I do not get sufficient volume on stations operating over 350 meters, to use the loud speaker. I made the coils thus: the diameter of the form, upon which the primary and the secondary is wound is 2 1/4" in diameter. The primary consists of 9 turns. The secondaries consist of 50 turns. The diameter of the form upon which the 40-turn tickler is wound is 1 3/4". I used No. 24 double silk covered wire.—John Curran, 1241 Montclair Ave., Detroit, Mich.

Add 5 turns to the secondaries. Add 3 turns to the tickler coil.

I HAVE heard the 1926 Model Diamond of the Air and was very well pleased with it. I wish to construct one myself. I have two old style .0003 mfd. variable condensers. I would like to have the coil data, so as to construct the RFT and the 3-circuit tuner. (2) I would also like to have the data on the loop for this receiver.—H. J. Schlossin, 119 Edgewood Ave., Station B, Buffalo, N. Y.

The primary consists of 15 turns. The secondaries consists of 65 turns. The tickler consists of 35 turns. For winding the primary and the secondary use a form 3 1/2" in diameter and 4" high. For winding the tickler use a form 2 3/4" in diameter. Use No. 24 silk over cotton covered wire. For winding the tickler, use No. 26 single silk covered wire. (2) See the Oct. 31 issue of RADIO WORLD.

HOW MANY turns should be placed on the tickler of the 3-circuit tuner, in the Diamond, the secondary consisting of 45 turns and wound on a form 3 1/4" in diameter using No. 24 silk over cotton covered wire? The tickler form should be 2 3/4" in diameter. (2) Should there be any fixed condenser in the B+ detector lead?—C. E. Hines, 703 Central Bank, Memphis, Tenn.

(1) There are 28 turns of No. 26 single silk covered wire. (2) This condenser should not be needed. In case you do not get enough regeneration, this condenser

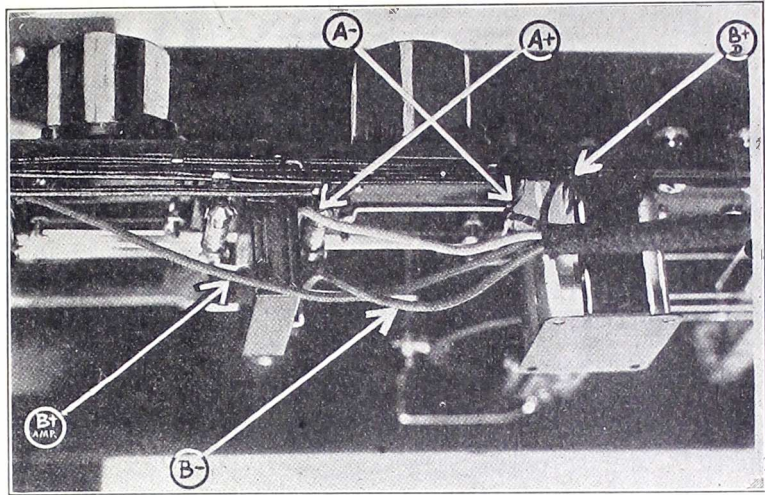

FIG. 1, detail of the detector jack wiring of the 1926 Model Diamond of the Air.

may be placed here. Use .0001 or .00025 mfd.

HOW MANY volts should be placed on the plate of the detector and the radio-frequency amplifier tubes in the 1926 Model Diamond of the Air? (2) Why do I have to turn the tickler coil all the way over in order to get any kind of volume from the set? There are 31 turns of No. 26 SCC wire wound on the tubing 2 3/4" in diameter. (3) How can I stop body capacity, which is present when I put my hand near the grid leak?—Sidney Larson, Heron Lake, Minn.

(1) About 45 volts is O. K. (2) If you increase the number of turns on the coil you will not have to do this, e.g., by placing 5 more turns on the coil, the regenerative action of the tube circuit will be more violent. (3) See the answer to Mr. Snyder's query.

I BUILT the 1926 Model Diamond of the Air and am having some trouble with it. As a 3-tube set, it works great, but as soon as the radio-frequency tube is connected in the circuit, the signals are absolutely dead.—Eugene R. Feci, Plymouth, Mass.

The primary or the secondary leads of the RFT must be shorted or open circuited. See if the leads from the windings going to the binding posts are not broken. Follow the blueprint.

I HAVE built six 1926 Model Diamond of the Air receivers and have had the same trouble with every one of them. (1) I made the coils myself, thus: 9 turns on the primary and 57 turns for the secondary wound on a tubing 3 1/4" in diameter using No. 24 double cotton covered wire. I do not receive the low wave stations (below 345 meters) loud. (2) The C battery does not change the volume at all, nor does it change the quality of the signals. Why is this? (3) I have a Delco farm lighting plant. I have a 45-volt dry cell B battery connected in series with the 58-volt battery portion of the output of the generator. Is this O. K., or does it hurt the batteries? (4) How can I charge my wet B batteries with a generator (D. C.) giving 40 volts at 20 amperes.—Isaac Everett, Lytton, R. F. D., Delta, O.

(1) You have too many turns on the secondaries. Take 9 turns off each secondary. (2) Very seldom will you find that the C battery noticeably increases the volume of the receiver. It will improve the quality of reception, if you have it hooked up properly, also conserve B battery juice. (3) You are injuring both the batteries from the plant and the outside B battery.

Use all external B batteries to obtain full satisfaction. The amperage of the external battery is low, in comparison to that of the lighting batteries. One has more internal resistance than the other. Conjunctive use would cause both to run down, due to energy wasted. (4) You can only charge one 22 1/2-volt unit at a time. In order to do this, you will need a 160-ohm, 1/4 ampere resistance.

I HAVE completed the 1926 Model Diamond of the Air and went after distant stations. The results were wonderful. As I kept using the set, the volume decreased, until I could hear absolutely no signals. I examined and re-examined the set, but could find no trouble with the set. I found, however, that the B batteries had dropped to 12 volts. I get reception now, but hardly worth while talking about. I receive WJZ fairly well, but WEAF comes in on a whisper. How can I repair my set so that I can receive signals as I did at first.—E. M. Scurerman, 24 South Walnut St., Nantcoke, Pa.

Weak batteries or shorted leaks probably cause your troubles. Test. Replace the defective unit.

HOW are the battery cable leads connected in the 1926 Model Diamond?—John Leznick, 673 Fifty-fourth Street, Brooklyn, N. Y.

If you use six leads in the cable, follow Fig. 2, where five are shown, and in addition use the sixth lead for B plus RF, not shown. If you use five leads, with common B plus for detector and RF, then follow Fig. 1 exactly. If you have only a 5-lead cable and desire a separate B plus for RF, disconnect B minus from A plus lead in the set and use the erstwhile B minus lead for B plus RF. The B minus and A plus in that case are connected by a separate piece of wire direct from battery to battery. The 5-lead cable method described last is the most popular and probably is electrically preferable.

PLEASE GIVE the electrical diagram of the Diamond of the Air, with 2 stages of transformer coupled audio-frequency amplification, instead of the resistance coupled audio-frequency amplification. (2) What should be the voltage applied to the plates of the amplifier tubes so as to obtain maximum volume with clarity also? (3) Will the Muter resistance coupled amplifier work in the Diamond of the Air?—J. E. Torrence, Virginia Apts., Greenwood, S. C.

(1) See the Jan. 23 issue of RADIO WORLD. (2) 112 1/2 volts. (3) Yes.

A THOUGHT FOR THE WEEK
RADIO has only five letters, but its uses are myriad, and no man can say, with any degree of certainty, that the following year will not see greater developments in and more uses for radio than have been developed during any other year in radio history.

RADIO WORLD



Radio World's Slogan: "A radio set for every home."

TELEPHONES BRVANT 0558, 0559
 PUBLISHED EVERY WEDNESDAY
 (Dated Saturday of same week)
 FROM PUBLICATION OFFICE
HENNESSY RADIO PUBLICATION CORPORATION
 145 WEST 45th STREET, NEW YORK, N. Y.
 (Just East of Broadway)
 ROLAND HENNESSY, President
 M. B. HENNESSY, Vice-President
 FRED S. CLARK, Secretary and Manager
 European Representatives: The International News Co.
 Broom's Bldgs., Chancery Lane, London, Eng.
 Paris, France: Brenano's, 38 Avenue de l'Opera
 Chicago: A. T. Sears & Son, Peoples Gas Bldg.
 Cincinnati Office: Radio World, 301 Provident Bk. Bldg.,
 7th and Vine Sts. Telephone Canal 753 and 379.
 San Francisco: Lloyd B. Chappell, 656 O'Farrell St.

EDITOR, Roland Burke Hennessy
 MANAGING EDITOR, Herman Bernard
 TECHNICAL EDITOR, Lewis Winner
 CONTRIBUTING EDITOR, John F. Rider

SUBSCRIPTION RATES

Fifteen cents a copy, \$6.00 a year, \$3.00 for six months, \$1.50 for three months. Add \$1.00 a year extra for foreign postage, Canada, 50 cents.
 Receipt by new subscribers of the first copy of RADIO WORLD mailed to them after sending in their order is automatic acknowledgment of their subscription order. Changes of address should be received at this office two weeks before date of publication. Always give old address also. State whether subscription is new or a renewal.

ADVERTISING RATES

General Advertising		
1 Page, 7 1/4" x 11"	482 lines	\$300.00
1/2 Page, 7 1/4" x 5 1/2"	231 lines	150.00
1/2 Page, 8 1/2" x 5 1/2"	231 lines	150.00
1/4 Page, 4 1/2" x 5 1/2"	115 lines	75.00
1 Column, 2 1/4" x 11"	154 lines	100.00
1 inch		10.00
Per Agate Line		.75
Times Discount		
52 consecutive issues		20%
28 times consecutively or E. O. W. one year		15%
4 consecutive issues		10%

WEEKLY, dated each Saturday, published Wednesday.
 Advertising forms close Tuesday, eleven days in advance of date of issue.

CLASSIFIED ADVERTISEMENTS

Ten cents per word. Minimum, 10 words. Cash with order. Business Opportunities ten cents per word, \$1.00 minimum.

Entered as second-class matter, March 23, 1922, at the Post Office at New York, N. Y., under the act of March 3, 1879.

JANUARY 30, 1926

HE LOST BY A NECK



By Dan Napoli

BY DAVID SARNOFF

Vice-President and General Manager, Radio Corporation of America

"The Country As a Whole Is Not Yet Adequately Served by Radio Broadcasting"—"Why Should the Small Town Dweller in Many Cases Be Cut Off from the Cultural and Entertainment Advantages Inherent in Broadcasting?"

THE art of broadcast transmission has but recently emerged from the stage-coach period. They are comparatively few broadcasting stations in the United States the useful range of which is more than fifty miles—a range entirely adequate to the requirements of local broadcasting, but far from adequate in the establishment of a national service.

The local broadcasting station has established itself as a permanent factor in the broadcasting picture. It has a distinct function to perform and interests to serve. Like the local newspaper in the field of journalism, the local broadcasting station can and does give expression to community interests. Insofar as it renders such service it has a solid purpose for existence and a field of its own. Yet, with all that has been done in the creation of a web of local stations in the United States, the fact must be admitted that the country as a whole is not yet adequately served by radio broadcasting. There is a multiplicity of entertainment in some parts of the country, and a dearth of broadcasting in other parts. In the larger cities the radio listener has a wide choice of program; in many smaller towns he is restricted to the offerings of the nearest local station. Certain areas remain completely uncovered by the useful range of any good broadcasting station.

And why should not the American farmer, in his lonely prairie home, have the same character of service so freely available to his city brother? Why should the small town dweller in many cases be cut off from the cultural and entertainment advantages inherent in radio broadcasting? If radio is a welcome service in the city it is a necessity on the farm.

Increasingly the need becomes clearer for a system of nation-wide broadcasting, ready for any national or public emergency, with facilities adequate enough to cover the entire country, and to span the oceans if need be.

True, a sufficient number of stations to cover a considerable part of the country may be, and often are, interlinked by wire to act as one transmitting unit, but the fact must be faced that whereas the President of the United States might pick up his telephone today and talk across the country to San Francisco, he

could not do so by radio, without vast preparation, considerable expense and the voluntary co-operation of many broadcasting stations. Unless and until the best programs in the air can be received at will in every home in the country; until in a national emergency, a single voice is able to deliver its message to every home equipped with a radio set, we shall not have achieved the ideal of a public service envisioned for radio.

And while we are considering national broadcasting, international broadcasting is knocking at our doors. The Secretary of Commerce has well said that we are at the threshold of international exchange of ideas by direct speech through radio broadcasting. We have shown in experimental demonstrations that this can be done. The chimes of London have been made to ring in Washington and New York homes, and men in America and England, whose voices have been carried across the ocean by radio, have greeted each other in speech. If we are to receive organized programs broadcast to us from the capitals of Europe, it is clear that our own system of broadcast communication must be stretched to span the seas. For, in the exchange of programs contemplated between this country and Europe, we must be able to give as well as to receive.

The contribution made by the Radio Corporation of America towards the solution of the problem of both a national and international broadcasting service, has been in the erection and experimental operation of a powerful broadcasting station at Bound Brook, N. J. This station is a great laboratory of the air, in the broadcasting experiments of which the public has been invited. The aim is to demonstrate the utility of super-power transmission in radio broadcasting, and to determine to what extent a system of super-power stations, joined by wire or eventually connected by radio delay, would meet the need of a nation-wide service.

CONGRESSMEN BROADCAST

Each Wednesday and Saturday night members of the House of Representatives broadcast from WCAP or WRC, Washington, discussing public questions. The R. C. A. organized the series. It is proving very popular.

Freshman Sets Record; \$1,793,924 in Month

The Chas. Freshman Co., Inc., New York and Chicago, manufacturers of the line of Freshman Masterpiece 5-tube radio receiving sets, reports gross sales of the month of December the largest that the company has ever enjoyed. The total was \$1,793,924.95.

These enormous sales for December, although the company's 2,200 authorized dealers had procured, with their November purchases, sufficient merchandise, in their opinion, to have taken care of the holiday business, clearly show that the demand for Freshman Masterpiece radio receivers was far in excess of the dealers' anticipations.

It further shows that the demand during the winter months will be very large and

that the sales of the Chas. Freshman Co., Inc., will continue to be high.

Storad Enlarges Plant

The Storad Manufacturing Co., Cleveland, Ohio, formerly The Cleveland Engineering Laboratories Co., has just reorganized and has increased its capital to finance expansion of its plant and business.

Heretofore the company has manufactured Storad Storage A and B batteries exclusively. The present expansion is being made to take care of production and distribution of the Storad Automatic Power Supply Unit which is just ready to be announced to the public. This supply unit is said to be the most complete power unit yet placed on the market. It is automatic in action and is controlled entirely by the set switch. Other products will be added to the Storad line in the near future.

Directors of the new company include A. M. Bachr, W. K. Fleming and R. B. Clark of Cleveland, Ohio, and F. J. McDonald of Akron, Ohio. Mr. McDonald is the engineer in charge of production, while Mr. Fleming will act in the capacity of consulting engineer.

McPHILBIN RADIO CORP. EXPANDS

For the convenience of their city trade, the McPhilbin Radio Corporation has opened new and spacious quarters occupying the entire seventh floor at 245 West 55th Street, New York City. Miss H. E. Edlin greets the trade with a cordial welcome, W. P. Powers looks after the city accounts. Among the lines handled are DeForest, Kolster Radio, Priess, Ray-o-Vac, Marko storage batteries, and R. C. A. tubes. The McPhilbin headquarters remain in Jamaica, and the energetic Artie Kissner, well-known to all the trade, works from there.

New Corporations

Resonance Laboratories, radio, N. Y. City, \$111,100; H. G. and J. B. Opdycke, H. C. Muckey. (Atty., F. M. Holahan, 233 Broadway, N. Y. City).

Rappaport & Glansten, radio, N. Y. City, \$25,000; M. and S. Rappaport, M. Glansten. (Atty., A. P. Wilkes, 63 Park Row, N. Y. City).

New Radiohorn Process Corp., radio equipment, N. Y. City, \$300,000; C. and A. Berlin, B. T. Endlich. (Attys., Berlin & Berlin, 44 Court St., N. Y. City).

Stoner & Heath, radio and automotive supplies, N. Y. City; \$20,000; P. W. Mack, W. W. Scharp, G. W. Hoehn. (Atty., H. S. Goodspeed, 522 5th Ave., N. Y. City).

McPhilbin Keator, make radio sets, N. Y. City, 2,000 common, no par; H. Bogdich, E. F. Meisler, S. Platt. (Attys., Fisher & Deimet, 331 Madison Ave., N. Y. City).

SLEEPER'S SALES INCREASE

Gordon C. Sleeper, president of the Sleeper Radio Corporation, Long Island City, announced corporation ended 1925 with record-breaking December shipments reaching \$174,068, the total shipments for

the last quarter amounting to \$457,247. This business compares with \$51,769 for December, 1924, and \$202,560 for the last quarter of that same year. The increase is more than 100 per cent.

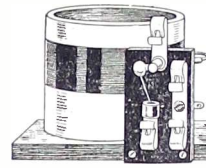

Long Distance Radio, \$2.95

Lambert's newest crystal success. No tubes. No batteries. No grief. Always ready. Works 600 miles. Fully guaranteed. We pay postage. Order direct from this ad. Leon Lambert, Wichita, Kansas.

LISTEN TO YOUR LOCAL STATIONS

THE TALKING BOOK

Reg. U. S. Pat. Off.
A complete radio set in the form of a book, bound in fine cloth with gold stamping. Equipped with Towers head phones and antenna. Guaranteed range fifteen miles. An ideal auxiliary to a tube set. Costs nothing to operate and lasts forever. Just the set for the children and fine for the traveling man.

PRICE FIVE DOLLARS, sent prepaid.
Mfd. by
LISTEN-IN PUBLISHING CO.
110 Main St. Cambridge, Mass.
Publishers of the Listen-In Studio Record.
If you live within ten miles of a broadcasting station write for exclusive agency.

THINK MAN! THINK !!

You can now make an Electric Light Socket Radio Receiver out of any battery-operated set, radio circuit or parts, and eliminate forever all A. B. and C batteries, chemicals, chargers, continuous trouble, upkeep expense, disappointments and save easily \$75 a year.

Anyone—you, your battery-charging, electrical and radio service man or dealer—can make it in short time at reasonable expense. Thousands are now doing it and thousands are now in the homes.

It will be as good as POWEROLA, the famous 5-tube no-battery electric radio (universal for A. C. or D. C.) now demonstrated and sold by your local electric light company, radio, electrical or music dealer, and tested and endorsed by Popular Radio, Radio Broadcast, Radio News and all highest and leading authorities, and engineers, as being powerful, practical, perfect, dependable and constant in performance.

REMEMBER—YOU DON'T HAVE TO JUNK OR THROW AWAY YOUR OLD SET OR PARTS. THEY CAN NOW BE MADE INTO AN UP-TO-DATE ELECTRIC RADIO, THE LATEST AND BEST IN RADIO PERFECTION AND PLEASURE.

Send \$1.00 and we will mail you booklet containing new and hitherto unpublished diagrams, information and literature, showing how to make any old or new radio set, circuit and parts into an Electric Radio.

Powerola Radio Corp'n
Dept. R.W., 1845 B'way, N. Y. City

The AIRGAP SOCKET
"It gets that last mile"
Electrically and Mechanically its Perfect.
AIRGAP PRODUCTS CO. Mfr.
188 N.J. R. Rd. Ave. Newark, N.J.



From zero to five million ohms without a jerk.
\$2.25

CLAROSTAT

AGAIN Clarostat scores a hit! This time Herbert E. Hayden specifies Clarostat for the Thoroughbred Amplifier in this issue. He knows that no other resistor will give equally good tone quality and modulation.

If your dealer cannot supply you write the American Mechanical Laboratories, 285-7 N. Sixth St., Brooklyn, N. Y.

GET LONDON NEW 1926 MODEL SUPER



Recognized as the most powerful radio receiver in existence. Wired to give the results of 8 tubes. Awarded first prize for distant reception. The first three tubes give you six stages of amplification, three magnetic coils for each tube or eleven sets of transformer parts. The tone is truly remarkable and the most distant stations are obtainable with amazing clearness on the loud speaker. B batteries last 6 to 8 months with this receiver. Sets are sold on a 10-day trial. Large circular describing set with 8 different cable cabinets to pick from available on request. Size of set 9 by 30. List price \$45.00.

Coast-to-Coast Reception Guaranteed
MERCURY ELECTRIC CORP'N
46 West Burnside Ave. New York, N. Y.

SPECIAL ANNOUNCEMENT Regarding the FENWAY

Did you know, Mr. Radio Fan, that the Fenway is proclaimed the greatest set in radio—the Acme of Perfection?
Did you know that New York Radio Fans have gone simply wild over it?
Did you know that it brings in stations from one coast to the other almost nightly?
Did you know that it can be built for less than \$150.00?
Did you know that Chas. W. Down is the only authorized Fenway dealer in New York City?
And that he stocks all parts as specified by Mr. Fenway himself?
Certain other things regarding this set will be published in this space again next week. Better watch for them, eh?

**At all events, LOOK UP DOWN
711 EIGHTH AVENUE
NEW YORK CITY**

SELECTIVE TRAP

(Continued from page 8)

of the single circuit jack in the output. The G post on AF2 goes to one terminal of C6. The other terminal of this condenser goes to the G post on the socket which will hold the second AF amplifying tube. This also goes to the one terminal of a fixed resistance, R6. The other terminal of this resistance goes to the clip, to which one terminal of R5 went. These two terminals will go to the minus post on the C battery. In other words, the grids of

these two tubes will have a variable grid bias. The F+ post of the socket which will hold the first AF amplifying tube goes to the F+ post of the socket which will hold the second AF amplifying tube. The F- post of these two sockets connect together also. Now the F- post connections of these two tubes go to one terminal of a ballast resistance. The other terminal of this ballast resistance goes to the A- post on the terminal strip. The P post on the socket which will hold the second AF amplifying tube goes to the P post on AF3. The G post on AF3 goes to one terminal of the blocking condenser, C7. The other terminal of C7 goes to the G post on the socket holding the last AF amplifying tube. It also goes to one terminal of R7. The other terminal of R7 goes to the C- post. The F- post of this last tube goes to one terminal of R3. The other terminal of R3 goes to the A- post on the terminal strip. The F+ post on this socket goes to one terminal of a filament switch, S2. All the F+ posts connect together. The other terminal of the filament switch S2 goes to the A+ B- post on the terminal strip. The plus of the C battery goes to the A- post on the terminal strip. The top of the single circuit jack goes to the P post on the last socket. That completes the wiring of the master receiver.

Now as to the wiring of the trap unit. The primary of the tuner is already connected in the circuit. The beginning of the secondary winding of the tuner, goes to the rotary plates of C1 and to the A- post on the terminal strip. The ending of this secondary winding goes to one

terminal of a grid condenser and leak. The other terminal of this leak and condenser goes to the G post on the socket. In series with the negative leg of the filament is a ballast resistance. The P post on this socket goes to one terminal of the tickler winding. The other tickler winding terminal goes to the top terminal of the jack. The bottom terminal of the jack goes to the 45-volt post. A switch is inserted in series with the F+ post, which goes to the A+ post.



Replaces Dry Cells

The 3-IN-1—Storage B Battery, with Rectifier, and Charger for ANY house current, all in one unit, with plug, cord, binding posts; made exactly as your A battery. Storage efficiency at DRY CELL COST. 100w, \$18; 150w, \$25; 135w, only \$23 and made especially for Diamond of the Air, and R. C. A. power tube. At no extra cost arranged to charge from Delco 32r or other low voltage lighting systems.

Service Men and Agents Wanted Everywhere. REPP-NORTON BATTERY CO., 202 W. 20th, New York

\$1.50 for YOUR OLD RADIO TUBES

regardless make or condition, toward purchase of each new standard \$2.50 tube. Positively guaranteed. We do not sell rebuilt or bootleg tubes. Agents wanted.

SUPER-SERVICE LABORATORIES
Dept. 53. Room 58. 39 West Adams, Chicago, Ill.

Panels

and Sub-panels for

Diamond of the Air—All Models
FENWAY SUPER-HET.
BROWNING-DRAKE.
B-T COUNTERPHASE.

Also Cut to Any Size. Mail Orders Promptly Filled.

Cortlandt Panel Engraving Co.
79 Cortlandt Street New York City

SANGAMO CONDENSERS

Heat proof, moisture proof, fume proof. Guaranteed to be accurate to within 10% under all temperature and humidity conditions. The following capacities are regularly carried in stock:

0.0004	0.00175	0.0008	0.005
0.0005	0.002	0.001	0.006
0.0006	0.0025	0.0012	0.007
0.0007	0.003	0.00175	0.0075
0.0008	0.0035	0.002	0.008
0.001	0.004	0.0025	0.01
0.0012	0.005	0.003	0.012
0.0015	0.006	0.0035	0.015
	0.007	0.004	

ROSSITER & CO., Inc.

WHOLESALE DISTRIBUTORS
136 Liberty St., New York

MERCHANDISER - EXECUTIVE - Unusual capabilities, manufacturing, importing, retail merchandising, collegian, 33, character; now managing well-known business; seeks reputable connection; possibility investment. Box OXX, RADIO WORLD.

RIX

- Complete Parts for B Battery
- Eliminator with instructions... \$14.75
 - Straight Line Freq. Condensers:—
 - .0003 \$1.40
 - .00035 1.54
 - .0005 1.65
 - Apco Chargers 9.75
 - Full Wave Chargers 12.95
 - Balkite Chargers 12.95
 - Standard Transformers 1.00
 - 3 Circuit Tuners 95

\$4.75

APOLLO



A loud speaker of surprising musical quality and volume. In the class with high-priced speakers. Artistically designed. Swan neck type. Adjustable unit where volume and tone are at all times under perfect control. Send no money. Just pay the postman

RIX RADIO SUPPLY HOUSE, INC.
Dept. 43, 5505 FOURTH AVENUE
BROOKLYN, N. Y.

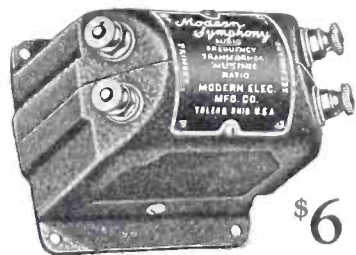

Results Count!

Everyone wants results when they have a radio receiver. You don't get it to look at—you want to hear something. Why not make that listening soothing and pleasant by installing Modern Symphony Transformers? All the original softness and mellowness of music is yours when you replace your old antiquated transformers with new Symphonies.

Modern Electric Mfg. Co., Toledo, O.

Represented by
GRAY SALES CO.

611 Widener Bldg., Philadelphia

RADIO WORLD'S QUICK-ACTION CLASSIFIED ADS.

10 Cents a Word. 10 Words Minimum. Cash With Order.

AGENTS!
START PROFITABLE BUSINESS with no investment! Distribute quality food and toilet products among friends and neighbors. 100% clear profit, and free automobile. Limited offer. Desk B1-3, Healtho Products Co., Cincinnati, O.

ATTENTION RADIO FANS! A seven-tube tuned RF set for \$26.50; tremendous distance and volume. Guaranteed. Circular free. J. S. Radio Co., 86 E. 4th St., New York.

BULLDOGS
BEAUTIFUL REGISTERED BULL PUPS, \$15. Bulldogs, 501 Rockwood, Dallas, Texas.

PATENTS—Write for free Guide Books and "Record of Invention Blank" before disclosing inventions. Send model or sketch of your invention for our inspection and instructions free. Terms reasonable. Radio, Chemical, Mechanical, Electrical and Trademark experts. Victor J. Evans Co., 924 Ninth, Washington, D. C.

DX SUPER-HETERODYNE, by J. E. Anderson, appeared in RADIO WORLD dated Nov. 21. Sent on receipt of 15c, or start your subscription with that number. RADIO WORLD, 145 W. 45th St., New York City.

LISTEN in every Friday at 7 P. M., E.S.T., and hear Herman Bernard, managing editor of RADIO WORLD, broadcast a talk on radio problems, through WGBS, 315.6 meters, the Gimbel Bros. station, N. Y. City.

HELP WANTED MALE
EARN \$110 to \$250 monthly, expenses paid as Railway Traffic Inspector. We secure position for you after completion of 3 months' home study course or money refunded. Excellent opportunities. Write for Free Booklet, G-161 Stand. Business Training Inst., Buffalo, N. Y.

High Mu Tubes and Power Tubes

(Continued from page 5)

After this point is reached and the load is greater than the supply, the decrease of power transfer is more gradual. (Fig. 4). This drawing is illustrative of the power

LOUD SPEAKER RECEPTION

from either coast on three tubes

- Blueprint and instructions..... \$1.00
- Necessary low loss coil..... \$2.50
- Beautiful finished instrument..... \$35.00

S. A. TWITCHELL CO.

1930 Western Avenue Minneapolis, Minn.

RADIO AGENTS WANTED

5 Tube Demons trator FREE!

Earn \$25 to \$100 a week, part or full time. Everyone a prospect. Complete line standard sets and accessories, \$5. to \$80. Write today for illustrated catalog and exclusive selling plan for live dealers and community agents. 20TH CENTURY RADIO CO., 1101 Coca Cola Bldg., Kansas City, Mo.

G-K BINDING POSTS

engraved or plain. For engraved ones, specify from following: Ant., Gnd., A-, A+, B-, B+ Det., B+ Amp. EACH

15c

Binding Post strip complete by mail \$1.25

Ganio-Kramer Company, Inc.

238-R West 53d Street New York, N. Y.

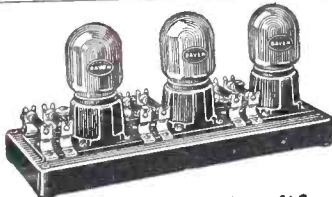

The Daven Super-Amplifier

for volume and tone quality
3 STAGES RESISTANCE COUPLED
ECONOMICAL DISTORTIONLESS
Easily added to any set
Saves Several Hours' Assembly
For Sale by All Good Dealers

1926 RADIO CATALOG & LOG BOOK



Get Our 1926 Beautiful Illustrated Catalog!

Which contains all latest Standard Radio Merchandise AT SLASHED PRICES!!

And Up-to-Date Log Book

IT WILL PAY YOU TO BUY FROM US. We carry one of the largest lines of Radio in the East.

Don't miss the wonderful opportunity to participate in this Great Sale.

Flush your request at once.

To cover the cost of mailing Enclose 10c.

ECONOMY RADIO SALES COMPANY
288 6th Ave. Dept. E New York
DEAL DIRECT AND SAVE REAL MONEY
(No Dealers)

ULTRA-LOWLOSS CONDENSER

SPECIAL CUTLASS PLATES DISTRIBUTE THE STATIONS. EVENLY OVER THE DIAL. SIMPLIFIES TUNING. CAPACITY 0008 MFD.

\$5.00

PHENIX RADIO CORP., 116-F East 25 St., N.Y. C.

Free Mailing Lists

Will help you increase sales! Send for FREE catalog giving complete list and prices on thousands of classified names of your best prospective customers. National, State and Local. Individuals, Professions, Business Concentrations.

99% Guaranteed 5¢ each by refund of

ROSS-Gould Co. 313 N. 10th St. St. Louis

High Amplification Constant Required of Tubes with Resistors or Impedances in Plate Circuit —This Requires High Plate Impedance Which Unfits the High-Mu Tube for the Last Stage, Because of Disparity Between Speaker and Tube Impedances.

transfer between the tube and the load. Assuming the internal plate-to-filament resistance of a power tube to be 4,000 ohms at a certain plate potential value, and the impedance of the loud speaker to be the same value, it is apparent that the greatest power transfer occurs at that value.

At this stage another factor enters into the discussion, that of the internal plate-to-filament resistance for a certain value of amplification constant. Unfortunately the design of the modern tube is such that a high value of plate-to-filament impedance cannot be avoided if the amplification factor is high. As the mu of the tube is decreased in design, the internal plate-to-filament impedance decreases. And since the design of the average loud speaker is such that the winding has an impedance approximating 4,000 to 5,000 ohms, it is essential that the tube supplying the speaker with power have the same or nearly the same impedance, if the maximum transfer of power from the tube to the loud speaker is to be obtained. If the impedances are equal the maximum power will be transferred, if unequal, the power transferred will be less, but if the load is less than the supply the difference or loss in power will be more marked than if the load is greater than the supply. (Fig. 5).

As it happens, unfortunate though it be, the internal plate-to-filament impedance

of the average high mu tube is in the neighborhood of 25,000 to 30,000 ohms at the usual plate voltage, say 135 volts, which impedance is from four to five times that of the loud speaker winding, with the result that very little power is transferred, less than would be were the loud speaker impedance four times that of the tube. It is for this reason that

(Concluded on next page)

FREE RADIO BOOK.

Science has invented a new kind of coil. Now have it on your present set. Gives 4 great advantages otherwise impossible. Write for new book just published showing many new ideas. Also 8 new circlod circuits. Address Electrical Research Laboratories, R.W., 2548 Cottage Grove Avenue, Chicago.

Vacuum Tubes Rebuilt \$1.00 each



POSITIVELY GUARANTEED equal to new tubes in every respect. Money will be refunded if tubes prove unsatisfactory for any reason other than burn-outs.

Send us your broken and burned out tubes by parcel post. (Not necessary to insure or guard against breakage). We make return shipments by parcel post C. O. D. and try to maintain 24-hour service.

HARVARD RADIO LABORATORIES

200 Old Colony Avenue South Boston, Mass.

Save 20 to 50% FREE RADIO CATALOG

LATEST IN HOOK-UPS AND RADIO

Get the lowest rock-bottom prices on radio parts, sets, kits. New free Radio Catalog and Guide brimful of standard, reliable, guaranteed goods. Over 100 latest hook-ups and illustrations. Be sure to get this thrifty book before you buy. It puts money in your pocket. Saves you as much as half on a set. Also please include name of radio fan. Send letter or postal NOW.

THE BARAWIK COMPANY

103-114 S. Canal St., Chicago, U. S. A.

NOW \$350.00 C.O.D.

THE RABAT SENIOR 4200 MIL. AMPS. CAPACITY

Direct from factory to you

A TWO YEAR GUARANTEE

We guarantee this battery to have a capacity of 4200 mil.-amps. at a 30 mil.-amp. per hour discharge. It will operate on any set from one to nine tubes, and will give service from four to eight weeks on a five tube set without recharging. More volume, clearer and more distinct reception and greater distances are assured by using Rabat Senior Batteries. Batteries are shipped out fully charged and ready to use when received.

BUILT IN TWO SIZES:

- 12 cell, 24 volt size..... \$3.50
- 24 cell, 48 volt size..... 7.00
- RABAT SUPER CHARGER FOR "B" BATTERIES..... \$ 3.00
- RABAT DOUBLE DUTY "A" AND "B" CHARGER..... 11.00

THE RADIO RABAT CO.

1243 OREGON AVENUE

CLEVELAND, OHIO

FREE BOOKLET FOR INVENTORS
 IF YOUR INVENTION is new and useful it is patentable. Send me your sketch.
 Z. M. POLACHEK, 78 Wall St., New York
 Reg. Patent Attorney-Engineer

VEBY HIGH-MU TUBES
 Made especially for Resistance Coupled Amplifiers. Now you can get more volume with greater clarity.
 A. F. 29 for the 1st and 2nd Stage \$3.00
 A. F. 8 Power Tube for the 3rd Stage 4.50
VEBY RADIO CO.
 47-51 Morris Avenue Newark, N. J.

To-day-in every good set



Less wiring—Fewer losses

Full, clear, rich tone depends on more than on just good apparatus. It depends, first of all, upon careful, compact wiring. AMPERITE eliminates complicated wiring, avoiding leaks and losses. Requires no attention. Controls the filament perfectly, bringing the utmost out of each individual tube. Permits use of any tubes or combination of tubes. Used in all popular construction sets. Price, \$1.10.
 There is an AMPERITE for every tube
 Write for free book-ups
Radiall Company
 Dept. B. W-4, 50 Franklin St., N. Y. City

AMPERITE
 The "SELF-ADJUSTING" Rheostat

New and Improved
FRESHMAN MASTERPIECE
 AT AUTHORIZED FRESHMAN DEALERS ONLY

TWO-FOR-ONE SUBSCRIPTION OFFER

Radio World has made arrangements
 —To offer a year's subscription FREE for any one of the following publications with one year's subscription for RADIO WORLD;
 —RADIO NEWS or
 —POPULAR RADIO or
 —RADIO BROADCAST or
 —SCIENCE AND INVENTION or
 —RADIO DEALER or
 —RADIO JOURNAL or
 —RADIO (San Francisco) or
 —THE EXPERIMENTER or
 —RADIO AGE

This is the way to get two publications
 —for the price of one;
 —Send \$4.00 today for RADIO WORLD
 —for one year (regular price
 —for 52 numbers)
 —and select any one of the other
 —nine publications for twelve months.

—Add \$1.00 a year extra for
 —Canadian or Foreign Postage.
 —Present RADIO WORLD subscribers
 —can take advantage of this offer by
 —extending subscriptions one year
 —if they send renewals NOW.

RADIO WORLD'S Special Two-For-Price-of-One SUBSCRIPTION BLANK
 RADIO WORLD, 145 West 45th St., N. Y. City;
 Enclosed find \$6.00, for which send me RADIO WORLD for twelve months (52 numbers), beginning..... and also, without additional cost, Radio News, or Popular Radio, or Radio Broadcast, or Science and Invention, or Radio Dealer, or Radio (San Francisco), or The Experimenter, or Radio Journal, or Radio Age (or \$10.00 for two yearly subscriptions).

Name

Street Address

City and State

Indicate if renewal
 Offer Good Until
 Feb. 17, 1926.

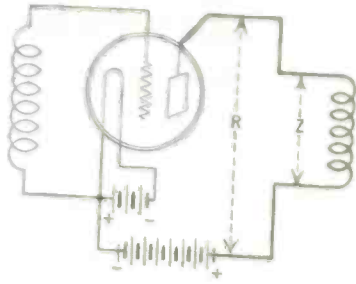

FIG. 4

(Concluded from preceding page)
 high mu tubes are impractical when employed as the output tubes, that is, as the tubes supplying the loud speaker.
 On the other hand, the power tube is designed to have a plate-to-filament impedance at the voltage specified by the tube manufacturer, approximating very closely that of the usual run of good loud



The Edison Element "B" Battery has long been the marvel of battery users, thereby surpassing all others. The See-Jay Battery is constructed from genuine alkaline elements and connected with a non-corrosive connector. 100-volt Alkaline Rechargeable "11" Battery and factory made charger for \$12.00; 140-volt, \$17.00. Write for literature or send 20c for sample cell. Send no money—pay on delivery.
SEE-JAY BATTERY CO., 915 Brook Ave., N. Y. City

TROUBLED WITH INTERFERENCE?

We have the cue. Build the Rider Wave Trap.
 Sold in kit form, with Money-Back Guarantee Complete kit, including panel and hookup. \$8.95
JOHN F. RIDER LABORATORIES
 145 West 45th Street New York City

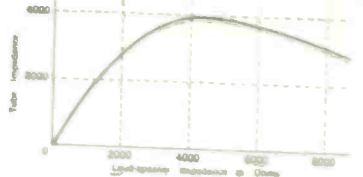

FIG. 5

speakers, thus affording the maximum energy transfer. The adaptability of the regular 201A tube in preference to the high mu tube for the last stage is also due to the lower plate impedance. In addition, the design of the elements in the power tube are such as to permit a greater input and distortionless amplification within the tube.
 Conversely the power tube is not adaptable as the amplifying tube feeding into a resistance, and a study of these two brings to light the difference between voltage and power amplification.

Cannibal Feaster Acquires a Radio
 SAN FRANCISCO.

A radio set finally has fallen into the hands of Charlie Arawangi of Suva, former cannibal chief and the life of the party at many a feast.
 The chief, now 90 or more years old, has had a radio set shipped to him. Some time ago a European planter showed him how to make two coconuts grow where but one had grown before, and the discovery made Charlie prosperous.
 Reports reaching here say that he then bought a motor car and hired a beach comber to drive it for him. Reaching out for some more civilization, he ordered a radio, which promises to be the finest thing of its kind in the South Seas.
 Charlie freely admits, seafaring men say, that in the old days he stalked the mangroves and the mango trees in search of those particular luncheon items relished only by cannibals.

FREE!
 Our Latest 100 Page RADIO CATALOG

BEFORE you build be sure to consult our latest 100 page radio catalog. A dependable guide for set-builders. Knows down sets and bits for all the latest circuits. No finer or more complete assortment to be found anywhere. Latest designed parts—Acme, All-American, Bremer-Tully, Carter, Freshman, Prust, General Instrument, Walbert, etc. And the prices—every one quoted means a big saving for you!

Write for your FREE copy today!
CHICAGO SALVAGE STORE 509 So. State St. Chicago, U.S.A. Dept. R.W.



A Simple Audio Amplifier for Any Detector Circuit



CONDENSERS
VERNIERS
RHOSTATS

AMSCO PRODUCTS, Inc. New York City

FIXED RESISTORS
Micamold
FIXED CONDENSERS

Accurate, Constant in Value,
Indestructible.
"Made of Mica and Moulded
in Bakelite"

At Good Radio Stores
G.D. RADIO CORP.,
Flushing and Porter Ave.,
Brooklyn, N. Y.

ACCURACY GUARANTEED
-VALUES REMAIN CONSTANT

MOULDED UNDER
PRESSURE OF 50
TONS

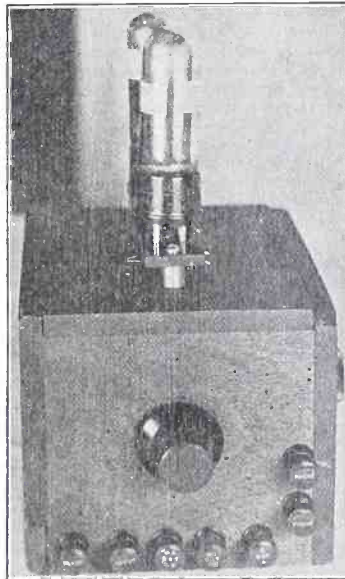

FIG. 8, a view of the finished amplifier with the tubes in place.

(Continued from page 3)

tubes are mounted in the sockets. It is a good plan to fit them in the sockets before the final assembly is made to make sure that a good clean cutting contact is made with the tube prongs.

Engravings Help

So many home-made radio sets are made with all sorts of dials and knobs that point to absolutely no line, zero mark, or other starting point. I am at a loss to understand sometimes how the user is able to tell when his tubes are on and off, or by looking at the dials which direction (on acquainted with the use of transfer en-

a condenser for instance) will mean an increase or decrease in capacity, etc.

For the benefit of the fan who is not gravings allow me to say that this simple

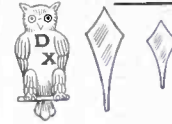

D-X OWL

EUREKA JR.

EUREKA

EAST ORANGE, N. J.
C. W. BUTTS, INC.
40 HEDDEN PLACE
Samples for Stamps.

EUREKA DIAL POINTERS

10c EACH
Polished Nickel or Gilt.
D-X Owl Pointer
Nickel 10c
Gold Plated 15c

FREE!

12-Cell — 24-Volt Storage 'B' Battery

Positively given free with each purchase of a WORLD Storage Battery. You must send this ad with your order. WORLD Batteries are famous for their guaranteed quality and service. Backed by years of successful manufacture and thousands of satisfied users. Equipped with Solid Rubber Case, an insurance against acid and leakage. You save 60 per cent and get a

2-Year Guarantee

Bond in Writing

World Est. 1897

Approved and Listed as Standard by Leading Authorities including Radio News Laboratories, Popular Science Institute of Standards, Radio Broadcast Laboratories, Radio in the Home, and Lefax, Inc.

Set your Radio Dials at 210 meters for the new 1000 watt World Storage Battery Station, W.S.B.C., Chicago. Watch for announcements.

World STORAGE BATTERIES

WOLA • WFAF • WGN • WJZ • KHJ • KGO • KFAF • WJY • KOA

VENUS

V-201A, 5 volts at filament.
V-199, 3 1/2 volts at filament.
Fully Guaranteed.

\$1.50

YOU CAN SAVE MONEY

without any risk whatever by purchasing Venus tubes. Equally efficient as radio or audio amplifiers or as detectors.

If your dealers cannot supply you, order direct

(Dealers, Write for Attractive Proposition)

VENUS RADIO CORP.

220 Fulton Street New York City
Exclusive N. Y. Distributors of Modern Line.

BLUE PRINT FOR 1926

Diamond of the Air

A blue print for wiring the circuit that has swept the country may be obtained by sending 50c in stamps, money order, cash or check. This blue print is full size and is personally certified by Herman Bernard.

RADIO DIVISION

THE COLUMBIA PRINT

145 West 45th Street New York City

The "ANTENNATROL"

The Remarkable Four-Tube Receiver Described by Herbert E. Hayden in This Issue of RADIO WORLD

Uses

**HAMMARLUND CONDENSERS
and SPACE-WOUND COILS**

Which, You Will Agree
With Mr. Hayden, Are

"Most Gratisfyingly Efficient"

HAMMARLUND MFG. CO., 424-438 W. 33rd St., New York

For Better Radio
Hammarlund
PRECISION
CONDENSER

(Concluded from preceding page) and neat fashion of designating the various parts, to say nothing of the zero and other marks, is well worth a little explanation.

RADIO INVENTIONS

Protected by U. S. and Foreign Patents.

Mason, Fenwick & Lawrence

Patent and Trade Mark Lawyers
Washington, D. C., New York, Chicago
Established over sixty years.

REFERENCES:

- Life Savers, Inc., Port Chester, N. Y.
- Stephen F. Whitman & Son, Philadelphia.
- Pacific Coast Biscuit Co., Seattle, Wash.
- Loft, Inc., New York City
- Sprague, Warner & Co., Chicago.
- The Warren Co., Atlanta, Ga.
- A. Baldwin & Co., New Orleans, La.
- Joseph Burnett Co., Boston.

Send description and sketch.

"Bruno"

MAGIC DIAL



The Newest Wonder in Radio
Makes condensers that are not straight-line frequency tune as if they were. Moulded Bakelite. No gears, no back lash **\$2.50**

"Bruno Slo-Moshen" Vernier Dial, \$2

POWERTONE KIT

Complete Kit for 5-Tube, 1-Control "Bruno" Powertone; Drilled, Engraved Panel; Free Radio World Hookup **\$22.50**
With Cabinet, \$2.50 extra

POWERTONE ELECTRIC CO.
Subsidiary of Bruno Radio Corp.
223 Fulton Street New York City

NOTICE REGARDING

Diamond of the Air Nameplates

The demand for Diamond of the Air nameplates has been so tremendous that the big stock we ordered is rapidly being depleted. A new order has been placed with the manufacturers for an additional large quantity of nameplates. Therefore, if you do not receive your nameplate immediately, do not worry, as your name is on our list, and you will receive one as soon as we receive the new lot.
RADIO WORLD, 145 W. 45th St., N. Y. C.

FILL OUT AND MAIL NOW

SUBSCRIPTION BLANK

RADIO WORLD

RADIO WORLD

145 West 45th Street, New York City
(Just East of Broadway)

Please send me RADIO WORLD for months, for which

please find enclosed \$.....

SUBSCRIPTION RATES	
Single Copy	15c
Three Months	3.50
Six Months	3.00
One Year, 52 Issues	6.00
Add \$1.00 a Year for Foreign Postage; 50c for Canadian Postage.	

LIST OF PARTS
Two audio-frequency transformers. (Thordarson).
One 20-ohm rheostat, R1.
One variable resistor, R2 (Clarostat).
One 2-gang UX socket strip (Radio Engineering Lab.).
Seven marked binding posts (Phone, Phone, B+ Amp., A Bat. +, B-; A-; Input, Input).
One by-pass condenser (optional).
Two flexible leads for C battery; bus bar; screws, nuts, solder.

tion. Fig. 5 shows how this is accomplished, by selecting one of the other sides of the little box, and having suitably mounted the 20-ohm rheostat for tube control. Open a package of Bruno Engravings, and by following the simple directions, they are easily applied.

A Collodion Safeguard



COLLODION being a binder, put it in a wide-necked bottle, to avoid having the cork stick so tightly that a small cork will break off, as above, when a little tension is applied.

ELIMINATE! STATIC!

Enjoy perfect reception regardless of weather conditions.

"The Static Eliminator," the newest and most startling thing in radio, cuts out practically all static with little loss of volume! And in addition it will help increase selectivity, tune out local stations, sharpen signals, remove noises, lessen interference and prevent re-radiation.

Use it with any receiving set—simply hook it up between aerial and ground in accordance with our instructions and enjoy perfect reception unmarred by static.

SATISFACTION ABSOLUTELY GUARANTEED
Mail order today

\$1.00
Postpaid

STATIC ELIMINATOR COMPANY
622 United Bank Bldg. Cincinnati, O.

An article on Low-Loss Coils Analyzed by the Bureau of Standards, appeared in our Jan. 16 issue. Sent on receipt of 15c, or start sub. with that issue. **RADIO WORLD, 145 W. 45th St., N. Y. C.**

THOUSANDS OF BARGAINS
FACTORY GUARANTEED MDSE. BY MAIL
Genuine New Radiotron or Cunningham Tubes
UY-100—200—301A—WD-11—12 **\$1.98**
C289—300—301A—C11—12
Fresh Burgess or Eveready "B" Batteries
22 1/2 Volt large size \$1.30—15 Volt large size \$2.30
Write for Free new Complete Catalog on Sets and Parts.
STONE ELECTRIC CO., 714 Pine St., St. Louis, Mo.
All Mdse. F.O.B. St. Louis, Mo. Dept. W

RADIO TUBES
FACTORY PRICES!

LOW IMPEDANCE, genuine thoriated filament, quarter ampere 201-A type. Silvered and tipless. Will improve any set. **GUARANTEED.**

79c Each, Postpaid
TRELLCOTT CO.
2118 Hale Ave. Louisville, Ky.

OUR NEW CATALOGUE

Just completed—filling hundreds of BARGAINS, will be mailed to you upon receipt of name and address.

GET YOUR NAME ON OUR MAILING LIST

SIMPLEX RADIO SUPPLY CO.
1800 LAFAYETTE AVE. Dept. D, ST. LOUIS, MO.

PANELS

RADIO and HARD RUBBER
RETAIL ANY SIZE WHOLESALE
"PRICE LIST MAILED ON REQUEST"

HARD RUBBER
SHEETS—RODS—TUBING

Special Hard Rubber Parts Made to Order
Send Sample or Sketch for Quotation
NEW YORK HARD RUBBER TURNING CO.
212 CENTRE ST. NEW YORK

DX
Quality
Volume
Selectivity

All that you desire—more than you expect—are at your command if you build

RADIO WORLD'S
1926 Model

DIAMOND

OF THE

AIR

The 5-tube set for home construction that works splendidly on either loop or outdoor aerial.

Read Herman Bernard's full exposition of how to build the set that is sweeping the country.

Constructional data, in text and diagrams, appeared in the Sept. 12, 19 and 26 issues; valuable laboratory data in the Nov. 21, 28 and Dec. 5 issues. Any of these issues, 15c a copy.

Send 75c and get all six!

Full-sized blueprint of the wiring, 50c extra.

Send \$6 now for a year's subscription and get these six copies, the blueprint and nameplate **FREE!**

RADIO WORLD
145 West 45th Street New York City
Send for a free name plate

GET MORE OUT OF YOUR SET.
The world's greatest variable grid leak, distributed by the North American Bretwood Co. is selling enormously, and is giving universal satisfaction. Send \$1.50 for a Bretwood Grid Leak. North American, Bretwood Co., 145 W. 45th St., N. Y. C.

This Knob Brings in DX

A delightful expression of appreciation lights every countenance when the Bretwood Variable Grid Leak is put in a set and the result is judged *by your own ears!*

The Bretwood Variable Grid Leak may be used in any set employing a tube as detector. The single hole, panel mount enables one to put it in a set in five minutes.

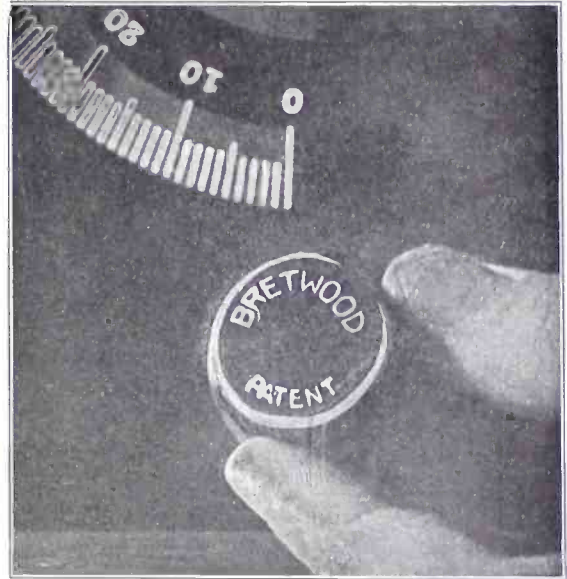

When the King Wanted a Leak He Commanded Bretwood

“Send Me Another BRETWOOD Variable Grid Leak

I received the Bretwood Variable Grid Leak last night and it sure did bring in stations. Denver was as far as I could get until last night when, with the Bretwood in my set, I brought in KFI, Los Angeles, and KPO, San Francisco, Calif., clear and fine.

JOS. L. MAIRE,
4026 Gresham St.,
Pittsburgh, Pa.

I thank you for your letter in relation to the condenser. If this is as good as the Bretwood grid leak, I sure can wait. With your grid leak I was able to bring in with good volume 15 W Stations in one week with a Diamond of the Air set from a city hard to get out of.

Thanking you again,
F. W. Collingwood,
3442 Sacramento St.,
San Francisco, Calif.

Gridleak received and tested out, and find it is the only variable leak I ever used that is really variable.

Enclosed find \$1.50 for which please send me another one.

F. E. STAYTON,
Box 240, Ardmore, Okla.

I think it is about the best grid leak I have ever used. Have made quite a few sets and this beats them all. Get DX very plainly and clearly.

WM. HEBERSON,
2510 N. Franklin St.,
Philadelphia, Pa.

Fit for
a King



1/4 to 10
Megohms

Bretwood, Ltd., London, Eng., Sole Patentees and Owners

More DX, Clearer Reception, Smoother Control in Regenerative Sets Assured Price, \$1.50

The Bretwood Variable Grid Leak may be installed in any set in five minutes by single hole panel mounting.

The North American Bretwood Co., 145 W. 45th St., N. Y. City

Sole Distributors for United States

Canadian Representative, Radio, Ltd., Phillips Square, Montreal

NOTE TO RADIO MANUFACTURERS

Write for Wholesale Rates

A set with a FIXED Grid Leak may work perfectly where tested, while it needs a VARIABLE Grid Leak so that set may be adjusted to the locality where used.

THE NORTH AMERICAN BRETWOOD CO., 145 West 45th Street, New York City.

Gentlemen: Enclosed find \$1.50 for which you will please send me one Bretwood Variable Grid Leak prepaid. Satisfaction guaranteed or my money back after trial within ten days of receipt by me.

NAME
STREET CITY
STATE

Nothing More to Buy!

THE MOST SENSATIONAL RADIO OFFER EVER MADE
AND IS POSSIBLE ONLY BECAUSE WE ARE
RESPONSIBLE MANUFACTURERS

Air Service guaranteed products are sold throughout the world. Thousands of users already know we stand back of every statement we make.

With a full realization of the serious meaning of every word we say now, you cannot buy a more efficient five-tube receiver than the new Air Service AEOLUS at any price. Besides being beautiful in appearance, it will do anything that any five-tube receiver has ever done under the same circumstances.

It is unusually powerful and clear of tone. It is very selective and a sure distance getter. Best quality apparatus including straight line frequency condensers and bakelite is used throughout.

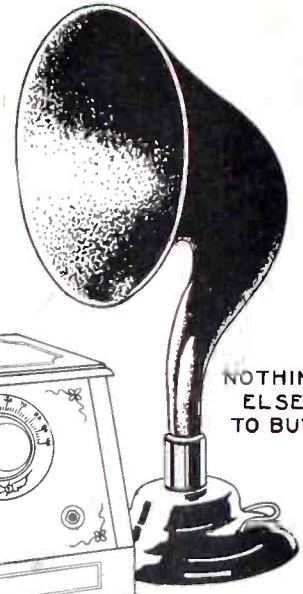

NOTHING
ELSE
TO BUY

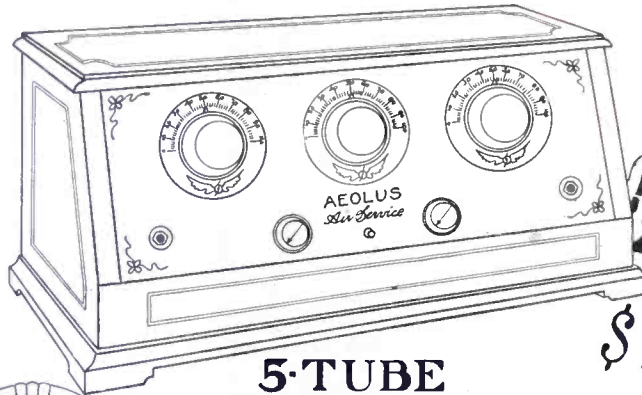

\$57⁵⁰

**5-TUBE
TUNED RADIO FREQUENCY
COMPLETE**

WHAT YOU GET

- 1 Five-tube Air Service AEOLUS Receiver. Mahogany two-tone sloping cabinet, size 7" x 18". A beauty.
- 1 Six-volt 100-ampere storage "A" battery. Hard rubber case. Two-year guarantee.
- 2 Large size 45-volt "B" batteries (long life).
- 1 Swan-shaped loud speaker. Large bell. Gold finish. A revelation in tone quality.
- 5 Air Service Blue Ribbon Tubes—201A type. Laboratory matched. High amplification factor and low impedance.
- 100 Feet stranded enamel aerial wire.
- 50 Feet lead-in wire. 14 gauge. Highly insulated.
- 50 Feet terminal connection wire.
- 2 Weatherproof porcelain insulators.
- 1 Protecto lightning arrester. Passed by National Board of Underwriters.
- 50 Feet high-tension insulated ground wire.
- 1 Phone plug.
- 1 Grade A ground clamp.
- 1 Log sheet. Full instructions.

**OUR PRICE
COMPLETE
COMBINATION**

\$57.50

ALL SHIPMENTS MADE WITHIN TWENTY-FOUR HOURS
If C. O. D. shipments are desired at least 20% of price must be sent with order

OUR GUARANTEE

*If after receiving the merchandise it is not all we claim,
you are privileged to return it to us in good condition
for full refund.*

American Interstate Radio Service

183 Greenwich Street

New York City

