

6 TROUBLE-SHOOTING ARTICLES:

1924

# RADIO WORLD

Title Reg. U. S. Pat. Off.

Vol. 5. No. 15. ILLUSTRATED EVERY WEEK

Silencing the Parasite Noises, by Charles H. M. White.

Using Phones for Trouble-Shooting, by Byrt C. Caldwell.

Making the Superdyne Work Right, by Brewster Lee.

Reducing Losses Due to Insulation, by Dennis J. O'Flaherty.

How to Pep Up Your Aerial, by N. N. Bernstein.

Avoiding Tube Blowouts, by Herman Bernard.

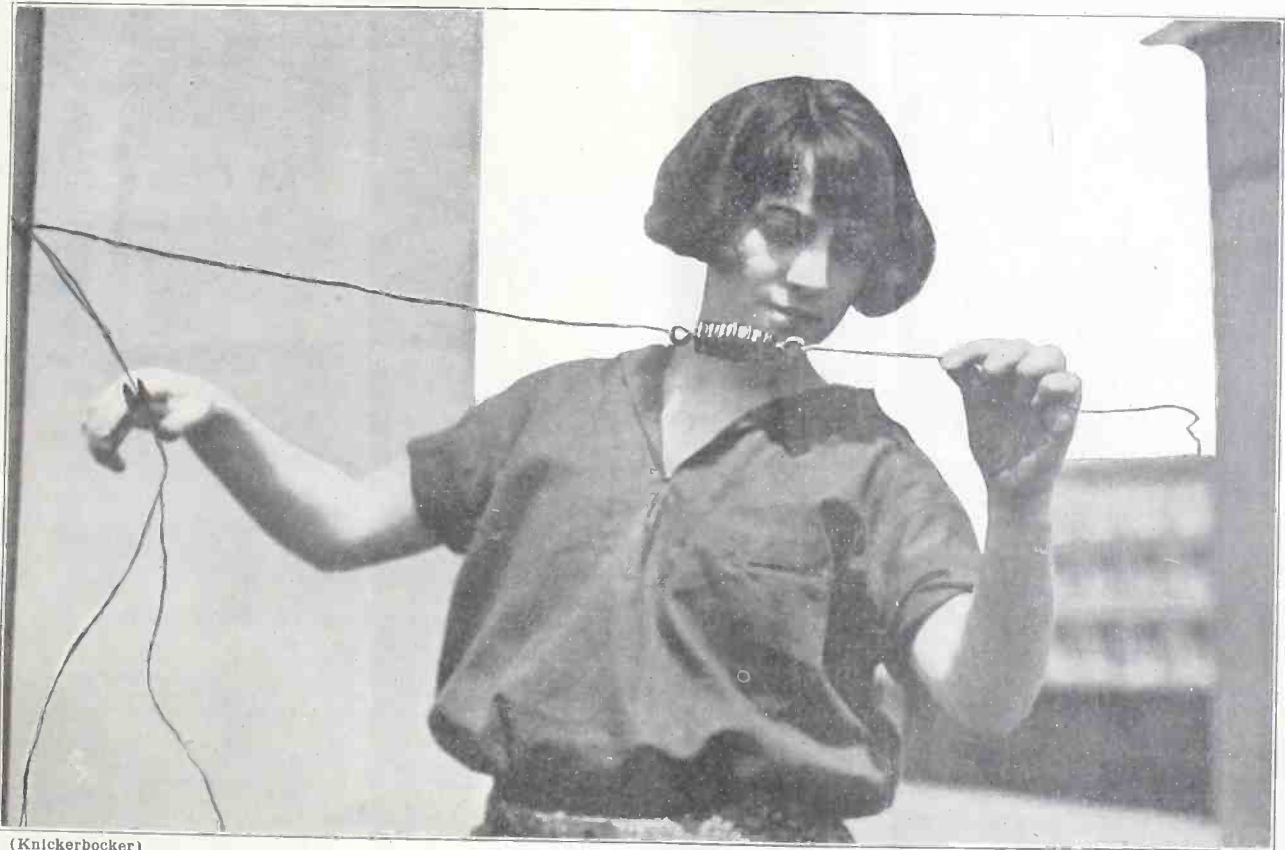

(Knickerbocker)

THIS IS THE WAY to fasten the ends of your aerial, with the insulator kept a safe distance—about three feet—from the support. Wire may be used to connect the insulator to the support. Observing the three-foot rule may help to pep up your aerial.

DX ON A TUBE AND A CRYSTAL

By J. E. ANDERSON

MAKING TUNING SQUEAL-PROOF

By A. P. PECK

WHAT MAKES YOUR SET WORK

By NEAL FITZALAN

Listen  
in on  
W.L.W.

# Still Better

## New Crosley Radio Receivers

**P**ROVING that Crosley Radio Receivers have made Satisfied Customers, the Crosley Radio Corporation sold more receiving sets last year than any other manufacturer in the world.

The new Crosley line illustrated here is still better as shown by laboratory tests and by reports from users of performance under all weather conditions.

**Listen in on a Crosley—compare it with other receivers—then you will choose a Crosley!**

**CROSLY 50**—A new one tube Armstrong Regenerative Receiver. We believe this to be the most efficient one tube receiver ever put on the market. Price .....\$14.50

*Crosley 51-A, two tube amplifier may be added at \$18.00*

**CROSLY 51**—Two tube regenerative receiver, the biggest selling radio receiver in the world. Gives loud speaker volume on local and distant stations under average conditions. Price, \$18.50

*Crosley 51-A, one tube amplifier may be added at \$14.00*

**CROSLY 52**—A new three tube Armstrong Regenerative Receiver. Provides loud speaker volume on distant stations under practically all conditions. Price .....\$30.00

**CROSLY 51-P**—This is our new portable set. It is the Crosley Model 51, two tube receiver mounted in a leatherette covered carrying case, battery space and all self-contained. Price, \$25.00

**CROSLY TRIRDYN 3R3**—This three tube receiver gives the efficiency and volume of five tubes. We believe it is the most efficient receiver on the market at any price for bringing in long distance stations. Price, \$65.00

**CROSLY TRIRDYN 3R3 SPECIAL**—The same as the Trirdyn 3R3 except cabinet is larger to contain "A" and "B" dry cell batteries and accessories. A beautiful set to match the highest grade of furniture. Price, \$75.00



Crosley 50, \$14.50



Crosley 51, \$18.50

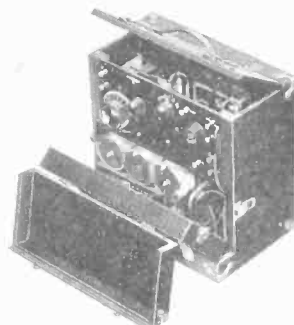

Crosley 51-P, \$25.00



Crosley 52, \$30.00

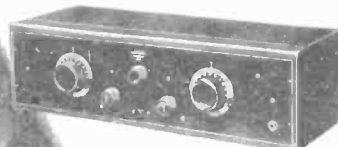

Crosley Trirdyn 3R3, \$65.00  
and below  
Trirdyn Special, \$75.00

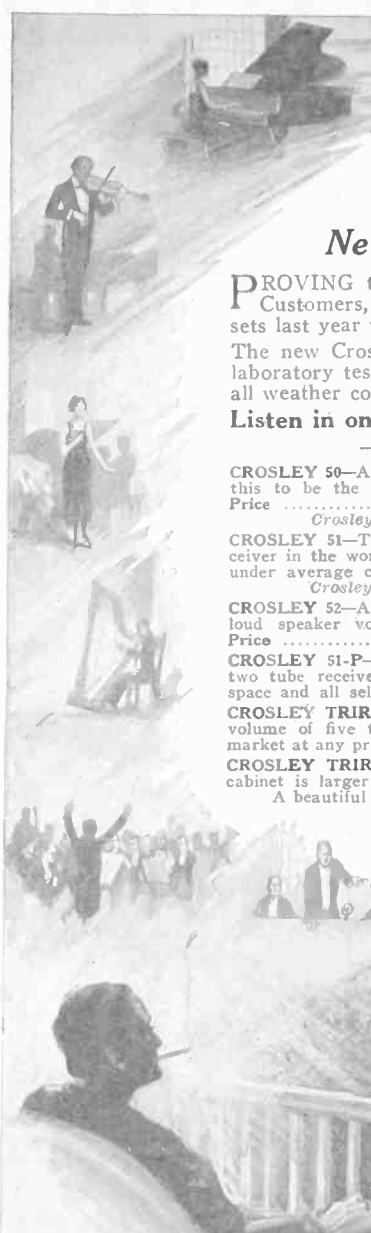

# CROSLY

Better-Cost Less  
Radio Products

**MAIL THIS COUPON TODAY**  
The Crosley Radio Corporation,  
7401 Alfred Street, Cincinnati, O.  
Gentlemen:—Please mail me free of charge your complete catalog of Crosley instruments and parts together with booklet entitled "The Simplicity of Radio."  
Name .....  
Address .....

All Crosley Regenerative Receivers licensed under Armstrong U. S. Patent 1,113,149.

# THE CROSLY RADIO CORPORATION

POWEL CROSLY, JR., President

7401 ALFRED STREET

CINCINNATI, OHIO

The Crosley Radio Corporation owns and operates broadcasting station WLW.

# RADIO WORLD

[Entered as second-class matter, March 26, 1922, at the Post Office at New York, N. Y., under the Act of March 3, 1879]

A Weekly Paper Published Every Wednesday and Dated Saturday, by Hennessy Radio Publications Corporation from Publication Office, 1493 Broadway, New York, N. Y. Phones: Lackawanna 6976 & 2063.

Vol. V. No. 15. Whole No. 119.

July 5, 1924

15c. per copy, \$6.00 a year

## DX on One Tube and a Crystal

A SET ADAPTABLE FOR PORTABLE USE ON VACATIONS

By J. E. Anderson

HERE is still, or is once more, a keen interest in sensitive, selective, single tube receiving sets which, on a headset, will bring in signals from stations located a thousand miles away, or which will pick up with fair degree of audibility the signals from local stations without the use of an outdoor antenna. Unfortunately for all concerned, many of the one-tube sets that are built with this object in view are vicious radiators, and any one of them will cause more racket on the roof on an otherwise quiet evening than a convention of all the neighborhood cats gathered on the back fence. But there is no need for this racket, because sensitive and selective sets may be built without an excess of regeneration and by using a single tube. A set of this kind is described herewith, the diagram of which is shown in Fig. 1.

The circuit is a radio-frequency amplifier followed by a crystal detector. It is adaptable for portable use and fits into vacation needs. It has two tuned circuits, and this fact, taken with the radio-frequency amplification obtained in the tube, makes the set very selective. Undesired signals, as well as disturbing noises, are effectively eliminated. The quality of the signals will be very good because of the excellence of the crystal detector in this respect.

There are two coupling transformers,  $L_1L_2$  and  $L_3L_4$  in the circuit.  $L_1$  and  $L_2$  are wound on the same tube, which should either be 3" bakelite or cardboard.  $L_1$ , the antenna coil, consists of 12 turns of No. 22 double cotton covered magnet wire, and  $L_2$  of 45 turns of the same kind of wire. Both these coils are wound in the same direction on the tube, with a separation between them of about one-fourth inch. The first terminal should be connected to the antenna, the second to the ground, the third to the C battery, and the fourth to the grid, counting from the beginning of  $L_1$  to the end of  $L_2$ . This makes the ground and the C terminals come together on the supporting tube.  $L_3$  should consist of 45 turns of No. 22 double cotton covered magnet wire on a tube 3" in diameter, and  $L_4$  of 38 turns of the same kind of wire on a tube  $3\frac{1}{2}$ " in diameter. These two coils are mounted concentrically, that is, one inside the other.

The two tuning condensers,  $C_2$  and  $C_4$ , which are connected across the secondaries  $L_2$  and  $L_4$ , should each be variable air condensers having a maximum capacity of .0005 microfarad. The variable condenser  $C_1$  is a very small vernier condenser which is used to prevent oscillations and to control regeneration. It is connected between the grid of the tube and the upper side of the second tuned circuit. If this condenser does not operate satisfactorily with the connection of the transformer  $L_3L_4$  made one way, reverse the leads to  $L_3$ . Use that method of connection which gives the best signals.  $C_5$  is a by-pass condenser across the telephones. This is

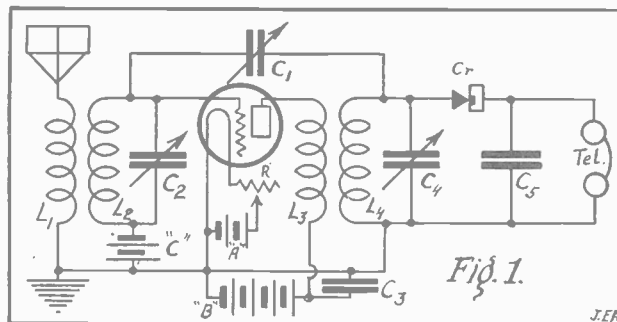

FIG. 1—Circuit diagram of J. E. Anderson's 1-tube radio-frequency amplifier and crystal detector set. C-1 is a neutralizing condenser, connected from the grid of the tube to the secondary of the second coupling transformer. The C battery is  $4\frac{1}{2}$  volts when used with 45 volts on the plate. For a  $67\frac{1}{2}$ -volt B battery the C battery should be 6 volts.

not absolutely necessary but will help somewhat. Its value should be about .001 microfarad.  $C_3$  is a large by-pass condenser across the plate battery. Its value should be .1 microfarad or greater. Smaller condensers here will work quite well if the large size cannot be obtained.

Since this circuit is to be operated on a headset, the small dry cell tubes may be used with good results. A UV199 or similar tube is recommended. For this tube the filament rheostat should be 30 ohms and the voltage of the A battery should be  $4\frac{1}{2}$  volts. The plate potential may have any value from 20 to 90 volts. Much better results may be expected with voltage above 60 than with less, provided the proper grid bias is used. The correct bias values may be obtained from the wrapper in which the tube comes.

A good outdoor antenna is required with this circuit if any but local signals are to be received satisfactorily. For local signals a loop or an indoor open circuit type of antenna may be employed.

Since a UV199 or similar tube may be used with this circuit to good advantage, only a small A battery will be required. Also since the set is intended for headset operation only, the B battery may also be of the smaller sizes available for this purpose.

If the circuit is made up into a portable set, it may be used with either a loop or open wire type antenna.

Parts needed for the construction of this set:

- |   |   |
|---|---|
| Two coupling transformers, as described.              | One B battery, 20 to 90 volts.  |
| Two variable condensers, .0005 microfarad.            | One C battery, voltage depending on B voltage.                              |
| One small vernier condenser.                          | Two 3" dials and one 2" dial.   |
| Two by-pass condensers, one .001 mfd. and one .1 mfd. | Seven binding posts.  |
| One crystal detector.                                 | A panel 7" x 12" and a base-board 7" x $10\frac{1}{2}$ " x $\frac{1}{4}$ ". |
| One tube socket, UV199.                               | A cabinet.  |
| One vacuum tube, UV199.                               | One headset.  |
| One 30-ohm rheostat.                                  | Ground and antenna wire.  |
| One A battery, $4\frac{1}{2}$ volts.                  | Connecting wire, solder, screws and nuts.                                   |

# Reducing Losses Due to Insulation

*How to make your variable condensers into low-loss ones and adapt your variocoupler for fully efficient service.*

Fig. 1.

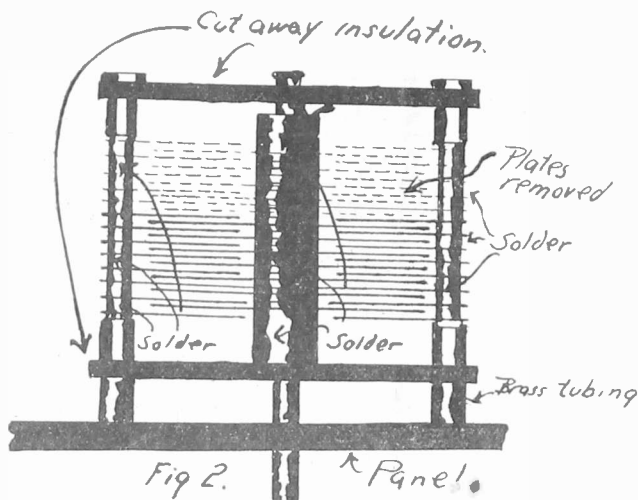
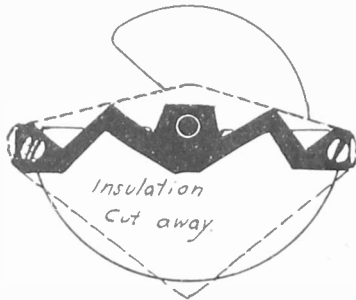

A HACKSAW is all you really need to convert your variable condensers into low-loss ones. The dotted lines in Fig. 1 show your condenser insulation as it now looks. The black zigzag line shows what is left after the hacksaw is used. Air is the best dielectric, and air is substituted for bakelite with telling effect. Stronger signals result, greater distance is obtained and stations never heard on the set before come in with a wonderful whang. Fig. 2 shows how insulation was cut away, plates removed, and soldered connections made. The reduction in the number of plates leaves the condenser still covering the broadcast band.

*By Dennis J. O'Flaherty*

**A** SHORT time ago I was asked to examine the receiver which a friend had constructed, a single-tube affair.

"Isn't it a peach?" he asked.

And it was, as far as looks were concerned. With its glistening black bakelite insulation, its shining coils and its spaghetti covered wires, it was a handsome machine.

"I got Omaha last night," he said. "How's that?"

"Pretty good," was the answer.

And shortly with a hacksaw the writer set to work. In the first place, the receiver was stripped of all the wiring, its beautiful glossy black, red, green and yellow spaghetti. (I heard a groan beside me.) Then the variable condensers were removed. They were of a type which were considered good before the low-loss condensers appeared. There are a number of different makes which all appear identical, and the chances are extremely good that your receiver, too, incorporates them. Both bakelite end plates were removed, and then three of the fixed plates, and three of the movable

plates. Fig. 2 shows the end of the condenser from which the plates were removed. (Another groan and the complaint: "My condensers hardly cover the high wavelengths now. Why remove the plates?") And then it was explained to him that the 15 plates would cover the broadcasting band of wavelengths as certainly as did the 21 plates previously.

The hacksaw was then brought into play and all but a small part of the bakelite end plates was cut away. Fig. 1 shows how this is done. The dotted lines show the original end plate and the black portion shows the part which is left. Only enough to hold the shaft, and two of the three bolts which support the fixed plates, was left. The zigzag effect isn't for looks. You will find that this is the easiest manner in which the insulation can be cut out. Both end plates are cut in the same manner.

A piece of aluminum solder was next obtained and all of the fixed and movable plates were carefully soldered together. (This is a fairly difficult task. Although not absolutely necessary, it will improve the condenser.)

The condenser was then assembled. Washers, cut from the discarded plates, were slipped on the shafts to fill up the space. Instead of the short machine screws which hold the front insulating plate to the condenser, long ones were employed, and pieces of brass tubing, about a half inch in length were slipped over these to hold the condenser away from the panel. The copper shielding was removed. ("You won't need that now," was the answer to my friend's protest.) The condensers were assembled right on the panel. "You now have as perfect a pair of low-loss condensers as were ever made," he was told.

His 180° variocoupler was then removed. All of the wire was removed, and with a great deal of care the tube was sawed into the shape of a grid (Fig. 3). Only the front half of the stator is shown, but the whole of that, and the rotor, too, was cut away.

A new spool of wire was taken, and both parts were rewound, the rotor as before but the stator with 50 turns, with no taps. They are not needed to cover the broadcasting wavelengths, and besides taps on a coupler lose about three-quarters of the received energy on many receivers, due to imperfect connections, panel dielectric losses, dead end losses, etc.

The receiver was now completely reassembled. It was then carefully rewired. Only two or three inches of spaghetti were used in the entire set, and only in places where two wires crossed close together.

The results the receiver produced were far better than before. Stations which had never before been heard came in clear and with good volume, and distant stations which had previously been heard through a "haze" now came in strong and undistorted. And in addition the selectivity of the receiver was increased at least 100 per cent. A wavetrap which had formerly been found necessary to tune out the locals was discarded, although these locals could now be brought in almost twice as loud.

If you have a receiver which has spaghetti-covered wires, a variocoupler, variometer, tuned radio-frequency transformer, or other like instrument which is made of insulating tubing, and condensers with a large amount of insulation, you can undoubtedly greatly improve  
(Concluded on page 11)

## Designs Pigmy Tube

## New Target for DX Sharpshooters

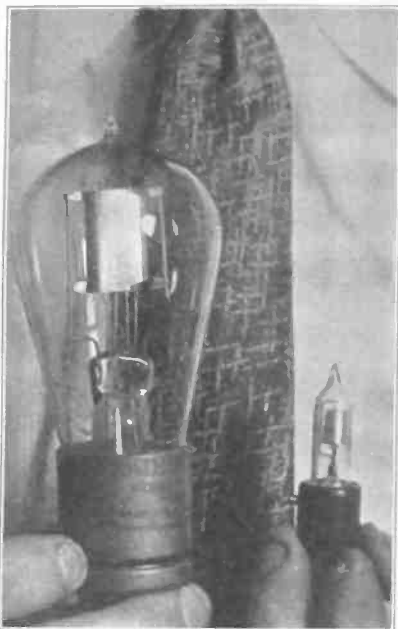

(Kadel & Herbert)

**THE SMALLEST** vacuum detector tube in captivity, made by a New York radio fan. It is contrasted with a UV200.

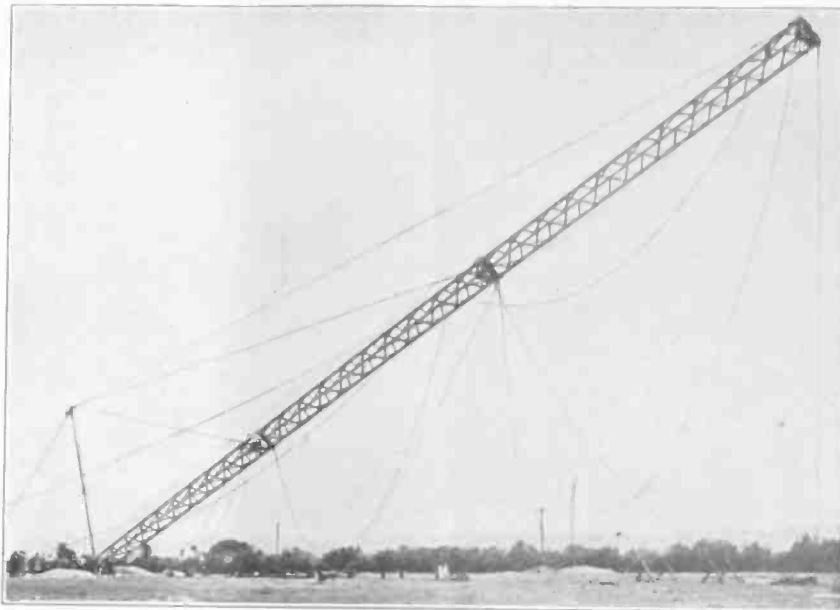

(Kadel & Herbert)

**GETTING** the 6-ton, 200-foot wireless antenna mast into position is no easy job. This is being erected at Melbourne, Australia, by a new broadcasting station there. This will be a new mark for DX listeners to shoot at this winter. Places like Havana, Honolulu and England by that time possibly will have become "locals." Some super-super set of the future will get Australia on the loudspeaker as if it were on the next block.

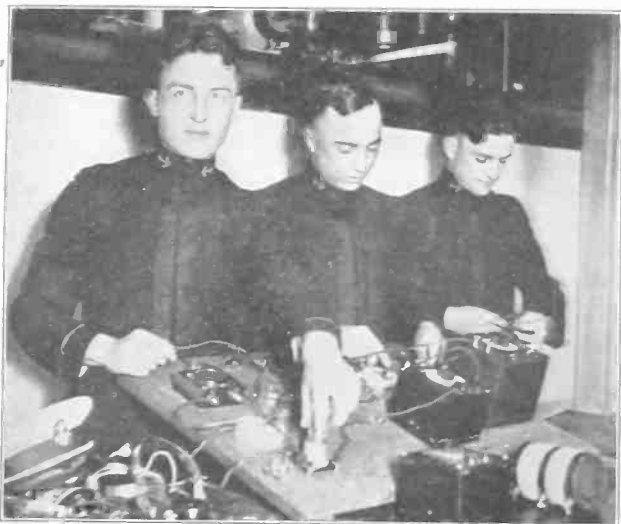

(Fotograms)

**BEFORE** a Midshipman can be graduated from the U. S. Naval Academy at Annapolis he must master a course in radio. J. W. Buxton, J. M. Worthington and R. E. Mills (left to right) are experimenting with a regenerative transmitting and receiving set as part of their studies in the senior class.

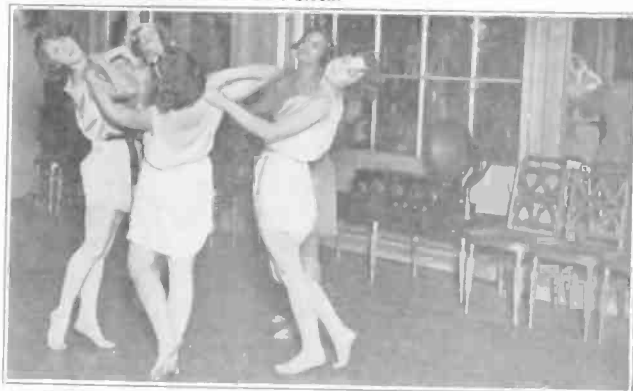

(Kadel & Herbert)

**LOUIS H. CHALIF**, well-known New York dancing master, demonstrates the value of radio to society pupils. The group is dancing to the strains of a Chopin selection by the Waldorf-Astoria Philharmonic orchestra, broadcast through WEAF nightly. These young women are all socially prominent, and are studying to become professional dancing teachers. Left to right: Margaret Montgomery, Trenton, N. J.; Verna Watson, Toronto; Frances Chalif, New York City; Mrs. Henry A. Bishop, Jr. (Gloria Gould), New York City, and Ada Barker.



(Kadel & Herbert)

**HAS A NOVELTY**—Sterling G. Sears, of Brooklyn, N. Y., uses one Neutrodyne coil and a condenser to tune the grid circuit of a regenerative set and gets distance. The other knob controls a variometer wired in the plate circuit. The set is very selective, owing to its clever design and excellent workmanship.



**THE RADIO DOCTOR**, of Lincoln, Neb., is the title earned by T. H. Elbourne, who holds the distance record for the Sleeper Monotrol, averaging totals of 21,500 miles per night in a series of official tests. Perfect radio enjoyment is enhanced by his congenial surroundings.

# 4,000,000 HEAR CONVENTION

*Greater Interest Manifested than in any other Radiocast Event*

## 20 STATIONS SEND OUT SPEECHES

**T**HE Democratic Presidential Convention, held in Madison Square Garden, New York City, was heard by 4,000,000 persons, it was estimated.

More extensive arrangements for radiocasting and for listening in were made for this event than for

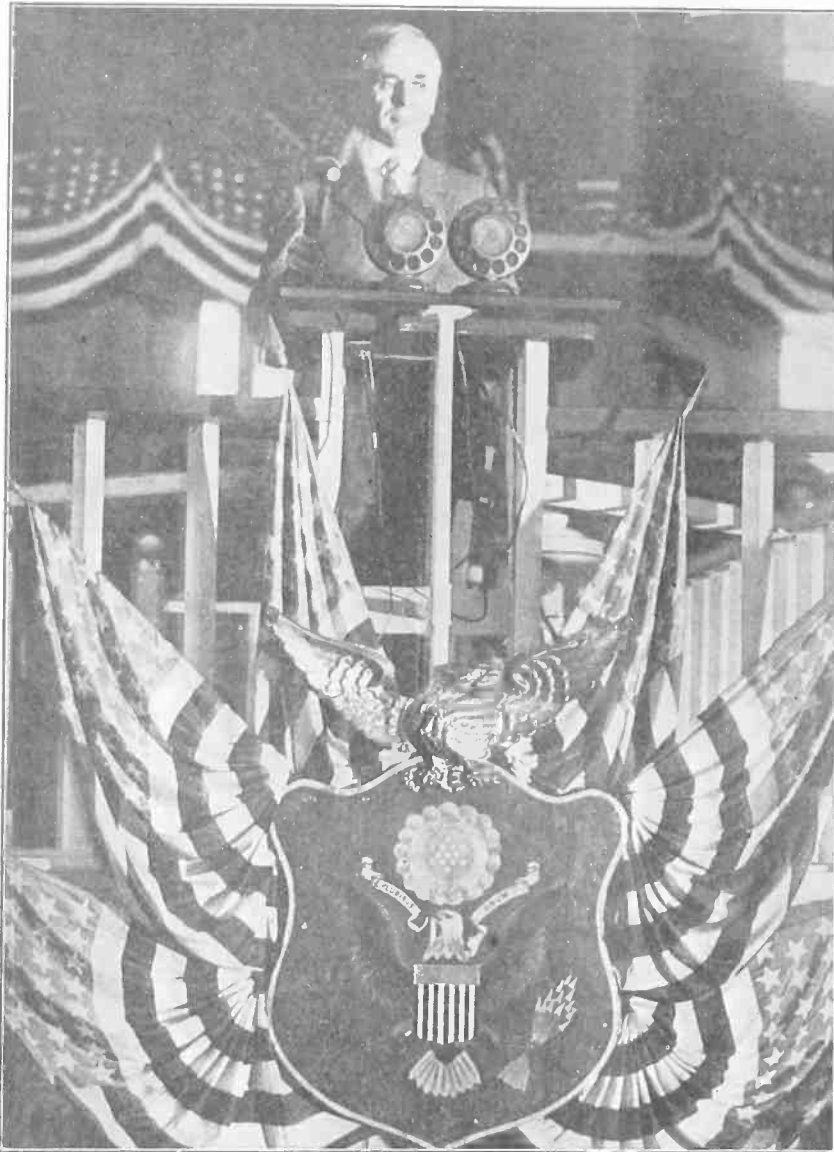

(Underwood & Underwood)

**BEFORE THE LECTERN**, Cordell Hull, chairman of the National Democratic Committee (above), before beginning his opening remarks at the Presidential Convention at Madison Square Garden, looked for a moment like some graven image in a flourishingly patriotic setting. Five American flags, disposed in fan shape, framed the national emblem on which sat the proud and mighty eagle. As Mr. Hull pounded his gavel before the microphone a hush fell upon the vast assemblage. The gavel beats, like the shot at Concord, was "heard" round the world." Soon two more microphones were erected and the convention was radiocast through four microphones.

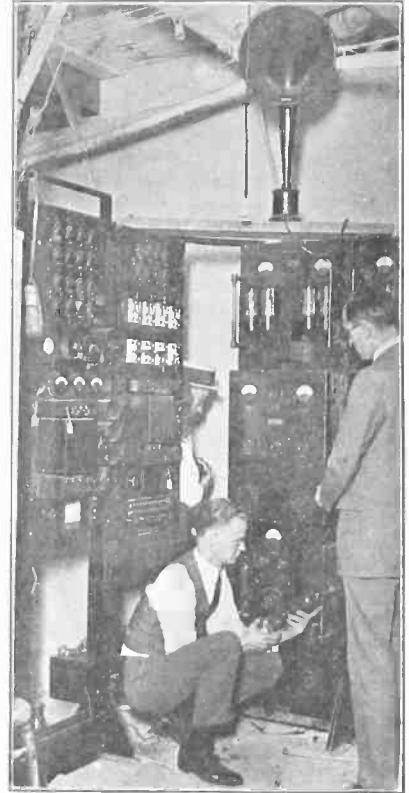

(Kadel & Herbert)

**IN THE INSTALLATION ROOM** engineers were busily engaged seeing that the amplifying and radiocasting was properly accomplished. They listened in on their own loud speaker. The photo shows only a section of the extensive installation, one of the most complete ever made.

(Keystone)

**AT RIGHT** Patrick Cardinal Hayes, of New York City, is shown opening the proceedings at Madison Square Garden with a prayer that lasted four minutes. Note that four microphones (shown in the white circle) were used. The photograph also gives some idea of the scene of crowded humanity in the famous structure that within a year will be no more.



# McNAMEE AND WHITE THE ANNOUNCERS



(International Newsreel)

MADISON SQUARE PARK, which Madison Square Garden faces, was the gathering place of interested crowds who listened to the radiocast convention. A set on a delivery wagon picked up the radiocast signals and a huge amplifier, which fed four large white horns, delivered sufficient volume to render the speeches and music audible all over the park. It was great fun listening in, though reception could scarcely be called DX work!



(Kadel & Herbert)

DOWN came the amplifying horns after the occasion for their use had ended. The magnets made the speeches audible all over the Garden.



(Kadel & Herbert)

WHITE IN THE WHITE HOUSE—Although the White House in which Major J. Andrew White is crouching should properly be spelt with small initials, it was a capital attraction at the convention. From this glass-enclosed coop Major White, famous announcer, let the nation know, through WJZ and WGY, what was happening at the convention that selected its choice for occupancy of the real White House.

any other in the history of radio. Twenty stations radiocast the most interesting parts of the proceedings, through co-operation with WEAf and WJZ, New York City stations

that made the fundamental preparations for bringing the convention to the ears of all fans in the United States who cared to listen. As for the interest manifested, it was unsurpassed by any aroused on previous occasions. In radio stores; where power amplifiers often emit-

ted intense volume to the delight of the listeners, men and women congregated in the cities for most of the radiocasting was done in the daytime, when business kept them away from home. In hotels, where advance preparations also had been

(Continued on page 26)

# Silencing the Parasite Noises

*Scratchy Sounds and Rattles often blamed on static are caused by poor connections in the set. Charles H. M. White, expert, gives tips on jacks, sockets, batteries and leaks for a troubleshooting expedition*

*By Charles H. M. White*

Consulting Engineer

MANY noises in receivers are attributed to static but really are not static but noises which originate within the receiver itself. Take some night that you think static is exceedingly heavy on your set. Go over to the man next door and listen in. You will be very much surprised to find that the "static" next door is nowhere near as strong as your static, which fact goes to prove that your trouble did not originate in the atmosphere. Static is nowhere near as heavy as most persons think. In the first days of the popularity of radio broadcast reception many poorly designed and constructed radio receivers were in use. These makeshifts were of course very noisy and the general excuse advanced to cover all sorts of sins in construction and electrical workmanship was the "atmospheric static." But as the art of radio construction of broadcast receivers advanced the volume of static became less and less. During last August I had better long-distance reception than all the following Winter. Yet August is considered the heavy static month. Thousands of other radio fans will also recall the excellent radio reception that was possible during last summer.

Home-made "static" can arise from many sources. One of the most common and yet the most unsuspected source is the contact points in the telephone jacks. There are many poorly constructed jacks that give perfect results when new but as they wear the contact points become dirty. Electrically imperfect contact results, which means a contact of varying resistance, and therefore an artificial variation in the voice current which takes the general characteristic of scratchy noise similar to static. Look over your telephone jacks and see if they make firm contact. As a conclusive test you can cut the jack out of the circuit by soldering the phone or loud speaker connections permanently in the circuit. If you then notice a change in the purity of the received note then your jack was imperfect. Never purchase a cheap jack; all good jacks have pure silver contact points. By the use of silver contact points the resistance of the contact surface is held more constant and lower, since silver has the lowest resistance to the flow of electrical currents. Reduce the number of jacks in your receiver to a minimum, since any type of contact in radio work which is not soldered is a dangerous contact and is liable to develop noise in time.

Another very common source of trouble are the contact points in the tube socket. Many of the cheaper sockets have contact metals which are absolutely devoid of spring action, which means that after a tube is removed several times from the socket the little spring in the contacts that originally existed has been exhausted and the metal is "dead." Right at this very moment there are thousands of radio sockets now in

use that are in this condition. As an interesting experiment try soldering the tube prongs directly to the filament, grid, and plate leads in the set. In nine cases out of ten you will note an improvement in quality as well as volume. While it is true that the side and double wipe contact sockets present a higher grade and more scientific contact, still there is much improvement to be made in eliminating varying contact resistance at the four contact points. At the present moment I am daily trying to perfect an entirely new development along this line which will materially eliminate socket noises.

Battery noise is another factor in producing "static." Yet, like real static it is often blamed for too many noises. The new dry cell tubes are more sensitive to battery disturbance than storage battery tubes. This is quite apparent when one stops to consider the extremely minute current flowing. It is a well known fact that small currents are more affected by local changes or action, which occur in a dry cell, than medium-sized currents. This fact is quite apparent when doing laboratory work on a sensitive balancing instrument such as a potentiometer (not the radio potentiometer). Here a small storage battery is used, and even when a storage cell is used it is impossible to maintain a constant current unless the cell is in a half discharged condition. A storage cell half discharged holds a voltage of 2.0 for a long, steady period, but a fully-charged cell has a higher and less stable voltage, and, a discharged cell has a lower and rapidly falling voltage after certain period of discharge is passed. Caution! To obtain the full quiet benefits from the use of storage A and B batteries do NOT fully charge or over-charge them and do not allow them to go discharged for long periods. Keep them charged frequently up to the half-way point where the voltage is constant and the noises caused by varying voltage is at a minimum. On account of the steadiness of a storage battery voltage it is even preferred in some cases for A battery service, although dry cell tubes are used. Yet, if a good standard make of dry cells be used and replaced as soon as they become old and noisy, no prejudice need be held against their economical use.

Grid leaks, poorly insulated audio-transformers and poorly soldered connections form the main concluding causes of "static." Some of the variable leaks are extremely microphonic and subject to temperature and atmospheric changes. Naturally a variable grid leak of this type is injurious to quiet reception as well as very inefficient because it fails to hold the correct critical adjustment. In many cases it will be found to distinct advantage to employ a well-known and calibrated standard fixed grid resistor.

Especially in reflex circuits that are growing old does the trouble of transformer insulation become a serious one. There is tremendous surge of energy in all reflex receivers and the apparatus used therein must be so designed to withstand these high energy or voltage surges, much the same as a dike or sea wall must stand the severe onslaughts of a rough sea year after year. On first trial most any audio-frequency transformer will work fairly well, but the test of time soon shows up the poorly insulated one. The Acme Apparatus Company have done much research in reflex circuits and I often use their AF transformers, among other good ones.

Nothing is to be gained by hastening an assembly job by making poor and hasty soldered connections. Well clean and solder every connection. A rough connection is worse than an open circuit, since it makes a poor electrical contact and also a lot of noise.



# Using Phones for Trouble Shooting

How to Construct a Valuable Instrument for Eliminating Extraneous Sounds

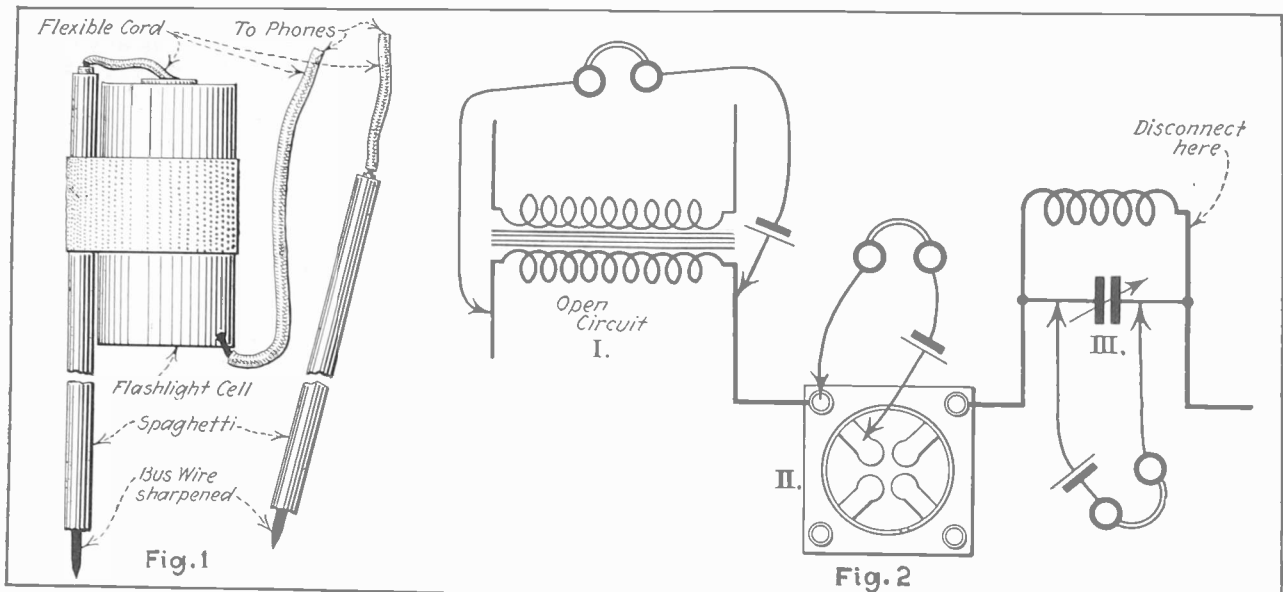

TO A FLASHLIGHT DRY CELL a piece of spaghetti-insulated bus bar, with a sharpened end, is attached, the blunt end going to one terminal of the cell (Fig. 1). The other terminal is tapped by a second piece of bus bar, similarly insulated. Flexible cord connects the bus bar to the battery. Fig. 2 shows how this device is used (I) to test for an open circuit in an AF transformer, (II) a socket prong and (III) in a coil.

By Byrt C. Caldwell

A VALUABLE instrument for discovering poor connections is made from several pieces of bus wire, spaghetti, flexible cord, and a small single flashlight cell. Often rattles and scratches, wrongly blamed on static, are the result of easily discovered loose connections.

Two pieces of bus wire, each about eight inches in length, are sharpened at one end. A piece of spaghetti is slipped over each to come within a quarter or half inch of the pointed end. The flashlight cell is taped to one of these as shown (Fig. 1). The wire is connected to the middle post of the cell by means of a piece of flexible cord. A piece of flexible cord several feet in length is soldered to the zinc of the cell, and one to the other piece of bus wire. These wires are connected to the earphones.

Now, wherever there is a connection of any kind, soldered or otherwise, touch the pointed wires, one on each side of the connection, pressing them firmly into the metal. There should be a click when the connection is first made, and then there should be no further sound. But when you test a connection and, instead of quiet, there is a continuous

rattle or faint crackle, you will know that that connection is defective. Fix it.

This instrument will serve many a purpose in locating trouble. Fig. 2 shows three methods in which it may be used.

In the first position (Fig. 2) it is used for testing an open connection in a transformer. In the second it is shown testing for a loose socket connection. In the third it is shown testing for a short-circuited condenser. In the last case be sure that any connection through a coil, etc., is opened, as otherwise the current will flow through the coil, will give a click in the phones, and will give the impression that the condenser is short-circuited.

It will be found that this little instrument will serve a hundred purposes, for it will find any short circuit, open circuit or loose connection in the receiver.

As the phones have a high resistance the instrument may be used while the set is in operation without fear of blowing the tubes through an accidental short circuit. This makes it doubly valuable. However, it must be noticed that the spaghetti must cover all of the wire except the point in this case.

## BY PIERRE BOUCHERON

One of the Pioneer Amateurs and now a noted figure in the trade. He is chairman of the Boy Committee of the Associated Manufacturers of Electrical Supplies.

*Radio Has Taken  
the Boy Off the  
Street Corner*

RADIO this summer has taken the American boy off the street corner and placed him in his home-made laboratory. Instead of lurid novels, he now reads the radio magazines and the radio sections of the newspapers. Incidentally, in scanning the news columns for radio news he is absorbing a large amount of cultural information on other subjects. Previously, he devoured only the comic sections and left the rest of the newspaper practically untouched.

Radio is teaching the boy a greater appreciation of music than he could possibly have attained from painful music lessons or lectures on the subject. It has given him a more graphic knowledge of current events. Radio Sunday sermons bring the teachings of religion home to him.

Every well-organized Boy Scout troop in the country has now its own radio signalling outfit, and the interests and activities of this important movement everywhere are being linked in an

effective whole through the agency of the new art of communication. Through radio hundreds of thousands of potential defenders of the nation are being trained.

From an educational standpoint it is clear that nothing could have served so to quicken the boys' interest in physical and mechanical studies as has radio. His absorbing interest in the subject has taught him the faculty of concentration in his other studies.

But the gain is not all one-sided. The youth of the nation perhaps have done as much for radio as the art has done for them. For the fact remains that it was the boy who first sold the idea of radio to the entire family. It is the boy who keeps the older folks informed of developments in the radio art; it is the boy who determines very largely the type and character of radio equipment which the family shall buy; and it is the boy who this summer is making a radio a year-round necessity.

# Making the Superdyne Work Right

*Grid leak may be eliminated in some cases with improved results. This circuit will not work at all with poor or run-down B batteries. Broad tuning can be remedied by reducing the number of turns on the primary even down to one turn. How to accomplish this.*

*By Brewster Lee*

**M**OST of the trouble that users of the Superdyne circuit encounter is due to actual inefficiency in the wiring itself or difficulty in tuning. The trouble shooting is gone about in much the same manner as with every other radio receiver.

If after the set is wired and hooked-up to the batteries, antenna, ground and earphones it fails to function or works poorly, all the wiring should be carefully checked with the diagram, following each wire in the set from beginning to end, comparing it with the wiring in the diagram. To do this conveniently, paste up the accompanying reproduced circuit diagram. As all Superdyne circuits are the same this diagram may be followed in tracing your wiring.

Begin with the antenna and ground connection, examining the antenna wires and lead-in and the ground connection to see that there is no corrosion or broken wires to either. This examination should be carried on throughout the wiring, paying special attention to the soldered connections on the binding posts, jacks and rheostats, as these are the commonest sources of trouble. The wires on the rheostats have a habit of becoming loose through heat from the resistance wire and the mechanical disturbance of turning the rheostat knob frequently. Loosening happens at the tube sockets also, as a result of inserting and twisting the tubes into place, which sometimes requires a little force. In jacks the tendency is to jerk the plug in and out when changing from detector to amplifier operation. These shocks loosen the fine soldered connections at the ends

of the jack leaves, quite frequently resulting in a break. However small this break or open circuit may be, the set will fail to function from that point on. Therefore it is well to determine the mechanical strength of the connection by testing its rigidity with the fingers. The joint is passable when it does not break at a fairly firm pull. Joints very often lose their tenacity with age, therefore, although the connection looks and is electrically sound, a slight jar may break it. Many cases are known where the connection actually touched, but due to poor solder and flux being used, corrosion set in and the result was a high resistance joint. It is a good idea to wash the joints by dipping them in wood or grain alcohol before applying the soldering iron. At any rate, both parts **MUST** be clean for a good electrical and mechanical connection.

After all the wiring has been thoroughly examined and found to be correct and efficient, the builder should again give the set the "once-over" with a view to seeing how much shorter any or all leads in the cabinet may be made. Whenever there is a chance to save an inch or even less, the trouble will be repaid with interest by increased results. Care should be taken so as to run grid and plate wires at angles to each other. It is not necessary to run all wires parallel, although this is done to a great extent by many novices just for good looks. Always remember that the shortest distance to a given point is a straight line. It matters not if a wire from a socket binding post is run from the baseboard up to a jack diagonally, then taking a short bend horizontally to the jack instead of going up vertically. In fact, it is much more efficient to run the wire in direct lines wherever possible. The A battery wires and ground leads from the various parts can be bunched as closely together as desired, provided they are properly insulated from one another by insulating tubing. These wires may be a bit longer if that will make the job more convenient. It is well to run all A battery and ground wires near the panel, so as to be out of the way of the grid and plate connections. Although it is very important to keep the grid and plate leads as short as possible they must be kept at least two or three inches apart, and should cross only at angles.

Poor wiring is the cause of many a set oscillating all over the dials and makes it practically impossible to

*(Concluded on next page)*

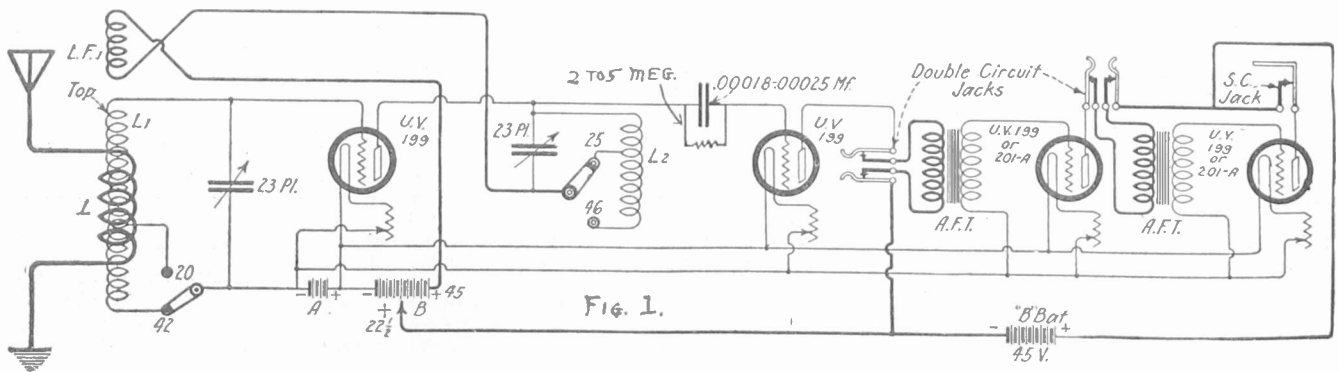

PASTE THIS UP ON THE INSIDE OF YOUR CABINET so that when trouble shooting on your Superdyne you will always have it as a guide. Should a wire fall off or some other accident happen to the set, you will immediately be able to locate the trouble and remedy it by consulting the above reproduced circuit diagram of the Superdyne. A good idea in wiring the set is to use tiny sections of different colored insulating tubing for the filament, grid and plate wires to facilitate tracing.

# Tips on Operating the Superdyne

(Concluded from preceding page)

control or tune the circuit. It is also of the utmost importance that the A and B batteries be in the best of condition, and connections firmly made. **Poor or run-down batteries will not work the Superdyne.**

After all the wiring has been examined and checked, test the coils for open circuits and the condensers for short circuits. An article on how to test coils and condensers will be found on page 9 of this issue, and should be referred to for complete information and instruction for doing this testing. A battery and ear-phones are used to find the open or closed circuits.

**The grid leak shown in the diagram can be omitted, as it was found that it lessened the efficiency of the available signal. However, some sets require a very high resistance, or very low leak. High resistance and low leakage are synonymous. The lesser the resistance, the greater the electrical leak. A 10 or 12 megohm (twelve million ohms) leak is sometimes required.**

If broad tuning is encountered after the set is brought into operation, the primary winding on the coupler can be lessened to as low as one turn. Two or three turns are found to be sufficient for sharp tuning in the great majority of instances. To decrease the number of turns of the primary, just disconnect one end and unwind until the desired amount is left.

Contrary to the method obtaining in tuning the Reflex or Neutrodyne set, the setting of the dials on the Superdyne depends to a great extent on one another. Those who have had experience with regenerative receivers remember that first the antenna was tuned, then the grid circuit and last the plate circuit.

In the Superdyne the antenna is aperiodic. That is, the primary inductance is fixed permanently in a semi-tuned state. No variation in this tuning is necessary, as the variation is taken care of by the grid tuning condenser of the first or radio-frequency tube.

To tune the Superdyne, set the rotor of the coupler in the position where absolutely no noise or hiss is heard in the phones. This is called loose coupling, and in this case reduces the feedback from the plate to grid circuit. Next, vary the grid and plate condensers simultaneously but slowly in the same general direction until a signal is heard. Now tune the first condenser (grid) until the loudest signal is obtained. Then slowly vary the rotor and plate condenser until the signal comes in with maximum volume and clarity. There is no set rule as to which (coupler, rotor or plate condenser) to turn first, as the position of one depends on the setting of the other. It is one of those peculiar things which the experimenter must learn himself. In general, the rotor is varied a bit and the plate condenser brought up until the signal becomes loudest. Then the rotor is turned back or forth a trifle and the condenser again tuned until the point is reached where the loudest signal is obtained without the circuit going into oscillation.

In the Superdyne, we are enabled to obtain this high degree of resonance by what is known as reverse feedback, which was explained in an article by N. N. Bernstein, Technical Editor of RADIO WORLD, in the issue of May 24, as follows:

**“Reverse magnetic feedback, the principle employed in the Superdyne, is the putting of a positive bias on the grid, so as to counteract the natural tendency of the**

**Setting the dials differs from Neutrodyne Method, in that dials are independent. Start with rotor set so there is no hiss or noise, which reduces feedback from plate to grid. Vary the condensers simultaneously in same direction until signal is heard.**

circuit to oscillate, the energy from the plate being fed back to the grid in a reverse magnetic or inductive direction. This reversal of direction counteracts the tendency of the tube to oscillate, thus allowing the circuit to be tuned to resonance without the tube spilling over.”

The reverse action is obtained here by turning the rotor of the coupler in the opposite direction to that accustomed to in the regenerative set.

The adjustment of the radio-frequency and detector tube is usually very critical, and for stations nearby may have to be turned down to the minimum. A 30-ohm rheostat with vernier adjustment is desirable for any detector tube used in this circuit.

A good deal of patience and tolerance is necessary before the tuning of the Superdyne is mastered, but, once learned, it pays big dividends in the wonderful results to be conjured from twisting the dials properly.

Even with the Superdyne, DX comes in better in Winter than in Summer, therefore tune in only for the locals and middle-distance stations now.

## Avoiding Signal Losses

(Concluded from page 4)

your receiver in every way by following the suggestions given in this account. Your Neutrodyne, your Superdyne, reflex or any other receiver can be improved. Always remember that air is the perfect insulator. The less solid insulation used, the better in every respect.

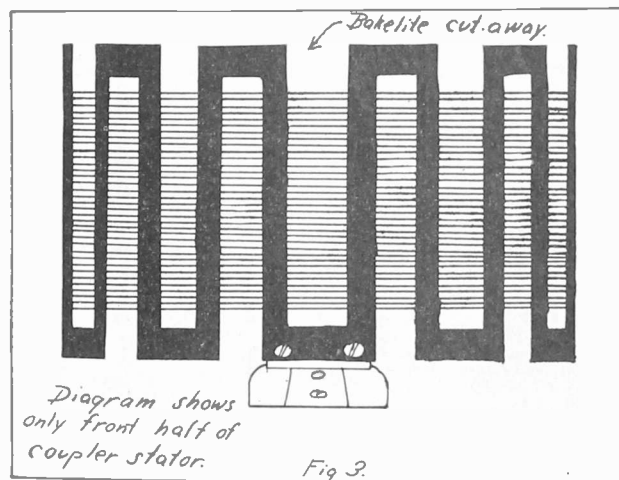

FIG. 3—View of front half of a variocoupler after most of the tube that absorbs signal energy has been removed.

# Putting DL Coils in 4-Tube Reflex

## The Radio University

A Question and Answer Department conducted by RADIO WORLD for its Readers by its Staff of Experts. Address Letters to Radio University Department, RADIO WORLD, 1493 Broadway, New York City.

campers. In this, you may use the parts mentioned above. Your Erla selectoformer can be used in place of the variocoupler shown in the diagram.

I have a copy of RADIO WORLD for June 14 and am interested in the Super Power 4-Tube Reflex. It speaks about putting a 50-turn honeycomb coil in the place marked X on the diagram. I fail to find any place marked X. Referring to the variocoupler primary, is this to be tapped the same as in the standard coupler and the ground connected to the switch arm? What size potentiometer and rheostat do you suggest?—L. R. Wathyns, care Max Ams Machine Co., Bridgeport, Conn.

The accompanying diagram, Fig. 22, shows the position of the honeycomb coil. The variometer is standard, and is connected as you say. The potentiometer may be from 200 to 400 ohms, and the rheostats 30 ohms each.

Substantially the same question as answered

Will you please explain the symbols for the A battery connections, the tube, the AF transformer, jack and plug.—Frank Casey, 10145 116th Street, Richmond Hill, L. I.

The filament is designated as F+ and F- on the socket. These are the same as A+ and A-

The tube is sometimes represented by the socket, but most often by a circle with the component parts (three elements) therein. The audio-frequency transformer is represented by two coils, each signified by a series of loops, the p.f. separated by parallel lines representing the

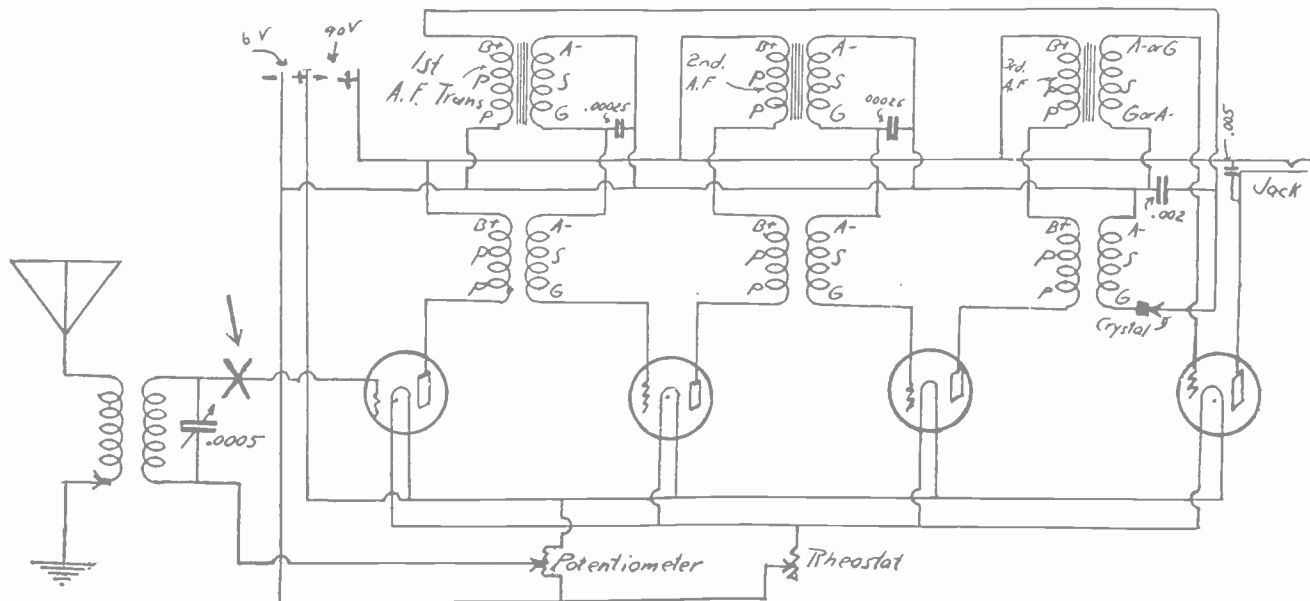

FIG. 22—Diagram of Byrt C. Caldwell's Super-Power 4-Tube Reflex circuit, showing where the honeycomb coil is placed in the wiring.

on battery and circuit diagrams. The filament in the circuit diagram is an inverted U. The grid is a zigzag line, the plate a parallelogram.

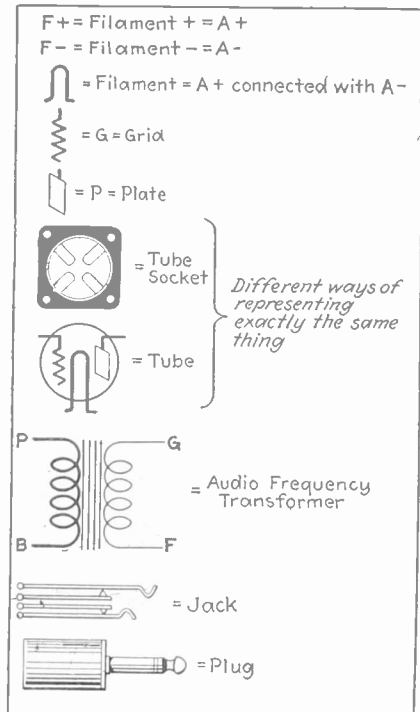

FIG. 21—Symbols of tube, socket, AF transformer and jack.

transformer core. The primary winding is marked P and B or P1 and P2 on the transformer; the secondary G and F, or S1 and S2. A double-circuit jack is shown in the diagram (Fig. 21). For the last stage of AF a single-circuit jack is used. The plug is never shown in circuit diagrams.

1. Will the enclosed hook-up using push-pull transformers work satisfactorily using UV-199 tubes? 2. If not, what ratio transformers should I use in the first and second stages of AF amplification to be added to a single circuit regenerative set? My object is to build up to loud speaker volume on distance.—J. M. Hubler, 535 Arkansas Ave., San Antonio, Tex.

1. Yes, although UV-201A tubes will give you more volume. 2. Should you wish to use separate stages, place a 5-to-1 AF transformer in the first stage, and a 4-to-1 or 3-to-1 in the second stage. You should be able to get distance on the loud speaker with this arrangement.

I have the following apparatus and would like to use it to make a reflex set or regenerative receiver for portable use. Please give me a hook-up for these parts: 1 Thordarson AF transformer, 1 American RF transformer, tube sockets, 1 potentiometer, 2 rheostats, 1 23-plate variable condenser, 1 grid condenser and leak, 1 Erla selectoformer. I also have all the necessary jacks, wire, etc.—Wm. H. Cain, care The San Jose Journal, San Jose, Ill.

J. E. Anderson, in RADIO WORLD for April 26, describes a good portable 2-tube reflex set for

above was asked by the following, and Fig. 22 serves for all: Herbert J. House, 507 Second Ave., Tarentum, Pa.; Leo Ottenfeld, 1362 N. Lincoln St., Chicago; E. B. Leland, Room 1212, 17 Battery Place, New York City.

As I am a beginner in radio I would like some information on making an indoor loop antenna. If possible, please publish some diagrams showing the construction of a loop.—S. Bernstein, 710 Main St., Keokuk, Iowa.

A complete article discussing loops and their construction, by B. J. Bongart, will be published in an early issue of RADIO WORLD. You can get more information from that than is possible in these columns.

I have built the Neutrad Unit as described in RADIO WORLD for April 12 to use with a Clapp-Eastham 1-tube regenerative receiver, but it does not seem to work well. There is an improvement when I connect the honeycomb coil ends to the antenna and ground binding posts on the set. What can be the trouble?—James Fulton, General Delivery, Tacoma, Wash.

You do not mention what kind of a tube you use with the unit, neither do you tell how much plate voltage you apply to the radio-frequency tube. Suggest you use either a UV199 or UV201A and put at least 45 volts on the plate. This will give you a fairly strong signal in your detector tube. The selectivity of this combination is pretty sharp, so you must be careful in tuning in on distant stations.

## Join RADIO WORLD'S University Club

And Get Full Question and Answer Service for the Coming 52 Weeks. RADIO WORLD, 1493 Broadway, New York City:

Enclosed find \$6.00 for RADIO WORLD for one year (52 Nos.) and also consider this as an application to join RADIO WORLD'S University Club, which gives me free information in your Radio University Department for the coming year.

Name .....  
Street .....  
City and State.....

# How to Tune Without Radiating

*Tips to the Owners of Regenerative Sets by An Expert*

By **A. P. Peck**

Associate, Institute of Radio Engineers

**E**VEN if you have a single circuit tuner, the worst of the squealers, it is not necessary to let it squeal. You can control this action as easily as you can control the wavelength of the set. You only need to know your set and its action to prevent squeals. The writer is not condemning the various attempts at preventing radiation by the addition of tubes or filter circuits, as most of them are good and accomplish the purpose. However, he realizes that many broadcast listeners have sets that will squeal if improperly tuned. They can learn to control and tune their sets properly.

Even a single circuit set will not radiate if it is not oscillating. Therefore keep your set out of oscillation. This can always be done by not advancing the tickler to a point where a squeal is heard in the phones. When this happens, the signals are distorted and unpleasant and the set is in oscillation. Therefore it is radiating and causing disagreeable noises in your neighbors' sets. You may be getting a little more volume out of your set, but on the other hand, look at the trouble you are causing.

The correct procedure for tuning a single circuit tuner is as follows: Set the tickler at or very close to zero. Vary the switch arms controlling the number of turns in the primary and turn the series antenna condenser until a station is heard. All adjustments must be made slowly and carefully, otherwise you may pass over the wavelength setting of a station without hearing it. When you hear a station, tighten the tickler coupling until the signal strength comes to maximum. Do not advance the tickler coil to a point where a squeal is heard. To do so causes oscillation and radiation.

At first this method of tuning may be difficult but after you log a few stations, you will have no serious

trouble. This method is the direct opposite of tuning in on a whistle, and as you hear no sound of the carrier wave, but only the voice or music, it is very easy to pass over the station. The carrier wave is not audible until the detector tube of the receiving set is in oscillation, and oscillation is what we are trying to avoid. You will get just as loud signals this way and you will be helping radio reception by others. Soon after trying this method you will learn to manipulate your tickler dial and the tuning controls together so as to keep the circuit at its most sensitive point without allowing the detector to oscillate. This is done by keeping the tickler set at a point where the tube almost but not quite oscillates. This setting will vary as the tuning is changed. Therefore the tickler position must be manipulated with one hand while the other hand changes the wavelength.

Nor is the single circuit the only radiating offender. Two and three circuit tuners also set up oscillations and radiate. However, when the secondary circuit is loosely and inductively coupled to the antenna circuit, the amount of radiation is greatly reduced. The so-called untuned primary is probably one of the best behaved of the simple circuit family. The step-down transformation between the secondary and the primary cuts down the amount of oscillating current that gets to the aerial to a very great extent. The two variometer and coupler circuit is the next in line as an oscillator and so it goes on up the line to the worst ones, the tickler feed-back in the single circuit tuner and the many variations of the Colpitts. The latter was originally designed as a transmitting circuit and as such is great stuff. Since it invaded the receiving field things have begun to happen. This is probably the only circuit in which it is next to impossible to control the oscillations. The best thing to do with it is to junk it or else make such changes in it as will render it more stable in operation.



(Fotograms)

**AN AMERICAN SPHINX**, located at an amusement park on Long Island, has it all over his Egyptian cousin. The expression on Mr. Sphinx, Jr.'s face here just goes to show how times have changed. The original, over in Egypt, has probably never had the pleasure of hearing American broadcasting stations.



(Foto Topics)

**THIS GROUP OF HAPPY CHILDREN**, out for a Summer lawn party, bring their own music, so that the Royal Entertainer may do her dance whenever the King and Queen want to be entertained. The price of a band, saved by the use of the radio receiving set, goes towards the purchase of more ice cream and cake for the kiddies, who enjoy nothing better than a radio outing in Central Park, New York City.



**A THOUGHT FOR TODAY**—Each time I see Freedom's Banner wave it thrills me with delight anew and inspires a still deeper devotion to my Country. My radio brings within my earshot the vast domain over which Old Glory flies.



**After my Mother and my Flag—my Radio!**

# RADIO WORLD

Title Reg. U. S. Pat. Off.

TELEPHONE LACKAWANNA 2062, 6976  
PUBLISHED EVERY WEDNESDAY  
(Dated Saturday of same week)  
FROM PUBLICATION OFFICE,  
HENNESSY RADIO PUBLICATIONS CORPORATION  
ROLAND BURKE HENNESSY, President  
M. B. HENNESSY, Vice-President  
FRED S. CLARK, Secretary and Manager  
1493 BROADWAY, NEW YORK, N. Y.  
Boston Representative: Chas. H. M. White, 78 Stuart  
Chicago Representative: Mat H. Friedman, 519 East 60th  
Street, Chicago, Ill.  
Cincinnati Representative: Samuel H. Jaffee, 1117  
Provident Bank Bldg., Cincinnati, O.  
European Representative: The International News Co.,  
Brems Bldgs., Chancery Lane, London, Eng., Paris,  
France. Brentano's 38 Avenue de l'Opera.

EDITOR, Roland Burke Hennessy  
MANAGING EDITOR, Herman Bernard  
TECHNICAL EDITOR, N. N. Bernstein

## SUBSCRIPTION RATES

Fifteen cents a copy \$6.00 a year, \$3.00 for six months, \$1.50 for three months. Add \$1.00 a year extra for foreign postage. Canada, 50 cents.

Receipt by new subscribers of the first copy of RADIO WORLD mailed to them after sending in their order, is automatic acknowledgment of their subscription order. Changes of address should be received at this office two weeks before date of publication. State whether subscription is new or a renewal.

## ADVERTISING RATES

FLAT RATE—Page, 7½x11", \$150; half page, 8¼ D. C. or 5½x3 col., \$75; quarter page, 4¼ D. C., \$37.50; one col., 2½x11", \$50—\$75 per inch. Back cover page, two colors, \$250. Preferred positions 20% extra.

## CLASSIFIED ADVERTISEMENTS

Five cents per word. Minimum, 10 words. Cash with order.

Entered as second-class matter, March 28, 1923, at the Post Office at New York, New York, under the act of March 3, 1879.

JULY 5, 1924

## The Convention Gives Radio Its Greatest Impetus

**N**O broadcast event ever has given radio such a push forward as has the Democratic Convention. The tense interest in who would be nominated for President—an element of suspense not present at the Republican Convention—stimulated a tremendous interest. If there were a Presidential convention every year the radio dealers and fans would not complain on that account. Sets were overhauled, new sets were bought by persons who had held aloof from radio, frenzied activities were displayed by experimenters who "build their own" to get best reception in time, and the chief topic of conversation (excepting only the question "Who will be nominated?") was, "How did you enjoy listening in?"

## Avoiding Tube Blow-outs

By Herman Bernard

**M**ANY an experimenter is spending at least twice as much for tubes as he should. Some are trebling the necessary expense. This is due to burning out tubes. It is a common misfortune. Why not remedy it? The money thus thrown away can be used for more advantageous radio purposes than adorning the graveyard of tubes that have gone west. A certain pride stirs most of us to the belief that our careful attention to indelible warnings posted in the recesses of our mind will spare us the sinking feeling of having blown out a tube. But, alas, the Nemesis of tube destruction somehow will pursue us with villainous rigor and—flash!—there go three tubes at once! Fifteen dollars, please! At this stage we figure that the expense of buying the new tubes will be about all we care to bear this week, and we will have to forego safety fuses, though they cost only \$1.50 or so for the three tubes. Ten per cent., therefore, is the insurance rate on three tubes, but if you figure with correct foresight you will see that the fuses can be used after your tubes have come to the natural end that marks the finale of a long period of useful service. Therefore, decide on safety fuses—and put them in now! Not everybody will heed this advice. Therefore, some pointers addressed to the reckless, yet none the less pertinent to all comers:

**1.** Be very careful when installing filament wiring. This is the first wiring job to be tackled in constructing a set. Run these wires low. After the A battery wiring is completed, try it out. If the tubes light, then you are progressing nicely. Do NOT connect any B battery leads to your set until after you have found that, by the lighting test, your A battery leads are properly connected.

**2.** After connecting your B leads, insert only one tube (if yours is a multi-tube set), because if there is any trouble, better to have it in one tube than in three. If you use UV201A, Myers' tube or equivalent storage battery tubes, do not try out any tube with the maximum B battery voltage you intend to employ. Try out the detector tube on 22½ volts of B battery on the plate (the most it will require), but also try out all RF and AF stages with 22½ volts of B battery, because the aforementioned tubes, even if 22½ volts are erroneously delivered to their filaments, will not necessarily burn out. If the B current is being fed to the

filament the tube will light with abnormal brilliancy. If that happens, take out the tube right away and hunt for the trouble with some trouble-shooting device. (See page 9.) Muffled reception, or none at all, is the result from excessive voltage in the filament. If you've been guilty of giving the filament B battery current, and the tube henceforth lights on 6 volts but doesn't percolate, keep the tube lighted for half an hour. This likely will restore the tube to a functioning condition.

**3.** When hunting for trouble, remove all tubes, inserting them again when necessary for testing purposes. Many attempts to find minor shortcomings result in fatalities in tube ranks, and the remedy becomes worse than the ailment.

**4.** Keep a budget on what you spend for tubes. Write in some special little book what tubes you bought, from whom, at what date, and leave a margin for remarks. You can thus keep a mortuary record (if you must dodge safety fuses) and also measure the natural life of the tubes you buy. If your comparative tube cost doesn't go down, instead of up, be more attentive to precautionary advice. (And watch those totals closely!)

**5.** Remove your ring when sticking your hand behind the panel. The ring may cause 90 additional volts to go where only 6 should be "by rights."

**6.** Do NOT use a screwdriver or the like for making momentary connections in your testing work. Use some flexible wire, single strand preferred, such as annunciator wire. But be sure it is well insulated. Even if you decide it is, slip some spaghetti over it, to make doubly sure, and leave only ¼" of bare wire protruding.

**7.** Above all, take your time at all trouble-shooting. Especially when helping others, do not let yourself be rushed just because your admiring and confident friends are impatient to listen in on some particular program on the air at the moment. You may blow out tubes to replace which they may not show any spontaneous eagerness to pay. And if you do not use safety fuses yourself, at least put them in sets you make that others may use.

# RADIOCAST PROGRAMS

## Thursday, July 3

**WOO, Philadelphia, 590m (590k), E. S. D. S. T.—12 Noon**, luncheon music by the Tea Room orchestra. 12:55 P. M., time signals. 4:45 P. M., grand organ and trumpets. 7:30 P. M., sports results and police reports. 7:40 P. M., Philadelphia Record news budget to American advertising delegates on S. S. Republic en route to London. 10:55 P. M., time signals and weather forecast.

**WEB, St. Louis, Mo., 273m (1100k), C. S. T.—**Regular schedule: Monday, 8 to 9:45 P. M.; 11 to 12 Midnight. Wednesday, 8 to 9:45 P. M.; 11 to 12 Midnight. Friday, 8 to 9:45 P. M.; 11 to 12 Midnight. Saturday, 11 to 1 A. M.

**WRC, Washington, 469m (640k), E. S. T.—5:15 P. M.**, instruction in international code. 6 P. M., children's hour by Peggy Albion. 6:20 P. M., baseball scores. 7:45 P. M., talk on motoring, auspices American Automobile Association. 8 P. M., musical program announced. 9 P. M., dance program by signals and weather forecasts. P. M., time signals and weather forecasts.

**WKSJ, St. Louis, Mo., 546m (550k), C. S. T.—**8 P. M., Silverman's orchestra concert broadcast direct from Lyric Skydome.

**WLW, Cincinnati, O., 423m (709k), E. S. T.—**10:30 A. M., weather forecast and business reports. 1:30 P. M., business reports. 3 P. M., market reports. 4 P. M., talk, "Why We Are Interested in Ethers," by Mrs. Winifred Ellerbrook; piano solos by Miss Adelaide Apfel. 5:15 P. M., baseball results. 10 P. M., "The Great Divide," arranged in Radario form by Mr. and Mrs. Henry Florsheim; incidental music by Instrumental Trio. 11:15 P. M., popular program by the Doherty Melody Boys.

**WGI, Medford, Mass., 360m (830k), E. S. D. S. T.—**6:30 P. M., closing stock market reports; agricultural reports; Boston police reports. 6:45 P. M., code practice. 7 P. M., meeting Amrad Big Brother club. 7:30 P. M., evening program: Talk by Geoffrey L. Whalen, "The Radio Movie Man"; address by Richard K. Morton. 8:15 P. M., music; weather report, and time.

**WEAF, New York, 492m (610k), E. S. D. S. T.—**Program subject to change in order to broadcast events from Democratic National Convention, Madison Square Garden. 11 A. M., musical program and talks to housewives; Consolidated margin and weather reports. 4 to 6 P. M., Charles Phillips, pianist; Elsie Peck, soprano; Lawrence Gardner, cornetist; children's hour program. 6 to 12 P. M., dinner music from Rose Room, Hotel Waldorf-Astoria; midweek services, Greater N. Y. Federation of Churches; Edith Heinlein, pianist; Louise Pascova, soprano; Josephine Forsythe, soprano; health talk, auspices New York Health Speakers Service; Arthur Michaud, tenor; Vincent Lopez and his orchestra.

**WMAQ, Chicago, 448m (670k), C. S. D. S. T.—**4 P. M., sports results. 4:10 P. M., lessons in household arts by Mrs. Elizabeth O. Hiller. 6 P. M., Chicago theatre organ. 6:30 P. M., Hotel LaSalle orchestra. 8 P. M., Barnett Harris, nature study club. 8:15 P. M., weekly talk for Boy Scouts. 8:30 P. M., talk by Rockwell R. Stephens, auto editor. 8:45 P. M., weekly investment talk. 9 P. M., first of a series of garden talks by James H. Burdett. 9:15 P. M., program by Mrs. Wayne Misner, contralto; Miss Hansen, mezzo-soprano, and Miss Weber, pianist.

**WOC, Davenport, Ia., 484m (620k), C. S. T.—**10 A. M., garden and household hints. 10:55 A. M., time signals. 11 A. M., weather and river forecast. 11:05 A. M., market quotations. 12 Noon, chimes concert. 12:15 P. M., weather forecast. 1 P. M., closing stocks and markets, including weekly report of stock market. 2:15 P. M., chimes concert. 6:30 P. M., Sandman's Visit. 6:50 P. M., sport news and weather forecast. 9 P. M., orchestra program.

**WNAC, Boston, 278m (1080k), E. S. D. S. T.—**10 A. M., WNAC women's club talks. 10:30 P. M., broadcast from Madison Square Garden, New York, Democratic National Convention. 6:30 P. M., WNAC dinner dance from Hotel Westminster. 7:30 P. M., broadcast from Madison Square Garden, New York, Democratic National Convention. If the Democratic Convention adjourns before the end of the week concert programs will be broadcast each evening starting at 8 P. M.

**WIP, Philadelphia, 599m (590k), E. S. D. S. T.—**3:30 P. M., concert by Comfort's Philharmonic orchestra—Soloists, Jenny Kneeder Johnson, soprano, and Dell Angelo, trumpet soloist. 6 P. M., weather forecast. 6:05 P. M., dinner music by William Smith and his dance orchestra. 6:45 P. M., agricultural livestock and produce market reports. 7 P. M., Uncle Wip's stories and roll call for the children. 8 P. M., "Timely Talks to Motorists," by Gene Hoag, secretary Automobile Club of Philadelphia. 8:15 P. M., concert by Comfort's Philharmonic orchestra—Soloist, Jenny Kneeder Johnson, soprano. 8:45 P. M., concert by Veselica, concert band—Soloist, Miss Margaret Keever, contralto, broadcast direct from WIP control station on the Steel Pier. Atlantic City. 11:15 P. M., dance music by LeRoyale orchestra from Cafe L'Aiglon.

**WDAR, Philadelphia, 395m (780k), E. S. D. S. T.—**12 Noon, organ recital from the Stanley Theatre; features from the studio; Arcadia concert; orches-



**GEORGE D. HAY**, at left, announcer at WLS, Sears-Roebuck Agricultural Foundation Station, Chicago, with his locomotive whistle. You can always tell when WLS is coming on the air by listening for the familiar toot-toot. The other boys are Ford Rush and Robert Northrop, regular entertainers at the studio.

tra. 2 P. M., Arcadia concert orchestra; Mrs. Anna B. Scott will talk on the "Market Basket." 4:30 P. M., recital from studio. 5:30 P. M., educational talk by member of faculty of the Peirce School. 5:45 P. M., baseball scores. 7:30 P. M., Dream Daddy with the boys and girls.

**WJZ, New York, 455m (660k), E. S. D. S. T.—**11 A. M., National Democratic Convention. 4 P. M., Eleanor Gunn's fashion talk. 4:10 P. M., daily menu. 4:15 P. M., "The Progress of the World." 5:30 P. M., State and Federal agricultural reports; Farm and Home reports; closing quotations New York Stock Exchange; foreign exchange quotations; Evening Post news. 7 P. M., Pershing Square Cafe Savarin Ensemble. 7:20 P. M., financial developments of the day. 8 P. M., weekly French lesson. 8:30 P. M., Auditorium concert, direct from Wanamaker auditorium. 10:30 P. M., Hotel Majestic orchestra.

**WJY, New York, 405m (740k), E. S. D. S. T.—**7:30 P. M., George A. Leach, baritone. 7:45 P. M., "Progress in Industrial Disease Prevention," by Leland E. Cofer (Dept. of Labor). 8:30 P. M., Stadium concert, New York Philharmonic orchestra, direction of Willem Hoogstraten. (Note—in case there is no evening session of the Democratic Convention this date, the Stadium concert will be broadcast by WJZ—455 meters.)

**WOR, Newark, N. J., 405m (740k), E. S. D. S. T.—**6:15 P. M., Albert E. Sonn, technical editor, weekly talk on "Radio for the Layman." 6:30 P. M., "Music While You Dine"—Tom Cooper's Country Club orchestra. 7:20 P. M., resume of the day's sports.

**WAAM, Newark, N. J., 263m (1140k), E. S. D. S. T.—**7:30 P. M., James Vincent Moore, Paquita Cortez and Dolly Pinkus, singing and entertaining. 8 P. M., Walter Storey, review of current motion pictures. 8:15 P. M., Mlle. A. Van den Brandeler, operatic numbers. 8:45 P. M., Sam Taub, sport editor, in his weekly review and predictions. 9 P. M., Victor Wilbur, baritone, popular numbers. 9:15 P. M., Rev. Dr. Arthur W. Brooks, scientific astrologer and vocation guidance expert, talking on "Turn of the Wheel of Events," followed by horoscopes for the radio audience. 10 P. M., Charles J. Sander's dance orchestra.

**WHN, New York, 360m (830k), E. S. D. S. T.—**5 P. M., Buddy Baldwin's Nassau Hotel orchestra. 6:7 P. M., Around the Alamac's Festive Board; overture by Olcott Vail's Trio; jests by toastmaster; talks and songs by renowned folk and dance music by Paul Specht and his Alamac orchestra. 7 P. M., sport period by Thornton Fisher. 9:30 P. M., Chas. Strickland's orchestra from Palisades Amusement Park. 10 P. M., Sara V. Turits, soprano. 10:15 P. M., Harry Jentes, novelty piano solos. 10:30 P. M., Roseland dance orchestra. 11 P. M., Harry Hock and his entertainers. 11:15 P. M., Sylvia Brown, popular singer. 11:20 P. M., Ross Fowler, baritone. 11:30 P. M., Original James Boys from the El Fey restaurant.

**KDKA, Pittsburgh, 326m (920k), E. S. D. S. T.—**5:30 P. M., dinner concert by the KDKA Little Symphony orchestra. 6 P. M., baseball scores. 6:30 P. M., the children's period. 6:45 P. M., "Experimental Coal Mine of the U. S. Bureau of Mines," by J. W. Paul. 7 P. M., baseball scores; "Your Garden This Summer," prepared by the Radio Garden editor. 7:15 P. M., special program arranged by the National Stockman and Farmer. 7:40 P. M., market reports. 8 P. M., patriotic concert by KDKA Little Symphony orchestra, assisted by Miss Clara Stadelman, soprano. 9:55 P. M., time signals; weather forecast; baseball scores. 10 P. M., concert.

**WBZ, Springfield, 337m (890k), E. S. T.—**6 P. M., Leo Reisman Hotel Lenox ensemble. 7 P. M., results of games Eastern, American and National leagues. 7:05 P. M., market reports; letter from the New England Homestead; "At the Theatres,"

with A. L. S. Wood. 7:30 P. M., bedtime story. 7:40 P. M., Lou's Novelty orchestra; Boston studio. 10:50 P. M., time signals; weather reports. **KYW, Chicago, 536m (560k), C. S. D. S. T.—**6:35 P. M., talk on "Sports," by Leo Fisher. 6:45 P. M., talk on "Finance and Markets," by Mr. Thos. Hoynes. 7 P. M., "Twenty Minutes of Good Reading," by Rev. C. J. Permin. 7:20 P. M., musical program by Vesta Murray Watkins, soprano and reader; W. B. Freeman, dramatic reader; Ben Ray, concertina. 8:15 P. M., "Safety First" talk by Mr. C. Z. Elkin. 9:10-30 P. M., late studio program.

**WSB, Atlanta, Ga., 429m (700k), C. S. T.—**2:30 P. M., markets; weather. 3:30 P. M., play-by-play baseball broadcast; news; sport summary; Bonnie Barnhardt's Burgess bedtime story. 8 P. M., recital by Dr. Charles A. Sheldon, city organist. 9:30 P. M., ringside broadcast of Tiger Flowers versus Lee Anderson boxing bout for world's colored light-heavyweight championship at Atlanta Auditorium-Armory.

**KHJ, Los Angeles, 395m (760k), P. T.—**6 P. M., Art Hickman's concert orchestra. 6:45 P. M., children's program, piano pupils of Dorothy Caselman; bedtime story by Uncle John. 8:10 P. M., program courtesy of Grace Eaton Dow, presenting Katherine Stilwell, soprano; Los Angeles and his Mexican orchestra. 10:11 P. M., Art Hickman's dance orchestra.

## Friday, July 4

**WMC, Memphis, Tenn., 500m (600k), C. S. T.—**8:30 P. M., special Independence Day program, to be announced. 11 P. M., frolic by the steamer Idlewild orchestra, direction of Bob Miller.

**WGI, Medford, Mass., 360m (830k), E. S. D. S. T.—**12:40 P. M., New England farmers' forecast. 12:45 P. M., closing report on farmers' produce market. 6:30 P. M., stock market reports; code practice; Boston police reports. 7 P. M., meeting Amrad Big Brother club. 7:30 P. M., evening program: Selected verses by Mr. Charles L. H. Wagner, radio poet; patriotic program arranged by Grace Radford Olin; weather report and time.

**WEAF, New York, 492m (610k), E. S. D. S. T.—**Program subject to change in order to broadcast events from Democratic National Convention, Madison Square Garden. 11 A. M., musical program and market and weather reports. 6 to 10 P. M., dinner music from Rose Room, Hotel Waldorf-Astoria; The Happiness Boys—Billy Jones and Ernest Hare; B. Fischer's "Astor Coffee" orchestra.

**WOC, Davenport, Ia., 484m (620k), C. S. T.—**12 Noon, chimes concert. 12:15 P. M., weather forecast. 1 P. M., closing stocks and markets. 5:45 P. M., chimes concert. 6:30 P. M., Sandman's Visit. 6:50 P. M., sport news and weather forecast. 8 P. M., musical program: Jesse Clinton, guitar; Fred Sutterlin, ukulele; Gerard Hinrichs, pianist; Nat Ozmon, entertainer. 9 P. M., weekly tourists' road bulletin.

**WNAC, Boston, 278m (1080k), E. S. D. S. T.—**6:30 P. M., W. N. A. C. dinner dance, Checker Inn Orchestra, from Checker Inn. 8 P. M., band concert, broadcast from Parkman Band Stand, Boston.

**WIP, Philadelphia, 599m (590k), E. S. D. S. T.—**3:05 P. M., visiting artists and chats with celebrities, broadcast from WIP control station on the Steel Pier, Atlantic City. 3:30 P. M., concert by Comfort's Philharmonic Orchestra; soloists, Jenny Kneeder Johnson, soprano, and Edwin McKnight, xylophone soloist. 6 P. M., weather forecast. 6:05 P. M., dinner music by the Jordan Lewis Dance Orchestra. 6:45 P. M., agriculture, livestock and produce market reports. 7 P. M., Uncle Wip's bedtime stories and roll call for the children.

**WJZ, New York, 455m (660k), E. S. D. S. T.—**1 P. M., Hotel Ambassador Trio. 7:20 P. M., financial developments of the day. 8:15 P. M., Time's Pop Question game. 8:30 P. M., July Fourth celebration—"Sons of the American Revolution," Brig. Gen. Oliver B. Brdgm, president. 10:30 P. M., Harold Stern's Hotel Belleclair Towers orchestra.

**WJY, New York, 405m (740k), E. S. D. S. T.—**7:30 P. M., Leonard Nelson and his Knickerbocker orchestra, direct. 8:10 P. M., Goldman band concert, Edwin Franko Goldman, conductor, direct from Mall, Central Park; All-American program, Frances Sebel, soprano-soloist. 10 P. M., Mary Gleason, "Recitation—Patriotic."

**WOR, Newark, N. J., 405m (740k), E. S. D. S. T.—**6:15 P. M., joint program by Beulah Rowland, contralto; Alice Rodenbaugh, soprano, and Adele Beattys, accompanist. 6:30 P. M., Moon stories for children. 7 P. M., joint program by Beulah Rowland, contralto; Alice Rodenbaugh, soprano, and Adele Beattys, accompanist. 7:20 P. M., resume of the day's sports.

**WHN, New York, 360m (830k), E. S. D. S. T.—**6 P. M., around the Alamac's Festive Board, overture by Olcott Vail's trio; jests by toastmaster; talks and songs by renowned folk; dance music by Paul Specht and his Alamac orchestra. 7 P. M., Sport Period by Thornton Fisher. 9:30 P. M., "Fourth of July," by William D. Bosler of the National Security League. 9:45 P. M., Chas. Strickland's orchestra, Palisades Amusement Park. 10:15 P. M., Flo Williams, soprano, popular songs. 10:30 P. M., Roseland dance orchestra. 11 P. M., musical program. 11:30 P. M., original James Boys from the El Fey restaurant.

**KDKA, Pittsburgh, 326m (920k), E. S. D. S. T.—**2 P. M., Independence Day concert. 2:15 P. M., baseball scores. 5 P. M., baseball scores. 5:30 P. M., organ recital by Howard R. Webb. 6 P. M., baseball scores. 6:30 P. M., special radio party for the children. 6:45 P. M., Fourth of July program. (Continued on page 18)

# Pepping Up Your Aerial for Best Results

By N. N. Bernstein

Technical Editor

**W**ITH most present-day receiving sets it is not necessary to have a long aerial, stretching away over five roofs, and usually hanging low onto clothes lines and others' antennae. In the old days, when crystals and inefficient tube sets were the only reception means available, a long antenna was necessary, particularly due to the longer wavelengths then used in the transmission of press and time signals, so popular with the old-timers. Nowadays, more especially with broadcasting done on wavelengths as low as 94 meters, a short, well constructed antenna is required.



(Knickerbocker)

FIG. 3.—The lead-in is drawn over the courtyard diagonally, and fastened to the wall insulator as shown. The installation is being examined by N. N. Bernstein, technical editor of RADIO WORLD. The wire is run from this point on in a direct line to the window where the wire enters the building.

possible over surrounding objects, well insulated and erected "according to Hoyle."

The first requirement is a couple of rolls of good quality antenna wire, stranded preferred. Never use iron or picture hanging wire in any part of the antenna or ground circuits. Purchase three or four good antenna insulators, porcelain or electros, and a half dozen lead-in or wall insulators. One too many is always safer than one too few.

In Fig. 1 the two young lady radioists demonstrate the proper way to start the aerial, beginning it at least seven feet above the roof, as required by law. The first insulator is fastened about three feet from the supporting pole to keep the end of the wire a fair distance away from that obstruction. After fastening the end of the wire, as shown in Fig. 1, another insulator was fastened to the post shown in Fig. 2 to support the wire on its way to the lead-in. Here the antenna was securely twisted together with a cleaned end of the

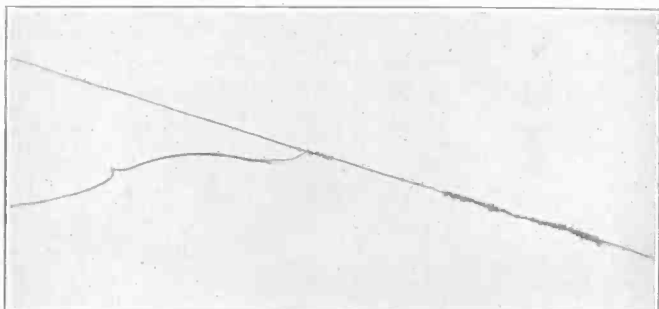

(Knickerbocker)

FIG. 4.—This is an actual photograph of an aerial to which the lead-in wire is twisted. In a short time the elements will oxidize the exposed connection, thereby causing a high resistance joint which hinders the signal.

insulated lead-in wire, then soldered and taped to prevent corrosion by the action of the elements.

The lead-in was brought across the court diagonally and fastened to the wall insulator as shown in Fig. 3. All lead-in wires should be kept at least one foot away from the edge of the roof, as shown.

The lead-in is then run directly in as straight a line as possible to the window nearest to where the set is located.

Let us now examine one of the other installations. Fig. 4 is a bona fide photograph of an antenna, showing the most slipshod method of fastening a lead-in to an aerial. With a connection like this the best of receivers will often fail to function well.

Fig. 5 shows the continuation of the same lead-in, and is acutely wound around the wooden pole as pictured, with no insulation other than the insulation on the wire itself. It is first twisted around the nail, then a few turns around the pole and a double hitch thrown in for good measure. The poor abused signal, after encountering the high resistance obstruction, as shown in Fig. 4, is forced to wind this tortuous path, twisting and bending in all directions in its effort to get to the set.

Fig. 6 shows the lead-in passing over the top of the wall, fastened thereto with bare wire, and rubbing right up against the roof, and so on down to the set. Is it any wonder that good receivers fail to function with a layout like this? There are, without doubt, many such installations made by beginners who do not know the value of a properly erected antenna, but who should forthwith hie themselves to the nearest radio store, invest a dollar or two in new equipment, and provide themselves with an efficient aerial.

Examine your antenna every few months to see that the insulation does its duty, and that connections are efficient.

After a poor aerial is supplanted with an adequate one, greater volume and



(Knickerbocker)

FIG. 1.—The antenna is started from one support insulator is made fast about three feet from the close to the pole. In stretching the wire, make the antenna as far away from



(Knickerbocker)

FIG. 2.—The insulator is fastened to on its way to the lead-in about three in the picture, from the pole to the shows what you

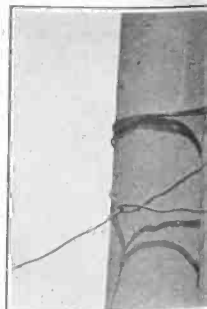

(Knickerbocker)

A BAD LEAD-IN, with support and devoid of



# in Volume, Tone Quality and Distance



pole at least seven feet over the roof. The first thing to be done is to see that the end of the aerial wire does not come down to the ground, and that there are no kinks or knots in it. Keep it clear of surrounding objects as possible.



second pole to support the antenna from the pole. The wire shown is only a few inches and should be avoided.



directly around the insulator. (Fig. 5.)

distance may be expected. Such sets as for instance the three-circuit tuner show surprising increase in volume when the aerial is pepped up. In one instance I know that the audibility meter reading showed 40 per cent. improvement when a really good aerial was substituted for a shipshod one. If a fan or experimenter is keen for low-loss condensers, because of their excellent efficiency, yet disregards the proprieties as to aerial installation, he is steering a contradictory and illogical course. The aerial is the virtual beginning of all things in broadcast reception and is

worthy of first consideration in the process of pepping up signal strength, quality of tone and DX range.

The question is often asked: "Why use only one wire for receiving? Why not put four or five wires together? Won't that be better to get the stations?"

As good or better receiving results are obtained with the use of one wire for reception, though a multiplicity of wires is better for transmitting. In receiving, the amount of current collected by the single-wire antenna is very small, therefore, the single wire can comfortably accommodate it. In transmitting, where as much current as possible is shot out to the antenna, the largest possible radiating surface is required. Where sending and receiving are done on one antenna, the latest type, now very

popular, is the cage antenna, constructed of a number of copper wires, all of the same length, fastened to the outer edge of metal hoops, the hoops spaced 20 to 30 feet apart. The over length varies from 50 to 150 feet.

The old type of antenna (Fig. 7) is composed of ten lengths of wire, each about 20 feet long, connected in parallel. Much better receiving results could be had if the antenna was a single wire about 100 feet long. A single wire with one insulator at each end has a higher leak resistance than a multiplicity of wires.



(Keystone)  
FIG. 7.—This is the type of antenna in vogue before broadcasting began. It consists of a number of wires in parallel, fastened to a spreader at each end by an insulator. The greater number of insulators in parallel, the lesser the resistance. Hence, use a single wire.

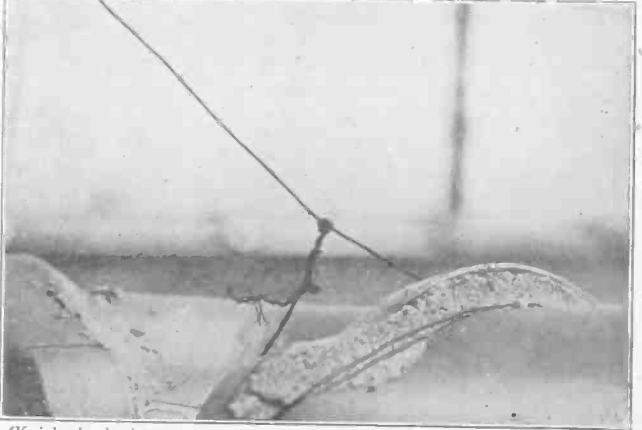

(Knickerbocker)  
FIG. 6.—This lead-in, held fast by a length of bare wire with absolutely no insulation, gives the signal a chance to leak off into the ground in any but the dryest weather.

RADIO WORLD  
ISSUE OF JULY 5, 1924

Vol. 5. No. 15. Whole No. 119.

Illustrated

Every Week

TABLE OF CONTENTS

DX on One Tube and a Crystal, by J. E. Anderson... Page 3
Reducing Losses Due to Insulation, by Dennis J. O'Flaherty... Page 4
News and Features Told in Photos... Page 5
Radio Features of the Democratic Convention Told in Text and Pictures... Pages 6 and 7
Silencing Parasite Noises, by Charles H. M. White... Page 8
Using Phones for Trouble-Shooting, by Byrt C. Caldwell... Page 9
Making the Superdyne Work Right, by Brewster Lee... Pages 10 and 11
Radio University (Questions and Answers)... Page 12
How to Tune a Regenerative Set, by A. P. Peck... Page 13
Editorial... Page 14
Avoiding Tube Blow-outs, by Herman Bernard... Page 14
Advance Radiocast Programs... Pages 15, 18 and 19
Pepping Up Your Aerial, by N. N. Bernstein, Technical Editor... Pages 16 and 17
The Radio Primer—What Makes Your Set Work, by Neal Fitzalan... Page 20
The Radio Trade... Page 22
Latest News... Page 23

"It can't be done" is the frequent assertion of persons who really mean they can't do the given task themselves. Asked if he could devise a one-tube set that uses the same tube for a stage of radio-frequency amplification, detection and a stage of audio-frequency amplification (no crystal being used), A. P. Peck, noted associate of the Institute of Radio Engineers, said: "I'll try." He tried—and tried—and tried. He confided his aim to some radio friends. They warned him about the impossibility of the task, citing the problem of tube overload, characteristic curve, etc. But still the inventive genius that has earned Peck his enviable reputation kept him at work. Then, finally—yes—HE DID IT! And he got local stations on a loud speaker on one tube!! Read in next week's RADIO WORLD, issue of July 15, of how he did it.

The Mid-Summer Number of RADIO WORLD, dated July 19, will contain articles on topics of absorbing interest to those desiring best reception in hot weather. "Loops," by B. J. Bongart, answers the thousand and one questions propounded on this subject. Which type of loop is best? Why? The loop is better than the outdoor aerial for summer work, therefore be sure to read this authoritative article. "Getting a Strangle Hold on Static," by N. N. Bernstein, Technical Editor, is another important contribution by an expert. He shows how you can get the smile—if not the laugh—on this mid-summer bugaboo. "Adventures with the Superdyne," by Brewster Lee, tells of remarkable summer results obtained with this receiver. Mr. Lee's warm indorsement of the Superdyne is backed up by laudatory letters from RADIO WORLD readers who constructed this set from data (but not parts) furnished by Mr. Bernstein in his splendid 3-part article published in RADIO WORLD, issues of May 17, 24 and 31.

Programs

Friday, July 4 (continued from page 15)

gram. 7:30 P. M., concert. 9:55 P. M., time signals, weather forecast, baseball scores.
WBZ, Springfield, 337m (890k), E. S. T.—6 P. M., dinner concert by WBZ trio, Springfield studio. 7 P. M., results of games, Eastern, American and National Leagues. 7:05 P. M., "Little Deeds of Kindness," dramatized story. 7:30 P. M., bedtime story. 10 P. M., concert arranged by William L. Anderson, Maxwell's orchestra. 10:55 P. M., time signals, weather reports. 11 P. M., concert by Royal Fife and Drum Corps of Hartford and the WBZ trio.
KYW, Chicago, 536m (560k), C. S. D. S. T.—5 P. M., news, financial and final markets. 5:45 P. M., children's bedtime story. 6 P. M., dinner concert broadcast from Congress Hotel. 7:20 P. M., talks auspices of the American Farm Bureau Federation. 8 to 11:30 P. M., midnight revue.
WSB, Atlanta, Ga., 429m (700k), C. S. T.—Noon, entertainment. 3:30 P. M., play-by-play baseball broadcast, news, sport summary, Bonnie Barnhardt's Burgess bedtime story. 8 P. M., Independence Day concert by William B. Griffith mandolin and guitar ensemble. 10:45 P. M., third annual Fourth of July jamboree by Atlanta Journal hired help.
KHJ, Los Angeles, 395m (760k), P. T.—6 P. M., Art Hickman's concert orchestra. 6:45 P. M., special children's program. 7 to 10 P. M., program courtesy of Barker Bros., arranged by Claire Forbes Crane.

Saturday, July 5

WRC, Washington, 469m (640k), E. S. T.—5:15 P. M., instruction in international code. 6 P. M., children's hour by Peggy Albion. 6:20 P. M., baseball scores. 7:45 P. M., Bible talk by Chaplain Thomas L. Kirkpatrick, U. S. Navy. 8 P. M., musical program announced. 9 P. M., dance program by Dessorff's Northern Collegians. 9:55 P. M., time signals.
KSD, St. Louis, Mo., 456m (590k), C. S. T.—8 P. M., Missouri Theatre orchestra, organ and specialties broadcast direct from that theatre.
WLW, Cincinnati, O., 423m (709k), E. S. T.—10:30 A. M., weather forecast and business reports. 1:30 P. M., market reports.
WGI, Medford, Mass., 360m (830k), E. S. D. S. T.—6:30 P. M., code practice; New England weather forecast; crop notes. 7 P. M., meeting, Amrad Big Brother club. 7:30 P. M., talk on current events by David M. Cheney; musicale; weather report and time.

WEAF, New York, 492m (610k), E. S. D. S. T.—4 to 6 P. M., Bob Fridkin's Clifford Lodge orchestra; Christine M. Frichin, soprano. 6 to 12 P. M., dinner music from Rose Room, Hotel Waldorf-Astoria; Francis Moore, pianist; bedtime story; Gertrude Bronenkant, lyric soprano; Albert Slack, tenor; Veronica Wiggins, contralto; Cuban program with Antonio Utraro, baritone; Nilo Mendez, pianist; Juan Pulido, baritone, and Mariano Meier, tenor; Vincent Lopez and his orchestra.
WMAQ, Chicago, 448m (670k), C. S. D. S. T.—6:30 P. M., Hotel LaSalle orchestra. 8 P. M., Chicago Rapid Transit band. 9 P. M., weekly Balaban and Katz Chicago theatre revue. Note—There is a possibility that the Democratic National Convention in session in New York City may run into this week—if this should happen, the above program would be canceled and the convention broadcast.
WOC, Davenport, Ia., 484m (620k), C. S. T.—9 A. M., opening market quotations. 10 A. M., garden and household hints. 10:55 A. M., time signals. 11 A. M., weather and river forecast. 11:05 A. M., Government bulletins. 11:15 A. M., closing market quotations. 12 Noon, chimes concert. 12:15 P. M., weather forecast. 5:45 P. M., chimes concert. 6:30 P. M., Sandman's Visit. 6:50 P. M., sport news and weather forecast. 9 P. M., orchestra program, The Palmer School.
WNAC, Boston, 278m (1080k), E. S. D. S. T.—10:30 A. M., broadcast from Madison Square Garden, New York, Democratic National Convention. 6:30 P. M., WNAC dinner dance, Checker Inn orchestra, from Checker Inn. 7:30 P. M., broadcast from Madison Square Garden, New York, Democratic National Convention.
WIP, Philadelphia, 509m (590k), E. S. D. S. T.—6 P. M., weather forecast. 6:05 P. M., dinner music by William Smith and his dance orchestra. 6:45 P. M., agriculture, livestock and produce market reports. 7 P. M., Uncle Wip's bedtime stories and roll call for the children. 8 P. M., concert by Comfort's Philharmonic orchestra; solosit, Jenny Knedder Johnson, soprano. 8:45 P. M., concert by Vessella's Concert band; solosit, Miss Margaret Keever, contralto. 10:15 P. M., dance music by Bob Lehmar's orchestra broadcast from WIP control station, Steel Pier, Atlantic City. 11:05 P. M., organ recital by Karl Bonawitz, from Germantown theatre.
WDAR, Philadelphia, 395m (760k), E. S. D. S. T.—11:45 A. M., daily almanac. Noon, organ recital from Stanley theatre; Features from studio; Arcadia Concert orchestra. 2 P. M., Arcadia Concert orchestra. 4:30 P. M., dance program. 5:45 P. M., baseball scores. 7:30 P. M., Dream Daddy with the boys and girls.
WJZ, New York, 455m (660k), E. S. D. S. T.—5 P. M., "Photoplay Writing," Roy C. Jones. 5:30 P. M., State and Federal agricultural reports;

New Broadcasters

CLASS A BROADCASTING STATIONS NEWLY LICENSED

Table with 3 columns: Call, Station, Kcs. M. W.
KFAJ—University of Colorado, Boulder, Col. 1150 261 100
KFQM—Texas Highway Bulletin, Austin, Texas 1120 268 100
KFQN—Third Baptist Church, Portland, Ore. 1060 283 5
KFQO—Meier Radio Shop, Russell, Kan. 1150 261 10
KFQP—George S. Carson, Jr., Iowa City, Ia. 1340 224 10
WDBX—Otto Baur, New York City 1290 233 5
WDBZ—Boy Scouts of America, Kingston, N. Y. 1290 233 5
WEBA—The Electric Shop, Highland Park, N. J. 1290 233 15
WTX—H. G. Saal Co., Chicago 1120 268 10
TRANSFERRED FROM CLASS C TO CLASS A
KFBS—The Trinidad Gas & Electric Supply Co., and Chronicle News Publ. Co., Trinidad, Col. 1070 280 10
WEV—Hurburt-Still Electrical Co., Houston, Tex. 1140 263 100

Farm and Home reports; closing quotations New York Stock Exchange; foreign exchange quotations; Evening Post news. 8:45 P. M., "Chopping Out a Slice of Frequency" by Dr. Alfred N. Goldsmith, chief broadcast engineer, R. C. A. 10 P. M., two piano ensemble—Erno Bolog and Carl Hayos. 11 P. M., Club Lido Venice orchestra.

WOR, Newark, N. J., 405m (740k), E. S. D. S. T.—6:15 P. M., "Music While You Dine," Ernie Crickett's Cinderella orchestra. 7:20 P. M., resume of the day's sports. 8 P. M., Gene Ingraham's orchestra. 8:35 P. M., recital by Michael de Sants, harpist. 8:50 P. M., concert by Julius Woelzl, recording pianist. 9:15 P. M., Prof. Edward Jones Kilduff, of New York University, in "How to Get a Better Job." 9:40 P. M., program by Charles Kindelberger, tenor. 10:30 P. M., Gotham Entertainers of New York City.

WHN, New York, 360m (830k), E. S. D. S. T.—6 P. M., around the Alamac festive board, overture by Olcott Vail's trio; jests by toastmaster; talks and songs by renowned folk; dance music by Paul Specht and his Alamac orchestra. 7:30 P. M., musical program. 8 P. M., Jimmy Flynn, tenor, popular songs. 8:30 P. M., Ace Brigade and his 14 Virginians from the Monte Carlo. 9 P. M., Ellen Montague Cross, soprano. 9:15 P. M., Josiah B. Free bartone, Muriel Snyder accompanist. 9:30 P. M., George Roberts and Jimmy Doyle, popular program. 9:45 P. M., Fitzpatrick Brothers singing old-time melodies. 10:11 P. M., special men's program. 11 P. M., Jimmy Clarke and his entertainers. 11:30 P. M., musical program. 12:12:45 P. M., Broadway Jones and his orchestra.

KDKA, Pittsburgh, 326m (920k), E. S. D. S. T.—6 P. M., baseball scores; winner concert continued. 6:30 P. M., the children's periods. 6:45 P. M., "Last Minute Helps to Teachers." 7 P. M., baseball scores. 7:15 P. M., feature. 8 P. M., concert by the Westinghouse band and assisting soloist.

WBZ, Springfield, Mass., 337m (890k), E. S. T.—6:30 P. M., Leo Reisman and his Brunswick orchestra. 7 P. M., results of games, Eastern, American and National Leagues. 7:05 P. M., market report. 7:10 P. M., Leo Reisman Hotel Lenox ensemble. 7:30 P. M., bedtime story. 7:40 P. M., concert by the Hotel Kimball trio. 9 P. M., concert arranged by Boston Conservatory of Music; Katherine Carver, pianist; Iride Pilla, soprano; Harold Doyle, violinist. 10:55 P. M., time signals, weather reports.

KYW, Chicago, 536m (560k), C. S. D. S. T.—5:02 to 5:18 P. M., news, financial and final markets. 6 P. M., winner concert broadcast from Congress Hotel. 7 P. M., musical program. 8 P. M., talk by Vivette Gorman, Home Economics Department. 8:05 P. M., short stories, articles and humorous sketches. 9:15 to 12:30 A. M., late show.

WSB, Atlanta, Ga., 429m (700k), C. S. T.—Noon, entertainment. 2:30 P. M., markets, weather. 3:30 P. M., play-by-play baseball broadcast, news, sport summary, Bonnie Barnhardt's Burgess bedtime story. 8 P. M., Mountaineer square dance by Mud Creek Symphony orchestra. 10:45 P. M., "Georgia Peach Night."

KHJ, Los Angeles, 395m (760k), P. T.—6 to 6:30 P. M., Art Hickman's Concert orchestra. 6:45 to 7:30 P. M., children's program, bedtime story by Uncle John. 8 to 10 P. M., de luxe program. 10 to 11 P. M., Art Hickman's dance orchestra.

Sunday, July 6

WOO, Philadelphia, 509m (590k), E. S. D. S. T.—10:30 A. M., morning services from Bethany Presbyterian Church; organ recital at 10:30 by Miss Caroline Quigg. 2:25 P. M., musical exercises opening regular Sunday afternoon session of Bethany Sunday School. 3:15 P. M., old-time hymns and melodies and sacred chimes recital.

WHAS, Louisville, Ky., 400m (750k), C. S. T.—9:57 A. M., organ music. 10 A. M., church services, auspices Broadway Christian Church; the Rev. Dr. W. N. Briney, pastor; Mrs. Harry W. Long, organist and choir director. 4 P. M., concert under direction of Miss Marguerite A. King.
WGY, Schenectady, N. Y., 380m (790k), E. S. T.—9:45 A. M., service of First Methodist Episcopal Church, Schenectady; sermon by the Rev. Dr. Philip L. Frick. 6:30 P. M., service of Albany Street M. E. Church, Schenectady; sermon by the Rev. Cassius J. Miller.

KGO, Oakland, Cal., 312m (960k), P. T.—3:30 P. M., concert by KGO Little Symphony orchestra and soloists, Carl Rhodehamel conducting. (Continued on next page)

# Super-Power Stations Planned

TEN superpower radio radiocasting stations covering the entire United States and replacing the present comparatively large number of sending plants are planned by the large electrical and radio companies.

This was announced by Pierre Boucheron, of the Radio Corporation of America. He amplified his remarks on the subject originally presented at the convention of the Associated Manufacturers of Electrical Supplies. The gist of these remarks was published in RADIO WORLD last week. Mr. Boucheron also said that recent discoveries, when put into general use, would entirely eliminate the so-called "interference" commonly encountered by wireless receivers, producing strange shrieks and whistling sounds in the loud speakers, provided the sets are properly adjusted.

"There are now," said Mr. Boucheron, "about five hundred broadcasting stations in this country, and this is entirely too many. It is planned, not only for the sake of efficiency, but for economical reasons, to establish ten huge stations, each covering a certain zone and capable of sending, for example, over a 500-meter distance.

"This would not interfere in any way with local stations which take care of local needs, since they would, of course, operate on different and distinct wave lengths.

"It also is proposed to maintain these superpower stations on a sound economical basis, since the present method can not continue. It costs about \$100,000 a year to operate a first-class sending station now, and it is not possible to make any charge for the service.

"It is planned, first, that the radio industry shall tax itself 2 per cent. of the gross sales, this money to be placed in a foundation fund for the maintenance of the huge stations. It is also hoped that persons of wealth will contribute to this foundation fund so that a permanent source of revenue for the stations be established. Radio, as every one knows, is only in its infancy, and certainly such benefactors would be well warranted for the good of the general public and the country."

The perfecting of three new types of receivers which do not radiate and also eliminate noises in receiving sets was referred to by Mr. Boucheron, who said that since so many of the older models were in use it would take some time for the improved ones to get into wide general use.

## Programs

(Continued from preceding page)

WGI, Medford, Mass., 360m (830k), E. S. D. S. T.—5 P. M., twilight program: "Adventure Hour," conducted by Youth's Companion; musical; talk under auspices Greater Boston Federation of Churches.

KFI, San Francisco, 469m (640k), P. T.—10 A. M., L. A. Church Federation service, 4 P. M., Secular concert, 6:45 P. M., San Diego concert orchestra, 8 P. M., Ambassador Hotel concert orchestra, 9 P. M., Examiner concert, 10 P. M., Theron Bennett's orchestra.

WIP, Philadelphia, 509m (590k), E. S. D. S. T.—7:30 P. M., evening service broadcast from Holy Trinity Church, Rev. Floyd W. Tompkins, D.D., rector, 9:30 P. M., special Sunday evening concert, with prominent soloists, broadcast from WIP control station on the Steel Pier, Atlantic City.

KGW, Portland, Ore., 492m (610k), P. T.—6 P. M., church services conducted by Rt. Rev. Walter Taylor Sumner, Bishop Episcopal Diocese of Oregon.

KYW, Chicago, 536m (560k), C. S. D. S. T.—10 A. M., Sunday morning service broadcast from St. Chrysostom's Episcopal Church, Rev. Norman Hutton, rector, 1:30 P. M., studio chapel service WCAE, Pittsburgh, 462m (650k), E. S. D. S. T.—3:30 P. M., People's Radio Church services by Rev. E. J. Meachem, 7 P. M., dinner concert from William Penn Hotel.

KPO, San Francisco, 423m (710k), P. T.—11 A. M., undenominational and non-secretarian church services; soloist, Mr. Gwyn J. Tebault, contralto; organ selection by Theodore J. Irwin, 8:30-10 P. M., concert by Rudy Seiger's Fairmont Hotel orchestra.

WSB, Atlanta, Ga., 429m (700k), C. S. T.—11 A. M., First Presbyterian Church service, 5 P. M., Charlie Tillman revival broadcast, 7 P. M., Wesley Memorial Church service

### Monday, July 7

WOO, Philadelphia, 509m (590k), E. S. D. S. T.—7:30 P. M., sports results and police reports; dinner music by A. Candelori and his Hotel Adelphia orchestra, 8:30 P. M., musical program: Herman Gatter, tenor; Edwin Grant Rorke, baritone; Emma M. Faulkner, pianist; Harriette G. Ridley, accompanist, 9:10 P. M., Fox Theatre Grand Orchestra, 10 P. M., grand organ recital, Mary E. Vogt, 10:30 P. M., dance program by Vincent Rizzo and his Hotel Sylvani orchestra.

WWJ, Detroit, 517m (580k), E. S. T.—10:25 A. M., weather forecast, 11:55 A. M., Arlington time, 12 Noon, Detroit News orchestra, 3 P. M., Detroit News orchestra, 3:50 P. M., weather forecast, 3:55 P. M., market reports and baseball scores, 7 P. M., Detroit News orchestra, 7:30 P. M., concert by Schmeman's concert band.

CKAC, Montreal, 425m (710k), E. S. D. S. T.—1:45 P. M., Mount Royal Hotel concert orchestra, 4 P. M., weather, news, stocks, music.

WFAA, Dallas, Tex., 476m (630k), C. S. T.—12:30 P. M., address, Capt. S. C. Kile, United States Veterans' Bureau, "About the Bonus," 8:30 P. M., L. J. Cook and his string band, Heat and static are relative terms, Keep your radio going and encourage the stations to give their best, Radio must not be seasonal.

WMC, Memphis, Tenn., 500m (600k), C. S. T.—8:30 P. M., regular Monday night request program by the Gayoso Hotel orchestra.

WHAS, Louisville, Ky., 400m (750k), C. S. T.—4 P. M., selections by the Alamo theatre orchestra; police bulletins; weather forecast for Kentucky, Indiana and Tennessee; "Just Among Home Folks," a daily humorous column; Dick Quinlan's Golden Derby Orchestra, Walnut Theatre; late news bulletins, 4:50 P. M., local livestock, produce and grain market reports, 4:55 P. M., baseball scores, 5 P. M., Central Standard time.

WGY, Schenectady, N. Y., 380m (790k), E. S. T.—1 P. M., music and one-act play, "I'm Going," Triston Bernard, 5 P. M., produce and stock market quotations; news bulletins; baseball results, 5:15 P. M., review of week's sports, "Joe" Haubner, 7:40 P. M., baseball results, 7:45 P. M., address, "Some Facts About Bees and Honey," R.

B. Willson, New York State College of Agriculture, 8 P. M., program of old time songs.

KGO, Oakland, Cal., 312m (960k), P. T.—3 P. M. musical program; speaker furnished, courtesy Parent-Teacher Associations San Francisco, 4 P. M., Hotel St. Francis dance orchestra, 6:45 P. M. stock exchange and weather reports, and news items, 8 P. M., educational program, with musical numbers; courses in agriculture, Spanish music economics and literature.

KFI, San Francisco, 469m (640k), P. T.—5 P. M., Evening Herald news bulletins, 5:30 P. M., Examiner news bulletins, 8 P. M., Evening Herald concert, 9 P. M., Examiner concert, 10 P. M., Ambassador Cocoanut Grove orchestra.

KGW, Portland, Ore., 492m (610k), P. T.—11:30 A. M., weather forecast, 3:30 P. M., literary program by Portland Library Association, 7:15 P. M., police reports, 7:30 P. M., baseball scores, weather forecast and market reports, 8:10 P. M., concert featuring Harriet Leach, soprano; Florence Leach, contralto; Loise Jacobson, pianist, and others.

WCAE, Pittsburgh, 462m (650k), E. S. D. S. T.—3:30 P. M., baseball scores; library news, 4:30 P. M., stock market reports; The Sunshine Girl, 6:30 P. M., dinner concert from William Penn Hotel, 7:30 P. M. Uncle Kaybee, 7:45 P. M., baseball scores, 9 P. M., radio ukulele lesson by C. Martin McGee, 9:30 P. M., musical program by the Witting Six orchestra, 11 P. M., late concert.

KPO, San Francisco, 423m (710k), P. T.—2:30 P. M., violin solos by Violet Silver; program by Lawrence Swales & Co., Musical Buffons; banjo solos by H. L. Elliott, 4:30 P. M., Rudy Seiger's Fairmont Hotel orchestra, 5:30 P. M., children's hour stories by "Big Brother," 7 P. M., organ recital by Theodore J. Irwin, 9 P. M., Karl Koenig, basso, accompanied by M. S. Jones; Jean Mirk, soprano, 10 P. M., E. Max Bradfield's versatile band.

### Tuesday, July 8

WOO, Philadelphia, 509m (590k), E. S. D. S. T.—12 Noon, luncheon music by the Tea Room orchestra, 12:55 P. M., time signals, 4:45 P. M., grand organ and trumpets, 7:30 P. M., sports results and police reports, 7:40 P. M., Philadelphia Record news bulget to the American advertising delegates on the S. S. Republic en route to London, 10:55 P. M., time signals.

WWJ, Detroit, 517m (580k), E. S. T.—10:25 A. M., weather forecast, 11:55 A. M., Arlington time, 12 Noon, Detroit News orchestra, 3 P. M., con-

cert by Schmeman's concert band, 3:50 P. M., weather forecast, 3:55 P. M., market reports and baseball scores, 5 P. M., baseball scores, 7 P. M., Detroit News orchestra, 7:30 P. M., concert by Schmeman's concert band.

CKAC, Montreal, 425m (710k), E. S. D. S. T.—4 P. M., weather, stock, news, 7 P. M., kiddie's stories in French and English, 7:30 P. M., special classical concert by Rex Battle's orchestra, 8:30 P. M., La Presse studio concert, 10:30 P. M., dance program by Joseph C. Smith and his Mount Royal Hotel orchestra.

WFAA, Dallas, Tex., 476m (630k), C. S. T.—1:30 P. M., address, DeWitt McMurray editor The Semi Weekly Farm News in a melody of humor, pathos and wisdom, 8:30 P. M., Miss Lucile Lechner and assisting entertainers, 11:12 P. M., musicians from the Melba Theatre.

WMC, Memphis, Tenn., 500m (600k), C. S. T.—8:30 P. M., program by Jules Gargaro and company of local artists, 11 P. M., midnight frolic by Hines' Tennesseans from the Steiner Princess.

WHAS, Louisville, Ky., 400m (750k), C. S. T.—4:50 P. M., local livestock, produce and grain market reports, 4:55 P. M., baseball scores, 5 P. M., Central Standard time, 7:30 P. M. concert by the Manning Hawaiian and Jug orchestra; Clarence F. Manning steel guitar; J. W. Manning, guitar; V. E. Manning, jug; Mrs. V. E. Manning, ukulele; an interesting historical episode; late important news bulletins; baseball scores; Central Standard time.

WGY, Schenectady, N. Y., 380m (790k), E. S. T.—1 P. M., music and address "Selecting Gifts for the Summer Bride," Fleeta H. Mitson, 5 P. M., produce and stock market quotations; news bulletins; baseball results, 6 P. M., dinner music by Joseph A. Chickene and his Clover Club orchestra, 7:40 P. M., baseball scores, 7:45 P. M., travelogue "A Polar Cruise," by Dr Sigel Roush, WGY orchestra.

KGO, Oakland, Cal., 312m (960), P. T.—4 to 5:30 P. M. concert orchestra of Hotel St. Francis, 6:45 P. M., stock exchange and weather reports, and news items, 8 P. M., Neapolitaine Four one-act comedy, "The Florist Shop"; Merle Floyd, dramatic soprano; Edwin Heinsobhn, baritone, Part II, Etude Musical Club of Oakland; Etude Club Chorus; Vocal Trio, 10 P. M. to 1 A. M., Hotel St. Francis dance orchestra.

KFI, San Francisco, 469m (640k), P. T.—5 P. M., Evening Herald news bulletins, 5:30 P. M., Examiner news bulletins, 6:45 P. M., Dorice Gordon—vocal and instrumental concert, 8 P. M., Am-

(Concluded on page 25)

## Who Is America's Most Popular Radio Entertainer?

Everybody is interested in this query: Who is America's most popular radio entertainer? You have your favorite. Who is she or he? Let us know your choice, whether a comedian, an opera singer, a jazz band, or a story-teller.

RADIO WORLD wants to be able to tell the world the name of the entertainer who stands highest in the regard of listeners-in.

Use the accompanying blank and mail to Broadcasting Manager, RADIO WORLD, Cut off. Fill out. Mail today.

BROADCASTING MANAGER, RADIO WORLD, 1493 Broadway, New York City.

Dear Sir:

My favorite entertainer is.....Station.....  
 Name.....  
 Street Address.....  
 City and State.....

Yearly subscribers for RADIO WORLD may, when sending in their \$6.00 for a yearly subscription, vote the entire fifty-two issues in advance for their favorite entertainer, when they so designate their desire to do so. In the June 7 issue there was published a tally showing H. M. Snodgrass, of WOS, Jefferson City, Mo., leading. Another tally will be made and published in an early issue.

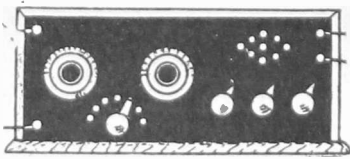

# The RADIO PRIMER

Information and Instruction  
for the Beginner

## The Journey of a Broadcast Signal

EXPLAINING WHAT MAKES YOUR SET WORK

By Neal Fitzalan

Consulting Engineer

CONSIDERING the explanation of what makes it possible to hear the radio waves, a subject broached in RADIO WORLD recently, Fig. 1 illustrates a broadcasting station, showing the studio and aerial wires on the towers. The small

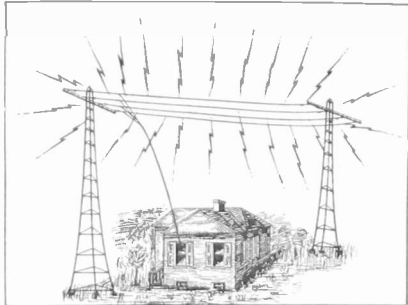

FIG. 1—The waves we do not see are shown by the flashes emanating from the radio antenna. These waves spread in all directions, down into the earth and up into space and to all points of the compass simultaneously. This is proven by broadcast signals being received at the bottom of mines and in airplanes at great distances from the transmitting station.

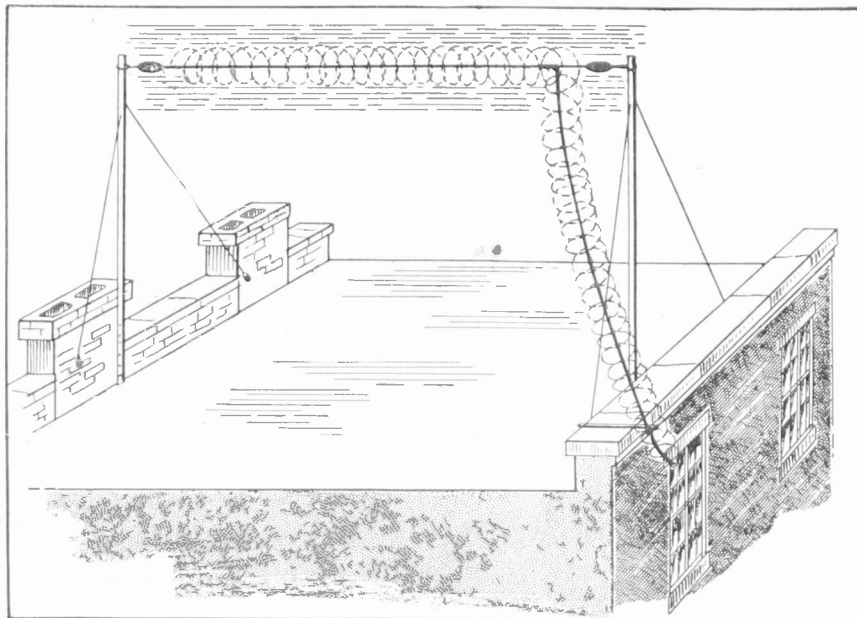

FIG. 2—The radio waves, represented by the straight lines surrounding the antenna, are absorbed, as shown by the whorls, around the wire itself. The lead-in also acts as a collector, as does all the wire in the complete circuit, including the coils in the set. The exposed wires, however, come in more direct contact with the passing wave, thereby being able to draw the maximum amount of energy from it. All stray noises such as static and power circuit leaks are absorbed at the same time as the signals themselves.

electrical flashes illustrate the radio waves emanating from the wires in all directions. There are very few broadcasting stations situated so free from surrounding objects, such as trees, hills, or which, when located in a city, are away from tall buildings or steel structures. Buildings situated close to broadcasting stations often have very detrimental effects on the waves sent out by the antenna. The steel in the framework of the buildings absorbs a great deal of the energy and as a result blocks the signal from getting out well.

This is very noticeable in almost every New York station. WEAJ, located near the Hudson River, atop a 25-story building, reaches out excellently in all directions outside of Greater New York. There is a section, however, centering on Central Park, New York City, where signals from this station are very weak. The map shows that between this dead spot and WEAJ there are located the greatest number of buildings in a direct line than from any other station. Further on in this same direction, past Central Park, WEAJ signals become stronger and stronger, because the signals which pass over this interference are clear to continue on their way to be intercepted by the proper receiving antennae. This same effect is noticed where signals must pass a mountain range or forest, which again acts as an obstacle to radio waves, which are absorbed in the ground through the trees and mineral deposits in the mountains.

Besides this interference there are some natural "dead spots" located in fortunately few places throughout the land. The United States Bureau of Standards as yet is unable to furnish complete data and information on this subject.

Fig. 2 illustrates a common type of receiving antenna, a number of which can

be seen on one apartment house roof. The straight lines designate the passing radio wave, while the circular whorls indicate what part of the energy is absorbed from the air. While acting as a collector for the radio waves, the antenna will also pick up all the stray electrical noises which pass, such as car line motor and trolley sparks, static and high-power generators. Contrary to what might be expected, the hundreds of different wireless signals travelling simultaneously through the air do not bump into one another

## Beginners' Dictionary

**DETECTOR**—The agency, either tube or crystal, for changing the high-frequency (inaudible) electrical currents to those of low frequency (audible). This is called rectification.

or get all tangled up, although no two come from the same direction. The reason is that each wave is on a different wave frequency than the other. No matter how minute that difference is, they will pass each other by and go on to their particular destiny. Should two waves be on exactly the same wave, the receiving set will hear both combined, yet they still will not break each other up.

Where there are many antennae erected on one roof a noticeable decrease on signal strength will be apparent in each receiver, as compared with a receiving set using a lone aerial on a roof. This decrease is caused by the multiplicity of wires, each going to a different set, each wire absorbing as much energy from the air as it can. This would naturally tend to decrease the fund of energy available over one roof. It is remarkable, however, that this phenomenon is apparent mostly when several of the sets in one house are tuned to the same station. This again proves that each radio wave goes its way through the ether "minding its own business." This phenomenon also accounts for lightning discharges not striking a house with an antenna on it. Although the receiving set may be tuned to a certain wavelength, natural electrical disturbances, which have no definite wavelength at all, travel down the antenna to the ground together with the tuned signal.

Fig. 3 is a schematic diagram of how the signal travels down the antenna, through the coils, to the crystal (or tube) where it is rectified, and through the earphones, where it is at last heard. The arrows theoretically show how the inaudible high frequency current comes down the antenna, goes into tuning coil to the ground, and back to the antenna. The arrows also show the current going as far as the detector, where half of it, which flows from the antenna, is allowed to pass, and the other half rejected and returned to the antenna. Should the entire current be allowed to reach the phones, which would happen if there was no crystal obstructing the way, no sound would be heard because the current is of such a high frequency as to be inaudible to the human ear. The crystal, however, chops this direct current in half, causing a pulsating direct current to flow through the earphone circuit. This kind of a current affects the magnets of the phones, causing them alternately to pull and release the diaphragms. When the diaphragm moves, we hear the signal. Thus we have followed the broadcast signal from its source, accompanying it on its trying journey over mountain and housetop to its final destiny in the diaphragm of the earphones.

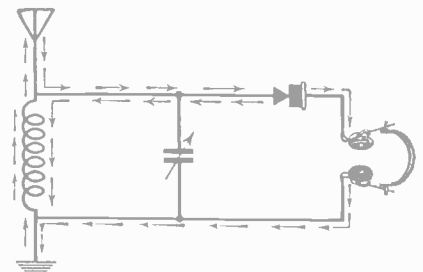

FIG. 3—The arrows show theoretically the journey of the signal in its passage down the antenna, through the detector and into the earphones.



# MAGNAVOX

## The Reproducer Supreme with a Human Throat

The marvelous semi-dynamic mechanism of M4 shown in sectional view at right.

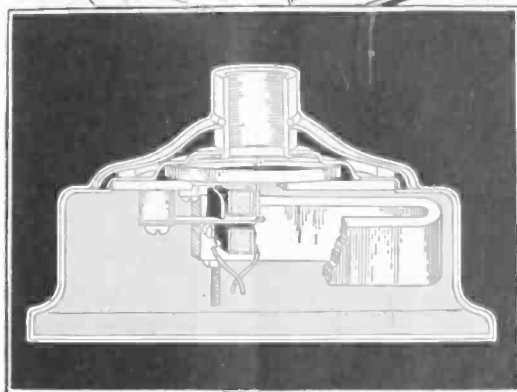

**B**ETWEEN Magnavox and ordinary "loud speakers" there are certain essential differences hidden away in the base of the instrument, insuring for Magnavox utmost clearness of tone.

The quality of radio speech or music is largely determined *before* the sound enters the horn—which makes it so important to select a Reproducer on account of its scientific construction, not merely its outward appearance.

Among instruments operated without a battery, nothing compares with the clear, sweet tone, always true in pitch, produced by the new Magnavox M4.

With the R3 and R2 Reproducers the user secures the advantage of perfect *volume control*—an exclusive feature which greatly increases the enjoyment of radio reception.

The strongest guarantee of mechanical excellence is the Magnavox trade mark—always look for it.

### Reproducers

M4—the latest Magnavox achievement: requires no battery . . . . . \$25.00

- M1—also constructed on the semi-dynamic principle, requiring no battery . . . . . \$30.00
- R3—famous electro-dynamic type: new model with Volume Control . . . . . \$35.00
- R2—same as R3 but larger size: new model with Volume Control . . . . . \$50.00

### Combination Sets

A1-R and A2-R—the only instruments combining electro-dynamic Reproducer and Power Amplifier in one unit . . . . . \$59.00, \$85.00

### Power Amplifiers

A1, AC-2-C, AC-3-C—the most efficient audio-frequency Amplifiers: one, two and three stage \$27.50 to \$60.00

To obtain the fullest enjoyment from your receiving set, equip it with the Magnavox— for sale at good dealers everywhere.

**THE MAGNAVOX COMPANY**  
OAKLAND, CALIFORNIA

New York Office: 350 West 31st Street

Canadian Distributors:  
Perkins Electric Limited, Toronto, Montreal, Winnipeg



M4



R3

## MR. D. X. HOUND

Radio World's Own Artist Creates An  
Enjoyable Character

By HAL SINCLAIR



## The Radio Trade

Rova Incorporates for  
\$15,000,000 as Radio  
Manufacturing Firm

DOVER, DEL.

**R**OVA Radio Corporation, Wilmington, was granted a charter to manufacture, capitalization being \$15,000,000. The Corporation Trust Company of America acted for the incorporators.

Coincident with the receipt of the above dispatch, the fact was made public in New York City that Rova Radio Stores Corporation was incorporated to act as the holding and operating concern for the Rova chain stores and wholesale and jobbing departments. Stores are located in New York City and Newark, N. J. The capitalization consists of 150,000 shares (there is no preferred stock), 40,000 certificates of trust being offered to the public at \$9.25. All told there are 75,000 certificates of the total 150,000. The trust agreement expires May 27, 1929.

It was noted that the Delaware charter was for manufacturing, while the other was a "Stores" corporation, whose prospectus emphasized the liquid nature of the assets, due to absence of any manufacturing. Thus it was assumed manufacture of the reflex and portable sets Rova is making would be undertaken on a large scale.

The prospectus for the stores corporation, issued by Carden, Green & Co., investment brokers, sets forth:

"The books of the consolidated companies have been audited by Messrs. Marwick, Mitchell & Company. Their examination, according to the books of the consolidated companies, revealed earnings for the three months ended March 31st, 1924, in excess of \$50,000. A further test examination made by this firm of accountants of the accounts of one retail store, for the period from April 1st to May 3, 1924, disclosed a recorded profit of \$3,170.82. The sales of this store during this period represented approximately one-fifth of the sales from the eight retail stores comprising the organization, but does not include sales of the wholesale department. The total sales by the consolidated companies for the three months ended March 31, 1924, were \$467,267.39.

"Earnings of the consolidated companies for the first quarter of 1924 ended March 31st, approximately 30 per cent on \$9.25 the offering price of Rova Radio Stores Corporation shares, should be greatly

augmented by economies of operation through consolidated control."

## Literature Wanted

**I**F you want radio literature from dealers, jobbers and manufacturers, send your name and address to Service Editor, **RADIO WORLD**, 1493 Broadway, New York City.

Charles Zirkel 539 Liberty Ave., Brooklyn, N. Y.  
Fuller Nance, 522 Rossiter Ave., Baltimore.  
Memphis Radio Exchange, dealers, 78 South Main St., Memphis, Tenn.  
Harold Andrews, R.F.D. No. 2, Box 234, Wheeling, W. Va.  
Vincent J. Doyle, 1423 N. Robinson St., Philadelphia.  
W. Willis, 153 Brighton Ave., Boston.  
Frank Baker, Box 95, Whitesboro, Tex.  
C. L. Hopkins, 406 E. Second Ave., Roselle, N. J.  
W. Abeles, dealer, 1198 Third Ave., New York City.  
E. J. Tarrell, Box 642, Wolf Point, Mont.  
Gene Sly, Belle Fourche, S. D.  
Faith Jewelry Co., dealers, Faith, S. D.  
Palmer & Gibson, dealers, Box 336A, Farmington, New Mex.  
Sun Recharger Mfg. Co., dealers, 4344 Cottage Grove Ave., Chicago.

"ROLLS ROYCE"  
RADIO TUBES

Like their name, significant of quality, durable and powerful. Bring in distance with a maximum of volume and clearness.

Type 200—5 volts, 1 ampere Detector Tube

Type 201A—5 volts, .25 ampere Amplifier and Detector

Type 199—3-4 volts, .06 ampere Amplifier and Detector

Type 198—3-4 volts, .06 ampere With Standard Base—Amplifier and Detector

Type 12—1 1/2 volts, .25 ampere Platinum Filament—Amplifier and Detector

"The Rolls Royce of Radio Tubes"

ALL TYPES

Type 202 Five (5) Watt Transmitter, \$3.00

EVERY TUBE GUARANTEED

to work in Radio Frequency. Especially adapted for Neutrodyne, Reflex and Super Heterodyne Sets.

Shipped Parcel Post C. O. D.

When ordering mention type.

Rolls Royce Tube Co.

71 Norward St. Dept. W Newark, N. J.

\$2.50

## New Corporations

Tested Radio Products, New York City, \$10,000; B. A. Allen, E. B. Ingraham, C. H. Hickock, Attorney, O. Powell, 220 Broadway.

Presto Radio Corp., Brooklyn, N. Y., \$250,000; R. W. Miller, J. Sarge, C. Bergman, Attorney, J. Aronson, Grand Central Terminal, New York City.

Armley Radio Corp., New York City, 2,500 shares common stock, no par value; G. Hall, A. D. Mar, H. Barstow, Attorney, L. Bereson, 27 William St.

Lego Corporation, New York City, radio parts, \$5,000. L. E. Gross, J. Lamtel, E. G. Osterman, Attorney, I. E. Felix 217 Broadway.

Niagara Radio Stores, Niagara Falls, N. Y., 250 shares preferred stock, \$100 each; 1,000 common no par value; A. and F. L. Mesersmith, R. D. Pfohl, Attorneys, Nicholson & Knowles.

Livingston Battery Corp., Queens, N. Y., \$5,000; J. M. and A. Livingston, Attorney, H. H. Livingston, Rockaway Park, N. Y.

Hodges & Sons Electric Corp., \$10,000; W. H. Hodges, Mary Hodges, George R. Hodges, Boswell, Pa. By Delaware Registration Trust Co.

## RECEIVERS APPOINTED

Phonofax Products, Inc., New York City, manufacturers of loud speakers, 705 Whitlock Ave. Clifford McChryste appointed, under \$5,000 bond. Liabilities, about \$20,000; assets, about \$10,000.

## JUDGMENTS

Against Triangle Radio Supply Co., Inc., by Deforest Radio Tel. and Tel. Co., \$4,268.25.

## CAPITAL INCREASES

Haynes-Griffin Radio Service, New York City, 1,000 shares common stock, no par value, to 1,000 common, \$100 each.

Ware Radio Corp., New York City, 7,500 shares common stock, no par value to 75,000 no par value, 3,000 preferred same as heretofore.

## Coming Events

**JULY 7 TO 12**—Radio show, Bangor, Me., auspices R. C. A.

**JULY 21 TO 26**—Radio show, Burlington, Vt., auspices R. C. A.

**AUG. 16-21**—Radio Exposition, San Francisco, conducted by Pacific Radio Trade Association.

**SEPT. 22-28**—First Annual International Radio Show, Madison Square Garden, New York City.

**OCT. 2-11**—Exposition, Grand Central Palace, New York City, under auspices of American Radio Exposition Co.

**NOV. 3-8**—Third Annual National Radio Show, Grand Central Palace. S. L. Rothafel (Roxy) and "his gang" will broadcast from the convention.

## SOMETHING NEW

Green Radio Applause Cards

Bound in Book Form

with stubs on which records of Radio Artist are kept after card is detached and sent, a Log Book and Card combined, all for 1c. 25 CARDS 25c.

Sent by mail postpaid. No stamps. Address

PLATTSBURGH RADIO SUPPLY CO.

PLATTSBURGH, N. Y.

DEALERS: Write for sample and terms.

Business Opportunities  
Radio and Electrical

Rates: 40c a line; Minimum 3 lines.

BUSINESS OPPORTUNITIES

**GOOD GOING BATTERY BUSINESS**, best section of city. Apply 351 Amsterdam Ave., N. Y. C.

**ESTABLISHED IMPORTER** of electrical goods would admit partner, \$5,000 to \$10,000; unfilled orders on hand. G. B., Room 5734, Grand Central Terminal Building, N. Y. C.

**RADIOPHONE** manufacturer desires exclusive representation, commission basis. Eastern, 53 West Grand, Elizabeth, N. J.

# Photos to Be Loud Speaker Without a Radiocast, Paris to N. Y. Horn Is Invented

PARIS. EDUARD BELIN, inventor of a way to transmit photographs by radio, sent via the ether a picture of Gen. Gustave A. Fernie from a few miles outside of Paris to the office of the "Matin." A second picture proved better in results than its predecessor.

M. Belin is filled with confidence that he can send wireless pictures across the Atlantic, and an attempt at such transmission between Paris and New York is to be made within a few weeks by him in co-operation with the "Matin."

## Dealer Convicted of Crime of Operating Speaker

ATTORNEY PAUL JOACHIM of Brooklyn, N. Y., is seeking an appeal from a decision of Magistrate Lawrence Gresser of Jamaica, Queens County, which fixes the curfew hour for radio loud speakers at 9 p. m.

Augustus Estu, who operates a radio supplies shop at 401A Jamaica Ave., Woodhaven, was found guilty of disorderly conduct by the magistrate because neighbors objected to the loud speaker he operates from his store to attract trade. Many residents of the neighborhood had complained of the noise of the instrument. The magistrate in suspending sentence after finding Estu guilty, declared that he believed Estu had not purposely disturbed the neighborhood, but ordered that the instrument be discontinued after 9 o'clock.

### NEWS NUGGETS

IN A SHORT acceptance speech after receiving the Radio Cup, an annual award of the Executive Radio Council, Second District, given to the radio amateur whose experimental work during the year most benefits him for the honor, John L. Reinhart declared that he had turned over to the Navy Department his entire developments on a radio transmitter functioning on 10 meters. He further declared that his system could be adapted to any amateur station operating today, within less than ten minutes. \* \* \*

LONDON.

USING for the first time telephonically the radio beam system through which the wireless waves are thrown in a particular direction, William Marconi, inventor of the wireless, is reported to have spoken from the Poldhu station in Cornwall to Buenos Aires. The accounts stated also that Dr. Thomas Breton, Argentine Minister of Agriculture, who is visiting in England, spoke to War Minister Justo, and that subsequent cable messages from Buenos Aires said Dr. Breton's voice had been heard there. \* \* \*

THE TEST conducted by the Westinghouse Electric & Mfg. Co. from WBZ, their Springfield, Mass., station, with the Gordon Bennett balloon racers in Europe was successful. A cablegram received from Pilot Van Orden of the racing balloon Goodyear III, which was sent from Amsterdam, Holland, reads: "Heard call letters 2:37 Monday morning.—Van Orden." None of the balloons in the race was equipped with transmitting apparatus, so the attempts to reach them were necessarily confined to sending messages.

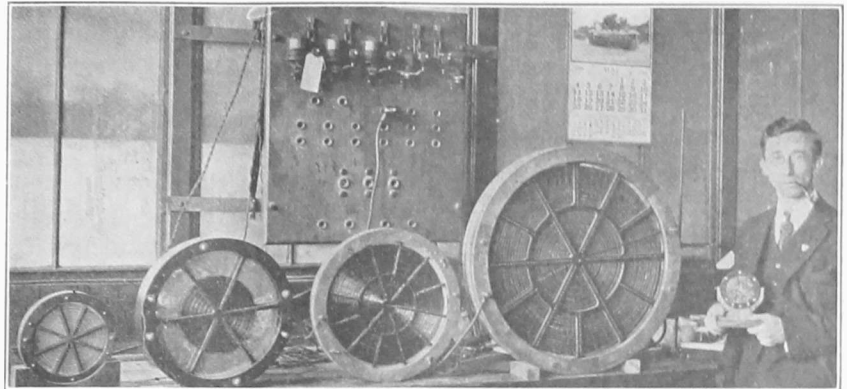

NO HORN is required in this loud speaker, known as the induction type. It can be heard outdoors 500 feet away. Dr. C. W. Hewlett, the inventor, is shown with his "brain child."

AUTOMOBILE tourists who visit the camping ground at Schenectady this summer will be furnished radio entertainment by the municipality. A giant, hornless loud speaker that emits signals equally from both sides has been installed near the camp ground. Listeners within 500 feet of the apparatus may enjoy music and speech of great volume and free from distortion. It is known as an induction loud speaker and was developed in the Research Laboratory of the General Electric Company.

The induction loud speaker is different from the household variety using a horn. Dr. C. W. Hewlett, physicist, is the inventor. The speech amplifier has been made in many different sizes, but the type used to entertain tourists and residents of Schenectady measures forty-two inches in diameter. The working diameter of the diaphragm is thirty-six inches. The device consists essentially of two large flat coils of wire mounted close to each other in a frame which holds a thin aluminum diaphragm between the coils. These coils

carry direct current which produces a radial field in the space occupied by the diaphragm and these same coils carry the amplified voice currents and induce in the diaphragm corresponding currents which, by their interaction with the radial magnetic field, cause the diaphragm to vibrate and give off sound waves. The features of the new amplifier are: It has no iron in it and does not depend on permanent magnets; no horn is necessary; sound is thrown out equally from both sides.

The diaphragm is acted on at all points of its surface so that it vibrates as a whole rather than being allowed to break up in partial vibrations.

The voltage amplifier consists of two stages of 201A Plotrons and one 210 Plotron coupled in cascade by resistance and capacity. The power amplifier consists of a one kilowatt low impedance Plotron. The plate current for all these tubes is supplied by a 2,000-volt, full-wave kenetron rectifier which is operated from the alternating current lighting mains.

## FOR VACATION — FOR ALL SUMMER

JULY FOURTH LABOR DAY EVERY DAY

### S-U-P-E-R-D-Y-N-E

The Circuit Featured by RADIO WORLD

The most satisfactory radio circuit yet developed. Any locality, all conditions. Equal in all respects to five tube Neutrodyne, but more simple to tune and no critical adjustments.

Local and Long Distance With or Without Aerial  
With or Without Ground—Maximum Volume—Perfect Reproduction

Our engineers have developed the coils for this circuit to its highest perfection. Coils for Superdyne (complete with diagram)..... \$6.50  
(Note—These coils have been developed by and are distributed solely through us, and should not be confused with inferior coils.)

Kits consisting of two Flewelling Condensers and complete set of coils (with diagram)..... \$19.50

Complete parts assembled on engraved Radion Panel, and base panel with necessary bus bar ready to wire (diagram and plan furnished) at ..... \$65.00

Contrary to usual practice, all parts included in this kit are the very best quality on the market, and workmanship first class.

### RESULTS GUARANTEED

Vacation Supplies of the highest quality on short notice  
Flewelling Condensers in Stock. Mail orders solicited

WALLACE RADIO COMPANY, Inc.

135 LIBERTY STREET,

NEW YORK

## Hoover Considers New Plans for Remedying Overcrowding of Air

BROADCASTING stations are on the increase. There were 577 stations licensed to broadcast, as of May 1, compared to the peak of 591 last May. Deletions in the past few days have cut down the total. New stations are still coming in, 27 having been added during April, 1924, while 19 dropped out of the aerial entertaining profession. The gain in January was 7; February, 14, and March 20. The distribution on May 1 was as fol-

lows: Class A, 371; Class B, 52; Class C, 152, and Class D, development stations, 2. Wave lengths from Class B stations are exhausted, as are practically all the wave lengths allocated for Class A stations.

Secretary Hoover probably will ask for a re-allocation of the eighty wave lengths now allotted to broadcasters, with a view to redistributing them in a better manner, if one can be found at the forthcoming conference. Instead of distributing them on the basis of frequencies, with a waste space between the wave lengths assigned, it is possible that a new method may be devised, which, it is said, would make a dozen more wave lengths available.

Another plan would be to eliminate the 152 Class C stations, which have been permitted to continue on the original 360 meter wave, or transfer them to A or B stations, and make that wave length available for general use in the several zones.

Reviving interest in the building of high powered and high class broadcasting stations has entirely exhausted the available wave lengths between 303 and 546 meters. It is impossible to give new B stations exclusive waves, and as a consequence, wave lengths now in use may be shared by neighboring stations. Operating time must be divided, as is done in Washington by WRC and WCAP, which broadcast on alternate nights.

There are 52 Class B stations operating with 500 watts or more power, and broadcasting high-class entertainment and features, but applications for almost a dozen similar stations are on file in the department. Prospective broadcasters, who hope to get Class B licenses, are warned that they will have to operate part time

and share wave lengths already assigned to one or more stations, as is the practice with Class A stations, the department points out.

### COSMOPOLITAN PHUSIFORMER

"The Missing Link in Radio"

15-17 WEST 18th ST. NEW YORK

### RADIO MAP FREE

Big Broadcasting Station List.

Also Radio Bargain List. Just Out.

The RADIO SHACK

America's Largest Radio Dealers  
Dept. RW. 7-5  
55 Vesey St. New York

### THEY'RE SHOT!

That's the common expression when using dry "B" batteries. Purchase the economy way. Put together a "Hawley" rechargeable "B" storage battery at dry cell prices. These are put up in various size units by the oldest and largest pioneer dealer in this line and consist of everything for the actual construction of battery with the highest quality material such as special flat bottom glass cells, rubber stoppers, etc., together with large size Edison elements. Sold on an unconditional guarantee of greater volume, clearness and satisfaction or your money refunded with no ifs nor ands. An 8-page illustrated folder of instructions showing simple putting together, making of charger and charging free with all orders. Complete units as follows: 22 volt, \$2.95; 45-volt, \$5.75; 90-volt, \$8.95; 100-volt, \$9.95; 135-volt, \$12.75; 200-volt, \$17.90. Complete sample cell \$5c prepaid. Wanted dealers to write. "A" batteries at special price. Order direct or write for my literature and 30-day trial offer and guarantee. Orders shipped same day received. B. W. SMITH, DANBURY, CONN.

Write for a copy today



A new twenty-four page booklet will be sent, gratis, to those interested in building their own receiving sets.

A simplified method of construction is described. Illustrations and diagrams.

On Request

EISEMANN MAGNETO CORPN.  
William N. Shaw President  
Dept. L  
165 BROADWAY, NEW YORK

### Navy Eliminating Use of Spark Sets

RECENT advances in radio communication in the Navy include the gradual elimination of spark sets and the substitution of tube transmitting sets, until the sparks have been almost eliminated. The employment of multiplex radio operation, and the application of automatic recorders in the reception of radio press reports are other advances effected recently.

In submarine communication the increase alone, due to new installations, is from 10 to 100 miles, with the spark sets, and between 200 to 600 miles with the tube sets.

Radio equipment for capital ships will eventually include separate receiving rooms on flagships, aircraft carriers, and battleships so that they may operate in duplex.

Reports from the fleet indicate that the copying of press reports with an automatic recorder has met with success and may lead to the reduction of the number of operators necessary to man the many circuits aboard naval vessels.

### Full List of Broadcasting Stations

in the United States, including Call Letters, Wave Length and Kilocycles, appeared in RADIO WORLD dated May 17. 15c per copy or start your subscription with that number. RADIO WORLD, 1493 Broadway, New York City

### PRE-AMPLIFIER

A Radio Frequency Amplifier of TREMENDOUS POWER

Gets distance, volume, less static. Attachable to any receiving set. Price complete with tube, \$25.00.

Send for Circular

S. A. TWITCHELL

1930 Western Avenue Minneapolis, Minn.

The Ultimate Radio Receiver

### THE FLEX-O-DYNE CO.

1674 Broadway (At 52nd St.)  
New York, N. Y.

Circle 4569

### RADIO RECORD

Keep a permanently bound record of all stations you have received and how you received them. Radio Record 5 1/2" x 14"—600 lines. All broadcasting stations listed, and indexed with space for new stations—\$1.00 Postpaid.

THE BEADLE PRINTING CO.  
MITCHELL SOUTH DAKOTA  
Applause Cards 60 for \$1.00 Postpaid.

### COAST TO COAST

Every Turn STAR No  
A Tap COIL Soldering  
SEND FOR LITERATURE  
STAR RADIO PRODUCTS CO.  
711 S. DEARBORN ST. CHICAGO, ILL.

### ACH SHARP TUNER

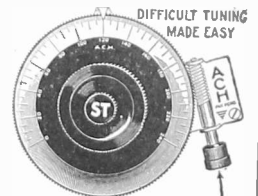

Mail Orders Prepaid Why the A.C.H. is different  
3 in. DIAL \$2.50 (150-10-1)  
4 in. DIAL \$5.00 (215-10-1)  
5/16 REC. 1/4-3/16 BUSHINGS \$3 EACH

Send for Circular D

A. C. Hayden Radio & Research Co.  
Brockton, Mass., U. S. A.



### WE REPAIR RADIO TUBES

WD-11 ... \$2.50	DV-2 ... \$2.50
WD-12 ... 2.50	DV-6A ... 2.50
UV-200 ... 2.50	UV-199 ... 2.50
UV-201 ... 2.50	C-299 ... 2.50
C-300 ... 2.50	UV-201A ... 2.50
C-301 ... 2.50	C-301A ... 2.50
DV-6 ... 2.50	Maroon ... 2.50
DV-1 ... 2.50	Moorhead ... 2.50
6 v. Plain Detector ... 2.50	
6 v. Plain Amplifier ... 2.50	

Mail orders solicited and promptly attended to.

Dealers and agents write for special discounts.

H. & H. RADIO CO.

P. O. Box 22-B

Clinton-Hill Station

Newark, N. J.



# Programs

Tuesday, July 8

(Continued from page 19)

basador Coconut Grove orchestra. 9 P. M., Examiner concert. 10 P. M., Don Meany arranging concert.

**KGW, Portland, Ore., 492m (610k), P. T.—11:30 A. M.**, weather forecast; 3:30 P. M., children's program. 7:15 P. M., police reports. 7:30 P. M., baseball scores, weather forecast and market reports. 8 P. M., concert provided by Seiberling-Lucas Music Co.

**WCAE, Pittsburgh, 462m (650k), E. S. D. S. T.—3:30 P. M.**, baseball scores. 4:30 P. M., stock market reports; The Sunshine Girl. 6:30 P. M., dinner concert from William Penn Hotel. 7:30 P. M., Uncle Kaybee. 7:45 P. M., baseball scores. 9:30 P. M., musical program by Nevin Trio and co-operating vocalists.

**KPO, San Francisco, 423m (710k), P. T.—2:30 P. M.**, organ recital by Theodore J. Irwin. 4:30 P. M., Rudy Seiger's Fairmont Hotel orchestra.

5:30 P. M., children's hour stories by "Big Brother." 7 P. M., Rudy Seiger's Fairmont Hotel orchestra. 8 P. M., program of American music in honor of the British Fleet. 10 P. M., E. Max Bradfield's versatile band.

Wednesday, July 9

**WWJ, Detroit, 517m (580k), E. S. T.—10:25 A. M.**, weather forecast. 11:55 A. M., Arlington time. 12 Noon, Detroit News orchestra. 3 P. M., concert by Schmemman's Concert band. 3:50 P. M., weather forecast. 3:55 P. M., market reports and baseball scores. 5 P. M., baseball scores. 7 P. M., Detroit News orchestra. 7:30 P. M., concert by Schmemman's concert band.

**CKAC, Montreal, 425m (710k), E. S. D. S. T.—1:45 P. M.**, Mount Royal Hotel luncheon concert. 4 P. M., weather, stock, news, music.

**WFAA, Dallas, Tex., 476m (630k), C. S. T.—12:30 P. M.**, musical program by the Jackrabbits orchestra.

**WHAS, Louisville, Ky., 400m (750k), C. S. T.—4:50 P. M.**, local livestock produce and grain market reports. 4:55 P. M., baseball scores. 5 P. M., Central Standard time. 7:30 P. M., concert direction of Mrs. J. E. Harmon, Jr., of New Albany, Ind.; late important news bulletins; baseball scores; Central Standard time.

**WGY, Schenectady, N. Y., 380m (790k), E. S. T.—11:30 A. M.**, stock market report. 11:40 A. M., produce market report. 11:45 A. M., weather report. 11:55 A. M., time signals. 5 P. M., produce and stock market quotations; news bulletins; baseball results. 5:30 P. M., Adventure Story.

**KGO, Oakland, Cal., 312m (960k), P. T.—3 P. M.**, short musical program; address, "Responsibilities of the Press," by James E. Wales. 4 P. M., concert orchestra of the Hotel St. Francis. 6:45 P. M., stock exchange and weather reports, and news items.

**KFI, San Francisco, 469m (640k), P. T.—5 P. M.**, Evening Herald news bulletins. 5:30 P. M., Examiner news bulletins. 6:45 P. M., Nick Harris detective stories and concert. 8 P. M., Evening Herald concert. 9 P. M., Examiner concert. 10 P. M., Hollywoodland orchestra. 11 P. M., Ambassador Coconut Grove orchestra.

**KGW, Portland, Ore., 492m (610k), P. T.—11:30 A. M.**, weather forecast. 3:30 P. M., talk by Jeanette P. Cramer, home economics editor of The Oregonian. 7:15 P. M., police reports. 7:30 P. M., baseball scores, weather forecast and market reports. 8 P. M., concert. 10 P. M., dance music by George Olsen's Metropolitan orchestra of the Hotel Portland; solos by Rayberta and Margory Reed, juvenile artists.

**WCAE, Pittsburgh, 462m (650k), E. S. D. S. T.—3 P. M.**, piano recital by Fred Rosenfield. 3:30 P. M., baseball scores. 4:30 P. M., stock market reports, Uncle Kaybee. 6:30 P. M., dinner concert from William Penn Hotel. 7:30 P. M., The Sunshine Girl. 7:45 P. M., baseball scores. 9:30 P. M., musical program by J. V. Krabec's Bohemian orchestra.

## MAHOGANITE and BLACK RADIAN PANELS

DIALS, KNOBS, TUBING, SOCKETS MAHOGANITE BINDING POSTS

"THAT SPECIAL SIZE" FOR YOUR PHONOGRAPH, PORTABLE OR SUPER

ALL STOCK SIZES WHOLESALE RETAIL

Send for Complete Price List  
New York Hard Rubber Turning Co.  
212 Centre Street New York City

## NEUTRODYNE PARTS

Full set of Neutroformers, Variable Condensers with dials, and Neutrodons \$13.25

Above parts are Genuine Workrite Neutroformers, made under Hazeltine patents.

Complete parts for three tube Neutrodyne tuner, (tubes, batteries, or phones not included), drilled panel, tube sockets, rheostats, fixed condensers, jack, binding posts, wire, spaghetti, and blue prints.

COMPLETE FOR \$19.95

Postage additional on all shipments. Ask for our price list.

Send no money—Order by postcard—Pay the Postman.

RADIO SURPLUS STORES  
HELENA, MONTANA

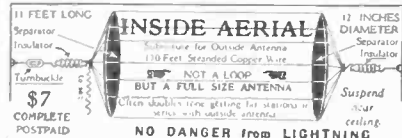

Or \$5, if four set owners' addresses are sent to us. Details about KILLING NOISE IN Radio Sets FREE! INTER-STATE SIGNAL CO., DEPT. 2, COLUMBUS, O.

10c Brings You Our New 48-Page Radio Catalog Includes Thousands of Unequalled Radio Bargains

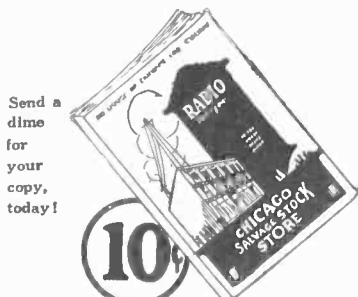

CHICAGO SALVAGE STOCK STORE  
Dept. W6, 500 South State Street  
CHICAGO

Burnt-Out Tubes Replaced for \$2.50



A Wonderful Tube for Your Superdyne.

The Only Tube with a written Replacement Guarantee Against Breakage or Blowout.

Burnt-out, Defective or Broken Tubes of any brand or make whatever will be replaced by a brand new (not refilled) Royaltron Tube, at a cost of only \$2.50.

It is with the Object of Advertising the MERITS of ROYALTRON Tubes, that we make the above unusual offer.

Every ROYALTRON Tube is accompanied by a money-back guarantee.

Approved by the Radio News and World Laboratories

ROYAL MANUFACTURING CO.  
Department W. O.

200 BROADWAY NEW YORK  
Dealers, distributors and agents, write or wire immediately for unusual proposition.

WLW Now Radiocasting on 423-Meter Wave

WLW, the radio station of the Crosley Radio Corporation, is now radiocasting on its new wavelength—423 meters—final plans for the change having been made as a result of a special request made by Powel Crosley, Jr., owner of the station, to officials of the Department of Commerce.

This wavelength is the same as is used by KPO, at Oakland, Cal., but because of the great distance between the two stations and the difference in time, there will be no interference. It also is the same as will be used by WBAV, of Columbus, O., but that station and WLW will divide operating time. Friday night will remain silent night so far as Cincinnati is concerned.

## Super CRYSTAL

NEW NON-METALLIC HOUSING ELIMINATES SCRATCHES AND SQUEALING

Wonderful new crystal—has millions of sensitive spots—long life—cannot short-circuit. FITS ANY STANDARD DETECTOR

At your dealers—otherwise send purchase price and you will be supplied postpaid. Write for Reflex drawing 107.

**50¢**

**Chas. Freshman Co. Inc.**  
Radio Condenser Products  
106 Seventh Avenue, New York City

The "Goode" Two-o-One

A

Le Ton d'argent

Guaranteed



BY MAIL ONLY

\$2.39

Postpaid

QUARTER AMPERE AMPLIFIER-DETECTOR  
**RADIO TUBE**

GUARANTEED SATISFACTORY

All "GOODE" Tubes Sold Direct to the Consumer—No Dealer Profits

ONE—"Goode" Detector-Amplifier ..... \$2.39  
THREE—"Goode" Detector-Amplifiers ..... \$6.42  
(All postage prepaid)

The "Goode" Two-o-One A Tube amplifies or detects. It is a quarter ampere, six volts, standard base silvered tube. Send express or postal money order or New York draft to—

The Goode Tube Corporation  
Incorporated  
EVANSVILLE INDIANA

M. B. SLEEPER RADIO DESIGN & CONSTRUCTION FOR EXPERIMENTERS, REFLEX & RADIO FREQUENCY, \$1.00. The Columbia Print, 1493 Broadway, N. Y. C.

# Farm and City Enjoy the Convention

(Continued from page 7)  
carefully made, loungers bestirred themselves from their vantage points on cozily upholstered divans

to hie themselves, atremble with interest, to the mezzanine floor, or wherever else the loud speaker could be heard. Busy salesmen interrupted their poker games and even elevator operators recklessly adjourned to the room which was

the fascination of all who could hear. On street corners and in parks,  
(Continued on page 30)

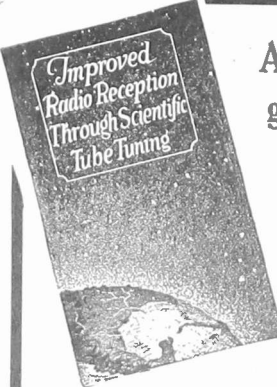

Are you getting DX?

This book will show you how to get more!

It tells all about vacuum tubes and how to control them so as to get greatest D X, most volume and longest life from tubes and batteries. How to get maximum regeneration, clearest signals. Tells how vacuum tubes work.

IT'S FREE! WRITE FOR IT TO  
D X INSTRUMENT CO.  
Dept. RW-721 Harrisburg, Penna.

PETER J. CONSTANT, INC.

91 Seventh Ave. New York City  
Direct Factory  
DISTRIBUTORS FOR  
25 Leading Manufacturers

NEW TUBES

MANUFACTURERS' SALE

Price, \$2.25 each

All Types—All Guaranteed  
Send No Money—Pay Postman

WALTER SCOTT & CO.

636 HIGHLAND AVE., NEWARK, N. J.

Free Sample Solos

for Saxophone—Cornet—Trombone—or Clarinet.  
Name Instrument.  
VIRTUOSO MUSIC SCHOOL, Dept. 26, Concord, Mass.

Record Your Radio Stations  
On RADEX Log Cards to Match Your Set

Copyright 1934  
by S. T. Aston & Son



Telephone  
FRANKLIN 2153

100 Cards, Mahogany Finish or Oak Cabinet, and Index Dividers, Complete, \$3.00. A Useful Accessory to Any Set. Give Name of Your Set or Sketch of Dial Arrangement. Sent Postpaid on Receipt of Cash or Money Order.

S. T. ASTON & SON

114 WORTH STREET NEW YORK CITY

## SUPERDYNE



ORIGINAL GLOBE COILS  
(Single Mounting)

Wound with silk wire on bakelite to correct specifications. C. O. D. Parcel Post .....

\$6.25

Complete 4-Tube Set, K. D. Panels Drilled, Fitted .....

\$35.00

GLOBE RADIO EQUIPMENT

217 W. 125TH ST. NEW YORK CITY

## Cleartone Clear-o-Dyne Model 70

Only a Few Weeks Old—and Fully Approved

Beautiful  
and  
Efficient

\$75.00



4 Tubes  
Selective  
Long  
Range  
Logable

The new Clear-o-Dyne model 70 has been enthusiastically received and heartily approved by hundreds who say that this wonderful receiver performs better than any four tube set ever tested.

The beautifully etched gold finished panels and the distinctive Cleartone solid mahogany cabinets together with the features of selectivity, log-ability and loud speaker volume means a source of education and a real pleasure for all. Send to us for complete circular matter and our special offer.

**DEALERS and JOBBERS:** You will want our line of loud speaker receiving sets, all of which are guaranteed and are of finest material and workmanship. Our interesting proposition will be sent upon receipt of your request for detailed information.

Model 80 Super Clear-o-Dyne.....	\$120.00	Super Clear-o-Dyne Model 182.....	\$190.00
Model 60 .....	60.00	Clear-o-Dyne Model 70.....	75.00
Model 61 .....	75.00	Clear-o-Dyne Model 71.....	90.00
Model 62 .....	120.00	Clear-o-Dyne Model 72.....	135.00

The Cleartone Radio Company : : Cincinnati, Ohio

FILL OUT AND MAIL NOW

SUBSCRIPTION BLANK

# RADIO WORLD

RADIO WORLD

1493 Broadway, New York City

Please send me RADIO WORLD for.....months, for which  
please find enclosed \$.....

**SUBSCRIPTION RATES:**

Single Copy .....	\$ .15
Three Months .....	1.50
Six Months .....	3.00
One Year, 52 Issues.....	6.00

Add \$1.00 a Year to Foreign Postage; 50c for Canadian Post-  
age.



DAVEN  
RESISTO-COUPLER

## Resistance Coupled Amplification

The tone quality from a DAVEN RESISTANCE COUPLED AMPLIFIER is the most perfect known to the radio art.

The Daven Resisto-Coupler, illustrated, greatly simplifies the construction in building up one of these distortionless amplifiers. Sold everywhere .....\$1.50

Read our booklet, "RESISTORS — THEIR APPLICATION TO RADIO RECEPTION," by Zeh Bouck.

Price 15 cents

DAVEN RADIO CORP.

"RESISTOR SPECIALISTS"  
9½ Campbell Street  
Newark, N. J.

# New Schedule for Code Transmission In Frequency Test

THE Bureau of Standards is transmitting special signals of standard frequency on announced dates. The last previously announced schedule was published in May. The next schedule is herewith announced. The signals can be heard and utilized in general east of the Mississippi River.

These special signals of standard frequency are of use to testing laboratories, transmitting station operators, and others in standardizing wavemeters and adjusting transmitting and receiving apparatus. The transmissions on July 7 include the frequencies used by amateurs, those on August 5 ship and point-to-point communication, those on September 5 ship communication, those on September 22 broadcasting. The accuracy of these signals is better than three-tenths of one per cent. Information on how to use them is given in Bureau of Standards Letter Circular No. 92, which may be obtained on application from the Bureau of Standards, Washington, D. C.

All transmissions are by unmodulated continuous-wave telegraphy. A complete frequency transmission includes a "general call," a "standard frequency signal," and "announcements." The "general call" is given at the beginning of the eight-minute period and continues for about two minutes. This includes a statement of the frequency. The "standard frequency signal" is a series of very long dashes with the call letters WWV intervening. This signal continues for about four minutes. The "announcements" are on the same frequency as the "standard frequency signal" just transmitted, and contain a statement of the measured frequency. An announcement of the next frequency to be transmitted is then given. There is then a four-minute interval while the transmitting set is adjusted for the next frequency. The schedule appears in the next column.

THE SCHEDULE:

Frequencies in Kilocycles (Meters in Parentheses)	July			
	7	8	Sept. 22	Sept. 23
11:00 to 11:08 P. M. ...	1363 (220)	125 (240)	300 (1000)	550 (545)
11:12 to 11:20 P. M. ....	1410 (210)	133 (225.4)	315 (952)	650 (461)
11:25 to 11:32 P. M. ...	1500 (200)	143 (2097)	345 (869)	750 (400)
11:36 to 11:44 P. M. ....	1600 (187)	155 (1934)	375 (800)	833 (360)
11:48 to 11:56 P. M. ....	1700 (176)	166.5 (1800)	425 (705)	1000 (300)
12:00 to 12:08 A. M. ....	1800 (167)	205 (1463)	500 (600)	1200 (250)
12:12 to 12:20 A. M. ....	1900 (158)	260 (1153)	600 (500)	1350 (222)
12:24 to 12:32 A. M. ....	2000 (150)	315 (952)	666 (450)	1500 (200)

NEW STATION WILL OPEN IN DENVER IN A FEW MONTHS

WORK has been started on the Denver, Col., broadcasting station of the General Electric Company. In the late fall or early winter a new voice will be on the air. This station will complete the General Electric's nation-girdling system of three stations, the first of which, WGY, opened at Schenectady, N. Y., early in 1922 and the second, KGO, at Oakland, Calif., early in 1924.

## PEIRCE SCHOOL of Business Administration

Two Year Business Administration Course (college-grade) contains as many credit hours of instruction as usual college course of four years. One who takes this course is therefore ready for business two years sooner than one who takes a four year course.

Accounting Course prepares for C. P. A. examinations  
Executive Secretary Course, stenographic Secretary Course  
Pleasant living accommodations, both sexes 40th Year Book, Six weeks' Summer School—June 30 to August 8

PEIRCE SCHOOL OF BUSINESS ADMINISTRATION  
Pine Street, West of Broad Philadelphia



## ULTRADYNE

the Improved Super-Heterodyne. Send 50c for book giving complete details of drilling, assembling, wiring and tuning 8 and 8 tube ULTRADYNE Receivers.

50c

Phenix Radio Corp., 5-9 Beekman St., N. Y. C.

"Can't Lose 'Em"



Bakelite, Engraved, Nickel-plated with Inlay  
Panels Cut, Drilled, Engraved  
Dealers Write for Terms  
CORTLANDT PANEL ENGRAVING CO.  
31 Cortlandt Street New York City

RADIO FACTORY REPRESENTATIVES WANTED BY RADIO WORLD. Represent this live weekly and make money. Address, Circulation Manager, RADIO WORLD, 1493 Broadway, New York City.



Write Today For Descriptive Folder of the

## NEW HOWARD 5-TUBE NEUTRODYNE

This Remarkable Set has Created a Sensation Among Radio Enthusiasts. Beautiful Walnut Cabinet with Special Howard Neutroformers, Tube Sockets and Rheostats.

Licensed by Independent Radio Manufacturers, Inc.  
NEUTRODYNE  
Pat. March 21, 1923 and April 1, 1924  
Machine Pats. Nos. 1,450,080 and 1,485,228  
Other Patents Pending

HOWARD MFG. COMPANY  
4248 No. Western Ave. Chicago, Ill.

# WD-12



Radiotron WD-12 is the dry cell tube with the standard base—can be used in any set equipped with standard sockets.

It is one of the most popular of detector tubes, and gives most satisfactory volume as audio frequency amplifier—operating on a single 1½ volt dry cell.

Price \$5.00

Be sure that every tube you buy is marked RA-DIOTRON.

Radio Corporation of America  
Sales Offices: Dept. 3002  
233 Broadway, New York  
10 So. La Salle Street, Chicago, Ill.  
433 California Street, San Francisco, Cal.

# Radiotrons



## RADOLENE

The "liquid spaghetti." Applied with a brush, forms an insulating coat that looks well and that resists high voltage.

RADOLENE is the only form of insulating covering for wiring and coils that can be applied after the set has been completely built.

Each portion of the circuit can be coated with a different color if desired.

RED, GREEN, GOLD and PURPLE  
Complete Set ..... \$1.00

SEND NO MONEY. Pay postman \$1.00 plus a few pennies postage upon delivery.

J. L. LEWIS, Inc. 132 WEST 32nd STREET NEW YORK CITY

GRAM'S RADIO MAP IN TWO COLORS—Best map on the market, 35c. The Columbia Print, 1493 Broadway, N. Y. C.

# The Weekly Rebus

CAN you decipher this Rebus? Send your answer to Rebus Editor, RADIO WORLD, 1493 Broadway, New York City, and mention Rebus No. 8. The names and addresses of those sending in the correct answer will be published, so be sure to write your full name and address very plainly. A list of the correct answers of Rebus drawings will be published in RADIO WORLD soon after the twelfth Rebus has been printed.



REBUS NO. 8

At that time a list will be compiled of all those who correctly answered all the Rebus puzzles, and their names will be enrolled on the Rebus Honor Roll. The Rebuses previous to No. 7 were published May 17, May 24, May 31, June 7, June 14, June 21 and June 25.

REBUS NO. 5

- Wm. D. Lahn, 861 Dumont Ave., Brooklyn, N. Y.
- Melvin E. Peterkin, 10020 89th Ave., Richmond Hill, N. Y.
- Frank Wessale, Waconia, Minn.
- Allen Brande, 1091 Payne Ave., St. Paul, Minn.
- H. V. Arney, 430 Elm St., Wabash, Ind.

REBUS NO. 6

- Charles H. Zirkel, 539 Liberty Ave., Brooklyn, N. Y.
- Allen Brande, 1091 Payne Ave., St. Paul, Minn.
- D. G. Huyler, 244 William St., New York City
- Miss Betty Rhine, 623 West 20th St., New York City.
- Edwin Blalock, Box 315, Montgomery, Ala.
- Alader Nazy, 772 Ninth Ave., New York City.
- Joseph Mirabello, 1856 Benson Ave., Brooklyn, N. Y.
- Wm. D. Lahn, 861 Dumont Ave., Brooklyn, N. Y.
- G. C. Duncan, 1001 Praetorian Bldg., Dallas, Tex.

## 750 Physicians Hear One Patient's Heartbeats

CHICAGO  
SEVEN HUNDRED AND FIFTY stethoscopes, connected by radio, enabled as many physicians to study the heartbeats of one patient while the American Medical Association convention was in session here.

For Maximum Amplification Without Distortion and Tube Noises use the well known  
**Como Duplex Transformers**  
Push-Pull  
Send for literature.  
**COMO APPARATUS COMPANY**  
446 Tremont St. Boston, Mass.

**BRISTOL AUDIOPHONE**  
MORE THAN A LOUD SPEAKER  
Bristol Audiophone, Sr., 15-in. Horn. \$30.00  
Bristol Audiophone, Jr., 11-in. Horn. \$22.50  
Bristol Single Stage Power Amplifier \$25.00  
Write for Bulletin 3006-W  
**The Bristol Company**  
Waterbury, Conn.

# ACME

for amplification

**Free Mailing Lists**  
Will help you increase sales  
Send for FREE catalog, giving counts and prices on thousands of classified names of your best prospective customers—National, State and Local, individuals, Professions, Business Concerns.  
**99% Guaranteed 5¢ each**  
by refund of  
**ROSS-Gould Co., 315 N. St. Louis**

**"GET HASTINGS, NEB."**  
We Will Mail Free the Hook-up of  
**"Killoch Kilo Koupler"**  
Most Wonderful Coil  
A CIRCUIT WELL WORTH WHILE!  
Build a two-tube set, one stage of R. F., using neutredyno principle, and detector. Full details in Radio World, issue April 12. Send 15 cents.  
**David Killoch Company**  
Dodge Building, 45 West Broadway  
Corner Park Place, New York City

**Radio Record Map.**  
Large scale map of U. S. Lists over 700 Broadcasting stations with wave lengths. Space for recording date, hour, and dial readings. Size 28 x 34. Price 25 cents postpaid. If not satisfied, return map and money will be refunded.  
**RADIO RECORD MAP CO.**  
205 Caxton Bldg. Cleveland, O.

**Federal RADIO Products**  
Over 130 standard radio parts, each bearing the Federal iron-clad performance guarantee.  
Write for Catalog.  
**FEDERAL TELEPHONE & TELEGRAPH CO.**  
Buffalo, N. Y.

**FAHNESTOCK CLIPS**  
"Popular Wherever Radio Is Used"  
14 Sizes in Beautiful Display Case  
Dealers write for big money-making proposition.  
**FAHNESTOCK ELECTRIC CO.**  
Long Island City, L. I.

**\$25 FOR \$10**  
THE FAMOUS  
**BEL - CANTO**  
ACOUSTICAL LOUD SPEAKER  
Direct from Factory to You.  
Delivered free C. O. D. to your door.  
**Bel-Canto Mfg. Co.**  
General Office and Factory: Dept. R.W.,  
417-419-421 E. 34th St., N. Y. City  
Telephone Vanderbilt 8959

USE  
**EVEREADY**  
**Radio Batteries**  
-they last longer

For Your Summer Vacation and For New Subscribers Only  
**Subscribe NOW and Receive Another Radio Publication Without Extra Cost**

Radio World has made arrangements

- to offer a year's subscription for
- any one of the following publications
- with one year's subscription for
- RADIO WORLD,
- RADIO NEWS or
- POPULAR RADIO or
- RADIO BROADCAST or
- WIRELESS AGE or
- RADIO DEALER or
- RADIO (San Francisco).

This is the way to get two publications

- for the price of one;
- Send \$6.00 today for RADIO WORLD
- for one year (regular price
- for 52 numbers)
- and select any one of the other
- six publications for twelve months—
- Add \$1.00 a year extra for
- Canadian or Foreign postage.
- Present RADIO WORLD subscribers
- can take advantage of this offer by
- extending subscriptions one year NOW.
- Or order thru your newsdealer.

**RADIO WORLD'S SPECIAL TWO-FOR-PRICE-OF-ONE SUBSCRIPTION BLANK**

RADIO WORLD, 1493 Broadway, New York City.  
Enclosed find \$6.00, for which send me RADIO WORLD for twelve months (52 numbers, beginning ..... and also without additional cost, Radio News, or Popular Radio, or Radio Broadcast, or Wireless Age, or Radio Dealer, or Radio for twelve months, beginning ..... Put a circle around the other publication you want.

Indicate if renewal  
This Offer Good  
Until  
July 15, 1924

Name .....

Street Address .....

City and State .....



**TOWER'S Scientific**  
 WEIGHS ONLY 80Z  
 Perfect Tone Makes  
**\$2.95**  
 Plus a few cents postage



**OUR \$200,000.00 COMPANY STANDS SQUARELY BACK OF EVERY HEADSET**

**WORLD'S GREATEST HEADSET VALUE**

now \$2.95, with Notable Improvements  
 Longer Cord (full 5 feet), Stronger Magnets, Higher Resistance, Increase of Sensitivity, Perfect Tone Mates  
**EVERY SET TESTED BY LICENSED RADIO OPERATORS**

*Send no money - Order on a Post-Card*

THE TOWER MFG. CO., Dept. D.98 BROOKLINE AVENUE, BOSTON, MASS.



## Join the A. B. C. NOW

THE American Broadcast Club, formed under the auspices of RADIO WORLD, has for its object the promotion of the welfare of the broadcast listeners of the United States, Canada and Mexico.

Membership is open to all interested in radio in any way, either as broadcast listener, dealer, manufacturer, wholesaler or jobber.

A novel feature of the A. B. C. is that membership entails no duties or obligations whatever. There are no dues. All you have to do is enroll. That will signify your interest in radio and make you one of the thousands unselfishly united in a common interest.

### New Members of the A. B. C.

- A. C. Partridge, Box 382, Augusta, Me.
- Mrs. A. C. Partridge, Box 382, Augusta, Me.
- B. S. Wrisht, 223 West 70th St., New York City.
- James Woodward, dealer, 46th St. and Killam Ave., Norfolk, Va.
- Clarence Feller, 505 Cypress St., Massillon, O.
- Howard P. Jackson, 8 Neptune St., West Lynn, Mass.
- Arthur G. Enterline, wholesaler, 434 Broadway, Milton, Pa.
- C. W. Stauffiger, 214 Erskine St., Detroit.
- C. S. Heffner, 305 21st St., Sharpsburg, Pa.
- Rollin Jenney, 414 Jackson Ave., Endicott, N. Y.
- John Slavin, 91 Walnut St., Brookline, Mass.
- J. M. Cormany, dealer, Box 424, Lenoir City, Tenn.
- L. Morano, 127 Lake Ave., Greenwich, Conn.
- Francis Prohasha, Springdale, Pa.
- R. M. Allen, 319 N. Oregon St., El Paso, Tex.
- Gordon Schwarz, Laurence Ave., Dumont, N. J.
- J. L. Davis, dealer, 234 E. Main St., Wabasha, Ind.
- Gustave Simmons, Columbus, Mont.
- Wm. F. Donaldson, 1312 Corporation St., Beaver, Pa.
- G. W. Johnson, 4056 44th Ave., S. W., Seattle, Wash.
- Mrs. Eva L. Rhodes, 1004 West St., Utica, N. Y.
- Ellsworth Crome, 2312 Wilson St., Wheeling, W. Va.
- Victor J. Pache, 133 Penobscot St., Rumford, Me.

P. J. Dailing, Logan Ark  
 W. C. Hill, 3221 Columbus Ave., So., Minneapolis, Minn  
 Chester Rand, 172 Winthrop Ave., Revere, Mass

M. B. SLEEPER RADIO DESIGN & CONSTRUCTION FOR EXPERIMENTERS, REFLEX & RADIO FREQUENCY—Mailed on receipt of \$1.00. The Columbia Print, 1493 Broadway, New York City.

A. B. C. Editor, RADIO WORLD, 1493 Broadway, New York City.

Please enroll me as a member of the American Broadcast Club.

Name .....

Address .....

City or Town.....

State .....

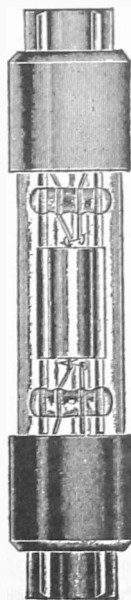

(Actual Size)

## AROUND THE WORLD!

A New Zealand amateur got Alabama (10,000) miles on one Myers Tube—heard the signals and message perfectly. Certified by Radio News.

This remarkable performance indicates that there is no limit to long-distance reception with Myers Tubes because their design is right.

## Myers Tubes

Practically Unbreakable

add to the efficiency of any set by cutting out noise, tube hiss and interference.

Two types: Dry Battery and Universal (for storage battery). Write for free circuit diagrams.

Insist on the New Improved Myers Tubes—at reliable dealers—otherwise send purchase price and be supplied postpaid.

**5** EACH, complete with clips ready to mount on your set; no sockets or other equipment necessary.

**F. B. Myers Co. Ltd.**  
*Radio Vacuum Tubes*

240 CRAIG STREET W.  
 MONTREAL, CANADA

# Convention on the Air

(Continued from page 26)

where special sets with elaborate amplifying devices were installed in cities, crowds gathered and listened with a self-silence almost awesome. Occasionally cheers would interrupt this silence—cheers for the favorite whose name was that moment coming from the lips of a convention orator. On the farm the toiling agriculturist stopped to listen in, his family at his side, for subjects were being discussed that were close to his heart and closer to his purse. The ears of the nation were trained on the convention—the first Democratic Presidential Convention ever radiocast. The Cleveland Convention where the Republicans nominated Coolidge and Dawes, was eclipsed in point of interest because in Cleveland the choice for first place was a foregone conclusion. In New York City it was a sizzling prob-

lem and puzzle for the longest while.

Twenty radiophone stations extending from Boston to Kansas City and from Buffalo to Atlanta broadcast the convention.

The following stations were connected to the microphones in the Garden by land wires: WEAF, WJZ, New York City; WGY, Schenectady, N. Y.; WRC, WCAP, Washington, D. C.; WMAQ, WGN, WLS, Chicago; KSD, St. Louis; WGR, Buffalo; WLW, Cincinnati; WDAF, Kansas City; WSB, Atlanta; WNAC, WTAT, Boston; WJAR, Providence; WTAM, WJAX, Cleveland; WDBH, Worcester; KDKA, Pittsburgh. In cities where two or more stations were scheduled to broadcast they alternated daily in sending out the events from the convention.

All stations except WJZ and WGY used the American Telephone and Telegraph Company wire line service and WEAF's announcer, Graham McNamee, who served as official announcer for all stations at the Republican National Convention. WJZ and WGY employed Western Union wires and their own announcer, Major J. Andrew White, vice-president of the Haynes-Griffin Radio Service, Inc., large New York City retailers.

Radio impresarios arranged their programs as usual, but all were subject to change to accommodate the convention broadcasting. Operators were on continuous watch at the ends of the wires in the radio studios so that they could connect the Madison Square microphone into the radio transmitting circuits when interesting events took place.

New York City's municipal station did not broadcast the convention, because only an experimental license was granted the station. This enabled engineers to test the installation "on the air" but did not permit broadcasting regular programs. It was reported that the equipment would be thoroughly tested and ready for service late in July.

Three Western Electric trucks equipped with radio receivers and amplifiers were stationed at City Hall Park, Washington Square, and Madison Square. The proceedings from the convention were picked

(Concluded on next page)

**FOR SALE**—3-tube radio set, solid mahogany cabinet; tunes easily, excellent workmanship; reception loud and clear. 800 miles on horn. Wonderful opportunity to obtain a good set at very low price. Phone 1363 New Rochelle for particulars, or address E. Pratt, 21 Grant St., New Rochelle, N. Y.

## WHAT IS AN INVENTION?

How to obtain a patent and other valuable information is supplied in our FREE Booklet. Write for a copy today.

**MANUFACTURERS PATENT CO., Inc.**  
70 WALL STREET, NEW YORK

## Perpetual Radio Fuse \$2.50

\$100.00 reward if you can blow your tubes with this protector in your circuit according to our instructions. **SUPER ULTRADYNE Transformers**, complete set including blue print..... \$16.00  
**ULTRA SYNCHRODYNE Coils**, set of three..... \$7.00  
Including blue print. With condensers..... \$17.00  
**DEALERS and JOBBERS**, we have an attractive territory proposition.  
**THE STANLEY RADIO COMPANY, Manufacturers**  
2947 Lorain Avenue Cleveland, Ohio

## IS YOUR NEUT RIGHT?

To revitalize unneutralizable Neutrodyne, we devised this Kladag Coast-to-Coast Circuit. Uses same panel, etc., as Neut, except three less parts. Merely rewire. Success certain. Necessary stabilizer, 22 feet gold sheathed wire, circuit and complete, simple instructions—\$5.00 prepaid. Many have already rebuilt their Neuts—and written wonderful testimonials. Thousands will do it. Be FIRST—have the finest five tube set in your neighborhood, revitalize others' Neuts. Description, etc.—10c.  
Radio Lists—2c. Stamps accepted.  
**KLADAG LABORATORIES, Kent, Ohio**

## \$15 Set Gets 2,000 Miles

The Essex Radio Special, the receiving set with a sensitive, gets you more distant stations clearer and sweeter than sets costing ten times its price. \$15 Set complete with cabinet, without tube or batteries. \$20 Set complete with cabinet, tube and batteries.

## ESSEX RADIO SERVICE

617 West 125th St. New York  
Detailed information on request.

## MAGNAVOX

R 3 or M 1

\$21.95

## THE RADIO EXCHANGE

511 Seventh Street, Sioux City, Iowa

## Latest Developments in the SUPERDYNE CIRCUIT In Text and Diagrams

RADIO WORLD dated May 17, 24 and 31 contains a series of three articles covering all the angles of the famous Superdyne Circuit. The original Superdyne Circuit articles appeared in Radio World last December, and the three issues in which they appeared are now completely out of print. That is the reason why we have published the Superdyne series in the May 17, 24 and 31 issues. 15c. per copy, three for 45c., or start your subscription with any number.

**SPECIAL SUBSCRIPTION:** Send \$6.00 for one year's subscription and we will send you our issues of May 17, 24 and 31 as a premium.

RADIO WORLD, 1493 Broadway, N. Y. City

## PROTRACTORS FOR DIAL SETTINGS

3-Inch—Nickel—0 to 180 Degrees \$3.50 Gross

R. H. MEEHAN CO. 61 Leonard St. N. Y. City

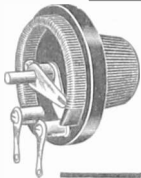

## ARAGON SILVER RHEOSTAT

The most attractive Rheostat on the market. Smooth gliding—and with perfect contact.

75c

ARAGON RADIO CO. 6 E. LAKE ST. CHICAGO

## "SUPER-HET"

### THAT GOT SCOTLAND

Build Your Own "Rolls-Royce"

### SPECIAL KIT OFFER

Kit comprising 3 Roca Intermediate Transformers, 1 Roca 10,000 meter Coupler, 1 Roca Oscillator Coupler... \$39.50

Dealers write for special offer.

If your dealer cannot supply you, send his name and your remittance direct to

### SUPER-SALES-SERVICE

Mail Order Department: 214 WEST 34th STREET

Factory: 112 CHAMBERS STREET NEW YORK CITY

FREE! Descriptive Catalogue on request.

# RADIO WORLD'S QUICK-ACTION CLASSIFIED ADS.

5 CENTS A WORD. 10 WORDS MINIMUM. TELEPHONE YOUR CLASSIFIED IF IN A HURRY. RADIO WORLD'S PHONE NOS. ARE LACKAWANNA 2062-6976.

**AUTO OWNERS**—Windshield match box holder, 25c. Klear view auto glare shield, 50c. L. A. Gowen, No. 19 Sherburne St., Sanford, Maine.

**MAKE YOUR OWN B BATTERIES**—Using ordinary drinking glasses, other material cheap and easily obtainable. Strong and steady voltage. Easily and quickly made. Instructions with photographs, fifty cents. P. D. Cox, High Springs, Fla.

**WE WANT REPRESENTATIVES** for our radio cabinet line. Your chance to represent us in your locality. Write for descriptive literature and discount. Dealers and jobbers write us. Special discount for sample. Carlson Cabinet Works, 21 Market Street, Jamestown, New York.

**PATENTS**—Write for free Guide Book and Record of Invention Blank before disclosing inventions. Send model or sketch of your invention for our prompt Examination and Instructions. No charge for the above information. Radio, Electrical, Chemical, Mechanical and Trademark experts. Victor J. Evans & Co., 294 Ninth, Washington, D. C.

**SELL 4 TUBE CROSLLEY XJ SET**, cost \$55.00; sell for \$35.00. C. Rynning, Pontiac, Ill.

**FREE APPARATUS** for securing subscriptions for "RADIO." Write today for complete lists of premiums and our special subscription offer. "RADIO" Pacific Bldg., San Francisco, Calif.

**RADIO WORLD'S CLASSIFIED DEPARTMENT.** If you want to buy, sell or exchange anything, use RADIO WORLD'S Quick-Action Classified Department, 5 cents per word, 10 words minimum. RADIO WORLD, 1493 Broadway, New York City.

**FULL LIST OF BROADCASTING STATIONS** in Radio World dated May 17th, 1924, mailed on receipt of 15c or start your subscription with that number. RADIO WORLD, 1493 BROADWAY, NEW YORK CITY.

**GET THOSE SUPERDYNE COPIES** THE Superdyne Circuit, brought up to date in diagrams and text, in RADIO WORLD for May 17, 24, 31. Per copy, 15c; the three copies, 45c, or start your subscription with the first number. RADIO WORLD, 1493 Broadway, New York City.

**GRAM'S RADIO MAP IN TWO COLORS**—Best map on the market, 35c. The Columbia Print, 1493 Broadway, N. Y. C.

\$3.95 — TUBES — \$3.95

**GUARANTEED NEW GENUINE RADIO-TUBES.** ALL TYPES SENT POSTAGE PREPAID. GENERAL SALES SERVICE, ONSET, MASS.

**HOW TO KILL RADIATION**—See RADIO WORLD, February 23, March 1, 8, 28, April 12, 1924. 15c a copy. RADIO WORLD, 1493 Broadway, New York City.

**PATENTS—SEND DRAWING OR MODEL FOR EXAMINATION AND OPINION.** Booklet free. WATSON E. COLEMAN, Patent Lawyer, 644 G Street, Washington, D. C.

**MAGNOVOX R3**—Latest nationally advertised reproducers; electrical modulator. List, \$35.00. Introductory, \$25.00. The factory sealed carton is your guarantee. Radio Central, Dept. W, Abilene, Kansas.

**HOOK-UPS FOR EVERYBODY**—"Henley's 222 Radio-Circuit Designs." Mailed for \$1.00 postpaid. The Columbia Print, 1493 Broadway, New York City.

# Radio's Domain Widened by Convention

**Four Microphones Before Each Speaker Carry His Voice Throughout the United States**

(Continued from preceding page)

up by radio from either WEAJ or WJZ, amplified and then broadcast from the

horns erected on top of a telescopic mast on the back of the trucks. The output from the horns were audible over two blocks, so that crowds in the parks were able to hear the convention speeches.

The convention was opened by Cordell Hull, chairman of the National Democratic Committee, who stood before two microphones for a while. However, the convention was radiocast through four microphones, plainly visible when Patrick

Cardinal Hayes delivered the invocation. His prayer lasted four minutes. It was carried across the continent by land wires and via the ether.

And while all the speeches were being made engineers were busy in the installation room, watching out carefully, so that the nation would get splendid reception. Radio fans agreed that the result was a most satisfactory accomplishment.

The convention gave radio a big boost.

## HOW TO MAKE THE

??????

What shall we call it?

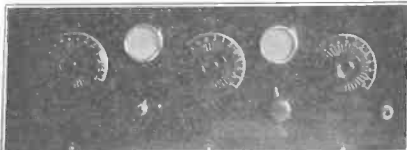

After a great deal of experimenting and testing, we have evolved what is undoubtedly the most sensitive, most selective, and most satisfactory two tube receiver which has ever been designed. In fact, it is more sensitive than any three tube receiver, more so than all but a few, a very few, four and five tube receivers.

The receiver uses but two tubes, and yet it is extremely sensitive, equal in this respect to the five tube tuned radio frequency receivers such as the neutrodyne. By that we mean that under ordinarily good conditions, the receiver will bring in stations from all over the country on the loud speaker! And with but two tubes!

**SELECTIVITY.** No more selective receiver has ever been made. Local stations may be tuned out, and stations a thousand miles or more can be tuned in without the least interference, even if their wavelengths are but a few meters apart.

**-tone.** A crystal detector is used, and as a consequence, the tone is perfect. There is no howling, and no radiation.

**PRICE.** At the cost of an ordinary two tube receiver, you can make this super-sensitive, super-selective super receiver. In the directions, instructions are given, so that with a little work, and at no cost, you can use low priced apparatus, and so change this, that it is equal in efficiency to the highest priced equipment. This alone is worth the price of the direction many times over.

If you are going to build a receiver, if you build receivers for others, or if you are going to build any kind of a receiver, you should order today.

We sell the complete outfit of parts for this receiver, assembled, ready for wiring, or we sell the receiver, ready for operation, with a guarantee of perfect results.

When you order your directions, suggest a name for this wonderful receiver. As soon as a satisfactory name is received, we shall present to the person who suggested it, one of these receivers, made from the best parts which money will buy. Will you be the winner? Order now!

**PRICE**—Complete instructions, hook-up, diagrams, etc., etc.

**\$1.50**

Dealers! Write us for prices on this lightning seller.

**The Biltmore Radio Co.**

Dept. W-4 Boston 30, Mass.

**THOUSANDS** find it profitable to buy from us direct by mail. Build your set, using standard parts at the lowest New York prices.

SEND FOR PRICE LIST

**DIXIE RADIO COMPANY**  
133 7th Ave. New York City

### RADIO CRYSTALS

MOUNTED, UNMOUNTED, BULK  
Packed under your own label if desired.

Dealers and Jobbers—Write us for lowest prices on Quality Crystals.

**MELODIAN CO. OF AMERICA**  
INDEPENDENCE, MISSOURI

## RADIOGRAMS—THE MARCH OF EVENTS

**FAMOUS PLAYERS-LASKY** have decided to abandon their proposed radio station at the Long Island studios, which they were going to use as a publicity tie-up with their productions, as they are unable to obtain the necessary type of equipment, it is reported.

**HIRAM PERCY MAXIM**, the inventor, upon whom a honorary degree of Doctor of Science was conferred by Colgate University at its 106th commencement, has been president of the American

Radio Relay League from its beginning. Mr. Maxim was the first to conceive the idea of organizing a non-commercial association of radio amateurs and, from that time to this, he has championed the cause of the transmitting amateurs of the country.

**HAROLD HYMANS**, 33, radio engineer, disappeared. He lived at 2463 Valentine Avenue, Bronx, New York City, and is the father of two children. He was last seen by business acquaintances

# THE BROOKLYN RADIO SERVICE CO.

Send 5c. in stamps for catalogue.

**BROOKLYN**  
577 Myrtle Ave.  
Send Money Order ONLY!

MAIL ORDER DEPT.

PHONES	SOCKETS	TRANSFORMERS
Western Elect. .... \$9.45	Fada ..... \$0.79	Coto Coils ..... \$0.69
Federal ..... 4.50	Tillman ..... .31	Aemo R-2, 3, 4 ..... 3.25
Brands ..... 3.95	De Forest ..... .50	Aemo 30K Super-Het-erodyne ..... 4.20
Baldwin Type C ..... 7.29	Bell ..... .69	Atwater Kent ..... 3.80
Ambassador ..... 3.98	Hoosick Falls ..... .60	Tri Coil A ..... 1.90
N. & K. .... 6.50	Pacent, 199 ..... .40	Erie Reflex ..... 3.28
Frost ..... 3.25	Federal ..... .75	Rasla RT6 ..... 3.00
	General Radio ..... .85	Rela CR ..... 3.25
	Workrite, 199 ..... .60	Owl ..... .65
		UV 1714 ..... 3.60
		RR 1716 ..... 6.75

LOUD SPEAKERS	TRANSFORMERS—PUSH PULL	DIALS
Magnavox, M-1 ..... \$21.95	Como Duplex ..... \$9.90	Amsco, 2" ..... \$0.30
Pathe ..... 11.98	All American ..... 9.50	Amsco, 3" ..... .50
Manhattan ..... 15.00	Modern ..... 10.00	Amsco, 4" ..... .79
Music Master ..... 21.95		De Forest, 3" ..... .35
Magnavox, R-3 ..... 24.50		De Forest, 4" ..... .40
Plugs Included		Pathe, 2" ..... .30
		Pathe, 3" ..... .40
		Pathe, 4" ..... .55
		Federal, 3" ..... .50
		Federal, 4" ..... 1.15

CHARGERS	TRANSFORMERS—AUDIO	VOLT METERS
Reetigon, 2 Amp. .... \$14.40	Star, 3 to 1 ..... \$2.60	Jewel, 0-50 Volts ..... \$2.25
Reetigon, 5 Amp. .... 22.40	Star, 6 to 1 ..... 2.95	Jewel, 0-12-120 Volts ..... 9.85
Tungar, 2 Amp. .... 14.40	U. V. 712 ..... 5.20	Sterling, 0-50 Volts ..... 1.75
Tungar, 5 Amp. .... 22.40	Modern, 4 to 1 ..... 3.95	Sterling, 0-35 Amp. .... .89
Aemo A, 2 Amp. .... 9.75	Modern, 10 to 1 ..... 4.40	Sterling, 0-35 Amp., 0-50 Volts, combination ..... 3.00
Aemo A & B, 2 Amp. .... 11.20	Aemo ..... 3.25	
Ward Leonard, D. C. .... 8.75	All American ..... 3.35	
	Federal No. 65 ..... 4.90	
	Thorderson, 3 1/2 to 1 ..... 3.20	
	Thorderson, 6 to 1 ..... 3.20	
	Jefferson No. 41 ..... 3.20	
	Amertran ..... 4.55	
	Erie, 3 to 1 ..... 3.75	
	Erie, 6 to 1 ..... 3.95	
	Federal No. 226 ..... 3.25	

### BROOK-RAD "B" BATTERIES

A "B" Battery with an unconditional guarantee. Tested and approved by the Tribune Institute. NOTE OUR PRICES, 4 SIZES:

22 1/2 Small ..... \$1.00	45 Volt Medium ..... \$2.80
22 1/2 Large ..... 2.00	45 Volt Large ..... 3.75

Allow us to quote on any parts or standard sets.

### The Popular Neutrodyne!

This receiver is rapidly becoming the "Old Reliable." A five-tube tuned radio frequency set that any inexperienced fan can operate.

SEE RADIO WORLD for March 15, 22 and 29, and get all the details which will enable you to build this reliable and powerful five-tube neutrodyne outfit. The three copies for 45c, or sent free if you send \$6.00 for yearly subscription. NOW!

RADIO WORLD, 1493 Broadway, N. Y. C.

### AMERICAN MAP CO.'S RADIO MAP and GUIDE of the United States, Canada and West Indies

FOURTH EDITION NOW READY

A convenient and practical listing of all broadcasting cities, call signals, locations, stations, wave lengths, etc.  
Indexed separately by call signals and titles.  
American Radio Relay and Time Divisions accurately located on map, together with all broadcasting titles.  
This includes a separate book containing a full list of the stations, call signals, wave lengths, etc. Mailed on receipt of \$1.00, parcel post prepaid, or send \$8.00 for Radio World for one year (or renew your present subscription at once) and we will send you the Radio Map and Guide FREE.

THE COLUMBIA PRINT

1493 Broadway New York City

# Are YOU in This Line?



Every year the average Radio fan spends over \$20.00 just to replace the 91½% vacuum tubes destroyed by accident.

Of course, you don't line up on a certain day to pay the tax as shown, but the actual financial result is just the same.

For 50 cents per tube, RADECO SAFETY FUSES offer a permanent exemption from Radio's heaviest tax.

File your claim for exemption with us by mail or with your dealer.

Insist on RADECO FUSES. The fuse that stood the most exacting tests at the Massachusetts Institute of Technology.

When ordering state type of tube used. One fuse only is needed for each tube.

*"RADECO FOR SECURITY"*

#### AGENTS

Make Big Money selling on RADECO SALES PLAN. Mail coupon now for full particulars.

RADIO EQUIPMENT CO.,  
20 Stuart Street, Boston, Mass.

Gentlemen:

Please send full particulars of your sales plan which will enable me to make large commissions selling your products.

NAME .....

ADDRESS .....

## RADIO EQUIPMENT COMPANY

*New England's Oldest Exclusive  
Radio House*

20 Stuart Street

Boston, Mass.