

1922

The Latest In Radio Every Seven Days—15c A COPY
 OUR OWN SPECIAL BROADCASTING MAP IN THIS ISSUE

RADIO WORLD

Entered as second-class matter, March 28, 1922, at the post office at New York, New York, under the act of March 3, 1879

I L L U S T R A T E D

MAY
 20th,
 1922

15c
 A COPY
 1 year, \$6.00
 6 mos., 3.00
 3 mos., 1.50



(e. P. & A. Photo)

The voice of radio will be heard by them this summer! Miss Mildred Fenn (aloft) and Miss Mildred Redmond (on deck) taking the first steps in equipping their little motor-boat with a wireless outfit.

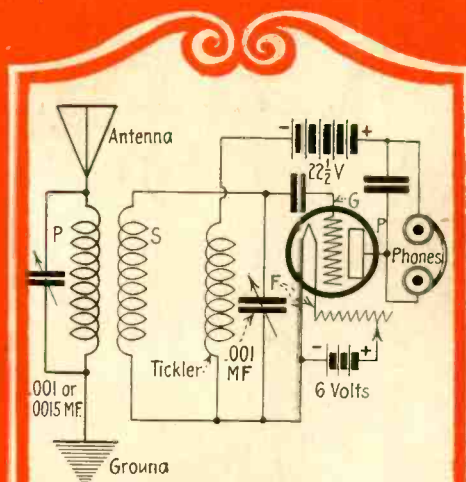

A subscriber made a regenerative set from this diagram, published originally in *Radio World* No. 5, dated April 29, and picked up over seven different broadcasting stations.

Full description inside this issue.

**Our Aim Is
 Service**

May, Linwood, White, Ehlert, Bragdon—All in this issue.

De FOREST

"SYNONYMOUS FOR GOOD
RADIO EQUIPMENT ALL
OVER THE WORLD"



Radio instruments are among the most scientific of all instruments and their manufacture requires not only mechanical skill, but scientific knowledge and appreciation of delicate and intricate instruments. De Forest radio apparatus for amateur, commercial and laboratory use has long been recognized by scientists, engineers and operators as the finest in the world. No attempt has ever been made to meet price competition, our aim having been to provide the radio man with instruments and apparatus which would give efficient, dependable service under the exacting conditions which radio communication has to meet with.

Broadcasting brought about a tremendous demand for radio receiving equipment. Apparatus had to be developed suitable for use by Mr. Average Citizen and his family and production had to reach huge figures almost overnight. Yet in spite of the demand for sets, sets, more sets, we adhere to our policy of the past Decade: Every set manufactured by us is made of the best materials, carefully and accurately constructed and is thoroughly tested before leaving our laboratory.

The Everyman Receiver

A simple, easily adjusted, crystal detector receiving set in a handsome walnut finished cabinet, complete with receivers at \$25.

Radiohome Receiver

A De Forest radiophone with a vacuum tube detector at \$36. Antenna, phones, batteries and vacuum tube bring the total cost to about \$75.

DT-800 Amplifier

A two-stage amplifier in cabinet identical with those of the Everyman and Radiohome and giving signal strength sufficient to operate a horn. \$35.

Interpanel MR-6 Receiver

A set unsurpassed in appearance, efficiency and dependability and having a highly selective tuning system with 150-25,000 meter wavelength range. Price, \$112.

**De FOREST RADIO TEL. &
TEL. CO.**

Jersey City, N. J.



Teleradio

(TRADE MARK)
**WIRELESS APPARATUS
OF
QUALITY and EFFICIENCY**

Manufacturers of
Crystal Receiving Sets
Fixed Telephone Condensers
Fixed Grid Condensers
Grid Leak and Condensers
Double Headsets 2,000 and 3,000 Ohms
Variable Condensers 23 and 43 Plate
Mounted Fuse Terminals for
Filament Circuit
Lightning Arresters
V. T. Sockets
Rheostats
Mounted Crystal Detectors

Teleradio

Engineering Corporation

Home Office and Factory
484-490 Broome St., New York
BRANCH OFFICES
466 Winona Ave., Phila., Pa.
609 Chamber of Commerce Bldg.
Pittsburgh, Pa.
227 West Side Bldg.,
Kansas City, Mo.
171-2nd St., San Francisco, Calif.

KNOWN FROM COAST TO COAST

G - W SLIDERS



Advertised and sold all over the country because it is Absolutely the Best Slider. Slides easily. Cannot cut or damage wire. Makes perfect electrical contacts. For better tuning, insist upon G-W Sliders. They cost no more.

HIGHLY POLISHED BRASS

3/16" 25c, 1/4" 30c
Ask for G-W Slider Rods
GEHMAN & WEINERT
42 Walnut St. Newark, N. J.

A COMPLETE KNOCKDOWN RADIO SET

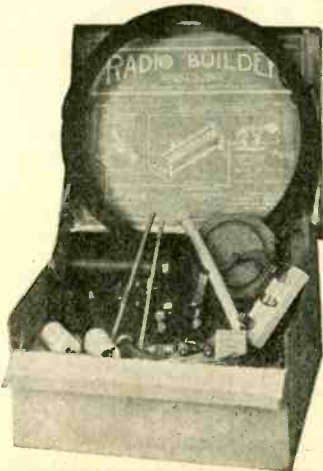

Everything except the phones

Includes

**COMPLETE INSTRUCTIONS WITH
EACH SET**

Aerial, Ground Switch, Tuning Coil,
Rods, Sliders and all parts necessary.

\$6.50

The parts in this set are
"THE EQUAL OF THE BEST"

Dealers Write

LIBERTY RADIO CO.

106 LIBERTY ST., N. Y. C.

Greatest BATTERY BARGAINS Ever Heard of

Buy direct from the battery builder
and save from 50% to 100%

Compare these prices.

STORAGE BATTERIES

80 to 100 Ampere hours \$11.00
100 to 110 Ampere hours 14.00
110 to 125 Ampere hours 16.00
These batteries can also be used for
starting and lighting Automobiles
as well as Radio.

"B" BATTERIES

The Famous Cyclone Make

	Regular Price	Our Price
22½ Volt	\$1.50	\$1.20
Variable 22½ Volt	2.00	1.50
Variable 45 Volt	4.00	3.00

RADIOTRONS, \$6.00

Radiotron U.V.201 amplifying tubes
Mail Orders filled upon receipt of
money order or certified check

Lexington Vulcanizing Co.

565 LEXINGTON AVE., N. Y.
Phone—Plaza 1826



Our Variometer



We Manufacture Moradio Parts
and Appliances for
Wireless Apparatus

MORELAND SALES CORP.

30 Ogden St., Newark, N. J.

RADIO WORLD

[Copyright, 1922, by Radio World Co., New York, N. Y.]

A WEEKLY JOURNAL, PUBLISHED EVERY WEDNESDAY AND DATED SATURDAY BY RADIO WORLD COMPANY, FROM PUBLICATION OFFICE, 1493 BROADWAY, NEW YORK, N. Y.

Vol. I. No. 8.

May 20, 1922

15c. per copy, \$6.00 a year

The Middle Boy Hears the Radio Music

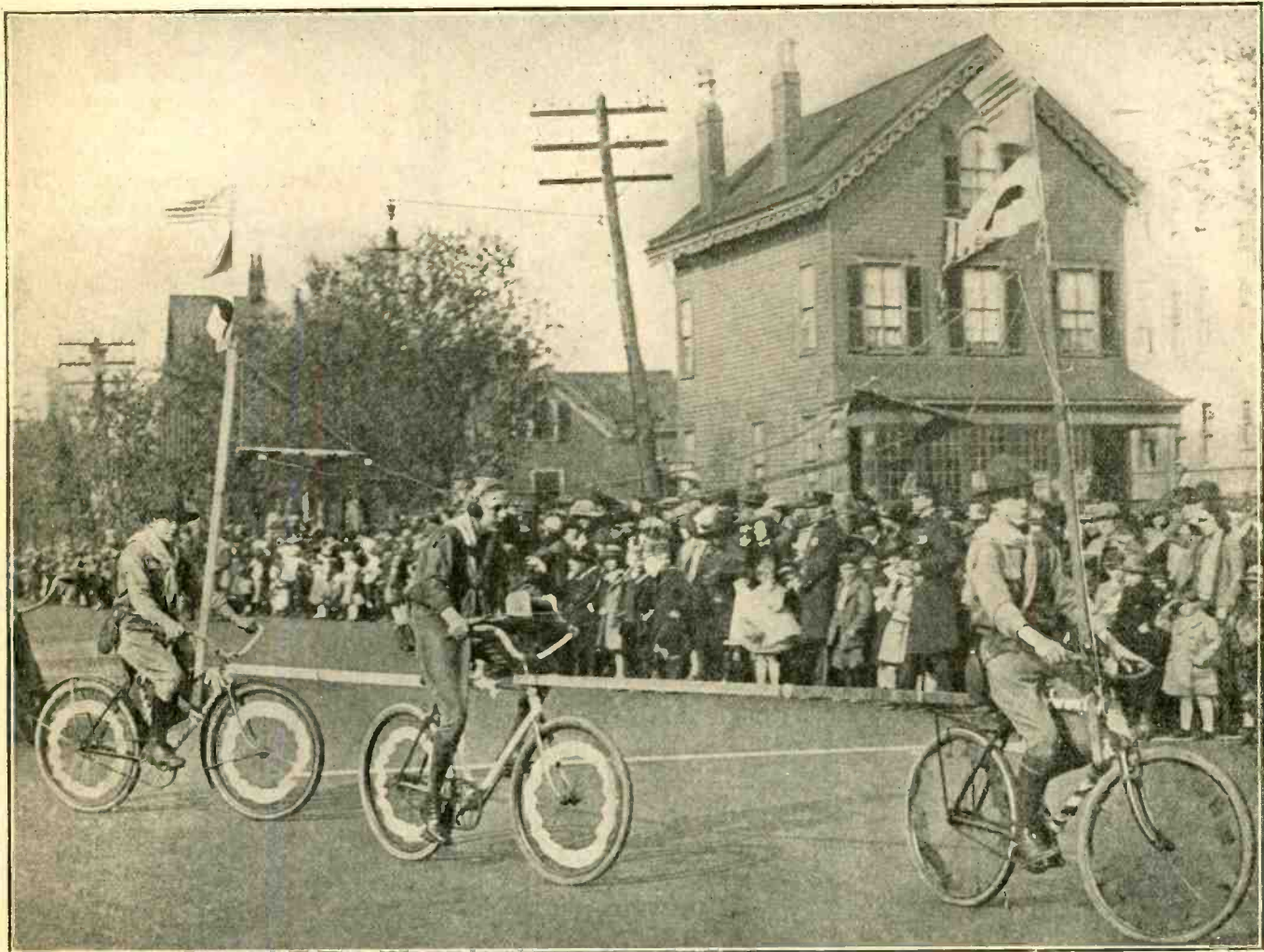

(c. Photograms, N. Y.)

The Boy Scouts of America are doing their share in finding new uses for radio. Thirty thousand youngsters recently paraded in Jersey City, New Jersey, and the "Radio Trio," shown in the photograph, was the greatest attraction. The scout on the middle wheel is enjoying the stunt—for he, alone, is hearing the music. His comrades are carrying the antenna.

"IT is difficult to look into the future of radio," says Dr. Charles P. Steinmetz, chief consulting engineer of the General Electric Company, "for it is such a big thing. One thing is certain however. Uninterrupter communication throughout the world is now a reality because of radio."

The radio "bug" has forced its way into the Michigan State Prison. Seventeen hundred men there will soon listen to the "music from the air."

A number of American concerns have representatives in Europe looking for radio material and arranging for its production in some of the idle European factories.

Radiograms

Press reports from Europe are now transcribed at radio stations, through an automatic recording device similar in operation to the phonograph record. The receiving record runs fast while the reproducing machine runs slowly so that the code may be deciphered easily.

A number of enthusiasts are able to predict, with a fair degree of accuracy, cloudy or rainy weather. When the static in the air is heavy, which is indicated by a loud hissing sound in the receiver, one may be certain that bad weather is close at hand.

A radio station has been established on Jan Mayen Island in the Arctic Ocean. It is operated by Norwegians.

The club cars of the Pioneer Limited, the fast C. M. & St P., R. R., train between Chicago, St. Paul and Minneapolis, will be equipped with radio for the benefit of passengers. All the important news of the day will be received.

L. C. Porter, of Newark, N. J., president of the Society of Motion Picture Engineers, says that motion pictures may be transmitted by radio. "It is possible," says Mr. Porter, "that we will exhibit in our educational institutions educational pictures broadcast by radio."

The B Battery and Plate Current

By George W. May, R. E.

USING vacuum tubes either for detector or amplifiers of radio receiving-sets must be equipped with some sort of a battery for supplying high voltage to the necessary plates. It is most essential that this high voltage be required to have the tubes operate properly. This battery is termed the B battery, to distinguish it from the A battery of six volts, and supplies the proper voltage of $22\frac{1}{2}$ volts. Every little precaution must be taken; because, if this battery should be connected into the filament circuit, the tube will burn out immediately.

Various types of B batteries are now on the market and, of course, supply the necessary voltage. Due to the fact that we need a very high voltage with a very small low amperage on the plate of the tube, it is evident that the drain on the battery is very small and, in turn, should last a long time. In fact, the battery will die

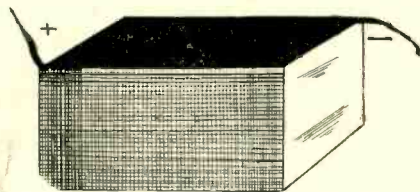

Figure 1. B-battery of the non-variable type.

from age long before the actual current is used up by the tube. In using these so-called B batteries, they can be placed out of sight for many months.

The battery to be considered is the small-type battery that can be carried. They are plenty good enough for ordinary work and will serve very well. However, with certain sets, variation of the B battery will have to be done as every bit of the voltage can be practically used. With the beginner who uses a radiotron tube, U.V.-200, it will be found that this tube will not function properly if the plate voltage exceeds $22\frac{1}{2}$ volts. In fact, it will operate on voltages that are less than the above voltage.

With the varied type battery, if the beginner tests out his tube by experimenting with the different taps of the battery, he will find that his tube will operate perfectly between 16 and 18 volts. This is just for the detector tube. After the tube has been in operation for some time, the voltage will drop, and, of course, a raise in voltage will have to be made. In connecting up the B batteries to your

set, always be sure that the proper connections are made and, as a good check, look over the wiring very carefully. If the connections are not made correctly no signals will be heard.

The beginner who is starting in and does not care to buy a ready-made battery, can make his own by

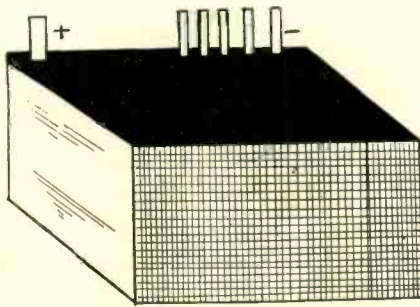

Figure 2. This larger size also a B-battery, is known as the variable type. This battery can be used where a change of voltage is required

simply going to the nearest electrical store and purchasing ten flashlight batteries. By connecting them up he will have a ready-made B battery that will answer the purpose of plate current. Caution should be taken to secure the proper connections in regard to polarity. Connect the positive to the negative, and so on, until all of the batteries are connected. In this manner, when it is completed, the batteries should have a negative and a positive pole, respectively. Due to the air surrounding these batteries, it

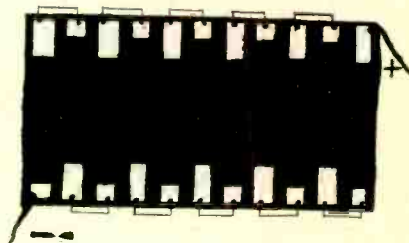

Figure 3. Assembly of flashlight batteries showing the necessary connections. Note the positive and negative poles. The small white squares represent the negative; the large ones are positive.

is a wise stunt to seal them up with some sort of a sealing wax—corrosion will ruin these batteries in time, if this is not done. The best way is to take each battery and dip it in paraffine for a few seconds, so that it will be coated with the wax. This will keep the battery and lengthen its life.

If the beginner reads over the above information regarding B batteries he will have a practical idea of their operation and care.

The beginner in using a B battery should test out to see if he has sufficient current for the tubes he intends to use. Once in a great while, a battery giving 45 volts is sold with the idea that it can be cut down to $22\frac{1}{2}$ volts. In order for the unexperienced man to work with B batteries, he should familiarize himself with the different batteries in order to know the exact amount of voltage needed.

Doctor's Car Equipped with Radio Set

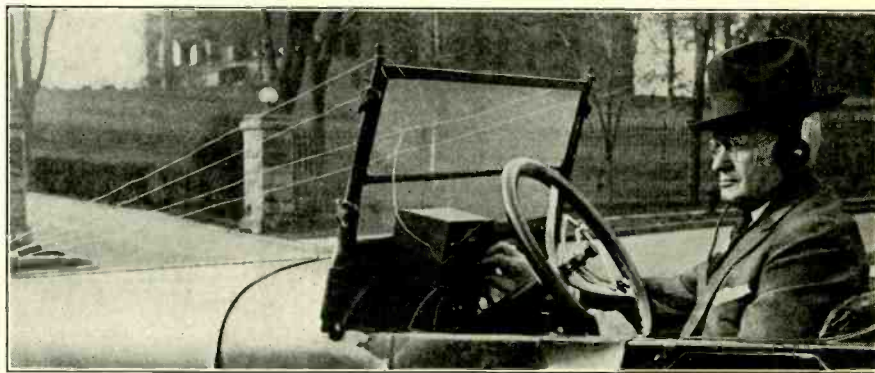

(c. Kadel & Herbert News Service)

Many folks, no doubt, have seen motor cars equipped in various ways, with radio. The question often arises, with much comment, as to the actual working conditions of such a proposed set. In recent issues of Radio World, different types of radio-equipped automobiles have been shown whereby signals and voice could be received over a short range of distance. This same reception applies to the antenna on this car. Dr. L. P. Rubin permitted this photograph to be taken of his radio-equipped automobile, whereby he is able to keep in touch with broadcasting stations within short range of his position. The antenna is strung on the car as can be seen in the photograph. The metal frame of the car is used as a ground.

New Radiophone for Postal Airplane



(c. Underwood & Underwood)

The man in this photograph holding a section of radio equipment is J. C. Henderson, second assistant postmaster-general. He has been inspecting the new 100-watt tube-type radiophone which is intended for use on the airplanes carrying the United States mail. The man in the aviation uniform is L. Hamilton Lee, postal pilot, who holds the six-hour record from Chicago to Washington, D. C. Strapped to him is the mouthpiece transmitter through which a pilot speaks when in flight.

18,761 Messages, Month's Record

Members of the American Radio Relay League, the national organization of radio amateurs, during the month of February, transmitted direct, or relayed, 18,761 messages. These messages were moved by 283 stations. During this month, the busiest amateur station in the country was Yankton College, 9YAK, of Yankton, South Dakota, which handled 604 messages. Of the eleven divisions into which the A. R. R. L. divides the country, the Atlantic division was the most active. Seventy-four stations transmitted 4,172 messages during the month. The second division was the West Gulf, which

handled 3,174 messages. The old-fashioned spark set is still well ahead of the continuous wave among amateurs. Seventy-four per cent. of the messages were sent by spark stations.

Radio From North Pole

CAPTAIN RONALD AMUNDSEN, the explorer, who is contemplating a five-year trip to the Arctic regions, proposes to keep in touch with civilization by radiotelephony. For the use of Captain Amundsen, a powerful wireless set has been purchased from the Marconi Company

in London. Captain Amundsen claims that his ice-bucking polar cruiser, "Maude," will be able to send messages in code a distance of 2,000 miles. This means that he will be in touch with all stations in the Far North. Linked up with this powerful radio equipment will be sets of American make. Captain Amundsen will start on his journey about June 1.

Condenser Not Always Useful

A phone condenser does no particular good. This is not because of a peculiar nature of the spark, or because of the phones, but because the condenser is supplied in some other way. Generally the condenser action is supplied by the wires in the phone cords.

The Radio Primer

A. B. C. of Radio for the Beginner Who Must Have the Facts Put Plainly and Tersely, and all Terms Fully Explained

Radio Terms at a Glance

DAMPING.—When electromagnetic impulses are sent to the antenna the latter vibrates or, as it is termed, oscillates for an appreciable time; but, sooner or later, the waves will die out. This gradual decrease is called the *damping*. High resistance in the antenna circuit causing a loss in heat is one cause of damping.

DECREMENT.—A term seldom used by the broadcast enthusiast since he is not bothered by it. Decrement is the percentage of decrease in two consecutive waves by some fault in the antenna which produces damping. Damping is the name of the thing itself, while the decrement is the amount of damping.

IMPEDANCE. — (*Im-ped-entz*) — Means hindrance and refers to the throttling of an electric current as it passes around a circuit. If a steady current such as comes from a storage battery is allowed to flow around a wire circuit, there is a certain friction, called "resistance," which tends to limit the amount of this current that can flow. But if the current, instead of being a steady one, is an alternating current—one that flows first in one direction and then in the other—another kind of friction called "reactance" is produced. The impedance combines reactance and resistance.

GRID POTENTIAL. — The amount of voltage placed on that part of a vacuum tube known as the grid when a radio wave enters the detector circuit. This potential is something adjusted by a dry battery known as the "C" battery.

S. S. C. WIRE; S. C. C. WIRE; D. C. C. WIRE.—All of these terms refer to the kind of insulation used on the wire. In the order given, the translations are as follows: Single silk covered; single cotton covered; double cotton covered. The words "single" and "double" refer to the number of layers of the material.

SPAGHETTI TUBING.—A special tubing made of highly insulating fabric. The tubing is used to slip over the connecting wires of receiving sets to prevent short circuits and to give the wiring a neat appearance.

ANTI-CAPACITY SWITCH. — Switches embodying a type of construction and method of operation which does not introduce a condenser effect where such a thing would not be desirable.

POTENTIOMETER. — (*Po-tent-she-om-e-ter*). — A resistance coil usually provided with a means of varying the amount of resistance it is desired to use.

The Beginner's Catechism

By Edward Linwood

What is a vacuum tube?

A vacuum tube is a glass bulb shaped very much like the bulb of an incandescent lamp and of similar size. It contains three elements, respectively the grid, filament, and plate. It is given the name of *vacuum* tube because the air within it has been reduced to an exceedingly low figure.

* * *

What is the grid?

The grid may be either a network of fine wire of tungsten tantalum, or

nickel, or a perforated plate of one of the same metals. One end of the grid is connected to the tuning coil and the other end left free.

* * *

What is the filament?

The filament is usually made of finely drawn tungsten wire coiled in a spiral similar to the filament in the ordinary house-light. The filament is heated to incandescence by a 6-volt storage battery. The battery must not be over 6 volts.

What is the plate?

The plate may be either a flat plate of nickel, or, as in some tubes, it may take a cylindrical form completely enclosing the other two elements.

* * *

What part does the grid play?

The grid, being the end of the wire from the tuning coil is affected by the radio waves as they strike the aerial and enter the receiving set. These waves are first positive and then negative. The grid, being connected to the same circuit is, likewise, alternately positive and negative. When waves are coming in the aerial, the grid—in its position inside the tube, acts as a magnet would if first one pole were pointed toward the filament and plate and then the other pole. In other words, the grid causes the space within the tube to become positive and negative repeatedly.

* * *

What part does the filament play?

The function of the filament is to provide those minute charges of electricity called electrons. Scientists discovered, many years ago, that when a body was heated to high brilliancy

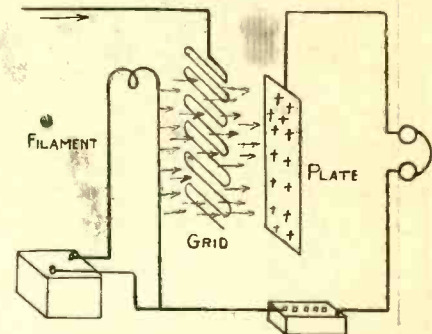

Graphic representation of a vacuum tube showing the relation between various parts and how the electrons pass from the hot filament through the grid.

the atmosphere about it was charged negatively, that is, if a metal plate were placed near the incandescent body and connected to a sensitive instrument, the latter showed that a current of negative electricity was given off. The reason for inserting the filament into the vacuum tube, strictly speaking, was not a radio reason but an electrical reason.

* * *

What part does the plate play?

The plate completes what the filament starts. The plate being connected in the circuit so that it is always positive attracts the negative particles from the hot filament. Otherwise, there would be no place for these electrons to go. The plate is never heated to incandescence or even to redness. The current passing through it is very slight, somewhere in the order of decimal 5 to 2 milliamperes. As the common house light

Big Track Meet Radios Results

The first radio broadcasting station at a track meet was used at the big athletic tournament at Des Moines, Iowa, when the State College recently held its spring program. So great is the interest in college athletics that whenever a new figure is hung up, it is of first importance not only to every institution of learning in the United States

but to every graduate. At the Des Moines meeting a special broadcasting-station was erected. The instruments were installed in the booth shown in the photograph. As fast as an event took place, the news was broadcasted. Every college and university with a receiving set was listening in.

(c. Underwood & Underwood)

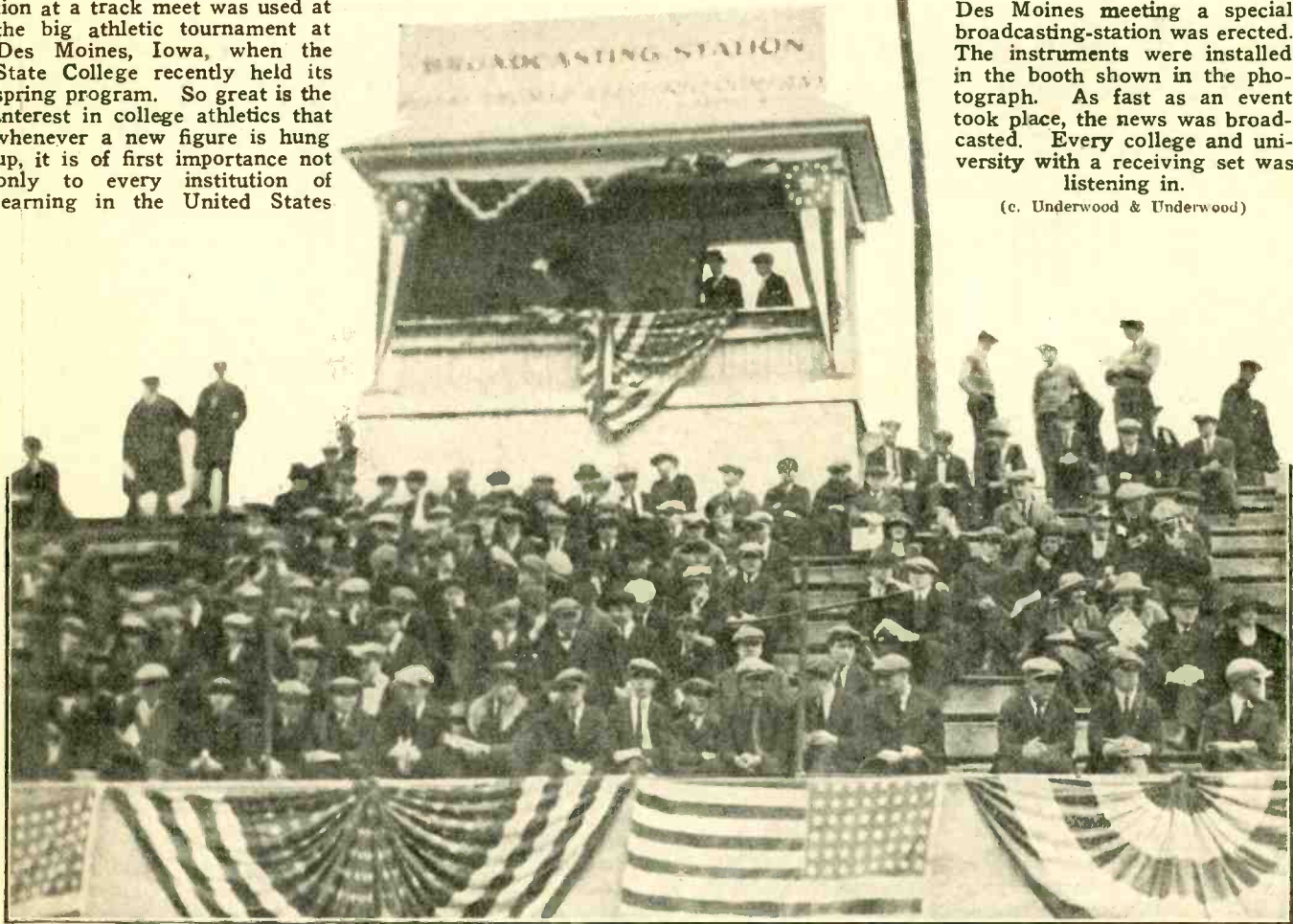

(Continued from preceding page) consumes about half an ampere, it is a simple matter to appreciate the almost negligible current flowing in the vacuum-tube plate.

* * *

How do these three elements work together to act as a detector?

In the illustration, the three parts are shown in the same relation which they assume in the tube. First the filament, then the grid, and finally the plate.

Referring to the description of the filament, (see opposite page) it will be understood that the little charges, electrons, fly off the hot filament and travel over to the cold plate. But in doing this they are forced to pass through the fine wires or the perforated gauze which comprises the grid. Some of the charges might succeed in working around the side of the grid, but since they travel with tremendous speed, they naturally seek the shortest line to their objective. Therefore, they pass through the grid or they do not reach the plate.

If the grid is merely a series of cold wires, unconnected to any other elec-

tric source, there is no particular reason why all the electrons, should not reach the plate. But the grid in a vacuum tube is connected to the aerial. It, therefore, carries an electric current. What happens when these negative electrons strike the grid which is alternately positive and negative? The answer to that question explains the operation of the vacuum tube as a detector.

* * *

What would happen to these electrons if the wave on the grid became positive?

Practically everyone, has experimented with a simple magnet of the horse-shoe, or U-shaped, type and remembers that the magnet would attract a pin, but that after the pin had touched the magnet it could not again be attracted. Instead it would be forced away from the magnet when the latter was brought near it. This action is based on the magnetic fact that "likes repel, unlikes attract." When the magnet was first brought near the pin, the latter was neutral, it was neither positive nor negative.

Assuming that the positive pole of the magnet was nearest the pin, the pin would be attracted to the positive pole. But the instant that it touched this pole it, also, became positively charged. If, then, the pin were released and the north, or positive, pole of the magnet again brought near it, the like poles repelled each other.

In the vacuum tube, the same fact holds. The electrons are always negative. If the wave on the grid happened to be positive, the grid would attract the negative electrons and not only allow them to pass through, but would even propel them as they passed. The greater the positive charge on the grid, the faster the electrons could pass to the plate.

* * *

When the wave on the grid changes to negative, what happens?

If the grid is charged with negative electricity, the electrons are prevented from either passing through the fine wires composing the grid or from coming anywhere near it. The heavier the negative charge the more effective the grid in holding back or suppressing the electron flow to the plate.

Emergency Surgery Directed by Radio

By George H. Flint

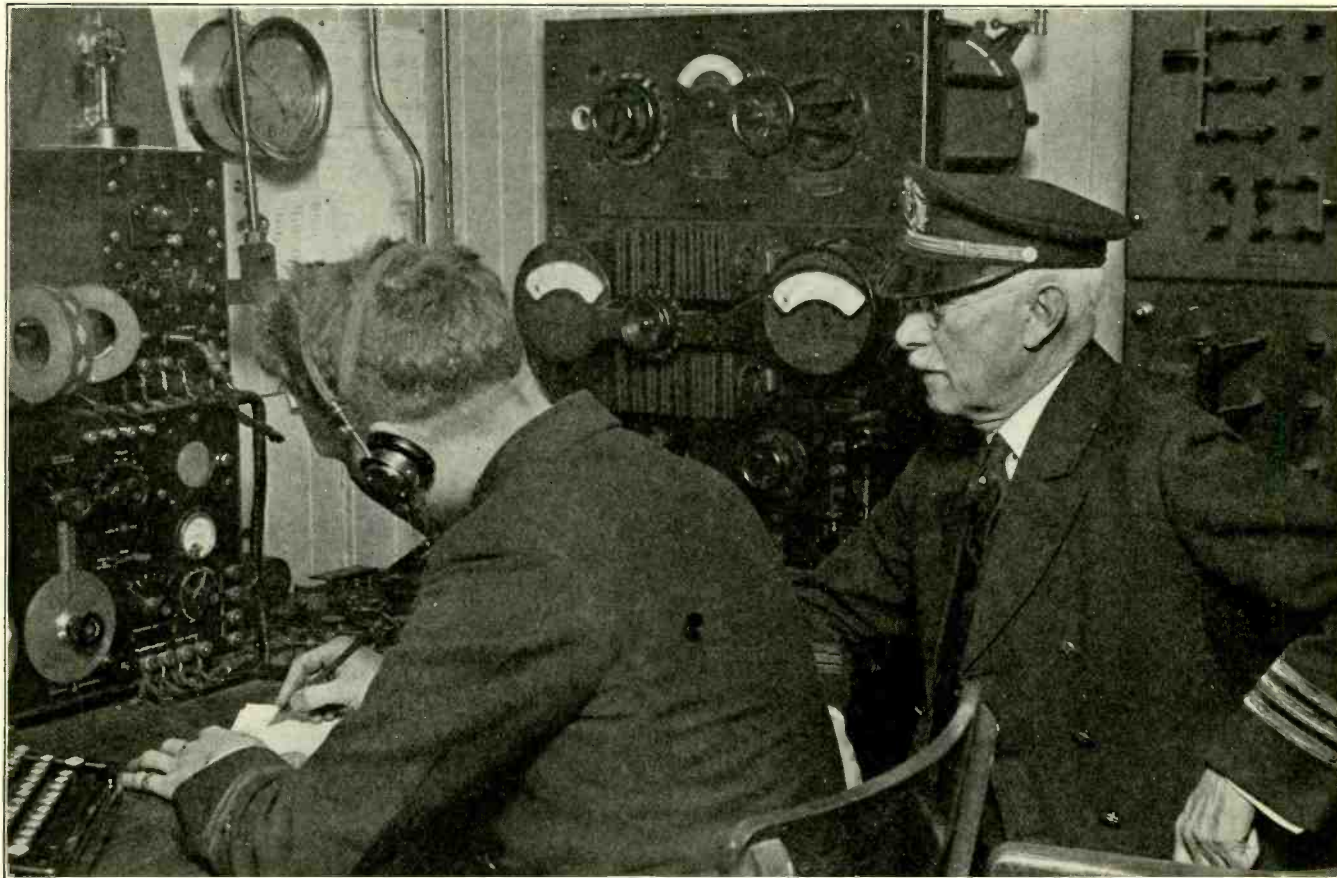

(Marine Photo Service)

Dr. Michael A. Rebert, surgeon of the steamship "Lone Star State," recently renamed "President Taft," of the United States Lines, giving directions by radio for the treatment of a sick man on a passing vessel.

A RECENT survey of the medical situation in the great fleet of vessels operated by the United States Lines reveals many startling and interesting facts regarding the greatly enhanced service of ship surgeons as a result of wireless communication. To-day, the ship surgeon is not only on duty constantly, caring for the ills of the passengers and crew, but he is being made more and more available for consultation with all vessels within wireless call.

Surgeons of the United States Lines have a more or less ocean-wide practice. In the days before the perfection of wireless, the surgeon confined his activities to the vessel on which he served. Nowadays, however, he is liable to be aroused in the middle of the night to hasten to the wireless room to listen to a diagnosis sent through the ether.

Within the last few years, investigation shows that the surgeons of the United States Lines have been called upon to prescribe for a score or more cases which were brought to them through the medium of wireless. It was aboard the "America," of the

United States Lines, that the first wireless telephone was installed. In two voyages, it was completely demonstrated that it was a success.

By wireless telephone, the ship's surgeon, Dr. Roy B. Henline, was told one night to give specific directions to a sick captain of a freighter 300 miles away. Dr. Henline had been aroused by the wireless operator and told that the commander of a small freight boat, who believed himself to be dying, decided he needed the services of a physician. Over the wireless telephone, Dr. Henline asked for the man's symptoms. Being informed, the doctor diagnosed the case as ptomaine poisoning. He prescribed remedies normally carried in the medicine chest of all small vessels, and having given his medical advice, retired again. In the morning, he was greeted with a wireless message of thanks from the ptomaine-stricken commander who stated that the remedies prescribed had relieved his trouble.

Among the surgeons of the United States Lines fleet is one who is a pioneer in wireless surgery—Dr. Wil-

liam S. Irwin, of the "Centennial State," which plies between New York and London. Some nine years ago, Dr. Irwin, then serving on a vessel plying between New York and Central American ports, was summoned to the wireless room, one day, and informed that the keeper of a lighthouse on a lonely island in the Caribbean Sea was suffering as a result of an injury to his leg, and that immediate medical attention was necessary. The island had five persons as its population, these being the lighthouse tender, his wife, a wireless operator and two other workmen, one of whom acted as cook.

Dr. Irwin asked for a complete history of the case. Across 800 miles of sea, the details were given him in dots and dashes. The lighthouse keeper had fallen, broken a leg, and gangrene had developed. Dr. Irwin came to the conclusion that immediate amputation was necessary to save the life of the sufferer. It was out of the question for the ship to get to the island, for the surgeon realized that the time consumed would be too great. He inquired whether or not the others on

Motor-Car Radio Making Rapid Strides

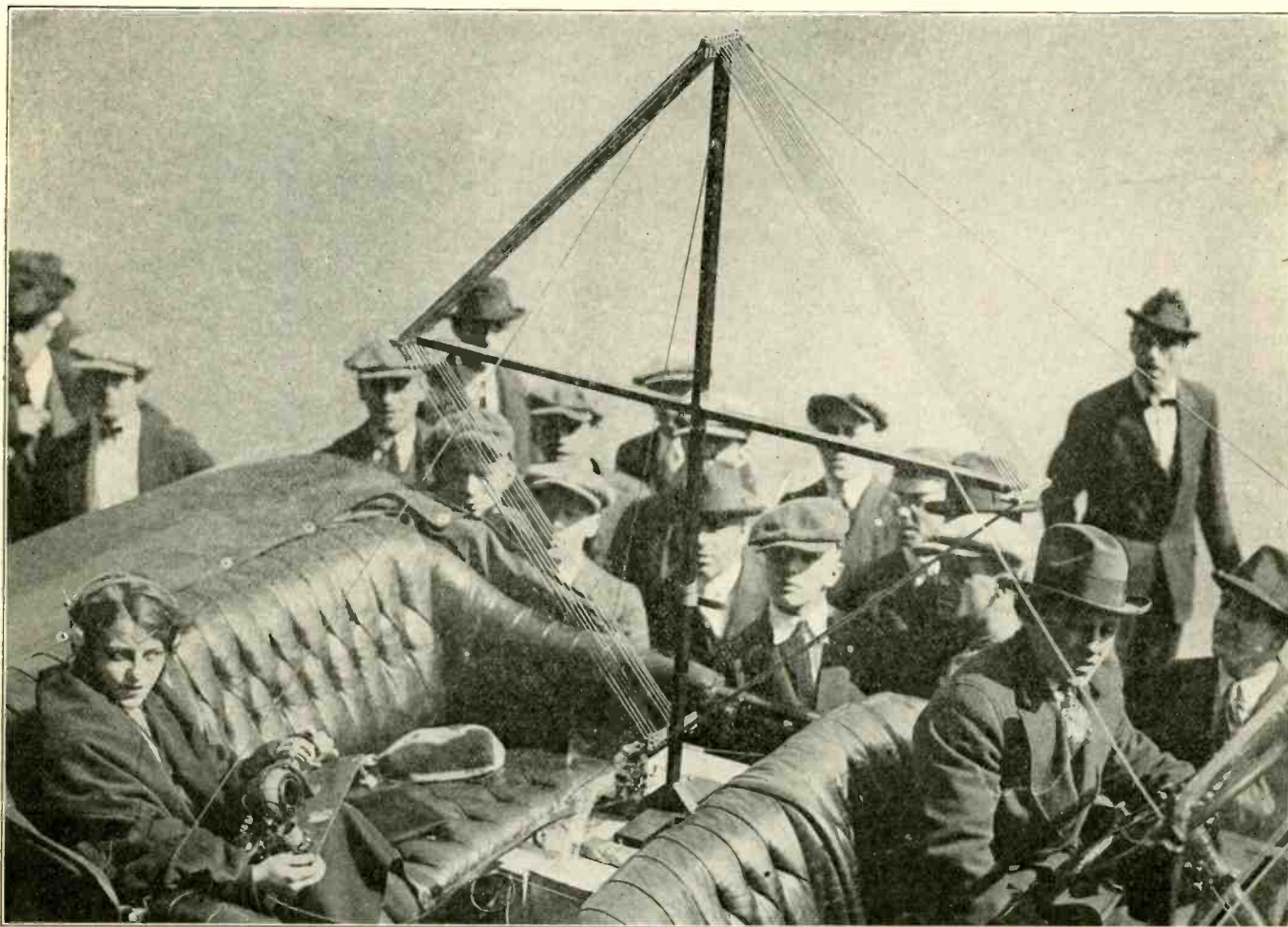

(c. Underwood & Underwood)

Now that the out-o'-door days are approaching, radio folk are not packing their receiving sets in moth bags but are putting them to important use. The photograph shows that Miss Shirley Ward had an ambitious set devised for her motor-car. With the aid of a tube in the set, and the batteries—which are on the floor of the car underneath the loop aerial—it should be possible for her to pick up signals.

(Continued from preceding page)

the island would be willing to attempt the necessary amputation, provided he gave them specific directions. Receiving an answer in the affirmative, Dr. Irwin detailed through the ether the process necessary for cutting off the injured man's limb. The surgical portion of the operation was performed by the cook, using as his instruments a butcher's knife and a kitchen saw. Inasmuch as no anesthetics were available, the injured man had to grin and bear it. During the next two or three days, Dr. Irwin received wireless communications regarding the state of the patient and found that, having a robust constitution, he was doing well. Several months thereafter, when Dr. Irwin's vessel was within wireless-talking distance of the island, he communicated with his patient, and found that he was well on the road to recovery. Only a few weeks ago, doctor and patient met for the first time—on the arrival day of the "Centennial State"

in the port of New York. A message that came from the pier informed Dr. Irwin that a man with one leg desired to see him. When Dr. Irwin reached the pier, the one-legged man grasped him by the hand and said, "Doctor, you don't know me; but you should inasmuch as you are responsible for taking off my leg."

Dr. W. S. Ford, of the "Potomac," of the United States Lines, aided and abetted the stork by wireless. Late one night, Dr. Ford was aroused to read a message which came from a freighter in mid-Atlantic which read as follows: "Captain's wife on board. Expect arrival of stork before we can reach port. Please assist." Dr. Ford detailed, in language that could be understood by a layman, the necessary directions to the far-off freighter, over which the stork hovered. Two days later, Dr. Ford received another message which read: "Have a new son. Don't know your first name, doctor, but will call him Napoleon Ford. A thousand thanks. God bless you."

Operated Over 4,200 Miles

Through the daily operation of its Cavite station to Honolulu, a distance of about 4,200 miles, which has maintained a 24-hour a day service for some time, the United States Navy believes it holds a record. Using a 500-kw., arc-transmitter, even San Francisco has heard Cavite's messages. When it does, Honolulu is notified and does not relay the message, as is ordinarily done, in transmitting 7,000 miles over the Pacific.

Recruiting by Radio

The Army Air Service recruiting station at Mitchell Field, N. Y. has adopted a novel plan of recruiting by radiotelephone. A broadcasting message calling for recruits for the Air Service was sent out recently and letters are being received from far and wide, in reply. The latest response came from an applicant in Buffalo, New York. By means of radio and other facilities, twenty-eight recruits were secured.

Design of an Amateur Receiving Set

By C. White

TO fully understand the design of an apparatus of any kind it is necessary to become well acquainted with the principles involved. E. L. Bragdon, in recent issues of RADIO WORLD, carefully explained tuning, which is the fundamental theory underlying the reception of radio waves transmitted through the ether. But in order to further augment his discussion, I shall briefly review the entire theory of radio communication.

Let us take, first, for our example of radio waves the case of visual disturbance of a smooth, quiet, water surface. If a stone be thrown into a pond of still water, there is immediately sent out from the spot where the stone pierced the water surface, a circular wave or ripple. This wave, impinging on a branch or twig projecting above the water line, is broken, forming another ring around the branch, then reuniting, it progresses onward until it is finally damped out by the resistance offered by the water. Here we have a perfect hydraulic analogy of a radio transmitting and receiving station.

Radio waves travel through the ether at the rate of light, which is 300,000,000 meters per second. If the length of one wave be 300 meters, then the number of waves that will be sent out in one second is 1,000,000. This latter figure is commonly called frequency. But, in wireless, we are accustomed to rate the characteristics of a wave by the wave length, and not the frequency, although, recently, the terms "radio" and "audio frequency" are very common. There is no definite line of demarcation between the two; but it may be stated that the audio-frequency range is from 40 to 10,000 waves (or cycles) per second, while radio frequency ranges from 10,000 to 3,000,000 or more cycles per second. Hence to receive or interpret signals sent out at radio frequency, we must have some method or device to bring such a high pulse within the range of audibility. This purpose is accomplished by the detector.

For a circuit to receive a certain type of wave it must literally offer an "open door," or the wave will not "come in." The tuned circuit is the "open door," and when we tune, which is the adjusting of the relative amounts of inductance and capacity, it is the "opening" which we are trying to accomplish. Suppose the cir-

cuit is tuned and we place our phones across the right part, we hear nothing, because the pulse of vibration is above the range of our ears. But upon introduction of a detector into the phone circuit, the pulse is immediately rendered audible.

To get down to brass tacks, let us study the case of one particular elementary receiver, such as shown in Figure 1. To tune that type of circuit, we can change the value of the capacity and the inductance by mov-

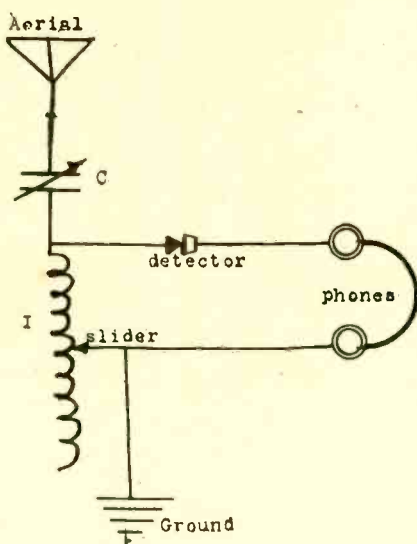

C.—A variable (or fixed) condenser of .001 mfd., or .0005 mfd.

I.—Single coil variable inductance (tuning coil.)

ing the plates of the condenser and the slider on the tuning coil until we get the maximum sound, then finer adjustments can be made on the detector, by searching for a more sensitive spot. Mathematically tuning is nothing more than satisfying the following equation:

$$I \times C = \frac{W \times W}{355 \times 10,000,000}$$

$$\text{or } I \times C = \frac{W^2}{355 \times 10,000,000}$$

I is the inductance in milli-henries.
C represents the capacity in microfarads.
W is the wavelength in meters.

The alert reader will immediately observe from the above formula that there are any number of values of I and C which will satisfy the equation for a certain given value of W, which is fixed by the sending station. Yes, it is quite true, that, from the mathematical standpoint, there is an infinite number of satisfying possibilities; but, on the other hand, from the practical standpoint, there are only a few good solutions.

It is this fact that allows considerable flexibility in design and construction. Now, for example, say we wished to build a set of the type illustrated, capable of receiving a maximum wave-length of 595 meters. We are also limited by the fact that the maximum capacity of a 43-plate variable condenser is .001 (1/100) microfarad. Substituting 595 for W and .001 for C and solving for I, we find that the tuning coil must have an inductance of .1 (1/10) millihenrie. If the maximum capacity available had been .0005 micro-farad (i. e. a 23-plate condenser) I would have to be .2 milli-henrie. Of course fixed condensers could be substituted instead of variable condensers, if the designer so desires, without upsetting the mathematical treatment in any way.

After having determined the value of I we can determine with the aid of the following equation, the actual specifications of a single-layer coil:

$$I = \frac{K \times D \times D \times N \times N \times L}{1,000,000}$$

$$\text{or } I = \frac{K \times D^2 \times N^2 \times L}{1,000,000}$$

I is the inductance desired in milli-henries.

D is the diameter of the coil in inches.

N the number of turns of wire per inch, length of the coil.

L the total length of the coil in inches.

K a number depending on the ratio of D/L (given in table).

Ratio: D/L	K
.05 (1/20) or less	25
0.5 (1/2)	21
1.0 (1/1)	17
1.5 (3/2)	15
2.0 (2/1)	13
3.0 (3/1)	11
4.0 (4/1)	9

D the diameter of the coil depends upon the size of the core or tube we are going to use; while N is fixed by the size of the wire to be used and the closeness of the winding.

It is obvious that the only things that are left for us to determine is K and L: for we have previously calculated the value of I which we wish to obtain.

The best way to work the formula is to substitute the value of D and N, which we know from the kind of material we are going to buy or already have, then make a guess at L, and using this guess value for L, determine by means of the table a corresponding number for K. If after solving the formula we find that the answer for I is larger than that we want, it is obvious that our guess for L was too LARGE, and we should make another guess, trying the for-

(Continued on next page)

Radio Concert for Shut-in Soldiers



(c. Underwood & Underwood)

The most elaborate concert ever sent out by radio was one given by four artists at the Naval Station, Anacostia, D. C., for the benefit of the wounded soldiers in the military hospitals at New York, Boston, Philadelphia, Baltimore, Washington, D. C. and Norfolk, Va. The illustration shows the interior of the broadcasting station with the concert players in view. Left to right: Grete von Bayer; Byrd Mock, chairman, concert committee; Adele R. Bush, H. K. Brown, educational director, Marie Howe Spurr, Patricia Ryan, American prima donna, William van Anandel, Dutch pianist; Elsa Louise Raner, Polish violinist; Richard Lorlebug, Commander Albert Hoyt Taylor, inventor of broadcasting apparatus.

Successful Experimenting with Radio World Stunt

RADIO WORLD No. 5, dated April 29, contained an article, "A Circuit for Amateurs to Experiment With," with an original diagram. The article and diagram were the work of Fred. Chas. Ehlert, of our editorial staff. The diagram described a regenerative circuit employing a tickler coil in the plate circuit. It was self-explanatory. Mr. J. J. Casmay, a RADIO WORLD subscriber, who asks us to withhold his address, tried the experiment. That he was unusually successful, is shown by his letter which follows:

Editor, RADIO WORLD: Referring to Mr. Ehlert's diagram in RADIO WORLD No. 5 dated April 29, I wish to state that his regeneration circuit worked with remarkable results. The set was constructed by

myself as described, and, when finished. I heard WJZ, KDKA, 2 BX, 2 BML, XFI, and others in the 1st, 2nd, 3rd, 4th, 8th, and 9th districts. Using 600-meter coils. I heard NAM, NAX, WCC, NCZ, NBD, NAN, NAH, and others, I also heard the

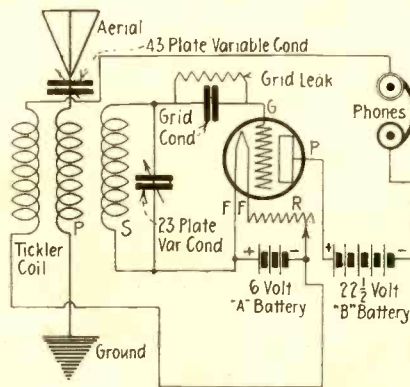

Circuit employing tickler coil set to produce regeneration. Drawn by S. Newman.

steamer "Sunbeam" entering the English Channel. I used a 65-foot 4-wire antenna and 3 stages of amplification.

The same night the steamer "Anetta" was copied off the Florida Coast. Then I used a V.T.-1 J tube. The variable across the grid and filament is essential, as the coils give only a slight increase and decrease of wave length.

If listening to compass stations is desired, the secondary and tickler must be kept close together. Move the primary about 6 inches from the other two coils, and turn the variable to about 80 degrees. This circuit may be doubtful to many, but just try it if you have a good tube that will oscillate, and you will be surprised with the results obtained.—J. J. CASMAY.

Operators who witnessed and copied the above, as well as Mr. Casmay, are 3 AI and 3 OVX.

For the benefit of RADIO WORLD readers who may have overlooked this experiment, we reprint both circuits in this issue—one on our front cover and the other herewith.

(Continued from preceding page)
mula again. If the second guess make I come out smaller than desired, then we are assured that the right value of L lies between the two guesses. On the third guess, one can always hit close enough to approximate the length the coil should have.

Suppose we want to design a coil to have a maximum inductance of .2 milli-henries. The coil is to be wound on a 2-inch tube with wire capable of having 20 turns to an inch, thus making our value of D equal to 2 and N equal to 20. Next, let us guess 10 inches for L, and, by using the table, we can see that the nearest value of K is 25 approximately. Then if we

make the above substitutions in the equation, I will come out to be about .4 millihenries, which is too large. Now we must try another value of L, which is smaller than 10, let's say 6 inches. Our value for D and N will be the same as before, but L will be 6 and K (from the nearest number corresponding to the ratio 2/6) will be 21. On using these numbers in the formula, we find that I comes out about .2 milli-henries, just the amount we wanted. Thus showing that very often one can guess close enough to the right value of L, on the second trial.

In design work we should always add a little more to the results we get

by formula so as to allow for slight error, not only in approximate formula, but also in the actual carrying out of the construction work.

Take, for instance, the problem just solved, it would be far better to make the coil 7 inches long then 6 inches; because, by so doing, we actually know that we are on the safe side of the fence. Again, always design for the critical condition, which in the problem just set forth was the maximum wave-length that it was desired to receive, and not the minimum. A bridge designer always designs the bridge to carry the maximum load, when he knows that smaller loads can be handled safely.

Will Radio Replace the Phonograph Will Radio Keep People from Church Will Radio Hurt the Theaters Will Radio Increase Authors' Royalties

By Everett Ewing

A TITANIC interrogation point, reaching from horizon to zenith, thrown suddenly across the sky by some powerful and little understood force, might startle more persons than have been amazed by the phenomenal development of the radiotelephone.

But it is unlikely that it could start more inquiry or create greater interest.

Questions are being asked—some for information merely; others aiming for early installation of receiving sets that the benefits of the wireless telephone may be had. These questions are being hurled at electrical-supply dealers, electrical manufacturers, amateur radio-experimenters, scientists, inventors.

Another class of questions come from those who are not certain that their sources of income will not be affected. The economic phase of the communications revolution has them puzzled.

Manufacturers of phonographs, talking machines, voice and music reproducing records; manufacturers of player-pianos and of other musical instruments; writers of songs, music composers; preachers, lecturers, and other platform artists—all are among those who see the bread-and-butter side of the problem that has come out of the air. They do not know the answers—yet. Here are just a few of the questions:

Will the radiotelephone take the place of the phonograph as an agency for entertainment in the home?

Will broadcasting sermons keep people from attending church services.

Will broadcasting popular music decrease the royalties of the song writers and composers?

What will happen to the income of artists in grand opera? To principals and chorus in musical productions? To vaudeville stars?

What will be the effect on box-office receipts of theaters presenting such entertainment?

Can manufacturers prevent the broadcasting of what appears competitive entertainment?

Should preachers keep transmitting equipment out of their churches?

Will song writers and composers be able to compel makers of radio equipment to pay them for the use of their words and music?

How will the radiophone's popularity affect the opera stars, the musical-comedy players and the vaudeville folk?

How about the theater's future?

How long will this radio craze last?

These and scores of other questions are being asked.

A titanic interrogation point seems to have been thrown across the sky with startling suddenness.

* * *

Last Armistice Day, after elaborate preparations had been made to perform a latter-day-magic feat, President Harding spoke to a throng estimated at a hundred thousand, in Arlington Cemetery, Washington, D. C., and his words were carried by long-distance telephone connections to 30,000 persons in New York City and to 20,000 more in San Francisco. Amplifiers and repeating units at points along the circuit from Washington to New York, and to San Francisco, produced the miracle of carrying the President's voice across the continent in less than one-fiftieth of a second!

That, little more than four months ago, was hailed the acme of achievement. The pinnacle of progress, in communication at least, had been reached.

With such equipment, it was frankly forecast, the President of the United States might, if he so desires, talk from the White House to gatherings assembled in every State in the Union. The head of any vast organization might speak to its every member scattered throughout the nation, and hundreds of miles apart—speak once and be heard many times, each time at some point on the circuit.

* * *

To-day, no such elaborate hooking up of circuit, installation of amplifiers and use of repeating units are necessary—no great and expansive system of wires.

To-day, such widespread communication is possible without wires—save the short lengths used as antenna or aeri-als, or in the coils in the little

boxes which transform vibrations caught from the air to the voice or sound waves sent broadcast on what is known as a wave length.

Great broadcasting stations have been established—some of them have been broadcasting a daily program regularly for more than a year. At first, enthusiastic amateur radio-operators and electrical experimenters formed the audiences. Their numbers grew steadily. Many of them were boys who caught the voices—the musical and other sounds. They interested adult friends and parents in their experiments. For a time the radio sets were looked upon as toys—entertaining, amusing toys.

Manufacturers of receiving sets, having wider range than the crude equipment many youngsters possessed, arranged better programs—interested noted singers, lecturers, preachers, in participating in the giving of wireless entertainment, instruction, and information—and sent them broadcast.

The receiving set found its way into the homes of business and professional men who found the novelty of it all to be refreshing and restful. The tired business man, after supper and his evening paper, lighted pipe or cigar, comfortably settled himself before his receiver set, lighted its bulbs, turned a knob or two, not unlike those on safe combinations, until a whistling sound was heard. Then, giving the receiver's "tickler" a twirl or two, he sat back to smoke and listen. With the few slight, simple movements, he had swung in on the wave length of Pittsburgh, of Chicago, of Newark, or Springfield, Massachusetts, or one of the other broadcasting stations.

Perhaps it was Pittsburgh he caught first. Perhaps the program there was not to his liking. All right. He could get what he did like. Simple movements of knob on dial "cut out" Pittsburgh, and "cut in" on Chicago's wave length, or Newark's, or Springfield's. "Ah! that's more like it," he'd decide.

Music—the violin — *Humoresque*. A pipe organ, full, rich, mellow—"The Pilgrims' Chorus".

And then comes the New York

(Continued from preceding page)

stock review; the cotton market; other market news and views; government statements; the weather forecast. And as the broadcaster swings through his schedule into agricultural information, more interesting to the farmer than to him, the tired business man "cuts out." He wants to hear *Humoresque* again. He crosses the room to the record cabinet, finds the number, places it on the machine and, starting the motor, his phonograph plays the encore.

* * *

Right there is the answer to the talking-machine maker's question. Music that comes in over the wireless does not remain, to be tapped at will. Music that comes from the record is, in a measure, permanent. The appetite, awakened by the radiophone, is appeased by the phonograph.

In the case of sermons, the answer is similar. The central idea is much the same.

Reverend Stuart Nye Hutchison, pastor of East Liberty Presbyterian Church, Pittsburgh, one of the preachers whose sermons have been broadcasted and who, through the receiver he has installed in his Pittsburgh home, has heard the preaching of others, is enthusiastic for the broadcasting of sermons. While visiting a former charge at Norfolk to conduct a week's series of Lenten services, Dr. Hutchison declared:

"Broadcasting sermons is going to prove a good thing for the church. It is going to interest them in the church, awaken a desire to attend services, and increase the sizes of congregations. When his sermon is sent broadcast, a preacher is heard by half a million people. I know of no other way such a vast audience can be reached."

Churches are not likely to reject so powerfully an ally as the radiotelephone.

Artists in the opera, in musical comedy *revues* and vaudeville, whose work is reproduced on the phonograph, draw royalties from the record manufacturers. These have nothing to lose in contributing their services to the broadcasters, when consideration is given the fact that, by wireless, they are heard by an ever-growing audience in which are many who have never before heard them. These hearers are potential purchasers of the discs preserving their voices. That which pleases creates desire for further enjoyment.

* * *

Song writers and composers present the most difficult of the many questions, or so it seems to-day, for

Use Radio in Mimic Warfare



(c. Underwood & Underwood)

The military review of the Lane High School, Chicago, was conducted by its students entirely through radio service. Major E. S. Pearsall gave orders in his office which were transmitted direct to the field of battle, and from there relayed to the field officer through a megaphone. The photograph shows the receiving set, antenna, and megaphone of the student officers.

they actually are, or have been, in conference with the leading receiving apparatus manufacturers who are the most prominent broadcasters. The purpose of these conferences is the reaching of some understanding with reference to payment for the use of their songs.

Musical productions, vaudeville acts, and other vocal entertainment management afford the song writers a certain protection of their rights in the music sung at the shows. Royalties are fattened for the authors—directly and indirectly. People "out front" hear and like the songs; the airs stand by, they can be whistled. And, in a day or so, those persons are to be found buying the music they whistle.

So, after all, the song writer's royalty problem may not be so difficult as the song writers think. Chances are that it will solve itself. Hearing the song *via* wireless cer-

tainly should make as pleasing an impression as hearing it across the footlights. Increased sales of meritorious work would seem in natural sequence.

* * *

Need the theater worry about the future? The theater advertises; believes in advertising—if the display columns of newspaper amusement pages form any sort of a gauge. Pick up any paper. Turn to the amusement pages. Accompanying, or somewhere near, the theater's paid announcement is a story of the play, or a review. Often the article tells the whole thing—even "gives away" the point the production hinges upon—the climax; makes plain the most tense situation; tells where lies the suspense and the secret of interest.

That doesn't hurt the "show;" doesn't curtail attendance. On the contrary, box-office receipts are swelled. The people want to see what they have read or heard about.

The principle is the same as going to a fire, or to see where a wreck occurred. The most central point in the United States, psychologically, cannot be elsewhere than "in Missouri"—which is where, figuratively, most of us are from.

The future of the theater appears safe enough. Under the curiosity-impelling influence of the radiophone, the theatre should thrive.

* * *

The radiotelephone is in its infancy. It is still in crude shape, wonderful as it appears to be. The radiotelephone is an improvement on the wireless telegraph, just as wire communication was improved when the human voice, instead of "dots and dashes" alone, could be flashed over it. Possibilities with the radiotelephone are limitless.

Inventive genius and scientific mind are probing those possibilities now, and discoveries are being made so rapidly that they fairly daze the layman.

Radiotelephony owes its tremendous popularity to-day to the fact that it is pliable in the hands of those who have little or no technical knowledge of electricity. Any one of average intelligence possessing a receiving set can tune it to the wave length that carries the entertainment, instruction, or information one desires.

The "radio craze," as that term is used, is here to stay. There is no craze in reality. The radiotelephone is not a fad—it has passed the toy stage. It is practical and most useful, and with vast powers inherent, gives promise of becoming the one great agency that answers not only the questions it has prompted but many other and graver questions.

Radio Merchandising

The Service Radio World Gives

LET RADIO WORLD be your amplifier. Its advertising columns will broadcast your your trade message to over 70,000 radio buyers every week.

Without cost, RADIO WORLD is prepared to render the following valuable service:

Giving technical advice and suggestions by radio experts.

Preparing advertising copy.

Attending to all the details of making proper cuts or illustrations.

Selecting right type to give pleasing typographic effect to advertising copy.

Suggesting reliable advertising agents.

A quick, reliable printer. A successful experienced man to prepare

your catalogues, booklets, leaflets, and other literature, relieving a busy manufacturer of all such details.

Suggesting an expert to write your circular letters.

RADIO WORLD even knows of some capitalists willing to put substantial backing in promising radio ventures.

RADIO WORLD's mission is to interest, inform and amuse the radio fan; to serve, assist, and bring profitable results to manufacturers and radio distributors who use its advertising columns.

For quick action and personal service, address Fred S. Clark, manager, RADIO WORLD, 1493 Broadway, New York, N. Y.

Communicate with Them

Editor, RADIO WORLD: I want addresses of firms, that are manufacturing radio sets, and selling to dealers. The writer would like to get in touch with such firms selling on a commission basis.—E. M. Kennedy, 989 Dayton Ave., St. Paul, Minn.

Editor, RADIO WORLD: Would you be kind enough to send me the names of any firms or persons who would sell their radio sets and equipment on the easy-payment plan.—Arthur Sherman, 63 Tremont St., Taunton, Mass.

Editor, RADIO WORLD: We are desirous of securing the distribution of a complete radio outfit, and would appreciate your furnishing us with the names and addresses of manufacturers that are producing crystal and tube sets.—The Van Kerr Co., 5 Columbus Circle, New York, N. Y.

De Forest President Predicts Radio Success

THOSE who see in the present radio development no more than a boom period, hold views that are not in accord with Charles Gilbert, president and general manager of the De Forest Radio Telephone and Telegraph Company. This company recently completed plans for moving the De Forest Laboratories and factory from the small High Bridge station, New York City, to new and greatly enlarged quarters at Jersey City, N. J.

"Only the surface has so far been scratched," says Mr. Gilbert. "I make this statement after a careful study of the experience which the De Forest Company has had, going back a number of years.

"There had been many indications that the public would awaken to a full realization of the possibilities of the radio art; but, apparently, the time had not arrived when people were ready to recognize what could be done with radio apparatus.

"With the present widespread use of broadcasting, however, and with a knowledge on the part of the public of what can be done in the way of receiving news, music, and educational information, radio will never be permitted to lapse back into its previous dormant state.

"Just what particular line of development the art will follow, it is hard to say. The De Forest Company is establishing itself for a continuous and permanent growth, however with the feeling that radio will play each year an increasingly more important part in the life of this and other nations."

The recently acquired property of the De Forest Company in Jersey City is the former plant of the Franco-American Food Company, at Central Avenue and Franklin Street, covering an entire city block, with 32,000 square feet available for immediate use.

Editor, RADIO WORLD: We have a live-wire high-pressure sales force and are anxious to secure a complete radio line for distribution in Chicago territory. A live-wire house that can make prompt deliveries, can secure real distribution through us in the Chicago territory. Let us hear from you at once.—Old Line Agency Company, American Bond and Mortgage Building, Chicago. Thomas Connelly, manager.

Don't Be Afraid to Buy Good Sets

Time was, on meeting Bill. I'd ask, "What's the news?" Now that I have a radio set, I tell Bill the news.

Every "live wire" should have a radio in his home. Conan Doyle tells us even the "dead ones" use radio. He suspects the messages that spiritists receive from the other world are in regard to radio. But it takes a good medium to receive them.

Radio material is now more plentiful. A smart boy can get all the necessary material to build a practical outfit consisting of tuner, detector, and telephones for about \$20. A crystal set complete, having an auditory range under favorable conditions of fifteen to twenty miles, costs about \$25.

A real good vacuum-tube outfit with amplifier, so that a whole family may enjoy distinctly received messages from a broadcasting station, could be put up for \$40 up to its cost. One gets in motoring the same exhilaration, good fresh air, and the same beauty of scenery, whether he be in a Ford or a Rolls-Royce, and so, your radio-receiving set, like the motorcar, is largely a matter of personal taste and what you can afford. If I could afford a three-hundred dollar radio outfit, I certainly would not buy a thirty-dollar one. On the other hand, if \$30 were all I could afford at the moment, that is the price I would pay. I would not miss the entertainment, information, and fun, I could give my family and myself now, with the low-price radio outfits, simply in the hope that I might be able to buy a better one later.

SUBSCRIPTION BLANK



RADIO WORLD CO.,

1493 Broadway, New York City.

Please send me RADIO WORLD for months, for which

please find enclosed \$

SUBSCRIPTION RATES:

Single Copy	\$.15
Three Months	1.50
Six Months	3.00
One Year (52 issues) ..	6.00
Add \$1.00 a Year for Foreign and Canadian Postage.	

Inventor Says He Can Steer Torpedo by Radio from England to New York

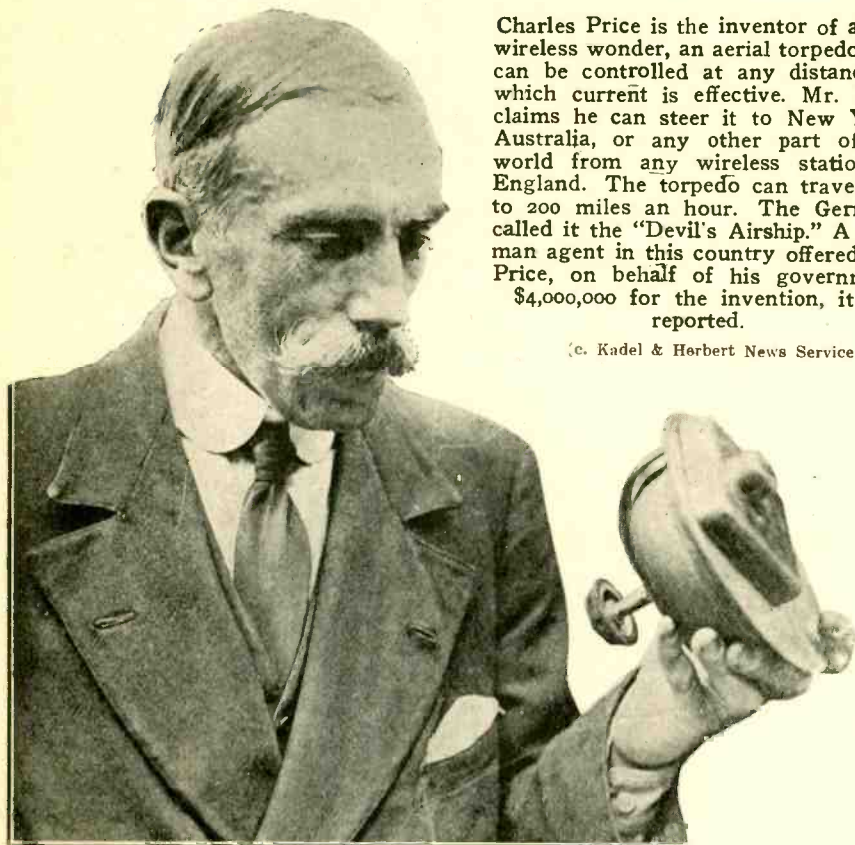

Charles Price is the inventor of a new wireless wonder, an aerial torpedo that can be controlled at any distance to which current is effective. Mr. Price claims he can steer it to New York, Australia, or any other part of the world from any wireless station in England. The torpedo can travel 175 to 200 miles an hour. The Germans called it the "Devil's Airship." A German agent in this country offered Mr. Price, on behalf of his government, \$4,000,000 for the invention, it is reported.

(C. Kadel & Herbert News Service)

New Radio Firms and Corporations

THERE were filed with the Secretary of State of New York, at Albany, during April, the papers of fifty-six corporations dealing in radio apparatus. Their aggregate capitalization is \$1,759,600. The number of incorporations in April was 1,534, as compared with 1,717 in March. All but 238 of the companies incorporated in April are located in New York City.

RADIO WORLD receives many requests for the addresses of the new corporations published in its merchandising department. So far as is possible, the addresses of the lawyers of these firms are given. Address your communications to them.

Multiple Storage Battery Corp., 350 Madison Ave., New York, N. Y.

Mook Electric Co., 342 North Avenue, New Rochelle, N. Y.

R. Goldman, 12 North Ave., New Rochelle, N. Y.

W. C. Poellnitz, 89 North Ave., New Rochelle, N. Y.

Clartone Radio Sales Co., 1607 First National Bank Bldg., Detroit.

The Stine Screw Holes Co., Waterbury, Conn.

Rokay Electric Co., Ingomar, O.

Midget Radio Co., 211 N. Jackson St., West Frankfort, Ill.

Harry B. Reinhart, Oxford and 24th Sts., Philadelphia. Opened a radio department for amateurs only.

The Ogden Wireless Laboratories, 1012 Ogden Ave., New York, N. Y.

Philadelphia Wireless Sales Corp., 1533 Pine St., Philadelphia.

H. C. Spratley Co., 357 Main St., Poughkeepsie, N. Y. Manufacturers and jobbers.

Aerophone Radio Corporation, Wilmington, Del.

Aerophone Radio Corporation, Cincinnati.

United States Radio Corp., Chicago.

World Radio Corporation, St. Louis.

Famous Radio Corporation, Pittsburgh.

Paramount Radio Corporation, Detroit.

Reliance Radio Corporation, Denver, Colorado.

Consolidated Radio Corp., Dallas, Texas.

Amalgamated Radio Corp., St. Paul, Minn.

Broadcast Radio Corporation, Louisville, Ky.

Vytaphone Radio Corporation, Baltimore.

Interstate Radio Co., Manhattan, contracting and electrical work, \$27,000; E. D. Hayward, L. T. McManus, F. Scotts. (Attorneys, McKercher & Link, 40 Rector St., New York.)

Great Eastern Radio Corp., Wilmington, Del., electro or electro magnetic communications, \$2,000,000. (Corporation Trust Co. of America.)

Standard Electric Sales Co., electrical equipment, \$50,000; Wallace L. Fleming, Ross D. Cummings, Harold E. Johnson, Chicago. (Corporation Maintenance and Service Co.)

Scientific Radio Company, Manhattan, radio sets, \$10,000; R. Jones, M. Libby, D.

S. Finck. (Attorney, J. L. Rosenberg, 15 Park Row.)

Glassel Radio Corp., Brooklyn, \$50,000; F. W. Glassel, A. S. Salver, T. C. Torrey. (Attorney, M. H. Winkler, 50 Wall St., New York)

Atlas Radio Corp., operate systems, \$1,000,000; Chas. Graff, Jr., New York. (Registrar & Transfer Co., New York.)

Harriman Radio Manufacturing Corp., install radio apparatus, \$75,000,000; Frederick C. Harriman, Myron Coldsoll, Chas. Freshman, New York. (Colonial Charter Co.)

American Radio News Corp., Manhattan, transmit messages by radio, \$250,000; M. Singer, L. H. Axman, I. W. Hirschfield. (Attorneys, Eppstein & Axman, 175 5th Ave., New York.)

Broadway Radio Corp., Manhattan, merchandise and electrical works, \$10,000; A. H. Michaels, G. T. Berinati, J. H. Nototny. (Attorneys, Almy, Van Gordon & Evans, 46 Cedar St., New York.)

Radio Course Co., Manhattan, correspondence course, \$5,000; G. Thurston, W. R. McAlevey. (Attorney, J. D. H. Hoyt, 15 East 40th St., New York.)

Radio Board of Commerce

THE National Radio Chamber of Commerce, organized for the purpose of remedying some adverse conditions that have come to the surface in the radio industry—the natural and inevitable result of its rapid growth—and to keep manufacturers in closer touch, held its first meeting at the Hotel Brevoort, New York, on May 5.

Eligibility to membership in the new organization will not depend on the size of a concern but on the quality and dependability of the product manufactured. It is proposed to organize a credit bureau for the interchange of credit information. The following are the officers:

President, Alexander Eisemann, of the Freed-Eisemann Radio Corporation; first vice-president, Randall Keator, of the De Forest Telephone and Telegraph Company; second vice-president, William Dubilier Condenser Company; secretary, Joseph D. R. Freed, of the Freed-Eisemann Radio Corporation, and treasurer, F. Hinners, of the Home Radio Corporation.

Deals Wholesale Only

Editor, RADIO WORLD: Believing that any radio concern, in the best interests of its patrons, should establish itself either as a retail or wholesale business only. The Radio Stores Corporation has given up its retail interests.

We have leased an entire floor at 222 W. 34th Street, New York City, where we will now maintain our warehouse and executive offices. At present we are well stocked and in a position to supply the need of the dealer and distributor exclusively.—Radio Stores Corporation, New York, N. Y., by F. W. Cumming, treasurer.

Coming Events

INTERNATIONAL RADIO SHOW—71st Regiment Armory, 34th St., and Park Ave., New York City. May 22 to 27.

MILO E. WESTBROOKE RADIO SHOW—Leiter Building, Chicago, June 25 to July 1.

CHELSEA RADIO ASSOCIATION SHOW—Hudson Guild, 436 West 27th St., New York City. Evenings of May 26 and 27.

FIRST CENTRAL WEST RADIO SHOW. Auditorium, Milwaukee, Wis. Week of June 21.

Radio World's Up-to-the-Minute M

Call Letters	Wave Length	Operated By and Location
WBU	360	1 City of Chicago, Chicago
KYW	360	2 Westinghouse Co., Chicago
WMH	360-485	3 Precision Elec. Co., Cincinnati
WLW	360	4 Crosley Manufacturing Co., Cincinnati
WHK	360	5 Warren R. Cox, Cleveland
WFO	366-485	6 Riker Kumler Co., Dayton
KIZ	360-485	7 Reynolds Radio Co., Denver, Colo.
WWJ	360-485	8 Detroit News Co., Detroit, Mich.
WHW	485	9 Stuart W. Seeley, East Lansing, Mich.
KDKA	360	10 Westinghouse Co., East Pittsburgh, Pa.
KFU	360	11 Precision Shop, Gridley, Cal.
WRK	360	12 Doron Bros. Elec. Co., Hamilton, Ohio
KGC	360	13 Hamilton Mfg. Co., Hollywood, Cal.
WLK	360	14 Hamilton Mfg. Co., Indianapolis
WOH	360	15 Hatfield Electric Co., Indianapolis
WOS	360	16 Mo. State Marketing Bureau, Jefferson City, Mo.
WNO	360	17 Wireless Tel. Co. of Hudson County, N. J.
WQO	360	18 Western Radio Co., Kansas City, Mo.
KLP	360	19 Colin B. Kennedy, Los Altos, Cal.
KJS	360	20 Bible Institute, Los Angeles
KQL	360	21 Arno A. Kluge, Los Angeles
KYJ	360	22 Leo Meyberg Co., Los Angeles
KOG	360	23 Western Radio Co., Los Angeles
WHA	360-485	24 University of Wisconsin, Madison, Wis.
WGI	360	25 Amer. Radio & Research Corp., Medford Hill-side, Mass.
WLB	360-485	26 University of Minn., Minneapolis, Minn.
WGH	360-485	27 Light and Water Power Co., Montgomery, Ala.
WCR	360	28 Bamberger & Co., Newark, N. J.
WJZ	360	29 Westinghouse Co., Newark, N. J.
WCJ	360	30 A. C. Gilbert Co., New Haven, Conn.
WJX	360	31 De Forest Radio Co., New York City
WDT	360	32 Ship Owners Radio Co., New York City
WVP	1450	33 United States Army, New York City
KZM	360	34 Preston D. Allen, Oakland, Cal.
KZY	360	35 A-P Radio Supplies Co., Oakland, Cal.
KLS	360	36 Warner Bros., Oakland, Cal.
WOU	360-485	37 Metropolitan Utilities, Omaha, Neb.
KLB	360	38 J. J. Dunn & Co., Pasadena, Cal.
WGL	360	39 Thomas J. Howlett, Philadelphia
WOK	360	40 Pine Bluff Co., Pine Bluff, Ark.
KOV	360	41 Doubleday Hill Electric Co., Pittsburgh
WPB	360	42 Hamilton Elec. Co., Pittsburgh
KGF	360	43 Pomona Fixture Co., Pomona, Cal.
WOZ	360-485	44 Palladium Printing Co., Richmond, Ind.
WHQ	360-485	45 Rochester Times, Rochester, N. Y.
WOC	360-485	46 Karlowa Radio Co., Rock Island, Ill.
WDY	360	47 Radio Corp. of Amer., Roselle Park, N. J.
KVO	360	48 J. C. Hobrecht, Sacramento, Cal.
KUO	360	49 Examiner Printing Co., San Francisco
KGB	360	50 Edwin L. Lorden, San Francisco
KDN	360	51 Meyberg Co., San Francisco
KYY	360	52 Radio Shop, San Francisco
KOW	360	53 Charles D. Herrold, San Jose, Cal.
WGY	360	54 General Elec. Co., Schenectady, N. Y.
WRL	360	55 Union College, Schenectady, N. Y.
KJR	360	56 Vincent I. Kraft, Seattle, Wash.
KFC	360	57 Northern Radio & Elec. Co., Seattle, Wash.
KHO	360	58 Louis Wasmer, Seattle, Wash.
WBZ	360	59 Westinghouse Co., Springfield, Mass.
KJO	360	60 C. O. Gould, Stockton, Cal.
KWG	360	61 Portable Wireless Co., Stockton, Cal.
KJJ	360	62 Radio Shop, Sunnyvale, Cal.
WRW	360	63 Tarrytown Radio Research Co., Tarrytown, N. Y.
WHU	360	64 William B. Duck Co., Toledo, Ohio
WSZ	360-485	65 Marshall-Gerken Co., Toledo, Ohio
WJK	360	66 Service Radio Equipment Co., Toledo, Ohio
WDM	360	67 Church of the Convent, Washington, D. C.
WDW	360	68 Radio Construction Co., Washington, D. C.
WJH	360	69 White and Boyer, Washington, D. C.
4 CD	200	70 Carter Electric Co., Atlanta, Ga.
5 ZU	200	71 State University, Austin, Texas
8 UX	200	72 Radioart Store, Akron, Ohio
8 BYV	200	73 Columbus Spec. Co., Columbus
8 YO	200	74 Ohio State University, Columbus
2 XJ	Various	75 American Tel. & Tel. Co., Deal Beach, N. J.
WAL	360-485	76 McCook Army Station, Dayton
WRR	450	77 Dallas Texas, Dallas, Texas
WLO	360-450	78 United States Army, Fairfield, Ohio
WQB	360	79 C. D. Tuska & Co., Hartford, Conn.
2 IA	200	80 Jersey Review, Jersey City, N. J.
9 YY	200	81 State University, Lincoln, Neb.
200		82 R. B. Howell, Omaha, Neb.
1 XAD	200	83 Thomas Giffen, Pawtucket, R. I.
10 J	200	84 Robert F. Farnum, Pawtucket, R. I.
WPB	360	85 Newspaper Printing Co., Pittsburgh
WCL	360	86 Philadelphia
360		87 U. S. Govt., Catalina Island, Cal.
360		88 Edward Streigel, Buffalo, N. Y.
360		89 Brooklyn, N. Y.
WBN	360	90 Bradley Institute, Peoria, Ill.
WBAE	360	91 Dayton Co., Minneapolis, Minn.
WBAH	360	92 Desert News, Salt Lake City, Utah
KZN	360	93 First Presbyterian Church, Seattle, Wash.
KTW	360	94 Marshall-Gerken Co., Toledo, Ohio
WBA	360	95 Public Market and Dep't Stores, Seattle, Wash.
KZC	360	96 Sterling Elec. Co., Minneapolis, Minn.
WBAD	360	97 Tulane University, New Orleans, La.
WAAC	360	98 Thearle Music Co., San Diego, Cal.
KYF	360	99 Harrisburg, Pa.
WBAM	360	100 I. B. Renssely, New Orleans, La.

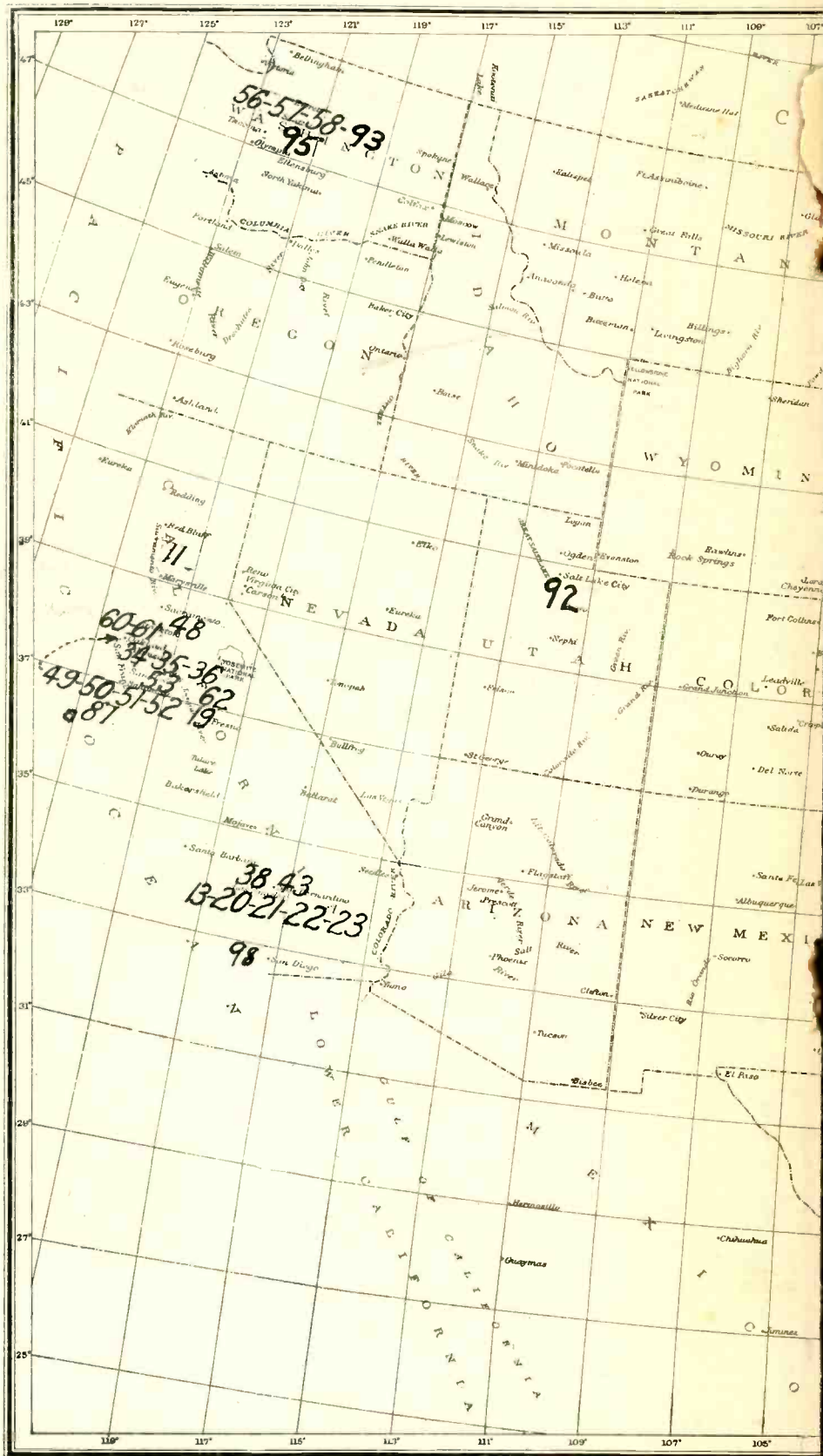

Save this map and add to it w
Government. This

Map of Licensed Broadcasting Stations

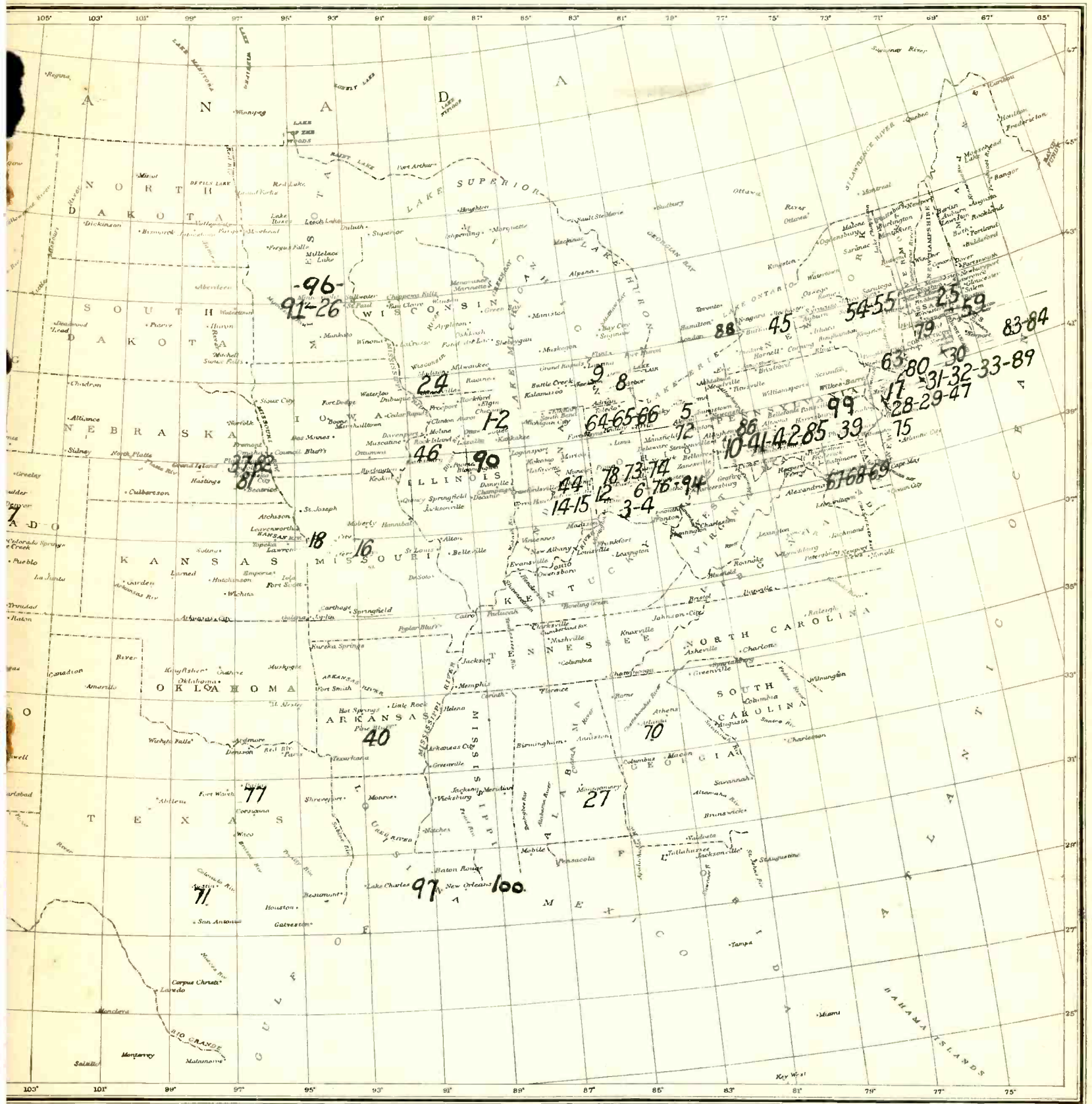

Whenever new official stations are established by the United States news will be published immediately in Radio World.

Radio World's Hall of Fame



(c. Underwood & Underwood)

JACK BINNS

Jack Binns, famous radio operator, who saved the lives of 3,000 human beings, when the steamer "Republic" sank after being in collision with the "Florida." Ever since this catastrophe, Mr. Binns has shown great courage stepping ahead in the radio industry, always trying hard to attain some higher elements and practical results for the benefit of the science. Mr. Binns is now a radio expert and radio editor of the New York "Tribune."

Musical Artists Entertain Mid-West Fans



(Photo by L. J. Neumann, Cincinnati)

This picture was taken while the broadcasting was in operation. From left to right, the operator, W. M. Knox, R. Gorno, G. Gorno, and Powell Crosley, Jr., owner of the station.

THREE eminent musicians, Romeo Gorno, pianist; Giacinto Gorno, baritone, and William Morgan Knox, violinist, recently entertained thousands of wireless enthusiasts when their music was broadcasted by WLW, operated by the Crosley Manufacturing Company, Cincinnati.

It was one of the highest-class concerts ever "put on" in this part of the United States. Many letters received by the operators of WLW attested

the approval of fans from many points in the Middle-West.

Romeo Gorno, who was born in Cremona, Italy, is known in musical circles of both Europe and the United States. Giacinto Gorno, who was born and educated in Milan, Italy, is one of the most famous baritones in this country. Mr. Knox is a native of Cincinnati; but his musical education was completed at the Royal Conservatory at Antwerp, Belgium.

Nearly 19,000 Transmitting Stations

THE Department of Commerce will soon issue its 19,000th transmitting license. There are now 18,894 stations of various classes entitled to transmit radio signals.

On April 28, the number of amateurs licensed and listed in their nine districts was 15,061, but as these reports come in only monthly, the number has probably already passed 16,000. A survey of all broadcasting licenses gives a total of 212, thirty of which were issued within the last ten days.

The balance of the stations are of course commercial, ship, and special stations, which do not increase as fast as the amateur and the popular broadcasting stations.

Between April 23 and 27, twenty licenses were issued. Among them there were three colleges—James Millikin, Decatur, Illinois; Tulane University, New Orleans; and Bradley Polytechnic, Peoria, Illinois — two newspapers, a church, and another police department, all offering entertainment except the last. The complete list is as follows:

- April 24th
- WBAE—Bradley Polytechnic Institute, Peoria, Ill.
 - WBAH—Dayton Company, Minneapolis
 - KZN—Deseret News, Salt Lake City
 - WBAG—Diamond State Fibre Co., Bridgeport, Pa.
 - KTW—First Presbyterian Church, Seattle, Washington.
 - WBA—Marshall Gerkin Co., Toledo
 - WBAF—Fred M. Middleton, Moorestown, N. J.
 - KZC—Public Market and Department Stores Co., Seattle, Wash.
 - WBAD—Sterling Electric Co. & Journal Printing Co., Minneapolis, Minn.
 - WBAN—Wireless Phone Corporation, Paterson, N. J.
- April 26th
- WIZ—Cino Radio Mfg. Co., Cincinnati
 - KUY—Coast Radio Company, El Monte, Calif.
 - WBAK—Pennsylvania State Police, Harrisburg, Pa.
 - WBAM—I. B. Rennysen, New Orleans, La.
 - WAAC—Tulane University of Louisiana, New Orleans, La.
- April 27th
- KNN—Bulldock's, Los Angeles
 - KSC—Hale & Company, San Jose, Calif.
 - WBAO—James Millikin University, Decatur, Ill.
 - KNT—North Coast Products Company, Aberdeen, Wash.
 - KYF—Thearle Music Company, San Diego, Calif.

MAGNAVOX

PROGRAM

- SPORTING NEWS
- VAUDEVILLE
- GRAND OPERA
- SERMONS
- LECTURES
- WEATHER REPORTS
- GREAT WORLD NEWS EVENTS
- CONCERT
- BAND OR ORCHESTRAL MUSIC
- ENTERTAINMENT for the CHILDREN

Without a Magnavox Radio no wireless receiving set is complete.

MORE wonderful day by day grows the range of entertainment, recreation and information supplied by radio programs broadcasted in all parts of the country.

All you require to enjoy these programs in your own home is a receiving set equipped with the Magnavox Radio. With it, it is possible for the entire family to hear all that is in the air as if it were being played by your phonograph.

Any radio dealer will demonstrate for you, or write to us for descriptive booklet and name of nearest dealer.

The Magnavox Company
Oakland, California
New York Office: 370 Seventh Ave.
Penn. Terminal Bldg.

Radio brings it
MAGNAVOX
tells it

Radio and the Woman

Women Appeal to Broadcasting Stations to Aid Disabled Soldiers---Club Members Expected to Study Radio Technique---How Radio Helped Impoverished Woman---No Objection to Female Operators on Land---All the Latest News Regarding Wireless Activities of Women

By *Crystal D. Tector*

BROADCASTING stations receive numerous written requests from sympathetic and patriotic women who ask that the needs of disabled soldiers be given full publicity. One woman who has the interest of our boys at heart, suggests that women all over the country engage to hold, at a prearranged time, a radio concert and tea, the proceeds to be devoted to helping these heroes.

A Newark branch of the Y. W. C. A., will give a radio concert this month.

In this department, some weeks ago, I asked when women at the lower end of Fifth Avenue would be heard to the same extent that women at the upper end of the great thoroughfare have been heard from. This query has brought forth the statement that receiving sets have been installed in many Washington Square studios and that women writers and artists are studying radio.

The very latest freak notice to be served on us, is to the effect that an inventor has perfected a machine that will send perfume by wireless. "Can you beat it?"

Mrs. August Belmont is soon to broadcast a talk on the Red Cross. The Westinghouse station will enable her to do this.

Watch this department for future interesting accounts of clever work performed in radio by members of a large organization of young American girls.

Salesmen in a well-known sporting-goods shop which carries a good stock of radio supplies, state that women customers display expert judgment and selection in radio purchases.

Grover Muthersbaug, radio instructor at South High School, Broadway and Fullerton Avenue, Cleveland, Ohio, predicts that his girl

students will be able to receive twelve and send ten words a minute at the end of the term.

One woman writes that since she has taken up the study of radio she has not been to a theatre or a fashion show.

Miss Abby Morrison, expert radio operator and instructor, is writing a book on radio.

At a woman's radio club, the officers of which complain that they have experienced difficulty in getting members to speak freely on technical subjects, a new bylaw has been adopted whereby, at stated intervals, each member is expected to deliver an article on wireless. A good way, it seems to me, to overcome shyness in a girl who hesitates to express herself.

A soft-throated resident of Atlanta, Georgia, tells me that her city has a broadcasting station which has not been particularly successful as yet,



(c. Keystone View Co.)

Amateur radio shows are quite a fad nowadays in the big New York hotels. Recently one was held in The Pennsylvania, when a number of young women were instructed in the mysteries of radio. In the photograph, from left to right are: N. R. Keller, demonstrator; Miss Ethel Gladwin and Miss Gladys Callagy learning how to operate a receiving set.

but that when it does arrive at a high point of efficiency, she, in conjunction with many other southern women, will request that speeches and lectures be more numerous than musical programs.

WHN (Ridgewood, Long Island, 360 meters), is devoting the hours of from 9 to 11 o'clock every morning to subjects of direct interest to women. These subjects are, "Hours for Women," including fashion-grams, "Beauty Talks," "Beauty Preparations before Retiring," and health talks.

Officials of the Radio Corporation of America state that though the law of the seas may prevent women from holding positions as wireless operators aboard ship, no such scruples regarding employment on land stands between them and a girl who proves her fitness for the work.

Women of Selma, Alabama and vicinity, listen in on programs broadcast from Chicago and Pittsburg.

An interesting tale of an invalid who had been left alone in the world, with small means of support, came to light recently.

Lonely hours filled with thoughts of future and troublesome efforts to make ends meet, prompted her to look about for employment. After a fruitless search for work, the idea came to her to send out personal letters to mothers living in or near her neighborhood, stating that, for a certain sum she would assume the responsi-

bility and care of their children during hours when it would be convenient to the mothers to leave them with her. Such success followed this venture that the invalid was enabled to install a radio-receiving set to help amuse the children.

She tells me that though she provides care for those kiddies, she has the broadcasting stations to thank for keeping them contented.

* * *

What a novelty it is to be entertained without having to pay war tax!

* * *

So that their summer camp shall not lack the benefits to be derived from radio, a number of girl vacationists have started to raise a fund which will enable them to install a receiving set.

* * *

It is well worth rising at 9 o'clock in the morning to hear WHN at Ridgewood, Long Island sends out its "Hours for Women."

* * *

To Miss Nellie Hoover, student in the Peabody High School of Pittsburgh, fell the honor of explaining to thousands of listeners in, how the Junior Civic Club benefits school and community and prepares the student for future duties.

This honor came to her as a result of a competition to determine which member the club should speak for the organization, by radio.

* * *

A dear old gentlewoman of Flushing, Long Island, combines her love for children with her interest in wireless when she invites all the kiddies she knows, to come to her between two and three o'clock each day and listen in on her receiving set.

* * *

Above the howl of masculine protests uttered in Washington against taking navy radio out of politics, rises Miss Alice Robertson's approval, clear, firm and decisive:

"I always doubted the advisability of using government radio stations for broadcasting political talks," she says, "the idea of allowing *no one* to use them for this purpose is right."

* * *

According to a statement made in a recent address by Edward T. Black, head of the engineering department of the United Y. M. C. A., Schools, a number of women students have enrolled in the radio extension courses of that organization.

* * *

As an inducement to the feminine taste and beauty-loving eye, a firm just off Park Place, New York City, is displaying attractive receiving sets



(c. International)

"This is the sort of concert you can attend without having to remove your hat and veil," says Lois Wilson, of the motion pictures, as she smiles at you from the improvised receiving station in the studio where she works

with woodwork of bird's-eye maple and others made of mahogany. Nothing but the polished surface and the dials are conspicuously in evidence. "Boudoir sets" is the name the designer applies to them.

* * *

Miss Alice Paul, vice-president of the National Women's Party, sent the news of the dedication of the new national headquarters building at Washington, D. C., by radio.

* * *

This bit of laughter is from one of my recent communications: "The other night, while dressing for a party, I said to my husband, 'John, hook up!' I meant my dress, of course,

but John dashed into the living room and the next thing I knew music was coming through the receiving set."

* * *

In a letter to a radio publication, a woman criticizes the editor in no gentle tones because, as she claims, the press has placed too little stress on the seriousness with which women take radio—that is considered naught but a pastime for them though many are studying it with dead-in-earnest interest in the hope of making it their business. I back up this view. Radio will give many women an opportunity to earn a living. There will be many positions which they will fill to better advantage than men.

Keeping Tabs on the Game by Radio



(c. Kadel & Herbert News Service)

A wire attached to the antenna of the building, in the photograph, and connected with the radio set on the ground, permits Robert Koerner, an up-to-date New York boy, to give his pals the latest baseball scores as they are broadcast. The score-board records the runs made up to the fourth inning in a National League game.

Answers to Readers

IN RADIO WORLD, No. 5, dated April 29, page 27, there is a diagram of a long-wave receiver. As I am interested in such a set, I would like to know if the variable condenser which shunts the tickler coil is a 43-plate or a 23-plate condenser?—James T. Deasy, Glen Cove, L. I.

The condenser you mention is a 43-plate condenser.

* * *

Would it be possible for me to use a U-V 201 amplifying tube in the detector-tube socket and make it act as a detector?—Louis Hansen, Charlotte, N. C.

The U-V 201 is an amplifying tube and will not work as a detector. The tubes will function fairly well with a varied plate-voltage of some 35 to 40 volts. If possible secure a detector tube.

* * *

How much and what size wire will it take to rewind a single-magnet 75-ohm receiver and a double-magnet receiver in order to receive the messages as a standard 2,000-ohm receiver.—W. S. A., Tarrytown, N. Y.

Get in touch with some telephone company and see if they will sell you some of their special No. 34 B. & S., gauge single silk-covered or enamelled wire, which is used exclusively for telephone-receiver magnet-winding.

* * *

What should be the resistance of a pair of telephones suitable for receiving the radiophone concerts?—M. E. E., Woodhaven, N. Y.

Resistance should be from 500 to 2,000 ohms. The 2,000-ohm receivers are standard for radio reception. These may be purchased at any store that sells radio apparatus.

* * *

How many plates should be used in a variable condenser for inserting with antenna?—Charles Morelack, Bethlehem, Pa.

Use a 43-plate variable condenser which, if inserted in series with antenna, will cut down the wave length. A smaller condenser will cut down the wave too much and decrease the signal strength.

CUSTOM TAILOR MADE
To fit your individual car
Made in our custom shops after your order is received. We ship ordinarily in 2 or 3 days. Perfect fit guaranteed when correct name, year and model of car is given. You can easily apply it yourself. We furnish instructions and all necessary tacks, welts and fasteners. Our catalog No. 10 with samples is free for the asking.
LIBERTY TOP & TIRE CO.
Dept. R-2, Cincinnati, O.

\$4.40 and up
Parcels Post Paid

ELECTRICAL SPECIALTIES
Auto — Electric & Magnet Wires.
Dealers write for magnetic wire price lists, on 1- 1/2 and 1/4-lb. spools
RICHMOND ELECTRIC CO.
181 McDougal St. Brooklyn, N. Y.

\$4.00 **3000 Ohms**

TOWER'S SUPER-SENSITIVE RADIO PHONES

IMMEDIATE DELIVERIES — POST PAID
Audibility Unsurpassed—Money Back if Dissatisfied
Antenna Wire 7 strand Tipped, 150 Ft., \$1.60
TOWER MANUFACTURING COMPANY
11 Station St., Brookline, Mass.

Full Line of **RADIO Sets and Equipment**
Marvel Receiving Sets. \$15.00
3-inch Hard Rubber Dials 1.00
4-inch Hard Rubber Dials 1.50
Kloster Vernier Rheostats 1.50
Dealers: Write for Discounts
NEW YORK RADIOPHONE CO.
32 UNION SQ. — NEW YORK CITY

RAD-WIN-CO
WINDINGS

For your particular needs, submit specifications and we will do the rest. Orders for receiving set assembling to your own design solicited.

Radio Winding Corporation
154-158 WEST 18th ST., NEW YORK
Phone, Watkins 8686

43-plate Variable Condensers (.001 M.F.)	\$6.00
25-plate Variable Condensers (.0005 M.F.)	4.50
11-plate Variable Condensers (.00025 M.F.)	4.00
3-plate Variable Condenser (used as a Vernier)	3.00

Above prices include knob, pointer, and dial. Hard Rubber Panels for above, \$0.75
Immediate shipments from stock.
Discounts to Bona Fide Dealers
F. JOS. LAMB COMPANY
1970 Franklin Street Detroit, Mich.

DEALERS!
We Manufacture
Vario Couplers
Phone Condensers
Vario Condensers
Sliders
Detectors
IMMEDIATE DELIVERIES
WIRELESS SERVICE
D. S. Rosen
147 FOURTH AVE., NEW YORK
Cor. 14th St. Tel. Stuyvesant 6582

Wholesale and Retail
Radio Supplies
PARK ROW CYCLE & RADIO CO.
29 Park Row, N. Y. C.
Entrance Basement Store.

RADIO FINANCING
Cash advanced to Radio Manufacturers and Wholesalers on their outstanding accounts at lowest rates.
STANDARD TRADING CO.
COMMERCIAL FINANCING
491 Broadway, New York

Fire Underwriters Modify Radio Rules Amateurs! This Is Important!

THE widespread installation of radio receiving-sets has necessitated a revision of the fire regulations created by the National Board of Fire Underwriters. Through its bulletin, "Safeguarding America Against Fire," new and important fire-prevention rules of vital interest to all having radio receiving-sets, are made public. These specifications, which RADIO WORLD publishes in full, were drawn up by a special committee of the National Fire Protection Association, the authority for the National Electrical Code; whose findings are standards of engineering practice. Besides the underwriting organizations represented, engineers acting for the American Radio Relay League, American Telephone and Telegraph Company, Radio Corporation of America, and the Independent Telephone Association also participated.

The Underwriters state, in their bulletin, that a receiving set having an indoor antenna is considered devoid of hazard. With any receiving set, the principal danger is from lightning brought in through the antenna to the equipment or to some part of the building. Where there is no exterior antenna, this danger is removed.

The following specifications are for receiving stations only:

Antenna

a. Antenna outside of buildings shall not cross over or under electric light or power wires of any circuit carrying current of more than six hundred volts or railway, trolley or feed wires, nor shall it be so located that a failure of either antenna or of the above mentioned electric light or power wires can result in a contact between the antenna and such electric light or power wires.

Antenna shall be constructed and installed in a strong and durable manner and shall be so located as to prevent accidental contact with light and power wires by sagging or swinging.

Splices and joints in the antenna span, unless made with approved clamps or splicing devices, shall be soldered.

Antenna installed, inside of buildings are not covered by the above specifications.

Lead-in Wires

b. Lead-in wires shall be of copper, approved copper-clad steel or other approved metal which will not corrode excessively, and in no case shall they be smaller than No. 14 B. & S. gage except that approved copper-clad steel not less than No. 17 B. & S. gage may be used.

Lead-in wires on the outside of buildings shall not come nearer than four (4) feet to electric light and power wires unless separated therefrom by a continuous

and firmly fixed non-conductor that will maintain permanent separation. The non-conductor shall be in addition to any insulation on the wire.

Lead-in wires shall enter building through a noncombustible, non-absorptive insulative bushing.

Protective Device

c. Each lead-in wire shall be provided with an approved protective device properly connected and located (inside or outside the building) as near as practicable to the point where the wire enters the building. The protector shall not be placed in the immediate vicinity of easily ignitable stuff, or where exposed to inflammable gases, or dust, or flying of combustible materials.

The protective device shall be an approved lightning arrester which will operate at a potential of five hundred (500) volts or more.

The use of an antenna grounding switch is desirable, but does not obviate the necessity for the approved protective device required in this section. The antenna grounding switch if installed shall, in its closed position, form a shunt around the protective device.

Protective Ground Wire

d. The ground wire may be bare or insulated and shall be of copper or approved copper-clad steel. If of copper the ground wire shall be not smaller than No. 14 B. & S. gage, and if approved copper-clad steel it shall be not smaller than No. 17 B. & S. gage. The ground wire shall be run in as straight a line as possible to a good permanent ground. Preference shall be given to water piping. Gas piping shall not be used for grounding protective devices. Other permissible grounds are grounded steel frames of buildings or other grounded metallic work in the building and artificial grounds such as driven pipes, plates, cones.

The ground wire shall be protected against mechanical injury. An approved clamp shall be used wherever the ground wire is connected to pipes or piping.

Wires Inside Buildings

e. Wires inside buildings shall be securely fastened in a workmanlike manner and shall not come nearer than two (2) inches to any electric light or power wire unless separated therefrom by some continuous and firmly fixed non-conductor making a permanent separation. This non-conductor shall be in addition to any regular insulation on the wire. Porcelain tubing or approved flexible tubing may be used for encasing wires to comply with this rule.

f. The ground conductor may be run inside or outside of building. When receiving equipment ground wire is run in full compliance with rules for Protective Ground Wire, in Section d., it may be used as the ground conductor for the protective device.

Solved!

By Kathleen Mather

I sure did feel quite in despair
At the radio talks everywhere,
Till the RADIO WORLD
All the secrets unfurled—
And, now, I'm quite "up in the air."

A European Receiving Set for Radio

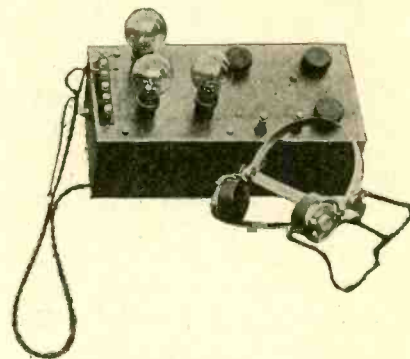

(c. Wide World Photos)

This is the new Marconi receiver designed to make it possible for the average householder to enjoy the advantages of wireless in the home without much structural work and expense. The photograph shows a detector and two-step amplifier which can be very easily seen, and of course necessary inductances and capacities for the various wave lengths.

"Radio Mush" Out of Navy Menu

RECENT experiments conducted at the Mare Island Naval Radio Station, San Francisco, it is reported, have eliminated "mush" and harmonic interference by means of a current transformer.

This current transformer, installed with the 30- and 100-kw., arcs at the low and high power stations in Mare Island, has proven entirely satisfactory, in eliminating the arc "mush" and harmonics which had been interfering with receiving thereabouts. About a week ago, tests were conducted with the co-operation of commercial stations in the vicinity, and a summary of the reports received showed that these companies experienced no interference while the high-power arcs at the Naval stations were in operation.

"Mush" is known as oscillations other than the true wave, which act as a sort of "wet blanket" over incoming signals being received at a neighboring station. Actually, it is composed of small and sudden irregularities in the antenna current of arc transmitters. Previously, it has been practically impossible to tune out the so-called "mush."

The harmonic of a wave is also troublesome, as it is a wave whose frequency is a multiple of that of the original wave; its wave length being a sub-multiple of the length of the given wave.

**DEPENDABLE
TESCO LINE**

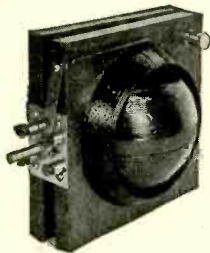

Unmounted
\$6.50

Panel
Mounted
\$8.50

No. 41 Precision Variometer
Mail Orders Filled From Stock
DEALERS: Write for Bulletin, R-10
Manufactured by
The Eastern Specialty Co.
3551 N. 5th St., Philadelphia, Pa.

IMMEDIATE DELIVERY

Discounts to jobbers and dealers
AERIAL WIRE.

19 strand tinned silicon bronze
VARIABLE CONDENSERS

11-21-23-43 Plate
EISEMANN HEAD PHONES

Super-sensitive
Variometers Variocouplers

Binding Posts Contact Points
"ECHOPHONE" LOUD

SPEAKER SETS

General Auto Electric Co.
281 Halsey St.,
Newark New Jersey

This Boy Broke Radiophone Record



(c. International)

Harrison Holliday, 19 years old, of San Francisco, recently shattered the Pacific Coast long-distance radiophone record, by reaching Vancouver, British Columbia, and Launga Beach, Orange County, California. Young Holliday has been a "wireless wiz" since his boyhood. For several years he operated a station at his home, officially licensed under the United States Department of Commerce as 6 BN. The entire equipment of his station including the wireless apparatus was installed by himself and his chum, Harold R. Shaw.

AS TO BACK NUMBERS OF RADIO WORLD

Our supply of back numbers of **RADIO WORLD** (Nos. 1 to 7) is limited. We will take orders for the first seven issues until the supply is exhausted. If you want these numbers, or want your subscription to start with any special number, let us know.

Radio World Co., 1493 Broadway, New York City. (Adv.)

What a Brother Says

RADIO WORLD, a weekly paper devoted exclusively to the newly popularized wireless art, continues to gain in favor. Aside from its helpful articles on the construction and operation of receiving sets, **RADIO WORLD** is attractively illustrated with half-tone newsy photographs of a national range of interest.—Newark, N. J., "Call."

Loud Speakers \$45

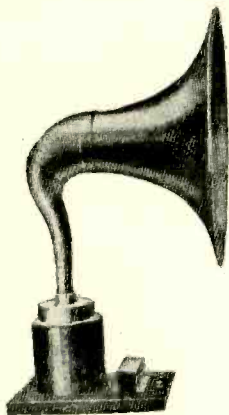

DIALS

VARIOMETERS

VARIOCOUPERS

TELEPHONE HEAD-SETS

Dealers Write For Your Discount

Robin Radio Mfg., Co.

47 WARREN ST., NEW YORK CITY

**"SCOT"
CRYSTAL DETECTOR**

Assemble Your Own and Save a Dollar

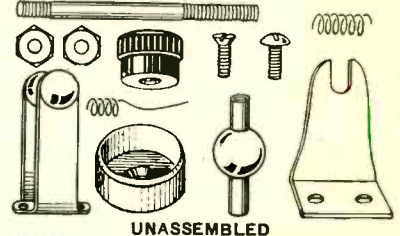

UNASSEMBLED

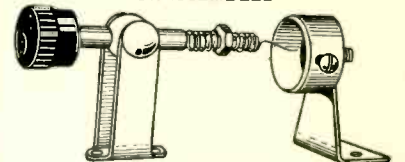

ASSEMBLED

Complete Parts As Illustrated. All Brass, Heavily Nickel Plated **40c**

ASK YOUR DEALER
BY MAIL, 45c. NO STAMPS
Manufacturer, Jobbers and Dealers write or see us for Proposition.

Scot Novelty Company
33 SPRINGFIELD AVE.
Newark New Jersey

Radio Patents

RECENTLY ISSUED

RADIO WORLD is making a special effort to give its readers regular weekly service regarding the news of radio patents, granted or pending, at the United States Patent Office, Washington, D. C. The first installment of this important service appears herewith, and will be continued from week to week as the material is issued by the Patent Office.

A patent simply because it is a

patent, must be a very valuable thing. It is interesting to know that 75 per cent. of the patent claims allowed by the United States patent-office cover worthless devices. The patent office has no control over this matter.

If you have money to invest in radio proceed cautiously. If you are not sure, ask a friend who knows something about radio to help you reach a decision.

the service on such systems. It is the purpose of the invention to provide a service observer's set, or listening-in apparatus, which is adapted to be used simultaneously with a plurality of circuits and which may be associated with such circuits in a manner so that there will be no interference, such as cross-talk, between circuits.

CARL F. HIGH, Madison, Wisconsin, has invented improvements for storage-battery cells.

His invention relates to cells for storage batteries, and its objects are to construct

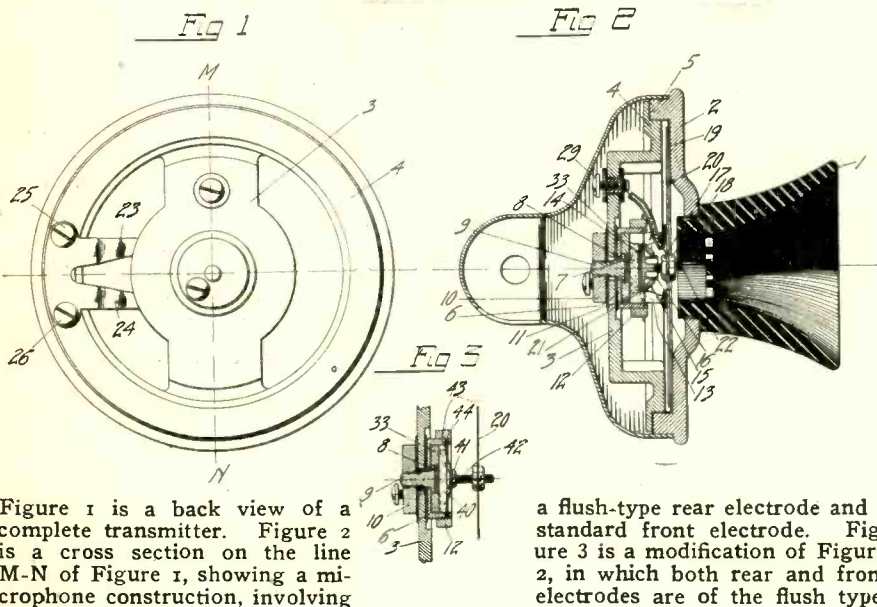

Figure 1 is a back view of a complete transmitter. Figure 2 is a cross section on the line M-N of Figure 1, showing a microphone construction, involving

a flush-type rear electrode and a standard front electrode. Figure 3 is a modification of Figure 2, in which both rear and front electrodes are of the flush type.

ALEXANDER E. KEITH, Hinsdale, Ill., has invented an improvement in telephone transmitters which has for its object to provide a microphone structure in which the detrimental effects due to an inactive mass of granulated carbon or other comminuted material is eliminated; and in which the possibility of the occurrence commonly known as, "packing," is reduced to a minimum.

* * *

KARL S. VAN DYKE, Chicago, records an invention relating to signaling circuits, and more particularly to arrangements for maintaining synchronism between alternating currents separately generated at different stations of a signaling system.

One of the features of the invention is the provision of means whereby alternating currents supplied from two independent

sources may be automatically maintained at the same frequency.

Another feature of the invention is the provision whereby alternating currents supplied at the receiving station of a signaling system may be maintained in synchronism with carrier currents received from a distant sending station.

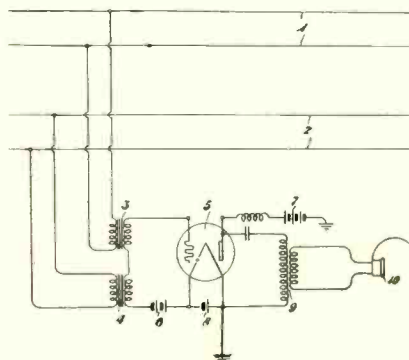

The advantages of the arrangements of this invention are, in general, that one amplifier and listening set can be used simultaneously on as many different circuits as desired.

GEORGE CRISSON, Hackensack, New Jersey, a service-observing set which relates to communication systems and more particularly to arrangements for observing

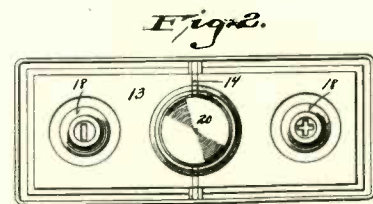
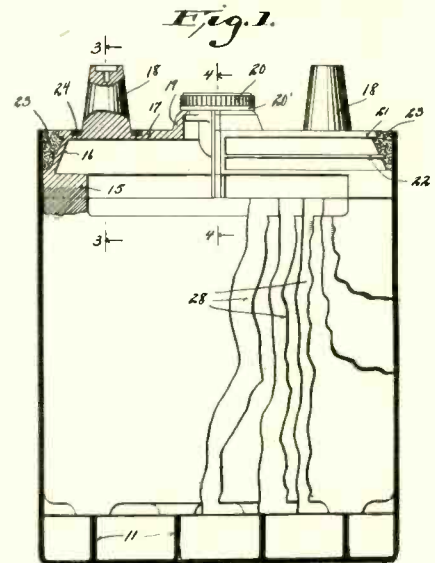

a cell which will be more durable than those now known and in which the plates will be securely held in their proper position, and in which provisions are made to counteract the effects of acid creepage.

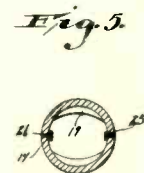
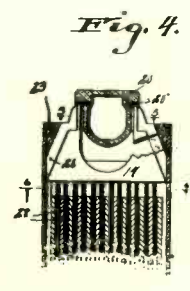
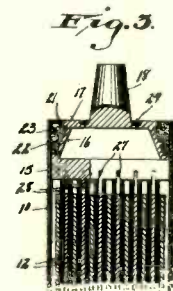
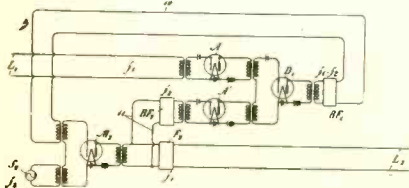

Figure 1 is a vertical section. Figure 2 is a plan view. Figure 3 is a section taken substantially on the line 3-3 of Figure 1, with a part broken to show the grouping strap. Figure 4 is a section taken on the line 4-4 of Figure 1. Figure 5 is a section on the line 5-5. Figure 6 is a section on the line 6-6.



Mr. Van Dyke's invention designates a circuit whereby a frequency generated at a distant point may be applied to the apparatus shown at the station of the figure.

RADIO WORLD

PUBLISHED EVERY WEDNESDAY (Dated SATURDAY OF SAME WEEK)
 FROM PUBLICATION OFFICE, 1493 BROADWAY, NEW YORK, N. Y.—PHONE, BRYANT 4796
 BY RADIO WORLD COMPANY

ROLAND BURKE HENNESSY, Editor and Proprietor - - - - - 1493 Broadway, New York
 FRED S. CLARK, Manager - - - - - 1493 Broadway, New York

ASSOCIATE EDITORS:
 ROBERT MACKAY - - - - - FRED. CHAS. EHLERT
 CENTRAL-WESTERN ADVERTISING REPRESENTATIVES:
 W. B. ZIFF CO., 608 S. Dearborn St., Chicago.

SUBSCRIPTION RATES

Fifteen cents a copy. \$6.00 a year. \$3.00 for six months. \$1.50 for three months.
 Add \$1.00 a year extra for postage to Canada and foreign countries.
 Receipt by new subscribers of the first copy of RADIO WORLD mailed to them after sending in their order, is automatic acknowledgment of their subscription order and payment therefor.

ADVERTISING INFORMATION

MECHANICAL REQUIREMENTS:

Size of page: 12 inches deep—9 inches wide.
 Size of type page: 10½ inches deep—7¼ inches wide.
 Three columns, 147 lines each—441 lines to the page.

CUTS:

All plates should be mounted. We can use screens up to and including 133. We prefer 120 screen half-tone. We cannot use matrices.

ADVERTISING RATES:

One page: One time—\$150.00.
 Half, Quarter, Third and Two-thirds pages at proportional rates.
 One inch, one time—\$5.00. Per agate line, \$0.40.
 On four consecutive issues, 10% discount.
 On thirteen consecutive issues, 15% discount.
 Terms: 30 days Net. 2% 10 days.

CLASSIFIED ADVERTISEMENTS:

Five cents per word. Minimum, 10 words. Discount of 10% on 4 consecutive issues—15% on thirteen consecutive issues. Cash with order.

Cover and preferred position rates made known on application

Entered as second-class matter, March 28, 1922, at the Post Office at New York, New York, under the act of March 3, 1879.

IMPORTANT NOTICE:

While every possible care is taken to state correctly matters of fact and opinion in technical and general writings covering the radio field, and every line printed is gone over with a scrupulous regard for the facts, the publisher hereby disclaims any responsibility for statements regarding questions of patents, priority of claims, the proper working out of technical problems, or other matters that may be printed in good faith and on information furnished by those supposed to be trustworthy. This statement is made in good faith and to save time and controversy over matters which the publisher cannot possibly have control.

A NEW VARIABLE CONDENSER



Manufactured by Radio Stores Corporation. Patent Pending. Type VC-1

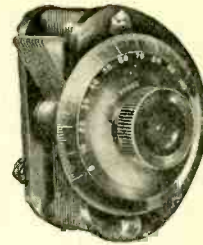

Concealed Counterweight. Brass Studs through Aluminum Plates: Die Cast Shaft Held in True Center Through Brass Bushings. Binding Posts Mounted on Separate Metal Straps. No Insulating Material Tapped—Brass Inserts Throughout.

Immediate Shipment

List—23 Plate \$4.25
 43 Plate 4.75

Complete with Knob, Dial and Counter Weight. Each packed in individual carton.

RADIO STORES CORPORATION

National Distributors and Manufacturers
 218-222 W. 34th St., New York City

¼" Sliders—Brass, 20c.; Nickel, 25c.

¼" Slider Rods—Brass, 15c; Nickel, 20c.

Crystal Detectors, nickel plated on Mahogany base, \$1.00

Double Nickel Slider Tuning Coils, \$3.00

Contact Points, threaded with nuts—20c. dozen.

Compo. cap, Nickel base Binding Posts—7c., each

Plain Nickel Binding Posts—3½c., each

Liberal Discounts to Dealers

F. JOS. LAMB COMPANY

1970 Franklin St. Detroit, Mich.

Distributors of Everything in

RADIO

Mail us your orders

CITY SUPPLY CO.

56 Warren St., N. Y. City

Radio Cabinets

and

BATTERY BOXES

Sheip & Vandegrift, Inc.

814-32 N. Lawrence St.

Philadelphia, Pa.

VARIOMETERS VARIOCOUPERS

Price **YANKEE** \$6.00

YANKEE RADIO SUPPLIES

1615 Stiles St.

Philadelphia, Penna.

points on buying
 storage batteries

read the **RADIO RED BOOK**
 25¢ 406 W. 31st St. 25¢

SOMETHING DIFFERENT

A Radio Directory

WHERE to Buy

WHAT to Buy in all matters
 pertaining to

RADIO

Read the

RADIO RED BOOK

25c—406 West 31st St.—25c

how far will a
 set receive?

read the **RADIO RED BOOK**
 25¢ 406 W. 31st St. 25¢

EXPERIMENTAL WORK

Designing metal patterns, spinning and turning
 Chucks, Tools and Dies for drawing stamping,
 forming combination

Over 30 years experience

MOLLER 7 VALENTINE STREET
 Opposite Proctors Theatre
 MOUNT VERNON, N. Y.

Ideal Variable Condenser



A full capacity
 "Variable" of genuine
 merit and excellent
 design.

Bakelite Plates top
 and bottom.

PRICES:

43 Plate \$4.75

23 Plate 3.75

11 Plate 3.00

VIKING VERNIER CONDENSER

3 Plate
 Red fibre top and bot-
 tom. Ensures finer
 tuning with a



"Variable," or can be used as a Variable
 Phone or Grid Condenser. Awarded "Even-
 ing Mail" Certificate of Excellence. \$1.50
 Price

DEALERS—Write us for terms on these 2
 Sterling Novelties.

VIKING RADIO Co.

25 DEY ST. NEW YORK (Rector 7058)

RADIO HANDBOOK

How and why radio
 works and essential in-
 formation to get results.
 48 pp., illustrated. Send
 Agents Wanted

RADIO HANDBOOK PUB. CO.
 Sheridan Bldg., 9th & Sansom Sts., Phila., Pa.

Radio Will Help Oratory

ALTHOUGH a few men in public life have already broadcast radio speeches to constituents, says "The Evening World," New York, the wireless telephone is not likely to play a great part in the coming fall campaign. But if radio outfits multiply as they have in the last year, if the manufacturers of equipment meet the demand, the radio is likely to play an important role in the election of the next President.

Radio may almost revolutionize campaigning. For years candidates have been swinging around the circle. But even with the most arduous work, an aspirant to the Presidency cannot address more than a small fraction of his constituents.

The custom has been for the candidate to repeat his speech, introducing new material every day for newspaper broadcasting. But if speeches may be broadcasted direct to home telephones and to amplifiers in halls, these repetitions will no longer serve. The candidate will need to prepare new speeches. He can go into details on each subject as he treats it.

Radio would make it possible to address a whole section of the country at once. It would make possible a direct appeal to a considerable fraction of the voters.

These are possibilities—almost probabilities—of 1924. Political affairs would benefit if this development comes. Candidates couldn't dodge issues so easily. Oratory and ideas would have an opportunity to come back into their own as moving forces in public life.



TURNNEY'S
Unexcelled Radio
Products

Voxola 7½ x 9 x 5½ \$30.00
Monoplex
11 x 11 x 4¼ .. 40.00
Multiplex
11 x 16½ x 4¼ .. 65.00
Head Set (Non
Fatigue 8 oz.) .. 6.50
Socket .. .60
Two-Way Plug .. 1.20
Plex 4½ x 5 x 4¾ .. 5.50
Duplex 16½ x 4 x 6 15.00
Vitacone
8¼ x 11 x 4¼ .. 20.00
Amplifier
8¼ x 11 x 4¼ .. 20.00
Send for descriptive catalog of complete Turney Radio Products

Rex Radio Sales Corporation
National Distributors of
TURNNEY
UNEXCELLED RADIO PRODUCTS

Get on the band wagon for prompt delivery — Ask about the Turney Spider Web Coil—and Non Fatigue 8 Oz. Head Set.

Liberal discounts to jobbers and dealers.

REX RADIO SALES CORPORATION
Distributors of "EVERYTHING RADIO"
1452 Broadway, New York Phone: Bryant 6456

\$4.00 Radio Set \$4.00

CLEARTONE "LITTLE GIANT"
Little in Size but Giant in Strength

Guaranteed to receive up to twenty-five miles as clearly as any set costing twenty-five dollars more. Set is enclosed in neat black seal grain leatherette box and is complete with detector and galena. Money back guarantee. Send in your order to-day with money order or cash.

We also carry in stock an electric aerial that does away with the trouble and dangers of the outside aerial. Price \$5.00 only.

Ask for complete list of our lines of equipment and parts. We carry tuning coils, secondary coils, Vario-couplers, Primary Coils, Secondary vario-coupler Rotors, Superior Phones, Silver Cats Whisker Sliders, etc. We fill orders within 24 hours. Let us hear from you.

DEALERS: We have a special proposition on quantity orders that is a winner. Three Detroit manufacturers of radio equipment are represented exclusively by ourselves. Hitch up to us and profit.

CLEARTONE RADIO SALES COMPANY
Dept. P—3. 1617 First National Bank Bldg., Detroit, Mich.

TESTED RADIO MATERIAL ONLY	
43 plate variable condensers (panel type) .00125	\$4.50
23 plate variable condensers (panel type) .006	3.50
2,200-ohm head sets	8.00
3,000-ohm head sets	6.50
Spider web, inductances primary, secondary, tickler, mounted with binding posts	6.00
Tube sockets60
Federal amplifiers, two stage	58.00
Turney tube receivers (spider web)	40.00
Amplifying transformers	6.90
Tuska 0-800 meter couplers	7.50
JJN couplers \$4.50—Variometers	4.35
Drawing regenerative receivers50
Regenerative tuner mounted spider web 0-1,000 meters	15.00
Wholesale & Retail	
Mail orders filled upon receipt of money order	
ROBIN ENGINEERING COMPANY 201 West 49th Street, New York	

VARIOMETERS UNWIRED

Mahogany wood turned cup, white wood ball ready for wiring. Range 175 to 600 meters. Ready for immediate delivery in any quantity. Workmanship guaranteed.

SAMPLE SET, \$1.10

The Ever Ready Woodworking Co.
810-12 East 5th St., New York City
Phone Orchard 5585

WHAT DO YOU KNOW ABOUT RADIO?

Do You Know

- the cheapest way to build a radio set?—how to read a wiring diagram?
- how to overcome problems of construction that confront the amateur?
- how to locate leaks and other faults? All this and much more information is found in

HOW TO BUILD YOUR OWN RADIO SET - 25c
By JAMES R. CAMERON

Do You Know

- the meanings of the 700 radio terms now in use, and by these definitions the relation of each radio part to every other?—the laws amateur radio operators must comply with?—the tables you must constantly have reference to? These things and various charts and other necessary data are in

RADIO DICTIONARY - 50c
By JAMES R. CAMERON

Do You Know

- how to repair, adjust and operate your particular type of set—how to get longer life out of your radiotron tubes?—how to eliminate interference?
- how to lengthen the life of batteries and how to restore them if accident weakens them?—how to remedy generator, amplifier, detector and other troubles? These problems are solved for you and there are many easily understood charts, profuse illustration and every other helpful hint the amateur needs in the big book.

RADIO FOR BEGINNERS - \$1.00
By JAMES R. CAMERON

Buy Them Today from Your Dealer or Direct from
Technical Book Company
130 West 42nd Street New York City

TRADE **URSA** MARK
DEALERS
 Ready for immediate delivery
 in all sizes.
Hard Rubber Panels
Dials, Switches

UNIVERSAL RADIO
SERVICE ASSOCIATION
 300 MADISON AVE., DEPT. A.
 NEW YORK CITY

Dealers Attention!

We can supply you with a complete
 line of Radio Parts and Sets
 Also Variable Condensers 23 and
 43 Plate

RADIO DEPARTMENT OF
SIGNAL SYSTEMS
SERVICE CO.

1 East 42nd St., New York City
 Telephone Vanderbilt 10022

WOLVERINE AERIAL
ELIMINATE OUTSIDE AND INSIDE WIRES
 Attach the Wolverine Aerial to any electric light
 socket in your home and receive good results from
 your receiving set. Fool proof and no danger. It
 comes ready to use; just screw into light socket
 and connect to aerial post of set. Save cost of
 wire and lightning switches. Will operate on bulb
 or crystal sets. Guaranteed to give good results.
 Price \$3.50, postpaid. (\$4.00 west of Rockies.)
 Dealers and Agents Wanted. **WOLF RADIO COM-**
PANY, 208W Scherer Bldg., Detroit, Mich.

PAPER TUBES FOR WIRELESS

ALL SIZES ON HAND
 FOR IMMEDIATE DELIVERY
 WHOLESALE AND RETAIL

BAEHM PAPER CO., INC.
 219 FULTON STREET NEW YORK
 Bet. Church and Greenwich Sts.

RADIO CABINETS
 Manufactured
 in any Style, Size or Quantity

A. E. CHERNACK & CO., INC.
 314 E. 75th ST., NEW YORK
 Phone Rhineland 2747

FOR IMMEDIATE DELIVERY
 No. 22 Enameled Magnet Wire. 35c. lb.
 On full spools. (7 to 12 lb.)

F. JOS. LAMB COMPANY
 1970 Franklin St. Detroit, Mich.

TRADE **HPMCO** MARK
 Reg. U. S. Patent Office

ANOTHER "HPMCO" QUALITY PRODUCT

The Biggest Little Things in Radio

The BUTTS' Duplex and Multiplex
 Phone and Wire Clips. By means of
 these clips four sets of phones or more
 may instantly be applied to two binding
 posts as illustrated. They are made of
 spring brass nickel plated. A positive
 lock for wire and phone leads.

The "Butts" Clip Sells For 5c Each

Dealers Write for Your Discounts

HEDDEN PLACE MACHINE CO.
 41 HEDDEN PLACE
 EAST ORANGE NEW JERSEY

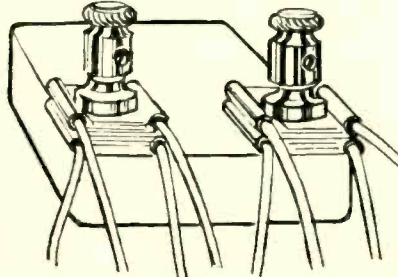

The Cost of Static

STATIC is a spoiler of broadcasting programs, but that is the least serious of its offenses, says "The Mail," New York. It is costing the world millions of dollars yearly. The powerful trans-oceanic radio stations would be quite unnecessary if static did not exist. Since it does exist, reliable communication is possible only when great power is used. Hence the large stations, which cost hundreds of thousands to build, to say nothing of the expense of upkeep. And we have nothing but static to blame. If some one invented a cheap, positive static eliminator it would be worth at least one million dollars in cold cash. It would be possible to use one quarter of the power that is now used to "push" our messages through to the other side. This would also mean that radio messages could be sent for one-quarter of the present rate. Every message sent today helps pay for the upkeep of an enormous station. A static eliminator would put radio development ahead fifty years. Not only that, but it would scrap the cables of the world in five years' time. The cable companies would no longer be able to maintain a rate that would match radio.

Hook-up the Receiver

THE genial actuary of a life-insurance company has worked out the following table: It's all mighty interesting—but suppose it rains on Labor Day?

Every year has	365 days
If you sleep eight hours a day it equals	122 "
This leaves	243 "
If you rest eight hours a day.....	122 "
This leaves	121 "
There are 52 Sundays	52 "
This leaves	69 "
If you have half-day Saturday ..	26 "
This leaves	43 "
If you have 1½ hours for lunch..	28 "
This leaves	15 "
Two weeks' vacation	14 "
This leaves	1 day
And on Labor Day nobody works	1 "

Twenty Years from Now

Twenty years from now, when pocket wireless-outfits will be as common as watches are now, we will be boasting that we saw the pioneer's devices. Times will be so changed, with so many now unthought-of marvels, that the people of 1942 will yawn at us, just as we look bored when an old soldier reminiscences.—Toledo (O.) News Bee.



NOVO
"B" BATTERIES
 FOR RADIO OUTFITS
 Noiseless—Dependable—Guaranteed
 All standard sizes 22½ to 105 volts.
 For Sale by Leading Dealers

NOVO MFG. CO.
 NEW YORK—424-438 W. 33rd St.
 CHICAGO—531 So. Dearborn St.

ENCO
"B" BATTERY

No wires used in any of its construction

VARIABLE and REFILLABLE
 For refills use standard flashlight unit cells **17c**

Enco Electric Novelty Co.
 603 W. 130th ST., New York City

20% TO 33 1/3% OFF ON RADIO SUPPLIES

That's the club's motto
CLUB'S OBJECT

Saving of dollars and a united voice to be reckoned with in matters of interest to Radio Amateurs.

Membership fee, the small sum of 25 cents per month.
 Membership blank mailed upon request.

CORUBIA ELECTRICAL PURCHASING CLUB
 145-147 East 23rd St.,
 Bet. Lexington & 3rd Ave., N. Y. C.

DEALERS

We can make prompt shipments on

Variometers	Crystals
Variocouplers	Crystal Detectors
Switch Levers	(enclosed)
Variable Condensers (23-43 Plate)	Pony Insulators
Switch Points	Fixed Condensers
	Radio Plate

CLARK & TILSON
 51 East 42nd Street
 NEW YORK CITY
 Tel. Vanderbilt 5462

HAYNES TESTED EQUIPMENT

This is an exclusive radio shop. We sell nothing else. For honest values and satisfactory results call on us.

The HAYNES RADIO Shop
 629 Lexington Ave., New York
 At 54th Street Plaza 6801



**RIGHT—ALL WAYS
VARIABLE CONDENSERS**

3 PLATE	\$2.00
13 PLATE	2.75
23 PLATE	3.50
43 PLATE	4.25

Absolutely Guaranteed

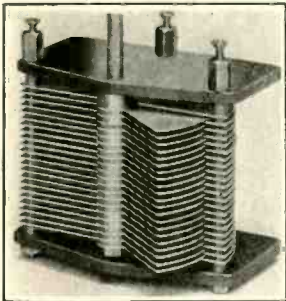

A condenser built for all times—
not to satisfy abnormal demand.
Heavy Plates, Turned Brass Washers,
3/4-inch Brass Shaft, Genuine Bakelite
Ends, Positive constant contact on rotary plate-self adjusting.

DEALERS—JOBBER
We ARE making delivery.
Oidar Radio Mfg. Corp.
508 W. 55th St. New York City

Phones, Sockets, Rheostats
and Radi-o-plate on hand

"C" RADIO JACK
158 Fulton St., N. Y. C.

Subscribe for RADIO WORLD: 1 yr., \$6.

**JOBBER—
DEALERS**

Write for discounts on our
**"RELIANCE"
TUNING COIL \$5.00
CRYSTAL SET**



Wound with No. 21 enameled wire
on specially treated tubing, neat in
appearance, efficient in receiving,
has a range of 600 meters.

IMMEDIATE DELIVERY
We also manufacture:—
A small set at \$4.00
A 2 slide tuner at \$3.50
Unmounted coils in 3 sizes, 6x3,
8x3, 8x3 1/2" at \$1.00, \$1.25 and \$1.50
respectively.

RELIANCE MFG. CO.
354 Mulberry St.
NEWARK NEW JERSEY

The "Lone Amateur"

Editor, RADIO WORLD: In the article in
RADIO WORLD No. 4, dated April 22, en-
titled "Why Is One Wire Considered
Sufficient for a Receiving Station," Ed-
ward Linwood says that most amateurs
are concerned primarily in broadcasts,
which are sent, with a few exceptions.

I think it is high time that a definite
distinction be made between the "novice,"—
who has appeared in great numbers, due
to broadcasting—and "amateurs."

Broadcasting is accepted by amateurs as
another step in development. But they are
far from primarily concerned. We, who
have been in the game for some time,
know, from our own experience, that the
"true amateur" is working for develop-
ment of sets to be able to cover distances,
as shown by the recent trans-Atlantic
transmission by amateurs. We want to
"reach out" and talk to our neighbors in
Texas, Colorado, California, etc. We do
not gauge the efficiency of our receiving
set by how loud we get these broadcasts,
but by the distance we cover, and some re-
markable distances have been covered by
this group of amateurs throughout the en-
tire world.

I feel confident that I am expressing the
opinion of all the amateurs in this matter.
But will more of the old timers express
themselves on this subject?—E. C. Run-
quist, A. M. I. R. E., New York City.

Finds Aerials Unnecessary

Editor, RADIO WORLD: While fooling
with the wires and connections on my two-
slide crystal receiver-set, I discovered that
by connecting by ground to my gas stove,
and the binding post for my aerial wire to
the coldwater pipe with a short wire, I had
a perfect circuit on which I heard WJZ's
concert more distinctly, if anything, than
when I used my ordinary aerial on the
roof. I now have dismantled my aerial
and am using this new circuit exclusively
with splendid results. In the daytime,
when the signals once were weak they now
are as strong as during the evenings. It
seems that aerials are quite unnecessary.—
F. C. Herskind, New York City.

RADIO INVENTIONS
and other ideas prompt-
ly patented by reliable
Patent Attorneys &
Engineers. Call or
write. FREE ADVICE.

ASK MANUFACTURERS
FOR PATENT CO.
520 FIFTH AVE
NEW YORK

Magnet Wire Price Lists

PARCELS POST PREPAID
MONEY WITH ORDER

	1 lb.	1/2 lb.	1/4 lb.
	Spools	Spools	Spools
No. 20	.60	.45	.35
No. 22	.65	.50	.40
No. 24	.70	.55	.45
No. 26	.80	.60	.45

State Whether Enamelled or Single Cotton
Covered Wire Is Desired

No. 14 Stranded Antenna Wire, 90c.
1 hun. ft. coil.

No. 14 Solid Antenna Wire, 55c.
1 hun. ft. coil.

Damp Proof Bell Wire, 60c., Lb Coil
Dealers Write

RICHMOND ELECTRIC CO.
AUTO ELECTRIC AND MAGNET WIRES
181 McDougal St., Brooklyn, N. Y.

YOU'LL WANT THEM !

FOR
YOUR
HOME-
MADE
SET



No. 742
panel
mounting
Gives that
snappy
finish

No. 742. BH Nickle plated solid
brass panel mounting, 8-32 thread.
gives the finishing touch to your
panel. Set of four—25 cents

No. 840. Complete BH Antenna
Equipment

This set includes
100 ft. Antenna Wire; 35 ft. Rubber cov-
ered Stranded Wire; 2 Antenna Insulators;
8 Porcelain Cleats; 1 Double Throw Switch;
1 Porcelain Tube; 1 Ground Clamp; 3 Por-
celain Knobs; 2 Screw Eyes and Blue Print
for Hook-up.

As satisfactory and complete as you can
get if you paid \$5.00

Complete set\$2.85
At your dealers or direct from us
(express prepaid)

BUTTERS-HORLICK RADIO CO.
258 Washington Street, Boston, Mass.

BAKELITE Panels cut to order.
All thicknesses in stock.
Gorton Machine Engraving to order.
F. JOS. LAMB COMPANY
1970 Franklin St. Detroit, Mich.

Complete Your Files by Getting the First

seven numbers of RADIO WORLD and
save them so that you can have 52 copies
bound at the end of the year. If your news-
dealer cannot supply you with the copies, he
can get back numbers through the American
News Co. and its branches, or copies at
15 cents each, will be sent direct from
publication office, or better still, subscribe
and have your subscription start. RADIO
WORLD CO., 1493 Broadway, New York,

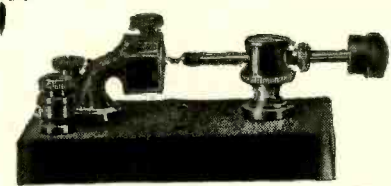

The Turret-Top Detector

A Worthy Example of the EMSCO Line

Decidedly the best detector so far pro-
duced. Sturdy and well made of the best
materials. "Turret-Top" swivel adjust-
ment permits the greatest range of adjust-
ment and holds the phosphor-bronze "cat
whisker contactors" steadily in any position.
Thumblock assures permanent adjustment.
Locking-notch feature of binding posts ex-
clusive with this detector. Unbreakable base.
A fair example of EMSCO quality and value.

Binding Posts—Single and Double

Wound Rotors—3"—3 1/2"
Single Slide Tuners—6"—8"
Double Slide Tuners—6"—8"
Square Rods Cut and Drilled

3-16 x 7	1-4 x 7
x 8	x 8
x 10	x 10
x 12	x 12

x 16 x 7 — Extension Thread

Enamel Wound Coils
6" x 3" 8" x 3" 8" x 3 1/2"

Weatherproof Strain Insulators — Varlo-
Couplers — Slider Knobs—3-16" and 1-4"

You take no chances when you buy
EMSCO products. Behind each article is
the skill of many years experience, making
wireless and electrical equipment. That is
why the trademark, EMSCO, always signi-
fies outstanding merit. Reliable dealers
handle EMSCO products. If your dealer
write us.

Electric Mfg. & Sales Co.
87 ACADEMY ST., NEWARK, N. J.

RADIO WORLD'S QUICK ACTION CLASSIFIED ADS

This department is intended for everybody who wants quick action on short announcements covering the buying, selling, exchanging or general merchandising in the radio field. Readers of RADIO WORLD will find that it pays to read these columns every week. Advertisers will get a ten-day service here—that is, copy received for this department will appear in RADIO WORLD on the news-stands ten days after copy reaching us.

The rate for this RADIO WORLD QUICK ACTION CLASSIFIED AD. DEPT. is 5c. per word (minimum of 10 words, including address), 10% discount for 4 consecutive insertions, 15% for 13 consecutive insertions (3 months). Changes will be made in standing classified advs., if copy is received at this office before 4 P. M. on any second Tuesday preceding date of publication. RADIO WORLD CO., 1493 Broadway, New York City. (Phone, Bryant 4796.)

Enclose self-addressed envelope and receive free illustrated bulletin of 22 up to date Blueprints of Receiving and Transmitting designs. We are the largest firm in the country specializing solely in Blueprints. Number 349 gives full constructional and other data for building Crystal Receiver for only \$5.06. Ask for bulletin 44. Experimenters Information Service, 45 Pinehurst Ave., New York.

Wanted.—A few Western Electric VT-1's, VT-2's and head sets for use in our laboratory. Must be perfect. State quantity and lowest price. Reading Radio Shop, Box 6, Reading, Mass.

Wanted.—Men—Boys over 17. Become Railway Mail Clerks. Commence \$183 month. Common education sufficient. List positions free. Write immediately. Franklin Institute, Dept. E 152, Rochester, N. Y.

Wanted for spot cash. High grade Radio outfits, parts, attachments and materials of standard makes. No home made apparatus will interest us. Address F. J. Lamb, 1938 Franklin St., Detroit, Mich.

AMERICAN MADE TOYS

Manufacturers wanted for large production and home-workers on smaller scale for Metal Toys and Novelties, Toy Soldiers, Cannons, Cowboys, Indians, Buffalo Bills, Wild Animals, Whistles, Bird-Whistles, Race-horses, Prize-fighters, Wag-tail Pups, Barking-dogs, and hundreds of other articles. Hundreds and thousands made complete per hour. No experience or other tools needed. Bronze casting forms complete outfit from \$5.00 up. We buy these goods all year, paying fixed prices. Contract orders placed with manufacturers. Exceptionally high prices paid for painted goods. An enormous business for this year offers industrious men an excellent opportunity to enter this field. Write us only if you mean real business. Catalog and information free. Metal Cast Products Co., 1696 Boston Road, New York.

Free.—Complete antenna outfit with each \$25.00 De Forest Everyman receiving set. Call Room 27, 1966 Broadway, New York City.

- 100 ft. 7 strand Copper Aerial Wire \$.71
- 100 ft. Hard Drawn Copper Aerial Wire49
- Aerial Insulators23
- Nickel Plated Binding Posts..... .04
- 22 1/2 Volt small "B" Battery90
- 22 1/2 Volt large "B" Battery 1.40
- 22 1/2 Volt large variable "B" Battery 1.90
- 45 Volt double size Variable "B" Battery 2.80
- Nickel Plated Constant Points doz. .20
- Nickel Plated Switch Arms57
- Branch Lighting Protectors 2.37
- Porcelain Vacuum Tube Sockets56
- 1/4 inch Slider and 10 inch Rod45
- Coils wound on Tube75
- Crystal Detectors, (N. Y.) 1.20
- Mounted Tested Galena25

LIBERTY RADIO CO.

Church and Liberty Streets, New York City, N. Y.
Phone Rector 3432

Crystal Set That Gets Radio Concerts. Build it right boys. Plans and full instructions for building at low cost, high grade fine adjustable Crystal Receiving Set, fifty cents postpaid. Dept. R. D. Shaw Mfg. Co., Galesburg, Kans.

Build Your Own Radiophone.—Send ten cents for instruction book. Radio Service Institute, U. S. Bank Building, Washington, D. C.

"Radio Inventions of merit developed or financed." H. William Baer, 162 Wood St., Waterbury, Conn.

We buy your Radio goods. Head sets wanted. Radio Shop, 1246 Gates Ave., Brooklyn, N. Y.

Bargains.—Camara, \$3; Chuch, \$4; \$50 Cornet; \$28 Mele; \$9 Foxom. East Haven, Conn.

High Grade Antenna Wire. Best quality 7 strand No. 22, tinned copper, non-corrosive antenna wire. Only 1c. per foot. The Kehler Radio Laboratories, Dept. W., Abilene, Kans.

We Buy second hand radio goods, any description. Columbus Shop, 874 Columbus Ave. (103d). Open evenings to 10 o'clock.

The Standard Radio Log and Record.—A Continuous Diary and Record of all station activities. Provision for recording Calls Received and Sent with location, distance, wave length and other information. Sections for keeping records of Calls Frequently Used, Station Data, License Numbers, Equipment Inventory, Notable Performances, etc. Flexible binding, 48 pages and cover. Price 30c., prepaid or from your dealer. etalife Publishing Company, 56 Harrison Ave., Springfield, Mass.

THIS MONTH'S SPECIAL

Complete aerial outfit—100 feet hard drawn copper wire—50 feet rubber covered wire—four 4" antenna insulators—1 lightning switch—1 porcelain tube—1 ground clamp—\$2.50, complete, postpaid—Remit postal or express money order to M. J. Winkler, 220 West 42nd St., New York.

Wireless phone "B" Battery—direct from manufacturer. Large \$2.00, small, \$1.00. Postpaid, 22 1/2 volts. Wireless phone "B" Battery Co., 321 Canal St., New York.

Radioists, Attention!—Immediate delivery (by return mail) guaranteed on all our apparatus. UV-201 Radiotrons, Detector or Amplifier, \$6.50. Clapp-Eastham HR Regenerative and Amplifier sets in stock, \$39.00. Galena per crystal, \$0.10. Write for our price lists. Wireless Experimental Testing Station, c/o Workers Outfitting Store, Johnson City, N. Y.

Antenna Wire. No. 14 Copper 45c. (per 100 Ft.); 7 strands No. 22—90c. (per 100 Ft.); Weight 2 lbs. Immediate deliveries. Chas. L. Manning, 1558 Miller St., Utica, N. Y.

Complete Blue Print instructions on home made Radio sets. Easy to read. Both Crystal and Tube. Send 50c. Eastern Radio Exchange, Southboro, Mass.

Write your messages on an Eterna Writing tablet. No pen or pencil needed. Everlasting. 35 cents, prepaid. Walker, 54 North Ninth St., Newark, N. J.

GREBE SETS

Including their Latest Creation

C—R—10

MURDOCK Phones and Condensers

MOULDED Variometers Variocouplers

Panels drilled for above—no extra charge
Mail orders shipped in 24 hours

Brooklyn Wireless Installation & Supply Co.

876-A Flatbush Ave., Brooklyn, N. Y.
Tel. Flatbush 2012

You will find many Special Values in our display advertisement in Radio World issue May 13 and May 27.

BEACON RADIO and ELEC. CO.
246 Greenwich St., N. Y. C.

First Big Radio Dinner of Society of Arts and Sciences

A BIG RADIO DINNER took place at the Hotel Pennsylvania, Sunday evening, April 30. It was given under the auspices of the Society of Arts and Sciences—an institution that has fostered many successful dinners for the advancement of civilization, at which many men and women in public life have given free rein to their views. The radio dinner was largely attended. The principal speaker was Hudson Maxim, the inventor. Other speakers were David Saranoff, general manager, Radio Corporation of America; William Wade Hinshaw, president, Society of American Singers; Jack Binns, hero of the steamship "Republic."

IMMEDIATE DELIVERY

Estru-Variometers and Vario-Couplers

Lattice type, Sharp tuning, Maximum efficiency

Variometer \$5.00
Vario-Coupler 4.50

Head Phones:

Frost, 3000 Ohm \$6.00
Frost, 2000 Ohm 5.00

Mail orders promptly filled
Dealers write for our proposition
Complete Radio Equipment

NORTHERN RADIO SUPPLY CORPORATION

542 WEST WASHINGTON STREET
MAIN 2230-2276 CHICAGO, ILL.

DEALERS

On Hand For—IMMEDIATE DELIVERY

- Contact Points
- Switch Stops
- Aerial Wire
- Magnet Wire
- Spaghetti
- Porcelain Tubes
- Ground Clamps
- Binding Posts
- Slider Rods
- Sliders
- Copper Lugs
- Phone Condensers

- Novo B Batteries
- Contact Switches
- Tubes and End Blocks
- Midget Comp. Insulators
- Porcelain Insulators
- Lightning Arrestors
- Fahnestock Connectors
- Mounted Crystals
- Radion Dials
- Radion Panels
- Variable Condensers
- Vacuum Tube Sockets

Out of town orders given prompt attention

RADIO ACCESSORIES CO.

220 WEST 42ND STREET NEW YORK, N. Y.

BOYS DO NOT FAIL

To obtain your copy of these instructions. Worth many times the small amount we ask. How to construct a variometer, how to construct a variocoupler and an amplifying transformer. Detailed instructions of either for fifteen cents or put four dimes in an envelope and get the three with diagrams of connections for your set. Save money by constructing your own. We have left no details to guess about. We enclose list of all parts how much of each to get and where to obtain same.

Newco Radio & Electrical Supply Co.
Stratford, Conn.

Broadcast Bill's Radiolays

(Copyright, 1922, Westinghouse Electric & Manufacturing Co.)

I'VE never heard an angel sing, don't s'pose I ever will, but I've been hearin' just as good as sure as my name's Bill. I heard a song the other night that made my heart rejoice, I wondered if the singer was as pretty as her voice; she sang a song as soft and sweet it sounded like a bird awarblin' at the break of day the kind I've often heard down yonder in the pasture lot all wet with mornin' dew er sailin' way up in the sky a speck agin the blue. Now folks that there is music when it makes you think of spring an' meadow larks an' violets an' all that sort a thing, the more I hear, the more I like that hifalutin singin', an' all day long them purty tunes is in my head a ringin'. My wife, she can't get over how it's changed my disposition: I



tell her it's a new disease called "Radio Condition;" I just can't keep from whistlin' and a singin' all day through. Yep! I guess I've changed a lot, I uster be so blue, a worryin' about the farm an' them two kids o' mine; but all the crops have turned out well, the boys are doin' fine. An' here I sit each evenin' with them things tight on my head, an' I just keep on listnin' till its time to go to bed. The fellows loafin' at the store can't seem to figger out why I stay round the house so much, er what it's all about; o' course you get a lot of news down at Si Perkins' store, but since I got my wireless set I hear a whole lot more, an' best of all, I like them songs sung by some purty gal, her songs are sweet, I'll bet she's neat. Doggone! You know me, Al.

Back Numbers of Radio World

If you were not able to get the first seven issues of RADIO WORLD, your news-dealer can probably get the copies through his wholesaler, or copies will be mailed from this office direct, at 15 cents per copy. RADIO WORLD CO., 1493 Broadway, New York, N. Y. (Adv.)

Preserve our Broadcasting Map. See pages 16 and 17 this issue.

"WISDOM."

Everything in Radio Is Available Here—We Are Manufacturers and Distributors of High Grade Parts and Complete Equipment.

"It is good business wisdom to place your full requirements with us"

Prompt Shipments Await Your Orders On:

"Nerco" 2200 Ohm Phones	Binding Posts
Crystal Detectors	Stops
Variable Condensers	Galena Cups
(23 and 43 Plates)	Arm Contact Switches
Fixed Condensers	Switch contact points
Dials and Knobs	Insulators
Variocouplers	Magnet wire
Variometers	Tuning coils—with two sliders
Rheostats	V. T. Sockets

"NERCO" PHONES ON HAND AT ALL TIMES

De Forest Sets Complete Including the M R 6's.
Federal Sets Complete With Phones.

ASK US about our little set complete with "Nerco" phones

Listed at **\$11.50** It's a Marvel

Dealers and Jobbers Write for Proposition

Wiener Wireless Specialty Co.

Telephone—Market 5668
21 ACADEMY STREET
NEWARK, NEW JERSEY

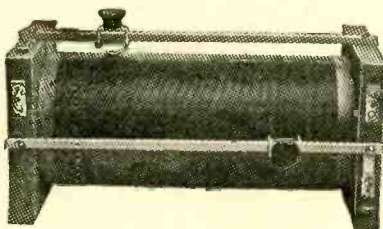

"Essex" Tuning Coils—Double Slide—Enameled wire—Good for loading coils.

LIST PRICE, \$3.00



"Essex" Polished Wood 8-inch Rotors

LIST PRICE, 50c

ATTRACTIVE DISCOUNTS TO DEALERS
3/16" Sliders, 3/16" Slide Rods, Mounted Crystals, .001 Fixed Condensers, Crystal Detectors, Lightning Arresters

ESSEX MANUFACTURING COMPANY

NEWARK

117 Mulberry Street

NEW JERSEY

KEYSTONE VARIABLE CONDENSERS

21 Plate
\$3.80

43 Plate
\$4.75

Our selection of materials and built-up type design give assurance of low energy loss and high efficiency.

Agents and Jobbers write for information.

KEYSTONE MOTOR COMPANY

OAKS, MONTG. CO., PA.

Vernier Rheostat

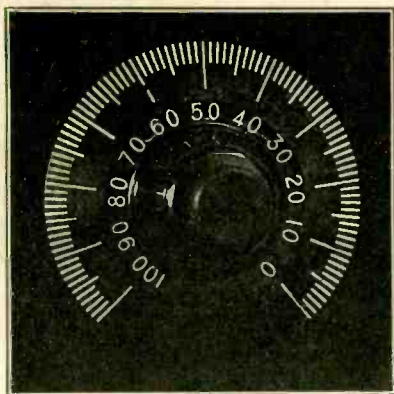

Panel Mt. with Dial
PRICE \$2.50

The Smallest!

REGULAR RHEOSTAT WITHOUT
DIALS \$1.10

**TECO.
RADIO CO.**

P. O. BOX 3362
BOSTON, MASS.

Vernier Rheostat

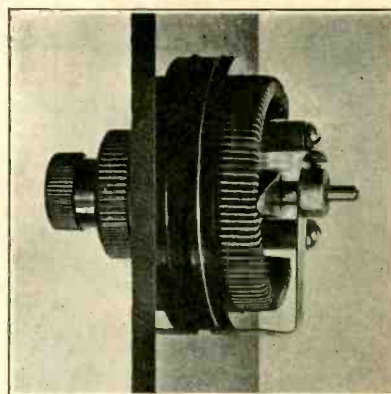

Panel Mt. without Dial
PRICE \$1.65

The Best!

REGULAR RHEOSTAT WITH
DIALS \$2.00

Distributors

Wetmore-Savage Co.

76-78 Pearl Street,

Boston, Mass.

Can you maintain that critical adjustment on your V. T.?

TeCo's New Vernier Rheostat makes it possible for you to obtain and hold that necessary fine adjustment of filament current to render your receiving circuits in their most sensitive condition.

SPECIFICATIONS

DIAMETER OF RHEOSTAT 2".
RESISTANCE 6 OHMS.
BASES MADE OF REAL BAKELITE
SPECIAL ALLOY WIRE TO REDUCE LOSS IN HEAT.

With our Vernier Rheostat it is possible to obtain variations of one-one thousandth (1/1000) of an ampere.

Our attachment does not interfere with any previous method of panel or table mounting.

A recent development in the design of rheostats for use with receiving tubes. This instrument consists of a conventional form of rheostat, with the addition of a finely adjustable Vernier attachment. The latter consists of one turn of resistance wire wound about the bakelite form and continuously variable by means of an extra contact. This contact is operated by means of a small knob, the shaft of which passes through the hollow shaft of the larger control knob, which regulates the resistance by turns. The elements of the rheostat are so built that, with one ampere flowing in the circuit, one complete turn of the Vernier control only changes that current one-tenth of an ampere. With such a small change, it is easy to obtain a variation of as small as one milli-ampere.

The VERNIER RHEOSTAT eliminates the necessity of a B-battery potentiometer and the extra space it requires. After all, it is not a fine control of either plate or filament sources that we require for our detectors, but a finely adjustable balance of the two, which will allow us to operate on the best point of the filament-current, plate-voltage characteristic to obtain maximum efficiency in detection. This consideration is quite necessary in using the later types of vacuum tubes which are very critical in operation.