

Radio Topics

May, 1923



20 Cents

MANHATTAN
ELECTRICAL SUPPLY CO., INC.

MAKERS OF THE FAMOUS



MANHATTAN
RADIO HEAD SET

OLDEST AND LARGEST
DISTRIBUTORS OF

Radio  **Corporation**
of America

GREBE **RADIO**

*The clean sanitary headband of
the Manhattan headset is a good
feature for summer use*

KENNEDY
EQUIPMENT

114 SO. WELLS ST., CHICAGO

NEW YORK

ST. LOUIS

SAN FRANCISCO



Buy at the Radio Store where they display this sign—the distinguishing mark of Blairco Proven Products.



ATLAS HEAD PHONES

The only high-grade receiver set offered at a reasonable price. Sensitiveness and adaptability positively is unequalled. Price \$9.00.

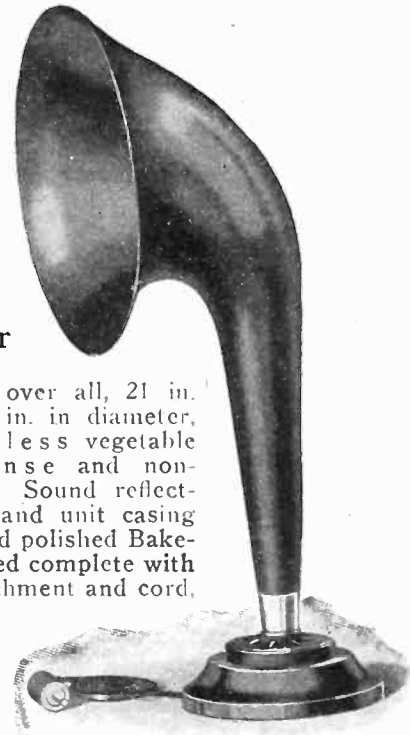

Atlas Loud Speaker

Height over all, 21 in. Horn, 11 in. in diameter, of seamless vegetable fibre, dense and non-vibrating. Sound reflecting base and unit casing of dark red polished Bakelite. Priced complete with horn attachment and cord, \$25.00.

The ATLAS Gives Tone Volume With Perfect Tone Control

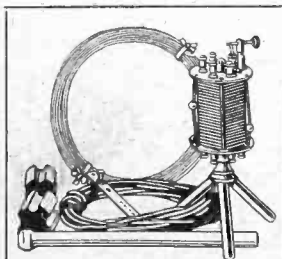

Blairco "4" Crystal Set

Takes 4 head phones—Enables 4 to listen as well as 1. All nicked steel 9 in. high. Price only \$7.50.

Complete with copper clad aerial, waterproof lead-in and ground wire, strain and wall tube insulators, lightning arrester ground wire clamp and set of \$9.00 Blairco Headphones, \$17.50.

Dealers: An unbeatable profit opportunity is offered you in the Blairco Proven Products. Write quick for our proposition.

Multiplied enjoyment with your radio follows the use of a loud speaker which, set in any convenient spot, throws out the tones so that a roomful of family and friends can hear.

But in selecting the loud speaker, bear in mind that loudness without clearness is mere noise—and get an ATLAS.

With the Atlas you get the true tone of the original—clear, pure, exquisitely sweet—and perfectly controlled. Tone distortion, distracting mechanical sounds, confusing echoes and blasts—all are noticeably absent.

All is due to the patented double composition diaphragm—found only in the Atlas. And to the use of finer materials which, with scientific assembling, also insures permanence.

A typical example of the extra quality afforded at no extra cost by all radio equipment sold under the Blairco trademark.

No matter what you want in Radio, buy at the "Blairco" Radio store and get dependable value. Every article sold under the Blairco trade name, whether our own make or others, is of proved superiority. Exacting tests have proved it the best of its kind, bar none!

If you have no Blairco dealer, write us now for Folder and Prices

Mitchell Blair Co.

"First With the Best"

1429 So. Michigan Ave., Chicago

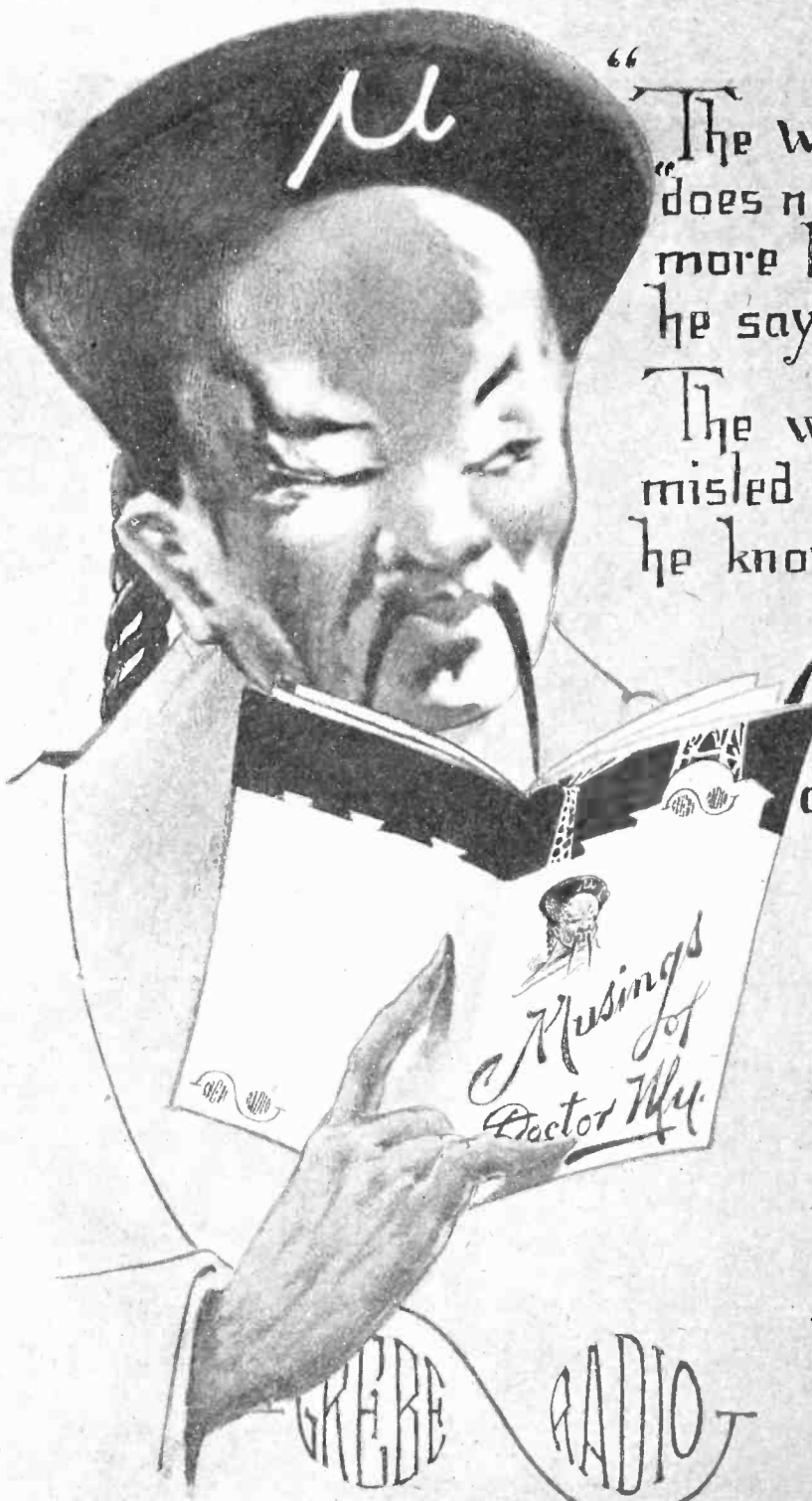

“The wise man,” said Confucius,
“does not esteem a person
more highly, because of what
he says. —”

The wise radioist is not
mised by extravagant claims,
he knows that only a

Grebe Receiver
can come up to his
expectations.
Doctor Mu.

GREBE RADIO

A. H. GREBE & CO., Inc.
Richmond Hill, N. Y.

Western Branch
451 East 3rd Street, Los Angeles, Cal.



Write for
“Musings of
Dr. Mu.”

Licensed under Armstrong
U. S. Pat. No. 1113149

Radio Topics

An Illustrated Monthly Devoted to Radio

Volume III

MAY, 1923

Number 4



Little Frankie Lee, the juvenile movie star, now playing the title role in "Terwilliger," a Frank Borzage production, is a dyed-in-the-wool radio fan, and every minute he's not working at the studio he's listening for music from afar.

CONTENTS

	Page
The Girl on the Cover—Billie Dove, Metro Pictures Star	
Trying to End Radio Chaos.....	7
An Efficient Amateur Station.....	8
Music Publishers Issue Drastic Order.....	9
WLW Celebrates Its Second Anniversary.....	10
Apparatus Photographs Sound.....	11
Entertaining the Public Ticklish Task.....	12
Radio in Mine Rescue Work, J. Farrell.....	13
Elementary Electrical Principles, Harvey M. Anthony.....	15
Department of Radio Engineering, The Ultra Audion System, by Robert J. Casey.....	17
Answers to Correspondence.....	19
A Page of Hook-up for the Amateur.....	20
Grid Leak Is Important Part.....	21
The Audible Air, J. J. Graf.....	22
The Radio Transmitter, B. R. Cummings.....	23
"Ain't Radio Grand," E. W. Cornelius.....	25
The First Radiophone Station.....	27
New and Novel Radio Patents.....	29

PUBLISHED MONTHLY BY RADIO TOPICS

Entered as second-class matter at the Postoffice at Oak Park, Ill., February 25, 1922, under the Act of Congress of March 3, 1879.

Business and Editorial Office at 1112 North Blvd., Oak Park, Ill.

Chicago Phone Austin 9300.

New York Office: 24 Broadway

Copyright 1923, by Radio Topics

RADIO TOPICS

The National Radio Monthly



FOUNDED 1921

PUBLISHED EVERY MONTH BY
RADIO TOPICS, Publishers

1112 North Blvd.

OAK PARK, ILLINOIS, U. S. A.

J. RAY MURRAY, EDITOR
NANKO C. BOS, Managing Editor
WM. M. HIGHT, Business Manager

PUBLISHING AND EDITORIAL OFFICES

Chicago Phone: Austin 9300 Oak Park Phone: Oak Park 3200

Twenty Cents the Copy From All Newsdealers. By Subscription:
To the United States and Possessions, Cuba and Mexico, \$2.00 the
Year. Remit by U. S. Money Order, Express Money Order, Check or
by Draft, payable in U. S. Funds.
To Canada—By Subscription, \$3.00 the Year. Single Copies 25 cents
—Canadian or U. S. Funds.

RADIO TOPICS is on sale the 10th of preceding month.
Text and advertising forms close the 22nd of second
month preceding issue.

Vol. III

May, 1923

No. 4

Hoover to the Rescue

BECAUSE of the failure of Congress to enact the White radio control measure into law, giving the Secretary of Commerce power to regulate radio communication, matters were brought to a head recently in Washington at the Second Annual Radio Conference. The findings of the meeting will be found elsewhere and the various recommendations will doubtless meet with the approval of every fair-minded radio enthusiast.

Secretary Hoover is said to have made the remark, "The situation is worse than was anticipated" after receiving the report of his inspectors, and the various recommendations made will undoubtedly be approved by him and soon be actively applied.

Of course only actual experience will tell whether the plan formulated will bring order out of chaos, and while there are many important details still to be threshed out, especially in allocating wavelengths, it is a step in the right direction. The new wavelengths are a sort of compromise and whether or not these will relieve the congestion and interferences which now exist remains to be seen when the changes are made.

However, those instrumental in bringing about even these slight changes should be congratulated for the splendid step made in such a short time.

And the session just closed demonstrates the necessity for the passage of the White bill as soon as possible when Congress again convenes. Hoover asks that radio users co-operate in every way to preserve the art in the United States, and this is needed to make the recommendations of the committee a success, but Congress should also be willing to do its part as the need is urgent.

Copyrighted Music Barred

THE blow has fallen. The American Society of Composers, Authors and Publishers, through its attorneys, has served notice on all broadcasting stations that they must cease broadcasting music, the copyright of which is controlled by this society.

Hence every broadcasting station in the United States on the night of April 12 was compelled to revise its program to avoid prosecution. The radio broadcasting stations were notified on that day by the Society of Composers and Publishers that they must pay a license fee ranging from \$200 to \$5,000 for the right to broadcast—and popularize—music, the copyrights of which are owned or controlled by the members of the A. S. C. A. P.

Rather than submit to this extortion, the various stations throughout the country used classical music only in place of popular airs and will continue to do so until a decision is made. The society went so far as to notify KYW and WDAP, two Chicago stations that broadcast dance music played by hotel orchestras, that they would be subject to fine if they continued, notwithstanding these orchestras and hotels pay tribute to the society for the use of the music played.

Another blow to progress and to radio.

Sailors Get Relief via Radio

A YEAR ago the U. S. Government Department of Health announced that it had completed arrangements to expand its medical service to American seamen, by prescribing by radio for any sailor who might be taken ill at sea. Messages for aid are forwarded to the health department by the ship's radio via the Radio Corporation of America or the Independent Wireless Telegraph Company. Since the first of the year the diseases and mishaps aboard ship that have been treated or diagnoses made include appendicitis, asthma, cramps, heart disease, hernia, influenza, infected teeth, ptomaine poisoning and swallowing broken glass. Several cases necessitated the exchange of several messages to obtain clear information as to cause of trouble.

A Good Move

THE government's first step in the process of clearing up the air, which is nightly clogged with a myriad of telegraph signals, was the issuance of an order that the government is going to enforce silence among all amateurs between the hours of 7:30 and 10:30 p. m.

All new licenses issued, according to Radio Inspector E. A. Beane of the Central District, will specify the hours when amateurs may operate. Notice will be sent to all amateurs holding licenses to this effect, and unless they comply with the order their licenses will be revoked.

The reallocations of wavelengths for certain stations will meet with the approval of every fair minded radio fan. We don't want the other kind on the air.

In London they are accusing the radio of luring folks to the public houses. Radio may lure them there, but it doesn't make them cock-eyed drunk.

Trying to End Radio Chaos

NATIONAL RADIO CONFERENCE PROPOSES DEFINITE ALLOCATION OF WAVELENGTHS AND OTHER IMPORTANT CHANGES

THE Second Annual Radio Conference, which concluded its hearings in Washington, D. C., on March 24, is now trying to solve the problem of how to relieve the congested traffic conditions of radio transmission.

Experts and government officials were unanimous in the opinion that President Harding and Secretary Hoover should open to public use the wave band area hitherto reserved for military and government service and that broadcasting stations should be given individual wavelengths on which they may continue their services with less interference to other users.

The primary object of the conference was to parcel out among radio users new and less conflicting bands of wavelengths and prescribe operating conditions which will allow commercial services, broadcasters, marine navigators, the army, navy and amateurs to be less hampered in their operations.

The present powers of the Commerce Department, it was decided at the conference, are sufficient to establish and enforce the new regulations and thus bring order out of chaos in the radio field.

Previously all broadcasting was confined to three wavelengths—360, 400 and 485 meters. Now it is proposed to extend the field from 222 meters to 545 meters. Within it stations can be assigned individual wavelengths and divided into two classes.

Establish New Classifications

The high power Class "A" stations, corresponding to the present Class "B"—now operating on 360 meters—will be permitted a range of from 288 meters to 545 meters, while low powered stations (the new Class B), can use wavelengths from 222 to 288 meters.

The report says this will enable the higher power stations, which are distributed throughout the country in fifty localities and practically covering the United States, to be within the reach of every radio fan. Suitable wavelengths have also been provided for upwards of 500 existing lower power stations.

The field of the amateur's activities should also be extended,

according to the report, allowing a band extending from 150 meters to 222 meters, in place of the 200 meters wavelength now used. The 200 to 222 meters length can be reserved for high grade continuous wave telegraph transmission operating under special license and technical and training schools can also occupy this band. The report confines spark amateurs to the 175 meters to 200 meters radius.

Ships using 450 meter waves are to keep silent between the hours of 7 and 11 p. m., during which most of the broadcasting is done.

Permits Reading Telegrams

The reading of telegrams or letters by broadcasting stations should be permitted, the report says, so long as the signer is not addressed in person and so long as the text matter is of general interest.

Another recommendation pertaining to relaying messages or similar broadcasting is that simultaneous rebroadcasting be permitted as a service only on a broadcasting wavelength and with the authority of the original broadcaster and of the department of commerce.

The Secretary of Commerce also has the power to regulate the hours and wavelengths, in licensing stations, and to revoke or withhold licenses when such action is necessary to prevent interference detrimental to the public good.

The conference urged the fullest co-operation of all broadcasting

stations and the public with the department of commerce in adjusting all local broadcasting problems.

Separates High-class Station

Spokesmen for commercial companies and manufacturers addressed the meeting and asked that special arrangements be made in regard to the wavelengths assigned high power, high class broadcasting stations, by separating their wave bands from those of less efficient stations. Amateur representatives also sought relief from the congested conditions now existing.

Manufacturers of parts and radio equipment also pointed out the importance of care and moderation in readjusting the wavelengths, so that the 2,500,000 receiving sets now in the hands of the public might not be made un-serviceable.

The American Society of Composers, Authors and Publishers were present and stated they would strive to extend the copyright laws to give them royalties from broadcasting stations using their music.

Hiram Gets Top Price

By C. M. BUCHANAN

THE price of hogs was going down and things were looking bad; the last big load that Hiram sold had made him fighting mad. "I've worked and slaved to make 'em fat and lost a lot of cash. I'll say that raising hogs these days is really very rash. I'll fool those birds next trip," said Hi, "I'll know what I'm about. Not one blamed pig shall leave the farm till prices turn about. I'll sit down next my radio and listen in each night—and when the price of pork goes up I'll make a hasty flight." So Hiram Jones kept watch each day upon the market change, and when the price had started up Hi hustled to the range. He loaded up his pigs and shoats and shouted, "Now, let's go." He got the highest market price and thanked the radio.

An Efficient Amateur Station

THIS station, located at 847 Chicago avenue, Evanston, Ill., has well demonstrated what painstaking and persistent work can do toward making a good station.

There are two transmitters, a 10-watt and a 100-watt. So far the 10-watt set has done the best work, both in distance covered and in reliability and steadiness. The circuit used is the inductive coupled Hartley, which gives sharpest tuning and puts all the radiated energy on one wave.

The set is mounted on an old cabinet which formerly housed a long wave set. The only controls used are aerial switch and filament rheostats. Three meters are on the panel, by means of which the exact functioning of the set is easily determined.

Acme Transformer Used

The plate supply is furnished by an Acme 200-watt transformer, giving an output of 500 volts. An



A. L. Charles at his receiver, Station 9BRE, Evanston, Ill.

electrolytic rectifier of twenty jars and a filter system consisting of three one mfd condensers and fifteen Henrys of choke transform the AC to DC. The current put on the tubes is 400 V at 100MA. The tubes can run for twenty minutes without heating beyond a dull pink. The key is placed in the negative lead of the high voltage, and a chopper is used for local work.

So far this set has been heard in every district. Reports have been received from forty states, in Canada and Porto Rico.

Since January 1 traffic has been handled with 210 stations and 300 messages have been relayed,

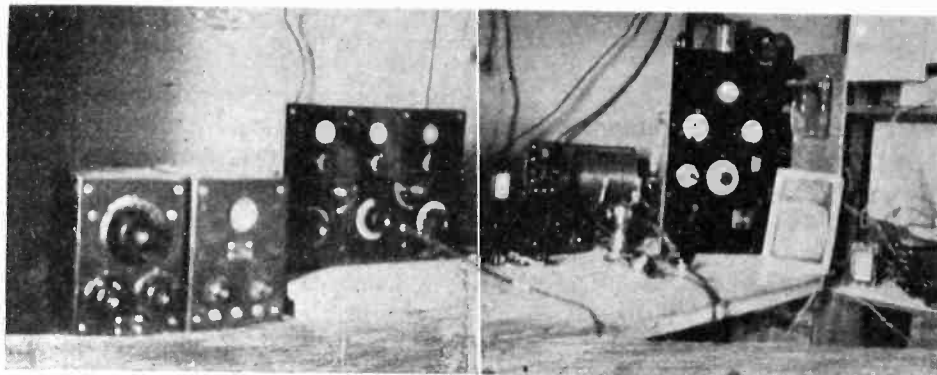

Two views of Station 9BRE, Evanston, Ill., owned and operated by Alexander Maxwell and A. L. Charles. The circuit is an inductive coupled Hartley, and has been successfully operated for some time by these two young men.

The 100-watt set in itself is good, but it is a failure because the power line will not deliver enough current to make it function properly, except in the early hours of the morning. It uses the same system as the 10-watt, only it is tight coupled, and uses more filter. So far twenty states have delivered the reports.

Counterpoise has Ten Wires

The aerial is an eight-wire cage 70 feet high, 48 feet long. One end is supported by a mast on the roof, the other by a tall chimney. A counterpoise consisting of ten wires, each 50 feet long, and the whole spread out to form a 45-degree fan, completes the open circuit. All joints are soldered, and porcelain insulation is used throughout.

The receiver in general use is a freak circuit, consisting of coupler, one step of radio, and detector. The receiver, however, is unfit for anything but CW. Although not as planned, the results have been so very satisfactory that no changes have been made. Several other receivers, amplifiers and the like are scattered about. They are used at times when spark or music is desired, which is very seldom. Bell wire is used throughout for wiring, and all joints are soldered.

An old navy battery supplies the filament current, and a Tungar charger keeps it in good health. Reports from anyone hearing this station will be highly appreciated, and all cards will be QSLed same day received.

The station is owned and operated by Alexander Maxwell (XAM) and A. L. Charles (AC).

Deaf Made to Hear by Radio

Recently in Paris two persons who had been deaf for years hear over the radio. One an old man of 77 years, deaf the last 40 years, gained his hearing and a young boy of 13 years, deaf since birth, heard for the first time in his life, human voices and music.

This occurred at Marconi House. A doctor had brought with him two young persons deaf since birth and a third child who had lost its hearing at the age of six following an attack of meningitis. The witnesses present today describe the scene.

Each in his turn, the children were placed before a loud speaker and two among them, including the one deaf since birth, distinctly heard human voices. Unfortunately, the third experienced only a slight sensation in the ears.

Dr. Yearsley declares that the experiment is very encouraging and that, lacking the power to cure deafness, he will continue his research to the end that adults who are deaf can be given sensations they have never known or of which they have lost the habit.

School Exams by Radio

In New York they are sending school examinations via radio. The first school to adopt this novel means of communication to the classroom was the Haaren High School, where, on April 4, between 1:15 and 1:45 p. m., Station WJZ at Newark broadcast a series of accounting problems which the students worked out on adding machines while listening to the problems from a high power receiver.

Music Publishers Issue Warning

SOCIETY OF COMPOSERS AND AUTHORS DEMANDS \$5,000 A YEAR FEE FROM BROADCASTING STATIONS FOR POPULARIZING THEIR MUSIC

WAR has been declared! War between the American Society of Authors, Publishers and Composers, who control the copyrighted music, and the broadcasting stations throughout the country. As a result more than 2,000,000 radio enthusiasts are now tuning in on programs devoted to classical music, where heretofore they listened to jazz and other popular song hits which largely dominated the broadcasted programs.

The society of composers demanded a license fee from every broadcasting station sending out copyrighted songs or music, ranging from \$250 to \$5,000 a year. Newspaper stations were asked to pay \$250 and the electrical companies the larger fee.

The Westinghouse Electric and Manufacturing Company, which operates four stations, has issued the following statement:

"It has been and will continue to be our constant endeavor to furnish the public without charge the best programs we can devise, but the condition under which permission to broadcast the copyrighted music of the publishers' organization could be obtained would involve a considerable addition to the already heavy burden under which we are operating.

"These conditions are further fraught with possible future complications which might readily become so embarrassing as to interfere with the continued successful operation of the stations, so we have decided to eliminate the copyrighted music."

Chicago Hard Hit

"The middle west was hit especially hard," says the Chicago Tribune, "as the large Chicago broadcasters have announced that they will not submit to what they call a 'holdup,' but will omit from their programs copyrighted material. Some of the New York and Newark broadcasting stations have submitted to the demands of the publishers and paid the license fee, but only the radio fans with powerful instruments in the middle west can enjoy their programs."

The music publishers maintain, according to E. C. Mills, chairman of the executive board, that the broadcasting stations are commercial institutions and should be made to pay for the use of the songs. He admitted that the sta-

tions do not directly receive any profits but pointed out that the concerns operating them are using them for advertising purposes.

Affects Many Stations

The various other Chicago stations, besides KYW, have taken the same stand that the Westinghouse people have, and neither the Board of Trade station on the Drake Hotel, WDAP, the Daily News, WMAQ, nor any of the others are using any copyrighted popular music in their evening programs. The fact that Jack Chapman's orchestra at the Drake Hotel, and Isham Jones' College Inn orchestra both pay license

fees for the use of copyrighted numbers controlled by the music publishers, does not permit their music to be broadcasted by stations WDAP or KYW. Likewise the Sunday evening concert at Orchestra Hall, Chicago, had to be eliminated because of several songs controlled by the publishers' society.

New Florida Station

Construction of a huge radio terminal and claimed to be the second largest in the country, has been started at Haileah, near Miami, Fla., by the Tropical Radio Telegraph Company. The plant is to handle all of the South American, Central America and West Indian business and will cost about \$250,000.

The towers will be 437 feet high, with a span of 1,050 feet. Electrical material for the plant is being prepared in northern factories. Two hundred and thirty tons of steel will be used in the construction, and 1,600 tons of concrete.

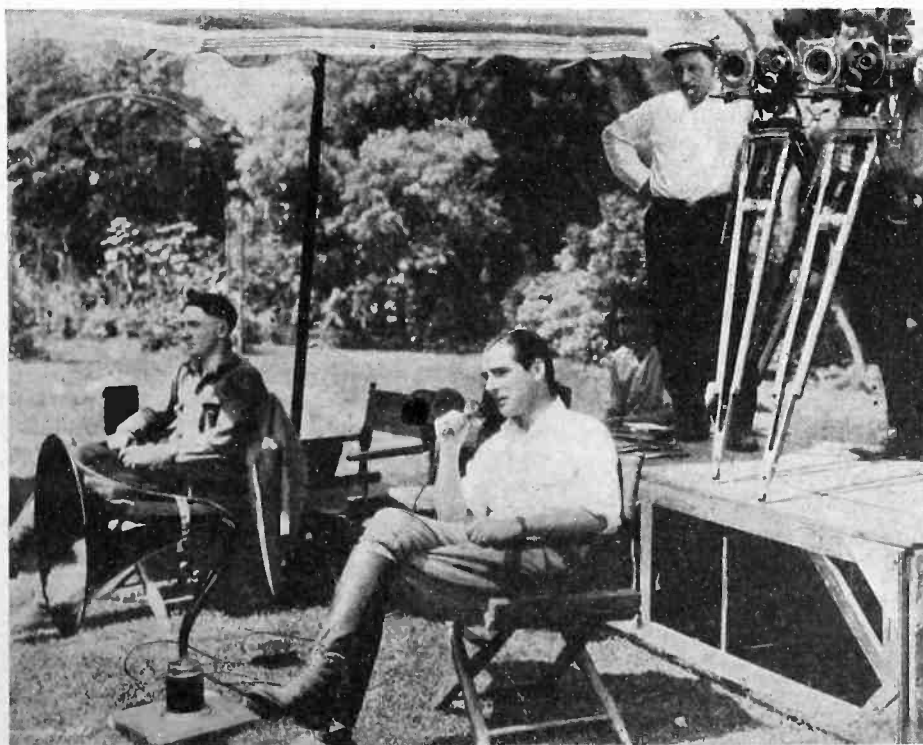

There's more than one way to use a Magnavox. For instance, Rex Ingram, the Metro Pictures Corporation director, uses one to advantage while directing big scenes for "Where the Pavement Ends," in which his wife, Alice Terry, stars.

WLW Celebrates 2nd Anniversary

THE Crosley Manufacturing Company, Cincinnati, Ohio, home of the broadcasting station WLW, celebrated its second anniversary on March 21. This celebration, however, applies to the radio division.

It was two years ago on Washington's birthday that Powel Crosley, 3d, wanted his dad, Powel Crosley, Jr., president of the company which bears his name, to purchase a radio receiving set for him. His classmates had one and boylike, he too, wanted one. So dad set out to get it for him.

When Mr. Crosley went to the Precision Equipment Company to buy the radio set, he found the prices were very high. In fact, too high for the material and workmanship contained in the set. With a little persuasion, he induced his son to wait a while and promised that he would have a radio set.

Prices Too High

Mr. Crosley knew merchandising values. He quickly understood the price asked for radio apparatus two years ago was not in proportion to the cost of labor and selling. It was too high. Then he began to think of the great number of boys who, he believed, would be the ultimate buyers of radio apparatus, and who would want a radio set at a reasonable price.

With the idea in mind that there must be thousands who would want a set, he called in an engineer and together they designed a low priced radio set. The first of these wonderful epoch making receivers was ready March 21, 1921.

The famous Crosley socket, with its design for mounting upon a panel or base, and the variable condenser with its book-type action, and other distinctive apparatus now well known in the Crosley line, came as a result of a little boy wanting a radio set.

"Better—Costs Less"

There is no tablet to mark the spot where the first of the Cros-

ley radio products were made but there is a far greater reminder of the Crosley line in the national advertising campaign now being carried on in Radio Topics, The Saturday Evening Post and other periodicals.

The full significance of the meaning of the trademark slogan: "Better—costs less" can only be appreciated when you see the new radio receiving sets and note the low prices asked for them and see the big value in efficient service and workmanship. Complete receiving sets may now be purchased in the Crosley line at the same cost that a few parts would cost of some other make.

It is interesting to note that within two years from the time Powel Crosley, Jr., went to The Precision Equipment Company to inquire the cost of a radio receiving set, he purchased the company. That, indeed, is one of the many romances of the radio industry.

The Crosley Manufacturing Company has one large factory where the large line of radio ap-

paratus is manufactured. Another factory makes the cabinets while a third establishment is the printing plant. All of these places are within easy reach of one another and under the direction of Mr. Crosley.

Radio Lures 'Em

According to the London Daily News a new peril is worrying religious bodies in England.

Young people, it is said, are flocking to the public houses to hear radio concerts.

Religious bodies have become thoroughly alarmed, and have declared war on the local justices' ruling that licensed premises having a music license may, by virtue of that license, install a listening-in set in their bars.

The Manchester and Salford Council of Christian Congregations and a number of other bodies are joining in a petition to the Manchester and Salford licensing justices to receive deputations at or before the annual licensing sessions next week and the week after.

Archdeacon Aspinall, who is taking a prominent part in the opposition, objects to the label "Kill-joy," and says he does not look upon the movement as a temperance crusade.

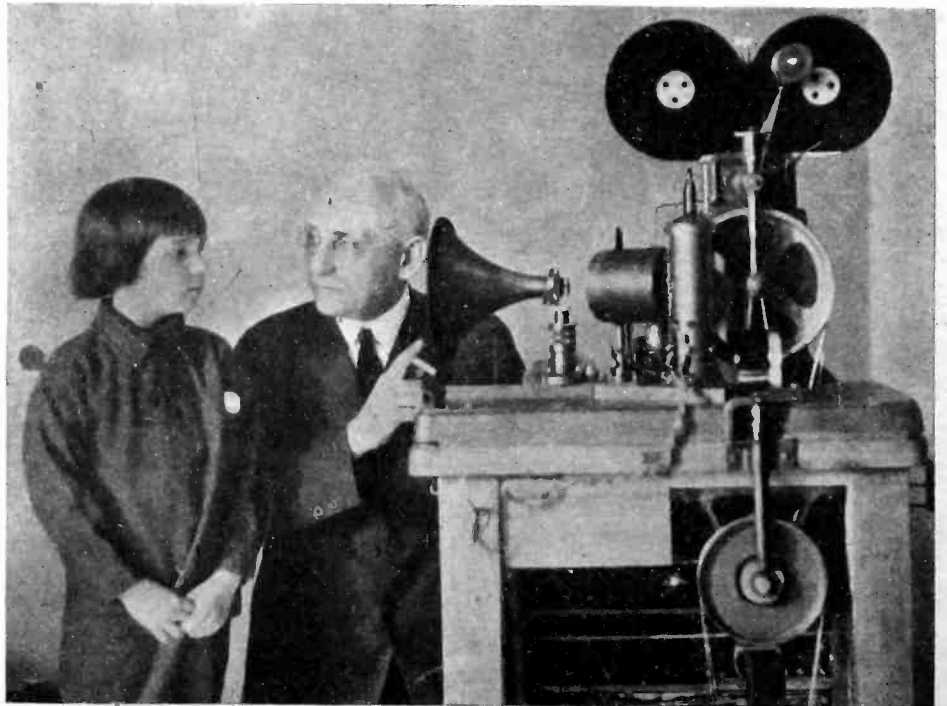

Jackie Coogan, the most popular boy in films, is learning all about the Pallophotophone from C. A. Hoxie of the General Electric Company, the inventor. Recently Jackie talked into the apparatus, and when he returned to California he heard his own voice over the radio, 3,000 miles away.

This Apparatus Photographs Sound

By C. A. HOXIE

General Engineering Laboratory of the General Electric Company

A CONCISE definition of the Pallophotophone would describe it as a successful device for taking reproduceable moving pictures of sounds, just as the motion picture camera does of objects.

Many attempts have been made to devise such an apparatus, but hitherto there has been no device of this sort that will record sounds accurately. The phonograph is, of course, excepted from this category, as it is in no sense photographic. The difficulty that has halted many promising devices in their embryonic stage, and has prevented the success of others, is that of securing a vibrating system sufficiently accurate and sensitive to record the sound vibrations on a photographic film. Naturally, the most effective medium of transposition is light; the problem, then, was to devise an apparatus fulfilling the requirements of sensitivity and accuracy in transposing sound waves to light vibrations. This has been done successfully in the Pallophotophone by using a third or intermediary medium, electricity, as represented by a photo-electric cell and amplifying tube circuit.

How the recording and reproduction of sound is accomplished by the Pallophotophone is best understood from a description of the apparatus and the principles on which its operation depends. In reality, there are several mechanical and electrical differences in the type used for recording and that used for reproduction, the necessity for which will appear upon consideration of the operating characteristics. Since its development the device, or at least the major portion of it, has been utilized as a "pick-up" for radio broadcasting, taking the place of the microphone ordinarily used. Its greatest use, so far, has been in connection with wireless. Therefore, only that phase of its field will be considered here.

A Delicate Apparatus

The essential principle of the Pallophotophone recording apparatus is very simple, the actual construction very delicate. A schematic diagram of the apparatus (Fig. 1) gives an idea of the general arrangement. The

IN the April RADIO TOPICS we described briefly the Pallophotophone, the invention of C. A. Hoxie. This month we are able to give our readers a more full and complete description of the device and how it works. Recently Jackie Coogan, the movie star, talked into the Pallophotophone in New York and after he had returned to California, heard his own voice broadcasted from station WGY, Schenectady, N. Y.

"I got a thrill when I heard myself talk to myself three thousand miles away," said Jackie on the day of the test.

operation is as follows: Light from the incandescent lamp A is concentrated upon the mirror C by the lens B. The beam from the mirror passes through the lens D and the slot in the film container, producing, when the film is at rest, a narrow, oblong figure. The mirror is fastened to a diaphragm in the horn E. Sound waves, passing into the horn, cause a vibration of the diaphragm, which vibration is transmitted to the mirror, and causes the beam of light to oscillate across the slot in the film holder.

The resultant effect on the film is a series of waves, with peaks whose sharpness depends on the speed with which the film is moved past the slot. Fig. 2 is a section of film, showing how the sound produced by speaking the letter "a" is recorded. The success of the recording device is due to the extreme sensitivity of the vibrating system. Without going into the details of its construction, it may be said that vibrations are amplified

about 2,000 times on the film. Therefore, the slightest overtones, or harmonics, of the human voice are faithfully reproduced on the film, and with sufficient amplitude for reproduction. As to the magnitude of amplification necessary, it is possible, by focussing the light so as to cover a very small area, and hence giving it more intensity, to use a very small amplitude of vibration. Amplitude of 1/16 of an inch is enough to produce very clear speech or music. Therefore, by using a space of 1/8 inch for each, eight records side by side could be made on a standard moving picture film. An idea of the delicacy of the vibrating system can be obtained from its weight. The diaphragm and mirror combined weigh .1 of a grain, or half as much as the head of a common pin. The actual physical arrangement of the apparatus is shown in Fig. 3. The film passes from one of the motor driven drums, down past the slot, and up, being wound on the second drum.

How It Operates

The arrangement of the reproducing apparatus is shown diagrammatically in Fig. 4. As may be seen, it is considerably different from that used

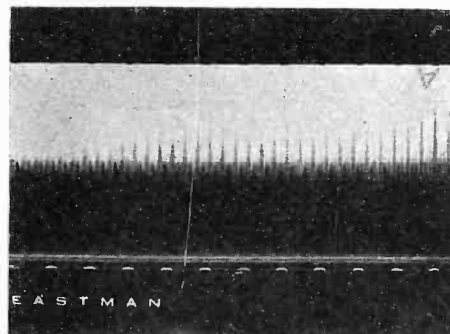

A section of the film showing impression made by the voice and reproduced by the Pallophotophone. (Fig. 2).

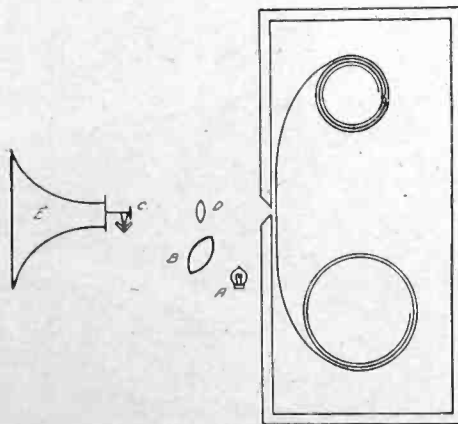

Complete diagram of the Pallophotophone recording apparatus (Fig. 1).

in recording, although somewhat the same in physical appearance. Briefly, the operation is as follows: The film upon which the sounds have been recorded, as explained previously, is passed between a light source consisting of an incandescent lamp and concentrating lens, and a photo-electric cell which is in the circuit of a vacuum tube. The figure also shows how the reproducing circuit compares to an ordinary radio transmission circuit employing a microphone transmitter.

As the vibrating system is the heart of the recording apparatus, so the photo-electric cell is that of the reproducing apparatus. The basic principle of the photo-electric cell has been known for some time, and various substances, selenium among the best known, have been utilized in de-

vices employing this principle. There is, however, this difference between selenium and the active element of the cell used in the Pallophotophone. It is the resistance of selenium that varies according to the intensity of the light to which it is exposed, thus varying the amount of current that can flow through it, while, with the new cell, its electron emission is governed by the intensity of the light falling on it. The action of selenium tends to be sluggish, and it has a resultant lag that confuses the sounds produced by speech. The new cell has no appreciable lag, and the transmission of speech is correspondingly accurate.

The operation of the apparatus is as follows: As can be seen from the diagram, the photo-electric cell and two batteries are connected in the circuit with the grid of a vacuum tube. It is obvious from a consideration of the diagram that any change in the current flowing through the cell and the resistance in series with the cell will produce a corresponding change in the E. M. F. impressed on the grid. When the film carrying the sound record passes between the cell and the light, the varying degrees of light which it permits to fall on the cell cause a varying amount of electron emission in the cell, and thereby create a potential difference in the grid circuit. Current then flows in that circuit in amounts directly proportional to the intensities of the light admitted to the cell through the film, and at frequencies corresponding to the frequency of the vibrations recorded on the film. The remainder of the circuit, and its action, are pre-

cisely similar to those of the standard radio transmitting equipment.

When reproducing, the film is moved past the slot at the same rate of speed as that at which the record was made. As in the recording apparatus, it is unrolled from one drum and wound on the other by means of a small electric motor. The apparatus is very simple to operate; in fact, once the proper adjustments have been made, it practically operates itself.

A recent development in the application of the Pallophotophone is the

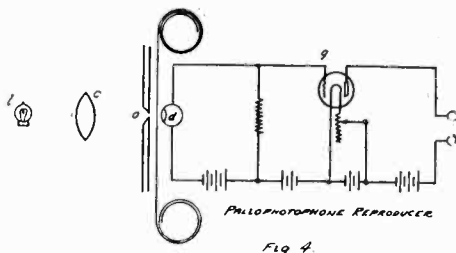

The circuit of the Pallophotophone.

use of the recording apparatus, less the film carrier mechanism, as a pick-up for broadcasting stations, to take the place of the microphone pick-up usually used. The arrangement of the apparatus and the circuit employed are shown in Fig. 5. In this case the vibrating beam of light from the mirror on the diaphragm falls directly on the window of the photo-electric cell. The beam is so focussed that only half its width penetrates the window of the cell when the mirror is at rest. Thus, as it swings according to the vibrations of the dia-

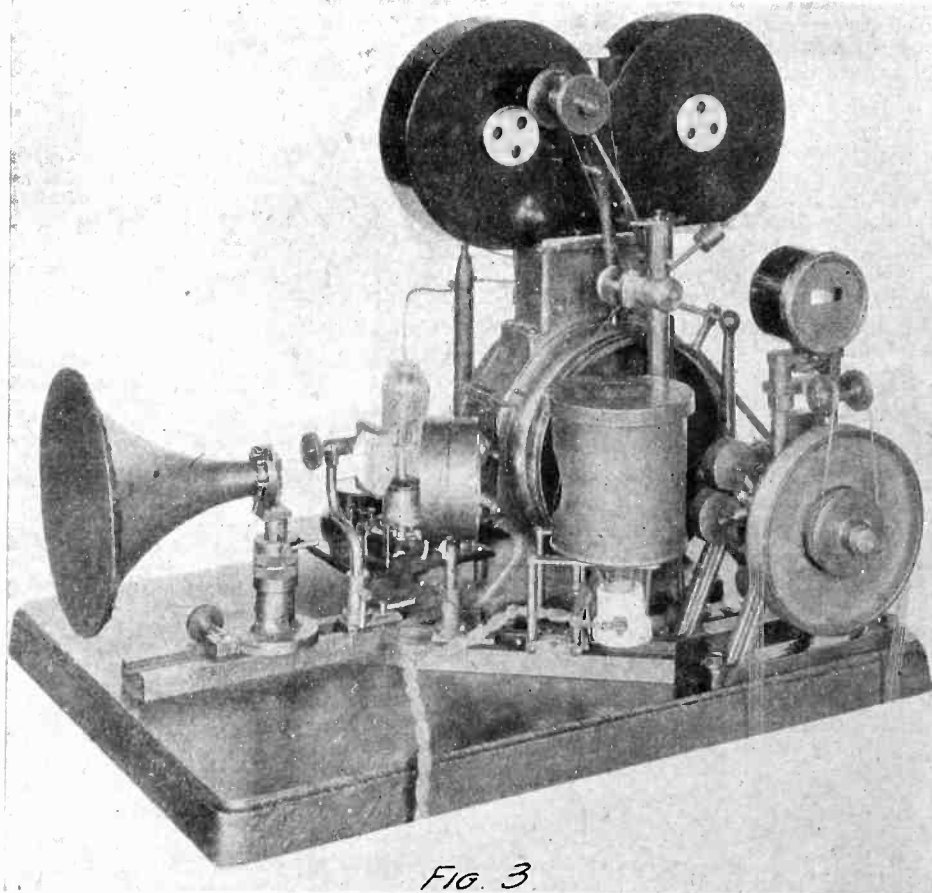

Photo of the Pallophotophone Recorder invented by C. A. Hoxie and whose performance is described in the accompanying article.

phragm, the beam causes variations in the electron emission of the cell, the rest of the circuit being exactly similar to that used to reproduce from a film. In this application it shows considerable improvement over the microphone, since the flexibility of its vibrating system is much greater and the accuracy with which the sound is transmitted is correspondingly increased.

Wins Hoover Cup for Best Station

FREDERICK B. OSTMAN, Ridgewood, N. J., has been awarded the Hoover cup for the best amateur radio station, under the auspices of the American Radio Relay League board of directors. Announcement that Mr. Ostman's station, 20M, had been chosen as the winner was made by Hiram Percy Maxim, president of the A. R. R. L., at the league's headquarters, Hartford, Conn.

This trophy is the highest honor in amateur radio and is awarded by the Department of Commerce through Secretary Herbert Hoover to the best all-around amateur station, the major part of which is home-made. The entries are judged not alone on station arrangement of equipment, but on nine factors which the A. R. R. L. Board of Direction considers necessary in an ideal station.

The essentials considered in making the award include extent to which apparatus is home-made, ingenuity in design, construction and arrangement; efficiency of transmitter, consistent transmitting range, efficiency of receiver, obedience to United States laws and local co-operative regulations, quality of operator's sending, amount of traffic handled, accuracy, completeness and neatness of station log.

In making the award two other stations among the list of entries were considered particularly — 2FZ, operated by F. Frimerman, of 740 Prospect avenue, New York, and 5ZA, operated by Louis Falconi, of Roswell, N. M. The latter was the winner of the Hoover cup last year. Any licensed amateur radio station in the United States or its possessions is eligible to participate in the contest.

Radio in Mine Rescue Work

By J. FARRELL

ONE scarcely picked up a newspaper last fall without reading of some new horror in mine disasters. One disaster alone took a toll of 87 lives. Nearly 2,000 fatal accidents occurred in coal mines during the year.

Much of this irreparable loss of human life could have been prevented through the establishment of effective means of communication between the entombed miners and rescue parties. Mine telephone systems have proved satisfactory for this purpose where the wiring is well insulated, but very often the circuits are broken by falling rocks, and grounding due to worn insulation, or to extreme dampness. The hope of the mining industry is therefore being directed toward the possible utilization of radio in such emergencies.

Recent experiments with radio along this line conducted by the United States Bureau of Mines in co-operation with the Westinghouse Company hold promise of the effective use of radio in mine rescue work. The experiments have proved conclusively that electromagnetic waves can be made to travel through solid strata. Signals have been heard distinctly through 50 feet of coal. Messages from station KDKA, 18 miles away, were heard 100 feet below ground. Messages sent from within the mine could be heard outside the mine at a distance of 750 feet.

Vertical Antenna Used

In the experiments only short wave lengths which are known to suffer absorption were used, KDKA sending on 360 meters and the instruments within the mine sending on 200 to 300 meters. In all experiments the vertical antenna were found to give the better results, as horizontal antenna gave practically no reception. A loop of a single turn was also used with fair results. Further experiments are to be made to determine whether the use of longer wave lengths will permit of reception at greater distances.

In receiving messages inside the mine from KDKA the receiving station, an ordinary tube set, was located about 50 feet from a 6-inch bore hole from the surface of the mine, lined with iron pipe and containing electric light wires which extended throughout the mine. It is thought that the presence of these wires greatly assisted in the reception inasmuch as when the set was removed to a place in the mine free from wires and tracks the signals were only faintly audible through 50 feet of cover.

A Westinghouse 20-watt B. T. model T. F. transmitter sending out continuous waves of 200 to 300 meters length was used in sending messages within the mine. Signals were heard distinctly through 50 feet of coal strata. The sending antenna consisted of two wires, each 50 feet long, stretched horizontally in opposite directions from the instrument and supported by dry sticks about 5 feet above the floor.

Track Used for Ground

Ground connection was made by a copper lead to the track in the floor of the drift. At a dis-

tance of 320 feet signals were very weak, and there was no measurable depression of the plate current unless the tickler were brought up to the oscillating point. To gain a quantitative idea of the transmission of the radiated energy a milliammeter graduated in tenths of a milliamper was inserted in the plate circuit of the receiving apparatus. At 245 feet a depression of .03 milliamper was obtained and the audibility of the signals was appreciably better than before.

At 210 feet the depression was .07 milliamper; at 140 feet it was .20 milliamper; at 100 feet .70 milliamper, and at 50 feet .80 milliamper. At a distance of 100 feet straight down the entry the depression was .50 milliamper, either with or without ground connection. In general, the ground connection was found to be a minor factor in the reception of signals, merely laying a few feet of rubber insulated wire on the floor of the drift giving satisfactory grounding by virtue of its condenser effect. Without vertical component in the receiving antenna no signals could be received at all.

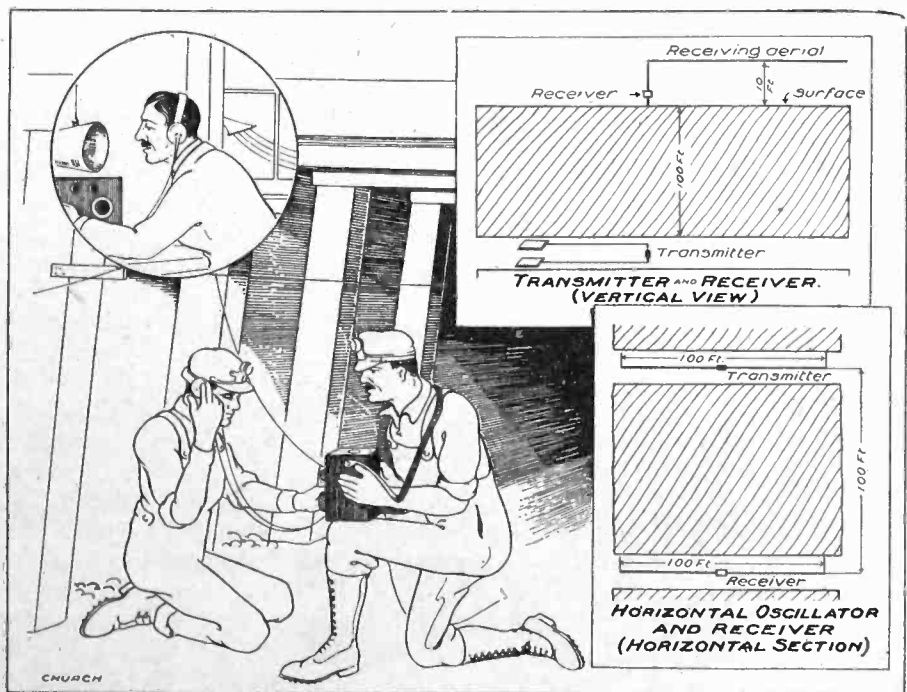

How the radio sending and receiving apparatus may be applied to mine rescue work. The diagrams at right illustrate the different uses of transmitter and receiving aerial.

In the second series of experiments the two branches of antenna were connected to the instrument so that oscillation would take place from one branch to the other, the apparatus thus being analogous to a Hertz oscillator. The ground connection was removed. This arrangement gave a radiation of the electric field in the horizontal plane as horizontal lines of force, whereas in the preceding test, the electric lines of force were vertical, being radiated by the vertical portion of the antenna. The receiving antenna consisted of two branches each about 50 feet long. At a point 100 feet directly down the entry from the sending instrument the current depression was .45 when the receiving antenna extended horizontally from the instrument in opposite directions, and in a direction perpendicular to the direction of the sending instrument. When the receiving antenna was held in the line of the sending antenna the depression was .15.

At a distance of 100 feet laterally from the sending instrument with coal walls intervening, as shown in the diagram, signals were very faint, and there was no depression in the millimeter. With one antenna elevated and the other lowered, however, a depression of .02 or .03 was recorded. When the tips of the antenna were joined together near the instrument so as to make a single-turn loop, there was no measurable depression when the loop lay horizontally on the ground, but with the loop still horizontal but elevated about three feet the depression was .02. With one side of the loop elevated near the roof and the other on the

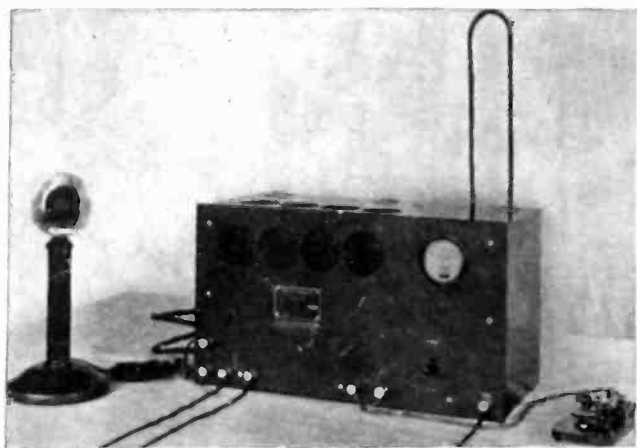

Type of wireless telephone transmitter used by Bureau of Mines in recent experiments demonstrating the possibilities of using wireless in communicating with miners under ground.

ground the depression was .15 when the plane of the loop was parallel to the sending antenna, but with the plane of the loop at right angles no signals were detected.

In another series of experiments two galvanized iron sheets about 7 feet by 5 feet were attached to the antenna wires of the sending instrument, and grounded by leveling the moist ground and laying the metal sheets flat upon it. No radiation could be obtained because of the high resistance of the earth part of the circuit. One plate was then elevated about six inches upon dry sticks, and there was a sufficient decrease in the resistance to permit the oscillator to operate.

At 140 feet the receiving antenna was grounded by attaching the tips to iron rods driven about one foot into the floor of the entry. A depression of .13 to .16 was obtained, according to the location of the iron rods. With short wires used as antenna and the grounding stakes brought close to the instrument the depression was only .01 to .04.

Galvanized Plates for Ground

The galvanized iron plates were then placed 5½ feet apart, one directly above the other, the planes of the plates being horizontal. Each plate was supported on fairly dry sticks of wood so that fair insulation was obtained. The distance of the plates from the sending instrument was about 40 feet. The antenna current was one ampere. At 140 feet a short receiving antenna with one end elevated and the other to ground gave no appreciable depression, but a 50-foot antenna in a direction approximately at right angles to the direction of the sending instrument gave a depression of .28.

The receiving instrument was then taken outside the mine to a point about 750 feet from the sending instrument, and the antenna hoisted to a nearby flag pole. Signals could be detected but there was no depression in the millimeter without using the "tickler."

The receiving instrument was then taken to a point on the

surface directly above the sending instrument, as shown in the second diagram, the distance between the two being about 100 feet. Signals could be heard with a 50-foot antenna stretched in opposite directions but no depression was obtained. Grounding the tip of the antenna destroyed all signals. Signals could still be heard at a point on the surface 250 feet away, but there was no depression. Signals on 360 meter wavelength from station KDKA were heard very strongly but also

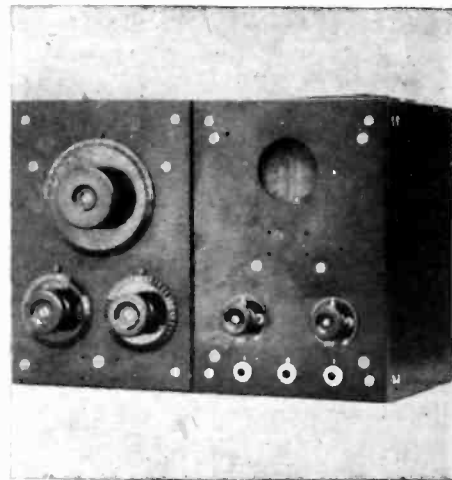

Photo of receiving apparatus used in tests of Bureau of Mines under ground.

gave no depression of the current.

In another series of experiments the plates were removed from the sending antenna and the antenna wires were attached by loops of electrician's tape parallel to the electric light wires for about 50 feet and parallel to the telephone wires for another 50 feet. Outside the mine, 750 feet away, a very loose coupling to either the light wires or the telephone wires gave the signals with great intensity, the depression being .80 milliamperes in the former case and .30 in the latter.

300 Experts Gather

The American Radio Relay League, Hartford, Conn., is gathering data on interference on broadcasting in every section of the U. S. A. by means of official observing stations.

F. H. Schnell, traffic manager of the League, is appointing official observers whose duties will be to record every class of interference on broadcast waves between 360 and 400 meters. About 300 will be appointed, an average of six in each state and only the most skilled amateurs will be selected.

Elementary Electrical Principles

This is the Fifth Article of This Instructive Course, and Deals With the Principles of Batteries

By Harvey Mitchell Anthony

THERE are several ways in which electrical energy may be created. Probably the most familiar is the method of generating electricity by means of the dynamo or generator in which a number of copper wire conductors are wound around an armature and this armature rotates through a magnetic field. This principle of generation will be taken up in a later article. The other important method of generation is by chemical action. This method will be discussed in this article. A few general remarks will be beneficial before discussing this method.

Many years ago it was discovered that if two unlike metals were brought together so as to make contact with each other a small electromotive force or pressure was developed. This was termed a "contact-electromotive force."

There is always a small voltage or difference of potential set up when any two dissimilar substances make contact. Under this condition, even though this voltage is present, it is so very feeble that it is entirely useless so far as any commercial application is concerned. However, it was later discovered that if two unlike metals were brought into contact with each other and heated at the point of contact, this voltage would be considerably increased.

This principle really did exhibit interest and was made of commercial use in the instrument which we know as the pyrometer. The pyrometer is based upon the following action: Two small pieces of metal are joined by contact at one end and the other end of each piece is attached to a wire. The wires leading from this combination are run out to a device for measuring the voltage at the contact.

This measuring instrument is a very sensitive voltmeter which will record extremely feeble voltages. Now, when the contact joint of this combination of metals is subject to heat, the voltage at the contact will become greater as the heat becomes greater.

Thus, from this arrangement it is possible to measure heat and temperatures which are entirely too high for our ordinary thermometers.

While this may appear as a very ordinary matter to discuss when dealing with batteries, it is in fact the simplest means of generating electricity. In reality, it is a truly wonderful discovery. The metals themselves composing this simple little combination must of course have very high melting points or they themselves would be melted by the heat to which they were subjected.

Pyrometer metals often used are platinum, with a melting point of 3191 degrees F., and rhodium, with a melting point of approximately 3540 degrees F. A pyrometer of this form may be used in finding the temperatures in glass furnaces and iron mills.

A temperature of 2786 is required to melt iron and 2588 for glass. The voltage generated when the pyrometer is placed in the furnace is recorded by the voltmeter which is calibrated to read, not in volts, but in degrees of temperature. The

EDITOR'S NOTE.—The first of Mr. Anthony's articles on Elementary Electric Principles appeared in the January, 1923, issue of RADIO TOPICS, and, owing to the immense amount of work involved in classifying and reading the answers to the questions appended, we must ask (1), that all answers be written on uniform size of paper; (2), that you put rings around your answers, preferably with a red pencil, and (3), that you write as clearly as possible, as neatness will count in grading the papers.

There will be one more paper following this, treating upon the subject of measuring instruments.

greater the heat the greater will be the voltage and the higher the needle will swing on the scale. In other words, the reading of the instrument will be proportioned to the temperature at the point of contact of the metals.

* * *

This is a very elementary method of generating electricity. The writer simply uses it to give the student something to think about in connection with batteries. If you as true students wish to get down and think real hard, turn your thoughts to this remarkable thing of how, what we call electricity, can be generated and actually set into motion by two little pieces of metal touching each other and this voltage even made stronger by the application of some heat.

You usually think of the wonders of the world in terms of the Brooklyn Bridge, Niagara Falls or the Woolworth Building, but stop and think for a moment. Turn your attentions to the little things and try to fathom their mysteries of creation.

Just as there is a difference of voltage set up between two unlike metals in contact, so is there a difference of voltage set up between met-

als immersed in liquids. There is always this difference present: it never fails. This may be called chemical generation of electricity.

This article intends mainly to discuss this chemical generation. There are two principal types of batteries—one is the primary cell and the other is the secondary cell commonly called the storage cell. The terms cell and battery may be confusing at first. A battery may be composed of one, two, three or many cells.

The primary type cell consists essentially of two electrodes such as copper and zinc immersed in a solution known as the electrolyte. These electrodes must be unlike in nature. It would be impossible to use two coppers or two zincs.

We will discuss an example of a simple cell. You may construct a simple cell in the following manner. A glass tumbler is filled two-thirds full of a solution of sulphuric acid and water. Use about four times as much water as acid. Pour the acid into the water slowly and stir rapidly. Never pour water into acid or you may have an explosion.

Place into this solution a strip of copper cut about one inch wide and five inches long. This will act as the positive pole. A piece of zinc strip of the same size will do for the negative pole. Then attach wires to the zinc and copper strips and run to a door bell. You will note the acid solution eating away the zinc strip.

This process is a chemical reaction taking place at the zinc and this is the seat of the electrical energy which passes over the wires and magnetizes the bell, causing it to ring. Simple, isn't it? But the simplicity of it is not so much emphasized here as the real wonder of it. It is the mystery underlying this action which is quite sufficient to turn any deep-thinking boy into a study of those great problems of the universe which the Creator has placed at our disposal and invited us to solve.

* * *

Thus, in order to have a battery for the generation of an electric current, it is necessary to have at least three things: two dissimilar metals and an electrolyte. The electrolyte must eat more rapidly on one of these metals than the other. This is the fundamental principle of the primary battery. A primary battery is one, making a long story short, which exhausts itself in this manner and cannot be revived. When the zinc strip is eaten away it is gone forever. To renew the battery means replacing the zinc. The copper will last many times longer than the zinc.

Let us discuss another form of the

tend to increase rather than decrease the efficiency of the set. The direct lead from aerial circuit to plate has opened the way to unlimited experiment. And the result is a stream of Ultra Audion hookups in endless variety. DeForest himself might fail to recognize some of them. He might marvel at all of them.

A Few Hookups

A few of the group—just a few—are pictured in the diagram accompanying this article. Their similarity becomes evident only when one considers the elements that made up the original Ultra Audion, an inductance with leads to plate and grid, a tuning condenser in the ground lead, and the usual allotment of batteries, tube, socket, rheostat and phones.

Figure 1 shows a circuit which has been tried out principally in Chicago with excellent results. In laboratory tests it has proved to be the most efficient of the modifications.

It has the added advantage of simple construction. The builder can easily wind his own coil and buy the remainder of the set for a very few dollars. The coil is 150 turns of No. 22 scc on a two-inch core. It is tapped at the 25th and 35th turns and then at every tenth turn up to and including the 95th. The last two taps are taken from the 125th and 150th turns.

The arrangement of grid leak is important. If the leak is shunted across the grid condenser it is quite as likely to admit the positive B battery potential to the grid as it is to provide an egress for positive charges from the grid to the ground.

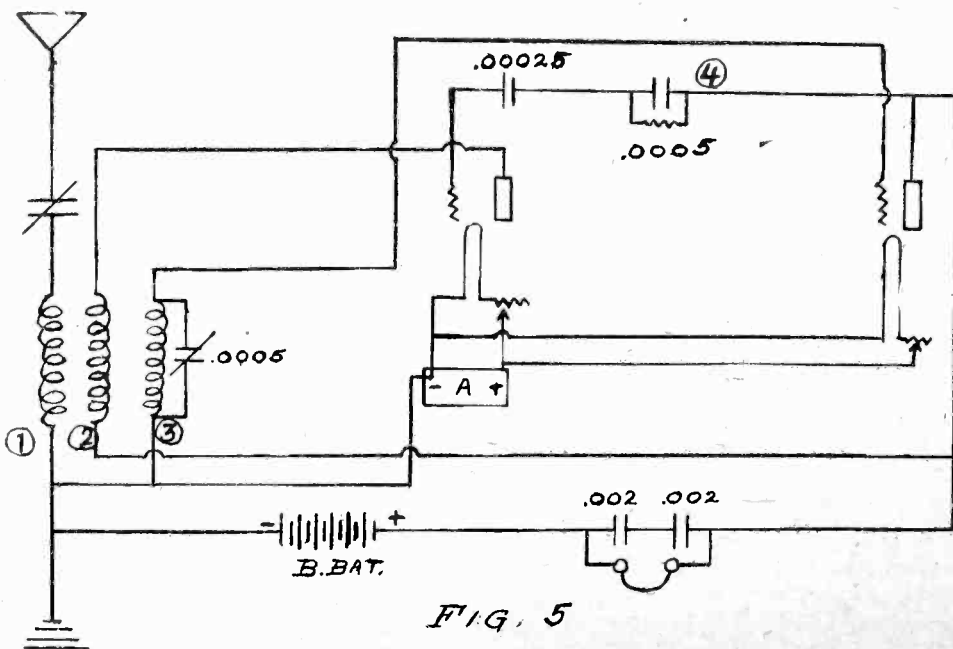

FIG. 5

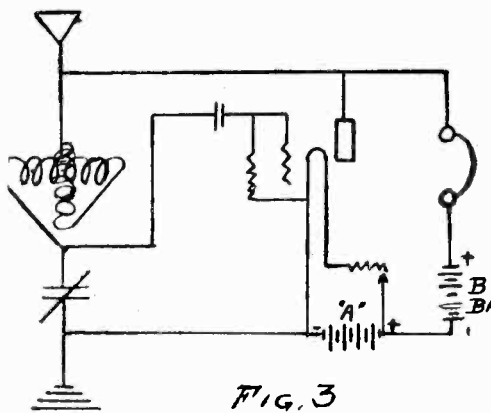

FIG. 3

Uses Honeycomb Coil

Figure 2 shows the connection of a honeycomb coil as an inductance in this circuit. This hookup has been popular during the last two or three months and is quite efficient, although naturally the fixed inductance does not permit the fine tuning possible with a tapped coil. Figure 3 is almost exactly the same circuit except for the use of a variometer as an inductance. Such a set functions very well, is highly selective, and a great distance getter.

In figure 4 is shown a magnetically coupled Ultra Audion in which the phones are tastefully hung onto the aerial and the B battery is grounded. A split variometer sometimes is substituted for the variocoupler. In this circuit the grid leak is in its accustomed place across the grid condenser.

Figure 5 is a sketch of the Smith retroactive circuit based on the Ultra Audion. It is almost a copy of the super regenerative in principle but not in action, for this one has been known to work. In-

ductances 1, 3 and 4 are 35 turn honeycomb coils. No. 2 is a 50 turn honeycomb. Condenser values are indicated in this sketch.

This circuit seems to approach the ultimate in wiring troubles. But it is by no means so difficult to build and tune as might be expected. The ordinary three coil mounting provides for most of the connections. After that the wiring is hardly more complicated than in the tapped coil set. It seems to be a principle of the Ultra Audion that everything is connected with everything else and that the currents get so bewildered they have no option but to pass through the phones.

Simple Ultra Audion

It is possible to make an Ultra Audion with a coil of bell wire for an inductance and two leaves of tin foil in a fold of cardboard separated by a wedge for a condenser. If the batteries are connected negative to negative in this simple set the grid leak may be eliminated. Signals will be quite audible though weak. A rheostat may be approximated by a length of resistance wire in the A bat-

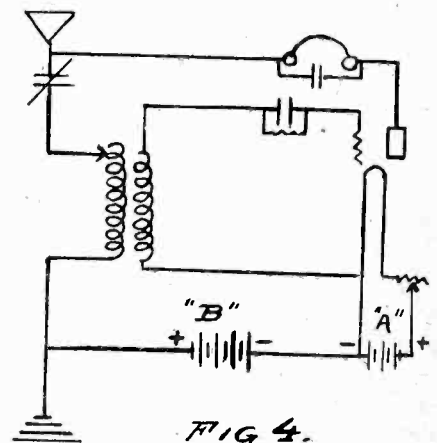

FIG. 4.

tery lead with an ordinary spring clip to tap it. And the binding posts may be cut to four. Of these one will serve for the aerial and one phone connection. A second will take the positive B battery connection and the other phone lead. Negative B battery and positive A battery may be hooked to the third. The ground and negative B battery leads will be attached to the fourth.

The set will not work without a lamp, and there are numerous precedents supporting the use of batteries and headphones. Otherwise it closely approximates the elemental.

Correspondence With the Institute

The Director of Radio Topics Institute will answer any questions puzzling radio fans in this department. Make your letters as short as possible, write on one side of the paper only, and give name and address. This is your department. Use it.

Too Much Whistling

CINCINNATI, O.: Made hook-up on a wooden panel as a tryout and got PWX Cuban Telephone Co., Havana, Cuba, clear and fairly loud. Was so pleased I bought panel of formica and built it carefully adding one step audio using s. c. c. instead of s. s. c. No. 24 and 28 in both sets. The first hook-up was very selective as I could get WOC and WGM and WGY through WLW here, but this last try I get a lot of whistling and get nothing much louder than with detector alone and have not got Cuba since. And, by the way, got Los Angeles KNX fine with single tube. The only difference from your hook-up and mine is absence of an automatic filament lighting jack as I did not know how to connect same in. I have two circuit generative set with two-stage audio, that is, a hammer and home built, but believe yours is more selective and gets the distance better.

I have two friends who are building sets from hearing my first one and would surely appreciate it if you can straighten me out. I use a Bradley stat on detector and variable grid leak.—Durham & Co., L. A. Nye, 1051 Delta avenue, Cincinnati, Ohio.

ANSWER: Your squealing is due to regeneration in your set. The best way to eliminate this is to make all wires as short as possible and get your parts as close as possible to each other, thereby cutting down long leads, crossed leads and eventually squeals.

Your circuit is very good, only why not try and connect negative B battery to positive A battery?

WATERBURY, CONN.: For a month I have been using a single WD-11 tube in a regenerative single circuit set of my own make and have had very satisfactory results. Wishing to get volume enough to operate a loud speaker, I have made a two-stage amplifier but the results with the WD-11 tubes have been very unsatisfactory. There is the desired amplification, but the tube noises resulting from the amplification are very objectionable.

The fault does not seem to be with any one tube, but common to all which I have tried. The slightest jarring of the set causes the tube elements to vibrate and sets up a ringing noise in the set. This is not a squeal or howl due to unintended feedback, but a ringing sound. Upon investigation I found that this sound could be heard in the detector alone and increased with each tube added. I am interested to learn if any others have experienced this trouble when using these tubes. For a single tube set they are very desirable, but for a set using amplification I have found them poor for the reason above stated.

Would be pleased to receive any comments you may make on the above, and

am enclosing stamped addressed envelope.—A. L. Parke, Waterbury, Conn.

ANSWER: In reading over your communication to the Institute we find that you are having the same trouble that many more of our readers have had.

We would advise you to eliminate the WD-11 tubes from your amplifier and substitute thereon tubes of the WV-202 or the 302 class.

Two Steps of R. F.

STEELTON, PA.—In the February, 1923, issue of RADIO TOPICS, on page 18, you illustrate and describe a receiving set with two stages of radio frequency amplification.

Would like very much if you would let us know the make of the different units used in this set, such as Radio and Audio Transformers, Grid and By-Pass Condensers, Grid Leaks and Tuning Condenser. Also let us know if all wiring should be covered with Spaghetti tubing.

We would like, if possible, to build up a set that will bring in stations on the Pacific Coast loud and clear enough for loud speaker use.

RETTBERG BROS.,
Steelton, Pa.

ANSWER—All parts and material used in the construction of two stage radio frequency amplifier, as shown on page 18, February issue, can be purchased from the Go-to-Coil Co., Providence, R. I.

Spaghetti tubing can be used if wiring is going to be confined to small space.

Grid condenser is Dubilier .00025 By-Pass Dubilier .002.

Tuning Condenser can be purchased from the above named concern, using list numbers as shown in drawings.

Chargers for Batteries

RICHLAND, GA.: I use a regular Ford storage battery with my radio and am looking for a charger to charge same. The reason I am having trouble finding one is that our light plant here is 110-volt 133 cycle alternating current. One company offered to build me one but said they would have to make a special job of it which made it out of reason.

I would appreciate it if you could give

me the name of a company that makes a specialty of building chargers for the above current and sells them at prices about the same as for the standard current.

Would I have to have a special transformer for 133 cycle to use the new detector and amplifier tubes which are operated from a stepdown transformer off of 110 A. C. house lighting supply?—Lamar Richardson, Richland, Ga.

ANSWER: The utilization of 110-volt A. C. for lighting filament of amplifier and detector tubes has met with slight success. All complain of a slight hum which is present even with the best of filtering system. As it stands at present it is not feasible. For the lighting of filament on C. W. transmitters it is used every day. Some hum is present but where D. C. is used for a plate potential this hum is ironed out.

You should have no trouble purchasing a suitable charger for your A battery. The Automatic Electrical Devices Co., 134 W. 3rd street, Cincinnati, Ohio, sells a battery charger for \$18.50, specifying that same can be attached to any alternating current circuits of any frequency or voltage. This looks very reasonable and we would advise you to write to them.

DECATUR, ILL.—Will you please send me hook-up or what to buy to make a set using WD-11 tubes.

REAVES STOBEL,

1422 W. Decatur St., Decatur, Ill.

ANSWER—From your inquiry we gather that you wish to construct a set using a WD-11 tube.

An easily constructed set wherein you can use a WD-11 tube was described in our January number. Also the Reinartz tuner in the February number.

The Frost Jac-Box

The new Frost Jac-box, which allows the use of four sets of head phones or loud speaker, practically quadruples the use of any radio receiver, and will be found a valuable addition to any set.

It is handsomely finished, being made of polished oak with nickel plated metal parts and a felt base. It comes with a ten-inch cord and No. 139 cord tip plug. There is also another style with tips at free end of cord adapted for use with sets having binding posts instead of jacks. You can tune your loud speaker with this jack box without disconnecting or adding extra telephone up to three pairs.

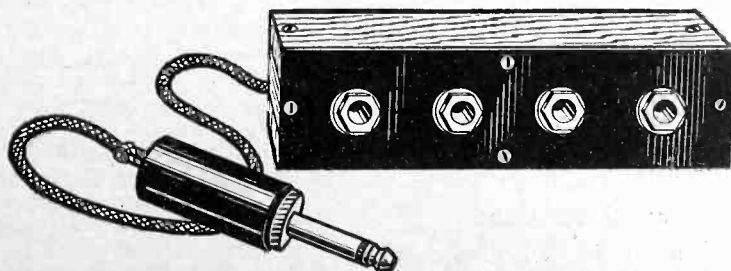

The New Frost Jac-Box

Grid Leak Is Important Part

ITS OPERATION IS SIMPLE, BUT IT PERFORMS ONE OF THE MOST IMPORTANT FUNCTIONS IN YOUR SET

THERE is probably no more insignificant piece of apparatus in a radio receiver than the grid leak, and yet it is one of the most important. It can make or ruin the most expensive receiver designed for its use, despite the fact that in its simplest form it can be just a pencil mark between two points. It is in reality the weakest link in the radio chain of parts. But do not overlook its importance.

Upon its rests the responsibility for fully 70 per cent of the radio sickness, and almost always in diagnosing the case of a sick set look at the leak. Unless it is constructed right and then used right in the receiver, the receiver it is used in will never function properly.

In order to understand thoroughly the importance of this unit it is necessary that a full knowledge of its function should be possessed by every radio fan.

After all, this operation is really very simple and can be understood without any technicalities whatsoever. It is bound up in the valve-like action of the vacuum tube when that remarkable instrument is being used as a detector in the receiver. By this time even the newly initiated fan knows that the detector tube makes it possible to reproduce the sounds which are put into the microphone at the transmitting station.

How the Tube Works

Now the manner in which the vacuum tube does this is as follows: The electro-magnetic waves which travel through the ether and are picked up by the receiving aerial set up a high-frequency current in the tuning elements of the receiver itself. The tuning element, of course, must be in resonance with the incoming wave. That is in turn applied across the grid and filament of the vacuum tube.

It is then that the tube as a detector gets in its valuable work. When the filament is lighted it emits electrons. These little particles are negative electricity. Since the place of the vacuum tube has a high voltage battery connected to it in such way that a positive potential is maintained on the plate, the electrons will be attracted there, because unlikes attract each other.

When the current impressed on the grid is positive the grid will aid in this passage from the filament to the plate. When, however, the grid is negative it will resist their passage, because like and like repel each other, and since the electrons are negative and the grid is negative there will be no further flow.

Controls the Tube

In this manner the vacuum tube acts as a valve, allowing only one-half of the alternating current to pass

through it and completely checking the other half. The result is that there is a flow of pulsating current in the plate circuit which is going in one direction only, and it is this which actuates the telephones and reproduces audible signals.

During the normal operation of the tube as a detector it will happen that an excessive negative charge will become lodged upon the grid because of the electronic stream from the filament. This charge tries to go somewhere when it reaches the full capacity of the grid element. It will leak out through the pocket of the tube, or even the walls of the tube along the path of least resistance. This action, however, is too slow and permits the grid to accumulate a full negative charge before leakage begins.

It is necessary in order to keep the tube from blocking up to provide a pathway for this excessive charge to leak off without in any way interfering with the other normal function of the tube or the circuit associated with it. That is the exact job of the grid leak.

Not Too High Resistance

Now, if this leak is to function properly it must be neither too high a resistance nor too low. Moreover, it must be so placed that it will form a path of least resistance for the charge to leak off. It is here that the most important point to remember should be stated. In the detector the return of the grid circuit must be to the positive side of the filament circuit. The word "must" in this case cannot be overemphasized.

The reason is very simple and is bound up in the elementary principle that unlikes attract and likes repel each other. Since, therefore, it is a negative charge which we wish to get rid of, we must have a positive potential at the other side of the circuit in order to attract the negative charge—hence the reason for completing the grid circuit at the positive side of the filament.

The grid leak functions normally without interfering with the high fre-

quency currents which are impressed on the grid when a signal is received. The latter find an easy pathway through the grid condenser, because of their high frequency.

Easily Made

The grid leak can be made of a pencil mark, or a line of India ink drawn between the two terminals of the grid condenser, but if this practice is followed, great care must be exercised in order to be sure that the line is continuous throughout, and also that it is making contact with the terminals. The resistance leakage path thus provided can be varied by increasing or decreasing the width and thickness of the line until the correct value is obtained for the particular tube.—Chicago Journal.

Can Talk From Trolley Cars

A new system of wireless telephoning from a moving trolley car was demonstrated publicly for the first time by the Third Avenue Railway Company in the Bronx, New York City. Conversations of the utmost clearness were carried on between the passengers and an operator in the company's substation at Brook avenue as the car rattled up and down the St. Ann's avenue line for about a mile and a half. The demonstration was made by engineers from the General Electric Company at Schenectady, who have been working out details for more than a year.

The apparatus is expected eventually to be utilized by electric railroads all over the country. Its chief practical value, according to the Third Avenue system, is the aid it will give in emergency repair work.

"When something happens to one of our cars and we send an emergency wagon out at present we know nothing until some member of the crew hunts up a telephone booth and communicates with the office," said Mr. Huff. "We expect at first to equip all emergency wagons with the wireless telephone and to place instruments in the starters' booths."

W. R. G. Baker, engineer in charge of radio transmission for the General Electric, explained that the new system is an ordinary radio outfit except that instead of transmitting waves broadcast through the air by antenna the instrument is connected directly to the trolley feed wires by a condenser. It does not interfere with other wireless messages, nor can they be picked up from the air at random. An extremely long wave length, about 18,000 cycles, is used.

Entertaining Public a Ticklish Task

By ROBERT J. STANTON

ENDEAVORING to entertain an audience of over a million people every night throughout the year is a stupendous task and the program managers of KYW, Chicago, the radiophone broadcasting station of the Westinghouse Electric and Manufacturing Company, are striving constantly to add variety to the concerts to please all classes of the invisible audience.

One of the greatest sources of information concerning the desires of the audience is contained in the thousands of letters which the KYW management receives. One letter will carry the plea, "give us more jazz dance music," while another read, "cut out that barbarian tom-tom and book more classical selections."

To satisfy those of the audience who desire popular music and those that prefer classical selections, the managers of KYW decided to book a greater proportion of classical music for the regular evening musical program which is broadcasted from 8 to 9 o'clock, and to devote one night each week to a program of dance music and popular songs. This plan led to the development of the Friday midnight revues which have taken the country by storm and are said to be one of the most popular radio entertainments in America.

Musical Revues

As KYW is located in practically the heart of Chicago's theatrical district, it was not difficult to transport the entire cast and chorus of musical comedies appearing in local playhouses. The program of many of these revues have consequently been furnished by musical comedy stars of national repute.

The first two were by "Shuffle Along," the famous colored show which has had a record-breaking run in Boston and Chicago, and the "Greenwich Village Follies." Closely following the brilliant programs furnished by these shows came "Spice of 1922," "The French Doll," "Lilies of the Field" and a return engagement of the "Greenwich Follies."



Miss Adele Beattys, who is among the notable artists who have recently appeared at the Westinghouse station KYW, Chicago. She is the musical directress of "Greenwich Village Follies," and arranged the midnight shows broadcast from that station.

At present the music publishers of Chicago are co-operating with KYW, and programs furnished by such well-known publishers as Jerome H. Remick, Will Rossiter, Leo Feist and Waterson, Berlin and Snyder have entertained the midnight radio prowlers with the very latest song hits.

Isham Jones Orchestra

Several months ago a special telephone line was installed in the College Inn, Hotel Sherman's famous cafe, through arrangements made with Mr. Frank Bering, manager of the hotel. By means of this special line KYW is now able to broadcast the dance music played by Isham Jones and his College Inn orchestra and the music played by this famous group of syncopators is a regular feature of the early musical programs and the midnight revues.

As proof of the popularity of the midnight revues is shown by the following letters which are duplicates of thousands of others

received every day at the station:

Station KYW

Gentlemen:

I'll wager you can't put on a finer program than you did last night in the Friday midnight revue.

Station KYW

Gentlemen:

The concert given over KYW Friday night was wonderful. I would have listened in all night if you had kept on sending and I put down my headphones with reluctance at 2:15 a. m. The midnight revue is appreciated. Keep it up.

Because there is very little interference from other stations at the time the midnight revues are broadcast, they have been heard in every state of the union and in Canada. These revues will continue to be broadcast by KYW every Friday night from 10 p. m. to 2 a. m. and those of the future will hold many pleasant surprises for the invisible audience.

Will Add Two New Stations

Plans are nearing completion for the erection of two more giant radio broadcasting stations by the General Electric Company, according to an announcement recently made by Martin P. Rice, director of broadcasting for that company.

One of the new stations will be located near San Francisco, and the other is indefinitely placed at somewhere between the Pacific and Atlantic coasts. Both will be modeled after General Electric Company station WGY at Schenectady, N. Y.

In each city visited Mr. Rice received assurance of co-operation from the Chamber of Commerce and municipal officials, who were alive to the advantages and prestige which may accrue to the city which is the home of a powerful broadcasting station.

The expansion of radio broadcasting by the General Electric Company from one to three stations is part of the program agreed upon some time ago by the General Electric Company, the Radio Corporation of America and the Westinghouse Electric. This plan contemplates the erection of nine large broadcasting stations. Of this number the Westinghouse has now three in operation—those at Pittsburgh, Pa.; Chicago, Ill., and Springfield, Mass. The Radio Corporation has two stations under construction.

The Audible Air

By J. J. GRAF

EDITOR'S NOTE:—Mr. Graf, like many others, views with trepidation the present reckless establishment of too many broadcasting stations.

Mr. Graf is one of the pioneers in wireless transmission, having successfully established the sending of code messages from a moving railway train many years ago. In those days the air was comparatively free from any interference aside from those furnished by nature. Therefore he looks with alarm upon upon the "polluting of the air by amateurs and other individuals" who have no regard for the people's rights. Government regulation is necessary to correct this and when we get the proper legislation it should be enforced.

RADIO, like the rose that blooms in June, has had a beautiful but short existence. The perfume is still apparent, but the flower is already wilting and the looms are weaving the shroud of another forgotten achievement.

Radio, when correctly interpreted, belongs in the realms of art. It has hewn its own niche in the granite halls of painting, sculpture, music and architecture and like these should be protected by a tribunal that knows not only radio, but also the arts with which it has elected to associate.

Air Pollution

Selfishness of individuals, amateurs and some ambitious corporations are polluting the atmosphere with grief and brickbats. If this condition is permitted to progress the people will suffer a great loss. They were given an opportunity to participate in a variety of entertainment not generally available to but a few and were also given knowledge and news of vital interest.

The matter broadcasted by the pioneer stations is properly diversified, but always of such merit that

reflected a keen interest in the public's approval.

The Westinghouse and General Electric companies are certainly entitled to a generous appreciation of their long and costly efforts in perfecting radio and their unselfish attitude in practically giving it to the people.

It is not my intention to discredit all of the other broadcasting efforts, but I feel that the general situation was not bettered by their entrance in the field and that the pioneers were making a rapid and highly commendable progress in providing the facility so that it could be enjoyed by all of the people.

Broadcasting and reception must be disassociated in the quarrel that is now raging and no matter how sincere the idealist or socialist may be, the rights of the patentee are entitled to respect. After he has unquestionably surmounted great difficulties at the cost of many sacrifices, he has earned compensation and should not need to consider your or my approval as to its source. It should be remembered that wireless received many smiles of derision and but few words of encouragement or commendation before Jack Bins made his heroic effort and the new queen of the Atlantic, the great Titanic, floundered and slipped beneath the surface of a calm sea. Likewise the original achievements of radio by the General Electric and Western Electric companies during the years of 1913 and 1917 received only passive interest. It was not until 1920 when the perfection of this wonderful work startled the world and received the unanimous acclaim of the people.

A Vast Industry

The amateur and the government in its solicitude towards him should give radio some consideration in its industrial relationship. Before its advent it is fair to estimate that several hundred men were engaged in the manufacture of amateur apparatus, whereas today at least 100,000 men and women are employed in the industry, which will either expand or

collapse, depending on reasonable regulation.

The Department of Commerce is giving no consideration to that portion of the country's population that exists inland at considerable distances of the oceans and banks of the Great Lakes. Amateur regulations as to wave lengths and their decrement are not enforced and very frequently disregarded, with the result that thousands of people are deprived of that portion of the air which the government says belongs to them.

The fact that the navy insists that it still requires the large number of wave bands that it arbitrarily appropriated when wireless was a suckling infant, is an admission that it has not progressed with its growth, certainly improvements of apparatus and scientific development has continually increased sharpness of definite waves, which naturally has produced many additional routes of communication in their allocated atmospheric space.

Received Fight News by Air

For the first time in history, Argentine was joined with New York by radio when the high power station Radio Central at Rocky Point, Long Island, transmitted a complete description of the recent Firpo-Brennan bout, round by round, direct from the ringside at Madison Square Garden, New York City, which was received but an instant later in the homes of hundreds of South Americans within hearing distance of the local broadcast station there.

No previous attempt had been made to intentionally furnish South America with a radio service, especially of a character which involves a definite schedule as in the case of the recent demonstration where minutes were as precious as hours to the anxious listeners located over 6,000 miles from the scene. In spite of the great distance separating the two points, only a fraction of a minute was required to have the reports of each round in the hands of the fight fans in Argentine.

The Radio Transmitter

By B. R. CUMMINGS

Radio Engineer, General Electric Company

A RADIO transmitter is primarily an alternator. Instead of generating the usual commercial frequencies, however, radio transmitters generate frequencies in the order of from 20,000 to 1,000,000 or 2,000,000 cycles. Obviously the usual form of alternator cannot be employed for this purpose, and the system used is usually one which is not dependent on moving mechanical parts. The function of a radio transmitting equipment is to generate alternating current at these frequencies and transfer its output to the antenna system.

The antenna system consisting of aerial wires, inductance units, and a ground system, or counterpoise, forms a series alternating current circuit, which represents the load on the transmitter. Frequencies of this magnitude (so-called radio frequencies) are essential in order that efficient radiation of energy be obtained from the antenna. Of the total power in the antenna, the percentage that is radiated decreases very rapidly as the frequency is lowered, or (which is the same thing) as the wavelength is increased.

Radio transmitters in order to be applicable for commercial use must usually be capable of generating any one of a number of frequencies, and in many cases must be so designed that the frequency of its output can be changed by throwing a single switch. This requirement is brought about by the fact that in commercial traffic it is customary to use one wavelength for calling purposes and then to transfer to a second wavelength for communication, keeping the calling wave free for calling purposes.

When the transmitter is used for telephony, a modulation system is incorporated in the radio transmitter proper. For telephony this modulation or control system consists of a group of radiotrons termed modulators. The function of the modulators is to vary the amplitude of the radio-frequency alternating current in the antenna circuit in such a manner that the envelope of the maximum amplitudes of the radio frequency alternations reproduces the wave form of the voice.

Rating Modern Transmitters

Modern radio transmitters are rated in terms of their output in watts or kilowatts, which is in keeping with the rating of other electrical machinery. For example, when we speak of a "one kilowatt transmitter" we mean a transmitter which puts one kilowatt of power into the antenna system. Radio transmitters are

built with outputs from as low as one watt or less to as high as several hundred kilowatts. The largest single radio transmitter was built by the United States Navy Department at Bourdeaux, France, and has a capacity of 1200 kilowatts.

This station, known as the Lafayette station, call letters "LY," sends on a wavelength of approximately 23,400 meters and can be readily heard in the United States.

The proportion of the input into the antenna system which is actually radiated into space depends upon a number of things, chief among which are the wavelengths at which transmission is carried and the resistance of the antenna system, including the ground or counterpoise.

License Must Be Obtained

It is permissible for anyone to maintain and operate a radio transmitting station, providing a license is obtained from the United States Department of Commerce for such operation, and providing transmission is carried on in accordance with the rules and regulations of the Department of Commerce, and in accordance with any restrictions placed upon the equipment by the manufacturers.

In a previous paper the term "wavelength" was defined. The wavelength which may be used by radio transmitting stations are assigned by the Department of Commerce. All wavelengths be-

low 600 meters are assigned to commercial work, those below 200 being assigned to so-called "amateur transmission." The wavelengths 360 and 400 meters have been approved by the Department of Commerce for radio broadcasting, although these wavelengths have not as yet been established by law.

All wavelengths between 600 and 1600 meters are reserved for the exclusive use of the United States government and are used by the various government departments, including the army and navy, for radio communication between shore stations, warships of all types and aircraft. The necessity for restricting a band of wavelengths for government use, thereby insuring freedom from interference from commercial radio traffic, is, of course, obvious. Wavelengths above 1600 meters are available for commercial radio work.

To secure a license for the operation of a radio transmitting station it is necessary that the applicant be able both to send and receive the Continental Code at a rate depending upon the class of license requested, and to give assurance that he is capable of operating his own apparatus. The restriction that licenses are given only to people capable of receiving the Continental Code is based upon international regulations, which require that all transmitting stations cease sending immediately and give absolute priority to any distress signals from a ship at sea. Obviously, therefore, the operator of any transmitter must be able to receive and identify such distress signals in order that he may be able to comply with this requirement.

Ship's Requirements

Since 1912 it has been required by law that every ship cruising more than 200 miles from shore, and carrying fifty or more persons aboard, including the crew, be equipped with a radio transmitter

and receiver capable of communicating a specified distance. Not only must such equipment be installed on all vessels, but must be inspected by an inspector of the Department of Commerce each time the vessel puts into port. If the inspector of the Department of Commerce finds that the radio equipment is not, in his opinion, capable of carrying on the required communication and gives indication of unreliability, he reports this condition to the commanding officer of the vessel. Any vessel which sails without remedying this condition is subject to a penalty of \$5,000.

This requirement is, of course, fundamentally intended for the safety of the personnel aboard the vessel, and in this connection it is interesting to note that probably no other piece of electrical or other equipment is so apt to be called upon at any time to be responsible for the safety of hundreds or thousands of people as the radio transmitter. The most difficult engineering in the building of radio transmitters is not in establishing electrical circuits which will function as required, but in the selection of materials and in establishing the necessary safety factors, which will insure reliable service under the extremely varying conditions of installation and operation.

A Boost and a Good Hint

I THINK the covers on Radio are wonderful and are a credit to radio. The printing and copy of "R. T." is well done. It is a pleasure to read it. But the great failing of "R. T." is the same as all the other magazines and radio papers; they forget all about the amateur. "R. T." is no doubt welcomed by the broadcasting stations, but why shouldn't it be welcomed by everyone connected with radio? I have been studying radio for a number of years and I still fail to find very many items in plain English. I think that in every issue there should be the start of a new "kindergarten class." In every issue there should be a first grade, and a second, and a third. In this way everyone would be pleased and accommodated. And plenty comedy and stories of amateurs' experiences.

A. L. CHARLES,
Evanston, Ill.

A 10-Watt C W Transmitter

By MALCOLM H. ROMBERG, E. E.

AFTER numerous requests the INSTITUTE went in search of a small C W transmitter which with the employment of the standard alternating current and step-up transformer, could with the addition of two five-watt tubes, make a suitable C W transmitter of small wattage capacity.

In our search we found such a transmitter in use at one of our former colleague's home and he was having the time of his life with it.

Distances covered varied, in accordance with the use of either the regular antenna or counterpoise, or counterpoise and ground combined. It can be said, however, if the experimenter wishes to raise sufficient noise locally he can attach his counterpoise. Attaching the counterpoise and regular ground, out-of-town transmission can be effected.

Material Necessary

One Acme 110-volt primary, 1500-volt secondary (split) with filament lighting winding transformer.

One Murdock .0017 transmitting condenser.

One rheostat, with resistance sufficient to withstand a flow of 4 to 5 amperes.

Two 5-watt vacuum tubes.

Two V T sockets.

One 0 to 150 milliamper meter of any standard make.

One .001 variable condenser, suitable to stand the voltage used.

One Radio Corporation inductance.

One 0 to 5 radiation ammeter.

Herewith is diagram giving complete hook-up of this transmitter.

A New Amplifier

Many amplifiers of sound distort it without mercy. It is claimed that the following device is free from this defect. The vibrating part is a cone of fine silk fabric around which is wound a spiral of fine aluminum wire in one or more layers. The angle of the cone is 90 degrees. This is introduced into the space between the pole pieces of an electromagnet which have the same angle. The cone fits over one of these.

When telephonic currents are sent through the aluminum wire there are forces exerted upon the latter by reason of the interaction between its magnetic field and that of the electromagnet. Since the spiral has no natural period of its own, it does not reproduce the sound with distortion. Great distinctness is claimed as well as great intensity.—Journal of the Franklin Institute.

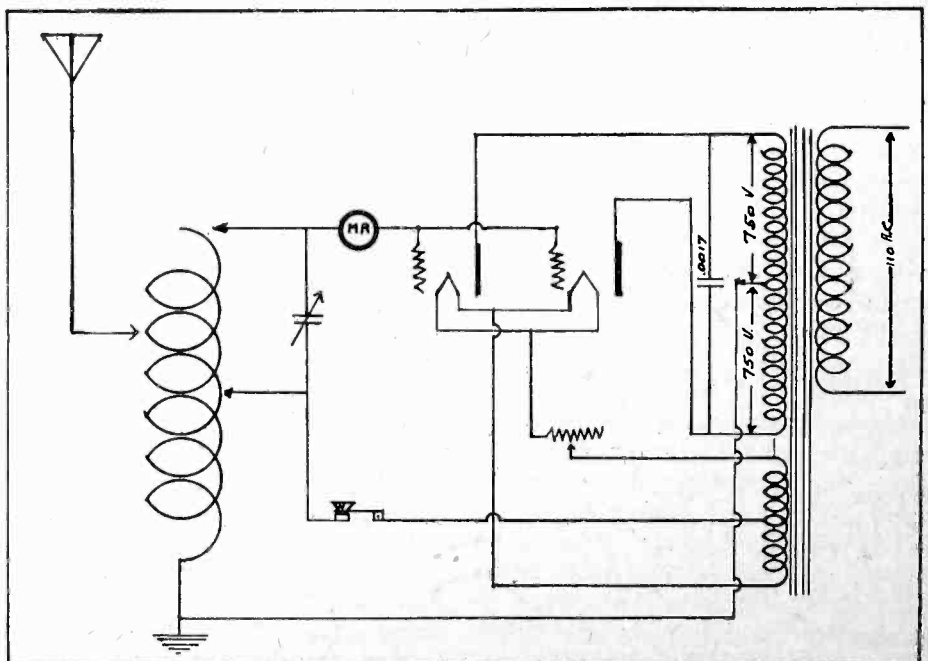

A simple circuit for 10-watt straight C. W. transmitter

"Aint Radio Grand!"

By E. W. CORNELIUS

THERE is an epidemic raging. It's Radioitis. This strange germ is sweeping the United States. It will soon be sweeping the floors for the women. If it continues to spread there will be funny things happening in ten years from now. I understand that aeroplanes are now being controlled by the radio germ.

Ten years from now we'll have vest pocket stations for broadcasting and receiving. Then people can get married by radio and they won't have to be at their own wedding. The mail order houses will see that the rings get there on time.

The minister can be eating his supper between words and can make a lot of extra fives right at home. Of course, if the check don't get to the minister on time and he don't run charge accounts he can take care of other couples until the check does arrive.

Ministers will be disturbed at all hours of the night, but they will be glad to get the fives, and they won't have to get out of bed. This will also save crowding at the churches and a lot more people will get married because they can look up their wives and husbands when they have time. In this way they wouldn't have to delay getting married because they were too busy.

And then there would be fewer divorces because the husbands could call on their wives the next day, and with all the wedding excitement of the first night over, it wouldn't bother them so much when their wives took their beautiful shapes off the hooks in the clothes closet. And the women wouldn't mind it so much when their husbands deposit their glass eyes and their teeth on the dresser and set their wooden legs in a corner for a coat rack. You see after the first night they don't care what happens because they got through the "I do's" and the "I wills" without fainting more than eight times. And then they could

get to the sink for water while they had the phones on their ears, and the wedding takes place.

When that time comes the women will be getting married in bed, in the street cars, on the beach and in the bath tubs. It won't make any difference and they'll have prize contests to see who can have the most exciting wedding. The sad part will be that so many girls will forget to turn off the water and drown.

* * *

Every time a girl wants a marcel wave she'll get the hairdresser on the line and drop a dollar in the slot. Then she'll wrap her hair around the ground wire and the hairdresser will turn on a shot of hot air. I suppose, though, that all the women in the neighborhood will be butting in on the hot air, and the new hairdressers' union will go on a strike and cut off the hot air supply.

The men can order their suppers by direct line, according to their daily tastes. The butchers and grocers will have to have a switchboard. Many husbands will get the butchers on their line direct from their offices and they'll be cancelling wifie's orders for beans and sardines and making them for steaks instead.

The telephone company will be connecting their coin boxes to our radio sets. They'll have a law made that it would be a restraint of trade if we didn't drop our nickels in their boxes. When we wanted to hear the opera the operator would say, "Drop your nickel, please!" and in forty seconds she'd bawl, "Your five minutes are up, kindly deposit another nickel, please!"

Well, anyway, the opera would be ten cents cheaper and we wouldn't have to go through the agony of looking at their faces. Or rather at their throats to see what they had for supper.

* * *

The railroads would be taking us on trips at excursion rates of

one cent per mile. Every time we go to a station the conductor would yell, "Deposit five cents, please. Next stop will be Yellowstone Park." Then we'd get off and get on a motor bus. Of course they'd let us hear the bus running so we'd be convinced that we were there and not being cheated. Then they'd take us through the forests and let us hear the trees rustling, and the bootleggers. And they'd tease the bears so they'd growl for us and we wouldn't get bit, either, even if we did growl back at them. That way we could go to California for the winter without having it interfere with business.

Well, getting back home again, pa and ma could go in different rooms and fight through the ether. Ma wouldn't get any more black eyes and pa wouldn't stop any more rolling pins. The neighbors wouldn't have to turn out their lights and strain their ears to hear the fuss. All they'd have to do would be tune in and enjoy the fight as they read their evening paper.

There would probably be a lot



(J. W. McGuirk in Chicago Herald-Examiner.)

of interference from fellows taking ma's part and girls taking pa's part. It would be fierce if the telephone company made you drop ten cents to hear a fight—instead of a nickel. It would sure be hard on the neighbors.

Of course pa would call up girls and tell them nice things and ma would think he was talking to her. When pa began snoring the neighbors would shut off their machines. Station WDAP, Chicago, would run snoring contests. They just start on time for that now. The fun of it would be that we wouldn't know who the champion snorer was until we tuned in the next night. Wouldn't it be great if your wife or husband won the puncture-proof detector tube?

Reno will surely lose its reputation because whenever a woman wanted a divorce she would have the judge and jurors tune in and then pick a fight with her husband for the evidence.

The railroads would have a law, doubtless, compelling us to take an excursion trip to Reno. The railroads could report to the switchboard operator at Reno that we had paid our fare and were eligible for a divorce. Then the operator would switch us on to the judge's wire.

Of course, if we got a genuine Reno divorce we'd have to make arrangements with the eat houses to get our meals there. And we'd have to ring up or buzz up the hotel manager to find out how our room looked and how many bed-bugs were on hand and what the color of the bed sheets were. When we got the information we'd mail our check. Then after the restaurant, the hotel and the judge split the cash, we'd get the divorce by return mail.

Well, after all, I suppose the price of shoes will go up because there will be fewer of them used. And the shoemakers will make ear phones and head sets so they'll get us coming and going anyway. And the government will make us pay a vehicle tax to keep the air in repair. The commercial lines will be advertised by air instead of billboards. It's air either way, either by billboard or ether. And we'll have to pay for it just the same one way as the other.

Practical Rheostat and Plug

TWO very important features of every receiving outfit are the rheostat and telephone plug. The Pacent rheostat pictured here has many splendid qualities besides its compactness. It is a combination instrument, serving equally well as a panel-mounted instrument, or as a laboratory instrument when mounted on table or board. It has a winding of special resistance wire held rigidly and permanently in place on an insulating core which will not warp.

The slider arm makes positive contact with the successive turns of the resistance winding and slides in either direction with a smooth, velvety "feel."

It is easily removed, one screw is all that has to be loosened and the handle and shaft come off in one piece. There is a simple adjustment which takes care of the thickness of panel.

The rheostat being equipped with three binding posts permits of "tuning up" in a clockwise direction when either panel or table mounted. It can be used in a number of circuits also.

The Pacent new Universal plug No. 40, which sells for fifty cents, will do everything that can be expected of any plug, it is claimed. No tools are required to attach card to the plug connectors. It is simply necessary to insert the tip in the hole provided in the spring connector and then move the con-

ductor slightly so that the cord tip can be slipped into the slot provided therefore in the shell of the plug.

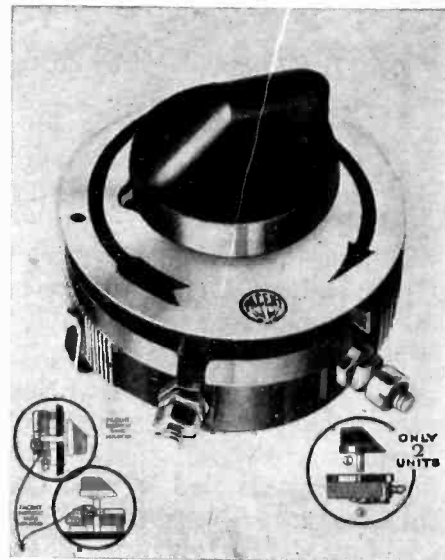

The New Pacent Rheostat

Listeners 9,000 Miles Apart Pick Up WGY Signals

ELECTRICAL pulsations from the antenna of WGY, the Schenectady broadcasting station of the General Electric Company were radiated so widely that they were received on two different days in places 9,000 miles apart.

The postmaster of Wailuku, Hawaii, and a radio engineer in London, England, at practically the same instant were greeted with "Merry Christmas and a Happy New Year" from Secretary of Navy Edwin Denby. The postmaster, A. L. Costa, heard the message of good-will at 5:45 p. m. December 24, and Captain H. J. Round picked up the words at 4:15 a. m. December 25. The message was broadcasted at 11:15 December 24, but the actual words of the greeting were spoken December 13 at 1 p. m. in Washington, D. C., where a photograph of a speech by the secretary of navy was made by the Pallophotophone. This photograph, made on motion picture film, was reproduced at WGY Christmas eve.

In writing WGY, Postmaster Costa stated that "I heard your station very clearly and picked you up just as a man with a solid voice was finishing his talk

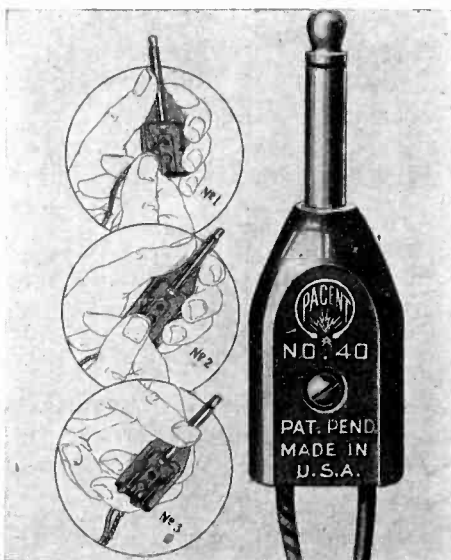

Four Views of the Pacent Universal Plug for Radio Work

The First Radiophone Station

AN IDEA THAT WAS SUGGESTED BY A NEWSPAPER ADVERTISEMENT;
TO WHAT PROPORTIONS IT HAS GROWN

THE first man to conceive the widespread use and popular appeal of radio was Harry Phillips Davis, vice-president of the Westinghouse Electric and Manufacturing Company. The idea occurred to him one morning in September, 1920, while reading an advertisement in a Pittsburgh newspaper. In a corner of a full page ad he came across this: "Mr. Conrad will send out phonograph records this evening." The line referred to the store's amateur radio department and was in explanation to local radio fans that Mr. Frank Conrad, who had operated his station intermittently since the war, would send out by radio, phonograph records on a certain evening.

He went to Mr. Conrad, assistant chief engineer of the Westinghouse Company, and announced: "Frank, I am going to close your station," and paradoxical as it may seem this was the actual start of radio broadcasting as we now know it in America. The concerts on regular schedule, advance programs, and entertainment of all kinds in the air, all resulted in the closing of Mr. Conrad's station and the opening of KDKA, the first radiophone station in the world.

The Conrad station was very well known to amateurs all over the country, for it was one of the few amateur stations licensed to operate during the war. This special operating was in the interests of government research work which the Westinghouse Company was doing and also to test some apparatus.

Widened Its Scope

Mr. Davis was struck with the fact that the radiophone fundamentality did not lend itself only to private communication but that it had a universal field of usefulness and that through it, one could communicate to hundreds, thousands or millions; all could listen who had the suitable "ear," for if a certain class of people were in-



He Opened Station KDKA

HARRY PHILLIPS DAVIS, vice president of the Westinghouse Electric & Manufacturing Company, was the first to foresee the popularity of radio, and formally opened Station KDKA by broadcasting election returns November 11, 1920, from the experimental station, East Pittsburgh, Pa. This was the first radiophone station in the world. Today there are over 250 broadcasting stations in the United States.

terested enough to listen to music from a few records, there was a possibility of increasing this small audience of radio listeners to an enormous number by sending out entertainments, current events, etc., in a regular and interesting manner. Why confine one's audience to a small portion of the country? Why not build a big station and let everyone, who wanted to, hear? Why not make radio broadcasting a public service?

"Frank, my idea is that you stop sending from your station and we will start a regular service from our experimental station here at East Pittsburgh," Mr. Davis advanced. "We can arrange for a suitable wavelength, and I believe if we do this it will be the beginning of a radio broadcasting public service which seems to me to have wonderful possibilities."

The conference with Mr. Conrad lasted a short time and Mr. Davis called other conferences before actual work on the broadcasting started. It was not until November 11, 1920, that KDKA was formally opened with the broadcasting of election returns.

The remainder of the history of KDKA is now common property. Everyone, almost, now knows that there are over 200 broadcasting stations in the United States

and that the radio audience numbers into the millions each night.

A Little Ad Did It

Not everyone knows, however, that it was a single line in a newspaper which suggested to the vice-president of one of the largest electrical manufacturing companies in the world, the big thing of turning a scientific novelty into a new kind of public service by unfolding a new field of communication.

Mr. Davis was one of the best equipped men in the electrical industry to take up the difficult problems of broadcasting. He has been a leader in the electrical industry since his college days, and has been issued nearly 100 patents covering electrical apparatus. He is an engineering genius and is known, not only as a designing engineer of high rank, but also as a man who gets things done. His ability to accomplish results rapidly has already been proved in the history of his company's broadcasting achievements.

Mr. Davis was born at Somersworth, New Hampshire. He graduated from the Worcester Polytechnic Institute with the degree of B. S. in Electrical Engineering in 1890, and after a trip to Europe and a few months spent with the Thompson-Houston Company, entered the Detail Engineering-Department of the Westinghouse Company, in 1891.

ELEMENTARY PRINCIPLES

(Continued from page 16)

primarily by the area of the plates exposed to the electrolyte and the amount of active material or paste in the plates. It is this paste which acts as the electrodes. Then in most cells we find more than one positive and one negative plate. There is nearly always a group of positives and another group of negatives. The average capacity in amperes for a positive plate is 50 amperes per square foot of positive plate surface. Only the positive plate is considered when figuring capacity in this manner.

Often there are four or more positive plates in a group, per cell. There is always one more negative than positive. That is, if there are four positives there are five negatives, etc. The positive plates of the positive group and the negative plates of the negative group are separated by wood or rubber strips called separators. The function of the separator is to hold the individual plates apart, thereby preventing internal short-circuiting. Often these separators become defective, due to the action of the acid on them and they must be replaced. This is called reinsulating the battery. All the chemical action of charge and discharge in the battery takes place through these separators.

* * *

Numerous troubles arise in connection with storage batteries. It is possible to give only a few of these troubles and cite their causes. "Buckling," is a common disease. This may be due to several causes.

Probably the most common is excessive charging which will set up great chemical stress in the plate, raise the temperature and cause a warping process. The whole surface

of the plate will undergo this strain and bend out of shape. "Sulfating" is another common disease and is frequently attributed to prolonged discharge, or in many cases may be caused by not charging the battery full up at regular intervals. A white substance will form on the surface of the plates and this substance, which is the sulphate component of the acid, will crystallize, appearing like lime. This will be hard and prevent the acid in the electrolyte from entering the paste of the plate. In other words, the layer of sulphate acts as a hard wall through which the chemical action must take place with great difficulty.

Thus when present it checks the current flow inside the cell, increases the internal resistance, and therefore cuts down the capacity of the battery. "Treeing" is another trouble which occurs when the separators become weak or contain little holes due to the decomposition of the wood by the acid. Lead paste fills these little holes or cracks and causes short circuits which will allow the plates to discharge themselves within the cell itself. Often this happens and the owner of the battery is unmindful of the trouble.

"Corrosion" is another disease; however, this is nearly always present on the top of the battery box. This is caused by acid spray accumulating on the top of the battery during the charging process and when the vent caps are off the cell tops. Every time a battery is charged and removed from the charging line, it should be thoroughly sponged with fresh water to remove this acid spray and such other deposit which may be present. "Evaporation" also takes place in a battery, and the water gets away. This is not a trouble, but a natural occurrence. It is only the water which is lost during

evaporation. The acid does not evaporate with the water, but remains in the cell. The water may be replaced by adding some distilled or pure water to the electrolyte to make up for what is gone.

At all times the electrolyte should cover the tops of the plates because the chemical action inside the cell must take place through this electrolyte, which acts as a medium for the molecules to pass back and forth from positive to negative plates. If the water line becomes low, of course, no chemical action will occur above the water line and the plates will become out of balance, chemically speaking.

* * *

The normal rate of charge of a storage battery is eight amperes and such a current should not be exceeded. If more than this is used trouble usually follows.

One of the most important matters concerning the charging of a battery is that of temperature. Many persons are not correctly informed upon this fact. If the temperature of the electrolyte exceeds 100 degrees F. the acid will not only attack the paste and destroy it, but it will attack and destroy the lead grid as well. When the lead grid is weakened the paste will fall to the bottom of the cell and make a deposit there.

As long as the temperature is fairly low the lead grid will not suffer, but on high temperatures acid will crumble lead and make it very brittle. A thermometer should be used very frequently and this heat watched. Ninety degrees is a temperature which really should not be exceeded. When the heat rises much above this on charging the battery, cut down the charging rate in amperes.

Often when one is trying to hasten a charge the heat will run up as high as 130 degrees or more. Good judgment on a person's part will never permit this, for the life of a battery will be shortened many months. Also on charging you should be careful to have the vent caps removed from the cell tops so the gas will not accumulate within the cell and cause an explosion.

Direct current must be used. Incandescent lamps may be used for resistance, or a coil of iron or German silver wire may be used in case the incandescent lamp method is not desired. An ammeter is a very valuable instrument, which should be used if available. The meter is a compass for the electrician and by its use only will the correct current value be known.

Be sure and watch the polarity of both battery terminals and charging lines. The positive post of the battery is connected to the positive side of the charging line; the negative battery post to the negative line wire.

If you do not know which is which of the charging wires, use the following method: Fill a cup about half full of hydrant water and place the line wires in the water, keeping them separated about one inch—the negative wire will bubble. Connect this negative battery post and the other or positive wire to the positive bat-

(Continued on page 34)

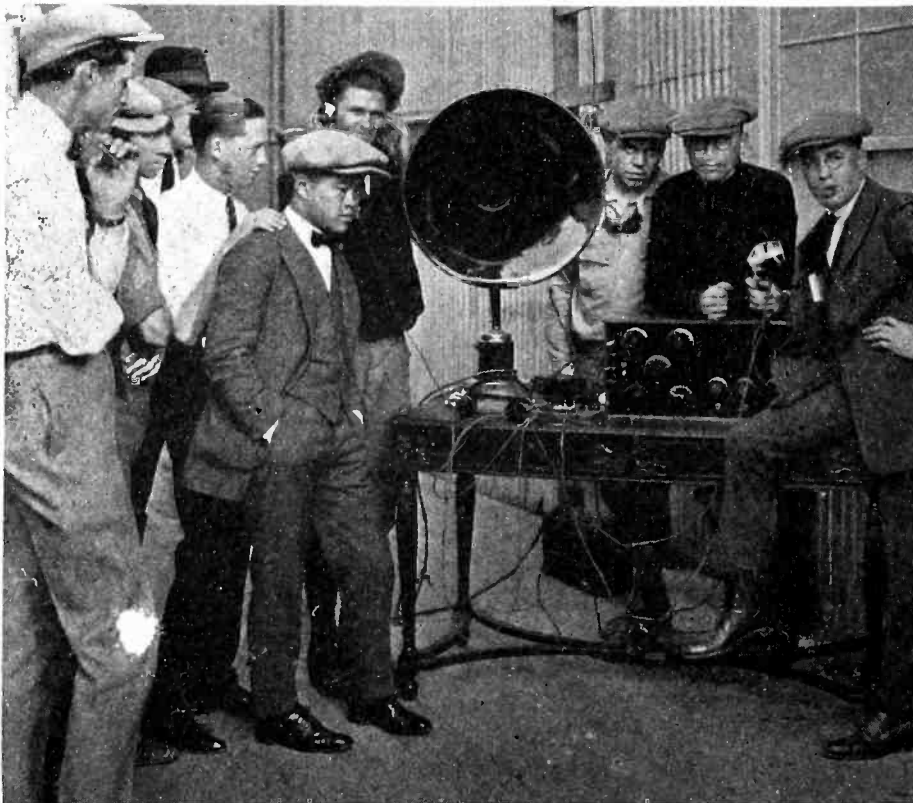

Radio interests picture studio employees. A scene at the famous Players-Lasky plant, Hollywood. Clyde Ewing, foreman electrician, is sitting on table.

A Page of Hook-Ups

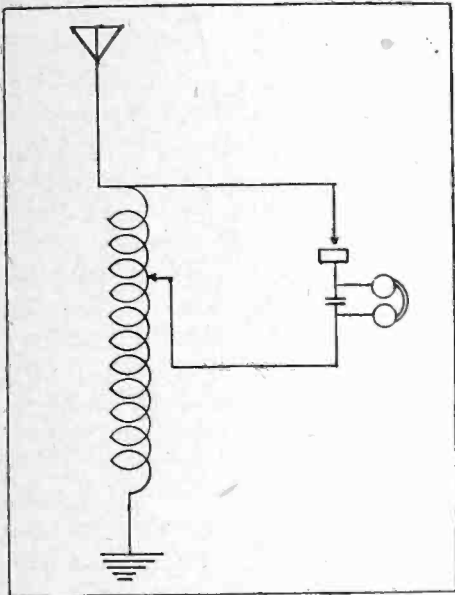

No. 1. Simple crystal set. Using a plain inductance.

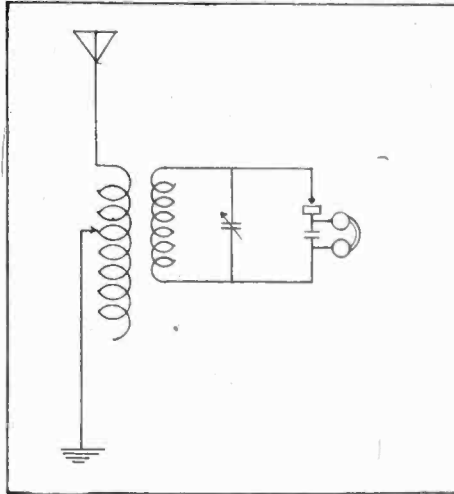

No. 2. Tuned crystal set, using a vario-coupler and variable condenser across the secondary.

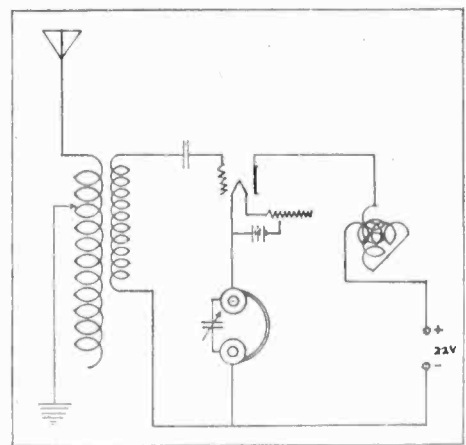

No. 3. Simple regenerative circuit. Using variometer in the plate circuit.

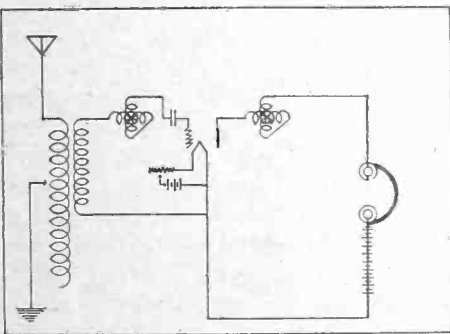

No. 4. Tuned plate regenerative circuit. Using vario-coupler and two variometers.

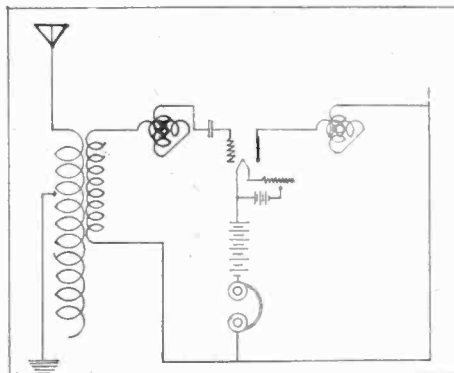

No. 5. Another tuned plate regenerative circuit, showing difference in connections of vario-coupler and using the two variometers only.

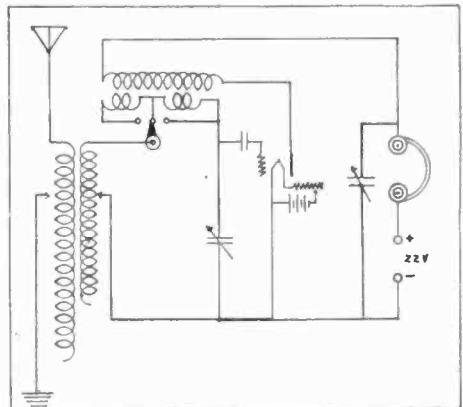

No. 6. Simple regenerative receiver. Using vario-coupler and variometer, same being used independently.

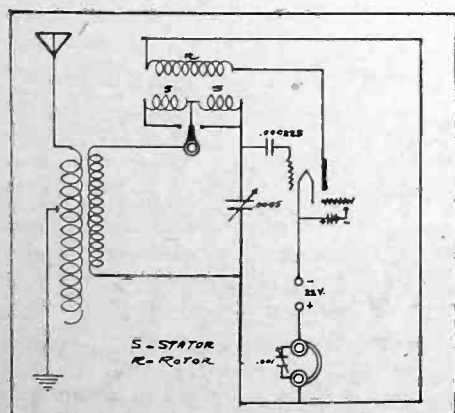

No. 7. Simple regenerative receiver. This circuit is the same as No. 6 with the exception of connections pertaining to the "B" battery and telephones.

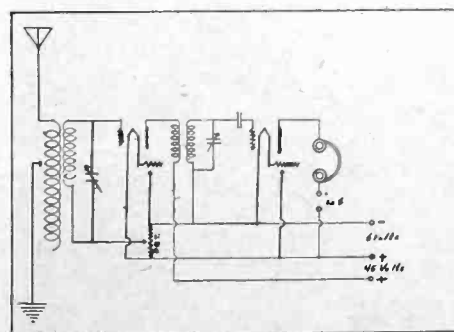

No. 8. Radio and audio-frequency circuit, using vario-coupler and standard radio-frequency transformer. The secondary of the transformer is tuned with a 3-plate variable condenser.

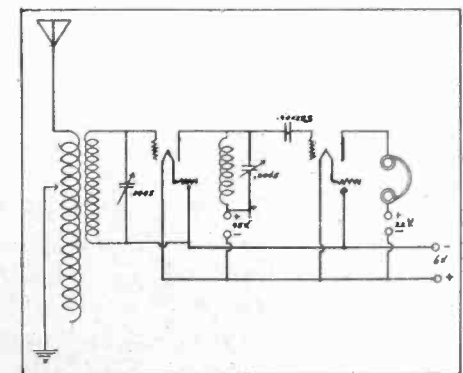

No. 9. Tuned plate radio-frequency and audio-frequency circuit.

Radio Church Services A Godsend

THAT the broadcasting of religious services has increased church attendance, that radio has been a real help to the work of the church and has brought satisfaction and comfort to hundreds and thousands of people, is the opinion of the ministers of Schenectady who have been co-operating with M. P. Rice, director of broadcasting of the General Electric Company, in the transmission of church services.

From the inauguration of the radio church service by WGY October 1, 1922, the studio management has co-operated very closely with the Ministerial Association of Schenectady, N. Y. The Ministerial Association, which is made up of pastors of all the evangelical churches, named a committee of which the Rev. Robert W. Anthony, pastor of the First Presbyterian Church is the head, to assist the studio manager in the assignment of clergymen for the vesper services and in planning the order in which the services of different denominations should be broadcast.

Morning and Evening Services

In nearly every case the morning and evening services of a church are broadcast. The church is connected to the transmitting equipment of the broadcasting station by means of land wires. Two microphones are placed in the church, one for the preacher and another for choir and organ. But for the presence of the microphones the church congregation would not be aware that the service, ordinarily limited to the four walls of the church, was going out into thousands of homes over a great territory.

Summarizing the first six months of broadcasting of religious services, the Rev. Mr. Anthony made the following report:

"The first services were held on Sunday, October 1, when the morning service of the First

Methodist Church and a vesper service from the studio were broadcast, and services have been broadcast regularly from that date. Recently, an evening service has been added to the program. On Thanksgiving day, the union service of the First Presbyterian and First Reformed churches was sent out through WGY. New Year's eve came on Sunday evening, so a special community watch-night service, commencing at 9 p. m. was arranged at the First Methodist Church and sent out through the station. A community three hours' service from 12 to 3 p. m. was broadcast Good Friday.

"As far as possible, each church equipped with an organ and good musical leadership, has taken its turn. The ministers whose churches are not equipped with pipe organs have as a rule had charge of the vesper service. Occasionally out-of-town churches have been invited to send out their services.

A Boon for Shut-ins

"At once the participating ministers began to receive letters of appreciation, telephone calls, and words of gratitude from members of their congregation or acquaint-

ances whom they met in the city. This made it possible to visualize the radio congregation. A large number of those listening in are aged and shut-in; some of them are partially deaf, others are blind, still others are helpless cripples. One patient sufferer for thirteen years, recently said that Sunday had been the longest day in the week until the broadcasting of religious services began, and now it is the best and brightest day in the week for her. Deaf people who have not been able to hear the ordinary church service can hear distinctly the service by radio. Mothers with little children who on that account are unable to go out to church, have been made happy by listening to the religious services. The gratitude and joy of people of this sort has been a revelation to the ministers who have participated. People who have not gone to church for years are listening with the keenest interest and with growing friendliness toward the church. Many of these send either through the mail or by some friend, a small offering to the church whose service they have heard. People in the country, unable to leave their farms, have thoroughly appreciated the broadcasting of religious services. Boys and girls have tested out their home-made sets by listening in on the 4:30 vesper service."

After-Dinner Speaker Beats Record

We had many long distance speakers at banquets before radio was discovered, but that's something else again, as the poet says. However, on March 6, C. G. Du Bois, president General Electric, addressed a meeting in Chicago, while he was in New York, by means of long distance lines of the A. T. & T. Company. The Western Electric public address system amplified the speech at the banquet at the LaSalle Hotel so that 850 engineers heard it.



Two WGY musicians well known to the Eastern radio fans. Edward Rice, violin, and Earl Rice, pianist.



New and Novel Radio Patents



A NEW DIAL KNOB

(Patent No. 1,445,812. Issued to Charles P. Whittall, Longmeadow, Mass., under date of Feb. 20, 1923.)

The present invention relates to dial knobs such as are used for adjusting various rotatable parts of radio apparatus.

The invention has for its object to provide an improved molded dial knob of light but rugged construction and of distinctive and pleasing appearance and one which is particularly well adapted for economical quantity production.

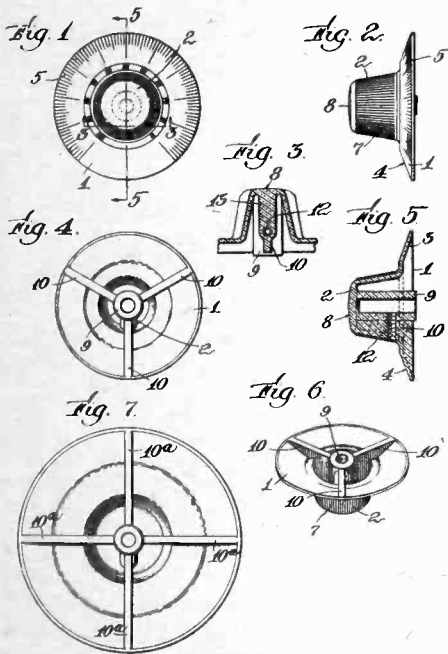

C. P. Whittall's New Dial Knob

Fig. 1 is a view, in front elevation, of the improved dial knob;

Fig. 2 is a side elevational view thereof;

Fig. 3 is a detail sectional view taken along the line 3-3 of Fig. 1;

Fig. 4 is a rear elevational view of the dial knob;

Fig. 5 is a sectional view taken along the line 5-5 of Fig. 1;

Fig. 6 is a perspective view of the dial knob showing the rear side thereof; and

Fig. 7 is a rear elevational view of a dial knob of larger diameter showing a modified arrangement of stiffening ribs.

The illustrated dial knob comprises an annular dial portion 1 and a centrally disposed knob portion 2, the dial and knob portions being integrally formed of molded dielectric material. As shown clearly in Fig. 5, the dial knob is of shell-like construction, the walls of the shell being made quite thin to save material and to reduce weight. The dial portion is dished or in other words is formed with a flaring margin 3 affording upon its outer side an annular beveled surface 4 bearing a vernier 5 the graduations of which are adapted to co-operate with a suitable mark or indicator (not shown) upon a stationary part of the radio apparatus. The hollow knob portion is of frusto-conical shape and its sloping side walls provide a beveled exterior which is knurled as indicated at 7 in Figs. 2 and 6. The small or front end of the hollow knob is closed by an outwardly convex end wall 8 while the large or rear end of the knob is open and the side wall merges, at the open end of the knob, with the inner peripheral portion of the dial.

WAVE METER

(Patent No. 1,448,575. Issued to George H. Stevenson of Rye, N. Y., under date of March 13, 1923.)

This invention relates to wave-meters and similar electrical apparatus, and more particularly, to means whereby the frequency calibration of such apparatus will not be rendered incorrect by the opening or closing of a key connected to the circuits of the apparatus.

In connection with the accompanying drawings Fig. 1 is a circuit diagram involving the essential features of the invention; and Fig. 2 is a cross-sectional view of a cabinet in which the wave-meter is contained, showing the structure of the key and a push-button for operating it.

Referring to Fig. 1, the wave-meter circuit comprises a resonant high frequency circuit including a coil 1 and a suitable variable condenser 2. The variable condenser is usually calibrated with a scale which indicates wave-lengths to which the tuned circuit will be resonant when it includes a coil 1 of specified inductance. A detector 3, preferably consisting of a crystal of pyrites, but which may consist of any suitable detector of the crystal, thermionic or other type, is connected across the terminals of the capacity 2 by a circuit 4. The circuit 4 includes a condenser 5 whose capacity is small compared to that of the condenser 2. By placing the condenser 5 in series with the detector 3, the effect of the capacity inherent in the detector and its associated elements upon the tuning of the circuit 1, 2 is reduced to a negligible degree. In the case of a circuit dealing with the usual radio frequencies, that is, from one hundred thousand to two million cycles per second, the capacity 5 should be of the order of 10×10^{-12} to 12×10^{-12} farads. A jack 6 is provided, by means of which the telephone receiver or other suitable indicating instrument may be connected around the detector 3.

The circuit described may be used to determine the wave-length of electro-magnetic waves by introducing the coil 1 into the field of the waves whose frequency is to be determined and varying the condenser 2 until a maximum indication is obtained in the telephone receiver. The calibration of the capacity 2 may be in wave-lengths or in frequencies which may be read off directly or, if preferred, in capacity units from which the wave-length may be computed if the constants of the coil 1 are known.

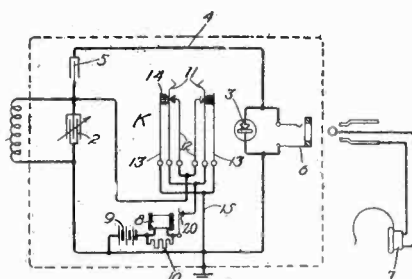

Fig. 1.

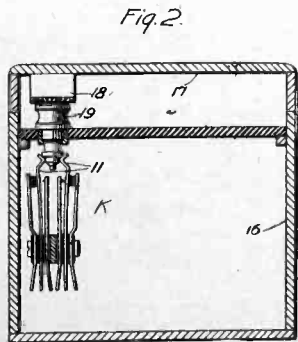

Fig. 2.

New Wave Meter and Electrical Decive

ELECTRODYNAMIC RECEIVER

(Patent No. 1,448,279. Issued to Edwin S. Prindham and Peter J. Jensen, of Oakland, Calif., under date of March 13, 1923.)

This invention relates to telephones and more specifically to improvements in the moving coil type of telephone receivers. It comprises an annular coil rigidly connected to the diaphragm. This coil is disposed, so as to be freely movable, in a strong concentric magnetic field produced either by a permanent or an electromagnet. The magnetic field is so

Fig. 1.

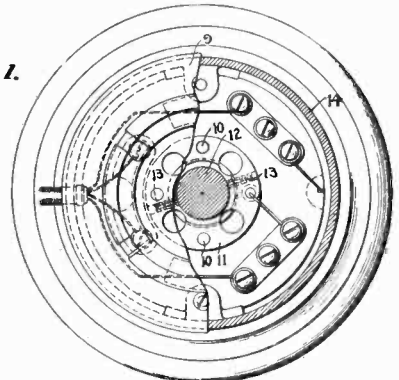
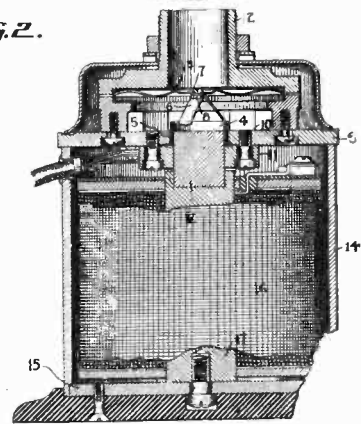

Fig. 2.



Electrodynamic Receiver

arranged that the lines of force cut the annular coil at all points in the same direction. This is accomplished by having one of the poles of the magnet within the coil and the other completely surrounding it.

In the accompanying drawings is shown two devices of magnetizing structure, namely permanent magnet and an electromagnet.

Fig. 1 shows a plan view of the device using an electromagnet as the magnetizing structure.

Fig. 2 shows a vertical cross-section of the device shown in Fig. 1.

Fig. 3 shows an enlarged detail sectional view of a portion of the device shown in Fig. 2.

Fig. 4 shows a vertical cross-section of the device in modified form using a permanent magnet as the magnetizing structure.

Fig. 5 is a diagram showing the electrical connections for the receiver.

Referring in detail to the drawings, 2 is the sound box, 3 the diaphragm, 4 an insulator frame with a trough or depression cut into it and forming an annular groove in which the coil 5 is fixed. This insulator frame 4 is rigidly attached to the diaphragm by means of the bracket support 6 and is held in place on the diaphragm by the screw 7 and lock nut 8. The pole piece 9 is provided with a circular hole of sufficiently great diameter to admit the coil 5 with a few thousandths of an inch clearance. Rigidly attached to the pole piece 9 by means of the set screws 10-10 is the spacing ring 11. The inside diameter of this spacing ring is a few thousandths of an inch less than the inside diameter of the insulator frame 4. The pole piece 12 is of substantially the same diameter as the inside diameter of the spacing ring 11. The pole piece is held securely in position in the

spacing ring 11 by means of set screws 13-13.

The assembly is then a unit and can be placed on any magnetizing structure designed for it.

In Fig. 4, we have shown the assembly adapted to be used with a permanent magnet. In this case, the inner pole piece 12 is fixed to an extension 12a of one of the poles S. The pole piece 9 is fixed to the pole N of a permanent magnet. The sound box with the diaphragm and coil are fixed in relation to the pole piece 9 and may be removed as a unit from the structure.

In Fig. 1 we have shown the receiver head assembly which is the name given to the sound box diaphragm, coil and upper pole piece, adapted to be placed upon an electromagnetic structure. The electromagnetic structure consists of an iron cylinder 14, and iron base 15. The magnetizing coil 16 wound on the core 17 is placed within the iron cylinder to form a substantially closed magnetic circuit when the pole pieces 9 and 12 are in position. The iron core 17 of the magnetizing coil 16 is bored out to form a seat for the pole piece 12 so as to make a good magnetic contact. It will be seen that the receiver head can be assembled as a unit apart

Fig. 4

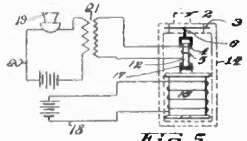

Fig. 5

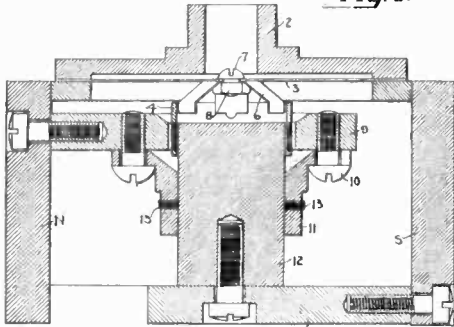
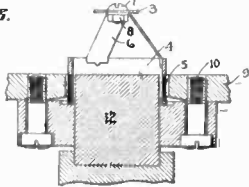

Fig. 5



Electrodynamic Receiver

from the magnetizing structure and can be placed on or removed from any magnetizing structure adapted to receive it.

ELECTRIC SIGNAL CONTROL

(Patent No. 1,445,929. Issued to Walter R. G. Baker, Schenectady, N. Y., under date of Feb. 20, 1923.)

This invention relates to the production of electric waves and more particularly to methods and apparatus for producing a succession of waves which may be modified in accordance with impulses produced, for example, at a controlling or signaling station.

Apparatus of this character usually consists of a source of electric power, means for converting the energy of said source into current of an oscillatory character and a transmitter for suitably modifying the character of the oscillations. An amplifier for the initial signaling impulses is often used and this as well as the oscillator may consist of a vacuum discharge device which comprises an anode, cathode and discharge controlling grid. A suitable source of current is connected between the anode and cathode and the current from this source is modified by changing the potential of the grid in accordance with the impulses which it is desired to transmit. It is proposed to provide a single source of current for the oscillator and amplifier. When, however, an attempt is made to change the potential of this source to change the output of the oscillator, as for example when it is desired to increase the distance over which messages are to be sent, it is found that amplifier which is likewise

influenced by the changed potential will not operate as effectively unless a corresponding change is made in the normal potential applied to the grid. My present invention provides for the simultaneous changing of the potential of the common source above referred to and of the potential applied to the amplifier grid.

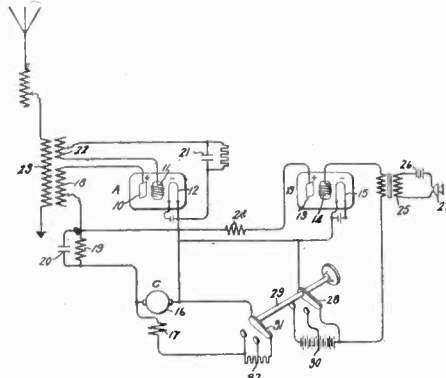

The Baker Electrical Apparatus

WAVE METER WITH CATHODE TUBE

(Patent No. 1,446,425. Issued to August Leif of Berlin, Germany, under date of Feb. 20, 1923.)

Wave meters provided with a cathode tube are well known and it has heretofore been proposed to provide such meters with a back-coupling whereby the wave meter operates as a sender, and the tunings are determined by means of the telephone in a receiver at maximum receiving tone strength.

The invention consists in transforming a normal oscillating circuit, which is back-coupled to an audion tube, into a sounding sender by very simple means. The means employed consists in an electromagnetic buzzer which is connected in the circuit between the anode or plate circuit and the oscillating circuit.

The arrangement may be particularly simplified if the magnets of the buzzer are wound with suitable thin wire and the interrupter connected in the anode circuit in such a manner that it is operated by the anode current as a self-interrupter.

Fig. 1 is a diagrammatic representation of a wave meter embodying the invention, and Fig. 2 is a diagrammatic representation of a wave meter having a buzzer in its anode circuit arranged to be operated by the anode current.

The drawing exemplifies a circuit arrangement in which A is the antenna, E the receiver, W the wave meter circuit and K the audion tube, the grid G which is connected to the anode circuit through a back-coupling L. R is a resistance and M the coil of the buzzer S operating as a self-interrupter.

The current for heating the filament of the tube K passes from the portion 1 of the battery through the switches F and D, thence to the filament, and finally through the switches B and C to the negative side of the battery.

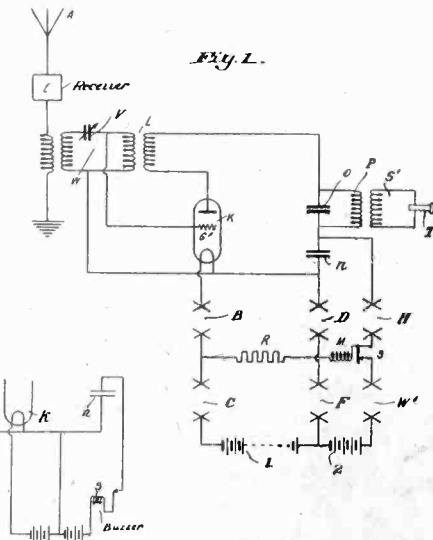

Fig. 2. Wave Meter With Cathode Tube

The plate circuit of the tube K may be traced from the portions 1 and 2 of the battery in series through the switch W, buzzer S, switch H, back-coupling L, tube K, and switches B and C. The radio-frequencies generated by the tube K are short-circuited around the battery 1, 2 through the condenser N. The buzzer circuit is from the battery through switch W, coil M, resistance R, and switch C back to the battery.

DUPLEX CARRIER WAVE SYSTEM

(Patent No. 1,448,408. Issued to Jacob S. Jammer, New York City, under date of March 13, 1923.)

This invention relates in general to duplex transmission or signaling systems and more particularly to carrier current telephone systems. The principles of the invention are more particularly adapted for application in systems employing conductive circuits throughout but may be applied in systems in which the high frequency transmission is carried on through the natural media.

An object of the invention is to provide systems of the type wherein a single apparatus is used to modulate waves passing in one direction and to detect waves passing in the other direction with improved line balancing impedance means. Individual means are provided for balancing the high frequency line separately for each carrier frequency.

A further object is to provide means in connection with the modulator-detector for compensating for the attenuation produced in the circuit by the various apparatus.

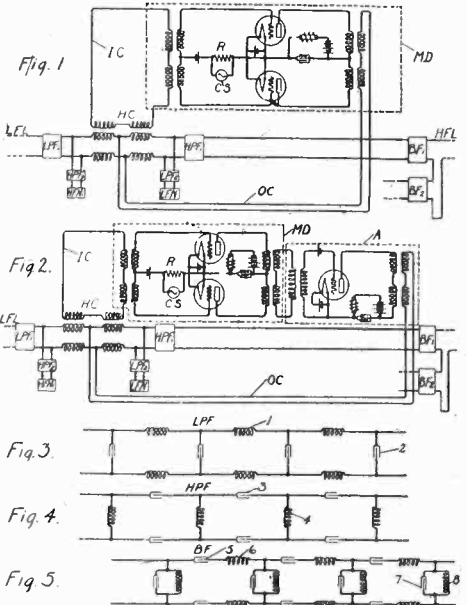

Duplex Carrier Wave System

A preferred form of the invention adapted for multiplex systems of carrier current wire transmission wherein several low frequency lines are connected to a single high frequency line comprises a single modulator-detector preferably of the push pull repeater type, but in general, of any suitable type, connected between each low frequency line and the high frequency line by means of a hybrid coil. By the expression "hybrid coil" is meant a three-winding transformer having four pairs of terminals, one pair being adapted for connection to a line, another pair being adapted for connection to a balancing impedance means, and the third and fourth pairs being conjugate with respect to each other when the first and second mentioned pairs are connected to identical impedances. Band filters separate the various high frequency carrier waves, while high-pass filters keep the low frequency out of the high frequency line and the high frequency balancing net work, and low-pass filters keep the high frequency out of the low frequency line and the low frequency balancing net work.

The invention is illustrated in the accompanying drawings wherein Fig. 1 diagrammatically represents one arrangement of apparatus comprising a modulator-detector station; Fig. 2 includes in addition to the elements of Fig. 1, an amplifier; while Figs. 3, 4 and 5 represent typical forms of low-pass filter, high-pass filter and band filter respectively, adapted for use in the circuits of Figs. 1 and 2.

A MICROMETER RHEOSTAT

NOW READY, OUR NEW
25 OHM RHEOSTATS

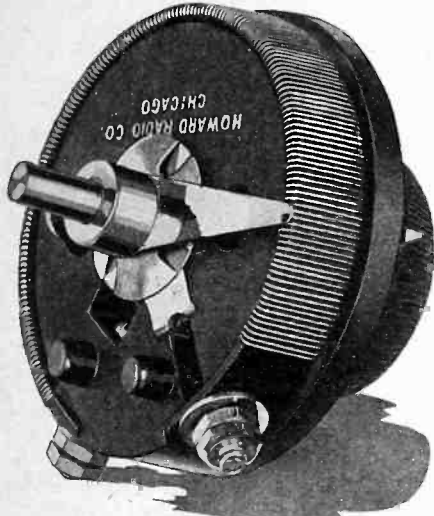

Suitable for use with 201-A or 301-A
Quarter Ampere VACUUM TUBES.
PRICE \$1.10

As implied by the name, this new Rheostat is provided with a POSITIVE and EXTREMELY SENSITIVE CONTROL.

By its use "gas tubes" may be operated at the peak of the receiving efficiency.

The desired control is obtained by turning the SINGLE KNOB through less than ONE complete turn.

THINK OF IT! ANY FRACTION of the resistance contained in a wire EIGHTY INCHES LONG may be inserted in the circuit by operating the SINGLE KNOB through LESS THAN A COMPLETE TURN.

Also, duplicate settings can be made at any time, without difficulty.

SPECIFICATIONS

Resistance—zero to approximately seven ohms.
Current carrying capacity 1½ amperes.
Temperature co-efficient practically zero.
Base and knob—special heat resisting composition.

PRICE \$1.50

Price including special dial described below,
\$1.75

MICROMETER ATTACHMENT (Patent Pending). The micrometer attachment described in connection with the above rheostat has been so designed that it can be placed on any regular Howard rheostat in about one minute's time. Price for attachment only 50 cents.

HOWARD MICROMETER
RHEOSTAT

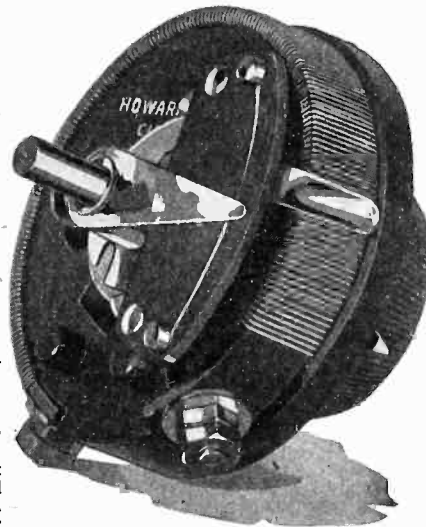

Patent Pending

Special MICROMETER RHEOSTAT DIAL (Patent Pending). We manufacture a special dial for use with micrometer rheostat and attachments described above.

The dial differs from any other rheostat dial on the market. It indicates the position of the contact blades and therefore duplicate settings on the main as well as the micrometer portions of the rheostat are easily made. The dial is graduated in ohms and fractions of ohms. Price, dial only, 25 cents. Ask your dealer to show you samples.

MANUFACTURED
BY

HOWARD RADIO COMPANY
4248 NORTH WESTERN AVE., CHICAGO, ILL., U. S. A.

Liberal Discounts to
the Electrical and
Jobbing Trade

RADIO PANELS

and other insulation for Wireless Work

BAKELITE-DILECTO

Grade XX Black was used by the Government during the war for this purpose. It is the

STANDARD OF THE WORLD

THE CONTINENTAL FIBRE COMPANY
NEWARK, DEL.

New York, 233 Broadway.
Pittsburgh, 301 Fifth Ave.
Los Angeles, 411 S. Main St.

Chicago, 332 S. Michigan Ave.
San Francisco, 75 Fremont St.
Rochester, N. Y., 85 Plymouth Ave. S.
Seattle, Wash., 1927 First Ave. S.

Say you saw it in "Radio Topics" when writing to advertisers.

The Receiver that Satisfies Telmaco

Type B-R Receiver



fully meets the requirements of the discriminating purchaser because of the following features:

EFFICIENCY OF OPERATION: Securing volume, distance (1500 miles with single tube is not unusual), selectivity. Broadcasting stations one-half mile distant are tuned out by a slight turn of condenser dial.

EASE OF OPERATION enabling the novice to secure satisfactory results.

HIGHEST QUALITY OF WORKMANSHIP AND MATERIALS.

PRICE within the reach of everybody.

Manufactured exclusively for us by the Tri-City Radio Electric Supply Co., licensed under Armstrong U. S. Patent No. 1113149, October 6th, 1914.

Specifications:

Panel—Formica, grained and machine engraved. **Vario-Coupler**—Telmaco special silk wound with loading inductance. **Condenser**—Special 13-plate with Bakelite ends. **Rheostat**—Single knob control. **Socket**—Highly nickeled shell, Bakelite base. **Dials**—are polished, presenting pleasing contrast with dull panel. **Telmaco Adjustable Vernier Handle**—secures extremely fine tuning and entirely eliminates body capacity effects. **Workmanship**—manufactured according to Telmaco's rigid specifications. **This Guarantees Your Satisfaction.** Either 6 volt or 1½ volt tube may be used.

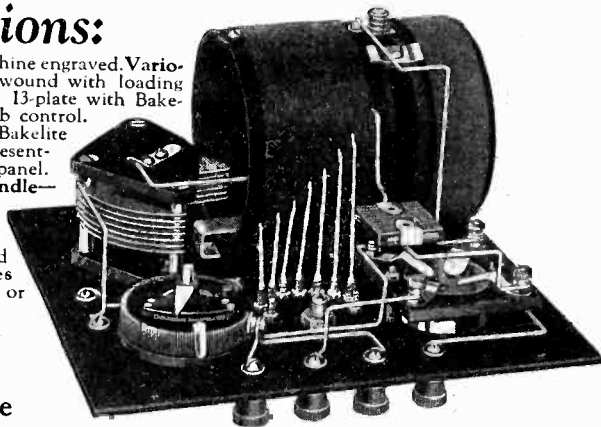

TELMACO Type B-A Two Stage A. F. Amplifier

Matches the above in size and construction. The greatest Amplifier value on the market. Price \$20.00.

RADIO DIVISION

TELEPHONE MAINTENANCE CO.

20 S. Wells Street, Dept. C

Chicago, Illinois

Price \$25

The ultimate in value

TELMACO

Quality Radio Exclusively

Bona Fide Jobbers

If our salesmen have not reached you with our proposition, write or wire for it today

FOR SALE A REAL TREAT FOR SALE

1-0 to 300 Jewell milliamperemeter, \$4.00; 1-0 to 500 Jewell milliamperemeter, \$4.00; 1-0 to 5 Jewell Radiation Ammeter, \$7.00; 1 Radio Corporation Inductance, \$7.50; 2 .0015 DeForest Variable Transmitting Condensers, \$8.00 each; 6 W. E. Sockets, 75c each; 2-5 watt transmitting tubes U V 202, \$4.00 each; 1 filament transformer 8-10-12 volt taps (home-made), \$2.50; 2 choke coils (home-made), \$5.00 for two; 1 Joy-Kelsey Microphone, \$3.00; 1 W. E. Modulation Transformer, \$3.00; 1 Boston Key \$4.00.

Above can be had all mounted on panel for \$85.00. The only thing necessary for immediate operation of set is motor-generator or C. W. transformer A. C. Or will sell individual parts.

Address Box X B, Radio Topics, Oak Park, Irl.

(Continued from Page 28)

tery post, close the switch, use about an eight-ampere current strength, and as the charge continues pay close attention to the thermometer and hydrometer readings. If the temperatures rises upwards to 100 degrees, cut down the charging rate to about half or four amperes. When the hydrometer reading reaches 1.280 or 1.300 and will read no higher after an hour has passed, you can consider the battery as having attained the highest charge it will have under the conditions. Remove battery from the charging line, screw on the vent caps, and rinse off the acid spray with cold water.

A storage battery, if purchased new, should last for three or four years with proper care. As stated above, it might be necessary to renew the separators every other year to assure good plate insulation. This should be done only by experienced battery men.

Problems and Questions

1. What determines the voltage of a primary cell? Give a brief description of the primary cell and its theory of operation.

2. Discuss the "B" battery as regards the following points: Construction, internal action when not in use, how connected for high voltages, factors which prolong its life. What voltage do you use for your plate E. M. F.?

3. One dry cell gives a normal voltage of 1.2 volts. If this is true and supposing you need 60 volts for your plate E. M. F., how many of these cells would you use and how should they be connected.

4. What is the advantage of connecting cells in series? In parallel?

5. Name all the parts of the ordinary storage cell and explain as best you can the theory of operation on both charge and discharge. For what purpose is the hydrometer used and how does it work?

6. Name several common diseases which occur in storage batteries. Discuss their causes and how the troubles may be remedied.

7. In a storage cell there are six positive plates and seven negatives. These measure 4 inches by 5 inches. If the average capacity is 50 amperes per square foot of positive plate surface what will be the capacity of this cell? Use the positive plate surface in calculating this and also remember that each positive plate has two sides which are figured in total surface.

8. A man wishes to go from place to place and give a motion picture lecture from his automobile. His picture machine lamp requires 15 amperes and 50 volts arc-voltage. Without any additional resistance in the arc-lamp line other than that of the arc itself, how many cells will he need in his storage battery to give this voltage? If his battery has a capacity of 75 ampere-hours, how many hours can he operate and give his show from one complete charge? If the battery is 75% efficient, how many hours will he need to charge his battery if he uses a charging rate of 5 amperes? (Capacity is another word for output and should not be considered as input; it is what a battery can actually give out as work.)

Say you saw it in "Radio Topics" when writing to advertisers.

CROSLEY Model X
\$55
 A 4 tube
 Radio
 Frequency Set



Not until you have listened in on a Crosley Model X can you appreciate the wonders of radio. For sale by Good Dealers Everywhere. Free Catalog on Request.

CROSLEY MANUFACTURING COMPANY
 Alfred St. Cincinnati, Ohio

CROSLEY Model Vc
\$20
 Regenerative Receiver Set



Licensed
 under Armstrong
 U.S. Patent No. 1113,149

Stations more than 1,000 miles away are being covered regularly on this set. Name "Crosley" used by permission of The Crosley Mfg. Co. Write for Free Catalog.

THE PRECISION EQUIPMENT CO.
 Powell Crosley Jr. President
 Gilbert Ave. Cincinnati, Ohio

PATENTS

To the Man with an Idea

I offer a comprehensive, experienced, efficient service for his prompt, legal protection and the development of his proposition. Send sketch of model and description, for advice as to cost, search through prior United States patents etc. Preliminary advice gladly furnished without charge. My experience and familiarity with various arts frequently enable me to accurately advise clients as to probable patentability before they go to any expense.

Booklet of valuable information and form for properly disclosing your idea free on request. Write today.

Richard B. Owen, Patent Lawyer
 81 Owen Bldg., Washington, D. C.
 2278-M Woolworth Bldg., N.Y. City

"BUILD YOUR OWN" With "RASCO" Parts!

If you need small radio parts in a rush, "RASCO" will supply them cheaper, better and quicker than any one. Be sure to get our great 68-page catalog. Over 500 different parts, 300 illustrations. This catalog contains 75 Vacuum Tube Hook-Ups, all values being shown. Due to great cost, catalog sent only upon receipt of 15c, stamps or coin.

Radio Specialty Co., Inc.
 96 B Park Place, New York



A New Radio Loud Speaker

THE Dictograph Products Corporation, 220 West 42nd Street, New York City, has placed on the market the Dictogrand Radio loud speaker. This new loud speaker is mounted in a mahogany finished hardwood cabinet and can, by means of an adjusting dial in the front of the cabinet, increase or decrease the air gap or distance between the pole shoes and an especially made secret alloy diaphragm. The adjusting mechanism operates through a shaft pinion and gear. Changing the air gap varies the pull of the magnet upon the diaphragm, thus enabling the loud speaker to be tuned up in complete harmony and resonance with the receiving set.

The unit is an entirely new and novel arrangement consisting of laminated shoes with special dictograph coils wound with No. 44 magnet wire. The harsh jarring sounds, the noises and overtones, defects common to all other loud speakers, have been overcome in the Dictogrand.

The diaphragm is of special composition, restricted solely to Dictograph loud speaker production. The entire unit is subjected to a rigid inspection and test both during sub-assembly and final completion, it is said, and is guaranteed against all mechanical and electrical defects for a period of one year.

The horn is of spun copper, handsomely finished in mahogany. The tone-arm is a die casting especially designed for resonance and lack of vibration. Each loud speaker is equipped with five feet of flexible silk cord with standard terminals.

The Dictogrand radio loud speaker is designed to operate on any vacuum tube receiving set, using two stages of amplification, but good results are often secured on sets employing but one stage of amplification, dependent upon the type set used and the distance from the broadcasting station.



BURGESS RADIO BATTERIES

Are the accepted standard for radio circuits. Leading manufacturers recommend Burgess Batteries and they are specified by radio engineers. Being designed and built by radio engineers brings a guarantee of satisfactory service to you.

BURGESS "B" BATTERIES

Burgess "B" Batteries can be furnished in several types or styles and in varying capacities. Drop in to your dealer's store today. Select the Burgess "B" best fitted to the requirements of your set and invest confidently, knowing that in the judgment of thousands of users the Burgess is the one best radio battery.

BURGESS No. 6 BATTERIES

Are recommended and have proven highly satisfactory for use in "A" or filament circuits where the 1 1/2 volt vacuum tubes are used



BURGESS BATTERY COMPANY
 Engineers Manufacturers
 Dry Batteries

Flashlight Radio Ignition Telephone

General Sales Office:
 Harris Trust Bldg., Chicago

Laboratories and Works:
 Madison, Wisconsin

Branches:
 New York Boston Washington
 St. Paul - Kansas City New Orleans

In Canada: **BURGESS BATTERIES, Ltd.**
 Winnipeg Toronto Montreal

BURGESS RADIO BATTERIES

"ASK ANY RADIO ENGINEER"

Say you saw it in "Radio Topics" when writing to advertisers.

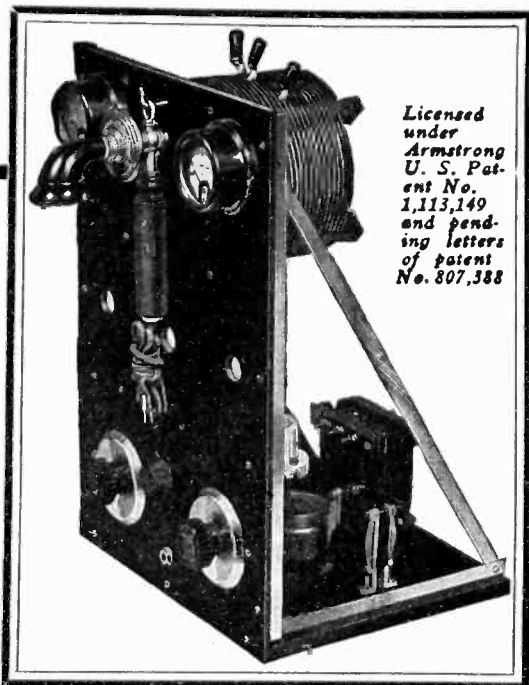

Licensed
under
Armstrong
U. S. Pat-
ent No.
1,113,149
and pend-
ing letters
of patent
No. 807,388

The BENWOOD CW Transmitter

Simple, compact, up-
to-the-minute construc-
tion—incorporating all
the improvements made
possible by our years
of experimenting, AND
IT GETS RESULTS!

1500 Miles With CW! 1100 Miles Voice!

**Music Heard 40 Feet From Phones by
Stations in 300 to 400 Miles Radius**

THESE are actual results obtained by our testing station WEB using the Benwood CW Transmitter shown herewith. You can get just as good results with it. This high-class set is just the thing for your broadcasting and DX work—using CW, ICW, Modulated Buzzer or Voice Transmission. An ideal set for the local radio club or the more progressive amateur. Think of the range this set will give you! If centrally located, you will be heard in almost every state in the Union. It is manufactured exclusively by and for the Benwood Co. and combines the best in material, workmanship and design.

Radiates 1½ to 3 Amps on Average Antenna

We guarantee that this outfit will radiate 1½ amperes on the average amateur antenna. It will radiate 2 to 3 amperes when used with an antenna whose fundamental wave length is 225 to 275 meters. That is why you can get such wonderful results. The set comes to you completely assembled with all parts mounted on panel, as shown, and completely wired. You can start sending as soon as you attach to antenna and ground. The outfit is complete with motor generator minus tubes, and consists of the following: Panel 12x18x3-16, angle supports, hardwood base, 3 tube sockets, 1 power rheostat, 1 80-watt filament trans., 1 modulation trans., 1 CW inductance, 1 hand transmitter, 1 0-3 Radiation meter, 1 0-500 milliammeter, 1 21 plate condenser, 1 43 plate condenser, 1 tapped condenser, 1 L300 choke coil, 1 2,000 volt filter condenser, 1 10,000 ohm grid leak, plug and jack connection for microphone buzzer and CW, 1 600 volt 220 watt motor-generator. Boxed for shipment, \$350.00 f. o. b. St. Louis, Mo.

CATALOG: Send 10c in stamps for the Benwood catalog and price list, also complete catalog and price list of DeForest radio equipment.

DEALERS: We manufacture a complete line of radio apparatus. We have stock on hand and ready to ship. Write or wire for our attractive proposition. New price list just issued.

The **BENWOOD** Co. INC
"WORLD-WIDE MAIL ORDER SERVICE"

1115 OLIVE STREET

ST. LOUIS, MO.

FROSTONES
Best for Your
Radio
Set
Bring in
programs clear and
sweet; free from distor-
tion. Highest quality—biggest val-
ue. 2000 ohms \$6; 3000 ohms, \$6.
HERBERT H. FROST, Inc.
154 W. Lake St. - Chicago

I WILL PAY \$1.00 IN TRADE each for a copy of Vol. 2, Nos. 2 and 7 of Radio Topics. Write before sending. Paul Franklin Johnson, 560 E. Colorado St., Pasadena, Calif.

Patents procured and trade-marks registered. Advice and terms upon request. Robb, Robb & Hill, 1421 Hanna Bldg., Cleveland, Ohio; 960 McLachlen Bldg., Washington, D. C.

**GERMAN
MAUSER**
Reg. price \$25.00
\$12.75
with perfect safety device

Guaranteed Genuine
Latest model 9 sho
automatic. Shoots
Standard cartridges—
lies flat in the pocket—
World's famous Luger
25 cal. \$19.95—Hand
Ejector Revolver,
swing out cylinder 32
cal. \$16.75. 38 cal.
\$17.75. Allbrand new
latest models—guaranteed genuine imported.

SEND NO MONEY Pay postman on del-
ivery plus postage.
Satisfaction guaranteed or money promptly refunded.

\$6.75
25 cal. Vest Pocket Automatic—25 cal. Blue
Steel Army Automatic \$8.25. 32 cal. \$10.25.
Military Trench Automatic—32 cal. 10 shot,
extra magazine FREE, \$11.45. Imported Top
Break Revolver, 32 cal. \$8.45, 38 cal. \$8.75.

IMPORT SALES CO., 942 Broadway, Dept. 000, New York

Milwaukee Radio Club Changes Name

THE Milwaukee Amateurs' Radio Club has been incorporated under the laws of the State of Wisconsin as a non-stock body, and its name changed to the Milwaukee Radio Amateurs' Club, Inc.

The incorporators were L. S. Baird, C. N. Crapo and Attorney L. J. Topolinski, the society's general counsel, through whose efforts state incorporation was brought about.

In addition to including the past purposes of the club and those of the American Radio Relay League, Inc., the articles of organization provide that the society may own and operate an amateur radio station and may associate itself with the A. R. R. L. as a Milwaukee section or local chapter.

Meetings are continued, being held weekly at 7:45 p. m. Thursdays in the trustees' room of the Milwaukee Public Museum. Business Manager L. S. Baird recently received the appointment as A. R. R. L. Central Division Publicity Manager, and in order to devote proper attention to his new duties his chairmanship of the meetings and papers committee has been transferred to H. F. Wareing, president of the society. This committee is now arranging for a series of lectures on timely radio topics. R. E. Lathrop, 9ATX, of the club's technical committee, represented Wisconsin at the Michigan State A. R. R. L. convention held at Flint, Mich., and upon his return gave the Milwaukee club members a lengthy report.

Radio frequency amplification has been the subject of several general discussions at meetings, and a paper entitled "Intervals Radio Frequency Transformers" was presented by I. H. Strassman, 9AHO. Mr. Strassman, who is A. R. R. L. City Manager, has also reported from time to time the progress being made in ridding the air of unlicensed stations. These offenders have operated much to the discomfort of both the radiophone listeners and the amateurs.

Say you saw it in "Radio Topics" when writing to advertisers.

Stations Heard at 7ZU

Dec. 1, 1922, to Jan. 23, 1923
 C.W. 3BVL (3YO) (4BV) 4CN
 (4HH) 4YA 5ABB 5DI 5EK 5CJ
 5IX 5JN 5MA 5MU 5NN 5PX 5QS
 5SF 5SK 5TJ 5UO 5XV 5XAJ 5XL
 5XD 5ZK 5ZAV 5ZAK 5ZS 5ZM 5ZA
 5ZH 6ALU 6AJH 6ARF 6ANH (6AK)
 6AWT 6APJ 6ATQ 6ASK 6AIX
 6AQQ 6APW 6ARB 6AUU 6BA
 (6BU) 6BUM 6BDF 6BIP 6BIQ
 6BU 6BCC 6BCJ 6BH 6BOE (6BVF)
 6BIH 6BHH 6BIC (6BVW) 6CKM
 6CC 6CBI 6EA 6FF 6OX 6IF 6LU
 6KA 6NS 6RM 6RR 6RE (6TI)
 6VF 6VM 6XAD 6XK (6ZO) 6ZS
 6ZH 6ZT (6ZX) 6ZZ 7AR 7ABY
 7ABB 7AFS 7ABH 7BA 7BK 7DA
 7DP) (7DX) (7EY) 7FR 7KB 7KE
 7KR 7MC (7MO) 7NA (7NF) 7OE
 7OM 7PF (7QB) 7SA 7SC (7SJ) 7TQ
 7VF 7XC (7ZC) (7ZV) 8AZD 8AMU
 8APT 8BO 8BK 8BDO 8BOZ 8BK
 (8BXX) 8CIA 8CJH 8DV (8PT)
 (8VY) 8YD) (8ZY) 8ZZ 8ZW
 9AQU 9AOG 9ARF 9AMB 9AFD
 (9awm) (9asf) 9aot 9afm 9ah 9aua
 9aqv 9abu (9ahh) 9apw 9aya 9arz
 9aap 9auu (9arz) (9asu) 9amt 9aul
 9ayu 9amj (9aig) 9aza 9aws 9ajs 9apw
 9awh 9aou 9abv (9ajh) 9ayi 9aod 9aad
 9afs 9adf 9ayu 9aau 9avj 9aoj 9afo

9axj (9atn) 9aig 9asf 9acy (9aij) 9aor
 9bkk 9bkj 9bre 9bxt 9bjq 9bsq 9bed
 9bvy 9bcf 9bly 9blo 9bko 9bzi 9bji (9bsg)
 9bjv 9bik 9bx 9bdr 9baa (9bp) 9bch
 9bzig 9bxf 9bxm 9bxi 9bkh 9bsz 9bmn
 9bjk 9bpt 9baf 9bkw 9bzz (9bhq)
 9bmy 9bbf 9bxq 9bri 9cns 9cfk (9cm)
 (9ceb) 9clq 9cxn (9cfy) 9cfv 9cpu
 (9cac) 9cny 9cde 9cdv 9clc (9ccv)
 9cj 9caa 9ce 9cgy 9cwr 9cc 9chn
 (9ctg) (9dsg) (dkb 9did 9dsd 9deh
 9dio 9dnb 9dyg 9dpd 9dge 9dpf 9dta
 9dca (9dxq) 9dok 9dsm 9dey 9dcy
 9dte 9ddy 9ddn 9dgn 9dac 9eak 9fm
 9gk 9clq 9io (9kp) (9mf) 9mo (9ps)
 (9qf) (9rc) 9qr (9rk) 9uf 9uh 9ve 9vm
 9vk 9xaq 9xac 9xm (9yu) (9yaj) 9yw
 9zaa 9zaf (9zn) 9zt 9zy.
 Fone (9asf) 9cls (9asf) (9yy) 9gk
 5za 9zaf (9ccv).
 Canadian (5cn).

Interesting Booklet

The Detroit News, Station WWJ, has printed a booklet containing a brief history of various broadcasting stations maintained by newspapers of the country, giving pictures of the entertainers and other matter of interest to the radio fan.

How to build the Reinartz Receiver

is told, complete with illustrations and diagrams, in the latest addition to the "Chi-Rad" Handbook-Catalog.

Our Handbook also includes:

1. Technical discussions of standard radio apparatus and equipment.

2. Radio definitions, wireless codes, wire tables, definitions, etc.

Pin this ad to your letter and mail it, together with a dime, for your copy of the Handbook.

Send for it today!

Chicago Radio Apparatus Co.
 415 S. Dearborn Street, Chicago



R. T

"THE BETTER RADIO" PIRASCO

The Perasco Kewpie

is the most efficient tube radio receiving set produced. Measures only 6"x 6"x8". All contained in a neat cabinet.

To hear any station within 1,000 miles, just connect your aerial, ground batteries and put a tube in the socket.

PERASCO KEWPIE - - \$25

Using WD-II tubes, it works on one dry cell.

A 2-stage amplifier is made to match the receiver. It will increase signals a hundred-fold and work a loud speaker.

PA-III, 2-Stage Amp., \$40.00

Combination Perasco Kewpie receiver and 2-stage amplifier **\$60.00**

(Send for descriptive folder.)

Perry Radio Supply Co.

218 Washington Blvd.
 River Forest, Ill.



Thrills !!!

THRILLS never end when you have a Tuska Popular—the regenerative receiving set that experts recommend. Signals clear and sharp come in night after night from far-away stations. And for nearby programs, plenty of volume without distortion. Every part Tuska-made; known for 12 years as fine radio instruments.

THE C. D. TUSKA CO., Hartford, Conn.

Tuska Popular No. 225
 Regenerative Receiving Set, Tuska receiver, detector and 2-stage amplifier, licensed under Armstrong U. S. Patent No. 1,113,149. Catalog No. 14-A, showing Popular and other sets, on request.

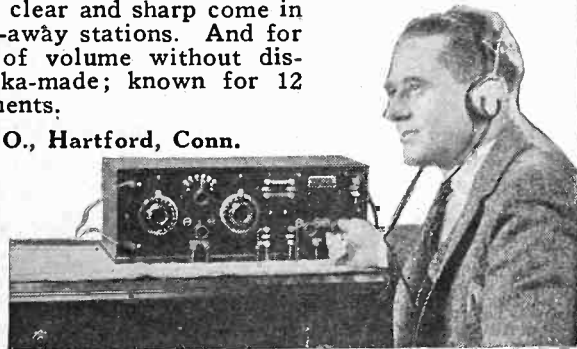

TUSKA RADIO

25c Trouble With Your Set?

POSTPAID

Ever think how important the Grid Circuit is? Mica insulation, wax treated Grid Condenser. Can be used as bi-pass condenser on amplifying transformers, etc.

DEALERS—ATTRACTIVE PROPOSITION



DEPT. S

OF ILLINOIS

SUMMIT, ILL.



Kellogg V-T Socket

the durable socket

Kellogg molded lamp sockets fit all standard four prong based vacuum tubes. Extra heavy solid base 7-16 inches thick.

75c ea. Four German silver springs with rounded ends firmly held in position in deep grooves, cannot touch mounting surface. Double end nickel plated binding posts. Connections can be made under the socket as well as above. A practically indestructible construction. 75c each, postpaid.

COMPLETE RADIO EQUIPMENT

The item above is merely a sample of the excellent line of radio equipment that is handled by the Apex Radio Company, Inc. All orders for sockets or other standard equipment will be filled the day received. Send two cent stamps for our new price bulletin.

APEX RADIO CO., INC.
 6914 S. Halsted St.
 Chicago, Ill.

OTHERS MAY FOLLOW
➡ NONE SHALL LEAD ➡

Radio Topics

*The Greatest \$2.00 a Year Radio Publication
in the Country*

THE MOST LIBERAL OFFER OF THEM ALL

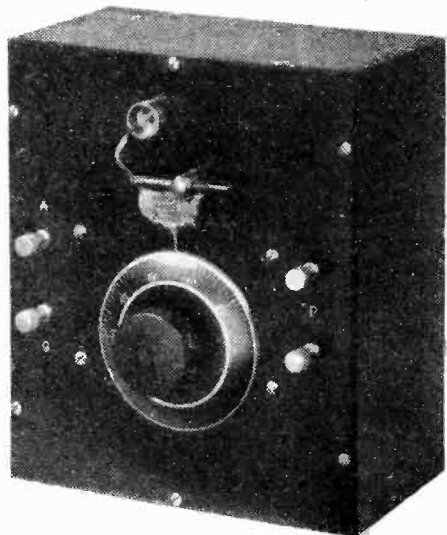

A STATES RADIO CORPORATION
CRYSTAL SET FREE

Your opportunity to get
this Super Crystal Set

With But Little Effort

THREE one-year subscriptions or one three-year
subscription \$6.00.

FOUR one-year subscriptions or one four-year
subscription includes head phone \$8.00.

A CRYSTAL SET
A CRYSTAL SET
A CRYSTAL SET

FREE

Radio Topics—1112 North Boulevard, Oak Park Ill.

Inclosed find six dollars in payment of the following three one-year subscriptions, for which I am to be sent one crystal set, or \$8.00 for four one-year subscriptions, which includes head phone.

NAME	NAME	NAME
ADDRESS	ADDRESS	ADDRESS
CITY	CITY	CITY
STATE	STATE	STATE

Amateurs Beat Old Records

Although the warm weather is almost here when radio transmission over long distance is much more difficult than during the winter months, there is no let-up in the number of messages being handled by the radio amateurs.

In the month of March all records were smashed with a total of 160,100 messages, F. H. Schnell, traffic manager of the American Radio Relay League, announced at the A. R. R. L. headquarters here today. The total for February was 121,592, showing a gain of 38,508 messages in one month.

According to the report it is only a matter of weeks before the spark may be thrust out of existence entirely; 143,319 messages were handled by CW and 16,781 by spark.

The credit for the greatest number of messages ever sent by an individual station goes to 8-ZD, owned by Perry Wiggin and F. B. Westervelt, of Pittsburgh, Pa. With only six operators at the key 2,855 messages were relayed by this station in March. Individuals may file messages without charge at any amateur radio station in the country.

Radio Fans Confuse Wave and Frequency

There is much need of a clearer understanding of the relation between the terms "wave length" and "frequency," says Crosley Weekly. The subject is certainly not complex in any way, and perhaps a little visualization will assist the beginner in comprehending just what "wave length" is and what relation it bears to frequency.

If we compare the radio wave to a wave traveling along the surface of a body of water, the wave length is that distance measured from the crest of one wave to the crest of the next, and for convenience and uniformity in radio circles this distance is expressed in meters. A 360-meter wave would measure about two-tenths of a mile between the adjacent tops of the waves. A 400-meter wave is about one-quarter of a mile long.

Some idea of the speed with which a radio wave progresses may be gained when it is realized that 833,000 of these 360-meter waves march past a given point in a second; 833,000 is the frequency, and is expressed in "cycles" per second.

The "cycle" represents a complete rise and fall of the wave.

Since the waves move along at a velocity of 300 million meters (which is 186,000 miles) per second, it can be understood that just 833,000 waves 360 meters in length can pass in one second. Here's the principle: The wave length may be determined by dividing the frequency into 300 millions, and vice versa, the frequency may be found by dividing the wave length into 300 millions. From this it is evident that at high wave length the frequency is low, while a short wave length is very high. The higher the wave length the lower the frequency.

It has been proposed by many European scientists that the term "wave length" be dropped and that the frequency be stated instead. Indeed it would seem more logical should this be done, although it would not be quite as convenient as the smaller number representing the length of the wave.

With our present system of designation it should be remembered that the wave length and the frequency are inversely proportional to each other.

STATEMENT OF THE OWNERSHIP, MANAGEMENT, CIRCULATION, ETC., REQUIRED BY THE ACT OF CONGRESS OF AUGUST 24, 1912.

Of Radio Topics, published monthly at Oak Park, Ill., for April, 1923.

State of Illinois, County of Cook, ss.

Before me, a notary public in and for the state and county aforesaid, personally appeared William M. Hight, who, having been duly sworn according to law, deposes and says that he is the business manager of the Radio Topics and that the following is, to the best of his knowledge and belief, a true statement of the ownership, management (and if a daily paper, the circulation), etc., of the aforesaid publication for the date shown in the above caption, required by the Act of August 24, 1912, embodied in section 443, Postal Laws and Regulations, printed on the reverse of this form, to wit:

1. That the names and addresses of the publisher, editor, managing editor, and business managers are:

Publisher, Radio Topics, Inc., Oak Park, Ill.
Editor, J. Ray Murray, Oak Park, Ill.
Managing editor, Nanko C. Bos, Oak Park, Ill.

Business manager, William M. Hight, Oak Park, Ill.

2. That the owners are: (Give names and addresses of individual owners, or, if a corporation, give its name and the names and addresses of stockholders owning or holding 1 per cent or more of the total amount of stock.)
Nanko C. Bos, 200 S. Humphrey ave., Oak Park, Ill.

B. W. Stolte, 3554 S. Halsted st., Chicago, Ill.
John N. Bos, 200 S. Humphrey ave., Oak Park, Ill.

Telfer MacArthur, 1112 North Blvd., Oak Park, Ill.

3. That the known bondholders, mortgagees, and other security holders owning or holding 1 per cent or more of total amount of bonds, mortgages or other securities are: (If there are none, so state.)
None.

4. That the two paragraphs next above, giving the names of the owners, stockholders, and security holders, if any, contain not only the list of stockholders and security holders as they appear upon the books of the company but also, in cases where the stockholder or security holder appears upon the books of the company as trustee or in any other fiduciary relation, the name of the person or corporation for whom such trustee is acting, is given; also that the said two paragraphs contain state-

Both Selling Fast Because the Price is Right!

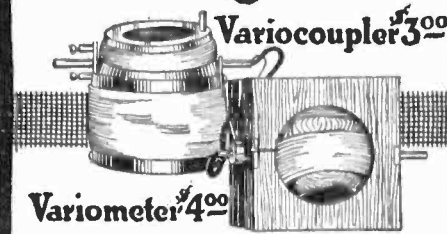

Set of Three

2 Variometers \$8.00

1 Variocoupler \$3.00

Special \$10.00

Send Your Order in To-day

OUR NAME PROTECTS YOU

CHICAGO RADIO APPARATUS CO.
415 So. Dearborn Chicago.

Public Sales

We Have Purchased

122,000 Pair

U. S. ARMY MUNSON LAST SHOES

Sizes 5½ to 12, which was the entire surplus stock of one of the largest U. S. Government shoe contractors.

This shoe is guaranteed one hundred per cent solid leather, color dark tan, bellows tongue, dirt and waterproof. The actual value of this shoe is \$6.00. Owing to this tremendous buy we can offer same to the public at \$2.95.

Send correct size. Pay postman on delivery or send money order. If shoes are not as represented we will cheerfully refund your money promptly upon request.

National Bay State Shoe Company

296 Broadway, New York, N. Y.

ments embracing affiant's full knowledge and belief as to the circumstances and conditions under which stockholders and security holders who do not appear upon the books of the company as trustees, hold stock and securities in a capacity other than that of a bona-fide owner; and this affiant has no reason to believe that any other person, association, or corporation has any interest direct or indirect in the said stock, bonds, or other securities than as so stated by him.

5. That the average number of copies of each issue of this publication sold or distributed, through the mails or otherwise, to paid subscribers during the six months preceding the date shown above is—

(This information is required from daily publications only.)

WILLIAM M. HIGHT,
Business Manager.

Sworn to and subscribed before me this 13th day of April, 1923.

(Seal)

M. WALPOLE.

(My commission expires June 30, 1925.)

Railroad Fare



Student Winding a Stator

To the Great Shops of

Coyne

We pay your railroad fare to Chicago—the Electrical Center of the World—from any place in the United States. Grasp the opportunity to see the country at our expense. Come to Coyne—learn electricity in 3½ months. Get a complete training so you can make big money as Power Plant Operator, Superintendent, Telephone man, Construction worker, auto, truck or tractor electrician, battery man, radio expert, or you can go into business for yourself as electrical contractor, dealer, auto ignition or battery expert and make from \$3,000 to \$20,000 a year. Hundreds of our graduates today are making big money and you can do the same if you grasp this opportunity—act now.

Learn Electricity In 3½ Months

No books or useless theory. You are trained on \$100,000 worth of electrical equipment. Everything from door bells to power plants. You work on motors, generators, house-wiring, autos, batteries, radio, switch-boards, power plants—everything to make you an expert ready to step right into a position paying from \$45 to \$100 a week.

Radio Course FREE

We include the following free with the regular course:

(1) A complete course in auto, truck and tractor electricity and storage batteries. Greatest outlay of auto, electrical and battery equipment in the country.

(2) Course in Radio—the marvel of the age. Constructing, installing and operating. You can build your own wireless telephone set.

(3) A life scholarship in the Coyne school. You can stay as long as you wish and return for further training at any time in the future.

Earn While You Learn

We help students to secure jobs to earn a good part of their expense while studying.

Send Coupon Now

Don't delay a minute—send that coupon in right now for our big free catalog and full particulars of Free Railroad Fare offer. Act now!

B. W. COOKE, President

Coyne Trade and Engineering School
Dept. 5993 1300-1310 W. Harrison St., CHICAGO

B. W. Cooke, Pres. Coyne Trade and Engineering School,
Dept. 5993 1300-1310 W. Harrison St., Chicago, Ill.

Dear Sir: Please send me free your big catalog and full particulars of your special offer of Free Railroad Fare and two extra courses.

Name

Address

Distance Doesn't Stop Radio Waves

Words spoken in a public hall in Schenectady reached a radio listener in San Francisco, Cal., 2,550 miles away, before they were heard by a listener 150 feet from the speaker.

That statement looks a bit fantastic, but it is mathematically true. The apparent absurdity becomes reasonable when it is realized that the speed of sound is 1,126 feet per second at a temperature of 68 degrees Fahrenheit and the speed of electrical vibrations or radio waves is 186,000 miles per second.

The listener in the back of the hall in Schenectady, 150 feet from the speaker heard the words in 0.1332 seconds.

A microphone connected to the radio transmitting equipment of WGY, the General Electric Company station, was two feet in front of the speaker and picked up the words in 0.002 seconds.

Time required to transform sound waves into electrical energy, 0.002 seconds.

Time required for electrical vibrations or waves to pass from Schenectady to San Francisco—0.0137 seconds.

Time required at receiving end to convert electrical vibrations into sound vibrations—0.001 seconds.

Total elapsed time from the speaker in Schenectady to the radio listener in San Francisco—0.0187.

Listener in hall heard words in 0.1332 seconds.

San Francisco man heard words 0.1145 seconds sooner.

The period of time elapsing between the spoken word and its reception via radio 2,550 miles away can be illustrated as follows: 0.0187 seconds is time required for a spectator at a baseball game to hear the impact of bat against ball when he is standing twenty-one feet from the batter.

Broadcasts Speech Backwards

Those who never heard English spoken backward listened to a demonstration by radio on March 30, when WGY, the Schenectady station of the General Electric Company, broadcast part of a Pallophotophone speech by reversing the film.

The Pallophotophone is an instrument which photographs or records sound on motion picture film. The film looks just like mo-

tion picture film, but the photographed image consists of a series of up and down lines of varying degrees of amplitude and frequency. Everyone is familiar with the result obtained by reversing the motion picture; falling buildings are rebuilt; the man jumping off the wall is seen jumping back when the film is reversed. The same thing occurs when a speech film is reversed, the speech is given backward.

Friday evening, March 30, WGY broadcast an address by David Sarnoff, vice president and general manager of the Radio Corporation of America, and also an address by Dr. Frank Crane, the inspirational writer. Upon the completion of the Crane address two paragraphs were broadcast backward.

New UV 199 Tube

The Radio Corporation of America has issued the new UV 199 vacuum tube for general sale, together with its socket, and an adapter that has been developed for it. This is one of the most important releases of the year, as the new tube is undoubtedly one of the most remarkable that has yet been developed.

It operates on dry cells and has a filament current of only 60 milliamperes—or, in other words, 60-1000 of an ampere. The filament requires three volts.

In making the announcement it was stated that full production on this tube had not yet been reached, but it was expected that a rapid increase would soon be effected.

The chief value of the new tube is in circuits where three or more tubes are used. This is because of its remarkable low current consumption. The little tube is extremely hard and makes an excellent amplifier both of audio and audio-frequencies. Its filament is constructed of thoriated tungsten. It will stand upward of 100 volts upon its plate.

Since the filament requires three volts for satisfactory operation there is an important point to remember by those who employ it. Three volts can be obtained by joining two dry cells in series, but as the voltage of such cells drops very rapidly it is necessary to use three of them in series. Consequently it is not of advantage to use these tubes in circuits of less than three tubes, unless a special rheostat of 30 ohms is employed. When three tubes are used on the same battery, each being joined in parallel to the battery, a rheostat of 10 ohms in series with all three will give the necessary control.

The sun-dodgers of the Chicago Board of Trade station WDAP are a bunch of regular fellows. They've chipped in and bought over 500 crystal sets for shut-ins and the Boy Scouts lent their aid by going around and installing them.

A Very Simple and Compact Receiving Set

A small, compact, and efficient receiving set that has proven its ability in the reception of long distance, is found in the PERASCO Kewpie. This little outfit presents many radical features both in its construction and design that are not to be found even in receivers many times its price.

Because of its simplicity of control, the first thought would be that of broad tuning and much interference. However, on actual



tests this receiver has separated broadcasting stations having approximately the same signal strength and varying in wave length only 5 per cent. On distant reception it has proven to be equally efficient.

Being designed to be operated on a WD-11 tube, its upkeep as well as its compactness has been cut to the minimum, making it suitable for a portable outfit to be taken on vacation trips. One other advantage of the Kewpie on a trip is its special circuit which enables it to be operated with only a ground connection, if necessary, without losing any of its efficiency.

The slanting panel gives a distinctive effect not found in any other receiving outfit of similar design. An amplifier of the same size as the Kewpie is built as an addition to go with the Kewpie when a loud speaker is desired to be operated. This amplifier also uses the WD-11 tubes.

The combination of the Kewpie with the PA-III two-stage amplifier gives one a very flexible, compact and easily operated radio receiving outfit of proven merit.

We have chain grocery stores, and now I see we're getting a lot of chain radio stores. By and by somebody will put one of these Piggly Wiggly radio mixup stations on every corner and we can go on a regular spree.

6 Years of Amplification

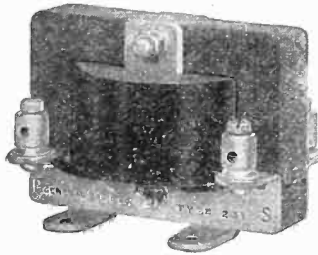

Type 231-A
Amplifying Transformer
Price \$5.00

For six years the General Radio Co. has been supplying audio-frequency amplifying transformers. From time to time changes have been made to meet the changing conditions. The Type 231-A Amplifying Transformer represents the latest and best developments in design and construction. As a testimonial to General Radio design, over 50,000 transformers have been sold, which were copies of our present or previous models.

We have maintained a development laboratory since 1915 where radio problems are studied and analyzed. We have supplied the Bureau of Standards, the Naval and Signal Corps radio laboratories with many of their radio research instruments. Why do you, too, not purchase instruments whose quality has been proven, and that are guaranteed?

Send for FREE RADIO BULLETIN 911T
and learn more about our instruments

GENERAL RADIO COMPANY

Massachusetts Avenue and Windsor Street
CAMBRIDGE 39 MASSACHUSETTS

Standardize on GENERAL RADIO COMPANY equipment throughout—
DO NOT CONFUSE the products of the GENERAL RADIO CO. with those of other concerns using the words "General Radio." The GENERAL RADIO CO. has been manufacturing radio and scientific instruments for many years. It has no affiliation with any other company.

WANTED

Cash for Old Gold, Platinum, Silver, Diamonds, Liberty Bonds, War, Thrift, Unused Postage Stamps, False Teeth, Magneto Points, Jobs, Any Valuables. Mail in today. Cash sent, return mail. Goods returned in ten days if you're not satisfied. Ohio Smelting Co., 336 Hippodrome Bldg., Cleveland, Ohio.

ESTRU

Lattice Variometers
List Price \$5

Dalton, Whittier, True
2905 West Madison Street
CHICAGO



**Talk
Number
3**

SIGNAL

Facts from the Factory

Did you ever stop to think why SIGNAL Radio outfits are different—why they satisfy the keen radio student who knows and insists upon the best, yet are so simple in operation that the amateur readily obtains perfect results—why they—

But, before you read one word further, just look at the SIGNAL Vernier Rheostat above. It's the first successful vernier using a single knob for control. Like all SIGNAL apparatus, it is built like a watch—with jeweler's precision.

Our corps of expert research engineers present the latest developments in radio first. So for the newest and best in Radio, ask for SIGNAL—It's your protection.

SIGNAL Electric
Mfg. Co.

Factory and General Offices
1901 BROADWAY, MENOMINEE, MICH.

Atlanta, Boston, Cleveland, Chicago, Minneapolis, Montreal,
New York, Pittsburgh, St. Louis, San Francisco, Toronto.

(2204C) You'll find our local address in your Telephone Directory.



SIGNAL Vernier
Rheostat

A simple coupling between the main contact and the vernier contact, carries the main contact by vernier to point nearest proper tuning. From here a fine adjustment is obtained by revolving the knob in the opposite direction. Furnished both with or without knob and pointer, so dial to match others of set may be used.

Information Coupon

Signal Electric Mfg. Co.
1901 Broadway
Menominee, Mich.

Please send catalog and bulletins giving complete information about SIGNAL Radio equipment to name and address written in margin.

Say you saw it in "Radio Topics" when writing to advertisers.

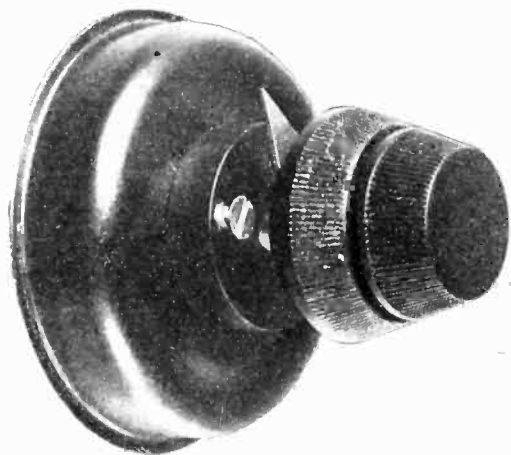

As Noiseless and Smooth as a Bird Thru the Air

☐ Gone are the scratching and noises as you vary the current to your tubes.

☐ Can you imagine anything more perfect and smooth in operation than a resistance wire passing through a well of mercury?

☐ Then there is another wire which gives a vernier adjustment.

☐ No need to turn back the rheostat to shut off the tube; just a touch of the fingers and a bearing switch throws it in or out.

☐ There is also a Gollos Potentiometer on the same principle.

☐ They come ready for panel mounting and template furnished. A Gollos Mercury Rheostat sent postpaid for only.....\$2.00

Dealers Desired

GOLLOS DEVICES, Not Inc.

"Perfect Noiseless Rheostats"

118 N. La Salle Street :: CHICAGO

Suite 704

The Gollos Mercury Rheostat

"BUILD YOUR OWN" WITH "RASCO" PARTS!

THE Radio Specialty Company—"RASCO" for short—now in its third year, is unquestionably the most unique radio parts supply house in the United States, if not in the whole world. This Company makes a specialty of very small orders. No order is too small to get immediate and prompt attention. The reason is simple: 80% of our orders are small. The reputation of this house was built upon service. Ask any of your radio acquaintances what they think of "RASCO" service, "RASCO" promptness. Thousands upon thousands of unsolicited testimonials are in our files, to prove that we serve the public as it has never been served in radio merchandise before. Be sure to get our great 68-page catalog, containing over 500 different parts. Catalog contains over 300 illustrations.

Order direct from this page. All goods sent prepaid in 24 hours. We pay all transportation charges. Money refunded if goods do not satisfy



RADIO FREQUENCY TRANSFORMERS
The best Radio Frequency Transformer developed so far. Designed for us by Mr. R. E. Lacault, Associate Editor of RADIO NEWS. For wavelengths of 320 to 420 meters. Air core. Guaranteed to do the work. This Transformer brings in the long distances.
R-2800, Radio Frequency Transformer, size 1 1/2" x 2 1/2" \$2.00

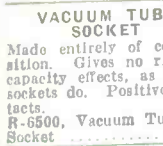

VACUUM TUBE SOCKET
Made entirely of composition. Gives no rise to capacity effects, as metal sockets do. Positive contacts.
R-6500, Vacuum Tube Socket \$35



ANTENNA CONNECTOR
Made entirely of aluminum. Will not rust. The four wires go to upper holes. Lower hole takes lead-in. Don't solder your aerial. Dimensions, 2" high, 1 1/2" wide.
R-999, Antenna Connector \$30

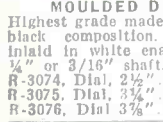

MOULDED DIALS
Highest grade made. Brilliant black composition. Figures inlaid in white enamel. For 1/4" or 3/16" shaft.
R-3074, Dial, 2 1/2" \$55
R-3075, Dial, 3 1/2" 65
R-3076, Dial, 3 3/4" 80



FLUTED KNOBS
Made of best black composition, provided with 8/32" bushing. Height 1". Diameter 1 1/4".
R-2055, Fluted Knob \$15



"RASCO" POSTS
R-650, Post made entirely of best black composition—8/32" screw—each \$08
R-202, Post has nickel-plated bottom part, each 08
Dozen, each style 90

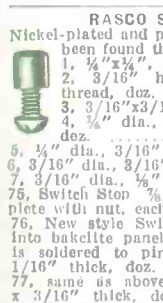

RASCO SWITCH POINTS
Nickel-plated and polished. The following have been found the most popular.
1, 1/4" dia., 6/32" thread, doz. \$35
2, 3/16" high, 1/4" dia., 6/32" thread, doz. 35
3, 3/16" x 3/16", 4-36 thread, doz. 35
4, 1/4" dia., 1/8" thick; shank 6/32" dia., doz. 40
5, 1/4" dia., 3/16" thick; shank 4-36, doz. 40
6, 3/16" dia., 3/16" thick; shank 4-36, doz. 40
7, 3/16" dia., 1/8" thick; shank 4-36, doz. 40
75, Switch Stop 7/8" long, 4-36 thread, complete with nut, each 04
76, New style Switch Point, to be pressed into bakelite panels with forced fit. Wire is soldered to pin end. Head 1/4" dia., 1/16" thick, doz. 40
77, same as above, but head is 1/4" dia. x 3/16" thick, doz. 40

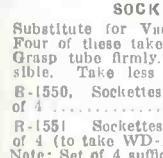

SOCKETTES
Substitute for Vacuum Tube Socket. Four of these take one Vacuum Tube. Grasp tube firmly. Best contact possible. Take less room. Are better.
B-1550, Sockettes, nickleled, set of 4 \$25
B-1551, Sockettes, nickleled, set of 4 (to take WD-11 Tube) 25
Note: Set of 4 sufficient to hold 1 Tube.



VACUUM TUBE FUSES
Insure your tubes against blow outs.
R-2575, Fuse, 1 ampere \$15
R-2576, Fuse, 1 1/2 ampere 15
R-2577, Fuse, 2 ampere 15

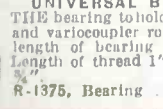

UNIVERSAL BEARING
This bearing to hold variometer and varicoupler rotors. Total length of bearing 2 1/4". Outside shaft, 1 1/4". Length of thread 1". Length of threaded sleeve, 3/4".
R-1375, Bearing \$25

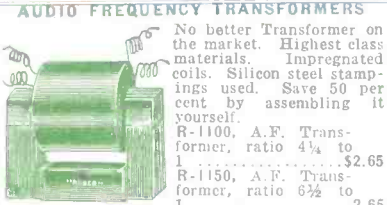

AUDIO FREQUENCY TRANSFORMERS
No better Transformer on the market. Highest class materials. Impregnated coils. Silicon steel stampings used. Save 50 per cent by assembling it yourself.
R-1100, A.F. Transformer, ratio 4 1/4 to 1 \$2.65
R-1150, A.F. Transformer, ratio 6 1/2 to 1 2.65

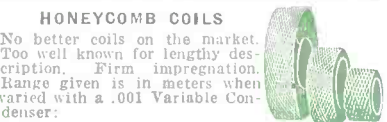

"RASCO" BABY DETECTOR
Base is solid black composition; mounted on same is nickel holder and binding post, which holds the fluted hard rubber knob with its sliding rod member. Patent nickel detector cup and binding post. Patent cup holds crystal.
R-1898, Baby Detector, with Galena \$50

HONEYCOMB COILS
No better coils on the market. Too well known for lengthy description. Firm impregnation. Range given is in meters when varied with a .001 Variable Condenser:

No.	Turns	Range	Price
R-5000	25	120-250	\$4.40
R-5001	35	175-450	.45
R-5002	50	240-720	.50
R-5003	75	390-910	.55
R-5004	100	500-1450	.60
R-5005	150	600-2000	.65
R-5006	200	900-2500	.75
R-5007	250	1200-3500	.80
R-5008	300	1500-4500	.85
R-5009	400	2000-5000	1.00
R-5010	500	2800-6100	1.15
R-5011	600	4000-10000	1.30
R-5012	750	5000-12000	1.45
R-5013	1000	7900-15000	1.70
R-5014	1250	9750-19500	1.95
R-5015	1500	14500-26500	2.20



"RASCO" LUBRICATED PANEL SWITCH
Our patent spring fork holds the switch handle always at a uniform tension. At the same time it insures best contact possible. New wiping contact covers every portion of the switch point. Double leaf blades used.
R-1921, "Rasco" Switch \$40

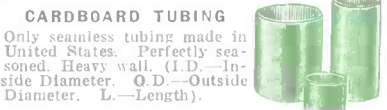

PANEL SWITCH LEVER
Impossible for this lever not to make positive contact. Leg radius 1 1/2". Nickel-plated and polished. Lock fork holds the screw (in which it rotates) securely. Loose contact impossible.
R-200, Switch Lever \$30

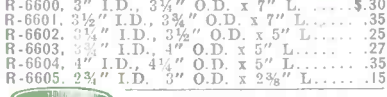

"RASCO" NAME PLATES
The circular plate is our new Binding Post Name Plate. Diameter, 3/4". These denominations: PHONES, GROUND, OUTPUT, "A" BATTERY, "B" BATTERY, LOUD SPEAKER, GRID, LOAD, "C" BATTERY, AERIAL, INPUT, BATTERY, LOOP, TICKLER, PLATE, "D" BATTERY, FILAMENT.
R-6000 to 6019, Binding Post Name Plates, each denomination \$03
Dozen 30

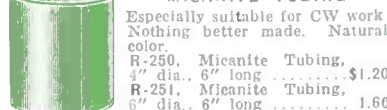

"RASCO" CONDENSERS
R-5050, Phone Condensers, each \$20
R-5055, Grid Condensers, each 20
R-5059, Grid Leak Condensers, each 30



COPPER FOIL
Thinnest copper foil made, .001" thick. Comes 4" wide.
R-5025, Coper Foil, per ft. \$10
10-ft. length 80

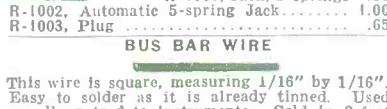

RADIO CEMENT
Weather resisting. Used particularly for cementing covered wires. Coils covered with this cement require no form. Wires hold together solely with this cement.
R-1750, Cement, 2-oz. bottle \$50

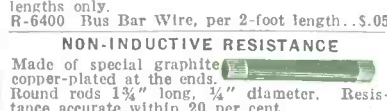

TELEPHONE SHELL AND CAP
For the experimenter we list this composition shell and cap. No holes in shell whatsoever. Takes standard 2 1/2" diaphragm.
R-2700, Shell-and-Cap, complete \$65
R-2701, Shell only 40

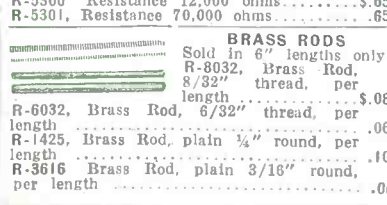

CONDENSER
INCREASE CURRENT

VERNIER
Cleverest vernier made. Can be used with any dial. Soft rubber ring engages dial. Does away with vernier condenser. We guarantee results. All metal parts moulded in best black composition. Nothing to come apart. Biggest hit of the season.
R-1450, Vernier \$30

CONDENSER
INCREASE CURRENT (Right)
R-840 "INCREASE CURRENT" (Left) Each 10

TELEPHONE SHELL AND CAP
For the experimenter we list this composition shell and cap. No holes in shell whatsoever. Takes standard 2 1/2" diaphragm.
R-2700, Shell-and-Cap, complete \$65
R-2701, Shell only 40

MICA DIAPHRAGMS
Made of special India mica in two sizes, 2 1/2" diameter and 1-13/16" diameter. Excellent for experimentation in telephone work.
R-2550, Diaphragm, 2 1/2" \$20
R-2551, Diaphragm, 1-13/16" 15

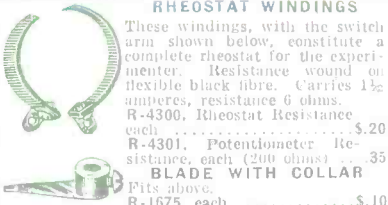

RHEOSTAT WINDINGS
These windings, with the switch arm shown below, constitute a complete rheostat for the experimenter. Resistance wound on flexible black fibre. Carries 1 1/2 amperes, resistance 6 ohms.
R-4300, Rheostat Resistance each \$20
R-4301, Potentiometer Resistance, each (200 ohms) 35

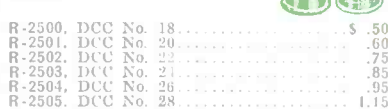

BLADE WITH COLLAR
Fits above.
R-1675, each \$10

MAGNET WIRE
We list only best qualities. "DCC" means Double Cotton Covered. "GS" means Green Silk. "E" stands for Enamelled. The following come on 8-ounce spools:

R-2500, DCC No. 18 \$50
R-2501, DCC No. 20 60
R-2502, DCC No. 22 75
R-2503, DCC No. 24 85
R-2504, DCC No. 26 95
R-2505, DCC No. 28 1.15
R-2506, DCC No. 30 1.65

R-2507, GS No. 20 \$50
R-2508, GS No. 22 55
R-2509, GS No. 24 60
R-2510, GS No. 26 65
R-2511, GS No. 30 1.05
R-2512, GS No. 32 1.30
R-2513, GS No. 36 1.85

R-2514, E No. 20 \$45
R-2515, E No. 22 55
R-2516, E No. 24 60
R-2517, E No. 26 65
R-2518, E No. 30 70
R-2519, E No. 32 80
R-2520, E No. 36 1.00

R-890, equals No. 28 B&S, per foot \$02
R-891, equals No. 21 B&S, per foot 01
R-892, equals No. 20 B&S, per foot 03
R-893, equals No. 14 B&S, per foot 04

Discounts of 10 per cent in 100-foot lots.



The "Rasco" Catalog
CONTAINS 75 VACUUM TUBE HOOK-UPS. 300 ILLUSTRATIONS. 500 ARTICLES. 68 PAGES.

All Armstrong Circuits: These important circuits are explained clearly, all values having been given leaving out nothing that could puzzle you. Just to name a few of the Vacuum Tube circuits: The V.T. as a detector and one-step amplifier; Armstrong circuits; one-stage radio frequency amplifier and detector; three stage audio-frequency amplifier; short wave regenerative circuits; 4-stage radio frequency detector; Armstrong super-regenerative circuit; two stage radio frequency amplifier coupled to a two-circuit tuner, using two-stage tuner regenerative receiver; two stage audio-frequency amplifier, using crystal or V.T.; one stage radio frequency detector, two stages audio-frequency with feedback coupling to first tube; power amplifier with loud speaker; regenerative receiver and one stage amplifier for DX work; one stage radio frequency detector with feedback coupling; three stages radio frequency, two stages audio-frequency loop reception; crystal detector with rectification; one tube super-regenerative receiver; short wave regenerative receiver with two variocouplers, capacity-coupled tuner; trap circuit to eliminate interference; selective circuit to eliminate interference. The catalog contains 300 illustrations. An account of its great cost, it cannot be distributed free of charge. Mailed only upon receipt of

15 Cents in Stamps or Coin.

This business was originated with the sole idea in mind to cater to the radio amateur who has small orders. ALL OF OUR ORDERS ARE SMALL. THAT IS WHY YOUR SMALL ORDER CAN NEVER BE SIDE-TRACKED BY US. A trial order will make you a life customer. Order from the above illustrations. 24-hour service guaranteed. "WE CAN ONLY DISAPPOINT YOU ONCE." Try us with a 50c. order and make us prove what we say. Prices include delivery to your door.

Radio Specialty Co.
96B Park Place, New York City
Oldest and Original Exclusive Radio Parts House in U. S.
Factories: Brooklyn, N. Y. — Elkridge, Md.

DEALERS
Get Our Special Proposition



Concertola, Jr.

WorkRite Reduces Prices

Good News for Radio Fans

Here is the opportunity for you to get WorkRite Variometers and Variocouplers at prices less than those asked for inferior unknown instruments. The new WorkRite Super Variometer and WorkRite Super 180° Variocoupler, with 12 taps and wound with green silk are now \$3.50 each. Last spring they sold for \$6.00.

Don't wait any longer. Equip your set with WorkRite parts at once. Remember the prices.

WorkRite Super Variometer, each.....\$3.50
 WorkRite 180° Super Variocoupler, each.....\$3.50

Faith in You

is what caused us to make this big reduction in prices. In order to maintain it we must increase our sales largely. We must sell 10 instruments where we previously sold one. But we know that you will justify us in this faith.



WorkRite 180° Super-Variocoupler

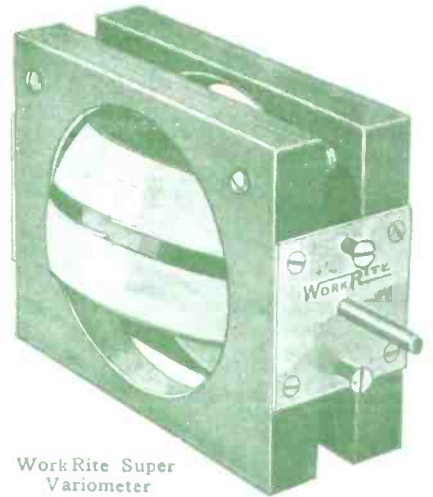

WorkRite Super Variometer

Complete List of WorkRite Products

Three Day Trial! If after you have tried the Concertola on your set you find that it does not work satisfactorily return it and we will refund your money.

These instruments are designed for use with vacuum tube sets having two-stage amplification.

- WorkRite Concertola, Jr., with Cord and Phone Unit.....\$12.00
- WorkRite Concertola, Sr., with Cord and Phone Unit.....\$24.00
- WorkRite Super Variometer. Very sensitive and sharp to tune. Price.....\$3.50
- WorkRite 180° Super Variocoupler. Range 180 to 800 meters. Price.....\$3.50
- WorkRite Concert Headset. Try a WorkRite side by side with any on the market. Price.....\$8.50
- WorkRite E-Z-Tune Dial. Has a grip on the rim where you can grasp it for fine adjustments. Price.....75c
- WorkRite Super Vernier Rheostat. Has 50,000 possible adjustments. Price.....\$1.50
- WorkRite Type "A" Hydrometer. You need one to keep your "A" Battery in condition. Price.....75c
- WorkRite Concertolas. Loud Speakers of Quality.
- WorkRite Concertola, Jr.....\$12.00
- WorkRite Concertola, Sr.....\$24.00



Concertola, Sr.

WorkRite Concertolas

These Loud Speakers are becoming more popular every day. And no wonder when you consider that they have no metal except in the phone units and therefore do away with that "tin-panny" tone entirely.

READ WHAT ONE OF THE THOUSANDS OF CONCERTOLA FANS WRITES US:

Regarding the WorkRite Concertola received some time ago, I wish to advise that it is the best \$12.00 worth I have ever bought. Stations in the following cities have all come in very QSA, even on warm nights, with the Concertola:

St. Louis, Louisville, Pittsburgh, Detroit, Schenectady, Dallas, Texas, Fort Worth, Texas, Atlanta, Ga., Havana, Cuba, Charlotte, N. C., Chicago, Cleveland and many others. These stations can be heard all over the room with ease on warm nights, and all over the house on colder nights. With every good word for the Concertola, I am,

EARL E. DAESCH,

1103 Columbia Terrace, Parkersburg, W. Va.

THE WORKRITE MFG. CO.

5548 Euclid Avenue
 CLEVELAND, OHIO

(BRANCH OFFICE, 2204 MICHIGAN AVE., CHICAGO)

Say you saw it in "Radio Topics" when writing to advertisers.