

RADIO TODAY



Prospects Everywhere!
SPOT 'EM!—and GO AFTER 'EM!

MARCH



OUT FOR A BIG YEAR IN 1938

1937 was one of the best years in the entire history of General Electric Radio — IN FACT THE YEAR OF OUR GREATEST PROGRESS.

General Electric's 1938 Touch Tuning models are leaders in design and performance, priced to give great value for the consumer's dollar, and a generous profit opportunity to the dealer.

The 1938 G-E Radio line was supported by an advertising and promotional campaign second to none in effectiveness. Over 500 leading news-

papers — the large circulation magazines — and radio broadcasting spotlighted and dramatized General Electric's powerful radio story.

As a result, more dealers than ever before are now lined up with General Electric Radio.

General Electric Radio sales to date this year are 50 per cent greater than the corresponding period of last year.

General Electric Radio is progressively planning for a still greater progress in 1938.

GENERAL  ELECTRIC

What will
MALLORY
YAXLEY
DO NEXT?



HERE'S ANSWER NO. 2

A complete new line of

P. R. MALLORY & CO. INC.
**MALLORY
YAXLEY**

MIDGET

UNIVERSAL REPLACEMENT

VOLUME CONTROLS
with **PLUG-IN SHAFTS**

(Pat. Applied For)

NOW 56 New Volume Controls
give you the range of
over 1000 exact replacements

Now—your problem of how to make a wide range of volume control replacements quickly and economically is definitely solved.

No large stocks to carry. No more delays that lose business and customer good-will! No more sending away for "exact replacement" controls you don't have when you need them.

Through the development of the new Yaxley Midget Volume Controls and the introduction of the new Yaxley Plug-In Shaft, Mallory-Yaxley offers the greatest advance in volume control servicing ever known in radio history.

Yaxley Midget Volume Controls—plain, single tap, double tap and duals—are available in resistance values from 5,000 ohms to 3 megohms inclusive and in all necessary tapers. They have flexibility—adaptability—universality—and snap-on switches! But—overshadowing all these advantages is the Yaxley Plug-In Shaft!

A single set of Yaxley Plug-In Shafts multiplies

the usefulness of any one of these controls by 17—or more.

For Example—10 new Yaxley Midget Controls plus 17 shafts give you the servicing equality of 170 ordinary Exact Replacement Controls with fixed shafts.

Now—let's go a step further! Multiply seventeen or more exact replacement possibilities by the fifty-six known basic type controls. To cover such a service range with fixed shafts (so-called "specials") would mean you would need *one* each of 952 individual controls. Yaxley Midget Volume Controls with Yaxley Plug-In Shafts provide the same service stock with only 56 controls and 17 Plug-In Shafts. And—the fact of the matter is that 90% of your replacements will be covered by about 12 of these 56 types of controls plus 6 or more of the 17 Yaxley Plug-In Shafts!

Now you can replace controls *exactly, easily* and *quickly* because Yaxley Plug-In Shafts reduce the required investment and multiply the usefulness of *every control* 17 (or more) times.

Order Yaxley Midget Volume Controls—and Yaxley Plug-In Shafts—from your distributor today!

● **WHAT WILL MALLORY-YAXLEY DO NEXT?**

Watch for further important announcements!

Use

P. R. MALLORY & CO. INC.
MALLORY
REPLACEMENT
CONDENSERS...VIBRATORS

P. R. MALLORY & CO., Inc.
INDIANAPOLIS INDIANA
CABLE ADDRESS—PELMALLO

Use

YAXLEY
REPLACEMENT
VOLUME CONTROLS

NEVER IN RCA VICTOR HISTORY HAVE SUCH VALUES BEEN OFFERED! FEATURE THESE SPECTACULAR BARGAINS AND YOU'LL SELL 'EM LIKE HOT CAKES!

Two More SALES
SENSATIONS
from RCA Victor

THIS RCA VICTOR TABLE MODEL IS A SALES WOW...

Model 94-X, a 4-tube AC-DC set which provides unusually fine tone. Among its splendid sales features are the clock-type dial, dynamic speaker, beam power output, built-in antenna. Has RCA Metal Tubes, receives state police calls as well as domestic programs. Yes—and its cost is amazingly low! A real price leader that'll bring in customers by the score! Get price from your distributor!

RCA presents the "Magic Key" every Sunday, 2 to 3 p. m., E. S. T., on the NBC Blue Network



← ANOTHER OUTSTANDING RCA VICTOR VALUE

The distinctive beauty, performance and low price of this radio will bring you scores of sales. So, just imagine how many more sales you'll make when you tell prospects that RCA Victor Model 95-T has RCA Metal Tubes, Magnetite Core Transformers, clock-type dial, dynamic speaker, and other fine features. And the price—see your distributor at once!



RCA Victor

A SERVICE OF THE RADIO CORPORATION OF AMERICA

RCA MANUFACTURING
CO., INC.
CAMDEN, NEW JERSEY

Over 300 million RCA radio tubes have been purchased by radio users... In tubes, as in radio sets, it pays to go RCA ALL THE WAY

HEAT RELIEF

AT A PRICE TO
ATTRACT THOUSANDS!



\$159⁵⁰
LIST
F.O.B. FACTORY

NO INSTALLATION
PROBLEM

NO WATER PIPES
TO CONNECT

NO WIRING TO IN-
STALL

NO FLOOR SPACE
REQUIRED

FITS ON WINDOW
SILL

(Window Sealing-Panels
Furnished)

PLUGS INTO LIGHT
SOCKET

A self-contained electric refrigeration plant which circulates air over cold coils where it is cooled, cleaned, de-humidified—then distributed throughout the room.

DISTRIBUTORS - DEALERS!

WRITE at once for details, discounts, merchandising plans on this sensational new space cooler!

A practical unit capable of sufficient volume to cool and de-humidify *effectively*—built for **DEPENDABLE** performance—priced to convert widespread desire into *widespread sales!*

Nothing you can sell has such a deep rooted appeal as **RELIEF** from heat and humidity. Thousands of women in thousands of kitchens; doctors, lawyers, dentists, hotels, hospitals, clubs—all are your market. Be prepared to cash in on the urgent demand that sweeps every community every year with the arrival of hot and humid weather! Time is getting short. **Act NOW!**

NOTE! The Johnson Space Cooler is not a makeshift air conditioner. It is just what its name implies—a *space cooler*, which definitely cools entire small rooms or prescribed areas in large rooms. It is the product of a company noted for *quality* manufacture, makers of such specialized products as household refrigerators and the famous Sea-Horse Outboard Motors.

JOHNSON MOTORS, 2040 MONMOUTH BLVD., GALESBURG, ILL.

JOHNSON
Space Cooler

THE SWEETEST CONDENSER EVER DEVELOPED FOR THE SERVICEMAN!

CARRY A CARTON
OF TEN TO TAKE CARE
OF EVERY SERVICE
Requirement



THE C-D
⁸⁸ *Beaver* ⁹⁹
TYPE BR ETCHED
FOIL ELECTROLYTICS

Type BR etched foil electrolytic capacitor is the smallest... and just about the "sweetest"... filter condenser ever developed. Study these features and see if you don't agree that the smart thing to do is to carry a stock of ten "Beavers" with you.

- 1 SMALL... one-fifth the size of corresponding types for similar capacity and voltage range. Will easily fit into most confined space.
- 2 A cinch to hook-up. No mounting brackets, no pol nuts, riveting or similar assembly operations. Just wire in... as you would a tubular condenser. Avoid headaches, delays, and eliminate exact duplicates.
- 3 Both terminals carefully insulated; protective cardboard sleeve supplied with unit. Polarity clearly indicated. Hermetic seal assures long life.
- 4 Available in single capacity units only. Capacities 4, 8, 12, 16, 20 and 40 mfd., 150 volts, D.C., and up to 8 mfd., at 450 volts, D.C.

Demand the condenser with the C-D emblem... hallmark of quality for twenty-eight years.

Ask your local C-D distributor to show you a handy carton of ten "Beavers."

Get set for maximum profits... Stock up with Type BR.

Cable Address: "CORDU"

**CORNELL  DUBILIER
ELECTRIC CORPORATION**

1022 Hamilton Blvd., So. Plainfield, N. J.

**AFTER A LONG,
HARD WINTER—**

**RADIOS NEED
MILLIONS OF NEW**

PHILCO TUBES



IN MILLIONS of homes, the family radios are finishing a long hard Winter. They've been tuned in for hours at a stretch . . . all day and all evening . . . and the tubes have been carrying the full load.

That's why Spring is one of the best times of all to go after tube business! And the surest way to get that replacement tube business is to go after it with tubes that everyone knows by name.

And there's no better known name in radio than PHILCO — the only name that has ever appeared on more than ten million sets! Go after that replacement tube business now with Philco Tubes! They're the natural first choice of every Philco owner . . . and that means the biggest group of all. And Philco is the best-known name to every other radio owner, too. That's why they all look with added favor on the dealer who offers Philco Tubes!

The Easiest Tubes in the World to Sell

The Handiest Refrigerator Ever Built!

Sell the SHELVADOR

Here's a refrigerator in which a woman can get at things easily. Nothing gets lost. The shelves in the door permit storing of small items so ingeniously that you can actually get **MORE FOOD** in the Shelvador than in any refrigerator of equal size.

This is still the greatest sales story in the refrigerator field . . .



With Built-In RADIO

The kitchen is fast becoming an important room, for informal entertaining finds it the center of attraction. This is a feature women are liking and smart dealers are taking full advantage of it.

THE SWEETEST SALES STORY EVER TOLD

*PLUS- these
All Greater
Values*

1. Faster Freezing
2. Greater Ice-Making Capacity
3. Crosley Quick-Release Cube Tray
4. Lower Cost Refrigeration
 - Short Running Time
 - Low Operating Cost
 - Long Life Due to Short Running Time
5. Safe Refrigeration
 - Low Box Temperature
 - 18-Point Temperature Control
 - Powerful Hermetic Unit
6. More Rugged Construction
and best of all—**MORE USABLE SPACE**
with the exclusive shelves-in-the-door.



THE CROSLEY RADIO CORPORATION • CINCINNATI
POWEL CROSLEY, Jr., President

Home of "the Nation's Station"—WLW—500,000 watts—70 on your dial

The new, improved Electrosaver Hermetic Unit is more efficient, more economical than ever before. Each unit is individually tested in the Crosley Proving Ground for operating performance under the most severe extremes of temperature and humidity.

CROSLEY SHELVADOR

It wasn't a good *guess*...it was
GOOD JUDGMENT

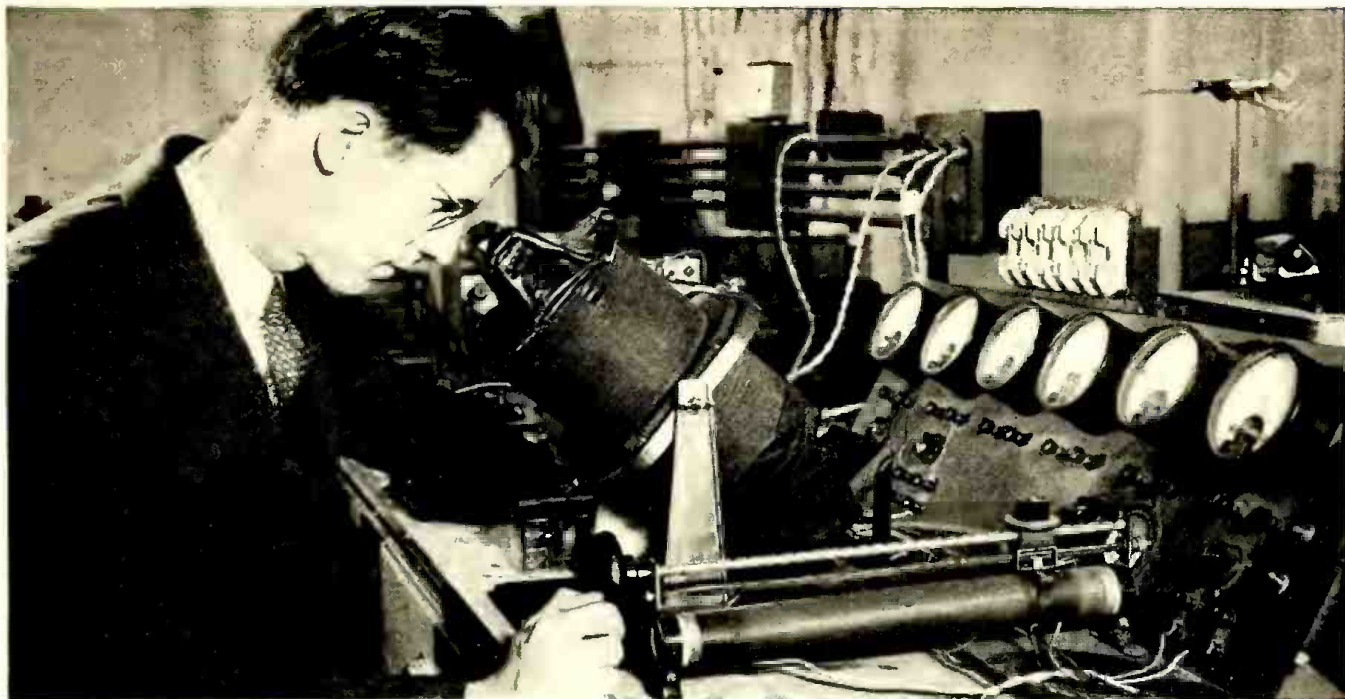

Sixteen years ago RCA men knew radio so well that they based the development of their business on the belief some day every home in the United States would have a radio . . . Today, 26 million homes and 5 million cars have them.

FROM radio's inception RCA men have been *radio men*. They have obeyed radio's demand for unremitting research, for tireless exercise of ingenuity, for constant thinking. It is but natural that these men, through their own labors, should have acquired *good judgment* in all that pertains to radio.

Twelve years ago, when RCA founded the National Broadcasting Company, RCA men were veterans in radio communications, a youthful but already mature art. Some years earlier they had foreseen the coming of broadcasting, had realized its opportunities for service.

So it was *good judgment*, not good guessing, which enabled RCA men to predict—when radio receivers were laboratory apparatus—that virtually every home would have a radio instrument. Recent figures place the number of radio equipped homes in the United States at 26,428,797.

It is the unceasing endeavor of RCA to apply to all branches of radio, at all times, the good judgment of which its unmatched experience has made it the fortunate possessor.

Foremost of all the facts that good judgment recognizes about radio is . . . only by genuine service in the public interest can radio hold its rightful place.

**IN RADIO—AND TELEVISION
 —IT'S RCA ALL THE WAY**

Only the Radio Corporation of America is engaged in every phase of radio. Its long experience and its resources are coordinated for the advancement of Radio Communications, Broadcasting and Manufacture.

RCA presents the "Magic Key" every Sunday, 2 to 3 P. M., E. S. T., on NBC Blue Network



RADIO CORPORATION OF AMERICA
 RADIO CITY, NEW YORK

RCA MANUFACTURING CO., INC.

RCA INSTITUTES, INC.

RCA COMMUNICATIONS, INC.

NATIONAL BROADCASTING COMPANY

RADIOMARINE CORPORATION OF AMERICA

Radio



*RADIO GOES TO COLLEGE... published January, 1936 by CBS. We will be glad to mail you this study on request.

goes to College

TURN *where we may, investigate whom we will, radio is discovered an intimate and important and active part of daily living!*

College investigators, last Spring, at the request of the COLUMBIA BROADCASTING SYSTEM, studied the radio habits of college students. They found that over 95% of the students listen *regularly* to radio. Even more interesting is the amount of college-time spent listening to radio. The average male student reports listening 3 hours *each day*. The average woman student listens 2 hours and 52 minutes *each day*. This is remarkable when you consider what a busy person the undergraduate is! And conclusive evidence, once again, of how well radio reaches *everybody*: young and old—and class-markets as well as mass-markets.

The complete study* shows that America's million-odd undergraduates are remarkably like everyone else where radio is concerned. They are today's leaders of young people everywhere; tomorrow's leaders in business and society. And radio—*without special effort—without extra cost* reaches them *at the same time* it reaches the rest of the country. *For everybody likes to listen!*

But this is no surprise. It confirms the findings of radio advertisers—and other radio research. (A year ago the CBS study of "THE VERY RICH—AND RADIO" arrived at much the same conclusion as the college-study. Like everybody else, the Very Rich also like to listen—and do!)

Yet, in the cloistered halls of learning we unearthed fresh material on a fine point. Everyone knows a few people who habitually do more than one thing at a time. Such people read while they eat, write while they telephone and—if they're at college—they study while radio-listening. But not *all* people double-up their activities. If we take the undergraduate as a guide, we find that *most* people prefer doing *one* thing at a time. Of the 2,487 college students interviewed, 61.3% stressed the fact that they do *not* listen to their radios while studying. But there's another simpler way of determining *how well* people concentrate when they listen to radio. Make a deliberate mistake of any kind on the air. Or make an offer. You will then quickly learn, from billowing bags of mail, just how intently the average listener listens when his radio is tuned-in! And *that* is a basic reason for radio's brilliant record of success.

THE COLUMBIA BROADCASTING SYSTEM





Radio goes to College

TURN where we may, investigate whom we will, radio is discovered an intimate and important and active part of daily living!

College investigators, last Spring, at the request of the COLUMBIA BROADCASTING SYSTEM, studied the radio habits of college students. They found that over 95% of the students listen *regularly* to radio. Even more interesting is the amount of college-time spent listening to radio. The average male student reports listening 3 hours *each day*. The average woman student listens 2 hours and 52 minutes *each day*. This is remarkable when you consider what a busy person the undergraduate is! And conclusive evidence, once again, of how well radio reaches *everybody*: young and old—and class-markets as well as mass-markets.

The complete study* shows that America's million-odd undergraduates are remarkably like everyone else where radio is concerned. They are today's leaders of young people everywhere; tomorrow's leaders in business and society. And radio—*without special effort—without extra cost* reaches them *at the same time* it reaches the rest of the country. For *everybody* likes to listen!

But this is no surprise. It confirms the findings of radio advertisers—and other radio research. (A year ago the CBS study of "THE VERY RICH—AND RADIO" arrived at much the same conclusion as the college-study. Like *everybody* else, the Very Rich also like to listen—and do!)

Yet, in the cloistered halls of learning we unearthed fresh material on a fine point. Everyone knows a few people who habitually do more than one thing at a time. Such people read while they eat, write while they telephone and—if they're at college—they study while radio-listening. But not *all* people double-up their activities. If we take the undergraduate as a guide, we find that *most* people prefer doing one thing at a time. Of the 2,487 college students interviewed, 61.3% stressed the fact that they do not listen to their radios while studying. But there's another simpler way of determining *how well* people concentrate when they listen to radio. Make a deliberate mistake of any kind on the air. Or make an offer. You will then quickly learn, from billowing bags of mail, just how intently the average listener listens when his radio is tuned-in! And *that* is a basic reason for radio's brilliant record of success.

THE COLUMBIA BROADCASTING SYSTEM

*RADIO GOES TO COLLEGE... published January, 1938 by CBS. We will be glad to mail you this study on request.

Staff—

DARRELL BARTEE
G. H. MAYORGA
M. H. NEWTON
B. V. SPINETTA
VINTON K. ULRICH

LEE ROBINSON
Sales Manager



ORÉSTES H. CALDWELL
Editor

M. CLEMENTS
Publisher

Copyright 1938
Caldwell-Clements, Inc.
480 Lexington Ave.
New York, N. Y.

Tel. PLaza 3-1340

Vol. IV, No. 3

“THE AMERICAN WAY OF DOING THINGS”

Let's talk frankly about American Broadcasting. For, every radio man—every listener—has a stake in our present system

Radio in the United States today is free!

It is **free** to the listener.

It is **free** of government control.

And it can be **used freely** by those who have a message to tell. Having so far avoided the government muzzling and taxing which hampers radio in other countries, American radio is first, last, and all the time, a popular servant of the people!

As a result American broadcasting supplies the finest programs anywhere in the world. The most costly talent is an everyday affair. Music, news, drama, and entertainment, are available 18 hours a day, at the turn of a dial. All these come without cost—without fee—to every listener. In consequence the largest listening audience in the world—37,000,000 radios—has been built up. Measured by the standards of radio in other countries, American broadcasting is a shining example of progress for other nations to copy.

But there are those who would tear down this splendid structure built in “the American Way of Doing Things.”

Contributed nothing!

There are those who would impose intolerable burdens upon America's now-free radio—who would restrict its operation in ways detrimental to the public interest—who would inject the dangers of government operation into our free institution of broadcasting.

These critics who themselves have contributed nothing to radio's vast record of achievement, would revamp and revise the present structure to fit their own whims or political arguments, unmindful that radio as it stands today has been tested through 15 years of searching trial and effort.

These critics seize upon single minor incidents of program oversight, such as the Mae West broadcast—yet overlook the hundreds of thousands of hours of wonderful musical and cultural programs which are the rule in broadcasting. And, frowning at radio, they overlook the far more objectionable obscene text and pictures which certain illustrated magazines are bringing into American homes, carried by U. S. mailmen.

Impossible taxes

Others of these tinkers—and wreckers—of American radio, would put impossible taxes on American broadcasting stations. The Boylan bill, proposing a tax of \$1 per watt on small stations, and \$3 per watt on large ones, is an example of this vicious attempt to control broadcasting through intolerable taxes.

Others would eventually head American radio into government control and government operation, substituting Washington bureaucrats and political appointees for present highly-paid entertainment executives chosen by reason of their expert qualifications alone.

License fees for listeners!

And in the wake of government control and operation, would come a Federal license on radio receiving sets—a pall on home enjoyment and education in the form of the heavy hand of the government tax-collector, taxing sets and tubes.

These are some of the steps in the vicious program of federal control and taxation, already disclosed by movements underway at Washington.

Wake up—gentlemen of the radio industry!

It is time, therefore, that radio men and radio listeners woke up to the presence of the forces that are about to imperil radio listening and “the American Way of Doing Things.”

American broadcasting—like all other human

institutions—has some faults. But broadcasting’s shortcomings are minor—and merely serve to accentuate the merits of an otherwise magnificent—truly miraculous—public service. American broadcasting is sound and healthy, and has grown strong and vital under its own initiative.

In the best interests of American radio, the present system must be retained along its present broad principles of private operation.

Americans don’t want:

- Government ownership of broadcasting.
 - Censorship of programs.
 - Limitation of station service.
 - Political domination of radio.
 - Bureaucratic administration of programs.
 - Taxes or licenses for radio listening.
- Those are not “the American Ways of Doing Things.”

ONLY IN THE UNITED STATES IS RADIO COMPLETELY FREE

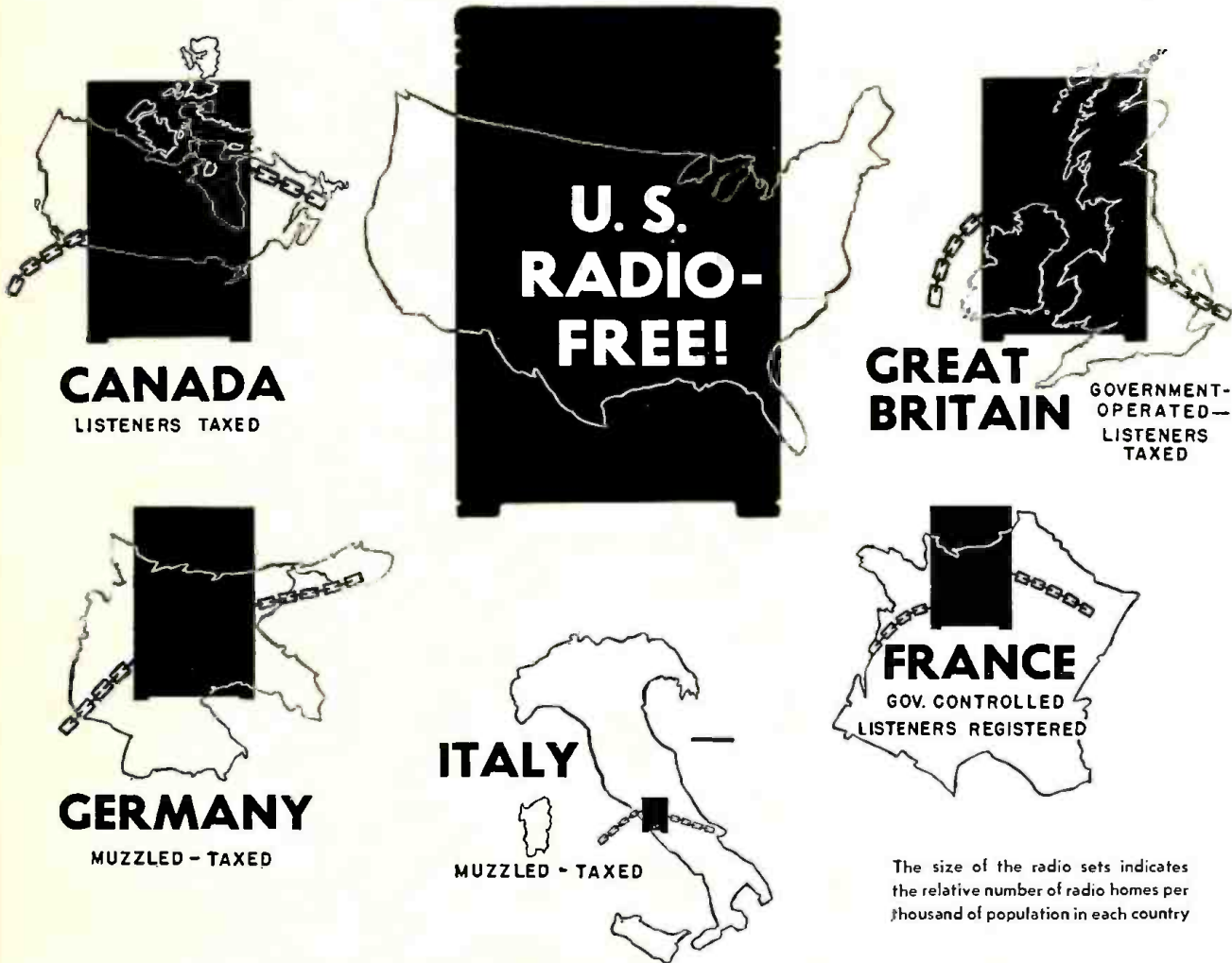

The United States leads in radio because radio in the U. S. offers the best programs—because radio in the U. S. is free!



Dr. Lee de Forest today. The radio inventor at his home, 5106 Wilshire Boulevard, Los Angeles.

RECORD IN RADIO EXPORTS

★ For the fourth consecutive year American radio exports in 1937 reached a new peak, with an increase of 14.4 per cent over 1936 exports. Total 1937 exports were \$32,357,417, compared with \$28,284,251 in 1936, \$25,454,188 in 1935, and \$24,856,592 in 1934.

As compiled by the RMA, radio parts and accessories accounted for the larger portion of the increased exports in 1937. In dollar volume there was an increase of 34.9 per cent in parts and accessory exports; 25.7 per cent increase in loudspeakers; 15.7 per cent in tubes; 1.9 per cent in receiving sets, and 47.6 per cent in transmitting apparatus. While the larger portion of exports occurred during the last half of 1937, previous percentages of increase were not maintained.

U.S. APPLIANCES SOLD

★ The electrical vacuum cleaner business experienced its second highest January in the industry's history, according to the latest figures released by the Vacuum Cleaner Manufacturers' Association. Sales for the month this year were 118,127, compared to 117,810 for December, 1937, and 124,756 for the record January in 1937.

Total sales of cleaners for the year 1937 were set at 1,706,336 units, including both floor cleaners and hand cleaners. A preliminary figure issued by RADIO TODAY, 1,094,000 cleaners, referred only to floor units.

Reports on factory shipments of household washing machines, from the American Washing Machine Manufacturers' Association show that January units for 1938 totaled 72,611, compared to 55,843 in December and 121,754 in January, 1937. The Association's complete figures for the year 1937 show that total washer units amounted to 1,642,019.

8,064,780 SETS IN '37; 92,055,000 TUBES

★ Exceeding most estimates and expectations, radio sets sold by manufacturers in the fourth quarter of 1937, totaled 1,992,980, bringing the year's total up to 8,064,780. The 1937 total thus came within 2 per cent of the 1936 record, 8,248,755 sets. These figures, obtained from licensees, refer to number of sets reported sold by manufacturers to distributors and dealers. Actual sales to the public are believed to be considerably less, owing to the large inventory carried over by the trade in warehouses and retail stocks.

Tube sales reported by manufacturers for the last quarter of 1937 fell off to 18,275,000 units—only 59 per cent of the same quarter of 1936. The total tube sales for the year 1937—both initial equipment and replacement tubes—thus totaled only 92,055,000 tubes, or 6 per cent below 1936.

Complete official set and tube figures for the past two years follow:

	1936	Sets
1st quarter	1,287,462
2nd quarter	1,697,444
3rd quarter	2,330,959
4th quarter	2,932,890
Total	8,248,755

1937	
1st quarter 1,579,136
2nd quarter 1,769,499
3rd quarter 2,723,165
4th quarter 1,992,980
Total 8,064,780

Tube sales by quarters:

1936		Tubes
1st quarter	18,475,077
2nd quarter	19,971,773
3rd quarter	28,965,512
4th quarter	30,891,846
Total	98,304,208

1937		Tubes
1st quarter	22,393,997
2nd quarter	24,389,213
3rd quarter	26,994,000
4th quarter	18,277,790
Total	92,055,000

RADIO-TAX CAMPAIGN TO SENATE

★ The RMA campaign to repeal or modify the Federal 5 per cent radio excise tax is now being waged vigorously in the Senate at Washington, following omission of any action on radio in the House tax-revision bill reported March 2. Revenue needs of the government, with the radio tax raising over \$6,000,000 annually, were given as the principal cause for omission by the House Ways and Means Committee of action on the radio tax. The House Committee report stated that undesirable "nuisance" taxes "should be removed when possible, but unfortunately the revenue requirements of the government are such that very little revenue can be spared at this time."

Despite the House action, the RMA is leading anew the effort before the Senate Committee, generally regarded as more liberal than the House. RMA members and distributors, dealers and broadcasters are now urged to concentrate appeals on the Senate.

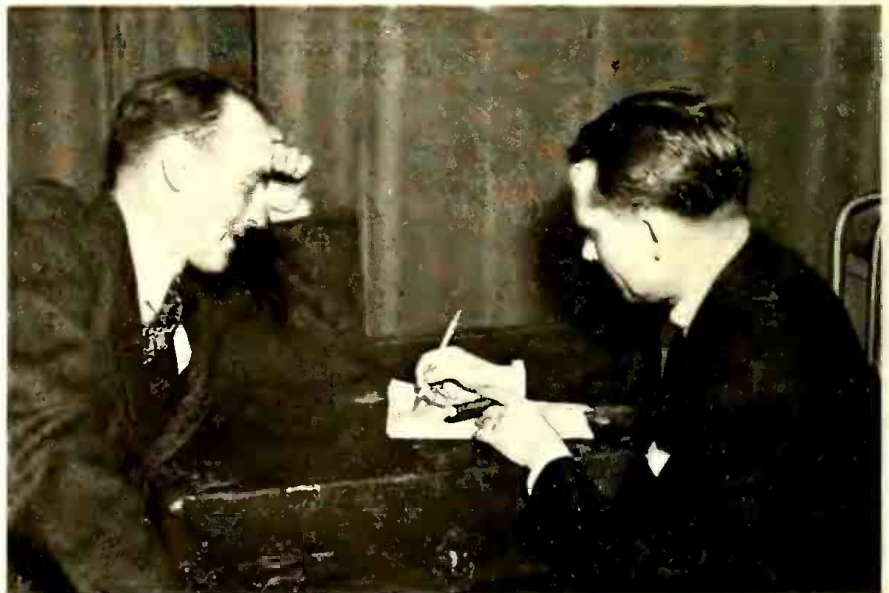

Vance Woodcox, RCA-Victor vice-president, checks up package-goods sales with Joseph B. Elliott, manager of Boston district office.



Broadcasters and public are all getting excited about facsimile. Here's the Finch home printer, for attachment to any radio.

CONVENTIONS DURING CHICAGO PARTS SHOW

★ Five conventions will be held in conjunction with the 1938 National Radio Parts Trade Show at the Stevens Hotel, in Chicago, June 8 to 11.

Activities of the week will start on the day preceding the opening of the Trade Show with the annual convention of the Radio Manufacturers Association. Annual conventions of the Sales Managers Club, "The Representatives," and the National Association of Radio Parts Distributors will open on Thursday, June 9, at 10 A.M.

Throughout the entire four-day period the annual convention of Radio Servicemen of America will feature technical lectures and business sessions.

"FOSTER LOCAL MUSIC TALENT"

★ The United States' greatest promotion of music, National Music Week, has been set as usual for the first week in May and opens this year on May 1. David Sarnoff of RCA, who is chairman of the Music Week Committee, comments that the event is half a celebration of widespread music activity, half a stimulus to musical projects and to fuller enjoyment.

Scores of national organizations, the musical ones as well as the Parent-Teachers, Boy Scouts, YWCA, YMCA, etc., are represented on the committee, and all the local chap-

ters of these groups are expected to break into song when the time comes. Since all radio dealers and distributors are acquainted with these local groups, it appears to be the ideal time to go out and sell, in a special way, the networks' musical-educational features. Via better radio sets.

THE DUMMIES STILL MAKE DUMMY TUBES

★ In Chicago, a few manufacturers are still cluttering up their sets with dummy tubes in an effort to impress the public with many-tubed sets. The Chicago Better Business Bureau is hot on their heels. It will be remembered that RADIO TODAY started the skirmish nationally last November, with the publication of a trade-shaking exposé on the same subject.

The Chicago Bureau reproduces in its bulletin, an ad showing a radio priced at \$39.50. The bulletin goes on: "The advertisement indicates that the radio contains '15 tubes.' Experts who examined the set stated that 8 of the so-called tubes are so connected that the filaments light, but the other elements of the tube perform no useful function. It was found these tubes can be removed without stopping or interfering with the performance of the receiver. According to one expert, this radio is 'actually a 7-tube receiver and could be reduced to a 6-tube."



Fred E. Johnston, new chief radio engineer for Stewart-Warner, has been active in radio since 1909.



The trend of 1938 auto-radio, is drawn by March Fisher, Philco auto-radio manager.

"A local retailer advertised a new 1938 10-tube radio at \$16.88. Three of the ten tubes are resistors or ballast tubes in glass envelopes shaped like tubes.

"A radio purchased from a local retailer was described as having 15 tubes, a 14-inch speaker, and the capacity to bring in world-wide reception.

"When examined by a competent radio man, it was revealed that only 7 of the 15 tubes performed a useful purpose and that the other 8 could be removed without stopping the operation of the receiver."

"GET THE MONEY!"

★ A word on collecting accounts from Leslie Rucker, of Washington, D. C., parts jobber:

"Remember this, boys, the man who collects his money and pays his bills and owns his home and a nice car is the respected citizen. Even though he may be a so-and-so for collecting, he is still the good dresser and prosperous, and is respected as such.

"Banks lend money. Unless you are a bank don't try to compete with the banks.

"Collect your money and dog the life out of the man or woman who fails to pay you—and, Mister, you will succeed. Call them ten times a day if you can reach them and they will pay. You may lose a customer but you will live better."

END THIS "DOG-EAT-DOG!"

Control of production would cure many of radio's trade evils
Vigorous selling and promotion now needed to rebuild industry

★ THOUSANDS of radio dealers have written RADIO TODAY to report distressing trade situations and difficulties they are experiencing in their own territories.

Manufacturers are accused of over-producing, overloading jobbers, dumping, making an excessive number of models in each line, and lack of control over their distributors.

Distributors are accused of selling every two-by-four outlet, supplying discount houses, extending ridiculous terms and careless credits, and refusing to cooperate in price maintenance measures for retailers.

Retailers are accused of utter disregard of good selling practices, lack of knowledge of the product, transshipping, price cutting, poor representation and general lack of aggressive selling effort. A summary of all these trade evils appeared under the title "Dealer Volcano Erupts" in our issue for February (pages 12, 13, and 18).

Enemy number 1

Analyzing these thousands of dealers' complaints, and presenting the situation thus revealed, to leading figures in the radio industry, the editors have developed much constructive discussion and comment which has in turn been finally crystallized into a set of principles for the guidance of the radio industry.

Radio's enemy No. 1—according to all the experts called in to feel the pulse of our sick industry—is Over-

Production. In the wake of this No. 1 evil, many other evils follow. If these other ills are to be cured, elimination of over-production is first on the list. Already the RMA is collecting monthly statistics of radio-set manufacturers, as a first step to study—and remedy—overproduction. If production can be controlled, and factory outputs can be kept in step with sales, many difficulties will automatically clear.

Indiscriminate appointment of new outlets and new dealers, without respect to the sales possibilities of the surrounding territory and the consequent hardships worked on all dealers thereafter, has been another major evil indulged in by an industry crazed to find outlets for excessive volume.

Better prices

The whole price structure in radio is in need of stiffening. With fair-trade laws operating in most states, prices can be firmed and dealers' margins protected, if the industry wants a sound price situation. Trade-in allowances, courtesy discounts, industrial-plant buying, and discount-house operations are all factors in price maintenance.

Special compensation in the form of spiffs, salesmen's commissions, dealer cruises, premiums and "deals," must be cleaned up. Misleading advertising (counterfeit sets with dummy tubes, for example) will have to be stopped, with the responsibility

for policing up to those who have the good name of radio at heart.

The unit values of radios must be raised by sales of more quality sets, to offset the popular tide toward inexpensive radios. Quality sets can be sold only if the radio man will take the trouble to "demonstrate the difference" between a good radio and a cheap radio.

All in same boat!

All the groups in radio—dealers, distributors, manufacturers, servicemen and broadcasters—have a common interest. All should recognize this mutuality so that the various groups work together for the general benefit of radio.

While many industry leaders have been consulted by the editors of RADIO TODAY, and have collaborated in the ideas appearing in the foregoing, and in the Platform of Fifteen Planks for Better Radio Business shown on these pages, certain well known figures permitted themselves to be quoted directly as follows:

End liquidation

"Briefly, if there is to be any relief at all within the industry, I feel it should come from the manufacturers in the form of controlled production," declares Frank W. Greusel, well-known Milwaukee distributor with long experience in association work. "To me it seems a terrific indictment against the industry that

Control factory outputs!

Go out and sell!

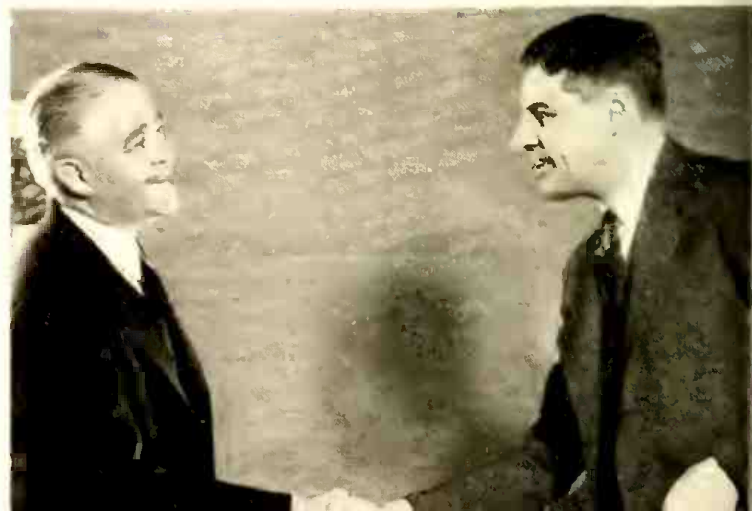

the intelligent producers of today should not be able to coordinate their thinking to a point where the industry can be made profitable to everyone without repeating constantly the liquidation process which seems to be a regular and accepted practice. Certainly within a limited number of brands is a heavy percentage of the total volume which should make it practical to improve conditions to a great extent."

"If it were possible to adopt a definite, carefully-arrived-at policy and follow it out, a great deal would be accomplished," comments Ernest Alschuler, president of Electrical Research Laboratories, Chicago. "I feel that radio stands almost alone as an industry, without any concerted cooperative effort on the part of the leaders, but rather there is a determination of dog-eat-dog.

paper advertisements as, 'how much is your radio worth?'—'Name your own allowance'—'if you are waiting for the top allowance on your present radio, now is the time to act.'

"If we could actually secure a policy of operation, even though it might be broad in every sense, we could not help but obtain a more satisfactory condition than the unstable one we now have."

Selective dealerships

William H. Ingersoll, marketing authority and Fair Trade expert of national prominence, believes that what the radio industry needs is more interest on the part of manufacturers in the health of their radio outlets.

Mr. Ingersoll, who is now active in the radio and appliance field as a special advisor to New York dealer

Fair-trade

"Dealers should avoid lines which are marketed without regard to their interests. Under current circumstances, they should avoid the products which are sold without fair trade agreements, they should ignore manufacturers who have no formal trade-in policy, and they should be cool to that merchandise which is available to their prospects through discount houses and other illegitimate outlets."

Mr. Ingersoll believes that great benefits would be forthcoming from more cooperation between radio dealers and the broadcasters, and that distributors and manufacturers should remember that their product is sold to be listened to.

He has great faith in the Fair Trade laws which are in force today.

RADIO TODAY'S PLATFORM FOR BETTER BUSINESS IN RADIO

1. Control production.
2. Restrict retail outlets to potentialities of territory.
3. Maintain resale prices under fair-trade laws.
4. Fix trade-in allowances.
5. Limit number of lines carried.
6. Cut out "courtesy discounts", industrial buying, and "discount houses."
7. Eliminate spiffs, cruises, special compensation.
8. Clean up misleading advertising.
9. Raise unit level of receiver sales.
10. Demonstrate quality sets "to show the difference."
11. Put an end to "rackets" and dishonest practices.
12. Cooperate with broadcasters.
13. Tie-in all groups — manufacturers, distributors, dealers and service men.
14. Promote radio in papers and on air.
15. Sell vigorously — in the store, by telephone and in the home.

Stabilize

"Some of the answers as disclosed in your 'Volcano Erupt' article are interesting and quite intelligent, and if a committee would analyze and act on some of the criticisms, there is no doubt but that material benefit could be had. Broadly, as we all now operate, there is no consideration for a policy—no effort to operate as a unit—but independent action for individual benefit. The result is uncertainty in the minds of everyone, resulting from cut prices, misleading advertising and the multitude of sins brought out in the article appearing in your February issue and vividly confirmed by current news-

organizations, has observed the procedure in other industries and says flatly that the current evils of the radio business are more fatal and more foolish than the mistakes being made in other fields.

He proposes that manufacturers use definite standards in the selection of dealers, and that unqualified outlets be checked out of the field. He feels that dealers should be able to count on trade areas that are protected and fixed.

"Dealers should limit their lines, and not fret about occasional customers asking for merchandise they do not stock. They should develop more confidence in their talent to sell what products they have.

and insists that radio men, pulling together, will find the regulations extremely beneficial. He declares that strong trade associations of radio dealers can exert powerful influence in the direction of cleaner business, and is today lending his support to the formation of a national organization of radio and appliance dealers.

Action, not complaints

"Unless an all-inclusive plan is devised that will bring all elements who benefit from radio into a great cooperative movement the existing intolerable conditions in the industry not only won't be cured but will grow even worse," comments Ben Gross, of Gross Sales, Inc., New

York. "Any industry that so functions as to make it impossible for retailers to profit from the sale of its products, is doomed to failure. Manufacturers have shown an utter disregard for this condition and have thus been parties to the destruction of the best efforts of the trade. Public confidence and trust in radio as a business and in the men engaged therein has been destroyed by the selfish greed of certain factors.

"Complaint, criticism and resolving will never cure the condition. The conflicting groups will not get together on such a platform to affect a cure-all because of a lack of mutual trust.

"A common ground of a new nature must be found. Something that will engage public interest and which will be free of personal conflict between groups, something that will benefit all. Upon that as a foundation of constructive joint effort, a new spirit can be created that will bring about harmony of action to rebuild the industry along sound lines.

"Five point plan"

"There are five major elements interested in radio: 1—Broadcasters and program sponsors, 2—Public utilities, 3—Radio manufacturers,

"A little hand shall lead them" to push-button tuning—Master Krumm of Sentinel tests his father's photographic skill.



4—Radio distributors, 5—Radio retailers and servicemen.

"I propose a revival of the plan presented to the Industry in 1934, then approved unanimously by the boards of directors of the national associations of radio manufacturers and radio wholesalers. That plan known as the 'Five-Point Plan for Revitalization of the Radio Industry,' can well be brought up to date, revamped to suit present conditions, and adjusted to satisfy all elements and factors. It can be made the vehicle for rebuilding this grand business to greater heights than ever known and to restore public respect and confidence in radio and in the people in the industry.

"Without some such all enveloping movement, all segregated efforts will go for naught because the destruction has already gone too far to be reversed by anything but a tremendous effort engaged in simultaneously by all."

Hot turnover

"The major answer to the question of what makes a prosperous retail radio business is still the same as ever," declares Harry Boyd Brown, Philco merchandising manager. "And this one answer, to a very large degree, remedies those developments which hurt the industry. For the retail radio dealer it simply amounts to stocking that radio merchandise which has the widest public acceptance and which offers the greatest value for the money—and then stocking nothing else, thereby getting the necessary speed in turnover. This sounds like a simple, old-fashioned formula, but it's as true now as it ever was.

"If the radio dealer concentrates on hot merchandise he keeps his investment down, gets fast turnover, and makes a satisfactory profit.

Sell old customers

If the radio dealer will vigorously sell, that will provide the solution of most of the difficulties the trade is experiencing, comments Ross L. Siragusa, president of Continental Radio & Television Corp., Chicago. Every survey made of American homes has shown that radio sets now in use are on the average three to four years old and need replacing. If the radio man will energetically follow up his old accounts of a few years before, he will find a lot of sales awaiting him. Meanwhile he should be cautious in his buying, limiting his commitments to his needs, so as not to load his store up with needless in-

FOR LOCAL LISTENING!



RCA Victor launches a new trend with its Symphony model. Designed for nearby stations only, with emphasis on tone. No distance sensitivity; no short-waves. Push buttons; no dial.

ventory. Six to four weeks commitments should be the limit—for, the distributor can well gamble on two to three weeks, and the factory on the balance.

If the dealer will buy as he needs, and sell hard every hour in the day, radio's troubles will be at end.

Controlling

Volumes have been written on the troubles of radio distribution, and volumes more undoubtedly will be written before the complete solution to the problem is found. The situation is a complex one, requiring much patient study and effort.

Yet when the salient points of the present trade dilemma are all analyzed, it appears that two principles set down on this page among the Fifteen Planks, have, after all, a controlling influence on present radio-trade picture.

First comes intelligent control of production by the manufacturers, based on knowledge of purchasing power for the radio merchandise involved.

Selling will sell

Second comes the matter of even more vigorous selling by the radio trade, to move the merchandise already in store or warehouse. To this end, all the combined arts of advertising, window display, store arrangement, telephone canvassing and home demonstrations must be marshaled.

Selling will sell. And the radio recession has no terrors for the radio man who is "eternally at it" selling radios—early and late, hour after hour, calling, selling, demonstrating, closing.

Selling will sell!

★ WITH only one automobile in four equipped with radio, the automotive field today offers radio's biggest unsaturated market. Thousands of car-owners in every community are prospects for auto-radios. The motorist is progressively becoming more conscious of the full advantages of "listening while you ride." Newspaper advertising, circulars, and dealer effort have all contributed.

During 1938 an additional opportunity for selling auto-radio is presented by the present doldrums in new-car production. With automotive dealers making a determined effort to clear the congested used-car market, and with many car-owners reconciled to keeping their present cars another season, auto-radio presents an immediate means of modernizing all these old-car models. "Be up-to-date with auto-radio" will be the 1938 motto of many a merry motorist and used-car dealer.



PROFITS IN 1938 AUTO-RADIO

Present owners and used car market should speed radio sales
 Push-button control, lever tuning, and single-unit receiver models

Push-button tuning has definitely taken hold in the auto-radio field. Lever tuning models are available in the lower price brackets, while electric motor mechanisms are used in other models.

To date, push-button tuning has been announced by Admiral, Arvin, Belmont, Chevrolet, Crosley, Deleo, Motorola, Trav-ler and Zenith. Prices on these models range from \$25 to \$79.95.

Single-unit sets

Some of the sets are designed for mounting behind the instrument panel and are complete in a single unit. These receivers, designed primarily for use in the older car models are priced from \$20—and considering

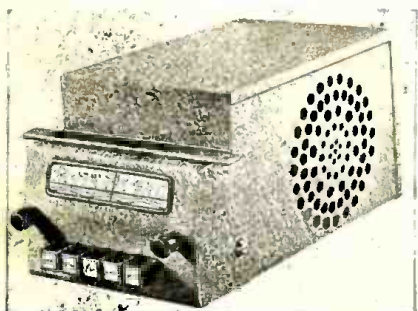

Admiral sub-dash receiver with push-button tuning and slide rule scale.

the low cost, perform remarkably well. And almost every manufacturer has included in its line one of these single-unit sets for mounting on the panel.

For maximum radio enjoyment the radio dealer has many models in the \$40 to \$60 class. And the features are automatic tuning, high power output, exceptional tone quality, custom dash controls. Temperature compensation of the tuned circuits has been added in some models to stabilize reception.

Then too, there are many engineering developments taking place in auto radio design which ordinarily do not receive much publicity. A few of them follow.

Most of the effort in the improvement of signal to noise ratio matter is being put forth by the receiver manufacturer rather than by the car manufacturer—not because of any unwillingness by the latter, but more because the former has so much more to work with.

Interference reduced

Principal sources of interference on a motor car are ignition radiation and tire static. The suppression of ignition noise at the source is not as feasible as its suppression within the receiver. The practice of employing

a single suppressor resistor in the distributor lead has superseded the use of a suppressor for each plug. Tire static has been greatly relieved by applying well-designed collectors to front and sometimes rear wheel bearings.

Automatic noise suppression

Interference suppression within the receiver, however, has been made remarkably effective. Let us examine some of the features of one particular receiver bearing on improvements in the signal to noise ratio.

Antenna stage gain has been in-



Custom dash controls are featured on this Admiral set made by Continental.

MORE AUTO RADIOS

creased to a maximum of about forty, with consequent reduction of noise.

An automatic noise suppression circuit has been incorporated whereby inverse feedback of the high audio

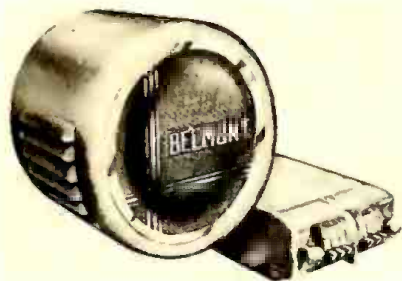

Belmont's model 677 with lever type push button tuning for 6 stations.



Trav-Ler type 711 with 7 metal tubes and cowl type speaker—\$59.95.

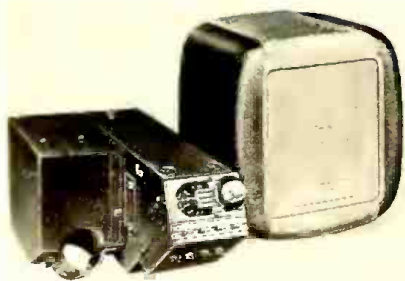

Push button tuning and separate speaker are featured in Zenith 5M294.

frequencies occurs automatically in inverse proportion to signal level. This circuit is designed to become operative when the signal drops to 7 microvolts, and the automatic tone control effect increases as the signal continues to fall below this level.

An adaptation of the usual local-distance switch may be used to reduce the set's sensitivity until its threshold is about 70 microvolts. However, this circuit has a trigger effect such that once a carrier exceeds the threshold, the signal is thereafter held, regardless of how much further its level may have dropped. Hence the receiver is made unusually quiet with respect to external noises, as atmospherics, street car interference, etc.

To compensate for the acoustical interference of mechanical and wind noise due to high speed driving, a wind-actuated volume-increasing switch comes into play at about 40 miles per hour (high gear). This switch, being located behind the cooling fan, is actuated by a combination of car speed and engine speed, so that the noise of first or second speed driving is automatically accounted for.

Easy installation

In general the 1938 cars have been designed with very considerable thought on behalf of reducing radio installation effort.

This reduction of effort, however, exists only for the receivers expressly engineered for the individual cars, and there is a tendency to increase the installation difficulties for "universal" type receivers.

The growing popularity of instrument panel receivers illustrates this point; space and contour considerations virtually limit the installation to that of a receiver expressly designed for the particular car.

Car manufacturer's influence

Push-button tuning has taken a firm hold of the contract auto-radio field by virtue of its success as a sales stimulant. Being stressed as a strong feature by the independent receiver manufacturers as well as by at least one car manufacturer, it bids fair to become almost universal on future receiver designs. Any technical objections which might now be raised on the subject of complexity and chance for failure in the field are already being answered by the designing engineers of the receiver manufacturers. Push-buttons have come to motordom to stay—at least for another year!

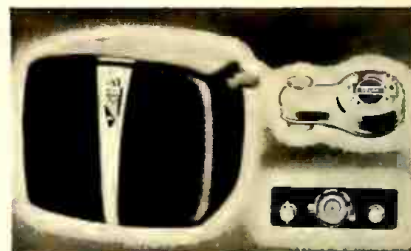

Delco's new line includes automatic tuning, custom controls.

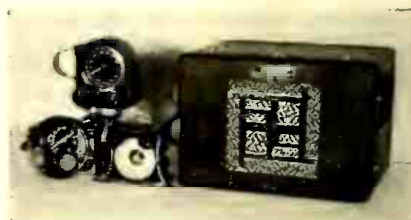

Cavalier Motors provide choice of steering column, and instrument panel controls.



Lever tuning for 5 stations is offered in this compact Belmont model 577.

ADDITIONAL SPECIFICATIONS OF AUTO RADIO SETS CONTINUED FROM FEBRUARY

Model No.	List price	No. of tubes	Watts audio power	Amps. batt. drain	R.F. amp.	Size	Speaker Type	Location	Tone control	Reception control	Type & location tuning ant. vibrator controls	Type of ant.	Type of chassis	Dimensions of chassis	I.F. peak	Features
Belmont Radio Corp., 1257 Fullerton Ave., Chicago, Ill.—"Belmont"																
677	NS	6-OM	5½	7.0	Yes	8	EE	Set	Yes	Yes	Lever-IP	{75-350 μmS}	Non S	8½x8½x16	465	1,2,3,4,5,7
577	NS	5-OM	2½	5.6	No	5	EE	Set	No	No	Dir-Lever	{75-350 μmS}	Non S	6x6x11½	465	9,7
Cavalier Motor Associates, Ltd., 1028 Linden Ave., Baltimore, Md.—"Autophone"																
M85T	25.95	5-0	2	5	Yes	6	EE	Set	NS	NS	Dir	NS	Non S	10x7x7	TRF	1
M85S	30.95	5-0	3	5½	No	6	EE	Set	NS	NS	Rem-IP	Hi-lo	Non S	9½x7½x6½	456	1
Zenith Radio Corp., 6001 Dickens Ave., Chicago, Ill.—"Zenith"																
5M291	29.95	5-0	5	7	No	8	EE	{Cowl}	Yes	No	Dir	Hi-lo	Non S	5½x6½x11½	456	4,9
5M294	39.95	5-0	5	7	No	8	EE	{Hldr-IP}	Yes	No	Dir-PB	Hi-lo	Non S	5½x6½x11½	456	4,9
6M292	44.95	6-0	6	7½	Yes	8	EE	Set	Yes	Yes	Rem-IP	Hi-lo	Non S	6½x8½x9½	252½	1,2,4
6M293	49.95	6-0	6	7½	Yes	8	EE	{Cowl}	Yes	Yes	Rem-IP	Hi-lo	Non S	6½x8½x9½	252½	1,2,4
6M295	59.95	6-0	6	7½	Yes	8	EE	{Hldr-IP}	Yes	Yes	Rem-PB	Hi-lo	Non S	6½x8½x10½	252½	1,2,4

For explanation of codes used in this tabulation and for a complete listing of 20 other auto radio manufacturers, please refer to page 20 of the February issue of RADIO TODAY.

Sets listed in the February issue were Automatic, Admiral, Fada, Motorola, General Electric, Tiffany-Tone, Howard, Airline, Arvin, Pacific, DeWald, Radolek, RCA-Victor, Philco Transitone, Trav-Ler, Troy, Universal, Delco, Lafayette, and Zephyr.

GREAT FOR '38

Admiral

UNDER DASH AUTO RADIO

with Original
**TOUCH-O-MATIC
PUSH BUTTON**

tuning

\$ **24.⁹⁵**



**SELF
CONTAINED
SPEAKER**

**AUTOMATIC
VOLUME
CONTROL**

**FULL VISION
SLIDE RULE
DIAL**

**PUSH
BUTTON
TUNING**

LAST year we presented the first auto radio equipped with automatic tuning. Again, a step ahead of the parade, we have developed an underdash auto radio with built-in automatic tuning . . . all at a sensationally low price.

Five stations are easily and quickly assigned for automatic tuning. A mere push on the button instantly and accurately rotates the variable condenser and dial to the desired station with the same precision and accuracy as if carefully tuned-in by hand.

Tuning scale, push-buttons and other controls are inclined to face driver. Ready vision promotes safety while driving.

Specifications: Model 55 Auto Radio
5 multi purpose tubes employed in ultra sensitive and selective superheterodyne circuit so as to give 7 tube performance . . . special electro dynamic speaker . . . plug type antenna connector . . . no suppressors required . . . automatic volume control . . . full vision slide rule dial (calibrated 535 to 1530 KC) with large easy-to-read numerals . . . compact metal cabinet 5-7/8" wide x 10-15/16" deep x 5-7/8" high . . . fits all cars . . . readily mounted flush below instrument panel. List price \$24.95.





A sample of expert emphasis on quality consoles—a window display which sets off the appeal of higher-priced sets, by Weeks & Dickinson, Binghamton, N. Y.

SALES THAT COUNT UP

Larger sets point in direction of plus profit

★ DEALERS are checking up on how many of their prospect-families have a satisfactory radio listening future.

Part of the plan is to see that each member of the family has the necessary personal receiver, because the house will be a shambles if everybody makes a pass at the same dial. And part of the plan is to see that the family has a first-rate center-sponsor for radio interest—a fine quality console with all the technical trimmings and all the musical reach of a master instrument.

Sound proposition

Consoles, it happens, are not only the biggest contribution that a dealer can make to the modern fireside, but they are also the most profitable sets to handle and many a dealer is thinking hard right now about how to hike his profit. Consoles are easily presented as the original radio equipment of the home, and they give the dealer a chance to drag out all the intelligent arguments.

Sales ammunition for this brand of "selling up" was presented in Part II of the February issue of

RADIO TODAY; the important arguments in favor of the quality consoles were outlined. The material was promptly picked up by dealers and distributors all over the country, and the campaign to see that every home has at least one big receiver was under way.

Worth selling

"Our task is to sell this idea to dealers versus allowing them to take the path of least resistance permitting too many customers to walk out with a \$10 or \$20 radio," was what Parker H. Ericksen of Fairbanks Morse wrote to his jobber organizations. Mr. Ericksen's suggestion was that dealers be encouraged to tack up the RADIO TODAY pages in sales rooms. He advised jobber salesmen to "show the dealer that it's the kind of conversation that he can use to improve his own radio sales."

"More consoles would be sold and the radio business as a whole would be on a far more profitable basis if more radio dealers would explain the five points—(presented in the magazine under the head "To Really Enjoy Radio Today—Every Home Must

Have A Quality Console') (1) regarding tonal quality, (2) regarding speakers, (3) regarding size, (4) regarding selectivity and sensitivity, and (5) regarding reproducing ability," was the advice of the Fairbanks Morse executive.

More action taken

Gross Sales, Inc., New York representatives for Stromberg Carlson, saw fit to blanket their dealer organization with this story on quality consoles. The suggestion was that the pages be put up in stores and otherwise kept in mind during all sales presentations.

The Stromberg offices were also for using the material as direct mailing pieces, and suggested that it would form the basis for lively feature stories on local newspaper radio pages, if dealers would call it to the attention of radio editors in their areas.

Pages picked up

Another idea was that the two pages should be distributed at all sales meetings for the remainder of the year. The theory was that the message should be repeated over and over again to drive home the thought that higher priced receivers can be profitably promoted right in the midst of a trend toward lower-priced merchandise.

Dealers who were looking for a chance to talk about something else besides price were attracted by the magazine display as an attractive possibility for part reproduction in local advertising.

Others found it effective to show the material to prospects personally, particularly in musical type stores, and among customers who are tone-conscious. In some quarters the pages were hooked up with serious musical concerts on the networks.

Hurdling high prices

As to whether the public is greatly discouraged about high prices of consoles, one answer is found in the statement from Merwin Lewis, radio man of Crofton, Neb.

"The good radios are really the cheapest to buy. They are generally designed better, have better parts, and work better than the others."

From Thomas J. Wilson, dealer in New Athens, Ill., comes the view that "The public is willing to pay for something better if educated correctly."

NOW WE CAN
SELL THE
LABYRINTH

-AND ELECTRIC
FLASH TUNING

Men—we're Switching
to Stromberg-Carlson!

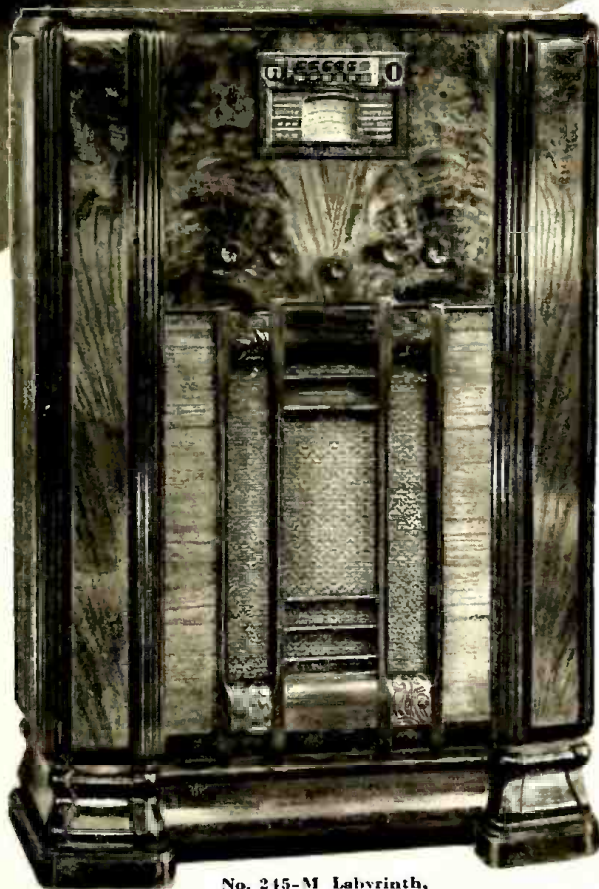

No. 245-M Labyrinth,
Electric Flash Tuning

Right now is the time to pick the radio line you want for 1938-39. And it is significant that so many dealers and distributors have already signed up with Stromberg-Carlson.

Each year, for 14 years, Stromberg-Carlson has given the trade fine merchandise that sold at a real net profit. Each year Stromberg-Carlson has introduced features that set performance standards for the whole industry. Each year Stromberg-Carlson has presented new cabinet styles that set the mode for all.

Look at the record. Total Shielding was a Stromberg-Carlson development. Remote Control Tuning was pioneered by Stromberg-Carlson in 1930. The Labyrinth, admitted by all to be the greatest tonal advance in radio history, is an exclusive Stromberg-Carlson feature. Electric Flash Tuning, considered by consumer and service man to be the most efficient tuning system on the market, is found only on the new Stromberg-Carlsons.

A new season is coming. It will prove again that "There is nothing finer than a Stromberg-Carlson."



THE ACOUSTICAL LABYRINTH, which no one can duplicate without infringing many patents, does away with faults of ordinary radio reproduction. It gives tone which is pure and natural... ear-conditioned.



ELECTRIC FLASH TUNING. Touch a button and the station you want comes in, perfectly tuned, without a second's delay. The pre-selected stations are clearly indicated. Station is kept exactly in tune by the perfected Automatic Frequency Control.

STROMBERG-CARLSON TELEPHONE MFG. CO., ROCHESTER, N. Y.

*There is nothing
finer than a*

Stromberg-Carlson

THE SERVICE-INSTRUMENT RACKET

Inferior test equipment marketed by false claims. Cheap designs sacrifice usefulness in effort to lower costs

★ **CHEAP**, inferior test equipment which has invaded the radio service field represented as quality merchandise, is being damned by many servicemen who have written **RADIO TODAY** asking for an exposé of such "lousy practices."

Not only does the serviceman get gypped, but the customers for whom the radio man repairs sets, get gypped in turn. Either the repairs and adjustments are inferior, or the serviceman must take a longer time to get the set into operation. Resulting poor reception or higher costs, affects the business of the broadcasters and the set manufacturers, as well as the serviceman and his customers. Reliable, accurate test instruments are a necessity to efficient radio service.

Chief trouble, it appears, lies with the mail selling methods of some companies. Grossly misrepresented in descriptive literature, many unsuspecting servicemen are roped in and buy this inferior equipment. And then the hooked serviceman finds that he cannot get his money back.

Misrepresentation

But even some of the instruments sold over the jobbers' counters are just as bad. Claims for accuracy in many instances are without foundation. Instruments are described as having a "2 per cent accurate meter" when the multiplier resistors are 5 per cent, 10 per cent or even 25 per cent off. Thus the serviceman is led to believe that he is getting a voltmeter that is rated at 2 per cent while the error is many times greater.

To be specific **RADIO TODAY** has just tested a test oscillator which is direct-reading from 110 to 22,000. Manufacturer claims ½ per cent accuracy on I.F. and B.C. bands and 2 per cent on the higher frequencies. Actual tests show inaccuracies up to 6% on the short waves. In addition portions of two of the bands are dead in spots—no oscillations whatsoever are produced.

Then, too, this unit is advertised as having a variable audio-frequency output—available direct or as a modulator. Range is supposedly 25-10,000 cycles—yet when AC operated it is impossible to get the neon-tube

oscillator to produce more than 700 cycles. On DC the neon oscillator will work up to about 5,000 cycles. And as might be expected, the explanatory printed matter does not state that the audio oscillator uses a neon tube and produces saw-tooth waveform.

This saw-tooth oscillator created so much overmodulation of the R. F. oscillator that signals on the weather band of the set were heard while the oscillator was tuned from 100 to 350 KC—set being held at 250 KC.

The output meter that is advertised by the manufacturer is a miniature type neon lamp. While this type unit may be satisfactory on high-voltage circuits, it certainly does not fulfill the definition of an output meter. In **RADIO TODAY**'s tests, however, it was impossible to get sufficient output on a 12-tube set, without overloading, to operate this output meter.

Flimsy construction

Further investigation of this test oscillator showed that it was built as cheaply as the cheapest midget radio. Oscillator inductances were wound on rough wood dowels and connected by flexible wire to the wave switch. Small wonder that the unit was unstable and changed frequency when handled.

The chassis supporting the "guts" was flimsy and bent under its own weight. Certainly not the type of construction one expects in a unit that is relied upon as a standard.

The unit was power-line operated on AC or DC—uses a 6A7 as a rectifier tube and another 6A7 triode-connected as oscillator. There was no such thing as a line filter. R. F. energy fed into the power line and signal in the radio set—even when the oscillator was not connected to the set—was many times greater than the local broadcasting stations. In no way whatsoever, was it possible to attenuate the signal of the oscillator so that it was less than that picked up from the local stations. Alignment below AVC level was consequently impossible.

The output of the oscillator when

connected to a 12-tube set as directed, provided so much signal that the set was immediately overloaded even at the minimum output when the oscillator was tuned anywhere near the frequency to which the set was tuned. All sorts of unexpected things occurred. The audio output decreased when the signal was tuned in to exact resonance due to the overloading. Also the AVC voltage decreased at resonance, probably because of overloading the amplifier tubes. Even with the signal generator set for minimum voltage, the receiver developed 3 to 4 volts AVC bias.

1—frequency AC voltmeters

Condenser-type voltmeter multipliers are used in some AC voltmeters. While the voltmeters can be made accurate on sine wave 60 cycle current or any specific commercial frequency, on any other frequencies the voltmeter will be in great error. If the serviceman will recall elementary electricity, he will remember that the reactance of a condenser varies with frequency. Yet do the manufacturers of this type equipment tell the serviceman that the AC voltmeter is accurate for only 60 cycles?

Some of the set manufacturers in their service data state the volts across the voice coil for a given signal input with a test oscillator modulated at 400 or 1,000 cycles. A 60 cycle voltmeter therefore will indicate to the serviceman that something is wrong in the set, since it will not read the voltage specified in the service notes—yet the trouble is only in the voltmeter.

Condenser type multipliers used on a meter designed for a single AC frequency may have advantages over the use of resistance multipliers. One manufacturer takes advantage of condenser multipliers to provide but one scale for both AC and DC voltage measurements. The use of condenser or reactance multipliers for a single frequency meter (power line voltage) should not be confused with practice of using condenser multipliers in a so-called audio frequency voltmeter.

A test oscillator is regarded by the serviceman as a frequency standard

upon which he can align the trimmers in a radio set, yet some of these oscillators themselves use *unstable* receiver-type mica trimmers so as to match the coils to the dial calibration. Also high-grade mica trimmers unless sealed are as likely to get out of alignment as those in a radio set, since a signal generator receives extremely rough treatment in the hands of most servicemen.

Trimmers in test oscillators

High-quality stable trimmers in oscillators are not to be condemned since they do not have the shortcomings of ordinary mica trimmers. In fact many high-grade laboratory type signal generators employ air-trimmer condensers so as to permit easy re-calibration of the instrument in case of drift or change of tubes.

Servicemen can guard themselves against poorly constructed oscillators by asking their jobbers to show them the inside of the unit. Accuracy of dial calibration of the oscillator can be easily checked on the I. F. bands by picking up the harmonics on a broadcast receiver while zero beated against a broadcast station of which the frequency is known. For instance the 175 and 350 KC settings produce 4th and 2nd harmonics respectively at 700 KC, the frequency of WLW. On the BC band direct comparison with station frequencies is possible. Remember, though, that a 1 per cent oscillator may have a 10 KC error in calibration at 1,000 KC and still be within the rated accuracy.

By using a reference oscillator and receiver, short wave calibration can be easily checked. The reference oscillator is zero-beated with a broadcast station using the set as an audible indicator tuned to the BC station. If the BC station were on 1,000 kilocycles, harmonics will be produced at multiples of 1,000, namely 2,000, 3,000, 4,000, etc., to 25,000. Using the receiver, now tuned to the harmonics, the oscillator under test is then zero beated at each of these harmonics and the dial calibration checked. Starting at 2 megacycles and counting the harmonics, the serviceman can easily keep track of the harmonics. Also the calibration of the receiver dial can be used as a check—but do not place too much reliance on the receiver dial calibration.

Voltmeter calibration

Voltmeters are easily checked against one known to be good. A 400 volt power supply with a variable resistor will provide a means of checking the calibration over the whole scale. Remember that 2 per cent means that the maximum error does not exceed 2 per cent of the full scale reading. In other words a 100-volt range rated at 2 per cent may be off 2 volts for *any point on the scale*. A 2 volt deviation at 25 volts is allowable, even though it is 8 per cent of 25. When comparing the calibration of volt and milliammeters, they should be both connected in the circuit at the same time. (Remember that both meters may be in error—one plus, the other minus, so that the

apparent error may be as much as twice the actual.)

Milliammeters are checked similarly, but the units are placed in series instead of in parallel as were the voltmeters.

Ohmmeters can be checked against one known to be good. Different resistors are measured on the accurate instrument and a comparison made of the reading when the resistors are measured on the instrument being checked. Or if available, precision resistors (1 per cent) of known value may be used to check the ohmmeter.

Low-impedance tube voltmeters

Even though vacuum tube voltmeters are supposed to be capable of measurements at radio frequencies, some of the units are almost useless. High-capacity voltmeter leads detune tuned circuits, low input impedance of the unit, reduces the voltage to a point where measurement of it is meaningless. A quick check on the amount of detuning caused by a vacuum tube voltmeter can be easily checked by attaching the unit across the grid of an I. F. or R. F. amplifier and noting the amount the AVC voltage changes by watching the cathode ray tuning indicator. The greater the change in the AVC voltage, the poorer the unit is.

As a DC instrument the capacity in the leads of a vacuum tube voltmeter is inconsequential. However, some units have a resistor connected across the grid to the cathode. (Continued on page 60)

A few of the bad practices found in some of the cheap all-wave oscillators.

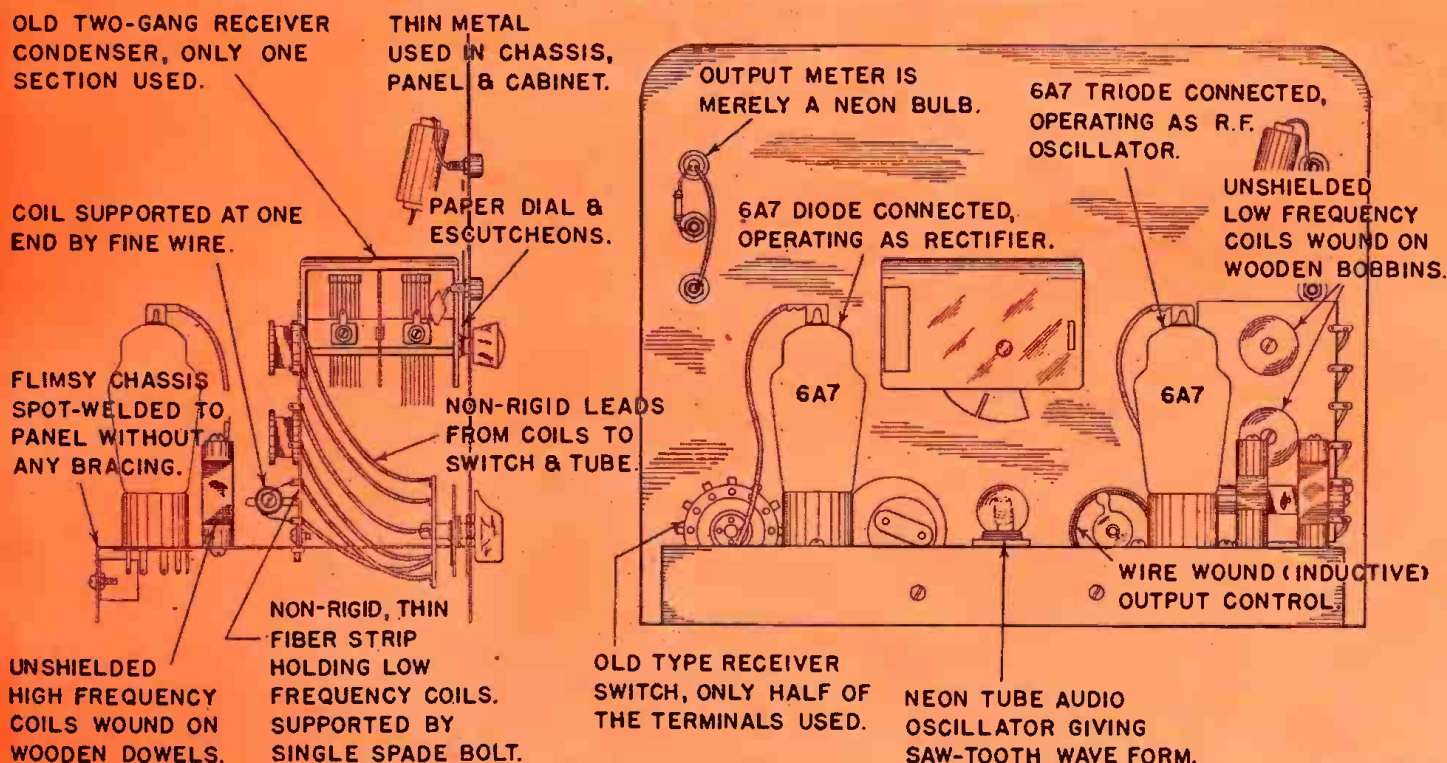

NEW THINGS

Latest news of radio products from the manufacturers



Heavy-duty resistors

★ Heavy-duty resistors with an improved coating. Superior operation under abnormal atmospheric conditions. 100 per cent greater life on accelerated salt solution immersion tests. New coating known as type C. Standard units still available with type A coating. International Resistance Co., 401 N. Broad St., Philadelphia, Pa.—**RADIO TODAY**—see also advt. p. 41.

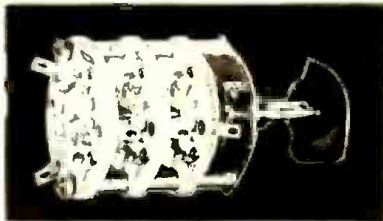

Low-loss switches

★ Complete line of selector switches with Isolantite insulator. Operate with DC potentials up to 1000 volts. Contacts will operate in transmittings rated up to 100 watts. Switches designed for use in amateur radio transmitters and in receivers where extremely low-losses are desirable. Centralab, 900 E. Keefe Ave., Milwaukee, Wis.—**RADIO TODAY**—see also advt. p. 52.



AC operated test oscillator

★ All-wave signal generator with fundamental output from 100-30,000 KC. in 6 bands. Scale length over 50 inches—accuracy of calibration 2 per cent. High R.F. output of 1

volt. Minimum signal of 2 microvolts. Internal 500 cycle oscillator for modulation and A.F. output of 8 volts. Jacks for frequency modulator and external A.F. modulator. Model 153—net \$29.95. RCA Mfg. Co., Cooper St., Camden, N. J.—**RADIO TODAY**.



Police auto radio converter

★ Short-wave converter for use with standard auto radio. Permits reception of police and other signals from 1500-2500 KC. Uses 2 metal tubes and has r.f. amplifier stage. High sensitivity and quiet operation. ABC Radio Labs., 3334 N. New Jersey St., Indianapolis, Ind.—**RADIO TODAY**—see also advt. p. 55.

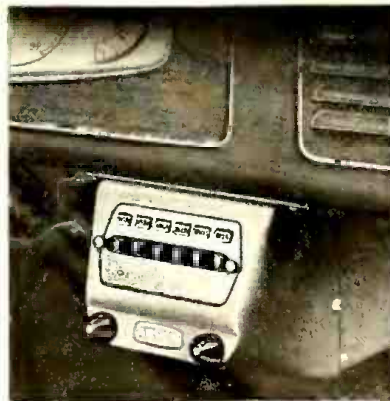

Arvin P.B. auto radio

★ 5-tube auto radio with 6-station direct control board push-button automatic tuning. Station variator control knob increases tuning range of set so that it is possible to get 2 additional stations on either side of each push-button setting. Also compensates for climatic conditions. Model 6—list \$24.95.

Push-button mechanism (electric) for models 22A, 32, 42 selecting 6 stations. Used with regular dial control. List \$17.95. Noblitt-Sparks Industries, Columbus, Ind.—**RADIO TODAY**—see also advt. p. 31.

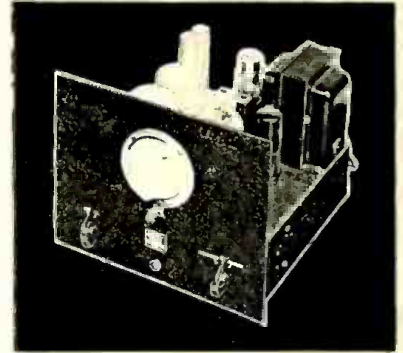

Meissner signal shifter

★ Electron-coupled oscillator and amplifier-doubler for providing variable frequency excitation for amateur transmitters. Ganged condenser provides accurate tracking over whole band. For operation on 10, 20, 40, 80, 160 meter bands. Vernier type dial for accurate calibration. Frequency unaffected by loading. Meissner Mfg. Co., 7th & Belmont. Mt. Carmel, Ill.—**RADIO TODAY**.



Oil burner ignition suppressors

★ Suppressor resistors for use with oil burners. Confines the radiation from the ignition system to a radius of a few inches around the oil burner. Made in 2 types. OB12 is a carbon resistor with brass caps receiving wires up to 1/8 inch diameter. OB14 is a 14,000 ohm wire wound unit designed for mounting on the transformer terminal. List \$1. Continental Carbon, Inc., 13900 Lorain Ave., Cleveland, Ohio—**RADIO TODAY**—see also advt. p. 45.

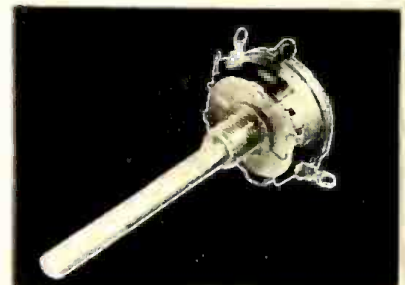

Midget radio controls

★ Compact composition-type volume controls with taps for tone compensation and units for auto radios. Tapped controls have ad-a-switch feature—will match any existing circuit requirement. Auto controls will service approximately 95 per cent of such receivers—switch can also be added. Clarostat Mfg. Co., Inc., 287 N. 6th St., Brooklyn, N. Y.—**RADIO TODAY**.



School sound system

★ Sound system designed for use in small schools. Will handle up to 16 rooms. All-wave radio tuner, master call and return speech. P.M. speakers with wall mounting baffles. Compact and low in cost. Model JS-118. Webster-Chicago, 5622 Bloomingdale Ave., Chicago, Ill.—RADIO TODAY—see also advt. p. 37.

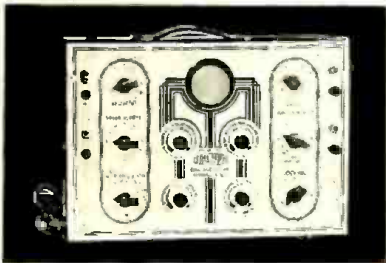

Oscillograph wobbulator

★ Oscillograph and frequency modulator using 2-inch tube. Scope has 10-45,000 cycle sweep and pattern locking control. Wobbulator employs an oscillator operating at 840 KC. synchronized to linear sweep circuit. Model 77-2. Triumph Mfg. Co., 1417 W. Lake St., Chicago, Ill.—RADIO TODAY.

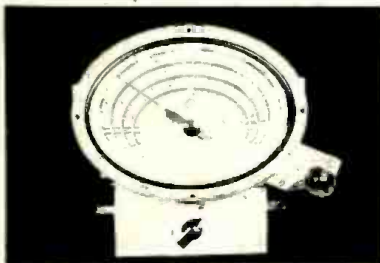

Short-wave receiver kit

★ All-wave receiver tuning 540-22,000 KC. Tuner unit (illustrated) is wired, aligned, and tracked at factory and requires practically no adjustments when incorporated into receiver. Set has phase inversion in audio system, band-pass link-circuit I.F. transformers. Browning 83. Browning Labs., Inc., 750 Main St., Winchester, Mass.—RADIO TODAY.

Silver-plated mica condenser

★ Mica capacitor designed especially for push button tuning. Capacity tolerance within 3 per cent, extremely high "Q" and excellent retrace. Temperature coefficient of plus .003/degree Centigrade. 100 volts DC test. Range 10 to 1100 mmfd. Encased in low-loss bakelite. Type 2R. Cornell-Dubilier Corp., S. Plainfield, N. J.—RADIO TODAY—see also advt. p. 4.

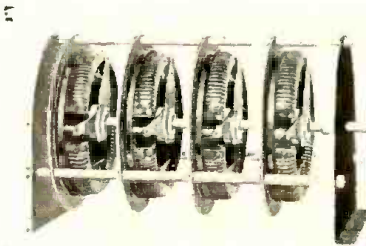

Tandem rheostat assembly

★ High-wattage tandem rheostats for circuits requiring simultaneous variation of more than 1 control. Universal couplings between units eliminate lost motion and permit easy positive operation. This special construction available for 300, 500, 1000 watt units. Standard tandem assemblies available for 25-watt and larger units. Ohmite Mfg. Co., 4835 Flournoy St., Chicago, Ill.—RADIO TODAY—see also advt. p. 55.



True-fidelity receiver kit

★ Band-pass tuned radio frequency receiver kit designed for high quality reception of strong broadcast signals. Kit includes all coils, variable condenser, dials, and chassis and panel. Uses standard transformers, condensers, etc. Available as a tuner unit or a complete receiver with push-pull 2A3 output tubes. Bulletin describing receiver may be had upon request. List for coils and variable condenser \$15. J. W. Miller Co., 5917 S. Main St., Los Angeles, Calif.—RADIO TODAY.

Vibrapowr auto vibrators

★ Complete line of replacement auto vibrators. Operates and starts on voltages from 3 to 8. Lower coil drain gives higher efficiency. Arnco iron pole piece. Tungsten contacts. Bakelite and mica insulation. Cadmium plated to prevent rust. Moulded rubber jacket sound proofs unit. Pauley-James Corp., 4619 Ravenswood Ave., Chicago, Ill.—RADIO TODAY.

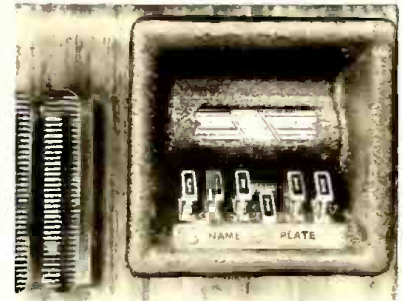

Franklin mechanical P.B. tuner

★ Mechanical type of push button tuner using no motor. Compact unit consists of sturdy frame mounting six or more stations selector buttons with a corresponding number of cams on a common drive shaft. Cable drive transmits cam shaft action to variable condenser. Positive action assures permanent accuracy. Complete information will be sent to radio set manufacturers upon request. A. W. Franklin Mfg., 175 Varick St., New York, N. Y.—RADIO TODAY.



Electro-Voice microphone

★ Double-button carbon microphone with internal shock absorber. Extremely low noise level. Combination locking stand and cable connector. Button current 3 to 20 mils. Black and chromium finish. Model 100. Electro-Voice Mfg. Co., 338 E. Colfax Ave., South Bend, Ind.—RADIO TODAY.

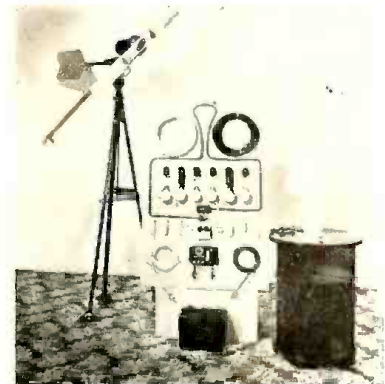

Wincharger lighting kit

★ 6-volt farm lighting outfit. Consists of a heavy-duty storage battery, wire, six electric lights, 2 wall outlets, table lamp, and deluxe Wincharger. Low cost of outfit permits sale to average farmer. Operating cost is 50 cents a year. Wincharger Corp., Sioux City, Iowa—RADIO TODAY.

MORE NEW THINGS

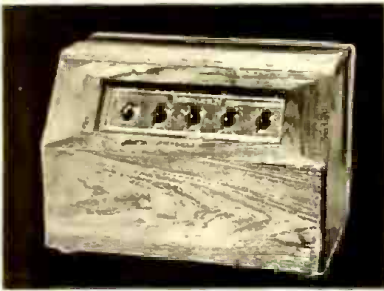

Thordarson amplifiers

★ Modernly styled amplifiers housed in walnut case with outputs from 8 to 60 watts. Controls protected by door with window—controls illuminated and easily seen. Units feature dual tone controls, inverse feedback, universal output impedances, and field supply current. Model T-20W25 with 25-watt output—list \$121.85 with tubes. Flat response within 1 DB from 35 to 15,000 cycles. Amplifier Div., Thordarson Electric Mfg. Co., 500 W. Huron St., Chicago, Ill.—RADIO TODAY—see also advt. p. 49.



Minicap tubular condensers

★ Dry electrolytic condensers of extremely small dimensions. Hermetically sealed in metal cans. Available in single-section types only—to avoid interaction between units. Available in 23 different stock sizes at 100, 150, 300, 450 volt ratings. Solar Mfg. Corp., 599 Broadway, New York, N. Y.—RADIO TODAY—see also advt. p. 63.

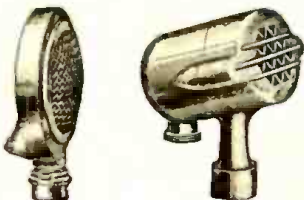

Crystal and dynamic mikes

★ Crystal type mike (left) with semi-directional characteristics. Cable plug at base of unit. Model B9 with 8-inch cable—list \$22.50.

Type D7T is an extremely small high-impedance dynamic microphone with output level of minus 55 DB. Also available in low impedance as model D7. 1½ inch diameter. Weigh only 8½ ounces. Complete with 12½ foot cable with plug. List \$22.50. American Microphone Co., 1915 S. Western Ave., Los Angeles, Calif.—RADIO TODAY—see also advt. p. 54.

DC sound amplifier

★ 10-watt amplifier kit using 25L6 tubes for DC operation. Gain of 139 DB makes it possible to use any type of microphone. Described in bulletin PA-15. Kit includes transformers and chassis. Jefferson Electric Co., Bellwood, Ill.—RADIO TODAY.

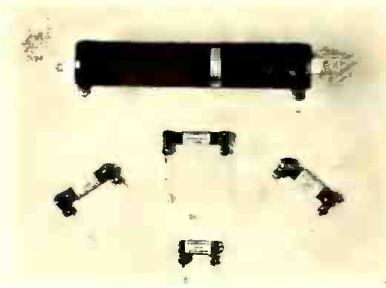

Lectrohm resistors

★ Wire-wound vitreous enameled resistors in sizes from 5 to 200 watts. Space-wound on low-loss ceramic forms with wire having low-temperature coefficient. Tolerances can be held as close as 1 per cent. Available in fixed, tapped, adjustable types with pig-tail or soldering lug terminals. 5-watt unit measures 5/16 diameter by 1 inch. 200-watt unit is 1½ diameter by 12 inches. Lectrohm, Inc., 5133 W. 25th Place, Cicero, Ill.—RADIO TODAY.

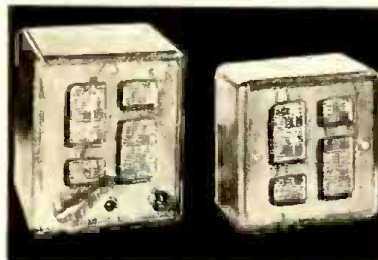

Communi-Call interphone

★ Wired-type of loudspeaking intercommunicating systems. 2-station unit illustrated. Operates on AC or DC. Equipped with 50 feet of interconnecting cable. Volume control and talk switch on master unit. Model 100—list \$25 complete. Multiple station systems also available. Chicago Sound Systems Co., 160 E. Illinois St., Chicago, Ill.—RADIO TODAY.

Headphone kit

★ Kit for making possible the use of headphones with all recent Stromberg-Carlson sets. Kit includes matching transformer, volume control, headphones, plug and jack. Stromberg-Carlson Telephone Mfg. Co., 100 Carlson Rd., Rochester, N. Y.—RADIO TODAY.

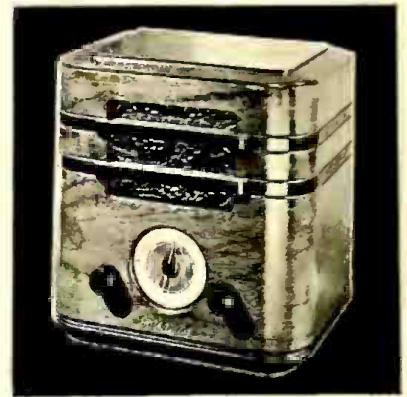

RCA table type receivers

★ 4-tube AC-DC tuned R.F. set covering 530-1800 KC. Clock type dial—metal tubes. 1½ watts output—dynamic speaker. Walnut-finished cabinet—8¼ x 8½ x 5¾ inches. Model 94-X—list \$14.95.



7-tube dual-band superhet tuning 530-1720, 2300-22,000 KC. Straight-line dial—magic eye tuning indicator. Power output of 4 watts. 20:1 vernier dial. Variable tone control. Automatic tone compensation. Iron-core I.F. transformers. Model 87-T-1—list \$49.95. RCA Mfg. Co., Front and Cooper Sts., Camden, N. J.—RADIO TODAY—see also advt. p. 2.



Amperite compact mike

★ Velocity microphone featuring small size. Size of head is only 1¼ x 2¾ x 1¾ inches. Frequency response with 2 DB from 60-7500 cycles. Complete with output transformer, cable connector and switch. Output level minus 70 DB (open line). Case of molded rubber with chrome trim. High-impedance model ACH, low-impedance model ACL—list \$25 with 25-foot cable. Amperite Co., 561 Broadway, New York, N. Y.—RADIO TODAY—see also advt. p. 35.

Spectacular

NEW BELMONT AUTO RADIOS

WITH THE

Completely Automatic
BEL-MONITOR
Tuning

**NO TRIMMERS—KEYS ADJUSTED BY
THE AUTO OWNER WITHOUT TOOLS!**

Exclusive features make these new auto radios the most saleable the country has ever seen. Imagine six-station automatic tuning that *anyone* can adjust in three minutes without tools! And the visual dial changes with the key.

And they are beautiful—Model 677, the 6-tube de luxe model (mounted with one bolt, by the way) is finished in color with the tuner in grained walnut. Contains 8 tuned circuits, a beam-power tube, and an 8-inch dynamic speaker. No mechanical connections between the two units—and only *one cable* for electrical connections. No tubes in tuning head.

Model 577 is a 5-tube one unit model with every sales feature you ever heard of—including BEL-MONITOR automatic tuning.

Like all BELMONT receivers they are **PRICED TO SELL!**

If you intend to do an auto-set business this Spring, write the factory for full details!



5-TUBE A-C SUPER

This beautiful model 526 A-C superheterodyne bakelite table set sells in the lowest price bracket, yet it is fully equipped with built-in BEL-MONITOR automatic tuning! Write for details.



Patents Pending

BELMONT RADIO CORPORATION
General Offices: 1257 Fullerton Ave., Chicago



MORE NEW THINGS



Record player

★ Attachment for playing records through radio set or an amplifier. High-impedance magnetic pick-up. Self-starting synchronous motor. 8-inch turntable accommodating 10 and 12-inch records. Operates on 110 AC, 60 cycles only. Solid walnut cabinet. Model PB Jr.—list \$19.95. Sonora Electric Phonograph Corp., 132 W. 22nd St., New York, N. Y.—RADIO TODAY.

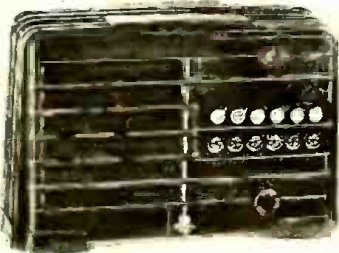

Miracle tuning Emerson

★ 5-tube AC operated superhet with push-button tuning for 6 stations. Push buttons easily set up from the front. 6½-inch speaker—automatic volume control. Output of 3 watts. Model BE-198 in walnut bakelite cabinet—list \$19.95. In ivory—list \$25.95. Emerson Radio & Phonograph Corp., 111 Eighth Ave., New York, N. Y.—RADIO TODAY.



Yaxley switch

★ Multiple push-button switch for interphones, push-button tuners, telephone systems, frequency selectors, set analyzers, tube checkers, meter switching, etc. Silver-plated contacts. Sliding, wiping contact

motion. Pushing any button automatically releases the button which has previously been depressed. One type designed for circuit closing operations, other for circuit transfers. P. R. Mallory & Co., Ind., Indianapolis, Ind.—RADIO TODAY—see also advt. p. 1.

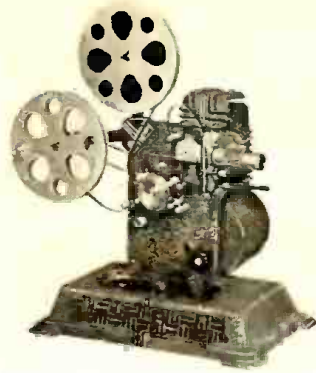

Irwin 8 mm projector

★ AC-DC type movie projector for 8 mm film. Single film feed sprocket which maintains proper loops at all times. All controls on one side. Solid cast construction. Fan type shutter, 200 foot capacity. Forced draft ventilation. Hi-speed motor re-wind. Tilting device—quick framing device. Finished in brown and chromium. Zephyr 8—list \$18.95. Irwin Corp., 27 W. 20th St., New York, N. Y.—RADIO TODAY.

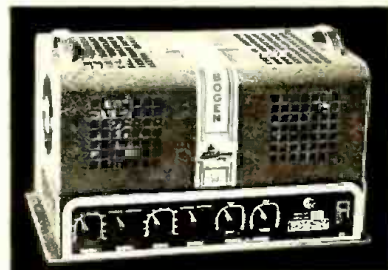

High-gain amplifier

★ 18-watt power amplifier with electronic bass and treble tone controls. 2 mike input channels and 2 phono inputs. Tapped output transformer. High impedance mike input. Peak output of 25 watts. Model CX-18—list \$72.50 less tubes. David Bogen Co., 663 Broadway, New York, N. Y.—RADIO TODAY—see also advt. p. 59.

Electric shaver filter

★ Noise-eliminating filter to be used with electric shavers. Filter unit simply plugs into the power line and the shaver plugs into the filter. Philco Radio & Television Corp., Tioga & C Sts., Philadelphia, Pa.—RADIO TODAY.



Col-Mar auto aerial

★ Telescoping type auto antenna that drops out of sight when not used. Vacuum suction raises and lowers the rod. Circle inset shows appearance when aerial is not in use. . . Just touch a button and up it goes. Requires only short lead-in to radio. Brass alloy rod chrome plated. Bakelite insulation. Pioneer Specialty Co., 521 St. Jean Ave., Detroit, Mich.—RADIO TODAY.

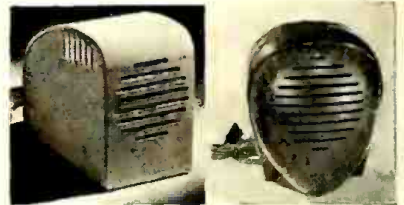

Zenith radio nurse

★ Carrier-type one-way communication device. Guardian ear is placed in room from which reception is desired. Device merely plugged into electric outlet—no connecting wires. Voice unit plugged into power line picks up all sounds in the room with the ear unit. Ear and voice units may be moved around as desired and will operate anywhere in the home. List per pair—\$29.95. Zenith Radio Corp., 6001 Dickens Ave., Chicago, Ill.—RADIO TODAY.



Electric phonograph

★ AC operated electric phonograph with 6-watt amplifier. High-fidelity crystal pick-up. Push-pull output tubes—dynamic speaker. Constant-speed motor. Plays 10 and 12-inch records. Tone compensation circuit. Walnut cabinet. Ramco model 106—list \$75. Regal Amplifier Mfg. Corp., 14 W. 17th St., New York, N. Y.—RADIO TODAY—see also advt. p. 56.



METAL TUBES? THEY MAKE A RADIO MODERN!

Yes—and CUNNINGHAM METAL TUBES are the service man's special—designed, engineered and manufactured expressly for him!

Metal Tubes offer EXTRA advantages. Some of these "extras" include:

1. The elimination of noises arising from external tube shielding—and you can prove this with a demonstration.
2. They assure better performance because of perfect self shielding.
3. Sturdier construction that makes them "vibration proof."
4. They're easier to change.

Besides, Metal Tubes offer many other *proofs* of merit—all summed up in this statement: They make a radio *modern* because they give *modern* performance.



Over 90,000,000 Cunningham Radio Tubes have been sold for replacement service work.

A PRODUCT OF THE RCA MANUFACTURING COMPANY

Free! \$500.00 worth of RCA Test Equipment

For full details and entry blanks, see the March issue of RCA Radio Service News... a local Cunningham distributor... or write to the "Modernization Contest Editor," RCA Manufacturing Co., Inc., Camden, N. J.



Cunningham Radio Tubes

STANDARD SINCE 1915

MORE NEW THINGS



Radiart auto antennas

★ Complete line of auto antennas made of non-rusting material with durable plating. High quality insulation and lead-ins. Zephyr type R7 illustrated at top—list \$3.95. Speedline type R5 at bottom lists for \$4.95. Radiart Corp., Cleveland, Ohio—RADIO TODAY.—see also advt. p. 50.

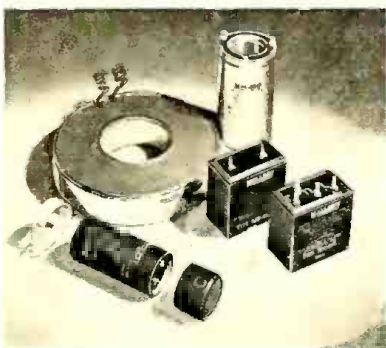

Motor capacitor replacements

★ Complete line of capacitors for motor starting, consisting of 106 units, of which only 22 are required to serve 90 per cent of the field applications. Nine universal replacements may be used in a wide variety of application, although they do not duplicate the physical appearance. P. R. Mallory & Co., Indianapolis, Ind.—RADIO TODAY—see also advt. p. 1.



Antenna-power extension

★ Flat woven cable for antenna and power connections. Provides neat connection to chairside type radios. Five wires used—two for power, two for antenna, and one for ground connection. Plugs into standard power receptacle—antenna

connections on face of plug. Available in 7, 10, 14 foot lengths. 10 foot cord code 510WFCA—list \$3. Alden Products Co., 715 Center St., Brockton, Mass.—RADIO TODAY.

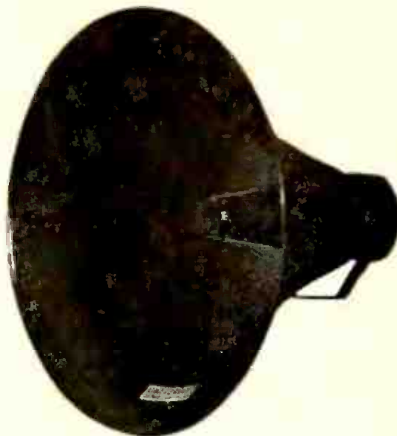

Trumpet speaker

★ Air column speaker with internal folding to save space. Equivalent to a 3½-foot exponential horned—length reduce to less than one half. P.M. dynamic unit capable of handling 25 watts. Horn made of aluminum and weighs 4 pounds exclusive of speaker unit. University Labs., 191 Canal St., New York, N. Y.—RADIO TODAY.



Radio chair

★ Stuffed chair or sofa with radio set built into the arm. Hinged lid covers set when not in use. Standard table type radio set fits into special compartment. Diamona Parlor Furniture Co., 76 Traverse St., Boston, Mass.—RADIO TODAY.

Telegraph recorder

★ Tape type recorder for code signals. Operates at speeds up to 200 words per minute. Band pass filter for recording through interference—low pass filter for weak signals when noise level is high. Housed in crackle finished aluminum cabinet. Universal Signal Appliances, 64 W. 22nd St., New York, N. Y.—RADIO TODAY.



Mycalex insulation

★ Radio parts using leadless Mycalex for insulation. Available in all sizes and shapes for high frequency equipment. Illustrated is a tube socket using Mycalex. Light weight especially desirable in aircraft equipment. High mechanical strength. Withstand high voltages and not damaged by temporary flash overs. Can be machined and held to same tolerances as metal. Electronic Mechanics, Inc., 201 E. 12th St., New York, N. Y.—RADIO TODAY.



Grebe T.R.F. set

★ 5-tube AC-DC tuned radio frequency table radio. Beam power output tubes. Tunes broadcast band. Special model available with 835-2,050 meter band. Comes in black, ivory, walnut, green and red. Challenger 5. Grebe Mfg. Co., 119 Fourth Ave., New York, N. Y.—RADIO TODAY.



Television components

★ Complete line of transformers and deflecting yokes for cathode ray television. Magnetic deflection yoke available constructed to provide maximum amplitude and minimum defocussing control. Transformer coupled to amplifier tubes. Type T700 yoke illustrated—list \$12. Kenyon Transformer Co., Inc., 840 Barry St., New York, N. Y.—RADIO TODAY.

NEW LOW-PRICED ARVIN CAR RADIO WITH Push-Button Tuning

MODEL 6 • COMPLETE

\$24.95
LIST



SIX-STATION DIRECT
CONTROL BOARD
WITH AUTOMATIC
PUSH-BUTTON TUNING

STATION
VARIATOR
EXPANDS TUNING
RANGE

**No Dial to Watch
... No Need to Take
Eyes Off Road... It's
All Tuned by Touch**

Just push a button and tune in any one of 6 favorite stations automatically...

Station settings are easy to make or change for any locality. Simply remove front panel plate and set condenser screws for peak reception of stations.

A slight turn of this knob, to left or right, gets two to four additional stations at each push-button setting, when driving within their receiving range.

Example: automatic setting, WLW, 700 kc. Turn left: WOR, 710 kc.; WGN, 720 kc. Turn right: CFRB, 690 kc.; WPTF, 680 kc.

● This new Arvin Model 6 is a powerful car radio with 5 tubes that do the work of 7. It has exceptional station-getting ability and fine selectivity. In fact, its all-over performance is equal to or better than many higher-priced sets with an extra tube and dial tuning. This is all due to the Arvin fixed condenser circuit which permits each push-button setting to be balanced perfectly for maximum station reception. Dynamic speaker in specially designed radio case provides fine tone quality. Sloping direct control board is at convenient angle under instrument panel. Easy installation in car. Special aerial, \$2.50 list. Order from your jobber. Noblitt-Sparks Industries, Inc., Columbus, Indiana.

**THE CONVENIENCE AND SAFETY OF PUSH-BUTTON TUNING PLUS
THE FLEXIBILITY OF DIAL TUNING... ALL DONE BY TOUCH**



Here is the "Guardian Ear" unit of Zenith's new wireless "Radio Nurse." Plugged into the nearest outlet, it reports everything to "voice" unit in another room.

INTER-PHONES AND RADIO

A Team for Spring Merchandising

★ THE March-April season finds radio and intercommunication nicely paired for dealer promotion.

The public has had time to identify the radio store as the sales and service headquarters for the inter-phones. Manufacturers of the 'phones have branched into many fields—from the nursery to industrial plants, and have spent millions of dollars to present this equipment as "popular communication" having a vital place in modern life. The device is pretty well established as a necessity in offices, stores, factories, hotels, hospitals, schools and in private homes.

Recently the inter-phones have been advertised and demonstrated on national networks and have appeared widely in popular magazines. This promotion has accentuated the use of the systems in homes, and therefore has a terrific effect on the industry.

Prospects convinced

After all, office workers, industrial employees, all persons involved in any type of business live in homes. And if in these homes they get an introduction to the simpler types of inter-phones, they will see the possible applications in their various lines of business. Thus all income levels will be blanketed with an understanding of the value and the need of such communication.

All this took place just as the warmer months began to arrive, so that outside sales work can flourish all over again. Leg-work becomes pleasant and profitable.

Lease ownership plan

The Radiofone company has introduced a plan which permits the dealer's representative "to sell equipment on the same basis as a telephone installation, water cooler installation, or air-conditioning installation thereby increasing the number of calls in a working day." The company now suggests that an ordinary salesman may now call upon a prospect with only a circular and a form of lease ownership contract. Radiofone took this step because, where the actual equipment was carried along and a demonstration staged, it was necessary to employ extremely high-salaried salesmen.

This company explains that "the prospect should be approached on the basis of his need for intercommunication service and the offer to install Radiofone equipment on a lease ownership basis will not meet any resistance. It should be pointed out that, unlike the rental of telephones, etc., the amount of money paid monthly on the lease basis applies toward complete ownership by the customer after a 20-month period

The customer, if he so desires, has the privilege of purchasing the equipment at any time during the 20-month period, at prices fixed by you to meet varying conditions."

Radio nurse

With the introduction of its one-way communication device known as the "Radio Nurse" the Zenith company goes to town with the idea of safety and convenience in homes where children or invalids need a simple and dependable and portable connection with their keepers.

The Nurse has annexed itself a series of dramatic sales points which will register effectively in many homes. In any domestic situation where it is important that persons in one room know what is going on in another room, a demonstration of the highly sensitive device will be appropriate. Engineered to meet a definite need, and priced within the reach of most prospects, the Nurse starts out on a promising career.

'Phones back stage

A likely spot to sell good-sized installations is in the local theater, according to incidents in Philadelphia reported by Phileo. The call-boy has been replaced by Philco-Phones in the Locust theater in that city, with excellent success.

In this case "the master unit of the system was placed behind the set for the stage manager of the company. The remote speaking units were placed in dressing-rooms on the first, second, third and fourth floors and another unit was placed in the box office, connecting that point directly with back-stage.

"This makes possible simultaneous curtain calls to dressing rooms on all floors. It also eliminates the function of the call-boy whose job it was to climb the many flights of stairs many times before curtain time. As it also provides communication with one of any desired number of units, the system allows the stage manager to speak in privacy with the occupant of a dressing room as well as issue calls."

Elevator market

The use of inter-phones in elevators, which has been developed mainly by David Bogen Co., has pointed to a new and important market for special installations. Because of the large number of elevators in the country for which the equipment has not even been suggested, the possibilities are great.

They're "TOPS" in Quality

— thanks to Sylvania's strict "no repair" policy.



Every tube that leaves the Sylvania factory is "tops" in quality — you can be sure of that.

For Sylvania's famous "no repair" policy—inaugurated a few years ago—calls for the *complete destruction* of every tube that does not satisfactorily pass scores of tests for quality and performance.

This policy — unique with Sylvania—is positive insurance of top-quality tubes . . . *your* guarantee of pleased tube customers, repeat sales.

SYLVANIA

SET-TESTED RADIO TUBES

HYGRADE SYLVANIA CORPORATION ALSO MANUFACTURES THE FAMOUS HYGRADE LAMP BULBS.



SOUND SALES START UP IN MARCH

★ As shown by the chart, based on records of previous years, it is in March that sound sales start climbing, in preparation for outdoor "public address" activity. The graph above indicates the seasonal buying of sound equipment by dealers, illustrating how the peak of the sound year comes with the advent of good outdoor weather.

Signalizing this renewal of sound-equipment activity, the April issue of RADIO TODAY will contain a special section on Selling Sound. This will be a complete selling and buying aid for the sound specialist and for radio men who are interested in entering this growing field. Sound applications, installations and equipment

will be described in detail, and there will be full reports on successful selling and servicing methods that have landed PA business at a profit.

PROSPECTS EVERYWHERE

★ Within easy reach of the gentleman on the front cover of this issue of RADIO TODAY are a number of "sound" prospects which will stand a re-check.

Assuming that the gent lives in a town of average size, and whether he uses a map or not, he can count on substantial sound sales and service possibilities in the town hall, the bus terminal, two or three churches, the hotel, the ball park, several schools and their associated playgrounds and gymnasiums, as well as a series of talking signs and window demonstrations.

In line with the revived interest in intercommunicating systems, the dealer may count on a good reception in offices, manufacturing plants, drug stores, restaurants and lunch counters, department and variety stores, the undertaker, and a couple of shoe stores. All these in addition to the countless opportunities in the residential sections of the town.

HOT DAYS NEED "P.A."

★ The ballroom of a hotel in an Atlantic seaboard city had been selected for an important sales meeting. About two hundred persons gathered and the moderate size of the group, together with the excellent acoustics of the room, led the opening speaker to the natural assumption that he could get along very well without the "mike." But the day being excessively warm, the hotel management had set up half a dozen fans in the rear of the ballroom in an effort to keep a circulation of air during the lengthy meeting. The speaker, therefore, was working against a noise level he had not anticipated.

After three minutes of general cupping of hands to ears and of whispered "What did he say?" to next seat neighbors while the speaker perspired and shouted—the audience rose as one and demanded, "Use the mike." The speaker accepted the request—dropped his voice to normal conversational tone—continued his presentation easily and naturally. The audience listened comfortably—concentrating its attention on the business at hand, not on its inability to hear—and pronounced the meeting the most successful in years. The individual members of the audience went home to their communities and territories thoroughly convinced on one point—no meeting, large or small, can be efficiently conducted without a sound reinforcing system.

CHAPERONING WITH SOUND

★ Another use for outdoor "sound" installations is suggested by an item in the Atlanta (Ga.) *Constitution*.

At the local Hollywood Cemetery each night, reports the *Constitution*, two churchmen station themselves with megaphones to scare away petting parties.

Just as the boy friend says to the girl, "Let's have another little drink, honey," comes the strident admonition from the darkness: "The eyes of the Lord are in every place, beholding the evil and the good." In most cases this puts a sudden stop to the exchange of pleasantries and in a few seconds the car moves on.

(To page 36)



The sound business is afire these days. This RCA equipment was altogether successful at a recent blaze in Chicago and the idea catches on all over the country. Raymond Rosen & Co., Philadelphia jobbers, feature it locally.

AMPERITE

offers
"ADJUSTABLE RESPONSE"
 (HIGHER OR LOWER PITCH WITH THE SAME MICROPHONE)

... made possible by
THE ACOUSTIC COMPENSATOR

(pat. pend.)

Here is an improvement of great value at no extra cost! Exclusive with Amperite, the Acoustic Compensator gives you these advantages:

- (1) With the flip of a finger, you can now lower or raise the response of the microphone—without introducing any peaks or other undesirable effects. (Not a volume control. Gradually changes operation of the microphone from constant velocity to constant pressure.)
- (2) Permits adjustment of the microphone for most desirable response for close talking or distant pickup.
- (3) Makes the system immediately adjustable to any "taste," room condition, or equipment.

MODELS RBMR, RBMk. with Acoustic Compensator: Frequency range 40 to 11000 CPS. Output, -65 db. Complete with switch, cable connector and 25' of cable . . . \$42.00 LIST. Chrome, \$43.00 LIST.
 MODELS RBHn, RBMn. without acoustic compensator, \$42.00 LIST

IMPROVES ANY "LOW-COST" INSTALLATION ON 4 COUNTS!

P. A. Men, you can improve those "price" jobs by using the popular Amperite Model RAH (or RAL). You will get better results because (1) it is excellent for both speech and music; (2) has flat response without undesirable peaks; (3) reduces feedback; (4) stands up under rough handling, changes in temperature, pressure or humidity. . . . Frequency range 60 to 7500 cps. Output, -68 db.

MODEL RAH (Hi-imp.) with 12' of cable; MODEL RAL (200 ohms) with 8' of cable. . . . ONLY \$22.00 LIST

NEW LOW-PRICED CONTACT MICROPHONE . . . \$12.00 LIST

The success of our Model KTH (\$22.00 List) has created a demand for a popular-priced Amperite Contact Microphone. The new model listed below can be used on most radio sets made since 1935 and on all P.A. systems. It "makes an ordinary violin sound like a Strad" . . . gives a small piano the tone of a Grand. And yet, there is no distortion. No unnatural effects. No "fingering noises." Installation is simple . . . no changes in strings or instruments . . . attached without tools.

Operates with either high or low gain amplifiers. Has frequency response of 40 to 9000 cps. Output, -40 db. 20' of cable.

MODEL SKH (Hi-imp); SKL (200 ohms) \$12.00 LIST
 SKH or SKL with foot-operated volume control \$20.00 LIST
 Professional Model KTH (or KTL) \$22.00 LIST

"TOPS IN MIKES"

Station KVOL, of Lafayette, La., writes us, unsolicited: ". . . the Amperite mikes have been in service here for almost three years, and have proven themselves to be 'tops' in mikes. They have broadcast in the rain and in the hot sun. They have even been dropped, but they always came through in fine shape . . ." The Amperite Studio Velocity Model SR80n now has -56 db output. Frequency range 40 to 15000 cps. Triple shielded, fitted with switch, (optional), cable connector, and 25' of cable.
 MODEL SR80n (200 ohms): \$80.00 LIST
 MODEL SR80Hn (Hi-imp.). . . \$80.00 LIST

Sales Aids for the P. A. Man Amperite offers the following co-operation to P.A. Men.

- (1) FREE Window Decal advertising your Sound Service. Size 5 1/4 x 9 1/4, finished in 4 striking colors.
- (2) FREE Window Display, 11 x 17.
- (3) Special Sound Equipment Letterheads. Samples and prices on request.
- (4) FREE use of cut for printing business cards, etc.

Write for these valuable sales helps, and new Illustrated Bulletins, today!

AMPERITE Co. 561 BROADWAY, N. Y. U. S. A. CABLE ADDRESS ALKEM, NEW YORK



VELOCITY

AMPERITE

MICROPHONES

SELLING SOUND

MISSIONARY IN CHINA TRAVELS WITH SOUND

★ Further news about the development of public address equipment as an aid to travelling missionaries comes from Central China. Father Christopher Sullivan, representing the Catholic Mission there, has outfitted his mission car with Webster-Chicago mobile speaker equipment. The Father has special duties at present, filling the needs of the refugees from the war-torn sections of the country.

In this case, the altar in the trailer is revealed by opening a section of the

side of the car. This lowered section forms a platform, and two carpeted steps are used at its edge. Turret projectors containing the speakers are used at the right and at the left of the altar.

SOUND HELPS SHIPS DOCK

★ Bigger and better passenger ships have presented a tremendous problem in docking. Even the average and smaller vessels have long been handicapped by the limited acoustical power of the human voice aided by a megaphone. Equipment which can stand the gaff of salt atmosphere should find a very useful purpose in transmitting instructions for handling the fore and after lines.

RECORDERS CLICK FOR DEALER

★ A new flourish in business has been stirred up at Wurlitzer's in New York City. The store started a promotion on recording machines and got such a lively reaction that the whole staff is smiling over the stunt.

The recorders were displayed in windows and modestly advertised in local newspapers. Mail pieces went out to selected lists. The parade to the store was started by vocalists, instrumentalists, musical arrangers, composers, etc., and scores of non-professional persons interested in singing or speaking were also attracted.

People get such a kick out of having their own efforts recorded and "played back," that the equipment is dead easy to advertise and demonstrate. Most folks suspect themselves

of having hidden talent in their voices anyway. Some are anxious to find out how they sound "on the air," some are seeking novelty gadgets for home entertainment, some want records of rehearsals, and others are just training their voices or getting acquainted with a mike.

Under the direction of department head Alfred C. Tuftery, the store centers the activity in a small room inexpensively lined with curtains. Presto equipment is being featured. The store also records and sells personal records from 50c and up, which the customers make for greeting cards, auditions, and for all sorts of stunts in voice production.

Wurlitzer's find that the recorder business naturally stimulates the sale of record players, hikes store traffic, and makes many valuable acquaintances in the musical world.

as well as the gangplanks for both arrivals and departures.

If the loudspeaker mountings are made flexible the same equipment may be made to serve a useful purpose in speeding up the loading and unloading of the ship's cargo. This is particularly important today, as the advent of oil burners has eliminated the lay-overs for coaling. The large investment in ships automatically necessitates the shortest possible time in port, since floating stock has no earning power except at sea. Successful ship operators view with decided favor any proposals which will speed up their port operations.

AMPLIFIED GONG

★ At Severance Hall in Cleveland, which is the home of the Cleveland Orchestra, a special sound installation has been engineered to employ a Deagan gong for three purposes: as the tone used by the orchestra for tuning their instruments, to call members of the orchestra to their places, and to signal the audience into the auditorium.

An orchestra official, Adella Prentiss Hughes, says that "because the 440A is a beautiful sound as well as the note to which all instruments of an orchestra are tuned and because chime gongs for audience calls became so common, I took the problem to A. L. Williams, president of the Brush Development Co."

Gong, microphone and amplifying system are located in the basement. The system includes 15 crystal speaker outlets, so that orchestra members on the lower floor, the foyers, promenade balcony and the office, may hear, and tune their instruments before they go to the stage.

LAMP POSTS LEARN TO TALK

★ The military experts in England are "thinking of everything" in their preparation for possible war. One of their recent problems was how to guide police and military motor vehicles along the city streets when all lights are out, in anticipation of an air raid. According to Dr. E. E. Free, New York scientist, recent experiments indicate that "talking lamp posts" may be the answer.

During air-raid "blackouts," motor vehicles are able to keep on roadways if the curbs are painted white, but it is difficult to identify cross streets. The suggestion is that corner lamp posts be equipped with loudspeakers and electric phonographs repeating softly but continually the names of the intersecting streets.



A section of the window display at Wurlitzer's, NYC, featuring recorders.

SELLING RECORDS

RECORD SOCIETY

★ A brand new stimulation for the sale of records is the formation of the Victor Record Society, recently announced by Thomas F. Joyce, RCA advertising manager. The plan is designed to hike the number of record-players in use, to attract new fans, and to garner extra profits for the dealer. Details were worked out after extensive experiments in ten different U. S. cities.

To join, a customer pays \$6 membership fee and buys \$9 worth of Victor records of his selection. He gets a new record-player which plays through his radio, ordinarily costing \$14.95. He also gets a monthly Society review, in addition to the booklet, "The Music America Loves Best," and correspondence privileges with the RCA music director. The Society plan is supported by a terrific advertising campaign.

If the customer buys \$60 worth of Victor records, at the rate of not less than \$1 worth per week, he is eligible to receive a dividend of \$1.50 in discs of his choice for each \$15 of accumulated purchases, up to \$60.

For the dealer, the plan results in a normal cut from the membership fees, and the virtual insurance of a \$60 additional volume from most of the Society members.

WAX WORTH WATCHING

★ **FREDDY MARTIN** and his orchestra playing Mammy Bong with vocal refrain by the Martin-Aires Trio and My Day, with vocal by Elmer Feldcamp—Bluebird B7420.

BUNNY BERIGAN and his orchestra playing Outside of Paradise from the Republic film of the same name, and A Serenade to the Stars from the Universal film "Mad About Music," both with vocal by Gail Keese—Victor 25781.

LOUIS ARMSTRONG and his orchestra playing Let That Be a Lesson to You, from Warner Bros.' "Hollywood Hotel" with VC by Armstrong and Struttin' With Some Barbecue—Decca 1661.

FREDDIE RICH and his orchestra playing Whistle While You Work and I'm Wishing, both from the Walt Disney feature "Snow White," both with VC by The Clubmen—Decca 1631.

BOB SYLVESTER and his orchestra playing I See Your Face Before Me from "Between the Devil" and Down Where the Trade Winds Blow from "Hawaii Calls," both with VC by Olga Vernon—Vocalion 3946.

RUSS MORGAN playing Home Town with VC by Jimmy Lewis and Moonlight on the Sunset Trail with VC by Russ Morgan—Brunswick 8066.

HORACE HEIDT and his Brigadiers playing Ti-Pi-Tin, with VC by Lysbeth Hughes, Larry Cotton, The Kings and Glee Club and A Shack in the Back of the Hills, with VC by Larry Cotton—Brunswick 8078.

RAY NOBLE and his orchestra playing The Moon of Manakora from "The Hurricane" and I Hadn't Anyone 'Till Now, both with VC by Tony Martin—Brunswick 8079.

JERRY BLAINE and his Streamline Rhythm playing Ti-Pi-Tin with VC by Phyllis Kenny and Streamline Trio and Prove It, with VC by Phyllis Kenny—Bluebird B7448.

GUY LOMBARDO and his Royal Canadians playing Ti-Pi-Tin, with VC by male trio, and Let's Sail to Dreamland, with VC by Carmen Lombardo—Victor 25786.



announcing MULTI-STAGE INVERSE FEED-BACK

In
Model 2L-25



PARTICULARLY ADAPTED TO CRITICAL INSTALLATIONS

Another big improvement in tone quality by Webster-Chicago . . . Beam type circuit, using Multi-stage Inverse Feed-Back.

Model 2L-25 Amplifier, Underwriters' Laboratories Approved, marks another milestone in the tone history of Sound. Just listen to it at your distributors and make your own comparisons. Distortion is kept to 2½% at 25 watts. The frequency characteristic is plus or minus 1½ d.b. from 50 to 10,000 cycles. Multi-Stage Degeneration. From these unusual values it can be easily appreciated that Model 2L-25 is particularly adaptable to the most critical installations, (where crowds do not exceed 4,000). Economically priced.

- 4 Stage, 7-Tube Beam Circuit
- 2 High Gain Inputs
- Electronic Mixing Circuit
- Multi-Stage Degeneration
- Underwriters' Laboratories Approved

WEBSTER-CHICAGO

**LICENSED
UNDER
ALL
IMPORTANT
PATENTS**

WEBSTER-CHICAGO

Section M-9, 5622 Bloomingdale Ave., Chicago, Ill.

Send me more information on Model 2L-25
 General Catalog

Name

Address

City..... State.....

DYNAMIC TESTING GETS EXPERTS' "OK"

Servicemen, jobbers, and manufacturers acclaim
Radio Today's new method of radio servicing

★ At a recent meeting of the N. Y. Chapter of the Radio Servicemen of America, RADIO TODAY's Service Editor, Vinton K. Ulrich pointed out that Dynamic Servicing is not merely gain-testing or stage-by-stage testing, although it does make use of those test principles.

Dynamic Servicing goes much further than to locate the defective stage. The procedure now being developed by RADIO TODAY will enable the serviceman to spot the exact difficulty in a defective stage. (Naturally if the stage is completely dead, it cannot be analyzed dynamically—but since such a state of affairs indicates something radically out of order, the trouble can be found without difficulty using ordinary test methods.)

Locating troubles by dynamic analysis is the co-ordination of many methods of many engineers—and RADIO TODAY for the first time is organizing the various ideas, simplifying them and putting them into a simple procedure that will save the serviceman much time in repairing radio sets.

Visual or aural analysis

In order to make dynamic servicing the simplest form of radio testing, whether or not an oscilloscope is used, RADIO TODAY is now conducting a series of tests which will aid in developing the specific test procedure to be employed in each stage. Future articles in RADIO TODAY will give complete details of how to employ dynamic testing in every day radio work.

Letters from radio set manufacturers indicate that they are in favor of dynamic servicing and consequently it can be assumed that as the procedure is developed, service notes will contain the essential data for dynamic testing. A few of the comments follow:

Service Manager, G. H. Glassman of Fairbanks, Morse & Co. states, "To my way of thinking, Mr. Ulrich's so-called *Dynamic Testing is the most practical method of testing a radio receiver, when we consider the matter from an all-round standpoint.*" I might go so far as to say that I believe, in a measure, it is used by all servicemen. This statement must be qualified, however, in view of the fact that heretofore to the best of my knowledge no definite procedure has ever been set up and I doubt very much if any servicemen has a definite procedure when making such a check. Further, I do not believe any testing equipment specifically designed for the purpose of such testing has ever been available.

Save time

"If this system can be properly worked out, it will be of benefit to radio-set manufacturers in that it *will give the radio serviceman on the*

*All italics in this article are the Editor's.

outside a better picture of what is actually going on and what may be wrong with the receiver than is true today. More important in my mind is the benefit that can be derived by the serviceman himself inasmuch as after having become thoroughly familiar with this system of analysis he will be able to save much time in his work.

"Summing this all up in a few words," Mr. Glassman declares, "I believe Mr. Ulrich's idea is a *step in the right direction* and I shall follow developments with interest."

A. T. Alexander, service manager of Motorola writes, "I, personally, feel that this is *the beginning of a very interesting and valuable discussion*, and I feel that it is right in line with an idea which we started last year in our service notes, and are continuing this year with a little expansion.

Localizing trouble

"Since we are already using at least a small portion of this system through the advocacy of stage gain measurements throughout the receiver, as a quick method of localizing the source of trouble, I, personally, foresee some of the discussion which will come up in future articles."

"*I think that the dynamic method of analysis will work in very nicely with the other types of tests,*" writes Samuel C. Milbourne, Service Engineer of Supreme Instruments Corporation. "Radio servicing is becoming such a complicated business that no one test or set of tests can properly be called universal.

"Of course, it is easy to pick flaws in any system and the most obvious flaw in a dynamic analysis is that

when you come to a dead stage, the stage is no longer in a dynamic condition and, therefore, you must resort to ohmmeter, milliammeter and voltmeter measurements to determine the open circuits or shorted circuit."

"One thought which occurs to us at the present time is that as far as the radio manufacturer is concerned," comments J. M. Bowmaster, service manager for Sparton, "the equivalent of 'Dynamic' testing is already in use where work is being done by the manufacturer's own servicemen. That is to say, in our own case Sparton radio receivers being tested in Sparton Radio Service Departments by men who are familiar with Sparton radio receivers are actually given an equivalent of the dynamic method. This is undoubtedly because such manufacturer's servicemen are more familiar with the product than anyone else and failures or abnormalities in the set are most quickly located by following a procedure very similar to the 'Dynamic' method proposed by Mr. Ulrich."

Henry L. Paiste, Jr., sales engineer of Philco says, "Bob Herr asked me to read over Mr. Ulrich's article on 'Dynamic Testing of Radio Sets.' This is rather a fancy name for a stage-by-stage method of gain testing of radio circuits. But, it is in line with the practice followed by better servicemen in most parts of the country. We have recommended it in a very small way to servicemen in various meetings and in written articles on the subject for the past several years.

Full performance of set

"The stage-by-stage measurements of radio performance is highly recommended to Philco dealers and servicemen, and has been for the past several years, as a method of saving time and avoiding unnecessary testing in locating failure or weakness in a receiver on test."

"As far as the general adoption of such a method of testing is concerned," states J. N. Golten, service manager of Stewart-Warner Corp., "any improvement in the methods or equipment used by servicemen is bound to react favorably toward all radio manufacturers, since such increased knowledge can enable the serviceman to give his customer the full benefits of the performance the radio set is capable of delivering."

"We are in favor of the type of testing this article covers," writes L. E. Priscal, service manager for Erla, "but at the present time the serviceman really does not have the kind of equipment that will permit him to make some of the tests outlined in the article. Naturally, we approve of anything that will help the repairman to do a better job faster, but we frankly feel that with the type of equipment the average serviceman has today, he would not be able to make

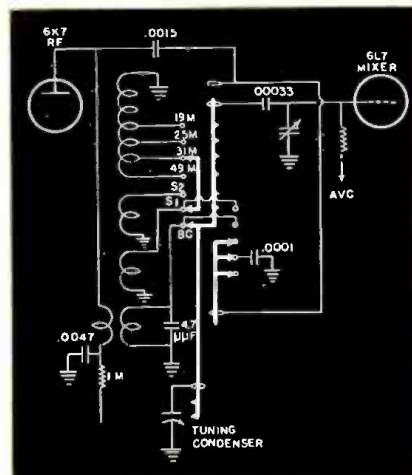

With dynamic testing the actual circuits and values of parts are less important. Chief item is that all the parts are working in proper relationship with one another. (Circuit above is the bandspread arrangement of coils in current RCA-Victor sets.)

some of the checks the article describes and most of those who do have the equipment that would permit them to make the checks do not have enough technical knowledge to make them correctly or to determine from their checks what is occurring in the stage under test.

"It does have definite advantages over point-to-point and voltage methods of checking defective radios, but when viewed from the serviceman's side, it does have definite limitations—at least, at the present time."

Dynamic vs. static testing

"I am sure no one can disagree with the statement that receivers should be tested under dynamic rather than static conditions," states Tobe C. Deutschmann. "Such testing particularly in the radio frequency circuits should reveal certain types of condenser trouble which do not show up in the conventional test procedures."

And from servicemen in the field RADIO TODAY has received numerous letters commenting on the method and asking for more data. One serviceman-engineer "predicts that eventually yours (dynamic) will be the accepted standard of procedure." And he adds, "I know it will pay the servicemen to follow you. . . . There is no doubt in my mind that you are about to render a great service to many servicemen and listeners alike. . . . It is the one road forward."

Stan Gilhooly of Van Dyke, Mich., writes, ". . . very interesting. Could you give us more on this subject in future issues of RADIO TODAY. . . . I am thinking of adopting this method of testing and would like to get started."

Out in Cicero, Ill., Leo Lewandowski would like us, "to go in more detail on this systematic testing of receivers for me and others in future articles." Leo further says, "I have read your article and like it very much."

More details wanted

"Would like to use this method of testing but first would like to have all the details," requests John Hall of Long Eddy, N. Y.

From Washington, D. C., Larry Lastic writes, "Appreciate the information in the Feb. issue, Dynamic Testing of Radio Sets . . . may I have the privilege of asking more detailed, constructive data."

Wells Electric Co., in Bluffton, Ind., says, ". . . we think it fine. Do you have any booklet or paper of the technique of this system, showing the step by step method through an entire set with full details?" (Not yet, but we will soon have it in RADIO TODAY, month by month—Editor.)

"Very, very interesting to me," comments Earl Beecher of Allentown, Pa. ". . . I would like to learn more about this type of servicing radios."

"Your article 'Dynamic Testing' is of great value to servicemen," writes H. Elliott of Hopewell, Va.

Carl Evans, Concord, N. H., parts jobber believes, "that the system has its points, as quite frequently minor troubles will be found which wouldn't have been found otherwise. This requires more replacement parts, and hence more parts business for the jobber. This also means more satisfaction for the consumer, which improves good-will for the serviceman."

DELCO PUSH BUTTON TUNER

★ Home type push button tuning mechanisms have been described in previous issues of RADIO TODAY*.

Latest development in this field is automatic tuning for auto radios. In the auto sets both motor and lever type mechanisms are employed.

The Delco system which is to be described and explained this month is a motor operated device which goes directly to the selected station. The station selector is mechanical in operation since the device does not depend upon electrical contacts for stopping at the desired station.

Unlike the home type mechanisms, the Delco auto radio tuner employs push buttons that operate electric relays to work the cams and levers in the device. In previous mechanisms the push button has been mechanically coupled to the device.

The diagram on page 44 shows how the device is wired and indicates the important parts of the unit. For simplification the six buttons and the associated relays have been represented by a single push button. Actually the six of them are in parallel.

A double contact push button is employed with a magnet or hold-down coil to keep the contacts closed until the station is selected by the mechanism. When this double contact button is depressed, one set of contacts

(To page 44)

*RCA, G-E, Sparton described on page 24 of Sept. 1937; Stewart-Warner, Admiral on page 42 Oct. 1937; Motorola, Detroit page 46 Nov. 1937; Wells-Gardner on page 28 Dec. 1937.

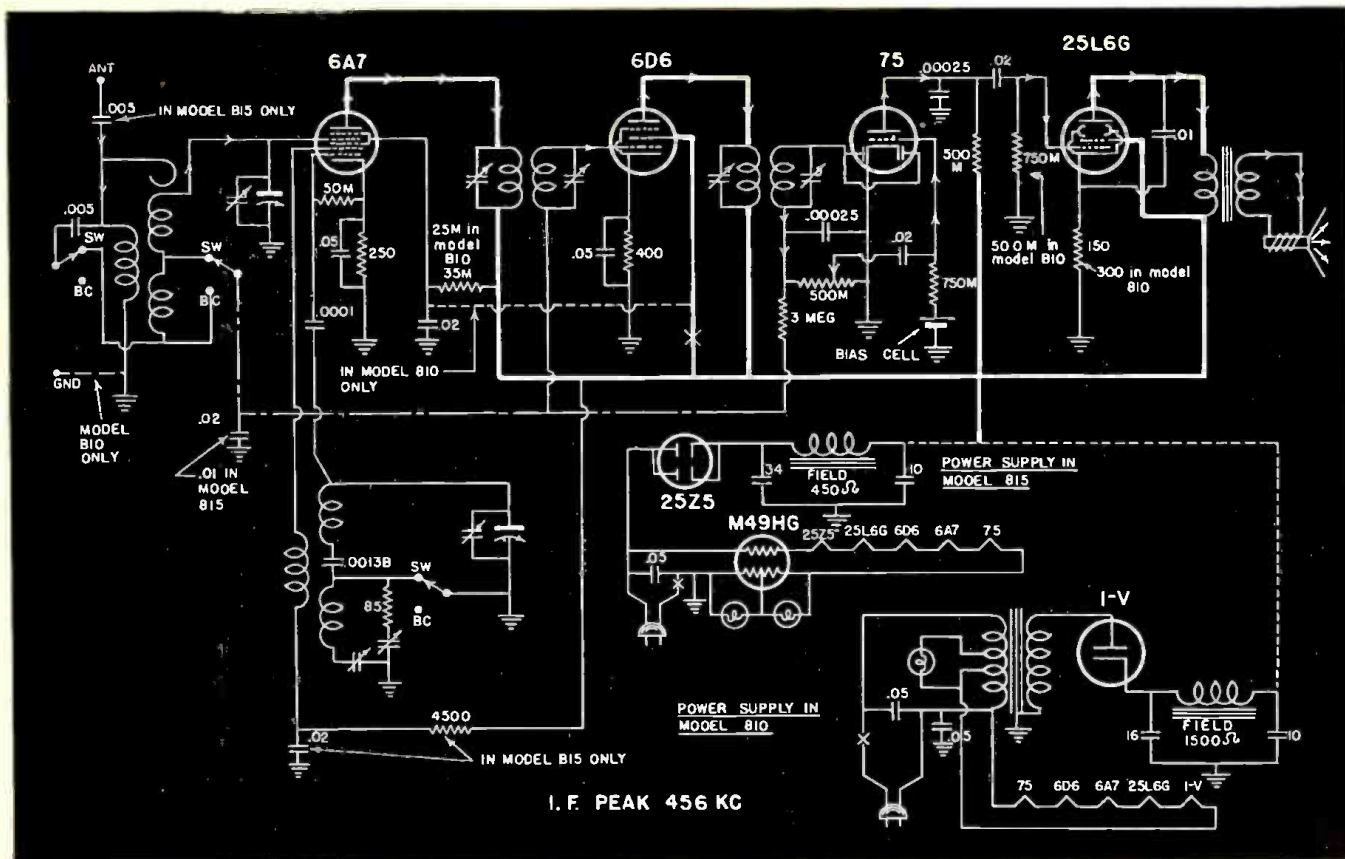

Air King's models 810 and 815 are very similar, though one is designed for AC operation and the other for DC. Main difference is in the power supply. Note the series filament circuit in the AC model.

APPLIANCES IN ACTION

APPLIANCES IN HOMES

★ The electrical way of living has continued to catch on nicely in American homes, according to the latest figures on the subject.

Preliminary totals released by the Edison Electric Institute show that the use of domestic electric service in 1937 increased 14 per cent over the previous year. The 1938 consumption amounted to 15,659,000,000 kwhr., while the total for 1937 is set, in the first figures, at 17,820,000,000 kwhr. Of the latter figure, the use of appliances accounted for 11,454,175,000 kwhr.

The Institute report includes figures on saturation, which are of smash interest to the merchandisers of appliances in 1938. Of the 14 appliances listed, saturation ranges from 2 per cent for water heaters to 106 per cent for (socket) radios. Running close to radio for top place in saturation are flatirons, rated at 103 per cent. Saturation figures are based on a summation of annual sales, less an estimated replacement demand.

As for the kwhr. per year, per appliance, normal use in 1937, the figures range from 15 for electric clocks to 3,300 for water heaters. Radio is rated as 100, well up among the major appliances and certainly high enough to invite the interest of the utility companies.

The complete figures are lined up:

	No. of appliances in homes	Saturation	Kwhr. per year, per appliance, normal use
	Dec. 31, 1937		
Refrigerators	11,300,000	50%	420
Radios (socket sets)	23,750,000	106%	100
Ranges	1,775,000	8%	1,200
Flatirons	23,100,000	103%	80
Water Heaters	528,000	2%	3,300
Oil Burners	1,360,000	6%	250
Washing Machines	11,050,000	49%	30
Vacuum Cleaners	11,175,000	50%	24
Toasters	10,500,000	47%	30
Electric Clocks	11,500,000	51%	15
Ironing Machines	1,315,000	6%	125
Percolators	6,000,000	27%	36
Space Heaters	4,750,000	21%	50
Roasters	650,000	3%	250

PLEASANTAIRE ENTERS THIRD SEASON

★ Pleasantaire Corporation, Washington, D. C., first showed its new 1938 Model B room-cooler during the New York Heating and Ventilating Exposition, marking its third season. According to Richard F. Roper, Pleasantaire president, the new room-cooler incorporates 15 important refinements, including Morocco finish



Pleasantaire Model B-2000 room-cooler.

optional in ivory or brown. Uni-fin grille, fresh-air opening with spun-glass filter, and a smoke and stale-air exhaust. Basic refrigeration principles remain the same and new floating rubber mountings for the 500-watt refrigeration mechanism insure reliable operation of the condensation exhaust fan.

Pleasantaire sales this year will be direct to dealers. The nationally advertised list price is \$199.50 f.o.b. factory, with discounts to dealers of 40 per cent in lots of six or more and 33 1/3 per cent in lots of one to five. Backing dealers is the Pleasantaire Package Plan, a detailed merchandising plan for selling room coolers, copies of which are being sent to dealers on request.

The company maintains that its product should be sold direct to specialty dealers as an appliance rather than through contractors. The whole campaign stresses "relief from hot weather suffering." Factory is already booked up on March manufacturing and is accepting orders for April and subsequent production.

Steem-Electric iron



★ A new iron which contains a water chamber from which steam emerges through holes at the tip of the ironing surface. Distribution of steam

does away with sprinkling, dampening and rolling. Holds 1 pint of water, uses AC or DC current. Home model, \$12.95. Available in larger commercial model. The Steem Electric, 11 W. 42nd St., New York, N. Y.—RADIO TODAY.

Air Healthifier

★ Presented in three models for humidifying, washing and circulating the air in home, office or shop. Reservoir holds three gallons of water, which is pumped to 12 moisture cell "distributors" below the fan. Current used is rated in amount similar to that used by 40-watt lamp. Installation consists of simply plugging in—



no plumbing required. Zephyr model (end table style illustrated herewith) is 27 in. long, 16 in. wide, 24 in. high, \$83.50. Sentinel model is 16 x 16 x 24, \$64.50. Companion model is 28 x 16 x 26, \$80.50. Lion Mfg. Co., 2640 Belmont Ave., Chicago, Ill.—RADIO TODAY.

Samson rubber-bladed air-coolers



★ New line includes 24 different models; stationary, oscillating, desk and pedestal styles in sizes from 6 to 24 inches, for home, business and auto use. Flexible blades covered by 5-year guarantee. Consumes 195 watts; velocity is 850 rpm. Samson United Corp., Rochester, N. Y.—RADIO TODAY.

(To page 53)

**THE GREATEST THING
THAT CAN BE SAID ABOUT
ANY RESISTANCE UNIT
IS—THAT IT IS MADE**

by

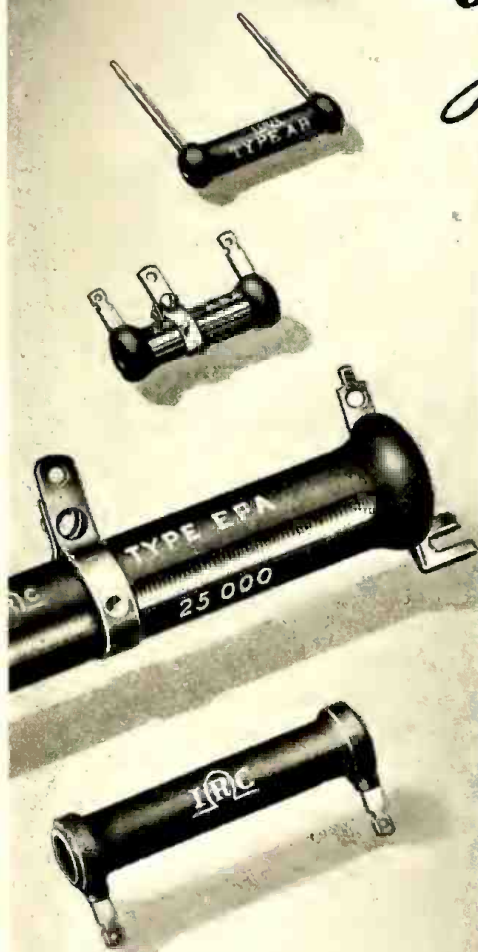

**IRC POWER WIRE
WOUND RESISTORS**



**IRC INSULATED
Metallized
RESISTORS**

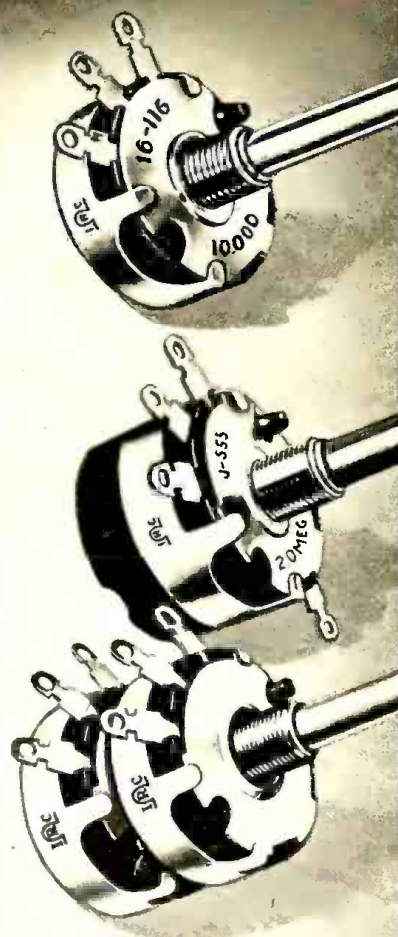

**Type CS STANDARD and SPECIAL
REPLACEMENT CONTROLS**

INTERNATIONAL RESISTANCE COMPANY

401 NORTH BROAD STREET, PHILADELPHIA, PA

Factories or Licensees in Canada, England, France, Germany, Italy, Denmark and Australia

**MAKERS OF RESISTANCE UNITS OF MORE TYPES, IN MORE SHAPES, FOR
MORE APPLICATIONS THAN ANY OTHER MANUFACTURER IN THE WORLD**

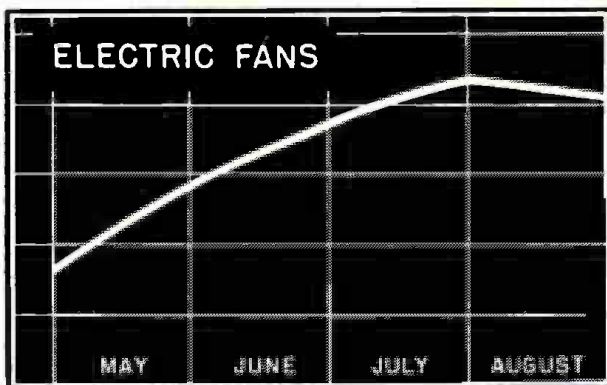
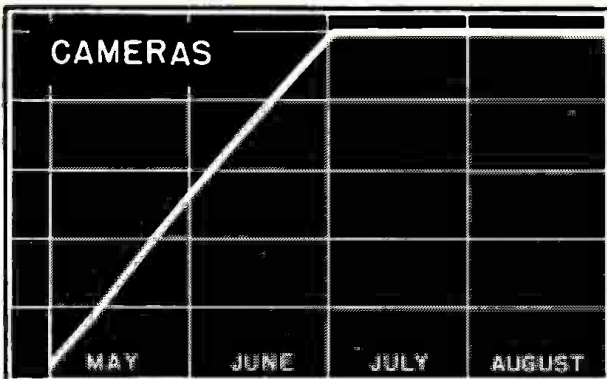
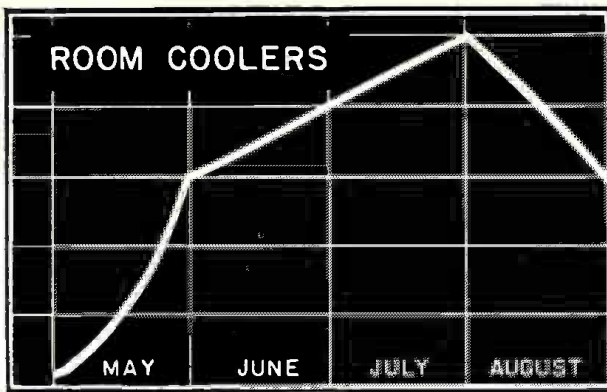

U P G O O S A L E S

ground to selling their products.

The new model coolers are more compact and employ new tricks in design which were picked up in last year's experience. Most of them are "room-proved" and fit right in with the popular demand for complete "air happiness." The cabinets of some are created this year by big names in the design field.

Meanwhile the marketing of the cooling devices is expertly based on the fact that people may not be buying as many luxury items as they were last year. Merchandisers are playing up the health angle and have made detailed studies of human lungs as they are concerned with the industry of air conditioning. It turns out that room coolers are not luxury items. Increased efficiency in offices, health and comfort at home are sound and economical investments.

Cameras click

When the population starts to rush out-if-doors this Spring, millions of cameras will be taken along. The picture-taking craze which swept the nation as a fad has remained to become an American custom.

While radio men are outfitting their customers with portable radios and auto sets, cameras and projectors work in as ideal additions to stock. Camera displays fit in neatly with Spring displays and the manufacturers are making them available at once.

Snapshots and demonstration films will now concern outdoor Spring activity as displayed in radio windows and counters, and have what it takes as attention-getters for prospects who are thinking about those very things. Soon youngsters will be playing outside, and that is one of the chief reasons why parents will buy.

Camera buyers keep coming back for films and accessories, particularly at this season when a great deal of film is used. This means traffic, as well as more prospects for radio and appliances.

The blades

For a long time, fans have been used as traffic builders and prospect-getters. This Spring they have new characteristics and new advantages to radio men, the field has moved smartly toward more profit for the retailer.

The merchandise has been streamlined, quieted, and utility-designed for multiple uses. The fans have a new safety angle and many have been styled for particular rooms in the home, so that a series may be sold to a single customer.

★ AMONG the plans being cooked up by dealers these days are some snappy projects in Spring merchandising.

As the warm days come along, there are new chances to fight the recession, new ways to get folks into stores, and new merchandise with exceptional appeal. Dealers report that Spring promotion this season will get an unusual play, because things have been dull and any additional merchandise which looks like a good bet will be played to the limit. Sales efforts will be scaled up to get the profit figures back where they belong.

Among the chief items of interest to dealers who are counting on Spring prosperity are room-coolers, cameras and electric fans. All these come in with the high temperatures, and have been of special interest to radio outlets.

Right now dealers have a special welcome for merchandise on which there is price protection, and no trade-in problems. Supplementary lines, which involve less fuss about time payments, more unit sales, and fewer service problems, are downright attractive at the moment.

Selling comfort

A great deal has taken place in the space-cooler field since last year, and it is good news to the dealer. More manufacturers have entered the field and are taking pains to sell the idea to the public on a national scale. Many of them have introduced lower-priced units in a substantial attempt to reach homes with lower incomes, while some of the veteran specialists stick to higher prices and use more features and more engineering back-



IN THE U. S. AIR CORPS, TOO,
RAYTHEONS
DO THEIR "BIT"!

Zooming through the air at breath-taking speed with machine guns barking, communications between the U. S. air fleets, and ground headquarters *must go through!* To weather such gruelling tests a tube *must* be sturdy... *must* be designed and tested to perform consistently and smoothly under all circuit conditions! This is the punishment Raytheons take *every day* in the U.S. Aviation service—and still render efficient and dependable performance!

These potent reasons helped convince engineers of many leading licensed set manufacturers that these same Raytheon tubes are *the best* for *their sets*. Profit from the combined experience of these men who know.

Choose Raytheons for *your* replacements and enjoy greater permanent tube profits!



RAYTHEON

CHICAGO SAN FRANCISCO NEW YORK
ATLANTA NEWTON, MASS.

"WORLD'S LARGEST EXCLUSIVE RADIO TUBE MANUFACTURERS"

DELCO PUSH BUTTON TUNER

(Continued from page 39)

sends current through its relay which trips the station selector arm (relay armature).

The other set on contacts sends current through the hold-down coil and hold-down relay, both of which are connected across the battery. The hold-down coil keeps the push button that was depressed in the down position until the station has been selected.

The hold-down relay has two sets of contacts, one of which closes the circuit to the motor and the magnetic clutch, while the second contact mutes the audio of the set during tuning.

A single-pole double-throw switch is used for switching in either the forward or reverse fields. This switch is operated by the cam shown in the lower left hand part of the chart.

The cams (only one of 6 shown) have a high and a low side which serves to govern the direction in which the motor rotates. The lever which is pulled into contact with the cam by the relay is mechanically connected to a system of levers so that the direction of the motor is always such that the mechanism goes direct to the desired station. Further explanation of this type of mechanism will be found on page 42 of the October 1937 issue of *RADIO TODAY*.

When the motor has rotated the cam to the point where the desired station is, the lever will drop into the notch on the cam. Then the movement of the lever opens the stop-start switch thereby turning off the motor, de-energizing the magnetic clutch, opening the audio mute contacts on the hold-down relay, and de-energizing the hold-down coil thereby permitting the button to release and assume normal position. Also the lever (armature)

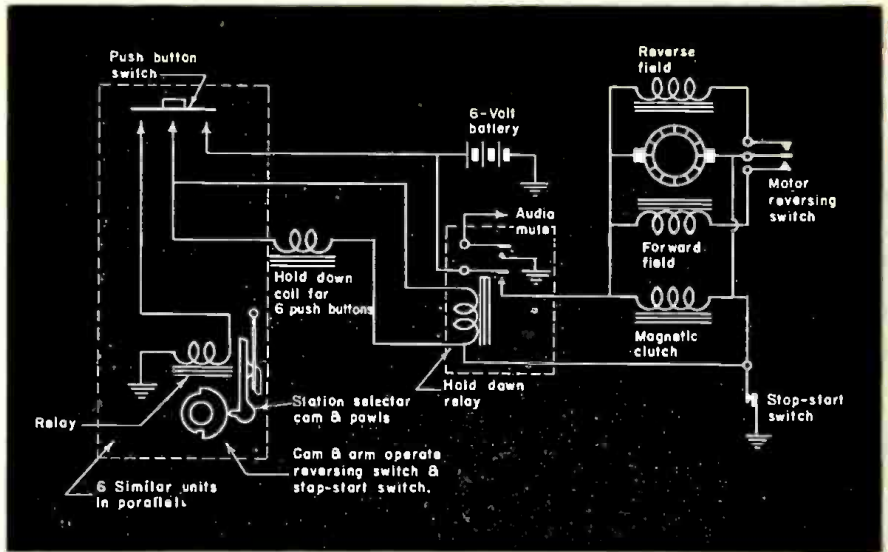

Schematic of the electric push button tuner used in the current Delco auto radio sets. Note that the push buttons are separated from the mechanism through the use of relays.

comes out of the notch in the cam since the relay no longer holds it down.

Set up of stations is easily accomplished without the use of any tools. The button to be set up is depressed and the mechanism allowed to come to a rest. Then button is held down and the station is tuned in manually. When the button is held down after the mechanism has come to a rest, the relay armature pawl is held in the cam slot, locking the cam in position. The cam is allowed to slip on its shaft during the manual tuning process, by a clutch spring which is part of the cam shaft assembly.

WILCOX-GAY 7-TUBE RECEIVER

★ The Wilcox-Gay A36, A-37, 7J7, 7K7 radio sets employ the same chassis, which is a 7-tube superhet.

Set has a tuned R.F. stage on all bands and uses separate coils which are selected by the wave-band switch. There are slight variations between the early late models which are indicated on the accompanying schematic circuit.

I.F. and R.F. alignment of the set follows the usual procedure. Trimmer locations are shown on the chassis layout. (To page 46)

WILCOX GAY MODELS A36, A37, 7J7, 7K7

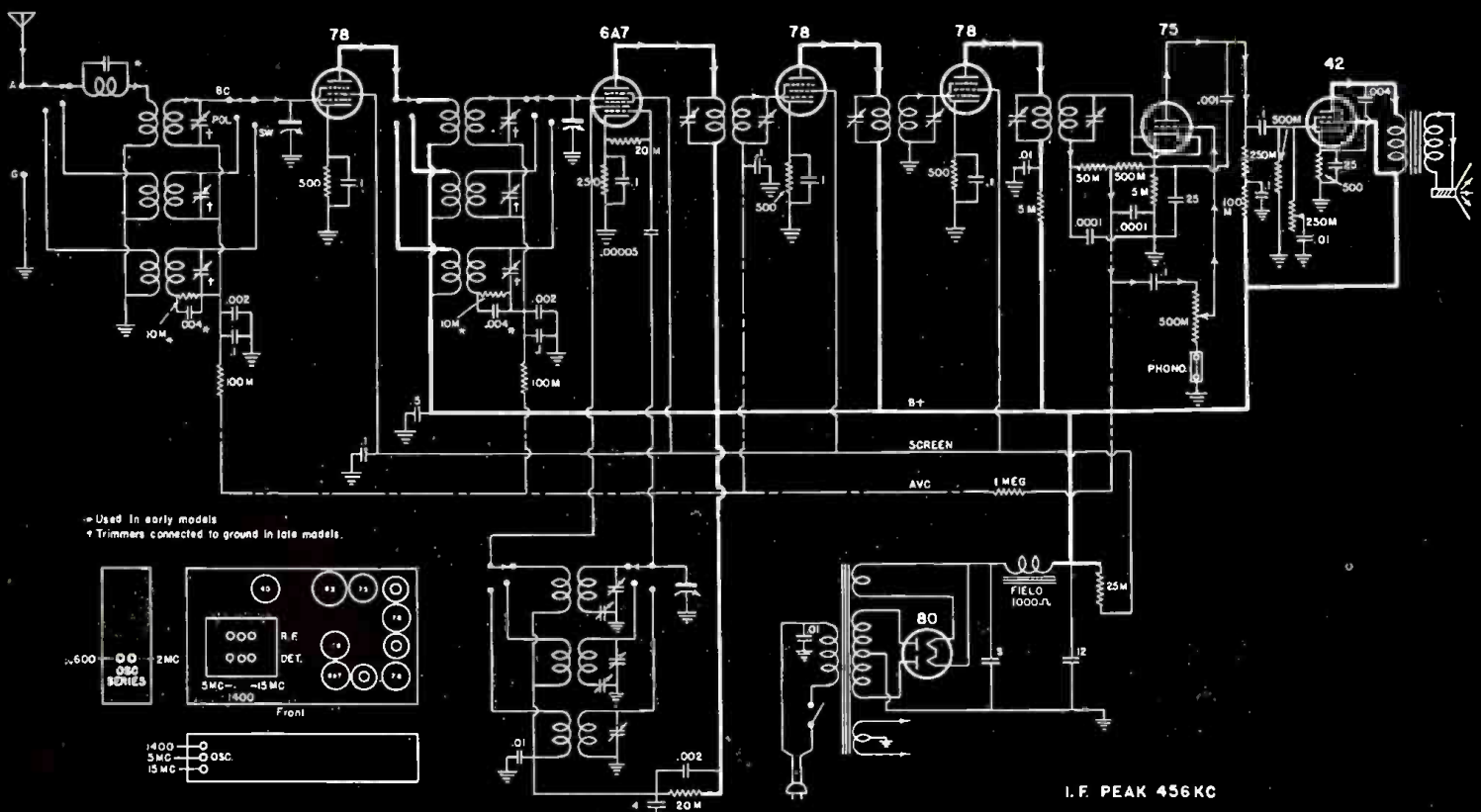



Out where the test begins—miles from the nearest station—your car needs SUPPRESSORS

- T20
- CONTINENTAL S19
- S27
- S21
- T11
- T13
- S20A
- T17

CONTINENTAL CARBON suppressors are adaptable to every type of spark plug employed in modern cars. Efficient 5000 ohm suppressors for the plugs—10,000 ohm suppressors for the distributor assure maximum suppression of ignition interference without noticeable effect on engine performance. T20 and S19 are new types for distributors and plugs and can be installed without tools in a few moments' time. **RECOMMEND CONTINENTAL SUPPRESSORS ON EVERY RADIO EQUIPPED CAR YOU SERVICE!** List price, 30c each.

CONTINENTAL CARBON Inc.

13910 LORAIN AVENUE, CLEVELAND, OHIO
or Toronto, Ontario, Canada

The **Dictionary TELLS IT BEST**

Theory: Fundamental principles underlying a science.
Practice: The accomplishing of a set of principles.

Successful servicemen, learning theory first, are never troubled by circuit changes or complicated problems.

You Need Theory if you are to succeed in Practice . . .

For "knowledge of the fundamentals" needed in modern service work depend on

RIDER BOOKS for Theory

- AFC SYSTEMS: Absorb AFC knowledge and cash in! Here's a book you need. 144 pages. Hard covers. . . . \$1.00
- THE CATHODE RAY TUBE: Oscillograph data, etc., and an introduction on the newer Cathode Ray Tubes. 366 pages, 450 illus. . . . \$2.50
- Other Rider Books: Servicing Super-heterodynes; Aligning Philco Receivers—\$1.00 each. "Hour o Doy with Rider" books on AVC Control; on Resonance & Alignment; on A.C. Distribution in Radio Receivers; on D-C Distribution—60c for each book.

RIDER MANUALS for Practice

Rider Manuals are used daily by thousands of servicemen as a practical guide through the most complicated receivers. Volume VIII, covering 1937-38, contains the most comprehensive compilation of service data available. Covers 1715 models of over 100 manufacturers plus a 64-page "How It Works" section dealing with the basic theory behind the electrical operations of modern receivers. **VOL. VIII**—Covering 1937-8—\$10.00 1650 pages—Plus 128 page Index—Plus 64 page Supplement

ORDER TODAY

YOU NEED ALL 8 Rider MANUALS

JOHN F. RIDER, Publisher
1440 Broadway, New York, N. Y., U. S. A.

LET'S FACE FACTS

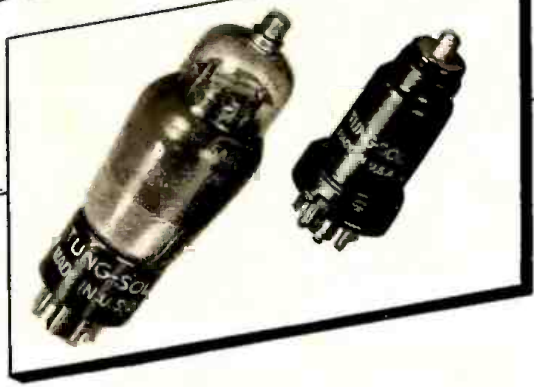

TUNG-SOL knows that nothing any manufacturer can do will enable dealers to "get rich" through the sale of radio tubes. Tung-Sol knows, too, that given a fair opportunity, the dealer can make radio tubes one of his most profitable lines. That is why the Tung-Sol consignment plan is offered—not as a gold mine—but as a sound merchandising plan which enables the dealer to make all the profit possible from the sale of Tubes.

The plan is simplicity itself. An adequate stock of Tung-Sol dependable tubes is placed in your custody. Once a month you report and pay for the tubes sold. Capital ordinarily tied up in tubes then becomes available for investment in other merchandise. Furthermore, you are protected from cut-price competition as well as losses due to obsolescence or price reductions.

If you are a responsible dealer, equipped to service radio, you will want the details. Write our nearest Sales Office.

TUNG-SOL
Tone-flow Radio Tubes

TUNG-SOL LAMP WORKS, INC.
Dept. C Radio Tube Division

SALES OFFICES: ATLANTA • BOSTON • CHICAGO • DALLAS
KANSAS CITY • LOS ANGELES • DETROIT • NEW YORK
GENERAL OFFICES, NEWARK, N. J.

MORE SERVICE NOTES

BELMONT MODELS 761 & 860

★ The Belmont models 761 and 860 are from a circuit viewpoint alike except that the 860 has a cathode ray tuning indicator. Actually the two receivers employ somewhat different tuning mechanisms.

Set uses a 3-gang condenser which provides from pre-selector antenna stage on the broadcast band. On the short-wave bands the set is a 2-gang job employing a doublet type antenna system which is automatically switched in by the band switch.

The 1st detector coil system is of the usual series type where the coils for the lower frequencies are shorted out progressively as the band is changed. The coil system in the oscillator circuit is somewhat different. First of all for the BC band, the SW and BC coils are in series and POL coil is out of the circuit from an inductance point of view. However, the BC parallel trimmer is in series with the POL coil and trimmer. The series trimmer capacity is the resultant of all the series condensers.

On the POL band, the POL and BC secondary oscillator coils are in parallel. On the SW band the BC and POL coils are shorted. Also the BC and POL series padders are shorted. Consequently for short wave the oscillator circuit is reduced to the SW coils and the .003 series condensers.

Because of the interlocking trimmers, alignment must be made definitely in the following order—BC band, SW band, POL band. First the oscillator parallel trimmer is adjusted, then the 1st detector, and then the series padder (BC band only).

Frequencies and location of the trimmers is given in the auxiliary chart shown on the accompanying schematic.

AUTO RADIO SERVICE ASS'N

★ In metropolitan New York and New Jersey a group of 10 auto-radio stations have formed what is known as United Auto Radio Service. The purpose of this organization, declares M. M. McCullough of MacAdams Equipment, New York City, is to benefit the individual members by group co-operation. This includes purchasing, standardizing policies, and co-operative service to dealers and customers.

As an example, a Guarantee Certificate is given customers having a car radio installed by a member station which entitles the owner to obtain "No Charge" service at any other member station, during the 90-day warranty period, assuring prompt, convenient service.

The association has been in operation for about a year and is working

out very well. It has enabled the members to obtain service contracts which no individual member could handle alone. Exchange of information and group buying has also proven very beneficial.

DE LUXE RADIO INSTALLATION

★ Radiomen should contact the architects who are planning large homes for wealthy individuals, according to Jensen Radio Mfg. Co., who tell us that Philip Greeley of Washington, D. C., has just completed extensive radio installation calling for simultaneous five-channel operation throughout the house.

Usually these jobs are overlooked by servicemen. But every home construction job from about \$25,000 up is a prospect for a custom radio installation. The radioman must approach the architect and person who is to own the home, and sell them on the idea before construction is complete.

The home which Greeley installed his radio system cost about \$300,000 which is several hundred times the cost of the radio set-up.

In order to provide for reception of any one of five channels at 19 speaker locations it is necessary to use five tuners and five amplifiers. To insure high-fidelity reception tuned radio frequency tuners are employed feeding 2A3 amplifiers, each having its separate power supply.

A 5-pair transmission line connects the output of each amplifier to the station selector switch at each speaker location. And to match the line, a speaker transformer is used at each remote location. Volume control is

BELMONT MODELS 761 & 860 Series A

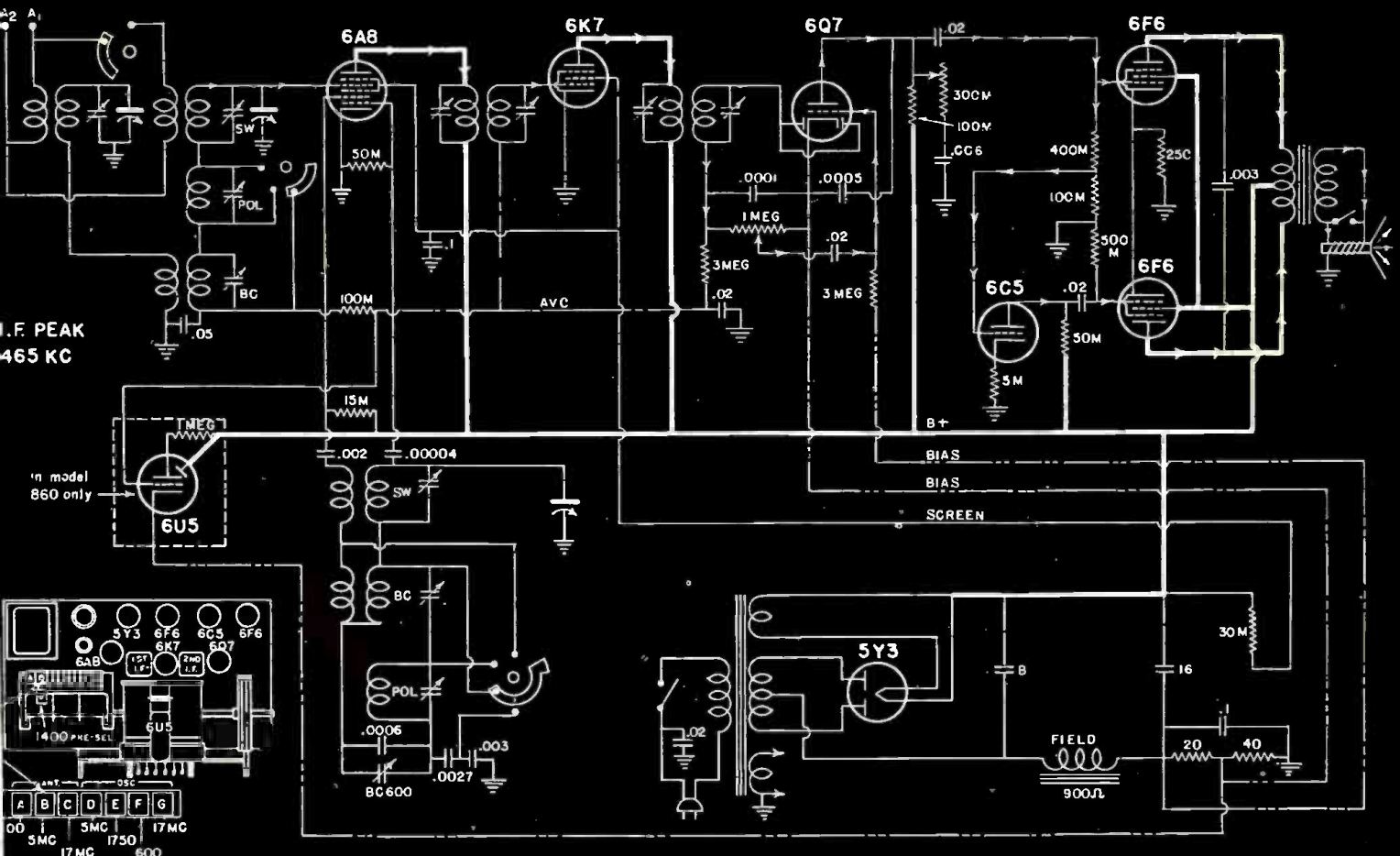

ONLY THIS NEW WESTON OSCILLATOR

gives you **ALL** these features!

Constant signal level at all frequencies (A.A.C.)
 . . . Constant frequencies—no padders—no trimmers . . . Guaranteed accuracy at all frequencies ($\frac{1}{2}\%$ on I.F.—B.C.)—(1% on Short Wave) . . . Constant impedance attenuator (100 ohms) . . . Permanent hand calibration—large 330° fully visible dial . . . Output readings directly in microvolts . . . Signal strength 100,000 microvolts . . . Fundamental frequencies fifty kc—30 meg.—6 individually hand calibrated scales . . . Freedom from drift and feedback . . . For use with all standard oscillographs and frequency modulators . . . Rapid band selection . . . Accurate alignment . . . Fifty percent modulation on all bands . . . Stable operation.



WESTON
Instruments

Weston Electrical Instrument Corp.
 597 Frelinghuysen Ave., Newark, N. J.
 Send me bulletin describing Model 776 Oscillator.

Name.....
 Address.....
 City..... State.....

Now you can test All Automotive and Home Battery Radio 6V. VIBRATORS

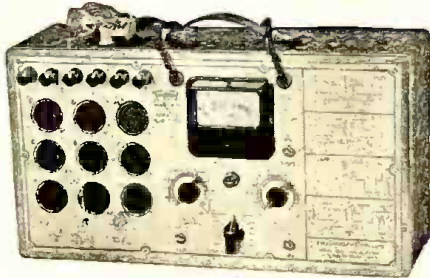

with Model 1670
VIBRATOR-TESTER
An Approved
DeLuxe Model

DEALER PRICE \$24.00
(Metal Case)

Locate Service Troubles Quickly
Sell More Vibrators

- Tests All Types 6 V. Vibrators
- Three Scale Triplett Instrument
- Uses Approved 500 Ohms Load

This new Triplett Vibrator Tester has been constructed with the engineering cooperation of leading manufacturers of vibrators. It will test all types and makes (6 volts) as used in automotive and home battery receivers. A load of 5000 ohms recommended by vibrator engineers is applied. The 3-scale meter shows the following: 0-10 volt scale shows voltage input to the vibrator; the GOOD-BAD scale shows output; scale marked 0-100 per cent shows per cent of output voltage as reflected by change in input voltage. Low damped meter permits needle to follow voltage fluctuations caused by faulty vibrator contacts. Sold with complete instructions on how to test.

Model 1670 in Portable Metal Case with Black Wrinkle Finish . . . Attractive Etched Panel.
DEALER NET. \$24.00

Model 1670 in Portable Leatherette Case with Removable Cover and Compartment for Accessories.
DEALER NET. \$28.00

See Your Jobber Write for More Information

TRIPLET
Precision
ELECTRICAL INSTRUMENTS

The Triplett Electrical Instrument Co.,
193 Harmon Dr., Bluffton, Ohio

Please send me Details on Model 1670
 Complete Catalog

Name

Address

City..... State.....

MORE PROFITS FROM SERVICING



Custom radio installations often require the use of built-in speakers.

effected by a constant impedance attenuator in the voice coil circuit.

Speaker equipment is comprised of 4 A-12 Jensen dynamics and 15 PM-8-C units. Specially designed grilles are used to cover the speakers which are mounted flush with the walls as shown in the accompanying illustration.

While such complete installations are relatively few in number, sales-minded radiomen should not pass them up for the profits are correspondingly greater. And one installation always leads to another—for "keeping up with the Joneses" is always popular sport among the rich.

AUDIO AVC CONTROL

★ In some of the early Stromberg-Carlson sets in the 20 series, an unusual form of AVC circuit was used. Several requests from readers have prompted us to explain this system of AVC, which is illustrated in the accompanying diagram.

First of all a triode type tube is operated as a dual diode in a delayed AVC circuit and audio detector. The cathode and grid are used as the elements of the detector circuit for providing an audio signal.

Note that the cathode goes to the hot side of the coil. Going back to the theory of the vacuum tube, we recall that current will flow only when the plate is positive with respect to the cathode. In this instance the plate can be regarded as the diode plate.

The incoming I.F. signal is an AC wave which has both positive and negative peaks. Now when the wave is negative the cathode instantaneously becomes negative with respect to the plate. Therefore a diode current flows through the detector load resistor of 250,000 ohms—in other words, the negative part of the wave is rectified or detected.

In the usual form of diode detector, the plate is connected to the hot side of the coil and positive part of the wave is rectified. In these S-C models, just the opposite is true.

Now the audio signal across the detector diode load is applied to the

plate of the tube through a .04 mfd. condenser (some models .1 mfd.). Considering only the plate and cathode of the tube, it will be noticed that the cathode is 12½ volts positive with respect to the plate. No plate current will flow, consequently, until the plate is more than 12½ positive.

When the positive peak of the audio signal across the detector diode load resistor exceeds 12½ volts, a current will flow from the plate to cathode through the 500,000 ohm AVC load resistor. As is always the case with usual diode rectifiers, the rectified voltage is negative with respect to ground. Thus the plate and cathode work similarly to the usual delayed AVC circuit. The one difference is that the audio voltage is rectified instead of I.F. voltage.

Therefore the volume output of the set will be dependent upon the audio signal strength instead of carrier signal strength.

The arrow heads in the diagram show the path of the audio signals.

General Electric models K50P, K54P, K60P, K65P **SW switch does not center**

★ Remove the clip fitted into the slot in the end of the switch shaft. Cut a slot in the end of the shaft and solder a floor nail into it. Now when the switch is turned the nail will fall against either one or the other side of the protruding bakelite wall, holding the switch in place in either position.

Grunow models 701, 801, 901 **Interference from airport beacons**

★ Realign the i-f at a new frequency say 255 or 270 Kc. This calls for complete realignment of the r-f and oscillator systems. Another method is to obtain an old i-f transformer designed for an i-f of 260 Kc. or 262 Kc., and place either the primary or secondary in series with the antenna. The trimmer across this section of the transformer can then be adjusted until the interfering signals are cut out.

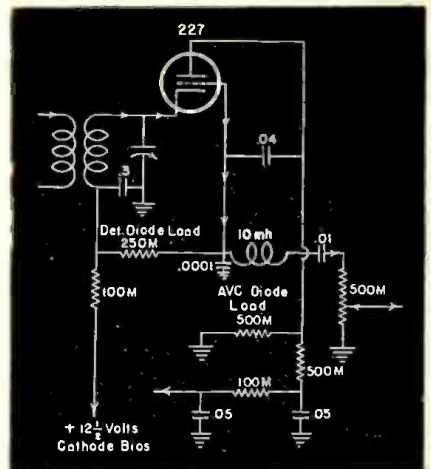

AVC and 2nd detector circuit employed in early Stromberg sets.

RCA PUSH BUTTON TRIMMER TUNING

★ In the larger type RCA sets using trimmer type tuning for push button operation, the change over from manual to PB tuning is accomplished by the wave-change switch.

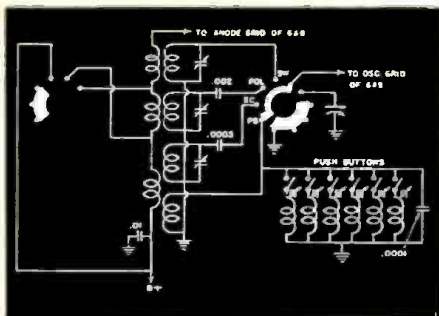
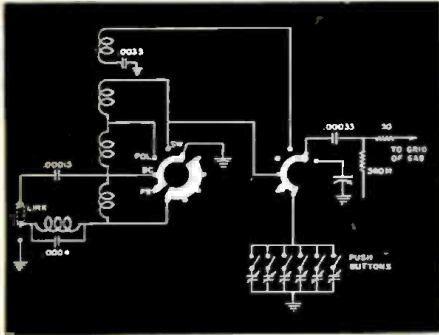

Illustrated in the accompanying chart, is the circuit employed in these sets. Switch is shown in push button position. Note that in the 1st detector, trimmer condensers are substituted for the condenser gang. In all other positions the variable gang condenser is used.

In the oscillator circuit, trimmer type inductances with iron cores are used in place of the usual BC coil. A fixed condenser is used for resonating the circuit. The switch in the PB position cuts in the trimmer inductances which are connected across coil which is inductively coupled to the anode coil of the oscillator tube. Adjustment of the oscillator stage is made by varying the position of the iron cores.

ALLOW SET TO HEAT

★ Alignment or set-up of the new automatic and push-button receivers should not take place until the set has operated at least 20 minutes, according to many of the manufacturers. Reason being that set tuning drifts considerably the first few minutes, and if the push buttons are set up before the drift is complete, the tuning will not be perfect after the set has heated up. Even if the set uses A.F.C., it is necessary to allow all the parts to reach operating temperature before setting up.

March, 1938



PRESENTING

THORDARSON AMPLIFIERS

NEW

DESIGN APPEAL
CONSTRUCTION
PERFORMANCE

- Solid Walnut Cabinet
- Illuminated Dials
- Protected Controls
- Window Visibility Dials
- Low Distortion at all audible frequencies
- Dual Tone Control
- Multiple inputs with individual controls
- Universal output impedance selected by convenient "plug-in" connectors

Spectacular is the word which best describes the many features of these new amplifiers. *Spectacular* is the word which best describes their recent announcement by nationwide "Telephone Broadcast" to the trade in principal cities all over the country. *Spectacular* is the word which best describes the new sales appeal of this line. Check the features above and see just how much Thordarson amplifiers give you to sell. Be the first in your territory with the latest, in fact most advanced, amplifier on the market.

Engineered—Styled—Modernized

"They Speak for Themselves"

See your jobber or write the factory direct for new FREE Catalog No. 600-C.

AMPLIFIER DIVISION OF

THORDARSON ELECTRIC MFG. CO.
500 W. HURON ST., CHICAGO, ILL.

LEARN ABOUT RADIART'S

NEW

Anti-Rattler

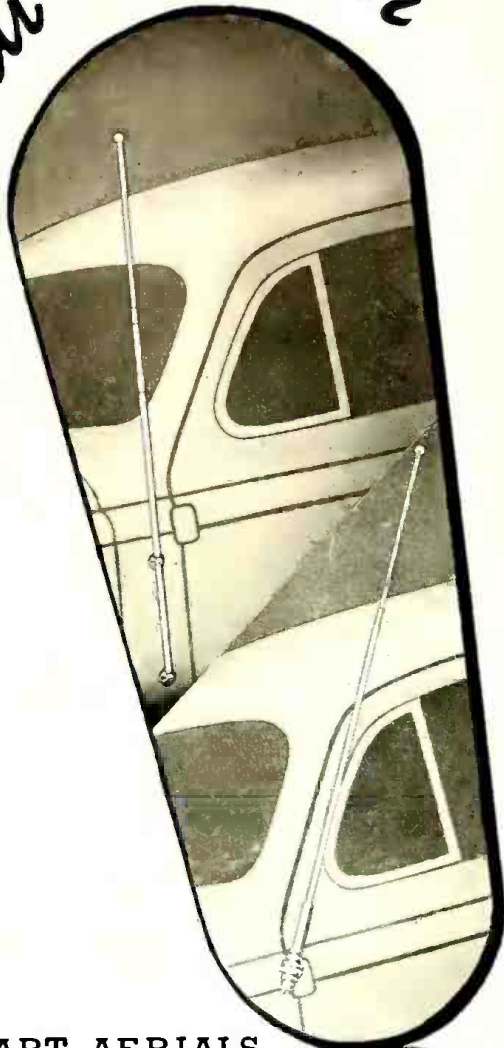

RADIART AERIALS
are
BETTER AERIALS

The anti-Rattler (Patent Applied for) which at last quiets that maddening noise of long telescopic aerials, is just the most recent of Radiart's unique auto aerial improvements. The styling — the positive contacts — the one-man installation — the GUARANTY against rust, tarnish or corrosion — WRITE for new folder that tells the story of Radiart quality and profit.



THE RADIART CORP.
DEPT. A., CLEVELAND, O., MAKERS OF
RADIART VIBRATORS

It's RADIART
for AERIALS in '38

**"PINCOR"
POWER
SUPPLY
UNITS**

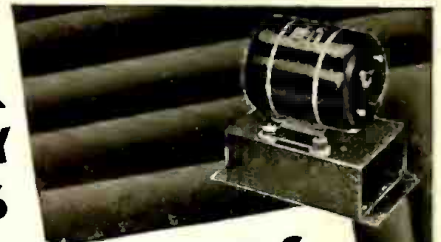

**DYNAMOTORS
GEN-E-MOTORS
CONVERTERS**

"PINCOR" dynamotors, gen-e-motors and rotary converters provide the last word in power supply units for air craft, police, marine and auto radios; also for public address systems. Now widely used by leading air lines and municipal and federal agencies throughout the world. Available in a wide range of capacities for every requirement. Compact, light weight. Sturdily constructed to assure long dependable service. Write for complete information.

PIONEER GEN-E-MOTOR CORPORATION
Manufacturer of "PINCOR" Products
Dept. R-2C, 466 W. Superior St., Chicago, Ill.
Export Address: 25 Warren St., New York, N. Y.
Cable: Simontrice

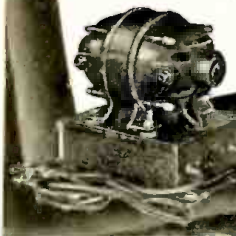

**OTHER
"PINCOR" PRODUCTS**

RED TOP and **GOLD CROWN** gas - engine driven electric light and power plants. 100 to 2000 watts; alternating or direct current; air or water cooled; remote control. Send for literature.



Convention Time, Too!

Starting Tuesday morning, June 7, and continuing through Saturday evening, June 11, the Stevens Hotel, in Chicago, will fairly radiate with radio industry activity.

CONVENTIONS SCHEDULED

At The Time Of The

1938 NATIONAL RADIO PARTS TRADE SHOW

Are Listed Below:

- RADIO MANUFACTURERS ASSOCIATION
- SALES MANAGERS CLUB "REPRESENTATIVES"
- RADIO SERVICEMEN OF AMERICA
- NAT'L ASSN. OF RADIO PARTS DISTRIBUTORS

B C - N U

RADIO PARTS CITY
STEVENS HOTEL — CHICAGO
June 8, 9, 10 and 11, 1938

RADIO PARTS MANUFACTURERS NATIONAL TRADE SHOW
53 WEST JACKSON BOULEVARD — CHICAGO, ILLINOIS

MORE SERVICE DATA

ELECTROLYTIC CONDENSER COLOR CODE FOR FAIRBANKS-MORSE 1938 SETS

★ With the positive (+) or center solder lug toward you, read the colored markings as follows from left to right.

Left Hand or Capacity Color

Black	0 to 9 mfd.
Brown	9 to 19 mfd.
Red	19 to 29 mfd.
Orange	29 to 39 mfd.
Yellow	39 to 49 mfd.

Second From Left or Maximum Voltage Color

Black	0 to 99 volts
Brown	99 to 199 volts
Red	199 to 299 volts
Orange	299 to 399 volts
Yellow	399 to 499 volts
Green	499 to 599 volts

If a third (blue) stripe is shown, the condenser is a regulator and should be in the position farthest from the rectifier tube in the filter circuit.

MICA VIBRATOR CONDENSER REPLACEMENT

★ An ingenious replacement for the vibrator two-section condensers consist of two "postage stamp" bakelite-molded mica condensers held together by twisting together and solder-dipping two of their leads to form one terminal, while the remaining two leads provide the other two terminals. In fact, these condensers are similar to those made for a manufacturer whose specifications call for 2500-volt AC test. The handy

combination designed for replacement in Motorola 65 and 70 sets provides the superior characteristics of mica condensers to withstand the vibration, heat and humidity of usual vibrator service, in place of the usual paper unit, and is actually lower in cost than the customary paper replacement, states Aerovox Corp., who are manufacturing the units.

AUTO SIGN GETS BUSINESS

★ A horizontal-type yellow-and-blue cardboard "Radio Service" sign about 14 inches long by 5 inches high, can be made up for automobile use. The card is set on the ledge inside the rear window while driving so as to be readable from the rear. While parked on a service call or other business, it can be set in the windshield or side window of the front seat. Often its use, while the car is parked, leads to inquiries and further service work. It also acts as a protection against objection to parking, since the policeman or traffic officer knows the business of the driver and usually extends friendly cooperation which leads to still more service business.

Kolster-Brandes models B15, B16

Low volume

★ When this trouble is experienced, it is a good plan to take no chances with the grid resistors, but to replace them with new 3,000 ohm units. For best results use wire wound units.

Echophone model S5

Dead

★ First remove the cardboard cover from the coils at the end of the chassis. Next, move the coils close together, making sure to keep them at 90 degrees angle with respect to each other.



Neat, orderly shop of A. J. Davis, Waukesha, Wis., almost doubles his efficiency. And to illustrate that point RADIO TODAY has shown Mr. Davis twice.

GET THIS EQUIPMENT ALMOST FREE!

.. with **Purchases of ARCTURUS TUBES**

DOWN PAYMENTS AS LOW AS \$3.00!

Down payments in the Arcturus Deal are without question the lowest ever offered — as low as \$3.00 in some cases! On an average you pay only about ONE-SIXTH the amounts required by other deals! This means an actual cash saving to you.

AND REMEMBER THIS IMPORTANT POINT: Under the Arcturus Equipment Deal not one cent has been added to our regular tube prices. You buy standard tubes at STANDARD PRICES, less standard discounts. To pay more than these standard prices on a deal probably means you are actually paying cash for the equipment. Think it over! Remember, also, that the Arcturus plan is still further geared to your needs in that required tube purchases are surprisingly low.

EXTRA PROFIT FOR YOU!

In short, the ARCTURUS EQUIPMENT DEAL brings you the opportunity of a lifetime to modernize your shop with the latest standard equipment—at almost no cost to you. You obtain possession of the equipment IMMEDIATELY—and finance it by your purchases of Radio's finest, best engineered tubes. Thus you profit twice from every tube you sell. You can't lose!

MAIL THE COUPON NOW!

ARCTURUS

ARCTURUS RADIO TUBE CO., Newark, N. J. T-5
Without cost or obligation on my part, send details of your new equipment deal.

Name

Street

City..... State.....

I am a dealer I am a serviceman

My jobber is.....

For your convenience this coupon can be pasted on a penny postcard

Centralab conquers 8 months of Rain!



... "climatic conditions here are severe . . . our 8-month rainy season plays havoc with radios. Since changing to Centralab we have replaced only three controls. Centralab is the remedy to our troubles in the way of 'comebacks', and we recommend them 100 per cent."

H. H. WRIGHT

Gen. Mgr.

DAY & NIGHT GARAGE CORP.
Panama City, Rep. of Panama

Down in Panama City where Mr. Wright is manager of the DAY AND NIGHT GARAGE CORP. it rains 8 months in the year . . .

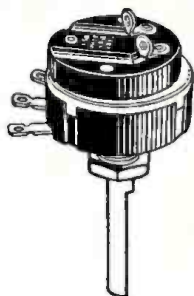

and the humidity plays havoc with radios. That's why Old Man Centralab is happy to quote from Mr. Wright's letter.

**Get the Centralab
Volume Control Guide**

Centralab

Milwaukee, Wis.

Division of Globe Union, Inc.

BRITISH CENTRALAB, Ltd.
Canterbury Road, Kilburn
London, N. W. 6, England

FRENCH CENTRALAB CO.
118 Avenue Ledru-Rollin
Paris XI, France

RSA REPORTS ITS MEMBERSHIP PROGRESS

★ We have now affiliated twenty-four local chapters in all parts of the country. Twelve petitions for affiliation from twelve additional local groups are on file in the national office at the present time.

The first issue of our house organ as well as the advance circuit diagrams on the Zenith radios went forward to our members on February 28, 1938.

The RSA wishes to take this means of thanking RADIO TODAY for its splendid efforts in behalf of the organization.

Chapter news

Freeport—Don Stover and S. A. Frank were chosen for nominees for District 10. Local dues were increased to \$5.00 a year—this sum to include national dues and a one year's subscription to a trade publication.

Flint—The Flint Chapter is celebrating its first year of existence and its affiliation with RSA, with a dinner and dance.

A membership drive got under way at the last meeting at which time the following officers were elected for 1938: Pres., Worden Stiles; Vice-Pres., Harold Wilke; Sec'y, James Pugh; Treas., Walter Mudge.

Binghamton—John Rose was nominated for the office of director from District 19 at the first meeting held in February.

Metropolitan N. Y.—Meetings are held the second and fourth Monday of each month at the Hotel Victoria. A telephone has been installed in the name of RSA in downtown New York, for the convenience of members and other interested parties.

The Technical Meetings are under the direct supervision of Ed Mandeville. The Chapter officers are: Chairman, George Duvall; Sec'y, Selig Rosengarten; Treas., J. J. Gonoud.

Manchester, N. H.—At a meeting of the Assn. of Radio Technicians, Chapter of RSA, held on February 1, 1938, a new constitution was submitted and accepted.

An interesting open forum was held on several subjects pertaining to radio at a meeting held February 15, 1938. Advertising was discussed and plans laid out to conduct a regular cooperative advertising campaign starting in the late summer and early fall.

★ Radio and appliance dealers of New Jersey have associated themselves in a new type of organization, the *Radio Electric Appliance League*, "combining the buying power of the chains, the personal service of the neighborhood store, with the combined skill of a hundred or more alert dealers in sales

promotion and merchandising." Membership is by invitation only. Officers are *Harold Veith*, *Franklin Furniture Co.*, Englewood, N. J., president; *Edward Gilseman*, *Gilseman Piano Co.*, Union City, N. J. vice-president; *William Kuss*, *Kuss Bros.*, Hackensack, N. J., secretary; and *C. W. Perdue*, *Perdue Radio Co., Inc.*, Montclair, N. J., treasurer. Managing director is *H. L. M. Capron*, 48 Overlook Road, Verona, N. J.

★ *Emerson Radio & Phonograph Co.* are cooperating with *Procter & Gamble* by awarding 40 radios as daily prizes, for a period of 30 days, in a huge nation-wide contest starting Mar. 28th on Camay soap. Coast to coast broadcasts, color pages in leading magazines, 300,000 grocery store displays, and \$1,000 daily cash prizes are parts of the stunt. Emerson model selected is the AM-169, 6-tube AC-DC superhet.

DEALERS GET TOGETHER NATIONALLY

★ First national meeting to be held in connection with the formation of a National Association of Radio and Appliance Dealers is set for Mar. 21 at the Hotel Commodore, New York City. The conclave opens at 9 a.m. and will include a special program and dinner at 7 p.m. It is expected that some 50 different U. S. cities will send representatives of their respective electrical associations, and that guests will number between 300 and 400.

Arrangements are being made by an organization committee of which *Russell A. Atkinson*, 4 Ralph Ave., Brooklyn, N. Y., is chairman. Reservations must be made by Sunday, Mar. 20.

SUCCESSFUL SALES ENGINEER WANTED

★ One of the largest manufacturers in the radio accessory field has an opening for an experienced radio sales engineer. The man wanted must be acquainted with all phases of the industry. Ability to do contact work essential. For the man who qualifies, the position offers unusual opportunity for a permanent and profitable connection. Write fully of your qualifications and experience. All correspondence strictly confidential. Address Box 123, Radio Today, 480 Lexington Ave., New York, N. Y.

MINICAM MAGNET

★ Bright new display for the "Minicam" camera is forthcoming from *Universal Camera Corp.*, 32 W. 23rd St., New York City. Designed for window or counter use and featuring the low price of the product, the display is free to dealers. It has a place to attach an actual camera.

APPLIANCES

(From page 40)

Goodman turntable displays



★ A whirling device for displaying small appliances and radio items. Turntables come with triple-tray superstructure of heavy gauge metal 9, 12 and 15 in. in diameter. Overall height 23 in.; can be taken down in sections. AC motor operated, carrying loads up to 75 lbs.; does not burn out if overloaded or stalled. Has three moving parts, self-lubricated No radio interference; daily operation cost estimated at 1c. With superstructure, \$20.00; without, \$17.50. Goodman's Rotary Radio Display Specialties, 19 W. 34th St., New York, N. Y.—RADIO TODAY—see also advt. p. 64.

Beverage and beverage-food coolers



★ Pelco line for hotels, restaurants, dairies, bowling alleys, lunch rooms, etc., includes two beverage coolers and two beverage-food coolers. Latter models are represented here by Model 112, with beverage compartment and refrigerator chamber below it. All models operate on "floating ice" principle, which means that a freezing cycle forms ice on the walls, and an "off" cycle allows the ice to break away and float. Thermostatically controlled. Finished in red baked enamel. No installation except plug-in to light socket. Refrigeration Division, The Portable Elevator Mfg. Co., Bloomington, Ill.—RADIO TODAY.



Auto Radios For 1938 by TRAV-LER

These new 7-Tube Trav-ler models have full 8 watts power output. Sensitivity is 1.5 microvolts at one watt output. Has full A.V.C. and three-gang variable condenser. Has the very latest features including iron core coils.

**TRAV-LER
RADIO**

7-TUBE AUTO SET with external 8 in. electro dynamic speaker—Model 711—Price, \$59.95

7-TUBE RADIO with self-contained 6 1/2 in. electro dynamic speaker—Model 710—Price \$49.95

The Trav-Ler Electric Automatic Tuning Unit is simple and accurate. No drift or backlash—instantly set up from the driver's seat without tools—any station on any button—6 buttons—motor driven. Mounting holes provided for easy installation. Price..... \$17.95

TRAV-LER RADIO & TELEVISION CORP. 1938

1921 1036 WEST VAN BUREN ST., CHICAGO, ILL.

AC AND AC-DC HOME SETS AUTO SETS BATTERY SETS

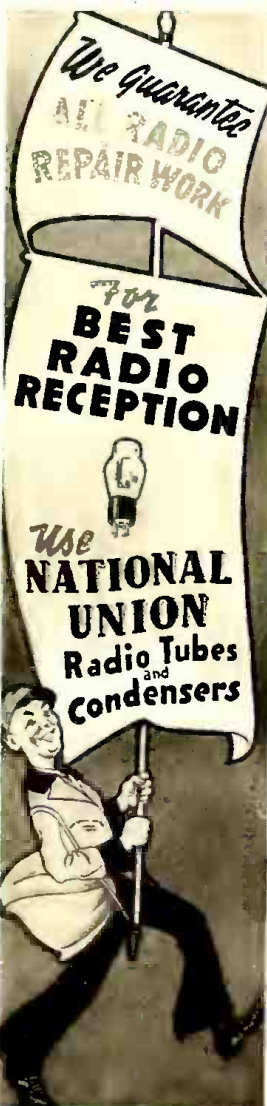

FREE EQUIPMENT given with purchases of NATIONAL UNION

Radio Tubes and Condensers

KEEPS THOUSANDS OF
SERVICE ENGINEERS

AT THE HEAD OF THE PROFIT PARADE!

● You can be up in the front lines for more business, more profits, too. You have to be well equipped to do it though. You need testers, analyzers, circuit data, technical information! These things would cost you lots of money if you had to buy them. Fortunately, you don't . . . you can get them *Free* the Easy National Union way. Here's all you have to do. Select what you need. Contract to purchase National Union radio tubes and/or condensers—make a small deposit which is refunded when your purchase contract is complete. You get the equipment right away . . . use it while you complete your purchases . . . then, it's yours free and clear. Easy . . . isn't it? Why not start on the N.U. free equipment plan. . . . Now?

**N.U. TUBES and CONDENSERS are
QUALITY PRODUCTS**

● Thousands of top notchers in the Radio Service Engineering profession are depending on National Union quality. It's the kind of precision and value that makes good friends for you. National Union quality will never let you down. . . . The National Union guarantee is your assurance.

NATIONAL UNION THE ROAD TO BETTER BUSINESS

1. Full guarantee on highest quality radio tubes.
2. Cut price business not solicited.
3. Price Protection.
4. N. U. jobber stocks are complete...No hunting for odd types.
5. Timely business building aids.

NATIONAL UNION RADIO CORPORATION RT-338
570 Lexington Avenue
New York City

Who is the nearest N.U. distributor?

Name.....

Address

City..... State.....



Two Tube Checkers In One!

QUALITY STANDARD
OF THE RADIO
INDUSTRY



Dynastest 2-in-1 Counter and Portable Checker

\$34.50

FREE
COURSE IN
VISUAL SERVICE
WITH ANY C-B UNIT

ACCURATELY calibrated against mutual conductance standards established on our master laboratory instrument, the C-B Dynastest 2-in-1 Tube Checker affords most conclusive indication of actual tube efficiency attainable in a checker of moderate cost. Rapidly and completely checks all tubes on simple "Good-Bad" scale, including ballast tubes and rectifiers. Special high sensitivity neon check for inter-element

leakage. Improved flexible switching system anticipates future tubes. New, quick-finding, numerically indexed, copyrighted, easy-reading chart detachably mounted inside cover, with extra display wall chart. Handiest and most compact instrument made. Dimensions, with cover only 11 1/2 x 9 3/4 x 5. All-steel, unweld construction, beautifully finished in C-B dark green, military gray, black and silver. Cabled wiring. Easily your best buy!

2827 W. 19th St. **The CLOUGH-BREngle CO.** Chicago, Illinois



NEW B9 CRYSTAL MICROPHONE

List Price
\$22.50
8' cable and plug

A small, lightweight, crystal microphone, with good response and high output. It is semi-directional and notably free from feedback. This unit has a wide range of applications, enhanced by the available accessories. The B9 is singular in that it is equipped with a plug at the microphone, thus making cable replacement a simple operation. Chrome finish. Complete with plug and 8' cable. Standard 5/8-27 fitting.



REQUEST CATALOG NO. 27 FOR COMPLETE DETAILS

All crystal microphones licensed under patents of The Brush Development Co.

AMERICAN MICROPHONE CO., INC.
LOS ANGELES, CALIF.

JANETTE ROTARY CONVERTERS

FOR CONVERTING DIRECT TO ALTERNATING CURRENT



● Built in capacities from 35 to 3250 volt amperes—with or without all wave filters. Dynamotor construction—economical to operate—ruggedly built for years of trouble-free service—used or recommended by the largest manufacturers of sound apparatus—in use in all countries of the world—Send for prices and data.

Janette Manufacturing Company

556-558 West Monroe Street Chicago, Ill. U.S.A.
BOSTON - NEW YORK - PHILADELPHIA - CLEVELAND - MILWAUKEE - LOS ANGELES
DETROIT - SEATTLE

NEW BOOKLETS

★ In a new catalog 400-AX, three transformers for use with the new Kinescope television tubes, along with three new replacement type output transformers and a new modulation transformer, are announced by Thordarson Electric Mfg. Co., 500 W. Huron St., Chicago, Ill. Copies are free from jobbers or will be mailed on request from Chicago. Company has also issued supplement 243S, a complete listing of replacement transformers for all 1937-1938 broadcast receivers listed in Rider's Volume VIII, free to all registered Encyclopedia owners. Original Encyclopedia plus supplement is available free from jobbers, or for 15c from Chicago.

★ Released by Wholesale Radio Service Co., 100 Sixth Ave., New York City, is the new Spring and Summer catalog 71, featuring new Lafayette receivers, advanced PA systems, and a new camera section. Copies come from New York or from branch offices.

★ A new stamp and premium book has been issued by Tilton Electric Corp., 15 E. 26th St., New York City, on Extat products. Booklet lists several dozen premiums available for coupons earned singly for each 5c unit of purchase.

★ A new style data book on carbon composition fixed resistors has been released by Centralab, 99 E. Keefe St., Milwaukee, Wis. Copies will be sent to those writing for form 647.

★ A special folder with over 160 replacement listings of motor starting capacitors, by motor make and model number, will be sent on request by P. R. Mallory & Co., Inc., Indianapolis, Ind. The folder indicates what capacitors to use, tells how to install, how to test, etc.

★ International Trading Corp., 386 Lamington Road, Bombay, India, has issued a 42-page catalog of radios, parts and appliances.

★ Recently published by Philson Mfg. Co., Inc., 156 Chambers St., New York City, is a folder on auto radio aerials, including side cowl, door hinge, window pole, rear bumper, running board and "Top-tenna" types.

★ The David Bogen Co., 663 Broadway, New York City, have 3 new and complete catalogs of their sound equipment: a 16-page catalog of amplifiers, complete sound systems and public address accessories; an 8-page catalog of wireless, wired intercommunication systems and paging systems; a 4-page catalog on centralized institutional program systems and school systems. Bogen Co. have also issued new specification sheets on all sound equipment. All material available on request.

JIM QUAM Says



When we hear all this talk about business being off, we start wondering. We're doing very nicely ourselves — factory running near capacity, orders coming in, the future looks pretty good, and we're very happy.

Perhaps we're more fortunate — but we suspect that those dark glasses the girls all wore last summer are now the style in business. Personally, we don't like them — or the rose colored kind, either. And, though we may be wrong, when you look at business prospects without glasses, they're really not so bad. Maybe, after a spell of just "sawing wood," we'll find business pretty much all right. And, in the meantime, let us show you how much better it would be with a true-toned Quam Speaker in your set.

QUAM-NICHOLS CO.
33rd Place & Cottage Grove CHICAGO 1674 Broadway NEW YORK





Model 600 & 700 Model 500

SHORT WAVE CONVERTERS FOR CAR RADIOS

Can be attached to any car radio. Has on and off switch. Does not affect the reception on the standard broadcast bands. MODEL 600—covers 49, 31, 25, 20, 19 and 16 meter bands. Designed for reception of American and Foreign short wave broadcast. Especially adapted to use in tropical countries and the more remote parts of the world. Distance range 5000 to 10000 miles. A very attractive unit. List Price **\$24.95**

MODEL 700—Long wave converter covers 135 to 410 Kc. Used in U. S. to receive government weather reports, ships at sea, etc., in cars and boats of the water front districts. Designed also for use in Europe and Asia. List Price **\$24.95**

For Use of Police and Other Law Enforcement Officers

MODEL 100—Police converter with fixed condenser. Covers 1500 to 2600 kilocycles. List Price **\$11.95**

MODEL 800—Super Sensitive police converter with fixed condenser. Covers 1500 to 2600 kc. Two metal tubes, exceptional distance range. List Price **\$15.95**

MODEL 200—Police converter with variable condenser and illuminated dial. Covers 1500 to 5500 kilocycles. List Price **\$17.95**

MODEL 500—Police converter with two metal tubes, variable condenser and illuminated dial. Very sensitive. Exceptional distance range. List Price **\$21.95**

ALL WAVE ANTENNAS—Model A—Hinge Mount telescopic, 60 in. long. List Price **\$3.50**

JOBBERS AND DEALERS WANTED

A B C RADIO LABORATORIES
3334 N. New Jersey Street
Indianapolis, Indiana, U. S. A.

AMERICAN FAIR TRADE LEAGUE

★ Radio looks with genuine interest to a New York City event set for April 4—a big testimonial dinner to be given for U. S. Senators Capper, Miller and Tydings, to celebrate the adoption of the Miller-Tydings Fair Trade Act, and the passage of the Fair Trade laws in 42 states.

To serve as a clearing house for detailed information on all the state and national laws, the American Fair Trade League will be reorganized and revived at this dinner, which is expected to have a guest list of 2,000.

The American Fair Trade League was founded 25 years ago by Mr. Justice Brandeis and William H. Ingersoll. The latter is now a member of the organizing committee, which includes Russell A. Atkinson, chairman of the League of Metropolitan Appliance Retailers.

★ Hal P. Shearer, president and general manager of the *Connecticut Telephone & Electric Corp.* as well as vice-president and general manager of *Air Devices Corp.*, both of Meriden, Conn., has purchased the controlling interest in Halson Radio Mfg. Co., Norwalk, Conn., and will move the plant to Meriden. The new firm will be known as *Halson Radio & Television, Inc.*, and will start production of long and short wave sets and television devices about Mar. 20. Mr. Shearer has leased 25,000 sq. ft. of floor space in an old Aeolian plant in Meriden to house the Halson operations. He will retain his highly successful connections with the other Meriden firms and dedicates his new project to an expected upturn in business. Charles and Phillip Halpern, former owners of the Halson company, will be active, along with Benjamin Fox, chief engineer.

★ F. B. Connelly Co. of Portland and Seattle have been appointed distributors for *Emerson* in Western Washington and the state of Oregon. Sales meetings have been held recently with Charles Weiser, Pacific Coast manager for Emerson, outlining his company's plans for the season.

The Portland branch of the Connelly company have moved into a new building (more than twice the size of the former one) at 835 N.W. Flanders St. The firm now has four floors with all modern facilities, and assures its dealers of improved service.

THEY CAN'T BE BEAT!

OHMITE Brown Devils



Take the best resistance wire, wind it accurately on the best available ceramic forms, completely seal it against moisture and corrosion with special OHMITE VITREOUS ENAMEL—that's an OHMITE BROWN DEVIL! It's the simple story of a perfected design, conscientiously built to give the ultimate in resistor performance. Behind it, of course, is a long history of painstaking research for the best in materials and processes.

Try OHMITE BROWN DEVILS now. In 1 to 100,000 ohm units rated at 10 and 20 watts—they simply can't be beat!

See Your Jobber or Write for Catalog 16.

OHMITE MANUFACTURING CO.
4847 W. Flournoy Ave. Chicago, U. S. A.



OHMITE

RHEOSTATS RESISTORS TAP SWITCHES

"The World's Best Value"



KADETTE RADIOS

INTERNATIONAL RADIO CORPORATION, ANN ARBOR, MICHIGAN, U.S.A.

"TOKFONE"—The 1938 Sensation!

**Gives You Everything
PEP • PUNCH • PRICE**



**TOKFONE, Jr.
Master Station**

"TOKFONE," Jr.

Consisting of Master, Remote Station and 50 ft. of wire.



**TOKFONE, Jr.
Remote Station**

**AT
AMAZINGLY
LOW PRICE**

**The Biggest Buy in
Communication Systems**

NOTHING CAN TOUCH IT!

GET YOUR SHARE!

.. CRASH THIS FERTILE MARKET!

If you're in a position to "CASH-IN" with FAST MOVING-LOW PRICED intercommunication systems then you owe it to yourself to get in touch with REGAL—NOW!

• Note These Facts! •

OTHER TOKFONE SYSTEMS—adaptable to meet all requirements—from 2 to 40 stations—beautifully hand-rubbed cabinets—NO PREFERENCES—NO TRICKS—No Makeshifts—All New Merchandise—Special Units if Necessary—No Quotas—No Contracts—Buy as You Need Them—Manufactured in our own factory—we stock them.

We also Manufacture P.A. Equipment in the following sizes: 6, 12, 15, 30, 60 Watt—Amplifiers—Parts used are: Aerovox-Thordarson—I.R.C.—Parmet-Rola—Clarostat-Eby and Holyoke—Nothing but the best.

**SEND FOR CATALOG SHOWING COMPLETE LINE!
REGAL AMPLIFIER MANUFACTURING CORP.
14 WEST 17th STREET Cable address "Ramcamp" NEW YORK CITY**

SALES AID

MISS SYLVANIA SINGS



★ A new window display has been added to Hygrade Sylvania's "Girl" series. The handsome blonde who is familiar as "Winking Girl," "Kicking Girl" and "Opera Girl" now hits a high "C" as a radio artist.

In this display the singing voice is shown opposite the yowl of an alley cat. Both figures appear behind a fence picketed with representative tube types. Background is rich blue, and flasher lights are provided to illuminate the cat's green eyes and the word "tubes."

Sylvania has also announced a new counter and wall sign for dealers and servicemen. It features the company's 6-months' guarantee plan by reproducing a guarantee certificate. It is lithographed in three colors on heavy cardboard and ties in with Spring sales drives. It has an easel for standing display, and a cord for hanging on a wall.

RECOTON EYE-CATCHER

★ A new display for counter or window is being released by Recoton Corp., 178 Prince St., New York City. The placard is a lively-colored card which identifies the dealer with phonograph needles, and illustrates the Recoton needle with its special shaft and round point. Actual packages of needles are not used in the display, as many dealers have found it unwise to keep such small items out on the counter. This placard is designed to remind the customer, while the dealer keeps his actual stock elsewhere.

MOVIE TRAILERS FOR DEALERS

★ Now available to farm radio dealers is a series of 60-second movie trailers suggesting the use of 6-volt farm radios equipped with Winchargers. The films will be made available to those writing to Wincharger Corp. Sioux City, Iowa. These movies show the pleasure of "big city" radio reception for 50c a year power operating cost, and dramatize the advantages of



**Model
430
DEALER
PRICE, Only
\$19.80**

**Judged by the
number in use . . .
TODAY'S MOST
POPULAR
TUBE TESTER**

- HAS LINE VOLTAGE ADJUSTMENT
- HAS LEAKAGE AND SHORT TEST
- USES TRIPLETT DIRECT READING INSTRUMENT (GOOD-BAD) SCALE

Readrite

Positively Checks Radio Tubes According to Latest Recommendations of Tube Engineers. Five flush type sockets provide for all tubes. The tester operation is very simple and indicates condition of the tube for dealer and customer on Direct Reading (GOOD-BAD) colored scale of Triplett instrument. Will also test for interelement shorts and leakages. Complete in attractive, sturdy, quartered-oak case. Sloping etched panel of silver and black. Suitable for portable or counter use.

Model 431 same as 430 except has Readrite (GOOD-BAD) Meter
Dealer Price \$15.90

**A MODIFIED EMISSION TYPE TESTER
APPROVED CIRCUIT**

READRITE METER WORKS, 319 COLLEGE AVE., BLUFFTON, O.
Please send me more information on Model 430.
Model 431
Name _____
Address _____
City _____
State _____

wind power. The appearance of the films is the first step in a new and widespread dealer cooperative advertising campaign soon to be opened by the company.

★ A bit of Chicago radio news which made fine reading turned up recently when Paul J. Pfohl, RCA Radiotron representative, announced the birth of a son, Roger Lee. P. O. Krumm, purchasing agent for Sentinel, took a striking photo of Roger Lee and soon thereafter the picture appeared on a birth announcement deftly prepared in the form of a miniature 4-page edition of the magazine, "Life."

★ There is plenty of optimism these days at the plant of Quam-Nichols Co., manufacturer of loud speakers, for according to Jim Quam, president of the company, February shipments were within \$97.00 of last year's figures and March shipments may run ahead of last year.

★ Another marriage at Wholesale Radio Service Co., New York City, is that of Guy Maken, assistant purchasing agent, to Miss Florence Roscher, Brooklyn, N. Y.

★ E. F. Carter has been named assistant chief engineer for Hygrade Sylvania radio tubes, according to chief engineer R. M. Wise. Mr. Carter has been in the firm's engineering dept. for 8 years, with various promotions, and has been handling the duties of assistant chief since last September.

★ J. B. Price, Eastern Division mgr. for Utah Radio Products Co., Chicago, with headquarters in New York, first president and one of the founders of the "Representatives" resigned from this organization this week, owing to his inability to give sufficient time to the activities of this group of trade members. To his keen regret, Mr. Price found it necessary to resign, not only as a member, but as Chairman of the Board of Governors, and as a member of the committee sponsoring the special train to the Chicago Parts Show in June.

★ Before leaving for Florida on a well deserved vacation, George Russell, Sentinel sales manager, commented upon the fact that several of the company's jobbers had reported exceptional success on intensive sales drives over a period of the past two or three weeks. These jobbers are sending their men out to cooperate with their dealers wherever possible and the results are apparently well worthwhile. Mr. Russell found all Sentinel jobbers going after business actively in Minneapolis, Omaha, Denver and Kansas City, which he visited recently on his sales swing.

★ The Radio Reel Co., Tacoma, Wash., who recently introduced the Hush-Tone radio volume control, has informed the trade that because of added improvements the list price of this attractively packaged accessory is now \$8.50, with standard trade discounts.

Listen RADIO SERVICEMEN!

FOR a long time there had been a real need for a Radio Servicemen's Organization that could band together the competent radio servicemen in a democratic, self-governing association without subsidy from or control by any other division of the radio industry.

Radio Servicemen of America, Inc., has this as its prime objective.

But to achieve this end and win a place for the service group as a recognized factor in this complex industry, four things are necessary:

- A** The selection of only qualified members.
- B** A direct voice in the affairs of the association by every individual through elected, regional representatives.
- C** The insistence upon rigid ethical professional standards that will earn a right to the confidence and cooperation of manufacturers and publishers.
- D** A quality of service that will earn the respect and patronage of the public.

These objectives are assured in the newly completed plan of Radio Servicemen of America, Inc. **HERE'S WHY!**

- 1** There are 20 districts, each of which is represented by elected representatives, for all the affiliated chapters in that district.
- 2** Qualifications for membership are determined by local chapters.
- 3** Local membership in a local chapter where such local chapters exist, is necessary to full membership in the national organization.
- 4** Quality, not quantity is the membership aim.

BUT SERVICE TO ITS OWN MEMBERSHIP is a Big Personal Reason WHY YOU SHOULD HAVE A MEMBERSHIP IN RADIO SERVICEMEN OF AMERICA, INC.

Regular mailings of advance information on new circuits. . . . A monthly house organ, exclusively for members. . . . A publicity program in newspapers, trade publications and on the air. . . . Free, expert technical information. . . . A National Speakers' Bureau to provide authoritative speakers for local chapters. . . . An educational program in the interest of better servicing. . . . Membership costs only \$2.00 a YEAR for national dues for 1938.

DON'T WAIT!

Fill out the application. We will send you full details of the organization, more application blanks . . . everything you need to join this new and important effort to organize servicemen for better servicing and more profit. Mail the blank today with your check to

RADIO SERVICEMEN OF AMERICA, Inc.
JOE MARTY, Jr., Executive Secretary, 304 S. DEARBORN ST., CHICAGO, ILL.

◆ SPONSORED BY RMA AND SALES MANAGERS' CLUBS ◆

RADIO SERVICEMEN OF AMERICA, Inc.
 (Incorporated Not for Profit)
 304 S. Dearborn St., Chicago, Ill.

Application for Membership

Gentlemen:
 I hereby make application for membership in the Radio Servicemen of America, Inc.

Affiliated with Local Chapter in

Personal Name

Home Address

City

State

Firm Name

Address

Telephone (home)

(firm)

Years' Experience

Age

Membership in other Associations

Whole or part time Radio Serviceman

If part time, what portion is devoted to Radio Servicing (1/4, 1/2, 2/3, etc.)

What are your other duties

Education other than Radio

Radio Training or Courses

Testing Equipment

It is my sincere desire to become a member and adhere to your principles of fair competition and ethics and if accepted do solemnly swear (or affirm) that I will faithfully fulfill my obligation as a member of the Radio Servicemen of America, Inc.

Signed

Applicant

Approved: Chapter Secretary

Executive Secretary

Enclosed Check M. O. Cash

— 1938 —
TOPSTREAM
MOBILE AERIALS
ARE BEST

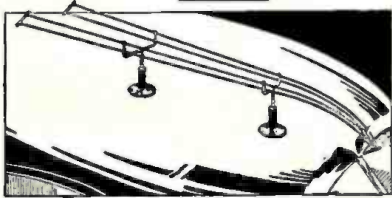

- MAXIMUM PICKUP
- EXCLUSIVE "KNEE ACTION" MOUNTING
- TEN MODELS TO FIT EVERY CAR
- WARRANTED RUST PROOF
- PRICES MOST REASONABLE
- LICENSED AND MANUFACTURED UNDER PATENT 105067

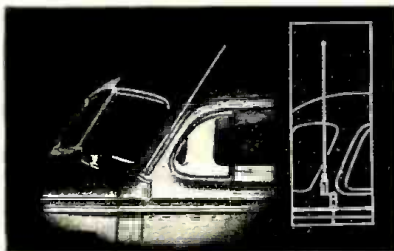

Sales Offices in All Principal Cities
 For Descriptive & Price Folder, consult
 your nearest jobber or write to
TOPSTREAM, INC.
 1811 S. LYNDALE AVE., MINNEAPOLIS, MINN.



New

RECOTON

Phono-Attachment

Its original design makes a definite prospect of an owner of ANY type radio console (fits on top) . . . midget (underneath). The SINGLE FRONT OPENING makes this possible. High fidelity crystal pickup giving studio tone. Genuine walnut cabinet—hand rubbed lacquer finish. Write for other features.

AUTOMATIC DISPENSER CUPS

Press the center—
 a needle appears.
 Always works.
 Novel :: Useful
 Decorative



RECOTON CORP.
 178 Prince St., New York

JOBBERS

★ *Brown Supply Co.* of St. Louis and *Charles F. Scott* of Scranton, Pa., have been appointed distributors for Stromberg-Carlson, it was announced by *Lee McCanne*, radio sales manager for *Stromberg*. The up-state New York territory previously sold by the *Graybar Electric Co.* of Syracuse has been divided into three sections. The Watertown area has been taken over by the *Hudson Valley Asbestos Corp.*, Albany Stromberg-Carlson distributor. The Binghamton-Auburn section has been converted into a direct dealer territory, to be contacted by *Lawrence Loveless*, while the Syracuse and Oswego region will be served by *Stanley Manson*, also as a Stromberg-Carlson direct dealer area.

★ To get complete details of the new *Zenith* auto radio line, and to hear about the company's new "Radio Nurse," the firm's distributors met recently at three regional conventions: Feb. 28 at the Sir Francis Drake Hotel in San Francisco; March 4 at the general offices of the Zenith Corp. in Chicago, and March 7 at the Waldorf Astoria Hotel in New York City.

★ *Bruno-New York, Inc.*, and *Krich-Radisco, Inc.*, Newark, N. J., were hosts to about 150 dealers at a presentation of several new *RCA-Victor* products held at the Hotel Pennsylvania on March 8th. *T. F. Joyce*, advertising and sales promotion manager of the *RCA-Victor Co., Inc.*, was in charge of the presentation which featured the new Victor Record player and the new Victor Symphony receiver. Mr. Joyce presented a most effective sales story in connection with these products, also commenting upon the extraordinary progress that has been made in the development of the Victor Records Society.

★ *C. A. Stoll*, 139 Alton Ave., Dayton, Ohio, has been appointed representative for *Clarostat Mfg. Co., Inc.*, Brooklyn, N. Y. Mr. Stoll replaces *W. W. Boes*, and is an expert on resistance problems.

HICKOK RADIO TESTING INSTRUMENTS

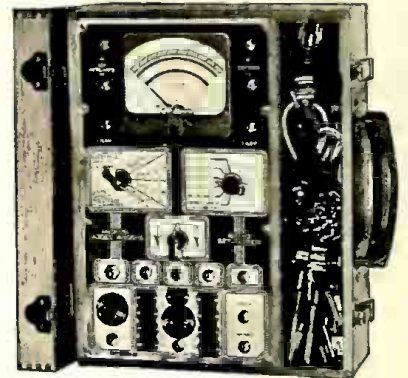

**HIGHEST
 ACCURACY**
for 20 Years

As a pioneer developer and builder of radio testing equipment and as an outstanding manufacturer in this field for many years, Quality and Accuracy have had first consideration in every Hickok Instrument.

For absolute reliability use these
HICKOK TESTING INSTRUMENTS

- Tube Testers
- Set Testers
- Oscillographs
- Signal Generators
- Zero Current Voltmeters
- Volt-Ohm-Milliammeters
- Frequency Modulators
- Appliance Testers
- Panel Instruments

Write today for a copy of latest catalog showing all of these Hickok Radio Testing Instruments.

HICKOK
ELECTRICAL INSTRUMENT CO.
 10419 Dupont Ave. Cleveland, Ohio

**A GOOD NAME
 GOES A LONG WAY**



Ken-Rad means perfect radio performance to the user. It means increased business for the dealer. It pays to tie in with Ken-Rad.

KEN-RAD TUBE & LAMP CORP.
 OWENSBORO, KY.

★ **KEN-RAD** ★
 DEPENDABLE RADIO TUBES



"Bob" Campion (center), the Raytheon representative, is photographed with James Gould, left, and R. L. Ross of R. L. Ross Co., San Antonio jobbers.

★ *Haskel A. Blair*, sales manager for *David Bogen Co.*, sound equipment manufacturers, has been touring the Southwest to call on sound specialists and parts jobbers. Mr. Blair also went to Mexico to establish distribution for Bogen and to aid salesmen with outlines of the new merchandising and sales features of Bogen intercommunicators and PA equipment.

★ Two execs of *General Electric's* radio division, *C. M. Wilson*, sales manager, and *Arthur A. Brandt*, advertising manager returned recently from a long field trip through the major markets. They found retail sales increasing, GE jobbers generally optimistic.

★ *Braid Electric Co.*, Nashville, Tenn., *Zenith* distributors of which *Ben. S. Gambill* is president, have recently been appointed jobbers for Middle Tennessee for the *Kelvinator* line of domestic appliances. Mr. Gambill reports that new Kelvinator dealers are rapidly being named.

★ *Philco's* New York division, headed by *Hal Sheer*, was the winner of the company's *Sales Manager's Cup* competition. The Cup is awarded to the division leading the country in auto radio sales at the half-year mark.

Cliff S. Bettinger, *Philco's* Pacific division manager, has announced final standings for the later half of 1937. In receivers *Heine Grimm* was first; in XX models, *Harold Dishon*; in auto radio, *Eustace Vynne*. Placing first in final standings for *Philco* distributors was *Ralph Drew*, Fresno, Calif.

★ *F. G. Klock* and *J. J. Shapiro*, executives of *Universal Camera Corp.*, 32 W. 23rd St., New York City, have returned from a U. S. tour which amounted to a survey of the camera industry, conducted with a view of lending further merchandising aid to *Univex* dealers and distributors. *Universal Camera* recently opened a company branch in Toronto, Canada, at 345 Adelaide St.

★ Introduced by *Weston Electrical Instruments Corp.*, Newark, N. J., is a new idea to aid servicemen in convenient purchasing of test instruments. A "quick facts" tag is now attached to each unit, which gives a concise summary of what the instrument will do.

★ "Free Passes" to *Radio Parts City*, the home of the 1938 *National Radio Parts Trade Show* at the *Hotel Stevens* in Chicago June 8-11, are being issued to companies who contract for space up to the middle of March. Firms get 1,000 passes for each booth occupied.

★ *National Union Radio Corp.* has a new district manager, *J. J. (Jack) McBride*, to cover Indiana, Ohio, Michigan, Northern Kentucky and the city of Chicago, according to *NU* general sales manager *Homer H. Kunkler*. Mr. McBride's experience has been with *Grunow*, *RCA*, and others; he will now contact dealers and distributors in the interest of *NU* product merchandising.

★ *Albert Finkel* of *J.F.D. Mfg. Co.*, 4111 Ft. Hamilton Pkwy., Brooklyn, N. Y., will shortly establish headquarters in Chicago, covering Illinois, Ohio, Wisconsin, Missouri, Iowa and Kansas.

BOGEN SOUND SYSTEMS

"ALWAYS FIRST WITH THE LATEST"

Bogen has consistently pioneered important improvements in sound. Recent surveys of sound specialists show that Bogen equipment is gaining preference rapidly because of its advanced design and high performance.

UNIVERSAL MOBILE SYSTEM

For 6 volt DC and 110 volt AC

A TIMELY SYSTEM FOR THIS PERIOD OF THE YEAR — FOR MOBILE OR STATIONARY JOBS.

No plug in power packs. Instantaneous switch over. 28 watts undistorted—peak 35 watts. Universal microphone input. Duo stage electron mixing. "Standby" switch for battery economy.

CP28D System . . . list \$256.50

Consists of C-28 amplifier with phono assembly. Sylvania tubes. "Transducer" bullet hand mike, with 25 ft. shielded rubber covered cable, 2 Jensen PM12B dynamic speakers, each with 10 ft. rubber covered cable and polarized plug.

DAVID BOGEN CO., Inc.
663 Broadway, New York City



PIONEERS IN PUBLIC ADDRESS DEVELOPMENT



Use the MOTOR that sells RADIO-PHONOGRAPHS

POPULAR PRICED radio-phonographs equipped with General Industries Flyer Motors sell better. They demonstrate better — and it is fine playing by the phonograph that swings sales of combinations. You are sure of high-fidelity reproduction, regardless of changing record drag . . . Go after the growing business in combination sets. Install Flyer Motors.

HAVE YOU TESTED MODEL V?

Types for AC or universal AC-DC. Popular Model V, with governor control, has set-screw speed adjustment. Find out how remarkably efficient Flyer Motors are. Order samples for testing. Please specify exact voltage and frequency of current you use.

The GENERAL INDUSTRIES CO. 3838 Taylor Street
Elyria, Ohio

QUALITY RECOGNIZED BY ALL



ELECTROMETER SERIES 700 \$49.95

A complete laboratory of compact size for thorough tube analyzing and point to point set testing, incorporating 22 ranges for measurements of A.C. and D.C. voltages, current resistance, decibel and output.

Accuracy guaranteed by use of wire wound shunts of 1% tolerance and matched resistors of 1% tolerance.

Endorsed and used by leading engineering concerns, broadcast stations and institutions.

See "PRECISION" instruments at your distributors or write for literature.

**PRECISION
APPARATUS CORP.**
821 EAST NEW YORK AVENUE
BROOKLYN, NEW YORK

SERVICE INSTRUMENT RACKETS

(Continued from page 23)

sequently, such a meter cannot be classified as a no-current drain type meter even on DC since the resistance is not infinite.

Wave form in audio oscillators

While variable audio oscillators are not widely used, some of the units are greatly lacking. Wave form in some cases is extremely bad, being chock full of harmonics. Examination on an oscilloscope will readily reveal the status of the waveform. Naturally, the distortion will be greater at low frequencies. From about 150 cycles up, the wave-form should be substantially linear. The frequency calibration of the audio oscillators is easily checked by using a piano and feeding the oscillator into a speaker.

The audible frequency spectrum published on page 2 of Part II of Radio Today for January shows the frequencies of the various piano keys. Comparison should be made by adjusting the audio oscillator to zero beat with the piano. Middle C for instance is 256 KC on the Physical scale. (Usually pianos are tuned on the International pitch which places middle C at 261.6 instead of 256). While the highest note on the piano is 4,048 or C⁴, harmonics can be zero beated the same as with a R. F. oscillator. C⁴ on the International pitch scale will be 4,192 cycles. However, for most practical purposes, the Physical scale with its middle C at 256 will be satisfactory.

Tube testers are an item that are hard to evaluate, since their usefulness is dependent more upon the manufacturer's preliminary work on determining the tube limits. (Boundaries for good and bad units). Even the best of material and workmanship will not make a good tube tester unless the limits have been accurately determined. Seems that the best guide is to buy from the reputable manufacturers in the tube tester field.

Short-comings of tube testers

There are other shortcomings in tube testers. Some units place too high a voltage on battery type tubes and consequently will spoil the filament because of too great an emission. Sockets in the testers should not grip the tube prongs too tight since with constant use they will

PRECISION EQUIPMENT IS APPROVED



SERIES 840 L -VOLT-OHM- DECIBEL - MILLIAMMETER

including a
2500 VOLT A.C. and D.C. RANGE
and a 1000 M.A. RANGE

Specifications
* 5 A.C.—D.C. VOLTAGE RANGES from 0 to 2500 volts at 1000 ohms per volt.
* 4 D.C. CURRENT RANGES from 0 to 1 amp.
* 5 OUTPUT RANGES
* 3 RESISTANCE RANGES from 0 to 10 megs. (provision for self-contained batteries).
* 5 DECIBEL RANGES from -10 to plus 63DB

Net price less batteries and test leads..... \$19.95

**PRECISION
APPARATUS CORP.**
821 EAST NEW YORK AVENUE
BROOKLYN, NEW YORK

1938 RADOLEK
The Most Complete Radio
Buying Guide FREE

Everything you need in radio. It's all in this new RADOLEK RADIO PROFIT GUIDE. Every repair part for every receiver. Newest radio receivers. New 1938 model public address amplifiers, outputs for 5 to 100 watts. New model public address speakers. Test instruments. Technical books. Special equipment. Leading standard brands. Every item guaranteed. It must be right or we make it right.

And everything under one roof. You get what you want promptly, and exactly what you want. Radolek's immense stock plus Radolek's efficient organization insures you fastest service. 25,000 service men depend on this service and benefit by Radolek's lowest prices. Send now for your copy of Radolek's Radio Profit Guide. It will help you make more money.

---RADOLEK---
601 W. Randolph, Chicago, Dept. D-17
Send me the 1938 Radolek Radio Profit Guide FREE.

Name

Address

Service man? Dealer? Experimenter?

CROWE INTER- CHANGEABLE ON-THE-PANEL CONTROLS



NEARLY four million auto radio sets, new within the last three years, offer you an unusual opportunity.

Sell Crowe On-the-Panel Controls to re-install these still-serviceable radios in new cars and to replace old-fashioned underdash or steering column controls in owners' present cars.

Crowe Controls are interchangeable for all cars and most makes of radios. Airplane or porthole dials. Easy to install. Economical to stock.

See Your Jobber
Go after your share of this replacement business. Get a stock of Crowe Controls from your jobber.

ASK FOR
BULLETIN

CROWE NAME PLATE & MFG. CO.
1745 GRACE STREET CHICAGO
CABLE ADDRESS: CRONAME-CHICAGO

soon wear out. In a receiver this is not true, for in the usual life of the set, the tubes will not be removed more than a dozen times, but in tube testers the sockets are used thousands of times. Then, too, there is the convenience angle. For rapid, accurate operation the controls should be handily located, and tube charts easily read.

A few other minor items that have been noticed follow. Some ohmmeters in order to achieve measurement of extremely high resistances use voltages as high as 300 or 400

without an automatic protective switch. Contact across such a voltage while not dangerous is uncomfortable. When using a hi-voltage ohmmeter the serviceman should consider the circuit under test and not use high voltages with low voltage components unless he is planning an overhead test.

Also some of these megohmmeters have poorly insulated terminals and the collection of dust and oil soon places a resistance of a few megohms across the terminals. Then the measured values of high resistors are in error.

THORDARSON'S UNIQUE DEMONSTRATION

★ The new Thordarson amplifier line was introduced to parts distributors throughout the country on March 7th in one of the most unique sales presentations ever sponsored



Center row—V. K. Ulrich, technical editor, RADIO TODAY; Charlie Cooper and John De Blasi.

in the radio parts industry. Thordarson jobbers gathered in the evening in Boston, New York, Buffalo, Philadelphia, Washington, D. C., Detroit, Atlanta, New Orleans, St. Louis, Dallas, Tulsa, Salt Lake City, Portland, Ore., Los Angeles, San Francisco, Kansas City, Mo., and Minneapolis.

★ Newest part of the engineering expansion program under way at *Andrea Radio Corp.* is the addition of *James Bonelli* to the staff. Mr. Bonelli was a research engineer at *F. A. D. Andrea, Inc.*, from 1928 to 1934, and in his new berth will again work under pioneer *Frank A. D. Andrea*. New personnel will be divided between the increasing demands of the export dept. and the special requirements of the firm's new domestic line.

Recently the company put in a novel display of "Climate Sealed" receivers at Rockefeller Center,

a representative group of distributors and amplifier experts from Chicago and vicinity. At the close, the jobbers in the different cities were the guests of the Thordarson sales representatives, and the new amplifier line was thoroughly inspected by the distributors and their sales organizations.

New York City, on the "concourse" near where the famous Radio City guide tours start.

★ *Mary Ellen DeWees*, weighing 7 lb. 15 ounces, arrived Feb. 20, at the home of *Mr. and Mrs. Clifford DeWees*. Mary's gifted father is the advertising manager of the *Stewart-Warner*, radio and refrigerator divisions, and her advent was signalized by the mailing of a dainty ten-page three-color folder, with pictures in baby-blue and baby-pink, captioned in running verse around the theme "All for one and one for all; ever at her beck and call."



Noises DIAGNOSED

- By all means include on AEROVOX NOISE ANALYZER in your servicing equipment. It solves those line-noise problems—quickly, accurately, profitably.
- Merely plugs in between noisy appliance and line, or between set and line. Turning of knob cuts in different types of filters. Dial indicates AEROVOX NOISE ELIMINATOR to use to duplicate results.
- Indispensable to the well-equipped serviceman. Standard equipment with leading service organizations. Obtainable at \$7.50 net cost.



Noises KILLED

- Six different types of line filters or AEROVOX NOISE ELIMINATORS to choose from in effectively killing those line noises.
- Simply plug in between appliance attachment-cord plug and outlet, or between set attachment-cord plug and outlet.
- For best results, use NOISE ANALYZER to select type and installation method for given application.

Ask your local AEROVOX jobber to show you the Noise Analyzer and the Noise Eliminators. Ask for your copy of "Clear Reception." Or write us direct.



NOW!

PUSH BUTTON TUNING

for EVERY Radio

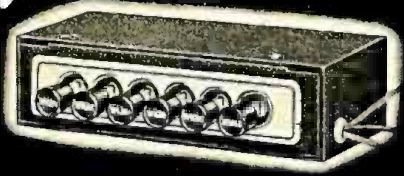

Every customer you have is a prospect for a push button installation. This device makes ANY radio a modern, up-to-the-minute push button set. Installed in a few minutes. Increase your profits by selling this compact, fool-proof unit! Write today for complete details!

Model B6 for 2 Gang Var. Cond. Receivers

LIST \$660

Service man's Net Price \$395

Model B61A for 3 and 4 Gang Var. Cond. Receivers

LIST \$725

Service man's Net Price \$425

- Only 3 leads to connect.
- 5 Push Buttons.
- Compact 5 1/4" wide, 1 1/2" high, 2 1/2" deep.
- Adaptable for remote control.
- Manual control of receiver as well as push button control.

- Completely shielded by metal container.
- Unit complete with instructions, oscutcheon, station tabs, hardware, etc.

AUTOMATIC DEVICE MANUFACTURERS
Dept. 4C, 4243 West Ogden Ave., Chicago, U. S. A.

★ *J. H. Clippinger*, vice-president and general sales manager of *Continental Radio & Television Corp.*, Chicago, narrowly missed participation in the recent Los Angeles flood. "J.H." barely managed to leave the Coast before the floods started raging. He returned to Chicago with substantial orders from the leading Coast centers, after visiting the trade with *Lou Willis*, Pacific Coast representative for *Admiral*.

★ *Earl Dietrich*, manager of distributor sales for the *Raytheon Production Corp.*, is back after a six weeks' swing around the Southeast circuit. He brought interesting reports of *Raytheon* distributors, indicating *Raytheon* tube sales ahead of the corresponding sales last year. The new *Raytheon Tube Data Book* is meeting with an enthusiastic reception everywhere and orders are coming in far beyond expectations. While on this trip, Mr. Dietrich attended the ham-fest Feb. 27, sponsored by the *Cameradio Co.*, Pittsburgh, Pa., leading parts jobbers. Notwithstanding a raging blizzard which made traveling most impossible, more than 900 attended. Generally speaking, Earl found the Southeastern states in better shape than those sections of the country in the industrial belt, with the jobbers anticipating favorable business for the remainder of the year.

★ Back into the radio business after a long absence on account of ill health, *Fred J. Wessner* has joined *Webster-Chicago* as sales promotion manager. Mr. Wessner was formerly sales manager for *National Union*. His offices will now be located at *Webster-Chicago's* home offices at 5622 *Bloomington Ave.*, Chicago. As he moved in, Mr. Wessner said: "Our plans are

Complete Electric Plants

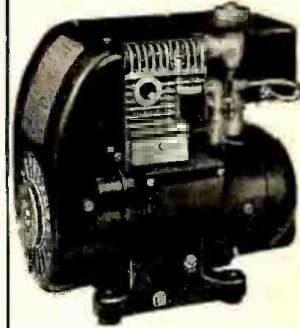

NEW
1938
MODELS
SIZES
350 to 5000
WATTS

COMPLETE POWER UNITS

Operating A.C. Radio, PUBLIC ADDRESS SYSTEMS, SOUND CARS, MOTION PICTURE EQUIPMENT, and RADIO TRANSMITTERS. Also furnish Power for Lights, Water Systems, Refrigerators, all Household Appliances for FARMS, CAMPS, LAKE HOMES, or STANDBY SERVICE. For use anywhere Power Line Current is not available.

A PLANT FOR EVERY PURPOSE

110 Volt A.C., 6, 12, 32 and 110 Volt, D.C. as well as Combination A.C.-D.C. Units. Anyone can Operate. COMPLETE, READY TO RUN.

WRITE FOR DETAILS ON DEALERS' PROPOSITION AND TERRITORY

D. W. ONAN & SONS
589 Royalston Ave., Minneapolis, Minn.

FREE

1938 CATALOG

new spring catalog

LAFAYETTE PUBLIC ADDRESS SYSTEMS

•

LAFAYETTE RADIOS

•

CAMERAS

Featuring the famous Lafayette economy line of Public Address — now completely redesigned! Amplifiers, advanced sound equipment . . . handsomer, finer in tone, greater in sales appeal! Latest systems, from 5 to 175 watts . . . new professional type recording equipment . . . de luxe portable line. Send for FREE catalog now — see P.A. on parade and more profits for you!

MAIL COUPON NOW

WHOLESALE RADIO SERVICE CO. INC.
NEW YORK, N.Y. • CHICAGO, ILL. • ATLANTA, GA.
100 SIXTH AVENUE 901 W. JACKSON BLVD. 240 PEACHTREE STREET
BOSTON, MASS. • BRONX, N.Y. • NEWARK, N.J. • JAMAICA, L.I.

WHOLESALE RADIO SERVICE CO., INC.
901 W. Jackson Blvd., Chicago • 100 Sixth Ave., New York
(MAIL TO NEAREST WAREHOUSE)
Rush the NEW SPRING Catalog No. 71-12C8

Name _____
Address _____
City _____ State _____

PASTE COUPON ON PENNY POST CARD



Wessner joins Webster-Chicago

to materially increase our program of sales assistance to jobbers and dealers as well as to improve upon our technical help liason with the trade."

E. H. RIETZKE PRES. OF CREI

IS RADIO . . . Just a Job to You?

If you can equip yourself with the necessary training . . . Radio can offer you a future no other industry can. Continuous new developments have created opportunities for technically trained men, who have kept their knowledge up with Radio's fast pace.

YOU CAN'T BLUFF YOUR WAY
CREI courses are planned only for serious-minded men who know that it takes Training to qualify for and to hold the big jobs and salaries that go with them. Let us suggest the course best suited for you and the easy ways of paying for it.

Write for the CREI "TESTED PLAN"

Paste the coupon below on a penny post card and receive your copy of this interesting and inspiring booklet.

CAPITOL RADIO Engineering Institute

MAIL THIS COUPON TODAY!

CAPITOL RADIO ENGINEERING INSTITUTE
Dept. RY3, 14th and Park Rd., Washington, D. C.
Please send me complete details and FREE illustrated 48-page booklet—"A Tested Plan for a Future in PRACTICAL RADIO ENGINEERING."

Name _____
Address _____
City _____ RY3

• INDEX •
TO ADVERTISEMENTS

	Page
ABC RADIO LABORATORIES.....	55
AEROVOX CORP.	61
ALLIED RADIO CORP.....	64
AMERICAN MICROPHONE CO., INC.....	54
AMPERITE CO.	35
ARCTURUS RADIO TUBE CO.....	51
AUTOMATIC DEVICE MFRS.....	62
BELMONT RADIO CORP.....	27
BOGEN CO., INC., DAVID.....	59
CAPITOL RADIO ENGINEERING INSTITUTE	62
CENTRALAB	52
CLOUGH-BRENGLE CO.	54
COLUMBIA BROADCASTING SYSTEM, INC. 8, 9	
CONTINENTAL CARBON, INC.....	45
CONTINENTAL RADIO & TELEVISION CORP. 19	
CORNELL-DUBILIER ELEC. CORP.....	4
CROSLY RADIO CORP.....	6
CROWE NAME PLATE & MFG. CO.....	60
GALVIN MFG. CORP.....	Cover 4
GENERAL ELECTRIC CO.....	Cover 2
GENERAL INDUSTRIES CO.....	59
GOODMAN'S DISPLAY SPECIALTIES.....	64
HICKOK ELECTRICAL INSTRUMENT CO....	58
HYGRADE SYLVANIA CORP.....	33
INTERNATIONAL RADIO CORP.	55
INTERNATIONAL RESISTANCE CO.....	41
JANETTE MFG. CO.	54
JOHNSON MOTORS	3
KEN-RAD TUBE & LAMP CORP.....	58
MALLORY & CO., INC., P. R.....	1
NATIONAL UNION RADIO CORP.....	53
NOBLITT-SPARKS INDUSTRIES, INC.....	31
OHMITE MFG. CO.....	55
ONAN & SONS, D. W.....	62
PHILCO RADIO & TELEV. CORP., TUBE DIV. 5	
PIONEER GEN-E-MOTOR CORP.....	50
PRECISION APPARATUS CORP.....	60
QUAM-NICHOLS CO.	55
RADIART CORP.	50
RADIO CORP. OF AMERICA.....	7
RADIO PARTS SHOW.....	50
RADIO SERVICE MEN OF AMERICA, INC... 57	
RADOLEK	60
RAYTHEON PRODUCTION CORP.....	43
RCA MFG. CO., INC., RADIOTRON DIV..... 29	
RCA MFG. CO., INC., RCA-VICTOR DIV..... 2	
READRITE METER WORKS.....	56
RECOTON CORP.	58
REGAL AMPLIFIER MFG. CORP.....	56
RIDER, JOHN F.....	45
SOLAR MFG. CORP.....	63
STROMBERG-CARLSON TELE. MFG. CO..... 21	
THORDARSON ELECTRIC MFG. CO.....	49
TOPSTREEM, INC.	58
TRAV-LER RADIO & TELEVISION CORP.... 53	
TRIPLETT ELEC. INSTRUMENT CO.	48
TUNG-SOL LAMP WORKS, INC.....	45
WARD PRODUCTS CORP.....	Cover 3
WEBSTER-CHICAGO	37
WESTON ELEC. INSTRUMENT CORP.....	47
WHOLESALE RADIO SERVICE CO., INC..... 62	

While every precaution is taken to insure accuracy, we cannot guarantee against the possibility of an occasional change or omission in the preparation of this index.

STARTLING



Illustration Exact Size.

**8 MFD . . . 100 VOLTS WORKING
SMALLER METAL SEALED**

SOLAR MINICAP Dry Electrolytic Capacitors mark much more than an advance in an art. They mean that filters now occupy less space, cost less, have longer life because of permanent sealing, are used in single units to simplify both production and stock-keeping, and are "standard" parts.

Solar engineers have been the pioneers in advanced methods of making radically smaller dry electrolytic capacitors. "little giants", introduced three years ago, were the original ultra-compact dries. Now we announce further size reduction, superior characteristics and outstanding utility in the new Minicaps. You will find them in thousands of radio sets—and they will stay there.

Details upon Request.

SOLAR MFG. CO., 599 Bway., New York



Southern jobbers huddle at Atlanta, Ga., for recent merchandising session with Hygrade Sylvania sales executives.

★ From 21 radio and electric wholesale supply houses in the South came representatives for a big tube sales conference held by Hygrade Sylvania recently at Atlanta, Ga. Complete merchandising plans for 1938 were outlined and a long string of new tube sales promotion were presented. Those at the conference are shown in the exclusive photo presented herewith. (1) A. J. Wheeler, Chattanooga Paper and Woodware Co., Chattanooga, Tenn.; (2) F. J. Gordon, Beck and Gregg Hdwe. Co., Atlanta, Ga.; (3) William Rawson, Clary-Marsh, Inc., Birmingham,

Ala.; (4) W. W. Orr, Freck Radio Supply Co., Asheville, N. C.; (5) T. T. Freck, same firm; (6) W. A. Shuler, Shuler Supply Co., New Orleans, La.; (7) Harold Davis, Harold Davis, Inc., Jackson, Miss.; (8) Eben E. Nelson, Nelson Radio and Supply Co., Mobile, Ala.; (9) W. Ross Hahn, Tele Radio Supply Co., Knoxville, Tenn.; (10) E. C. Ammerman, Radio Accessories Co., Orlando, Fla.; (11) Frank Lampe, Dixie Radio Supply Co., Columbia, S. C.; (12) G. C. Hoffman, same firm; (13) H. M. Carpenter, Thurrow Distributors, Inc., Tampa, Fla.; (14) J. C. Jordan, Specialty Distributing Co., Atlanta, Ga.; (15) J. A. Rawson, Clary-Marsh, Inc., Birmingham, Ala.; (16) G. C. Dickey, Radio Electric Co., Birmingham, Ala.; (17) Fred Daly, Birmingham Electric Co., Birmingham, Ala.; (18) Paul Lambeth, Lambeth Electric Supply Co., Winston-Salem, N. C.; (19) F. F. Dill, Chattanooga Paper and Woodware Co., Chattanooga, Tenn.; (20) Harry Kerlin, Radio Electric Co., Birmingham, Ala.; (21) D. M. McInnes, Teague Hardware Co., Montgomery, Ala.; (22) J. C. Luttrell, Atlanta Phonograph Co., Atlanta, Ga.; (23) Fred A. Morris, Specialty Distributing Co., Atlanta, Ga.; (24) C. W. Chapman, Fulwiler and Chapman, Atlanta, Ga.; (25) R. H. Ammerman, Radio Accessories Co., Orlando, Fla.; (26) Ira J. Pardee, Tele Radio Supply Co., Chattanooga, Tenn.; (27) Reis M. Hillard, Tele Radio Supply Co., Knoxville, Tenn.; (28) John C. Carter, same firm; (29) B. W. Krell, Dixie Radio Co., Columbia, S. C.; (30) J. T. Fulwiler, Fulwiler and Chapman, Atlanta, Ga.; (31) Paul S. Ellison, Hygrade Sylvania Corp., New York, N. Y.; (32) F. F. Baudry, Dixie Radio Co., Columbia, S. C.; (33) L. E. Salmon, Tennessee Valley Electric Supply Co., Tupelo, Miss.; (34) A. L. Milk, Hygrade Sylvania Corp., Emporium, Pa.; (35) H. L. Garvin, Garvin Electric Co., Atlanta, Ga.; (36) R. P. Almy, Hygrade Sylvania Corp., New York, N. Y.; (37) H. W. Frisbee, Specialty Distributing Co., Atlanta, Ga.

★ L. H. Sullivan has resigned as manager of RCA's farm radio division, and will soon announce his future plans.

★ The *Detrola Corp.* of Detroit, announces it has secured an injunction in chancery against Marks Stores, Inc., doing business as Boyer's Haunted Shacks. This injunction ordered Marks Stores, Inc., to stop the use of "Pee Wee" or a hand in any form or manner in advertising or offering for sale its radio merchandise similar to the *Detrola* copyrighted material.

★ New radio and appliance store in Davenport, Iowa, is *L. K. Wild Appliances*, at 218 Brady St. *L. K. Wild*, the owner, has been with the local branch of *Schneiderhahn's* retail store for the last 11 years.

● Get this brand new guide to Everything in Radio, FREE—just send coupon! Service men and service departments everywhere find what they want, quickly, in ALLIED'S Catalog. Over 12,000 exact duplicate and replacement parts for building or repairing any circuit; all leading lines of Testers—analyzers, tube-checkers, set-testers, meters, signal generators; revolutionary new Sound Systems, 10 to 70 watts, portable, mobile, permanent, Builder's Kits, Amateur Gear, books, tools, etc.—and 36 sensational new "Knight" Radios, with newest features—Push-Button Tuning, etc., at new low prices, sets for every purpose—some under \$10, ideal price-leaders for dealers. You'll find 164 pages of special values in ALLIED'S new Spring Catalog—just out! Send Coupon now for FREE copy.

ALLIED RADIO CORP.
 833 W. Jackson Blvd. Dept. 15-C
 Chicago, Ill.
 Send me your new Spring-and-Summer Catalog—FREE.
 NAME
 ADDRESS
FREE-SEND COUPON

LIGHT! ACTION! SOUND!
 FOR YOUR WINDOW, SHOWROOM OR CONVENTIONS

Used in sales promotion and advertising departments to increase orders from retailers and to get new accounts.

A sensational new display unit with great drawing-power. Comes ready for use; place in position and plug into any AC outlet. . . Sets can be played while the unit is in motion. . . Three models—No. 1A—100 lbs. carrying capacity, net price \$18.00; No. 2A—125 lbs., \$20.00; No. 3A—150 lbs., \$23.00. . . Easily holds 4 or 5 midsets at one time, or combination of console and midset or end table.

Rotating surface can be increased by adding larger disk. Base can be skirted with concealed lights to illuminate the display. . . **Special introductory offer**—Genuine Lamituxe message band, on which advertising message can be placed and illuminated.

We have a variety of turntables without illumination, from \$9 to \$15. Carrying capacity 25-75 lbs.

Mystery Motion Display. makes articles glide zig-zag style continuously—any mdse. up to 5 lbs.



GOODMAN'S

"ROTARY RADIO DISPLAY SPECIALTIES"

Helps you to move your present stock
 19 W. 34TH ST. Tel.: Wisconsin 7-8951 NEW YORK

MAKE MORE MONEY WITH WARD AERIALS!

The Line That's EASY TO SELL, EASY TO INSTALL

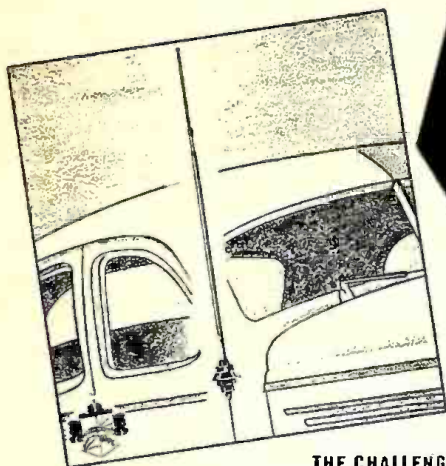

THE CHALLENGER

A low-priced, fast-selling telescopic hinge-type aerial. Features the new Easy-Tilt contour bracket. Rust-proof. Fits all cars. No drilling or cementing required. Full size. Heavy construction.

SELLS AT
ONLY
\$1.95

SELLS AT
ONLY
\$3.50

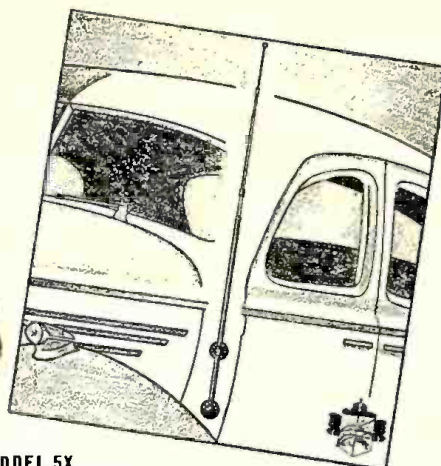

MODEL 5X

A real profit maker for you! A quality, 3-section cowl mounting aerial. Rust-proof. Beautiful bright plate finish. Same type as featured by leading car makers. Heavy construction. Easily installed.

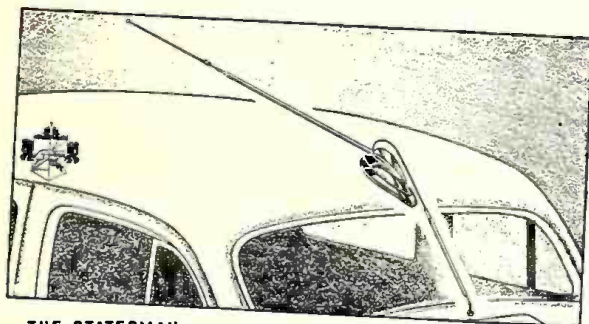

THE STATESMAN

A new WARD top aerial that fits all cars. Top bar extends to 35½ inches. Telescopic cowl bar permits windshields to open. Guaranteed rust-proof. Easy, fast installation.

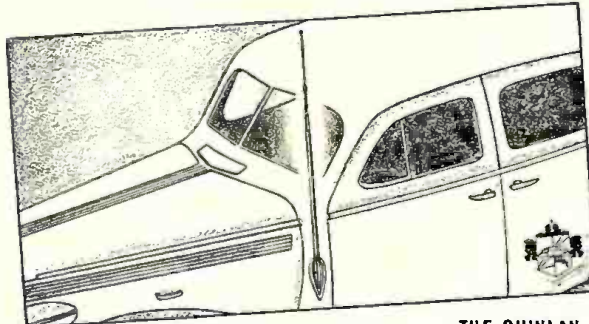

THE QUINLAN

A streamlined, 2-section, side-cowl aerial, with attractive guaranteed rust and corrosion-proof finish. Telescopic, extends from 28½ to 49½ inches. No soldering. Easily installed.

● There's big money in selling car aerials—when you sell the WARD line. That's because this "easy-to-sell," "easy-to-install" line is *complete* with models at prices to suit every prospect.

Each model fits any style or make of car with no "top drilling" required. And backing up this "all-star" line is WARD'S kit of salesmakers — newspaper advertisements, envelope stuffers, counter display, window decals — everything you need to step up sales is furnished!

Write *today* for complete details on this new money-making opportunity.

WARD'S NEW COUNTER DISPLAY — This colorful, attractive counter display unit will do a real selling job for you. It's *free* for WARD dealers.

FREE!!

Send today for free catalog showing WARD'S complete line of car and home aerials, with new reduced prices now in effect.



The **WARD PRODUCTS Corp.**

WARD BUILDING

CLEVELAND, OHIO

IN CANADA: 500 KING STREET, WEST, TORONTO, ONTARIO

BREAKING ALL RECORDS!

AMERICA'S *Finest* CAR RADIO
IS TODAY'S *Fastest* SELLING RADIO

Motorola

**ELECTRIC
PUSH-BUTTON TUNING**

**"ACE" FEATURES THAT
MAKE SELLING EASY**

- ♠ ELECTRIC Push-Button TUNING
AUTOMATIC — FAST —
ACCURATE
- ♥ ACOUSTINATOR — Personal
Preference Selector —
THRILLINGLY NEW
- ♣ AUTOMATIC "Spot" TUNING
"CLICK"—Your Station's on
the Spot
- ♦ EXACTLY MATCHES
THE DASH OF ALL CARS



MODEL
"8-60"
ELECTRIC
Push-Button
TUNING . . . 6
Tubes—Acous-
tinator . . . Col-
ored Buttons
for Favorite
Network
Stations
\$59.95

**COLORFUL
NETWORK
BUTTONS**



MODEL "8-70"
AUTOMATIC "Spot" TUNING
Acoustinator Equipped
8 Tubes — Push Pull
8" External Permanent
Magnet Dynamic Speaker
\$69.95



MODEL "8-30"
6 Tubes — 5½" Speaker
Streamlined Styling
3-Gang Tuning Condenser
Matches All Cars
\$29.95



MODEL "8-50"
AUTOMATIC "Spot" TUNING
Acoustinator Equipped
6 Tubes — 8" Speaker
Installs Over Steering Post
Matches All Cars
\$49.95



MODEL "8-40"
AUTOMATIC "Spot" TUNING
6 Tubes — 6½" Speaker
Tone and Sensitivity Controls
3-Gang Tuning Condenser
Matches All Cars
\$39.95



"GOLDEN VOICE"
ELECTRIC Push-Button
TUNING
8 Tubes—8" Permanent
Magnet Dynamic Speaker
Beam Power Tube
The Finest Money Can Buy
\$79.95

WRITE YOUR DISTRIBUTOR or GALVIN MFG. CORPORATION, CHICAGO

**NOW SELL THE RADIO
THAT PEOPLE WANT TO BUY!**

Motorola
AMERICA'S FINEST AUTO RADIO